

UNITED STATES PATENT AND TRADEMARK OFFICE

BEFORE THE PATENT TRIAL AND APPEAL BOARD

INTEL CORPORATION,
Petitioner,

v.

QUALCOMM INCORPORATED,
Patent Owner.

IPR2019-00129
Patent 9,154,356 B2

Before MICHELLE N. WORMMEESTER, AMANDA F. WIEKER, and
AARON W. MOORE, *Administrative Patent Judges*.

WORMMEESTER, *Administrative Patent Judge*.

JUDGMENT
Final Written Decision
Determining No Challenged Claims Unpatentable
35 U.S.C. § 318(a)

I. INTRODUCTION

Intel Corporation¹ (“Petitioner”) filed a Petition (Paper 3, “Pet.”) requesting an *inter partes* review of claims 2–6 and 10 of U.S. Patent No. 9,154,356 B2 (Ex. 1401, “the ’356 patent”). Qualcomm Incorporated (“Patent Owner”) filed a Preliminary Response. Paper 7 (“Prelim. Resp.”). Pursuant to 35 U.S.C. § 314, we instituted an *inter partes* review of challenged claims 2–6 and 10 based on all the grounds presented in the Petition. Paper 9 (“Inst. Dec.”). Patent Owner filed a Response (Paper 13, “PO Resp.”), Petitioner filed a Reply (Paper 20, “Pet. Reply”), and Patent Owner filed a Sur-reply (Paper 26, “PO Sur-reply”). On February 27, 2020, we conducted an oral hearing. A copy of the transcript (Paper 35, “Tr.”) is included in the record.

We have jurisdiction under 35 U.S.C. § 6(b). For the reasons that follow, we determine that Petitioner has not shown by a preponderance of the evidence that claims 2–6 and 10 of the ’356 patent are unpatentable. This final written decision is issued pursuant to 35 U.S.C. § 318(a).

II. BACKGROUND

A. *Related Proceedings*

The parties identify a federal district court case in which Patent Owner asserted the ’356 patent against Apple: *Qualcomm Incorporated v. Apple Incorporated*, No. 3:17-cv-02398 (S.D. Cal.). Pet. 1; Paper 4, 1. Petitioner indicates that the district court has dismissed this case. Paper 8, 1.

¹ Intel Corporation identifies itself and Apple Inc. (“Apple”) as real parties in interest. Paper 3, 1.

The parties also identify an International Trade Commission (“ITC”) investigation in which Patent Owner asserted the ’356 patent against Apple. Pet. 1; Paper 4, 1. According to Petitioner, the ITC has terminated the investigation. Paper 14, 2.

In addition, the parties identify four other petitions for *inter partes* review involving the ’356 patent that Petitioner has filed, namely, Cases IPR2019-00047, IPR2019-00048, IPR2019-00049, and IPR2019-00129. Pet. 1; Paper 4, 1.

B. The ’356 Patent

The ’356 patent describes low noise amplifiers. Ex. 1401, 1:15–16. Figure 6A, which is reproduced below, illustrates an example of a low noise amplifier according to the ’356 patent. *Id.* at 1:54–55.

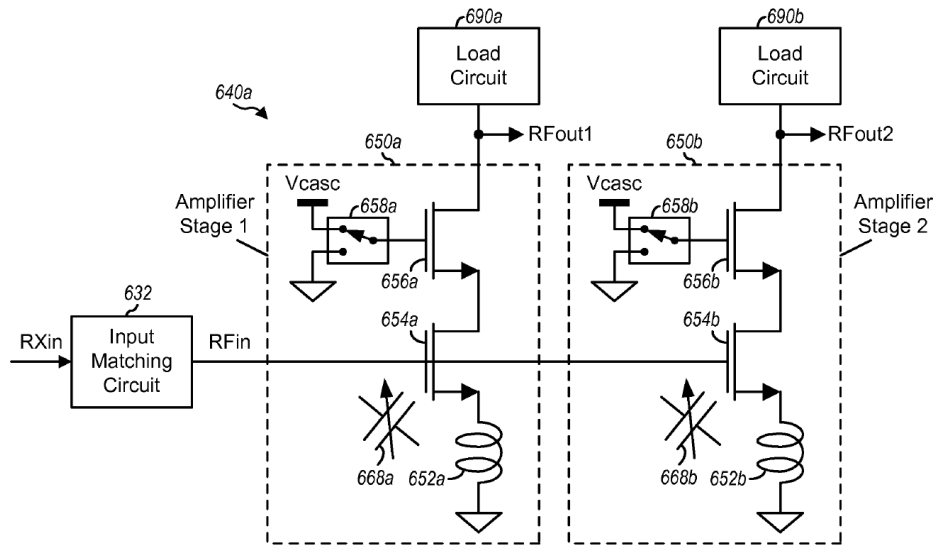

FIG. 6A

In particular, Figure 6A shows carrier aggregation low noise amplifier 640a, which has two amplifier stages 650a and 650b. *Id.* at 7:44–49. Amplifier stage 650a includes source degeneration inductor 652a, gain transistor 654a, cascode transistor 656a, and switch 658a. *Id.* at 7:58–8:4. Similarly,

amplifier stage 650b includes source degeneration inductor 652b, gain transistor 654b, cascode transistor 656b, and switch 658b. *Id.* at 8:4–9. Both amplifier stages 650a and 650b are coupled to common input matching circuit 632 and to respective load circuits 690a and 690b. *Id.* at 7:47–49.

In operation, matching circuit 632 receives receiver input signal RX_{in}, performs input matching for low noise amplifier 640a, and provides input RF signal RF_{in} to low noise amplifier 640a. *Id.* at 7:49–52. Input RF signal RF_{in} may include transmissions on one set of carriers or transmissions on two sets of carriers in the same band, each set including one or more carriers. *Id.* at 7:55–57, 8:16–18, 8:30–32. An RF signal with transmissions on multiple sets of carriers is called a carrier aggregated RF signal. *Id.* at 8:16–18.

Low noise amplifier 640a operates in either a non-carrier aggregation (non-CA) mode or a carrier aggregation (CA) mode, depending on the type of input RF signal it receives. *Id.* at 8:24–32, 8:36–44. In the non-CA mode, low noise amplifier 640a receives transmissions on one set of carriers and provides one output RF signal to one load circuit. *Id.* at 8:30–32. Only one amplifier stage is enabled, while the other amplifier stage is disabled. *Id.* at 8:46–47. To illustrate, Figure 6C is reproduced below.

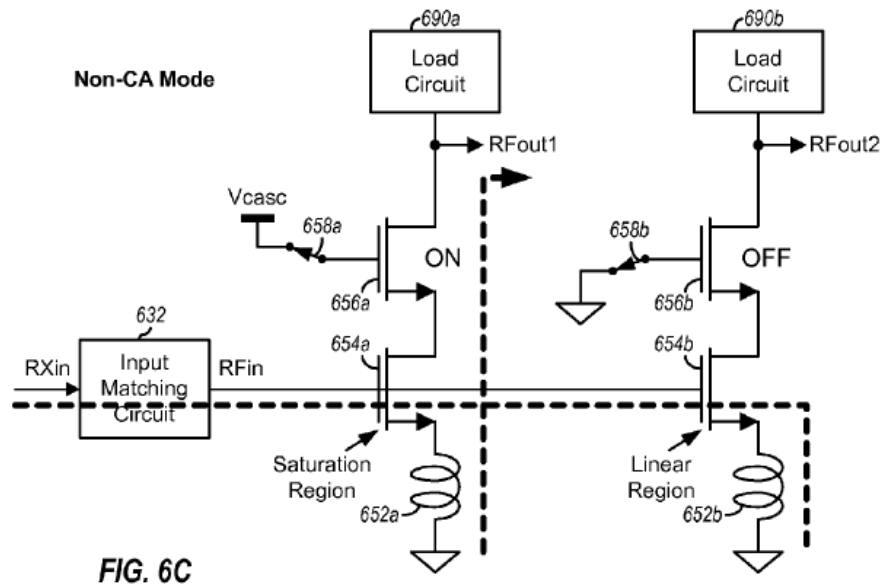

Figure 6C shows low noise amplifier 640a operating in the non-CA mode. *Id.* at 8:45–46. Amplifier stage 650a is enabled by connecting the gate of cascode transistor 656a to the Vcasc voltage via switch 658a, and amplifier stage 650b is disabled by shorting the gate of cascode transistor 656b to circuit ground via switch 658b. *Id.* at 8:47–52. Amplifier stage 650a amplifies the input RF signal and provides an output RF signal to load circuit 690a. *Id.* at 8:52–54.

In the CA mode, low noise amplifier 640a receives transmissions on two sets of carriers and provides two output RF signals to two load circuits, one output RF signal for each set of carriers. *Id.* at 8:32–35. Both amplifier stages are enabled. *Id.* at 8:37–38. To illustrate, Figure 6B is reproduced below.

Explore Litigation Insights

Docket Alarm provides insights to develop a more informed litigation strategy and the peace of mind of knowing you're on top of things.

Real-Time Litigation Alerts



Keep your litigation team up-to-date with **real-time alerts** and advanced team management tools built for the enterprise, all while greatly reducing PACER spend.

Our comprehensive service means we can handle Federal, State, and Administrative courts across the country.

Advanced Docket Research



With over 230 million records, Docket Alarm's cloud-native docket research platform finds what other services can't. Coverage includes Federal, State, plus PTAB, TTAB, ITC and NLRB decisions, all in one place.

Identify arguments that have been successful in the past with full text, pinpoint searching. Link to case law cited within any court document via Fastcase.

Analytics At Your Fingertips



Learn what happened the last time a particular judge, opposing counsel or company faced cases similar to yours.

Advanced out-of-the-box PTAB and TTAB analytics are always at your fingertips.

API

Docket Alarm offers a powerful API (application programming interface) to developers that want to integrate case filings into their apps.

LAW FIRMS

Build custom dashboards for your attorneys and clients with live data direct from the court.

Automate many repetitive legal tasks like conflict checks, document management, and marketing.

FINANCIAL INSTITUTIONS

Litigation and bankruptcy checks for companies and debtors.

E-DISCOVERY AND LEGAL VENDORS

Sync your system to PACER to automate legal marketing.