



US008442473B1

(12) **United States Patent**  
**Kaukovuori et al.**

(10) **Patent No.:** **US 8,442,473 B1**  
(45) **Date of Patent:** **May 14, 2013**

(54) **METHODS OF RECEIVING AND RECEIVERS**

(75) Inventors: **Jouni Kristian Kaukovuori**, Vantaa (FI); **Aamo Tapio Parssinen**, Espoo (FI); **Antti Oskari Immonen**, Helsinki (FI)

(73) Assignee: **Renesas Mobile Corporation**, Tokyo (JP)

(\* ) Notice: Subject to any disclaimer, the term of this patent is extended or adjusted under 35 U.S.C. 154(b) by 35 days.

(21) Appl. No.: **13/300,004**

(22) Filed: **Nov. 18, 2011**

(30) **Foreign Application Priority Data**

Nov. 17, 2011 (GB) ..... 1119888.4

(51) **Int. Cl.**  
**H04B 1/26** (2006.01)

(52) **U.S. Cl.**  
USPC ..... **455/323; 455/334; 455/550.1; 375/324**

(58) **Field of Classification Search** ..... 455/313, 455/323, 324, 334, 339-341, 550.1; 375/324  
See application file for complete search history.

(56) **References Cited**

**U.S. PATENT DOCUMENTS**

6,356,746	B1 *	3/2002	Katayama	.....	455/324
6,785,529	B2 *	8/2004	Ciccarelli et al.	.....	455/324
7,526,052	B2 *	4/2009	Davidoff et al.	.....	375/350
7,783,275	B2 *	8/2010	Wakayama et al.	.....	455/333
2003/0138032	A1	7/2003	Shi et al.		
2004/0224654	A1	11/2004	Javor et al.		
2007/0211837	A1	9/2007	Zipper		
2008/0112470	A1	5/2008	Cleveland et al.		
2010/0104001	A1	4/2010	Lee et al.		

2010/0118923	A1	5/2010	Pal	
2010/0210272	A1	8/2010	Sundström et al.	
2011/0268232	A1	11/2011	Park et al.	..... 375/344

**FOREIGN PATENT DOCUMENTS**

EP	2 141 818	A1	1/2010
EP	2 378 670	A2	10/2011
WO	WO 00/11794	A1	3/2000
WO	WO 2010/092167		8/2010
WO	WO 2010/129584	A1	11/2010
WO	WO 2013/024450	A1	2/2013

**OTHER PUBLICATIONS**

R4-113595, 3GPP TSG RAN WG4 Meeting #59AH, Bucharest, Romania, Jun. 27-Jul. 1, 2011, ST-Ericsson/Ericsson, "Non-Contiguous Carrier Aggregation Configurations", (5 pages).

(Continued)

*Primary Examiner* — Nhan Le

(74) *Attorney, Agent, or Firm* — Lucas & Mercanti LLP; Robert P. Michal

(57) **ABSTRACT**

Data transmitted via a combination of radio frequency RF signals using carrier aggregation CA is received, each RF signal occupying a respective RF band, the bands being arranged in two groups separated in frequency by a first frequency region, the first of the two groups occupying a wider frequency region than the second group. Inphase and quadrature components of the RF signals are filtered using a first bandpass filter bandwidth to give first bandpass filtered components and filtered using a second bandpass filter bandwidth, different from the first bandpass filter bandwidth, to give second bandpass filtered components. A reconfigurable receiver is configurable to a first mode to receive the combination of RF signals, and is also configurable to at least a second mode. A filter is configured, in different modes, to use a first or a lowpass bandpass filter bandwidth.

**20 Claims, 18 Drawing Sheets**

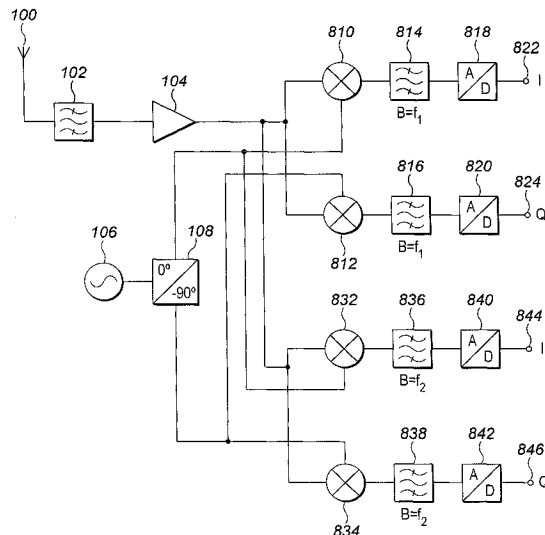

## OTHER PUBLICATIONS

R4-113494, TSG-RAN Working Group 4 (Radio) Meeting #59AH, Bucharest, Romania, Jun. 27-Jul. 1, 2011, ZTE, "Handling the Interferences in the NC\_GAP in NC\_4CHSDPA", (3 pages).

3GPP TS 25.101 (see Table 7.2C), User Equipment (UE) radio transmission and reception (FDD) Specification Detail (4 pages). Available on-line: <http://www.3gpp.org/ftp/specs/html-info/25101.htm>, Feb. 21, 2012.

Ericsson, 3 GPP TSG-RAN Meeting #51, RP-110416, Kansas City, Missouri, USA Mar. 15-18, 2011, "Non-contiguous 4C-HSDPA Operation, Core-Part, 4C Performance Part" (13 pages).

Nokia Corporation, 3GPP TSG-RAN Meeting #52, RP-110732, Bratislava, Slovakia, May 31, Jun. 3, 2011, "LTE Carrier Aggregation Enhancements, Core-Part, Performance" (17 pages).

Ericsson, 3GPP TSG-RAN Meeting #60, Tdoc R4-114401, Athens, Greece, Aug. 22, 26, 2011, "Feedback on non contiguous carrier aggregation feasibility," (2 pages).

Renesas Electronics Europe, 3GPP TSG-RAN WG4 Meeting #58, RF-111965, Shanghai, China, Apr. 10-15, 2011, "Considerations on RSTD measures and carrier aggregation." (9 pages).

Ericsson, 3GPP TSG-RAN WG4 Meeting #61, R4-115583, San Francisco, California, Nov. 14-18, 2011, "Scenarios for non-continuous intra-band CA," (7 pages).

Non-Final Office Action dated Feb. 28, 2013 issued in a related U.S. Appl. No. 13/677,776 (12 pages).

UKIPO Combined Search and Examination Report under Sections 17 and 18(3) dated Mar. 15, 2012 issued in a related British Application No. GB1119887.6 (5 pages).

UKIPO Combined Search and Examination Report under Sections 17 and 18(3) dated Mar. 19, 2012 issued in a related British Application No. GB1119888.4 (5 pages).

UKIPO Combined Search and Examination Report under Section 17 and 18(3) dated Dec. 7, 2012 issued in a related British Application No. GB1219626.7 (6 pages).

PCT Notification of Transmittal of the International Search Report and the Written Opinion and PCT International Search Report, PCT Written Opinion mailed Feb. 25, 2013 issued in a related PCT Application No. PCT/IB2012/056441 (15 pages).

Pietro Andreani, et al., "A CMOS  $g_m$ -C Polyphase Filter with High Image Band Rejection," Solid-State Circuits Conference, 2000, Proceedings of the 26 Round European, IEEE, pp. 272-275, XP031952366 (4 pages).

Nokia et al., 3GPP TSG-RAN WG4 Meeting 2010 AH#4, R4-103677, Xi'an, China, Oct. 11-15, 2010, "Image Rejection in intraband carrier aggregation" (8 pages).

Toru Kitayabu., "Concurrent Dual-Band Receiver for Spectrum Aggregation System," Radio and Wireless Symposium, 2009, RWS 2009, IEEE, Piscataway, NJ, USA, pp. 634-637 XP031457487 (4 pages).

PCT Notification of Transmittal of the International Search Report and the Written Opinion and PCT International Search Report, PCT Written Opinion mailed Mar. 13, 2013, all of which was issued in a related PCT Application No. PCT/IB2012/056440 (15 pages).

\* cited by examiner

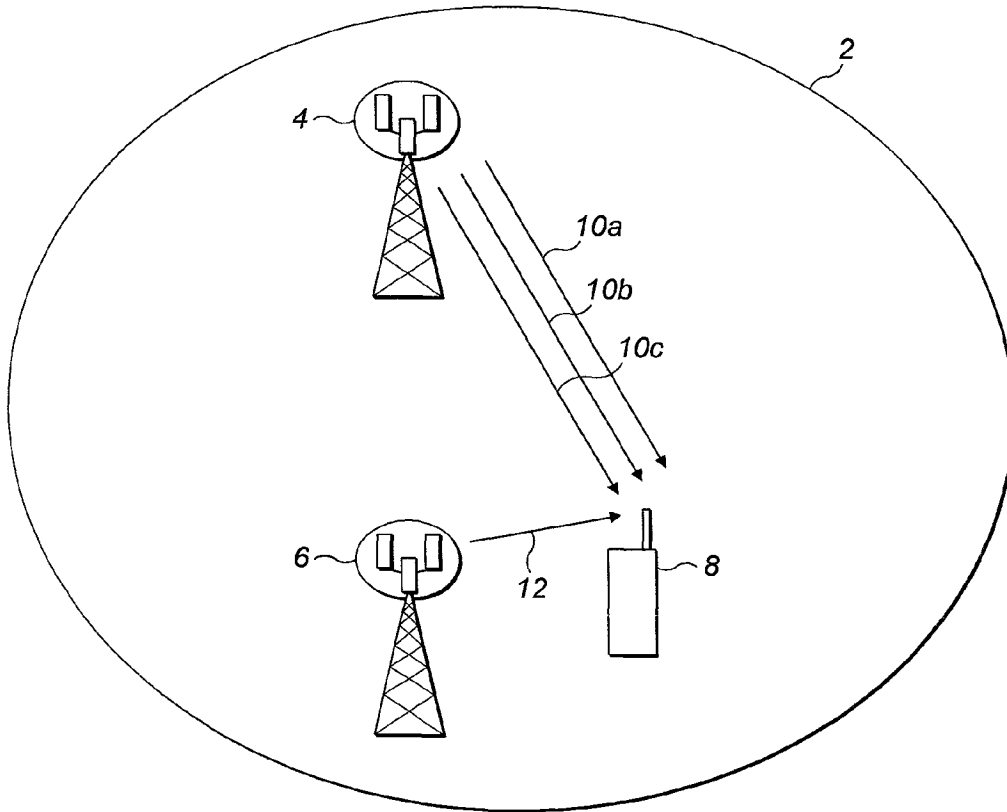

FIG. 1

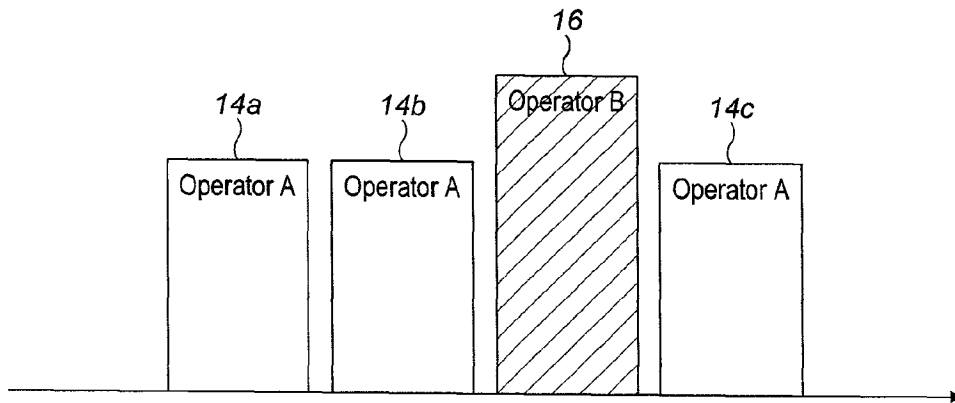

FIG. 2

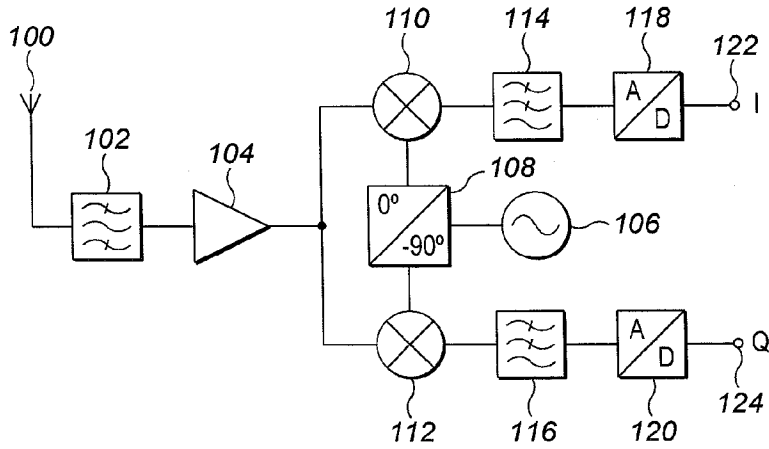

FIG. 3

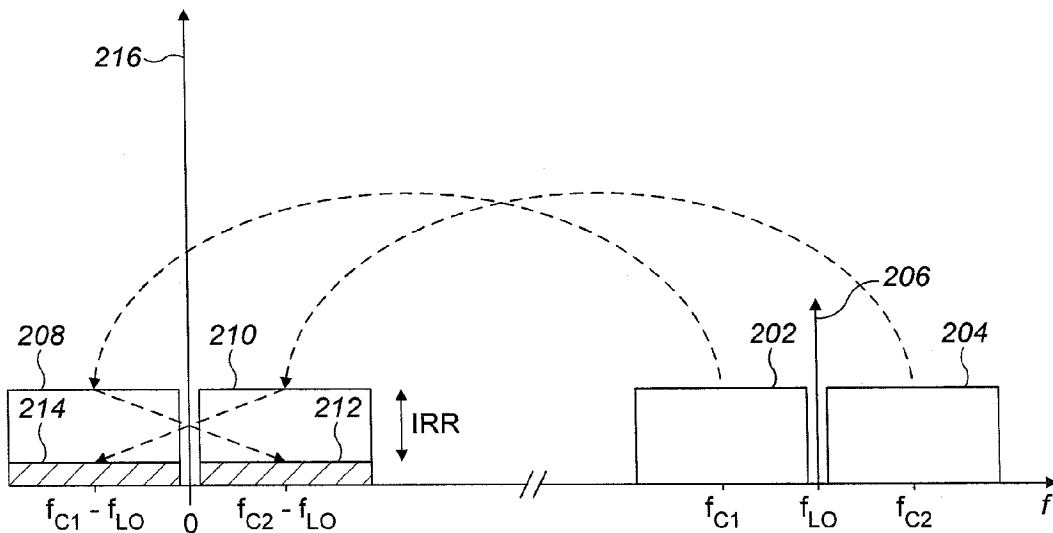

FIG. 4

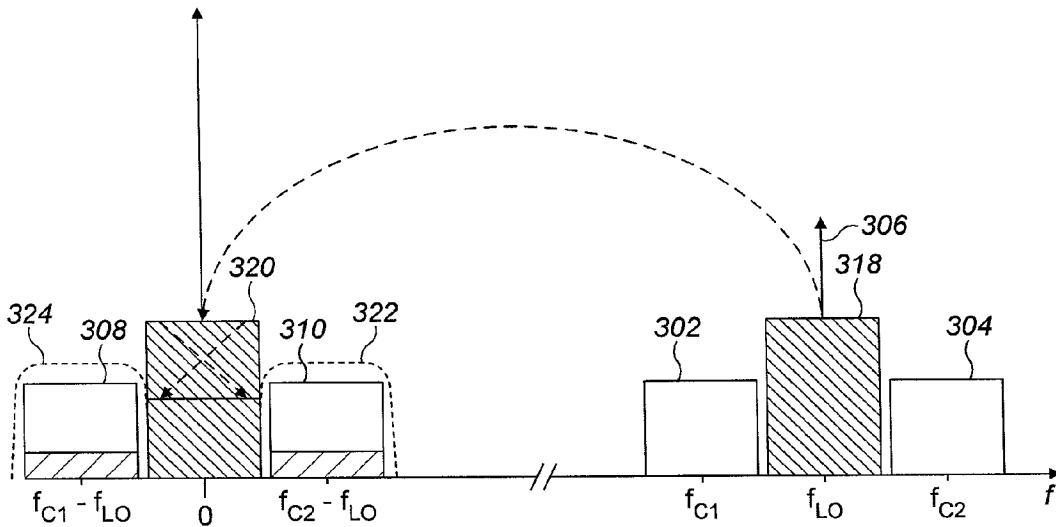

FIG. 5

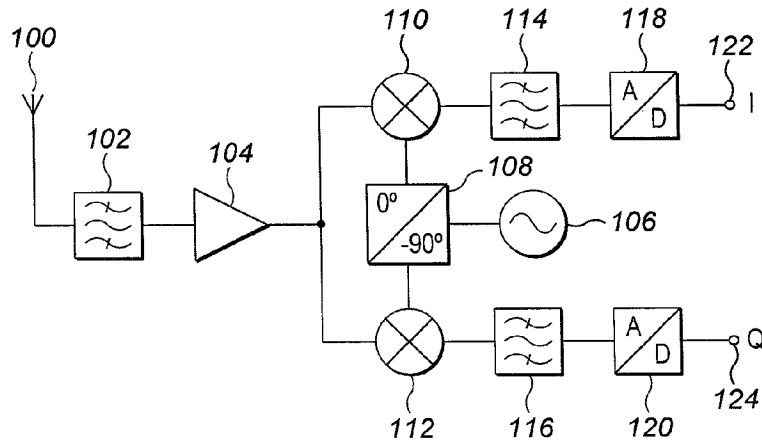

FIG. 6

# Explore Litigation Insights

Docket Alarm provides insights to develop a more informed litigation strategy and the peace of mind of knowing you're on top of things.

## Real-Time Litigation Alerts



Keep your litigation team up-to-date with **real-time alerts** and advanced team management tools built for the enterprise, all while greatly reducing PACER spend.

Our comprehensive service means we can handle Federal, State, and Administrative courts across the country.

## Advanced Docket Research



With over 230 million records, Docket Alarm's cloud-native docket research platform finds what other services can't. Coverage includes Federal, State, plus PTAB, TTAB, ITC and NLRB decisions, all in one place.

Identify arguments that have been successful in the past with full text, pinpoint searching. Link to case law cited within any court document via Fastcase.

## Analytics At Your Fingertips



Learn what happened the last time a particular judge, opposing counsel or company faced cases similar to yours.

Advanced out-of-the-box PTAB and TTAB analytics are always at your fingertips.

## API

Docket Alarm offers a powerful API (application programming interface) to developers that want to integrate case filings into their apps.

## LAW FIRMS

Build custom dashboards for your attorneys and clients with live data direct from the court.

Automate many repetitive legal tasks like conflict checks, document management, and marketing.

## FINANCIAL INSTITUTIONS

Litigation and bankruptcy checks for companies and debtors.

## E-DISCOVERY AND LEGAL VENDORS

Sync your system to PACER to automate legal marketing.