



- (51) **International Patent Classification:**
H04B 7/04 (2006.01) *H04J 11/00* (2006.01)
- (21) **International Application Number:**
PCT/KR2011/004933
- (22) **International Filing Date:**
6 July 2011 (06.07.2011)
- (25) **Filing Language:** English
- (26) **Publication Language:** English
- (30) **Priority Data:**
61/364,806 16 July 2010 (16.07.2010) US
- (71) **Applicant (for all designated States except US):** **LG ELECTRONICS INC.** [KR/KR]; 20, Yeouido-dong, Yeongdeungpo-gu, Seoul 150-721 (KR).
- (72) **Inventors; and**
- (75) **Inventors/Applicants (for US only):** **LIM, Suhwan** [KR/KR]; 533, Hogue-Dong, Dongan-Gu, Anyang, Gyeonggi-Do 431-080 (KR). **JUNG, Manyoung** [KR/KR]; 533, Hogue-Dong, Dongan-Gu, Anyang, Gyeonggi-Do 431-080 (KR). **YANG, Yoonoh** [KR/KR]; 533, Hogue-

Dong, Dongan-Gu, Anyang, Gyeonggi-Do 431-080 (KR). **LEE, Sangwook** [KR/KR]; 533, Hogue-Dong, Dongan-Gu, Anyang, Gyeonggi-Do 431-080 (KR).

(74) **Agent:** **PARK, Jang-Won**; 3rd Floor, Shinyoung Wacoal Bldg., 49-4 Nonhyun-dong, Gangnam-gu, SEOUL 135-814 (KR).

(81) **Designated States (unless otherwise indicated, for every kind of national protection available):** AE, AG, AL, AM, AO, AT, AU, AZ, BA, BB, BG, BH, BR, BW, BY, BZ, CA, CH, CL, CN, CO, CR, CU, CZ, DE, DK, DM, DO, DZ, EC, EE, EG, ES, FI, GB, GD, GE, GH, GM, GT, HN, HR, HU, ID, IL, IN, IS, JP, KE, KG, KM, KN, KP, KR, KZ, LA, LC, LK, LR, LS, LT, LU, LY, MA, MD, ME, MG, MK, MN, MW, MX, MY, MZ, NA, NG, NI, NO, NZ, OM, PE, PG, PH, PL, PT, RO, RS, RU, SC, SD, SE, SG, SK, SL, SM, ST, SV, SY, TH, TJ, TM, TN, TR, TT, TZ, UA, UG, US, UZ, VC, VN, ZA, ZM, ZW.

(84) **Designated States (unless otherwise indicated, for every kind of regional protection available):** ARIPO (BW, GH, GM, KE, LR, LS, MW, MZ, NA, SD, SL, SZ, TZ, UG, ZM, ZW), Eurasian (AM, AZ, BY, KG, KZ, MD, RU, TJ, TM), European (AL, AT, BE, BG, CH, CY, CZ, DE, DK,

[Continued on next page]

(54) **Title:** TRANSMISSION METHOD AND APPARATUS FOR CARRIER AGGREGATION AND UPLINK MIMO

[Fig. 4]

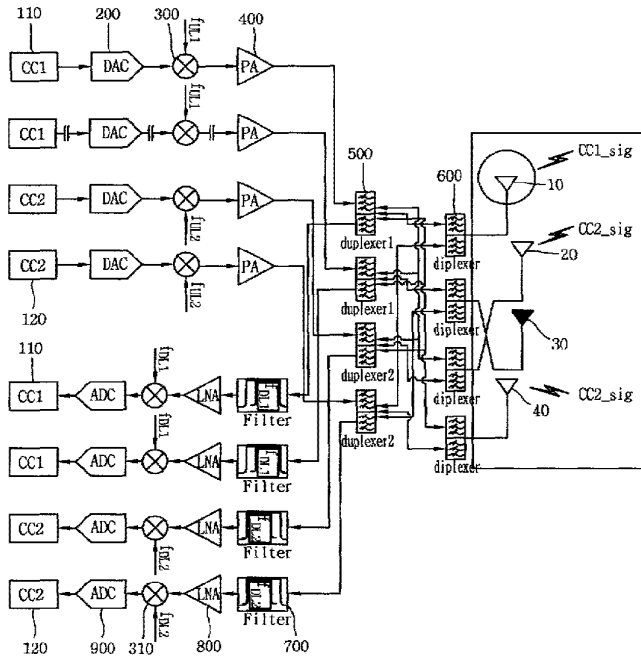

(57) **Abstract:** A transmission method for carrier aggregation, more particularly, for uplink MIMO and carrier aggregation, in a method for transmitting an uplink signal by the carrier aggregation in a terminal having at least four antennas, includes receiving a grant signal for transmission of the uplink signal, the grant signal including information related to use of a primary cell and a secondary cell, determining one antenna or at least two antennas to use the primary cell, determining one antenna or at least two antennas to use the secondary cell, and transmitting a first uplink signal to the primary cell and a second uplink signal to the secondary cell using the respective determined antennas.

WO 2012/008705 A2



EE, ES, FI, FR, GB, GR, HR, HU, IE, IS, IT, LT, LU,
LV, MC, MK, MT, NL, NO, PL, PT, RO, RS, SE, SI, SK,
SM, TR), OAPI (BF, BJ, CF, CG, CI, CM, GA, GN, GQ,
GW, ML, MR, NE, SN, TD, TG).

Published:

— *without international search report and to be republished
upon receipt of that report (Rule 48.2(g))*

Description

Title of Invention: TRANSMISSION METHOD AND APPARATUS FOR CARRIER AGGREGATION AND UPLINK MIMO

Technical Field

- [1] The present disclosure relates to transmission for carrier aggregation, and more particularly, a transmission method and apparatus for multi-antenna based carrier aggregation.

Background Art

- [2] MIMO is a short term of Multi Input and Multi Output, and indicates an method for improving data transmission and reception efficiency by adapting a multiple transmit antenna and a multiple receive antenna, breaking with an method using one transmit antenna and one receive antenna. That is, the MIMO technology is to implement capacity increase and performance improvement by using multiple antennas at a transmitting end (transmitter) or a receiving end (receiver) in a wireless communication system. Here, MIMO is also referred to a multiple antenna (multi-antenna).
- [3] Summarizing the aforementioned, a multi-antenna technology adapts a technology of aggregating data segments received via various antennas, without being dependent on a single antenna route, in order to receive one entire message. The multi-antenna technology can improve data rate within a specific range or increase a system range for a specific data rate, accordingly, it is an attractive next generation mobile communication technology, which can be broadly used for mobile communication terminals, relays and the like, namely, expected to overcome throughput limit of mobile communications, which has reached the limitation due to data communication extension or the like.
- [4] In general, when a transport channel experiences deep fading, if a different version or a replica of a transmitted signal is not additionally transmitted, it is difficult for a receiver to determine the transmitted signal. A resource corresponding to the different version or the replica is referred to as diversity, and is one of the most important factors that contribute to reliable transmission over a wireless channel.
- [5] The use of the diversity can maximize data transfer capacity or data transfer reliability. A system for implementing the diversity by using multiple Tx antennas and multiple Rx antennas is referred to as a MIMO system or a multiple antenna system.
- [6] A multiple antenna scheme includes space frequency block coding (SFBC), space time block coding (STBC), cyclic delay diversity (CDD), frequency switched transmit diversity (FSTD), time switched transmit diversity (TSTD), precoding vector switching (PVS), spatial multiplexing (SM), generalized cyclic delay diversity

(GCDD), selective virtual antenna permutation (S-VAP), etc. Such a MIMO scheme may also be considered as a measure for improving a data rate and reliability in a communication system having a multiple cell structure.

[7] LTE-Advanced (LTE-A) system, which is one of systems following three generation wireless communication systems, is undergoing a standardization work for a terminal, which can support not only the MIMO system but also a Carrier Aggregation (CA), which is a scheme for transmitting more data to a terminal or User Equipment (UE) using different multiple carriers. The LTE-A is a technology for aggregating a plurality of unit carriers, which are used in the conventional LTE release-8/9, to be used simultaneously. Such technology aims to extending a bandwidth up to 100 MHz.

[8] In other words, a carrier, which was defined fully up to 20 MHz in the conventional LTE release-8/9, is redefined as a component carrier, and one terminal is allowed to use maximum 5 component carriers by the carrier aggregation (CA) technology. Hereinafter, a terminal is referred to as User Equipment (UE).

[9] The CA is a way to get high throughput by aggregating a used band for each component carrier. There are three types of carrier aggregations which are intra-band contiguous aggregation, intra-band non-contiguous aggregation and inter-band non-contiguous aggregation for LTE-Advanced CA.

[10] Consequently, in wireless communication systems, such as the LTE-Advanced system, following the three generation system, it is very important to provide a UE's radio frequency (RF) architecture for supporting a combination of CA and MIMO system. However, such UE RF architecture has not been effectively provided yet.

Disclosure of Invention

Solution to Problem

[11] Therefore, an aspect of the detailed description is to provide an apparatus and method having UE RF architecture, capable of effectively supporting a combination system of Carrier Aggregation (CA) and an uplink MIMO in a wireless communication system.

[12] To achieve these and other advantages and in accordance with the purpose of the present invention, as embodied and broadly described herein, there is provided a transmission method for uplink Multi-Input Multi-Output (MIMO) and Carrier Aggregation (CA), in a method for transmitting an uplink signal by CA in a terminal having at least four antennas, the method including receiving a grant signal for transmission of an uplink signal, the grant signal including information related to use of a primary cell and a secondary cell, determining one antenna or at least two antennas to use the primary cell, determining one antenna or at least two antennas to use the secondary cell, and transmitting a first uplink signal to the primary cell and a

- second uplink signal to the secondary cell using the respective determined antennas.
- [13] The antenna to use the primary cell may not overlap the antenna to use the secondary cell. When at least two antennas are to use the primary cell, the at least two antennas may not be adjacent to each other. When two antennas are to use the secondary cell, the at least two antennas may not be adjacent to each other.
- [14] The transmission of the first uplink signal to the primary cell and the second uplink signal to the secondary cell using the respective determined antennas may be an inter-band or intra-band transmission.
- [15] In accordance with another aspect of the detailed description, there is provided a transmission method for uplink Multi-Input Multi-Output (MIMO) and Carrier Aggregation (CA), in a method for transmitting an uplink signal by CA in a terminal having at least four antennas, the method including receiving a grant signal for transmission of the uplink signal, the grant signal including information related to use of a primary cell and a secondary cell, determining at least four antennas to use the primary cell at a frame or sub-frame time interval, determining at least two antennas to use the secondary cell at a frame or sub-frame time interval, and transmitting a first uplink signal to the primary cell and a second uplink signal to the secondary cell using the respective determined antennas.
- [16] A time to use the primary cell and a time to use the secondary cell may not overlap each other, and when at least two antennas are to use the secondary cell, the at least two antennas may not be adjacent to each other.
- [17] The transmission of the first uplink signal to the primary cell and the second uplink signal to the secondary cell using the respective determined antennas may be an inter-band or intra-band transmission. The sub-frame or frame time interval may be in the range of 1 ms (millisecond) to 10 ms (millisecond).

Advantageous Effects of Invention

- [18] In accordance with the transmission method for uplink MIMO and carrier aggregation, an efficient connection structure between the carrier aggregation and the uplink MIMO may be proposed, which derives an effect of maximizing bandwidth expansion in the wireless communication system.

Brief Description of Drawings

- [19] FIG. 1 is an overview of an intra-band Carrier aggregation (CA) in accordance with the related art;
- [20] FIG. 2 is an overview of an inter-band CA in accordance with the related art;
- [21] FIG. 3 is a block diagram illustrating a general UE transmitter (Tx) architecture for uplink (UL)-MIMO and CA of a multiple antenna in accordance with the related art;

Explore Litigation Insights

Docket Alarm provides insights to develop a more informed litigation strategy and the peace of mind of knowing you're on top of things.

Real-Time Litigation Alerts



Keep your litigation team up-to-date with **real-time alerts** and advanced team management tools built for the enterprise, all while greatly reducing PACER spend.

Our comprehensive service means we can handle Federal, State, and Administrative courts across the country.

Advanced Docket Research



With over 230 million records, Docket Alarm's cloud-native docket research platform finds what other services can't. Coverage includes Federal, State, plus PTAB, TTAB, ITC and NLRB decisions, all in one place.

Identify arguments that have been successful in the past with full text, pinpoint searching. Link to case law cited within any court document via Fastcase.

Analytics At Your Fingertips



Learn what happened the last time a particular judge, opposing counsel or company faced cases similar to yours.

Advanced out-of-the-box PTAB and TTAB analytics are always at your fingertips.

API

Docket Alarm offers a powerful API (application programming interface) to developers that want to integrate case filings into their apps.

LAW FIRMS

Build custom dashboards for your attorneys and clients with live data direct from the court.

Automate many repetitive legal tasks like conflict checks, document management, and marketing.

FINANCIAL INSTITUTIONS

Litigation and bankruptcy checks for companies and debtors.

E-DISCOVERY AND LEGAL VENDORS

Sync your system to PACER to automate legal marketing.