

(19) **United States**

(12) **Patent Application Publication** (10) **Pub. No.: US 2004/0005915 A1**

**Hunter** (43) **Pub. Date: Jan. 8, 2004**

(54) **IMAGE TRANSMISSION**

**Publication Classification**

(76) Inventor: **Andrew Arthur Hunter, Bristol (GB)**

(51) **Int. Cl.<sup>7</sup> ..... H04B 1/38; H04M 1/00**

(52) **U.S. Cl. .... 455/575.1; 455/552.1; 455/550.1**

Correspondence Address:

**LOWE HAUPTMAN GILMAN & BERNER**

**LLP**

**Suite 300**

**1700 Diagonal Road**

**Alexandria, VA 22314 (US)**

(57) **ABSTRACT**

An image is automatically transferred between a camera and a communications device over a wireless link in response to an indication of contact being established over a wireless data network between the communication device and at least one predetermined destination resource or type of destination resource. The image is transferred from the communication device on to the data network through a data network interface.

(21) Appl. No.: **10/440,398**

(22) Filed: **May 19, 2003**

(30) **Foreign Application Priority Data**

May 17, 2002 (GB) ..... 0211250.6

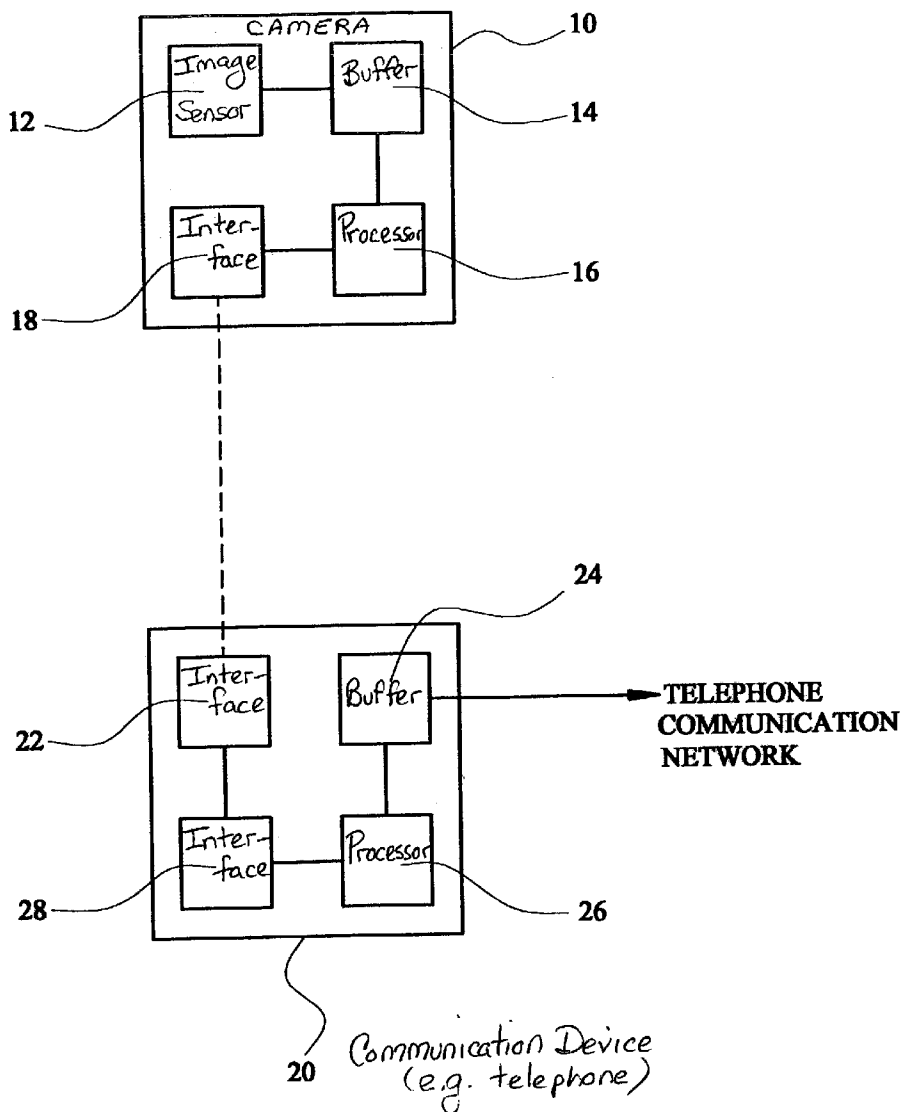

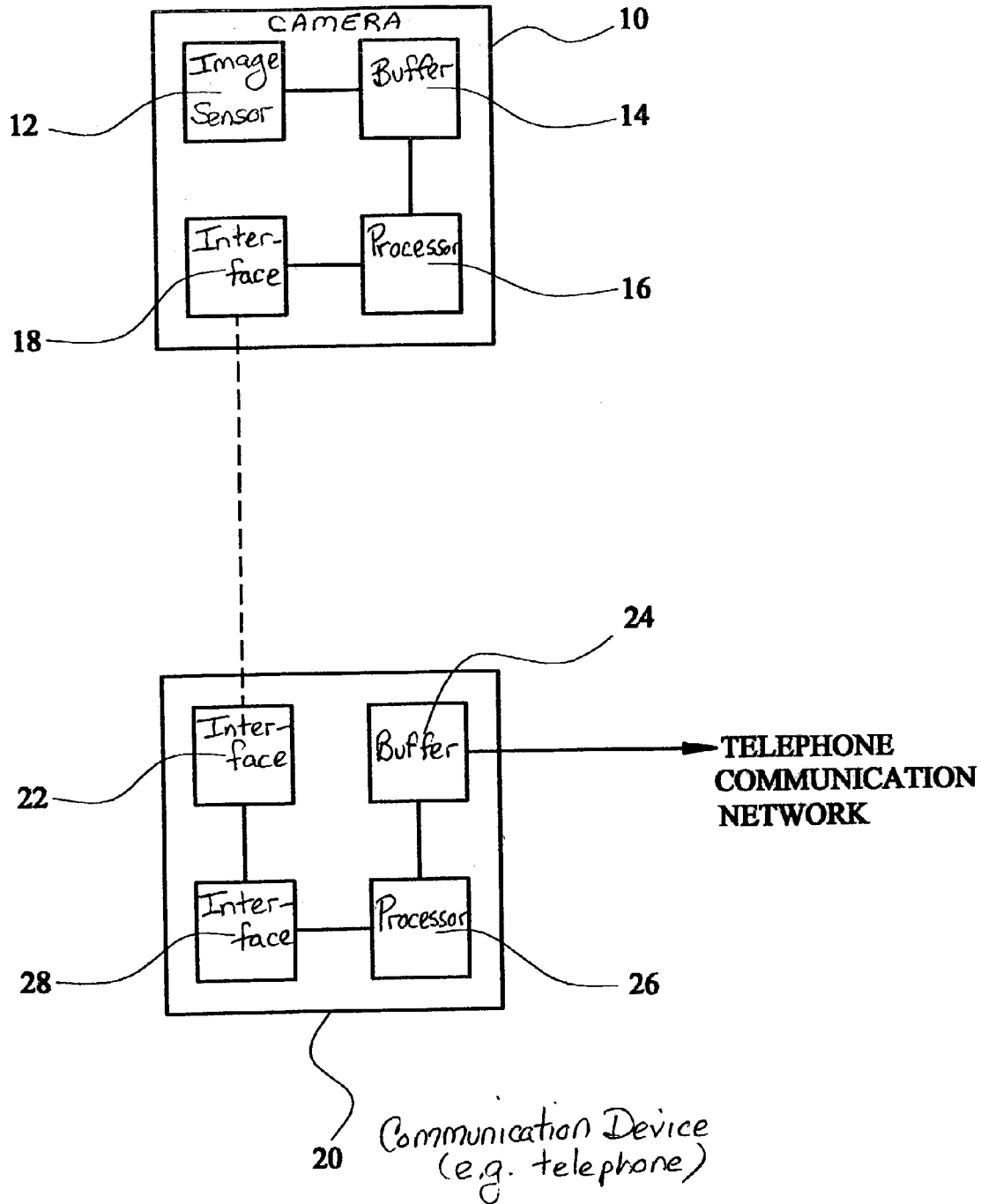

## IMAGE TRANSMISSION

### FIELD OF THE INVENTION

[0001] This invention relates to transmission of image data.

### BACKGROUND TO THE INVENTION

[0002] Image capture devices, such as digital still or video cameras, are well known. In the light of recent technological advances, it is now possible to make such devices very small, small enough in fact to be embedded or disposed in, or otherwise mounted in or on, wearable devices such as eyeglasses, name badges, headgear, etc. and, for some time, service personnel, such as firemen and soldiers, have deployed such 'wearable' cameras during the performance of certain duties. In general, the purpose of such small, wearable cameras is to enable them to be carried (or worn) for a large part of every day, as opposed to being carried occasionally. They may also be arranged to be extremely convenient to use, either operating autonomously or by very simple user actions or interactions, or by voice commands, gestures, etc. Further, mobile telephone networks are evolving so as to be able to transmit data at sufficient rates and resolution to support video or still image data, if required.

[0003] Thus, it is known to provide a mobile telephone or similar device which can transmit image data captured by an image capture device across a telephone network to one or more desired recipients. In general, the image capture device is adapted to be embedded in a mobile telephone, or plugged into a communication port provided on the mobile phone in order to facilitate the transmission of image data from the camera to the mobile telephone for transmission and, in fact, mobile telephones with embedded cameras have been used to demonstrate the capabilities of the next generation of telephone infrastructure. However, such cameras add to the cost and size of the telephones and, because the telephones themselves are not truly wearable, they spend much of the time in the pocket, briefcase or handbag of a user.

[0004] U.S. Pat. No. 5,806,005 describes a portable image transfer system including a digital still camera which captures images in digital form and stores the images in a camera memory, a cellular telephone transmitter, and a central processing unit (CPU). The CPU controls the camera memory to cause it to output data representing an image and the CPU controls the cellular telephone transmitter to cause a cellular telephone to transmit the data received from the camera memory. A receiving station is coupled to the cellular telephone transmitter by a cellular network to receive image data and store the images. In order to enable the transmission of images captured by the camera across the cellular telephone network, it is necessary to establish a data link between the camera memory and the cellular telephone. This is established via the CPU and facilitated by a series of user and CPU commands.

[0005] Some existing digital cameras can be made to interoperate with telephones, but they require conscious interaction by the user, firstly to aim the camera and capture images and secondly to establish a data connection with a mobile telephone. It will be appreciated that this level of conscious interaction during a telephone call (when the user's attention should be primarily directed to the telephone conversation itself) is inappropriate.

[0006] Thus, in the case of all known systems, it is required to provide a physical wired data link between a camera and a mobile telephone in order to facilitate the transmission of image data captured by the camera across the mobile telephone network, or for the user to physically interact in some specific way with the mobile telephone and/or the camera in order to establish a communication link between them, which is inconvenient, especially if the user is actually conducting a telephone conversation with another party using the mobile telephone at the time that the communication link is required to be used. Further, unless the user has remembered to perform the specific action to establish the communication link before commencing the telephone call, the call may be temporarily disrupted while the user establishes the required communication link prior to the transmission of image data across the telephone network.

[0007] Mobile telephones are known with embedded cameras, but these do not facilitate convenient sending of images from an independently functioning and physically separate camera such as a wearable camera. Bespoke systems are also known, for example as disclosed in Japanese Patent Application Publication number 2002-187492 (Denso Corp) or DE-A-4238275 (Manowski), that combine a camera and mobile radio or telephone, but such systems do not facilitate convenient connection for image communication from an independent camera.

[0008] Some independent cameras can be connected to mobile phones directly or via a portable computer such as a laptop. For example these have been used by journalists for sending images from digital cameras back to publishers' offices. It is usually necessary to connect the camera and the phone by a wire link. Specific interaction with the camera or the phone is required to establish the connection or initiate image transfer.

[0009] Image transmission is only necessary or appropriate for a subset of telephone calls. For example, it may be appropriate to send images to a website when a phone accesses a particular data service or it may be appropriate to send images during a call to or from a video phone. For this reason a permanent connection to the phone is not appropriate. When making a call to a video phone it would be possible to anticipate a need to transmit images and to configure the connection in advance but it would be better to have the connection established without manual preparation. In other cases, such as receiving a call from a video phone, it may be necessary to connect the camera and initiate image transmission after the call has been answered, for example by sending display commands as in Japanese Patent Application Publication number 2002-044285 (Seiko Instruments Inc). It is not easy to maintain a voice conversation while interacting with a phone and or a camera to initiate image transfer, for example by attaching a detachable camera as described in EP-A 09751342 or by configuring a Bluetooth link between a phone and a camera.

### SUMMARY OF THE INVENTION

[0010] In accordance with a first aspect of the invention, there is provided a system for image capture and communication, comprising: a camera with an image memory and a first wireless communication interface; a communication device with a second wireless communication interface and a data network interface; and a user interface for creating a

trigger event, wherein on creation of a trigger event, images from the image memory are transmitted over a wireless link established between the wireless communication interfaces and transmitted to a data network through the data network interface.

[0011] In accordance with a second aspect of the invention, there is provided a communication device programmed for onward communication of received images, the communication device comprising: a wireless communication interface for wireless communication with a camera; a data network interface for connection to a data network; and a processor programmed to recognise a trigger event, and on recognition of a trigger event to establish communication of images received over a wireless link to the camera through the wireless communication interface to the data network through the data network interface.

[0012] In accordance with a third aspect of the invention, there is provided a camera programmed for onward communication of received images, the camera comprising: image capture apparatus comprising an image sensor and an image memory; a wireless communication interface; and a processor programmed to recognise a trigger event, and on recognition of a trigger event to communicate one or more images from the image memory to a communication device through the wireless communication interface over a wireless link for onward transmission from the communication device.

[0013] In accordance with a fourth aspect of the invention, there is provided method of capturing and communicating images, comprising the steps of: programming a camera and a communications device to recognize a trigger event; one of the camera and the communications device recognising occurrence of the trigger event, and communicating with the other of the camera and the communications device by a wireless link therebetween; transferring images between the camera and the communications device over the wireless link; and transferring said images from the communications device on to a data network through a data network interface.

[0014] In accordance with a fifth aspect of the present invention, there is provided apparatus for transmitting image data captured by one or more image capture devices across a telephone network, comprising means for automatically establishing a wireless data link between said apparatus and said one or more image capture devices for transmitting image data captured by said one or more image capture devices to said apparatus, and/or automatically initiating data transmission therebetween, said data link being automatically established and/or said data transmission being automatically initiated in response to the performance of an operation in respect of said one or more image capture devices and/or said apparatus, said operation being unrelated to the establishment of said data link, or in response to some event related to said apparatus and said one or more image capture devices in relation to one another.

[0015] In accordance with a sixth aspect of the present invention, there is provided an image capture device comprising means for automatically establishing a wireless data link between said image capture device and apparatus for transmitting images captured by said image capture device across a telephone network for transmitting image data captured by said image capture device to said apparatus,

and/or automatically initiating data transmission therebetween, said data link being automatically established and/or said data transmission being automatically initiated in response to the performance of an operation in respect of said image capture device or said apparatus, said operation being unrelated to the establishment of said data link, or in response to some event related to said apparatus and said image capture device in relation to one another.

[0016] The or each image capture device may be wearable by a user, for example, by being incorporated into a pair of eyeglasses, some form of headgear, or by being provided with a clip or other fastening means to enable it to be clipped or otherwise fastened about the user's person. However, the camera need not be wearable or portable. For example, it may be advantageous to provide cameras in public places (i.e. environmental cameras) to which a mobile telephone within a field of view of the camera can automatically establish a data link or initiate data transmission, thereby achieving video telephone calls without the complexity of cameras embedded in such telephones and with a better viewpoint. Thus, a data link can be established for transmission of image data from an image capture device to a mobile telephone or the like for transmission of the image data across a telephone network if desired, without having to move the image capture device itself, i.e. it can remain in place about the user's person.

[0017] The data link may be established, or data transmission may be initiated, automatically by the performance of some unrelated operation in respect of the mobile telephone or other communication apparatus, for example, switching it on, making a telephone call, making a telephone call to one or more predetermined numbers, searching the 'phone book' stored in the apparatus, receiving or answering a telephone call, etc. Alternatively, however, the data link may be established simply because the image capture device and the mobile telephone are within a predetermined distance of each other, irrespective of whether the telephone is being used or is even switched on to make or receive telephone calls.

[0018] The data link may immediately give rise to data transmission, or may enable transmission to take place automatically on occurrence of some future action, e.g. the camera autonomously capturing a picture, or a user issuing a voice command to the camera.

[0019] The establishment of a data link between the camera and a mobile telephone provides a number of potential advantages, for example:

[0020] 1. It allows images from the camera to be viewed on the screen of the phone (perhaps specifically when the phone is not being used for some other purpose, e.g. triggered by the action of ending a call). In other words, the camera may be a very small wearable camera with no viewfinder or way of reviewing photographs, such that in one exemplary embodiment of the invention, when the phone is not being used to make calls, etc. it can be used as the viewfinder or as a way of reviewing captured images.

[0021] 2. The purpose of the data link may be to establish a user interface with the camera via the phone, and in one exemplary embodiment of the

invention, it may even be possible to use the telephone keypad to send commands to the camera.

[0022] 3. The screen of the phone could also be used to allow one or more photos to be viewed and selected prior to transmission across the telephone network.

[0023] 4. Alternatively, establishment of a link may simply enable data communication between the phone and the camera e.g. to exchange status information such as frame sizes and frame rates or data transfer rates

[0024] 5. Establishment of the link or some other action to initiate data transmission may cause the camera configuration to change, e.g. may switch it on or change from low to high power operation or from low to high resolution mode, etc.

[0025] In any event, once a data link has been established, the image capture device may be arranged to periodically transmit a frame of image data to the mobile telephone to be transmitted, stored or discarded, according to whether or not the mobile telephone user actually wishes to transmit image data at that time. In a preferred embodiment, the mobile telephone may comprise a selection switch which, when actuated, causes image data to be selectively stored or transmitted across the telephone network. Thus, if the selection switch is not actuated, no image data is stored or transmitted, and image data (if any) sent from the image capture device to the mobile telephone is discarded. Alternatively or additionally, there may be a means to activate storage or transmission of images to a mobile telephone as a result of an operation of the camera, such as a touch or voice command.

[0026] The data link, once established may comprise a one-way data link from said image capture device to said mobile telephone or similar apparatus. In this case, when the event or circumstance occurs which causes the above-mentioned wireless data link to be established, the mobile telephone may transmit an initial signal, in response to receipt of which the image capture device may send an acknowledgement signal, after which process, a one-way data link is established from the image capture device to the mobile telephone across which the image capture device periodically transmits captured image data for transmission (or not) across the telephone network by the mobile telephone. In another embodiment, the image capture device (or the mobile telephone) may be arranged to transmit a relatively weak, short range enquiry signal periodically until it is acknowledged by the mobile telephone (or image capture device), thereby indicating that the two units are within a predetermined distance of each other and causing a data link to be established.

[0027] Of course, the data link may be two-way, in the sense that once it has been established it may be able to support communication by the mobile telephone to the image capture device as well as transmission of image data from the image capture device to the mobile telephone. In this case, for example, the mobile telephone may be arranged to transmit a trigger signal to the image capture device causing it to capture an image and transmit the corresponding image data to the mobile telephone for transmission thereof across the telephone network, if desired.

[0028] The data link may be supported by any suitable communication protocol, including short range radio waves or infra-red communication, for example. Images may be transmitted across the telephone network using progressive data transmission (i.e. so that detail can be sent progressively) with the result that such transmission can be terminated when sufficient detail has been sent.

[0029] In general, the present invention is intended to provide means for establishing a wireless data link between the image capture device and the mobile telephone, irrespective of whether communication actually takes place between them, without the need for specific user interaction with either unit.

[0030] It will be appreciated that the data link or data transmission established or initiated by the present invention may also be terminated as a result of an unrelated action or operation.

[0031] It is known for mobile telephones to support data instead of or as well as voice calls, in which case the present invention can be taken to relate also to the establishment of a data link or the initiation of data transmission as a result of use of a telephone to access a data service, e.g. an internet page such as a photo website or a photo printing service.

#### BRIEF DESCRIPTION OF THE DRAWINGS

[0032] An embodiment of the present invention will now be described by way of example only and with reference to the accompanying drawing, in which:

[0033] The sole FIGURE is a schematic block diagram of apparatus according to an exemplary embodiment of the present invention.

#### DETAILED DESCRIPTION OF THE INVENTION

[0034] Referring to The sole FIGURE of the drawings, apparatus according to an exemplary embodiment of the present invention, comprises a wearable camera **10**, preferably head-mountable (embedded in or mounted on headgear, eyeglasses, etc.) comprising an image sensor **12**, an image buffer **14** for storing image data representing one or more frames of captured image data, a processor **16** and a wireless communication interface **18**. It will be appreciated that wearable cameras generally can operate without much conscious effort by their users. Further, they are not generally hidden in a user's pocket or handbag, but are worn so as to be ready for use as and when required. They can be head-mounted so that they track the approximate gaze of the wearer, and enable the user to capture images of scenes generally within their field of view without having to actually aim the camera in a separate operation. As such, it will be appreciated that they are particularly well suited for use during a telephone conversation.

[0035] The apparatus also comprises a communication device **20** comprising a second wireless communication interface **22**, an image storage buffer **24** for storing image data received from the camera **10**, a processor **26** and a primary wireless communications interface **28** providing a connection to a data network. For the preferred embodiment discussed here, communication device **20** is a mobile telephone and the data network is a cellular telephony network

# Explore Litigation Insights

Docket Alarm provides insights to develop a more informed litigation strategy and the peace of mind of knowing you're on top of things.

## Real-Time Litigation Alerts



Keep your litigation team up-to-date with **real-time alerts** and advanced team management tools built for the enterprise, all while greatly reducing PACER spend.

Our comprehensive service means we can handle Federal, State, and Administrative courts across the country.

## Advanced Docket Research



With over 230 million records, Docket Alarm's cloud-native docket research platform finds what other services can't. Coverage includes Federal, State, plus PTAB, TTAB, ITC and NLRB decisions, all in one place.

Identify arguments that have been successful in the past with full text, pinpoint searching. Link to case law cited within any court document via Fastcase.

## Analytics At Your Fingertips



Learn what happened the last time a particular judge, opposing counsel or company faced cases similar to yours.

Advanced out-of-the-box PTAB and TTAB analytics are always at your fingertips.

## API

Docket Alarm offers a powerful API (application programming interface) to developers that want to integrate case filings into their apps.

## LAW FIRMS

Build custom dashboards for your attorneys and clients with live data direct from the court.

Automate many repetitive legal tasks like conflict checks, document management, and marketing.

## FINANCIAL INSTITUTIONS

Litigation and bankruptcy checks for companies and debtors.

## E-DISCOVERY AND LEGAL VENDORS

Sync your system to PACER to automate legal marketing.