



IN THE UNITED STATES PATENT AND TRADEMARK OFFICE

730.00 08/483291

HONORABLE COMMISSIONER OF PATENTS AND TRADEMARKS Washington, D.C. 20231

DOCKET NO. 9438-1 Prior Application: Examiner: D. Kenealy Group Art Unit: 3301

Sir:

This is a request for filing a [X] continuation [] divisional application under 37 CFR § 1.60, of pending prior application:

Serial No.: 07/956,653 Filed: October 2, 1992 Inventor: James E. Jervis

For: MEDICAL DEVICES INCORPORATING SIM ALLOY ELEMENTS

- 1. [X] Enclosed is a complete copy of the prior application... 2. [] A verified statement to establish small entity status... 3. [] No additional fee is required or [X] the fee has been calculated as shown below:

Table with 7 columns: Column 1, Column 2, Column 3, Current Number of Claims, Number Previously Paid for, Number of Extra Claims, RATE Non-Small Entity, RATE Small Entity, FEE. Rows include BASIC FEE, TOTAL CLAIMS, INDEPENDENT, and First presentation of multiple dependent claim.

TOTAL FEE \$ 730.00

* If the entry in Column 1 is less than the entry of Column 2, write "0" in Column 3. ** If the number of Total Claims previously paid for is less than 20, write "20" in this space. *** If the number of Independent Claims previously paid for is less than 3, write "3" in this space.

- 4. [X] The Commissioner is hereby authorized to charge payment of any additional fees... 5. [X] Enclosed is the fee of \$ 730.00 by Check No. 5855. 6. [] Cancel in this application original claims... 7. [] Amend the specification by inserting before the first line the sentence: - this is a [] continuation, [] division, of application Serial No. filed

8. Transfer the drawings from prior application to this application and add said prior applications as of the filing date accorded this application. A duplicate copy of this sheet is enclosed for filing in the prior application file. (May only be used if signed by person authorized by § 1.138 and before payment of base issue fee.)
9. New formal drawings are enclosed.
10. Priority of application serial no. _____, filed on _____ (date) in _____ (country) is claimed under 35 USC 119.
11. The prior application is assigned of record to _____.
12. The power of attorney in the prior application is to Herbert G. Burkard, Reg. No. 24,500 and James W. Peterson, Reg. No. 26,057. An Associate Power of Attorney is to Jeffrey G. Sheldon, Reg. No. 27,953, Sheldon & Mak, 225 South Lake Avenue, 9th Fl., Pasadena, CA 91101
(name, registration number, address).
- a. The power appears in the original papers in the prior application.
- b. Since the power does not appear in the original papers, a copy of the power in the prior application is enclosed.
- c. Address all future communications to Jeffrey G. Sheldon, Esq., (818) 796-4000
Sheldon & Mak, 225 South Lake Avenue, Suite 900, Pasadena, California 91101
(May only be completed by applicant, attorney or agent of record)
13. A preliminary amendment is enclosed.
14. I hereby verify that the attached papers are a true copy of prior application Serial No. 07/956,653 as originally filed on October 2, 1992.

The undersigned declares further that all statements made herein of his or her own knowledge are true and that all statements made on information and belief are believed to be true; and further that these statements were made with the knowledge that willful false statements and the like so made are punishable by fine or imprisonment, or both, under section 1001 of Title 18 of the United States Code and that such willful false statements may jeopardize the validity of the application or any patent issuing thereon.

Date: 6/7/95

SHELDON & MAK
By: *Jeffrey G. Sheldon*
JEFFREY G. SHELDON
Reg. No.: 27,953

- Attorney or agent of record
 Filed under § 1.34(a)

225 South Lake Avenue
Suite 900
Pasadena, California 91101
(818) 796-4000 (213) 681-9000



CERTIFICATE OF EXPRESS MAIL

"EXPRESS MAIL" mailing label number RB638341759US

Date of Deposit: June 7, 1995

I hereby certify that:

1. CONTINUATION PATENT APPLICATION ENTITLED "MEDICAL DEVICES INCORPORATING SIM ALLOY ELEMENTS" TRANSMITTAL SHEET
2. PRELIMINARY AMENDMENT
3. COPY OF PRIOR APPLICATION SERIAL NO. 07/956,653 INCLUDING OATH/DECLARATION AND DRAWINGS.
4. INFORMATION DISCLOSURE STATEMENT AND PTO-1449 FORMS (NO REFERENCES INCLUDED)
5. CHECK NO. 5855 FOR \$730.00 FILING FEE
6. POSTCARD

are being deposited with the United States Postal Service "Express Mail Post Office to Addressee" service under 37 CFR 1.10 on the date indicated above and is addressed to the Commissioner of Patents and Trademarks, Washington, D.C. 20231.

Marilyn C. Paik

Typed or Printed Name of Person Mailing Paper or Fee

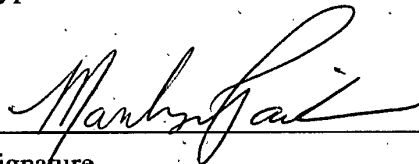

Signature

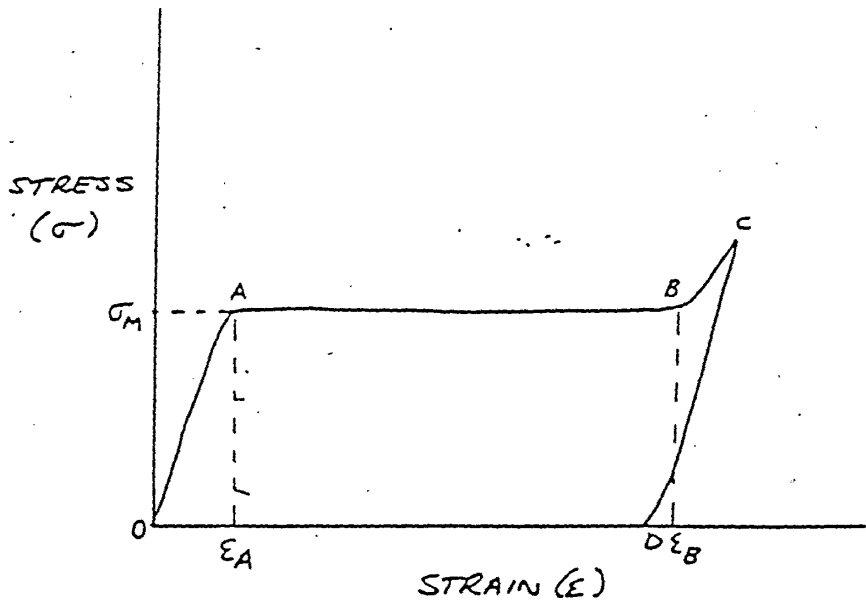
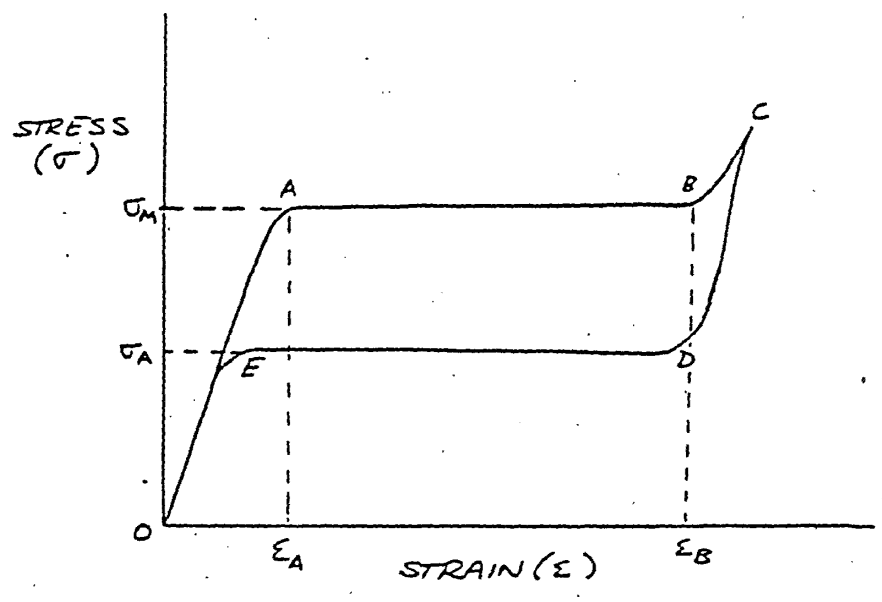

FIGURE 1

FIGURE 2



08/483291

Fig. 4

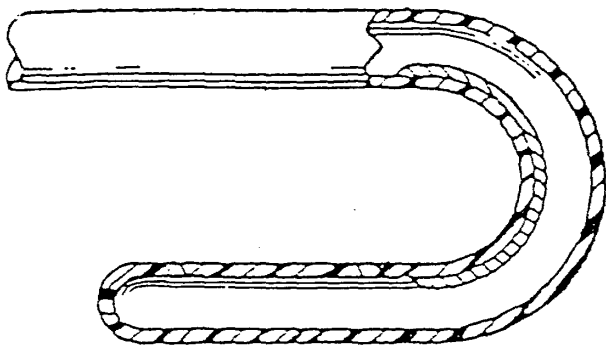

Fig. 3



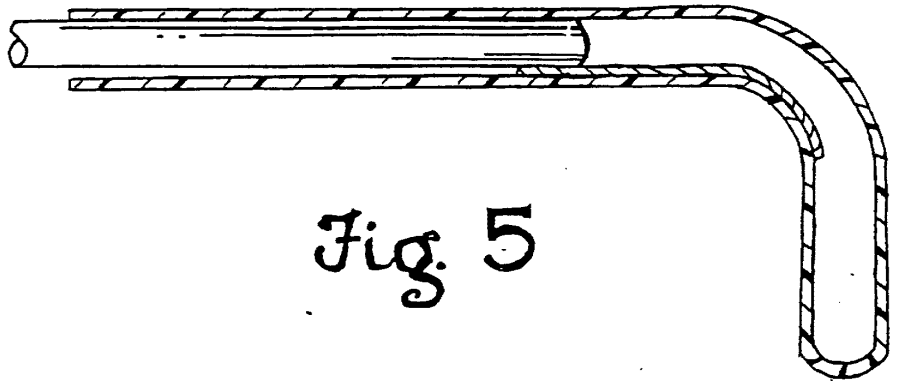

Fig. 5

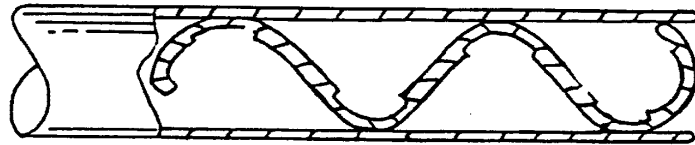

Fig. 6

330
3-

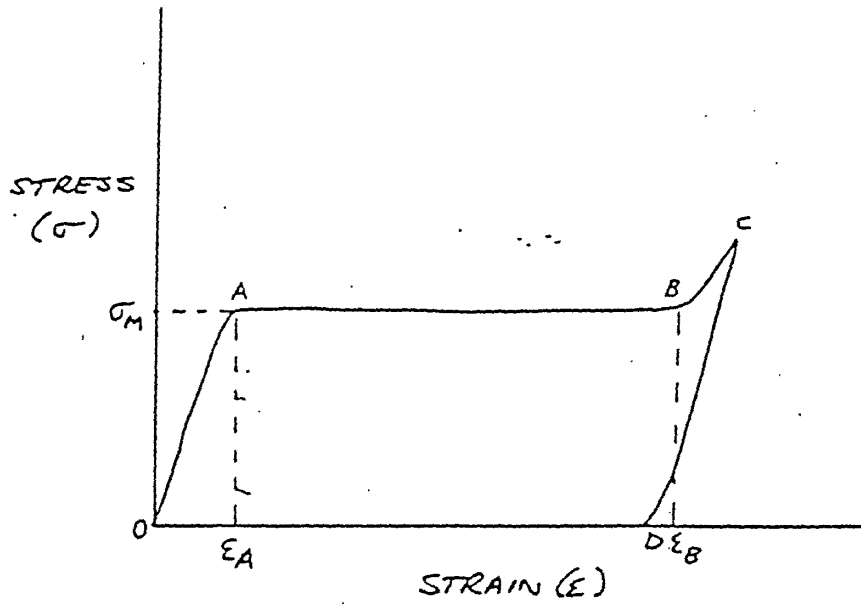

FIGURE 1

FIGURE 2

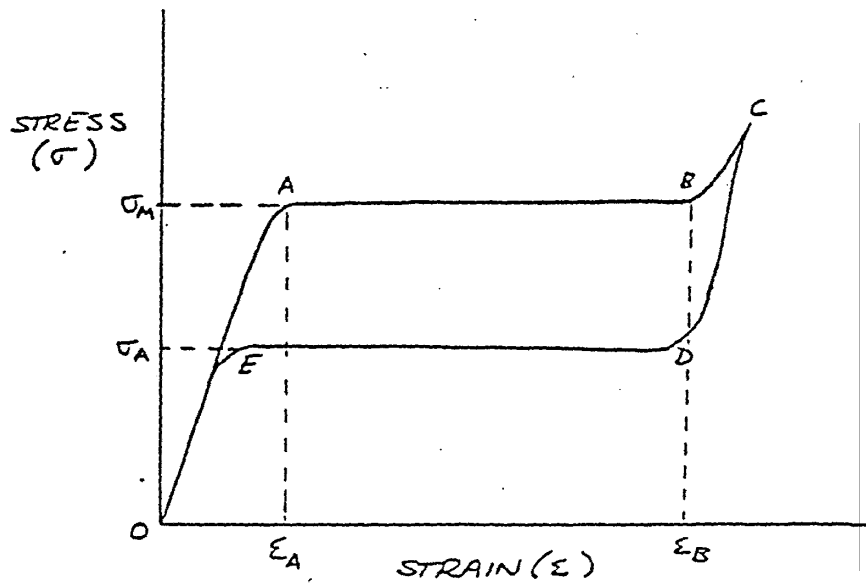

Fig. 4

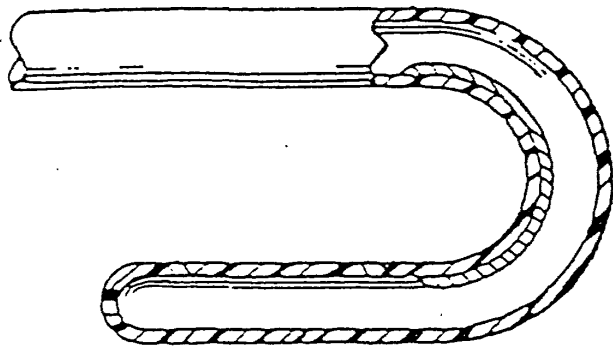

Fig. 3





a2

MP0884-US1

-2-

*INS. a1*BACKGROUND OF THE INVENTIONField of the Invention

This invention relates to medical devices incorporating shape memory alloys, and to improvements therein.

5 Introduction to the Invention

Materials, both organic and metallic, capable of possessing shape memory are well known. An article made of such materials can be deformed from an original, heat-stable configuration to a second, heat-unstable configuration. The article is said to have shape memory for the reason that, upon the application of heat alone, it can be caused to revert, or to attempt to revert, from its heat-unstable configuration to its original, heat-stable configuration, i.e. it "remembers" its original shape.

Among metallic alloys, the ability to possess shape memory is a result of the fact that the alloy undergoes a reversible transformation from an austenitic state to a martensitic state with a change in temperature. This transformation is sometimes referred to as a thermoelastic martensitic transformation. An article made from such an alloy, for example a hollow sleeve, is easily deformed from its original configuration to a new configuration when cooled below the temperature at which the alloy is transformed from the austenitic state to the martensitic state.

The temperature at which this transformation begins is usually referred to as M_s and the temperature at which it finishes M_f . When an article thus deformed is warmed to the temperature at which the alloy starts to revert back to austenite, referred to as A_s (A_f being the temperature at which the reversion is complete) the deformed object will begin to return to its original configuration.

Many shape memory alloys (SMAs) are known to display stress-induced martensite (SIM). When an SMA sample exhibiting stress-induced martensite is stressed at a temperature above M_s (so that the austenitic state is initially stable), but below M_d (the maximum temperature at which martensite formation can occur even under stress) it first deforms elastically and then, at a critical stress, begins to transform by the formation of stress-induced martensite. Depending on whether the temperature is above or below A_s , the behavior when the deforming stress is released differs. If the temperature is below A_s , the stress-induced martensite is stable; but if the temperature is above A_s , the martensite is unstable and transforms back to austenite, with the sample returning (or attempting to return) to its original shape. The effect is seen in almost all alloys which exhibit a thermoelastic martensitic transformation, along with the shape memory effect. However, the extent of the temperature range over which SIM is seen and the stress and strain ranges for the effect vary greatly with the alloy.

In copending and commonly assigned U.S. Patent Application (Docket No. MPO873-US1) to Quin, ^{now U.S. Patent No. 4,505,767} the disclosure of which is incorporated herein by reference, a nickel/titanium/vanadium alloy having SIM over a wide temperature range is disclosed.

Shape memory alloys have found use in recent years in, for example, pipe couplings (such as are described in U.S. Pat. Nos. 4,035,007 and 4,198,081 to Harrison and Jervis), electrical connectors (such as are described in U.S. Pat. No 3,740,839 to Otte & Fischer), switches (such as are described in U.S. Patent No. 4,205,293), actuators, etc.

Various proposals have also been made to employ shape memory alloys in the medical field. For example, U.S. Pat. No. 3,620,212 to Fannon et al. proposes the use of an SMA intrauterine contraceptive device, U.S. Pat. No. 3,786,806 to Johnson et al. proposes the use of an SMA bone plate; U.S. Pat. No. 3,890,977 to Wilson proposes the use of an SMA element to bend a catheter or cannula, etc.

These medical SMA devices rely on the property of shape memory to achieve their desired effects. That is to say, they rely on the fact that when an SMA element is cooled to its martensitic state and is subsequently deformed, it will retain its new shape; but when it is warmed to its austenitic state, the original shape will be recovered.

However, the use of the shape memory effect in medical applications is attended with two principal disadvantages. First, it is difficult to control the transformation temperatures of shape memory alloys with accuracy as they are usually extremely composition-sensitive, although various techniques have been proposed (including the blending by powder metallurgy of already-made alloys of differing transformation temperatures: see U.S. Pat. No. 4,310,354 to Fountain et al.). Second, in many shape memory alloys there

is a large hysteresis as the alloy is transformed between austenitic and martensitic states, so that reversing of the state of an SMA element may require a temperature excursion of several tens of degrees Celsius. The combination of these factors with the limitation that (a) it is inconvenient to have to engage in any temperature manipulation, and (b) human tissue cannot be heated or cooled beyond certain relatively narrow limits (approximately 0° - 60°C for short periods) without suffering temporary or permanent damage is expected to limit the use that can be made of SMA medical devices. It would thus be desirable to develop a way in which the advantageous property of shape memory alloys, i.e. their ability to return to an original shape after relatively substantial deformation, could be used in medical devices without requiring the delicacy of alloying control and/or the temperature control of placement or removal needed by present shape memory alloy devices.

DESCRIPTION OF THE INVENTION

Summary of the Invention

I have discovered that if, in a medical device containing a shape memory alloy element which uses the shape memory property of that alloy, an element which shows the property of stress-induced martensite is used instead, an improved device results.

Accordingly, this invention provides a medical device intended for use within a mammalian body, or in such proximity to a mammalian body that the device is substantially at body temperature, which device comprises a shape memory alloy element, the improvement in which comprises the substitution of an alloy element which displays stress-induced martensite at said body temperature for the shape memory alloy element.

Brief Description of the Drawing

Figures 1 and 2 illustrate the stress-strain behavior of an alloy which exhibits constant stress versus strain behavior due to stress-induced martensite.

Detailed Description of the Preferred Embodiments

5
The invention will be discussed first by introducing the concept of stress-induced martensite and the effect achievable by its use, and then by examples showing how SIM alloy elements can be substituted for conventional SMA elements in medical devices to achieve the beneficial effect of the invention.

10
The Figures illustrate the phenomenon of stress-induced martensite by means of stress-strain curves. In both Figure 1 and Figure 2, the alloy is at a temperature between M_s and M_d so that it is initially austenitic; and it will be assumed for the purposes of this discussion that M_s is equal to M_f , and A_s equal to A_f . Figure 15
1 shows the case when the temperature is below A_s , so that any martensite formed by the applied stress is stable; while Figure 2 shows the case where the temperature is above A_s , so that austenite is the only stable phase at zero stress.

20
In Figure 1, when a stress is applied to the alloy, it deforms elastically along the line DA. At a critical applied stress, c_M , the austenitic alloy begins to transform to (stress-induced) martensite. This transformation
25

5

10

15

a
20

takes place at essentially constant stress until the alloy becomes fully martensitic at point B. From that point on, as further stress is applied, the martensite yields first elastically and then plastically (only elastic deformation is shown at point C). When the stress is released, the martensite recovers elastically to point D, at which there is zero residual stress, but a non-zero residual strain. Because the alloy is below A_s , the deformation is not recoverable until heating above A_s results in a reversion to austenite. At that point, if the sample is unrestrained, the original shape will be essentially completely recovered; if not, it will be recovered to the extent permitted by the restraint. However, if the material is then allowed to re-cool to the original temperature at which it was deformed (or a temperature where SIM behavior of this type is seen), the stress produced in the sample will be constant regardless of the strain provided that the strain lies within the "plateau" region of the stress-strain curve. That is, for a strain between ϵ_B and ϵ_A , the ~~stress~~ ^{stress} will be σ_M . This means that a known, constant force (calculable from σ_M) can be applied over a wide (up to 5% or more for certain Ni/Ti alloys) strain range. Thus, though this resembles the conventional shape memory effect, because the alloy shows SIM and is below A_s a constant force can be achieved.

25

In Figure 2, when a stress is applied to the alloy, it deforms elastically along line DA, then by SIM along line AB, and by deformation of the martensite to point C, just as in Figure 1. However, the stress-strain behavior on unloading is significantly different, since the alloy is above A_s

and the stable phase is therefore austenite. As the stress is removed, the alloy recovers elastically from C to D; then, at a critical stress, σ_A , the alloy reverts to austenite without requiring a change in temperature. Thus reversion occurs at essentially constant stress. Finally if the stress is removed from the reverted austenite, it recovers elastically along line ED. The recoverable deformation associated with the formation and reversion of stress-induced martensite has been referred to as pseudoelasticity. While σ_M may be comparatively high, e.g. 50 ksi, σ_A is usually substantially lower; e.g. less than 10 ksi; thereby creating a constant-force spring with an effective working range of about 5% ($\epsilon_B - \epsilon_A$). The shape change available in the SMA is thus mechanically, rather than thermally, actuated and controlled, permitting a greater control over a device incorporating it.

Suitable alloy for this invention i.e. those displaying stress-induced martensite at temperatures near mammalian body temperature (35°-40°C), may be selected from known SMAs by those of ordinary skill in the art, having regard to this disclosure by ~~testing~~ ^{testing} for the existence of the SIM effect at the desired temperature. A particularly preferred alloy is the nickel/titanium/vanadium alloy of U.S. Patent Application No. ~~06/541,844~~ ^{06/541,844} (~~Docket No. MPD673-US1~~), ^{now U.S. Patent No. 4,505,767} referred to previously.

a
 08/18/01
 a
 (INS. 037)

25 The invention will now be discussed in detail by some Examples of the use of an SIM alloy.

Example I. Heart Valves

30 Akins, in U.S. Patent No. 4,233,690, the disclosure of which is incorporated herein by reference, describes the use of a shape memory alloy ring to hold a sewing cuff to the body of an artificial heart valve. The ring is made in the austenitic phase, cooled to the martensitic phase, deformed, placed around the valve body, and heated or allowed to warm to cause reversion to the austenitic phase and recovery of the ring into engagement with the valve body.

However, this technique has not found commercial acceptance. Present medical technique requires that the valve body be capable of being rotated relative to the cuff, thereby enabling the surgeon to set the rotational orientation of the valve after it has been sewn into place. This is desirable because the techniques used make it difficult to visualize or accomplish optimal orientation during initial placement.

In order to accomplish the desired torque control to permit the desired rotation and yet ensure a firm hold of the cuff on the valve body, precise control of the pressure exerted on the valve body by the ring is needed. This is difficult because there are substantial manufacturing tolerances in the valve body which may be made, for example, of pyrolytic graphite or ceramics, etc. Because the austenite stress-strain curve is extremely steep, it is not considered practical to use the simple shape memory technique proposed by Akins. Indeed, Akins does not even address the issue of rotation of the cuff with respect to the valve body.

However, if an SIM alloy is used instead of conventional shape memory, the process may be considerably simplified.

First, if the alloy has a stress-strain curve like that of Figure 1, the alloy ring may be made just as for Akins. The ring is then expanded from its initial austenitic state by the formation of SIM. When the ring is placed about the valve body, it needs only to be heated above A_f and allowed to cool to its original temperature for the ring to

engage the valve body with a constant force, even if the valve body has a deviation from the specified size. The torque may thus be controlled to the desired level despite manufacturing tolerances.

5 Second, if the alloy has a stress-strain curve like that of Figure 2, the ring may be expanded, placed over the valve body, and the stress released all at the same temperature. Because the austenitic phase is stable, the stress-induced martensite spontaneously reverts to austenite until recovery is restrained by the ring engaging the valve body. Because 10 the reversion to austenite takes place at constant stress, a constant force (and hence constant torque) may be obtained regardless of manufacturing tolerances. Close temperature control is not required, either; and the fact that the 15 patient in a heart valve replacement operation is conventionally cooled as much as 15°C or so below normal body temperature does not affect the operation of the ring.

To control the torque at a sufficiently low level, it may be desirable for the alloy ring to be other than a 20 solid ring, such as, for example, a continuous helical spring, a flat zigzag spring, etc. Such variations permit the achievement of a greater range of movement with constant force and a reduction in the force exerted by the ring on the valve body, since the ring recovers in a bending mode 25 rather than in tension.

Example II. Catheters And Cannulas

Wilson, in U.S. Patent No. 3,890,977, the disclosure of which is incorporated herein by reference, discloses a catheter or cannula (both being included hereinafter in the word "catheter") made of, or containing, an SMA element to cause all or a portion of the catheter to deploy in a useful form once introduced into a living body.

However, again this device has not been commercialized. Possible defects of the device which have prevented commercialization include (i) the inability to slowly emplace the catheter in a desired position when the transition temperature of the alloy is below body temperature (since the SMA element will attempt to revert to its original shape as it reaches body temperature), thus limiting the ability of the physician to place the device carefully and precisely; or alternatively, if the transition temperature of the alloy is above body temperature, the requirement that the device be heated to a temperature above body temperature to cause recovery and that the device be placed so as not to change shape again when it re-cools (since the body temperature is below the transition temperature); (ii) the inability to remove the device easily; and (iii) the need for controlled temperature storage to prevent premature reversion to austenite of the SMA, with consequent shape change.

The issue of removal of a catheter is especially significant, and not addressed by Wilson. Consider, for example, a tracheal puncture catheter. This should be

straight for easy insertion into the trachea through a puncture into the front of the neck, but should curve after insertion so that the flow of air or oxygen through the catheter passes axially down the trachea rather than impinging on the surface of the trachea and damaging it. If a shape memory catheter is used as contemplated by Wilson, it would presumably become austenitic and bend after insertion (see Figures 1a and 1b, and corresponding text, of Wilson). But removal would require either cooling to below the transition temperature (which could easily mean cooling to so low a temperature that the tracheal tissue is damaged), removal in the bent shape (presumably damaging tissue), or forcing the austenitic SMA to straighten to permit direct removal (unlikely to be satisfactory since the austenitic alloys e.g. of Ni/Ti may have yield strengths of 100 ksi or more, and force sufficient to cause plastic deformation would be required).

If an SIM element is used instead, however, removal can be accomplished almost as easily as insertion. If the catheter is made in a bent shape (as in Wilson), it can be straightened by insertion of a straight pin down the catheter axis, the catheter deforming by the formation of stress-induced martensite. Insertion of the catheter into the trachea is accomplished while the catheter is straight, at whatever rate is desired (permitting easy and accurate placement); and the pin is gradually withdrawn to permit the catheter to take up its desired shape as the martensite reverts to austenite. [It is assumed here that the stress-strain curve of the alloy at the temperature of use is of the form of Figure 2, so spontaneous reversion occurs on removal of the stress induced by the pin]. When removal is desired, it may be achieved simply by the gradual insertion of the pin, straightening the catheter and permitting easy withdrawal. Insertion of the catheter into the body and pin removal may, of course, take place simultaneously if desired, as may pin reinsertion and removal of the catheter from the body.

Example III. IUDS

Fannon et al., in U.S. Patent No. 3,620,212, the disclosure of which is incorporated herein by reference, discloses an intrauterine contraceptive device (an IUD) proposed to be formed of a shape memory alloy. The device is suggested to be deformed in the martensitic phase (the transition temperature being below the temperature of the uterus), and the deformed device insulated with, e.g., wax and inserted ~~it~~. Removal is contemplated only by using two SMA elements in opposition, the higher temperature one being martensitic at body temperature but strong enough so that, if heated, it will overcome the lower temperature element and deform the IUD back to a removable shape. The heating contemplated is electrical. The storage problem discussed in Example II also exists here, so that the device must be stored below its transition temperature.

By the use of an SIM element, however, these disadvantages may be overcome. Again, assume that the alloy is SIM pseudoelastic, i.e. that it has the stress-strain curve of Figure 2. Then an IUD may be formed into the desired shape in the austenitic state, and deformed by compression into a tubular placement device (the deformation being such that the strain levels lie within the "plateau" of the stress-strain curve). When the placement device is inserted into the uterus, the IUD may be deployed by extrusion of the IUD from the placement device. Deployment is then controlled but immediate, so that the physician may satisfy himself with placement. Removal is the reversal of placement: the placement device is inserted into the uterus, the IUD deformed by withdrawal into the placement device, and the placement device withdrawn. Temperature control is not required.

Example IV. Bone Plates

Johnson et al., in U.S. Patent No. 3,786,806, the disclosure of which is incorporated herein by reference, propose the use of Ni/Ti SMA bone plates in fracture fixation. The plate is deformed in its martensitic state, screwed to the two ends of the bone it is desired to compress together, and warmed (or allowed to warm) to the austenitic state, when the plate contracts, compressing the bone ends together.

Because of the high elastic moduli of the austenitic shape memory alloys, it will be difficult to control the amount of force ^{which} may be applied by a bone plate of the type proposed by Johnson et al., and precision placement of the bone ends and elongation of the plate will be required.

If, however, an SIM pseudoelastic bone plate is used, it will be easily possible to elongate the plate and fasten it to the bone ends without requiring high precision. Because of the comparatively large (e.g. 5%) strain range at essentially constant stress, the force which will be put on the bone ends to compress them will be readily adjustable (by the size of the plate, for example) and will be insensitive to precise placement of the bone ends and/or elongation of the plate. Also, the recovery of the plate, since it is controlled by mechanical restraint, may be as gradual as desired, achieving excellent force and time control, and permitting the surgeon to make adjustments as desired.

Example V. Marrow Nails

5 Baumgart et al., in U.S. Patent No. 4,170,990, the disclosure of which is incorporated herein by reference, discloses the use of the two-way shape memory effect (where an SMA element exhibits a first shape in the austenitic state and a second in the martensitic state, and spontaneously changes between the two shapes with a change in temperature) in, inter alia, ^{implants, such as} marrow nails (see Figures 1a through 1e, and corresponding text, of Baumgart et al.). *as*

10 The method proposed, however, requires the use of a wide temperature range in order to cause the phase change which is the origin of the two-way shape memory effect (5°C to 60°C for the water used to cool or heat the nail). In addition, it requires the manufacture of two-way shape memory elements, which is generally more complex than the manufacture of conventional shape memory elements; and precise control of the ^{transition} ~~transition~~ temperature is required. *a*

20 However, if an SIM pseudoelastic alloy element is employed, these disadvantages may be overcome. If internal tangs, which may be gripped by an inserted tool, are provided within a marrow nail of the type shown in Figure 1a of Baumgart et al., then the nail may be radially compressed by the application of stress by such a tool. When the nail is released by the tool, it will expand to fill the bone channel with a constant force (not readily available by Baumgart et al.); and it may 25 be withdrawn by the reverse procedure.

Example VI. Dental Arch Wire

Andreasen, in U.S. Patent No. 4,037,324, the disclosure of which is incorporated herein by reference, proposes the use of dental arch wires made of Ni/Ti alloys instead of conventional 18-8 stainless steel wires. The wires are stated to be of lower elastic modulus and higher elastic limit than stainless steel, which is stated to be advantageous. Heat recovery of an SMA wire is also suggested as a technique for orthodonture.

The technique of using the conventional shape memory effect is not believed to have found clinical application, possibly because such a technique would require rapid placement of the wire in its martensitic state to avoid premature recovery, and would result in rapid recovery with extremely high forces, which would be painful for the patient.

The use of a wire which displays lower elastic modulus and higher elastic limit than stainless steel has found some application, however. Otsuka et al. in Metals Forum, v. 4, pp. 142-52 (1981) have suggested that this behavior may be the result of elasticity enhanced by cold working and martensite-to-martensite pseudoelasticity in an alloy which has a transition temperature below body temperature. The alloy, then, is martensitic rather than austenitic in its undeformed state.

While the use of an enhanced elasticity wire may offer some advantages over the more usual stainless steel wire, it remains the situation that the amount of motion in the teeth that may be produced by an arch wire without further adjustment

is largely limited by the pain tolerance of the patient (since the force applied by the arch wire is proportional to the deformation of the wire). However, if an SLM pseudoelastic wire is used, it can exert a relatively constant force (chosen by the dentist to be sufficient to cause tooth movement but not painful) over a strain range of up to 5%. The load may be applied mechanically, and is thus more readily established, and no precise temperature control of the alloy is needed as would be required for the shape memory effect.

Example VII. Coil Stents and Filters

The use of tubular coiled wire stent grafts has been discussed in the medical literature since 1969. Although the coils helped maintain patency of the vessels in which they were placed, they were difficult of insertion unless narrow enough to significantly narrow the lumen of the vessel. Recently it has been proposed, see Radiology, v. 147, pp. 259-60 and pp. 261-3 (1983), the disclosures of which are incorporated herein by reference, to use SMA wire to form these tubular coils. The wire, which has a transformation temperature below body temperature, is introduced through a catheter after being straightened in its martensitic state. When the wire is heated, the coil re-forms.

INS. C2 →
Because of the difficulty of controlling the transformation temperature accurately, it has proved necessary to cool the straightened wire during insertion and/or to heat the wire to form the coil after insertion. These procedures add to the complexity of the operation.

5 If an SIM pseudoelastic wire is used to form the coil, which is then isothermally deformed by loading into a catheter, then the need for temperature control is avoided. The wire remains straight when in the catheter, but re-forms the coil spontaneously when it is extruded from the catheter. Accurate placement is thus readily obtainable, since there is no urgency as might be required with a conventional shape memory effect element.

10 It has similarly been proposed to use SMA wire to form a filter for emplacement by catheter in the vena cava to trap blood clots. The filter is formed in the austenitic state, the wire straightened in the martensitic state and inserted, and the filter re-forms on warming. Just as for the coil stents discussed above, the use of an SIM pseudo-
15 elastic wire would greatly simplify manufacture and insertion of such a vena cava filter, permitting accurate placement with no need for urgency or temperature manipulation.

Example VIII. Bone Staples. Clips. etc.

20 Bone staples are frequently used to hold fragments of fractured bone together when the fracture is fixed, and may be used in some cases as a replacement for bone plates in the same situation. Sometimes the staples are inserted into drilled holes, sometimes merely driven into the bone directly.

25 It would be desirable to have a bone staple which provided a controlled force between the tines which would tend to hold the staple in place. Shape memory alloys have been proposed for this application, but again the problem of accurate placement while operating quickly enough to prevent the shape change associated with the martensite-to-austenite transition and/or the need for temperature control complicate their use.

If an SIM alloy is used, these disadvantages may be readily overcome. If the alloy is below A_s , it may be replaced in the martensitic state. Brief heating will then be required to cause it to become austenitic, but on re-cooling to body temperature, a constant force can be achieved. If the alloy is above A_s , the staple can be held deformed by a moderate force, then released after insertion to also provide an accurately-known force. In either event, removal is easier than if the alloy is purely austenitic, as discussed above for Examples II and V, for example.

Similarly, SIM alloy (especially alloy which is pseudoelastic, above A_s at its utilization temperature) may be used to manufacture vascular clips, etc. The alloy element here acts as a constant force spring over a wide strain range (greater than conventional elastic metals), resulting in ease of use.

From the foregoing, it is clear that, in a situation where narrow temperature differences are available or preferable, as often is the case in medical applications, mechanically constrained shape change is a much more useful solution than heat actuated shape change. It offers a degree of control heat actuation does not, it offers easier alloy composition control, it eases mating part tolerance requirements, and it offers simple mechanical reversal at minimal stress levels, all without heating, cooling or insulation complications.

It will be obvious to those skilled in the art, having regard to this disclosure, that other variations on this invention beyond those specifically exemplified here, and other medical devices making use of stress-induced martensite, may be made. Such variations are, however, to be considered as coming within the scope of this invention as limited solely by the following claims.

I claim:

add a6

1. In a medical device intended for use within a mammalian body, or in such proximity to a mammalian body that the device is substantially at body temperature, which device comprises a shape memory alloy element, the improvement which comprises the substitution of an alloy element which displays stress-induced martensite at said body temperature for the shape memory alloy element.
2. The device of claim 1 which is a heart valve, the alloy element being a ring employed to hold a sewing cuff onto the valve body.
3. The device of claim 1 which is a catheter, the alloy element being the catheter or a part thereof which causes the catheter to assume a bent shape.
4. The device of claim 3 which is a tracheal catheter.
5. The device of claim 1 which is an intrauterine contraceptive device.
6. The device of claim 1 which is a bone plate.
7. The device of claim 1 which is a marrow nail.
8. The device of claim 1 which is a dental arch wire.
9. The device of claim 1 which is a bone staple.
10. The device of claim 1 which is a clip.

Add B1

Add C4

DECLARATION AND POWER OF ATTORNEY (Page 1)

Raychem Case No.
MFO884-US1

As a below named inventor, I hereby declare that:
my residence, post office address and citizenship are as stated below next
to my name; I believe I am the original, first and sole inventor (if only
one name is listed below) or an original, first and joint inventor (if plural
names are listed below) of the subject matter which is claimed and for which
a patent is sought on the invention entitled: Medical Devices Incorporating
SIM Alloy Elements

the specification of which
X is attached hereto

was filed on _____ as Application Serial No. _____
and was amended on _____ (if applicable).

I hereby state that I have reviewed and understand the contents of the above
identified specification, including the claims, as amended by any amendment
referred to above. I acknowledge the duty to disclose information which is
material to the examination of this application in accordance with
37 CFR §1.56(a).

I hereby claim foreign priority benefits under 35 U.S.C. §119 of any foreign
application(s) for patent or inventor's certificate listed below and have
also identified below any foreign application for patent or inventor's
certificate having a filing date before that of the application, on which
priority is claimed:

PRIOR FOREIGN APPLICATIONS

Application Number	Country	Date Of Filing	Priority Claimed
NONE			Yes ___ No ___
			Yes ___ No ___

I hereby claim the benefit under 35 U.S.C. § 120 of any United States appli-
cation(s) listed below and, insofar as the subject matter of each of the
claims of this application is not disclosed in the prior United States
application in the manner provided by the first paragraph of 35 U.S.C. §112,
I acknowledge the duty to disclose material information as defined in 37 CFR
§1.56(a) which occurred between the filing date of the prior application
and the national or PCT international filing date of this application:

PRIOR UNITED STATES APPLICATIONS

Application Number	Date Of Filing	Status
NONE		Pending ___ Patented ___ Abandoned ___
		Pending ___ Patented ___ Abandoned ___

I hereby appoint the following attorney(s) and/or agent(s) to prosecute
this application and to transact all business in the Patent and Trademark
Office connected therewith:

Herbert G. Burkard, Reg. No. 24,500
and James W. Peterson, Reg. No. 26,057

Address all telephone calls to: James W. Peterson
at (415)361- 5854

Address all correspondence to: Patent Department
Raychem Corporation
300 Constitution Drive
Menlo Park, CA 94025

DR 489201

U.S. Serial No:

October 14, 1983



MPDEB4-US1

CONFORMED COPY

MEDICAL DEVICES INCORPORATING
SIM ALLOY ELEMENTS

James E. Jervis

ABSTRACT OF THE DISCLOSURE

5 Medical devices which are currently proposed to use elements made from shape memory alloys may be improved by the use of stress-induced martensite alloy elements instead. The use of stress-induced martensite decreases the temperature sensitivity of the devices, thereby making them easier to install and/or remove.

I hereby declare that all statements made herein of my own knowledge are true and that all statements made on information and belief are believed to be true; and further that these statements were made with the knowledge that willful false statements and the like so made are punishable by fine or imprisonment, or both, under 18 U.S.C. §1001 and that such willful false statements may jeopardize the validity of the application or any patent issued thereon.

FULL NAME OF SOLE OR FIRST INVENTOR	INVENTOR'S SIGNATURE	DATE
JAMES E. JERVIS	<i>James E. Jervis</i>	10/14/85
RESIDENCE	CITIZENSHIP	
Atherton, California	U.S.A.	
POST OFFICE ADDRESS		
496 Walsh Road, Atherton, CA 94025		

FULL NAME OF SECOND JOINT INVENTOR, IF ANY	INVENTOR'S SIGNATURE	DATE
RESIDENCE	CITIZENSHIP	
POST OFFICE ADDRESS		

FULL NAME OF THIRD JOINT INVENTOR, IF ANY	INVENTOR'S SIGNATURE	DATE
RESIDENCE	CITIZENSHIP	
POST OFFICE ADDRESS		

FULL NAME OF FOURTH JOINT INVENTOR, IF ANY	INVENTOR'S SIGNATURE	DATE
RESIDENCE	CITIZENSHIP	
POST OFFICE ADDRESS		

FULL NAME OF FIFTH JOINT INVENTOR, IF ANY	INVENTOR'S SIGNATURE	DATE
RESIDENCE	CITIZENSHIP	
POST OFFICE ADDRESS		

BAR CODE LABEL 	<h1>U.S. PATENT APPLICATION</h1>
---	----------------------------------

SERIAL NUMBER 08/483,291	FILING DATE 06/07/95 RULE 60	CLASS 606	GROUP ART UNIT 3301
-----------------------------	------------------------------------	--------------	------------------------

APPLICANT JAMES E. JERVIS, ATHERTON, CA.

****CONTINUING DATA*******

VERIFIED <i>Yes</i>	THIS APPLN IS A CON OF AND A DIV OF WHICH IS A DIV OF WHICH IS A CON OF WHICH IS A CON OF WHICH IS A CON OF WHICH IS A CON OF	07/956,653 10/02/92 07/682,243 04/09/91 PAT 07/252,019 09/27/88 PAT 07/177,817 03/30/88 07/047,824 05/08/87 06/865,703 05/21/86 PAT 06/541,852 10/14/83 ABN	5,190,546 5,067,957 4,665,906
------------------------	---	---	-------------------------------------

****FOREIGN/PCT APPLICATIONS*******

VERIFIED
Noel, Z

FOREIGN FILING LICENSE GRANTED 08/10/95

STATE OR COUNTRY	SHEETS DRAWING	TOTAL CLAIMS	INDEPENDENT CLAIMS	FILING FEE RECEIVED	ATTORNEY DOCKET NO.
CA	3	10	3	\$730.00	9438-1

ADDRESS

JEFFREY G SHELDON
 SHELDON & MAK
 225 SOUTH LAKE AVENUE SUITE 900
 PASADENA CA 91101

TITLE

MEDICAL DEVICES INCORPORATING SIM ALLOY ELEMENTS

This is to certify that annexed hereto is a true copy from the records of the United States Patent and Trademark Office of the application which is identified above.

By authority of the
 COMMISSIONER OF PATENTS AND TRADEMARKS

Date _____ Certifying Officer _____

PATENT APPLICATION SERIAL NO. 08/483291

U.S. DEPARTMENT OF COMMERCE
PATENT AND TRADEMARK OFFICE
FEE RECORD SHEET

210 TL 07/10/95 08483291
1 101 730.00 CK

PATENT APPLICATION FEE DETERMINATION RECORD

Effective October 1, 1994

Application or Docket Number

483291

CLAIMS AS FILED - PART I

FOR	(Column 1) NUMBER FILED	(Column 2) NUMBER EXTRA
BASIC FEE		
TOTAL CLAIMS	10 minus 20 = *	
INDEPENDENT CLAIMS	3 minus 3 = *	
MULTIPLE DEPENDENT CLAIM PRESENT		

SMALL ENTITY		OR	OTHER THAN SMALL ENTITY	
RATE	FEE		RATE	FEE
	365.00	OR		730.00
x\$11=		OR	x\$22=	
x38=		OR	x76=	
+120=		OR	+240=	
TOTAL		OR	TOTAL	730

* If the difference in column 1 is less than zero, enter "0" in column 2

CLAIMS AS AMENDED - PART II

AMENDMENT A

	(Column 1) CLAIMS REMAINING AFTER AMENDMENT		(Column 2) HIGHEST NUMBER PREVIOUSLY PAID FOR	(Column 3) PRESENT EXTRA
Total	* 24	Minus	** 20	= 21
Independent	* 6	Minus	*** 3	= 3
FIRST PRESENTATION OF MULTIPLE DEPENDENT CLAIM				

SMALL ENTITY		OR	OTHER THAN SMALL ENTITY	
RATE	ADDITIONAL FEE		RATE	ADDITIONAL FEE
x\$11=		OR	x\$22=	402
x38=		OR	x76=	240
+120=		OR	+240=	260
TOTAL ADDIT. FEE		OR	TOTAL ADDIT. FEE	

AMENDMENT B

	(Column 1) CLAIMS REMAINING AFTER AMENDMENT		(Column 2) HIGHEST NUMBER PREVIOUSLY PAID FOR	(Column 3) PRESENT EXTRA
Total	*	Minus	**	=
Independent	*	Minus	***	=
FIRST PRESENTATION OF MULTIPLE DEPENDENT CLAIM				

SMALL ENTITY		OR	OTHER THAN SMALL ENTITY	
RATE	ADDITIONAL FEE		RATE	ADDITIONAL FEE
x\$11=		OR	x\$22=	
x38=		OR	x76=	
+120=		OR	+240=	
TOTAL ADDIT. FEE		OR	TOTAL ADDIT. FEE	

AMENDMENT C

	(Column 1) CLAIMS REMAINING AFTER AMENDMENT		(Column 2) HIGHEST NUMBER PREVIOUSLY PAID FOR	(Column 3) PRESENT EXTRA
Total	*	Minus	**	=
Independent	*	Minus	***	=
FIRST PRESENTATION OF MULTIPLE DEPENDENT CLAIM				

SMALL ENTITY		OR	OTHER THAN SMALL ENTITY	
RATE	ADDITIONAL FEE		RATE	ADDITIONAL FEE
x\$11=		OR	x\$22=	
x38=		OR	x76=	
+120=		OR	+240=	
TOTAL ADDIT. FEE		OR	TOTAL ADDIT. FEE	

* If the entry in column 1 is less than the entry in column 2, write "0" in column 3.
 ** If the "Highest Number Previously Paid For" IN THIS SPACE is less than 20, enter "20."
 *** If the Highest Number Previously Paid For" IN THIS SPACE is less than 3, enter "3."
 The Highest Number Previously Paid For" (Total or Independent) is the highest number found in the appropriate box in column 1.



PATENT
9438-1\MP0884-US8

V. Douglas
As Pled
9-25-95

IN THE UNITED STATES PATENT AND TRADEMARK OFFICE

In re application of:)	Group Art Unit: 3301
JAMES E. JERVIS)	(Prior Application)
Serial No. Continuation of 07/956,653)	Examiner: KENEALY, D
Filed: Herewith)	(Prior Application)
For: MEDICAL DEVICES INCORPORATING)	
SIM ALLOY ELEMENTS)	Pasadena, California

PRELIMINARY AMENDMENT

Honorable Commissioner of
Patents and Trademarks
Washington, D. C. 20231

Sir:

Please amend the above-identified patent application
as follows:

IN THE SPECIFICATION

Page 2, before the heading "Background of the
Invention", insert:

-- CROSS-REFERENCE TO RELATED APPLICATIONS

This application is a continuation of Application
Serial No. ⁰¹956,653 filed on October 2, 1992, which is a
divisional of Application Serial No. ⁰¹682,243 filed on April 9,

a1

1991, now U.S. Patent No. 5,190,546, which is a divisional of
Serial No. ^{07/}252,019 filed on September 27, 1988, now U.S. Patent
No. 5,067,957, which is a continuation of Application Serial No. ^{07/}177,817 filed March 30, 1988, now abandoned; which is a
continuation of Application Serial No. ^{07/}047,824 filed May 8, 1987,
now abandoned; which is a continuation of Application Serial No. ^{06/}865,703 filed May 21, 1986, now U.S. Patent No. 4,665,906; which
is a continuation of Application Serial No. ^{06/}541,852 filed October
14, 1983, now abandoned.

a
Cont.

Page 3, line 28, after Quin insert --now U.S. Patent
No. 4,505,767--.

Page 4, line 26, delete "power" and insert --powder--.

Page 6, line 4, after "martensite," please insert --

--Figure 3 is a side elevation view of a partial
section of a catheter of the present invention in a stressed
configuration.

Figure 4 is a side elevation view of the catheter of
Figure 3 in an unstressed configuration.

ar

Fig. 5 is a tracheal catheter, which is curved in its unstressed configuration, partially straightened by a straight pin restraint.

*Q2
Cont.*

Fig. 6 shows an IUD formed at least partly from a pseudoelastic shape-memory alloy being restrained in a deformed shape by a restraining tube.

Page 7, line 19, delete "E_p" and insert --E_A--.

Page 7, line 19, delete "strain" and insert --stress--.

Page 8, line 20, delete "theart" and insert --the art--.

Page 8, line 21, delete "tsting" and insert --testing--.

Page 8, line 24, after "(Docket No. MP0873-US1)" insert --now U.S. Patent No. 4,505,767--.

Page 8, between lines 24 and 25, insert the following paragraph:

--The following table sets forth transformation temperature data for alloys disclosed in US-4505767:

Q3

A

T,0240

TABLE

Composition (atomic percent)

<u>Ni</u>	<u>Ti</u>	<u>V</u>	<u>M_s</u>	<u>A(90)</u>
49.50	43.50	7.00	-107	-88
50.00	44.00	6.00	-96	-84
49.00	43.00	8.00	-83	-61
50.00	45.00	5.00	-42	-33
49.00	45.00	6.00	-35	-12
50.50	48.00	1.50	-32	-6
48.50	44.50	7.00	-30	-13
50.00	46.00	4.00	-11	7
48.50	45.00	6.50	-10	15
49.00	45.50	5.50	-10	14
48.00	44.25	7.75	-7	8
48.50	45.50	6.00	-5	27
41.50	38.50	20.00	-2	86
46.50	43.50	10.00	-1	50
36.25	33.75	30.00	0	42
49.50	46.00	4.50	6	35
48.00	46.00	6.00	12	36
47.75	45.75	6.50	20	54
47.50	45.50	7.00	26	58
48.50	46.50	5.00	27	58
45.00	45.00	10.00	30	71
47.50	46.50	6.00	32	71
46.50	46.50	7.00	34	70

*α₃
Cont.*

The A(90) temperature is the temperature at which the transformation from the martensitic phase to the austenitic phase is 90% complete.

Page 11, line 17, delete "by" and insert --be--.

Page 13, line 9, delete "it".

Page 14, line 12, delete "whch" and insert --which--.

Page 14, line 9, after "together." insert - The Johnson

a4
et al. bone plate is of generally oblong configuration, overlaps a bone fracture and is secured by two screws to one portion of the bone and by two other screws to the other portion of the bone--.

Page 15, line 8, before "marrow nails" insert
--implants, such as--.

Page 15, line 9, insert after "Baumgart et al."

a5
--Marrow nails according to Baumgart et al. comprise a tube of memory alloy which has been split along its longitudinal axis and which may have a circular, elliptical, clover-leaf or other rotation preventing cross section, which may also be variable along the axis of the nail. A prepared marrow nail having a reduced diameter is loosely inserted into a slightly, or not at all, pre-drilled marrow channel of a bone which has been broken or fractured. By means of a heating probe the marrow nail is heated and thus expands. This achieves a relative fixing of the two bone ends along the marrow channel axis. Compression of the fracture is effected by the available muscle tension. If it should be necessary, the marrow nail may also be additionally prestretched along its longitudinal axis so that it is additionally compressed in the longitudinal direction when heated. In this case it is necessary, however, to anchor the nail at both of its ends which anchoring can be effected, for

example, by sprockets or teeth on the outer surface of the
nail.---

as
cont.

Page 15, line 17, delete "transition" and insert
--transition--.

IN THE DRAWINGS

Please add Figures 3-6 to the drawings.

IN THE CLAIMS

Cancel claims 1 to 10.

Add new claims 11 to 20 as follows:

11. A medical device for use within a mammalian body,
or in such proximity to a mammalian body that the device is
substantially at body temperature, the device comprising an
element which comprises a shape memory alloy which:

(a) displays stress induced martensite behavior
at body temperature; and

(b) has an A(90) temperature of not more than
0°C.

12. A device as claimed in claim 11, which includes a
restraint by means of which the shape memory alloy element is
held in a deformed configuration to allow it to be positioned

ab

A

within or in proximity to a mammalian body, the deformation occurring through the formation of stress induced martensite.

13. A device as claimed in claim 12, in which the restraint is hollow, and the shape memory alloy element is deformed in such a way that it is compressed transversely, and is positioned within the restraint, the restraint preventing transverse expansion of the element.

14. A device as claimed in claim 13, in which the restraint is a catheter.

15. A device as claimed in claim 13, in which the shape memory alloy element is an intrauterine contraceptive device.

16. A device as claimed in claim 13, in which the shape memory alloy element is a filter for a blood vessel.

17. A device as claimed in claim 12, in which the shape memory alloy element is tubular, and the restraint is positioned within the shape memory alloy element to deform it.

18. A device as claimed in claim 17, in which the shape memory alloy element is a tracheal catheter.

*at
Cond.*

19 20. A method for compressing two ends of a mammalian bone together at body temperature, the method comprising the steps of:

(a) providing a bone plate formed from a pseudoelastic shape-memory alloy, wherein the shape-memory alloy can display reversible stress-induced martensite at about body temperature such that the shape-memory alloy has a stress-induced martensitic state and an austenitic state; the bone plate being (i) elongated when the alloy is in its stressed-induced martensitic state and (ii) shortened when they alloy is in its austenitic state;

(b) stressing the bone plate at a temperature greater than the A_s of the alloy for placing the alloy in its stressed-induced martensitic state and elongating the bone plate;

(c) attaching the stressed and elongated bone plate to the two ends of the bone at a temperature greater than the A_s of the alloy; and

(d) releasing the stress from the bone plate so that at least a portion of the alloy transforms from its stress-induced martensitic state to its austenitic state so that the bone plate compresses the two ends of the bone together at essentially constant stress.

20. An assembly, which comprises:

(a) a bone in which an aperture is formed, and

(b) an element which is formed at least partially from a shape memory alloy which displays stress induced martensite behavior at body temperature,

the element being positioned so that it is deformed by the walls of the aperture by the formation of stress induced martensite, and thereby exerts a force outwardly on the walls of the aperture.

*all
cont.*

REMARKS

Entry of the amendments is respectfully requested. All the amendments to the specification and drawings are the same as were made in the parent application.

Claims 11-19 correspond to claims 11-18 and 54, respectively, of parent application Serial Number 956,653. Claim 20 corresponds to claim 29 of parent application serial number 682,243.

Respectfully submitted,

SHELDON & MAK

6/7/95
Date

By: Jeffrey G. Sheldon

Jeffrey G. Sheldon
Reg. No. 27,953

225 South Lake Avenue, 9th Floor
Pasadena, California 91101
(818) 796-4000



08/483291

AP3

9438-1

IN THE UNITED STATES PATENT AND TRADEMARK OFFICE

In re application of:) Group Art Unit: 3301
) (Prior Application)
 JAMES E. JERVIS)
)
 Serial No. Continuation of 07/956,653) Examiner: KENEALY, D
) (Prior Application)
)
 Filed: Herewith)
)
 For: MEDICAL DEVICES INCORPORATING)
 SIM ALLOY ELEMENTS) Pasadena, California

INFORMATION DISCLOSURE STATEMENT

Honorable Commissioner of
Patents and Trademarks
Washington, D. C. 20231

Sir:

Attached hereto are PTO-1449 forms listing documents believed relevant to the subject application. These forms list all the references cited in the parent application. It is respectfully requested that these documents be considered by the Examiner and an initialled copy of each form be returned to the undersigned.

Copies of the references are available in the file of the parent application Serial No. 07/956,653. It is believed that these cited references are relevant to claims pending in the present application for the same reason as discussed in the parent application. If the Examiner would like a further description, or copies of any of the references, please call the undersigned.

It should be noted the word "prior" has been deleted from the forms.

It is believed that this disclosure complies with the requirements of 37 C.F.R. 1.56 and the Manual of Patent Examining Procedures Section 707.05 (b). If for some reason the Examiner considers otherwise, it is respectfully requested that the undersigned be called so that any deficiencies can be remedied.

Respectfully submitted,

SHELDON & MAK

6/7/95
Date

By: 

Jeffrey G. Sheldon
Reg No. 27,953

225 South Lake Avenue, 9th Floor
Pasadena, California 91101
(818) 796-4000

UTILITY SERIAL NUMBER 08/083291	PATENT DATE OCT 23 2001	PATENT NUMBER
CLASS 606	DATE 06/07/95	CLASS 606
RULE 80	GROUP ART UNIT 3201	EXAMINER

JAMES E. JERVIE, ATHERTON, CA

CONTINUING DATA**
 VERIFIED THIS APPLN IS A CON OF 07/956,653 10/02/92
 AND A DIV OF 07/682,243 04/09/91 PAT 5,190,546
 WHICH IS A DIV OF 07/252,019 09/27/88 PAT 5,067,957
 WHICH IS A CON OF 07/177,617 03/30/88 PAT 5,111,951
 WHICH IS A CON OF 07/047,824 05/08/87 PAT 5,111,951
 WHICH IS A CON OF 06/865,703 05/21/86 PAT 4,665,906
 WHICH IS A CON OF 06/541,852 10/14/83 ABN 5,111,951

FOREIGN/PCT APPLICATIONS**
 VERIFIED
 None JL

FOREIGN FILING LICENSE GRANTED 08/10/95

Foreign priority claimed 35 USC 110 conditions met	<input type="checkbox"/> yes <input checked="" type="checkbox"/> no	AS FILED	STATE OR COUNTRY CA	SHEETS DRWGS. 3	TOTAL CLAIMS 10	INDEP. CLAIMS 3	FILING FEE RECEIVED \$730.00	ATTORNEY'S DOCKET NO. 9438-1
Address: JEFFREY G SHELDON SHELDON & MAK 225 SOUTH LAKE AVENUE SUITE 900 PASADENA CA 91101								

MEDICAL DEVICES INCORPORATING SIM ALLOY ELEMENTS.
 U.S. DEPT. of COMM. Pat. & TM Office-PTO

PARTS OF APPLICATION FILED SEPARATELY		Everett Williams Applications Examiner	
NOTICE OF ALLOWANCE MAILED 5/10/01		CLAIMS ALLOWED Total Claims: 22, Print Claim: 1	
ISSUE FEE Amount Due: 1,270.00 Date Paid: 5-10-01	Assistant Examiner	DRAWING Sheets Drwg: 4, Figs. Drwg: 7, Print Fig: 3, 4	
Label Area	JUSTINE T. YU PRIMARY EXAMINER	ISSUE BATCH NUMBER G18	
PREPARED FOR ISSUE			
WARNING: The information disclosed herein may be restricted. Unauthorized disclosure may be prohibited by the United States Code Title 35, Sections 122, 181 and 388. Possession outside the U.S. Patent & Trademark Office is restricted to authorized employees and contractors only.			

Form PTO-022A (Rev. 09/92) Formal Drawings (city) ISSUE FEE IN FILE (FACE)

SEARCHED

Class	Sub.	Date	Exmr.
606	78 6c 108 62 68 200 195 198	10/21/86	JL
623	1		
updated 9/12/97			R

SEARCH NOTES

	Date	Exmr.
APS	10/18/86	JL

INTERFERENCE SEARCHED

Class	Sub.	Date	Exmr.
Adj of	above	4/19/01	R

(RIGHT OUTSIDE)

Staple Issue Slip Here

POSITION	ID NO.	DATE
CLASSIFIER	21	7/11/95
EXAMINER	20	8/10
TEST	710	8-10-95
VERIFIER	HKJ	8/10
CORR. CORR.		
SPEC. HAND		
FILE MAINT.		
DRAFTING		

INDEX OF CLAIMS

Claim	Date	
	Final	Original
1		
2		
3		
4		
5		
6		
7		
8		
9		
10		
11		
12		
13		
14		
15		
16		
17		
18		
19		
20		
21		
22		
23		
24		
25		
26		
27		
28		
29		
30		
31		
32		
33		
34		
35		
36		
37		
38		
39		
40		
41		
42		
43		
44		
45		
46		
47		
48		

Claim	Date	
	Final	Original
51		
52		
53		
54		
55		
56		
57		
58		
59		
60		
61		
62		
63		
64		
65		
66		
67		
68		
69		
70		
71		
72		
73		
74		
75		
76		
77		
78		
79		
80		
81		
82		
83		
84		
85		
86		
87		
88		
89		
90		
91		
92		
93		
94		
95		
96		
97		
98		
99		
100		

SYMBOLS
 ✓ Rejected
 = Allowed
 - (Through numerical) Cancelled
 + Restricted
 N Non-elected
 I Interference
 A Appeal
 O Objected



AMENDMENT COVER SHEET

GP3301

026

DOCKET NO. 9438-1/MP0884-U

IN RE APPLICATION OF: JAMES E. JERVIS

SERIAL NO.: 08/483,291

FILED: June 7, 1995

FOR: MEDICAL DEVICES INCORPORATING SIM ALLOY ELEMENTS

HONORABLE COMMISSIONER OF PATENTS AND TRADEMARKS Washington, D.C. 20231

GROUP 330

Sir:

Transmitted herewith is a paper in the above-identified application. Any necessary extension of time period set for this paper is hereby requested.

- No additional fee is required. The fee has been calculated as shown below:

Table with 4 columns: Extension Period, Rate Non-Small Entity, Rate Small-Entity, Fee. Rows include First, Second, Third, and Fourth month after time period set.

- TOTAL EXTENSION FEE FEE FOR EXTRA CLAIMS added by Amendment in this response:

Table with 7 columns: Column 1 (Number of Claims after Amendment), Column 2 (Number Previously Paid for), Column 3 (Number of Extra Claims), Rate Non-Small Entity, Rate Small-Entity, Fee. Rows include Total Claims, Independent, and First presentation of multiple dependent claim.

TOTAL FEE FOR EXTRA CLAIMS \$

- * If the entry in Column 1 is less than the entry of Column 2, write "0" in Column 3. ** If the number of Total Claims previously paid for is less than 20, write "20" in this space. *** If the number of Independent Claims previously paid for is less than 3, write "3" in this space.

- Enclosed is the fee of \$ by Check No. Please charge Deposit Account No. 19-2090 in the amount of \$ The Commissioner is hereby authorized to charge payment of any additional fees, in particular the following fees, associated with this communication, or credit any overpayment to Deposit Account No. 19-2090:

Any filing fees under 37 C.F.R. § 1.16 for the presentation of extra claims Any patent application processing fees under 37 C.F.R. § 1.17

Date: 7/14/95 By: Jeffrey G. Sheldon, Reg. No.: 27,953

CERTIFICATE OF MAILING: I hereby certify that the above-identified correspondence, which is attached, is being deposited with the U.S. Postal Service as first class mail in an envelope addressed to: Commissioner of Patents and Trademarks, Washington, D. 20231 on July 14, 1995

Date Signed: July 14, 1995 By: Sheldon & MAK Signature Type or Print Name

Sheldon & MAK Lake Avenue, 9th Floor California 91101



SPE 3301

V. Davis #4/BuB

PATENT 9438-1\MP0884-US8

9-29-95

IN THE UNITED STATES PATENT AND TRADEMARK OFFICE

In re application of:) Group Art Unit: 3301
) (Prior Application)
 JAMES E. JERVIS) Examiner: KENEALY, D
) (Prior Application)
 Serial No. 08/483,291)
)
 Filed: June 7, 1995)
)
 For: MEDICAL DEVICES INCORPORATING)
 SIM ALLOY ELEMENTS) Pasadena, California

SUPPLEMENTAL PRELIMINARY AMENDMENT

RECEIVED
AUG 01 1995
GROUP 330

Honorable Commissioner of
Patents and Trademarks
Washington, D. C. 20231

Sir:

Please amend the above-identified patent application
as follows:

IN THE SPECIFICATION

Please amend the specification to make the present
application a divisional of the parent application.

IN THE CLAIMS

Please add the following claims to the application:

Sub C3/1

B/

21. A medical device for insertion into a mammalian
body, the device comprising (i) a hollow placement device and
(ii) a memory alloy element formed at least partly from a

B

pseudoelastic shape-memory alloy, the alloy displaying reversible stress-induced martensite at about body temperature such that it has a stress-induced martensitic state and an austenitic state, the memory alloy element having (i) a deformed shape when the alloy is in its stress-induced martensitic state and (ii) a different unstressed shape when the alloy is in its austenitic state;

the memory alloy element being within the hollow placement device, the hollow placement device stressing the memory alloy element at a temperature greater than the A_s of the alloy so that the memory alloy element is in its deformed shape;

wherein the memory alloy element can be extruded from the hollow placement device at a temperature greater than the A_s of the alloy to transform at least a portion of the alloy from its stress-induced martensitic state so that the memory alloy element transforms from its deformed shape to its unstressed shape, and wherein the device is adapted so that the transformation can occur without any change in temperature of the placement device or the memory alloy element.

22. The medical device of claim 21 wherein the memory alloy element is an intrauterine contraceptive device.

23. The device of claim 21 wherein the memory alloy element is a stent ~~graft~~;

24. The device of claim 21 wherein the memory alloy element is a filter for trapping blood clots.

*B/C
cont.*
25. The invention of claim 21 wherein the transformation occurs without any change in the state of the placement device.

REMARKS

The claims added to this application are claims that were cancelled in the parent application as not being examined, as being directed to a non-elected species. Due to the addition of these claims to this application, the present application is now a divisional application.

Respectfully submitted,

SHELDON & MAK

7/14/95
Date

By: *Jeffrey G. Sheldon*

Jeffrey G. Sheldon
Reg. No. 27,953

225 South Lake Avenue, 9th Floor
Pasadena, California 91101
(818) 796-4000

Raychem

MP884-US8

RECEIVED

IN THE UNITED STATES PATENT AND TRADEMARK OFFICE

FEB 15 96

In re the Application of)	Group Art Unit:
JAMES E. JERVIS)	Examiner:
Serial No. 08/483,291)	Raychem Corporation
Filed: June 6, 1995)	300 Constitution Drive
For: MEDICAL DEVICES)	Menlo Park, CA 94025
INCORPORATING SIM ALLOY)	February 1, 1996
ELEMENT)	

GROUP: 330

5
power to
inspect +
make copies
2-15-95

POWER TO INSPECT AND MAKE COPIES

Honorable Assistant Commissioner for Patents
Washington, D.C. 20231

Sir:

This communication gives Shonda Reed-Baten and Jennifer Harris of Barbara Harris & Associates the right to inspect and make copies of our patent application titled Medical Devices Incorporating Sim Alloy Element, U.S. Serial No. 08/483,291, filed June 6, 1995.

If you have any questions or concerns, please feel free to call the undersigned at (415) 361-3338.

Respectfully submitted,

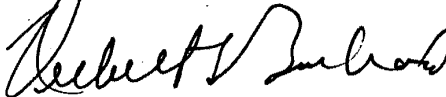

Herbert G. Burkard
Registration No. 24,500
Tel. No. (415) 361-3338

(FILE 'USPAT' ENTERED AT 10:48:33 ON 08 MAY 96)

L1 713 S (STRESS INDUCE# MARTINSIT###) OR SIM
L2 73 S L1 AND (SURGICAL OR MEDICAL)
L3 9 S L2 AND BODY TEMPERATURE

=> d 1-9

1. 5,415,660, May 16, 1995, Implantable limb lengthening nail driven by a shape memory alloy; Michael P. Campbell, et al., 606/62, 63, 67, 68 [IMAGE AVAILABLE]
2. 5,409,015, Apr. 25, 1995, Deformable tip super elastic guidewire; Thomas J. Palermo, 128/772 [IMAGE AVAILABLE]
3. 5,190,546, Mar. 2, 1993, **Medical** devices incorporating **SIM** alloy elements; James E. Jervis, 606/78; 128/833; 148/402, 563; 606/60, 62, 68, 108, 200 [IMAGE AVAILABLE]
4. 5,067,957, Nov. 26, 1991, Method of inserting **medical** devices incorporating **SIM** alloy elements; James E. Jervis, 606/108; 128/833; 606/67, 69, 78; 623/2 [IMAGE AVAILABLE]
5. 5,035,712, Jul. 30, 1991, Self-adjusting prosthesis attachment; Erik L. Hoffman, 623/16, 18, 23 [IMAGE AVAILABLE]
6. 5,002,563, Mar. 26, 1991, Sutures utilizing shape memory alloys; Walter R. Pyka, et al., 606/222, 78, 223 [IMAGE AVAILABLE]
7. 4,991,602, Feb. 12, 1991, Flexible guide wire with safety tip; Curtis A. Amplatz, et al., 128/772, 657; 604/164, 280 [IMAGE AVAILABLE]
8. 4,665,906, May 19, 1987, **Medical** devices incorporating **sim** alloy elements; James E. Jervis, 606/78 [IMAGE AVAILABLE]
9. 4,665,069, May 12, 1987, Analgesic composition and method of relieving pain; Barnett Rosenberg, 514/78, 267, 671, 817, 969, 970 [IMAGE AVAILABLE]

=>



**UNITED STATES DEPARTMENT OF COMMERCE
Patent and Trademark Office**

Address: COMMISSIONER OF PATENTS AND TRADEMARKS
Washington, D.C. 20231

08/483,291

APPLICATION NUMBER	FLING DATE	FIRST NAMED APPLICANT	ATTORNEY DOCKET NO.
08/483,291	06/07/95	JERVIS	

08/483,291 06/07/95 JERVIS

EXAMINER

YU, J

F301/0829

ART UNIT PAPER NUMBER

6

JEFFREY G SHELDON
SHELDON & MAK
225 SOUTH LAKE AVENUE SUITE 500
PASADENA CA 91101

DATE MAILED:

05/27/96

This is a communication from the examiner in charge of your application.
COMMISSIONER OF PATENTS AND TRADEMARKS

OFFICE ACTION SUMMARY

- Responsive to communication(s) filed on _____
- This action is FINAL.
- Since this application is in condition for allowance except for formal matters, prosecution as to the merits is closed in accordance with the practice under *Ex parte Quayle*, 1935 D.C. 11; 453 O.G. 213.

A shortened statutory period for response to this action is set to expire _____ month(s), or thirty days, whichever is longer, from the mailing date of this communication. Failure to respond within the period for response will cause the application to become abandoned. (35 U.S.C. § 133). Extensions of time may be obtained under the provisions of 37 CFR 1.136(a).

Disposition of Claims

- Claim(s) 11-25 is/are pending in the application.
- Of the above, claim(s) _____ is/are withdrawn from consideration.
- Claim(s) _____ is/are allowed.
- Claim(s) _____ is/are rejected.
- Claim(s) _____ is/are objected to.
- Claims 11-25 are subject to restriction or election requirement.

Application Papers

- See the attached Notice of Draftsperson's Patent Drawing Review, PTO-948.
- The drawing(s) filed on _____ is/are objected to by the Examiner.
- The proposed drawing correction, filed on _____ is approved disapproved.
- The specification is objected to by the Examiner.
- The oath or declaration is objected to by the Examiner.

Priority under 35 U.S.C. § 119

- Acknowledgement is made of a claim for foreign priority under 35 U.S.C. § 119(a)-(d).
- All Some* None of the CERTIFIED copies of the priority documents have been
 - received.
 - received in Application No. (Series Code/Serial Number) _____
 - received in this national stage application from the International Bureau (PCT Rule 17.2(a)).

*Certified copies not received: _____

- Acknowledgement is made of a claim for domestic priority under 35 U.S.C. § 119(e).

Attachment(s)

- Notice of Reference Cited, PTO-892
- Information Disclosure Statement(s), PTO-1449. Paper No(s) _____
- Interview Summary, PTO-413
- Notice of Draftsperson's Patent Drawing Review, PTO-948
- Notice of Informal Patent Application, PTO-152

- SEE OFFICE ACTION ON THE FOLLOWING PAGES -

Serial Number: 08/483,291

-2-

Art Unit: 3301

Part III DETAILED ACTION

1. Restriction to one of the following inventions is required under 35 U.S.C. 121:

Group I. Claims 11-18 and 21-25, drawn to a medical device, classified in Class 606, subclass 78.

Group II. Claim 19, drawn to a method of compressing two ends of a bone together, classified in Class 606, subclass 105.

Group III. Claim 20, drawn to an assembly, classified in Class 623, subclass 16.

2. The inventions are distinct, each from the other because of the following reasons:

Inventions of group I, II and III are related as product and process of use. The inventions can be shown to be distinct if either or both of the following can be shown: (1) the process for using the product as claimed can be practiced with another materially different product or (2) the product as claimed can be used in a materially different process of using that product (M.P.E.P. § 806.05(h)). In the instant case the method of compressing two ends of bones together can be performed by a wire. In addition, inventions I and III are prima facie independent and distinct inventions. Invention I is directed to the medical device for use within a mammalian body, or in such proximity to a mammalian body that the device is substantially at

Art Unit: 3301

body temperature. Invention III is directed to an assembly of an aperture is formed in a bone having a shape memory alloy being positioned and deformed in the wall of the aperture, and thereby exerts a force outwardly on the walls of the aperture. Because these inventions are distinct for the reasons given above and has acquired a separate status in the art because of their recognized divergent subject matter, restriction for examination purposes as indicated is proper.

3. In addition, with the elected of group I invention, applicant must also elect one of the following species. This application contains claims directed to the following patentably distinct species of the claimed invention:

Species 1: The shape memory alloy is an intrauterine contraceptive device;

Species 2: The shape memory alloy is a filter;

Species 3: The shape memory alloy is a tubular bar;

Species 4: The shape memory alloy is a tracheal catheter;

Species 5: The shape memory alloy is a stent graft.

Applicant is required under 35 U.S.C. § 121 to elect a single disclosed species for prosecution on the merits to which the claims shall be restricted if no generic claim is finally held to be allowable. Currently, 11 and 21 are generic.

Applicant is advised that a response to this requirement must include an identification of the species that is elected

Serial Number: 08/483,291

-4-

Art Unit: 3301

consonant with this requirement, and a listing of all claims readable thereon, including any claims subsequently added. An argument that a claim is allowable or that all claims are generic is considered nonresponsive unless accompanied by an election.

Upon the allowance of a generic claim, applicant will be entitled to consideration of claims to additional species which are written in dependent form or otherwise include all the limitations of an allowed generic claim as provided by 37 C.F.R. § 1.141. If claims are added after the election, applicant must indicate which are readable upon the elected species. M.P.E.P. § 809.02(a).

Should applicant traverse on the ground that the species are not patentably distinct, applicant should submit evidence or identify such evidence now of record showing the species to be obvious variants or clearly admit on the record that this is the case. In either instance, if the examiner finds one of the inventions unpatentable over the prior art, the evidence or admission may be used in a rejection under 35 U.S.C. § 103 of the other invention.

3. A telephone call was made to Jeffrey G. Sheldon on May 14, 1996 to request an oral election to the above restriction requirement, but did not result in an election being made.
4. Applicant is advised that the response to this requirement to be complete must include an election of the invention to be examined even though the requirement be traversed.
5. Any inquiry concerning this communication or earlier communications from the examiner should be directed to Justine Yu whose telephone number is (703) 308-2675.

Any inquiry of a general nature or relating to the status of this application should be directed to the Group receptionist whose telephone number is (703) 308-0858.

Serial Number: 08/483,291

-5-

Art Unit: 3301

JY.

Justine Yu

May 13, 1996

ROBERT A. HAFNER
S.P.E.
ART UNIT 331



GW 7-23-96
#7 selection

PATENT
9438-1\MP0884-US8

IN THE UNITED STATES PATENT AND TRADEMARK OFFICE

In re application of:) Group Art Unit: 3301
JAMES E. JERVIS)
Serial No. 08/483,291) Examiner: J. YU
Filed: June 7, 1995)
For: MEDICAL DEVICES INCORPORATING)
SIM ALLOY ELEMENTS)
Pasadena, California)

RECEIVED
JUL 15 1996
GROUP 3300

RESPONSE TO OFFICE ACTION

Honorable Commissioner of
Patents and Trademarks
Washington, D. C. 20231

Sir:

I HEREBY CERTIFY THAT THIS CORRESPONDENCE IS BEING DEPOSITED WITH THE U.S. POSTAL SERVICE AS FIRST CLASS MAIL IN ANY ENVELOPE ADDRESSED TO COMMISSIONER OF PATENTS AND TRADEMARKS, WASHINGTON, D C 20231 ON

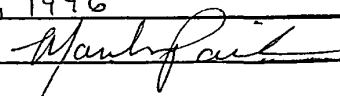
June 28, 1996
6/28/96 
(DATE SIGNED)

In response to the Office Action of May 29, 1996, Applicant elects, with traverse, to prosecute claims in Group I, namely claims 11-18 and 21-25, drawn to a medical device. Applicant further elects the stent graft species.

It is respectfully submitted that all the claims in this application deal with SIM metals and are therefore related and have a common thread. Thus, the claims are not directed to independent and distinct inventions.

PATENT
9438-1\MP0884-US8

For the reasons set forth above, it is respectfully requested that the Examiner examine all the claims in the application.

The Commissioner is hereby authorized to charge payment of any fees associated with this communication to Deposit Account No. 19-2090.

Respectfully submitted,

SHELDON & MAK

Date June 28, 96

By: _____

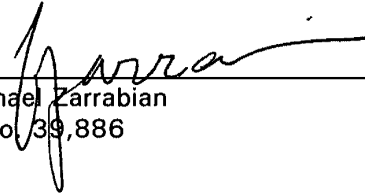
F. Michael Zarrabian
Reg. No. 39,886

225 South Lake Avenue, 9th Floor
Pasadena, California 91101
(818) 796-4000

*** APPLICATION INFORMATION DISPLAY ***

09/03/96 18:12			DETAIL	CONTENTS:		
SC/SN:	07/956653		INFORMATION:	45 WPIR O 11/06/95		
FILDT:	10/02/92			44 N084 B 08/17/95		
PATNO:		PUBNO:	E961671	43 DGP1 O 08/28/95		
ISSDT:	00/00/00	PUBDT:	00/00/00	42 DGM1 I 08/25/95		
ABNDT:	00/00/00	PGPUB CL/SC:	/ .	41 DGUI I 08/24/95		
APPL:	JERVIS			40 DGR1 I 08/17/95		
LOC:	9200	LOCDT:	02/28/96	BATNO:	000	39 N/= N 07/06/95
CHG-LOC:		IE TEAM:	00	ISSNO:	00	38 CNTA A 06/29/95
CHGTO-NAME:	NO NAME FOUND					37 EXIN O 06/26/95
TOT ACT:	06	STATUS:	095	STADT:	10/10/95	36 N/AP I 06/07/95
RESP CD:		START DT:	/ /	DUE DT:	/ /	35 XT/G I 06/07/95
EXMR NO/NAME:	69591/KENEALY, DAVID					34 MAIL O 04/26/95
DOCKET DATE:	/ /	GAU:	3301	L R CD:	01	33 CTAV O 04/26/95
ATTY DOCK #:	9438	LOST N		LOST DT	00/00/00	32 DISQ C 04/18/95
APPLN TYPE:	1	TYPE SM ENT:	0	UNMAT PET:	N	31 N/AP I 03/13/95
CURR CL/SC:	606/078.000 FOR PRIOR CL: N PET FAOM:					30 FWDX E 04/04/95
TITLE OF INVENTION:	UNAVAIL FOR ACTION: N PP UNAVAIL:					0
MEDICAL DEVICES INCORPORATING SIM ALLOY ELEMENTS						

END OF DISPLAY

TO DISPLAY CONTENTS: PUSH SEND

*** APPLICATION INFORMATION DISPLAY ***

09/03/96 18:14			DETAIL	CONTENTS:		
SC/SN:	07/682243		INFORMATION:	32 FOND Y 06/19/96		
FILDT:	04/09/91			31 SRCH Y 06/17/96		
PATNO:	5190546	PUBNO:	F682243	30 FOND Y 06/14/96		
ISSDT:	03/02/93	PUBDT:	00/00/00	29 LOST Y 06/07/96		
ABNDT:	00/00/00	PGPUB CL/SC:	/ .	28 FOND Y 06/28/95		
APPL:	JERVIS			27 SRCH Y 06/28/95		
LOC:	9200	LOCDT:	07/25/96	BATNO:	000	26 LOST Y 06/02/95
CHG-LOC:		IE TEAM:	00	ISSNO:	09	25 PGM/ O 03/02/93
CHGTO-NAME:	NO NAME FOUND					24 WPIR O 01/25/93
TOT ACT:	02	STATUS:	150	STADT:	02/17/93	23 N084 B 08/10/92
RESP CD:		START DT:	/ /	DUE DT:	/ /	22 N271 O 10/15/92
EXMR NO/NAME:	66114/ROONEY, KEVIN					21 FWDX E 08/04/92
DOCKET DATE:	/ /	GAU:	3301	L R CD:	01	20 A.NA I 07/20/92
ATTY DOCK #:	7757	LOST N		LOST DT	00/00/00	19 FWDX E 08/04/92
APPLN TYPE:	1	TYPE SM ENT:	0	UNMAT PET:	N	18 A.NA I 07/07/92
CURR CL/SC:	606/078.000 FOR PRIOR CL: N PET FAOM:					17 N/= N 05/15/92
TITLE OF INVENTION:	UNAVAIL FOR ACTION: N PP UNAVAIL:					0
MEDICAL DEVICES INCORPORATING SIM ALLOY ELEMENTS						

END OF DISPLAY

TO DISPLAY CONTENTS: PUSH SEND

*** APPLICATION INFORMATION DISPLAY ***

09/03/96 18:15			DETAIL	CONTENTS:		
SC/SN:	07/252019		INFORMATION:	33 LOST Y 08/27/96		
FILDT:	09/27/88			32 DISQ C 02/18/93		
PATNO:	5067957	PUBNO:	E959292	31 FOND Y 07/29/92		
ISSDT:	11/26/91	PUBDT:	00/00/00	30 LOST Y 07/29/92		
ABNDT:	00/00/00	PGPUB CL/SC:	/ .	29 PGM/ O 11/26/91		
APPL:	JERVIS			28 M327 O 11/06/91		
LOC:	9210	LOCDT:	08/30/96	BATNO:	000	27 WPIR O 10/23/91
CHG-LOC:	9210	IE TEAM:	00	ISSNO:	48	26 N271 O 09/23/91
CHGTO-NAME:	NO NAME FOUND					25 FWDX E 09/23/91

3

TOT ACT: 04 STATUS: 150 STADT: 11/14/91 24 A.NA I 08/01/91
 RESP CD: START DT: / / DUE DT: / / 23 N084 B 08/06/91
 EXMR NO/NAME: 66114/ROONEY, KEVIN 22 N/= N 05/06/91
 DOCKET DATE: / / GAU: 3301 L R CD: 01 21 CNTA A 05/06/91
 ATTY DOCK #: MP0884-US5 LOST Y LOST DT 08/27/96 20 FWDX E 02/22/91
 APPLN TYPE: 2 TYPE SM ENT: 0 UNMAT PET: N 19 A... I 02/11/91
 CURR CL/SC: 606/108.000 FOR PRIOR CL: N PET FAOM: 18 MS44 I 02/11/91
 TITLE OF INVENTION: UNAVAIL FOR ACTION: N PP UNAVAIL: 0
 METHOD OF INSERTING MEDICAL DEVICES INCORPORATING SIM ALLOY ELEMENTS

END OF DISPLAY

TO DISPLAY CONTENTS: PUSH SEND
 *** APPLICATION INFORMATION DISPLAY ***
 09/03/96 18:16

		DETAIL	CONTENTS:
SC/SN: 07/177817		INFORMATION:	14 TMOS E 08/29/96
FILDT: 03/30/88			13 SRCH Y 07/31/96
PATNO:	PUBNO: F177817		12 LOST Y 07/26/96
ISSDT: 00/00/00	PUBDT: 00/00/00		11 AFWC 0 12/05/88
ABNDT: 09/27/88	PGPUB CL/SC: / .		10 MAIL 0 00/00/00
APPL: JERVIS			09 ABN3 0 12/05/88
LOC: 33D1	LOCDT: 12/05/88	BATNO:	08 MAIL 0 09/07/88
CHG-LOC: 92FO	IE TEAM: 00	ISSNO: 00	07 CTAV 0 08/30/88
CHGTO-NAME: NO NAME FOUND			06 A.NE I 08/15/88
TOT ACT: 03	STATUS: 166	STADT: 12/05/88	05 AF/D I 08/15/88
RESP CD:	START DT: / /	DUE DT: / /	04 MS44 I 08/15/88
EXMR NO/NAME: 65820/SAM, CHARLES			03 MAIL 0 08/05/88
DOCKET DATE: 06/08/88	GAU: 3301	L R CD: 01	02 CTRF F 06/20/88
ATTY DOCK #: MP884-US4	LOST Y	LOST DT 07/31/96	01 DOCK D 06/08/88
APPLN TYPE: 2	TYPE SM ENT: 0	UNMAT PET: N	/ /
CURR CL/SC: 128/092.000	FOR PRIOR CL: N	PET FAOM:	/ /
TITLE OF INVENTION: UNAVAIL FOR ACTION: N	PP UNAVAIL: 0		
MEDICAL DEVICES INCORPORATING SIM ALLOY ELEMENTS			

END OF DISPLAY

TO DISPLAY CONTENTS: PUSH SEND
 *** APPLICATION INFORMATION DISPLAY ***
 09/03/96 18:18

		DETAIL	CONTENTS:
SC/SN: 07/047824		INFORMATION:	12 FOND Y 08/30/96
FILDT: 05/08/87			11 TMOS E 08/29/96
PATNO:	PUBNO: F047824		10 SRCH Y 07/31/96
ISSDT: 00/00/00	PUBDT: 00/00/00		09 AFWC 0 06/08/88
ABNDT: 03/30/88	PGPUB CL/SC: / .		08 MAIL 0 05/06/88
APPL: JERVIS			07 ABN2 0 05/06/88
LOC: 33D1	LOCDT: 06/08/88	BATNO:	06 XT/G I 04/04/88
CHG-LOC: 92FO	IE TEAM: 00	ISSNO: 00	05 DOCK D 10/21/87
CHGTO-NAME: NO NAME FOUND			04 A.PE I 05/08/87
TOT ACT: 01	STATUS: 166	STADT: 05/06/88	03 MAIL 0 09/30/87
RESP CD:	START DT: / /	DUE DT: / /	02 CTRF F 09/21/87
EXMR NO/NAME: 66024/NO NAME FOUND			01 DOCK D 08/07/87
DOCKET DATE: 08/07/87	GAU: 3306	L R CD: 01	/ /
ATTY DOCK #: MP0884-US3	LOST N	LOST DT 00/00/00	/ /
APPLN TYPE: 1	TYPE SM ENT: 0	UNMAT PET: N	/ /
CURR CL/SC: 128/092.000	FOR PRIOR CL: N	PET FAOM:	/ /
TITLE OF INVENTION: UNAVAIL FOR ACTION: N	PP UNAVAIL: 0		
MEDICAL DEVICES INCORPORATING SIM ALLOY ELEMENTS			

3

END OF DISPLAY

TO DISPLAY CONTENTS: PUSH SEND

*** APPLICATION INFORMATION DISPLAY ***

09/03/96 18:19

DETAIL

CONTENTS:

SC/SN: 06/865703	INFORMATION:	95 LOST Y 08/29/96	
FILDT: 05/21/86		34 FOND Y 03/13/96	
PATNO: 4665906	PUBNO: F865703	33 TMOS E 12/18/95	
ISSDT: 05/19/87	PUBDT: 00/00/00	32 SRCH Y 12/06/95	
ABNDT: 00/00/00	PGPUB CL/SC: / .	31 SRCH Y 11/17/95	
APPL: JERVIS		30 LOST Y 11/15/95	
LOC: 9210	LOCDT: 06/27/96	BATNO: 000	29 LOST Y 09/29/95
CHG-LOC:	IE TEAM: 00	ISSNO: 20	28 TMOS E 09/28/95
CHGTO-NAME: NO NAME FOUND			27 SRCH Y 08/29/95
TOT ACT: 01	STATUS: 115	STADT: 03/18/87	26 LOST Y 08/16/95
RESP CD:	START DT: / /	DUE DT: / /	25 TMOS E 06/12/95
EXMR NO/NAME: 61508/SHEDD, CHARLES			24 SRCH Y 05/12/95
DOCKET DATE: / /	GAU: 3306	L R CD: 01	23 LOST Y 05/12/95
ATTY DOCK #: MPO884-US2	LOST Y	LOST DT 08/29/96	22 FOND Y 08/04/94
APPLN TYPE: 1	TYPE SM ENT: 0	UNMAT PET: N	21 TMOS E 07/27/94
CURR CL/SC: 128/092.0YN	FOR PRIOR CL: N	PET FAOM:	20 SRCH Y 07/19/94
TITLE OF INVENTION: UNAVAIL FOR ACTION: N	PP UNAVAIL:	0	
MEDICAL DEVICES INCORPORATING SIM ALLOY ELEMENTS			

END OF DISPLAY

TO DISPLAY CONTENTS: PUSH SEND

*** APPLICATION INFORMATION DISPLAY ***

09/03/96 18:20

DETAIL

CONTENTS:

SC/SN: 06/541852	INFORMATION:	71 LOST Y 08/28/96	
FILDT: 10/14/83		70 TMOS E 08/19/96	
PATNO:	PUBNO: F541852	69 SRCH Y 08/16/96	
ISSDT: 00/00/00	PUBDT: 00/00/00	68 LOST Y 08/09/96	
ABNDT: 05/22/86	PGPUB CL/SC: / .	67 TMOS E 08/01/96	
APPL: JERVIS		66 SRCH Y 07/31/96	
LOC: 9100	LOCDT: 06/26/96	BATNO: N73	65 LOST Y 07/23/96
CHG-LOC: 9210	IE TEAM: 00	ISSNO: 00	64 LOST Y 07/22/96
CHGTO-NAME: NO NAME FOUND			63 SRCH Y 07/18/96
TOT ACT: 02	STATUS: 164	STADT: 05/22/86	62 TMOS E 07/18/96
RESP CD:	START DT: / /	DUE DT: / /	61 LOST Y 07/08/96
EXMR NO/NAME: 61508/SHEDD, CHARLES			60 SRCH Y 07/01/96
DOCKET DATE: / /	GAU: 3303	L R CD: 01	59 LOST Y 06/25/96
ATTY DOCK #: MPO884-US1	LOST Y	LOST DT 08/28/96	58 SRCH Y 06/17/96
APPLN TYPE: 1	TYPE SM ENT: 0	UNMAT PET: N	57 LOST Y 05/31/96
CURR CL/SC: 128/092.000	FOR PRIOR CL: N	PET FAOM:	56 TMOS E 03/29/96
TITLE OF INVENTION: UNAVAIL FOR ACTION: N	PP UNAVAIL:	0	
MEDICAL DEVICES INCORPORATING SIM ALLOY ELEMENTS			

END OF DISPLAY

TO DISPLAY CONTENTS: PUSH SEND

***** CONTINUITY AND FOREIGN/PCT DATA DISPLAY *****

SC/SN: 06/541852	CODE	PARENT	SN	STATUS	FIL	DATE	PAT.	NO
FILDT: 10/14/83	/	/	/	/	/	/	/	/
PATNO:	/	/	/	/	/	/	/	/
ISSDT: 00/00/00	/	/	/	/	/	/	/	/
APPL: JERVIS	/	/	/	/	/	/	/	/
PCT/FOREIGN APPLICATION DATA:	/	/	/	/	/	/	/	/
ETYNO PCT/FOR.APPL NO	/	/	/	/	/	/	/	/
CO.CD	/	/	/	/	/	/	/	/
FIL DT	/	/	/	/	/	/	/	/

=> d his

(FILE 'USPAT' ENTERED AT 15:32:02 ON 24 SEP 96)

L1 8 S PSEUDOELASTIC AND (SHAPE MEMORY ALLOY OR SMA) AND STRESS

-IN

L2 5 S L1 AND (STENT OR GRAFT)

=> d 1-5

1. 5,345,937, Sep. 13, 1994, Steerable cannula; Lee M. Middleman, et al., 128/657, 772; 600/143; 604/95, 280 [IMAGE AVAILABLE]

2. 5,231,989, Aug. 3, 1993, Steerable cannula; Lee M. Middleman, et al., 128/657, 772; 604/95, 280; D24/112, 130, 133 [IMAGE AVAILABLE]

3. 5,190,546, Mar. 2, 1993, Medical devices incorporating SIM alloy elements; James E. Jervis, 606/78; 128/833; 148/402, 563; 606/60, 62, 68, 108, 200 [IMAGE AVAILABLE]

4. 5,067,957, Nov. 26, 1991, Method of inserting medical devices incorporating SIM alloy elements; James E. Jervis, 606/108; 128/833; 606/67, 69, 78; 623/2 [IMAGE AVAILABLE]

5. 4,665,906, May 19, 1987, Medical devices incorporating sim alloy elements; James E. Jervis, 606/78 [IMAGE AVAILABLE]

=>

4, 955, 889

4, 666, 485

14. 4,577,543, Mar. 25, 1986, Construction of a monolithic reinforced catheter with flexible portions; **Bruce C. Wilson**, 87/11; 57/6, 7; 87/1, 6, 9; 138/123; 604/280, 282 [IMAGE AVAILABLE]
15. 4,559,711, Dec. 24, 1985, Workpiece gaging apparatus; William L. De Boynton, et al., 33/199R [IMAGE AVAILABLE]
16. 4,522,054, Jun. 11, 1985, Emergency rescue apparatus; Randall J. Wilson, et al., 72/392, 453.16, 464, 705 [IMAGE AVAILABLE]
17. 4,467,150, Aug. 21, 1984, Electronic keyboard; Richard Leitermann, et al., 200/5A, 292, 517; 361/680; 400/479, 488 [IMAGE AVAILABLE]
18. 4,402,691, Sep. 6, 1983, Aseptic connection barrier system and method; Arthur L. Rosenthal, et al., 604/411, 29, 905 [IMAGE AVAILABLE]
19. 3,890,977, Jun. 24, 1975, Kinetic memory electrodes, catheters and cannulae; **Bruce C. Wilson**, 604/281, 21 [IMAGE AVAILABLE]

5. 5,211,183, May 18, 1993, Steerable memory alloy guide wires; **Bruce C. Wilson**, 128/772, 657 [IMAGE AVAILABLE]
6. D 332,247, Jan. 5, 1993, License plate frame; **Bruce R. Wilson**, D12/193 [IMAGE AVAILABLE]
7. 5,143,085, Sep. 1, 1992, Steerable memory alloy guide wires; **Bruce C. Wilson**, 128/772, 657; 604/95, 280 [IMAGE AVAILABLE]
8. 5,025,799, Jun. 25, 1991, Steerable memory alloy guide wires; **Bruce C. Wilson**, 128/772, 657; 604/95, 281 [IMAGE AVAILABLE]

(FILE 'USPAT' ENTERED AT 13:22:24 ON 17 OCT 96)

L1 13 S PSEUDOELASTIC? AND (STENT OR GRAFT)
L2 238 S SUPERELASTIC OR PSEUDOELASTIC SHAPE MEMORY ALLOY
L3 23 S L2 AND (STENT OR GRAFT)
L4 1 S SUPERELASTIC (P)PSEUDOELASTIC SHAPE MEMORY ALLOY

=> d l3 1-23

1. 5,554,181, Sep. 10, 1996, **Stent**; Gladwin S. Das, 623/1; 606/194 [IMAGE AVAILABLE]
2. 5,540,712, Jul. 30, 1996, **Stent** and method and apparatus for forming and delivering the same; Stephen J. Kleshinski, et al., 606/198; 623/1 [IMAGE AVAILABLE]
3. 5,538,513, Jul. 23, 1996, Catheter tube having a filamentous reinforcing layer; Naofumi Okajima, 604/282; 138/124; 604/280 [IMAGE AVAILABLE]
4. 5,527,322, Jun. 18, 1996, Device and method for suturing of internal puncture sites; Enrique J. Klein, et al., 606/144; 112/169; 606/139, 145 [IMAGE AVAILABLE]
5. 5,522,819, Jun. 4, 1996, Dual coil medical retrieval device; Virgil B. Graves, et al., 606/113, 110 [IMAGE AVAILABLE]
6. 5,514,154, May 7, 1996, Expandable stents; Lilip Lau, et al., 606/195, 108, 194; 623/13 [IMAGE AVAILABLE]
7. 5,505,735, Apr. 9, 1996, Surgical anchor and method for using the same; Lehmann K. Li, 606/72, 75, 232 [IMAGE AVAILABLE]
8. 5,505,699, Apr. 9, 1996, Angioplasty device; Michael R. Forman, et al., 604/96; 128/772, 898; 604/280; 606/198 [IMAGE AVAILABLE]
9. 5,480,423, Jan. 2, 1996, Prosthesis delivery; Adrian C. Ravenscroft, et al., 623/1; 606/194, 195; 623/66 [IMAGE AVAILABLE]
10. 5,421,955, Jun. 6, 1995, Expandable stents and method for making same; Lilip Lau, et al., 216/48, 65; 604/95; 606/198 [IMAGE AVAILABLE]
11. 5,417,699, May 23, 1995, Device and method for the percutaneous suturing of a vascular puncture site; Enrique J. Klein, et al., 606/144; 112/80.03, 169; 604/900; 606/139, 223 [IMAGE AVAILABLE]
12. 5,409,460, Apr. 25, 1995, Intra-luminal expander assembly; John F. Krumme, 604/107 [IMAGE AVAILABLE]

13. 5,372,600, Dec. 13, 1994, ****Stent**** delivery systems; Mordechay Beyar, et al., 606/108, 194 [IMAGE AVAILABLE]
14. 5,346,508, Sep. 13, 1994, Apparatus and method for performing diagnostics and intravascular therapies; Roger Hastings, 607/99; 128/692 [IMAGE AVAILABLE]
15. 5,345,937, Sep. 13, 1994, Steerable cannula; Lee M. Middleman, et al., 128/657, 772; 600/143; 604/95, 280 [IMAGE AVAILABLE]
16. 5,333,624, Aug. 2, 1994, Surgical attaching apparatus; H. Jonathan Tovey, 128/897; 600/37; 606/151 [IMAGE AVAILABLE]
17. 5,330,482, Jul. 19, 1994, Endoscopic extraction devices, wire basket stone extractors, ****stent**** retrievers, snares and method of constructing the same; Rebecca C. Gibbs, et al., 606/113; 228/262.31; 428/660, 685; 606/106, 127 [IMAGE AVAILABLE]
18. 5,231,989, Aug. 3, 1993, Steerable cannula; Lee M. Middleman, et al., 128/657, 772; 604/95, 280; D24/112, 130, 133 [IMAGE AVAILABLE]
19. 5,190,546, Mar. 2, 1993, Medical devices incorporating SIM alloy elements; James E. Jervis, 606/78; 128/833; 148/402, 563; 606/60, 62, 68, 108, 200 [IMAGE AVAILABLE]
20. 5,067,957, Nov. 26, 1991, Method of inserting medical devices incorporating SIM alloy elements; James E. Jervis, 606/108; 128/833; 606/67, 69, 78; 623/2 [IMAGE AVAILABLE]
21. 4,950,227, Aug. 21, 1990, ****Stent**** delivery system; Michael A. Savin, et al., 604/8; 606/192; 623/1 [IMAGE AVAILABLE]
22. 4,665,906, May 19, 1987, Medical devices incorporating sim alloy elements; James E. Jervis, 606/78 [IMAGE AVAILABLE]
23. 4,230,823, Oct. 28, 1980, Polyurethane foams and elastomers based on modified polyether polyols; Heinrich Alberts, et al., 521/137, 158; 525/50, 529; 528/75; 568/667 [IMAGE AVAILABLE]

=>

L1 8 S PSEUDOELASTIC AND (SHAPE MEMORY ALLOY OR SMA) AND STRESS
-IN
L2 5 S L1 AND (STENT OR GRAFT)
L3 8 S (PSEUDOELASTIC OR SUPERELASTIC) AND (SHAPE MEMORY ALLOY
OR
=>



UNITED STATES DEPARTMENT OF COMMERCE
 Patent and Trademark Office
 Address: COMMISSIONER OF PATENTS AND TRADEMARKS
 Washington, D.C. 20231

APPLICATION NUMBER	FILING DATE	FIRST NAMED APPLICANT	ATTORNEY DOCKET NO.
08/483,291	06/07/95	JERVIS	J 9438-1
			EXAMINER
JEFFREY G SHELDON SHELDON & MAK 225 SOUTH LAKE AVENUE SUITE 900 PASADENA CA 91101			
F3M1/1029			
			PART UNIT PAPER NUMBER
			3301 8
			DATE MAILED: 10/29/96

This is a communication from the examiner in charge of your application.
 COMMISSIONER OF PATENTS AND TRADEMARKS

OFFICE ACTION SUMMARY

- Responsive to communication(s) filed on _____
- This action is FINAL.
- Since this application is in condition for allowance except for formal matters, prosecution as to the merits is closed in accordance with the practice under *Ex parte Quayle*, 1935 D.C. 11; 453 O.G. 213.

A shortened statutory period for response to this action is set to expire 3 month(s), or thirty days, whichever is longer, from the mailing date of this communication. Failure to respond within the period for response will cause the application to become abandoned. (35 U.S.C. § 133). Extensions of time may be obtained under the provisions of 37 CFR 1.136(a).

Disposition of Claims

- Claim(s) 11-25 is/are pending in the application.
- Of the above, claim(s) 15-20, 22, 24 is/are withdrawn from consideration.
- Claim(s) _____ is/are allowed.
- Claim(s) 11-14, 21, 23, 25 is/are rejected.
- Claim(s) _____ is/are objected to.
- Claims _____ are subject to restriction or election requirement.

Application Papers

- See the attached Notice of Draftsperson's Patent Drawing Review, PTO-948.
- The drawing(s) filed on _____ is/are objected to by the Examiner.
- The proposed drawing correction, filed on _____ is approved disapproved.
- The specification is objected to by the Examiner.
- The oath or declaration is objected to by the Examiner.

Priority under 35 U.S.C. § 119

- Acknowledgement is made of a claim for foreign priority under 35 U.S.C. § 119(a)-(d).
 - All Some* None of the CERTIFIED copies of the priority documents have been
 - received.
 - received in Application No. (Series Code/Serial Number) _____
 - received in this national stage application from the International Bureau (PCT Rule 17.2(a)).

*Certified copies not received: _____

- Acknowledgement is made of a claim for domestic priority under 35 U.S.C. § 119(e).

Attachment(s)

- Notice of Reference Cited, PTO-892
- Information Disclosure Statement(s), PTO-1449, Paper No(s) _____
- Interview Summary, PTO-413
- Notice of Draftsperson's Patent Drawing Review, PTO-948
- Notice of Informal Patent Application, PTO-152

- SEE OFFICE ACTION ON THE FOLLOWING PAGES -

Art Unit: 3301

DETAILED ACTION

1. This Office action is responsive to the amendment filed 7/5/96. As directed by the amendment, claims 11-25 are presently pending in this application.
2. Applicant's election with traverse of invention Group I, specie 5 in Paper No. 7 is acknowledged. The traversal is on the ground(s) that all the claims in this application deal with SIM metals and are therefore related and have a common thread. This is not found persuasive because the claimed inventions, namely Group I, II, and III, are distinct from each other.

Group I is directed to the medical device having different species such as an intrauterine contraceptive device, a filter, a tracheal catheter, a tubular bar, and a stent graft. Group II is directed to the method of compressing two ends of a bone together. However, such claimed method steps can be performed by a wire. In addition, group III is directed to the assembly of an aperture which is formed in a bone and having a shape memory alloy being positioned and deformed in a wall of the aperture. However, the inventions I and III are different inventions. Because these claimed inventions are prima facie independent and distinct, and has acquired a separate status in the art because of their recognized divergent subject matter, restriction for examination purposes as indicated is proper. Since applicant fails to prove or provide convincing argument that the alternative example suggested by the Examiner cannot be accomplished, see

Art Unit: 3301

M.P.E.P. § 806.05(h), in addition, because applicant did not distinctly and specifically point out the supposed errors in the restriction requirement, the election has been treated as an election without traverse (MPEP 818.03(a)). Hence, the requirement is still deemed proper and is therefore made **FINAL**.

3. Claims 15-20, 22, and 24 are withdrawn from further consideration by the examiner, 37 C.F.R. § 1.142(b), as being drawn to the non-elected invention Groups II, III, and non-elected species of invention Group I. Election was made **without** traverse in Paper No. 7.

2. The drawings are objected to under 37 CFR 1.83(a). The drawings must show every feature of the invention specified in the claims. Therefore, the stent graft as recited in claim 23 must be shown or the feature(s) canceled from the claim(s). No new matter should be entered.

3. Claim 11 is rejected under 35 U.S.C. 112, first paragraph, as based on a single means claim which covered every conceivable means for achieving the stated purpose was held nonenabling for the scope of the claim. A single means claim, i.e., where a means recitation does not appear in combination with another recited element of means, is subject to an undue breadth rejection under 35 U.S.C. 112, *In re Hyatt*, 708 F.2d 712, 218 USPQ 195 (Fed. Cir. 1983). See MPEP 2164.08(a) and 2181.

Art Unit: 3301

4. Claims 11-14, 21, 23, and 25 are rejected under 35 U.S.C. 112, second paragraph, as being indefinite for failing to particularly point out and distinctly claim the subject matter which applicant regards as the invention.

Claim 11 is incomplete for omitting the essential structure of the device and the element. In addition, the second "which" in line 4 is unclear as to which part is being referred to, the element, or the shape memory alloy. Line 2 the terminology "or in such proximity to a mammalian body" is indefinite, and line 7 the symbol A(90) is unclear. In claim 12, the terminology "means of which" is unclear and not understood, and the term "is held" is confusing as to which part is that the SMA being held, and how to perform that function. Line 3 the word "it" is unclear. Further, the term "in proximity to a mammalian body" is vague and indefinite. In claim 13, line 3 the term "such a way" is indefinite. In claim 14, there has no structure for the catheter. Similar to the stent graft in claim 23. In claim 21, the phrase "the memory alloy element can be extruded from the hollow placement device" is unclear as to how is the function being performed. In claim 25, the term "the state" lacks antecedent basis.

5. The following is a quotation of the appropriate paragraphs of 35 U.S.C. 102 that form the basis for the rejections under this section made in this Office action:

A person shall be entitled to a patent unless --

(b) the invention was patented or described in a printed publication in this or a foreign country or in public use or on sale in this country, more than one year prior to the date of application for patent in the United States.

Art Unit: 3301

(e) the invention was described in a patent granted on an application for patent by another filed in the United States before the invention thereof by the applicant for patent, or on an international application by another who has fulfilled the requirements of paragraphs (1), (2), and (4) of section 371(c) of this title before the invention thereof by the applicant for patent.

6. Claim 11 is rejected under 35 U.S.C. 102(b) or (e) as being anticipated by Quin.

Quin discloses one set of data showing that the alloy have different compositions and the temperature at which the transformation from the martensitic phase to the austenitic phase is 90% complete. Since it is unknown that which is the earliest priority date of the subject matter being introduced by the applicant, the Examiner assumed that the claim can be rejected by 35 U.S.C. 102(b) if the Quin patented the invention more than one year prior to the date of application for patent in the US. Otherwise, the claim is rejected by 102(e).

7. The following is a quotation of 35 U.S.C. 103(a) which forms the basis for all obviousness rejections set forth in this Office action:

(a) A patent may not be obtained though the invention is not identically disclosed or described as set forth in section 102 of this title, if the differences between the subject matter sought to be patented and the prior art are such that the subject matter as a whole would have been obvious at the time the invention was made to a person having ordinary skill in the art to which said subject matter pertains. Patentability shall not be negated by the manner in which the invention was made.

8. Claims 11-14 are rejected under 35 U.S.C. 103(a) as being unpatentable over Wilson in view of Quin.

Art Unit: 3301

Wilson discloses a shape memory rod 16 being positioned in the catheter 10(restrain). Wilson lacks the description of the SMA has an A(90) temperature of not more than 0 degree C. However, the teaching in column 2, lines 14-16 of Wilson discloses that the transitional temperature of the alloy can be varied depending upon relative composition from -396 to +331 degree F. In addition, Quin teaches a group of alloys with varied compositions and have the A(90) temperature. Therefore, having a particular alloy with A(90) property instead of Wilson's alloy would be an obvious design choice.

9. Claims 21, 23, and 25 are rejected under 35 U.S.C. 103(a) as being unpatentable over Balko et al in view of Seader(Encyclopedia of Chemical Technology publication). Balko shows a nitinol (SMA) wire formed a graft structure 22 which is placed inside the sheath head 50 (hollow placement device). Balko lacks the description of the nitinol is a pseudo elastic SMA. However, the teaching on page 733 of Seader discloses that the nitinol has the superelastic behavior (pseudo elastic behavior). Therefore, it is obvious that the nitinol has the pseudo elastic properties.
10. The non-statutory double patenting rejection, whether of the obviousness-type or non-obviousness-type, is based on a judicially created doctrine grounded in public policy (a policy reflected in the statute) so as to prevent the unjustified or improper timewise extension of the "right to exclude" granted by a patent. *In re Thorington*, 418 F.2d 528, 163 USPQ 644 (CCPA 1969); *In re Vogel*, 422 F.2d 438, 164 USPQ 619 (CCPA 1970); *In re Van Ornum*, 686 F.2d 937, 214 USPQ 761 (CCPA 1982); *In re*

Art Unit: 3301

Longi, 759 F.2d 887, 225 USPQ 645 (Fed. Cir. 1985); and *In re Goodman*, 29 USPQ2d 2010 (Fed. Cir. 1993).

A timely filed terminal disclaimer in compliance with 37 CFR 1.321(b) and (c) may be used to overcome an actual or provisional rejection based on a non-statutory double patenting ground provided the conflicting application or patent is shown to be commonly owned with this application. See 37 CFR 1.78(d).

Effective January 1, 1994, a registered attorney or agent of record may sign a terminal disclaimer. A terminal disclaimer signed by the assignee must fully comply with 37 CFR 3.73(b).

11. Claims 21, 23, and 25 are rejected under the judicially created doctrine of obviousness-type double patenting as being unpatentable over claims 30 and 34 of U.S. Patent No. 5,067,957. Although the conflicting claims are not identical, they are not patentably distinct from each other because the difference between the patented claims and the proposed application claims are minor and obvious from each other. The only difference is that the patented claims are method claims, and the proposed claims are the apparatus claims. In the instant claims 21 and 25 the structural elements are included in the patented method claim 30, and claim 23 the structural elements are included in the patented claim 34.

12. The prior art made of record and not relied upon is considered pertinent to applicant's disclosure. Middleman et al, Suzuki, Sugita et al, and Fountain et al are cited to show the other shape memory alloys.

Serial Number: 08/483,291

Page 8

Art Unit: 3301

13. Any inquiry concerning this communication or earlier communications from the examiner should be directed to Justine Yu whose telephone number is (703) 308-2675.

Any inquiry of a general nature or relating to the status of this application or proceeding should be directed to the Group receptionist whose telephone number is (703) 308-0858.

ROBERT A. HAFER
S.P.E.
ART UNIT 331



Justine Yu

October 21, 1996

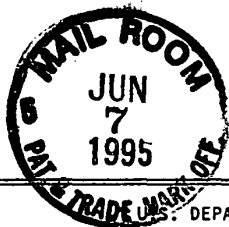

FORM PTO-1449 U.S. DEPARTMENT OF COMMERCE PATENT AND TRADEMARK OFFICE

ATTORNEY DOCKET NO.: 9438-1 SERIAL NO.: 68/483.291

LIST OF ART CITED BY APPLICANT (Use several sheets if necessary)

APPLICANT: JAMES E. JERVIS

FILING DATE: Herewith GROUP:

U.S. PATENT DOCUMENTS

Examiner Initial		DOCKET NUMBER							DATE	NAME	CLASS	SUBCLASS	FILING DATE IF APPROPRIATE
<i>JL</i>	AA-1	4	3	1	0	3	5	4	01/12/82	FOUNTAIN, ET AL.			
<i>Per MJL</i>	AB-1	4	4	9	0	1	1	2	09/02/82 12-25-84	TANAKA	433	20	
<i>JL</i>	AC-1	5	1	9	0	5	4	6	03/02/93	JERVIS	606	78	
	AD-1												
	AE-1												
	AF-1												
	AG-1												
	AH-1												
	AI-1												
	AJ-1												
	AK-1												

FOREIGN PATENT DOCUMENTS

		DOCKET NUMBER							DATE	COUNTRY	CLASS	SUBCLASS	TRANSLATION	
													YES	NO
<i>JL</i>	AL-1	0	1	4	0	6	2	1	05/08/85	E.P.O.				
<i>Per MJL</i>	AM-1	0	1	4	5	1	6	6	6/1985	E.P.O.			/	
<i>JL</i>	AN-1	1	0	0	9	5	6		6/1985	JAPAN APPLICATION			/	
<i>JL</i>	AO-1	1	6	0	0	0	0	0	10/14/81	GREAT BRITAIN	F16L	21/00		
	AP-1	DE	28	02	5	7	1	C2	GERMANY	C22F	1700			

OTHER ART (Including Author, Title, Date, Pertinent Pages, etc.)

	AO-1	Brief communication dated August 13, 1991, in German.
	AR-1	Communication pursuant to Article 115(2) EPC and Opposition papers dated September 28, 1992.
	AS-1	Communication of a Notice of Opposition dated August 7, 1990. Opposition papers in German.

EXAMINER: *JL* DATE CONSIDERED: *6/16/96*

EXAMINER: Initial if reference considered, whether or not citation is in conformance with MPEP 609; Draw line through citation if not in conformance and not considered. Include copy of this form with next communication to applicant.

3

FORM PTO-1449		U.S. DEPARTMENT OF COMMERCE PATENT AND TRADEMARK OFFICE			ATTORNEY DOCKET NO.: 9438-1			SERIAL NO.: 08/483,291						
LIST OF ART CITED BY APPLICANT (Use several sheets if necessary)					APPLICANT: JAMES E JERVIS									
					FILING DATE: Herewith					GROUP:				
U.S. PATENT DOCUMENTS														
Examiner Initial		DOCKET NUMBER							DATE	NAME	CLASS	SUBCLASS	FILING DATE IF APPROPRIATE	
	AA													
	AB													
	AC													
	AD													
	AE													
	AF													
	AG													
	AH													
	AI													
	AJ													
	AK													
FOREIGN PATENT DOCUMENTS														
		DOCKET NUMBER							DATE	COUNTRY	CLASS	SUBCLASS	TRANSLATION	
													YES	NO
<i>JL</i>	AL-2	4	1	5	4	6			3/1983	JAPAN			/	
<i>JL</i>	AM-2	4	4	0	4	7			3/1983	JAPAN			/	
<i>JL</i>	AN-2	5	0	9	5	1			3/1983	JAPAN			/	
<i>JL</i>	AO-2	56	2	8	9	8	0		7/1981	JAPAN			/	
<i>JL</i>	AP-2	57	1	1	9	7	4	4	7/1982	JAPAN			/	
OTHER ART (Including Author, Title, Date, Pertinent Pages, etc.)														
	AQ-2	EPO Search Report dated June 12, 1986.												
<i>JL</i>	AR-2	Jackson, "55-Nitinol--The Alloy with a Memory: Its Physical Metallurgy, Properties, and Applications," NASA-SP5110 (1972)												
<i>JL</i>	AS-2	Mazer, "Therapeutic Embolization of the Renal Artery with Gianturco Coils: Limitations and Technical Pitfalls," Radiology, 138:37-46 (Jan. 1981)												
EXAMINER <i>JL</i>										DATE CONSIDERED 60/116/84				
EXAMINER: Initial if reference considered, whether or not citation is in conformance with MPEP 609; Draw line through citation if not in conformance and not considered. Include copy of this form with next communication to applicant.														

FORM PTO-1449	U.S. DEPARTMENT OF COMMERCE PATENT AND TRADEMARK OFFICE	ATTORNEY DOCKET NO.: 9438-1	SERIAL NO.: 09/483,291										
LIST OF ART CITED BY APPLICANT (Use several sheets if necessary)		APPLICANT: JAMES E. JERVIS											
		FILING DATE: Herewith	GROUP:										
U.S. PATENT DOCUMENTS													
Examiner Initial		DOCKET NUMBER						DATE	NAME	CLASS	SUBCLASS	FILING DATE IF APPROPRIATE	
	AA												
	AB												
	AC												
	AD												
	AE												
	AF												
	AG												
	AH												
	AI												
	AJ												
	AK												
FOREIGN PATENT DOCUMENTS													
		DOCKET NUMBER						DATE	COUNTRY	CLASS	SUBCLASS	TRANSLATION	
												YES	NO
	AL-3	57	1	0	1	6	3	2/1982	JAPAN			/	
	AM-3	57	7	5	6	4	7	5/1982	JAPAN			/	
	AN-3	57	9	5	4	5	2	6/1980	JAPAN			/	
	AO-3												
	AP-3												
OTHER ART (Including Author, Title, Date, Pertinent Pages, etc.)													
	AO-3	Melton, et al., "Alloys with Two-Way Shape Memory Effect," Mechanical Engineering, March, 1980, pp. 42-43											
	AR-3	Perkins, "Shape Memory Effects in Alloys," Plenum Press, NY 1975. (Pages 29-59, Rodriguez article; pages 59-89, Shimizu article; pages 273-304, Perkins article.)											
	AS-3	Robinson, "Metallurgy: Extraordinary Alloys that Remember their Past," Science, Vol. 191, No. 4230 (May, 1976)											
EXAMINER <i>JL</i>										DATE CONSIDERED 10/16/96			
EXAMINER: Initial if reference considered, whether or not citation is in conformance with MPEP 609; Draw line through citation if not in conformance and not considered. Include copy of this form with next communication to applicant.													

FORM PTO-1449	U.S. DEPARTMENT OF COMMERCE PATENT AND TRADEMARK OFFICE	ATTORNEY DOCKET NO.: 9438-1	SERIAL NO.: 08/483/291					
LIST OF ART CITED BY APPLICANT (Use several sheets if necessary)		APPLICANT: JAMES E. JERVIS	FILING DATE: Herewith					
		GROUP:						
U.S. PATENT DOCUMENTS								
Examiner Initial		DOCKET NUMBER	DATE	NAME	CLASS	SUBCLASS	FILING DATE IF APPROPRIATE	
	AA							
	AB							
	AC							
	AD							
	AE							
	AF							
	AG							
	AH							
	AI							
	AJ							
	AK							
FOREIGN PATENT DOCUMENTS								
		DOCKET NUMBER	DATE	COUNTRY	CLASS	SUBCLASS	TRANSLATION	
							YES	NO
	AL							
	AM							
	AN							
	AO							
	AP							
OTHER ART (Including Author, Title, Date, Pertinent Pages, etc.)								
<i>oz</i>	AQ-4	Wagner, "What You Can Do with that 'Memory Alloy,'" Materials Engineering, 70 (1969) Oct., pp. 28-31.						
<i>pe</i>	AR-4	Wasilewski, "The Effects of Applied Stress on the Martensitic Transformation in TiNi," Metallurgical Transactions, 2: Nov 1971, pp 2973-2981						
<i>pe</i>	AS-4	Wayman, "Some Applications of Shape-Memory Alloys," Journal of Metals, June, 1980, pp. 129-137.						
EXAMINER <i>JAZ</i>					DATE CONSIDERED <i>20/10/96</i>			
EXAMINER: Initial if reference considered, whether or not citation is in conformance with MPEP 609; Draw line through citation if not in conformance and not considered. Include copy of this form with next communication to applicant.								

FORM PTO-1449	U.S. DEPARTMENT OF COMMERCE PATENT AND TRADEMARK OFFICE	ATTORNEY DOCKET NO.: 9438-1	SERIAL NO.: 08/483,291			
LIST OF ART CITED BY APPLICANT (Use several sheets if necessary)		APPLICANT: JAMES E. JERVIS				
		FILING DATE: Herewith				
U.S. PATENT DOCUMENTS						
Examiner Initial	DOCKET NUMBER	DATE	NAME	CLASS	SUBCLASS	FILING DATE IF APPROPRIATE
AA						
AB						
AC						
AD						
AE						
AF						
AG						
AH						
AI						
AJ						
AK						
FOREIGN PATENT DOCUMENTS						
DOCKET NUMBER	DATE	COUNTRY	CLASS	SUBCLASS	TRANSLATION	
					YES	NO
AL						
AM						
AN						
AO						
AP						
OTHER ART (Including Author, Title, Date, Pertinent Pages, etc.)						
<i>Jr</i>	AQ-5	Physik in Unserer Zeit, 1977, Nr. 2, Verlag Chemie GmbH, Seite 33, and translation thereof.				
	AR-5					
	AS-5					
EXAMINER <i>J. J. Jervis</i>				DATE CONSIDERED <i>10/18/91</i>		
EXAMINER: Initial if reference considered, whether or not citation is in conformance with MPEP 609; Draw line through citation if not in conformance and not considered. Include copy of this form with next communication to applicant.						

FORM PTO-1449		U.S. DEPARTMENT OF COMMERCE PATENT AND TRADEMARK OFFICE				ATTORNEY DOCKET NO. 9438-1				SERIAL NO. <i>08/483,291</i>					
LIST OF ART CITED BY APPLICANT (Use several sheets if necessary)										APPLICANT: James E. Jervis					
										FILING DATE: Herewith				GROUP:	
U.S. PATENT DOCUMENTS															
Examiner Initial		DOCKET NUMBER								DATE	NAME	CLASS	SUBCLASS	FILING DATE IF APPROPRIATE	
<i>J</i>	AA	4	1	9	8	0	8	1	04/15/80	HARRISON, ET AL.					
<i>J</i>	AB	4	5	0	5	7	6	7	03/19/85	QUIN					
<i>R</i>	AC	4	9	2	5	4	4	5	05/15/90	SAKAMOTO, ET AL.					
	AD														
	AE														
	AF														
	AG														
	AH														
	AI														
	AJ														
	AK														
FOREIGN PATENT DOCUMENTS															
		DOCKET NUMBER								DATE	COUNTRY	CLASS	SUBCLASS	TRANSLATION	
														YES	NO
	AL														
	AM														
	AN														
	AO														
	AP														
OTHER ART (Including Author, Title, Date, Pertinent Pages, etc.)															
	AR														
	AS														
	AT														
EXAMINER <i>Jester 2</i>										DATE CONSIDERED <i>6/16/88</i>					
EXAMINER: Initial if reference considered, whether or not citation is in conformance with MPEP 609; Draw line through citation if not in conformance and not considered. Include copy of this form with next communication to applicant.															

FORM PTO-148 U.S. DEPARTMENT OF COMMERCE PATENT AND TRADEMARK OFFICE

ATTORNEY DOCKET NO. 9438-1 SERIAL NO. 09/483/291

LIST OF ART CITED BY APPLICANT (Use several sheets if necessary)

APPLICANT JAMES E. JERVIS

FILING DATE Herewith GROUP

U.S. PATENT DOCUMENTS

Examiner Initial	DOCUMENT NUMBER	DATE	NAME	CLASS	SUBCLASS	FILING DATE IF APPROPRIATE
JZ	AA 3 3 4 8 5 4 8	10-24-67	CHARDACK	128	418	
↑	AB 3 4 1 6 5 3 1	12-17-68-	EDWARDS	128	348	
Poly FV W	AC 3 4 1 9 0 1 1	12-31-78 68	WILLIAMSON	125	350	
↓	AD 3 5 0 0 8 2 0	3-17-70	T.H.O. ALMEN	128	303	
	AE 3 5 1 6 4 1 2	06-23-70	ACKERMAN	128	418	
	AF 3 5 3 9 0 3 3	11-10-70	TAFEEEN	128	221	
	AG 3 6 2 0 2 1 2	11-1971	FANNON, JR.	128	130	
Poly MP	AH 3 7 2 9 0 0 8	04-24-81 73	BERKOVITS	128	418	
	AI 3 7 4 0 8 3 9	06-26-73	OTTE, ET AL.	29	628	
↓	AJ 3 7 8 6 8 0 6	1-1974	JOHNSON, ET AL.	128	92YN	
JZ	AK 3 8 5 7 3 9 1	12-21-74	LERNER	128	127	

FOREIGN PATENT DOCUMENTS

	DOCUMENT NUMBER	DATE	COUNTRY	CLASS	SUBCLASS	TRANSLATION	
						YES	NO
JZ	AL 8 5 0 0 6 7	7-81	SU	128	92YN		
JZ	AM 9 4 0 7 5 9	11-80	SU	128	92YN		
JZ	AN 0 1 0 5 6 6 9	4-84	EPO				
JZ	AO 0 1 2 9 6 3 4	4-85	EPO				
JZ	AP 0 1 3 2 3 4 4	4-85	EPO				

OTHER ART (Including Author, Title, Date, Pertinent Pages, Etc.)

AI	Otsuka, et al., SHAPE-MEMORY-ALLOYS; <u>Metals-Forum</u> , Vol. 4, No. 3 (1981), pp. 142-52
AS	Dotter, Charles-T., TRANSLUMINAL EXPANDABLE-NITINOL COIL STENT GRAFTING: PRELIMINARY REPORT; <u>Radiology</u> , Vol. 147, pp 259-260
AT	Cragg, et al., <u>Radiology</u> ; (April 1983) Vol. 147, pp 261-263

EXAMINER Justin V. DATE CONSIDERED 10/16/86

EXAMINER: Initial if reference considered, whether or not citation is in conformance with MPEP 600; Draw line through citation if not in conformance and not considered. Include copy of this form with next communication to applicant.

FORM PTO-1448 U.S. DEPARTMENT OF COMMERCE PATENT AND TRADEMARK OFFICE

ATTORNEY DOCKET NO. 9438-1 SERIAL NO. 64/483,291

LIST OF ART CITED BY APPLICANT (Use General sheets if necessary)

APPLICANT JAMES E. JERVIS

FILING DATE Herewith GROUP

U.S. PATENT DOCUMENTS													
Examiner Initial		DOCUMENT NUMBER						DATE	NAME	CLASS	SUBCLASS	FILING DATE IF APPROPRIATE	
JZ	AA	3	8	6	8	9	5	6	3-4-75	ALFIDI, ET AL.	128	345	
	AB	3	8	8	9	6	6	6	6-17-75 -	LERNER	128	127	-
	AC	3	8	9	0	9	7	7	6-19-75	WILSON	604	281	
	AD	3	9	3	9	8	2	8	2-24-76	MOHR, ET AL.	128	92B	
	AE	3	9	6	0	1	4	7	6-1-76	MURRAY	128	92B	
	AF	4	0	3	3	3	3	1	7-5-77	GUSS, ET AL.	128	2M	
	AG	4	0	3	5	0	0	7	7-12-77	HARRISON, ET AL.	285	381	
	AH	4	0	3	7	3	2	4	7-1977	ANDREASEN	433	24	
	AI	4	1	4	9	9	1	1	04-17-79	CLABBURN	148	11.5R	
	AJ	4	1	7	0	9	9	0	10-1974	BAUMGART, ET AL.	128	92YN	
	AK	4	1	9	7	5	9	3	4-15-80	KASTER, ET AL.	3	1.5	

FOREIGN PATENT DOCUMENTS														
		DOCUMENT NUMBER						DATE	COUNTRY	CLASS	SUBCLASS	TRANSLATION		
												YES	NO	
JZ	AL	1	0	0	1	0	3	4	12-7-76	CANADA	128	93		
JZ	AM	1	1	1	0	4	4	7	8-1984	SU	128	92YN		
JZ	AN	1	1	1	3	1	1	0	9-1984	SU	128	92YN		
	AO	1	4	9	1	6	2	8		GERMANY				
JZ	AP	2	1	0	6	1	9	0	4-7-83	UK				

OTHER ART (Including Author, Title, Date, Pertinent Pages, Etc.)

JZ	AR	Schetky, L. McDonald, "SHAPE MEMORY ALLOYS", Scientific America, Nov. 1979, Pages 74-82
JZ	AS	Buehler, et al., "55-NITINOL UNIQUE WIRE ALLOY WITH A MEMORY", Wire Journal June 1963, pp 41-49
JZ	AT	Portsmann, et al., "P WAVE SYNCHRONOUS PACING USING ANCHORED ATRIAL ELECTRODE IMPLANTED WITHOUT THORACOTOMY", July 1972, The American Journal of Cardiology Vol. 30, pp 74-76

EXAMINER *JZ* DATE CONSIDERED 10/16/96

EXAMINER: Initial if reference considered, whether or not citation is in conformance with MPEP 809; Draw line through citation if not in conformance and not considered. Include copy of this form with next communication to applicant.

FORM PTD-1448 U.S. DEPARTMENT OF COMMERCE PATENT AND TRADEMARK OFFICE

ATTORNEY DOCKET NO. 9438-1 SERIAL NO. 28/483,291

LIST OF ART CITED BY APPLICANT (Use Several sheets if necessary)

APPLICANT JAMES E. JERVIS

FILING DATE Herewith GROUP

U.S. PATENT DOCUMENTS													
Examiner Initial		DOCUMENT NUMBER							DATE	NAME	CLASS	SUBCLASS	FILING DATE IF APPROPRIATE
JL	AA	4	2	0	5	2	9	3	5-27-80	MELTON, ET AL.	337	140	
	AB	4	2	3	0	1	2	3	10-28-80-	HAWKINS, JR.	128	658	
	AC	4	2	3	3	6	9	0	11-1980	AKINS	623	2	
	AD	4	3	0	7	7	2	3	12-29-81	FINNEY	128	349R	
	AE	4	3	1	0	3	5	4	1-12-82	FOUNTAIN, ET AL.	75	211	
	AF	4	3	7	8	8	1	1	4-5-83	LEVITAN	128	757	
	AG	4	4	0	1	4	3	3	8-30-83	LUTHER	604	159	
	AH	4	4	1	1	6	5	5	10-25-83	SCHRECK	604	165	
	AI	4	4	2	5	9	0	8	1-17-84	SIMON	128	1R	
	AJ	4	4	2	7	0	0	0	1-24-84	VEDA	128	6	
JL	AK	4	4	5	2	2	3	6	6-5-84	UTSUGI	128	4	

FOREIGN PATENT DOCUMENTS														
		DOCUMENT NUMBER							DATE	COUNTRY	CLASS	SUBCLASS	TRANSLATION	
													YES	NO
JL	AL	2	1	1	4	0	0	5	8-83	UK	128	92YN		
	AM	2	5	2	9	0	8	3		FRANCE				
JL	AN	2	7	0	3	5	2	9	3-8-78	GERMANY				ABSTRACT
	AO	3	1	4	7	7	2	2		GERMANY				
	AP	3	3	0	5	2	6	7	8-84	DE	128	92YN		

OTHER ART (Including Author, Title, Date, Pertinent Pages, Etc.)	
JL	AR Baumgart, et al., "MEMORY ALLOYS - PROPERTIES, PHENOMENOLOGICAL THEORY AND APPLICATIONS", 1976 (Reference #1 from Opposition)
	AS Bennisman, et al., "STUDY OF THE MEMORY ALLOY NICKEL-TITANIUM AND OBSERVATIONS ON ITS APPLICATION IN THE FIELD OF MEDICINE", 1979 (Reference 2 from Opposition)
JL	AT Bennisman, et al., "OSTEOSYNTHESIS STAPLES MADE OF NICKEL-TITANIUM, MANUFACTURE PRELIMINARY EXPERIMENTS AND CLINICAL USE THEREOF", 1982 (Ref. #3 from Opposition)

EXAMINER *J. J. [Signature]* DATE CONSIDERED 10/16/96

EXAMINER: Initial if reference considered, whether or not citation is in conformance with MPEP 806; Draw line through citation if not in conformance and not considered. Include copy of this form with next communication to applicant.

FORM PTD-1448 U.S. DEPARTMENT OF COMMERCE PATENT AND TRADEMARK OFFICE	ATTORNEY DOCKET NO. 9438-1	SERIAL NO. 08/483,291
LIST OF ART CITED BY APPLICANT (Use Several sheets if necessary)	APPLICANT JAMES E. JERVIS	
	FLING DATE Herewith	GROUP

U.S. PATENT DOCUMENTS													
Examiner Initial		DOCUMENT NUMBER							DATE	NAME	CLASS	SUBCLASS	FLING DATE OF APPROPRIATE
Jr	AA	4	4	8	5	8	1	6	12-14-84	KRUMME	128	334R	
↑	AB	4	4	9	0	1	1	2	12-25-84-	TANAKA, ET AL.	433	20	
	AC	4	4	9	4	5	3	1	1-22-85	GIANTURCO	128	1R	
	AD	4	5	0	5	7	6	7	3-19-85	QUIN	148	402	
	AE	4	5	0	9	5	1	7	4-9-85	ZIBELIN	128	319	
	AF	4	5	1	2	3	3	8	4-23-85	BALKO, ET AL.	128	1R	
	AG	4	5	4	3	0	9	0	9-24-85	McCOY	604	95	
	AH	4	5	5	6	0	5	0	12-3-85	HODGSON, ET AL.	128	1R	
	AI	4	5	8	6	3	3	5	5-6-86	HOSODA, ET AL.	60	528	
✓	AJ	4	6	0	1	2	8	3	7-22-86	CHIKAMA	128	4	
Jr	AK	4	6	1	6	6	5	6	10-14-86	NICHOLSON, ET AL.	128	360	

FOREIGN PATENT DOCUMENTS														
		DOCUMENT NUMBER							DATE	COUNTRY	CLASS	SUBCLASS	TRANSLATION	
													YES	NO
Jr	AL	3	2	2	5	1	5	1A1	1-84	GERMANY			X	
Jr	AM	5	8	2	5	1	4	0	2-83	JAPAN			ABSTRACT	
Jr	AN	5	8	2	9	4	4	3	2-83	JAPAN			X	
Jr	AO	5	8	4	1	5	4	6	3-83	JAPAN			PARTIAL	
Jr	AP	5	8	4	4	0	4	7	3-83	JAPAN			PARTIAL	

OTHER ART (Including Author, Title, Date, Pertinent Pages, Etc.)												
Jr	AR	Baumgart, et al., "MECHANICAL PROBLEMS IN THE USE OF THE MEMORY EFFECT FOR OSTEOSYNTHESIS PLATES", 1977 (Ref. 04 from Opposition)										
Jr	AS	Suzuki, Yuchi, "SHAPE MEMORY AND SUPER-ELASTICITY EFFECTS IN Ni-Ti ALLOYS. (Translation provided). Kirk-Othmer, Encyclopedia of Chemical Technology, 3rd Ed., Vpl. 20, pp. 7-26-7-36.										
	AT											

EXAMINER <i>Jr</i>	DATE CONSIDERED 10/16/86
--------------------	--------------------------

EXAMINER: Initial if reference considered, whether or not citation is in conformance with MPEP 600; Draw line through citation if not in conformance and not considered. Include copy of this form with next communication to applicant.

FORM PTO-1449		U.S. DEPARTMENT OF COMMERCE PATENT AND TRADEMARK OFFICE				ATTORNEY DOCKET NO. 9438-1			SERIAL NO. <i>CS/483:291</i>						
LIST OF ART CITED BY APPLICANT (Use several sheets if necessary)						APPLICANT: James E. Jervis			GROUP:						
						FILING DATE: Herewith									
U.S. PATENT DOCUMENTS															
Examiner Initial		DOCKET NUMBER							DATE	NAME	CLASS	SUBCLASS	FILING DATE IF APPROPRIATE		
<i>Jc</i>	AA	3	5	5	8	3	6	9	1-26-71	Wang, et al.	148	11.5			
	AB	3	6	0	5	7	2	5	9-20-71	Bentov	128	2.05R			
	AC	3	7	5	7	7	6	8	9-11-73	Kline	128	2H			
	AD	3	7	8	9	8	4	1	2-5-74	Antoshkiw	128	2.05			
	AE	4	0	8	0	7	0	6	3-28-78	Heilman	29	173			
	AF	4	6	6	5	9	0	6	5-87	Jervis	128	92YN			
	AG														
	AH														
	AI														
	AJ														
	AK														
FOREIGN PATENT DOCUMENTS															
		DOCKET NUMBER							DATE	COUNTRY	CLASS	SUBCLASS	TRANSLATION		
													YES	NO	
	<i>Jc</i>	AL	5	8	5	0	9	5	1	3-25-83	JAPAN				Partial
	<i>Jc</i>	AM	5	9	9	7	1	1	5	6/84	JAPAN				Abstract
	<i>Jc</i>	AN	6	0	4	5	3	5	6	3/85	JAPAN				X
	<i>Jc</i>	AO	6	2	2	0	8	2	7	4/84	JAPAN				Partial
	<i>Jc</i>	AP	6	4	7	6	8	2	4	3/89	JAPAN				Abstract
OTHER ART (Including Author, Title, Date, Pertinent Pages, etc.)															
	<i>Jc</i>	AR	Ling, et al., VARIATION IN THE SHAPE RECOVERY TEMPERATURE IN NI-TI ALLOYS, <i>Mat'l's Sc. & Eng.</i> , Vol. 48, pp 241-247 (1981).												
			Baumgart, et al., ZUR 5-DIMENSIONEN-SKOLILOGENOPERATION MITTELS DRANTEN AUS MEMORY LEGIERUNGEN, <i>Arch. Orth. Traum. Surg.</i> 91, pp. 67-75 (1978).												
		AS	Suzuki, <i>KINZOKU (Metal)</i> 51, pp. 15-18 (1981).												
		AT													
EXAMINER <i>Jc</i>										DATE CONSIDERED <i>10/16/88</i>					
EXAMINER: Initial if reference considered, whether or not citation is in conformance with MPEP 609; Draw line through citation if not in conformance and not considered. Include copy of this form with next communication to applicant.															

*copy
to MSJ*

FORM PTO-1449	U.S. DEPARTMENT OF COMMERCE PATENT AND TRADEMARK OFFICE	ATTORNEY DOCKET NO. 9438-1	SERIAL NO. 281463 241										
LIST OF ART CITED BY APPLICANT (Use several sheets if necessary)		APPLICANT: James E. Jervis											
		FILING DATE: Herewith	GROUP:										
U.S. PATENT DOCUMENTS													
Examiner Initial	DOCKET NUMBER							DATE	NAME	CLASS	SUBCLASS	FILING DATE IF APPROPRIATE	
AA													
AB													
AC													
AD													
AE													
AF													
AG													
AH													
AI													
AJ													
AK													
FOREIGN PATENT DOCUMENTS													
	DOCKET NUMBER							DATE	COUNTRY	CLASS	SUBCLASS	TRANSLATION	
												YES	NO
	AL		7	3	3	0	8	9-3-83	EPO				X
	AM		7	9	4	8	6	10-22-82	EPO				X
	AN		1	0	2	6	8	5-27-83	EPO				
	AU	1	3	9	9	3	6	4	8-21-70	FRANCE			X
	AP	8	2	1	1	0	6	1	12/83	FRANCE			ABSTRACT
OTHER ART: (Including Author, Title, Date, Pertinent Pages, etc.)													
	AR	Watanabe, STUDIES ON NEW SUPERELASTIC NI-TI ORTHODONTIC WIRE, J. Jap. Soc. for Dental Apparatus & Mat'ls., Vol. 23, No. 61, pp. 47-57 (1981). Oonishi, Clinical Magazine: Orthopaedic Surgery, 32, p. 1180 (1981).											
	AS	Sullivan, VARIABLE STIFFENING DEVICE FOR COLONOSCOPY, Gastrointestinal Endoscopy, Vol. 36 No. 6, pp. 642-3 (1990).											
	AT												
EXAMINER <i>J. L. Z.</i>										DATE CONSIDERED 10/16/96			
EXAMINER: Initial if reference considered, whether or not citation is in conformance with MPEP 609; Draw line through citation if not in conformance and not considered. Include copy of this form with next communication to applicant.													

*NOTE
Page 14*

FORM PTO-1449 U.S. DEPARTMENT OF COMMERCE PATENT AND TRADEMARK OFFICE ATTORNEY DOCKET NO. 9438-1 SERIAL NO. CS/483, 29/

LIST OF ART CITED BY APPLICANT
(Use several sheets if necessary)

APPLICANT: James E. Jervis
FILING DATE: Herewith GROUP:

U.S. PATENT DOCUMENTS

Examiner Initial		DOCKET NUMBER							DATE	NAME	CLASS	SUBCLASS	FILING DATE IF APPROPRIATE
	AA												
	AB												
	AC												
	AD												
	AE												
	AF												
	AG												
	AH												
	AI												
	AJ												
	AK												

FOREIGN PATENT DOCUMENTS

Make
pertinent
MPEP
entries

		DOCKET NUMBER							DATE	COUNTRY	CLASS	SUBCLASS	TRANSLATION	
													YES	NO
<i>JL</i>	AL	58	1	3	3	2	2	5	8/83	JAPAN			X	
<i>JL</i>	AH	3	0	8	6	3	8	4	1-24-85	AUSTRALIA			X	
<i>JL</i>	AH	8	3	0	1	5	7	6	5/83	AUSTRALIA			X	
	AD													
	AP													

OTHER ART (Including Author, Title, Date, Pertinent Pages, etc.)

	AR	
	AS	
	AT	

EXAMINER *JL* DATE CONSIDERED 10/11/84

EXAMINER: Initial if reference considered, whether or not citation is in conformance with MPEP 609; Draw line through citation if not in conformance and not considered. Include copy of this form with next communication to applicant.

Notice of References Cited

Application No. 08/483,291	Applicant(s) Jervis		
Examiner Justine Yu	Group Art Unit 3301	Page 1 of 1	

U.S. PATENT DOCUMENTS

*		DOCUMENT NO.	DATE	NAME	CLASS	SUBCLASS
x	A	4,505,767	Mar. 1985	Quin	148	402
x	B	3,890,977	Jun. 1975	Wilson	604	281
x	C	5,067,957	Nov. 1991	Jervis	606	108
x	D	4,665,906	May 1987	Jervis	606	78
	E	4,512,338	Apr. 1985	Balko et al	606	78
	F	4,310,354	Jan. 1982	Fountain et al	75	211
	G	4,969,890	Nov. 1990	Sugita et al	623	1
	H	5,231,989	Aug. 1993	Middleman et al	604	280
	I					
	J					
	K					
	L					
	M					

FOREIGN PATENT DOCUMENTS

*		DOCUMENT NO.	DATE	COUNTRY	NAME	CLASS	SUBCLASS
	N						
	O						
	P						
	Q						
	R						
	S						
	T						

NON-PATENT DOCUMENTS

*		DOCUMENT (Including Author, Title, Source, and Pertinent Pages)	DATE
x	U	Seader, Shape-Memory Alloys, Encyclopedia of Chemical Technology, Volume 20, Third Edition, pages 726-736	1975
x	V	Auzuki, Shape Memory and Super-elasticity Effects in NiTi Alloys, The central Research Laboratory	1982
	W		
	X		

* A copy of this reference is not being furnished with this Office action.
(See Manual of Patent Examining Procedure, Section 707.05(a).)

NOTICE OF DRAFTSPERSON'S PATENT DRAWING REVIEW

PTO Draftpersons review all originally filed drawings regardless of whether they are designated as formal or informal. Additionally, patent Examiners will review the drawings for compliance with the regulations. Direct telephone inquiries concerning this review to the Drawing Review Branch, 703-305-8404.

The drawings filed (insert date) 6-7-95 are

A. not objected to by the Draftsperson under 37 CFR 1.84 or 1.152.

B. objected to by the Draftsperson under 37 CFR 1.84 or 1.152 as indicated below. The Examiner will require submission of new, corrected drawings when necessary. Corrected drawings must be submitted according to the instructions on the back of this Notice.

- DRAWINGS.** 37 CFR 1.84(a): Acceptable categories of drawings:
 - Black ink. Color.
 - Not black solid lines. Fig(s) _____
 - Color drawings are not acceptable until petition is granted. Fig(s) _____
- PHOTOGRAPHS.** 37 CFR 1.84(h)
 - Photographs are not acceptable until petition is granted. Fig(s) _____
 - Photographs not properly mounted (must use crystal board or photographic double-weight paper). Fig(s) _____
 - Poor quality (half-tone). Fig(s) _____
- GRAPHIC FORMS.** 37 CFR 1.84 (i)
 - Chemical or mathematical formula not labeled as separate figure. Fig(s) _____
 - Group of waveforms not presented as a single figure, using common vertical axis with time extending along horizontal axis. Fig(s) _____
 - Individual waveform not identified with a separate letter designation adjacent to the vertical axis. Fig(s) _____
- TYPE OF PAPER.** 37 CFR 1.84(e)
 - Paper not flexible, strong, white, smooth, nonshiny, and durable. Sheet(s) _____
 - Erasures, alterations, overwritings, interlineations, cracks, greases, and folds (copy machine marks) not accepted. Fig(s) 1-6
 - Mylar, vellum papers not acceptable (too thin). Fig(s) _____
- SIZE OF PAPER.** 37 CFR 1.84(f): Acceptable sizes:
 - 21.6 cm. by 35.6 cm. (8 1/2 by 14 inches)
 - 21.6 cm. by 33.1 cm. (8 1/2 by 13 inches)
 - 21.6 cm. by 27.9 cm. (8 1/2 by 11 inches)
 - 21.0 cm. by 29.7 cm. (DIN size A4)

All drawing sheets not the same size. Sheet(s) 2,3

Drawing sheet not an acceptable size. Sheet(s) _____
- MARGINS.** 37 CFR 1.84(g): Acceptable margins:

Paper size			
21.6 cm. X 35.6 cm.	21.6 cm. X 33.1 cm.	21.6 cm. X 27.9 cm.	21.0 cm. X 29.7 cm.
(8 1/2 X 14 inches)	(8 1/2 X 13 inches)	(8 1/2 X 11 inches)	(DIN Size A4)
T 5.1 cm. (2")	2.5 cm. (1")	2.5 cm. (1")	2.5 cm.
L .64 cm. (1/4")	.64 cm. (1/4")	.64 cm. (1/4")	2.5 cm.
R .64 cm. (1/4")	.64 cm. (1/4")	.64 cm. (1/4")	1.5 cm.
B .64 cm. (1/4")	.64 cm. (1/4")	.64 cm. (1/4")	1.0 cm.

Margins do not conform to chart above. Sheet(s) _____

Top (T) _____ Left (L) _____ Right (R) _____ Bottom (B) _____
- VIEWS.** 37 CFR 1.84(h)

REMINDER: Specification may require revision to correspond to drawing changes.

 - All views not grouped together. Fig(s) _____
 - Views connected by projection lines or lead lines. Fig(s) _____
 - Partial views. 37 CFR 1.84(h) 2
 - View and enlarged view not labeled separately or properly Fig(s) _____
 - Sectional views. 37 CFR 1.84 (h) 3
 - Hatching not indicated for sectional portions of an object. Fig(s) _____
 - Cross section not drawn same as view with parts in cross section with regularly spaced parallel oblique strokes. Fig(s) _____
- ARRANGEMENT OF VIEWS.** 37 CFR 1.84(i)
 - Views do not appear on a horizontal, left-to-right fashion where page is either upright or turned so that the top becomes the right side, except for graphs. Fig(s) _____
- SCALE.** 37 CFR 1.84(k)
 - Scale not large enough to show mechanism with crowding when drawing is reduced in size to two-thirds in reproduction. Fig(s) _____
 - Indication such as "actual size" or scale 1/2" not permitted. Fig(s) _____
- CHARACTER OF LINES, NUMBERS, & LETTERS.** 37 CFR 1.84(l)
 - Lines, numbers & letters not uniformly thick and well defined, clean, durable, and black (except for color drawings). Fig(s) 1-6
- SHADING.** 37 CFR 1.84(m)
 - Solid black shading areas not permitted. Fig(s) _____
 - Shade lines, pale, rough and blurred. Fig(s) _____
- NUMBERS, LETTERS, & REFERENCE CHARACTERS.** 37 CFR 1.84(p)
 - Numbers and reference characters not plain and legible. 37 CFR 1.84(p)(1) Fig(s) 1-6
 - Numbers and reference characters not oriented in same direction as the view. 37 CFR 1.84(p)(1) Fig(s) _____
 - English alphabet not used. 37 CFR 1.84(p)(2) Fig(s) _____
 - Numbers, letters, and reference characters do not measure at least .32 cm. (1/8 inch) in height. 37 CFR(p)(3) Fig(s) _____
- LEAD LINES.** 37 CFR 1.84(g)
 - Lead lines cross each other. Fig(s) _____
 - Lead lines missing. Fig(s) _____
- NUMBERING OF SHEETS OF DRAWINGS.** 37 CFR 1.84(i)
 - Sheets not numbered consecutively, and in Arabic numerals, beginning with number 1. Sheet(s) _____
- NUMBER OF VIEWS.** 37 CFR 1.84(u)
 - Views not numbered consecutively, and in Arabic numerals, beginning with number 1. Fig(s) _____
 - View numbers not preceded by the abbreviation Fig. Fig(s) _____
- CORRECTIONS.** 37 CFR 1.84(w)
 - Corrections not made from prior PTO-948. Fig(s) _____
- DESIGN DRAWING.** 37 CFR 1.152
 - Surface shading shown not appropriate. Fig(s) _____
 - Solid black shading not used for color contrast. Fig(s) _____

COMMENTS:



AMENDMENT COVER SHEET

DOCKET NO. 9438-1/MP0884-US8

IN RE APPLICATION OF: JAMES E. JERVIS
SERIAL NO. 08/483,291

FILED: June 7, 1995

FOR: MEDICAL DEVICES INCORPORATING SIM ALLOY ELEMENTS

HONORABLE COMMISSIONER OF
PATENTS AND TRADEMARKS
Washington, D.C. 20231

RECEIVED
PARTY
MAY 2 1997
OFFICE OF THE COMMISSIONER

Sir:

Transmitted herewith is a paper in the above-identified application. Any necessary extension of time, including additional extensions of time other than requested herein, from time period set for this paper is hereby requested.

- No additional fee is required.
- The fee has been calculated as shown below:

	RATE	RATE	FEE
	Non-Small Entity	Small-Entity	
FIRST MONTH AFTER TIME PERIOD SET	110.00	55.00	\$
SECOND MONTH AFTER TIME PERIOD SET	390.00	195.00	\$390.00
THIRD MONTH AFTER TIME PERIOD SET	930.00	465.00	\$
FOURTH MONTH AFTER TIME PERIOD SET	1,470.00	735.00	\$

TOTAL EXTENSION FEE 395.00

FEE FOR EXTRA CLAIMS added by Amendment in this response:

	Column 1	Column 2	Column 3	RATE Non-Small Entity	RATE Small-Entity	FEE
TOTAL CLAIMS	41	MINUS **20	* = 21	x 22	x 11	\$462.00
INDEPENDENT	6	MINUS ***4	* = 2	x 80	x 40	\$80.00
First presentation of multiple dependent claim				+ 260	+ 130	\$260.00

TOTAL FEE FOR EXTRA CLAIMS \$802.00

- * If the entry in Column 1 is less than the entry of Column 2, write "0" in Column 3.
- ** If the number of Total Claims previously paid for is less than 20, write "20" in this space.
- *** If the number of Independent Claims previously paid for is less than 3, write "3" in this space.

Enclosed is the fee of \$: by Check No.

Please charge Deposit Account No. 19-2090 in the amount of \$ 1,197.00

The Commissioner is hereby authorized to charge payment of any additional fees, in particular the following fees, associated with this communication, or credit any overpayment to Deposit Account No. 19-2090:

Any filing fees under 37 C.F.R. § 1.16 for the presentation of extra claims
Any patent application processing fees under 37 C.F.R. § 1.17

Date: 3/28/97
By: Sheldon & Mak
Jeffrey G. Sheldon, Reg. No.: 27,953

CERTIFICATE OF MAILING: I hereby certify that the above-identified correspondence, which is attached, is being deposited with the U.S. Postal Service as first class mail in an envelope addressed to: Assist. Commissioner for Patents, Washington, D.C: 20231 on March 28, 1997

Date Signed: March 28, 1997

SHELDON & MAK
225 South Lake Avenue, 9th Floor
Pasadena, California 91101
(818) 798-4000

By: *Marilyn C. Paik*
Marilyn C. Paik
Signature
Type or Print Name

2: \MCP\PTO\FORMS\TRANSMTL\9438-1CV

March 28, 1997

3301

ext.



205-597

PATENT 9438-1

IN THE UNITED STATES PATENT AND TRADEMARK OFFICE

#9 ext & amdt. C

Application of: JAMES E. JERVIS

Examiner: R. A. Hafer

Serial No.: 08/483,291

Group Art Unit: 331

Filing Date: June 7, 1995

For: MEDICAL DEVICES INCORPORATING SIM ALLOY ELEMENTS

Pasadena, California

310 25 10
310 25 11
310 25 12
310 25 13
310 25 14
310 25 15
310 25 16
310 25 17
310 25 18
310 25 19
310 25 20
310 25 21
310 25 22
310 25 23
310 25 24
310 25 25
310 25 26
310 25 27
310 25 28
310 25 29
310 25 30
310 25 31
310 25 32
310 25 33
310 25 34
310 25 35
310 25 36
310 25 37
310 25 38
310 25 39
310 25 40
310 25 41
310 25 42
310 25 43
310 25 44
310 25 45
310 25 46
310 25 47
310 25 48
310 25 49
310 25 50
310 25 51
310 25 52
310 25 53
310 25 54
310 25 55
310 25 56
310 25 57
310 25 58
310 25 59
310 25 60
310 25 61
310 25 62
310 25 63
310 25 64
310 25 65
310 25 66
310 25 67
310 25 68
310 25 69
310 25 70
310 25 71
310 25 72
310 25 73
310 25 74
310 25 75
310 25 76
310 25 77
310 25 78
310 25 79
310 25 80
310 25 81
310 25 82
310 25 83
310 25 84
310 25 85
310 25 86
310 25 87
310 25 88
310 25 89
310 25 90
310 25 91
310 25 92
310 25 93
310 25 94
310 25 95
310 25 96
310 25 97
310 25 98
310 25 99
310 25 100

2 mos. ext. granted/gu

AMENDMENT

Assistant Commissioner for Patents
Washington, D. C. 20231

RECEIVED

MAY 2 1997

GROUP 3360

Sir:

In response to the Office Action of October 29, 1996, please amend the above-identified Application as follows:

IN THE SPECIFICATION

At page 6, line 4, after the description of Figures 3-6 added by the Preliminary Amendment, please add the following:

Figure 7 shows a guide catheter, transport catheter, and compacted wire coil stent according to the present invention.

C1

At page 17, at the end of line 23 insert: According to Dotter et al.,

Radiology 147: 259-260, a compacted nitinol coil is readily positioned in a narrowed

C2

arterial segment and then expanded to its original form with a luminal diameter approximately equal to that of the adjacent, relatively normal, blood vessel. Expansion of the coil anchors it against the slightly stretched, but otherwise intact, surrounding blood vessel. Several means have been found to facilitate the placement of the nitinol coil stent. One of the simplest involves the use of conventional catheterization techniques to position a large-bore guide catheter 102 (as shown in Fig. 7) close to the site of intended stent 103 placement. The coil 103 is wedged-loaded over the inner end of an inner coaxial transport catheter 104 that has a closed tip and multiple side holes evenly spaced within the surrounding nitinol coil stent.

C2
Cont.

According to Cragg et al., Radiology 147: 261-262, straightened nitinol coils were passed through a 10-F Teflon catheter in the abdominal aorta. The nitinol coils were fastened to a threaded guiding wire to allow accurate placement after being deposited in the aorta. Once the wire was extruded from the catheter, precise placement of the newly formed coil was accomplished by advancing or withdrawing the guide wire in the aorta. Detachment of the coil was achieved by unscrewing the guide wire from the distal end of the coil. After coil placement, the catheter and guide wire were withdrawn and the arteriotomy was closed.

DRAWINGS

Please add Fig. 7 to the drawings.

☺

IN THE CLAIMS

Cancel claims 11-20, 22, and 24, without prejudice to presenting these claims in a continuation application.

Claim 23, line 2, delete "graft".

Claim 25, line 2, delete "the" (first occurrence).

Please amend claim 21 as follows:

~~21.~~ (Amended) A medical device for insertion into a mammalian body, the device comprising

(a) [(i)] a hollow placement device; [and]

C3
(b) [(ii)] a memory alloy element formed at least partly from pseudoelastic shape-memory alloy, the alloy displaying reversible stress-induced martensite at about body temperature such that it has a stress-induced martensitic state and an austenitic state, the memory alloy element having (i) a deformed shape when the alloy is in its stress-induced martensitic state and (ii) a different unstressed shape when the alloy is in its austenitic state; and

(c) a guide wire;

the memory alloy element being within the hollow placement device, and the placement device being guidable by the guide wire, the hollow placement device stressing the memory alloy element at a temperature greater than the A_s of the alloy so that the memory alloy element is in its deformed shape,

C3
cont.

wherein the memory alloy element can be extruded from the hollow placement device by the guide wire at a temperature greater than the A_s of the alloy to transform at least a portion of the alloy from its stress-induced martensitic state so that the memory alloy element transforms from its deformed shape to its unstressed shape, and wherein the [device is adapted] alloy is selected so that the transformation can occur without any change in temperature of the placement device or the memory alloy element.

Please add the following claims to the application.

C4

6
28. A medical device which comprises:

- (a) a stent for endarterial placement within a human body so that the stent is substantially at human body temperature, the stent comprising a shape memory alloy which displays stress-induced martensite behavior at body temperature; and
- (b) a restraint holding the stent in a deformed configuration at a temperature less than the body temperature of the human for endarterial positioning of the stent within the human body in its deformed configuration, the deformation occurring through the formation of stress-induced martensite;

wherein the stent is sufficiently deformed that when the stent is at human body temperature removal of the restraint from the stent, without change in temperature of the device, releases at least a portion of the stent from its deformed configuration.

7
29. A device as claimed in ~~28~~⁶, in which the restraint is hollow, and the stent is positioned at least partially within the restraint.

⁸
~~28~~. A device as claimed in claim ~~26~~⁶ or ~~27~~⁷, in which the restraint is a catheter.

⁹
~~28~~. A device as claimed in claim ~~26~~⁶ or ~~27~~⁷, in which the stent has a transverse dimension and a longitudinal dimension, and wherein the stent is deformed by its transverse dimension being reduced, and wherein the restraint prevents transverse expansion of the stent.

¹⁰
~~30~~. The device of claim ~~26~~⁶, wherein the shape memory alloy element is sufficiently deformed that removal of the restraint from the shape memory alloy releases at least a portion of the shape alloy element from its deformed configuration without change in state of the restraint.

Cy
Cont.

¹¹
~~31~~. A medical device suitable for placement within a mammalian body for treatment of the mammalian body, the device comprising:

(a) a stent formed at least partly from a pseudoelastic shape-memory alloy, the alloy having a reversible stress-induced martensitic state and an austenitic state, the memory alloy element having (i) a deformed shape when the alloy is in its stress-induced martensitic state and (ii) a different, unstressed shape; and

(b) restraining means engaging and stressing the stent at a temperature less than the body temperature of the mammal and greater than the A_s of the alloy for positioning the stent within the mammalian body while the stent is in its deformed shape;

wherein the alloy is selected so that removal of the restraining means from the stent at a temperature greater than the A_s of the alloy when the device is placed within

the mammalian body, transforms at least a portion of the alloy from its stressed-induced martensitic state so that the stent transforms from its deformed relatively straightened shape towards its unstressed relatively coiled shape, without any change in temperature of the restraining means or the stent being required for the transformation of the alloy.

15
32.

A medical device for treatment of a mammalian body, the device comprising:

(a) a memory alloy stent formed at least partly from a pseudoelastic shape-memory alloy, the alloy displaying reversible stress-induced martensite at about the mammalian body temperature such that it has a stress-induced martensitic state and an austenitic state, the memory alloy stent having (i) a deformed relatively straightened shape when the alloy is in its stress-induced martensitic state and (ii) a different unstressed relatively coiled shape; and

(b) a hollow restraining member with the memory alloy stent being within the restraining member, the restraining member engaging and stressing the memory alloy stent at a temperature less than the body temperature of the mammal and greater than the A_s of the alloy for positioning the memory alloy stent within the human body while the memory alloy coil stent is in its deformed relatively straightened shape;

wherein the restraining member and the memory alloy stent are movable relative to each other to transform at least a portion of the alloy from its stress-induced martensitic state at a temperature greater than the A_s of the alloy so that the memory alloy element transforms from its deformed shape towards its unstressed relatively coiled shape, and wherein the alloy is selected so that the transformation can occur without any change in temperature of the restraining member or the memory alloy coil stent.

16
~~38.~~

A medical device suitable for placement within a mammalian body for treatment of the mammalian body, the device comprising (i) a restraint, and (ii) a coil stent formed at least partly from a pseudoelastic shape-memory alloy,

the alloy displaying reversible stress-induced martensite by virtue of being above its A_s and above its M_s and below its M_d at about body temperature;

such that it has a stress-induced martensitic state and an austenitic state, the element having (i) a relatively straightened shape when the alloy is in its stress-induced martensitic state and (ii) a different relatively coiled shape;

wherein the restraint is (i) stressing the coil stent at a temperature less than the body temperature of the mammal for placement of the coil stent in its relatively straightened shape in the mammalian body and (ii) is capable of being at least partially removed from the coil stent while the coil stent is within the body at the body temperature and the coil stent is therefore at an operating temperature greater than the A_s and M_s and below the M_d of the alloy,

such removal of the restraint causing at least a portion of the alloy to transform from its stress-induced martensitic state to its austenitic state so that the coil stent spontaneously transforms from its relatively straightened shape towards its relatively coiled shape,

and such transformation can occur without a change in temperature of the restraint or of the coil stent from the operating temperature.

18
~~34.~~

A medical device comprising:

(a) a wire stent formed at least partly from a pseudoelastic shape memory alloy, the alloy displaying reversible stress-induced martensite at about human

body temperature such as it has a deformed shape when the alloy is in its stress-induced martensitic state and a different unstressed shape when the alloy is in its austenitic state; and

(b) a restraint stressing the wire stent at a temperature greater than the A_s of the alloy so that the wire stent is in its deformed shape,

wherein the stent can be disengaged from the restraint upon placement in a human so that the stent transforms from its deformed shape to its unstressed shape, and

wherein the alloy is selected so that the transformation can occur without any change in temperature of the restraint or the wire stent.

Cy
Cont.

¹⁷~~35~~. The device of claim ~~21, 31, 32, or 33~~^{1, 11, 15, 16}, wherein the mammalian body is a human body.

⁵~~36~~. The device of claim ~~21~~¹, wherein the hollow placement device is a catheter.

³~~37~~. The device of claim ~~28~~², including a guide wire for endarterial placement of the stent graft.

¹⁹~~38~~. The device of claim ~~26, 31, 32, 33 or 34~~^{6, 11, 15, 16, 18}, including a guide wire for endarterial placement of the stent.

^C 39. The device of claim 11 wherein the radially expanded shape is a coil shape.

36

¹²
~~40.~~ The device of claim ¹¹~~31~~, wherein the transformation of the alloy occurs without any change in state of the restraining means.

²⁰
~~41.~~ The device of claim ^{15 16 18}~~32, 33, or 34~~, wherein the transformation of the alloy occurs without any change in state of the restraint.

²¹
~~42.~~ The device of claim ^{1 15 16 18}~~31, 32, 33, or 34~~, wherein the restraint is a catheter.

C-4
Cont.

43. The device of claim 39 wherein the stent is within the catheter.

¹³
~~44.~~ The device of claim ¹¹~~31~~ wherein the restraining means is a catheter.

¹⁴
~~45.~~ The device of claim ¹³~~44~~ wherein the stent is within the catheter.

²²
~~46.~~ The device of claim ^{1 11 15 18}~~26, 31, 32, or 34~~ wherein the stent is a coil stent.

REMARKS

Claims 21, 23, 25, and 26-46 are in this application. Claims 11-20, 22, and 24 are canceled by this amendment. Claims 26-46 are added by this amendment. Claims 11-14, 21, 23, and 25 were rejected under 35 U.S.C. § 112. Claim 11 was rejected under 35 U.S.C. § 102. Claims 11-14, 21, 23, and 25 were rejected under 35 U.S.C. § 103. Claims 21, 23, and 25 were rejected for obviousness-type double patenting.

In view of the amendments to the claims, and the remarks below, it is respectfully submitted that all of the claims in the application are in condition for allowance. Accordingly, reexamination, reconsideration, and allowance are respectfully requested.

ENTRY OF AMENDMENTS

Entry of the amendments to the specification, the new drawing, and the new claims is respectfully requested. They raise no issues of new matter.

In particular, the new drawing, the description of the drawing, and the addition to page 17 of the specification are taken from two articles that were incorporated in the original specification by reference at page 17, lines 16-20, namely Radiology, Volume 47, pages 259-260 and pages 261-3 (1983). For the convenience of the Examiner, copies of those documents are provided herewith. Adding a drawing and language to the specification already incorporated by reference does not raise issues of new matter. See MPEP § 804.01.

NEW CLAIMS

Allowance of the new claims is believed appropriate. These claims correspond to, and generally are narrower versions of claims that were allowed in the parent application, with the correspondence as follows:

SERIAL NO. 07/956,953
19, 20, 21, 25, 26, 27, 28, 57

SERIAL NO. 08/483,291
26, 27, 28, 29, 30, 31, 32, 33

For the same reasons the claims were allowed in the parent application, it is respectfully submitted they should be allowed in this application, as well as the claims dependent therefrom. It is also believed that the other claims presented herein are likewise allowable in view of commonality of allowable subject matter.

DRAWING OBJECTION

The drawings were objected to for failure to show a stent graft. This rejection has been obviated by the addition of Fig. 7.

REJECTION UNDER 35 U.S.C. § 112

Claim 11-14, 21, 23, and 25 were rejected under 35 U.S.C. § 112. Claims 11-14 have been cancelled, without prejudice, subject to their presentation in a continuation application. As to the objections to claims 21, 23, and 25, it is respectfully submitted that the amendments to these claims obviate the objections raised.

Accordingly, it is respectfully submitted that by the amendments to the claims, the rejection under 35 U.S.C. § 112 has been obviated.

REJECTION OVER QUIN

Claims 11-14 were rejected over Quin U.S. Patent No. 4,505,767. However, as noted by the Examiner, the present application claims priority from Application Serial No. 541,852 which was filed on the same day as the Quin application. Since the specification filed herewith is identical to that originally filed, the claim of priority is good. Moreover, since all of the claims submitted under examination are supported by

the specification as originally submitted and contain no new matter, they are all entitled to the priority date of October 14, 1983. Accordingly, the rejection should not have been made. However, the rejection has been obviated by cancellation of the claims, without prejudice.

REJECTION UNDER 35 U.S.C. § 103

Claims 21, 23, and 25 were rejected over the combination of Balko et al. Patent No. 4,512,338 and Seader (Encyclopedia of Chemical Technology publication). This rejection is respectfully traversed.

Balko describes a stent made out of nitinol, i.e., essentially what is described in the Radiology articles that are discussed in the present application. The Office Action appears to suggest that the basis of the rejection is that all nitinol alloys exhibit SIM behavior, and thus the invention is obvious.

Firstly, it should be noted the references relied upon herein were before the Patent Office and claims broader than those presented herewith were allowed. The claims presented herein are due to a species election requirement in the parent application. If the generic invention is unobvious, then the species likewise must be unobvious.

Secondly, the rejection is based on a false assumption that all nitinol alloys would be effective in a medical device for use in mammalian bodies. This is not accurate. As stated in the Quin patent:

"The extent of the temperature range over which SIM is seen and the stress and strain ranges for the effect vary greatly with the alloy." (Column 2, lines 31-34)

Quin goes on to say that her invention, which is incorporated by reference in the present application, was a discovery that "the addition of appropriate amounts of vanadium to nickel/titanium shape memory alloys permits the production of workable alloys exhibiting stress-induced martensite in a physiologically acceptable temperature range . . ." (column 3, lines 55-59). There is no suggestion in Balko that his alloy should be selected to have SIM behavior in a physiologically useful temperature range.

Furthermore, there is no suggestion in either of these references to actually use an SIM alloy to take advantage of its properties. In fact, the references teach away, in that Balko et al. requires a temperature change to effect a change in state. A difficulty with such an approach is easily envisioned, in that as a coil stent is warmed up to reach body temperature as it is inserted, it can prematurely expand before it is removed from the restraint, thereby interfering with removal. Optionally, external heating is required, which introduces its own complications (see Balko et al., column 5, lines 57 et seq.). The simplicity of the present invention, where the coil stent achieves its desired configuration without the requirement of any external heating or cooling provides predictability and simplicity in the operating theater, advantages not taught or suggested by either of these references.

Accordingly, removal of the rejection under 35 U.S.C. § 103 is respectfully requested.

DOUBLE-PATENTING REJECTION

Claims 21, 23, and 25 were rejected for double-patenting in view of U.S. Patent No. 5,007,957. However, device claims were restricted out of the '957 application as a result of a restriction requirement. Attached is a copy of the Office Action. Accordingly, the double-patenting rejection is inappropriate. See MPEP § {806.05(f).

In view of the above remarks, a notice of allowance is respectfully requested.

Respectfully submitted,

SHELDON & MAK

By:  

Jeffrey G. Sheldon
Reg. No. 27,953

Date

225 South Lake Avenue, 9th Floor
Pasadena, California 91101
(818) 796-4000

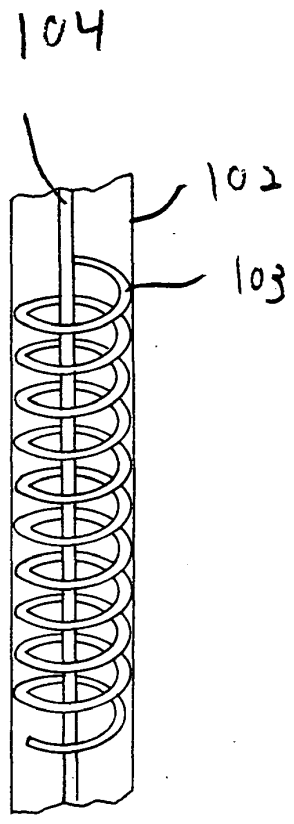

Fig 7.



UNITED STATES DEPARTMENT OF COMMERCE
 Patent and Trademark Office
 Address: COMMISSIONER OF PATENTS AND TRADEMARKS
 Washington, D.C. 20231

APPLICATION NUMBER	FILING DATE	FIRST NAMED APPLICANT	ATTY. DOCKET NO.
08/483,291	06/07/95	JERVIS	J 9438-1
			EXAMINER
F3M1/0918			
JEFFREY G SHELDON SHELDON & MAK 225 SOUTH LAKE AVENUE SUITE 900 PASADENA CA 91101			VUL. ART UNIT PAPER NUMBER 11
			3301 DATE MAILED: 09/18/97

This is a communication from the examiner in charge of your application.
 COMMISSIONER OF PATENTS AND TRADEMARKS

OFFICE ACTION SUMMARY

- Responsive to communication(s) filed on 4/2/97 (Amendment)
- This action is FINAL.

Since this application is in condition for allowance except for formal matters, prosecution as to the merits is closed in accordance with the practice under *Ex parte Quayle*, 1935 D.C. 11; 453 O.G. 213.

A shortened statutory period for response to this action is set to expire 3 month(s), or thirty days, whichever is longer, from the mailing date of this communication. Failure to respond within the period for response will cause the application to become abandoned. (35 U.S.C. § 133). Extensions of time may be obtained under the provisions of 37 CFR 1.136(e).

Disposition of Claims

- Claim(s) 21, 23, 25-46 is/are pending in the application.
- Of the above, claim(s) _____ is/are withdrawn from consideration.
- Claim(s) _____ is/are allowed.
- Claim(s) 21, 23, 25-46 is/are rejected.
- Claim(s) _____ is/are objected to.
- Claim(s) _____ are subject to restriction or election requirement.

Application Papers

- See the attached Notice of Draftsperson's Patent Drawing Review, PTO-948.
- The drawing(s) filed on _____ is/are objected to by the Examiner.
- The proposed drawing correction, filed on 4/2/97 is approved disapproved.
- The specification is objected to by the Examiner.
- The oath or declaration is objected to by the Examiner.

Priority under 35 U.S.C. § 119

- Acknowledgment is made of a claim for foreign priority under 35 U.S.C. § 119(a)-(d).
- All Some* None of the CERTIFIED copies of the priority documents have been
- received.
- received in Application No. (Series Code/Serial Number) _____
- received in this national stage application from the International Bureau (PCT Rule 17.2(a)).

*Certified copies not received: _____

- Acknowledgment is made of a claim for domestic priority under 35 U.S.C. § 119(e).

Attachment(s)

- Notice of Reference Cited, PTO-892
- Information Disclosure Statement(s), PTO-1449, Paper No(s) _____
- Interview Summary, PTO-413
- Notice of Draftsperson's Patent Drawing Review, PTO-948
- Notice of Informal Patent Application, PTO-152

-SEE OFFICE ACTION ON THE FOLLOWING PAGES-

Art Unit: 3301

DETAILED ACTION

1. This office action is responsive to the amendment filed 4/2/97. As directed by the amendment, claims claim 21 was amended, claims 11-20, 22, and 24 were canceled, and claims 26-46 were added. Thus, claims 21, 23, and 25-46 are presently pending in this application.

2. The following is a quotation of 35 U.S.C. 103(a) which forms the basis for all obviousness rejections set forth in this Office action:

(a) A patent may not be obtained though the invention is not identically disclosed or described as set forth in section 102 of this title, if the differences between the subject matter sought to be patented and the prior art are such that the subject matter as a whole would have been obvious at the time the invention was made to a person having ordinary skill in the art to which said subject matter pertains. Patentability shall not be negated by the manner in which the invention was made.

3. Claims 21, 23, 25, and 26-46 are rejected under 35 U.S.C. 103(a) as being unpatentable over Balko et al in view of Seader(Encyclopedia of Chemical Technology publication) and Foster, Jr..

Balko shows a nitinol (SMA) wire formed a graft structure 22 which is placed inside the sheath head 50 (hollow placement device). Balko lacks the description of the nitinol which is a pseudo elastic SMA. However, the teaching on page 733 of Seader discloses that the nitinol has the superelastic behavior (pseudo elastic behavior). Therefore, it is obvious that the nitinol has the pseudo elastic properties. In addition, it is well known in the art that the pseudoelastic material (nitinol) would have reversible stress induced martensite state at a body temperature. Therefore, it is obvious that Balko's nitinol would has the same property as claimed.

Art Unit: 3301

Balko differs from the present invention in that Balko lacks a guide wire. However, it is well known in the art that the guide wire is used for guiding a catheter into the body. In addition, Foster shows a stylet 16 (guide wire). Therefore, it would have been obvious to one of ordinary skill in the art at the time the invention was made to provide Balko's device with a guide wire in order to guide the catheter into a desire location.

4. The non-statutory double patenting rejection, whether of the obviousness-type or non-obviousness-type, is based on a judicially created doctrine grounded in public policy (a policy reflected in the statute) so as to prevent the unjustified or improper timewise extension of the "right to exclude" granted by a patent. *In re Thorington*, 418 F.2d 528, 163 USPQ 644 (CCPA 1969); *In re Vogel*, 422 F.2d 438, 164 USPQ 619 (CCPA 1970); *In re Van Ornum*, 686 F.2d 937, 214 USPQ 761 (CCPA 1982); *In re Longi*, 759 F.2d 887, 225 USPQ 645 (Fed. Cir. 1985); and *In re Goodman*, 29 USPQ2d 2010 (Fed. Cir. 1993).

A timely filed terminal disclaimer in compliance with 37 CFR 1.321(b) and © may be used to overcome an actual or provisional rejection based on a non-statutory double patenting ground provided the conflicting application or patent is shown to be commonly owned with this application. See 37 CFR 1.78(d).

Effective January 1, 1994, a registered attorney or agent of record may sign a terminal disclaimer. A terminal disclaimer signed by the assignee must fully comply with 37 CFR 3.73(b).

5. Claims 21 and 23 are rejected under the judicially created doctrine of obviousness-type double patenting as being unpatentable over claims 1-2 of U.S. Patent No.5,231,989. Although the conflicting claims are not identical, they are not patentably distinct from each other because the difference between the patented claims and the proposed application claims are minor and obvious from each other. In the instant claims ²¹~~22~~ and 23, all elements are included in the claims

17

Art Unit: 3301

1-2 of Pat. 5,231,989. The recitation of "placement device" is merely obvious variation over the "elongated tube" from claim 1 of the Pat. No. 5,231,989, the "memory alloy element" or "stent" is merely obvious variation in wording over the "elastic member", and the "guide wire" is a variation over the "straightener" from claims 1-2 of Pat. No. 5,231,989. The alternate terminology is obvious and merely limits the claim slightly but it does not change the scope of the claim.

6. Claims 21 and 23 are rejected under 35 U.S.C. 102(e) as anticipated by or, in the alternative, under 35 U.S.C. 103(a) as obvious over Middleman et al.

Middleman discloses an elastic member 60 (stent) formed from superelastic material which is located inside an elongated tube (catheter). Middleman further discloses a straightener (guide wire) and the elastic member are capable of relative axial movement.

Middleman differs from the present invention in that only the names for each claimed parts are different. However, having a different name is considered as an obvious design choice and fails to patentably define over the prior art.

7. Applicant's arguments with respect to claims 21, 23, and 25-46 have been considered but are moot in view of the new ground(s) of rejection.

Applicant first objects to Balko's reference and states that the rejection is based on a false assumption that all nitinol alloys would be effective in a medical device for use in mammalian

Art Unit: 3301

bodies. However, the examiner relied only on the fact that Balko discloses of introducing a shaped memory nitinol alloy stent into the body. It is well known that the nitinol represents a group of alloys and some of the nitinol alloys propose the reversible stress-induced martensite property. In addition, there has no base to support the allegation that Balko's alloy doesn't chose to have SIX behavior.

Applicant further argues that Balko's alloy requires a temperature change to effect a change in state. However, as noted by the applicant and at the last paragraph of page 13 that the external heating is **optionally** required. As discloses in column 3, lines 54-57 of Balko that the Nitinol wire 24 has been alloyed to exhibit a martensite transformation temperature somewhat below the normal body temperature range. In addition, in column 5, lines 57-67 of Balko discloses that heating the wire in any of the embodiments to its transformation temperature **could be accomplished other than solely by conduction and convection from the body** but by infrared radiation, when the body temperature is not exclusively relied upon as the source of heat for the wire, its reformation temperature could be increased above body temperatures **if necessary**. Therefore, it is obvious that Balko's alloy is not necessary to require infrared radiation but depends on the condition of the patient. Therefore, the rejection still stands.

8. Applicant's amendment necessitated the new ground(s) of rejection presented in this Office action. Accordingly, **THIS ACTION IS MADE FINAL**. See MPEP. § 706.07(a). Applicant is reminded of the extension of time policy as set forth in 37 CFR 1.136(a).

Art Unit: 3301

A shortened statutory period for response to this final action is set to expire THREE MONTHS from the date of this action. In the event a first response is filed within TWO MONTHS of the mailing date of this final action and the advisory action is not mailed until after the end of the THREE-MONTH shortened statutory period, then the shortened statutory period will expire on the date the advisory action is mailed, and any extension fee pursuant to 37 CFR 1.136(a) will be calculated from the mailing date of the advisory action. In no event will the statutory period for response expire later than SIX MONTHS from the date of this final action.

9. Any inquiry concerning this communication or earlier communications from the examiner should be directed to Justine Yu whose telephone number is (703) 308-2675.

Any inquiry of a general nature or relating to the status of this application or proceeding should be directed to the Group receptionist whose telephone number is (703) 308-0858.

Justine Yu
September 13, 1997

ROBERT A. HAFNER
S.P.E.
ART UNIT 331

Notice of References Cited

Application No. 08/483,291	Applicant(s) Jervis
Examiner Justine Yu	Group Art Unit 3301
Page 1 of 1	

U.S. PATENT DOCUMENTS

	DOCUMENT NO.	DATE	NAME	CLASS	SUBCLASS
A	4,485,805	Dec. 1984	Foster, Jr.	606	195
B					
C					
D					
E					
F					
G					
H					
I					
J					
K					
L					
M					

FOREIGN PATENT DOCUMENTS

	DOCUMENT NO.	DATE	COUNTRY	NAME	CLASS	SUBCLASS
N						
O						
P						
Q						
R						
S						
T						

NON-PATENT DOCUMENTS

	DOCUMENT (Including Author, Title, Source, and Pertinent Pages)	DATE
U		
V		
W		
X		



UNITED STATES DEPARTMENT OF COMMERCE
 Patent and Trademark Office
 Address: COMMISSIONER OF PATENTS AND TRADEMARKS
 Washington, D.C. 20231

APPLICATION NUMBER	FILING DATE	FIRST NAMED APPLICANT	ATTORNEY DOCKET NO.
08/483,291	06/07/95	JERVIS	J-9438-1

JEFFREY G SHELDON
 SHELDON & MAK
 225 SOUTH LAKE AVENUE SUITE 900
 PASADENA CA 91101

F3M1/0508

EXAMINER

YU, J

ART UNIT PAPER NUMBER

3301

410

DATE MAILED: 05/08/97

INTERVIEW SUMMARY

All participants (applicant, applicant's representative, PTO personnel):

- (1) Jeffrey Sheldon (Applicant's rep.) (3) Justine Yu (Examiner)
 (2) Edward Brown (4)

Date of interview: 5/5/97

Type: Telephonic Personal (copy is given to applicant applicant's representative)

Exhibit shown or demonstration conducted: Yes No If yes, brief description:

Agreement was reached. was not reached.

Claim(s) discussed:

Identification of prior art discussed:

Description of the general nature of what was agreed to if an agreement was reached, or any other comments:

Verified that there was only one preliminary Amendment filed 7/17/95.

(A fuller description, if necessary, and a copy of the amendments, if available, which the examiner agreed would render the claims allowable must be attached. Also, where no copy of the amendments which would render the claims allowable is available, a summary thereof must be attached.)

1. It is not necessary for applicant to provide a separate record of the substance of the interview.

Unless the paragraph above has been checked to indicate to the contrary, A FORMAL WRITTEN RESPONSE TO THE LAST OFFICE ACTION IS NOT WAIVED AND MUST INCLUDE THE SUBSTANCE OF THE INTERVIEW. (See MPEP Section 713.04). If a response to the last Office action has already been filed, APPLICANT IS GIVEN ONE MONTH FROM THIS INTERVIEW DATE TO FILE A STATEMENT OF THE SUBSTANCE OF THE INTERVIEW.

2. Since the Examiner's interview summary above (including any attachments) reflects a complete response to each of the objections, rejections and requirements that may be present in the last Office action, and since the claims are now allowable, this completed form is considered to fulfill the response requirements of the last Office action. Applicant is not relieved from providing a separate record of the interview unless box 1 above is also checked.

Examiner Note: You must sign this form unless it is an attachment to another form.

Justine Yu



PATENT
Attorney Docket Number 9438-1

Sm
4-14-98
#13
& Declaration

IN THE UNITED STATES PATENT AND TRADEMARK OFFICE

In re application of: JAMES E. JERVIS
Serial No.: 08/483,291
Filed: June 7, 1995
For: **MEDICAL DEVICES
INCORPORATING SIM ALLOY
ELEMENTS**

Examiner: Justine Yu
Group Art Unit: 3301

RESPONSE

BOX AF
Assistant Commissioner for Patents
Washington, D. C. 20231

Sir:

The following remarks are submitted in response to the final Office Action, Paper Number 11, mailed September 18, 1997. Additional documents accompanying this response include the following: (1) Declaration of Dr. Lee Middleman under 37 C.F.R. §1.132; (2) a copy of U.S. Patent No. 5,597,378, to Jervis, entitled "Medical Devices Incorporating SIM Alloy Elements"; (3) a Petition for a Three-Month Extension of Time under 37 C.F.R. §1.136(a); (4) a Conditional Notice of Appeal; and (5) an Associate Power of Attorney giving the undersigned authority to prosecute the subject application.

REMARKS

STATUS OF THE CLAIMS

Claims 21, 23, and 25-46 are presently pending in the subject application. Reconsideration and reexamination of these claims is respectfully requested.

CLAIM REJECTIONS

Claims 21, 23, 25, and 26-46 were rejected under 35 U.S.C. §103(a), as being unpatentable over U.S. Patent No. 4,512,338 to Balko et al. ("Balko") in view of Seader Encyclopedia of Chemical Technology publication ("Seader"), and U.S. Patent No. 4,485,805 to Foster, Jr. ("Foster"). Claims 21 and 23 were rejected under the judicially created doctrine of obviousness-type double patenting, as being unpatentable over claims 1 and 2 of U.S. Patent No. 5,231,989 to Middleman et al. ("the '989 patent"). In addition, Claims 21 and 23 were rejected under 35 U.S.C. §102(e), as being anticipated by, or in the alternative, under 35 U.S.C. §103(a), as being obvious over U.S. Patent No. 5,231,989 to Middleman et al.

Applicant respectfully traverses these rejections for the following reasons and for reasons supported by the accompanying expert declaration of Dr. Lee Middleman under 37 C.F.R. §1.132 ("Middleman Decl."). Evidence in the form of affidavits or declarations submitted under 37 C.F.R. §1.132 must be considered by the Examiner, if timely submitted. See M.P.E.P. §716.01. The Middleman Declaration submitted herewith is timely, as it is being submitted with a first response after final rejection for the purpose of overcoming a new ground of rejection made in the final rejection. See M.P.E.P. §716.01.

In view of the reasons discussed below and the accompanying declaration, Applicant respectfully requests that the rejections of claims 21, 23, and 25-46 be withdrawn and that these claims be allowed.

THE PRESENT INVENTION

The present invention is directed to a species of a very basic improvement in medical devices. Prior to the present invention, shape memory alloys have been known to be used in medical devices. The difficulty with shape memory alloys is that to get a change in shape, one of three techniques needed to be used: (a) keep the device cold until it is to be used; (b) externally heat the device for use; or (c) rely on heating from body warmth so that the device would change its shape.

All of these alternatives have significant disadvantages, including lack of reproducibility, difficulty of use in the operating room, additional steps in use and the length of time required to have the device warm up to change shape. It is well known to one skilled in the art that the longer a patient is on the operating table, the greater the chance of complications that may result from an operation.

Applicant's present invention is a fundamental invention that uses stress-induced martensite material in place of conventional shape memory alloy material. For this very basic invention, Applicant has already been awarded by the U.S. Patent Office the following U.S. patents: (1) U.S. Patent No. 5,597,378, entitled "Medical Devices Incorporating SIM Alloy Elements"; (2) U.S. Patent No. 5,190,546, entitled "Medical Devices Incorporating SIM Alloy Elements"; (3) U.S. Patent No. 5,067,957, entitled "Method of Inserting Medical Devices Incorporating SIM Alloy Elements"; and,

(4) U.S. Patent No. 4,665,906, entitled "Medical Devices Incorporating SIM Alloy Elements." At least some of these patents have claims broader than claims presented in the present application.

In particular, the present invention is directed to a species of Applicant's basic invention, namely, a medical device for insertion into a mammalian body, preferably in the form of a stent. The device comprises a hollow placement device, a memory alloy element formed at least partly from pseudoelastic shape-memory alloy, and a guide wire. The alloy displays reversible stress-induced martensite (SIM) at about body temperature such that it has a stress-induced martensitic state and an austenitic state. The memory alloy element has a deformed shape when the alloy is in its stress-induced martensitic state, and a different unstressed shape when the alloy is in its austenitic state. The memory alloy element is positioned within the hollow placement device, and the placement device is guidable by the guide wire. The hollow placement device stresses the memory alloy element at a temperature greater than the A_s (temperature at which the alloy starts to revert back to austenite) of the alloy so that the memory alloy element is in its deformed shape. The memory alloy element can be extruded from the hollow placement device by the guide wire at a temperature greater than the A_s of the alloy to transform at least a portion of the alloy from its stress-induced martensitic state, so that the memory alloy element transforms from its deformed shape to its unstressed shape. The alloy is selected so that the transformation can occur without any change in temperature of the placement device or the memory alloy element.

The medical device incorporating SIM alloy elements of the present invention provides significant advantages over known medical devices, including those disclosed in the cited references. The present invention discloses a memory alloy formed at least partly from a pseudoelastic shape memory alloy that displays reversible stress-induced martensite at about body temperature, and the

present invention requires no temperature change to effect a change in state of the shape memory alloy. Thus, none of the disadvantages associated with heating the shape memory alloy with body heat alone or with external heating sources exist with the present invention. In addition, the simplicity of the present invention, where the device attains its desired configuration without the requirement of any external heating or cooling, provides predictability and ease of operation.

REJECTION OVER BALKO, SEADER, and FOSTER

Applicant initially submits that the cited Balko reference was previously before the Patent Office and claims broader than those presented herewith were allowed by the Patent Office, i.e., in U.S. Patent No. 5,597,378, to Jervis, entitled "Medical Devices Incorporating SIM Alloy Elements," the parent case of the subject application. A copy of U.S. Patent No. 5,597,378 is enclosed herewith. The claims presented herein are due to a species election requirement in the parent application, and Applicant submits that if the generic invention is nonobvious, then the species must similarly be nonobvious. Moreover, the Examiner relies on the secondary references of Seader for teaching that nitinol has pseudoelastic properties and Foster for teaching a stylet (guide wire). Along with Balko, teachings that nitinol has pseudoelastic properties and teachings of a guide wire were also already considered by the U.S. Patent Office in allowing claims broader than those presented herein.

The Office Action sets forth at page 2 that Balko shows a nitinol (SMA) wire formed graft structure 22 which is placed inside the sheath head 50 (hollow placement device) and that Balko lacks the description of the nitinol which is a pseudoelastic SMA, but that the teaching on page 733 of Seader discloses that the nitinol has the superelastic (pseudoelastic) behavior, and therefore, it is obvious that the nitinol has the pseudoelastic properties. In addition, the Office Action sets forth at

page 3 that Balko differs from Applicant's invention in that Balko lacks a guide wire, but that it is well known in the art that a guide wire is used for guiding a catheter into the body, and that Foster shows a stylet 16 (guide wire), and that it would have been obvious to one of ordinary skill in the art at the time the invention was made to provide Balko's device with a guide wire in order to guide the catheter into a desired location.

Applicant submits that a person skilled in the art would not have been motivated at the time of the invention to combine Balko, Seader, and Foster in the way suggested by the Examiner. Moreover, it would not be obvious to substitute the nitinol of Seader or the guide wire of Foster to arrive at Applicant's claimed invention because there is no suggestion, teaching, or motivation in Balko, Seader, or Foster to combine them to arrive at Applicants' claimed invention.

Balko does not disclose a memory alloy formed at least partly from a pseudoelastic shape memory alloy that displays reversible stress-induced martensite at about body temperature (Middleman Decl., ¶11). Lee Middleman, an expert in the field of stress-induced martensite (SIM) alloy elements, provides, "I find no suggestion or teaching in Balko, Seader, or Foster to make the nitinol disclosed in Balko from a stress-induced martensite alloy" (Middleman Decl., ¶11). Nitinol can only exhibit properties of a SIM material if it undergoes a treatment process to make it exhibit the properties of a SIM material. Such a treatment process is time consuming and expensive and is not suggested or taught by Balko. Moreover, even if the nitinol in Balko were to exhibit SIM properties, there is no suggestion or teaching in the references that the SIM phenomenon is to occur in the temperature range around the body temperature of a mammal (typically 35 degrees Celsius to 40 degrees Celsius) (Middleman Decl., ¶12). No such teaching is provided in Balko or the other cited references.

In addition, Balko requires a temperature change to effect a change in state utilizing SMA materials, wherein such temperature change results from body heating alone, or body heating in combination with external heating (see Balko, col. 5, lines 57-67). There is no suggestion in Balko or the other references to use nitinol without a temperature change, whether it be by heating the nitinol with body heat alone, or whether it be by heating the nitinol with body heat and an external heating source (Middleman Decl., ¶13).

There are also significant advantages provided by the present invention that are not disclosed, suggested, or taught by any of the cited references. The present invention does not require any external heating or cooling, is simple to operate, and is cost effective. Moreover, Lee Middleman discusses the disadvantages and problems of Balko which are not found in the claimed invention, as follows:

...For the Balko device, a doctor has to rely on heating the nitinol for it to work. If the doctor relies solely on body heating, this slows up the surgical procedure. Needless to say, anything that slows up a medical procedure is undesirable in that the chance for infection and the chance for adverse patient reactions increase as the length of a medical procedure increases. Also, a device that relies on body heating to change shape exhibits inconsistent performance because of the dependence on heating by the body, which rate of heating can differ from patient-to-patient and from operating room to operating room. I know from personal experience with sutures made of SMA materials that inconsistent heating made the sutures difficult to use in an operating room. If the doctor has to rely on heating the nitinol by means of an external heating source, an additional step is added to the procedure and the possibility of overheating and injury is increased. If electric heating is used, there is a potential for electrical shock or an electric burn to the patient. In spite of these disadvantages of the Balko procedure, there is no suggestion in Balko or the other references of a medical device where transformation can occur without a change in temperature.

(Middleman Decl., ¶14).

Thus, in view of the foregoing, Applicant's claimed invention is not obvious over the cited references and is not shown, suggested, or taught by the cited references. Moreover, the present

claims are the result of a species election requirement in the parent application, and thus, Applicant submits, if the generic invention is nonobvious, then the species likewise must be nonobvious.

Claims 31-33

In addition to the reasons set forth above why the claimed invention is not obvious over the cited references, there are features in various of the narrower claims for which Applicant submits that no prima facie case of obviousness has been made. With respect to claims 31, 32, and 33, the invention is further limited in that removal of a restraining means or restraint from the stent transforms at least a portion of the alloy from its stress-induced martensitic state so that the stent transforms from its deformed relatively straightened shape towards its unstressed relatively coiled shape, without any change in temperature of the restraining means or the stent being required for the transformation of the alloy. These limitations are neither taught nor suggested by any of the cited references, either alone or in combination. In particular, Applicant submits that Balko is deficient in that if the wire alloy coil of Balko is warmed up to reach body temperature as it is inserted, it can prematurely expand before it is removed from the sheath, and interfere with or hinder removal. Thus, Applicant submits that these claim limitations further distinguish Applicant's invention over the cited references.

Further, with respect to the dependent claims, Applicant submits that since the independent claims are nonobvious and patentably distinguishable over the cited references as discussed above, it follows that the dependent claims are also nonobvious and patentably distinguishable over the cited references.

Accordingly, Applicant respectfully requests that the rejection of claims 21, 23, 25, and 26-46, under 35 U.S.C. § 103(a), as being unpatentable over the cited references, be withdrawn.

DOUBLE PATENTING REJECTION

Claims 21 and 23 have been rejected under the doctrine of obviousness-type double patenting as being unpatentable over claims 1-2 of U.S. Patent No. 5,231,989 to Middleman (“the ‘989 patent”). In particular, the Office Action sets forth at page 4 that the recitation of “placement device” in claim 21 is an obvious variation over the “elongated tube” from claim 1 of the ‘989 patent; that the recitation of “memory alloy element” of claim 21 and “stent” of claim 23 are obvious variations over the “elastic member” of claims 1-2 of the ‘989 patent; and that the recitation of “guide wire” in claim 21 is an obvious variation over the “straightening means” of claims 1-2 of the ‘989 patent.

Applicant respectfully traverses this obviousness-type double patenting rejection for the following reasons and for reasons supported by the accompanying Middleman Declaration.

Applicant submits that claims 21 and 23 are not obvious over claims 1-2 of the ‘989 patent because the device of the ‘989 patent functions very differently than the device claimed in claims 21 and 23 of the subject application (Middleman Decl., ¶17). The device in the ‘989 patent uses an elastic member made of SIM material to bend or unbend a bendable elongated tube (“transforming the elastic member from one shape to another for correspondingly bending or unbending the distal segment of the (elongate) tube” (claim 1(c)) (Middleman Decl., ¶17). In contrast, the device claimed in the subject application uses a non-bendable hollow placement device to bend and unbend a memory alloy made of a SIM material (“the hollow placement device stressing the memory alloy element...so that the memory alloy element is in its deformed shape” (claim 21) (Middleman Decl., ¶17). Thus,

the concept of the invention disclosed in the '989 patent and the concept of the invention claimed in the subject application are diametrically opposed (Middleman Decl., ¶17).

Applicant respectfully requests the Examiner to direct her attention to the drawings attached as Exhibit B to the Middleman Declaration. These drawings clearly show the differences between the device of claims 1 and 2 of the '989 patent and the device of claims 21 and 23 of the subject application. Thus, Applicant submits that claims 21 and 23 of the subject application are not obvious over claims 1 and 2 of the '989 patent (see Middleman Decl., ¶19).

Applicant further submits that the double-patenting rejection is improper because the '989 patent was already previously found to be nonobvious by the Patent Office over the earlier Jervis Patent No. 4,665,906, and the present Jervis application is a continuation of Jervis Patent No. 4,665,906. Middleman made his invention long after Jervis made his invention, and Jervis Patent No. 4,665,906 is even cited as prior art on the cover page of the '989 patent (see U.S. Patent No. 5,231,989 and Middleman Decl., ¶17). Accordingly, since the claims of the '989 patent are not obvious in view of claims 21 and 23 of the present Jervis invention, Applicant respectfully requests that the obviousness-type double patenting rejection of claims 21 and 23 in view of the '989 patent be withdrawn.

REJECTION UNDER 35 U.S.C. §102(e)

Applicant submits that U.S. Patent No. 5,231,989 to Middleman is not prior art under 35 U.S.C. §102(e) to the subject application, as the subject application claims priority from application serial number 06/541,852, having a filing date of October 14, 1983 (abandoned in favor of application serial number 06/865,703, now U.S. Patent No. 4,665,906). The filing date of the '989 patent is

February 15, 1991. Since all of the claims submitted under examination are supported by the specification as originally submitted and contain no new matter, they are all entitled to the priority date of October 14, 1983. Accordingly, Applicant respectfully requests that the rejection of claims 21 and 23 under 35 U.S.C. §102(e) in view of the '989 patent be withdrawn.

CONCLUSION

In view of the foregoing remarks and in view of the accompanying declaration, Applicant submits that the claim rejections are overcome and that the subject application is in condition for allowance, and such action is respectfully requested.

Respectfully submitted,

SHELDON & MAK

March 18, 1998
Date

By: Karin E. Peterka
Karin E. Peterka
Reg. No. 35,976

225 South Lake Avenue
9th Floor
Pasadena, California 91101
Phone: (626) 796-4000
Facsimile: (626) 795-6321

EXPRESS MAIL, mailing label no. EM262828897US
Date of Deposit: March 18, 1998

I hereby certify that this paper is being deposited with the United States Postal Service "Express Mail Post Office to Addressee" under 37 C.F.R. § 1.10 on the date indicated above and is addressed to:
Box AF, Assistant Commissioner for Patents, Washington, DC 20231

Sandra Spencer
Sandra Spencer

PATENT
9438-1

IN THE UNITED STATES PATENT AND TRADEMARK OFFICE

In re application of: JAMES E. JERVIS

Examiner: Justine Yu

Serial No.: 08/483,291

Group Art Unit: 3301

Filed: June 7, 1995

For: **MEDICAL DEVICES
INCORPORATING SIM ALLOY
ELEMENTS**



DECLARATION OF DR. LEE MIDDLEMAN UNDER 37 CFR 1.132

BOX AF
Assistant Commissioner for Patents
Washington, D. C. 20231

Sir:

I, Dr. Lee M. Middleman, hereby declare as follows:

BACKGROUND

1. I am an expert in material use and selection of materials for medical devices, and I have special knowledge of stress-induced martensite ("SIM") alloy elements.
2. Attached as Exhibit A, I enclose a copy of my curriculum vitae, a list of United States patents for which I am an inventor, and a list of publications I have authored or co-authored.
3. I have received seven patents relating to the use of materials in medical devices, all of which relate to the use of SIM material.

2:\exam\9438-1\9438-1\9438-1\exam\Decl.stp

1

4. I hold a B.A. Degree in physics, which I obtained in only three years, from Johns Hopkins University in Baltimore, Maryland, and I hold a Ph.D. in physics, which I obtained in only five years, from Stanford University in Stanford, California. In my first year of graduate school, I was one of the few science majors within the small number of recipients nationwide (less than one thousand) of a Woodrow Wilson Fellowship, an academic fellowship based primarily on grades, interviews, and faculty recommendations. In my remaining four years of graduate school, I was the recipient of four yearly National Science Foundation Fellowships, an academic fellowship based primarily on grades and recommendations.

5. I am currently employed at Nellcor Puritan Bennett Incorporated in Pleasanton, California (which has been recently purchased by Mallinckrodt Inc.). I have been employed at Nellcor since 1991. My current job title is Vice President, Product Development, Hospital Business Group. This group has yearly sales of nearly \$600,000,000. At Nellcor, I am in charge of the development of medical devices for respiratory impaired patients.

6. Previous to my current employment, I was employed from 1985-1991 and from 1976-1983, at Raychem Corporation in Menlo Park, California (which has since sold certain divisions to Medtronic, Inc. in Minneapolis, Minnesota, and of which Medtronic, Inc. is the assignee of the subject patent application). My last job title at Raychem was General Manager, Medical Ventures. Among my projects at Raychem, I worked on the development and design of medical devices employing shape memory alloys ("SMA"), and in particular SIM elements and components.

7. I do not currently have a financial relationship with Medtronic, Inc. or Raychem.

Corporation except on an occasional consulting basis for which I am compensated at my usual consulting rate.

8. I am being compensated at my usual consulting rate by Medtronic, Inc., for the consulting work I have performed in preparing this Declaration.

MATERIALS REVIEWED

9. In preparation for this declaration, I reviewed the above-identified patent application and pending claims, the office action dated September 18, 1997 for this application, U.S. Patent No. 4,512,338 to Balko et al. ("Balko"), U.S. Patent No. 4,485,805 to Foster, Jr. ("Foster"), my own U.S. Patent No. 5,231,989 to Middleman et al. ("my '989 patent"), and the Seader article from the Encyclopedia of Chemical Technology publication ("Seader").

CONCLUSIONS

10. I wish in this declaration to correct some misconceptions that appear in the office action dated September 18, 1997. In short, I conclude that the Patent Office is incorrect in stating that the claims of the subject Jarvis application are obvious in view of Balko, Foster and Seader, and that they are obvious in view of claims 1 and 2 of my '989 patent. I have many technically based reasons for this conclusion, which I will now present.

11. First, Balko does not disclose a memory alloy formed at least partly from a pseudoelastic shape memory alloy that displays reversible stress-induced martensite at about body temperature. I find no suggestion or teaching in Balko, Seader, or Foster to make the nitinol disclosed in Balko from a stress-induced martensite alloy. Although nitinol can exhibit the

properties of an SIM material, it can do so only if it undergoes a treatment process to make it exhibit the properties of an SIM material. This process requires an extensive, time consuming, and expensive procedure. Where is the suggestion in Balko or any of the other references to use nitinol exhibiting SIM behavior rather than less expensive conventional Nitinol? There is no such suggestion, and any such idea can only come from hindsight.

12. Even if the nitinol in Balko were to exhibit SIM properties, there is no suggestion or teaching in the references that the SIM phenomenon is to occur in the temperature range around the body temperature of a mammal. Nitinol can be treated to exhibit SIM properties in selected temperature ranges as low as 0 degrees Celsius or as high as 60 degrees Celsius. For the nitinol to be effective in a medical device, the SIM behavior must be exhibited at temperatures which a mammalian body can tolerate (typically 35 degrees Celsius to 40 degrees Celsius). No such teaching is provided in the cited references.

13. Further, Balko requires a temperature change to effect a change in state utilizing SMA materials (see col. 5, lines 57-67). The temperature change results from body heating alone, or body heating in combination with external heating. There is no suggestion in Balko or the other references to use nitinol without a temperature change, whether it be by heating the nitinol with body heat alone, or whether it be by heating the nitinol with body heat and an external heating source.

14. The Jarvis invention has significant practical advantages compared to what is taught by Balko. For the Balko device, a doctor has to rely on heating the nitinol for it to work. If the doctor relies solely on body heating, this slows up the surgical procedure. Needless to say, anything that slows up a medical procedure is undesirable in that the chance for infection and the

chance for adverse patient reactions increase as the length of a medical procedure increases. Also, a device that relies on ^dby heating to change shape exhibits inconsistent performance because of the dependance on heating by the body, which rate of heating can differ from patient-to-patient and from operating room to operating room. I know from personal experience with sutures made of SMA materials that inconsistent heating made the sutures difficult to use in an operating room. If the doctor has to rely on heating the nitinol by means of an external heating source, an additional step is added to the procedure and the possibility of overheating and injury is increased. If electric heating is used, there is a potential for electrical shock or an electric burn to the patient. In spite of these disadvantages of the Balko procedure, there is no suggestion in Balko or the other references of a medical device where transformation can occur without a change in temperature.

Linn

15. In view of the differences discussed above, it would not have been obvious at the time the invention was made in 1983 to have converted the nitinol of Balko into an SIM material and to have removed the heating step.

16. I am the inventor of the subject matter claimed in United States Patent Number 5,231,989, ("my '989 patent"), issued on August 3, 1993, entitled "Steerable Cannula," and cited in the office action dated September 18, 1997, in the subject application.

17. The device in claims 1 and 2 of my '989 patent functions very differently than the device claimed in the present Jervis application and does not render it obvious. I made my invention long after Jervis made his invention, and in fact, Jervis Patent Number 4,665,906 is cited as prior art on the cover page of my '989 patent. The device in my '989 patent uses an elastic member made of a SIM material to bend or unbend a bendable elongated tube ("transforming the

elastic member from one shape to another for correspondingly bending or unbending the distal segment of the (elongate) tube," (see claim 1(c)). In contrast, the device in the claims of the Jervis application uses a non-bendable hollow placement device to bend and unbend a memory alloy made of a SIM material ("the hollow placement device stressing the memory alloy element...so that the memory alloy element is in its deformed shape" (see claim 21)). These are diametrically opposed concepts.

18. To clearly show the differences between the '989 patent and the present Jervis invention, attached herewith as Exhibit B are drawings of the device of the '989 patent and the device of the present Jervis invention showing how the respective devices look before and after bending.

19. In view of this significant difference between the present Jervis invention and my '989 patent, the claimed Jervis invention is not obvious over claims 1 and 2 of my '989 patent.

I further declare that all statements made herein of my own knowledge are true, and that all statements made on information and belief are believed to be true, and further that these statements were made with the knowledge that willful false statements and the like so made are punishable by fine or imprisonment, or both, under the provisions of 18 U.S.C. §1001, and that such willful false statements may jeopardize the validity of this application and any patent or patents resulting therefrom.

Lee M. Middleman
Lee M. Middleman

Feb 2, 1998
Date

LEE M. MIDDLEMAN, PhD
16 Coalmine View
Portola Valley, CA 94028
(415) 851-0535

CAREER SUMMARY:

- Strong entrepreneurial experience in startup companies and within large corporations.
- Over twenty-five years experience creating and directing product development leading to many hundreds of millions of dollars of highly profitable new business.
- Successful market explorations leading to new applications for proprietary technologies, thus defining new business opportunities.
- Broad career in a wide range of products and technologies, directing manufacturing, marketing, and development.

PROFESSIONAL HISTORY:

1991 - present Vice President, Product Development, Hospital Business Group (1995 - present)
Nellcor Puritan Bennett Incorporated, Pleasanton, CA

- Currently directing the product development for the \$500-million Hospital Business Group including sensors, monitors, ventilators, and OEM products (200 people at four sites)
- Led the integration team that merged the \$100-million Bennett Division into Hospital Group, including R&D, marketing, and manufacturing. Was responsible for site and personnel consolidation decisions and organizational structure recommendations.
- Directed the integration of Infrasonics, Inc., a \$25-million ventilator company, into the Hospital Group.
- Set new, aggressive time-to-market, schedule adherence, and COGS targets for all Hospital development projects, while reducing direct R&D expenses from 6% to 4%.

Vice President and General Manager, Sensors and Monitoring Systems Division (1994 - 1995)

- Managed product development and manufacturing for the \$250-million patient monitoring and accessories division.
- Focused renewed executive interest in manufacturing strategy including disaster recovery plans, inventory control, and performance metrics.
- Strengthened interaction between manufacturing and development to ensure that both rapid time-to-market and manufacturability goals were met.

Senior Technical Director, Sensor and OEM Division (1991 - 1994)

- Created product development strategy for new division. Redirected the existing sensor development team to focus on a few projects of significant impact to business.
- Directed the performance upgrade of the major sensor product line (\$150 million business), while introducing four new products.
- Established a research group to develop new optoelectronic-based sensors and fiber-optic based products.
- Was responsible for OEM electronic module product development including hardware and software development
- Directed a technical team of 40 engineers, scientists, and technicians in electronic hardware, software, optoelectronics, mechanical design, and chemistry.

EXHIBIT A

LEE M. MIDDLEMAN, PhD, page 2

1985 - 1991

General Manager, Medical Ventures (1989 - 1991)
Raychem Corporation, Menlo Park, CA

- Performed an in-depth analysis of the medical device markets. Identified Raychem technologies that could impact trends in these markets.
- Created the business plan for entry into the surgical instrument market. For cash flow reasons, Raychem licensed the technology and patents to a major medical company.
- Disclosed twenty-four inventions using Raychem technologies. Awarded seven patents. Additional patent applications were filed.
- Directed an engineering team to design and construct prototypes for animal and clinical trials.

Director of Technologies, Corporate Technology Division (1985 - 1989)

- Directed the departments performing materials research and product development in three key Raychem technologies: conductive polymers, electronic ceramics, and optical materials.
- Performed technical assessment of technologies and projects of potential acquisition candidates.
- Established and led the optical-fiber program in direct support of a major, new, internal venture.

1983 - 1985

Vice President, Research and Development
Taliq Corporation, Mountain View, CA

- Led a technical effort which took a new, liquid-crystal display from laboratory demo to a characterized materials technology with demonstrated reliability and environmental stability.
- Attracted and hired a strong technical team for this new corporation to perform hardware and software development, materials and process development, and manufacturing engineering. Managed the prototype manufacturing.
- Performed exploratory marketing for light-shutter applications of this technology.

1976 - 1983

Director of Technologies, Corporate Technology Division (1982-1983),
Raychem Corporation, Menlo Park, CA

- Directed research and development in the three major technologies of the corporation with a staff of 90 scientists and engineers.
- Produced and implemented the strategic plan for mature and new technologies. Strengthened the program by focusing resources on the most promising projects: conductive polymers, electrochemistry, and elastic-memory polymers.

Technical Director, Corporate Technology Division (1980 - 1982)

- Provided technical leadership and general management to 35 scientists and engineers in a major, proprietary electronic materials technology, conductive polymer composites.
- Created a new department to develop in-house capability in computer-aided design, product/materials modeling, and electronics system design.

LEE M. MIDDLEMAN, PhD, page 3

Department Manager, PolySwitch® Program (1978 - 1980)

- Conceived and reduced to practice a unique electronic switch for overload protection of low-voltage circuits. Was awarded 5 basic US patents on products developed.
- Built and directed the successful PolySwitch product development and manufacturing engineering team (15 people).
- Working with marketing and sales teams, created a business plan and performed market research leading to the launching of a new product division (\$400-million sales, 1997).

1970 - 1976

Vice President and Co-founder

Nuclear Semiconductor, Inc., Mountain View, CA (now a division of Thermo Instruments.)

- Co-founded Nuclear Semiconductor, Inc., in 1970 to develop ultra-high-performance semiconductor radiation detectors. Made the key technical contributions. Directed the technical development. Established research laboratories and manufacturing facilities.
- Directed the successful introduction of state-of-the-art products including X-ray fluorescence analyzers and accessories for use in materials analysis (\$3-million sales, 1976).

PATENTS AND

PUBLICATIONS:

Twenty one US patents granted; four additional US patent applications and many foreign patent applications filed. Fifteen publications.

EDUCATION:

PhD Physics, Stanford University, Stanford, California
Woodrow Wilson Fellow, National Science Foundation Fellow
BA Physics, Johns Hopkins University, Baltimore, Maryland

LEE M. MIDDLEMAN

PATENTS:

- US 3,963,922 "X-Ray Fluorescence Device," June 15, 1976
- US 4,238,812 "Circuit Protection Devices Comprising PTC Elements," December 9, 1980
- US 4,276,466 "Heater with Distributed Heater Element," June 30, 1981
- US 4,315,237 "PTC Devices Comprising Oxygen Barrier Layers," February 9, 1982
- US 4,317,027 "Circuit Protection Devices," February 23, 1982
- US 4,329,726 "Circuit Protection Devices Comprising PTC Elements," May 11, 1982
- US 4,352,083 "Circuit Protection Devices," September 28, 1982
- US 4,379,220 "Method of Heating Liquid," April 5, 1983
- US 4,413,301 "Circuit Protection Devices Comprising PTC Elements," November 1, 1983
- US 4,450,496 "Protection of Certain Electrical Systems by Use of PTC Devices," May 22, 1984
- US 4,475,138 "Circuit Protection Devices Comprising PTC Element," October 2, 1984
- US 4,904,850 "Laminar Electrical Heaters," February 27, 1990
- US 5,002,563 "Sutures Utilizing Shape Memory Alloys," March 26, 1991
- US 5,231,989 "Steerable Cannula," August 3, 1993
- US 5,345,937 "Steerable Cannula," September 13, 1994
- US 5,469,845 "Disposable Pulse Oximeter Sensor," November 28, 1995
- US 5,486,183 "Device or Apparatus for Manipulating Matter," January 23, 1996
- US 5,509,923 "Device for Dissecting, Grasping, or Cutting an Object," April 23, 1996
- US 5,601,572 "Device or Apparatus for Manipulating Matter Having an Elastic Ring Clip,"
February 11, 1997
- US 5,632,746 "Device or Apparatus for Manipulating Matter," May 27, 1997
- US 5,678,544 "Disposable Pulse Oximeter Sensor," October 21, 1997

One additional patent allowed. Many foreign filings.

Five new patent applications awaiting examination.

LEE M. MIDDLEMAN

PUBLICATIONS:

"Electron-Induced Fission in U-238, Bi-209 and Ta-181", H. R. Bowman, *et al*, The Physical Review, 168, 4, pp. 1396-1398 (1968).

"Electron and Bremsstrahlung Induced Fission of Heavy and Medium Heavy Nuclei", L. G. Moretto, *et al*, The Physical Review, 179, 4, pp. 1176-1187 (1969).

"Linearity and Resolution of Semiconductor Radiation Detectors", H. R. Zulliger, D. W. Aitken, and L. M. Middleman, IEEE Trans. Nucl. Sci., NS-16, 47 (1969).

"Measurement of Cross Section for X-Ray Production by High-Energy Electrons", L. M. Middleman, R. L. Ford, and R. Hofstadter, The Physical Review, 2, 4, pp. 1429-14443 (1970).

"Properties of Ion-Implanted Silicon Detectors", H.R. Zulliger, W. E. Drummond and L. M. Middleman, IEEE Trans. Nucl. Sci., NS-19, 3 (1972).

"Trace Element Analysis in Specimens Using an Energy Dispersive Spectrometer Mounted on a Scanning Electron Microscope", L. M. Middleman and J. D. Geller, Scanning Electron Microscope/1976, O. Johari (ed.) (1976).

"Conductive Polymer Composites and Their Application in Current Control Devices", L. M. Middleman, invited paper, XII Colloque National, Groupe Francais des Polymeres, November 22-24, 1982, Montpellier, France.

"Electron Transport Processes in Conductive-Filled Polymers", R. D. Sherman, L. M. Middleman, and S. M. Jacobs, Polymer Engineering and Science, 23, No. 1, pp. 36-43 (1983).

"Static Fatigue of Optical Fibers in Bending", D. Roberts, E. Cuellar, L. M. Middleman, and J. Zucker, SPIE Symposium on Optoelectronics and Fiber Optics Applications in Science and Engineering, Cambridge, Massachusetts, September 21-26, 1986.

"Effect of Buffer Coating on Static Fatigue of Optical Fibers in Bending", E. Cuellar, D. Roberts, and L. M. Middleman, Optical Fiber Communication/International Optics and Optical Fiber Communication Conference (OFC/IOOC'87), Reno, Nevada, January 19-22, 1987.

PUBLICATIONS (cont'd):

"Static Fatigue Lifetime of Optical Fibers in Bending", E. Cuellar, D. Roberts, and L. M. Middleman, Annual Military Fiber Optics and Communications Conference, Washington, D.C., March 16-19, 1987.

"Bimodal Flaw Distribution in Optical Fiber and its Effect on Static Fatigue", D. Roberts, E. Cuellar, L. M. Middleman, D. Nelson, and J. Ritter, Annual Meeting of the American Ceramic Society, Pittsburgh, PA., April 26-30, 1987.

"Static Fatigue of Optical Fibers in Bending. II Effect of Humidity and Proof Stress of Static Fatigue Lifetimes", D. Roberts, E. Cuellar, and L. M. Middleman, SPIE Symposium on Fiber Optics and Integrated Optoelectronics (SPIE's O-E/Fibers '87), San Diego, CA., August 16-21, 1987.

"Improvements in Optical Fiber Reliability via High Fatigue Resistant Composition", S. T. Gulati, J. D. Helfinstine, and G. S. Glaesemann (Corning Glass Works) and D. R. Roberts, E. Cuellar, and L. M. Middleman, SPIE Symposium on Fiber Optics and Integrated Optoelectronics (SPIE's O-E/Fibers), San Diego, CA., August 16-21, 1987.

"Design Requirements for Optical Fiber in Bending", D. R. Roberts, E. Cuellar, and L. Middleman, SPIE Proceedings of Fiber Optics Reliability: Benign and Adverse Environments III, Boston, MA., September 5-7, 1989.

DEVICE IN MIDDLEMAN PATENT NUMBER 5,231,989

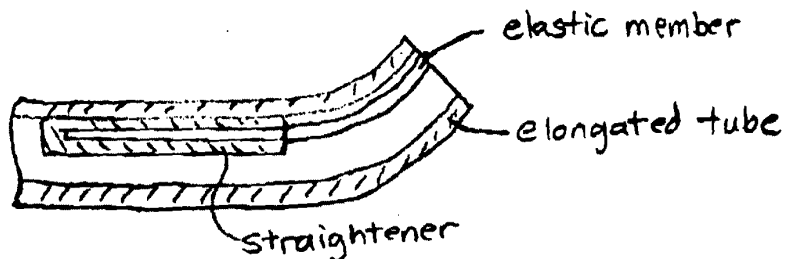
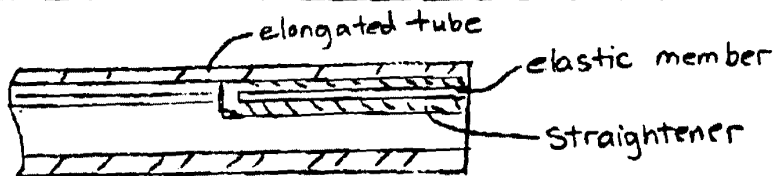

DEVICE IN JERVIS PATENT APPLICATION

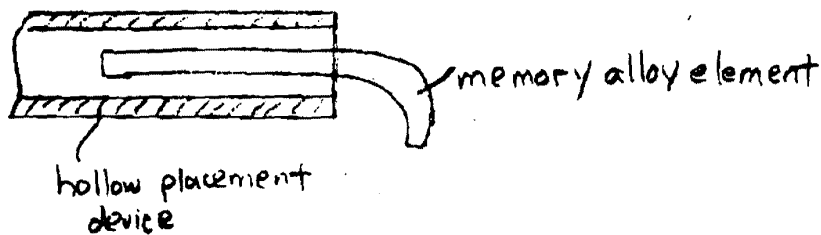
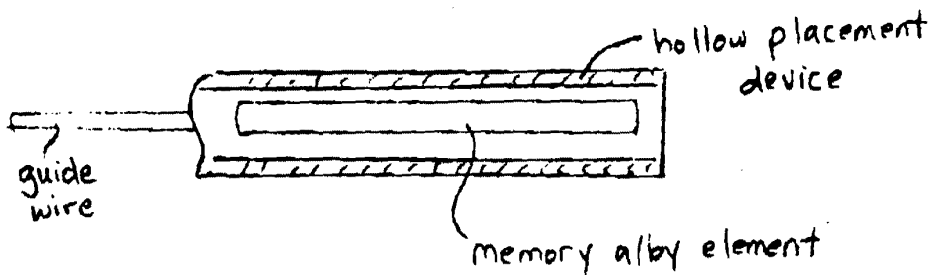

Exhibit
B



AELGAU 3301 \$

PATENT
9438-1

IN THE UNITED STATES PATENT AND TRADEMARK OFFICE

PRT of #B

In re application of: JAMES E. JERVIS
Serial No.: 08/483,291
Filed: June 7, 1995
For: **MEDICAL DEVICES
INCORPORATING SIM ALLOY
ELEMENTS**

Examiner: Justine Yu
Group Art Unit: 3301

RECEIVED
MAR 31 1998
GROUP 3200

TRANSMITTAL LETTER

BOX AF
Assistant Commissioner for Patents
Washington, D. C. 20231

Dear Sir:

Transmitted herewith are the following documents:

- (1) an Amendment in response to the Office Action, Paper No. 11, mailed September 18, 1997;
- (2) a Declaration of Dr. Lee Middleman under 37 C.F.R. §1.132;
- (3) a Petition for a Three (3) Month Extension of Time to respond to the Office Action, pursuant to 37 C.F.R. §1.136(a), extending the period for response from December 18, 1997 to March 18, 1998;
- (4) a petition fee in the amount of \$950.00, check number 8530, to cover the Petition for a Three-Month Extension of Time;
- (5) a Conditional Notice of Appeal;

33/ES/1230 WILLIAM 0000027 00483291
01 FEB 17 950.00 OP
02 FEB 19 310.00 OP

- (6) a fee to cover the Conditional Notice of Appeal in the amount of \$310.00, check number 8532;
- (7) an Associate Power of Attorney;
- (8) a Certificate of Express Mailing; and,
- (9) a return receipt postcard.

The Commissioner is hereby authorized to charge payment of any additional fees associated with this communication, if such fees are due, to Deposit Account No. 19-2090.

Respectfully submitted,
SHELDON & MAK

Date: March 18, 1998

By: Karin E. Peterka
Karin E. Peterka
Reg. No. 35,976

Karin E. Peterka, Esq.
SHELDON & MAK
225 South Lake Avenue, Suite 900
Pasadena, California 91101
Tel.: (626) 796-4000
Fax: (626) 795-6321

EXPRESS MAIL mailing label no. EM262828897US
Date of Deposit March 18, 1998
I hereby certify that this paper is being deposited with the United States Postal Service "Express Mail Post Office to Addressee" service under 37 C.F.R. § 1.10 on the date indicated above and is addressed to the BOX AF, Assistant Commissioner For Patents, Washington, D.C. 20231

Sandra Spencer
Sandra Spencer



IN THE UNITED STATES PATENT AND TRADEMARK OFFICE

PATENT
9438-1

4-14-98

#14

In re application of: JAMES E. JERVIS

Examiner: Justine Yu

Serial No.: 08/483,291

Group Art Unit: 3301

Filed: June 7, 1995

For: **MEDICAL DEVICES INCORPORATING
SIM ALLOY ELEMENTS**

CONDITIONAL NOTICE OF APPEAL

BOX AF
Assistant Commissioner for Patents
Washington, D. C. 20231

Sir:

Applicant conditionally appeals to the Board of Patent Appeals and Interferences to the Board of Patent Appeals and Interferences from the final rejection set forth in the Office Action, Paper Number 11, mailed September 18, 1997.

This Appeal should be entered only if the accompanying Response does not place the subject application in condition for allowance.

PATENT
9438-1

Enclosed is the required \$310.00 (large entity) fee, check number 8532, for filing this Notice of Appeal. The Commissioner is hereby authorized to charge payment of any additional fees associated with this communication or credit any overpayment to Deposit Account No. 19-2090.

This Notice is submitted in triplicate.

Respectfully submitted,

SHELDON & MAK

March 18, 1998
Date

By: Karin E. Peterka
Karin E. Peterka
Reg. No. 35,976

Karin E. Peterka, Esq.
SHELDON & MAK
225 South Lake Avenue, Suite 900
Pasadena, California 91101
Tel.: (626) 796-4000
Fax: (626) 795-6321

EXPRESS MAIL mailing label no. EM262828897US
Date of Deposit March 18, 1998
I hereby certify that this paper is being deposited with the United States Postal Service "Express Mail Post Office to Addressee" service under 37 C.F.R. § 1.10 on the date indicated above and is addressed to the BOX AF, Assistant Commissioner For Patents, Washington, D.C. 20231

Sandra Spencer
Sandra Spencer



PATENT
9438-1

SM
4-14-95

IN THE UNITED STATES PATENT AND TRADEMARK OFFICE

In re application of: JAMES E. JERVIS

Examiner: Justine Yu

Serial No.: 08/483,291

Group Art Unit: 3301

Filed: June 7, 1995

For: **MEDICAL DEVICES
INCORPORATING SIM ALLOY
ELEMENTS**

#15

ASSOCIATE POWER OF ATTORNEY

BOX AF
Assistant Commissioner for Patents
Washington, D. C. 20231

Sir:

Please recognize Karin E. Peterka, Reg. No. 35,976, of Sheldon & Mak, 225 South Lake Avenue, 9th Floor, Pasadena, California 91101, as associate attorney with power to inspect and copy the record of the above-identified application and to make corrections and additions thereto.

Please continue to address all communications to: Sheldon & Mak, 225 South Lake Avenue, 9th Floor, Pasadena, California 91101-3021, ATTN: Jeffrey G. Sheldon. Please direct all telephone calls to Jeffrey G. Sheldon at (626) 796-4000.

Date: February 13, 1998

By: *Jeffrey G. Sheldon*
Jeffrey G. Sheldon
Reg. No. 25,953



SM

PATENT
9438-1

IN THE UNITED STATES PATENT AND TRADEMARK OFFICE

4-14-98

In re application of: JAMES E. JERVIS
Serial No.: 08/483,291
Filed: June 7, 1995
For: **MEDICAL DEVICES
INCORPORATING SIM ALLOY
ELEMENTS**

Examiner: Justine Yu
Group Art Unit: 3301

#12
Ext
3mos

**PETITION FOR THREE-MONTH EXTENSION OF TIME
UNDER 37 C.F.R. §1.136(a)**

BOX AF
Assistant Commissioner for Patents
Washington, D. C. 20231

Sir:

Applicant hereby petitions, pursuant to 37 C.F.R. §1.136(a), for a three (3) month extension of time to respond to the Office Action, Paper No. 11, mailed September 18, 1997. The period for response was previously set to elapse December 18, 1997, and is accordingly hereby extended to March 18, 1998, which is still within the six-month statutory period for response.

Applicants' Response to the Office Action mailed September 18, 1997, is submitted herewith.

Also submitted is the petition fee in the amount of \$950.00, check number 8530, to cover this Petition for a Three-Month Extension of Time. The entity is a large entity.

PATENT
9438-1

The Commissioner is hereby authorized to charge payment of any additional fees associated with this communication, if such fees are due, to Deposit Account No. 19-2090.

Respectfully submitted,
SHELDON & MAK

Date: March 18, 1998

By: Karin E. Peterka
Karin E. Peterka
Reg. No. 35,976

Karin E. Peterka, Esq.
SHELDON & MAK
225 South Lake Avenue, Suite 900
Pasadena, California 91101
Tel.: (626) 796-4000
Fax: (626) 795-6321

EXPRESS MAIL mailing label no. EM262828897US
Date of Deposit March 18, 1998
I hereby certify that this paper is being deposited with the United States Postal Service "Express Mail Post Office to Addressee" service under 37 C.F.R. § 1.10 on the date indicated above and is addressed to the BOX AF, Assistant Commissioner For Patents, Washington, D.C. 20231

Sandra Spencer
Sandra Spencer



UNITED STATES DEPARTMENT OF COMMERCE
Patent and Trademark Office

Address: COMMISSIONER OF PATENTS AND TRADEMARKS
Washington, D.C. 20231

08/483291

SERIAL NUMBER	FILING DATE	FIRST NAMED APPLICANT	J	ATTORNEY DOCKET NO.
08/483,291	06/07/95	JERVIS	J	9438-1

JEFFREY G SHELDON
SHELDON & MAK
225 SOUTH LAKE AVENUE SUITE 900
PASADENA CA 91101

GM41/0423

EXAMINER	
YU, J	
ART UNIT	PAPER NUMBER
3733	16

DATE MAILED: 04/23/98

Below is a communication from the EXAMINER in charge of this application
COMMISSIONER OF PATENTS AND TRADEMARKS

ADVISORY ACTION

THE PERIOD FOR RESPONSE:

- is extended to run _____ from the date of the Final Rejection
- continues to run _____ from the date of the Final Rejection
- expires three months from the date of the final rejection or as of the mailing date of this Advisory Action, whichever is later. In no event however, will the statutory period for response expire later than six months from the date of the final rejection.

Any extension of time must be obtained by filing a petition under 37 CFR 1.136(a), the proposed response and the appropriate fee. The date on which the response, the petition, and the fee have been filed is the date of the response and also the date for the purposes of determining the period of extension and the corresponding amount of the fee. Any extension fee pursuant to 37 CFR 1.137 will be calculated from the date that the shortened statutory period for response expires as set forth above.

Appellant's Brief is due in accordance with 37 CFR 1.192(a).

Appellant's response to the final rejection, filed _____, has been considered with the following affect, but it is not deemed to place the application in condition for allowance:

1. The proposed amendments to the claim and/or specification will not be entered and the final rejection stands because:
 - a. There is no convincing showing under 37 CFR 1.116(b) why the proposed amendment is necessary and was not earlier presented.
 - b. They raise new issues that would require further consideration and/or search. (See Note).
 - c. They raise the issue of new matter. (See Note).
 - d. They are not deemed to place the application in better form for appeal by materially reducing or simplifying the issues for appeal.
 - e. They present additional claims without cancelling a corresponding number of finally rejected claims.

NOTE: _____

2. Newly proposed or amended claims _____ would be allowed if submitted in a separately filed amendment cancelling the non-allowable claims.

3. Upon the filing of an appeal, _____ the status of the claims in this application would be as follows:

Allowed claims: _____
 Claims objected to: _____
 Claims rejected: 21, 23, and 25-46

However:

- a. The rejection of claims _____ on references is deemed to be overcome by applicant's response.
- b. The rejection of claims _____ on non-reference grounds only is deemed to be overcome by applicant's response.

4. The affidavit, exhibit or request for reconsideration has been considered but does not overcome the rejection.

5. The affidavit or exhibit will not be considered because applicant has not shown good and sufficient reasons why it was not earlier presented.

The proposed drawing correction has has not been approved by the examiner.

Other *The final rejection remains applicable. The Declaration is unconvincing since the Sender disclosure reaches usage in the medical device field and at body heat (pg. 733) - disclosure of which the Declaration did not directly address.*

[Signature]
Richard J. Adams



6-25-98

PATENT
Attorney Docket Number 9438-1

IN THE UNITED STATES PATENT AND TRADEMARK OFFICE

In re application of: JAMES E. JERVIS
Serial No.: 08/483,291
Filed: June 7, 1995
For: **MEDICAL DEVICES
INCORPORATING SIM ALLOY
ELEMENTS**

Examiner: Justine Yu
Group Art Unit: 3733

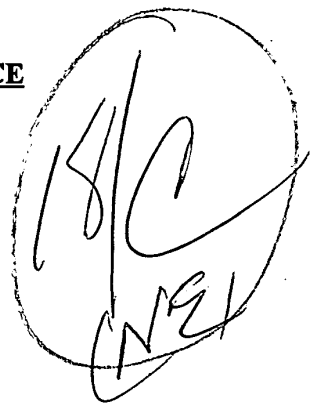

AMENDMENT AFTER FINAL

BOX AF
Assistant Commissioner for Patents
Washington, D. C. 20231

RECEIVED
JUN 23 1998

GROUP 3200

Sir:

This Amendment after the final rejection is submitted concurrently with Applicant's Appeal Brief for the above-identified patent application. Applicant respectfully requests that the following amendments to the claims be entered:

IN THE CLAIMS:

Please cancel claims 39 and 43, without prejudice.

In claim 42, after the word "claims," please delete the number "21."

REMARKS

Applicant submits this Amendment after the final rejection of the claims to cancel dependent claims 39 and 43, and to amend dependent claim 42 to delete the dependency from claim 21. Upon a further review of the claims appealed from the final rejection, Applicant noted that claim 39 depended from a cancelled claim 11, and claim 43 depended from claim 39. Thus, Applicant wishes to delete dependent claims 39 and 43 from the application and withdraw the appeal with respect to dependent claims 39 and 43. Further, Applicant noted that dependent claim 42 incorrectly depended from claim 21 and wishes to amend claim 42 to delete the dependency from claim 21. No new matter has been added with these amendments to the claims. Applicant respectfully requests the entry of these claim amendments by the Examiner.

The Commissioner is hereby authorized to charge payment of any additional fees associated with this communication, if such fees are due, to Deposit Account No. 19-2090.

Respectfully submitted,

SHELDON & MAK

June 18, 1998
Date

By: Karin E. Peterka
Karin E. Peterka
Reg. No. 35,976

225 South Lake Avenue
9th Floor
Pasadena, California 91101
Phone: (626) 796-4000
Facsimile: (626) 795-6321

EXPRESS MAIL, mailing label no. EL057219663US
Date of Deposit: June 18, 1998

I hereby certify that this paper is being deposited with the United States Postal Service "Express Mail Post Office to Addressee" under 37 C.F.R. § 1.10 on the date indicated above and is addressed to:
Box AF, Assistant Commissioner for Patents, Washington, DC 20231

Sandra Spencer
Sandra Spencer



PATENT
Attorney Docket Number 9438-1

IN THE UNITED STATES PATENT AND TRADEMARK OFFICE

6-25-98
#19

In re application of: JAMES E. JERVIS
Serial No.: 08/483,291
Filed: June 7, 1995
For: **MEDICAL DEVICES
INCORPORATING SIM ALLOY
ELEMENTS**

Examiner: Justine Yu
Group Art Unit: 3733

APPEAL BRIEF SUBMITTED UNDER 37 C.F.R. §1.192

BOX AF
Assistant Commissioner for Patents
Washington, D. C. 20231

RECEIVED

JUN 23 1998

GROUP 3200

Sir:

Applicant submits this brief in connection with the appeal from the final rejection mailed

September 18, 1997, in the above-identified application. Pursuant to the Notice of Appeal mailed

06/22/1998 SSALLEEKU 00000104 08483291

01 FC:120 March 18, 1998, Applicant seeks reversal by the Board of the Examiner's final rejection of the claims.



TABLE OF CONTENTS

	<u>Page No.</u>
I. INTRODUCTION.....	1
II. THE REAL PARTY IN INTEREST.....	3
III. RELATED APPEALS AND INTERFERENCES.....	3
IV. STATUS OF THE CLAIMS.....	3
V. STATUS OF AMENDMENTS.....	4
VI. SUMMARY OF THE INVENTION.....	4
A. Problems With The Prior Art.....	4
B. The Present Invention.....	7
C. The Present Invention Solves The Problems Of The Prior Art.....	12
VII. ISSUES.....	13
VIII. GROUPING OF THE CLAIMS.....	14
IX. ARGUMENT.....	15
A. The Rejection of Claims 21, 23, 25, and 26-46, Under U.S.C. §103(a), Over U.S. Patent No. 4,512,338 to Balko et al., in View of Seader (Encyclopedia of Chemical Technology publication), and U.S. Patent No. 4,485,805 to Foster, Jr. Should Be Reversed	15
1. The Prior Art	15
a. Balko, et al.	15
b. Seader	16
c. Foster, Jr.	16

2.	The Examiner Has Failed To Establish A Prima Facie Case Of Obviousness.....	16
a.	The Proposed Combination Of References Does Not Produce Applicant's Claimed Invention.....	17
b.	There Is No Teaching Or Suggestion In The Cited References For The Proposed Combination.....	20
c.	The Group 2 Claims Are Independently Patentable.....	23
3.	The Examiner Has Misedevaluated The Prior Art Against Applicant's Claimed Invention.....	23
4.	The Examiner Did Not Give Proper Weight To The Expert Declaration Of Dr. Lee Middleman.....	26
B.	The Obviousness-Type Double Patenting Rejection Of Claims 21 and 23, Over Claims 1 and 2 of U.S. Patent No. 5,231,989 to Middleman et al. Should Be Reversed.....	27
C.	The Rejection Of Claims 21 And 23, Under 35 U.S.C. §102(e), Or In The Alternative, Under 35 U.S.C. §103(a), Over U.S. Patent No. 5,231,989 To Middleman et al. Should Be Reversed.....	31
X.	CONCLUSION.....	32

APPENDICES

Appendix A	The Claims On Appeal.....	33
Appendix B	Related Jervis Patents.....	34
1.	U.S. Patent No. 5,597,378 to Jervis	
2.	U.S. Patent No. 5,190,546 to Jervis	
3.	U.S. Patent No. 5,067,957 to Jervis	
4.	U.S. Patent No. 4,665,906 to Jervis	
Appendix C	Declaration Of Dr. Lee Middleman.....	35



I. INTRODUCTION

This appeal is taken from the final rejection of September 18, 1997, of claims 21, 23, and 25-46. The claims on appeal are presented in **Appendix A** attached hereto.

Remarkably, many of the appealed claims are narrower than claims in patents already issued by different Examiners in substantially the same art. It is apparent that this particular Examiner has a standard of patentability different than that mandated by 35 U.S.C. §103 and followed by other Examiners in the U.S. Patent and Trademark Office.

The application on appeal is a continuation of Application Serial No. 07/956,653, filed on October 2, 1992, now U.S. Patent No. 5,597,378 (attached hereto in **Appendix B**), which is a divisional of Application Serial No. 07/682,243, filed on April 9, 1991, now U.S. Patent No. 5,190,546 (attached hereto in **Appendix B**), which is a divisional of Application Serial No. 07/252,019, filed on September 27, 1988, now U.S. Patent No. 5,067,957 (attached hereto in **Appendix B**), which is a continuation of Application Serial No. 07/177,817, filed on March 30, 1988, now abandoned, which is a continuation of Application Serial No. 07/047,824, filed on May 8, 1987, now abandoned, which is a continuation of Application Serial No. 06/865,703, filed on May 21, 1986, now U.S. Patent No. 4,665,906 (attached hereto in **Appendix B**), which is a continuation of Application Serial No. 06/541,852, filed on October 14, 1983, now abandoned.

Applicant respectfully requests that the Board reverse the Examiner's rejection of the claims on appeal for the following reasons:

1. The Examiner erred in rejecting the claims on appeal under 35 U.S.C. §103(a), because the Examiner failed to establish a prima facie case of obviousness, misevaluated the references cited against Applicant's claimed invention, and did not

give proper weight to the expert declaration of Dr. Lee Middleman (attached hereto in **Appendix C**).¹

2. The Examiner erred in rejecting claims 21 and 23 for obviousness-type double patenting over claims 1 and 2 of U.S. Patent No. 5,231,989 to Middleman et al., because the device claimed in the U.S. Patent No. 5,231,989 patent covers a very different invention than the device of Applicant's claims 21 and 23, and because claims 1 and 2 of U.S. Patent No. 5,231,989 were previously found to be nonobvious by the U.S. Patent Office over the earlier U.S. Patent No. 4,665,906 to Jarvis (attached hereto in **Appendix B**). U.S. Patent No. 4,665,906 is the grandparent case of the present application and has essentially the same disclosure as the disclosure of the present application.
3. The Examiner erred in rejecting claims 21 and 23 under 35 U.S.C. §102(e), or in the alternative, under 35 U.S.C. §103(a), over U.S. Patent No. 5,231,989 to Middleman et al., because U.S. Patent No. 5,231,989 does not qualify as prior art under 35 U.S.C. §102(e), and because the device claimed in U.S. Patent No. 5,231,989 covers a very different invention than the device of Applicant's claims 21 and 23.

¹ Dr. Lee Middleman is an expert in material use and selection of materials for medical devices, and is the inventor of U.S. Patent No. 5,231,989, issued on August 3, 1993, entitled "Steerable Cannula," which was cited as prior art in the final office action of December 18, 1998.

II. THE REAL PARTY IN INTEREST

This application was assigned to Medtronic, Inc., by an assignment dated October 4, 1996, and recorded in the United States Patent and Trademark Office at Reel/Frame 8907/0388.

III. RELATED APPEALS AND INTERFERENCES

To the Applicant's and undersigned's knowledge, there are no related appeals or interferences which will directly affect or be directly affected by or have a bearing on the Board's decision in the pending appeal.

IV. STATUS OF CLAIMS

This appeal is taken from the final rejection of September 18, 1997, finally rejecting pending claims 21, 23, and 25-46. Applicant withdraws the appeal with respect to dependent claims 39 and 43, and concurrent with the filing of this appeal brief, Applicant submits an amendment subsequent to the final rejection which cancels dependent claims 39 and 43, without prejudice, and which amends dependent claim 42. Applicant wishes to cancel claims 39 and 43 because claim 39 inadvertently depends from cancelled claim 11, and claim 43 depends from claim 39. Applicant wishes to amend dependent claim 42 to delete the incorrect dependency from claim 21. No new matter has been added with these amendments to the claims. Claims 1-20, 22, and 24 were previously cancelled, without prejudice. The claims on appeal are presented in **Appendix A** attached hereto.

V. STATUS OF AMENDMENTS

Claims 21, 23, and 25-46 were finally rejected in the office action dated September 18, 1997. A response to the final office action and conditional notice of appeal were submitted to the United States Patent Office on March 18, 1998. This response to the final office action included the Declaration of Dr. Lee Middleman (attached hereto in **Appendix C**). The advisory action dated April 23, 1998, stated that the final rejection remained applicable. All amendments filed prior to the final rejection have been entered by the Examiner.

Concurrent with the filing of this appeal brief, Applicant submits an amendment subsequent to the final rejection, which cancels dependent claims 39 and 43, without prejudice, and amends dependent claim 42 in this application for the reasons discussed above. This amendment after final rejection submitted herewith has not yet been acted upon by the Examiner.

VI. SUMMARY OF THE INVENTION

A. Problems With The Prior Art

Prior to the present invention, shape memory alloys had been known to be used in medical devices. However, the use of shape memory alloys in medical applications presented significant problems which greatly limited the use

1. Difficult To Control Transformation Temperature

It is difficult to control the transformation temperatures of shape memory alloys with accuracy as they are usually extremely composition-sensitive (see specification, pg. 4, lines 22-24). For example, tubular stent grafts are typically deployed remotely into the body via a catheter. However,

the stent graft tends to take on the temperature of the body during the procedure as the physician maneuvers the device into the correct position for deployment. The difficulty of controlling the transformation temperature accurately for the shape memory alloy material in this procedure is evident. It has proved necessary to cool the stent during insertion into the body and to heat the stent after insertion, and these steps add complexity to an already complex procedure (see generally, specification, pg. 17, lines 24-28).

2. Large Hysteresis Hinders Reversibility Of Shape

In many known shape memory alloys there is a large hysteresis as the alloy is transformed between austenitic and martensitic states, so that reversing of the state of a shape memory alloy element may require a temperature change of several tens of degrees Celsius (see specification, pg. 4, line 28 to pg. 5, line 4).

3. Temperature Change Is Required To Effect A Change In Shape

Known shape memory alloys require a temperature change to effect a change in shape, and such temperature change is typically achieved by relying on body heat alone or by using external heating sources to heat the shape memory alloy. Not only is it inconvenient to have to engage in any temperature manipulation, but human tissue cannot be heated or cooled beyond certain relatively narrow limits (approximately 0 degrees Celsius to 60 degrees Celsius for short periods) without suffering temporary or permanent damage (see specification, pg. 5, lines 4-11). Moreover, as stated by Dr. Middleman (Appendix C), if a doctor relies solely on body heat to heat a shape memory alloy,

this slows up the surgical procedure.² It is well known to one skilled in the art that the longer a patient is on the operating table, the greater the chance of complications that may result from an operation. In addition, if a doctor relies upon an external heating source, such as electric heating, to heat a shape memory alloy, there is the potential for electrical shock or an electric burn to a patient (see Footnote 2, and Middleman Decl., ¶14).

4. Treatment Process Required To Exhibit Properties Of SIM Material

In order for certain known shape memory alloys, such as the nitinol disclosed in the Seader reference cited by the Examiner, to exhibit properties of a stress-induced martensite (SIM) material, such shape memory alloys must undergo an extensive, time consuming, and expensive treatment process.³ Moreover, for a shape memory alloy, such as nitinol, to be effective in a medical device,

² "...for the Balko device, a doctor has to rely on heating the nitinol for it to work. If the doctor relies solely on body heating, this slows up the surgical procedure. Needless to say, anything that slows up a medical procedure is undesirable in that the chance for infection and the chance for adverse patient reactions increase as the length of a medical procedure increases. Also, a device that relies on body heating to change shape exhibits inconsistent performance because of the dependence on heating by the body, which rate of heating can differ from patient-to-patient and from operating room to operating room. I know from personal experience with sutures made of SMA materials that inconsistent heating made the sutures difficult to use in an operating room. If the doctor has to rely on heating the nitinol by means of an external heating source, an additional step is added to the procedure and the possibility of overheating and injury is increased. If electric heating is used, there is a potential for electrical shock or an electric burn to the patient." Middleman Decl., ¶14.

³ "...Although nitinol can exhibit the properties of an SIM material, it can do so only if it undergoes a treatment process to make it exhibit the properties of an SIM material. This process requires an extensive, time consuming, and expensive procedure..." Middleman Decl., ¶11.

the SIM behavior must be exhibited at a temperature which a mammalian body can tolerate, which is typically about 35 degrees Celsius to 40 degrees Celsius.⁴

B. The Present Invention

Applicant's basic invention is to use a special class of materials in medical devices so that a change in shape is realized without a change in temperature being required. In particular, the medical device of Applicant's invention comprises a shape memory element made of a stress induced martensite (SIM) material that is held in a deformed configuration by a restraint (see specification, pg. 5, lines 25-31). Removal of the restraint results in the shape memory alloy element changing shape towards its non-deformed configuration. The shape memory alloy of the present invention has the ability to return to its original shape after substantial deformation and does not require the delicacy of alloying control and/or the temperature control of placement or removal needed by prior art shape memory alloy devices (see specification, pg. 5, lines 13-17).

For this basic invention, Applicant has already been awarded the following four U.S. patents (attached herewith in **Appendix B**), which contain various claims broader than the claims presented in this appeal:

⁴ "...Nitinol can be treated to exhibit SIM properties in selected temperature ranges as low as 0 degrees Celsius or as high as 60 degrees Celsius. For the nitinol to be effective in a medical device, the SIM behavior must be exhibited at temperatures which a mammalian body can tolerate (typically 35 degrees Celsius to 40 degrees Celsius)..." Middleman Decl. ¶12.

1. U.S. Patent No. 5,597,378 - Claims 1 and 10 are broader than the claims on appeal.⁵

The claims on appeal are the result of a species election requirement in the parent application, and in particular, claims 26, 27, 28, 29, 30, 31, and 32, on appeal, correspond to and are generally narrower versions of claims 1, 2, 3, 7, 8, 9, and 10, respectively, that were allowed in U.S. Patent No. 5, 597,378.

-
- ⁵ 1. A medical device which comprises:

(a) an element for use within a human body or in such proximity to a human body that the device is substantially at human body temperature, the element comprising a shape memory alloy which displays a stress-induced martensite behavior at body temperature; and

(b) a restraint holding the shape memory alloy element in a deformed configuration at a temperature less than the body temperature of the human for positioning the shape memory alloy element within or in proximity to the human body in its deformed configuration, the deformation occurring through the formation of stress-induced martensite;

wherein the shape memory alloy element is sufficiently deformed that when the shape memory alloy element is at human body temperature removal of the restraint from the shape memory alloy element, without change in temperature of the device, releases at least a portion of the shape memory alloy element from its deformed configuration.

10. A medical device for treatment of a mammalian body, the device comprising:

(a) a memory alloy element formed at least partly from a pseudoelastic shape-memory alloy, the alloy displaying reversible stress-induced martensite at about human temperature such that it has a stress-induced martensitic state and an austenitic state, the memory alloy element having (i) a deformed shape when the alloy is in its stress-induced martensitic state and (ii) a different unstressed shape; and

(b) a hollow restraining member with the memory alloy element being within the restraining member, the restraining member engaging and stressing the memory alloy element at a temperature less than the body temperature of the human and greater than the A_s of the alloy for positioning the memory alloy element within or in proximity to the mammalian body while the memory alloy element is in its deformed shape;

wherein the restraining member and the memory alloy element are movable relative to each other to transform at least a portion of the alloy from its stress-induced martensitic state at a temperature greater than the A_s of the alloy so that the memory alloy element transforms from its deformed shape toward its unstressed shape, and wherein the alloy is selected so that the transformation can occur without any change in temperature of the restraining member or the memory alloy element.

2. U.S. Patent No. 5,190,546 - Claim 27 is broader than the claims on appeal.⁶
3. U.S. Patent No. 5,067,957 - Claim 1 is broader than the claims on appeal.⁷
4. U.S. Patent No. 4,665,906 - Claim 1 is broader than the claims on appeal.⁸

⁶ 27. A method for removing from a mammalian body a medical device comprising a memory alloy element at least partly formed from a pseudoelastic shape memory alloy, the alloy displaying reversible stress-induced martensite at about body temperature such that it has a stress-induced martensitic state and an austenitic state, the device having (i) a removable shape when the alloy is in its stress-induced martensitic state and (ii) a different non-removable shape when the alloy is in its austenitic state, the device being positioned in a mammalian body and being in its non-removable shape, the method comprising the steps of:

(a) stressing the device so that the alloy transforms toward its stress-induced martensitic state and the device transforms to its removable shape, without changing the temperature of the device; and,

(b) withdrawing the transformed device from the mammalian body.

⁷ 1. A method of medical treatment of a mammal which comprises the steps of:

(a) providing a device comprising an element which comprises a shape memory alloy which displays stress induced martensite behavior at body temperature of the mammal, the element being restrained in a deformed configuration, the restraining means stressing the element thereby inducing stress induced martensite in the alloy;

(b) positioning the device so that the shape memory alloy element is within a mammalian body or in such proximity to a mammalian body that the element and the restraining means are substantially at body temperature; and,

(c) at least partially removing the restraining means from the element thereby transforming the element from the deformed configuration, the transformation occurring with the element and the restraining means being substantially at body temperature.

⁸ 1. A method of installing a pseudoelastic shape-memory alloy medical device within a mammalian body, or in such proximity to a mammalian body that the device is substantially at body temperature wherein the pseudoelastic shape-memory alloy medical device displays reversible stress-induced martensite at body temperature, the method comprising:

deforming the medical device into a deformed shape different from a final shape, said deforming occurring by the formation of stress-induced martensite;

restraining the deformed shape of the medical device by the application of a restraining means;

positioning the medical device and restraining means within, or in proximity to, the body;

removing the restraining means;

isothermally transforming the device from the deformed shape into the final shape.

In addition, the primary reference, U.S. Patent No. 4,512,338 to Balko et al., as cited by the Examiner in the present application, was previously considered by the U.S. Patent Office in the first three patents listed above.

In addition, although the secondary reference of Seader, as cited by the Examiner in the present application, was not actually previously considered by the U.S. Patent Office in the above-listed patents, equivalent references teaching that nitinol has superelastic behavior were considered by the U.S. Patent Office in the above-listed patents. For example, the reference, Suzuki, Yuchi, "Shape Memory and Super-Elasticity Effects in Ni-Ti Alloys," (Translation provided), Kirk-Othmer, Encyclopedia of Chemical Technology, 3rd Ed., vol. 20, pp. 7-26-7-36, was previously considered by the U.S. Patent Office in U.S. Patent Nos. 5,597,378 and 5,190,546. In addition, the following references were previously considered by the U.S. Patent Office in the first three patents listed above: Buehler, et al., "55-Nitinol Unique Wire Alloy With A Memory," Wire Journal, June 1963, pp.41-49; U.S. Patent No. 4,509,517 to Zibelin, entitled "Kidney Stone Instrument," disclosing the use of Nitinol; and, U.S. Patent No.4,505,767 to Quin, entitled "Nickel/Titanium/Vanadium Shape Memory Alloy," disclosing nickel/titanium alloys having stress-induced martensite.

The present invention is directed to the species useful as stents. In this species, the restraint is a hollow placement device, and the memory alloy element that is to be placed in a mammalian body is within the placement device. A guide wire is provided so that the memory alloy element can be extruded from the placement device into a desired location. The alloy is selected so that the memory alloy element changes shape without any change in temperature of the placement device or the memory alloy element.

The invention, as recited in claim 32, is best understood with regard to Figure 7 below. Figure 7 shows a hollow placement device 102, a shape memory alloy element 103, and a guide wire 104. The element 103 is in the form of a coil stent for placement in a blood vessel or the like. By use of the guide wire 104, the stent 103 can be extruded from the hollow placement device 102 into a blood vessel at a desired location, and then it can expand in size.

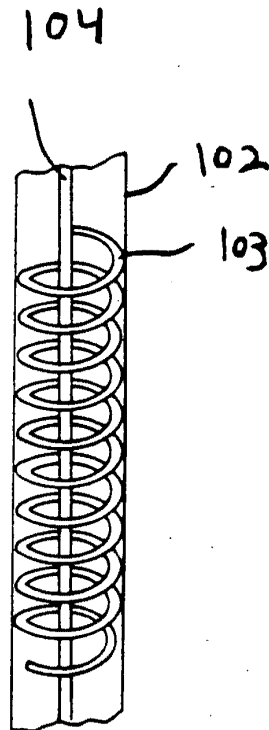

Fig 7.

C. **The Present Invention Solves The Problems Of The Prior Art**

Applicant's medical device incorporating SIM alloy elements solves the problems associated with the prior art and provides significant advantages over the prior art.

1. **No Temperature Change Is Required To Effect A Change In Shape**

Applicant's invention is a significant improvement over the prior art. A doctor or user of the medical device of Applicant's invention can insert the device into a mammalian body, and the memory alloy element transforms from its deformed shape to its unstressed shape by itself without requiring a change in temperature of the placement device or the memory alloy element. In Applicant's invention, if a stent made from a material which exhibits stress-induced martensite properties at body temperature is delivered from a catheter, then the need for temperature control is avoided (see generally, specification, pg. 18, lines 1-3). The stent remains pseudoelastically deformed when in the catheter but re-forms spontaneously when it is released from the catheter. Accurate placement of the stent is then readily obtainable, since there is no urgency to avoid premature heating and deployment of the device, as might be required with a conventional shape memory effect element (see generally, specification, pg. 18, lines 4-8).

Because Applicant's invention requires no temperature change to effect a change in shape of the shape memory alloy, the problems with transformation temperature and hysteresis are avoided. In addition, none of the disadvantages associated with heating the shape memory alloy with body heat alone or with external heating sources exist with the present invention. Rather, the simplicity of the present invention, where the device attains its desired configuration without the requirement of any external heating or cooling, provides predictability, dependability, and ease of use.

2. No Treatment Process Is Required To Exhibit Properties Of SIM Material

The memory alloy element of Applicant's invention is formed at least partly from pseudoelastic shape memory alloy that displays reversible stress-induced martensite at about body temperature. Unlike the prior art, and specifically the Seader reference, Applicant's memory alloy element does not require a treatment process to make it exhibit the properties of an SIM material. Such a process is extensive, time consuming, and expensive and is avoided by the present invention.

VII. ISSUES

- A. Whether claims 21, 23, and 25-46 are unpatentable under 35 U.S.C. §103(a) over U.S. Patent No. 4,512,338 to Balko et al. in view of Seader (Encyclopedia of Chemical Technology publication) and U.S. Patent No. 4,485,805 to Foster?
1. Did the Examiner Fail to Establish a Prima Facie Case of Obviousness?
 2. Did the Examiner Miscalculate the Prior Art Against Applicant's Invention?
 3. Did the Examiner Fail to Give Proper Weight to the Expert Declaration of Dr. Lee Middleman?
- B. Whether claims 21 and 23 are unpatentable under the judicially created doctrine of obviousness-type double patenting over claims 1 and 2 of U.S. Patent No. 5,231,989 to Middleman et al.?
1. Did the Examiner Fail to Recognize the Significant Differences Between Claims 21 and 23 of Applicant's Invention and Claims 1 and 2 of U.S. Patent No. 5,231,989?

2. Did the Examiner Fail to Recognize that U.S. Patent No. 5,231,989 was Previously Found to be Nonobvious by the U.S. Patent Office Over the Earlier Patent No. 4,665,906 to Jervis, the Grandparent Case of the Present Application?
- C. Whether claims 21 and 23 are unpatentable under 35 U.S.C. §102(e), or in the alternative, under 35 U.S.C. §103(a) over U.S. Patent No. 5,231,989 to Middleman et al.?
1. Did the Examiner Fail to Recognize that U.S. Patent No. 5,231,989 Does Not Qualify as Prior Art Under 35 U.S.C. §102(e) or Under 35 U.S.C. §103(a)?

VIII. GROUPING OF THE CLAIMS

For purposes of this appeal brief only, the rejected claims do not stand or fall together, and the claims in any one or more groups may be patentable over any other.

Group 1: Claims 21, 23, 25-31, 34-38, 40-42, and 44-46 are directed to a medical device for insertion into a mammalian body, the device comprising a hollow placement device; a memory alloy element formed at least partly from a pseudoelastic shape-memory alloy, the memory alloy element having a deformed shape when the alloy is in its stress-induced martensitic state and a different unstressed shape when the alloy is in its austenitic state; and a guide wire.

Group 2: Claims 32, 33, 35, 38, 41-42, and 46 contain all of the limitations of the Group 1 claims, with the additional limitations that the memory alloy stent has

a deformed straightened shape when the alloy is in its stress-induced martensitic state, and a different unstressed coiled shape.

IX. ARGUMENT

A. The Rejection of Claims 21, 23, 25, and 26-46, Under U.S.C. §103(a), Over U.S. Patent No. 4,512,338 to Balko et al., in View of Seader (Encyclopedia of Chemical Technology publication), and U.S. Patent No. 4,485,805 to Foster, Jr. Should Be Reversed

1. The Prior Art

a. Balko, et al

Balko, et al. ("Balko") discloses a process using a shape memory alloy, such as nitinol wire, which has been previously fabricated in its parent phase to form a longitudinally oriented coil of adjacent wire loops and thereafter cooled to its martensite phase and reshaped to a relatively straight shape. The shape memory alloy is utilized as an intra-luminal device to reinforce or replace a weakened or otherwise damaged vessel (see Abstract). Deployment of the device into the body requires heating of the wire to its transformation temperature which can be accomplished by conduction or convection from the body, as well as by external heating sources such as infrared radiation (see col. 5, lines 57-68).

The Examiner cites Balko as showing "nitinol (SMA) wire formed as a graft structure 22 which is placed inside the sheath head 50 (hollow placement device)" (see final office action, pg.2).

However, Balko does not teach use of an SIM material or use of a shape memory alloy that exhibits properties of an SIM material at about body temperature. In addition, Balko does not teach a shape memory alloy that transforms from a deformed shape to an unstressed shape without any change in temperature of the shape memory alloy.

b. Seader

Seader is a chapter on shape-memory alloys from the Encyclopedia of Chemical Technology. Seader discloses that an early medical device exploits the superelastic behavior of nitinol (see pg. 733), and also discloses a shape-memory plate that can be warmed by body heat or artificially heated by diathermy (see pg. 733). The Examiner cites Seader as showing that “nitinol has superelastic behavior (pseudo elastic behavior)” (see final office action, pg. 2).

c. Foster, Jr.

Foster, Jr. (“Foster”) discloses an intra-gastric weight loss system apparatus and method comprising a balloon-type device which can be placed in a person’s stomach through the mouth without surgery. The Examiner cites Foster as showing “a stylet 16 (guide wire)” (see final office action, pg. 3).

2. The Examiner Has Failed To Establish A Prima Facie Case Of Obviousness

The Examiner bears the burden of establishing a prima facie case of obviousness based on the prior art. In re Geiger, 815 F. 2d 686 (Fed. Cir. 1987). On pages 2-3 of the final office action, the Examiner states the following reasoning for the rejection of claims 21, 23, 25, and 26-46 under 35 U.S.C. §103(a):

Balko shows a nitinol (SMA) wire formed graft structure 22 which is placed inside the sheath head 50 (hollow placement device). Balko lacks the description of the nitinol which is a pseudoelastic SMA. However, the teaching on page 733 of Seader discloses that the nitinol has the superelastic (pseudoelastic) behavior. Therefore, it is obvious that the nitinol has the pseudoelastic properties. In addition, it is well known in the art that the pseudoelastic material (nitinol) would have reversible stress induced martensite state at a body temperature. Therefore, it is obvious that Balko’s nitinol would have the same property as claimed.

Balko differs from the present invention in that Balko lacks a guide wire. However, it is well known in the art that a guide wire is used for guiding a catheter into the body. In addition, Foster shows a stylet 16 (guide wire). Therefore, it would have been obvious to one of ordinary skill in the art at the time the invention was made to provide Balko's device with a guide wire in order to guide the catheter into a desired location.

a. The Proposed Combination Of References Does Not Produce Applicant's Claimed Invention

The Examiner's rejection under 35 U.S.C. §103(a) is deficient for a number of reasons. First, the Examiner has failed to establish a prima facie case of obviousness because the proposed combination of the references as suggested by the Examiner does not produce Applicant's invention recited in the rejected claims. To establish a prima facie case of obviousness, the prior art reference or references, when combined, must teach or suggest all the claim limitations. M.P.E.P. 706.02(j), citing In re Vaeck, 947 F.2d 488, 20 U.S.P.Q. 2d 1438 (Fed. Cir. 1991).

Applicant's independent claim 21, which is in the Group 1 claims, recites the following:

21. A medical device for insertion into a mammalian body, the device comprising
- (a) a hollow placement device;
 - (b) a memory alloy element formed at least partly from pseudoelastic shape-memory alloy, the alloy displaying reversible stress-induced martensite at about body temperature such that it has a stress-induced martensitic state and an austenitic state, the memory alloy element having (i) a deformed shape when the alloy is in its stress-induced martensitic state and (ii) a different unstressed shape when the alloy is in its austenitic state; and
 - (c) a guide wire;
the memory alloy element being within the hollow placement device, and the placement device being guidable by the guide wire, the hollow placement device stressing the memory alloy element at a temperature greater than the A_s of the alloy so that the memory alloy element is in its deformed shape,
wherein the memory alloy element can be extruded from the hollow placement device by the guide wire at a temperature greater than the A_s of the alloy to transform at least a portion of the alloy from its stress-induced martensitic state so that the memory alloy element transforms from its deformed shape to its unstressed shape, and wherein the alloy is selected so that the transformation can occur without any change in temperature of the placement device or the memory alloy element. (emphasis added)

The proposed combination of Balko, Seader, and Foster does not provide Applicant's claimed feature of "a memory alloy element formed at least partly from pseudoelastic shape-memory alloy, the alloy displaying reversible stress-induced martensite at about body temperature." Dr. Lee Middleman, an expert in the field of stress-induced martensite (SIM) alloy elements, declares the following:

Balko does not disclose a memory alloy formed at least partly from a pseudoelastic shape memory alloy that displays reversible stress-induced martensite at about body temperature. I find no suggestion or teaching in Balko, Seader, or Foster to make the nitinol disclosed in Balko from a stress-induced martensite alloy. Although nitinol can exhibit the properties of an SIM material, it can do so only if it undergoes a treatment process to make it exhibit the properties of an SIM material. This process requires an extensive, time consuming, and expensive procedure. Where is the suggestion in Balko or any of the other references to use nitinol exhibiting SIM behavior rather than less expensive conventional Nitinol? There is no such suggestion, and any such idea can only come from hindsight.

See Middleman Decl., ¶11.

In addition, the combination of Balko, Seader, and Foster does not provide Applicant's claimed feature of "the alloy is selected so that the transformation can occur without any change in temperature of the placement device or the memory alloy element." Unlike Applicant's claimed invention, Balko requires a temperature change to effect a change in shape utilizing SMA materials, wherein such temperature change results from body heating alone, or body heating in combination with external heating (see Balko, col. 5, lines 57-67). There is no suggestion in Balko, Seader, or Foster, to use nitinol without a temperature change, whether it be by heating the nitinol with body heat alone, or whether it be by heating the nitinol with body heat and an external heating source (see Middleman Decl., ¶13)⁹. Because Balko requires a temperature change to effect a change in state,

⁹ "Further, Balko requires a temperature change to effect a change in state utilizing SMA materials (see col. 5, lines 57-67). The temperature change results from body heating alone, or body heating in combination with external heating. There is no suggestion in Balko or the other

problems may easily arise. For example, when the coil stent of Balko is heated to reach body temperature as it is inserted it can prematurely expand before it is removed from the restraint, thereby interfering with removal. External heating may also be used which introduces its own complications (see Balko, col. 5, lines 57-68).

Moreover, the combination of Balko, Seader, and Foster does not provide Applicant's claimed feature of a "guide wire" or "the placement device being guidable by the guide wire." Foster discloses a stiffener rod or stylette 16 that is "run down the lumen to within 1" of the distal end of the naso-gastric tube" but only "after the tip 24 of the naso-gastric tube 14 is confirmed to be in the stomach" (see col. 4, lines 32-35). Thus, Foster does not disclose a stylette or guide wire that guides the naso-gastric tube into the stomach of a patient. Rather, Foster discloses a stylette that is only inserted after the naso-gastric tube is already in the stomach. In contrast, Applicant claims "a guide wire" and "the placement device being guidable by the guide wire." Thus, one skilled in the art would not be motivated to modify Balko with the stylette of Foster because the stylette of Foster is not used as a guiding apparatus.

Thus, the proposed combination of Balko, Seader, and Foster does not produce Applicant's claimed invention. Because the proposed combination suggested by the Examiner does not provide each and every element contained in the claimed invention, as discussed above, the rejection under 35 U.S.C. §103(a) is improper. See In re Sung Nam Cho, 1 U.S.P.Q. 2d 1662 (Fed. Cir. 1987).

references to use nitinol without a temperature change, whether it be by heating the nitinol with body heat alone, or whether it be by heating the nitinol with body heat and an external heating source." Middleman Decl., ¶13.

**b. There Is No Teaching Or Suggestion In The Cited
References For The Proposed Combination**

A second deficiency of the prima facie case of the Examiner is that there is no teaching or suggestion in any of the cited references to make the proposed combination suggested by the Examiner. Obviousness cannot be established by combining the teachings of the prior art to produce the claimed invention absent some teaching or suggestion supporting the combination. In re Fritch, 972 F. 2d 1260, 23 U.S.P.Q. 2d 1780, 1783-84 (Fed. Cir. 1992). Further, when making an obviousness determination, elements of separate prior patents cannot be combined when there is no suggestion or such combination anywhere in those patents. Panduit Corp. v. Dennison Mfg. Co., 810 F. 2d 1561, 1568, 1 U.S.P.Q. 2d 1593, 1597 (Fed. Cir.), cert. denied, 481 U.S. 1052 (1987). It is the burden of the Examiner to establish why one having ordinary skill in the art would have been led to the claimed invention by the express teachings or suggestions found in the prior art, or by implications contained in such teachings or suggestions. In re Sernaker, 702 F. 2d 989, 995, 217 U.S.P.Q. 1, 6 (Fed. Cir. 1983). It is incumbent upon the Examiner to establish a factual basis to support a rejection. See In re Fine, 837 F. 2d 1071, 1073, 5 U.S.P.Q. 2d 1596, 1598 (Fed. Cir. 1988).

Not only is there no suggestion in the references to make the combination, but as the expert Dr. Lee Middleman states, it is not obvious to make such a combination. Dr. Middleman declares:

...it would not be obvious at the time the invention was made in 1983 to have converted the nitinol of Balko into an SIM material and to have removed the heating step.

See Middleman Decl., ¶15.

Dr. Middleman further declares:

Even if the nitinol of Balko were to exhibit SIM properties, there is no suggestion or teaching in the references that the SIM phenomenon is to occur in the temperature range around the body temperature of a mammal. Nitinol can be treated to exhibit SIM properties in selected temperature ranges as low as 0 degrees Celsius or as high as 60 degrees Celsius. For the nitinol to be effective in a medical device, the SIM behavior must be exhibited at temperatures which a mammalian body can tolerate (typically 35 degrees Celsius to 40 degrees Celsius). No such teaching is provided in the cited references.

See Middleman Decl., ¶12.

Seader discloses a shape-memory alloy that is warmed by body heat or artificially heated by diathermy (pg. 733), but Seader does not disclose a shape memory alloy that does not require a temperature change. Nor does Seader disclose a shape memory alloy that undergoes a treatment process to make it exhibit properties of an SIM material. Thus, there is no suggestion in Balko or Seader to modify Balko with the nitinol of Seader to arrive at Applicant's claimed invention. Moreover, there is no suggestion in Balko or Foster to modify Balko with the stylette of Foster because, as discussed above, the stylette of Foster is not used to guide anything. Rather, Foster discloses a stylette that is only inserted after the naso-gastric tube is already in the stomach. Thus, even if Balko were modified with the stylette of Foster, one would not arrive at Applicant's claimed invention.

The Examiner's obviousness rejection is improper because the Examiner has identified no suggestion in the prior art of the desirability of the combination proposed by the Examiner. It was improper for the Examiner to modify the device of Balko to use the nitinol of Seader and the guide wire of Foster to arrive at Applicant's claimed invention because a person skilled in the art would not have been motivated at the time of the invention to combine the references in the way suggested by the Examiner. The Examiner has identified nothing in the references that suggests the desirability of the modifications.

In fact, the only document of record in this prosecution which suggests the desirability of the combination proposed by the Examiner is the Applicant's specification. However, the use of the claimed invention as an instruction manual or template to piece together the teachings of the prior art is impermissible hindsight. Grain Processing Corp. v. American Maize-Products Co., 840 F. 2d 902, 907, 5 U.S.P.Q. 2d 1788, 1792 (Fed. Cir. 1988). The Examiner's rejection runs afoul of a basic mandate inherent in Section 103, namely, that it is not appropriate to pick and choose from the references to reconstruct piecemeal the Applicant's invention in light of the disclosure of Applicant. In re Rothermel and Waddell, 125 U.S.P.Q. 328, 331 (CCPA 1960). As stated by the CCPA in Rothermel, at page 331:

The Examiner and the Board in rejecting the appealed claims did so by what appears to us to be a piecemeal reconstruction of the prior art patents in light of appellants' disclosure...It is easy now to attribute to this prior art the knowledge which was first made available by appellants and then to assume that it would have been obvious to one having the ordinary skill of the art to make these suggested reconstructions. While such a reconstruction of the art may be an alluring way to rationalize the rejection of claims, it is not the type of rejection which the statute authorizes. 35 U.S.C. §103 is very specific in requiring that the rejection on the grounds the invention would have been obvious must be based on the comparison between the prior art and the subject matter as a whole at the time the invention was made.

The Examiner used hindsight to reconstruct Applicant's invention, and Dr. Middleman agrees (see Middleman Decl., ¶11)¹⁰.

In sum, the Examiner has failed to establish a prima facie case of obviousness. The proposed combination of references does not produce the claimed invention. Moreover, there is no suggestion or teaching in the cited references to make the combination. Further, the claims on appeal are the

¹⁰"...Where is the suggestion in Balko or any of the other references to use nitinol exhibiting SIM behavior rather than less expensive conventional Nitinol? There is no such suggestion, and any such idea can only come from hindsight." Middleman Decl., ¶11.

result of a species election requirement in the parent application, and Applicant urges the Board to recognize that if the generic invention is nonobvious, then the species must similarly be nonobvious.

c. The Group 2 Claims Are Independently Patentable

The claims of Group 2 are narrower than the claims of Group 1, and are therefore nonobvious over the cited references for the reasons as discussed above with regard to Group 1. In addition, the claims of Group 2 have the following limitation: “the memory alloy stent having (i) a deformed relatively straightened shape when the alloy is in its stress-induced martensitic state and (ii) a different unstressed relatively coiled shape” (see claims 32, 33). This limitation is not provided by the proposed combination of Balko, Seader, and Foster. Nor is this limitation taught or suggested by Balko, Seader, or Foster. Thus, the claims of Group 2 are nonobvious over the cited references.

3. The Examiner Has Miscalculated The Prior Art Against Applicant’s Claimed Invention

The Examiner bases the final rejection upon a miscalculation and mischaracterization of the prior art because the Examiner did not understand the significant nonobvious differences between Applicant’s claimed invention and the devices disclosed in the cited references. At page 5 of the final office action, the Examiner states the following:

...the examiner relied only on the fact that Balko discloses introducing a shape memory nitinol alloy stent into the body. It is well known that the nitinol represents a group of alloys and some of the nitinol alloys propose the reversible stress-induced martensite property. In addition, there is no base to support the allegation that Balko’s alloy doesn’t choose to have SIM behavior.

Although the Examiner asserts that it is well known in the art that some of the nitinol alloys propose the reversible stress induced martensite state property, there is a significant difference between conventional nitinol and nitinol which must be treated to exhibit the properties of an SIM material at body temperature. According to Dr. Middleman,

Although nitinol can exhibit the properties of an SIM material, it can do so only if it undergoes a treatment process to make it exhibit the properties of an SIM material. This process requires an extensive, time consuming, and expensive procedure. Where is the suggestion in Balko or any of the other references to use nitinol exhibiting SIM behavior rather than less expensive conventional nitinol?

See Middleman Decl., ¶11.

One skilled in the art would know that there are differences in nitinol alloys and that nitinol would exhibit the properties of an SIM material at body temperature only if properly treated to achieve this. Thus, the Examiner mischaracterizes the nitinol disclosed in Seader and wrongly contends that it is the same as Applicant's shape memory alloy displaying stress-induced martensite properties at body temperature.

Further, at page 5 of the final office action, the Examiner states the following:

Applicant further argues that Balko's alloy requires a temperature change to effect a change in state. However, as noted by the Applicant and at the last paragraph of page 13 [of the Amendment filed by Applicant in response to the office action of October 29, 1996] that the external heating is optionally required. As disclosed in col. 3, lines 54-57 of Balko that the nitinol wire 24 has been alloyed to exhibit a martensite transformation temperature somewhat below the normal body temperature range. In addition, in col. 5, lines 57-67 of Balko discloses that heating the wire in any of the embodiments to its transformation temperature could be accomplished other than solely by conduction and convection from the body but by infrared radiation, when the body temperature is not exclusively relied upon as the source of heat for the wire, its reformation temperature could be increased above body temperatures if necessary. Therefore, it is obvious that Balko's alloy is not necessary to require infrared radiation but depends on the condition of the patient.

Regardless of whether Balko warms the shape memory alloy by body heat alone or by an external heating source, the Examiner misevaluates Balko by failing to recognize that Balko requires a temperature change to effect a change in shape and Applicant's invention does not require a temperature change. In addition, Seader discloses a shape-memory alloy that is warmed by body heat or artificially heated by diathermy (pg. 733). Neither Balko nor Seader discloses a shape-memory alloy that does not require a temperature change. Nor does Balko or Seader disclose a shape memory alloy that undergoes a treatment process to make it exhibit properties of an SIM material at body temperature. Thus, there is no suggestion to modify Balko with the nitinol of Seader to arrive at Applicant's claimed invention

Further, the Examiner is wrong in her contention that by merely modifying Balko with the nitinol of Seader and the stylette of Foster that one skilled in the art would arrive at Applicant's claimed invention. The Examiner misevaluates Foster and states that Foster discloses a guide wire. However, unlike Applicant's invention, Foster does not disclose a guide wire that guides a device into place. Rather, Foster discloses a stylette that is only inserted into the body after the naso-gastric tube is already in the stomach.

Moreover, the advantages of Applicant's invention cannot be overstated. There are significant advantages provided by the present invention that are not disclosed, suggested, or taught by any of the cited references. The present invention does not require any external heating or cooling, is simple and easy to use, has good reproduceability, predictability and dependability, and is cost effective. This is further evidence of the nonobviousness of the claimed invention.

In sum, the Examiner's entire rejection under 35 U.S.C. §103(a) is based upon a misreading and misevaluation of the cited references. Thus, the Board is urged to reverse the Examiner's rejection.

4. The Examiner Did Not Give Proper Weight To The Expert Declaration Of Dr. Lee Middleman

Even if a prima facie case of obviousness exists, it is obviated by the expert declaration of Dr. Lee Middleman.

However, the Examiner did not give sufficient or proper weight to the expert declaration of Dr. Lee Middleman, an inventor of U.S. Patent No. 5,231,989, a patent cited by the Examiner in the final office action. In particular, in the advisory action dated April 23, 1998, the Examiner states the following with respect to the Middleman Declaration:

The Declaration is unpersuasive since the Seader disclosure teaches usage in the medical devices field and at body heat (p. 733)-disclosures of which the Declaration did not directly address.

Applicant disagrees with the Examiner. The Middleman Declaration did indeed discuss the Seader reference with regard to its use at body heat, and Applicant is puzzled by the Examiner's assertion to the contrary. Applicant directs the Board's attention to the paragraph 13 of the Middleman Declaration in which Dr. Middleman states the following:

Further, Balko requires a temperature change to effect a change in state utilizing SMA materials (see col. 5, lines 57-67). The temperature change results from body heating alone, or body heating in combination with external heating. There is no suggestion in Balko or the other references to use nitinol without a temperature change, whether it be by heating the nitinol with body heat alone, or whether it be by heating the nitinol with body heat and an external heating source. (emphasis added)

An expert's testimony in the form of an affidavit or declaration is entitled to weight in resolving the ultimate legal conclusion of obviousness under 35 U.S.C. §103. Ex parte George, 21 U.S.P.Q. 2d 1058 (Bd. Pat. App. & Int'f 1991). In reviewing an examiner's opinion on appeal, the Board must consider all relevant facts in determining obviousness. In re Piasecki, 745 F.2d 1468, 1472 (Fed. Cir. 1984). Thus, the opinion of Dr. Middleman should have been given the proper weight it deserved by the Examiner.

B. The Obviousness-Type Double Patenting Rejection of Claims 21 and 23, Over Claims 1 and 2 of U.S. Patent No. 5,231,989 to Middleman et al. Should Be Reversed

In the final office action, the Examiner rejected claims 21 and 23 under the judicially created doctrine of obviousness-type double patenting, as being unpatentable over claims 1 and 2 of U.S. Patent No. 5,231,989 to Middleman et al. ("the '989 patent"). In the final office action, at pages 3-4, the Examiner states the following reasoning for the obviousness-type double patenting rejection of claims 21 and 23:

Although the conflicting claims are not identical, they are not patentably distinct from each other because the difference between the patented claims and the proposed application claims are minor and obvious from each other. In the instant claims 21 and 23, all elements are included in the claims 1-2 of U.S. Patent No. 5,231,989. The recitation of "placement device" [in Applicant's claim 21] is merely an obvious variation over the "elongated tube" from claim 1 of the U.S. Patent No. 5,231,989; the "memory alloy element" or "stent" [of Applicant's claim 21] is merely an obvious variation in wording over the "elastic member" [of claims 1-2 of the U.S. Patent No. 5,231,989]; and the of "guide wire" [of Applicant's claim 21] is an obvious variation over the "straightener" ["straightening means"] from claims 1-2 of U.S. Patent No. 5,231,989. The alternate terminology is obvious and merely limits the claims slightly but it does not change the scope of the claim.

The Examiner erred in not recognizing the significant differences between Applicant's invention recited in claims 21 and 23 and the invention set forth in claims 1-2 of U.S. Patent No.

5,231,989 to Middleman ('the '989 patent'). A combination of old elements can be found to be nonobvious if it produces a different function, operation, or result than previously performed. Sagrada v. Ag. Pro. Inc., 475 U.S. 273, 96 S. Ct. 1532 (1976); Anderson's Black Rock v. Pavement Salvage Co., 396 U.S. 57, 90 S.C. 305 (1969). Further, the Examiner has not given the proper weight due to the declaration of Dr. Lee Middleman. As the inventor of the '989 patent, Dr. Lee Middleman recognizes and admits the differences between claims 1 and 2 of his '989 patent and claims 21 and 23 of Applicant's invention.¹¹ Such an admission should be given strong weight by the Examiner, which it was not.

Applicant respectfully requests the Board to direct their attention to the drawings attached as Exhibit B to the Middleman Declaration (see **Appendix C**). These drawings clearly show the differences between the device of claims 1 and 2 of the '989 patent and the device of claims 21 and 23 of the present application, before and after bending of the device. Claims 1 and 2 of the '989 patent disclose an elastic member made of SIM material to bend or unbend a bendable elongated tube. In contrast, claims 21 and 23 of the present application disclose a non-bendable hollow placement device to bend and unbend a memory alloy made of a SIM material.

¹¹ "The device in claims 1 and 2 of my '989 patent functions very differently than the device claimed in the present Jervis application and does not render it obvious. I made my invention long after Jervis made his invention, and in fact, Jervis Patent Number 4,665,906 is cited as prior art on the cover page of my '989 patent. The device in the '989 patent uses an elastic member made of SIM material to bend or unbend a bendable elongated tube ("transforming the elastic member from one shape to another for correspondingly bending or unbending the distal segment of the (elongate) tube" (claim 1(c)). In contrast, the device in the claims of the Jervis application uses a non-bendable hollow placement device to bend and unbend a memory alloy made of a SIM material ("the hollow placement device stressing the memory alloy element...so that the memory alloy element is in its deformed shape" (claim 21). These are diametrically opposed concepts." Middleman Decl., ¶17.

As indicated by Dr. Lee Middleman, because Applicant's claims 21 and 23 and the claims 1 and 2 of the '989 patent cover very different inventions, Applicant's invention is not obvious over claims 1 and 2 of the '989 patent.¹²

Further, the Examiner's double-patenting rejection is improper because the '989 patent was already previously found to be nonobvious by the U.S. Patent Office over the earlier Jervis Patent No. 4,665,906, the grandparent case of the present application with essentially the same disclosure as set forth in the disclosure of the present application. Middleman made his invention long after Jervis made his invention, and Jervis Patent No. 4,665,906 is even cited as prior art on the cover page of the '989 patent (see U.S. Patent No. 5,231,989, and Middleman Decl., ¶17).

Courts have set forth two tests for obviousness-type double patenting rejections. The usual test is a "one-way" patentability test in which, in order to find double-patenting, the later claimed subject matter must be obvious in view of the earlier claimed subject matter. See In re Goodman, 11 F. 3d 1046, 1052, 29 U.S.P.Q. 2d 2010, 2015 (Fed. Cir. 1993) (where the applicant filed a continuation application for a broad claim while seeking early issuance of a narrow species claim, the court applied the "one-way" patentability test, and because PTO action did not dictate the rate of prosecution, the court looked only to see if the pending application claims were patentably distinct from the issued patent).

However, in certain circumstances, courts have imposed a "two-way" patentability test in which in, order to find double-patenting, the later claimed subject matter must be obvious in view of the earlier patent claimed subject matter and the earlier patent claimed subject matter must be obvious

¹² "In view of the significant difference between the present Jervis invention and my '989 patent, the claimed Jervis invention is not obvious over claims 1 and 2 of my '989 patent." Middleman Decl., ¶19.

in view of the later claimed subject matter. See In re Braat, 937 F. 2d 589, 593, 19 U.S.P.Q. 2d 1289, 1292 (Fed. Cir. 1991) (where the court applied the “two-way” patentability test and examined each claim to determine whether it was an obvious variant of the other, rather than just examining the application claim for patentable distinctiveness from the patent claim, and where the court noted that because applications for basic and improvement patents should not be penalized by the rate of progress of the application through the PTO, a matter over which the applicant does not have complete control, the two-way test applied, and the court reversed the Board’s double patenting rejection).

In the present case, under the one-way double-patenting test, the double-patenting rejection is improper and should be reversed because the ‘989 patent was already previously allowed by the Patent Office over the earlier Jervis Patent No. 4,665,906 (attached hereto in **Appendix B**). Middleman made his invention long after Jervis made his invention, and Jervis Patent No. 4,665,906 is cited as prior art on the cover page of the ‘989 patent (see Footnote 11, Middleman Decl., ¶17). Thus, since the claims of the ‘989 patent are not obvious in view of the Jervis invention, the double-patenting rejection is obviated.

Further, under the two-way double-patenting test, the double-patenting rejection should also be reversed. As argued above, the device in claims 1 and 2 of the ‘989 patent covers a very different invention than the device of claims 21 and 23 of the subject application, and does not render it obvious (see Footnote 11, Middleman Decl., ¶17).

Accordingly, since the claims of the ‘989 patent are nonobvious in view of claims 21 and 23 of the present Jervis invention, Applicant respectfully requests that the Board reverse the Examiner’s obviousness-type double patenting rejection of claims 21 and 23 in view of the ‘989 patent.

C. The Rejection of Claims 21 and 23, Under 35 U.S.C. §102(e), or in the Alternative, Under 35 U.S.C. §103(a), Over U.S. Patent No. 5,231,989 to Middleman et al. Should Be Reversed

In the final office action, the Examiner rejected claims 21 and 23 under 35 U.S.C. §102(e), as being anticipated by, or in the alternative, under 35 U.S.C. §103(a), as being obvious over U.S. Patent No. 5,231,989 to Middleman et al.

The Examiner erred in rejecting claims 21 and 23 under 35 U.S.C. §102(e), as being anticipated by U.S. Patent No. 5,231,989 to Middleman, because U.S. Patent No. 5,231,989 does not qualify as prior art under 35 U.S.C. §102(e). As indicated by the genealogy of the present application as set forth in the Introduction of this Appeal Brief, the application on appeal has an effective filing date of October 14, 1983. Claims 21 and 23, as well as the other claims on appeal are supported by the specification as originally submitted and contain no new matter. Thus, claims 21 and 23, and the other claims on appeal are entitled to the priority date of October 14, 1983. Since the filing date of U.S. Patent No. 5,231,989 to Middleman et al. is February 15, 1991, which is almost eight (8) years after the October 14, 1983 priority date, the Examiner has erred in rejecting claims 21 and 23 under 35 U.S.C. §102(e) and under 35 U.S.C. §103(a).

Accordingly, Applicant respectfully requests that the Board reverse the Examiner's rejection of claims 21 and 23 under 35 U.S.C. §102(e) and under 35 U.S.C. §103(a).

X. CONCLUSION

In view of the foregoing arguments, Applicant respectfully requests that the Board reverse the Examiner's rejection of claims 21, 23, 25-38, 40-42, and 44-46.

This appeal brief is being filed in triplicate, pursuant to 37 C.F.R. §1.192(a).

A check in the amount of \$310.00 to cover the fee for filing this brief under 37 C.F.R. §1.17(f) is enclosed with the accompanying Transmittal Letter. Please charge any additional fees associated with this appeal brief or credit any overpayment to Deposit Account No. 19-2090 pursuant to authorization provided in the Transmittal Letter, a duplicate copy of which is enclosed.

Respectfully submitted,

SHELDON & MAK

June 18, 1998
Date

By: Karin E. Peterka
Karin E. Peterka
Reg. No. 35,976

225 South Lake Avenue
9th Floor
Pasadena, California 91101
Phone: (626) 796-4000
Facsimile: (626) 795-6321

APPENDIX A

APPENDIX B



APPENDIX A
CLAIMS ON APPEAL

21. A medical device for insertion into a mammalian body, the device comprising

- (a) a hollow placement device;
- (b) a memory alloy element formed at least partly from pseudoelastic shape-memory alloy, the alloy displaying reversible stress-induced martensite at about body temperature such that it has a stress-induced martensitic state and an austenitic state, the memory alloy element having (i) a deformed shape when the alloy is in its stress-induced martensitic state and (ii) a different unstressed shape when the alloy is in its austenitic state; and

- (c) a guide wire;

the memory alloy element being within the hollow placement device, and the placement device being guidable by the guide wire, the hollow placement device stressing the memory alloy element at a temperature greater than the A_s of the alloy so that the memory alloy element is in its deformed shape,

wherein the memory alloy element can be extruded from the hollow placement device by the guide wire at a temperature greater than the A_s of the alloy to transform at least a portion of the alloy from its stress-induced martensitic state so that the memory alloy element transforms from its deformed shape to its unstressed shape, and wherein the alloy is selected so that the transformation can occur without any change in temperature of the placement device or the memory alloy element.

23. The device of claim 21 wherein the memory alloy element is a stent.

25. The invention of claim 21 wherein the transformation occurs without any change in state of the placement device.

26. A medical device which comprises:

(a) a stent for endarterial placement within a human body so that the stent is substantially at human body temperature, the stent comprising a shape memory alloy which displays stress-induced martensite behavior at body temperature; and

(b) a restraint holding the stent in a deformed configuration at a temperature less than the body temperature of the human for endarterial positioning of the stent within the human body in its deformed configuration, the deformation occurring through the formation of stress-induced martensite;

wherein the stent is sufficiently deformed that when the stent is at human body temperature removal of the restraint from the stent, without change in temperature of the device, releases at least a portion of the stent from its deformed configuration.

27. A device as claimed in 26, in which the restraint is hollow, and the stent is positioned at least partially within the restraint.

28. A device as claimed in claim 26 or 27, in which the restraint is a catheter.

29. A device as claimed in claim 26 or 27, in which the stent has a transverse dimension and a longitudinal dimension, and wherein the stent is deformed by its transverse dimension being reduced, and wherein the restraint prevents transverse expansion of the stent.

30. The device of claim 26, wherein the shape memory alloy element is sufficiently deformed that removal of the restraint from the shape memory alloy releases at least a portion of the shape alloy element from its deformed configuration without change in state of the restraint.

31. A medical device suitable for placement within a mammalian body for treatment of the mammalian body, the device comprising:

(a) a stent formed at least partly from a pseudoelastic shape-memory alloy, the alloy having a reversible stress-induced martensitic state and an austenitic state, the memory alloy element having (i) a deformed shape when the alloy is in its stress-induced martensitic state and (ii) a different, unstressed shape; and

(b) restraining means engaging and stressing the stent at a temperature less than the body temperature of the mammal and greater than the A_s of the alloy for positioning the stent within the mammalian body while the stent is in its deformed shape;

wherein the alloy is selected so that removal of the restraining means from the stent at a temperature greater than the A_s of the alloy when the device is placed within the mammalian body, transforms at least a portion of the alloy from its stressed-induced martensitic state so that the stent transforms from its deformed relatively straightened shape towards its unstressed relatively

coiled shape, without any change in temperature of the restraining means or the stent being required for the transformation of the alloy.

32. A medical device for treatment of a mammalian body, the device comprising:

(a) a memory alloy stent formed at least partly from a pseudoelastic shape-memory alloy, the alloy displaying reversible stress-induced martensite at about the mammalian body temperature such that it has a stress-induced martensitic state and an austenitic state, the memory alloy stent having (i) a deformed relatively straightened shape when the alloy is in its stress-induced martensitic state and (ii) a different unstressed relatively coiled shape; and

(b) a hollow restraining member with the memory alloy stent being within the restraining member, the restraining member engaging and stressing the memory alloy stent at a temperature less than the body temperature of the mammal and greater than the A_s of the alloy for positioning the memory alloy stent within the human body while the memory alloy coil stent is in its deformed relatively straightened shape;

wherein the restraining member and the memory alloy stent are movable relative to each other to transform at least a portion of the alloy from its stress-induced martensitic state at a temperature greater than the A_s of the alloy so that the memory alloy element transforms from its deformed shape towards its unstressed relatively coiled shape, and wherein the alloy is selected so that the transformation can occur without any change in temperature of the restraining member or the memory alloy coil stent.

33. A medical device suitable for placement within a mammalian body for treatment of the mammalian body, the device comprising (i) a restraint, and (ii) a coil stent formed at least partly from a pseudoelastic shape-memory alloy,

the alloy displaying reversible stress-induced martensite by virtue of being above its A_s and above its M_s and below its M_d at about body temperature;

such that it has a stress-induced martensitic state and an austenitic state, the element having (i) a relatively straightened shape when the alloy is in its stress-induced martensitic state and (ii) a different relatively coiled shape;

wherein the restraint is (i) stressing the coil stent at a temperature less than the body temperature of the mammal for placement of the coil stent in its relatively straightened shape in the mammalian body and (ii) is capable of being at least partially removed from the coil stent while the coil stent is within the body at the body temperature and the coil stent is therefore at an operating temperature greater than the A_s and M_s and below the M_d of the alloy,

such removal of the restraint causing at least a portion of the alloy to transform from its stress-induced martensitic state to its austenitic state so that the coil stent spontaneously transforms from its relatively straightened shape towards its relatively coiled shape,

and such transformation can occur without a change in temperature of the restraint or of the coil stent from the operating temperature.

34. A medical device comprising:

(a) a wire stent formed at least partly from a pseudoelastic shape memory alloy, the alloy displaying reversible stress-induced martensite at about human body temperature such as

it has a deformed shape when the alloy is in its stress-induced martensitic state and a different unstressed shape when the alloy is in its austenitic state; and

(b) a restraint stressing the wire stent at a temperature greater than the A_s of the alloy so that the wire stent is in its deformed shape,

wherein the stent can be disengaged from the restraint upon placement in a human so that the stent transforms from its deformed shape to its unstressed shape, and

wherein the alloy is selected so that the transformation can occur without any change in temperature of the restraint or the wire stent.

35. The device of claims 21, 31, 32, or 33, wherein the mammalian body is a human body.

36. The device of claim 21, wherein the hollow placement device is a catheter.

37. The device of claim 23, including a guide wire for endarterial placement of the stent.

38. The device of claims 26, 31, 32, 33 or 34, including a guide wire for endarterial placement of the stent.

40. The device of claim 31, wherein the transformation of the alloy occurs without any change in state of the restraining means.

41. The device of claims 32, 33, or 34, wherein the transformation of the alloy occurs without any change in state of the restraint.

42. The device of claims 32, 33, or 34, wherein the restraint is a catheter.

44. The device of claim 31 wherein the restraining means is a catheter.

45. The device of claim 44 wherein the stent is within the catheter.

46. The device of claims 26, 31, 32, or 34 wherein the stent is a coil stent.

LEE M. MIDDLEMAN

PUBLICATIONS:

"Electron-Induced Fission in U-238, Bi-209 and Ta-181", H. R. Bowman, *et al*, The Physical Review, 168, 4, pp. 1396-1398 (1968).

"Electron and Bremsstrahlung Induced Fission of Heavy and Medium Heavy Nuclei", L. G. Moretto, *et al*, The Physical Review, 179, 4, pp. 1176-1187 (1969).

"Linearity and Resolution of Semiconductor Radiation Detectors", H. R. Zulliger, D. W. Aitken, and L. M. Middleman, IEEE Trans. Nucl. Sci., NS-16, 47 (1969).

"Measurement of Cross Section for X-Ray Production by High-Energy Electrons", L. M. Middleman, R. L. Ford, and R. Hofstadter, The Physical Review, 2, 4, pp. 1429-1443 (1970).

"Properties of Ion-Implanted Silicon Detectors", H.R. Zulliger, W. E. Drummond and L. M. Middleman, IEEE Trans. Nucl. Sci., NS-19, 3 (1972).

"Trace Element Analysis in Specimens Using an Energy Dispersive Spectrometer Mounted on a Scanning Electron Microscope", L. M. Middleman and J. D. Geller, Scanning Electron Microscope/1976, O. Johari (ed.) (1976).

"Conductive Polymer Composites and Their Application in Current Control Devices", L. M. Middleman, invited paper, XII Colloque National, Groupe Francais des Polymeres, November 22-24, 1982, Montpellier, France.

"Electron Transport Processes in Conductive-Filled Polymers", R. D. Sherman, L. M. Middleman, and S. M. Jacobs, Polymer Engineering and Science, 23, No. 1, pp. 36-43 (1983).

"Static Fatigue of Optical Fibers in Bending", D. Roberts, E. Cuellar, L. M. Middleman, and J. Zucker, SPIE Symposium on Optoelectronics and Fiber Optics Applications in Science and Engineering, Cambridge, Massachusetts, September 21-26, 1986.

"Effect of Buffer Coating on Static Fatigue of Optical Fibers in Bending", E. Cuellar, D. Roberts, and L. M. Middleman, Optical Fiber Communication/International Optics and Optical Fiber Communication Conference (OFC/IOOC'87), Reno, Nevada, January 19-22, 1987.

PUBLICATIONS (cont'd):

"Static Fatigue Lifetime of Optical Fibers in Bending", E. Cuellar, D. Roberts, and L. M. Middleman, Annual Military Fiber Optics and Communications Conference, Washington, D.C., March 16-19, 1987.

"Bimodal Flaw Distribution in Optical Fiber and its Effect on Static Fatigue", D. Roberts, E. Cuellar, L. M. Middleman, D. Nelson, and J. Ritter, Annual Meeting of the American Ceramic Society, Pittsburgh, PA., April 26-30, 1987.

"Static Fatigue of Optical Fibers in Bending. II Effect of Humidity and Proof Stress of Static Fatigue Lifetimes", D. Roberts, E. Cuellar, and L. M. Middleman, SPIE Symposium on Fiber Optics and Integrated Optoelectronics (SPIE's O-E/Fibers '87), San Diego, CA., August 16-21, 1987.

"Improvements in Optical Fiber Reliability via High Fatigue Resistant Composition", S. T. Gulati, J. D. Helfinstine, and G. S. Glaesemann (Corning Glass Works) and D. R. Roberts, E. Cuellar, and L. M. Middleman, SPIE Symposium on Fiber Optics and Integrated Optoelectronics (SPIE's O-E/Fibers), San Diego, CA., August 16-21, 1987.

"Design Requirements for Optical Fiber in Bending", D. R. Roberts, E. Cuellar, and L. Middleman, SPIE Proceedings of Fiber Optics Reliability: Benign and Adverse Environments III, Boston, MA., September 5-7, 1989.

PATENT
Attorney Docket Number 9438-1

APPENDIX C

IN THE UNITED STATES PATENT AND TRADEMARK OFFICE

In re application of: JAMES E. JERVIS

Examiner: Justine Yu

Serial No.: 08/483,291

Group Art Unit: 3301

Filed: June 7, 1995

For: MEDICAL DEVICES
INCORPORATING SIM ALLOY
ELEMENTS

DECLARATION OF DR. LEE MIDDLEMAN UNDER 37 CFR 1.132

BOX AP
Assistant Commissioner for Patents
Washington, D. C. 20231

Sir

I, Dr. Lee M. Middleman, hereby declare as follows.

BACKGROUND:

1. I am an expert in material use and selection of materials for medical devices, and I have special knowledge of stress-induced martensite ("SIM") alloy elements.
2. Attached as Exhibit A, I enclose a copy of my curriculum vitae, a list of United States patents for which I am an inventor, and a list of publications I have authored or co-authored.
3. I have received seven patents relating to the use of materials in medical devices, all of which relate to the use of SIM material.

4. I hold a B.A. Degree in physics, which I obtained in only three years, from Johns Hopkins University in Baltimore, Maryland, and I hold a Ph.D. in physics, which I obtained in only five years, from Stanford University in Stanford, California. In my first year of graduate school, I was one of the few science majors within the small number of recipients nationwide (less than one thousand) of a Woodrow Wilson Fellowship, an academic fellowship based primarily on grades, interviews, and faculty recommendations. In my remaining four years of graduate school, I was the recipient of four yearly National Science Foundation Fellowships, an academic fellowship based primarily on grades and recommendations.

5. I am currently employed at Nellcor Puritan Bennett Incorporated in Pleasanton, California (which has been recently purchased by Mallinckrodt Inc.). I have been employed at Nellcor since 1991. My current job title is Vice President, Product Development, Hospital Business Group. This group has yearly sales of nearly \$600,000,000. At Nellcor, I am in charge of the development of medical devices for respiratory impaired patients.

6. Previous to my current employment, I was employed from 1985-1991 and from 1976-1983, at Raychem Corporation in Menlo Park, California (which has since sold certain divisions to Medtronic, Inc. in Minneapolis, Minnesota, and of which Medtronic, Inc. is the assignee of the subject patent application). My last job title at Raychem was General Manager, Medical Ventures. Among my projects at Raychem, I worked on the development and design of medical devices employing shape memory alloys ("SMA"), and in particular SIM elements and components.

7. I do not currently have a financial relationship with Medtronic, Inc. or Raychem

Corporation except on an occasional consulting basis for which I am compensated at my usual consulting rate.

8. I am being compensated at my usual consulting rate by Medtronic, Inc., for the consulting work I have performed in preparing this Declaration.

MATERIALS REVIEWED

9. In preparation for this declaration, I reviewed the above-identified patent application and pending claims, the office action dated September 18, 1997 for this application, U.S. Patent No. 4,512,338 to Balke et al. ("Balke"), U.S. Patent No. 4,485,805 to Foster, Jr. ("Foster"); my own U.S. Patent No. 5,231,989 to Middleman et al. ("my '989 patent"), and the Seader article from the Encyclopedia of Chemical Technology publication ("Seader").

CONCLUSIONS

10. I wish in this declaration to correct some misconceptions that appear in the office action dated September 18, 1997. In short, I conclude that the Patent Office is incorrect in stating that the claims of the subject Jarvis application are obvious in view of Balke, Foster and Seader, and that they are obvious in view of claims 1 and 2 of my '989 patent. I have many technically based reasons for this conclusion, which I will now present.

11. First, Balke does not disclose a memory alloy formed at least partly from a pseudoelastic shape memory alloy that displays reversible stress-induced martensite at about body temperature. I find no suggestion or teaching in Balke, Seader, or Foster to make the nitinol disclosed in Balke from a stress-induced martensite alloy. Although nitinol can exhibit the

properties of an SMA material, it can do so only if it undergoes a treatment process to make it exhibit the properties of an SMA material. This process requires an extensive, time consuming, and expensive procedure. Where is the suggestion in Balko or any of the other references to use nitinol exhibiting SMA behavior rather than less expensive conventional Nitinol? There is no such suggestion, and any such idea can only come from hindsight.

12. Even if the nitinol in Balko were to exhibit SMA properties, there is no suggestion or teaching in the references that the SMA phenomenon is to occur in the temperature range around the body temperature of a mammal. Nitinol can be treated to exhibit SMA properties in selected temperature ranges as low as 0 degrees Celsius or as high as 60 degrees Celsius. For the nitinol to be effective in a medical device, the SMA behavior must be exhibited at temperatures which a mammalian body can tolerate (typically 35 degrees Celsius to 40 degrees Celsius). No such teaching is provided in the cited references.

13. Further, Balko requires a temperature change to effect a change in state utilizing SMA materials (see col. 5, lines 57-67). The temperature change results from body heating alone, or body heating in combination with external heating. There is no suggestion in Balko or the other references to use nitinol without a temperature change, whether it be by heating the nitinol with body heat alone, or whether it be by heating the nitinol with body heat and an external heating source.

14. The Jarvis invention has significant practical advantages compared to what is taught by Balko. For the Balko device, a doctor has to rely on heating the nitinol for it to work. If the doctor relies solely on body heating, this slows up the surgical procedure. Needless to say, anything that slows up a medical procedure is undesirable in that the chance for infection and the

chance for adverse patient reactions increase as the length of a medical procedure increases. Also, a device that relies on ^dbody heating to change shape exhibits inconsistent performance because of the dependance on heating by the body, which rate of heating can differ from patient-to-patient and from operating room to operating room. I know from personal experience with sutures made of SMA materials that inconsistent heating made the sutures difficult to use in an operating room. If the doctor has to rely on heating the nitinol by means of an external heating source, an additional step is added to the procedure and the possibility of overheating and injury is increased. If electric heating is used, there is a potential for electrical shock or an electric burn to the patient. In spite of these disadvantages of the Balke procedure, there is no suggestion in Balke or the other references of a medical device where transformation can occur without a change in temperature.

15. In view of the differences discussed above, it would not have been obvious at the time the invention was made in 1983 to have converted the nitinol of Balke into an SIM material and to have removed the heating step.

16 I am the inventor of the subject matter claimed in United States Patent Number 5,231,989, ("my '989 patent"), issued on August 3, 1993, entitled "Steerable Catheter," and cited in the office action dated September 18, 1997, in the subject application.

17 The device in claims 1 and 2 of my '989 patent functions very differently than the device claimed in the present Jervis application and does not render it obvious. I made my invention long after Jervis made his invention, and in fact, Jervis Patent Number 4,665,906 is cited as prior art on the cover page of my '989 patent. The device in my '989 patent uses an elastic member made of a SIM material to bend or unbend a bendable elongated tube ("transforming the

Linn

elastic member from one shape to another for correspondingly bending or unbending the distal segment of the (elongate) tube." (see claim 1(c)). In contrast, the device in the claims of the Jervis application uses a non-bendable hollow placement device to bend and unbend a memory alloy made of a SIM material ("the hollow placement device stressing the memory alloy element, so that the memory alloy element is in its deformed shape" (see claim 21)) These are diametrically opposed concepts.

18. To clearly show the differences between the '989 patent and the present Jervis invention, attached herewith as Exhibit B are drawings of the device of the '989 patent and the device of the present Jervis invention showing how the respective devices look before and after bending.

19. In view of this significant difference between the present Jervis invention and my '989 patent, the claimed Jervis invention is not obvious over claims 1 and 2 of my '989 patent.

I further declare that all statements made herein of my own knowledge are true, and that all statements made on information and belief are believed to be true, and further that these statements were made with the knowledge that willful false statements and the like so made are punishable by fine or imprisonment, or both, under the provisions of 18 U.S.C. §1001, and that such willful false statements may jeopardize the validity of this application and any patent or patents resulting therefrom.

Lee M. Middleman

Feb 2, 1998
Date

LEE M. MIDDLEMAN, PhD

16 Coalmine View
 Portola Valley, CA 94028
 (415) 851-0535

CAREER SUMMARY:

- Strong entrepreneurial experience in startup companies and within large corporations.
- Over twenty-five years experience creating and directing product development leading to many hundreds of millions of dollars of highly profitable new business.
- Successful market explorations leading to new applications for proprietary technologies, thus defining new business opportunities.
- Broad career in a wide range of products and technologies, directing manufacturing, marketing, and development.

PROFESSIONAL HISTORY:

1991 - present Vice President, Product Development, Hospital Business Group (1995 - present)
 Nellcor Puritan Bennett Incorporated, Pleasanton, CA

- Currently directing the product development for the \$500-million Hospital Business Group including sensors, monitors, ventilators, and OEM products (200 people at four sites)
- Led the integration team that merged the \$100-million Bennett Division into Hospital Group, including R&D, marketing, and manufacturing. Was responsible for site and personnel consolidation decisions and organizational structure recommendations.
- Directed the integration of Infrasonics, Inc., a \$25-million ventilator company, into the Hospital Group.
- Set new, aggressive time-to-market, schedule adherence, and COGS targets for all Hospital development projects, while reducing direct R&D expenses from 6% to 4%.

Vice President and General Manager, Sensors and Monitoring Systems Division (1994 - 1995)

- Managed product development and manufacturing for the \$250-million patient monitoring and accessories division.
- Focused renewed executive interest in manufacturing strategy including disaster recovery plans, inventory control, and performance metrics.
- Strengthened interaction between manufacturing and development to ensure that both rapid time-to-market and manufacturability goals were met.

Senior Technical Director, Sensor and OEM Division (1991 - 1994)

- Created product development strategy for new division. Redirected the existing sensor development team to focus on a few projects of significant impact to business.
- Directed the performance upgrade of the major sensor product line (\$150 million business), while introducing four new products.
- Established a research group to develop new optoelectronic-based sensors and fiber-optic based products.
- Was responsible for OEM electronic module product development including hardware and software development
- Directed a technical team of 40 engineers, scientists, and technicians in electronic hardware, software, optoelectronics, mechanical design, and chemistry.

EXHIBIT A

LEE M. MIDDLEMAN, PhD, page 2

1985 - 1991

General Manager, Medical Ventures (1989 - 1991)
Raychem Corporation, Menlo Park, CA

- Performed an in-depth analysis of the medical device markets. Identified Raychem technologies that could impact trends in these markets.
- Created the business plan for entry into the surgical instrument market. For cash flow reasons, Raychem licensed the technology and patents to a major medical company.
- Disclosed twenty-four inventions using Raychem technologies. Awarded seven patents. Additional patent applications were filed.
- Directed an engineering team to design and construct prototypes for animal and clinical trials.

Director of Technologies, Corporate Technology Division (1985 - 1989)

- Directed the departments performing materials research and product development in three key Raychem technologies: conductive polymers, electronic ceramics, and optical materials.
- Performed technical assessment of technologies and projects of potential acquisition candidates.
- Established and led the optical-fiber program in direct support of a major, new, internal venture.

1983 - 1985

Vice President, Research and Development
Taliq Corporation, Mountain View, CA

- Led a technical effort which took a new, liquid-crystal display from laboratory demo to a characterized materials technology with demonstrated reliability and environmental stability.
- Attracted and hired a strong technical team for this new corporation to perform hardware and software development, materials and process development, and manufacturing engineering. Managed the prototype manufacturing.
- Performed exploratory marketing for light-shutter applications of this technology.

1976 - 1983

Director of Technologies, Corporate Technology Division (1982-1983),
Raychem Corporation, Menlo Park, CA

- Directed research and development in the three major technologies of the corporation with a staff of 90 scientists and engineers.
- Produced and implemented the strategic plan for mature and new technologies. Strengthened the program by focusing resources on the most promising projects: conductive polymers, electrochemistry, and elastic-memory polymers.

Technical Director, Corporate Technology Division (1980 - 1982)

- Provided technical leadership and general management to 35 scientists and engineers in a major, proprietary electronic materials technology, conductive polymer composites.
- Created a new department to develop in-house capability in computer-aided design, product/materials modeling, and electronics system design.

LEE M. MIDDLEMAN, PhD, page 3

Department Manager, PolySwitch® Program (1978 - 1980)

- Conceived and reduced to practice a unique electronic switch for overload protection of low-voltage circuits. Was awarded 5 basic US patents on products developed.
- Built and directed the successful PolySwitch product development and manufacturing engineering team (15 people).
- Working with marketing and sales teams, created a business plan and performed market research leading to the launching of a new product division (\$400-million sales, 1997).

1970 - 1976

Vice President and Co-founder

Nuclear Semiconductor, Inc., Mountain View, CA (now a division of Thermo Instruments.)

- Co-founded Nuclear Semiconductor, Inc., in 1970 to develop ultra-high-performance semiconductor radiation detectors. Made the key technical contributions. Directed the technical development. Established research laboratories and manufacturing facilities.
- Directed the successful introduction of state-of-the-art products including X-ray fluorescence analyzers and accessories for use in materials analysis (\$3-million sales, 1976).

PATENTS AND PUBLICATIONS:

Twenty one US patents granted; four additional US patent applications and many foreign patent applications filed. Fifteen publications.

EDUCATION:

PhD Physics, Stanford University, Stanford, California
Woodrow Wilson Fellow, National Science Foundation Fellow
BA Physics, Johns Hopkins University, Baltimore, Maryland

LEE M. MIDDLEMAN

PATENTS:

- US 3,963,922 "X-Ray Fluorescence Device," June 15, 1976
- US 4,238,812 "Circuit Protection Devices Comprising PTC Elements," December 9, 1980
- US 4,276,466 "Heater with Distributed Heater Element," June 30, 1981
- US 4,315,237 "PTC Devices Comprising Oxygen Barrier Layers," February 9, 1982
- US 4,317,027 "Circuit Protection Devices," February 23, 1982
- US 4,329,726 "Circuit Protection Devices Comprising PTC Elements," May 11, 1982
- US 4,352,083 "Circuit Protection Devices," September 28, 1982
- US 4,379,220 "Method of Heating Liquid," April 5, 1983
- US 4,413,301 "Circuit Protection Devices Comprising PTC Elements," November 1, 1983
- US 4,450,496 "Protection of Certain Electrical Systems by Use of PTC Devices," May 22, 1984
- US 4,475,138 "Circuit Protection Devices Comprising PTC Element," October 2, 1984
- US 4,904,850 "Laminar Electrical Heaters," February 27, 1990
- US 5,002,563 "Sutures Utilizing Shape Memory Alloys," March 26, 1991
- US 5,231,989 "Steerable Cannula," August 3, 1993
- US 5,345,937 "Steerable Cannula," September 13, 1994
- US 5,469,845 "Disposable Pulse Oximeter Sensor," November 28, 1995
- US 5,486,183 "Device or Apparatus for Manipulating Matter," January 23, 1996
- US 5,509,923 "Device for Dissecting, Grasping, or Cutting an Object," April 23, 1996
- US 5,601,572 "Device or Apparatus for Manipulating Matter Having an Elastic Ring Clip,"
February 11, 1997
- US 5,632,746 "Device or Apparatus for Manipulating Matter," May 27, 1997
- US 5,678,544 "Disposable Pulse Oximeter Sensor," October 21, 1997

One additional patent allowed. Many foreign filings.

Five new patent applications awaiting examination.



6-25-98

PATENT
9438-1

IN THE UNITED STATES PATENT AND TRADEMARK OFFICE

In re application of: JAMES E. JERVIS
Serial No.: 08/483,291
Filed: June 7, 1995
For: **MEDICAL DEVICES
INCORPORATING SIM ALLOY
ELEMENTS**

Examiner: Justine Yu
Group Art Unit: 3733

#17
EJ
for me
①

**PETITION FOR ONE-MONTH EXTENSION OF TIME
UNDER 37 C.F.R. §1.136(a)**

BOX AF
Assistant Commissioner for Patents
Washington, D. C. 20231

Sir:

Applicant hereby petitions, pursuant to 37 C.F.R. §1.136(a), for a one (1) month extension of time to file the Appeal Brief enclosed herewith. The period for response was previously set to
06/22/1998 SSALLEEKU 00000104 08483291
02 FC:115 elapse May 18, 1997, and is accordingly hereby extended to June 18, 1998, which is still within the
110.00 OP
period for response.

Also submitted is the petition fee in the amount of \$110.00, check number 008744, to cover this Petition for a One-Month Extension of Time. The entity is a large entity.

PATENT
9438-1

The Commissioner is hereby authorized to charge payment of any additional fees associated with this communication, if such fees are due, to Deposit Account No. 19-2090.

Respectfully submitted,
SHELDON & MAK

Date: June 18, 1998

By: Karin E. Peterka
Karin E. Peterka
Reg. No. 35,976

Karin E. Peterka, Esq.
SHELDON & MAK
225 South Lake Avenue, Suite 900
Pasadena, California 91101
Tel.: (626) 796-4000
Fax: (626) 795-6321

EXPRESS MAIL mailing label no. EL057219663US
Date of Deposit June 18, 1998
I hereby certify that this paper is being deposited with the United States Postal Service "Express Mail Post Office to Addressee" service under 37 C.F.R. § 1.10 on the date indicated above and is addressed to the BOX AF, Assistant Commissioner For Patents, Washington, D.C. 20231

Sandra Spencer
Sandra Spencer



A# 6W 3733
9

PATENT
9438-1

IN THE UNITED STATES PATENT AND TRADEMARK OFFICE

37C1

In re application of: JAMES E. JERVIS
Serial No.: 08/483,291
Filed: June 7, 1995
For: **MEDICAL DEVICES
INCORPORATING SIM ALLOY
ELEMENTS**

Examiner: Justine Yu
Group Art Unit: 3733

RECEIVED
JUN 23 1998
GROUP 3200

TRANSMITTAL LETTER

BOX AF
Assistant Commissioner for Patents
Washington, D. C. 20231

Dear Sir:

Transmitted herewith are the following documents:

- (1) an Appeal Brief (and two additional copies) in the above-identified patent application;
- (2) an Amendment after final;
- (3) a check number 008742 in the amount of \$310.00, to cover the fee for filing this brief under 37 C.F.R. §1.17(f);
- (4) a check number 008744 in the amount of \$110.00 to cover the fee for a petition for a one month extension of time;
- (5) a certificate of express mailing; and,
- (6) a return receipt postcard.

The Commissioner is hereby authorized to charge payment of any additional fees associated with this appeal brief or credit any overpayment to Deposit Account No. 19-2090.

Respectfully submitted,
SHELDON & MAK

Date: June 18, 1998

By: Karin E. Peterka
Karin E. Peterka
Reg. No. 35,976

Karin E. Peterka, Esq.
SHELDON & MAK
225 South Lake Avenue, Suite 900
Pasadena, California 91101
Tel.: (626) 796-4000
• Fax: (626) 795-6321

◦ EXPRESS MAIL mailing label no. EL057219663US
Date of Deposit June 18, 1998
I hereby certify that this paper is being deposited with the United States Postal Service "Express Mail Post Office to Addressee" service under 37 C.F.R. § 1.10 on the date indicated above and is addressed to the BOX AF, Assistant Commissioner For Patents, Washington, D.C. 20231

Sandra Spencer
Sandra Spencer

08/483,291



UNITED STATES DEPARTMENT OF COMMERCE
Patent and Trademark Office
Address: COMMISSIONER OF PATENTS AND TRADEMARKS
Washington, D.C. 20231

SERIAL NUMBER	FILED DATE	FIRST NAMED APPLICANT	ATTORNEY DOCKET NO.
	08/07/95	JERVIS	9438-1

JEFFREY G SHELDON
SHELDON & MAK
225 SOUTH LAKE AVENUE SUITE 900
PASADENA CA 91101

QM41/0806

EXAMINER	
YU, J	
ART UNIT	PAPER NUMBER
3733	20

DATE MAILED: 08/06/95

Below is a communication from the EXAMINER in charge of this application
COMMISSIONER OF PATENTS AND TRADEMARKS

ADVISORY ACTION

THE PERIOD FOR RESPONSE:

- a) is extended to run 6 months or continues to run _____ from the date of the final rejection
- b) expires three months from the date of the final rejection or as of the mailing date of this Advisory Action, whichever is later. In no event however, will the statutory period for the response expire later than six months from the date of the final rejection.

Any extension of time must be obtained by filing a petition under 37 CFR 1.136(a), the proposed response and the appropriate fee. The date on which the response, the petition, and the fee have been filed is the date of the response and also the date for the purposes of determining the period of extension and the corresponding amount of the fee. Any extension fee pursuant to 37 CFR 1.17 will be calculated from the date of the originally set shortened statutory period for response or as set forth in b) above.

- Appellant's Brief is due in accordance with 37 CFR 1.192(a).
- Applicant's response to the final rejection, filed 6/18/96 has been considered with the following effect, but it is not deemed to place the application in condition for allowance:

- 1. The proposed amendments to the claim and/or specification will not be entered and the final rejection stands because:
 - a. There is no convincing showing under 37 CFR 1.116(b) why the proposed amendment is necessary and was not earlier presented.
 - b. They raise new issues that would require further consideration and/or search. (See Note).
 - c. They raise the issue of new matter. (See Note).
 - d. They are not deemed to place the application in better form for appeal by materially reducing or simplifying the issues for appeal.
 - e. They present additional claims without cancelling a corresponding number of finally rejected claims.

NOTE: _____

- 2. Newly proposed or amended claims _____ would be allowed if submitted in a separately filed amendment cancelling the non-allowable claims.
- 3. Upon the filing an appeal, the proposed amendment will be entered will not be entered and the status of the claims will be as follows:

Claims allowed: _____
Claims objected to: _____
Claims rejected: 21, 23, 25-38, 40-42, and 44-46

However:
 Applicant's response has overcome the following rejection(s): _____

- 4. The affidavit, exhibit or request for reconsideration has been considered but does not overcome the rejection because _____
- 5. The affidavit or exhibit will not be considered because applicant has not shown good and sufficient reasons why it was not earlier presented.

- The proposed drawing correction has has not been approved by the examiner.
- Other

Michael A. Brown

MICHAEL A. BROWN
PRIMARY EXAMINER



UNITED STATES DEPARTMENT OF COMMERCE
Patent and Trademark Office
 Address: COMMISSIONER OF PATENTS AND TRADEMARKS
 Washington, D.C. 20231

SERIAL NUMBER	FILING DATE	FIRST NAMED APPLICANT	ATTORNEY DOCKET NO.
08/483,291	06/07/95	JERVIS	J 9438-1

QM41/0930
 [JEFFREY G SHELDON
 SHELDON & MAK
 225 SOUTH LAKE AVENUE SUITE 900
 PASADENA CA 91101]

EXAMINER	
YU, J	
ART UNIT	PAPER NUMBER
3733	21

DATE MAILED: 09/30/98

Please find below a communication from the EXAMINER in charge of this application.

Commissioner of Patents



UNITED STATES DEPARTMENT OF COMMERCE
Patent and Trademark Office
ASSISTANT SECRETARY AND COMMISSIONER OF
PATENTS AND TRADEMARKS
Washington, D.C. 20231

MAILED
SEP 30 1998
Group 3700

**BEFORE THE BOARD OF PATENT APPEALS
AND INTERFERENCES**

Paper No. 21

Application Number: 08/483,291
Filing Date: 07 June 1995
Appellant(s): Jervis

Karin E. Peterka
For Appellant

EXAMINER'S ANSWER

Art Unit: 3733

This is in response to appellant's brief on appeal filed 6/18/98.

(1) *Real Party in Interest*

A statement identifying the real party in interest is contained in the brief.

(2) *Related Appeals and Interferences*

A statement identifying the related appeals and interferences which will directly affect or be directly affected by or have a bearing on the decision in the pending appeal is contained in the brief.

(3) *Status of Claims*

The statement of the status of the claims contained in the brief is incorrect. A correct statement of the status of the claims is as follows:

This appeal involves claims 21, 23, 25-31, 34-38, 40-42, and 44-46.

Claims 32 and 33 are allowed.

(4) *Status of Amendments After Final*

The appellant's statement of the status of amendments after final rejection contained in the brief is incorrect.

Art Unit: 3733

The amendment after final rejection filed on 6/18/98 has been entered.

(5) *Summary of Invention*

The summary of invention contained in the brief is deficient because on page 13, line 4, appellant erroneously concludes that the nitinol as described by the Seader reference requires a treatment process to make it exhibit the properties of an SIM material, and appellant's memory alloy element does not require a treatment process to make it exhibit the properties of an SIM material. This conclusion is not well taken because both Balko and appellant use nitinol (refer to the preliminary amendment filed on 6/7/95). In addition, there is no basis to support the allegation of Balko's nitinol in view of Seader reference requires an extensive, time consuming and expensive treatment process to make it exhibit the properties of an SIM material.

(6) *Issues*

The appellant's statement of the issues in the brief is correct.

(7) *Grouping of Claims*

Appellant's brief includes a statement that claims 21, 23, 25-31, 34-38, 40-42, and 44-46 in Group 1 and claims 32, 33, 35, 38, 41-42, and 46 in Group 2 do not stand or fall together and provides reasons as set forth in 37 CFR 1.192(c)(7) and (c)(8).

Art Unit: 3733

(8) *Claims Appealed*

The copy of the appealed claims contained in the Appendix to the brief is correct.

(9) *Prior Art of Record*

The following is a listing of the prior art of record relied upon in the rejection of claims under appeal.

4,512,338	Balko et al	4-1985
4,485,805	Foster, Jr.	12-1984
J.D. Seader, "Separation Systems Synthesis", Encyclopedia of Chemical Technology, third edition, volume 20, (1982), pages 726-736.		
5,231,989	Middleman et al	8-1993

Art Unit: 3733

(10) Grounds of Rejection

The following ground of rejection is applicable to the appealed claims.

1. The following is a quotation of 35 U.S.C. 103(a) which forms the basis for all obviousness rejections set forth in this Office action:

(a) A patent may not be obtained though the invention is not identically disclosed or described as set forth in section 102 of this title, if the differences between the subject matter sought to be patented and the prior art are such that the subject matter as a whole would have been obvious at the time the invention was made to a person having ordinary skill in the art to which said subject matter pertains. Patentability shall not be negated by the manner in which the invention was made.

2. Claims 21, 23, 25, and 26-31, 34-38, 40-42, and 44-46 are rejected under 35 U.S.C. 103(a) as being unpatentable over Balko et al in view of Seader(Encyclopedia of Chemical Technology publication) and Foster, Jr..

Balko teaches a nitinol (SMA) wire forming a graft structure 22 being placed inside the sheath head 50 (hollow placement device). Balko further teaches that the nitinol material having martensite transformation temperature at approximately body temperature, such as 37°C (column 3, lines 63-66) (martensite-austenite transformation). Balko lacks the description of that the nitinol is a pseudo elastic SMA. However, the teaching on page 731, lines 13-20 and page 733, line 6 of Seader discloses the nitinol having superelastic behavior (or pseudoelastic behavior) which would have stress-induced martensite-martensite transformation, and the deformation strain

Art Unit: 3733

is reversible through stress release and not by a temperature-induced phase change. Therefore, it is obvious that Balko's nitinol graft would have the same property as claimed such that the alloy formed at least partly from pseudoelastic shape-memory alloy, the alloy would display reversible stress-induced martensite at about body temperature such that it would have a stress-induced martensitic state and an austenitic state, the memory alloy element having a deformed shape when the alloy is in its stress-induced martensitic state and a different unstressed shape when the alloy is in its austenitic state.

Balko differs from the present invention in that Balko lacks a guide wire. However, it is notoriously old and well known in the art that the guide wire is necessary and being used for guiding a catheter into the body. In addition, Foster shows a stylet 16 (guide wire). Therefore, it would have been obvious to one of ordinary skill in the art at the time the invention was made to provide Balko's device with a guide wire in order to guide the catheter into a desire location.

3. The non-statutory double patenting rejection, whether of the obviousness-type or non-obviousness-type, is based on a judicially created doctrine grounded in public policy (a policy reflected in the statute) so as to prevent the unjustified or improper timewise extension of the "right to exclude" granted by a patent. *In re Thorington*, 418 F.2d 528, 163 USPQ 644 (CCPA 1969); *In re Vogel*, 422 F.2d 438, 164 USPQ 619 (CCPA 1970); *In re Van Ornum*, 686 F.2d 937, 214 USPQ 761 (CCPA 1982); *In re Longi*, 759 F.2d 887, 225 USPQ 645 (Fed. Cir. 1985); and *In re Goodman*, 29 USPQ2d 2010 (Fed. Cir. 1993).

A timely filed terminal disclaimer in compliance with 37 CFR 1.321(b) and © may be used to overcome an actual or provisional rejection based on a non-statutory double patenting ground provided the conflicting application or patent is shown to be commonly owned with this application. See 37 CFR 1.78(d).

Art Unit: 3733

Effective January 1, 1994, a registered attorney or agent of record may sign a terminal disclaimer. A terminal disclaimer signed by the assignee must fully comply with 37 CFR 3.73(b).

4. Claims 21 and 23 are rejected under the judicially created doctrine of obviousness-type double patenting as being unpatentable over claims 1-2 of U.S. Patent No. 5,231,989. Although the conflicting claims are not identical, they are not patentably distinct from each other because the difference between the patented claims and the proposed application claims are minor and obvious from each other. In the instant claims 21 and 23, all elements are included in the claims 1-2 of Pat. 5,231,989. The recitation of "placement device" is merely obvious variation over the "elongated tube" from claim 1 of the Pat. No. 5,231,989, the "memory alloy element" or "stent" is merely obvious variation in wording over the "elastic member", and the "guide wire" is a variation over the "straightener" from claims 1-2 of Pat. No. 5,231,989. The alternate terminology is obvious and merely limits the claim slightly but it does not change the scope of the claim.

5. Claims 21 and 23 are rejected under 35 U.S.C. 102(e) as anticipated by or, in the alternative, under 35 U.S.C. 103(a) as obvious over Middleman et al.

Middleman discloses an elastic member 60 (stent) formed from superelastic material which is located inside an elongated tube (catheter). Middleman further discloses a straightener (guide

Art Unit: 3733

wire) and the elastic member are capable of relative axial movement (see claims 1 and 2 of Middleman).

Middleman differs from the present invention in that only the names for each claimed parts are different. However, having a different name is considered as an obvious design choice and fails to patently define over the prior art.

6. *Claims 32 and 33 are allowed.*

(11) *Response to Argument*

Appellant argues that Balko does not have the same material as claimed. Especially on page 15 of the Brief, the Appellant's description of the Balko reference such that "Balko does not teach use of an SIM material or use of a shape memory alloy that exhibits properties of an SIM material at about body temperature" is incorrect. First, both of Balko and instant application use the nitinol alloy. Next, Balko in column 3, lines 54-66 teaches the shape memory alloy, nitinol wire, having martensite transformation temperature of approximately 37°C, when the wire is exposed to the heat of the surrounding body tissue, the wire is permitted to reach and exceed the martensite transformation phase, accordingly, initiate reformation into its coiled form (column 4, lines 21-27). While it is true that Balko does not explicitly disclose that the wire transforms from a deformed shape to an unstressed shape without any change in temperature of the shape memory alloy, it is well known in the art that

Art Unit: 3733

the nitinol can exhibit the properties of an SIM or superelastic material at a constant temperature (refer to Seader disclosure on page 730 and 733 as explained above). Seader on page 730, third paragraph, and on page 733, second paragraph, clearly discloses that the Nitinol has a known superelastic behavior or SIM behavior. Since the nitinol inherently has the characteristic of SIM material as one of its properties, Balko does disclose the shape memory nitinol would have properties of an SIM material at about the body temperature.

Applicant on page 19, lines 5-7 of the Brief argues that Foster does not disclose a stylet or guide wire that guides the naso-gastric tube into the stomach of a patient. While it is true that Foster discloses a stylette that is inserted after the naso-gastric tube is already in the stomach, however, the teaching in column 4, lines 32-42 of Foster discloses that the stylette 16 being used to guide a balloon 11 into the desired location and after confirmation of the placement of the balloon 11 in the stomach the stylette 16 is removed. In addition, as stated in the rejection above, a stylette or guide wire is notoriously old and well known in the art for guiding a flexible catheter into the desired location. Therefore, the feature of having a guidewire for guiding a catheter into the body fails to patentably define over the prior art.

On page 26 of the Brief, appellant states that "the examiner did not give proper weight to the expert declaration of Dr. Lee Middleman". The statement is incorrect. The declaration to Dr. Lee middleman was thoroughly reviewed and found to be unpersuasive for the following reasons: (1) the declaration states Dr. Lee Middleman's opinion such that "find no suggestion or teaching in Balko, Seader, or Foster to make the nitinol disclosed in Balko

Art Unit: 3733

from a stress-induced martensite alloy” (page 3, lines 19-20). This opinion is not persuasive because there is no basis to support the allegation that Balko’s nitinol can not exhibit SIM properties. In addition, as noted by the appellant, nitinol can exhibit the properties of an SIM material. (2) Dr. Middleman further states that “there is no suggestion in Balko or any of the other references to use nitinol without a temperature change” (paragraph 13). While it is true that Balko is silent on the use of nitinol without a temperature change, it is inherent in the characteristic of the nitinol such that nitinol would be able to exhibit the SIM at the constant temperature (refer to the teaching on page 731, paragraph 3 of Seader). In addition, the teaching on page 733, paragraphs 4 and 6 of the Seader disclosure teaches usage in the medical device field and the nitinol undergoes superelastic behavior at body heat. Since the declaration did not directly address the Seader disclosure, therefore, the declaration is found not persuasive.

On page 23, lines 6-10 of the Brief, appellant argues that the limitation of “the memory alloy stent having (I) a deformed relatively straightened shape when the alloy is in its stress-induced martensitic state and (ii) a different unstressed relatively coiled shape in claims 32 and 33 is not provided by the combination of Balko, Seader, and Foster reference” is correct. Claims 32 and 33 are allowable over the prior art of record.

On page 28 of the Brief, appellant argues that “claims 1 and 2 of the ’989 patent disclose an elastic member made of SIM material to bend or unbend a bendable elongated tube. In contrast, claims 21 and 23 of the present application disclose a non-bendable hollow

Art Unit: 3733

placement device to bend and unbend a memory alloy made of a SIM material". The argument is not well taken because of the following reasons: first, the claimed invention first refers to a hollow placement device, the language of "non-bendable" is irrelevant because the language is not supported by the present claims. Next, claims 1 and 2 of '989 patent claim an article comprising an elongated tube, an elastic member being a memory alloy element formed at least partly from a superelastic shape-memory alloy, the alloy displaying reversible stress-induced martensite at about body temperature such that it has a stress-induced martensite state containing relatively more martensite and an austenitic state containing relatively more austenite. In the instant claims 21 and 23, appellant claims a medical device having a hollow placement device, and a memory alloy element which having the same characteristic as presented in claims 1 and 2 of '989 patent. Therefore, it is obvious that claims 21 and 23 of the present application and claims 1 and 2 of '989 patent cover the same subject matters or same invention. The examiner notes that euphemistic differences in claim language does not elevate the claims to a non-obvious or distinct invention.

On page 31 of the Brief, appellant argues that U.S. Patent No. 5,231,989 does not qualify as prior art under 35 U.S.C. §102(e). The examiner rejects the claims 21 and 23 under 35 U.S.C. §102(e) along with the double patenting rejection because both of the '989 patent and the present application are commonly owned by the same assignee and having different inventive entities. Therefore, the rejection to claims 21 and 23 under double patenting along with 35 U.S.C. §102(e) is proper.

Application/Control Number: 08/483,291

Page 12

Art Unit: 3733

For the above reasons, it is believed that the rejections should be sustained.

Respectfully submitted,



Justine Yu
September 29, 1998



Richard J. Apley
Supervisory Patent Examiner
Group 3700

225 South Lake Avenue
9th Floor
Pasadena, California 91101



SM
12-9-98
PATENT

Attorney Docket Number 9438-1

#22

IN THE UNITED STATES PATENT AND TRADEMARK OFFICE

In re application of: JAMES E. JERVIS

Serial No.: 08/483,291

Filed: June 7, 1995

For: **MEDICAL DEVICES
INCORPORATING SIM ALLOY
ELEMENTS**

Examiner: Justine Yu

Group Art Unit: 3733

RECEIVED

DEC - 7 1998

Group 3700

REPLY BRIEF SUBMITTED UNDER 37 C.F.R. §1.193(b)

BOX AF
Assistant Commissioner for Patents
Washington, D. C. 20231

Sir:

Appellant submits this Reply Brief (in triplicate), pursuant to 37 C.F.R. §1.193(b), in reply to the Examiner's Answer mailed September 30, 1998, in connection with the appeal filed in the above-identified application.

Also filed with this Reply Brief is a Request for Oral Hearing, pursuant to 37 C.F.R. §1.194, along with the accompanying fee of \$260.00, pursuant to 37 C.F.R. §1.17(g).

TABLE OF CONTENTS

	<u>Page No.</u>
I. INTRODUCTION.....	1
II. THE REPLY BRIEF SHOULD BE ENTERED PURSUANT TO 37 C.F.R. §1.193(b).....	1
III. ARGUMENT.....	4
A. The Examiner is Incorrect in the Assertion that Seader Teaches that Nitinol Inherently has the Characteristics of SIM Material.....	4
B. The Examiner is Incorrect in the Assertion that Foster Discloses a Stylette Used to Guide a Balloon.....	6
C. The Examiner is Incorrect in the Assertion that Claims 21 and 23 of the Present Invention Cover the Same Invention as Claims 1 and 2 of the '989 Patent.....	7
D. The Examiner is Incorrect in the Assertion that Because the Subject Application and the '989 Patent are Commonly Owned by the Same Assignee, the Rejection of Claims 21 and 23 Under 35 U.S.C. §102(e) is Proper.....	8
IV. CONCLUSION.....	9

I. INTRODUCTION

This Reply Brief is filed in response to the Examiner's Answer mailed on September 30, 1998, in connection with the appeal from the final rejection mailed September 18, 1997, in the subject application. The Examiner's Answer raised new points of argument.

In the Appeal Brief filed by Appellant on June 18, 1998, Appellant sought reversal by the Board of the Examiner's final rejection of claims 21, 23, and 25-38, 40-42, and 44-46 (dependent claims 39 and 43 were withdrawn from appeal and canceled in an amendment filed subsequent to the final rejection, an amendment which the Examiner has entered).

In the Examiner's Answer, Appellant acknowledges that the Examiner indicated that independent claims 32 and 33 are allowable over the prior art of record. Thus, claims 21, 23, 25-31, 34-38, 40-42, and 44-46 are presently on appeal.

II. THE REPLY BRIEF SHOULD BE ENTERED PURSUANT TO 37 C.F.R. §1.193(b)

The Examiner's Answer raised new points of argument. According to 37 C.F.R. §1.193(b), Appellant may file a Reply Brief directed only to such new points of argument. Since Appellant's Reply Brief deals only with new points of argument raised in the Examiner's Answer, Appellant respectfully submits this Reply Brief in accordance with 37 C.F.R. §1.193(b).

In the Examiner's Answer, the Examiner for the first time indicated that claims 32 and 33 are allowable over the prior art of record. In particular, the Examiner stated the following:

On page 23, lines 6-10 of the Brief, Appellant argues that the limitation of "the memory alloy stent having (i) a deformed relatively straightened shape when the alloy is in its stress-induced martensitic state and (ii) a different unstressed relatively coiled shape in claims 32 and 33 is not provided by the combination of Balko, Seader, and Foster references" is correct. Claims 32 and 33 are allowable over the prior art of record.

See Examiner's Answer, page 10.

In the Examiner's Answer, with respect to the obviousness rejection of the claims over Balko in view of Seader, the Examiner for the first time argued that it is inherent in the characteristic of nitinol that such nitinol exhibits SIM properties at constant temperature. In particular, the Examiner argued the following:

...[B]oth Balko and the instant application use the nitinol alloy. Next, Balko, in column 3, lines 54-66 teaches the shape memory alloy, nitinol wire, having martensite transformation temperature of approximately 37 °C, when the wire is exposed to the heat of the surrounding body tissue, the wire is permitted to reach and exceed the martensite transformation phase, accordingly, initiate reformation into its coiled form (column 4, lines 21-27). While it is true that Balko does not explicitly disclose that the wire transforms from a deformed shape to an unstressed shape without any change in temperature of the shape memory alloy, it is well known in the art that the nitinol can exhibit the properties of an SIM or superelastic material at a constant temperature...Seader on page 730, third paragraph, and on page 733, second paragraph, clearly discloses that the nitinol has a known superelastic behavior or SIM behavior. Since the nitinol inherently has the characteristic of SIM material as one of its properties, Balko does disclose the shape memory nitinol would have properties of an SIM material at about the body temperature.

See Examiner's Answer, page 8 to page 9.

Further, in the Examiner's Answer, the Examiner for the first time argued that Foster discloses a stylette that is used to guide a balloon into the desired location. In particular, the Examiner argued the following:

Applicant on page 19, lines 5-7 of the Brief argues that Foster does not disclose a stylet or guide wire that guides the naso-gastric tube into the stomach of a patient. While it is true that Foster discloses a stylette that is inserted after the naso-gastric tube is already in the stomach, however, the teaching in column 4, lines 32-42 of Foster discloses that the stylette 16 being used to guide a balloon 11 into the desired location and after confirmation of the placement of the balloon 11 in the stomach, the stylette 16 is removed....

See Examiner's Answer, page 9.

Further, in the Examiner's Answer, with respect to the obviousness-type double patenting rejection of claims 21 and 23, over claims 1 and 2 of U.S. Patent No. 5,231,989, the Examiner for the first time argued the following:

...the claimed invention first refers to a hollow placement device, [and] the language of "non-bendable" is irrelevant because the language is not supported by the present claims. Next, claims 1 and 2 of the '989 patent claim an article comprising an elongated tube, an elastic member being a memory alloy element formed at least partly from a superelastic shape memory alloy, the alloy displaying reversible stress induced martensite at about body temperature such that it has a stress-induced martensite state containing relatively more martensite and an austenitic state containing relatively more austenite. In the instant claims 21 and 23, appellant claims a medical device having a hollow placement device, and a memory alloy element which having the same characteristic as presented in claims 1 and 2 of the '989 patent. Therefore, it is obvious that claims 21 and 23 of the present application and claims 1 and 2 of the '989 patent cover the same subject matter of the same invention.

See Examiner's Answer, page 11.

Further, in the Examiner's Answer, with respect to the claims 21 and 23 under 35 U.S.C. §102(e), or in the alternative, under 35 U.S.C. §103(a), the Examiner for the first time argued the following:

...The Examiner rejects the claims 21 and 23 under 35 U.S.C. §102(e), along with the double patenting rejection because both the '989 patent and the present application are commonly owned by the same assignee and having different inventive entities. Therefore, the rejection to claims 21 and 23 under double patenting along with 35 U.S.C. §102(e) is proper.

See Examiner's Answer, page 11.

III. ARGUMENT

A. The Examiner is Incorrect in the Assertion that Seader Teaches that Nitinol Inherently has the Characteristics of SIM Material

In the Examiner's Answer, with respect to the obviousness rejection of the claims over Balko in view of Seader, the Examiner for the first time argued that it is inherent in the characteristic of nitinol that such nitinol exhibits SIM properties. The Examiner is plainly wrong.

The portion of Seader referred to by the Examiner (page 731, paragraph 3 of Seader) says nothing about nitinol inherently having the characteristic of exhibiting SIM properties. Rather, Seader discloses that a nitinol alloy has a martensite phase, and thus exhibits shape memory behavior, only if it is heated to an "elevated temperature" (page 726, paragraph 1) and "cooled at a certain rate" (page 726, paragraph 2). Moreover, even if such an alloy has a martensite phase, this does not mean it is superelastic (i.e. SIM). In addition, Seader discloses the ability of alloys "under certain conditions to exhibit superelastic behavior" (page 731, paragraph 3). Such an alloy is superelastic only if it is "deformed well beyond the point of the initial single-coalesced martensite stage" (page 731, paragraph 3). Further, only some nitinol alloys can exhibit superelastic behavior, a fact acknowledged by Seader when he says "when many (not all) of the martensitic alloys are deformed..." (page 731, paragraph 3).

The Examiner's argument that all nitinol inherently exhibits SIM behavior makes as much sense as arguing that all birds are capable of being carrier pigeons. In fact, only some birds can be carrier pigeons, and only if they are properly trained. Likewise, only some nitinol alloys have the capability of exhibiting SIM behavior, and only if they are appropriately treated.

Not only has the Examiner misinterpreted and mischaracterized Seader, the Examiner fails to acknowledge that her position is contrary to the facts presented by an acknowledged expert in the field. Dr. Lee Middlemen states that nitinol can exhibit the properties of an SIM material “only if it undergoes a treatment process... (that is) extensive, time consuming, and expensive...” (see Middleman Decl., paragraph 11). Thus, Dr. Middleman’s declaration is consistent with the teachings of Seader. Moreover, as previously argued in Appellant’s Appeal Brief, and contrary to the Examiner’s position, the Declaration of Dr. Lee Middleman does address the Seader reference (see Middleman Declaration, paragraph 13).

In addition, the Examiner also fails to recognize that her position is inconsistent with the teachings of U.S. Patent No. 4,505,767 to Quin which was before the Examiner in the subject application and which was relied upon by the Examiner in the office action dated October 29, 1996. Quin, like Seader, discloses that only certain nickel/titanium alloys exhibit SIM properties and require cold-working to develop the SIM properties (col. 3, lines 3-15).

Thus, what should the Board rely on - the plain language of Seader, Quin, and Dr. Middleman, or the factually incorrect speculation of the Examiner?

In view of the above arguments, the Examiner’s entire rejection under 35 U.S.C. §103(a) must fail. It is a house of cards built upon technically incorrect speculation. If all nitinol alloys do not exhibit SIM behavior, then no prima facie case of obviousness has been made. Only with hindsight would one skilled in the art replace Balko’s shape memory alloy that requires heat to transform with an SIM material that does not require such heat. Just as Appellant’s basic invention has already been found patentable by other examiners, the Board should likewise find Appellant’s invention to be patentable by reversing the rejection of the claims under 35 U.S.C. §103(a).

B. The Examiner is Incorrect in the Assertion that Foster Discloses a Stylette Used to Guide a Balloon

The Examiner cites the secondary reference Foster for its disclosure of a stiffener rod or stylette 16 as a guide wire, and argues that Foster discloses that the stylette is used to guide a balloon into the desired location, and after confirmation of the placement of the balloon in the stomach, the stylette is removed.

The Examiner is wrong. The stylette in Foster is inserted into a naso-gastric tube after the naso-gastric tube is already inserted into the stomach. Thus, it is not a guide wire. In particular, Foster only discloses that a pull string 15 is used to place a balloon 11 in a patient's stomach (col. 4, lines 13-15) and that the balloon 11 is placed in position in the patient's stomach by passing the standard naso-gastric tube 14 through the mouth (col. 4, lines 28-30). After the tip 24 of the tube 14 is confirmed to be in the stomach, a metal stiffener (stylette) 16 is run down the lumen to within 1 inch of the distal end of the naso-gastric tube (col. 4, lines 32-35). The balloon 11 with the fill tube 13 attached is rolled up and inserted into a rubber finger cot 17 to which the pull string 15 is attached (col. 4, lines 35-38). Then, by pulling the string 15 through the lumen of the naso-gastric tube 14, the balloon 11 containing finger cot 17 is drawn down into the stomach (col. 4, lines 38-40). After confirmation of the placement of the balloon 11 in the stomach, the stylette 16 is removed and the balloon 11 is inflated with saline plus contrast media (col. 4, lines 40-43).

Thus, the Examiner has failed to establish a prima facie case of obviousness because the proposed combination of references does not produce Appellant's claimed invention. Accordingly,

Appellant respectfully requests that the Board reverse the Examiner's rejection of the claims under 35 U.S.C. §103(a).

C. The Examiner is Incorrect in the Assertion that Claims 21 and 23 of the Present Invention Cover the Same Invention as Claims 1 and 2 of the '989 Patent

In the Examiner's Answer, with respect to the obviousness-type double patenting rejection of claims 21 and 23, over claims 1 and 2 of U.S. Patent No. 5,231,989 ("the '989 patent"), the Examiner argues that the language of "non-bendable" in Appellant's Brief is irrelevant because the language is not supported by the present claims (see Examiner's Answer, page 11). The Examiner misses the point of Appellant's argument. Appellant claims "the hollow placement device stressing the memory alloy element at a temperature greater than the A(s) of the alloy so that the memory alloy element is in its deformed shape" (see claim 21). If the hollow placement device of the present invention were bendable, it could not stress the memory alloy element as required by claims 21 and 23. In contrast, in the '989 patent, the hollow member is bent by the elastic member made of SIM material ("transforming the elastic member from one shape to another for correspondingly bending or unbending the distal segment of the (elongate) tube" (claim 1(c)) The hollow member cannot be used to stress the elastic member. Thus, the subject matter of claims 21 and 23 is not obvious over claims 1 and 2 of the '989 patent.

Further, the Examiner ignores the fact that Appellant claims a guide wire such that the hollow placement device is guidable by the guide wire. In contrast, the '989 patent claims a "straightening means capable of preventing the elastic member from bending." The guide wire in Applicant's

invention is used to guide rather than straighten, and thus performs a different function from the straightening means of the '989 patent.

Accordingly, Applicant respectfully requests that the Board reverse the Examiner's obviousness-type double patenting rejection of claims 21 and 23 in view of the '989 patent.

D. The Examiner is Incorrect in the Assertion that Because the Subject Application and the '989 Patent are Commonly Owned by the Same Assignee, the Rejection of Claims 21 and 23 Under 35 U.S.C. §102(e) is Proper

In the Examiner's Answer, the Examiner argues for the first time that the rejection of claims 21 and 23 under 35 U.S.C. §102(e), along with the double patenting rejection is proper, on the basis that both the '989 patent and the present application are commonly owned by the same assignee and have different inventive entities. The Examiner is wrong.

According to M.P.E.P. §706.02(a), for a §102(e) rejection to apply, the reference must be a U.S. Patent with a filing date earlier than the effective filing date of the application. Thus, whether the '989 patent and the subject application are commonly owned by the same assignee is irrelevant because the '989 patent does not qualify as prior art under 35 U.S.C. §102(e) to the subject application. Moreover, the common assignee requirement applies to a double patenting rejection (see M.P.E.P. §706.02(b)) or a provisional rejection under 35 U.S.C. §102(e) where the reference is a copending U.S. Patent application (see M.P.E.P. §706.02(f)). The '989 patent is an issued patent and is not a copending application.

As indicated by the genealogy of the subject application, which was previously set forth in Appellant's Appeal Brief, the application on appeal has an effective filing date of October 14, 1983. Claims 21 and 23, as well as the other claims on appeal are supported by the specification as originally

submitted and contain no new matter. Thus, claims 21 and 23, and the other claims on appeal are entitled to the priority date of October 14, 1983. Since the filing date of U.S. Patent No. 5,231,989 to Middleman et al. is February 15, 1991, which is almost eight (8) years after the October 14, 1983 priority date, the Examiner erred in rejecting claims 21 and 23 under 35 U.S.C. §102(e) and in the alternative under 35 U.S.C. §103(a).

Thus, the Examiner has not presented any good reason why the rejection of claims 21 and 23 under 35 U.S.C. §102(e) is without merit. Accordingly, Applicant respectfully requests that the Board reverse the Examiner's rejection of claims 21 and 23 under 35 U.S.C. §102(e), or in the alternative, under 35 U.S.C. §103(a).

IV. CONCLUSION

In view of the foregoing arguments, Applicant respectfully requests that the Board reverse the Examiner's rejection of claims 21, 23, 25-31, 34-38, 40-42, and 44-46.

Please charge any additional fees associated with this reply brief or credit any overpayment
to Deposit Account No. 19-2090.

Respectfully submitted,

SHELDON & MAK

November 30, 1998
Date

By: Karin E. Peterka
Karin E. Peterka
Reg. No. 35,976

Karin E. Peterka, Esq.
SHELDON & MAK
225 South Lake Avenue, Suite 900
Pasadena, California 91101
Tel.: (626) 796-4000
Fax: (626) 795-6321

EXPRESS MAIL mailing label no.: EL121767250US
Date of Deposit: November 30, 1998
I hereby certify that this paper is being deposited with the
United States Postal Service "Express Mail Post Office to
Addressee" service under 37 C.F.R. § 1.10 on the date
indicated above and is addressed to the ATTN: , Assistant
Commissioner For Patents, Washington, D.C. 20231

Stuart Duckworth
Stuart Duckworth



PATENT
Attorney Docket No. 9438-1

*Noted
OK, 12/10/98*

IN THE UNITED STATES PATENT AND TRADEMARK OFFICE

In re application of: JAMES E. JERVIS

Examiner: Justine Yu

Serial No.: 08/483,291

Group Art Unit: 3301

Filed: June 7, 1995

For: **MEDICAL DEVICES INCORPORATING
SIM ALLOY ELEMENTS**

12998
RECEIVED

UTC - 7 1998

Group 3700

#23

REQUEST FOR ORAL HEARING FOR APPEAL, PURSUANT TO 37 C.F.R. §1.194

BOX AF
Assistant Commissioner for Patents
Washington, D. C. 20231

Sir:

Applicant respectfully requests an oral hearing for appeal in the above-identified case, now before the Board of Appeals, pursuant to 37 C.F.R. §1.194. Accompanying this Request for Oral Hearing for Appeal is the required \$260.00 fee (check number 9208), as set forth in 37 C.F.R. §1.17(g), for filing this Request for Oral Hearing for Appeal.

12/04/1998 ZADDALLA 00000059 08483291

01 FC:121

260.00 GP

The Commissioner is hereby authorized to charge payment of any additional fees associated with this communication or credit any overpayment to Deposit Account No. 19-2090.

Respectfully submitted,

SHELDON & MAK

November 30, 1998
Date

By: Karin E. Peterka
Karin E. Peterka
Reg. No. 35,976

Karin E. Peterka, Esq.
SHELDON & MAK
225 South Lake Avenue, Suite 900
Pasadena, California 91101
Tel.: (626) 796-4000
Fax: (626) 795-6321

EXPRESS MAIL mailing label no.: **EL121767250US**
Date of Deposit: **November 30, 1998**
I hereby certify that this paper is being deposited with the United States Postal Service "Express Mail Post Office to Addressee" service under 37 C.F.R. § 1.10 on the date indicated above and is addressed to the ATTN: , Assistant Commissioner For Patents, Washington, D.C. 20231

Stuart Duckworth
Stuart Duckworth

AF | GP 3733 #



PATENT
9438-1

IN THE UNITED STATES PATENT AND TRADEMARK OFFICE

In re application of: JAMES E. JERVIS
Serial No.: 08/483,291
Filed: June 7, 1995
For: **MEDICAL DEVICES
INCORPORATING SIM ALLOY
ELEMENTS**

Examiner: Justine Yu
Group Art Unit: 3733

RECEIVED
DEC - 7 1998
Group 3700

TRANSMITTAL LETTER

BOX AF
Assistant Commissioner for Patents
Washington, D. C. 20231

Dear Sir:

Transmitted herewith are the following documents:

- (1) a Reply to the Examiner's Answer mailed September 30, 1998, (and two additional copies) in the above-identified patent application;
- (2) a Request for Oral Hearing;
- (3) a check number 9208 in the amount of \$260.00, to cover the filing fee for the Request for Oral Hearing under 37 C.F.R. §1.17(f);
- (4) a certificate of express mailing; and,
- (5) a return receipt postcard.

12/04/1998 ZABDALLA 00000059 08483291

01-FC:121

260.00 OP

PATENT
9438-1

The Commissioner is hereby authorized to charge payment of any additional fees associated with this appeal brief or credit any overpayment to Deposit Account No. 19-2090.

Respectfully submitted,
SHELDON & MAK

Date: November 30, 1998

By: Karin E. Peterka
Karin E. Peterka
Reg. No. 35,976

Karin E. Peterka, Esq.
SHELDON & MAK
225 South Lake Avenue, Suite 900
Pasadena, California 91101
Tel.: (626) 796-4000
Fax: (626) 795-6321

EXPRESS MAIL mailing label no. EL121767250US
Date of Deposit November 30, 1998
I hereby certify that this paper is being deposited with the United States Postal Service "Express Mail Post Office to Addressee" service under 37 C.F.R. § 1.10 on the date indicated above and is addressed to the ATTN: Board of Patent Appeals and Interferences, Assistant Commissioner For Patents, Washington, D.C. 20231

Stuart Duckworth
Stuart Duckworth



**UNITED STATES DEPARTMENT OF COMMERCE
Patent and Trademark Office**

Address: COMMISSIONER OF PATENTS AND TRADEMARKS
Washington, D.C. 20231

08/483,291

SERIAL NUMBER	FILING DATE	FIRST NAMED APPLICANT	ATTORNEY DOCKET NO.
08/483,291	06/07/95	JERVIS	J 9438-1

QM41/1215

JEFFREY G SHELDON
SHELDON & MAK
225 SOUTH LAKE AVENUE SUITE 900
PASADENA CA 91101

EXAMINER	
YU, J	
ART UNIT	PAPER NUMBER
3733	24

DATE MAILED: 12/15/98

Please find below a communication from the EXAMINER in charge of this application.

Commissioner of Patents

The reply brief filed 11/30/98 has been entered and considered. The rejection to claims 21 and 23 under 35U.S.C. 102(e)/103(a) in section 5 of the Examiner's Answer is withdrawn. The application has been forwarded to the Board of Patent Appeals and Interferences for decision on the appeal.

Justine Yu

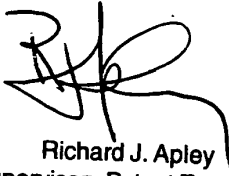
Richard J. Apley
Supervisory Patent Examiner
Group 3700

MAILED

1999 - 6 2000

PAT. & T.M. OFFICE
BOARD OF PATENT APPEALS
AND INTERFERENCES
399



UNITED STATES DEPARTMENT OF COMMERCE
Patent and Trademark Office
ASSISTANT SECRETARY AND COMMISSIONER OF
PATENTS AND TRADEMARKS
Washington, D.C. 20231

Paper No: 25

Jeffrey G. Sheldon
Sheldon & Mak
225 South Lake Avenue
Suite 900
Pasadena, CA 91101

Appeal No:	1999-2649
Appellant:	Jervis, James E.
Application No:	08/483,291
Hearing Room:	A
Hearing Docket:	B
Hearing Date:	Wednesday, February 07, 2001
Hearing Time:	1:00 PM
Location:	Room 12C07 CRYSTAL GATEWAY 2 1225 Jefferson Davis Highway Arlington, VA 22202

NOTICE OF HEARING

CONFIRMATION REQUIRED WITHIN TWENTY-ONE DAYS

Your attention is directed to 37 CFR § 1.194(a).
The above identified appeal will be heard by the Board of Patent Appeals and Interferences on the date indicated. Hearings will commence at the time set and as soon as the argument in one appeal is concluded, the succeeding appeal will be taken up.
The time allowed for argument is twenty minutes unless additional time is requested and permitted before the argument is commenced.

CONFIRMATION OR WAIVER OF THE HEARING IS REQUIRED.

This form must be completed below and filed with the Board of Patent Appeals and Interferences preferably by facsimile within TWENTY-ONE (21) DAYS from the mailing date of this notice indicating confirmation or waiver of the hearing. A copy of this form may alternatively be filed by mail if facsimile is not available.

Failure to file this form within this time period will be construed as a waiver of the request for oral hearing.

37 CFR § 1.136(a) does not apply.

By order of the Board of Patent Appeals and Interferences

BPAI HEARINGS FAX No:
(703) 308-6199
See 1108 Off. Gaz. Pat. Trademark
Office 15 (Nov. 14, 1989)

BPAI Mailing Address:
BOARD OF PATENT APPEALS AND INTERFERENCES
COMMISSIONER OF PATENTS AND TRADEMARKS
WASHINGTON, D.C. 20231

Clerk of the Board (703)-308-9797

In all communications relating to this appeal, please identify the appeal by its number.

CHECK ONE:

- HEARING ATTENDANCE CONFIRMED
- HEARING ATTENDANCE WAIVED

Signature of Attorney/Agent/Appellant

Date

Registration No.

MAILED

1999-2649

REGISTRATION OFFICE
BOARD OF PATENT APPEALS
AND INTERFERENCES



UNITED STATES DEPARTMENT OF COMMERCE
Patent and Trademark Office
ASSISTANT SECRETARY AND COMMISSIONER OF
PATENTS AND TRADEMARKS
Washington, D.C. 20231

399

Response due 12-27-00

Paper No: 28

27 26

Jeffrey G. Sheldon
Sheldon & Mak
225 South Lake Avenue
Suite 900
Pasadena, CA 91101

Appeal No:
Appellant:
Application No:
Hearing Room:
Hearing Docket:
Hearing Date:
Hearing Time:
Location:

1999-2649
Jervis, James E.
08/483,291
A
B
Wednesday, February 07, 2001
1:00 PM
Room 12C07 CRYSTAL GATEWAY 2 1225 Jefferson Davis Highway Arlington, VA 22202

NOTICE OF HEARING

CONFIRMATION REQUIRED WITHIN TWENTY-ONE DAYS

Your attention is directed to 37 CFR § 1.194(a).

The above identified appeal will be heard by the Board of Patent Appeals and Interferences on the date indicated. Hearings will commence at the time set and as soon as the argument in one appeal is concluded, the succeeding appeal will be taken up.

The time allowed for argument is twenty minutes unless additional time is requested and permitted before the argument is commenced.

CONFIRMATION OR WAIVER OF THE HEARING IS REQUIRED.

This form must be completed below and filed with the Board of Patent Appeals and Interferences preferably by facsimile within TWENTY-ONE (21) DAYS from the mailing date of this notice indicating confirmation or waiver of the hearing. A copy of this form may alternatively be filed by mail if facsimile is not available.

Failure to file this form within this time period will be construed as a waiver of the request for oral hearing.

37 CFR § 1.136(a) does not apply.

By order of the Board of Patent Appeals and Interferences

BPAI HEARINGS FAX No:
(703) 308-6199
See 1108 Off. Gaz. Pat. Trademark
Office 15 (Nov. 14, 1989)

BPAI Mailing Address:
BOARD OF PATENT APPEALS AND INTERFERENCES
COMMISSIONER OF PATENTS AND TRADEMARKS
WASHINGTON, D.C. 20231

Clerk of the Board (703)-308-9797

In all communications relating to this appeal, please identify the appeal by its number.

CHECK ONE:

- HEARING ATTENDANCE CONFIRMED
- HEARING ATTENDANCE WAIVED

Jeffrey G. Sheldon

Signature of Attorney/Agent/Appellant

12/14/00 27,953

Date

Registration No.

**facsimile
TRANSMITTAL**

to: Board of Patent Appeals and Interferences
fax #: (703) 308-6199
re: **Appeal No. 1999-2649**
U.S. Patent Application Serial No. 08/483,291
For: Medical Devices Incorporating SIM Alloy Elements
Filing Date: June 7, 1995
Applicant: James E. Jervis
Attorney Docket No. 9438-1
date: December 15, 2000
pages: page(s) total, including this cover sheet: 2
If you do not receive all the pages, please call: Marilyn, ext. 385

Following is confirmation of attendance at the oral hearing for the above-identified matter.

CONFIDENTIALITY NOTICE: The documents accompanying this facsimile transmission contain privileged and confidential information. Do not disclose to, or discuss this information with, anyone other than those identified above. Unauthorized disclosure is strictly prohibited. If you receive this facsimile in error, please notify us by telephone immediately.

From the desk of...

JEFFREY G. SHELDON
Sheldon & Mak
225 So. Lake Avenue, 9th Floor
Pasadena, CA 91101
Phone: (626) 796-4000
Fax: (626) 795-6321

**UNITED STATES DISTRICT COURT
DISTRICT OF MINNESOTA
FOURTH DIVISION**

Medtronic, Inc.,

Plaintiff,

v.

Boston Scientific Corporation
and SciMed Life Systems, Inc.,

Defendants.

Civil Action No. 99-1035 RHK/FLN

**DEFENDANTS, BOSTON SCIENTIFIC
CORP. AND SCIMED LIFE SYSTEMS,
INC.'s SUBMISSION PURSUANT TO
35 U.S.C. § 282**

United States Patents

3620212	Nov., 1971	Fannon, Jr.
3868956	Mar., 1975	Alfidi et al.
3890977	Jun., 1975	Wilson
4035007	Jul., 1977	Harrison et al.
4037324	Jul., 1977	Andreasen
4170990	Oct., 1979	Baumgart et al.
4198081	Apr., 1980	Harrison et al..
4233690	Nov., 1980	Akins
4411655	Oct., 1983	Schreck
4490112	Jan., 1985	Tanaka
4494531	Jan., 1985	Gianturco
4425908	Jan., 1984	Simon
4512338	Apr., 1985	Balko et al.
4310354	Jan., 1982	Fountain et. al.
3786806	Jan., 1974	Johnson et. al

Publications

Otsuka, et al., Shape Memory Alloys, Metals Forum, vol. 4, No. 3 (1981), pp. 142-152.

Dotter, Charles T., Transluminal Expandable Nitinol Coil Stent Grafting: Preliminary Report, Radiology, vol. 147, pp. 259-260.

Cragg et al., "A New Percutaneous Vena Cava Filter", AJR 141:601-604, 1983

Cragg, et al., Radiology, (Apr. 1983) vol. 147, pp. 261-263.

Schctky, L. McDonald, "Shape Memory Alloys", Scientific America, Nov. 1979. pp. 74-82.

Baumgart, et al., "Mechanical Problems in the use of the Memory Effect for Osteosynthesis Plates", 1977

Watanabe, Studies on New Superelastic Ni-Ti Orthodontic Wire, J. Jap. Soc. for Dental Apparatus & Mat'ls., vol. 23, No. 61, pp. 47-57 (1981)

Melton, et al., "Alloys With Two Way Shape Memory Effect", Mechanical Engineering, March 1980, p. 42,43.

Hughes, James L MD, US Army Medical Research And Development Command, "Evaluation Of Nitinol For Use As A Material In The Construction Of Orthopaedic Implants" (1976)(BSC 51031- 51115)Contract No. DAMD 17-74-C-4041.

Robinson, "Metallurgy: Extraordinary Alloys That Remember Their Past", Science, vol. 191, no. 4230, March 1976

Wayman, "Some Applications of Shape-Memory Alloys," Journal of Metals, Jun., 1980, pp. 129-137.

Oonishi, Clinical Magazine: Orthopaedic Surgery, 32, p. 1180 (1981).

Cragg et al. "Nitinol Spiral Vena Caval Filter," 1986 (PX 88), Seminars in Interventional Radiology, 3:3; 227-230.

Simon et al., "A Vena Cava Filter Using Thermal Shape Memory Alloy", Radiology 1977
(125:89-94)

Cragg et al., "Percutaneous Arterial Grafting," Radiology 1984; 150:45-49.

Person(s) who may be relied upon as the prior inventor or as having prior knowledge of
or as having previously used or offered for sale the invention of the patent in suit:

Andrew Cragg

Joseph Rysavy
4313 Eighth Street, N.W.
Rochester, MN 55901

Gunner Lund
John Hopkins Medical Institution
East Baltimore, MD

Flavio Castenada

Willfido Castaneda-Zuniga

Kurt Amplatz

DATED this 18th day of December, 2000.

FULBRIGHT & JAWORSKI LLP
DORSEY & WHITNEY LLP

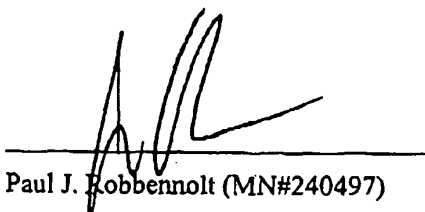

Paul J. Robbennolt (MN#240497)

220 South Sixth Street
Minneapolis, MN 55402
Telephone: (612) 340-2600

John E. Lynch
John A. Bauer
David A. Rubin
FULBRIGHT & JAWORSKI LLP
666 Fifth Avenue
New York, New York 10103
Telephone: (212) 318-3000

Attorneys for Defendants,

BOSTON SCIENTIFIC CORPORATION
SCIMED LIFE SYSTEMS, INC.

CERTIFICATE OF SERVICE

I, John A. Bauer, hereby certify that a copy of the foregoing DEFENDANTS', BOSTON SCIENTIFIC CORPORATION AND SCIMED LIFE SYSTEMS, INC., SUBMISSION PURSUANT TO 35 U.S.C. § 282 was served by facsimile on December 18, 2000 to

Celeste P. Grant
ROBIN, KAPLAN, MILLER & CIRESI
800 Lasalle Avenue, Suite 2800
Minneapolis, MN 55402

on this 18th day of December, 2000.

John A. Bauer

UNITED STATES DISTRICT COURT
DISTRICT OF MINNESOTA

MEDTRONIC, INC.,)	
a Minnesota corporation,)	
)	
Plaintiff,)	
)	Civil File No. 99-CV-1035 RHK/JMM
v.)	
)	
BOSTON SCIENTIFIC CORPORATION)	
a Delaware Corporation,)	DEFENDANTS' ANSWER
)	AND COUNTERCLAIMS
SCIMED LIFE SYSTEMS, INC.,)	
a Delaware corporation,)	
)	
Defendants.)	

In answer to Medtronic, Inc.'s ("Medtronic") Complaint served July 7, 1999 (the "Complaint"), Boston Scientific Corporation and SciMed Life Systems, Inc. ("BSC", "SciMed", respectively) respond to the specific paragraphs of the Complaint as follows:

SPECIFIC DENIALS

The numbering of the paragraphs herein corresponds to the numbering of the paragraphs in the Complaint.

1. Paragraph 1 states a legal conclusion which does not require an answer but to the extent an answer is required, the allegations are denied.

2. Defendants admit on information and belief that Medtronic is a Minnesota corporation with a principal place of business at 7000 Central Avenue N.E., Minneapolis,

Minnesota, but otherwise defendants are without sufficient information to permit them to form a belief as to the allegations of paragraph 2.

3. Admitted.

4. Denied. SciMed is a Minnesota Corporation.

5. Admitted that this Court has jurisdiction, venue is proper, and defendants have done business in this district. Defendants deny the remaining allegation stated in paragraph 5.

6. Defendants admit that on January 28, 1997, United States Patent No. 5,597,378 entitled "Medical Devices Incorporating SIM Alloy Elements" was issued. Defendants are without sufficient knowledge or information to permit them to form a belief as to the other allegations of paragraph 6, and therefore deny same.

7. Defendants are without sufficient knowledge or information to permit them to form a belief as to the allegations of paragraph 7, and therefore deny same.

8. Defendants admit that on November 26, 1991, United States Patent No. 5,067,957 entitled "Method of Inserting Medical Devices Incorporating SIM Alloy Elements" was issued. Defendants are Defendants are without sufficient knowledge or information to permit them to form a belief as to the allegations of paragraph 8, and therefore deny same.

9. Defendants are without sufficient knowledge or information to permit them to form a belief as to the allegations of paragraph 9, and therefore deny same.

10. Defendants restate and incorporate by reference their answers to paragraphs 1-9 of the Complaint.

11. Defendants admit that defendants have manufactured, sold, offered for sale or distributed the RADIUS™ STENT in the United States, including Minnesota, but otherwise deny all other allegations stated in paragraph 11.

12. Denied.

13. Defendants restate and incorporate by reference their answers to paragraphs 1-9 of the Complaint.

14. Defendants admit that defendants have manufactured, sold, offered for sale or distributed the RADIUS™ STENT in the United States, including Minnesota, but otherwise deny all other allegations stated in paragraph 14.

15. Denied.

First Affirmative Defense

16. U.S. Patent Nos. 5,597,378 (the “378 patent”) and 5,067, 957 (the “957 patent”)(collectively referred to as the “patents in suit”) are invalid on one or more grounds pursuant to 35 U.S.C. §§ 1 *et seq.*, including but not limited to §§ 102, 103, and 112.

Second Affirmative Defense

17. No conduct of defendants constitutes infringement of any of the patents in suit under any provision of 35 U.S.C. § 271.

COUNTERCLAIMS

Defendants allege as follows:

18. BSC is a Delaware Corporation with a principal place of business at One Boston Scientific Place, Natick, Massachusetts 01760-1537.

19. SciMed is a Minnesota Corporation with its principle place of business at One SciMed Place, Maple Grove, Minnesota 55311.

20. On information and belief, plaintiff Medtronic is a Minnesota corporation with a principal place of business at 7000 Central Avenue N.E., Minneapolis, Minnesota, 55432 and is subject to personal jurisdiction in this District by virtue of its filing of the Complaint in this action and by its conduct of business in this District.

21. Upon information and belief, Medtronic is the owner of U.S. Patent No. 4,665,906 (the "906 patent").

22. The '906 patent is intimately related to the '957 and '378 patents: (a) the '906 patent has the same specification as the '957 and '378 patents; (b) James E. Jarvis is the sole named inventor on all three patents; and (c) the claims of the patents are directed to patentably indistinct subject matter as demonstrated by the fact that the '378 patent is "terminally disclaimed" over the '906 patent. (A terminal disclaimer is filed where the claimed subject matter of two or more commonly owned patents is not patentably distinct.)

23. In view of the especially close relationship between the subject matter claimed in the '957 and '378 patents and that of the '906 patent, defendants possess a reasonable apprehension that Medtronic will also assert that the '906 patent is infringed by defendants'

making, using, selling, and/or offering for sale the RADIUS™ STENT. A controversy thus exists between defendants and Medtronic as to the nature and scope of rights arising under the '906 patent.

24. Accordingly, subject matter jurisdiction of the counterclaims exists under 28 U.S.C. §§ 1331, 1332, 1338, 2201, and 2202.

COUNT I

DECLARATION OF PATENT INVALIDITY

25. Defendants restate and incorporate by reference its answers and allegations in paragraphs 1 - 24 of its Answer and Counterclaims.

26. Medtronic claims to own the '957 and '378 patents, and on information and belief, is the owner of the '906 patent (the '957, '378, and '906 patents will be referred to collectively as the "Medtronic patents").

27. Each of the Medtronic patents is invalid on one or more grounds pursuant to 35 U.S.C. §§ 1 *et seq.*, including but not limited to §§ 102, 103, and 112.

COUNT II

DECLARATION OF NONINFRINGEMENT

28. Defendants restate and incorporate by reference its allegations in paragraphs 1 - 27 of its Answer and Counterclaims.

29. No conduct of defendants constitutes infringement of any of the Medtronic patents under any provision of 35 U.S.C. § 271.

WHEREFORE, Defendants request that this Court enter judgment dismissing the Complaint and in favor of Defendants on their counterclaims that the Medtronic patents are invalid and are not infringed by defendants.

For an order directing Medtronic to pay defendants' attorney's fees and its costs in connection with this litigation.

For such other and further relief as shall seem just and proper to the Court.

DATED this 10th day of September, 1999.

DORSEY & WHITNEY LLP



Peter S. Hendrixson (MN# 44027)
Robert R. Reinhart (MN# 90566)
David E. Bruhn (MN# 187045)
Paul J. Robbennolt (MN #240497)
220 South Sixth Street
Minneapolis, Minnesota 55402
Telephone: (612) 340-2600

FULBRIGHT & JAWORSKI LLP

John E. Lynch
John A. Bauer
James Zubok
666 Fifth Avenue
New York, New York 10103
Telephone: (212) 318-3000
Facsimile: (212) 752-5958

Attorneys for Defendants,
BOSTON SCIENTIFIC CORPORATION
SCIMED LIFE SYSTEMS, INC.

UNITED STATES DISTRICT COURT
DISTRICT OF MINNESOTA

MEDTRONIC, INC.,
a Minnesota corporation,

Plaintiff,

v.

BOSTON SCIENTIFIC CORPORATION
a Delaware Corporation, and

SCIMED LIFE SYSTEMS, INC.,
a Delaware corporation,

Defendants.

Civil File No. 99-CV-1035 RHK/FLN

**DEFENDANTS' AMENDED
ANSWER TO PLAINTIFF'S
FIRST AMENDED
COMPLAINT FOR PATENT
INFRINGEMENT**

In answer to plaintiff Medtronic, Inc.'s ("Medtronic") First Amended Complaint for Patent Infringement served April 17, 2000 (the "First Amended Complaint"), defendants Boston Scientific Corporation ("BSC") and SciMed Life Systems, Inc. ("SciMed") admit, deny and allege as follows:

FIRST DEFENSE

The numbering of the paragraphs herein corresponds to the numbering of the paragraphs in the First Amended Complaint.

1. Paragraph 1 states a legal conclusion which does not require an answer, but, to the extent an answer is required, the allegations are denied.

2. Defendants admit on information and belief that Medtronic is a Minnesota corporation with a principal place of business at 7000 Central Avenue N.E., Minneapolis,

Minnesota, but otherwise defendants are without sufficient information to permit them to form a belief as to the allegations of paragraph 2.

3. Admitted.

4. Denied. SciMed is a Minnesota Corporation.

5. Defendants admit that this Court has jurisdiction, venue is proper, and defendants have done business in this district. Defendants deny the remaining allegations set forth in paragraph 5.

6. Defendants admit that on January 28, 1997, United States Patent No. 5,597,378 entitled "Medical Devices Incorporating SIM Alloy Elements" was issued. Defendants are without sufficient knowledge or information to permit them to form a belief as to the remaining allegations set forth in paragraph 6, and therefore deny the same.

7. Defendants are without sufficient knowledge or information to permit them to form a belief as to the allegations set forth in paragraph 7, and therefore deny the same.

8. Defendants admit that on November 26, 1991, United States Patent No. 5,067,957 entitled "Method of Inserting Medical Devices Incorporating SIM Alloy Elements" was issued. Defendants are without sufficient knowledge or information to permit them to form a belief as to the remaining allegations set forth in paragraph 8, and therefore deny the same.

9. Defendants are without sufficient knowledge or information to permit them to form a belief as to the allegations set forth in paragraph 9, and therefore deny the same.

10. Defendants restate and incorporate by reference their answers to paragraphs 1-9 of the First Amended Complaint.

11. Defendants admit that defendants have manufactured, sold, offered for sale or distributed the RADIUS™ STENT in the United States, including Minnesota, but otherwise deny all other allegations set forth in paragraph 11.

12. Denied.

13. Defendants admit that they have had actual knowledge of the '378 patent for some time, but otherwise deny all other allegations stated in paragraph 13.

14. Defendants restate and incorporate by reference their answers to paragraphs 1-9 of the First Amended Complaint.

15. Defendants admit that defendants have manufactured, sold, offered for sale or distributed the RADIUS™ STENT in the United States, including Minnesota, but otherwise deny all other allegations set forth in paragraph 15.

16. Denied.

17. Defendants admit that they have had actual knowledge of the '957 patent for some time, but otherwise deny all other allegations set forth in paragraph 17.

SECOND DEFENSE

18. U.S. Patent Nos. 5,597,378 (the "378 patent") and 5,067, 957 (the "957 patent")(collectively referred to as the "patents in suit") are invalid on one or more grounds pursuant to 35 U.S.C. §§ 1 *et. seq.*, including but not limited to §§ 102, 103, and 112.

THIRD DEFENSE

19. No conduct of defendants constitutes infringement of any of the patents in suit under any provision of 35 U.S.C. § 271.

COUNTERCLAIMS

Defendants allege as follows:

20. BSC is a Delaware Corporation with a principal place of business at One Boston Scientific Place, Natick, Massachusetts 01760-1537.

21. SciMed is a Minnesota Corporation with its principle place of business at One SciMed Place, Maple Grove, Minnesota 55311.

22. On information and belief, plaintiff Medtronic is a Minnesota corporation with a principal place of business at 7000 Central Avenue N.E., Minneapolis, Minnesota, 55432, and is subject to personal jurisdiction in this District by virtue of its filing of the Complaint in this action and by its conduct of business in this District.

23. Accordingly, subject matter jurisdiction of the counterclaims exists under 28 U.S.C. §§ 1331, 1332, 1338, 2201, and 2202.

COUNT I

DECLARATION OF PATENT INVALIDITY

24. Defendants restate and incorporate by reference its allegations set forth in paragraphs 1 - 23 of its Amended Answer and Counterclaims.

25. Medtronic claims to own the '957 and '378 patents (the "patents in suit").

26. Each of the patents in suit is invalid pursuant to United States patent law, including 35 U.S.C. §§ 102, 103, 112 and/or 116.

COUNT II

DECLARATION OF NONINFRINGEMENT

27. Defendants restate and incorporate by reference its allegations in paragraphs 1 - 26 of its Amended Answer and Counterclaims.

28. No conduct of defendants constitutes infringement of any of the patents in suit under any provision of 35 U.S.C. § 271.

WHEREFORE, Defendants request that this Court enter judgment dismissing the First Amended Complaint in its entirety and enter judgment in favor of Defendants on their counterclaims as follows:

- A. Declaring that the patents in suit are invalid;
- B. declaring that the patents in suit are not infringed by defendants;
- C. declaring that the patents in suit are unenforceable against defendants;
- D. directing Medtronic to pay defendants' attorney's fees and costs incurred in connection with this litigation; and
- E. granting such other and further relief as shall the Court shall deem just and equitable.

Dated: May 1, 2000

FULBRIGHT & JAWORSKI LLP
DORSEY & WHITNEY LLP



Robert R. Reinhart (MN# 90566)
David E. Bruhn (MN# 187045)
Paul Robbennolt (MN#240497)
DORSEY & WHITNEY LLP
220 South Sixth Street
Minneapolis, MN 55402
Telephone: (612) 340-2600

Attorneys for Defendants

John E. Lynch
John A. Bauer
James Zubok
FULBRIGHT & JAWORSKI LLP
666 Fifth Avenue
New York, New York 10103
Telephone: (212) 318-3000
Facsimile: (212) 752-5958

Attorneys for Defendants,
BOSTON SCIENTIFIC CORPORATION
SCIMED LIFE SYSTEMS, INC.

DEVICE IN MIDDLEMAN PATENT NUMBER 5,231,989

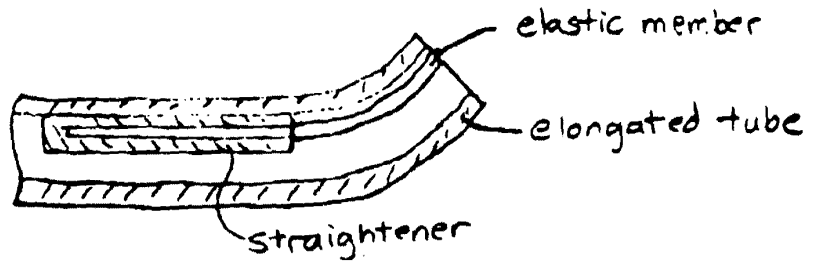
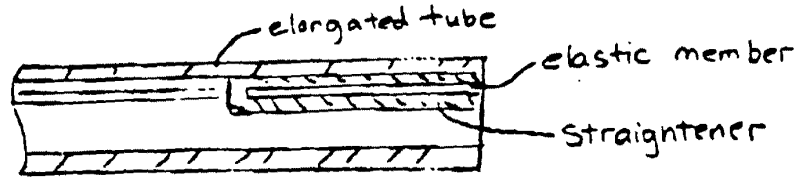

DEVICE IN JERVIS PATENT APPLICATION

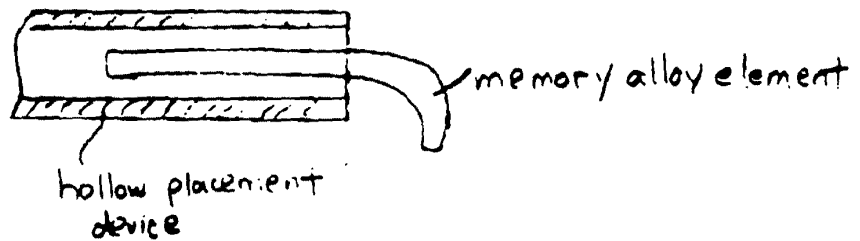
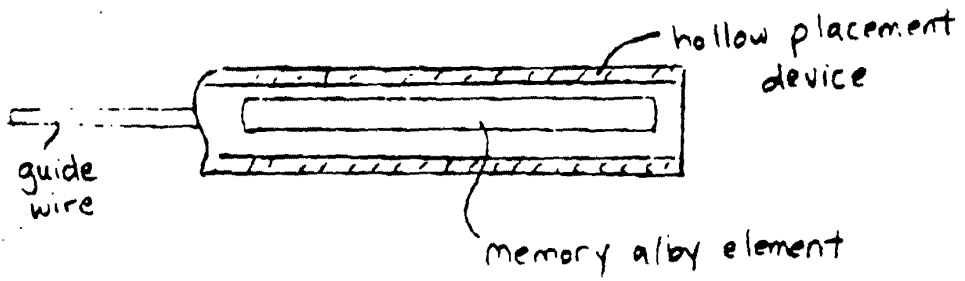

Exhibit
B

DISCLAIMER NOTICE

THIS DOCUMENT IS BEST QUALITY PRACTICABLE. THE COPY FURNISHED TO DTIC CONTAINED A SIGNIFICANT NUMBER OF PAGES WHICH DO NOT REPRODUCE LEGIBLY.

1907

4/1/79

①

LEVEL

AD A103197

DTIC
FILE #
AUS 2 4 1981
H

EVALUATION OF NITINOL FOR USE AS A MATERIAL IN THE
CONSTRUCTION OF ORTHOPAEDIC IMPLANTS

DTIC FILE COPY

ALL INFORMATION CONTAINED
HEREIN IS UNCLASSIFIED
EXCEPT WHERE SHOWN
OTHERWISE

DISTRIBUTION STATEMENT A
Approved for public release;
Distribution Unlimited

81 8 20 039

MEM00433

Final Rpt. 11-17-82 100/16

EVALUATION OF NITINOL FOR USE AS A MATERIAL IN
THE CONSTRUCTION OF ORTHOPAEDIC IMPLANTS

Final Scientific Report Covering the Period from
December 1, 1973 to December 31, 1976.

Completed ¹¹ December, 1976 *1831*

Author: ¹¹ James L. Hughes, M.D.

Supported by the U.S. Army Medical Research and Development
Command
Fort Detrick,
Frederick, Maryland 21701

Contract No. DAMD 17-74-C-4041

Performing Organization: Johns Hopkins University
School of Medicine
CMSC 9
600 N. Wolfe Street
Baltimore, Maryland 21205

311-1111-1111

Approved for Public Release: Distribution Unlimited

The findings in this report are not to be construed as an
official Department of the Army position unless designated
by other authorized documents.

Approved for Release	<input checked="" type="checkbox"/>
Approved for Distribution	<input checked="" type="checkbox"/>
Approved for Public Release	<input checked="" type="checkbox"/>
Approved for General Release	<input checked="" type="checkbox"/>
Approved for Limited Release	<input type="checkbox"/>
Approved for Restricted Release	<input type="checkbox"/>
Approved for Confidential Release	<input type="checkbox"/>
Approved for Secret Release	<input type="checkbox"/>
Approved for Top Secret Release	<input type="checkbox"/>
Approved for Special Access Release	<input type="checkbox"/>
Approved for Other Release	<input type="checkbox"/>
Approved for No Release	<input type="checkbox"/>

111111

MEM00435

SECURITY CLASSIFICATION OF THIS PAGE (When Data Entered)

REPORT DOCUMENTATION PAGE		READ INSTRUCTIONS BEFORE COMPLETING FORM	
1. REPORT NUMBER	2. GOVT ACCESSION NO.	3. RECIPIENT'S CATALOG NUMBER	
	AD-A103	197	
4. TITLE (and Subtitle)	5. TYPE OF REPORT & PERIOD COVERED		
EVALUATION OF NITINOL FOR USE AS A MATERIAL IN THE CONSTRUCTION OF ORTHOPAEDIC IMPLANTS	Final Scientific Report 12-1-1973 to 12-31-1976		
	6. PERFORMING ORG. REPORT NUMBER		
7. AUTHOR(s)	8. CONTRACT OR GRANT NUMBER(s)		
James L. Hughes, M.D.	DAMD 17-74-C-4041		
9. PERFORMING ORGANIZATION NAME AND ADDRESS	10. PROGRAM ELEMENT, PROJECT, TASK AREA & WORK UNIT NUMBERS		
Johns Hopkins University, School of Medicine, CMSC 9, 600 N. Wolfe Street, Baltimore, Maryland 21205			
11. CONTROLLING OFFICE NAME AND ADDRESS	12. REPORT DATE		
U.S. Army Medical Research & Development Command, Fort Detrick, Frederick, Maryland 21701			
	13. NUMBER OF PAGES		
	33		
14. MONITORING AGENCY NAME & ADDRESS (if different from Controlling Office)	15. SECURITY CLASS. (of this report)		
	Unclassified		
	16. DECLASSIFICATION/DOWNGRADING SCHEDULE		
16. DISTRIBUTION STATEMENT (of this Report)			
Approved for public release. distribution unlimited.			
17. DISTRIBUTION STATEMENT (of the abstract entered in Block 20, if different from Report)			
18. SUPPLEMENTARY NOTES			
19. KEY WORDS (Continue on reverse side if necessary and identify by block number)			
Nitinol; Nickel-Titanium Alloy; Orthopaedic Implants; Bio-compatibility.			
20. ABSTRACT (Continue on reverse side if necessary and identify by block number)			
Certain characteristics of alloys of titanium and mixed (Nitinol) suggest that they may be superior materials from which to fashion Orthopaedic implants. Previous studies revealed that these alloys possess a critical transition temperature (TTR) over which the alloys undergo a highly unique electronic change and atomic repositioning associated with drastically altered mechanical properties such as elastic modulus and yield strength. Furthermore,			

DD FORM 1473 EDITION OF 1 NOV 68 IS OBSOLETE

SECURITY CLASSIFICATION OF THIS PAGE (When Data Entered)

MEM00436

This prototype was also tested by inserting it in a reamed hole in a femur.

COOK
Exhibit 1002-0267

Continuation of block 20. (Abstract)

when nitinol alloys are plastically deformed below the TTR, they are capable of reversible and forceful total recovery of shape when heated to temperatures exceeding the TTR. This study investigated the bio-compatibility of nitinol alloys and the ability of these alloys to display their "shape memory" properties in vivo.

All tests concerned with the biologic acceptability of the nitinol alloys showed no adverse tissue reaction to the nitinol alloy when compared to titanium and 316-L stainless steel. These studies included the effect of nitinol alloy powder on human fibroblasts cultured in Leighton tubes, the effect of nitinol alloy filings on collagen synthesis in fetal rat calvaria tissue, and the tissue response to nitinol implants placed in the subcutaneous tissue of standard laboratory mice.

Nitinol bone plates containing a strain gauge were manufactured. These plates were pre-stressed below the TTR and held in a pre-stressed manner until applied to the femora of sheep, after which the restraining device was removed allowing the alloy to return to its original shape. The force transmitted through the plate to the bone was documented by monitoring the strain gauges at periodic intervals. Data obtained in this fashion revealed that the nitinol alloy retained the "mechanical memory" in vivo.

A hip prosthesis and intermedullary rod were constructed using internal fixation components produced of nitinol. These were placed into a human femur with the temperature of the units below the TTR. Firm fixation of the metallic components within the bone by changes in shape of the nitinol components as the temperature exceeded the TTR demonstrated the feasibility of utilizing nitinol alloy in the production of certain orthopaedic implants.

MEM00437

TABLE OF CONTENTS

TITLE PAGE.....1
COVER SHEET.....2
DD 1473 FORM.....3
TABLE OF CONTENTS.....4
TABLE OF CONTENTS OF THE BODY.....5
BODY.....6

MEM00438

new dimension to healing fractured bones. However, my initial

TABLE OF CONTENTS

	PAGE
<u>Phase 1.</u>	
Background and Discussion.....	1
Objectives.....	1
Materials.....	2
Method and Results.....	3
Conclusions.....	6
<u>Phase 2.....</u>	7
<u>Appendix A</u>	
The In Vivo Compatibility of Nitinol.....	2
Important Design Considerations.....	2
Summary.....	7
Table I.....	9
Potential Biaxial Strain-Heat-Recovery.....	13
Nitinol Bone Plate Mounting Technique.....	13
Steps to be Taken.....	15
<u>Appendix A (cont.) NAVAL ORDNANCE LABORATORY, WHITE OAK</u>	
Metallurgical History.....	1
Plate Machining.....	2
Alloy Controls.....	3
Bone Plate Variations.....	4
Bone Plate Operation.....	4
Plate Straining Variation.....	5

MEM00439

TABLE OF CONTENTS (CONT.)

Appendix A (cont.)

Figure 1, A, B, C.....

Figure 2.....

Figure 3.....

Figure 4.....

Added Notes on the Bone Plate Design.....

Figure 2, Proposed Nitinol Bone Plate.....

Figure 3.....

Figure 4.....

Appendix B

Figure 1.....

Figure 2.....

Figure 3.....

Figure 4.....

Bone Cavity Preparation.....

Active Nitinol Pin.....

Advantages.....

Intramedullary Rod.....

Intramedullary Rod.....

Inverted-Taper Hip Prosthesis.....

Table I: Nitinol Alloy Composition Chosen for Experimental Studies.....

Table II: Summary of the Arc-Melted Alloys Produced and Their Ultimate Use.....

Figure I: Nitinol Implant Specimen.....

Figure IIa: Leighton Tube Slides in the Presence of Nitinol Powder.....

MEM00440

TABLE OF CONTENT (CONT.)

Figure IIB: Leighton Slide Tissue Controls.....

Figure IIC: Comparison of Tissue Culture Slides at 20 Days.....

Figure III.....

Figure IVA: Insertion of Implant Specimen in Mouse.....

Figure IVB: Implant Specimen in Place Above the Scapular Area.....

Figure IVc: Implant Specimen Embedded in Tissue.....

Figure V: Preparation of Tissue Sections Following Removal of Implant Specimen Nine Weeks Post-Surgery

Figure Va: Tissue and Implant Embedded in Methymethacrylate.....

Figure Vb: Removal of Implant from Tissue Block.....

Figure Vc: Tissue Sectioning.....

Figure Vd: Normal Tissue Surrounding Implant.....

Figure VI: Nitinol Plate with Strain Gauge Cell.....

Figure VIIa: Plate Application.....

Figure VIIB: Plate in Place on Sheep Femur.....

Figure VIII: Measurements of the Strain Gauge Cells Taken at Weekly Intervals.....

Figure IX: Nitinol Plates on Sheep Femora.....

Figure IXa: Early Radiograph Following Plate Application.

Figure IXb: Later Radiograph Revealing Early Bone Formation.....

Figure Xa: Normal Bone Formation at the Edge of the Plate

Figure Xb: Edge of Bone After Removal of Nitinol Plate Bone is Alive and Normal.....

Figure XI: Plate Fractured After Stress.....

MEM00441

TABLE OF CONTENT (CONT.)

Figure XII: Initial Measurement of Force Taken with the Plate in Place on Sheep Femora.....

Figure XIII: Prototypes of Hip Prosthesis and Intramedullary Rod.....

Figure XIV: Nitinol Hip Prosthesis with Self-Deploying Tabs.....

Figure XV: Hip Prosthesis in Place in Sheep Femur.....

Figure XVI: Nitinol Intramedullary Rod.....

Figure XVII: Intramedullary Rod in Cadaver Femur.....

Figure XVIIa: Deployed Position.....

Figure XVIIb: Non-Deployed Position.....

Figure XVIII: Nitinol Washers with Alternating Screws of Stainless Steel and Titanium.....

MEM00442

EVALUATION OF NITINOL FOR USE AS A MATERIAL IN THE
CONSTRUCTION OF ORTHOPAEDIC IMPLANTS
Army Contract, DAMD contract 17-74-C-4041

PHASE I, 1 December 1973-20 February 1975

BACKGROUND AND DISCUSSION

The near equiatomic alloys of titanium and nickel with their unique "shape memory" displayed future potential as superior materials for orthopaedic implants. It was the purpose of phase I of this project to investigate and evaluate the in vivo biologic acceptance of such materials, given the generic name NITINOL (NI-Ti-Naval Ordnance Laboratory). Previous studies by Buehler¹ have shown that each of these alloys possesses a critical transition temperature range (TTR) over which the alloys undergoes a highly unique electronic change and atomic repositioning. This TTR can be varied through alloy composition changes in excess of 100⁰C down through the liquid nitrogen temperature (-196⁰C). Certain mechanical properties such as elastic modulus and yield strength, also vary drastically as the alloys are moved through the TTR. Furthermore, when NITINOL alloys are plastically deformed below the TTR (up to 8%), they are capable of reversible and forceful total recovery when heated to temperatures exceeding the TTR. The greater the amount of strain, up to 8%, the larger is the recovery stress or force produced.

OBJECTIVES

1. Investigate the corrosion resistance of NITINOL alloys of varying composition when exposed to biologic fluids for different time periods based on earlier work by Castleman, et al. (personal communication) that revealed that NITINOL was, in fact, biologically acceptable.

¹Results of this work may be found in Appendix A.

MEM00443

2. Demonstrate that these alloys continued to display their "shape memory" properties in vivo.

MATERIALS

To study the biocompatibility of NITINOL, it was necessary to look at several alloy compositions. Because various potential medical devices require certain design characteristics, representative alloys spanning the temperatures and recovery stresses were investigated in order to provide for a broad spectrum of future applications (see Table I). The primary difference between each alloy was in the nickel-cobalt relationship. Such changes altered the heat recovery range. The immediate wrought configuration and ultimate use of each alloy may be found in Table II. The following four NITINOL materials were prepared for this investigation:

1. Filings and powder. Fine filings and powder required for fibroblast tissue studies were produced by filing a 4.5mm diameter alloy rod with a tungsten carbide file.
2. Inolant specimens (see fig. 1). NITINOL alloys were machined into implant specimens whose axis was the same as the principal axis of the original hot swaged rod. The dumbbell configuration allowed for ingrowth of tissue which could then effectively resist wandering of the implant in the tissue.
3. Washers. Washers were prepared, but were not used until phase II of this project and will be described further at that point.
4. Bone plates. Contracting bone plates were designed and machined as outlined in Appendix A to determine whether or not NITINOL alloys would continue to exhibit memory recovery when heated through the recovery range in vivo.

MEM00444

temperature in either position A or C (Ref. "B").

METHOD AND RESULTS

The following studies were performed in order to determine tissue response to various NITINOL alloys.

1. The first study utilized NITINOL powder alloys I, IV, and V in human fibroblasts cultured in Leighton tubes with McCoy's culture medium plus calf serum. Titanium and 316-L stainless steel were used as controls. In this short-term experiment, morphology and cell counts were checked as gross barometers of tissue toxicity. At 20 and 25 days, no significant differences in morphology or cell counts among the three metals were revealed (see fig.2)

2. The second study was carried out by Dr. Gerald Finerman and his staff at UCLA. Filings from each of the 5 alloys as well as from titanium and stainless steel were placed in buffered fetal rat calvaria tissue in order to determine their effects both on general protein and on collagen synthesis (see fig.3). With over a hundredfold concentration range for each of the substances, no statistically significant differences from the controls were found. Shaded areas on the graph in fig.3 indicate the range for control values, and in all cases, experimental values fell within these ranges.

3. The third portion of phase I utilized the small dumbbell-shaped implants beneath the skin of standard laboratory mice (fig.4). Each of the five alloys was tested on 27 mice, nine implants left for one week, nine for three weeks, and nine for nine weeks. The animals were fed a standard diet and watered ad libitum. Activity was not restricted. For surgery, the mice were anesthetized with ether. A small incision over the sacral area was made with a hemostat subcutaneously approaching the scapular area

MEM00445

posteriorly. The chromic suture material was passed from the sacrum cephalad and emerged with the needle superior to the scapula. The implant was then pulled from the sacrum into the scapular area and locked with a chromic suture. Implants were not left over the sacrum as originally planned because of the animals' ability to get to this area and disturb the implants. At one, three, and nine weeks, the mice were sacrificed and the implant was removed in toto. Specimens were observed for gross irritation and discoloration. The metal was not explanted from the surrounding tissue in order to preserve the interface.

The metal, together with the surrounding tissue, was then embedded in methylmethacrylate. The extreme hardness of the metal, however, prevented the microtome from cutting sections. It was therefore necessary to place the entire block in an acid solution and to pass a current through the metal. The NITINOL implant then popped out, allowing sections to be cut with the microtome. Although small bits of the fibrous layer in contact with the metal were lost, representative sections in most of the preparations were obtained (Fig. 5)

No gross necrosis and/or color changes were observed by macroscopic examination of the tissue samples in the NITINOL, stainless steel, or titanium tests. Microscopic tissue response was evaluated by studying the fibrous membrane immediately adjacent to stainless steel, titanium or alloy implants, by observing the cellular activity of the connective tissues around the membrane, and by checking the muscle around the implant for signs of degeneration and/or abnormal cellular infiltrates. An early fibroblastic response in the formation of a membrane around the implant was revealed in all cases. At nine weeks, vasculature and blood vessels surrounding the area appeared normal. There were no giant cells present or

MEM00446

degeneration of the muscle layers or loose connective tissue. No significant differences between the control and the NITINOL implant tissue sections were noted.

4. The final step in phase I was to study NITINOL plates as designed and machined in App. A. The plates were instrumented using strain gauge cells glued into the plate (fig. 6). Two small wedges were drawn into the straining cavity during cooling of the plate. Because the outside diameter of the wedges was larger than the entrance diameter, the straining cavity was effectively elongated. With the straining device in place, the plate was then dipped into 90% alcohol at -150°C . This temperature was monitored by probe thermometer during plate cooling. As the plate and the straining device were cooled, a wrench was used to apply active forces to the straining device. Once this device was sufficiently elongated, and the wedges were in place, the plates were allowed to warm to room temperature and were standardized with a hep strain gauge cell.

Following standardization, the plates were gas sterilized for implantation in sheep femora. The hind legs of the sheep were prepped and draped for a lateral incision. Either the dorsal or lateral aspect of the femur was selected, dependent upon how well the plate mated itself to the bone. Standard placement of the screws was achieved using a torque of 40 kiloponds of force. The straining device was then removed, and the pressure was recorded in kilopounds (fig. 7).

Measurements of the strain gauge cells were taken at weekly intervals (fig. 8). The sheep were fed standard diets with water ad libitum. No restrictions were placed on activity. The plates were left on for 1-2 months. Radiographs of the femora were taken at two-week intervals (fig. 9).

MEM00447

PHASE II, Ending January 31, 1976

Phase I revealed that:

1. NITINOL appeared to be biologically acceptable in vivo.
2. The distinct and unusual characteristics of NITINOL would indeed function in a biological environment.

Based upon the findings in phase I, phase II combined the efforts of the Johns Hopkins University School of Medicine, Division of Orthopaedic Surgery and the Naval Surface Weapons Center in White Oak, Md. to produce a new implant technology. Under primary consideration were the problems surrounding fixation of prostheses to the hip and the possibilities of using a NITINOL intramedullary rod (App. 8).

Mr. Dave Goldstein and Mr. John Tidings of the Naval Surface Weapons Center designed and manufactured both a prototype hip prosthesis and an intramedullary rod (fig. 13). The prototype hip prosthesis was fabricated with heat-activated self-deploying NITINOL tabs (fig. 14). This prosthesis was inserted in a cadaver femur at a temperature of 0°F. Upon warming to 70°F, the tabs deployed and formed a structurally rigid assembly with the femur (fig. 15). This was considered to be a strong indicator of feasibility of a self-deploying NITINOL prosthesis. Removal of the prosthesis was achieved after recooling the femur to 0°F and then pulling at opposite ends of the assembly. The insertion and removal process was videotaped through an image intensifier at the University of Mississippi. A copy of this tape is available through Mr. David Goldstein at the Naval Surface Weapons Laboratory.

An intramedullary rod was also designed using a bulbous NITINOL assembly which would fix internally and cause increased stability (fig. 16)

MEM00448

that some means are available by which the impacting force can

This prototype was also tested by inserting it in a reamed hole in a femur after flattening of the NITINOL elements at 0°C. As with the hip prosthesis, withdrawal was possible by re-chilling the bone/rod assembly. The embedded device in the expanded mode was impossible to withdraw, thus indicating that exceptional stability was achieved in the femur. Radiography illustrated both the deployed and non-deployed position of the NITINOL elements in relationship to the bone (fig. 17).

One added experiment to investigate use of NITINOL in orthopaedic biomaterials tested NITINOL washers that were implanted into sheep femora with alternating stainless steel and titanium screws. These were implanted in two sheep in 1975 and remain in place. Stress reactions around the screws can be observed in fig. 18, but there was no evidence of toxicity related to the interaction of the different metals. On physical examination, no lymph adenopathy or reaction in the soft tissue surrounding the implant were present. The sheep have continued to graze and perform the usual duties of sheep without any alteration of their normal lifestyle. The sheep will be sacrificed at a later time and studies of the histological compatibility of NITINOL, stainless steel, and titanium will be undertaken at that time.

Problems encountered with the above project were primarily centered around the difficulties in: 1.) standardization of the titanium-nickel ratio into an appropriate temperature mode for use in the body, and 2.) attempting to work with an extremely hard material. Despite these technical problems, it appears that NITINOL can be successfully utilized in the manufacture of properly designed orthopaedic implants and will deploy in the body as expected. The positive findings in both phases of this project merit further attention in the future.

MEM00449

At about 280°F the constrained wire was released and allowed to

Appendix A

Dr. S. M. Perren
Laboratorium für Experimentelle Chirurgie
Schweizerisches Forschungsinstitut
CH-7270 DAVOS-PLATZ
Switzerland

Dear Dr. Perren:

I have received a copy of your letter addressed to Dr. Lee H. Riley, M.D., dated 10 November 1972. I have made a very careful study of the letter's contents in order to respond in a thorough and proper manner.

I feel the first response correspondence should deal primarily with design considerations. This would consider such aspects as the strain-heat-recovery of the Nitinol, contracting force and the effects of varied strain as a function of temperature and time, selection of an optimum alloy "transition temperature range" (TTR) and various miscellaneous required data in order to make your measurements meaningful.

Also, in light of the following discussions, we should jointly consider whether the present proposed bone plate design is optimum for experiments with the Nitinol alloys. While these thought processes may appear somewhat time consuming, I feel that fewer experiments may be needed to conclusively test the value of a contracting Nitinol bone plate system.

To preface what follows, I definitely feel a contracting Nitinol bone plate is a novel approach and it could add a

MEM00450

6. The Nitinol plate is then warmed causing it to

new dimension to healing fractured bones. However, my initial concern lies in the area of the contracting force. With the contracting force potential of the Nitinol, means may be required to lessen or moderate this force. I have devoted a section of my following write-up to this aspect.

The In Vivo Compatibility of Nitinol

During the discussions following a recent talk that I gave in San Francisco, California, U.S.A., a Dr. Alan A. Johnson, Ph.D., Department Head, Department of Materials Science and Engineering, Washington State University, reported that he had tested binary TiNi-base alloys (Nitinols) in vivo on beagle dogs. His study was only to determine the biocompatibility. His tests centered around plates that were merely fastened to the front leg bones of the beagle. Some plates had been embedded for as much as 18 months. He summarized his results by stating that there had been no evidence of irritation or inflammation in the plate area and that a thin fibrous sheath had formed over the plate.

It would appear, based upon these data and our own successful crevice corrosion results on cobalt-modified Nitinol in seawater, that this aspect will present no problem and may be set aside at this time.

Important Design Considerations

The Nitinol materials undergo what is commonly termed a "martensitic transition" (transformation). This transition is in part described in the literature; see references A, B, C and D, enclosed. The term "martensitic transition" is used

hers only to denote an atom "shear" movement associated with the application of a "shear force." A second feature of the Nitinol alloy system is the unique electron bonding change that occurs as a function of heating and cooling through the transition temperature range (TTR). The combination of atomic shearing and electron bonding change provide the strain-heat-recovery behavior and the unusual force that accompanies this recovery.

I have enclosed reference E in an effort to have the basic design principles better understood. The information and data in reference E were extracted from a "Nitinol Characterization Study" performed at Goodyear Aerospace Corporation for the NASA organization. In this study three alloy compositions were used, which were labeled A, B and C. Information on the three alloys is given in Table II (Ref. E). Figure 5 (Ref. E) graphically illustrates (as a function of resistivity) the key critical temperatures as they relate to the martensitic transition in the Nitinol materials. The symbol definitions are given in the upper right-hand corner of Figure 5 (Ref. E).

It should be emphasized that heat-recoverable straining must be performed below the M_D temperature. Further, the A_S temperature must be reached (on heating) before the onset of dimensional recovery can occur. Also, the precise temperatures of A_S and M_D can be varied considerably by altering the alloy composition. This latter point is described in some detail on

3

APPENDIX A (cont.)

MEM00452



NAVAL ORDNANCE LABORATORY
WHITE OAK

COOK
Exhibit 1002-0283

pages 111 and 112 (Ref. A). In a practical sense recovery temperatures (A_g) may be established by alloying as low as liquid N_2 (-196°C) or at various levels up to about $+100^\circ\text{C}$. This A_g temperature flexibility is a most important design consideration and will be discussed in more detail below.

Following along in reference E it can be seen in Figure 6 that there is a definite relation between strain-heat-recovery (bend in this case) and the electrical resistance (resistivity)-temperature profile. The optimum recovery occurs in a material with proper cold working (below M_D temperature) coupled with a proper final anneal; see Figure 6 (Ref. E), upper right panel.

Typical engineering stress-elongation curves (in tension) are presented in Figures 14 and 15 (Ref. E). Note the change in curve shape both below and above the transition temperature range (TTR). This may be seen more clearly in my general curves given in reference F. The vast differences in curve shape are directly attributable to the electron bonding changes that occur between the A_g temperature on heating (M_S on cooling) and the M_D temperature. These bonding changes are most evident in the elastic modulus (E) and the yield strength (Y.S.), and the change is summarized graphically in Figure 16 (Ref. E). Stated in simple terms the Nitinol materials are very ductile and flexible ($E = 3.5 \times 10^6$ psi) and possess low strength (Y.S. = 10×10^3 psi) below the A_g (on heating). The application of heat causes a change to predominantly covalent bonding to take place above the A_g , which sharply changes the E to about 13×10^6 psi and the Y.S. to about 80×10^3 psi. The resultant alloy,

above its transition temperature range ($\gg \lambda_s$) is thus quite strong and rigid. Certainly, above λ_s it represents an engineering type material that one can work with in a design sense. Therefore, in designing a suitable bone plate alloy one must be certain to have body temperature definitely above the λ_s - M_D range (Fig. 16, Ref. E) of the alloy. Such an alloy will provide, at body temperature, a suitable immobilizing bone plate structure and yet will receive sufficient heat from the body to contract with great force.

To be an effective means of forcing together or impacting the fractured bone sections the "mechanical memory" must be capable of exerting an adequate force--yet not too large a force. Figure 28 (Ref. E) shows typical tensile recovery stress versus temperature curves at various prestrain levels (when straining is done below the M_D - λ_s range). One can immediately note certain key points; for example, the maximum recovery stress appears to be associated with a tensile strain of 8%. Also, the recovery stress increases as a function of strain up to the 8% strain level. Another important fact is the temperature change (ΔT) that is required to reach the maximum recovery stress. In each strain level up to 8% the ΔT from onset of thermal recovery to the "knee" of the curve is increasing with increasing prestrain. To best illustrate these points I have extracted the curves of three prestrain conditions (2, 4 and 8%) and these are shown in reference G. In brief these curves are obtained by prestraining a Nitinol wire sample

a given amount (for example, 2, 4, 8, etc.) , then resistance heating the strained wire to increasingly higher temperatures while providing the necessary force (arrows, Ref. C) to maintain the prostrained length. Knowing the sample cross section area, curves of recovery stress versus temperature are attained.

It has been previously established that the initiation of recovery ($A_{0.2}$) is a variable of the alloy composition. Since body temperature is fairly constant (about 37°C), some interesting design possibilities arise.

Assume the above 2, 4 and 8% recovery stress-temperature curves and further assume that through allowing these curves can be moved sidewise in position with respect to the temperature axis. With these assumptions established now position body temperature vertically across the curves, as shown in reference II by the dashed lines. Body temperature is 37°C; however, it is shown at four different locations. This graphical representation is simpler than moving the curves sidewise and provides an equivalent result.

Now one may observe the following: if body temperature is at position A the 4% strain will produce the greatest recovery stress followed by 2% and least by 8%. In position B, the 4% strain gives greatest recovery stress while the 2% and 8% are equivalent. In position C the 4% and 8% are equivalent while 2% lags behind. At position D the 8% strain is providing much the largest recovery stress with the 4% and 2% dropping down in order.

From the representation given in reference II the importance of alloy design (composition) can be seen. Where should the A_g temperature (onset of recovery) be with respect to a fixed body temperature? How much temperature change (ΔT) is required to provide the proper bone impacting force? Further, how much impacting stress is desired or can be tolerated by the bones? Or, will the bone screws be stripped from the bone threads if the load becomes excessive? A still further consideration is: what might the curve of impacting force as a function of time look like--particularly if the bone mending is accompanied by contraction and thus strain reduction? I have conjectured graphically in reference I on this aspect. No effort has been made to put these curves in any proportionate scale. The curves are merely given to graphically show the relationship of impacting force, the A_g to body temperature change and the possible effects of reduced strain during bone mending.

In summary, it would appear that situation D (Ref. II and I) is least complex. Maximum impacting force occurs immediately on heating the D1 prestrained plate to body temperature. Then any lowering of the strain will be accompanied by a least lowering of the impacting force. The other representations (body temperature at A, C in Ref. II and I) merely show what might occur with very careful A_g to body temperature control. However, these latter possibilities would probably require a very careful alloying study in order to be able to place body

MEM00456

temperature in either position A or C (Ref. H).

Now let us address the design considerations dealing with the contracting force (recovery stress) associated with the Nitinol material. Figure 28 (Ref. E) shows the magnitude of the "recovery stress" for an annealed uniaxial-strained 0.1 inch diameter wire (rod). To assure continued pressure at the fracture interface during healing one would probably tend to use a strain (stretch) approaching that which will provide nearly complete heat-induced recovery. Further study of Figures 29 through 31 would set that strain (stretch) level somewhere in the 6% to 8% range. Also using a 6% to 8% strain will provide a significant amount of plate "stretch" even in rather short bone plates. A stretch of 0.060 inch to 0.080 inch per inch of stretched bone plate would allow adequate tolerance during initial bone mating, healing accommodation, etc. Further, as was indicated earlier, if this initial accommodation causes a moderate drop in strain (stretch) the load (force) associated with the lower strain values will still be quite high (see Figures 29-31, Ref. E).

Assuming the use of strain levels of 6% to 8%, one must be concerned with the kind of recovery stress or force this will produce. Using Figure 29 (Ref. E) data for a 0.1 inch diameter wire (rod), one is able to derive the data given in Table I. These data show the relative magnitude of recovery stress one might expect from a 12 mm x 4mm Nitinol bone plate cross section when strained (stretched) to various levels. On a 1.0 square

MEM00457

Table I. Impacting Force Potential of Nitinol Strained to Various Levels

Strain (%)	Maximum Recovery Stress (lb/in ²)	Impacting stress (force) produced by the subject		
		1.0 in. x 4 mm bone plates	1.0 in. x 4 mm bone interface	2.0 in. x 4 mm bone interface
6	60,000	5000 psi (5000 lbs)	2900 psi (2900 lbs)	2900 psi (2900 lbs)
6	60,000	4590 psi (4590 lbs)	2295 psi (2295 lbs)	2295 psi (2295 lbs)
4	45,000	3330 psi (3330 lbs)	1665 psi (1665 lbs)	1665 psi (1665 lbs)
2	27,000	1995 psi (1995 lbs)	999 psi (999 lbs)	999 psi (999 lbs)

* Based on an annealed 0.1 inch diameter wire (rod), NASA Report CR-1433.

** Bone plate--approximate cross section dimensions 12 mm x 4 mm x 46 mm² = 0.074 in. x 2.

FIG 1

MEM00458

inch of bone interface the impacting stress varies from 1995 psi to 5920 psi. While a 2.0 square inch interface varies from 998 psi to 2960 psi. Observing the generally lower recovery stress trend for larger diameter wire and sheet (Figures 29-31, Ref. 2) might indicate some general lowering in a wrought bone plate section. How much lower the recovery stress values (at various strains) might be in the proposed 12 mm x 4 mm bone plate section is unknown. Since the recovery stress (force) is a function of the orientation and degree of microtwinning, one would have to actually determine the recovery stress at various strains in the 12 mm x 4 mm bone plate experimentally.

Now one has to ask the question, "What level of impacting force is optimum to expedite bone healing?" Is that impacting force attained, or exceeded in the proposed bone plates and experiments?

The maximum impacting forces (recovery stresses) shown in Table I cannot be exceeded in the 12 mm x 4 mm proposed bone plate. Higher impacting forces could only result from larger bone plate section size. Chances are very good that the values given in Table I are higher than can be expected in the more massive wrought bone plate section.

How then does one reduce the impacting force while employing a fairly large strain or stretch in the plate? Below are listed some suggested techniques:

1. Use a lower prestrain (stretch) but somehow extend the length of the strained zone. For example, 8% strain over

EXHIBIT
STRAIN
2/11

2 inches = 0.160 inch of stretch. While the same 0.160 inch stretch is possible using a 4% strain over 4 inches. While the stretch is similar the recovery stress for 4% strain is considerably lower than in the 8% situation.

2. Reduce the cross sectional area of the portion of the bone plate that is strained (stretched). This will lessen the recovery stress proportional to the area of the stretched portion; however, it will also reduce the stiffness of the bone plate in the thinned section. The latter limitation may affect the ability of the plate to immobilize bending or lateral movement in the fractured area.

3. Establish the TTR, through alloying, so that body temperature (37°C) falls on the sloping portion of the recovery stress-temperature curve (See Fig. 27, Ref. E and Ref. H, lines A, B and C). However, observing Ref. H, lines A and B and referring to my prior discussion--one can see potential problems when the strain level lessens (contraction) the impacting stress can actually increase.

4. Use overstraining as a means of forcing the maximum recovery stress down to a lower level. One can observe this trend in Figures 28 (10% curve), 29 through 31. However, to employ this scheme one would have to know more about the recovery stress vs temperature profile for overstraining sections like those utilized in bone plates.

5. Employ a two-piece bone plate that is designed to telescope or slide one piece within another but yet maintain

MEM00460

Fig. 3. Forced Recovery After Axial Straining

rigid alignment of the fractured bone sections. This scheme, if at all suitable, would allow initial fastening of the plate(s) to the fractured bone sections followed by the attachment of a stretched Nitinol element(s). In this case the contracting (impacting) force could be accurately controlled based on the straining and cross-sectional area of the contracting Nitinol element(s).

6. Another possible method of reducing the contracting force might utilize the buckling action of a spring component built into the bone plate proper. A crude attempt at a design is offered in reference J. Here one could use one or more stretched and contracting Nitinol wire or rod elements that would produce a force moderated by the compressive straining (bending) of a designated portion of the plate. Reference J shows a typical proposed middle section. If this middle section were designed properly it seems that elastic bending could be made to occur sideways as illustrated while minimizing upward bending. Perhaps to accomplish this a considerably different Nitinol element mounting cut-out webbing design would be necessary. The illustrations in reference J are merely employed to suggest the use of the bone plate itself to control more accurately the impacting force. Whether or not a multicomponent contracting bone plate is feasible still remains a question.

In summary, six "techniques" have been suggested as possible means of controlling or moderating the impacting force produced by the uniaxial contracting force of the Nitinol. This is not to imply that the above are the only means of controlling the impacting force. The major intent of this exercise is to show

that some means are available by which the impacting force can be adjusted. Further variations are definitely possible and it is hoped the above will encourage original thoughts and techniques that may prove more desirable.

Potential Biaxial Strain-Heat-Recovery

The Nitinol material always exhibits a heat-recovery which is in opposition to the prestrain direction. This suggests the possibility for multiaxial straining and complex bone plate performance. How much recoverable straining is possible in two or more directions simultaneously is unknown. Perhaps it bears some relation to the 0.1 level of uniaxial prestrain. This point is made merely to suggest that multiaxial movement is probably available from Nitinol. If this could add a highly useful aspect to bone healing, some experimentation should be initiated to better understand the complex strain-heat-recovery as a prelude to bone plate design.

Nitinol Bone Plate Mounting Technique

Assume the use of a Nitinol composition that has a TTR significantly below body temperature (see point D, Ref. H). Now, then, does one mount such a plate without triggering contraction during the mounting process?

In principle, if one can believe fully the data in reference K, it is apparently possible to suppress the heat-actuated recovery. In reference K the bent Nitinol wire was allowed to recover elastically, then it was constrained in position while it was heated well above its normal unstrained TTR ($T_s = 100^\circ\text{C}$).

At about 280°F the constrained wire was released and allowed to freely recover. The data in reference K indicate about 95% recovery under these conditions. From these data one might assume a similar behavior when constrained following stretching and heating well above the TTR. This latter point should be checked experimentally before considering it for bone plate use. If the constrained recovery is permissible then the following bone plate mounting steps are suggested.

1. The carefully machined plate is immersed in a suitable sterile refrigerated bath to lower its temperature well below the M_D-A_2 range for the alloy used. Partial chilling of the strained area only may be employed if there are attendant advantages.

2. Strain the chilled bone plate using a suitable mechanical or hydraulic straining device. Some pre-designed gripping holes, lugs, etc., will have to be provided in the plate to assure uniform straining.

3. Use the straining device or other device placed in the gripping holes, lugs, etc., to constrain recovery on subsequent heating above the A_2 temperature range.

4. Conventionally mount the bone plate using the screwing action to provide initial impacting load.

5. With the plate(s) screw-fastened in position re-chill the stretched (strained) Nitinol plate section that has been constrained from contracting during the initial warming during screw mounting. When the plate is chilled the constraining device is removed.

Nitinol plate is then warmed causing it to
load the fracture interface. The load-level
function of time was discussed earlier.
The removal of the plate may be accomplished by
chilling the contracting section of the plate. This
keeps the contracting load long enough to allow easy
removal of the screws.
An alternative to step 3 above would be to maintain the
load of the stretched portion below the A_2 . During instal-
lation, if possible, it is felt the method described
is preferable.

Taken

suggested that the addressee and others receiving
review it and submit their suggestions directly to
combine those suggestions into a second open letter.

letter respond to the various suggestions.

pressing design questions appear to be in the
area (stretch) and the associated impacting forces.
I stated a level of load for impacting sheep tibia of
1000 lbs. My immediate question centers on whether or
not this level is optimum for healing, or whether it is
inconsistent with compression produced by conical screws.

In prior discussions you can appreciate the intricacies
of in-recovery stress of the Nitinol materials as well
as the relative levels of inherent recovery stress. This then



NAVAL ORDNANCE LABORATORY
WHITE OAK

SILVER SPRING, MARYLAND 20910

IN REPLY REFER TO
211453rej

5 June 1974

Dr. James L. Hughes, M.D.
Assistant Professor of Orthopedic Surgery
Department of Orthopaedic Surgery
The Johns Hopkins Hospital
Baltimore, Maryland 21205

Dear Sir:

I am in hopes with this summary letter to convey many of the details pertaining to the modified-Nitinol alloy bone plates for use under Army Contract DAMD-17-74-C-4041.

METALLURGICAL HISTORY

Alloy Composition. The bone plates were made from an alloy with the composition $Ti_{.5}Ni_{.45}Co_{.05}$ with a transition temperature range (or recovery temperature range) measured to be about $-52^{\circ}C$ to $-18^{\circ}C$ (see letter of 4 Feb 1974 to J. L. Hughes).

Alloying and Casting. Eighteen 150-gram melts were weighed with the wt % composition as follows: Ti = 67.38 grams, Ni = 74.32 grams, Co = 8.30 grams (or $Ti_{.5}Ni_{.45}Co_{.05}$). Each 150-gram charge was melted multiple times on a water-cooled copper hearth using a nonconsumable arc technique.* All melting is performed in a partial atmosphere of purified argon to avoid alloy contamination. Repeated alloy melting is done to insure composition homogeneity. The final product is a 150-gram "button" about 2 inches in diameter by 3/8 inch thick.

Three of these alloyed "buttons" are then remelted together to form a bar. The finished 450-gram bar measures about 1 inch thick x 1-1/8 inches wide x 4-1/4 inches long. Using this procedure 18 alloy buttons were made and these were then remelted into 6 rectangular bars.

Metallurgical Processing. The arc cast bars, as described above, were then given the following processing operations.

*Considerable delay was encountered in this operation due to atmospheric humidity and its adsorption on the internal components in the arc-melting chamber.

MEM00465

APPENDIX B

Dr. James L. Hughes, M.D.

1. The arc-cast bars were hot rolled to the rough thickness of 3/8". Initial rolling passes were performed at 850°C and the temperature was lowered gradually to a final rolling temperature of 600° to 650°C. The reason for the lower finishing temperature was to induce a finely textured micro-twinning in the bone plate stock to enhance the strain-heat-recovery behavior.
2. The hot rolled plates were press-flattened using a heating temperature in the 600° to 650°C range.
3. On cooling to room temperature the hot rolled plates were cut longitudinally using an abrasive cut-off wheel. The cut plates are shown in Fig. 1(A), attached.
4. The cut plate sections from 3 above are then surface ground to a width of $0.550 \pm \begin{matrix} .020 \\ .000 \end{matrix}$ inch.
5. The cut-and-ground bars from 4 above are heated to the 600° to 650°C range and press forged to form the strain gage cavity section off line with the bar ends.

PLATE MACHINING

Machining. The following machining steps were taken to obtain the finished bone plate.

1. The upset forged bars were reground on their side surfaces to a width of about 0.550 inch.
2. The bottom surfaces of the end sections were surface ground in-line and flat.
3. The rough ends were abrasively cut to length and mill finished* to insure accuracy.
4. The remaining unmachined surfaces were sanded or ground to remove any surface oxide left from the "hot" processing operations. Clean oxide-free surfaces were necessary for trouble-free EDM (electrical discharge machining) of the holes, cavities, etc.† The bars as delivered to the Main NOL shop for EDM are shown in Fig. 1(b), attached.
5. Upon return from EDM each bar was hand ground on a specially contoured SiC grinding wheel. This grinding operation provided the

*All milling, turning, etc., required use of tungsten carbide tooling.
†EDM was difficult until the surface oxide was removed and an adequate electrical path to the work piece was obtained.

Dr. James L. Hughes, M.D.

reduced sections on either side of the strain gage call (see Fig. 2, attached).

6. The next operation was to hand grind or sand the approximately 2-inch radius on the upper portion of the end sections of the bone plates. Considerable care was exercised to avoid uneven grinding of the parallel side sections of the straining cavity (see Fig. 2, attached). Uneven, cross-sectional areas in these straining sections could lead to nonuniform straining and highly unpredictable heat-recovery. The upper and lower views of a plate, at this stage, are shown in Fig. 1(c).

7. Tungsten carbide end and ball mills were then employed to finish machine the screw holes, screw slots, screw countersinks, inner wall of the strain cavity and the strain gage call.

8. As of this writing the concave undersurfaces of the plate ends have not been finish machined. This will be accomplished by either ball milling using a 1-inch radius ball mill or making a series of longitudinal passes with a contoured surface-grinding wheel.

9. Finally, hand grinding and sanding using various abrasive grits will be employed to remove all sharp edges and roughness.

Post-Machining Treatment. The finish machined bars will be washed carefully in trichloroethylene to thoroughly degrease them. Then they will be heated for several minutes in boiling water to remove any possible surface contamination due to absorption of hydrogen into the metallic surface, the possible hydrogen contamination coming from the EDM operation.

ALLOY CONTROLS

Very few controls or checks were possible during the plate preparation to assure a uniform composition from plate to plate. Most of the assurance comes from the following:

1. Careful alloy component weighing prior to melting.
2. Care in melting, both in handling the weighed charges and in preventing gaseous and interstitial contamination (e.g., the formation of Ti_4Ni_2O , Ti_4Ni_2N , TiC , etc.).
3. Qualitative damping to crudely determine the approximate transition temperature range and be certain that the dry ice temperature is below this critical temperature.
4. A thin "tang" was abrasively cut from the edge of one of the hot rolled plates (see Fig. 1(a)). This tang was sanded to reduce a short section to ~ 0.057 inch thick. The test piece was cooled in dry ice until its temperature had equilibrated to that of the dry ice. It was then

FIGURE
NITINOL WASHERS WITH ALTERNATING SCREWS OF STAINLESS STEEL
AND TITANIUM

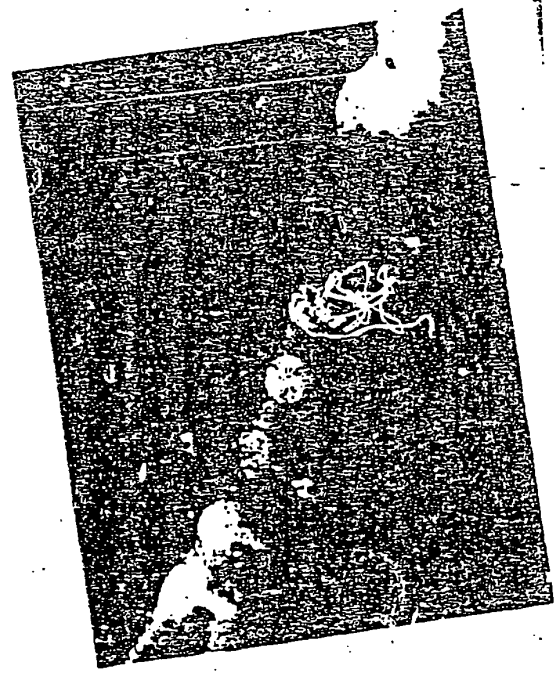
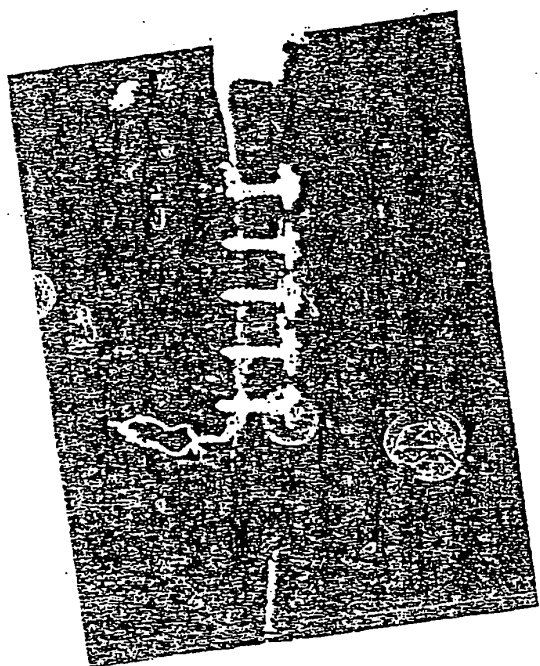

MEM00468

Dr. James L. Hughes, M.D.

1. Chill bone plate, straining pliers and constraining fixture in crushed dry ice.
2. When the plate, pliers and fixture have reached the dry ice temperature, insert the two 3/8" diameter stretching lugs on the pliers into the bone plate.
3. Slowly (possibly by steps) elongate the straining cavity. Monitor the amount of strain by constantly checking the length of the plate. For example, the straining legs on the straining cavity are ~ 0.525 inch long. Therefore, a 4% strain would be $.04 \times .625 = .025$ inch. Check the unstrained (initial) length of the plate when cooled to dry ice temperature. This length plus the 0.025 inch would represent the length of a 4% strained plate. NOTE: DO NOT ATTEMPT TO STRAIN THE PLATE UNLESS IT IS AT A TEMPERATURE NEAR THE DRY ICE TEMPERATURE. The latter could result in permanent deformation and/or fracture of the wall of the straining cavity.
4. Once the plate is strained to the desired level the chilled constraining fixture is inserted and adjusted so that its lugs will prevent any contraction during the installation of the plate.
5. Following installation the screw in the constraining fixture is backed off allowing the plate to contract. This contraction should follow previous measurements as shown in Fig. 3, attached. The force of contraction against the screw at 17°C may be large enough that pliers or a wrench will be required to hold the side of the constraining fixture while the set screw is backed off allowing contraction of the bone plate.

It is suggested that the above steps be practiced on simulated bones, at room temperature, in order to master the manipulation of the Nitinol bone plate.

PLATE STRAINING VARIATION

In accordance with an indirect communication from Dr. S. Perren it was suggested that the straining cavity could be given a "bent" or "bowed out" memory configuration. This is shown in Fig. 4(B). Then on cooling to dry ice temperature the side walls of the bowed cavity could be bent back straight (see Fig. 4(C)). Warming to body temperature would cause the straight walls (Fig. 4(C)) to revert back to the bowed configuration (Fig. 4(B)). If the bone screws are fastened while the strain walls are maintained straight, then when bowing was allowed to occur the fracture interface would be loaded.

While this scheme appears to be a suitable alternative to tensile straining there may be certain drawbacks. These are:

MEM00469

Dr. James L. Hughes, M.D.

1. The recovery force, from a bending mode, may be quite low.
2. Considerable bowing is required to derive much axial contraction. Further, this bowing is somewhat limited by the maximum outer fiber straining that can completely recover.
3. Considerable care must be exercised in the bowing operation. This probably should be done in the 550° to 650°C range. This is a temperature range of larger plasticity. Some early experiments to deform (bow) a bone plate at room temperature, when the TTR was -52°C to -18°C, resulted in early low strain fracture. This can be seen by observing the small experimental plate attached.
4. If bowing the side walls is to be attempted, in addition to the 550° to 650°C temperature, special plate holding fixtures and heated spreading mandrel will probably be needed in order to symmetrically accomplish the task.
5. Assuming now that a suitable bowed memory configuration is obtained then it would require certain specific steps to deploy this plate. These are:
 - a. Chill the plate, suitable pliers and the constraining fixture in dry ice.
 - b. Bend bowed strain cavity walls straight--probably with pliers.
 - c. Insert constraining fixture and adjust to prevent bowing on heating.
 - d. Fasten plate to fractured bone sections.
 - e. Back off on set screw in the constraining fixture allowing the walls to bow and load the fracture interface.

Additional questions will probably arise in the use of these plates. However, the above writeup should serve to address and answer many of the obvious questions.

Sincerely yours,

William J. Buehler
WILLIAM J. BUEHLER
Magnetism & Metallurgy Division

MEM00470

FIG 1

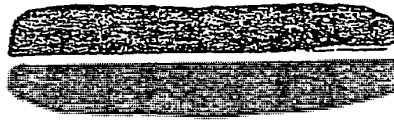

A



B



C

MEM00471

FIG. 2

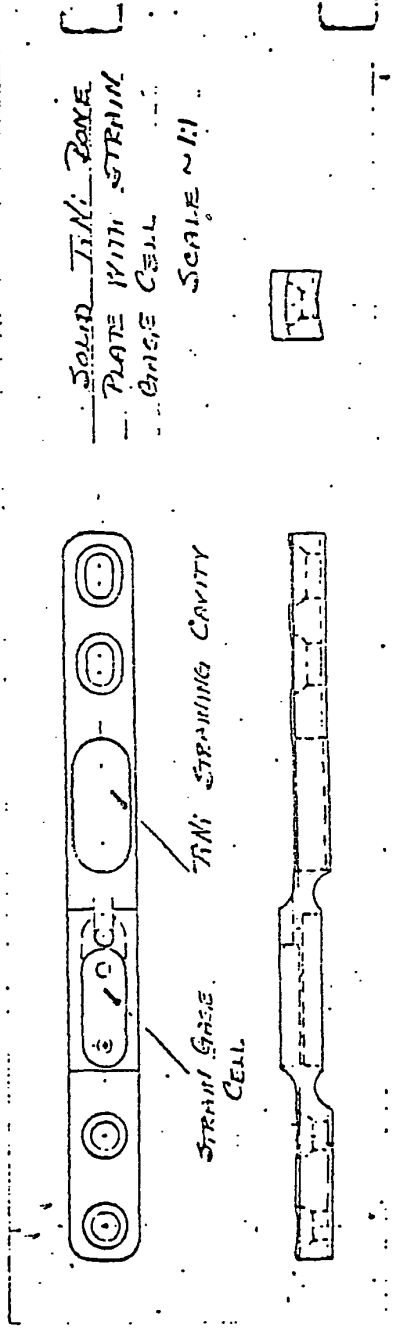

MEM00472

Fig 3 Percent Recovery After Axial Straining
 a Co-Molded Nylon Bone Plate (T12:
 -52°C to -12°C), Restrainted Recovery
 (27°C), Chilling to -76°C, Remaining
 Restrainted and Reheating to 37°C

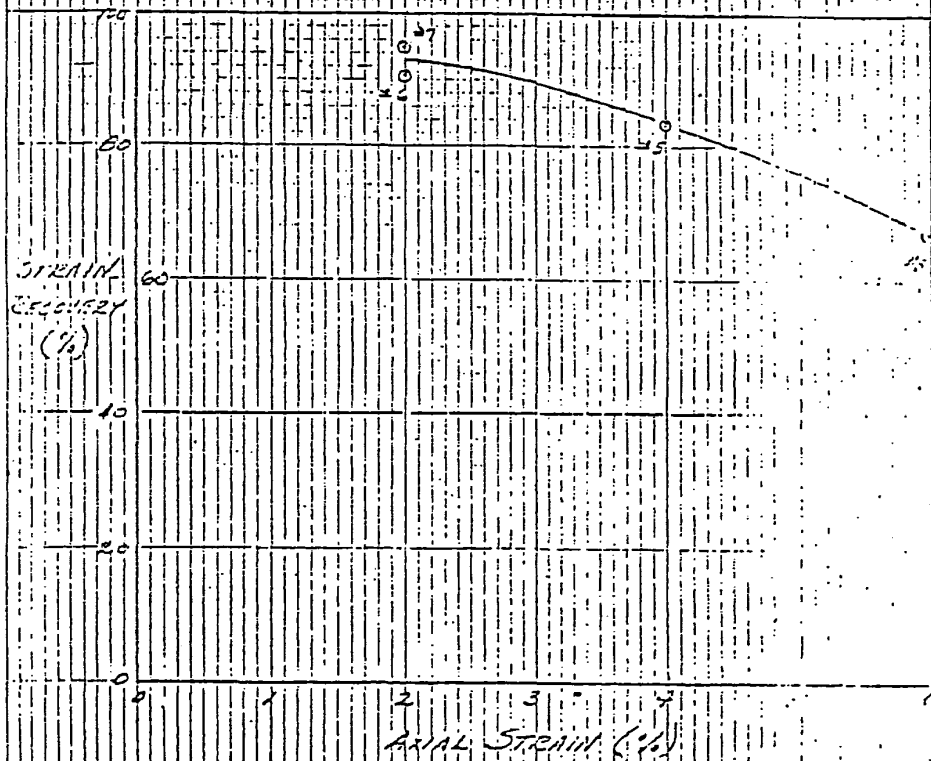

MEM00473

FIG. A

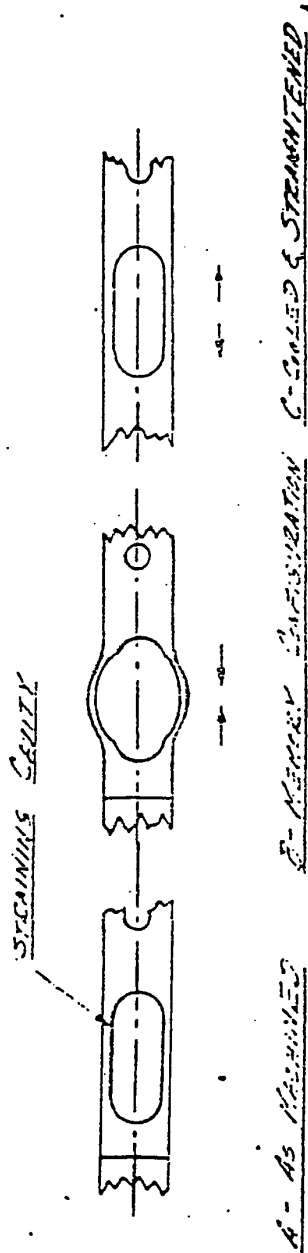

Table II

MEM00474

Added Notes on the Bone Plate Design

The attached drawing is the design consensus of John Tydings and myself. Initially we are discounting the Nitinol section joined (probably by hammer swaging) to a titanium-based alloy to form the end sections of the plate. In the overall view, the harder machining of Nitinol may be more than outweighed by mechanical joining problems, sterilization, etc. In addition to the mechanical drawing, I have also made a three-dimensional sketch showing more realistically the proposed plate.

Observing the drawing(s) (Figure 1 and/or 2) it can be seen how we plan to chill and stretch the "TiNi Straining Cavity." The locking wedge will have a taper that will not allow it to "hack out" under the contracting load of the warming bone plate. If this should be a problem then we have alternative schemes that can be used and are almost equally as simple. Further, if the wedge technique works, wedges of varying thickness can be employed to provide variable initial strain, e.g., 2%, 4%, 6% etc.

The design of the bone plate is based upon its use as shown schematically in Figure 3 (A-D). The section called the "TiNi Straining Cavity" would be chilled and strained below the TTR of the alloy (Figure 3-B). Recovery would be constrained during installation and warming, by the use of the locking wedge. This is shown schematically in Figure 3-C. Then the wedge could be carefully ejected allowing contraction and loading of the fracture (Figure 3-D). The graph given in Figure 3 shows the extent of recovery when one first constrains recovery and then removes the constraint and allows free recovery.

MEM00475

PROPOSED NITINOL BONE PLATE



A-A



B-B

A B



A B

17. 205 2. 6 24

MEM00476

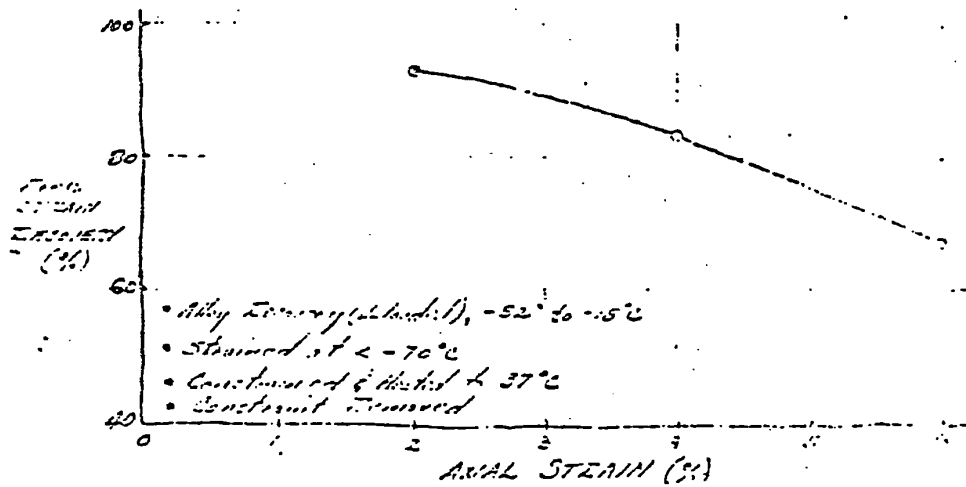
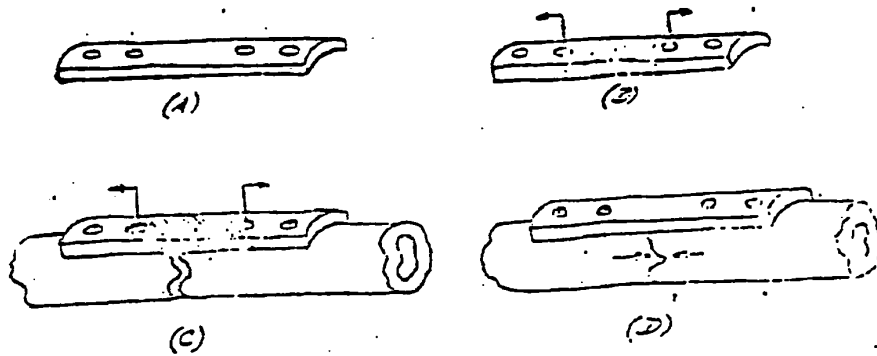

Lab. 12. 504

MEM00477

Fig 4

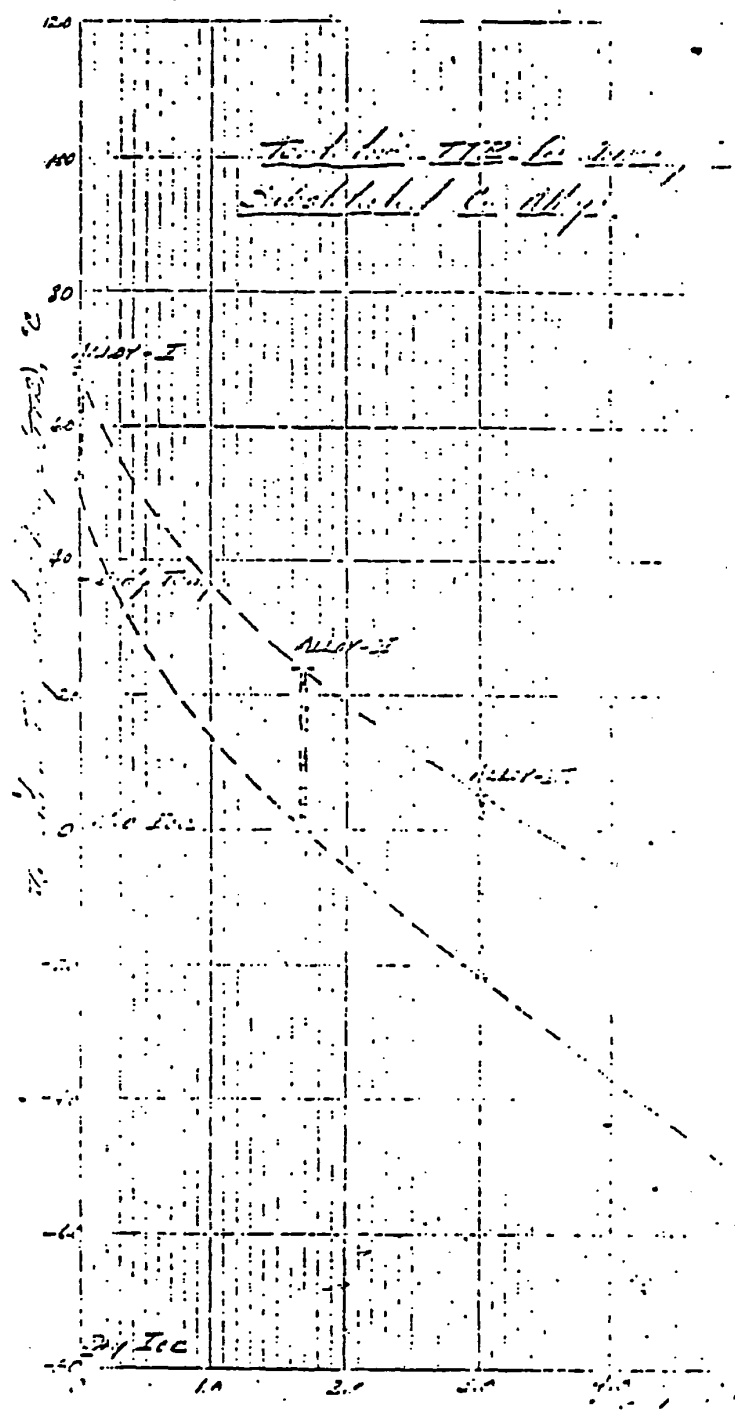

MEM00478

Fig. 1

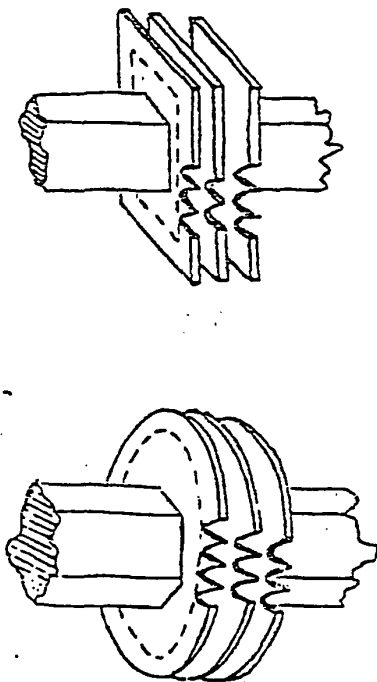

Top View



Combination

FIG. 2

MEM00479

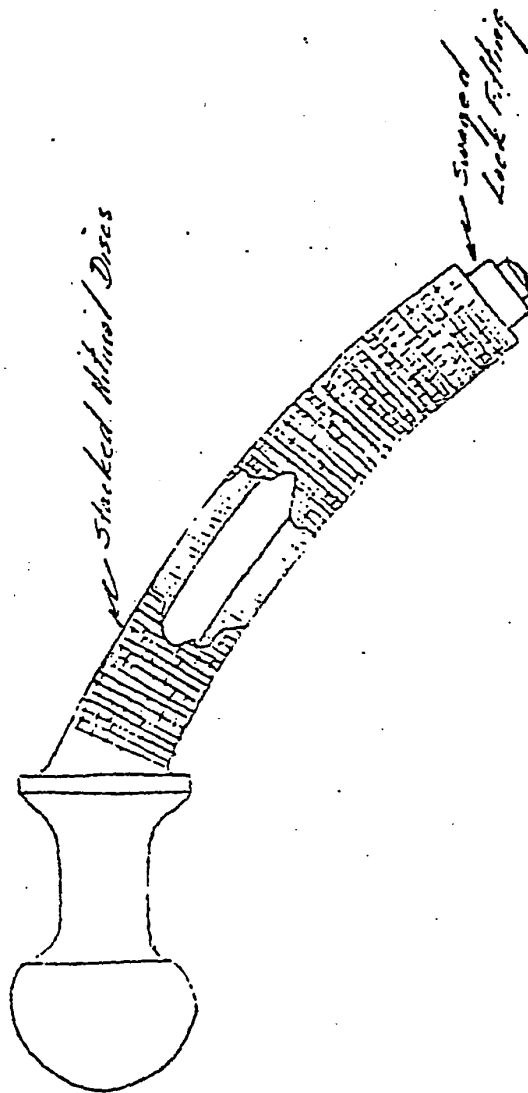

FIG. 3

MEM00480

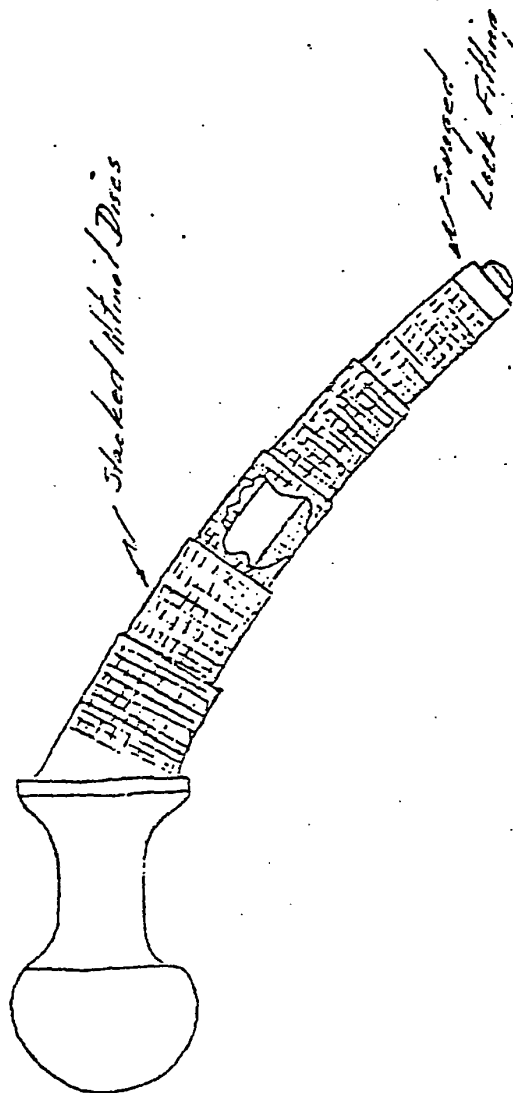

FIG. 4

MEM00481

Toxic Cavity Preparation

1. Insert curved drill pin into soft bone
2. Trace out cavity using progressively larger cutters which follow curved drill pin

Options:

- a. Flexible broach may be used to cut a shaped cavity (e.g., square, hexagonal, etc.). Broach would be guided by a curved drill pin and powered by low cycle vibrator.
- b. Use flexible broach to cut a square-to-round tapered cavity.
- c. Use flexible broach to cut kerfway(s) to prevent twisting of the metallic pin.

Deform Initial Pin

1. Deform in structure which is composed of stacked initial sized discs. See Figures 1, 2, 3 and 4 attached.
2. Deform teeth upward after shifting structure below TTR of initial.
3. Insert pin quickly into prepared cavity
4. On warming to body temperature teeth

MEM00482

will deploy radially outward and dig into wall of bone easily. An interference fit is provided by making the bevel bone cavity smaller than the deployed dental disc.

Advantages

1. Use of standard cellulose for pin adapted to accept "active" dental elements.
2. Fine teeth will prevent structure for ingrowth of tissue.
3. No plastic required.
4. Maximum dental recovery performance associated with the body maintenance sheet material.
5. Maximum rate associated with dental will be maintained.

MEM00483

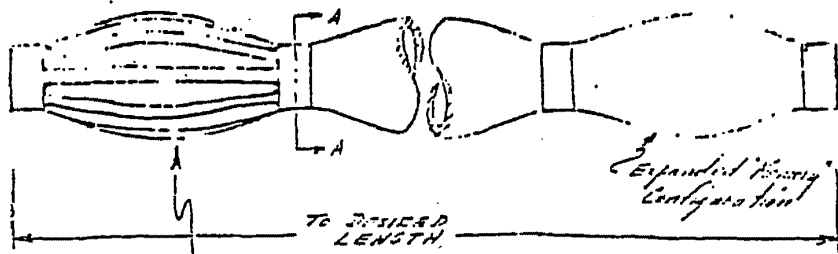

6% strain = bend radii of 1 inch
for 0.094 inch diameter wire

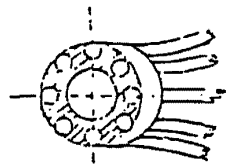

Aluminum & Stainless
Steel Rings

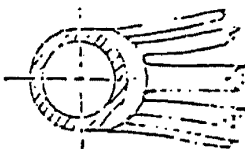

Actual Tubular
Construction

SECTION A-A

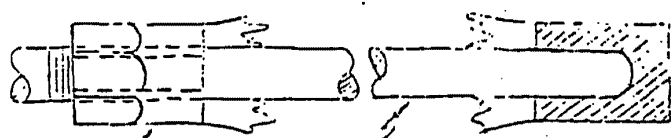

Stainless Steel Rod

End Pieces Either
Stainless Steel or Actual
Depending upon Design Above

INTRAMEDULLARY ROD

MEM00484

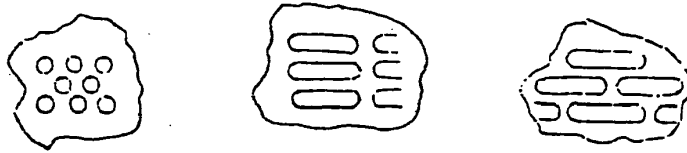
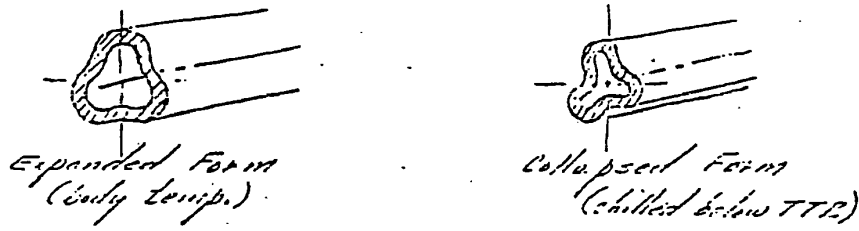

Possible Variations in Porosity

Construction Details:-

- Tube, if porous, would be punched from sheet
- Next, roll into tubular form
- Etch on beam with (if needed)
- Hot-form to 'expanded form' shape

INTRAMEDULLARY ROD

FIGURE 5

PREPARATION OF TISSUE SECTIONS FOLLOWING REMOVAL OF IMPLANT SPECIMEN
NINE WEEKS POST-SURGERY

MEM00485

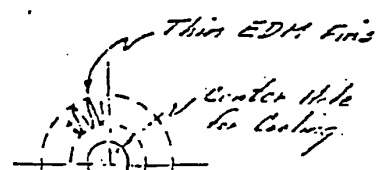
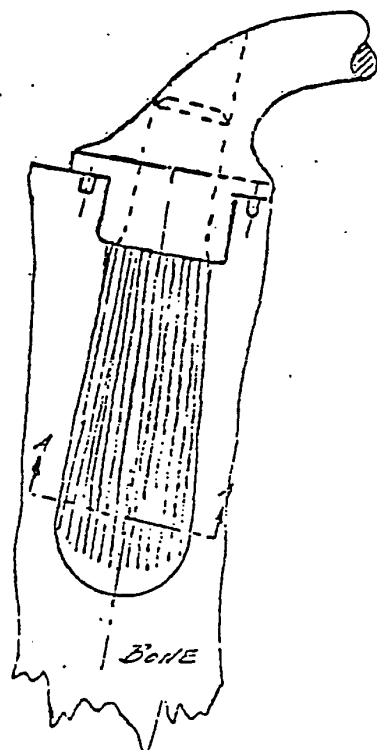

SECTION A-A
(Warm Configuration)



Shape Variation

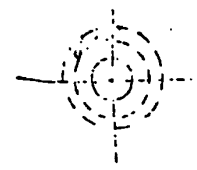

SECTION A-A
(Cold Retained)

INVERTED-TAPER HIP PROSTHESIS

MEM00486

Table I

TITINOL Alloy Compositions Chosen for Experimental Studies*

<u>Alloy No.</u>	<u>Charge Composition</u>	<u>Approximate Heat Recovery range (°C)†</u>
I	TiNi	52 to 63
II	Ti _{.5} Ni _{.483} Co _{.017}	0 to 24
III	Ti _{.5} Ni _{.47} Co _{.03}	-22 to 5
IV	Ti _{.5} Ni _{.45} Co _{.05}	-52 to -19
V	Ti _{.5} Ni _{.43} Co _{.07}	-60 to -40

*Charge Materials were: Ti, commercial purity sponge
 Ni, Mond carbonyl nickel
 Co, High purity grade (MRC)

†based upon bending wrought sheet specimens below transition range followed by heating to induce recovery under no load.

MEM00487

Table II

Summary of the Arc-Melted Alloys Produced and Their Ultimate Use

Alloy No.*	Arc-Melted Buttons-150gr.	Arc-Melted Bars (150gr), Bars (450gr)	Hot Wrought Shape	Component Produced
I	2	2 (150gr)	hot swaged (dia) 13mm, 4.5 mm	<ul style="list-style-type: none"> • filings • implant specimens • washers (4)
II	2	2 (150gr)	hot swaged (dia) 13mm, 4.5mm	<ul style="list-style-type: none"> • filings • implant specimens • washers (4)
III	2	2 (150gr)	hot swaged (dia) 13mm, 4.5mm	<ul style="list-style-type: none"> • filings • implant specimens • washers (4)
IV	2	2 (150gr)	hot swaged (dia) 13mm, 4.5mm	<ul style="list-style-type: none"> • filings • implant specimens • washers (4)
V	2	2 (150gr)	hot swaged (dia) 13mm 4.5mm	<ul style="list-style-type: none"> • filings • implant specimens • washers (4)
V	12	4 (450gr)	hot rolled into plate 9.6mm thick	<ul style="list-style-type: none"> • contracting bone plates (8)

*See Table I for information on the compositions and heat recovery ranges of the five alloys listed.

MEM00488

FIGURE 7

FIGURE 1
NITINOL IMPLANT SPECIMEN

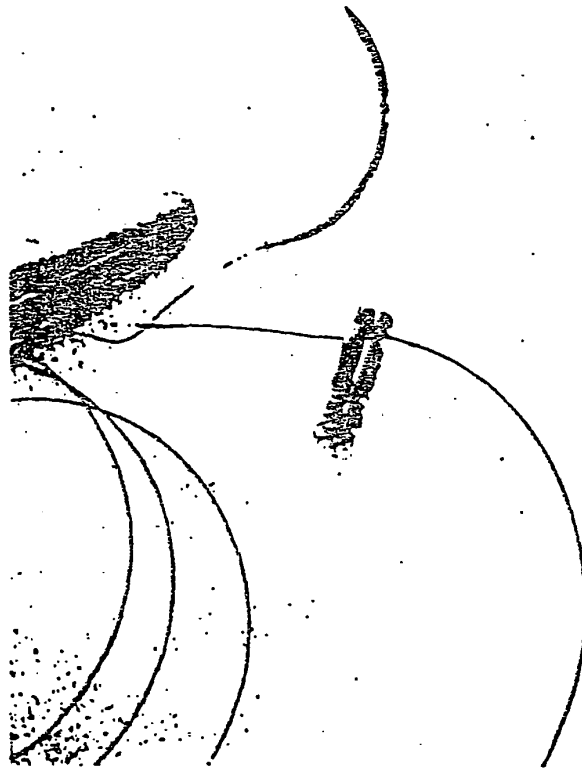

MEM00489

FIGURE 1

171 205 206 207

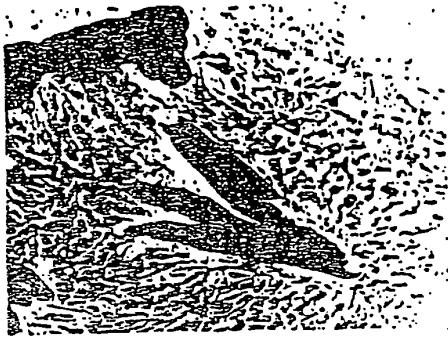

ALLOY IV
DAY 5

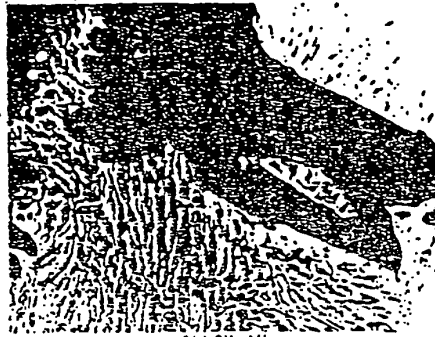

ALLOY IV
DAY 7

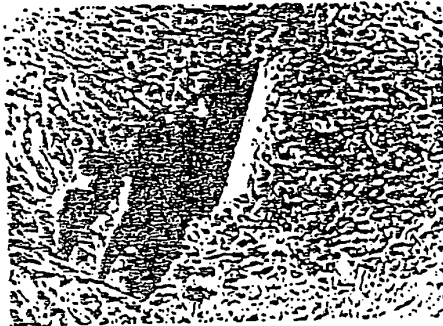

ALLOY I
DAY 9

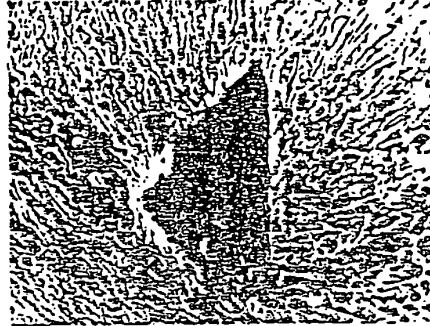

ALLOY I
DAY 11

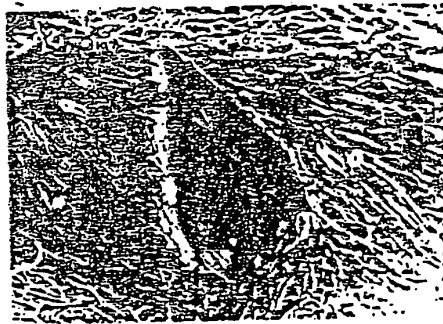

ALLOY V
DAY 13

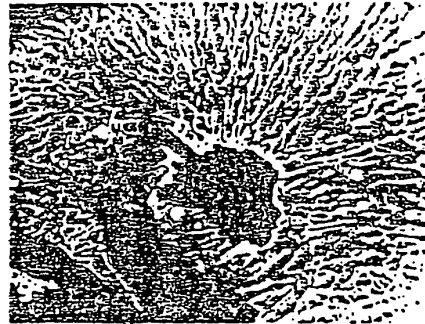

ALLOY V
DAY 15

FIGURE 2a

LEIGHTON TUBE SLIDES IN THE PRESENCE OF MITINOL POWDER

MEM00490

FIGURE a

Feb. 12, 204

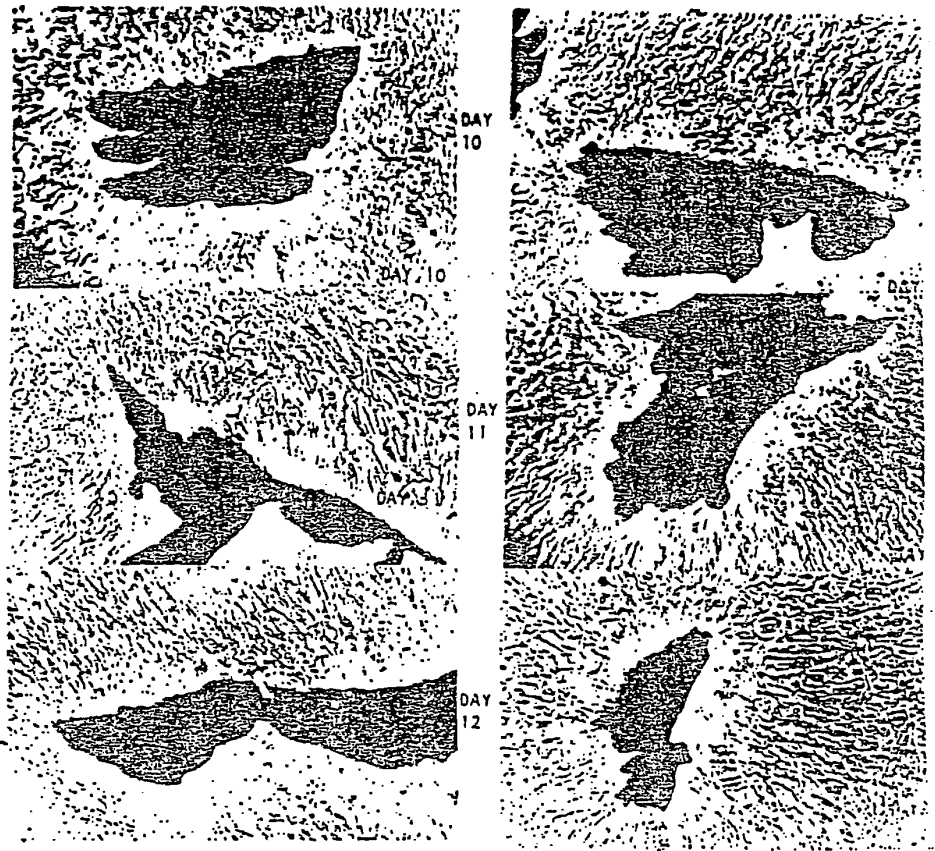

STAINLESS STEEL

FIGURE 2b

TITANIUM

LEIGHTON SLIDE TISSUE CONTROLS

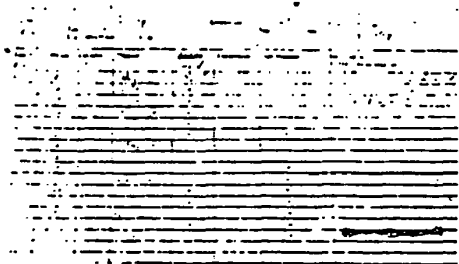

MEM00491

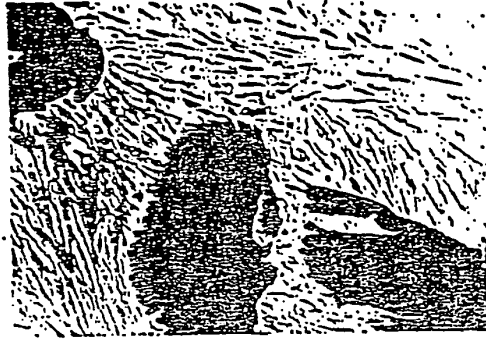
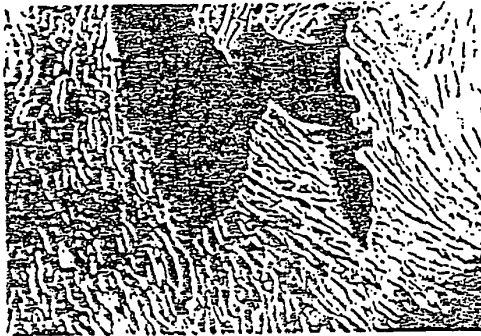

FIGURE 2c
COMPARISON OF TISSUE CULTURE
SLIDES AT 20 DAYS

ALLOY IV
DAY 20



ALLOY V
DAY 20



STAINLESS STEEL
DAY 20

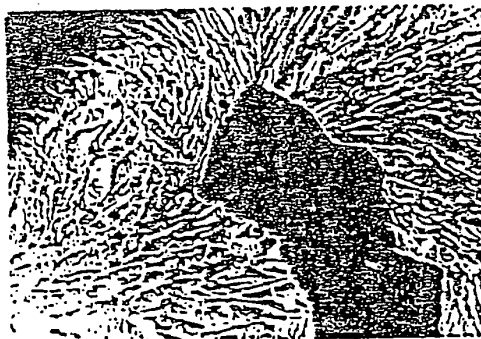

TITANIUM
DAY 20

MEM00492

FIGURE 11

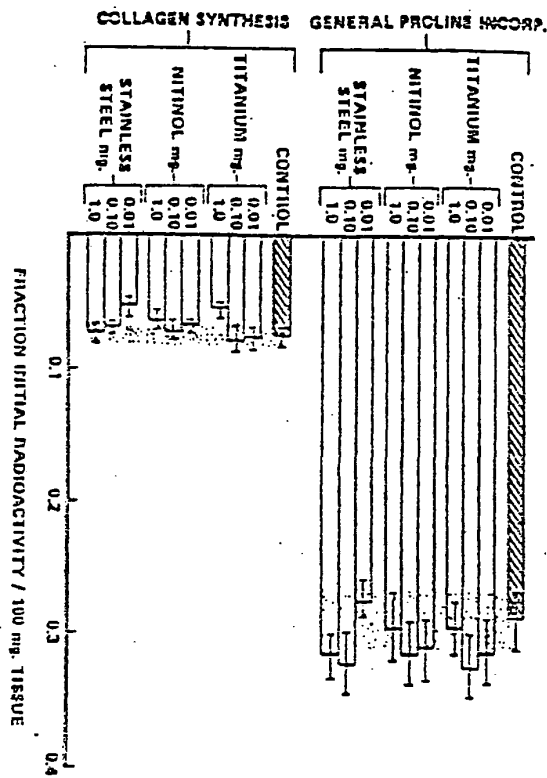

FIGURE 3

MEM00494

FIGURE 13

FIGURE 4a

INSERTION OF IMPLANT SPECIMEN IN MOUSE

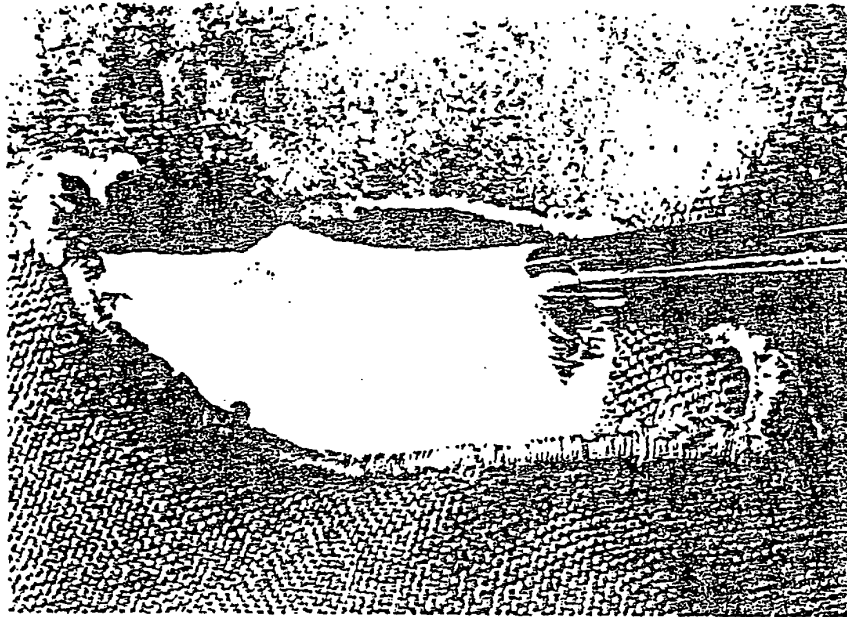

MEM00495

FIGURE 14

TITINOL HIP PROSTHESIS WITH SELF-DEPLACEMENT

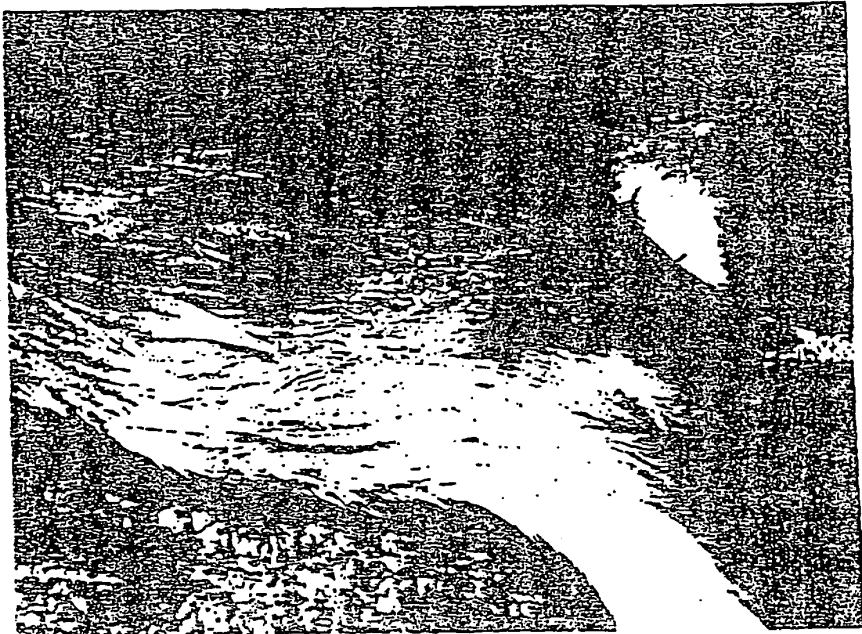

MEM00496

COOK
Exhibit 1002-0327



MEM00497

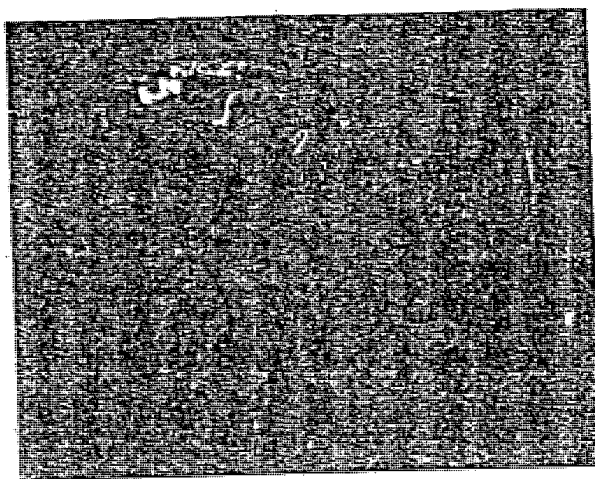

FIGURE 5a

TISSUE AND IMPLANT EMBEDDED IN METHYMETHACRYLATE

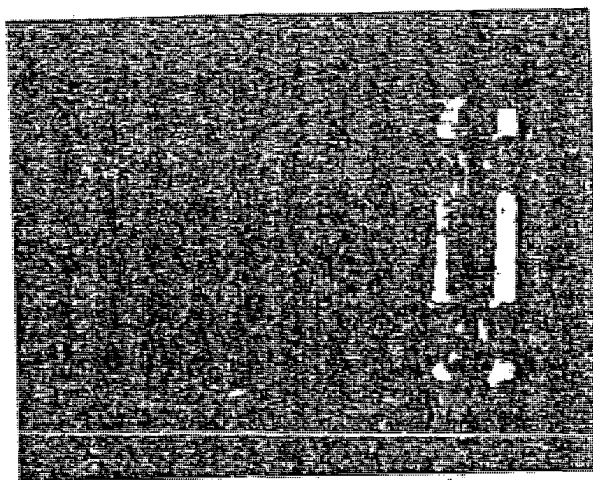

FIGURE 5b

REMOVAL OF IMPLANT FROM TISSUE BLOCK

MEM00498



FIGURE 5c
TISSUE SECTIONING

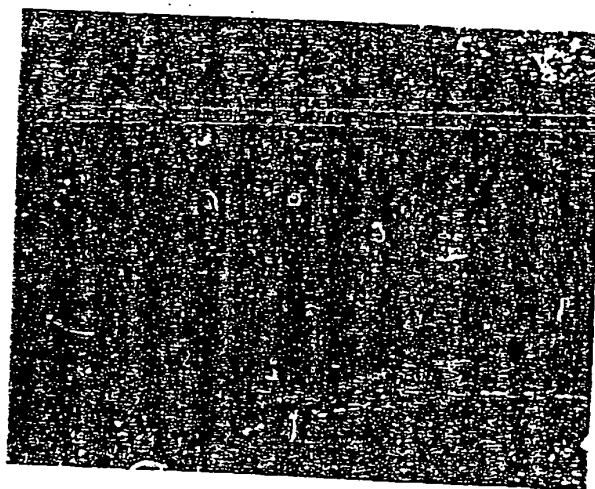
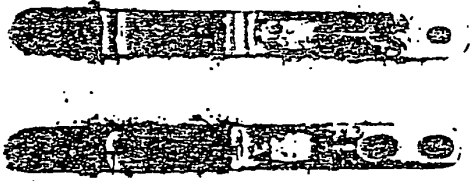
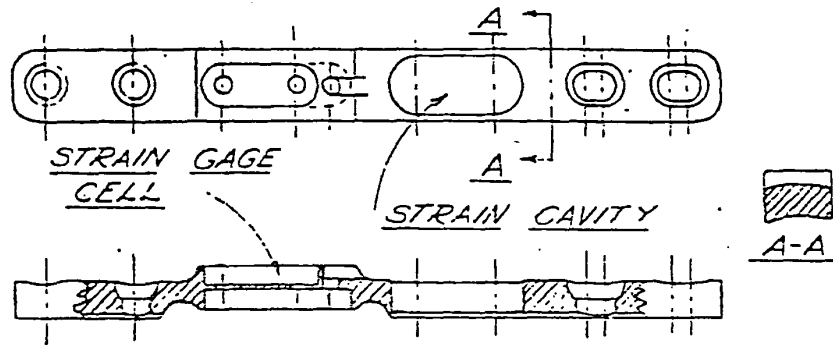

FIGURE 5d
NORMAL TISSUE SURROUNDING IMPLANT

MEM00499

STRAIN GAUGE CELL



*KIT. 1052 base
 plate with both a
 "strain gage cell"
 and slotted screw
 holes on one end
 for adjustment. Draw-
 ing above shows
 major details. Some
 plate length ~ 12.9
 cm. Photographs
 of left above two
 finish mounting
 base plates.*

MEM00500

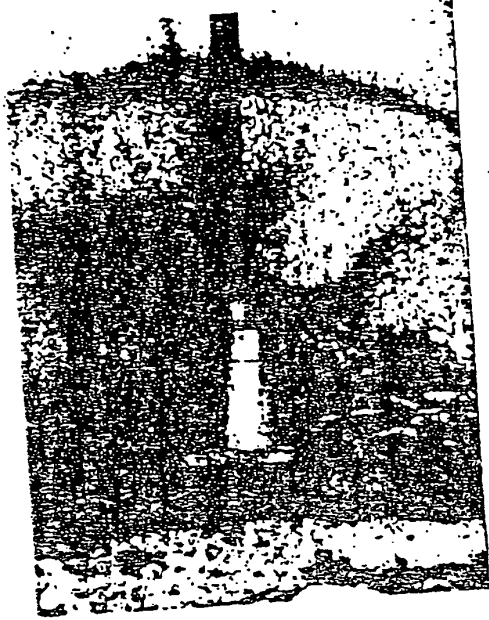

FIGURE 7a
PLATE APPLICATION

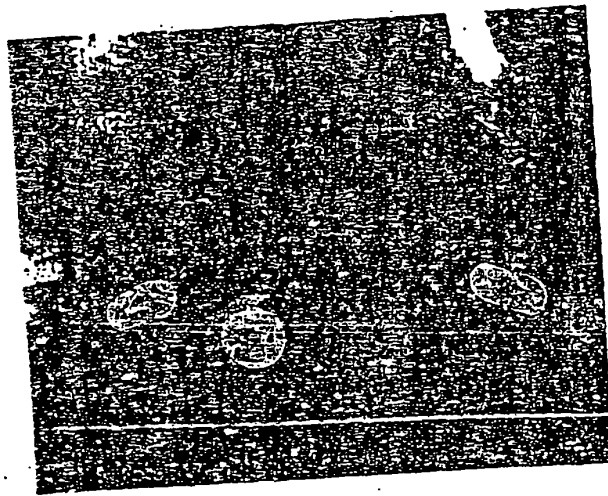
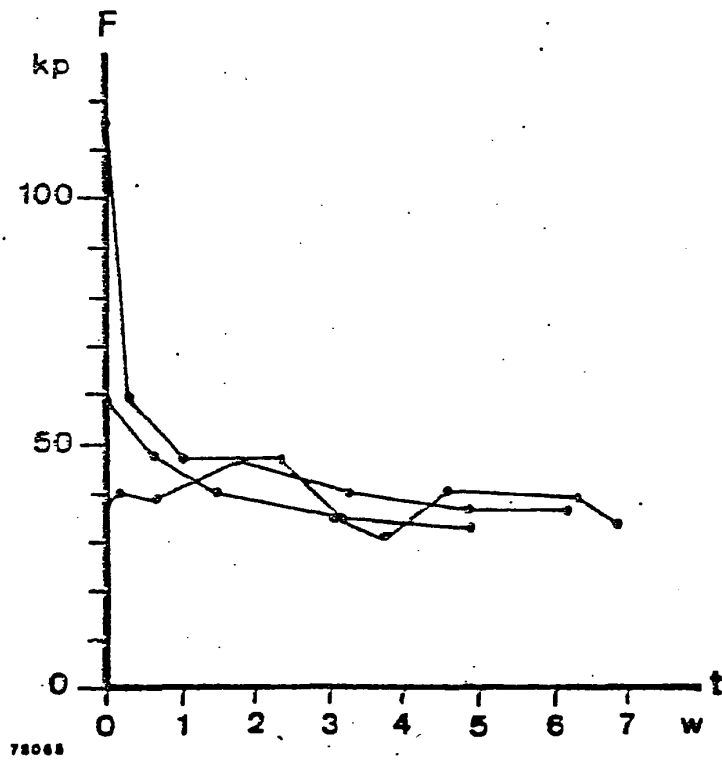

FIGURE 7b
PLATE IN PLACE ON SHEEP FEMUR

MEM00501

MEASUREMENTS OF THE STRAIN GAUGE CELLS TAKEN AT WEEKLY INTERVALS



MEM00502

TITINOL PLATES ON SHEEP PERONE

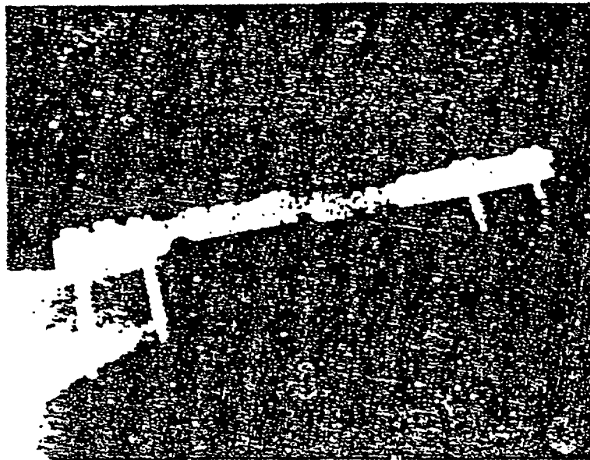

FIGURE 9a

EARLY RADIOGRAPH FOLLOWING PLATE APPLICATION

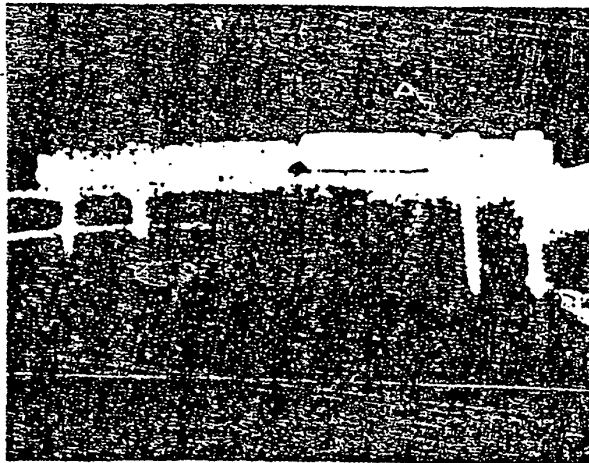

FIGURE 9b

LATER RADIOGRAPH REVEALING EARLY BONE FORMATION

MEM00503

FIGURE 106

EDGE OF BONE AFTER REMOVAL OF MITINOL PLATE
BONE IS ALIVE AND NORMAL

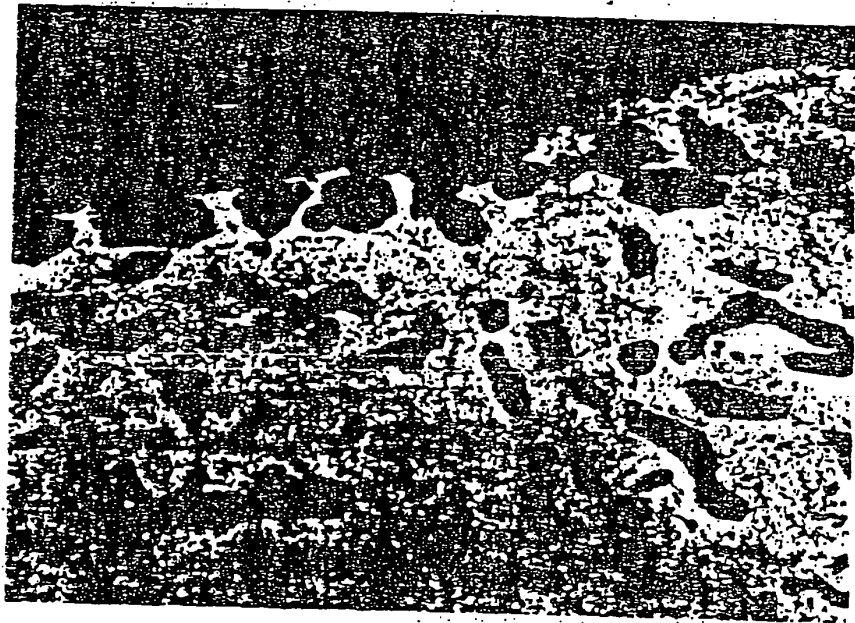

MEM00504

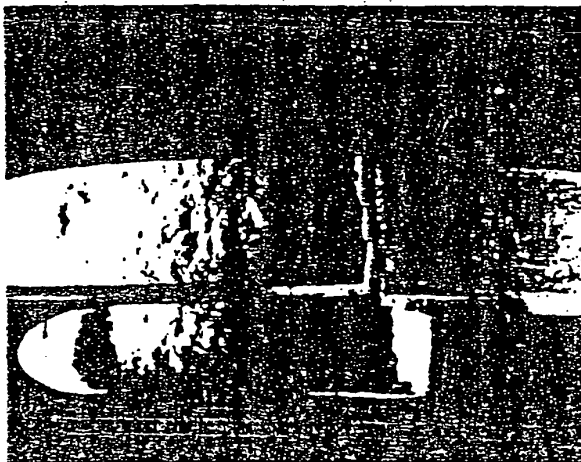

MEM00505

INITIAL MEASUREMENT OF FORCE TAKEN WITH THE PLATE IN PLACE
ON SHEEP FEMORA



MEM00506

PROTOTYPES OF HIP PROSTHESIS AND INTRAMEDULLARY ROD

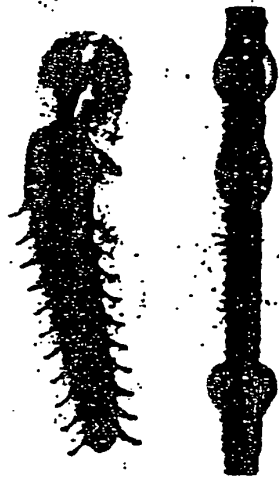

MEM00507

MEMORANDUM FOR THE RECORD



MEM00508

COOK
Exhibit 1002-0339

DEVICE IN MIDDLEMAN PATENT NUMBER 5,231,989

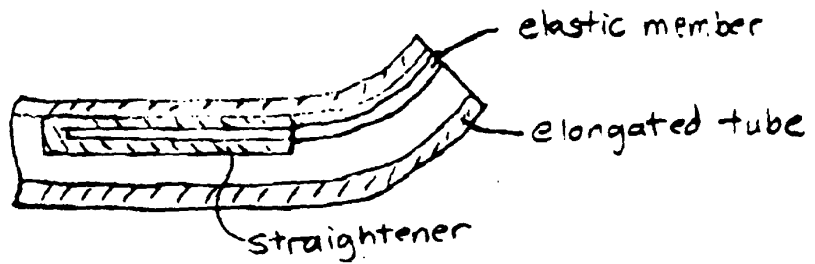
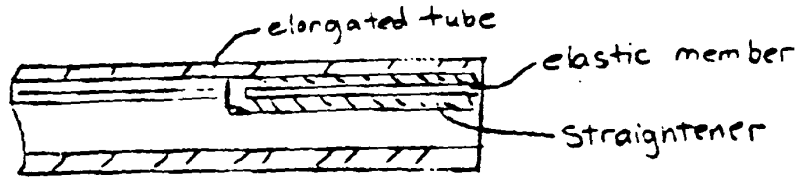

DEVICE IN JERVIS PATENT APPLICATION

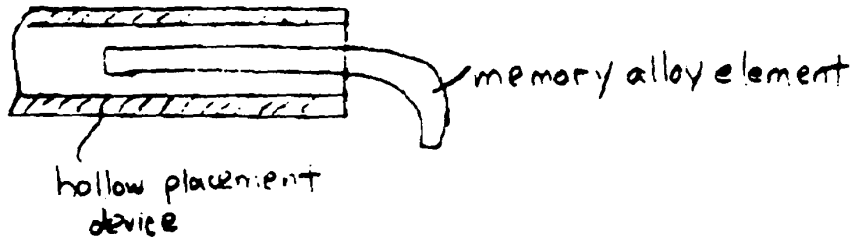
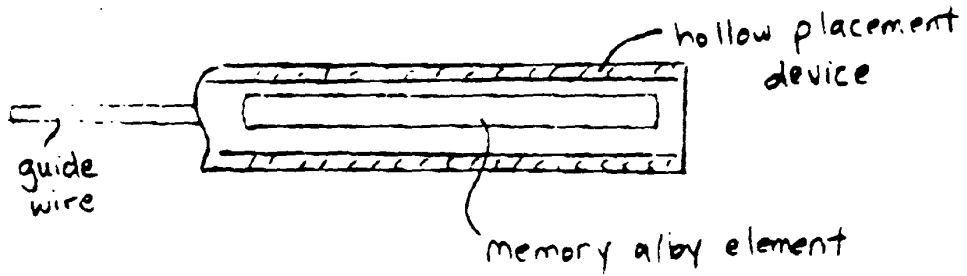

Exhibit
B

The opinion in support of the decision being entered today was not written for publication and is not binding precedent of the Board.

Paper No. 27

UNITED STATES PATENT AND TRADEMARK OFFICE

BEFORE THE BOARD OF PATENT APPEALS
AND INTERFERENCES

Ex parte JAMES E. JERVIS

Appeal No. 1999-2649
Application 08/483,291

HEARD: February 7, 2001

MAILED

FEB 26 2001

**PAT. & TM. OFFICE
BOARD OF PATENT APPEALS
AND INTERFERENCES**

Before CALVERT, FRANKFORT, and BAHR, Administrative Patent Judges.

CALVERT, Administrative Patent Judge.

DECISION ON APPEAL

This is an appeal from the final rejection of claims 21, 23, 25 to 31, 34 to 38, 40 to 42 and 44 to 46. Claims 32, 33, 39 and 43 were also finally rejected, but the examiner states on page 2 of the answer that claims 32 and 33 are allowed, and claims 39

Appeal No. 1999-2649
Application 08/483,291

and 43 were canceled by an amendment filed with appellant's brief.

The involved invention generally concerns medical devices made of shape memory alloys (SMA) which display the property of stress-induced martensite (SIM)¹. The particular subject matter in issue is defined by the claims on appeal, which are reproduced in Appendix A of appellant's brief.

The references applied in rejecting the claims on appeal are:

Foster, Jr.	4,485,805	Dec. 4, 1984
Balko et al. (Balko)	4,512,338	Apr. 23, 1985
Middleman et al. (Middleman)	5,231,989	Aug. 3, 1993
		(filed Feb. 15, 1991)

Schetky, Shape-Memory Alloys, 20 Kirk-Othmer Encyclopedia of Chemical Technology 726-736 (3d Ed. 1982).²

The appealed claims stand finally rejected on the following grounds:

¹At the oral hearing counsel for appellant pointed out that the statement in the first paragraph on page 13 of the brief, to the effect that appellant's memory alloy element does not require treatment to obtain SIM properties, is incorrect.

² The examiner incorrectly refers to this reference as "Seader", which is the name of the author of a preceding entry. We will refer to it in this decision as "Kirk-Othmer."

Appeal No. 1999-2649
Application 08/483,291

(1) Claims 21, 23, 25 to 31, 34 to 38, 40 to 42 and 44 to 46, unpatentable over Balko in view of Kirk-Othmer and Foster, under 35 U.S.C. § 103(a).

(2) Claims 21 and 23, unpatentable for obviousness-type double patenting over claims 1 and 2 of Middleman.

(3) Claims 21 and 23, unpatentable over Middleman under either 35 U.S.C. § 102(e) or 103(a).

Rejection (1)

Balko discloses a medical device in which an element such as wire element 24 or 34 is carried within a sheath 20 or 36, and is released from the sheath at a desired position in a vessel 16, 30 or other body channel. The element is made of an SMA, such as Nitinol, which has a martensite transformation temperature somewhat below or about body temperature (37°C). The temperature of the element is maintained below the transformation temperature until it is in position, as by using an insulating sheath. When the element is released from the sheath it is warmed by the body tissue to a temperature above its martensite transformation temperature, and reforms into its coiled form (col. 4, lines 13 to 27). Balko does not disclose that the SMA used displays SIM, but the examiner, citing Kirk-Othmer page 731, lines 13 to 20 [sic: 14 to 21], and page 733, line 6, takes the position that

Appeal No. 1999-2649
Application 08/483,291

Nitinol can exhibit SIM (superelastic) properties, and therefore that the Nitinol disclosed by Balko would inherently have SIM properties at about body temperature.

The cited portion on page 731 of Kirk-Othmer reads:

The other property peculiar to marmem alloys is the ability under certain conditions to exhibit superelastic behavior. Although in one sense, the 3-8% apparently recoverable strain of the memory effect is truly an extended or pseudoelastic behavior, an even further elastic range is possible. When many of the martensitic alloys are deformed well beyond the point of the initial single-coalesced martensite stage, a stress-induced martensite-martensite transformation can occur. In this mode of deformation strain is reversible through stress release and not by a temperature-induced phase change, and recoverable strains as high as 17% have been observed.

Page 733, line 6, states that an early medical device (an orthodontic brace) "exploits the superelastic behavior of Nitinol." We do not read these portions of Kirk-Othmer as disclosing that all Nitinol exhibits superelastic (SIM) properties, but only that "many" of the martensitic alloys do "when deformed well beyond the point of the initial single-coalesced martensite stage." This is consistent with the declaration of Dr. Middleman³, a coinventor of the above-listed '989 patent, that (para. 11, pages 3 to 4):

³ Declaration of Dr. Lee Middleman under 37 CFR § 1.132, dated Feb. 2, 1998, filed Mar. 18, 1998.

Appeal No. 1999-2649
Application 08/483,291

Although nitinol can exhibit the properties of an SIM material it can do so only if it undergoes a treatment process to make it exhibit the properties of an SIM material. This process requires an extensive, time consuming and expensive procedure.

In basing a rejection on the ground that the prior art would inherently possess a claimed property, the examiner bears the initial burden of establishing a prima facie case, as by showing that the claimed and prior art products are identical or substantially identical or are produced by identical or substantially identical processes. See, e.g., In re Best, 562 F.2d 1252, 1255, 195 USPQ 430, 433-34 (CCPA 1977). In the present case, we consider the examiner's statement on page 8 of the answer that "both of Balko and [the] instant application use the nitinol alloy" to be overly broad. Balko specifically discloses the use of SMAs, particularly nickel-titanium alloys (nitinol), which "completely recover to their original shape on being raised to a higher temperature" (col. 3, lines 37 to 39), whereas appellant discloses the use of SMAs which display SIM properties, i.e., in which the shape change is "mechanically, rather than thermally, actuated and controlled" (specification, page 8, lines 13 to 16). The alloy preferred by appellant is nickel-titanium-vanadium, as disclosed in Quin Patent No.

Appeal No. 1999-2649
Application 08/483,291

4,505,767 (*id.*, page 8, lines 22 to 24). As shown by Kirk-Othmer and the Middleman declaration, nitinol does not exhibit SIM properties unless it receives additional treatment, of which there is no suggestion in Balko. We therefore conclude that the examiner has not made out a prima facie case that the SMAs disclosed by Balko would inherently display SIM properties.

The Foster patent contains no disclosure concerning SMAs, and was cited by the examiner only as evidence of the obviousness of using a guide wire (recited in claims 21, 37 and 38). In the view we take of this case, further consideration of Foster is unnecessary.

Each of independent claims 21, 26, 31 and 34 requires, in varying language, a memory alloy element (claim 21) or a stent (claims 26, 31 and 34) formed at least partly from an alloy which displays SIM behavior.

In view of the foregoing discussion, the combination of Balko and Kirk-Othmer would not have suggested or rendered obvious these limitations.

Moreover, claim 21, for example, additionally recites "wherein the alloy is selected so that the transformation can occur without any change in temperature of the placement device or the memory alloy element," and similar limitations are

Appeal No. 1999-2649
Application 08/483,291

contained in the last three lines of claim 26, the last six lines of claim 31, and the last two lines of claim 34. Even if it were to be assumed that the nitinol disclosed by Balko would exhibit some SIM properties, these limitations would not be met because Balko does not teach transformation without a change in temperature, but rather, Balko's entire disclosure is directed toward using an alloy which will transform when the temperature rises from below body temperature to body temperature (or when otherwise heated, see col. 5, lines 57 to 67).

Accordingly, rejection (1) will not be sustained.

Rejection (2)

The examiner asserts that claims 21 and 23 are obvious over claims 1 and 2 of the commonly-assigned Middleman patent.⁴ According to the examiner, the "elongated tube" of patent claim 1 corresponds to the "hollow placement device" of claim 21, "elastic member" of patent claim 1 to the "memory alloy element" of claim 21, and the "straightening means" of patent claim 1 to the "guide wire" of claim 21.

⁴Our understanding is that the Middleman patent and the present application are both currently assigned to Medtronic, Inc.

Appeal No. 1999-2649
Application 08/483,291

Appellant argues that this rejection should be reversed regardless of whether we apply the "one-way test" for obviousness-type double patenting (In re Goodman, 11 F.3d 1046, 1052, 29 USPQ2d 2010, 2015 (Fed. Cir. 1993)), or the more stringent "two-way test" (In re Braat, 937 F.2d 589, 593, 19 USPQ2d 1289, 1292 (Fed. Cir. 1991)). Since we conclude that the rejection does not pass the "one-way test," the question of which test to apply is moot.

Considering the language of claims 1 and 2 of Middleman in relation to claim 21, we agree with the examiner that the "hollow placement device" recited in claim 21 is met by the "elongated tube" recited in claim 1, and the "memory alloy element" of claim 21 finds response in the "elastic member" recited in claim 1 (as modified by claim 2). However, claim 21 further recites "the hollow placement device stressing the memory alloy element . . . so that the memory alloy element is in its deformed shape," the "deformed shape" being "when the alloy is in its stress-induced martensitic state." There are no such limitations in claims 1 and 2 of the patent; rather, claim 1 recites the opposite, namely, "the elastic member [memory alloy element] being sufficiently stiff to cause the distal segment [of the elongated tube (claim 21's "hollow placement device")] to bend when the

Appeal No. 1999-2649
Application 08/483,291

elastic member is in its bent shape," the "bent shape" being defined in claim 2 as being "when the alloy is in its stress-induced martensitic state" (col. 17, lines 34 and 35). Since claim 21 requires that the hollow placement device stresses the memory element so that it is in its SIM state, while claims 1 and 2 of the patent require that the elastic member (memory alloy element) cause the tube (hollow placement device) to bend when the member is in its SIM state, i.e., that the tube does not stress the elastic member, we find no basis for concluding that the quoted limitations of claim 21 would be obvious over the structure recited in patent claims 1 and 2, or vice versa.

Rejection (2) therefore will not be sustained.

Rejection (3)

We will not sustain this rejection.

A reference does not qualify as prior art under 35 U.S.C. § 102(e)/103 unless it is a U.S. patent with an effective filing date prior to the effective filing date of the application. MPEP § 706.02(a), p. 700-11, col. 1, para. (A) (Feb. 2000); see, e.g., In re Scheiber, 587 F.2d 59, 199 USPQ 782, (CCPA 1978). Here, appellant asserts at page 31 of the brief, and the examiner does not disagree, that the effective filing date of the claims on

Appeal No. 1999-2649
Application 08/483,291

appeal is October 14, 1983,⁵ a date well prior to the February 15, 1991, (effective) filing date of the Middleman patent. Since Middleman does not meet the § 102(e)/ § 103 prerequisite of having an earlier effective filing date it does not qualify as prior art under those sections of the statute, regardless of the fact that Middleman and the present application have a common assignee and different inventive entities, as noted by the examiner on page 11 of the answer.

⁵ The filing date of application 06/541,852, the first in the chain of applications resulting in the present case.

Appeal No. 1999-2649
Application 08/483,291

Conclusion

The examiner's decision to reject claims 21, 23, 25 to 31, 34 to 38, 40 to 42 and 44 to 46 is reversed.

REVERSED



IAN A. CALVERT
Administrative Patent Judge



CHARLES E. FRANKFORT
Administrative Patent Judge

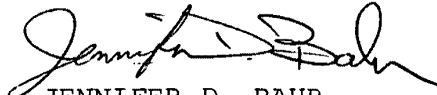

JENNIFER D. BAHR
Administrative Patent Judge

)
)
)
)
) BOARD OF PATENT
)
) APPEALS AND
)
) INTERFERENCES
)
)

IAC:pgg

Appeal No. 1999-2649
Application 08/483,291

Jeffrey G. Sheldon
Sheldon & Mak
225 South Lake Avenue Suite 900
Pasadena, CA 91101



3733 #281

PATENT
Attorney Docket Number 9438-1

IN THE UNITED STATES PATENT AND TRADEMARK OFFICE

In re application of: JAMES E. JERVIS

Examiner: Justine Yu

Serial No.: 08/483,291

Group Art Unit: 3733

Filed: June 7, 1995

For: **MEDICAL DEVICES
INCORPORATING SIM ALLOY
ELEMENTS**

RECEIVED
MAR 13 2001
TC 3700 MAIL ROOM

SUPPLEMENTAL INFORMATION DISCLOSURE STATEMENT

Assistant Commissioner for Patents
Washington, D. C. 20231

Sir:

Attached is a Form PTO-1449 listing documents believed to be relevant to the above-identified application. It is respectfully requested that these documents be considered by the Examiner and an initialled copy of the form be returned to the undersigned.

RECEIVED
2001 MAR 15 AM 9:35
BOARD OF PATENT APPEALS
AND INTERFERENCE
TC 3700 MAIL ROOM
APR -5 2001

It should be noted that the word "prior" has been deleted from the form.

It is believed that this disclosure complies with the requirements of 37 C.F.R. 1.51 and the Manual of Patent Examining Procedures Section 707.05(b). If for some reason the Examiner considers otherwise, it is respectfully requested that the undersigned be called so that any deficiencies can be promptly remedied.

Some part of the documents may have markings thereon. No significance is meant to be attached to the markings.

This Information Disclosure Statement should be considered pursuant to 37
C.F.R. § 1.17(p) in that the fee of \$180.00 set forth in Section 1.17(p) is enclosed.

The Commissioner is hereby authorized to charge payment of any additional fees,
in particular the following fees, associated with this communication, or credit any overpayment
to Deposit Account No. 19-2090:

Respectfully submitted,

SHELDON & MAK

By: _____

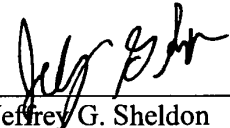
Jeffrey G. Sheldon
Reg. No. 27,953

3/8/2001

Date

SHELDON & MAK
225 South Lake Avenue, Suite 900
Pasadena, California 91101
Tel.: (626) 796-4000
Fax: (626) 795-6321

INFORMATION DISCLOSURE CITATION <i>(Use Several sheets if necessary)</i>	Docket Number 9438-1	Application Number 08/483,291
	Applicant(s) JAMES E. JERVIS	
	Filing Date June 7, 1995	Group Art Unit 3733

U.S. PATENT DOCUMENTS

EXAMINER INITIAL	REF	DOCUMENT NUMBER	DATE	NAME	CLASS	SUBCLASS	FILING DATE IF APPROPRIATE
	A						
	B						
	C						
	D						
	E						
	F						
	G						
	H						
	I						
	J						
	K						

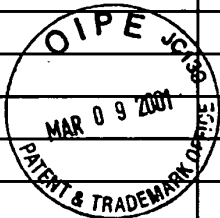

RECEIVED
MAR 13 2001
TDC 3/10 MAIL ROOM

FOREIGN PATENT DOCUMENTS

	REF	DOCUMENT NUMBER	DATE	COUNTRY	CLASS	SUBCLASS	TRANSLATIO	
							YES	NO
	L							
	M							
	N							
	O							
	P							

AND INTERFERENCES
MAR 15 11 57 AM '01
MAIL ROOM

OTHER ART (Including Author, Title, Date, Pertinent Pages, Etc.)

R	Cragg, Andrew et al., <u>Nitinol Spiral Vena Caval Filter</u> , Seminars in Interventional Radiology, 3:3, September 1986
S	Simon et al., <u>A Vena Cava Filter Using Thermal Shape Memory Alloy</u> ", Radiology 1977 (125:89-94)
T	Cragg et al, Percutaneous Arterial Grafting, Radiology 1984 (150:45-49)

RECEIVED
APR -5 2001
MAIL ROOM

EXAMINER	DATE CONSIDERED
----------	-----------------

*EXAMINER: Initial if reference considered, whether or not citation is in conformance with MPEP 609; Draw line through citation if not in conformance and not considered. Include copy of this form with next communication to applicant.

3733
\$

PATENT
Attorney Docket Number 9438-1

RECEIVED
BOARD OF PATENT APPEALS
AND INTERFERENCES
2001 MAR 19 AM 9:49

IN THE UNITED STATES PATENT AND TRADEMARK OFFICE

In re application of: JAMES E. JERVIS

Examiner: Justine Yu

Serial No.: 08/483,291

Group Art Unit: 3733

Filed: June 7, 1995



For: **MEDICAL DEVICES
INCORPORATING SIM ALLOY
ELEMENTS**

INFORMATION DISCLOSURE STATEMENT

RECEIVED
MAR 15 2001
TC 3700 MAIL ROOM
AND INTERFERENCES

Assistant Commissioner for Patents
Washington, D. C. 20231

Sir:

Attached is a Form PTO-1449 listing documents believed to be relevant to the above-identified application. It is respectfully requested that these documents be considered by the Examiner and an initialled copy of the form be returned to the undersigned.

It should be noted that the word "prior" has been deleted from the form.

It is believed that this disclosure complies with the requirements of 37 C.F.R. 1.56 and the Manual of Patent Examining Procedures Section 707.05(b). If for some reason the Examiner considers otherwise, it is respectfully requested that the undersigned be called so that any deficiencies can be promptly remedied.

Some part of the documents may have markings thereon. No significance is meant to be attached to the markings.

03/13/2001 RHARIS1 00000131 08483291

01 FC:126

180.00 0P

This Information Disclosure Statement should be considered pursuant to 37
C.F.R. § 1.17(p) in that the fee of \$180.00 set forth in Section 1.17(p) is enclosed.

The Commissioner is hereby authorized to charge payment of any additional fees,
in particular the following fees, associated with this communication, or credit any overpayment
to Deposit Account No. 19-2090:

Respectfully submitted,

SHELDON & MAK

By: _____

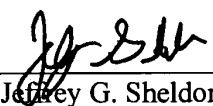
Jeffrey G. Sheldon
Reg. No. 27,953

3/7/2001
Date

SHELDON & MAK
225 South Lake Avenue, Suite 900
Pasadena, California 91101
Tel.: (626) 796-4000
Fax: (626) 795-6321

INFORMATION DISCLOSURE CITATION <i>(Use Several sheets if necessary)</i>	Docket Number 9438-1	Application Number 08/483,291
	Applicant(s) JAMES E. JERVIS	
	Filing Date June 7, 1995	Group Art Unit 3733

U.S. PATENT DOCUMENTS

EXAMINER INITIAL	REF	DOCUMENT NUMBER	DATE	NAME	CLASS	SUBCLASS	FILING DATE IF APPROPRIATE
	A						
	B						
	C						
	D						
	E						
	F						
	G						
	H						
	I						
	J						
	K						

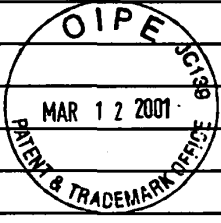

2001 MAR 19 AM 9:49
 COM RD OF PATENT APPEALS
 ATTOR GENERAL REFERENDES
 RECEIVED

FOREIGN PATENT DOCUMENTS

	DOCUMENT NUMBER	DATE	COUNTRY	CLASS	SUBCLASS	TRANSLATIO	
						YES	NO
	L						
	M						
	N						
	O						
	P						

OTHER ART (Including Author, Title, Date, Pertinent Pages, Etc.)

R	Complaint for Patent Infringement, Medtronic v. Boston Scientific Corporation et al., United States District Court, Civil File No. 99-1035-RHK/FLN, District of Minnesota, July 7, 1999
S	First Amended Complaint for Patent Infringement, Medtronic v. Boston Scientific Corporation et al., United States District Court, District of Minnesota, Civil File No. 99-1035-RHK/FLN, March 31, 2000
T	Defendants, Boston Scientific Corp. and Scimid Life Systems, Inc.'s Submission Pursuant to 35 U.S.C. § 282, Medtronic v. Boston Scientific Corporation et al., United States District Court, District of Minnesota, Civil File No. 99-1035-RHK/FLN, December 8, 2000

EXAMINER	DATE CONSIDERED
----------	-----------------

*EXAMINER: Initial if reference considered, whether or not citation is in conformance with MPEP 609; Draw line through citation if not in conformance and not considered. Include copy of this form with next communication to applicant.

Form PTO -A820
(also form PTO-1449)

RECEIVED
 MAR 15 2001
 T 3700 MAIL ROOM
 SHEET 1 OF 2

INFORMATION DISCLOSURE CITATION <i>(Use Several sheets if necessary)</i>	Docket Number 9438-1	Application Number 08/483,291
	Applicant(s) JAMES E. JERVIS	
	Filing Date June 7, 1995	Group Art Unit 3733

U.S. PATENT DOCUMENTS

EXAMINER INITIAL	REF	DOCUMENT NUMBER	DATE	NAME	CLASS	SUBCLASS	FILING DATE IF APPROPRIATE
	A						
	B						
	C						
	D						
	E						
	F						
	G						
	H						
	I						
	J						
	K						



RECEIVED
 MAR 19 AM 9:49
 STANDARD PATENT SERVICES

FOREIGN PATENT DOCUMENTS

	DOCUMENT NUMBER	DATE	COUNTRY	CLASS	SUBCLASS	TRANSLATIO	
						YES	NO
	L						
	M						
	N						
	O						
	P						

OTHER ART (Including Author, Title, Date, Pertinent Pages, Etc.)

	R	Defendants Answer and Counterclaims, Medtronic v. Boston Scientific Corporation et al., United States District Court, District of Minnesota, Civil File No. 99-1085-RHK/FLN, May 1, 2000
	S	Cragg, Andrew et al., <u>A New Percutaneous Vena Cava Filter</u> , American Journal of Roentgenology, September 1983
	T	Hughes, M.D., James L., <u>Evaluation of Nitinol For Use As A Material In The Construction of Orthopaedic Implants</u> , John Hopkins University School of Medicine, December 1976

EXAMINER	DATE CONSIDERED
----------	-----------------

*EXAMINER: Initial if reference considered, whether or not citation is in conformance with MPEP 609; Draw line through citation if not in conformance and not considered. Include copy of this form with next communication to applicant.

Form PTO -A820
(also form PTO-1449)

RECEIVED
 MAR 15 2001
 TC 370 MAIL ROOM



UNITED STATES DEPARTMENT OF COMMERCE
Patent and Trademark Office

NOTICE OF ALLOWANCE AND ISSUE FEE DUE

QM22/0510

JEFFREY G SHELDON
SHELDON & MAK
225 SOUTH LAKE AVENUE SUITE 900
PASADENA CA 91101

APPLICATION NO.	FILING DATE	TOTAL CLAIMS	EXAMINER AND GROUP ART UNIT	DATE MAILED
08/483,291	06/07/95	022	YU, J	3764 05/10/01
First Named Applicant	JERVIS,		35 USC 154(b) term ext. =	0 Days.
TITLE OF INVENTION	MEDICAL DEVICES INCORPORATING SIM ALLOY ELEMENTS			

ATTY'S DOCKET NO.	CLASS-SUBCLASS	BATCH NO.	APPLN. TYPE	SMALL ENTITY	FEE DUE	DATE DUE
3	9438-1	606-078.000	G18	UTILITY	NO \$1240.00	08/10

THE APPLICATION IDENTIFIED ABOVE HAS BEEN EXAMINED AND IS ALLOWED FOR ISSUANCE AS A PATENT. PROSECUTION ON THE MERITS IS CLOSED.

THE ISSUE FEE MUST BE PAID WITHIN THREE MONTHS FROM THE MAILING DATE OF THIS NOTICE OR THIS APPLICATION SHALL BE REGARDED AS ABANDONED. THIS STATUTORY PERIOD CANNOT BE EXTENDED.

HOW TO RESPOND TO THIS NOTICE:

I. Review the SMALL ENTITY status shown above.

If the SMALL ENTITY is shown as YES, verify your current SMALL ENTITY status:

- A. If the status is changed, pay twice the amount of the FEE DUE shown above and notify the Patent and Trademark Office of the change in status, or
- B. If the status is the same, pay the FEE DUE shown above.

If the SMALL ENTITY is shown as NO:

- A. Pay FEE DUE shown above, or
- B. File verified statement of Small Entity Status before, or with, payment of 1/2 the FEE DUE shown above.

II. Part B-Issue Fee Transmittal should be completed and returned to the Patent and Trademark Office (PTO) with your ISSUE FEE. Even if the ISSUE FEE has already been paid by charge to deposit account, Part B Issue Fee Transmittal should be completed and returned. If you are charging the ISSUE FEE to your deposit account, section "4b" of Part B-Issue Fee Transmittal should be completed and an extra copy of the form should be submitted.

III. All communications regarding this application must give application number and batch number. Please direct all communications prior to issuance to Box ISSUE FEE unless advised to the contrary.

IMPORTANT REMINDER: Utility patents issuing on applications filed on or after Dec. 12, 1980 may require payment of maintenance fees. It is patentee's responsibility to ensure timely payment of maintenance fees when due.

PATENT AND TRADEMARK OFFICE COPY

Notice of Allowability	Application No.	Applicant(s)	
	08/483,291	JERVIS, JAMES E.	
	Examiner	Art Unit	
	Justine Yu	3764	

-- The MAILING DATE of this communication appears on the cover sheet with the correspondence address--

All claims being allowable, PROSECUTION ON THE MERITS IS (OR REMAINS) CLOSED in this application. If not included herewith (or previously mailed), a Notice of Allowance and Issue Fee Due or other appropriate communication will be mailed in due course. **THIS NOTICE OF ALLOWABILITY IS NOT A GRANT OF PATENT RIGHTS.** This application is subject to withdrawal from issue at the initiative of the Office or upon petition by the applicant. See 37 CFR 1.313 and MPEP 1308.

1. This communication is responsive to Board of Appeals decision dated 02-26-01.
2. The allowed claim(s) is/are 21, 23, 25-38, 40-42 and 44-46.
3. The drawings filed on _____ are acceptable as formal drawings.
4. Acknowledgment is made of a claim for foreign priority under 35 U.S.C. § 119(a)-(d) or (f).
 - a) All b) Some* c) None of the:
 1. Certified copies of the priority documents have been received.
 2. Certified copies of the priority documents have been received in Application No. _____.
 3. Copies of the certified copies of the priority documents have been received in this national stage application from the International Bureau (PCT Rule 17.2(a)).

* Certified copies not received: _____.
5. Acknowledgment is made of a claim for domestic priority under 35 U.S.C. § 119(e).

Applicant has THREE MONTHS FROM THE "MAILING DATE" of this communication to file a reply complying with the requirements noted below. Failure to timely comply will result in ABANDONMENT of this application. **THIS THREE-MONTH PERIOD IS NOT EXTENDABLE FOR SUBMITTING NEW FORMAL DRAWINGS, OR A SUBSTITUTE OATH OR DECLARATION. This three-month period for complying with the REQUIREMENT FOR THE DEPOSIT OF BIOLOGICAL MATERIAL is extendable under 37 CFR 1.136(a).**

6. Note the attached EXAMINER'S AMENDMENT or NOTICE OF INFORMAL APPLICATION (PTO-152) which gives reason(s) why the oath or declaration is deficient. A SUBSTITUTE OATH OR DECLARATION IS REQUIRED.
7. Applicant MUST submit NEW FORMAL DRAWINGS
 - (a) including changes required by the Notice of Draftsperson's Patent Drawing Review(PTO-948) attached
 - 1) hereto or 2) to Paper No. _____.
 - (b) including changes required by the proposed drawing correction filed _____, which has been approved by the examiner.
 - (c) including changes required by the attached Examiner's Amendment / Comment or in the Office action of Paper No. _____.

Identifying indicia such as the application number (see 37 CFR 1.84(c)) should be written on the drawings. The drawings should be filed as a separate paper with a transmittal letter addressed to the Official Draftsperson.

8. Note the attached Examiner's comment regarding REQUIREMENT FOR THE DEPOSIT OF BIOLOGICAL MATERIAL.

Any reply to this letter should include, in the upper right hand corner, the APPLICATION NUMBER (SERIES CODE / SERIAL NUMBER). If applicant has received a Notice of Allowance and Issue Fee Due, the ISSUE BATCH NUMBER and DATE of the NOTICE OF ALLOWANCE should also be included.

Attachment(s)

- | | |
|--|--|
| 1 <input type="checkbox"/> Notice of References Cited (PTO-892) | 2 <input type="checkbox"/> Notice of Informal Patent Application (PTO-152) |
| 3 <input checked="" type="checkbox"/> Notice of Draftsperson's Patent Drawing Review (PTO-948) | 4 <input type="checkbox"/> Interview Summary (PTO-413), Paper No. _____ |
| 5 <input type="checkbox"/> Information Disclosure Statements (PTO-1449), Paper No. _____ | 6 <input type="checkbox"/> Examiner's Amendment/Comment |
| 7 <input type="checkbox"/> Examiner's Comment Regarding Requirement for Deposit of Biological Material | 8 <input type="checkbox"/> Examiner's Statement of Reasons for Allowance |
| | 9 <input type="checkbox"/> Other |

Everett Williams
For Justine Yu
Primary Examiner

Art Unit: 3764

Information Disclosure Statement

1. The information disclosure statement filed on 3/9/01 and 3/12/01 fails to comply with 37 CFR 1.97(d) because it lacks a statement as specified in 37 CFR 1.97(e). It has been placed in the application file, but the information referred to therein has not been considered.

2. Any inquiry concerning this communication or earlier communications from the examiner should be directed to Justine Yu whose telephone number is (703) 308-2675. The examiner can normally be reached on Tuesday - Friday from 8:30 AM - 6:00 PM. The examiner can also be reached on alternate Mondays.

If attempts to reach the examiner by telephone are unsuccessful, the examiner's supervisor, Mickey Yu, can be reached on (703) 308-2672. The fax phone number for the organization where this application or proceeding is assigned is (703) 305-3590.

Any inquiry of a general nature or relating to the status of this application or proceeding should be directed to Everett Williams whose telephone number is (703) 305-1708.

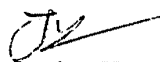
Justine Yu

April 19, 2001

PART B - ISSUE FEE TRANSMITTAL

Complete and mail this form, together with your fee, to: **Box ISSUE FEE**
 Assistant Commissioner for Patents
 Washington, D.C. 20501



9438-1
 B&B

MAILING INSTRUCTIONS: This form should be used for transmitting the ISSUE FEE. Blocks 1 through 4 should be completed as appropriate. All further correspondence including the Issue Fee Receipt, the Patent, drawings and notification of maintenance fees will be mailed to the current correspondence address as indicated unless corrected below or directed otherwise in Block 1, by (a) specifying a new correspondence address; and/or (b) indicating a separate "FEE ADDRESS" for maintenance fee notifications.

Note: The certificate of mailing below can only be used for domestic mailings of the Issue Fee Transmittal. This certificate cannot be used for any other accompanying papers. Each additional paper, such as an assignment or formal drawing, must have its own certificate of mailing.

Certificate of Mailing

I hereby certify that this Issue Fee Transmittal is being deposited with the United States Postal Service with sufficient postage for first class mail in an envelope addressed to the Box Issue Fee address above on the date indicated below.

Norman Anderson (Depositor's name)
 [Signature] (Signature)
 8-4-01 (Date)

CURRENT CORRESPONDENCE ADDRESS (Note: Lightly make-up with any corrections or use Block 1)
 JEFFREY G SHELDON
 SHELDON & MAK
 225 SOUTH LAKE AVENUE SUITE 900
 PASADENA CA 91101
 QM22/0510

APPLICATION NO.	FLING DATE	TOTAL CLAIMS	EXAMINER AND GROUP ART UNIT	DATE MAILED
08/483,291	06/07/95	022	YU, J	3764 05/10/01

First Named Applicant: JERVIS, 35 USC 154(b) term ext. = 0 Days.

TITLE OF INVENTION MEDICAL DEVICES INCORPORATING SIM ALLOY ELEMENTS

Issue Fees/Formal Drawings due 8/10/01

ATTYS DOCKET NO.	CLASS-SUBCLASS	BATCH	APPL. TYPE	SMALL ENTITY	FEE DUE	DATE DUE
3 9438-1	606-078.000	G18	UTILITY	NO	\$1240.00	08/10/01

1. Change of correspondence address or indication of "Fee Address" (37 CFR 1.333). Use of PTO form(s) and Customer Number are recommended, but not required.

Change of correspondence address (or Change of Correspondence Address form PTO/SB/122) attached.

"Fee Address" indication (or "Fee Address" indication form PTO/SB/47) attached.

2. For printing on the patent front page, list (1) the names of up to 3 registered patent attorneys or agents OR, alternatively, (2) the name of a single firm (having as a member a registered attorney or agent) and the names of up to 2 registered patent attorneys or agents. If no name is listed, no name will be printed.

1 Sheldon & Mak
 2
 3

3. ASSIGNEE NAME AND RESIDENCE DATA TO BE PRINTED ON THE PATENT (print or type)
 PLEASE NOTE: Unless an assignee is identified below, no assignee data will appear on the patent. Inclusion of assignee data is only appropriate when an assignment has been previously submitted to the PTO or is being submitted under separate cover. Completion of this form is NOT a substitute for filing an assignment.

(A) NAME OF ASSIGNEE
 Medtronic, Inc.

(B) RESIDENCE (CITY & STATE OR COUNTRY)
 Minneapolis, MN

Please check the appropriate assignee category indicated below (will not be printed on the patent)

Individual corporation or other private group entity government

4a. The following fees are enclosed (make check payable to Commissioner of Patents and Trademarks):

Issue Fee
 Advance Order - # of Copies 10

4b. The following fees or deficiency in these fees should be charged to:

DEPOSIT ACCOUNT NUMBER 19-2909
 (ENCLOSE AN EXTRA COPY OF THIS FORM)

Issue Fee
 Advance Order - # of Copies 10

The COMMISSIONER OF PATENTS AND TRADEMARKS IS requested to apply the Issue Fee to the application identified above.

(Authorized Signature) DANTON K. FRK, 31,695 (Date)

NOTE: The Issue Fee will not be accepted from anyone other than the applicant, a registered attorney or agent, or the assignee or other party in interest as shown by the records of the Patent and Trademark Office.

Start-up Hour Statement: This form is estimated to take 0.2 hours to complete. Time will vary depending on the needs of the individual case. Any comments on the amount of time required to complete this form should be sent to the Chief Information Officer, Patent and Trademark Office, Washington, D.C. 20501. DO NOT SEND FEES OR COMPLETED FORMS TO THIS ADDRESS. SEND FEES AND THIS FORM TO: Box Issue Fee, Assistant Commissioner for Patents, Washington D.C. 20501

Under the Paperwork Reduction Act of 1996, no persons are required to respond to a collection of information unless it displays a valid OMB control number.

08/13/2001 HTEKLUZ 00000018 08483291
 01 FC:142 1240.00 DP
 02 FC:561 30.00 DP

TRANSMIT THIS FORM WITH FEE



B

9438-1

30aa

IN THE UNITED STATES PATENT AND TRADEMARK OFFICE

In re application of: JERVIS, James E.	Group Art Unit: 3764
Serial No.: 08/483,291	Examiner: Yu, J.
Filed: 06/07/95	Batch No. G18
For: MEDICAL DEVICES INCORPORATING SIM ALLOY ELEMENTS	

TRANSMITTAL OF FORMAL DRAWINGS

Patent and Trademark Office
Washington, D.C. 20231

Attention: Official Draftsman

Dear Sir:

Please find (4) sheets of formal drawing(s) for this application. Each sheet of drawing indicates the serial number and Group Art Unit on the reverse side of the drawing.

Respectfully submitted,
SHELDON & MAK, INC

Date: 8/7/2001

By:
Danton K. Mak
Reg. No. 31,695

SHELDON & MAK
225 South Lake Avenue, 9th Floor
Pasadena, California 91101
(626) 796-4000

CERTIFICATE OF MAILING: I hereby certify that this paper is being deposited with the U.S. Postal Service as First Class Mail in an envelope addressed to:

Patent and Trademark Office, Washington, D.C. 20231
Attention: Official Draftsman

Date signed: 8-7-01

By:
Norman Anderson

J:\Medtronic\9438-1\Trans Formals.wpd

6306141

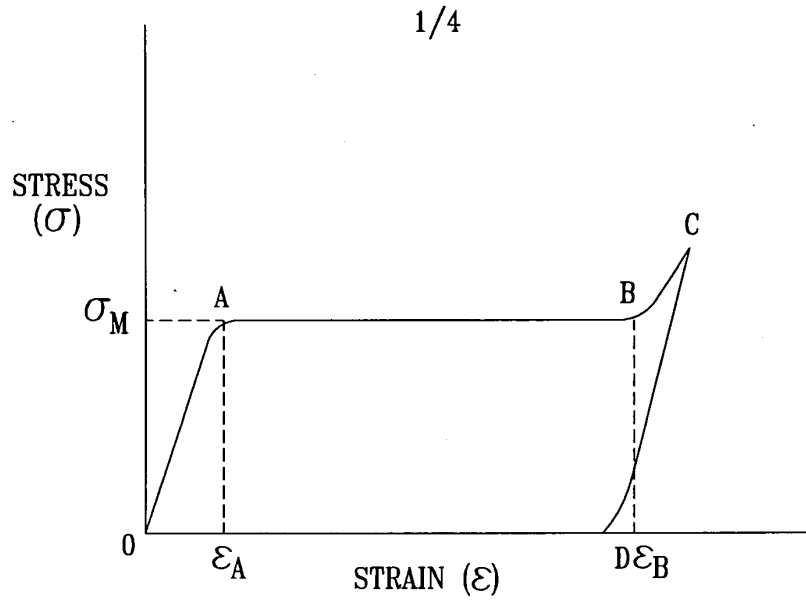

Fig. 1

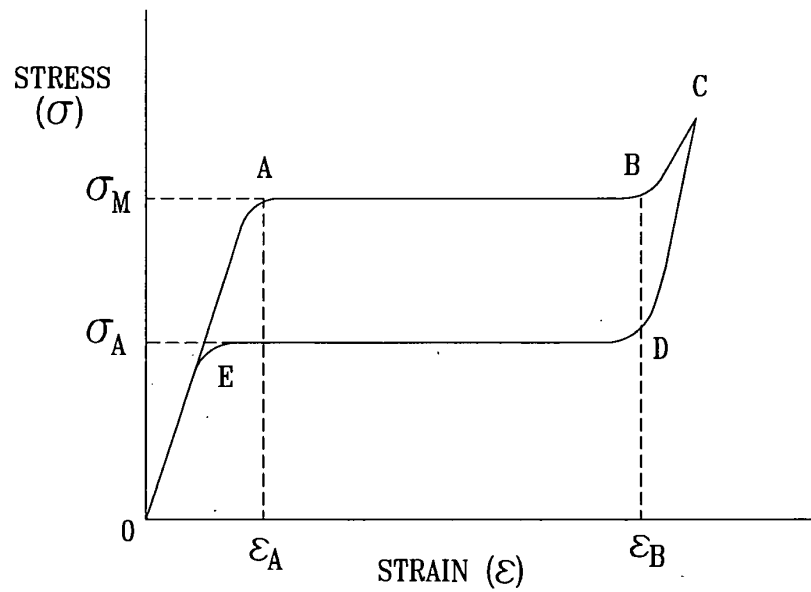
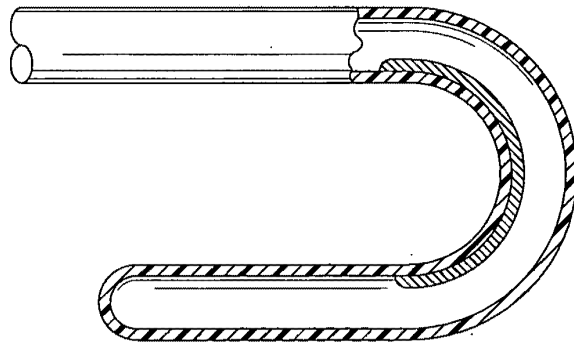

Fig. 2

FIG. 3



FIG. 4



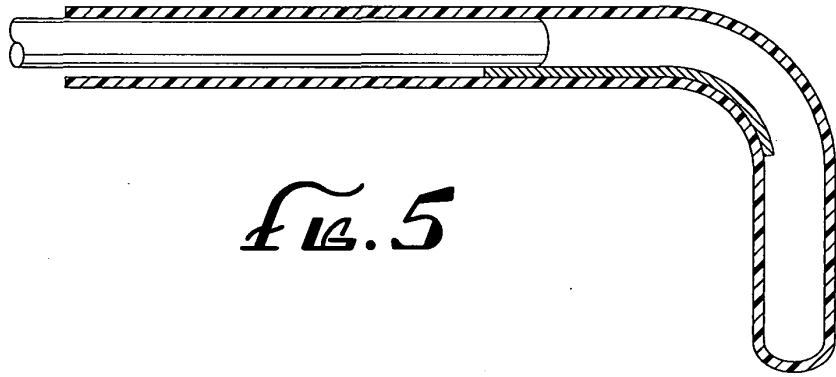

FIG. 5

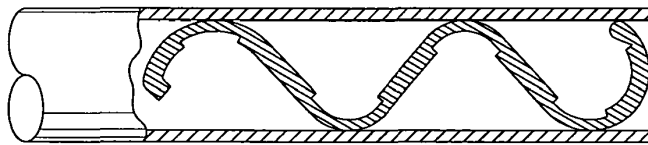

FIG. 6

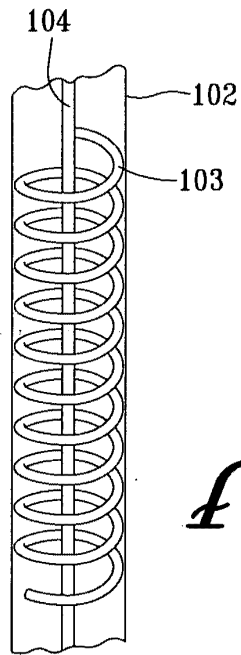
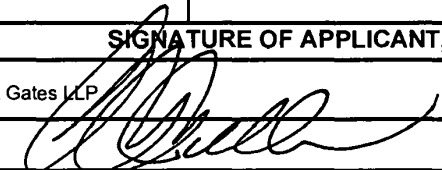

Fig. 7

Under the Paperwork Reduction Act of 1995, no persons are required to respond to a collection of information unless it displays a valid OMB control number.

TRANSMITTAL FORM	Application Number	08/483,291 (Pat No. 6,306,141)
	Filing Date	06/07/1995
	First Named Inventor	James E. Jervis
	Art Unit	
	Examiner Name	
(to be used for all correspondence after initial filing)		
Total Number of Pages in This Submission	139	Attorney Docket Number 1951288.00284

ENCLOSURES (Check all that apply)		
<input checked="" type="checkbox"/> Fee Transmittal Form <input type="checkbox"/> Fee Attached <input type="checkbox"/> Amendment/Reply <input type="checkbox"/> After Final <input type="checkbox"/> Affidavits/declaration(s) <input type="checkbox"/> Extension of Time Request <input type="checkbox"/> Express Abandonment Request <input type="checkbox"/> Information Disclosure Statement <input type="checkbox"/> Certified Copy of Priority Document(s) <input type="checkbox"/> Reply to Missing Parts/ Incomplete Application <input type="checkbox"/> Reply to Missing Parts under 37 CFR 1.52 or 1.53	<input type="checkbox"/> Drawing(s) <input type="checkbox"/> Licensing-related Papers <input checked="" type="checkbox"/> Petition <input type="checkbox"/> Petition to Convert to a Provisional Application <input type="checkbox"/> Power of Attorney, Revocation <input type="checkbox"/> Change of Correspondence Address <input type="checkbox"/> Terminal Disclaimer <input type="checkbox"/> Request for Refund <input type="checkbox"/> CD, Number of CD(s) _____ <input type="checkbox"/> Landscape Table on CD	<input type="checkbox"/> After Allowance Communication to TC <input type="checkbox"/> Appeal Communication to Board of Appeals and Interferences <input type="checkbox"/> Appeal Communication to TC (Appeal Notice, Brief, Reply Brief) <input type="checkbox"/> Proprietary Information <input type="checkbox"/> Status Letter <input checked="" type="checkbox"/> Other Enclosure(s) (please identify below): Express Mail Certification, Application for Patent Term Extension under 37 USC 156, including exhibits
Remarks		

SIGNATURE OF APPLICANT, ATTORNEY, OR AGENT			
Firm Name	K&L Gates LLP		
Signature			
Printed name	Louis C. Cullman		
Date	11 June 2008	Reg. No.	39645

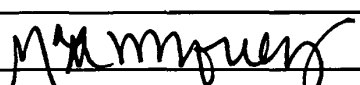
CERTIFICATE OF TRANSMISSION/MAILING		
I hereby certify that this correspondence is being facsimile transmitted to the USPTO or deposited with the United States Postal Service with sufficient postage as first class mail in an envelope addressed to: Commissioner for Patents, P.O. Box 1450, Alexandria, VA 22313-1450 on the date shown below:		
Signature		
Typed or printed name	Mari Vasquez	Date 11 June 2008

This collection of information is required by 37 CFR 1.5. The information is required to obtain or retain a benefit by the public which is to file (and by the USPTO to process) an application. Confidentiality is governed by 35 U.S.C. 122 and 37 CFR 1.11 and 1.14. This collection is estimated to 2 hours to complete, including gathering, preparing, and submitting the completed application form to the USPTO. Time will vary depending upon the individual case. Any comments on the amount of time you require to complete this form and/or suggestions for reducing this burden, should be sent to the Chief Information Officer, U.S. Patent and Trademark Office, U.S. Department of Commerce, P.O. Box 1450, Alexandria, VA 22313-1450. DO NOT SEND FEES OR COMPLETED FORMS TO THIS ADDRESS. SEND TO: Commissioner for Patents, P.O. Box 1450, Alexandria, VA 22313-1450.

If you need assistance in completing the form, call 1-800-PTO-9199 and select option 2.

Under the Paperwork Reduction Act of 1995 no persons are required to respond to a collection of information unless it displays a valid OMB control number

Effective on 12/08/2004. Fees pursuant to the Consolidated Appropriations Act, 2005 (H.R. 4818).		Complete if Known	
FEE TRANSMITTAL		Application Number	08/483,291 (Pat No. 6,306,141)
For FY 2007		Filing Date	06/07/1995
<input type="checkbox"/> Applicant claims small entity status. See 37 CFR 1.27		First Named Inventor	James E. Jervis
TOTAL AMOUNT OF PAYMENT (\$)		Examiner Name	
	1,120.00	Art Unit	
		Attorney Docket No.	1951288-00284

METHOD OF PAYMENT (check all that apply)

Check Credit Card Money Order None Other (please identify): _____

Deposit Account Deposit Account Number: 503207 Deposit Account Name: K&L Gates, LLP

For the above-identified deposit account, the Director is hereby authorized to: (check all that apply)

Charge fee(s) indicated below Charge fee(s) indicated below, except for the filing fee

Charge any additional fee(s) or underpayments of fee(s) under 37 CFR 1.16 and 1.17 Credit any overpayments

WARNING: Information on this form may become public. Credit card information should not be included on this form. Provide credit card information and authorization on PTO-2038.

FEE CALCULATION

1. BASIC FILING, SEARCH, AND EXAMINATION FEES

Application Type	FILING FEES		SEARCH FEES		EXAMINATION FEES		Fees Paid (\$)
	Fee (\$)	Small Entity Fee (\$)	Fee (\$)	Small Entity Fee (\$)	Fee (\$)	Small Entity Fee (\$)	
Utility	300	150	500	250	200	100	_____
Design	200	100	100	50	130	65	_____
Plant	200	100	300	150	160	80	_____
Reissue	300	150	500	250	600	300	_____
Provisional	200	100	0	0	0	0	_____

2. EXCESS CLAIM FEES

Fee Description	Fee (\$)	Small Entity Fee (\$)
Each claim over 20 (including Reissues)	50	25
Each independent claim over 3 (including Reissues)	200	100
Multiple dependent claims	360	180

Total Claims **Extra Claims** **Fee (\$)** **Fee Paid (\$)**

_____ - 20 or HP = _____ x _____ = _____

HP = highest number of total claims paid for, if greater than 20.

Indep. Claims **Extra Claims** **Fee (\$)** **Fee Paid (\$)**

_____ - 3 or HP = _____ x _____ = _____

HP = highest number of independent claims paid for, if greater than 3.

3. APPLICATION SIZE FEE

If the specification and drawings exceed 100 sheets of paper (excluding electronically filed sequence or computer listings under 37 CFR 1.52(e)), the application size fee due is \$250 (\$125 for small entity) for each additional 50 sheets or fraction thereof. See 35 U.S.C. 41(a)(1)(G) and 37 CFR 1.16(s).

Total Sheets	Extra Sheets	Number of each additional 50 or fraction thereof	Fee (\$)	Fee Paid (\$)
_____	_____	_____	_____	_____

_____ - 100 = _____ / 50 = _____ (round up to a whole number) x _____ = _____

4. OTHER FEE(S)

Description	Fee (\$)	Fees Paid (\$)
Non-English Specification, \$130 fee (no small entity discount)	_____	_____
Other (e.g., late filing surcharge): 37 CFR 1.20(i)(1)	_____	_____
		1,120.00

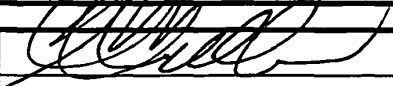
SUBMITTED BY		
Signature		Registration No. 39,645 (Attorney/Agent)
Name (Print/Type)	Louis C. Cullman	Telephone 949-253-0900
		Date 11 June 2008

This collection of information is required by 37 CFR 1.136. The information is required to obtain or retain a benefit by the public which is to file (and by the USPTO to process) an application. Confidentiality is governed by 35 U.S.C. 122 and 37 CFR 1.14. This collection is estimated to take 30 minutes to complete, including gathering, preparing, and submitting the completed application form to the USPTO. Time will vary depending upon the individual case. Any comments on the amount of time you require to complete this form and/or suggestions for reducing this burden, should be sent to the Chief Information Officer, U.S. Patent and Trademark Office, U.S. Department of Commerce, P.O. Box 1450, Alexandria, VA 22313-1450. DO NOT SEND FEES OR COMPLETED FORMS TO THIS ADDRESS. SEND TO: Commissioner for Patents, P.O. Box 1450, Alexandria, VA 22313-1450.

If you need assistance in completing the form, call 1-800-PTO-9199 and select option 2.

IN THE UNITED STATES PATENT AND TRADEMARK OFFICE

Patent No. : 6,306,141
Issued : October 23, 2001
Inventors : James E. Jervis
Assignee : Medtronic, Inc.
Filed : June 7, 1995
Title : Medical Devices Incorporating SIM Alloy Elements
Attorney Docket no. : 1951288.00284

08483291
06000001 13250
07/07/2000 RLOGAN 1120.00 DA
01 FC:1457

EXPRESS MAIL CERTIFICATION

Date of Deposit: 6/11/08

I hereby certify that this transmittal letter and any other papers and fees referred to in this transmittal letter as being attached to or enclosed herein are being deposited with the United States Postal Service with sufficient postage in an envelope addressed to: Mail Stop: Hatch-Waxman PTE, Commissioner for Patents, P.O. Box 1450, Alexandria, VA 22313-1450.

TRANSMITTAL LETTER

Dear Sir:

Transmitted herewith is an application for extension of patent term of United States patent number 6,306,141 pursuant to 35 U.S.C. § 1.56(d) and 37 C.F.R. § 1.740. Also enclosed herewith pursuant to 37 C.F.R. § 1.740(b) are two (2) additional copies of the application including Exhibits A-F, for a total of three (3) copies. This application is being submitted within the sixty (60) day period permitted for submission pursuant to 37 C.F.R. § 1.720(f).

In accordance with 37 C.F.R. § 1.740(a)(14), the Commissioner is authorized to charge the filing fee of \$1,120.00 pursuant to 37 C.F.R. § 1.20(j), and any additional fee which may be required in connection with this application to Deposit Account No. 13-2546. Attached herewith is a Power of Attorney (Exhibit A) granting the undersigned the right to act as Applicant's agent with respect to this matter.

Respectfully Submitted,

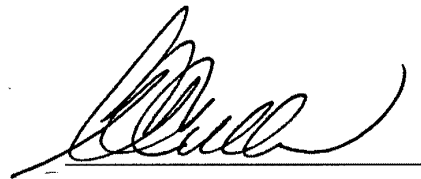
A handwritten signature in black ink, appearing to read "L. Cullman", is written over a horizontal line.

Louis C. Cullman
Registration No. 39,645
Customer No. 45,200

On behalf of:
Michael J. Jaro
Vice President and Chief Patent Counsel
Medtronic, Inc.
710 Medtronic Parkway
M/S LC340
Minneapolis, MN 55432
(753) 505-2519

●

●

IN THE UNITED STATES PATENT AND TRADEMARK OFFICE

●

Patent No. : 6,306,141
Issued : October 23, 2001
Inventors : James E. Jervis
● Assignee : Medtronic, Inc.
Filed : June 7, 1995
Title : Medical Devices Incorporating SIM Alloy Elements
● Attorney Docket no. : 1951288.00284

●

APPLICATION FOR PATENT TERM EXTENSION UNDER 35 U.S.C. § 156

●

Mail Stop: Hatch-Waxman PTE
Commissioner for Patents
P.O. Box 1450
● Alexandria, VA 22313-1450

RE: Application for Patent Term Extension Pursuant to 35 U.S.C. § 156 (37 C.F.R. §
1.740) United States Patent Number 6,306,141.

●

Dear Sir:

●

Enclosed is an application for patent term extension pursuant to 37 C.F.R. § 1.710 et seq. Applicant, Medtronic, Inc., represents that it is the assignee of record and owner of the entire interest in and to United States patent number (USPN) 6,306,141 (the '141 patent) (Exhibit B) by an Assignment recorded on October 4, 1996, on Reel 8907, Frame 0388 (Exhibit C). James E. Jervis is the sole named inventor of the above identified patent.

●

The '141 patent issued on October 23, 2001. The application corresponding to the '141 patent, United States patent application serial number (USPASN) 08/483,291, was filed June 7, 1995 and is a continuation of USPASN 07/956,653, filed October 2, 1992, now USPN 5,597,378, which is a division of USPASN 07/682,243, filed April 9, 1991, now USPN

●

5,190,546, which is a division of USPASN 07/252,019, filed September 27, 1988, now USPN 5,067,957, which is a continuation of USPASN 07/177,817, filed March 30, 1988, now abandoned, which is a continuation of USPASN 07/047,824, filed May 8, 1987, now abandoned, which is a continuation of USPASN 06/865,703, filed May 21, 1986, now USPN 4,665,906, which is a continuation of USPASN 06/541,852, now abandoned.

Pursuant to Section 201(a) of the Drug Price Competition and Patent Term Restoration Act of 1984, 35 U.S.C. § 156, Applicant hereby requests that the term of the above identified United States patent be extended. The following information is submitted in accordance with 35 U.S.C. § 156(d) and 37 C.F.R. § 1.710 et seq. and follows the numerical format set forth in 37 C.F.R. § 1.740(a).

(1) Complete identification of the approved product as by appropriate chemical and generic name, physical structure or characteristics:

The approved product is the Talent™ Abdominal Stent Graft System. This device is indicated for the endovascular treatment of abdominal aortic aneurysms with or without iliac involvement. The Talent Abdominal Stent Graft System is a medical device product comprised of an implantable stent graft, and a disposable delivery system.

The implantable stent graft portion of the delivery system consists of four configurations: (1) Bifurcated (aorto-iliac) stent graft, (2) Contralateral iliac limb, (3) Iliac extension cuff, and (4) Aortic extension cuff. Each stent graft configuration is comprised of nitinol metal springs attached to polyester fabric graft material and is introduced separately into the patient's vascular system. Platinum-iridium radiopaque markers are sewn onto the stent graft to aid in visualization of the stent graft under fluoroscopy and to facilitate accurate placement of the device.

The CoilTrac Delivery System is a single use, disposable system used to deliver all stent graft configurations. It is a flexible catheter constructed of three concentric, single lumen polymer shafts: (1) an outer introducer sheath (graft cover), (2) a pushrod, and (3) a guidewire lumen. A metallic coil with cup plunger is attached to the distal end of the pushrod to maintain stent graft position during deployment.

- (2) Complete identification of the federal statute including the applicable provisions of law under which the regulatory review occurred:

Regulatory review occurred under Section 515 and 520(g) of the Federal Food, Drug and Cosmetics Act, 21 U.S.C. § 360(e).

- (3) Identification of the date on which the product received permission for commercial marketing or use under the provision of law under which the applicable regulatory review period occurred:

Approval under Section 515 of the Federal Food Drug and Cosmetics Act was received April 15, 2008.

- (4) In the case of a drug product, an identification of each active ingredient in the product and as to each active ingredient, a statement that it has not been previously approved for commercial marketing or use under the Federal Food, Drug and Cosmetic Act, the Public Health Service Act, or the Virus-Serum-Toxin Act, or a statement of when the active ingredient was approved for commercial marketing or use (either alone or in combination with other active ingredients), the use for which it was approved, and the provision of law under which it was approved:

Identification of an active ingredient is not believed to be required as the FDA approved product is a medical device and not a "drug product," within the meaning of 35 U.S.C. § 156(f).

- (5) Statement that the present application is being submitted within the sixty day period permitted for submission pursuant to § 1.720(f) and an identification of the date of the last day on which the application could be submitted:

The application is being submitted within the sixty-day period permitted for submission pursuant to 37 C.F.R. § 1.720(f). The last day on which the application can be submitted is June 13, 2008.

- (6) Complete identification of the patent for which an extension is being sought by the name of the inventor, the patent number, the date of issue, and the date of expiration:

The patent for which an extension is being sought is United States patent number 6,306,141 (the '141 patent), filed on June 7, 1995. The '141 patent issued October 23, 2001 to James E. Jarvis, the sole inventor. The '141 patent is scheduled to expire October 23, 2018.

- (7) Copy of the patent for which an extension is being sought, including the entire specification (including claims) and drawings:

A complete copy of United States patent number 6,306,141 is submitted herewith as Exhibit B.

- (8) Copy of any disclaimer, certificate of correction, receipt of maintenance fee payment, or re-examination certificate issued in the patent:

No disclaimers, certificates of correction or reexamination certificates have been obtained. Maintenance fee payment receipts are attached hereto as Exhibit D.

- (9) Statement that the patent claims the approved product, or a method of using or manufacturing the approved product, and a showing which lists each applicable patent claim and demonstrates the manner in which at least one such patent claim reads on: (i) the approved product, if the listed claims include any claim to the approved product; (ii) the method of using the approved product, if the listed claims include any claim to the method of using the approved product; and (iii) the method of manufacturing the approved product, if the listed claims include any claim to the method of manufacturing the approved product:

United States patent number 6,306,141 (the '141 patent) claims the approved Talent Abdominal Stent Graft System. The applicable claims are independent claims 1, 6 and 18, and dependent claims 2, 3, 4, 5, 7, 8, 9, 10, 17, 19, 20 and 21.

For example, claim 1 claims and reads on the approved device as follows:

Claim Chart Comparing Claim 1 of U.S. patent number 6,306,141 element-by-element with the Talent Abdominal Stent Graft System.

At the onset it must be noted that the claims of the '141 patent are subject to Claim Construction Orders filed in the United States District Court for the Northern District of California on October 19, 2007 (Case C 06-04455 JSW, Document 91), included herein as Exhibit E; and on February 6, 2008 (Case C 07-00567 MMC, Document 92), included herein as Exhibit F. The following chart is consistent with both District Courts' claim constructions.

Claim 1 of U.S. Patent Number 6,306,141	The Approved Product
1. A medical device for insertion into a mammalian body, the device comprising	The Talent Abdominal Stent Graft System (the "Talent Stent Graft System") is a medical device for insertion into a mammalian body.
(a) a hollow placement device;	The Talent Stent Graft System comprises a hollow placement device which is part of the delivery system, consisting of an outer introducer sheath that covers the stent graft residing in its cavity. The hollow placement device assists in positioning the stent into a mammalian body. (See Instructions for Use (IFU), pages 9-10) (Included herein as Exhibit G).
(b) a memory alloy element formed at least partly from pseudoelastic shape-memory alloy, the alloy displaying reversible stress-induced martensite at about body temperature such that it has a stress-induced martensitic state and an austenitic state, the memory alloy element having (i) a deformed shape when the alloy is in its stress-induced martensitic state and (ii) a different unstressed shape when the alloy is in its austenitic state; and	Each stent graft, or memory alloy element, is comprised of nitinol, a pseudoelastic shape-memory alloy. The nitinol alloy used in the Talent Stent Graft System displays reversible stress-induced martensite and an austenitic state, having (i) a deformed shape when it is in its stress-induced martensitic state and (ii) a different unstressed shape when the alloy is in its austenitic state. (See <i>Self-Expanding Nitinol Stents-Materials and Design Considerations</i> Eur Radiol. 2004 Feb;14(2):292-301 (included herein as Exhibit H) for a detailed discussion on memory alloys used to made medical devices.)

Claim 1 of U.S. Patent Number 6,306,141	The Approved Product
(c) a guide wire;	The delivery system for the Talent Stent Graft System includes a guide wire (pushrod) that is used to position the system at the proper location in the patient's vascular system and is used to force the memory alloy element out of the hollow placement device. (See Exhibit G, page 9-10.)
the memory alloy element being within the hollow placement device, and the placement device being guidable by the guide wire,	The stent graft of the Talent Stent Graft System is within the introducer sheath and the introducer sheath is guidable by the pushrod to position the stent graft within the patient's vascular system. (See Exhibit G, page 9-10.)
the hollow placement device stressing the memory alloy element at a temperature greater than the A_s of the alloy so that the memory alloy element is in its deformed shape,	The introducer sheath stresses the stent graft (memory alloy element) at a temperature greater than the A_s of the alloy so that the stent graft is in its deformed, compressed shape. (See Exhibit G, page 5, and page 10, figure 5, number 5, ("Introducer Sheath.") The stent graft has been compressed and held in the deformed shape by a introducer sheath (see Exhibit G, page 10, figure 5, number 5 "Introducer Sheath;" and page 41.)
wherein the memory alloy element can be extruded from the hollow placement device by the guide wire at a temperature greater than the A_s of the alloy to transform at least a portion of the alloy from its stress-induced martensitic state so that the memory alloy element transforms from its deformed shape to its unstressed shape,	The stent graft can be extruded from the hollow placement device using the guide wire (pushrod). (See Exhibit G, page 10.) At a temperature greater than the A_s of the nitinol used, when the introducer sheath is removed, the stent graft transforms from its deformed shape to its stable unstressed austenite condition and original shape. (See Exhibit G, page 5, Table 1; and page 41.)
and wherein the alloy is selected so that the transformation can occur without any change in temperature of the placement device or the memory alloy element.	The nitinol alloy composition of the Talent Stent Graft System is selected so that transformation occurs without a change in temperature of the placement device or memory alloy element.

- (10) Statement of relevant dates and information pursuant to 35 U.S.C. § 156(g) in order to enable the Secretary of Health and Human Services or the Secretary of Agriculture, as appropriate, to determine the applicable regulatory review period as follows: (i) For a patent claiming a human drug, antibiotic, or human biological product: (A) the effective date of the investigational new drug (IND) application and the IND number; (B) the date on which a new drug application (NDA) was initially submitted and the NDA number; and (C) the date on which the NDA was approved; (ii) For a patent claiming a new animal drug: (A) the date a major health or environmental effects test on the drug were initiated; (B) the date on which a new animal drug application (NADA) was initially submitted and the NADA number; and (C) the date on which the NADA was approved; (iii) For a patent claiming a veterinary biological product: (A) the date the authority to prepare an experimental biological product under the Virus-Serum-Toxin Act became effective; (B) the date an application for a license was submitted under the Virus-Serum-Toxin Act; and (C) the date the license issued; (iv) For a patent claiming a food or color additive: (A) The date a major health or environmental effects test on the additive was initiated and any available substantiation of that date; (B) the date on which a petition for product approval under the Federal Food, Drug and Cosmetic Act was initially submitted and the petition number; and (C) the date on which the FDA published a Federal Register notice listing the additive for use; (v) For a patent claiming a medical device:

The relevant dates and information pursuant to 35 U.S.C. § 156(g) needed to enable the Secretary of Health and Human Services to determine the applicable regulatory review period are as follows:

- (A) Effective date of the investigational device exemption (IDE) and the IDE number, if applicable, or the date on which the Applicant began the first clinical investigation involving the device, if no IDE was submitted, and any available substantiation of that date:

Conditional approval of the Applicant's IDE was dated April 11, 1997. The Applicant's IDE number is G970065.

- (B) Date on which the application for product approval or notice of completion of a product development protocol under Section 515 of the Federal Food, Drug and Cosmetic Act was initially submitted and the number of the application:

A Pre-Market Approval (PMA) application for the Talent Abdominal Stent Graft System was submitted October 18, 2007. The PMA number is P070027.

(C) Date on which the application was approved or the protocol declared to be completed:

The Talent Abdominal Stent Graft System PMA was approved on April 15, 2008.
(Approval Letter is attached hereto as Exhibit I.)

(11) Brief Description of the Significant Activities Undertaken by the Marketing Applicant during the Applicable Regulatory Review Period with Respect to the Approved Product and the Significant Dates of Such Activities:

The Marketing Applicant during the regulatory review process was Medtronic Vascular¹, Inc., a wholly owned subsidiary of Medtronic, Inc., owner of United States patent number 6,306,141.

The applicable regulatory review period for the Talent Abdominal Stent Graft System, pursuant to 37 C.F.R. § 1.777(c)(2) and (d)(1)(i), begins the date on which the patent issued and ends the date on which the PMA was approved. The '141 patent issued October 23, 2001 and the PMA was approved on April 15, 2008. The relevant significant communications of substance (all via letter unless otherwise noted) with the FDA and the dates related to such communications are identified below:

Date	To FDA	From FDA	Comments
8-Nov-96		X	Pre-IDE Acknowledgement Letter
12-Mar-97	X		Original IDE Application (IDE G970065) Talent Endoluminal Spring Stent Graft System Submission
11-Apr-97		X	Original IDE Application Talent Endoluminal Spring Stent Graft System Conditional Approval Letter
9-Oct-97	X		G970065/S007 Request Study Expansion: Phase I Feasibility Submission
23-Nov-98	X		G970065/S031 Request Study Expansion: Phase II LPS Study Submission
16-Dec-99		X	G970065/S058 Request Study Expansion to Phase III Modified Approval Letter
13-Mar-01	X		G970065/S085 Request Pre-PMA Meeting Submission
12-Oct-01	X		G970065/S113 Request Study Expansion: LPS EU/CU Arm Submission
31-Oct-01	X		G970065/S115 Aneurysm Rupture Report Update Submission
2-Nov-01		X	G970065/S113 Request Study Expansion: LPS EU/CU Arm Approval Letter
3-Nov-01	X		G970065/S117 Request to Re-opening IDE & Study Expansion: Enhanced LPS Arm Submission

¹ World Medical, Inc. was the initial Marketing Applicant, initially filing the IDE application. Arterial Vascular Engineering, Inc. later acquired World Medical, Inc. and was in turned acquired by Medtronic, Inc.

Date	To FDA	From FDA	Comments
5-Dec-01		X	G970065/S117 Request to Re-opening IDE & Study Expansion: Enhanced LPS Arm Conditional Approval Letter
11-Dec-01		X	G970065/S117 Enhanced TALENT LPS Conditional Approval Letter
7-Feb-02		X	G970065/S119 Response to 5-Dec-01 FDA Letter: Enhanced LPS Study Arm Approval Letter
27-Mar-02	X		G970065/S125 2001 Annual Progress Report Submission
26-Apr-02		X	G970065/S125 2001 Annual Progress Report Additional Information Letter
1-May-02	X		G970065/S128 Notification of Emergency Use: Dr. Mewissen Submission
2-May-02		X	G970065/S127 Notification of Emergency Use: Dr. Hodgson Approval Letter
3-May-02	X		G970065/S129 Notification of Two Emergency Use Cases: Dr. Tetter / Dr. Sanchez Submission
28-May-02	X		G970065/S130 Notification of Emergency Use: Dr. Vouyouka Submission
30-May-02	X		G970065/S131 Notification of Emergency Use: Dr. Balko Submission
31-May-02	X		G970065/S132 Aneurysm Rupture Report Update Submission
7-Jun-02	X		G970065/S133 <u>5-Day Notice</u> Modifications to Low Risk LPS Protocol Submission
7-Jun-02	X		G970065/S134 Response to 26-Apr-02 FDA Letter: Annual Report Questions Submission
13-Jun-02	X		G970065 No Number Assigned Review of Suggested Format: Clinical Review Submission
27-Jun-02	X		G970065/S135 Aneurysm Rupture Report Update Submission
10-Jul-02	X		G970065/S138 <u>5-Day Notice</u> Define Implementation of Dimensional Standardization (UniDoc) Submission
8-Aug-02	X		G970065/S141 <u>5-Day Notice</u> Addition of Two Talent Stent Graft Manufacturing Sites Submission
9-Aug-02	X		G970065/S142 <u>5-Day Notice</u> Use of Enhanced LPS for EU/CU Study Arm Submission
3-Feb-03	X		G970065/S153 Aneurysm Rupture Report Update: Submission
14-Mar-03	X		G970065/161 Request Study Expansion: Phase II EU/CU Submission
9-Apr-03		X	G970065/161 Request Study Expansion: Phase II EU/CU Approval Letter

Date	To FDA	From FDA	Comments
12-Aug-03	X		G970065/S171 Request Study Expansion: Continued Access Submission
10-Sep-03		X	G970065/S171 Request Study Expansion: Continued Access Disapproval Letter
10-Oct-03	X		G970065/S173 Notification of Informed Consent Deviation and Use of a Custom Device Submission
18-Nov-03	X		G970065/S174 Request Extension for Progress Report Due 22-Sep-03 to 16-Feb-04 Submission
3-Dec-03	X		G970065/177 Request for Approval of CoilTrac Delivery System in EU/High Risk Patient Population Submission
23-Dec-03		X	G970065/177 Request for Approval of CoilTrac Delivery System in EU/High Risk Patient Population Disapproval Letter
22-Jan-04	X		G970065/S180 Notification of Recall: AAA and TAA Stent Graft System devices Submission
4-Feb-04	X		G970065/S185 Notification of Company Name Change Submission
4-Mar-04	X		G970065/S189 2003 Annual Progress Report Submission
24-Sep-04	X		G970065/S197 Six-Month Current Investigator List Submission
27-Oct-04		X	G970065/S197 Six-Month Current Investigator List Deficiency
1-Nov-04	X		G970065/S199 Notification of Lapse in IRB Approval Submission
6-Jan-05	X		G970065/S201 Response to FDA letter dated 27-Oct-04 re S197 Submission
9-Feb-05		X	G970065/S201 Response to FDA letter dated 27-Oct-04 re S197 Reply
15-Apr-05	X		G970065/S203 APR Submission
19-May-05		X	G970065/S203 APR Additional Information Letter
8-Jul-05	X		G970065/SXX Response to FDA letter dated 19-May-05 re S203 Submission
31-Oct-05	x		G970065/SXX Notification of Supporting Information for physician sponsored IDE Submission
3-Feb-06	X		M060003 Modular shell Submission Submission
22-Feb-06		X	PMA Shell # M060003 PMA Shell Application Acknowledgement of Receipt & Assignment of Number
14-Mar-06		X	I060133 Submission receipt and Pre-IDE Number Acknowledgement

Date	To FDA	From FDA	Comments
15-Mar-06		x	M06003/M000 PMA application for modular review Approval
24-Apr-06		X	M06003/M001 PMA Module Original Acknowledgement
30-Jun-06		X	M06003/M03 PMA Module Original Acknowledgement
18-Aug-06	X		M060003/M002/A001 Amendment to Modular Submission Submission
5-Sep-06		X	M060003/M002/A001 Amendment to Modular Submission Acknowledgement
5-Sep-06		X	M060003/M003 PMA Module Original Acknowledgement
24-Oct-06		X	G970065/S_ Extension Request - APR Submission
10-Nov-06	X		G970065/S_ Withdrawal Request of S208 (C/U Request) Submission
15-Nov-06	X		G970065/S210 2006 Annual Progress Report Submission
21-Nov-06		X	M060003/M004 PMA Module Acknowledgement
1-Dec-06	X		G970065/S Study Arm Closeout Plan (5 Study Arms) Submission
1-Dec-06		X	M060003/M001 PMA Module Original Pre Clinical Animal Testing Approval
5-Dec-06		X	M060003/M002 Manufacturing Module Approval
5-Dec-06		X	M060003/M003 Bio/Compatibility/Sterility/Package Module Approval
12-Jan-07	X		M060003 Pre-read for pre-PMA meeting on Jan 25, 2007 Submission
19-Jan-07	X		M060003 Pre-IDE Information IDE I060133-Amendment to pre-read package for 1/25/07 FDA meeting Submission
26-Jan-07	X		IDE G970065/S_ Response to FDA Letter dated Dec. 14, 2006 re: S210 Submission
16-Feb-07	X		I060133/S_ Teleconference Meeting Minutes on Jan. 10, 2007 re: SVS Control Dataset Submission
16-Feb-07	X		I060133/S_ Meeting Minutes: Talent AAA (I060133,M060003) Pre-PMA Meeting Submission

Date	To FDA	From FDA	Comments
13-Mar-07		X	M060003/A001 Shell Application (?) (Should be Meeting Minutes for 1/10/07 Teleconference for SVS Dataset) Acknowledgement Letter
10-Apr-07	X		IDE G970065/S_ Annual Progress Report Submission
16-Apr-07	X		IDE 970065/S_ IDE Annual Progress Report Amendment Submission
19-Jun-07	X		IDE 970065/S215 Response to FDA Letter dated May 9, 2007 re: S213 Submission
23-Jul-07	X		I060133/S_ FDA Pre-PMA Meeting Jan. 25, 2007 Meeting Minutes (resend) Submission
26-Jul-07	X		G970065/S_ Change in Contact Information Submission
17-Oct-07	X		PMA M060003/M005 Clinical Module Submission
18-Oct-07		X	P070027 Acknowledgement Letter
19-Nov-07	X		P070027/A_ Response to FDA Questions re: MRI Safety and Compatibility & Additional aging testing for 2 Year shelf Life Submission
4-Jan-08	x		P070027 Teleconference and submission of the statistical analysis plan from the PMA.
7-Jan-08		X	P070027 The Office of Compliance (OC), CDRH completed the review of the GMP activities for the PMA and determined that preapproval inspections will not be necessary.
31-Jan-08		X	P070027 Request for additional information regarding proposed labeling.
5-Feb-08	X		P070027/A_ 3 Month Clinical Update Submission
20-Feb-08	X		P070027 Medtronic Response to FDA request for additional information
21-Mar-08	X		P070027/A_ Removal of Converter/Occluder Components & Implementation of Electronic Patient Labeling Submission
10-Apr-08	X		G970065/S217 2008 APR Submission
15-Apr-08		X	P070027 PMA Approval

- (12) Statement that in the opinion of the Applicant the patent is eligible for the extension and a statement as to the length of extension claimed, including how the length of extension was determined:

The Applicant respectfully asserts that United States patent number 6,306,141 (the '141 patent) is eligible for extension under 35 U.S.C. § 156 and 37 C.F.R. § 1.720 based on the following facts:

- a. The '141 patent claims the approved device, the Talent Abdominal Stent Graft System. The manner in which the claims of the '141 patent claim and read on the approved device and the process for using and making the approved device are provided herein.
- b. The term of the '141 patent has never been extended.
- c. The term of the '141 patent will not expire before submission of this application.
- d. This patent term extension application is being submitted by Medtronic, Inc, the '141 patent owner of record, in accordance with 35 U.S.C. § 156(d)(1)-(4) and 37 C.F.R. § 1.740.
- e. The Talent Abdominal Stent Graft System has been subject to a regulatory review period as defined in 35 U.S.C. § 156, prior to the first commercial marketing or use.
- f. The April 15, 2008 approval for commercial marketing and use of the Talent Abdominal Stent Graft System is the first permitted commercial marketing or use of the device under the Federal Food, Drug and Cosmetic Act.
- g. This application for patent term extension is being submitted less than sixty days from April 15, 2008, the date the approved device first received permission for commercial marketing and use.
- h. No other patent term has been extended for the same regulatory review period for the Talent Abdominal Stent Graft System.

The Applicant respectfully asserts that United States patent number 6,306,141 is eligible for a **1,183 day** extension as calculated pursuant to 37 C.F.R. § 1.777.

Calculations under 37 C.F.R. § 1.777

Date testing began: April 11, 1997 (IDE conditionally approved)
Date the PMA was submitted: October 18, 2007
Date of FDA Approval: April 15, 2008
Date U.S. Patent 6,306,141 issued: October 23, 2001

1. Calculations under 37 C.F.R. § 1.777(c)(1)

Determine the number of days in the period beginning on the date a clinical investigation on humans involving the device began and ending the date an application (PMA) was initially submitted with respect to the device under section 515 of the Federal Food, Drug, and Cosmetic Act:

- i) Clinical investigations on humans are deemed to have begun on the date that the FDA determines that an Investigation Device Exemption (IDE) required under section 520(g) of the FDCA (21 U.S.C. 360j (g)) is substantially complete. In this case, the records indicated that on April 11, 1997, the Medtronic Vascular IDE number G970065 received a Conditional Approval. Thus, April 11, 1997 will be used for the initial calculations.
- ii) The PMA was initially filed October 18, 2007.
- iii) The experimental period is calculated as the time between April 11, 1997 and October 18, 2007, or **3,842 days**.

2. Calculations under 37 C.F.R. § 1.777(c)(2)

Determine the number of days in the period beginning on the date the application (PMA) was initially submitted with respect to the device under section 515 of the Federal Food, Drug and Cosmetic Act, and ending on the date such application was approved under such Act or the period beginning on the date a notice of completion of a product development protocol was initially submitted under section 515(f)(5) of the Act and ending on the date the protocol was declared completed under section 525(f)(6) of the Act:

- i) The PMA was initially submitted October 18, 2007.
- ii) The PMA was approved April 15, 2008.
- iii) The PMA approval period is calculate as the time between October 18, 2007, and April 15, 2008. Thus the PMA approval period was **181 days**.

The Sum of 37 C.F.R. § 1.777(c)(1) and (c)(2) equals 4023 days.

3. Calculations under 37 C.F.R. § 1.777(d)(1)

Subtract from the number of days determined by the Secretary of Health and Human Services to be in the regulatory review period pursuant to 37 C.F.R. § 1.777(c):

- i) Subtract the number of days in the periods of paragraphs (c)(1) and (c)(2) of this section which were on and before the date on which the patent issued:

The '141 patent issued October 23, 2001. 1,656 days in the periods of paragraphs (c)(1) and (c)(2) of this section were on or before October 23, 2001.

- ii) Subtract the number of days in the periods of paragraphs (c)(1) and (c)(2) of this section during which it is determined under 35 U.S.C. § 156(d)(2)(B) by the Secretary of Health and Human Services that Applicant did not act with due diligence:

Zero for United States patent number 6,306,141.

- iii) Subtract one-half the number of days remaining in the period defined by paragraph (c)(1) of this section after that period is reduced in accordance with paragraphs (d)(1)(i) and (ii) of this section; half days will be ignored for purposes of subtraction:

$$[[(c)(1) + (c)(2)] - [(d)(1)(i) + (d)(1)(ii)]] / 2 = \\ (4023) - (1656) = 2367 / 2 = 1183.5 \text{ days}$$

Therefore, the maximum extension available for the '141 patent is 1,183 days, and will extend the term of the patent to January 18, 2022.

4. Calculations Under 37 C.F.R. § 1.777(d)(2)

Add the number of days determined by paragraph (d)(1) of this section to the original term of the '141 patent as shortened by a terminal disclaimer:

The original term of the '141 patent ends October 23, 2018 and this term is not subject to a terminal disclaimer. Therefore, the new expiration date calculated for the '141 patent remains **January 18, 2022.**

5. Calculations Under 37 C.F.R. § 1.777(d)(3)

Add 14 years to the date of approval of the application (PMA) under Section 515 of the Federal Food, Drug and Cosmetic Act or the date a product development protocol was declared completed under Section 515(f)(6) of the Act:

The Talent Abdominal Stent Graft System PMA was approved on April 15, 2008. 14 years added to the PMA approval date is **April 15, 2022**.

6. Calculations Under 37 C.F.R. § 1.777(d)(4)

Compare the dates for the ends of the periods obtained pursuant to paragraphs (d)(2) and (d)(3) of this section with each other and select the earlier date:

The earlier date between paragraphs (d)(2) and (d)(3) is **January 18, 2022**.

7. Calculations Under 37 C.F.R. § 1.777(d)(5)

If the original patent was issued after September 24, 1984:

United States patent number 6,306,141 was filed after September 24, 1984.

- (i) Add 5 years to the original expiration date of the patent or earlier date set by terminal disclaimer:

The original expiration date of the '141 patent was October 23, 2018. Five years added to the original expiration date would be **October 23, 2023**.

- (ii) Compare the dates obtained pursuant to paragraphs (d)(4) and (d)(5)(i) of this section with each other and select the earlier date:

The earlier date between paragraphs (d)(4) and (d)(5)(i) is **January 18, 2022**.

8. Calculations Under 37 C.F.R. § 1.777(d)(6)

If the original patent was issued before September 24, 1984:

United States patent number 6,306,141 was filed after September 24, 1984 and therefore, 37 C.F.R. § 1.777(d)(6) is not applicable.

Therefore, Applicant respectfully asserts that the '141 patent is eligible for a **1,183 day** extension of patent term, extending the original expiration of the patent term to **January 18, 2022**.

- (13) Statement that the Applicant acknowledges a duty to disclose to the Director of the United States Patent and Trademark Office and the Secretary of Health and Human Services any information which is material to the determination of entitlement to the extension sought:

The Applicant acknowledges his duty to disclose to the Commissioner of Patents and trademarks and the Secretary of Health and Human Services any information which is material to the determination of entitlement to the extension sought. The Applicant has no disclosures that are material to the determination of entitlement to the extension sought.

However, the Applicant wishes to make the following facts of record:

The claims of United States Patent Number 6,306,141 (the '141 patent) (Exhibit B) are subject to Claim Construction Orders filed in two separate cases filed in United States District Court for the Northern District of California. In *Medtronic, Inc. v. W.L. Gore & Associates, Inc.*, Case number C 06-04455 JSW, the court issued a Claim Construct Order on October 19, 2007, construing terms in the '141 patent, and related United States patents 5,067,957 (the '957 patent) and 5,190,546 (the '546 patent). In *Medtronic, Inc. v. AGA Medical Corp.*, Case number C 07-567 MMC, the court issued an Order Construing Claims on February 6, 2008, also construing the '141 patent, the '957 patent and the '546 patent. The information herein presented is consistent with both District Courts' claim constructions.

The claims of the '957 patent and related United States patents 5,597,378 were also interpreted in *Medtronic, Inc. v. Boston Scientific Corp. & SciMed Life Systems, Inc.*, Case number 99-1035 (RHK/FLN), in United States District Court for the District of Minnesota. The *Medtronic v. Boston Scientific* court's claim construction applies only to the interpretation of the claims in the '957 and '378 patents and does not apply to the '141 patent claims.

- (14) The prescribed fee for receiving and acting upon the application for extension:

The Commissioner is hereby authorized to charge payment of the patent term extension application fee pursuant to 37 C.F.R. §1.20 (j)(1) in the amount of \$1,120.00 to Deposit Account number 13-2546.

- (15) The name address and telephone number of the person to whom inquires and correspondences relating to the application for patent term extension are to be directed:

Michael J. Jaro
Vice President and Chief Patent Counsel
Medtronic, Inc.
710 Medtronic Parkway
M/S LC340
Minneapolis, MN 55432

(753) 505-2519

- (16) Duplicate Copies:

This application is being submitted with two (2) duplicate copies pursuant to 37 C.F.R. § 1.740(b).

A

IN THE UNITED STATES PATENT AND TRADEMARK OFFICE

Applicant : Medtronic, Inc.
In Re : U.S. Patent No. 6,306,141 B1
Issued : October 23, 2001
Title : Medical Devices Incorporating SIM Alloy Elements
Inventor(s) : James E. Jervis
Docket No. : 19 51288.000284

APPLICATION FOR PATENT TERM EXTENSION UNDER 35 U.S.C. § 156

POWER OF ATTORNEY

Commissioner for Patents
 P.O. Box 1450
 Alexandria, VA 22313-1450

Dear Sir:

Medtronic, Inc., the assignee of record of the above-identified patent hereby appoints:

Louis C. Cullman
 Registration No. 39645
 K&L Gates, LLP
 1900 Main Street
 Suite 600
 Irvine, CA 92614

as its attorney to transact all business in the United States Patent and Trademark Office in connection with the Application for Patent Term Extension.

Respectfully submitted,

Dated: 5/21/08

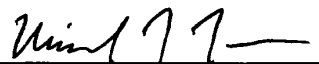
 Michael J. Jaro
 Vice President
 Chief Patent Counsel
 Medtronic, Inc.



US006306141B1

B

(12) **United States Patent**
Jervis

(10) **Patent No.:** US 6,306,141 B1
(45) **Date of Patent:** Oct. 23, 2001

- (54) **MEDICAL DEVICES INCORPORATING SIM ALLOY ELEMENTS**
- (75) **Inventor:** James E. Jervis, Atherton, CA (US)
- (73) **Assignee:** Medtronic, Inc., Minneapolis, MN (US)
- (*) **Notice:** Subject to any disclaimer, the term of this patent is extended or adjusted under 35 U.S.C. 154(b) by 0 days.
- (21) **Appl. No.:** 08/483,291
- (22) **Filed:** Jun. 7, 1995

Related U.S. Application Data

- (60) Continuation of application No. 07/956,653, filed on Oct. 2, 1992, which is a division of application No. 07/682,243, filed on Apr. 9, 1991, now Pat. No. 5,190,546, which is a division of application No. 07/252,019, filed on Sep. 27, 1988, now Pat. No. 5,067,957, which is a continuation of application No. 07/177,817, filed on Mar. 30, 1988, now abandoned, which is a continuation of application No. 07/047,824, filed on May 8, 1987, now abandoned, which is a continuation of application No. 06/865,703, filed on May 21, 1986, now Pat. No. 4,665,906, which is a continuation of application No. 06/541,852, filed on Oct. 14, 1983, now abandoned.

- (51) **Int. Cl.⁷** A61B 17/56
- (52) **U.S. Cl.** 606/78
- (58) **Field of Search** 606/78, 60, 108, 606/62, 68, 200, 195, 198; 623/1

(56) **References Cited**

U.S. PATENT DOCUMENTS

3,348,548	10/1967	Chardack	128/418
3,416,531	12/1968	Edwards	128/348
3,419,010	12/1968	Williamson	125/350
3,500,820	3/1970	Almen	128/303
3,516,412	6/1970	Ackerman	128/418
3,539,033	11/1970	Tafeen	128/221
3,558,369	1/1971	Wang et al.	148/11.5

3,605,725	9/1971	Bentov	128/2.05 R
3,620,212	11/1971	Fannon, Jr.	128/130
3,729,008	4/1973	Berkovits	128/418
3,740,839	6/1973	Otte et al.	29/628
3,757,768	9/1973	Kline	128/2 M
3,786,806	1/1974	Johnson et al.	128/92 YN
3,789,841	2/1974	Antoshkiw	128/2.05
3,857,391	12/1974	Lerner	128/127
3,868,956	3/1975	Alfidi et al.	128/345
3,889,666	6/1975	Lerner	128/127
3,890,977	6/1975	Wilson	604/281
3,939,828	2/1976	Mohr et al.	128/92 B
3,960,147	6/1976	Murray	128/92 B
4,033,331	7/1977	Guss et al.	128/2 M
4,035,007	7/1977	Harrison et al.	285/381
4,037,324	7/1977	Andreasen	433/24
4,080,706	3/1978	Heilman	29/173
4,149,911	4/1979	Clabburn	148/11.5 R
4,170,990	10/1979	Baumgart et al.	128/92 YN

(List continued on next page.)

FOREIGN PATENT DOCUMENTS

8301576	5/1983	(AU)
3086384	1/1985	(AU)

(List continued on next page.)

OTHER PUBLICATIONS

Jackson, "55-Nitinol—The Alloy with a Memory: Its Physical Metallurgy, Properties, and Applications," NASA-SP5110 (1972).

(List continued on next page.)

Primary Examiner—Justine R. Yu

(74) *Attorney, Agent, or Firm*—Sheldon & Mak

(57) **ABSTRACT**

Medical devices which are currently proposed to use elements made from shape memory alloys may be improved by the use of stress-induced martensite alloy elements instead. The use of stress-induced martensite decreases the temperature sensitivity of the devices, thereby making them easier to install and/or remove.

22 Claims, 4 Drawing Sheets

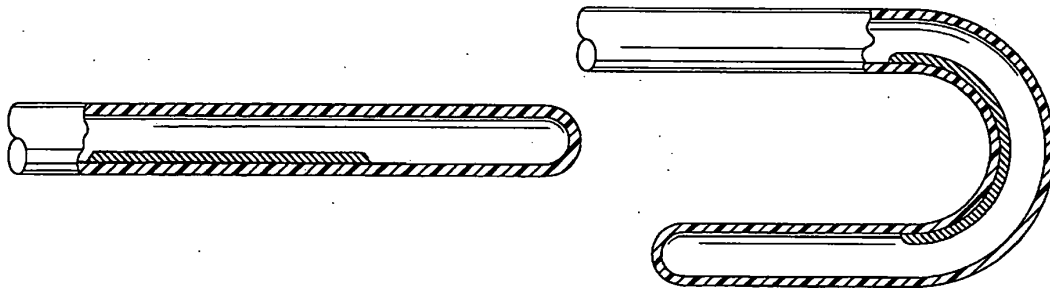

U.S. PATENT DOCUMENTS

4,197,593	4/1980	Kaster et al.	3/1.5
4,198,081	4/1980	Harrison et al.	
4,205,293	5/1980	Melton et al.	337/140
4,230,123	10/1980	Hawkins, Jr.	128/658
4,233,690	11/1980	Akins	623/2
4,307,723	12/1981	Finney	128/349 R
4,310,354	1/1982	Fountain et al.	75/211
4,378,811	4/1983	Levitan	128/757
4,401,433	8/1983	Luther	604/159
4,411,655	10/1983	Schreck	604/165
4,425,908	1/1984	Simon	128/1 R
4,427,000	1/1984	Ueda	128/6
4,452,236	6/1984	Utsugi	128/4
4,485,805	12/1984	Foster, Jr.	606/195
4,485,816	12/1984	Krumme	128/334 R
4,490,112	12/1984	Tanaka	433/20
4,494,531	1/1985	Gianturco	128/1 R
4,505,767	3/1985	Quin	148/402
4,509,517	4/1985	Zibelin	128/319
4,512,338	4/1985	Balko et al.	128/1 R
4,543,090	9/1985	McCoy	604/95
4,556,050	12/1985	Hodgson et al.	128/1 R
4,586,335	5/1986	Hosoda et al.	60/528
4,601,283	7/1986	Chikama	128/4
4,616,656	10/1986	Nicholson et al.	128/360
4,665,906	5/1987	Jervis	128/92 YN
4,925,445	5/1990	Sakamoto et al.	
5,190,546	3/1993	Jervis	606/78
1001034	12/1976	(CA)	128/93

FOREIGN PATENT DOCUMENTS

2703529	3/1978	(DE)	
3225151A1	1/1984	(DE)	
102685	5/1983	(EP)	
0105669	4/1984	(EP)	
0129634	1/1985	(EP)	
0132344	1/1985	(EP)	
0140621	5/1985	(EP)	
0145166	6/1985	(EP)	
8211061	12/1983	(FR)	
1600000	10/1981	(GB)	F16L/21/00
2106190	4/1983	(GB)	
2114005	8/1983	(GB)	128/92 YN
56-28980	7/1981	(JP)	
57-10163	2/1982	(JP)	
57-75647	5/1982	(JP)	
57-95452	6/1982	(JP)	
57-119744	7/1982	(JP)	
5825140	2/1983	(JP)	
5829443	2/1983	(JP)	
41546	3/1983	(JP)	
44047	3/1983	(JP)	
50951	3/1983	(JP)	
5841546	3/1983	(JP)	
5844047	3/1983	(JP)	
5850951	3/1983	(JP)	
58133225	8/1983	(JP)	
6220827	4/1984	(JP)	
5997115	6/1984	(JP)	
6045356	3/1985	(JP)	
100956	6/1985	(JP)	
6476824	3/1989	(JP)	
940759	11/1980	(SU)	128/92 YN
850067	7/1981	(SU)	128/92 YN
1110447	8/1984	(SU)	128/92 YN
1113110	9/1984	(SU)	128/92 YN

OTHER PUBLICATIONS

Mazer, "Therapeutic Embolization of the Renal Artery with Gianturco Coils: Limitations and Technical Pitfalls," *Radiology*, 138:37-46 (Jan. 1981).

Perkins, "Shape Memory Effects in Alloys," Plenum Press, NY 1975. (pp. 29-59, Rodriguez article; pp. 59-89, Shimizu article; pp. 273-304, Perkins article.)

Robinson, "Metallurgy: Extraordinary Alloys that Remember their Past," *Science*, vol. 191, No. 4230 (May, 1976).

Wagner, "What You Can Do with that 'Memory Alloy,'" *Materials Engineering*, 70 (1969) Oct. pp. 28-31.

Wasilewski, "The Effects of Applied Stress on the Martensitic Transformation in TiNi," *Metallurgical Transactions*, 2: Nov. 1971, pp. 2973-2981.

Wayman, "Some Applications of Shape-Memory Alloys," *Journal of Metals*, Jun., 1980, pp. 129-137.

Physik in Unserer Zeit, 1977, Nr. 2, Verlag Chemie GmbH, Seite 33, and translation thereof.

Dotter, Charles T., Transluminal Expandable Nitinol Coil Stent Grafting: Preliminary Report, *Radiology*, vol. 147, pp. 259-260.

Cragg, et al., *Radiology*, (Apr. 1983) vol. 147, pp. 261-263.

Schetky, L. McDonald, "Shape Memory Alloys," *Scientific America*, Nov. 1979, pp. 74-82.

Buehler, et al., "55-Nitinol Unique Wire Alloy with a Memory," *Wire Journal* Jun. 1963, pp. 41-49.

Portsmann, et al., "P Wave Synchronous Pacing Using Anchored Atrial Electrode Implanted Without Thoracotomy," Jul. 1972, *The American Journal of Cardiology* vol. 30, pp. 74-76.

Baumgart, et al., "Memory Alloys-Properties, Phenomenological Theory and Applications", 1976 (Reference #1 from Opposition).

Bennsmann, et al., "Study of the Memory Alloy Nickel-Titanium and Observations on its Application in the Field of Medicine", 1979 (Reference 2 from Opposition).

Bennsmann, et al., "Osteosynthesis Staples Made of Nickel-Titanium, Manufacture Preliminary Experiments and Clinical Use Thereof", 1982 (Ref. #3 from Opposition).

Baumgart, et al., "Mechanical Problems in the Use of the Memory Effect for Osteosynthesis Plates", 1977 (Ref. #4 from Opposition).

Suzuki, Yuchi, Shape Memory and Super-Elasticity Effects in Ni-Ti Alloys. (Translation provided).

Kirk-Othmer, *Encyclopedia of Chemical Technology*, 3rd Ed., vol. 20, pp. 7-26-7-36.

Ling, et al., Variation in the Shape Recovery Temperature in Ni-Ti Alloys, *Mat'ls Sc. & Eng.*, vol. 48, pp. 241-247 (1981).

Watanabe, Studies on New Superelastic Ni-Ti Orthodontic Wire, *J. Jap. Soc. for Dental Apparatus & Mat'ls.*, vol. 23, No. 61, pp. 47-57 (1981).

Oonishi, *Clinical Magazine: Orthopaedic Surgery*, 32, p. 1180 (1981).

Sullivan Variable Stiffening Device for Colonoscopy, *Gastrointestinal Endoscopy*, vol. 36 No. 6, pp. 642-643 (1990).

* cited by examiner

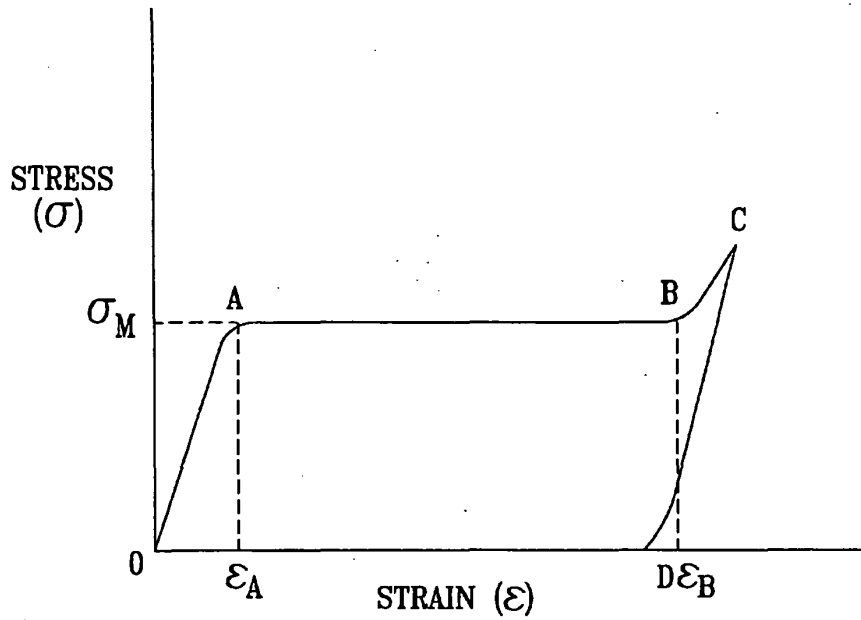

FIG. 1

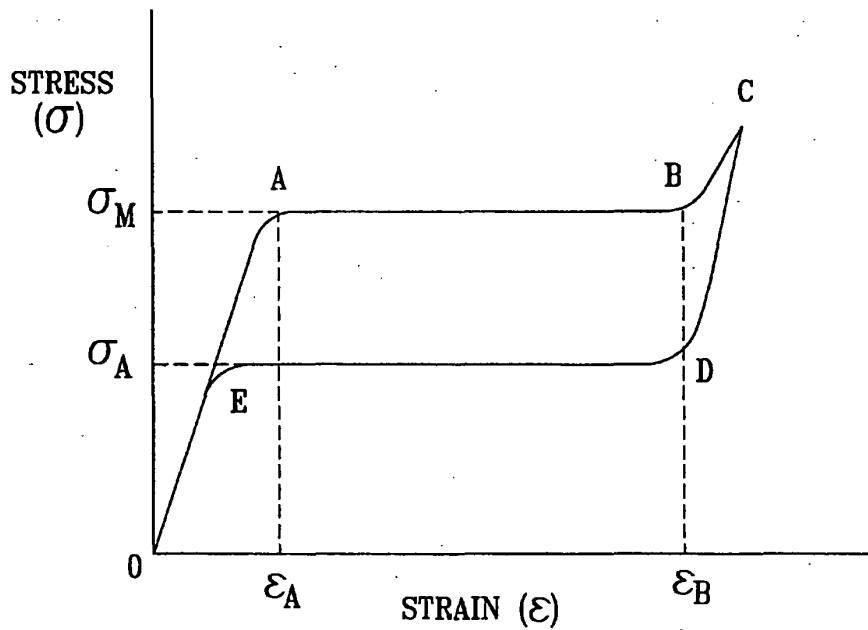

FIG. 2

FIG. 3

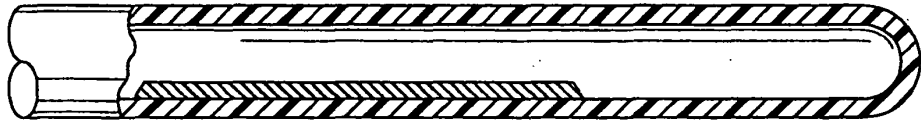
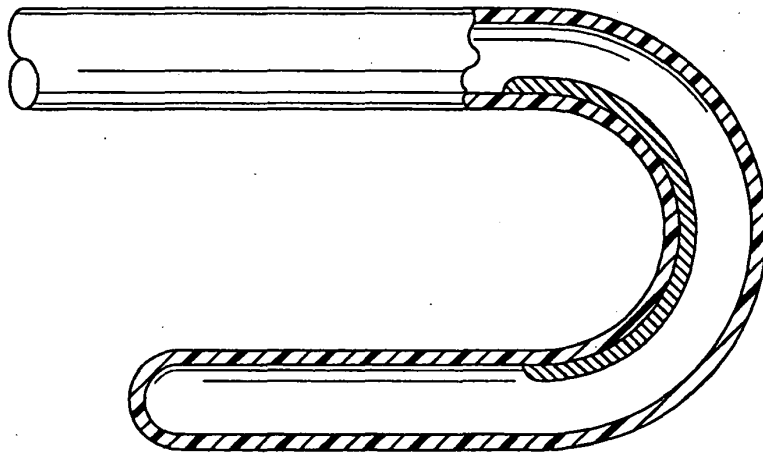

FIG. 4



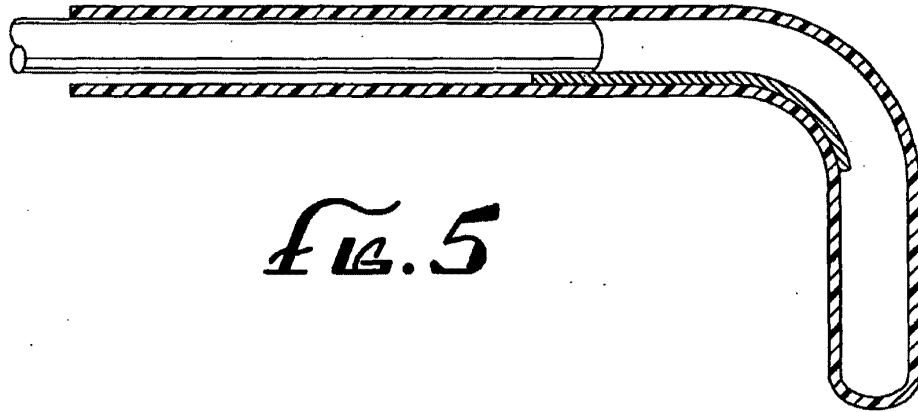

Fig. 5

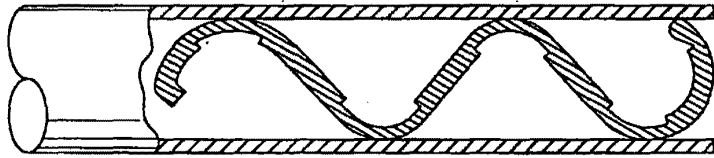

Fig. 6

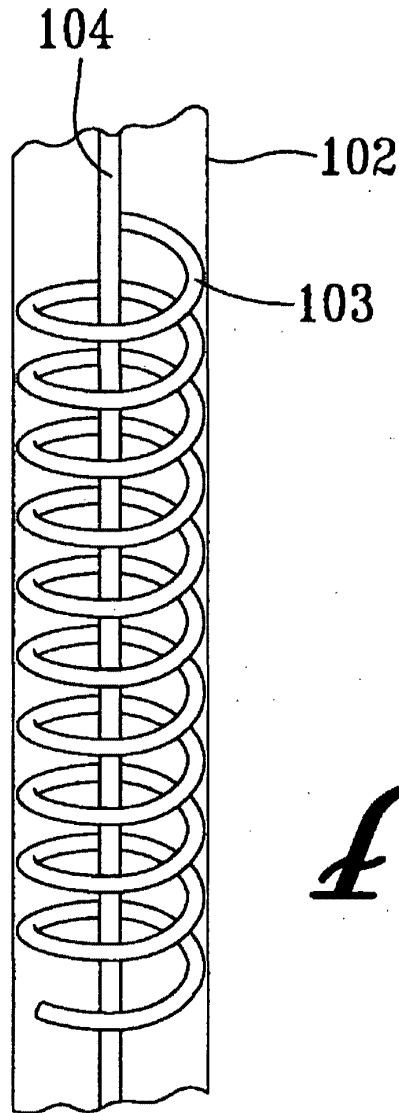

FIG. 7

MEDICAL DEVICES INCORPORATING SIM ALLOY ELEMENTS

CROSS-REFERENCE TO RELATED APPLICATIONS

This application is a continuation of application Ser. No. 07/956,653 filed on Oct. 2, 1992, which is a divisional of application Ser. No. 07/682,243 filed on Apr. 9, 1991, now U.S. Pat. No. 5,190,546, which is a divisional of Ser. No. 07/252,019 filed on Sep. 27, 1988, now U.S. Pat. No. 5,067,957, which is a continuation of application Ser. No. 07/177,817 filed Mar. 30, 1988, now abandoned; which is a continuation of application Ser. No. 07/047,824 filed May 8, 1987, now abandoned; which is a continuation of application Ser. No. 06/865,703 filed May 21, 1986, now U.S. Pat. No. 4,665,906; which is a continuation of application Ser. No. 06/541,852 filed Oct. 14, 1983, now abandoned.

BACKGROUND OF THE INVENTION

1. Field of the Invention

This invention relates to medical devices incorporating shape memory alloys, and to improvements therein.

2. Introduction to the Invention

Materials, both organic and metallic, capable of possessing shape memory are well known. An article made of such materials can be deformed from an original, heat-stable configuration to a second, heat-unstable configuration. The article is said to have shape memory for the reason that, upon the application of heat alone, it can be caused to revert, or to attempt to revert, from its heat-unstable configuration to its original, heat-stable configuration, i.e. it "remembers" its original shape.

Among metallic alloys, the ability to possess shape memory is a result of the fact that the alloy undergoes a reversible transformation from an austenitic state to a martensitic state with a change in temperature. This transformation is sometimes referred to as a thermoelastic martensitic transformation. An article made from such an alloy, for example a hollow sleeve, is easily deformed from its original configuration to a new configuration when cooled below the temperature at which the alloy is transformed from the austenitic state to the martensitic state. The temperature at which this transformation begins is usually referred to as M_s and the temperature at which it finishes M_f . When an article thus deformed is warmed to the temperature at which the alloy starts to revert back to austenite, referred to as A_s (A_f being the temperature at which the reversion is complete) the deformed object will begin to return to its original configuration.

Many shape memory alloys (SHAs) are known to display stress-induced martensite (SIM). When an SMA sample exhibiting stress-induced martensite is stressed at a temperature above M_s (so that the austenitic state is initially stable), but below M_f (the maximum temperature at which martensite formation can occur even under stress) it first deforms elastically and then, at a critical stress, begins to transform by the formation of stress-induced martensite. Depending on whether the temperature is above or below A_s , the behavior when the deforming stress is released differs. If the temperature is below A_s , the stress-induced martensite is stable; but if the temperature is above A_s , the martensite is unstable and transforms back to austenite, with the sample returning (or attempting to return) to its original shape. The effect is seen in almost all alloys which exhibit a thermoelastic martensitic transformation, along with the shape memory

effect. However, the extent of the temperature range over which SIM is seen and the stress and strain ranges for the effect vary greatly with the alloy.

In copending and commonly assigned U.S. Patent Application (Docket No. MP0873-US1) to Quin now U.S. Pat. No. 4,505,767, the disclosure of which is incorporated herein by reference, a nickel/titanium/vanadium alloy having SIM over a wide temperature range is disclosed.

Shape memory alloys have found use in recent years in, for example, pipe couplings (such as are described in U.S. Pat. Nos. 4,035,007 and 4,198,081 to Harrison and Jervis), electrical connectors (such as are described in U.S. Pat. No. 5 3,740,839 to Otte & Fischer), switches (such as are described in U.S. Pat. No. 4,205,293), actuators, etc.

Various proposals have also been made to employ shape memory alloys in the medical field. For example, U.S. Pat. No. 3,620,212 to Fannon et al. proposes the use of an SMA intrauterine contraceptive device, U.S. Pat. No. 3,786,806 to Johnson et al. proposes the use of an SMA bone plate, U.S. Pat. No. 3,890,977 to Wilson proposes the use of an SMA element to bend a catheter or cannula, etc.

These medical SMA devices rely on the property of shape memory to achieve their desired effects. That is to say, they rely on the fact that when an SMA element is cooled to its martensitic state and is subsequently deformed, it will retain its new shape; but when it is warmed to its austenitic state, the original shape will be recovered.

However, the use of the shape memory effect in medical applications is attended with two principal disadvantages. First, it is difficult to control the transformation temperatures of shape memory alloys with accuracy as they are usually extremely composition-sensitive, although various, techniques have been proposed (including the blending by powder metallurgy of already-made alloys of differing transformation temperatures: see U.S. Pat. No. 4,310,354 to Fountain et al.). Second, in many shape memory alloys there is a large hysteresis as the alloy is transformed between austenitic and martensitic states, so that reversing of the state of an SMA element may require a temperature excursion of several tens of degrees Celsius. The combination of these factors with the limitation that (a) it is inconvenient to have to engage in any temperature manipulation, and (b) human tissue cannot be heated or cooled beyond certain relatively narrow limits (approximately 0°-60° C. for short periods) without suffering temporary or permanent damage is expected to limit the use that can be made of SMA medical devices. It would thus be desirable to develop a way in which the advantageous property of shape memory alloys, i.e. their ability to return to an original shape after relatively substantial deformation, could be used in medical devices without requiring the delicacy of alloying control and/or the temperature control of placement or removal needed by present shape memory alloy devices.

DESCRIPTION OF THE INVENTION

SUMMARY OF THE INVENTION

I have discovered that if, in a medical device containing a shape memory alloy element which uses the shape memory property of that alloy, an element which shows the property of stress-induced martensite is used instead, an improved device results.

Accordingly, this invention provides a medical device intended for use within a mammalian body, or in such proximity to a mammalian body that the device is substantially at body temperature, which device comprises a shape

memory alloy element, the improvement in which comprises the substitution of an alloy element which displays stress-induced martensite at said body temperature for the shape memory alloy element.

BRIEF DESCRIPTION OF THE DRAWINGS

FIGS. 1 and 2 illustrate the stress-strain behavior of an alloy which exhibits constant stress versus strain behavior due to stress-induced martensite.

FIG. 3 is a side elevation view of a partial section of a catheter of the present invention in a stressed configuration.

FIG. 4 is a side elevation view of the catheter of FIG. 3 in an unstressed configuration.

FIG. 5 is a tracheal catheter, which is curved in its unstressed configuration, partially straightened by a straight pin restraint.

FIG. 6 shows an IUD formed at least partly from a pseudoelastic shape-memory alloy being restrained in a deformed shape by a restraining tube.

FIG. 7 shows a guide catheter, transport catheter, and compacted wire coil stent according to the present invention.

DETAILED DESCRIPTION OF THE PREFERRED EMBODIMENTS

The invention will be discussed first by introducing the concept of stress-induced martensite and the effect achievable by its use, and then by examples showing how SIM alloy elements can be substituted for conventional SMA elements in medical devices to achieve the beneficial effect of the invention.

The Figures illustrate the phenomenon of stress-induced martensite by means of stress-strain curves. In both FIG. 1 and FIG. 2, the alloy is at a temperature between M_s and M_d so that it is initially austenitic; and it will be assumed for the purposes of this discussion that M_s is equal to M_p and A_s equal to A_f . FIG. 1 shows the case when the temperature is below A_s , so that any martensite formed by the applied stress is stable; while FIG. 2 shows the case where the temperature is above A_s , so that austenite is the only stable phase at zero stress.

In FIG. 1, when a stress is applied to the alloy, it deforms elastically along the line DA. At a critical applied stress, c_M , the austenitic alloy begins to transform to (stress-induced) martensite. This transformation takes place at essentially constant stress until the alloy becomes fully martensitic at point B. From that point on, as further stress is applied, the martensite yields first elastically and then plastically (only elastic deformation is shown at point C). When the stress is released, the martensite recovers elastically to point D, at which there is zero residual stress, but a non-zero residual strain. Because the alloy is below A_s , the deformation is not recoverable until heating above A_s results in a reversion to austenite. At that point, if the sample is unrestrained, the original shape will be essentially completely recovered: if not, it will be recovered to the extent permitted by the restraint. However, if the material is then allowed to re-cool to the original temperature at which it was deformed (or a temperature where SIM behavior of this type is seen), the stress produced in the sample will be constant regardless of the strain provided that the strain lies within the "plateau" region of the stress-strain curve. That is, for a strain between E_B and E_A , the stress will be σ_M . This means that a known, constant force (calculable from σ_M) can be applied over a wide (up to 5% or more for certain Ni/Ti alloys) strain range. Thus, though this resembles the conventional shape memory

effect, because the alloy shows SIM and is below A_s , a constant force can be achieved.

In FIG. 2, when a stress is applied to the alloy, it deforms elastically along line DA, then by SIM along line AB, and by deformation of the martensite to point C, just as in FIG. 1. However, the stress-strain behavior on unloading is significantly different, since the alloy is above A_s and the stable phase is therefore austenite. As the stress is removed, the alloy recovers elastically from C to D then, at a critical stress, c_A , the alloy reverts to austenite without requiring a change in temperature. Thus reversion occurs at essentially constant stress. Finally if the stress is removed from the reverted austenite, it recovers elastically along line EO. The recoverable deformation associated with the formation and reversion of stress-induced martensite has been referred to as pseudoelasticity. While σ_M may be comparatively high, e.g. less than 50 ksi; c_A is usually substantially lower e.g. less than 10 kis; thereby creating a constant-force spring with an effective working range of about 5% ($c_B - c_A$). The shape change available in the SMA is thus mechanically, rather than thermally, actuated and controlled, permitting a greater control over a device incorporating it.

Suitable alloy for this invention i.e. those displaying stress-induced martensite at temperatures near mammalian body temperature (35°-40° C.), may be selected from known SMAs by those of ordinary skill in the art, having regard to this disclosure by testing for the existence of the SIM effect at the desired temperature. A particularly preferred alloy is the nickel/titanium/vanadium allot of U.S. patent application Ser. No. 06/541,844 now U.S. Pat. No. 4,505,767, referred to previously.

The following table sets forth transformation temperature data for disclosed in U.S. Pat. No. 4,505,767:

TABLE

Composition (atomic percent)				
Ni	Ti	V	M_s	A(90)
49.50	43.50	7.00	-107	-88
50.00	44.00	6.00	-96	-84
49.00	43.00	8.00	-83	-61
50.00	45.00	5.00	-42	-33
49.00	45.00	6.00	-35	-12
50.50	48.00	1.50	-32	-6
48.50	44.50	7.00	-30	-13
50.00	46.00	4.00	-11	7
48.50	45.00	6.50	-10	15
49.00	45.50	5.50	-10	14
48.00	44.25	7.75	-7	8
48.50	45.50	6.00	-5	27
41.50	38.50	20.00	-2	86
46.50	43.50	10.00	-1	50
36.25	33.75	30.00	0	42
49.50	46.00	4.50	6	35
48.00	46.00	6.00	12	36
47.75	45.75	6.50	20	54
47.50	45.50	7.00	26	58
48.50	46.50	5.00	27	58
45.00	45.00	10.00	30	71
47.50	46.50	6.00	32	71
46.50	46.50	7.00	34	70

The A(90) temperature is the temperature at which the transformation from the martensitic phase to the austenitic phase is 90% complete.

The invention will now be discussed in detail by some Examples of the use of an SIM alloy.

EXAMPLE I

Heart Valves

Akins, in U.S. Pat. No. 4,233,690, the disclosure of which is incorporated herein by reference, describes the use of a

shape memory alloy ring to hold a sewing cuff to the body of an artificial heart valve. The ring is made in the austenitic phase, cooled to the martensitic phase, deformed, placed around the valve body, and heated or allowed to warm to cause reversion to the austenitic phase and recovery of the ring into engagement with the valve body.

However, this technique has not found commercial acceptance. Present medical technique requires that the valve body be capable of being rotated relative to the cuff, thereby enabling the surgeon to set the rotational orientation of the valve after it has been sewn into place. This is desirable because the techniques used make it difficult to visualize or accomplish optimal orientation during initial placement.

In order to accomplish the desired torque control to permit the desired rotation and yet ensure a firm hold of the cuff on the valve body, precise control of the pressure exerted on the valve body by the ring is needed. This is difficult because there are substantial manufacturing tolerances in the valve body which may be made, for example, of pyrolytic graphite or ceramics, etc. Because the austenite stress-strain curve is extremely steep, it is not considered practical to use the simple shape memory technique proposed by Akins. Indeed, Akins does not even address the issue of rotation, of the cuff with respect to the valve body.

However, if an SIM alloy is used instead of conventional shape memory, the process may be considerably simplified.

First, if the alloy has a stress-strain curve like that of FIG. 1, the alloy ring may be made just as for Akins. The ring is then expanded from its initial austenitic state by the formation of SIM. When the ring is placed about the valve body, it needs only to be heated above A_s and allowed to cool to its original temperature for the ring to engage the valve body 6 constant force, even if the valve body has a deviation from the specified size. The torque may thus be controlled to the desired level despite manufacturing tolerances.

Second, if the alloy has a stress-strain curve like that of FIG. 2, the ring may be expanded, placed over the valve body, and the stress released all at the same temperature. Because the austenitic phase is stable, the stress-induced martensite spontaneously reverts to austenite until recovery is restrained by the ring engaging the valve body. Because the reversion to austenite takes place at constant stress, a constant force (and hence constant torque) may be obtained regardless of manufacturing tolerances. Close temperature control is not required, either; and the fact that the patient in a heart valve replacement operation is conventionally cooled as much as 15° C. or so below normal body temperature does not affect the operation of the ring.

To control the torque at a sufficiently low level, it may be desirable for the alloy ring to be other than a solid ring, such as, for example, a continuous helical spring, a flat zigzag spring, etc. Such variations permit the achievement of a greater range of movement with constant force and a reduction in the force exerted by the ring on the valve body, since the ring recovers in a bending mode rather than in tension.

EXAMPLE II.

Catheters And Cannulas

Wilson, in U.S. Pat. No. 3,890,977, the disclosure of which is incorporated herein by reference, discloses a catheter or cannula (both being included hereinafter in the word "catheter") made of, or containing, an SMA element to cause all or a portion of the catheter to deploy in a useful form once introduced into a living body.

However, again this device has not been commercialized. Possible defects of the device which have prevented com-

mercialization include (i) the inability to slowly emplace the catheter in a desired position when the transition temperature of the alloy is below body temperature (since the SMA element will attempt to revert to its original shape as it reaches body temperature), thus limiting the ability of the physician to place the device carefully and precisely; or alternatively, if the transition temperature of the alloy is above body temperature, the requirement that the device be heated to a temperature above body temperature to cause recovery and that the device be placed so as not to change shape again when it re-cools (since the body temperature is below the transition temperature); (ii) the inability to remove the device easily; and (iii) the need for controlled temperature storage to prevent premature reversion to austenite of the SMA, with consequent shape change.

The issue of removal of a catheter is especially, significant, and not addressed by Wilson. Consider, for example, a tracheal puncture catheter. This should be straight for easy insertion into the trachea through a puncture into the front of the neck, but should curve after insertion so that the flow of air or oxygen through the catheter passes axially down the trachea rather than impinging on the surface of the trachea and damaging it. If a shape memory catheter is used as contemplated by Wilson, it would presumably become austenitic and bend after insertion (see FIGS. 1a and 1b, and corresponding text, of Wilson). But removal would require either cooling to below the transition temperature (which could easily mean cooling to so low a temperature that the tracheal tissue is damaged), removal in the bent shape (presumably damaging tissue), or forcing the austenitic SMA to straighten to permit direct removal (unlikely to be satisfactory since the austenitic alloys e.g. of Ni/Ti may have yield strengths of 100 ksi or more, and force sufficient to cause plastic deformation would be required).

If an SIM element is used instead, however, removal can be accomplished almost as easily as insertion. If the catheter is made in a bent shape (as in Wilson), it can be straightened by insertion of a straight pin down the catheter axis, the catheter deforming by the formation of stress-induced martensite. Insertion of the catheter into the trachea is accomplished while the catheter is straight, at whatever rate is desired (permitting easy and accurate placement), and the pin is gradually withdrawn to permit the catheter to take up its desired shape as the martensite reverts to austenite. [It is assumed here that the stress-strain curve of the alloy at the temperature of use is of the form of FIG. 2, so spontaneous reversion occurs on removal of the stress induced by the pin]. When removal is desired, it may be achieved simply by the gradual insertion of the pin, straightening the catheter and permitting easy withdrawal. Insertion of the catheter into the body and pin removal may, of course, take place simultaneously if desired, as may pin reinsertion and removal of the catheter from the body.

EXAMPLE III

IUDS

Fannon et al., in U.S. Pat. No. 3,620,212, the disclosure of which is incorporated herein by reference, discloses an intrauterine contraceptive device (an IUD) proposed to be formed of a shape memory alloy. The device is suggested to be deformed in the martensitic phase (the transition temperature being below the temperature of the uterus), and the deformed device insulated with, e.g., wax and inserted. Removal is contemplated only by using two SMA elements in opposition, the higher temperature one being martensitic at body temperature but strong enough so that, if heated, it

will overcome the lower temperature element and deform the IUD back to a removable shape. The heating contemplated is electrical. The storage problem discussed in Example II also exists here, so that the device must be stored below its transition temperature.

By the use of an SIM element, however, these disadvantages may be overcome. Again, assume that the alloy is SIM pseudoelastic, i.e. that it has the stress-strain curve of FIG. 2. Then an IUD may be formed into the desired shape in the austenitic state, and deformed by compression into a tubular placement device (the deformation being such that the strain levels lie within the "plateau" of the stress-strain curve). When the placement device is inserted into the uterus, the IUD may be deployed by extrusion of the IUD from the placement device. Deployment is then controlled but immediate, so that the physician may satisfy himself with placement. Removal is the reversal of placement: the placement device is inserted into the uterus, the IUD deformed by withdrawal into the placement device, and the placement device withdrawn. Temperature control is not required.

EXAMPLE IV

Bone Plates

Johnson et al., in U.S. Pat. No. 3,786,806, the disclosure of which is incorporated herein by reference, propose the use of Ni/Ti SMA bone plates in fracture fixation. The plate is deformed in its martensitic state, screwed to the two ends of the bone it is desired to compress together, and warmed (or allowed to warm) to the austenitic state, when the plate contracts, compressing the bone ends together. The Johnson et al. bone plate is of generally oblong configuration, overlaps a bone fracture and is secured by two screws to one portion of the bone and by two other screws to the other portion of the bone.

Because of the high elastic moduli of the austenitic shape memory alloys, it will be difficult to control the amount of force which may be applied by a bone plate of the type proposed by Johnson et al., and precision placement of the bone ends and elongation of the plate will be required.

If, however, an SIM pseudoelastic bone plate is used, it will be easily possible to elongate the plate and fasten it to the bone ends without requiring high precision. Because of the comparatively large (e.g. 5%) strain range at essentially constant stress, the force which will be put on the bone ends to compress them will be readily adjustable (by the size of the plate, for example) and will be insensitive to precise placement of the bone ends and/or elongation of the plate. Also, the recovery of the plate, since it is controlled by mechanical restraint, may be as gradual as desired, achieving excellent force and time control, and permitting the surgeon to make adjustments as desired.

EXAMPLE V

Marrow Nails

Baumgart et al., in U.S. Pat. No. 4,170,990, the disclosure of which is incorporated herein by reference, discloses the use of the two-way shape memory effect (where an SMA element exhibits a first shape in the austenitic state and a second in the martensitic state, and spontaneously changes between the two shapes with a change in temperature) in, inter alia, implants, such as marrow nails (see FIGS. 1a through 1e, and corresponding text, of Baumgart et al.). Marrow nails according to Baumgart et al. comprise a tube of memory alloy which has been split along its longitudinal

axis and which may have a circular, elliptical, clover-leaf or other rotation preventing cross section, which may also be variable along the axis of the nail. A prepared marrow nail having a reduced diameter is loosely inserted into a slightly, or not at all, pre-drilled marrow channel of a bone which has been broken or fractured. By means of a heating probe the marrow nail is heated and thus expands. This achieves a relative fixing of the two bone ends along the marrow channel axis. Compression of the fracture is effected by the available muscle tension. If it should be necessary, the marrow nail may also be additionally prestretched along its longitudinal axis so that it is additionally compressed in the longitudinal direction when heated. In this case it is necessary, however, to anchor the nail at both of its ends which anchoring can be effected, for example, by sprockets or teeth on the outer surface of the nail.

The method proposed, however, requires the use of a wide temperature range in order to cause the phase change which is the origin of the two-way shape memory effect (5° C. to 60° C. for the water used to cool or heat the nail). In addition, it requires the manufacture of two-way shape memory elements, which is generally more complex than the manufacture of conventional shape memory elements; and precise control of the transition temperature is required.

However, if an SIM pseudoelastic alloy element is employed, these disadvantages may be overcome. If internal tangs, which may be gripped by an inserted tool, are provided within a marrow nail of the type shown in FIG. 1a of Baumgart et al., then the nail may be radially compressed by the application of stress by such a tool. When the nail is released by the tool, it will expand to fill the bone channel with a constant force (not readily available by Baumgart et al.); and it may be withdrawn by the reverse procedure.

EXAMPLE VI

Dental Arch Wire

Andreasen, in U.S. Pat. No. 4,037,324, the disclosure of which is incorporated herein by reference, proposes the use of dental arch wires made of Ni/Ti alloys instead of conventional 18-8 stainless steel wires. The wires are stated to be of lower elastic modulus and higher elastic limit than stainless steel, which is stated to be advantageous. Heat recovery of an SMA wire is also suggested as a technique for orthodonture.

The technique of using the conventional shape memory effect is not believed to have found clinical application, possibly because such a technique would require rapid placement of the wire in its martensitic state to avoid premature recovery, and would result in rapid recovery with extremely high forces, which would be painful for the patient.

The use of a wire which displays lower elastic modulus and higher elastic limit than stainless steel has found some application, however. Otsuka et al. In Metals Forum, v. 4, pp. 142-52 (1981) have suggested that this behavior may be the result of elasticity enhanced by cold working and martensite-to-martensite pseudoelasticity in an alloy which has a transition temperature below body temperature. The alloy, then, is martensitic rather than austenitic in its undeformed state.

While the use of an enhanced elasticity wire may offer some advantages over the more usual stainless steel wire, it remains the situation that the amount of motion in the teeth that may be produced by an arch wire without further adjustment is largely limited by the pain tolerance of the

patient (since the force applied by the arch wire is proportional to the deformation of the wire). However, if an SIM pseudoelastic wire is used, it can exert a relatively constant force (chosen by the dentist to be sufficient to cause tooth movement but not painful) over a strain range of up to 5%. The load may be applied mechanically, and is thus more readily established, and no precise temperature control of the alloy is needed as would be required for the shape memory effect.

EXAMPLE VII

Coil Stents and Filters

The use of tubular coiled wire stent grafts has been discussed in the medical literature since 1969. Although the coils helped maintain patency of the vessels in which they were placed, they were difficult of insertion unless narrow enough to significantly narrow the lumen of the vessel. Recently it has been proposed, see *Radiology*, v. 147, pp. 259-60 and pp. 261-3 (1983), the disclosures of which are incorporated herein by reference, to use SMA wire to form these tubular coils. The wire, which has a transformation temperature below body temperature, is introduced through a catheter after being straightened in its martensitic state. When the wire is heated, the coil re-forms. According to Dotter et al., *Radiology* 147: 259-260, a compacted nitinol coil is readily positioned in a narrowed arterial segment and then expanded to its original form with a luminal diameter approximately equal to that of the adjacent, relatively normal, blood vessel. Expansion of the coil anchors it against the slightly stretched, but otherwise intact, surrounding blood vessel. Several means have been found to facilitate the placement of the nitinol coil stent. One of the simplest involves the use of conventional catheterization techniques to position a large-bore guide catheter 102 (as shown in FIG. 7) close to the site of intended stent 103 placement. The coil 103 is wedged-loaded over the inner end of an inner coaxial transport catheter 104 that has a closed tip and multiple side holes evenly spaced within the surrounding nitinol coil stent.

According to Cragg et al., *Radiology* 147: 261-262, straightened nitinol coils were passed through a 10-F Teflon catheter in the abdominal aorta. The nitinol coils were fastened to a threaded guiding wire to allow accurate placement after being deposited in the aorta. Once the wire was extruded from the catheter, precise placement of the newly formed coil was accomplished by advancing or withdrawing the guide wire in the aorta. Detachment of the coil was achieved by unscrewing the guide wire from the distal end of the coil. After coil placement, the catheter and guide wire were withdrawn and the arteriotomy was closed.

Because of the difficulty of controlling the transformation temperature accurately, it has proved necessary to cool the straightened wire during insertion and/or to heat the wire to form the coil after insertion. These procedures add to the complexity of the operation.

If an SIM pseudoelastic wire is used to form the coil, which is then isothermally deformed by loading into a catheter, then the need for temperature control is avoided. The wire remains straight when in the catheter, but re-forms the coil spontaneously when it is extruded from the catheter. Accurate placement is thus readily obtainable, since there is no urgency as might be required with a conventional shape memory effect element.

It has similarly been proposed to use SMA wire to form a filter for emplacement by catheter in the vena cava to trap

blood clots. The filter is formed in the austenitic state, the wire straightened in the martensitic state and inserted, and the filter re-forms on warming. Just as for the coil stents discussed above, the use of an SIM pseudo-elastic wire would greatly simplify manufacture and insertion of such a vena cava filter, permitting accurate placement with no need for urgency or temperature manipulation.

EXAMPLE VIII

Bone Staples, Clips, etc.

Bone staples are frequently used to hold fragments of fractured bone together when the fracture is fixed, and may be used in some cases as a replacement for bone plates in the same situation. Sometimes the staples are inserted into drilled holes, sometimes merely driven into the bone directly.

It would be desirable to have a bone staple which provided a controlled force between the tines which would tend to hold the staple in place. Shape memory alloys have been proposed for this application, but again the problem of accurate placement while operating quickly enough to prevent the shape change associated with the martensite-to-austenite transition and/or the need for temperature control complicate their use.

If an SIM alloy is used, these disadvantages may be readily overcome. If the alloy is below A_s , it may be emplaced in the martensitic state. Brief heating will then be required to cause it to become austenitic, but on recoiling to body temperature, a constant force can be achieved. If the alloy is above A_s , the staple can be held deformed by a moderate force, then released after insertion to also provide an accurately-known force. In either event, removal is easier than if the alloy is purely austenitic, as discussed above for Examples II and V, for example.

Similarly, SIM alloy (especially alloy which is pseudoelastic, above A_s at its utilization temperature) may be used to manufacture vascular clips, etc. The alloy element here acts as a constant force spring over a wide strain range (greater than conventional elastic metals), resulting in ease of use.

From the foregoing, it is clear that, in a situation where narrow temperature differences are available or preferable, as often is the case in medical applications, mechanically constrained shape change is a much more useful solution than heat actuated shape change. It offers a degree of control heat actuation does not, it offers easier alloy composition control, it eases mating part tolerance requirements, and it offers simple mechanical reversal at minimal stress levels, all without heating, cooling or insulation complications.

It will be obvious to those skilled in the art, having regard to this disclosure, that other variations on this invention beyond those specifically exemplified here, and other medical devices making use of stress-induced martensite, may be made. Such variations are, however, to be considered as coming within the scope of this invention as limited solely by the following claims.

I claim:

1. A medical device for insertion into a mammalian body, the device comprising
 - (a) a hollow placement device;
 - (b) a memory alloy element formed at least partly from pseudoelastic shape-memory alloy, the alloy displaying reversible stress-induced martensite at about body temperature such that it has a stress-induced martensitic state and an austenitic state, the memory alloy element

11

having (i) a deformed shape when the alloy is in its stress-induced martensitic state and (ii) a different unstressed shape when the alloy is in its austenitic state; and

(c) a guide wire;

the memory alloy element being within the hollow placement device, and the placement device being guidable by the guide wire, the hollow placement device stressing the memory alloy element at a temperature greater than the A_s of the alloy so that the memory alloy element is in its deformed shape,

wherein the memory alloy element can be extruded from the hollow placement device by the guide wire at a temperature greater than the A_s of the alloy to transform at least a portion of the alloy from its stress-induced martensitic state so that the memory alloy element transforms from its deformed shape to its unstressed shape, and wherein the alloy is selected so that the transformation can occur without any change in temperature of the placement device or the memory alloy element.

2. The device of claim 1 wherein the memory alloy element is a stent.

3. The device of claim 2, including a guide wire for endarterial placement of the stent graft.

4. The invention of claim 1 wherein the transformation occurs without any change in the state of the placement device.

5. The device of claim 1, wherein the hollow placement device is a catheter.

6. A medical device which comprises:

(a) a stent for endarterial placement within a human body so that the stent is substantially at human body temperature, the stent comprising a shape memory alloy which displays stress-induced martensite behavior at body temperature; and

(b) a restraint holding the stent in a deformed configuration at a temperature less than the body temperature of the human for endarterial positioning of the stent within the human body in its deformed configuration, the deformation occurring through the formation of stress-induced martensite;

wherein the stent is sufficiently deformed that when the stent is at human body temperature removal of the restraint from the stent, without change in temperature of the device, releases at least a portion of the stent from its deformed configuration.

7. A device as claimed in 6, in which the restraint is hollow, and the stent is positioned at least partially within the restraint.

8. A device as claimed in claim 6 or 7, in which the restraint is a catheter.

9. A device as claimed in claim 6 or 7, in which the stent has a transverse dimension and a longitudinal dimension, and wherein the stent is deformed by its transverse dimension being reduced, and wherein the restraint prevents transverse expansion of the stent.

10. The device of claim 6, wherein the shape memory alloy element is sufficiently deformed that removal of the restraint from the shape memory alloy releases at least a portion of the shape alloy element from its deformed configuration without change in state of the restraint.

11. A medical device suitable for placement within a mammalian body for treatment of the mammalian body, the device comprising:

(a) a stent formed at least partly from a pseudoelastic shape-memory alloy, the alloy having a reversible

12

stress-induced martensitic state and an austenitic state, the memory alloy element having (i) a deformed shape when the alloy is in its stress-induced martensitic state and (ii) a different, unstressed shape; and

(b) restraining means engaging and stressing the stent at a temperature less than the body temperature of the mammal and greater than the A_s of the alloy for positioning the stent within the mammalian body while the stent is in its deformed shape;

wherein the alloy is selected so that removal of the restraining means from the stent at a temperature greater than the A_s of the alloy when the device is placed within the mammalian body, transforms at least a portion of the alloy from its stress-induced martensitic state so that the stent transforms from its deformed relatively straightened shape towards its unstressed relatively coiled shape, without any change in temperature of the restraining means or the stent being required for the transformation of the alloy.

12. The device of claim 11, wherein the transformation of the alloy occurs without any change in state of the restraining means.

13. The device of claim 11 wherein the restraining means is a catheter.

14. The device of claim 13 wherein the stent is within the catheter.

15. A medical device for treatment of a mammalian body, the device comprising:

(a) a memory alloy stent formed at least partly from a pseudoelastic shape-memory alloy, the alloy displaying reversible stress-induced martensite at about the mammalian body temperature such that it has a stress-induced martensitic state and an austenitic state, the memory alloy stent having (i) a deformed relatively straightened shape when the alloy is in its stress-induced martensitic state and (ii) a different unstressed relatively coiled shape; and

(b) a hollow restraining member with the memory alloy stent being within the restraining member, the restraining member engaging and stressing the memory alloy stent at a temperature less than the body temperature of the mammal and greater than the A_s of the alloy for positioning the memory alloy stent within the human body while the memory alloy coil stent is in its deformed relatively straightened shape;

wherein the restraining member and the memory alloy stent are movable relative to each other to transform at least a portion of the alloy from its stress-induced martensitic state at a temperature greater than the A_s of the alloy so that the memory alloy element transforms from its deformed shape towards its unstressed relatively coiled shape, and wherein the alloy is selected so that the transformation can occur without any change in temperature of the restraining member or the memory alloy coil stent.

16. A medical device suitable for placement within a mammalian body for treatment of the mammalian body, the device comprising (i) a restraint, and (ii) a coil stent formed at least partly from a pseudoelastic shape-memory alloy,

the alloy displaying reversible stress-induced martensite by virtue of being above its A_s and above its M_s and below its M_d at about body temperature;

such that it has a stress-induced martensitic state and an austenitic state, the element having (i) a relatively straightened shape when the alloy is in its stress-induced martensitic state and (ii) a different relatively coiled shape;

13

wherein the restraint is (i) stressing the coil stent at a temperature less than the body temperature of the mammal for placement of the coil stent in its relatively straightened shape in the mammalian body and (ii) is capable of being at least partially removed from the coil stent while the coil stent is within the body at the body temperature and the coil stent is therefore at an operating temperature greater than the A_s and M_s and below the M_s of the alloy,

such removal of the restraint causing at least a portion of the alloy to transform from its stress-induced martensitic state to its austenitic state so that the coil stent spontaneously transforms from its relatively straightened shape towards its relatively coiled shape,

and such transformation can occur without a change in temperature of the restraint or of the coil stent from the operating temperature.

17. The device of claim 1, 11, 15, or 16, wherein the mammalian body is a human body.

18. A medical device comprising:

(a) a wire stent formed at least partly from a pseudoelastic shape memory alloy, the alloy displaying reversible stress-induced martensite at about human body temperature such as it has a deformed shape when the alloy

14

is in its stress-induced martensitic state and a different unstressed shape when the alloy is in its austenitic state; and

(b) a restraint stressing the wire stent at a temperature greater than the A_s of the alloy so that the wire stent is in its deformed shape,

wherein the stent can be disengaged from the restraint upon placement in a human so that the stent transforms from its deformed shape to its unstressed shape, and

wherein the alloy is selected so that the transformation can occur without any change in temperature of the restraint or the wire stent.

19. The device of claim 6, 11, 15, 16 or 18, including a guide wire for endarterial placement of the stent.

20. The device of claim 15, 16, or 18, wherein the transformation of the alloy occurs without any change in state of the restraint.

21. The device of claim 1, 15, 16, or 18, wherein the restraint is a catheter.

22. The device of claim 1, 11, 15, or 18 wherein the stent is a coil stent.

* * * * *



United States Patent and Trademark Office

Home | Site Index | Search | Guides | Contacts | eBusiness | eBiz alerts | News | Help



C

Assignments on the Web > Patent Query

Patent Assignment Abstract of Title

NOTE: Results display only for issued patents and published applications. For pending or abandoned applications please consult USPTO staff.

Total Assignments: 1

Patent #: 6306141

Issue Dt: 10/23/2001

Application #: 08483291

Filing Dt: 06/07/1995

Inventor: JAMES E. JERVIS

Title: MEDICAL DEVICES INCORPORATING SIM ALLOY ELEMENTS

Assignment: 1

Reel/Frame: 008907/0388

Recorded: 11/18/1996

Pages: 8

Conveyance: ASSIGNMENT OF ASSIGNORS INTEREST (SEE DOCUMENT FOR DETAILS).

Assignor: RAYCHEM CORPORATION

Exec Dt: 10/04/1996

Assignee: MEDTRONIC, INC.

7000 CENTRAL AVENUE N.E.
MINNEAPOLIS, MINNESOTA 55432

Correspondent: SHELDON & MAK

KARIN E. PETERKA
225 S. LAKE AVE.
9TH FL.
PASADENA, CA 91101

If you have any comments or questions concerning the data displayed, contact PRD / Assignments at 571-272-3350. v.2.0.1
Web interface last modified: April 20, 2007 v.2.0.1

Search Results as of: 06/11/2008 02:30 PM

| .HOME | INDEX | SEARCH | eBUSINESS | CONTACT US | PRIVACY STATEMENT

2

1
2
3
4
5
6
7
8
9
10
11
12
13
14
15
16
17
18
19
20
21
22
23
24
25
26
27
28

United States District Court
For the Northern District of California

NOT FOR CITATION

**IN THE UNITED STATES DISTRICT COURT
FOR THE NORTHERN DISTRICT OF CALIFORNIA**

MEDTRONIC, INC., et al.

Plaintiffs,

No. C 06-04455 JSW

v.

CLAIM CONSTRUCTION ORDER

W.L. GORE & ASSOCIATES, INC.,

Defendant.

Plaintiffs, Medtronic, Inc., Medtronic USA, Inc., and Medtronic Vascular, Inc. (collectively "Medtronic"), filed this suit in which they allege that Defendant W.L. Gore & Associates, Inc. ("Gore"), infringes U.S. Patent Nos. 5,067,957 ("the '957 Patent"), 5,190,546 ("the '546 Patent"), and 6,306,141 ("the '141 Patent") (collectively, "the Jervis Patents"). Plaintiffs also allege that Gore infringes U.S. Patent Nos. 4,886,062 ("the '062 Patent"), 6,656,219 ("the '219 Patent"), and 6,923,828 ("the '828 Patent") (collectively, "the Wiktor Patents").

On August 14, 2007, pursuant to *Markman v. Westview Instruments, Inc.*, 517 U.S. 370 (1996), the Court held a claim construction hearing to construe disputed claim terms from the patents-in-suit. Having carefully considered the parties' papers, including their supplemental briefs, having heard the parties' arguments, and having considered the relevant legal authorities, the Court construes the disputed terms and phrases as set forth in the remainder of this Order.

//
//

United States District Court
For the Northern District of California

1 **BACKGROUND**

2 This case involves alleged infringement of two patent families, the Jervis Patents and the
3 Wiktor Patents, each of which are directed, in general, to medical devices or methods for
4 implanting such medical devices into a human body.

5 **A. The Jervis Patents.**

6 The Jervis Patents are directed to medical devices, or methods for implanting such
7 devices, that utilize shape memory alloys (“SMAs”).¹ As Jervis acknowledges in his patents, it
8 was well known that certain materials are capable of possessing shape memory. Jervis also
9 explains that:

10 An article made of [a material capable of possessing shape memory] can be
11 deformed from an original, heat-stable configuration to a second, heat-
12 unstable configuration. The article is said to have shape memory for the
13 reason that, upon the application of heat alone, it can be caused to revert, or
14 to attempt to revert, from its heat-unstable configuration to its original, heat-
15 stable configuration, *i.e.* it “remembers” its original shape.

16 Among metallic alloys, the ability to possess shape memory is a result of the
17 fact that the alloy undergoes a reversible transformation from an austenitic
18 state to a martensitic state with a change in temperature. This transformation
19 is sometimes referred to as a thermoelastic martensitic transformation. An
20 article made from such an alloy, ... is easily deformed from its original
21 configuration to a new configuration when cooled below the temperature at
22 which the alloy is transformed from the austenitic state to the martensitic
23 state. The temperature at which this transformation begins is usually referred
24 to as M_s and the temperature at which it finishes M_f . When an article thus
25 deformed is warmed to the temperature at which the alloy starts to revert
26 back to austenite, referred to as A_s (A_f being the temperature at which the
27 reversion is complete) the deformed object will begin to return to its original
28 configuration.

21 (Bianrosa Decl., Ex. 1 (‘957 Patent, 1:23-49)).² Thus, there are two key phases involved in
22 taking advantage of the properties of SMAs: (1) the *formation* of martensite from austenite; and
23 (2) the *reversion* of martensite to austenite.

26 ¹ Gore submits an article from a 1979 issue of *Scientific American*, which
27 contains a useful discussion about the austenitic and martensitic states of shape memory
28 alloys. (See Declaration of Jennifer Bianrosa (“Bianrosa Decl.”), Ex. 4.)

² The Court cites to references within the patents-in-suit in the following
format: “column:line” or “column:line-column:line.”

1 Jervis also notes that there are disadvantages associated with using SMA devices for
2 medical purposes, including the fact that “it is difficult to control the transformation
3 temperatures of shape memory alloys with accuracy, as they are usually composition-
4 sensitive[.]” (*Id.*, 2:32-35.) Jervis also notes that “there is a large hysteresis as the alloy is
5 transformed between austenitic and martensitic states, so that reversing of the state of an SMA
6 element may require a temperature excursion of several tens of degrees Celsius.” (*Id.*, 2:39-43.)

7
8 Jervis concludes his discussion of the Background of the Invention as follows:

9 The combination of these factors with the limitation that (a) it is
10 inconvenient to have to engage in any temperature manipulation, and (b)
11 human tissue cannot be heated or cooled beyond certain relatively narrow
12 limits ... without suffering temporary or permanent damage is expected to
13 limit the use of SMA medical devices. It would thus be desirable to develop
14 a way in which the advantageous properties of shape memory alloys, i.e.
their ability to return to an original shape after relatively substantial
deformation, could be used in medical devices without requiring the
delicacy of alloying control and/or the temperature control of placement or
removal needed by present shape memory alloy devices. (*Id.*, col. 2, ll. 51-
58.)

15 (*Id.*, 2:43-58.)

16 Jervis then summarizes the invention and notes that “if, in a medical device containing a
17 shape memory alloy element which uses the shape memory property of that alloy, an element
18 which shows the property of stress-induced martensite is used instead, an improved device
19 results.” (*Id.*, 2:62-66; *see also id.*, 3:1-6.)

20 **B. The Wiktor Patents.**

21 The Wiktor Patents are directed to intravascular stents. According to Medtronic, “[t]he
22 Wiktor invention addresses the problem of distortions in the length and shape of a helically-
23 coiled wire device when it is expanded from a small diameter to a larger diameter.” (Medtronic
24 Br. at 3:27-28.) Wiktor purportedly resolved this problem through the use of “zig-zag” bends,
25 which permit a device to be sized and shaped more predictably when it expands. (*Id.* at 3:27-
26 4:9.)

27 Wiktor describes his invention in the specification as comprising “an open-ended wire
28 formed device of basically cylindrical shape and made of a softer-then [*sic*] spring type metal

1 and fitted over an inflatable element of a typical balloon type catheter. ... The wire formed
2 device is intended to act as a permanent prosthesis stent and is implanted transluminarely.”
3 (*See, e.g.,* Bianrosa Decl., Ex. 5 ('062 Patent, 1:14-22).)

4 ANALYSIS

5 A. Legal Standard.

6 “It is a bedrock principle of patent law that the claims of a patent define the invention to
7 which the patentee is entitled the right to exclude.” *Innova/Pure Water, Inc. v. Safari Water*
8 *Filtration Sys., Inc.*, 381 F.3d 1111, 1115 (Fed. Cir. 2004). The interpretation of the scope and
9 meaning of disputed terms in patent claims is a question of law and exclusively within the
10 province of a court to decide. *Markman*, 517 U.S. at 372. The inquiry into the meaning of the
11 claim terms is “an objective one.” *Innova/Pure Water*, 381 F.3d at 1116. As a result, when a
12 court construes disputed terms, it “looks to those sources available to the public that show what
13 a person of skill in the art would have understood the disputed claim language to mean.” *Id.* In
14 most cases, a court’s analysis will focus on three sources: the claims, the specification, and the
15 prosecution history. *Markman v. Westview Instruments, Inc.*, 52 F.3d 967, 979 (Fed. Cir. 1995)
16 (en banc), *aff’d*, 517 U.S. 370 (1996). However, on occasion, it is appropriate to rely on
17 extrinsic evidence regarding the relevant scientific principles, the meaning of technical terms,
18 and the state of the art at the time the patent issued. *Id.* at 979-81.

19 The starting point of the claim construction analysis is an examination of the specific
20 claim language. A court’s “claim construction analysis must begin and remain centered on the
21 claim language itself, for that is the language that the patentee has chosen to particularly point
22 out and distinctly claim the subject matter which the patentee regards as his invention.”
23 *Innova/Pure Water*, 381 F.3d at 1116 (internal quotations and citations omitted). Indeed, in the
24 absence of an express intent to impart a novel meaning to a term, an inventor’s chosen language
25 is given its ordinary meaning. *York Prods., Inc. v. Cent. Tractor Farm & Family Center*, 99
26 F.3d 1568, 1572 (Fed. Cir. 1996). Thus, “[c]laim language generally carries the ordinary
27 meaning of the words in their normal usage in the field of the invention.” *Invitrogen Corp. v.*
28 *Biocrest Mfg., L.P.*, 327 F.3d 1364, 1367 (Fed. Cir. 2003); *see also Renishaw v. Marposs*

1 *Societa' per Azioni*, 158 F.3d 1243, 1248 (Fed. Cir. 1998) (recognizing that “the claims define
2 the scope of the right to exclude; the claim construction inquiry, therefore, begins and ends in
3 all cases with the actual words of the claim”). A court’s final construction, therefore, must
4 accord with the words chosen by the patentee to mete out the boundaries of the claimed
5 invention.

6 The claims do not stand alone. Rather, “they are part of ‘a fully integrated written
7 instrument.’” *Phillips v. AWH Corp.*, 415 F.3d 1303, 1315 (Fed. Cir. 2005) (en banc) (quoting
8 *Markman*, 52 F.3d at 978). The written description, the drawings, and, if included in the record,
9 the prosecution history, each provide context and clarification regarding the intended meaning
10 of the claim terms. *Teleflex, Inc. v. Ficoso N. Am. Corp.*, 299 F.3d 1313, 1324-25 (Fed. Cir.
11 2002). The specification “may act as a sort of dictionary, which explains the invention and may
12 define terms used in the claims.” *Markman*, 52 F.3d at 979. The specification also can indicate
13 whether the patentee intended to limit the scope of a claim, despite the use of seemingly broad
14 claim language. *SciMed Life Sys., Inc. v. Advanced Cardiovascular Sys., Inc.*, 242 F.3d 1337,
15 1341 (Fed. Cir. 2001) (when the specification “makes clear that the invention does not include a
16 particular feature, that feature is deemed to be outside the reach of the claims of the patent, even
17 though the language of the claims, read without reference to the specification, might be
18 considered broad enough to encompass the feature in question”).

19 Intent to limit the claims can be demonstrated in a number of ways. For example, if the
20 patentee “acted as his own lexicographer,” and clearly and precisely “set forth a definition of
21 the disputed claim term in either the specification or prosecution history,” a court will defer to
22 that definition. *CCS Fitness, Inc. v. Brunswick Corp.*, 288 F.3d 1359, 1366 (Fed. Cir. 2002). In
23 order to so limit the claims, “the patent applicant [must] set out the different meaning in the
24 specification in a manner sufficient to give one of ordinary skill in the art notice of the change
25 from ordinary meaning.” *Innova/Pure Water*, 381 F.3d at 1117. In addition, a court will adopt
26 an alternative meaning of a term “if the intrinsic evidence shows that the patentee distinguished
27 that term from prior art on the basis of a particular embodiment, expressly disclaimed subject
28 matter, or described a particular embodiment as important to the invention.” *CCS Fitness*, 288

1 F.3d at 1367. Likewise, the specification may be used to resolve ambiguity “where the ordinary
2 and accustomed meaning of the words used in the claims lack sufficient clarity to permit the
3 scope of the claim to be ascertained from the words alone.” *Teleflex*, 299 F.3d at 1325.

4 Limitations from the specification (such as from the preferred embodiment) may not be
5 read into the claims, absent the inventor’s express intention to the contrary. *Id.* at 1326; *see*
6 *also CCS Fitness*, 288 F.3d at 1366 (“[A] patentee need not ‘describe in the specification every
7 conceivable and possible future embodiment of his invention.’”) (quoting *Rexnord Corp. v.*
8 *Laitram Corp.*, 274 F.3d 1336, 1344 (Fed. Cir. 2001)). To protect against this result, a court’s
9 focus should remain on understanding how a person of ordinary skill in the art would
10 understand the claim terms. *Phillips*, 415 F.3d at 1323.

11 If the analysis of the intrinsic evidence fails to resolve any ambiguity in the claim
12 language, a court then may turn to extrinsic evidence, such as expert declarations and testimony
13 from the inventors. *Intel Corp. v. VIA Techs., Inc.*, 319 F.3d 1357, 1367 (Fed. Cir. 2003)
14 (“When an analysis of *intrinsic* evidence resolves any ambiguity in a disputed claim term, it is
15 improper to rely on extrinsic evidence to contradict the meaning so ascertained.”) (emphasis in
16 original). When considering extrinsic evidence, a court should take care not to use it to vary or
17 contradict the claim terms. Rather, extrinsic evidence is relied upon more appropriately to
18 assist in determining the meaning or scope of technical terms in the claims. *Vitronics Corp. v.*
19 *Conceptronic, Inc.*, 90 F.3d 1576, 1583-84 (Fed. Cir. 1996).

20 Dictionaries also may play a role in the determination of the ordinary and customary
21 meaning of a claim term. In *Phillips*, the Federal Circuit reiterated that “[d]ictionaries or
22 comparable sources are often useful to assist in understanding the commonly understood
23 meanings of words....” *Phillips*, 415 F.3d at 1322. The *Phillips* court, however, also
24 admonished that district courts should be careful not to allow dictionary definitions to supplant
25 the inventor’s understanding of the claimed subject matter. “The main problem with elevating
26 the dictionary to ... prominence is that it focuses the inquiry on the abstract meaning of the
27 words rather than on the meaning of claim terms within in the context of the patent.” *Id.* at
28

1 1321. Accordingly, dictionaries necessarily must play a role subordinate to the intrinsic evidence.

2 In addition, a court has the discretion to rely upon prior art, whether or not cited in the
3 specification or the file history, but only when the meaning of the disputed terms cannot be
4 ascertained from a careful reading of the public record. *Vitronics*, 90 F.3d at 1584. Referring to
5 prior art may make it unnecessary to rely upon expert testimony, because prior art may be
6 indicative of what those skilled in the art generally understood certain terms to mean. *Id.*

7 **B. Claim Construction.**

8 **1. "Stress-induced martensite"**

9 The parties agree that "stress-induced martensite," is martensite that is formed from
10 austenite by the application of stress. The crux of the dispute is whether martensite must form
11 by the application of stress alone or whether temperature also is a factor in the process. Gore
12 urges the former, and the Court shall refer to Gore's proposed inclusion of this requirement as
13 the "isothermal limitation."

14 Medtronic correctly notes that the disputed claim term does not contain an "isothermal
15 limitation." When the Court looks at all the claims in which the term is used, it appears that
16 when Jervis included an "isothermal" limitation, he either did so expressly or did so in
17 connection with the reversion of the stress-induced martensite to austenite. (*See, e.g.*, '957
18 Patent, 11:26-36, 12:14-25; '546 Patent, 11:62-66, 13:10-13; '141 Patent, 11:12-20.)³

19 The Court also considers the claim language in light of the specification of which it is a
20 part. *See Markman*, 52 F.3d at 979. In the Background of the Invention section of the
21 specification, Jervis states:

22 Many [SMAs] are known to display stress-induced martensite (SIM). When
23 an SMA sample exhibiting stress-induced martensite is stressed at a
24 temperature above M_s (so that the austenitic state is initially stable), but
25 below M_d (the maximum temperature at which martensite formation can
26 occur even under stress) it first deforms elastically and then, at a critical
27 stress, begins to transform by the formation of stress-induced martensite.
Depending on whether the temperature is above or below A_s , the behavior
when the deforming stress is released differs. If the temperature is below A_s ,
the stress-induced martensite is stable; but if the temperature is above A_s , the
martensite is unstable and transforms back to austenite, with the sample

28 ³ The '546 and '141 Patents are attached as Exhibits 2 and 3, respectively, to
the Bianrosa Declaration.

1 returning (or attempting to return) to its original shape. This effect is seen
2 in almost all alloys which exhibit a thermoelastic martensitic transformation,
3 along with the shape memory effect. However, the extent of the temperature
4 range over which SIM is seen and the stress and strain ranges for the effect
5 vary greatly with the alloy.
6 ('957 Patent. 1:50-2:2.) This portion of the specification supports Medtronic's assertion that
7 temperature will be a factor in the *formation* of stress-induced martensite. Similarly, there are
8 references in the specification that suggests the "isothermal" limitation referred to the reversion
9 process. (*See, e.g., id.*, 4:1-2 ("the alloy reverts to austenite without requiring a change in
10 temperature".))
11 Gore contends that the prosecution history of the Jervis Patents demonstrates that Jervis
12 "repeatedly disclaimed use of temperature change as part of his invention." (Opp. Br. at 7:13-
13 14.) For example, Gore refers to a Response to Office Action, dated January 27, 1996, in which
14 Jervis states, "[s]trictly speaking the Applicant is taking advantage of the shape memory effect
15 ... [t]he difference is that the material transforms isothermally instead of over a temperature
16 range." (Bianrosa Decl., Ex. 8 at p. 3.)⁴ The paragraph immediately preceding this statement
17 demonstrates that Jervis was responding to the Examiner's concern that "while Applicant is
18 claiming a device and method whereby a shape memory alloy is utilized it appears that the
19 shape memory effect is not utilized." It also is directed to the Examiner's request for
20 clarification of the invention. (*Id.*) Jervis responds by noting that he was, in fact, taking
21 advantage of the shape memory effect, albeit through the use of an alloy that displays stress-
22 induced martensite at body-temperatures. (*Id.* at pp. 3-6.)
23 Similarly, when Jervis distinguished the Shreck reference, he noted that martensite can
24 be formed by cooling or by the application of stress. However, the discussion does not suggest
25 that temperature plays no factor in the formation of stress-induced martensite. Other references
26 cited actually support Plaintiff's position that the "isothermal" reference pertains to the
27 reversion of martensite to austenite, rather than to its formation from austenite in the first
28 instance. (*See, e.g.,* Bianrosa Decl., Ex. 12 at p. 4.) Having considered the references in the

⁴ This response was submitted to the USPTO during the prosecution of an application, subsequently abandoned, that was a predecessor to the application that issued as the '957 Patent.

1 prosecution history upon which Gore relies, the Court finds that they do not support a
2 conclusion that, in order to distinguish his invention over prior art, Jervis limited the term
3 “stress-induced martensite” to martensite that is formed solely by the application of stress.

4 Accordingly, the Court construes the term “stress-induced martensite” to mean:
5 **“martensite that forms from austenite due to stress.”**

6 **2. “Shape memory alloy element” and “Memory alloy element”**

7 The primary dispute between the parties is whether these terms must be construed to
8 require that the “shape memory alloy element” be placed in a deformed shape, *i.e.* its
9 martensitic state, solely by the application of stress. For the reasons set forth above, the Court
10 rejects Gore’s arguments on this point.

11 Accordingly, the Court construes the term “shape memory alloy element” to mean: **“a**
12 **device or device component made of an alloy that can be caused to revert, or to attempt to**
13 **revert, from its unstable deformed shape to its stable, original state.”**

14 **3. “Restraining means” “Restraining member” and “Restraint”**

15 With respect to these terms, the parties dispute (1) whether they should be construed to
16 include the location at which the restraining means is positioned, and (2) whether the
17 construction should include an isothermal limitation. For the reasons previously set forth, the
18 Court rejects Gore’s proposed construction to the extent it includes the isothermal limitation.

19 With respect to the position of the restraining means, the asserted claims generally are
20 silent on this point. (*See, e.g.*, ‘957 Patent, claims 1-3, 5-7.) In other claims, Jervis expressly
21 provides for a specific position. Furthermore, as Medtronic notes, one such claim expressly
22 contradicts Gore’s proposed construction. (*Compare* ‘957 Patent, claim 10 (memory alloy
23 element is within restraining member) *with* ‘957 Patent, claim 14 (restraining means is within
24 hollow memory alloy element).) Similarly, where Jervis required that the temperature be above
25 the austenite start temperature, he expressly included such a requirement in the claims. (*See,*
26 *e.g.*, ‘957 Patent, claims 10, 18.) Medtronic thus argues that the presumption of claim
27 differentiation should apply to these claims.

28

1 In general, the doctrine of claim differentiation recognizes “that different words or
2 phrases used in separate claims are presumed to indicate that the claims have different meanings
3 and scope.” *Andersen Corp. v. Fiber Composites, LLC*, 474 F.3d 1361, 1369 (Fed. Cir. 2007)
4 (quoting *Karlin Tech. Inc. v. Surgical Dynamics, Inc.*, 177 F.3d 968, 971-72 (Fed. Cir. 1999)).
5 Thus, there is a presumption that “[t]o the extent the absence of such difference in meaning and
6 scope would make a claim superfluous, ... the difference between claims is significant.” *Id.*
7 (quoting *Tandon Corp. v. U.S. Int’l Trade Comm’n*, 831 F.2d 1017, 1023 (Fed. Cir. 1987)).
8 That presumption may be overcome, however, by the written description of the patent or its
9 prosecution history. *Id.* Here, Gore has offered no argument in opposition to Medtronic’s
10 claim differentiation argument. Furthermore, although the position of the restraining means and
11 the austenite start temperature are not the only differences in the claims, the Court has examined
12 the claims in light of the specification, and finds no reason why the presumption of claim
13 differentiation should not apply.

14 The Court also has reconsidered its tentative construction of these terms, as they are
15 used in the ‘141 Patent, and concludes that Medtronic’s proposed construction should be
16 adopted as to all patents in which the terms are used.

17 Accordingly, the Court construes the terms “restraining means,” “restraining member,”
18 and “restraint” to mean: **“a device that prevents the transformation of the shape memory
19 alloy element back into its original shape.”**

20 **4. “Wherein the memory alloy element can be extruded from the hollow
21 placement device by the guide wire”**

22 This disputed phrase appears in independent claim 1 and in dependent claims 2, 3, 4, 5
23 and 22 of the ‘141 Patent.⁵ Claim 1 reads, in pertinent part:

24 A medical device for insertion into a mammalian body, the device comprising (a) a
25 hollow placement device; (b) a memory alloy element formed at least partly from
26 pseudo-elastic shape memory alloy, ...; and (c) a guide wire;
27 the memory alloy element being within the hollow placement device, and the
28 placement device being guidable by the guide wire, ... , wherein the memory alloy
element can be extruded from the hollow placement device by the guide wire

⁵ Claims 2-5 and Claims 22 each depend from Claim 1.

1 (See '141 Patent, 10:6-11:20.)

2 The parties agree that this disputed phrase should be construed to require that "the device
3 or memory alloy element is forced out of the hollow placement device by a guide wire." The crux
4 of the dispute is over the meaning of "guide wire," which derives its antecedent basis from
5 subsection (c) of the claim. The plain language of the claim suggests that the term "a guide wire"
6 should mean what it says, *i.e.*, a wire that is used to guide a device. Medtronic, however, argues
7 that the specification and prosecution history demonstrate that Jervis did not intend for the term to
8 be restricted to a "wire," but rather that he intended the term to be construed broadly enough to
9 encompass a catheter. As support for this argument, Medtronic notes that Jervis describes Figure 7
10 as disclosing "a guide catheter, a transport catheter, and compacted wire coil stent according to the
11 present invention." ('141 Patent, 3:21-22.)

12 Medtronic's argument also is supported by the prosecution history of the '141 Patent,
13 during which Jervis appealed a final rejection and in his appeal brief referred to element 104 of
14 Figure 7 as a "guide wire." (Declaration of Ellen J. Wang in Support of Medtronic's Claim
15 Construction Brief ("Wang Decl."), Ex. F at 11.) The specification of the '141 Patent refers to
16 element 104 as a "transport catheter." ('141 Patent, 9:28.) Thus, these references support
17 Medtronic's argument that "a guide wire" need not be construed to literally encompass a "wire,"
18 and that it should be construed more broadly.

19 Gore argues that this term should be construed to include a reference to the fact that the
20 guide wire "is also used to guide the hollow placement device into a mammalian body." However,
21 the clause that immediately precedes the disputed "wherein" phrase provides that "the memory
22 alloy element being within the hollow placement device, and the placement device being guidable
23 by the guide wire...." This clause therefore explains that the guide wire is used to guide the hollow
24 placement device. The Court concludes there is no need to include such a limitation in the
25 disputed phrase.

26 Accordingly, the Court construes the phrase "wherein the memory alloy element can be
27 extruded from the hollow placement device by the guide wire," to mean: **"the device or memory**
28

1 alloy element is forced out of the hollow placement device by the guide wire, which is a device
2 that assists in positioning another device.”

3 5. “Catheter at least partly formed from a pseudoelastic shape-memory alloy”

4 This phrase is found in independent claim 18 of the ‘957 Patent, and the crux of the dispute
5 is over the proper construction of the term “catheter.” The parties agree that, however “catheter”
6 is construed, it must be made, at least in part, of a pseudoelastic shape-memory alloy. (*See*
7 Amended Joint Claim Construction Statement, Ex. A at 3.)

8 The claim language suggests that the term catheter should be given its ordinary meaning in
9 the field, namely “a hollow, flexible tube for insertion into a body cavity, duct or vessel to allow
10 the passage of fluids or distend a passage way.” (*See, e.g.,* Wang Decl., Ex. G.) Medtronic,
11 however, argues that Jervis acted as his own lexicographer and defined the term “catheter” to
12 include “cannulas,” which do not necessarily transport fluids. (*See* ‘957 Patent, 5:59-62 (“Wilson
13 ... discloses a catheter or cannula (both being included hereinafter in the word ‘catheter’)....”);
14 Wang Decl., Ex. H (cannula, in surgical field, means “a tube to be inserted into a cavity or duct”).)

15 Dependent claim 21 of the ‘957 Patent, however, claims “[t]he method of claim 18 wherein
16 the catheter is a cannula.” The use of the term “cannula,” is the only significant difference
17 between the two claims. Thus, if the Court construes the term “catheter” to include a “cannula,” it
18 could be argued that dependent claim 21 is superfluous. If, however, the Court determined that a
19 “catheter” could not include a cannula, independent claim 1 would be narrower than dependent
20 claim 21. In this situation, the Court concludes that the doctrine of claim differentiation is
21 overcome by the specification and concludes that Jervis acted as his own lexicographer and
22 defined the term “catheter” to include “cannulas.”

23 Gore’s construction, which includes a reference to the catheter’s function, is offered
24 primarily out of a concern that the term not be construed so as to encompass a stent. (*See* Gore Br.
25 at 18.) However, the specification of the ‘957 Patent sets forth examples of medical devices
26 unitizing SMAs. One such example discusses catheters and cannulas. (‘957 Patent, 5:59-6:57.)
27 Another such example discusses coil stents and filters. (*Id.*, 9:20-57.) Because of this distinction,
28 the Court concludes that a person of ordinary skill in the art would understand from the

1 specification that the term “catheter” is intended to be something different than a stent. As such,
2 the Court concludes that phrase should not be construed to include a reference to the function of
3 the “catheter.”

4 Accordingly, the Court construes the term “catheter at least partly formed from a
5 pseudoelastic shape-memory alloy” to mean: **“a tube inserted into a cavity or duct that is made
6 of, at least in part, a pseudoelastic shape-memory alloy.”**

7 **6. “Stent”**

8 The term “stent” is used in both the ‘141 Patent and each of the Wiktor Patents. Medtronic
9 argues for a construction of this term that would be applied uniformly to each of the patents. Gore
10 contends that the term “stent” in the Jervis ‘141 Patent should be construed differently from the
11 term “stent” in the Wiktor Patents. The Court concurs with Gore that the terms have different
12 meanings in the ‘141 Patent and the Wiktor Patents. The Court, however, is not persuaded by
13 many of the limitations Gore seeks to include in the construction of the term.

14 **a. The ‘141 Patent.**

15 Gore argues that the term “stent” in the ‘141 Patent means “a wire, typically in the shape of
16 a tubular coil, used to keep a body vessel open.” To the extent Gore is seeking a construction that
17 includes a reference to the material from which the stent is made, the claims expressly note that the
18 stent is composed of a memory alloy or a shape memory alloy. (*See* ‘141 Patent, 11:22-23 (“The
19 device of claim 1 wherein the memory alloy element is a stent.”); *id.*, col. 11:32-36 (“... the stent
20 comprising a shape memory alloy ...”).) Furthermore, independent claim 18 specifically claims a
21 “*wire stent*,” and dependent claim 22 specifically claims “[t]he device of claim 1, 11, 15 or 18
22 wherein the stent is a *coil stent*. (*Id.*, 13:22, 14:22-23 (emphasis added).)

23 As previously noted, the doctrine of claim differentiation recognizes “that different words
24 or phrases used in separate claims are presumed to indicate that the claims have different meanings
25 and scope.” *Andersen Corp.*, 474 F.3d at 1369 (quoting *Karlin Tech. Inc. v. Surgical Dynamics,*
26 *Inc.*, 177 F.3d 968, 971-72 (Fed. Cir. 1999)); *see also Accumed LLC v. Stryker, Inc.*, 483 F.3d 800,
27 806 (Fed. Cir. 2007) (quoting *Liebel-Flarsheim Co. v. Medrad, Inc.*, 358 F.3d 898, 910 (Fed. Cir.
28 2004)) (“[T]he presence of a dependent claim that adds a particular limitation raises a presumption

1 that the limitation in question is not found in the independent claim.”) The presumption of claim
2 differentiation “is especially strong when the limitation in dispute is the only meaningful
3 difference between an independent and dependent claim, and one party is urging that the limitation
4 in the dependent claim should be read into the independent claim.” *SunRace Roots Enter. Co. v.*
5 *SRAM Corp.*, 336 F.3d 1298, 1303 (Fed. Cir. 2003). The Court has considered Gore’s arguments
6 but finds that the specification and prosecution history submitted do not overcome the presumption
7 that the dependent claims differ in scope from the independent claims.

8 Accordingly, the Court construes the term “stent,” as used in the ‘141 Patent, to mean: “a
9 supporting device.”

10 **b. The Wiktor Patents.**

11 With respect to the Wiktor Patents, Gore argues that the term “stent,” should be construed
12 to mean “a bare low memory metal wire stent without any attached fabric or graft material that
13 would be obstructive to any supportive vessels.” Gore relies on language in the specification that
14 refers to “[t]he stent of this invention is characterized by the low memory level of the relatively
15 easily deformable metal used for the wire.” (‘062 Patent, 2:51-54.)

16 Medtronic again relies on the principles of claim differentiation in support of its proposed
17 construction. For example, Medtronic notes that dependent claim 2 of the ‘828 Patent claims
18 “[t]he intravascular stent of claim 1, wherein said helically coiled wire is a low memory metal.”
19 (Bianrosa Decl., Ex. 7 (‘828 Patent, 7:53-54); *see also id.*, 8:57-59.) The “low memory metal”
20 limitation is the only meaningful difference between that claim and independent claim 1 of the
21 ‘828 Patent. It also is the only meaningful difference between independent claim 14 and
22 dependent claim 17 of the ‘062 Patent. Thus, the presumption of claim differentiation is especially
23 strong. *SunRace Roots*, 336 F.3d at 1303.

24 Gore also relies on cases such as *Honeywell Int’l Inc. v. IIT Indus., Inc.*, 452 F.3d 1312
25 (Fed. Cir. 2006), *Inpro II Licensing v. T-Mobile USA, Inc.*, 450 F.3d 1350 (Fed. Cir. 2006), and
26 *Astrazeneca AB v. Mut. Pharm Co.*, 384 F.3d 1333 (Fed. Cir. 2004) to argue that Wiktor disclosed
27 only balloon-expandable stents in the specification and also disparaged, and thereby disavowed,
28

1 self-expanding or resilient stents.⁶ It is true that the Wiktor Patents generally discuss balloon-
2 expandable stents, especially in the context of the preferred embodiment. As the Federal Circuit
3 has noted, however, “the applicant’s choice to describe only a single embodiment does not mean
4 that the patent clearly and unambiguously disavowed other embodiments.” *Home Diagnostics,*
5 *Inc. v. Lifescan, Inc.*, 381 F.3d 1352, 1357 (Fed. Cir. 2004); *see also Phillips*, 415 F.3d at 1323
6 (“In particular, we have expressly rejected the contention that if a patent describes only a single
7 embodiment, the claims of the patent must be construed as being limited to that embodiment ...”).
8 In addition, Wiktor notes that “other applications not specifically mentioned herein are possible
9 and no limitations in scope for this invention are intended or implied without departing from the
10 basic principles of this invention.” (‘062 Patent, col. 4, ll. 8-11.) This language provides further
11 support for the Court’s conclusion that Wiktor did not disavow clearly the use of self-expanding or
12 resilient stents. *See, e.g., Pfizer, Inc. v. Ranbaxy Labs. Ltd.*, 457 F.3d 1284, 1289 (Fed. Cir. 2006)
13 (rejecting claim construction that would limit claims to disclosed embodiments where specification
14 stated that the examples were illustrative and should be read as limiting the scope of the
15 invention).

16 Further, although Wiktor describes the benefits of a low memory level metal wire, and
17 refers to prior art that used spring devices, Wiktor does not say resilient metal is unsuitable to
18 achieve the object of his invention, namely a stent which expands radially. The Court also does
19 not find Wiktor’s reference in the specification to the fact that the stent is “characterized” by the
20 use of low memory metal to be dispositive. *See, e.g., Amgen Inc. v. Hoechst Marion Roussel, Inc.*,
21 314 F.3d 1313, 1326 (Fed. Cir. 2003) (concluding that statement that the invention is “uniquely
22 characterized” by a particular feature did not limit the claims where the claim language did not
23 contain such a limitation and where argument was undermined by doctrine of claim
24 differentiation).

25
26 ⁶ Gore argues, without support, that a person of ordinary skill in the art would
27 understand that a “balloon-expandable stent” would be made of a low memory metal, rather
28 than a resilient or self-expanding metal. Based on the parties’ discussion of shape-memory
alloys, the Court understands Gore’s argument to be that a “low memory metal” is one that
does not “remember” its initial shape easily and, thus, requires some additional force to
return it to its original shape.

1 Furthermore, during the prosecution history of the '062 Patent, the Examiner suggested
2 that Wiktor include a "low-memory metal" limitation to distinguish his invention over prior art.
3 Wiktor declined to do so, and the Examiner allowed the claims as written. In addition, the '219
4 and '828 Patents issued with claims directed specifically to low memory metals, a fact which adds
5 further support to Medtronic's argument that the Examiner did not understand the stent of the
6 invention to require a low memory metal in all embodiments. *See, e.g., Home Diagnostics*, 381
7 F.3d at 1358 (noting that related patents that issued with specific limitations supported a broader
8 construction of the disputed term which did not contain those limitations). For all of these reasons,
9 the Court cannot find a clear and unambiguous intent to disavow self-expanding or resilient stents,
10 and the Court concludes that the term should not be limited to low memory metals.

11 Gore also argues that the "stent" of the Wiktor patent cannot include graft material, *i.e.* it is
12 a "bare" wire stent. Medtronic asserts that the Court should not so limit the claims, because the
13 specification notes that the stent can be used for the repair of aneurysms or to support artificial
14 vessels or liners of vessels. Looking at the claims in which the term stent is used, the claims refer
15 to a stent body comprised of a "wire." There is nothing in the claims that discloses the use of
16 material attached to the wire. Further, with the exception of the reference cited by Medtronic,
17 there is no other reference in the specification of material attached to the wire that forms the stent
18 body. Thus, the Court concludes that the claims, read in light of the specification, do not support a
19 construction that would be so broad as to include the combination of a wire stent with material
20 attached.

21 Accordingly, the Court construes the term "stent," as used in the Wiktor Patents to mean:
22 **"a supporting device, without any attached fabric or graft material."**

23 **7. "Zig-zag means"**

24 The parties agree that this term is a means-plus-function term that must be construed under
25 35 U.S.C. § 112 ¶ 6, which permits a patentee to define a particular function in the claim and a
26 corresponding structure in the specification. *See Kemco Sales, Inc. v. Control Papers Co.*, 208
27 F.3d 1352, 1360 (Fed. Cir. 2000). Construction of a means-plus-function claim involves a two-
28 step process. *Medical Instrumentation & Diagnostics Corp. v. Elektra AB*, 344 F.3d 1205, 1210.

1 (Fed. Cir. 2003). In the first step, the Court must identify the particular claimed function. *Id.* In
2 the second step, the Court looks to the specification and identifies the structure that corresponds to
3 that function. *Id.* A structure is a “corresponding structure” only if that element is necessary to
4 perform the function recited in the claim and is clearly linked to that function by the disclosure in
5 the specification. *Asyst Techs., Inc. v. Empak, Inc.*, 268 F.3d 1364, 1370 (Fed. Cir. 2001). The
6 patentee’s “duty to clearly link or associate structure to the claimed function” represents the fair
7 exchange for the convenience of employing means-plus-function claim limitations. *Budde v.*
8 *Harley-Davidson, Inc.*, 250 F.3d 1369, 1377 (Fed. Cir. 2001).

9 Medtronic contends that the Court should construe the functional aspect of this term as: “to
10 allow expansion of the device radially without substantial change in longitudinal length.”

11 Medtronic asks that the Court construe the structural aspect of the term as: “wire elements bent
12 into a pattern of reversing bends that may vary in shape and tightness and their equivalents.”

13 Gore contends that any definition of the function of the zig-zag means must include a
14 requirement that expansion occurs “by externally applied forces.” Gore agrees that the structure
15 refers to the wire zig-zags but argues that the Court should construe the structure to require that the
16 wire zig-zags be formed of low memory metal. For the reasons previously stated, the Court rejects
17 Gore’s arguments as to both of these proposed restrictions on the claim term.

18 The claims at issue demonstrate that the zig-zag means allow or permit radial expansion of
19 the stent from a first to a second diameter “without significantly altering body length along the
20 longitudinal axis.” (*See* ‘062 Patent, 6:3-7.) Nothing in this claim language suggests that the zig-
21 zag means allow or permit the stent body to expand *solely* by the application of outside forces. For
22 the reasons set forth in connection with the term stent, the Court also concludes that the
23 construction of the term “zig-zag means” should not exclude the possibility of self-expanding or
24 resilient wires.

25 The Court also has considered Gore’s argument that the prosecution history supports its
26 position that the function of the zig-zag means must include a reference to externally applied
27 forces to achieve expansion. (*See* Gore Br. at 20:19-2; Bianrosa Decl., Ex. 14.) Gore’s brief,
28 however, omits the portion of the information disclosure statement wherein Wiktor distinguished

1 his invention from the prior art cited on the basis that there was “no teaching in the prior art of a
2 helical stent which expands radially *without reducing the axial length.*” (Bianrosa Decl., Ex. 14 at
3 5 (emphasis added).) This reference does not alter the Court’s conclusion that the claims should
4 not be limited to devices that are expanded only by the application of external forces.

5 Accordingly, the Court construes the term “zig-zag means” to mean:

6 **Function: to allow expansion of the device radially without a substantial change in
7 longitudinal length.**

8 **Structure: the wire elements bent into a pattern of reversing bends that may vary in
9 shape and tightness and their equivalents.**

10 **8. “Expand” and variations.**

11 Medtronic contends that the Court should construe this term, and its variations, to mean
12 “enlarge from a first to a second larger dimension.” Medtronic’s proposed construction is in
13 accord with the plain meaning of the term “expand.” *See, e.g., Webster’s Ninth New Collegiate*
14 *Dictionary* at 436 (“to open up; to increase the extent, number, volume or scope of”). Gore, in
15 contrast, argues that the Court should construe this term, and its variations, to require that the
16 device expanded is a “low memory metal stent,” which is expanded by a balloon rather than by its
17 own resilience. For the reasons previously stated, the Court rejects Gore’s proposed construction.

18 The Court finds further support for its conclusion from the claims of the ‘062 Patent, which
19 do not contain the “balloon-expandable” limitation proposed by Gore. In contrast, dependent
20 claim 2 of the ‘219 Patent does contain such a limitation, whereas independent claim 1 of that
21 patent, does not. (*See* Bianrosa Decl., Ex. 6 (“‘219 Patent, 8:2-11.)) Similarly, dependent claim 15
22 of the ‘828 Patent requires the use of a balloon, whereas claim 14 of the ‘828 Patent, from which
23 claim 15 depends, contains no such limitation. (‘828 Patent, 8:29-59.) Moreover, the use of the
24 balloon in the dependent claims is the only meaningful distinction from the independent claims.
25 Thus, the presumption of claim differentiation weighs against Gore’s proposed construction. *See*
26 *SunRace Roots*, 336 F.3d at 1303.

27 Accordingly, the Court construes the term “expand” (and its variations) to mean: “to
28 **enlarge from a first to a second larger dimension.**”

1
2
3
4
5
6
7
8
9
10
11
12
13
14
15
16
17
18
19
20
21
22
23
24
25
26
27
28

9. Method Claims 9, 10, and 12 of the '062 Patent.

The final dispute between the parties pertains to whether method Claims 9, 10 and 12 of the '062 Patent require that the steps recited be performed separately and be performed in the particular order recited. The method claims at issue read as follows:

- 9. A method of forming a radially expandable stent for implantation within a body vessel comprising: bending a wire in a zig-zag pattern; and winding the wire around a form in a coil.
- 10. The method of claim 9 wherein the step of bending includes forming the zig-zag pattern in the wire generally in a plane and the step of winding the wire includes winding with the zig-zag pattern flat against the form.
- 12. A method of forming a radially-expandable stent for implantation within a body vessel comprising: forming a wire into a sinusoidal shape; forming the wire into a coil having a first diameter and a first longitudinal length, so that later radial outward deformation of the cylinder to a second larger diameter does not significantly alter the longitudinal length.

('062 Patent, 6:15-32).

"Unless the steps of a method actually recite an order, the steps are not ordinarily construed to require one." *Interactive Gift Express, Inc. v. Compuserve, Inc.*, 256 F.3d 1323, 1342-43 (Fed. Cir. 2001). The Federal Circuit has developed a two-part test to determine whether the steps of a method claim "that do not otherwise recite an order, must nonetheless be performed in the order in which they are written." *Altiris, Inc. v. Symantec Corp.*, 318 F.3d 1363, 1369 (Fed. Cir. 2003) (citing *Interactive Gift*, 256 F.3d at 1342-43). The first step requires a court to examine the "claim language to determine if, as a matter of logic or grammar, [the steps] must be performed in the order written." *Id.* If the claim language does not suggest that a particular order is required, a court "next look[s] to the rest of the specification to determine whether *it* 'directly or implicitly requires such a narrow construction.' ... If not, the sequence in which such steps are written is not a requirement." *Id.* at 1370 (quoting *Interactive Gift*, 256 F.3d at 1343) (emphasis in original). This same analysis applies to the issue of whether the recited steps must be performed separately. *See Moba B.V. v. Diamond Automation, Inc.*, 325 F.3d 1306, 1314-15 (Fed. Cir. 2003).

Gore concedes that the language of the claims does not require that the steps be performed separately and also concedes that the claim language does not require that the steps be performed in the order in which they are recited. Gore asserts, however, that the specification of the '062

1 Patent implicitly requires that the wire first be bent into a zig-zag pattern and then wound around a
2 form in a coil. (*See Gore Br.* at 22-24.) Gore finds support for its position in references in the
3 specification wherein Wiktor states that the zig-zag wire is “performed” and “subsequently”
4 wound around a form. Gore also points the Court to references in the specification describing
5 Figure 1. (*See, e.g., ‘062 Patent* 2:55-62, 3:1-2, 3:11-17, 3:35-38, 4:14-16, 4:52-58.)

6 Wiktor, however, clearly identifies Figure 1 as the “preferred embodiment.” (*Id.*, 3:52,
7 4:6-11.) In general, a court should not limit a disputed claim term to the preferred embodiment,
8 even when the specification only describes a single embodiment. *See Phillips*, 415 F.3d at 1323
9 (“In particular, we have expressly rejected the contention that if a patent describes only a single
10 embodiment, the claims of the patent must be construed as being limited to that embodiment. ...
11 That is not just because Section 112 of the Patent Act requires that the claims themselves set forth
12 the limits of the patent grant, but also because persons of ordinary skill in the art rarely would
13 confine their definitions of terms to the exact representations depicted in the embodiments.”).

14 For example, in the *Altiris* case, although the specification only disclosed “a single
15 ‘preferred’ embodiment,” which set forth a particular order, the patentee did not state that the order
16 was important and did not disclaim any other order of the steps. *Altiris*, 318 F.3d at 1371.
17 Similarly, in this case, the specification also describes a single preferred embodiment. As in the
18 *Altiris* case, however, Wiktor did not state that the order of the steps was an important feature of
19 his invention. There also is not a clear disclaimer of any other order of the steps.

20 Moreover, the prosecution history submitted to the Court does not suggest that Wiktor
21 disclaimed any other order of the steps. *See, e.g., Loral Fairchild Corp. v. Sony Corp.*, 181 F.3d
22 1313, 1321 (Fed. Cir. 1999) (noting that, in addition to claim language, statements by the inventor
23 during the prosecution history limited process claim to the sequence of the steps set forth in claim
24 language). Finally, after noting that the figures represented the preferred embodiment, Wiktor
25 stated that “it is understood that other applications not specifically mentioned herein are possible
26 and no limitations in scope of this invention are intended or implied without departing from the
27 basic principles of this invention.” (*‘062 Patent*, 4:6-11.) This language again suggests that the
28

United States District Court
For the Northern District of California

1 claims should not be limited to the disclosed preferred embodiment. *See Pfizer, Inc.*, 457 F.3d at
2 1289.⁷

3 Accordingly, the Court adopts Medtronic's proposed construction and concludes that the
4 steps of the method claims in dispute need not be performed separately or in a particular order.

5 **CONCLUSION**

6 Based on the analysis set forth above, the Court adopts the foregoing constructions of the
7 disputed terms and phrases. The parties are ordered to submit a further joint case management
8 report pursuant to Patent Standing Order ¶ 13 by no later than November 9, 2007.

9 **IT IS SO ORDERED.**

10
11 Dated: October 19, 2007

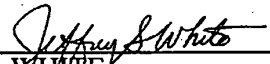

JEFFREY S. WHITE
UNITED STATES DISTRICT JUDGE

12
13
14
15
16
17
18
19
20
21
22
23
24
25
26 ⁷ Gore also relies on *LizardTech, Inc. v. Earth Res. Mapping Inc.*, 424 F.3d
27 1336 (Fed. Cir. 2005) presumably because, as noted, the '062 Patent only discloses a single
28 preferred embodiment. In *Lizard Tech*, however, the court resolved an issue related to the
validity of the patent and concluded that certain claims were invalid for lack of written
description. Gore may, in the future, have an argument in favor of invalidity. Resolution of
that issue however, is premature at this time.

E

Return To:

**USPTO
Home
Page**

**Finance
Online
Shopping
Page**



**United States
Patent and
Trademark Office**

Patent Maintenance Fees		06/11/2008 02:29 PM EDT	
Patent Number:	6306141	Application Number:	08483291
Issue Date:	10/23/2001	Filing Date:	06/07/1995
Window Opens:	10/23/2008	Surcharge Date:	04/24/2009
Window Closes:	10/23/2009	Payment Year:	
Entity Status:	LARGE		
Customer Number:	28390		
Street Address:	MEDTRONIC VASCULAR, INC. IP LEGAL DEPARTMENT		
City:	SANTA ROSA		
State:	CA		
Zip Code:	95403		
Phone Number:	(707) 566-1375		
Currently there are no fees due.			

[Need Help?](#) | [USPTO Home Page](#) | [Finance Online Shopping Page](#)

Return To:

**USPTO
Home
Page**



**United States
Patent and
Trademark Office**

**Finance
Online
Shopping
Page**

Patent Bibliographic Data		06/11/2008 02:	
Patent Number:	6306141	Application Number:	08483291
Issue Date:	10/23/2001	Filing Date:	06/07/1995
Title:	MEDICAL DEVICES INCORPORATING SIM ALLOY ELEMENTS		
Status:	8th year fee window opens: 10/23/2008		Entity:
Window Opens:	10/23/2008	Surcharge Date:	04/24/2009
Fee Amt Due:	Window not open	Surchg Amt Due:	Window not open
Fee Code:	1552	MAINTENANCE FEE DUE AT 7.5 YEARS	
Surcharge Fee Code:			
Most recent events (up to 7):	11/22/2005 03/29/2005	Payor Number Assigned. Payment of Maintenance Fee, 4th Year, Large Entity. --- End of Maintenance History ---	
Address for fee purposes:	MEDTRONIC VASCULAR, INC. IP LEGAL DEPARTMENT 3576 UNOCAL PLACE SANTA ROSA, CA 95403		
<input type="button" value="Run Another Query"/>			

[Need Help?](#) | [USPTO Home Page](#) | [Finance Online Shopping Page](#)

F

For the Northern District of California

1
2
3
4
5
6
7
8
9
10
11
12
13
14
15
16
17
18
19
20
21
22
23
24
25
26
27
28

IN THE UNITED STATES DISTRICT COURT
FOR THE NORTHERN DISTRICT OF CALIFORNIA

MEDTRONIC, INC., et al.,

No. C 07-567 MMC

Plaintiffs

ORDER CONSTRUING CLAIMS

v.

AGA MEDICAL CORPORATION,

Defendant

Before the Court are the parties' respective submissions regarding the proper construction of five disputed and five undisputed terms as contained in three patents, specifically, U.S. Patent 5,067,957 ("957 Patent"), U.S. Patent 5,190,546 ("546 Patent"), and U.S. Patent 6,306,141 ("141 Patent"). Plaintiffs Medtronic, Inc., Medtronic USA, Inc., and Medtronic Vascular, Inc. (collectively, "Medtronic") and defendant AGA Medical Corporation ("AGA") have submitted briefing and evidence in support thereof. The matter came on regularly for hearing on January 22, 2008. James J. Elacqua of Dechert LLP appeared on behalf of Medtronic. Peter J. Armenio and Young J. Park of Kirkland & Ellis LLP appeared on behalf of AGA. Having considered the papers submitted and the arguments of counsel, the Court rules as follows.

1 **A. Disputed Terms¹**

2 **1. "Shape Memory Alloy," "Displays," and "Behavior"**

3 The terms "shape memory alloy," "displays," and "behavior" appear in the '957
4 Patent, Claims 1-3, 5-13, 16-17, 30-31, 33, 36-37, and 40-41, in the '546 Patent, Claim 27,
5 and in the '141 Patent, Claims 1-14 and 17-21. The parties identify the use of the disputed
6 terms as follows:

- 7 a. "a shape memory alloy which displays stress-induced martensite
8 behavior at body temperature"; and
9 b. "pseudoelastic shape memory alloy . . . display/displays/displaying
10 reversible stress-induced martensite at about body/human body
11 temperature."

12 With respect to the former, Medtronic argues the proper construction is "a shape
13 memory alloy that exhibits the characteristics of stress-induced martensite at body
14 temperature." With respect to the latter, Medtronic argues the proper construction is "a
15 pseudoelastic shape memory alloy . . . that exhibits reversible stress-induced martensite at
16 about body/human body temperature." AGA proposes a single construction for both
17 phrases: "a shape memory alloy containing at least nickel, titanium and vanadium that can
18 form stress-induced martensite at body temperature."²

19 The Court finds "shape memory alloy which displays stress-induced martensite
20 behavior at body temperature" is properly construed as "a shape memory alloy that exhibits
21 stress-induced martensite at body temperature."³ The Court also finds "pseudoelastic
22 shape memory alloy . . . display/displays/displaying reversible stress-induced martensite at
23 about body/human body temperature" is properly construed as "pseudoelastic shape

24 ¹ As to each of the disputed terms, where the Court has adopted a party's proposed
25 construction, that construction is set forth below without further discussion. Where the
26 Court has adopted one party's construction, but with some modification, an explanation is
27 provided.

28 ² The parties' respective positions as set forth herein are, unless otherwise indicated,
taken from their briefs.

³ The Court's construction omits the words "the characteristics of," to address AGA's
argument that said construction be understood as requiring that the "shape memory alloy"
actually exhibit stress-induced martensite, rather than merely appear to do so.

1 memory alloy . . . that exhibits reversible stress-induced martensite at about body/human
2 body temperature.”

3 **2. “Stent”**

4 The term “stent” appears in the ‘141 Patent, Claims 2-3, 6-14, and 17-21. Medtronic
5 argues “stent” should be construed as “a supporting device.” AGA argues “stent” should be
6 construed as “a device used to maintain the patency of a body vessel.”⁴

7 The Court finds “stent” is properly construed as “a supporting device.”

8 **3. “Guide Wire”**

9 The term “guide wire” appears in the ‘141 Patent, Claims 1-5, 17, 19, and 21.
10 Medtronic argues “guide wire” should be construed as “a device that assists in positioning
11 another device.” AGA argues “guide wire” should be construed as “a wire that is used to
12 guide a placement device within the body.”⁵

13 The Court finds “guide wire” is properly construed as “a wire or catheter that assists
14 in positioning another device.”⁶

15 **4. “Hollow Restraining Member”**

16 The term “hollow restraining member” appears in the ‘957 Patent, Claims 10-13.
17 Medtronic argues “hollow restraining member” should be construed as “a hollow device that
18 prevents the transformation of the shape memory alloy element back into its original
19 shape.” AGA argues “hollow restraining member” should be construed as “an elongated
20 hollow structure that can deform the shape memory alloy.”⁷

21 _____
22 ⁴ At the claim construction hearing, AGA expanded its proposed construction to
replace the word “vessel” with the word “structure.”

23 ⁵ At the claim construction hearing, AGA expanded its proposed construction to
24 include the words “or a device” following the word “wire.”

25 ⁶ The Court’s construction replaces the word “device” with “wire or catheter.” This
26 modification is supported by the specification and the prosecution history, wherein the term
“catheter” is used interchangeably with the term “guide wire.” See, e.g., ‘141 Patent, col. 9,
27 l. 38 (identifying Figure 7, 104 as a “transport catheter”); Yang Decl. in Supp. of Opening
Claim Constr. Brief Ex. 15 at 11 (identifying Figure 7, 104 as a “guide wire”).

28 ⁷ At the claim construction hearing, AGA omitted from its proposed construction the
word “elongated.”

1 The Court finds "hollow restraining member" is properly construed as "a hollow
2 device that prevents the transformation of the shape memory alloy element back into its
3 original shape."⁸

4 **5. "Hollow Placement Device"**

5 The term "hollow placement device" appears in the '957 Patent, Claims 30-31, 33,
6 and 36 and in the '141 Patent, Claims 1-5, 17, and 21. Medtronic argues "hollow
7 placement device" should be construed as "a hollow device capable of stressing or
8 deforming a shape memory alloy element." AGA argues "hollow placement device" should
9 be construed as "an elongated hollow tube for positioning an object within the body."⁹

10 The Court finds "hollow placement device" is properly construed as "a hollow device
11 for positioning an object within the body."¹⁰

12 **B. Undisputed Terms**

13 The Court adopts the following constructions, jointly submitted by the parties. (See
14 Amended Joint Claim Construction and Prehearing Statement, filed November 16, 2007,
15 Ex. D.)

16 1. The term "stress induced martensite" ('957 Patent, Claims 1-3, 5-13, 16-17, 30-
17 31, 33, 36-37, 40-41; '546 Patent, Claim 27; '141 Patent, Claims 1-14, 17-21) is construed
18 as "martensite that forms from austenite due to stress."

19 2. The term "transverse dimension" ('141 Patent, Claim 9) is construed as "in a
20 direction perpendicular to the longitudinal axis."

21 _____
22 ⁸ To the extent the "hollow restraining member" may perform additional functions, as
23 set forth in a particular claim or claims, the Court finds it unnecessary to repeat those
24 functions in the construction of the term itself. See, e.g., '957 Patent, col. 12, ll. 5-9
(directing placement of "the memory alloy element within a hollow restraining member . . .
for placing the alloy in its stress-induced martensitic state and the memory alloy element in
its deformed shape").

25 ⁹ At the claim construction hearing, AGA omitted from its proposed construction the
26 words "elongated tube."

27 ¹⁰ To the extent the "hollow placement device" may perform additional functions, as
28 set forth in a particular claim or claims, the Court finds it unnecessary to repeat those
functions in the construction of the term itself. See, e.g., '141 Patent, col. 11, ll. 8-9
(describing the "hollow placement device" as "stressing the memory alloy element").

1
2
3
4
5
6
7
8
9
10
11
12
13
14
15
16
17
18
19
20
21
22
23
24
25
26
27
28

3. The terms "reversible stress induced martensite" and "reversible stress induced martensitic state" ('957 Patent, Claims 5-13, 16-17, 30-31, 33, 36-37, 40-41; '546 Patent, Claim 27; '141 Patent, Claims 1-5, 11-14, 17-21) are construed as "stress induced martensite that can revert to austenite."

4. The terms "extruding" and "extruded" ('957 Patent, Claims 30-31, 33, 36; '141 Patent, Claims 1-5, 17, 21) are construed as "forced out."

5. The terms "restraining means" and "restraint" ('957 Patent, Claims 1-3, 5-13, 16-17, 30-31, 33, 36-37, 40-41; '141 Patent, Claims 11-14, 17, 19) are construed as "a device component that prevents the transformation of the shape memory alloy element back into its original shape."

IT IS SO ORDERED.

Dated: February 6, 2008

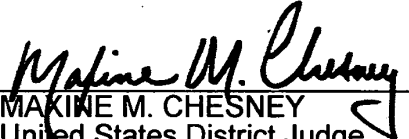
MAKINE M. CHESNEY
United States District Judge

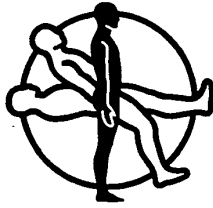

Medtronic

Talent™ Abdominal Stent Graft System

Instructions for Use

STERILE	EO
---------	----

IMPORTANT!

- Do not attempt to use the Talent Abdominal Stent Graft with the CoilTrac Delivery System before completely reading and understanding the information contained in this booklet.
- Carefully inspect all product packaging for damage or defects prior to use. Do not use this product if any sign of damage or breach of the sterile barrier is observed.
- These devices are supplied STERILE for single use only. After use, dispose of the delivery catheters in accordance with hospital, administrative, and/or government policy. Do not resterilize.
- Caution: Federal (U.S.) Law restricts this device to sale by or on the order of a physician

Talent™ Abdominal Stent Graft System

Instructions for Use

Table of Contents

1.0 DEVICE DESCRIPTION	5
1.1 DEVICE COMPONENTS	7
1.2 DELIVERY SYSTEM	9
2.0 INDICATIONS	11
3.0 CONTRAINDICATIONS	11
4.0 WARNINGS AND PRECAUTIONS	11
4.1 GENERAL	11
4.2 PATIENT SELECTION, TREATMENT, AND FOLLOW-UP.....	11
4.3 IMPLANT PROCEDURE.....	12
4.4 MAGNETIC RESONANCE IMAGING (MRI) SAFETY SECTION	13
5.0 ADVERSE EVENTS	13
5.1 OBSERVED ADVERSE EVENTS	13
5.2 POTENTIAL ADVERSE EVENTS	13
5.3 DEVICE-RELATED ADVERSE EVENTS REPORTING	13
6.0 SUMMARY OF CLINICAL STUDY	14
6.1 STENT GRAFT ANALYSIS	14
6.2 DELIVERY SYSTEM ANALYSIS	14
6.3 PATIENT ACCOUNTABILITY AND FOLLOW-UP	15
6.4 DEMOGRAPHIC AND BASELINE MEDICAL HISTORY DATA.....	17
6.5 BASELINE ANEURYSM DATA	19
6.6 DEVICES IMPLANTED.....	21
6.7 STUDY RESULTS	22
6.8 SAFETY.....	22
6.9 EFFECTIVENESS	29
6.10 ACUTE PROCEDURAL DATA.....	34
6.11 COIL TRAC DELIVERY SYSTEM PERFORMANCE DATA.....	35
7.0 PATIENT SELECTION	36
7.1 INDIVIDUALIZATION OF TREATMENT.....	36
8.0 PATIENT COUNSELING INFORMATION	36
9.0 HOW SUPPLIED	36
9.1 CONTENTS	36
9.2 STERILITY AND STORAGE	37
10.0 CLINICAL USE INFORMATION	37
10.1 RECOMMENDED SKILLS AND TRAINING.....	37
10.2 MATERIAL RECOMMENDED FOR DEVICE IMPLANTATION.....	37
10.3 PRE-TREATMENT PLANNING.....	37
11.0 DIRECTIONS FOR USE – STENT GRAFT SYSTEM	39
11.1 PICTORIAL REFERENCES	39

11.2 VASCULAR ACCESS AND ARTERIOTOMY 39
11.3 IMPLANTATION OF THE BIFURCATED STENT GRAFT 39
11.4 IMPLANTATION OF THE CONTRALATERAL LIMB 45
11.5 AORTIC AND ILIAC EXTENSIONS 47
12.0 IMAGING GUIDELINES AND POST-OPERATIVE FOLLOW-UP..... 49
 12.1 GENERAL 49
 12.2 CONTRAST AND NON-CONTRAST CT RECOMMENDATIONS 49
 12.3 ABDOMINAL RADIOGRAPHS 50
 12.4 ULTRASOUND 50
 12.5 MRI SAFETY AND COMPATIBILITY 50
 12.6 ADDITIONAL SURVEILLANCE AND TREATMENT 51
13.0 DEVICE-RELATED ADVERSE EVENTS REPORTING 51
14.0 PATIENT MATERIALS AND TRACKING INFORMATION 51
15.0 CONFIGURATIONS AVAILABLE 52
16.0 EXPLANATION OF SYMBOLS..... 54

List of Tables

Table 1: Stent Graft Materials	5
Table 2: Patient and Imaging Accountability – Test Group ¹	15
Table 3: Patient Accountability – SVS Control.....	16
Table 4: Patient Demographics, Test Group vs. SVS Control.....	17
Table 5: Baseline Medical History, Test Group vs. SVS Control	18
Table 6: Baseline SVS Classification, Test Group Only	19
Table 7: Baseline Maximum Aneurysm Diameters, Test Group vs. SVS Control (Site Reported)	19
Table 8: Distribution of Baseline Maximum Aneurysm Diameters, Test Group vs. SVS Control (Site Reported)	19
Table 9: Baseline Aneurysm Characteristics, Test Group.....	20
Table 10: Total Number of Talent Abdominal Stent Grafts Implanted at Initial Procedure.....	21
Table 11: Primary Safety Endpoint: Freedom from MAEs within 30 Days, Test Group vs. SVS Control..	22
Table 12: Primary Safety Endpoint: MAE Components within 30 Days, Test Group vs. SVS Control	22
Table 13: Freedom from MAEs within 365 Days, Test Group vs. SVS Control	23
Table 14: MAE Components within 365 Days, Test Group vs. SVS Control.....	23
Table 15: Details of Kaplan-Meier Estimates of Freedom from MAEs (0 to 365 Days), Test Group vs. SVS Control	24
Table 16: Freedom from All-Cause Mortality within 30 Days, Test Group vs. SVS Control.....	25
Table 17: Freedom from Aneurysm-Related Mortality within 365 Days, Test Group vs. SVS Control.....	25
Table 18: Details of Kaplan-Meier Estimates of Freedom from Aneurysm-Related Mortality within 365 Days, Test Group vs. SVS Control.....	26
Table 19: Freedom from All-Cause Mortality within 365 Days, Test Group vs. SVS Control.....	27
Table 20: Details of Kaplan-Meier Estimates of Freedom from All-Cause Mortality within 365 Days, Test Group vs. SVS Control	28
Table 21: Primary Effectiveness Endpoint: Successful Aneurysm Treatment, Test Group	29
Table 22: Primary Effectiveness Endpoint: Successful Aneurysm Treatment, Test Group	29
Table 23: Migration-Free at 12 Months, Test Group (Core Lab).....	30
Table 24: Stent Graft Patency at 12 Months, Test Group (Core Lab)	30
Table 25: Freedom from Secondary Endovascular Procedures within 365 Days, Test Group.....	30
Table 26: Loss of Stent Graft Integrity at 12 Months, Test Group (Core Lab)	31
Table 27: Type I/III Endoleak-Free at 12 Months, Test Group (Core Lab)	31
Table 28: Summary of All Endoleaks at 1 Month and 12 Months, Test Group (Core Lab).....	32
Table 29: Aneurysm Rupture within 365 Days, Test Group	33
Table 30: Aneurysm Change from 1 Month to 12 Months, Test Group (Core Lab and Site-Reported)	33
Table 31: Acute Procedural Data, Test Group and SVS Control	34
Table 32: CoilTrac Delivery System: Delivery and Deployment Success	35
Table 33: CoilTrac Delivery System: Patients with Clinically Relevant Adverse Events [Within 30 Days].....	35
Table 34: Talent Abdominal Stent Graft System Oversizing Guidelines.....	38
Table 35: Guideline for balloon diameter to volume.....	44
Table 36: Recommended Imaging Schedule for Endovascular Graft Patients	49
Table 37: Accepted Imaging Protocols.....	50
Table 38: Bifurcated Stent Grafts with the CoilTrac Delivery System	52
Table 39: Contralateral Limbs with the CoilTrac Delivery System	52
Table 40: Iliac Extension Cuffs with CoilTrac Delivery System	53
Table 41: Aortic Extension Cuffs with CoilTrac Delivery System	53

List of Figures

Figure 1: Overview of Talent Abdominal Stent Graft Components..... 6
Figure 2: Talent Abdominal Bifurcated Stent Graft 7
Figure 3: Talent Abdominal Contralateral Iliac Limb 8
Figure 4: Talent Abdominal Iliac (Left) and Aortic (Right) Extension Cuffs 8
Figure 5: CoilTrac Delivery System..... 10
Figure 6: Kaplan-Meier Estimates of Freedom from MAEs (0 to 365 Days), Test Group vs. SVS Control..... 24
Figure 7: Kaplan-Meier Estimates of Freedom from Aneurysm-Related Mortality within 365 Days, Test Group vs. SVS Control..... 26
Figure 8: Kaplan-Meier Estimates of Freedom from All-Cause Mortality within 365 Days, Test Group vs. SVS Control..... 28
Figure 9: Position the System 40
Figure 10: Deploy the Proximal End..... 42
Figure 11: Deploy the Distal End..... 43
Figure 12: Modeling the Stent Graft with the Balloon 44
Figure 13: Proper Docking of Contralateral Limb to Contralateral Leg..... 46
Figure 14: Talent Stent Graft System with the Modeling Balloon 47
Figure 15: Orienting Iliac Extension Cuff..... 48
Figure 16: Orienting the Aortic Extension Cuff..... 48

1.0 DEVICE DESCRIPTION

The Talent™ Abdominal Stent Graft System is comprised of two main components: an implantable stent graft and a disposable delivery system. The pre-loaded stent graft is advanced to the aneurysm location over a guidewire and, upon retraction of an introducer sheath (graft cover), expands to the indicated diameter. During deployment and expansion, the stent graft is intended to form proximal and distal seal zones surrounding the aneurysm location.

The Talent Abdominal Stent Graft System is modular and consists of four stent graft component configurations:

- Bifurcated (aorto-iliac)
- Contralateral iliac limb
- Iliac extension cuff
- Aortic extension cuff

Each component is introduced separately into the patient's vascular system. Each stent graft component is comprised of nitinol metal springs attached to polyester fabric graft material. For all configurations the proximal and distal springs are attached to connecting bars to provide additional columnar strength to the stent graft. The springs are sewn to the polyester fabric graft using polyester suture material. Radiopaque markers, made out of platinum-iridium in the shape of a figure eight (aka, Figur8), are sewn onto the stent graft to aid in visualization of the stent graft under fluoroscopy and to facilitate accurate placement of the device. See Table 1 for a listing of stent graft materials and Figure 1 for an overview of stent graft components.

The stent graft is designed to be placed in the native vessel such that the unconstrained stent graft diameter is larger than the diameter of the native vessel into which it is to be placed. This "oversizing" helps to exclude the aneurysm from aortic blood flow and ensure that the stent graft is held in place. The amount of oversizing required is dependent on the diameter of the native vessel. See Table 34 for oversizing guidelines and Section 15.0 available device configurations.

Table 1: Stent Graft Materials

Stent Graft Component	Material
Springs	Nitinol wire
Connecting Bar	Nitinol wire
Mini-Support Spring (FreeFlo only)	Nitinol wire
Stent Fabric	Woven polyester
Sutures	Braided polyester suture
Figur8 Radiopaque Markers	Platinum-Iridium wire

Figure 1: Overview of Talent Abdominal Stent Graft Components

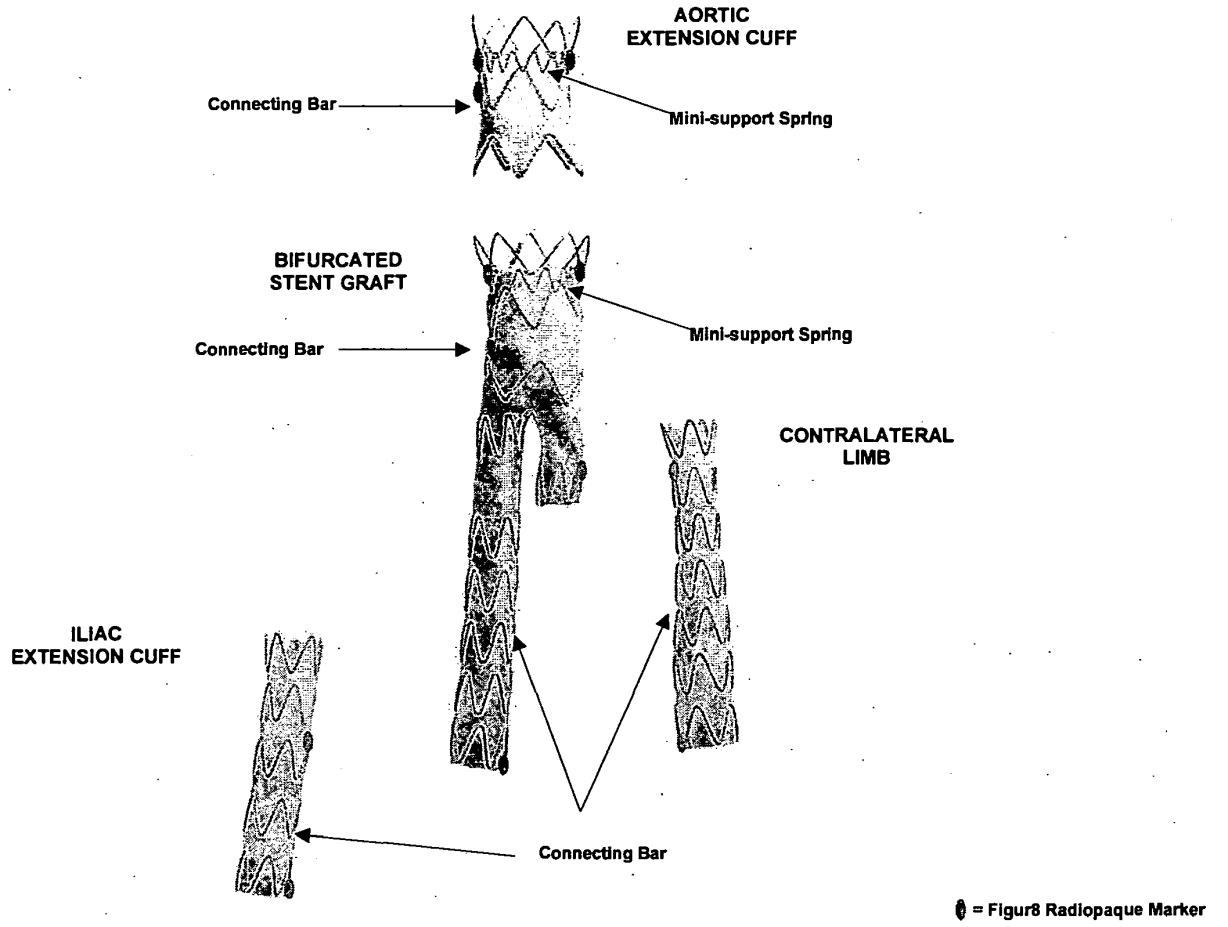

1.1 Device Components

Each of the four stent graft configurations is described in the following section.

1.1.1 Bifurcated Stent Graft

The bifurcated component (Figure 2) is the primary component which is inserted into the patient's aorta. The proximal end of all bifurcated stent grafts has a bare spring that is not covered with graft material to allow for supra-renal fixation. Bifurcated stent grafts with a proximal diameter greater than 22mm have a mini-support spring to aid in sealing. The proximal end configuration in which a bare spring and mini-support spring are present is called the 'FreeFlo' configuration. The proximal end configuration in which a bare spring is present without a mini-support spring is called a 'Bare Spring' configuration.

The stent graft bifurcates into two smaller iliac diameters; one of which is placed into the ipsilateral iliac artery, and the other of which is available to receive the contralateral iliac component. The distal end of the short contralateral leg is 14mm in diameter for all sizes of stent grafts so that it can receive all available contralateral limb stent graft configurations. In contrast the distal end of the ipsilateral leg is available in 12, 14, 16, 18 and 20mm diameters. The distal iliac ends of the stent graft have Closed Web configurations.

Figure 2: Talent Abdominal Bifurcated Stent Graft

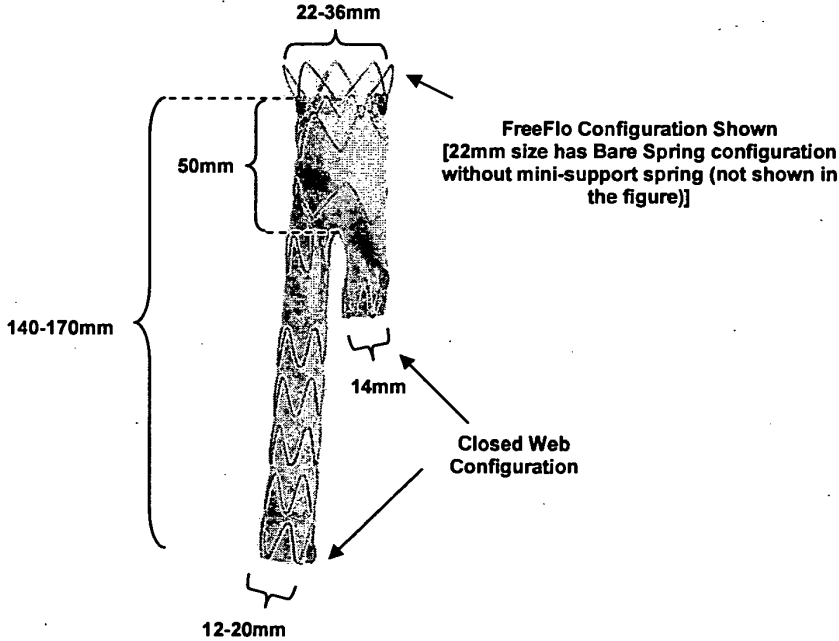

1.1.2 Contralateral iliac limb

The contralateral iliac limb component (Figure 3) is implanted after the bifurcated component to provide a conduit for blood flow into the contralateral iliac artery. The contralateral iliac limb is introduced through the patient's contralateral iliac artery and mated to the short contralateral stub leg on the bifurcated stent graft.

The proximal end of the contralateral iliac limb has an Open Web configuration in which the outline of the most proximal spring is covered. The proximal diameter is 14mm for all limb sizes, so that all limbs can dock with all available bifurcated stent graft configurations. The distal end of the limb has a Closed Web configuration.

Figure 3: Talent Abdominal Contralateral Iliac Limb

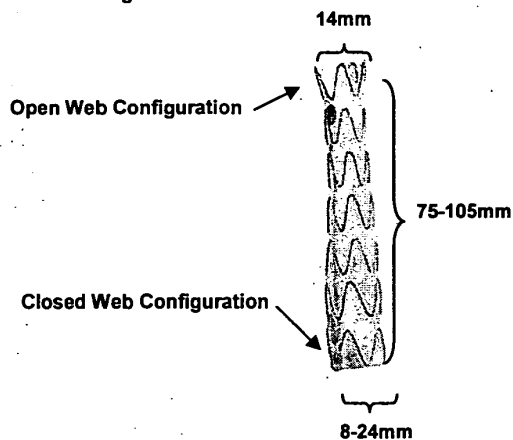

1.1.3 Aortic and Iliac Extension Cuffs

1.1.3.1 The aortic and iliac extension cuff components (Figure 4) are used to extend the lengths of implanted devices as needed based on the patient's anatomy.

Figure 4: Talent Abdominal Iliac (Left) and Aortic (Right) Extension Cuffs

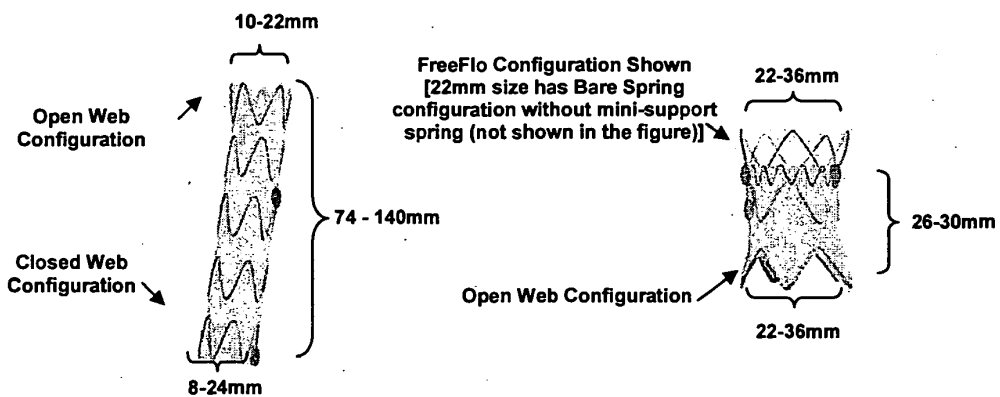

1.2 Delivery System

The CoilTrac Delivery System is a single use, disposable system used to deliver all stent graft configurations.

The CoilTrac Delivery System is shown in Figure 5. It is a flexible catheter constructed of three concentric, single lumen, polymer shafts (an outer introducer sheath [graft cover], a pushrod, and a guidewire lumen). A metallic coil with cup plunger is attached to the distal end of the pushrod to maintain stent graft position during deployment. A polymeric, atraumatic tapered tip is attached to the guidewire lumen at the distal end of the delivery system to facilitate tracking through tortuous and calcified vessels. The radiopaque, tapered tip and marker on the distal end of the introducer sheath (graft cover) aid in fluoroscopic visualization. A compliant balloon is located on the distal end of the delivery system to aid in stent graft modeling if necessary. Various valves contained within the delivery system maintain hemostasis and prevent blood loss and leaking during the procedure.

Figure 5: CoilTrac Delivery System

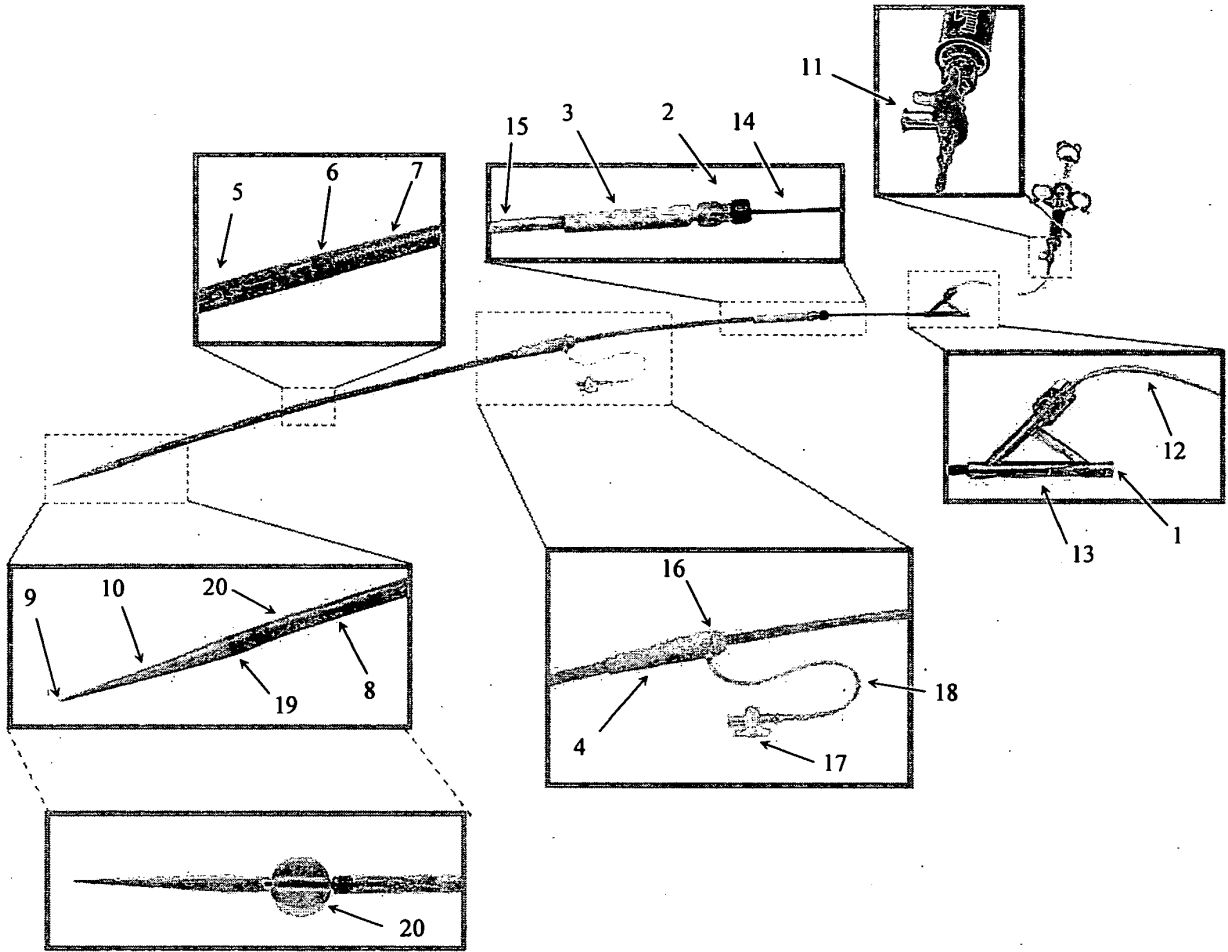

1	Guidewire Exit Port	11	Stopcock
2	Tuohy Borst	12	Inflation Port
3	Luer Handle	13	Y-Connector
4	Sheath Hub	14	Guidewire Lumen
5	Introducer Sheath (Graft Cover)	15	Pushrod
6	Cup Plunger	16	Hemostasis Valve
7	Pushrod Coil Spring	17	Stopcock
8	Radiopaque "Bullet"	18	Sideport Extension
9	Distal Point	19	Radiopaque Marker
10	Tapered Tip	20	Balloon

2.0 INDICATIONS

The Talent Abdominal Stent Graft is indicated for the endovascular treatment of abdominal aortic aneurysms with or without iliac involvement having:

- Iliac/femoral access vessel morphology that is compatible with vascular access techniques, devices, and/or accessories;
- A proximal aortic neck length of ≥ 10 mm;
- Proximal aortic neck angulation $\leq 60^\circ$;
- Distal iliac artery fixation length of ≥ 15 mm;
- An aortic neck diameter of 18–32mm and iliac artery diameters of 8–22mm; and
- Vessel morphology suitable for endovascular repair.

3.0 CONTRAINDICATIONS

The Talent Abdominal Stent Graft is contraindicated in:

- Patients who have a condition that threatens to infect the graft.
- Patients with sensitivities or allergies to the device materials (see Table 1).

4.0 WARNINGS AND PRECAUTIONS

4.1 General

- Read all instructions carefully. Failure to properly follow the instructions, warnings and precautions may lead to serious consequences or injury to the patient
- The Talent Abdominal Stent Graft System should only be used by physicians and teams trained in vascular interventional techniques, including training in the use of the device. Specific training expectations are described in Section 10.1.
- Always have a vascular surgery team available during implantation or reintervention procedures in the event that conversion to open surgical repair is necessary

4.2 Patient Selection, Treatment, and Follow-Up

- The Talent Abdominal Stent Graft System is not recommended in patients unable to undergo or who will not be compliant with the necessary preoperative and postoperative imaging and implantation studies as described in Section 12.0.
- The Talent Abdominal Stent Graft System is not recommended in patients who cannot tolerate contrast agents necessary for intra-operative and post-operative follow-up imaging.
- The Talent Abdominal Stent Graft System is not recommended in patients exceeding weight and/or size limits which compromise or prevent the necessary imaging requirements
- Prior to the procedure, pre-operative planning for access and placement should be performed. See Section 10.3. Key anatomic elements that may affect successful exclusion of the aneurysm include severe proximal neck angulation ($> 60^\circ$); short proximal aortic neck (< 10 mm); and thrombus and/or calcium at the arterial implantation sites, specifically the proximal aortic neck and distal iliac artery interface. Irregular calcification and/or plaque may compromise the fixation and sealing of the implantation sites. Necks exhibiting these key anatomic elements may be more conducive to graft migration.
- Iliac conduits may be used to ensure the safe insertion of the delivery system if the patient's access vessels (as determined by treating physician) preclude safe insertion of the delivery system.
- Inappropriate patient selection may contribute to poor device performance.
- The safety and effectiveness of the Talent Abdominal Stent Graft System has not been evaluated in patients who:
 - Are less than 18 years of age
 - Are pregnant or lactating
 - Have a dominant patent inferior mesenteric artery and an occluded or stenotic celiac and/or superior mesenteric artery
 - Have aneurysmal involvement or occlusion (surgically performed or naturally occurring) of the bilateral internal iliac arteries
 - Have vessels and/or aneurysm dimensions that cannot accommodate the Talent Abdominal Stent Graft as per the indications in Section 2.0.
 - Have no distal vascular bed (one vessel lower extremity run-off required)
 - Have contraindications for use of contrast medium or anticoagulation drugs
 - Have an uncorrectable coagulopathy
 - Have a mycotic aneurysm
 - Have circumferential mural thrombus in the proximal aortic neck
 - Have had a recent (within 3 months) myocardial infarction (MI), cerebral vascular accident (CVA), or major surgical intervention
 - Have traumatic aortic injury
 - Have leaking, pending rupture or ruptured aneurysms

- Have pseudoaneurysms resulting from previous graft placement
- Require a revision to previously placed endovascular stent grafts.
- Have genetic connective tissue disease (e.g., Marfan's or Ehlers-Danlos' Syndromes)
- Have concomitant thoracic aortic or thoracoabdominal aneurysms
- Are patients with active systemic infections
- The long-term performance of endovascular grafts has not yet been established. All patients should be advised that endovascular treatment requires lifelong, regular follow-up to assess their health and the performance of their endovascular graft. Patients with specific clinical findings (e.g., endoleaks, enlarging aneurysms or changes in the structure or position of the endovascular graft) should receive enhanced follow-up. Specific follow-up guidelines are described in Section 12.0.
- After endovascular graft placement, patients should be regularly monitored for perigraft flow, aneurysm growth or changes in the structure or position of the endovascular graft. At a minimum, annual imaging is required, including: 1) abdominal radiographs to examine device integrity (stent fracture, separation between bifurcated device and proximal cuffs or limb extensions, if applicable), and 2) contrast and non-contrast CT to examine aneurysm changes, perigraft flow, patency, tortuosity and progressive disease. If renal complications or other factors preclude the use of image contrast media, abdominal radiographs and duplex ultrasound may provide similar information.
- Patients experiencing reduced blood flow through the graft limb and/or leaks may be required to undergo secondary interventions or surgical procedures.
- Intervention or conversion to standard open surgical repair following initial endovascular repair should be considered for patients experiencing enlarging aneurysms and/or endoleak. An increase in aneurysm size and/or persistent endoleak may lead to aneurysm rupture.

4.3 Implant Procedure

- Exercise care in handling and delivery technique to aid in the prevention of vessel rupture.
- Studies indicate that the danger of micro-embolization increases with increased duration of the procedure.
- Renal complications may occur:
 - From an excess use of contrast agents.
 - As a result of emboli or a misplaced stent graft. The radiopaque marker along the edge of the stent graft should be aligned immediately below the lower-most renal arterial origin.
- Inadequate seal zone may result in increased risk of leakage into the aneurysm or migration of the stent graft. Other possible causes of migration are deployment of the proximal spring into a thrombus-filled or severely angled vessel wall.
- Systemic anticoagulation should be used during the implantation procedure based on hospital and physician preferred protocol. If heparin is contraindicated, an alternative anticoagulant should be considered.
- Minimize handling of the constrained endoprosthesis during preparation and insertion to decrease the risk of endoprosthesis contamination and infection.
- Improper placement of the stent graft may also cause an endoleak or occlusion of arteries (other than the renals), which may prevent blood flow necessary to organs and extremities, necessitating surgical removal of the device.
- During general handling of the CoilTrac Delivery System, avoid bending or kinking the introducer sheath (graft cover) because it may cause the Talent Abdominal Stent Graft to prematurely and improperly deploy.
- Never advance or retract the CoilTrac Delivery System from the vasculature without the use of fluoroscopy.
- Do not continue advancing any portion of the delivery system if resistance is felt during advancement of the guidewire or delivery system. Stop and assess the cause of resistance. Vessel or catheter damage may occur. Exercise particular care in areas of stenosis, intravascular thrombosis or in calcified or tortuous vessels.
- The balloon must be DEFLATED before initiating deployment of the stent graft. If resistance is experienced during initial deployment, check to ensure that the modeling balloon is completely deflated.
- Do not retract the introducer sheath (graft cover) before placing the delivery system in the proper anatomical position, as this will initiate deployment of the stent graft. The Talent Abdominal Stent Graft cannot be reconstrained or drawn back into the introducer sheath (graft cover), even if the stent graft is only partially deployed. If the introducer sheath (graft cover) is accidentally withdrawn, the device will prematurely deploy and could be placed too high or too low.
- Do not rotate the introducer sheath (graft cover) during deployment, as this may torque the device and cause it to spin on deployment or cause twisting of the iliac limb.
- High pressure injections of contrast media made at the edges of the stent graft immediately after implantation can cause endoleaks.
- When ballooning the stent graft, there is an increased risk of vessel injury and/or rupture, and possible patient death, if the balloon's proximal and distal radiopaque markers are not completely within the covered (graft fabric) portion of the stent graft.
- Do not exceed maximum inflation diameter (40mm for the 30mm balloon and 20mm for the 20mm balloon). Rupture of the balloon may occur. Adhere to balloon inflation parameters as described in this

booklet and on the product label. Over-inflation may result in damage to the vessel wall and/or vessel rupture, or damage to the stent graft.

- Any endoleak left untreated during the implantation procedure must be carefully monitored after implantation.

4.4 Magnetic Resonance Imaging (MRI) Safety Section

MRI may be used on the graft only under specific conditions. See Section 12.5 for details.

5.0 ADVERSE EVENTS

5.1 Observed Adverse Events

The clinical study for the Test Group was a multicenter, prospective study conducted at 13 sites across the US, which included 166 test patients. Major adverse events observed in this study are provided in Section 6.7.

5.2 Potential Adverse Events

Adverse events that may occur and/or require intervention include, but are not limited to:

- Amputation
- Anesthetic complications and subsequent attendant problems (e.g., aspiration)
- Aneurysm enlargement
- Aneurysm rupture and death
- Aortic damage, including perforation, dissection, bleeding, rupture and death
- Arterial or venous thrombosis and/or pseudoaneurysm
- Arteriovenous fistula
- Bleeding, hematoma or coagulopathy
- Bowel complications (e.g., ileus, transient ischemia, infarction, necrosis)
- Cardiac complications and subsequent attendant problems (e.g., arrhythmia, myocardial infarction, congestive heart failure, hypotension, hypertension)
- Claudication (e.g., buttock, lower limb)
- Death
- Edema
- Embolization (micro and macro) with transient or permanent ischemia or infarction
- Endoleak
- Fever and localized inflammation
- Genitourinary complications and subsequent attendant problems (e.g., ischemia, erosion, fistula, incontinence, hematuria, infection)
- Hepatic failure
- Impotence
- Infection of the aneurysm, device access site, including abscess formation, transient fever and pain
- Lymphatic complications and subsequent attendant problems (e.g., lymph fistula)
- Neurologic local or systemic complications and subsequent attendant problems (e.g., confusion, stroke, transient ischemic attack, paraplegia, paraparesis, paralysis)
- Occlusion of device or native vessel
- Pulmonary/respiratory complications and subsequent attendant problems (e.g., pneumonia, respiratory failure, prolonged intubation)
- Renal complications and subsequent attendant problems (e.g., artery occlusion, contrast toxicity, insufficiency, failure)
- Stent graft: improper component placement; incomplete component deployment; component migration; suture break; occlusion; infection; stent fracture; graft twisting and/or kinking; insertion and removal difficulties; graft material wear; dilatation; erosion; puncture and perigraft flow
- Surgical conversion to open repair
- Vascular access site complications, including infection, pain, hematoma, pseudoaneurysm, arteriovenous fistula, dissection.
- Vascular spasm or vascular trauma (e.g., iliofemoral vessel dissection, bleeding, rupture, death)
- Vessel damage
- Wound complications and subsequent attendant problems (e.g., dehiscence, infection, hematoma, seroma, cellulitis)

5.3 Device-Related Adverse Events Reporting

See Section 13.0

6.0 SUMMARY OF CLINICAL STUDY

6.1 Stent Graft Analysis

The clinical study for the Test Group was a multicenter, prospective study conducted at 13 sites across the US. The Test Group included patients diagnosed with abdominal aortic aneurysms, with or without involvement of the iliac arteries. A total of 166 patients were enrolled in this study. An independent core lab reviewed CT scans and abdominal x-rays to assess aneurysm changes, device position and integrity, and endoleaks. A Clinical Events Committee (CEC) adjudicated Major Adverse Events (MAEs) for the Test Group.

The Control Group (SVS Control) was a compilation of the pivotal open surgical control groups from three approved abdominal aortic aneurysm (AAA) endograft Premarket Approval (PMA) submissions. The SVS Control represented a change from the original IDE protocol, and was used because the SVS Control was more comprehensive than the original IDE Control Group. The data aggregation and analysis were conducted under the auspices of the Society for Vascular Surgery (SVS). Outcomes from a total of 243 patients treated at facilities across the US were included in the SVS Control.

The pivotal analysis included endpoints that were modified from the endpoints listed in the original IDE protocol to endpoints and other metrics that are consistent with current literature and other EVAR clinical studies. The primary safety endpoint for this analysis was the proportion of patients free from a MAE within 30 days of the index procedure (based on a composite MAE rate), compared to the open surgical control. The primary effectiveness endpoint for this analysis was successful aneurysm treatment¹. Other study endpoints and analyses were presented based on follow-up at pre-discharge, 1 month, 6 months, and 12 months.

6.2 Delivery System Analysis

Subsequent to enrollment in the pivotal trial, the delivery system was updated to the CoilTrac Delivery System. In order to evaluate the clinical performance of the CoilTrac Delivery System, a single-center cohort of 137 patients from an independent data set was evaluated.

The analysis of this independent data set supports the clinical performance of the CoilTrac Delivery System, demonstrated by delivery and deployment success rate, as well as, clinically relevant adverse events rates observed within the 30 day post-procedure period.

¹ Successful aneurysm treatment was a composite endpoint including patients who had technical success (successful delivery and deployment of the Talent Stent Graft) at the initial procedure and were free from:

- Aneurysm growth > 5mm at 12 months, as evaluated by the core lab; and
- Post-operative interventions to correct Type I/III endoleaks at anytime up to 12 months (Type II endoleaks are generally considered to be non-device related).

6.3 Patient Accountability and Follow-Up

For the Test Group, 13 sites enrolled a total of 166 patients. Four (4) patients had technical failure and did not receive a stent graft and therefore did not have any imaging follow-up. 162 patients who received the stent graft were eligible for clinical and imaging follow-up at 1 month follow-up interval. Of these 162 patients, 100% (162/162) had a clinical follow-up and 98.8% (160/162) had imaging follow-up. CT imaging was performed on 96.3% (156/162) patients.

At the 6 month follow-up interval, 152 patients were eligible for clinical and imaging follow-up. Of these, 90.1% (137/152) had clinical follow-up and 81.6% (124/152) had imaging follow-up. CT imaging was performed on 78.9% (120/152) patients.

At the 12 month follow-up interval, 142 patients were eligible for clinical and imaging follow-up. Of these 97.2% (138/142) had clinical follow-up and 93.0% (132/142) had imaging follow-up. CT imaging was performed on 91.5% (130/142) patients.

Detailed patient accountability and follow-up is provided in Table 2

Table 2: Patient and Imaging Accountability – Test Group¹

Interval (Analysis Window)	Patient follow-up			Patients with imaging performed at time interval (Core Lab)		Patients with adequate imaging to assess the parameter				Patient events occurring before next visit				
	Eligible	Clinical Follow-up	Imaging Follow-up	CT Imaging	KUB Imaging	Aneurysm size increase	Endoleak	Migration	Integrity	Technical Failure	Conversion to Surgery	Death	Withdrawal	Lost to Follow-up
Originally Enrolled	166									4				
Events after implant but before a 1 Month visit											0	0	0	0
1 Month (Day 1-90)	162	162	160	156	141		150	143	136					
Events after 1 Month visit but before a 6 Month visit											0	5	5	0
6 Month (Day 91-304)	152	137	124	120	103	118	114	120	101					
Events after 6 Month visit but before a 12 Month visit											0	5	5	0
12 Month (≥ Day 305 ²)	142	138	132	130	112	128	120	128	110					

¹ Data analysis sample size varies for each of the timepoints above and in the following tables. This variability is due to patient availability for follow-up, as well as, quantity and quality of images available from specific timepoints for evaluation. For example, the number and quality of images available for evaluation of endoleak at 6 months is different than the number and quality of images available at 12 months due to variation in the number of image exams performed, the number of images provided from the clinical site to the Core Lab, and/or the number of images with acceptable evaluation quality.

² In cases where 12 month imaging follow-up data were not available, subsequent imaging follow-up data were used.

The SVS Control included 243 patients. Detailed patient accountability and follow-up is provided in Table 3 below. At the 1 month follow-up interval, 239 patients were eligible and 98.7% (236/239) had clinical follow-up. At the 6 month follow-up interval, 230 patients were eligible and 90.9% (209/230) had clinical follow-up. At the 12 month follow-up interval, 219 patients were eligible and 97.7% (214/219) had clinical follow-up.

Table 3: Patient Accountability – SVS Control

Interval (Analysis Window)	Patient follow-up		Patients with events occurring before next visit	
	Eligible	Clinical Follow-up	Death	Withdrawal/ Lost to Follow-up
Originally enrolled	243			
Events after procedure but before 1 Month visit			4	0
1 Month visit (Day 1-90)	239	236		
Events after 1 Month visit but before 6 Month visit			7	2
6 Month visit (Day 91-304)	230	209		
Events after 6 Month visit but before 12 Month visit			5	6
12 Month visit (≥ Day 305)	219	214		

6.4 Demographic and Baseline Medical History Data

Table 4 through Table 6 provide the demographics and baseline medical characteristics of the Test Group and SVS Control patients. Medtronic observed that the Test Group was older and had more co-morbidities than the patients within the SVS Control.

Table 4: Patient Demographics, Test Group vs. SVS Control

Parameter	Statistics/Category	Test Group	SVS Control	p-value
Age (years)				
	n	166	243	
	Mean \pm SD	74.1 \pm 7.49	70.1 \pm 7.49	< 0.001
	Median	76.0	70.0	
	Min, max	51, 89	46, 86	
Gender % (m/n)				
	Male	91.6% (152/166)	81.5% (198/243)	0.004
Ethnicity % (m/n)				
	White, non-Hispanic	92.8% (154/166)	94.9% (168/177)	0.501
	Non-White	7.2% (12/166)	5.1% (9/177)	

Table 5: Baseline Medical History, Test Group vs. SVS Control

Body System / Condition	Test Group %(m/n) ¹	SVS Control %(m/n) ¹	p-value
Cardiovascular			
Angina	16.9% (28/166)	17.4% (23/132)	> 0.999
Arrhythmia	44.0% (73/166)	11.5% (28/243)	< 0.001
Cardiac revascularization ²	38.6% (64/166)	46.1% (112/243)	0.154
Congestive heart failure	28.3% (47/166)	4.9% (12/243)	< 0.001
Coronary artery disease	56.0% (93/166)	61.3% (149/243)	0.306
Hypertension	83.7% (139/166)	66.7% (162/243)	< 0.001
Myocardial infarction	38.6% (64/166)	34.2% (83/243)	0.401
Peripheral vascular disease	46.4% (77/166)	15.6% (38/243)	< 0.001
Renal³			
Renal insufficiency	54.8% (91/166)	N/A	N/A
Renal failure	N/A	4.1% (10/243)	N/A
Neurological³			
Cerebral vascular accident	22.9% (38/166)	N/A	N/A
Cerebrovascular disease	N/A	12.8% (31/243)	N/A
Other abnormal body systems			
Diabetes	15.7% (26/166)	11.9% (29/243)	0.303
Chronic obstructive pulmonary disease	39.2% (65/166)	30.0% (73/243)	0.070
Tobacco use	84.9% (141/166)	85.6% (208/243)	0.887

¹ Denominator is 166 patients in the Test Group and 243 patients in the SVS Control.

² Cardiac Revascularization includes Coronary Artery Bypass Grafting (CABG) or PTCA.

³ SVS Control reported "Renal Failure" and "Cerebrovascular Diseases", but Test Group reported "Renal Insufficiency" and "Cerebral Vascular Accident", respectively. These categories are not comparable.

Table 6: Baseline SVS Classification, Test Group Only

SVS Classification	Test Group %(m/n)
SVS 0	6.0% (10/166)
SVS 1	47.6% (79/166)
SVS 2	41.0% (68/166)
SVS 3	5.4% (9/166)

6.5 Baseline Aneurysm Data

Table 7 through Table 9 provide the baseline aneurysm diameters and morphologies of the Test Group and SVS Control.

Table 7: Baseline Maximum Aneurysm Diameters, Test Group vs. SVS Control (Site Reported)

Aneurysm Characteristics	Statistics	Test Group Site Reported	SVS Control Site Reported	p-value
Maximum aneurysm diameter (mm)	n	166	214	
	Mean \pm SD	57.1 \pm 8.49	56.9 \pm 11.59	0.826
	Median	55.0	54.8	
	Min, max	43, 87	31, 100	

Table 8: Distribution of Baseline Maximum Aneurysm Diameters, Test Group vs. SVS Control (Site Reported)

Maximum Aneurysm Diameter	Test Group Site-Reported %(m/n)	SVS Control Site-Reported %(m/n)
< 30mm	0.0% (0/166)	0.0% (0/214)
30-39mm	0.0% (0/166)	2.3% (5/214)
40-49mm	14.5% (24/166)	21.5% (46/214)
50-59mm	51.8% (86/166)	42.5% (91/214)
60-69mm	22.3% (37/166)	20.1% (43/214)
70-79mm	8.4% (14/166)	8.4% (18/214)
80-89mm	3.0% (5/166)	3.3% (7/214)
\geq 90mm	0.0% (0/166)	1.9% (4/214)

Table 9: Baseline Aneurysm Characteristics, Test Group

Dimension	Statistics	Site Reported	Core Lab Reported
Maximum aneurysm diameter (mm)	n	166	156
	Mean ± SD	57.1 ± 8.49	55.0 ± 9.26
	Median	55	53
	Min, Max	43, 87	38, 88
Proximal neck diameter (mm)	n	165	156
	Mean ± SD	25.6 ± 3.35	25.3 ± 3.58
	Median	26	26
	Min, Max	16, 32	16, 32
Right iliac diameter (mm)	n	164	155
	Mean ± SD	9.3 ± 1.55	9.2 ± 1.53
	Median	9	9
	Min, Max	6, 16	6, 14
Left iliac diameter (mm)	n	164	155
	Mean ± SD	9.3 ± 1.46	9.3 ± 1.55
	Median	9	9
	Min, Max	6, 14	6, 15
Proximal neck length (mm)	n	166	154
	Mean ± SD	23.9 ± 12.88	22.9 ± 12.48
	Median	20	21
	Min, Max	3, 85	3, 75
Aortic neck angle (°)	n	157	127
	Mean ± SD	18.7 ± 15.40	30.5 ± 15.80
	Median	19	30
	Min, Max	0, 60	0, 72

6.6 Devices Implanted

Table 10 provides a breakdown of the number of Talent Abdominal Stent Grafts implanted per patient.

Table 10: Total Number of Talent Abdominal Stent Grafts Implanted at Initial Procedure

Number of Devices Implanted	Test Group %(m/n) ¹
1	0.0% (0/162)
2	42.0% (68/162)
3	32.7% (53/162)
4	22.2% (36/162)
5	3.1% (5/162)
≥ 6	0.0% (0/162)

¹ Denominator is 162 patients with implanted devices.

6.7 Study Results

Results for the safety and effectiveness of the Talent Abdominal Stent Graft are presented in Section 6.8 and 6.9 below.

6.8 Safety

Primary Safety Endpoint: Freedom from MAEs within 30 Days

Through 30 days, patients who received the Talent Abdominal Stent Graft experienced a lower rate of MAEs than patients treated with open surgery. Table 11 and Table 12 provide an analysis of freedom from MAEs within 30 days.

Table 11: Primary Safety Endpoint: Freedom from MAEs within 30 Days, Test Group vs. SVS Control

Freedom from Major Adverse Event (MAE) within 30 Days	Test Group N = 166 % (m/n)	SVS Control N = 243 % (m/n)	95% Exact Confidence Interval of Difference ^{1,2}
Freedom from MAEs within 30 Days	89.2% (148/166)	44.0% (107/243)	(36.9%, 52.6%)

¹ Confidence level was not adjusted for multiplicity. Confidence interval for difference (Test - SVS Control) in percentage was calculated by the exact method.

² Difference represents the (% of patients free from MAEs within 30 days in the population treated with the test device) - (% of patients free from MAEs within 30 days in the population undergoing open surgical repair)

Table 12: Primary Safety Endpoint: MAE Components within 30 Days, Test Group vs. SVS Control

Major Adverse Event (MAE) within 30 Days ¹	Test Group N = 166 %(m/n)	SVS Control N = 243 %(m/n)	95% Exact Confidence Interval of Difference ^{2,3}
MAE rate at 30 days	10.8% (18/166)	56.0% (136/243)	N/A
All-cause Death	1.8% (3/166)	2.9% (7/243)	(-4.4%, 2.8%)
Myocardial Infarction	1.8% (3/166)	5.3% (13/243)	(-7.6%, 0.4%)
Renal Failure	1.8% (3/166)	2.9% (7/243)	(-4.4%, 2.8%)
Respiratory Failure	3.0% (5/166)	5.8% (14/243)	(-7.0%, 1.7%)
Paraplegia	0.0% (0/166)	0.4% (1/243)	(-2.3%, 2.0%)
Stroke	1.2% (2/166)	1.2% (3/243)	(-2.6%, 3.3%)
Bowel Ischemia	0.6% (1/166)	0.0% (0/243)	(-1.0%, 3.6%)
Procedural Blood Loss ≥ 1000cc	5.4% (9/166)	51.0% (124/243)	(-52.6%, -38.1%)

¹ A patient may report multiple MAEs; hence, number of patients with any MAE may not be the sum of those in each MAE category.

² Confidence level was not adjusted for multiplicity. Confidence intervals for difference (Test - SVS Control) in percentage were calculated by the exact method.

³ Difference represents the (% of patients with MAEs within 30 days in the population treated with the test device) - (% of patients with MAEs within 30 days in the population undergoing open surgical repair)

Freedom from MAEs within 365 Days

At 365 days, treatment with the Talent Abdominal Stent Graft continued to perform favorably when compared to open surgery. Table 13 and Table 14 provide an analysis of freedom from MAEs at 365 days, and Figure 6 and Table 15 depict the corresponding Kaplan-Meier plot.

**Table 13: Freedom from MAEs within 365 Days,
Test Group vs. SVS Control**

Freedom from MAEs within 365 Days	Test Group N = 166 % (m/n)	SVS Control N = 243 % (m/n)	95% Exact Confidence Interval of Difference ^{1,2}
Freedom from MAEs within 365 Days	80.4% (123/153)	41.7% (100/240)	(29.4%, 47.2%)

¹ Confidence level was not adjusted for multiplicity. Confidence interval for difference (Test - SVS Control) in percentage was calculated by the exact method.

² Difference represents the (% of patients free from MAEs within 365 days in the population treated with the test device) - (% of patients free from MAE within 365 days in the population undergoing open surgical repair)

**Table 14: MAE Components within 365 Days,
Test Group vs. SVS Control**

MAEs within 365 Days ¹	Test Group N = 166 % (m/n)	SVS Control N = 243 % (m/n)	95% Exact Confidence Interval of Difference ^{2,3}
MAE rate at 365 days	19.6% (30/153)	58.3% (140/240)	N/A
All-cause Death	6.5% (10/153)	7.5% (18/240)	(-6.1%, 5.0%)
Myocardial Infarction	3.9% (6/153)	7.9% (19/240)	(-8.9%, 1.4%)
Renal Failure	3.3% (5/153)	2.9% (7/240)	(-3.2%, 5.0%)
Respiratory Failure	3.9% (6/153)	6.3% (15/240)	(-6.8%, 3.0%)
Paraplegia	0.0% (0/153)	0.4% (1/240)	(-2.4%, 2.2%)
Stroke	2.6% (4/153)	1.7% (4/240)	(-2.1%, 5.0%)
Bowel Ischemia	0.7% (1/153)	0.0% (0/240)	(-0.9%, 3.9%)
Procedural Blood Loss ≥1000 cc	5.9% (9/153)	51.7% (124/240)	(-52.9%, -38.1%)

¹ A patient may report multiple MAEs; hence, number of patients with any MAE may not be the sum of those in each MAE category.

² Confidence level was not adjusted for multiplicity. Confidence intervals for difference (Test - SVS Control) in percentage were calculated by the exact method.

³ Difference represents the (% of patients with MAEs within 365 days in the population treated with the test device) - (% of patients with MAEs within 365 days in the population undergoing open surgical repair)

Figure 6: Kaplan-Meier Estimates of Freedom from MAEs (0 to 365 Days),
Test Group vs. SVS Control

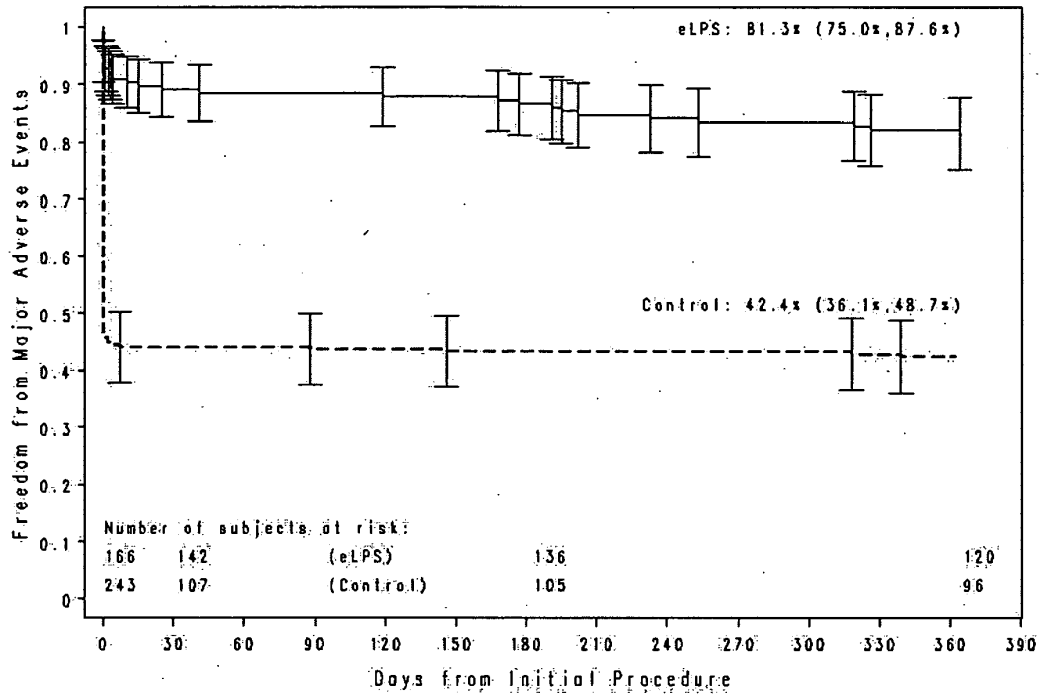

Note: eLPS, as described in the figure above, refers to the Test Group.

Table 15: Details of Kaplan-Meier Estimates of Freedom from MAEs (0 to 365 Days),
Test Group vs. SVS Control

	Test Group			SVS Control		
	Treatment to 30 days	31 days to 182 days	183 days to 365 days	Treatment to 30 days	31 days to 182 days	183 days to 365 days
No. at Risk	166	142	136	243	107	105
No. of Events	18	4	8	136	2	2
No. Censored	6	2	8	0	0	7
Kaplan-Meier Estimate	0.891	0.866	0.813	0.440	0.432	0.424

Freedom from All-Cause Mortality within 30 Days

Table 16 provides the summary of patients with freedom from all-cause mortality at 30 days for the Test Group and SVS Control.

Table 16: Freedom from All-Cause Mortality within 30 Days, Test Group vs. SVS Control

Secondary Endpoint	Test Group %(m/n)	SVS Control %(m/n)	95% Exact Confidence Interval of Difference ^{1,2}
Freedom from All-Cause Mortality within 30 Days	98.2% (163/166)	97.1% (236/243)	(-2.8%, 4.4%)

¹ Confidence level was not adjusted for multiplicity. Confidence interval for difference (Test - SVS Control) in percentage was calculated by the exact method.

² Difference represents the (% of patients free from all-cause mortality within 30 days in the population treated with the test device) - (% of patients free from all-cause mortality within 30 days in the population undergoing open surgical repair)

Freedom from Aneurysm-Related Mortality within 365 Days

Table 17 and Figure 7 provide the analysis and Kaplan-Meier plot of freedom from aneurysm-related mortality at 365 days. Additional detail is provided in Table 18.

Notably, there were no conversions to surgery or aneurysm ruptures in the Test Group within 365 days. See Table 29 for aneurysm rupture results.

Table 17: Freedom from Aneurysm-Related Mortality within 365 Days, Test Group vs. SVS Control

Secondary Endpoint	Test Group N = 166 % (m/n)	SVS Control N = 243 % (m/n)	95% Exact Confidence Interval of Difference ^{1,2}
Freedom from Aneurysm-Related Mortality within 365 Days	97.9% (143/146)	96.4% (217/225)	(-2.8%; 5.4%)

¹ Confidence level was not adjusted for multiplicity. Confidence interval for difference (Test - SVS Control) in percentage was calculated by the exact method.

² Difference represents the (% of patients free from aneurysm-related mortality within 365 days in the population treated with the test device) - (% of patients free from aneurysm-related mortality within 365 days in the population undergoing open surgical repair)

Figure 7: Kaplan-Meier Estimates of Freedom from Aneurysm-Related Mortality within 365 Days, Test Group vs. SVS Control

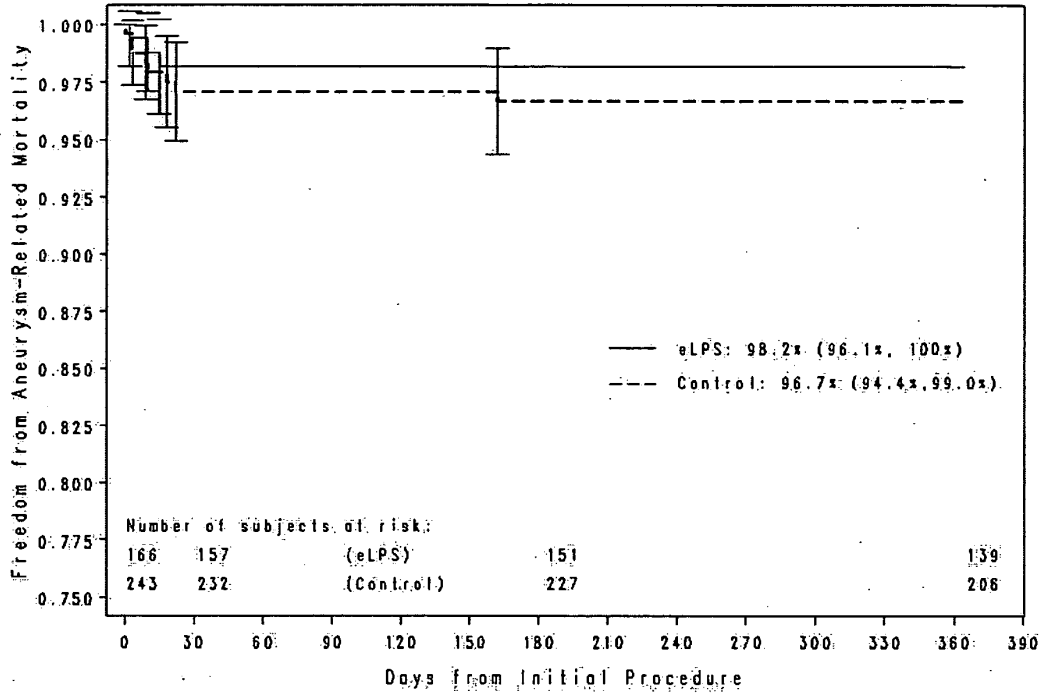

Note: eLPS, as described in the figure above, refers to the Test Group.

Table 18: Details of Kaplan-Meier Estimates of Freedom from Aneurysm-Related Mortality within 365 Days, Test Group vs. SVS Control

	Test Group			SVS Control		
	Treatment to 30 days	31 days to 182 days	183 days to 365 days	Treatment to 30 days	31 days to 182 days	183 days to 365 days
No. at Risk	166	157	151	243	232	227
No. of Events	3	0	0	7	1	0
No. Censored	6	6	12	4	4	21
Kaplan-Meier Estimate	0.982	0.982	0.982	0.971	0.967	0.967

Freedom from All-Cause Mortality within 365 Days

Table 19 and Figure 8 provide the analysis and Kaplan-Meier plot of freedom from all-cause mortality at 365 Days. Additional detail is provided in Table 20.

Table 19: Freedom from All-Cause Mortality within 365 Days, Test Group vs. SVS Control

Related Analysis	Test Group % (m/n)	SVS Control % (m/n)	95% Exact Confidence Interval of Difference ^{1,2}
Freedom from All-Cause Mortality within 365 Days	93.5% (143/153)	92.5% (222/240)	(-5.0%, 6.1%)

¹ Confidence level was not adjusted for multiplicity. Confidence interval for difference (Test - SVS Control) in percentage was calculated by the exact method.

² Difference represents the (% of patients free from all-cause mortality within 365 days in the population treated with the test device) - (% of patients free from all-cause mortality within 365 days in the population undergoing open surgical repair)

Figure 8: Kaplan-Meier Estimates of Freedom from All-Cause Mortality within 365 Days, Test Group vs. SVS Control

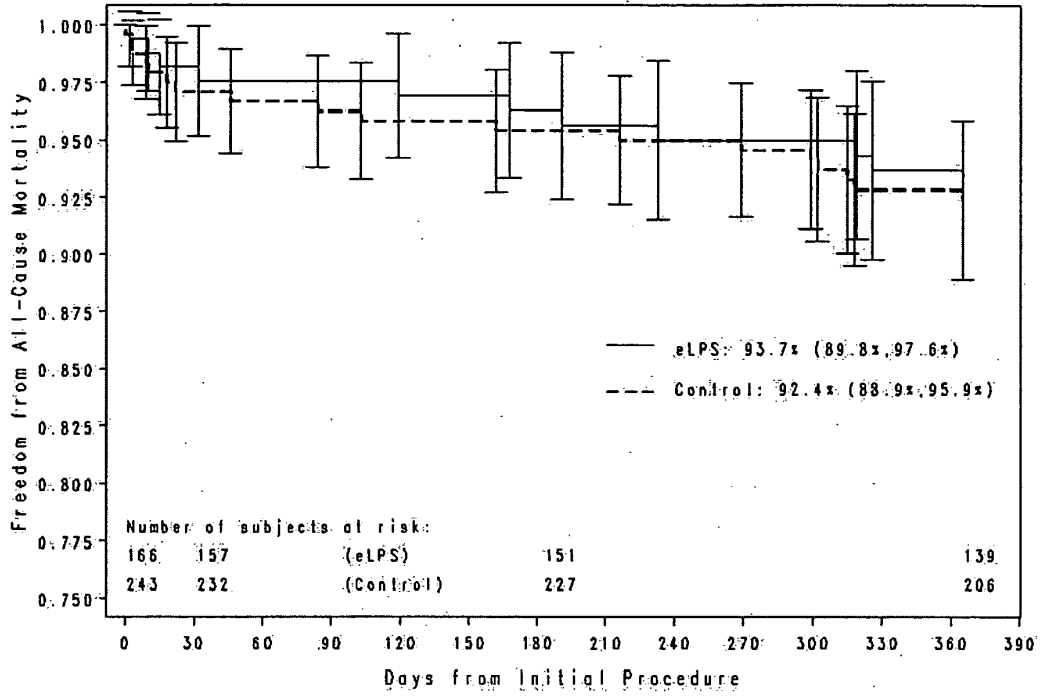

Note: eLPS, as described in the figure above, refers to the Test Group.

Table 20: Details of Kaplan-Meier Estimates of Freedom from All-Cause Mortality within 365 Days, Test Group vs. SVS Control

	Test Group			SVS Control		
	Treatment to 30 days	31 days to 182 days	183 days to 365 days	Treatment to 30 days	31 days to 182 days	183 days to 365 days
No. at Risk	166	157	151	243	232	227
No. of Events	3	3	4	7	4	7
No. Censored	6	3	8	4	1	14
Kaplan-Meier Estimate	0.982	0.963	0.937	0.971	0.954	0.924

6.9 Effectiveness

Primary Effectiveness Endpoint: Successful Aneurysm Treatment

The primary effectiveness endpoint, successful aneurysm treatment, was a composite endpoint including patients who had technical success (successful delivery and deployment of the Talent Stent Graft) at the initial procedure and were free from:

- Aneurysm growth > 5mm at 12 months, as evaluated by the core lab; and
- Post-operative interventions to correct Type I/III endoleaks at anytime up to 12 months (Type II endoleaks are generally considered to be non-device related).

Other clinically relevant measures (see Table 23 through Table 30) of stent graft effectiveness were also evaluated and are provided separately in the sections below.

As shown in Table 21, the Talent Abdominal Stent Graft achieved a successful aneurysm treatment rate of 90.2%. Table 22 provides details regarding patients who have failed the successful aneurysm treatment endpoint.

Table 21: Primary Effectiveness Endpoint: Successful Aneurysm Treatment, Test Group

Primary Effectiveness Endpoint	Test Group %(m/n)	95% Exact Confidence Interval ¹
Successful Aneurysm Treatment	90.2% (110/122)	(83.4%, 94.8%)

¹ Confidence level was not adjusted for multiplicity. Confidence interval for the percentage was calculated by the exact (binomial) method.

Table 22: Primary Effectiveness Endpoint: Successful Aneurysm Treatment, Test Group

Patients with Primary Effectiveness Failure	Test Group %(m/n)
Unsuccessful (Failure) Aneurysm Treatment	9.8% (12/122)
Technical Failure ¹	3.3% (4/122)
Aneurysm Growth > 5mm at 12 Months (Core Lab)	2.5% (3/122) ²
Post-Operative Interventions To Correct Type I/III Endoleaks	4.1% (5/122)

¹ All four technical failures were due to access difficulties. Note: These failures were associated with a prior iteration delivery system.

² Of these three patients, two died at day 600 and 692, respectively. One patient death was attributed to a possible device-related cause (patient refused further treatment). No additional adverse events were identified with the other patient death.

Other Effectiveness Data**Table 23: Migration-Free at 12 Months, Test Group (Core Lab)**

Other Effectiveness Data	Test Group %(m/n)	95% Exact Confidence Interval ³
Migration-Free at 12 Months ¹	99.2% (128/129) ²	(95.8%, 100.0%)

¹ Migration is defined as evidence of proximal or distal movement of the stent graft > 10mm relative to fixed anatomic landmarks.

² At three-year follow-up, the patient was admitted for endovascular repair of Type I endoleak (proximal).

³ Confidence level was not adjusted for multiplicity. Confidence interval for the percentage was calculated by the exact (binomial) method.

Table 24: Stent Graft Patency at 12 Months, Test Group (Core Lab)

Other Effectiveness Data	Test Group %(m/n)	95% Exact Confidence Interval ¹
Stent Graft Patency at 12 Months	100.0% (120/120)	(97.0%, 100.0%)

¹ Confidence level was not adjusted for multiplicity. Confidence interval for the percentage was calculated by the exact (binomial) method.

Table 25: Freedom from Secondary Endovascular Procedures within 365 Days, Test Group

Other Effectiveness Data	Test Group %(m/n)	95% Exact Confidence Interval ²
Secondary Endpoint: Freedom from Secondary Endovascular Procedures within 365 days	96.5% (138/143) ¹	(92.0%, 98.9%)

¹ The 5 patients who received a secondary endovascular procedure are characterized as follows:

Three (3) patients had endoleaks detected at day 1, 1, and 32, with secondary procedures at Day 69, 74, and 95, respectively. Aortic cuffs were placed to correct Type I endoleaks (proximal). Repairs were successful.

One (1) patient had endoleak detected at day 103, with a secondary procedure at day 168. Two (2) iliac limb extensions were placed to correct the Type I endoleak (distal). Repair was successful.

One (1) patient had graft-blush detected post-procedure, with a secondary procedure at day 183. An aortic cuff and iliac extension were placed to correct graft blush and stitch hole endoleak. Repair was successful.

² Confidence level was not adjusted for multiplicity. Confidence interval for the percentage was calculated by the exact (binomial) method.

Table 26: Loss of Stent Graft Integrity at 12 Months, Test Group (Core Lab)

Other Effectiveness Data	Test Group %(m/n)	95% Exact Confidence Interval ³
Loss of Stent Graft Integrity at 12 Months ¹	2.7% (3/110) ²	(0.6%, 7.8%)

¹ Loss of stent graft integrity is defined as the occurrence of stent graft wire and/or connecting bar fracture. Of these 3 patients, 2 had a connecting bar fracture – one at the proximal main body and the other at the level of the left iliac (source for locations is patient files). The third patient had a graft wire fracture, located on the second spring row at the proximal aspect of the graft.

² Of the 3 patients with loss of stent graft integrity, one patient expired at approximately 2 years due to stroke (CVA). The stent graft did not cause or contribute to the patient death. Another patient had no endoleak reported at the 1, 6 or 12 month visits. At the 4 year follow-up there were no endoleaks reported. The remaining patient withdrew from the study 2 years and four months following the procedure. This patient had no clinical sequelae reported during follow-up.

³ Confidence level was not adjusted for multiplicity. Confidence interval for the percentage was calculated by the exact (binomial) method.

Table 27: Type I/III Endoleak-Free at 12 Months, Test Group (Core Lab)

Other Effectiveness Data	Test Group %(m/n)	95% Exact Confidence Interval ⁴
Endoleak-Free (Type I/III) at 12 Months ¹	93.4% (113/121) ^{2,3}	(87.4%, 97.1%)

¹ Endoleak-free (Type I/III) at 12 months is defined as patients who did not have Type I/III endoleak at 12 months time point and did not have a secondary endovascular intervention to treat a Type I/III endoleak.

² The 8 patients that were not endoleak-free, include 5 patients that required a secondary endovascular procedure to treat their endoleaks (previously referenced in Table 22 and Table 25) and 3 patients that did not require secondary procedures.

³ One (1) patient had a secondary procedure to correct an endoleak at 6 months post implant. However this patient was not assessable for endoleak at the 12 month follow-up visit. This represents an increase of 1 in the denominator in the above table as compared to the number of patients assessable for endoleaks in Table 2

⁴ Confidence level was not adjusted for multiplicity. Confidence interval for the percentage was calculated by the exact (binomial) method.

Table 28: Summary of All Endoleaks at 1 Month and 12 Months, Test Group (Core Lab)

Endoleaks at 12 Months	Core Lab Reported at 1 Month ¹ %(m/n)	Core Lab Reported at 12 Months ¹ %(m/n)
Endoleaks of any type	19.3% (29/150)	9.2% (11/120)
Type I	9.3% (14/150)	2.5% (3/120) ^{2,3}
Type II	8.7% (13/150)	5.8% (7/120)
Type III	0.0% (0/150)	0.0% (0/120)
Type IV	0.0% (0/150)	0.0% (0/120)
Indeterminate	1.3% (2/150)	0.8% (1/120)

¹ Endoleaks reported are not cumulative but represent the number of endoleaks present at each time point.

² Of these 3 patients, one patient withdrew from the study (post a three year follow-up) prior to a secondary procedure to treat the endoleak. For the remaining two patients no secondary procedures were reported and no additional clinical sequelae were reported. All three Type I endoleaks at 12 months were persistent from a previous follow-up visit, of which one was a secondary endoleak.

³ The 5 patients that required secondary procedures to treat their endoleaks (previously referenced in Table 22 and Table 25) are not captured in this table because their endoleaks had been resolved prior to the 12 month time point.

Table 29: Aneurysm Rupture within 365 Days, Test Group

Other Effectiveness Data	Test Group %(m/n)	95% Exact Confidence Interval ¹
Aneurysm rupture within 365 days post implantation	0.0% (0/143)	(0.0%, 2.5%)

¹ Confidence level was not adjusted for multiplicity. Confidence interval for the percentage was calculated by the exact (binomial) method.

**Table 30: Aneurysm Change from 1 Month to 12 Months,
Test Group (Core Lab and Site-Reported)**

Change in Maximum Aneurysm Diameter from 1 Month to 12 Months	Site Reported %(m/n)	Core Lab Reported %(m/n)
Increase More than 5mm	4.5% (6/133)	2.3% (3/128)
Stable ¹	60.9% (81/133)	64.1% (82/128)
Decrease More than mm	34.6% (46/133)	33.6% (43/128)

¹ Stable refers to no change (increase or decrease) of more than 5 mm.

6.10 Acute Procedural Data

As shown below, the clinical utility measures of the Talent Abdominal Stent Graft are improved as compared to surgery with respect to procedure duration, blood loss, length of time in the ICU and hospital, and usage of general anesthesia. See Table 31 for further information.

Table 31: Acute Procedural Data, Test Group and SVS Control

Acute Procedural Data	Statistics	Test Group	SVS Control	95% Confidence Interval of Difference ^{1,2}
Duration of procedure (min)	N	166	241	
	Mean ± SD	167.3 ± 53.17	196.4 ± 82.99	(-43.5, -14.8)
	Median	155.0	180.0	
	Min, max	85, 417	57, 498	
Contrast Use (cc)	N	163		
	Mean ± SD	152.7 ± 81.50		
	Median	150.0		
	Min, max	15, 370		
Patients receiving general anesthesia	% (m/n)	40.4% (67/166)	98.7% (222/225)	(-65.7%, -50.4%)
Estimated blood loss (cc)	N	165	241	
	Mean ± SD	335.0 ± 282.36	1347.5 ± 1346.91	
	Median	250.0	1000.0	(-800.0, -600.0)
	Min, max	25, 1750	50, 10763	
Patients requiring blood transfusion	% (m/n)	18.2% (30/165)	56.8% (75/132)	(-48.6%, -28.0%)
Time in ICU (hours)	N	166	243	
	Mean ± SD	19.3 ± 73.88	74.3 ± 178.41	
	Median	0.0	36.0	
	Min, max	0, 864	0, 1728	
Overall hospital stay (days)	n	166	225	
	Mean ± SD	3.6 ± 6.38	8.2 ± 7.97	(-6.1, -3.2)
	Median	2.0	6.0	
	Min, max	1, 79	0, 72	

¹ Confidence level was not adjusted for multiplicity. Confidence intervals for difference (Test-SVS Control) in means were calculated using a t-distribution. Confidence intervals for difference (Test-SVS Control) in percentages were calculated by the exact method. Confidence intervals for difference (Test-SVS Control) in medians were calculated using Hodges-Lehmann estimation of location shift. Confidence interval for Time in ICU is not calculated due to a large number of ties in the data (i.e. large number of "0 hours" reported in the Test Group).

² For Duration of Procedure and Overall Hospital Stay, difference represents the (mean of specific acute procedural parameter in the population treated with the test device) - (mean of specific acute procedural parameter in the population undergoing open surgical repair). For Patients Receiving General Anesthesia and Patients Requiring Blood Transfusion, difference represents the (% of patients with the specific acute procedural parameter for the population treated with the test device) - (% of patients with the specific acute procedural parameter for the population undergoing open surgical repair). For Estimated Blood Loss, difference represents the median shift of estimated blood loss between the two treatment groups (Test-SVS Control).

6.11 CoiTrac Delivery System Performance Data

6.11.1 Delivery and Deployment Success

Subsequent to enrollment in the pivotal trial, the delivery system was updated to the CoiTrac Delivery System. In order to evaluate the clinical performance of the CoiTrac Delivery System, a single-center cohort of 137 patients from an independent data set was evaluated. The analysis of this independent data set supports the clinical performance of the CoiTrac Delivery System, demonstrated by delivery and deployment success rate, as well as, clinically relevant adverse events rates observed within the 30 day post-procedure period.

Table 32 presents the rate of successful delivery and deployment of the Talent Abdominal Stent Graft using the CoiTrac Delivery System. A 100% success rate was achieved in 137 patients treated. Successful delivery and deployment was defined as an initial successful implant procedure that was not aborted and did not involve delivery system malfunction.

Table 32: CoiTrac Delivery System: Delivery and Deployment Success

Device	Performance Measure (Site-Reported)	N = 137 % (m/n)	95% Exact Confidence Interval ¹
Talent Abdominal Stent Graft with the CoiTrac Delivery System	Successful Stent Graft Delivery and Deployment	100.0% (137/137)	(97.3%, 100.0%)

¹ Confidence level was not adjusted for multiplicity. Confidence interval for the percentage was calculated by the exact (binomial) method.

6.11.2 Clinically Relevant Adverse Events Within 30 Days

Table 33 presents the clinically relevant adverse events occurring intra-and peri-operatively for the patients implanted with the Talent Abdominal Stent Graft using the CoiTrac Delivery System.

The overall rate of patients with at least one clinically relevant adverse event is 15.3% (21/137) with a two-sided 95% exact confidence interval (9.7%, 22.5%). There were no reports of rupture, surgical conversion, branch vessel occlusion or migration.

Table 33: CoiTrac Delivery System: Patients with Clinically Relevant Adverse Events [Within 30 Days]

Category	N = 137 %(m/n)
All-cause mortality	1.5% (2/137) ¹
AAA rupture	0.0% (0/137)
Conversion to open repair	0.0% (0/137)
Branch vessel occlusion: renal artery/superior mesenteric artery	0.0% (0/137)
Stent graft occlusion	1.5% (2/137)
Stent graft migration	0.0% (0/137)
Device-specific endoleaks	8.8% (12/137) ²
Access site wound infection	2.2% (3/137)
Access site wound hematoma	3.6% (5/137)

¹ Both deaths were unrelated to the aneurysm, procedure, or device.

² Type I endoleak = 7 patients, Type III endoleak = 0 patients, Unknown Type endoleak = 5 patients

7.0 PATIENT SELECTION

7.1 Individualization of Treatment

Medtronic recommends that the Talent Abdominal Stent Graft System component diameters be selected as described in Table 34. The length of the Talent Abdominal Stent Graft should extend from the distal edge of the lowest renal artery to just above the origin of the internal iliac (hypogastric) artery. In addition, the aortic length should be > 1.0cm longer than the main body portion of the chosen bifurcated model. All lengths and diameters of the devices necessary to complete the procedure should be available to the physician, especially when pre-operative case planning measurements (treatment diameters/lengths) are not certain. This approach allows for greater intraoperative flexibility to achieve optimal procedural outcomes. The warnings and precautions previously described in Section 4.0 should be carefully considered relative to each patient before use of the Talent Stent Graft System. Additional considerations for patient selection include, but are not limited to:

- Patient's age and life expectancy
- Co-morbidities (e.g., cardiac, pulmonary or renal insufficiency prior to surgery, morbid obesity)
- Patient's suitability for open surgical repair
- Patient's anatomical suitability for endovascular repair
- The risk of aneurysm rupture compared to the risks of endovascular repair
- Ability to tolerate general, regional or local anesthesia
- Iliofemoral access vessel size and morphology (minimal thrombus, calcium and/or tortuosity) should be compatible with vascular access techniques of the various delivery catheter profiles. The Talent Abdominal Stent Graft System is delivered through a vascular introducer sheath (graft cover).
- Adequate iliac/femoral access compatible with the required delivery systems (a diameter of > 7 mm)
- Non-aneurysmal aortic neck between the renal arteries and the aneurysm:
 - A proximal aortic neck length of ≥ 10 mm
 - Proximal aortic neck angulation $\leq 60^\circ$
 - An aortic diameter of 18–32mm
- Common iliac artery distal fixation site:
 - Distal iliac artery fixation length of ≥ 15 mm
 - Iliac artery diameters of 8–22mm
- Freedom from significant femoral/iliac artery occlusive disease that would impede flow through the vascular graft.

The final treatment decision is at the discretion of the physician and patient.

8.0 PATIENT COUNSELING INFORMATION

The physician should consider the following points when counseling the patient about this endovascular device and procedure:

- Differences between endovascular repair and open surgical repair
 - Risks related to open surgical repair
 - Risks related to endovascular repair
 - Risks related to non-interventional treatment (medical management)
- Pros and cons of open surgical repair and endovascular repair, including the fact that endovascular repair possesses potential advantages related to its minimally invasive approach. It is possible that subsequent endovascular or open surgical repair of the aneurysm may be required. Regular follow-up, including imaging of the device, should be performed as recommended in Table 36 (Section 12.0), or more frequently in patients with enhanced surveillance needs.
- The long term effectiveness of endovascular repair has not been established
- Symptoms of aneurysm rupture
- Further counseling information can be found in the Patient Information Booklet

Medtronic recommends that physicians use the Medtronic Patient Information Booklet to aid in describing risks associated with use of the Talent Abdominal Stent Graft System with the patient. Additionally Medtronic recommends that detailed patient specific risks also be discussed.

9.0 HOW SUPPLIED

9.1 Contents

The Talent Abdominal System components are available in the configurations identified in Section 15.0.

In addition to the device, each carton contains:

- One (1) set of patient tracking materials
- One (1) instructions for use reference

9.2 Sterility and Storage

- Never attempt to resterilize a Talent Abdominal Stent Graft or CoilTrac Delivery System. Resterilization may adversely affect the proper mechanical function of the stent graft or delivery system and could result in patient injury and/or conversion to an open surgical procedure.
- For single use only. Delivery systems are disposable; do not reuse.
- Store at room temperature in a dark, dry place

10.0 CLINICAL USE INFORMATION

10.1 Recommended Skills and Training

Physicians using the Talent Abdominal Stent Graft System must be trained in vascular interventional procedures and in the use of this device.

The recommended skill/knowledge requirements for physicians using the Talent Abdominal Stent Graft System are outlined below:

10.1.1 Patient selection:

- Knowledge of the natural history of abdominal aortic aneurysms and comorbidities associated with abdominal repair; and
- Knowledge of image interpretation, stent graft selection and sizing.

10.1.2 Physician skills and experience

Either the individual physician operator or a combined, multidisciplinary team should possess extensive procedural skills and experience with:

- Femoral cutdown, arteriotomy, and repair;
- Non-selective and selective catheterization;
- Live fluoroscopic and angiographic image interpretation;
- Embolization;
- Angioplasty;
- Endovascular stent graft placement;
- Snare techniques;
- Appropriate use of contrast material; and
- Techniques to minimize radiation exposure.

10.2 Material Recommended for Device Implantation

At the time of surgery, it is recommended that physicians have available:

- At least one additional set of Talent Abdominal Stent Grafts (of the sizes intended for implantation) in the event that a device is contaminated or damaged during attempted placement
- Additional Talent Abdominal Stent Grafts (one size larger and one size smaller) in the event that the original measurement underestimated or overestimated vessel sizes
- Additional aortic and iliac extension cuffs of various lengths and diameters to customize the implant in order to fit the anatomy of the individual patient
- Fluoroscope with digital angiography capabilities and the ability to record and recall imaging
- Contrast media
- Introducer sheaths for vascular access to access arteries and to perform diagnostic imaging
- Assorted angiographic catheters, angioplasty catheters, graduated pigtail catheters
- Assorted guidewires
- Reliant® Stent Graft Balloon Catheter and other materials recommended by the Reliant Instructions for Use
- Heparin and heparinized saline solution
- Sterile lubricant
- Surgical instruments and supplies

10.3 Pre-Treatment Planning

Correct sizing of the aorta and iliac vessels must be determined before implantation of the Talent Abdominal Stent Graft System. Medtronic Vascular recommends using spiral computer aided tomography (CT) as well as angiograms of both the iliacs and aorta. These images should be available for review during the procedure.

Each Talent Abdominal Stent Graft System must be sized appropriately to fit the patient's anatomy. Sizing must be to the vessel wall, not thrombus. Proper sizing of the device is the responsibility of the physician. See the recommended oversizing guidelines in Table 34.

- Vessel over-distension and damage may be caused by excessive oversizing of the stent graft in relation to the diameter of the blood vessel.
- Undersizing of the stent graft may lead to device migration and/or endoleaks.

Physicians may consult Medtronic Vascular for guidance in determining proper device dimensions based on the physician's assessment of the patient's anatomical measurements.

Table 34: Talent Abdominal Stent Graft System Oversizing Guidelines

Native Vessel Diameter (mm)	Recommended Talent Diameter (mm)	
	Iliac	Aorta
8	8	
9-10	10	
11-12	12	
13-14	14	
15	16	
16-17	18	
18-19	20	22
20-21	22	24
22	24	26
23		
24-25		28
26-27		30
28-29		32
30-31		34
32		36

Relevant materials should be readily available as listed in Section 10.2. Cutdown and vessel access are required and in some cases vessel by-pass may be required. A vascular surgical team should be readily available (i.e., within the same facility) in case of emergency conversion to an open surgical repair.

To reduce the risk of thromboembolism, it is recommended that patients are anticoagulated during the procedure, at the discretion of the physician.

If necessary, open narrow iliac vessels with standard Percutaneous Transluminal Angioplasty (PTA) catheters prior to Talent Abdominal Stent Graft System placement (according to standard endovascular procedures). If necessary, dilate the vessel with a tapered vessel dilator. A step-up approach is recommended for vessel dilation.

11.0 DIRECTIONS FOR USE – STENT GRAFT SYSTEM

11.1 Pictorial References

For pictorial references of the Talent Abdominal Stent Graft components and CoilTrac Delivery System, refer to Figure 1 and Figure 5 respectively.

11.2 Vascular Access and Arteriotomy

Following aseptic procedural guidelines perform arteriotomies at the access sites. Place a guidewire in the ipsilateral femoral artery and advance it above the renal arteries. From the contralateral side femoral artery, place a second guidewire directed to the abdominal aorta. Over the guidewire, place an angiography catheter above the renal arteries.

11.3 Implantation of the Bifurcated Stent Graft

11.3.1 Preparation of the CoilTrac Delivery System

11.3.1.1 Carefully inspect the sterile package for damage or defects before opening. Do not use product after the "Use By" date on the package. If the integrity of the sterile package has been compromised or the packaging or product is defective, do not use the product. Contact your Medtronic Vascular representative for return information.

11.3.1.2 Remove the package transport wire from the catheter tip. Then, hold the push rod firmly and draw the introducer sheath (graft cover) back a few millimeters (no more than 5mm) to loosen the fit between the graft cover and the stent graft.

11.3.1.3 Prepare balloon.

11.3.1.3.1 Connect an inflation device to the opened stopcock on the balloon inflation port. Draw a vacuum on the balloon and close the stopcock.

11.3.1.3.2 Fill the inflation device with heparinized saline solution and open the stopcock.

11.3.1.3.3 Hold the catheter with the distal tip and balloon pointing down.

11.3.1.3.4 Partially inflate the balloon.

11.3.1.3.5 Draw back on the inflation device to deflate the balloon.

11.3.1.3.6 Repeat steps 11.3.1.3.3 through 11.3.1.3.5 until all air in the balloon is removed. Each time these steps are repeated, more air is displaced with liquid. Some changes in the catheter orientation may be necessary to vent all the air.

11.3.1.3.7 When all air in the balloon has been removed, draw a vacuum in the balloon (using the connected inflation device) and close the stopcock.

CAUTION: Ensure a vacuum is drawn on the balloon before proceeding, as pressure in the balloon could interfere with deployment of the stent graft.

11.3.1.4 Connect a syringe filled with heparinized saline solution to the stopcock on the sideport extension and open the stopcock.

11.3.1.5 While holding the device upright, flush the introducer sheath (graft cover) with the heparinized saline solution (tapping the sheath to aid in releasing air bubbles). Close the stopcock and remove the syringe. Always leave the stopcock closed when not in use.

11.3.1.6 Connect a syringe filled with heparinized saline solution to the guidewire exit port. Flush the guidewire lumen with the heparinized saline solution and remove the syringe.

11.3.1.7 Re-seat the tip by holding the sheath hub firmly and pulling back on the guidewire lumen until a smooth transition with the sheath and tip is achieved. Place the cup plunger such that the distal stent graft spring is encapsulated in the cup plunger. Tighten the tuohy borst valve.

CAUTION: When re-seating the tip, ensure that the proximal graft spring does not overlap the radiopaque "bullet". This may prevent the stent graft from deploying properly.

11.3.2 Align the stent graft radiopaque markers with the patient's anatomy

11.3.2.1 Before inserting the device into the vasculature, visualize the radiopaque markers on the stent graft to identify positioning of the device within the sheath.

11.3.2.2 Alignment

Turn the delivery system to align the marker on the short stub leg with the patient's contralateral iliac artery

11.3.3 Introduce System

11.3.3.1 Advance the delivery system over the guidewire so that the most proximal spring of the stent graft and the radiopaque markers are visualized at the target location in the proximal aortic neck (Figure 9).

CAUTION: Never advance or retract the CoilTrac Delivery System from the vasculature without the use of fluoroscopy.

CAUTION: Do not continue advancing any portion of the delivery system if resistance is felt during advancement of the guidewire or delivery system. Stop and assess the cause of resistance. Vessel or catheter damage may occur. Exercise particular care in areas of stenosis, intravascular thrombosis or in calcified or tortuous vessels.

CAUTION: Never use the pushrod to advance the delivery system through the patient's anatomy; this may cause inadvertent deployment. The Talent Abdominal Stent Graft cannot be reconstrained or drawn back into the introducer sheath (graft cover), even if the stent graft is only partially deployed. The sheath hub should be used to advance the system.

Figure 9: Position the System

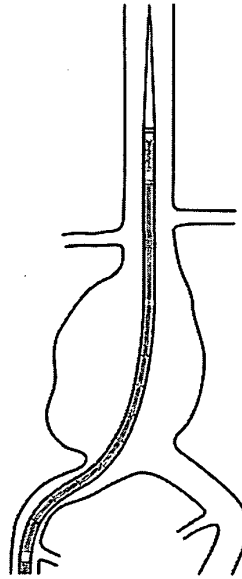

11.3.3.2 Inject contrast media into the abdominal aorta and mark the position of the target location, either on the imaging screen or on the patient's body. Adjust the position of the stent graft such that the top edge of the graft fabric, as indicated by two radiopaque markers, is just below the lowest renal artery.

CAUTION: When aligning the position of the CoilTrac Delivery System so that the Talent Abdominal Stent Graft is in proper position for deployment within the vessel, BE SURE THAT THE FLUOROSCOPE IS ANGLED PERPENDICULARLY TO THE CENTER LINE OF THE INFRARENAL AORTA TO AVOID PARALLAX OR OTHER SOURCES OF VISUALIZATION ERROR. ALIGN THE TARGET AREA/FIXATION ZONE (E.G., NECK) IN THE CENTER OF THE FIELD. Some cranial-caudal angulation of the I-I tube may be necessary to achieve this, especially if there is anterior angulation of the aneurysm neck.

NOTE: Contrast media may be injected to identify the location of the lower renal artery and verify the position before fully deploying the device. Once the proper proximal position has been identified, do not move the patient or imaging equipment. The angiographic catheter can be removed prior to deployment. However, if the angiographic catheter is not removed until after deployment, ensure that the tip is straightened (pigtail catheter) with a guidewire before removal so that the stent graft is not pulled down.

11.3.3.3 Confirm Position

Ensure that the distal portion of the contralateral stub leg is above the aortic bifurcation and within the aneurysmal sac, and not within the iliac vessel. Rotate the delivery system until the radiopaque marker on the distal-most spring of the short leg is aligned with the contralateral iliac artery

CAUTION: Before initial deployment, position the stent graft slightly higher than the targeted location.

NOTE: Conformance of the Talent Abdominal Stent Graft to the morphology of a patient's vasculature is enhanced when the connecting bar is oriented on the outside of the most severe bend of the vessel.

11.3.4 Deploy Proximal End

11.3.4.1 Prior to drawing back the introducer sheath (graft cover) to deploy the stent graft, verify that the end of the push rod plunger is firmly positioned against the bottom of the stent graft and that the tuohy borst valve is tightened. Under fluoroscopy, proper positioning is indicated by a clearance of approximately 1mm between the push rod coil spring and stent graft distal spring.

CAUTION: Failure to seat the plunger against the stent graft end may result in incorrect positioning.

11.3.4.2 Prior to deployment, at the discretion of the physician it may be appropriate to decrease the patient's blood pressure to avoid inadvertent displacement of the stent graft upon withdrawal of the sheath.

11.3.4.3 Verify that the balloon is deflated. Holding the push rod stationary with one hand while slowly withdrawing the introducer sheath (graft cover) with the other hand, align the introducer sheath (graft cover) marker band with the middle of the radiopaque bullet. This will indicate that the balloon is free of the introducer sheath (graft cover) and the stent graft is positioned for deployment.

WARNING: The balloon must be DEFLATED before initiating deployment of the stent graft. If resistance is experienced during initial deployment, check to ensure that the modeling balloon is completely deflated.

CAUTION: Never advance the push rod; use sufficient resistance only to hold it stationary. Do not rotate the introducer sheath (graft cover) during deployment.

11.3.4.4 Hold the push rod stationary with one hand while slowly withdrawing the introducer sheath (graft cover) with the other hand until the two proximal-most springs are past the introducer sheath (graft cover) radiopaque marker.

CAUTION: Do not retract the introducer sheath (graft cover) before placing the delivery system in the proper anatomical position, as this will initiate deployment of the stent graft. The Talent Abdominal Stent Graft cannot be reconstrained or drawn back into the introducer sheath (graft cover), even if the stent graft is only partially deployed. If the introducer sheath (graft cover) is accidentally withdrawn, the device will prematurely deploy and could be placed too high or too low.

11.3.4.5 Use angiography to verify the position of the stent graft in relation to the renal arteries. If the stent graft position is too high, loosen the tuohy borst valve and pull down on the guidewire lumen only, see Figure 10. This will pull the entire system down. Verify that the balloon is deflated before pulling down. Ensure that the distal edge of the contralateral stub leg of the bifurcated stent graft remains above the aortic bifurcation.

Figure 10: Deploy the Proximal End

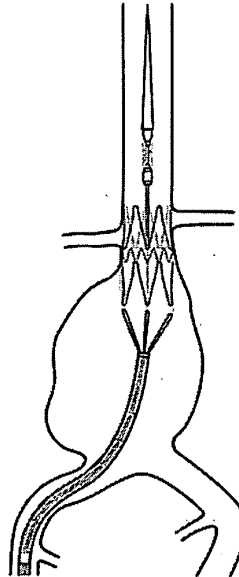

11.3.5 Deploy Distal End

11.3.5.1 After confirming the correct position of the stent graft, also confirm that the push rod's cup plunger is still encapsulating the bottom of the stent graft. Under fluoroscopy, proper positioning is indicated by a clearance of approximately 1mm between the push rod coil spring and stent graft distal spring. Tighten the tuohy borst valve.

11.3.5.2 Once the proximal end of the stent graft has been positioned, continue to withdraw the introducer sheath (graft cover) until the distal spring is released from the plunger. If the distal spring does not fully release from the plunger, slowly rotate (less than 90°) and pull back on the push rod a few millimeters until the distal-most spring releases from the plunger. See Figure 11.

CAUTION: Do not rotate the introducer sheath (graft cover) during deployment, as this may torque the device and cause it to spin on deployment or cause twisting of the iliac limb.

Figure 11: Deploy the Distal End

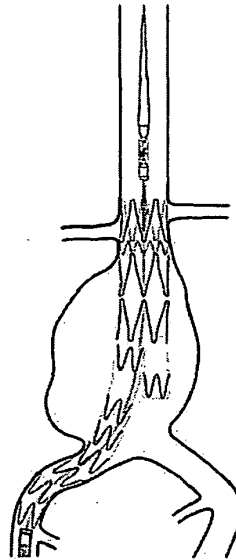

11.3.6 Angiogram

11.3.6.1 Using angiography, determine if any endoleaks are present, and verify the position of the implanted stent graft.

CAUTION: High pressure injections of contrast media made at the edges of the stent graft immediately after implantation can cause endoleaks.

If endoleaks are detected, they should be treated by using the balloon to model the stent graft against the vessel wall. See Section 11.3.7. A minor endoleak that does not seal after re-ballooning may seal spontaneously within several days. Major endoleaks that cannot be corrected by ballooning may be corrected by adding a Talent Abdominal Stent Graft extension cuff to the previously placed stent graft. Placing an extension immediately is the most reliable course of endoleak management for both minor and major endoleaks.

If balloon modeling of the stent graft is not performed, proceed to Section 11.3.8.

11.3.7 Balloon Modeling of Stent Graft

11.3.7.1 Open the tuohy borst valve (turn counter-clockwise) to allow free movement of the guidewire lumen.

11.3.7.2 Move the guidewire lumen distally until the balloon is within the first covered spring.

WARNING: When ballooning the stent graft, there is an increased risk of vessel injury and/or rupture, and possible patient death, if the balloon's proximal and distal radiopaque markers are not completely within the covered (graft fabric) portion of the stent graft.

11.3.7.3 Open the stopcock on the inflation port. Inflate the balloon to firmly model the proximal covered spring, see Figure 12. Using fluoroscopy, watch for stent graft movement. Proper modeling should show very slight outward expansion of stent graft with balloon inflation. Be careful not to over-inflate-stop inflation upon observation of stent graft expansion. Over inflation of balloon can cause graft tears and/or vessel dissection or rupture.

WARNING: Do not exceed maximum inflation diameter (40mm for the 30mm balloon and 20mm for the 20mm balloon). Rupture of the balloon may occur. Adhere to balloon inflation parameters as described in this booklet and on the product label. Over-inflation may result in damage to the vessel wall and/or vessel rupture, or damage to the stent graft.

NOTE: Care should be taken when inflating the balloon, especially with calcified, tortuous, stenotic, or otherwise diseased vessels. Inflate slowly. It is recommended that a backup balloon be available.

The table below is a guideline for determining the volume of solution (25% contrast/ 75% saline is recommended) required to obtain a given balloon expansion diameter:

Table 35: Guideline for balloon diameter to volume

20mm Balloon		30mm Balloon	
Diameter	CC's (ml) ¹	Diameter	CC's (ml) ¹
10mm	2	10mm	2
15mm	3	20mm	6
20mm	5	30mm	15
		40mm	31

¹ Syringe accuracy +/- 5%

CAUTION: Table 35 is only a guide. Balloon expansion should be carefully monitored with the use of fluoroscopy.

11.3.7.4 Fully deflate balloon. If further modeling is required, move the balloon distally to the next location requiring modeling. Inflate the balloon to firmly model the spring to the aortic wall. Using fluoroscopy, watch for stent graft movement. Proper modeling should show very slight outward expansion of the stent graft with balloon inflation. Over inflation of balloon can cause graft tears and/or vessel dissection or rupture.

11.3.7.5 As necessary, repeat steps 11.3.7.3 and 11.3.7.4 until the entire stent graft has been modeled.

Figure 12: Modeling the Stent Graft with the Balloon

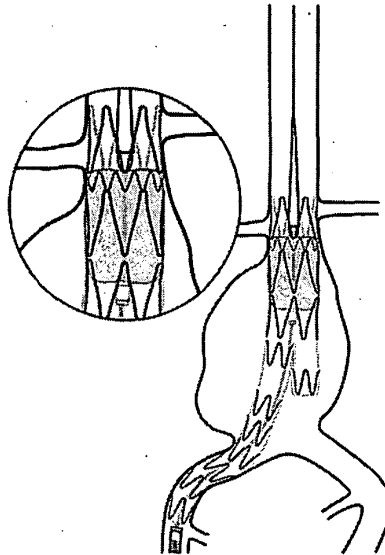

11.3.7.6 If desired, an angiogram may be performed following balloon modeling using the procedure described in Section 11.3.6.

11.3.7.7 If there is any focal area narrowing, use a PTA balloon (inflated diameter < graft diameter). If the area is still narrow after ballooning, place a stent graft extension. Do not leave any focal area untreated with significant narrowing or abrupt kinks of the connecting bar; this can lead to thrombosis, damage of the stent graft, or result in an incomplete distal seal.

11.3.8 Delivery System Removal

11.3.8.1 Ensure the balloon is deflated. Close the stopcock on the inflation port.

11.3.8.2 Withdraw the guidewire lumen into the introducer sheath (graft cover), re-establishing the smooth transition of the tip with the introducer sheath (graft cover). This can be verified by fluoroscopic examination of the introducer sheath (graft cover) marker band aligning with the radiopaque tip.

11.3.8.3 Tighten the tuohy borst Valve.

11.3.8.4 Gently remove the CoilTrac Delivery System. Do not use excessive force. Use fluoroscopy to ensure that the stent graft does not move during the withdrawal.

NOTE: Maintain vessel access until all Talent Abdominal Stent Graft components are placed.

11.4 Implantation of the Contralateral Limb

11.4.1 Prepare the CoilTrac Delivery System

Prepare the CoilTrac Delivery System using the procedure described in Section 11.3.1.

11.4.2 Align the stent graft radiopaque markers with the patient's anatomy

11.4.2.1 Visualize the radiopaque markers on the stent graft to identify positioning of the device within the sheath.

11.4.2.2 Turn the delivery system until the radiopaque markers, indicating the location of the connecting bar, are oriented on the outside of the most severe bend of the vessel.

11.4.2.3 Observe the position of the delivery system's side port; use it as a reference in case the sheath turns during advancement in the aorta.

11.4.3 Introduce System

11.4.3.1 On the patient's contralateral side, insert a guidewire through the short stub leg and the aortic neck portion of the previously placed bifurcated Talent Abdominal Stent Graft.

11.4.3.2 Advance the CoilTrac Delivery System over the guidewire and into the short stub leg of the deployed bifurcated stent graft. The connecting bar should always be oriented on the outside of the most severe bend of the vessel.

CAUTION: Do not continue advancing any portion of the delivery system if resistance is felt during advancement of the guidewire or delivery system. Stop and assess the cause of resistance. Vessel or catheter damage may occur. Exercise particular care in areas of stenosis, intravascular thrombosis or in calcified or tortuous vessels.

11.4.4 Confirm Position

To ensure proper docking of the contralateral limb, align the stub leg radiopaque marker with the proximal contralateral limb marker, ensuring at least 3cm of overlap between the components. The proximal spring of the iliac mating section should be inside and completely above the distal spring of the short leg. See Figure 13.

Figure 13: Proper Docking of Contralateral Limb to Contralateral Leg

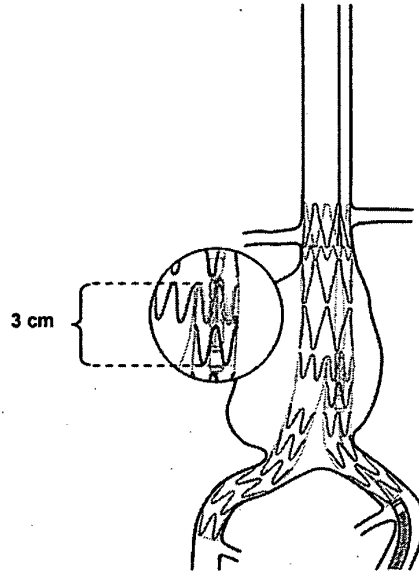

11.4.5 Deploy Stent Graft

Hold the push rod stationary and begin to slowly draw back the introducer sheath (graft cover), verifying that the proximal spring is deploying in the correct position within the short leg. When deployed, the proximal-most spring of the iliac section should open inside of and just proximal to the distal-most spring of the short stub leg, "interconnecting" the two sections together. Complete deployment of the contralateral iliac segment.

CAUTION: Ensure through fluoroscopic visualization that the proximal section of the stent graft is not pulled down when deploying the contralateral limb in the short stub leg (contralateral side).

NOTE: Do not rotate the delivery system during deployment, as this may alter the orientation of the connecting bar.

11.4.6 Model Contralateral Limb

As necessary, the contralateral iliac limb can be modeled (see Figure 14) using the procedure outlined in Section 11.3.7.

Figure 14: Talent Stent Graft System with the Modeling Balloon

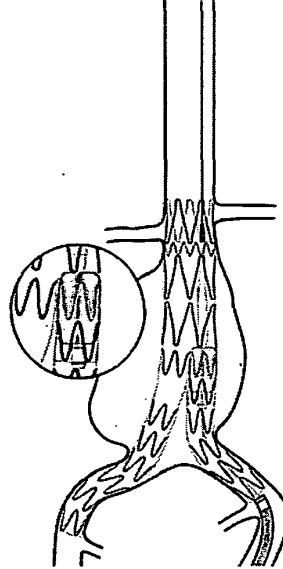

11.4.7 Delivery System Removal

Remove the delivery system using the procedure described in Section 11.3.8.

11.4.8 Procedure Completion for Implantation of Stent Graft Main Body

At the completion of the procedure, perform angiography to assess the Talent Abdominal Stent Graft for proximal and distal endoleaks and to verify the position of the implanted stent graft in relation to the aneurysm and renal arteries. Endoleaks at the attachment or connection sites should be treated by using a modeling balloon, such as the Reliant Stent Graft Balloon Catheter, to model the stent graft against the vessel wall. Major endoleaks that cannot be corrected by re-ballooning may be treated by adding Talent Stent Graft Extension Cuff(s) to the previously placed stent graft.

CAUTION: Any endoleak left untreated during the implantation procedure must be carefully monitored after implantation.

If aortic and/or iliac extensions are needed, proceed to Section 11.5, otherwise continue to Section 11.4.9.

11.4.9 Close the Entry Site

11.4.9.1 Remove the introducer and the guidewire. Repair the entry site with standard closure techniques.

11.4.9.2 If, during placement of the Talent Abdominal Stent Graft, the arteries used for access to the aorta are injured, additional endovascular and/or surgical procedures to repair the injury will need to be performed. If vascular repair becomes necessary, follow appropriate institutional guidelines, including guidelines regarding continuation or termination of the overall stent graft procedure.

11.5 Aortic and Iliac Extensions

11.5.1 Usage of Radiopaque Markers to Ensure Minimum Overlap

In the event that an extension (iliac or aortic extension cuff) is used, the mating sections are joined by aligning specific radiopaque markers. These radiopaque markers indicate the MINIMUM recommended overlap. The radiopaque markers used for mating are offset 30mm from the end of the extension. The edges of the graft material and the connecting bar are indicated by the proximal and distal radiopaque markers. See Figure 15 and Figure 16 for orientation of iliac and aortic cuffs.

Figure 15: Orienting Iliac Extension Cuff

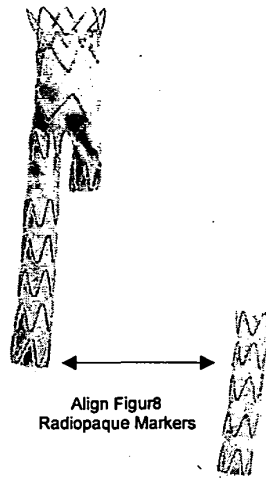
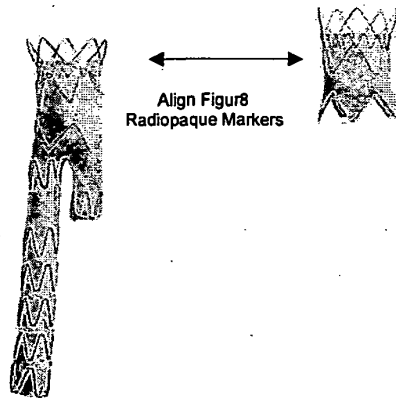

Figure 16: Orienting the Aortic Extension Cuff



11.5.2 Close the Entry Site

11.5.2.1 Close the entry site using the procedure described in Section 11.4.9.

12.0 IMAGING GUIDELINES AND POST-OPERATIVE FOLLOW-UP

12.1 General

All patients should be advised that endovascular treatment requires life-long, regular follow-up to assess their health and the performance of their endovascular graft. Patients with specific clinical findings (e.g., endoleaks, enlarging aneurysms, or changes in the structure or position of the endovascular graft) should receive additional follow-up. Patients should be counseled on the importance of adhering to the follow-up schedule, both during the first year and at yearly intervals thereafter. Patients should be informed that regular and consistent follow-up is a critical part of ensuring the ongoing safety and effectiveness of endovascular treatment of AAAs.

Physicians should evaluate patients on an individual basis and prescribe follow-up relative to the needs and circumstances of each individual patient. The recommended imaging schedule is presented in Table 36. This schedule outlines the minimum requirement for patient follow-up and should be maintained even in the absence of clinical symptoms (e.g., pain, numbness, weakness). Patients with specific clinical findings (e.g., endoleaks, enlarging aneurysms, or changes in the structure or position of the stent graft) should receive follow-up at more frequent intervals.

Annual imaging follow-up may include abdominal radiographs and both contrast and non-contrast CT examinations and duplex ultrasounds. If renal complications or other factors preclude the use of image contrast media, abdominal radiographs, non-contrast CT, and duplex ultrasound should be used.

- The combination of contrast and non-contrast CT imaging provides information on aneurysm diameter change, endoleak, patency, tortuosity, progressive disease, fixation length and other morphological changes.
- The abdominal radiographs provide information on device integrity (separation between components and stent fracture).
- Duplex ultrasound imaging may provide information on aneurysm diameter change, endoleak, patency, tortuosity and progressive disease. In this circumstance, a non-contrast CT may be performed to use in conjunction with the ultrasound, since ultrasound may be less reliable. Ultrasound may be a less reliable and sensitive diagnostic method compared to CT.

Table 36 lists the minimum requirements for imaging follow-up for patients with the Talent Abdominal Stent Graft.

Table 36: Recommended Imaging Schedule for Endovascular Graft Patients

Interval	Angiogram	CT ¹ [Contrast & Non-Contrast]	Abdominal Radiographs
Pre-procedure		X ²	
Procedural	X		
1 Month		X ^{3,4}	
12 Months (annually thereafter)		X ^{3,4}	X

¹A six month follow-up with CT Scan is recommended if an endoleak is reported at 1 month after the procedure

²Imaging should be performed within 6 months before the procedure.

³Duplex ultrasound may be used for those patients experiencing renal failure or who are otherwise unable to undergo contrast enhanced CT scan. With ultrasound, non-contrast CT is still recommended.

⁴If a Type I or III endoleak is present, prompt intervention and additional follow-up post-intervention is recommended. See Section 12.6..

Ultimately, it is the physician's responsibility, based on previous clinical results and the overall clinical picture, to determine the appropriate imaging schedule for a particular patient.

12.2 Contrast and Non-Contrast CT Recommendations

- Film sets should include all sequential images at the lowest possible slice thickness (<3mm). Do not perform large slice thickness (>3mm) and/or omit consecutive CT images/film sets, as this prevents precise anatomical and device comparisons over time.
- All images should include a scale for each film/image. Images should be arranged no smaller than 20:1 images on 14 inch X 17 inch sheets if film is used.
- Both non-contrast and contrast runs are required, with matching or corresponding table positions.
- Pre-contrast and contrast run slice thicknesses and intervals must match.
- DO NOT change patient orientation or re-landmark the patient between non-contrast and contrast runs.

Non-contrast and contrast enhanced baseline and follow-up imaging are important for optimal patient surveillance. It is important to follow accepted imaging protocols during the CT exam. Table 37 lists examples of accepted imaging protocols.

Table 37: Accepted Imaging Protocols

IV contrast	Non-Contrast	Contrast
	No	Yes
Acceptable machines	Spiral capable of > 40 seconds	Spiral capable of > 40 seconds
Injection volume	N/A	150cc
Injection rate	N/A	> 2.5cc/sec
Injection mode	N/A	Power
Bolus timing	N/A	Test bolus: SmartPrep, C.A.R.E. or equivalent
Coverage - start	Diaphragm	1 cm superior to celiac axis
Coverage - finish	Proximal femur	Profunda femoris origin
Collimation	<3mm	<3mm
Reconstruction	2.5 mm throughout - soft algorithm	2.5mm throughout - soft algorithm
Axial DFOV	32cm	32cm
Post-injection runs	None	None

12.3 Abdominal Radiographs

The following views are suggested:

- Four films: supine-frontal (AP), cross-table lateral, 30 degree LPO and 30 degree RPO views centered on the umbilicus.
- Record the table-to-film distance and use the same distance at each subsequent examination.

Ensure the entire device is captured on each single image (formatted lengthwise).

If there is any concern about the device integrity (e.g., kinking, stent breaks, migration), it is recommended to use magnified views. The attending physician should evaluate films for device integrity (entire device length including components) using 2-4X magnification visual aid.

12.4 Ultrasound

Ultrasound imaging may be performed in place of contrast CT when patient factors preclude the use of image contrast media. In order to help support accurate evaluation, ultrasound images should be paired with non-contrast CT images. A complete aortic duplex should be videotaped and analyzed for maximum aneurysm diameter, endoleaks, stent patency and stenosis. Included on the videotape should be the following information as outlined below:

- Transverse and longitudinal imaging should be obtained from the level of the proximal aorta, including complete imagery from the mesenteric and renal arteries to the iliac bifurcations to determine if endoleaks are present. Utilize color flow and color power angiography (if available).
- Spectral analysis confirmation should be performed for any suspected endoleaks.
- Transverse and longitudinal imaging of the maximum aneurysm should be obtained.

12.5 MRI Safety and Compatibility

Non-clinical testing has demonstrated that the Talent Abdominal Stent Graft is MR Conditional. It can be scanned safely in both 1.5T & 3.0T MR systems under the following conditions:

1.5 Tesla Systems:

- Static magnetic field of 1.5 Tesla
- Spatial gradient field of 1000 Gauss/cm
- Maximum whole-body-averaged specific absorption rate (SAR) of 4W/kg for 15 minutes of scanning.

Based on non-clinical testing, the device was determined to produce a temperature rise of less than 1°C at a maximum whole body averaged specific absorption rate (SAR) of 4 W/kg for 15 minutes of MR scanning in a 64MHz whole body transmit coil, which corresponds to a static field of 1.5T. The maximum whole body averaged specific absorption rate (SAR) was derived by calculation and verified by calorimetry.

3.0 Tesla Systems:

- Static magnetic field of 3.0 Tesla
- Spatial gradient field of 1000 Gauss/cm
- Maximum whole-body-averaged specific absorption rate (SAR) of 4W/kg for 15 minutes of scanning (or the maximum SAR allowed by the MR System, whatever is less).

Based on non-clinical testing, the device was determined to produce a temperature rise of less than 1°C at a maximum whole body averaged specific absorption rate (SAR) of 4 W/kg for 15 minutes of MR scanning in a 3 Tesla Siemens TrioTIM (VB 13 Software) MR scanner. The maximum whole body averaged specific absorption rate (SAR) was derived by calculation and verified by calorimetry.

Image Artifact (1.5 Tesla & 3 Tesla Systems):

MR image quality may be compromised if the area of interest is in the same area or relatively close to the position of the device. Therefore, it may be necessary to optimize MR imaging parameters for the presence of this implant. The image artifact extends approximately 5 and 8mm from the device, both inside and outside the device lumen when scanned in non-clinical testing using the sequence: spin echo and gradient echo, respectively in a 3.0T Siemens TrioTIM (VB 13 Software) MR system with a whole body coil.

Patients with Talent Abdominal Stent grafts implanted in the abdominal aorta may safely undergo MRI for Normal Mode and First Level Controlled Operating Mode of the MR System, as defined in IEC Standard 60601-2-33.

12.6 Additional Surveillance and Treatment

Additional surveillance and possible treatment is recommended for:

- Aneurysms with endoleak
- Aneurysm enlargement, > 5mm of maximum diameter (regardless of endoleak status)
- Migration
- Inadequate seal length
- Fracture

Consideration for reintervention or conversion to open repair should include the attending physician's assessment of an individual patient's co-morbidities, life expectancy, and the patient's personal choices. Patients should be counseled that subsequent re-intervention, including the fact that catheter-based and open surgical conversion may become necessary following an endograft procedure.

13.0 DEVICE-RELATED ADVERSE EVENTS REPORTING

Any adverse event (clinical incident) involving the Talent Abdominal Stent Graft System should be reported to Medtronic Vascular immediately. To report an incident, call (800) 465-5533 (in the US).

14.0 PATIENT MATERIALS AND TRACKING INFORMATION

The Talent Abdominal Stent Graft System is packaged with additional specific information which includes:

- **Temporary Patient Identification Card** that includes both patient and stent graft information. Physicians should complete this card and instruct the patient to keep this card in their possession at all times. The patients should refer to this card anytime they visit additional health practitioners, particularly for any additional diagnostic procedures (e.g. MRI). This temporary identification card should only be discarded when permanent identification card is received.
- **Device Tracking Form** to be completed by the hospital staff and forwarded to Medtronic for the purposes of tracking all patients who received a Talent Abdominal Stent Graft (as required by Federal Regulation). The hospital's submission of the device tracking form to Medtronic is also required for a patient to receive the permanent identification card.

Upon receipt of the device tracking form, Medtronic will mail the patient a **permanent identification card**. This card includes important information regarding the implanted stent graft. Patients should refer to this card anytime they visit health practitioners, particularly for any diagnostic procedures (e.g. MRI). Patients should carry this card with them at all times. In addition a patient information booklet (PIB) will be provided to the physicians during training and additional copies will be available upon request. The PIB will also be available online on the Medtronic website (www.medtronic.com). This booklet provides patients with basic information on abdominal aortic aneurysms and endovascular repair therapy.

15.0 CONFIGURATIONS AVAILABLE

Table 38: Bifurcated Stent Grafts with the CoilTrac Delivery System

OD (Fr.)	Bifurcated (mm x mm)	Covered Length (mm)	Proximal Configuration	Distal Configuration
24	36x20 36x18	155, 170	FreeFlo	Closed Web
	34x20 34x18 34x16			
	32x20 32x18 32x16 32x14			
	30x20 30x18 30x16 30x14			
22	28x20 28x18 28x16 28x14	140, 155, 170	FreeFlo	Closed Web
	26x18 26x16 26x14 26x12			
	24x14 24x12			
	22x14 22x12	140, 155	Bare Spring	

The delivery system working length is 45cm. The total length of the stent graft can be determined by adding approximately 15mm to the covered length shown above.

Table 39: Contralateral Limbs with the CoilTrac Delivery System

OD (Fr.)	Contralateral Limb (mm x mm)	Covered Length (mm)	Proximal Configuration	Distal Configuration	
20	14x24 14x22	75, 90, 105	Open Web	Closed Web	
18	14x20 14x18 14x16 14x14 14x12				
	14x10 14x8				105

The delivery system working length is 45cm. The total length of the stent graft can be determined by adding approximately 15mm to the covered length shown above.

Table 40: Iliac Extension Cuffs with CoilTrac Delivery System

OD (Fr.)	Iliac Extension (mm x mm)	Covered Length (mm)	Proximal Configuration	Distal Configuration
20	22x22	79	Open Web	Closed Web
	22x18	74		
	18x24 18x22	80		
	18x18 18x16 18x14 18x12	140		
18	20x16	74		
	20x20	79		
	18x20 18x18 18x16	80		
	18x14	75		
	18x12	80		
	16x16			
	16x12	75		
	14x14	80		
	14x10	75		
	12x12	81		
	12x08	75		
10x10	81			

The delivery system working length is 45cm. The total length of the stent graft can be determined by adding approximately 15mm to the covered length shown above.

Table 41: Aortic Extension Cuffs with CoilTrac Delivery System

OD (Fr.)	Aortic Extension (mm)x(mm)	Covered Length (mm)	Proximal Configuration	Distal Configuration		
22	36x36	26	FreeFlo	Open Web		
	34x34	28				
	32x32					
	30x30					
20	28x28	29				
	26x26	30				
	24x24					
	22x22					
					Bare Spring	

The catheter working length is 45cm. The total length of the stent graft can be determined by adding approximately 30mm to the covered length shown above.

M707213B001

16.0 EXPLANATION OF SYMBOLS

Explanation of symbols that may appear on product labeling.



Contents: One (1) TALENT™ ABDOMINAL Stent Graft System with COILTRAC
One (1) set of patient tracking materials
One (1) instructions for use reference



Do not use if package is damaged



Non-pyrogenic



Peel here



Pull tab to open



Store at room temperature in a dark, dry place



MR Conditional

Rx only

CAUTION: Federal (USA) law restricts this device for sale by or on order of a physician.



Sterilized using ethylene oxide

MANUFACTURER:
MEDTRONIC, INC.
710 Medtronic Parkway NE
Minneapolis, MN 55432-5604
U.S.A.
Tel: (763) 514-4000
Fax: (763) 514-4879
www.medtronic.com

MANUFACTURED IN:
MEDTRONIC VASCULAR
3576 Unocal Place
Santa Rosa, CA 95403
U.S.A.
Tel: (707) 525-0111
Fax: (707) 525-0114

U. S. CUSTOMER SERVICE / PRODUCT INQUIRIES
Tel: (800) 961-9055
Fax: (800) 929-2133

© 2008 Medtronic
All Rights Reserved



M707213B001

Rev A

Protected by one or more of the following United States patents: 5,190,546; 5,591,195; 5,713,917; 6,287,315; 6,306,141; 6,102,938; & 6,344,052. Additional patents pending in the United States as well as other countries. Licensed under U.S. Patent 5,871,536.

H

Self-Expanding Nitinol Stents — Material and Design Considerations

Dieter Stoeckel, Alan Pelton, Tom Duerig

Nitinol Devices & Components
a Johnson & Johnson company
47533 Westinghouse Drive
Fremont, CA 94539 USA
Phone 510-623-6996, Fax 510-623-6995

Abstract

Nitinol (Nickel-Titanium) alloys exhibit a combination of properties which make these alloys particularly suited for self-expanding stents. Some of these properties cannot be found in engineering materials used for stents today. The paper explains the fundamental mechanism of shape memory and superelasticity and how they relate to the characteristic performance of self-expanding stents. Nitinol stents are manufactured to a size slightly larger than the target vessel size and delivered constrained in a delivery system. After deployment they position themselves against the vessel wall with a low, chronic outward force. They resist outside forces with a significantly higher radial resistive force. Despite the high nickel content of Nitinol, its corrosion resistance and biocompatibility is equal to that of other implant materials. The most common Nitinol stents are listed and described.

Introduction

When Charles Dotter experimented with Nitinol wire coils as intra-arterial scaffolds back in the early nineteen eighties, Nitinol was known only for its unusual shape memory effect [1]. A coil wound to a small diameter and delivered through a catheter into the vessel, would expand to a larger diameter, e.g. the diameter of the vessel lumen, upon warming with 60°C saline solution (Fig. 1). Although the shape memory effect looked like ideally suited for the scaffolding of vessels, it took many more years for Nitinol stents to appear in the market. Dotter clearly was

ahead of his time. The melting and processing of Nitinol, an intermetallic compound of titanium and nickel, had not been fully developed with consistent quality, nor had the properties of this material been fully understood. Today, twenty years after Dotter's experiments, Nitinol stents are self-expanding without the need for post-deployment heating. They are superelastic, i.e. crush recoverable, exert a gentle chronic outward force and are generally more physiologically compatible than balloon-expandable stents. All major medical device companies as well as

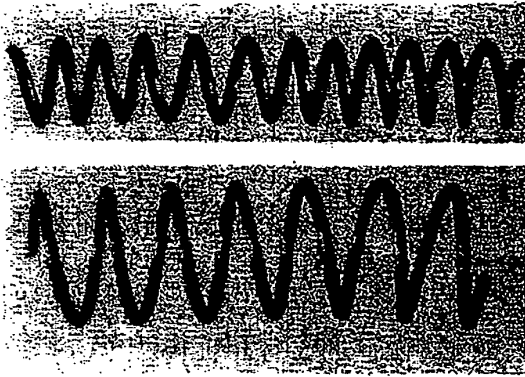

Fig.1 Nitinol coil stent used by Dotter [1], coiled for delivery and heat expanded

many smaller producers now offer Nitinol stents for (mainly peripheral) vascular and non-vascular indications.

In the following, after a brief explanation of the mechanisms of shape memory and superelasticity, we will describe the unique material properties of Nitinol and how they relate to the performance characteristics of Nitinol stents.

Superelasticity and Shape Memory in Nitinol

Conventional stent materials, like stainless steel or cobalt based alloys, exhibit a distinctly different elastic deformation behavior from that of the structural materials of the living body. The elastic deformation of these metals and alloys is limited to approx. 1% strain, and elongation typically increases and decreases linearly (proportionally) with the applied force. In contrast, natural materials, like hair, tendon and bone can be elastically deformed, in some cases, up to 10% strain in a non-linear way [2]. When the deforming stress is released, the strain is recovered at lower stresses. As shown in Fig. 2, the loading/unloading cycle is characterized by a pronounced hysteresis.

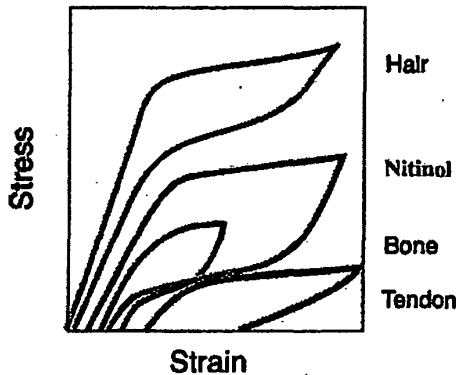

Fig. 2 Biomechanical compatibility of Nitinol: deformation characteristics of Nitinol and living tissues [2]

A similar behavior is found with Nitinol alloys, equiatomic or near-equiatomic intermetallic compounds of titanium and nickel. Fig. 3 shows a characteristic stress/strain curve for a Nitinol alloy wire at body temperature (as will be shown later, the properties of Nitinol alloys are strongly temperature dependent). As with natural materials, the loading and unloading curves show plateaus, along which large deflections (strains) can be accumulated on loading, or recovered on unloading, without significant increase, or decrease, respectively, in loads (stress). Because deformation of more than 10% strain can be elastically recovered, this behavior is called superelasticity.

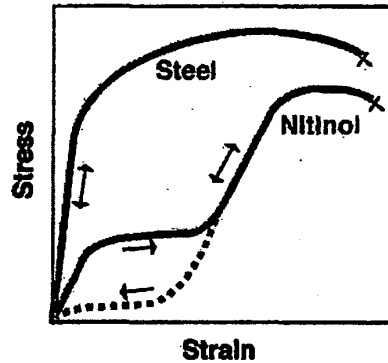

Fig. 3 Schematic stress-strain diagram for Nitinol and stainless steel

Superelastic Nitinol appears macroscopically to be simply very elastic. However, the mechanism of deformation is quite different from conventional elasticity, or simply stretching of atomic bonds. When a stress is applied to Nitinol, and after a rather modest elastic deformation, the material yields to the applied stress by changing its crystal structure. This stress induced phase transformation allows the material to change shape as a direct response to the applied stress. When the stresses are removed, the material reverts to the original structure and recovers its original shape. While superelasticity is the result of a stress induced phase transformation, shape memory is the result of a thermal phase transformation. In fact, when superelastic Nitinol is cooled to below a critical temperature (the transformation temperature, which is dependent on alloy composition and processing history), it also changes its crystal structure. If no force is applied, this phase change is not accompanied by a shape change. The material can be plastically deformed in the low temperature phase, but the original shape can be restored by heating above the transformation temperature [3].

Self-expanding Nitinol stents are manufactured with a diameter larger than that of the target vessel. Their transformation temperature is typically set to 30 degrees C. They can be easily crimped at or below room temperature and placed in a delivery system. To prevent premature

expansion during delivery into the body, the stent is constrained by a retractable sheath or other means. At the treatment site it is released from the delivery system and expands until it hits the vessel wall and conforms to it. Now at body temperature, the stent is superelastic.

Material Considerations

Nitinol is an alloy composed of 55 w.% nickel and balance titanium. It has found widespread acceptance as a material of choice for medical implants and devices [4]. It derives its unique properties from a solid state transformation, which can be triggered thermally or mechanically, and is dependent on the composition and processing history of the material. This adds another level of complexity to the material specification and may explain why ASTM specifications [5,6,7] describing material composition and test methods have only recently been issued. In addition to, or even instead of, the commonly known material characteristics like chemical composition, Young's modulus, yield strength, ultimate tensile strength and elongation to failure, properties like transformation temperature, upper and lower plateau stress, recoverable strain and permanent set have to be taken into account. As mentioned above, these properties are strongly dependent on the processing history and play an important role in the design and manufacturing of self-expanding stents.

Biocompatibility and Corrosion

It is now well understood that Nitinol requires controlled processing to achieve optimal shape memory and superelastic properties [8]. In the same way, surface processing is required in order to promote optimal corrosion resistance and biocompatibility. Properly treated Nitinol implants are very corrosion resistant and biocompatible [9]. Nitinol, like titanium and stainless steel a.o., is a self-passivating material, i.e. it forms a stable surface oxide layer that protects the base material from general corrosion [10]. Considering the high nickel content of the alloy, there are, understandably, concerns that nickel may dissolve from the material due to corrosion and cause adverse effects. On the other hand, other alloys that contain high levels of nickel, such as MP35N (a Co alloy with 35 weight % Ni), or 300 series stainless steel (approx. 10 w.% Ni) exhibit good biocompatibility, and have long been used as implants in orthodontics, orthopedics and cardiovascular applications [11]. Several studies have measured nickel release during the exposure of Nitinol implants to body fluids. During an *in vitro* dissolution study of Nitinol dental archwires in saliva [12], it was found that Nitinol appliances released an average of 13.05 mg/day nickel, which is significantly below the estimated average dietary intake of 200-300 mg/day. In another study [13], orthodontic patients with Nitinol appliances had Ni-concentration in their blood measured during a period of 5

months. Results showed no significant increase in the nickel blood level throughout the study.

A comparative *in vitro* cell culture study [14] measured nickel release from Nitinol and 316L stainless steel in fibroblast and osteoblast cell culture media. In both media, nickel levels were higher in the Nitinol group the first day and decreased rapidly with time to achieve similar levels as 316L after 8 days. It is important to highlight that even though higher levels of nickel were measured in the Nitinol group, nickel did not reach toxic values and cell proliferation or cell growth near the implant surface was not affected. Furthermore, in this study, Nitinol was only mechanically polished while stainless steel was electropolished. The authors speculated that passivation treatments, such as electropolishing, would decrease the nickel release from Nitinol. To evaluate the effect of different surface treatment methods on the Ni-ion release, Trepanier et al [15] immersed mechanically polished and electropolished samples of Nitinol, MP35N and 316L stainless steel in Hank's physiological solution at 37 degrees C for a period of greater than 1000 hours (Fig 4). It was found that samples that were prepared by mechanical polishing released higher amounts of Ni-ions than those prepared by electropolishing. Surface analysis data demonstrate that the electropolishing process removes excess nickel from the surface and forms a layer enriched in titanium (in the form of TiO₂). In contrast, the mechani-

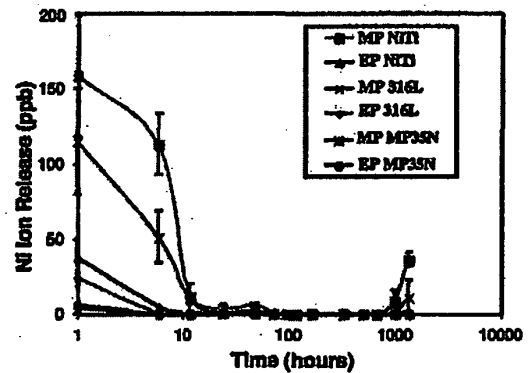

Fig 4: Ni ion release from Nitinol, MP35N and stainless steel (MP: mechanically polished, EP: electropolished)

Material	Surface Condition	Ni:Ti	Ni:Cr
Nitinol	Mech. Polished	0.18	
Nitinol	Electropolished	0.04	
MP35N	Mech. Polished		0.4
MP35N	passivated		0.08
316L SS	Mech. Polished		0.11
316L SS	Electropolished		0.07

Table 1: Ratio of Ni to Ti in the surface of mechanically, electropolished or passivated samples of Nitinol, MP35N and stainless steel

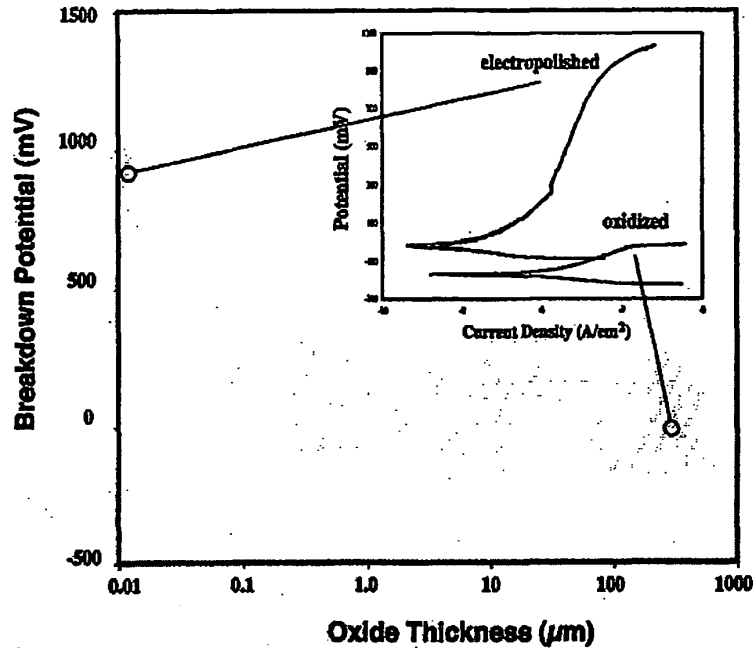

Fig. 5 Break-down potential as a function of oxide thickness on Nitinol (oxide created by varying heat treatment time and temperature); insert: results of potentiostatic corrosion tests of Nitinol samples with electropolished and oxidized surfaces

cally polished samples have a relatively high concentration of nickel in the surface (Table 1). Furthermore, the mechanically polished Nitinol and MP35N samples show an increase in Ni ion release after 1000 hours. This may be due to corrosion activity (pitting) after the initial 1000 hour time period in the non-passivated samples.

ASTM standard F2129 provides a quantitative method recognized by the FDA for the accelerated assessment of the corrosion resistance of implant materials [16]. The most relevant data derived from this test is the break-down potential E_{bd} , since most biomaterials corrode locally by pit formation. A high breakdown potential indicates that the material is very stable and resists pitting. Although no official limits have been established, materials with an E_{bd} \approx 500 mV are considered sufficiently corrosion resistant and safe for the use as implants. This value is used by Cordis, a Johnson & Johnson company, as the internal standard for all Nitinol implants. It corresponds with the corrosion resistance of the stainless steel Palmaz-Schatz stent as a predicative device, the stent with the longest implantation history.

Anodic polarization tests per ASTM F2129 have been used to evaluate the influence of surface preparation on the corrosion susceptibility of Nitinol stents. Trepanier et al. [17] have shown that electropolished Nitinol stents have

excellent corrosion resistance with breakdown potentials (E_{bd}) greater than 800 mV, whereas the E_{bd} of non-electropolished stents was on the order of 200 mV. It was further shown that the breakdown potential of electropolished stents was degraded to less than 500 mV after thermal treatments in the 400°C to 500°C range. This led to the conclusion that optimal corrosion and biocompatibility results are obtained with a thin, titanium oxide (TiO_2) surface layer formed after electropolishing (passivation) treatments. It further appears that uniformity, rather than thickness, of the oxide is most important to protect the material from corrosion. More recent studies [18] correlate E_{bd} with the thickness of the oxide layer created by heat-treating electropolished Nitinol samples (Fig.5).

To improve the radiopacity of Nitinol stents, markers are often attached to the stent struts. However, when coupling Nitinol with dissimilar materials, galvanic corrosion effects have to be considered. Markers are typically made from high density materials like gold, platinum, or tantalum, Nitinol and tantalum are galvanically similar and thus, the combination has no significant effect on the corrosion resistance. In contrast, gold and platinum are more noble than Nitinol (or stainless steel) and can cause severe galvanic corrosion of the Nitinol (or stainless steel) stent. Therefore, the use of the noble metals as markers

requires either an insulating layer between the stent and the marker or the assembly has to be coated with a protective coating.

In 1999, the medical community as well as the device industry were alerted to the corrosion issue by reports by Riepe et al [19] on the observation of severely corroded Nitinol graft scaffolds from explanted Stentor aortic stent grafts after 5 months implantation (Fig. 6). It was preliminarily speculated that cell-induced electrochemical corrosion or active cellular destruction of the surfaces (e.g., osteo-clasts-bone) might have been responsible for the severe corrosion. However, subsequent cell culture testing with Nitinol test samples performed by Riepe's group did not induce any corrosion [20]. Further analysis of the failed components revealed an oxide thickness of 0.2-0.3 μm (determined by Auger analysis) and an E_{oc} of 280 mV (from anodic polarization tests). In contrast, 12 month explants of electropolished graft scaffolds examined by Pelton et al showed no signs of corrosion. The oxide thickness on these devices was approximately 0.01 μm and the $E_{\text{oc}} > 900$ mV. This highlights the importance of optimized surface preparation. Most Nitinol stents marketed today have electropolished surfaces. There have been no further reports on corrosion cases.



Fig 6: top: heavily corroded Nitinol explant (5 months [19]), bottom: electropolished Nitinol explant (12 months, with Ta marker attached)

Material Specific Device Characteristics

The most unusual property of Nitinol alloys is *stress hysteresis*. While in most engineering materials stress increases linearly with strain upon loading and decreases

along the same path upon unloading (as shown in Fig. 3 with steel as an example), Nitinol exhibits a distinctly different behaviour. After an initial linear increase in stress with strain, large strains can be obtained with only a small further stress increase. This is called the loading plateau. The end of this plateau is reached at about 8% strain. Unloading from the end of the plateau region, causes the stress to decrease rapidly until a lower plateau (unloading plateau) is reached. Strain is recovered in this region with only a small decrease in stress. The last portion of the deforming strain is finally recovered in a linear fashion.

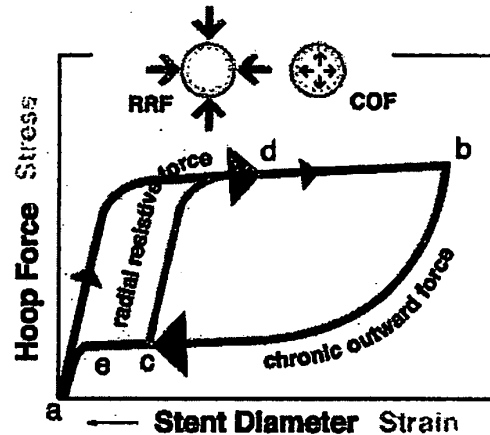

Fig. 7 Schematic stress hysteresis and concept of biased stiffness as demonstrated with the cycle insertion into delivery system/deployment/compression of a stent

The stress hysteresis or path dependence of Nitinol results in a device feature termed *biased stiffness* [21]. This concept is illustrated in Figure 7, which again shows a schematic superelastic stress-strain curve for Nitinol, illustrating both non-linear response and hysteresis. Using this graph, we will follow the cycle of crimping a stent into a delivery system, deploying it and have it expand and interact with the vessel. For this purpose, the axes have been changed from stress - strain to hoop force - stent diameter. A stent of a given size larger than the vessel (point a) is crimped into a delivery system (point b), then packaged, sterilized and shipped. After insertion to the target site, the stent is released into a vessel, expanding from b until movement is stopped by impingement with the vessel (point c). At this point, further expansion of the stent is prevented. Because the stent did not expand to its pre-set shape, it continues to exert a low outward force, termed *chronic outward force* or COF. However, it will resist recoil pressures or any other external compression forces with forces dictated by the loading curve from point c to d, which is substantially steeper (stiffer) than the unloading line (towards e). These forces are called *radial resistive forces* or RRF [22].

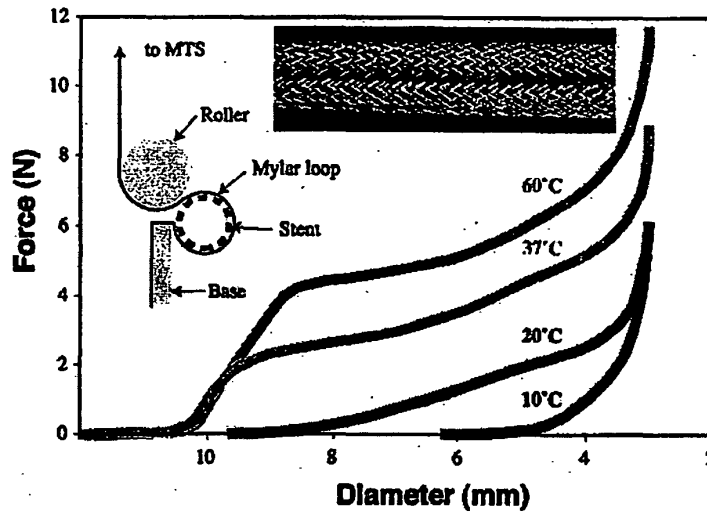

Fig. 8 Unloading curves of Nitinol stents (Cordis SMART) at different deployment temperatures; insert: radial force test set-up, schematic

The unusual elastic hysteresis of Nitinol allows the continuing opening force of the stent acting on the vessel wall, COF, to remain very low even through large deflections and oversizing of the stent. Meanwhile the forces generated by the stent to resist compression, RRF, increase rapidly with deflection until the plateau stress is reached. Although most self-expanding stent placements are preceded by a percutaneous transluminal balloon angioplasty, there are indications that the chronic outward force of a Nitinol stent placed without previous PTA causes the vessel to remodel with less intimal hyperplasia than if PTA is performed prior to stenting [23].

Another unusual feature of Nitinol stents is their *temperature dependent stiffness*. Stents with a transition temperature of 30 degrees C feel quite weak when squeezed or crushed at room or lower temperature. In contrast, they feel much stiffer when squeezed at temperatures above 30 degrees. Fig. 8 shows actual unloading curves of a Nitinol stent (Cordis SMART Stent) with a diameter of 10 mm at different temperatures. The test set-up (insert) is described in [24]. As can be seen from this graph, the chronic outward force actually doubles when the temperature is increased from 20 to 37 degrees C. As mentioned before, the transition temperature of the stent can be adjusted to a certain extent during processing. This gives the designer another option to increase or decrease the radial forces of the stent without changing the design or physical dimensions, as for each degree that the transition temperature is below body temperature, the loading and unloading forces increase by approximately 4 N/mm².

Kink resistance is an important feature of Nitinol for stents in superficial vessels that could be deformed

through outside forces. The carotid artery is a prime example. There is a perceived risk for balloon-expandable stents in carotid arteries to be permanently deformed through outside pressure resulting in a partially or completely blocked vessel, once the buckling strength of the stent is exceeded. Although Nitinol stents typically don't have the buckling strength of stainless steel stents, they cannot be permanently deformed through outside forces. Nitinol stents can be completely compressed (crushed) flat and will return to their original diameter when the deforming force is removed (Fig. 9). A quantitative analysis of the forces relevant to the performance of superelastic stents can be found in [22].

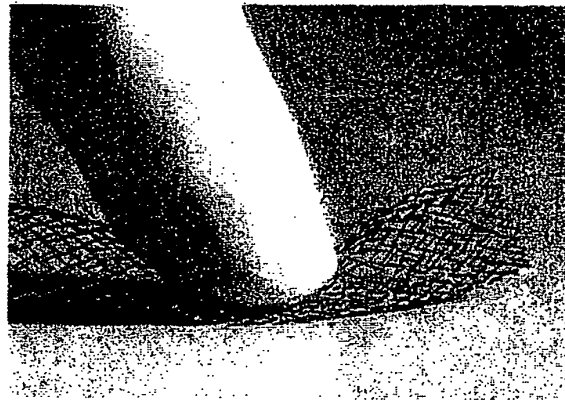

Fig. 9 Extrem deformation of a Nitinol stent (Cordis SMART); the stent will recover after the load is removed

Nitinol is non-ferromagnetic with a lower magnetic susceptibility than stainless steel. *MRI compatibility* is directly related to the susceptibility properties of a

material, relative to human tissue. Therefore, Nitinol produces less artifacts than stainless steel, similar to pure titanium. It has to be noted, however, that processing of the material can influence the quality of the MR image substantially.

Nitinol Stent Designs

In the following, we will try to list and describe the self-expanding Nitinol stents currently being marketed or in evaluation (Table 2). Designs included in this survey have been documented in brochures and company websites. Like others, this review is clearly not complete and may describe stents that are not yet, no longer, or not world-wide available.

Wire-based Stent Designs

The evolution of Nitinol stent designs is clearly linked to the development of the material itself. Early on, Nitinol was only available in wire form. Consequently, early Nitinol stents were wire coils, similar to Dotter's experimental device. Today, coil stents made from round or flat Nitinol wire are still available. They are mainly used for non-vascular applications (e.g. Endocare's Horizon Stent for the relief of bladder outlet obstruction), with the exception of the IntraCoil Stent (Intratherapeutics, Fig. 10), which is indicated for the treatment of patients with superficial femoral artery and popliteal artery lesions. One advantage of simple wire coils is their retrievability in certain applications. As described earlier, Nitinol loses its stiffness when cooled. The EndoCare Horizon or the D&E Memokath prostatic stents can be retrieved from the prostate by chilling the device with cold solution. The stents become soft and pliable and can be retrieved with a grasping forceps (Fig. 11).

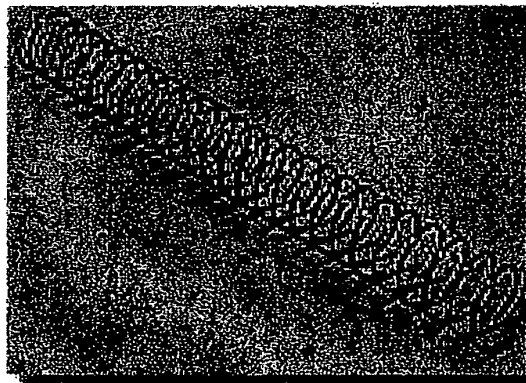

Fig. 10 Intracoil stent (IntraTherapeutics)

Other early wire based stent designs are the Cragg Stent (MinTec, Fig. 12), a sinusoidal coil with peak-to-valley suture connections for vascular and non-vascular applications, and the knitted Ultraflex Esophageal Stent

(Microvasiva, BSC). Newer designs are the ZA biliary Stent (Cook, Fig. 13), a modified knitted design, and the braided Expander Stent (Medicorp). The Boston Scientific Symphony Stent is a wire formed design with struts welded to form hexagonal cells. While wire based stents generally are very flexible, the Symphony Stent is quite rigid (Fig. 14).

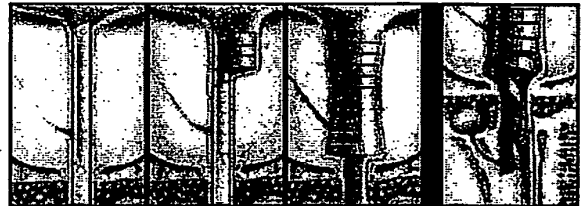

Fig. 11: Deployment and retrieval (far right) of the Horizon stent (EndoCare)



Fig. 12: Cragg Stent



Fig. 13: Cook ZA knitted stent

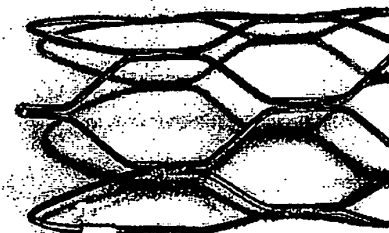

Fig. 14: Welded Symphony Stent (BSC)

Company Name	Product Name	Fabrication Method	Comments	
Bard	Memotherm	Laser cut tube		[25]
Bard	Memotherm-Flexx	Laser cut tube		
Bard	Luminexx	Laser cut tube	Welded Ta markers	[26]
BBraun	Vascuflex SE	Laser cut tube		[27]
Biotronik	Philon	Laser cut tube	SiC coated	[28]
BSC	Radius	Laser cut tube		
BSC	Symphony	Welded wire	Sleeve P1fr markers	[29]
BSC	Ultraflex	Knitted wire		
Bolton Medical	Sprinter	Braided wire		[30]
Campus	Campus	Laser cut tube		[31]
Cook	ZA	Knitted wire	Sleeve Au markers	[32]
Cook	Zilver	Laser cut tube	Coined Au markers	
Cordis	SMART	Laser cut tube		[33]
Cordis	SMARTeR	Laser cut tube	Coined Ta markers	
Cordis	SMARTControl	Laser cut tube	Coined Ta markers	
Cordis	Precise	Laser cut tube		
EndoCare	Horizon	Flat wire coil		[34]
EndoTex	NexStent	Laser cut tube		[35]
Engineers&Doctors	Memokath	Wire Coil		[36]
FlexStent Medical	FlexStent	Braided wire	Au coated	[37]
Guidant	Dynalink	Laser cut tube		[38]
Intratherapeutics	IntraCoil	Wire coil		[39]
Intratherapeutics	Prot g	Laser cut tube		
Intratherapeutics	Prot g GPS	Laser cut tube	Coined Ta markers	
Intratherapeutics	EndoCoil	Flat wire coil		
Intratherapeutics	EsophaCoil-SR	Flat wire coil		
Jomed	Jostent SelfX	Laser cut tube		[40]
Jotec	FlowStent Diamond	Laser cut tube	DLC coated	[41]
Medicorp	Expander	Braided wire		[42]
Medtronic AVE	Bridge SE	Laser cut tube		[43]
Optimed	Sinus	Laser cut tube		[44]
Optimed	Sinus-Aorta	Laser cut tube		
Optimed	Sinus-Flex	Laser cut tube	DLC coated (opt)	
Optimed	Sinus-TIPPS	Laser cut tube	Pre-shaped	
Optimed	Sinus-REPO	Laser cut tube	DLC coated (opt)	
Vascular Architects	Aspire	dual rail ladder coil	ePTFE covered	[45]

Table 2: List of popular Nitinol self-expanding stents

Sheet-based Stent Designs

A perceived disadvantage of braided or knitted wire-based stents is the crossing of the filaments. This increases the wall thickness of the stent and the delivery profile. Moreover, there are concerns about fretting corrosion or the wear of the Nitinol at the cross-over points. When Nitinol sheet became available, Angiomed (Bard) developed the first laser-cut Nitinol stent by cutting a pattern from sheet, rolling it up and welding at specific strut locations (Fig. 15).

An interesting sheet based Nitinol stent is the experimental ratcheting EndoTex stent, similar to the design suggested by Sigwart (Fig. 16) [46]. It is chemically etched from thin Nitinol sheet to produce a series of windows and a locking feature at one edge. It is rolled up to a small diameter roll and placed onto a PTCA balloon. The assembly is then placed into the vessel and the diameter of the stent is adjusted by inflating the balloon. As the balloon expands, the stent uncoils to the desired diameter to prop open the vessel. The stent is locked into place by unique tabs that slide into the stent windows upon balloon deflation. This design provides a wide range of diameters to custom fit for each treatment. It combines balloon expandability with the superelasticity after deployment. However, it has some of the perceived disadvantages of the knitted wire stents with non-uniform cross-section and potential fretting cross-over points.

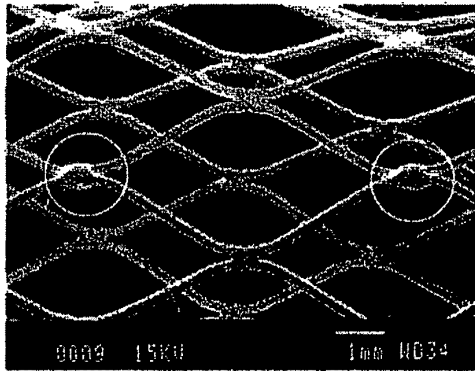

Fig. 15: Sheet-based Memotherm Stent with lap welded struts

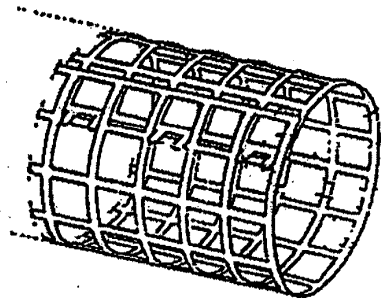

Fig. 16 Concept of a sizable superelastic stent [44]

Vascular Architect's aSpire stent uses a dual-rail ladder type frame that is also etched from Nitinol sheet and covered with ePTFE. It is helically coiled onto a delivery system that allows deployment with a variable pitch to keep vessel sidebranches open.

Tube-based Stent Designs

In the mid 1990s, Nitinol seamless tubing appeared in the market in production quantities. With it came laser cutting of tubular Nitinol components. Today, by far most self-expanding Nitinol stents are produced by laser cutting of Nitinol tubing. Early examples are the Angiomed (Bard) Memotherm and the Scimed Radius stents. The Memotherm was a rigid, closed-cell design with a diamond shaped pattern similar to the original Palmaz balloon expandable stent. The Radius, on the other hand, is a flexible open-cell design with sequential rings and periodic peak-to-peak non-flex bridges. Most laser-cut Nitinol stents employ variations and/or combinations of these basic design features (Fig. 17, Fig. 18). There are Nitinol stents in the market that are coated with silicon carbide (SiC) or diamond like carbon (DLC). It is probably fair to state that these developments are more driven by product differentiation than actual scientific considerations [47].

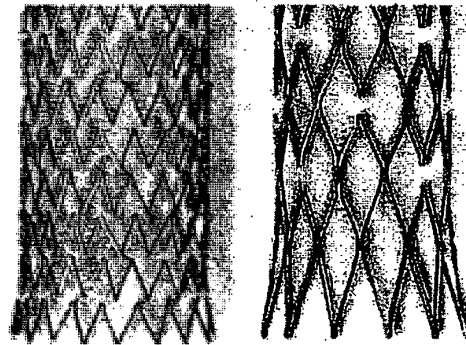

Fig. 17: Laser-cut tubular Nitinol stents, left: SMART Stent (Cordis), right: Memotherm Stent (Bard)

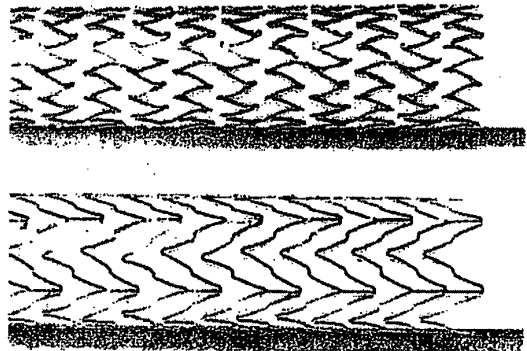

Fig. 18: Laser-cut tubular Nitinol stents, top: Jostent SelfX Stent (Jomed), bottom: Dynalink Stent (Guidant)

Radiopacity Enhancements

Theoretical calculations as well as experimental studies show that the radiopacity of Nitinol is similar to that of stainless steel for equivalent dimensions. However, as the stent profiles continue to shrink to accommodate smaller delivery systems, the cross section decreases with a concomitant decrease in x-ray visibility. Therefore, to improve the fluoroscopic visibility of the Nitinol stents, radiopaque markers are often attached or integrated into the design of the stent. The Optimized Sinus stent family, for example, features a set of tab markers at the stent ends that are integral parts of the stent cut out of the tubing (Fig. 19). The advantage of this approach is that there are no compatibility issues, as no dissimilar metals are involved. On the other hand, it allows only moderate visibility improvement. Tantalum markers are riveted or coined into eyelet-shaped tabs at the ends of the Cordis Smarter and SmartControl stents (Fig. 20). As mentioned earlier, Tantalum and Nitinol are close together in the galvanic series of metals, i.e. galvanic corrosion is not a problem. The Cook Zilver stent is of similar design, but uses gold markers instead of Tantalum. It is assumed that the entire stent is coated with a thin polymer layer to protect it from galvanic corrosion.

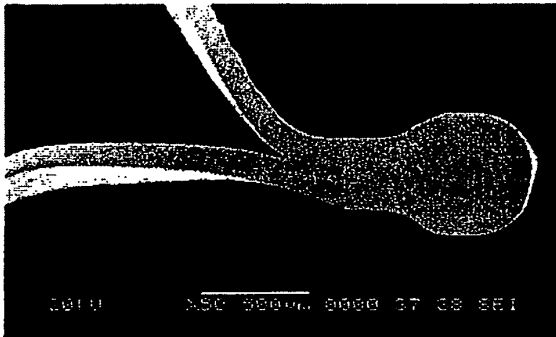

Fig. 19 Nitinol marker of the Sinus stent (Optimed)

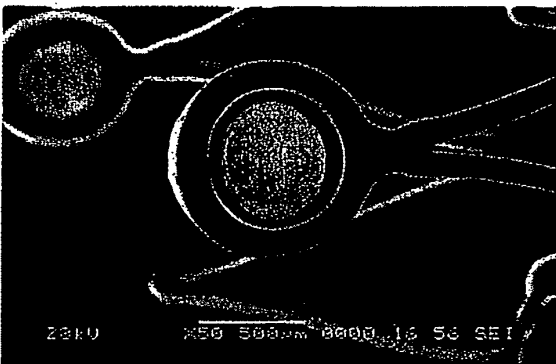

Fig. 20 Coined Tantalum markers of the SMARTeR stent (Cordis)

Tantalum tabs are welded to the ends of the Bard Luminexx stents (Fig. 21). Because of the large mass of these tabs, the X-ray visibility of this stent is very good. There are concerns, however, that brittle interface layers can be created during welding of Nitinol and Tantalum.

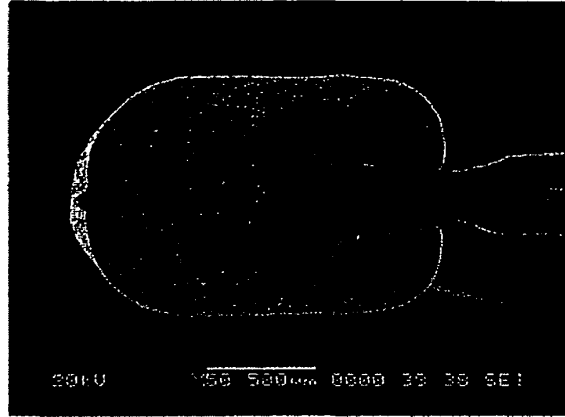

Fig. 21 Welded Tantalum markers of the Luminexx Stent (Bard)

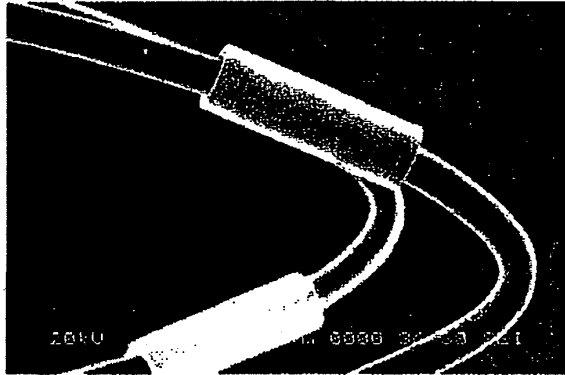

Fig. 22 Platinum-Iridium sleeve marker of the Symphony stent (Boston Scientific)

Platinum-Iridium sleeves are used as markers for the wire-based BSC Symphony stent (Fig. 22) while the Cook ZA knitted stent uses Gold sleeves. As mentioned above compatibility issues have to be considered when using these material combinations.

References

- [1] Dotter CT, Buschmann PAC, McKinney MK, Risch J (1983) Transluminal expandable nitinol coil stent grafting: preliminary report. *Radiology* 147:259
- [2] Shabalovskaya S (1996) On the nature of the biocompatibility and medical applications of NiTi shape memory and superelastic alloys. *BioMed Mat Eng* 6: 267
- [3] Duerig TW, Melton KN, Wayman CM, Stoeckel D (1990) *Engineering Aspects of Shape Memory Alloys*. Butterworth-Heinemann Ltd, London
- [4] Stoeckel D (2000) Nitinol medical devices and implants. *Min Invas Ther & Allied Technol* 9:81
- [5] ASTM F 2063-00 (2002) Standard Specification for Wrought Nickel-Titanium Shape Memory Alloys for Medical Devices and Surgical Implants.
- [6] ASTM F 2004-00 (2002) Test Method for Transformation Temperature of Nickel-Titanium Alloys by Thermal Analysis.
- [7] ASTM F 2082-01 (2002) Method for the Determination of Transformation Temperature of Nickel-Titanium Shape Memory Alloys by Bend and Free Recovery.
- [8] Pelton AR, DiCello J, Miyazaki S (2000) Optimisation of processing and properties of medical grade Nitinol wire. *Min Invas Ther & Allied Technol* 9:107
- [9] Wever DJ, Veldhuizen, AG, Sanders, MM, Schakenraad, JM (1997) Cytotoxic, allergic and genotoxic activity of a nickel-titanium alloy. *Biomaterials* 18:1115.
- [10] Wever DJ, Veldhuizen, AG, de Vries, J, Bussocher, HJ, Uges, DRA, van Horn, JR (1998) Electrochemical and surface characterization of a nickel-titanium alloy. *Biomaterials* 19:761.
- [11] Brown SA, Hughes PJ, Merritt K (1988) In vitro studies of fretting corrosion of orthopaedic materials. *J. Orthop. Res.*, 6:572.
- [12] Barrett RD, Bishara SE, Quinn JK (1993) Biodegradation of orthodontic appliances, part I biodegradation of nickel and chromium in vitro. *Am. J. Orthod. Dentofac. Orthop.*, 103:8.
- [13] Bishara SE, Barrett RD, Selim, MI (1993) Biodegradation of orthodontic appliances, part II changes in the blood level of nickel. *Am. J. Orthod. Dentofac. Orthop.*, 103:115.
- [14] Ryhanen J, Niemi E, Serlo W, Niemel E, Sandvik P, Pernu H, Salo T (1997) Biocompatibility of nickel-titanium shape memory metal and its corrosion behavior in human cell cultures. *J. Biomed. Mater. Res* 35:451.
- [15] Trepanier C, Venugopalan R, Messer R, Zimmerman J, Pelton AR (2000) Effect of passivation treatments on nickel release from Nitinol Proc. Soc. for Biomater. 1043.
- [16] ASTM F2129-01 (2002) Standard test method for conducting cyclic potentiodynamic polarization measurements to determine the corrosion susceptibility of small implant devices.
- [17] Trepanier C, Tabizian, M, Yahia, L.H, Bilodeau, L, Piron, DL (1998) Effect of modification of oxide layer on NiTi stent corrosion resistance. *J. Biomed. Mater. Res* 43:433.
- [18] Trepanier C, Fino J, Zhu L, Pelton AR (2002) Corrosion resistance of oxidized Nitinol. Accepted for publication SMST-2002.
- [19] Heintz C, Riepe G, Birken L, Kaiser B, Chafke N, Morlock M, Dellling G, Imig H (2001) Corroded Nitinol Wires in Explanted Aortic Endografts: An Important Mechanism of Failure? *J Endovasc Ther* 8:248
- [20] Kaiser E (2002) Cell-induced corrosion in vitro. 2nd European Sym Vaso Biomat. Hamburg
- [21] Duerig TW, Pelton AR, Stoeckel D (1996) The Use of Superelasticity in Medicine. *Metall* 50:569
- [22] Duerig TW, Tolomeo DE, Wholey M (2000) An overview of superelastic stent design. *Min Invas Ther & Allied Technol* 9:235
- [23] Harnek J, Zoucas E, Stenram U, Cwikiel W (2002) Insertion of Self-Expandable Nitinol Stents Without Previous Balloon Angioplasty Reduces Restenosis Compared with PTA Prior to Stenting. *Cardiovasc Intervent Radiol* 5:430
- [24] Duda S, Wiskirchen J, Tepe G, Bitzer M, Kaulich TW, Stoeckel D, Claussen C (2000) Physical Properties of Endovascular Stents: An Experimental Comparison. *JVIR* 11:645
- [25] BARD company literature
- [26] www.luminexx.de
- [27] www.bb Braun.de
- [28] www.biotronik.de
- [29] Boston Scientific company literature
- [30] www.boltonmedical.com
- [31] www.campusgmbh.de
- [32] Cook company literature
- [33] Cordis company literature
- [34] www.endocare.com
- [35] www.endotex.com
- [36] www.engineers-doctors.com
- [37] www.flexatent.com
- [38] www.guldant.com
- [39] www.intratherapeutics.com
- [40] www.iomed.com
- [41] www.icltes-med.com
- [42] www.medicorp.fr
- [43] www.medtronicave.com
- [44] Optimed company literature
- [45] www.vasculararchitects.com
- [46] Sigwart U (1996) The Coiled Sheet Concept.

[47] In: Sigwart U (ed) Endoluminal Stenting. W.B. Saunders Company Ltd, London, pp 249-250
Stoeckel D, Bonsignore C, Duda S (2002) A survey of stent designs. Min Invas Ther & Allied Technol.11:137



Food and Drug Administration
9200 Corporate Boulevard
Rockville MD 20850

APR 15 2008

Mr. Mark Spreeman
Senior Regulatory Affairs Manager
Medtronic Vascular
3576 Unocal Place
Santa Rosa, CA 95403

Re: P070027
Talent™ Abdominal Stent Graft System
Filed: October 18, 2007
Amended: November 20, 2007 and February 6, and March 24, 2008
Procode: MIH

Dear Mr. Spreeman:

The Center for Devices and Radiological Health (CDRH) of the Food and Drug Administration (FDA) has completed its review of your premarket approval application (PMA) for the Talent™ Abdominal Stent Graft System. This device is indicated for the endovascular treatment of abdominal aortic aneurysms with or without iliac involvement having:

- Iliac/femoral access vessel morphology that is compatible with vascular access techniques, devices, and/or accessories;
- A proximal aortic neck length of ≥ 10 mm;
- Proximal aortic neck angulation $\leq 60^\circ$;
- Distal iliac artery fixation length of ≥ 15 mm;
- An aortic neck diameter of 18–32mm and iliac artery diameters of 8–22mm; and
- Vessel morphology suitable for endovascular repair.

We are pleased to inform you that the PMA is approved. You may begin commercial distribution of the device in accordance with the conditions described below and in the "Conditions of Approval" (enclosed).

The sale, distribution, and use of this device are restricted to prescription use in accordance with 21 CFR 801.109 within the meaning of section 520(e) of the Federal Food, Drug, and Cosmetic Act (the act) under the authority of section 515(d)(1)(B)(ii) of the act. FDA has also determined that, to ensure the safe and effective use of the device, the device is further restricted within the

meaning of section 520(e) under the authority of section 515(d)(1)(B)(ii), (1) insofar as the labeling specify the requirements that apply to the training of practitioners who may use the device as approved in this order and (2) insofar as the sale, distribution, and use must not violate sections 502(q) and (r) of the act.

In addition to the post-approval requirements outlined in the enclosure, you have agreed to the following conditions of approval:

1. You have agreed to provide a clinical update to physician users at least annually. At a minimum, this update will include, for your pivotal study cohort and your post-approval study cohort, a summary of the number of patients for whom data are available, with the rates of aneurysm rupture, secondary endovascular procedures, conversion to surgical repair, aneurysm-related mortality, major adverse events, endoleak, aneurysm enlargement, prosthesis migration, and patency. Reports of losses of device integrity, reasons for conversion and causes of aneurysm-related death and rupture are to be described. A summary of any explant analysis findings are to be included. Additional relevant information from commercial experience within and outside of the US is also to be included. The clinical updates for physician users and the information supporting the updates must be provided in supplements to your PMA.
2. In addition to the periodic report (often referred to as annual report) requirements outlined in the enclosure, you have agreed to provide the following data in a separate post-approval study report. You have agreed to perform a post-approval study for Talent™ Abdominal to evaluate the longer-term safety and effectiveness of the Talent™ Abdominal Stent Graft System through five years of implantation. The primary endpoint for this study is freedom from aneurysm-related mortality at 5 years. Aneurysm-related mortality is defined as:

Death from rupture of the abdominal aortic aneurysm or from any procedure intended to treat the AAA. If a death occurred within 30 days of any procedure intended to treat the AAA, then it is presumed to be aneurysm related.

This study is expected to include 260 patients, 166 endovascular patients from the original pivotal study cohort, as well as enrollment of an additional 94 patients at up to 30 investigational sites. At 1 month, 12 months, and, at each annual visit, a contrast enhanced CT scan, abdominal x-ray and physical examination will be conducted. All data will be entered into a database, analyzed, and submitted in post-approval reports to the FDA, and a final report will be submitted after completion of the follow-up and analysis. This follow-up plan will allow an evaluation of aneurysm-related mortality, major adverse events, migration, patency, endoleaks, device integrity, aneurysm enlargement, aneurysm rupture, secondary endovascular procedures and conversion to open surgical repair over time.

Upon completion of this post-approval study, you must provide a supplement with revised labeling that reflects the study findings.

3. You have also agreed to perform an evaluation to better understand the overall outcomes in females and non-Caucasians undergoing endovascular aneurysm repair (EVAR) with the Talent Abdominal Stent Graft System. This evaluation will include a subset evaluation of the females and non-Caucasians enrolled in the post-approval study described in item 2 above, as well as a summary of the current literature research results of females and non-Caucasians having undergone EVAR. This evaluation is to include descriptive statistics to summarize literature-derived outcomes in patients with the EVAR therapy, literature-derived Talent Abdominal Stent Graft-specific outcomes, and post-approval study outcomes in female and non-Caucasians populations. Findings of this evaluation must be provided with each regular post-approval study report update until the completion of the post-approval study described in item 2 above.

Within 30 days of your receipt of this letter, you must submit a PMA supplement that includes a complete protocol of your post-approval study. Your PMA supplement should be submitted in triplicate to the address below and reference the PMA number above to facilitate processing.

Expiration dating for this device has been established and approved at 2 years.

CDRH does not evaluate information related to contract liability warranties, however you should be aware that any such warranty statements must be truthful, accurate, and not misleading, and must be consistent with applicable Federal and State laws.

CDRH will notify the public of its decision to approve your PMA by making available a summary of the safety and effectiveness data upon which the approval is based. The information can be found on the FDA CDRH Internet HomePage located at <http://www.fda.gov/cdrh/pmapage.html>. Written requests for this information can also be made to the Dockets Management Branch, (HFA-305), Food and Drug Administration, 5630 Fishers Lane, Rm. 1061, Rockville, MD 20852. The written request should include the PMA number or docket number. Within 30 days from the date that this information is placed on the Internet, any interested person may seek review of this decision by requesting an opportunity for administrative review, either through a hearing or review by an independent advisory committee, under section 515(g) of the Federal Food, Drug, and Cosmetic Act (the act).

Failure to comply with any postapproval requirement constitutes a ground for withdrawal of approval of a PMA. Commercial distribution of a device that is not in compliance with these conditions is a violation of the act.

You are reminded that, as soon as possible and before commercial distribution of your device, you must submit an amendment to this PMA submission with copies of all approved labeling in final printed form. The labeling will not routinely be reviewed by FDA staff when PMA

Page 4 - Mr. Mark Spreeman

applicants include with their submission of the final printed labeling a cover letter stating that the final printed labeling is identical to the labeling approved in draft form. If the final printed labeling is not identical, any changes from the final draft labeling should be highlighted and explained in the amendment.

All required documents should be submitted in triplicate, unless otherwise specified, to the address below and should reference the above PMA number to facilitate processing.

PMA Document Mail Center (HFZ-401)
Center for Devices and Radiological Health
Food and Drug Administration
9200 Corporate Blvd.
Rockville, Maryland 20850

If you have any questions concerning this approval order, please contact Dorothy Abel at (240) 276-4169.

Sincerely yours,

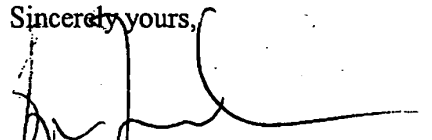

Bram D. Zuckerman, M.D.
Director
Division of Cardiovascular Devices
Office of Device Evaluation
Center for Devices and
Radiological Health

Enclosure

CONDITIONS OF APPROVAL

PREMARKET APPROVAL APPLICATION (PMA) SUPPLEMENT. Before making any change affecting the safety or effectiveness of the device, submit a PMA supplement for review and approval by FDA unless the change is of a type for which a "Special PMA Supplement-Changes Being Effected" is permitted under 21 CFR 814.39(d) or an alternate submission is permitted in accordance with 21 CFR 814.39(e) or (f). A PMA supplement or alternate submission shall comply with applicable requirements under 21 CFR 814.39 of the final rule for Premarket Approval of Medical Devices.

All situations that require a PMA supplement cannot be briefly summarized; therefore, please consult the PMA regulation for further guidance. The guidance provided below is only for several key instances.

A PMA supplement must be submitted when unanticipated adverse effects, increases in the incidence of anticipated adverse effects, or device failures necessitate a labeling, manufacturing, or device modification.

A PMA supplement must be submitted if the device is to be modified and the modified device should be subjected to animal or laboratory or clinical testing designed to determine if the modified device remains safe and effective.

A "Special PMA Supplement - Changes Being Effected" is limited to the labeling, quality control and manufacturing process changes specified under 21 CFR 814.39(d)(2). It allows for the addition of, but not the replacement of previously approved, quality control specifications and test methods. These changes may be implemented before FDA approval upon acknowledgment by FDA that the submission is being processed as a "Special PMA Supplement - Changes Being Effected." This procedure is not applicable to changes in device design, composition, specifications, circuitry, software or energy source.

Alternate submissions permitted under 21 CFR 814.39(e) apply to changes that otherwise require approval of a PMA supplement before implementation of the change and include the use of a 30-day PMA supplement or annual postapproval report (see below). FDA must have previously indicated in an advisory opinion to the affected industry or in correspondence with the applicant that the alternate submission is permitted for the change. Before such can occur, FDA and the PMA applicant(s) involved must agree upon any needed testing protocol, test results, reporting format, information to be reported, and the alternate submission to be used.

Alternate submissions permitted under 21 CFR 814.39(f) for manufacturing process changes include the use of a 30-day Notice. The manufacturer may distribute the device 30 days after the date on which the FDA receives the 30-day Notice, unless the FDA notifies the applicant within 30 days from receipt of the notice that the notice is not adequate.

POSTAPPROVAL REPORTS. Continued approval of this PMA is contingent upon the submission of postapproval reports required under 21 CFR 814.84 at intervals of 1 year from the date of approval of the original PMA. Postapproval reports for supplements approved under the original PMA, if applicable, are to be included in the next and subsequent annual reports for the original PMA unless specified otherwise in the approval order for the PMA supplement. Two copies identified as "Annual Report" and bearing the applicable PMA reference number are to be submitted to the PMA Document Mail Center (HFZ-401), Center for Devices and Radiological Health, Food and Drug Administration, 9200 Corporate Blvd., Rockville, Maryland 20850. The postapproval report shall indicate the beginning and ending date of the period covered by the report and shall include the following information required by 21 CFR 814.84:

1. Identification of changes described in 21 CFR 814.39(a) and changes required to be reported to FDA under 21 CFR 814.39(b).
2. Bibliography and summary of the following information not previously submitted as part of the PMA and that is known to or reasonably should be known to the applicant:
 - a. unpublished reports of data from any clinical investigations or nonclinical laboratory studies involving the device or related devices ("related" devices include devices which are the same or substantially similar to the applicant's device); and
 - b. reports in the scientific literature concerning the device.

If, after reviewing the bibliography and summary, FDA concludes that agency review of one or more of the above reports is required, the applicant shall submit two copies of each identified report when so notified by FDA.

ADVERSE REACTION AND DEVICE DEFECT REPORTING. As provided by 21 CFR 814.82(a)(9), FDA has determined that in order to provide continued reasonable assurance of the safety and effectiveness of the device, the applicant shall submit 3 copies of a written report identified, as applicable, as an "Adverse Reaction Report" or "Device Defect Report" to the PMA Document Mail Center (HFZ-401), Center for Devices and Radiological Health, Food and Drug Administration, 9200 Corporate Blvd., Rockville, Maryland 20850 within 10 days after the applicant receives or has knowledge of information concerning:

1. A mix-up of the device or its labeling with another article.
2. Any adverse reaction, side effect, injury, toxicity, or sensitivity reaction that is attributable to the device and:
 - a. has not been addressed by the device's labeling; or
 - b. has been addressed by the device's labeling but is occurring with unexpected severity or frequency.

3. Any significant chemical, physical or other change or deterioration in the device, or any failure of the device to meet the specifications established in the approved PMA that could not cause or contribute to death or serious injury but are not correctable by adjustments or other maintenance procedures described in the approved labeling. The report shall include a discussion of the applicant's assessment of the change, deterioration or failure and any proposed or implemented corrective action by the applicant. When such events are correctable by adjustments or other maintenance procedures described in the approved labeling, all such events known to the applicant shall be included in the Annual Report described under "Postapproval Reports" above unless specified otherwise in the conditions of approval to this PMA. This postapproval report shall appropriately categorize these events and include the number of reported and otherwise known instances of each category during the reporting period. Additional information regarding the events discussed above shall be submitted by the applicant when determined by FDA to be necessary to provide continued reasonable assurance of the safety and effectiveness of the device for its intended use.

REPORTING UNDER THE MEDICAL DEVICE REPORTING (MDR) REGULATION.

The Medical Device Reporting (MDR) Regulation became effective on December 13, 1984. This regulation was replaced by the reporting requirements of the Safe Medical Devices Act of 1990 which became effective July 31, 1996 and requires that all manufacturers and importers of medical devices, including in vitro diagnostic devices, report to the FDA whenever they receive or otherwise become aware of information, from any source, that reasonably suggests that a device marketed by the manufacturer or importer:

1. May have caused or contributed to a death or serious injury; or
2. Has malfunctioned and such device or similar device marketed by the manufacturer or importer would be likely to cause or contribute to a death or serious injury if the malfunction were to recur.

The same events subject to reporting under the MDR Regulation may also be subject to the above "Adverse Reaction and Device Defect Reporting" requirements in the "Conditions of Approval" for this PMA. FDA has determined that such duplicative reporting is unnecessary. Whenever an event involving a device is subject to reporting under both the MDR Regulation and the "Conditions of Approval" for a PMA, the manufacturer shall submit the appropriate reports required by the MDR Regulation within the time frames as identified in 21 CFR 803.10(c) using FDA Form 3500A, i.e., 30 days after becoming aware of a reportable death, serious injury, or malfunction as described in 21 CFR 803.50 and 21 CFR 803.52 and 5 days after becoming aware that a reportable MDR event requires remedial action to prevent an unreasonable risk of substantial harm to the public health. The manufacturer is responsible for submitting a baseline report on FDA Form 3417 for a device when the device model is first reported under 21 CFR 803.50. This baseline report is to include the PMA reference number. Any written report and its envelope is to be specifically identified, e.g., "Manufacturer Report," "5-Day Report," "Baseline Report," etc.

Any written report is to be submitted to:

Food and Drug Administration
Center for Devices and Radiological Health
Medical Device Reporting
PO Box 3002
Rockville, Maryland 20847-3002

Additional information on MDR is available at <http://www.fda.gov/cdrh/devadvice/351.html>



UNITED STATES PATENT AND TRADEMARK OFFICE

Commissioner for Patents
United States Patent and Trademark Office
P.O. Box 1450
Alexandria, VA 22313-1450
www.uspto.gov

JUL 7 2008

Office of Regulatory Policy
Food and Drug Administration
10903 New Hampshire Ave., Bldg. 51, Rm. 6222
Silver Spring, MD 20993-0002

Attention: Beverly Friedman

The attached application for patent term extension of U.S. Patent No. 6,306,141 was filed on June 11, 2008, under 35 U.S.C. § 156.

The assistance of your Office is requested in confirming that the product identified in the application, TALENT™ Abdominal Stent Graft System, has been subject to a regulatory review period within the meaning of 35 U.S.C. § 156(g) before its first commercial marketing or use and that the application for patent term extension was filed within the sixty-day period beginning on the date the product was approved. Since a determination has not been made whether the patent in question claims a product which has been subject to the Federal Food, Drug and Cosmetic Act, or a method of manufacturing or use of such a product, this communication is NOT to be considered as notice which may be made in the future pursuant to 35 U.S.C. § 156(d)(2)(A).

Our review of the application to date indicates that the subject patent would be eligible for extension of the patent term under 35 U.S.C. § 156.

Inquiries regarding this communication should be directed to Raul Tamayo at (571) 272-7728 (telephone) or (571) 273-7728 (facsimile).

Mary C. Till
Legal Advisor
Office of Patent Legal Administration
Office of the Deputy Commissioner
for Patent Examination Policy

cc: Michael J. Jaro
Medtronic, Inc.
710 Medtronic Parkway
M/S LC340
Minneapolis, MN 55432



DEPARTMENT OF HEALTH & HUMAN SERVICES

Food and Drug Administration
Rockville MD 20857

FEB 18 2009

Re: Talent Abdominal Stent Graft System
Docket No. FDA-2008-E-0568

The Honorable Jon Dudas
Under Secretary of Commerce for Intellectual Property
Director of the United States Patent and Trademark Office
Mail Stop Hatch-Waxman PTE
P.O. Box 1450
Alexandria, VA 22313-1450

Dear Director Dudas:

This is in regard to the application for patent term extension for U.S. Patent No. 6,306,141 filed by Medtronic, Inc. under 35 U.S.C. § 156. The medical device claimed by the patent is Talent Abdominal Stent Graft System, which was assigned premarket approval (PMA) No. P070027.

A review of the Food and Drug Administration's official records indicates that this product was subject to a regulatory review period before its commercial marketing or use, as required under 35 U.S.C. § 156(a)(4). Our records also indicate that it represents the first permitted commercial marketing or use of the product, as defined under 35 U.S.C. § 156(f)(1).

The PMA was approved on April 15, 2008, which makes the submission of the patent term extension application on June 11, 2008, timely within the meaning of 35 U.S.C. § 156(d)(1).

Should you conclude that the subject patent is eligible for patent term extension, please advise us accordingly. As required by 35 U.S.C. § 156(d)(2)(A) we will then determine the applicable regulatory review period, publish the determination in the *Federal Register*, and notify you of our determination.

Please let me know if we can be of further assistance.

Sincerely yours,

Jane A. Axelrad
Associate Director for Policy
Center for Drug Evaluation and Research

Dudas - Talent Abdominal Stent Graft System
Patent No. 6,306,141
Page 2

cc: Michael J. Jaro
Medtronic, Inc.
Vice President and Chief Patent Counsel
710 Medtronic Parkway M/S LC340
Minneapolis, MN 55432



UNITED STATES PATENT AND TRADEMARK OFFICE

MAR 25 2009

Commissioner for Patents
United States Patent and Trademark Office
P.O. Box 1450
Alexandria, VA 22313-1450
www.uspto.gov

Office of Regulatory Policy
Food and Drug Administration
10903 New Hampshire Ave., Bldg. 51, Rm. 6222
Silver Spring, MD 20993-0002

Attention: Beverly Friedman

Dear Ms. Axelrad:

Transmitted herewith is a copy of the application for patent term extension of U.S. Patent No. 6,306,141. The application was filed on June 11, 2008, under 35 U.S.C. § 156.

The patent claims a product that was subject to regulatory review under the Federal Food, Drug and Cosmetic Act. Subject to final review, the subject patent is considered to be eligible for patent term extension. Thus, a determination by your office of the applicable regulatory review period is necessary. Accordingly, notice and a copy of the application are provided pursuant to 35 U.S.C. § 156(d)(2)(A).

Inquiries regarding this communication should be directed to Raul Tamayo at (571) 272-7728 (telephone) or (571) 273-7728 (facsimile).

Mary C. Till
Legal Advisor
Office of Patent Legal Administration
Office of the Deputy Commissioner
for Patent Examination Policy

cc: Michael J. Jaro
Medtronic, Inc.
710 Medtronic Parkway
M/S LC340
Minneapolis, MN 55432

RE: TALENT™ Abdominal Stent Graft System
Docket No.: FDA-2008-E-0568



DEPARTMENT OF HEALTH & HUMAN SERVICES

Food and Drug Administration
Rockville MD 20857

Re: Talent Abdominal Stent Graft System
Docket No.: FDA-2008-E-0568

AUG 19 2009

The Honorable Jon Dudas
Undersecretary of Commerce for Intellectual Property
Director of the United States Patent and Trademark Office
Mail Stop Hatch-Waxman PTE
P.O. Box 1450
Alexandria, VA 22313-1450

Dear Director Dudas:

This is in regard to the application for patent term extension for U.S. Patent No. 6,306,141, filed by Medtronic, Inc., under 35 U.S.C. section 156 et seq. We have reviewed the dates contained in the application and have determined the regulatory review period for Talent Abdominal Stent Graft System, the medical device claimed by the patent.

The total length of the regulatory review period for Talent Abdominal Stent Graft System is 4,024 days. Of this time, 3,843 days occurred during the testing phase and 181 days occurred during the approval phase. These periods of time were derived from the following dates:

1. The date an exemption under section 520(g) of the Federal Food, Drug, and Cosmetic Act involving this device became effective: April 11, 1997.

FDA has verified the applicant's claim that the date the investigational device exemption (IDE) required under section 520(g) of the Federal Food, Drug, and Cosmetic Act for human tests to begin became effective on April 11, 1997.

2. The date the application was initially submitted with respect to the device under section 515 of the Federal Food, Drug, and Cosmetic Act: October 18, 2007.

FDA has verified the applicant's claim that the premarket approval application (PMA) for Talent Abdominal Stent Graft System (PMA P070027) was initially submitted on October 18, 2007.

3. The date the application was approved: April 15, 2008.

FDA has verified the applicant's claim that PMA P070027 was approved on April 15, 2008.

This determination of the regulatory review period by FDA does not take into account the effective date of the patent, nor does it exclude one-half of the testing phase as required by 35 U.S.C. section 156(c)(2).

Please let me know if we can be of further assistance.

Sincerely yours,

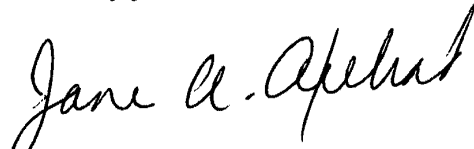

Jane A. Axelrad
Associate Director for Policy
Center for Drug Evaluation and Research

cc: Michael J. Jaro
Medtronic, Inc.
Vice President and Chief Patent Counsel
710 Medtronic Parkway M/S LC340
Minneapolis, MN 55432

2. *The date the application was initially submitted with respect to the human drug product under section 505(b) of the act:* November 17, 2005. FDA has verified the applicant's claim that the new drug application (NDA) 21-911 for BANZEL was initially submitted on November 17, 2005.

3. *The date the application was approved:* November 14, 2008. FDA has verified the applicant's claim that NDA 21-911 was approved on November 14, 2008.

This determination of the regulatory review period establishes the maximum potential length of a patent extension. However, the U.S. Patent and Trademark Office applies several statutory limitations in its calculations of the actual period for patent extension. In its application for patent extension, this applicant seeks 819 days of patent term extension.

Anyone with knowledge that any of the dates as published are incorrect may submit to the Division of Dockets Management (see **ADDRESSES**) written or electronic comments and ask for a redetermination by November 3, 2009. Furthermore, any interested person may petition FDA for a determination regarding whether the applicant for extension acted with due diligence during the regulatory review period by March 3, 2010. To meet its burden, the petition must contain sufficient facts to merit an FDA investigation. (See H. Rept. 857, part 1, 98th Cong., 2d sess., pp. 41-42, 1984.) Petitions should be in the format specified in 21 CFR 10.30.

Comments and petitions should be submitted to the Division of Dockets Management. Three copies of any mailed information are to be submitted, except that individuals may submit one copy. Comments are to be identified with the docket number found in brackets in the heading of this document. Comments and petitions may be seen in the Division of Dockets Management between 9 a.m. and 4 p.m., Monday through Friday.

Dated: June 23, 2009.

Jane A. Axelrad,

Associate Director for Policy, Center for Drug Evaluation and Research.

[FR Doc. E9-21428 Filed 9-3-09; 8:45 am]

BILLING CODE 4160-01-S

DEPARTMENT OF HEALTH AND HUMAN SERVICES

Food and Drug Administration

[Docket No. FDA-2008-E-0568]

Determination of Regulatory Review Period for Purposes of Patent Extension; TALENT ABDOMINAL STENT GRAFT SYSTEM

AGENCY: Food and Drug Administration, HHS.

ACTION: Notice.

SUMMARY: The Food and Drug Administration (FDA) has determined the regulatory review period for TALENT ABDOMINAL STENT GRAFT SYSTEM and is publishing this notice of that determination as required by law. FDA has made the determination because of the submission of an application to the Director of Patents and Trademarks, Department of Commerce, for the extension of a patent which claims that medical device.

ADDRESSES: Submit written comments and petitions to the Division of Dockets Management (HFA-305), Food and Drug Administration, 5630 Fishers Lane, rm. 1061, Rockville, MD 20852. Submit electronic comments to <http://www.regulations.gov>.

FOR FURTHER INFORMATION CONTACT: Beverly Friedman, Office of Regulatory Policy, Food and Drug Administration, 10903 New Hampshire Ave., Bldg. 51, rm. 6222, Silver Spring, MD 20993-0002, 301-796-3602.

SUPPLEMENTARY INFORMATION: The Drug Price Competition and Patent Term Restoration Act of 1984 (Public Law 98-417) and the Generic Animal Drug and Patent Term Restoration Act (Public Law 100-670) generally provide that a patent may be extended for a period of up to 5 years so long as the patented item (human drug product, animal drug product, medical device, food additive, or color additive) was subject to regulatory review by FDA before the item was marketed. Under these acts, a product's regulatory review period forms the basis for determining the amount of extension an applicant may receive.

A regulatory review period consists of two periods of time: A testing phase and an approval phase. For medical devices, the testing phase begins with a clinical investigation of the device and runs until the approval phase begins. The approval phase starts with the initial submission of an application to market the device and continues until permission to market the device is granted. Although only a portion of a

regulatory review period may count toward the actual amount of extension that the Director of Patents and Trademarks may award (half the testing phase must be subtracted as well as any time that may have occurred before the patent was issued), FDA's determination of the length of a regulatory review period for a medical device will include all of the testing phase and approval phase as specified in 35 U.S.C. 156(g)(3)(B).

FDA recently approved for marketing the medical device, TALENT ABDOMINAL STENT GRAFT SYSTEM. The TALENT ABDOMINAL STENT GRAFT SYSTEM is indicated for the endovascular treatment of abdominal aortic aneurysms with or without iliac involvement having: Iliac/femoral access vessel morphology that is compatible with vascular access techniques, devices, and/or accessories; a proximal aortic neck length of ≥ 10 millimeters (mm); proximal aortic neck angulation $\leq 60^\circ$ distal iliac artery fixation length of ≥ 15 mm; an aortic neck diameter of 18 to 32 mm and iliac artery diameters of 8 to 22 mm; and vessel morphology suitable for endovascular repair. Subsequent to this approval, the Patent and Trademark Office received a patent term restoration application for TALENT ABDOMINAL STENT GRAFT SYSTEM (U.S. Patent No. 6,306,141) from Medtronic, Inc., and the Patent and Trademark Office requested FDA's assistance in determining this patent's eligibility for patent term restoration. In a letter dated February 18, 2009, FDA advised the Patent and Trademark Office that this medical device had undergone a regulatory review period and that the approval of TALENT ABDOMINAL STENT GRAFT SYSTEM represented the first permitted commercial marketing or use of the product. Thereafter, the Patent and Trademark Office requested that FDA determine the product's regulatory review period.

FDA has determined that the applicable regulatory review period for TALENT ABDOMINAL STENT GRAFT SYSTEM is 4,024 days. Of this time, 3,843 days occurred during the testing phase of the regulatory review period, while 181 days occurred during the approval phase. These periods of time were derived from the following dates:

1. *The date an exemption under section 520(g) of the Federal Food, Drug, and Cosmetic Act (the act) (21 U.S.C. 360j(g)) involving this device became effective:* April 11, 1997. FDA has verified the applicant's claim that the date the investigational device exemption (IDE) required under section

520(g) of the act for human tests to begin became effective April 11, 1997.

2. *The date an application was initially submitted with respect to the device under section 515 of the act (21 U.S.C. 360e):* October 18, 2007. FDA has verified the applicant's claim that the premarket approval application (PMA) for TALENT ABDOMINAL STENT GRAFT SYSTEM (PMA P070027) was initially submitted October 18, 2007.

3. *The date the application was approved:* April 15, 2008. FDA has verified the applicant's claim that PMA P070027 was approved on April 15, 2008.

This determination of the regulatory review period establishes the maximum potential length of a patent extension. However, the U.S. Patent and Trademark Office applies several statutory limitations in its calculations of the actual period for patent extension. In its application for patent extension, this applicant seeks 1,183 days of patent term extension.

Anyone with knowledge that any of the dates as published are incorrect may submit to the Division of Dockets Management (see ADDRESSES) written or electronic comments and ask for a redetermination by November 3, 2009. Furthermore, any interested person may petition FDA for a determination regarding whether the applicant for extension acted with due diligence during the regulatory review period by March 3, 2010. To meet its burden, the petition must contain sufficient facts to merit an FDA investigation. (See H. Rept. 857, part 1, 98th Cong., 2d sess., pp. 41–42, 1984.) Petitions should be in the format specified in 21 CFR 10.30.

Comments and petitions should be submitted to the Division of Dockets Management. Three copies of any mailed information are to be submitted, except that individuals may submit one copy. Comments are to be identified with the docket number found in brackets in the heading of this document.

Comments and petitions may be seen in the Division of Dockets Management between 9 a.m. and 4 p.m., Monday through Friday.

Dated: June 8, 2009.

Jane A. Axelrad,
Associate Director for Policy, Center for Drug Evaluation and Research.

[FR Doc. E9-21424 Filed 9-3-09; 8:45 am]

BILLING CODE 4160-01-S

DEPARTMENT OF HEALTH AND HUMAN SERVICES

National Institutes of Health

Government-Owned Inventions; Availability for Licensing

AGENCY: National Institutes of Health, Public Health Service, HHS.

ACTION: Notice.

SUMMARY: The inventions listed below are owned by an agency of the U.S. Government and are available for licensing in the U.S. in accordance with 35 U.S.C. 207 to achieve expeditious commercialization of results of federally-funded research and development. Foreign patent applications are filed on selected inventions to extend market coverage for companies and may also be available for licensing.

ADDRESSES: Licensing information and copies of the U.S. patent applications listed below may be obtained by writing to the indicated licensing contact at the Office of Technology Transfer, National Institutes of Health, 6011 Executive Boulevard, Suite 325, Rockville, Maryland 20852-3804; telephone: 301/496-7057; fax: 301/402-0220. A signed Confidential Disclosure Agreement will be required to receive copies of the patent applications.

Antigenic Chimeric Tick-Borne Encephalitis Virus/Dengue Virus Type 4 Recombinant Viruses

Description of Technology: The tick-borne encephalitis virus (TBEV) complex is a group of viruses that can cause severe neurotropic disease and up to thirty percent (30%) mortality. While these viruses can be found in many parts of the world, the largest impact of the disease occurs in Europe and Russia, where approximately fourteen thousand (14,000) hospitalized TBEV cases occur annually. TBEV is in the family Flaviviridae, genus flavivirus and is composed of a positive-sense single stranded RNA genome that contains 5' and 3' non-coding regions and a single open reading frame encoding ten (10) proteins. At present, a vaccine or FDA approved antiviral therapy is not available.

The inventors have previously developed a WNV/Dengue4Delta30 antigenic chimeric virus as a live attenuated virus vaccine candidate that contains the WNV premembrane and envelope (prM and E) proteins on a dengue virus type 4 (DEN4) genetic background with a thirty nucleotide deletion (Delta30) in the DEN4 3'-UTR. Using a similar strategy, the inventors

have generated an antigenic chimeric virus, TBEV/DEN4Delta30. This chimeric virus also contains attenuating mutations within the E and nonstructural NS5 proteins. Preclinical testing results with the derived virus indicate that chimerization of TBEV with DEN4Delta30 and introduction of the attenuating mutations decreased neuroinvasiveness and neurovirulence in mice. The TBEV/DEN4delta30 vaccine candidate was safe, immunogenic, and provided protection in monkeys against challenge with TBE viruses.

This application claims live attenuated chimeric TBEV/DEN4Delta30 vaccine compositions. Also claimed are methods of treating or preventing TBEV infection in a mammalian host, methods of producing a subunit vaccine composition, isolated polynucleotides comprising a nucleotide sequence encoding a TBEV immunogen, methods for detecting TBEV infection in a biological sample and infectious chimeric TBEV.

Applications: Development of Tick-Borne Encephalitis Virus vaccines, therapeutics and diagnostics.

Advantages: Live attenuated chimeric vaccine, known regulatory pathway, potential for lasting immunity with fewer doses.

Development Status: Vaccine candidates have been synthesized and preclinical studies have been performed.

Inventors: Alexander G. Pletnev, Amber R. Engel, Brian R. Murphy (NIAID).

Patent Status: U.S. Provisional Application No. 61/181,982 filed 28 May 2009 (HHS Reference No. E-078-2009/0-US-01).

Licensing Status: Available for licensing.

Licensing Contact: Peter A. Soukas, J.D.; 301-435-4646; soukasp@mail.nih.gov.

Collaborative Research Opportunity: The NIAID is seeking statements of capability or interest from parties interested in collaborative research in preclinical study of the long-term immunity induced by the TBEV/DEN4 vaccine candidate against highly virulent TBE viruses and in the clinical trials of this vaccine in humans. Please contact Michael Piziali, NIAID Office of Technology Development, at 301-496-2644 for more information.

Monoclonal Antibodies That React With the Capsule of *Bacillus anthracis*

Description of Technology: *Bacillus anthracis* is the causative agent of anthrax and is surrounded by a



Department of Health and Human Services

Public Health Service

MAY 14 2010

Food and Drug Administration
Rockville, MD 20857

Re: Talent Abdominal Stent Graft System
Docket No. FDA-2008-E-0568

The Honorable David J. Kappos
Under Secretary of Commerce for Intellectual Property
Director of the United States Patent and Trademark Office
Mail Stop Hatch-Waxman PTE
P.O. Box 1450
Alexandria, VA 22313-1450

Dear Director Kappos:

This is in regard to the patent term extension application for U.S. Patent No. 6,306,141 filed by Medtronic, Inc. under 35 U.S.C. § 156. The patent claims Talent Abdominal Stent Graft System, premarket approval application (PMA) P070027.

In the September 4, 2009, issue of the Federal Register (74 Fed. Reg. 45865), the Food and Drug Administration published its determination of this product's regulatory review period, as required under 35 U.S.C. § 156(d)(2)(A). The notice provided that on or before March 3, 2010, 180 days after the publication of the determination, any interested person could file a petition with FDA under 35 U.S.C. § 156(d)(2)(B)(i) for a determination of whether the patent term extension applicant acted with due diligence during the regulatory review period.

The 180-day period for filing a due diligence petition pursuant to this notice has expired and FDA has received no such petition. Therefore, FDA considers the regulatory review period determination to be final.

Please let me know if we can provide further assistance.

Sincerely yours,

Jane A. Axelrad
Associate Director for Policy
Center for Drug Evaluation and Research

cc: Michael J. Jaro
Medtronic, Inc.
Vice President and Chief Patent Counsel
710 Medtronic Parkway M/S LC340
Minneapolis, MN 55432



MAR 23 2011

Michael J. Jaro
Medtronic, Inc.
710 Medtronic Parkway
M/S LC340
Minneapolis, MN 55432

In Re: Patent Term Extension
Application for
U.S. Patent No. 6,306,141

NOTICE OF FINAL DETERMINATION

A determination has been made that U.S. Patent No. 6,306,141, claims of which cover the medical device TALENT® Abdominal Stent Graft System, is eligible for patent term extension under 35 U.S.C. § 156. The period of extension has been determined to be 1,270 days.

A single request for reconsideration of this final determination as to the length of extension of the term of the patent may be made if filed within one month of the date of this notice. Extensions of time under 37 CFR § 1.136(a) are not applicable to this time period. In the absence of a request for reconsideration, the Director will issue a certificate of extension, under seal, for a period of 1,270 days.

The period of extension, if calculated using the Food and Drug Administration determination of the length of the regulatory review period published in the Federal Register of September 4, 2009 (74 Fed. Reg. 45865), would be 1,274 days. Under 35 U.S.C. § 156(c):

$$\begin{aligned}
\text{Period of Extension} &= \text{RRP} - \text{PGRRP} - \text{DD} - \frac{1}{2}(\text{TP} - \text{PGTP})^1 \\
&= 4,024 \text{ days} - 1,657 - 0 - \frac{1}{2}(3,843 - 1,657 \text{ days}) \\
&= 1,274 \text{ days (3.5 years)}
\end{aligned}$$

Since the regulatory review period began April 11, 1997, before the patent issued (October 23, 2001), only that portion of the regulatory review period occurring after the date the patent issued has been considered in the above determination of the length of the extension period 35 U.S.C. § 156(c). (From April 11, 1997, to and including October 23, 2001, is 1,657 days; this period is subtracted from the number of days occurring in the testing phase according to the FDA determination of the length of the regulatory review period.) No determination of a lack of due diligence under 35 U.S.C. § 156(c)(1) was made.

¹ Consistent with 35 U.S.C. § 156(c), “RRP” is the total number of days in the regulatory review period, “PGRRP” is the number of days of the RRP which were on and before the date on which the patent issued, “DD” is the number of days of the RRP that the applicant did not act with due diligence, “TP” is the testing phase period described in paragraphs (1)(B)(i), (2)(B)(i), (3)(B)(i), (4)(B)(i), and (5)(B)(i) of subsection (g) of 35 U.S.C. § 156, and “PGTP” is the number of days of the TP which were on and before the date on which the patent issued, wherein half days are ignored for purposes of the subtraction of ½ (TP - PGTP).

However, the 14 year exception of 35 U.S.C. § 156(c)(3) operates to limit the term of the extension in the present situation, because it provides that the period remaining in the term of the patent measured from the date of approval of the approved product plus any patent term extension cannot exceed fourteen years. The period of extension calculated above, 1,274 days, would extend the patent from October 23, 2018, to April 19, 2022, which is beyond the 14-year limit (the approval date is April 15, 2008, thus the 14 year limit is April 15, 2022). The period of extension is thus limited to April 15, 2022, by operation of 35 U.S.C. § 156(c)(3). Accordingly, the period of extension is the number of days to extend the term of the patent from its original expiration date, October 23, 2018, to and including April 15, 2022, or 1,270 days.

The limitations of 35 U.S.C. 156(g)(6) do not operate to further reduce the period of extension determined above.

Upon issuance of the certificate of extension, the following information will be published in the Official Gazette:

U.S. Patent No.:	6,306,141
Granted:	October 23, 2001
Original Expiration Date ² :	October 23, 2018
Applicant:	James E. Jervis
Owner of Record:	Medtronic, Inc.
Title:	Medical Devices Incorporating SIM Alloy Elements
Product Trade Name:	TALENT® Abdominal Stent Graft System
Term Extended:	1,270 days
Expiration Date of Extension:	April 15, 2022

Any correspondence with respect to this matter should be addressed as follows:

By mail:	Mail Stop Hatch-Waxman PTE	By FAX:	(571) 273-7728
	Commissioner for Patents		
	P.O. Box 1450		
	Alexandria, VA 22313-1450.		

²Subject to the provisions of 35 U.S.C. § 41(b).

Telephone inquiries related to this determination should be directed to Raul Tamayo at (571) 272-7728.



Mary C. Till
Senior Legal Advisor
Office of Patent Legal Administration
Office of the Associate Commissioner
for Patent Examination Policy

cc: Office of Regulatory Policy
Food and Drug Administration
10903 New Hampshire Ave., Bldg. 51, Rm. 6222
Silver Spring, MD 20993-0002

RE: TALENT® Abdominal Stent
Graft System
Docket No.: FDA-2008-E-0568

Attention: Beverly Friedman



UNITED STATES PATENT AND TRADEMARK OFFICE

JUL 5 2011

Commissioner for Patents
United States Patent and Trademark Office
P.O. Box 1450
Alexandria, VA 22313-1450
www.uspto.gov

Michael J. Jaro
Medtronic, Inc.
710 Medtronic Parkway
M/S LC340
Minneapolis, MN 55432

In Re: Patent Term Extension
Application for
U.S. Patent No. 6,306,141

Dear Mr. Jaro:

A certificate under 35 U.S.C. § 156 is enclosed extending the term of U.S. Patent No. 6,306,141 for a period of 1,270 days. While a courtesy copy of this letter is being forwarded to the Food and Drug Administration (FDA), you should directly correspond with the FDA regarding any required changes to patent expiration dates.

Inquiries regarding this communication should be directed to Raul Tamayo by telephone at (571) 272-7728, or by e-mail at raul.tamayo@uspto.gov.



Mary C. Till
Senior Legal Advisor
Office of Patent Legal Administration
Office of the Associate Commissioner
for Patent Examination Policy

cc: Office of Regulatory Policy
Food and Drug Administration
10903 New Hampshire Ave., Bldg. 51, Rm. 6222
Silver Spring, MD 20993-0002

RE: TALENT® Abdominal Stent
Graft System
FDA Docket No.: FDA-2008-E-0568

Attention: Beverly Friedman

UNITED STATES PATENT AND TRADEMARK OFFICE

(12) CERTIFICATE EXTENDING PATENT TERM
UNDER 35 U.S.C. § 156

(68) PATENT NO. : 6,306,141
(45) ISSUED : October 23, 2001
(75) INVENTOR : James E. Jervis
(73) PATENT OWNER : Medtronic, Inc.
(95) PRODUCT : TALENT® Abdominal Stent Graft System

This is to certify that an application under 35 U.S.C. § 156 has been filed in the United States Patent and Trademark Office, requesting extension of the term of U.S. Patent No. 6,306,141 based upon the regulatory review of the product TALENT® Abdominal Stent Graft System by the Food and Drug Administration. Since it appears that the requirements of the law have been met, this certificate extends the term of the patent for the period of

(94) 1,270 days

from October 23, 2018, the original expiration date of the patent, subject to the payment of maintenance fees as provided by law, with all rights pertaining thereto as provided by 35 U.S.C. § 156(b).



I have caused the seal of the United States Patent and Trademark Office to be affixed this 30th day of June 2011.

David J. Kappos

David J. Kappos
Under Secretary of Commerce for Intellectual Property and
Director of the United States Patent and Trademark Office



08/483291 [Handwritten initials]

ALSTON & BIRD LLP

One Atlantic Center
1201 West Peachtree Street
Atlanta, GA 30309-3424

404-881-7000
Fax: 404-253-8216
www.alston.com

Christopher B. Kelly

Direct Dial: 404-881-4416

Email: chris.kelly@alston.com

May 7, 2013

VIA UPS NEXT-DAY AIR DELIVERY

Mail Stop PATENT BOARD
Patent Trial and Appeal Board
United States Patent and Trademark Office
P.O. Box 1450
Alexandria, VA 22313-1450

Re: Motion to Submit Exhibit for IPR2013-00269

To Whom it May Concern:

Pursuant to the Motion to Submit Exhibit filed on May 6, 2013 by Petitioner Lombard Medical Technologies PLC ("Petitioner") in *Inter Partes* Review case number IPR2013-00269, please find enclosed three compact discs containing Lombard Exhibit 1016, Lombard Exhibit 1017, and Lombard Exhibit 1026, respectively.

In accordance with the PRPS guidelines, these exhibits were initially prepared for submission in MPEG-4 Part 14 format (.mp4), each having a file size less than 25 megabytes. The PRPS system was unable to accept these files and Petitioner's counsel was informed by the Patent Trial and Appeal Board (PTAB) that only earlier versions of the MPEG standard could be accepted by the PRPS system. Accordingly, the enclosed CDs contain the exhibits in the earlier .mpg format.

As the .mpg format causes the size of the files to increase above the 25 megabyte limit of the PRPS system, Petitioner's counsel was asked by the PTAB to file the enclosed Motion to Submit Exhibit along with its Petition for *Inter Partes* Review of U.S. Patent No. 6,306,141 and forward CDs containing the Exhibit files to the PTAB. Accordingly, the enclosed Motion was filed with the Petition on May 6, 2013 via the PRPS system, and the requested CDs containing Lombard Exhibits 1016, 1017, and 1026 are now enclosed for consideration by the PTAB.

Should the PTAB have any questions or concerns regarding this matter, they are encouraged to contact the undersigned Petitioner's counsel at (404) 881-4416.

May 7, 2013
Page 2

Sincerely,

A handwritten signature in black ink, appearing to read "C. B. Kelly". The signature is fluid and cursive, with the first and last letters of each name being capitalized and prominent.

Christopher B. Kelly
Reg. No. 62,573
Backup Counsel for Petitioner
ALSTON & BIRD LLP

Enclosure

cc: Steven D. Hemminger, Reg. No. 30,755
Lead Counsel for Petitioner

ARTIFACT SHEET

Enter artifact number below. Artifact number is application number + artifact type code (see list below) + sequential letter (A, B, C ...). The first artifact folder for an artifact type receives the letter A, the second B, etc..
Examples: 59123456PA, 59123456PB, 59123456ZA, 59123456ZB

08483291VA

Indicate quantity of a single type of artifact received but not scanned. Create individual artifact folder/box and artifact number for each Artifact Type.

CD(s) containing:

computer program listing

Doc Code: Computer

pages of specification

and/or sequence listing

and/or table

Doc Code: Artifact

content unspecified or combined

Doc Code: Artifact

Artifact Type Code: P

Artifact Type Code: S

Artifact Type Code: U

Stapled Set(s) Color Documents or B/W Photographs

Doc Code: Artifact Artifact Type Code: C

Microfilm(s)

Doc Code: Artifact Artifact Type Code: F

Video tape(s)

Doc Code: Artifact Artifact Type Code: V

Model(s)

Doc Code: Artifact Artifact Type Code: M

Bound Document(s)

Doc Code: Artifact Artifact Type Code: B

Confidential Information Disclosure Statement or Other Documents
marked Proprietary, Trade Secrets, Subject to Protective Order,
Material Submitted under MPEP 724.02, etc.

Doc Code: Artifact Artifact Type Code X

Other, description: _____

Doc Code: Artifact Artifact Type Code: Z

March 8, 2004

Under the Paperwork Reduction Act of 1995, no persons are required to respond to a collection of information unless it displays a valid OMB control number.

CHANGE OF CORRESPONDENCE ADDRESS <i>Patent</i> Address to: Mail Stop Post Issue Commissioner for Patents P.O. Box 1450 Alexandria, VA 22313-1450	Patent Number	6,306,141
	Issue Date	October 23,2001
	Application Number	08/483,291
	Filing Date	June 7, 1995
	First Named Inventor	JERVIS, James E.
	Attorney Docket Number	G25108

Please change the Correspondence Address for the above-identified patent to:

The address associated with Customer Number: 28390

OR

Firm or Individual Name

Address

City	State	ZIP
Country		
Telephone	Email	

This form cannot be used to change the data associated with a Customer Number. To change the data associated with an existing Customer Number use "Request for Customer Number Data Change" (PTO/SB/124).

This form will not affect any "fee address" provided for the above-identified patent. To change a "fee address" use the "Fee Address Indication Form" (PTO/SB/47).

I am the:

Patentee.

If the Patentee was not the applicant for patent (37 CFR 1.42), then a Statement under 37 CFR 3.73(c) (Form PTO/AIA/96 or equivalent) is enclosed or was filed on _____. See 37 CFR 3.71.

Attorney or agent of record. Registration Number 44,881.

Patent practitioner acting in a representative capacity whose correspondence address is the correspondence address of record. Notice has been given to the patentee or owner. Registration Number 44,881.

Signature /Theodore P. Lopez/

Typed or Printed Name Theodore P. Lopez

Date May 16, 2013 Telephone (707) 591-2839

NOTE: This form must be signed in accordance with 37 CFR 1.33. See 37 CFR 1.4(d) for signature requirements and certifications. Submit multiple forms if more than one signature is required, see below*.

*Total of _____ forms are submitted.

This collection of information is required by 37 CFR 1.33. The information is required to obtain or retain a benefit by the public which is to file (and by the USPTO to process) an application. Confidentiality is governed by 35 U.S.C. 122 and 37 CFR 1.11 and 1.14. This collection is estimated to take 3 minutes to complete, including gathering, preparing, and submitting the completed application form to the USPTO. Time will vary depending upon the individual case. Any comments on the amount of time you require to complete this form and/or suggestions for reducing this burden, should be sent to the Chief Information Officer, U.S. Patent and Trademark Office, U.S. Department of Commerce, P.O. Box 1450, Alexandria, VA 22313-1450. DO NOT SEND FEES OR COMPLETED FORMS TO THIS ADDRESS. **SEND TO: Mail Stop Post Issue, Commissioner for Patents, P.O. Box 1450, Alexandria, VA 22313-1450.**

If you need assistance in completing the form, call 1-800-PTO-9199 and select option 2.

Privacy Act Statement

The **Privacy Act of 1974 (P.L. 93-579)** requires that you be given certain information in connection with your submission of the attached form related to a patent application or patent. Accordingly, pursuant to the requirements of the Act, please be advised that: (1) the general authority for the collection of this information is 35 U.S.C. 2(b)(2); (2) furnishing of the information solicited is voluntary; and (3) the principal purpose for which the information is used by the U.S. Patent and Trademark Office is to process and/or examine your submission related to a patent application or patent. If you do not furnish the requested information, the U.S. Patent and Trademark Office may not be able to process and/or examine your submission, which may result in termination of proceedings or abandonment of the application or expiration of the patent.

The information provided by you in this form will be subject to the following routine uses:

1. The information on this form will be treated confidentially to the extent allowed under the Freedom of Information Act (5 U.S.C. 552) and the Privacy Act (5 U.S.C. 552a). Records from this system of records may be disclosed to the Department of Justice to determine whether disclosure of these records is required by the Freedom of Information Act.
2. A record from this system of records may be disclosed, as a routine use, in the course of presenting evidence to a court, magistrate, or administrative tribunal, including disclosures to opposing counsel in the course of settlement negotiations.
3. A record in this system of records may be disclosed, as a routine use, to a Member of Congress submitting a request involving an individual, to whom the record pertains, when the individual has requested assistance from the Member with respect to the subject matter of the record.
4. A record in this system of records may be disclosed, as a routine use, to a contractor of the Agency having need for the information in order to perform a contract. Recipients of information shall be required to comply with the requirements of the Privacy Act of 1974, as amended, pursuant to 5 U.S.C. 552a(m).
5. A record related to an International Application filed under the Patent Cooperation Treaty in this system of records may be disclosed, as a routine use, to the International Bureau of the World Intellectual Property Organization, pursuant to the Patent Cooperation Treaty.
6. A record in this system of records may be disclosed, as a routine use, to another federal agency for purposes of National Security review (35 U.S.C. 181) and for review pursuant to the Atomic Energy Act (42 U.S.C. 218(c)).
7. A record from this system of records may be disclosed, as a routine use, to the Administrator, General Services, or his/her designee, during an inspection of records conducted by GSA as part of that agency's responsibility to recommend improvements in records management practices and programs, under authority of 44 U.S.C. 2904 and 2906. Such disclosure shall be made in accordance with the GSA regulations governing inspection of records for this purpose, and any other relevant (*i.e.*, GSA or Commerce) directive. Such disclosure shall not be used to make determinations about individuals.
8. A record from this system of records may be disclosed, as a routine use, to the public after either publication of the application pursuant to 35 U.S.C. 122(b) or issuance of a patent pursuant to 35 U.S.C. 151. Further, a record may be disclosed, subject to the limitations of 37 CFR 1.14, as a routine use, to the public if the record was filed in an application which became abandoned or in which the proceedings were terminated and which application is referenced by either a published application, an application open to public inspection or an issued patent.
9. A record from this system of records may be disclosed, as a routine use, to a Federal, State, or local law enforcement agency, if the USPTO becomes aware of a violation or potential violation of law or regulation.

Under the Paperwork Reduction Act of 1995, no persons are required to respond to a collection of information unless it displays a valid OMB control number.

STATEMENT UNDER 37 CFR 3.73(b)

Applicant/Patent Owner: Medtronic, Inc.

Application No./Patent No.: 6,306,141 Filed/Issue Date: October 23, 2001

Titled: Medical Devices Incorporating Sim Alloy Elements

Medtronic, Inc., a Corporation

(Name of Assignee) (Type of Assignee, e.g., corporation, partnership, university, government agency, etc.)

states that it is:

- 1. the assignee of the entire right, title, and interest in;
- 2. an assignee of less than the entire right, title, and interest in (The extent (by percentage) of its ownership interest is _____ %); or
- 3. the assignee of an undivided interest in the entirety of (a complete assignment from one of the joint inventors was made)

the patent application/patent identified above, by virtue of either:

A. An assignment from the inventor(s) of the patent application/patent identified above. The assignment was recorded in the United States Patent and Trademark Office at Reel 008907, Frame 0388, or for which a copy therefore is attached.

OR

B. A chain of title from the inventor(s), of the patent application/patent identified above, to the current assignee as follows:

1. From: _____ To: _____

The document was recorded in the United States Patent and Trademark Office at Reel _____, Frame _____, or for which a copy thereof is attached.

2. From: _____ To: _____

The document was recorded in the United States Patent and Trademark Office at Reel _____, Frame _____, or for which a copy thereof is attached.

3. From: _____ To: _____

The document was recorded in the United States Patent and Trademark Office at Reel _____, Frame _____, or for which a copy thereof is attached.

Additional documents in the chain of title are listed on a supplemental sheet(s).

As required by 37 CFR 3.73(b)(1)(i), the documentary evidence of the chain of title from the original owner to the assignee was, or concurrently is being, submitted for recordation pursuant to 37 CFR 3.11.

[NOTE: A separate copy (i.e., a true copy of the original assignment document(s)) must be submitted to Assignment Division in accordance with 37 CFR Part 3, to record the assignment in the records of the USPTO. See MPEP 302.08]

The undersigned (whose title is supplied below) is authorized to act on behalf of the assignee.

/Theodore P. Lopez/
Signature

May 20, 2013
Date

Theodore P. Lopez
Printed or Typed Name

Patent Counsel III
Title

This collection of information is required by 37 CFR 3.73(b). The information is required to obtain or retain a benefit by the public which is to file (and by the USPTO to process) an application. Confidentiality is governed by 35 U.S.C. 122 and 37 CFR 1.11 and 1.14. This collection is estimated to take 12 minutes to complete, including gathering, preparing, and submitting the completed application form to the USPTO. Time will vary depending upon the individual case. Any comments on the amount of time you require to complete this form and/or suggestions for reducing this burden, should be sent to the Chief Information Officer, U.S. Patent and Trademark Office, U.S. Department of Commerce, P.O. Box 1450, Alexandria, VA 22313-1450. DO NOT SEND FEES OR COMPLETED FORMS TO THIS ADDRESS. SEND TO: Commissioner for Patents, P.O. Box 1450, Alexandria, VA 22313-1450.

If you need assistance in completing the form, call 1-800-PTO-9199 and select option 2.

Privacy Act Statement

The **Privacy Act of 1974 (P.L. 93-579)** requires that you be given certain information in connection with your submission of the attached form related to a patent application or patent. Accordingly, pursuant to the requirements of the Act, please be advised that: (1) the general authority for the collection of this information is 35 U.S.C. 2(b)(2); (2) furnishing of the information solicited is voluntary; and (3) the principal purpose for which the information is used by the U.S. Patent and Trademark Office is to process and/or examine your submission related to a patent application or patent. If you do not furnish the requested information, the U.S. Patent and Trademark Office may not be able to process and/or examine your submission, which may result in termination of proceedings or abandonment of the application or expiration of the patent.

The information provided by you in this form will be subject to the following routine uses:

1. The information on this form will be treated confidentially to the extent allowed under the Freedom of Information Act (5 U.S.C. 552) and the Privacy Act (5 U.S.C. 552a). Records from this system of records may be disclosed to the Department of Justice to determine whether disclosure of these records is required by the Freedom of Information Act.
2. A record from this system of records may be disclosed, as a routine use, in the course of presenting evidence to a court, magistrate, or administrative tribunal, including disclosures to opposing counsel in the course of settlement negotiations.
3. A record in this system of records may be disclosed, as a routine use, to a Member of Congress submitting a request involving an individual, to whom the record pertains, when the individual has requested assistance from the Member with respect to the subject matter of the record.
4. A record in this system of records may be disclosed, as a routine use, to a contractor of the Agency having need for the information in order to perform a contract. Recipients of information shall be required to comply with the requirements of the Privacy Act of 1974, as amended, pursuant to 5 U.S.C. 552a(m).
5. A record related to an International Application filed under the Patent Cooperation Treaty in this system of records may be disclosed, as a routine use, to the International Bureau of the World Intellectual Property Organization, pursuant to the Patent Cooperation Treaty.
6. A record in this system of records may be disclosed, as a routine use, to another federal agency for purposes of National Security review (35 U.S.C. 181) and for review pursuant to the Atomic Energy Act (42 U.S.C. 218(c)).
7. A record from this system of records may be disclosed, as a routine use, to the Administrator, General Services, or his/her designee, during an inspection of records conducted by GSA as part of that agency's responsibility to recommend improvements in records management practices and programs, under authority of 44 U.S.C. 2904 and 2906. Such disclosure shall be made in accordance with the GSA regulations governing inspection of records for this purpose, and any other relevant (*i.e.*, GSA or Commerce) directive. Such disclosure shall not be used to make determinations about individuals.
8. A record from this system of records may be disclosed, as a routine use, to the public after either publication of the application pursuant to 35 U.S.C. 122(b) or issuance of a patent pursuant to 35 U.S.C. 151. Further, a record may be disclosed, subject to the limitations of 37 CFR 1.14, as a routine use, to the public if the record was filed in an application which became abandoned or in which the proceedings were terminated and which application is referenced by either a published application, an application open to public inspection or an issued patent.
9. A record from this system of records may be disclosed, as a routine use, to a Federal, State, or local law enforcement agency, if the USPTO becomes aware of a violation or potential violation of law or regulation.

Electronic Acknowledgement Receipt

EFS ID:	15815290
Application Number:	08483291
International Application Number:	
Confirmation Number:	3269
Title of Invention:	MEDICAL DEVICES INCORPORATING SIM ALLOY ELEMENTS
First Named Inventor/Applicant Name:	JAMES E. JERVIS
Correspondence Address:	JEFFREY G SHELDON SHELDON & MAK 225 SOUTH LAKE AVENUE SUITE 900 - PASADENA CA 91101 US - -
Filer:	Theodore Patrick Lopez/Kimberly Wellington
Filer Authorized By:	Theodore Patrick Lopez
Attorney Docket Number:	9438-1
Receipt Date:	20-MAY-2013
Filing Date:	07-JUN-1995
Time Stamp:	12:16:21
Application Type:	Utility under 35 USC 111(a)

Payment information:

Submitted with Payment	no
------------------------	----

File Listing:

--

Document Number	Document Description	File Name	File Size(Bytes)/ Message Digest	Multi Part /.zip	Pages (if appl.)
1	Change of Address	ChgCorrespAddress.pdf	268785 11ad9b67947f757c27c54135c1f9e300f6b262	no	2
Warnings:					
Information:					
2	Assignee showing of ownership per 37 CFR 3.73.	373bsb0096.pdf	422865 2edfb5bd9c2b2b3790d083e07d88d909a577cf0	no	2
Warnings:					
Information:					
Total Files Size (in bytes):			691650		
<p>This Acknowledgement Receipt evidences receipt on the noted date by the USPTO of the indicated documents, characterized by the applicant, and including page counts, where applicable. It serves as evidence of receipt similar to a Post Card, as described in MPEP 503.</p> <p><u>New Applications Under 35 U.S.C. 111</u> If a new application is being filed and the application includes the necessary components for a filing date (see 37 CFR 1.53(b)-(d) and MPEP 506), a Filing Receipt (37 CFR 1.54) will be issued in due course and the date shown on this Acknowledgement Receipt will establish the filing date of the application.</p> <p><u>National Stage of an International Application under 35 U.S.C. 371</u> If a timely submission to enter the national stage of an international application is compliant with the conditions of 35 U.S.C. 371 and other applicable requirements a Form PCT/DO/EO/903 indicating acceptance of the application as a national stage submission under 35 U.S.C. 371 will be issued in addition to the Filing Receipt, in due course.</p> <p><u>New International Application Filed with the USPTO as a Receiving Office</u> If a new international application is being filed and the international application includes the necessary components for an international filing date (see PCT Article 11 and MPEP 1810), a Notification of the International Application Number and of the International Filing Date (Form PCT/RO/105) will be issued in due course, subject to prescriptions concerning national security, and the date shown on this Acknowledgement Receipt will establish the international filing date of the application.</p>					

UNITED STATES PATENT AND TRADEMARK OFFICE

BEFORE THE PATENT TRIAL AND APPEAL BOARD

LOMBARD MEDICAL TECHNOLOGIES PLC
Petitioner

v.

MEDTRONIC, INC.
Patent Owner

Case IPR2013-00269
Patent 6,306,141 B1

Before SALLY C. MEDLEY, STEPHEN C. SIU, and JOSIAH C. COCKS,
Administrative Patent Judges.

MEDLEY, *Administrative Patent Judge.*

JUDGMENT
Termination of the Proceeding
37 C.F.R. § 42.73

On October 21, 2013, and pursuant to 35 U.S.C. § 317(b) and 37 C.F.R. § 42.74, the parties filed a true copy of a settlement agreement along with a joint request to treat the settlement agreement as business confidential, to be kept separate from the patent file. In addition, the parties

Case IPR2013-00269
Patent 6,306,141 B1

filed a joint motion to terminate the proceeding pursuant to 35 U.S.C. § 317.

This case is in the preliminary proceeding¹ stage; no institution of a trial has been made. Based on the facts of this case, it is appropriate to enter judgment.² Therefore, the joint motion to terminate the proceeding is *granted*.

Accordingly, it is

ORDERED that the parties' joint request that the settlement agreement be treated as business confidential information, to be kept separate from the patent file is *granted*; and

FURTHER ORDERED that the joint motion to terminate the proceeding is *granted*; and

FURTHER ORDERED that the proceeding is *terminated*.

¹ A preliminary proceeding begins with the filing of a petition for instituting a trial and ends with a written decision as to whether a trial will be instituted. 37 C.F.R. § 42.2.

² A judgment means a final written decision by the Board, or a termination of a proceeding. 37 C.F.R. § 42.2.

Case IPR2013-00269
Patent 6,306,141 B1

PETITIONER:

Steven D. Hemminger
Christopher B. Kelly
ALSTON & BIRD LLP
steve.hemminger@alston.com
chris.kelly@alston.com

PATENT OWNER:

Justin J. Oliver
Daniel S. Glueck
FITZPATRICK, CELLA, HARPER & SCINTO
MEDVASCIPR@fchs.com

Under the Paperwork Reduction Act of 1995, no persons are required to respond to a collection of information unless it displays a valid OMB control number.

POWER OF ATTORNEY OR REVOCAION OF POWER OF ATTORNEY WITH A NEW POWER OF ATTORNEY AND CHANGE OF CORRESPONDENCE ADDRESS	Application Number	08/483,291
	Filing Date	June 7, 1995
	First Named Inventor	JERVIS, James E.
	Title	Medical Devices Incorporating Sim Alloy Elements
	Art Unit	3764
	Examiner Name	YU, Justine R.
	Attorney Docket Number	PA0007268.07

I hereby revoke all previous powers of attorney given in the above-identified application.

A Power of Attorney is submitted herewith.

OR

I hereby appoint Practitioner(s) associated with the following Customer Number as my/our attorney(s) or agent(s) to prosecute the application identified above, and to transact all business in the United States Patent and Trademark Office connected therewith:

28390

OR

I hereby appoint Practitioner(s) named below as my/our attorney(s) or agent(s) to prosecute the application identified above, and to transact all business in the United States Patent and Trademark Office connected therewith:

Practitioner(s) Name	Registration Number

Please recognize or change the correspondence address for the above-identified application to:

The address associated with the above-mentioned Customer Number.

OR

The address associated with Customer Number:

<input type="checkbox"/> Firm or Individual Name			
Address			
City	State	Zip	
Country			
Telephone	Email		

I am the:

Applicant/Inventor.

OR

Assignee of record of the entire interest. See 37 CFR 3.71.
Statement under 37 CFR 3.73(b) (Form PTO/SB/96) submitted herewith or filed on May 20, 2013.

SIGNATURE of Applicant or Assignee of Record

Signature	/Theodore P. Lopez/	Date	January 23, 2014
Name	Theodore P. Lopez	Telephone	+1 (707) 591-2839
Title and Company	Patent Counsel III, Medtronic, Inc.		

NOTE: Signatures of all the inventors or assignees of record of the entire interest or their representative(s) are required. Submit multiple forms if more than one signature is required, see below*.

*Total of _____ forms are submitted.

This collection of information is required by 37 CFR 1.31, 1.32 and 1.33. The information is required to obtain or retain a benefit by the public which is to file (and by the USPTO to process) an application. Confidentiality is governed by 35 U.S.C. 122 and 37 CFR 1.11 and 1.14. This collection is estimated to take 3 minutes to complete, including gathering, preparing, and submitting the completed application form to the USPTO. Time will vary depending upon the individual case. Any comments on the amount of time you require to complete this form and/or suggestions for reducing this burden, should be sent to the Chief Information Officer, U.S. Patent and Trademark Office, U.S. Department of Commerce, P.O. Box 1450, Alexandria, VA 22313-1450. DO NOT SEND FEES OR COMPLETED FORMS TO THIS ADDRESS. SEND TO: **Commissioner for Patents, P.O. Box 1450, Alexandria, VA 22313-1450.**

If you need assistance in completing the form, call 1-800-PTO-9199 and select option 2.

Privacy Act Statement

The **Privacy Act of 1974 (P.L. 93-579)** requires that you be given certain information in connection with your submission of the attached form related to a patent application or patent. Accordingly, pursuant to the requirements of the Act, please be advised that: (1) the general authority for the collection of this information is 35 U.S.C. 2(b)(2); (2) furnishing of the information solicited is voluntary; and (3) the principal purpose for which the information is used by the U.S. Patent and Trademark Office is to process and/or examine your submission related to a patent application or patent. If you do not furnish the requested information, the U.S. Patent and Trademark Office may not be able to process and/or examine your submission, which may result in termination of proceedings or abandonment of the application or expiration of the patent.

The information provided by you in this form will be subject to the following routine uses:

1. The information on this form will be treated confidentially to the extent allowed under the Freedom of Information Act (5 U.S.C. 552) and the Privacy Act (5 U.S.C. 552a). Records from this system of records may be disclosed to the Department of Justice to determine whether disclosure of these records is required by the Freedom of Information Act.
2. A record from this system of records may be disclosed, as a routine use, in the course of presenting evidence to a court, magistrate, or administrative tribunal, including disclosures to opposing counsel in the course of settlement negotiations.
3. A record in this system of records may be disclosed, as a routine use, to a Member of Congress submitting a request involving an individual, to whom the record pertains, when the individual has requested assistance from the Member with respect to the subject matter of the record.
4. A record in this system of records may be disclosed, as a routine use, to a contractor of the Agency having need for the information in order to perform a contract. Recipients of information shall be required to comply with the requirements of the Privacy Act of 1974, as amended, pursuant to 5 U.S.C. 552a(m).
5. A record related to an International Application filed under the Patent Cooperation Treaty in this system of records may be disclosed, as a routine use, to the International Bureau of the World Intellectual Property Organization, pursuant to the Patent Cooperation Treaty.
6. A record in this system of records may be disclosed, as a routine use, to another federal agency for purposes of National Security review (35 U.S.C. 181) and for review pursuant to the Atomic Energy Act (42 U.S.C. 218(c)).
7. A record from this system of records may be disclosed, as a routine use, to the Administrator, General Services, or his/her designee, during an inspection of records conducted by GSA as part of that agency's responsibility to recommend improvements in records management practices and programs, under authority of 44 U.S.C. 2904 and 2906. Such disclosure shall be made in accordance with the GSA regulations governing inspection of records for this purpose, and any other relevant (*i.e.*, GSA or Commerce) directive. Such disclosure shall not be used to make determinations about individuals.
8. A record from this system of records may be disclosed, as a routine use, to the public after either publication of the application pursuant to 35 U.S.C. 122(b) or issuance of a patent pursuant to 35 U.S.C. 151. Further, a record may be disclosed, subject to the limitations of 37 CFR 1.14, as a routine use, to the public if the record was filed in an application which became abandoned or in which the proceedings were terminated and which application is referenced by either a published application, an application open to public inspection or an issued patent.
9. A record from this system of records may be disclosed, as a routine use, to a Federal, State, or local law enforcement agency, if the USPTO becomes aware of a violation or potential violation of law or regulation.

Electronic Acknowledgement Receipt

EFS ID:	18005341
Application Number:	08483291
International Application Number:	
Confirmation Number:	3269
Title of Invention:	MEDICAL DEVICES INCORPORATING SIM ALLOY ELEMENTS
First Named Inventor/Applicant Name:	JAMES E. JERVIS
Customer Number:	28390
Filer:	Theodore Patrick Lopez/Kimberly Wellington
Filer Authorized By:	Theodore Patrick Lopez
Attorney Docket Number:	9438-1
Receipt Date:	23-JAN-2014
Filing Date:	07-JUN-1995
Time Stamp:	15:26:57
Application Type:	Utility under 35 USC 111(a)

Payment information:

Submitted with Payment	no
------------------------	----

File Listing:

Document Number	Document Description	File Name	File Size(Bytes)/ Message Digest	Multi Part /.zip	Pages (if appl.)
1	Power of Attorney	P726807PTORevPOA.pdf	921287 <small>6b45aaa6a4ed95d0cee4a3e56ac0e2e3a1d24058</small>	no	2

Warnings:

Information:

This Acknowledgement Receipt evidences receipt on the noted date by the USPTO of the indicated documents, characterized by the applicant, and including page counts, where applicable. It serves as evidence of receipt similar to a Post Card, as described in MPEP 503.

New Applications Under 35 U.S.C. 111

If a new application is being filed and the application includes the necessary components for a filing date (see 37 CFR 1.53(b)-(d) and MPEP 506), a Filing Receipt (37 CFR 1.54) will be issued in due course and the date shown on this Acknowledgement Receipt will establish the filing date of the application.

National Stage of an International Application under 35 U.S.C. 371

If a timely submission to enter the national stage of an international application is compliant with the conditions of 35 U.S.C. 371 and other applicable requirements a Form PCT/DO/EO/903 indicating acceptance of the application as a national stage submission under 35 U.S.C. 371 will be issued in addition to the Filing Receipt, in due course.

New International Application Filed with the USPTO as a Receiving Office

If a new international application is being filed and the international application includes the necessary components for an international filing date (see PCT Article 11 and MPEP 1810), a Notification of the International Application Number and of the International Filing Date (Form PCT/RO/105) will be issued in due course, subject to prescriptions concerning national security, and the date shown on this Acknowledgement Receipt will establish the international filing date of the application.

UNITED STATES PATENT AND TRADEMARK OFFICE

BEFORE THE PATENT TRIAL AND APPEAL BOARD

EDWARDS LIFESCIENCES CORPORATION

Petitioner

v.

MEDTRONIC, INC.

Patent Owner

Case IPR2014-00362

Patent 6,306,141 B1

Before SALLY C. MEDLEY, STEPHEN C. SIU, and JOSIAH C. COCKS,
Administrative Patent Judges.

MEDLEY, *Administrative Patent Judge.*

JUDGMENT

Termination of the Proceeding

37 C.F.R. § 42.73

On June 6, 2014, and pursuant to 35 U.S.C. § 317(b) and 37 C.F.R. § 42.74, the parties filed a true copy of a settlement agreement along with a joint request to treat the settlement agreement as business confidential, to be kept separate from the patent file. In addition, the parties filed a joint motion to terminate the proceeding pursuant to 35 U.S.C. § 317.

Case IPR2014-00362
Patent 6,306,141 B1

This case is in the preliminary proceeding¹ stage; no institution of a trial has been made. Based on the facts of this case, it is appropriate to enter judgment.² Therefore, the joint motion to terminate the proceeding is *granted*.

Accordingly, it is

ORDERED that the parties' joint request that the settlement agreement be treated as business confidential information, to be kept separate from the patent file, is *granted*; and

FURTHER ORDERED that the joint motion to terminate the proceeding is *granted*; and

FURTHER ORDERED that the proceeding is *terminated*.

PETITIONER:

¹ A preliminary proceeding begins with the filing of a petition for instituting a trial and ends with a written decision as to whether a trial will be instituted. 37 C.F.R. § 42.2.

² A judgment means a final written decision by the Board, or a termination of a proceeding. 37 C.F.R. § 42.2.

Case IPR2014-00362
Patent 6,306,141 B1

David S. Moreland
Gregory Carlin
MEUNIER CARLIN & CURFMAN, LLC
dmoreland@mcciplaw.com
gcarlin@mcciplaw.com

PATENT OWNER:

John J. Molenda
Sharon A. Israel
MAYER BROWN LLP
jmolenda@mayerbrown.com
sisrael@mayerbrown.com