

## Recent advances in dental optics – Part I: 3D intraoral scanners for restorative dentistry



Silvia Logozzo<sup>a,\*</sup>, Elisabetta M. Zanetti<sup>a</sup>, Giordano Franceschini<sup>a</sup>, Ari Kilpelä<sup>b</sup>, Anssi Mäkynen<sup>b</sup>

<sup>a</sup> Department of Industrial Engineering, University of Perugia, Via Duranti, 93 06125 Perugia, Italy

<sup>b</sup> Department of Electrical Engineering, University of Oulu, P.O.BOX 8000, FI-90014 Oulu, Finland

### ARTICLE INFO

Available online 17 September 2013

#### Keywords:

Intraoral scanner  
Digital dental impressions  
Triangulation  
Confocal microscopy  
Optical coherence tomography

### ABSTRACT

Intra-oral scanning technology is a very fast-growing field in dentistry since it responds to the need of an accurate three-dimensional mapping of the mouth, as required in a large number of procedures such as restorative dentistry and orthodontics. Nowadays, more than 10 intra-oral scanning devices for restorative dentistry have been developed all over the world even if only some of those devices are currently available on the market. All the existing intraoral scanners try to face with problems and disadvantages of traditional impression fabrication process and are based on different non-contact optical technologies and principles. The aim of this publication is to provide an extensive review of existing intraoral scanners for restorative dentistry evaluating their working principles, features and performances.

© 2013 Elsevier Ltd. All rights reserved.

### 1. Background

Three-dimensional scanning of the mouth is required in a large number of procedures in dentistry such as restorative dentistry and orthodontics. The aim of the 3D mapping of the oral cavity is to create *digital impressions*.

Restorative dentistry is of course the main field that require the application of very accurate 3D intraoral scanners. For the realization of any dental prosthesis it is necessary to realize three-dimensional mathematical models of the dentition, performing a reverse engineering procedure. Then the prosthesis can be realized by means of CAD/CAM systems.

At present, according to the traditional work flow, this procedure starts at the dentist's office, and the steps leading to prosthesis's creation are as follows:

- the dentist captures the traditional impression by means of impression trays and impression materials;
- the dentist sends the impression tray to the dental laboratory;
- the laboratory's technician pours plaster inside the tray;
- after the hardening he scans the plaster model to have the 3D virtual digital model of the full arch;
- the technician can design the prosthesis by means of CAD/CAM systems and send the file to a milling machine;
- the milling machine produces the prosthesis;
- the prosthesis is applied by the dentist and refined inside the patient's mouth to verify and adjust the occlusion.

Basically, the 3D digital model is used to design the prosthesis and as an input to the program of the milling machine referring to CAD/CAM systems. It can also be used to perform surgery simulations or to build plastic models of the teeth by means of rapid prototyping techniques.

The whole traditional process is often slow and affected by errors. Furthermore, although the traditional impression taking process is very cheap, it is certainly bothering for the patient and, at the present state of the art, definitively obsolete.

By means of devices here described, the dentist can scan the teeth in vivo and he can directly create the virtual 3D model of the dentition. This allows bypassing the dental laboratory for a lot of steps.

According to the state of the art, there are three kinds of workflows in restorative dentistry. The traditional workflow has been described above; it is the oldest and is illustrated in Fig. 1.

*Abbreviations:* AFI, accordion fringe interferometry; AWS, active wave-front sampling; CAD/CAM, computer aided design/computer aided manufacturing; CLSM or LSCM, confocal laser scanning microscopy; HIPAA, health insurance portability and accountability act; LASER, light amplification by stimulated emission of radiation; LED, light emitting diode; MEMS, micro electro-mechanical system; NA, numerical aperture; OCT, optical coherence tomography; OBJ, alias wavefront technologies file format; PLY, polygon file format or Stanford triangle format; PMT, photo-multiplier tube; SLA, stereo-lithography; S/N or SNR, signal-to-noise ratio; USB, universal serial bus

\* Corresponding author. Tel.: +39 348 7142939.

*E-mail addresses:* [sililog@hotmail.com](mailto:sililog@hotmail.com) (S. Logozzo), [elisabetta.zanetti@unipg.it](mailto:elisabetta.zanetti@unipg.it) (E.M. Zanetti), [giordano.franceschini@unipg.it](mailto:giordano.franceschini@unipg.it) (G. Franceschini), [arik@ee.oulu.fi](mailto:arik@ee.oulu.fi) (A. Kilpelä), [anssi.makynen@ee.oulu.fi](mailto:anssi.makynen@ee.oulu.fi) (A. Mäkynen).

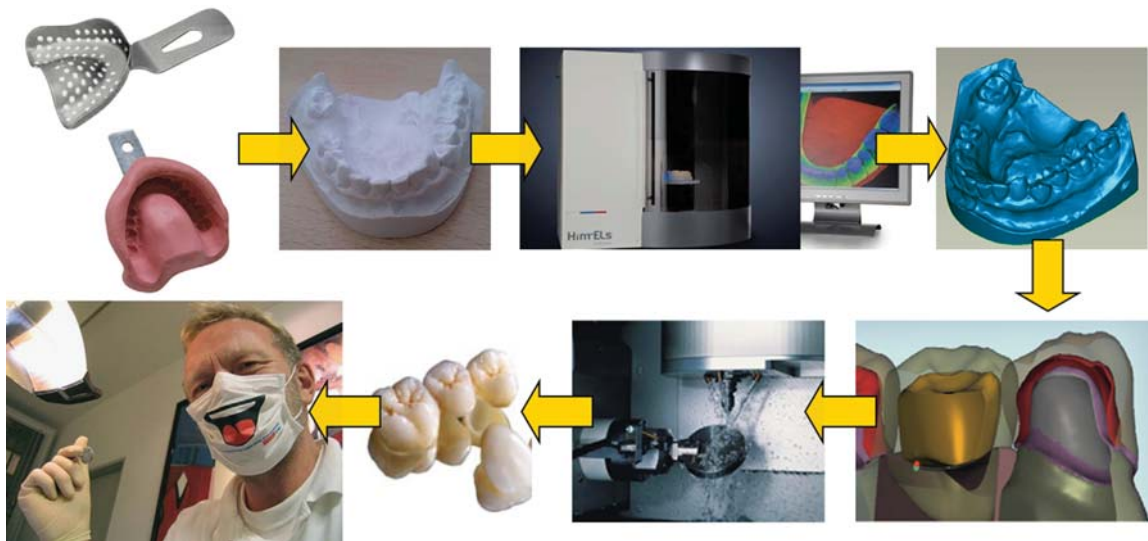

Fig. 1. Traditional workflow for dental impressions.

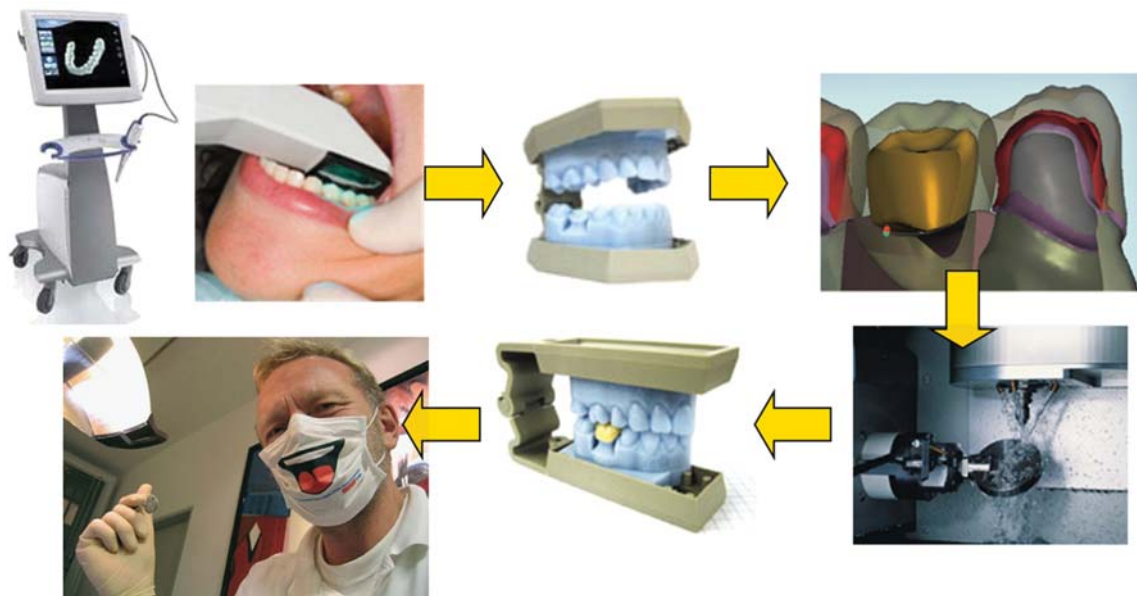

Fig. 2. Former digital workflow for dental impressions.

Sometimes the plaster pouring can be skipped because the impression tray is directly scanned.

The second kind of workflow is the 'former digital workflow'. The term 'former' is used to distinguish this method from the newest one, that is mentioned here as 'rapid digital workflow'. The 'former' digital workflow can be followed by a clinician who owns a standalone intraoral scanner, which is not equipped with a milling unit. The former digital workflow is reported in Fig. 2.

According to the former digital workflow, the steps for prosthesis creation are as follows:

- the dentist captures the digital impression by means of an intraoral scanning device;
- the dentist sends the digital prescription to a laboratory;
- the lab downloads the digital file and uses customized software to digitally cut the die and mark the margins;
- the SLA model is generated by using CAD/CAM systems;
- the technician can proceed with his preferred finishing technique:

- pressing with wax patterns,
- digitally designed and milled full contour glass ceramic restoration by means of CAD/CAM systems (the technician must also design the program for the milling machine by means of CAM systems);
- the final restoration is then sent to the doctor for seating.

The third kind of workflow is the rapid digital workflow. This workflow can be followed when the clinician owns an intraoral scanner equipped with an in-office milling unit. The rapid digital workflow is shown in Fig. 3.

According to the rapid digital workflow, the steps for prosthesis creation are as follows:

- the dentist captures the digital impression by means of an intraoral scanning device;
- the dentist designs the restoration and the software automatically generates the program for the milling unit;
- the final restoration is milled in a few minutes;

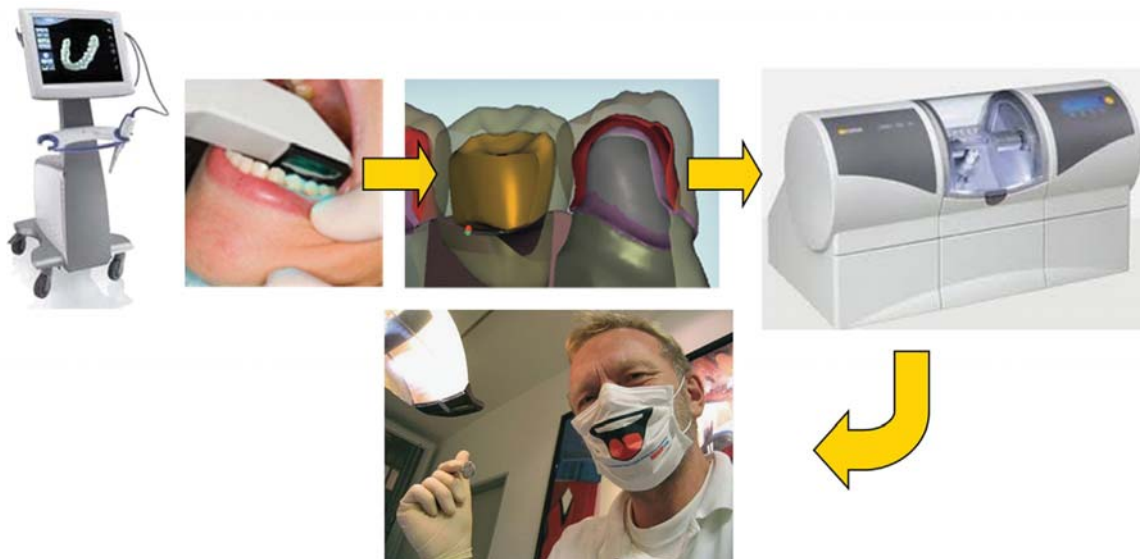

Fig. 3. Rapid digital workflow for dental impressions.

As a result of the application of 3D intraoral scanners, some of the disadvantages related to the traditional workflow can be overcome, as:

- Mould instability;
- Mould transport and packaging;
- Plaster pouring and solidification;
- Delamination;
- Lacerations on margins;
- Contact between the tray and the teeth;
- Geometrical and dimensional inconsistencies between the plaster model and the real teeth.

3D Intraoral scanners can therefore entail the following advantages:

- Implementation of highly accurate models;
- Traditional workflow simplification;
- Possibility to create and periodically update a database of dentitions for future interventions;
- Possibility to simulate surgery interventions on the digital model;

Overcoming all the prior disadvantages.

## 2. Introduction

The application of CAD/CAM methodologies to the dental field was the brainchild of Dr. Francois Duret in his thesis, presented at the Université Claude Bernard, Faculté d'Odontologie, in Lyon, France in 1973, and entitled 'Empreinte Optique' (Optical Impression). In detail, he developed and patented a CAD/CAM device in 1984. The developed system was presented at the Chicago Mid-winter Meeting in 1989, and was able to fabricate a dental crown in 4 h [2,3].

Digital impressions have been introduced, and successfully used, for a number of years, in orthodontics, as well, including Cadent's IOC/OrthoCad, DENTSPLY/GAC's OrthoPlex, Stratos/Orametrix's SureSmile, and EMS'RapidForm, but the introduction of the first digital intraoral scanner for restorative dentistry was in the 1980s by a Swiss dentist, Dr. Werner Mörmann, and an

fundamentals for CEREC<sup>®</sup> by Sirona Dental Systems LLC (Charlotte, NC), introduced in 1987, as the first commercially available CAD/CAM system for dental restorations [2,4]. Ever since, research and development by a lot of companies have improved the technologies and created in-office intraoral scanners, which are increasingly user-friendly and produce precisely fitting dental restorations. These systems are capable of capturing three-dimensional virtual images of tooth preparations; restorations may be directly fabricated from such images (using CAD/CAM systems) or the same images can be used to create accurate master models, for the restorations in a dental laboratory [2].

Nowadays, more than 10 intra-oral scanning devices for restorative dentistry exist all over the world. In this paper all these devices are mentioned and 11 are described and analysed. Existing devices are based on different non-contact optical technologies such as confocal microscopy, optical coherence tomography, active and passive stereovision and triangulation, interferometry and phase shift principles. Basically, all these devices combine more than one of the cited imaging techniques to minimize the noise arising when scanning inside an oral cavity as, for example: noise related to the optical features of the target surfaces (translucency and the different reflectivity of target materials such as teeth, gums, preparations, resins, etc.), to wetness and to random relative motions. Also several typologies of structured light sources and optical components are employed. The analysed intra-oral scanning devices for restorative dentistry are listed below:

- (1) CEREC<sup>®</sup> – by Sirona Dental System GmbH (Germany)
- (2) iTero – by CADENT Ltd (Israel)
- (3) E4D – by D4D TECHNOLOGIES, Llc (USA)
- (4) Lava<sup>™</sup>C.O.S. – by 3M ESPE (USA)
- (5) IOS FastScan – by IOS TECHNOLOGIES, Inc. (USA)
- (6) MIA3d<sup>™</sup> – by Densys3D Ltd (Israel)
- (7) DPI-3D – by DIMENSIONAL PHOTONICS INTERNATIONAL, Inc. (USA)
- (8) 3D Progress – by MHT S.p.A. (Italy) and MHT Optic Research AG (Switzerland)
- (9) directScan – by HINT – ELS GmbH (Germany)
- (10) trios – by 3SHAPE A/S (Denmark)
- (11) Bluescan<sup>®</sup>-I – A●TRON3D<sup>®</sup> GmbH (Austria)

Only some of these are already commercially available. As

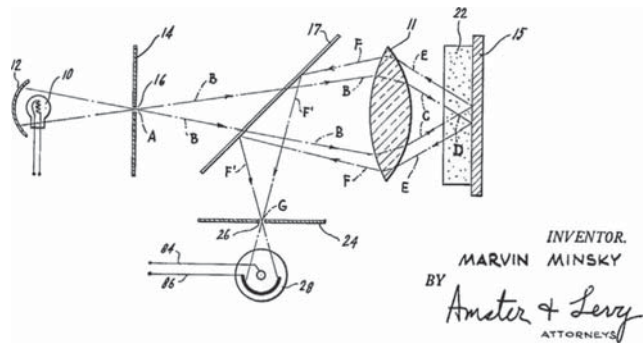

Fig. 4. Confocal microscopy principle [6].

digital impressions are achievable, also some disadvantages subsist. For example, it is often necessary to apply some coatings (to minimize the noise of the measurement) and to rest the camera wand on a tooth to get a steady focus. Moreover, the 3D virtual model is often reconstructed by post-processing single images (acquired from a single perspective); accordingly the reconstruction is not performed in real time with a continuous data capture. Furthermore, data concerning the accuracy of the available instruments are often missing [1].

Some other new intra-oral scanners have been recently presented at International Dental Show 2013 in Cologne:

- (12) Planscan – Planmeca Oy (Finland)
- (13) Condor – Remedent Inc. (Belgium)
- (14) CS 3500 – Carestream Health, Inc. (USA)
- (15) DigImprint – Steinbichler Optotechnik GmbH (Germany)

### 3. Confocal laser scanner microscopy and devices

Confocal laser scanning microscopy (CLSM or LSCM) is a technique to acquire in-focus images from selected depths, a process known as optical sectioning (high-resolution optical images with depth selectivity) [5]. Images are acquired point-by-point and reconstructed by a computer. By using this technique, one can reconstruct the surface profile of opaque specimens and obtain the interior imaging of non-opaque specimens.

A conventional microscope sees as far into the specimen as the light can penetrate, whereas a confocal microscope only images one depth level at a time.

The CLSM achieves a controlled and highly limited depth of focus.

The principle of confocal microscopy was originally patented by Marvin Minsky in 1961 [6], but it took another 30 years and the development of lasers for CLSM to become a standard technique, toward the end of the 1980s.

In a CLSM technique a laser beam passes through an aperture (14 in Fig. 4) and then is focused by an objective lens (11 in Fig. 4) into a small focal volume, within or on the surface of a specimen; in biological applications the specimen may be fluorescent. Scattered and reflected laser light, as well as any fluorescent light from the illuminated spot, is then re-collected by the objective lens.

A beam-splitter (17 in Fig. 4) separates off some portion of the light into the detection apparatus (28 in Fig. 4).

This apparatus, in fluorescence confocal microscopy, has also a filter, which selectively passes the fluorescent wavelengths while blocking the original excitation wavelength. After passing a pinhole (24 in Fig. 4), the light intensity is detected by a photo-



Fig. 5. iTero digital impression system [2].

avalanche photodiode (APD)), transforming the light signal into an electrical one which is recorded by a computer [7].

The limited detector aperture obstructs the light which is not coming from the focal point. The out-of-focus light is suppressed: most of the returning light is blocked by the pinhole, which results in sharper images than those from conventional fluorescence microscopy techniques and permits to obtain images of planes located at various depths within the sample (sets of such images are also known as ‘z stacks’) [5].

The detected light, originating from an illuminated volume element within the specimen, represents one pixel in the resulting image. The brightness of a resulting image pixel corresponds to the relative intensity of the respective detected light. The beam is scanned across the sample in the horizontal plane by using one or more servo-controlled oscillating mirrors.

Slower scans provide a better signal-to-noise ratio, resulting in better contrast and higher resolution. Information can be collected from different focal planes by raising or lowering the microscope stage or objective lens. The computer can generate a three-dimensional picture of a specimen by assembling a stack of these two-dimensional images, from successive focal planes [5].

#### 3.1. iTero by CADENT LTD (IL)

The Cadent iTero digital impression system by Cadent LTD, IL (Fig. 5) came into the market in early 2007. iTero system employs a parallel confocal imaging technique (Fig. 6) [8]. As shown in Fig. 7, an array of incident red laser light beams (36), passing through a



Fig. 6. iTero's wand [2,9].

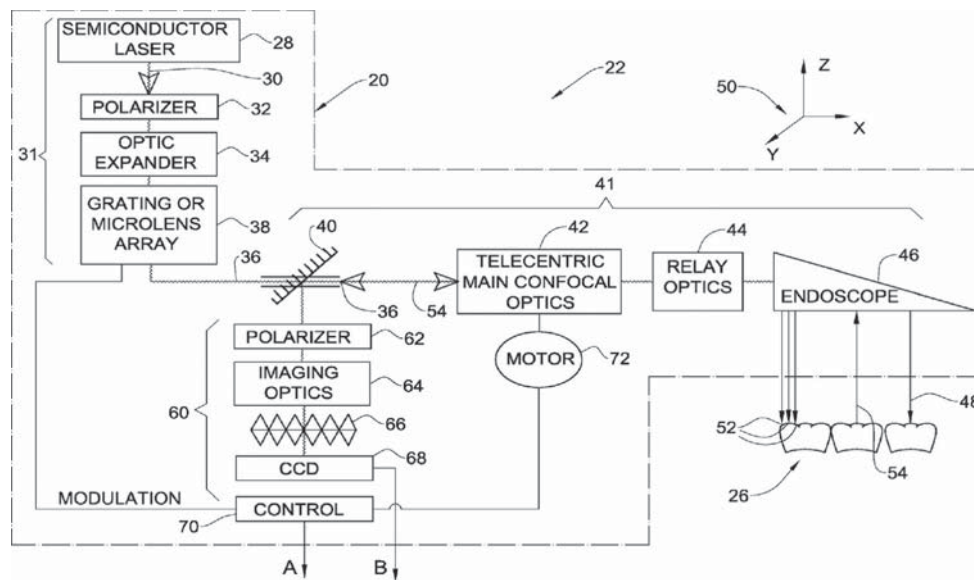

Fig. 7. iTero scanning system [8].

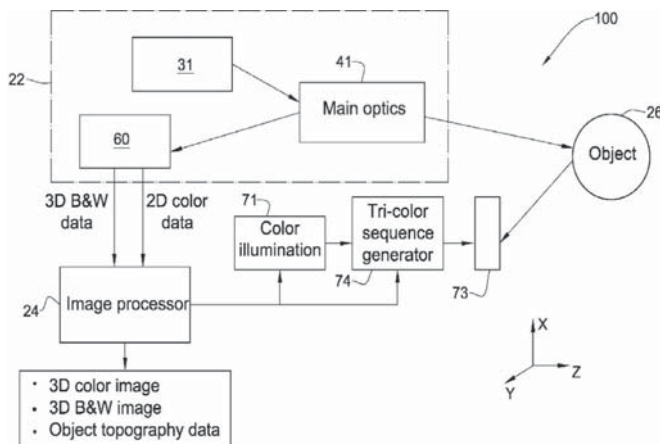

Fig. 8. iTero colour imaging system [11].

The focusing optics defines one or more focal planes beyond the probing face, in a position which can be tuned by a motor (72).

The beams generate illuminated spots on the structure and the intensity of returning light rays is measured for various positions of the focal plane. The topology of the three dimensional structure of the teeth is reconstructed on the basis of spot-specific positions yielding a maximum intensity of the reflected light beams (Fig. 7)

This technique allows iTero capturing all structures and materials in the mouth, without the need to apply any coating to the patient's teeth [9]. The complete three-dimensional representation of the entire structure can be obtained assembling surface topologies of adjacent portions, taken at two or more different angular perspectives [10]. The iTero camera capability of scanning without the need of coating powders is advantageous, however it requires the addition of a colour wheel to the acquisition unit itself (Fig. 8), resulting in a camera with a larger scanner head, compared to the other systems [2]. In fact, also a two-dimensional (2D) colour image of the 3D structure of teeth is taken at the same angle and orientation with respect to the structure. As a consequence, each X–Y point on the 2D coloured image corresponds to one point on the 3D scan, having the same relative X–Y values. The coloured image (Fig. 8) is obtained illuminating the target surface with three beams having three complementary colours (red, green or blue light), and combining the respective monochromatic images to create a full colour image. The three beams are obtained from the same white light source, with colour filters. The filters are arranged as sectors of a rotatable disc, coupled to a motor [11]. Capturing the digital impression requires following a series of steps for every impression which the operator is guided through. These include five scans of the prepared area: occlusal, lingual, buccal, and interproximal contacts of the adjacent teeth [2], and require approximately 15 or 20 s per prepared tooth. Then buccal and lingual 45° angle views of the remaining teeth in the quadrant

# Explore Litigation Insights

Docket Alarm provides insights to develop a more informed litigation strategy and the peace of mind of knowing you're on top of things.

## Real-Time Litigation Alerts



Keep your litigation team up-to-date with **real-time alerts** and advanced team management tools built for the enterprise, all while greatly reducing PACER spend.

Our comprehensive service means we can handle Federal, State, and Administrative courts across the country.

## Advanced Docket Research



With over 230 million records, Docket Alarm's cloud-native docket research platform finds what other services can't. Coverage includes Federal, State, plus PTAB, TTAB, ITC and NLRB decisions, all in one place.

Identify arguments that have been successful in the past with full text, pinpoint searching. Link to case law cited within any court document via Fastcase.

## Analytics At Your Fingertips



Learn what happened the last time a particular judge, opposing counsel or company faced cases similar to yours.

Advanced out-of-the-box PTAB and TTAB analytics are always at your fingertips.

## API

Docket Alarm offers a powerful API (application programming interface) to developers that want to integrate case filings into their apps.

## LAW FIRMS

Build custom dashboards for your attorneys and clients with live data direct from the court.

Automate many repetitive legal tasks like conflict checks, document management, and marketing.

## FINANCIAL INSTITUTIONS

Litigation and bankruptcy checks for companies and debtors.

## E-DISCOVERY AND LEGAL VENDORS

Sync your system to PACER to automate legal marketing.