



US005088032A

# United States Patent [19]

[11] Patent Number: **5,088,032**

**Bosack**

[45] Date of Patent: **Feb. 11, 1992**

[54] **METHOD AND APPARATUS FOR ROUTING COMMUNICATIONS AMONG COMPUTER NETWORKS**

Primary Examiner—Gareth D. Shaw  
Assistant Examiner—Kevin A. Kriess  
Attorney, Agent, or Firm—Lyon & Lyon

[75] Inventor: **Leonard Bosack**, Atherton, Calif.

[57] **ABSTRACT**

[73] Assignee: **Cisco Systems, Inc.**, Menlo Park, Calif.

An improved method and apparatus for routing data transmissions among computer networks. The computer networks are interconnected with a series of gateway circuits. Each gateway identifies all destination computers to which it is connected and identifies the path or paths to each destination computer. For each identified path, the gateway stores the topological delay time for a transmission, the path bandwidth for the narrowest bandwidth segment of a path and a number corresponding to the reliability of the path. When a transmission is received, the gateway examines the various paths in accordance with a predetermined algorithm which also considers the channel occupancy of each path to determine a best path for transmission. The data transmission is then directed over the best path. If more than one path exists, the data may be directed in multiplex fashion over two or more paths with the amount of data on each path being related to the quality of the path. The routing information to destination networks is broadcast periodically by each gateway circuit to its neighboring gateway circuits.

[21] Appl. No.: **149,820**

[22] Filed: **Jan. 29, 1988**

[51] Int. Cl.<sup>5</sup> ..... **H04Q 11/04; H04J 3/26**

[52] U.S. Cl. .... **395/200; 370/94.1; 364/284; 364/284.3; 364/284.4; 364/242.94; 364/229; 364/229.3; 364/229.4; 364/229.5; 364/DIG. 1**

[58] Field of Search ... **364/200 MS File, 900 MS File; 370/94, 94.1, 94.3, 60.1**

[56] **References Cited**

**U.S. PATENT DOCUMENTS**

4,314,367	2/1982	Bakka et al. ....	370/60
4,532,625	7/1985	Stover .....	370/58
4,709,365	11/1987	Beale et al. ....	371/11
4,736,363	4/1988	Aubin et al. ....	370/60
4,748,658	5/1988	Gopal et al. ....	379/221
4,825,206	4/1989	Brice, Jr. et al. ....	340/825.02
4,833,468	5/1989	Larson et al. ....	340/825.8
4,862,496	8/1989	Kelly et al. ....	379/221
4,905,233	2/1990	Cain et al. ....	370/94.1
4,939,726	7/1990	Flammer et al. ....	370/94.1

**64 Claims, 11 Drawing Sheets**

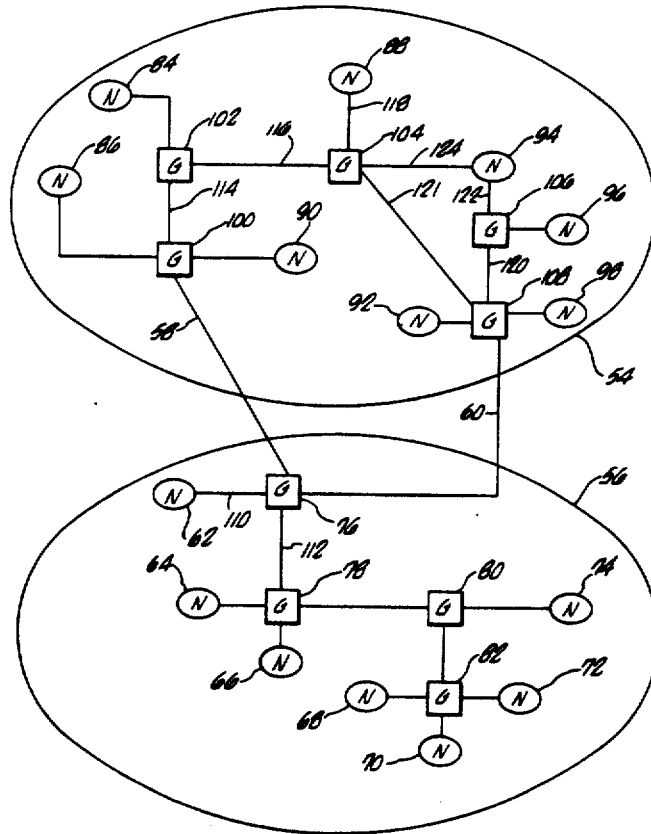

FIG. 1A  
(PRIOR ART)

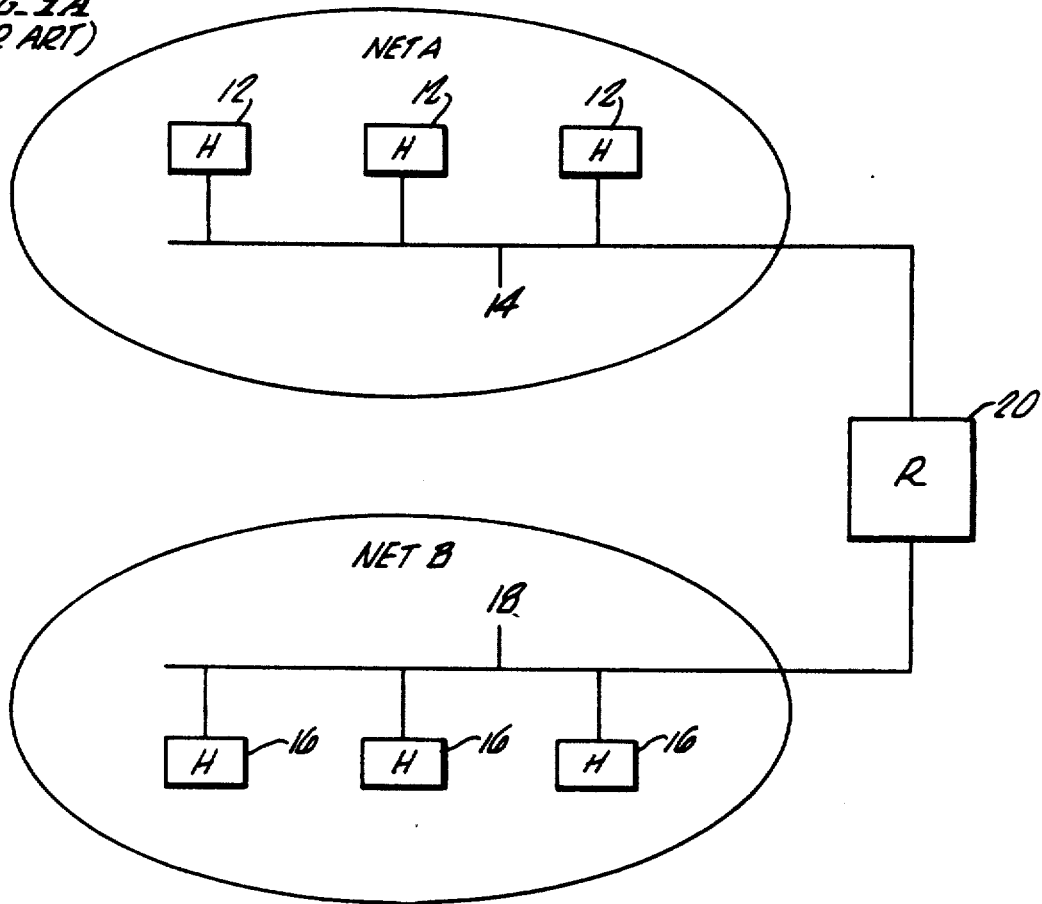
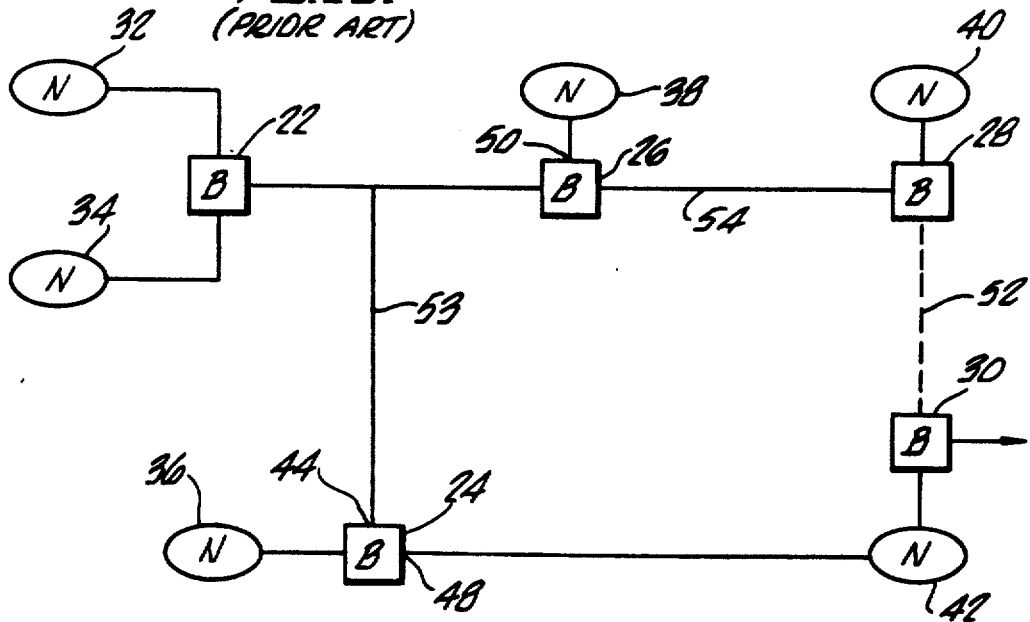

FIG. 1B.  
(PRIOR ART)



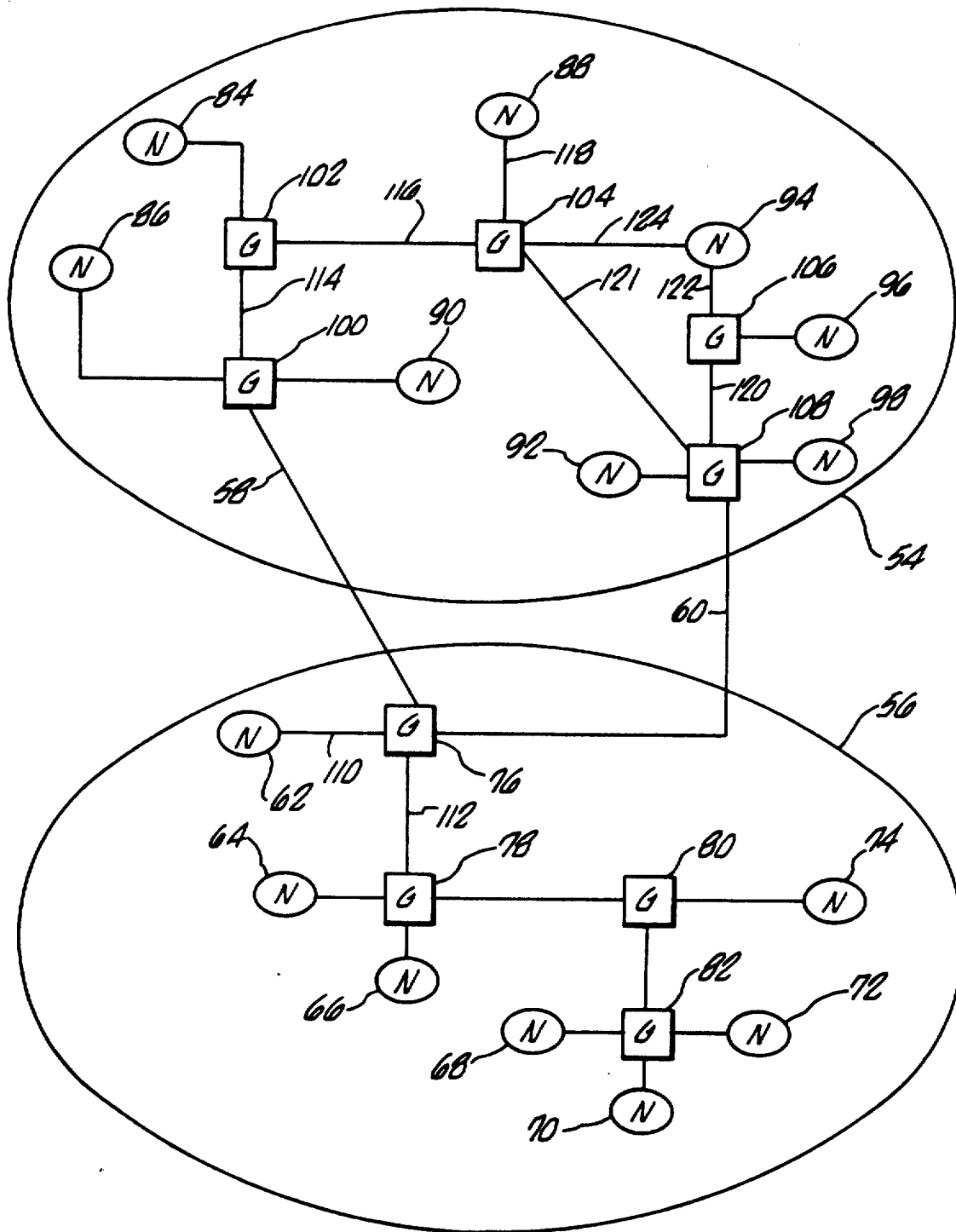

FIG. 2.

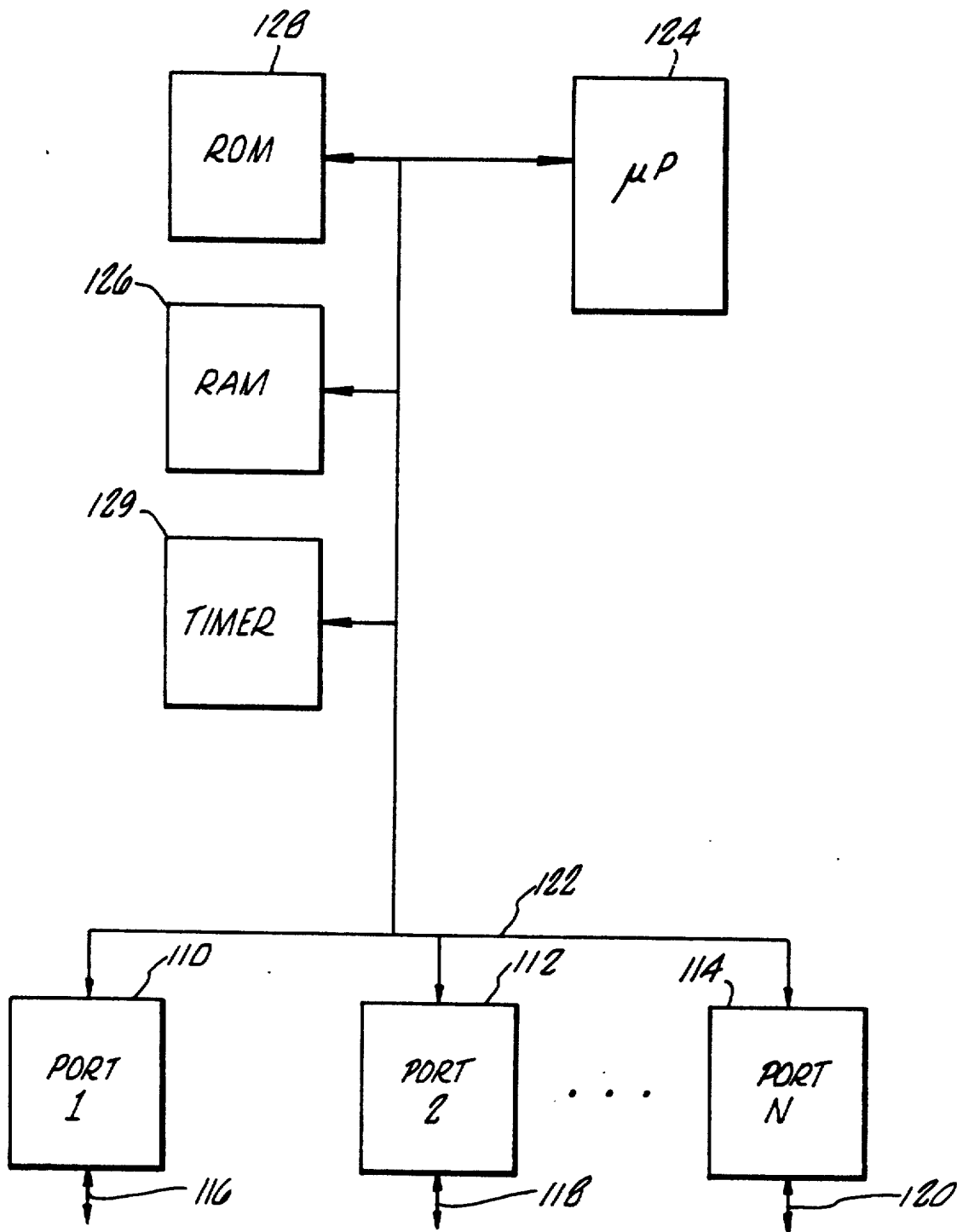

FIG. 3.

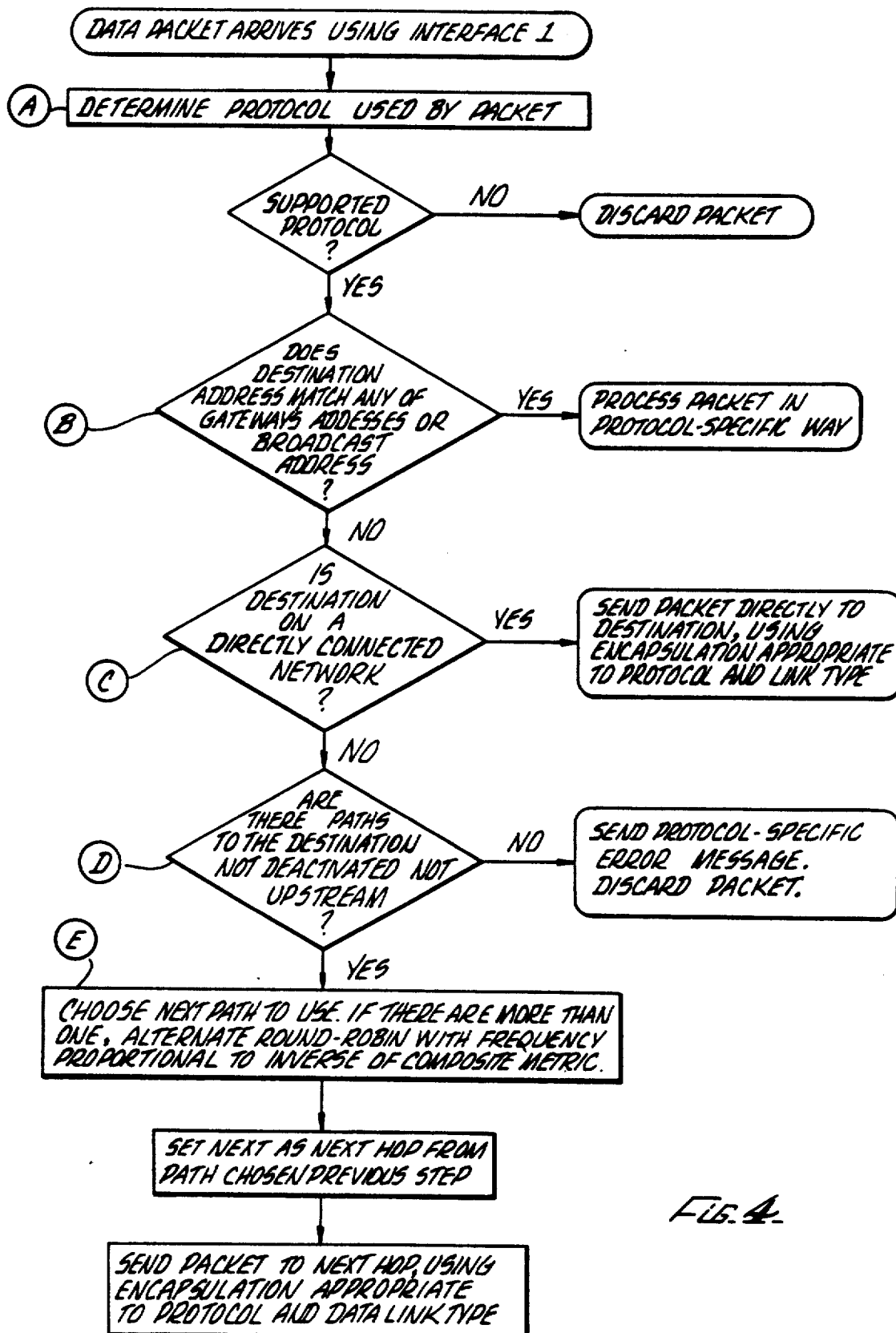

FIG. 4.

# Explore Litigation Insights

Docket Alarm provides insights to develop a more informed litigation strategy and the peace of mind of knowing you're on top of things.

## Real-Time Litigation Alerts



Keep your litigation team up-to-date with **real-time alerts** and advanced team management tools built for the enterprise, all while greatly reducing PACER spend.

Our comprehensive service means we can handle Federal, State, and Administrative courts across the country.

## Advanced Docket Research



With over 230 million records, Docket Alarm's cloud-native docket research platform finds what other services can't. Coverage includes Federal, State, plus PTAB, TTAB, ITC and NLRB decisions, all in one place.

Identify arguments that have been successful in the past with full text, pinpoint searching. Link to case law cited within any court document via Fastcase.

## Analytics At Your Fingertips



Learn what happened the last time a particular judge, opposing counsel or company faced cases similar to yours.

Advanced out-of-the-box PTAB and TTAB analytics are always at your fingertips.

## API

Docket Alarm offers a powerful API (application programming interface) to developers that want to integrate case filings into their apps.

## LAW FIRMS

Build custom dashboards for your attorneys and clients with live data direct from the court.

Automate many repetitive legal tasks like conflict checks, document management, and marketing.

## FINANCIAL INSTITUTIONS

Litigation and bankruptcy checks for companies and debtors.

## E-DISCOVERY AND LEGAL VENDORS

Sync your system to PACER to automate legal marketing.