

COTS[®]

JOURNAL

UAVs

LEAD PUSH FOR EMBEDDED SUPERCOMPUTING



Volume 7 Number 10 October 2005

www.cotsjournalonline.com



DOCKET
ALARM

Find authenticated court documents without watermarks at docketalarm.com.



Hardware Assets

Supercomputing Technology

Reconfigurable Processing Design Suits UAV Radar Apps

UAV-based radar electronics require supercomputing performance in a compact space. A reconfigurable computer architecture offers the compute density to fit the bill.

Peter Buxa, Computer Engineer,
Air Force Research Laboratory, Sensors Directorate
David Caliga, Applications Technology Manager,
SRC Computers

Keeping size, weight and power down to a minimum has always ranked high for radar electronic subsystems designed for military aircraft. Now, with today's emphasis on man-portable or small Unmanned Air Vehicles (UAVs), those requirements are becoming even more critical. Designing Synthetic Aperture Radar (SAR) capabilities into such form-factors requires processing architectures that are reconfigurable and capable of real-time processing while still fulfilling size, weight and power requirements.

With all that in mind, engineers at the Air Force Research Laboratory (AFRL) and SRC Computers sought to demonstrate the performance gain of a two-dimensional Synthetic Aperture Radar (2-D SAR) backprojection algorithm running on SRC's Compact MAP processor architecture compared to a MATLAB and C implementation of the algorithm. Starting with a backprojection algorithm, originally written in MATLAB, the compute-intensive routines of the algorithm were converted into C Language and compiled using SRC's Carte Programming Environment, which targets the MAP reconfig-

urable hardware. The algorithm was then benchmarked on the Compact MAP processor in order to demonstrate processor performance in a small form-factor suitable for man-portable or small UAV applications (Figure 1).

Algorithm Tradeoffs

The Spotlight Synthetic Aperture Radar (SAR) Backprojection algorithm is considered to be the "gold standard" of the SAR imaging techniques. A spotlight SAR image is a two- (or three-) dimensional mapping of received radar energy. A SAR sensor illuminates a target area with a series of linear frequency modulation pulses. The location of an individual scatterer is determined by measuring the range and Doppler (range rate) and comparing this to a central reference

point, called the motion compensation point. As more pulses are used, the azimuth (or cross-range) resolution increases.

There are several algorithms that have been developed to form spotlight SAR images. In deciding which algorithm to use, there is a tradeoff between computational efficiency and imaging accuracy. For instance, the simplest algorithm orders the pulses into a rectangular array and performs a two-dimensional Fourier transform. However, the resultant image will not be very accurate, as the algorithm does not compensate for scatterer motion through the synthetic aperture. The most accurate image formation algorithm is the tomographic backprojection. The backprojection algorithm calculates an exact

solution for every pixel in the image. However that approach has very high computational cost. There have been numerous algorithms developed that have acceptable accuracy with much less computational time than the backprojection algorithm. The most popular of these is the polar format algorithm.

The polar format algorithm has low computational cost, but it has some limitations that make the backprojection algorithm more attractive. For instance, when using backprojection the user



Figure 1

AAI's Shadow, shown here, is an example of the class of small UAVs designed to carry small payloads. Highly integrated SAR electronics enable such craft to perform detailed reconnaissance tasks.

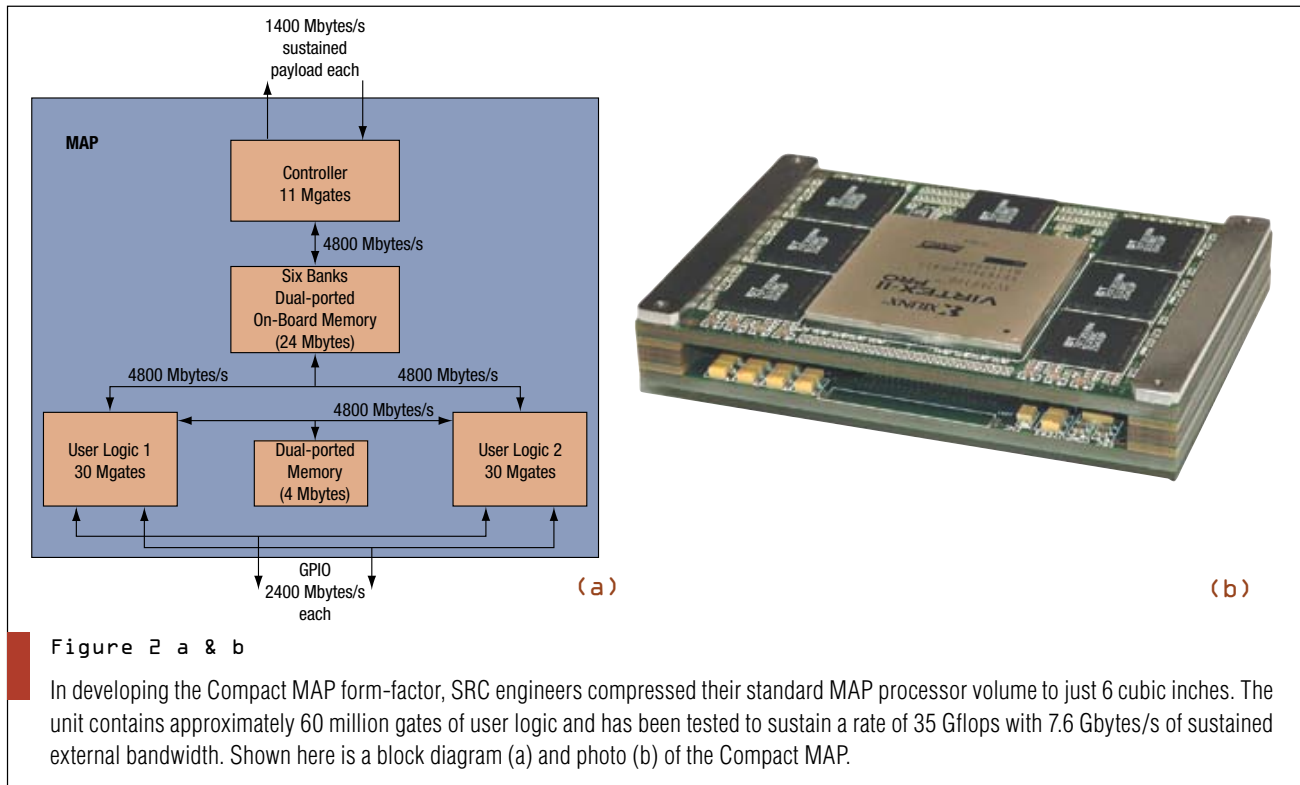

Figure 2 a & b

In developing the Compact MAP form-factor, SRC engineers compressed their standard MAP processor volume to just 6 cubic inches. The unit contains approximately 60 million gates of user logic and has been tested to sustain a rate of 35 Gflops with 7.6 Gbytes/s of sustained external bandwidth. Shown here is a block diagram (a) and photo (b) of the Compact MAP.

can choose any imaging grid, while there is only one imaging grid available for the polar format algorithm. Moreover, the backprojection algorithm offers an intrinsic ability to add or subtract pulses from an image—a capability that is unavailable in any other imaging algorithm.

Despite its compute-heavy drawback, the backprojection algorithm is attractive since it produces the most accurate images and can be customized depending on mission requirements. The challenge then is to craft a processing architecture that's reconfigurable and capable of real-time processing while fulfilling size, weight and power requirements for man-portable or small UAV systems.

Integrated by an Order of Magnitude

In developing the Compact MAP form-factor, SRC engineers compressed their standard MAP processor by an order of magnitude down to just 6 cubic inches, while at the same time increasing its processing performance. The resulting

Compact MAP contains approximately 60 million gates of user logic and has been tested to sustain a rate of 35 Gflops with 7.6 Gbytes/s of sustained external bandwidth. A block diagram of the MAP along with a photograph of the Compact MAP are shown in Figures 2a and 2b. The Compact MAP can be either air-cooled or spray-cooled for harsh environments. The air-cooled portable system is shown in Figure 3.

The 2-D SAR Backprojection algorithm written in MATLAB was developed by the Air Force Research Laboratory (AFRL) for prototyping and evaluation with SAR datasets. The dataset was synthetically generated using a simulated wide-band (7-13 GHz) complex radar backscatter, 360 degrees around a 3-D CAD model of a backhoe shown in Figure 4.

The 2-D dataset for this study contained one slice at 10 degrees elevation of the full 3-D dataset, resulting in 5,040 1-D projections. After computation by the 2-D SAR Backprojection algorithm, a 2-D image of 1001 x 1001 pixels was formed. Using a standard Intel 2.8 GHz Pentium

4, one compute run of the full 2-D dataset took 1.3 hours running MATLAB code. The study implemented the original MATLAB code in several forms. The compute performance of each implementation was timed for comparison with the original MATLAB code. The resulting speedups are compared in Table 1.

The imaging routine—called `image_2d.mc`—implemented on the MAP took advantage of many of the optimization techniques supported by the MAP Compiler. These optimizations included: spreading the computational array across multiple On-Board Memory Banks, using Block RAM arrays, using two User Logic Chips and overlapping DMAs with compute operations. The initial performance gain was 75x for the MATLAB-MAP version versus the original MATLAB version.

The MAP performance of a compute loop when pipelined is one iteration of the loop every clock. The major consumer of computational time was the summation of the contributions of each swath to every pixel in the 2-D image. This summation loop took one clock per

Hardware Assets

Implementation	Speedup	Description
MATLAB only	1x	The MATLAB Only implementation computation time for the imaging routine, image_3d.m, was 99.9% of the total computational time.
C code only	4.2x	This implementation converted all of the original MATLAB code into the C Language. The converted imaging routine, image_3d.c, utilized the optimized Intel IPP FFT routine.
MATLAB – MAP	151x	The imaging routine, image_3d.c used in the “C Code Only” implementation was modified to image_3d.mc, and compiled to the MAP using the Carte Programming Environment.
C – MAP	153x	This implementation used the main.c from the “C Code Only” implementation in conjunction with the MAP imaging subroutine, image_3d.mc

Table 1

The compute performance of each implementation of the backprojection algorithm was timed for comparison with the original MATLAB code. The resulting speedups are compared here.

image pixel for a total of 1002001 clocks. This compares to the time to perform the 16K complex FFT of 22975. The image summation was then split across the two User Logic FPGAs in the MAP, giving an additional 2x speedup. The microprocessor environment used in the study was an Intel 2.8 GHz P4 running Linux. The MATLAB–MAP implementation took only 28 seconds to process all 5040 1-D lines.

Using Two MAPs

If two MAPs were to be utilized, the system would provide a super-linear

speedup of the application. The first MAP could compute the scaling, FFT and post-FFT scaling for ten swaths. These ten swath vectors would then be sent to the second MAP which would perform the image update using all ten vectors concurrently, yielding a speedup of 750x compared to the original MATLAB code.

There’s a clear performance increase of running the SAR 2-D Backprojection algorithm on the SRC Compact MAP. Until now, use of the backprojection algorithm in a real-time SAR system was difficult due to onboard processing con-

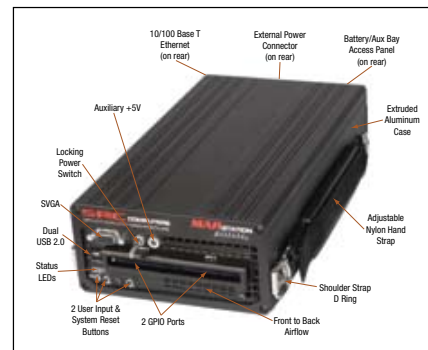

Figure 3

The Compact MAP is offered in either air-cooled or spray-cooled enclosure formats for harsh environments. The air-cooled portable system is shown here.

straints—such as size, weight and power. With the development of SRC’s Compact MAP processor, a real-time backprojection implementation is practical, even onboard small UAV systems.

LeRoy Gorham, and Lt. Mathew Lukacs of the Air Force Research Laboratory, Sensors Directorate were also co-authors of this article. ■■

SRC Computers
Colorado Springs, CO.
(719) 262-0213.
[www.srccomputers.com].

