

(12) UK Patent Application (19) GB (11) 2472978 (13) A

(43) Date of A Publication

02.03.2011

(21) Application No: <b>0914716.6</b>	(51) INT CL: <b>H04B 7/08</b> (2006.01) <b>H04L 1/00</b> (2006.01) <b>H04L 27/26</b> (2006.01)
(22) Date of Filing: <b>24.08.2009</b>	(56) Documents Cited: <b>GB 2448481 A</b> <b>WO 2009/132203 A1</b> <b>US 20060221894 A1</b> "3GPP TR 45.192 V7.0.0; Feasibility study for evolved GSM/EDGE Radio Access Network (GERAN) (Release 7)", 12 Oct 2006. Downloaded from <a href="http://www.3gpp.org/ftp/Specs/html-info/45912.htm">http://www.3gpp.org/ftp/Specs/html-info/45912.htm</a> on 18 Nov 2009. <b>C. GESSNER: "T&amp;M Requirements for Mobile Radios with Receive Diversity and Advanced Receivers", May 2006, RHODE &amp; SCHWARZ Application Note 1MA88. Downloaded from <a href="http://www.shop.rohde-schwarz.com/www/downcnt.nsf/ANFileByANNoForInternet/3D7728599C7BEECD1257178003C8BF9/\$file/1MA88_0e.pdf">http://www.shop.rohde-schwarz.com/www/downcnt.nsf/ANFileByANNoForInternet/3D7728599C7BEECD1257178003C8BF9/\$file/1MA88_0e.pdf</a> on 18/11/09</b>
(71) Applicant(s): <b>Vodafone Group plc</b> <b>(Incorporated in the United Kingdom)</b> <b>Vodafone House, The Connection, NEWBURY, Berkshire, RG14 2FN, United Kingdom</b>	(58) Field of Search: INT CL <b>H04B, H04L</b> Other: <b>Online: WPI, EPODOC, TXTE, TXTT, INSPEC, XPI3E, XPIEE, XPESP, INTERNET</b>
(72) Inventor(s): <b>Trevor Michael Gill</b> <b>Ralf Irmer</b>	
(74) Agent and/or Address for Service: <b>Vodafone Group plc</b> <b>Vodafone House, The Connection, NEWBURY, Berkshire, RG14 2FN, United Kingdom</b>	

(54) Title of the Invention: **Adaptive use of multiple receiver chains**  
Abstract Title: **A multi-antenna receiver is switched between receiver diversity mode and carrier aggregation mode on the basis of network or/and terminal parameters**

(57) A multi-antenna receiving terminal can be switched between a receiver diversity mode (Fig. 1), in which the same data is received at each of a plurality of different antenna, and a carrier aggregation mode (Fig.2). In the carrier aggregation mode data has data been multiplexed across multiple carrier frequencies and each carrier is received by a different respective antenna. A network element (e.g.eNodeB) decides whether to switch between modes based on a network parameter, such as load, or a channel quality indication and instructs the receiving terminal accordingly. Carrier aggregation mode is also known as spectrum aggregation mode, dual carrier mode and dual cell mode.

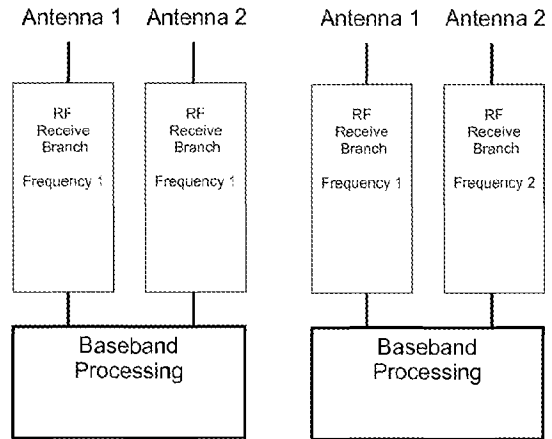
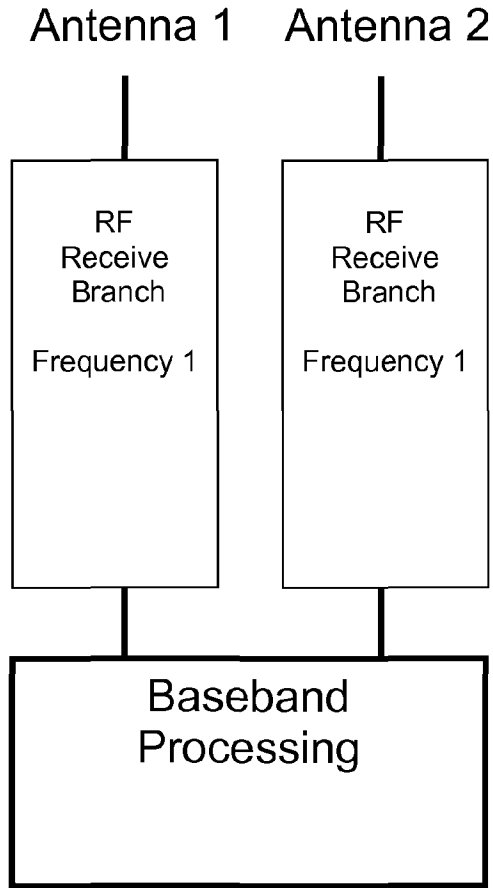

Fig 1

Fig 2

GB 2472978 A



**Fig 1**

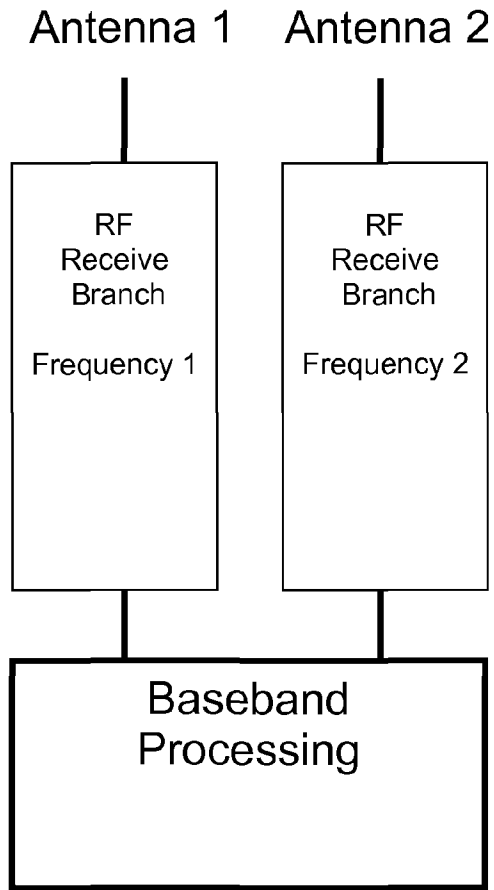

**Fig 2**

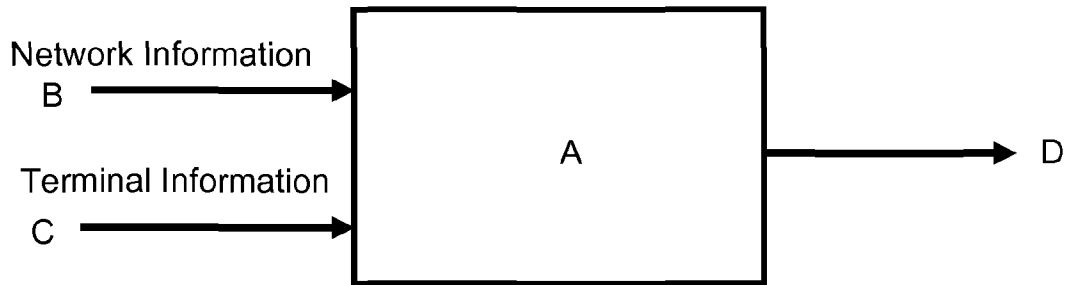

**Fig 3**

## ADAPTIVE USE OF MULTIPLE RECEIVER CHAINS

The present invention relates to a system using multiple receiver chains adaptively to increase cellular telecommunications network capacity at different load levels. In particular, the invention increases the data throughput supported by a mobile broadband terminal and increases the capacity of the supporting network.

A known technique for increasing the capacity of a cellular telecommunications network such as HSDPA, LTE, WiFi or WiMAX is to bond together two parallel carriers. This approach is called carrier or spectrum aggregation.

The conventional solution to implement carrier aggregation would be to duplicate the entire receiver hardware, or substantial parts of it, with substantial added cost.

High performance receivers already have duplicated hardware with two parallel receiver chains. These are currently used to implement another well known technique called receiver diversity. Receiver diversity can itself substantially increase the throughput of a terminal and the capacity of the associated network.

HSDPA (High Speed Downlink Packet Access) is a packet-based data service in the 3rd generation W-CDMA (Wideband Code Division Multiple Access) systems, which provides high-speed data transmission (with different theoretical peak download rates according to the HSDPA technology step e.g. 7.2/10.8/16.2/21.6/28.8/42 Mbps over a 5MHz bandwidth) to support multimedia services.

# Explore Litigation Insights

Docket Alarm provides insights to develop a more informed litigation strategy and the peace of mind of knowing you're on top of things.

## Real-Time Litigation Alerts



Keep your litigation team up-to-date with **real-time alerts** and advanced team management tools built for the enterprise, all while greatly reducing PACER spend.

Our comprehensive service means we can handle Federal, State, and Administrative courts across the country.

## Advanced Docket Research



With over 230 million records, Docket Alarm's cloud-native docket research platform finds what other services can't. Coverage includes Federal, State, plus PTAB, TTAB, ITC and NLRB decisions, all in one place.

Identify arguments that have been successful in the past with full text, pinpoint searching. Link to case law cited within any court document via Fastcase.

## Analytics At Your Fingertips



Learn what happened the last time a particular judge, opposing counsel or company faced cases similar to yours.

Advanced out-of-the-box PTAB and TTAB analytics are always at your fingertips.

## API

Docket Alarm offers a powerful API (application programming interface) to developers that want to integrate case filings into their apps.

## LAW FIRMS

Build custom dashboards for your attorneys and clients with live data direct from the court.

Automate many repetitive legal tasks like conflict checks, document management, and marketing.

## FINANCIAL INSTITUTIONS

Litigation and bankruptcy checks for companies and debtors.

## E-DISCOVERY AND LEGAL VENDORS

Sync your system to PACER to automate legal marketing.