

## DECLARATION OF GERARD P. GRENIER

I, Gerard P. Grenier, am over twenty-one (21) years of age. I have never been convicted of a felony, and I am fully competent to make this declaration. I declare the following to be true to the best of my knowledge, information and belief:

1. I am Senior Director of Publishing Technologies of The Institute of Electrical and Electronics Engineers, Incorporated (“IEEE”).
2. IEEE is a neutral third party in IPR2019-00047.
3. Neither I nor IEEE itself is being compensated for this declaration.
4. Among my responsibilities as Senior Director of Publishing Technologies, I act as a custodian of certain records for IEEE.
5. I make this declaration based on my personal knowledge and information contained in the business records of IEEE.
6. As part of its ordinary course of business, IEEE publishes and makes available technical articles, proceedings and standards. These publications are made available for public download through the IEEE digital library, IEEE Xplore.
7. It is the regular practice of IEEE to publish articles and other writings including article abstracts and make them available to the public through IEEE Xplore. IEEE maintains copies of publications in the ordinary course of its regularly conducted activities.
8. The article below has been attached as Attachment A to this declaration:

A.	B. G. Perumana et al, "Resistive-Feedback CMOS Low-Noise Amplifiers for Multiband Applications," IEEE Transactions on Microwave Theory and Techniques, Vol. 56, Issue, May 2008.
----	--

9. I obtained a copy of Attachment A through IEEE Xplore, where it is maintained in the ordinary course of IEEE’s business. Attachment A is a true and correct copy of the Attachment, as it existed on or about May 3, 2018.
10. The article and abstract from IEEE Xplore shows the date of publication. IEEE Xplore populates this information using the metadata associated with the publication.
11. B. G. Perumana et al, "Resistive-Feedback CMOS Low-Noise Amplifiers for Multiband Applications" was published in IEEE Transactions on Microwave Theory

and Techniques, Vol. 56, Issue 5. IEEE Transactions on Microwave Theory and Techniques, Vol. 56, Issue 5 was published in May 2008. Copies of this publication were made available no later than the last day of the publication month. The article is currently available for public download from the IEEE digital library, IEEE Xplore.

12. I hereby declare that all statements made herein of my own knowledge are true and that all statements made on information and belief are believed to be true, and further that these statements were made with the knowledge that willful false statements and the like are punishable by fine or imprisonment, or both, under 18 U.S.C. § 1001.

I declare under penalty of perjury that the foregoing statements are true and correct.

Executed on: 5 November 2018

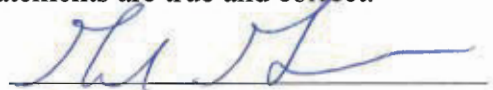
A handwritten signature in blue ink, appearing to be "M. S.", written over a horizontal line.

# ATTACHMENT A

Access provided by:  
**IEEE Staff**  
Sign Out

**Browse**

**My Settings**

**Get Help**

Browse Journals & Magazines > IEEE Transactions on Microwav... > Volume: 56 Issue: 5

[Back to Results](#) | [Next >](#)

# Resistive-Feedback CMOS Low-Noise Amplifiers for Multiband Applications

[View Document](#)

**59**  
Paper Citations

**3**  
Patent Citations

**3569**  
Full Text Views

## Related Articles

Global exponential stability of recurrent neural networks for synthesizing linea...

Measurement of the impulsive noise environment for satellite-mobile radio system...

[View All](#)

**5**  
Author(s)

Bevin G. Perumana ; Jing-Hong C. Zhan ; Stewart S. Taylor ; Brent R. Carlton ; Joy Laskar

[View All Authors](#)

<b>Abstract</b>	Authors	Figures	References	Citations	Keywords	Metrics	Media
-----------------	---------	---------	------------	-----------	----------	---------	-------

### Abstract:

Extremely compact resistive-feedback CMOS low-noise amplifiers (LNAs) are presented as a cost-effective alternative to multiple narrowband LNAs using high-Q inductors for multiband wireless applications. Limited linearity and high power consumption of the inductorless resistive-feedback LNAs are analyzed and circuit techniques are proposed to solve these issues. A 12-mW resistive-feedback LNA, based on current-reuse transconductance boosting is presented with a gain of 21 dB and a noise figure (NF) of 2.6 dB at 5 GHz. The LNA achieves an output third-order intercept point (IP3) of 12.3 dBm at 5 GHz by reducing loop-gain rolloff and by improving linearity of individual stages. The active die area of the LNA is only 0.012 mm<sup>2</sup>. A 9.2-mW tuned resistive-feedback LNA utilizing a single compact low-Q on-chip inductor is presented, showing an improved tradeoff between performance, power consumption, and die area. At 5.5 GHz, the fully integrated LNA achieves a measured gain of 24 dB, an NF of 2 dB, and an output IP3 of 21.5 dBm. The LNA draws 7.7 mA from the 1.2-V supply and has a 3-dB bandwidth of 3.94 GHz (4.04-7.98 GHz). The LNA occupies a die area of 0.022 mm<sup>2</sup>. Both LNAs are implemented in a 90-nm CMOS process and do not require any costly RF enhancement options.

**Published in:** IEEE Transactions on Microwave Theory and Techniques ( Volume: 56, Issue: 5, May 2008 )

**Referenced in:** IEEE RFIC Virtual Journal

**Page(s):** 1218 - 1225

**INSPEC Accession Number:** 9966513

**Date of Publication:** 12 May 2008

**DOI:** 10.1109/TMTT.2008.920181

**ISSN Information:**

**Publisher:** IEEE

**Sponsored by:** IEEE Microwave Theory and Techniques Society

## Contents

[Download PDF](#)

[Download Citation](#)

[View References](#)

[Email](#)

### SECTION I. Introduction

Low-Noise Amplifiers (LNAs) occupy a significant percentage of the total die area in wireless front-ends today. This is because the performance of the LNA is dependent on the Q's of the multiple on-chip inductors. Since the area requirement of high-Q on-chip inductors is high, the die area occupied by the LNA is also high. Often, costly process steps are required to enhance the Q of the

[Full Text](#)

[Authors](#)

[References](#)

Request Permissions

Export to Collabratec

Alerts

Keywords

Related Articles

Back to Top

inductive source degeneration [1], the predominant LNA implementation used in CMOS wireless front-ends, require three high-Q inductors for achieving input impedance matching, high gain, and low noise figure (NF). In spite of the high die area requirements, cascode LNAs have been used extensively in narrowband wireless applications because they provide high gain, low noise, and high linearity at relatively low power consumption. With the advent of multiple-input multiple-output (MIMO), multistandard, and multiband wireless systems; however, the use of the area intensive cascode LNAs is becoming increasingly expensive, leading to the pursuit of alternative LNA implementations.

A multiband receiver can be implemented by using a single multiband or wideband LNA, as shown in Fig. 1. Cascode LNAs based on inductive source degeneration are not suitable for this implementation since it is extremely difficult to switch the three on-chip inductors to make the same cascode LNA work across all the required frequency bands without compromising performance. Multiband receivers can also be implemented by using multiple narrowband LNAs, each designed for a different frequency band, as shown in Fig. 2. If cascode LNAs with inductive degeneration are used for this implementation, the die area and cost will both be prohibitively high.

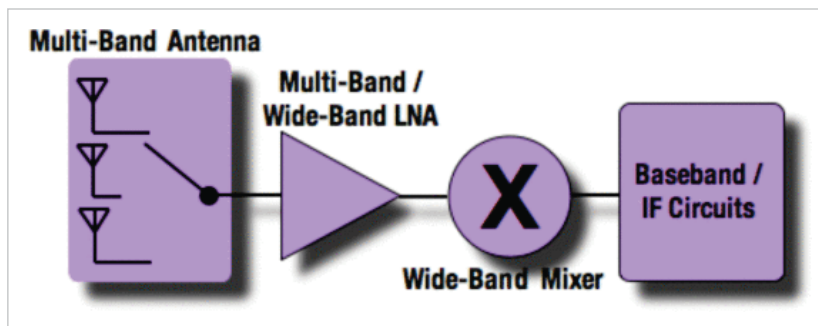

Fig. 1. Multiband receiver implementation using a multiband/wideband LNA.

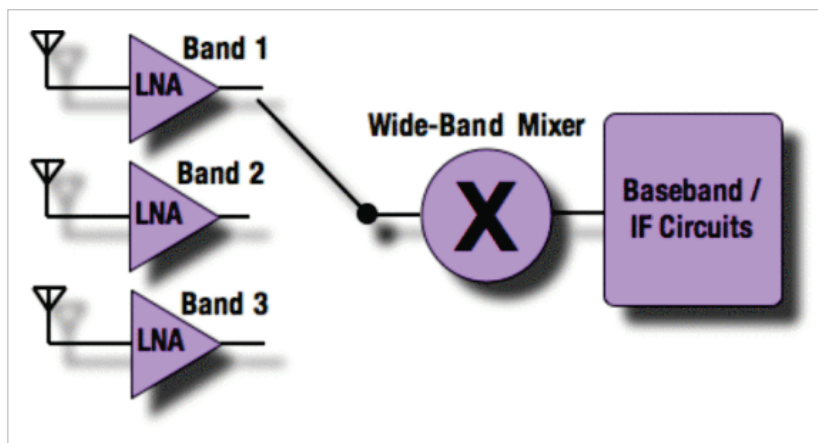
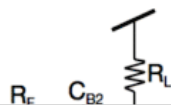

Fig. 2. Multiband receiver implementation using multiple narrowband LNAs.

Inductorless resistive-feedback CMOS LNAs [2]–[3][4] have been shown to be a viable option for implementing multiband receivers, as shown in Fig. 1. These circuits require very small die area and can be implemented in a digital CMOS process without any additional RF enhancements. Hence, this approach can potentially significantly reduce the cost of the wireless front-end implementation. Resistive-feedback LNAs achieve high gain and reasonably low NF [4]. However, novel circuit techniques are required to reduce power consumption and improve linearity.



# Explore Litigation Insights

Docket Alarm provides insights to develop a more informed litigation strategy and the peace of mind of knowing you're on top of things.

## Real-Time Litigation Alerts



Keep your litigation team up-to-date with **real-time alerts** and advanced team management tools built for the enterprise, all while greatly reducing PACER spend.

Our comprehensive service means we can handle Federal, State, and Administrative courts across the country.

## Advanced Docket Research



With over 230 million records, Docket Alarm's cloud-native docket research platform finds what other services can't. Coverage includes Federal, State, plus PTAB, TTAB, ITC and NLRB decisions, all in one place.

Identify arguments that have been successful in the past with full text, pinpoint searching. Link to case law cited within any court document via Fastcase.

## Analytics At Your Fingertips



Learn what happened the last time a particular judge, opposing counsel or company faced cases similar to yours.

Advanced out-of-the-box PTAB and TTAB analytics are always at your fingertips.

## API

Docket Alarm offers a powerful API (application programming interface) to developers that want to integrate case filings into their apps.

## LAW FIRMS

Build custom dashboards for your attorneys and clients with live data direct from the court.

Automate many repetitive legal tasks like conflict checks, document management, and marketing.

## FINANCIAL INSTITUTIONS

Litigation and bankruptcy checks for companies and debtors.

## E-DISCOVERY AND LEGAL VENDORS

Sync your system to PACER to automate legal marketing.