

**United States Patent and Trademark Office
Before the Patent Trial and Appeal Board**

Intel Corporation
Petitioner,
v.
Qualcomm Incorporated
Patent Owner

Case Nos: IPR2019-00047, IPR2019-00048, and IPR2019-00049

Petitioner's Demonstrative Exhibits

Inter Partes Review of U.S. Patent No. 9,154,356

April 7, 2020

**Intel 1041
Intel v. Qualcomm
IPR2019-00047**

Agenda

- Introduction
- Technology Background
- U.S. Patent No. 9,154,356
- Claim Construction
- Overview of Prior Art for IPR2019-00047
- Disputed Issues for IPR2019-00047
- Overview of Prior Art for IPR2019-00048 and IPR2019-00049
- Disputed Issues for IPR2019-00048 and IPR2019-00049

Introduction

Introduction: Previous '356 Patent IPRs

IPR2019-00128

Grounds	Reference(s)	Challenged Claims
Ground I	Anticipated by <i>Lee</i>	1, 7, 8, 11, 17, and 18
Ground II	Obvious over <i>Lee</i>	7 and 8
Ground III	Obvious over <i>Lee</i> in view of <i>Feasibility Study</i>	1, 7, 8, 11, 17, and 18

IPR2019-00129

Grounds	Reference(s)	Challenged Claims
Ground I	Anticipated by <i>Lee</i>	2-6
Ground II	Obvious over <i>Lee</i> in view of <i>Youssef</i>	10
Ground III	Obvious over <i>Lee</i> in view of <i>Feasibility Study</i>	2-6
Ground IV	Obvious over <i>Lee</i> in view of <i>Feasibility Study</i> and <i>Youssef</i>	10

Introduction: Instituted Grounds

IPR2019-00047

Grounds	Reference(s)	Challenged Claims
Ground I	Claims 1, 11, 17, 18	Anticipated by Uehara
Ground II	Claims 7 and 8	Obvious over Uehara in view of Perumana
Ground III	Claim 10	Obvious over Uehara in view of Youssef
Ground IV	Claims 1, 11, 17, 18	Obvious over Uehara in view of Feasibility Study
Ground V	Claims 7 and 8	Obvious over Uehara in view of Feasibility Study and Perumana
Ground VI	Claim 10	Obvious over Uehara in view of Feasibility Study and Youssef

Introduction: Instituted Grounds

IPR2019-00048

Grounds	Reference(s)	Challenged Claims
Ground I	Claims 1, 17, 18	Obvious over Jeon in view of Xiong
Ground II	Claims 9 and 10	Obvious over Jeon in view of Xiong and Youssef
Ground III	Claims 1, 17, 18	Obvious over Jeon in view of Xiong and Feasibility Study
Ground IV	Claims 9 and 10	Obvious over Jeon in view of Xiong, Feasibility Study, and Youssef

IPR2019-00049

Grounds	Reference(s)	Challenged Claims
Ground I	Claims 2-8, 11	Obvious over Jeon in view of Xiong
Ground II	Claims 2-8, 11	Obvious over Jeon in view of Xiong and Feasibility Study

Introduction: Prior Adjudication

ITC Markman Order

In spite of this explanation with examples, Qualcomm and Staff make an **unusual argument** that the construction of “carrier aggregation” should incorporate language not used to describe “carrier aggregation” in the ’356 patent specification. (SMBr. at 12

A bandwidth limitation like the one proposed by Staff and Qualcomm would steer “carrier aggregation” away from how the applicant characterized the invention and toward prior art the applicant distinguished from the invention. Moreover, as mentioned

Technology Background

Technology Background: Wireless System

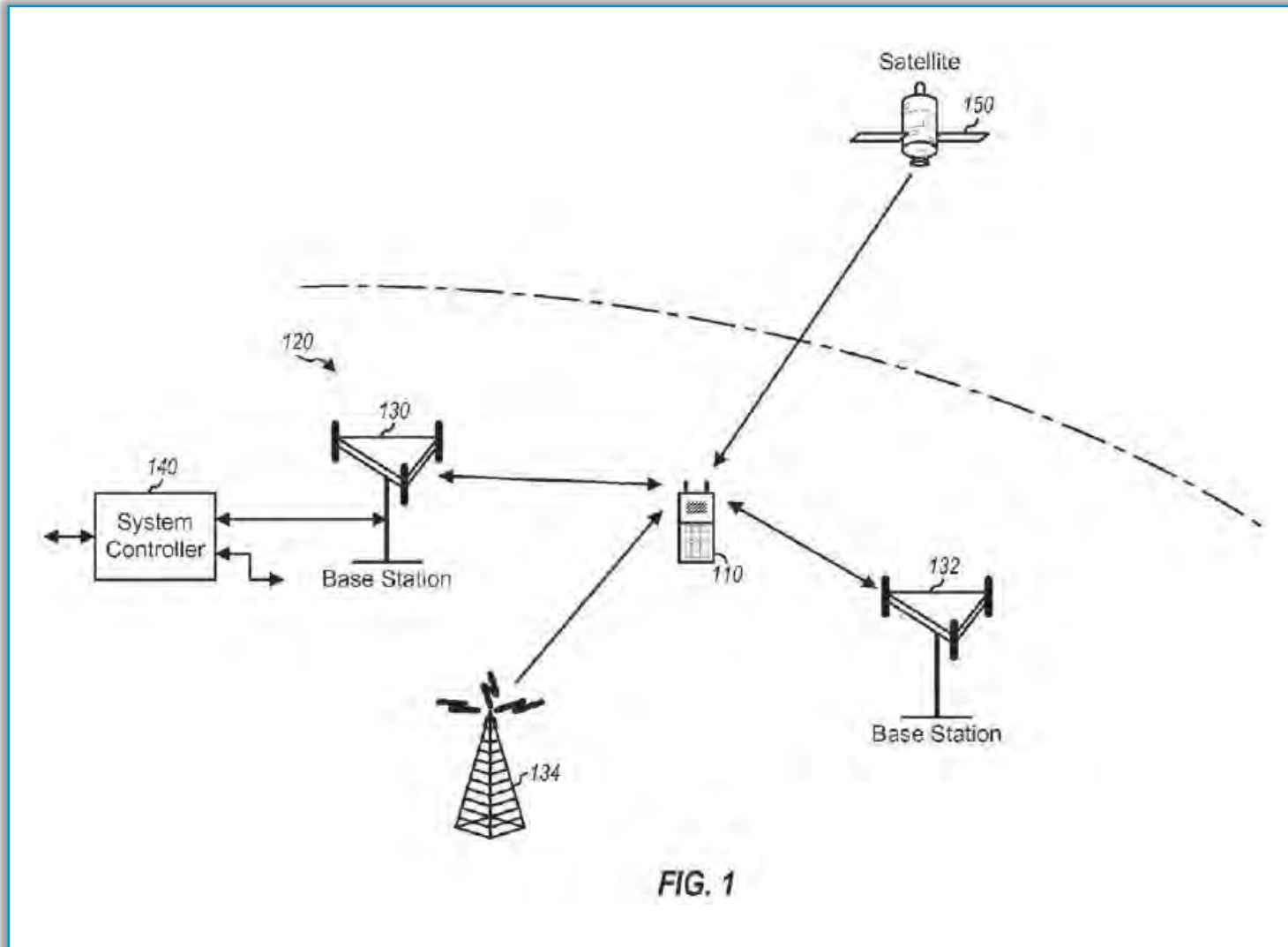
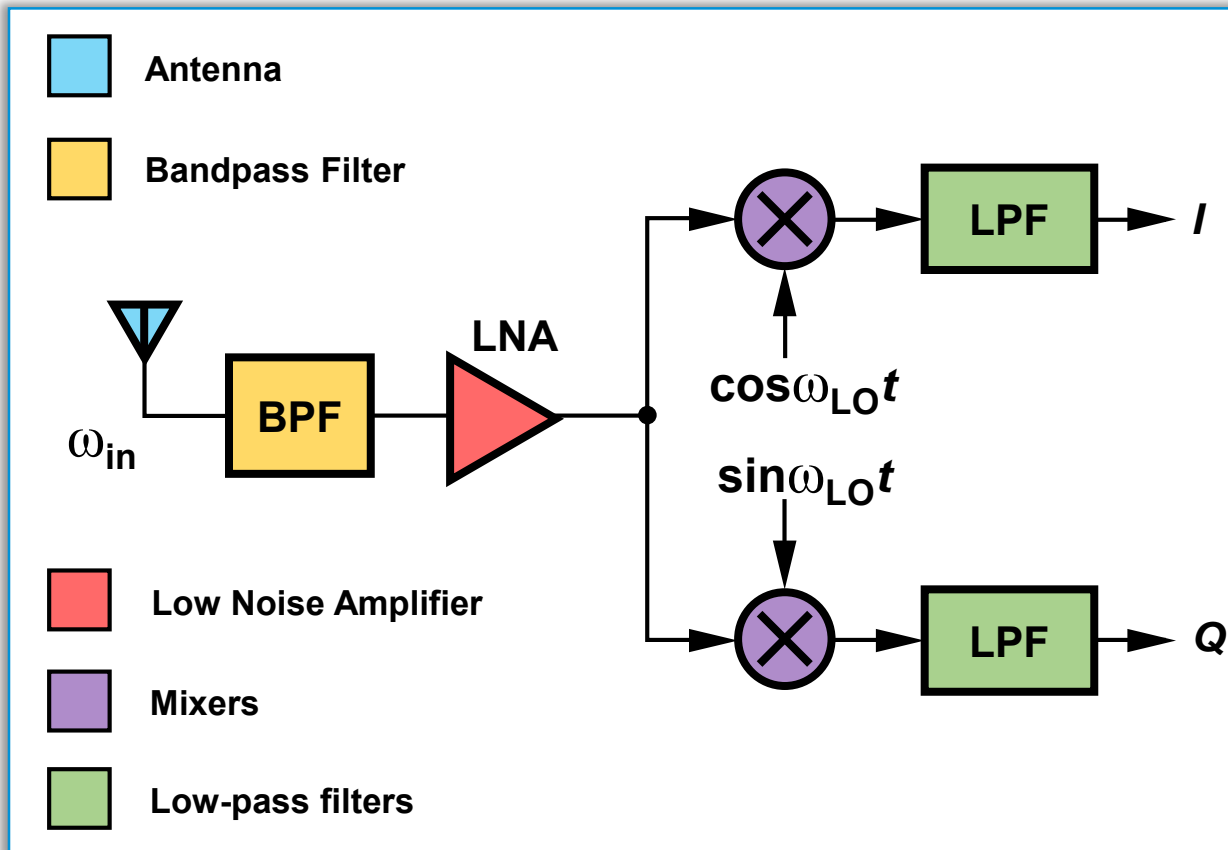

FIG. 1

Technology Background: Basic Receiver



- “antenna for receiving signals”
- “low noise amplifier for amplifying the signals”
- “mixers for down conversion”
- “various filters for removing undesired signals”

Technology Background: Carrier Aggregation

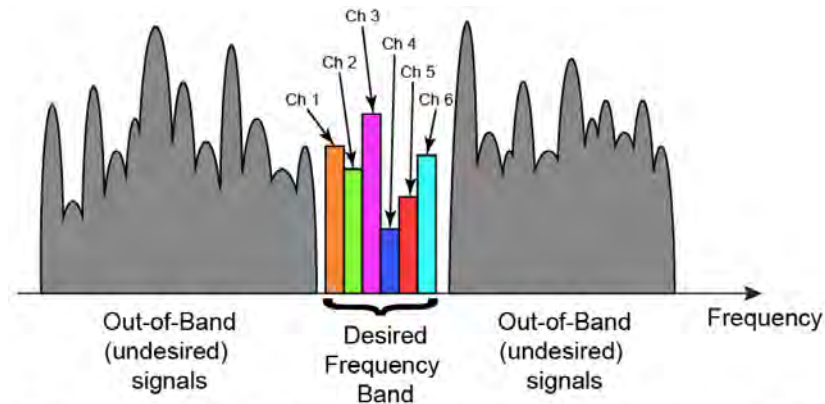

Figure 2. An input RF signal containing multiple frequencies as collected by the antenna.

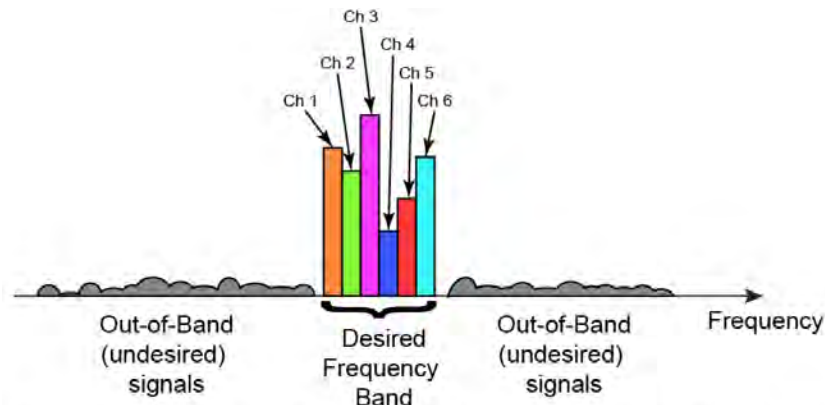
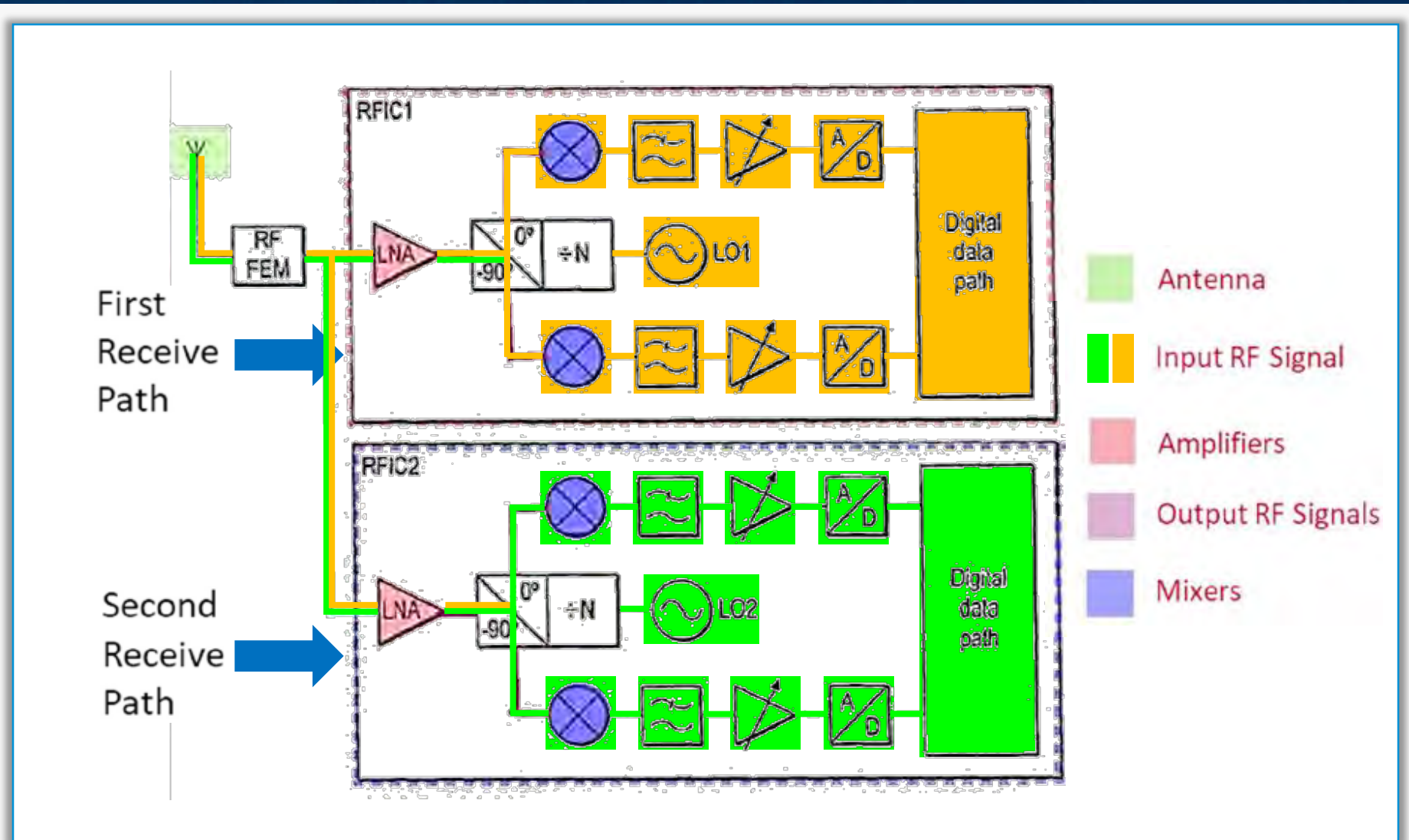

Figure 3. Frequencies in an input RF signal after the BPF attenuates out-of-band carriers and the LNA amplifies the remaining frequencies.

Technology Background: Carrier Aggregation



Technology Background: Carrier Aggregation

3GPP TR 36.912 V9.1.0 (2009-12)

Technical Report

3rd Generation
Technical Specification Group Radio
Further Advancements for E-UTRA



5.1 General

LTE-Advanced extends LTE Rel-8 with support for *Carrier Aggregation*, where two or more *component carriers* (CCs) are aggregated in order to support wider transmission bandwidths up to 100MHz and for spectrum aggregation.

It shall be possible to configure all component carriers which are LTE Rel-8 compatible, at least when the aggregated numbers of component carriers in the UL and the DL are the same. Not all component carriers may necessarily be LTE Rel-8 compatible.

A terminal may simultaneously receive or transmit one or multiple component carriers depending on its capabilities:

- An LTE-Advanced terminal with reception and/or transmission capabilities for carrier aggregation can simultaneously receive and/or transmit on multiple component carriers.
- An LTE Rel-8 terminal can receive and transmit on a single component carrier only, provided that the structure of the component carrier follows the Rel-8 specifications.

The present document has been developed within the 3rd Generation Partnership Project (3GPPTM) and may be further elaborated for the purposes of 3GPP.

This document has not been subject to any approval process by the 3GPP Organizational Partners and shall not be implemented. This Specification is provided for future development work within 3GPP only. The Organizational Partners accept no liability for any use of this Specification. Specifications and reports for implementations of the 3GPPTM systems should be obtained via the 3GPP Organizational Partners' Publications Office.

i

INTEL 1304

U.S. Patent No. 9,154,356

U.S. Patent No. 9,154,356

(10) **Patent No.:** US 9,154,356 B2
 (45) **Date of Patent:** Oct. 6, 2015

(54) **LOW NOISE AMPLIFIERS FOR CARRIER AGGREGATION**

(57) **ABSTRACT**

Low noise amplifiers (LNAs) supporting carrier aggregation are disclosed. In an exemplary design, an apparatus includes first and second amplifier stages, e.g., for a carrier aggregation (CA) LNA or a multiple-input multiple-output (MIMO) LNA. The first amplifier stage receives and amplifies an input radio frequency (RF) signal and provides a first output RF signal to a first load circuit when the first amplifier stage is enabled. The input RF signal includes transmissions sent on multiple carriers at different frequencies to a wireless device. The second amplifier stage receives and amplifies the input RF signal and provides a second output RF signal to a second load circuit when the second amplifier stage is enabled. Each amplifier stage may include a gain transistor coupled to a cascode transistor.

United States Patent
Tasic et al.

(10) **Patent No.:** US 9,154,356 B2
 (45) **Date of Patent:** Oct. 6, 2015

(54) **LOW NOISE AMPLIFIERS FOR CARRIER AGGREGATION**

(75) **Inventors:** Aleksandar Miodrag Tasic, San Diego, CA (US); Anshu Bomi Dawarwalla, San Diego, CA (US)

(73) **Assignee:** QUALCOMM Incorporated, San Diego, CA (US)

(*) **Notice:** Subject to any disclaimer, the term of this patent is extended or adjusted under 35 U.S.C. 154(b) by 0 days.

(21) **App. No.:** 13/590,423
 (22) **Filed:** Aug. 21, 2012

(65) **Prior Publication Data**
 US 2013/015548 A1 Nov. 28, 2013

Related U.S. Application Data

(60) **Provisional application No. 61/652,064, filed on May 25, 2012.**

(51) **Int. Cl.**
 H04L 27/06 (2006.01)
 H04L 27/26 (2006.01)
 H03G 3/20 (2006.01)
 H03F 1/22 (2006.01)
 H03F 3/193 (2006.01)

(52) **U.S. Cl.**
 CPC: H04L 27/2647 (2013.01); H03F 1/223 (2013.01); H03F 3/193 (2013.01); H03G 3/20 (2013.01); H03F 3/72 (2013.01); H03G 3/20 (2013.01)

(58) **Field of Classification Search**
 CPC: H04L 27/2647; H04L 27/2649; H04L 27/38; H03H 7/40; H03G 3/20
 USPC: 375/316; 317; 318; 345; 349; 340; 455/130; 132; 136; 234.1; 370/542
 See application file for complete search history.

References Cited
 U.S. PATENT DOCUMENTS
 3,911,364 A 10/1975 Langsoeth et al.
 4,035,728 A 7/1977 Ishikawa et al.
 (Continued)

FOREIGN PATENT DOCUMENTS
 CN 1523912 A 8/2004
 CN 1922793 A 2/2007
 (Continued)

OTHER PUBLICATIONS
 International Search Report and Written Opinion—PCT/US2013/042726—ISA/EPO—Oct. 2, 2013.
 (Continued)

Primary Examiner—Khanh C Tran
 (74) **Attorney, Agent, or Firm**—Ramin Mobarhan

(57) **ABSTRACT**
 Low noise amplifiers (LNAs) supporting carrier aggregation are disclosed. In an exemplary design, an apparatus includes first and second amplifier stages, e.g., for a carrier aggregation (CA) LNA or a multiple-input multiple-output (MIMO) LNA. The first amplifier stage receives and amplifies an input radio frequency (RF) signal and provides a first output RF signal to a first load circuit when the first amplifier stage is enabled. The input RF signal includes transmissions sent on multiple carriers at different frequencies to a wireless device. The second amplifier stage receives and amplifies the input RF signal and provides a second output RF signal to a second load circuit when the second amplifier stage is enabled. Each amplifier stage may include a gain transistor coupled to a cascode transistor.

20 Claims, 17 Drawing Sheets

'356 Patent: Alleged Problem in the Prior Art

(12) **United States Patent**
Tasic et al.

(10) Patent No.
(45) Date of Patent

(54) **LOW NOISE AMPLIFIERS FOR CARRIER AGGREGATION**

(56) R
U.S. PA
3,911,364 A
4,035,728 A

(75) Inventors: **Aleksandar Miodrag Tasic**, San Diego, CA (US); **Anosh Bond Davierwalla**, San Diego, CA (US)

(73) Assignee: **QUALCOMM Incorporated**, San Diego, CA (US)

(*) Notice: Subject to any disclaimer, the term of this patent is extended or adjusted under 35 U.S.C. 154(b) by 0 days.

(21) Appl. No.: **13,590,423**

(22) Filed: **Aug. 21, 2012**

(65) **Prior Publication Data**
US 2013/015548 A1 Nov. 28, 2013
Related U.S. Application Data
(60) Provisional application No. 61/652,064, filed on May 25, 2012.

(51) **Int. Cl.**
H04L 27/06 (2006.01)
H04L 27/26 (2006.01)
H03G 3/20 (2006.01)
H03F 1/22 (2006.01)
H03F 3/73 (2006.01)
(Continued)

(52) **U.S. CL.**
CPC *H04L 27/2647* (2013.01); *H03F 1/223* (2013.01); *H03F 3/73* (2013.01); *H03G 3/20* (2013.01); *H03F 3/72* (2013.01); *H03G 3/20* (2013.01)

(53) **Field of Classification Search**
CPC *H04L 27/2647*; *H04L 27/2649*; *H04L 27/38*; *H03H 7/40*; *H03G 3/20*
USPC 375/316; 317; 318; 345; 349; 340; 455/130; 132; 136; 234; 1; 370/542
See application file for complete search history.

FOREIGN
CN 15239
CN 19227

OTHER
International Search Rep
042726—ISA/EPO—Oa

Primary Examiner—
(74) Attorney, Agent,
(57)

Low noise amplifiers are disclosed. In an example, a first and second amplifier (CA) LNA or a multi-carrier LNA. The first amplifier amplifies a radio frequency (RF) signal to a first load impedance. The input RF signal is a first and second multiple carriers at different frequencies. The second amplifier amplifies the RF signal and provides a load circuit when the amplifier stage may be a cascode transistor.

20 Claims

A wireless device may support carrier aggregation, which is simultaneous operation on multiple carriers. A carrier may refer to a range of frequencies used for communication and may be associated with certain characteristics. For example, a carrier may be associated with system information describing operation on the carrier. A carrier may also be referred to as a component carrier (CC), a frequency channel, a cell, etc. It is desirable to efficiently support carrier aggregation by the wireless device.

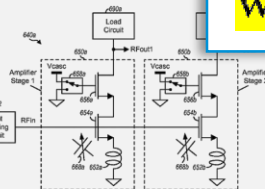

'356 Patent: File History

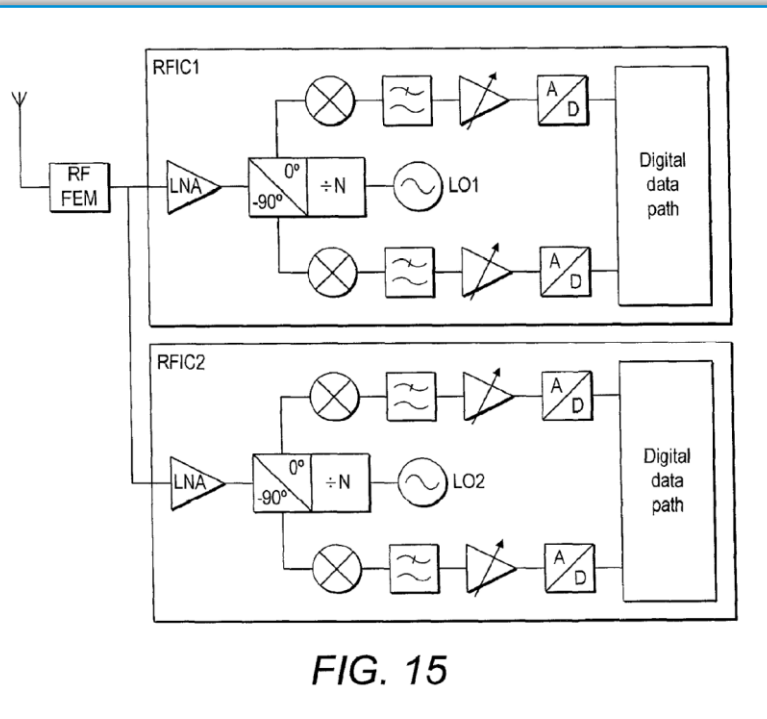

-00047 IPR, Ex. 1025 (Kaukovouri) at Fig. 15

3. Claims 1, 11-12, 14 and 17 are rejected under pre-AIA 35 U.S.C. 102(e) as being anticipated by Kaukovouri et al. U.S. Patent 8,442,473.

Regarding claim 1, Kaukovouri et al. discloses an apparatus (FIG. 15 embodiment) comprising:

a first amplifier stage configured to receive and amplify an input radio frequency (RF) signal and provide a first output RF signal to a first load circuit when the first amplifier stage is enabled, the input RF signal employing carrier aggregation comprising transmissions sent on multiple carriers at different frequencies to a wireless device, the

-00047 IPR, Ex. 1016 at 2 (annotated)

'356 Patent: File History

IN THE UNITED STATES PATENT AND TRADEMARK OFFICE

Application No. : 13/590,423 Confirmation No. :
Applicant : Aleksandar Modrag Tasic
Filed : August 21, 2012
Art Unit : 2631
Examiner : Khanh C. Tran
Docket No. : 121973
Customer No. : 23696

AMENDMENT

Commissioner for Patents
P.O. Box 1450
Alexandria, VA 22313-1450

Sir:

In response to an Office Action dated December 26, 2012, your identified application as follows:

Amendments to the Claims are reflected in the listing of claims at the end of this paper.

Remarks/Arguments begin on page 7 of this paper.

Attorney Docket No. 121973
Customer No. 23696

- 1 -

INTEL 1020

I. (Currently amended) An apparatus comprising:

a first amplifier stage configured to be **independently enabled or disabled**, the first amplifier stage further configured to receive and amplify an input radio frequency (RF) signal and provide a first output RF signal to a first load circuit when the first amplifier stage is enabled, the input RF signal employing carrier aggregation comprising transmissions sent on multiple carriers at different frequencies to a wireless device, the first output RF signal including at least a first carrier of the multiple carriers; and a second amplifier stage configured to be **independently enabled or disabled**, the second amplifier stage further configured to receive and amplify the input RF signal and provide a second output RF signal to a second load circuit when the second amplifier stage is enabled, the second output RF signal including at least a second carrier of the multiple carriers different than the first carrier.

'356 Patent: File History

Reasons for Allowance

The following is an examiner's statement of reasons for allowance:

4. Claims are allowable over prior art of record because the cited references

either singularly or in combination cannot teach or suggest "a first amplifier stage configured to be independently enabled or disabled ..." and "a second amplifier stage configured to be independently enabled or disabled ..." as set forth in the independent claims 1, 17 and 19.

 UNITED STATES PATENT AND TRADEMARK OFFICE

NOTICE OF ALLOWANCE AND FEES DUE

1365 720 02/22/2013
QUALCOMM INCORPORATED
5775 MOREHOUSE DR.
SAN DIEGO, CA 92121

APPLICATION NO.	FILING DATE	FIRST NAMED INVENTOR
13570423	09/21/2012	Aleksander Moding Tesse

TITLE OF INVENTION: LOW NOISE AMPLIFIERS FOR CARRIER AGGREGATION

APPLN. CYCLE	ENTITY STATUS	ISSUE FEE DUE	PUBLICATION FEE DUE	ISSUE PAID
nonprovisional	UNDISCOUNTED	\$960	\$0	

THE APPLICATION IDENTIFIED ABOVE HAS BEEN EXAMINED AND IS A PROSECUTION ON THE MERITS IS CLOSED. THIS NOTICE OF ALLOWANCE THIS APPLICATION IS SUBJECT TO WITHDRAWAL FROM ISSUE AT THE PETITION BY THE APPLICANT. SEE 37 CFR 1.313 AND MPEP 1308.

THE ISSUE FEE AND PUBLICATION FEE (IF REQUIRED) MUST BE PAID MAILING DATE OF THIS NOTICE OR THIS APPLICATION SHALL BE STATUTORY PERIOD CANNOT BE EXTENDED. SEE 35 U.S.C. 151. THE FEE NOT REFLECT A CREDIT FOR ANY PREVIOUSLY PAID ISSUE FEE IN THE PREVIOUSLY BEEN PAID IN THIS APPLICATION (AS SHOWN ABOVE), IT WILL BE CONSIDERED A REQUEST TO REAPPLY THE PREVIOUSLY PAID FEE.

HOW TO REPLY TO THIS NOTICE:

I. Review the ENTITY STATUS shown above. If the ENTITY STATUS is shown as SMA entity status still applies.
If the ENTITY STATUS is the same as shown above, pay the TOTAL FEE(S) DUE shown.
If the ENTITY STATUS is changed from that shown above, on PART B - FEE(S) TRANS "Change in Entity Status (from status indicated above)".
For purposes of this notice, small entity fees are 1/2 the amount of undiscounted fees, and a fee.

II. PART B - FEE(S) TRANSMITTAL, or its equivalent, must be completed and returned (USPTO) with your ISSUE FEE and PUBLICATION FEE (if required). If you are charged of Part B - Fee(s) Transmittal should be completed and an extra copy of the form should request to reapply a previously paid issue fee must be clearly made, and delays in process the paper as an equivalent of Part B.

III. All communications regarding this application must give the application number. Please Mail Stop ISSUE FEE unless advised to the contrary.

IMPORTANT REMINDER: Utility patents issuing on applications filed on or after Dec. 12, 1980 may require payment of maintenance fees. It is patentee's responsibility to ensure timely payment of maintenance fees when due.

Page 1 of 3 ENTEL 1022
PTOL-85 (Rev. 02/13)

'356 Patent: Overview of Claim 1

1. An apparatus comprising:
 - a first amplifier stage configured to be independently enabled or disabled, the first amplifier stage further configured to receive and amplify an input radio frequency (RF) signal and provide a first output RF signal to a first load circuit when the first amplifier stage is enabled, the input RF signal employing carrier aggregation comprising transmissions sent on multiple carriers at different frequencies to a wireless device, the first output RF signal including at least a first carrier of the multiple carriers; and
 - a second amplifier stage configured to be independently enabled or disabled, the second amplifier stage further configured to receive and amplify the input RF signal and provide a second output RF signal to a second load circuit when the second amplifier stage is enabled, the second output RF signal including at least a second carrier of the multiple carriers different than the first carrier.

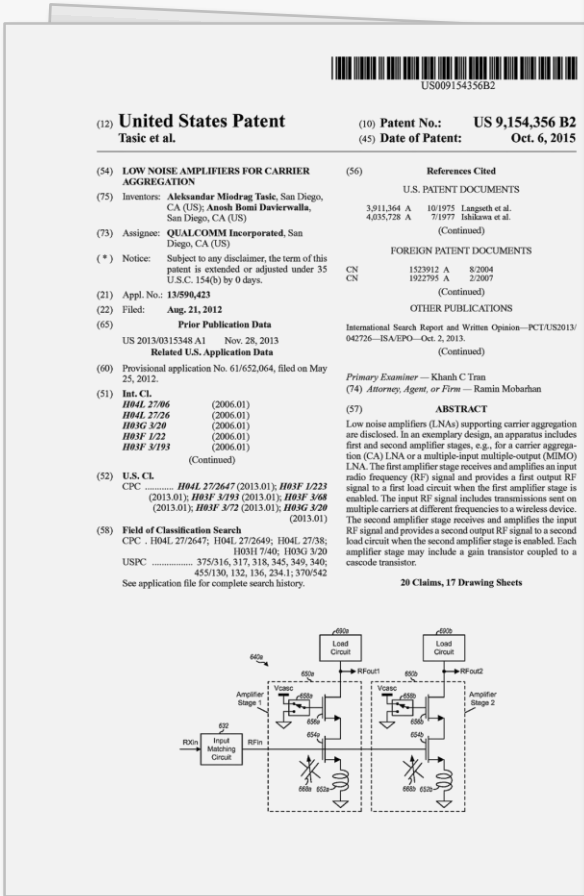

'356 Patent: Overview of Claim 17

17. A method comprising:
amplifying a first input radio frequency (RF) signal with a first amplifier stage to obtain a first output RF signal when the first amplifier stage is enabled, the first amplifier stage configured to be independently enabled or disabled, the first input RF signal employing carrier aggregation comprising transmissions sent on multiple carriers at different frequencies to a wireless device, the first output RF signal including at least a first carrier of the multiple carriers; and
amplifying the first input RF signal or a second input RF signal with a second amplifier stage to obtain a second output RF signal when the second amplifier stage is enabled, the second amplifier stage configured to be independently enabled or disabled, the second output RF signal including at least a second carrier of the multiple carriers different than the first carrier.

US009154356B2

(12) United States Patent Tasic et al.	(10) Patent No.: US 9,154,356 B2 (45) Date of Patent: Oct. 6, 2015
(54) LOW NOISE AMPLIFIERS FOR CARRIER AGGREGATION	(56) References Cited
(75) Inventors: Aleksandar Miodrag Tasic, San Diego, CA (US); Anshu Bomi Davierwalla, San Diego, CA (US)	3,911,364 A 10/1975 Langsoth et al. 4,035,728 A 7/1977 Ishikawa et al. (Continued)
(73) Assignee: QUALCOMM Incorporated, San Diego, CA (US)	FOREIGN PATENT DOCUMENTS
(*) Notice: Subject to any disclaimer, the term of this patent is extended or adjusted under 35 U.S.C. 154(b) by 0 days.	CN 1523912 A 8/2004 CN 1922793 A 2/2007 (Continued)
(21) Appl. No.: 13,590,423	OTHER PUBLICATIONS
(22) Filed: Aug. 21, 2012	International Search Report and Written Opinion—PCT/US2013/042726—ISA/EPO—Oct. 2, 2013. (Continued)
(65) Prior Publication Data US 2013/015548 A1 Nov. 28, 2013	<i>Primary Examiner</i> —Khanh C Tran (74) <i>Attorney, Agent, or Firm</i> —Ramin Mobarhan
Related U.S. Application Data	(57) ABSTRACT
(60) Provisional application No. 61/652,064, filed on May 25, 2012.	Low noise amplifiers (LNAs) supporting carrier aggregation are disclosed. In an exemplary design, an apparatus includes first and second amplifier stages, e.g., for a carrier aggregation (CA) LNA or a multiple-input multiple-output (MIMO) LNA. The first amplifier stage receives and amplifies an input radio frequency (RF) signal and provides a first output RF signal to a first load circuit when the first amplifier stage is enabled. The input RF signal includes transmissions sent on multiple carriers at different frequencies to a wireless device. The second amplifier stage receives and amplifies the input RF signal and provides a second output RF signal to a second load circuit when the second amplifier stage is enabled. Each amplifier stage may include a gain transistor coupled to a cascode transistor.
(51) Int. Cl. <i>H04L 27/06</i> (2006.01) <i>H04L 27/26</i> (2006.01) <i>H03G 3/20</i> (2006.01) <i>H03F 1/22</i> (2006.01) <i>H03F 3/193</i> (2006.01) (Continued)	
(52) U.S. Cl. CPC <i>H04L 27/2647</i> (2013.01); <i>H03F 1/223</i> (2013.01); <i>H03F 3/193</i> (2013.01); <i>H03F 3/08</i> (2013.01); <i>H03F 3/72</i> (2013.01); <i>H03G 3/20</i> (2013.01)	
(58) Field of Classification Search CPC <i>H04L 27/2647</i> ; <i>H04L 27/2649</i> ; <i>H04L 27/38</i> ; <i>H03H 7/40</i> ; <i>H03G 3/20</i> USPC 375/316, 317, 318, 345, 349, 340, 455/130, 132, 136, 234, 234.1; 370/542 See application file for complete search history.	

20 Claims, 17 Drawing Sheets

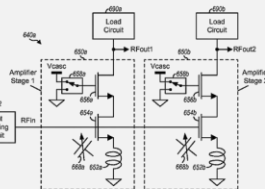

Overview of '356 Patent

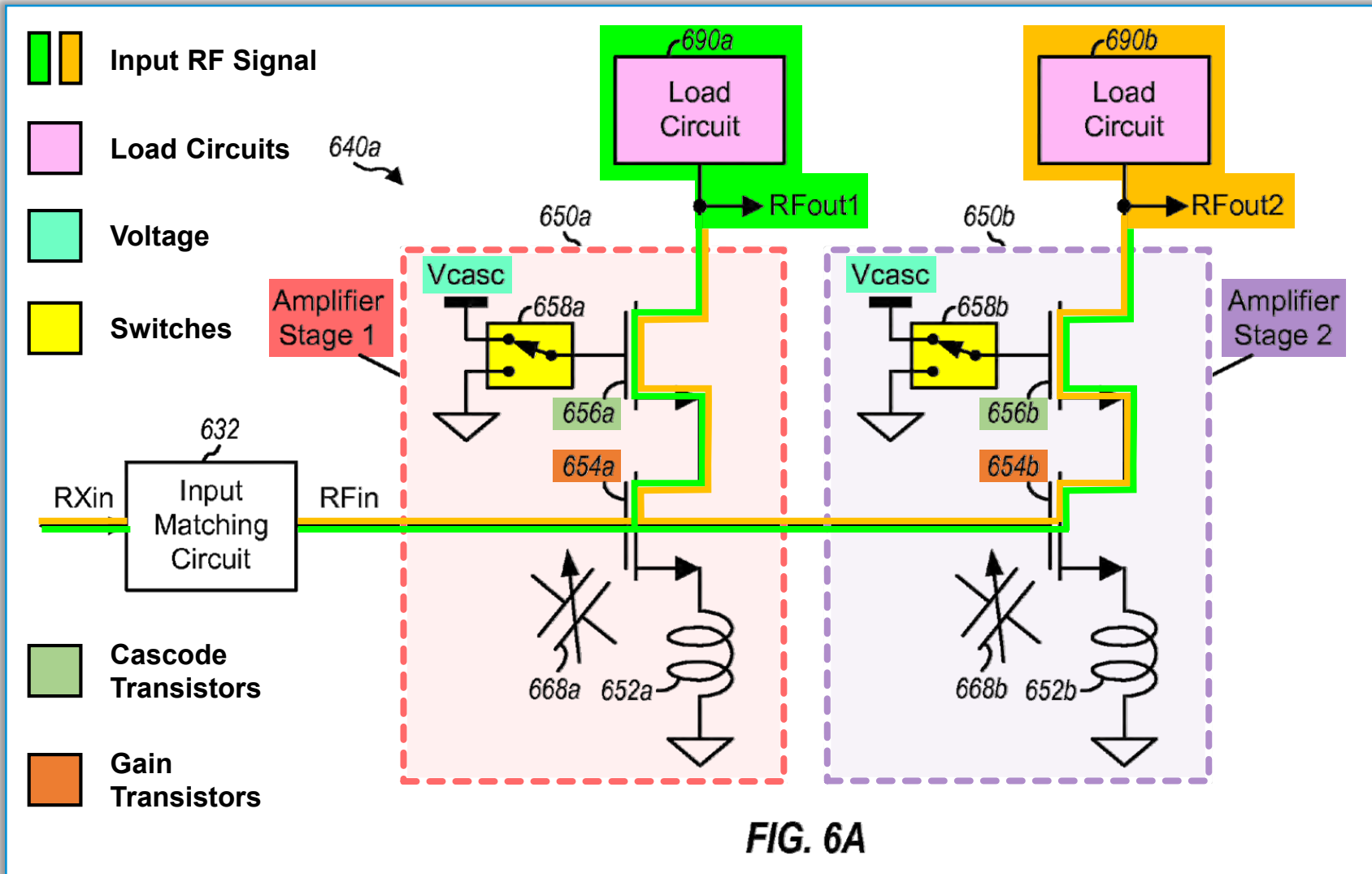

Claim Construction of “Carrier Aggregation”

Claim Construction: “Carrier Aggregation”

“carrier aggregation”

Petitioner

**“simultaneous operation
on multiple carriers”**

Patent Owner

**“[1] simultaneous operation
on multiple carriers
[2] that are combined as
a single virtual channel
[3] to provide higher bandwidth”**

Claim Construction: “Carrier Aggregation”

1. An apparatus comprising:
 - a first amplifier stage configured to be independently enabled or disabled, the first amplifier stage further configured to receive and amplify an input radio frequency (RF) signal and provide a first output RF signal to a first load circuit when the first amplifier stage is enabled, the input RF signal employing carrier aggregation comprising transmissions sent on multiple carriers at different frequencies to a wireless device, the first output RF signal including at least a first carrier of the multiple carriers; and
 - a second amplifier stage configured to be independently enabled or disabled, the second amplifier stage further configured to receive and amplify the input RF signal and provide a second output RF signal to a second load circuit when the second amplifier stage is enabled, the second output RF signal including at least a second carrier of the multiple carriers different than the first carrier.

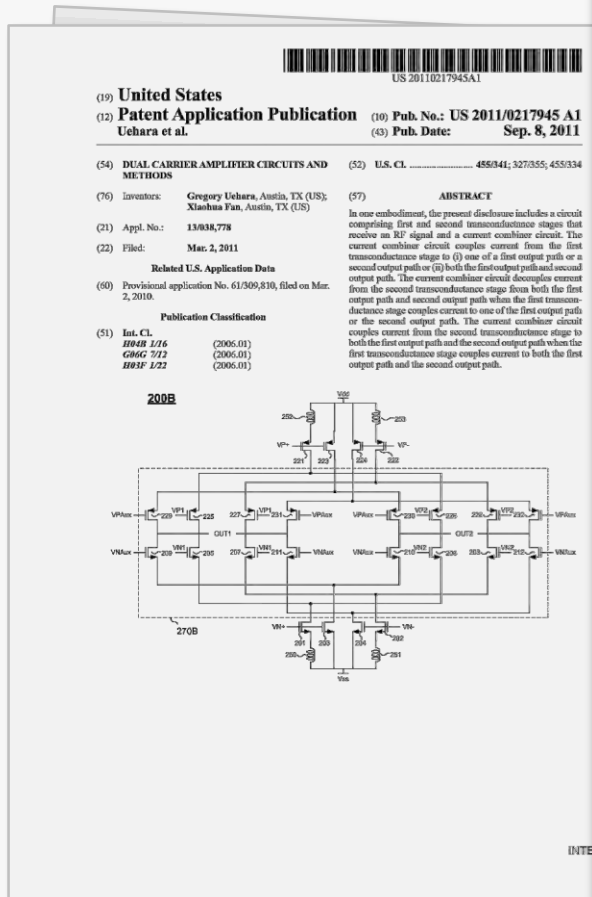

Claim Construction: “Carrier Aggregation”

DOCKET NO.: 0107131-00573US1
Filed on behalf of Intel Corporation
By: David L. Cavanaugh, Reg. No. 36,476
John V. Hobgood, Reg. No. 61,540
Benjamin S. Fernandez, Reg. No. 55,172
Wilmer Cutler Pickering Hale and Dorr LLP
1875 Pennsylvania Ave., NW
Washington, DC 20006
Tel: (202) 663-6000
Email: David.Cavanaugh@wilmerhale.com
John.Hobgood@wilmerhale.com
Ben.Fernandez@wilmerhale.com

UNITED STATES PATENT AND TRADEM
BEFORE THE PATENT TRIAL AND APPEALS

INTEL CORPORATION
Petitioner

v.

QUALCOMM INCORPORATED
Patent Owner

Case IPR2019-00047

DECLARATION OF PATRICK FAY
U.S. PATENT NO. 9,154,356
CLAIMS 1, 7, 8, 10, 11, 17, and 18

62. This construction is consistent with the understanding of persons having ordinary skill in the art. As described above, carrier aggregation is commonly understood to mean sending data to or from a radio on multiple carriers at the same time. Carrier aggregation is known to have multiple uses and is not limited to any particular use. In light of this multi-purpose operation, it is my conclusion that “simultaneous operation on multiple carriers” captures the meaning of “carrier aggregation” to a person having ordinary skill in the art.

INTEL 1002

Claim Construction: “Carrier Aggregation”

(12) **United States Patent**
Tasic et al. (10) Patent No.: US 9,154,356 B2
(45) Date of Patent: Oct. 6, 2015

(54) **LOW NOISE AMPLIFIERS FOR CARRIER AGGREGATION**
(75) Inventors: **Aleksandar Miodrag Tasic**, San Diego, CA (US); **Anshu Bomi Daverwalla**, San Diego, CA (US)
(73) Assignee: **QUALCOMM Incorporated**, San Diego, CA (US)
(* Notice: Subject to any disclaimer, the term of this patent is extended or adjusted under 35 U.S.C. 154(b) by 0 days.

(21) Appl. No.: **13/590,423**
(22) Filed: **Aug. 21, 2012**
(65) **Prior Publication Data**
US 2013/015548 A1 Nov. 28, 2013
Related U.S. Application Data

(60) Provisional application No. 61/652,064, filed on May 25, 2012.

(51) **Int. Cl.**
H04L 27/06 (2006.01)
H04L 27/26 (2006.01)
H03G 3/20 (2006.01)
H03F 1/22 (2006.01)
H03F 3/193 (2006.01)
(Continued)

(52) **U.S. CL.**
CPC *H04L 27/2647* (2013.01); *H03F 1/223* (2013.01); *H03F 3/193* (2013.01); *H03F 3/08* (2013.01); *H03F 3/72* (2013.01); *H03G 3/20* (2013.01)

(58) **Field of Classification Search**
CPC: *H04L 27/2647*; *H04L 27/2649*; *H04L 27/38*; *H03H 7/40*; *H03G 3/20*
USPC: 375/316, 317, 318, 345, 349, 340, 455/130, 132, 136, 234, 1; 370/542
See application file for complete search history.



(56) References Cited:
U.S. PATENT AND TRADEOFFICE DOCUMENTS
3911,364 A
4,035,728 A
FOREIGN PATENT AND TRADEOFFICE DOCUMENTS
CN 152391
CN 192275
OTHER PUBLICATIONS
International Search Report
042726—ISA/EPO—October 2012
(Continued)

Primary Examiner—**Khamb C. Tran**
(74) Attorney, Agent, or Firm

(57) **Low noise amplifiers** are disclosed. In an example, a first and second amplifier (CA) LNA or a multi-carrier LNA. The first amplifier amplifies a radio frequency (RF) signal to a first load circuit. The input RF signal includes multiple carriers at different frequencies. The second amplifier amplifies the RF signal and provides a load circuit when the first amplifier stage may include a gain transistor coupled to a cascade transistor.

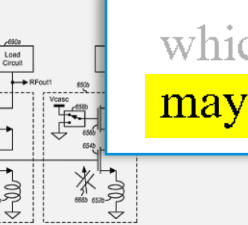

A wireless device may support carrier aggregation, which is simultaneous operation on multiple carriers. A carrier may

Wireless device 110 may support carrier aggregation, which is operation on multiple carriers. Carrier aggregation

which is operation on multiple carriers. Carrier aggregation may also be referred to as multi-carrier operation. Wireless

Claim Construction: “Carrier Aggregation”

- ***Phillips v. AWH Corp.***,
415 F.3d 1303, 1315 (Fed. Cir. 2005) (en banc)
 - “[T]he specification is always highly relevant to the claim construction analysis. Usually, it is dispositive; it is the single best guide to the meaning of a disputed term.” (internal quotation marks omitted)

Claim Construction: “Carrier Aggregation”

ITC Construction of “Carrier Aggregation” Under *Phillips*

In sum, free from artificial limitations, the proper construction of “carrier aggregation” comes straight from the specification of the ’356 patent: “simultaneous operation on multiple carriers.”

-00047 IPR, Ex. 1036 (Markman CC Order) Appx.A at 30 (annotated)

- ***Rembrandt Wireless Techs., L.P. v. Samsung Elecs. Co.***, 853 F.3d 1370, 1377 (Fed. Cir. 2017)
 - “the Board in IPR proceedings operates under a broader claim construction standard than the federal courts”

-00047 IPR, Paper 19 (Petitioner’s Reply to POR) at 2

Claim Construction: “Carrier Aggregation”

Qualcomm

Qualcomm’s proposed construction is “simultaneous operation on multiple carriers that are combined as a single virtual channel to provide higher bandwidth”

“simultaneous operation on multiple carriers”

A wireless device may support carrier aggregation, which is simultaneous operation on multiple carriers. A carrier may

-00047 IPR, Ex. 1001 ('356 Patent) at 1:32-33 (annotated)

“that are combined as a single virtual channel to provide higher bandwidth”

- “single virtual channel” and “higher bandwidth” do not appear in the '356 specification

Claim Construction: “Carrier Aggregation”

Qualcomm

Qualcomm argues that the '356 specification's statements regarding “carrier aggregation” do not meet the standard for lexicography

Phillips v. AWH Corp.

“[T]he **specification** is always highly relevant to the claim construction analysis. Usually, it is dispositive; it is the **single best guide to the meaning of a disputed term.**”

(internal quotation marks omitted)

Claim Construction: “Carrier Aggregation”

Qualcomm

Qualcomm relies primarily on disclosure in the '356 patent that focuses on LTE

'356 Patent

tems (GNSS), etc. Wireless device 110 may support one or more radio technologies for wireless communication such as LTE, cdma2000, WCDMA, GSM, 802.11, etc.

Claim Construction: “Carrier Aggregation”

Qualcomm

Qualcomm argues that its distinguishing of the '356 claims over Hirose supports its construction

'356 File History

Regarding amended independent claims 1 and 17, Applicant's amended independent claims 1 and 17 recite, *inter alia*, “the [] input RF signal employing *carrier aggregation*,” which is not disclosed in Hirose. Generally, Applicant's claimed invention recites “carrier aggregation” which results in an *increased aggregated* data rate. In contrast, Hirose transmits the same signals over different paths which results in *redundant* data at a *common* data rate. Specifically, the

-00047 IPR, Ex. 1015 (Patent Owner's June 6, 2014 Response) at 7 (annotated)

Applicant respectfully asserts that Hirose's “satellite wave signal and ground wave signal” do not result in “carrier aggregation” as claimed by Applicant in amended independent claims 1 and 17. As stated, Applicant's amended independent claims 1 and 17 recite, *inter alia*, “the [] input RF signal employing *carrier aggregation*,” while Hirose discloses *redundant* data at a *common* data rate. Specifically, Hirose discloses:

-00047 IPR, Ex. 1015 (Patent Owner's June 6, 2014 Response) at 7-8 (annotated)

Claim Construction: “Carrier Aggregation”

Qualcomm

Qualcomm argues that Intel’s construction renders claim language redundant

'356 Patent

1. An apparatus comprising:
a first amplifier stage configured to be independently enabled or disabled, the first amplifier stage further configured to receive and amplify an input radio frequency (RF) signal and provide a first output RF signal to a first load circuit when the first amplifier stage is enabled, the input RF signal employing ~~carrier aggregation~~ [*simultaneous operation on multiple carriers*] comprising transmissions sent on multiple carriers at different frequencies to a wireless device, the first output RF signal including at least a first carrier of the multiple carriers;

- Intel’s construction includes the concept of “simultaneous operation”

Claim Construction: “Carrier Aggregation”

Qualcomm

Qualcomm argues that Intel’s construction reads out “aggregation”

Fay Declaration

27. Patent Owner argues that the Petition’s BRI construction reads out the word “aggregation.” POR, 30-31. I disagree. When the claimed “input RF signal” employs “simultaneous operation on multiple carriers,” those carriers will be aggregated along the input RF signal. Pet., 51-53 (“input RF signal includes ‘two channels encoded around two different carrier frequencies (i.e., *dual carriers*).’”). Thus, “carrier aggregation” in the context of the challenged claims accounts for aggregation (i.e., collected together, assembled, as defined in the POR, 30), because the multiple carriers would be present simultaneously in the input RF signal.

28. Because the ’356 patent describes “carrier aggregation” as encompassing wireless devices that support “one or more radio technologies for wireless communication such as LTE, cdma2000, WCDMA, GSM, 802.11, etc.,” when two or more carriers in a carrier aggregated signal are received according to “one or more” of these technologies, those carriers are all aggregated in the input RF signal (e.g. “RFin” in FIG. 6A) that enters the amplifier.

Claim Construction: “Carrier Aggregation”

Qualcomm

Qualcomm argues that its construction is supported by extrinsic evidence

Phillips v. AWH Corp.

However, while **extrinsic evidence** “can shed useful light on the relevant art,” we have explained that it is “**less significant than the intrinsic record** in determining ‘the legally operative meaning of claim language.’ ”

In sum, **extrinsic evidence** may be useful to the court, but it is **unlikely to result in a reliable interpretation of patent claim scope** unless considered in the context of the intrinsic evidence.

IPR2019-00047

Overview of Prior Art for IPR2019-00047

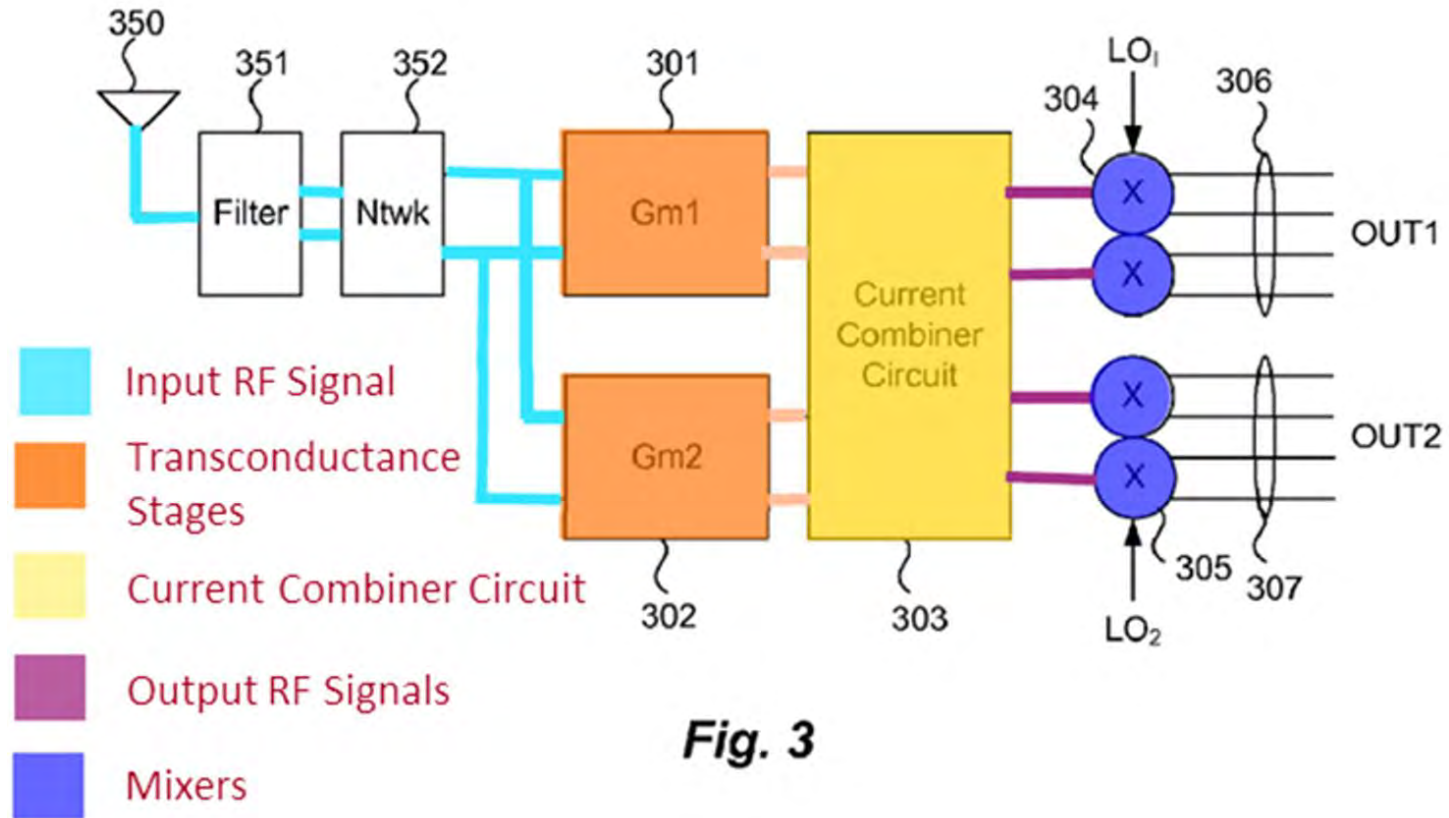

Fig. 3

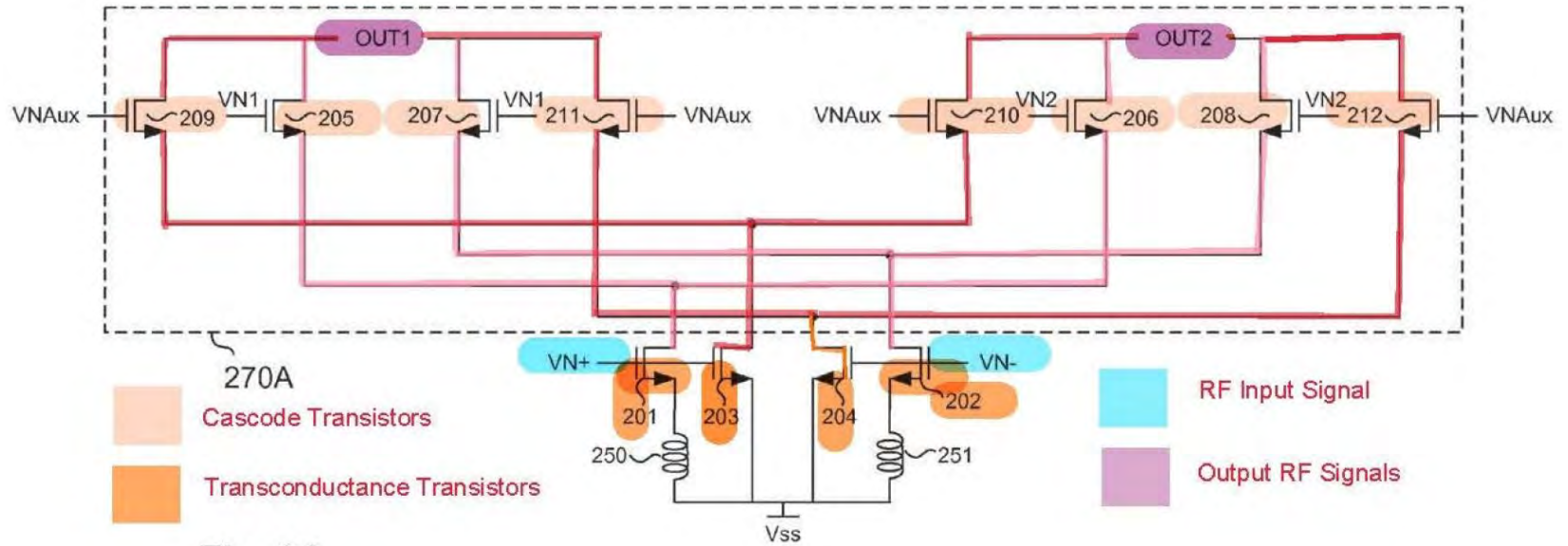

Fig. 2A

Perumana

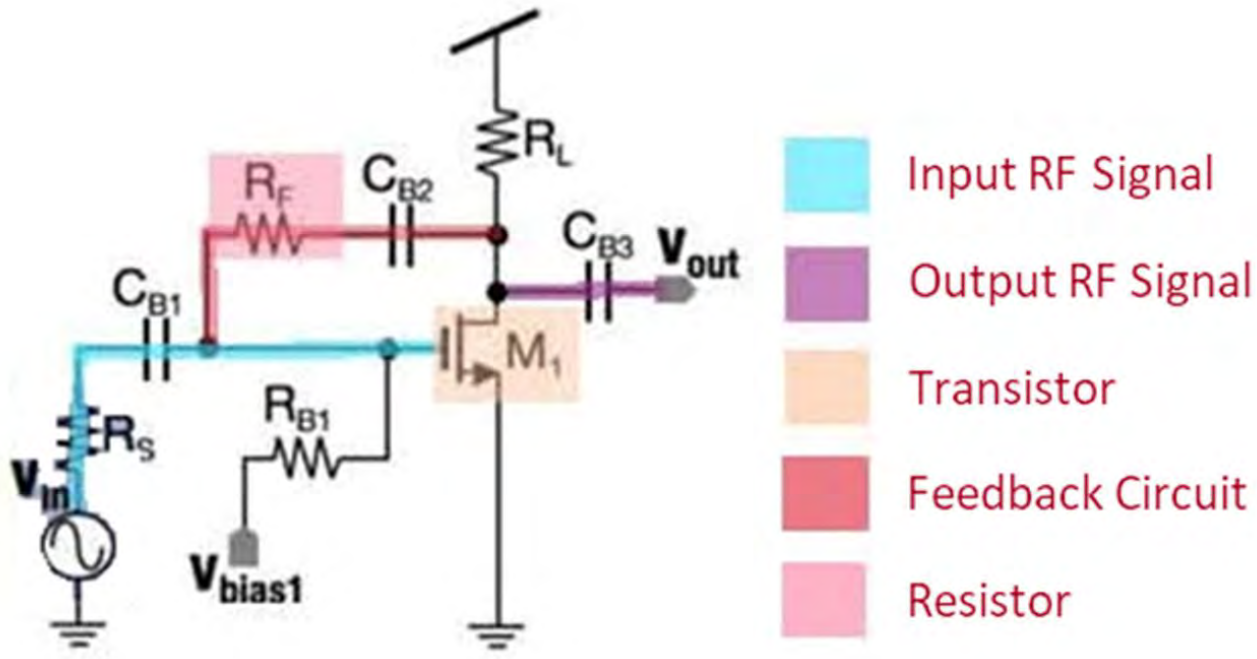

Figure 3(a)

Digitally-Controlled RF Passive Attenuator in 65 nm CMOS for Mobile TV Tuners

Ahmed Youssef and James Haslett
Electrical and Computer Engineering Department
University of Calgary
Alberta, Canada

Abstract—A novel VHF/UHF passive attenuator linearization circuit suitable for mobile TV applications has been designed and implemented in 65 nm CMOS technology. The proposed attenuator has a wide gain range of 48 dB that can be digitally programmed in 3 to 6 dB steps. At every gain setting, the input and output of the attenuator are matched to 50 Ω to facilitate its integration into mobile TV tuners.

I. INTRODUCTION

Mobile TV is one of the latest features to be added to cell phones and other hand-held devices. The low cost, low power, and small size demands of this application have pushed researchers to use nanometer CMOS technologies in designing high performance tuner chip sets. The bulky RF filters (i.e., SAW filters) usually used in traditional TV-tuner tuners to suppress far-away interferer blockers are thus not an option for these integrated tuners. This results in tightening the linearity requirement of the RF front-end needed for mobile TV reception, and hence demands innovative design techniques to adhere to the low power necessities for this application [1].

The RF-AGC (Automatic gain control) technique has been proposed recently in the literature as one of the low power solutions that can help mobile TV receivers achieve their stringent linearity requirements [2]–[4]. Decreasing the RF gain at large input signal levels helps the receiver pass larger signals without any degradation in the output SNR (Signal-to-Noise Ratio). Although there are many mechanisms to vary the RF gain in receivers, the efficacy of any given mechanism depends on the amount of the dynamic range that can be achieved while decreasing the RF gain.

This paper proposes an RF attenuator linearization circuit used to vary the RF gain of mobile TV receivers while maximizing their dynamic range. The paper describes a passive attenuator designed, implemented in 65 nm CMOS technology and characterized in the lab. Additionally, a 5 bit linear thermometer decoder [5] integrated in the same test chip is used to program the gain of the attenuator. The decoder sets the gain value according to the signal level received at the attenuator input. Also, an on-chip programmable matching network is used to provide a stable 50 Ω input resistance

This paper proposes an RF attenuator linearization circuit used to vary the RF gain of mobile TV receivers while maximizing their dynamic range. The paper describes a

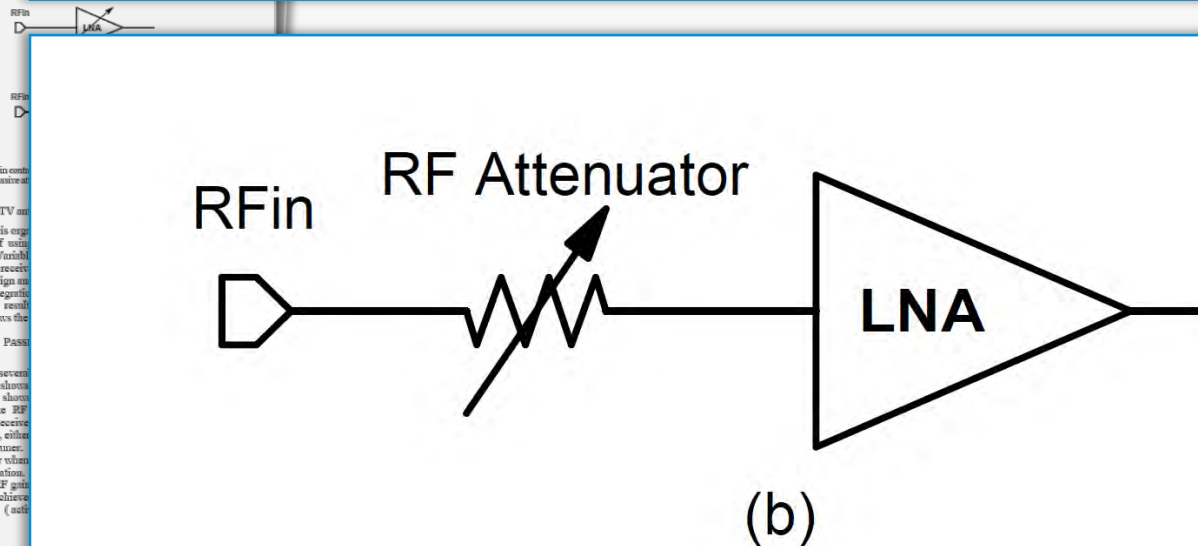

Feasibility Study

3GPP TR 36.912 V9.1.0 (2009-12)

Technical Report

3rd Generation Partnership Project;
Technical Specification Group Radio Access Network;
Feasibility study for
Further Advancements for E-UTRA (LTE-Advanced)
(Release 9)

LTE-Advanced extends LTE Rel.-8 with support for *Carrier Aggregation*, where two or more *component carriers* (CCs) are aggregated in order to support wider transmission bandwidths up to 100MHz and for spectrum aggregation.

The present document has been developed within the 3rd Generation Partnership Project (3GPPTM) and may be further elaborated for the purposes of 3GPP.

The present document has not been subject to any approval process by the 3GPP Organizational Partners and shall not be implemented.
This Specification is provided for future development work within 3GPP only. The Organizational Partners accept no liability for any use of this Specification.
Specifications and reports for implementations of the 3GPPTM systems should be obtained via the 3GPP Organizational Partners' Publications Office.

i

INTEL 1304

Disputed Issues for IPR2019-00047

Disputed Issues for IPR2019-00047

- Anticipation by Uehara
 - Claims 1, 11, 17, 18
- Motivation to Combine Uehara and Perumana
 - Claims 7 and 8
- Motivation to Combine Uehara and Youssef
 - Claim 10
- Motivation to Combine Uehara and Feasibility Study
 - Claims 1, 7, 8, 10, 11, 17, 18

Anticipation by Uehara

Anticipation by Uehara

Configured to be independently enabled or disabled

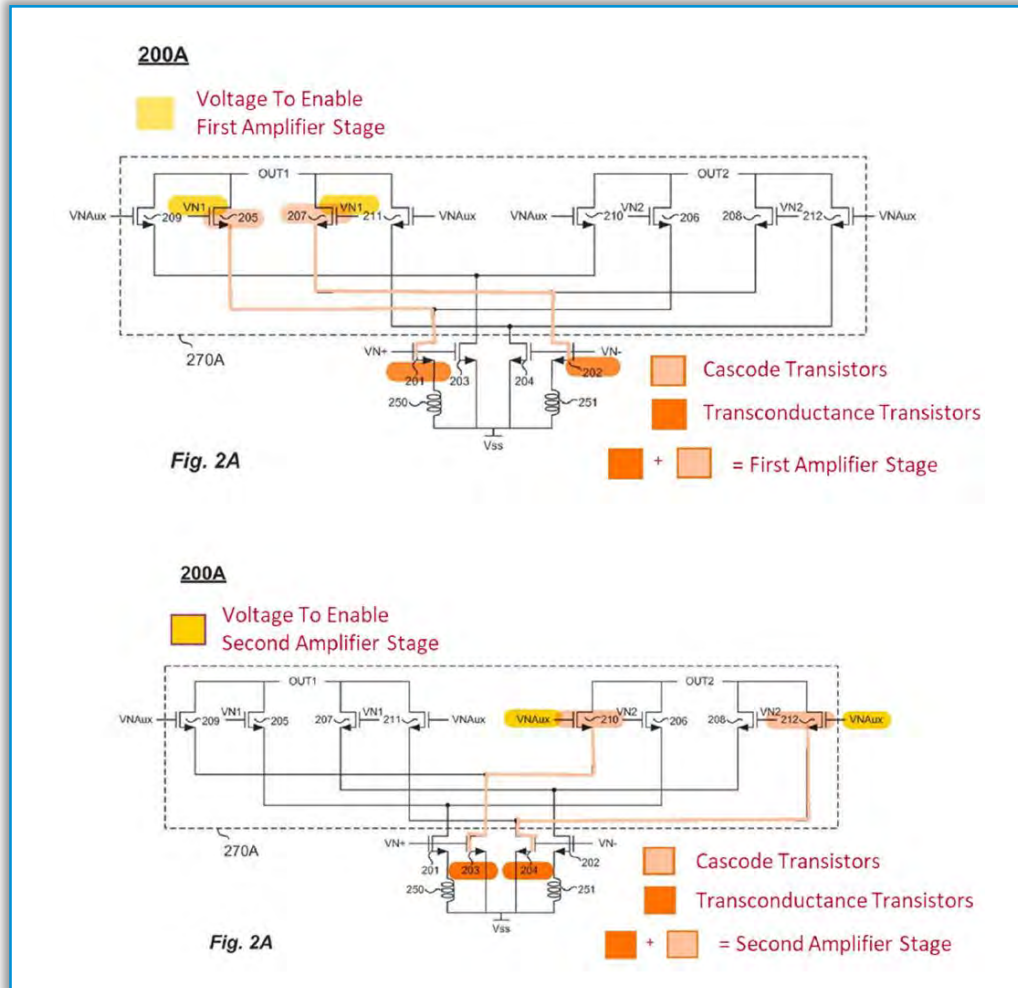

Anticipation by Uehara

Configured to be independently enabled or disabled

(19) United States
(12) Patent Application Publication (10) Pub. No. Uehara et al. (45) Pub. No. 2011/0217945A1

(54) DUAL CARRIER AMPLIFIER CIRCUITS AND METHODS (52) U.S. CL. (57) In one embodiment, the circuit comprising first and second transistors, the first transistor receiving an RF signal and the second transistor receiving a second RF signal, the first transistor outputting a first current and the second transistor outputting a second current, the first current and the second current being combined to produce a combined current, the combined current being outputted from the circuit.

(76) Inventors: Gregory Uehara, Austin, TX (US); Xiaohua Fan, Austin, TX (US)

(21) Appl. No.: 13/938,778

(22) Filed: Mar. 2, 2011

Related U.S. Application Data
(60) Provisional application No. 61/509,810, filed on Mar. 2, 2010.

Publication Classification
(51) Int. Cl. H04B 1/16 (2006.01) G06G 7/12 (2006.01) H03F 1/22 (2006.01)

OUT2. Cascode transistors 205 and 207 may be selectively turned on or off by controlling voltage VN1 at the gate of transistor 205 and the gate of transistor 207, thereby coupling or decoupling current from transistors 201 and 202 from output path OUT1. Likewise, cascode transistors 206 and 208

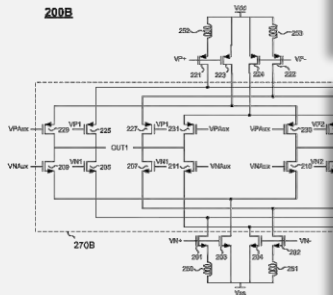

OUT2. Accordingly, in this example, cascode transistors 209-212 may be selectively turned on or off together by controlling voltage VNAux at the gate of each transistor 209-212, thereby coupling or decoupling current from transistors 203 and 204 to or from output path OUT1 and output path OUT2.

INTEL 1003

Anticipation by Uehara

Configured to be independently enabled or disabled

DOCKET NO.: 0107131-00573US1
Filed on behalf of Intel Corporation
By: David L. Cavanaugh, Reg. No. 36,476
John V. Hobgood, Reg. No. 61,540
Benjamin S. Fernandez, Reg. No. 55,172
Gregory H. Lantier, *pro hac vice*
Wilmer Cutler Pickering Hale and Dorr LLP
1875 Pennsylvania Ave., NW
Washington, DC 20006
Tel: (202) 663-6000
Email: David.Cavanaugh@wilmerhale.com
John.Hobgood@wilmerhale.com
Ben.Fernandez@wilmerhale.com
Gregory.Lantier@wilmerhale.com

UNITED STATES PATENT AND TRADE

BEFORE THE PATENT TRIAL AND AP

INTEL CORPORATION
Petitioner

v.

QUALCOMM INCORPORAT
Patent Owner

Case IPR2019-00047
U.S. Patent No. 9,154,356

DECLARATION OF PATRICK FAY, PH. D.
PETITIONER'S REPLY

configured to be independently enabled or disabled. Each amplifier stage in Uehara, as identified by the Petition, has a distinct control voltage (VN1, VNAux), and a cascode transistor that can be “selectively enabled.” Ex. 1003, ¶36. A POSITA would understand that, based on the two distinct control voltages (VN1, VNAux) that each can take on two values, Uehara teaches at least four operational/control states, which I have summarized in Table 1 below:

State	VN1 (stage 101)	VNAux (stage 102)
1	ON	OFF
2	OFF	ON
3	ON	ON
4	OFF	OFF

Anticipation by Uehara

Configured to be independently enabled or disabled

- VNI and VNAux are independent of VN2

	VN1 (Stage 101)	VNAux (Stage 102)	VN2 (Stage 101)
1'	ON	OFF	OFF
2'	OFF	OFF	ON
3'	ON	ON	ON

Table 2: Patent Owner's Arguments Regarding One Specific Use Case of Uehara

But even as shown in Table 2, the state of VNAux and VN1 are independent of one another because VNAux can be either OFF (1') or ON (3') when VN1 is ON.

DOCKET NO.: 0107131-00573US1
Filed on behalf of Intel Corporation
By: David L. Cavanaugh, Reg. No. 36,476
John V. Hobgood, Reg. No. 61,540
Benjamin S. Fernandez, Reg. No. 55,172
Gregory H. Lantier, *pro hac vice*
Wilmer Cutler Pickering Hale and Dorr LLP
1875 Pennsylvania Ave., NW
Washington, DC 20006
Tel: (202) 663-6000
Email: David.Cavanaugh@wilmerhale.com
John.Hobgood@wilmerhale.com
Ben.Fernandez@wilmerhale.com
Gregory.Lantier@wilmerhale.com

UNITED STATES PATENT AND TRADEMARK OFFICE

BEFORE THE PATENT TRIAL AND APPEAL BOARD

INTEL CORPORATION
Petitioner

v.

QUALCOMM INCORPORATED,
Patent Owner

Case IPR2019-00047
U.S. Patent No. 9,154,356

DECLARATION OF PATRICK FAY, PH. D. IN SUPPLEMENTARY
PETITIONER'S REPLY

Intel 1039
Intel v. Qualcomm
IPR2019-00047

Anticipation by Uehara

Configured to be independently enabled or disabled

DOCKET NO.: 0107131-00573US1
Filed on behalf of Intel Corporation
By: David L. Cavanaugh, Reg. No. 36,476
John V. Hobgood, Reg. No. 61,540
Benjamin S. Fernandez, Reg. No. 55,172
Gregory H. Lantier, *pro hac vice*
Wilmer Cutler Pickering Hale and Dorr LLP
1875 Pennsylvania Ave., NW
Washington, DC 20006
Tel: (202) 663-6000
Email: David.Cavanaugh@wilmerhale.com
John.Hobgood@wilmerhale.com
Ben.Fernandez@wilmerhale.com
Gregory.Lantier@wilmerhale.com

UNITED STATES PATENT AND TRADEMARK OFFICE

BEFORE THE PATENT TRIAL AND APPEAL BOARD

INTEL CORPORATION
Petitioner

v.

QUALCOMM INCORPORATED,
Patent Owner

Case IPR2019-00047
U.S. Patent No. 9,154,356

DECLARATION OF PATRICK FAY, PH. D. IN SUPPORT OF
PETITIONER'S REPLY

Intel 1039
Intel v. Qualcomm
IPR2019-00047

consistent with Table 1, above. *Id.* In Table 3 below, I add the dual-carrier operational states described in paragraph [0032] of Uehara (these dual carrier states from [0032] are denoted 3'' and 4''). Comparing states 1' and 3'', it is clear that VNAux can be either ON or OFF if VN1 is ON and VN2 is OFF. Likewise, comparing states 2' and 4'', VNAux can be either ON or OFF if VN1 is OFF and VN2 is ON. Thus, VNAux is not dependent on state of the VN1 (or VN2) signals in the embodiment described in paragraph [0032]. Furthermore, since VN1

State	VN1 (Stage 101, OUT1)	VNAux (Stage 102, OUT1 and OUT2)	VN2 (Stage 101, OUT2)
1'	ON	OFF	OFF
2'	OFF	OFF	ON
3''	ON	ON	OFF
4''	OFF	ON	ON

Table 3: Operational Use Case Described in ¶[0031] (single carrier modes) and ¶[0032] (dual carrier modes) of Uehara.

Anticipation by Uehara

Providing a first/second output RF signal to a first/second load circuit

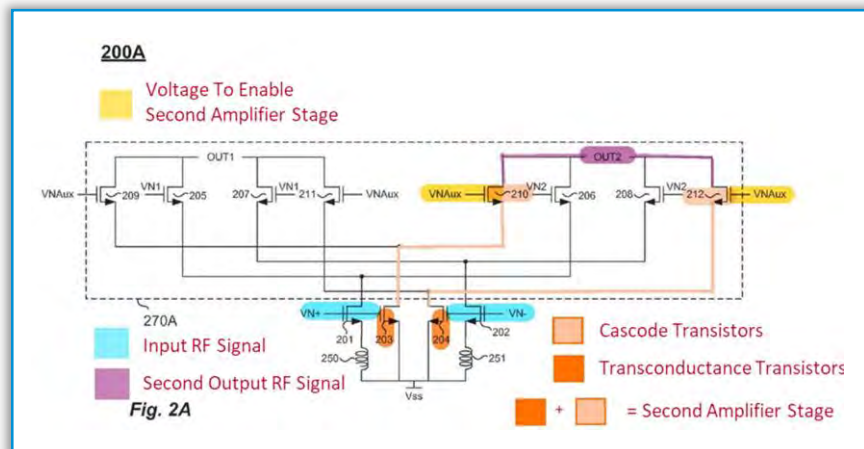
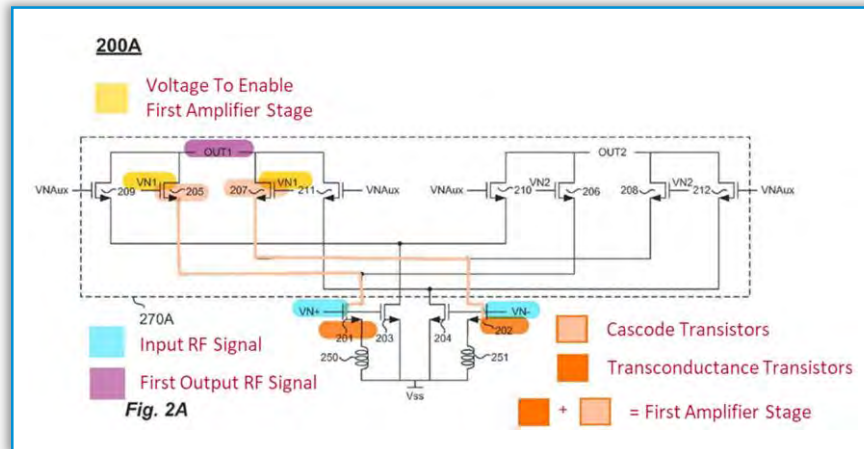

Anticipation by Uehara

Providing a first/second output RF signal to a first/second load circuit

1. An apparatus comprising:
 - a first amplifier stage configured to be independently enabled or disabled, the first amplifier stage further configured to receive and amplify an input radio frequency (RF) signal and provide a first output RF signal to a first load circuit when the first amplifier stage is enabled, the input RF signal employing carrier aggregation comprising transmissions sent on multiple carriers at different frequencies to a wireless device, the first output RF signal including at least a first carrier of the multiple carriers; and
 - a second amplifier stage configured to be independently enabled or disabled, the second amplifier stage further configured to receive and amplify the input RF signal and provide a second output RF signal to a second load circuit when the second amplifier stage is enabled, the second output RF signal including at least a second carrier of the multiple carriers different than the first carrier.

-00047 IPR, Ex. 1001 ('356 Patent) at Claim 1 (annotated)

Qualcomm's Expert

Q Focus just on the claim language. You would agree that the claim does not require the first amplifier stage to provide a first output RF signal only to a first load circuit when the first amplifier stage is enabled; correct?

A The word "only" does not appear in the claim. That's facial. I'll agree with that.

-00047 IPR, Ex. 1040 (Foty Tr.) at 48:10-16 (annotated)

Anticipation by Uehara

Providing a first/second output RF signal to a first/second load circuit

- Each of the amplifier stages in Uehara is already **“configured”** to provide an output RF signal **“when ... enabled”**

State	VN1 (stage 101)	VNAux (stage 102)
1	ON	OFF
2	OFF	ON
3	ON	ON
4	OFF	OFF

Table 1: Basic Control Voltage Configuration of Uehara Amplifier Stages

Anticipation by Uehara

The input RF signal employing carrier aggregation

Term	Petitioner's Construction
“carrier aggregation”	“simultaneous operation on multiple carriers”

from an antenna. In some wireless applications, an RF signal may include multiple channels with multiple carrier frequencies. To process such signals, an LNA may send the amplified

improved amplifiers for driving different signal paths. Particular embodiments further provide processing for dual or multi-carrier signals, such as in a wireless receiver.

Anticipation by Uehara

The input RF signal employing carrier aggregation

Term	Petitioner's Construction
“carrier aggregation”	“simultaneous operation on multiple carriers”

work 352. The RF signal may include two channels encoded around two different carrier frequencies (i.e., dual carriers), for example. The dual carrier signal may be amplified by

[0033] By incorporating one or more additional “Gm” stages when driving multiple output paths, the performance of the amplifier circuit 100 may be maintained across different output loads. Specifically, when driving two output paths simultaneously, a second transconductance stage is enabled to maintain substantially similar gain, Noise Figure (“NF”), linearity, and input impedance matching. In this example, the

Anticipation by Uehara

The input RF signal employing carrier aggregation

Patent Owner's Cited Reference (GB 2472978)

and instructs the receiving terminal accordingly. **Carrier aggregation mode** is also known as spectrum aggregation mode, **dual carrier mode** and dual cell mode.

Uehara

work 352. **The RF signal may include** two channels encoded around two different carrier frequencies (i.e., **dual carriers**), for example. The dual carrier signal may be amplified by

Anticipation by Uehara

The input RF signal employing carrier aggregation

- Uehara’s “dual carriers” are “aggregated”

39. Patent Owner also argues that the Petition ignores the meaning of “aggregation.” This is incorrect. When dual carriers are received simultaneously in the amplification circuit of Uehara, they are aggregated at the input. See POR, 30 (“Aggregate means ‘to collect together, assemble.’”). This is true regardless of whether or not the two carriers originate from a common source, or whether or not they are logically related to one another (*e.g.*, at the baseband level). The two carriers do not somehow travel down separate sides of the wire or avoid one another along the input.

Anticipation by Uehara

The input RF signal employing carrier aggregation

- Uehara teaches “higher bandwidth”

increased bandwidth, Uehara also teaches this. Bandwidth is the amount of spectrum available for data transmission. A receiver that operates simultaneously on multiple carriers **increases bandwidth** because carriers occupy frequency ranges and transmitting data over multiple carriers increases bandwidth to the sum of the carriers’ frequency ranges, as would have been understood by a person of ordinary skill in the art at the time of the Patent Owner’s alleged conception date for the ’356 patent. *See supra* ¶41 at Figure 7 (showing carriers occupying

bandwidth). Uehara teaches that “[t]he RF signal may include *two channels encoded around two different carrier frequencies.*” EX1003-Uehara ¶47

(emphasis added). Uehara’s use of two channels provides **greater bandwidth** than one channel. *See* Section III.C. Specifically, by sending data over two or more

Anticipation by Uehara

The input RF signal employing carrier aggregation

- Uehara teaches increased aggregated data rate

90. Uehara also teaches employing carrier aggregation to increase an aggregated data rate. When the total amount of data entering a wireless device increases, the wireless device (and the user of the device) experiences an “increased aggregated data rate.” Uehara discloses “two channels encoded around two different carrier frequencies.” EX1003-Uehara ¶47. When non-redundant data is transmitted over these dual carriers, the data rate to the wireless device of Uehara increases because the device is receiving more data per unit of time. This is different than Hirose (EX1024-Hirose), which Patent Owner distinguished during prosecution. Specifically, Uehara does not require the data sent over the dual carriers to be redundant data. *See* EX1015 at 2 (June 6, 2014 Resp. to Office Action). Moreover, Uehara provides an example of an implementation of an

Anticipation by Uehara

The input RF signal employing carrier aggregation

- Uehara teaches increased aggregated data rate

Action). Moreover, Uehara provides an example of an implementation of an “Enhanced Data rates for GSM Evolution” wireless system in which an LNA receives a dual carrier signal. EX1003-Uehara ¶48. Uehara selectively couples the “LNA outputs to the two down converters using the current combiner circuits of each LNA *as illustrated above.*” *Id.* ¶49 (referring to the current combiner circuits 270A of Figure 2A and 303 of Figure 3 (emphasis added)). Down conversion and other circuits “translat[e] the information in each channel of the RF signal into digital data.” *Id.* ¶49. A person of ordinary skill in the art would have understood that the “enhanced data rate” achieved in this implementation in Uehara is an increased data rate.

Motivation to Combine Uehara and Perumana

Motivation to Combine Uehara and Perumana

(12) **United States Patent**
Tasic et al. (10) Patent No.: US 9,154,356 B2
(45) Date of Patent: Oct. 6, 2015

(54) **LOW NOISE AMPLIFIERS FOR CARRIER AGGREGATION**
(56) **References Cited**
U.S. PATENT DOCUMENTS
(75) Inventors: **Aleksandar Miodrag Tasic**, San Diego, CA (US); **Anosh Bomi Daverwalla**, San Diego, CA (US)
3,911,364 A 10/1975 Langsoeth et al.
4,035,728 A 7/1977 Ishikawa et al.
(Continued)

(73) Assignee: **QUALCOMM Incorporated**, San Diego, CA (US)
(* Notice: Subject to any disclaimer, the term of this patent is extended or adjusted under 35 U.S.C. 154(b) by 0 days.

(21) Appl. No.: **13,590,423**
(22) Filed: **Aug. 21, 2012**

(65) **Prior Publication Data**
US 2013/015548 A1 Nov. 28, 2013
Related U.S. Application Data

(60) Provisional application No. 61/652,064, filed on May 25, 2012.
Primary Examiner—
(74) *Attorney, Agent,*

(51) **Int. Cl.**
H04L 27/06 (2006.01)
H04L 27/26 (2006.01)
H03G 3/29 (2006.01)
H03F 1/22 (2006.01)
H03F 3/193 (2006.01)
(Continued)

(52) **U.S. CL.**
CPC *H04L 27/2647* (2013.01); *H03F 1/223* (2013.01); *H03F 3/193* (2013.01); *H03F 3/08* (2013.01); *H03F 3/72* (2013.01); *H03G 3/29* (2013.01)

(58) **Field of Classification Search**
CPC *H04L 27/2647*; *H04L 27/06*; *H03H 7/40*; *H03G 3/20*
USPC *375/316*; *317*; *318*; *345*; *349*; *340*; *455/130*; *132*; *136*; *234*; *1370/542*
See application file for complete search history.

20 Claims

7. The apparatus of claim 1, further comprising:
a **feedback circuit** coupled between an output and an input of at least one of the first and second amplifier stages.
8. The apparatus of claim 7, the **feedback circuit** comprising a resistor, or a capacitor, or both a resistor and a capacitor.

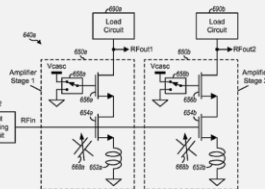

Motivation to Combine Uehara and Perumana

Inductorless resistive-feedback CMOS LNAs [2]–[4] have been shown to be a viable option for implementing multiband receivers, as shown in Fig. 1. These circuits require very small die area and can be implemented in a digital CMOS process without any additional RF enhancements. Hence, this approach can potentially significantly reduce the cost of the wireless front-end implementation. Resistive-feedback LNAs achieve high gain and reasonably low NF [4]. However, novel circuit techniques are required to reduce power consumption and improve linearity.

Inductorless resistive-feedback CMOS LNAs [2]–[4] have been shown to be a viable option for implementing multiband receivers, as shown in Fig. 1. These circuits require very small

Resistive-Feedback CMOS Amplifiers for Multiband

Bevin G. Perumana, Student Member, IEEE, Ting-Hong C. Zhu, Member, IEEE, Brent R. Carlson, Member, IEEE, and Joy Lakkar

Abstract—Extremely compact resistive-feedback CMOS low-noise amplifiers (LNAs) are presented as a cost-effective alternative to multiple narrowband LNAs using high-Q inductors for multiband wireless applications. Limited linearity and high power consumption of the inductorless resistive-feedback LNAs are analyzed and circuit techniques are proposed to solve these issues. A 12-mW resistive-feedback LNA, based on current-source transconductance boosting is presented with a gain of 21 dB and a noise figure (NF) of 2.6 dB at 5 GHz. The LNA achieves an output third-order intercept point (IP3) of 12.3 dBm at 5 GHz by reducing loop-gain rolloff and by improving linearity of individual stages. The active die area of the LNA is only 0.082 mm². A 3.2-mW tuned resistive-feedback LNA utilizing a single compact low-Q on-chip inductor is presented, showing an improved tradeoff between performance, power consumption, and die area. At 5.5 GHz, the fully integrated LNA achieves a measured gain of 24 dB, an NF of 2 dB, and an output IP3 of 21.8 dBm. The LNA draws 7.7 mA from the 1.2-V supply and has a 3-dB bandwidth of 3.94 GHz (4.04–7.98 GHz). The LNA occupies a die area of 0.022 mm². Both LNAs are implemented in a 90-nm CMOS process and do not require any costly RF enhancement options.

Index Terms—CMOS low-noise amplifier (LNA), feedback amplifiers, multiband wireless receivers.

1. INTRODUCTION

LOW-NOISE amplifiers (LNAs) occupy a significant percentage of the total die area in wireless front-ends today. This is because the performance of the LNA is dependent on the Q's of the multiple on-chip inductors. Since the area requirement of high-Q on-chip inductors is high, the die area occupied by the LNA is also high. Often, costly process steps are required to enhance the Q of the on-chip inductors to further improve the performance of RF circuits. The design of these circuits readily requires a higher number of simulation and verification iterations. Cascode amplifiers with inductive source degeneration [1], the predominant LNA implementation used in

Multi-Band Amplifier



Fig. 1. Multiband amplifier.



Fig. 2. Multiband amplifier.

CMOS wireless front-ends for achieving input matching and low noise figure (NF). In spite of their high performance, LNAs have been implemented in digital CMOS processes because of their low linearity at relatively high input powers. The use of multiple-input resistive-feedback LNAs for multiband wireless applications is becoming increasingly attractive, leading to the pursuit of alternative LNA implementations.

A multiband receiver can be implemented by using a single multiband or wideband LNA, as shown in Fig. 1. Cascode LNAs

based on inductive source degeneration (on-chip inductors) at all the required frequencies, as shown in Fig. 1, suffer from the inductive source degeneration and can be implemented in digital CMOS processes without any additional RF enhancements. Inductorless resistive-feedback LNAs have been shown to be a viable option for implementing multiband receivers, as shown in Fig. 1. These circuits require very small die area and can be implemented in a digital CMOS process without any additional RF enhancements. Hence, this approach can potentially significantly reduce the cost of the wireless front-end implementation.

Manuscript received September 1, 2007; revised January 18, 2008.

B. G. Perumana was with the Communications Circuits Laboratory, Intel Corporation, Hillsboro, OR 97124 USA. He is now with the Georgia Institute of Technology, Atlanta, GA 30332 USA (e-mail: bperumana@gatech.edu).

J.-H. C. Zhu was with the Communications Circuits Laboratory, Intel Corporation, Hillsboro, OR 97124 USA. He is now with the RF Division, Mediatech, Hillsboro, OR 97124 USA.

S. S. Taylor and B. R. Carlson are with the Communications Circuits Laboratory, Intel Corporation, Hillsboro, OR 97124 USA.

J. Lakkar is with the Georgia Institute of Technology, School of Electrical and Computer Engineering, Georgia Institute of Technology, Atlanta, GA 30332 USA.

Color versions of one or more of the figures in this paper are available online at <http://ieeexplore.ieee.org>.

Digital Object Identifier 10.1109/TMTT.2008.9200181

0018-9452/08/0000-0000 © 2008 IEEE

Motivation to Combine Uehara and Perumana

Petitioner's Reply to Patent Owner's Response
IPR2019-00047

DOCKET NO.: 0107131-00573US1
Filed on behalf of Intel Corporation
By: David L. Cavanaugh, Reg. No. 36,476
John V. Hobgood, Reg. No. 61,540
Benjamin S. Fernandez, Reg. No. 55,172
Gregory H. Lantier, *pro hac vice*
Wilmer Cutler Pickering Hale and Dorr LLP
1875 Pennsylvania Ave., NW
Washington, DC 20006
Tel: (202) 663-6000
Email: David.Cavanaugh@wilmerhale.com
John.Hobgood@wilmerhale.com
Ben.Fernandez@wilmerhale.com
Gregory.Lantier@wilmerhale.com

UNITED STATES PATENT AND TRADEMARK OFFICE
BEFORE THE PATENT TRIAL AND APPEALS BOARD

INTEL CORPORATION
Petitioner

v.

QUALCOMM INCORPORATED
Patent Owner

Case IPR2019-00047
U.S. Patent No. 9,154,356

PETITIONER'S REPLY TO PATENT OWNER'S RESPONSE

incorrect for the reasons identified above in Section III, Patent Owner does not dispute that Uehara in view of Perumana teaches each limitation of claims 7 and 8, but rather argues that Petitioner “fails to sufficiently articulate” why a POSITA would have combined Perumana and Uehara. POR, 48-50. As evidenced by the

Motivation to Combine Uehara and Perumana

DOCKET NO.: 0107131-00573US1
Filed on behalf of Intel Corporation
By: David L. Cavanaugh, Reg. No. 36,476
John V. Hobgood, Reg. No. 61,540
Benjamin S. Fernandez, Reg. No. 55,172
Wilmer Cutler Pickering Hale and Dorr LLP
1875 Pennsylvania Ave., NW
Washington, DC 20006
Tel: (202) 663-6000
Email: David.Cavanaugh@wilmerhale.com
John.Hobgood@wilmerhale.com
Ben.Fernandez@wilmerhale.com

UNITED STATES PATENT AND TRADEM
BEFORE THE PATENT TRIAL AND AP

INTEL CORPORATION
Petitioner

v.

QUALCOMM INCORPORATE
Patent Owner

Case IPR2019-00047

DECLARATION OF PATRICK FA
U.S. PATENT NO. 9,154,356
CLAIMS 1, 7, 8, 10, 11, 17, and

INTEL 1002

118. A person of ordinary skill would have coupled the feedback circuit of Perumana between the output and input of at least one amplifier stage of Uehara. As described in Section III.D.2, feedback circuits were commonly added to low noise amplifiers before the Patent Owner's alleged conception date for the '356 patent in order to improve the stability, input matching, and frequency response of the amplifier. Perumana further explains that adding a feedback circuit to an LNA "can potentially significantly reduce the cost of the wireless front-end implementation" and provides "high gain and reasonably low NF [noise figure]." EX1008-Perumana at 1218-19. A person having ordinary skill in the art would

Motivation to Combine Uehara and Perumana

119. A person of ordinary skill in the art would have also found it desirable to increase the bandwidth of the amplifier of Uehara, which could have been achieved using the feedback circuit of Perumana. Compared to alternative configurations, the resistive feedback circuit of Perumana offers broadband operation in a compact die size and without using exotic process options. Uehara concerns simultaneous multi-carrier operation. *See* EX1003-Uehara ¶7; *see also id.* ¶47. Because the different carriers can be far apart on the frequency spectrum, the amplifier of Uehara benefits from increased bandwidth. Moreover, an amplifier with broader bandwidth would be able to process a greater range of carrier frequencies. Perumana explains that feedback circuits are a “viable option” for wideband and multiband receivers, *see* EX1008-Perumana at 1218 (“Inductorless resistive-feedback CMOS LNAs [2]-[4] have been shown to be a viable option for implementing *multiband receivers.*” (emphasis added)). Thus, a

DOCKET NO.: 0107131-00573US1

Filed on behalf of Intel Corporation

By: David L. Cavanaugh, Reg. No. 36,476
John V. Hobgood, Reg. No. 61,540
Benjamin S. Fernandez, Reg. No. 55,172
Wilmer Cutler Pickering Hale and Dorr LLP
1875 Pennsylvania Ave., NW
Washington, DC 20006
Tel: (202) 663-6000
Email: David.Cavanaugh@wilmerhale.com
John.Hobgood@wilmerhale.com
Ben.Fernandez@wilmerhale.com

UNITED STATES PATENT AND TRADEMARK OFFICE
BEFORE THE PATENT TRIAL AND APPEAL BOARD

INTEL CORPORATION
Petitioner

v.

QUALCOMM INCORPORATED
Patent Owner

Case IPR2019-00047

DECLARATION OF PATRICK FAY, Ph.D.
U.S. PATENT NO. 9,154,356
CLAIMS 1, 7, 8, 10, 11, 17, and 18

Motivation to Combine Uehara and Perumana

DOCKET NO.: 0107131-00573US1
Filed on behalf of Intel Corporation
By: David L. Cavanaugh, Reg. No. 36,476
John V. Hobgood, Reg. No. 61,540
Benjamin S. Fernandez, Reg. No. 55,172
Gregory H. Lantier, *pro hac vice*
Wilmer Cutler Pickering Hale and Dorr LLP
1875 Pennsylvania Ave., NW
Washington, DC 20006
Tel: (202) 663-6000
Email: David.Cavanaugh@wilmerhale.com
John.Hobgood@wilmerhale.com
Ben.Fernandez@wilmerhale.com
Gregory.Lantier@wilmerhale.com

UNITED STATES PATENT AND TRADEMARK OFFICE

BEFORE THE PATENT TRIAL AND APPEAL BOARD

INTEL CORPORATION
Petitioner

v.

QUALCOMM INCORPORATED,
Patent Owner

Case IPR2019-00047
U.S. Patent No. 9,154,356

DECLARATION OF PATRICK FAY, PH. D. IN SUPPORT
PETITIONER'S REPLY

Intel v
IPR

42. Patent Owner argues that Perumana's statement that "novel circuit techniques are required to reduce power consumption and improve linearity" is an "explicit admonition" that points to disadvantages associated with Figure 3(a) of Perumana. POR, 50. When read in context, however, this statement neither identifies any disadvantages with Figure 3(a) of Perumana, nor presents any inconsistency with the stated reasons to combine or reasonable expectations of success in my initial Declaration or the Petition. Rather, that statement in Perumana merely serves to introduce the additional solution presented in the rest of Perumana's paper. *Id.* In fact, this quote reinforces the Petition's stated reasons to combine, by demonstrating that a POSITA would have been considering performance (e.g., power consumption, linearity) and implementation cost in implementing feedback circuits, as expressly identified in the Petition's (and my) reasons to combine. Pet., 69-70. This is confirmed by my initial declaration. Ex.

Motivation to Combine Uehara and Youssef

Motivation to Combine Uehara and Youssef



US009154356B2

(12) **United States Patent**
Tasic et al. (10) Patent No.: US 9,154,356 B2
(45) Date of Patent: Oct. 6, 2015

(54) **LOW NOISE AMPLIFIERS FOR CARRIER AGGREGATION**
(75) Inventors: Aleksandar Miodrag Tasic, San Diego, CA (US); Anshu Bomi Daverwalla, San Diego, CA (US)

(56) **References Cited**
U.S. PATENT DOCUMENTS
3,911,364 A 10/1975 Langsoth et al.
4,035,728 A 7/1977 Ishikawa et al.
(Continued)

(73) Assignee: QUALCOMM Incorporated, San Diego, CA (US)
(*) Notice: Subject to any disclaimer, the term of this patent is extended or adjusted under 35 U.S.C. 154(b) by 0 days.

FOREIGN PATENT DOCUMENTS
CN 152391
CN 192251

(21) Appl. No.: 13/590,423
(22) Filed: Aug. 21, 2012
(65) Prior Publication Data
US 2013/015548 A1 Nov. 28, 2013

OTHER PUBLICATIONS

International Search Report

042726—ISA/EPO—Out

Related U.S. Application Data
(60) Provisional application No. 61/652,064, filed on May 25, 2012.

Primary Examiner—

(74) Attorney, Agent, or

(51) Int. Cl.
H04L 27/06 (2006.01)
H04L 27/26 (2006.01)
H03G 3/20 (2006.01)
H03F 1/22 (2006.01)
H03F 3/193 (2006.01)
(Continued)

(57) Low noise amplifiers are disclosed. In an example, a first and second amplifier (CA) LNA or a multi-carrier LNA. The first amplifier receives a radio frequency (RF) signal to a first load circuit. The second amplifier stage receives and amplifies the input RF signal and provides a second output RF signal to a second load circuit when the second amplifier stage is enabled. Each amplifier stage may include a gain transistor coupled to a cascode transistor.

(52) U.S. CL
CPC H04L 27/2647 (2013.01); H03F 1/223 (2013.01); H03F 3/193 (2013.01); H03F 3/08 (2013.01); H03F 3/72 (2013.01); H03G 3/20 (2013.01)

(58) **Field of Classification Search**
CPC : H04L 27/2647; H04L 27/2649; H04L 27/38; H03H 7/40; H03G 3/20
USPC : 375/316, 317, 318, 345, 349, 340, 455/130, 132, 136, 234.1; 370/542
See application file for complete search history.

20 Claims, 17 Drawing Sheets

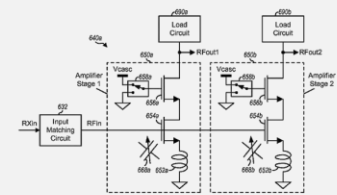

10. The apparatus of claim 1, further comprising: an **attenuation circuit** coupled to the first and second amplifier stages and configured to receive the input RF signal.

Motivation to Combine Uehara and Youssef

Digitally-Controlled RF Passive Attenuator in 65 nm CMOS for Mobile TV Tuners

Ahmed Youssef and James Haslett
Electrical and Computer Engineering Department
University of Calgary
Alberta, Canada

Abstract—A novel VHF/UHF passive attenuator linearization circuit suitable for mobile TV applications has been designed and implemented in 65 nm CMOS technology. The proposed attenuator has a wide gain range of 48 dB that can be digitally programmed in 3 to 6 dB steps. At every gain setting, the input and output of the attenuator are matched to 50 Ω to facilitate its integration into mobile TV tuners.

I. INTRODUCTION

Mobile TV is one of the latest features to be added to cell phones and other hand-held devices. The low cost, low power, and small size demands of this application have pushed researchers to use nanometer CMOS technologies in designing high performance tuner chip sets. The bulky RF filters (i.e., SAW filters) usually used in traditional TV-tuner tuners to suppress far-away interferer blockers are thus not an option for these integrated tuners. This results in tightening the linearity requirement of the RF front-end needed for mobile TV reception, and hence demands innovative design techniques to adhere to the low power necessities for this application [1].

The RF-AGC (Automatic gain control) technique has been proposed recently in the literature as one of the low power solutions that can help mobile TV receivers achieve their stringent linearity requirements [2]-[4]. Decreasing the RF gain at large input signal levels helps the receiver pass larger signals without any degradation in the output SNR (Signal-to-Noise Ratio). Although there are many mechanisms to vary the RF gain in receivers, the efficacy of any given mechanism depends on the amount of the dynamic range that can be achieved while decreasing the RF gain.

This paper proposes an RF attenuator linearization circuit used to vary the RF gain of mobile TV receivers while maximizing their dynamic range. The paper describes a passive attenuator designed, implemented in 65 nm CMOS technology and characterized in the lab. Additionally, a 5 bit linear thermometer decoder [5] integrated in the same test chip is used to program the gain of the attenuator. The decoder sets the gain value according to the signal level received at the attenuator input. Also, an on-chip programmable matching network is used to provide a stable 50 Ω input resistance

This paper proposes an RF attenuator linearization circuit used to vary the RF gain of mobile TV receivers while maximizing their dynamic range. The paper describes a

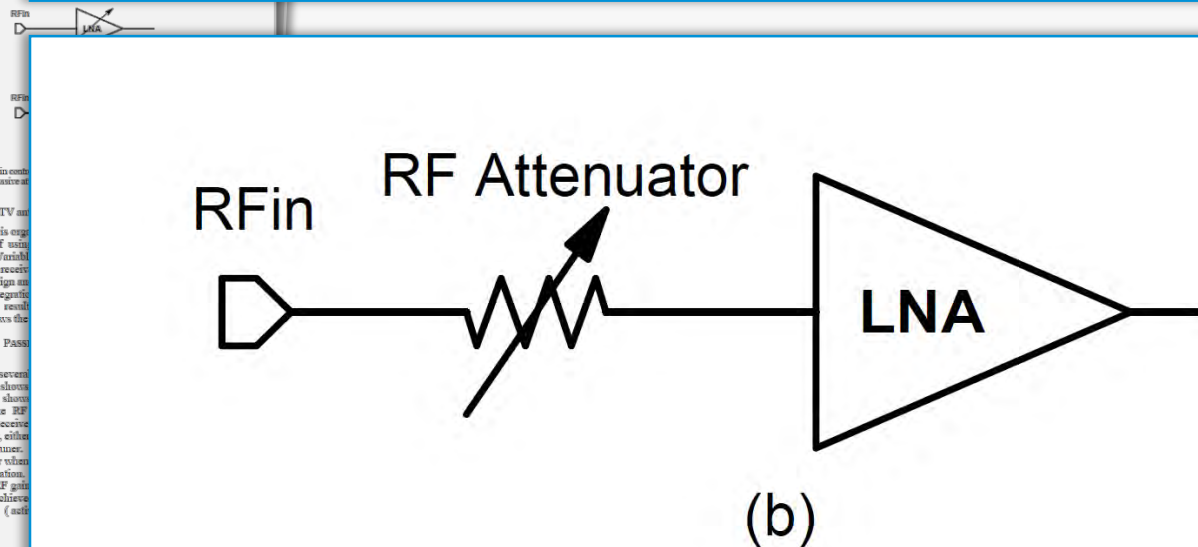

Motivation to Combine Uehara and Youssef

Uehara

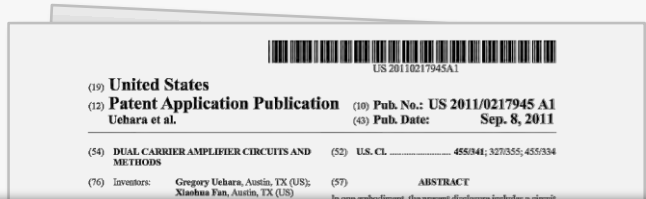

[0048] FIG. 4 shows a system 400 using an amplifier circuit according to one embodiment. System 400 is an example of an implementation of an Evolved EDGE wireless system. Enhanced Data rates for GSM Evolution (“EDGE”) (also known as Enhanced GPRS (EGPRS) or Enhanced Data rates for Global Evolution) is a digital mobile phone technology that enables data transmission across wireless networks such as GSM. In this example, system 400 includes an antenna 401

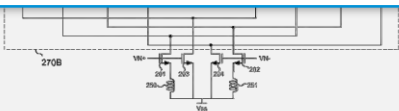

INTEL 1003

Youssef

Digitally-Controlled RF Passive Attenuator in 65 nm CMOS for Mobile TV Tuner ICs

Ahmed Youssef and James Haslett
Electrical and Computer Engineering Department
University of Calgary
Alberta, Canada

Edward Youssoufian
Newport Media Inc.
Lake Forest, California, USA

Abstract—A novel VHF/UHF passive attenuator linearization circuit suitable for mobile TV applications has been designed and characterized in 65 nm CMOS technology. The circuit



Mobile TV is one of the latest features to be added to cell phones and other hand-held devices. The low cost, low power, and small size demands of this application have pushed researchers to use nanometer CMOS technologies in designing high performance tuner chip sets. The bulky RF filters (i.e.,

been proposed recently in the literature as one of the low power solutions that can help mobile TV receivers achieve their stringent linearity requirements [2]–[4]. Decreasing the RF gain at large input signal levels helps the receiver process larger signals without any degradation in the output SNR (Signal-to-Noise Ratio). Although there are many mechanisms to vary the RF gain in receivers, the efficiency of any given mechanism depends on the amount of the dynamic range that can be achieved while decreasing the RF gain.

This paper proposes an RF attenuator linearization circuit used to vary the RF gain of mobile TV receivers while minimizing their dynamic range. The paper describes a passive attenuator designed, implemented in 65 nm CMOS technology and characterized in the lab. Additionally, a 5 bit linear thermometer decoder [5] integrated in the same test chip is used to program the gain of the attenuator. The decoder sets the gain value according to the signal level received at the attenuator input. Also, an on-chip programmable matching network is used to provide a stable 50 Ω input resistance

with its integration with the rest of the mobile TV system. Measurement results are given in Section IV, and finally Section V draws the conclusions.

II. PASSIVE GAIN CONTROL VERSUS ACTIVE GAIN CONTROL

There are several ways to achieve gain control in RF front-ends. Fig. 1a shows a VG-LNA used to control the RF gain, while Fig. 1b shows a programmable passive attenuator used to control the RF gain. Both techniques are capable of preventing a receiver from clipping at large input signal levels and, in theory, either one can be used to boost the linearity of a mobile TV tuner. However, the difference between them becomes clear when the receiver dynamic range (DR) is taken into consideration. Having the attenuator control (passive control) the RF gain results in a DR value that is far superior to that achieved when gain is controlled by a VG-LNA (active control), especially at the higher

978-1-4244-5309-2/10/\$26.00 ©2010 IEEE

1999

INTEL 1409

Motivation to Combine Uehara and Youssef

Fay Declaration

DOCKET NO.: 0107131-00573US5
Filed on behalf of Intel Corporation
By: David L. Cavanaugh, Reg. No. 36,476
John V. Hobgood, Reg. No. 61,540
Benjamin S. Fernandez, Reg. No. 55,172
Wilmer Cutler Pickering Hale and Dorr LLP
1875 Pennsylvania Ave., NW

129. A person of ordinary skill in the art would have coupled an attenuation circuit of Youssef to the first and second amplifier stages of Uehara to in order to prevent signal clipping and to suppress interfering signals. As

130. Furthermore, a person of ordinary skill would have been motivated to couple the attenuation circuit of Youssef to the first and second amplifier stages of Uehara to increase the receiver linearity (IIP3) and maintain a wide dynamic range. See EX1009-Youssef at 1999. As Youssef explains, traditional techniques

DECLARATION OF PATRICK FAY, PH.D.
U.S. PATENT NO. 9,154,356
CHALLENGING CLAIMS 2, 3, 4, 5, 6, and 10

INTEL 1402

Youssef

ends. Fig. 1a shows a VG-LNA used to control the RF gain, while Fig. 1b shows a programmable passive attenuator used to control the RF gain. Both techniques are capable of preventing a receiver from clipping at large input signal levels and, in theory, either one can be used to boost the linearity of a mobile TV tuner. However, the difference between them

TV applications presents several challenges. Such an attenuator has to achieve certain characteristics so that it can protect the RF performance of a mobile TV receiver in the presence of interferer blockers as high as 0 dBm. Typically, it

suppress far-away interferer blockers are thus not an option for these integrated tuners. This results in tightening the linearity requirement of the RF front-end needed for mobile TV reception, and hence demands innovative design techniques to the mobile TV antenna for the entire gain range. This paper is organized as follows. Section II discusses the advantages of using passive gain control over active gain.

V. CONCLUSION

A novel RF attenuator linearization circuit has been proposed to overcome the shortcomings of having the VG-LNA alone control the mobile TV front-end gain. The attenuator designed in 65 nm CMOS technology enables a low power, highly linear, wide dynamic range front-end realization with low noise figure at sensitivity level. The attenuator design can be scaled to any application that requires a wide dynamic range RF front-end.

Motivation to Combine Uehara and Youssef

DOCKET NO.: 0107131-00573US1
Filed on behalf of Intel Corporation
By: David L. Cavanaugh, Reg. No. 36,476
John V. Hobgood, Reg. No. 61,540
Benjamin S. Fernandez, Reg. No. 55,172
Gregory H. Lantier, *pro hac vice*
Wilmer Cutler Pickering Hale and Dorr LLP
1875 Pennsylvania Ave., NW
Washington, DC 20006
Tel: (202) 663-6000
Email: David.Cavanaugh@wilmerhale.com
John.Hobgood@wilmerhale.com
Ben.Fernandez@wilmerhale.com
Gregory.Lantier@wilmerhale.com

UNITED STATES PATENT AND TRADE

BEFORE THE PATENT TRIAL AND AP

INTEL CORPORATION
Petitioner

v.

QUALCOMM INCORPORATED
Patent Owner

Case IPR2019-00047
U.S. Patent No. 9,154,356

DECLARATION OF PATRICK FAY, PH. D.
PETITIONER'S REPLY

does not exclude operation on UHF/VHF bands. A POSITA would have

understood the UHF and VHF carriers described in Youssef to be within the “two channels encoded around two different carrier frequencies (i.e., dual carriers)” in

Uehara, and would have understood that receiving carriers at UHF and/or VHF frequencies using the combination of Uehara and Youssef described in the Petition would not have involved changing the capacitance values of C1, C2, or C3 of the attenuation circuit of Youssef.

Intel 1039
Intel v. Qualcomm
IPR2019-00047

Motivation to Combine Uehara and Youssef

DOCKET NO.: 0107131-00573US1
Filed on behalf of Intel Corporation
By: David L. Cavanaugh, Reg. No. 36,476
John V. Hobgood, Reg. No. 61,540
Benjamin S. Fernandez, Reg. No. 55,172
Gregory H. Lantier, *pro hac vice*
Wilmer Cutler Pickering Hale and Dorr LLP
1875 Pennsylvania Ave., NW
Washington, DC 20006
Tel: (202) 663-6000
Email: David.Cavanaugh@wilmerhale.com
John.Hobgood@wilmerhale.com
Ben.Fernandez@wilmerhale.com
Gregory.Lantier@wilmerhale.com

UNITED STATES PATENT AND TRADE

BEFORE THE PATENT TRIAL AND AP

INTEL CORPORATION
Petitioner

v.

QUALCOMM INCORPORAT
Patent Owner

Case IPR2019-00047
U.S. Patent No. 9,154,356

DECLARATION OF PATRICK FAY, PH. D
PETITIONER'S REPLY

45. Second, tuning RF circuitry (*e.g.*, by selecting capacitance values) is well within the capabilities of a person of ordinary skill in the art. As stated in the Petition, the combination of Uehara with Youssef “could have been implemented with *well-known circuit design and manufacturing techniques* and would have produced predictable results.” Pet., 76. In fact, Youssef first describes C1, C2, and C3, in functional/design terms. Ex. 1009, 2001 (“the capacitance values of these capacitors would set the lower frequency limit of the attenuator”). “To support the VHF band, 70 pF and 30 pF *capacitances were chosen* for the attenuator (C3) and the matching network caps (C1&C2) respectively.” *Id.* The

Motivation to Combine Uehara and Feasibility Study

Motivation to Combine Uehara and Feasibility Study

3GPP TR 36.912 V9.1.0 (2009-12)

LTE-Advanced extends LTE Rel.-8 with support for *Carrier Aggregation*, where two or more *component carriers* (CCs) are aggregated in order to support wider transmission bandwidths up to 100MHz and for spectrum aggregation.

Carrier aggregation is supported for both contiguous and non-contiguous component carriers with each component carrier limited to a maximum of 110 Resource Blocks in the frequency domain using the LTE Rel-8 numerology

It is possible to configure a UE to aggregate a different number of component carriers originating from the same eNB and of possibly different bandwidths in the UL and the DL. In typical TDD deployments, the number of component

The present document has been developed within the 3rd Generation Partnership Project (3GPPTM) and may be further elaborated for the purposes of 3GPP.

This Specification is provided for future development work within 3GPP only. The Organizational Partners accept no liability for any use of this Specification. Specifications and reports for implementation of the 3GPPTM system should be obtained via the 3GPP Organizational Partners' Publications Offices.

i

INTEL 1004

Motivation to Combine Uehara and Feasibility Study

- “[A] POSITA would have found it obvious to turn to the receiver front end of Uehara in order to process the carrier aggregated input RF signal of the Feasibility Study and would have been motivated to combine those references.”
 - “The Feasibility Study recognizes that wireless mobile devices can be configured to operate with input RF signals employing carrier aggregation.”
 - “The Feasibility Study further suggests that an ideal receiver for noncontiguous intra-band and inter-band carrier aggregation would have multiple RF front-ends.”
 - “The Feasibility Study characterizes an “RF front end” as having its own gain control (amplifier), mixer, and analog-to-digital conversion.”
 - “Uehara teaches a wireless receiver using multiple signal paths for different carriers, in which each of the multiple signal paths includes its own amplifier, mixer, and analog-to-digital conversion.”
 - “Uehara thus teaches the exact type of receiver that the Feasibility Study recognizes would work with signals employing carrier aggregation.”

Motivation to Combine Uehara and Feasibility Study

DOCKET NO.: 0107131-00573US1
Filed on behalf of Intel Corporation
By: David L. Cavanaugh, Reg. No. 36,476
John V. Hobgood, Reg. No. 61,540
Benjamin S. Fernandez, Reg. No. 55,172
Wilmer Cutler Pickering Hale and Dorr LLP
1875 Pennsylvania Ave., NW
Washington, DC 20006
Tel: (202) 663-6000
Email: David.Cavanaugh@wilmerhale.com
John.Hobgood@wilmerhale.com
Ben.Fernandez@wilmerhale.com

UNITED STATES PATENT AND TRADEMARK OFFICE
BEFORE THE PATENT TRIAL AND APPEALS BOARD

INTEL CORPORATION
Petitioner

v.

QUALCOMM INCORPORATED
Patent Owner

Case IPR2019-00047

DECLARATION OF PATRICK FAY
U.S. PATENT NO. 9,154,356
CLAIMS 1, 7, 8, 10, 11, 17, and

INTEL 1002

video streaming and video gameplay. Carrier aggregation is also a feature of LTE-Advanced and other systems, such as HSPA+. *Id.* A person of ordinary skill would have therefore been motivated to use the input RF signal employing carrier aggregation of the Feasibility Study with the receiver architecture of Uehara in order to achieve these benefits and support the feature of LTE-Advanced.

136. There would have been a reasonable expectation of success in using the carrier-aggregated input RF signals as described in the Feasibility Study with the receiver front-end of Uehara. The Feasibility Study recommends a receiver

IPR2019-00048 and IPR2019-00049

Overview of Prior Art for IPR2019-00048 and IPR2019-00049

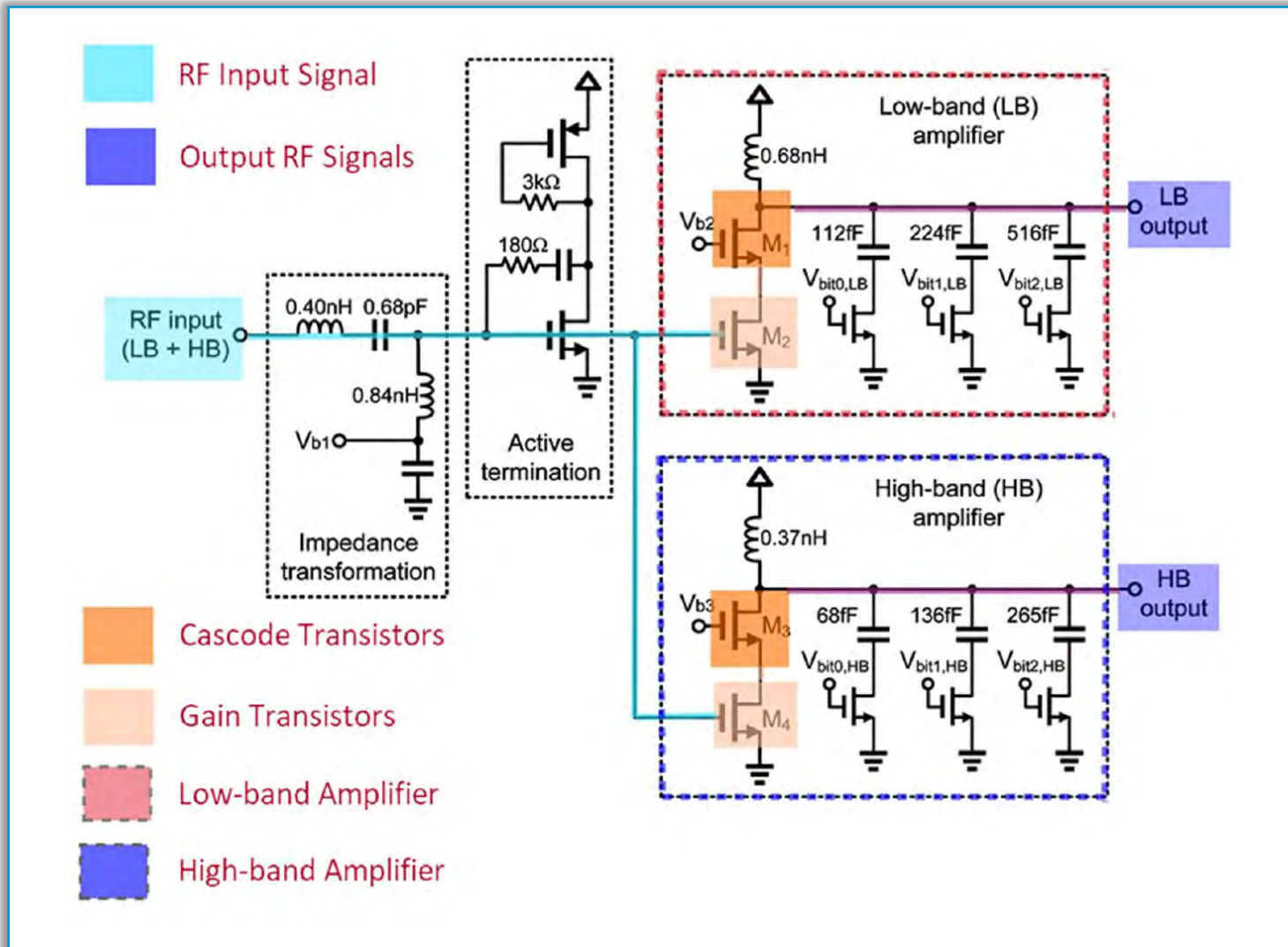

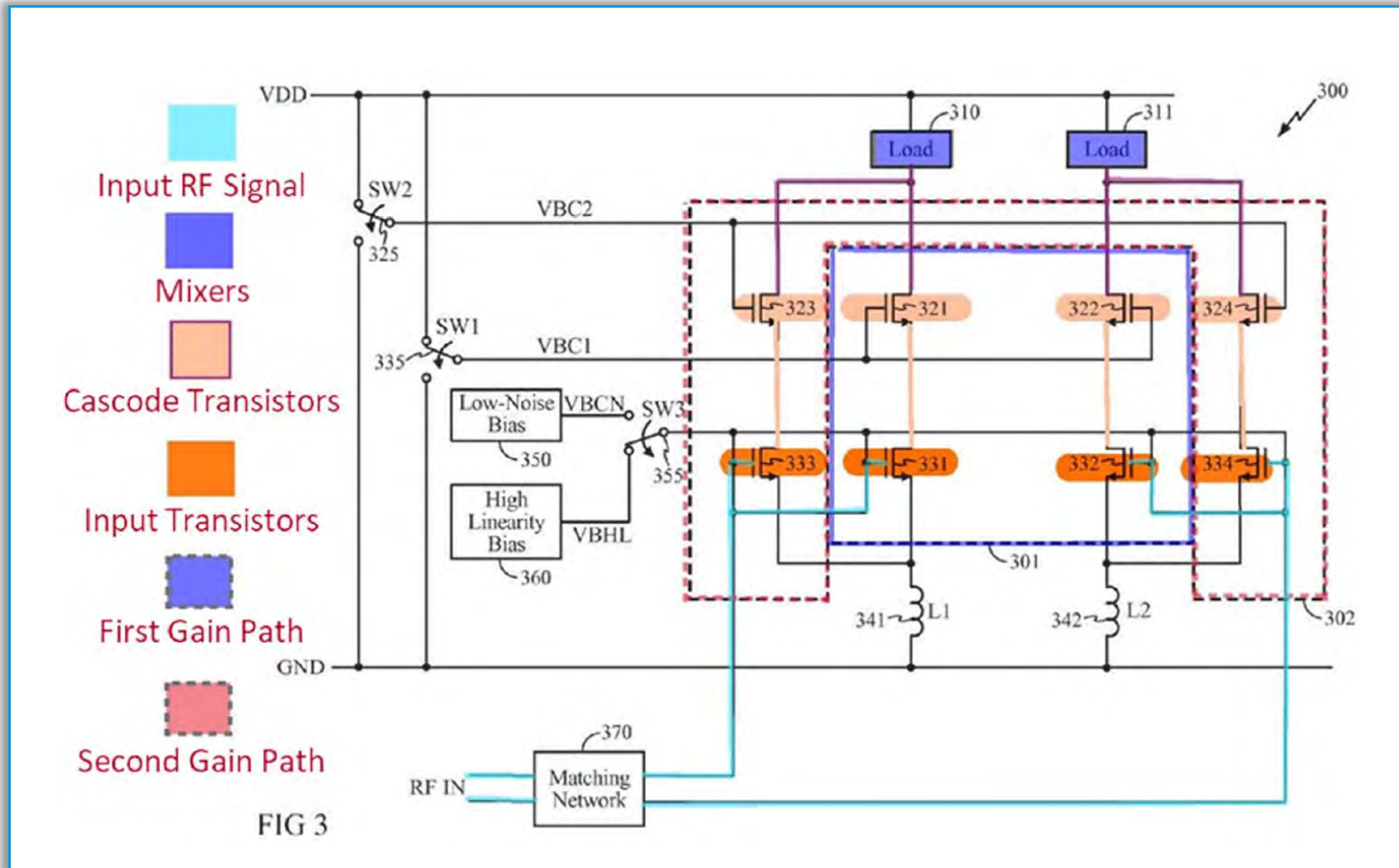

Feasibility Study

3GPP TR 36.912 V9.1.0 (2009-12)

Technical Report

3rd Generation Partnership Project;
Technical Specification Group Radio Access Network;
Feasibility study for
Further Advancements for E-UTRA (LTE-Advanced)
(Release 9)

LTE-Advanced extends LTE Rel.-8 with support for *Carrier Aggregation*, where two or more *component carriers* (CCs) are aggregated in order to support wider transmission bandwidths up to 100MHz and for spectrum aggregation.

The present document has been developed within the 3rd Generation Partnership Project (3GPPTM) and may be further elaborated for the purposes of 3GPP.
This Specification has not been subject to any approval process by the 3GPP Organizational Partners and shall not be implemented.
This Specification is provided for future development work within 3GPP only. The Organizational Partners accept no liability for any use of this Specification.
Specifications and reports for implementation of the 3GPPTM system should be obtained via the 3GPP Organizational Partners' Publications Offices.

i

INTEL 1104

Digitally-Controlled RF Passive Attenuator in CMOS for Mobile TV Tuners

Ahmed Youssef and James Haslett
Electrical and Computer Engineering Department
University of Calgary
Alberta, Canada

Abstract—A novel XRFUHF passive attenuator linearization circuit suitable for mobile TV applications has been designed and implemented in 65 nm CMOS technology. The proposed attenuator has a wide gain range of 48 dB that can be digitally programmed in 3 to 6 dB steps. At every gain setting, the input and output of the attenuator are matched to 50 Ω to facilitate its integration into mobile TV tuners.

I. INTRODUCTION

Mobile TV is one of the latest features to be added to cell phones and other hand-held devices. The low cost, low power, and small size demands of this application have pushed researchers to use nanometer CMOS technologies in designing high performance tuner chip sets. The bulky RF filters (i.e., SAW filters) usually used in traditional TV-set tuners to suppress far-away interferer blockers are thus not an option for these integrated tuners. This results in tightening the linearity requirement of the RF front-end needed for mobile TV reception, and hence demands innovative design techniques to adhere to the low power necessities for this application [1].

The RF-AGC (Automatic gain control) technique has been proposed recently in the literature as one of the low power solutions that can help mobile TV receivers achieve their stringent linearity requirements [2]-[4]. Decreasing the RF gain at large input signal levels helps the receiver pass larger signals without any degradation in the output SNR (Signal-to-Noise Ratio). Although there are many mechanisms to vary the RF gain in receivers, the efficacy of any given mechanism depends on the amount of the dynamic range that can be achieved while decreasing the RF gain.

This paper proposes an RF attenuator linearization circuit used to vary the RF gain of mobile TV receivers while maximizing their dynamic range. The paper describes a passive attenuator designed, implemented in 65 nm CMOS technology and characterized in the lab. Additionally, a 5 bit linear thermometer decoder [5] integrated in the same test chip is used to program the gain of the attenuator. The decoder sets the gain value according to the signal level received at the attenuator input. Also, an on-chip programmable matching network is used to provide a stable 50 Ω input resistance

This paper proposes an RF attenuator linearization circuit used to vary the RF gain of mobile TV receivers while maximizing their dynamic range. The paper describes a

Figures 1. RF gain control programmable passive att

to the mobile TV an
This paper is org
advantages of gain
control (i.e., Variab
a mobile TV receiv
attenuator design m
with in its integrat
Measurement result
Section V draws the

II. PASS

There are seven
ends. Fig. 1a shows
while Fig. 1b show
to control the RF
preventing a receive
and, in theory, either
mobile TV tuner,
becomes clear when
into consideration
control) the RF gain
to that achieve a
a VG-LNA (acti

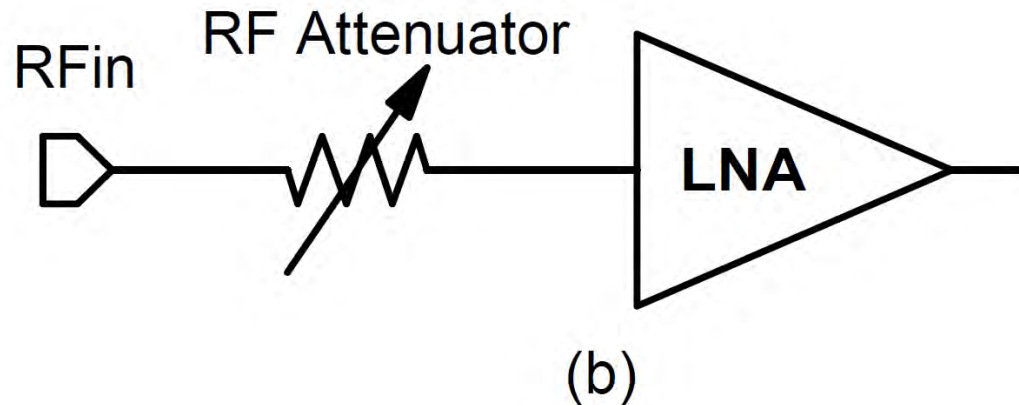

Disputed Issues for IPR2019-00048 and IPR2019-00049

Disputed Issues for IPR2019-00048 and IPR2019-00049

- Obviousness Based on Jeon and Xiong
 - Claims 1, 2-8, 11, 17, 18
- Motivation to Combine Jeon, Xiong, and Youssef
 - Claims 9 and 10
- Motivation to Combine Jeon, Xiong, and Feasibility Study
 - Claims 1, 2-11, 17, 18

Obviousness Based on Jeon and Xiong

Obviousness Based on Jeon and Xiong

Configured to be independently enabled or disabled

Jeon

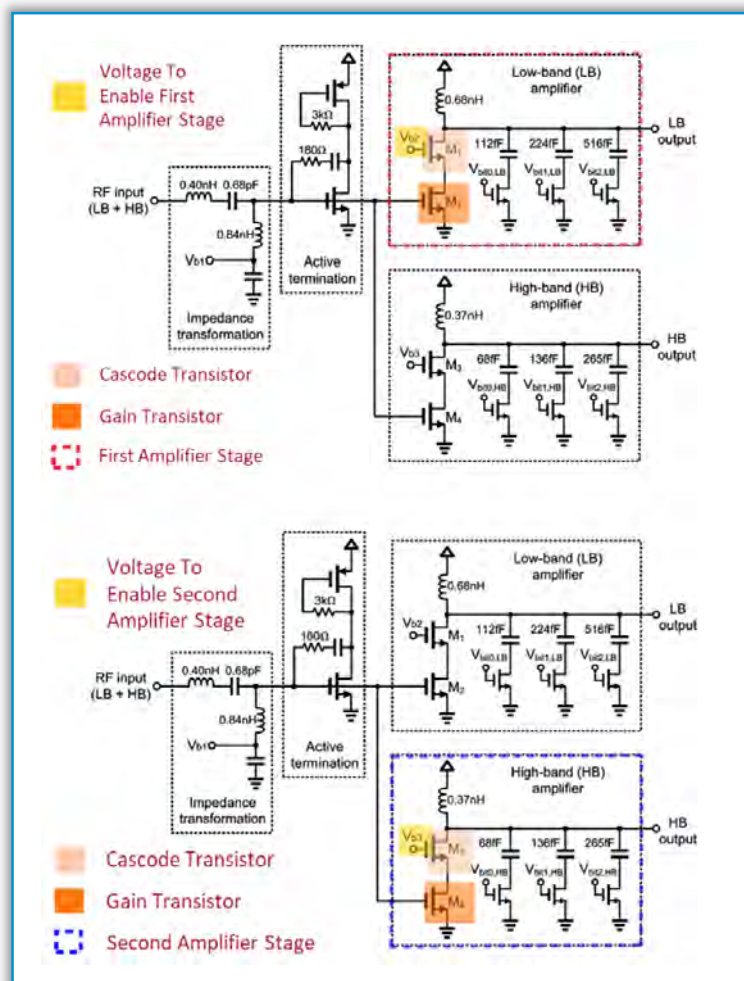

Obviousness Based on Jeon and Xiong

Configured to be independently enabled or disabled

Jeon

A Scalable 6-to-18 GHz Concurrent Dual-Band Quad-Beam Phased-Array Receiver in 180nm CMOS

Sunggun Jeon, Member, IEEE, Yu-Jin Wang, Student Member, IEEE, Hyeon Seon, Student Member, IEEE, Arun Natarajan, Avdi Babalola, Member, IEEE, Ali Hajimiri, Member, IEEE

Abstract—This paper reports a 6-to-18 GHz integrated phased-array receiver implemented in 180nm CMOS. The receiver is easily scalable to build a very large-scale phased-array system. It concurrently forms four independent beams at two different frequencies from 6 to 18 GHz. The nominal conversion gain of the receiver ranges from 16 to 24 dB over the entire band with the worst-case cross-band and cross-polarization rejections are achieved at 48 dB and 40 dB, respectively. Phase shifting is performed in the LO path by a digital phase rotator with the worst-case RMS phase error and amplitude variations of 0.5° and 0.4 dB, respectively, over the entire band. A four-element phased-array receiver system is implemented based on four receiver chips. The measured array pattern agrees well with the theoretical ones with a peak-to-null ratio of over 23.5 dB.

Index Terms—CMOS, concurrent, large-scale phased arrays, multi-band, multi-beam, phased arrays, scalable, triplex.

1. INTRODUCTION

PHASED arrays steer the beam direction electronically, bringing many benefits such as high directivity, interference rejection, signal-to-noise ratio improvement, and fast scanning response [1]–[4]. For this reason, phased arrays have been extensively employed in radar and communication systems in the areas of military, space, and radio astronomy since their advent in the 1950s [5]. [6]. Recently, substantial attention is also drawn in civil applications including high-speed point-to-point communications and car radars [4], [7].

Benefits of phased arrays increase with the number of elements combined in the array. This gives rise to the desire to make very large-scale phased arrays (up to 10⁶ elements) for high-precision radars, long-range sensors, or high-directivity communication systems. One of the major obstacles in implementing large scale phased arrays lies in the high complexity and cost to assemble the whole array system. Traditionally, phased-array systems have been built using a module-based approach. Most transceiver/oscillator components, such as

low-noise amplifiers (LNAs), mixers, filters, mixers, and LO synthesizers, are implemented in separate modules and then integrated externally [3], [6]. This approach usually uses discrete components and is costly, but also due to the complicated configuration and assembly, it is difficult to scale up the number of elements. Integrated CMOS solutions offer reduction in cost and size of such systems. However, it is difficult to integrate a large-scale receiver to be implemented on a single chip because of the large number of elements. Recently, a CMOS RF front-end-based phased-array receiver [8] transmitter [11], and a 24 GHz and 77 GHz phased-array transceiver [9] have been reported. These reports show that the use of CMOS technology reduces the cost compared to the conventional silicon-based counterparts.

There is a trend in radar and communication systems to use multi-band and multi-beam systems [13]. Furthermore, an antenna system must be able to operate in a wide range of frequencies. These trends also apply to phased arrays. However, none of the previous work has addressed the multi-band and multi-beam operation in a wide range of RF frequencies.

In this work, we integrated RF front-end-based concurrent dual-band quad-beam phased-array receiver elements on a single CMOS chip. The receiver is programmable to concurrently receive two RF frequencies between 6 and 18 GHz (in total) while forming four independently-controlled beams with separate phase shifting operation. The receiver is also easily scalable toward very large-scale phased arrays because additional receiver chips can be added to increase the number

The RF signals from two frequencies are then selectively amplified by two separate cascode amplifiers (M_1-M_2 , M_3-M_4) that have tunable LC output loads. A 3-bit switched capacitor bank at each output load is tuned to cover the entire LB and HB frequencies. This allows for the digital tuning of the amplifier so that it can provide the maximum gain at the desired frequency while attenuating out-of-band signals prior to the first down-conversion.

Sunggun Jeon is with the School of Electrical and Electronic Engineering, Seoul National University, Seoul, Korea (e-mail: sjjeon@plaza.snu.ac.kr). Yu-Jin Wang is with the School of Electrical and Electronic Engineering, Seoul National University, Seoul, Korea (e-mail: yjwang@plaza.snu.ac.kr). Hyeon Seon is with the School of Electrical and Electronic Engineering, Seoul National University, Seoul, Korea (e-mail: hseon@plaza.snu.ac.kr). Arun Natarajan is with the Department of Electrical Engineering, California Institute of Technology, Pasadena, CA 91125 USA. Avdi Babalola is with the IBM T. J. Watson Research Center, Yorktown Heights, NY 10598 USA. Ali Hajimiri is with the Intel Corporation, Hillsdale, NJ 07033 USA.

Obviousness Based on Jeon and Xiong

Configured to be independently enabled or disabled

Jeon

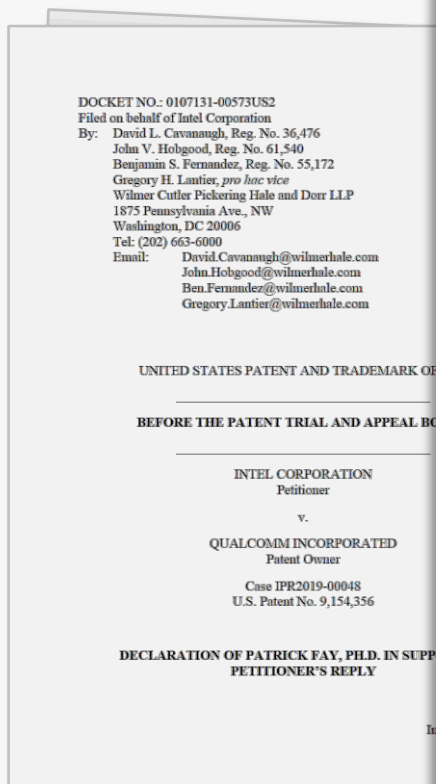

Each of the amplifier stages identified, above, is *configured* to be independently enabled or disabled at least in part due to the presence of distinct voltage signals (V_{b2} and V_{b3}) used to enable respective cascode transistors (M_1 and M_3). Ex. 1105, FIG. 6. My initial declaration explained that because Jeon uses two separate voltages to enable two separate cascode transistors, a POSITA “would have known the input voltage V_{b2} [(or V_{b3})] allows the first amplifier stage [(or second amplifier stage)] to be configured to be independently enabled or disabled”. Ex. 1102, ¶¶80, 94. Further, during operation Jeon explicitly teaches that “RF signals at two frequencies are then *selectively* amplified by two separate cascode amplifiers (M_1 – M_2 , M_3 – M_4)”—showing that each amplifier can be enabled or disabled independently. Ex. 1105, 2665.

Obviousness Based on Jeon and Xiong

Configured to be independently enabled or disabled

Xiong

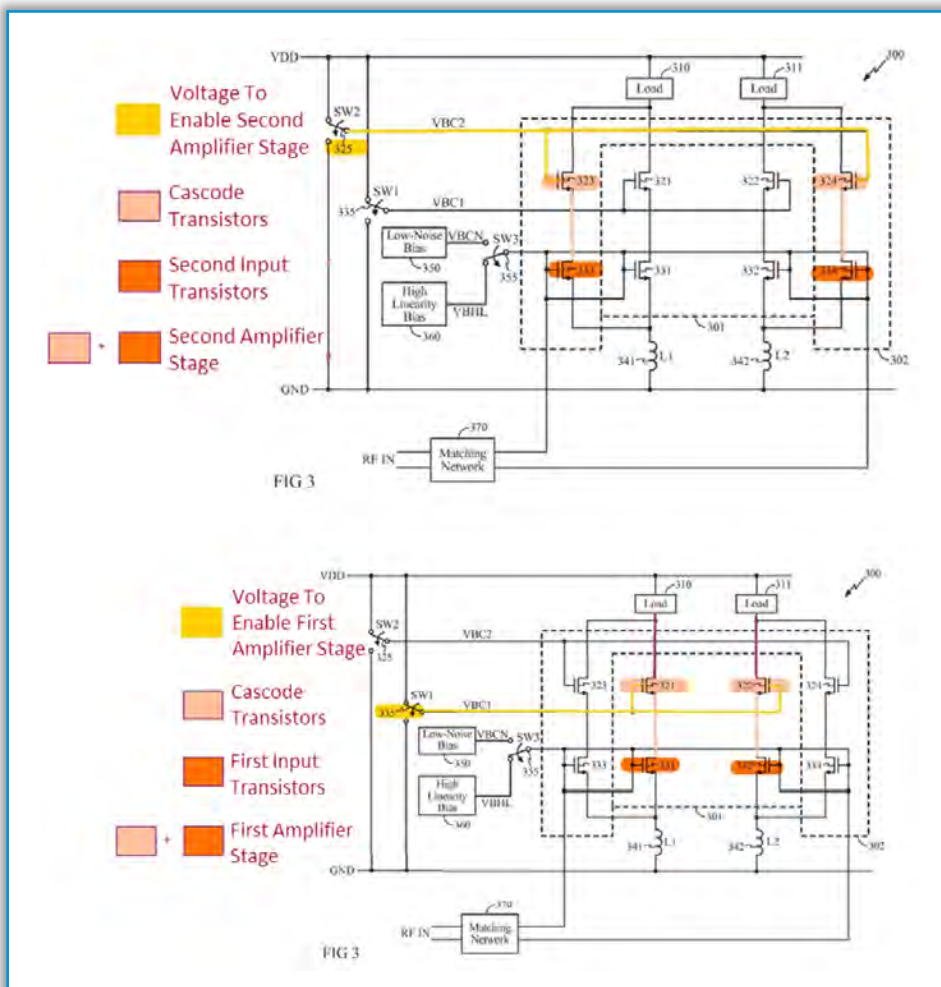

Obviousness Based on Jeon and Xiong

Configured to be independently enabled or disabled

Xiong

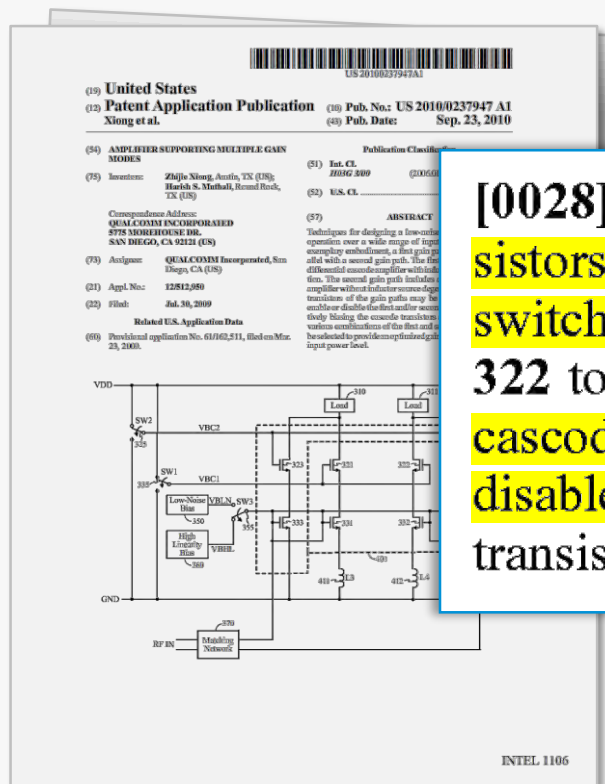

[0028] As further shown in FIG. 3, the first cascode transistors 321, 322 may be selectively enabled or disabled by a switch SW1 335, which pulls the gates of the transistors 321, 322 to either a high or a low voltage. Similarly, the second cascode transistors 323, 324 may be selectively enabled or disabled by a switch SW2 325, which pulls the gates of the transistors 323, 324 to either a high or a low voltage.

Obviousness Based on Jeon and Xiong

Configured to be independently enabled or disabled

Xiong

However, Patent Owner's singling out of a single use case of the circuitry of Xiong fails to rebut the Petition's showing that the amplifier stages of Xiong are configured to be independently enabled or disabled. Each amplifier stage in Figure 3 of Xiong, as identified in my initial declaration, has its own switch (325 and 335) to supply a voltage (VBC1 and VBC2) to respective cascode transistors (321/322 and 323/324). Ex. 1106, ¶28. A POSITA would understand that Xiong teaches at least four operational/control states, which I have listed in Table 1 below:

State	SW1 335 (VBC1)	SW2 325 (VBC2)
1	ON	OFF
2	OFF	ON
3	ON	ON
4	OFF	OFF

Table 1: Basic Control Voltage Configuration of Xiong Amplifier Stages

Obviousness Based on Jeon and Xiong

Motivation to Combine Jeon and Xiong

DOCKET NO.: 0107131-00573US2
Filed on behalf of Intel Corporation
By: David L. Cavanaugh, Reg. No. 36,476
John V. Hobgood, Reg. No. 61,540
Benjamin S. Fernandez, Reg. No. 55,172
Wilmer Cutler Pickering Hale and Dorr LLP
1875 Pennsylvania Ave., NW
Washington, DC 20006
Tel: (202) 663-6000
Email: David.Cavanaugh@wilmerhale.com
John.Hobgood@wilmerhale.com
Ben.Fernandez@wilmerhale.com

UNITED STATES PATENT AND TRADEM

BEFORE THE PATENT TRIAL AND AP

INTEL CORPORATION
Petitioner

v.

QUALCOMM INCORPORATE
Patent Owner

Case IPR2019-00048

DECLARATION OF PATRICK FAY
U.S. PATENT NO. 9,154,356
CLAIMS 1, 9, 10, 17, and 18

INTEL 1102

83. A person of ordinary skill in the art would have added the switches that enable or disable amplifier stages in Xiong to the dual-cascode amplifier in Jeon. Adding switches would permit the amplifier of Jeon to independently enable or disable each amplifier stage whether or not any other amplifier stage is enabled or disabled. Modifying Jeon to include the switches of Xiong also would have permitted Jeon to operate in multiple modes, while consuming less power. See EX1106-Xiong ¶¶27-30 (teaching multiple modes of operation), 34 (“[P]rovision of the switch SW1 335, along with SW2 325, may advantageously allow the entire LNA 400 to be powered on or off when desired.”). Jeon teaches a tunable

Obviousness Based on Jeon and Xiong

Motivation to Combine Jeon and Xiong

DOCKET NO.: 0107131-00573US2
Filed on behalf of Intel Corporation
By: David L. Cavanaugh, Reg. No. 36,476
John V. Hobgood, Reg. No. 61,540
Benjamin S. Fernandez, Reg. No. 55,172
Wilmer Cutler Pickering Hale and Dorr LLP
1875 Pennsylvania Ave., NW
Washington, DC 20006
Tel: (202) 663-6000
Email: David.Cavanaugh@wilmerhale.com
John.Hobgood@wilmerhale.com
Ben.Fernandez@wilmerhale.com

UNITED STATES PATENT AND TRADEMARK OFFICE

BEFORE THE PATENT TRIAL AND APPEAL BOARD

INTEL CORPORATION
Petitioner

v.

QUALCOMM INCORPORATED
Patent Owner

Case IPR2019-00048

DECLARATION OF PATRICK FAY, PH.D.
U.S. PATENT NO. 9,154,356
CLAIMS 1, 9, 10, 17, and 18

INTEL 1102

2660. Thus, Jeon implicitly teaches that concurrent dual-band operation is not needed in some cases, such that either the HB or the LB amplifier would remain unused. Xiong teaches enabling and disabling different amplifier stages for different modes of operation. *See* EX1106-Xiong ¶¶27-30 (teaching a “high linearity” and a “low noise” mode). Specifically, Xiong explains that different input RF signals may benefit from different amplifier characteristics, such as a low power signal benefiting from a high-gain, low noise LNA, and a high-power signal benefiting from good linearity to avoid distortion. *See id.* ¶5. Xiong uses independently enabled or disabled amplifier stages to achieve these different modes depending on the characteristics of the input signal (i.e. power level).

Obviousness Based on Jeon and Xiong

Motivation to Combine Jeon and Xiong

DOCKET NO.: 0107131-00573US2
Filed on behalf of Intel Corporation
By: David L. Cavanaugh, Reg. No. 36,476
John V. Hobgood, Reg. No. 61,540
Benjamin S. Fernandez, Reg. No. 55,172
Gregory H. Lantier, *pro hac vice*
Wilmer Cutler Pickering Hale and Dorr LLP
1875 Pennsylvania Ave., NW
Washington, DC 20006
Tel: (202) 663-6000
Email: David.Cavanaugh@wilmerhale.com
John.Hobgood@wilmerhale.com
Ben.Fernandez@wilmerhale.com
Gregory.Lantier@wilmerhale.com

UNITED STATES PATENT AND TRADEMARK OFFICE

BEFORE THE PATENT TRIAL AND APPEAL BOARD

INTEL CORPORATION
Petitioner

v.

QUALCOMM INCORPORATED
Patent Owner

Case IPR2019-00048
U.S. Patent No. 9,154,356

DECLARATION OF PATRICK FAY, PH.D. IN SUPPORT OF
PETITIONER'S REPLY

Intel 1139
Intel v. Qualcomm
IPR2019-00048

42. Patent Owner also mischaracterizes the motivation to combine to require adding more from Xiong to Jeon than argued in the Petition. As stated in the Petition, a POSITA would have found it obvious to use Xiong's switches to "selectively enable or disable" Jeon's cascode transistors to save power. *See* Pet., 47-49; Ex. 1102, ¶¶83-86. Contrary to Patent Owner's arguments on pages 45-46 of the POR, the Petition does not rely (nor does it need to rely) on Xiong's discussions that are specific to its adding/subtracting gain paths. Pet., 47-49. In other words, a POSITA would have understood how to modify the amplifier stages of Jeon using the switching topology of Xiong to make them "selectively enabled or disabled" to save power as taught by Xiong, and would not have been deterred

Obviousness Based on Jeon and Xiong

Providing a first/second output RF signal to a first/second load circuit

First Output RF Signal

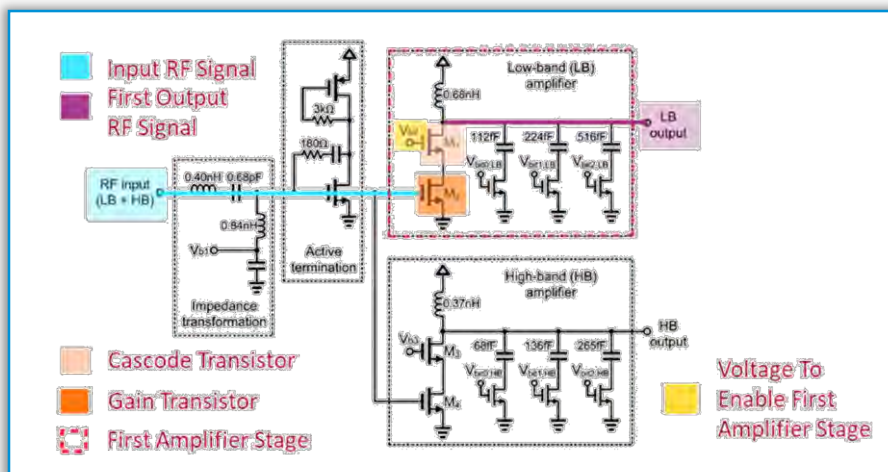

presented in Fig. 4. Since it is a concurrent dual-band receiver, the incoming RF signal contains two frequencies at LB and HB respectively, and feeds a front-end tunable concurrent amplifier (TCA). The TCA amplifies, filters, and finally splits the RF signal into two separate outputs; one at LB and the other at HB. Each of the two signals goes through separate double down-conversion by subsequent RF and IF mixers. The IF mixers generate the I and Q components of the

Obviousness Based on Jeon and Xiong

Providing a first/second output RF signal to a first/second load circuit

Second Output RF Signal

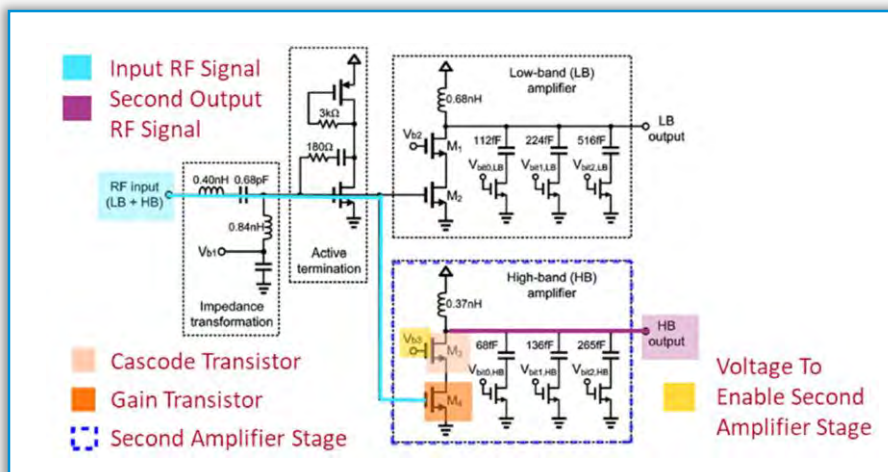

presented in Fig. 4. Since it is a concurrent dual-band receiver, the incoming RF signal contains two frequencies at LB and HB respectively, and feeds a front-end tunable concurrent amplifier (TCA). The TCA amplifies, filters, and finally splits the RF signal into two separate outputs; one at LB and the other at HB. Each of the two signals goes through separate double down-conversion by subsequent RF and IF mixers. The IF mixers generate the I and Q components of the

Obviousness Based on Jeon and Xiong

Providing a first/second output RF signal to a first/second load circuit

DOCKET NO.: 0107131-00573US2
Filed on behalf of Intel Corporation
By: David L. Cavanaugh, Reg. No. 36,476
John V. Hobgood, Reg. No. 61,540
Benjamin S. Fernandez, Reg. No. 55,172
Gregory H. Lantier, *pro hac vice*
Wilmer Cutler Pickering Hale and Dorr LLP
1875 Pennsylvania Ave., NW
Washington, DC 20006
Tel: (202) 663-6000
Email: David.Cavanaugh@wilmerhale.com
John.Hobgood@wilmerhale.com
Ben.Fernandez@wilmerhale.com
Gregory.Lantier@wilmerhale.com

UNITED STATES PATENT AND TRADE

BEFORE THE PATENT TRIAL AND AP

INTEL CORPORATION
Petitioner

v.

QUALCOMM INCORPORAT
Patent Owner

Case IPR2019-00048
U.S. Patent No. 9,154,356

DECLARATION OF PATRICK FAY, PH.D.
PETITIONER'S REPLY

44. Patent Owner's argument that Xiong only teaches a single amplifier

with a single load is beside the point, because the Petition relies on Xiong for only the switches SW1 335 and SW2 325 and not for the load circuits 310 and 311.

Pet., 44-49, 50-51, 56-58, 59-60. Jeon already teaches outputting the first and second output RF signals (LB output and HB output) to separate load circuits. Ex. 1105, 2663. Modifying Jeon to include the switches of Xiong would not change the output of the amplifier stages, which would continue to be provided to separate loads when the cascode transistors M_1 and M_3 of Jeon are enabled by the switches of Xiong. Pet., 44-49, 50-51, 56-58, 59-60.

Obviousness Based on Jeon and Xiong

The input RF signal employing carrier aggregation

Term	Petitioner's Construction
“carrier aggregation”	“simultaneous operation on multiple carriers”

Jeon

concurrent amplifier in Figure 6 is “a **dual-band signal containing two different frequencies** concurrently, one in the **low band** (LB) from 6 to 10.4 GHz and the other in the **high band** (HB) from 10.4 to 18 GHz.” Ex. 1105, 2662. When the

Obviousness Based on Jeon and Xiong

The input RF signal employing carrier aggregation

DOCKET NO.: 0107131-00573US2
Filed on behalf of Intel Corporation
By: David L. Cavanaugh, Reg. No. 36,476
John V. Hobgood, Reg. No. 61,540
Benjamin S. Fernandez, Reg. No. 55,172
Wilmer Cutler Pickering Hale and Dorr LLP
1875 Pennsylvania Ave., NW
Washington, DC 20006
Tel: (202) 663-6000
Email: David.Cavanaugh@wilmerhale.com
John.Hobgood@wilmerhale.com
Ben.Fernandez@wilmerhale.com

UNITED STATES PATENT AND TRADEMARK OFFICE

BEFORE THE PATENT TRIAL AND APPEAL BOARD

INTEL CORPORATION
Petitioner

v.

QUALCOMM INCORPORATED
Patent Owner

Case IPR2019-00048

DECLARATION OF PATRICK FAY, PH.D.
U.S. PATENT NO. 9,154,356
CLAIMS 1, 9, 10, 17, and 18

INTEL 1102

18 GHz.” EX1105-Jeon at 2662 (emphasis added). Low-band and high-band frequency ranges comprise different, non-overlapping carriers, as acknowledged by the ’356 patent and as was known well before the ’356 patent. *See* EX1101-’356-Patent at 2:59-63 (“Low-band, mid-band, and high-band refer to three groups of bands (or band groups), with each band group including a number of frequency bands (or simply, “bands”) . . . Each band . . . includes one or more carriers.”).

This means that the dual-band input RF signal necessarily contains two carriers at different frequencies. Jeon thus teaches an input RF signal comprising

transmissions sent on multiple carriers at different frequencies. Furthermore, Jeon teaches the input RF signal employing carrier aggregation because it describes receiving “a dual-band signal containing two different frequencies *concurrently*,” as required for simultaneous operation on multiple carriers. EX1105-Jeon at 2662 (emphasis added). Finally, Jeon teaches that the multi-carrier signal is sent to a wireless device because the signal is transmitted, and received, wirelessly by a receiver.¹⁶ *See* EX1105-Jeon at 2660, 2662.

Obviousness Based on Jeon and Xiong

The input RF signal employing carrier aggregation

Patent Owner's Cited Reference (GB 2472978)

and its expert rely for their construction teaches that “*Carrier aggregation mode is also known as spectrum aggregation mode, dual carrier mode* and dual cell

Jeon

concurrent amplifier in Figure 6 is “a *dual-band signal containing two different frequencies* concurrently, one in the *low band* (LB) from 6 to 10.4 GHz and the other in the *high band* (HB) from 10.4 to 18 GHz.” Ex. 1105, 2662. When the

Obviousness Based on Jeon and Xiong

The input RF signal employing carrier aggregation

- Jeon's dual carriers are "aggregated"

47. Patent Owner further argues that the Petition ignores the meaning of "aggregation." POR, 46. This is incorrect – when dual carriers are received simultaneously in the amplification circuit of Jeon, they are aggregated at the single input of the TCA of Jeon. See POR, 30 ("Aggregate means 'to collect together, assemble.'"). This is true regardless of whether or not the two carriers originate from a common source, or whether or not they are logically related to one another (*e.g.*, at the baseband level). The two carriers do not somehow travel down separate sides of the wire or avoid one another along the input.

Obviousness Based on Jeon and Xiong

The input RF signal employing carrier aggregation

- Jeon teaches “higher bandwidth”

for data transmission. A receiver that operates simultaneously on multiple carriers increases bandwidth because carriers occupy frequency ranges and transmitting data over multiple carriers increases bandwidth to the sum of the carriers' frequency ranges, as would have been understood by a person of ordinary skill in the art at the time of the Patent Owner's alleged conception date for the '356 patent. *See supra* ¶ 41 at Fig. 7 (showing carriers occupying bandwidth); *see also* EX1101-'356-Patent at 1:32-35 (noting that a “carrier may refer to a range of frequencies”), Figs. 2A-2D (showing carriers occupying bandwidth). Jeon teaches “a dual-band signal containing two different frequencies concurrently.” EX1105-Jeon at 2662. Jeon's use of two frequency channels provides greater bandwidth than one channel. *See* Section III.C. Specifically, by sending data over two or more carriers, the bandwidth for data transmission necessarily increases to the sum of the first carrier's frequency range and the second carrier's frequency range.

Obviousness Based on Jeon and Xiong

The input RF signal employing carrier aggregation

- Jeon teaches increased aggregated data rate

91. Jeon also teaches employing carrier aggregation to increase an aggregated data rate. When the total amount of data entering a wireless device increases, the wireless device (and the user of the device) experiences an “increased aggregated data rate.” Jeon discloses an “incoming RF signal [that] contains two frequencies at LB and HB respectively.” EX1105-Jeon at 2663. When non-redundant data is transmitted over these two frequencies, the data rate to the wireless device of Jeon increases because the device is receiving more data per unit of time. This is different than Hirose (EX1124-Hirose), which the Patent Owner distinguished during prosecution. Specifically, Jeon does not require the data sent over the dual carriers to be redundant data. See EX1115 at 2 (June 6, 2014 Resp. to Office Action). A person having ordinary skill in the art would have

Obviousness Based on Jeon and Xiong

Claim 3

US009154356B2

(12) **United States Patent**
Tasic et al.

(10) **Patent No.:** US 9,154,356 B2
(45) **Date of Patent:** Oct. 6, 2015

(54) **LOW NOISE AMPLIFIERS FOR CARRIER AGGREGATION**

(56) **References Cited**

(75) **Inventors:** Aleksandar Miodrag Tasic, San Diego, CA (US); Anosh Bomi Davierwalla, San Diego, CA (US)

(73) **Assignee:** QUALCOMM Incorporated, San Diego, CA (US)

(*) **Notice:** Subject to any disclaimer, the term of this patent is extended or adjusted under 35 U.S.C. 154(b) by 0 days.

(21) **Appl. No.:** 13590423

(22) **Filed:** Aug. 21, 2012

(23) **Pub. No.:** 2013/015348 A1

(24) **Pub. Date:** Nov. 28, 2013

(41) **Filed:** Aug. 21, 2012

(42) **Pub. No.:** 2013/015348 A1

(43) **Pub. Date:** Nov. 28, 2013

(51) **Int. Cl.**
H04L 27/06 (2006.01)
H04L 27/26 (2006.01)
H03G 3/20 (2006.01)
H03F 3/22 (2006.01)
H03F 3/193 (2006.01)

(52) **U.S. Cl.**
CPC: H04L 27/0647 (2013.01); H03F 3/223 (2013.01); H03F 3/193 (2013.01); H03G 3/08 (2013.01); H03F 3/72 (2013.01); H03G 3/20 (2013.01)

(53) **Field of Classification Search**
CPC: H04L 27/2647; H04L 27/2649; H04L 27/38; H03H 7/40; H03G 3/20
USPC: 375/316, 317, 318, 345, 349, 349, 455/130, 132, 136, 234.1; 370/542
See application file for complete search history.

(74) **Attorney, Agent, or Firm:**

20 Claims

3. The apparatus of claim 2, the first amplifier stage further comprising a **first inductor** coupled to the first gain transistor, and the second amplifier stage further comprising a **second inductor** coupled to the second gain transistor.

Obviousness Based on Jeon and Xiong

Claim 3

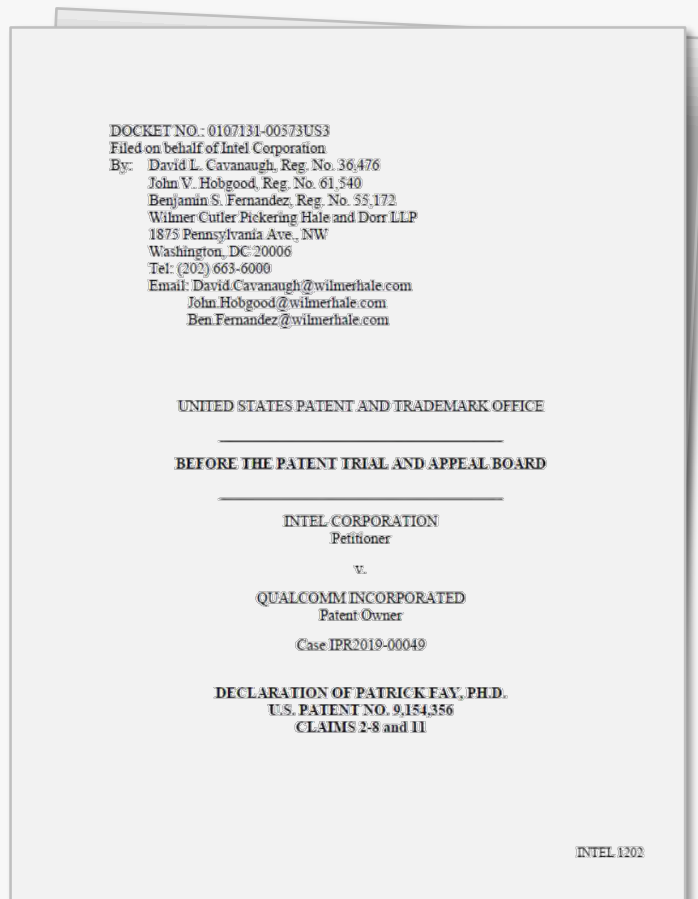

106. As described above, a person of ordinary skill would have attached a first inductor to the first gain transistor of Jeon, according to the teaching of Xiong. A person of ordinary skill would have also coupled a second inductor to a second gain transistor in Jeon to achieve the same benefits of impedance matching with low noise figure as is achieved for the first amplifier stage according to the teaching of Xiong. In particular, the amplifier stages of Jeon are shown to be separate amplifiers providing different outputs. See EX1205-Jeon at 2663, Fig. 6. Moreover, Jeon shows that the two outputs are in different frequency bands. See *id.* (showing “LB” low-band output and “HB” high-band output). A person of ordinary skill would have understood that amplifiers providing different outputs could benefit from the use of different inductance values, particularly if those outputs were targeted to cover different frequency ranges as in Jeon. The impedance matching conditions required for optimal low noise amplifier operation are a function of frequency, and so the choice of source degeneration inductance is also a function of the intended amplifier frequency of operation.

Obviousness Based on Jeon and Xiong

Claim 3

DOCKET NO.: 0107131-00573US3
Filed on behalf of Intel Corporation
By: David L. Cavanaugh, Reg. No. 36,476
John V. Hobgood, Reg. No. 61,340
Benjamin S. Fernandez, Reg. No. 55,172
Gregory H. Lantier, *pro hac vice*
Wilmer Cutler Pickering Hale and Dorr LLP
1375 Pennsylvania Ave., NW
Washington, DC 20006
Tel: (202) 663-6000
Email: David.Cavanaugh@wilmerhale.com
John.Hobgood@wilmerhale.com
Ben.Fernandez@wilmerhale.com
Gregory.Lantier@wilmerhale.com

UNITED STATES PATENT AND TRADEM

BEFORE THE PATENT TRIAL AND AP

INTEL CORPORATION
Petitioner

v.

QUALCOMM INCORPORATE
Patent Owner

Case IPR2019-00049
U.S. Patent No. 9,154,356

DECLARATION OF PATRICK FAY, PH. D.
PETITIONER'S REPLY

¶¶104-07. Patent Owner asserts that “Petitioner fails to sufficiently articulate a motivation to select and combine the references in this manner to improve the input impedance.” POR, 49. To the contrary, the Petition, at pages 65-66, articulated several reasons to combine the references in the manner claimed: (1) source degeneration inductors were well-known and among the finite number of alternatives used to provide impedance matching, (2) source degeneration inductors would have improved similar systems in the same way (*e.g.*, to improve linearity, Ex. 1206, ¶32), and (3) there was reasonable expectation of success involving well-known circuit design and manufacturing techniques that would have produced predictable results. *See also* Ex. 1202, ¶¶104-05. Patent Owner does not rebut any of these reasons.

Motivation to Combine Jeon, Xiong, and Youssef

Motivation to Combine Jeon, Xiong, and Youssef

Claims 9, 10

(12) **United States Patent**
Tasic et al.

(10) Patent No.
(45) Date of P...

(54) **LOW NOISE AMPLIFIERS FOR CARRIER**

(56) R...

(75) Inventors: Aleksandar Miodrag Tasic, San Diego, CA (US); Anosh Bomi Davierwalla, San Diego, CA (US)

(73) Assignor: QUALCOMM Incorporated, San Diego, CA (US)

(*) Notice: Subject to any disclaimer, the term of this patent is extended or adjusted under 35 U.S.C. 154(b) by 0 days.

(21) Appl. No.: 13590423

(22) Filed: Aug. 21, 2012

(65) **Prior Publication Data**
US 2013/0315348 A1 Nov. 28, 2013
Related U.S. Application Data
(60) Provisional application No. 61/652,064, filed on May 25, 2012.

(51) **Int. Cl.**
H04L 27/06 (2006.01)
H04L 27/26 (2006.01)
H03G 3/20 (2006.01)
H03F 1/22 (2006.01)
H03F 3/193 (2006.01)
(Continued)

(52) **U.S. CL.**
CPC: H04L 27/2647 (2013.01); H03F 1/223 (2013.01); H03F 3/193 (2013.01); H03G 3/68 (2013.01); H03F 3/72 (2013.01); H03G 3/20 (2013.01)

(58) **Field of Classification Search**
CPC: H04L 27/2647; H04L 27/2649; H04L 27/38; H03H 7/40; H03G 3/20
USPC: 375/316, 317, 318, 345, 349, 349, 455/130, 132, 136, 234.1; 370/542
See application file for complete search history.

(10) Patent No. (45) Date of P...
U.S. PA...
3,911,364 A
4,035,728 A
FOREIGN
CN 152391
192275
OTHER
International Search Rep
042726—ISA/EPO—A...

Primary Examiner...
(74) Attorney, Agent...

(57)
Low noise amplifiers (LNA) are disclosed. In an exemplary design, an apparatus includes a first and second amplifier stages, e.g., for a carrier aggregation (CA) LNA or a multiple-input multiple-output (MIMO) LNA. The first amplifier stage receives and amplifies an input radio frequency (RF) signal to a first load impedance. The second amplifier stage receives and amplifies the RF signal and provides a load circuit when the first amplifier stage may be cascode transistor.

20 Clai...

9. The apparatus of claim 1, further comprising:
a first attenuation circuit coupled to the first amplifier stage and configured to receive the input RF signal; and
a second attenuation circuit coupled to the second amplifier stage and configured to receive the input RF signal.

10. The apparatus of claim 1, further comprising:
an attenuation circuit coupled to the first and second amplifier stages and configured to receive the input RF signal.

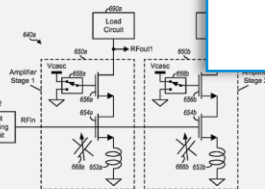

Motivation to Combine Jeon, Xiong, and Youssef

Digitally-Controlled RF Passive Attenuator in CMOS for Mobile TV Tuners

Ahmed Youssef and James Haslett
Electrical and Computer Engineering Department
University of Calgary
Alberta, Canada

Abstract—A novel XRFUHF passive attenuator linearization circuit suitable for mobile TV applications has been designed and implemented in 65 nm CMOS technology. The proposed attenuator has a wide gain range of 48 dB that can be digitally programmed in 3 to 6 dB steps. At every gain setting, the input and output of the attenuator are matched to 50 Ω to facilitate its integration into mobile TV tuners.

I. INTRODUCTION

Mobile TV is one of the latest features to be added to cell phones and other hand-held devices. The low cost, low power, and small size demands of this application have pushed researchers to use nanometer CMOS technologies in designing high performance tuner chip sets. The bulky RF filters (i.e., SAW filters) usually used in traditional TV-set tuners to suppress far-away interferer blockers are thus not an option for these integrated tuners. This results in tightening the linearity requirement of the RF front-end needed for mobile TV reception, and hence demands innovative design techniques to adhere to the low power necessities for this application [1].

The RF-AGC (Automatic gain control) technique has been proposed recently in the literature as one of the low power solutions that can help mobile TV receivers achieve their stringent linearity requirements [2]-[4]. Decreasing the RF gain at large input signal levels helps the receiver pass larger signals without any degradation in the output SNR (Signal-to-Noise Ratio). Although there are many mechanisms to vary the RF gain in receivers, the efficacy of any given mechanism depends on the amount of the dynamic range that can be achieved while decreasing the RF gain.

This paper proposes an RF attenuator linearization circuit used to vary the RF gain of mobile TV receivers while maximizing their dynamic range. The paper describes a passive attenuator designed, implemented in 65 nm CMOS technology and characterized in the lab. Additionally, a 5 bit linear thermometer decoder [5] integrated in the same test chip is used to program the gain of the attenuator. The decoder sets the gain value according to the signal level received at the attenuator input. Also, an on-chip programmable matching network is used to provide a stable 50 Ω input resistance

This paper proposes an RF attenuator linearization circuit used to vary the RF gain of mobile TV receivers while maximizing their dynamic range. The paper describes a

Fig. 1. RF gain control programmable passive attenuator

to the mobile TV antenna. This paper is organized as follows. Section II describes the advantages of gain control (i.e., Variable Gain Amplifier) in a mobile TV receiver. Section III describes the design of the proposed attenuator. Section IV describes the measurement results. Section V discusses the conclusions. Appendix A provides the test results.

II. PASSIVE ATTENUATOR

There are several methods to control the RF gain of a receiver. Fig. 1a shows a variable gain amplifier (VGA) which is used to control the RF gain of a receiver. Fig. 1b shows a passive attenuator which is used to control the RF gain of a receiver. The passive attenuator is preferred over the VGA because it does not require a DC bias and, in theory, it does not add noise to the signal. The passive attenuator also becomes clear when the receiver is used as a mobile TV tuner. The passive attenuator is used to control the RF gain of the receiver. The passive attenuator is used to control the RF gain of the receiver. The passive attenuator is used to control the RF gain of the receiver.

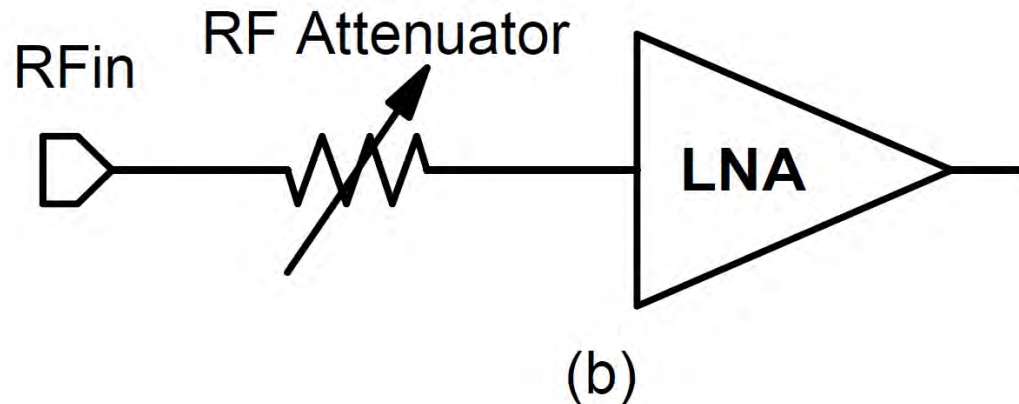

Motivation to Combine Jeon, Xiong, and Youssef

Fay Declaration

Section III.D.3, attenuation circuits were commonly used to provide impedance matching and gain control, as well as suppression of interference signals and prevention of signal clipping before the Patent Owner's alleged conception date

DOCKET NO.: 0107131-00573US2
Filed on behalf of Intel Corporation

alternatives, such as variable gain LNAs. *Id.* The use of programmable attenuation circuits allows the amplifier gain to be modified in response to operational conditions (e.g., signal strength), while at the same time maintaining or improving linearity (IIP3). Thus, as Youssef explains, an attenuator enables “a low

BEFORE THE PATENT TRIAL AND APPEAL BOARD

figure.” *Id.* at 2001. A person of ordinary skill would have been motivated to couple the attenuation circuit of Youssef to the first amplifier stage of the amplifier of Jeon in view of Xiong in order to achieve such “low power, highly linear, wide dynamic range” front-end realizations.

INTEL 1102

Youssef

ends. Fig. 1a shows a VG-LNA used to control the RF gain, while Fig. 1b shows a programmable passive attenuator used to control the RF gain. Both techniques are capable of preventing a receiver from clipping at large input signal levels and, in theory, either one can be used to boost the linearity of a mobile TV tuner. However, the difference between them

Ahmed Youssef and James Haultt
Electrical and Computer Engineering Department

Edward Youssefian
Newport Media Inc.

TV applications presents several challenges. Such an attenuator has to achieve certain characteristics so that it can protect the RF performance of a mobile TV receiver in the presence of interferer blockers as high as 0 dBm. Typically, it

high performance tuner chips use the VG-LNA circuit (i.e., SAW filters) usually used in traditional TV-set tuners to suppress far-away interferer blockers are thus not an option for these integrated tuners. This results in highlighting the linearity to the mobile TV antenna for the entire gain range.

V. CONCLUSION

A novel RF attenuator linearization circuit has been proposed to overcome the shortcomings of having the VG-LNA alone control the mobile TV front-end gain. The attenuator designed in 65 nm CMOS technology enables a low power, highly linear, wide dynamic range front-end realization with low noise figure at sensitivity level. The attenuator design can be scaled to any application that requires a wide dynamic range RF front-end.

Motivation to Combine Jeon, Xiong, and Youssef

DOCKET NO.: 0107131-00573US2
Filed on behalf of Intel Corporation
By: David L. Cavanaugh, Reg. No. 36,476
John V. Hobgood, Reg. No. 61,540
Benjamin S. Fernandez, Reg. No. 55,172
Gregory H. Lantier, *pro hac vice*
Wilmer Cutler Pickering Hale and Dorr LLP
1875 Pennsylvania Ave., NW
Washington, DC 20006
Tel: (202) 663-6000
Email: David.Cavanaugh@wilmerhale.com
John.Hobgood@wilmerhale.com
Ben.Fernandez@wilmerhale.com
Gregory.Lantier@wilmerhale.com

UNITED STATES PATENT AND TRADE

BEFORE THE PATENT TRIAL AND AP

INTEL CORPORATION
Petitioner

v.

QUALCOMM INCORPORAT
Patent Owner

Case IPR2019-00048
U.S. Patent No. 9,154,356

DECLARATION OF PATRICK FAY, PH.D.
PETITIONER'S REPLY

amplifier architecture in Jeon. Ex. 1105, 2660. A POSITA would have understood processing the UHF and VHF carriers described in Youssef to be within the “applications” that might “require the transceiver to operate in a wide range of RF frequencies” supported by the amplifier architecture in Jeon, and would have understood that receiving carriers at UHF and/or VHF frequencies using the combination of Jeon, Xiong, and Youssef proposed in the Petition would not have involved changing the capacitance values of C1, C2, or C3 of the attenuation circuit of Youssef. Ex. 1102, ¶¶117-18.

Intel 1139
Intel v. Qualcomm
IPR2019-00048

Motivation to Combine Jeon, Xiong, and Youssef

DOCKET NO.: 0107131-00573US2
Filed on behalf of Intel Corporation
By: David L. Cavanaugh, Reg. No. 36,476
John V. Hobgood, Reg. No. 61,540
Benjamin S. Fernandez, Reg. No. 55,172
Gregory H. Lantier, *pro hac vice*
Wilmer Cutler Pickering Hale and Dorr LLP
1875 Pennsylvania Ave., NW
Washington, DC 20006
Tel: (202) 663-6000
Email: David.Cavanaugh@wilmerhale.com
John.Hobgood@wilmerhale.com
Ben.Fernandez@wilmerhale.com
Gregory.Lantier@wilmerhale.com

UNITED STATES PATENT AND TRADE

BEFORE THE PATENT TRIAL AND AP

INTEL CORPORATION
Petitioner

v.

QUALCOMM INCORPORAT
Patent Owner

Case IPR2019-00048
U.S. Patent No. 9,154,356

DECLARATION OF PATRICK FAY, PH.D.
PETITIONER'S REPLY

52. *Second*, tuning RF circuitry (*e.g.*, by selecting capacitance values) is well within the capabilities of a person of ordinary skill in the art. As stated in the Petition and my initial declaration, the combination of Jeon and Xiong with Youssef “could have been implemented with *well-known circuit design and manufacturing techniques* and would have produced predictable results.” Pet., 67-68; Ex. 1102, ¶118. In fact, Youssef first describes C1, C2, and C3, in functional/design terms. Ex. 1109, 2001 (“the capacitance values of these capacitors would set the lower frequency limit of the attenuator”). “To support the VHF band, 70 pF and 30 pF *capacitances were chosen* for the attenuator (C3) and the matching network caps (C1&C2) respectively.” *Id.* The ’356 patent also

IPR2019-00048

Motivation to Combine Jeon, Xiong, and Feasibility Study

Motivation to Combine Jeon, Xiong, and Feasibility Study

3GPP TR 36.912 V9.1.0 (2009-12)

Technical Report

LTE-Advanced extends LTE Rel.-8 with support for *Carrier Aggregation*, where two or more *component carriers* (CCs) are aggregated in order to support wider transmission bandwidths up to 100MHz and for spectrum aggregation.

Carrier aggregation is supported for both contiguous and non-contiguous component carriers with each component carrier limited to a maximum of 110 Resource Blocks in the frequency domain using the LTE Rel-8 numerology

It is possible to configure a UE to aggregate a different number of component carriers originating from the same eNB and of possibly different bandwidths in the UL and the DL. In typical TDD deployments, the number of component

The present document has been developed within the 3rd Generation Partnership Project (3GPPTM) and may be further elaborated for the purposes of 3GPP.
This Specification has not been subject to any approval process by the 3GPP Organizational Partners and shall not be implemented.
This Specification is provided for future development work within 3GPP only. The Organizational Partners accept no liability for any use of this Specification.
Specifications and reports for implementation of the 3GPPTM system should be obtained via the 3GPP Organizational Partners' Publications Offices.

i

INTEL 1104

Motivation to Combine Jeon, Xiong, and Feasibility Study

- “A person of ordinary skill in the art would have found it obvious to use the input RF signal employing carrier aggregation of the Feasibility Study with the concurrent multiband receiver and amplifier of Jeon in view of Xiong.”
 - “[T]he Feasibility Study recognizes that wireless mobile devices can be configured to operate with input RF signals employing carrier aggregation.”
 - “[The Feasibility Study] also recognizes that an ideal receiver for carrier aggregation would have multiple RF front-ends to allow for processing of far-apart carriers to support inter-band carrier aggregation and noncontiguous intra-band carrier aggregation.”
 - “‘RF front end’ refers to the components between the antenna and the baseband, including filters, amplifiers, and mixers.”
 - “Jeon in view of Xiong teaches the use of such multiple front-ends because its wireless receiver uses multiple processing paths (each of which includes an amplifier and a mixer set) for different frequency bands.”
 - “Therefore, the receiver in Jeon in view of Xiong has the ‘multiple front ends’ that the Feasibility Study recommends for carrier aggregation.”

Motivation to Combine Jeon, Xiong, and Feasibility Study

DOCKET NO.: 0107131-00573US2
Filed on behalf of Intel Corporation
By: David L. Cavanaugh, Reg. No. 36,476
John V. Hobgood, Reg. No. 61,540
Benjamin S. Fernandez, Reg. No. 55,172
Wilmer Cutler Pickering Hale and Dorr LLP
1875 Pennsylvania Ave., NW
Washington, DC 20006
Tel: (202) 663-6000
Email: David.Cavanaugh@wilmerhale.com
John.Hobgood@wilmerhale.com
Ben.Fernandez@wilmerhale.com

UNITED STATES PATENT AND TRADEM

BEFORE THE PATENT TRIAL AND APPEAL BOARD

INTEL CORPORATION
Petitioner

v.

QUALCOMM INCORPORATE
Patent Owner

Case IPR2019-00048

DECLARATION OF PATRICK FAY
U.S. PATENT NO. 9,154,356
CLAIMS 1, 9, 10, 17, and 18

Study at 8. A person of ordinary skill would have thus been motivated to use the carrier-aggregated input RF signal taught in the Feasibility Study with the concurrent dual-band receiver taught by Jeon in view of Xiong in order to achieve these benefits and support this increasingly popular feature of LTE-Advanced and other systems.

129. There would have been a reasonable expectation of success in doing so because the receiver of Jeon in view of Xiong already supports concurrent dual-band operation, which means that it can already process multiple carriers at different frequencies simultaneously. Any further modifications to Jeon in view of