



[54] SYSTEM AND METHOD FOR SINGLE SIGN-ON TO A PLURALITY OF NETWORK ELEMENTS

[75] Inventor: Jingsha He, San Jose, Calif.

[73] Assignee: MCI Communications Corporation, Washington, D.C.

[21] Appl. No.: 08/848,327

[22] Filed: Apr. 30, 1997

[51] Int. Cl.⁶ G06F 13/00

[52] U.S. Cl. 713/201

[58] Field of Search 395/188.01, 187.01, 395/186, 200.59, 726; 364/222.5, 286.4, 286.5; 380/4, 23, 30; 711/163, 164; 713/200, 201, 202

[56] References Cited

U.S. PATENT DOCUMENTS

5,305,456	4/1994	Boitana	395/700
5,586,260	12/1996	Hu	395/200.2
5,606,668	2/1997	Shwed	395/200.11
5,684,950	11/1997	Dare et al.	395/187.01
5,721,780	2/1998	Ensor et al.	380/25
5,768,503	6/1998	Olkin	395/187.01
5,768,504	6/1998	Kells et al.	395/187.01
5,815,665	9/1998	Teper et al.	395/200.59
5,862,323	1/1999	Blakley, III et al.	395/188.01

OTHER PUBLICATIONS

Bryant, "Designing an Authentication System: a Dialog in Four Scenes", pp. 1-18, <http://web.mit.edu/kerberos/www/dialogue.html>, Dec. 1988.

Neuman et al., "Kerberos: An Authentication Service for Computer Networks", pp. 1-11, USC/ISI Tech. Report #ISI/RS-94-399, <http://nii.isi.edu/publications/kerberos-neuman-tso.html>, and/or IEEE Communications Magazine, vol. 32, No. 9, pp. 33-38, Sep. 1994.

Orfali et al., "Essential Client/Server Survival Guide", pp. 105-128 and 147-160, Van Nostrand Reinhold Publishing Company, Dec. 1994.

Primary Examiner—Robert W. Beausoliel, Jr.

Assistant Examiner—Stephen C. Elmore

[57] ABSTRACT

A secured network permits a single sign-on ("SSO") of users to a plurality of network elements. Data structures, procedures and system components that support the SSO functionality in a distributed networked environment are included in the secured network. The SSO functionality can be implemented and integrated into an existing network platform or used as the backbone protocol to new network installations. DCE-based features as well as ERA and EAC can be utilized as the foundation for the implementation. The SSO functionality may be implemented and integrated without requiring significant low level development or major modifications in a network.

9 Claims, 12 Drawing Sheets

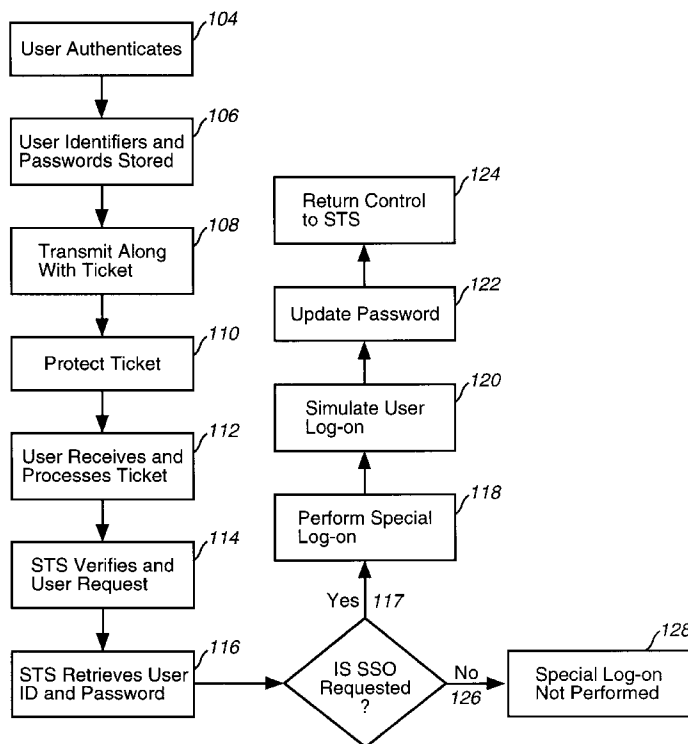

102 ↗

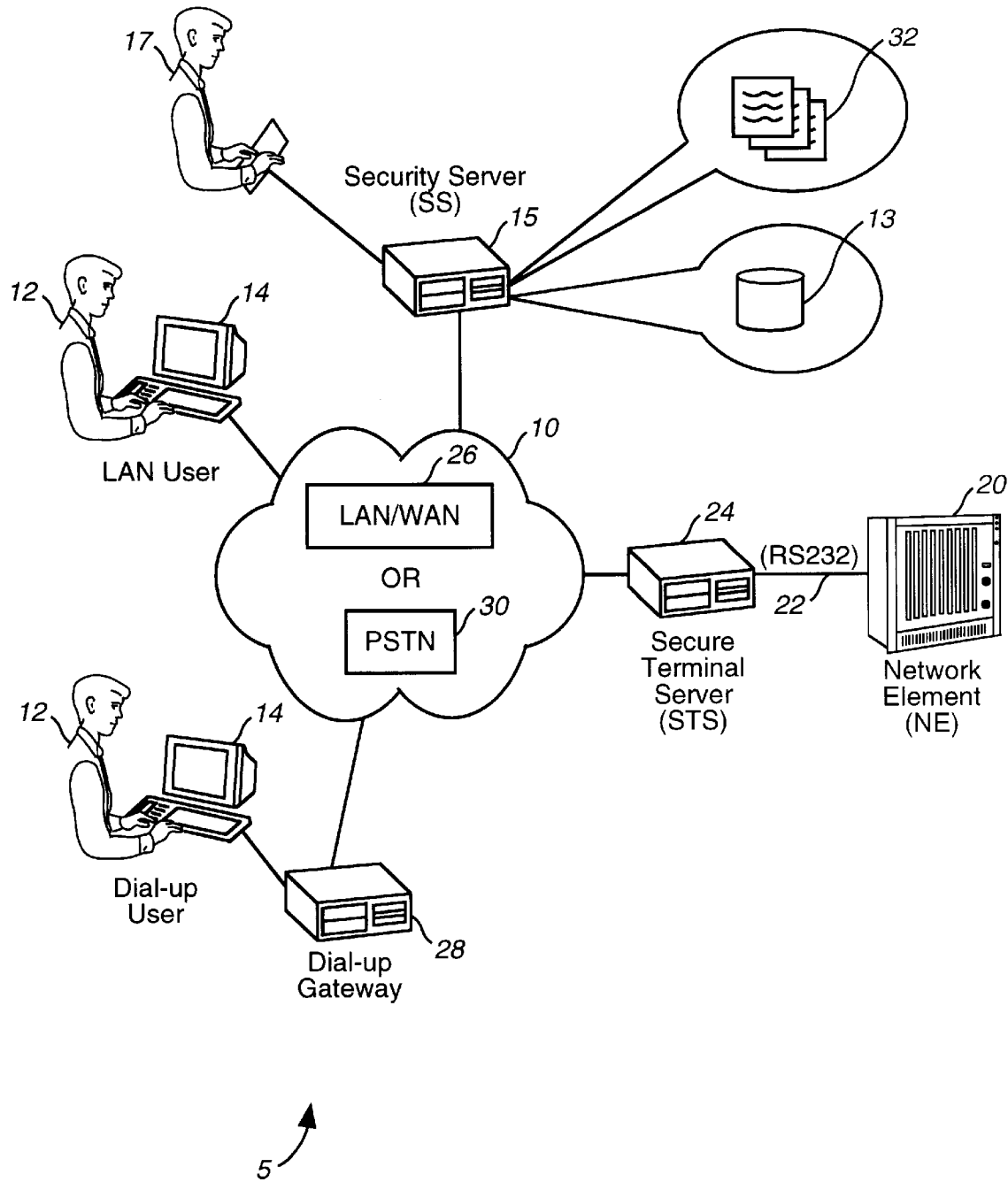

FIG. 1

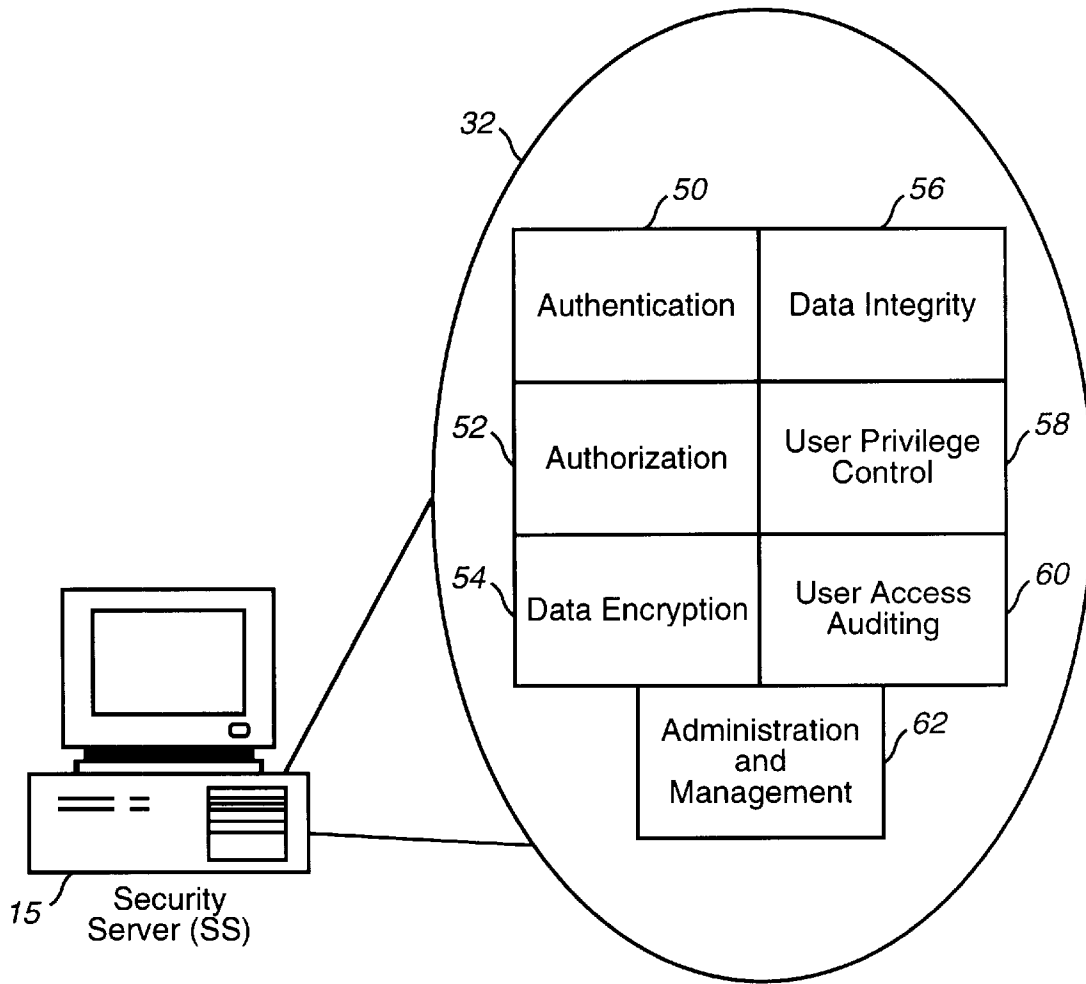

FIG. 2

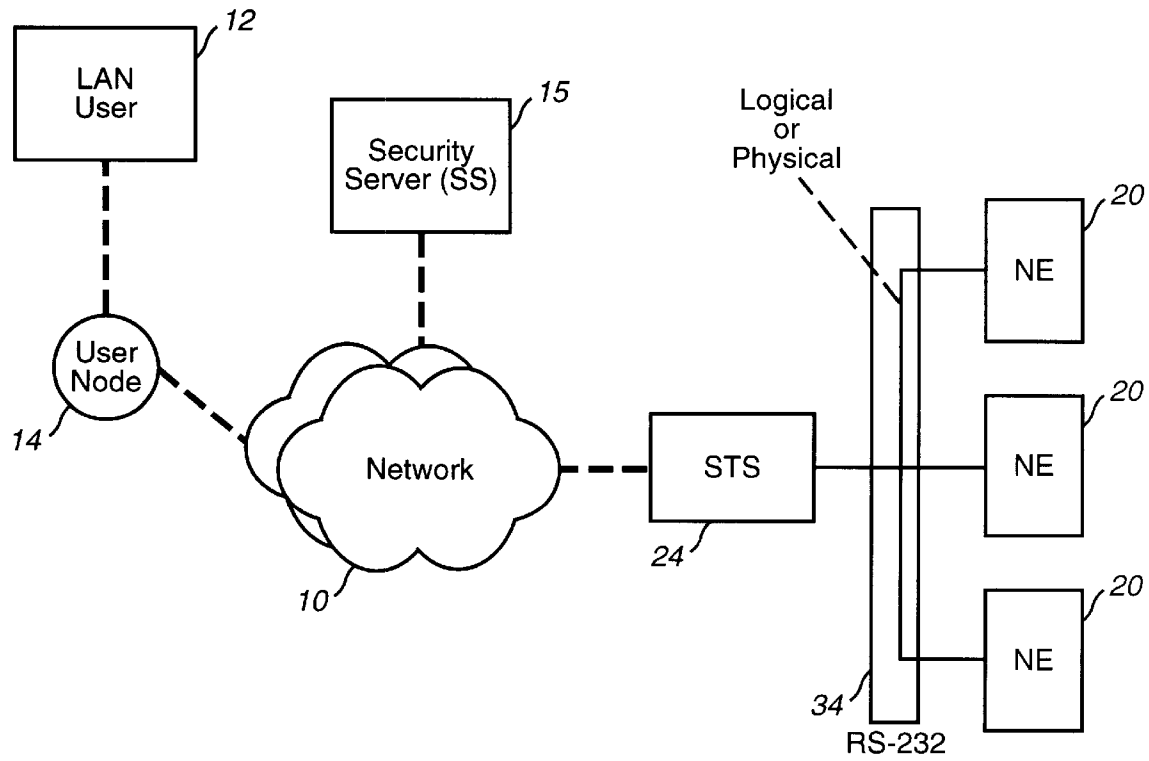

FIG. 3

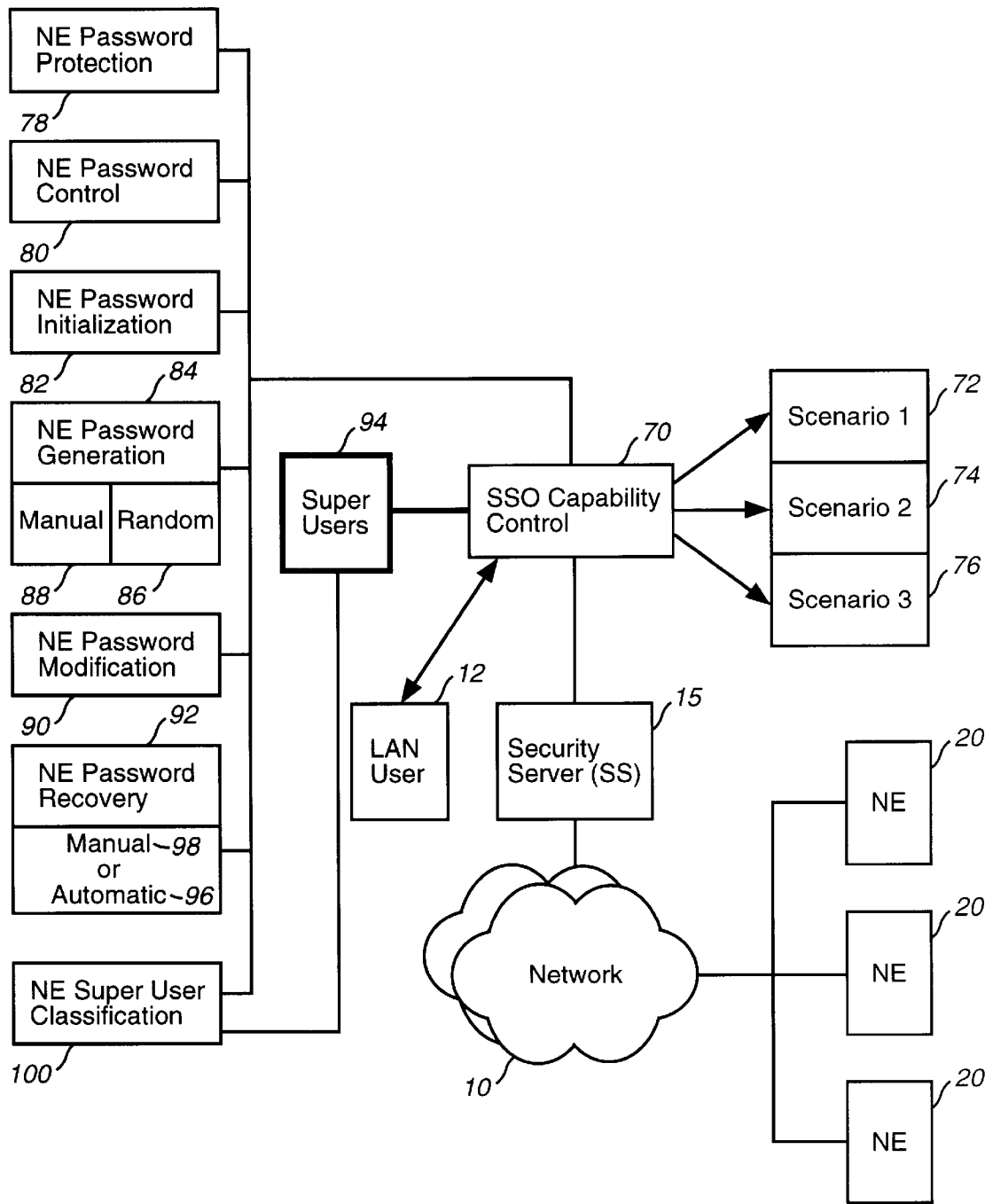

FIG. 4

Explore Litigation Insights

Docket Alarm provides insights to develop a more informed litigation strategy and the peace of mind of knowing you're on top of things.

Real-Time Litigation Alerts



Keep your litigation team up-to-date with **real-time alerts** and advanced team management tools built for the enterprise, all while greatly reducing PACER spend.

Our comprehensive service means we can handle Federal, State, and Administrative courts across the country.

Advanced Docket Research



With over 230 million records, Docket Alarm's cloud-native docket research platform finds what other services can't. Coverage includes Federal, State, plus PTAB, TTAB, ITC and NLRB decisions, all in one place.

Identify arguments that have been successful in the past with full text, pinpoint searching. Link to case law cited within any court document via Fastcase.

Analytics At Your Fingertips



Learn what happened the last time a particular judge, opposing counsel or company faced cases similar to yours.

Advanced out-of-the-box PTAB and TTAB analytics are always at your fingertips.

API

Docket Alarm offers a powerful API (application programming interface) to developers that want to integrate case filings into their apps.

LAW FIRMS

Build custom dashboards for your attorneys and clients with live data direct from the court.

Automate many repetitive legal tasks like conflict checks, document management, and marketing.

FINANCIAL INSTITUTIONS

Litigation and bankruptcy checks for companies and debtors.

E-DISCOVERY AND LEGAL VENDORS

Sync your system to PACER to automate legal marketing.