

## INTERNATIONAL SEARCH REPORT

International application No  
PCT/IB2007/000099

C(Continuation). DOCUMENTS CONSIDERED TO BE RELEVANT

Category*	Citation of document, with indication, where appropriate, of the relevant passages	Relevant to claim No.
A	WO 95/33471 A (M D SERV EUROP S A [FR]; HELLGREN LARS [SE]; MOHR VIGGO [NO]; VINCENT) 14 December 1995 (1995-12-14) the whole document	26
A	WO 03/000061 A (TRANSUCRANIA S A [ES]; PIVOVAROV PAVEL PETROVICH [ES]; PIVOVAROV EUGEN) 3 January 2003 (2003-01-03) the whole document	1-28
A	DATABASE WPI Week 198810 Derwent Publications Ltd., London, GB; AN 1988-068398 XP002430959 & JP 63 023819 A (KAO CORP) 1 February 1988 (1988-02-01) abstract	1-28

# INTERNATIONAL SEARCH REPORT

International application No.  
PCT/IB2007/000099

## Box II Observations where certain claims were found unsearchable (Continuation of item 2 of first sheet)

This International Search Report has not been established in respect of certain claims under Article 17(2)(a) for the following reasons:

1.  Claims Nos.: —  
because they relate to subject matter not required to be searched by this Authority, namely:  

Although claims 22-26 are directed to a method of treatment of the human/animal body, the search has been carried out and based on the alleged effects of the compound/composition.
2.  Claims Nos.:  
because they relate to parts of the International Application that do not comply with the prescribed requirements to such an extent that no meaningful International Search can be carried out, specifically:
3.  Claims Nos.:  
because they are dependent claims and are not drafted in accordance with the second and third sentences of Rule 6.4(a).

## Box III Observations where unity of invention is lacking (Continuation of item 3 of first sheet)

This International Searching Authority found multiple inventions in this international application, as follows:

1.  As all required additional search fees were timely paid by the applicant, this International Search Report covers all searchable claims.
2.  As all searchable claims could be searched without effort justifying an additional fee, this Authority did not invite payment of any additional fee.
3.  As only some of the required additional search fees were timely paid by the applicant, this International Search Report covers only those claims for which fees were paid, specifically claims Nos.:
4.  No required additional search fees were timely paid by the applicant. Consequently, this International Search Report is restricted to the invention first mentioned in the claims; it is covered by claims Nos.:

### Remark on Protest

- The additional search fees were accompanied by the applicant's protest.
- No protest accompanied the payment of additional search fees.

# INTERNATIONAL SEARCH REPORT

Information on patent family members

International application No PCT/IB2007/000099
---

Patent document cited in search report	Publication date	Patent family member(s)	Publication date	
US 4036993	A	19-07-1977	CA 1068542 A1	24-12-1979
			FR 2308320 A1	19-11-1976
			JP 932246 C	14-11-1978
			JP 51125773 A	02-11-1976
			JP 53007508 B	18-03-1978
			NO 753131 A	26-10-1976
			SU 727109 A3	05-04-1980
DE 3038190	A1	23-04-1981	JP 56064767 A	02-06-1981
			NO 803050 A	13-04-1981
			SE 431502 B	13-02-1984
			SE 7908433 A	12-04-1981
WO 2005075613	A	18-08-2005	EP 1727882 A1	06-12-2006
			US 2005192634 A1	01-09-2005
WO 02102394	A	27-12-2002	CA 2449898 A1	27-12-2002
			CN 1516592 A	28-07-2004
			EP 1406641 A2	14-04-2004
			JP 2004534800 T	18-11-2004
US 2004241249	A1	02-12-2004	NONE	
WO 9533471	A	14-12-1995	AU 7278094 A	04-01-1996
WO 03000061	A	03-01-2003	NONE	
JP 63023819	A	01-02-1988	NONE	

(19) World Intellectual Property Organization  
International Bureau



(43) International Publication Date  
27 September 2007 (27.09.2007)

PCT

(10) International Publication Number  
WO 2007/108702 A1

- (51) International Patent Classification:  
A01K 73/04 (2006.01)
- (21) International Application Number:  
PCT/NO2007/000111
- (22) International Filing Date: 22 March 2007 (22.03.2007)
- (25) Filing Language: Norwegian
- (26) Publication Language: English
- (30) Priority Data:  
20061315 23 March 2006 (23.03.2006) NO
- (71) Applicant (for all designated States except US): AKER  
SEAFOODS HOLDING AS [NO/NO]; Fjordalléen 16,  
N-0250 Oslo (NO).
- (72) Inventors; and
- (75) Inventors/Applicants (for US only): ERNSTEN, Robert  
[NO/CR]; Kilometro Cinco, Golfito (CR). ÅRSKOG,  
Roar [NO/NO]; Nordre Vartdal, Vartdal, N-6150 Ørsta  
(NO). KJÆRSTAD, Jan, H. [NO/NO]; NO-6280 Søvik  
(NO).
- (74) Agent: LANGFELDT, Jens, F., C.; Zacco Norway AS,  
P.O. Box 2003, Vika, N-0125 Oslo (NO).

- (81) Designated States (unless otherwise indicated, for every  
kind of national protection available): AE, AG, AL, AM,  
AT, AU, AZ, BA, BB, BG, BH, BR, BW, BY, BZ, CA, CH,  
CN, CO, CR, CU, CZ, DE, DK, DM, DZ, EC, EE, EG, ES,  
FI, GB, GD, GE, GH, GM, GT, HN, HR, HU, ID, IL, IN,  
IS, JP, KE, KG, KM, KN, KP, KR, KZ, LA, LC, LK, LR,  
LS, LT, LU, LY, MA, MD, MG, MK, MN, MW, MX, MY,  
MZ, NA, NG, NI, NO, NZ, OM, PG, PH, PL, PT, RO, RS,  
RU, SC, SD, SE, SG, SK, SL, SM, SV, SY, TJ, TM, TN,  
TR, TT, TZ, UA, UG, US, UZ, VC, VN, ZA, ZM, ZW.
- (84) Designated States (unless otherwise indicated, for every  
kind of regional protection available): ARIPO (BW, GH,  
GM, KE, LS, MW, MZ, NA, SD, SL, SZ, TZ, UG, ZM,  
ZW), Eurasian (AM, AZ, BY, KG, KZ, MD, RU, TJ, TM),  
European (AT, BE, BG, CH, CY, CZ, DE, DK, EE, ES, FI,  
FR, GB, GR, HU, IE, IS, IT, LT, LU, LV, MC, MT, NL, PL,  
PT, RO, SE, SI, SK, TR), OAPI (BF, BJ, CF, CG, CI, CM,  
GA, GN, GQ, GW, ML, MR, NE, SN, TD, TG).

Published:  
— with international search report

For two-letter codes and other abbreviations, refer to the "Guidance Notes on Codes and Abbreviations" appearing at the beginning of each regular issue of the PCT Gazette.

(54) Title: A TRAWL DEVICE

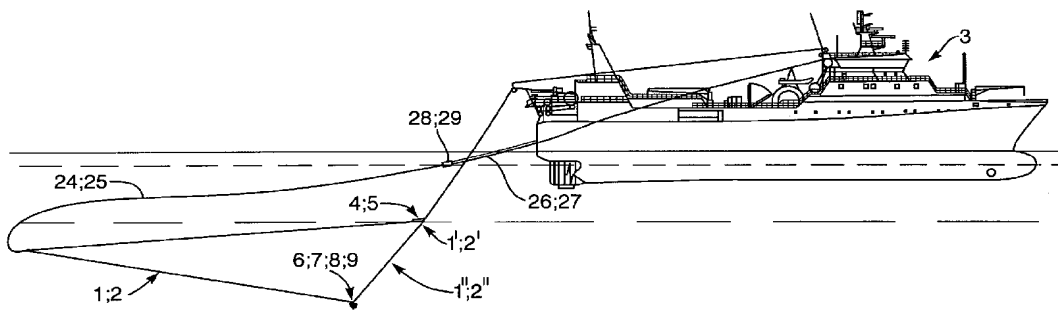

(57) Abstract: A trawl device that is towed after a trawl vessel, wherein the trawl, for spreading open the opening of the trawl, has an elongate hydrofoil to which the trawl, by its upper transverse length of the trawl opening, is attached, and also has a weight or weights attached to at least one position in the lower part of the trawl opening, for example, the two lower corners of the trawl opening. The device can be used with one or more trawls that are towed side by side, or with two trawls one above the other and fastened to a common trawl.



WO 2007/108702 A1

## A TRAWL DEVICE

The present invention relates to a trawl device for towing after a trawl vessel, wherein the trawl cooperates with a means for spreading open the opening of the trawl, as defined in more detail in the preamble of claim 1.

To elucidate the prior art, reference is made, inter alia, to Norwegian Patent Application 20053371, Norwegian Patent 307541.

In the standard methods of trawling, the trawl is towed behind a trawl vessel using adapted lines with or without otter boards, optionally with the use of a weight or weights attached to the trawl or the trawl lines or by using so-called steering lead weights which in terms of function correspond to otter boards, whereby seafood/biomass such as fish, shrimp and krill and/or other seafood/biomass is gathered in a trawl bag.

After such a trawl bag has been more or less filled with seafood/biomass, it is normally hauled aboard the vessel and emptied. Alternatively, the trawl bag or sack is emptied whilst floating alongside the vessel. Some types of seafood/biomass, such as for instance krill, have a short lifetime after being gathered in the trawl and brought to the surface before they die and rapidly begin to decompose, their value as a raw material thus diminishing considerably. In general, it is important for all forms of seafood/biomass that it should come to the vessel undamaged and as quickly as possible for further processing, as delays in this process usually substantially diminish the quality of the seafood/biomass. Seafood/biomass that is subjected to rough handling and crushing through being gathered in a trawl bag, hauled on board the vessel and then emptied from the trawl bag, or by mechanical pumping from the trawl bag for collection on board the vessel, will also be of reduced quality and value because of the damage it suffers. The reduction in value will also extend to by-products from seafood/biomass such as roe, liver or the like. Seafood/biomass that is caught in a traditional manner will also largely be dead the moment it comes aboard the vessel.

Norwegian Patent Application 20053371 therefore describes a solution the object of which is to more efficiently convey undamaged and live seafood/biomass gathered by the trawl to a seafood/biomass receiving vessel, of particular importance for the gathering and conveying of krill, shrimp and other types of seafood/biomass, including all forms of fish, where conveyance to a production vessel for further processing and

continuous, non-stop preservation on board can take place in controlled forms during continuous or prolonged trawling. The patent application indicates that this solution can involve the use of a conveying hose for conveying the seafood/biomass from the rear portion of the trawl to the vessel, fluid, e.g., seawater, being injected into the conveying hose in order, by injector effect, to bring the seafood/biomass up to the vessel, and where the injector, which is, for example, depth-adjustable, is in an upper area of the conveying hose which has a marked gradient towards the sea surface.

In recognition of the fact that otter boards and steering weights are heavy to handle and take up a great deal of space on board, there has long been felt a need, in connection with trawling, for example, for krill, to simplify the spreading open of the trawl opening in a fairly straightforward manner, and especially in those cases where trawling takes place continuously and there is a need for good manoeuvrability of the trawl and simultaneous assurance that the trawl opening remains maximally open, even when the trawl vessel changes course, for example, by trawling parallel to and in the opposite direction of earlier trawl paths.

To this end, the aim is to spread open the opening of the trawl, according to the invention, in that said means, instead of, for example, otter boards, is comprised of an elongate hydrofoil to which the trawl, by its upper transverse length of the trawl opening, is attached, and is also comprised of a weight or weights that is/are fastened to at least one position in the lower part of the trawl opening, for example, the two lower corners of the trawl opening.

“Hydrofoil” in this context is understood as a flat body or an aerofoil-like body (body with wing cross-section) which during movement in water is affected hydrodynamically.

Additional embodiments of the device are set forth in subsidiary claims 2 – 15.

The invention will now be described in more detail with reference to the attached drawing figures.

Fig. 1 is a side view of the device according to the invention when being towed by a trawl vessel.

Fig. 2 is a top view of the device in Fig. 1.

Fig. 3 is a side view of the device according to the invention in connection with bottom trawling.

Fig. 4 is a schematic perspective view of the device as shown used in Figs. 1 and 2.

Fig. 5 shows a modified use of the device according to the invention.

Fig. 6 shows the embodiment in Fig. 5 under tow by a trawl vessel.

The figures show the use of two trawls 1, 2 which are towed simultaneously by a trawl vessel 3. A person of skill in the art will, of course, understand that as an alternative only one trawl may be towed, or more than two trawls, e.g., three or four, may be towed.

As mentioned above, it is important, in a simple manner and without requiring otter boards, to be able to spread open the opening of the trawl, and for this purpose there is used, according to the invention, an elongate hydrofoil 4; 5 to which the trawl 1; 2, by its upper transverse length 1'; 2' of the trawl opening 1''; 2'', is attached, and also weights 6, 7; 8, 9 that are attached to the two lower corners 1''', 1''''; 2''', 2'''' of the trawl opening 1''; 2''.

The hydrofoil 4; 5 is connected to the trawl vessel 3 via at least one tow line 10; 11. The tow line 10; 11 is connected to the hydrofoil 4; 5 via at least two branches 10' - 10''''; 11' - 11'''' from the tow line. If more than one trawl is towed, the trawls could advantageously be spread apart in that respective tow lines 10; 11 extend from cantilevered booms 12; 13 on the vessel 3 which are pivotal along an arc 12'; 13' as shown in Fig. 2. In some cases, depending on the design or outfitting of the vessel, it is possible to trawl with two or even more trawls simultaneously, for example, if the respective trawls lie at different distances from the vessel, lie at different depths or by controlling the hydrofoil are spread laterally.

As shown most clearly in Fig. 4, each weight 6; 7; 8; 9 is suspended from a respective line 14; 15; 16; 17 which extends from an end area 4', 4''; 5', 5'' of the respective hydrofoil 4; 5.

The hydrofoil 4; 5 may optionally be equipped with at least one upright wing 18; 19 which serves as a rudder for lateral steering and stabilisation of the hydrofoil. It is also possible to allow the hydrofoil 4; 5, in its upper surface, to be equipped with adjustable flaps 20, 21; 22; 23 which are upwardly tiltable for adjusting the lifting power of the hydrofoil in water during the towing of the hydrofoil and the trawl. It is conceivable that the wing and/or the flaps can be remote-controllable from the vessel, or that they are pre-set before the trawls are placed in the sea. As indicated in Fig. 4, the trawl 1; 2 may be attached to the hydrofoil 3; 4 at at least three points. However, it is of course possible to fasten the trawl at more points than only three, and therefore it should be understood that the trawl can be attached to the hydrofoil at discrete points or continuously along the whole of the length of the hydrofoil.

Whether the trawl is attached to the hydrofoil at its rear area, its underside or its forward area depends on the chosen design of the hydrofoil and where it is most expedient, hydrodynamically, to make the attachment.

When trawling for, say, krill, but also certain other types of biomass/seafood, it will also be possible, when using the present invention, to arrange in a known way per se a conveying hose 24; 25 for conveying the seafood/biomass from the rear portion of the trawl 1; 2 to the vessel 3, fluid, e.g., seawater or air, or a mixture of seawater and air, being injected into the conveying hose 24; 25 from the vessel via a hose 26; 27 and an injector 28; 29, in order, by injector effect, to bring the seafood/biomass up to the vessel, and where the injector 28; 29 which, for example, is depth-adjustable, is in an upper area of the conveying hose 24; 25 where it has a marked gradient towards the sea surface.

The present example as shown in Figs. 1 – 4 also permits the trawls to be mutually independent as regards at least one of the following parameters: the size of each trawl, the distance of the trawls from each other transverse to the direction of travel of the trawl vessel, the distance between the trawl mouth and the stern of the trawl vessel, the depth of the trawls and the mesh size of the trawls.

Figs. 5 and 6 show a solution where two trawl bags 30, 31 are placed one above the other and interconnected via a hydrofoil 32. The uppermost 30 of the trawl bags is fastened at a lower portion 30' of the trawl opening to the hydrofoil 32 at at least three points 33-35. The upper portion 30'' of the trawl opening of the trawl bag 30 is equipped with a plurality of floats 36, and tension lines 37, 38 connecting respective



outer ends of the upper portion 30'' with respective outer portions of the hydrofoil 32 will expediently be present. The lowermost 31 of the trawl bags is fastened at an upper portion 31' of the trawl opening to the hydrofoil 32 at at least three points 39-41. The lower portion 31'' of the trawl opening of the trawl bag 31 is equipped at its outer ends with a respective lead weight or respective weight 42, 43, and tension lines 44, 45 connecting respective outer ends of the lower portion 31'' with respective outer portions of the hydrofoil 32 will expediently be present. The hydrofoil 32 with the trawl bags 30, 31 fastened thereto is towed by means of a tow line 46 from a trawl vessel 47, the tow line 46 running down to the centre of the hydrofoil 32 and having branches 46', 46'' to the outer ends of the hydrofoil 32.

Suction hoses or conveying hoses 49, 50 are, preferably together, run down from the trawl vessel 47 and underneath the lowest 31 of the trawl bags, the hose 49 running to the downstream end 30''' of the upper trawl bag 30 whilst the hose 50 is connected to the downstream end 31''' of the lower trawl bag 31. Injectors 51, 52 are connected in a rising portion of the hoses 49, 50 to effect pumping of the catch on board the trawl vessel 47.

One advantage of the solution shown in Figs. 5 and 6 is that a change of the trawling direction can be made somewhat faster than with two juxtaposed trawls, and only one common hydrofoil is needed, which with regard to possible limited storage space on board the trawl vessel 47 may be advantageous.

The location of the attachment points 33-35 and 39-41 on the hydrofoil for the trawl 30 and 31, respectively, may be instrumental in how the hydrofoil will move in the sea when towed, i.e., has a tendency to move upwards, endeavours to remain at one level, or seeks to move downwards.

By using just this one hydrofoil 32, it is thus possible to spread open the openings of two trawls simultaneously, the weights 42, 43 causing the lower transverse length of the lower trawl 31 opening to be kept at approximately the correct size, and similarly the floats 36 and the tension lines 37, 38 causing the upper transverse length of the upper trawl opening to be kept at approximately the correct and desired size.

P a t e n t   c l a i m s

1.

A trawl device for towing at least one trawl after a trawl vessel, the trawl cooperating with a means for spreading open the opening of the trawl, characterised in that said means is comprised of an elongate hydrofoil to which the trawl, by its upper transverse length of the trawl opening, is attached, and is also comprised of a weight or weights attached to at least one position in the lower part of the trawl opening, for example, the two lower corners of the trawl opening.

2.

A device as disclosed in claim 1, characterised in that the hydrofoil is connected to the trawl vessel via at least one tow line.

3.

A device as disclosed in claim 2, characterised in that the tow line is connected to the hydrofoil via at least two branches from the tow line.

4.

A device as disclosed in claim 2 or 3, characterised in that the tow line extends from a cantilevered boom on the vessel.

5.

A device as disclosed in claim 1, characterised in that each weight is suspended from a line that extends from an end area of the hydrofoil.

6.

A device as disclosed in one or more of the preceding claims, characterised in that the hydrofoil is equipped with at least one upright wing that serves as a rudder for lateral steering and stabilisation of the hydrofoil.

7.

A device as disclosed in any one of the preceding claims, characterised in that the hydrofoil, in its upper or lower surface, is equipped with adjustable flaps that are upwardly tiltable for adjusting the lifting power of the hydrofoil in water during the towing of the hydrofoil and the trawl.

8.

A device as disclosed in claim 1, characterised in that the trawl is attached to the hydrofoil at at least three locations.

9.

A device as disclosed in claim 1, characterised in that the trawl is attached at discrete points or continuously along the whole of the length of the hydrofoil.

10.

A device as disclosed in claim 1, 8 or 9, characterised in that the trawl is attached to the hydrofoil at its rear area, its underside or its forward area.

11.

A device as disclosed in any one of the preceding claims, characterised in that in a known way per se there is arranged a conveying hose for conveying the seafood/ biomass from the rear portion of the trawl to the vessel, fluid, e.g., seawater, being injectable into the conveying hose via an injector which is connected to a fluid supply hose from the vessel in order, by ejector effect, to bring the seafood/biomass up to the vessel, and where the injector, which is, for example, depth-adjustable, is in an upper area of the conveying hose which has a marked gradient towards the sea surface.

12.

A device as disclosed in any one of the preceding claims, characterised in that on the upper side of the hydrofoil and located above the trawl attached to the hydrofoil there is arranged an additional trawl, the lower transverse length of the trawl opening of the additional trawl being attached to the hydrofoil, and that the upper transverse length of the trawl opening of this additional trawl is provided with a plurality of floats.

13.

A device as disclosed in claim 12, characterised in that from each end of the hydrofoil a tension line is extended to a respective outer end of said upper transverse length of the trawl opening of the additional trawl.

14.

A device as disclosed in any one of claims 1 – 11, characterised in that the trawl vessel is arranged to tow at least two trawls, each of which is equipped with hydrofoil and associated weight or weights.

15.

A device as disclosed in claim 14, characterised in that the trawls are mutually independent as regards at least one of the following parameters: the size of each trawl, the distance of the trawls from one another transverse to the direction of travel of the trawl vessel, the distance between the trawl mouth and the stern of the trawl vessel, the depth of the trawls and the mesh size of the trawls

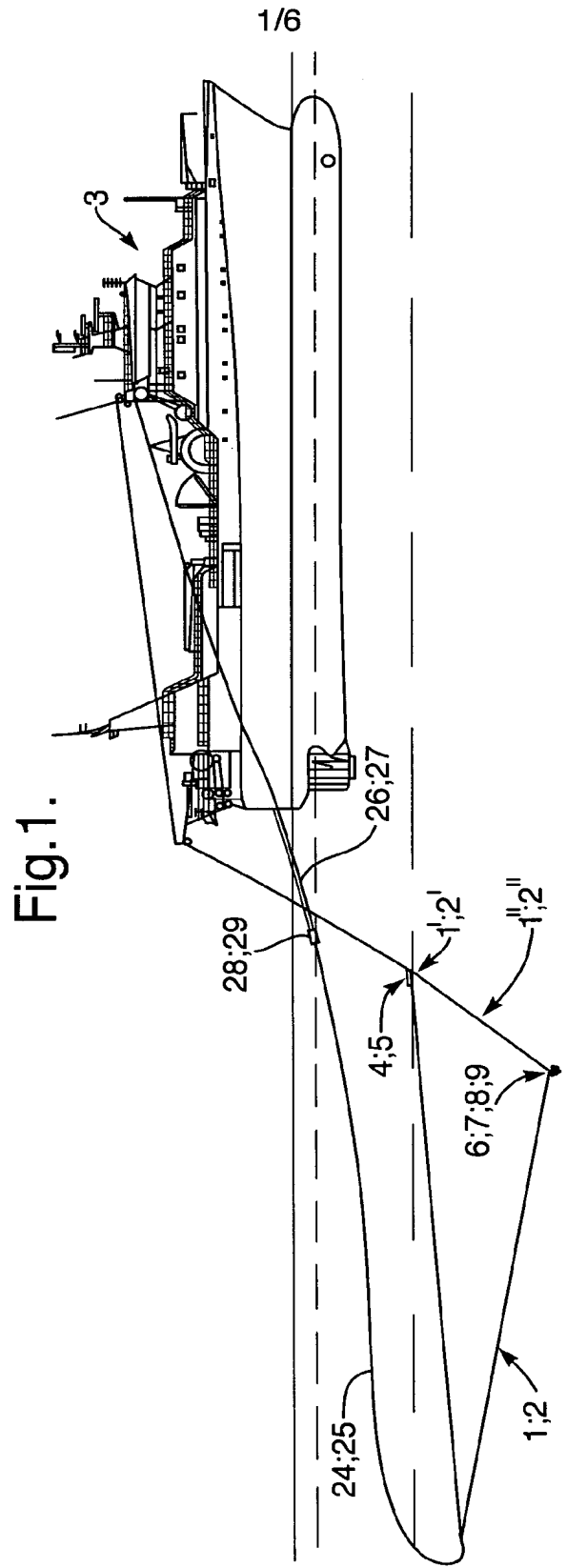
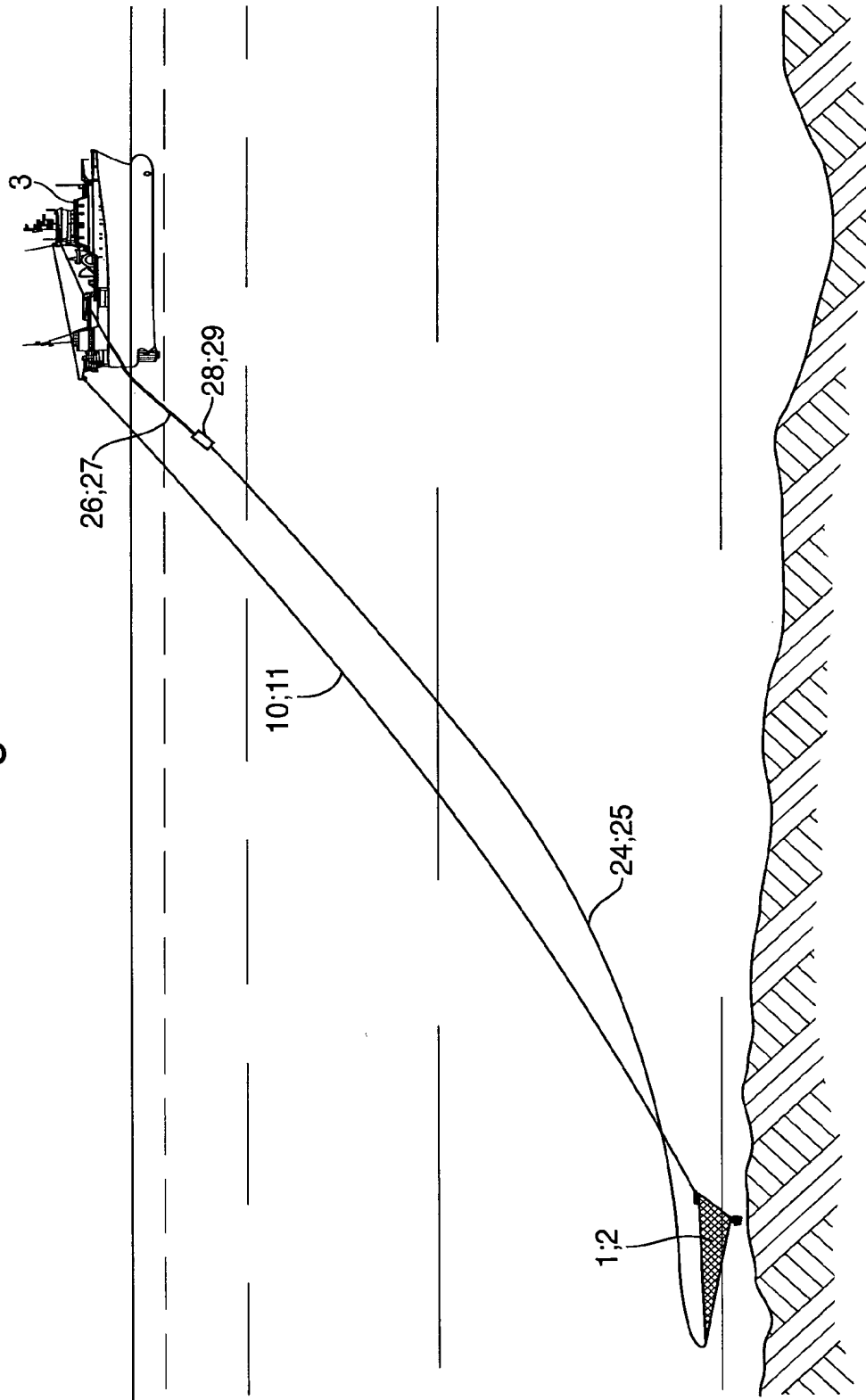



Fig.3.



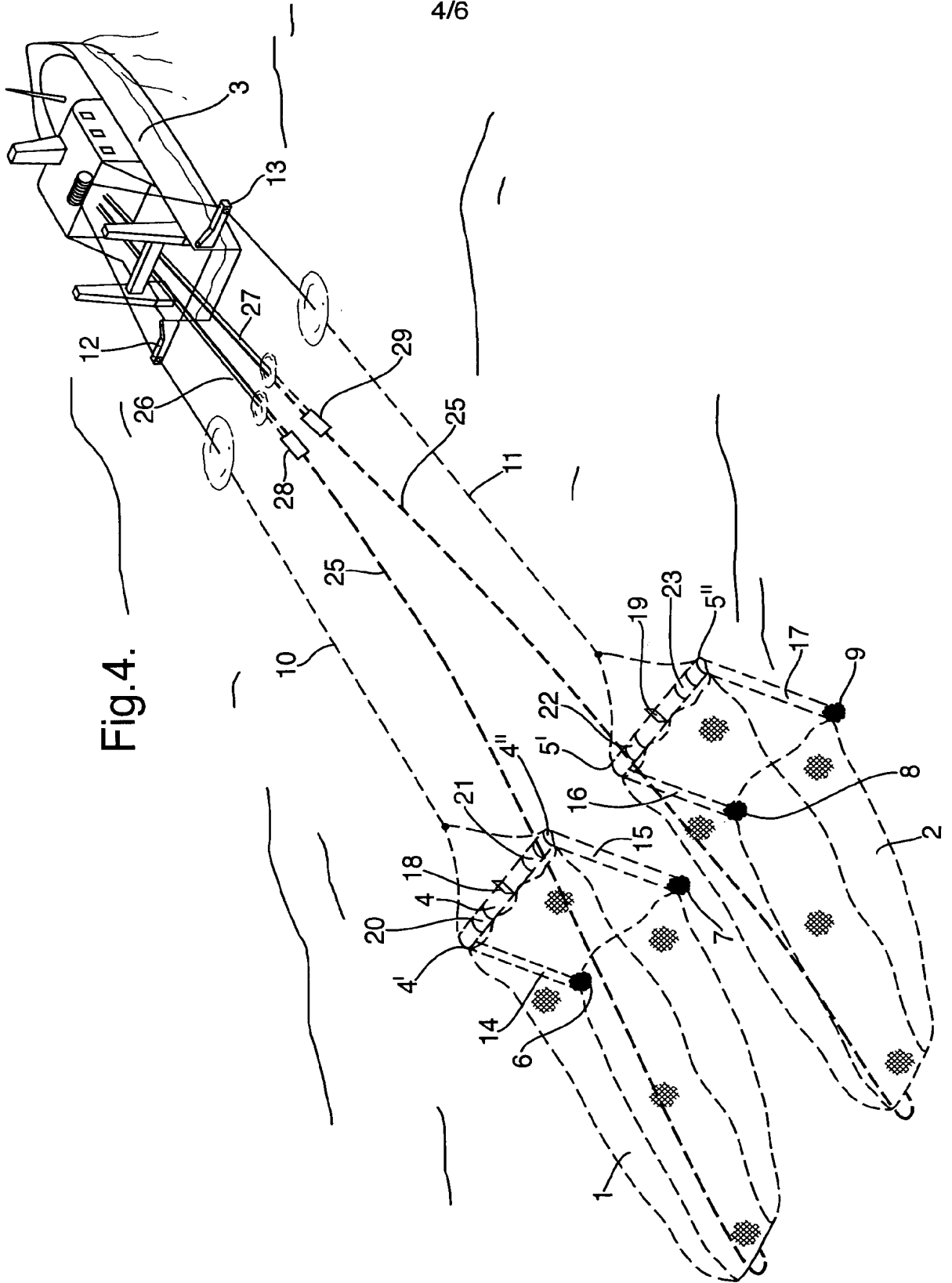

Fig.4.



Fig.5.

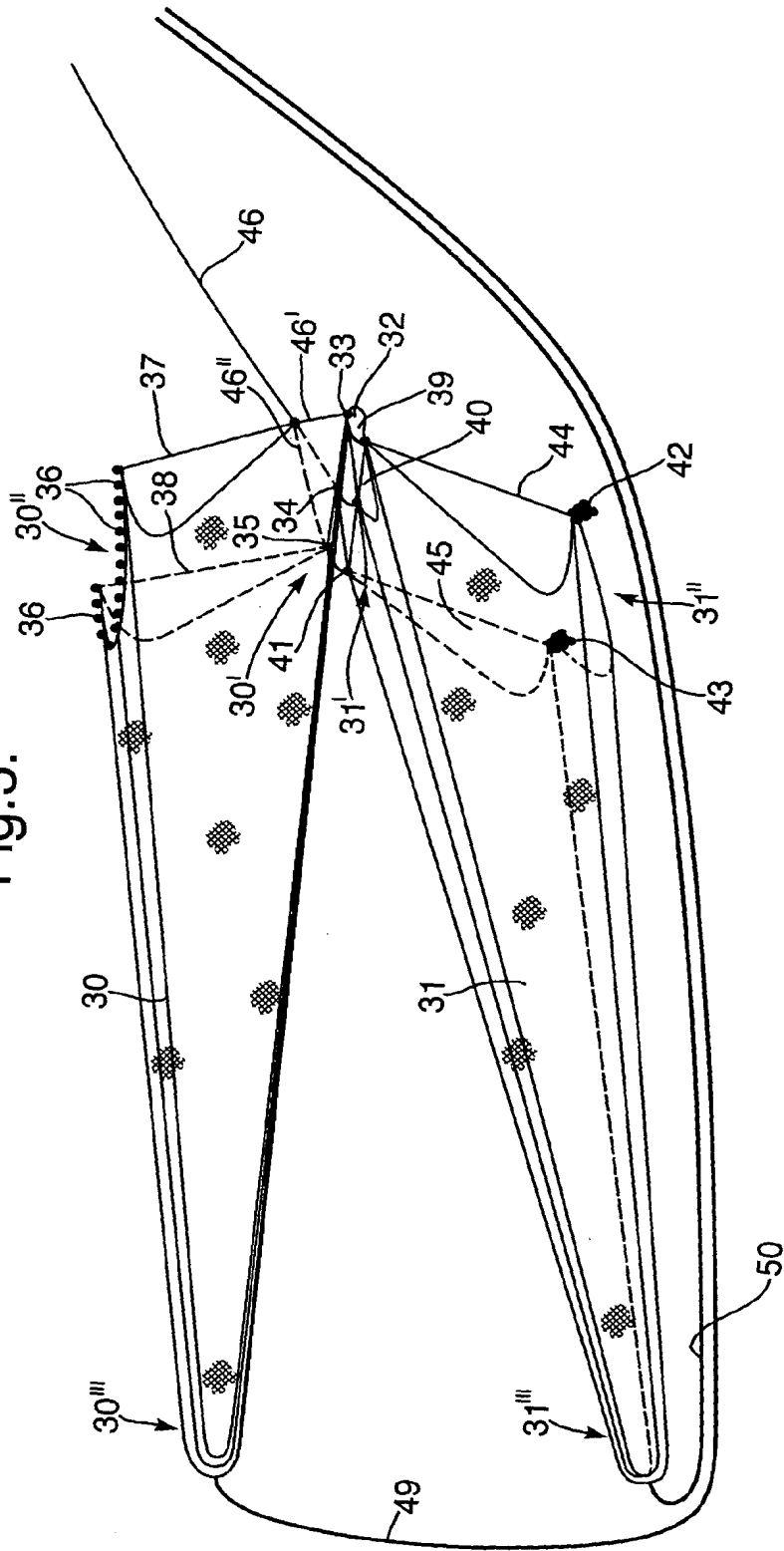
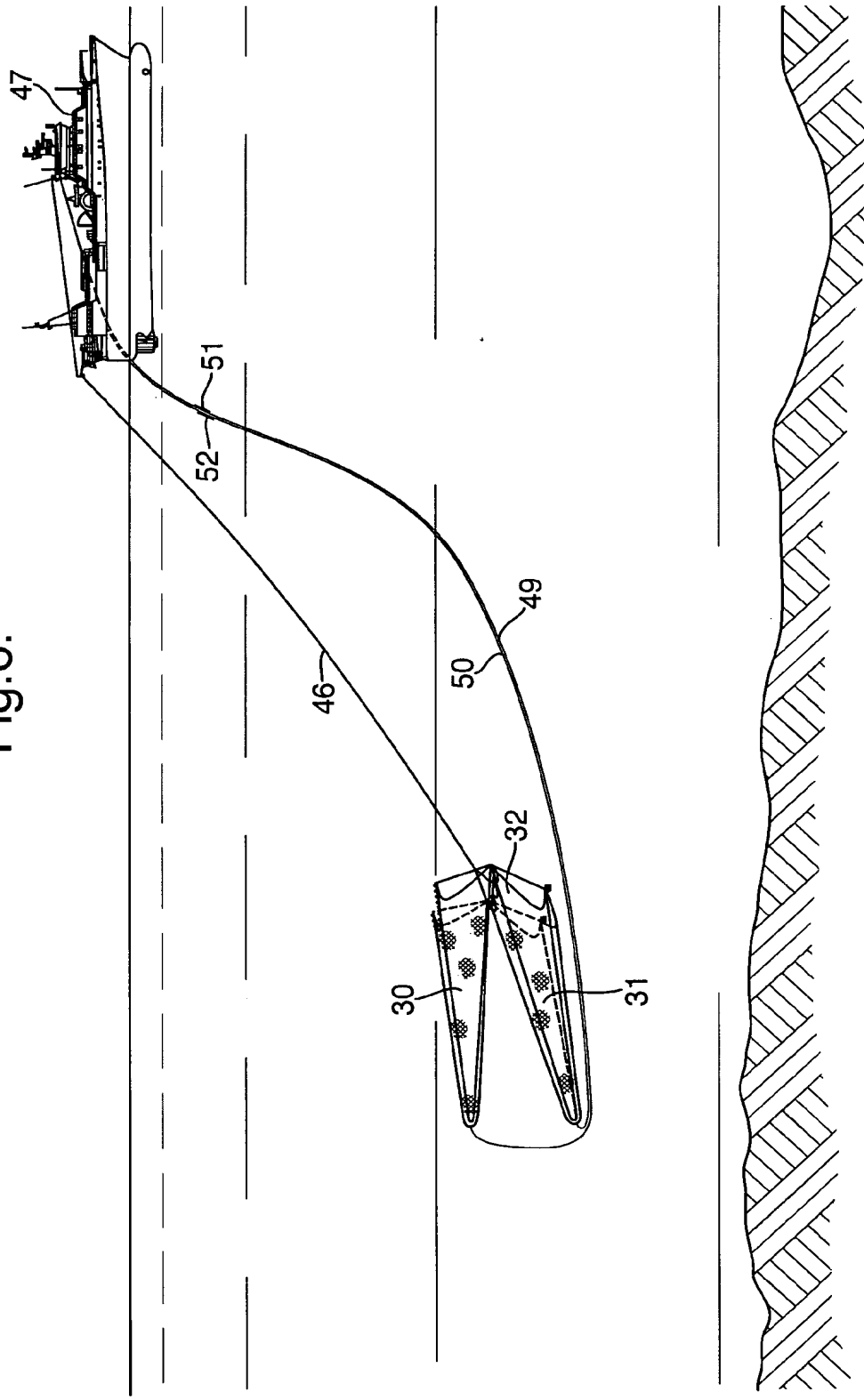

Fig. 6.



## INTERNATIONAL SEARCH REPORT

International application No.

PCT/NO2007/000111

<b>A. CLASSIFICATION OF SUBJECT MATTER</b>		
IPC: see extra sheet According to International Patent Classification (IPC) or to both national classification and IPC		
<b>B. FIELDS SEARCHED</b>		
Minimum documentation searched (classification system followed by classification symbols)		
IPC: A01K		
Documentation searched other than minimum documentation to the extent that such documents are included in the fields searched		
SE,DK,FI,NO classes as above		
Electronic data base consulted during the international search (name of data base and, where practicable, search terms used)		
EPO-INTERNAL, WPI DATA, PAJ		
<b>C. DOCUMENTS CONSIDERED TO BE RELEVANT</b>		
Category*	Citation of document, with indication, where appropriate, of the relevant passages	Relevant to claim No.
X	US 5201137 A (THERET ET AL), 13 April 1993 (13.04.1993), column 3, line 43 - line 50, figures 3,4, abstract	1-6,8-10, 14-15
Y	--	11
Y	US 1447553 A (MACK R HUDSON), 6 March 1923 (06.03.1923), page 2, line 10 - line 37, figure 1	11
A	GB 176327 A (JEAN-BAPTISTE J A VIGNERON), 22 February 1923 (22.02.1923), page 2, line 129 - line 130; page 3, line 1 - line 5	1-15
<input checked="" type="checkbox"/> Further documents are listed in the continuation of Box C. <input checked="" type="checkbox"/> See patent family annex.		
<p>* Special categories of cited documents:</p> <p>"A" document defining the general state of the art which is not considered to be of particular relevance</p> <p>"E" earlier application or patent but published on or after the international filing date</p> <p>"L" document which may throw doubts on priority claim(s) or which is cited to establish the publication date of another citation or other special reason (as specified)</p> <p>"O" document referring to an oral disclosure, use, exhibition or other means</p> <p>"P" document published prior to the international filing date but later than the priority date claimed</p> <p>"T" later document published after the international filing date or priority date and not in conflict with the application but cited to understand the principle or theory underlying the invention</p> <p>"X" document of particular relevance: the claimed invention cannot be considered novel or cannot be considered to involve an inventive step when the document is taken alone</p> <p>"Y" document of particular relevance: the claimed invention cannot be considered to involve an inventive step when the document is combined with one or more other such documents, such combination being obvious to a person skilled in the art</p> <p>"&amp;" document member of the same patent family</p>		
Date of the actual completion of the international search		Date of mailing of the international search report
1 June 2007		05 -06- 2007
Name and mailing address of the ISA/ Swedish Patent Office Box 5055, S-102 42 STOCKHOLM Facsimile No. +46 8 666 02 86		Authorized officer  Hans Nordström/EK Telephone No. +46 8 782 25 00

Form PCT/ISA/210 (second sheet) (April 2007)

INTERNATIONAL SEARCH REPORT

International application No.  
PCT/NO2007/000111

C (Continuation). DOCUMENTS CONSIDERED TO BE RELEVANT

Category*	Citation of document, with indication, where appropriate, of the relevant passages	Relevant to claim No.
A	US 20060048436 A1 (ERNSTEN ET AL), 9 March 2006 (09.03.2006), figures 1,5, claim 12, abstract  -- -----	11

**International patent classification (IPC)**  
**A01K 73/04 (2006.01)**

**Download your patent documents at [www.prv.se](http://www.prv.se)**

The cited patent documents can be downloaded at [www.prv.se](http://www.prv.se) by following the links:

- In English/Searches and advisory services/Cited documents (service in English) or
- e-tjänster/anförda dokument (service in Swedish).

Use the application number as username.

The password is **NYDIEXSXFJ**.

Paper copies can be ordered at a cost of 50 SEK per copy from PRV InterPat (telephone number 08-782 28 85).

Cited literature, if any, will be enclosed in paper form.

## INTERNATIONAL SEARCH REPORT

Information on patent family members

28/04/2007

International application No.

PCT/NO2007/000111

US	5201137	A	13/04/1993	CA	2035882	A	10/02/1991
				EP	0437574	A	24/07/1991
				FR	2650731	A,B	15/02/1991
				IS	3608	A	10/02/1991
				NO	911069	A	18/03/1991
				PT	94944	A	31/03/1992
				WO	9101633	A	21/02/1991
				ZA	9005840	A	24/04/1991

---

US	1447553	A	06/03/1923	NONE
----	---------	---	------------	------

---

GB	176327	A	22/02/1923	NONE
----	--------	---	------------	------

---

US	20060048436	A1	09/03/2006	AP	200603490	D	00/00/0000
				AU	2004255123	A	20/01/2005
				BR	PI0412530	A	19/09/2006
				CA	2512584	A	20/01/2005
				CN	1738531	A	22/02/2006
				EP	1643830	A	12/04/2006
				IS	7903	A	20/06/2005
				KR	20060036371	A	28/04/2006
				NO	20033198	D	00/00/0000
				NO	20053371	A	11/07/2005
				RU	2005118557	A	20/01/2006
				WO	2005004593	A	20/01/2005

---

(19) World Intellectual Property Organization  
International Bureau



(43) International Publication Date  
17 January 2008 (17.01.2008)

PCT

(10) International Publication Number  
WO 2008/006607 A2

(51) International Patent Classification:

A61K 31/122 (2006.01) A61K 35/60 (2006.01)  
A61K 31/231 (2006.01) A61P 9/00 (2006.01)  
A61K 31/232 (2006.01) A61P 19/00 (2006.01)

(21) International Application Number:

PCT/EP2007/006241

(22) International Filing Date: 13 July 2007 (13.07.2007)

(25) Filing Language: English

(26) Publication Language: English

(30) Priority Data:

20063291 14 July 2006 (14.07.2006) NO  
20063292 14 July 2006 (14.07.2006) NO  
20063988 6 September 2006 (06.09.2006) NO

(71) Applicant (for all designated States except US): NAT-  
TOPHARMA ASA [NO/NO]; Henrik Ibsens gate 100, PB  
2896 Solli, N-0203 Oslo (NO).

(72) Inventors; and

(75) Inventors/Applicants (for US only): VERMEER, Cees

[NL/NL]; Universiteit van Maastricht, Universiteitsin-  
gel 50, P.O. Box 616, NL-6200 MD Maastricht (NL).  
**SCHURGERS, Leon, J.** [NL/NL]; Universiteit van  
Maastricht, Universiteitsingel 50, P.O. Box 616, NL-6200  
MD Maastricht (NL). **KLAVENESS, Jo** [NO/NO]; Henrik  
Ibsens gate 100, PB 2896 Solli, N-0203 Oslo (NO). **VIK,  
Hogne** [NO/NO]; Henrik Ibsens gate 100, PB 2896 Solli,  
N-0203 Oslo (NO). **VIK, Anne, Bjernebye** [NO/NO];  
Henrik Ibsens gate 100, PB 2896 Solli, N-0203 Oslo (NO).  
**WESTBYE, Stein** [NO/NO]; Henrik Ibsens gate 100, PB  
2896 Solli, N-0203 Oslo (NO).

(74) Agent: HUYGENS, Arthur, Victor; Octrooibureau Huy-  
gens, P.O. Box 86, NL-3400 AB IJsselstein (NL).

(81) Designated States (unless otherwise indicated, for every  
kind of national protection available): AE, AG, AL, AM,  
AT, AU, AZ, BA, BB, BG, BH, BR, BW, BY, BZ, CA, CH,  
CN, CO, CR, CU, CZ, DE, DK, DM, DO, DZ, EC, EE, EG,  
ES, FI, GB, GD, GE, GH, GM, GT, HN, HR, HU, ID, IL,  
IN, IS, JP, KE, KG, KM, KN, KP, KR, KZ, LA, LC, LK,  
LR, LS, LT, LU, LY, MA, MD, ME, MG, MK, MN, MW,  
MX, MY, MZ, NA, NG, NI, NO, NZ, OM, PG, PH, PL,  
PT, RO, RS, RU, SC, SD, SE, SG, SK, SL, SM, SV, SY,

[Continued on next page]

(54) Title: PHARMACEUTICAL AND NUTRACEUTICAL PRODUCTS COMPRISING VITAMIN K<sub>2</sub>

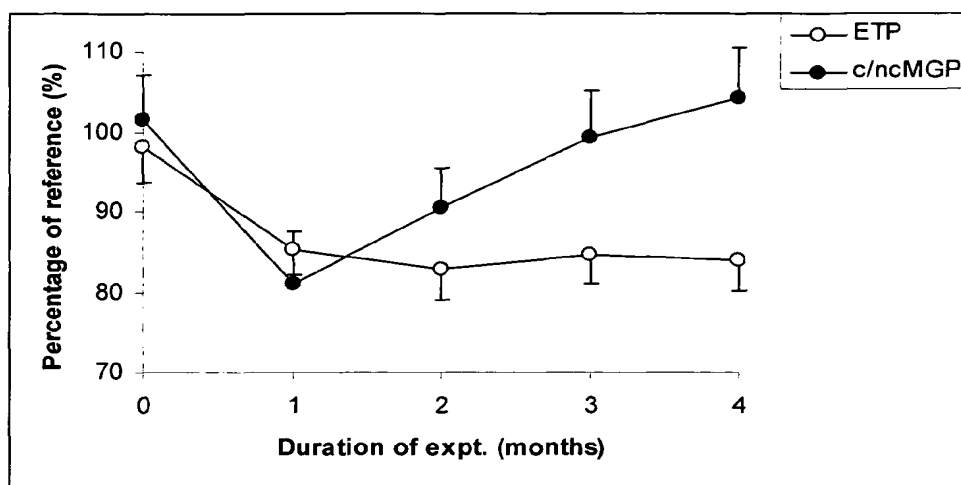

(57) Abstract: A pharmaceutical and nutraceutical product is provided comprising vitamin K<sub>2</sub> or a compound within the vitamin K<sub>2</sub> class of compounds, optionally and preferably in combination with one or more polyunsaturated fatty acids, either in purified form or as a marine oil (i.e. fish and/or krill oil). Also provided is the use of vitamin K<sub>2</sub> or a compound within the vitamin K<sub>2</sub> class of compounds, preferably in combination with one or more polyunsaturated fatty acids, either in purified form or as a marine oil, in the treatment or prophylaxis of disorders related to bone, cartilage and the cardiovascular system. Preferred compounds within the vitamin K<sub>2</sub> class of compounds are MK-7, MK-8, MK-9 and MK-10, in particular MK-7 or MK-9. The marine oil is preferably krill oil or fish oil.

WO 2008/006607 A2



TJ, TM, TN, TR, TT, TZ, UA, UG, US, UZ, VC, VN, ZA, ZM, ZW.

PT, RO, SE, SI, SK, TR), OAPI (BF, BJ, CF, CG, CI, CM, GA, GN, GQ, GW, ML, MR, NE, SN, TD, TG).

**(84) Designated States** (*unless otherwise indicated, for every kind of regional protection available*): ARIPO (BW, GH, GM, KE, LS, MW, MZ, NA, SD, SL, SZ, TZ, UG, ZM, ZW), Eurasian (AM, AZ, BY, KG, KZ, MD, RU, TJ, TM), European (AT, BE, BG, CH, CY, CZ, DE, DK, EE, ES, FI, FR, GB, GR, HU, IE, IS, IT, LT, LU, LV, MC, MT, NL, PL,

**Published:**

— *without international search report and to be republished upon receipt of that report*

*For two-letter codes and other abbreviations, refer to the "Guidance Notes on Codes and Abbreviations" appearing at the beginning of each regular issue of the PCT Gazette.*



## Pharmaceutical and nutraceutical products comprising vitamin K<sub>2</sub>

### Field of the invention

5 This invention relates to pharmaceutical and nutraceutical products comprising vitamin K<sub>2</sub> or a compound within the vitamin K<sub>2</sub> class of compounds, in particular in combination with one or more of a polyunsaturated fatty acid, fish oil and krill oil, and their use in the treatment or prophylaxis of disorders related to bone, cartilage and the cardiovascular system. In particular, the invention relates also to the use of such products  
10 in the treatment and/or prevention of osteoporosis, atherosclerosis and osteoarthritis.

### Background art

#### Vitamin K<sub>2</sub>

Vitamin K<sub>2</sub> is a group of compounds called menaquinones ("MK") which are all  
15 2-methyl-3-all-trans-polyprenylated-1,4-naphthoquinones having the following structural formula:

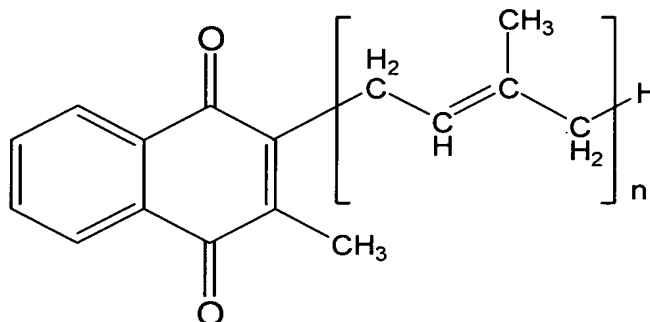

The chemical difference between the different MKs relates to the number of isoprene units in the side chain. The various MKs are normally referred to as MK-2, MK-3,  
20 MK-4, MK-6 and so on. The number refers to the number of isoprene units (n=2, n=3, n=4, n=6, ...).

The term vitamin K<sub>2</sub> refers to the naturally occurring mixture of the different MK substances. MK-2 through MK-13 are naturally present in animal and human tissue. Dietary sources of vitamin K<sub>2</sub> are typically fermented foods, notably cheese and curd  
25 cheese. Also certain flatfish and eel may contain some vitamin K<sub>2</sub>. "Natto", which is produced from fermented soy beans, is a popular source of vitamin K<sub>2</sub> as a "health product" in Japan. The daily intake of vitamin K<sub>2</sub> can vary over a wide range and can typically be from a few µg to several milligrams; generally below 50 µg. Vitamin K<sub>2</sub> is claimed to have several beneficial effects for human health, mainly related to the  
30 cardiovascular system and bone metabolism.

**CONFIRMATION COPY**

### Osteoporosis

Osteoporosis is a medical condition characterized by decreased bone mass and changes in the micro architecture of the bone. It is estimated that more than 200 million woman have osteoporosis worldwide. Osteoporosis and osteoporotic fractures are increasing all over the world mainly as a result of the fast growing elderly population. Treatment of osteoporosis today includes typical hormone therapy, intake of calcium and vitamin D and drug treatment using bisphosphonates.

### Atherosclerosis

Atherosclerosis is a cardiovascular disease that can affect the arteries of several vital organs including brain, heart, kidneys as well as arms and legs. In most Western countries, atherosclerosis is the leading cause of death. The number of deaths from atherosclerosis is about twice the number of deaths from all cancer diseases together. Atherosclerosis is a slow, progressive disease which might start as early as in childhood. In atherosclerosis the arteries loose their elasticity and harden. There are several conditions associated with the development and progression of the disease including risk factors like obesity, diabetes, hypertension and smoking. Whereas strictly medically speaking atherosclerosis is generally defined as an inflammatory disease of the arterial tunica intima, arteriosclerosis is defined more broadly and also comprises other forms of vascular disease such as Mönckeberg's sclerosis of the media.

### Arthrosis and arthritis

Arthrosis, inflammatory arthritis, rheumatoid arthritis and osteoarthritis are diseases of the cartilage and they are characterized by articular degeneration. Pathologically, there is an alteration in the cartilage structure. These diseases affect the joints and the disease can often easily been diagnosed by X-ray. Several types of drugs are today used for treatment of these diseases. These include simple analgesics, NSAIDs, COX 2 inhibitors, corticosteroids and glucosamine.

### Effect of vitamin K<sub>2</sub> on osteoporosis, atherosclerosis, arthrosis and arthritis

During the last years several publications describe a positive effect of intake of vitamin K<sub>2</sub> on osteoporosis; see, for example, W. Sakamoto *et al.* in *Osteoporosis International* 16, 1604-1610 (2005); M. Kaneki in *Clinical Calcium* 15, 605-610 (2005); J. Iwamoto *et al.* in *Current Pharmaceutical Design* 10, 2557-2576 (2004); K. Nakayama in *Horumon to Rinsho* 52, 339-349 (2004); S. Shiomi *et al.* in *American Journal of Gastroenterology* 97, 978-981 (2002) and T. Hosoi in *Bone (Osaka)* 14, 95-97 (2000).

There are several publications related to the use of vitamin K<sub>2</sub> or Natto for

treatment of atherosclerosis or similar conditions; see, for example, Y. Ozawa in *Gifu Daigaku Igakubu* 50, 20-26 (2002); L. J. Schurgers *et al* in *Zeitschrift für Kardiologie* 90 (Suppl. 3), iii57-iii63 (2001); Y. Seyama in *Clinical Calcium* 9, 873-878 (1999); H. Kawashima *et al.* in *Jap. Journal of Pharmacology* 75, 135-143 (1997) and J. M. Geleijnse  
5 *et al.* in *the Journal of Nutrition* 134, 3100-3105 (2004).

In a recent paper, T. Neoqi *et al.* (*Arthritis & Rheumatism* 54, 1255-1261 (2006)) reported that low levels of serum vitamin K are associated with an increased prevalence of osteoarthritis.

#### 10 Fish oil, krill oil and n-3 PUFA

Polyunsaturated fatty acids, or PUFAs, are long-chain fatty acids containing two or more double bonds. Interest in them arises from their potential in therapeutic applications, and food and nutritional applications. They occur throughout animal, plant, algae, fungi and bacteria and are found widely in many lipid compounds such as  
15 membranes, storage oils, glycolipids, phospholipids, sphingolipids and lipoproteins. They are produced commercially from selected seed plants, and some marine sources.

PUFAs are grouped into two series on the basis of the position of the terminal double bond being 3C or 6C from the terminal carbon atom of the fatty acid chain. Some examples are: The 3-series PUFA, also referred to as omega-3 or (n-3) PUFA, includes  
20 omega-3 fatty acid-rich dietary oils, such as fish oil, krill oil, eicosapentaenoic acid (EPA), docosahexaenoic acid (DHA), linolenic acid (LA), and alpha-linolenic acid (ALA). The 6-series PUFA includes gamma-linolenic acid (GLA) and arachidonic acid (AA).

Krill is a group of shrimp-like marine animals living in the Arctic and Antarctic regions. The size of krill is normally between 5 and 50 mm. There are several species of krill.  
25 The Arctic species include *T. inermis*, *T. rushii*, *T. longicauda* and *M. norvegica*, while the Antarctic species include *E. superba* and *E. crystallorhynchus*. Krill and krill related products have been suggested as components in feed for fish; see, for example, KR 2005031319, KR 2004087618, JP 2003070426, US 6153251, EP 729708, SU 1784152, JP 05030923, JP 0465454 and JP 61274653.

30 Furthermore, krill and krill-based products are used as fish baits (see, for example, CN 1820626), in combination with conjugated linoleic acid for treatment and prophylaxis of diseases (US 2006078625), as additives to inhibit oxidation of lipids (WO 2005075613), as fertilizer (CN 1502589), in foodstuff (JP 2004065152 and WO 2003/003857), for treatment of cardiovascular diseases, arthritis, skin cancer, diabetes and  
35 premenstrual syndrome (WO 2002/102394), as a source for enzyme for treatment of acne and other diseases (US 5958406, US 5945102, US 6030612, WO 96/24371 and WO 93/24142) and as a source for multifunctional enzymes ( US 6030612). Krill enzymes have

further been suggested for treatment of thrombosis (WO 95/33471) and in use for manufacture of compositions for dental use (WO 95/33470).

Krill or krill based-products are also suggested as fungicides (JP 07033619), as antidiabetic agents (JP 04042369), and proteins from krill have been suggested for  
5 manufacture of health foods (JP 01137952). Other patent documents related to krill and krill components are: dentifrices comprising krill fatty acids (JP 2568833), cosmetics containing proteases extracted from krill for skin cleansing (JP 63218610), anti-inflammatory proteinase from krill (JP 61068419), thrombus dissolvent (EP 170115), enzyme composition as digestion promoter (WO 85/04809), chitin preparation (PL 114387),  
10 carotenoid preparations (PL 113328, crabmeat-like food (JP 57125677, JP 57079863 and JP 67050848), antihypertensives (JP 54119011) and krill-based food (JP 60046947, JP 61023987 and JP 55040218).

The total lipid content of krill varies from species to species. There are also variations of the total lipid content during the year. The lipid composition of krill also varies  
15 for each species during the year. The total lipid in krill is typically between 5 and 60%. The percentage of total triglycerols and wax esters of total lipid in krill can vary over a wide range; each from almost zero to 70%. In addition to triglycerols and wax esters, krill lipid, hereafter krill oil, comprises phospholipids, sterols, free fatty acids and fatty alcohols. Typical phospholipids include compounds like phosphatidylcholines and phosphatidyl-  
20 ethanolamines. The krill oil can be in the form of raw oil obtained from krill or in the form of purified or modified oil. Unsaturated compounds and polyunsaturated compounds form a large portion of the fatty compounds in krill oil. The main fatty acid constituents in krill oil are the following fatty acids: 14 : 0, 16 : 0, 16 : 1 (n-7), 18 : 0, 18 : 1, 18 : 1 (n-9), 18 : 1 (n-7), 18 : 2 15 (n-6), 18 : 3 (n-3), 18 : 4 (n-3), 20 : 1 (n-9), 20 : 5 (n-3), 22 : 1 (n-11), 22  
25 : 6 (n-3).

For references on composition of krill oil, see, for example: S. Falk-Perdersen *et al.* in *Can. J. Fish Aquat. Sci.* 57 ( Suppl. 3) 178-191 (2000), F. Alonzo *et al.* in *Marine Ecology: Progress Series* 296, 65-79 (2005), N. Kusumoto *et al.* in *J. Oleo Science* 53, 45-51(2004) and references herein.

30

Although there are several pharmaceutical products on the market for treatment of osteoporosis and cardiovascular disease, there still exists an urgent need for alternative approaches.

### 35 **Summary of the invention**

It has now been surprisingly found that vitamin K<sub>2</sub> and polyunsaturated fatty acids (PUFAs) can be formulated together in a stable formulation with long shelf life.

Thus, in a first aspect, the present invention provides a pharmaceutical or nutraceutical product comprising vitamin K<sub>2</sub> or at least one compound within the vitamin K<sub>2</sub> class of compounds (MK) in combination with at least one of a PUFA, either purified or in the form of fish oil or krill oil.

5 It was also found that vitamin K<sub>2</sub>, and in particular MK-7, does not counteract the anticoagulant effect of marine oils or n-3 PUFA.

It was further found that the higher menaquinones, in particular MK-7 and higher, counteract potential artery calcification-inducing effects of marine oils.

10 It was further found that higher menaquinones, in particular MK-7 and higher, counteract potentially negative aspects of marine oils on bone health.

It was further found that higher menaquinones, in particular MK-7 and higher, counteract potentially negative aspects of marine oils on cartilage health.

15 It was further found, in cell culture studies, that MK-7 is taken up better than other K vitamins. MK-8 and MK-9 are taken up somewhat less, but at a comparable level, whereas MK-4 and vitamin K<sub>1</sub> are taken up to a much lower extent.

It was further found, in cell culture studies, that the long-chain menaquinones, in particular MK-8 and MK-9, are less likely to interfere with oral anticoagulant treatment than other forms of vitamin K.

20 Thus, in a second aspect, the present invention provides a pharmaceutical or nutraceutical product comprising at least one of MK-7, MK-8, MK-9 and MK-10, preferably in combination of at least one of a PUFA, either purified or in the form of fish oil or krill oil, for promoting at least one of cardiovascular health, bone health and cartilage health in humans and animals.

25 In a third aspect, the present invention provides the use of at least one of MK-7, MK-8, MK-9 and MK-10, preferably in combination of at least one of a PUFA, either purified or in the form of fish oil or krill oil, for promoting at least one of cardiovascular health, bone health and cartilage health in humans and animals. A typical and preferred example of said use is for the preparation of a medicament for preventing or treating at least one of cardiovascular-, bone- and cartilage-related diseases or disorders. The  
30 medicament may be provided as a single medicament or as a kit.

In a fourth aspect, the present invention provides a method of prophylaxis or treatment of at least one of atherosclerosis, arteriosclerosis, osteoporosis, osteoarthritis or an inflammatory or degenerative disease of the cartilage, comprising administering to a human or animal a pharmaceutical or nutraceutical product or medicament as defined  
35 hereinbefore.

In a fifth aspect, the present invention relates to counteracting certain negative aspects of fish oil, krill oil and PUFA containing foods and food supplements, thus

reinforcing the beneficial aspects of said marine oils and PUFA for public health.

In a sixth aspect, the present invention provides a kit comprising vitamin K<sub>2</sub> or a compound within the vitamin K<sub>2</sub> class of compounds (MK) and at least one of a PUFA, either purified or in the form of fish oil or krill oil.

5 In a preferred embodiment of the invention, a PUFA, as used herein, is an omega-3 PUFA, for example eicosapentanoic acid (EPA) or docosahexaenoic acid (DHA).

These and other aspects of the present invention will be discussed in more detail in the following detailed description and examples.

## 10 **Brief description of the drawings**

Figure 1 shows the endogenous thrombin potential (ETP), reflecting the total thrombin activity during coagulation. Carboxylated and non-carboxylated Matrix Gla-Protein (MGP) species were monitored using sandwich ELISAs based on conformation-specific antibodies with normal pooled plasma as a reference. The change in MGP  
15 carboxylation was significant after one month, but significance was lost during months 3 and 4. See Experiment 2 below.

Figure 2 shows in the same experiment as in Figure 1 carboxylated and non-carboxylated osteocalcin species in serum using conformation-specific osteocalcin kits. The change in osteocalcin carboxylation was significant after one month, but significance  
20 was lost during months 3 and 4. See Experiment 3 below.

Figure 3 shows the exceptional stability of MK-7 dissolved in fish oil and krill oil. Samples were prepared in sealed glass bottles and kept in a dark place at room temperature, 40°C and 100°C, respectively. At regular times, samples were taken and analyzed for their MK-7 content. No loss of MK-7 was observed, even after 2 weeks at  
25 100°C. See Experiment 4 below.

Figure 4 shows the stability of vitamins K<sub>1</sub>, MK-4, MK-7, MK-8 and MK-9 in three cell culture media (used for growing the three different cell types described below, respectively) with no cells present. See Experiment 5 below.

Figures 5A-C show dose-response curves for cellular vitamin K uptake in three  
30 different cell types; cells were grown until 80% confluence after which vitamin K (i.e., K<sub>1</sub>, MK-4, MK-7, MK-8 and MK-9) was added in different concentrations. Figure 5D shows a plot of the MK-7 uptake in the three cell types at the same scale. See Experiment 6 below.

Figures 6A-C show the cellular uptake of vitamins K<sub>1</sub>, MK-4, MK-7, MK-8 and MK-9 in the three different cell types as a function of time; cells were grown in the culture  
35 media described in Experiment 5. In all cases a mixture of these K vitamins was added to the cells after they had grown to 80% confluence. See Experiment 7 below.

Figures 7A-C show the extent to which the effect of warfarin is bypassed by the

various forms of vitamin K (as measured by K epoxide formation). The more KO formed the higher the extent of bypassing via the enzyme DT diaphorase. See Experiment 8.

Figures 8A-C show the extent to which the various forms of vitamin K are utilized in the absence of warfarin, but under conditions of cell starvation. The more KO  
5 formed, the lesser a vitamin K species is recycled. See Experiment 9 below.

### Definitions

The term "polyunsaturated fatty acid" as used herein refers to any polyunsaturated fatty acid, whether in the form of a triglyceride, a physiologically  
10 acceptable ester, a free fatty acid or a physiologically acceptable salt of a polyunsaturated fatty acid. More specifically, the term is used to indicate omega-3 fatty acids, and omega-3 fatty acid-rich dietary oils such as fish oil and krill oil. In the literature, omega-3 fatty acids are also known as (n-3) polyunsaturated fatty acids or n-3 PUFA.

The term "krill oil" as used herein is meant to indicate all lipophilic components  
15 in krill and can be raw krill oil, purified krill oil, compounds from krill oil and derivatives of components from krill oil.

As used herein, fish oil and krill oil are collectively designated as "marine oils".

The term "vitamin K<sub>2</sub>", as used herein, refers to naturally occurring menaquinones (MKs) or mixtures thereof.

20 The term "compound within the vitamin K<sub>2</sub> class of compounds", as used herein, refers to a single menaquinone (MK) compound.

The term "mainly MK-7" as used herein refers to compositions wherein at least 90% of all vitamin K<sub>2</sub> compounds in the composition, according to HPLC analysis, is MK-7.

### 25 Detailed description of the invention

The present invention is primarily based on certain surprising findings in in-depth studies to the pharmacological properties of vitamin K<sub>2</sub>, and in particular the higher menaquinones (MK-7, MK-8, MK-9 and MK-10), and combinations of these compounds with PUFAs, in pure form or in the form of fish oil or krill oil. These findings provide new  
30 possibilities and challenges for improved products in the pharmaceutical and nutraceutical field relating to the prophylaxis or treatment of certain cardiovascular-related, bone-related and cartilage-related disorders and, more in general, result in beneficial effects to the health of humans and animals.

These findings will be discussed in more detail below.

35

#### Health effects of fish oil, krill oil and n-3 PUFA

Several health aspects of n-3 PUFA have been reported including a marked

beneficial effect on cardiovascular disease. As has been reviewed by Van Schoonbeek *et al.* (*Journal of Nutrition* 133, 657-660 (2003)), the beneficial effects of n-3 PUFA and marine oils are based on multiple mechanisms including the reduction of blood platelet activity, a more favorable blood lipid profile and a reduction of blood coagulability.

5           The hypocoagulant effect of marine oil and n-3 PUFA is mainly attributed to a lowering of the hepatic vitamin K status and a concomitant decrease of the vitamin K-dependent clotting factors II, VII, IX, and X, leading to a decreased thrombin forming potential. C.M.A. Nieuwenhuys *et al.* concluded that "*Prolonged administration of n-3 but not n-6 PUFAs can lead to a hypocoagulable state of plasma through a reduced capacity*  
10 *of vitamin K-dependent thrombin generation with unchanged thrombin inactivation by antithrombin III*". A specific inhibition of vitamin K-dependent clotting factor synthesis was also reported by C. Leray *et al.* (*Arteriosclerosis, Thrombosis, and Vascular Biology* 22, 459-463 (2001)). This is consistent with the observation by L.J. Schurgers *et al.* (*Journal of Lipid Research* 43, 878-884 (2002)), that some dietary oils may interfere with vitamin K  
15 absorption and metabolism in human volunteers. Direct evidence for interference with vitamin K metabolism was given by C.M.A. Nieuwenhuys *et al.* (*Thrombosis Research* 104, 137-147 (2001)) showing that fish oil and n-3 PUFAs decreased the vitamin K levels in the liver (i.e. the place where the clotting factors are synthesized). Furthermore, M. Andriamampandry *et al.* (*Medical Sciences* 321, 415-421 (1998)) demonstrated that the  
20 mild anticoagulant effect of fish oil was completely reversed by a slight increase of vitamin K<sub>1</sub> intake.

It has now surprisingly been found that vitamin K<sub>2</sub>, notably MK-7, does not reverse the beneficial effect of fish oil. In dosages typically between 1 and 10 µg/day, MK-7 did not affect the extrinsic thrombin potential (ETP), which is the most sensitive measure  
25 for thrombosis risk. Hence, mixtures of vitamin K<sub>2</sub> with n-3 PUFA or marine oil combine the beneficial effects of both kinds of compounds and even worked synergistically in animal models and human volunteers. In doses of 100 µg MK-7 per day and higher the ETP lowering effect of marine oils was completely reversed. It should be noted that these doses of MK-7 relate to a marine oil intake of 5 grams per day. At higher fish or krill oil  
30 consumption also the dose required for interference with the ETP is higher.

#### Cardiovascular health

Though a poor vitamin K status may have a mild anticoagulant (i.e. antithrombotic) effect, vitamin K is required in another aspect of vascular health. Matrix  
35 Gla-Protein (MGP) is a vitamin K-dependent protein synthesized in the arterial vessel wall. It is activated by vitamin K-dependent carboxylation and in its carboxylated form it acts as a powerful inhibitor of vascular calcification. Using conformation-specific antibodies, it was



demonstrated by Schurgers *et al.* (*Arteriosclerosis, Thrombosis and Vascular Biology* 25, 1629-1633 (2005)) that atherosclerosis and vascular calcification are closely associated with poor vitamin K status of the vessel wall, and in a prospective clinical trial L.A.J.L.M. Braam *et al.* (*Thrombosis & Haemostasis* 91, 373-380 (2004)) found that high dose vitamin K-supplementation (1 mg/day) had major advantages for vascular elasticity. We have found that marine oil and n-3 PUFA not only favorably decrease the production of vitamin K-dependent proteins in the liver (the clotting factors) but also decrease the vitamin K-status of extrahepatic tissues and thus decrease the activation (by glutamate carboxylation) of extra-hepatic vitamin K-dependent proteins including osteocalcin and matrix Gla-protein (MGP). This is an unwanted side-effect of marine oils and n-3 PUFA with potential detrimental outcomes for cardiovascular health, for bone health and for the development of diseases of the cartilage. The diminished carboxylation of the vascular calcification inhibitor MGP, for instance, is a major risk factor for vascular calcification, hypertension, myocardial infarction and cardiovascular death.

It has now surprisingly been found that higher menaquinones, notably MK-7, in dosages between 1 and 10 µg/day do not counteract the mild anticoagulant effect of marine oils (as measured by the ETP), but at the same time they effectively stimulate MGP carboxylation to levels similar to or even above the level in subjects not using marine oil. This is described in Experiment 2 below. Hence, MK-7 is an essential ingredient to maximally benefit from marine oil and n-3 PUFA containing foods and food supplements directly applied for cardiovascular health.

### Bone health

Marine oils and n-3 PUFA have also been found to have beneficial effects on bone health. In experimental animal models such oils markedly decrease the loss of bone in ovariectomized mice and food-restricted rats (D. Sun *et al.* *Journal of Bone and Mineral Research* 18, 1206-1216 (2003); Sun *et al.* *Bioscience, Biotechnology and Biochemistry* 68, 2613-2615 (2004)). It has been reported by many authors that low vitamin K intake, poor vitamin K status and impaired osteocalcin carboxylation are risk factors for the development and progression of osteoporosis. See for instance: S.L. Booth *et al.* *American Journal of Clinical Nutrition* 77, 512-516 (2003), P. Szulc *et al.* *Journal of Clinical Investigation* 91, 1769-1774 (1993), C. Vermeer *et al.* *European Journal of Nutrition* 43, 325-325 (2004). It has also been demonstrated that increased intake of vitamin K results in a decreased rate of bone loss in postmenopausal women (L.A.J.L.M. Braam *et al.* *Calcified Tissue International* 73, 21-26 (2003), M. Shiraki *et al.* *Journal of Bone and Mineral Research* 15, 515-521 (2000)). The dosages used in these studies range between 1 mg/day for K<sub>1</sub> and 45 mg/day for K<sub>2</sub>. In this light, the marine oil-induced decrease of

osteocalcin carboxylation must be regarded as a detrimental side-effect which may in part obscure the benefits of marine oil for bone health. The reported high dose vitamin K treatment may counteract this side-effect, but will also annihilate the mild anticoagulant effect reported to be beneficial for cardiovascular disease prevention.

5 It has now surprisingly been found that the higher menaquinones, notably MK-7, in the dose range between 1 and 10 µg/day did not counteract the mild anticoagulant effect of marine oils (as measured by the ETP), but at the same time effectively stimulated osteocalcin carboxylation to levels similar to or even above the level in subjects not using marine oil. This is described in Experiment 3 below. Hence MK-7 is an essential ingredient  
10 to maximally benefit from marine oil and n-3 PUFA containing foods and food supplements directly applied for bone health.

#### Cartilage health

Marine oils and n-3 PUFA have also been found to counteract degenerative  
15 and inflammatory joint disease such as observed in osteoarthritis, rheumatoid arthritis, and ankylosing spondylitis. In cell culture studies it was demonstrated that supplementation with n-3 PUFA, but not n-6 PUFA, causes a decrease in both degenerative and inflammatory aspects of chondrocyte metabolism, whilst having no effect on normal tissue homeostasis (C.L. Curtis *et al.*, *Proc. Nutr. Soc.* 61, 381-389 (2002)). Also population-  
20 based studies suggest a positive role of fish oil and n-3 PUFA for the treatment of osteoarthritis, rheumatoid arthritis and other diseases of the cartilage (see for instance: L.G. Cleland *et al.*, *Drugs* 63, 845-853 (2003) and M.J. James *et al.*, *Prostaglandins, Leukotriens and Essential Fatty Acids* 68, 399-405 (2003). As described above, marine oils and n-3 PUFA not only decrease the production of vitamin K-dependent proteins in the  
25 liver (the clotting factors) but also decrease the vitamin K-status of extrahepatic tissues and thus decrease the activation (by glutamate carboxylation) of extra-hepatic vitamin K-dependent proteins including osteocalcin and matrix Gla-protein (MGP). MGP is one of the most abundant proteins synthesized by cartilage, and vitamin K is needed for its activation by glutamate carboxylation. Poor MGP carboxylation has been associated with  
30 osteoarthritis, rheumatoid arthritis and ankylosing spondylitis. Clearly, a method is needed to counteract the marine oil-induced decrease of vitamin K status in cartilage.

It has now surprisingly been found that at nutritionally relevant doses MK-7 counteracts potentially negative aspects of marine oils on cartilage health. The fact that the higher menaquinones, notably MK-7, in the dose range between 1 and 10 µg/day do not  
35 counteract the mild anticoagulant effect of marine oil (as measured by the ETP), but at the same time effectively stimulate both osteocalcin carboxylation and MGP carboxylation to levels similar to or even above the level in subjects not using marine oil demonstrates that

MK-7 is capable of providing optimal vitamin K status in bone, including the cartilage in the joints during marine oil supplementation. Hence MK-7 is an essential ingredient to maximally benefit from marine oils and n-3 PUFA containing foods and food supplements directly applied for cartilage health.

5

#### Cell culture studies

In a series of cell culture experiments vitamin K uptake and metabolism under various conditions were investigated. The following forms of vitamin K were compared: K<sub>1</sub>, MK-4, MK-7, MK-8 and MK-9. They were tested in three different cell types: the vascular  
10 smooth muscle cells, the osteoblast-like MG-63 cell line and the hepatocyte-like HepG2 cell line. In all experiments the vitamins were used as a mixture containing 1 µmol/L of each vitamin.

It was found that in all cells MK-7 is taken up better than other K vitamins. MK-8 and MK-9 are taken up somewhat less, K<sub>1</sub> and MK-4 much less.

15

It was also found that in the presence of the anticoagulant warfarin, the membrane-bound enzyme VKOR is blocked and thus vitamin K cannot be recycled. After utilization, it remains in the oxidized form (K-epoxide); the amounts of epoxides represent the extent of utilization. It was found that long-chain menaquinones and in particular MK-9 cannot be reduced, and thus not be used as a coenzyme for carboxylase under these  
20 conditions. The more water-soluble vitamins K<sub>1</sub> and MK-4, however, may use the cytoplasmic enzyme DT-diaphorase for reduction and interfere with oral anticoagulant treatment. Therefore, long-chain menaquinones are less likely to interfere with oral anticoagulant treatment than other forms of vitamin K. This is an important safety aspect, and consistent with animal experiments that have been published previously (Craciun,  
25 A.M., Groenen-van Dooren, M.M.C.L., Thijssen, H.H.W., Vermeer, C. (1998). *Induction of prothrombin synthesis by K-vitamins compared in vitamin K-deficient and in brodifacoum-treated rats. Biochim. Biophys. Acta* 1380, 75-81.

In the absence of warfarin and in rich medium, no epoxides are formed at all. If the concentration of fetal calf serum in the culture medium is decreased, the nutritional  
30 status of the cells becomes suboptimal. Also under these conditions MK-4 and K<sub>1</sub> epoxides were mainly found. The conclusion now is different than for the warfarin experiment, however: the long chain menaquinones are utilized preferentially and successfully compete with K<sub>1</sub> and MK-4 at the level of reduction by VKOR. Therefore, it can be concluded that long-chain menaquinones are preferentially used by for gamma-  
35 carboxylation of various proteins. This is consistent with previously published cell-free enzyme kinetic studies showing that the Michaelis constant (K<sub>m</sub>) for vitamin K decreases with increasing length of its side chain (Buitenhuis, H.C., Soute, B.A.M., Vermeer, C.

(1990). *Comparison of the vitamins K<sub>1</sub>, K<sub>2</sub> and K<sub>3</sub> as cofactors for the hepatic vitamin K-dependent carboxylase. Biochim. Biophys. Acta 1034, 170-175).*

#### Formulation of products and dosages

5 It has now been found that vitamin K<sub>2</sub> and polyunsaturated fatty acids can be formulated together in a stable formulation with long shelf life. For example, MK-7 was mixed with fish oil or krill oil in a wide range of concentrations and these compositions remained stable under these conditions for at least 2 weeks at 100°C, for 6 months at 40°C and for 3 years at room temperature. Details of these studies are shown in Experiment 4  
10 below.

As defined above, the term "polyunsaturated fatty acid" (PUFA) refers to any PUFA in the form of a triglyceride, a physiologically acceptable ester, a free fatty acid or a physiologically acceptable salt thereof. Preferred compositions of PUFAs and menaquinones according to the present invention are PUFAs combined with mainly MK-7. More  
15 preferred composition of PUFA and MK substances according to the present invention are compositions wherein at least 95% of all vitamin K<sub>2</sub> compounds in the composition, according to HPLC analysis, is MK-7 with MK-6 as the main vitamin K<sub>2</sub> impurity. A typical ratio between MK-7 and MK-6 in compositions according to the present invention is in the range between 90 to 10 and 95 to 5.

20 Preferred compositions of vitamin K<sub>2</sub> or a compound within the vitamin K<sub>2</sub> class of compounds and PUFA according to the present invention are compositions comprising a PUFA selected from n-3 PUFAs. More preferred n-3 PUFAs according to the present invention are eicosapentaenoic acid (EPA) which is a 20:5 acid and docosahexaenoic acid (DHA) which is a 22:6 acid.

25 An even more preferred n-3 PUFA component in products according to the present invention is a combination of EPA and DHA. The most preferred ratio of EPA : DHA is within the range of 2:1 to 1:2.

In the most preferred composition according to the present invention, EPA and DHA are in the form of triglycerides or ethyl esters.

30 The formulations of the products and kits of the invention are preferably administered systematically (e.g. orally or parenterally). The most preferred dosage form according to the present invention is an oral dosage form; especially capsules and tablets. The dosage and route of administration will depend on factors such as the age and sex of the individual, the severity and nature of the disorder or disease, and the like, and can  
35 easily be determined by a person skilled in the art, usually a physician, or the instructions leaflet of the manufacturer are to be followed which usually accompany the product.

Tablets and capsules can be prepared by any conventional manner known in

the art. The capsules can for example be soft or hard gelatin capsules with in addition to vitamin K<sub>2</sub> or vitamin K<sub>2</sub> compounds and polyunsaturated fatty acid comprise of inactive pharmaceutically acceptable components, for example starch. Tablets according to the present invention may, for example, be prepared by direct compression or by compression  
5 of granules using conventional tablet machines. Tablets according to the present invention might in addition to vitamin K<sub>2</sub> or vitamin K<sub>2</sub> compounds and unsaturated fatty acid comprise of pharmaceutically acceptable inactive ingredients well known in the art. Such agents can for example be cellulose derivatives and magnesium stearate. Tablets according to the present invention can be coated with a gastric resistant coating, for  
10 example cellulose acetate phthalate.

The oral dosage forms, capsules and tablets, according to the present invention, have each a weight between 100 mg and 2 grams. The amount of vitamin K<sub>2</sub> or vitamin K<sub>2</sub> compounds in each tablet or capsule may vary over a wide range, depending inter alia upon factors such as the severity and nature of the disease or disorder, and the  
15 condition, sex and age of the patient. The amount of vitamin K<sub>2</sub> or a vitamin K<sub>2</sub> compound within the vitamin K<sub>2</sub> class of compounds in one tablet or capsule is typically between 1 and 500 µg, although higher amounts are also possible. Preferred dosages of vitamin K<sub>2</sub>, and notably MK-7, are between 2 and 300 µg, more preferably 5-50 µg, and most preferably between 10-20 µg per day.

The amount of unsaturated fatty acid in each tablet or capsule may also vary  
20 depending upon the nature of the unsaturated fatty acid, the severity and nature of the disease, age of the patient and frequency of administration of the tablet or capsule. The amount of unsaturated fatty acid in each tablet or capsule is typically between 300 and 1200 mg, preferably between 400 and 1000 mg, most preferably between 500 and 900  
25 mg.

The data presented show that at dosages as high as 10 µg per day marine oil (at a dose of about 5 g) and MK-7 can be combined without interfering with the mild anticoagulant effect of marine oil. Thus, MK-7 dosages between about 1 and at least 10 µg (evidently, the higher the better within said range) have been proven to be beneficial when  
30 administered to a human or animal. Dosages as high as 100 µg per day are not applicable for the purpose described here, because these dosages were found to counteract the effect of warfarin, which is an even stronger inhibitor of blood clotting factor carboxylation than n-3 PUFAs are. See, Schurgers, L.J., Teunissen, K.J.F., Hamulyák, K., Knapen, M.H.J., Vik, H., Vermeer, C. Vitamin K-containing dietary supplements: comparison of  
35 synthetic vitamin K<sub>1</sub> and natto-derived menaquinone-7. *Blood* 109 (2007) 3279-3283.

It will be understood that dosages of vitamin K and marine oils may also vary depending on the variety and quality of the marine oil. It is therefore recommended to use

mixtures of marine oils in order to maintain a constant ratio in the compositions

It will also be understood that vitamin K<sub>2</sub> or a compound within the vitamin K<sub>2</sub> class of compounds can also be formulated separately and independently from one or more polyunsaturated fatty acids (including fish oil and krill oil), for example in a pharmaceutical composition or a nutraceutical composition (food supplement). Suitable pharmaceutical compositions and typical dosages are similar to those described above or are known to a person skilled in the art. Suitable nutraceutical compositions and typical dosages are described, e.g. in EP1153548, the disclosure of which is herein incorporated by reference.

The compositions according to the present invention can optionally comprise other pharmaceutically or nutraceutically active components; for example vitamins like vitamin D or vitamin D derivatives; active drug compounds such as bisphosphonates, typically alendronate; or cardiovascular drugs, such as ACE inhibitors, for example enalapril, angiotensin II receptor antagonists, for example losartan, beta-blockers, for example propranolol, plasma lipid reducing components, such as statins, typically simvastatin, and other drugs.

Of the higher menaquinones, MK-7, MK-8, MK-9 and MK-10, the use of MK-7 is generally the most preferred, as will be understood from the disclosure herein. Also preferred is MK-9, both because of its beneficial and promising properties and because of its availability since it is easily made synthetically.

The present invention will now be further described with reference to the following examples and experimental work, which however are not to be construed as limiting the invention in any respect.

#### **Example 1. Capsule comprising EPA ethyl ester, DHA ethyl ester and MK-7**

An oil comprising 97% MK-7 and 3% MK-6 is mixed with EPA ethyl ester and DHA ethyl ester. Alpha-tocopherol is added, and the resulting oil is filled into hard gelatine capsules.

Each capsule contains:

MK-7	97 µg
MK-6	3 µg
EPA ethyl ester	463 mg;
DHA ethyl ester	375 mg
Alpha-tocopherol	4 mg

35

**Example 2. Cod liver oil comprising vitamin K<sub>2</sub>**

Vitamin K<sub>2</sub> is dissolved in cod liver oil (from EPAX, Norway) and filled into green glass bottles (250 ml) with a metal sealing. The bottles are labeled "Vitamin K<sub>2</sub> tran" for sale on the Norwegian market.

5 One daily dose (5ml) of this product contains:

Vitamin A:	250	µg
Vitamin D:	10	µg
Vitamin K <sub>2</sub> (MK-7):	10	µg
Fish oil:	1.2	g, of which DHA was 0.4 g and EPA was 0.6 g
10 Alpha-tocopherol:	4	mg

**Example 3: Capsule comprising krill oil and MK-7.**

Krill oil comprising polyunsaturated fatty acids in triglycerol form, phospholipids and other natural components (obtained from Enzymotec, Israel) is mixed with MK 7 and  
15 alpha-tocopherol. The resulting oil composition is filled into soft gel or hard gelatin capsules or prepared as an oil-containing granulate or solvent.

Each capsule contains:

MK-7	97	µg
MK-6	3	µg
20 Krill oil	700	mg
Alpha-tocopherol	4	mg

**Example 4: Krill oil comprising Vitamin K<sub>2</sub>**

Vitamin K<sub>2</sub> is dissolved in krill oil and filled into glass bottles (250 ml) with metal  
25 sealing. The bottles are labeled "Krilloljetran med Vitamin K" for sale on the Norwegian market or "Krill oil including vitamin K" for the US and UK market. One daily dose (5ml of krill oil) contains in the range between 5 and 500 µg Vitamin K<sub>2</sub>.

**Example 5: Fish feed comprising krill oil and Vitamin K<sub>2</sub>**

30 Vitamin K<sub>2</sub> (100 mg) is dissolved in krill oil (1 kg). Fish feed (from Skretting AS, Stavanger, Norway) is ground. Ground fish feed (20 kg) is mixed with krill oil comprising Vitamin K<sub>2</sub> (1 kg) using a blender. Water was added, and the semi-wet material is sieved (3 mm) and dried for 24 hours at 40°C to obtain a fish feed granulate.

The feed granulate contains about 5% krill oil and 2-100 ppm of vitamin K<sub>2</sub>.

35

**Example 6: MK-8 capsules**

An oil comprising MK-8 (HPCL analysis shows MK-8 higher than 70% of total Vitamin K2) is filled into soft gelatin capsules. Each capsule contains 5 µg of MK 8.

**5 Example 7: Capsules comprising EPA ethyl ester, DHA ethyl ester and blend of MK-8, MK-9 and MK-10.**

An oil comprising a blend of MK-8, MK-9, MK-10 is mixed with EPA ethyl ester and DHA ethyl ester. Alpha-tocopherol is added, and the resulting oil is filled into hard gelatin capsules.

10 Each capsule contains:

MK-8, MK-9, MK-10	50 µg
EPA ethyl ester	463 mg
DHA ethyl ester	375 mg
Alpha-tocopherol	4 mg

15

**Example 8: Cod liver oil comprising MK8**

MK8 (more than 65% according to HPLC analysis) is dissolved in cod liver oil and filled into green glass bottles (250 ml) with metal sealing. The bottles are labeled "Vitamin K2 tran" for sale on the Norwegian market.

20 One daily dose (5 ml) of this product contains:

Vitamin A	250 µg
Vitamin D	10 µg
MK-8	10 µg
Omega-3 fatty acids	1.2 g, of which DHA was 0.6 g and EPA was 0.4 g
25 dl-Alpha-tocopheryl acetate	6 mg

**Experiment 1: The carboxylation degree of osteocalcin in osteoarthritis, osteopathy and rheumatoid arthritis.**

Three patient groups were recruited and compared with age- and sex-matched  
 30 healthy subjects. The vitamin K status of each subject was recorded by measuring the ratio between carboxylated and uncarboxylated osteocalcin (cOC/ucOC ratio), which is the most sensitive biomarker for extrahepatic vitamin K status (B. Panis *et al.*, *Bone* 2006; 39:1123-1129). The patients suffering from osteoarthritis and chondropathy were relatively young and were compared with a young reference group (A), patients with rheumatoid  
 35 arthritis were older and thus compared with an older reference group (B). Conformation-specific assays for osteocalcin were obtained from Takara (Japan). See Table 1 below.

This experiment demonstrates that the vitamin K status (expressed as the



carboxylation degree of circulating osteocalcin) is significantly decreased in subjects with osteoarthritis, chondropathy and rheumatoid arthritis as compared to the healthy population.

Table 1

	Control A	Control B	Osteoarthritis	Chondropathy	Rheumatoid Arthritis
Age (years)	32	45	34	31	48
Gender (% men)	48	51	42	54	45
Number per group	30	30	27	49	29
cOC/ucOC ratio	1.39	1.28	1.04	0.71	0.38
Range	0.52-2.49	0.48-2.34	0.14-2.0	0.12-1.95	0.16-1.67
Difference Cntr A			P < 0.05	P < 0.005	
Difference Cntr B					P < 0.002

5

**Experiment 2: MGP carboxylation during long term fish oil intake and the effects of MK-7 intake at 10 µg/day.**

Twenty healthy males ( $43 \pm 8$  years of age) were enrolled in the study. The mean body mass index was  $25.1 \pm 3.5$  kg/m<sup>2</sup>. All subjects received 5 grams of fish oil (containing 35% EPA, 25% DHA and 10% other n-3 PUFA) per day during 4 months. During the last 3 months of the study all volunteers received additionally one soft gel capsule per day providing 10 µg of MK-7. Blood samples were collected in citrate every month to prepare platelet-rich plasma. The endogenous thrombin potential (ETP), reflecting the total thrombin activity during coagulation, was monitored according to H.C. Hemker *et al.* (*Pathophysiology of Haemostasis and Thrombosis* 2003;33:4-15). Carboxylated and non-carboxylated Matrix Gla-Protein (MGP) species were monitored using sandwich ELISAs based on conformation-specific antibodies obtained from VitaK BV (Maastricht, The Netherlands) with normal pooled plasma as a reference. See Figure 1. The ratio between carboxylated and non-carboxylated MGP is taken as a measure for vascular vitamin K status. All values are expressed as a percentage of those in the pooled reference plasma. The change in ETP was statistically significant ( $p < 0.05$ ) after one month and remained so during subsequent months. The change in MGP carboxylation was also significant after one month, but significance was lost during months 2, 3 and 4.

This experiment demonstrates that the fish-oil induced hypocoagulability is not counteracted by the low doses of MK-7 required to maintain MGP carboxylation at its original level.

**Experiment 3: Osteocalcin carboxylation during long term fish oil intake and the effects of MK-7 intake at 10 µg/day.**

In the same experiment as described above, also serum was collected, in which carboxylated and non-carboxylated osteocalcin species were monitored using the conformation-specific osteocalcin kits from Takara (Japan). The change in osteocalcin carboxylation was significant after one month, but significance was lost during months 3 and 4. See Figure 2. This experiment demonstrates that the fish-oil induced hypo-coagulability is not counteracted by the low doses of MK-7 required to maintain osteocalcin carboxylation at its original level.

10

**Experiment 4: Stability of MK-7 in fish oil and krill oil.**

Compositions as described in Examples 2 and 4 (MK-7 dissolved in fish oil and krill oil, respectively) were prepared to a final concentration of 2 µg of MK-7 per g of oil. Samples were prepared in sealed glass bottles and kept in a dark place at room temperature, 40°C and 100°C, respectively. At regular times, samples were taken and analyzed for their MK-7 content. See Figure 3. No loss of MK-7 was observed, even after 2 weeks at 100°C. This experiment demonstrates the exceptional stability of MK-7 dissolved in fish oil and krill oil.

**20 Experiments 5-9: Cell culture studies**

This series of cell culture experiments describe vitamin K uptake and metabolism under various conditions. The following forms of vitamin K were compared: K<sub>1</sub>, MK-4, MK-7, MK-8 and MK-9. They were tested in three different cell types: the vascular smooth muscle cells, the osteoblast-like MG-63 cell line and the hepatocyte-like HepG2 cell line. In all experiments the vitamins were used as a mixture containing 1 µmol/L of each vitamin. All data are the means of triplicate experiments.

25

The composition (v/v) of the various culture media was:

	HepG2	VSMC	MG63
EMEM (from Sigma)	87%	78%	87%
Fetal Calf Serum	10%	20%	10%
Penicillin/Streptomycin	1%	1%	1%
L-glutamine	1%	1%	1%
Sodium pyruvate	-	-	1%
Non-essential amino acids	1%	-	-

**Experiment 5**

30

Here we have checked the stability of the various forms of vitamin K (1 µM of each) in the three cell culture media with no cells present. The data are given in Figure 4.

*Conclusion:* In all three growth media the vitamins K<sub>1</sub>, MK-7, MK-8, and MK-9 were fairly stable over 48 hours, whereas MK-4 showed a decline to values between 70 and 80% of baseline for the first 24 hours and between 60 and 70% of baseline after 48 hours. The reason for this decline is still unclear, but conditions have to be chosen in such a way that the disappearance of MK-4 does not influence the data for cellular uptake of vitamin K. To keep MK-4 loss to a minimum, all further experiments were performed for not longer than 24 hours.

### Experiment 6

Cells were grown until 80% confluence after which vitamin K was added in different concentrations (see Figures 5A-C). The added vitamin K concentration is given as nmol/L of culture medium, the vitamin K recovered is given as nmol/g of cellular protein. Note the different scales for each vitamin.

#### *Conclusions:*

1. The dose-response curves for all vitamins are horizontal between 500 and 1000 nmol/L; hence we work in saturating conditions and even the decline of MK4 (presently not understood) will not affect the outcomes of further studies.
2. Surprisingly, there was an enormous difference in vitamin K uptake by the various cells, with vascular smooth muscle cells giving the highest and MG63 the lowest values. This is demonstrated in Figure 5D, where we have plotted MK-7 uptake in the three cell types at the same scale.
3. In all systems, but notably in the extrahepatic cells, MK-7 was taken up surprisingly better than the other K vitamins. This is further demonstrated in the following experiments.

### Experiment 7

Cellular uptake of K vitamins was followed in time. In all cases a mixture of the various K vitamins (1  $\mu$ mol/L final concentration in the culture medium) was added to the cells after they had grown to 80% confluence. The data are given in Figure 6. Surprisingly, MK-7 was taken up better than any of the other K vitamins. The mechanism behind this cellular preference for MK-7 is not quite clear.

#### *Conclusions:*

1. Uptake levels off after 4 h and reaches plateau levels at 8 h;
2. The rate of uptake and the value of the plateau levels are different for each vitamin;
3. MK-7 is taken up better than any of the other vitamins in all three cell systems.

### Experiment 8

Under normal conditions, all forms of vitamin K are taken up in their quinone form, and they are reduced into the hydroquinone before being active as a cofactor for the enzyme gammaglutamylcarboxylase. During the carboxylation they are oxidized into epoxides, which can be reduced by the membrane-bound enzyme VKOR. VKOR forms the target for drugs known as coumarin derivatives, which inactivate the enzyme and thus block the recycling of K epoxides. Vitamin K quinones (and not the epoxides) can be reduced by a second enzyme system, known as DT diaphorase. Hence the action of coumarin derivatives, such as warfarin, is antagonized by extra vitamin K. Also, each molecule of vitamin K that is used in the presence of warfarin, is converted into the corresponding epoxide, which cannot be used any further. Hence the K epoxide concentration is a direct measure for the amount of vitamin K used during warfarin treatment. Coumarin derivatives are widely used as oral anticoagulants; their mode of action is based on the inhibition of clotting factor carboxylation in the liver. Interference with coumarin derivatives is thus a potential risk of vitamin K supplements. Therefore we have investigated whether and to which extent the various K vitamins interfere with warfarin. In the study described, 10  $\mu\text{mol/L}$  of warfarin was added to the culture media 18 h before adding vitamin K. Also during incubation with K vitamins this concentration of warfarin was present. The results are shown in Figure 7.

In the MG63 cell line we could only identify MK-4 epoxide (MK4-O), in the other systems more K vitamins were detected in their epoxide form. In all cases it is obvious that the more water-soluble forms of vitamin K (MK-4 and  $K_1$ ) are capable of bypassing the effect of warfarin, whereas at increasing hydrophobicity the interference with warfarin becomes less. The most important cell type in this series is the HepG2 cell line, since this represents the hepatocytes, the place where blood clotting factors are synthesized. It is obvious from Figure 7 that there is an inverse correlation between interference with warfarin and hydrophobicity of the vitamin K species. MK-9 epoxides were hardly formed. At this time MK-10 and MK-11 are not commercially available, but it may be expected by extrapolation that these long chain menaquinones will not interfere at all, and can be safely given as a supplement even to patients on oral anticoagulant (coumarin) treatment.

#### *Conclusions:*

1. The short-chain K vitamins  $K_1$  and MK-4 interfere substantially with warfarin, whereas interference by long-chain menaquinones is less.
2. Utilization of K-vitamins in the presence of warfarin is inversely related to the length of the side chain: MK-7 > MK-8 > MK-9.
3. On the basis of these experiments it may be expected that MK-9 and MK-10 will not interfere in a clinically relevant way with oral anticoagulant treatment.

**Experiment 9**

After having demonstrated that long-chain menaquinones are absorbed well by the various cells, and that they are hardly used during warfarin treatment, it remains to be demonstrated that these vitamin K species are actively used under non-inhibited (warfarin-free) conditions. Since under standard cell culture conditions no epoxides are formed, we have applied sub-optimal growth conditions by decreasing the fetal calf serum in the culture medium to 1% (v/v). This resulted in substantial epoxide formation. The results are shown in Figure 8. Again, the short-chain vitamin K epoxides were found to accumulate, notably in the vascular smooth muscle MG63 cells. We interpret these data as preferential recycling of the long chain menaquinones under conditions of cell starvation. Alternatively, these data may be explained as no utilization of the long chain menaquinones. This was ruled out in an experiment in which VSMC and MG63 were grown at 1% FCS and with only one single form of vitamin K present (1  $\mu\text{mol/L}$ ). Using conformation-specific test kits for carboxylated osteocalcin (Takara, Japan) and carboxylated matrix Gla-protein (VitaK, the Netherlands) it was found that in vascular smooth muscle cells MGP carboxylation was stimulated by vitamin K<sub>1</sub>, MK-4 and MK-7 to reach the following MGP levels in the culture medium after 24 hours incubation:

- Carboxylated matrix Gla-protein in the presence of K<sub>1</sub>: 12.4 ng/mL, MK-4: 10.7 ng/mL, MK-7: 13.5 ng/mL.
- Carboxylated osteocalcin in the presence of K<sub>1</sub>: 3.2 ng/mL, MK-4: 4.1 ng/mL, MK-7: 3.9 ng/mL.

These data demonstrate that long chain menaquinones as well as K<sub>1</sub> and MK-4 are active cofactors for the vitamin K dependent carboxylase, and that the absence of epoxides must be the result of preferential recycling.

**Claims**

1. A pharmaceutical or nutraceutical product comprising vitamin K<sub>2</sub> or at least one compound within the vitamin K<sub>2</sub> class of compounds, in combination with at least one of a polyunsaturated fatty acid, either purified or in the form of a marine oil.  
5
2. A pharmaceutical or nutraceutical product, comprising at least one compound within the vitamin K<sub>2</sub> class of compounds which is selected from MK-7, MK-8, MK-9 and MK-10, for promoting at least one of cardiovascular health, bone health and cartilage health in humans and animals.  
10
3. A pharmaceutical or nutraceutical product according to claim 2, which further comprises at least one of a polyunsaturated fatty acid, either purified or in the form of a marine oil.  
15
4. Use of vitamin K<sub>2</sub> or at least one compound within the vitamin K<sub>2</sub> class of compounds, in combination with at least one of a polyunsaturated fatty acid, either purified or in the form of a marine oil, for promoting at least one of cardiovascular health, bone health and cartilage health in humans and animals.  
20
5. Use of at least one compound within the vitamin K<sub>2</sub> class of compounds, which is selected from MK-7, MK-8, MK-9 and MK-10, for promoting at least one of cardiovascular health, bone health and cartilage health in humans and animals.
- 25 6. Use of at least one compound within the vitamin K<sub>2</sub> class of compounds, which is selected from MK-7, MK-8, MK-9 and MK-10, in counteracting certain negative aspects of fish oil, krill oil and polyunsaturated fatty acids containing foods and food supplements, thus reinforcing the beneficial aspects of said marine oils and polyunsaturated fatty acids for public health.  
30
7. Use according to claim 5 or claim 6, wherein said at least one of MK-7, MK-8, MK-9 and MK-10 is in combination with at least one of a polyunsaturated fatty acid, either purified or in the form of a marine oil.
- 35 8. Use according to any one of the preceding claims, wherein said use is for the preparation of a medicament for preventing or treating at least one of cardiovascular-, bone- and cartilage-related diseases or disorders.

9. A method of prophylaxis or treatment of at least one of atherosclerosis, arteriosclerosis, osteoporosis, osteoarthritis or an inflammatory or degenerative disease of the cartilage, which comprises administering to a human or animal an effective amount of vitamin K<sub>2</sub> or at least one compound within the vitamin K<sub>2</sub> class of compounds, optionally  
5 in combination with an effective amount of at least one of a polyunsaturated fatty acid, either purified or in the form of a marine oil.
10. A method according to claim 9, which comprises administering to a human or animal an effective amount of at least one compound within the vitamin K<sub>2</sub> class of  
10 compounds which is selected from MK-7, MK-8, MK-9 and MK10.
11. A method according to claim 10, wherein the compound within the vitamin K<sub>2</sub> class of compounds is MK-7 or MK-9.
- 15 12. A method according to any one of claims 9-11, wherein the effective amount of at least one of a polyunsaturated fatty acid to be administered is in the form of fish oil or krill oil.
13. A kit comprising vitamin K<sub>2</sub> or a compound within the vitamin K<sub>2</sub> class of  
20 compounds and at least one of a polyunsaturated fatty acid, either purified or in the form of a marine oil.
14. A product according to claim 1 or the use according to claim 4, wherein said at least one compound within the vitamin K<sub>2</sub> class of compounds is selected from the group  
25 of MK-7, MK-8, MK-9 and MK-10.
15. A product according to any one of claims 1 to 3 or the use according to any one of claims 4 to 8, wherein said polyunsaturated fatty acid is in the form of fish oil or krill oil.  
30
16. A product according to any one of claims 1 to 3 or the use according to any one of claims 4 to 8, wherein said polyunsaturated fatty acid is a n-3 polyunsaturated fatty acid.
- 35 17. A product according to claim 16, wherein said polyunsaturated fatty acid is EPA or DHA or a mixture thereof.

18. A product according to claim 1, wherein said vitamin K<sub>2</sub> or at least one compound within the vitamin K<sub>2</sub> class of compounds and said fatty acid are provided in the same pharmaceutical composition.
- 5 19. A product according to anyone of the preceding claims, wherein said product is for oral administration.
20. A product according to claim 19, wherein said product is a tablet formulation or a capsule formulation.
- 10 21. A product according to claim 17, wherein said fatty acid is a combination of EPA and DHA in the form of their triglycerides or ethyl esters.
22. Use of vitamin K<sub>2</sub> or at least one compound within the vitamin K<sub>2</sub> class of  
15 compounds and at least one of a n-3 polyunsaturated fatty acid for the preparation of a medicament for the prophylaxis or treatment of atherosclerosis, arteriosclerosis, osteoporosis, osteoarthritis, or another inflammatory or degenerative disorder of the cartilage.
23. Use of vitamin K<sub>2</sub> or at least one compound within the vitamin K<sub>2</sub> class of  
20 compounds or a method of treatment or prophylaxis comprising administering vitamin K<sub>2</sub> or  
' at least one compound within the vitamin K<sub>2</sub> class of compounds as claimed in any one of  
the preceding claims, wherein the dosage of vitamin K<sub>2</sub> or at least one compound within  
the vitamin K<sub>2</sub> class of compounds, preferably MK-7 or MK-9, is in the range of between 1  
and 500 µg, preferably between 2 and 300 µg, more preferably 5-50 µg, and most  
25 preferably between 10-20 µg per day.



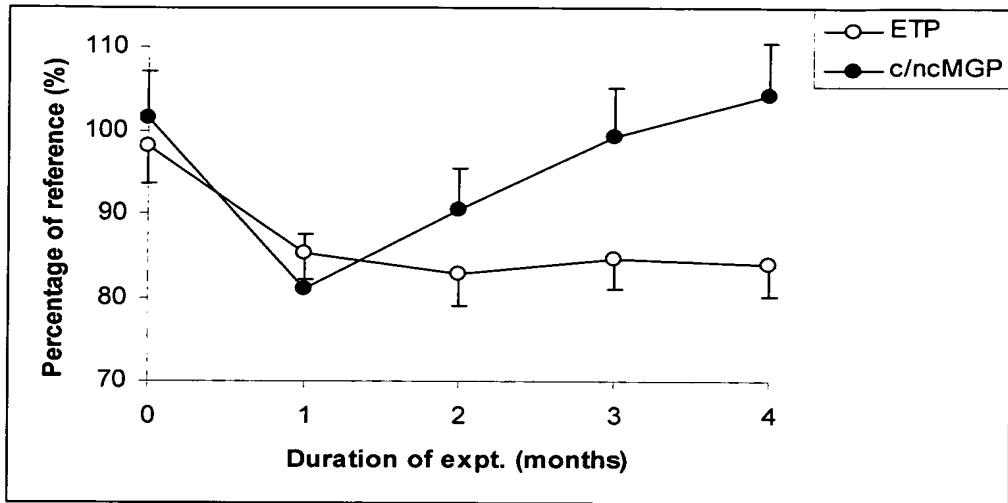

Fig. 1

2/9

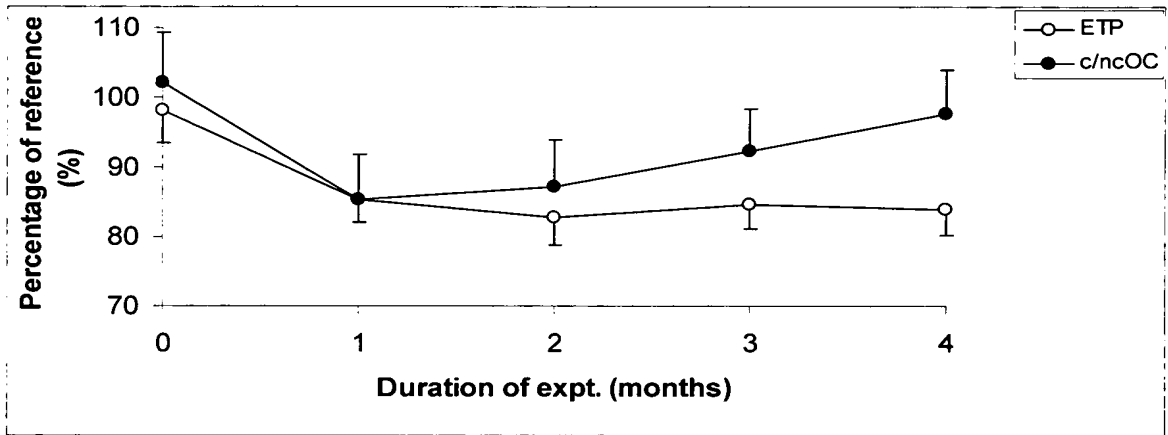

Fig. 2

3/9

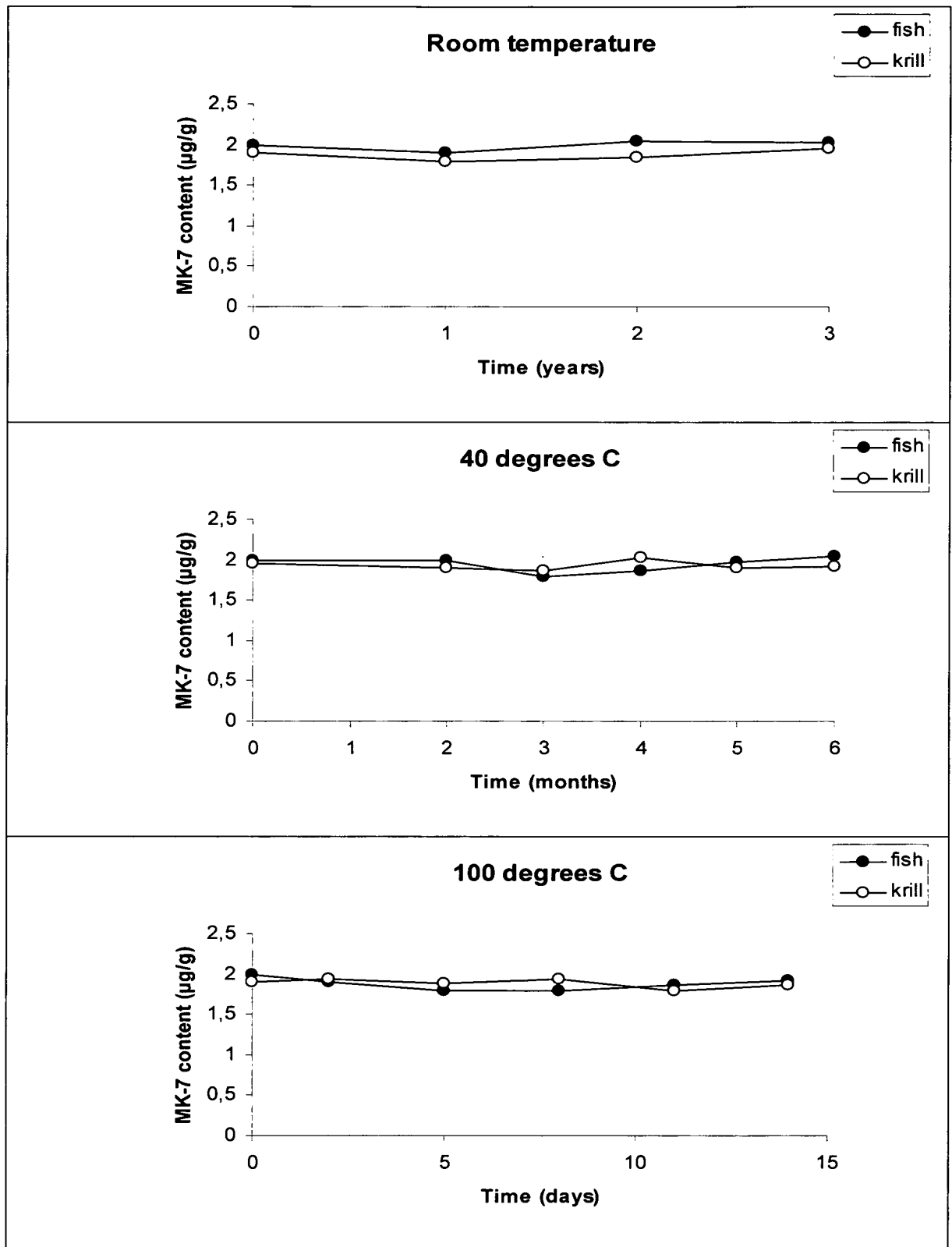

Fig. 3

4/9

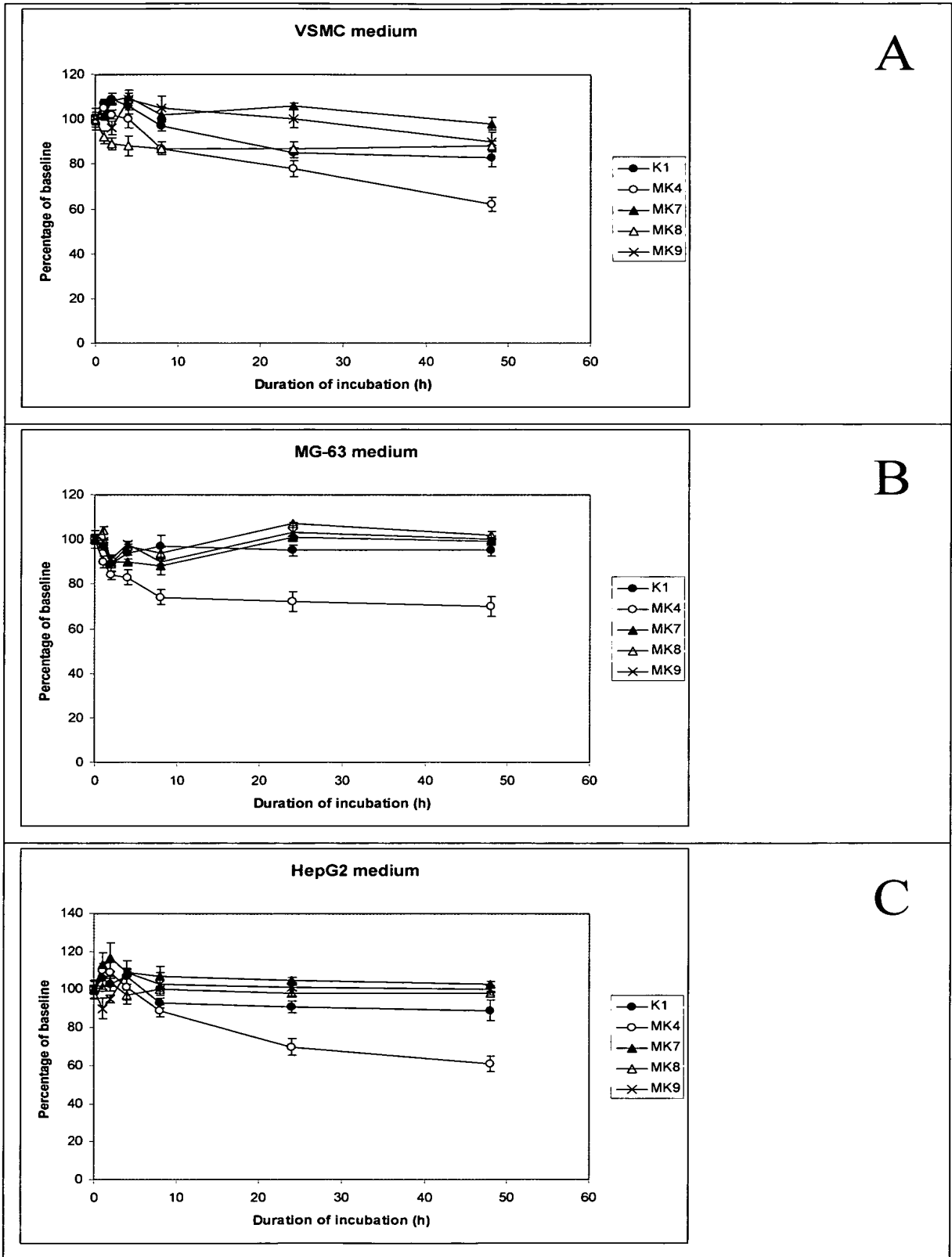

Fig. 4

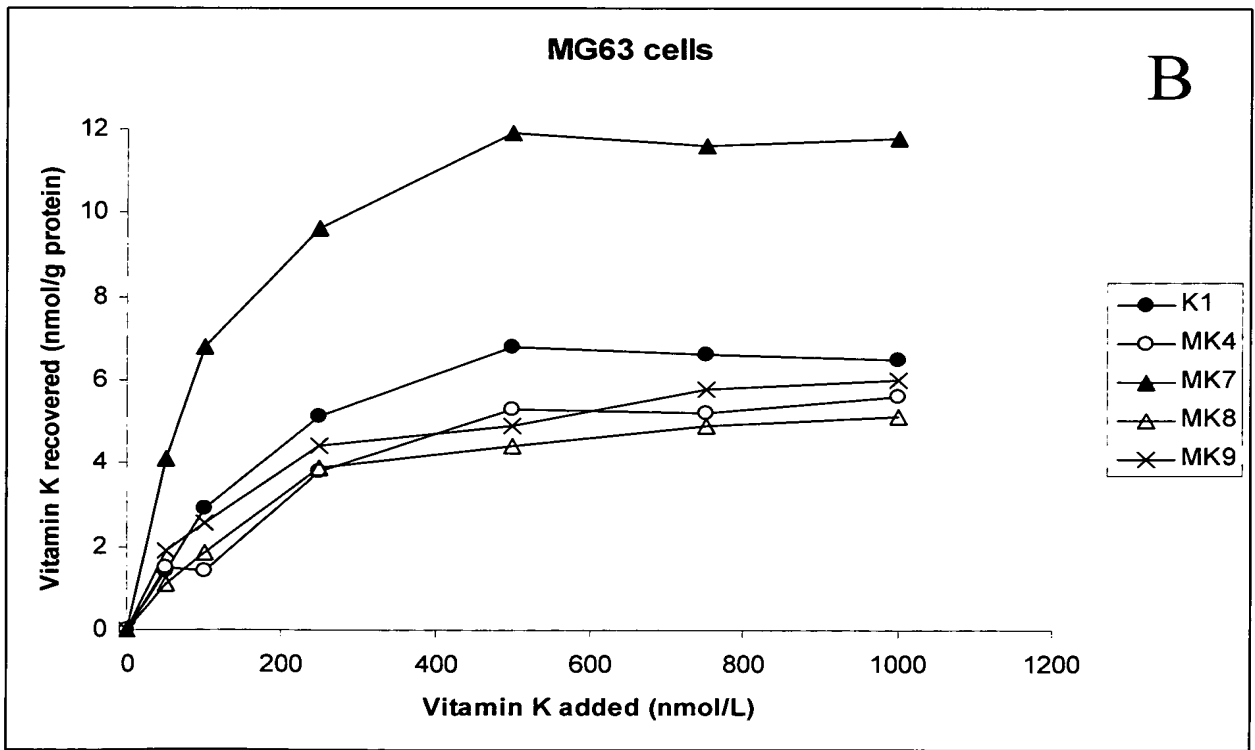
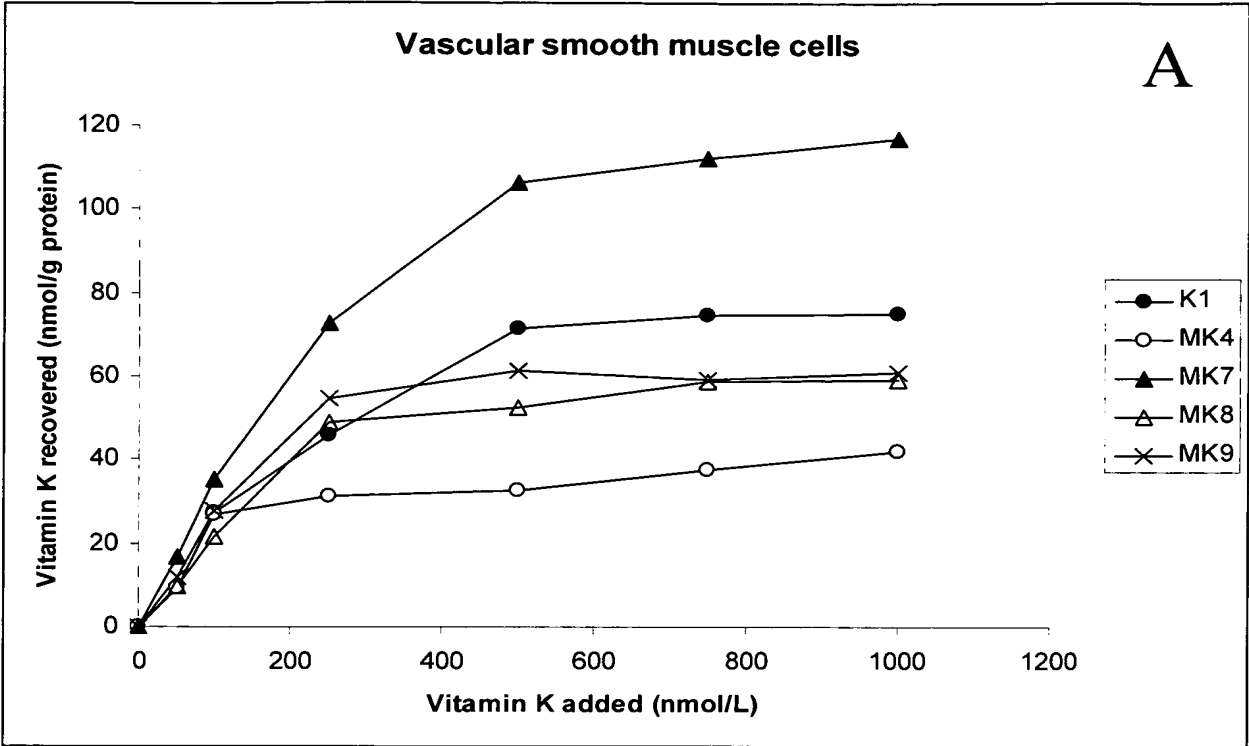

Fig. 5

6/9

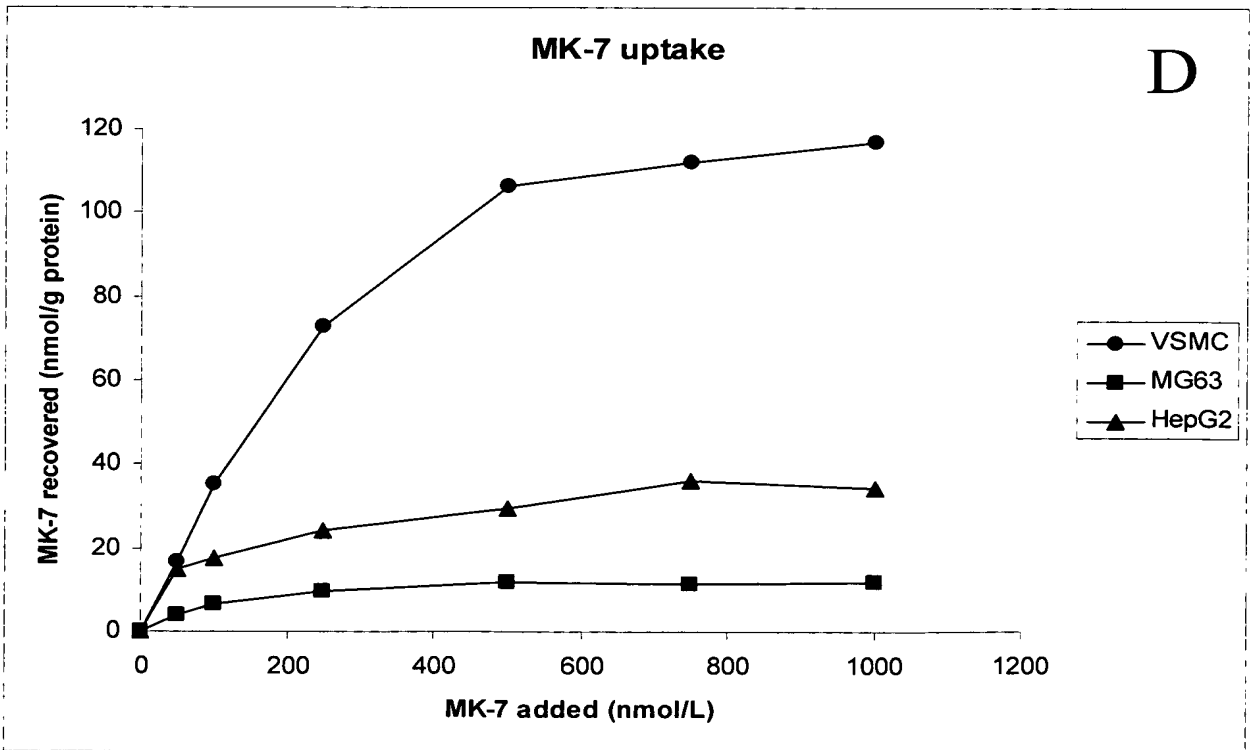
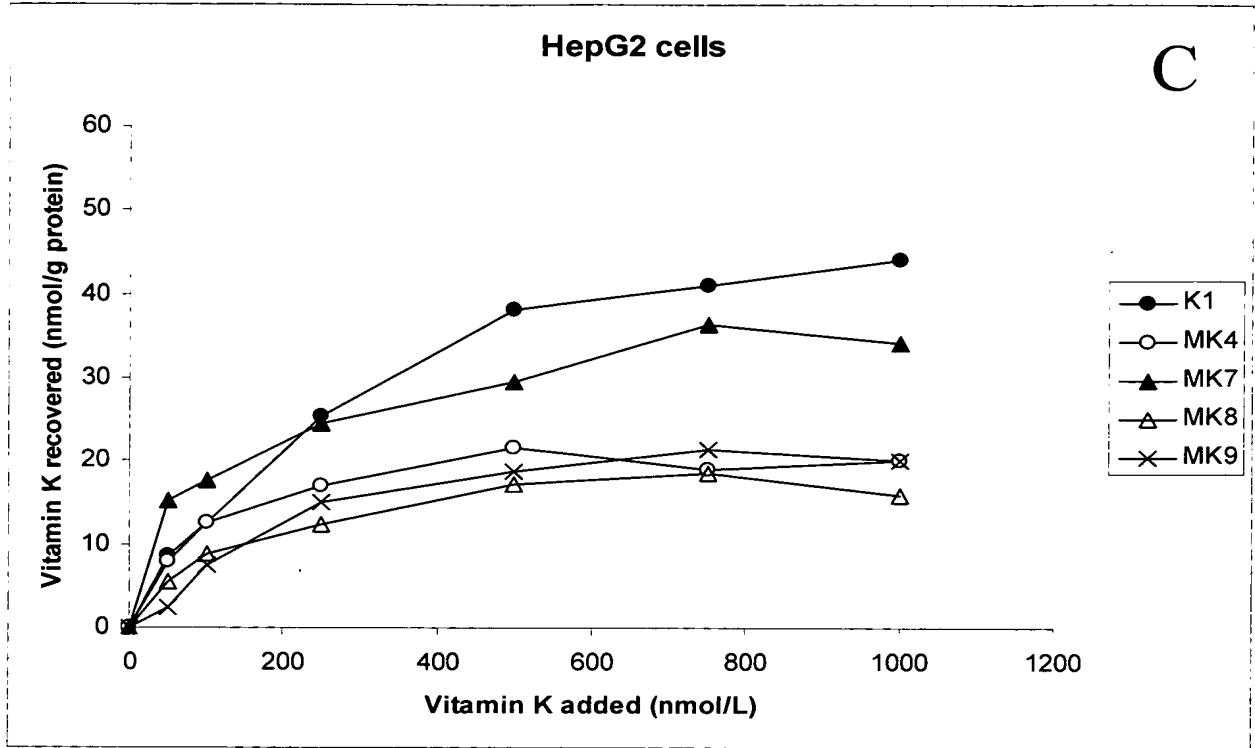

Fig. 5 (contn'd)

7/9

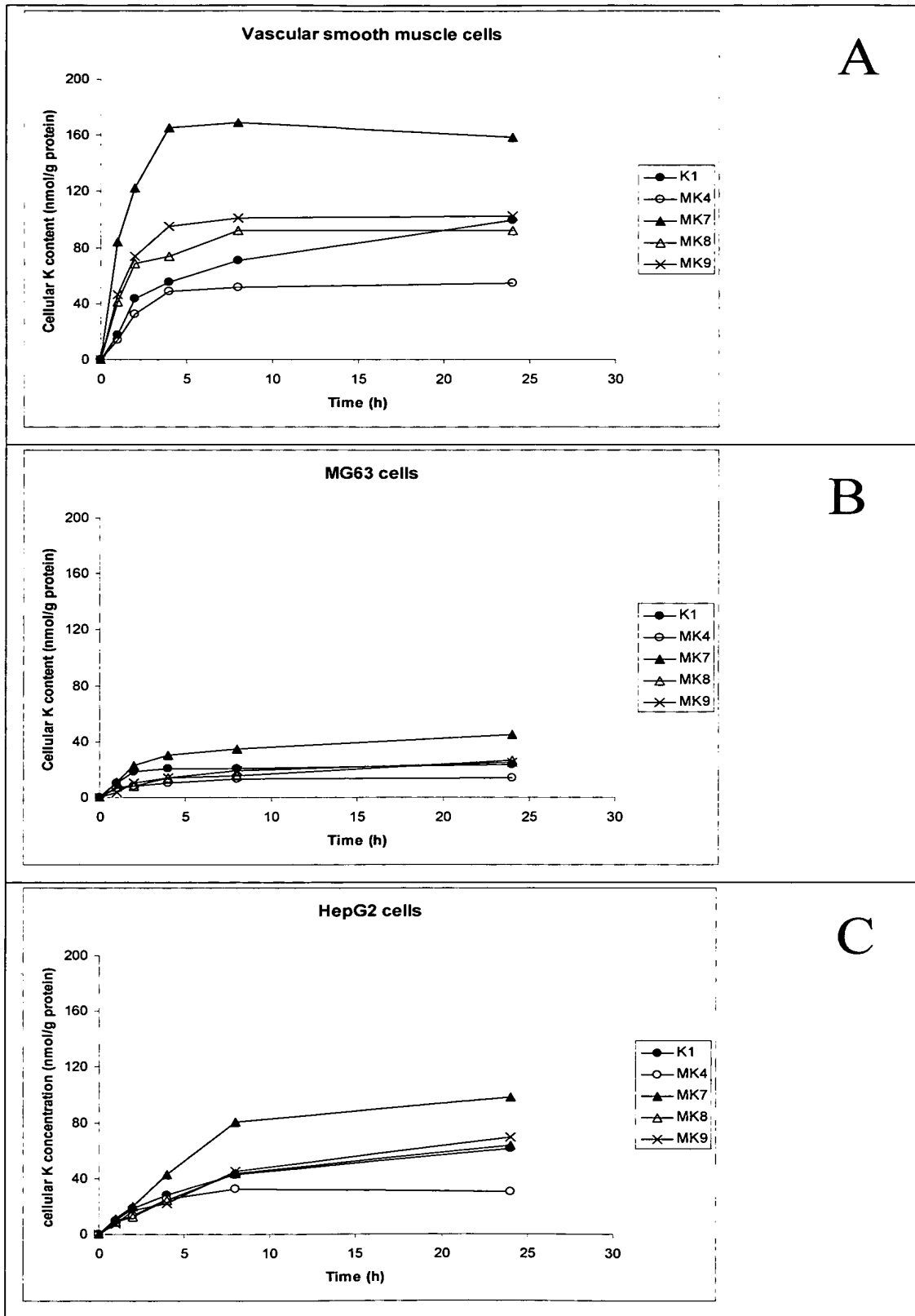

Fig. 6

8/9

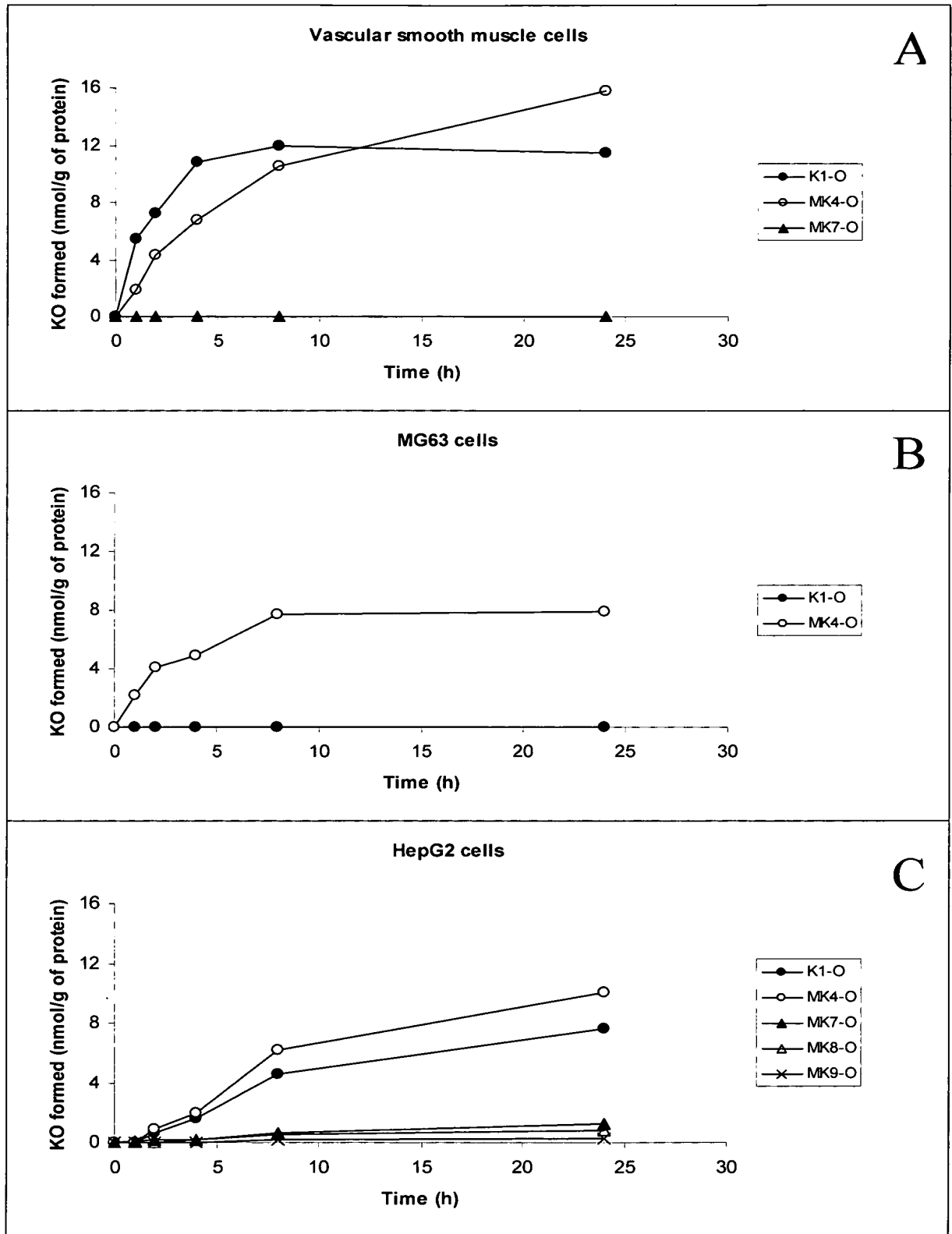

Fig. 7



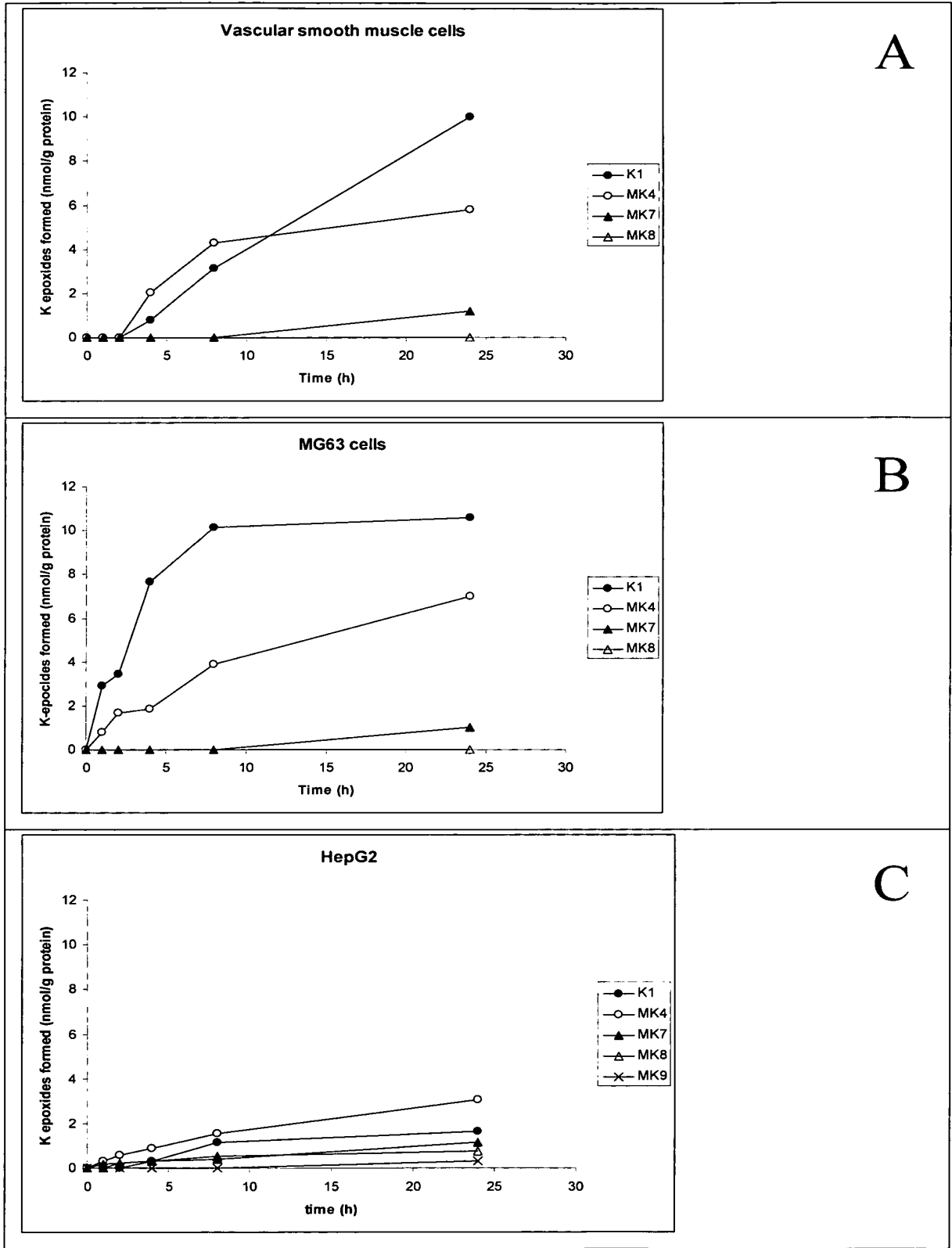

Fig. 8

(19) World Intellectual Property Organization  
International Bureau



(43) International Publication Date  
2 October 2008 (02.10.2008)

PCT

(10) International Publication Number  
WO 2008/117062 A1

(51) International Patent Classification:  
A61K 35/60 (2006.01)

[AU/AU]; Pyrmont Bridge Road, Camperdown, Sydney, NSW 2050 (AU). **MANCINELLI, Daniele** [NO/NO]; Grimvegen 14, N-6150 Orsta (NO).

(21) International Application Number:  
PCT/GB2008/001080

(74) Agent: **GOLDING, Louise**; Frank B. Dehn & Co., St Bride's House, 10 Salisbury Square, London EC4Y 8JD (GB).

(22) International Filing Date: 28 March 2008 (28.03.2008)

(25) Filing Language: English

(81) Designated States (unless otherwise indicated, for every kind of national protection available): AE, AG, AL, AM, AO, AT, AU, AZ, BA, BB, BG, BH, BR, BW, BY, BZ, CA, CH, CN, CO, CR, CU, CZ, DE, DK, DM, DO, DZ, EC, EE, EG, ES, FI, GB, GD, GE, GI, GM, GT, HN, HR, HU, ID, IL, IN, IS, JP, KE, KG, KM, KN, KP, KR, KZ, LA, LC, LK, LR, LS, LT, LU, LY, MA, MD, ME, MG, MK, MN, MW, MX, MY, MZ, NA, NG, NI, NO, NZ, OM, PG, PH, PL, PT, RO, RS, RU, SC, SD, SE, SG, SK, SL, SM, SV, SY, TJ, TM, TN, TR, TT, TZ, UA, UG, US, UZ, VC, VN, ZA, ZM, ZW.

(26) Publication Language: English

(30) Priority Data:  
60/920,483 28 March 2007 (28.03.2007) US  
60/975,058 25 September 2007 (25.09.2007) US  
60/983,446 29 October 2007 (29.10.2007) US  
61/024,072 28 January 2008 (28.01.2008) US

(71) Applicant (for all designated States except US): **AKER BIOMARINE ASA** [NO/NO]; Fjordalléen 16, PO BOX 1423 Vika, N-0115 Oslo (NO).

(84) Designated States (unless otherwise indicated, for every kind of regional protection available): ARIPO (BW, GH, GM, KE, LS, MW, MZ, NA, SD, SL, SZ, TZ, UG, ZM, ZW), Eurasian (AM, AZ, BY, KG, KZ, MD, RU, TJ, TM), European (AT, BE, BG, CH, CY, CZ, DE, DK, EE, ES, FI, FR, GB, GR, HR, HU, IE, IS, IT, LT, LU, LV, MC, MT, NL, NO, PL, PT, RO, SE, SI, SK, TR), OAPI (BF, BJ, CF, CG, CI, CM, GA, GN, GQ, GW, ML, MR, NE, SN, TD, TG).

(71) Applicant (for GB only): **GOLDING, Louise** [GB/GB]; Frank B. Dehn & Co., St Bride's House, 10 Salisbury Square, London EC4Y 8JD (GB).

(72) Inventors; and

(75) Inventors/Applicants (for US only): **BRUHEIM, Inge** [NO/NO]; Martavegen 6 A, N-6100 Volda (NO). **GRIINARI, Mikko** [FI/FI]; Kultarinnantie 1B, FIN-02660 Espoo (FI). **TILSETH, Snorre** [NO/NO]; Fantottasen 27 A, N-5027 Bergen (NO). **BANNI, Sebastiano** [IT/IT]; Viale Poetto 98, I-09126 Cagliari (IT). **COHN, Jeffrey**

Published:

- with international search report
- before the expiration of the time limit for amending the claims and to be republished in the event of receipt of amendments

(54) Title: BIOEFFECTIVE KRILL OIL COMPOSITIONS

(57) Abstract: This invention discloses new krill oil compositions characterized by having high amounts of phospholipids, astaxanthin esters and/or omega-3 contents. The krill oils are obtained from krill meal using supercritical fluid extraction in a two stage process. Stage 1 removes the neutral lipid by extracting with neat supercritical CO<sub>2</sub> or CO<sub>2</sub> plus approximately 5% of a co-solvent. Stage 2 extract the actual krill oils by using supercritical CO<sub>2</sub> in combination with approximately 20% ethanol. The krill oil materials obtained are compared with commercially available krill oil and found to be more bioeffective in a number of areas such as anti-inflammation, anti-oxidant effects, improving insulin resistances and improving blood lipid profile.



WO 2008/117062 A1

## BIOEFFECTIVE KRILL OIL COMPOSITIONS

### FIELD OF THE INVENTION

This invention relates to extracts from Antarctic krill that comprise bioactive fatty  
5 acids.

### BACKGROUND OF THE INVENTION

In the Southern Ocean, off the coast of Antarctica, Antarctic krill (*Euphausia superba*)  
can be found in large quantities, ranging from 300-500 million metric tons of biomass. It  
10 feeds on phytoplankton during the short Antarctic summer. During winter, however, its food  
supply is limited to ice algae, bacteria, marine detritus as well as depleting body protein for  
energy.

In order to isolate the krill oil from the krill, solvent extraction methods have been  
used. See, e.g., WO 00/23546. Krill lipids have been extracted by placing the material in a  
15 ketone solvent (e.g. acetone) in order to extract the lipid soluble fraction. This method  
involves separating the liquid and solid contents and recovering a lipid rich fraction from the  
liquid fraction by evaporation. Further processing steps include extracting and recovering by  
evaporation the remaining soluble lipid fraction from the solid contents by using a solvent  
such as ethanol. See, e.g., WO 00/23546. The compositions produced by these methods are  
20 characterized by containing at least 75 µg/g astaxanthin, preferably 90 µg/g astaxanthin.  
Another krill lipid extract disclosed contained at least 250 µg/g canastaxanthin, preferably 270  
µg/g canastaxanthin.

Krill oil compositions have been described as being effective for decreasing  
cholesterol, inhibiting platelet adhesion, inhibiting artery plaque formation, preventing  
25 hypertension, controlling arthritis symptoms, preventing skin cancer, enhancing transdermal  
transport, reducing the symptoms of premenstrual symptoms or controlling blood glucose  
levels in a patient. See, e.g., WO 02/102394. In yet another application, a krill oil  
composition has been disclosed comprising a phospholipid and/or a flavonoid. The  
phospholipid content in the krill lipid extract could be as high as 60% w/w and the EPA/DHA  
30 content as high as 35% (w/w). See, e.g., WO 03/011873.

Furthermore, nutraceuticals, pharmaceuticals and cosmetics comprising the  
phospholipid extract were disclosed. Previously, it was also shown that supercritical fluid  
extraction using neat CO<sub>2</sub> could be used to prevent the extraction of phospholipids in order to  
extract the neutral lipid fraction from krill, which comprised of esterified and free astaxanthin.

See, e.g., Yamaguchi et al., *J. Agric. Food Chem.* (1986), 34(5), 904-7. Supercritical fluid extraction with solvent modifier has previously been used to extract marine phospholipids from salmon roe, but has not been previously used to extract phospholipids from krill meal. See, e.g., Tanaka et al., *J. Oleo Sci.* (2004), 53(9), 417-424.

5           The methods described above rely on the processing of frozen krill that are transported from the Southern Ocean to the processing site. This transportation is both expensive and can result in degradation of the krill starting material. Data in the literature showing a rapid decomposition of the oil in krill explains why some krill oil currently offered as an omega-3 supplement in the marketplace contains very high amounts of partly decomposed  
10 phosphatidylcholine and also partly decomposed glycerides. Saether et al., *Comp. Biochem Phys. B* 83B(1): 51-55 (1986). The products offered also contain high levels of free fatty acids.

          What is needed in the art are methods for processing krill that do not require transport of frozen krill material over long distances and the products produced by those methods.

15

#### SUMMARY OF THE INVENTION

          In a first aspect of the invention is a composition characterized by comprising at least 65% (w/w) phospholipids.

          In another aspect of the invention is a composition obtained from aquatic or marine  
20 sources, characterized by comprising 65% (w/w) phospholipids.

          In yet another aspect of the invention is a composition obtained from krill, characterized by comprising at least 65% (w/w) phospholipids.

          In another aspect of the invention is a composition obtained from krill, characterized by comprising at least 65% (w/w) phospholipids and at least 39% omega-3 fatty acids (w/w).

25           In yet another aspect of the invention is a composition obtained from krill, characterized by comprising at least 65% (w/w) phospholipids, at least 39% omega-3 fatty acids (w/w) and at least 580 mg/kg astaxanthin esters.

          In another aspect of the invention is a composition obtained from krill, characterized by comprising at least 39% omega-3 fatty acids (w/w) and at least 580 mg/kg astaxanthin  
30 esters.

          In yet another aspect of the invention is a composition obtained from krill, characterized by comprising at least 65% (w/w) phospholipids and at least 580mg/kg astaxanthin esters.

In yet another aspect, the present invention provides a krill oil effective for reducing insulin resistance, improving blood lipid profile, reducing inflammation or reducing oxidative stress.

In some embodiments, the present invention provides compositions comprising: from  
5 about 3% to 10% ether phospholipids on a w/w basis; from about 35% to 50% non-ether  
phospholipids on w/w basis, so that the total amount of ether phospholipids and non-ether  
phospholipids in the composition is from about 48% to 60% on a w/w basis;  
from about 20% to 45% triglycerides on a w/w basis; and from about 400 to about 2500  
mg/kg astaxanthin. In some embodiments, the ether phospholipids are selected from the  
10 group consisting of alkylacylphosphatidylcholine, lyso-alkylacylphosphatidylcholine,  
alkylacylphosphatidylethanolamine, and combinations thereof. In some embodiments, the  
ether lipids are greater than 90% alkylacylphosphatidylcholine. In some embodiments, the  
non-ether phospholipids are selected from the group consisting of phosphatidylcholine,  
phosphatidylserine, phosphatidylethanolamine and combinations thereof. In some  
15 embodiments, krill oil composition comprises a blend of lipid fractions obtained from krill. In  
some preferred embodiments, krill is *Euphausia superba*, although other krill species also find  
use in the present invention. Other krill species include, but are not limited to *E. pacifica*, *E.*  
*frigida*, *E. longirostris*, *E. triacantha*, *E. vallentini*, *Meganyctiphanes norvegica*, *Thysanoessa*  
*raschii* and *Thysanoessa inermis*. In some embodiments, the compositions comprise from  
20 about 25% to 30% omega-3 fatty acids as a percentage of total fatty acids and wherein from  
about 80% to 90% of said omega-3 fatty acids are attached to said phospholipids. In some  
embodiments, the present invention provides a capsule containing the foregoing compositions.

In further embodiments, the present inventions provide compositions comprising: from  
about 3% to 10% ether phospholipids on a w/w basis; and from about 400 to about 2500  
25 mg/kg astaxanthin. In some embodiments, the compositions further comprise from about  
35% to 50% non-ether phospholipids on w/w basis, so that the total amount of ether  
phospholipids and non-ether phospholipids in the composition is from about 38% to 60% on a  
w/w basis. In some embodiments, the compositions further comprise from about 20% to 45%  
triglycerides on a w/w basis. In some embodiments, the ether phospholipids are selected from  
30 the group consisting of alkylacylphosphatidylcholine, lyso-alkylacylphosphatidylcholine,  
alkylacylphosphatidylethanolamine, and combinations thereof. In some embodiments, the  
ether lipids are greater than 90% alkylacylphosphatidylcholine. In some embodiments, the  
non-ether phospholipids are selected from the group consisting of phosphatidylcholine,  
phosphatidylserine, phosphatidylethanolamine and combinations thereof. In some

embodiments, krill oil composition comprises a blend of lipid fractions obtained from krill. In some preferred embodiments, krill is *Euphausia superba*, although other krill species also find use in the present invention. Other krill species include, but are not limited to *E. pacifica*, *E. frigida*, *E. longirostris*, *E. triacantha*, *E. vallentini*, *Meganyctiphanes norvegica*, *Thysanoessa raschii* and *Thysanoessa inermis*. In some embodiments, the compositions comprise about 5 25% to 30% omega-3 fatty acids as a percentage of total fatty acids and wherein from about 80% to 90% of said omega-3 fatty acids are attached to said phospholipids. In some embodiments, the present invention provides a capsule containing the foregoing compositions.

In some embodiments, the present invention provides a composition comprising at 10 least 65% (w/w) of phospholipids, said phospholipids characterized in containing at least 35% omega-3 fatty acid residues. In some preferred embodiments, the composition is derived from a marine or aquatic biomass. In some further preferred embodiments, the composition is derived from krill. In some embodiments, the composition comprises less than 2% free fatty acids. In some embodiments, composition comprises less than 10% triglycerides. In some 15 preferred embodiments, the phospholipids comprise greater than 50% phosphatidylcholine. In some embodiments, the composition comprises at least 500 mg/kg astaxanthin esters. In some embodiments, the composition comprises at least 500 mg/kg astaxanthin esters and at least 36% (w/w) omega-3 fatty acids. In some embodiments, the composition comprises less than about 0.5g/100g total cholesterol. In some embodiments, the composition comprises less 20 than about 0.45% arachidonic acid (w/w).

In some embodiments, the present invention provides a krill lipid extract comprising at least 500, 100, 1500, 2000, 2100, or 2200 mg/kg astaxanthin esters and at least 36% (w/w) omega-3 fatty acids. In further embodiments, the present invention provides a krill lipid extract comprising at least 100 mg/kg astaxanthin esters, at least 20% (w/w) omega-3 fatty 25 acids, and less than about 0.45% arachidonic acid (w/w).

In some embodiments, the present invention provides methods comprising administering the foregoing compositions to a subject in an amount effective for reducing insulin resistance, reducing inflammation, improving blood lipid profile and reducing oxidative stress.

30 In some embodiments, the present invention provides a krill lipid extract comprising greater than about 80% triglycerides and greater than about 90, 100, 500, 1000, 1500, 200, 2100 or 2200 mg/kg astaxanthin esters. In some embodiments, the krill lipid extract is characterized in containing from about 5% to about 15% omega-3 fatty acid residues. In some embodiments, the krill lipid extract is characterized in containing less than about 5%

phospholipids. In some embodiments, the krill lipid extract is characterized in comprising from about 5% to about 10% cholesterol.

In some embodiments, the present invention provides a krill meal composition comprising less than about 50g/kg total fat. In some embodiments, the krill meal composition comprises from about 5 to about 20 mg/kg astaxanthin esters. In some embodiments, the krill meal composition comprises greater than about 65% protein. In some embodiments, the krill meal composition of comprises greater than about 70% protein. In some further embodiments, the present invention provides an animal feed comprising the krill meal composition.

10 In some embodiments, the present invention provides methods of increasing flesh coloration in an aquatic species comprising feeding said aquatic species a composition comprising the krill meal described above. In some embodiments, the present invention provides methods of increasing growth and overall survival rate of aquatic species by feeding the krill meal described above.

15 In some embodiments, the present invention provides methods of producing krill oil comprising: a) providing krill meal; and b) extracting oil from said krill meal. In some embodiments, the krill meal is produced by heat-treating krill. In some embodiments, the krill meal is stored prior to the extraction step. In some embodiments, the extracting step comprises extraction by supercritical fluid extraction. In some embodiments, the supercritical  
20 fluid extraction is a two step process comprising a first extraction step with carbon dioxide and a low concentration of a co-solvent (e.g., from about 1-10% co-solvent) and a second extraction step with carbon dioxide and a high concentration of a co-solvent (e.g., from about 10-30% co-solvent). In preferred embodiments, the co-solvent is a C<sub>1</sub>-C<sub>3</sub> monohydric alcohol, preferably ethanol. In some embodiments, the present invention provides oil  
25 produced by the foregoing method.

In some embodiments, the present invention provides methods of production of krill oil comprising: a) providing fresh krill; b) treating said fresh krill to denature lipases and phospholipases in said fresh krill to provide a denatured krill product; and c) extracting oil from said denatured krill product. In some embodiments, the denaturation step comprises  
30 heating of said fresh krill. In some embodiments, the denaturation step comprises heating said fresh krill after grinding. In some embodiments, the methods further comprise storing said denatured krill product at room temperature or below between the denaturation step and the extraction step. In some embodiments, the enzyme denaturation step is achieved by application of heat. In some embodiments, the extraction step comprises use of supercritical

carbon dioxide, with or without use of a polar modifier. In some embodiments, the extraction step comprises use of ethanol. In some embodiments, the extraction step is comprises ethanol extraction followed by acetone to precipitation of phospholipids. In some embodiments, the denatured krill product is a meal. In some embodiments, the present invention provides oil  
5 produced by the foregoing method.

In some embodiments, the present invention provides a composition comprising oil extracted from krill having a phosphatidylcholine content of greater than about 50% (w/w). In some embodiments, the oil has a phosphatidylcholine content of greater than about 70% (w/w). In some embodiments, the oil has a phosphatidylcholine content of greater than about  
10 80% (w/w). In some embodiments, the composition comprises less than 2% free fatty acids. In some embodiments, the composition comprises less than 10% triglycerides. In some embodiments, the composition comprises at least 500 mg/kg astaxanthin esters. In some embodiments, the composition comprises less than about 0.45% arachidonic acid (w/w).

In some embodiments, the present invention provides composition comprising  
15 odorless krill oil. In some embodiments, the odorless krill oil comprises less than about 10 mg/kg (w/w) trimethylamine. In some further embodiments, the present invention provides an odorless krill oil produced by the method comprising: extracting a neutral krill oil from a krill oil containing material by supercritical fluid extraction to provide a deodorized krill material, wherein said neutral krill oil contains odor causing compounds and extracting a  
20 polar krill oil from said deodorized krill material by supercritical fluid extraction with a polar entrainer to provide an essentially odorless krill oil.

In some embodiments, the present invention provides a composition comprising krill oil containing less than about 70 micrograms/kilogram (w/w) astaxanthin esters. In some  
embodiments, the compositions comprise less than about 50 micrograms/kilogram (w/w)  
25 astaxanthin esters. In some embodiments, the compositions comprise less than about 20 micrograms/kilogram (w/w) astaxanthin esters. In some embodiments, the compositions comprise less than about 5 micrograms/kilogram (w/w) astaxanthin esters.

In some embodiments, the present invention provides a krill oil produced by the process comprising: pumping fresh krill from a trawl onto a ship, heating the krill to provide a  
30 krill material, and extracting oil from the krill material.

In further embodiments, the present invention provides a blended krill oil composition comprising: from about 45% to 55% w/w phospholipids; from about 20% to 45% w/w triglycerides; and from about 400 to about 2500 mg/kg astaxanthin. In some embodiments, the blended krill oil product comprises a blend of lipid fractions obtained from *Euphausia*



*superba*. In some embodiments, the composition comprises from about 25% to 30% omega-3 fatty acids as a percentage of total fatty acids and wherein from about 80% to 90% of said omega-3 fatty acids are attached to said phospholipids.

In still other embodiments, the present invention provides a *Euphausia superba* krill  
5 oil composition comprising: from about 30% to 60% w/w phospholipids; from about 20% to 50% triglycerides; from about 400 to about 2500 mg/kg astaxanthin; and from about 20% to 35% omega-3 fatty acids as a percentage of total fatty acids in said composition, wherein from about 70% to 95% of said omega-3 fatty acids are attached to said phospholipids.

In still further embodiments, the present invention provides a dietary supplement  
10 comprising encapsulated *Euphausia superba* krill oil comprising from about 30% to 60% w/w phospholipids; from about 20% to 50% triglycerides; from about 400 to about 2500 mg/kg astaxanthin; and from about 20% to 35% omega-3 fatty acids as a percentage of total fatty acids in said composition, wherein from about 70% to 95% of said omega-3 fatty acids are attached to said phospholipids.

In some embodiments, the present invention provides methods of making a *Euphausia  
15 superba* krill oil composition comprising: contacting *Euphausia superba* with a polar solvent to provide a polar extract comprising phospholipids; contacting *Euphausia superba* with a neutral solvent to provide a neutral extract comprising triglycerides and astaxanthin; combining said polar extract and said neutral extract to provide *Euphausia superba* krill oil  
20 comprising from about 30% to 60% w/w phospholipids; from about 20% to 50% triglycerides; from about 400 to about 2500 mg/kg astaxanthin; and from about 20% to 35% omega-3 fatty acids as a percentage of total fatty acids in said composition, wherein from about 70% to 95% of said omega-3 fatty acids are attached to said phospholipids. In some embodiments, the methods further comprise the step of encapsulating the *Euphausia superba*  
25 krill oil. In some embodiments, the present invention provides a *Euphausia superba* krill oil produced by the methods described above.

In some embodiments, the present invention provides methods of producing a dietary  
30 supplement comprising: contacting *Euphausia superba* with a polar solvent to provide an polar extract comprising phospholipids; contacting *Euphausia superba* with a neutral solvent to provide a neutral extract comprising triglycerides and astaxanthin; combining said polar extract and said neutral extract to provide *Euphausia superba* krill oil comprising from about 30% to 60% w/w phospholipids; from about 20% to 50% triglycerides; from about 400 to about 2500 mg/kg astaxanthin; and from about 20% to 35% omega-3 fatty acids as a percentage of total fatty acids in said composition, wherein from about 70% to 95% of said

omega-3 fatty acids are attached to said phospholipids; and encapsulating said *Euphausia superba* krill oil.

In some embodiments, the present invention provides methods of reducing diet-induced hyperinsulinemia, insulin insensitivity, muscle mass hypertrophy, serum adiponectin reduction or hepatic steatosis comprising in a subject exposed to a high fat diet: administering  
5 to said subject exposed to a high fat diet an effective amount of a krill oil composition under conditions such that a condition selected from the group consisting of diet-induced hyperinsulinemia, insulin insensitivity, muscle mass hypertrophy, serum adiponectin reduction and hepatic steatosis is reduced. The present invention is not limited to any  
10 particular krill oil composition. In some embodiments, the krill oil composition is a *Euphausia superba* krill oil composition. The present invention is not limited to any particular formulation of krill oil. In some embodiments, the krill oil composition is encapsulated. In some preferred embodiments, the effective amount of a krill oil composition is from 0.2 grams to 10 grams of said krill oil composition. In some embodiments, the krill  
15 oil composition comprises: from about 45% to 55% w/w phospholipids; from about 20% to 45% w/w triglycerides; and from about 400 to about 2500 mg/kg astaxanthin. In some embodiments, the krill oil composition comprises a blend of lipid fractions obtained from *Euphausia superba*. In some embodiments, the krill oil composition comprises from about 25% to 30% omega-3 fatty acids as a percentage of total fatty acids and wherein from about  
20 80% to 90% of said omega-3 fatty acids are attached to said phospholipids. In some embodiments, the krill oil composition comprises from about 30% to 60% w/w phospholipids; from about 20% to 50% triglycerides; from about 400 to about 2500 mg/kg astaxanthin; and from about 20% to 35% omega-3 fatty acids as a percentage of total fatty acids in said composition, and wherein from about 70% to 95% of said omega-3 fatty acids are attached to  
25 said phospholipids.

In some embodiments, the present invention provides methods of reducing diet-induced hyperinsulinemia, insulin insensitivity, muscle mass hypertrophy, serum adiponectin reduction or hepatic steatosis comprising in a subject consuming a high fat diet or a normal fat diet: administering to said subject consuming a high fat diet or a normal fat diet an effective  
30 amount of a krill oil composition under conditions such that a condition selected from the group consisting of diet-induced hyperinsulinemia, insulin insensitivity, muscle mass hypertrophy, serum adiponectin reduction and hepatic steatosis is reduced. The present invention is not limited to any particular krill oil composition. In some embodiments, the krill oil composition is a *Euphausia superba* krill oil composition. The present invention is not

limited to any particular formulation of krill oil. In some embodiments, the krill oil composition is encapsulated. In some preferred embodiments, the effective amount of a krill oil composition is from 0.2 grams to 10 grams of said krill oil composition. In some embodiments, the krill oil composition comprises: from about 45% to 55% w/w phospholipids; from about 20% to 45% w/w triglycerides; and from about 400 to about 2500 mg/kg astaxanthin. In some embodiments, the krill oil composition comprises a blend of lipid fractions obtained from *Euphausia superba*. In some embodiments, the krill oil composition comprises from about 25% to 30% omega-3 fatty acids as a percentage of total fatty acids and wherein from about 80% to 90% of said omega-3 fatty acids are attached to said phospholipids. In some embodiments, the krill oil composition comprises from about 30% to 60% w/w phospholipids; from about 20% to 50% triglycerides; from about 400 to about 2500 mg/kg astaxanthin; and from about 20% to 35% omega-3 fatty acids as a percentage of total fatty acids in said composition, and wherein from about 70% to 95% of said omega-3 fatty acids are attached to said phospholipids.

In some embodiments, the present invention provides methods of inducing diuresis in a subject comprising: administering to said subject an effective amount of a krill oil composition under conditions such that diuresis is induced. In some embodiments, the present invention provides methods of increasing muscle mass in a subject, comprising: administering to said subject an effective amount of a krill oil composition under conditions such that muscle mass is increased. In some embodiments, the present invention provides methods of decreasing protein catabolism in a subject, comprising: administering to said subject an effective amount of a krill oil composition under conditions such that protein catabolism is decreased. In some embodiments, the present invention provides methods of decreasing lipid content in the heart of a subject, comprising: administering to said subject an effective amount of a krill oil composition under conditions such that lipid content in the heart of the subject is decreased. In some embodiments, the present invention provides methods of decreasing lipid content in the liver of a subject, comprising: administering to said subject an effective amount of a krill oil composition under conditions such that lipid content in the liver of the subject is decreased.

## DESCRIPTION OF THE FIGURES

Figure 1. <sup>31</sup>P NMR analysis of polar lipids in krill oil.

Figure 2. Blood lipid profiles in Zucker rats fed different forms of omega-3 fatty acids (TAG = FO, PL1 = NKO and PL2 = Superba).

Figure 3. Plasma glucose concentration in Zucker rats fed different forms of omega-3 fatty acids.

Figure 4. Plasma insulin concentration in Zucker rats fed different forms of omega-3 fatty acids.

5 Figure 5. Estimated HOMA-IR values in Zucker rats fed different forms of omega-3 fatty acids.

Figure 6. The effect of dietary omega-3 fatty acids on TNF $\alpha$  production by peritoneal macrophages.

Figure 7. The effect of dietary omega-3 fatty acids on lipid accumulation in the liver.

10 Figure 8. The effect of dietary omega-3 fatty acids on lipid accumulation in the muscle.

Figure 9. The effect of dietary omega-3 fatty acids on lipid accumulation in the heart.

Figure 10. Relative concentrations of DHA in the brain in Zucker rats supplemented with omega-3 fatty acids.

15 Figure 11. Mean group body weights (g) in the collagen-induced male DBA/1 arthritic mice. B - PL2 is the krill oil group. \*  $p < 0.05$ , significantly different from Group A (Positive Control - Fish Oil) and Group C (Control).

Figure 12. Body weight for the various treatment groups.

Figure 13. Muscle weight for the various treatment groups.

20 Figure 14. Muscle to body weight ratio for the various treatment groups.

Figure 15. Serum adiponectin levels (ng/ml) for the various treatment groups.

Figure 16. Serum insulin levels for the various treatment groups.

Figure 17. Blood glucose (mmol/l) levels in the various treatment groups.

Figure 18. HOMA-IR values for the various treatment groups.

25 Figure 19. Liver triglyceride levels ( $\mu\text{mol/g}$ ) for the various treatment groups.

## DEFINITIONS

As used herein, "phospholipid" refers to an organic compound having the following  
30 general structure:

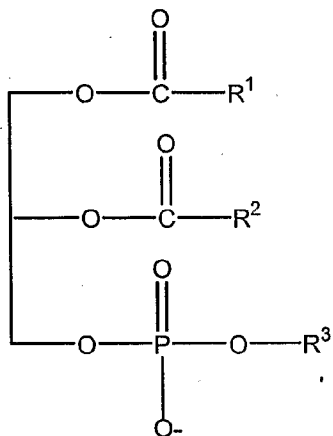

wherein R1 is a fatty acid residue, R2 is a fatty acid residue or  $-OH$ , and R3 is a  $-H$  or nitrogen containing compound choline ( $HOCH_2CH_2N^+(CH_3)_3OH^-$ ), ethanolamine ( $HOCH_2CH_2NH_2$ ), inositol or serine. R1 and R2 cannot simultaneously be  $OH$ . When R3 is an  $-OH$ , the compound is a diacylglycerophosphate, while when R3 is a nitrogen-containing compound, the compound is a phosphatide such as lecithin, cephalin, phosphatidyl serine or plasmalogen.

An "ether phospholipid" as used herein refers to a phospholipid having an ether bond at position 1 the glycerol backbone. Examples of ether phospholipids include, but are not limited to, alkylacylphosphatidylcholine (AAPC), lyso-alkylacylphosphatidylcholine (LAAPC), and alkylacylphosphatidylethanolamine (AAPE). A "non-ether phospholipid" is a phospholipid that does not have an ether bond at position 1 of the glycerol backbone.

As used herein, the term omega-3 fatty acid refers to polyunsaturated fatty acids that have the final double bond in the hydrocarbon chain between the third and fourth carbon atoms from the methyl end of the molecule. Non-limiting examples of omega-3 fatty acids include, 5,8,11,14,17-eicosapentaenoic acid (EPA), 4,7,10,13,16,19-docosahexanoic acid (DHA) and 7,10,13,16,19-docosapentanoic acid (DPA).

As used herein, astaxanthin refers to the following chemical structure:

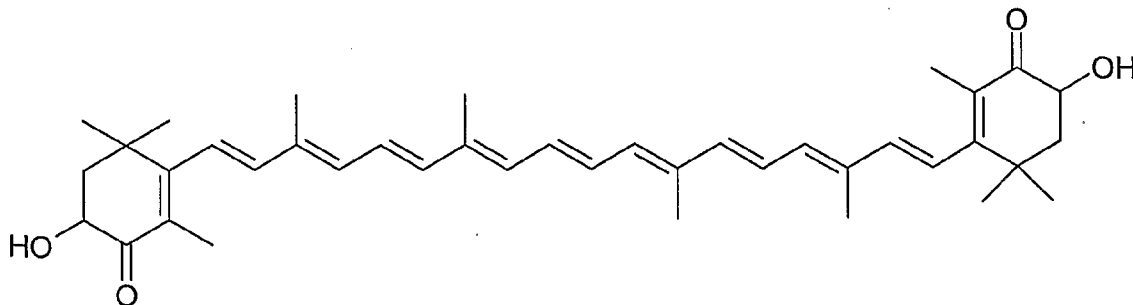

20

As used herein, astaxanthin esters refer to the fatty acids esterified to OH group in the astaxanthin molecule.

As used herein, the term w/w (weight/weight) refers to the amount of a given substance in a composition on weight basis. For example, a composition comprising 50% w/w phospholipids means that the mass of the phospholipids is 50% of the total mass of the composition (i.e., 50 grams of phospholipids in 100 grams of the composition, such as an oil).

#### DETAILED DESCRIPTION OF THE INVENTION

This invention discloses novel krill oil compositions characterized by containing high levels of astaxanthin, phospholipids, included an enriched quantities of ether phospholipids, and omega-3 fatty acids. The krill oils compositions are extracted from krill meal using supercritical fluid extraction (SFE) with a co-solvent modifier. The krill meal has been processed on board a ship in Antarctica using live krill as starting material in order to ensure the highest possible quality of the krill meal. The krill oils are extracted from the krill meal in two stages, in step 1 the neutral fraction is extracted using neat supercritical CO<sub>2</sub> or in combination with 5% ethanol. The neutral fraction consisted mostly of triglycerides and cholesterol. In stage 2, the polar lipids (phospholipids) are extracted by adding at least 20% ethanol to the supercritical CO<sub>2</sub> extraction medium.

The present invention provides methods to avoid decomposition of glycerides and phospholipids in krill oil and compositions produced by those methods. The product obtained by these new methods is virtually free of enzymatically decomposed oil constituents. The solution to the problem is to incorporate a protein denaturation step on fresh krill prior to use of any extraction technology. Denaturation can be achieved by thermal stress or by other means. After denaturation, the oil can be extracted by an optional selection of nonpolar and polar solvents including use of supercritical carbon dioxide. Krill is adapted to a very efficient nutrient digestion at very low temperatures. Therefore the enzymes are sensitive to heat and the step of applying thermal denaturation of lipases and phospholipases does not imply use of very high temperatures. Surprisingly, it has been found that the use of mild denaturation conditions can greatly enhance the quality of krill oil.

Additionally, a major obstacle of several processes of extraction is the cost of removing water. This is particularly true for methods feasible for extraction of highly unsaturated lipids where freeze drying has been regarded as the method of choice to avoid oxidative breakdown of lipids. However, the lipids in krill are surprisingly stable against

oxidative deterioration. Therefore, a process including moderate use of heat in the water removing process is feasible provided that the enzymes have been inactivated.

#### A. Krill Processing

5 The present invention provides methods for processing freshly caught krill at the site of capture and preferably on board a ship. After processing on board, the krill can be further subjected to extraction processes on board the ship or at a remote location away from the ship. The processing steps described herein also allow for the storage of krill material, preferably a krill meal for from about 1,2, 3, 4, 5, 6, 8, 9, 10, 11, or 12 months to about 24 to 36 months  
10 prior to processing.

In some preferred embodiments, freshly caught krill is first subjected to a protein denaturation step. The present invention is not limited to any particular method of protein denaturation. In some embodiments, the denaturation is accomplished by application of chemicals, heat, or combinations thereof. In some embodiments, freshly caught krill is wet  
15 pressed to obtain oil and meal. In some embodiments, the meal is then heated to a temperature of about 50°C to about 100°C for about 20 minutes to about an hour, preferably about 40 minutes to denature the proteins. In some embodiments, this material is then pressed to yield a press cake. When this method is used on krill, only a small amount of oil is released. Most of the oil is still present in the denatured meal. In some embodiments, antioxidants such as  
20 ethoxyquin or Vitamin E are added to the meal. However, as shown in the examples, the resulting meal is surprisingly stable. The stability can only partly be explained by addition of an antioxidant to the meal. This antioxidant can, after extraction of the oil from denatured meal, be removed by further processing steps. Alternatively the oil can be extracted rather shortly after production of the meal without any addition of antioxidant in the process.  
25 Further, storage conditions at a low to very low temperature can be applied if addition of antioxidant is not desired.

Krill oil extracted from denatured krill meal by supercritical fluid extraction even 19 months after the production of the meal contained virtually no decomposed phospholipids. This product turned out to be substantially different from samples of krill oil available in the  
30 market today. Previously described commercial krill processing procedures utilize krill that has been frozen immediately after catching followed by freeze drying and extraction at low temperatures. However, these processes only yield a suitable product if the time the krill is kept frozen is very short or the temperature is extremely low (-60° to -80°C). However, data provided herein clearly shows that if a step of denaturation of the proteins is added in front of

an optional extraction method, an excellent krill oil can be produced even after a long time of storage. This methodology also opens up for use of alternative methods to remove water prior to extraction, which in turn has a great impact on costs in full scale operation. If a long time of storage is desired, the denatured material should preferably be stored at low temperature preferably at -20°C.

In some embodiments, krill oil is extracted from the denatured krill meal. In some embodiments, the krill oil is extracted by contacting the krill meal with ethanol. In some embodiments, krill is then extracted with a ketone solvent such as acetone. In other embodiments, the krill oil is extracted by one or two step supercritical fluid extraction. In some embodiments, the supercritical fluid extraction uses carbon dioxide and neutral krill oil is produced. In some embodiments, the supercritical fluid extraction uses carbon dioxide with the addition of a polar entrainer, such as ethanol, to produce a polar krill oil. In some embodiments, the krill meal is first extracted with carbon dioxide followed by carbon dioxide with a polar entrainer, or vice versa. In some embodiments, the krill meal is first extracted with CO<sub>2</sub> supplemented with a low amount of a polar co-solvent (e.g., from about 1% to about 10%, preferably about 5%) such a C<sub>1</sub>-C<sub>3</sub> monohydric alcohol, preferably ethanol, followed by extraction with CO<sub>2</sub> supplemented with a high amount of a polar co-solvent (from about 10% to about 30%, preferably about 23%) such as such a C<sub>1</sub>-C<sub>3</sub> monohydric alcohol, preferably ethanol, or vice versa. Surprisingly, it has been found that use of a low amount of polar solvent in the CO<sub>2</sub> as an entrainer facilitates the extraction of neutral lipid components and astaxanthin in a single step. Use of the high of polar solvent as an entrainer in the other step facilitates extraction of ether phospholipids, as well as non-ether phospholipids.

The present invention is distinguished from previously described krill oil products, such as those described in U.S. Pat. No. 6,800,299 or WO 03/011873 and Neptune brand krill oil, by having substantially higher levels of non-ether phospholipids, ether phospholipids, and astaxanthin. The krill oils of the present invention also have unexpected and superior properties as compared to previously available krill oils. In particular, the krill oil of the present invention has been demonstrated to reduce blood LDL cholesterol levels, improve DHA transfer to the brain as well as reduce lipid accumulation in the liver and muscle while the previously described krill oil compositions do not have such a properties. Accordingly, in some embodiments, the present invention provides a krill oil composition, preferably a *Euphausia superba* krill oil composition, comprising from about 40% to about 60% w/w phospholipids, preferably from about 45% to 55% w/w phospholipids and from about 300 mg/kg astaxanthin to about 2500 mg/kg astaxanthin, preferably from about 1000 to about



2200 mg/kg astaxanthin, more preferably from about 1500 to about 2200 mg/kg astaxanthin. In some preferred embodiments, the compositions comprise greater than about 1000, 1500, 1800, 1900, 2000, or 2100 mg/kg astaxanthin. In some preferred embodiments, the krill oil compositions of the present invention comprise from about 1%, 2%, 3% or 4% to about 8%, 10%, 12% or 15% w/w ether phospholipids or greater than about 4%, 5%, 6%, 7%, 8%, 9% or 10% ether phospholipids. In some embodiments the ether phospholipids are preferably alkylacylphosphatidylcholine, lyso-alkylacylphosphatidylcholine, alkylacylphosphatidyl-ethanolamine or combinations thereof. In some embodiments, the krill oil compositions comprise from about 1%, 2%, 3% or 4% to about 8%, 10%, 12% or 15% w/w ether phospholipids and from about 30%, 33%, 40%, 42%, 45%, 48%, 50%, 52%, 54%, 55% 56%, 58% to about 60% non-ether phospholipids so that the total amount of phospholipids (both ether and non-ether phospholipids) ranges from about 40% to about 60%. One of skill in the art will recognize that the range of 40% to 60% total phospholipids, as well as the other ranges of ether and non-ether phospholipids, can include other values not specifically listed within the range.

In further embodiments, the compositions comprise from about 20% to 45% w/w triglycerides; and from about 400 to about 2500 mg/kg astaxanthin. In some embodiments, the compositions comprise from about 20% to 35%, preferably from about 25% to 35%, omega-3 fatty acids as a percentage of total fatty acids in the composition, wherein from about 70% to 95%, or preferably from about 80% to 90% of the omega-3 fatty acids are attached to the phospholipids. In some embodiments, the present invention provides encapsulated *Euphausia superba* krill oil compositions. In some embodiments, the present invention provides a method of making a *Euphausia superba* krill oil composition comprising contacting *Euphausia superba* with a polar solvent to provide a polar extract comprising phospholipids, contacting *Euphausia superba* with a neutral solvent to provide a neutral extract comprising triglycerides and astaxanthin, and combining said polar extract and said neutral extract to provide the *Euphausia superba* krill oils described above. In some embodiments, fractions from polar and non-polar extractions are combined to provide a final product comprising the desired ether phospholipids, non-ether phospholipids, omega-3 moieties and astaxanthin. In other embodiments, the present invention provides methods of making a *Euphausia superba* (or other krill species) krill oil comprising contacting a *Euphausia superba* preparation such as *Euphausia superba* krill meal under supercritical conditions with CO<sub>2</sub> containing a low amount of a polar solvent such as ethanol to extract neutral lipids and astaxanthin; contacting meal remaining from the first extraction step under

supercritical conditions with CO<sub>2</sub> containing a high amount of a polar solvent such as ethanol to extract a polar lipid fraction containing ether and non-ether phospholipids; and then blending the neutral and polar lipid extracts to provide the compositions described above.

The krill oil extracted by the methods of the present invention contains few enzymatic  
5 breakdown products. Examples of the krill oil compositions of the present invention are provided in Tables 9-24. In some embodiments, the present invention provides a polar krill oil comprising at least 65% (w/w) of phospholipids, wherein the phospholipids are characterized in containing at least 35% omega-3 fatty acid residues. The present invention is not limited to the presence of any particular omega-3 fatty acid residues in the krill oil  
10 composition. In some preferred embodiments, the krill oil comprises EPA and DHA residues. In some embodiments, the krill oil compositions comprise less than about 5%, 4%, 3% or preferably 2% free fatty acids on a weight/weight (w/w) basis. In some embodiments, the krill oil compositions comprise less than about 25%, 20%, 15%, 10% or 5% triglycerides (w/w). In some embodiments, the krill oil compositions comprise greater than about 30%,  
15 40%, 45%, 50%, 55%, 60%, or 65% phosphatidyl choline (w/w). In some embodiments, the krill oil compositions comprise greater than about 100, 200, 300, 400, or 500 mg/kg astaxanthin esters and up to about 700 mg/kg astaxanthin esters. In some embodiments, the present invention provides krill oil compositions comprising at least 500, 1000, 1500, 2000, 2100, or 2200 mg/kg astaxanthin esters and at least 36% (w/w) omega-3 fatty acids. In some  
20 embodiments, the krill oil compositions of the present invention comprise less than about 1.0g/100g, 0.5g/100g, 0.2g/100g or 0.1g/100g total cholesterol. In some embodiments, the krill oil compositions of the present invention comprise less than about 0.45

In some embodiments, the present invention provides a neutral krill oil extract comprising greater than about 70%, 75% 80%, 85% or 90% triglycerides. In some  
25 embodiments, the krill oil compositions comprise from about 50 to about 2500 mg/kg astaxanthin esters. In some embodiments, the krill oil compositions comprise from about 50, 100, 200, or 500 to about 750, 1000, 1500 or 2500 mg/kg astaxanthin esters. In some embodiments, the compositions comprise from about 1% to about 30% omega-3 fatty acid residues, and preferably from about 5%-15% omega-3 fatty acid residues. In some  
30 embodiments, the krill oil compositions comprise less than about 20%, 15%, 10% or 5% phospholipids.

In some embodiments, the present invention provides krill oil containing less than about 70, 60, 50, 40, 30, 20, 10, 5 or 1 micrograms/kilogram (w/w) astaxanthin esters. In some embodiments, the krill oil is clear or only has a pale red color. In some embodiments,

the low-astaxanthin krill oil is obtained by first extracting a krill material, such as krill oil, by supercritical fluid extraction with neat carbon dioxide. It is contemplated that this step removes astaxanthin from the krill material. In some embodiments, the krill material is then subjected to supercritical fluid extraction with carbon dioxide and a polar entrainer such as ethanol, preferably about 20% ethanol. The oil extracted during this step is characterized in containing low amounts of astaxanthin. In other embodiments, krill oil comprising astaxanthin is extracted by countercurrent supercritical fluid extraction with neat carbon dioxide to provide a low-astaxanthin krill oil.

In some embodiments, the present invention provides krill oil that is substantially odorless. By substantially odorless it is meant that the krill oil lacks an appreciable odor as determined by a test panel. In some embodiments, the substantially odorless krill oil comprises less than about 10, 5 or 1 milligrams/kilogram trimethylamine. In some preferred embodiments, the odorless krill oil is produced by first subjecting krill material to supercritical fluid extraction with neat carbon dioxide to remove odor causing compounds such as trimethylamine, followed by extraction with carbon dioxide with a polar entrainer such as ethanol.

In some embodiments, the present invention provides a delipidated krill meal produced after extraction of lipids from the krill meal. In some embodiments, the delipidated krill meal comprises krill protein. In some embodiments, the delipidated krill meal comprises less than about 200, 150, 120, 100, 75, 65, 60, 55, or 50 g/kg total fat. In some embodiments, the delipidated krill meal comprises from about 1 to about 100 mg/kg astaxanthin esters, and preferably from about 5 to about 20 mg/kg astaxanthin esters. In some embodiments, the delipidated krill meal comprises greater than about 60%, 65%, 70% or 75% krill protein. In some embodiments, the present invention provides animal feeds comprising the delipidated krill meal. In some embodiments, the animal feed is a fish feed or aquatic organism feed, such as shrimp feed, crab feed, or crawfish feed. In preferred embodiments, the krill meal is incorporated into complete ration for the target organism. In preferred embodiments, the feed is provided in pelleted form. In many instances, compounds such as astaxanthin are removed during delipidation. The methods of the present invention provide a delipidated krill meal that retains significant amounts of astaxanthin. Accordingly, in some embodiments, the present invention provides methods of feeding aquatic organisms, comprising providing to the aquatic organism a feed comprising the delipidated krill meal described above. In other embodiments, the present invention provides methods of increasing flesh coloration in an

aquatic species comprising feeding the aquatic species a comprising the delipidated krill meal described above.

## **B. Compositions Containing Krill Oil**

5 In some embodiments, the compositions of this invention (such as those described in the preceding sections) are contained in acceptable excipients and/or carriers for oral consumption. The actual form of the carrier, and thus, the composition itself, is not critical. The carrier may be a liquid, gel, gelcap, capsule, powder, solid tablet (coated or non-coated), tea, or the like. The composition is preferably in the form of a tablet or capsule and most  
10 preferably in the form of a soft gel capsule. Suitable excipient and/or carriers include maltodextrin, calcium carbonate, dicalcium phosphate, tricalcium phosphate, microcrystalline cellulose, dextrose, rice flour, magnesium stearate, stearic acid, croscarmellose sodium, sodium starch glycolate, crospovidone, sucrose, vegetable gums, lactose, methylcellulose, povidone, carboxymethylcellulose, corn starch, and the like (including mixtures thereof).  
15 Preferred carriers include calcium carbonate, magnesium stearate, maltodextrin, and mixtures thereof. The various ingredients and the excipient and/or carrier are mixed and formed into the desired form using conventional techniques. The tablet or capsule of the present invention may be coated with an enteric coating that dissolves at a pH of about 6.0 to 7.0. A suitable enteric coating that dissolves in the small intestine but not in the stomach is cellulose acetate  
20 phthalate. Further details on techniques for formulation for and administration may be found in the latest edition of Remington's Pharmaceutical Sciences (Maack Publishing Co., Easton, PA).

The dietary supplement may comprise one or more inert ingredients, especially if it is desirable to limit the number of calories added to the diet by the dietary supplement. For  
25 example, the dietary supplement of the present invention may also contain optional ingredients including, for example, herbs, vitamins, minerals, enhancers, colorants, sweeteners, flavorants, inert ingredients, and the like. For example, the dietary supplement of the present invention may contain one or more of the following: ascorbates (ascorbic acid, mineral ascorbate salts, rose hips, acerola, and the like), dehydroepiandrosterone (DHEA), Fo-  
30 Ti or Ho Shu Wu (herb common to traditional Asian treatments), Cat's Claw (ancient herbal ingredient), green tea (polyphenols), inositol, kelp, dulse, bioflavonoids, maltodextrin, nettles, niacin, niacinamide, rosemary, selenium, silica (silicon dioxide, silica gel, horsetail, shavegrass, and the like), spirulina, zinc, and the like. Such optional ingredients may be either naturally occurring or concentrated forms.

In some embodiments, the dietary supplements further comprise vitamins and minerals including, but not limited to, calcium phosphate or acetate, tribasic; potassium phosphate, dibasic; magnesium sulfate or oxide; salt (sodium chloride); potassium chloride or acetate; ascorbic acid; ferric orthophosphate; niacinamide; zinc sulfate or oxide; calcium pantothenate; copper gluconate; riboflavin; beta-carotene; pyridoxine hydrochloride; thiamin mononitrate; folic acid; biotin; chromium chloride or picolonate; potassium iodide; sodium selenate; sodium molybdate; phyloquinone; vitamin D3; cyanocobalamin; sodium selenite; copper sulfate; vitamin A; vitamin C; inositol; potassium iodide. Suitable dosages for vitamins and minerals may be obtained, for example, by consulting the U.S. RDA guidelines.

In further embodiments, the compositions comprise at least one food flavoring such as acetaldehyde (ethanal), acetoin (acetyl methylcarbinol), anethole (parapropenyl anisole), benzaldehyde (benzoic aldehyde), N butyric acid (butanoic acid), d or l carvone (carvol), cinnamaldehyde (cinnamic aldehyde), citral (2,6 dimethyloctadien 2,6 al 8, gera nial, neral), decanal (N decylaldehyde, capraldehyde, capric aldehyde, caprinaldehyde, aldehyde C 10), ethyl acetate, ethyl butyrate, 3 methyl 3 phenyl glycidic acid ethyl ester (ethyl methyl phenyl glycidate, strawberry aldehyde, C 16 aldehyde), ethyl vanillin, geraniol (3,7 dimethyl 2,6 and 3,6 octadien 1 ol), geranyl acetate (geraniol acetate), limonene (d , l , and dl ), linalool (linalol, 3,7 dimethyl 1,6 octadien 3 ol), linalyl acetate (bergamol), methyl anthranilate (methyl 2 aminobenzoate), piperonal (3,4 methylenedioxy benzaldehyde, heliotropin), vanillin, alfalfa (*Medicago sativa* L.), allspice (*Pimenta officinalis*), ambrette seed (*Hibiscus abelmoschus*), angelic (*Angelica archangelica*), Angostura (*Galipea officinalis*), anise (*Pimpinella anisum*), star anise (*Illicium verum*), balm (*Melissa officinalis*), basil (*Ocimum basilicum*), bay (*Laurus nobilis*), calendula (*Calendula officinalis*), (*Anthemis nobilis*), capsicum (*Capsicum frutescens*), caraway (*Carum carvi*), cardamom (*Elettaria cardamomum*), cassia, (*Cinnamomum cassia*), cayenne pepper (*Capsicum frutescens*), Celery seed (*Apium graveolens*), chervil (*Anthriscus cerefolium*), chives (*Allium schoenoprasum*), coriander (*Coriandrum sativum*), cumin (*Cuminum cyminum*), elder flowers (*Sambucus canadensis*), fennel (*Foeniculum vulgare*), fenugreek (*Trigonella foenum graecum*), ginger (*Zingiber officinale*), horehound (*Marrubium vulgare*), horseradish (*Armoracia lapathifolia*), hyssop (*Hyssopus officinalis*), lavender (*Lavandula officinalis*), mace (*Myristica fragrans*), marjoram (*Majorana hortensis*), mustard (*Brassica nigra*, *Brassica juncea*, *Brassica hirta*), nutmeg (*Myristica fragrans*), paprika (*Capsicum annum*), black pepper (*Piper nigrum*), peppermint (*Mentha piperita*), poppy seed (*Papayer somniferum*), rosemary (*Rosmarinus officinalis*), saffron (*Crocus sativus*), sage (*Salvia officinalis*), savory (*Satureia hortensis*, *Satureia*

montana), sesame (*Sesamum indicum*), spearmint (*Mentha spicata*), tarragon (*Artemisia dracunculus*), thyme (*Thymus vulgaris*, *Thymus serpyllum*), turmeric (*Curcuma longa*), vanilla (*Vanilla planifolia*), zedoary (*Curcuma zedoaria*), sucrose, glucose, saccharin, sorbitol, mannitol, aspartame. Other suitable flavoring are disclosed in such references as Remington's  
5 Pharmaceutical Sciences, 18th Edition, Mack Publishing, p. 1288-1300 (1990), and Furia and Pellanca, Fenaroli's Handbook of Flavor Ingredients, The Chemical Rubber Company, Cleveland, Ohio, (1971), known to those skilled in the art.

In other embodiments, the compositions comprise at least one synthetic or natural food coloring (e.g., annatto extract, astaxanthin, beet powder, ultramarine blue, canthaxanthin,  
10 caramel, carotenal, beta carotene, carmine, toasted cottonseed flour, ferrous gluconate, ferrous lactate, grape color extract, grape skin extract, iron oxide, fruit juice, vegetable juice, dried algae meal, tagetes meal, carrot oil, corn endosperm oil, paprika, paprika oleoresin, riboflavin, saffron, tumeric, tumeric and oleoresin).

In still further embodiments, the compositions comprise at least one phytonutrient  
15 (e.g., soy isoflavonoids, oligomeric proanthcyanidins, indol 3 carbinol, sulforaphane, fibrous ligands, plant phyosterols, ferulic acid, anthocyanocides, triterpenes, omega 3/6 fatty acids, conjugated fatty acids such as conjugated linoleic acid and conjugated linolenic acid, polyacetylene, quinones, terpenes, catechins, gallates, and quercetin). Sources of plant phytonutrients include, but are not limited to, soy lecithin, soy isoflavones, brown rice germ,  
20 royal jelly, bee propolis, acerola berry juice powder, Japanese green tea, grape seed extract, grape skin extract, carrot juice, bilberry, flaxseed meal, bee pollen, ginkgo biloba, primrose (evening primrose oil), red clover, burdock root, dandelion, parsley, rose hips, milk thistle, ginger, Siberian ginseng, rosemary, curcumin, garlic, lycopene, grapefruit seed extract, spinach, and broccoli.

In still other embodiments, the compositions comprise at least one vitamin (e.g.,  
25 vitamin A, thiamin (B1), riboflavin (B2), pyridoxine (B6), cyanocobalamin (B12), biotin, ascorbic acid (vitamin C), retinoic acid (vitamin D), vitamin E, folic acid and other folates, vitamin K, niacin, and pantothenic acid). In some embodiments, the particles comprise at least one mineral (e.g., sodium, potassium, magnesium, calcium, phosphorus, chlorine, iron,  
30 zinc, manganese, flourine, copper, molybdenum, chromium, selenium, and iodine). In some particularly preferred embodiments, a dosage of a plurality of particles includes vitamins or minerals in the range of the recommended daily allowance (RDA) as specified by the United States Department of Agriculture. In still other embodiments, the particles comprise an amino

acid supplement formula in which at least one amino acid is included (e.g., l-carnitine or tryptophan).

### C. Uses of Krill Oil

5 Previously, it was disclosed that omega-3 fatty acids have anti-inflammatory properties. See, e.g., Calder. *Am. J. Clin. Nutr.* 83 (2006) 1505S. In addition, it was disclosed that a phospholipid emulsion derived from a marine and/or synthetic origin comprising polyunsaturated fatty acids have anti-inflammatory and/or immuno-suppressive effects. See, e.g., 5,434,183. An embodiment of this invention is a krill oil composition  
10 effective for reducing inflammation i.e. reducing the levels of TNF- $\alpha$ , IL-1 beta, IL-6, IL-10, TGF beta and fibrinogen in the blood.

Type 2 diabetes is a metabolic disorder characterized by impaired glycemic control (high blood glucose levels). In type 2 diabetes, it is the tissue wide insulin resistance that contributes to the development of the disease. Strategies reducing insulin resistance or  
15 improving tissue sensitivity to insulin are recognized as beneficial in preventing type 2 diabetes. In healthy humans, a 3-week supplementation with fish oil (1.1 g EPA/d and 0.7 g DHA/d) decreased the insulin response to an oral glucose load by 40%. Omega-3 PUFA dietary enrichment resulted in lower glucose oxidation, higher fat oxidation, and increased glycogen storage; the glycemic response was unchanged, however, which indicates an  
20 improved sensitivity to insulin. In another embodiment of this invention is a krill oil composition effective for reducing the insulin resistance.

Krill oil has not been disclosed as being effective in treating one of the most important life style problems of modern societies, i.e., excess weight gain and obesity. Excess adipose tissue mass (overweight and obesity) is associated with low grade inflammation in adipose  
25 tissue and in the whole body reflecting the inflammatory mediators "spilling over" from fat tissue. Trayhurn et al., *Br. J. Nutrition* (2004), 92(3), 347-355. Inflammation appears to be an important link between obesity and metabolic syndrome/type-II diabetes as well as cardiovascular disease. Libby et al., *J. Amer. Coll. Card.* (2006), 48(9, Suppl. A), A33-A46. Thus, excess adipose tissue is an unhealthy condition. Weight reduction will improve the  
30 inflammatory condition, but persistent weight reduction is difficult to achieve. Omega-3 fatty acid supplementation may alleviate the inflammatory condition in adipose tissue and thus ideally complement the principal strategies of weight reduction i.e. low calorie diet and exercise. There are clinical studies in humans that demonstrate that omega-3 enhance the effect of very low calorie diet and exercise in reducing body fat mass. Kunesova et al.,

Physiological research / Academia Scientiarum Bohemoslovaca (2006), 55(1), 63-72.

Although diet and exercise regime may fail to result in consistent decrease in weight in long term, the effect of omega-3 fatty acids alleviating the inflammatory condition in the adipose tissue may persist generating a condition that can be described as "healthy adipose tissue".

5 Previously, it was shown that dietary omega-3 fatty acids can be used to reduce inflammation in adipose tissue without influencing level of obesity. Todoric et al., *Diabetologia* (2006), 49(9), 2109-2119. Reduction in adipose tissue inflammation was demonstrated by an increase in circulating levels of adiponectin. Adiponectin is an adipose tissue derived anti-inflammatory hormone. Results on the treatment of obese people with omega-3 fatty acids to  
10 alleviate circulating levels of inflammatory markers are inconclusive. Trebble et al., *Br. J. Nutrition* (2003), 90(2), 405-412. However, duration of these studies may not have been sufficient given the slow turnover of adipose tissue in humans. Itoh et al. found that 1.8 g/d of EPA increased adiponectin, a marker of adipose tissue derived inflammation, in a group of overweight subjects with metabolic syndrome. Itoh et al., *Arteriosclerosis, Thrombosis, and*  
15 *Vascular Biology* (2007), 27(9), 1918-1925.

An embodiment of the invention is the use of krill oil to increase serum adiponectin levels. Adiponectin is a protein hormone that modulates a number of metabolic processes, including glucose regulation and fatty acid catabolism. Adiponectin is exclusively secreted from adipose tissue into the bloodstream and is very abundant in plasma relative to many  
20 hormones. Levels of the hormone are inversely correlated with body mass index (BMI). The hormone plays a role in alleviating the metabolic dysregulation that may result in type 2 diabetes, obesity, atherosclerosis and non-alcoholic fatty liver disease (NAFLD). Díez et al., *Eur. J. Endocrinol.* 148 (3): 293-300; Ukkola et al., *J. Mol. Med.* 80 (11): 696-702.

Another embodiment of the invention is to use krill oil in an overweight and obese  
25 subjects for alleviating diet induced adipose tissue dysfunction and diet induced changes in the lipid metabolism.

In further embodiments, krill oil is effective in reducing risk factors of type 2 diabetes such as hyperinsulinemia and insulin resistance and cardiovascular disease risk factors in overweight subjects. In addition this invention discloses that krill oil is effective in preventing  
30 accumulation of fat in muscles and in the liver (liver steatosis).

It is well known in the art that the obese Zucker rat is a useful rat model to study metabolic Syndrome X and non-insulin dependent diabetes mellitus, including glucose tolerance, insulin resistance and hyperinsulinaemia. It has also been shown previously that astaxanthin is a powerful antioxidant, useful for prevention of oxidative stress in vivo and in



Zucker rats using vitamin E. See, e.g., Aoi et al., (2003). *Antioxidants & Redox Signaling*. 5(1):139-44; Laight et al., *Eur. J. Pharmacol.* 377 (1999) 89.

In yet another embodiment of the invention is a krill oil composition effective of improving the blood lipid profile by increasing the HDL cholesterol levels, decreasing the LDL cholesterol and triglyceride levels. Hence the novel krill oil composition is effective for treating metabolic syndrome. Metabolic syndrome is defined as the coexistence of 3 or more components selected from the group: abdominal obesity, high serum triglyceride levels, low HDL levels, elevated blood pressure and high fasting plasma glucose levels.

In another embodiment of the invention, the krill oil compositions are found to be effective and safe for the treatment of metabolic syndrome in humans.

In still other embodiments, the krill oil compositions of the present invention find use in increasing or inducing diuresis. In some embodiments, the krill oil compositions of the present invention find use in decreasing protein catabolism and increasing the muscle mass of a subject.

In some embodiments, the kill oil composition of the present invention find use in the treatment of fatty heart disease and non-alcoholic fatty acid liver disease. Thus, the krill oil compositions are useful for decreasing the lipid content of the heart and/or liver and/or muscle of a subject.

In yet another embodiment of the invention is a method to increase the transfer of DHA to the brain.

**EXAMPLE 1**

Antarctic krill (*Euphausia superba*) was captured and brought on board alive, before it was processed into krill meal, an oil (asta oil) and stickwater. The composition and properties of the krill meal was monitored during the processing and compared to a commercial competitor (Table 1 and 2). Furthermore, the amino acid composition of the krill meal and stickwater was determined (Table 3), showing that krill meal is a suitable feed source for to be used in aquaculture due to the presences of all the essential amino acids teleost fish require. During the krill meal processing a neutral oil (asta oil) is recovered, the chemical composition of the asta oil is shown in Tables 4 and 5.

**Table 1.** Composition of products from the processing line

	Round frozen krill	After decanter	After drier	Konstruktor Koshkin (Ukranian
--	--------------------	----------------	-------------	-------------------------------

				vessel)
Protein	13,5 g/100 g	20,9 g/100 g	58,5 g/100 g	60,2 g/100 g
Moisture	76,3 g/100 g	65,6 g/100 g	9,1 g/100 g	9,6 g/100 g
Lipid (Folch)	8,6 g/100 g	10 g/100 g	21,8 g/100 g	21,4 g/100 g
Free fatty acids	29,8 g/100 g	25,3 g/100 g	24,8 g/100 g	23,3 g/100 g
Total astaxanthin	53,3 mg/kg	81,3 mg/kg	145 mg/kg	126 mg/kg

**Table 2.** Lipid class composition in products from the processing line

Crude protein	Round frozen krill (g/100 g)	After decanter (g/100 g)	After drier (g/100 g)	Konstruktor Koshkin (Ukrainian vessel) (g/100 g)
Wax ester/cholesterol ester	2,5	3,0	1,9	3,3
Triglycerides/pigments	30,2	33,7	29,3	32,2
Free fatty acids	15,1	2,5	9,0	5,9
Monoglycerides	3,9	Nd	1,3	Nd
PE	6,6	10,4	7,9	6,3
PS	1,2	1,6	1,4	2,7
PI	1,9	2,0	2,1	3,5
PC	28	35,9	32,0	32,1
Sphingomyeline/lyso PC	2,0	0,5	3,0	3,0

Nd= not detected

5 **Table 3.** Amino acids in krill meal and stick water

Amino acid	Total in meal (g/100 g protein)	Free in meal (g/100g protein)	Free in stickwater (g/100 g protein)
Aspartic acid	10,5	0,02	0,22
Glutamic acid	13,5	0,007	0,51
Hydroxiprolin	<0,5	<0,001	<0,05
Serine	4,2	0,02	0,13
Glycine	4,4	0,18	3,28
Histidine	2,1	<0,01	<0,05
Arginine	6,7	0,56	4,86
Threonine	4,1	<0,01	0,22
Alanine	5,4	0,08	0,87
Proline	3,8	0,53	2,32

Tyrosine	4,0	0,01	0,2
Valine	5,0	0,02	0,13
Methionine	2,9	<0,01	0,12
Isoleucine	5,0	0,02	0,1
Leucine	7,8	0,14	0,19
Phenylalanine	4,4	0,01	0,1
Lysine	7,8	0,02	0,27
Cysteine/Cystine	1,4	<0,01	<0,05
Thryptophan	1,1	<0,02	<0,05
Creatinine		<0,01	<0,05
Asparagine		<0,01	0,05
Glutamine		<0,01	<0,05
3-aminopropanoic acid		0,5	8,99
Taurine		0,5	8,52
4-aminobutanoic acid		<0,01	<0,05
Citrulline		0,04	0,14
Carnosine		<0,01	<0,05
Anserine		<0,01	<0,05
Ornithine		0,02	1,04

3-aminopropanoic acid is also known as  $\beta$ -alanine

4-aminobutanoic acid is also known as  $\gamma$ -aminobutyric acid or GABA

**Table 4.** Composition and quality parameters of asta oil.

Moisture	0,14 g/100 g
Insoluble impurities	0,02 g/100 g
Unsaponifiable matter	1,5 g/100 g
Nitrogen	0,5 g/100 g
Free fatty acids	0,3 g/100 g
Peroxide value	<2 meq peroxide/kg oil
Ansidine value	<1
Phosphorous	23 mg/kg
Phospholipids	575 mg/kg
Astaxanthin	1245 mg/kg

5

10

**Table 5.** Fatty acid composition of the asta oil

<b>Fatty Acid</b>	<b>Asta oil</b>
<b>File</b>	
<b>C4:0</b>	0,00
<b>C6:0</b>	0,00
<b>C8:0</b>	0,00
<b>C10:0</b>	0,00
<b>C12:0</b>	0,00
<b>C14:0</b>	17,5
<b>C14:1</b>	0,00
<b>C15:0</b>	0,00
<b>C16:0</b>	19,3
<b>C16:1</b>	9,7
<b>C18:0</b>	1,2
<b>C18:1</b>	22,6
<b>C18:2N6</b>	1,4
<b>C18:3N6</b>	0,1
<b>C18:3N3</b>	0,7
<b>C18:4N3</b>	3,0
<b>C20:0</b>	0,1
<b>C20:1</b>	1,3
<b>C20:2N6</b>	<0,1
<b>C20:3N6</b>	0,1
<b>C20:4N6</b>	0,1
<b>C20:3N3</b>	<0,1
<b>C20:4N3</b>	0,2
<b>C20:5N3 (EPA)</b>	5,6
<b>C22:0</b>	0,1
<b>C22:1</b>	0,3
<b>C22:2N6</b>	0,0
<b>C22:4N6</b>	<0,1
<b>C22:5N6</b>	0,00
<b>C22:5N3</b>	0,2
<b>C22:6N3 (DHA)</b>	2,00
<b>C24:1</b>	0,03
<b>Total</b>	88,4
<b>Saturated</b>	38,0
<b>Monounsaturated</b>	33,9
<b>Polyunsaturated</b>	16,4
<b>Total</b>	88,4
<b>Omega-3</b>	11,9
<b>Omega-6</b>	1,6

**EXAMPLE 2**

The krill meal obtained in example 1 was then ethanol extracted according to the method disclosed in JP02215351. The results showed that around 22% fat from the meal could be extracted, somewhat lower than was extracted using Folch (25%). Table 6 shows the fatty acid composition of the krill meal and the krill oil extracted from the meal using ethanol. Table 7 shows the composition and properties of the krill meal and products before and after extraction, whereas table 8 shows the lipid composition.

**Table 6.** Fatty acid distribution in krill meal (g/100 g lipid) and the ethanol extracted krill oil.

Fatty Acid	Krill meal	EtOH KO
File		
C4:0	0,00	
C6:0	0,00	
C8:0	0,00	
C10:0	0,00	
C12:0	0,00	
C14:0	7,8	6,4
C14:1	0,00	
C15:0	0,00	
C16:0	15,8	14,7
C16:1	5,1	4,2
C18:0	0,9	0,7
C18:1	13,4	11,8
C18:2N6	1,1	1,2
C18:3N6	0,1	0,1
C18:3N3	0,4	0,4
C18:4N3	1,1	0,1
C20:0	0,1	0,1
C20:1	0,8	0,6
C20:2N6	<0,1	<0,1
C20:3N6	0,1	<0,1
C20:4N6	0,2	0,2
C20:3N3	<0,1	<0,1
C20:4N3	0,2	0,2
C20:5N3 (EPA)	10,5	10,4
C22:0	<0,1	<0,1
C22:1	0,5	0,4
C22:2N6	<0,1	<0,1
C22:4N6	<0,1	
C22:5N6	0,00	
C22:5N3	0,2	
C22:6N3 (DHA)	5,4	4,8
C24:1	0,03	

<b>Saturated</b>	24,6	21,9
<b>Monounsaturated</b>	19,9	17,0
<b>Polyunsaturated</b>	21,0	19,4
<b>Total</b>	65,5	58,2
<b>Omega-3</b>	18,2	17,0
<b>Omega-6</b>	1,3	

**Table 7.** Composition and properties of the krill meal and products after extraction

	Krill meal	Delipidated krill meal	EtOH extracted krill oil
Crude protein	586 g/kg	735 g/kg	
Fat (Folch)	250 g/kg	30 g/kg	
Moisture/ethanol	71 g/kg	134 g/kg	85 g/kg
Astaxanthin esters	144 mg/kg	10 mg/kg	117 mg/kg
Diesters	110 mg/kg	8,5 mg/kg	117 mg/kg
Monoesters	33 mg/kg	1,8 mg/kg	37 mg/kg
Biological digestible protein	854 g/kg protein	870 g/kg protein	
Flow number	4,8	1,9	
NH <sub>3</sub>	9 mg N/100 g	0	3 mg N/100 g
TMA	2 mg N/100 g	0	70 mg N/100 g
TMAO	125 mg N/100 g	0	456 mg N/100 g

5 **Table 8.** Lipid class distribution

	Krill meal	Delipidated krill meal	EtOH extracted KO
Cholesterol ester	3,5		
TG	32,7	37,4	31,1
FFA	7,8	14,1	16,0
Cholesterol	9,1	8,0	12,6
DG	1,1		3,3
MG	3,7		
Sphingolipid			2,8
PE	6,5	2,5	2,7
Cardiolipin		4,2	
PI	1,1	11,0	
PS	1,4		

PC	28,6	20,2	25,3
LPC	2,9	2,6	6,2
Total polar lipids	40,6	40,5	36,9
Total neutral lipids	54,2	59,5	63,1

### EXAMPLE 3

The krill meal obtained in example 1 was then subjected to a supercritical fluid extraction method in two stages. During stage 1, 12.1% fat (neutral krill oil) was removed using neat CO<sub>2</sub> only at 300 bars, 60° C and for 30 minutes. In stage 2, the pressure was increased to 400 bar and 20% ethanol was added (v/v) for 90 minutes. This resulted in further extraction of 9% polar fat which hereafter is called polar krill oil. The total fatty acid composition of the polar krill oil, the neutral krill oil and a commercial product obtained from Neptune Biotech (Laval, Quebec, Canada) are listed in Table 9. In addition the fatty acid composition for the phospholipids (Table 10), the neutral lipids (Table 11), the free fatty acids, diglycerides (Table 12), triglycerides, lyso-phosphatidylcholine (LPC) (Table 13), phosphatidylcholine (PC), phosphatidylethanolamine (PE) (Table 14), phosphatidylinositol (PI) and phosphatidylserine (PS) (Table 15) are shown. Table 16 shows the level of astaxanthin and cholesterol for the different fractions.

**Table 9.** Total fatty acids compositions of the krill oil products (% (w/w))

Fatty Acid	Total Fatty Acids		
	Neutral KO	Polar KO	NKO
File			
C4:0	0,00	0,00	0,00
C6:0	0,00	0,00	0,00
C8:0	0,00	0,00	0,00
C10:0	0,00	0,00	0,00
C12:0	0,47	0,04	0,24
C14:0	22,08	3,28	12,48
C14:1	0,33	0,01	0,17
C15:0	0,58	0,36	0,52
C16:0	27,03	29,25	23,25
C16:1	0,07	0,01	8,44
C18:0	1,72	1,03	1,42
C18:1	30,29	13,57	18,92
C18:2N6	2,10	1,96	1,71
C18:3N6	0,30	0,21	0,00
C18:3N3	0,69	1,02	1,32
C18:4N3	0,05	1,81	3,50

C20:0	0,06	0,00	0,05
C20:1	1,87	0,80	1,16
C20:2N6	0,05	0,05	0,05
C20:3N6	0,22	0,73	0,04
C20:4N6	0,00	0,00	0,49
C20:3N3	0,09	0,09	0,06
C20:4N3	0,24	0,51	0,33
C20:5N3 (EPA)	7,33	29,88	16,27
C22:0	0,01	0,06	0,05
C22:1	0,64	1,78	0,82
C22:2N6	0,00	0,00	0,00
C22:4N6	0,00	0,00	0,07
C22:5N6	0,00	0,03	0,00
C22:5N3	0,21	0,67	0,36
C22:6N3 (DHA)	3,51	12,61	8,17
C24:0	0,05	0,00	0,01
C24:1	0,03	0,25	0,11
Total	100,00	100,00	100,00
Saturated	52,00	34,01	38,01
Monounsaturated	33,22	16,43	29,61
Polyunsaturated	14,77	49,56	32,37
Total	100,00	100,00	100,00
Omega-3	12,11	46,58	30,02
Omega-6	2,67	2,98	2,35

Table 10. Fatty acid composition of the phospholipid fraction (% (w/w)).

Fatty Acid	Total Phospholipid		
	Neutral KO	Polar KO	Neptune KO
File			
C4:0	0,00	0,00	0,00
C6:0	0,00	0,00	0,00
C8:0	0,00	0,00	0,00
C10:0	0,00	0,00	0,00
C12:0	0,00	0,00	0,00
C14:0	0,01	0,00	0,00
C14:1	0,42	0,01	0,01
C15:0	2,52	0,00	0,00
C16:0	4,73	35,78	32,81
C16:1	0,19	0,17	0,19
C18:0	6,31	1,18	1,55
C18:1	38,40	15,58	13,54
C18:2N6	4,18	2,16	1,90
C18:3N6	0,18	0,22	0,19
C18:3N3	1,02	1,05	1,48



<b>C18:4N3</b>	3,08	1,62	2,15
<b>C20:0</b>	0,27	0,00	0,07
<b>C20:1</b>	2,55	1,02	0,78
<b>C20:2N6</b>	0,19	0,06	0,06
<b>C20:3N6</b>	0,00	0,14	0,10
<b>C20:4N6</b>	0,57	0,62	0,64
<b>C20:3N3</b>	0,43	0,08	0,09
<b>C20:4N3</b>	0,17	0,45	0,42
<b>C20:5N3 (EPA)</b>	20,58	25,53	26,47
<b>C22:0</b>	0,14	0,06	0,00
<b>C22:1</b>	0,00	2,09	1,94
<b>C22:2N6</b>	0,25	0,71	0,85
<b>C22:4N6</b>	0,44	0,00	0,03
<b>C22:5N6</b>	0,11	0,00	0,00
<b>C22:5N3</b>	0,00	0,60	0,63
<b>C22:6N3 (DHA)</b>	10,93	10,30	13,34
<b>C24:0</b>	1,77	0,30	0,37
<b>C24:1</b>	0,59	0,28	0,38
<b>Total</b>	100,00	100,00	100,00
<b>Saturated</b>	15,74	37,32	34,81
<b>Monounsaturated</b>	42,14	19,15	16,84
<b>Polyunsaturated</b>	42,12	43,53	48,34
<b>Total</b>	100,00	100,00	100,00
<b>Omega-3</b>	36,22	39,62	44,56
<b>Omega-6</b>	5,91	3,90	3,78

Table 11. Fatty acid composition of the total neutral lipid fraction (% (w/w)).

Fatty Acid	Total neutral lipid		
	Neutral KO	Polar KO	Neptune KO
<b>File</b>			
<b>C4:0</b>	0,00	0,00	0,00
<b>C6:0</b>	0,00	0,00	0,00
<b>C8:0</b>	0,00	0,00	0,00
<b>C10:0</b>	0,00	0,00	0,00
<b>C12:0</b>	0,00	0,00	0,00
<b>C14:0</b>	20,35	11,31	18,44
<b>C14:1</b>	0,30	0,29	0,25
<b>C15:0</b>	0,53	1,53	0,62
<b>C16:0</b>	23,79	0,49	24,11
<b>C16:1</b>	12,42	5,22	11,86
<b>C18:0</b>	1,54	3,27	1,67
<b>C18:1</b>	26,81	33,09	23,82

C18:2N6	1,68	2,37	1,79
C18:3N6	0,20	0,23	0,25
C18:3N3	0,59	0,62	0,03
C18:4N3	0,03	1,27	0,05
C20:0	0,07	0,00	0,06
C20:1	1,63	1,41	1,39
C20:2N6	0,04	0,00	0,05
C20:3N6	0,18	0,94	0,01
C20:4N6	0,00	0,00	0,00
C20:3N3	0,09	0,00	0,01
C20:4N3	0,18	0,41	0,23
C20:5N3 (EPA)	5,88	19,26	9,68
C22:0	0,02	0,00	0,03
C22:1	0,56	0,60	0,53
C22:2N6	0,00	0,00	0,00
C22:4N6	0,00	0,00	0,04
C22:5N6	0,01	0,00	0,00
C22:5N3	0,17	0,27	0,22
C22:6N3 (DHA)	2,74	17,22	4,64
C24:0	0,15	0,00	0,17
C24:1	0,03	0,21	0,06
<b>Total</b>	<b>100,00</b>	<b>100,00</b>	<b>100,00</b>
<b>Saturated</b>	46,45	16,60	45,10
<b>Monounsaturated</b>	41,75	40,82	37,91
<b>Polyunsaturated</b>	11,80	42,59	16,99
<b>Total</b>	<b>100,00</b>	<b>100,00</b>	<b>100,00</b>
<b>Omega-3</b>	9,68	39,05	14,86
<b>Omega-6</b>	2,11	3,54	2,14

Table 12. Fatty acid composition of the diglyceride and free fatty acids (% (w/w)).

Fatty Acid	Diglycerides			Free fatty acids		
	Neutral KO	Polar KO	Neptune KO	Neutral KO	Polar KO	Neptune KO
File						
C4:0	0,00	0,00	0,00	0,00	0,00	0,00
C6:0	0,00	0,00	0,00	0,00	0,00	0,00
C8:0	0,00	0,00	0,00	0,00	0,00	0,00
C10:0	0,00	0,00	0,00	0,00	0,00	0,00
C12:0	0,00	0,00	0,00	0,00	0,00	0,00
C14:0	13,85	14,35	12,22	5,86	7,19	5,45
C14:1	0,18	0,00	0,17	0,05	0,00	0,08
C15:0	0,49	1,08	0,66	0,46	1,60	0,45
C16:0	23,68	35,24	25,81	28,30	29,37	21,12
C16:1	9,49	6,80	0,09	3,27	3,08	4,91
C18:0	1,56	3,63	1,89	1,13	2,43	0,99

<b>C18:1</b>	23,67	19,85	23,82	14,50	14,77	17,41
<b>C18:2N6</b>	1,79	0,21	1,90	1,69	0,97	1,86
<b>C18:3N6</b>	0,17	0,00	0,01	0,14	0,00	0,22
<b>C18:3N3</b>	0,69	0,00	1,19	0,85	0,00	1,34
<b>C18:4N3</b>	1,92	0,00	2,75	1,30	0,00	2,72
<b>C20:0</b>	0,00	0,00	0,00	0,00	0,00	0,00
<b>C20:1</b>	1,09	0,00	1,01	0,48	0,00	0,57
<b>C20:2N6</b>	0,00	0,00	0,00	0,00	0,00	0,00
<b>C20:3N6</b>	0,13	0,00	0,00	0,08	0,00	0,05
<b>C20:4N6</b>	0,45	0,00	0,64	0,78	0,00	1,43
<b>C20:3N3</b>	0,00	0,00	0,00	0,00	0,00	0,00
<b>C20:4N3</b>	0,35	0,00	0,43	0,39	0,00	0,43
<b>C20:5N3 (EPA)</b>	14,03	9,80	18,00	24,33	23,57	25,36
<b>C22:0</b>	0,18	0,00	0,10	0,00	0,00	0,05
<b>C22:1</b>	0,41	0,00	0,57	0,80	0,69	0,37
<b>C22:2N6</b>	0,28	0,00	0,50	0,46	0,00	0,54
<b>C22:4N6</b>	0,00	0,00	0,00	0,00	0,00	0,00
<b>C22:5N6</b>	0,00	0,00	0,00	0,00	0,00	0,00
<b>C22:5N3</b>	0,20	0,00	0,27	0,34	0,00	0,32
<b>C22:6N3 (DHA)</b>	4,74	9,04	7,53	14,31	16,33	13,95
<b>C24:0</b>	0,64	0,00	0,42	0,49	0,00	0,39
<b>C24:1</b>	0,00	0,00	0,00	0,00	0,00	0,00
<b>Total</b>	100,00	100,00	100,00	100,00	100,00	100,00
<b>Saturated</b>	40,40	54,30	41,10	36,24	40,59	28,45
<b>Monounsaturated</b>	34,84	26,64	25,66	19,09	18,54	23,34
<b>Polyunsaturated</b>	24,77	19,06	33,24	44,67	40,87	48,22
<b>Total</b>	100,00	100,00	100,00	100,00	100,00	100,00
<b>Omega-3</b>	21,95	18,85	30,18	41,51	39,90	44,13
<b>Omega-6</b>	2,82	0,21	3,05	3,15	0,97	4,09

Table 13. Fatty acid composition of the triglyceride and lyso-phosphatidylcholine fractions (% (w/w)).

Fatty Acid	Triglycerides			Lyso PC		
	Neutral KO	Polar KO	Neptune KO	Neutral KO	Polar KO	Neptune KO
<b>File</b>						
<b>C4:0</b>	0,00	0,00	0,00	0,00	0,00	0,00
<b>C6:0</b>	0,00	0,00	0,00	0,00	0,00	0,00
<b>C8:0</b>	0,00	0,00	0,00	0,00	0,00	0,00
<b>C10:0</b>	0,00	0,00	0,00	0,00	0,00	0,00
<b>C12:0</b>	0,00	0,00	0,00	0,00	0,00	0,00
<b>C14:0</b>	23,06	26,65	25,13	19,38	4,27	2,87
<b>C14:1</b>	0,36	0,93	0,36	0,00	0,08	0,00

C15:0	0,56	2,64	0,78	0,00	0,52	0,45
C16:0	23,17	4,93	27,80	41,00	44,14	30,56
C16:1	13,68	11,58	0,04	0,00	1,84	2,24
C18:0	1,52	3,12	1,99	0,76	1,59	1,32
C18:1	27,83	34,39	27,92	6,65	14,24	11,29
C18:2N6	1,64	2,05	1,92	0,00	1,75	2,07
C18:3N6	0,20	0,00	0,30	0,00	0,00	0,06
C18:3N3	0,51	0,00	0,00	7,95	0,67	1,75
C18:4N3	1,99	0,00	4,83	0,00	1,11	2,46
C20:0	0,06	0,00	0,08	0,00	0,00	0,00
C20:1	1,67	0,00	1,76	0,00	0,52	0,00
C20:2N6	0,04	0,00	0,05	0,00	0,00	0,00
C20:3N6	0,05	0,00	0,01	0,00	0,00	0,54
C20:4N6	0,00	0,00	0,00	0,00	0,40	0,00
C20:3N3	0,05	0,00	0,07	0,00	0,00	0,00
C20:4N3	0,11	0,00	0,17	0,00	0,31	0,55
C20:5N3 (EPA)	2,10	7,97	4,44	0,00	18,59	28,48
C22:0	0,02	0,00	0,04	0,00	0,00	0,00
C22:1	0,37	0,00	0,42	0,00	1,46	0,91
C22:2N6	0,00	0,00	0,00	0,00	0,00	0,00
C22:4N6	0,01	0,00	0,01	0,00	0,00	0,00
C22:5N6	0,00	0,00	0,01	0,00	0,00	0,00
C22:5N3	0,10	0,00	0,16	0,00	0,41	0,62
C22:6N3 (DHA)	0,67	3,97	1,42	24,26	7,79	13,82
C24:0	0,26	1,78	0,26	0,00	0,32	0,00
C24:1	0,00	0,00	0,03	0,00	0,00	0,00
Total	100,00	100,00	100,00	100,00	100,00	100,00
Saturated	48,64	39,12	56,08	61,14	50,83	35,21
Monounsaturated	43,90	46,89	30,52	6,65	18,14	14,44
Polyunsaturated	7,45	13,99	13,41	32,20	31,02	50,35
Total	100,00	100,00	100,00	100,00	100,00	100,00
Omega-3	5,51	11,94	11,11	32,20	28,87	47,69
Omega-6	1,94	2,05	2,30	0,00	2,15	2,66

Table 14. Fatty acid composition of the phosphatidylcholine and the phosphatidylserine fractions (% (w/w)).

Fatty Acid	PC			PS		
	Neutral KO	Polar KO	Neptune KO	Neutral KO	Polar KO	Neptune KO
File						
C4:0	0,00	0,00	0,00	0,00	0,00	0,00
C6:0	0,00	0,00	0,00	0,00	0,00	0,00
C8:0	0,00	0,00	0,00	0,00	0,00	0,00

C10:0	0,00	0,00	0,00	0,00	0,00	0,00
C12:0	0,00	0,00	0,00	0,00	0,00	0,00
C14:0	0,75	3,29	2,77	7,60	9,52	2,31
C14:1	2,07	0,04	0,02	0,00	0,00	0,00
C15:0	1,34	0,00	0,00	3,83	0,00	0,00
C16:0	16,65	31,92	29,83	30,44	43,61	19,49
C16:1	0,96	0,01	0,17	9,96	3,47	2,79
C18:0	1,33	1,06	1,33	2,08	3,34	2,24
C18:1	34,34	13,55	11,16	0,00	7,37	11,87
C18:2N6	10,55	2,27	1,90	0,00	0,00	0,00
C18:3N6	1,44	0,25	0,20	0,00	0,00	0,00
C18:3N3	2,49	1,19	1,54	0,00	0,00	0,00
C18:4N3	2,38	1,92	2,41	0,00	0,00	0,00
C20:0	2,79	0,03	0,05	0,00	0,00	0,00
C20:1	2,42	0,82	0,74	0,00	0,00	0,00
C20:2N6	0,56	0,05	0,06	0,00	0,00	0,00
C20:3N6	0,67	0,13	0,09	0,00	0,00	0,00
C20:4N6	1,85	0,61	0,56	0,00	0,00	0,00
C20:3N3	3,94	0,07	0,06	0,00	0,00	0,33
C20:4N3	4,32	0,50	0,46	0,00	0,00	0,00
C20:5N3 (EPA)	1,08	29,85	30,09	25,84	15,81	16,35
C22:0	0,00	0,05	0,02	0,00	0,00	0,00
C22:1	2,77	0,00	1,87	0,00	0,00	0,00
C22:2N6	0,00	0,81	0,97	0,00	0,00	0,00
C22:4N6	0,00	0,01	0,02	0,00	0,00	0,00
C22:5N6	1,49	0,01	0,00	0,00	0,00	0,00
C22:5N3	1,48	0,67	0,68	0,00	0,00	0,00
C22:6N3 (DHA)	0,00	10,53	12,49	20,25	16,89	44,63
C24:0	2,34	0,10	0,18	0,00	0,00	0,00
C24:1	0,00	0,25	0,34	0,00	0,00	0,00
<b>Total</b>	<b>100,00</b>	<b>100,00</b>	<b>100,00</b>	<b>100,00</b>	<b>100,00</b>	<b>100,00</b>
<b>Saturated</b>	<b>25,19</b>	<b>36,46</b>	<b>34,18</b>	<b>43,95</b>	<b>56,47</b>	<b>24,04</b>
<b>Monounsaturated</b>	<b>42,56</b>	<b>14,67</b>	<b>14,29</b>	<b>9,96</b>	<b>10,84</b>	<b>14,65</b>
<b>Polyunsaturated</b>	<b>32,25</b>	<b>48,87</b>	<b>51,53</b>	<b>46,09</b>	<b>32,69</b>	<b>61,31</b>
<b>Total</b>	<b>100,00</b>	<b>100,00</b>	<b>100,00</b>	<b>100,00</b>	<b>100,00</b>	<b>100,00</b>
<b>Omega-3</b>	<b>15,69</b>	<b>44,73</b>	<b>47,73</b>	<b>46,09</b>	<b>32,69</b>	<b>61,31</b>
<b>Omega-6</b>	<b>16,56</b>	<b>4,13</b>	<b>3,81</b>	<b>0,00</b>	<b>0,00</b>	<b>0,00</b>

**Table 15.** Fatty acid composition of the phosphatidylinositol and phosphatidylethanolamine fractions (% (w/w)).

Fatty Acid	PI			PE		
	Neutral KO	Polar KO	Neptune KO	Neutral KO	Polar KO	Neptune KO
File						
C4:0	0,00	0,00	0,00	0,00	0,00	0,00
C6:0	0,00	0,00	0,00	0,00	0,00	0,00
C8:0	0,00	0,00	0,00	0,00	0,00	0,00
C10:0	0,00	0,00	0,00	0,00	0,00	0,00
C12:0	0,00	0,00	0,00	0,00	0,00	0,00
C14:0	11,15	5,82	5,72	14,42	4,60	0,83
C14:1	3,03	0,66	0,00	0,00	0,00	0,10
C15:0	5,86	1,95	3,18	0,00	1,30	0,23
C16:0	37,02	30,66	31,39	35,91	31,21	18,38
C16:1	18,05	2,24	1,16	0,00	1,51	0,75
C18:0	6,72	2,83	5,56	12,72	16,70	1,84
C18:1	18,15	24,77	14,23	36,96	19,91	18,45
C18:2N6	0,00	2,67	0,00	0,00	2,62	0,85
C18:3N6	0,00	0,00	0,00	0,00	0,00	0,00
C18:3N3	0,00	0,00	0,00	0,00	0,00	0,33
C18:4N3	0,00	0,00	0,00	0,00	0,00	0,00
C20:0	0,00	0,00	0,00	0,00	0,00	0,00
C20:1	0,00	0,00	0,00	0,00	0,00	0,00
C20:2N6	0,00	0,00	0,00	0,00	0,00	0,00
C20:3N6	0,00	0,00	0,00	0,00	0,00	1,15
C20:4N6	0,00	0,00	0,00	0,00	0,00	0,00
C20:3N3	0,00	0,00	0,00	0,00	0,00	0,00
C20:4N3	0,00	0,00	0,00	0,00	0,00	0,00
C20:5N3 (EPA)	0,00	17,60	20,45	0,00	10,76	21,26
C22:0	0,00	0,00	0,00	0,00	0,00	0,00
C22:1	0,00	0,00	0,00	0,00	0,00	0,00
C22:2N6	0,00	0,00	0,00	0,00	0,00	0,00
C22:4N6	0,00	0,00	0,00	0,00	0,00	0,00
C22:5N6	0,00	0,00	0,00	0,00	0,00	0,00
C22:5N3	0,00	0,00	0,00	0,00	0,00	0,67
C22:6N3 (DHA)	0,00	10,79	18,32	0,00	11,39	35,16
C24:0	0,00	0,00	0,00	0,00	0,00	0,00
C24:1	0,00	0,00	0,00	0,00	0,00	0,00
<b>Total</b>	<b>100,00</b>	<b>100,00</b>	<b>100,00</b>	<b>100,00</b>	<b>100,00</b>	<b>100,00</b>
<b>Saturated</b>	<b>60,76</b>	<b>41,26</b>	<b>45,84</b>	<b>63,04</b>	<b>53,81</b>	<b>21,28</b>
<b>Monounsaturated</b>	<b>39,24</b>	<b>27,67</b>	<b>15,39</b>	<b>36,96</b>	<b>21,42</b>	<b>19,30</b>
<b>Polyunsaturated</b>	<b>0,00</b>	<b>31,07</b>	<b>38,77</b>	<b>0,00</b>	<b>24,77</b>	<b>59,42</b>
<b>Total</b>	<b>100,00</b>	<b>100,00</b>	<b>100,00</b>	<b>100,00</b>	<b>100,00</b>	<b>100,00</b>

<b>Omega-3</b>	0,00	28,40	38,77	0,00	22,15	57,43
<b>Omega-6</b>	0,00	2,67	0,00	0,00	2,62	1,99

**Table 16.** Compositional data for the novel krill oil composition obtained and NKO krill oil.

Compounds	Neptune KO	Ethanol extracted KO	Polar KO	Neutral KO
<b>Astaxanthin esters</b>	472 mg/kg	117 mg/kg	580 mg/kg	98 mg/kg
<b>Astaxanthin free</b>	11 mg/kg	< 1 mg/kg	<1 mg/kg	<1 mg/kg
<b>Total cholesterol</b>	1 g/100g	12 g/100g	< 0,5 g/100g	5,7 g/100g

5

**EXAMPLE 4**

Neutral lipids were extracted from krill meal (138 kg) using SFE with neat CO<sub>2</sub> (solvent ratio 25 kg/kg) at 500 bar and 75 °C. The neutral lipids were fractionated at 200 bar (75 °C) and at 60 bar (35 °C) at separator S1 and S2, respectively. The extract obtained in S1 (19,6 kg) were characterized and the results can be found in Tables 17A-C. The extract in table S2 (0,4 kg) were rich in water and were not further used. Next, the polar lipids were extracted using CO<sub>2</sub> at 500 bar, 20% ethanol and at a temperature of 75 °C. Using a solvent ratio of 32 (kg/kg) and collecting an extract of 18,2 kg using a separator at 60 bars and 35°C. The polar lipids were collected and analyzed (Tables 18A-C). Next, the polar lipids were mixed in a 50/50 ratio with the neutral lipids collected from S1 before finally the ethanol was removed carefully by evaporation. The product obtained was red and transparent. If the ethanol is removed before the mixing if the fractions a transparent product is not obtained. The composition of the 50/50 red and transparent product can be found in Tables 19A-C.

15

**Table 17A** Fatty acid composition of the extract collected in S1

Fatty acid	Unit	Amount
14:0	g/100g	18,4
16:0	g/100g	22,2
18:0	g/100g	1,5
16:1 n-7	g/100g	10,9
18:1 (n-9) + (n-7) + (n-5)	g/100g	25,6

20:1 (n-9) + (n-7)	g/100g	1,8
22:1 (n-11) + (n-9) + (n-7)	g/100g	0,5
16:2 (n-4)	g/100g	1,3
16:4 (n-1)	g/100g	1,2
18:2 n-6	g/100g	1,3
18:3 n-3	g/100g	0,8
18:4 n-3	g/100g	2,9
20:5 n-3	g/100g	4,1
22:6 n-4	g/100g	1,7

**Table 17B.** Lipid class composition of the extract collected in S1

Lipid	Unit	Amount
Triacylglycerol	g/100g	84
Diacylglycerol	g/100g	0,7
Free fatty acids	g/100g	1,5
Cholesterol	g/100g	2,7
Cholesterol esters	g/100g	0,9

**Table 17C.** Miscellaneous analysis of the extract in S1.

Compound	Unit	Amount
Free astaxanthin	mg/kg	4,3
Astaxanthin esters	mg/kg	462
Trimethylamin	mg N/100 g	<1
Trimethylamineoxide	mg N/100 g	2

5

**Table 18A** Fatty acid composition of the extract collected after CO<sub>2</sub> and 20% ethanol in S1.

Fatty acid	Unit	Amount
14:0	g/100g	1,3
16:0	g/100g	13,8
18:0	g/100g	0,6
16:1 n-7	g/100g	0,9
18:1 (n-9) + (n-7) + (n-5)	g/100g	6,5
20:1 (n-9) + (n-7)	g/100g	0,6



22:1 (n-11) + (n-9) + (n-7)	g/100g	0,1
16:2 (n-4)	g/100g	<0,1
16:4 (n-1)	g/100g	<0,1
18:2 n-6	g/100g	0,8
18:3 n-3	g/100g	0,6
18:4 n-3	g/100g	1,0
20:5 n-3	g/100g	14,7
22:6 n-4	g/100g	6,5

**Table 18B.** Lipid class composition of the extract collected after CO<sub>2</sub> and 20% ethanol in S1.

Lipid	Unit	Amount
Triacylglycerol	g/100g	<0,5
Cholesterol	g/100g	<0,5
Phosphatidylethanolamine	g/100g	1,6
Phosphatidylcholine	g/100g	67
Lyso-phosphatidylcholine	g/100g	4,4

**Table 18C.** Miscellaneous analysis of the extract in S1.

Compound	Unit	Amount
Trimethylamin	mg N/100 g	422
Trimethylamineoxide	mg N/100 g	239

5

**Table 19A** Fatty acid composition of the final blended product obtained in Example 4 in S1.

Fatty acid	Unit	Amount
14:0	g/100g	9,7
16:0	g/100g	18,5
18:0	g/100g	1,0
16:1 n-7	g/100g	5,8
18:1 (n-9) + (n-7) + (n-5)	g/100g	16,0
20:1 (n-9) + (n-7)	g/100g	1,2
22:1 (n-11) + (n-9) + (n-7)	g/100g	1,0
16:2 (n-4)	g/100g	0,3
16:4 (n-1)	g/100g	<0,1

18:2 n-6	g/100g	1,0
18:3 n-3	g/100g	0,8
18:4 n-3	g/100g	2,1
20:5 n-3	g/100g	10,7
22:6 n-4	g/100g	4,7

**Table 19B.** Lipid class composition of the final blended product obtained in Example 4.

Lipid	Unit	Amount
Triacylglycerol	g/100g	53
Diacylglycerol	g/100g	1,3
Free fatty acids	g/100g	0,5
Cholesterol	g/100g	0,6
Cholesterol esters	g/100g	<0,5
Phosphatidylethanolamine	g/100g	<1
Phosphatidylcholine	g/100g	42
Lyso-phosphatidylcholine	g/100g	5,9

**Table 19C.** Miscellaneous analysis of the final blended product obtained in example 4.

Compound	Unit	Amount
Free astaxanthin	mg/kg	1,1
Astaxanthin esters	mg/kg	151
Trimethylamin	mg N/100 g	109
Trimethylamineoxide	mg N/100 g	80

5

### EXAMPLE 5

The asta oil obtained in example 1 was blended with the polar lipids obtained in example 4 in a ratio of 46:54 (v/v). Next the ethanol was removed by evaporation and a dark red and transparent product was obtained. The product was analyzed and the results can be found in Tables 20A-C. Furthermore, the product was encapsulated into soft gels successfully. During the encapsulation it was observed that any further increase in phospholipids and thereby viscosity will make it very difficult to encapsulate the final product.

10

**Table 20A** Fatty acid composition of the final blended product obtained in Example 5.

Fatty acid	Unit	Amount
14:0	g/100g	8,2
16:0	g/100g	17,7
18:0	g/100g	1,0
16:1 n-7	g/100g	4,9
18:1 (n-9) + (n-7) + (n-5)	g/100g	14,9
20:1 (n-9) + (n-7)	g/100g	1,1
22:1 (n-11) + (n-9) + (n-7)	g/100g	1,0
16:2 (n-4)	g/100g	0,4
16:4 (n-1)	g/100g	<0,1
18:2 n-6	g/100g	1,2
18:3 n-3	g/100g	0,8
18:4 n-3	g/100g	1,8
20:5 n-3	g/100g	10,6
22:6 n-4	g/100g	4,8

**Table 20B.** Lipid class composition of the final blended product obtained in Example 5.

Lipid	Unit	Amount
Triacylglycerol	g/100g	41
Diacylglycerol	g/100g	0,8
Free fatty acids	g/100g	1,2
Cholesterol	g/100g	0,4
Cholesterol esters	g/100g	0,3
Phosphatidylethanolamine	g/100g	0,6
Phosphatidylcholine	g/100g	51
Lyso-phosphatidylcholine	g/100g	<0,5
Total polar lipids	g/100g	52,4
Total neutral lipids	g/100g	43,6

5 **Table 20C.** Miscellaneous analysis of the final blended product obtained in Example 5

Compound	Unit	Amount
Free astaxanthin	mg/kg	12

Astaxanthin esters	mg/kg	1302
Trimethylamin	mg N/100 g	193
Trimethylamineoxide	mg N/100 g	1,7

**EXAMPLE 6**

Fresh krill was pumped from the harvesting trawl directly into an indirect steam cooker, and heated to 90C. Water and a small amount of oil were removed in a screw press before ethoxyquin (antioxidant) was added and the denatured meal was dried under vacuum at a temperature not exceeding 80C. After 19 months storage in room temperature, a sample of the denatured meal was extracted in two steps with supercritical CO<sub>2</sub> in laboratory scale at a flow rate of 2ml/min at 100C and a pressure of 7500 psi. In the second step 20% ethanol was added to the CO<sub>2</sub>. The two fractions collected were combined and analyzed by HPLC using ELS detection. The phosphatidylcholine was measured to 42.22% whereas the partly decomposed phosphatidylcholine was 1.68%. This data strongly contrasts the data obtained by analysis of a krill oil sample in the marketplace that showed a content of 9.05% of phosphatidylcholine and 4.60% of partly decomposed phosphatidylcholine.

**EXAMPLE 7**

Krill lipids were extracted from krill meal (a food grade powder) using supercritical fluid extraction with co-solvent. Initially, 300 bar pressure, 333°K and 5% ethanol (ethanol:CO<sub>2</sub>, w/w) were utilized for 60 minutes in order to remove neutral lipids and astaxanthin from the krill meal. Next, the ethanol content was increased to 23% and the extraction was maintained for 3 hours and 40 minutes. The extract was then evaporated using a falling film evaporator and the resulting krill oil was finally filtered. The product obtained was then analyzed and the results can be found in Table 21.

**Table 21.** Analysis of the krill oil obtained using supercritical fluid extraction.

Parameter	Value
Ethanol	1.11% w/w
Water Content	2.98 % w/w
C20:5 n-3 (EPA)	19.9
C22:6 n-3 (DHA)	11.3
Total Omega 3	35.7
Total Omega 6	3.0
Total Phospholipids	50.55 wt%
Ratio Omega3-PL/Total Omega 3	77.6 % w/w
Ratio EPA- PL/Total EPA	84.4 %w/w

Ratio DHA-PL/Total DHA	74.7 %w/w
Triglycerides	25.9 g/100g
Astaxanthin	2091 mg/kg
Peroxide Value	<0.1

### EXAMPLE 8

Krill oil was prepared according to the method described in example 7 extracting from the same krill meal. The oil was subjected to <sup>31</sup>P NMR analysis for the identification and quantification of the various forms of phospholipids. The analysis was performed according to the following methods: Samples (20 – 40 mg) were weighed into 1.5 ml centrifuge tubes. Next, NMR detergent (750 µl -10% Na cholate, 1% EDTA, pH 7.0 in H<sub>2</sub>O+D<sub>2</sub>O, 0.3 g L<sup>-1</sup> PMG internal standard) was added. Next, the tube was placed in a oven at 60°C and periodically shaken/sonicated until completely dispersed. The solution was then transferred to a 5 ml NMR tube for analysis. Phosphorus NMR spectra were recorded on the two-channel Bruker Avance300 with the following instrument settings: spectrometer frequency 121.498MHz, sweep width 24,271 Hz, 64,000 data points, 30 degree excitation pulse, 576 transients were normally taken, each with an 8 second delay time and f.i.d. acquisition time of 1.35 sec. Spectra were processed with a standard exponential weighting function with 0.2 Hz line broadening before Fourier transformation.

Peaks were identified using known chemical shifts. Deacylation of samples with monomethylamine was also used on two samples for confirmation of peak identity and to achieve better peak resolution. Example spectra are presented in Figure 1. Peak area integration gave relative molar amounts of each lipid class. Weight percent values were calculated using molecular masses calculated from a krill sample fatty acid profile (average chain length = 18.6). Total PL levels were calculated from the PMG internal standard peak. The quantification of the phospholipids are shown in table 25 for both the raw material, the final product and for a commercially available krill oil (Neptune Krill Oil). The main polar ether lipids of the krill meal are alkylacylphosphatidylcholine (AAPC) at 7-9 % of total polar lipids, lyso-alkylacylphosphatidylcholine (LAAPC) at 1 % of total polar lipids (TPL) and alkylacylphosphatidyl-ethanolamine (AAPE) at < 1 % of TPL.

**Table 22:** Phospholipid profiles

	<u>Type B krill powder</u>	<u>NK O</u>	<u>Krill Oil obtained in Example 7</u>
PC	66.0	68.6	75.3
AAPC	12.0	7.0	13.0
PI			
1LPC	1.2	1.3	0.4
PS			
2LPC	7.4	13.8	2.9
LAAPC	2.2	1.2	0.9
PE	6.0	3.4	3.4
AAPE			1.5
SM			
GPC		1.3	
DHSM			
NAPE		3.4	
CL	5.3		2.1
LPE			0.5
LCL			
<b>% PL in powder or lipid sample</b>	<b>8.3</b>	<b>30.0</b>	<b>47.9</b>

Analysis has been carried out on the fatty acid and ether/alcohol profiles of the AAPC. The following results are presented in Table 23.

**Table 23.** Fatty acid profile of the alkylacylphosphatidylcholine.

AAPC fatty acid composition	AAPC alcohol composition	alcohol %
20:5(n-3) – 46.9%;	16:0	47.6
22:6(n-3) – 36.1%;	18:1	17.8
18:1(n-9) – 4.6%	16:1	14.1
22:5(n-3) – 2.6%	14:0	10
20:4(n-6) – 1.9%	18:0	8.6
21:5(n-3) – 1.5%	18:2	5.1
18:2(n-6) – 0.9%	17:0	4.4
16:1(n-9) – 0.8%	15:0-i	2.1
16:0 – 0.7%	15:0	1.7
phytanic – 0.6%	20:1	1.4
18:3(n-3) – 0.5%	15:0-a	1.3

18:4(n-3) – 0.4%                      18:0-i              0.4  
18:1(n-7) – 0.4%  
24:1 – 0.4%  
14:0 – 0.3%

The rest of alcohols (i17:0, etc.), were less than 0.3% each. Only part of 20:1 was confirmed by GC-MS. Alcohol moieties composition of Krill AAPC was determined (identification was performed in the form of 1-alkyl-2,3-diTMS glycerols on GC-MS, % of total fatty alcohols were obtained by GC with FID). Ten other fatty acids were all below 0.3  
5 % by mass.

### EXAMPLE 9

The purpose of this experiment was to investigate the effect of different omega-3 fatty acid sources on metabolic parameters in the Zucker rat. The Zucker rat is a widely used model  
10 of obesity and insulin resistance. Obesity is due to a mutation in the leptin receptor which impairs the regulation of intake. Omega-3 sources compared in this study were fish oil (FO) and two types of krill oil. The krill oil were either from a commercial supplier (Neptune Krill oil) or prepared according to example 7 (Superba™). Four groups of rats (n = 6 per group) were fed *ad lib* either a control diet (CTRL) or a diet supplemented with a source of omega-3  
15 fatty acids (FO, NKO, Superba). All diets supplied same amount of dietary fatty acids, oleic acid, linoleic acid and linolenic acid. Omega-3 diets (FO, NKO and Superba™) were additionally balanced for EPA and DHA content. The Zucker rats were 4 wk old at the start of the study with average initial weight of 250 g. At this stage the Zucker rats can be characterized as being pre-diabetic. Rats were fed the test diets for 4 wk after which they were  
20 sacrificed and blood and tissue samples were collected. Data presented in the following figures are means ± SE. This example shows that supplementation of the Zucker rat with krill oil prepared as in example 7 results in an improvement of metabolic parameters characteristic of the obesity induced type two diabetic condition. The effect induced by the novel krill oil is often more pronounced than the effect of FO an in several cases greater than the effect  
25 induced by NKO. Specifically, the effects of the two types of krill oil differentiated with respect to the reduction of blood LDL cholesterol levels as well as lipid accumulation in the liver and muscle (Figure 2-9). Furthermore, the efficacy of transfer of DHA from the diet to the brain tissue was greatest with the krill oil prepared as in example 7 (Figure 10).

30

**EXAMPLE 11**

This example describes the effect of the supplementation of human diets with krill oil, fish oil (positive control), or a negative control oil (no omega-3 fatty acids) on blood urea nitrogen (BUN).

BUN measures the amount of nitrogen in the blood that comes from urea. BUN is used as a measure of renal function. Serum creatinine is, however, considered to be a more specific measure of renal function. In this study, krill oil decreased BUN by 11.8% while creatinine levels were unchanged. Thus, it is likely that the decrease in BUN is due to some other effect than improved renal function. BUN decreases if krill oil induced diuresis i.e. excretion of urine (diuretic effect).

BUN also decreases if body protein catabolism is reduced. Protein catabolism is a normal feature of body protein turnover. Many tissues express high protein turnover rates. For example the gastrointestinal system expresses high rates of protein turnover. In growing animals a reduction in GI protein catabolism improves weight gain. Mice supplemented with krill oil grew at a faster rate than mice supplemented with fish oil or control diet (Figure 11).

**Table 24.** The effect on blood urea nitrogen in humans for the different treatment groups.

	Control n = 23	Krill Oil n = 24	Menhaden oil n = 25	p
BUN, mg/dL				
Baseline	11.5 (7.8, 13.8)	11.5 (9.5, 13.5)	11.5 (9.5, 14.0)	0.523
Δ from baseline, %	11.0 (-14.3, 26.1)	-11.8 (-20.0, 1.5)	9.1 (-9.1, 35.7)	0.014r
Creatinine, mg/dL				
Baseline	0.9 (0.7, 0.9)	0.9 (0.7, 0.9)	0.8 (0.8, 1.0)	0.952r
(r)				
Δ from baseline, %	0.0 (-9.6, 2.9)	0.0 (-2.0, 5.9)	0.0 (-5.9, 6.7)	0.416

**EXAMPLE 12**

The purpose of this experiment was to investigate the effect of dietary krill oil on metabolic parameters in high-fat fed mice and to compare the effect of dietary krill oil with that of fish oil containing the same amount of omega-3 fatty acids. Four groups of C57BL/6



mice (n = 10 per group) were fed 1) chow (N), 2) high fat diet comprising 21% butter fat and 0.15% cholesterol (HF), 3) high fat diet + krill oil (HFKO) or 4) high fat diet + fish oil (HFFO). Treatment 3 contained 2.25% (w/w) krill oil as prepared in example 5 (except that the astaxanthin content was 500 ppm) which were equivalent to 0.36% omega-3 fatty acids. 5 Treatment 4 also contained 0.36% omega-3 fatty acids obtained from regular 18-12 fish oil. The diets were fed to the mice for 7 weeks with free access to drinking water. Data represented in this example means  $\pm$  SE. Columns not sharing a common letter are significantly different ( $P < 0.05$ ) by ANOVA followed by Tukey's multiple comparison test. N = normal chow diet (n = 10); HF = high-fat diet (n = 10); HFFO = high-fat diet 10 supplemented with fish oil (n = 9); HFKO = high-fat diet supplemented with krill oil (n = 8). The data are presented in Figures 18-25.

This example shows that supplementation of high-fat fed mice with krill oil results in an amelioration of diet-induced hyperinsulinemia, insulin resistance, increase in muscle lipid content (measured as a change in muscle mass), serum adiponectin reduction and hepatic 15 steatosis. These potentially beneficial atheroprotective effects were similar or greater than those achieved with a supplement containing a comparable level of omega-3 fatty acids (Figure 12-19).

**CLAIMS**

- 5 1. A composition comprising:  
from about 3% to 10% ether phospholipids on a w/w basis; and  
from about 400 to about 2500 mg/kg astaxanthin.
2. The composition of claim 1, further comprising from about 35% to 50% non-ether  
10 phospholipids on w/w basis, so that the total amount of ether phospholipids and non-ether  
phospholipids in the composition is from about 38% to 60% on a w/w basis.
3. The composition of claim 1 or claim 2, further comprising from about 20% to 45%  
triglycerides on a w/w basis.
- 15 4. The composition of any one of claims 1 to 3, wherein said ether phospholipids are  
selected from the group consisting of alkylacylphosphatidylcholine, lyso-  
alkylacylphosphatidylcholine, alkylacylphosphatidylethanolamine, and combinations thereof.
- 20 5. The composition of any one of claims 1 to 4, wherein said ether lipids are greater than  
90% alkylacylphosphatidylcholine.
6. The composition of any one of claims 1 to 5, wherein said non-ether phospholipids are  
selected from the group consisting of phosphatidylcholine, phosphatidylserine,  
25 phosphatidylethanolamine and combinations thereof.
7. The composition of any one of claims 1 to 6, wherein said composition comprises a  
blend of lipid fractions obtained from *Euphausia superba*.
- 30 8. The composition of any one of claims 1 to 7, wherein said composition comprises  
from about 25% to 40% omega-3 fatty acids as a percentage of total fatty acids and wherein  
from about 80% to 90% of said omega-3 fatty acids are attached to said phospholipids.

9. The composition of claim 1, further characterized in comprising at least 65% (w/w) of phospholipids, said phospholipids characterized in containing at least 35% omega-3 fatty acid residues.
- 5 10. The composition of any one of claims 1 to 9, wherein the composition is derived from a marine or aquatic biomass.
11. The composition of any one of claims 1 to 9, wherein the composition is derived from krill.
- 10 12. The composition of any one of claims 1 to 11, wherein said composition comprises less than 2% free fatty acids.
13. The composition of any one of claims 1 to 12, further characterized in that said phospholipids comprise greater than 50% phosphatidylcholine (w/w).
- 15 14. The composition of any one of claims 1 to 12, further characterized in that said phospholipids comprise greater than 70% phosphatidylcholine (w/w).
- 20 15. The composition of any one of claims 1 to 12, further characterized in that said phospholipids comprise greater than 80% phosphatidylcholine (w/w).
16. The composition of any one of claims 1 to 15, further characterized in comprising at least 36% (w/w) omega-3 fatty acids.
- 25 17. The composition of any one of claims 1 to 16, further characterized in comprising less than about 0.5g/100g total cholesterol.
18. The composition of any one of claims 1 to 17, further characterized in comprising less than about 0.45% arachidonic acid (w/w).
- 30 19. The composition of any one of claims 1 to 18, further characterized in being free from acetone.

20. The compositions of any one of claims 1 to 19, wherein said composition is odorless.
21. The composition of any one of claims 1 to 20, wherein said composition comprises less than about 10 mg/kg (w/w) trimethylamine.
- 5 22. A composition as claimed in claim 1 wherein said composition is a *Euphausia superba* krill oil composition comprising:  
from about 3% to about 10% w/w ether phospholipids;  
from about 27% to 50% w/w non-ether phospholipids so that the amount of total  
10 phospholipids in the composition is from about 30% to 60% w/w;  
from about 20% to 50% w/w triglycerides;  
from about 400 to about 2500 mg/kg astaxanthin; and  
from about 20% to 35% omega-3 fatty acids as a percentage of total fatty acids in said  
composition, wherein from about 70% to 95% of said omega-3 fatty acids are attached to said  
15 phospholipids.
23. A capsule containing the composition of any one of claims 1 to 22.
24. A dietary supplement comprising the composition of any one of claims 1 to 22.
- 20 25. A composition as claimed in any one of claims 1 to 22 for the prevention or treatment of diet-induced hyperinsulinemia, insulin insensitivity, muscle mass hypertrophy, serum adiponectin reduction or hepatic steatosis.
- 25 26. A composition as claimed in any one of claims 1 to 22 for inducing diuresis.
27. A composition as claimed in any one of claims 1 to 22 for increasing muscle mass.
28. A composition as claimed in any one of claims 1 to 22 for decreasing protein  
30 catabolism.
29. A composition as claimed in any one of claims 1 to 22 for prevention or treatment of fatty heart.

30. A composition as claimed in any one of claims 1 to 22 for prevention or treatment of fatty liver.
31. A composition as claimed in any one of claims 1 to 22 for prevention or treatment of  
5 insulin resistance, inflammation, blood lipid profile and oxidative stress.
32. A process for producing krill oil comprising:  
a) providing a denatured krill product; and  
b) extracting oil from said denatured krill product.
- 10 33. The process of claim 32, wherein said denatured krill product is produced by  
a) providing fresh krill;  
b) treating said fresh krill to denature lipases and phospholipases in said fresh krill  
to provide a denatured krill product; and  
15 c) extracting oil from said denatured krill product.
34. The process of claim 33 in which the denaturation step comprises heating of said fresh krill.
- 20 35. The process of claim 33 in which the denaturation step comprises heating said fresh krill after grinding.
36. The process of any one of claims 32 to 35, further comprising storing said denatured krill product at room temperature or below between the denaturation step and the extraction  
25 step.
37. The process of any one of claims 32 to 36, wherein the enzyme denaturation step is achieved by application of heat.
- 30 38. The process of any one of claims 32 to 36, wherein said denatured krill product is a krill meal.
39. The process of claim 38, wherein said krill meal is stored prior to said extraction step.

40. The process of any one of claims 32 to 39, wherein the extraction step comprises use of supercritical carbon dioxide, with or without use of a polar modifier.
41. The process of claim 40, wherein said supercritical fluid extraction is a two step  
5 process comprising a first extraction step with carbon dioxide and from 1 to 10% of a co-solvent and a second extraction with carbon dioxide and from 10-30% of a co-solvent, wherein said co-solvent is a C<sub>1</sub>-C<sub>3</sub> monohydric alcohol.
42. The process of any one of claims 32 to 41, wherein the extraction step comprises the  
10 use of ethanol.
43. The process of any one of claims 32 to 42, wherein the extraction step comprises ethanol extraction followed by acetone whereby to precipitate phospholipids.
- 15 44. A process for making a composition as claimed in claim 1 comprising:  
contacting *Euphausia superba* with a polar solvent to provide a polar extract comprising phospholipids;  
contacting *Euphausia superba* with a neutral solvent to provide a neutral extract comprising triglycerides and astaxanthin;  
20 combining said polar extract and said neutral extract to provide *Euphausia superba* krill oil comprising from about 3% to about 10% w/w ether phospholipids; from about 27% to 50% w/w non-ether phospholipids so that the amount of total phospholipids in the composition is from about 30% to 60% w/w; from about 20% to 50% w/w triglycerides; from about 400 to about 2500 mg/kg astaxanthin; and from about 20% to 35% omega-3 fatty acids  
25 as a percentage of total fatty acids in said composition, wherein from about 70% to 95% of said omega-3 fatty acids are attached to said phospholipids.
45. The process of any one of claims 32 to 44, further comprising encapsulating said krill oil.  
30
46. An oil produced by the processes of any one of claims 32 to 44.
47. A krill lipid extract comprising greater than about 80% triglycerides and greater than about 90 mg/kg astaxanthin esters.

48. The krill lipid extract of claim 47, characterized in containing from about 5% to about 15% omega-3 fatty acid residues.
- 5 49. The krill lipid extract of claim 47 or claim 48, characterized in containing less than about 5% phospholipids.
50. The krill lipid extract of any one of claims 47 to 49, characterized in comprising from about 5% to about 10% cholesterol.
- 10 51. A krill meal composition comprising less than about 50g/kg total fat.
52. The krill meal composition of claim 51 comprising from about 5 to about 20 mg/kg astaxanthin esters.
- 15 53. The krill meal composition of claims 51 or 52 comprising greater than about 65% protein.
54. The krill meal composition of any one of claims 51 to 53 comprising greater than  
20 about 70% protein.
55. An animal feed comprising the krill meal of any one of claims 51 to 54.
56. Use of the krill meal composition of any one of claims 51 to 54 to increase flesh  
25 coloration in an aquatic species.
57. Use of the krill meal composition of any one of claims 51 to 54 to increase growth and overall survival rate of aquatic species.
- 30 58. An odorless krill oil produced by the method comprising:  
extracting a neutral krill oil from a krill oil containing material by supercritical fluid extraction to provide a deodorized krill material, wherein said neutral krill oil contains odor causing compounds; and

extracting a polar krill oil from said deodorized krill material by supercritical fluid extraction with a polar entrainer to provide an essentially odorless krill oil.

59. A krill oil produced by the process comprising:

5 pumping fresh krill from a trawl onto a ship, heating the krill to provide a krill material, and extracting oil from the krill material.

10



FIGURE 1

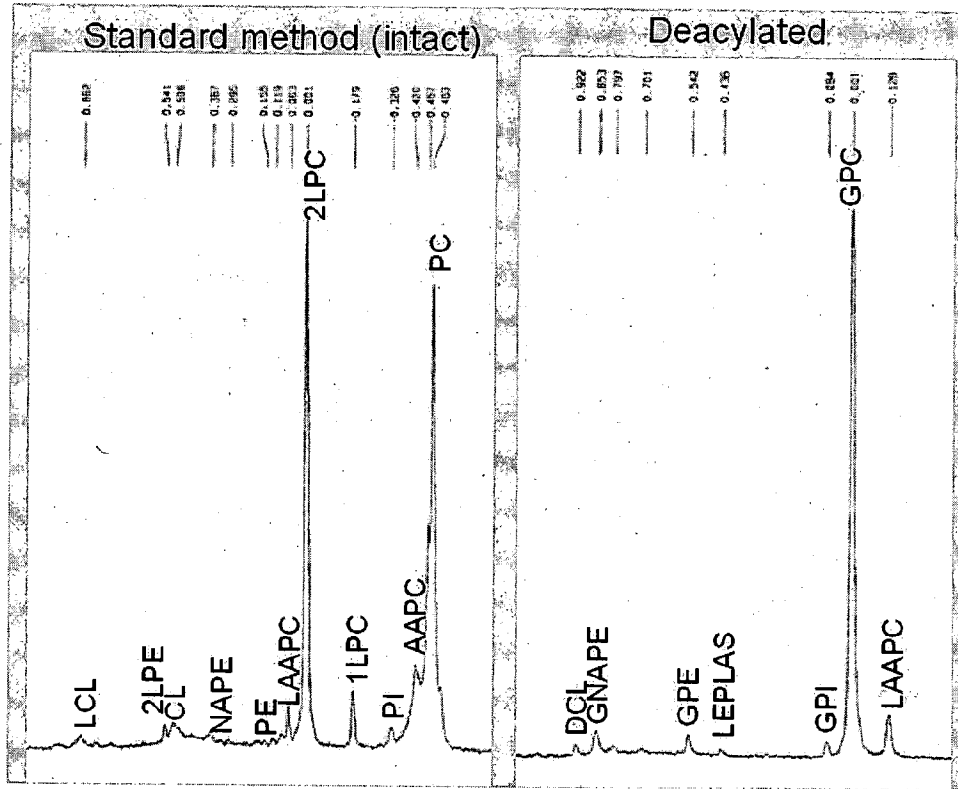

FIGURE 2

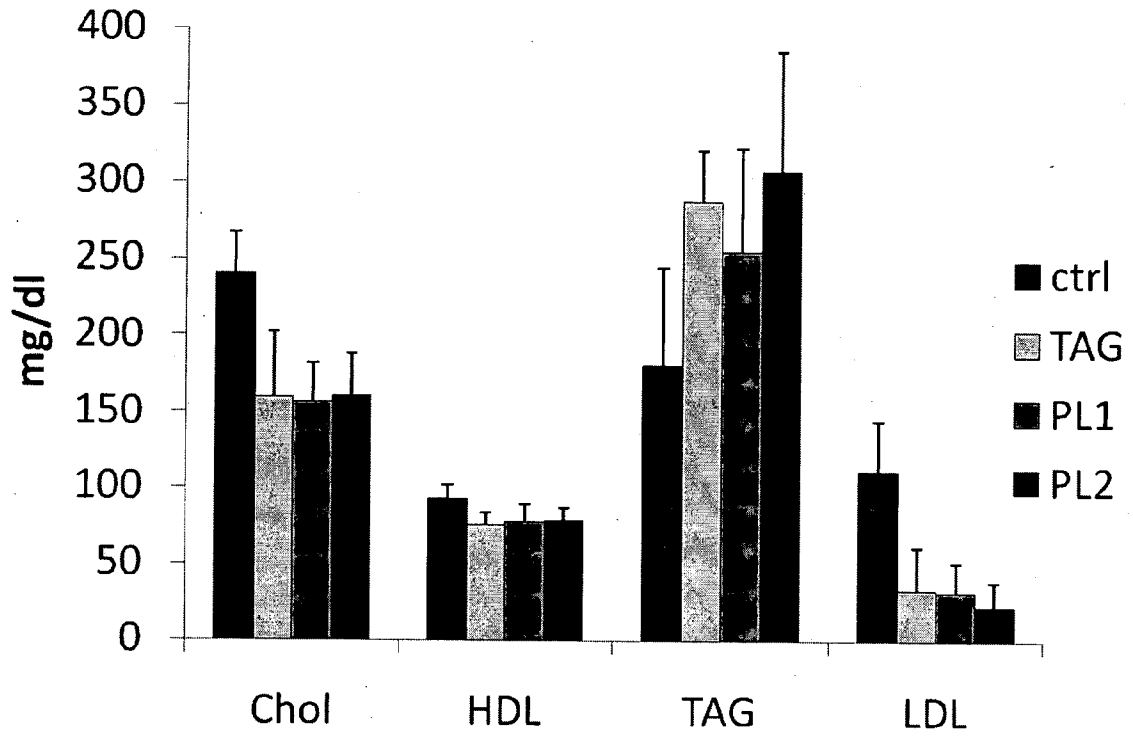

FIGURE 3

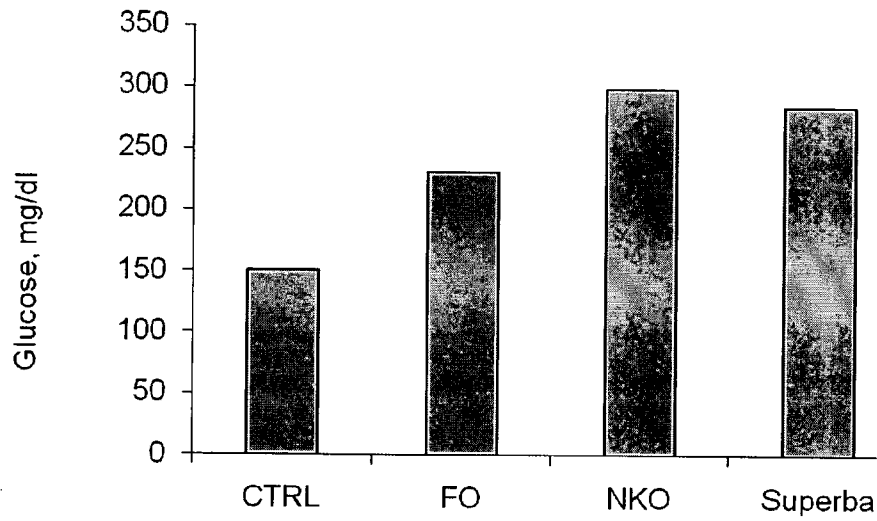

FIGURE 4

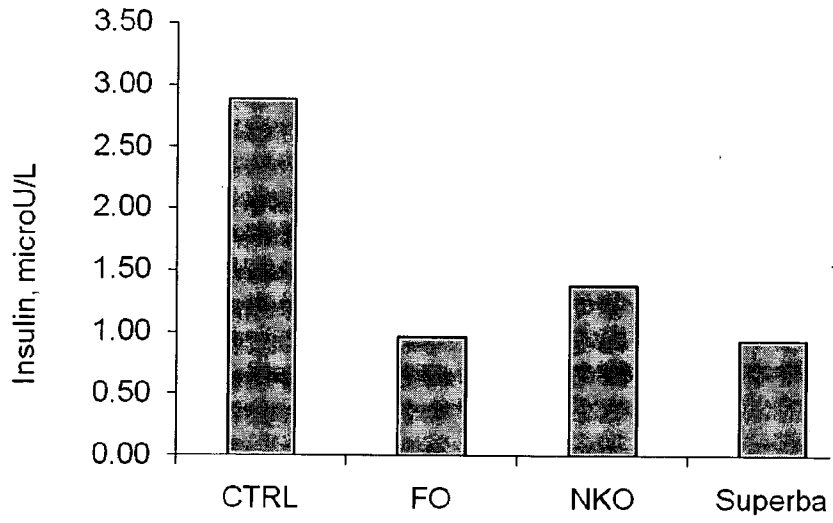

FIGURE 5

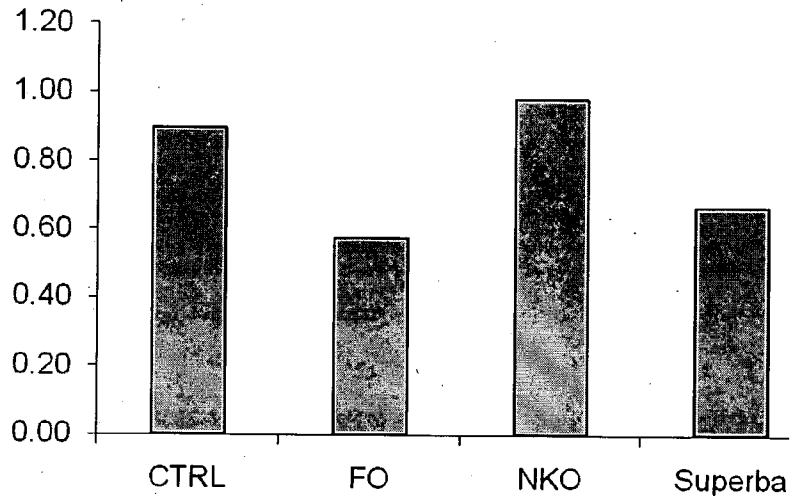

FIGURE 6

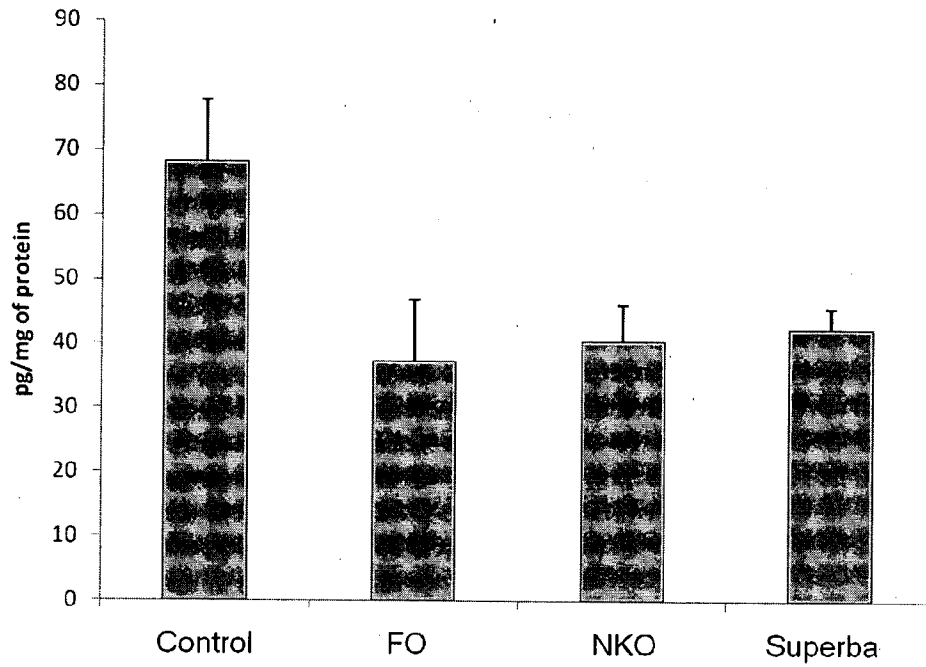

FIGURE 7

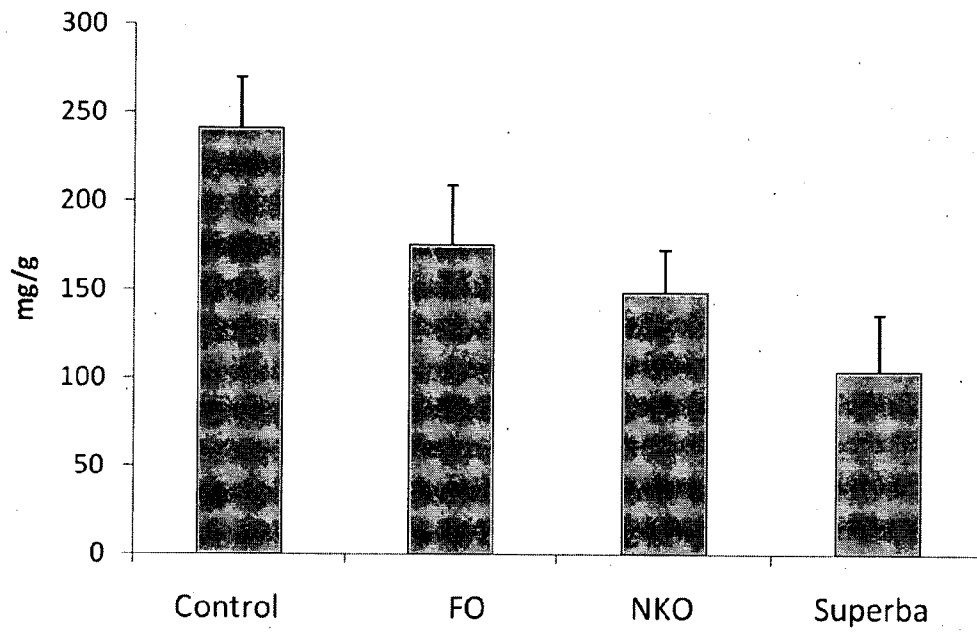

FIGURE 8

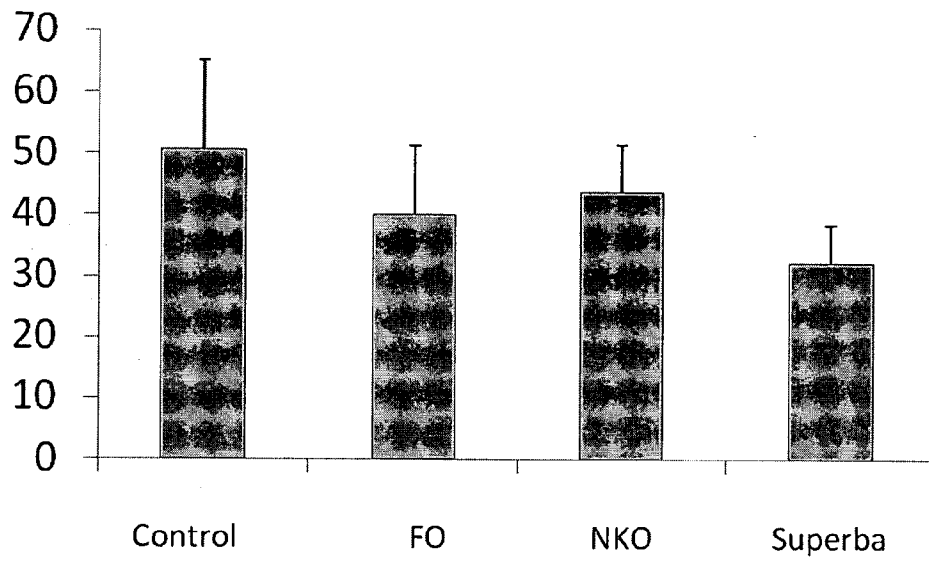



FIGURE 9

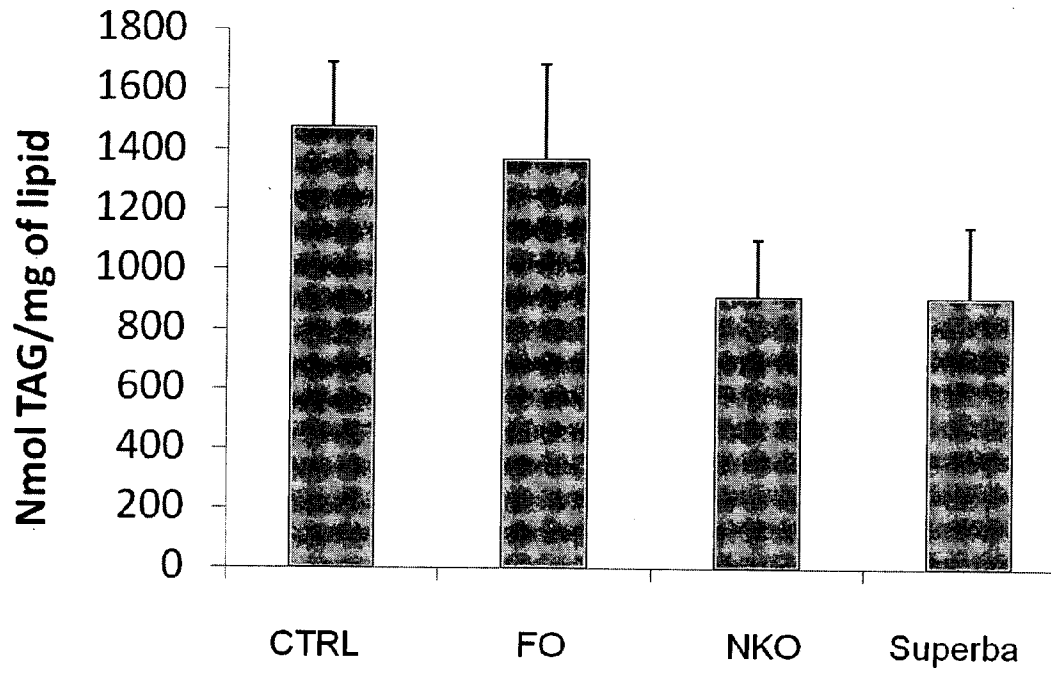

FIGURE 10

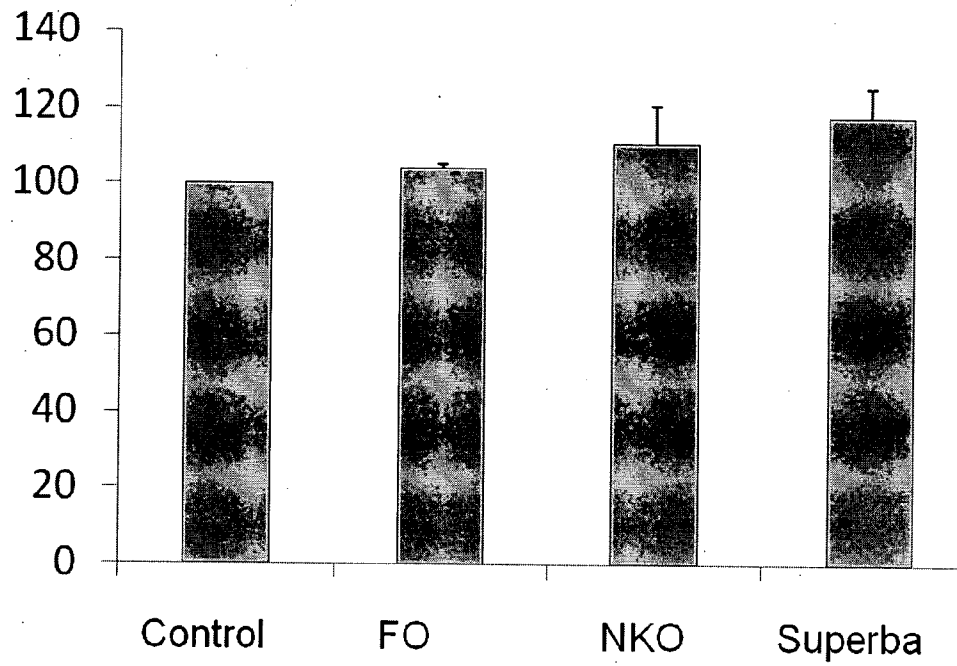
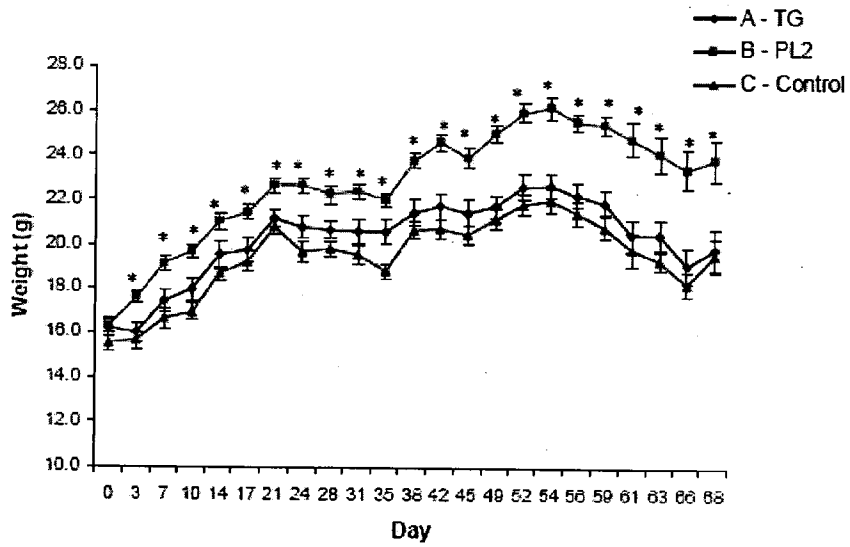

FIGURE 11



12/19

FIGURE 12

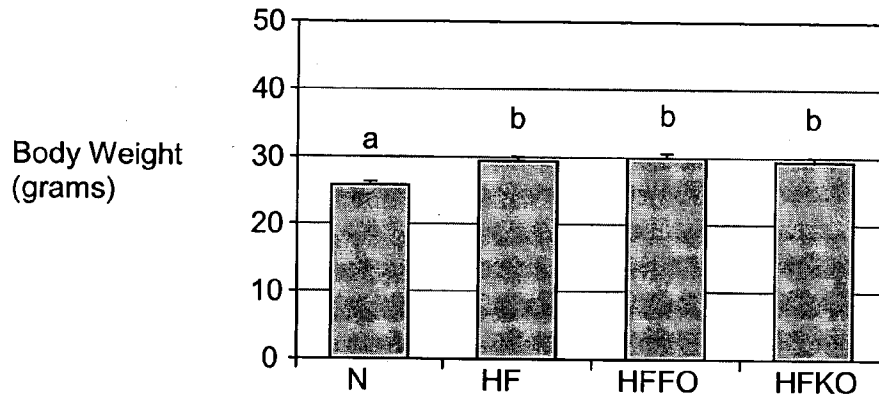

FIGURE 13

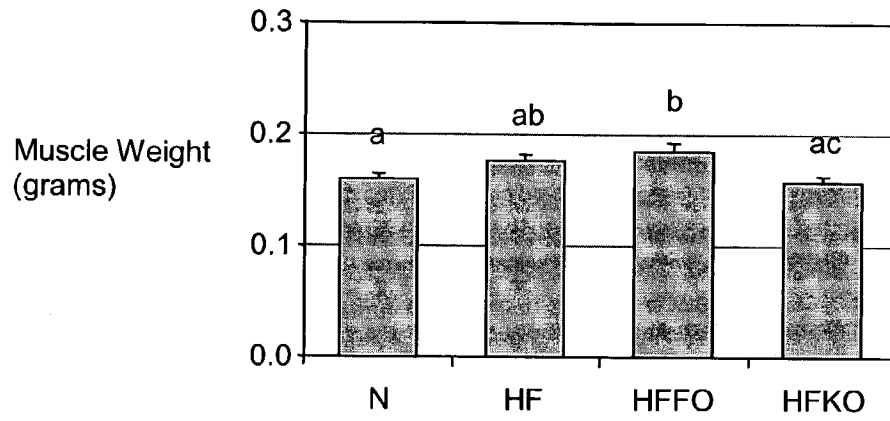

FIGURE 14

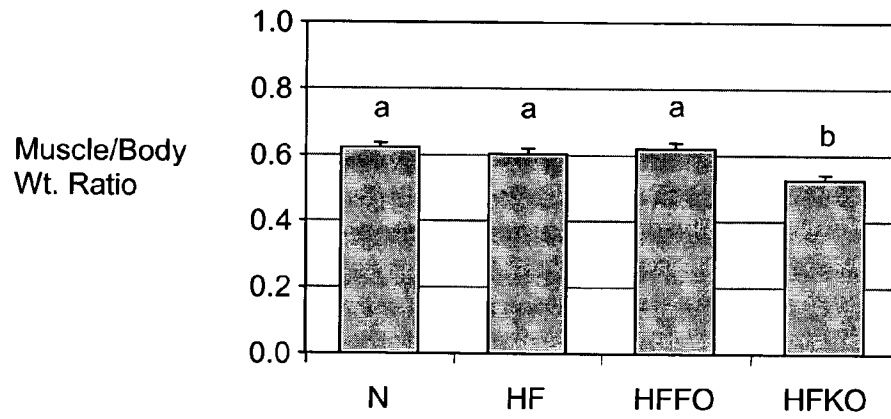

FIGURE 15

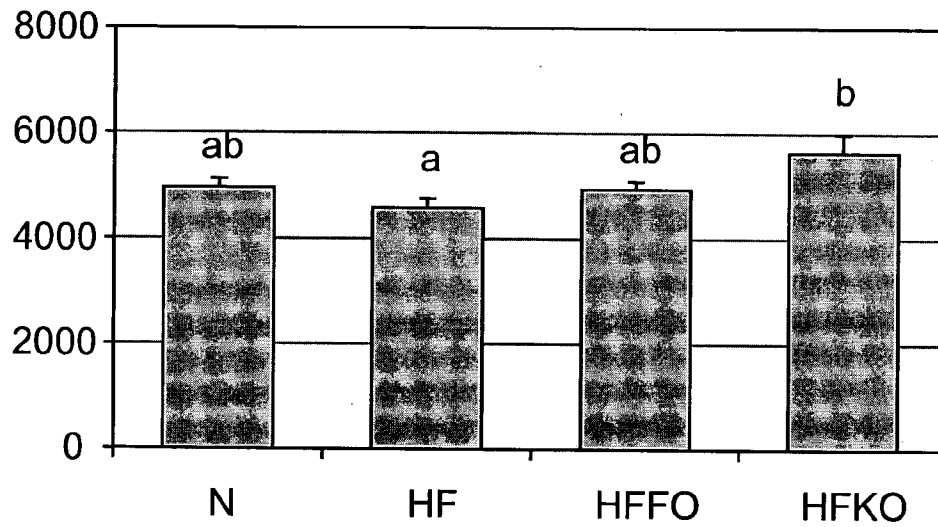

FIGURE 16

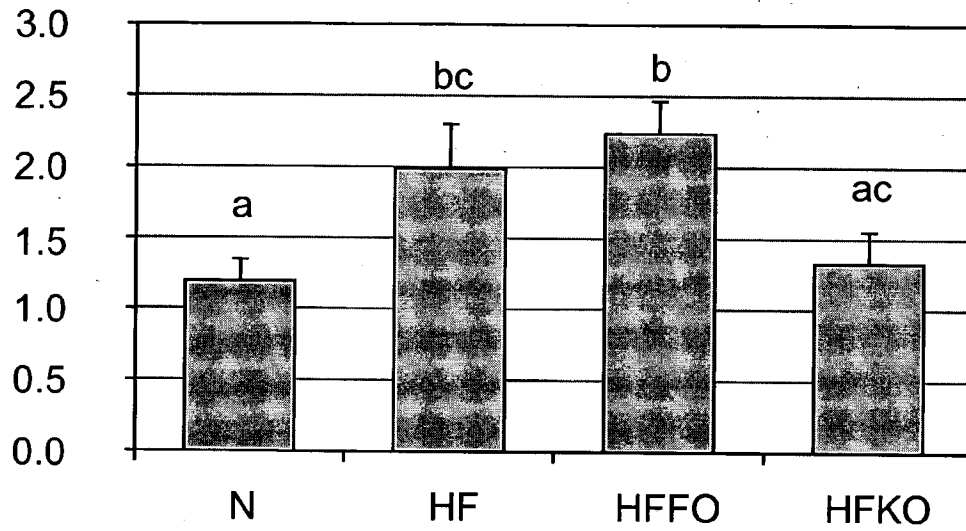



FIGURE 17

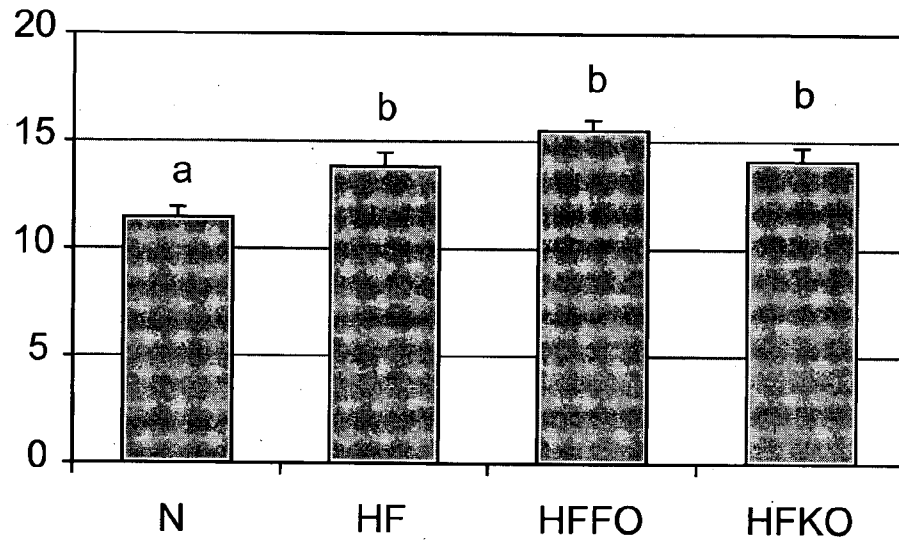

FIGURE 18

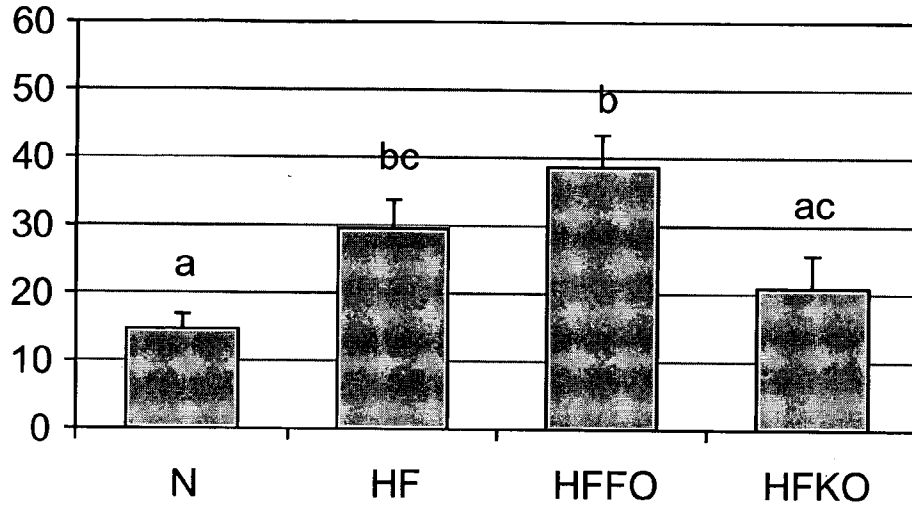
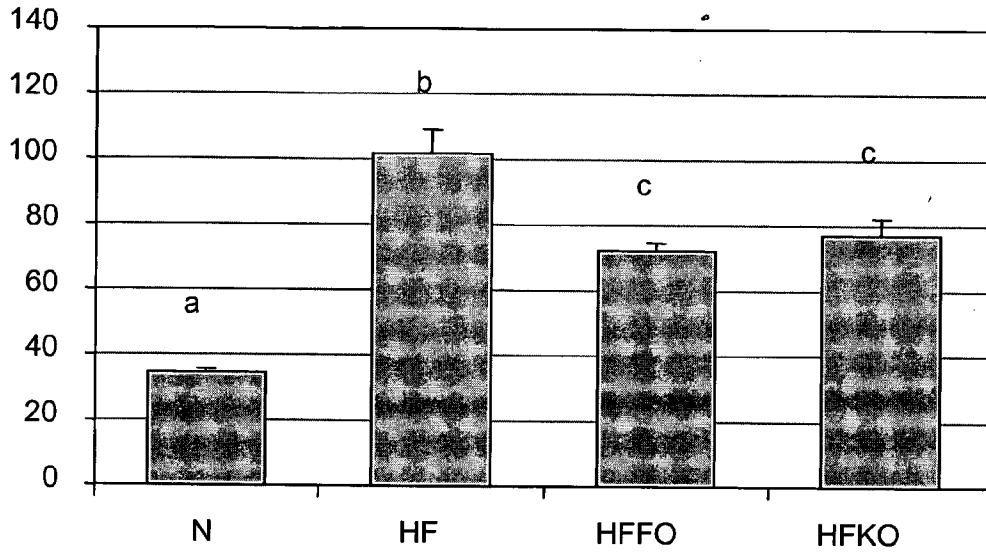

FIGURE 19



**INTERNATIONAL SEARCH REPORT**

International application No  
PCT/GB2008/001080

**A. CLASSIFICATION OF SUBJECT MATTER**  
INV. A61K35/60

According to International Patent Classification (IPC) or to both national classification and IPC

**B. FIELDS SEARCHED**

Minimum documentation searched (classification system followed by classification symbols)  
A61K

Documentation searched other than minimum documentation to the extent that such documents are included in the fields searched

Electronic data base consulted during the international search (name of data base and, where practical, search terms used)  
EPO-Internal, WPI Data

**C. DOCUMENTS CONSIDERED TO BE RELEVANT**

Category*	Citation of document, with indication, where appropriate, of the relevant passages	Relevant to claim No.
A	WO 02/102394 A (NEPTUNE TECHNOLOGIES & BIORESS [CA]; SAMPALIS TINA [CA]) 27 December 2002 (2002-12-27) cited in the application the whole document	1-31
A	US 4 119 619 A (ROGOZHIN SERGEI VASILIEVICH ET AL) 10 October 1978 (1978-10-10) the whole document	32-49, 59
A	WO 00/23546 A (UNIV SHERBROOKE [CA]; BEAUDOIN ADRIEN [CA]; MARTIN GENEVIEVE [CA]) 27 April 2000 (2000-04-27) the whole document	32-49, 59

Further documents are listed in the continuation of Box C.

See patent family annex.

\* Special categories of cited documents:

- \*A\* document defining the general state of the art which is not considered to be of particular relevance
- \*E\* earlier document but published on or after the international filing date
- \*L\* document which may throw doubts on priority claim(s) or which is cited to establish the publication date of another citation or other special reason (as specified)
- \*O\* document referring to an oral disclosure, use, exhibition or other means
- \*P\* document published prior to the international filing date but later than the priority date claimed

- \*T\* later document published after the international filing date or priority date and not in conflict with the application but cited to understand the principle or theory underlying the invention
- \*X\* document of particular relevance; the claimed invention cannot be considered novel or cannot be considered to involve an inventive step when the document is taken alone
- \*Y\* document of particular relevance; the claimed invention cannot be considered to involve an inventive step when the document is combined with one or more other such documents, such combination being obvious to a person skilled in the art.
- \*&\* document member of the same patent family

Date of the actual completion of the international search

16 July 2008

Date of mailing of the international search report

24/07/2008

Name and mailing address of the ISA/

European Patent Office, P.B. 5818 Patentlaan 2  
NL - 2280 HV Rijswijk  
Tel. (+31-70) 340-2040, Tx. 31 651 epo nl,  
Fax: (+31-70) 340-3016

Authorized officer

Engl, Brigitte

INTERNATIONAL SEARCH REPORT

International application No  
PCT/GB2008/001080

C(Continuation). DOCUMENTS CONSIDERED TO BE RELEVANT		
Category*	Citation of document, with indication, where appropriate, of the relevant passages	Relevant to claim No.
A	EP 1 127 497 A (NIPPON SUISAN KAISHA LTD [JP]) 29 August 2001 (2001-08-29) the whole document	51-57
X	YAMAGUCHI K ET AL: "Supercritical carbon dioxide extraction of oils from antarctic krill" JOURNAL OF AGRICULTURAL AND FOOD CHEMISTRY, AMERICAN CHEMICAL SOCIETY. WASHINGTON, US, vol. 34, 1 January 1986 (1986-01-01), pages 904-907, XP002430955 ISSN: 0021-8561 the whole document	58

# INTERNATIONAL SEARCH REPORT

Information on patent family members

International application No PCT/GB2008/001080
---

Patent document cited in search report	A	Publication date	Patent family member(s)	Publication date
WO 02102394	A	27-12-2002	CA 2449898 A1	27-12-2002
			CN 1516592 A	28-07-2004
			EP 1406641 A2	14-04-2004
			JP 2004534800 T	18-11-2004
US 4119619	A	10-10-1978	ES 465066 A1	01-09-1978
			FR 2373972 A1	13-07-1978
			JP 53101400 A	04-09-1978
WO 0023546	A	27-04-2000	AT 391763 T	15-04-2008
			AU 765464 B2	18-09-2003
			AU 6455299 A	08-05-2000
			BR 9914699 A	10-07-2001
			CA 2251265 A1	21-04-2000
			CN 1324394 A	28-11-2001
			EP 1123368 A1	16-08-2001
			JP 2002527604 T	27-08-2002
			NO 20011915 A	21-06-2001
			PL 347396 A1	08-04-2002
			RU 2236441 C2	20-09-2004
			UA 75029 C2	17-09-2001
			US 6800299 B1	05-10-2004
			ZA 200103235 A	20-06-2002
EP 1127497	A	29-08-2001	AU 6230399 A	22-05-2000
			CA 2345418 A1	11-05-2000
			CN 1324219 A	28-11-2001
			WO 0025608 A1	11-05-2000
			JP 2000139419 A	23-05-2000
			NO 20011590 A	11-06-2001

(19) World Intellectual Property Organization  
International Bureau



(43) International Publication Date  
5 March 2009 (05.03.2009)

PCT

(10) International Publication Number  
**WO 2009/027692 A2**

(51) International Patent Classification:

A23J 1/04 (2006.01) C11B 1/10 (2006.01)  
A23K 1/10 (2006.01) A23J 7/00 (2006.01)  
A23K 1/18 (2006.01) C07F 9/10 (2006.01)  
A23L 1/30 (2006.01)

(NO). SNORRE, Tilseth [NO/NO]; Fantoftsasen 27A, N-5072 Bergen (NO).

(74) Agents: GOLDING, Louise et al.; FRANK B. DEHN & CO., St Bride's House, 10 Salisbury Square, London EC4Y 8JD (GB).

(21) International Application Number:

PCT/GB2008/002934

(81) Designated States (unless otherwise indicated, for every kind of national protection available): AE, AG, AL, AM, AO, AT, AU, AZ, BA, BB, BG, BH, BR, BW, BY, BZ, CA, CH, CN, CO, CR, CU, CZ, DE, DK, DM, DO, DZ, EC, EE, EG, ES, FI, GB, GD, GE, GI, GM, GT, HN, HR, HU, ID, IL, IN, IS, JP, KE, KG, KM, KN, KP, KR, KZ, LA, LC, LK, LR, LS, LT, LU, LY, MA, MD, ME, MG, MK, MN, MW, MX, MY, MZ, NA, NG, NI, NO, NZ, OM, PG, PH, PL, PT, RO, RS, RU, SC, SD, SE, SG, SK, SL, SM, ST, SV, SY, TJ, TM, TN, TR, TT, TZ, UA, UG, US, UZ, VC, VN, ZA, ZM, ZW.

(22) International Filing Date: 29 August 2008 (29.08.2008)

(25) Filing Language: English

(26) Publication Language: English

(30) Priority Data:

60/968,765 29 August 2007 (29.08.2007) US

(84) Designated States (unless otherwise indicated, for every kind of regional protection available): ARIPO (BW, GH, GM, KE, LS, MW, MZ, NA, SD, SL, SZ, TZ, UG, ZM, ZW), Eurasian (AM, AZ, BY, KG, KZ, MD, RU, TJ, TM), European (AT, BE, BG, CH, CY, CZ, DE, DK, EE, ES, FI, FR, GB, GR, HR, HU, IE, IS, IT, LT, LU, LV, MC, MT, NL, NO, PL, PT, RO, SE, SI, SK, TR), OAPI (BF, BJ, CF, CG, CI, CM, GA, GN, GQ, GW, ML, MR, NE, SN, TD, TG).

(71) Applicant (for all designated States except US): AKER BIOMARINE ASA [NO/NO]; Fjordalleen 16, PO BOX 1423 Vika, N-0115 Oslo (NO).

(71) Applicant (for GB only): GOLDING, Louise [GB/GB]; Frank B. Dehn & Co., St Bride's House, 10 Salisbury Square, London EC4Y 8JD (GB).

(72) Inventors; and

(75) Inventors/Applicants (for US only): ØISTEIN, Høstmark [NO/NO]; Skalevikveien 23, N-5178 Loddefjord

Published:

— without international search report and to be republished upon receipt of that report



WO 2009/027692 A2

(54) Title: A NEW METHOD FOR MAKING KRILL MEAL

(57) Abstract: A new method for krill meal production has been developed using a two step cooking process. In the first step the proteins and phospholipids are removed from the krill and precipitated as a coagulum. In the second stage the krill without phospholipids are cooked. Following this, residual fat and astaxanthin are removed from the krill using mechanical separation methods. A novel krill meal product with superior nutritional and technical properties is prepared.

## A new method for making krill meal

### FIELD OF THE INVENTION

The invention relates to processing crustaceans such as krill to provide oil and meal products, and in particular to the production of oils containing astaxanthin and phospholipids comprising omega-3 fatty acid moieties and meal rich in astaxanthin.

### BACKGROUND OF THE INVENTION

Krill is a small crustacean which lives in all the major oceans world-wide. For example, it can be found in the Pacific Ocean (*Euphausia pacifica*), in the Northern Atlantic (*Meganyctiphanes norvegica*) and in the Southern Ocean off the coast of Antarctica (*Euphausia superba*). Krill is a key species in the ocean as it is the food source for many animals such as fish, birds, sharks and whales. Krill can be found in large quantities in the ocean and the total biomass of Antarctic krill (*E. superba*) is estimated to be in the range of 300-500 million metric tons. Antarctic krill feeds on phytoplankton during the short Antarctic summer. During winter, however, its food supply is limited to ice algae, bacteria, marine detritus as well as depleting body protein for energy. Virtue et al., Mar. Biol. 126, 521-527. For this reason, the nutritional values of krill vary during the season and to some extent annually. Phleger et al., Comp. Biochem. Physiol. 131B (2002) 733. In order to accommodate variations in food supply, krill has developed an efficient enzymatic digestive apparatus resulting in a rapid breakdown of the proteins into amino acids. Ellingsen et al., Biochem. J. (1987) 246, 295-305. This autoproteolysis is highly efficient also post mortem, making it a challenge to catch and store the krill in a way that preserves the nutritional quality of the krill. Therefore, in order to prevent the degradation of krill the enzymatic activity is either reduced by storing the krill at low temperatures or the krill is made into a krill meal.

During the krill meal process the krill is cooked so that all the active enzymes are denatured in order to eliminate all enzymatic activity. Krill is rich in phospholipids which act as emulsifiers. Thus it is more difficult to separate water, fat and proteins using mechanical separation methods than it is in a regular fish meal production line. In addition, krill becomes solid, gains weight and loose liquid more easily when mixed with hot water. Eventually this may lead to a gradual build up of coagulated krill proteins in the cooker and a non-continuous operation due to severe clogging problems. In order to alleviate this, hot steam must be added directly into the cooker. This operation is energy demanding and may also result in a degradation of unstable bioactive components in the krill such as omega-3 fatty acids,



phospholipids and astaxanthin. The presence of these compounds, make krill oil an attractive source as a food supplement, a functional food products and a pharmaceutical for the animal and human applications.

Omega-3 fatty acids have recently been shown to have potential effect of preventing cardiovascular disease, cognitive disorders, joint disease and inflammation related diseases such as rheumatoid arthritis. Astaxanthin is a strong antioxidant and may therefore assist in promoting optimal health. Hence, there is a need for a method of processing krill into a krill meal at more gentle conditions which prevents the degradation of these valuable bioactive compounds.

## SUMMARY OF THE INVENTION

The invention relates to processing crustaceans such as krill to provide oil and meal products, and in particular to the production of oils and other lipid extracts containing astaxanthin and phospholipids comprising omega-3 fatty acid moieties and meal rich in astaxanthin.

In some embodiments, the present invention provides compositions comprising less than about 150, 100, 10, 5, 2 or 1 mg/kg astaxanthin or from about 0.1 to about 1, 2, 5, 10 or 200 mg/kg astaxanthin, preferably endogenous, naturally occurring astaxanthin, from about 20% to about 50%, 15% to 45%, or 25% to 35% phospholipids on a w/w basis, and about 15% to 60%, about 20% to 50%, or about 25% to 40% protein on a w/w basis, wherein said phospholipids comprise omega-3 fatty acid residues. In some embodiments, the composition comprises a lipid fraction having an omega-3 fatty acid content of from about 5% to about 30%, from 10% to about 30%, or from about 12% to about 18% on a w/w basis. In some embodiments, the phospholipids comprise greater than about 60%, 65%, 80%, 85% or 90% phosphatidylcholine on a w/w basis. In some embodiments, the phospholipids comprise less than about 15%, 10%, 8% or 5% ethanolamine on a w/w basis. In some embodiments, the compositions comprise from about 1% to 10%, preferably 2% to 8%, and most preferably about 2% to 6% alkylacylphosphatidylcholine. In some embodiments, the compositions comprise from about 40% to about 70% triacylglycerol on a w/w basis. In further embodiments, the compositions comprise less than about 1% cholesterol. In some embodiments, the protein comprises from about 8% to about 14% leucine on a w/w basis and from about 5% to 11% isoleucine on a w/w basis.

In some embodiments, the present invention comprises an aqueous phase and a solid phase, said solid phase comprising from about 20% to about 40% phospholipids on a w/w

basis, and about 20% to 50% protein on a w/w basis, wherein said phospholipids comprise from about 10% to about 20% omega-3 fatty acid residues.

In other embodiments, the present invention provides krill compositions comprising astaxanthin, a protein fraction, and a lipid fraction, wherein said lipid fraction comprises less than about 10%, 5% or 3% phospholipids on a w/w basis. In some embodiments, the phospholipids comprise less than about 15%, 10% or 5% phosphatidylcholine on a w/w basis.

In some embodiments, the present invention provides a krill meal comprising astaxanthin and from about 8 % to about 31 % lipids, preferably from about 8% to about 10 or 18 % lipids, wherein said lipids comprises greater than about 80% neutral lipids on a w/w basis. In some embodiments, the krill meal comprises less than about 15%, 10%, 5%, 3% or 1% phospholipids. In some embodiments, the phospholipids comprise less than about 15%, 10% or 5% phosphatidylcholine on a w/w basis.

In some embodiments, the present invention provides methods of preparing a phospholipid composition from biological material or biomass comprising: mixing said biological material or biomass with water at a suitable temperature to form a solid phase and an aqueous phase comprising phospholipids and proteins; separating said solid phase from said aqueous phase; heating said aqueous phase at a temperature sufficient to form a phospholipid-protein precipitate; and separating said phospholipid-protein precipitate from said aqueous phase. In some embodiments, the present invention provides a phospholipid-protein precipitate obtained by using the foregoing method. In some embodiments, the biological material or biomass is krill. In other embodiments, the biological material or biomass is selected from crabs, shrimp, calanus, plankton, crayfish, eggs or other phospholipid containing biological materials or biomass. In some embodiments, the methods further comprise the step of forming a meal from said solid phase. In some embodiments, the step of forming a meal comprises: heating the solid phase in the presence of water; separating fat and protein in said solid phase; and drying said protein to form a meal. In some embodiments, the processes further comprise the steps of pressing and drying the coagulum to form a coagulum meal. In some embodiments, the drying is by hot air or steam. In some embodiments, the present invention provides a phospholipid-protein precipitate obtained by using the foregoing method. In some embodiments, the present invention provides a composition comprising a krill solid phase according to the foregoing methods. In some embodiments, the present invention provides a krill meal obtained by the foregoing methods.

In some embodiments, the present invention provides processes comprising: extracting a first lipid fraction from a krill biomass; extracting a second lipid fraction from a krill

biomass; and blending said first lipid fraction and said second lipid fraction to provide a krill lipid composition having a desired composition. In some embodiments, the one or more of the extracting steps are performed in the absence of substantial amounts of organic solvents. In some embodiments, the first lipid fraction is extracted by: mixing krill with water at a suitable temperature to form a solid phase and an aqueous phase comprising phospholipids and protein; separating said solid phase from said aqueous phase; heating said aqueous phase at a temperature sufficient to form a phospholipid-protein precipitate; separating said phospholipid-protein precipitate from said aqueous phase; and separating said phospholipids from said protein. In some embodiments, the second lipid fraction is extracted by: heating the solid phase in the presence of water; and separating fat and protein in said solid phase. In some embodiments, the first lipid fraction comprises a phospholipid fraction comprising greater than about 90% phosphatidylcholine on a w/w basis. In some embodiments, the second lipid fraction comprises greater than about 80% neutral lipids on a w/w basis.

In some embodiments, the present invention provides processes of producing a phospholipid composition from biological material or biomass comprising: mixing said biological material or biomass with water to increase the temperature of said biological material to about 25 to 80 °C , preferably to about 50 to 75 °C, and most preferably to about 60 to 75 °C to form a first solid phase and a first aqueous phase comprising phospholipids and proteins; separating said first solid phase from said first aqueous phase; and separating a protein and phospholipid fraction from said first aqueous phase. In some embodiments, the biomass is heated to the first temperature for at least 3 minutes, preferably from about 3 minutes to 60 minutes, more preferably from about 3 minutes to 20 minutes, and most preferably from about 3 minutes to 10 minutes. The present invention is not limited to the use of any particular biological materials or biomass. In some embodiments, the biological material is a marine biomass. In some preferred embodiments, the biological material or biomass comprises krill crabs, shrimp, calanus, plankton, crayfish, eggs or other phospholipid containing biological materials or biomass. The present invention is not limited to the use of any particular type of krill. In some embodiments, the krill is fresh, while in other embodiments, the krill is frozen. In some embodiments, the krill is of the species *Euphausia superba*. In some embodiments, the step of separating a protein and phospholipid fraction from said first aqueous phase comprises heating said first aqueous phase at a temperature sufficient to form a phospholipid-protein coagulate and separating said phospholipid-protein coagulate from said aqueous phase. In some embodiments, the processes utilize a second heating step. In some embodiments, the first aqueous phase is heated to over 80 °C, preferably

to about 80 to 120 °C, and most preferably to about 90 to 100 °C. In some embodiments, the krill milk is held at these temperatures for from about 1 minute to about 60 minutes, preferably about 1 minute to about 10 minutes, and most preferably for about 2 minutes to 8 minutes. In some embodiments, the heating is at atmospheric pressure, while in other  
5 embodiments, the pressure is greater than atmospheric pressure. In some embodiments, the processes further comprise the step of pressing said phospholipid-protein coagulate to form a coagulate liquid phase and a coagulate press cake. In some embodiments, the processes further comprise drying said coagulate press cake to form a coagulate meal. In some  
10 embodiments, the processes further comprise extracting a coagulate oil from said coagulate meal. In some embodiments, the processes further comprise the steps of pressing and drying the coagulum to form a coagulum meal. In some embodiments, the drying is by hot air or steam.

In some embodiments, the step of separating a protein and phospholipid fraction from said first aqueous phase comprises filtration of said aqueous phase to provide a phospholipid-  
15 protein retentate comprising proteins and phospholipids. In some embodiments, filtration is via membrane filtration. In some embodiments, the filtration comprises filtering said aqueous phase through a microfilter with a pore size of from about 50 to 500 nm. In some embodiments, the processes further comprise the step of dewatering said phospholipid-protein retentate to form a retentate liquid phase and a retentate concentrate. In some  
20 embodiments, the processes further comprise the step of removing water from said retentate concentrate so that said retentate concentrate is microbially stable. In some embodiments, the processes further comprise the step of extracting a retentate oil from said retentate concentrate. In some embodiments, the processes further comprise the step of heating said first solid phase and then pressing said first solid phase to form a first press cake and a second liquid phase. In some  
25 embodiments, the processes further comprise the step of drying said first press cake to provide a first krill meal. In some embodiments, the processes further comprise the steps of heating said second liquid phase and then separating said second liquid phase to provide a first krill oil and stickwater. In some embodiments, the stickwater is evaporated and added to said first press cake, and a meal is formed from said evaporated stickwater and said first press cake to  
30 provide a second krill meal. In some embodiments, the second liquid phase is heated to over 80 °C, preferably to about 80 to 120 °C, and most preferably to about 90 to 100 °C prior to said separation. In some embodiments, the processes further comprise the step of combining the previously described coagulate oil or the retentate oil and the first krill oil to provide a blended oil. In other embodiments, the coagulate oil, retentate oil, or oil pressed from the first

solid phase are combined with the coagulate meal or retentate. In further embodiments, the processes of the present invention comprise the further step of supplementing the meals or oils produced as described above with additional proteins, phospholipids, triglycerides, fatty acids, and/or astaxanthin to produce an oil or meal with a desired defined composition. As such, a person of skill in the art will readily recognize that the processes described above serve as a starting point for producing compositions that are further supplemented in subsequent process steps to produce a desired composition, such a composition containing elevated levels of proteins, lipids or astaxanthin. In some embodiments, the present invention provides the lipid-protein composition produced by the foregoing processes. In some embodiments, the present invention provides the coagulate meal produced by the foregoing processes. In some embodiments, the present invention provides the coagulate oil produced by the foregoing processes. In some embodiments, the present invention provides the retentate meal produced by the foregoing processes. In some embodiments, the present invention provides the retentate oil produced by the foregoing processes. In some embodiments, the present invention provides the krill meal produced by the foregoing processes. In some embodiments, the present invention provides a krill oil produced by the foregoing processes. In some embodiments, the present invention provides a blended oil produced by the foregoing processes. In some embodiments, the compositions of the present invention are supplemented with additional proteins, phospholipids, triglycerides, fatty acids, and/or astaxanthin to produce an oil or meal with a desired defined composition. As such, a person of skill in the art will readily recognize that the compositions described above serve as a starting point for producing compositions that are further supplemented in subsequent process steps to produce a desired composition, such a composition containing elevated levels of proteins, lipids or astaxanthin.

In some embodiments, the present invention provides processes comprising: heating a krill biomass to about 25 to 80 °C, preferably to about 50 to 75 °C, and most preferably to about 60 to 75 °C; separating said krill biomass into solid and liquid phases; extracting a first lipid fraction from said solid phase; extracting a second lipid fraction from said liquid phases; and blending said first lipid fraction and said second lipid fraction to provide a krill lipid composition having a desired composition. In some embodiments, the extracting steps are performed in the absence of substantial amounts of organic solvents. In some embodiments, the first lipid fraction comprises a phospholipid fraction comprising greater than about 90% phosphatidylcholine on a w/w basis. In some embodiments, the second lipid fraction comprises greater than about 80% neutral lipids on a w/w basis.

In some embodiments, the present invention provides krill compositions comprising from about 0.01 to about 200 mg/kg astaxanthin, from about 45% to about 65% fat w/w, and about 20% to 50% protein w/w, wherein said fat comprises omega-3 fatty acid residues. In some embodiments, the fat has an omega-3 fatty acid content of from about 10% to 30 %, preferably 15% to about 25% on a w/w basis. In some embodiments, the fat comprises from about 20% to about 50% phospholipids w/w, wherein said phospholipids comprise greater than about 65% phosphatidylcholine w/w and from about 1% to about 10% alkylacylphosphatidylcholine. In some embodiments, the phospholipids comprise less than about 10% ethanolamine on a w/w basis. In some embodiments, the fat comprises from about 40% to about 70% triacylglycerol w/w. In some embodiments, the compositions further comprise less than about 1% cholesterol. In some embodiments, the protein comprises from about 8% to about 14% leucine on a w/w basis and from about 5% to 11% isoleucine on a w/w basis.

In some embodiments, the present invention provides krill compositions comprising from about 10% to about 20% protein w/w, about 15% to about 30% fat w/w, and from about 0.01 to about 200 mg/kg astaxanthin. In some embodiments, the fat has an omega-3 fatty acid content of from about 10% to about 30% on a w/w basis. In some embodiments, the fat comprises from about 30% to about 50% phospholipids w/w. In some embodiments, the phospholipids comprise greater than about 65% phosphatidylcholine w/w. In some embodiments, the phospholipids comprise less than about 10% ethanolamine on a w/w basis. In some embodiments, the fat comprises from about 40% to about 70% triacylglycerol w/w. In some embodiments, the compositions comprise less than about 1% cholesterol. In some embodiments, the protein comprises from about 7% to about 13% leucine on a w/w basis and from about 4% to 10% isoleucine on a w/w basis.

In some embodiments, the present invention provides krill meal press cakes comprising from about 65% to about 75% protein w/w (dry matter) , from about 10% to about 25% fat w/w (dry matter), and from about 1 to about 200 mg/kg astaxanthin (wet base). In some embodiments, the fat comprises greater than about 30% neutral lipids and greater than about 30% phospholipids on a w/w basis. In some embodiments, the fat comprises from about 50 to about 60% neutral lipids w/w and from about 40% to about 55% polar lipids w/w. In some embodiments, the protein comprises from about 5% to about 11% leucine w/w and from about 3% to about 7% isoleucine w/w.

In some embodiments, the present invention provides krill meals comprising from about 65% to about 75% protein w/w (dry matter) , from about 10% to about 25% fat w/w

(dry matter), and from about 1 to about 200 mg/kg astaxanthin (wet base). In some embodiments, the fat comprises greater than about 30% neutral lipids and greater than about 30% phospholipids on a w/w basis. In some embodiments, the fat comprises from about 50 to about 60% neutral lipids w/w and from about 40% to about 55% polar lipids w/w. In some  
5 embodiments, the polar lipids comprise greater than about 90% phosphatidyl choline w/w. In some embodiments, the polar lipids comprise less than about 10% phosphatidyl ethanolamine w/w. In some embodiments, the protein comprises from about 5% to about 11% leucine w/w and from about 3% to about 7% isoleucine w/w.

In some embodiments, the present invention provides krill oil compositions  
10 comprising greater than about 1500 mg/kg total esterified astaxanthin, wherein said esterified astaxanthin comprises from about 25 to 35% astaxanthin monoester on a w/w basis and from about 50 to 70% astaxanthin diester on a w/w basis, and greater than about 20 mg/kg free astaxanthin.

In some embodiments, the present invention provides krill compositions comprising  
15 from about 3% to about 10% protein w/w, about 8% to about 20% dry matter w/w, and about 4% to about 10% fat w/w. In some embodiments, the fat comprises from about 50% to about 70% triacylglycerol w/w. In some embodiments, the fat comprises from about 30% to about 50% phospholipids w/w. In some embodiments, the phospholipids comprise greater than about 90% phosphatidyl choline w/w. In some embodiments, the fat comprises from about  
20 10% to about 25% n-3 fatty acids. In some embodiments, the fat comprises from about 10% to about 20% EPA and DHA.

In some embodiments, the krill compositions of the present invention are supplemented with additional proteins, phospholipids, triglycerides, fatty acids, and/or astaxanthin to produce an oil or meal with a desired defined composition. As such, a person  
25 of skill in the art will readily recognize that the krill compositions described above serve as a starting point for producing compositions that are further supplemented in subsequent process steps to produce a desired composition, such a composition containing elevated levels of proteins, lipids or astaxanthin.

The meal and oil compositions of the present invention described above are  
30 characterized in containing low levels, or being substantially free of many volatile compounds that are commonly found in products derived from marine biomass. In some embodiments, the meals and oils of the present invention are characterized as being substantially free of one or more of the following volatile compounds: acetone, acetic acid, methyl vinyl ketone, 1-penten-3-one, n-heptane, 2-ethyl furan, ethyl propionate, 2-methyl-2-pentenal, pyridine,

acetamide, toluene, N,N-dimethyl formamide, ethyl butyrate, butyl acetate, 3-methyl-1,4-heptadiene, isovaleric acid, methyl pyrazine, ethyl isovalerate, N,N-dimethyl acetamide, 2-heptanone, 2-ethyl pyridine, butyrolactone, 2,5-dimethyl pyrazine, ethyl pyrazine, N,N-dimethyl propanamide, benzaldehyde, 2-octanone,  $\beta$ -myrcene, dimethyl trisulfide, trimethyl pyrazine, 1-methyl-2-pyrrolidone. In other embodiments, the meals and oils of the present invention are characterized in containing less than 1000, 100, 10, 1 or 0.1 ppm (alternatively less than 10 mg/100g, preferably less than 1 mg/100 g and most preferably less than 0.1 mg/100 g) of one or more of the following volatile compounds: acetone, acetic acid, methyl vinyl ketone, 1-penten-3-one, n-heptane, 2-ethyl furan, ethyl propionate, 2-methyl-2-pentenal, pyridine, acetamide, toluene, N,N-dimethyl formamide, ethyl butyrate, butyl acetate, 3-methyl-1,4-heptadiene, isovaleric acid, methyl pyrazine, ethyl isovalerate, N,N-dimethyl acetamide, 2-heptanone, 2-ethyl pyridine, butyrolactone, 2,5-dimethyl pyrazine, ethyl pyrazine, N,N-dimethyl propanamide, benzaldehyde, 2-octanone,  $\beta$ -myrcene, dimethyl trisulfide, trimethyl pyrazine, 1-methyl-2-pyrrolidone. In further embodiments, the compositions of the present invention are characterized in comprising less than 10 mg/100g, and preferably less than 1mg/100 g (dry weight) of trimethylamine (TMA), trimethylamine oxide (TMAO) and/or lysophosphatidylcholine.

In some embodiments, the present invention provides systems for processing of marine biomass comprising: a mixer for mixing marine biomass and water to form a mixture having a defined temperature, wherein said mixture has a first solid phase and a first liquid phase. In some embodiments, the water is heated and said defined temperature of said mixture is from about 25 to 80 °C, preferably to about 50 to 75 °C, and most preferably to about 60 to 75 °C. In some embodiments, the systems further comprise a separator in fluid communication with said mixer for separating said first solid phase and said first liquid phase. In some embodiments, the first separator is a filter. In some embodiments, the systems further comprise a first heater unit in fluid communication with said first separator, wherein said first heater unit heats said first liquid phase to a defined temperature. In some embodiments, the defined temperature is about 80°C to about 100°C, preferably 90°C to about 100°C, most preferably 95°C to about 100°C. In some embodiments, the systems further comprise a microfilter in fluid communication with said mixer, wherein said liquid phase is separated into a retentate phase and a permeate phase by said microfilter. In some embodiments, the systems further comprise a prefilter in line with said microfilter. In some embodiments, the prefilter is a sieve. In some embodiments, the water is heated and said defined temperature of said mixture is from about 25 to 80 °C, preferably to about 50 to 75 °C, and most preferably to



about 60 to 75 °C. In some embodiments, the systems further comprise a first separator in fluid communication with said mixer for separating said first solid phase and said first liquid phase. In some embodiments, the first separator is a filter.

In some embodiments, the present invention provides krill compositions comprising  
5 from about 10% to about 20% protein w/w, about 15% to about 30% fat w/w, from about 0.01% to about 200 mg/kg astaxanthin, and less than about 1 mg/100g trimethyl amine, trimethyl amine, volatile nitrogen, or 1g/100g lysophosphatidylcholine or combinations thereof. In some embodiments, the fat has an omega-3 fatty acid content of from about 10% to about 25% on a w/w basis. In some embodiments, the fat comprises from about 35% to  
10 about 50% phospholipids w/w. In some embodiments, the phospholipids comprise greater than about 90% phosphatidylcholine w/w. In some embodiments, the phospholipids comprise less than about 10% ethanolamine on a w/w basis. In some embodiments, the fat comprises from about 40% to about 60% triacylglycerol w/w. In some embodiments, the compositions further comprise less than about 1% cholesterol. In some embodiments, the protein comprises  
15 from about 7% to about 13% leucine on a w/w basis and from about 4% to 10% isoleucine on a w/w basis.

In some embodiments, the present invention provides processes for processing of marine biomass comprising: providing a marine biomass and a mixer for mixing marine biomass and water to form a mixture having a defined temperature, wherein said mixture  
20 comprises a first solid phase and a first liquid phase. In some embodiments, the defined temperature of said mixture is from about 25 to 80 °C, preferably to about 50 to 75 °C, and most preferably to about 60 to 75 °C. In some embodiments, the processes further comprise the steps of separating said liquid phase from said solid phase, and heating said liquid phase to about 80°C to about 100°C, preferably 90°C to about 100°C, most preferably 95°C to about  
25 100°C, to produce a coagulate. In some embodiments, the coagulate comprises proteins and lipids. In some embodiments, the coagulate is separated from residual liquid by filtering.

In some embodiments, the present invention provides systems for processing of marine biomass comprising: a ship; a trawl net towable from said ship, said trawl net configured to catch the marine biomass; and a mixer for mixing said marine biomass and  
30 water to form a mixture having a defined temperature, wherein said mixture has a first solid phase and a first liquid phase. In some embodiments, the marine biomass is krill. In some embodiments, the krill is fresh krill and the trawl and ship are configured to deliver the fresh krill to the mixer. In some embodiments, system comprises a pump to transfer the biomass from the krill to the ship. In some embodiments, the system comprises a microfilter in fluid

communication with said mixer, wherein said microfilter separates said first solid phase and said first liquid phase. In some embodiments, the marine biomass is krill. In some embodiments, the krill is fresh krill.

In some embodiments, the present invention provides a pharmaceutical composition comprising one or more of the compositions described above in combination with a pharmaceutically acceptable carrier. In some embodiments, the present invention provides a food product comprising one or of the foregoing compositions. In some embodiments, the present invention provides a dietary supplement comprising one or more of the foregoing compositions. In some embodiments, the present invention provides an animal feed comprising one or more of the foregoing compositions.

## DESCRIPTION OF THE FIGURES

Figure 1 shows an overview of the process of making krill meal with a two stage cooking process.

Figure 2 is a graph of the Permeate flux as function of dry matter of the retentate (% °Brix).

Figure 3 is a graph of Average Flux as function of dry matter in retentate.

Figure 4 is a GC of the neutral fraction extracted from krill coagulate.

Figure 5 is a GC analysis of the neutral fraction extracted from krill coagulate.

Figure 6 is a GC of the polar fraction extracted from krill coagulate.

Figure 7 is a GC analysis of the polar fraction extracted from krill coagulate.

## DEFINITIONS

25

As used herein, "phospholipid" refers to an organic compound having the following general structure:

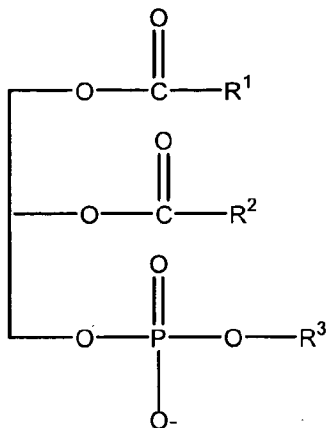

wherein R1 is a fatty acid residue, R2 is a fatty acid residue or -OH, and R3 is a -H or nitrogen containing compound choline (HOCH<sub>2</sub>CH<sub>2</sub>N<sup>+</sup>(CH<sub>3</sub>)<sub>3</sub>OH<sup>-</sup>), ethanolamine (HOCH<sub>2</sub>CH<sub>2</sub>NH<sub>2</sub>), inositol or serine. R1 and R2 cannot simultaneously be OH. When R3 is an -OH, the compound is a diacylglycerophosphate, while when R3 is a nitrogen-containing compound, the compound is a phosphatide such as lecithin, cephalin, phosphatidyl serine or plasmalogen.

An "ether phospholipid" as used herein refers to a phospholipid having an ether bond at position 1 the glycerol backbone. Examples of ether phospholipids include, but are not limited to, alkylacylphosphatidylcholine (AAPC), lyso-alkylacylphosphatidylcholine (LAAPC), and alkylacylphosphatidylethanolamine (AAPE). A "non-ether phospholipid" is a phospholipid that does not have an ether bond at position 1 of the glycerol backbone.

As used herein, the term omega-3 fatty acid refers to polyunsaturated fatty acids that have the final double bond in the hydrocarbon chain between the third and fourth carbon atoms from the methyl end of the molecule. Non-limiting examples of omega-3 fatty acids include, 5,8,11,14,17-eicosapentaenoic acid (EPA), 4,7,10,13,16,19-docosahexanoic acid (DHA) and 7,10,13,16,19-docosapentanoic acid (DPA).

As used herein, astaxanthin refers to the following chemical structure:

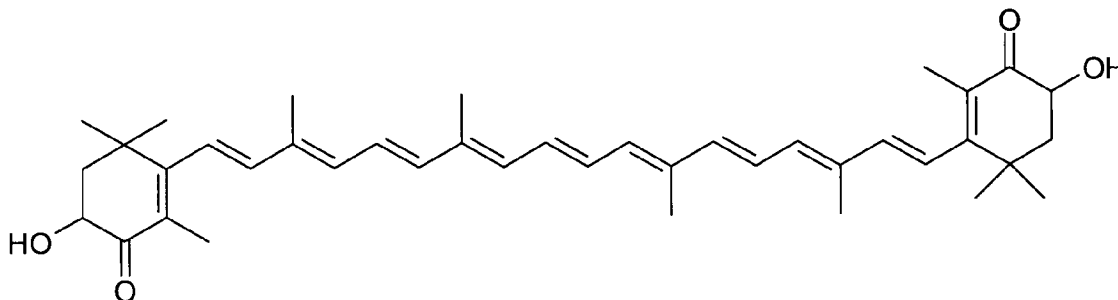

20

As used herein, astaxanthin esters refer to the fatty acids esterified to OH group in the astaxanthin molecule.

As used herein, the term w/w (weight/weight) refers to the amount of a given substance in a composition on weight basis. For example, a composition comprising 50%  
5 w/w phospholipids means that the mass of the phospholipids is 50% of the total mass of the composition (i.e., 50 grams of phospholipids in 100 grams of the composition, such as an oil).

As used herein, the term "fresh krill" refers to krill that is has been harvested less than about 12, 6, 4, 2 or preferably 1 hour prior to processing. "Fresh krill" is characterized in that products made from the fresh krill such as coagulum comprise less than 1 mg/100g TMA,  
10 volatile nitrogen or Trimethylamine oxide-N, alone or in combination, and less than 1g/100 g lysophosphatidylcholine.

#### **DETAILED DESCRIPTION OF THE INVENTION**

The invention relates to processing crustaceans such as krill to provide oil and meal  
15 products, and in particular to the production of oils containing astaxanthin and phospholipids comprising omega-3 fatty acid moieties and meal rich in astaxanthin. In some embodiments, the present invention provides systems and methods for the continuous processing of fresh or frozen krill into useful products, including krill oil, krill meal, and a krill protein/phospholipid coagulum.

20 Previous processes for treating marine biomasses such as krill have utilized a single high temperature treatment to provide a proteinaceous product. Pat No. SU220741; "Removing fats from the protein paste "Okean". Gulyaev and Bugrova, Konservnaya i Ovoshchesushil'naya Promyshlennost (1976), (4), 37-8; Amino acid composition of protein-coagulate in krill. Nikolaeva, VNIRO (1967), 63 161-4. However, these methods result in  
25 a product with a relatively low lipid content. The present invention describes a process in which the marine biomass such as krill is first heated at moderate temperatures to provide an aqueous phase which is subsequently heated at a higher temperature. This process provides a novel protein-lipid composition that has a higher lipid content than previously described compositions produced from marine biomasses. The compositions of the present invention  
30 are further distinguished from other krill oil supplements marketed for human use in that the described compositions are, in some embodiments, provided as solids or powders comprising a combination of krill lipids, including krill phospholipids and krill triglycerides, and krill-derived protein. These solids/powders may preferably be provided in capsules, gel capsules, or as tablets or caplets.

In some embodiments, the present invention provides solvent-free methods to produce a phospholipid-containing composition from a biomass such as krill, crabs, Calanus, plankton, eggs, crayfish, shrimp and the like without using organic solvents. In some embodiments, the biomass (preferably krill, freshly harvested or frozen) is heated to a temperature in the range of 25 to 80°C, preferably 40 to 75°C, and most preferably 60 to 75°C in order to dissolve/disperse lipids and proteins from the krill into the water phase, which is called krill milk. In some embodiments, the biomass is heated to and held at this first temperature for at least 3 minutes, preferably from about 3 minutes to 60 minutes, more preferably from about 3 minutes to 20 minutes, and most preferably from about 3 minutes to 10 minutes. In some 5 10 15 20 25 30

embodiments, the processes then utilize a second heating step. The proteins and phospholipids are precipitated out of the water phase produced from the first heating step by heating the krill milk (after removal of the krill solids) to a temperature of greater than about 80°C, preferably 80 to 120°C, most preferably 95 to 100°C. In some embodiments, the krill milk is held at these temperatures for from about 1 minute to about 60 minutes, preferably about 1 minute to about 10 minutes, and most preferably for about 2 minutes to 8 minutes. The water phase may be heated at atmospheric pressure, or the water phase may be heated in a closed system at an elevated pressure so that the temperature can be increased above 100°C. Accordingly, in some embodiments, the heating is at atmospheric pressure, while in other embodiments, the pressure is greater than atmospheric pressure. The precipitate formed (hereafter called a coagulum) can be isolated and characterized. In some embodiments, the processes further comprise the steps of pressing and drying the coagulum to form a coagulum meal. In some embodiments, the drying is by hot air or steam.

The solid phase (e.g., krill solids) is preferably used to make a krill meal which also has a novel composition. In other embodiments, the krill milk is microfiltered. The solid phase produced by microfiltration (called the retentate) is similar to that of the coagulum. Data show that the coagulum and retentate are low in cholesterol. In some embodiments, the retentate and coagulum are substantially free of cholesterol. In some embodiments, the retentate and coagulum comprise less than 1% cholesterol, preferably less than 0.1% cholesterol. This is a novel method to remove at least a portion of the lipids, such as phospholipids, from the krill. Removal of lipids from krill has previously required solvent extraction using liquids such as ethanol or other polar solvents. Solvent extraction is time-consuming and may also result in loss of material and is therefore not wanted. The krill used to separate out the coagulum had been stored frozen for 10 months prior to the experimentation. It is believed that due to the release of proteolytic enzyme activity during a

freezing/thawing process, more protein can be expected to be solubilized based on the processing of frozen krill than from fresh krill.

In some embodiments, the present invention provides systems and processes for processing a marine biomass. In preferred embodiments, the marine biomass is krill, preferably the Antarctic krill *Euphausia superba*. Other krill species may also be processed using the systems and processes of the present invention. In some embodiments, the krill is processed in a fresh state as defined herein. In some embodiments, the krill is processed on board a ship as described below within 12, 10, 8, 6, 4, or preferably 2 hours of catching the krill. In some embodiments, the krill is processed on board a ship within 1 or preferably 0.5 hours of catching the krill. In some embodiments, the ship tows a trawl that is configured to catch krill. The krill is then transferred from the trawl to the ship and processed. In some embodiments, the trawl comprises a pump system to pump the freshly caught krill from the trawl to the ship so that the krill can be processed in a fresh state. In preferred embodiments, the pump system comprises a tube that extends below the water the trawl and a pumping action is provided by injecting air into the tube below the waterline so that the krill is continuously drawn or pumped from the trawl, through the tube and on board the ship. Preferred trawling systems with pumps are described in PCT Applications WO 07/108702 and WO 05/004593, incorporated herein by reference.

Some embodiments of the systems and processes of the present invention are shown in Figure 1. As shown in Figure 1, fresh or frozen is krill is mixed in mixer with a sufficient amount of hot water from water heater to increase the temperature of the krill mass to approximately 40 to 75°C, preferably 50 to 75 °C, more preferably 60 to 75 °C, and most preferably about 60 to 70 °C. Many different types of water heaters are useful in the present invention. In some embodiments, the water heater is a steam heated kettle, while in other embodiments, the water heater is a scraped surface heat exchanger. The heated mass is then separated into liquid (krill milk) and krill solid fractions in a filter. In some embodiments, the separation is performed by sieving through a metal sieve. After separation, the krill milk is heated to approximately 90°C to 100°C, preferably to about 95°C to 100°C in a heater. Any type of suitable water or liquid heater may be used. In preferred embodiments, the heater is a scraped surface heat exchanger. This heating step produced a solid fraction (the coagulum described above) and a liquid fraction. In some preferred embodiments, the separator utilizes a filter as previously described. The present invention is not limited to the use of any particular type of filter. In some embodiments, the filter is a woven filter. In some embodiments, the filter comprises polymeric fibers. The coagulum is introduced into a

dewaterer. In some embodiments, the dewaterer is a press such as screw press. Pressing produces a liquid fraction and a press cake. The press cake is dried in a drier to produce coagulum meal.

5 The solid krill fraction is introduced into a dewaterer for dewatering. In some embodiments, the dewaterer is a press such as screw press. Pressing produces a press cake and a liquid fraction. The press cake is dried in a drier, such as an air drier or steam drier, to provide krill meal. The liquid fraction is centrifuged to produce a neutral krill oil containing high levels of astaxanthin and stickwater. In preferred embodiments, the stick water is added back into the krill press cake to make a full meal, including the various components of the  
10 stick water such as soluble proteins, amino acids, etc.

In alternative embodiments, the krill milk can be treated by microfiltration instead of by heating to form a coagulum. The krill milk is introduced into a microfilter. Microfiltration produces a fraction called a retentate and a liquid permeate. The retentate is concentrated by evaporation under vacuum to stability, water activity  $<0.5 A_w$ . Membrane filtration of  
15 cooking liquid is preferably performed at about 70 °C with a filter having a pore size of about 10 nm to about 1000nm, more preferably about 50 to about 500 nm, and most preferably about 100 nm. An exemplary filter is the P19-40 100 nm  $ZrO_2$  membrane. In some embodiments, the liquid fraction is prefiltered prior to microfiltration. In preferred embodiments, the prefilter is a roto-fluid sieve (air opening 100  $\mu m$ ).

20 In yet another embodiment of the invention is a novel and more efficient method of preparing krill meal. By removing the coagulum, the krill meal process is less susceptible to clogging problems and the use of hot steam in the cooker can be avoided. The data disclosed show the coagulum contains a high percentage of phospholipids, hence the separation of the fat in the new krill meal process can be obtained using mechanical methods as in standard fish  
25 meal processes. In fact, the separation of fat from the meal is important. Ideally, the krill meal should have a low fat value in order to have satisfactory technical properties. Mechanically separating the fat from the meal will result in a neutral oil rich in astaxanthin. If the neutral oil rich in astaxanthin stays in the meal, the astaxanthin may be degraded during the drying.

In some embodiments, the present invention provides a krill coagulate and retentate  
30 compositions. The compositions are characterized in containing a combination of protein and lipids, especially phospholipids. In preferred embodiments, the compositions are solids or powders and are provided as a meal. In some embodiments, the compositions comprise from about 20% to about 50% protein w/w, preferably about 30% to 40% protein w/w, and about 40% to 70% lipids w/w, preferably about 50% to 65% lipids w/w, so that the total amount of

proteins and lipids in the compositions of from 90 to 100%. In some embodiments, the lipid fraction contains from about 10 g to 30 g omega-3 fatty acid residues per 100 g of lipid, preferably about 15 g to 25 g omega-3 fatty acids residues per 100 g lipids (i.e., from 10 to 30% or preferably from 15 to 25% omega-3 residues expressed w/w as a percentage of total lipids in the composition). In some embodiments, the lipid fraction of the composition comprises from about 25 to 50 g polar lipids per 100 g lipids (25 to 50% w/w expressed as percentage of total lipids), preferably about 30 to 45 g polar lipids per 100 g total lipids (30 to 45% w/w expressed as percentage of total lipids), and about 50 to 70 g nonpolar lipids per 100 g lipids (50 to 70% w/w expressed as percentage of total lipids), so that the total amount of polar and nonpolar lipids is 90 to 100% of the lipid fraction. In some embodiments, the phospholipids comprise greater than about 60% phosphatidylcholine on a w/w basis. In some embodiments, the phospholipids comprise less than about 10% ethanolamine on a w/w basis. In some embodiments, the compositions comprise from about 20% to about 50% triacylglycerol on a w/w basis. In some embodiments, the compositions comprise less than about 1% cholesterol. In some embodiments, the protein fraction comprises from about 8% to about 14% leucine on a w/w basis and from about 5% to 11% isoleucine on a w/w basis. In some embodiments, the compositions comprise less than about 200, 10, 5 or 1 mg/kg naturally occurring or endogenous astaxanthin. In some embodiments, the compositions comprise from about 0.01 to about 200 mg/kg naturally-occurring astaxanthin. It will be recognized that the astaxanthin content of the composition can be increased by adding in astaxanthin from other (exogenous) sources, both natural and non-natural. Likewise, the compositions can be supplemented with exogenous proteins, triglycerides, phospholipids and fatty acids such as omega-3 fatty acids to produce a desired composition.

In yet another embodiment of the invention is a pre-heated krill composition. Non-limiting examples of the pre-heated krill composition is a krill composition comprising lipids with less than 10% or 5% phospholipids, and in particular phosphatidylcholine.

In yet another embodiment of the invention is a novel krill meal product produced from the solid phase left after the first heating step (i.e., the heating step at below 80 C). The krill meal has good nutritional and technical qualities such as a high protein content, low fat content and has a high flow number. Unexpectedly, the ratios of polar lipids to neutral lipids and EPA to DHA is substantially enhanced as compared to normal krill meal. In some embodiments, the krill meals comprise from about 60% to about 80% protein on a w/w basis, preferably from about 70% to 80% protein on a w/w basis, from about 5% to about 20% fat on a w/w basis, and from about 1 to about 200 mg/kg astaxanthin, preferably from about 50 to



about 200 mg/kg astaxanthin. In some embodiments, the fat comprises from about 20 to 40% total neutral lipids and from about 50 to 70% total polar lipids on a w/w basis (total lipids). In some embodiments, the ratio of polar to neutral lipids in the meal is from about 1.5:1 to 3:1, preferably about 1.8:1 to 2.5:1, and most preferably from about 1.8:1 to 2.2:1. In some  
5 embodiments, the fat comprises from about 20% to 40% omega-3 fatty acids, preferably about 20% to 30% omega-3 fatty acids. In some embodiments, the ratio of EPA:DHA is from about 1.8:1 to 1:0.9, preferably from about 1.4:1 to 1:1.

In still other embodiments, the present invention provides oil produced by the processes described above. In some embodiments, the oils comprise greater than about 1800  
10 mg/kg total esterified astaxanthin, wherein said esterified astaxanthin comprises from about 25 to 35% astaxanthin monoester on a w/w basis and from about 50 to 70% astaxanthin diester on a w/w basis, and less than about 40 mg/kg free astaxanthin.

The compositions of the present invention are highly palatable humans and other animals. In particular the oil and meal compositions of the present invention are characterized  
15 as containing low levels of undesirable volatile compounds or being substantially free of many volatile compounds that are commonly found in products derived from marine biomass. In some embodiments, the meals and oils of the present invention are characterized as being substantially free of one or more of the following volatile compounds: acetone, acetic acid, methyl vinyl ketone, 1-penten-3-one, n-heptane, 2-ethyl furan, ethyl propionate, 2-methyl-2-  
20 pentenal, pyridine, acetamide, toluene, N,N-dimethyl formamide, ethyl butyrate, butyl acetate, 3-methyl-1,4-heptadiene, isovaleric acid, methyl pyrazine, ethyl isovalerate, N,N-dimethyl acetamide, 2-heptanone, 2-ethyl pyridine, butyrolactone, 2,5-dimethyl pyrazine, ethyl pyrazine, N,N-dimethyl propanamide, benzaldehyde, 2-octanone,  $\beta$ -myrcene, dimethyl trisulfide, trimethyl pyrazine, 1-methyl-2-pyrrolidone. In other embodiments, the meals and  
25 oils of the present invention are characterized in containing less than 1000, 100, 10, 1 or 0.1 ppm (alternatively less than 10 mg/100g, preferably less than 1 mg/100 g and most preferably less than 0.1 mg/100 g) of one or more of the following volatile compounds: acetone, acetic acid, methyl vinyl ketone, 1-penten-3-one, n-heptane, 2-ethyl furan, ethyl propionate, 2-  
30 methyl-2-pentenal, pyridine, acetamide, toluene, N,N-dimethyl formamide, ethyl butyrate, butyl acetate, 3-methyl-1,4-heptadiene, isovaleric acid, methyl pyrazine, ethyl isovalerate, N,N-dimethyl acetamide, 2-heptanone, 2-ethyl pyridine, butyrolactone, 2,5-dimethyl pyrazine, ethyl pyrazine, N,N-dimethyl propanamide, benzaldehyde, 2-octanone,  $\beta$ -myrcene, dimethyl trisulfide, trimethyl pyrazine, 1-methyl-2-pyrrolidone. In further embodiments, the compositions of the present invention are characterized in comprising less than 10 mg/100g,

and preferably less than 1mg/100 g (dry weight) of trimethylamine (TMA), trimethylamine oxide (TMAO) and/or lysophosphatidylcholine.

In some embodiments, the compositions of this invention (such as those described in the preceding sections) are contained in acceptable excipients and/or carriers for oral consumption. In some embodiments, the present invention provides a pharmaceutical composition one or more of the foregoing compositions in combination with a pharmaceutically acceptable carrier. The actual form of the carrier, and thus, the composition itself, is not critical. The carrier may be a liquid, gel, gelcap, capsule, powder, solid tablet (coated caplet or non-coated), tea, or the like. The composition is preferably in the form of a tablet or capsule and most preferably in the form of a soft gel capsule. Suitable excipient and/or carriers include maltodextrin, calcium carbonate, dicalcium phosphate, tricalcium phosphate, microcrystalline cellulose, dextrose, rice flour, magnesium stearate, stearic acid, croscarmellose sodium, sodium starch glycolate, crospovidone, sucrose, vegetable gums, lactose, methylcellulose, povidone, carboxymethylcellulose, corn starch, and the like (including mixtures thereof). Preferred carriers include calcium carbonate, magnesium stearate, maltodextrin, and mixtures thereof. The various ingredients and the excipient and/or carrier are mixed and formed into the desired form using conventional techniques. The tablet or capsule of the present invention may be coated with an enteric coating that dissolves at a pH of about 6.0 to 7.0. A suitable enteric coating that dissolves in the small intestine but not in the stomach is cellulose acetate phthalate. Further details on techniques for formulation for and administration may be found in the latest edition of Remington's Pharmaceutical Sciences (Maack Publishing Co., Easton, PA).

The dietary supplement may comprise one or more inert ingredients, especially if it is desirable to limit the number of calories added to the diet by the dietary supplement. For example, the dietary supplement of the present invention may also contain optional ingredients including, for example, herbs, vitamins, minerals, enhancers, colorants, sweeteners, flavorants, inert ingredients, and the like. For example, the dietary supplement of the present invention may contain one or more of the following: ascorbates (ascorbic acid, mineral ascorbate salts, rose hips, acerola, and the like), dehydroepiandrosterone (DHEA), Fo-Ti or Ho Shu Wu (herb common to traditional Asian treatments), Cat's Claw (ancient herbal ingredient), green tea (polyphenols), inositol, kelp, dulse, bioflavonoids, maltodextrin, nettles, niacin, niacinamide, rosemary, selenium, silica (silicon dioxide, silica gel, horsetail, shavegrass, and the like), spirulina, zinc, and the like. Such optional ingredients may be either naturally occurring or concentrated forms.

In some embodiments, the dietary supplements further comprise vitamins and minerals including, but not limited to, calcium phosphate or acetate, tribasic; potassium phosphate, dibasic; magnesium sulfate or oxide; salt (sodium chloride); potassium chloride or acetate; ascorbic acid; ferric orthophosphate; niacinamide; zinc sulfate or oxide; calcium pantothenate; copper gluconate; riboflavin; beta-carotene; pyridoxine hydrochloride; thiamin mononitrate; folic acid; biotin; chromium chloride or picolonate; potassium iodide; sodium selenate; sodium molybdate; phyloquinone; vitamin D3; cyanocobalamin; sodium selenite; copper sulfate; vitamin A; vitamin C; inositol; potassium iodide. Suitable dosages for vitamins and minerals may be obtained, for example, by consulting the U.S. RDA guidelines.

In further embodiments, the compositions comprise at least one food flavoring such as acetaldehyde (ethanal), acetoin (acetyl methylcarbinol), anethole (parapropenyl anisole), benzaldehyde (benzoic aldehyde), N butyric acid (butanoic acid), d or l carvone (carvol), cinnamaldehyde (cinnamic aldehyde), citral (2,6 dimethyloctadien 2,6 al 8, gera nial, neral), decanal (N decylaldehyde, capraldehyde, capric aldehyde, caprinaldehyde, aldehyde C 10), ethyl acetate, ethyl butyrate, 3 methyl 3 phenyl glycidic acid ethyl ester (ethyl methyl phenyl glycidate, strawberry aldehyde, C 16 aldehyde), ethyl vanillin, geraniol (3,7 dimethyl 2,6 and 3,6 octadien 1 ol), geranyl acetate (geraniol acetate), limonene (d , l , and dl ), linalool (linalol, 3,7 dimethyl 1,6 octadien 3 ol), linalyl acetate (bergamol), methyl anthranilate (methyl 2 aminobenzoate), piperonal (3,4 methylenedioxy benzaldehyde, heliotropin), vanillin, alfalfa (*Medicago sativa* L.), allspice (*Pimenta officinalis*), ambrette seed (*Hibiscus abelmoschus*), angelic (*Angelica archangelica*), Angostura (*Galipea officinalis*), anise (*Pimpinella anisum*), star anise (*Illicium verum*), balm (*Melissa officinalis*), basil (*Ocimum basilicum*), bay (*Laurus nobilis*), calendula (*Calendula officinalis*), (*Anthemis nobilis*), capsicum (*Capsicum frutescens*), caraway (*Carum carvi*), cardamom (*Elettaria cardamomum*), cassia, (*Cinnamomum cassia*), cayenne pepper (*Capsicum frutescens*), Celery seed (*Apium graveolens*), chervil (*Anthriscus cerefolium*), chives (*Allium schoenoprasum*), coriander (*Coriandrum sativum*), cumin (*Cuminum cyminum*), elder flowers (*Sambucus canadensis*), fennel (*Foeniculum vulgare*), fenugreek (*Trigonella foenum graecum*), ginger (*Zingiber officinale*), horehound (*Marrubium vulgare*), horseradish (*Armoracia lapathifolia*), hyssop (*Hyssopus officinalis*), lavender (*Lavandula officinalis*), mace (*Myristica fragrans*), marjoram (*Majorana hortensis*), mustard (*Brassica nigra*, *Brassica juncea*, *Brassica hirta*), nutmeg (*Myristica fragrans*), paprika (*Capsicum annum*), black pepper (*Piper nigrum*), peppermint (*Mentha piperita*), poppy seed (*Papayer somniferum*), rosemary (*Rosmarinus officinalis*), saffron (*Crocus sativus*), sage (*Salvia officinalis*), savory (*Satureia hortensis*, *Satureia*

montana), sesame (*Sesamum indicum*), spearmint (*Mentha spicata*), tarragon (*Artemisia dracunculus*), thyme (*Thymus vulgaris*, *Thymus serpyllum*), turmeric (*Curcuma longa*), vanilla (*Vanilla planifolia*), zedoary (*Curcuma zedoaria*), sucrose, glucose, saccharin, sorbitol, mannitol, aspartame. Other suitable flavoring are disclosed in such references as Remington's  
5 Pharmaceutical Sciences, 18th Edition, Mack Publishing, p. 1288-1300 (1990), and Furia and Pellanca, Fenaroli's Handbook of Flavor Ingredients, The Chemical Rubber Company, Cleveland, Ohio, (1971), known to those skilled in the art.

In other embodiments, the compositions comprise at least one synthetic or natural food coloring (e.g., annatto extract, astaxanthin, beet powder, ultramarine blue, canthaxanthin,  
10 caramel, carotenal, beta carotene, carmine, toasted cottonseed flour, ferrous gluconate, ferrous lactate, grape color extract, grape skin extract, iron oxide, fruit juice, vegetable juice, dried algae meal, tagetes meal, carrot oil, corn endosperm oil, paprika, paprika oleoresin, riboflavin, saffron, tumeric, tumeric and oleoresin).

In still further embodiments, the compositions comprise at least one phytonutrient  
15 (e.g., soy isoflavonoids, oligomeric proanthcyanidins, indol 3 carbinol, sulforaphane, fibrous ligands, plant phytosterols, ferulic acid, anthocyanocides, triterpenes, omega 3/6 fatty acids, conjugated fatty acids such as conjugated linoleic acid and conjugated linolenic acid, polyacetylene, quinones, terpenes, catechins, gallates, and quercetin). Sources of plant phytonutrients include, but are not limited to, soy lecithin, soy isoflavones, brown rice germ,  
20 royal jelly, bee propolis, acerola berry juice powder, Japanese green tea, grape seed extract, grape skin extract, carrot juice, bilberry, flaxseed meal, bee pollen, ginkgo biloba, primrose (evening primrose oil), red clover, burdock root, dandelion, parsley, rose hips, milk thistle, ginger, Siberian ginseng, rosemary, curcumin, garlic, lycopene, grapefruit seed extract, spinach, and broccoli.

In still other embodiments, the compositions comprise at least one vitamin (e.g.,  
25 vitamin A, thiamin (B1), riboflavin (B2), pyridoxine (B6), cyanocobalamin (B12), biotin, ascorbic acid (vitamin C), retinoic acid (vitamin D), vitamin E, folic acid and other folates, vitamin K, niacin, and pantothenic acid). In some embodiments, the particles comprise at least one mineral (e.g., sodium, potassium, magnesium, calcium, phosphorus, chlorine, iron,  
30 zinc, manganese, flourine, copper, molybdenum, chromium, selenium, and iodine). In some particularly preferred embodiments, a dosage of a plurality of particles includes vitamins or minerals in the range of the recommended daily allowance (RDA) as specified by the United States Department of Agriculture. In still other embodiments, the particles comprise an amino

acid supplement formula in which at least one amino acid is included (e.g., l-carnitine or tryptophan).

In further embodiments, the present invention provide animal feeds comprising one or more the compositions described in detail above. The animal feeds preferably form a ration for the desired animal and is balanced to meet the animals nutritional needs. The compositions may be used in the formulation of feed or as feed for animals such as fish, including fish fry, poultry, cattle, pigs, sheep, shrimp and the like.

#### EXAMPLE 1

Four portions of krill were analysed for dry matter, fat, and protein. Most of the variation in the composition can be expected to be due to variation in the sampling. To include the effect of variation in storage time after thawing, raw material samples were also taken at different times during the working day. The observed variation in raw material input is inherent in all calculations of fat, dry matter and protein distributions based on the reported examples.

Table 1. Composition of krill (g/100 g)

	Dry matter	Fat	Fat free dry matter	Protein
Krill 1	21,40	7,80	13,60	11,80
Krill 2	22,13	7,47	14,66	12,96
Krill 3	23,78	7,44	16,34	14,60
Krill 4	23,07	7,55	15,52	13,83
<b>Mean</b>	<b>22,60</b>	<b>7,57</b>	<b>15,03</b>	<b>13,30</b>
SD	1,04	0,16	1,17	1,20
RSD	4,6 %	2,2 %	7,8 %	9,0 %

#### EXAMPLE 2

In this example a novel method for preparing krill meal was investigated. 800 g of preheated water (95-100 °C) and 200g of frozen krill (0 °C) were mixed in a cooker (cooker 1) at a temperature of 75 °C for 6 minutes. Next, the heated krill and the hot water were

separated by filtration. The preheated krill was further cooked (cooker 2) by mixing with 300 g hot water (95 °C) in a kitchen pan and kept at 90 °C for 2 minutes before separation over a sieve (1,0 × 1,5 mm opening). The heated krill was separated from the liquid and transferred to a food mixer and cut for 10 seconds. The disintegrated hot krill was added back to the hot water and centrifuged at 8600 × g (RCF average) for 10 minutes. The supernatant corresponding to a decanter liquid (DI) was decanted off. The liquid from cooking step 1 was heated to 95-100 °C to coagulate the extracted protein. The coagulum was separated over a sieve (1.0 × 1.5 mm opening) and a weight of 40 g was found. Figure 1 shows an overview of the process of making krill meal with a two stage cooking process.

10

### EXAMPLE 3

The total volatile nitrogen (TVN), trimethylamine (TMA) and trimethylamine oxide (TMAO) content were determined in the four products from the cooking test in example 2 (Table 2). The krill was fresh when frozen, so no TMA was detected in the products. The results show that TMAO is evenly distributed in the water phase during cooking of krill.

15

Table 2. Distribution of total volatile nitrogen (TVN), trimethylamine (TMA) and trimethylamine oxide (TMAO) in the products from the cooking procedure.

Products from test no.	10	Krill	Coagulum from cooker	Coagulate d cooker liquid	Decante r solids	Decante r liquid	SUM
Weight (wb)	g	200	97,6	711,1	90,3	294,7	
Dry matter	g/100 g	21,4	14,2	1,0	22,2	0,9	
Analytical values							
Total volatile nitrogen	mg N/100 g	8	1,3	1,2	2,3	1	
Trimethylamine-N	mg N/100 g	<1	<1	<1	<1	<1	
Trimethylamine oxid-N	mg N/100 g	107	19,2	13,5	10,4	13,1	
Quantities							
Total volatile nitrogen	mg N	15,0	1,3	8,5	2,1	2,9	14,8
Trimethylamine-N	mg N	-	-	-	-	-	-

Trimethylamine oxid-N	mg N	214	18,7	96,0	9,4	38,6	163
Distribution							
Total volatile nitrogen	% of input	100 %	8 %	57 %	14 %	20 %	99 %
Trimethylamine-N	% of input						
Trimethylamine oxid-N	% of input	100 %	9 %	45 %	4 %	18 %	76 %

In addition, fat, dry matter and astaxanthin were determined in the products (Table 3). It was observed that the major part of the astaxanthin in the krill was found in the press cake (Table 3). Only a minor part is found in the coagulum which contains more than 60 % of the lipid in the krill raw material. The cooking procedure with leaching of a protein-lipid emulsion increases the concentration of astaxanthin in the remaining fat. The results also show that the water free coagulum contains approximately 40% dry matter and 60% fat. The dry matter consist of mostly protein.

Table 3. Distribution of astaxanthin in the products from the cooking procedure.

Products from test no.	10	Krill	Coagulum from cooker	Coagulate d cooker liquid	Decante r solids	Decante r liquid	SUM
Weight (wb)	g	200	97,6	711,1	90,3	294,7	
Fat	g/100 g	7,8	10,3	0,1	5,3	0,2	
Fat free dry matter	g/100 g	13,6	3,9	0,9	16,9	0,8	
Analytical values							
Fri Astaxanthin	mg/kg	3	<1	<1	4,5	<1	
Astaxanthin esters	mg/kg	33	1,2	<0,02	59	0,18	
Conc. in lipid							
Fri Astaxanthin	mg/kg lipid	38	-	-	85	-	
Astaxanthin esters	mg/kg lipid	423	12	-	1111	113	
Quantities							
Free Astaxanthin	mg	0,6	-	-	0,4	-	0,4
Astaxanthin esters	mg	6,6	0,1	-	5,3	0,1	6,2
Distribution							
Free Astaxanthin	% of	100 %	-	-	68 %	-	68 %

	input % of input	100 %	2 %	-	81 %	1 %	83 %
Astaxanthin esters							

The coagulum from the cooking experiment in Example 2 were analysed for lipid classes. The coagulum lipid was dominated by triacylglycerol and phosphatidyl choline with a small quantity of phosphatidyl ethanolamine (Table 4).

5 Table 4. Distribution of lipid classes in the coagulum from cooking experiments.

Experiment		Krill	Coagulum F5	Coagulum F6
Fat (Bligh & Dyer)	g/100 g sample	7,8	11,8	9,9
Triacylglycerol	g/100 g fat	47	40	50
Diacylglycerol	g/100 g fat	<0,5	1	0,7
Monocylglycerol	g/100 g fat	<1	<1	<1
Free fatty acids	g/100 g fat	12	0,2	0,4
Cholesterol	g/100 g fat	0,3	<0,3	<0,3
Cholesterol esters	g/100 g fat	0,8	<0,3	<0,3
Phosphatidyl ethanolamine	g/100 g fat	5,3	2,3	2,2
Phosphatidyl inositol	g/100 g fat	<1	<1	<1
Phosphatidyl serine	g/100 g fat	<1	<1	<1
Phosphatidyl choline	g/100 g fat	33	43,1	42,3
Lyso-Phosphatidyl choline	g/100 g fat	2,4	<1	<1
Total polar lipids	g/100 g fat	41,3	45,5	44,5
Total neutral lipids	g/100 g fat	61,0	41,3	51,2
Sum lipids	g/100 g fat	102,3	86,8	95,7

The proportion of phosphatidyl choline increased from 33 % in krill to 42 – 46 % in the coagulum. The other phospholipids quantified, phosphatidyl ethanolamine and lyso-phosphatidyl choline, had lower concentrations in the coagulum than in krill. The free fatty acids were almost absent in the coagulum.

The cooking time in test F5 was 6.75 min, in test F6 it was 4.00 min. The results in *Table 4* show no dependence of the distribution of the lipid classes with the cooking time.



The amino acid composition of the coagulum is not much different the amino acid composition in krill. There seems to be a slight increase in the apolar amino acids in the coagulum compared to krill (Table 5). For a protein to have good emulsion properties it is the distribution of amino acids within the protein that is of importance more than the amino acid composition.

Table 5. Amino acids in coagulum from cooking Example 2.

		Coagulum F 10-2 mar/apr 2007	Coagulum 70-100°C 24.06.2006	Krill 24.06.2006
Aspartic acid	g/100 g protein	8,8	10,8	7,8
Glutamic acid	g/100 g protein	10,1	11,6	10,7
Hydroxiprolin	g/100 g protein	<0,10	<0,10	<0,10
Serine	g/100 g protein	4,3	4,6	3,0
Glycine	g/100 g protein	3,7	3,4	4,1
Histidine	g/100 g protein	1,7	1,6	1,6
Arginine	g/100 g protein	4,4	4,4	5,7
Threonine	g/100 g protein	5,2	5,6	3,4
Alanine	g/100 g protein	4,7	4,6	4,7
Proline	g/100 g protein	4,2	4,3	3,9
Tyrosine	g/100 g protein	4,3	4,7	2,7
Valine	g/100 g protein	6,4	6,6	4,2
Methionine	g/100 g protein	2,1	2,1	2,4
Isoleucine	g/100 g protein	8,0	8,5	4,5
Leucine	g/100 g protein	10,8	11,6	6,7

Phenylalanine	g/100 g protein	4,3	4,3	3,6
Lysine	g/100 g protein	7,5	8,2	6,2
Cysteine/Cystine	g/100 g protein	0,75		
Tryptophan	g/100 g protein	0,63		
Sum amino acids		91,9	96,9	75,2
Polar amino acids		47 %	48 %	51 %
Apolar amino acids		53 %	52 %	49 %

The fatty acid profile of the coagulum is presented in Table 6. The content of EPA (20:5) is about 12.4 g/100 g extracted fat and the content of DHA (22:6) is about 5.0 g/100 g extracted fat.

5 Table 6. Fatty acid content of coagulum

Fatty acid	Unit	Amount
14:0	g/100 extracted fat	11,5
16:0	g/100 extracted fat	19,4
18:0	g/100 extracted fat	1,1
20:0	g/100 extracted fat	<0,1
22:0	g/100 extracted fat	<0,1
16:1 n-7	g/100 extracted fat	7,0
18:1 (n-9) + (n-7) + (n-5)	g/100 extracted fat	18,4
20:1 (n-9) + (n-7)	g/100 extracted fat	1,3
22:1 (n-11) + (n-9) + (n-7)	g/100 extracted fat	0,8
24:1 n-9	g/100 extracted fat	0,1
16:2 n-4	g/100 extracted fat	0,6
16:3 n-4	g/100 extracted fat	0,2
16:4 n-4	g/100 extracted fat	<0,1
18:2 n-6	g/100 extracted fat	1,2
18:3 n-6	g/100 extracted fat	0,1
20:2 n-6	g/100 extracted fat	<0,1
20:3 n-6	g/100 extracted fat	<0,1
20:4 n-6	g/100 extracted fat	0,2
22:4 n-6	g/100 extracted fat	<0,1
18:3 n-3	g/100 extracted fat	0,8
18:4 n-3	g/100 extracted fat	2,5
20:3 n-3	g/100 extracted fat	<0,1
20:4 n-3	g/100 extracted fat	0,4
20:5 n-3	g/100 extracted fat	12,4
21:5 n-3	g/100 extracted fat	0,4

22:5 n-3	g/100 extracted fat	0,3
22:6 n-3	g/100 extracted fat	5,0

#### EXAMPLE 4

5 To evaluate the two stage cooking process described above, a laboratory scale test was performed. The tests are described below.

#### Materials and methods

**Raw material.** Frozen krill were obtained by Aker Biomarine and 10 tons were stored at Norway Pelagic, Bergen, and retrieved as required. The krill was packed in plastic bags in cardboard boxes with 2×12.5 kg krill. The boxes with krill were placed in a single layer on the floor of the process plant the day before processing. By the time of processing the krill varied from + 3 °C to -3 °C.

#### Analytical methods.

15 **Protein, Kjeldahl's method:** Nitrogen in the sample is transformed to ammonium by dissolution in concentrated sulfuric acid with copper as catalyst. The ammonia is liberated in a basic distillation and determined by titration, (ISO 5983:1997(E), Method A 01). Uncertainty: 1 %.

20 **Protein, Combustion:** Liberation of nitrogen by burning the sample at high temperature in pure oxygen. Detection by thermal conductivity. Percent protein in the sample is calculated by a multiplication of analysed percent nitrogen and a given protein factor, (AOAC Official Method 990.03, 16th ed. 1996, Method A 25).

**Moisture:** Determination of the loss in mass on drying at 103 °C during four hours (ISO 6496 (1999). Method A 04). Uncertainty: 4 %.

25 **Ash:** Combustion of organic matter at 550 °C. The residue remaining after combustion is defined as the ash content of the sample. (ISO 5984:2002. Method A 02). Uncertainty: 3 %.

**Fat, Ethyl acetate extraction:** Absorption of moisture in wet sample by sodium sulphate, followed by extraction of fat by ethyl acetate (NS 9402, 1994 (modified calculation). Method A 29).

30 **Fat, Soxhlet:** Extraction of fat by petroleum ether. Mainly the content of triglycerides is determined, (AOCS Official Method Ba 3-38 Reapproved 1993. Method A 03).

**Fat, Bligh and Dyer:** Extraction of fat by a mixture of chloroform, methanol, and water in the proportion 1:2:0.8 which build a single phase system. Addition of chloroform and water gives a chloroform phase with the lipids and a water/methanol phase. The lipids are determined in an aliquot of the chloroform phase after evaporation and weighing. The  
5 extraction includes both triglycerides and phospholipids. (E.G. Bligh & W.J. Dyer: A rapid method of total lipid extraction and purification. *Can.J.Biochem.Physiol.* Vol 37 (1959). Methode A 56).

**Astaxanthin:** Extraction with ethanol and di-chloromethane. Polar products are removed by open column chromatography on silica gel. Isomers are separated on normal  
10 phase HPLC on Si 60 column and detection at 470 nm. (Schierle J. & Härdi W. 1994. Determination of stabilized astaxanthin in Carophyll® Pink, premixes and fish feeds. Edition 3. Revised Supplement to: Hoffman P, Keller HE, Schierle J., Schuep W. Analytical methods for vitamins and carotenoids in feed. Basel: Department of Vitamin Research and Development, Roche. Method A 23)

**Moisture in oil:** Determination of actual water content of fats and oils by titration  
15 with Karl Fischer reagent, which reacts quantitatively with water, (AOCS Official Method CA 2e-84. Reapproved 1993. Method A 13).

Dry matter in stick water during processing is correlated to refract meter which gives °  
Brix. Amino acids were determined as urea derivatives by reversed phase HPLC with  
20 fluorescence detection. (Cohen S. A. and Michaud D. P., Synthesis of a Fluorescent Derivatizing Reagent, 6-Aminoquinolyl-N-Hydroxysuccinimidyl Carbamate, and Its Application for the Analysis of Hydrolysate Amino Acids via High-Performance Liquid Chromatography. *Analytical Biochemistry* **211**, 279-287, 1993. Method A42). TVB-N, TMA-N and TMAO-N were determined in a 6% trichloro-acetic acid extract by micro diffusion and  
25 titration. (Conway, E. I., and A. Byrne. An absorption apparatus for the micro determination of certain volatile substances. *Biochem. J.* 27:419-429, 1933, and Larsen, T, SSF rapport nr. A-152, 1991). Fatty acids were determined by esterifying the fatty acids to methyl esters, separate the esters by GLC, and quantify by use of C23:0 fatty acid methyl ester as internal  
30 standard.( AOCS Official Method Ce 1b-89, Method A 68). Lipids were separated by HPLC and detected with a Charged Aerosol Detector. Vitamins A, D and E were analysed at AnalyCen, Kambo.

## Results and discussion

**Raw material of krill.** Table 7 gives the results of analysis of the raw material of the krill that was used in the pilot trials. Besides the first trial, the same shipment of krill was used for all trials. The dry matter was about 21-22 %, fat 6 %, protein 13-14 %, salt 1 % pH, total volatile nitrogen (TVN) 18 mgN/100g, trimethylamine (TMA) 4 mg N/100g and trimethylamineoxide (TMAO) 135 mg N/100g. Compared to fish pH, TMAO and salt (Cl<sup>-</sup>) is high for krill.

Table 7. Analysis of raw krill on wet base (wb)

Sample:	Raw material of krill									
Analysis:	Dry matter	Fat, B&D	Protein	Ash	Salt	pH	TVN	TMA	TMAO	Marks
Date:	g/100 g	g/100 g	g/100 g	g/100 g	g/100 g		mg N/100 g	mg N/100 g	mg N/100 g	
07.08.2007	22,8	7,1	13,5	2,5						Saga Sea 04.07.06 Lot. L1
18.09.2007	21,3	6,0								
04.10.2007	21,6	6,3	13,5							Krillråstoff CO5S
04.10.2007	20,5	5,9	12,8							Krillråstoff AO6S
25.10.2007	22,1	6,0	13,9	2,9	1,1	7,4	20,8	5,8	128,3	Krillråstoff CO5S
25.10.2007	21,3	6,0	13,2	2,7	1,1	7,4	15,0	2,3	140,6	Krillråstoff AO6S
22.11.2007	21,9	5,9				7,8	17,9	3,5	123,7	
<b>Average</b>	<b>21,6</b>	<b>6,2</b>	<b>13,5</b>	<b>2,7</b>	<b>1,1</b>	<b>7,4</b>	<b>17,9</b>	<b>4,0</b>	<b>134,5</b>	

Table 8 gives the analysis of raw krill on dry base. If these figures are multiplied with 0.93 it will give the figures on meal base with 7 % water.

Table 8 Analysis of raw krill on dry base (db)

Sample:	Raw material of krill								
Analysis:	Dry matter	Fat, B&D	Protein	Ash	Salt	TVN	TMA	TMAO	
Date:	g/100 g	g/100 g	g/100 g	g/100 g	g/100 g	mg N/100 g	mg N/100 g	mg N/100 g	
07.08.2007	100	31,1	59,2	11,0					
18.09.2007	100	28,2		0,0					
04.10.2007	100	29,2	62,5	0,0					
04.10.2007	100	28,8	62,4	0,0					
25.10.2007	100	27,1	62,9	13,1	5,0	94,1	26,1	580,5	
25.10.2007	100	28,2	62,0	12,7	5,2	70,6	10,9	660,2	
22.11.2007	100	26,9				81,7	16,0	564,8	
<b>Average</b>	<b>100</b>	<b>28,5</b>	<b>62,5</b>	<b>12,3</b>	<b>5,1</b>	<b>82,4</b>	<b>18,5</b>	<b>620,4</b>	

**Separation of coagulum and pressing for krill oil.** 99 kg krill was processed by adding batches of 20 kg krill to 80 l of water at 95 °C in a steam heated kettle (200 l). The steam on the kettle was closed, and the krill and water were gently mixed manually for 3 minutes, and the mixed temperature became 75 °C (heating step no. 1). The heated krill was separated from the water by sieving. Sieved preheated krill (75°C) was added 20 kg hot water and heated to 85 °C within a minute, (heating step 2). The krill was sieved again and feed into the press. The liquid from step1 (krill milk) was coagulated at 95 °C. All the krill was cooked and the press liquid was separated for oil. From 99 kg krill about 0.5 kg of unpolished krill oil

was separated from the press liquid. Tables 9 and 10 provide an analysis of cooked krill after first cooking step on wet base and dry base.

Table 9 Analysis of cooked krill on wet base (wb)

Sample:	Cooked krill							
Analysis:	Dry matter	Fat, B&D	Protein	Ash	pH	TVN	TMA	TMAO
Date:	g/100 g	g/100 g	g/100 g	g/100 g		mg N/100 g	mg N/100 g	mg N/100 g
07.08.2007	20,2	4,7	13,5	2,2				
18.09.2007	19,8	4,6						
25.10.2007	15,2	3,2	10,3	2,0	8,2	10,5	3,5	75,4

5

Table 10 Analysis of cooked krill on dry base (db)

Sample:	Cooked krill							
Analysis:	Dry matter	Fat, B&D	Protein	Ash	TVN	TMA	TMAO	
Date:	g/100 g	g/100 g	g/100 g	g/100 g	mg N/100 g	mg N/100 g	mg N/100 g	
07.08.2007	100,0	23,3	66,8	10,9				
18.09.2007	100	23,2						
25.10.2007	100	21,1	67,8	13,2	69,3	23,1	496,3	

10 Compared to raw krill (Table 8) there is a reduction in dry matter for cooked krill. The fat content in dry matter is reduced because of the fat in the krill milk which is separated from the cooked krill. The content of protein is increased on dry base, but the ash seems to be at the same level. TMAO in the krill is reduced and is found in the cooking liquid.

15 **Micro filtration.** The krill milk (70 °C) from step 1 was coagulated at > 95 °C and separated from the liquid through microfiltration (Soby Miljøfilter). Coagulum was then pressed in a press and dried. Tables 11 and 12 gives analyses of coagulum on wet base and dry base. The dry matter of the coagulum was between 12.8 and 16.7 %. On dry base the fat content about 60 % and TMAO 340 mg N/100 g. The dry matter of the coagulum increased to 34-38 % by pressing. The fat content also increased on dry base (Table 13), but the TMAO  
20 was reduced to 145 mg N/100 g. After washing the press cake with 1 part water to 1 part press cake of coagulum and then press again, the TMAO was reduced to 45 mg N/100g on dry base (Table 18).

Table 11 Analysis of coagulum on wet base (wb)

Sample:	Coagulum						
Analysis:	Dry matter	Fat, B&D	Protein	Ash	TVN	TMA	TMAO
Date:	g/100 g	g/100 g	g/100 g	g/100 g	mg N/100 g	mg N/100 g	mg N/100 g
10.10.2007	12,8	7,9					
25.10.2007	14,3	8,3	5,4	1,0	5,9	2,3	48,6
31.10.2007	16,7	9,3	6,2				
<b>Average</b>	<b>14,6</b>	<b>8,5</b>	<b>5,8</b>				

Table 12 Analysis of coagulum on dry base (db)

Sample:	Coagulum						
Analysis:	Dry matter	Fat, B&D	Protein	Ash	TVN	TMA	TMAO
Date:	g/100 g	g/100 g	g/100 g	g/100 g	mg N/100 g	mg N/100 g	mg N/100 g
10.10.2007	100	61,7					
25.10.2007	100	58,0	37,8	7,0	41,0	16,4	340,1
31.10.2007	100	55,7	37,1				
<b>Average</b>	<b>100</b>	<b>58,5</b>	<b>37,4</b>				

5

Table 13 Analysis of press cake from coagulum on wet base

Sample:	Press cake of coagulum						Raw krill	Coagulum	Coagulum PK
Analysis:	Dry matter	Fat, B&D	TVN	TMA	TMAO	worked up	perss cake	per kg raw krill	
Date:	g/100 g	g/100 g	mg N/100 g	mg N/100 g	mg N/100 g	kg	kg	kg/kg	
22.11.2007	38,8	23,6	7,9	4,5	56,1	1000	54,2	0,0542	
11.12.2007	33,8	22,5	3,4	0	45,3	500	21,92	0,0438	
11.12.2007*	33,6	21,3	0	0	15,3	500	15	0,0300	

\*) After 1 wash (Press cake : water = 1:1)

10 **Membrane filtration.** Another way to collect the lipids from the krill milk is to separate by membrane filtration. For this to be possible the milk must not coagulate, but be brought to the membrane filter from the sieve (heating step no. 1).

Before the krill milk could enter the membrane filter the milk is pre-filtrated, which was done by the sieve (100 µm). The opening of the micro-filter was 100 nm. 80 kg krill was processed by starting by 80 kg water (95 °C) and 20 kg krill into the kettle as described. For  
 15 the first 2 batches of krill clean water was used (160 kg), but for the last 2 batches permeate from the membrane filter was used instead of water. The membrane filtration was followed with a refract meter calibrated for sugar solution (°Brix). The Brix-value is near the dry matter concentration in the process liquids. The flux value for the filter at about 60 °C was  
 20 350 l/m<sup>2</sup>/h for retentate with 7.8 °Brix (refract meter) and reduced to 290 l/m<sup>2</sup>/h when the Brix value increased to 9.9 °. The Brix value for the permeate was only 1 ° due to high

dilution when the amount to be filtered is small. See Figures 2 and 3. The permeate was golden and transparent.

All permeate was evaporated in a kettle to > 65 ° Brix. Retentate, 2 liter, was evaporated in a laboratory evaporator at 70 °C and 12 mm Hg. At 27.5 °Brix the retentate was still flowing well. As the concentration continued the retentate became more and more viscous, first as a paste and finely to a dry mass. The concentrated retentate (27 °Brix), permeate (> 65 °Brix) and dry retentate were analyzed and the results are given in Table 14 on sample base (% wb) and Table 15 on dry matter base (% db) (sample no 1, 2 and 3). A sample of coagulum was dried as for the retentate (sample no 4).

10

Table 14 Analysis of concentrate from retentate, permeate and coagulum on wet base (wb)

	Dry matter	Fat (polar+apolar) Bligh & Dyer	Crude Protein	Ash	TVN	TMA	TMAO	Water activity
Sample	% wb	% wb	% wb	% wb	mg N/100g wb	mg N/100g wb	mg N/100g wb	aw
No. 1 Concentrate of retentat	26,0	16,3	9,5	1,6	5,7	<1	99	0,978
No. 2 Consentrate of permeat	72,7	1,0	51,1	24,7	138	110	1 157	0,385
No. 3 Vakuüm dried retentate	64,9	39,3	24	4,1	12,8	29,4	196	0,875
No. 4 Vakuüm died coagulum	60,3	37,1	20,9	4,4	52,9	28,1	216	0,912

Table 15 Analysis of concentrate from retentate, permeate and coagulum on dry matter base (db)

	Dry matter	Fat (polar+apolar) Bligh & Dyer	Crude Protein	Ash	TVN	TMA	TMAO
Sample	% db	% db	% db	% db	mg N/100g db	mg N/100g db	mg N/100g db
No. 1 Concentrate of retentat	100,0	62,7	36,5	6,2	21,9	<1	382
No. 2 Consentrate of permeat	100,0	1,4	70,3	34,0	190	152	1 592
No. 3 Vakuüm dried retentate	100,0	60,6	37,0	6,3	19,7	45,3	302
No. 4 Vakuüm died coagulum	100,0	61,5	34,7	7,3	87,7	46,6	358

15

These results indicate that micro filtration of krill milk was promising and is an alternative to coagulate the krill milk. The protein portion was high in taurine. The content of fat, protein, ash and TMAO were almost similar between retentate and coagulum. Permeate can be concentrated to 70 % dry matter and will have a water activity below 0.4 at 25 °C which means that it can be stored at ambient temperature.

20

25

**Press cake and press liquid.** Tables 16 and 17 provide an analysis of press cake on wet and dry base from the different trials. The average amount of press cake per kg raw krill was found to be 0.23 kg. The dry matter of the press cake was between 44 and 48 %. The fat content in dry matter was reduced from 21 % before to 15-20 % after pressing. This will give a press cake meal from 14 to 18.5 % fat, about 67 % protein and 7 % moisture. TMAO was



reduced from about 500 mg N/100g dry matter in cooked krill to 95mg N/100g dry matter in the press cake.

Table 16 Analysis on wet base (wb) of press cake and calculations

Sample:	Press cake						Raw krill	Press cake	Kg press cake
Analysis:	Dry matter	Fat, B&D	Protein	TVN	TMA	TMAO	worked up		per kg raw krill
Date:	g/100 g	g/100 g	g/100 g	mg N/100 g	mg N/100 g	mg N/100 g	kg	kg	kg/kg
18.09.2007	48,1	8,0					327	90	0,28
04.10.2007	47,9	7,0	34,8						
10.10.2007	44,8	9,3					250	55	0,22
31.10.2007	47,4	7,2	33,8				709	143	0,20
22.11.2007	44,4	8,1		8,4	2,1	42,2	1000	226	0,23
11.12.2007	43,8	7,3		5,6	2,2	46,7	500	117	0,23
<b>Average:</b>	<b>46,1</b>	<b>7,8</b>	<b>34,3</b>	<b>7</b>	<b>2,2</b>	<b>44,5</b>			<b>0,23</b>

5

Table 17 Analysis on dry base (db) of press cake

Press cake					
Dry matter	Fat, B&D	Protein	TVN	TMA	TMAO
g/100 g	g/100 g	g/100 g	mg N/100 g	mg N/100 g	mg N/100 g
100	16,6				
100	14,6	72,7			
100	20,8				
100	15,2	71,3			
100	18,2		18,9	4,7	95,0
100	16,7		12,8	5,0	106,6
100	17,0	72,0	15,9	4,9	100,8

Oil was produced from the krill solids by centrifugation. Table 18. The oil was almost free for water and the content of astaxanthin was quite high (1.8 g/kg).

10

Table 18 Analysis of krill oil

Tricanter oil (krill oil)		Date:	Date:
		31.10.2007	22.11.2007
Astaxanthin, Free	mg/kg	22	29
Trans	mg/kg	12	14
9-cis	mg/kg	2,3	3,2
13-cis	mg/kg	5,4	7,8
Astaxanthin, Esters	mg/kg	1802	1785
Diester	mg/kg	1142	1116
Monoester	mg/kg	660	669
<b>Astaxanthin - total</b>	<b>mg/kg</b>	<b>1824</b>	<b>1814</b>
Water, Karl F.	g/100 g	0,17	0,04
FFA	g/100 g		0,9
Vitamin A	IE/kg		602730
Vitamin D3	IE/kg		<1000
Vitamin E (alfa-tokoferol)	mg/kg		630

Table 19 Analysis of press cake from coagulum on dry base

Sample:	Press cake of coagulum				
Analysis:	Dry matter	Fat, B&D	TVN	TMA	TMAO
Date:	g/100 g	g/100 g	mg N/100 g	mg N/100 g	mg N/100 g
22.11.2007	100	60,8	20,4	11,6	144,6
11.12.2007	100	66,6	10,1	0,0	134,0
11.12.2007*	100	63,4	0,0	0,0	45,5

\*) After 1 wash (Press cake : water = 1:1)

The yield of coagulum press cake was about 5 % of raw krill. The compositions of coagulum and retentate from micro filtration is compared in Table 20. There was hardly any difference between the products from the two process alternatives. Press cake of coagulum was dried, and Table 21 gives the analysis of the coagulum and final coagulum meal. The proximate composition based on dry matter did not change during drying, and the amino acid composition and fatty acid composition is near identical. There was some loss of phospholipids during drying. This is most probable caused by oxidation of fatty acids, but other chemical modification of the phospholipids may also be of consequence.

Table 20 Analysis of Retentate from micro filtration and Coagulum

		Retentat 25.10.07	Coagulum 25.10.07
Protein	g/100 g	5,8	5,4
Dry matter	g/100 g	13,5	14,3
Ash	g/100 g	1,1	1,0
Fat (B&D)	g/100 g	7,3	8,3
pH		8,5	
TFN	mg N/100 g	5,9	5,9
TMA	mg N/100 g	2,3	2,3
TMAO	mg N/100 g	61,0	48,6
<b>Lipid classes:</b>			
Triacylglycerol	g/100 g extracted fat	59,0	51
Diacylglycerol	g/100 g extracted fat	1,3	1
Monocylglycerol	g/100 g extracted fat	<1	<1
Free fatty acids	g/100 g extracted fat	3,8	3,2
Cholesterol	g/100 g extracted fat	<0,5	<0,5
Cholesterol esters	g/100 g extracted fat	1,0	0,8
Phosphatidyl ethanolamine	g/100 g extracted fat	1,8	3
Phosphatidyl inositol	g/100 g extracted fat	<1	<1
Phosphatidyl serine	g/100 g extracted fat	<1	<1
Phosphatidyl choline	g/100 g extracted fat	35,0	40
Lyso-Phosphatidyl choline	g/100 g extracted fat	0,8	1,2
Total polar lipids	g/100 g extracted fat	37,6	44,2
Total neutral lipids	g/100 g extracted fat	67,1	56,0
Sum lipids	g/100 g extracted fat	103,4	100,2
<b>Fatty acid composition:</b>			
14:0	g/100 g extracted fat	10,6	10,4
16:0	g/100 g extracted fat	16,4	16,2
18:0	g/100 g extracted fat	1,1	1,2
20:0	g/100 g extracted fat	0,1	0,1
22:0	g/100 g extracted fat	<0,1	<0,1
16:1 n-7	g/100 g extracted fat	6,3	6,4
18:1 (n-9)+(n-7)+(n-5)	g/100 g extracted fat	15,5	15,4
20:1 (n-9)+(n-7)	g/100 g extracted fat	1,1	1,1
22:1 (n-11)+(n-9)+(n-7)	g/100 g extracted fat	0,6	0,5
24:1 n-9	g/100 g extracted fat	0,1	0,1
16:2 n-4	g/100 g extracted fat	0,5	0,5
16:3 n-4	g/100 g extracted fat	0,2	0,2
18:2 n-6	g/100 g extracted fat	1,4	1,4
18:3 n-6	g/100 g extracted fat	0,2	0,2
20:2 n-6	g/100 g extracted fat	0,1	0,1
20:3 n-6	g/100 g extracted fat	0,1	0,1
20:4 n-6	g/100 g extracted fat	0,3	0,3
22:4 n-6	g/100 g extracted fat	<0,1	<0,1
18:3 n-3	g/100 g extracted fat	0,7	0,7
18:4 n-3	g/100 g extracted fat	1,7	1,7
20:3 n-3	g/100 g extracted fat	<0,1	<0,1
20:4 n-3	g/100 g extracted fat	0,3	0,3
20:5 n-3 (EPA)	g/100 g extracted fat	10,5	10,3
21:5 n-3	g/100 g extracted fat	0,3	0,3
22:5 n-3	g/100 g extracted fat	0,5	0,4
22:6 n-3 (DHA)	g/100 g extracted fat	5,1	5,0
Sum saturated fat acides	g/100 g extracted fat	28,2	27,9
Sum monoene fat acides	g/100 g extracted fat	23,6	23,4
Sum PUFA (n-6) fat acides	g/100 g extracted fat	2,1	2
Sum PUFA (n-3) feat acides	g/100 g extracted fat	19,1	18,7
Sum PUFA fat acides total	g/100 g extracted fat	21,9	21,4
Sum fat acides total	g/100 g extracted fat	73,7	72,7
EPA/DHA		2,1	2,1

Table 21 Analysis of Coagulum press cake and meal dried in a Rotadisc dryer on wet and dry base

		Coagulum press cake	Coagulum meal	Coagulum press cake	Coagulum meal
		22.11.2007	22.11.2007	22.11.2007	22.11.2007
Analysis:		wb	wb	db	db
Protein	g/100 g	14,6	35,3	37,6	37,4
Moisture	g/100 g	61,2	5,7	0,0	0,0
Fat B&D	g/100 g	23,6	55,1	60,8	58,4
Ash	g/100 g		5,9		6,3
TMA	mg N/100 g	4,5	7	11,6	7
TMAO	mg N/100 g	56,1	140	144,6	148
<b>Fatty acid composition:</b>					
14:0	g/100 g extracted fat	10,4	10,4		
16:0	g/100 g extracted fat	17	17		
18:0	g/100 g extracted fat	1,2	1,2		
20:0	g/100 g extracted fat	0,1	0,1		
22:0	g/100 g extracted fat	0,1	0,1		
16:1 n-7	g/100 g extracted fat	6,4	6,4		
18:1 (n-9)+(n-7)+(n-5)	g/100 g extracted fat	15,2	15,3		
20:1 (n-9)+(n-7)	g/100 g extracted fat	1,1	1,1		
22:1 (n-11)+(n-9)+(n-7)	g/100 g extracted fat	0,5	0,6		
24:1 n-9	g/100 g extracted fat	0,1	0,1		
16:2 n-4	g/100 g extracted fat	0,5	0,5		
16:3 n-4	g/100 g extracted fat	0,2	0,2		
18:2 n-6	g/100 g extracted fat	1,5	1,4		
18:3 n-6	g/100 g extracted fat	0,2	0,2		
20:2 n-6	g/100 g extracted fat	0,1	0,1		
20:3 n-6	g/100 g extracted fat	<0,1	<0,1		
20:4 n-6	g/100 g extracted fat	0,3	0,3		
22:4 n-6	g/100 g extracted fat	<0,1	<0,1		
18:3 n-3	g/100 g extracted fat	0,7	0,7		
18:4 n-3	g/100 g extracted fat	1,7	1,7		
20:3 n-3	g/100 g extracted fat	<0,1	<0,1		
20:4 n-3	g/100 g extracted fat	0,4	0,4		
20:5 n-3 (EPA)	g/100 g extracted fat	10,9	10,5		
21:5 n-3	g/100 g extracted fat	0,3	0,3		
22:5 n-3	g/100 g extracted fat	0,3	0,3		
22:6 n-3 (DHA)	g/100 g extracted fat	5,3	5,1		
Sum saturated fat acides	g/100 g extracted fat	28,7	28,7		
Sum monoene fat acides	g/100 g extracted fat	23,3	23,3		
Sum PUFA (n-6) fat acides	g/100 g extracted fat	2	2		
Sum PUFA (n-3) fat acides	g/100 g extracted fat	19,7	19		
Sum PUFA fat acides total	g/100 g extracted fat	22,4	21,7		
Sum fat acides total	g/100 g extracted fat	74,4	73,8		
<b>Amino acids:</b>					
Aspartic acid	g/100 g protein	10,5	10,5		
Glutamic acid	g/100 g protein	11,2	11,6		
Hydroxyproline	g/100 g protein	<0,10	<0,10		
Serine	g/100 g protein	4,3	4,2		
Glycine	g/100 g protein	4	4		
Histidine	g/100 g protein	2	1,9		
Arginine	g/100 g protein	4,8	4,7		
Threonine	g/100 g protein	4,9	4,9		
Alanine	g/100 g protein	4,8	4,9		
Proline	g/100 g protein	4,2	4,1		
Tyrosine	g/100 g protein	3,7	3,5		
Valine	g/100 g protein	6	5,9		
Methionine	g/100 g protein	2,4	2,4		
Isoleucine	g/100 g protein	6,9	6,7		
Leucine	g/100 g protein	9,6	9,4		
Phenylalanine	g/100 g protein	4,5	4,4		
Lysine	g/100 g protein	7,7	7,6		
Sum AA	g/100 g protein	91,5	90,7		
<b>Lipid classes:</b>					
Triacylglycerol	g/100 g extracted fat	48	63		
Diacylglycerol	g/100 g extracted fat	1,2	1,3		
Monocylglycerol	g/100 g extracted fat	<1	<1		
Free fatty acids	g/100 g extracted fat	3,2	3,1		
Cholesterol	g/100 g extracted fat	1,2	<0,5		
Cholesterol esters	g/100 g extracted fat	0,5	0,9		
Phosphatidyl ethanolamine	g/100 g extracted fat	3,1	1,1		
Phosphatidyl inositol	g/100 g extracted fat	<1	<1		
Phosphatidyl serine	g/100 g extracted fat	<1	<1		
Phosphatidyl choline	g/100 g extracted fat	38	34		
Lyso-Phosphatidyl choline	g/100 g extracted fat	1,2	<1		
Total polar lipids	g/100 g extracted fat	42	34,8		
Total neutral lipids	g/100 g extracted fat	54,6	67,9		
Sum lipids	g/100 g extracted fat	96,7	103,6		

**Krill meal.** Final krill meal was produced. Press cake and press cake with stick water concentrate were dried in a hot air dryer or steam drier. Table 22.

Table 22 Analysis of krill meal from

		Forberg	Forberg	Rota disc.
		Air dried	Air dried	Steam dried
		Press cake	Krill meal	Krill meal
		meal of krill	with stickwater	with stickwater
Date: 22.11.2007				
<b>Wet base:</b>				
Protein	g/100 g	66,4	63,6	66,3
Moisture	g/100 g	5,9	7,1	3,7
Fat Soxhlet	g/100 g	8,7	10,4	
Fat B&D	g/100 g	15,9	15,6	15,2
Ash	g/100 g	9,8	13,0	13,4
Salt	g/100 g	1,3	4,3	4,4
Water sol. protein	g/100 g prot.	11,1	28,0	27,1
pH		8,6	8,3	
TVN	mg N/100 g	18,8	39,9	38,6
TMA	mg N/100 g	11,1	22,2	29,8
TMAO	mg N/100 g	109,7	442,1	399,5
<b>Dry matter base:</b>				
Protein	g/100 g db	70,6	68,5	
Fat Soxhlet	g/100 g db	9,2	11,2	
Fat B&D	g/100 g db	16,9	16,8	15,8
Ash	g/100 g db	10,4	14,0	
Salt	g/100 g db	1,4	4,6	
TVN	mg N/100 g db	20,0	42,9	40,1
TMA	mg N/100 g db	11,8	23,9	30,9
TMAO	mg N/100 g db	116,6	475,9	414,9
<b>Astaxanthin on wet base:</b>				
Astaxanthin, Free	mg/kg	4,6	3,6	<1
Trans	mg/kg	2,5	1,9	<1
9-cis	mg/kg	0,4	0,4	<1
13-cis	mg/kg	1,3	0,9	<1
Astaxanthin, Esters	mg/kg	112,0	100	58,0
Diester	mg/kg	80,0	72,0	50,0
Monoester	mg/kg	32,0	27,0	8,1
Astaxanthin - total	mg/kg	116,6	103,6	58,0
<b>Astaxanthin on fat base:</b>				
Astaxanthin, Fritt	mg/kg fat	28,9	23,1	<7
Trans	mg/kg fat	15,7	12,2	<7
9-cis	mg/kg fat	2,5	2,6	<7
13-cis	mg/kg fat	8,2	5,8	<7
Astaxanthin, Estere	mg/kg fat	704,4	641,0	381,6
Diester	mg/kg fat	503,1	461,5	328,9
Monoester	mg/kg fat	201,3	173,1	53,3
Astaxanthin - totalt	mg/kg fat	733,3	664,1	381,6
<b>Amino acids:</b>				
Aspartic acid	g/100 g protein	10,6	9,2	9,2
Glutamic acid	g/100 g protein	14,1	12,4	12,3
Hydroxiprolin	g/100 g protein	<0,5	<0,5	0,1
Serine	g/100 g protein	4,2	3,7	3,8
Glycine	g/100 g protein	4,4	4,4	4,5
Histidine	g/100 g protein	2,3	1,9	1,9
Arginine	g/100 g protein	6,6	6,0	6,1
Threonine	g/100 g protein	4,3	3,7	4,1
Alanine	g/100 g protein	5,4	4,9	5,3
Proline	g/100 g protein	3,7	4,1	4
Tyrosine	g/100 g protein	4,4	3,1	4,7
Valine	g/100 g protein	5,1	4,4	4,5
Methionine	g/100 g protein	3,2	2,7	2,7
Isoleucine	g/100 g protein	5,3	4,5	4,5
Leucine	g/100 g protein	8,0	6,9	6,9
Phenylalanine	g/100 g protein	4,6	3,9	4
Lysine	g/100 g protein	8,2	7,0	6,6
Sum AA	g/100 g protein	94,4	82,8	85,2
<b>Lipide classes:</b>				
Triacylglycerol	g/100 g extracted fat		41,0	63
Diacylglycerol	g/100 g extracted fat		1,7	1,3
Monocylglycerol	g/100 g extracted fat		<1	<1
Free fatty acids	g/100 g extracted fat		8,8	3,1
Cholesterol	g/100 g extracted fat		2,4	<0,5
Cholesterol esters	g/100 g extracted fat		<0,5	0,9
Phosphatidyl ethanolamine	g/100 g extracted fat		3,6	1,1
Phosphatidyl inositol	g/100 g extracted fat		<1	<1
Phosphatidyl serine	g/100 g extracted fat		<1	<1
Phosphatidyl choline	g/100 g extracted fat		43,0	34
Lyso-Phosphatidyl choline	g/100 g extracted fat		1,1	<1
Total polar lipids	g/100 g extracted fat		47,2	34,8
Total neutral lipids	g/100 g extracted fat		54,2	67,9
Sum lipids	g/100 g extracted fat		101,4	103,6

**EXAMPLE 5**

Coagulum meal produced as described in Example 4 was extracted using lab scale SFE. 4,885g of coagulum (freeze dried over night) via a two step extraction: 1) SFE: CO<sub>2</sub>, 500 Bar, 60°C, 70min at a medium flow rate of 1,8ml/min of CO<sub>2</sub>; 2) SFE: CO<sub>2</sub>+15%EtOH, 500 Bar, 60°C, 70min at a medium flow rate of 2,5ml/min of CO<sub>2</sub>+EtOH. The first step extracted 1,576g of extracted neutral fraction (NF). As shown in Figures 4 and 5, the analysis at HPLC show lower than the detectable limit content on PL in the NF. It was extracted about 32.25% of the total material. Table 29 provides the peak areas of the components of the neutral fraction as determined by GC.

Table 29.

Rel.Area %	Peakname	Ret.Time min	Area mV*min	Height mV	Rel.Area %
0,29	n.a.	17,455	0,2864	2,271	0,29
<b>19,49</b>	<b>C14:0</b>	<b>24,073</b>	<b>19,0301</b>	<b>105,696</b>	<b>19,49</b>
<b>21,16</b>	<b>C16:0</b>	<b>32,992</b>	<b>20,6601</b>	<b>88,859</b>	<b>21,16</b>
<b>11,99</b>	<b>C16:1</b>	<b>36,197</b>	<b>11,7032</b>	<b>48,125</b>	<b>11,99</b>
3,5	n.a.	37,28	3,4166	14,344	3,5
1,57	n.a.	43,331	1,5375	6,141	1,57
<b>15,6</b>	<b>n.a.</b>	<b>46,425</b>	<b>15,2285</b>	<b>58,605</b>	<b>15,6</b>
8,81	n.a.	46,873	8,5983	30,65	8,81
0,93	n.a.	50,499	0,9055	3,164	0,93
1,56	n.a.	51,292	1,5216	5,746	1,56
1,67	n.a.	57,312	1,6281	4,78	1,67
2,03	n.a.	60,985	1,98	6,963	2,03
0,02	n.a.	67,761	0,0189	0,116	0,02
0,11	n.a.	68,833	0,1066	0,423	0,11
0,11	n.a.	71,705	0,1028	0,497	0,11
0,08	n.a.	74,053	0,0806	0,398	0,08
<b>3,92</b>	<b>C20:5 EPA</b>	<b>74,489</b>	<b>3,826</b>	<b>12,07</b>	<b>3,92</b>
0,11	n.a.	80,519	0,1095	0,48	0,11
0,08	C22:5 DPA	85,369	0,0785	0,41	0,08
<b>1,3</b>	<b>C22:6 DHA</b>	<b>87,787</b>	<b>1,2719</b>	<b>4,253</b>	<b>1,3</b>

The second step extracted a polar fraction of 1,023g corresponding to 20,95% of the total material. The polar fraction consisted mostly of PL and just less than 1% TG. See Figures 6 and 7. Table 30 provides the peak areas of the components of the polar fraction as determined by GC.

5

Table 30.

Rel.Area %	Peakname	Ret.Time min	Area mV*min	Height mV	Rel.Area %
2,87	C14:0	24,025	4,8099	28,243	2,87
<b>28,5</b>	<b>C16:0</b>	<b>33,084</b>	<b>47,7079</b>	<b>182,756</b>	<b>28,5</b>
1,82	C16:1	36,155	3,0402	13,166	1,82
1,13	n.a.	43,304	1,8848	8,208	1,13
3,89	n.a.	46,336	6,5129	27,429	3,89
5,46	n.a.	46,852	9,1467	35,825	5,46
2,15	n.a.	51,265	3,6015	14,095	2,15
1,6	n.a.	57,121	2,6735	7,213	1,6
1,72	n.a.	60,944	2,8832	10,686	1,72
2,03	n.a.	68,259	3,3913	8,025	2,03
<b>30,09</b>	<b>C20:5 EPA</b>	<b>74,599</b>	<b>50,3768</b>	<b>163,312</b>	<b>30,09</b>
<b>12,11</b>	<b>C22:6 DHA</b>	<b>87,832</b>	<b>20,2774</b>	<b>68,714</b>	<b>12,11</b>

- 10 The coagulate was dried over night with a weight loss of about 5,53% w/w. The total extracted was about 53,2% of the starting weight of the dried material.

#### EXAMPLE 6

- 15 Freshly harvested krill were processed into coagulum on board the ship either 10 minutes or six hours post harvest. The coagulum produced from both the 10 minute post harvest krill and the 6 hour post harvest krill contained less than 1mg/100g volatile nitrogen, less than 1 mg/100 g trimethylamine (TMA), and less than 1g/100g lysophosphatidylcholine. This can be compared to the coagulum produced from frozen krill in Example 4 above, which contained higher levels of volatile nitrogen, and lysophosphatidylcholine. The methods of the invention which utilize freshly harvested krill provide krill products that are characterized in  
20 being essentially free of TMA, volatile nitrogen, and lysophosphatidylcholine.

**EXAMPLE 7**

Coagulum meal, 250 g, and krill oil were mixed in a kitchen mixer. The aim was to add 300 – 500 mg astaxanthin/kg coagulum meal. If the oil contains 1500 mg astaxanthin/kg krill oil, at least 200 g oil should be added to one kg of coagulum meal. The flow of the meal was markedly reduced by addition of 10 % oil, and the oil came off on the packaging when the addition of oil was increased to 14 and 20 %. 3.5 kg coagulum from was thawed and milled on a Retsch ZM1 with a 2 mm sieve. The quantity of milled powder was 2.96 kg. The 2.96 kg dried coagulum was added 300 g krill oil in three portions. The knives in the mixer (Stephan UM12) were to far from the bottom to give a good mixing, so the mixture was mixed by hand and mixer intermittently. The astaxanthin content in the final mixture was 40 % lower than calculated. New analyses of astaxanthin were performed on the oil and on the fortified meal. The krill oil had been stored in a cold room at 3 °C for 4 months, and the astaxanthin content in the oil did not change during this storage . A new sample were drawn from the fortified meal after 4 weeks frozen storage, and the astaxanthin content was the same in both samples (Table 31).

**Table 31. Composition of steam dried coagulum fortified with 10 % krill oil.**

		Analysed Meal with oil	Calculated Meal with oil	New analysis Krill oil	New analysis Meal with oil
Dry matter	g/100 g	98.0	99.2		
Protein	g/100 g		33.6		
Fat (B&D)	g/100 g	58.9	60.7		
Ash	g/100 g		5.9		
Water soluble protein	g/100 g protein		15.8		
TFN	mg N/100 g		10		
TMA	mg N/100 g		10		
TMAO	mg N/100 g		113		
Astaxanthin, Free	mg/kg	2.5	4.9	27	2.8
Trans	mg/kg	1.4	2.5	14	1.5
9-cis	mg/kg	0.35	0.6	3.1	0.4
13-cis	mg/kg	0.57	1.2	6.2	0.7
Astaxanthin, Esters	mg/kg	193	338	1805	197
Diester	mg/kg	126	216	1128	127
Monoester	mg/kg	67	122	677	70
Astaxanthin - total	mg/kg	196	343	1832	200
Astaxanthin, Free	mg/kg lipid	4.2	8.1		
Trans	mg/kg lipid	2.4	4.2		
9-cis	mg/kg lipid	0.6	1.0		



13-cis	mg/kg lipid	1.0	2.0
Astaxanthin, Esters	mg/kg lipid	328	556
Diester	mg/kg lipid	214	356
Monoester	mg/kg lipid	114	200
Astaxanthin - total	mg/kg lipid	332	564
<hr/>			
Ffa	g/100 g extracted fat	4.4	
<hr/>			
Total polar lipids	g/100 g extracted fat	39.7	
Total neutral lipids	g/100 g extracted fat	60.1	

The astaxanthin content in fortified coagulum meal is 58 % of the amount in the ingredients. This reduction in astaxanthin takes place during mixing of dried coagulum and krill oil, and indicate that dried coagulum is easily oxidized.

## 5 Example 8

The dried coagulum meal was extracted by supercritical fluid extraction. The extracted oil was analyzed as presented in Tables 32-34.

### 10 Table 32. Lipid composition

Phosphatidylcholine	34 g/100 g lipid
Phosphatidylethanolamine	1,3 g/100 g lipid
Triglycerides	48 g/100 g lipid
Cholesterol	n.d.
Free fatty acids	1,0 g/100 g lipid

### Table 33. Fatty acid profile

Total saturated fatty acids	26,3 g/100 g lipid
Total omega-3 fatty acids	18,1 g/100 g lipid
Total fatty acids	67,3 g/100 g lipid

### Table 34. Miscellaneous properties

Astaxanthin	130 mg/kg
TMAO	87 mg N/100 g

TMA	<1 mg N/100 g
Viscosity at 25°C	61 mPa s

**Example 9**

- 5 Coagulum meal prepared as described above was administered to two human subjects and absorption of the product was determined by measuring omega-3 fatty acids in total lipids and in phospholipids in plasma. Subject 1 consumed 8g of coagulum in combination with yoghurt, whereas subject 2 consumed 8g of krill oil without yoghurt. The data is presented in Tables 35 (Subject 1) and 36 (Subject 2).

10

**Table 35**

Time (h)	C20:5 W3 (EPA)	C22:5 W3 (DPA)	C22:6 W3(DHA)
0	0.117	0.062	0.267
0.5	0.118	0.063	0.270
1	0.113	0.061	0.260
1.5	0.117	0.064	0.272
2	0.116	0.063	0.271
2.5	0.119	0.063	0.271
3	0.123	0.065	0.281
3.5	0.122	0.063	0.275
4	0.123	0.063	0.275
5	0.141	0.065	0.294
6	0.153	0.064	0.286
7	0.154	0.062	0.277
8	0.165	0.063	0.292
10	0.167	0.063	0.291
12	0.163	0.061	0.275
16	0.169	0.062	0.301
24	0.173	0.074	0.323

**Table 36**

Time (h)	C20:5 W3 (EPA)	C22:5 W3 (DPA)	C22:6 W3(DHA)
0	0.146	0.052	0.260
0.5	0.142	0.052	0.260
1	0.146	0.054	0.268
1.5	0.142	0.053	0.263
2	0.145	0.054	0.267
2.5	0.140	0.053	0.258

3	0.143	0.054	0.264
3.5	0.155	0.056	0.278
4	0.155	0.055	0.277
5	0.179	0.057	0.295
6	0.217	0.057	0.316
7	0.204	0.057	0.304
8	0.211	0.060	0.320
10	0.187	0.057	0.293
12	0.171	0.054	0.272
16	0.166	0.052	0.272
24	0.169	0.061	0.290

These data show that absorption patterns of the coagulum and krill oil are different for the two subjects. The EPA pattern in subject 1 (coagulum) shows that a high EPA level is maintained over a long time despite the fact that coagulum contains less lipid than the krill oil. The coagulum has also enriched the circulating PL pool which could be an indication of absorption/incorporation of krill oil fatty acids in PL form. We have previously observed that krill oil is more efficient in enriching tissue lipid fatty acid profiles than fish oil. These data indicate that coagulum is even more bioeffective than krill oil.

10

**Example 10.**

The phospholipid content of the retentate was further analyzed by NMR. Table 37 provides the results.

15

**Table 37.**

Phospholipid	% (w/w)
Phosphatidylcholine	16,5
Alkylacylphosphatidylcholine	1,7
Lyso-alkylacylphosphatidylcholine	0,28
2-lysophosphatidylcholine	0,52
Phosphatidylethanolamine	0,59
N-acylphosphatidylethanolamine	3,6
Total phospholipid	23,23

**Example 11**

This example provides an analysis of the volatile compounds in oil extracted from krill meal and oil extracted from coagulum meal. Table 38. Briefly, oil was extracted by SFE from regular krill meal or meal prepared from coagulum as described above. The oil prepared from coagulum meal had substantially reduced amounts of volatile compounds as compared to the oil prepared from regular krill meal. In particular, 1-penten-3-one was detected in oil prepared from regular krill meal and was absent in oil prepared from coagulum meal. 1-pentene-3-one have previously been identified has a key marker of fishy and metallic off-flavor in fish oil and fish oil enriched food products (Jacobsen et al., J. Agric Food Chem, 2004, 52, 1635-1641).

Table 38.

Compound	TIC peak area (Krill oil extracted from krill meal using SFE)	Description	TIC peak area (Krill oil extracted from coagulum using SFE)	Description
dimethyl amine	180403283		22848535	
trimethyl amine	255213688	old fish, strong bad	49040416	old fish
Ethanol	394615326	fresh	1426886614	vodka, ethanol
Acetone	875959		0	
acetic acid	36136270	weak smell	0	
methyl vinyl ketone	515892		0	
2-butanone	2807131	sweet	23124362	
ethyl acetate	6231705		404501	
1- [dimethylamino]- 2-propanone	23316404		15380603	
1-penten-3-one	5627101	rubbery	0	weak dishcloth

n-heptane	291386		0	
2-ethyl furan	1640866	weak sweet	0	
ethyl propionate	909959		0	
2-methyl-2-pentenal	6996219		0	
Pyridine	2085743		0	
Acetamide	6169014	pleasant	0	
Toluene	4359806		0	
N,N-dimethyl formamide	177968590	garden hose, mint	0	garden hose
ethyl butyrate	1122805		0	
2-ethyl-5-methyl furan	1550476	good, flower	427805	
butyl acetate	306001		856292	
3-methyl-1,4-heptadiene	1617339		0	weak rubber smell,
Isovaleric acid	1528541	foot sweat, weak	0	
methyl pyrazine	1335979	peculiar	0	
ethyl isovalerate	1043918	fruity	0	fruity
N,N-dimethyl acetamide	9895351		0	smell, solvent
2-heptanone	7397187	blue cheese	0	
2-ethyl pyridine	317424		0	
Butyrolactone	652076	butter, pleasant	0	
2,5-dimethyl pyrazine	2414087		0	
ethyl pyrazine	1909284	metallic	0	soft
N,N-dimethyl propanamide	1160830	unpleasant	0	
Benzaldehyde	3134653		0	
2-octanone	2068169	disgusting	0	
$\beta$ -myrcene	2618870		0	

dimethyl trisulfide	3279406	sewer	0	
n-decane	1851488		331629	
trimethyl pyrazine	4186679	unpleasant	0	
1-methyl-2-pyrrolidone	9577873		0	
Eucalyptol	0	peppermint	868411	
Asetofenoni	1146348	smell, pleasant	350688	

**Example 12**

Krill meal produced by the traditional process (Tables 39-42) was compared with krill meal produced from the solid fraction remaining after removal of krill milk (Tables 43-46).

5

Table 39

14:0	g/100g total fat	8,3	
16:0	g/100g total fat	15,4	
18:0	g/100g total fat	1,0	
20:0	g/100g total fat	<0,1	
22:0	g/100g total fat	<0,1	
16:1 n-7	g/100g total fat	4,7	
18:1 (n-9)+(n-7)+(n-5)	g/100g total fat	13,5	
20:1 (n-9)+(n-7)	g/100g total fat	0,9	
22:1 (n-11)+(n-9)+(n-7)	g/100g total fat	0,6	
24:1 n-9	g/100g total fat	0,1	
16:2 n-4	g/100g total fat	0,6	
16:3 n-4	g/100g total fat	0,3	
18:2 n-6	g/100g total fat	1,1	
18:3 n-6	g/100g total fat	0,1	
20:2 n-6	g/100g total fat	<0,1	
20:3 n-6	g/100g total fat	<0,1	
20:4 n-6	g/100g total fat	0,3	
22:4 n-6	g/100g total fat	<0,1	
18:3 n-3	g/100g total fat	0,8	
18:4 n-3	g/100g total fat	1,8	
20:3 n-3	g/100g total fat	<0,1	
20:4 n-3	g/100g total fat	0,4	
20:5 n-3	g/100g total fat	11,3	
21:5 n-3	g/100g total fat	0,4	
22:5 n-3	g/100g total fat	0,3	
22:6 n-3	g/100g total fat	6,5	

Table 40

* Fat Bligh & Dyer	%	22,8		
Sum saturated fatty acids	g/100g total fat	24,7		
Sum monounsaturated fatty acids	g/100g total fat	19,8		
Sum PUFA (n-6)	g/100g total fat	1,6		
Sum PUFA (n-3)	g/100g total fat	21,5		
Sum PUFA	g/100g total fat	24,0		
Sum fatty acids total	g/100g total fat	68,5		

5 Table 41

Triacylglycerol	g/100g total fat	46		
Diacylglycerol	g/100g total fat	1,0		
Monoacylglycerol	g/100g total fat	<1		
Free fatty acids	g/100g total fat	4,4		
Cholesterol	g/100g total fat	1,6		
Cholesterol ester	g/100g total fat	0,8		
Phosphatidylethanolamine	g/100g total fat	4,6		
Phosphatidylinositol	g/100g total fat	<1		
Phosphatidylserine	g/100g total fat	<1		
Phosphatidylcholine	g/100g total fat	37		
Lyso-Phosphatidylcholine	g/100g total fat	2,0		
Total polar lipids	g/100g total fat	36,2		
Totale neutral lipids	g/100g total fat	54,0		
Total sum lipids	g/100g total fat	96,2		

Table 42

Protein Kjeldahl (N*6,25)	%	60,9		
Total	%	92,7		
Salt (NaCl)	%	2,9		
Trimethylamine-N	Mg N/100 gram	4		
Trimethylaminoxide-N	Mg N/100 gram	149		
Free Astaxanthin	Mg/kg	<1		
Astaxanthin ester	Mg/kg	122		

10

Table 43

14:0	g/100g total fat	5,0		
16:0	g/100g total fat	13,9		
18:0	g/100g total fat	0,8		
20:0	g/100g total fat	<0,1		
22:0	g/100g total fat	<0,1		
16:1 n-7	g/100g total fat	3,0		
18:1 (n-9)+(n-7)+(n-5)	g/100g total fat	11,4		
20:1 (n-9)+(n-7)	g/100g total fat	0,5		
22:1 (n-11)+(n-9)+(n-7)	g/100g total fat	0,4		
24:1 n-9	g/100g total fat	0,1		
16:2 n-4	g/100g total fat	0,4		
16:3 n-4	g/100g total fat	0,2		
18:2 n-6	g/100g total fat	1,2		
18:3 n-6	g/100g total fat	0,1		
20:2 n-6	g/100g total fat	0,1		
20:3 n-6	g/100g total fat	0,1		
20:4 n-6	g/100g total fat	0,4		
22:4 n-6	g/100g total fat	<0,1		
18:3 n-3	g/100g total fat	0,7		
18:4 n-3	g/100g total fat	1,2		
20:3 n-3	g/100g total fat	0,1		
20:4 n-3	g/100g total fat	0,3		
20:5 n-3	g/100g total fat	13,1		
21:5 n-3	g/100g total fat	0,3		
22:5 n-3	g/100g total fat	0,3		
22:6 n-3	g/100g total fat	10,0		



Table 44

* Fat Bligh & Dyer	%	10,2		
Sum saturated fatty acids	g/100g total fat	19,7		
Sum monounsaturated fatty acids	g/100g total fat	15,3		
Sum PUFA (n-6)	g/100g total fat	1,8		
Sum PUFA (n-3)	g/100g total fat	26,1		
Sum PUFA	g/100g total fat	28,5		
Sum fatty acids	g/100g total fat	63,5		

Table 45

5

Triacylglycerol	g/100g total fat	25		
Diacylglycerol	g/100g total fat	0,7		
Monoacylglycerol	g/100g total fat	<1		
Free fatty acids	g/100g total fat	0,9		
Cholesterol	g/100g total fat	3,1		
Cholesterol ester	g/100g total fat	<0,5		
Phosphatidylethanolamine	g/100g total fat	12,8		
Phosphatidylinositol	g/100g total fat	<1		
Phosphatidylserine	g/100g total fat	<1		
Phosphatidylcholine	g/100g total fat	49		
Lyso-Phosphatidylcholine	g/100g total fat	1,3		
Total polar lipid	g/100g total fat	63,2		
Total neutral lipid	g/100g total fat	29,7		
Total sum lipid	g/100g total fat	92,9		

Table 46

Protein Kjeldahl (N*6,25)	%	73,9		
Total	%	90,2		
Salt (NaCl)	%	1,9		
Trimethylamine-N	Mg N/100 gram	7		
Trimethylaminoxide-N	Mg N/100 gram	224		
Free Astaxanthin	Mg/kg	2,8		
Astaxanthin ester	Mg/kg	89		

10

**CLAIMS**

- 5 1. A process for preparing phospholipid compositions from biological material comprising phospholipids and proteins comprising:
- mixing said biological material with water to increase the temperature of said biological material to about 25 to 80 °C to form a first solid phase and a first aqueous phase comprising said phospholipids and proteins;
- 10 separating said first solid phase from said first aqueous phase; and
- separating a protein and phospholipid fraction from said first aqueous phase.
2. The process of claim 1, wherein said biological material is krill.
3. The process of claims 2, wherein said krill is freshly harvested.
4. The process of claim 2, wherein said krill is frozen.
- 15 5. The process of claims 1 to 4, wherein said separating a protein and phospholipid fraction from said first aqueous phase comprises heating said first aqueous phase at a temperature sufficient to form a phospholipid-protein coagulate and separating said phospholipid-protein coagulate from said aqueous phase.
6. The process of claim 5, wherein said first aqueous phase is heated to greater than 80
- 20 °C to provide said phospholipid-protein coagulate.
7. The process of claim 5 or claim 6, further comprising the step of pressing said phospholipid-protein coagulate to form a coagulate liquid phase and a coagulate press cake.
8. The process of claims 5 to 7, further comprising the step of washing said phospholipid-protein coagulate.
- 25 9. The process of claim 7 or claim 8, further comprising drying said coagulate press cake to form a coagulate meal.

10. The process of claim 9, further comprising extracting a coagulate oil from said coagulate meal.
11. The process of any of claims 1 to 4, wherein said separating a protein and phospholipid fraction from said first aqueous phase comprises filtration of said aqueous phase  
5 to provide a phospholipid-protein retentate comprising proteins and phospholipids.
12. The process of claim 11, wherein said filtration is via membrane filtration.
13. The process of claim 11 or claim 12, further comprising the step of dewatering said phospholipid-protein retentate to form a retentate liquid phase and a retentate concentrate.
14. The process of claim 13, further comprising extracting a retentate oil from said  
10 retentate concentrate.
15. The process of claims 1 to 14, further comprising the step of supplementing the protein and phospholipid fraction with additional proteins, lipids, astaxanthin and combinations thereof.
16. An aqueous phase composition obtainable by the process of 1.
- 15 17. A coagulate meal obtainable by the process of claim 9.
18. A coagulate oil obtainable by the process of claim 10.
19. A retentate concentrate obtainable by the process of claim 13.
20. A retentate oil obtainable by the process of claim 14.
21. A krill composition comprising from about 0.01 to about 200 mg/kg astaxanthin, from  
20 about 45% to about 65% fat w/w, and about 20% to 50% protein w/w, wherein said fat comprises omega-3 fatty acid residues.
22. The composition of Claim 21, wherein said fat has an omega-3 fatty acid content of from about 10% to about 30% on a w/w basis.

25

23. The composition of claim 21 or claim 22, wherein said fat comprises from about 20% to about 50% phospholipids w/w, wherein said phospholipids comprise greater than about 65% phosphatidylcholine w/w and from about 2% to 10% alkylacylphosphatidylcholine w/w.
- 5 24. The composition of claim 23, wherein said phospholipids comprise less than about 10% ethanolamine on a w/w basis.
25. The composition of Claims 21 to 24, wherein said fat comprises from about 40% to about 70% triacylglycerol w/w.
- 10 26. The composition of Claims 21 to 25, comprising less than about 1% cholesterol.
27. The composition of Claims 21 to 26, wherein said protein comprises from about 8% to about 14% leucine on a w/w basis and from about 5% to 11% isoleucine on a w/w basis.
- 15 28. A krill composition comprising from about 10% to about 20% protein w/w, about 15% to about 30% fat w/w, and from about 0.01mg/kg to about 200 mg/kg astaxanthin.
- 20 29. A krill meal comprising from about 65% to about 75% protein w/w (dry matter) , from about 10% to about 25% fat w/w (dry matter), and from about 1 to about 200 mg/kg astaxanthin (wet base).
30. A krill meal as claimed in claim 29, wherein said meal is dried and supplemented with stickwater.
- 25 31. A krill meal as claimed in claim 30, wherein said meal is steam dried.
32. A krill oil composition comprising greater than about 1500 mg/kg total esterified astaxanthin, wherein said esterified astaxanthin comprises from about 25 to 35% astaxanthin monoester on a w/w basis and from about 50 to 70% astaxanthin diester on a w/w basis, and greater than about 20 mg/kg free astaxanthin.
- 30 33. A krill composition comprising from about 3% to about 10% protein w/w, about 8% to about 20% dry matter w/w, and about 4% to about 10% fat w/w.

34. A krill coagulum meal comprising,  
50-75% fat w/w, 30-50% protein w/w, and 1 to 200 mg/kg astaxanthin, wherein said  
fat comprises 15 to 30 g/100 g fat omega-3 fatty acid residues and 35 to 60g /100 g fat  
5 phosphatidylcholine.
35. A system for processing of marine biomass comprising:  
a mixer for mixing marine biomass and water to form a mixture having a defined  
temperature, wherein said mixture has a first solid phase and a first liquid phase.  
10
36. The system of claim 35, wherein said water is heated and said defined temperature of  
said mixture is from about 50°C to about 70°C.
37. The system of claim 35 or 36, further comprising a separator in fluid communication  
15 with said mixer for separating said first solid phase and said first liquid phase.
38. The system of claims 35 to 37, further comprising a first heater unit in fluid  
communication with said first separator, wherein said first heater unit heats said first liquid  
phase to a defined temperature.  
20
39. The system of claim 38, wherein said defined temperature is about 95°C to about  
100°C.
40. The system of claim 35, further comprising a microfilter in fluid communication with  
25 said mixer, wherein said liquid phase is separated into a retentate phase and a permeate phase  
by said microfilter.
41. A krill composition 50-75% fat w/w, 30-50% protein w/w, and 1 to 200 mg/kg  
astaxanthin, wherein said fat comprises 15 to 30 g/100 g fat omega-3 fatty acid residues and  
30 35 to 60g /100 g fat phosphatidylcholine, and less than about 1 mg/100g trimethyl amine,  
volatile nitrogen, or 1g/100g lysophosphatidylcholine or combinations thereof.
42. A process for processing of marine biomass comprising:

providing a marine biomass and a mixer for mixing marine biomass and water to form a mixture having a defined temperature, wherein said mixture comprises a first solid phase and a first liquid phase.

- 5 43. The process of claim 42, wherein said defined temperature of said mixture is from about 70 to about 75°C.
44. The process of claim 43, further comprising the steps of separating said liquid phase from said solid phase, and heating said liquid phase to about 90 to about 100°C to produce a  
10 coagulate comprising proteins and phospholipids.
45. A system for processing of marine biomass comprising:  
a ship;  
a trawl net towable from said ship, wherein said trawl net is configured to catch a  
15 marine biomass;  
a mixer for mixing said marine biomass and water to form a mixture having a defined temperature, wherein said mixture has a first solid phase and a first liquid phase.
46. The system of claim 45, comprising a  
20 microfilter in fluid communication with said mixer, wherein said microfilter separates said first solid phase and said first liquid phase.
47. The system of claims 45 or 46, wherein ship said mixer is fed with fresh krill.
- 25 48. A pharmaceutical composition comprising a composition as described in claims 17 to 34 and a pharmaceutical carrier.
49. A dietary supplement comprising a composition as described in claims 17 to 34.
- 30 50. An animal feed comprising a composition as described in claims 17 to 34.
51. A food product comprising a composition as described in claims 17 to 34.

FIGURE 1

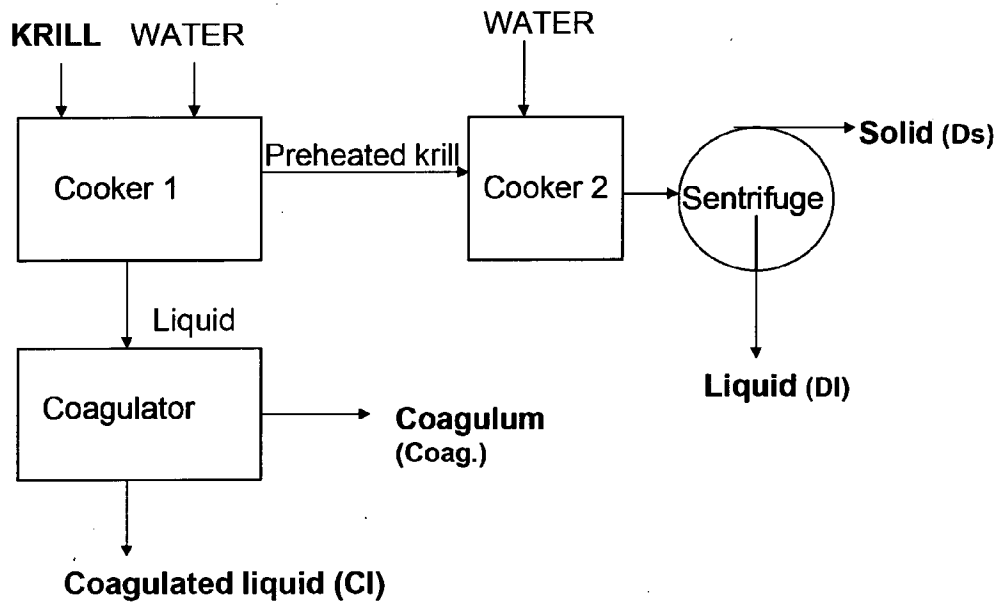

FIGURE 2

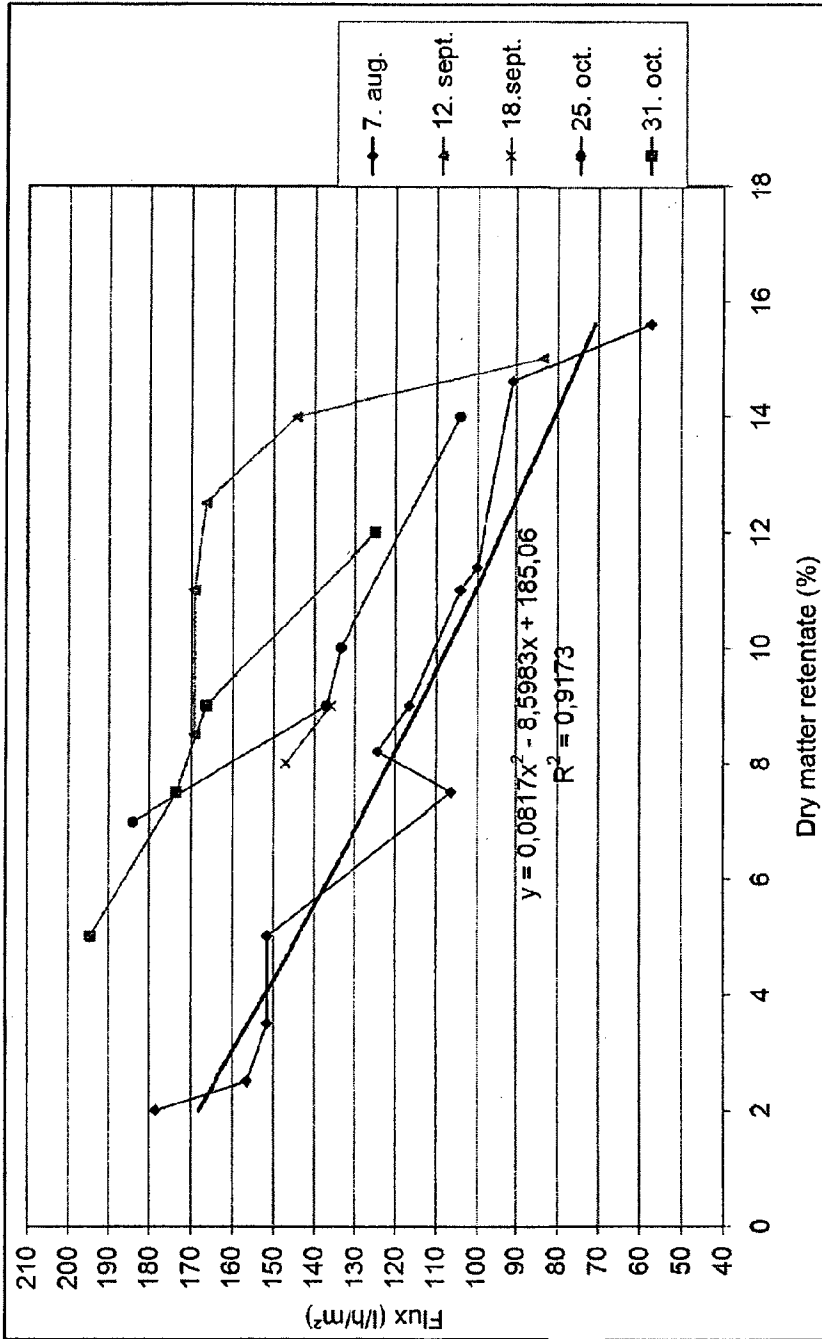



FIGURE 3

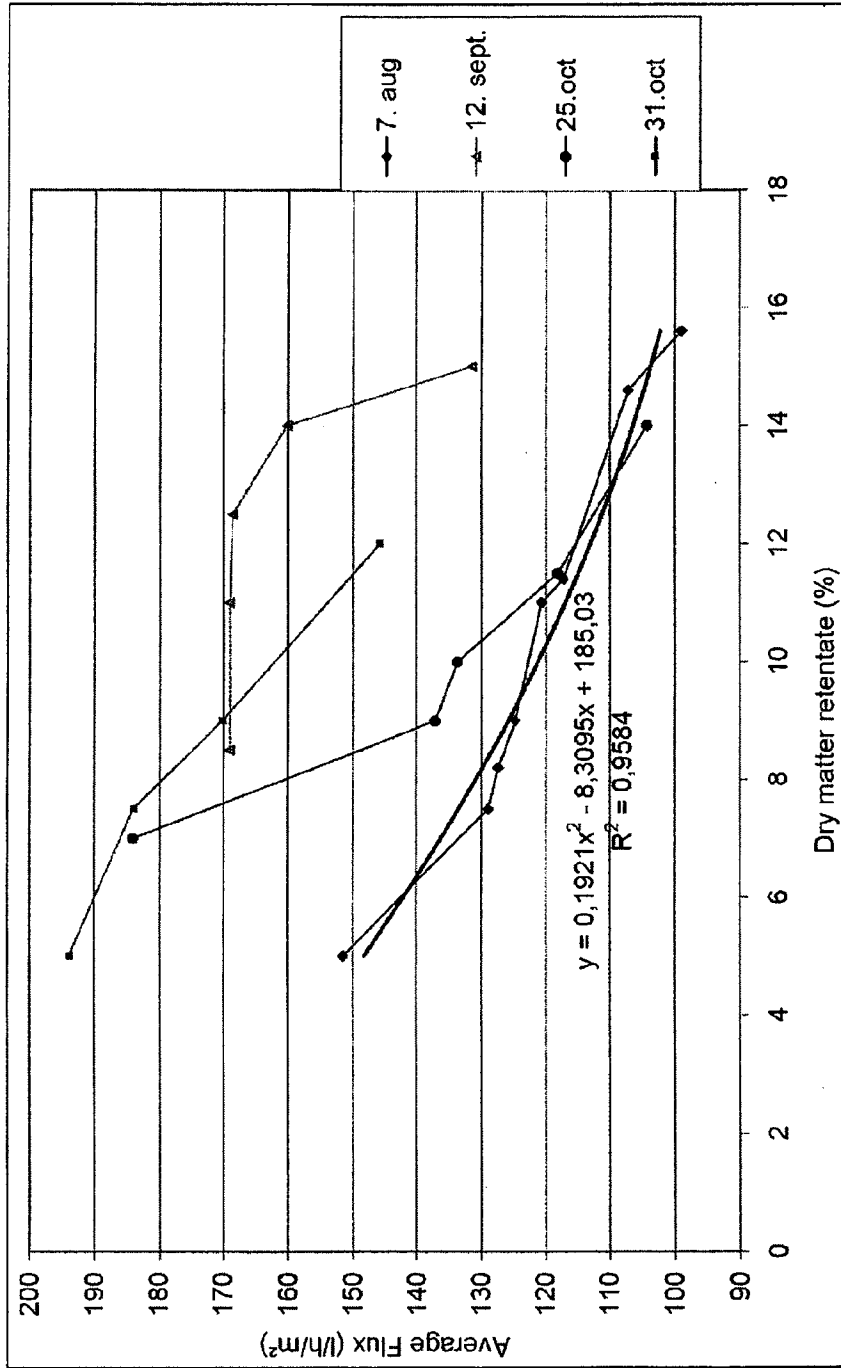
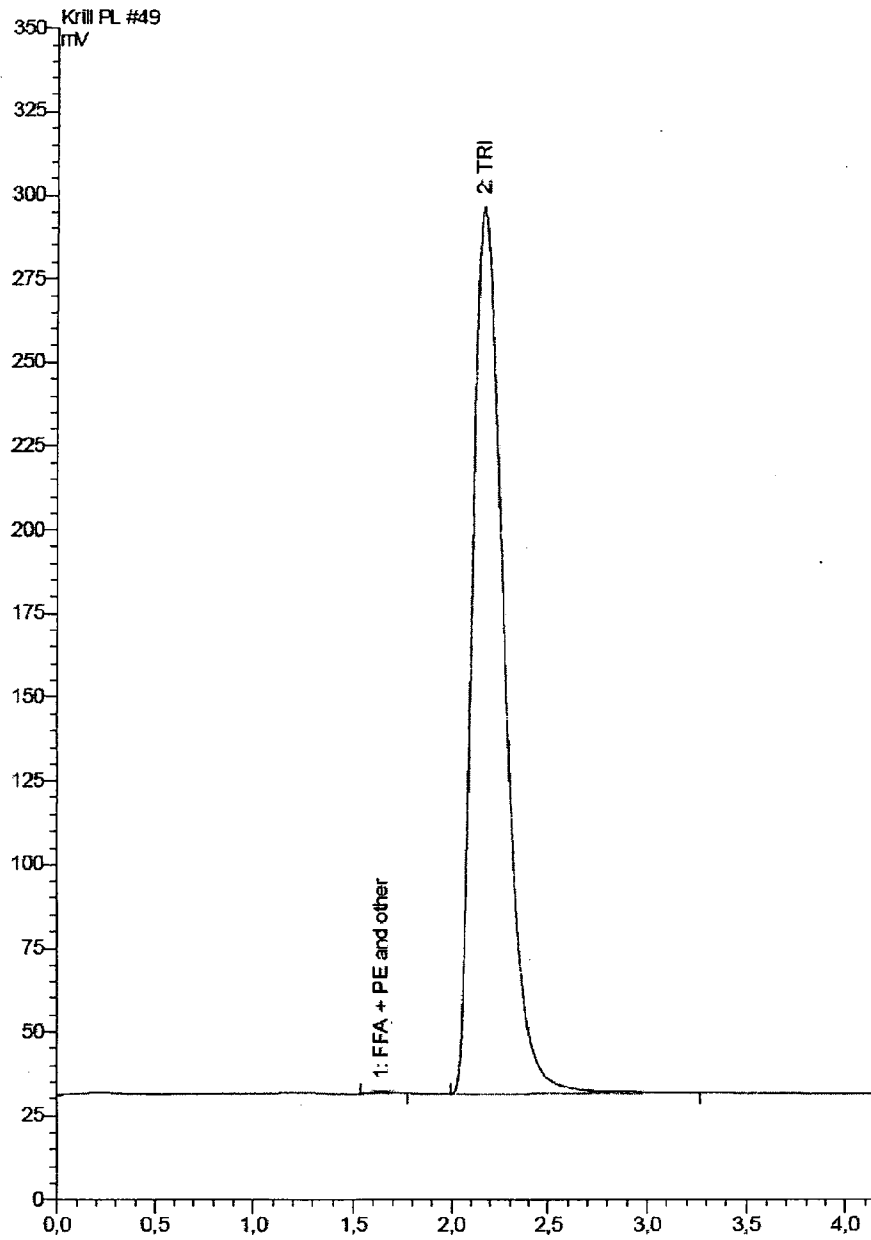
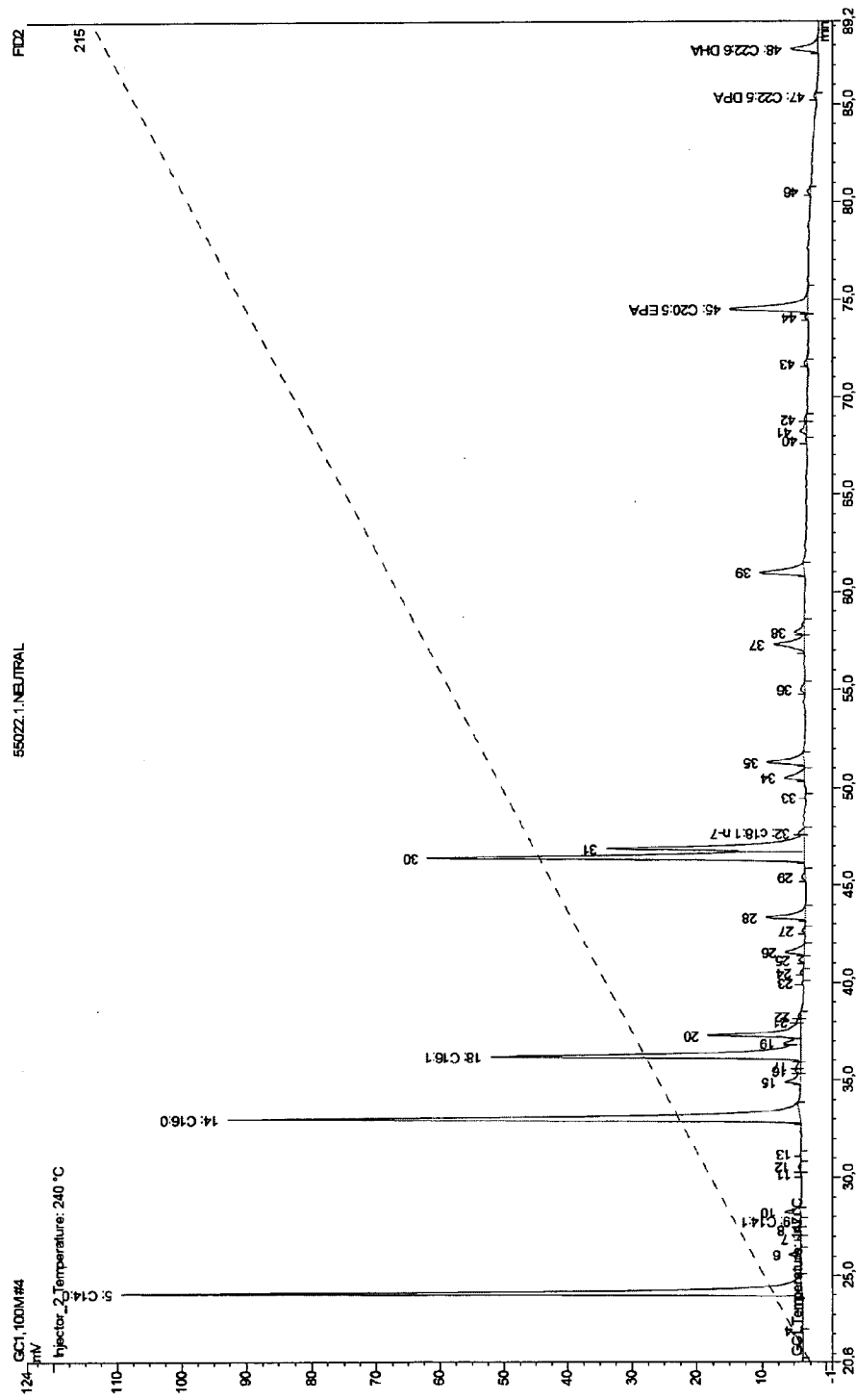

FIGURE 4



5/7

FIGURE 5



6/7

FIGURE 6

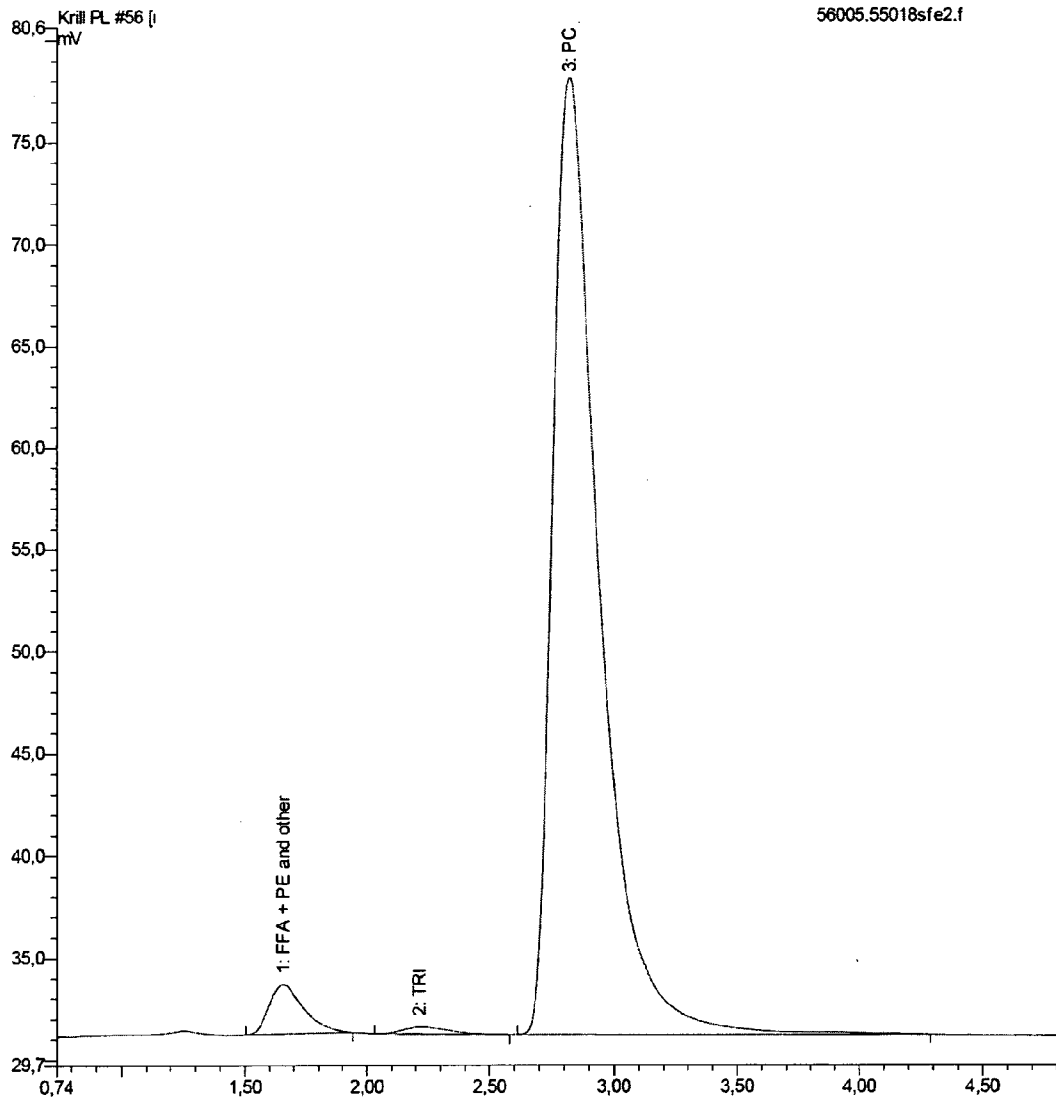

7/7

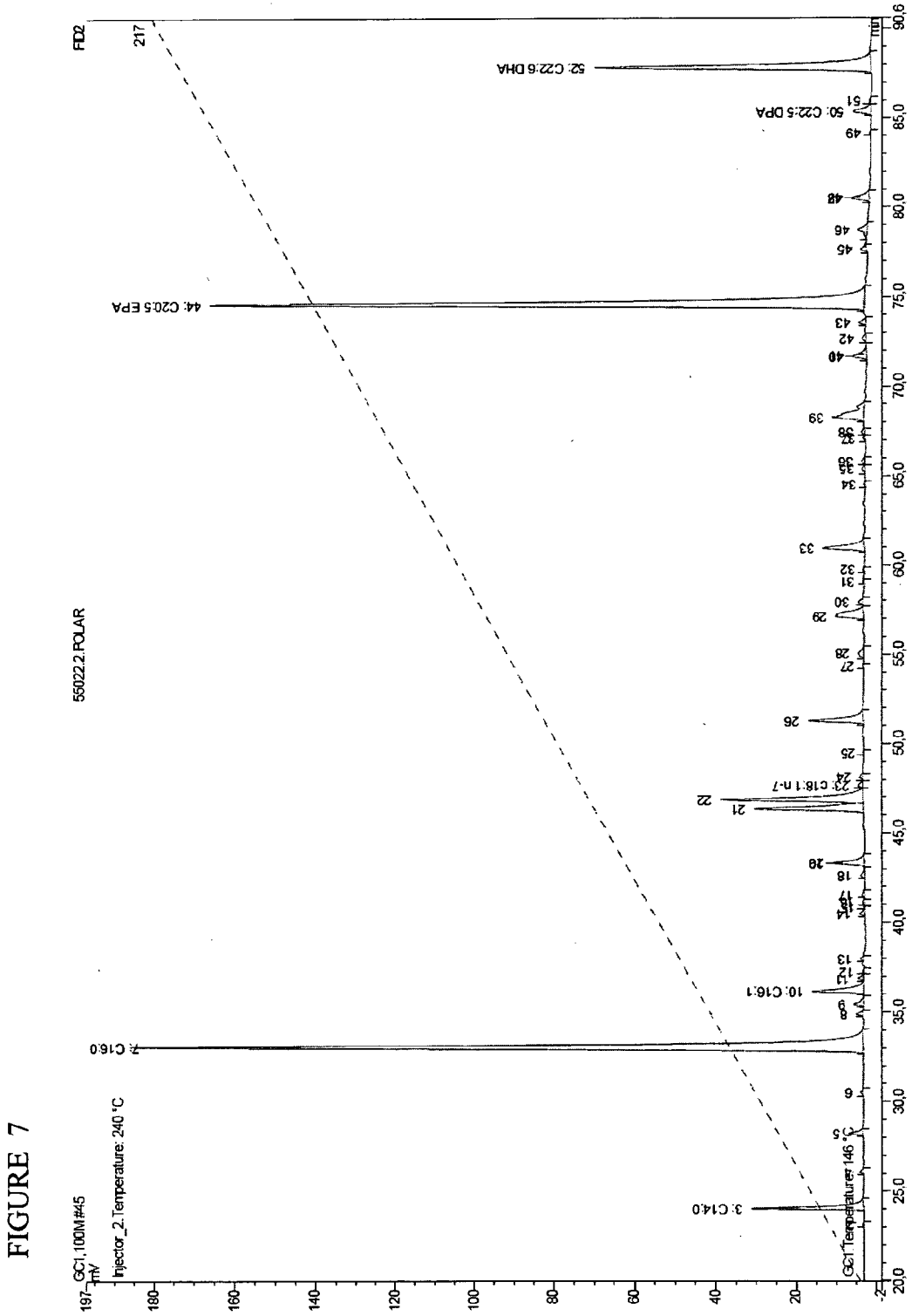

FIGURE 7

(19) World Intellectual Property Organization  
International Bureau



(43) International Publication Date  
26 April 2001 (26.04.2001)

PCT

(10) International Publication Number  
**WO 01/28526 A2**

- (51) International Patent Classification<sup>7</sup>: **A61K 9/20**
- (21) International Application Number: PCT/IT00/00424
- (22) International Filing Date: 20 October 2000 (20.10.2000)
- (25) Filing Language: Italian
- (26) Publication Language: English
- (30) Priority Data:  
MI99A002206 21 October 1999 (21.10.1999) IT
- (71) Applicant (for all designated States except US):  
**TRUFFINI & REGGE' FARMACEUTICI SRL** [IT/IT]; Via Oslavia, 18, I-20134 Milano (IT).
- (72) Inventors; and
- (75) Inventors/Applicants (for US only): **SENECI, Alessandro** [IT/IT]; Via Fratelli Cervi, Residenza del Parco, I-20090 Segrate (IT). **ALBERICO, Pia** [IT/IT]; Via Martino Anzi, 15, I-22100 Como (IT).
- (74) Agents: **PISTOLESI, Roberto**; Dragotti & Associati S.r.l., Galleria San Babila 4/C, I-20122 Milano et al. (IT).
- (81) Designated States (*national*): AE, AL, AM, AT, AU, AZ, BA, BB, BG, BR, BY, BZ, CA, CH, CN, CR, CU, CZ, DE, DK, DM, DZ, EE, ES, FI, GB, GD, GE, GH, GM, HR, HU, ID, IL, IN, IS, JP, KE, KG, KP, KR, KZ, LC, LK, LR, LS, LT, LU, LV, MA, MD, MG, MK, MN, MW, MX, MZ, NO, NZ, PL, PT, RO, RU, SD, SE, SG, SI, SK, SL, TJ, TM, TR, TT, TZ, UA, UG, US, UZ, VN, YU, ZA, ZW.
- (84) Designated States (*regional*): ARIPO patent (GH, GM, KE, LS, MW, MZ, SD, SL, SZ, TZ, UG, ZW), Eurasian patent (AM, AZ, BY, KG, KZ, MD, RU, TJ, TM), European patent (AT, BE, CH, CY, DE, DK, ES, FI, FR, GB, GR, IE, IT, LU, MC, NL, PT, SE), OAPI patent (BF, BJ, CF, CG, CI, CM, GA, GN, GW, ML, MR, NE, SN, TD, TG).

**Published:**

— Without international search report and to be republished upon receipt of that report.

For two-letter codes and other abbreviations, refer to the "Guidance Notes on Codes and Abbreviations" appearing at the beginning of each regular issue of the PCT Gazette.



**WO 01/28526 A2**

(54) Title: GASTRORESISTANT TABLETS FOR ALIMENTARY, DIETETIC AND THERAPEUTIC USE

(57) Abstract: A novel formulation for oral use is described, said formulation containing at least one active principle with a pharmaceutical, dietary or alimentary action, in combination with at least one fat and/or phospholipid in an amount of between 5 and 30 %, relative to the weight of the formulation; this formulation allows the slow release, over time, of the active principle under physiological conditions which simulate the digestive processes which normally take place in the stomach.

### **Gastroresistant tablets for alimentary, dietetic and therapeutic use**

The present invention relates to gastro-resistant formulations, preferably tablets, for alimentary or dietary use, which are obtained by mixing the composition with fat in order to achieve a prolonged release of the active principles contained therein to the organism.

The preparation of the gastro-resistant formulations is usually carried out so as to allow the active principle to be released and absorbed in a more or less retarded manner at the intestine level; alternatively, the active principle may be released and absorbed only in part at the stomach level, thus allowing a second fraction of the active principle to be released and absorbed at the intestine level.

The known technique for preparing gastro-resistant formulations with retarded release is as follows:

- A) Gastro-resistant formulations: these are tablets lined with gastro-resistant films, such as, for example, ethylcellulose, cellulose acetophthalate, polyacrylates, gum lac, keratine; the lined tablets are then coated with sugar.
- B) Layered formulations: they are prepared in the same manner as the gastro-resistant sugar-coated pills, with regard to coating of the tablets; a sprinkling powder such as starch or talcum, in which an active principle is dispersed using a water-soluble product such as gum arabic, agar-agar etc. as the adhesive, is attached layerwise to the coated core, in such a manner that the outermost layer and not the inner tablet is dissolved in the stomach.
- C) Capsules containing retarding agents; they are sugar cores in which the active principle is dispersed, followed by application of a protective coating as in para. A);
- D) Tablets in which retarding agents are dispersed in such a way that part of the active principle is present in the gastro-resistant retarding agents and part is present in the water-dispersible tablet;
- E) Multi-layered tablets in which one or more layers contain dissolution-retarding powders, such as cellulose-derived gum lacs so that the layers have different solubilities.

In general, they are formulations whose retarding effect is based on the use of excipients and/or adjuvants foreign to the mammalian organism, in particular of humans, which formulations are intended to maximize the absorption of the active

principle without taking into consideration the normal physiological digestive processes.

However, the use of such substances is usually not very desirable, in particular in the case of dietary formulations and/or in the case of food additives which are intended to achieve instead an absorption of the active principle according to a kinetic profile which is as close as possible to the normal human digestive processes.

The recourse to "natural" absorption profiles is anyway desirable, even in the case of therapeutic formulations, for example in all those classes of patients who would be harmed by administering them non-"physiological" excipients and/or adjuvants; obvious examples are pregnant women, very young children, allergic subjects, etc. Now, according to the subject-matter of the present invention, a novel formulation with retarded release has been found, said formulation allowing the active principles to be absorbed utilizing the physiological digestive activity, i.e. imitating what happens with food ingested in the usual manner.

The present invention relates to a formulation in tablet form for oral use, containing at least one active principle with a pharmaceutical, dietary or alimentary action in combination with at least one fat and/or phospholipid, as the vehicle, in an amount of between 5 and 30%, relative to the weight of the formulation; preferably, such fats and/or phospholipids are present in an amount of between 20 and 30%, relative to the weight of the formulation.

The fatty acids contained in the fats and phospholipids which can be used for the purposes of the present invention are normally selected from those containing hydrogenated and non-hydrogenated fatty acids, either of synthetic or natural origin, having a chain comprising between 3 and 20 carbon atoms, preferably between 14 and 18 carbon atoms, and mixtures thereof.

A non-limiting list of such acids comprises, for example, palmitic acid, stearic acid, myristic acid, lauric acid, caprylic acid, capric acid, etc.

From a practical point of view, the fats can normally be selected from among cocoa butter, hydrogenated palm oil, hydrogenated vegetable fats such as peanut butter, animal fats such as lard, butter, bacon fat separately or in a mixture thereof.

The phospholipids are instead preferably used as lecithins and, in particular, as soya lecithin. If desired, the abovementioned fats and phospholipids may also be



used in combination with alkali metal salts and/or alkaline earth metal salts of fatty acids having a chain comprising between 3 and 20 carbon atoms, preferably between 14 and 18 carbon atoms, or mixtures thereof, the preferred salts being those of sodium, potassium and calcium.

As indicated above, the active principles which can be used for the purposes of the present invention may have both a therapeutic and a dietary or alimentary action. The active principles with a therapeutic action may be selected from among non-steroid anti-inflammatory drugs (NSAID) and steroid anti-inflammatory drugs, tranquilizers, sleeping pills, anti-hypertensive, anti-histaminic and anti-asthmatic drugs; non-steroid anti-inflammatory drugs in turn may be selected from among ibuprofen, naproxen, ketoprofen, indomethacin, acetylsalicylic acid, mefenamic acid, flufenamic acid, etc.; the active principles with a dietary action may be selected from the group consisting of lactic acid microorganisms, beer yeasts, either as such or containing living cells, vitamins, minerals, amino acids, vegetable extracts, and derivatives thereof.

In the formulation according to the present invention, the active principle or principles, which may be used as such or in the form of esters or physiologically acceptable salts, can be mixed directly with said at least one fat and/or phospholipid without the addition of any excipients and/or adjuvants; in this case, the active principle or principles make up 70-95% by weight, preferably 75-90% by weight, of the formulation.

Alternatively, the abovementioned active principles may be used in combination with customary excipients and/or adjuvants known in the art; in this case, they are normally present in amounts of between 1 and 50%, preferably between 10 and 40%, relative to the total weight of the formulation.

The excipients used for the tablet according to the present invention may be selected from the group consisting of starches, maltodextrin, microcrystalline cellulose, talcum-modified cellulose, calcium carbonate, milk proteins, calcium stearate, magnesium stearate, sodium stearate, soya proteins or suitable inert powders, PVP, precipitated silica and are present in an amount of 10-30% by weight, preferably 20-30% by weight, relative to the total weight of the formulation.

In order to determine the release activity, over time, of an active principle contained in a formulation according to the present invention (the qualitative and quantitative composition of which is given in Example 1), the dissolution test described in Farmacopea Ufficiale Italiana (Official Italian Pharmacopeia) was carried out. The results of said test are shown in the table below.

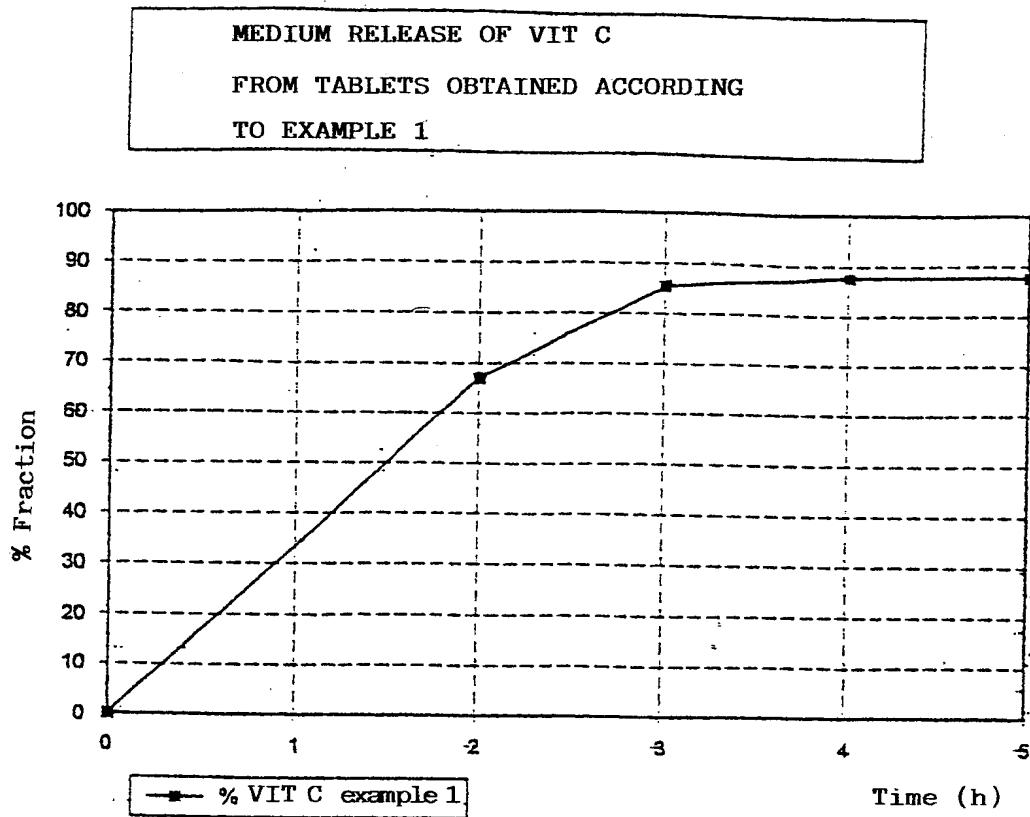

TABLE I

This dissolution test demonstrates the slow release, over time, of an active principle under physiological conditions which simulate the digestive processes which normally take place in the stomach.

The present invention is particularly suitable for the production of BIO-certified gastro-resistant tablets, provided that fats derived from biological cultivations and farms in accordance with current regulations are used.

The present invention furthermore relates to the process for the preparation of the formulations according to the present invention.

Said process comprises premixing an active principle as defined above in an amount of 1-50% by weight, relative to the total weight of the formulation, with the excipients as defined above, which in turn are present in an amount of 10-30%, relative to the total weight of the formulation. The mixture thus obtained by simple mixing at ambient temperature or by dry or wet granulation in accordance with the known technique is kneaded in a suitable kneader, usually a Z-type kneader or plunging-arm kneader, together with at least one fat and/or phospholipid in the melted state in an amount of between 5 and 30%, relative to the weight of the formulation.

The blend thus obtained is cooled to 5-20° C, preferably to 10°C-12° C, and then granulated, for example using an oscillating granulator of the Manesty type equipped with a perforated stainless steel plate having holes with a diameter of 1-4 mm, preferably 1-2 mm.

The granules thus obtained are compressed with a rotary tablet-compressing machine equipped with suitable punches. It is thus possible to obtain tablets of suitable weight.

In the case of tablets not containing added excipients and/or adjuvants, the active principle is mixed directly with the fat and/or phospholipid in the melted state; the mixture is then processed as described above.

In particular, the present invention is highly suitable for the preparation of layered tablets obtained with a suitable tablet-compressing machine such as, for example, a Manesty BB3B.

The process consists in compressing a layer obtained according to the prior art using one or more active principles mixed with known water-soluble or water-dispersible excipients and one layer obtained according to the present invention. If

desired, it is also possible to use more than two layers with different degrees of solubility.

The examples which follow are given in order to describe better the present invention without, however, limiting its scope.

**Example 1**

1000 tablets are prepared, being formed by a fast-dissolving layer (Layer A) obtained by kneading, in a Z-type kneader, the following components together with 10% strength Klucel/water:

proline (100 g),

lysine (100 g),

cystine (100 g),

sodium carboxymethylcellulose (20 g)

The blend thus obtained is dried for 12 hours at 40°C in a drying cabinet, the resulting mixture is granulated in a Manesty granulator equipped with a perforated stainless steel plate having holes with a 2-mm diameter, giving a yield of 321.8 g.

The granules thus obtained are mixed in a rotating-screw mixer (SAGA) with :

red lake N° 40 all lake (0.25 g),

vitamin A 5,000,000 IU/g (800 µg/cpr +30%) ( 2.31 g),

vitamin E 50% SD (16 mg/cpr +20%) (12.8 g),

vitamin C granules (49.5 g),

magnesium stearate (5 g),

copper gluconate Cu 14% (1.2 mg/cpr + 5%) (6 g),

zinc gluconate Zn 13.4% (10 mg/cpr + 5%) (52.2 g)

selenium-containing yeast 2,000 µg/g (0.055 µg/cpr + 5%) (19 g)

glutathione on yeast (25 mg/cpr + 20%) (15 g),

rapidly disintegrating PVP (20 g),

potato starch (10 g),

silica gel (3 g),

maltodextrin (5 g),

microcrystalline cellulose (2 g),

water (0.5 g),

giving a total yield of 524.36 g.

A second mixture is prepared and used to form the slow-dissolving layer (LAYER B) thus obtained:

lyophilized blueberry (15 g),  
microcrystalline cellulose (50 g),  
titanium dioxide (10 g),  
nucleic acids (50 g),  
blueberry extract 25% (50 g),  
copper gluconate (1.5 g),  
zinc gluconate (12.3 g),  
copper gluconate (1.5 g),  
zinc gluconate (13.8 g),  
selenium-containing yeast (9.5 g),  
glutathione on yeast (15 g),  
vitamin A 500,000 IU/g (4.63 g),  
vitamin E 50% SD (25.6 g),  
vitamin C EC 97% (99 g),

All these components are mixed and kneaded in a Z-type kneader together with melted hydrogenated palm oil (50 g).

The blend obtained is cooled to 12°C and granulated in an oscillating granulator equipped with a stainless steel plate having holes with a 2 mm diameter, giving a total yield of 408 g.

The two mixtures thus obtained can be compressed with an oval punch using a double-layered tablet-compressing machine (MANESTY BB3B) producing oval tablets with a weight of 0.932 g, in which the first layer weighing 0.524 g is fast-dissolving and the second layer weighing 0.408 g is gastro-resistant and slow-dissolving.

### **Example 2**

Example 1 is repeated, except that the following components are used:

Layer A (FAST-DISSOLVING)  
folic acid 98% (0.3 mg/cpr + 20%) (0.12 g)  
vitamin B6 33.1/3 (1.5 mg + 20%) (1.8 g)  
beta carotene 20% (4mg/cpr + 10%) (7.4 g)  
vitamin E 50% SD (116 mg/cpr) (12.8 g)

vitamin C EC 97 (120 mg/cpr +20%) (49.5 g)  
copper gluconate Cu 14% (1.2 mg/cpr) (6 g)  
zinc gluconate Zn 13.4% (10 mg/cpr) (52.3 g)  
selenium-containing yeast 2000 µg/g (55 µg/cpr) (19.3 g)  
lactose CD (150 g)  
microcrystalline cellulose (30 g)  
water (4 g)  
potato starch (30 g)  
rapidly disintegrating PVP (Kollidon CL) (10 g)  
silicagel (10 g)  
maltodextrin (8g)giving a total of 391.22 g:  
Layer B (SLOW-DISSOLVING)  
sulfomucopolysaccharides (25 g)  
Gingko biloba (30 g)  
copper gluconate Cu 14% (3 g)  
zinc gluconate Zn 13.4% (26.2 g)  
selenium-containing yeast 2,000 µg/g (9.7 g)  
microcrystalline cellulose (50 g)  
red iron oxide (5 g)  
folic acid (0.24 g)  
vitamin B6 33.1/3% (3.6 g)  
vitamin E 50% (25.6 g)  
vitamin C EC 97% (99 g)  
beta carotene 20% (14.8 g)  
melted hydrogenated palm oil (72 g)  
silica gel (0.5%),  
giving a total of 0.358 g.

Double-layered tablets weighing 0.749 g are prepared, the first layer of which weighing 0.391 g is fast-dissolving and the second one weighing 0.358 g is slow-dissolving.

The tablets can then be coated with a solution of  
10 % strength Klucel/water.

### Example 3

Example 1 is repeated, except that the following components are used:

Layer A (FAST-DISSOLVING)

acetylsalicylic acid 0.3 g

hydrogenated palm oil 0.1 g

lactose 0.2 g

Layer B (SLOW-DISSOLVING)

acetylsalicylic acid 0.2 g

lactose 0.1 g

magnesium stearate 0.01 g

pre-dried corn starch 0.1 g

**CLAIMS**

1. Formulation for oral use in tablet form, containing at least one active principle with a pharmaceutical, dietary or alimentary action, characterized in that it contains, as the vehicle, at least one fat and/or phospholipid in an amount of between 5 and 30%, preferably between 10 and 20%, relative to the weight of the formulation.
2. Formulation according to Claim 1, characterized in that said at least one fat and/or phospholipid contains hydrogenated and non-hydrogenated fatty acids, either of synthetic or natural origin, having a chain comprising between 3 and 20 carbon atoms, preferably between 14 and 18 carbon atoms, or mixtures thereof.
3. Formulation according to Claim 1, characterized in that said at least one fat and/or phospholipid is selected from among cocoa butter, hydrogenated palm oil, hydrogenated vegetable fats such as peanut butter, animal fats such as lard, butter, bacon fat and in that said phospholipids are selected from among lecithins, preferably soya lecithins.
4. Formulation according to Claim 1, characterized in that said at least one fat and/or phospholipid is used in combination with alkali metal salts and/or alkaline earth metal salts of fatty acids having a chain comprising between 3 and 20 carbon atoms, preferably between 14 and 18 carbon atoms, or mixtures thereof.
5. Formulation according to Claim 1, characterized in that said at least one active principle is present in an amount of 70-95%, preferably 75-90%, relative to the weight of the formulation, and in that said at least one active principle and said at least one fat and/or phospholipid make up 100% by weight of the formulation.
6. Formulation according to Claim 1, characterized in that said at least one active principle with a therapeutic action is selected from among non-steroid and steroid anti-inflammatory drugs, tranquilizers, sleeping pills, anti-hypertensive, anti-histaminic and anti-asthmatic drugs and in that said at least one active principle with a dietary or alimentary action is selected from the group consisting of lactic acid microorganisms, beer yeasts, either as such or containing living cells, vitamins, minerals, amino acids, vegetable extracts, and derivatives thereof.
7. Formulation according to Claim 1, containing: (a) from 1 to 50% by weight, preferably from 30 to 50% by weight, of said at least one active principle with a pharmaceutical, dietary or alimentary action; (b) from 5 to 30% by weight, preferably from 20 to 30% by weight, of said at least one fat and/or phospholipid; (c) from 10 to 30% by weight, preferably from 20 to 30% by weight, of excipients and/or adjuvants,



the sum of the components (a), (b) and (c) making up 100% by weight of the formulation.

8. Formulation according to Claim 7, characterized in that said excipients are selected from among starches, maltodextrin, microcrystalline cellulose, talcum-modified cellulose, calcium carbonate, milk proteins, calcium stearate, magnesium stearate, sodium stearate, soya proteins or suitable inert powders, PVP, and precipitated silica.

9. Process for the preparation of a formulation according to Claim 5 in which:

- a) said at least one active principle is mixed with said at least one fat and/or phospholipid in the melted state in the weight proportions defined above;
- b) the blend thus obtained is cooled to 5-20°C, preferably to 10°C-12°C, and then granulated using a granulator having holes with a diameter of between 1 and 4 mm, preferably between 1 and 2 mm;
- c) the granules thus obtained are then compressed.

10. Process for the preparation of a formulation according to Claim 7 in which:

- d) said at least one active principle is premixed at ambient temperature with said excipients and/or adjuvants in the weight proportions defined above;
- e) the mixture thus obtained is mixed with said at least one fat and/or phospholipid in the melted state in the weight proportions defined above;
- f) the blend thus obtained is cooled to 5-20°C, preferably to 10°C-12°C, and then granulated using a granulator having holes with a diameter of between 1 and 4 mm, preferably between 1 and 2 mm;
- g) the granules thus obtained are then compressed.

(19) World Intellectual Property  
Organization  
International Bureau



(43) International Publication Date  
10 June 2004 (10.06.2004)

PCT

(10) International Publication Number  
WO 2004/047554 A1

- (51) International Patent Classification<sup>7</sup>: A23K 1/18, 1/00, 1/16, A23D 9/013, A23L 1/30, 1/305, C11B 1/10
- (74) Agents: SCHREIBER, Wolfgang, F. et al.; Riederer Hasler & Partner Patentanwälte AG, Elestastrasse 8, CH-7310 Bad Ragaz (CH).
- (21) International Application Number:  
PCT/EP2003/013299
- (81) Designated States (*national*): AE, AG, AL, AM, AT, AU, AZ, BA, BB, BG, BR, BY, BZ, CA, CH, CN, CO, CR, CU, CZ, DE, DK, DM, DZ, EC, EE, ES, FI, GB, GD, GE, GH, GM, HR, HU, ID, IL, IN, IS, JP, KE, KG, KP, KR, KZ, LC, LK, LR, LS, LT, LU, LV, MA, MD, MG, MK, MN, MW, MX, MZ, NO, NZ, OM, PH, PL, PT, RO, RU, SC, SD, SE, SG, SK, SL, TJ, TM, TN, TR, TT, TZ, UA, UG, US, UZ, VC, VN, YU, ZA, ZM, ZW.
- (22) International Filing Date:  
26 November 2003 (26.11.2003)
- (84) Designated States (*regional*): ARIPO patent (BW, GH, GM, KE, LS, MW, MZ, SD, SL, SZ, TZ, UG, ZM, ZW), Eurasian patent (AM, AZ, BY, KG, KZ, MD, RU, TJ, TM), European patent (AT, BE, BG, CH, CY, CZ, DE, DK, EE, ES, FI, FR, GB, GR, HU, IE, IT, LU, MC, NL, PT, RO, SE, SI, SK, TR), OAPI patent (BF, BJ, CF, CG, CI, CM, GA, GN, GQ, GW, ML, MR, NE, SN, TD, TG).
- (25) Filing Language: English
- (26) Publication Language: English
- (30) Priority Data:  
02258116.9 26 November 2002 (26.11.2002) EP  
03255278.8 25 August 2003 (25.08.2003) EP
- (71) Applicant (*for all designated States except US*): PHARES PHARMACEUTICAL RESEARCH N.V. [NL/NL]; P.O.Box 6052, Emancipatie Boulevard 31, Curacao (AN).
- (72) Inventors; and
- (75) Inventors/Applicants (*for US only*): LEIGH, Steve [GB/NL]; P.O. Box 2943, NL-1000 CX Amsterdam (NL). KUNG, Elsa [CH/CH]; Rudolfstrasse 39, CH-4054 Basel (CH). VAN HOOGEVEST, Peter [NL/CH]; Breitenstrasse 3, CH-4416 Bubendorf (CH). TIEMESSEN, Henricus [NL/DE]; Grubenstrasse 7/2, 79576 Weil am Rhein (DE).
- Published:**  
— with international search report  
— before the expiration of the time limit for amending the claims and to be republished in the event of receipt of amendments
- For two-letter codes and other abbreviations, refer to the "Guidance Notes on Codes and Abbreviations" appearing at the beginning of each regular issue of the PCT Gazette.*



WO 2004/047554 A1

(54) Title: MARINE LIPID COMPOSITIONS

(57) Abstract: There is described marine phospholipids (MPL) compositions suitable for human, aquaculture applications comprising a dry composition comprising nutritional components selected from the group consisting of marine phospholipids, marine proteins and amino acid blends obtainable by fluid extraction of a dried marine raw material. The compositions have low amounts of neutral lipids and particularly low amounts of cholesterol and cholesterol esters. They may be used either as such in powder form and for preparing purified MPL compositions by ethanol extraction. Both forms may be used as nutritional supplements, ingredients for functional foods and to optimise the delivery and containment of nutritional components in multicomponent fish feed compositions. There is further described a blend of the purified, ethanol extracted MPL compositions mixed with marine, vegetable, microbial or MCT oils to form liquid preparations for hard or soft gel encapsulation. There is further described MPL concentrates comprising purified and clearly defined phospholipid types dispersed in hydrophilic medium which are nutritionally essential in larvae feed. Still further there is described MPL compositions in unit dosage forms as supplements to supply highly bioavailable omega-3 fatty acids for human use, optionally with biologically active compounds.

### Marine lipid compositions

This invention relates to marine phospholipid compositions (MPL) comprising long chain omega-3-fatty acids. The compositions are particularly suitable as supplements for human consumption, animal feed or for nutritional and embedment purposes in feed compositions for aquatic livestock and fish larvae.

#### BACKGROUND OF THE INVENTION

Phospholipids are amphipathic lipids which are components of all cell membranes. The phospholipid molecule comprises a phosphoric acid ester head group attached to a glycerol backbone with one or more usually two fatty acid chains. The head group may be neutral, anionic, cationic or zwitterionic depending on the pH. The different types of phospholipids are identified by their head groups. Regardless of the source, the most widely occurring natural phospholipid is phosphatidylcholine (PC) which has choline as a head group. The second most abundant is phosphatidylethanolamine (PE). Phosphatidyl inositol (PI), phosphatidyl serine (PS), sphingomyelin (SPM) and the monoacyl derivatives are usually found in smaller amounts. The chief difference between the phospholipids from different sources is reflected in the fatty acid profiles which vary according to chain length and degree of unsaturation.

The fatty acid moieties attached to phospholipids from natural sources have 14 to 24 carbon atoms. The unsaturated fatty acids mostly comprise C18 to C22 chains and may contain between one to six double bonds depending on the origin, i.e. marine, animal, or plant. Plant derived phospholipids usually do not contain fatty acids with a chain length of more than 18 carbon atoms. As an example about 65 wt% to 75 wt% of the fatty acids in soya (mainly C18) comprise one to three double bonds, approximately 60 wt% of which is the omega-6 linoleic acid with two double bonds. In comparison, egg phospholipids additionally comprise some longer chain fatty acids (C20 and C22 with four and 6 double bonds respectively). Marine phospholipids are characterised by very high levels of mostly long chain C 20 and C22 highly unsaturated fatty acids (HUFA), eicosapentaenoic acid (EPA) and docosahexaenoic

**CONFIRMATION COPY**

- 2 -

acid (DHA). The striking feature of marine phospholipid fatty acids is the prevailing presence of a double bond in the omega-3 position of the fatty acid chain.

Soya and egg phospholipids are widely employed for their ubiquitous and multi-functional properties. They are used extensively in all types of applications in the food and feed industries particularly as emulsifiers because of their amphiphilic nature. They are also employed as a rich source of unsaturated fatty acids such as linoleic, linolenic (soya), arachidonic and docosahexaenoic acid (egg) in nutritional and functional foods.

Phospholipids from plants do not contain the type of long chain highly unsaturated omega-3 fatty acids found in fish oils. The level of HUFAs in marine phospholipids is higher than in the corresponding oily triglycerides from the same source. Furthermore the bioavailability of the fatty acids is believed to be higher from phospholipids compared to triglycerides. This may be due to the amphiphilic properties of phospholipids reflected in better water dispersibility and/or their greater susceptibility to phospholipases compared to the glycerolysis of triglycerides. Thus marine phospholipids would appear to offer an extremely rich source of long chain omega-3 polyunsaturated fatty acids for incorporation into fish diets and as supplements for humans.

The prior art relating to marine phospholipids in aquaculture is chiefly concerned with preparing fish feed compositions from different marine sources and raw materials or biomass.

WO 00/27218 describes a composite dry feed for fish larvae to replace live feed comprising a matrix containing water-insoluble nutrients and phospholipids embedded in the particles and a method of preparing the feed particles.

WO 01/50884 describes a composite feed for feeding prey organisms suitable for aquaculture. The lipid component is derived from marine organisms such as fishmeal, phytoplankton or zoo plankton biomass.

- 3 -

EP 0 996 740 provides a particulate material with high proportion of DHA in the lipid fraction and a mean particle size between 5 microns to 10 microns, suitable as a nutritional supplement in aquaculture. The method describes a protein/phospholipid composition extracted from an aqueous suspension of broken algal cells using solvent extraction and removal of water by spray drying.

Feed compositions for normal fish diets employ phospholipid mixtures (lecithin) from soya to emulsify lipophilic and hydrophilic components and hold them together in the feed particles. However, in special balanced compositions for larvae start up feed and weaning, it is essential that well characterised phospholipids are used. The high percentage of esterified polyunsaturated fatty acids, the bio-membrane forming properties on top of the emulsifying properties, make marine phospholipids more effective to optimise nutritional properties and minimise leakage, particularly of water soluble nutrients. Compositions comprising selected marine phospholipids and other components can form versatile lipid aggregates which will entrap both water soluble and oil soluble compounds either by association or solubilisation in addition to emulsification. The entrapment depends on the type of aggregates, which may be bilayered or micellar, vesicular or non vesicular, according to the composition of the phospholipid mixture. Liposomes are one example of vesicular structures whilst micro emulsion droplets, micelles and mixed micelles are examples of non vesicular structures useful for entrapment. The outstanding feature of lipid aggregates derived from the MPL compositions described in this invention is their unexpected capacity for containment of both hydrophilic and lipophilic materials not only in human nutritional supplements and functional foods, but also in animal, fish and larvae feed compositions particularly in the presence of a destabilising medium like sea water.

#### SUMMARY OF THE INVENTION

The invention is in the area of 'particulate' and 'waxy' marine phospholipid compositions and 'HUFA concentrates' suitable as supplements in human nutrition and functional food and also for embedment and nutritional purposes in animal and fish feed microparticle compositions.

A ) Particulate marine phospholipid/marine protein and amino acid blend

The present invention relates to a marine phospholipid (MPL) composition suitable for human or aquaculture applications comprising a dry composition, i.e. in particulate or powdered form, comprising nutritional components selected from the group consisting of marine phospholipids, marine proteins, amino acids, minerals prepared by solvent or gas extraction under super or hypercritical conditions of a dried marine raw material comprising a major amount of polar and a lower amount of non polar (neutral) lipids. The dried marine raw material has low moisture content i.e. below 10 wt%.

The composition comprises,

- I). 10 wt% to 30 wt% total (polar and neutral) lipids;
- II) 70 wt% to 90 wt% marine proteins and amino acid blends.

70 wt% to 95 wt% of the total lipids in I) consist of polar lipids and 5 wt% to 30 wt% consist of neutral lipids.

Preferably, the composition comprises,

- I) 15 wt% to 30 wt% total (polar and neutral) lipids;
- II) 70 wt% to 85 wt% marine proteins and amino acid blends.

Preferably 80 wt% to 95 wt% of the total lipids in I) consist of polar lipids and 5 wt% to 20 wt% consist of neutral lipids.

The invention also describes a particulate composition wherein 40 wt% to 80 wt% of the polar lipids consist of phosphatidylcholine or mixtures of PC and the monoacyl derivative thereof, wherein said phosphatidylcholine and the monoacyl derivative are esterified with 30 wt% to 60 wt% HUFA's. The balance of 20 wt% to 60 wt% of the polar lipids in the composition contain phospholipids selected from the group consisting of phosphatidyl

- 5 -

ethanolamine (PE), phosphatidyl inositol (PI), phosphatidyl serine (PS), sphingomyelin (SPM) and the monoacyl derivatives thereof.

B) Purified, waxy marine phospholipid (MPL) composition

The invention further describes a purified, viscous or paste-like, waxy MPL composition prepared by ethanol extraction from a particulate MPL composition. The waxy MPL composition contains,

- i) 70 wt% to 95 wt% or more of total lipids,
- ii) 5 wt% to 30 wt% of neutral lipids.

The purified waxy MPL composition may be prepared by ethanol extraction of a dried composition comprising nutritional components selected from the group consisting of phospholipid/marine protein/amino acid/minerals blend.

The composition preferably contains not more than 15 wt% neutral lipids and at least 40 wt% of phosphatidylcholine or mixture of PC and the monoacyl derivative thereof, calculated on the basis of all the phospholipids, wherein at least 30 wt% of the fatty acids are omega-3 fatty acids esterified to the phospholipids.

The resulting waxy composition may be further blended with fish or vegetable oils to prepare a liquid composition that may be filled into hard or soft gelatine capsules or the like, as a supplement for human nutrition.

C) Water dispersible marine phospholipid (MPL) concentrate

The invention further provides water-dispersible marine phospholipid (MPL) concentrate in hydrophilic medium which may be prepared from a waxy composition for use in multicomponent fish and larvae feed compositions referred to as 'microparticles' for

- 6 -

optimising the containment and retention of oil soluble and water soluble nutritional components.

The embodiment includes a homogeneous water-dispersible concentrate which comprises:

- i) 25 wt% to 75 wt% of a marine phospholipid composition comprising PC or mixtures of PC and the monoacyl derivative in an amount of at least 40 wt% as the major component and minor amounts of a phospholipid selected from the group consisting of PE, PI, SPM and PS and their monoacyl derivatives,
- ii) 15 wt% to 75 wt% of ethanol or at least one polyol or mixtures thereof,
- iii) water to make 100%; and, optionally, further additives selected from the group consisting of polymers, nutritional components, stabilisers, preservatives, and antioxidants.

The invention also includes a method of preparing lipid aggregates for embedment in fish and larvae feed micro particles which comprises dispersing in water a lipid concentrate comprising,

- i) 25 wt% to 75 wt% of a marine phospholipid composition comprising PC or mixtures of PC and the monoacyl derivative in an amount of at least 40 wt% as the major component and minor amounts of at least one phospholipid selected from the group consisting of PE, PI, SPM and PS and their monoacyl derivatives,
- ii) 15 wt% to 75 wt% of ethanol or at least one polyol or mixtures thereof,
- iii) water to make 100%, and, optionally,
- iv) further additives selected from the group consisting of polymers, nutritional components, stabilisers, preservatives, and antioxidants;

In humans, MPLs are particularly useful as supplements to prevent coronary heart disease (CHD), to reduce elevated blood cholesterol and triglycerides, high blood pressure, high blood glucose and to treat several mental disorders (such as Alzheimer), premenstrual syndrome (PMS), inflammatory bowel disease, osteoarthritis, inflammatory skin diseases etc.



- 7 -

Omega-3 fatty acids also need to be supplied in aquaculture diets because of the inability of fish larvae to synthesise these compounds *de novo* from shorter chain precursors. Lack of these essential fatty acids impair growth levels.

The invention includes marine phospholipid blends which may be dry or waxy compositions and water dispersible concentrates in admixture with phospholipids selected from the group consisting of vegetable or egg phospholipids, enzyme modified phospholipids and synthetic and semi-synthetic phospholipids comprising C14 to C22 fatty acids with one to six double bonds, wherein the marine phospholipids preferably comprise the major component i.e. more than 50% by weight of the total mixture. The compositions may further comprise biologically active compounds.

#### DETAILED DESCRIPTION OF THE INVENTION

In this specification:

the numerical ranges with regard to the components in the compositions indicate exact and approximate (ca., about) ranges;

'lecithin' is used as a broad definition to describe mixtures comprising phosphatidylcholine (PC) and other types of phospholipids. It is not used interchangeably as a narrow definition to describe only PC. It also covers mixtures of phospholipids from different sources and mixtures thereof;

'marine phospholipid' (MPL) refers to the phospholipid compositions comprising predominantly long chain and highly unsaturated fatty acids obtained from a 'marine raw material' e.g. roe and milt of fish such as salmon, herring, capelin, saithe and cod, etc. It includes phospholipids from all forms of marine vegetation and life forms such as krill and other crustaceans and those prepared by synthesis or partial synthesis (e.g. enzymatic fatty acid exchange) involving phospholipids from other sources and different species. The term also extends to blends of marine phospholipids and egg or soya phospholipids with the said

MPL as the major component in the mixture. The phospholipid content may vary by up to +/- 25 wt% of the values normally quoted for different species depending on origin, source, climate and other seasonal factors. The definition also includes mixtures or blends comprising marine diacyl phospholipids and the monoacyl derivatives prepared by enzyme hydrolysis using phospholipase A2 on a suitable marine phospholipid substrate.

'polar lipids' are amphipatic lipids such as phospholipids, glycolipids and sphingolipids which are components of cell membranes from marine organisms;

'neutral lipids' are non polar lipids such as mono, di and triglycerides, free fatty acids and esters, cholesterol, cholesterol esters and carotenoids which are present in marine organisms;

'total lipids' are combined polar and neutral lipids;

"marine proteins and amino acids" refers to proteinaceous materials originating from marine organisms;

'concentrate' describes a standardised and defined mixture prepared from purified MPL comprising HUFAs, predominantly DHA and EPA in a water dispersible hydrophilic medium. The concentrate may comprise a mixture of marine phospholipids blended with soya, egg, synthetic, semisynthetic, and enzyme modified phospholipids. It may be a liquid or gel like composition suitable for preparing multicomponent feed for aquatic livestock including microparticles for fish larvae and weaning. It may also be administered as supplement for human use as such or in a unit dosage form.

'nutritional components' include all substances which are nutritionally valuable to humans, livestock, fish larvae, smelt and other marine species. Examples include phospholipids, proteins, amino acids, minerals, vitamins, fish protein hydrolysates, fish oil triglycerides and carbohydrates.

- 9 -

'long chain fatty acids' refer to fatty acids with more than 18 carbon atoms starting with eicosa (C20) and docosa (C22) fatty acids;

'highly unsaturated' fatty acids (HUFA) may have three or more usually four or more double bonds, e.g., tetraenoic(4), pentaenoic(5) and hexaenoic(6) which are either omega-6 or omega-3 fatty acids. Eicosatetraenoic acid (AA) is an omega-6 fatty acid, eicosapentaenoic acid (EPA) and docosahexaenoic acid (DHA) are omega-3 fatty acids;

'fluid extraction' means 'de-oiling' or removal of neutral lipids from a dried marine raw material using a solvent in liquid form, such as acetone, or a supercritical gas such as carbon dioxide, nitrous oxide or propane or mixtures thereof, under hypercritical (supercritical) conditions;

'ethanol extraction' describes the purification of a dry MPL composition after deoiling by using ethanol or related solvents such as methanol, isopropanol, tert-butanol, n-propanol and mixtures thereof to extract the polar lipids from proteins and amino acids and other impurities. A waxy MPL composition is obtained after removal of the ethanol or related solvent.

'particulate composition' describes a dried, powdered composition with average particle diameter above 0.5 mm with moisture content that is below 10%.

#### Preparation of marine phospholipid (MPL) compositions

Standard procedures to obtain purified or semi-purified phospholipids particularly from soya and egg are based on a multi-step fractionation and/or purification process starting from crude, commercial lecithins.

### Removal of lecithin from crude vegetable oils (Degumming)

Vegetable lecithins may be obtained by simple water degumming of crude oils or by other processes like specific centrifugation of the wet starting materials. However, because of the variable contents and compositions of MPLs from different origins, it is not very satisfactory to utilise currently available procedures based on marine raw materials and biomass with high water content to prepare marine phospholipids for human nutrition and fish feed compositions without modification of the process. Improved extraction methods are therefore required for preparing MPL compositions with desirable amounts of polar lipids and low amounts of neutral lipids which are preferred in human nutraceutical and functional food applications and for forming lipid aggregates embedded in feed microparticles.

### Drying

Drying using elevated temperatures or spray drying is usually employed to prepare MPL containing powders from crude, aqueous fish roe and milt, or biomass from broken marine algal cells containing large amounts of water. In this invention it is preferable to use alternative technologies, for example freeze drying or other low stress drying methods to dry the marine raw materials so that they have lower amounts of water prior to processing.

### Deoiling

Preferred methods for the removal of neutral lipids, such as triglycerides, cholesterol and cholesterol esters, from the dry marine raw material are, fluid extraction with suitable liquids for instance acetone, and gases like carbon dioxide or other suitable gases under supercritical conditions.

The product remaining after acetone or more preferably CO<sub>2</sub> extraction is a particulate composition comprising protein, amino acids, minerals, polar lipids and smaller (low) amounts of neutral lipids. The particulate MPL composition comprises 70 wt% to 90 wt% of

- 11 -

marine protein and amino acids, preferably below 80 wt%. The polar and neutral lipids amount to 10 wt% to 30 wt%, preferably above 15 wt%. The polar lipids amount to 70 wt% to 95 wt%, preferably above 80 wt% of the total lipids whilst the neutral lipids make up the balance amounting to 5 wt% to 20 wt%, preferably below 15 wt%. The moisture content is below 10 wt% whilst minerals and trace elements based on ash residues make up less than 10 wt%.

The composition may be used as such, in powder form in nutritional supplements, in unit dosage form, or for functional food applications, on its own or in combination with biologically active compounds. It may also be used as a supplement in fish feed microparticles. Typically, the composition is a free flowing powder.

#### Removal of proteins

The deoiled MPL powder may be further processed and purified using e.g. ethanol extraction to remove the phospholipids and leave behind proteins, amino acids and most minerals as by products. Besides ethanol, other solvents such as methanol, isopropanol, tert-butanol and n-propanol are equally suitable.

After removal of the ethanol or another suitable solvent by evaporation, the composition is a waxy, paste like material and comprises a purified MPL composition containing 70 wt% to 95 wt% (or more after column chromatography) of phospholipids, preferably above 75 wt% with a minimum PC content of 40 wt%, preferably between 60 wt% to 80 wt% as the major component. About 30 wt%, preferably above 40 wt% of the esterified fatty acids in the PC comprise HUFAs. Preferably the HUFAs comprise between 40 wt% to 60 wt% of the omega-3 fatty acids EPA and DHA. Other phospholipid types and typical amounts present are, PE (15 wt%), PI (10 wt%), SPM (5 wt%), PS (2 wt%) and their mono acyl derivatives (4 wt%). Also smaller amounts of glycolipids may be present.

The non polar (neutral) lipids total 5 wt% to 30 wt% of the waxy MPL composition, preferably below 15 wt%. The maximum amount of cholesterol and cholesterol esters is

about 8 wt%, preferably below 5 wt%. The phospholipid values are based on phosphorous-31 NMR determinations. This purified composition may also be used for preparing the MPL concentrates in a liquid form.

#### Further purification

If higher amounts of PC are required, further purification may be carried out using column chromatography with aluminium oxide or silica to yield PC enriched MPL having between 60 wt% to 95 wt% PC. Aluminium oxide is the material of choice if higher than 80 % PC concentration is desired.

It is essential that the MPL compositions provide the desired fatty acid profiles and also allow maximum containment and delivery of nutritional components in a suitable form. The idea behind this invention is to exploit the intrinsic properties of particular types of marine phospholipid in compositions which are nutritionally beneficial and furthermore have the capacity to contain nutritional and other components by association/complex formation.

Factors to be considered in using a particulate MPL composition as nutritional supplement and food additive for human use are,

- i) between 70 wt% to 95 wt% of phospholipids in the lipid fraction which contain 10 wt% to 30 wt% of total lipids,
- ii) phosphatidylcholine content more than 40 wt% , preferably more than 60 wt% of the phospholipids with at least 30 wt% of HUFAs, wherein the fatty acid profiles provide desired levels of DHA and EPA,
- iii) low amounts of neutral lipids, preferably below 15 wt%,
- iv) low in cholesterol and cholesterol esters, preferably below 5 %,
- iv) suitability as solid and conversion to liquid unit dosage forms.

Additional factors which may be taken into account in using a purified waxy MPL composition after fluid extraction for preparing the MPL concentrates suitable for nutritional and embedment purposes in fish feed micro particles are,

- 13 -

- i) compatibility with other nutritional components for maximum association,
- ii) steric effects of long chain highly unsaturated fatty acids which affect aggregate formation, structure, particle size and stability,
- iii) avoidance of more than 50% by weight of phospholipids with esterified C18:2 fatty acids and more saturated fatty acids which may cause increased membrane rigidity,
- iv) potential to prepare water dispersible compositions for providing maximum amounts of MPL in feed particles,
- v) avoidance of elevated temperatures and intensive mixing which may be deleterious in preparing concentrates that form lipid aggregates in water,
- vi) avoidance of organic solvents particularly ethanol which are commonly employed in (v) to solubilise phospholipids.
- vii) formation of small, homogeneous and stable lipid aggregates comprising nutritional components and optionally polymers for embedment in the feed microparticles,
- viii) industrially applicable method of incorporating into feed compositions such as microparticles comprising excipients such as binders and stabilisers,
- ix) stability of the aggregates between pH 5 to pH 8,
- x) charge on the head group and effect of divalent ions which may cause fusion of the lipid aggregates,
- xi) osmotic shock effects,
- xii) microbial contamination and overgrowth.

#### A)

The invention provides ready to use marine phospholipid (MPL) compositions suitable for human or aquaculture applications which may be a dry composition comprising nutritional components selected from the group consisting of marine phospholipids, marine proteins and amino acid blends obtainable by fluid extraction of a *dried* marine raw material with less than 50 wt% water, preferably less than 10 wt%.

- 14 -

A typical particulate composition prepared by fluid or supercritical gas extraction of the dry marine raw material comprises:

Protein and amino acids:	70 wt% to 90wt%
Total lipid (polar & non polar)	10 wt% to 30 wt%
Polar lipids:	70 wt% to 95 wt%
PC content:	40 wt% to 80 wt% (of polar lipids)
esterified HUFAs:	30 wt% to 40 wt% (of polar lipids)
Neutral (non polar) lipids:	5 wt% to 20 wt%
cholesterol, cholesterol esters:	< 8 wt%
free fatty acids:	< 5 wt%
Iodine value (of the lipid fraction):	110-130
Minerals, trace elements:	< 8 wt%
Water:	<10 wt%

#### B)

The invention also describes a method to prepare a purified, waxy marine phospholipid composition from a phospholipid/marine protein/ amino acid blend after acetone or more preferably supercritical gas treatment of a dried marine raw material, suitable for direct human consumption or other applications, obtainable by extraction of the phospholipids using solvents such as ethanol, methanol, isopropyl alcohol, tert-butanol and n-propyl alcohol, and mixtures thereof. The composition obtained is a purified, waxy marine phospholipid mixture with low amounts of neutral lipids suitable for preparing a water dispersible concentrate.

The waxy composition may also be blended or mixed with a neutral oil to prepare a liquid or gel like lipophilic composition which may be used in hard or soft gelatine capsules or the like for human nutritional purposes. The oil may be any physiologically acceptable neutral oil. Preferably it is a fish or a vegetable oil or it may be a medium chain triglyceride such as Miglyol and edible fatty acid esters, ethers. The amount of oil for blending may be between 25 wt% to 60 wt% or more depending on the purpose. The oil may simply be a diluent or it may be used as a supplement of unsaturated omega-6 fatty acids.



- 15 -

The waxy MPL composition comprises about 70wt% to about 95 wt% or more of phospholipids comprising at least 40 wt% phosphatidylcholine calculated on the basis of the total phospholipids present which comprise about 30% by weight of esterified omega-3 fatty acids and between 5 wt% to 30 wt% of neutral lipids. The purified phospholipid mixture may be preferred for preparing a water dispersible marine phospholipid (MPL) concentrate suitable for embedment in fish feed microparticles or as supplements of highly bioavailable long chain omega-3 fatty acids for human, animal and aquaculture use.

A typical specification of the purified, waxy MPL composition prepared by the method described in this invention comprises:

Polar lipids:	70 wt% to 95 wt%
PC content:	40 wt% to 80 wt%
esterified HUFAs:	30 wt% to 40 wt% of polar lipids
non polar (neutral) lipids:	5.0 wt% to 30 wt%
cholesterol, cholesterol esters:	< 8 wt%
free fatty acids:	< 5 wt%
Iodine value:	110 -130
ethanol:	< 2.5 wt%
minerals,trace elements (ash):	<2 wt%
water:	< 5 wt%

C)

In a further aspect, the invention describes a homogeneous water dispersible MPL concentrate which comprises:

- i) 25 wt% to 75 wt% of a MPL composition comprising PC or blend of PC and the monoacyl derivative prepared by enzyme hydrolysis in an amount of at least 40 wt% as the major component and minor amounts of other components including PE, PI, SPM, PS and their monoacyl derivatives,
- ii) 15 wt% to 75 wt% of glycerol or another polyol, or sugar,
- iii) 1 wt% to 50 wt% water,