

# United States Patent [19]

[11] Patent Number: **5,717,406**

Sanderford et al.

[45] Date of Patent: **Feb. 10, 1998**

## [54] ENHANCED POSITION CALCULATION

## [57] ABSTRACT

[75] Inventors: **H. Britton Sanderford**, New Orleans, La.; **Martin C. Poppe**, Burlington, Vt.

The invention discloses several computation and control techniques which use historic information as well as other cues in order to enhance the accuracy of a radio position fix. These computational techniques include neural networks, mapped grid coefficients as input to a set of simultaneous or differential equations, and table lookup of correction coefficients for known low accuracy positions. The invention further discloses techniques for receiver array synchronization so that all system elements in a particular coverage area obtain a time reference appropriate for time of flight radio location measurements. The invention further teaches techniques to enhance the accuracy of a position fix by use of both fixed references, which are located in a coverage area, as well as a mobile reference carried by a search team. The invention also discloses techniques to provide information appropriate to guide a search team to an unknown positioned transmitter that is located within a building or structure. The invention discloses techniques to train a central computing unit, by using actuarial data, so that multi-path errors resulting from fixed or mobile obstacles may be reduced.

[73] Assignee: **Sanconix Inc.**, New Orleans, La.

[21] Appl. No.: **487,522**

[22] Filed: **Jun. 7, 1995**

[51] Int. Cl.<sup>6</sup> ..... **G01S 3/02**

[52] U.S. Cl. .... **342/457; 342/363**

[58] Field of Search ..... **342/363, 457; 364/443, 449, 449.1**

## [56] References Cited

### FOREIGN PATENT DOCUMENTS

- 470 151 11/1993 Sweden .
- 0631453 A2 12/1994 Sweden .

Primary Examiner—Theodore M. Blum  
Attorney, Agent, or Firm—Oblon, Spivak, McClelland, Maier & Neustadt, P.C.

**47 Claims, 11 Drawing Sheets**

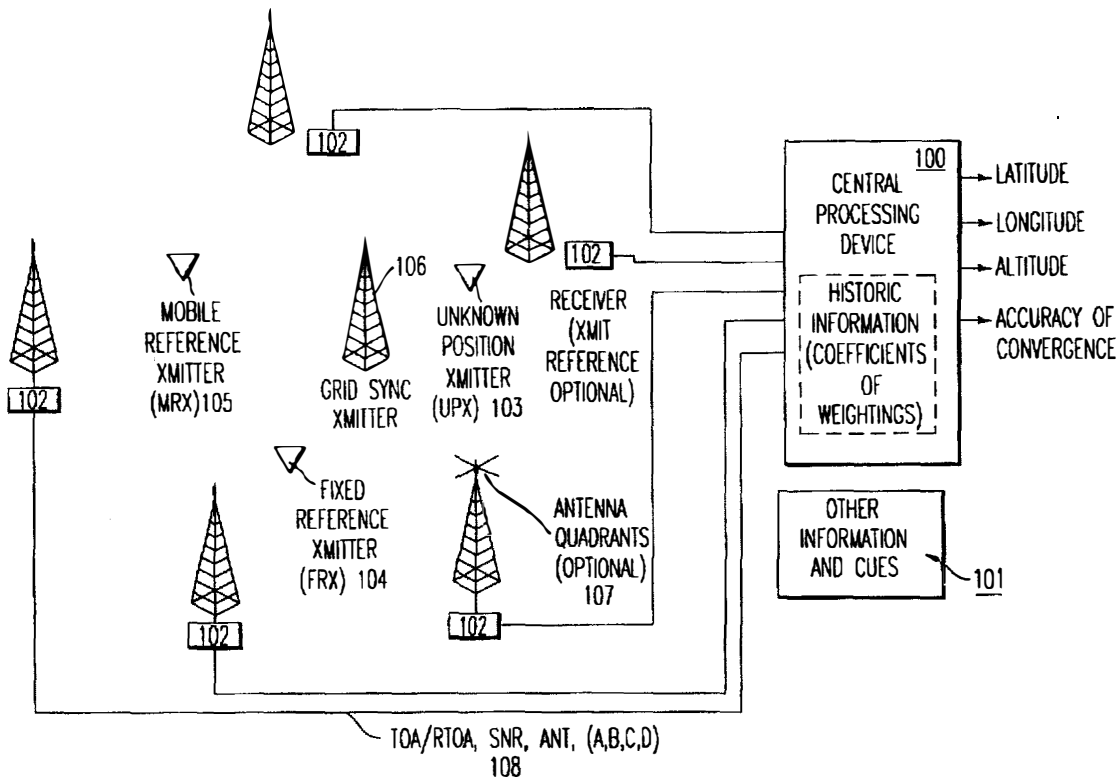

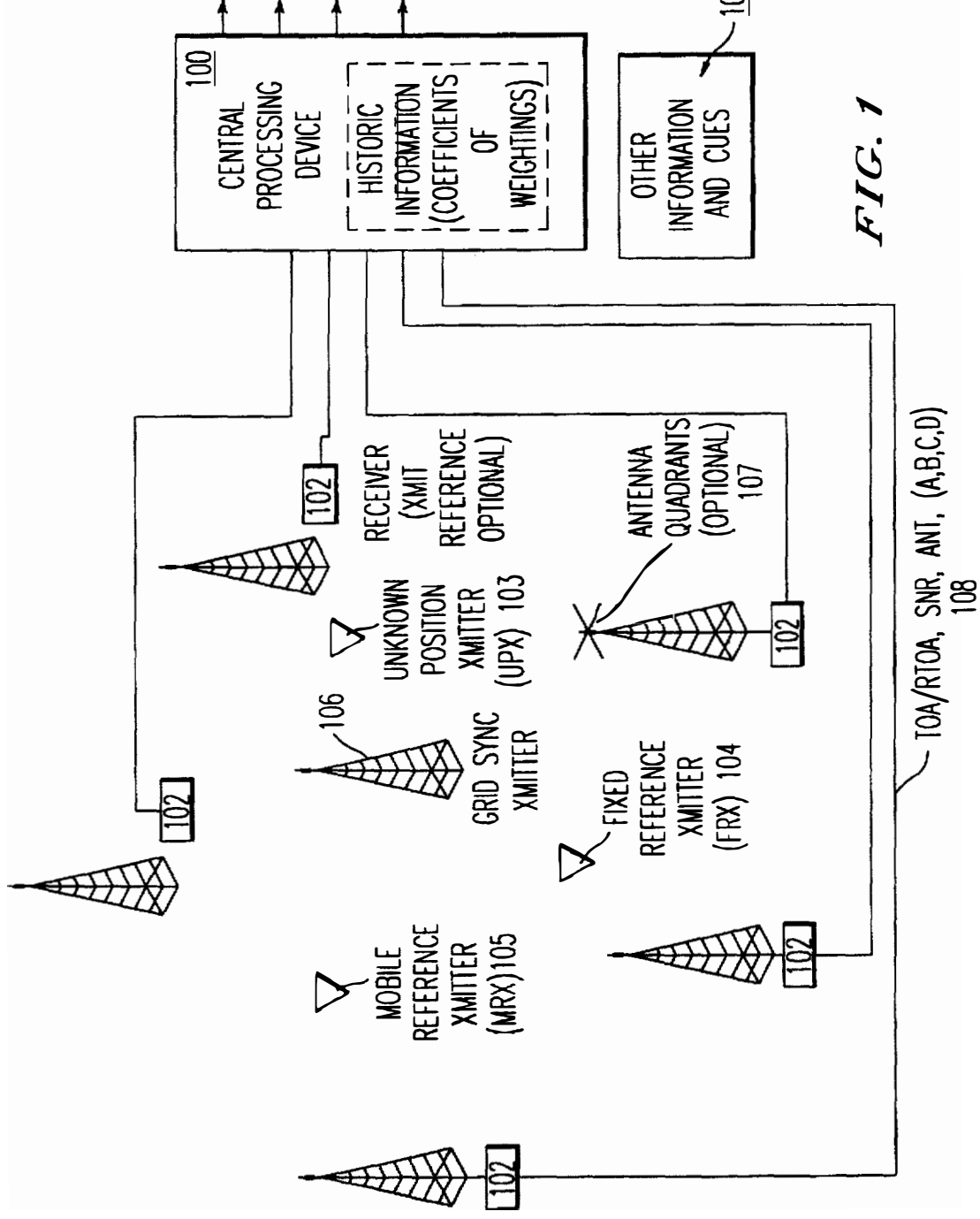

FIG. 1

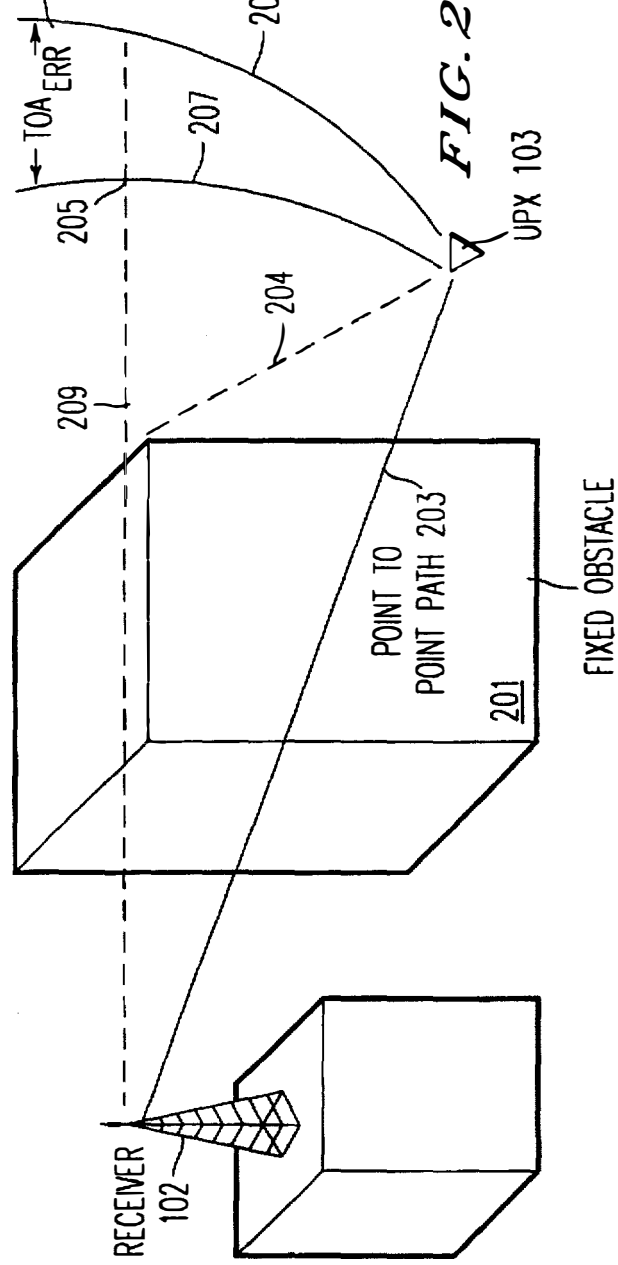

FIG. 2

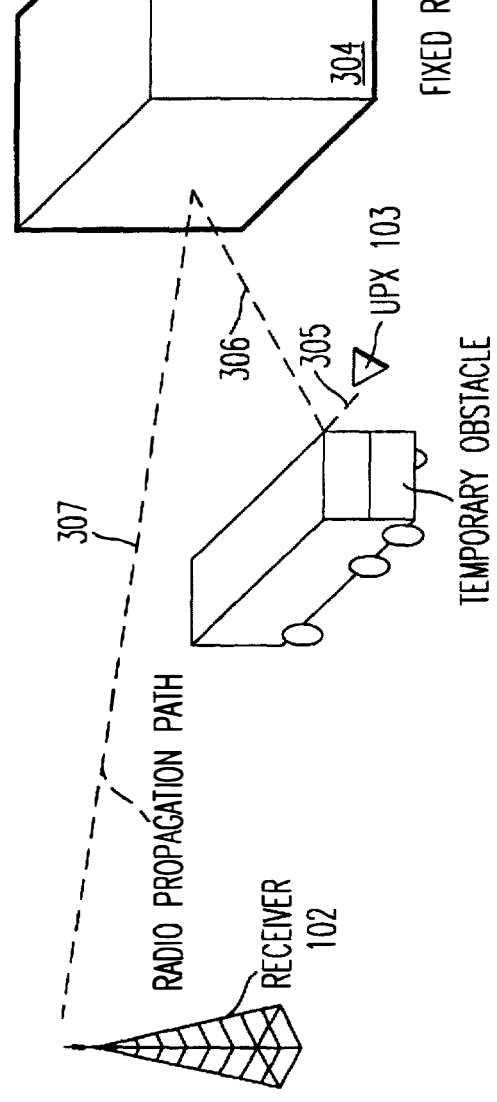
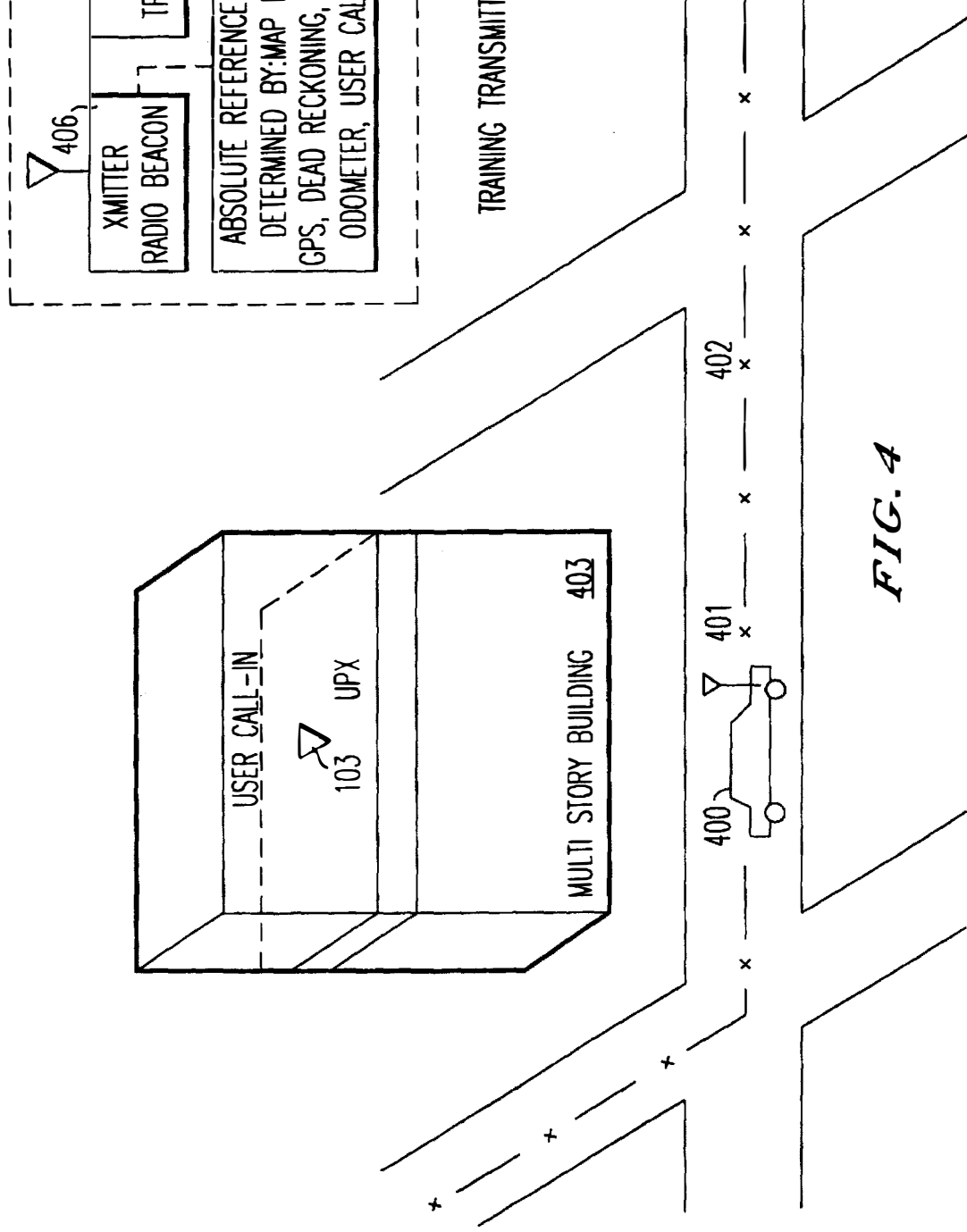

FIG. 3



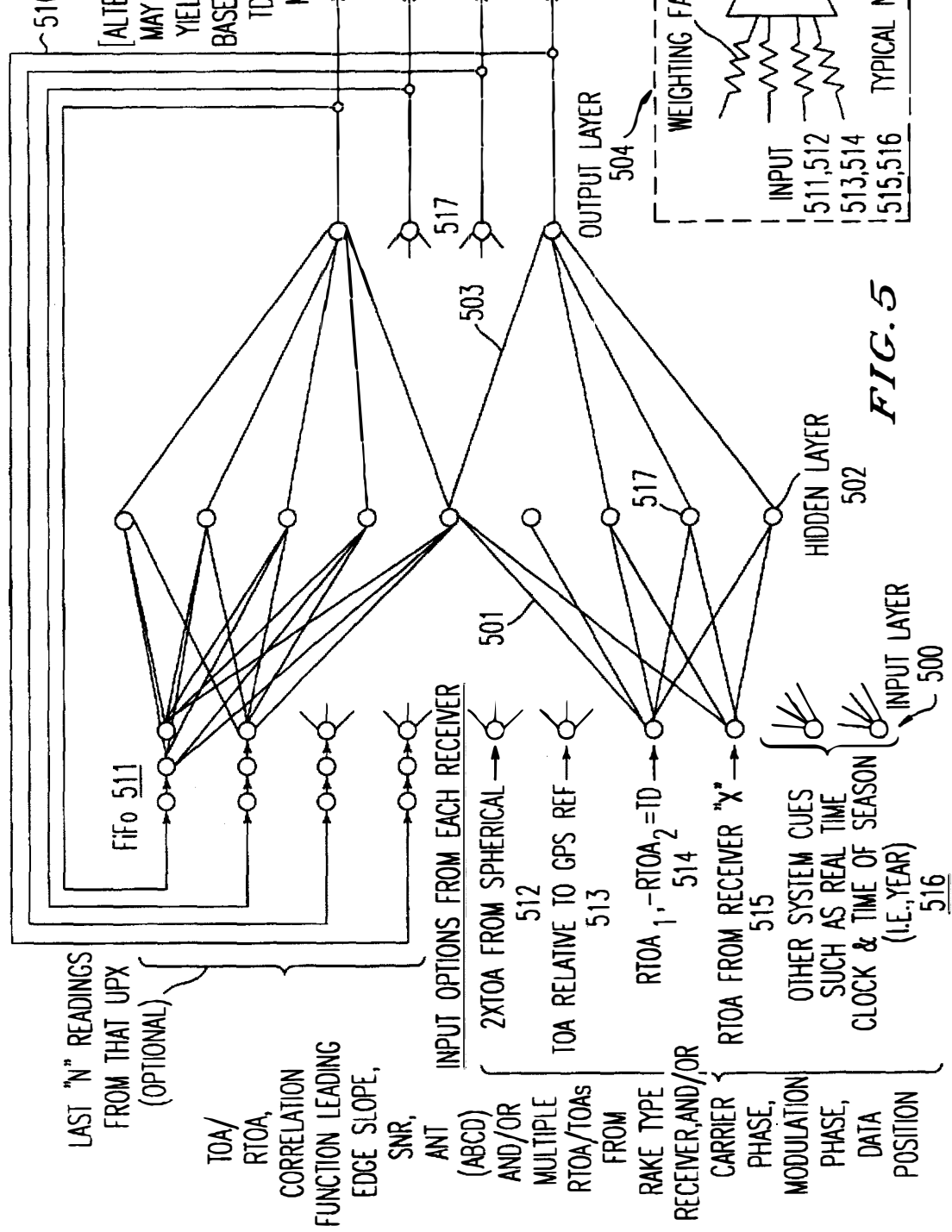

FIG. 5

# Explore Litigation Insights

Docket Alarm provides insights to develop a more informed litigation strategy and the peace of mind of knowing you're on top of things.

## Real-Time Litigation Alerts



Keep your litigation team up-to-date with **real-time alerts** and advanced team management tools built for the enterprise, all while greatly reducing PACER spend.

Our comprehensive service means we can handle Federal, State, and Administrative courts across the country.

## Advanced Docket Research



With over 230 million records, Docket Alarm's cloud-native docket research platform finds what other services can't. Coverage includes Federal, State, plus PTAB, TTAB, ITC and NLRB decisions, all in one place.

Identify arguments that have been successful in the past with full text, pinpoint searching. Link to case law cited within any court document via Fastcase.

## Analytics At Your Fingertips



Learn what happened the last time a particular judge, opposing counsel or company faced cases similar to yours.

Advanced out-of-the-box PTAB and TTAB analytics are always at your fingertips.

## API

Docket Alarm offers a powerful API (application programming interface) to developers that want to integrate case filings into their apps.

## LAW FIRMS

Build custom dashboards for your attorneys and clients with live data direct from the court.

Automate many repetitive legal tasks like conflict checks, document management, and marketing.

## FINANCIAL INSTITUTIONS

Litigation and bankruptcy checks for companies and debtors.

## E-DISCOVERY AND LEGAL VENDORS

Sync your system to PACER to automate legal marketing.