

7c943

1c370 U.S. PTO  
09/770838  
01/25/01

342	450
Class	Subclass

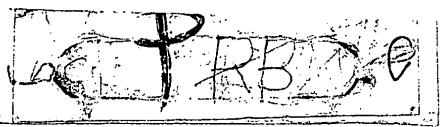

PATENT NUMBER

U.S. UTILITY Patent Application

INVENTOR: *TRJ* O.I.P.E. *TRJ* PATENT DATE: *10/10/03*  
 SCANNED *2/27/04* O.A. *TRJ*

APPLICATION NO.	CONT/PRIOR	CLASS	SUBCLASS	ART UNIT	EXAMINER
09/770838	D	342	450	3662	Phan

APPLICANTS: Charles Karr, Dennis Dupray  
 TITLE: Wireless location using signal fingerprinting  
 PTO-2040 12/99

ISSUING CLASSIFICATION			
ORIGINAL		CROSS REFERENCE(S)	
CLASS	SUBCLASS	CLASS	SUBCLASS (ONE SUBCLASS PER BLOCK)
342	450	342	457
INTERNATIONAL CLASSIFICATION			
G01S	3/02		

Continued on Issue Slip Inside File Jacket

**TERMINAL DISCLAIMER**

The term of this patent subsequent to \_\_\_\_\_ has been disclaimed.

The term of this patent not extend beyond the exp of U.S Patent. No. \_\_\_\_\_

The terminal \_\_\_\_\_ month this patent have been disc

DRAWINGS			CLAIMS ALLOWED	
Sheets Drwg.	Figs. Drwg.	Print Fig.	Total Claims	Print Claim for O.G.
62	47	5	75	58
<del>_____</del> (Assistant Examiner) (Date)			<b>NOTICE OF ALLOWANCE MAILED</b> <i>4/20/04</i> <i>8-27-03</i>	
<i>Phan</i> <b>DAOPHAN</b> PATENT EXAMINER (Primary Examiner)			<b>ISSUE FEE</b> Amount Due: <i>665</i> Date Paid: _____	
<i>Phan</i> (Legal Instrumental Examiner)			<b>ISSUE BATCH NUMBER</b> <i>10/10/03</i> (Date)	

**WARNING:** The information disclosed herein may be restricted. Unauthorized disclosure may be prohibited by the United States Code Title 35, Sections 122, 181, and 368. Possession outside the U.S. Patent & Trademark Office is restricted to authorized employees and contractors only.

Form PTO-436A (Rev. 099) FILED WITH:  DISK (CRF)  FICHE  CD-ROM  
 (Attached in pocket on right inside flap)

FORMAL DRAWINGS

(FACE)

BEST AVAILABLE COPY

BEST AVAILABLE COPY

SEARCHED			
Class	Sub.	Date	Exmr.
342	357.01	3/6/03	DP
	357.06		
	450		
	453		
	463-465		
	457		
	455		
456			
	457		
		updated 8/22/03 DP	
		updated 4/13/04 DP	

SEARCH NOTES (INCLUDING SEARCH STRATEGY)		
	Date	Exmr.

INTERFERENCE SEARCHED			
Class	Sub.	Date	Exmr.
342	357.01	3/6/03	DP
	357.06		
	450		
	453		
	463-465		
	457		
	455		
	456		
	457		

updated 8/22/03 DP (RIGHT OUTSIDE)



ISSUE SI,IP STAPLE AREA (for additional cross references)

POSITION	INITIALS	ID NO.	DATE
FEE DETERMINATION			
O.I.P.E. CLASSIFIER			
FORMALITY REVIEW	AS	943	4-9-1
RESPONSE FORMALITY REVIEW	mb	1020	5-4-01

BEST AVAILABLE COPY

FILE MARKS			
DRAFTING			

INDEX OF CLAIMS

4/13/04  
4/13/04

Claim	Date
Final	
Original	
1	
2	
3	
4	
5	
6	
7	
8	
9	
10	
11	
12	
13	
14	
15	
16	
17	
18	
19	
20	
21	
22	
23	
24	
25	
26	
27	
28	
29	
30	
31	

Claim	Date
Final	
Original	
32	252
33	253
34	254
35	255
36	256
37	257
38	258
39	259
40	260
41	261
42	262
43	263
44	264
45	265
46	266
47	267
48	268
49	269
50	270
51	271
52	272
53	273
54	274
55	275
56	276
57	277
58	278
59	279
60	280
61	281
62	282
63	283
64	284
65	285
66	286
67	287
68	288
69	289
70	290
71	291
72	292
73	293
74	294
75	295

- SYMBOLS
- ✓ ..... Rejected
  - ..... Allowed
  - (Through numeral) Canceled
  - ⊕ ..... Restricted
  - N ..... Non-elected
  - I ..... Interference
  - A ..... Appeal
  - O ..... Objected

If more than 150 claims or 10 actions staple additional sheet here

(LEFT INSIDE)

# BEST AVAILABLE COPY

## INDEX OF CLAIMS

4/13/04

4/13/04

Claim	Date
Final	
Original	
1	
2	
3	
4	
5	
6	
7	
8	
9	
10	
11	
12	
13	
14	
15	
16	
17	
18	
19	
20	
21	
22	
23	
24	
25	
26	
27	
28	
29	
30	
31	

Claim	Date
Final	
Original	
32	252
33	253
34	254
35	255
36	256
37	257
38	258
39	259
40	260
41	261
42	262
43	263
44	264
45	265
46	266
47	267
48	268
49	269
50	270
51	271
52	272
53	273
54	274
55	275
56	276
57	277
58	278
59	279
60	280
61	281
62	282
63	283
64	284
65	285
66	286
67	287
68	288
69	289
70	290
71	291
72	292
73	293
74	294
75	295
76	296
77	297
78	298
79	299
80	300
81	301

**SYMBOLS**

- ✓ ..... Rejected
- ..... Allowed
- (Through numeral) ..... Canceled
- + ..... Restricted
- N ..... Non-elected
- I ..... Interference
- A ..... Appeal
- O ..... Objected

01-29-01

A

1c960 U.S. PTO  
01/26/01

UTILITY CONTINUATION PATENT APPLICATION TRANSMITTAL  
for new nonprovisional applications under 37 CFR 1.53(b)

1c970 U.S. PTO  
09/770838  
01/26/01

Attorney Docket No.: 1003-1

Inventors: Dennis J. Dupray of 1801 Belvedere Street, Golden, Colorado 80401  
Charles L. Karr of 400 Sandbrook Lane, Tuscaloosa, Alabama 35405

Express Mail Label No.: EL545144476US

Title: "LOCATION OF A MOBILE STATION"

Prior Group Art Unit: 3662

Prior Examiner: Dao Phan

Assistant Commissioner for Patents  
Box Patent Application  
Washington, DC 20231

This is a Continuation application of pending prior application No. 09/194,367 filed November 24, 1998. The entire disclosure of the prior application, from which a copy of the oath or declaration is supplied, is considered to be part of the disclosure of the accompanying application and is hereby incorporated by reference.

Enclosed for filing with the above-identified utility patent application, please find the following:

1.  Copy of Oath/Declaration from the above-referenced pending prior application (37 CFR 1.63(d))
2.  Preliminary Amendment
3.  Return Postcard (MPEP 503) (should be specifically itemized)
4.  A check in the amount of \$1,119.00 is enclosed.
5.  Other:

**FEE CALCULATION:**

Cancel in this application original Claims 1 - 124 of the prior application before calculating the filing fee.

	(COL. 1) NO. FILED			(COL. 2*) NO. EXTRA	SMALL ENTITY			LARGE ENTITY	
					RATE	FEE		RATE	FEE
BASIC FEE:						\$355.00	OR		\$710.00
TOTAL CLAIMS:	96	-	20	76	X \$9 =	\$684.00	OR	X \$18 =	
INDEP. CLAIMS:	5	-	3	2	X \$40 =	\$80.00	OR	X \$80 =	
MULTIPLE DEPENDENT CLAIMS					+ \$135 =	\$0.00	OR	+ \$270 =	
*IF THE DIFFERENCE IN COL. 2 IS LESS THAN ZERO, ENTER "0" IN COL. 2.					TOTAL:	\$1,119.00			

**OTHER INFORMATION:**

1.  The Commissioner is hereby authorized to debit any underpayments or credit any overpayment to Deposit Account No. 19-1970.
2.  The Commissioner is hereby authorized to charge all required fees for extensions of time under §1.17 to Deposit Account No. 19-1970.
3.  Foreign Priority benefits are claimed under 35 USC §119 of Patent Application Serial No. filed
4.  The Small Entity Statement was filed in the above-referenced prior application. Small Entity status is still proper and desired.
5.  The prior application is assigned to TracBeam LLC.
6. Correspondence Address:

Dennis J. Dupray, Ph.D.  
1801 Belvedere Street  
Golden, Colorado 80401  
Telephone: (303) 863-2975  
Facsimile: (303) 863-0223

Respectfully Submitted,

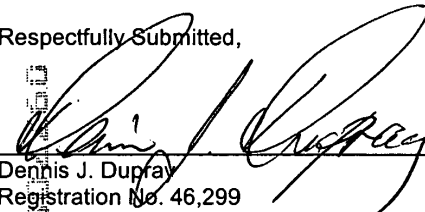
  
Dennis J. Dupray  
Registration No. 46,299

Date: Jan 26, 2001

# WIRELESS LOCATION USING MULTIPLE SIMULTANEOUS LOCATION ESTIMATORS

## FIELD OF THE INVENTION

5           The present invention is directed generally to a system and method for locating people or objects, and in particular, to a system and method for locating a wireless mobile station using a plurality of simultaneously activated mobile station location estimators.

## BACKGROUND OF THE INVENTION

### Introduction

10           Wireless communications systems are becoming increasingly important worldwide. Wireless cellular telecommunications systems are rapidly replacing conventional wire-based telecommunications systems in many applications. Cellular radio telephone networks ("CRT"), and specialized mobile radio and mobile data radio networks are examples. The general principles of wireless cellular telephony have been described variously, for example in U. S. Patent 5,295,180 to Vendetti, et al, which is incorporated herein by reference.

15           There is great interest in using existing infrastructures for wireless communication systems for locating people and/or objects in a cost effective manner. Such a capability would be invaluable in a variety of situations, especially in emergency or crime situations. Due to the substantial benefits of such a location system, several attempts have been made to design and implement such a system.

20           Systems have been proposed that rely upon signal strength and trilateration techniques to permit location include those disclosed in U.S. Patents 4,818,998 and 4,908,629 to Apsell et al. ("the Apsell patents") and 4,891,650 to Sheffer ("the Sheffer patent"). However, these systems have drawbacks that include high expense in that special purpose electronics are required. Furthermore, the systems are generally only effective in line-of-sight conditions, such as rural settings. Radio wave surface reflections, refractions and ground clutter cause significant distortion, in determining the location of a signal source in most geographical areas that are more than sparsely populated. Moreover, these drawbacks are particularly exacerbated in dense urban canyon (city) areas, where errors and/or conflicts in location measurements can result in substantial inaccuracies.

25           Another example of a location system using time of arrival and triangulation for location are satellite-based systems, such as the military and commercial versions of the Global Positioning Satellite system ("GPS"). GPS can provide accurate position determination (i.e., about 100 meters error for the commercial version of GPS) from a time-based signal received simultaneously from at least three satellites. A ground-based GPS receiver at or near the object to be located determines the difference between the time at which each satellite transmits a time signal and the time at which the signal is received and, based on the time differentials, determines the object's location. However, the GPS is impractical in many applications. The signal power levels from the satellites

00770939 04E604  
F09E7F0 00002200

are low and the GPS receiver requires a clear, line-of-sight path to at least three satellites above a horizon of about 60 degrees for effective operation. Accordingly, inclement weather conditions, such as clouds, terrain features, such as hills and trees, and buildings restrict the ability of the GPS receiver to determine its position. Furthermore, the initial GPS signal detection process for a GPS receiver is relatively long (i.e., several minutes) for determining the receiver's position. Such delays are unacceptable in many applications such as, for example, emergency response and vehicle tracking.

Differential GPS, or DGPS systems offer correction schemes to account for time synchronization drift. Such correction schemes include the transmission of correction signals over a two-way radio link or broadcast via FM radio station subcarriers. These systems have been found to be awkward and have met with limited success.

Additionally, GPS-based location systems have been attempted in which the received GPS signals are transmitted to a central data center for performing location calculations. Such systems have also met with limited success. In brief, each of the various GPS embodiments have the same fundamental problems of limited reception of the satellite signals and added expense and complexity of the electronics required for an inexpensive location mobile station or handset for detecting and receiving the GPS signals from the satellites.

Radio Propagation Background

The behavior of a mobile radio signal in the general environment is unique and complicated. Efforts to perform correlations between radio signals and distance between a base station and a mobile station are similarly complex. Repeated attempts to solve this problem in the past have been met with only marginal success. Factors include terrain undulations, fixed and variable clutter, atmospheric conditions, internal radio characteristics of cellular and PCS systems, such as frequencies, antenna configurations, modulation schemes, diversity methods, and the physical geometries of direct, refracted and reflected waves between the base stations and the mobile. Noise, such as man-made external sources (e.g., auto ignitions) and radio system co-channel and adjacent channel interference also affect radio reception and related performance measurements, such as the analog carrier-to-interference ratio (C/I), or digital energy-per-bit/Noise density ratio ( $E_{b/N_0}$ ) and are particular to various points in time and space domains.

RF Propagation in Free Space

Before discussing real world correlations between signals and distance, it is useful to review the theoretical premise, that of radio energy path loss across a pure isotropic vacuum propagation channel, and its dependencies within and among various communications channel types. Fig. 1 illustrates a definition of channel types arising in communications:

Over the last forty years various mathematical expressions have been developed to assist the radio mobile cell designer in establishing the proper balance between base station capital investment and the quality of the radio link, typically using radio energy field-strength, usually measured in microvolts/meter, or decibels.

First consider Hata's single ray model. A simplified radio channel can be described as:

$$G_i = L_p + F + L_t + L_m + L_b - G_t + G_r \quad (\text{Equation 1})$$

where  $G_i$  = system gain in decibels

$L_p$  = free space path loss in dB,

5  $F$  = fade margin in dB,

$L_t$  = transmission line loss from coaxials used to connect radio to antenna, in dB,

$L_m$  = miscellaneous losses such as minor antenna misalignment, coaxial corrosion, increase in the receiver noise figure due to aging, in dB,

10  $L_b$  = branching loss due to filter and circulator used to combine or split transmitter and receiver signals in a single antenna

$G_t$  = gain of transmitting antenna

$G_r$  = gain of receiving antenna

15 Free space path loss<sup>1</sup>  $L_p$ , as discussed in Mobile Communications Design Fundamentals, William C. Y. Lee, 2nd, Ed across the propagation channel is a function of distance  $d$ , frequency  $f$  (for  $f$  values < 1 GHz, such as the 890-950 MHz cellular band):

$$\frac{P_{or}}{P_t} = \frac{1}{(4\pi d f c)^2} \quad (\text{equation 2})$$

20 where  $P_{or}$  = received power in free space

$P_t$  = transmitting power

$c$  = speed of light,

25 The difference between two received signal powers in free space,

$$\Delta_p = (10) \log\left(\frac{P_{or2}}{P_{or1}}\right) = (20) \log\left(\frac{d_1}{d_2}\right) (dB) \quad (\text{equation 3})$$

indicates that the free propagation path loss is 20 dB per decade. Frequencies between 1 GHz and 2GHz experience increased values in the exponent, ranging from 2 to 4, or 20 to 40 dB/decade, which would be predicted for the new PCS 1.8 - 1.9 GHz band.

- 5 This suggests that the free propagation path loss is 20 dB per decade. However, frequencies between 1 GHz and 2 GHz experience increased values in the exponent, ranging from 2 to 4, or 20 to 40 dB/decade, which would be predicted for the new PCS 1.8 - 1.9 GHz band. One consequence from a location perspective is that the effective range of values for higher exponents is an increased at higher frequencies, thus providing improved granularity of ranging correlation.

#### Environmental Clutter and RF Propagation Effects

- 10 Actual data collected in real-world environments uncovered huge variations with respect to the free space path loss equation, giving rise to the creation of many empirical formulas for radio signal coverage prediction. Clutter, either fixed or stationary in geometric relation to the propagation of the radio signals, causes a shadow effect of blocking that perturbs the free space loss effect. Perhaps the best known model set that characterizes the average path loss is Hata's, "Empirical Formula for Propagation Loss in Land Mobile Radio", M. Hata, IEEE Transactions VT-29, pp. 317-325, August 1980, three pathloss models, based  
15 on Okumura's measurements in and around Tokyo, "Field Strength and its Variability in VHF and UHF Land Mobile Service", Y. Okumura, et al, Review of the Electrical Communications laboratory, Vol 16, pp 825-873, Sept. - Oct. 1968.

The typical urban Hata model for  $L_p$  was defined as  $L_p = L_{Hu}$ :

- 20
- $$L_{Hu} = 69.55 + 26.16 \log(f) - 13.82 \log(h_{BS}) - a(h_{MS}) + ((44.9 - 6.55 \log(H_{BS})) \log(d) [dB])$$
- (Equation 4)

where  $L_{Hu}$  = path loss, Hata urban

- 25  $h_{BS}$  = base station antenna height  
 $h_{MS}$  = mobile station antenna height  
 $d$  = distance BS-MS in km

- 30  $a(h_{MS})$  is a correction factor for small and medium sized cities, found to be:



$$11 \log(f) h_{MS} - 1.56 \log(f - 0.8) = a(h_{MS})$$

(Equation 5)

For large cities the correction factor was found to be:

5

$$a(h_{MS}) = 3.2 [\log 11.75 h_{MS}]^2 - 4.97$$

(Equation 6)

assuming f is equal to or greater than 400 mHz.

10

The typical suburban model correction was found to be:

$$L_{H_{suburban}} = L_{Hu} - 2 \left[ \log \left( \frac{f}{28} \right)^2 \right] - 5.4 [dB]$$

(Equation 7)

15

The typical rural model modified the urban formula differently, as seen below:

$$L_{H_{rural}} = L_{Hu} - 4.78 (\log f)^2 + 18.33 \log f - 40.94 [dB]$$

(Equation 8)

20

Although the Hata model was found to be useful for generalized RF wave prediction in frequencies under 1 GHz in certain suburban and rural settings, as either the frequency and/or clutter increased, predictability decreased. In current practice, however, field technicians often have to make a guess for dense urban and suburban areas (applying whatever model seems best), then installing a base stations and begin taking manual measurements. Coverage problems can take up to a year to resolve.

25 **Relating Received Signal Strength to Location**

Having previously established a relationship between d and  $P_{or}$ , reference equation 2 above: d represents the distance between the mobile station (MS) and the base station (BS);  $P_{or}$  represents the received power in free space) for a given set of unchanging environmental conditions, it may be possible to dynamically measure  $P_{or}$  and then determine d.

30 In 1991, U.S. Patent 5,055,851 to Sheffer taught that if three or more relationships have been established in a triangular space of three or more base stations (BSs) with a location database constructed having data related to possible mobile station (MS) locations, then arculation calculations may be performed, which use three distinct  $P_{or}$  measurements to determine an X,Y, two

5

CONFIDENTIAL

dimensional location, which can be projected onto an area map. The triangulation calculation is based on the fact that the approximate distance of the mobile station (MS) from any base station (BS) cell can be calculated based on the received signal strength. Sheffer acknowledges that terrain variations affect accuracy, although as noted above, Sheffer's disclosure does not account for a sufficient number of variables, such as fixed and variable location shadow fading, which are typical in dense urban areas with moving traffic.

Most field research before about 1988 has focused on characterizing (with the objective of RF coverage prediction) the RF propagation channel (i.e., electromagnetic radio waves) using a single-ray model, although standard fit errors in regressions proved dismal (e.g., 40-80 dB). Later, multi-ray models were proposed, and much later, certain behaviors were studied with radio and digital channels. In 1981, Vogler proposed that radio waves at higher frequencies could be modeled using optics principles. In 1988 Walfisch and Bertoni applied optical methods to develop a two-ray model, which when compared to certain highly specific, controlled field data, provided extremely good regression fit standard errors of within 1.2 dB.

In the Bertoni two ray model it was assumed that most cities would consist of a core of high-rise buildings surrounded by a much larger area having buildings of uniform height spread over regions comprising many square blocks, with street grids organizing buildings into rows that are nearly parallel. Rays penetrating buildings then emanating outside a building were neglected. Fig. 2 provides a basis for the variables.

After a lengthy analysis it was concluded that path loss was a function of three factors: (1) the path loss between antennas in free space; (2) the reduction of rooftop wave fields due to settling; and (3) the effect of diffraction of the rooftop fields down to ground level. The last two factors were summarily termed  $L_{ex}$ , given by:

$$L_{ex} = 57.1 + A + \log(f) + R - ((18 \log(H)) - 18 \log\left[1 - \frac{R^2}{17H}\right]) \text{ (Equation 9)}$$

The influence of building geometry is contained in A:

$$A = 5 \log\left[\left(\frac{d}{2}\right)^2\right] - 9 \log d + 20 \log\left\{\tan\left[2(h - H_{MS})\right]^{-1}\right\} \text{ (Equation 10)}$$

However, a substantial difficulty with the two-ray model in practice is that it requires a substantial amount of data regarding building dimensions, geometries, street widths, antenna gain characteristics for every possible ray path, etc. Additionally, it requires an inordinate amount of computational resources and such a model is not easily updated or maintained.

Unfortunately, in practice clutter geometries and building heights are random. Moreover, data of sufficient detail has been extremely difficult to acquire, and regression standard fit errors are poor; i.e., in the general case, these errors were found to be 40-60 dB. Thus the two-ray model approach, although sometimes providing an improvement over single ray techniques, still did not predict RF signal characteristics in the general case to level of accuracy desired (< 10dB).



- Slow fading loss or margin ( $L_{slow}$ )
- Fast fading loss or margin ( $L_{fast}$ )

Loss due to slow fading includes shadowing due to clutter blockage (sometimes included in  $L_p$ ). Fast fading is composed of multipath reflections which cause: 1) delay spread; 2) random phase shift or Rayleigh fading; and 3) random frequency modulation due to different Doppler shifts on different paths.

Summing the path loss and the two fading margin loss components from the above yields a total path loss of:

$$L_{total} = L_p + L_{slow} + L_{fast}$$

Referring to Fig. 3, the figure illustrates key components of a typical cellular and PCS power budget design process. The cell designer increases the transmitted power  $P_{TX}$  by the shadow fading margin  $L_{slow}$  which is usually chosen to be within the 1-2 percentile of the slow fading probability density function (PDF) to minimize the probability of unsatisfactorily low received power level  $P_{RX}$  at the receiver. The  $P_{RX}$  level must have enough signal to noise energy level (e.g., 10 dB) to overcome the receiver's internal noise level (e.g., -118dBm in the case of cellular 0.9 GHz), for a minimum voice quality standard. Thus in the example  $P_{RX}$  must never be below -108 dBm, in order to maintain the quality standard.

Additionally the short term fast signal fading due to multipath propagation is taken into account by deploying fast fading margin  $L_{fast}$ , which is typically also chosen to be a few percentiles of the fast fading distribution. The 1 to 2 percentiles compliment other network blockage guidelines. For example the cell base station traffic loading capacity and network transport facilities are usually designed for a 1-2 percentile blockage factor as well. However, in the worst-case scenario both fading margins are simultaneously exceeded, thus causing a fading margin overload.

In Roy, Steele's, text, *Mobile Radio Communications*, IEEE Press, 1992, estimates for a GSM system operating in the 1.8 GHz band with a transmitter antenna height of 6.4m and an MS receiver antenna height of 2m, and assumptions regarding total path loss, transmitter power would be calculated as follows:

Table I: GSM Power Budget Example

Parameter	dBm value	Will require
$L_{slow}$	14	
$L_{fast}$	7	
$L_{path}$	110	
Min. RX pwr required	-104	
		TXpwr = 27 dBm

5

Steele's sample size in a specific urban London area of 80,000 LOS measurements and data reduction found a slow fading variance of

$$\sigma = 7\text{dB}$$

10 assuming lognormal slow fading PDF and allowing for a 1.4% slow fading margin overload, thus

$$L_{slow} = 2\sigma = 14\text{dB}$$

The fast fading margin was determined to be:

15  $L_{fast} = 7\text{dB}$

In contrast, Xia's measurements in urban and suburban California at 1.8 GHz uncovered flat-land shadow fades on the order of 25-30 dB when the mobile station (MS) receiver was traveling from LOS to non-LOS geometries. In hilly terrain fades of +5 to -50 dB were experienced. Thus it is evident that attempts to correlate signal strength with MS ranging distance suggest that error ranges could not be expected to improve below 14 dB, with a high side of 25 to 50 dB. Based on 20 to 40 dB per decade,

20 Corresponding error ranges for the distance variable would then be on the order of 900 feet to several thousand feet, depending upon the particular environmental topology and the transmitter and receiver geometries.

## SUMMARY OF THE INVENTION

### OBJECTS OF THE INVENTION

It is an objective of the present invention to provide a system and method for to wireless telecommunication systems for accurately locating people and/or objects in a cost effective manner. Additionally, it is an objective of the present invention to provide such location capabilities using the measurements from wireless signals communicated between mobile stations and a network of base stations, wherein the same communication standard or protocol is utilized for location as is used by the network of base stations for providing wireless communications with mobile stations for other purposes such as voice communication and/or visual communication (such as text paging, graphical or video communications). Related objectives for the present invention include providing a system and method that:

- 10 (1.1) can be readily incorporated into existing commercial wireless telephony systems with few, if any, modifications of a typical telephony wireless infrastructure;
- (1.2) can use the native electronics of typical commercially available telephony wireless mobile stations (e.g., handsets) as location devices;
- (1.3) can be used for effectively locating people and/or objects wherein there are few (if any) line-of-sight wireless receivers for receiving location signals from a mobile station (herein also denoted MS);
- 15 (1.4) can be used not only for decreasing location determining difficulties due to multipath phenomena but in fact uses such multipath for providing more accurate location estimates;
- (1.5) can be used for integrating a wide variety of location techniques in a straight-forward manner; and
- (1.6) can substantially automatically adapt and/or (re)train and/or (re)calibrate itself according to changes in the environment and/or terrain of a geographical area where the present invention is utilized.
- 20

Yet another objective is to provide a low cost location system and method, adaptable to wireless telephony systems, for using simultaneously a plurality of location techniques for synergistically increasing MS location accuracy and consistency. In particular, at least some of the following MS location techniques can be utilized by various embodiments of the present invention:

- (2.1) time-of-arrival wireless signal processing techniques;
- 25 (2.2) time-difference-of-arrival wireless signal processing techniques;
- (2.3) adaptive wireless signal processing techniques having, for example, learning capabilities and including, for instance, artificial neural net and genetic algorithm processing;
- (2.4) signal processing techniques for matching MS location signals with wireless signal characteristics of known areas;
- (2.5) conflict resolution techniques for resolving conflicts in hypotheses for MS location estimates;
- 30 (2.6) enhancement of MS location estimates through the use of both heuristics and historical data associating MS wireless signal characteristics with known locations and/or environmental conditions.

Yet another objective provide location estimates in terms of time vectors, can be used to establish motion, speed, and an extrapolated next location in cases where the MS signal subsequently becomes unavailable.

#### DEFINITIONS

5 The following definitions are provided for convenience. In general, the definitions here are also defined elsewhere in this document as well.

(3.1) The term “wireless” herein is, in general, an abbreviation for “digital wireless”, and in particular, “wireless” refers to digital radio signaling using one of standard digital protocols such as CDMA, NAMPS, AMPS, TDMA and GSM, as one skilled in the art will understand.

10 (3.2) As used herein, the term “mobile station” (equivalently, MS) refers to a wireless device that is at least a transmitting device, and in most cases is also a wireless receiving device, such as a portable radio telephony handset. Note that in some contexts herein instead or in addition to MS, the following terms are also used: “personal station” (PS), and “location unit” (LU). In general, these terms may be considered synonymous. However, the later two terms may be used when referring to reduced functionality communication devices in comparison to a typical digital wireless mobile telephone.

15 (3.3) The term, “infrastructure”, denotes the network of telephony communication services, and more particularly, that portion of such a network that receives and processes wireless communications with wireless mobile stations. In particular, this infrastructure includes telephony wireless base stations (BS) such as those for radio mobile communication systems based on CDMA, AMPS, NAMPS, TDMA, and GSM wherein the base stations provide a network of cooperative communication channels with an air interface with the MS, and a conventional telecommunications interface with a Mobile Switch Center (MSC). Thus, an MS user within an area serviced by  
20 the base stations may be provided with wireless communication throughout the area by user transparent communication transfers (i.e., “handoffs”) between the user’s MS and these base stations in order to maintain effective telephony service. The mobile switch center (MSC) provides communications and control connectivity among base stations and the public telephone network.

(3.4) The phrase, “composite wireless signal characteristic values” denotes the result of aggregating and filtering a collection of measurements of wireless signal samples, wherein these samples are obtained from the wireless communication between an MS to be  
25 located and the base station infrastructure (e.g., a plurality of networked base stations). However, other phrases are also used herein to denote this collection of derived characteristic values depending on the context and the likely orientation of the reader. For example, when viewing these values from a wireless signal processing perspective of radio engineering, as in the descriptions of the subsequent Detailed Description sections concerned with the aspects of the present invention for receiving MS signal measurements from the base station infrastructure, the phrase typically used is: “RF signal measurements”. Alternatively, from a data processing  
30 perspective, the phrases: “location signature cluster” and “location signal data” are used to describe signal characteristic values between the MS and the plurality of infrastructure base stations substantially simultaneously detecting MS transmissions. Moreover, since the location communications between an MS and the base station infrastructure typically include simultaneous communications with more than one base station, a related useful notion is that of a “location signature” which is the composite wireless signal

09770828-013604  
105210-0280260

characteristic values for signal samples between an MS to be located and a single base station. Also, in some contexts, the phrases: "signal characteristic values" or "signal characteristic data" are used when either or both a location signature(s) and/or a location signature cluster(s) are intended.

5 SUMMARY DISCUSSION

The present invention relates to a wireless mobile station location system. In particular, such a wireless mobile station location system may be decomposed into: (i) a first low level wireless signal processing subsystem for receiving, organizing and conditioning low level wireless signal measurements from a network of base stations cooperatively linked for providing wireless communications with mobile stations (MSs); and (ii) a second high level signal processing subsystem for performing high level data processing for providing most likelihood location estimates for mobile stations.

More precisely, the present invention is a novel signal processor that includes at least the functionality for the high signal processing subsystem mentioned hereinabove. Accordingly, assuming an appropriate ensemble of wireless signal measurements characterizing the wireless signal communications between a particular MS and a networked wireless base station infrastructure have been received and appropriately filtered of noise and transitory values (such as by an embodiment of the low level signal processing subsystem disclosed in a copending PCT patent application titled, "Wireless Location Using A Plurality of Commercial Network Infrastructures," by F. W. LeBlanc, and the present applicant(s); <sup>A3</sup> ~~this copending patent application~~ <sup>A4</sup> being herein incorporated by reference), the present invention uses the output from such a low level signal processing system for determining a most likely location estimate of an MS.

That is, once the following steps are appropriately performed (e.g., by the LeBlanc copending application):

- (4.1) receiving signal data measurements corresponding to wireless communications between an MS to be located (herein also denoted the "target MS") and a wireless telephony infrastructure;
- (4.2) organizing and processing the signal data measurements received from a given target MS and surrounding BSs so that composite wireless signal characteristic values may be obtained from which target MS location estimates may be subsequently derived. In particular, the signal data measurements are ensembles of samples from the wireless signals received from the target MS by the base station infrastructure, wherein these samples are subsequently filtered using analog and digital spectral filtering.

the present invention accomplishes the objectives mentioned above by the following steps:

- (4.3) providing the composite signal characteristic values to one or more MS location hypothesizing computational models (also denoted herein as "first order models" and also "location estimating models"), wherein each such model subsequently determines one or more initial estimates of the location of the target MS based on, for example, the signal processing techniques 2.1 through 2.3 above. Moreover, each of the models output MS location estimates having substantially identical data structures (each such data structure denoted a "location hypothesis"). Additionally, each location hypothesis may also includes a confidence value indicating the likelihood

00770929-043604



09770939-04264  
102210-220200

or probability of the target MS whose location is desired resides in a corresponding location estimate for the target MS;

- 5
- (4.4) adjusting or modifying location hypotheses output by the models according to, for example, 2.4 through 2.6 above so that the adjusted location hypotheses provide better target MS location estimates. In particular, such adjustments are performed on both the target MS location estimates of the location hypotheses as well as their corresponding confidences; and
- (4.4) subsequently computing a “most likely” target MS location estimate for outputting to a location requesting application such as 911 emergency, the fire or police departments, taxi services, etc. Note that in computing the most likely target MS location estimate a plurality of location hypotheses may be taken into account. In fact, it is an important aspect of the present invention that the most likely MS location estimate is determined by
- 10
- computationally forming a composite MS location estimate utilizing such a plurality of location hypotheses so that, for example, location estimate similarities between location hypotheses can be effectively utilized.

Referring now to (4.3) above, the filtered and aggregated wireless signal characteristic values are provided to a number of location hypothesizing models (denoted First Order Models, or FOMs), each of which yields a location estimate or location hypothesis related to the location of the target MS. In particular, there are location hypotheses for both providing estimates of where the target MS likely to be and where the target MS is not likely to be. Moreover, it is an aspect of the present invention that confidence values of the location hypotheses are provided as a continuous range of real numbers from, e.g., -1 to 1, wherein the most unlikely areas for locating the target MS are given a confidence value of -1, and the most likely areas for locating the target MS are given a confidence value of 1. That is, confidence values that are larger indicate a higher likelihood that the target MS is in the corresponding MS estimated area, wherein 1 indicates that the target MS is absolutely NOT in the estimated area, 0 indicates a substantially neutral or unknown likelihood of the target MS being in the corresponding estimated area, and 1 indicates that the target MS is absolutely within the corresponding estimated area.

15

20

Referring to (4.4) above, it is an aspect of the present invention to provide location hypothesis enhancing and evaluation techniques that can adjust target MS location estimates according to historical MS location data and/or adjust the confidence values of location hypotheses according to how consistent the corresponding target MS location estimate is: (a) with historical MS signal characteristic values, (b) with various physical constraints, and (c) with various heuristics. In particular, the following capabilities are provided by the present invention:

25

- (5.1) a capability for enhancing the accuracy of an initial location hypothesis, H, generated by a first order model, FOM<sub>H</sub>, by using H as, essentially, a query or index into an historical data base (denoted herein as the location signature data base), wherein this data base includes: (a) a plurality of previously obtained location signature clusters (i.e., composite wireless signal characteristic values) such that for each such cluster there is an associated actual or verified MS locations where an MS communicated with the base station infrastructure for locating the MS, and (b)
- 30

09770939-013904  
105270-2280760

previous MS location hypothesis estimates from FOM<sub>i</sub> derived from each location signature clusters stored according to (a);

- (5.2) a capability for analyzing composite signal characteristic values of wireless communications between the target MS and the base station infrastructure, wherein such values are compared with composite signal characteristics values of known MS locations (these latter values being archived in the location signature data base). In one instance, the composite signal characteristic values used to generate various location hypotheses for the target MS are compared against wireless signal data of known MS locations stored in the location signature data base for determining the reliability of the location hypothesizing models for particular geographic areas and/or environmental conditions;
- (5.3) a capability for reasoning about the likeliness of a location hypothesis wherein this reasoning capability uses heuristics and constraints based on physics and physical properties of the location geography;
- (5.4) an hypothesis generating capability for generating new location hypotheses from previous hypotheses.

As also mentioned above in (2.3), the present invention utilizes adaptive signal processing techniques. One particularly important utilization of such techniques includes the automatic tuning of the present invention so that, e.g., such tuning can be applied to adjusting the values of location processing system parameters that affect the processing performed by the present invention. For example, such system parameters as those used for determining the size of a geographical area to be specified when retrieving location signal data of known MS locations from the historical (location signature) data base can substantially affect the location processing. In particular, a system parameter specifying a minimum size for such a geographical area may, if too large, cause unnecessary inaccuracies in locating an MS. Accordingly, to accomplish a tuning of such system parameters, an adaptation engine is included in the present invention for automatically adjusting or tuning parameters used by the present invention. Note that in one embodiment, the adaptation engine is based on genetic algorithm techniques.

A novel aspect of the present invention relies on the discovery that in many areas where MS location services are desired, the wireless signal measurements obtained from communications between the target MS and the base station infrastructure are extensive enough to provide sufficiently unique or peculiar values so that the pattern of values alone may identify the location of the target MS. Further, assuming a sufficient amount of such location identifying pattern information is captured in the composite wireless signal characteristic values for a target MS, and that there is a technique for matching such wireless signal patterns to geographical locations, then a FOM based on this technique may generate a reasonably accurate target MS location estimate. Moreover, if the present invention (e.g., the location signature data base) has captured sufficient wireless signal data from location communications between MSs and the base station infrastructure wherein the locations of the MSs are also verified and captured, then this captured data (e.g., location signatures) can be used to train or calibrate such models to associate the location of a target MS with the distinctive signal characteristics between the target MS and one or more base stations. Accordingly, the present invention includes one or more FOMs that may be generally denoted as classification models wherein such FOMs are trained or calibrated to associate particular composite wireless signal characteristic values with a geographical location where a target MS could likely generate the wireless signal samples from which the composite wireless signal characteristic values are derived. Further, the present invention includes the capability for training (calibrating) and retraining (recalibrating) such classification FOMs to automatically

09770929.012664  
105210.0260260

maintain the accuracy of these areas even though substantial changes to the radio coverage area may occur, such as the construction of a new high rise building or seasonal variations (due to, for example, foliage variations).

Note that such classification FOMs that are trained or calibrated to identify target MS locations by the wireless signal patterns produced constitute a particularly novel aspect of the present invention. It is well known in the wireless telephony art that the phenomenon of signal multipath and shadow fading renders most analytical location computational techniques such as time-of-arrival (TOA) or time-difference-of-arrival (TDOA) substantially useless in urban areas and particularly in dense urban areas. However, this same multipath phenomenon also may produce substantially distinct or peculiar signal measurement patterns, wherein such a pattern coincides with a relatively small geographical area. Thus, the present invention utilizes multipath as an advantage for increasing accuracy where for previous location systems multipath has been a source of substantial inaccuracies. Moreover, it is worthwhile to note that the utilization of classification FOMs in high multipath environments is especially advantageous in that high multipath environments are typically densely populated. Thus, since such environments are also capable of yielding a greater density of MS location signal data from MSs whose actual locations can be obtained, there can be a substantial amount of training or calibration data captured by the present invention for training or calibrating such classification FOMs and for progressively improving the MS location accuracy of such models. Moreover, since it is also a related aspect of the present invention to include a plurality stationary, low cost, low power "location detection base stations" (LBS), each having both restricted range MS detection capabilities and a built-in MS, a grid of such LBSs can be utilized for providing location signal data (from the built-in MS) for (re)training or (re)calibrating such classification FOMs.

In one embodiment of the present invention, one or more classification FOMs may each include a learning module such as an artificial neural network (ANN) for associating target MS location signal data with a target MS location estimate. Additionally, one or more classification FOMs may be statistical prediction models based on such statistical techniques as, for example, principle decomposition, partial least squares, or other regression techniques.

It is a further aspect of the present invention that the personal communication system (PCS) infrastructures currently being developed by telecommunication providers offer an appropriate localized infrastructure base upon which to build various personal location systems (PLS) employing the present invention and/or utilizing the techniques disclosed herein. In particular, the present invention is especially suitable for the location of people and/or objects using code division multiple access (CDMA) wireless infrastructures, although other wireless infrastructures, such as, time division multiple access (TDMA) infrastructures and GSM are also contemplated. Note that CDMA personal communications systems are described in the Telephone Industries Association standard IS-95, for frequencies below 1 GHz, and in the Wideband Spread- Spectrum Digital Cellular System Dual-Mode Mobile Station-Base Station Compatibility Standard, for frequencies in the 1.8-1.9 GHz frequency bands, both of which are incorporated herein by reference. Furthermore, CDMA general principles have also been described, for example, in U. S. Patent 5,109,390, to Gilhausen, et al, and CDMA Network Engineering Handbook by Qualcomm, Inc., each of which is also incorporated herein by reference.

AS  
a

Notwithstanding the above mentioned CDMA references, a brief introduction of CDMA is given here. Briefly, CDMA is an electromagnetic signal modulation and multiple access scheme based on spread spectrum communication. Each CDMA signal corresponds to an unambiguous pseudorandom binary sequence for modulating the carrier signal throughout a predetermined

00700904600  
10270220200

spectrum of bandwidth frequencies. Transmissions of individual CDMA signals are selected. Correlation processing of a pseudonoise waveform. In particular, the CDMA signals are separately detected in a receiver by using a correlator, which accepts only signal energy from the selected binary sequence and despreads its spectrum. Thus, when a first CDMA signal is transmitted, the transmissions of unrelated CDMA signals correspond to pseudorandom sequences that do not match the first signal. Therefore, these other signals contribute only to the noise and represent a self-interference generated by the personal communications system.

As mentioned in (1.7) and in the discussion of classification FOMs above, the present invention can substantially automatically retrain and/or recalibrate itself to compensate for variations in wireless signal characteristics (e.g., multipath) due to environmental and/or topographic changes to a geographic area serviced by the present invention. For example, in one embodiment, the present invention optionally includes low cost, low power base stations, denoted location base stations (LBS) above, providing, for example, CDMA pilot channels to a very limited area about each such LBS. The location base stations may provide limited voice traffic capabilities, but each is capable of gathering sufficient wireless signal characteristics from an MS within the location base station's range to facilitate locating the MS. Thus, by positioning the location base stations at known locations in a geographic region such as, for instance, on street lamp poles and road signs, additional MS location accuracy can be obtained. That is, due to the low power signal output by such location base stations, for there to be signaling control communication (e.g., pilot signaling and other control signals) between a location base station and a target MS, the MS must be relatively near the location base station. Additionally, for each location base station not in communication with the target MS, it is likely that the MS is not near to this location base station. Thus, by utilizing information received from both location base stations in communication with the target MS and those that are not in communication with the target MS, the present invention can substantially narrow the possible geographic areas within which the target MS is likely to be. Further, by providing each location base station (LBS) with a co-located stationary wireless transceiver (denoted a built-in MS above) having similar functionality to an MS, the following advantages are provided:

- (6.1) assuming that the co-located base station capabilities and the stationary transceiver of an LBS are such that the base station capabilities and the stationary transceiver communicate with one another, the stationary transceiver can be signaled by another component(s) of the present invention to activate or deactivate its associated base station capability, thereby conserving power for the LBS that operate on a restricted power such as solar electrical power;
- (6.2) the stationary transceiver of an LBS can be used for transferring target MS location information obtained by the LBS to a conventional telephony base station;
- (6.3) since the location of each LBS is known and can be used in location processing, the present invention is able to (re)train and/or (re)calibrate itself in geographical areas having such LBSs. That is, by activating each LBS stationary transceiver so that there is signal communication between the stationary transceiver and surrounding base stations within range, wireless signal characteristic values for the location of the stationary transceiver are obtained for each such base station. Accordingly, such characteristic values can then be associated with the known location of the stationary transceiver for training and/or calibrating various of the location processing modules of the present invention such as the classification FOMs discussed above. In particular, such training and/or calibrating may include:

- (i) (re)training and/or (re)calibrating FOMs;

0070939-016604  
PAGE 23 OF 2386

- (ii) adjusting the confidence value initially assigned to a location hypothesis according to how accurate the generating FOM is in estimating the location of the stationary transceiver using data obtained from wireless signal characteristics of signals between the stationary transceiver and base stations with which the stationary transceiver is capable of communicating;
- (iii) automatically updating the previously mentioned historical data base (i.e., the location signature data base), wherein the stored signal characteristic data for each stationary transceiver can be used for detecting environmental and/or topographical changes (e.g., a newly built high rise or other structures capable of altering the multipath characteristics of a given geographical area); and
- (iv) tuning of the location system parameters, wherein the steps of: (a) modifying various system parameters and (b) testing the performance of the modified location system on verified mobile station location data (including the stationary transceiver signal characteristic data), these steps being interleaved and repeatedly performed for obtaining better system location accuracy within useful time constraints.

It is also an aspect of the present invention to automatically (re)calibrate as in (6.3) above with signal characteristics from other known or verified locations. In one embodiment of the present invention, portable location verifying electronics are provided so that when such electronics are sufficiently near a located target MS, the electronics: (i) detect the proximity of the target MS; (ii) determine a highly reliable measurement of the location of the target MS; (iii) provide this measurement to other location determining components of the present invention so that the location measurement can be associated and archived with related signal characteristic data received from the target MS at the location where the location measurement is performed. Thus, the use of such portable location verifying electronics allows the present invention to capture and utilize signal characteristic data from verified, substantially random locations for location system calibration as in (6.3) above. Moreover, it is important to note that such location verifying electronics can verify locations automatically wherein it is unnecessary for manual activation of a location verifying process.

One embodiment of the present invention includes the location verifying electronics as a "mobile (location) base station" (MBS) that can be, for example, incorporated into a vehicle, such as an ambulance, police car, or taxi. Such a vehicle can travel to sites having a transmitting target MS, wherein such sites may be randomly located and the signal characteristic data from the transmitting target MS at such a location can consequently be archived with a verified location measurement performed at the site by the mobile location base station. Moreover, it is important to note that such a mobile location base station as its name implies also includes base station electronics for communicating with mobile stations, though not necessarily in the manner of a conventional infrastructure base station. In particular, a mobile location base station may only monitor signal characteristics, such as MS signal strength, from a target MS without transmitting signals to the target MS. Alternatively, a mobile location base station can periodically be in bi-directional communication with a target MS for determining a signal time-of-arrival (or time-difference-of-arrival) measurement between the mobile location base station and the target MS. Additionally, each such mobile location base station includes components for estimating the location of the mobile location base station, such mobile location base station location estimates being important when the mobile location base station is used for locating a target MS via, for example, time-of-arrival or time-difference-of-arrival measurements as one skilled in the art will appreciate. In particular, a mobile location base station can include:

(7.1) a mobile station (MS) both communicating with other components of the present invention (such as a location processing center included in the present invention);

(7.2) a GPS receiver for determining a location of the mobile location base station;

(7.3) a gyroscope and other dead reckoning devices; and

5 (7.4) devices for operator manual entry of a mobile location base station location.

Furthermore, a mobile location base station includes modules for integrating or reconciling distinct mobile location base station location estimates that, for example, can be obtained using the components and devices of (7.1) through (7.4) above. That is,

location estimates for the mobile location base station may be obtained from: GPS satellite data, mobile location base station data, ~~dead reckoning data~~ <sup>dead reckoning data</sup> provided by the location processing center, ~~dead reckoning data~~ <sup>dead reckoning data</sup> obtained from the mobile location base station vehicle ~~dead reckoning devices~~ <sup>dead reckoning devices</sup>, and location data manually input by an operator of the mobile location base station.

10 The location estimating system of the present invention offers many advantages over existing location systems. The system of the present invention, for example, is readily adaptable to existing wireless communication systems and can accurately locate people and/or objects in a cost effective manner. In particular, the present invention requires few, if any, modifications to commercial wireless communication systems for implementation. Thus, existing personal communication system infrastructure base stations and other components of, for example, commercial CDMA infrastructures are readily adapted to the present invention. The present invention can be used to locate people and/or objects that are not in the line-of-sight of a wireless receiver or transmitter, can reduce the detrimental effects of multipath on the accuracy of the location estimate, can potentially locate people and/or objects located indoors as well as outdoors, and uses a number of wireless stationary transceivers for location. The present invention employs a number of distinctly different location computational models for location which provides a greater degree of accuracy, robustness and versatility than is possible with existing systems. For instance, the location models provided include not only the radius-radius/TOA and TDOA techniques but also adaptive artificial neural net techniques. Further, the present invention is able to adapt to the topography of an area in which location service is desired. The present invention is also able to adapt to environmental changes substantially as frequently as desired. Thus, the present invention is able to take into account changes in the location topography over time without extensive manual data manipulation. Moreover, the present invention can be utilized with varying amounts of signal measurement inputs. Thus, if a location estimate is desired in a very short time interval (e.g., less than approximately one to two seconds), then the present location estimating system can be used with only as much signal measurement data as is possible to acquire during an initial portion of this time interval. Subsequently, after a greater amount of signal measurement data has been acquired, additional more accurate location estimates may be obtained. Note that this capability can be useful in the context of 911 emergency response in that a first quick course wireless mobile station location estimate can be used to route a 911 call from the mobile station to a 911 emergency response center that has responsibility for the area containing the mobile station and the 911 caller. Subsequently, once the 911 call has been routed according to this first quick location estimate, by continuing to receive additional wireless signal measurements, more reliable and accurate location estimates of the mobile station can be obtained.

Moreover, there are numerous additional advantages of the system of the present invention when applied in CDMA communication systems. The location system of the present invention readily benefits from the distinct advantages of the CDMA

spread spectrum scheme, namely, these advantages include the exploitation of radio frequency spectral efficiency and isolation by (a) monitoring voice activity, (b) management of two-way power control, (c) provisioning of advanced variable-rate modems and error correcting signal encoding, (d) inherent resistance to fading, (e) enhanced privacy, and (f) multiple "rake" digital data receivers and searcher receivers for correlation of signal multipaths.

5 At a more general level, it is an aspect of the present invention to demonstrate the utilization of various novel computational paradigms such as:

- 9 (8.1) providing a multiple hypothesis computational architecture (as illustrated best in ~~Fig. 8~~<sup>Figs. 8, 9</sup>) wherein the hypotheses are:
- (8.1.1) generated by modular independent hypothesizing computational models;
  - (8.1.2) the models are embedded in the computational architecture in a manner wherein the architecture allows for
- 10 substantial amounts of application specific processing common or generic to a plurality of the models to be straightforwardly incorporated into the computational architecture;
- (8.1.3) the computational architecture enhances the hypotheses generated by the models both according to past performance of the models and according to application specific constraints and heuristics without requiring feedback loops for adjusting the models;
  - (8.1.4) the models are relatively easily integrated into, modified and extracted from the computational architecture;
- 15 (8.2) providing a computational paradigm for enhancing an initial estimated solution to a problem by using this initial estimated solution as, effectively, a query or index into an historical data base of previous solution estimates and corresponding actual solutions for deriving an enhanced solution estimate based on past performance of the module that generated the initial estimated solution.

20 Note that the multiple hypothesis architecture provided herein is useful in implementing solutions in a wide range of applications. For example, the following additional applications are within the scope of the present invention:

- (9.1) document scanning applications for transforming physical documents in to electronic forms of the documents. Note that in many cases the scanning of certain documents (books, publications, etc.) may have a 20% character recognition error rate. Thus, the novel computation architecture of the present invention can be utilized by (i) providing a plurality of document scanning models
- 25 as the first order models, (ii) building a character recognition data base for archiving a correspondence between characteristics of actual printed character variations and the intended characters (according to, for example, font types), and additionally archiving a correspondence of performance of each of the models on previously encountered actual printed character variations (note, this is analogous to the Signature Data Base of the MS location application described herein), and (iii) determining any generic constraints and/or heuristics that are desirable to be satisfied by a plurality of the models. Accordingly, by comparing outputs from the first
- 30 order document scanning models, a determination can be made as to whether further processing is desirable due to, for example, discrepancies between the output of the models. If further processing is desirable, then an embodiment of the multiple hypothesis architecture provided herein may be utilized to correct such discrepancies. Note that in comparing outputs from the first order document scanning models, these outputs may be compared at various granularities; e.g., character, sentence, paragraph or page;





0070929-01601  
109210-5202200

Note that in some embodiments of the present invention, since there is a lack of sequencing between the FOMs and subsequent processing of location hypotheses, the FOMs can be incorporated into an expert system, if desired. For example, each FOM may be activated from an antecedent of an expert system rule. Thus, the antecedent for such a rule can evaluate to TRUE if the FOM outputs a location hypothesis, and the consequent portion of such a rule may put the output location hypothesis on a list of location hypotheses occurring in a particular time window for subsequent processing by the location center. Alternatively, activation of the FOMs may be in the consequents of such expert system rules. That is, the antecedent of such an expert system rule may determine if the conditions are appropriate for invoking the FOM(s) in the rule's consequent.

Of course, other software architectures may also be used in implementing the processing of the location center without departing from the scope of the present invention. In particular, object-oriented architectures are also within the scope of the present invention. For example, the FOMs may be object methods on an MS location estimator object, wherein the estimator object receives substantially all target MS location signal data output by the signal filtering subsystem. Alternatively, software bus architectures are contemplated by the present invention, as one skilled in the art will understand, wherein the software architecture may be modular and facilitate parallel processing. <sup>Further features and advantages</sup> Further features and advantages of the present invention are provided by the figures and detailed description accompanying this invention summary.

15

## BRIEF DESCRIPTION OF THE DRAWINGS

Fig. 1 illustrates various perspectives of radio propagation opportunities which may be considered in addressing correlation with mobile to base station ranging.

Fig. 2 shows aspects of the two-ray radio propagation model and the effects of urban clutter.

5 Fig. 3 provides a typical example of how the statistical power budget is calculated in design of a Commercial Mobile Radio ~~Service Provider network~~ **Provider (CMRS) network**

Fig. 4 illustrates an overall view of a wireless radio location network architecture, based on AIN principles.

Fig. 5 is a high level block diagram of an embodiment of the present invention for locating a mobile station (MS) within a radio coverage area for the present invention.

10 Fig. 6 is a high level block diagram of the location center 142.

Fig. 7 is a high level block diagram of the hypothesis evaluator for the location center.

Fig. 8 is a substantially comprehensive high level block diagram illustrating data and control flows between the components of the location center, as well the functionality of the components.

15 Fig. 9 is a high level data structure diagram describing the fields of a location hypothesis object generated by the first order models 1224 of the location center.

Fig. 10 is a graphical illustration of the computation performed by the most likelihood estimator 1344 of the hypothesis evaluator.

Fig. 11 is a high level block diagram of the mobile base station (MBS).

20 Fig. 12 is a high level state transition diagram describing computational states the Mobile Base station enters during operation.

Fig. 13 is a high level diagram illustrating the data structural organization of the Mobile Base station capability for autonomously determining a most likely MBS location from a plurality of potentially conflicting MBS location estimating sources.

Fig. 14 shows one method of modeling CDMA delay spread measurement ensembles and interfacing such signals to a typical artificial neural network based FOM.

25 Fig. 15 illustrates the nature of RF "Dead Zones", notch area, and the importance of including location data signatures from the back side of radiating elements.

Figs. 16a through 16c present a table providing a brief description of the attributes of the location signature data type stored in the location signature data base 1320.

30 Figs. 17a through 17c present a high level flowchart of the steps performed by function, "UPDATE\_LOC\_SIG\_DB," for updating location signatures in the location signature data base 1320; note, this flowchart corresponds to the description of this function in APPENDIX C.

00770830 012604  
PAGEID: 6660260

Figs. 18a through 18b present a high level flowchart of the steps performed by function, "REDUCE\_BAD\_DB\_LOC\_SIGS," for updating location signatures in the location signature data base 1320; note, this flowchart corresponds to the description of this function in APPENDIX C.

5 Figs. 19a through 19b present a high level flowchart of the steps performed by function, "INCREASE\_CONFIDENCE\_OF\_GOOD\_DB\_LOC\_SIGS," for updating location signatures in the location signature data base 1320; note, this flowchart corresponds to the description of this function in APPENDIX C.

Figs. 20a through 20d present a high level flowchart of the steps performed by function, "DETERMINE\_LOCATION\_SIGNATURE\_FIT\_ERRORS," for updating location signatures in the location signature data base 1320; note, this flowchart corresponds to the description of this function in APPENDIX C.

10 Fig. 21 presents a high level flowchart of the steps performed by function, "ESTIMATE\_LOC\_SIG\_FROM\_DB," for updating location signatures in the location signature data base 1320; note, this flowchart corresponds to the description of this function in APPENDIX C.

15 Figs. 22a through 22b present a high level flowchart of the steps performed by function, "GET\_AREA\_TO\_SEARCH," for updating location signatures in the location signature data base 1320; note, this flowchart corresponds to the description of this function in APPENDIX C.

Figs. 23a through 23b present a high level flowchart of the steps performed by function, "GET\_DIFFERENCE\_MEASUREMENT," for updating location signatures in the location signature data base 1320; note, this flowchart corresponds to the description of this function in APPENDIX C.

20 Fig. 24 is a high level illustration of context adjuster data structures and their relationship to the radio coverage area for the present invention;

Figs. 25a through 25b present a high level flowchart of the steps performed by the function, "CONTEXT\_ADJUSTER," used in the context adjuster 1326 for adjusting mobile station estimates provided by the first order models 1224; this flowchart corresponds to the description of this function in APPENDIX D.

25 Figs. 26a through 26c present a high level flowchart of the steps performed by the function, "GET\_ADJUSTED\_LOC\_HYP\_LIST\_FOR," used in the context adjuster 1326 for adjusting mobile station estimates provided by the first order models 1224; this flowchart corresponds to the description of this function in APPENDIX D.

Figs. 27a through 27b present a high level flowchart of the steps performed by the function, "CONFIDENCE\_ADJUSTER," used in the context adjuster 1326 for adjusting mobile station estimates provided by the first order models 1224; this flowchart corresponds to the description of this function in APPENDIX D.

30 Fig. 28a and 28b presents a high level flowchart of the steps performed by the function, "GET\_COMPOSITE\_PREDICTION\_MAPPED\_CLUSTER\_DENSITY," used in the context adjuster 1326 for adjusting mobile station estimates provided by the first order models 1224; this flowchart corresponds to the description of this function in APPENDIX D.

Figs. 29a through 29f present a high level flowchart of the steps performed by function, "GET\_PREDICTION\_MAPPED\_CLUSTER\_DENSITY\_FOR," used in the context adjuster 1326 for adjusting mobile station estimates provided by the first order models 1224; this flowchart corresponds to the description of this function in APPENDIX D.

Fig. 30 illustrates the primary components of the signal processing subsystem.

5 Fig. 31 illustrates how automatic provisioning of mobile station information from multiple CMRS occurs.

00770939 01001

Detailed Description Introduction

Various digital wireless communication standards have been introduced such as Advanced Mobile Phone Service (AMPS), Narrowband Advanced Mobile Phone Service (NAMPS), code division multiple access (CDMA) and Time Division Multiple Access (TDMA) (e.g.,

5 Global Systems Mobile (GSM). These standards provide numerous enhancements for advancing the quality and communication capacity for wireless applications. Referring to CDMA, this standard is described in the Telephone Industries Association standard IS-95, for frequencies below 1 GHz, and in J-STD-008, the Wideband Spread-Spectrum Digital Cellular System Dual-Mode Mobile

10 Station-Base station Compatibility Standard, for frequencies in the 1.8 - 1.9 GHz frequency bands. Additionally, CDMA general principles have been described, for example, in U.S. Patent 5,109,390, Diversity Receiver in a CDMA Cellular Telephone System by Gilhousen. There are numerous advantages of such digital wireless technologies such as CDMA radio technology. For example, the CDMA spread spectrum scheme exploits radio frequency spectral efficiency and isolation by monitoring voice activity, managing two-way power control, provision of advanced variable-rate modems and error correcting signal design, and includes inherent resistance to fading, enhanced privacy, and provides for multiple "rake" digital data receivers and searcher receivers for correlation of multiple

15 physical propagation paths, resembling maximum likelihood detection, as well as support for multiple base station communication with a mobile station, i.e., soft or softer hand-off capability. When coupled with a location center as described herein, substantial improvements in radio location can be achieved. For example, the CDMA spread spectrum scheme exploits radio frequency spectral efficiency and isolation by monitoring voice activity, managing two-way power control, provision of advanced variable-rate modems and error correcting signal design, and includes inherent resistance to fading, enhanced privacy, and provides for multiple "rake"

20 digital data receivers and searcher receivers for correlation of multiple physical propagation paths, resembling maximum likelihood detection, as well as support for multiple base station communication with a mobile station, i.e., soft hand-off capability. Moreover, this same advanced radio communication infrastructure can also be used for enhanced radio location. As a further example, the capabilities of IS-41 and AIN already provide a broad-granularity of wireless location, as is necessary to, for example, properly direct a terminating call to an MS. Such information, originally intended for call processing usage, can be re-used in conjunction with the location center described herein to provide wireless location in the large (i.e., to determine which country, state and city a particular

25 MS is located) and wireless location in the small (i.e., which location, plus or minus a few hundred feet within one or more base stations a given MS is located).

Fig. 4 is a high level diagram of a wireless digital radiolocation intelligent network architecture for the present invention. Accordingly, this figure illustrates the interconnections between the components, for example, of a typical PCS network configuration and various components that are specific to the present invention. In particular, as one skilled in the art will understand, a typical

30 wireless (PCS) network includes:

- (a) a (large) plurality of conventional wireless mobile stations (MSs) 140 for at least one of voice related communication, visual (e.g., text) related communication, and according to present invention, location related communication;
- (b) a mobile switching center (MSC) 112;

00770030 01904  
109210 00002200

(c) a plurality of wireless cell sites in a radio coverage area 120, wherein each cell site includes an infrastructure base station such as those labeled 122 (or variations thereof such as 122A - 122D). In particular, the base stations 122 denote the standard high traffic, fixed location base stations used for voice and data communication with a plurality of MSs 140, and, according to the present invention, also used for communication of information related to locating such MSs 140. Additionally, note that the base stations labeled 152 are more directly related to wireless location enablement. For example, as described in greater detail hereinbelow, the base stations 152 may be low cost, low functionality transponders that are used primarily in communicating MS location related information to the location center 142 (via base stations 122 and the MSC 112). Note that unless stated otherwise, the base stations 152 will be referred to hereinafter as "location base station(s) 152" or simply "LBS(s) 152";

5

(d) a public switched telephone network (PSTN) 124 (which may include signaling system links 106 having network control components such as: a service control point (SCP) 104, one or more signaling transfer points (STPs) 110.

10

Added to this wireless network, the present invention provides the following additional components:

- (10.1) a location center 142 which is required for determining a location of a target MS 140 using signal characteristic values for this target MS;
- (10.2) one or more mobile base stations 148 (MBS) which are optional, for physically traveling toward the target MS 140 or tracking the target MS;
- (10.3) a plurality of location base stations 152 (LBS) which are optional, distributed within the radio coverage areas 120, each LBS 152 having a relatively small MS 140 detection area 154;

15

Since location base stations can be located on potentially each floor of a multi-story building, the wireless location technology described herein can be used to perform location in terms of height as well as by latitude and longitude.

20

In operation, the MS 140 may utilize one of the wireless technologies, CDMA, TDMA, AMPS, NAMPS or GSM techniques for radio communication with: (a) one or more infrastructure base stations 122, (b) mobile base station(s) 148, (c) an LBS 152.

Referring to Fig. 4 again, additional detail is provided of typical base station coverage areas, sectorization, and high level components within a radio coverage area 120, including the MSC 112. Although base stations may be placed in any configuration, a typical deployment configuration is approximately in a cellular honeycomb pattern, although many practical tradeoffs exist, such as site availability, versus the requirement for maximal terrain coverage area. To illustrate, three such exemplary base stations (BSs) are 122A, 122B and 122C, each of which radiate referencing signals within their area of coverage 169 to facilitate mobile station (MS) 140 radio frequency connectivity, and various timing and synchronization functions. Note that some base stations may contain no sectors 130 (e.g. 122E), thus radiating and receiving signals in a 360 degree omnidirectional coverage area pattern, or the base station may contain "smart antennas" which have specialized coverage area patterns. However, the generally most frequent base stations 122 have three sector 130 coverage area patterns. For example, base station 122A includes sectors 130, additionally labeled a, b and c. Accordingly, each of the sectors 130 radiate and receive signals in an approximate 120 degree arc, from an overhead view. As one skilled in the art will understand, actual base station coverage areas 169 (stylistically represented by hexagons about the base

25

30



0970998-0364  
05210-8280260

Referring to Fig. 4 again, the location center (LC) 142 interfaces with the MSC 140 via dedicated transport facilities 178, using for example, any number of LAN/WAN technologies, such as Ethernet, fast Ethernet, frame relay, virtual private networks, etc., or via the PSTN 124. The LC 142 receives autonomous (e.g., unsolicited) command/response messages regarding, for example: (a) the state of the wireless network of each service provider, (b) MS 140 and BS 122 radio frequency (RF) measurements, (c) any MBSs 148, (d) location applications requesting MS locations using the location center. Conversely, the LC 142 provides data and control information to each of the above components in (a) - (d). Additionally, the LC 142 may provide location information to an MS 140, via a BS 122. Moreover, in the case of the use of a mobile base station (MBS) 148, several communications paths may exist with the LC 142.

The MBS 148 acts as a low cost, partially-functional, moving base station, and is, in one embodiment, situated in a vehicle where an operator may engage in MS 140 searching and tracking activities. In providing these activities using CDMA, the MBS 148 provides a forward link pilot channel for a target MS 140, and subsequently receives unique BS pilot strength measurements from the MS 140. The MBS 148 also includes a mobile station for data communication with the LC 142, via a BS 122. In particular, such data communication includes telemetering the geographic position of the MBS 148 as well as various RF measurements related to signals received from the target MS 140. In some embodiments, the MBS 148 may also utilize multiple-beam fixed antenna array elements and/or a moveable narrow beam antenna, such as a microwave dish 182. The antennas for such embodiments may have a known orientation in order to further deduce a radio location of the target MS 140 with respect to an estimated current location of the MBS 148. As will be described in more detail herein below, the MBS 148 may further contain a global positioning system (GPS), distance sensors, dead-reckoning electronics, as well as an on-board computing system and display devices for locating both the MBS 148 and MS 140. The computing and display provides a means for communicating the position of the target MS 140 on a map display to an operator of the MBS 148.

Each location base station (LBS) 152 is a low cost location device. Each such LBS 152 communicates with one or more of the infrastructure base stations 122 using one or more wireless technology interface standards. In some embodiments, to provide such LBS's cost effectively, each LBS 152 only partially or minimally supports the air-interface standards of the one or more wireless technologies used in communicating with both the BSs 122 and the MSs 140. Each LBS 152, when put in service, is placed at a fixed location, such as at a traffic signal, lamp post, etc., and wherein the location of the LBS may be determined as accurately as, for example, the accuracy of the locations of the infrastructure BSs 122. Assuming the wireless technology CDMA is used, each BS 122 uses a time offset of the pilot PN sequence to identify a forward CDMA pilot channel. In one embodiment, each LBS 152 emits a unique, time-offset pilot PN sequence channel in accordance with the CDMA standard in the RF spectrum designated for BSs 122, such that the channel does not interfere with neighboring BSs 122 cell site channels, nor would it interfere with neighboring LBSs 152. However, as one skilled in the art will understand, time offsets, in CDMA chip sizes, may be re-used within a PCS system, thus providing efficient use of pilot time offset chips, thereby achieving spectrum efficiency. Each LBS 152 may also contain multiple wireless receivers in order to monitor transmissions from a target MS 140. Additionally, each LBS 152 contains mobile station 140 electronics, thereby allowing the LBS to both be controlled by the LC 142, and to transmit information to the LC 142, via at least one neighboring BS 122.





native operations messages inherent in the product offering, without any special modification. In the second case the L-API includes a full suite of commands and messaging content specifically optimized for wireless location purposes, which may require some, although minor development on the part of the MSC vendor.

5 Signal Processor Description

Referring to Fig. 30, the signal processing subsystem receives control messages and signal measurements and transmits appropriate control messages to the wireless network via the location applications programming interface referenced earlier, for wireless location purposes. The signal processing subsystem additionally provides various signal identification, conditioning and pre-processing functions, including buffering, signal type classification, signal filtering, message control and routing functions to the location estimate modules.

There can be several combinations of Delay Spread/Signal Strength sets of measurements made available to the signal processing subsystem 20. In some cases the mobile station 140 (Fig. 4) may be able to detect up to three or four Pilot Channels representing three to four Base Stations, or as few as one Pilot Channel, depending upon the environment. Similarly, possibly more than one BS 122 can detect a mobile station 140 transmitter signal, as evidenced by the provision of cell diversity or soft hand-off in the CDMA standards, and the fact that multiple CMRS' base station equipment commonly will overlap coverage areas. For each mobile station 140 or BS 122 transmitted signal detected by a receiver group at a station, multiple delayed signals, or "fingers" may be detected and tracked resulting from multipath radio propagation conditions, from a given transmitter.

In typical spread spectrum diversity CDMA receiver design, the "first" finger represents the most direct, or least delayed multipath signal. Second or possibly third or fourth fingers may also be detected and tracked, assuming the mobile station contains a sufficient number of data receivers. Although traditional TOA and TDOA methods would discard subsequent fingers related to the same transmitted finger, collection and use of these additional values can prove useful to reduce location ambiguity, and are thus collected by the Signal Processing subsystem in the Location Center 142.

From the mobile receiver's perspective, a number of combinations of measurements could be made available to the Location Center. Due to the disperse and near-random nature of CDMA radio signals and propagation characteristics, traditional TOA/TDOA location methods have failed in the past, because the number of signals received in different locations are different. In a particularly small urban area, say less than 500 square feet, the number of RF signals and their multipath components may vary by over 100 percent.

Due to the large capital outlay costs associated with providing three or more overlapping base station coverage signals in every possible location, most practical digital PCS deployments result in fewer than three base station pilot channels being reportable in the majority of location areas, thus resulting in a larger, more amorphous location estimate. This consequence requires a family of location estimate location modules, each firing whenever suitable data has been presented to a model, thus providing a location estimate to a backend subsystem which resolves ambiguities.

In one embodiment of this invention using backend hypothesis resolution, by utilizing existing knowledge concerning base station coverage area boundaries (such as via the compilation a RF coverage database - either via RF coverage area simulations or

field tests), the location error ~~s~~ decreased. Negative logic Venn diagrams can be generated which deductively rule out certain location estimate hypotheses.

Although the forward link mobile station's received relative signal strength (RRSS<sub>BS</sub>) of detected nearby base station transmitter signals can be used directly by the location estimate modules, the CDMA base station's reverse link received relative signal strength (RRSS<sub>MS</sub>) of the detected mobile station transmitter signal must be modified prior to location estimate model use, since the mobile station transmitter power level changes nearly continuously, and would thus render relative signal strength useless for location purposes.

One adjustment variable and one factor value are required by the signal processing subsystem in the CDMA air interface case: 1.) instantaneous relative power level in dBm (IRPL) of the mobile station transmitter, and 2.) the mobile station Power Class.

By adding the IRPL to the RRSS<sub>MS</sub>, a synthetic relative signal strength (SRSS<sub>MS</sub>) of the mobile station 140 signal detected at the BS 122 is derived, which can be used by location estimate model analysis, as shown below:

$$SRSS_{MS} = RRSS_{MS} + IRPL \quad (\text{in dBm})$$

SRSS<sub>MS</sub>, a corrected indication of the effective path loss in the reverse direction (mobile station to BS), is now comparable with RRSS<sub>BS</sub> and can be used to provide a correlation with either distance or shadow fading because it now accounts for the change of the mobile station transmitter's power level. The two signals RRSS<sub>BS</sub> and SRSS<sub>MS</sub> can now be processed in a variety of ways to achieve a more robust correlation with distance or shadow fading.

Although Rayleigh fading appears as a generally random noise generator, essentially destroying the correlation value of either RRSS<sub>BS</sub> or SRSS<sub>MS</sub> measurements with distance individually, several mathematical operations or signal processing functions can be performed on each measurement to derive a more robust relative signal strength value, overcoming the adverse Rayleigh fading effects. Examples include averaging, taking the strongest value and weighting the strongest value with a greater coefficient than the weaker value, then averaging the results. This signal processing technique takes advantage of the fact that although a Rayleigh fade may often exist in either the forward or reverse path, it is much less probable that a Rayleigh fade also exists in the reverse or forward path, respectively. A shadow fade however, similarly affects the signal strength in both paths.

At this point a CDMA radio signal "direction-independent" net relative signal strength measurement is derived which is used to establish a correlation with either distance or shadow fading, or both. Although the ambiguity of either shadow fading or distance cannot be determined, other means can be used in conjunction, such as the fingers of the CDMA delay spread measurement, and any other TOA/TDOA calculations from other geographical points. In the case of a mobile station with a certain amount of shadow fading between its BS 122 (Fig. 2), the first finger of a CDMA delay spread signal is most likely to be a relatively shorter duration than the case where the mobile station 140 and BS 122 are separated by a greater distance, since shadow fading does not materially affect the arrival time delay of the radio signal.

By performing a small modification in the control electronics of the CDMA base station and mobile station receiver circuitry, it is possible to provide the signal processing subsystem 20 (reference Fig. 30) within the Location Center 142 (Fig. 1) with

00770838.01501  
TOP SECRET



00770839.012504

urgency of the time required to <sup>Subsystem 1220 supports</sup> order a location estimate, fewer or more signal measurements <sup>provided by the location A9</sup> samples can be taken and stored in the input queue(s) 7 accordingly.

a The signal processing <sup>Subsystem 1220 supports</sup> subsystem supports a variety of wireless network signaling measurement capabilities by detecting the capabilities of the mobile and base station through messaging structures <sup>provided by the location A9</sup> provided by the location application programming interface.

5 Detection is accomplished in the signal classifier 9 (Fig. 30) by referencing a mobile station database table within the signal processor database 26, which provides, given a mobile station identification number, mobile station revision code, other mobile station characteristics. <sup>Similarly, a</sup> ~~characteristics. Similarly, a~~ mobile switch center table 31 provides MSC characteristics and identifications to the signal classifier/filter 9. The signal classifier/filter adds additional message header information that further classifies the measurement data which allows the digital signal processor and image filter components to select the proper internal processing subcomponents to perform

10 operations on the signal measurement data, for use by the location estimate modules. Regarding service control point messages <sup>A10</sup> autonomously received from the input queue 7, the signal classifier/filter 9 <sup>determines</sup> determines via a signal processing database 26 query <sup>whether such a message</sup> that the message is to be associated with a home base station module. Thus appropriate header information is added to the message, thus enabling the message to pass through the digital signal processor 17 <sup>queue 21</sup> unaffected to the output ~~queue 21~~, and then to the router/distributor 23. The router/distributor 23 then routes the message to the HBS

15 first order model. Those skilled in the art will understand that associating location requests from Home Base Station configurations require substantially less data: the mobile identification number and the associated wireline telephone number transmission from the home location register are on the order of less than 32 bytes. Consequentially the home base station message type could be routed without any digital signal processing. Output queue(s) 21 are required for similar reasons as input queues 7: relatively large amounts of data must be held in a specific

20 a format for further location processing by the location <sup>estimate modules 1224</sup> ~~estimate modules~~. The router and distributor component 23 is responsible to directing specific signal measurement data types and structures to their appropriate modules. For example, the HBS FOM has no use for digital filtering structures, whereas the TDOA module would not be able to process an HBS response message.

The controller 15 is responsible for staging the movement of data among the signal processing subsystem 20 components input queue 25 a 7, digital signal processor 17, router/distributor 23 and the output queue 21, and to initiate signal <sup>measurements</sup> measurements within the wireless network, in response from an <sup>internet USB location</sup> ~~internet USB location~~ request message in <sup>Fig. 5</sup> Fig. 1, via the location application programming interface.

In addition the controller 15 receives autonomous messages from the MSC, via the location applications programming <sup>Fig. 30</sup> interface (Fig. 4) or L-API and the input queue 7, whenever a 9-1-1 wireless call is originated. The mobile switch center provides this <sup>by specifying</sup> autonomous notification to the location system as follows: ~~by specifying~~ the appropriate mobile switch center operations and 30 maintenance commands to surveil calls based on certain digits dialed such as 9-1-1, the location applications programming interface, in communications with the MSCs, receives an autonomous notification whenever a mobile station user dials 9-1-1. Specifically, a bi-directional authorized communications port is configured, usually at the operations and maintenance subsystem of the MSCs, or with their associated network element manager system(s), with a data circuit, such as a DS-1, with the location applications programming

00770899.015601  
109270.0000260

interface in Fig. 1. Next, the "a" capability of the mobile switch center is activated (the respective communications port). The exact implementation of the vendor-specific man-machine or Open Systems Interface (OSI) commands(s) and their associated data structures generally vary among MSC vendors, however the trace function is generally available in various forms, and is required in order to comply with Federal Bureau of Investigation authorities for wire tap purposes. After the appropriate surveillance commands are established on the MSC, such 9-1-1 call notifications messages containing the mobile station identification number (MIN) and, in phase I E9-1-1 implementations, a pseudo-automatic number identification (a.k.a. pANI) which provides an association with the primary base station in which the 9-1-1 caller is in communication. In cases where the pANI is known from the onset, the signal processing subsystem avoids querying the MSC in question to determine the primary base station identification associated with the 9-1-1 mobile station caller.

10 After the signal processing controller 15 receives the first message type, the autonomous notification message from the mobile switch center 112 to the location system 42, containing the mobile identification number and optionally the primary base station identification, the controller 15 queries the base station table 13 in the signal processor database 26 to determine the status and availability of any neighboring base stations, including those base stations of other CMRS in the area. The definition of neighboring base stations include not only those within a provisionable "hop" based on the cell design reuse factor, but also includes, in the case of CDMA, results from remaining set information autonomously queried to mobile stations, with results stored in the base station table. Remaining set information indicates that mobile stations can detect other base station (sector) pilot channels which may exceed the "hop" distance, yet are nevertheless candidate base stations (or sectors) for wireless location purposes. Although cellular and digital cell design may vary, "hop" distance is usually one or two cell coverage areas away from the primary base station's cell coverage area.

20 Having determined a likely set of base stations which may both detect the mobile station's transmitter signal, as well as to determine the set of likely pilot channels (i.e., base stations and their associated physical antenna sectors) detectable by the mobile station in the area surrounding the primary base station (sector), the controller 15 initiates messages to both the mobile station and appropriate base stations (sectors) to perform signal measurements and to return the results of such measurements to the signal processing system regarding the mobile station to be located. This step may be accomplished via several interface means. In a first case the controller 15 utilizes, for a given MSC, predetermined storage information in the MSC table 31 to determine which type of commands, such as man-machine or OSI commands are needed to request such signal measurements for a given MSC. The controller generates the mobile and base station signal measurement commands appropriate for the MSC and passes the commands via the input queue 7 and the locations application programming interface in Fig. 4, to the appropriate MSC, using the authorized communications port mentioned earlier. In a second case, the controller 15 communicates directly with base stations within having to interface directly with the MSC for signal measurement extraction.

Upon receipt of the signal measurements, the signal classifier 9 in Fig. 30 examines location application programming interface-provided message header information from the source of the location measurement (for example, from a fixed BS 122, a

CONFIDENTIAL

mobile station 140, a distributed antenna system 168 in Fig. 4 or message location data (to a home base station), provided by the location applications programming interface (LAPI) via the input queue 7 in Fig. 30 and determines whether or not device filters 17 or image filters 19 are needed, and assesses a relative priority in processing, such as an emergency versus a background location task, in terms of grouping like data associated with a given location request. In the case where multiple signal measurement requests are outstanding for various base stations, some of which may be associated with a different CMRS network, and additional signal classifier function includes sorting and associating the appropriate incoming signal measurements together such that the digital signal processor 17 processes related measurements in order to build ensemble data sets. Such ensembles allow for a variety of functions such as averaging, outlier removal over a timeperiod, and related filtering functions, and further prevent association errors from occurring in location estimate processing.

Another function of the signal classifier/low pass filter component 9 is to filter information that is not useable, or information that could introduce noise or the effect of noise in the location estimate modules. Consequently low pass matching filters are used to match the in-common signal processing components to the characteristics of the incoming signals. Low pass filters match Mobile Station, base station, CMRS and MSC characteristics, as well as to classify Home Base Station messages.

The signal processing subsystem contains a base station database table 13 (Fig. 30) which captures the maximum number of CDMA delay spread fingers for a given base station.

The base station identification code, or CLLI or common language level identification code is useful in identifying or relating a human-labeled name descriptor to the Base Station. Latitude, Longitude and elevation values are used by other subsystems in the location system for calibration and estimation purposes. As base stations and/or receiver characteristics are added, deleted, or changed with respect to the network used for location purposes, this database table must be modified to reflect the current network configuration.

Just as an upgraded base station may detect additional CDMA delay spread signals, newer or modified mobile stations may detect additional pilot channels or CDMA delay spread fingers. Additionally different makes and models of mobile stations may acquire improved receiver sensitivities, suggesting a greater coverage capability. A table may establish the relationships among various mobile station equipment suppliers and certain technical data relevant to this location invention.

Although not strictly necessary, the MIN can be populated in this table from the PCS Service Provider's Customer Care system during subscriber activation and fulfillment, and could be changed at deactivation, or anytime the end-user changes mobile stations. Alternatively, since the MIN, manufacturer, model number, and software revision level information is available during a telephone call, this information could be extracted during the call, and the remaining fields populated dynamically, based on manufacturer's specifications information previously stored in the signal processing subsystem 20. Default values are used in cases where the MIN is not found, or where certain information must be estimated.

A low pass mobile station filter, contained within the signal classifier/low pass filter 9 of the signal processing subsystem 20, uses the above table data to perform the following functions: 1) act as a low pass filter to adjust the nominal assumptions related to the maximum number of CDMA fingers, pilots detectable; and 2) to determine the transmit power class and the receiver thermal noise floor. Given the detected reverse path signal strength, the required value of SRSS<sub>MS</sub>, a corrected indication of the effective path

00770030-042501

loss in the reverse direction (mobile station to BS), can be calculated based data contained in the mobile station table 11, stored in the signal processing database 26.

a The effects of the <sup>maximum power number</sup> ~~maximum number~~ of CDMA fingers allowed and the maximum number of pilot channels allowed essentially form a low pass filter effect, wherein the least common denominator of characteristics are used to filter the incoming RF signal measurements such that a one for one matching occurs. The effect of the transmit power class and receiver thermal noise floor values is to normalize the characteristics of the incoming RF signals with respect to those RF signals used.

The signal classifier/filter 20 is in communication with both the input queue 7 and the signal processing database 26. In the early stage of a location request the signal processing subsystem 142 in Fig. 4, will receive the initiating location request from either an autonomous 9-1-1 notification message from a given MSC, or from a location application (for example, see Fig. 36), for which mobile station characteristics about the target mobile station 140 <sup>(Fig. 4)</sup> ~~(Fig. 4)~~ is required. Referring to Fig. 30, a query is made from the <sup>processing</sup> ~~signal processing~~ controller 15 to the signal processing database 26, specifically the mobile station table 11, to determine if the mobile station characteristics associated with the MIN to be located is available in ~~table 11~~ <sup>table 11. If the data</sup> ~~table 11~~. If the data exists then there is no need for the controller 15 to query the wireless network in order to determine the mobile station characteristics, thus avoiding additional real-time processing which would otherwise be required across the air interface, in order to determine the mobile station MIN characteristics. The resulting mobile station information may be provided either via the signal processing database 26 or alternatively a query may be performed directly from the signal processing subsystem 20 to the MSC in order to determine the mobile station characteristics.

a Referring now to Fig. 31, <sup>another location</sup> ~~location~~ application programming interface, <sup>L-API-CCS 239</sup> ~~L-API-CCS 139~~ to the appropriate CMRS customer care system provides the mechanism to populate and update the mobile station table 11 within the database 26. The <sup>L-API-CCS 239</sup> ~~L-API-CCS 139~~ contains its own set of separate input and output queues or similar implementations and security controls to ensure that provisioning data is not sent to the incorrect CMRS, and that a given CMRS cannot access any other CMRS' data. The interface 1155a to the customer care system for CMRS-A 1150a provides an autonomous or periodic notification and response application layer protocol type, consisting of add, delete, change and verify message functions in order to update the mobile station table 11 within the signal processing database 26, via the controller 15. A similar interface <sup>1155b</sup> ~~1155a~~ is used to enable provisioning updates to be received from CMRS-B customer care system 1150b.

Although the L-API-CCS application message set may be any protocol type which supports the autonomous notification message with positive acknowledgment type, the TIMI.5 group within the American National Standards Institute has defined a good starting point in which the <sup>L-API-CCS 239</sup> ~~L-API-CCS~~ could be implemented, using the robust OSI TMN X-interface at the service management layer. The object model defined in Standards proposal number TIMI.5/96-22R9, Operations Administration, Maintenance, and Provisioning (OAM&P) - Model for Interface Across Jurisdictional Boundaries to Support Electronic Access Service Ordering: Inquiry Function, can be extended to support the L-API-CCS information elements as required and further discussed below. Other choices in which the L-API-CCS application message set may be implemented include ASCII, binary, or any encrypted message set encoding using the Internet protocols, such as TCP/IP, simple network management protocol, http, https, and email protocols.



00770030.043804

Referring to the digital processor (DSP) 17, in communication with the classifier/LP filter 9, the DSP 17 provides a time series expansion method to convert non-HBS data from a format of an signal measure data ensemble of time-series based radio frequency data measurements, collected as discrete time-slice samples, to a three dimensional matrix location data value image representation. Other techniques further filter the resultant image in order to furnish a less noisy training and actual data sample to the location estimate modules.

After 128 samples (in one embodiment) of data are collected of the delay spread-relative signal strength RF data measurement sample: mobile station RX for BS-1 and grouped into a quantization matrix, where rows constitute relative signal strength intervals and columns define delay intervals. As each measurement row, column pair (which could be represented as a complex number or Cartesian point pair) is added to their respective values to generate a Z direction of frequency of recurring measurement value pairs or a density recurrence function. By next applying a grid function to each x, y, and z value, a three-dimensional surface grid is generated, which represents a location data value or unique print of that 128-sample measurement.

In the general case where a mobile station is located in an environment with varied clutter patterns, such as terrain undulations, unique man-made structure geometries (thus creating varied multipath signal behaviors), such as a city or suburb, although the first CDMA delay spread finger may be the same value for a fixed distance between the mobile station and BS antennas, as the mobile station moves across such an area, different finger-data are measured. In the right image for the defined BS antenna sector, location classes, or squares numbered one through seven, are shown across a particular range of line of position (LOP).

A traditional TOA/TDOA ranging method between a given BS and mobile station only provides a range along the arc, thus introducing ambiguity error. However a unique three dimensional image can be used in this method to specifically identify, with recurring probability, a particular unique location class along the same Line Of Position, as long as the multipath is unique by position but generally repeatable, thus establishing a method of not only ranging, but also of complete latitude, longitude location estimation in a Cartesian space. In other words, the unique shape of the "mountain image" enables a correspondence to a given unique location class along a line of position, thereby eliminating traditional ambiguity error.

Although man-made external sources of interference, Rayleigh fades, adjacent and co-channel interference, and variable clutter, such as moving traffic introduce unpredictability (thus no "mountain image" would ever be exactly alike), three basic types of filtering methods can be used to reduce matching/comparison error from a training case to a location request case: 1.) select only the strongest signals from the forward path (BS to mobile station) and reverse path (mobile station to BS), 2.) Convolute the forward path 128 sample image with the reverse path 128 sample image, and 3.) process all image samples through various digital image filters to discard noise components.

In one embodiment, convolution of forward and reverse images is performed to drive out noise. This is one embodiment that essentially nulls noise completely, even if strong and recurring, as long as that same noise characteristic does not occur in the opposite path.

The third embodiment or technique of processing CDMA delay spread profile images through various digital image filters, provides a resultant "image enhancement" in the sense of providing a more stable pattern recognition paradigm to the neural net

CONFIDENTIAL

location estimate model. For example, image histogram equalization can be used to rearrange the images' intensity values, or density recurrence values, so that the image's cumulative histogram is approximately linear.

Other methods which can be used to compensate for a concentrated histogram include: 1) Input Cropping, 2) Output Cropping and 3) Gamma Correction. Equalization and input cropping can provide particularly striking benefits to a CDMA delay spread profile image. Input cropping removes a large percentage of random signal characteristics that are non-recurring.

Other filters and/or filter combinations can be used to help distinguish between stationary and variable clutter affecting multipath signals. For example, it is desirable to reject multipath fingers associated with variable clutter, since over a period of a few minutes such fingers would not likely recur. Further filtering can be used to remove recurring (at least during the sample period), and possibly strong but narrow "pencils" of RF energy. A narrow pencil image component could be represented by a near perfect reflective surface, such as a nearby metal panel truck stopped at a traffic light.

On the other hand, stationary clutter objects, such as concrete and glass building surfaces, adsorb some radiation before continuing with a reflected ray at some delay. Such stationary clutter-affected CDMA fingers are more likely to pass a 4X4 neighbor Median filter as well as a 40 to 50 percent Input Crop filter, and are thus more suited to neural net pattern recognition.. However when subjected to a 4X4 neighbor Median filter and 40 percent clipping, pencil-shaped fingers are deleted. Other combinations include, for example, a 50 percent cropping and 4X4 neighbor median filtering. Other filtering methods include custom linear filtering, adaptive (Weiner) filtering, and custom nonlinear filtering.

The DSP 17 may provide data <sup>ensemble</sup> results, such as extracting the shortest time delay with a detectable relative signal strength, to the router/distributor 23, or alternatively results may be processed via one or more image filters 19, with subsequent transmission to the router/distributor 23. The router/distributor 23 examines the processed message data from the DSP 17 and stores routing and distribution information in the message header. The router/distributor 23 then forwards the data messages to the output queue 21, for subsequent queuing then transmission to the appropriate location estimator FOMs.

LOCATION CENTER HIGH LEVEL FUNCTIONALITY

At a very high level the location center 142 computes location estimates for a wireless Mobile Station 140 (denoted the "target MS" or "MS") by performing the following steps:

- (23.1) receiving signal transmission characteristics of communications communicated between the target MS 140 and one or more wireless infrastructure base stations 122;
- (23.2) filtering the received signal transmission characteristics (by a signal processing subsystem 1220 illustrated in Fig. 5) as needed so that target MS location data can be generated that is uniform and consistent with location data generated from other target MSs 140. In particular, such uniformity and consistency is both in terms of data structures and interpretation of signal characteristic values provided by the MS location data;

00770029  
1456743

(23.3) inputting the generated target MS location data to one or more MS location estimating models (denoted First order models or FOMs, and labeled collectively as 1224 in Fig. 5), so that each such model may use the input target MS location data for generating a "location hypothesis" providing an estimate of the location of the target MS 140;

5 (23.4) providing the generated location hypotheses to an hypothesis evaluation module (denoted the hypothesis evaluator 1228 in Fig. 5):

(a) for adjusting at least one of the target MS location estimates of the generated location hypotheses and related confidence values indicating the confidence given to each location estimate, wherein such adjusting uses archival information related to the accuracy of previously generated location hypotheses,

10 (b) for evaluating the location hypotheses according to various heuristics related to, for example, the radio coverage area 120 terrain, the laws of physics, characteristics of likely movement of the target MS 140; and

(c) for determining a most likely location area for the target MS 140, wherein the measurement of confidence associated with each input MS location area estimate is used for determining a "most likely location area"; and

15 a (23.5) outputting a most likely target MS location estimate to one or more applications 1232 (Fig. 2.0) requesting an estimate of the location of the target MS 140. <sup>application 126 (Fig. 5)</sup>

15 Location Hypothesis Data Representation

In order to describe how the steps (23.1) through (23.5) are performed in the sections below, some introductory remarks related to the data denoted above as location hypotheses will be helpful. Additionally, it will also be helpful to provide introductory remarks related to historical location data and the data base management programs associated therewith.

20 For each target MS location estimate generated and utilized by the present invention, the location estimate is provided in a data structure (or object class) denoted as a "location hypothesis" (illustrated in Table LH-1). Although brief descriptions of the data fields for a location hypothesis is provided in the Table LH-1, many fields require additional explanation. Accordingly, location hypothesis data fields are further described as noted below.

Table LH-1

FOM_ID	First order model ID (providing this Location Hypothesis); note, since it is possible for location hypotheses to be generated by other than the FOMs 1224, in general, this field identifies the module that generated this location hypothesis.
MS_ID	The identification of the target MS 140 to this location hypothesis applies.
pt_est	The most likely location point estimate of the target MS 140.
valid_pt	Boolean indicating the validity of "pt_est".





00770028.00000000

Additionally, in utilizing location hypotheses in, for example, the location evaluation 228 as in (23.4) above, it is important to keep in mind that each location hypothesis confidence value is a relative measurement. That is, for confidences,  $cf_1$  and  $cf_2$ , if  $cf_1 \leq cf_2$ , then for a location hypotheses  $H_1$  and  $H_2$  having  $cf_1$  and  $cf_2$ , respectively, the target MS 140 is expected to more likely reside in a target MS estimate of  $H_2$  than a target MS estimate of  $H_1$ . Moreover, if an area,  $A$ , is such that it is included in a plurality of location hypothesis target MS estimates, then a confidence score,  $CS_A$ , can be assigned to  $A$ , wherein the confidence score for such an area is a function of the confidences (both positive and negative) for all the location hypotheses whose (most pertinent) target MS location estimates contain  $A$ . That is, in order to determine a most likely target MS location area estimate for outputting from the location center 142, a confidence score is determined for areas within the location center service area. More particularly, if a function, "f", is a function of the confidence(s) of location hypotheses, and  $f$  is a monotonic function in its parameters and  $f(cf_1, cf_2, cf_3, \dots, cf_n) = CS_A$  for confidences  $cf_i$  of location hypotheses  $H_i$ ,  $i = 1, 2, \dots, N$ , with  $CS_A$  contained in the area estimate for  $H_i$ , then "f" is denoted a confidence score function. Accordingly, there are many embodiments for a confidence score function  $f$  that may be utilized in computing confidence scores with the present invention; e.g.,

(a)  $f(cf_1, cf_2, \dots, cf_n) = S cf_i = CS_A$ ;

(b)  $f(cf_1, cf_2, \dots, cf_n) = S cf_i^n = CS_A$ ,  $n = 1, 3, 5, \dots$ ;

(c)  $f(cf_1, cf_2, \dots, cf_n) = S (K_i * cf_i) = CS_A$ , wherein  $K_i$ ,  $i = 1, 2, \dots$  are positive system (tunable) constants (possibly dependent on environmental characteristics such as topography, time, date, traffic, weather, and/or the type of base station(s) 122 from which location signatures with the target MS 140 are being generated, etc.).

For the present description of the invention, the function  $f$  as defined in (c) immediately above is utilized. However, for obtaining a general understanding of the present invention, the simpler confidence score function of (a) may be more useful. It is important to note, though, that it is within the scope of the present invention to use other functions for the confidence score function.

**Coverage Area: Area Types And Their Determination**

The notion of "area type" as related to wireless signal transmission characteristics has been used in many investigations of radio signal transmission characteristics. Some investigators, when investigating such signal characteristics of areas have used somewhat naive area classifications such as urban, suburban, rural, etc. However, it is desirable for the purposes of the present invention to have a more operational definition of area types that is more closely associated with wireless signal transmission behaviors.

To describe embodiments of the an area type scheme used in the present invention, some introductory remarks are first provided. Note that the wireless signal transmission behavior for an area depends on at least the following criteria:

(23.8.1) substantially invariant terrain characteristics (both natural and man-made) of the area; e.g., mountains, buildings, lakes, highways, bridges, building density;

(23.8.2) time varying environmental characteristics (both natural and man-made) of the area; e.g., foliage, traffic, weather, special events such as baseball games;

(23.8.3) wireless communication components or infrastructure in the area; e.g., arrangement and signal communication characteristics of the base stations 122 in the area. Further, the antenna characteristics at the base stations 122 may be important criteria.

Accordingly, a description of wireless signal characteristics for determining area types could potentially include a characterization of wireless signaling attributes as they relate to each of the above criteria. Thus, an area type might be: hilly, treed, suburban, having no buildings above 50 feet, with base stations spaced apart by two miles. However, a categorization of area types is desired that is both more closely tied to the wireless signaling characteristics of the area, and is capable of being computed substantially automatically and repeatedly over time. Moreover, for a wireless location system, the primary wireless signaling characteristics for categorizing areas into at least minimally similar area types are: thermal noise and, more importantly, multipath characteristics (e.g., multipath fade and time delay).

Focusing for the moment on the multipath characteristics, it is believed that (23.8.1) and (23.8.3) immediately above are, in general, more important criteria for accurately locating an MS 140 than (23.8.2). That is, regarding (23.8.1), multipath tends to increase as the density of nearby vertical area changes increases. For example, multipath is particularly problematic where there is a high density of high rise buildings and/or where there are closely spaced geographic undulations. In both cases, the amount of change in vertical area per unit of area in a horizontal plane (for some horizontal reference plane) may be high. Regarding (23.8.3), the greater the density of base stations 122, the less problematic multipath may become in locating an MS 140. Moreover, the arrangement of the base stations 122 in the radio coverage area 120 in Fig. 4 may affect the amount and severity of multipath.

Accordingly, it would be desirable to have a method and system for straightforwardly determining area type classifications related to multipath, and in particular, multipath due to (23.8.1) and (23.8.3). The present invention provides such a determination by utilizing a novel notion of area type, hereinafter denoted "transmission area type" (or, "(transmission) area type" when both a generic area type classification scheme and the transmission area type discussed hereinafter are intended) for classifying "similar" areas, wherein each transmission area type class or category is intended to describe an area having at least minimally similar wireless signal transmission characteristics. That is, the novel transmission area type scheme of the present invention is based on: (a) the terrain area classifications; e.g., the terrain of an area surrounding a target MS 140, (b) the configuration of base stations 122 in the radio coverage area 120, and (c) characterizations of the wireless signal transmission paths between a target MS 140 location and the base stations 122.

In one embodiment of a method and system for determining such (transmission) area type approximations, a partition (denoted hereinafter as  $P_0$ ) is imposed upon the radio coverage area 120 for partitioning for radio coverage area into subareas, wherein each subarea is an estimate of an area having included MS 140 locations that are likely to have is at least a minimal amount of similarity in their wireless signaling characteristics. To obtain the partition  $P_0$  of the radio coverage area 120, the following steps are performed:

(23.8.4.1) Partition the radio coverage area 120 into subareas, wherein in each subarea is: (a) connected, (b) variations in the lengths of chords sectioning the subarea through the centroid of the subarea are below a predetermined threshold, (c) the subarea has an area below a predetermined value, and (d) for most locations (e.g., within a first

a second standard deviation or second deviation within the subarea whose wireless signaling characteristics have been verified, it is likely (e.g., within a first or second deviation) that an MS 140 at one of these locations will detect (forward transmission path) and/or will be detected (reverse transmission path) by a same collection of base stations 122. For example, in a CDMA context, a first such collection may be (for the forward transmission path) the active set of base stations 122, or, the union of the active and candidate sets, or, the union of the active, candidate and/or remaining sets of base stations 122 detected by "most" MSs 140 in . Additionally (or alternatively), a second such collection may be the base stations 122 that are expected to detect MSs 140 at locations within the subarea. Of course, the union or intersection of the first and second collections is also within the scope of the present invention for partitioning the radio coverage area 120 according to (d) above. It is worth noting that it is believed that base station 122 power levels will be substantially constant. However, even if this is not the case, one or more collections for (d) above may be determined empirically and/or by computationally simulating the power output of each base station 122 at a predetermined level. Moreover, it is also worth mentioning that this step is relatively straightforward to implement using the data stored in the location signature data base 1320 (i.e., the verified location signature clusters discussed in detail hereinbelow). Denote the resulting partition here as  $P_1$ .

5  
10  
15 (23.8.4.2) Partition the radio coverage area 120 into subareas, wherein each subarea appears to have substantially homogeneous terrain characteristics. Note, this may be performed periodically substantially automatically by scanning radio coverage area images obtained from aerial or satellite imaging. For example, EarthWatch Inc. of Longmont, CO can provide geographic with 3 meter resolution from satellite imaging data. Denote the resulting partition here as  $P_2$ .

20 (23.8.4.3) Overlay both of the above partitions of the radio coverage area 120 to obtain new subareas that are intersections of the subareas from each of the above partitions. This new partition is  $P_0$  (i.e.,  $P_0 = P_1 \text{ intersect } P_2$ ), and the subareas of it are denoted as " $P_0$  subareas".

Now assuming  $P_0$  has been obtained, the subareas of  $P_0$  are provided with a first classification or categorization as follows:

25 (23.8.4.4) Determine an area type categorization scheme for the subareas of  $P_1$ . For example, a subarea, A, of  $P_1$ , may be categorized or labeled according to the number of base stations 122 in each of the collections used in (23.8.4.1)(d) above for determining subareas of  $P_1$ . Thus, in one such categorization scheme, each category may correspond to a single number x (such as 3), wherein for a subarea, A, of this category, there is a group of x (e.g., three) base stations 122 that are expected to be detected by a most target MSs 140 in the area A. Other embodiments are also possible, such as a categorization scheme wherein each category may correspond to a triple: of numbers such as  
30 (5, 2, 1), wherein for a subarea A of this category, there is a common group of 5 base stations 122 with two-way signal detection expected with most locations (e.g., within a first or second deviation) within A, there are 2 base stations that are expected to be detected by a target MS 140 in A but these base stations can not detect the target MS, and there is one base station 122 that is expected to be able to detect a target MS in A but not be detected.



0977999-00260

(23.8.4.5) Determine area type categorization scheme for the subareas of  $P_2$  that the subareas of  $P_2$  may be categorized according to their similarities. In one embodiment, such categories may be somewhat similar to the naïve area types mentioned above (e.g., dense urban, urban, suburban, rural, mountain, etc.). However, it is also an aspect of the present invention that more precise categorizations may be used, such as a category for all areas having between 20,000 and 30,000 square feet of vertical area change per 11,000 square feet of horizontal area and also having a high traffic volume (such a category likely corresponding to a “moderately dense urban” area type).

(23.8.4.6) Categorize subareas of  $P_0$  with a categorization scheme denoted the “ $P_0$  categorization,” wherein for each  $P_0$  subarea, A, of  $P_0$  a “ $P_0$  area type” is determined for A according to the following substep(s):

(a) Categorize A by the two categories from (23.8.4.4) and (23.8.5) with which it is identified. Thus, A is categorized (in a corresponding  $P_0$  area type) both according to its terrain and the base station infrastructure configuration in the radio coverage area I20.

(23.8.4.7) For each  $P_0$  subarea, A, of  $P_0$  perform the following step(s):

(a) Determine a centroid, C(A), for A;

(b) Determine an approximation to a wireless transmission path between C(A) and each base station I22 of a predetermined group of base stations expected to be in (one and/or two-way) signal communication with most target MS I40 locations in A. For example, one such approximation is a straight line between C(A) and each of the base stations I22 in the group. However, other such approximations are within the scope of the present invention, such as, a generally triangular shaped area as the transmission path, wherein a first vertex of this area is at the corresponding base station for the transmission path, and the sides of the generally triangular shaped defining the first vertex have a smallest angle between them that allows A to be completely between these sides.

(c) For each base station I22,  $BS_i$ , in the group mentioned in (b) above, create an empty list,  $BS_i$ -list, and put on this list at least the  $P_0$  area types for the “significant”  $P_0$  subareas crossed by the transmission path between C(A) and  $BS_i$ . Note that “significant”  $P_0$  subareas may be defined as, for example, the  $P_0$  subareas through which at least a minimal length of the transmission path traverses. Alternatively, such “significant”  $P_0$  subareas may be defined as those  $P_0$  subareas that additionally are know or expected to generate substantial multipath.

(d) Assign as the transmission area type for A as the collection of  $BS_i$ -lists. Thus, any other  $P_0$  subarea having the same (or substantially similar) collection of lists of  $P_0$  area types will be viewed as having approximately the same radio transmission characteristics.

Note that other transmission signal characteristics may be incorporated into the transmission area types. For example, thermal noise characteristics may be included by providing a third radio coverage area I20 partition,  $P_3$ , in addition to the partitions of  $P_1$  and  $P_2$  generated in (23.8.4.1) and (23.8.4.2) respectively. Moreover, the time varying characteristics of (23.8.2) may be

00770939-04300  
103270-82802200

incorporated in the transmission area type frame work by generating multiple versions of transmission area types such that the transmission area type for a given subarea of  $P_0$  may change depending on the combination of time varying environmental characteristics to be considered in the transmission area types. For instance, to account for seasonality, four versions of the partitions  $P_1$  and  $P_2$  may be generated, one for each of the seasons, and subsequently generate a (potentially) different partition  $P_0$  for each season. Further, the type and/or characteristics of base station 122 antennas may also be included in an embodiment of the transmission area type.

Accordingly, in one embodiment of the present invention, whenever the term "area type" is used hereinbelow, transmission area types as described hereinabove are intended.

#### Location Information Data Bases And Data

#### 10 Location Data Bases Introduction

It is an aspect of the present invention that MS location processing performed by the location center 142 should become increasingly better at locating a target MS 140 both by (a) building an increasingly more detailed model of the signal characteristics of locations in the service area for the present invention, and also (b) by providing capabilities for the location center processing to adapt to environmental changes.

15 One way these aspects of the present invention are realized is by providing one or more data base management systems and data bases for:

(a) storing and associating wireless MS signal characteristics with known locations of MSs 140 used in providing the signal characteristics. Such stored associations may not only provide an increasingly better model of the signal characteristics of the geography of the service area, but also provide an increasingly better model of more changeable signal characteristic affecting environmental factors such as weather, seasons, and/or traffic patterns;

20

(b) adaptively updating the signal characteristic data stored so that it reflects changes in the environment of the service area such as, for example, a new high rise building or a new highway.

Referring again to Fig. 5 of the collective representation of these data bases is the location information data bases 1232. Included among these data bases is a data base for providing training and/or calibration data to one or more trainable/calibratable FOMs 1224, as well as an archival data base for archiving historical MS location information related to the performance of the FOMs. These data bases will be discussed as necessary hereinbelow. However, a further brief introduction to the archival data base is provided here. Accordingly, the term, "location signature data base" is used hereinafter to denote the archival data base and/or data base management system depending on the context of the discussion. The location signature data base (shown in, for example, Fig. 6 and labeled 1320) is a repository for wireless signal characteristic data derived from wireless signal communications between an MS 140 and one or more base stations 122, wherein the corresponding location of the MS 140 is known and also stored in the location signature data base 1320. More particularly, the location signature data base 1320 associates each such known MS location with the wireless signal characteristic data derived from wireless signal communications between the MS 140 and one or more base stations 122 at this MS location. Accordingly, it is an aspect of the present invention

30

to utilize such historical MS signal location data for enhancing the correctness and/or confidence in certain location hypotheses as will be described in detail in other sections below.

#### Data Representations for the Location Signature Data Base

There are four fundamental entity types (or object classes in an object oriented programming paradigm) utilized in the location signature data base 1320. Briefly, these data entities are described in the items (24.1) through (24.4) that follow:

(24.1) (verified) location signatures: Each such (verified) location signature describes the wireless signal characteristic measurements between a given base station (e.g., BS 122 or LBS 152) and an MS 140 at a (verified or known) location associated with the (verified) location signature. That is, a verified location signature corresponds to a location whose coordinates such as latitude-longitude coordinates are known, while simply a location signature may have a known or unknown location corresponding with it. Note that the term (verified) location signature is also denoted by the abbreviation, "(verified) loc sig" hereinbelow;

(24.2) (verified) location signature clusters: Each such (verified) location signature cluster includes a collection of (verified) location signatures corresponding to all the location signatures between a target MS 140 at a (possibly verified) presumed substantially stationary location and each BS (e.g., 122 or 152) from which the target MS 140 can detect the BS's pilot channel <sup>regardless</sup> of the classification of the BS in the target MS (i.e., for CDMA, regardless of whether a BS is in the MS's active, candidate or remaining base station sets, as one skilled in the art will understand). Note that for simplicity here, it is presumed that each location signature cluster has a single fixed primary base station to which the target MS 140 synchronizes or obtains its timing;

(24.3) "composite location objects (or entities)": Each such entity is a more general entity than the verified location signature cluster. An object of this type is a collection of (verified) location signatures that are associated with the same MS 140 at substantially the same location at the same time and each such loc sig is associated with a different base station. However, there is no requirement that a loc sig from each BS 122 for which the MS 140 can detect the BS's pilot channel is included in the "composite location object (or entity)"; and

(24.4) MS location estimation data that includes MS location estimates output by one or more MS location estimating first order models 1224, such MS location estimate data is described in detail hereinbelow.

It is important to note that a loc sig is, in one embodiment, an instance of the data structure containing the signal characteristic measurements output by the signal filtering and normalizing subsystem also denoted as the signal processing subsystem 1220 describing the signals between: (i) a specific base station 122 (BS) and (ii) a mobile station 140 (MS), wherein the BS's location is known and the MS's location is assumed to be substantially constant (during a 2-5 second interval in one embodiment of the present invention), during communication with the MS 140 for obtaining a single instance of loc sig data, although the MS location may or may not be known. Further, for notational purposes, the BS 122 and the MS 140 for a loc sig hereinafter will be denoted the "BS associated with the loc sig", and the "MS associated with the loc sig" respectively. Moreover, the location of the MS 140 at the time the loc sig data is obtained will be denoted the "location associated with the loc sig" (this location possibly being unknown).

In particular, for each (verified) loc sig includes the following:

(25.1) MS\_type: the make and model of the target MS 140 associated with a location signature instantiation; note that the type of MS 140 can also be derived from this entry; e.g., whether MS 140 is a handset MS, car-set MS, or an MS for location only. Note as an aside, for at least CDMA, the type of MS 140 provides information as to the number of fingers that may be measured by the MS., as one skilled in the will appreciate.

09770929-01604  
105670-0000260

(25.2) BS\_id: an identification of base station 122 (or, location base station 152) communicating with the target MS;

(25.3) MS\_loc: a representation of a geographic location (e.g., latitude-longitude) or area representing a verified/known MS location where signal characteristics between the associated (location) base station and MS 140 were received. That is, if the “verified\_flag” attribute (discussed below) is TRUE, then this attribute includes an estimated location of the target MS. If verified\_flag is FALSE, then this attribute has a value indicating “location unknown”.

Note “MS\_loc” may include the following two subfields: an area within which the target MS is presumed to be, and a point location (e.g., a latitude and longitude pair) where the target MS is presumed to be (in one embodiment this is the centroid of the area);

(25.4) verified\_flag: a flag for determining whether the loc sig has been verified; i.e., the value here is TRUE iff a location of MS\_loc has been verified, FALSE otherwise. Note, if this field is TRUE (i.e., the loc sig is verified), then the base station identified by BS\_id is the current primary base station for the target MS;

(25.5) confidence: a value indicating how consistent this loc sig is with other loc sigs in the location signature data base 1320; the value for this entry is in the range [0, 1] with 0 corresponding to the lowest (i.e., no) confidence and 1 corresponding to the highest confidence. That is, the confidence factor is used for determining how consistent the loc sig is with other “similar” verified loc sigs in the location signature data base 1320, wherein the greater the confidence value, the better the consistency with other loc sigs in the data base. Note that similarity in this context may be operationalized by at least designating a geographic proximity of a loc sig in which to determine if it is similar to other loc sigs in this designated geographic proximity and/or area type (e.g., transmission area type as elsewhere herein). Thus, environmental characteristics may also be used in determining similarities such as similar time of occurrence (e.g., of day, and/or of month), similar weather (e.g., snowing, raining, etc.). Note, these latter characteristics are different from the notion of geographic proximity since proximity may be only a distance measurement about a location. Note also that a loc sig having a confidence factor value below a predetermined threshold may not be used in evaluating MS location hypotheses generated by the FOMs 1224.

(25.6) timestamp: the time and date the loc sig was received by the associated base station of BS\_id;

(25.7) signal topography characteristics: In one embodiment, the signal topography characteristics retained can be represented as characteristics of at least a two-dimensional generated surface. That is, such a surface is generated by the signal processing subsystem 1220 from signal characteristics accumulated over (a relatively short) time interval. For example, in the two-dimensional surface case, the dimensions for the generated surface may be, for example, signal strength and time delay. That is, the accumulations over a brief time interval of signal characteristic measurements between the BS 122 and the MS 140 (associated with the loc sig) may be classified according to the two signal characteristic dimensions (e.g., signal strength and corresponding time delay). That is, by sampling the signal characteristics and classifying the samples according to a mesh of discrete cells or bins, wherein each cell corresponds to a different range of signal strengths and time delays a tally of the number of samples falling in the range of each cell can be maintained. Accordingly, for each cell, its corresponding tally may be interpreted as height of the cell, so that when the heights of all cells are considered, an undulating or mountainous surface is provided. In particular, for a cell mesh of appropriate fineness, the “mountainous surface”, is believed to, under most circumstances, provide a contour that is substantially

00770000-0000-0000-0000-000000000000

unique to the location of target MS 140. Note that in one embodiment, the signal strengths are typically obtained throughout a predetermined signal sampling time interval of 2-5 seconds as is discussed elsewhere in this specification. In particular, the signal topography characteristics retained for a loc sig include certain topographical characteristics of such a generated mountainous surface. For example, each loc sig may include: for each local maximum (of the loc sig surface) above a predetermined noise ceiling threshold, the (signal strength, time delay) coordinates of the cell of the local maximum and the corresponding height of the local maximum. Additionally, certain gradients may also be included for characterizing the "steepness" of the surface mountains. Moreover, note that in some embodiments, a frequency may also be associated with each local maximum. Thus, the data retained for each selected local maximum can include a quadruple of signal strength, time delay, height and frequency. Further note that the data types here may vary. However, for simplicity, in parts of the description of loc sig processing related to the signal characteristics here, it is assumed that the signal characteristic topography data structure here is a vector;

- (25.8) quality\_obj: signal quality (or error) measurements, e.g., Eb/No values, as one skilled in the art will understand;
- (25.9) noise\_ceiling: noise ceiling values used in the initial filtering of noise from the signal topography characteristics as provided by the signal processing subsystem 1220;
- (25.10) power\_level: power levels of the base station (e.g., 122 or 152) and MS 140 for the signal measurements;
- (25.11) timing\_error: an estimated (or maximum) timing error between the present (associated) BS (e.g., an infrastructure base station 122 or a location base station 152) detecting the target MS 140 and the current primary BS 122 for the target MS 140. Note that if the BS 122 associated with the loc sig is the primary base station, then the value here will be zero;
- (25.12) cluster\_ptr: a pointer to the location signature composite entity to which this loc sig belongs.
- (25.13) repeatable: TRUE iff the loc sig is "repeatable" (as described hereinafter), FALSE otherwise. Note that each verified loc sig is designated

as either "repeatable" or "random". A loc sig is repeatable if the (verified/known) location associated with the loc sig is such that signal characteristic measurements between the associated BS 122 and this MS can be either replaced at periodic time intervals, or updated substantially on demand by most recent signal characteristic measurements between the associated base station and the associated MS 140 (or a comparable MS) at the verified/known location. Repeatable loc sigs may be, for example, provided by stationary or fixed location MSs 140 (e.g., fixed location transceivers) distributed within certain areas of a geographical region serviced by the location center 142 for providing MS location estimates. That is, it is an aspect of the present invention that each such stationary MS 140 can be contacted by the location center 142 (via the base stations of the wireless infrastructure) at substantially any time for providing a new collection (i.e., cluster) of wireless signal characteristics to be associated with the verified location for the transceiver. Alternatively, repeatable loc sigs may be obtained by, for example, obtaining location signal measurements manually from workers who regularly traverse a predetermined route through some portion of the radio coverage area; i.e., postal workers ~~(as will be described in more detail hereinbelow).~~

A loc sig is random if the loc sig is not repeatable. Random loc sigs are obtained, for example, from verifying a previously unknown target MS location once the MS 140 has been located. Such verifications may be accomplished by, for example, a vehicle having one or more location verifying devices such as a GPS receiver and/or a manual location input capability becoming sufficiently close to the located target MS 140 so that the location of the vehicle may be associated with the wireless signal characteristics of the MS 140.



(26.2) A method for determining an "area type" corresponding to the signal transmission characteristics of the area(s) between the associated BS 122 and the associated MS 140 location for the loc sig. Note, such an area type may be designated by, for example, the techniques for determining transmission area types as described hereinabove.

5 (26.3) Other methods are contemplated for determining additional environmental characteristics of the geographical area between the associated BS 122 and the associated MS 140 location for the loc sig; e.g., a noise value indicating the amount of noise likely in such an area.

Referring now to the composite location objects and verified location signature clusters of (24.3) and (24.2) respectively, the following information is contained in these aggregation objects:

10 (27.1.1) an identification of the BS 122 designated as the primary base station for communicating with the target MS 140;

(27.1.2) a reference to each loc sig in the location signature data base 1320 that is for the same MS location at substantially the same time with the primary BS as identified in (27.1);

15 (27.1.3) an identification of each base station (e.g., 122 and 152) that can be detected by the MS 140 at the time the location signal measurements are obtained. Note that in one embodiment, each composite location object includes a bit string having a corresponding bit for each base station, wherein a "1" for such a bit indicates that the corresponding base station was identified by the MS, and a "0" indicates that the base station was not identified. In an alternative embodiment, additional location signal measurements may also be included from other non-primary base stations. For example, the target MS 140 may communicate with other base stations than its primary base station. However, since the timing for the MS 140 is typically derived from its primary base station and since timing synchronization between base stations is not exact (e.g., in the case of CDMA, timing variations may be plus or minus 1 microsecond) at least some of the location signal measurements may be less reliable than the measurements from the primary base station, unless a forced hand-off technique is used to eliminate system timing errors among relevant base stations;

20 (27.1.4) a completeness designation that indicates whether any loc sigs for the composite location object have been removed from (or invalidated in) the location signature data base 1320.

25 Note, a verified composite location object is designated as "incomplete" if a loc sig initially referenced by the verified composite location object is deleted from the location signature data base 1320 (e.g., because of a confidence that is too low). Further note that if all loc sigs for a composite location object are deleted, then the composite object is also deleted from the location signature data base 1320. Also note that common fields between loc sigs referenced by the same composite location object may be provided in the composite location object only (e.g., timestamp, etc.).

30 Accordingly, a composite location object that is complete (i.e., not incomplete) is a verified location signature cluster as described in (24.2).

Location Center Architecture

Fig. 5 presents a high level diagram of the location center 142 and the location engine 139 in the context of the infrastructure for the entire location system of the present invention.

It is important to note that the architecture for the location center 142 and the location engine 139 provided by the present invention is designed for extensibility and flexibility so that MS 140 location accuracy and reliability may be enhanced as further location data become available and as enhanced MS location techniques become available. In addressing the design goals of extensibility and flexibility, the high level architecture for generating and processing MS location estimates may be considered as divided into the following high level functional groups described hereinbelow.

Low Level Wireless Signal Processing Subsystem for Receiving and Conditioning Wireless Signal Measurements

A first functional group of location engine 139 modules is for performing signal processing and filtering of MS location signal data received from a conventional wireless (e.g., CDMA) infrastructure, as discussed in the steps (23.1) and (23.2) above. This group is denoted the signal processing subsystem 1220 herein. One embodiment of such a subsystem is described in the PCT patent application titled, "Wireless Location Using A Plurality of Commercial Network Infrastructures," by F. W. LeBlanc and the present inventor(s).

Initial Location Estimators: First Order Models

A second functional group of location engine 139 modules is for generating various target MS 140 location initial estimates, as described in step (23.3). Accordingly, the modules here use input provided by the signal processing subsystem 1220. This second functional group includes one or more signal analysis modules or models, each hereinafter denoted as a first order model 1224 (FOM), for generating location hypotheses for a target MS 140 to be located. Note that it is intended that each such FOM 1224 use a different technique for determining a location area estimate for the target MS 140. A brief description of some types of first order models is provided immediately below. Note that Fig. 6 illustrates another, more detailed view of the location system for the present invention. In particular, this figure illustrates some of the FOMs 1224 contemplated by the present invention, and additionally illustrates the primary communications with other modules of the location system for the present invention. However, it is important to note that the present invention is not limited to the FOMs 1224 shown and discussed herein. That is, it is a primary aspect of the present invention to easily incorporate FOMs using other signal processing and/or computational location estimating techniques than those presented herein. Further, note that each FOM type may have a plurality of its models incorporated into an embodiment of the present invention.

For example, (as will be described in further detail below), one such type of model or FOM 1224 (hereinafter models of this type are referred to as "distance models") may be based on a range or distance computation and/or on a base station signal reception angle determination between the target MS 140 from each of one or more base stations. Basically, such distance models 1224 determine a location estimate of the target MS 140 by determining a distance offset from each of one or more base stations 122, possibly in a particular direction from each (some of) the base stations, so that an intersection of each area locus defined by the base station offsets may provide an estimate of the location of the target MS. Distance model FOMs 1224 may compute such offsets based on:



007709904607260

- (a) signal timing measurements between the target mobile station 140 and one or more base stations 122; e.g., timing measurements such as time difference of arrival (TDOA), or time of arrival (TOA). Note that both forward and reverse signal path timing measurements may be utilized;
- (b) signal strength measurements (e.g., relative to power control settings of the MS 140 and/or one or more BS 122); and/or
- (c) signal angle of arrival measurements, or ranges thereof, at one or more base stations 122 (such angles and/or angular ranges provided by, e.g., base station antenna sectors having angular ranges of 120° or 60°, or, so called "SMART antennas" with variable angular transmission ranges of 2° to 120°).

Accordingly, a distance model may utilize triangulation or trilateration to compute a location hypothesis having either an area location or a point location for an estimate of the target MS 140. Additionally, in some embodiments location hypothesis may include an estimated error

Another type of FOM 1224 is a statistically based first order model 1224, wherein a statistical technique, such as regression techniques (e.g., least squares, partial least squares, principle decomposition), or e.g., Bollenger Bands (e.g., for computing minimum and maximum base station offsets). In general, models of this type output location hypotheses <sup>that are</sup> determined by performing one or more statistical techniques or comparisons between the verified location signatures in location signature data base 1320, and the wireless signal measurements from a target MS. Models of this type are also referred to hereinafter as a "stochastic signal (first order) model" or a "stochastic FOM" or a "statistical model."

Still another type of FOM 1224 is an adaptive learning model, such as an artificial neural net or a genetic algorithm, wherein the FOM may be trained to recognize or associate each of a plurality of locations with a corresponding set of signal characteristics for communications between the target MS 140 (at the location) and the base stations 122. Moreover, typically such a FOM is expected to accurately interpolate/extrapolate target MS 140 location estimates from a set of signal characteristics from an unknown target MS 140 location. Models of this type are also referred to hereinafter variously as "artificial neural net models" or "neural net models" or "trainable models" or "learning models." Note that a related type of FOM 1224 is based on pattern recognition. These FOMs can recognize patterns in the signal characteristics of communications between the target MS 140 (at the location) and the base stations 122 and thereby estimate a location area of the target MS. However, such FOMs may not be trainable.

Yet another type of FOM 1224 can be based on a collection of dispersed low power, low cost fixed location wireless transceivers (also denoted "location base stations 152" hereinabove) that are provided for detecting a target MS 140 in areas where, e.g., there is insufficient base station 122 infrastructure coverage for providing a desired level of MS 140 location accuracy. For example, it may be uneconomical to provide high traffic wireless voice coverage of a typical wireless base station 122 in a nature preserve or at a fair ground that is only populated a few days out of the year. However, if such low cost location base stations 152 can be directed to activate and deactivate via the direction of a FOM 1224 of the present type, then these location base stations <sup>152</sup> can be used to both locate a target MS 140 and also provide indications of where the target MS is not. For example, if there are location base stations 152 populating an area where the target MS 140 is presumed to be, then by activating these location base stations 152, evidence may be obtained as to whether or not the target MS is actually in the area; e.g., if the target MS 140 is detected by a location base station 152, then a corresponding location hypothesis having a location estimate corresponding to the coverage area of the location base station may have a very high confidence value. Alternatively, if the target MS 140 is not detected by a location base station

152, then a corresponding location hypothesis having a location estimate corresponding to the coverage area of the location base station may have a very low confidence value. Models of this type are referred to hereinafter as "location base station models."

Yet another type of FOM 1224 can be based on input from a mobile base station 148, wherein location hypotheses may be generated from target MS 140 location data received from the mobile base station 148.

5 Still other types of FOM 1224 can be based on various techniques for recognizing wireless signal measurement patterns and associating particular patterns with locations in the coverage area 120. For example, artificial neural networks or other learning models can be used as the basis for various FOMs.

Note that the FOM types mentioned here as well as other FOM types are discussed in detail hereinbelow. Moreover, it is important to keep in mind that a novel aspect of the present invention is the simultaneous use or activation of a potentially large number of such first order models 1224, wherein such FOMs are not limited to those described herein. Thus, the present invention provides a framework for incorporating MS location estimators to be subsequently provided as new FOMs in a straightforward manner. For example, a FOM 1224 based on wireless signal time delay measurements from a distributed antenna system for wireless communication may be incorporated into the present invention for locating a target MS 140 in an enclosed area serviced by the distributed antenna system. Accordingly, by using such a distributed antenna FOM, the present invention may determine the floor of a multi-story building from which a target MS is transmitting. Thus, MSs 140 can be located in three dimensions using such a distributed antenna FOM. Additionally, FOMs for detecting certain registration changes within, for example, a public switched telephone network can also be used for locating a target MS 140. For example, for some MSs 140 there may be an associated or dedicated device for each such MS that allows the MS to function as a cordless phone to a line based telephone network when the device detects that the MS is within signaling range. In one use of such a device (also denoted herein as a "home base station"), the device registers with a home location register of the public switched telephone network when there is a status change such as from not detecting the corresponding MS to detecting the MS, or visa versa, as one skilled in the art will understand. Accordingly, by providing a FOM that accesses the MS status in the home location register, the location engine 139 can determine whether the MS is within signaling range of the home base station or not, and generate location hypotheses accordingly. Moreover, other FOMs based on, for example, chaos theory and/or fractal theory are also within the scope of the present invention.

It is important to note the following aspects of the present invention relating to FOMs 1224:

25 (28.1) Each such first order model 1224 may be relatively easily incorporated into and/or removed from the present invention. For example, assuming that the signal processing subsystem 1220 provides uniform input interface to the FOMs, and there is a uniform FOM output interface, it is believed that a large majority (if not substantially all) viable MS location estimation strategies may be accommodated. Thus, it is straightforward to add or delete such FOMs 1224.

30 (28.2) Each such first order model 1224 may be relatively simple and still provide significant MS 140 locating functionality and predictability. For example, much of what is believed to be common or generic MS location processing has been coalesced into, for example: a location hypothesis evaluation subsystem, denoted the hypotheses evaluator 1228 and described immediately below. Thus, the present invention is modular and extensible such that, for example, (and importantly) different first order models 1224 may be utilized depending on the signal transmission characteristics of the geographic region serviced by an embodiment of the present invention. Thus, a simple configuration of the present invention may have a small number of FOMs 1224 for a simple wireless signal environment (e.g., flat terrain,

no urban canyons and low (location density). Alternatively, for complex wireless signal environments such as in cities like San Francisco, Tokyo or New York, a large number of FOMs 1224 may be simultaneously utilized for generating MS location hypotheses.

#### An Introduction to an Evaluator for Location Hypotheses: Hypothesis Evaluator

5 A third functional group of location engine 139 modules evaluates location hypotheses output by the first order models 1224 and thereby provides a “most likely” target MS location estimate. The modules for this functional group are collectively denoted the hypothesis evaluator 1228.

#### Hypothesis Evaluator Introduction

10 A primary purpose of the hypothesis evaluator 1228 is to mitigate conflicts and ambiguities related to location hypotheses output by the first order models 1224 and thereby output a “most likely” estimate of an MS for which there is a request for it to be located. In providing this capability, there are various related embodiments of the hypothesis evaluator that are within the scope of the present invention. Since each location hypothesis includes both an MS location area estimate and a corresponding confidence value indicating a perceived confidence or likelihood of the target MS being within the corresponding location area estimate, there is a monotonic relationship between MS location area estimates and confidence values. That is, by increasing an MS location area estimate, the corresponding confidence value may also be increased (in an extreme case, the location area estimate could be the entire coverage area 120 and thus the confidence value may likely correspond to the highest level of certainty; i.e., +1.0). Accordingly, given a target MS location area estimate (of a location hypothesis), an adjustment to its accuracy may be performed by adjusting the MS location area estimate and/or the corresponding confidence value. Thus, if the confidence value is, for example, excessively low then the area estimate may be increased as a technique for increasing the confidence value. Alternatively, if the estimated area is excessively large, and there is flexibility in the corresponding confidence value, then the estimated area may be decreased and the confidence value also decreased. Thus, if at some point in the processing of a location hypothesis, if the location hypothesis is judged to be more (less) accurate than initially determined, then (i) the confidence value of the location hypothesis can be increased (decreased), and/or (ii) the MS location area estimate can be decreased (increased).

25 In a first class of embodiments, the hypothesis evaluator 1228 evaluates location hypotheses and adjusts or modifies only their confidence values for MS location area estimates and subsequently uses these MS location estimates with the adjusted confidence values for determining a “most likely” MS location estimate for outputting. Accordingly, the MS location area estimates are not substantially modified. Alternatively, in a second class of embodiments for the hypothesis evaluator 1228, MS location area estimates can be adjusted while confidence values remain substantially fixed. Of course, hybrids between the first two embodiments can also be provided. Note that the present embodiment provided herein adjusts both the areas and the confidence values.

More particularly, the hypothesis evaluator 1228 may perform any or most of the following tasks:

30 (30.1) it utilizes environmental information to improve and reconcile location hypotheses supplied by the first order models 1224. A basic premise in this context is that the accuracy of the individual first order models may be affected by various environmental factors such as, for example, the season of the year, the time of day, the weather conditions, the presence of buildings, base station failures, etc.;

CONFIDENTIAL

6 (30.2) it enhances the accuracy of an initial location hypothesis generated by a FOM by using another FOM. The initial location hypothesis as, essentially, a query or index into the location signature data base 1320 for obtaining a corresponding enhanced location hypothesis, wherein the enhanced location hypothesis has both an adjusted target MS location area estimate and an adjusted confidence based on past performance of the FOM in the location service surrounding the target MS location estimate of the initial location hypothesis;

5 (30.3) it determines how well the associated signal characteristics used for locating a target MS compare with particular verified loc sigs stored in the location signature data base 1320 (see the location signature data base section for further discussion regarding this aspect of the invention). That is, for a given location hypothesis, verified loc sigs (which were previously obtained from one or more verified locations of one or more MS's) are retrieved for an area corresponding to the location area estimate of the location hypothesis, and the signal characteristics of these verified loc sigs are compared with the signal characteristics used to generate the location hypothesis for determining their similarities and subsequently an adjustment to the confidence of the location hypothesis (and/or the size of the location area estimate);

10 (30.4) the hypothesis evaluator 1228 determines if (or how well) such location hypotheses are consistent with well known physical constraints such as the laws of physics. For example, if the difference between a previous (most likely) location estimate of a target MS and a location estimate by a current location hypothesis requires the MS to:

- (a) move at an unreasonably high rate of speed (e.g., 200 mph), or
- (b) move at an unreasonably high rate of speed for an area (e.g., 80 mph in a corn patch), or
- (c) make unreasonably sharp velocity changes (e.g., from 60 mph in one direction to 60 mph in the opposite direction in 4 sec), then the confidence in the current Location Hypothesis is likely to be reduced.

15 Alternatively, if for example, the difference between a previous location estimate of a target MS and a current location hypothesis indicates that the MS is:

- (a2) moving at an appropriate velocity for the area being traversed, or
- (b2) moving along an established path (e.g., a freeway),

20 then the confidence in the current location hypothesis may be increased.

25 (30.5) the hypothesis evaluator 1228 determines consistencies and inconsistencies between location hypotheses obtained from different first order models. For example, if two such location hypotheses, for substantially the same timestamp, have estimated location areas where the target MS is likely to be and these areas substantially overlap, then the confidence in both such location hypotheses may be increased. Additionally, note that a velocity of an MS may be determined (via deltas of successive location hypotheses from one or more first order models) even when there is low confidence in the location estimates for the MS, since such deltas may, in some cases, be more reliable than the actual target MS location estimates;

30 (30.6) the hypothesis evaluator 1228 determines new (more accurate) location hypotheses from other location hypotheses. For example, this module may generate new hypotheses from currently active ones by decomposing a location hypothesis having a target MS

location estimate intersecting two radically different area types. Additionally, this module may generate location hypotheses indicating areas of poor reception; and

(30.7) the hypothesis evaluator 1228 determines and outputs a most likely location hypothesis for a target MS.

Note that the hypothesis evaluator may accomplish the above tasks, (30.1) - (30.7), by employing various data processing tools including, but not limited to, fuzzy mathematics, genetic algorithms, neural networks, expert systems and/or blackboard systems.

Note that, as can be seen in Figs. 6 and 7, the hypothesis evaluator 1228 includes the following four high level modules for processing output location hypotheses from the first order models 1224: a context adjuster 1326, a hypothesis analyzer 1332, an MS status repository 1338 and a most likelihood estimator 1334. These four modules are briefly described hereinbelow.

Context Adjuster Introduction.

The context adjuster 1326 module enhances both the comparability and predictability of the location hypotheses output by the first order models 1224. In particular, this module modifies location hypotheses received from the FOMs 1224 so that the resulting location hypotheses output by the context adjuster 1326 may be further processed uniformly and substantially without concern as to differences in accuracy between the first order models from which location hypotheses originate. In providing this capability, the context adjuster 1326 may adjust or modify various fields of the input location hypotheses. In particular, fields giving target MS 140 location estimates and/or confidence values for such estimates may be modified by the context adjuster 1326. Further, this module may determine those factors that are perceived to impact the perceived accuracy (e.g., confidence) of the location hypotheses: (a) differently between FOMs, and/or (b) with substantial effect. For instance, environmental characteristics may be taken into account here, such as time of day, season, month, weather, geographical area categorizations (e.g., dense urban, urban, suburban, rural, mountain, etc.), area subcategorizations (e.g., heavily treed, hilly, high traffic area, etc.). A detailed description of one embodiment of this module is provided in APPENDIX D hereinbelow. Note that, the embodiment described herein is simplified for illustration purposes such that only the geographical area categorizations are utilized in adjusting (i.e., modifying) location hypotheses. But, it is an important aspect of the present invention that various categorizations, such as those mentioned immediately above, may be used for adjusting the location hypotheses. That is, categories such as, for example:

(a) urban, hilly, high traffic at 5pm, or

(b) rural, flat, heavy tree foliage density in summer may be utilized as one skilled in the art will understand from the descriptions contained hereinbelow.

Accordingly, the present invention is not limited to the factors explicitly mentioned here. That is, it is an aspect of the present invention to be extensible so that other environmental factors of the coverage area 120 affecting the accuracy of location hypotheses may also be incorporated into the context adjuster 1326.

It is also an important and novel aspect of the context adjuster 1326 that the methods for adjusting location hypotheses provided in this module may be generalized and thereby also utilized with multiple hypothesis computational architectures related to various applications wherein a terrain, surface, volume or other "geometric" interpretation (e.g., a metric space of statistical samples) may be placed on a large body of stored application data for relating hypothesized data to verified data. Moreover, it is important to note that various techniques for "visualizing data" may provide such a geometric interpretation. Thus, the methods herein may be utilized in applications such as:

FOIA b 7 - D

- (a) sonar, radar, x-ray or infrared identification of objects such as occurs in robotic navigation, medical image analysis, geological, and radar imaging.

5 More generally, the novel computational paradigm of the context adjuster 1326 may be utilized in a number of applications wherein there is a large body of archived information providing verified or actual application process data related to the past performance of the application process.

10 It is worth mentioning that the computational paradigm used in the context adjuster 1326 is a hybrid of a hypothesis adjuster and a data base query mechanism. For example, the context adjuster 1326 uses an input (location) hypothesis both as an hypothesis and as a data base query or index into the location signature data base 1320 for constructing a related but more accurate location hypothesis. Accordingly, substantial advantages are provided by this hybrid architecture, such as the following two advantages.

15 As a first advantage, the context adjuster 1326 reduces the likelihood that a feedback mechanism is necessary to the initial hypothesis generators (i.e., FOMs 1224) for periodically adjusting default evaluations of the goodness or confidence in the hypotheses generated. That is, since each hypothesis generated is, in effect, an index into a data base or archive of verified application (e.g., location) data, the context adjuster 1326, in turn, generates new corresponding hypotheses based on the actual or verified data retrieved from an archival data base. Thus, as a result, this architecture tends to separate the computations of the initial hypothesis generators (e.g., the FOMs 1224 in the present MS location application) from any further processing and thereby provide a more modular, maintainable and flexible computational system.

20 As a second advantage, the context adjuster 1326 tends to create hypotheses that are more accurate than the hypotheses generated by the initial hypotheses generators. That is, for each hypothesis, H, provided by one of the initial hypothesis generators, G (e.g., a FOM 1224), a corresponding enhanced hypothesis, provided by the context adjuster 1326, is generated by mapping the past performance of G into the archived verified application data (as will be discussed in detail hereinbelow). In particular, the context adjuster hypothesis generation is based on the archived verified (or known) performance application data that is related to both G and H. For example, in the present wireless location application, if a FOM 1224, G, substantially consistently generates, in a particular geographical area, location hypotheses that are biased approximately 1000 feet north of the actual verified MS 140 location, then the context adjuster 1326 can generate corresponding hypotheses without this bias. Thus, the context adjuster 1326 tends to filter out inaccuracies in the initially generated hypotheses.

25 Therefore in a multiple hypothesis architecture where typically the generated hypotheses may be evaluated and/or combined for providing a "most likely" result, it is believed that a plurality of relatively simple (and possibly inexact) initial hypothesis generators may be used in conjunction with the hybrid computational paradigm represented by the context adjuster 1326 for providing enhanced hypotheses with substantially greater accuracy.

30 Additionally, note that this hybrid paradigm applies to other domains that are not geographically based. For instance, this hybrid paradigm applies to many prediction and/or diagnostic applications for which:

- (a) the application data and the application are dependent on a number of parameters whose values characterize the range of outputs for the application. That is, there is a set of parameters,  $p_1, p_2, p_3, \dots, p_N$  from which a parameter space  $p_1 \times p_2 \times p_3 \times \dots \times p_N$  is derived whose points characterize the actual and estimated (or predicted) outcomes. As examples, in the MS location system,  $p_1 =$  latitude and  $p_2 =$  longitude;



- (b) utilize some of the old hypotheses as previous target MS estimates for use in tracking the target MS 140, and/or
- (c) if sufficiently old, then delete the older location hypotheses.

Note that both the newly received location hypotheses and the previous location hypotheses that are updated (i.e., extrapolated) and still remain in the hypothesis analyzer 1332 will be denoted as "current location hypotheses" or "currently active location hypotheses".

5 The modules within the location hypothesis analyzer 1332 use various types of application specific knowledge likely substantially independent from the computations by the FOMs 1224 when providing the corresponding original location hypotheses. That is, since it is aspect of at least one embodiment of the present invention that the FOMs 1224 be relatively straightforward so that they may be easily modified as well as added or deleted, the processing, for example, in the hypothesis analyzer 1332 (as with the context adjuster 1326) is intended to compensate, when necessary, for this straightforwardness by providing substantially generic MS location processing capabilities that can require  
10 a greater breadth of application understanding related to wireless signal characteristics of the coverage area 120.

Accordingly, the hypothesis analyzer 1332 may apply various heuristics that, for example, change the confidence in a location hypothesis depending on how well the location hypothesis (and/or a series of location hypotheses from e.g., the same FOM 1224): (a) conforms with the laws of physics, (b) conforms with known characteristics of location signature clusters in an area of the location hypothesis MS 140 estimate, and (c) conforms with highly likely heuristic constraint knowledge. In particular, as illustrated best in Fig. 7, the location hypothesis  
15 analyzer 1332 may utilize at least one of a blackboard system and/or an expert system for applying various application specific heuristics to the location hypotheses output by the context adjuster 1326. More precisely, the location hypothesis analyzer 1332 includes, in one embodiment, a blackboard manager for managing processes and data of a blackboard system. Additionally, note that in a second embodiment, where an expert system is utilized instead of a blackboard system, the location hypothesis analyzer provides an expert system inference engine for the expert system. Note that additional detail on these aspects of the invention are provided hereinbelow.

20 Additionally, note that the hypothesis analyzer 1332 may activate one or more extrapolation procedures to extrapolate target MS 140 location hypotheses already processed. Thus, when one or more new location hypotheses are supplied (by the context adjuster 1224) having a substantially more recent timestamp, the hypothesis analyzer may invoke an extrapolation module (i.e., location extrapolator 1432, Fig. 7) for adjusting any previous location hypotheses for the same target MS 140 that are still being used by the location hypothesis analyzer so that all target MS location hypotheses (for the same target MS) being concurrently analyzed are presumed to be for substantially the same time.  
25 Accordingly, such a previous location hypothesis that is, for example, 15 seconds older than a newly supplied location hypothesis (from perhaps a different FOM 1224) may have both: (a) an MS location estimate changed (e.g., to account for a movement of the target MS), and (b) its confidence changed (e.g., to reflect a reduced confidence in the accuracy of the location hypothesis).

It is important to note that the architecture of the present invention is such that the hypothesis analyzer 1332 has an extensible architecture. That is, additional location hypothesis analysis modules may be easily integrated into the hypothesis analyzer 1332 as further  
30 understanding regarding the behavior of wireless signals within the service area 120 becomes available. Conversely, some analysis modules may not be required in areas having relatively predictable signal patterns. Thus, in such service areas, such unnecessary modules may be easily removed or not even developed.

Most Likelihood Estimator Introduction



TOP SECRET

The most likelihood estimator 1344 is a module for determining a "most likely" location estimate for a target MS being located by the location engine 139. The most likelihood estimator 1344 receives a collection of active or relevant location hypotheses from the hypothesis analyzer 1332 and uses these location hypotheses to determine one or more most likely estimates for the target MS 140. Still referring to the hypothesis evaluator 1228, it is important to note that not all the above mentioned modules are required in all embodiments of the present invention. In particular, for some coverage areas 120, the hypothesis analyzer 1332 may be unnecessary. Accordingly, in such an embodiment, the enhanced location hypothesis output by the context adjuster 1326 are provided directly to the most likelihood estimator 1344.

Control and Output Gating Modules

A fourth functional group of location engine 139 modules is the control and output gating modules which includes the location center control subsystem 1350, and the output gateway 1356. The location control subsystem 1350 provides the highest level of control and monitoring of the data processing performed by the location center 142. In particular, this subsystem performs the following functions:

- (a) controls and monitors location estimating processing for each target MS 140. Note that this includes high level exception or error handling functions;
- (b) receives and routes external information as necessary. For instance, this subsystem may receive (via, e.g., the public telephone switching network and Internet 1362) such environmental information as increased signal noise in a particular service area due to increase traffic, a change in weather conditions, a base station 122 (or other infrastructure provisioning), change in operation status (e.g., operational to inactive);
- (c) receives and directs location processing requests from other location centers 142 (via, e.g., the Internet 1368);
- (d) performs accounting and billing procedures;
- (e) interacts with location center operators by, for example, receiving operator commands and providing output indicative of processing resources being utilized and malfunctions;
- (f) provides access to output requirements for various applications requesting location estimates. For example, an Internet location request from a trucking company in Los Angeles to a location center 142 in Denver may only want to know if a particular truck or driver is within the Denver area. Alternatively, a local medical rescue unit is likely to request a precise location estimate as possible.

Note that in Fig. 6, (a)-(b) above are, at least at a high level, performed by utilizing the operator interface 1374.

Referring now to the output gateway 1356, this module routes target MS 140 location estimates to the appropriate location application(s). For instance, upon receiving a location estimate from the most likelihood estimator 1344, the output gateway 1356 may determine that the location estimate is for an automobile being tracked by the police and therefore must be provided according to a particular protocol.

## System Tuning and Adaptation: Adaptation Engine

A fifth functional group of location engine 139 modules provides the ability to enhance the MS locating reliability and/or accuracy of the present invention by providing it with the capability to adapt to particular operating configurations, operating conditions and wireless signaling environments without performing intensive manual analysis of the performance of various embodiments of the location engine 139.

5 That is, this functional group automatically enhances the performance of the location engine for locating MSs 140 within a particular coverage area 120 using at least one wireless network infrastructure therein. More precisely, this functional group allows the present invention to adapt by tuning or optimizing certain system parameters according to location engine 139 location estimate accuracy and reliability.

There are a number location engine 139 system parameters whose values affect location estimation, and it is an aspect of the present invention that the MS location processing performed should become increasingly better at locating a target MS 140 not only through building an increasingly more detailed model of the signal characteristics of location in the coverage area 120 such as discussed above regarding the location signature data base 1320, but also by providing automated capabilities for the location center processing to adapt by adjusting or "tuning" the values of such location center system parameters.

Accordingly, the present invention includes a module, denoted herein as an "adaptation engine" 1382, that performs an optimization procedure on the location center 142 system parameters either periodically or concurrently with the operation of the location center in estimating MS locations. That is, the adaptation engine 1382 directs the modifications of the system parameters so that the location engine 139 increases in overall accuracy in locating target MSs 140. In one embodiment, the adaptation engine 1382 includes an embodiment of a genetic algorithm as the mechanism for modifying the system parameters. Genetic algorithms are basically search algorithms based on the mechanics of natural genetics. The genetic algorithm utilized herein is included in the form of pseudo code in APPENDIX B. Note that to apply this genetic algorithm in the context of the location engine 139 architecture only a "coding scheme" and a "fitness function" are required as one skilled in the art will appreciate. Moreover, it is also within the scope of the present invention to use modified or different adaptive and/or tuning mechanisms. For further information regarding such adaptive mechanisms, the following references are incorporated herein by reference: Goldberg, D. E. (1989). Genetic algorithms for search, optimization, and machine learning. Reading, MA: Addison-Wesley Publishing Company; and Holland, J. H. (1975) Adaptation in natural and artificial systems. Ann Arbor, MI: The University of Michigan Press.

### Implementations of First Order Models

25 Further descriptions of various first order models 1224 are provided in this section.

### Distance First Order Models (TOA/TDOA)

As discussed in the Location Center Architecture Overview section herein above, distance models determine a presumed direction and/or distance that a target MS 140 is from one or more base stations 122. In some embodiments of distance models, the target MS location estimate(s) generated are obtained using radio signal analysis techniques that are quite general and therefore are not capable of taking into account the peculiarities of the topography of a particular radio coverage area. For example, substantially

all radio signal analysis techniques using conventional procedures (or formulas) are based on "signal characteristic measurements" such as:

- (a) signal timing measurements (e.g., TOA and TDOA),
- (b) signal strength measurements, and/or
- (c) signal angle of arrival measurements.

Furthermore, such signal analysis techniques are likely predicated on certain very general assumptions that can not fully account for signal attenuation and multipath due to a particular radio coverage area topography.

o Taking a CDMA or TDMA base station network as an example, each base station (BS) 122 is required to emit a constant signal-strength pilot channel pseudo-noise (PN) sequence on the forward link channel identified uniquely in the network by a pilot sequence offset and frequency assignment. It is possible to use the pilot channels of the active, candidate, neighboring and remaining sets, maintained in the target MS, for obtaining signal characteristic measurements (e.g., TOA and/or TDOA measurements) between the target MS 140 and the base stations in one or more of these sets.

Based on such signal characteristic measurements and the speed of signal propagation, signal characteristic ranges or range differences related to the location of the target MS 140 can be calculated. Using TOA and/or TDOA ranges as exemplary, these ranges can then be input to either the radius-radius multilateration or the time difference multilateration algorithms along with the known positions of the corresponding base stations 122 to thereby obtain one or more location estimates of the target MS 140. For example, if there are, four base stations 122 in the active set, the target MS 140 may cooperate with each of the base stations in this set to provide signal arrival time measurements. Accordingly, each of the resulting four sets of three of these base stations 122 may be used to provide an estimate of the target MS 140 as one skilled in the art will understand. Thus, potentially (assuming the measurements for each set of three base stations yields a feasible location solution) there are four estimates for the location of the target MS 140. Further, since such measurements and BS 122 positions can be sent either to the network or the target MS 140, location can be determined in either entity.

Since many of the signal measurements utilized by embodiments of distance models are subject to signal attenuation and multipath due to a particular area topography. Many of the sets of base stations from which target MS location estimates are desired may result in either no location estimate, or an inaccurate location estimate.

Accordingly, some embodiments of distance FOMs may attempt to mitigate such ambiguity or inaccuracies by, e.g., identifying discrepancies (or consistencies) between arrival time measurements and other measurements (e.g., signal strength), these discrepancies (or consistencies) may be used to filter out at least those signal measurements and/or generated location estimates that appear less accurate. In particular, such identifying <sup>by filtering</sup> may filtering can be performed by, for example, an expert system residing in the distance FOM.

A second approach for mitigating such ambiguity or conflicting MS location estimates is particularly novel in that each of the target MS location estimates is used to generate a location hypothesis regardless of its apparent accuracy. Accordingly, these location hypotheses are input to an alternative embodiment of the context adjuster 1326 that is substantially (but not identical to) the context adjuster as described in detail in APPENDIX D so that each location hypothesis may be adjusted to enhance its accuracy.



In one embodiment, a coverage area model utilizes both the detection and non-detection of base stations 122 by the target MS 140 (conversely, of the MS by one or more base stations 122) to define an area where the target MS 140 may likely be. A relatively straightforward application of this technique is to:

- 5 (a) find all areas of intersection for base station RF coverage area representations, wherein: (i) the corresponding base stations are on-line for communicating with MSs 140; (ii) the RF coverage area representations are deemed reliable for the power levels of the on-line base stations; (iii) the on-line base stations having reliable coverage area representations can be detected by the target MS; and (iv) each intersection must include a predetermined number of the reliable RF coverage area representations (e.g., 2 or 3); and
- 10 (b) obtain new location estimates by subtracting from each of the areas of intersection any of the reliable RF coverage area representations for base stations 122 that can not be detected by the target MS.

Accordingly, the new areas may be used to generate location hypotheses.

#### Location Base Station First Order Model

15 In the location base station (LBS) model (FOM 1224), a database is accessed which contains electrical, radio propagation and coverage area characteristics of each of the location base stations in the radio coverage area. The LBS model is an active model, in that it can probe or excite one or more particular LBSs 152 in an area for which the target MS 140 to be located is suspected to be placed. Accordingly, the LBS model may receive as input a most likely target MS 140 location estimate previously output by the location engine 139 of the present invention, and use this location estimate to determine which (if any) LBSs 152 to activate and/or deactivate for enhancing a subsequent location estimate of the target MS. Moreover, the feedback from the activated LBSs 152 may be provided to other FOMs 1224, as appropriate, as well as to the LBS model. However, it is an important aspect of the LBS model  
20 that when it receives such feedback, it may output location hypotheses having relatively small target MS 140 location area estimates about the active LBSs 152 and each such location hypothesis also has a high confidence value indicative of the target MS 140 positively being in the corresponding location area estimate (e.g., a confidence value of .9 to +1), or having a high confidence value indicative of the target MS 140 not being in the corresponding location area estimate (i.e., a confidence value of -0.9 to -1). Note that in some embodiments of the LBS model, these embodiments may have functionality similar to that of the coverage area first  
25 order model described above. Further note that for LBSs within a neighborhood of the target MS wherein there is a reasonable chance that with movement of the target MS may be detected by these LBSs, such LBSs may be requested to periodically activate. (Note, that it is not assumed that such LBSs have an on-line external power source; e.g., some may be solar powered). Moreover, in the case where an LBS 152 includes sufficient electronics to carry voice communication with the target MS 140 and is the primary BS for the target MS (or alternatively, in the active or candidate set), then the LBS model will not deactivate this particular LBS during its  
30 procedure of activating and deactivating various LBSs 152.

Stochastic First Order Model

The stochastic first order models may use statistical prediction techniques such as principle decomposition, ~~partial least squares~~, partial least squares, or other regression techniques for predicting, for example, expected minimum and maximum distances of the target MS from one or more base stations 122, e.g., Bollenger Bands. Additionally, some embodiments may use Markov processes and Random Walks (predicted incremental MS movement) for determining an expected area within which the target MS 140 is likely to be. That is, such a process measures the incremental time differences of each pilot as the MS moves for predicting a size of a location area estimate using past MS estimates such as the verified location signatures in the location signature data base 1320.

Pattern Recognition and Adaptive First Order Models

It is a particularly important aspect of the present invention to provide:

- 10 (a) one or more FOMs 1224 that generate target MS 140 location estimates by using pattern recognition or associativity techniques, and/or
- (b) one or more FOMs 1224 that are adaptive or trainable so that such FOMs may generate increasingly more accurate target MS location estimates from additional training.

Statistically Based Pattern Recognition First Order Models

15 Regarding FOMs 1224 using pattern recognition or associativity techniques, there are many such techniques available. For example, there are statistically based systems such as "CART" (anacronym for Classification and Regression Trees) by ANGOSS Software International Limited of Toronto, Canada that may be used <sup>AM</sup> ~~for automatically for detecting~~ or recognizing patterns in data that were unprovided (and likely previously unknown). Accordingly, by imposing a relatively fine mesh or grid of <sup>cell on the radio</sup> ~~cells of the radio~~ coverage area, wherein each cell is entirely within a particular area type categorization such as the transmission area types (discussed in the section, "Coverage Area: Area Types And Their Determination" above), the verified location signature clusters within the cells of each area type may be analyzed for signal characteristic patterns. If such patterns are found, then they can be used to identify at least a likely area type in which a target MS is likely to be located. That is, one or more location hypotheses may be generated having target MS 140 location estimates that cover an area having the likely area type wherein the target MS 140 is located. Further note that such statistically based pattern recognition systems as "CART" include software code generators for generating expert system software embodiments for recognizing the patterns detected within a training set (e.g., the verified location signature clusters).

25 Accordingly, although an embodiment of a FOM as described here may not be exceedingly accurate, it may be very reliable. Thus, since a fundamental aspect of the present invention is to use a plurality MS location techniques for generating location estimates and to analyze the generated estimates (likely after being adjusted) to detect patterns of convergence or clustering among the estimates, even large MS location area estimates are useful. For example, it can be the case that four different and relatively large MS location estimates, each having very high reliability, have an area of intersection that is acceptably precise and inherits the very high reliability from each of the large MS location estimates from which the intersection area was derived.

00770030 012501

0070629-012501  
10270629-012501

A similar statistically based FOM 1224 to the one above may be provided where the radio coverage area is decomposed substantially as above, but in addition to using the signal characteristics for detecting useful signal patterns, the specific identifications of the base station 122 providing the signal characteristics may also be used. Thus, assuming there is a sufficient density of verified location signature clusters in some of the mesh cells so that the statistical pattern recognizer can detect patterns in the signal characteristic measurements, an expert system may be generated that outputs a target MS 140 location estimate that may provide both a reliable and accurate location estimate of a target MS 140.

Adaptive/Trainable First Order Models

Adaptive/Trainable First Order Models

The term adaptive is used to describe a data processing component that can modify its data processing behavior in response to certain inputs that are used to change how subsequent inputs are processed by the component. Accordingly, a data processing component may be "explicitly adaptive" by modifying its behavior according to the input of explicit instructions or control data that is input for changing the component's subsequent behavior in ways that are predictable and expected. That is, the input encodes explicit instructions that are known by a user of the component. Alternatively, a data processing component may be "implicitly adaptive" in that its behavior is modified by other than instructions or control data whose meaning is known by a user of the component. For example, such implicitly adaptive data processors may learn by training on examples, by substantially unguided exploration of a solution space, or other data driven adaptive strategies such as statistically generated decision trees. Accordingly, it is an aspect of the present invention to utilize not only explicitly adaptive MS location estimators within FOMs 1224, but also implicitly adaptive MS location estimators. In particular, artificial neural networks (also denoted neural nets and ANNs herein) are used in some embodiments as implicitly adaptive MS location estimators within FOMs. Thus, in the sections below, neural net architectures and their application to locating an MS is described.

Artificial Neural Networks For MS Location

Artificial neural networks may be particularly useful in developing one or more first order models 1224 for locating an MS 140, since, for example, ANNs can be trained for classifying and/or associatively pattern matching of various RF signal measurements such as the location signatures. That is, by training one or more artificial neural nets using RF signal measurements from verified locations so that RF signal transmissions characteristics indicative of particular locations are associated with their corresponding locations, such trained artificial neural nets can be used to provide additional target MS 140 location hypotheses. Moreover, it is an aspect of the present invention that the training of such artificial neural net based FOMs (ANN FOMs) is provided without manual intervention as will be discussed hereinbelow.

Artificial Neural Networks That Converge on Near Optimal Solutions

It is as an aspect of the present invention to use an adaptive neural network architecture which has the ability to explore the parameter or matrix weight space corresponding to a ANN for determining new configurations of weights that reduce an objective or error function indicating the error in the output of the ANN over some aggregate set of input data ensembles. Accordingly, in one embodiment, a genetic algorithm is used to provide such an adaptation capability. However, it is also within the scope of the present invention to use other adaptive techniques such as, for example, simulated annealing, cascade correlation with multistarts, gradient descent with multistarts, and truncated Newton's method with multistarts, as one skilled in the art of neural network computing will understand.

Artificial Neural Networks as MS Location Estimators for First Order Models

Although there have been substantial advances in artificial neural net computing in both hardware and software, it can be difficult to choose a particular ANN architecture and appropriate training data for yielding high quality results. In choosing a ANN architecture at least the following three criteria are chosen (either implicitly or explicitly):

- (a) a learning paradigm: i.e., does the ANN require supervised training (i.e., being provided with indications of correct and incorrect performance), unsupervised training, or a hybrid of both (sometimes referred to as reinforcement);
- (b) a collection of learning rules for indicating how to update the ANN;
- (c) a learning algorithm for using the learning rules for adjusting the ANN weights.

Furthermore, there are other implementation issues such as:

- (d) how many layers a artificial neural net should have to effectively capture the patterns embedded within the training data. For example, the benefits of using small ANN are many. less costly to implement, faster, and tend to generalize better because they avoid overfitting weights to training patterns. That is, in general, more unknown parameters (weights) induce more local and global minima in the error surface or space. However, the error surface of smaller nets can be very rugged and have few good solutions, making it difficult for a local minimization algorithm to find a good solution from a random starting point as one skilled in the art will understand;
- (e) how many units or neurons to provide per layer;
- (f) how large should the training set be presented to provide effective generalization to non-training data
- (g) what type of transfer functions should be used.

However, the architecture of the present invention allows substantial flexibility in the implementation of ANN for FOMs 1224. In particular, there is no need to choose only one artificial neural net architecture and/or implementation in that a plurality of ANNs may be accommodated by the architecture of the location engine 139. Furthermore, it is important to keep in mind that it may not be necessary to train a ANN for a FOM as rigorously as is done in typical ANN applications since the accuracy and reliability in estimating the location of a target MS 140 with the present invention comes from synergistically utilizing a plurality of different MS



location estimators, each of which may be undesirable in terms of accuracy and/or reliability in some areas, but when their estimates are synergistically used as in the location engine 139, accurate and reliable location estimates can be attained. Accordingly, one embodiment of the present invention may have a plurality of moderately well trained ANNs having different neural net architectures such as: multilayer perceptrons, adaptive resonance theory models, and radial basis function networks.

5           Additionally, many of the above mentioned ANN architecture and implementation decisions can be addressed substantially automatically by various commercial artificial neural net development systems such as: "NEUROGENETIC OPTIMIZER" by BioComp Systems, wherein genetic algorithms are used to optimize and configure ANNs, and artificial neural network hardware and software products by Accurate Automation Corporation of Chattanooga, Tennessee, such as "ACCURATE AUTOMATION NEURAL NETWORK TOOLS.

#### 10    Artificial Neural Network Input and Output

It is worthwhile to discuss the data representations for the inputs and outputs of a ANN used for generating MS location estimates. Regarding ANN input representations, recall that the signal processing subsystem 1220 may provide various RF signal measurements as input to an ANN (such as the RF signal measurements derived from verified location signatures in the location signature data base 1320). For example, a representation of a histogram of the frequency of occurrence of CDMA fingers in a time delay versus signal strength 2-dimensional domain may be provided as input to such an ANN. In particular, a 2-dimensional grid of signal strength versus time delay bins may be provided so that received signal measurements are slotted into an appropriate bin of the grid. In one embodiment, such a grid is a six by six array of bins such as illustrated in the left portion of Fig. 14. That is, each of the signal strength and time delay axes are partitioned into six ranges so that both the signal strength and the time delay of RF signal measurements can be slotted into an appropriate range, thus determining the bin.

20           Note that RF signal measurement data (i.e., location signatures) slotted into a grid of bins provides a convenient mechanism for classifying RF measurements received over time so that when each new RF measurement data is assigned to its bin, a counter for the bin can be incremented. Thus in one embodiment, the RF measurements for each bin can be represented pictorially as a histogram. In any case, once the RF measurements have been slotted into a grid, various filters may be applied for filtering outliers and noise prior to inputting bin values to an ANN. Further, various amounts of data from such a grid may be provided to an ANN. In one embodiment, the tally from each bin is provided to an ANN. Thus, as many as 108 values could be input to the ANN (two values defining each bin, and a tally for the bin). However, other representations are also possible. For instance, by ordering the bin tallies linearly, only 36 need be provided as ANN input. Alternatively, only representations of bins having the highest tallies may be provided as ANN input. Thus, for example, if the highest 10 bins and their tallies were provided as ANN input, then only 20 inputs need be provided (i.e., 10 input pairs, each having a single bin identifier and a corresponding tally).

30           In addition, note that the signal processing subsystem 1220 may also obtain the identifications of other base stations 122 (152) for which their pilot channels can be detected by the target MS 140 (i.e., the forward path), or for which the base stations can detect a signal from the target MS (i.e., the reverse path). Thus, in order to effectively utilize substantially all pertinent location RF





00770028-012604

- (b) Determine a collection of base stations (or antenna sectors 130),  $B'$ , from the common set B, wherein  $B'$  is small (e.g., four or five).
- (c) Determine the area,  $A_{ANN}$ , to be associated with collection  $B'$  of base stations (antenna sectors). In one embodiment, this area is selected by determining an area containing the set L of locations of all verified location signature clusters determined in step (a) having location signature data from each of the base stations (antenna sectors) in the collection  $B'$ . More precisely, the area,  $A_{ANN}$ , may be determined by providing a covering of the locations of L, such as, e.g., by cells of a mesh of appropriately fine mesh size so that each cell is of a size not substantially larger than the maximum MS location accuracy desired.
- (d) Determine an additional collection, b, of base stations that have been previously detected (and/or are likely to be detected) by at least one MS in the area  $A_{ANN}$ .
- (e) Train the ANN on input data related to: (i) signal characteristic measurements of signal transmissions between MSs 140 at verified locations in  $A_{ANN}$ , and the base stations (antenna sectors) in the collection  $B'$ , and (ii) discrete inputs of detection states from the base stations represented in the collection b. For example, train the ANN on input including: (i) data from verified location signatures from each of the base stations (antenna sectors) in the collection  $B'$ , wherein each location signature is part of a cluster in the collection C; (ii) a collection of discrete values corresponding to other base stations (antenna sectors) in the area b containing the area,  $A_{ANN}$ .

Regarding (d) immediately above, it is important to note that it is believed that less accuracy is required in training a ANN used for generating a location hypothesis (in a FOM 1224) for the present invention than in most applications of ANNs (or other trainable/adaptive components) since, in most circumstances, when signal measurements are provided for locating a target MS 140, the location engine 139 will activate a plurality location hypothesis generating modules (corresponding to one or more FOMs 1224) for substantially simultaneously generating a plurality of different location estimates (i.e., hypotheses). Thus, instead of training each ANN so that it is expected to be, e.g., 92% or higher in accuracy, it is believed that synergies with MS location estimates from other location hypothesis generating components will effectively compensate for any reduced accuracy in such a ANN (or any other location hypothesis generating component). Accordingly, it is believed that training time for such ANNs may be reduced without substantially impacting the MS locating performance of the location engine 139.

#### Finding Near-Optimal Location Estimating Artificial Neural Networks

In one traditional artificial neural network training process, a relatively tedious set of trial and error steps may be performed for configuring an ANN so that training produces effective learning. In particular, an ANN may require configuring parameters related to, for example, input data scaling, test/training set classification, detecting and removing unnecessary input variable selection. However, the present invention reduces this tedium. That is, the present invention uses mechanisms such as genetic algorithms or other mechanisms for avoiding non-optimal but locally appealing (i.e., local minimum) solutions, and locating





particular, the difference in the selection states of the discrete ANN inputs between the two transmission power levels may provide useful additional information for more accurately estimating a location of a target MS.

5 It is important to note that when gathering RF signal measurements from a wireless base station network for locating MSs, the network should not be overburdened with location related traffic. Accordingly, note that network location data requests for data particularly useful for ANN based FOMs is generally confined to the requests to the base stations in the immediate area of a target MS 140 whose location is desired. For instance, both collections of base stations B' and b discussed in the context of training an ANN are also the same collections of base stations from which MS location data would be requested. Thus, the wireless network MS location data requests are data driven in that the base stations to queried for location data (i.e., the collections B' and b) are determined by previous RF signal measurement characteristics recorded. Accordingly, the selection of the collections B' and b are adaptable to 10 changes in the wireless environmental characteristics of the coverage area 120.

#### LOCATION SIGNATURE DATA BASE

Before proceeding with a description of other levels of the present invention as described in (24.1) through (24.3) above, in this section further detail is provided regarding the location signature data base 1320. Note that a brief description of the location signature data base was provided above indicating that this data base stores MS location data from verified and/or known locations (optionally with additional known 15 environmental characteristic values) for use in enhancing current target MS location hypotheses and for comparing archived location data with location signal data obtained from a current target MS. However, the data base management system functionality incorporated into the location signature data base 1320 is an important aspect of the present invention, and is therefore described in this section. In particular, the data base management functionality described herein addresses a number of difficulties encountered in maintaining a large archive of signal processing data such as MS signal location data. Some of these difficulties can be described as follows:

- 20 (a) in many signal processing contexts, in order to effectively utilize archived signal processing data for enhancing the performance of a related signal processing application, there must be an large amount of signal related data in the archive, and this data must be adequately maintained so that as archived signal data becomes less useful to the corresponding signal processing application (i.e., the data becomes "inapplicable") its impact on the application should be correspondingly reduced. Moreover, as archive data becomes substantially inapplicable, it should be filtered from the archive altogether. However, the 25 size of the data in the archive makes it prohibitive for such a process to be performed manually, and there may be no simple or straightforward techniques for automating such impact reduction or filtering processes for inapplicable signal data;
- (b) it is sometimes difficult to determine the archived data to use in comparing with newly obtained signal processing application data; and
- (c) it is sometimes difficult to determine a useful technique for comparing archived data with newly obtained signal processing application data. 30

It is an aspect of the present invention that the data base management functionality of the location signature data base 1320 addresses each of the difficulties mentioned immediately above. For example, regarding (a), the location signature data base is "self cleaning" in that by associating a confidence value with each loc sig in the data base and by reducing or increasing the confidences of archived verified loc sigs

according to how well their signal characteristic data compares with newly received verified location signature data, the location signature data base 1320 maintains a consistency with newly verified loc sigs.

The following data base management functional descriptions describe some of the more noteworthy functions of the location signature data base 1320. Note that there are various ways that these functions may be embodied. So as to not overburden the reader here, the details for one embodiment is provided in APPENDIX C. Figs. 16a through 16c present a table providing a brief description of the attributes of the location signature data type stored in the location signature data base 1320.

#### LOCATION SIGNATURE PROGRAM DESCRIPTIONS

The following program updates the random loc sigs in the location signature data base 1320. In one embodiment, this program is invoked primarily by the Signal Processing Subsystem.

#### 10 Update Location signature Database Program

#### Update\_Loc\_Sig\_DB(new\_loc\_obj, selection\_criteria, loc\_sig\_pop)

/\* This program updates loc sigs in the location signature data base 1320. That is, this program updates, for example, at least the location information for verified random loc sigs residing in this data base. The general strategy here is to use information (i.e., "new\_loc\_obj") received from a newly verified location (that may not yet be entered into the location signature data base) to assist in determining if the previously stored random verified loc sigs are still reasonably valid to use for:

15

(29.1) estimating a location for a given collection (i.e., "bag") of wireless (e.g., CDMA) location related signal characteristics received from an MS,

(29.2) training (for example) adaptive location estimators (and location hypothesizing models), and

20

(29.3) comparing with wireless signal characteristics used in generating an MS location hypothesis by one of the MS location hypothesizing models (denoted First Order Models, or, FOMs).

More precisely, since it is assumed that it is more likely that the newest location information obtained is more indicative of the wireless (CDMA) signal characteristics within some area surrounding a newly verified location than the verified loc sigs (location signatures) previously entered into the Location Signature data base, such verified loc sigs are compared for signal characteristic consistency with the newly verified location information (object) input here for determining whether some of these "older" data base verified loc sigs still appropriately characterize their associated location.

25

In particular, comparisons are iteratively made here between each (target) loc sig "near" "new\_loc\_obj" and a population of loc sigs in the location signature data base 1320 (such population typically including the loc sig for "new\_loc\_obj) for:

30

(29.4) adjusting a confidence factor of the target loc sig. Note that each such confidence factor is in the range [0, 1] with 0 being the lowest and 1 being the highest. Further note that a confidence factor here can be raised as



well as filtered depending on how well the target loc sig matches a consistent population of loc sigs to which it is compared. Thus, the confidence in any particular verified loc sig, LS, can fluctuate with successive invocations of this program if the input to the successive invocations are with location information geographically "near" LS.

5 (29.5) remove older verified loc sigs from use whose confidence value is below a predetermined threshold. Note, it is intended that such predetermined thresholds be substantially automatically adjustable by periodically testing various confidence factor thresholds in a specified geographic area to determine how well the eligible data base loc sigs (for different thresholds) perform in agreeing with a number of verified loc sigs in a "loc sig test-bed", wherein the test bed may be composed of, for example, repeatable loc sigs and recent random verified loc sigs.  
10

Note that this program may be invoked with a (verified/known) random and/or repeatable loc sig as input. Furthermore, the target loc sigs to be updated may be selected from a particular group of loc sigs such as the random loc sigs or the repeatable loc sigs, such selection being determined according to the input parameter, "selection\_criteria" while the comparison population may be designated with the input parameter, "loc\_sig\_pop". For example, to update confidence factors of certain random loc sigs near "new\_loc\_obj", "selection\_criteria" may be given a value indicating, "USE\_RANDOM\_LOC\_SIGS", and "loc\_sig\_pop" may be given a value indicating, "USE\_REPEATABLE\_LOC\_SIGS". Thus, if in a given geographic area, the repeatable loc sigs (from, e.g., stationary transceivers) in the area have recently been updated, then by successively providing "new\_loc\_obj" with a loc sig for each of these repeatable loc sigs, the stored random loc sigs can have their confidences adjusted.  
15  
20

Alternatively, in one embodiment of the present invention, the present function may be used for determining when it is desirable to update repeatable loc sigs in a particular area (instead of automatically and periodically updating such repeatable loc sigs). For example, by adjusting the confidence factors on repeatable loc sigs here provides a method for determining when repeatable loc sigs for a given area should be updated. That is, for example, when the area's average confidence factor for the repeatable loc sigs drops below a given (potentially high) threshold, then the MSs that provide the repeatable loc sigs can be requested to respond with new loc sigs for updating the data base. Note, however, that the approach presented in this function assumes that the repeatable location information in the location signature data base 1320 is maintained with high confidence by, for example, frequent data base updating. Thus, the random location signature data base verified location information may be effectively compared against the repeatable loc sigs in an area.  
25

30 INPUT:

new\_loc\_obj: a data representation at least including a loc sig for an associated location about which Location Signature loc sigs are to have their confidences updated.

selection\_criteria: a data representation designating the loc sigs to be selected to have their confidences updated (may be defaulted). The following groups of loc sigs may be selected: "USE\_RANDOM\_LOC\_SIGS" (this is the

00770030-013604



recent\_time:            period beyond which loc sigs are no longer considered recent. Note that "recent" loc sigs (i.e., more recent than "recent\_time") are not subject to the confidence reduction and filtering of this actions of this function.

#### Confidence Enhancement Program

5           The following program increases the confidence of verified Location Signature loc sigs that are (seemingly) of higher accuracy (i.e., in agreement with comparable loc sigs in the location signature data base 1320). Note that this program is invoked by "Update\_Loc\_Sig\_DB".

increase\_confidence\_of\_good\_DB\_loc\_sigs(nearby\_loc\_sig\_bag, error\_rec\_set, small\_error\_threshold, confidence\_increase\_factor, recent\_time);

10   Inputs:

loc\_sig\_bag:           A collection or "bag" of to be tested for determining if their confidences should be increased.

error\_rec\_set:         A set of error records (objects), denoted "error\_recs", providing information as to how much each loc sig in "loc\_sig\_bag" disagrees with comparable loc sigs in the location signature data base. That is, there is a "error\_rec" here for each loc sig in "loc\_sig\_bag".

15   small\_error\_threshold: The error threshold below which the errors are considered too small to ignore.

confidence\_increase\_factor: The factor by which to increase the confidence of loc sigs.

recent\_time:           Time period beyond which loc sigs are no longer considered recent. Note that "recent" loc sigs (i.e., more recent than "recent\_time") are not subject to the confidence reduction and filtering of this actions of this function.

20   Location Hypotheses Consistency Program

          The following program determines the consistency of location hypotheses with verified location information in the location signature data base 1320. Note that in the one embodiment of the present invention, this program is invoked primarily by a module denoted the historical location reasoner 1424 described sections hereinbelow. Moreover, the detailed description for this program is provided with the description of the historical location reasoner hereinbelow for completeness.

25   DB\_Loc\_Sig\_Error\_Fit(hypothesis, measured\_loc\_sig\_bag, search\_criteria)

      /\* This function determines how well the collection of loc sigs in "measured\_loc\_sig\_bag" fit with the loc sigs in the location signature data base 1320 wherein the data base loc sigs must satisfy the criteria of the input parameter "search\_criteria" and are relatively close to the MS location estimate of the location hypothesis, "hypothesis".

      Input: hypothesis: MS location hypothesis;

30       measured\_loc\_sig\_bag: A collection of measured location signatures ("loc sigs" for short) obtained from the MS (the data structure here is an aggregation such as an array or list). Note, it is assumed that there is at most

00770000 010001

one loc sig here per Base Station in this collection. Additionally, note that the input data structure here may be a location signature cluster such as the "loc\_sig\_cluster" field of a location hypothesis (cf. Fig. 9). Note that variations in input data structures may be accepted here by utilization of flag or tag bits as one skilled in the art will appreciate;

5 search\_criteria: The criteria for searching the verified location signature data base for various categories of loc sigs. The only limitation on the types of categories that may be provided here is that, to be useful, each category should have meaningful number of loc sigs in the location signature data base. The following categories included here are illustrative, but others are contemplated:

- (a) "USE ALL LOC SIGS IN DB" (the default),
- 10 (b) "USE ONLY REPEATABLE LOC SIGS",
- (c) "USE ONLY LOC SIGS WITH SIMILAR TIME OF DAY".

Further categories of loc sigs close to the MS estimate of "hypothesis" contemplated are: all loc sigs for the same season and same time of day, all loc sigs during a specific weather condition (e.g., snowing) and at the same time of day, as well as other limitations for other environmental conditions such as traffic patterns.

15 Note, if this parameter is NIL, then (a) is assumed.

Returns: An error object (data type: "error\_object") having: (a) an "error" field with a measurement of the error in the fit of the location signatures from the MS with verified location signatures in the location signature data base 1320; and <sup>(b1)</sup> ~~(a)~~ a "confidence" field with a value indicating the perceived confidence that is to be given to the "error" value. \*/

20 Location Signature Comparison Program

The following program compares: (a1) loc sigs that are contained in (or derived from) the loc sigs in "target\_loc\_sig\_bag" with (b1) loc sigs computed from verified loc sigs in the location signature data base 1320. That is, each loc sig from (a1) is compared with a corresponding loc sig from (b) to obtain a measurement of the discrepancy between the two loc sigs. In particular, assuming each of the loc sigs for "target\_loc\_sig\_bag" correspond to the same target MS location, wherein this

25 location is "target\_loc", this program determines how well the loc sigs in "target\_loc\_sig\_bag" fit with a computed or estimated loc sig for the location, "target\_loc" that is derived from the verified loc sigs in the location signature data base 1320. Thus, this program may be used: (a2) for determining how well the loc sigs in the location signature cluster for a target MS ("target\_loc\_sig\_bag") compares with loc sigs derived from verified location signatures in the location signature data base, and

30 (b2) for determining how consistent a given collection of loc sigs ("target\_loc\_sig\_bag") from the location signature data base is with other loc sigs in the location signature data base. Note that in (b2) each of the one or more loc sigs in "target\_loc\_sig\_bag" have an error computed here that can be used in determining if the loc sig is becoming inapplicable for predicting target MS locations.

Determine\_Location\_Signature\_Fit\_Errors(target\_loc, target\_loc\_sig\_bag, search\_area, search\_criteria, output\_criteria)

/\* Input: target\_loc: An MS location or a location hypothesis for an MS. Note, this can be any of the following:

- (a) An MS location hypothesis, in which case, if the hypothesis is inaccurate, then the loc sigs in "target\_loc\_sig\_bag" are the location signature cluster from which this location hypothesis was derived. Note that if this location is inaccurate, then "target\_loc\_sig\_bag" is unlikely to be similar to the comparable loc sigs derived from the loc sigs of the location signature data base close "target\_loc"; or
- (b) A previously verified MS location, in which case, the loc sigs of "target\_loc\_sig\_bag" were the loc sigs measurements at the time they were verified. However, these loc sigs may or may not be accurate now.

target\_loc\_sig\_bag: Measured location signatures ("loc sigs" for short) obtained from the MS (the data structure here, bag, is an aggregation such as array or list). It is assumed that there is at least one loc sig in the bag. Further, it is assumed that there is at most one loc sig per Base Station;

search\_area: The representation of the geographic area surrounding "target\_loc". This parameter is used for searching the Location Signature data base for verified loc sigs that correspond geographically to the location of an MS in "search\_area";

search\_criteria: The criteria used in searching the location signature data base. The criteria may include the following:

- (a) "USE ALL LOC SIGS IN DB",
- (b) "USE ONLY REPEATABLE LOC SIGS",
- (c) "USE ONLY LOC SIGS WITH SIMILAR TIME OF DAY".

However, environmental characteristics such as: weather, traffic, season are also contemplated.

output\_criteria: The criteria used in determining the error records to output in "error\_rec\_bag". The criteria here may include one of:

- (a) "OUTPUT ALL POSSIBLE ERROR\_RECS";
- (b) "OUTPUT ERROR\_RECS FOR INPUT LOC SIGS ONLY".

Returns: error\_rec\_bag: A bag of error records or objects providing an indication of the similarity between each loc sig in "target\_loc\_sig\_bag" and an estimated loc sig computed for "target\_loc" from stored loc sigs in a surrounding area of "target\_loc". Thus, each error record/object in "error\_rec\_bag" provides a measurement of how well a loc sig (i.e., wireless signal characteristics) in "target\_loc\_sig\_bag" (for an associated BS and the MS at "target\_loc") correlates with an estimated loc sig between this BS and MS. Note that the estimated loc sigs are determined using verified location signatures in the Location Signature data base. Note, each error record in "error\_rec\_bag"

includes: (a) a `base_station` indicating the base station to which the error record corresponds; and (b) a error measurement ( $>=0$ ), and (c) a confidence value (in  $[0, 1]$ ) indicating the confidence to be placed in the error measurement.

#### Computed Location Signature Program

The following program receives a collection of loc sigs and computes a loc sig that is representative of the loc sigs in the collection. That is, given a collection of loc sigs, “`loc_sig_bag`”, wherein each loc sig is associated with the same predetermined Base Station, this program uses these loc sigs to compute a representative or estimated loc sig associated with the predetermined Base Station and associated with a predetermined MS location, “`loc_for_estimation`”. Thus, if the loc sigs in “`loc_sig_bag`” are from the verified loc sigs of the location signature data base such that each of these loc sigs also has its associated MS location relatively close to “`loc_for_estimation`”, then this program can compute and return a reasonable approximation of what a measured loc sig between an MS at “`loc_for_estimation`” and the predetermined Base Station ought to be. This program is invoked by “`Determine_Location_Signature_Fit_Errors`”.

`estimate_loc_sig_from_DB(loc_for_estimation, loc_sig_bag)`

#### Geographic Area Representation Program

The following program determines and returns a representation of a geographic area about a location, “`loc`”, wherein: (a) the geographic area has associated MS locations for an acceptable number (i.e., at least a determined minimal number) of verified loc sigs from the location signature data base, and (b) the geographical area is not too big. However, if there are not enough loc sigs in even a largest acceptable search area about “`loc`”, then this largest search area is returned. “`DB_Loc_Sig_Error_Fit`”

`get_area_to_search(loc)`

#### Location signature Comparison Program

This program compares two location signatures, “`target_loc_sig`” and “`comparison_loc_sig`”, both associated with the same predetermined Base Station and the same predetermined MS location (or hypothesized location). This program determines a measure of the difference or error between the two loc sigs relative to the variability of the verified location signatures in a collection of loc sigs denoted the “`comparison_loc_sig_bag`” obtained from the location signature data base. It is assumed that “`target_loc_sig`”, “`comparison_loc_sig`” and the loc sigs in “`comparison_loc_sig_bag`” are all associated with the same base station. This program returns an error record (object), “`error_rec`”, having an error or difference value and a confidence value for the error value. Note, the signal characteristics of “`target_loc_sig`” and those of “`comparison_loc_sig`” are not assumed to be similarly normalized (e.g., via filters as per the filters of the Signal Processing Subsystem) prior to entering this function. It is further assumed that typically the input loc sigs satisfy the “`search_criteria`”. This program is invoked by: the program, “`Determine_Location_Signature_Fit_Errors`”, described above.

00770999:013301  
1032610:6600260

get\_difference\_measurement(target\_loc\_sig, comparison\_loc\_sig, comparison\_loc\_sig\_bag, search\_area, search\_criteria)

Input:

- target\_loc\_sig: The loc sig to which the "error\_rec" determined here is to be associated.
  - 5 comparison\_loc\_sig: The loc sig to compare with the "target\_loc\_sig". Note, if "comparison\_loc\_sig" is NULL, then this parameter has a value that corresponds to a noise level of "target\_loc\_sig".
  - comparison\_loc\_sig\_bag: The universe of loc sigs to use in determining an error measurement between "target\_loc\_sig" and "comparison\_loc\_sig". Note, the loc sigs in this aggregation include all loc sigs for the associated BS that are in the "search\_area".
  - 10 search\_area: A representation of the geographical area surrounding the location for all input loc sigs. This input is used for determining extra information about the search area in problematic circumstances.
  - search\_criteria: The criteria used in searching the location signature data base. The criteria may include the following:
    - (a) "USE ALL LOC SIGS IN DB",
    - (b) "USE ONLY REPEATABLE LOC SIGS",
    - 15 (c) "USE ONLY LOC SIGS WITH SIMILAR TIME OF DAY
- However, environmental characteristics such as: weather, traffic, season are also contemplated.

Detailed Description of the Hypothesis Evaluator Modules

Context Adjuster Embodiments

The context adjuster 1326 performs the first set of potentially many adjustments to at least the confidences of location hypotheses, and in some important embodiments, both the confidences and the target MS location estimates provided by FOMs 1224 may be adjusted according to previous performances of the FOMs. More particularly, as mentioned above, the context adjuster adjusts confidences so that, assuming there is a sufficient density verified location signature clusters captured in the location signature data base 1320, the resulting location hypotheses output by the context adjuster 1326 may be further processed uniformly and substantially without concern as to differences in accuracy between the first order models from which location hypotheses originate. Accordingly, the context adjuster adjusts location hypotheses both to environmental factors (e.g., terrain, traffic, time of day, etc., as described in 30.1 above), and to how predictable or consistent each first order model (FOM) has been at locating previous target MS's whose locations were subsequently verified.

Of particular importance is the novel computational paradigm utilized herein. That is, if there is a sufficient density of previous verified MS location data stored in the location signature data base 1320, then the FOM location hypotheses are used as an "index" into this data base (i.e., the location signature data base) for constructing new target MS 140 location estimates. A more detailed discussion of this aspect of the present invention is given hereinbelow. Accordingly, only a brief overview is provided here. Thus, since the location signature data base 1320 stores previously captured MS location data including:

0970029-01-001  
0970029-01-001

- (a) clusters of MS location signature signals (see the location signature data base section or a discussion of these signals) and
- (b) a corresponding verified MS location, for each such cluster, from where the MS signals originated,

the context adjuster 1326 uses newly created target MS location hypotheses output by the FOM's as indexes or pointers into the location signature data base for identifying other geographical areas where the target MS 140 is likely to be located based on the verified MS location data in the location signature data base.

In particular, at least the following two criteria are addressed by the context adjuster 1326:

- (32.1) Confidence values for location hypotheses are to be comparable regardless of first order models from which the location hypotheses originate. That is, the context adjuster moderates or dampens confidence value assignment distinctions or variations between first order models so that the higher the confidence of a location hypothesis, the more likely (or unlikely, if the location hypothesis indicates an area estimate where the target MS is NOT) the target MS is perceived to be in the estimated area of the location hypothesis regardless of the First Order Model from which the location hypothesis was output;
- (32.2) Confidence values for location hypotheses may be adjusted to account for current environmental characteristics such as month, day (weekday or weekend), time of day, area type (urban, rural, etc.), traffic and/or weather when comparing how accurate the first order models have previously been in determining an MS location according to such environmental characteristics. For example, in one embodiment of the present invention, such environmental characteristics are accounted for by utilizing a transmission area type scheme (as discussed in section 5.9 above) when adjusting confidence values of location hypotheses. Details regarding the use of area types for adjusting the confidences of location hypotheses and provided hereinbelow, and in particular, in APPENDIX D.

Note that in satisfying the above two criteria, the context adjuster 1326, at least in one embodiment, may use heuristic (fuzzy logic) rules to adjust the confidence values of location hypotheses from the first order models. Additionally, the context adjuster may also satisfy the following criteria:

- (33.1) The context adjuster may adjust location hypothesis confidences due to BS failure(s),
- (33.2) Additionally in one embodiment, the context adjuster may have a calibration mode for at least one of:
  - (a) calibrating the confidence values assigned by first order models to their location hypotheses outputs;
  - (b) calibrating itself.

A first embodiment of the context adjuster is discussed immediately hereinbelow and in APPENDIX D. However, the present invention also includes other embodiments of the context adjuster. A second embodiment is also described in Appendix D so as to not overburden the reader and thereby chance losing perspective of the overall invention.

A description of the high level functions in an embodiment of the context adjuster 1326 follows. Details regarding the implementation of these functions are provided in APPENDIX D. Also, many of the terms used hereinbelow are defined in APPENDIX D. Accordingly, the program descriptions in this section provide the reader with an overview of this first embodiment of the context adjuster 1326.



00770020:012604  
103210:000220

Context\_adjuster(loc\_hyp\_list)

This function adjusts the location hypotheses on the list, "loc\_hyp\_list", so that the confidences of the location hypotheses are determined more by empirical data than default values from the First Order Models I224. That is, for each input location hypothesis, its confidence (and an MS location area estimate) may be exclusively determined here if there are enough verified location signatures available within and/or surrounding the location hypothesis estimate.

This function creates a new list of location hypotheses from the input list, "loc\_hyp\_list", wherein the location hypotheses on the new list are modified versions of those on the input list. For each location hypothesis on the input list, one or more corresponding location hypotheses will be on the output list. Such corresponding output location hypotheses will differ from their associated input location hypothesis by one or more of the following: (a) the "image\_area" field (see Fig. 9) may be assigned an area indicative of where the target MS is estimated to be, (b) if "image\_area" is assigned, then the "confidence" field will be the confidence that the target MS is located in the area for "image\_area", (c) if there are not sufficient "nearby" verified location signature clusters in the location signature data base I320 to entirely rely on a computed confidence using such verified location signature clusters, then two location hypotheses (having reduced confidences) will be returned, one having a reduced computed confidence (for "image\_area") using the verified clusters in the Location Signature data base, and one being substantially the same as the associated input location hypothesis except that the confidence (for the field "area\_est") is reduced to reflect the confidence in its paired location hypothesis having a computed confidence for "image\_area". Note also, in some cases, the location hypotheses on the input list, may have no change to its confidence or the area to which the confidence applies.

Get\_adjusted\_loc\_hyp\_list\_for(loc\_hyp)

This function returns a list (or more generally, an aggregation object) of one or more location hypotheses related to the input location hypothesis, "loc\_hyp". In particular, the returned location hypotheses on the list are "adjusted" versions of "loc\_hyp" in that both their target MS I40 location estimates, and confidence placed in such estimates may be adjusted according to archival MS location information in the location signature data base I320. Note that the steps herein are also provided in flowchart form in Figs. 26a through 26c.

RETURNS: loc\_hyp\_list This is a list of one or more location hypotheses related to the input "loc\_hyp". Each location hypothesis on "loc\_hyp\_list" will typically be substantially the same as the input "loc\_hyp" except that there may now be a new target MS estimate in the field, "image\_area", and/or the confidence value may be changed to reflect information of verified location signature clusters in the location signature data base.

The function, "get\_adjusted\_loc\_hyp\_list\_for," and functions called by this function presuppose a framework or paradigm that requires some discussion as well as the defining of some terms. Note that some of the terms defined hereinbelow are illustrated in <sup>Fig. 24</sup> ~~Fig. 24~~.

Define the term the “cluster set” to be the set of all MS location point estimates, the values of the “pt\_est” field of the location hypothesis data type), for the present FOM, such that:

- (a) these estimates are within a predetermined corresponding area (e.g., the “loc\_hyp.pt\_covering” being such a predetermined corresponding area, or more generally, this predetermined corresponding area is determined as a function of the distance from an initial location estimate, e.g., “loc\_hyp.pt\_est”, from the FOM), and
- (b) these point estimates have verified location signature clusters in the location signature data base.

Note that the predetermined corresponding area above will be denoted as the “cluster set area”.

Define the term “image cluster set” (for a given First Order Model identified by “loc\_hyp.FOM\_ID”) to mean the set of verified location signature clusters whose MS location point estimates are in “the cluster set”.

Note that an area containing the “image cluster set” will be denoted as the “image cluster set area” or simply the “image area” in some contexts. Further note that the “image cluster set area” will be a “small” area encompassing the “image cluster set”. In one embodiment, the image cluster set area will be the smallest covering of cells from the mesh for the present FOM that covers the convex hull of the image cluster set. Note that preferably, each cell of each mesh for each FOM is substantially contained within a single (transmission) area type.

Thus, the present FOM provides the correspondences or mapping between elements of the cluster set and elements of the image cluster set.

confidence\_adjuster(FOM\_ID, image\_area, image\_cluster\_set)

This function returns a confidence value indicative of the target MS I40 being in the area for “image\_area”. Note that the steps for this function are provided in flowchart form in Figs. 27a and 27b.

**RETURNS:** A confidence value. This is a value indicative of the target MS being located in the area represented by “image\_area” (when it is assumed that for the related “loc\_hyp,” the “cluster set area” is the “loc\_hyp.pt\_covering” and “loc\_hyp.FOM\_ID” is “FOM\_ID”).

The function, “confidence\_adjuster,” (and functions called by this function) presuppose a framework or paradigm that requires some discussion as well as the defining of terms.

Define the term “mapped cluster density” to be the number of the verified location signature clusters in an “image cluster set” per unit of area in the “image cluster set area”.

It is believed that the higher the “mapped cluster density”, the greater the confidence can be had that a target MS actually resides in the “image cluster set area” when an estimate for the target MS (by the present FOM) is in the corresponding “the cluster set”.

Thus, the mapped cluster density becomes an important factor in determining a confidence value for an estimated area of a target MS such as, for example, the area represented by “image\_area”. However, the mapped cluster density value requires modification before it can be utilized in the confidence calculation. In particular, confidence values must be in the range [-1, 1]

105210:0220260

and a mapped cluster density does not have this constraint. Thus, a “relativized mapped cluster density” for an estimated MS area is desired, wherein this relativized measurement is in the range [-1, + 1], and in particular, for positive confidences in the range [0, 1]. Accordingly, to alleviate this difficulty, for the FOM define the term “prediction mapped cluster density” as a mapped cluster density value, MCD, for the FOM and image cluster set area wherein:

- 5 (i) MCD is sufficiently high so that it correlates (at least at a predetermined likelihood threshold level) with the actual target MS location being in the “image cluster set area” when a FOM target MS location estimate is in the corresponding “cluster set area”;

That is, for a cluster set area (e.g., “loc\_hyp.pt\_covering”) for the present FOM, if the image cluster set area has a mapped cluster density greater than the “prediction mapped cluster density”, then there is a high likelihood of the target MS being in the image cluster set area.

10 It is believed that the prediction mapped cluster density will typically be dependent on one or more area types. In particular, it is assumed that for each area type, there is a likely range of prediction mapped cluster density values that is substantially uniform across the area type. Accordingly, as discussed in detail hereinbelow, to calculate a prediction mapped cluster density for a particular area type, an estimate is made of the correlation between the mapped cluster densities of image areas (from cluster set areas) and the likelihood that if a verified MS location: (a) has a corresponding FOM MS estimate in the cluster set, and (b) is also in the particular area type, then the verified MS location is also in the image area.

Thus, if an area is within a single area type, then such a “relativized mapped cluster density” measurement for the area may be obtained by dividing the mapped cluster density by the prediction mapped cluster density and taking the smaller of: the resulting ratio and 1.0 as the value for the relativized mapped cluster density.

20 In some (perhaps most) cases, however, an area (e.g., an image cluster set area) may have portions in a number of area types. Accordingly, a “composite prediction mapped cluster density” may be computed, wherein, a weighted sum is computed of the prediction mapped cluster densities for the portions of the area that is in each of the area types. That is, the weighting, for each of the single area type prediction mapped cluster densities, is the fraction of the total area that this area type is. Thus, a “relativized composite mapped cluster density” for the area here may also be computed by dividing the mapped cluster density by the composite prediction mapped cluster density and taking the smaller of: the resulting ratio and 1.0 as the value for the relativized composite mapped cluster density.

25 Accordingly, note that as such a relativized (composite) mapped cluster density for an image cluster set area increases/decreases, it is assumed that the confidence of the target MS being in the image cluster set area should increase/decrease, respectively.

30 `get_composite_prediction_mapped_cluster_density_for_high_certainty(FOM_ID, image_area);`

The present function determines a composite prediction mapped cluster density by determining a composite prediction mapped cluster density for the area represented by “image\_area” and for the First Order Model identified by “FOM\_ID”.

OUTPUT: `composite_mapped_density` This is a record for the composite prediction

09770929:01300  
F052F0:2250260

pped cluster density. In particular, there are with two

(i) a "value" field giving an approximation to the prediction mapped cluster density for the First Order Model having id, FOM\_ID;

(ii) a "reliability" field giving an indication as to the reliability of the "value" field. The reliability field is in the range [0, 1] with 0 indicating that the "value" field is worthless and the larger the value the more assurance can be put in "value" with maximal assurance indicated when "reliability" is 1.

5

get\_prediction\_mapped\_cluster\_density\_for(FOM\_ID, area\_type)

10

The present function determines an approximation to a prediction mapped cluster density, D, for an area type such that if an image cluster set area has a mapped cluster density  $\geq D$ , then there is a high expectation that the target MS 140 is in the image cluster set area. Note that there are a number of embodiments that may be utilized for this function. The steps herein are also provided in flowchart form in Figs. 29a through 29h.

15

OUTPUT: prediction\_mapped\_cluster\_density This is a value giving an approximation to the prediction mapped cluster density for the First Order Model having identity, "FOM\_ID", and for the area type represented by "area\_type" \*/

20

It is important to note that the computation here for the prediction mapped cluster density may be more intense than some other computations but the cluster densities computed here need not be performed in real time target MS location processing. That is, the steps of this function may be performed only periodically (e.g., once a week), for each FOM and each area type thereby precomputing the output for this function. Accordingly, the values obtained here may be stored in a table that is accessed during real time target MS location processing. However, for simplicity, only the periodically performed steps are presented here. However, one skilled in the art will understand that with sufficiently fast computational devices, some related variations of this function may be performed in real-time. In particular, instead of supplying area type as an input to this function, a particular area, A, may be provided such as the image area for a cluster set area, or, the portion of such an image area in a particular area type. Accordingly, wherever "area\_type" is used in a statement of the embodiment of this function below, a comparable statement with "A" can be provided.

25

#### Location Hypothesis Analyzer Embodiment

30

Referring now to Fig. 7, an embodiment of the Hypothesis Analyzer is illustrated. The control component is denoted the control module 1400. Thus, this control module manages or controls access to the run time location hypothesis storage area 1410. The control module 1400 and the run time location hypothesis storage area 1410 may be implemented as a blackboard system and/or an expert system.

Accordingly, in the blackboard environment, and the control module 1400 determines when new location hypotheses may be entered onto the blackboard from other processes such as the context adjuster 1326 as well as when location hypotheses may be output to the most likelihood estimator 1344.

The following is a brief description of each submodule included in the location hypothesis analyzer 1332.

- 5 (35.1) A control module 1400 for managing or controlling further processing of location hypotheses received from the context adjuster. This module controls all location hypothesis processing within the location hypothesis analyzer as well as providing the input interface with the context adjuster. There are numerous embodiments that may be utilized for this module, including, but not limited to, expert systems and blackboard managers.
- 10 (35.2) A run-time location hypothesis storage area 1410 for retaining location hypotheses during their processing by the location hypotheses analyzer. This can be, for example, an expert system fact base or a blackboard. Note that in some of the discussion hereinbelow, for simplicity, this module is referred to as a "blackboard". However, it is not intended that such notation be a limitation on the present invention; i.e., the term "blackboard" hereinafter will denote a run-time data repository for a data processing paradigm wherein the flow of control is substantially data-driven.
- 15 (35.3) An analytical reasoner module 1416 for determining if (or how well) location hypotheses are consistent with well known physical or heuristic constraints as, e.g., mentioned in (30.4) above. Note that this module may be a daemon or expert system rule base.
- (35.4) An historical location reasoner module 1424 for adjusting location hypotheses' confidences according to how well the location signature characteristics (i.e., loc sigs) associated with a location hypothesis compare with "nearby" loc sigs in the location signature data base as indicated in (30.3) above. Note that this module may also be a daemon or expert system rule base.
- 20 (35.5) A location extrapolator module 1432 for use in updating previous location estimates for a target MS when a more recent location hypothesis is provided to the location hypothesis analyzer 1332. That is, assume that the control module 1400 receives a new location hypothesis for a target MS for which there are also one or more previous location hypotheses that either have been recently processed (i.e., they reside in the MS status repository 1338, as shown best in Fig. 6), or are currently being processed (i.e., they reside in the run-time location hypothesis storage area 1410). Accordingly, if the active\_timestamp (see Fig. 9 regarding location hypothesis data fields) of the newly received location hypothesis is sufficiently more recent than the active\_timestamp of one of these previous location hypotheses, then an extrapolation may be performed by the location extrapolator module 1432 on such previous location hypotheses so that all target MS location hypotheses being concurrently analyzed are presumed to include target MS location estimates for substantially the same point in time. Thus, initial location estimates generated by the FOMs using different wireless signal measurements, from different signal transmission time intervals, may have their corresponding dependent location hypotheses utilized simultaneously for determining a most likely target MS location estimate. Note that this module may also be daemon or expert system rule base.
- 25 (35.6) hypothesis generating module 1428 for generating additional location hypotheses according to, for example, MS location information not adequately utilized or modeled. Note, location hypotheses may also be decomposed here if, for example it is determined that a location hypothesis includes an MS area estimate that has subareas with radically different characteristics such as an MS area estimate that includes an uninhabited area and a densely populated area. Additionally, the hypothesis generating module 1428 may generate
- 30



## MS Status Repository Embodiment

The MS status repository 1338 is a run-time storage manager for storing location hypotheses from previous activations of the location engine 139 (as well as the output target MS location estimate(s)) so that a target MS may be tracked using target MS location hypotheses from previous location engine 139 activations to determine, for example, a movement of the target MS between evaluations of the target MS location. Thus, by retaining a moving window of previous location hypotheses used in evaluating positions of a target MS, measurements of the target MS's velocity, acceleration, and likely next position may be determined by the location hypothesis analyzer 1332. Further, by providing accessibility to recent MS location hypotheses, these hypotheses may be used to resolve conflicts between hypotheses in a current activation for locating the target MS; e.g., MS paths may be stored here for use in extrapolating a new location

## 10 Most Likelihood Estimator Embodiment

The most likelihood estimator 1344 is a module for determining a "most likely" location estimate for a target MS 140 being located (e.g., as in (30.7) above). In one embodiment, the most likelihood estimator performs an integration or summing of all location hypothesis confidence values for any geographic region(s) of interest having at least one location hypothesis that has been provided to the most likelihood estimator, and wherein the location hypothesis has a relatively (or sufficiently) high confidence. That is, the most likelihood estimator 1344 determines the area(s) within each such region having high confidences (or confidences above a threshold) as the most likely target MS 140 location estimates.

In one embodiment of the most likelihood estimator 1344, this module utilizes an area mesh,  $M$ , over which to integrate, wherein the mesh cells of  $M$  are preferably smaller than the greatest location accuracy desired. That is, each cell,  $c$ , of  $M$  is assigned a confidence value indicating a likelihood that the target MS 140 is located in  $c$ , wherein the confidence value for  $c$  is determined by the confidence values of the target MS location estimates provided to the most likelihood estimator 1344. Thus, to obtain the most likely location determination(s) the following steps are performed:

- (a) For each of the active location hypotheses output by, e.g., the hypothesis analyzer 1332 (alternatively, the context adjuster 1326), each corresponding MS location area estimate, LAE, is provided with a smallest covering,  $C_{LEA}$ , of cells  $c$  from  $M$ .
- (b) Subsequently, each of the cells of  $C_{LEA}$  have their confidence values adjusted by adding to it the confidence value for LAE. Accordingly, if the confidence of LEA is positive, then the cells of  $C_{LEA}$  have their confidences increased. Alternatively, if the confidence of LEA is negative, then the cells of  $C_{LEA}$  have their confidences decreased.
- (c) Given that the interval  $[-1.0, +1.0]$  represents the range in confidence values, and that this range has been partitioned into intervals,  $Int$ , having lengths of, e.g., 0.05, for each interval,  $Int$ , perform a cluster analysis function for clustering cells with confidences that are in  $Int$ . Thus, a topographical-type map may be constructed from the resulting cell clusters, wherein higher confidence areas are analogous to representations of areas having higher elevations.
- (d) Output a representation of the resulting clusters for each  $Int$  to the output gateway 1356 for determining the location granularity and representation desired by each location application 146 requesting the location of the target MS 140.

Of course, variations in the above algorithm also within the scope of the present invention. For example, some embodiments of the most likelihood estimator 1344 may:

- 5
- (e) Perform special processing for areas designated as “poor reception” areas. For example, the most likelihood estimator 1344 may be able to impose a confidence value of zero (i.e., meaning it is unknown as to whether the target MS is in the area) on each such poor reception area regardless of the location estimate confidence values unless there is a location hypothesis from a reliable and unanticipated source. That is, the mesh cells of a poor reception area may have their confidences set to zero unless, e.g., there is a location hypothesis derived from target MS location data provided by a mobile base station 148 that:
- 10
- (a) is near the poor reception area, (b) able to detect that the target MS 140 is in the poor reception area, and (c) can relay target MS location data to the location center 142. In such a case, the confidence of the target MS location estimate from the MBS location hypothesis may take precedence.
- (f) Additionally, in some embodiments of the most likelihood estimator 1344, cells  $c$  of  $M$  that are “near” or adjacent to a covering  $C_{EA}$  may also have their confidences adjusted according to how near the cells  $c$  are to the covering. That is, the assigning of confidences to cell meshes may be “fuzzified” in the terms of fuzzy logic so that the confidence value of each location hypothesis utilized by the most likelihood estimator 1344 is provided with a weighting factor depending on its proximity to the target MS location estimate of the location hypothesis. More precisely, it is believed that “nearness,” in the present context, should be monotonic with the “widthness” of the covering; i.e., as the extent of the covering increases (decreases) in a particular direction, the cells  $c$  affected beyond the covering also increases (decreases). Furthermore, in some embodiments of the most likelihood estimator 1344, the greater (lesser) the confidence in the LEA, the more (fewer) cells  $c$  beyond the covering have their confidences affected. To describe this technique in further detail, reference is made to Fig. 10, wherein an area  $A$  is assumed to be a covering  $C_{EA}$  having a confidence denoted “conf”. Accordingly, to determine a confidence adjustment to add to a cell  $c$  not in  $A$  (and additionally, the centroid of  $A$  not being substantially identical with the centroid of  $c$  which could occur if  $A$  were donut shaped), the following steps may be performed:
- 15
- (i) Determine the centroid of  $A$ , denoted  $Cent(A)$ .
- 20
- (ii) Determine the centroid of the cell  $c$ , denoted  $Q$ .
- (iii) Determine the extent of  $A$  along the line between  $Cent(A)$  and  $Q$ , denoted  $L$ .
- (iv) For a given type of probability density function,  $P(x)$ , such as a Gaussian function, let  $T$  be the beginning portion of the function that lives on the  $x$ -axis interval  $[0, t]$ , wherein  $P(t) = ABS(conf) =$  the absolute value of the confidence of  $C_{EA}$ .
- 25
- (v) Stretch  $T$  along the  $x$ -axis so that the stretched function, denoted  $sT(x)$ , has an  $x$ -axis support of  $[0, L/(1 + e^{[a(ABS(conf)-1)]})]$ , where  $a$  is in range of 3.0 to 10.0; e.g., 5.0. Note that  $sT(x)$  is the function,
- 30
- $$P(x * (1 + e^{[a(ABS(conf)-1)]})/L),$$
- on this stretched extent. Further note that for confidences of  $+1$  and  $-1$ , the support of  $sT(x)$  is  $[0, L]$  and for confidences at (or near) zero this support. Further, the term,
- $$L/(1 + e^{[a(ABS(conf)-1)]})$$





The following path sanity checks are incorporated into the computations of this module. These

- (1) do the predicted MS paths generally follow a known transportation pathway (e.g., in the case of a calculated speed of greater than 50 miles per hour are the target MS location estimates within, for example, .2 miles of a pathway where such speed may be sustained); if so (not), then increase (decrease) the confidence of the location hypotheses not satisfying this criterion;
- 5 (2) are the speeds, velocities and accelerations, determined from the current and past target MS location estimates, reasonable for the region (e.g., speeds should be less than 60 miles per hour in a dense urban area at 9 am); if so (not), then increase (decrease) the confidence of those that are (un)reasonable;
- (3) are the locations, speeds, velocities and/or accelerations similar between target MS tracks produced by different FOMs similar; decrease the confidence of the currently active location hypotheses that are indicated as "outliers" by this criterion;
- 10 (4) are the currently active location hypothesis target MS estimates consistent with previous predictions of where the target MS is predicted to be from a previous (most likely) target MS estimate; if not, then decrease the confidence of at least those location hypothesis estimates that are substantially different from the corresponding predictions. Note, however, that in some cases this may be over ruled. For example, if the prediction is for an area for which there is Location Base Station coverage, and no Location Base Station covering the area subsequently reports communicating with the target MS, then the predictions are incorrect and any current location hypothesis from the same FOM should not be decreased here if it is outside of this Location Base Station coverage area.
- 15

105210-220226

Notice from Fig. 7 that the analytical reasoner can access location hypotheses currently posted on the Run-time Location Hypothesis Storage Area. Additionally, it interacts with the Pathway Database which contains information concerning the location of natural transportation pathways in the region (highways, rivers, etc.) and the Area Characteristics Database which contains information concerning, for example, reasonable velocities that can be expected in various regions (for instance, speeds of 80 mph would not be reasonably expected in dense urban areas). Note that both speed and direction can be important constraints; e.g., even though a speed might be appropriate for an area, such as 20 mph in a dense urban area, if the direction indicated by a time series of related location hypotheses is directly through an extensive building complex having no through traffic routes, then a reduction in the confidence of one or more of the location hypotheses may be appropriate.

20

25

One embodiment of the Analytical Reasoner illustrating how such constraints may be implemented is provided in the following section. Note, however, that this embodiment analyzes only location hypotheses having a non-negative confidence value.

Modules of an embodiment of the analytical reasoner module 1416 are provided hereinbelow.

#### Path Comparison Module

30 The path comparison module 1454 implements the following strategy: the confidence of a particular location hypothesis is increased (decreased) if it is (not) predicting a path that lies along a known transportation pathway (and the speed of the target MS is sufficiently high). For instance, if a time series of target MS location hypotheses for a given FOM is predicting a path of the target MS that lies along an interstate

highway, the confidence of the currently active location hypothesis for this FOM should, in general, be increased. Thus, at a high level the following steps may be performed:

- 5
- (a) For each FOM having a currently active location hypothesis in the Run-time Location Hypothesis Storage Area (also denoted "blackboard"), determine a recent "path" obtained from a time series of location hypotheses for the FOM. This computation for the "path" is performed by stringing together successive "center of area" (COA) or centroid values determined from the most pertinent target MS location estimate in each location hypothesis (recall that each location hypothesis may have a plurality of target MS area estimates with one being the most pertinent). The information is stored in, for example, a matrix of values wherein one dimension of the matrix identifies the FOM and the a second dimension of the matrix represents a series of COA path values. Of course, some entries in the matrix may be undefined.
- 10
- (b) Compare each path obtained in (a) against known transportation pathways in an area containing the path. A value, `path_match(i)`, representing to what extent the path matches any known transportation pathway is computed. Such values are used later in a computation for adjusting the confidence of each corresponding currently active location hypothesis.

#### Velocity/Acceleration Calculation Module

15

The velocity/acceleration calculation module 1458 computes velocity and/or acceleration estimates for the target MS 140 using currently active location hypotheses and previous location hypothesis estimates of the target MS. In one embodiment, for each FOM 1224 having a currently active location hypothesis (with positive confidences) and a sufficient number of previous (reasonably recent) target MS location hypotheses, a velocity and/or acceleration may be calculated. In an alternative embodiment, such a velocity and/or acceleration may be calculated using the currently active location hypotheses and one or more recent "most likely" locations of the target MS output by the location engine 139. If the estimated velocity and/or acceleration corresponding to a currently active location hypothesis is reasonable for the region, then its confidence value may be incremented; if not, then its confidence may be decremented. The algorithm may be summarized as follows:

20

- (a) Approximate speed and/or acceleration estimates for currently active target MS location hypotheses may be provided using path information related to the currently active location hypotheses and previous target MS location estimates in a manner similar to the description of the path comparison module 1454. Accordingly, a single confidence adjustment value may be determined for each currently active location hypothesis for indicating the extent to which its corresponding velocity and/or acceleration calculations are reasonable for its particular target MS location estimate. This calculation is performed by retrieving information from the area characteristics data base 1450 (e.g., Figs. 6 and 7). Since each location hypothesis includes timestamp data indicating when the MS location signals were received from the target MS, the velocity and/or acceleration associated with a path for a currently active location hypothesis can be straightforwardly approximated. Accordingly, a confidence adjustment value, `vel_ok(i)`, indicating a likelihood that the velocity calculated for the  $i^{\text{th}}$  currently active location hypothesis (having adequate corresponding path information) may be appropriate is calculated using for the environmental characteristics of the location hypothesis' target MS location estimate. For example, the area characteristics data base 1450 may include expected maximum velocities and/or accelerations for each area type and/or cell of a cell mesh of the coverage area 120. Thus, velocities and/or accelerations above such maximum values may be indicative of anomalies in the MS location estimating process. Accordingly, in one embodiment, the most
- 25
- 30

00770030:013E04

recent location hypothesis fielding such extreme velocities and/or accelerations may their confidence values decreased. For example, if the target MS location estimate includes a portion of an interstate highway, then an appropriate velocity might correspond to a speed of up to 100 miles per hour, whereas if the target MS location estimate includes only rural dirt roads and tomato patches, then a likely speed might be no more than 30 miles per hour with an maximum speed of 60 miles per hour (assuming favorable environmental characteristics such as weather). Note that a list of such environmental characteristics may include such factors as: area type, time of day, season. Further note that more unpredictable environmental characteristics such as traffic flow patterns, weather (e.g., clear, raining, snowing, etc.) may also be included, values for these latter characteristics coming from the environmental data base 1354 which receives and maintains information on such unpredictable characteristics (e.g., Figs. 6 and 7). Also note that a similar confidence adjustment value,  $acc\_ok(i)$ , may be provided for currently active location hypotheses, wherein the confidence adjustment is related to the appropriateness of the acceleration estimate of the target MS.

Attribute Comparison Module

The attribute comparison module 1462 compares attribute values for location hypotheses generated from different FOMs, and determines if the confidence of certain of the currently active location hypotheses should be increased due to a similarity in related values for the attribute. That is, for an attribute A, an attribute value for A derived from a set  $S_{FOM1}$  of one or more location hypotheses generated by one FOM, FOM[1], is compared with another attribute value for A derived from a set  $S_{FOM2}$  of one or more location hypotheses generated by a different FOM, FOM[2] for determining if these attribute values cluster (i.e., are sufficiently close to one another) so that a currently active location hypothesis in  $S_{FOM1}$  and a currently active location hypothesis in  $S_{FOM2}$  should have their confidences increased. For example, the attribute may be a "target MS path data" attribute, wherein a value for the attribute is an estimated target MS path derived from location hypotheses generated by a fixed FOM over some (recent) time period. Alternatively, the attribute might be, for example, one of a velocity and/or acceleration, wherein a value for the attribute is a velocity and/or acceleration derived from location hypotheses generated by a fixed FOM over some (recent) time period.

In a general context, the attribute comparison module 1462 operates according to the following premise:

(38.1) for each of two or more currently active location hypotheses (with, e.g., positive confidences) if:

- (a) each of these currently active location hypotheses, H, was initially generated by a corresponding different FOM<sub>i</sub>;
- (b) for a given MS estimate attribute and each such currently active location hypothesis, H, there is a corresponding value for the attribute (e.g., the attribute value might be an MS path estimate, or alternatively an MS estimated velocity, or an MS estimated acceleration), wherein the attribute value is derived without using a FOM different from FOM<sub>i</sub>, and;
- (c) the derived attribute values cluster sufficiently well,

then each of these currently active location hypotheses, H, will have their corresponding confidences increased. That is, these confidences will be increased by a confidence adjustment value or delta.

Note that the phrase "cluster sufficiently well" above may have a number of technical embodiments, including performing various cluster analysis techniques wherein any clusters (according to some statistic) must satisfy a system set threshold for the members of the cluster being close enough to one another. Further, upon determining the (any) location hypotheses satisfying (38.1), there are various techniques that may



adjustment value computed by each adjustment submodule for adjusting the confidence of this location hypothesis. Note that each adjustment submodule determines:

- (a) whether the adjustment submodule may appropriately compute a confidence adjustment value for the location hypothesis supplied by the controller. (For example, in some cases there may not be a sufficient number of location hypotheses in a time series from a fixed FOM);
- (b) if appropriate, then the adjustment submodule computes a non-zero confidence adjustment value that is returned to the analytical reasoner controller.

Subsequently, the controller uses the output from the adjustment submodules to compute an aggregate confidence adjustment for the corresponding location hypothesis. In one particular embodiment of the present invention, values for the eight types of confidence adjustment values (described in sections above) are output to the present controller for computing an aggregate confidence adjustment value for adjusting the confidence of the currently active location hypothesis presently being analyzed by the analytical reasoner module 1416. As an example of how such confidence adjustment values may be utilized, assuming a currently active location hypothesis is identified by "i", the outputs from the above described adjustment submodules may be more fully described as:

TABLE 01601

15	path_match(i)	1	if there are sufficient previous (and recent) location hypotheses for the same target MS as "i" that have been generated by the same FOM that generated "i", and, the target MS location estimates provided by the location hypothesis "i" and the previous location hypotheses follow a known transportation pathway.
		0	otherwise.
20	vel_ok(i)	1	if the velocity calculated for the i <sup>th</sup> currently active location hypothesis (assuming adequate corresponding path information) is typical for the area (and the current environmental characteristics) of this location hypothesis' target MS location estimate;
		0.2	if the velocity calculated for the i <sup>th</sup> currently active location hypothesis is near a maximum for the area (and the current environmental characteristics) of this location hypothesis' target MS location estimate;
25	acc_ok(i)	0	if the velocity calculated is above the maximum.
		1	if the acceleration calculated for the i <sup>th</sup> currently active location hypothesis (assuming adequate corresponding path information) is typical for the area (and the current environmental characteristics) of this location hypothesis' target MS location estimate;
30		0.2	if the acceleration calculated for the i <sup>th</sup> currently active location hypothesis is near a maximum for the area (and the current environmental characteristics) of this location hypothesis' target MS location estimate;
		0	if the acceleration calculated is above the maximum.
	similar_path(i)	1	if the location hypothesis "i" satisfies (38.1) for the target MS path data attribute; 0 otherwise.
	velocity_similar(i)	1	if the location hypothesis "i" satisfies (38.1) for the target MS velocity attribute; 0 otherwise.

acceleration\_similar(i) if the location hypothesis "i" satisfies (38.1) for the target MS acceleration attribute; 0 otherwise.  
 extrapolation\_chk(i) | if the location hypothesis "i" is "near" a previously predicted MS location for the target MS; 0 otherwise.

5 Additionally, for each of the above confidence adjustments, there is a corresponding location engine 139 system settable parameter whose value may be determined by repeated activation of the adaptation engine 1382. Accordingly, for each of the confidence adjustment types, T, above, there is a corresponding system settable parameter, "alpha\_T", that is tunable by the adaptation engine 1382. Accordingly, the following high level program segment illustrates the aggregate confidence adjustment value computed by the Analytical Reasoner Controller.

10 target\_MS\_loc\_hyps <--- get all currently active location hypotheses, H, identifying the present target ;  
 for each currently active location hypothesis, hyp(i), from target\_MS\_loc\_hyps do  
 {  
 for each of the confidence adjustment submodules, CA, do  
 activate CA with hyp(i) as input;  
 15 /\* now compute the aggregate confidence adjustment using the output from the confidence adjustment submodules. \*/  
 aggregate\_adjustment(i) <--- alpha\_path\_match \* path\_match(i)  
 + alpha\_velocity \* vel\_ok(i)  
 + alpha\_path\_similar \* path\_similar(i)  
 + alpha\_velocity\_similar \* velocity\_similar(i)  
 20 + alpha\_acceleration\_similar \* acceleration\_similar(i)  
 + alpha\_extrapolation \* extrapolation\_chk(i);  
 hyp(i).confidence <--- hyp(i).confidence + aggregate\_adjustment(i);  
 }

FOUO: 01601

25 **Historical Location Reasoner**

The historical location reasoner module 1424 may be, for example, a daemon or expert system rule base. The module adjusts the confidences of currently active location hypotheses by using (from location signature data base 1320) historical signal data correlated with: (a) verified MS locations (e.g. locations verified when emergency personnel co-locate with a target MS location), and (b) various environmental factors to evaluate how consistent the location signature cluster for an input location hypothesis agrees with such  
 30 historical signal data.

This reasoner will increase/decrease the confidence of a currently active location hypothesis depending on how well its associated loc sigs correlate with the loc sigs obtained from data in the location signature data base.

FOR FIDELITY

Note that the embodiment hereinbelow is but one of many embodiments that may adjust the confidence of currently active location hypotheses appropriately. Accordingly, it is important to note other embodiments of the historical location reasoner functionality are within the scope of the present invention as one skilled in the art will appreciate upon examining the techniques utilized within this specification. For example, calculations of a confidence adjustment factor may be determined using Monte Carlo techniques as in the context adjuster 1326. Each such embodiment generates a measurement of at least one of the similarity and the discrepancy between the signal characteristics of the verified location signature clusters in the location signature data base and the location signature cluster for an input currently active location hypothesis, "loc\_hyp".

The embodiment hereinbelow provides one example of the functionality that can be provided by the historical location reasoner 1424 (either by activating the following programs as a daemon or by transforming various program segments into the consequents of expert system rules). The present embodiment generates such a confidence adjustment by the following steps:

- (a) comparing, for each cell in a mesh covering of the most relevant MS location estimate in "loc\_hyp", the location signature cluster of the "loc\_hyp" with the verified location signature clusters in the cell so that the following are computed: (i) a discrepancy or error measurement is determined, and (ii) a corresponding measurement indicating a likelihood or confidence of the discrepancy measurement being relatively accurate in comparison to other such error measurements;
- (b) computing an aggregate measurement of both the errors and the confidences determined in (a); and
- (c) using the computed aggregate measurement of (b) to adjust the confidence of "loc\_hyp".

The program illustrated in APPENDIX E provides a more detailed embodiment of the steps immediately above.

20 Location Extrapolator

The location extrapolator 1432 works on the following premise: if for a currently active location hypothesis there is sufficient previous related information regarding estimates of the target MS (e.g., from the same FOM or from using a "most likely" previous target MS estimate output by the location engine 139), then an extrapolation may be performed for predicting future target MS locations that can be compared with new location hypotheses provided to the blackboard. Note that interpolation routines (e.g., conventional algorithms such as Lagrange or Newton polynomials) may be used to determine an equation that approximates a target MS path corresponding to a currently active location hypothesis.

Subsequently, such an extrapolation equation may be used to compute a future target MS location. For further information regarding such interpolation schemes, the following reference is incorporated herein by reference: Mathews, 1992, Numerical methods for mathematics, science, and engineering. Englewood Cliffs, NJ: Prentice Hall.

30 Accordingly, if a new currently active location hypothesis (e.g., supplied by the context adjuster) is received by the blackboard, then the target MS location estimate of the new location hypothesis may be compared with the predicted location. Consequently, a confidence



adjustment value can be determined according to how well if the location hypothesis "i". That is, this confidence adjustment value will be larger as the new MS estimate and the predicted estimate become closer together.

Note that in one embodiment of the present invention, such predictions are based solely on previous target MS location estimates output by location engine 139. Thus, in such an embodiment, substantially every currently active location hypothesis can be provided with a confidence adjustment value by this module once a sufficient number of previous target MS location estimates have been output. Accordingly, a value, `extrapolation_chk(i)`, that represents how accurately the new currently active location hypothesis (identified here by "i") matches the predicted location is determined.

#### Hypothesis Generating Module

The hypothesis generating module 1428 is used for generating additional location hypotheses according to, for example, MS location information not adequately utilized or modeled. Note, location hypotheses may also be decomposed here if, for example it is determined that a location hypothesis includes an MS area estimate that has subareas with radically different characteristics such as an area that includes an uninhabited area and a densely populated area. Additionally, the hypothesis generating module 1428 may generate "poor reception" location hypotheses that specify MS location areas of known poor reception that are "near" or intersect currently active location hypotheses. Note, that these poor reception location hypotheses may be specially tagged (e.g., with a distinctive `FOM_ID` value or specific tag field) so that regardless of substantially any other location hypothesis confidence value overlapping such a poor reception area, such an area will maintain a confidence value of "unknown" (i.e., zero). Note that substantially the only exception to this constraint is location hypotheses generated from mobile base stations 148.

FOIA b 7 - D

## Mobile Base Station Location Subsystem Description

### Mobile Base Station Subsystem Introduction

Any collection of mobile electronics (denoted mobile location unit) that is able to both estimate a location of a target MS 140 and communicate with the base station network may be utilized by the present invention to more accurately locate the target MS.

5 Such mobile location units may provide greater target MS location accuracy by, for example, homing in on the target MS and by transmitting additional MS location information to the location center 142. There are a number of embodiments for such a mobile location unit contemplated by the present invention. For example, in a minimal version, such the electronics of the mobile location unit may be little more than an onboard MS 140, a sectored/directional antenna and a controller for communicating between them. Thus, the onboard MS is used to communicate with the location center 142 and possibly the target MS 140, while the antenna

10 monitors signals for homing in on the target MS 140. In an enhanced version of the mobile location unit, a GPS receiver may also be incorporated so that the location of the mobile location unit may be determined and consequently an estimate of the location of the target MS may also be determined. However, such a mobile location unit is unlikely to be able to determine substantially more than a direction of the target MS 140 via the sectored/directional antenna without further base station infrastructure cooperation in, for example, determining the transmission power level of the target MS or varying this power level. Thus, if the target MS or the mobile

15 location unit leaves the coverage area 120 or resides in a poor communication area, it may be difficult to accurately determine where the target MS is located. None-the-less, such mobile location units may be sufficient for many situations, and in fact the present invention contemplates their use. However, in cases where direct communication with the target MS is desired without constant contact with the base station infrastructure, the present invention includes a mobile location unit that is also a scaled down version of a base station 122. Thus, given that such a mobile base station or MBS 148 includes at least an onboard MS 140, a

20 sectored/directional antenna, a GPS receiver, a scaled down base station 122 and sufficient components (including a controller) for integrating the capabilities of these devices, an enhanced autonomous MS mobile location system can be provided that can be effectively used in, for example, emergency vehicles, <sup>airplanes</sup> ~~airplanes~~ and boats. Accordingly, the description that follows below describes an embodiment of an MBS 148 having the above mentioned components and capabilities for use in a vehicle.

As a consequence of the MBS 148 being mobile, there are fundamental differences in the operation of an MBS in

25 comparison to other types of BS's 122 (152). In particular, other types of base stations have fixed locations that are precisely determined and known by the location center, whereas a location of an MBS 148 may be known only approximately and thus may require repeated and frequent re-estimating. Secondly, other types of base stations have substantially fixed and stable communication with the location center (via possibly other BS's in the case of LBSs 152) and therefore although these BS's may be more reliable in their in their ability to communicate information related to the location of a target MS with the location center,

30 accuracy can be problematic in poor reception areas. Thus, MBS's may be used in areas (such as wilderness areas) where there may be no other means for reliably and cost effectively locating a target MS 140 (i.e., there may be insufficient fixed location BS's coverage in an area).



00770829: 013E04  
145210: 00002200

Before proceeding to further details of the MBS location subsystem 1508, an example of the operation of an MBS 148 in the context of responding to a 911 emergency call is given. In particular, this example describes the high level computational states through which the MBS 148 transitions, these states also being illustrated in the state transition diagram of Fig. 12. Note that this figure illustrates the primary state transitions between these MBS 148 states, wherein the solid state transitions are indicative of a typical "ideal" progression when locating or tracking a target MS 140, and the dashed state transitions are the primary state reversions due, for example, to difficulties in locating the target MS 140.

Accordingly, initially the MBS 148 may be in an inactive state 1700, wherein the MBS location subsystem 1508 is effectively available for voice or data communication with the fixed location base station network, but the MS 140 locating capabilities of the MBS are not active. From the inactive state 1700 the MBS (e.g., a police or rescue vehicle) may enter an active state 1704 once an MBS operator has logged onto the MBS location subsystem of the MBS, such logging being for authentication, verification and journaling of MBS 148 events. In the active state 1704, the MBS may be listed by a 911 emergency center and/or the location center 142 as eligible for service in responding to a 911 request. From this state, the MBS 148 may transition to a ready state 1708 signifying that the MBS is ready for use in locating and/or intercepting a target MS 140. That is, the MBS 148 may transition to the ready state 1708 by performing the following steps:

- (1a) Synchronizing the timing of the location subsystem 1508 with that of the base station network infrastructure. In one embodiment, when requesting such time synchronization from the base station infrastructure, the MBS 148 will be at a predetermined or well known location so that the MBS time synchronization may adjust for a known amount of signal propagation delay in the synchronization signal.
- (1b) Establishing the location of the MBS 148. In one embodiment, this may be accomplished by, for example, an MBS operator identifying the predetermined or well known location at which the MBS 148 is located.
- (1c) Communicating with, for example, the 911 emergency center via the fixed location base station infrastructure to identify the MBS 148 as in the ready state.

Thus, while in the ready state 1708, as the MBS 148 moves, it has its location repeatedly (re)-estimated via, for example, GPS signals, location center 142 location estimates from the base stations 122 (and 152), and an on-board deadreckoning subsystem 1527 having an MBS location estimator according to the programs described hereinbelow. However, note that the accuracy of the base station time synchronization (via the rubidium oscillator 1520) and the accuracy of the MBS 148 location may need to both be periodically recalibrated according to (1a) and (1b) above.

Assuming a 911 signal is transmitted by a target MS 140, this signal is transmitted, via the fixed location base station infrastructure, to the 911 emergency center and the location center 142, and assuming the MBS 148 is in the ready state 1708, if a corresponding 911 emergency request is transmitted to the MBS (via the base station infrastructure) from the 911 emergency center or the location center, then the MBS may transition to a seek state 1712 by performing the following steps:

- (2a) Communicating with, for example, the 911 emergency response center via the fixed location base station network to receive the PN code for the target MS to be located (wherein this communication is performed using the MS-like transceiver 1512 and/or the MBS operator telephony interface 1524).

- (2b) Obtaining a most recent target MS location estimate from either the 911 emergency center or the location center 142.
- (2c) Inputting by the MBS operator an acknowledgment of the target MS to be located, and transmitting this acknowledgment to the 911 emergency response center via the transceiver 1512.

5 Subsequently, when the MBS 148 is in the seek state 1712, the MBS may commence toward the target MS location estimate provided. Note that it is likely that the MBS is not initially in direct signal contact with the target MS. Accordingly, in the seek state 1712 the following steps may be, for example, performed:

- (3a) The location center 142 or the 911 emergency response center may inform the target MS, via the fixed location base station network, to lower its threshold for soft hand-off and at least periodically boost its location signal strength. Additionally, the target MS may be informed to scan for the pilot channel of the MBS 148. (Note the actions here are not, actions performed by the MBS 148 in the "seek state"; however, these actions are given here for clarity and completeness.)
- 10 (3b) Repeatedly, as sufficient new MS location information is available, the location center 142 provides new MS location estimates to the MBS 148 via the fixed location base station network.
- (3c) The MBS repeatedly provides the MBS operator with new target MS location estimates provided substantially by the location center via the fixed location base station network.
- 15 (3d) The MBS 148 repeatedly attempts to detect a signal from the target MS using the PN code for the target MS.
- (3e) The MBS 148 repeatedly estimates its own location (as in other states as well), and receives MBS location estimates from the location center.

20 Assuming that the MBS 148 and target MS 140 detect one another (which typically occurs when the two units are within .25 to 3 miles of one another), the MBS enters a contact state 1716 when the target MS 140 enters a soft hand-off state with the MBS. Accordingly, in the contact state 1716, the following steps are, for example, performed:

- (4a) The MBS 148 repeatedly estimates its own location.
- (4b) Repeatedly, the location center 142 provides new target MS 140 and MBS location estimates to the MBS 148 via the fixed location base infrastructure network.
- 25 (4c) Since the MBS 148 is at least in soft hand-off with the target MS 140, the MBS can estimate the direction and distance of the target MS itself using, for example, detected target MS signal strength and TOA as well as using any recent location center target MS location estimates.
- (4d) The MBS 148 repeatedly provides the MBS operator with new target MS location estimates provided using MS location estimates provided by the MBS itself and by the location center via the fixed location base station network.
- 30

When the target MS 140 detects that the MBS pilot channel is sufficiently strong, the target MS may switch to using the MBS 148 as its primary base station. When this occurs, the MBS enters a control state 1720, wherein the following steps are, for example, performed:

CONFIDENTIAL

(5a) The MBS 148 repeatedly estimates its own location.

(5b) Repeatedly, the location center 142 provides new target MS and MBS location estimates to the MBS 148 via the network of base stations 122 (152).

5 (5c) The MBS 148 estimates the direction and distance of the target MS 140 itself using, for example, detected target MS signal strength and TOA as well as using any recent location center target MS location estimates.

(5d) The MBS 148 repeatedly provides the MBS operator with new target MS location estimates provided using MS location estimates provided by the MBS itself and by the location center 142 via the fixed location base station network.

(5e) The MBS 148 becomes the primary base station for the target MS 140 and therefore controls at least the signal strength output by the target MS.

10 Note, there can be more than one MBS 148 tracking or locating an MS 140. There can also be more than one target MS 140 to be tracked concurrently and each target MS being tracked may be stationary or moving.

### MBS Subsystem Architecture

15 An MBS 148 uses MS signal characteristic data for locating the MS 140. The MBS 148 may use such signal characteristic data to facilitate determining whether a given signal from the MS is a "direct shot" or an multipath signal. That is, in one embodiment, the MBS 148 attempts to determine or detect whether an MS signal transmission is received directly, or whether the transmission has been reflected or deflected. For example, the MBS may determine whether the expected signal strength, and TOA agree in distance estimates for the MS signal transmissions. Note, other signal characteristics may also be used, if there are sufficient electronics and processing available to the MBS 148; i.e., determining signal phase and/or polarity as other indications of receiving a "direct shot" from an MS 140.

20 In one embodiment, the MBS 148 (Fig. 11) includes an MBS controller 1533 for controlling the location capabilities of the MBS 148. In particular, the MBS controller 1533 initiates and controls the MBS state changes as described in Fig. 12 above. Additionally, the MBS controller 1533 also communicates with the location controller 1535, wherein this latter controller controls MBS activities related to MBS location and target MS location; e.g., this performs the program, "mobile\_base\_station\_controller" described in APPENDIX A hereinbelow. The location controller 1535 receives data input from an event generator 1537 for generating event records to be provided to the location controller 1535. For example, records may be generated from data input received from: (a) the vehicle movement detector 1539 indicating that the MBS 148 has moved at least a predetermined amount and/or has changed direction by at least a predetermined angle, or (b) the MBS signal processing subsystem 1541 indicating that the additional signal measurement data has been received from either the location center 142 or the target MS 140. Note that the MBS signal processing subsystem 1541, in one embodiment, is similar to the signal processing subsystem 1220 of the location center 142 <sup>A16</sup> ~~may have multiple~~ <sub>A</sub> command schedulers. In particular, a scheduler 1528 for commands related to communicating with the location center 142, a scheduler 1530 for commands related to GPS communication (via GPS receiver 1531), a scheduler 1529 for commands related to the frequency and granularity of the reporting of MBS changes in direction and/or position via the MBS dead reckoning subsystem 1527

007000001000

(note that this scheduler is potentially optional and that such commands may be provided directly to the deadreckoning estimator 1544), and a scheduler 1532 for communicating with the target MS(s) 140 being located. Further, it is assumed that there is sufficient hardware and/or software to perform commands in different schedulers substantially concurrently.

In order to display an MBS computed location of a target MS 140, a location of the MBS must be known or determined.

5 Accordingly, each MBS 148 has a plurality of MBS location estimators (or hereinafter also simply referred to as location estimators) for determining the location of the MBS. Each such location estimator computes MBS location information such as MBS location estimates, changes to MBS location estimates, or, an MBS location estimator may be an interface for buffering and/or translating a previously computed MBS location estimate into an appropriate format. In particular, the MBS location module 1536, which determines the location of the MBS, may include the following MBS location estimators 1540 (also denoted baseline location estimators):

- (a) a GPS location estimator 1540a (not individually shown) for computing an MBS location estimate using GPS signals,
- (b) a location center location estimator 1540b (not individually shown) for buffering and/or translating an MBS estimate received from the location center 142,
- (c) an MBS operator location estimator 1540c (not individually shown) for buffering and/or translating manual MBS location entries received from an MBS location operator, and
- (d) in some MBS embodiments, an LBS location estimator 1540d (not individually shown) for the activating and deactivating of LBS's 152. Note that, in high multipath areas and/or stationary base station marginal coverage areas, such low cost location base stations 152 (LBS) may be provided whose locations are fixed and accurately predetermined and whose signals are substantially only receivable within a relatively small range (e.g., 2000 feet), the range potentially being variable. Thus, by communicating with the LBS's 152 directly, the MBS 148 may be able to quickly use the location information relating to the location base stations for determining its location by using signal characteristics obtained from the LBSs 152.

Note that each of the MBS baseline location estimators 1540, such as those above, provide an actual MBS location rather than, for example, a change in an MBS location. Further note that it is an aspect of the present invention that additional MBS baseline location estimators 1540 may be easily integrated into the MBS location subsystem 1508 as such baseline location estimators become available. For example, a baseline location estimator that receives MBS location estimates from reflective codes provided, for example, on streets or street signs can be straightforwardly incorporated into the MBS location subsystem 1508.

Additionally, note that a plurality of MBS location technologies and their corresponding MBS location estimators are utilized due to the fact that there is currently no single location technology available that is both sufficiently fast, accurate and accessible in substantially all terrains to meet the location needs of an MBS 148. For example, in many terrains GPS technologies may be sufficiently accurate; however, GPS technologies: (a) may require a relatively long time to provide an initial location estimate (e.g., greater than 2 minutes); (b) when GPS communication is disturbed, it may require an equally long time to provide a new location estimate; (c) clouds, buildings and/or mountains can prevent location estimates from being obtained; (d) in some cases signal reflections can substantially skew a location estimate. As another example, an MBS 148 may be able to use triangulation or

trilateralization technologies to obtain a location estimate; however, this assumes that there is sufficient (fixed location) infrastructure BS coverage in the area the MBS is located. Further, it is well known that the multipath phenomenon can substantially distort such location estimates. Thus, for an MBS 148 to be highly effective in varied terrains, an MBS is provided with a plurality of location technologies, each supplying an MBS location estimate.

5 In fact, much of the architecture of the location engine 139 could be incorporated into an MBS 148. For example, in some embodiments of the MBS 148, the following FOMs 1224 may have similar location models incorporated into the MBS:

- (a) a variation of the distance FOM 1224 wherein TOA signals from communicating fixed location BS's are received (via the MBS transceiver 1512) by the MBS and used for providing a location estimate;
- (b) a variation of the artificial neural net based FOMs 1224 (or more generally a location learning or a classification model) may be used to provide MBS location estimates via, for example, learned associations between fixed location BS signal characteristics and geographic locations;
- 10 (c) an LBS location FOM 1224 for providing an MBS with the ability to activate and deactivate LBS's to provide (positive) MBS location estimates as well as negative MBS location regions (i.e., regions where the MBS is unlikely to be since one or more LBS's are not detected by the MBS transceiver);
- 15 (d) one or more MBS location reasoning agents and/or a location estimate heuristic agents for resolving MBS location estimate conflicts and providing greater MBS location estimate accuracy. For example, modules similar to the analytical reasoner module 1416 and the historical location reasoner module 1424.

However, for those MBS location models requiring communication with the base station infrastructure, an alternative embodiment is to rely on the location center 142 to perform the computations for at least some of these MBS FOM models. That is, since each of the MBS location models mentioned immediately above require communication with the network of fixed location BS's 122 (152), it may be advantageous to transmit MBS location estimating data to the location center 142 as if the MBS were another MS 140 for the location center to locate, and thereby rely on the location estimation capabilities at the location center rather than duplicate such models in the MBS 148. The advantages of this approach are that:

- (a) an MBS is likely to be able to use less expensive processing power and software than that of the location center;
- 25 (b) an MBS is likely to require substantially less memory, particularly for data bases, than that of the location center.

As will be discussed further below, in one embodiment of the MBS 148, there are confidence values assigned to the locations output by the various location estimators 1540. Thus, the confidence for a manual entry of location data by an MBS operator may be rated the highest and followed by the confidence for (any) GPS location data, followed by the confidence for (any) location center location 142 estimates, followed by the confidence for (any) location estimates using signal characteristic data from LBSs. However, such prioritization may vary depending on, for instance, the radio coverage area 120. In an one embodiment of the present invention, it is an aspect of the present invention that for MBS location data received from the GPS and location center, their confidences may vary according to the area in which the MBS 148 resides. That is, if it is known that for a given area, there is a reasonable probability that a GPS signal may suffer multipath distortions and that the location center has in the past provided reliable location estimates, then the confidences for these two location sources may be reversed.



In one embodiment of the present invention, MBS operators may be requested to occasionally manually enter the location of the MBS 148 when the MBS is stationary for determining and/or calibrating the accuracy of various MBS location estimators.

There is an additional important source of location information for the MBS 148 that is incorporated into an MBS vehicle (such as a police vehicle) that has no comparable functionality in the network of fixed location BS's. That is, the MBS 148 may use deadreckoning information provided by a deadreckoning MBS location estimator 1544 whereby the MBS may obtain MBS deadreckoning location change estimates. Accordingly, the deadreckoning MBS location estimator 1544 may use, for example, an on-board gyroscope 1550, a wheel rotation measurement device (e.g., odometer) 1554, and optionally an accelerometer (not shown). Thus, such a deadreckoning MBS location estimator 1544 periodically provides at least MBS distance and directional data related to MBS movements from a most recent MBS location estimate. More precisely, in the absence of any other new MBS location information, the deadreckoning MBS location estimator 1544 outputs a series of measurements, wherein each such measurement is an estimated change (or delta) in the position of the MBS 148 between a request input timestamp and a closest time prior to the timestamp, wherein a previous deadreckoning terminated. Thus, each deadreckoning location change estimate includes the following fields:

- (a) an "earliest timestamp" field for designating the start time when the deadreckoning location change estimate commences measuring a change in the location of the MBS;
- (b) a "latest timestamp" field for designating the end time when the deadreckoning location change estimate stops measuring a change in the location of the MBS; and
- (c) an MBS location change vector.

That is, the "latest timestamp" is the timestamp input with a request for deadreckoning location data, and the "earliest timestamp" is the timestamp of the closest time, T, prior to the latest timestamp, wherein a previous deadreckoning output has its a timestamp at a time equal to T.

Further, the frequency of such measurements provided by the deadreckoning subsystem 1527 may be adaptively provided depending on the velocity of the MBS 148 and/or the elapsed time since the most recent MBS location update. Accordingly, the architecture of at least some embodiments of the MBS location subsystem 1508 must be such that it can utilize such deadreckoning information for estimating the location of the MBS 148.

In one embodiment of the MBS location subsystem 1508 described in further detail hereinbelow, the outputs from the deadreckoning MBS location estimator 1544 are used to synchronize MBS location estimates from different MBS baseline location estimators. That is, since such a deadreckoning output may be requested for substantially any time from the deadreckoning MBS location estimator, such an output can be requested for substantially the same point in time as the occurrence of the signals from which a new MBS baseline location estimate is derived. Accordingly, such a deadreckoning output can be used to update other MBS location estimates not using the new MBS baseline location estimate.

It is assumed that the error with ~~deadreckoning~~<sup>deadreckoning</sup> increases with deadreckoning distance. Accordingly, it is an aspect of the embodiment of the MBS location subsystem 1508 that when incrementally updating the location of the MBS 148 using deadreckoning and applying deadreckoning location change estimates to a "most likely area" in which the MBS 148 is believed to be, this area is



007700200200200

Particularly, if an MBS 148 is moving at typical rates of speed and acceleration, and with ~~disrupt changes in direction~~ <sup>changes in direction</sup>. For example, if the deadreckoning MBS location estimator 1544 indicates that the MBS 148 is moving in a northerly direction, then the street snapped to should be a north-south running street. Moreover, the MBS location snap to street module 1562 may also be used to enhance target MS location estimates when, for example, it is known or suspected that the target MS 140 is in a vehicle and the vehicle is moving at typical rates of speed. Furthermore, the snap to street location module 1562 may also be used in enhancing the location of a target MS 140 by either the MBS 148 or by the location engine 139. In particular, the location estimator 1344 or an additional module between the location estimator 1344 and the output gateway 1356 may utilize an embodiment of the snap to street location module 1562 to enhance the accuracy of target MS 140 location estimates that are known to be in vehicles. Note that this may be especially useful in locating stolen vehicles that have embedded wireless location transceivers (MSs 140), wherein appropriate wireless signal measurements can be provided to the location center 142.

**MBS Data Structure Remarks**

Assuming the existence of at least some of the location estimators 1540 that were mentioned above, the discussion here refers substantially to the data structures and their organization as illustrated in Fig. 13.

The location estimates (or hypotheses) for an MBS 148 determining its own location each have an error or range estimate associated with the MBS location estimate. That is, each such MBS location estimate includes a "most likely MBS point location" within a "most likely area". The "most likely MBS point location" is assumed herein to be the centroid of the "most likely area." In one embodiment of the MBS location subsystem 1508, a nested series of "most likely areas" may be provided about a most likely MBS point location. However, to simplify the discussion herein each MBS location estimate is assumed to have a single "most likely area". One skilled in the art will understand how to provide such nested "most likely areas" from the description herein. Additionally, it is assumed that such "most likely areas" are not grossly oblong; i.e., area cross sectioning lines through the centroid of the area do not have large differences in their lengths. For example, for any such "most likely area", A, no two such cross sectioning lines of A may have lengths that vary by more than a factor of two.

Each MBS location estimate also has a confidence associated therewith providing a measurement of the perceived accuracy of the MBS being in the "most likely area" of the location estimate.

A (MBS) "location track" is an data structure (or object) having a queue of a predetermined length for maintaining a temporal (timestamp) ordering of "location track entries" such as the location track entries 1770a, 1770b, 1774a, 1774b, 1778a, 1778b, 1782a, 1782b, and 1786a (Fig. 13), wherein each such MBS location track entry is an estimate of the location of the MBS at a particular corresponding time.

There is an MBS location track for storing MBS location entries obtained from MBS location estimation information from each of the MBS baseline location estimators described above (i.e., a GPS location track 1750 for storing MBS location estimations obtained from the GPS location estimator 1540, a location center location track 1754 for storing MBS location estimations obtained from the location estimator 1540 deriving its MBS location estimates from the location center 142, an LBS location track 1758 for storing MBS



(d) A "deadreckoning distance" indicating the total distance (e.g., wheel turns or odometer difference) since the most recently previous baseline entry for the corresponding MBS location estimator for the location track to which the location track entry is assigned.

For each MBS location track, there are two categories of MBS location track entries that may be inserted into a MBS location

5 track:

(a) "baseline" entries, wherein each such baseline entry includes (depending on the location track) a location estimate for the MBS 148 derived from: (i) a most recent previous output either from a corresponding MBS baseline location estimator, or (ii) from the baseline entries of other location tracks (this latter case being the for the "current" location track);

10 (b) "extrapolation" entries, wherein each such entry includes an MBS location estimate that has been extrapolated from the (most recent) location track head for the location track (i.e., based on the track head whose "latest timestamp" immediately precedes the latest timestamp of the extrapolation entry). Each such extrapolation entry is computed by using data from a related deadreckoning location change estimate output from the deadreckoning MBS location estimator 1544. Each such deadreckoning location change estimate includes measurements related to changes or deltas in the location of the MBS 148. More precisely, for each location track, each extrapolation entry is determined using: (i) a baseline entry, and (ii) a set of one or more (i.e., all later occurring) deadreckoning location change estimates in increasing "latest timestamp" order. Note that for notational convenience this set of one or more deadreckoning location change estimates will be denoted the "deadreckoning location change estimate set" associated with the extrapolation entry resulting from this set.

15 (c) Note that for each location track head, it is either a baseline entry or an extrapolation entry. Further, for each extrapolation entry, there is a most recent baseline entry, B, that is earlier than the extrapolation entry and it is this B from which the extrapolation entry was extrapolated. This earlier baseline entry, B, is hereinafter denoted the "baseline entry associated with the extrapolation entry." More generally, for each location track entry, T, there is a most recent previous baseline entry, B, associated with T, wherein if T is an extrapolation entry, then B is as defined above, else if T is a baseline entry itself, then  $T=B$ . Accordingly, note that for each extrapolation entry that is the head of a location track, there is a most recent baseline entry associated with the extrapolation entry.

20 Further, there are two categories of location tracks:

(a) "baseline location tracks," each having baseline entries exclusively from a single predetermined MBS baseline location estimator; and

30 (b) a "current" MBS location track having entries that are computed or determined as "most likely" MBS location estimates from entries in the other MBS location tracks.

MBS Location Estimating Strategy

In order to be able to properly compare the track heads to determine the most likely MBS location estimate it is an aspect of the present invention that the track heads of all location tracks include MBS location estimates that are for substantially the same (latest) timestamp. However, the MBS location information from each MBS baseline location estimator is inherently substantially unpredictable and unsynchronized. In fact, the only MBS location information that may be considered predictable and controllable is the deadreckoning location change estimates from the deadreckoning MBS location estimator 1544 in that these estimates may reliably be obtained whenever there is a query from the location controller 1535 for the most recent estimate in the change of the location for the MBS 148. Consequently (referring to Fig. 13), synchronization records 1790 (having at least a 1790b portion, and in some cases also having a 1790a portion) may be provided for updating each location track with a new MBS location estimate as a new track head. In particular, each synchronization record includes a deadreckoning location change estimate to be used in updating all but at most one of the location track heads with a new MBS location estimate by using a deadreckoning location change estimate in conjunction with each MBS location estimate from an MBS baseline location estimator, the location track heads may be synchronized according to timestamp. More precisely, for each MBS location estimate, E, from an MBS baseline location estimator, the present invention also substantially simultaneously queries the deadreckoning MBS location estimator for a corresponding most recent change in the location of the MBS 148. Accordingly, E and the retrieved MBS deadreckoning location change estimate, C, have substantially the same "latest timestamp". Thus, the location estimate E may be used to create a new baseline track head for the location track having the corresponding type for E, and C may be used to create a corresponding extrapolation entry as the head of each of the other location tracks. Accordingly, since for each MBS location estimate, E, there is a MBS deadreckoning location change estimate, C, having substantially the same "latest timestamp", E and C will be hereinafter referred as "paired."

High level descriptions of an embodiment of the location functions performed by an MBS 148 are provided in APPENDIX A hereinbelow.

## APPENDIX A: MBS Function Embodiments

### *Mobile Base Station Controller Program*

5 **mobile\_base\_station\_controller()**  
{  
*wait\_for\_input\_of\_first\_MBS\_location(event);* /\* "event" is a record (object) with MBS location data \*/  
WHILE (no MBS operator input to exit) DO  
    CASE OF (event): /\* determine the type of "event" and process it. \*/  
10       **MBS LOCATION DATA RECEIVED FROM GPS:**  
       **MBS LOCATION DATA RECEIVED FROM LBS:**  
       **MBS LOCATION DATA RECEIVED FROM ANY OTHER HIGHLY RELIABLE MBS LOCATION**  
          **SOURCES (EXCEPT LOCATION CENTER):**  
       {  
15           MBS\_new\_est <--- *get\_new\_MBS\_location\_using\_estimate(event);*  
            /\* Note, whenever a new MBS location estimate is entered as a baseline estimate <sup>into one of the location</sup> into the location tracks, the other  
            location tracks must be immediately updated with any deadreckoning location change estimates so that all  
            location tracks are substantially updated at the same time. \*/  
            deadreck\_est <--- *get\_deadreckoning\_location\_change\_estimate(event);*  
20           MBS\_curr\_est <--- **DETERMINE\_MBS\_LOCATION\_ESTIMATE**(MBS\_new\_est, deadreck\_est);  
            if (MBS\_curr\_est.confidence > a predetermined high confidence threshold) then  
                *reset\_deadreckoning\_MBS\_location\_estimator(event);*  
                    /\* deadreckoning starts over from here. \*/  
25           /\* Send MBS location information to the Location Center. \*/  
            if ( MBS has not moved since the last MBS location estimate of this type and is not now moving) then  
                {  
                    configure the MBS on-board transceiver (e.g., MBS-MS) to immediately transmit location signals to the fixed  
                    location BS network as if the MBS were an ordinary location device (MS);  
30              communicate with the Location Center via the fixed location BS infrastructure the following:  
                (a) a "locate me" signal,

00770039:042604  
105210:0500260

- (b) MBS\_curr\_est,
- (c) MBS\_new\_est and
- (d) the timestamp for the present event.

5 Additionally, any location signal information between the MBS and the present target MS may be transmitted to the Location Center so that this information may also be used by the Location Center to provide better estimates of where the MBS is. Further, if the MBS determines that it is immediately adjacent to the target MS and also that its own location estimate is highly reliable (e.g., a GPS estimate), then the MBS may also communicate this information to the Location Center so that the Location Center can: (a) associate any target MS location signature cluster data with the fixed base station infrastructure with the location provided by the MBS, and (b) insert this associated data into the location signature data base of the Location Center as a verified cluster of "random loc sigs";

/\* note, this transmission preferably continues (i.e., repeats) for at least a predetermined length of time of sufficient length for the Signal Processing Subsystem to collect a sufficient signal characteristic sample size. \*/

15 }  
else SCHEDULE an event (if none scheduled) to transmit to the Location Center the following: (a) MBS\_curr\_est, and (b) the GPS location of the MBS and the time of the GPS location estimate;

/\* Now update MBS display with new MBS location; note, MBS operator must request MBS locations on the MBS display; if not requested, then the following call does not do an update. \*/

20 update\_MBS\_operator\_display\_with\_MBS\_est(MBS\_curr\_est);

}  
*SINCE LAST MBS LOCATION UPDATE*

*MBS HAS MOVED A THRESHOLD DISTANCE: {*

25 deadreck\_est <--- get\_deadreckoning\_location\_change\_estimate(event);

/\* Obtain from MBS Dead Reckoning Location Estimator a new dead reckoning MBS location estimate having an estimate as to the MBS location change from the location of the last MBS location provided to the MBS. \*/

MBS\_curr\_est <---- DETERMINE\_MBS\_LOCATION\_ESTIMATE(NULL, deadreck\_est);

30 /\* this new MBS estimate will be used in new target MS estimates\*/

update\_MBS\_display\_with\_updated\_MBS\_location(MBS\_curr\_est);

SCHEDULE an event (if none scheduled) to request new GPS location data for MBS;





00770829.012604  
PAGE: 0000220

Processing Subsystem. For simplicity of discussion here, it is assumed that each MBS includes at least a scaled down version of the Signal Processing Subsystem (see FIG. 11). \*/

```
MS_new_est <--- DETERMINE_MS_MOST_RECENT_ESTIMATE(MBS_curr_est, MS_curr_est,  
MS_signal_data);
```

5 /\* May use forward and reverse TOA, TDOA, signal power, signal strength, and signal quality indicators. Note, "MS\_curr\_est" includes a timestamp of when the target MS signals were received. \*/

```
if (MS_new_est.confidence > min_MS_confidence ) then  
{
```

10 *mark\_MS\_est\_as\_temporary*(MS\_new\_est);

/\* Note, it is assumed that this MS location estimate is "temporary" in the sense that it will be replaced by a corresponding MS location estimate received from the Location Center that is based on the same target MS raw signal data. That is, if the Location Center responds with a corresponding target MS location estimate, E, while "MS\_new\_est" is a value in a "moving window" of target MS location estimates (as described hereinbelow), then E will replace the value of "MS\_new\_est". Note, the moving window may dynamically vary in size according to, for example, a perceived velocity of the target MS and/or the MBS. \*/

15 *MS\_moving\_window* <--- *get\_MS\_moving\_window*(event);  
/\* get moving window of location estimates for this target MS. \*/

20 *add\_MS\_estimate\_to\_MS\_location\_window*(MS\_new\_est, MS\_moving\_window);

/\* Since any given single collection of measurements related to locating the target MS may be potentially misleading, a "moving window" of location estimates are used to form a "composite location estimate" of the target MS. This composite location estimate is based on some number of the most recent location estimates determined. Such a composite location estimate may be, for example, analogous to a moving average or some other weighting of target MS location estimates. Thus, for example, for each location estimate (i.e., at least one MS location area, a most likely single location, and, a confidence estimate) a centroid type calculation may be performed to provide the composite location estimate. \*/

30 *MS\_curr\_est* <--- *DETERMINE\_MS\_LOCATION\_ESTIMATE*(MS\_moving\_window);

/\* DETERMINE new target MS location estimate. Note this may an average location or a weighted average location. \*/

```
remove_scheduled_events("TARGET_MS_SCHEDULE", event.MS_ID);
```





00770030-01204  
PAGE: 000260

```

else /* there is no corresponding "temporary" target MS location in the moving window; so
      this MS estimate must be too old; so don't use it. */
else /* the Location Center did not use the MS location data from the MBS even though the timestamp of
      the latest MS location data sent to the Location Center is older than the MS location data used by
5      the Location Center to generate the present target MS location estimate. Use the new MS location
      data anyway. Note there isn't a corresponding "temporary" target MS location in the moving
      window. */
      add_MS_estimate_to_MS_location_window(MS_new_est);
}
10 else /* the MS location estimate from the LC is not more recent than the latest MS location data sent to the LC from
      the MBS. */
      if (a corresponding target MS location estimate marked as "temporary" is still in the moving window)
          then /* It is assumed that this new target MS location data is still timely (note the target MS may be
                moving); so replace the temporary estimate with the Location Center estimate. */
                replace the temporary target MS location estimate in the moving window with "MS_new_est";
15          else /* there is no corresponding "temporary" target MS location in the moving window; so this MS
                estimate must be too old; so don't use it. */
                MS_curr_est <---- DETERMINE_MS_LOCATION_ESTIMATE(MS_moving_window);
                update_MBS_operator_display_with_MS_est(MS_curr_est);
20          reset_timer("LC_COMMUNICATION", event.MS_ID);
      }
      NO COMMUNICATION FROM LC: {
          /* i.e., too long a time has elapsed since last communication from LC. */
          SCHEDULE an event (if none scheduled) to request location data (MBS and/or target MS) from the Location Center,
25          the event is at a high priority;
          reset_timer("LC_COMMUNICATION", event.MS_ID);
      }
      REQUEST TO NO LONGER CONTINUE LOCATING THE PRESENT TARGET MS: {
          if (event not from operator) then
30          request MBS operator verification;
          else {
              REMOVE the current target MS from the list of MSs currently being located and/or tracked;
              SCHEDULE an event (if none scheduled) to send communication to the Location Center that the current target MS
              is no longer being tracked;

```

PURGE MBS location data related to current target MS except any exact location data for the target MS that has not been sent to the Location Center for archival purposes;

}  
}

5 **REQUEST FROM LOCATION CENTER TO ADD ANOTHER TARGET MS TO THE LIST OF MSs**

**BEING TRACKED: {**

/\* assuming the Location Center sends MBS location data for a new target MS to locate and/or track (e.g., at least a new MS ID and an initial MS location estimate), add this new target MS to the list of MSs to track. Note the MBS will typically be or transitioning to in the seek state.\*/

10 if (event not from operator) then

request MBS operator verification;

else {

INITIALIZE MBS with data received from the Location Center related to the estimated location of the new target MS; /\* e.g., initialize a new moving window for this new target MS; initialize MBS operator interface by graphically indicating where the new target MS is estimated to be. \*/

15

CONFIGURE MBS to respond to any signals received from the new target MS by requesting location data from the new target MS;

INITIALIZE timer for communication from LC; /\* A timer may be set per target MS on list. \*/

}  
}

20

**REQUEST TO MANUALLY ENTER A LOCATION ESTIMATE FOR MBS (FROM AN MBS OPERATOR): {**

/\* Note, MBS could be moving or stationary. If stationary, then the estimate for the location of the MBS is given high reliability and a small range (e.g., 20 feet). If the MBS is moving, then the estimate for the location of the MBS is given high reliability but a wider range that may be dependent on the speed of the MBS. In both cases, if the MBS operator indicates a low confidence in the estimate, then the range is widened, or the operator can manually enter a range.\*/

25

MS\_new\_est <--- get\_new\_MBS\_location\_est\_from\_operator(event; /\* The estimate may be obtained, for example, using a light pen on a displayed map \*/

30

if (operator supplies a confidence indication for the input MBS location estimate) then

MBS\_new\_est.confidence <--- get\_MBS\_operator\_confidence\_of\_estimate(event);

else MBS\_new\_est.confidence <--- 1; /\* This is the highest value for a confidence. \*/

deadreck\_est <--- get\_deadreckoning\_location\_change\_estimate(event);

00770830 042604

5  
10  
15  
20  
25

```

MBS_curr_est <--- DETERMINE_MBS_LOCATION_ESTIMATE(MBS_new_est, deadreck_est);
if (MBS_curr_est.confidence > a predetermined high confidence threshold) then
    reset_deadreckoning_MBS_location_estimator(event);
    update_MBS_operator_display_with_MBS_est(MBS_curr_est);

```

/\* Note, one reason an MBS operator might provide a manual MBS input is that the MBS might be too inaccurate in its location. Moreover, such inaccuracies in the MBS location estimates can cause the target MS to be estimated inaccurately, since target MS signal characteristic values may be utilized by the MBS to estimate the location of the target MS as an offset from where the MBS is. Thus, if there are target MS estimates in the moving window of target MS location estimates that are relatively close to the location represented by "MBS\_curr\_est", then these select few MS location estimates may be updated to reflect a more accurate MBS location estimate. \*/

```

MS_moving_window <--- get_MS_moving_window(event);
if (MBS has not moved much since the receipt of some previous target MS location that is still being used to location
    the target MS)
    then
    {
        UPDATE those target MS location estimates in the moving window according to the new MBS location estimate
            here;
        MS_curr_est <--- DETERMINE_MS_LOCATION_ESTIMATE(MS_moving_window);
        update_MBS_operator_display_with_MS_est(MS_curr_est);
    }
}

```

} /\* end case statement \*/

25 **Lower Level MBS Function Descriptions**

/\* PROCEDURE: DETERMINE\_MBS\_LOCATION\_ESTIMATE REMARKS:

It is assumed that with increasing continuous **dead reckoning** without additional MBS location verification, the potential **error** in the MBS location **increases**.

30 It is assumed that each MBS location estimate includes: (a) a most likely area estimate surrounding a central location and (b) a confidence value of the MBS being in the location estimate.

The **confidence value** for each MBS location estimate is a measurement of the likelihood of the MBS location estimate being correct. More precisely, a confidence value for a new MBS location estimate is a measurement that is adjusted according to the following criteria:

- 5 (a) the confidence value increases with the perceived accuracy of the new MBS location estimate (independent of any current MBS location estimate used by the MBS),
- (b) the confidence value decreases as the location discrepancy with the current MBS location increases,
- (c) the confidence value for the current MBS location increases when the new location estimate is contained in the current location estimate,
- 10 (d) the confidence value for the current MBS location <sup>decreases</sup> ~~decrease~~ when the new location estimate is not contained in the current location estimate, and

Therefore, the **confidence value** is an **MBS location likelihood measurement which takes into account the history of previous MBS location estimates.**

It is assumed that with each MBS location estimate supplied by the Location Center there is a default confidence value supplied which the MBS may change.

15 \*/

#### **DETERMINE\_MBS\_LOCATION\_ESTIMATE(MBS\_new\_est, deadreck\_est)**

/\* Add the pair, "MBS\_new\_est" and "deadreck\_est" to the location tracks and determine a new current MBS location estimate.

20 **Input: MBS\_new\_est** A new MBS baseline location estimate to use in determining the location of the MBS, but not a (deadreckoning) location change estimate

**deadreck\_est** The deadreckoning location change estimate paired with "MBS\_new\_est". \*/

{  
25 if (MBS\_new\_est is not NULL) then /\* the "deadreck\_est" is paired with "MBS\_new\_est" \*/

{  
if (all MBS location tracks are empty) then  
{  
30 insert "MBS\_new\_est" as the head of the location track of type, "MBS\_new\_est.type";  
insert "MBS\_new\_est" as the head of the current track; /\* so now there is a "MBS\_curr\_est" MBS location estimate to use \*/

MBS\_curr\_est <--- get\_curr\_est(MBS\_new\_est.MS\_ID); /\* from current location track \*/

}



0070030-012504  
FOUO:00000000

```
else /* there is at least one non-empty location track in addition to the current location track being non-
empty */
{
  if (MBS_new_est is of type MANUAL_ENTRY) then
5   { /* MBS operator entered an MBS location estimate for the MBS; so must use
      it */
      MBS_curr_est <--- add_location_entry(MBS_new_est, deadreck_est);
    }
  else /* "MBS_new_est" is not of type MANUAL_ENTRY */
10   if (the MBS location track of type, "MBS_new_est.type", is empty) then
      { /* some other location track is non-empty */
        MBS_curr_est <--- add_location_entry(MBS_new_est, deadreck_est);
      }
    else /* "MBS_new_est.type" location track is non-empty and "MBS_new_est"
15     is not of type MANUAL_ENTRY */
      { /* In the next statement determine if "MBS_new_est" is of at least
          minimal useful quality in comparison to any previous estimates of the
          same type; see program def'n below */
          continue_to_process_new_est <-- FILTER(MBS_new_est);
20         if (continue_to_process_new_est) then /* "MBS_new_est" is of sufficient quality to
            continue processing. */
            {
              MBS_curr_est <--- add_location_entry(MBS_new_est, deadreck_est);
              } /* end "MBS_new_est" not filtered out */
            else /* "MBS_new_est" is filtered out; do nothing */;
25           } /* end else */
        } /* end else at least one non-empty location track */
    }
  else /* MBS_new_est is NULL; thus only a deadreckoning output is to be added to location tracks */
30   {
      extrapolation_entry <--- create_an_extrapolation_entry_from(deadreck_est);
      insert_into_every_location_track(extrapolation_entry); /* including the "current location track" */
      MBS_curr_est <--- get_curr_est(MBS_new_est.MS_ID); /* from current location track */
    }
  }
}
```

09770939.04504  
FOSEFO-2620260

```

}
RETURN(MBS_curr_est);
} END /* DETERMINE_MBS_LOCATION_ESTIMATE */

```

```

5 add_location_entry(MBS_new_est, deadreck_est);

```

/\* This function adds the baseline entry, "MBS\_new\_est" and its paired deadreckoning location change estimate, "deadreck\_est" to the location tracks, including the "current location track". Note, however, that this function will roll back and rearrange location entries, if necessary, so that the entries are in latest timestamp order.

Returns: MBS\_curr\_est \*/

10 {

if (there is a time series of one or more dead reckoning extrapolation entries in the location track of type "MBS\_new\_est.type" wherein the extrapolation entries have a "latest timestamp" more recent than the timestamp of "MBS\_new\_est") then

```

{ /* Note, this condition may occur in a number of ways; e.g., (a) an MBS location estimate received from the Location Center could be delayed long enough (e.g., 1-4 sec) because of transmission and processing time; (b) the estimation records output from the MBS baseline location estimators are not guaranteed to be always presented to the location tracks in the temporal order they are created. */

```

15

```

roll back all (any) entries on all location tracks, including the "current" track, in "latest timestamp" descending order, until a baseline entry, B, is at the head of a location track wherein B is a most recent entry having a "latest timestamp" prior to "MBS_new_est"; let "stack" be the stack of a location track entries rolled off the location tracks, wherein an entry in the stack is either a baseline location entry and a paired deadreckoning location change estimate, or, an unpaired deadreckoning location change estimate associated with a NULL for the baseline location entry;

```

20

```

insert "MBS_new_est" at the head of the location track of type "MBS_new_est.type" as a new baseline entry;
insert the extrapolation entry derived from "deadreck_est" in each of the other baseline location tracks except the current track;

```

25

```

/* It is important to note that "deadreck_est" includes the values for the change in the MBS location substantially for the time period between the timestamp, T, of "MS_new_est" and the timestamp of the closest deadreckoning output just before T. Further note that if there are any extrapolation entries that were rolled back above, then there is an extrapolation entry, E, previously in the location tracks and wherein E has an earliest timestamp equal to the latest timestamp of B above. Thus, all the previous extrapolation entries removed can be put back if E is modified as follows: the MBS location change vector of E (denoted herein as E.delta) becomes E.delta - [location change vector of "deadreck_est"]. */

```

30

```

MBS_curr_est <--- UPDATE_CURR_EST(MBS_new_est, deadreck_est);

```

09770828-01264  
102210-8280260

```
if (the extrapolation entry E exists) then /* i.e., "stack" is not empty */
{
    modify the extrapolation entry E as per the comment above;
    /* now fix things up by putting all the rolled off location entries back, including
5     the "current location track" */
    do until "stack" is empty
    {
        stack_top <--- pop_stack(stack);
        /* "stack_top" is either a baseline location entry and a paired deadreckoning location change
10         estimate, or, an unpaired deadreckoning location change estimate associated with a NULL for the
        baseline location entry */
        MBS_next_est <--- get_baseline_entry(stack_top);
        deadreck_est <--- get_deadreckoning_entry(stack_top);
        MBS_curr_est <--- DETERMINE_MBS_LOCATION_ESTIMATE(MBS_next_est,
15         deadreck_est);
    }
}
else /* there is no deadreckoning extrapolation entries in the location track of type "MBS_new_est.type" wherein the
20     extrapolation entries have a "latest timestamp" more recent than the timestamp of "MBS_new_est". So just insert
    "MBS_new_est" and "deadreck_est".*/
{
    insert "MBS_new_est" at the head of the location track of type "MBS_new_est.type" as a new baseline entry;
    insert the extrapolation entry derived from "deadreck_est" in each of the other location tracks except the current track;
25     MBS_curr_est <--- UPDATE_CURR_EST(MBS_new_est, deadreck_est); /* see prog def'n below */
}
RETURN(MBS_curr_est);
} /* end add_location_entry */
```

30 **FILTER(MBS\_new\_est)**

**/\* This function determines whether "MBS\_new\_est" is of sufficient quality to insert into it's corresponding MBS location track. It is assumed that the location track of "MBS\_new\_est.type" is non-empty.**

Input: MBS\_new\_est A new MBS location estimate to use in determining the location of the MBS.

Returns: FALSE if "MBS\_new\_est" was processed here (i.e., filtered out),  
TRUE if processing with "MBS\_new\_est" may be continued. \*/

5 {  
continue\_to\_process\_new\_est <--TRUE; /\* assume "MBS\_new\_est" will be good enough to use as an MBS location estimate \*/  
/\* see if "MBS\_new\_est" can be filtered out. \*/  
if (the confidence in MBS\_new\_est < a predetermined function of the confidence(s) of previous MBS location estimates of  
type "MBS\_new\_est.type")  
10 /\* e.g., the predetermined function here could be any of a number of functions that provide a minimum threshold on  
what constitutes an acceptable confidence value for continued processing of "MBS\_new\_est". The following is an  
example of one such predetermined function:  $K * (\text{confidence of "MBS\_new\_est.type" location track head})$  for  
some  $K$ ,  $0 < K \leq 1.0$ , wherein  $K$  varies with a relative frequency of estimates of type  
"MBS\_new\_est.type" not filtered; e.g., for a given window of previous MBS location estimates of this type,  $K =$   
15  $(\text{number of MBS location estimates of "MBS\_new\_est.type" not filtered}) / (\text{the total number of estimates of this  
type in the window})$ . Note, such filtering here may be important for known areas where, for example, GPS signals  
may be potentially reflected from an object (i.e., multipath), or, the Location Center provides an MBS location  
estimate of very low confidence. For simplicity, the embodiment here discards any filtered location estimates.  
However, in an alternative embodiment, any such discarded location estimates may be stored separately so that,  
20 for example, if no additional better MBS location estimates are received, then the filtered or discarded location  
estimates may be reexamined for possible use in providing a better subsequent MBS location estimate. \*/  
then continue\_to\_process\_new\_est <-- FALSE;  
else if (an area for "MBS\_new\_est" > a predetermined function of the corresponding area(s) of entries in the location  
track of type "MBS\_new\_est.type")  
25 /\* e.g., the predetermined function here could be any of a number of functions that provide a maximum threshold  
on what constitutes an acceptable area size for continued processing of "MBS\_new\_est". The following are  
examples of such predetermined functions: (a) the identity function on the area of the head of the location track  
of type "MBS\_new\_est.type"; or, (b)  $K * (\text{the area of the head of the location track of type  
"MBS\_new\_est.type"})$ , for some  $K$ ,  $K \geq 1.0$ , wherein for a given window of previous MBS location estimates of  
30 this type,  $K = (\text{the total number of estimates in the window}) / (\text{number of these location estimates not filtered})$ ;  
note, each extrapolation entry increases the area of the head; so areas of entries at the head of each location  
track type grow in area as extrapolation entries are applied. \*/  
then continue\_to\_process\_new\_est <-- FALSE;





09770999-01381  
103210-860220

```

    (b) conceptually at least, the location change estimates output from the deadreckoning MBS
        location estimator that correspond with the removed extrapolation entries are then
        reapplied in timestamp order to the head of the target location track. */
}
5 else /* the centroid of "MBS_new_est", is contained in an area of "MBS_curr_est", but the confidence in
    "MBS_new_est" < confidence in "MBS_curr_est" */
{
    most_likely_est <-- determine a "most likely MBS location estimate" using the set S = {the MBS
        location estimate centroid(s) of any MBS location track heads contained in the MBS
10 estimated area of "adjusted_curr_est", plus, the centroid of "MBS_new_est"};
    /* Note, in the above statement, the "most likely MBS location estimate" may be determined
        using a number of different techniques depending on what function(s) is used to embody the
        meaning of "most likely". In one embodiment, such a "most likely" function is a function of
        the confidence values of a predetermined population of measurements (e.g., the selected
15 location track heads in this case) from which a "most likely" measurement is determined (e.g.,
        computed or selected). For example, in one embodiment, a "most likely" function may include
        selecting a measurement having the maximum confidence value from among the population of
        measurements. In a second embodiment, a "most likely" function may include a weighting of
        measurements (e.g., location track heads) according to corresponding confidence values of the
        measurements. For example, in the present context (of MBS location track heads) the
20 following steps provide an embodiment of a "most likely" function:
        (a) determine a centroid of area for each of the selected track heads (i.e., the location
            track heads having a point location estimate contained in the MBS estimated area of
            "adjusted_curr_est");
        (b) determine the "most likely location MBS position" P as a weighted centroid of the
            centroids from step (a), wherein the weighting of each of the centroids from (a) is
            provided by their corresponding confidence values;
        (c) output an area, Ai, as the "most likely MBS location area", wherein the centroid of
            Ai is P and Ai is the largest area within the MBS estimated area of
30 "adjusted_curr_est" satisfying this condition; and
        (d) set a confidence value for Ai as the average confidence value of "MBS_new_est",
            "MBS_curr_est" and the selected location track head used. */
    insert_into_location_track("current", most_likely_est);
}

```







(there has been an MBS operator indication of lack of confidence in the recently displayed MBS location estimates))

then /\* the MBS location system is likely unstable and/or inaccurate; check to see if this condition has been addressed in the recent past. \*/

5

{ /\* fix instability \*/

if (fix\_instability\_counter equal to 0) then /\* no instabilities have been addressed here within the recent past; i.e., "fix\_instability\_counter" has the following semantics: if it is 0, then no instabilities have been addressed here within the recent past; else if not 0, then a recent instability has been attempted to be fixed here. Note, "fix\_instability\_counter" is decremented, if not zero, each time a new baseline location entry is inserted into its corresponding baseline location track. Thus, this counter provides a "wait and see" strategy to determine if a previous performance of the statements below mitigated the (any) MBS location system instability. \*/

10

{

most\_likely\_est <-- determine a new "most likely MBS location estimate";[30.1]

15

/\* Note, a number of MBS location estimates may be generated and compared here for determining the "most\_likely\_est". For example, various weighted centroid MBS location estimates may be determined by a clustering of location track head entries in various ways.

In a first embodiment for determining a value (object) for "most\_likely\_est", a "most likely" function may be performed, wherein a weighting of location track heads according to their corresponding confidence values is performed. For example, the following steps provide an embodiment of a "most likely" function:

20

(a) obtain a set S having: (i) a centroid of area for each of the track heads having a corresponding area contained in a determined area surrounding the point location of "adjusted\_curr\_est" (e.g., the MBS estimated area of "adjusted\_curr\_est"), plus (ii) the centroid of "MBS\_new\_est";

25

(b) determine the "most likely location MBS position" P as a weighted centroid of the centroids of the set S from step (a), wherein the weighting of each of the centroids from (a) is provided by their corresponding confidence values;

30

(c) output an area, A, as the "most likely MBS location area" wherein A has P as a centroid and A is a "small" area (e.g., a convex hull) containing the corresponding the centroids of the set S; and

(d) set a confidence value for A as the average confidence value of the centroids of the set S.



estimates and the appropriate location track entry or entries will be put on the location track corresponding to the first parameter. \*/

}

} /\* check for instabilities \*/

5 MBS\_curr\_est <--- get\_curr\_est(MBS\_new\_est.MS\_ID); /\* from current location track \*/

} /\* try to use "MBS\_new\_est" \*/

RETURN(MBS\_curr\_est)

} /\* END resolve\_conflicts \*/

10

09770929 09501  
109210 82804260

## APPENDIX B: Pseudo code for a genetic algorithm

### Pseudo code for a genetic algorithm

```
5  Genetic_Algorithm (*decode, *fitness_function, parms)
   /* This program implements a genetic algorithm for determining efficient
      values of parameters for a search problem. The current best values of the parameters are received by the genetic algorithm in a data
      structure such as an array. If no such information is available, then the genetic algorithm receives random guesses of the parameter values.
      This program also receives as input a pointer to a decode function that provides the genetic algorithm with information about how the
10  parameters are represented by bit strings (see genetic algorithm references). The program also receives a pointer to a fitness function,
      "fitness_functions", that provides the genetic algorithm with information about how the quality of potential solutions should be determined.
      The program computes new, improved values of parameters and replaces the old values in the array "parms."
   */
   // assume that each particular application will have a specific fitness function and decoding
15  // scheme; otherwise, the procedure is the same every time
   // generate the initial population
   // generate a random population of binary strings containing popsize strings
   for i = 1 to popsize
     for j = 1 to string_length
20     string(i,j) = random(0,1)
   end loop on j
   end loop on i
   // keep generating new populations until finished
   do until finished
25   for i = 1 to popsize
     // transform the binary strings into parameters from the problem at hand; requires problem
       // specific function
     decode (string(i))
     // evaluate each string
30   evaluate (string(i))
   end loop on i
   // perform reproduction
   reproduce (population_of_strings)
```

00770939.01684  
FOIA b 7 - D

```
//perform crossover  
crossover (population_of_strings)  
//perform mutation  
mutate (population_of_strings)  
5 // evaluate the new population  
for i = 1 to popsize  
    // transform the binary strings into parameters  
    // from the problem at hand; requires problem  
    // specific function  
10 decode (string(i))  
    // evaluate the fitness of each string  
    evaluate (string(i,j))  
end loop on i  
if finished then report new results to the calling routine  
15 else go back to tip of do-until loop
```

## APPENDIX C: Location Database Maintenance Programs

### DATA BASE PROGRAMS FOR MAINTAINING THE LOCATION SIGNATURE DATA BASE

5 In the algorithms below, external parameter values needed are underlined>. Note that in one embodiment of the present invention, such parameters may be adaptively tuned using, for example, a genetic algorithm.

#### EXTERNALLY INVOCABLE PROGRAMS:

10 **Update\_Loc\_Sig\_DB(new\_loc\_obj, selection\_criteria, loc\_sig\_pop)**

/\* This program updates loc sigs in the Location Signature data base. That is, this program updates, for example, at least the location information for verified random loc sigs residing in this data base. Note that the steps herein are also provided in flowchart form in Fig. 17a through FIG. 17C.

15 **Introductory Information Related to the Function, "Update\_Loc\_Sig\_DB"**

The general strategy here is to use information (i.e., "new\_loc\_obj") received from a newly verified location (that may not yet be entered into the Location Signature data base) to assist in determining if the previously stored random verified loc sigs are still reasonably valid to use for:

- 20 (29.1) estimating a location for a given collection (i.e., "bag") of wireless (e.g., CDMA) location related signal characteristics received from an MS,
- (29.2) training (for example) adaptive location estimators (and location hypothesizing models), and
- (29.3) comparing with wireless signal characteristics used in generating an MS location hypothesis by one of the MS location hypothesizing models (denoted First Order Models, or, FOMs).

25 More precisely, since it is assumed that it is more likely that the newest location information obtained is more indicative of the wireless (CDMA) signal characteristics within some area surrounding a newly verified location than the verified loc sigs (location signatures) previously entered into the Location Signature DB, such verified loc sigs are compared for signal characteristic consistency with the newly verified location information (object) input here for determining whether some of these "older" data base verified loc sigs still appropriately characterize their associated location.

30 In particular, comparisons are iteratively made here between each (target) loc sig "near" "new\_loc\_obj" and a population of loc sigs in the location signature data base (such population typically including the loc sig for "new\_loc\_obj) for:

00770930:010001

5  
10  
15  
20  
25  
30

(29.4) adjusting confidence factor of the target loc sig. Note that each such confidence factor is in the range [0, 1] with 0 being the lowest and 1 being the highest. Further note that a confidence factor here can be raised as well as lowered depending on how well the target loc sig matches or is consistent with the population of loc sigs to which it is compared. Thus, the confidence in any particular verified loc sig, LS, can fluctuate with successive invocations of this program if the input to the successive invocations are with location information geographically "near" LS.

(29.5) remove older verified loc sigs from use whose confidence value is below a predetermined threshold. Note, it is intended that such predetermined thresholds be substantially automatically adjustable by periodically testing various confidence factor thresholds in a specified geographic area to determine how well the eligible data base loc sigs (for different thresholds) perform in agreeing with a number of verified loc sigs in a "loc sig test-bed", wherein the test bed may be composed of, for example, repeatable loc sigs and recent random verified loc sigs.

Note that this program may be invoked with a (verified/known) random and/or repeatable loc sig as input. Furthermore, the target loc sigs to be updated may be selected from a particular group of loc sigs such as the random loc sigs or the repeatable loc sigs, such selection being determined according to the input parameter, "selection\_criteria" while the comparison population may be designated with the input parameter, "loc\_sig\_pop". For example, to update confidence factors of certain random loc sigs near "new\_loc\_obj", "selection\_criteria" may be given a value indicating, "USE\_RANDOM\_LOC\_SIGS", and "loc\_sig\_pop" may be given a value indicating, "USE\_REPEATABLE\_LOC\_SIGS". Thus, if in a given geographic area, the repeatable loc sigs (from, e.g., stationary transceivers) in the area have recently been updated, then by successively providing "new\_loc\_obj" with a loc sig for each of these repeatable loc sigs, the stored random loc sigs can have their confidences adjusted.

Alternatively, in one embodiment of the present invention, the present function may be used for determining when it is desirable to update repeatable loc sigs in a particular area (instead of automatically and periodically updating such repeatable loc sigs). For example, by adjusting the confidence factors on repeatable loc sigs here provides a method for determining when repeatable loc sigs for a given area should be updated. That is, for example, when the area's average confidence factor for the repeatable loc sigs drops below a given (potentially high) threshold, then the MSs that provide the repeatable loc sigs can be requested to respond with new loc sigs for updating the DB. Note, however, that the approach presented in this function assumes that the repeatable location information in the DB is maintained with high confidence by, for example, frequent DB updating. Thus, the random verified DB location information may be effectively compared against the repeatable loc sigs in an area.

**INPUT:**

**new\_loc\_obj:** a data representation at least including a loc sig for an associated location about which Location Signature loc sigs are to have their confidences updated.



PLATE: 00000000

selection\_criteria: a data representation designating the loc sigs to be selected to have their confidences updated (may be defaulted). The following groups of loc sigs may be selected: "USE\_RANDOM\_LOC\_SIGS" (this is the default), USE\_REPEATABLE\_LOC\_SIGS", "USE\_ALL\_LOC\_SIGS". Note that each of these selections has values for the following values associated with it (although the values may be defaulted):

- 5 (a) a confidence reduction factor for reducing loc sig confidences,
- (b) a big\_error\_threshold for determining the errors above which are considered too big to ignore,
- (c) a confidence\_increase\_factor for increasing loc sig confidences,
- (d) a small\_error\_threshold for determining the errors below which are considered too small (i.e., good) to ignore.
- 10 (e) a recent\_time for specifying a time period for indicating the loc sigs here considered to be "recent".

loc\_sig\_pop: a data representation of the type of loc sig population to which the loc sigs to be updated are compared. The following values may be provided:

- 15 (a) "USE ALL LOC SIGS IN DB",
- (b) "USE ONLY REPEATABLE LOC SIGS" (this is the default),
- (c) "USE ONLY LOC SIGS WITH SIMILAR TIME OF DAY"

However, environmental characteristics such as: weather, traffic, season are also contemplated. \*/

*/\* Make sure "new\_loc\_obj" is in Location DB. \*/*

if (NOT new\_loc\_obj.in\_DB ) then /\* this location object is not in the Location Signature DB; note this can be determined by comparing the location and times/timestamp with DB entries \*/

20 DB\_insert\_new\_loc\_sig\_entries(new\_loc\_obj); // stores loc sigs in Location Signature DB

*/\* Determine a geographical area surrounding the location associated with "new\_loc\_obj" for adjusting the confidence factors of loc sigs having associated locations in this area. \*/*

DB\_search\_area <--- get\_confidence\_adjust\_search\_area\_for\_DB\_random\_loc\_sig(new\_loc\_obj.location);

25 */\* get the loc sigs to have their confidence factors adjusted. \*/*

DB\_loc\_sigs <--- get\_all\_DB\_loc\_sigs\_for(DB\_search\_area, selection\_criteria);

nearby\_loc\_sig\_bag <--- get loc sigs from "DB\_loc\_sigs" wherein for each loc sig the distance between the location associated with "new\_loc\_obj.location" and the verified location for the loc sig is closer than, for example, some standard deviation (such as the second standard deviation) of these distances for all loc sigs in "DB\_loc\_sigs";

30 */\* For each "loc sig" having its confidence factor adjusted do \*/*

for each loc\_sig[] in nearby\_loc\_sig\_bag do // determine a confidence for these random loc sigs

FOUO: 00000000

```

{
  /* Determine a search area surrounding the location associated with "loc
  sig" */
  loc <--- get_verified_location(loc_sig[i]);
  5  /* Determine the error corresponding to how well "loc sig" fits with the
  portion of the inputted type of loc sig population that is also in the search
  area. */
  BS <--- get_BS(loc_sig[i]);
  mark_as_unaccessible(loc_sig[i]); /* mark "loc_sig[i]" in the Location Signature DB so that it isn't retrieved. */
  10 DB_search_area2 <--- get_confidence_adjust_search_area_for_DB_loc_sigs(loc.location);
  /* Get search area about "rand_loc". Typically, the "new_loc_obj" would be in this search area */
  loc_sig_bag <--- create_loc_sig_bag(loc_sig[i]); /* create a loc sig bag having a single loc sig, "loc_sig[i]" */
  output_criteria <--- get_criteria_to_input_to "Determine_Location_Signature_Fit_Errors" indicating that the function
  should generate error records in the returned "error_rec_bag" only for the single loc sig in
  15 "loc_sig_bag". That is, the output criteria is: "OUTPUT ERROR_RECS FOR INPUT LOC SIGS
  ONLY".
  error_rec_bag[i] <--- Determine_Location_Signature_Fit_Errors(loc.location, loc_sig_bag,
  DB_search_area2, loc_sig_pop, output_criteria);
  unmark_making_accessible(loc_sig[i]); /* unmark "loc_sig[i]" in the Location Signature DB so that it can now be
  20 retrieved. */
}

/* Reduce confidence factors of loc sigs: (a) that are nearby to the location
associated with "new_loc_obj", (b) that have big errors, and (c) that have not
been recently updated/acquired. */
25 error_rec_set <--- make_set_union_of(error_rec_bag[i] for all i);
/* Now modify confidences of loc sigs in DB and delete loc sigs with very low confidences */
reduce_bad_DB_loc_sigs(nearby_loc_sig_bag, error_rec_set, selection_criteria.big_error_threshold,
selection_criteria.confidence_reduction_factor, selection_criteria.recent_time);

/* Increase confidence factors of loc sigs: (a) that are nearby to the location
30 associated with "new_loc_obj", (b) that have small errors, and (c) that have not
been recently updated/acquired. */

```

```

increase_confidence_of_good_DB_loc_sigs(nearby_loc_sig_bag, error_rec_set,
                                         selection_criteria.small_error_threshold,
                                         selection_criteria.confidence_increase_factor,
                                         selection_criteria.recent_time);

```

5 END OF Update\_Loc\_Sig\_DB

```

DB_Loc_Sig_Error_Fit(MS_loc_est, DB_search_area, measured_loc_sig_bag, search_criteria)

```

10 /\* This function determines how well the collection of loc sigs in "measured\_loc\_sig\_bag" fit with the loc sigs in the location signature data base wherein the data base loc sigs must satisfy the criteria of the input parameter "search\_criteria" and are relatively close to the MS location estimate of the location hypothesis, "hypothesis". Thus, in one embodiment of the present invention, the present function may be invoked by, for example, the confidence adjuster module to adjust the confidence of a location hypothesis.

Input: hypothesis: MS location hypothesis;

15 measured\_loc\_sig\_bag: A collection of measured location signatures ("loc sigs" for short) obtained from the MS (the data structure here is an aggregation such as an array or list). Note, it is assumed that there is at most one loc sig here per Base Station in this collection. Additionally, note that the input data structure here may be a location signature cluster such as the "loc\_sig\_cluster" field of a location hypothesis (cf. Fig. 9). Note that variations in input data structures may be accepted here by utilization of flag or tag bits as one skilled in the art will appreciate;

20 search\_criteria: The criteria for searching the verified location signature data base for various categories of loc sigs. The only limitation on the types of categories that may be provided here is that, to be useful, each category should have meaningful number of loc sigs in the location signature data base. The following categories included here are illustrative, but others are contemplated:

- 25 (a) "USE ALL LOC SIGS IN DB" (the default),
- (b) "USE ONLY REPEATABLE LOC SIGS",
- (c) "USE ONLY LOC SIGS WITH SIMILAR TIME OF DAY".

Further categories of loc sigs close to the MS estimate of "hypothesis" contemplated are: all loc sigs for the same season and same time of day, all loc sigs during a specific weather condition (e.g., snowing) and at the same time of day, as well as other limitations for other environmental conditions such as traffic patterns.

30 Note, if this parameter is NIL, then (a) is assumed.

Returns: An error object (data type: "error\_object") having: (a) an "error" field with a measurement of the error in the fit of the location signatures from the MS with verified location signatures in the Location Signature data base; and

(b) a "confidence" field with a value indicating the perceived confidence that is to be given to the "error" value.

\*/

if ("search\_criteria" is NIL) then

5 search\_criteria <--- "USE ALL LOC SIGS IN DB";

*/\* determine a collection of error records wherein there is an error record for each BS that is associated with a loc sig in "measure\_loc\_sig\_bag" and for each BS associated with a loc sig in a geographical area surrounding the hypothesis's location. \*/*

10 output\_criteria <--- "OUTPUT ALL POSSIBLE ERROR\_RECS";

*/\* The program invoked in the following statement is described in the location signature data base section. \*/*

error\_rec\_bag <--- Determine\_Location\_Signature\_Fit\_Errors(MS\_loc\_est, measured\_loc\_sig\_bag,  
DB\_search\_area, search\_criteria, output\_criteria);

15 */\* Note, "error\_rec\_bag" has "error\_rec's" for each BS having a loc sig in "DB\_search\_area" as well as each BS having a loc sig in "measured\_loc\_sig\_bag". \*/*

*/\* determine which error records to ignore \*/*

BS\_errors\_to\_ignore\_bag <--- get\_BS\_error\_recs\_to\_ignore(DB\_search\_area, error\_rec\_bag);

20 */\* Our general strategy is that with enough BSs having: (a) loc sigs with the target MS, and (b) also having verified locations within an area about the MS location "MS\_loc\_est", some relatively large errors can be tolerated or ignored. For example, if the MS location estimate, "MS\_loc\_est", here is indeed an accurate estimate of the MS's location and if an area surrounding "MS\_loc\_est" has relatively homogeneous environmental characteristics and the area has an adequate number of verified location signature clusters in the location signature data base, then there will be presumably enough comparisons between the measured MS loc sigs of "measured\_loc\_sig\_bag" and the estimated loc sigs, based on verified MS locations in the DB (as determined in "Determine\_Location\_Signature\_Fit\_Errors"), for providing "error\_rec\_bag" with enough small errors that these small errors provide adequate evidence for "MS\_loc\_est" being accurate.*

25 *Accordingly, it is believed that, in most implementations of the present invention, only a relatively small number of loc\_sig comparisons need have small errors for there to be consistency between the loc sigs of "measured\_loc\_sig\_bag" and the verified loc sigs in the location signature data base. That is, a few large errors are assumed, in general, to be less indicative of the MS location hypothesis being incorrect than small errors are*  
30 *indicative of accurate MS locations. Thus, if there were ten measured and estimated loc sig pairs, each associated with a different BS, then if four pairs have small errors, then that might be enough to have high confidence in*



00770820: 00000000

loc\_sig\_bag: The loc\_sigs to be tested for determining if their confidences should be lowered and/or these loc\_sigs removed.

error\_rec\_set: The set of "error\_rec" providing information as to how much each loc sig in "loc\_sig\_bag" disagrees with comparable loc\_sigs in the DB. That is, there is an "error\_rec" here for each loc sig in "loc\_sig\_bag".

big\_error\_threshold: The error threshold above which the errors are considered too big to ignore.

confidence\_reduction\_factor: The factor by which to reduce the confidence of loc\_sigs.

recent\_time: Time period beyond which loc\_sigs are no longer considered recent.

*/\* get loc\_sigs from the Location DB having both big absolute and relative errors (in comparison to other DB nearby loc\_sigs) \*/*

relatively\_big\_errors\_bag <--- get "error\_rec" in "error\_rec\_set" wherein each "error\_rec.error" has a size larger than, for example, the second standard deviation from the mean (average) of such errors;

big\_errors\_bag <--- get "error\_rec" in "relatively\_big\_errors\_bag" wherein each "error\_rec.error" has a value larger than "big\_error\_threshold";

DB\_loc\_sigs\_w\_big\_errors <--- get the loc\_sigs for "error\_rec" in "big\_errors\_bag" wherein each loc sig gotten here is identified by "error\_rec.loc\_sig\_id";

*/\* get loc\_sigs from the Location DB that have been recently added or updated \*/*

recent\_loc\_sigs <--- get\_recent\_loc\_sigs(loc\_sig\_bag, recent\_time); /\* Note, the function, "get\_recent\_loc\_sigs" can have various embodiments, including determining the recent location signatures by comparing their time stamps (or other time related measurements) with one or more threshold values for classifying location signatures into a "recent" category returned here and an a category for "old" or updatable location signatures. Note that these categories can be determined by a (tunable) system time threshold parameter(s) for determining a value for the variable, "recent\_time", and/or, by data driving this categorization by, e.g., classifying the location signatures according to a standard deviation, such as defining the "recent" category as those location signatures more recent than a second standard deviation of the timestamps of the location signatures in "loc\_sig\_bag". \*/

*/\* subtract the recent loc\_sigs from the loc\_sigs with big errors to get the bad ones \*/*

bad\_DB\_loc\_sigs <--- (big\_error\_DB\_loc\_sigs) - (recent\_loc\_sigs);

*/\* lower the confidence of the bad loc\_sigs \*/*

for each loc\_sig[i] in bad\_DB\_loc\_sigs do

loc\_sig[i].confidence <--- (loc\_sig[i].confidence) \* (confidence\_reduction\_factor);

00770030 012504  
F08270 0000400

```
/* for each bad loc sig, update it in the DB or remove it from use if its confidence
is too low */

/* Now delete any loc sigs from the DB whose confidences have become too low. */
for each loc_sig[i] in bad_DB_loc_sigs do
5   if (loc_sig[i].confidence < min_loc_sig_confidence) then
      {
          REMOVE_FROM_USE(loc_sig[i]);
          /* update composite location objects to reflect a removal of a referenced loc
sig */
10   verified_loc_entity <--- retrieve_composite_location_entity_having(loc_sig[i]);
          /* This gets all other (if any) loc sigs for the composite location object that were verified at the same time as
"loc_sig[i]". Note, these other loc sigs may not need to be deleted (i.e., their signal characteristics may have a
high confidence); however, it must be noted in the DB, that for the DB composite location entity having
"loc_sig[i]", this entity is no longer complete. Thus, this entity may not be useful as, e.g., neural net training
15   data. */
          mark "verified_loc_entity" as incomplete but keep track that a loc sig did exist for the BS associated with "loc_sig[i]";
          if ("verified_loc_entity" now references no loc sigs) then REMOVE_FROM_USE(verified_loc_entity);
      }
      else DB_update_entry(loc_sig[i]); // with its new confidence
20 } ENDOF reduce_bad_DB_loc_sigs

increase_confidence_of_good_DB_loc_sigs(nearby_loc_sig_bag, error_rec_set,
small_error_threshold, confidence_increase_factor, recent_time);

/* This program increases the confidence of verified DB loc sigs that are (seemingly) of higher accuracy (i.e., in agreement with
25 comparable loc sigs in the DB). Note that the steps herein are also provided in flowchart form in Figs. 19a through 19b.

Inputs:
loc_sig_bag: The loc sigs to be tested for determining if their confidences should be increased.
error_rec_set: The set of "error_recs" providing information as to how much each loc sig in "loc_sig_bag"
disagrees with comparable loc sigs in the DB. That is, there is an "error_rec" here for each loc sig in
30 "loc_sig_bag".
small_error_threshold: The error threshold below which the errors are considered too small to ignore.
confidence_increase_factor: The factor by which to increase the confidence of loc sigs.
```





determines how well the loc sigs in "target\_loc\_sig\_bag" fit with a computed or estimated loc sig for the location, "target\_loc" that is derived from the verified loc sigs in the location signature data base. Thus, this program may be used: (a2) for determining how well the loc sigs in the location signature cluster for a target MS ("target\_loc\_sig\_bag") compares with loc sigs derived from verified location signatures in the location signature data base, and (b2) for determining how consistent a given collection of loc sigs ("target\_loc\_sig\_bag") from the location signature data base is with other loc sigs in the location signature data base. Note that in (b2) each of the one or more loc sigs in "target\_loc\_sig\_bag" have an error computed here that can be used in determining if the loc sig is becoming inapplicable for predicting target MS locations Note that the steps herein are also provided in flowchart form in Figs. 20a through 20d.\* /

Determine\_Location\_Signature\_Fit\_Errors(target\_loc, target\_loc\_sig\_bag,  
search\_area, search\_criteria, output\_criteria)

/\* Input: target\_loc: An MS location or a location hypothesis for a particular MS. Note, this can be any of the following:

- (a) An *MS location hypothesis*, in which case, the loc sigs in "target\_loc\_sig\_bag" are included in a location signature cluster from which this location hypothesis was derived. Note that if this location is inaccurate, then "target\_loc\_sig\_bag" is unlikely to be similar to the comparable loc sigs derived from the loc sigs of the location signature data base close "target\_loc"; or
- (b) A *previously verified MS location*, in which case, the loc sigs of "target\_loc\_sig\_bag" are previously verified loc sigs. However, these loc sigs may or may not be accurate now.

target\_loc\_sig\_bag: Measured location signatures ("loc sigs" for short) obtained from the particular MS (the data structure here, bag, is an aggregation such as array or list). The location signatures here may be verified or unverified. However, *it is assumed that there is at least one loc sig in the bag. Further, it is assumed that there is at most one loc sig per Base Station. It is also assumed that the present parameter includes a "type" field indicating whether the loc sigs here have been individually selected, or, whether this parameter references an entire (verified) loc sig cluster; i.e., the type field may have a value of: "UNVERIFIED LOC SIG CLUSTER" or "VERIFIED LOC SIG CLUSTER";*

search\_area: The representation of the geographic area surrounding "target\_loc". This parameter is used for searching the Location Signature data base for verified loc sigs that correspond geographically to the location of an MS in "search\_area";

**search\_criteria:** The criteria used in searching the location signature data base. The criteria may include the following:

- (a) "USE ALL LOC SIGS IN DB",
- (b) "USE ONLY REPEATABLE LOC SIGS",
- (c) "USE ONLY LOC SIGS WITH SIMILAR TIME OF DAY".

However, environmental characteristics such as: weather, traffic, season are also contemplated.

**output\_criteria:** The criteria used in determining the error records to output in "error\_rec". The criteria here may include one of:

- (a) "OUTPUT ALL POSSIBLE ERROR\_RECS";
- (b) "OUTPUT ERROR\_RECS FOR INPUT LOC SIGS ONLY".

Returns: **error\_rec:** A bag of error records or objects providing an indication of the similarity between each loc sig in "target\_loc\_sig\_bag" and an estimated loc sig computed for "target\_loc" from stored loc sigs in a surrounding area of "target\_loc". Thus, each error record/object in "error\_rec" provides a measurement of how well a loc sig (i.e., wireless signal characteristics) in "target\_loc\_sig\_bag" (for an associated BS and the MS at "target\_loc") correlates with an estimated loc sig between this BS and MS. Note that the estimated loc sigs are determined using verified location signatures in the Location Signature DB. Note, each error record in "error\_rec" includes: (a) a BS ID indicating the base station to which the error record corresponds; and (b) an error measurement ( $> = 0$ ), and (c) a confidence value (in  $[0, 1]$ ) indicating the confidence to be placed in the error measurement. Also note that since "error\_rec" is an aggregate data type (which for many aggregate identifiers in this specification are denoted by the suffix "\_bag" on the identifier), it can be any one of a number data types even though it's members are accessed hereinbelow using array notation. \*/

```
/* get BS's associated with DB loc sigs in "search_area" that satisfy  
"search_criteria" */
```

```
DB_loc_sig_bag <--- retrieve_verified_loc_sigs(search_area, search_criteria);
```

```
// get all verified appropriate location signatures residing in the Location Signature data base.
```

```
// Note, some loc sigs may be blocked from being retrieved.
```

```
DB_BS_bag <--- get_BS(DB_loc_sig_bag); // get all base stations associated with at least one location
```

```
// signature in DB_loc_sig_bag. Note, some of these BSs may be low power "location
```

```
// BSs".
```

```
/* get BS's associated with loc sigs in "target_loc_sig_bag" */
```

```
target_BS_bag <--- get_BS(target_loc_sig_bag); // get all base stations associated with at least one
```

```
// location signature in "target_loc_sig_bag".
```

```
/* determine the BS's for which error records are to be computed */
```

case of "output\_criteria" including:

"OUTPUT ALL POSSIBLE ERROR\_RECS": /\* In this case, it is desired to determine a collection of error records wherein there is an error record for each BS that is associated with a loc sig in "target\_loc\_sig\_bag" and for each BS associated with a loc in the "search\_area" satisfying "search\_criteria". \*/

5 BS\_bag <--- (DB\_BS\_bag) union (target\_BS\_bag);

"OUTPUT ERROR\_RECS FOR INPUT LOC SIGS ONLY":

BS\_bag <--- target\_BS\_bag;

endcase;"

10 /\* for each BS to have an error record computed, make sure there are two loc sigs to compare: one loc sig derived from the "BS\_bag" loc sig data, and one from derived from the loc sigs in the Location Signature DB, wherein both loc sigs are associated with the location, "target\_loc". \*/

for each BS[i] in "BS\_bag" do

15 { /\* determine two (estimated) loc sigs at "target\_loc", one derived from "target\_loc\_sig\_bag" (if possible) and one derived from Location Signature DB loc sigs (if possible) \*/

comparison\_loc\_sig\_bag[i] <--- retrieve\_verified\_loc\_sigs\_for(BS[i], search\_area, search\_criteria);

20 /\* get all loc sigs for which BS[i] is associated and wherein the verified MS location is in "search\_area" (which surrounds the location "target\_loc") and wherein the loc sigs satisfy "search\_criteria". \*/

/\* now determine if there are enough loc sigs in the "comparison\_loc\_sig\_bag" to make it worthwhile to try to do a comparison. \*/

if ((SIZEOF(comparison\_loc\_sig\_bag[i])/(SIZEOF(search\_area))) < min\_threshold\_ratio(area\_type(search\_area))) then

25 /\* it is believed that there is not a dense enough number of verified loc sigs to compute a composite loc sig associated with a hypothetical MS at "target\_loc". \*/

error\_rec[i].error <--- invalid;

30 else /\* there are enough loc sigs in "comparison\_loc\_sig\_bag" to continue, and in particular, an estimated loc sig can be derived from the loc sigs in "comparison\_loc\_sig\_bag"; however, first see if a target loc sig can be determined; if so, then make the estimated loc sig (denoted "estimated\_loc\_sig[i]"). \*/

09770939-013601

```

{
  if (BS[i] is in target_BS_bag) then
    /* get a loc sig in "target_BS_bag" for BS[i]; assume at most one loc sig per BS in
       "target_loc_sig_bag" */
    target_loc_sig[i] <--- get_loc_sig(BS[i], target_loc_sig_bag);
  else /* BS[i] is not in "target_BS_bag", accordingly this implies that we are in the
       process of attempting to output all possible error records for all BS's: (a)
       that have previously been detected in the area of "search_area" (satisfying "search_criteria"), union,
       (b) that are associated with a loc sig in "target_loc_sig_bag". Note, the path here is performed when
       the MS at the location for "target_loc" did not detect the BS[i], but BS[i] has previously been detected
       in this area. */
    if (target_loc_sig_bag.type == "UNVERIFIED LOC SIG CLUSTER") then
      /* can at least determine if the MS for the cluster detected the BS[i]; i.e., whether BS[i]
         was in the set of BS's detected by the MS even though no loc sig was obtained for BS[i]. */
      if (BS_only_detected(target_loc_sig_bag, BS[i])) then /* detected but no loc sig */
        error_rec[i].error <--- invalid; /* can't determine an error if this is all the information
           we have */
      else /* BS[i] was not detected by the MS at "target_loc.location", so the pilot channel for BS[i] was
         in the noise; make an artificial loc sig at the noise ceiling (alternatively, e.g., a mean noise
         value) for the MS location at "target_loc" */
        target_loc_sig[i] <--- get_noise_ceiling_loc_sig(target_loc);
      else /* do nothing; there are no other types for "target_loc_sig_bag.type" that are currently used when
         outputting all possible error records for BS's */
        if (error_rec[i].error NOT invalid) then
          /* we have a "target_loc_sig" for comparing, so get the derived loc sig estimate obtained from the
             verified loc sigs in the location signature data base. */
          estimated_loc_sig[i] <--- estimate_loc_sig_from_DB(target_loc.location,
              comparison_loc_sig_bag[i]);
          /* The above call function provides an estimated loc sig for the location of "target_loc" and BS[i]
             using the verified loc sigs of "comparison_loc_sig_bag[i]" */
        }
      }
}

```

*/\* for each BS whose error record has not been marked "invalid", both "target\_loc\_sig" and "estimated\_loc\_sig" are now well-defined; so compute an*

*error record related to the difference between "target\_loc\_sig" and "estimated\_loc\_sig". \*/*

for each BS[i] in "BS\_bag" with error\_rec[i].error not invalid do /\* determine the error records for these base stations \*/

{

5     /\* Note, the "target\_loc\_sig" here is for an MS at or near the location for the center of area for "target\_loc". \*/  
   error\_rec[i] <--- get\_difference\_measurement(target\_loc\_sig[i], estimated\_loc\_sig[i],  
  comparison\_loc\_sig\_bag[i], search\_area, search\_criteria); /\* get a measurement of the difference  
  between these two loc sigs. \*/  
   error\_rec.loc\_sig\_id <--- target\_loc\_sig[i].id; /\* this is the loc sig with which this error\_rec is associated \*/  
10    error\_rec.comparison\_loc\_sig\_id\_bag <--- comparison\_loc\_sig\_bag[i];

}

RETURN(error\_rec);

ENDOF Determine\_Location\_Signature\_Fit\_Errors

15 estimate\_loc\_sig\_from\_DB(loc\_for\_estimation, loc\_sig\_bag)

/\* This function uses the verified loc sigs in "loc\_sig\_bag" to determine a single estimated (or "typical") loc sig derived from the loc sigs in the bag. Note, it is assumed that all loc sigs in the "loc\_sig\_bag" are associated with the same BS 122 (denoted the BS associated with the "loc\_sig\_bag") and that the locations associated with these loc sigs are near "loc\_for\_estimation". Further, note *that since the loc sigs are verified, the associated base station was the primary base station when the loc sig signal measurements were sampled.* Thus, the measurements are as precise as the infrastructure allows. Note that the steps herein are also provided in flowchart form in Fig. 21.

Input: loc\_for\_estimation A representation of a service area location.

loc\_sig\_bag A collection of verified loc sigs, each associated with the same base station and each associated with a service area location presumably relatively near to the location represented by "loc\_for\_estimation". \*/

25

est\_loc\_sig <--- extrapolate/interpolate a location signature for the location at "loc\_for\_estimation" based on loc sigs in "loc\_sig\_bag";

/\* Note, "est\_loc\_sig" includes a location signature and a confidence measure.

30

The confidence measure (in the range: [0, 1]) is based on: (a) the number of verified loc sigs in the search area; (b) how well they surround the center location of the new\_loc, and (c) the confidence factors of the loc sigs in "loc\_sig\_bag" (e.g., use average confidence value).

Note, for the extrapolation/interpolation computation here, there are many such extrapolation/interpolation methods available as one skilled in the art will appreciate. For example, in one embodiment of an extrapolation/interpolation method, the following steps are contemplated:

(39.1) Apply any pre-processing constraints that may alter any subsequently computed "est\_loc\_sig" values derived below). For example, if the BS associated with "loc\_sig\_bag" is currently inactive "location BS" (i.e., "active" meaning the BS is on-line to process location information with an MS, "inactive" meaning the not on-line), then, regardless of any values that may be determined hereinbelow, a value or flag is set (for the signal topography characteristics) indicating "no signal" with a confidence value of 1 is provided. Further, additional pre-processing may be performed when the BS associated with "loc\_sig\_bag" is a location BS (LBS) since the constraint that a pilot channel from such an LBS is likely to be only detectable within a relatively small distance from the BS (e.g., 1000 ft). For example, if the MS location, "loc\_for\_estimation", does not intersect the radius (or area contour) of such a location BS, then, again, a value or flag is set (for the signal topography characteristics) indicating "outside of LBS area" with a confidence value of 1 is provided. Alternatively, if (a) a determined area, A, including the MS location, "loc\_for\_estimation" (which may itself be, and likely is, an area), intersects (b) the signal detectable area about the location BS, then (c) the confidence factor value may be dependent on the ratio of the area of the intersection to the minimum of the size of the area in which the LBS is detectable and the size of the area of "loc\_for\_estimation", as one skilled in the art will appreciate.

Further, it is noteworthy that such pre-processing constraints as performed in this step may be provided by a constraint processing expert system, wherein system parameters used by such an expert system are tuned using the adaptation engine 1382.

(39.2) Assuming a value of "no signal" or "outside of LBS area" was not set above (since otherwise no further steps are performed here), for each of the coordinates (records), C, of the signal topography characteristics in the loc sig data structure, generate a smooth surface, S(C), of minimal contour variation for the set of points { (x,y,z) such that (x,y) is a representation of a service area location, and z is a value of C at the location (x,y) for some loc sig in "loc\_sig\_bag" wherein (x,y) is a point estimate (likely centroid) of the loc sig}. Note that a least squares technique, a partial least squares technique, or averaging on "nearby" (x,y,z) points may be used with points from the above set to generate other points on the surface S(C). Additionally, note that for at least some surfaces characterizing signal energy, the generation process for such a surface may use the radio signal attenuation formulas for urban, suburban, and rural developed by M. Hata in IEEE Trans, VT-29, pgs. 317-325, Aug. 1980, "Empirical Formula For Propagation Loss In Land Mobile Radio" (herein incorporated by reference). For example, Hata's formulas may be used in:

(39.2.1) Determining portions of the surfaces S(C) where there is a low density of verified loc sigs in "loc\_sig\_bag". In particular, if there is a very low density of verified loc sigs in "loc\_sig\_bag" for the service area surrounding the location of "loc\_for\_estimation", then by determining the area

00770039-0100

5

type(s) (e.g., transmission area type as described hereinabove, assuming a correspondence between the transmission area types and the more coarse grained categorization of : urban, suburban, and rural) between this location and the base station associated with "loc\_sig\_bag", and applying Hata's corresponding formula(s), a signal value z may be estimated according to these type(s) and their corresponding area extents between the MS and the BS. Note, however, that this option is considered less optimal to using the verified loc sigs of "loc\_sig\_bag" for determining the values of a surface S(C). Accordingly, a lower confidence value may be assigned the resulting composite loc sig (i.e., "est\_loc\_sig") determined in this manner; and relatedly,

10

(39.2.2) Determining a surface coordinate  $(x_0, y_0, z_0)$  of S(C) when there are nearby verified loc sigs in "loc\_sig\_bag". For example, by using Hata's formulas, an estimated surface value  $z_i$  at the location  $(x_0, y_0)$  may be derived from estimating a value  $z_i$  at  $(x_i, y_i)$  by adapting Hata's formula's to extrapolate/interpolate the value  $z_i$  from a nearby location  $(x_i, y_i)$  having a verified loc sig in "loc\_sig\_bag". Thus, one or more estimates  $z_i$  may be obtained used in deriving  $z_0$  as one skilled in statistics will appreciate. Note, this technique may be used when there is a moderately low density of verified loc sigs in "loc\_sig\_bag" for the service area surrounding the location of "loc\_for\_estimation". However, since such techniques may be also considered less than optimal to using a higher density of verified loc sigs of "loc\_sig\_bag" for determining the values of a surface S(C) via a least squares or partial least square technique, a lower confidence value may be assigned the resulting composite loc sig (i.e., "est\_loc\_sig") determined in this manner.

15

20

Further, recall that the values, z, for each loc sig are obtained from a composite of a plurality of signal measurements with an MS, and, that each value z is the most distinct value that stands out above the noise in measurements for this coordinate, C. So, for example in the CDMA case, for each of the coordinates C representing a finger of signal energy from or to some MS at a verified location, it is believed that S(C) will be a smooth surface without undulations that are not intrinsic to the service area near "loc\_for\_estimation".

25

(39.3) For each of the coordinates, C, of the signal topography characteristics, extrapolate/interpolate a C-coordinate value on S(C) for an estimated point location of "loc\_for\_estimation".

30

Further note that to provide more accurate estimates, it is contemplated that Hata's three geographic categories and corresponding formulas may be used in a fuzzy logic framework with adaptive mechanisms such as the adaptation engine 1382 (for adaptively determining the fuzzy logic classifications).

Additionally, it is also within the scope of the present invention to use the techniques of L. E. Vogler as presented in "The Attenuation of Electromagnetic Waves by Multiple Knife Edge Diffraction", US Dept of Commerce, NTIA nos, 81-86 (herein incorporated by reference) in the present context for estimating a loc sig between the base station associated with "loc\_sig\_bag" and the location of "loc\_for\_estimation". \*/

RETURN(est\_loc\_sig)

ENDOF estimate\_loc\_sig\_from\_DB

### get\_area\_to\_search(loc)

5 /\* This function determines and returns a representation of a geographic area about a location, "loc", wherein: (a) the geographic area has associated MS locations for an acceptable number (i.e., at least a determined minimal number) of verified loc sigs from the location signature data base, and (b) the geographical area is not too big. However, if there are not enough loc sigs in even a largest acceptable search area about "loc", then this largest search area is returned. Note that the steps herein are also provided in flowchart form in Figs. 22a through 22b. \*/

```
{
10   loc_area_type <--- get_area_type(loc); /*get the area type surrounding "loc"; note this may be
       a vector of fuzzy values associated with a central location of "loc", or, associated with an area having "loc".
       */

   search_area <--- get_default_area_about(loc); /* this is the largest area that will be used */
   saved_search_area <--- search_area; // may need it after "search_area" has been changed
15   search_area_types <--- get_area_types(search_area); // e.g., urban, rural, suburban, mountain, etc.
   loop until RETURN performed:
   {
       min_acceptable_nbr_loc_sigs <--- 0; // initialization
       for each area_type in "search_area_types" do
20       {
           area_percent <--- get_percent_of_area_of(area_type, search_area);
           /* get percentage of area having "area_type" */
           min_acceptable_nbr_loc_sigs <--- min_acceptable_nbr_loc_sigs +
25           [(get_min_acceptable_verified_loc_sig_density_for(area_type)) *
           (SIZEOF(search_area) * area_percentt / 100)];
       }

       /* Now get all verified loc sigs from the location signature data base whose associated MS location is in
       "search_area". */
       total_nbr_loc_sigs <--- get_all_verified_DB_loc_sigs(search_area);
30   if (min_acceptable_nbr_loc_sigs > total_nbr_loc_sigs)
       then /* not enough loc sigs in "search_area"; so return "saved_search_area" */
           RETURN(saved_search_area);
       else /* there is at least enough loc sigs, so see if "search_area" can be decreased */
       { saved_search_area <--- search_area;
```

156



0070099.01E01  
FOUO:660260

search\_area <--- decrease\_search\_area\_about(loc, search\_area,

```
}
}
}
5 ENDOF get_area_to_search
```

10 /\* For processing various types of loc sigs, particular signal processing filters may be required. Accordingly, in one embodiment of the present invention, a "filter\_bag" object class is provided wherein various filters may be methods of this object (in object-oriented terminology) for transforming loc sig signal data so that it is comparable with other loc sig signal data from, for example, an MS of a different classification (e.g., different power classification). It is assumed here that such a "filter\_bag" object includes (or references) one or more filter objects that correspond to an input filter (from the Signal Filtering Subsystem 1220) so that, given a location signature data object as input to the filter\_bag object,, each such filter object can output loc sig filtered data corresponding to the filter object's filter. Note, such a filter\_bag object may accept raw loc sig data and invoke a corresponding filter on the data. Further, a filter\_bag object may reference filter objects having a wide range of filtering capabilities. For example, adjustments to loc sig data according to signal strength may be desired for a particular loc sig comparison operator so that the operator can properly compare MS's of different power classes against one another. Thus, a filter may be provided that utilizes, for each BS, a corresponding signal strength change topography map (automatically generated and updated from the verified loc sigs in the location signature data base 1320) yielding signal strength changes detected by the BS for verified MS location's at various distances from the BS, in the radio coverage area. Additionally, there may also be filters on raw signal loc sig data such as quality characteristics so that loc sigs having different signal quality characteristics may be compared. \*/

```
get_difference_measurement(target_loc_sig, estimated_loc_sig,
                           comparison_loc_sig_bag, search_area, search_criteria)
```

25 /\* Compare two location signatures between a BS and a particular MS location (either a verified or hypothesized location) for determining a measure of their difference relative to the variability of the verified location signatures in the "comparison\_loc\_sig\_bag" from the location signature data base 1320. Note, it is assumed that "target\_loc\_sig", "estimated\_loc\_sig" and the loc sigs in "comparison\_loc\_sig\_bag" are all associated with the same BS 122. Moreover, it is assumed that "target\_loc\_sig" and "estimated\_loc\_sig" are well-defined non-NIL loc sigs, and additionally, that "comparison\_loc\_sig\_bag" is non-NIL. This function returns an error record, "error\_rec", having an error or difference value and a confidence value for the error value. Note, the signal characteristics of "target\_loc\_sig" and those of "estimated\_loc\_sig" are not assumed to be normalized as described in section (26.1) prior to entering this function so that variations in signal characteristics resulting from variations in (for example) MS signal processing and generating characteristics of different types of MS's may be reduced, as described in the discussion of the loc sig data type hereinabove. It is further assumed

that typically the input loc sigs satisfy the "search\_criteria". Note that the steps herein are also provided in flowchart form in Figs. 23a through 23c.

**target\_loc\_sig:** The loc sig to which the "error\_rec" determined here is to be associated. Note that this loc sig is associated with a location denoted hereinbelow as the "particular location".

**estimated\_loc\_sig:** The loc sig to compare with the "target\_loc\_sig", this loc sig: (a) being for the same MS location as "target\_loc\_sig", and (b) derived from verified loc sigs in the location signature data base whenever possible. However, note that if this loc sig is not derived from the signal characteristics of loc sigs in the location signature data base, then this parameter provides a loc sig that corresponds to a noise level at the particular MS location.

**comparison\_loc\_sig\_bag:** The universe of loc sigs to use in determining an error measurement between "target\_loc\_sig" and "estimated\_loc\_sig". Note, the loc sigs in this aggregation include all loc sigs for the associated Base Station I22 that are in the "search\_area" (which surrounds the particular MS location for "target\_loc\_sig") and satisfy the constraints of "search\_criteria". It is assumed that there are sufficient loc sigs in this aggregation to perform at least a minimally effective variability measurement in the loc sigs here.

**search\_area:** A representation of the geographical area surrounding the particular MS location for all input loc sigs. This input is used for determining extra information about the search area in problematic circumstances.

**search\_criteria:** The criteria used in searching the location signature data base I320. The criteria may include the following:

- (a) "USE ALL LOC SIGS IN DB",
- (b) "USE ONLY REPEATABLE LOC SIGS",
- (c) "USE ONLY LOC SIGS WITH SIMILAR TIME OF DAY

However, environmental characteristics such as: weather, traffic, season are also contemplated. \*/

```
error <--- 0; // initialization
```

```
/* get identifiers for the filters to be used on the input loc sigs */
```

```
filter_bag <--- get_filter_objects_for_difference_measurement(target_loc_sig, estimated_loc_sig, comparison_loc_sig_bag);
```

```
/* It is assumed here that each entry in "filter_bag" identifies an input filter to be used in the context of determining a difference measurement between loc sigs. Note, if all loc sigs to be used here are of the same type, then it may be that there is no need for filtering here. Accordingly, "filter_bag" can be empty. Alternatively, there may be one or more filter objects in "filter_bag". */
```

```
/* initializations */
```

00770839.012E01  
FOIb70839.012E01

```
/* for each filter, determine a difference measurement and confidence */
for each filter_obj indicated in filter_bag do
{
5   /* filter "target_loc_sig", "estimated_loc_sig" and loc sigs in "comparison_loc_sig_bag";
   note, each filter_obj can determine when it needs to be applied since each loc sig includes:
   (a) a description of the type (e.g., make and model) of the loc sig's associated MS, and (b) a
   filter flag(s) indicating filter(s) that have been applied to the loc sig. */
   target_loc_sig <--- filter_obj(target_loc_sig); /* filter at least the signal topography characteristics */
10  estimated_loc_sig <--- filter_obj(estimated_loc_sig); /* filter at least the signal topography characteristics */
   comparison_loc_sig_bag <--- filter_obj(comparison_loc_sig_bag); /* filter loc sigs here too */
}

/* determine a difference measurement and confidence for each signal topography
15 characteristic coordinate */
for each signal topography characteristic coordinate, C, of the loc sig data type do
{
   variability_measmt.val <--- get_variability_range(C, comparison_loc_sig_bag);
   /* This function provides a range of the variability of the C-coordinate. In one embodiment this measurement is a
20   range corresponding to a standard deviation. However, other variability measurement definitions are contemplated
   such as second, third or fourth standard deviations. */

   /* make sure there are enough variability measurements to determine the
   variability of values for this coordinate. */

   if (sizeof(comparison_loc_sig_bag) < expected_BS_loc_sig_threshold(search_area, search_criteria))
25     then /* use the data here, but reduce the confidence in the variability measurement. Note that it is expected
        that this branch is performed only when "comparison_loc_sig_bag" is minimally big enough to use (since this
        is an assumption for performing this function), but not of sufficient size to have full confidence in the values
        obtained. Note, a tunable system parameter may also be incorporated as a coefficient in the computation in the
        statement immediately below. In particular, such a tunable system parameter may be based on "search_area"
30     or more particularly, area types intersecting "search_area". */
        {
           variability_measmt_conf_reduction_factor <--- sizeof(comparison_loc_sig_bag)/
               expected_BS_loc_sig_threshold(search_area, search_criteria);

```

00770939-013601  
FOUO

```
    }  
else /* There is a sufficient number of loc sigs in "comparison_loc_sig_bag" so continue */  
{  
    variability_measmt_conf_reduction_factor <--- 1.0; //i.e., don't reduce confidence  
5    }  
  
    /* Now determine the C-coord difference measurement between the  
    "target_loc_sig" and the "estimated_loc_sig" */  
    delta <--- ABS(target_loc_sig[C] - estimated_loc_sig[C]); // get absolute value of the difference  
    if (delta > variability_measmt.val) then  
10    {  
        error <--- error + (delta/variability_measmt.val);  
    }  
} /* end C-coord processing */  
  
    /* construct the error record and return it */  
15    error_rec.error <--- error;  
  
    /* Get an average confidence value for the loc sigs in "comparison_loc_sig_bag" Note, we use  
    this as the confidence of each loc sig coordinate below. */  
    average_confidence <--- AVERAGE(loc_sig.confidence for loc_sig in "comparison_loc_sig_bag");  
    error_rec.confidence <--- MIN(target_loc_sig.confidence, estimated_loc_sig.confidence, (average_confidence *  
20        variability_measmt_conf_reduction_factor)); // presently not used  
    RETURN(error_rec);  
  
ENDOF get_difference_measurement
```

## APPENDIX D: Context Adjuster Embodiments

### *A description of the high level functions in a first embodiment of the Context Adjuster*

`context_adjuster(loc_hyp_list)`

5 /\* This function adjusts the location hypotheses on the list, "loc\_hyp\_list", so that the confidences of the location hypotheses are determined more by empirical data than default values from the First Order Models 1224. That is, for each input location hypothesis, its confidence (and an MS location area estimate) may be exclusively determined here if there are enough verified location signatures available within and/or surrounding the location hypothesis estimate.

This function creates a new list of location hypotheses from the input list, "loc\_hyp\_list", wherein the location hypotheses on  
10 the new list are modified versions of those on the input list. For each location hypothesis on the input list, one or more corresponding location hypotheses will be on the output list. Such corresponding output location hypotheses will differ from their associated input location hypothesis by one or more of the following: (a) the "image\_area" field (see Fig. 9) may be assigned an area indicative of where the target MS is estimated to be, (b) if "image\_area" is assigned, then the "confidence" field will be the confidence that the target MS is located in the area for "image\_area", (c) if there are not sufficient "nearby" verified location signature clusters in the  
15 location signature data base to entirely rely on a computed confidence using such verified location signature clusters, then two location hypotheses (having reduced confidences) will be returned, one having a reduced computed confidence (for "image\_area") using the verified clusters in the Location Signature DB, and one being substantially the same as the associated input location hypothesis except that the confidence (for the field "area\_est") is reduced to reflect the confidence in its paired location hypothesis having a computed confidence for "image\_area". Note also, in some cases, the location hypotheses on the input list, may have no  
20 change to its confidence or the area to which the confidence applies. Note that the steps herein are also provided in flowchart form in Figs. 25a and 25b.

\*/

{

`new_loc_hyp_list <--- create_new_empty_list();`

25 for each loc\_hyp[i] in loc\_hyp\_list do /\* Note, "i" is a First Order Model 1224 indicator, indicating the model that output "hyp\_loc[i]" \*/

{

`remove_from_list(loc_hyp[i], loc_hyp_list);`

30 if (NOT loc\_hyp[i].adjust) then /\* no adjustments will be made to the "area\_est" or the "confidence" fields since the "adjust" field indicates that there is assurance that these other fields are correct; note that such designations indicating that no adjustment are presently contemplated are only for the location hypotheses generated by the Home Base Station First Order Model, the Location Base Station First Order Model and the Mobil Base

CONFIDENTIAL

```

5
{
  loc_hyp[i].image_area <--- NULL; // no adjustment, then no "image_area"
  add_to_list(new_loc_hyp_list, loc_hyp[i]); // add "loc_hyp[i]" to the new list
}
10
else /* the location hypothesis can (and will) be modified; in particular, an "image_area" may be assigned, the
   "confidence" changed to reflect a confidence in the target MS being in the "image_area". Additionally, in some
   cases, more than one location hypothesis may be generated from "loc_hyp[i]". See the comments on FIG. 9 and
   the comments for "get_adjusted_loc_hyp_list_for" for a description of the terms here. */
{
15
  temp_list <--- get_adjusted_loc_hyp_list_for(loc_hyp[i]);
  new_loc_hyp_list <--- combine_lists(new_loc_hyp_list, temp_list);
}
  RETURN(new_loc_hyp_list);
}ENDOF
20

```

**get\_adjusted\_loc\_hyp\_list\_for(loc\_hyp)**  
 /\* This function returns a list (or more generally, an aggregation object) of one or more location hypotheses related to the input location hypothesis, "loc\_hyp". In particular, the returned location hypotheses on the list are "adjusted" versions of "loc\_hyp" in that both their target MS location estimates, and confidence placed in such estimates may be adjusted according to archival MS location information in the location signature data base 1320. Note that the steps herein are also provided in flowchart form in Figs. 26a through 26c.

**RETURNS:**    **loc\_hyp\_list**    This is a list of one or more location hypotheses related to the input "loc\_hyp". Each location hypothesis on "loc\_hyp\_list" will typically be substantially the same as the input "loc\_hyp" except that there may now be a new target MS estimate in the field, "image\_area", and/or the confidence value may be changed to reflect information of verified location signature clusters in the location signature data base.

**Introductory Information Related to the Function, "get\_adjusted\_loc\_hyp\_list\_for"**

This function and functions called by this function presuppose a framework or paradigm that requires some discussion as well as the defining of some terms. Note that some of the terms defined hereinbelow are illustrated in Fig. 24.

Define the term the “the cluster set” to be the set of all MS location point estimates (e.g., the values of the “pt\_est” field of the location hypothesis data type), for the present FOM, such that these estimates are within a predetermined corresponding area (e.g., “loc\_hyp.pt\_covering” being this predetermined corresponding area) and these point estimates have verified location signature clusters in the location signature data base.

Note that the predetermined corresponding area above will be denoted as the “cluster set area”.

Define the term “image cluster set” (for a given First Order Model identified by “loc\_hyp.FOM\_ID”) to mean the set of verified location signature clusters whose MS location point estimates are in “the cluster set”.

Note that an area containing the “image cluster set” will be denoted as the “image cluster set area” or simply the “image area” in some contexts. Further note that the “image cluster set area” will be a “small” area encompassing the “image cluster set”. In one embodiment, the image cluster set area will be the smallest covering of cells from the mesh for the present FOM that covers the convex hull of the image cluster set. Note that preferably, each cell of each mesh for each FOM is substantially contained within a single (transmission) area type.

Thus, the present FOM provides the correspondences or mapping between elements of the cluster set and elements of the image cluster set. \*/

```
{
  add_to_list(loc_hyp_list, loc_hyp); /* note the fields of “loc_hyp” may be changed below, but add “loc_hyp” to the list,
                                     “loc_hyp_list here */
  mesh <--- get_cell_mesh_for_model(loc_hyp.FOM_ID); /* get the mesh of geographic cells for the First Order Model for this
                                                       location hypothesis.*/
  pt_min_area <--- get_min_area_surrounding_pt(loc_hyp, mesh); /* Get a minimal area about the MS location point,
                                                                “pt_est” of “loc_hyp[i]” indicating a point location of the target MS. Note that either the “pt_est” field must be
                                                                valid or the “area_est” field of “loc_hyp[i]” must be valid. If only the latter field is valid, then the centroid of the
                                                                “area_est” field is determined and assigned to the “pt_est” field in the function called here. Note that the mesh of
                                                                the model may be useful in determining an appropriately sized area. In particular, in one embodiment, if
                                                                “loc_hyp.pt_est” is interior to a cell, C, of the mesh, then “pt_min_area” may correspond to C. Further note that
                                                                in at least one embodiment, “pt_min_area” may be dependent on the area type within which “loc_hyp.pt_est”
                                                                resides, since sparsely populated flat areas may be provided with larger values for this identifier. Further, this
                                                                function may provide values according to an algorithm allowing periodic tuning or adjusting of the values output,
                                                                via, e.g., a Monte Carlo simulation (more generally, a statistical simulation), a regression or a Genetic Algorithm.
                                                                For the present discussion, assume: (i) a cell mesh per FOM 1224; (ii) each cell is contained in substantially a
                                                                single (transmission) area type; and (iii) “pt_min_area” represents an area of at least one cell. */
  area <--- pt_min_area; // initialization
```

09770039:012501

```
pt_max_area <--- get_max_area_surrounding_pt(loc_hyp, mesh); /* Get the maximum area about "pt_est" that is
deemed worthwhile for examining the behavior of the "loc_hyp.FOM_ID" First Order Model (FOM) about "pt_est".
Note that in at least one embodiment, this value of this identifier may also be dependent on the area type within
which "loc_hyp.pt_est" resides. Further, this function may provide values according to an algorithm allowing
periodic tuning or adjusting of the values output, via, e.g., a Monte Carlo simulation (more generally, a statistical
simulation or regression) or a Genetic Algorithm. In some embodiments of the present invention, the value
determined here may be a relatively large proportion of the entire radio coverage area region. However, the tuning
process may be used to shrink this value for (for example) various area types as location signature clusters for
verified MS location estimates are accumulated in the location signature data base. */
5
min_clusters <--- get_min_nbr_of_clusters(loc_hyp.FOM_ID, area); /* For the area, "area", get the minimum number
("min_clusters") of archived MS estimates, L, desired in generating a new target MS location estimate and a related
confidence, wherein this minimum number is likely to provide a high probability that this new target MS location
estimate and a related confidence are meaningful enough to use in subsequent Location Center processing for outputting a
target MS location estimate. More precisely, this minimum number, "min_clusters," is an estimate of the archived MS
location estimates, L, required to provide the above mentioned high probability wherein each L satisfies the following
conditions: (a) L is in the area for "area"; (b) L is archived in the location signature data base; (c) L has a corresponding
verified location signature cluster in the location signature data base; and (d) L is generated by the FOM identified by
"loc_hyp.FOM_ID"). In one embodiment, "min_clusters" may be a constant; however, in another it may vary
according to area type and/or area size (of "area"), in some it may also vary according to the FOM indicated by
10
"loc_hyp.FOM_ID". */
15
pt_est_bag <--- get_pt_est_for_image_cluster_set(loc_hyp.FOM_ID, loc_hyp.pt_est, area); /* Get the MS location point
estimates for this FOM wherein for each such estimate: (a) it corresponds to a verified location signature cluster
(that may or may not be near its corresponding estimate), and (b) each such MS estimate is in "pt_min_area". */
/* Now, if necessary, expand an area initially starting with "pt_min_area" until at least
25
"min_clusters" are obtained, or, until the expanded area gets too big. */
while ((sizeof(pt_est_bag) < min_clusters) and (sizeof(area) <= pt_max_area) do
{
    area <--- increase(area);
    min_clusters <--- get_min_nbr_of_clusters(loc_hyp.FOM_ID, area); // update for new "area"
    pt_est_bag <--- get_pt_est_for_image_cluster_set(loc_hyp.FOM_ID, loc_hyp.pt_est, area);
30
}
attach_to(loc_hyp.pt_covering, area); // Make "area" the "pt_covering" field

if (sizeof(pt_est_bag) == 0) then /* there aren't any other FOM MS estimates having corresponding verified location
signature clusters; so designate "loc_hyp" as part of the second set as described above and return. */
```





007700030.013001

(c) In another embodiment, denoted herein as the two tier strategy, both the original FOM MS location estimate and confidence as well as the "image\_area" MS location estimate and a confidence are used. That is, two location hypotheses are provided for the target MS location, one having the FOM MS location estimate and one having the MS location estimate for "image\_area". However, the confidences of each of these location hypotheses may be reduced to reflect the resulting ambiguity of providing two different location hypotheses derived from the same FOM MS estimate. Thus, the computations for determining the confidence of "image\_area" may be performed even though there are less than the minimally required archived FOM estimates nearby to the original FOM target MS estimate. In this embodiment, a weighting(s) may be used to weight the confidence values as, for example, by a function of the size of the "image\_cluster\_set". For example, if an original confidence value from the FOM was 0.76 and "area" contained only two-thirds of the minimally acceptable number, "min\_clusters", then if the computation for a confidence of the corresponding "image\_area" yielded a new confidence of 0.43, then a confidence for the original FOM target MS estimate may be computed as  $[0.76 * (1/3)]$  whereas a confidence for the corresponding "image\_area" may be computed as  $[0.43 * (2/3)]$ . However, it is within the scope of the present invention to use other computations for modifying the confidences used here. For example, tunable system coefficients may also be applied to the above computed confidences. Additionally, note that some embodiments may require at least a minimal number of relevant verified location signature clusters in the location signature data base before a location hypothesis utilizes the "image\_area" as a target MS location estimate.

Although an important aspect of the present invention is that it provides increasingly more accurate MS location estimates as additional verified location signatures are obtained (i.e., added to the location signature data base), it may be the case that for some areas there is substantially no pertinent verified location signature clusters in the location signature data base (e.g., "image\_area" may be undefined). Accordingly, instead of using the original FOM generated location hypotheses in the same manner as the location hypotheses having target MS location estimates corresponding to "image\_areas" in subsequent MS location estimation processing, these two types of location hypotheses may be processed separately. Thus, a strategy is provided, wherein two sets of (one or more) MS location estimates may result:

- (i) one set having the location hypotheses with meaningful "image\_areas" as their target MS location estimates and
- (ii) a second set having the location hypotheses with their confidence values corresponding to the original FOM target MS estimates.

Since the first of these sets is considered, in general, more reliable, the second set may be used as a "tie breaker" for determining which of a number of possible MS location estimates determined using the first set to output by the Location Center. Note, however, if there are no location hypotheses in the first set, then the second set may be used to output a Location Center target MS location estimate. Further note that in determining confidences of this second set, the weighting of confidence values as described above is contemplated.

The steps provided hereinafter reflect a "two tier" strategy as discussed in (c) above.

\*/

TOP SECRET

/\* The following factor is analogous to the 2/3's factor discussed in (c) above. \*/

cluster\_ratio\_factor <--- min{(sizeof(pt\_est\_bag) / min\_clusters), 1.0};

/\* Now use "area" to obtain a new target MS location estimate and confidence based on  
5 archived verified loc sigs, but first determine whether "area" is too big to ignore the original  
target MS location estimate and confidence generated by the FOM . \*/

if (sizeof(area) > pt\_max\_area) then /\* create a loc\_hyp that is essentially a duplicate of the originally input "loc\_hyp"  
except the confidence is lowered by "(1.0 - cluster\_ratio\_factor)". Note that the original "loc\_hyp" will have its  
confidence computed below. \*/

10 { new\_loc\_hyp <--- duplicate(loc\_hyp); // get a copy of the "loc\_hyp"  
new\_loc\_hyp.image\_area <--- NULL; // no image area for this new loc\_hyp  
/\* Now modify the confidence of "loc\_hyp"; note, in the one embodiment, a system (i.e., tunable) parameter may also be  
used as a coefficient in modifying the confidence here. \*/  
new\_loc\_hyp.confidence <--- new\_loc\_hyp.confidence \* (1.0 - cluster\_ratio\_factor);  
15 add\_to\_list(loc\_hyp\_list, new\_loc\_hyp);  
}

/\* Now compute the "image\_area" field and a confidence that the target MS is in  
"image\_area" \*/

20 image\_cluster\_set <--- get\_verified\_loc\_sig\_clusters\_for(pt\_est\_bag); /\* Note, this statement gets the verified location  
signature clusters for which the target MS point location estimates (for the First Order Model identified by  
"loc\_hyp.FOM\_ID") in "pt\_est\_bag" are approximations. Note that the set of MS location point estimates  
represented in "pt\_est\_bag" is defined as a "cluster set" hereinabove. \*/

25 image\_area <--- get\_area\_containing(image\_cluster\_set); /\* Note, in obtaining an area here that contains these verified  
location signature clusters, various embodiments are contemplated. In a first embodiment, a (minimal) convex hull  
containing these clusters may be provided here. In a second embodiment, a minimal covering of cells from the mesh  
for the FOM identified by "loc\_hyp.FOM\_ID" may be used. In a third embodiment, a minimal covering of mesh cells  
may be used to cover the convex hull containing the clusters. It is assumed hereinbelow that the first embodiment is  
used. Note, that this area is also denoted the "image cluster set area" as is described hereinabove. \*/

attach\_to(loc\_hyp.image\_area, image\_area); /\* Make "image\_area" the "image\_area" field of "loc\_hyp". \*/

30 /\* In the following step, determine a confidence value for the target MS being in the area for "image\_area". \*/

confidence <--- confidence\_adjuster(loc\_hyp.FOM\_ID, image\_area, image\_cluster\_set);

/\* In the following step, reduce the value of confidence if and only if the number of MS point location estimates in  
"pt\_est\_bag" is smaller than "min\_clusters" \*/

```

loc_hyp.confidence <--- confidence * cluster_ratio_factor;
RETURN(loc_hyp_list);
}ENDOF get_adjusted_loc_hyp_list_for

```

5

**confidence\_adjuster(FOM\_ID, image\_area, image\_cluster\_set)**

*/\* This function returns a confidence value indicative of the target MS 140 being in the area for "image\_area". Note that the steps herein are also provided in flowchart form in Figs. 27a and 27b.*

**RETURNS:** A confidence value. This is a value indicative of the target MS being located in the area represented by "image\_area" (when it is assumed that for the related "loc\_hyp," the "cluster set area" is the "loc\_hyp.pt\_covering" and "loc\_hyp.FOM\_ID" is "FOM\_ID");

**Introductory Information Related to the Function, "confidence\_adjuster"**

This function (and functions called by this function) presuppose a framework or paradigm that requires some discussion as well as the defining of terms.

15 Define the term "mapped cluster density" to be the number of the verified location signature clusters in an "image cluster set" per unit of area in the "image cluster set area".

It is believed that the higher the "mapped cluster density", the greater the confidence can be had that a target MS actually resides in the "image cluster set area" when an estimate for the target MS (by the present FOM) is in the corresponding "the cluster set".

20 Thus, the mapped cluster density becomes an important factor in determining a confidence value for an estimated area of a target MS such as, for example, the area represented by "image\_area". However, the mapped cluster density value requires modification before it can be utilized in the confidence calculation. In particular, confidence values must be in the range [-1, 1] and a mapped cluster density does not have this constraint. Thus, a "relativized mapped cluster density" for an estimated MS area is desired, wherein this relativized measurement is in the range [-1, +1], and in particular, for positive confidences in the range [0, 1]. Accordingly, to alleviate this difficulty, for the FOM define the term "prediction mapped cluster density" as a mapped cluster density value, MCD, for the FOM and image cluster set area wherein:

(i) MCD is sufficiently high so that it correlates (at least at a predetermined likelihood threshold level) with the actual target MS location being in the "image cluster set area" when a FOM target MS location estimate is in the corresponding "cluster set area";

30 That is, for a cluster set area (e.g., "loc\_hyp.pt\_covering") for the present FOM, if the image cluster set area: has a mapped cluster density greater than the "prediction mapped cluster density", then there is a high likelihood of the target MS being in the image cluster set area.

09770039-012504

00770030-012501  
P09270-0000200

It is believed that the prediction mapped cluster density will typically be dependent on one or more area types. In particular, it is assumed that for each area type, there is a likely range of prediction mapped cluster density values that is substantially uniform across the area type. Accordingly, as discussed in detail hereinbelow, to calculate a prediction mapped cluster density for a particular area type, an estimate is made of the correlation between the mapped cluster densities of image areas (from cluster set areas) and the likelihood that if a verified MS location: (a) has a corresponding FOM MS estimate in the cluster set, and (b) is also in the particular area type, then the verified MS location is also in the image area.

Thus, if an area is within a single area type, then such a "relativized mapped cluster density" measurement for the area may be obtained by dividing the mapped cluster density by the prediction mapped cluster density and taking the smaller of: the resulting ratio and 1.0 as the value for the relativized mapped cluster density.

In some (perhaps most) cases, however, an area (e.g., an image cluster set area) may have portions in a number of area types. Accordingly, a "composite prediction mapped cluster density" may be computed, wherein, a weighted sum is computed of the prediction mapped cluster densities for the portions of the area that is in each of the area types. That is, the weighting, for each of the single area type prediction mapped cluster densities, is the fraction of the total area that this area type is. Thus, a "relativized composite mapped cluster density" for the area here may also be computed by dividing the mapped cluster density by the composite prediction mapped cluster density and taking the smaller of: the resulting ratio and 1.0 as the value for the relativized composite mapped cluster density.

Accordingly, note that as such a relativized (composite) mapped cluster density for an image cluster set area increases/decreases, it is assumed that the confidence of the target MS being in the image cluster set area should increase/decrease, respectively. \*/

```

20 {
    prediction_mapped_cluster_density <---
        get_composite_prediction_mapped_cluster_density_with_high_certainty
            (FOM_ID, image_area);
    /* The function invoked above provides a "composite prediction cluster density" (i.e., clusters per unit area) that is
25 used in determining the confidence that the target MS is in "image_area". That is, the composite prediction mapped
    cluster density value provided here is: high enough so that for a computed mapped cluster density greater than or equal
    to the composite prediction cluster density, and the target MS FOM estimate is in the "cluster set area", there is a high
    expectation that the actual target MS location is in the "image cluster set area". */
    max_area <--- get_max_area_for_high_certainty(FOM_ID, image_area); /* Get an area size value wherein it is highly
30 likely that for an area of size, "max_area", surrounding "image_area", the actual target MS is located therein. Note,
    that one skilled in the art will upon contemplation be able to derive various embodiments of this function, some
    embodiments being similar to the steps described for embodying the function,
    "get_composite_prediction_mapped_cluster_density_with_high_certainty" invoked above; i.e., performing a Monte
    Carlo simulation. */

```

00770829 04564  
10570 020260

Given the above two views, a positive confidence value for the area, "image\_area", can be calculated based on empirical data.

There are various embodiments that may be used to determine a confidence for the "image\_area". In general, such a confidence should vary monotonically with (a) and (b) below; that is, the confidence should increase (decrease) with:

- 5 (a) an increase (decrease) in the size of the area, *particularly* if the area is deemed close or relevant to the location of the target MS; and
- (b) an increase (decrease) in the size of the image cluster set (i.e., the number of verified location signature clusters in the area that each have a location estimate, from the FOM identified by "FOM\_ID"; in the "cluster set" corresponding to the "image\_cluster\_set;" e.g., the "cluster set" being a "loc\_hyp.pt\_covering").

10 As one skilled in the art will understand, there are many functions for providing confidences that vary monotonically with (a) and (b) above. In particular, for the cluster set area being "loc\_hyp.pt\_covering", one might be inclined to use the (area) size of the image cluster area as the value for (a), and the (cardinality) size of the image cluster set as the value for (b). Then, the following term might be considered for computing the confidence:

$$15 \quad \frac{\text{sizeof}(\text{image\_cluster\_set\_area}) * \text{sizeof}(\text{image\_cluster\_set})}{\text{sizeof}(\text{"image\_area"}) * \text{sizeof}(\text{"image\_cluster\_set"})}$$

However, since confidences are intended to be in the range [-1,1], a normalization is also desirable for the values corresponding to (a) and (b). Accordingly, in one embodiment, instead of using the above values for (a) and (b), ratios are used. That is, assuming for a "relevant" area, A (e.g., including an image cluster set area of "loc\_hyp.pt\_covering") that there is a very high confidence that the target MS is in A, the following term may be used in place of the term, sizeof("image\_area"), above:

$$20 \quad \min \{ \text{sizeof}(\text{"image\_area"}) / \text{sizeof}(A), 1.0 \}. \quad \text{[CAI.1]}$$

Additionally, for the condition (b) above, a similar normalization may be provided. Accordingly, to provide this normalization, note that the term,

$$25 \quad \text{sizeof}(\text{image\_area}) * \text{prediction\_mapped\_cluster\_density} \quad \text{[CAI.1.1]}$$

is analogous to sizeof(A) in [CAI.1]. That is, the expression of [CAI.1.1] gives a threshold for the number of verified location signature clusters that are likely to be needed in order to have a high confidence or likelihood that the target MS is in the area represented by "image\_area". Thus, the following term may be used for the condition (b):

$$30 \quad \min \{ \text{sizeof}(\text{image\_cluster\_set}) / \text{[(sizeof}(\text{image\_area}) * \text{prediction\_mapped\_cluster\_density)], 1.0} \} \quad \text{[CAI.2]}$$

As an aside, note that

$$\text{sizeof}(\text{image\_cluster\_set}) / \text{[(sizeof}(\text{image\_area}) * \text{prediction\_mapped\_cluster\_density}]$$

is equivalent to

$$\text{[(sizeof}(\text{image\_cluster\_set}) / \text{sizeof}(\text{image\_area})] / \text{(prediction\_mapped\_cluster\_density)}$$

and this latter term be interpreted as the ratio of: (i) the mapped cluster density for "image\_area" to (ii) an approximation of a cluster density providing a high expectation that the target MS is contained in "image\_area".

Note that the product of [CAI.1] and [CAI.2] provide the above desired characteristics for calculating the confidence. However, there is no guarantee that the range of resulting values from such products is consistent with the interpretation that has been placed on (positive) confidence values; e.g., that a confidence of near 1.0 has a very high likelihood that the target MS is in the corresponding area. For example, it can be that this product rarely is greater than 0.8, even in the areas of highest confidence. Accordingly, a "tuning" function is contemplated which provides an additional factor for adjusting of the confidence. This factor is, for example, a function of the area types and the size of each area type in "image\_area". Moreover, such a tuning function may be dependent on a "tuning coefficient" per area type. Thus, one such tuning function may be:

$$\min\left(\sum_{i=1}^{\text{number of area types}} [tc_i * \text{sizeof}(\text{area type}_i \text{ in "image\_area"}) / \text{sizeof}(\text{"image\_area"})], 1.0\right)$$

where  $tc_i$  is a tuning coefficient (determined in background or off-line processing; e.g., by a Genetic Algorithm or Monte Carlo simulation or regression) for the area type indexed by "i".

Note that it is within the scope of the present invention, that other tuning functions may also be used whose values may be dependent on, for example, Monte Carlo techniques or Genetic Algorithms.

It is interesting to note that in the product of [CAI.1] and [CAI.2], the "image\_area" size cancels out. This appears to conflict with the description above of a desirable confidence calculation. However, the resulting (typical) computed value:

$$\frac{\text{sizeof}(\text{image\_cluster\_set})}{[\text{max\_area} * \text{prediction\_mapped\_cluster\_density}]} \quad [\text{CAI.3}]$$

is strongly dependent on "image\_area" since "image\_cluster\_set" is derived from "image\_area" and "prediction\_mapped\_cluster\_density" also depends on "image\_area". Accordingly, it can be said that the product [CAI.3] above for the confidence does not depend on "raw" area size, but rather depends on a "relevant" area for locating the target MS.

**An embodiment of the confidence computation follows:**

```
*/
area_ratio <--- min((sizeof(image_area) / max_area), 1.0);
cluster_density_ratio <---
min( (sizeof(image_cluster_set) / [sizeof(image_area) * (prediction_mapped_cluster_density)]), 1.0);
tunable_constant <--- get_confidence_tuning_constant(image_area); // as discussed in the comment above
confidence <--- (tunable_constant) * (area_ratio) * (cluster_density_ratio); //This is in the range [0, 1]
RETURN(confidence);
```

} ENDOF confidence\_adjuster

get\_composite\_prediction\_mapped\_cluster\_density\_with\_high\_certainty

5

(FOM\_ID, image\_area);

/\* The present function determines a composite prediction mapped cluster density by determining a composite prediction mapped cluster density for the area represented by "image\_area" and for the First Order Model identified by "FOM\_ID". The steps herein are also provided in flowchart form in Fig. 28.

OUTPUT: composite\_mapped\_density This is a record for the composite prediction

10

mapped cluster density. In particular, there are with two fields:

(i) a "value" field giving an approximation to the prediction mapped cluster density for the First Order Model having id, FOM\_ID;

(ii) a "reliability" field giving an indication as to the reliability of the "value" field. The reliability field is in the range [0, 1] with 0 indicating that the "value" field is worthless and the larger the value the more assurance can be put in "value" with maximal assurance indicated when "reliability" is 1.\*/

15

{

/\* Determine a fraction of the area of "image\_area" contained in each area type (if there is only one, e.g., dense urban or a particular transmission area type as discussed in the detailed description hereinabove, then there would be a fraction having a value of 1 for this area type and a value of zero for all others). \*/

20

composite\_mapped\_density <--- 0; // initialization

for each area\_type intersecting "image\_area" do // "area\_type" may be taken from a list of area types .

{ /\* determine a weighting for "area\_type" as a fraction of its area in "image\_area" \*/

intersection <--- intersect(image\_area, area\_for(area\_type));

25

weighting <--- sizeof(intersection) / sizeof(area\_image);

/\* Now compute a prediction cluster density that highly correlates with predicting a location of the target MS for this area type. Then provide this cluster density as a factor of a weighted sum of the prediction cluster densities of each of the area types, wherein the weight for a particular area type's prediction cluster density is the fraction of the total area of "image\_area" that is designated this particular area type. Note that the following function call does not utilize information regarding the location of "image\_area". Accordingly, this function may access a precomputed table giving predication mapped cluster densities for (FOM\_ID, area\_type) pairs. However, in alternative embodiments of the present invention, the prediction mapped cluster densities may be computed specifically for the area of "image\_area" intersect "area\_type". \*/

30



FOIA b 7 - D

```

prediction_mapped_density <--- get_prediction_mapped_cluster_density_for(FOM_ID, area_type);
composite_mapped_density <--- composite_mapped_density +
                               (weighting * prediction_mapped_density);
}
5 RETURN(composite_mapped_density);
} ENDOF get_composite_prediction_mapped_cluster_density_with_high_certainty

get_prediction_mapped_cluster_density_for(FOM_ID, area_type)
/* The present function determines an approximation to a prediction mapped cluster density, D, for
10 an area type such that if an image cluster set area has a mapped cluster density >= D,
then there is a high expectation that the target MS 140 is in the image cluster set area. Note
that there are a number of embodiments that may be utilized for this function. The steps herein are also provided in flowchart
form in Figs. 29a through 29h.

OUTPUT: prediction_mapped_cluster_density This is a value giving an approximation to the
15 prediction mapped cluster density for the First Order Model having identity, "FOM_ID", and for the area type
represented by "area_type" */

Introductory Information Related to the Function,
"get_prediction_mapped_cluster_density_for"

20 It is important to note that the computation here for the prediction mapped cluster density may be more intense than
some other computations but the cluster densities computed here need not be performed in real time
target MS location processing. That is, the steps of this function may be performed only periodically (e.g., once a week), for each
FOM and each area type thereby precomputing the output for this function. Accordingly, the values obtained here may be stored in
a table that is accessed during real time target MS location processing. However, for simplicity, only the periodically performed
steps are presented here. However, one skilled in the art will understand that with sufficiently fast computational devices, some
25 related variations of this function may be performed in real-time. In particular, instead of supplying area type as an input to this
function, a particular area, A, may be provided such as the image area for a cluster set area, or, the portion of such an image area in
a particular area type. Accordingly, wherever "area_type" is used in a statement of the embodiment of this function below, a
comparable statement with "A" can be provided.

{
30 mesh <--- get_mesh_for(FOM_ID); /* get the mesh for this First Order Model; preferably each cell of "mesh" is substantially
in a single area type. */

```

CONFIDENTIAL

```
max_nbr_simulations get_Monte_Carlo_simulation_nbr(FOM_ID, area_type); /* This function outputs a value of the
maximum number of simulations to perform for estimating the prediction mapped cluster
density. Note that the output here may always be the same value such as 100. */
nbr_simulations_performed <--- 0; // initialization
5 while (nbr_simulations_performed <= max_nbr_simulations) do // determine a value for the "average mapped cluster
density" and a likelihood of this value being predictive of an MS location. */
{
representative_cell_cluster_set <--- get_representative_cell_clusters_for(area_type, mesh); /* Note, each activation
of this function should provide a different set of cell clusters from a covering from "mesh" of an (sub)area of
10 type, "area_type". There should ideally be at least enough substantially different sets of representative cell
clusters so that there is a distinct sets of cell clusters for each simulation number, j. Further note that, in one
embodiment, each of the "representative cell cluster sets" (as used here) may include at least a determined
proportion of the number of cells distributed over the area type. Moreover, each cell cluster (within a
representative cell cluster set) satisfies the following:
15 A. The cell cluster is a minimal covering (from "mesh") of a non-empty area, A, of type "area_type" ("A"
being referred to herein as the associated area for the cell cluster);
B. The cells of the cluster form a connected area; note this is not absolutely necessary; however, it is preferred
that the associated area "A" of "area_type" covered by the cell cluster have a "small" boundary with other
area types since the "image_areas" computed below will be less likely to include large areas of other area
20 types than "area_type;"
C. There is at least a predetermined minimal number (>= 1) of verified location signature clusters from the
location signature data base whose locations are in the associated area "A".
D. The cell cluster has no cell in common with any other cell cluster output as an entry in
"representative_cell_cluster_set" . */
25 if (representative_cell_cluster_set is NULL) then /* another representative collection of cell clusters could not be found; so
cease further simulation processing here, calculate return values and return */
break; // jump out of "simulation loop"
else /* there is another representative collection of cell clusters to use as a simulation */
{
30 for each cell cluster, C, in "representative_cell_clusters" do /* determine an approximation to the predictiveness of the
mappings between: (a) cluster set areas wherein each cluster set area is an area around a (FOM_ID) FOM
estimate that has its corresponding verified location in "C," and (b) the corresponding image areas for
these cluster set areas. Note, the location signature data base includes at least one (and preferably more)
```

FOIA b 7 - D

```
location signature clusters having verified locations in each cell cluster C as per the comment at (C) above.
*/
{ random_list <--- randomly_select_verified_MS_locs_in(C); /* select one or more verified MS
                                locations from C. */
5 mapped_density_sum <--- 0; // initialization
  for each verified location, "rand_verif_loc", in "random_list" do /* Let X denote the MS 140 estimate by the
                                present FOM of the verified location signature cluster of "rand_verif_loc"; let CS(X) denote
                                the cluster set obtained from the cluster set area (i.e., pt_area) surrounding X; this loop
                                determines whether the associated image area for the set CS(X) - X, (i.e., the image area for
10 CS(X) without "rand_verif_loc") includes "rand_verif_loc"; i.e., try to predict the location
                                area of "rand_verif_loc". */
    { loc_est <--- get_loc_est_for(rand_verif_loc, FOM_ID); /* get the FOM MS location
                                estimate for an MS actually located at "rand_verif_loc". */
      cluster_set <--- get_loc_est_surronding(loc_est, mesh); /* expand about "loc_est" until a minimal
15 number of other location estimates from this FOM are obtained that are different from
                                "loc_est", or until a maximum area is reached. Note, "cluster_set" could be empty, but
                                hopefully not. Also note that in one embodiment of the function here, the following functions
                                may be invoked: "get_min_area_surronding," "get_max_area_surronding" and
                                "get_min_nbr_of_clusters" (as in "get_adjusted_loc_hyp_list_for", the second function
20 of Appendix D): */
      image_set <--- get_image_of(cluster_set); /* "image_set" could be empty, but hopefully not */
      image_area <--- get_image_area(image_set); /* get convex hull of "image_set". Note, "image_area"
                                could be an empty area, but hopefully not. */
      if (rand_verif_loc is in image_area)
25         then /* this is one indication that the mapped cluster density: (sizeof[image_set]/image_area) is
                                sufficiently high to be predictive */
            predictions <--- predictions + 1;
      if (image_set is not empty) then
      {
30         density <--- sizeof(image_set) / sizeof(image_area); /* Get an approximation to the mapped cluster
                                density that results from "image_set" and "image_area." Note, that there is no
                                guarantee that "image_area" is entirely within the area type of "area_type." Also
                                note, it is assumed that as this mapped cluster density increases, it is more likely that
                                "rndm_verif_loc" is in "image_area". */
```

TOP SECRET

```
mapped_density_sum <--- mapped_density_sum + density,
    }
    } /* end loop for predicting location of a random MS verified location in cell cluster C. */
    total_possible_predictions <--- sizeof(random_list); // One prediction per element on list.
5    /* Now get average mapped density for the cell cluster C. */
    avg_mapped_density[C] <--- mapped_density_sum / total_possible_predictions;
    /* Now get the prediction probability for the cell cluster C. */
    prediction_probability[C] <--- predictions / total_possible_predictions;
    } /* end loop over cell clusters C in "representative_cell_clusters" */
10    nbr_simulations_performed <--- nbr_simulations_performed + 1;
    } //end else
    /* It would be nice to use the set of pairs (avg_mapped_density[C], prediction_probability[C]) for extrapolating a mapped
    density value for the area type that gives a very high prediction probability. However, due to the potentially small
    number of verified MS locations in many cells (and cell clusters), the prediction probabilities may provide a very small
15    number of distinct values such as: 0, 1/2, and 1. Thus, by averaging these pairs over the cell clusters of
    "representative_cell_clusters", the coarseness of the prediction probabilities may be accounted for. */
    avg_mapped_cluster_density[nbr_simulations_performed] <---
        avg_of_cell_mapped_densities(avg_mapped_density);
    avg_prediction_probability[nbr_simulations_performed] <---
20        avg_of_cell_prediction_probabilities(prediction_probability);
    } /* end simulation loop */
    /* Now determine a measure as to how reliable the simulation was. Note that "reliability" computed in the next statement is in
    the range [0, 1]. */
    reliability <--- nbr_simulations_performed / max_nbr_simulations;
25    if (reliability < system_defined_epsilon) then /* simulation too unreliable; so use a default high value for
        "prediction_mapped_cluster_density" */
        prediction_mapped_cluster_density <--- get_default_high_density_value_for(area_type);
    else /* simulation appears to be sufficiently reliable to use the entries of "avg_mapped_cluster_density" and
        "avg_prediction_probability" */
30    {
        /* A more easily discernible pattern between mapped cluster density and prediction probability may be provided by the set
        of pairs:
        S = {(avg_mapped_cluster_density[j], avg_prediction_probability[j])}, so that a mapped cluster density value
        having a high prediction probability (e.g., 0.95) may be extrapolated in the next statement. However, if it is
```



*A Second Embodiment of the Context Adjuster.*

Note that in this second embodiment of the Context Adjuster, it uses various heuristics to increment/decrement the confidence value of the location hypotheses coming from the First Order Models. These heuristics are implemented using fuzzy mathematics, wherein linguistic, fuzzy "if-then" rules embody the heuristics. That is, each fuzzy rule includes terms in both the "if" and the "then" portions that are substantially described using natural language — like terms to denote various parameter value classifications related to, but not equivalent to, probability density functions. Further note that the Context Adjuster and/or the FOM's may be calibrated using the location information from LBSs (i.e., fixed location BS transceivers), via the Location Base Station Model since such LBS's have well known and accurate predetermined locations.

Regarding the heuristics of the present embodiment of the context adjuster, the following is an example of a fuzzy rule that might appear in this embodiment of the Context Adjuster:

If <the season is Fall> then <the confidence level of Distance Model is increased by 5%>.

In the above sample rule, "Distance Model" denotes a First Order Model utilized by the present invention. To apply this sample rule, the fuzzy system needs a concrete definition of the term "Fall." In traditional expert systems, the term Fall would be described by a particular set of months, for example, September through November, in which traditional set theory is applied. In traditional set theory, an entity, in this case a date, is either in a set or it is not in a set, e.g. its degree of membership in a set is either 0, indicating that the entity is not in a particular set, or 1, indicating that the entity is in the set. However, the traditional set theory employed in expert systems does not lend itself well to entities that fall on set boundaries. For example, a traditional expert system could take dramatically different actions for a date of August 31 than it could for a date of September 1 because August 31 might belong to the set "Summer" while the date September 1 might belong to the set "Fall." This is not a desirable behavior since it is extremely difficult if not impossible to determine such lines of demarcation so accurately. However, fuzzy mathematics allows for the possibility of an entity belonging to multiple sets with varying degrees of confidence ranging from a minimum value of 0 (indicating that the confidence the entity belongs to the particular set is minimum) to 1 (indicating that the confidence the entity belongs to the particular set is maximum). The "fuzzy boundaries" between the various sets are described by fuzzy membership functions which provide a membership function value for each value on the entire range of a variable. As a consequence of allowing entities to belong to multiple sets simultaneously, the fuzzy rule base might have more than one rule that is applicable for any situation. Thus, the actions prescribed by the individual rules are averaged via a weighting scheme where each rule is implemented in proportion to its minimum confidence. For further information regarding such fuzzy heuristics, the following references are incorporated herein by reference: (McNeil and Freiberger, 1993; Cox, 1994; Kir and Folger, 1999; Zimmerman, 1991).

Thus, the rules defined in the fuzzy rule base in conjunction with the membership functions allow the heuristics for adjusting confidence values to be represented in a linguistic form more readily understood by humans than many other heuristic representations and thereby making it easier to maintain and modify the rules. The fuzzy rule base with its membership functions can be thought of as an extension

0070029-01001  
100210-000000

to a traditional expert system. Thus, since traditional expert systems are subsets of fuzzy systems, an alternative to a fuzzy rule base is a traditional expert system, and it is implicit that anywhere in the description of the current invention that a fuzzy rule base can be replaced with an expert system.

Also, these heuristics may evolve over time by employing adaptive mechanisms including, but not limited to, genetic algorithms to adjust or tune various system values in accordance with past experiences and past performance of the Context Adjuster for increasing the accuracy of the adjustments made to location hypothesis confidence values. For example, in the sample rule presented above:

If <the season is Fall> then <the confidence level of Distance Model is increased by 5%>

an adaptive mechanism or optimization routine can be used to adjust the percent increase in the confidence level of the Distance Model. For example, by accessing the MS Status Repository, a genetic algorithm is capable of adjusting the fuzzy rules and membership functions such that the location hypotheses are consistent with a majority of the verified MS locations. In this way, the Context Adjuster is able to employ a genetic algorithm to improve its performance over time. For further information regarding such adaptive mechanisms, the following references are incorporated herein by reference: (Goldberg, 1989; Holland, 1975). For further information regarding the tuning of fuzzy systems using such adaptive mechanisms, the following references are incorporated herein by reference: (Karr, 1991a, 1991b).

In one embodiment, the Context Adjuster alters the confidence values of location hypotheses according to one or more of the following environmental factors: (1) the type of region (e.g., dense urban, urban, rural, etc.), (2) the month of the year, (3) the time of day, and (4) the operational status of base stations (e.g., on-line or off-line), as well as other environmental factors that may substantially impact the confidence placed in a location hypothesis. Note that in this embodiment, each environmental factor has an associated set of linguistic heuristics and associated membership functions that prescribe changes to be made to the confidence values of the input location hypotheses.

The context adjuster begins by receiving location hypotheses and associated confidence levels from the First Order Models. The Context Adjuster takes this information and improves and refines it based on environmental information using the modules described below.

#### B.1 COA Calculation Module

As mentioned above each location hypothesis provides an approximation to the MS position in the form of a geometric shape and an associated confidence value,  $\alpha$ . The COA calculation module determines a center of area (COA) for each of the geometric shapes, if such a COA is not already provided in a location hypothesis. The COA Calculation Module receives the following information from each First Order Model: (1) a geometrical shape and (2) an associated confidence value,  $\alpha$ . The COA calculation is made using traditional geometric computations (numerical algorithms are readily available). Thus, following this step, each location hypothesis includes a COA as a single point that is assumed to represent the most likely approximation of the location of the MS. The COA Calculation Module passes the following information to the fuzzification module: (1) a geometrical shape associated with each first order model, (2) an associated confidence value, and (3) an associated COA.

#### B.2 Fuzzification Module

0070029-01504  
PAGE 10 OF 260

A fuzzification module receives the following information from the COA Calculation Module: (1) a geometrical shape associated with each First Order Model, (2) an associated confidence value, and (3) an associated COA. The Fuzzification Module uses this information to compute a membership function value ( $\mu$ ) for each of the M location hypotheses received from the COA calculation module (where the individual models are identified with an i index) for each of the N environmental factors (identified with a j index). In addition to the information received from the COA Calculation Module, the Fuzzification Module receives information from the Location Center Supervisor. The fuzzification module uses current environmental information such as the current time of day, month of year, and information about the base stations on-line for communicating with the MS associated with a location hypothesis currently being processed (this information may include, but is not limited to, the number of base stations of a given type, e.g., location base stations, and regular base stations, that have a previous history of being detected in an area about the COA for a location hypothesis). The base station coverage information is used to compute a percentage of base stations reporting for each location hypothesis.

The fuzzification is achieved in the traditional fashion using fuzzy membership functions for each environmental factor as, for example, is described in the following references incorporated herein by reference: (McNeil and Freiberger, 1993; Cox, 1994; Klir and Folger, 1999; Zimmerman, 1991).

Using the geographical area types for illustration purposes here, the following procedure might be used in the Fuzzification Module. Each value of COA for a location hypothesis is used to compute membership function values ( $\mu$ ) for each of five types of areas: (1) dense urban ( $\mu_{DU}$ ), (2) urban ( $\mu_U$ ), (3) suburban ( $\mu_S$ ), (4) rural plain ( $\mu_{RP}$ ), and (5) rural mountains ( $\mu_{RM}$ ). These membership function values provide the mechanism for representing degrees of membership in the area types, these area types being determined from an area map that has been sectioned off. In accordance with fuzzy theory, there may be geographical locations that include, for example, both dense urban and urban areas; dense urban and rural plane areas; dense urban, urban, and rural plane areas, etc. Thus for a particular MS location area estimate (described by a COA), it may be both dense urban and urban at the same time. The resolution of any apparent conflict in applicable rules is later resolved in the Defuzzification Module using the fuzzy membership function values ( $\mu$ ) computed in the Fuzzification Module.

Any particular value of a COA can land in more than one area type. For example, the COA may be in both dense urban and urban. Further, in some cases a location hypothesis for a particular First Order Model i may have membership functions  $\mu_{DU}^i$ ,  $\mu_U^i$ ,  $\mu_S^i$ ,  $\mu_{RP}^i$ , and  $\mu_{RM}^i$  wherein they all potentially have non-zero values. Additionally, each geographical area is contoured. Note that the membership function contours allow for one distinct value of membership function to be determined for each COA location (i.e., there will be distinct values of  $\mu_{DU}^i$ ,  $\mu_U^i$ ,  $\mu_S^i$ ,  $\mu_{RP}^i$ , and  $\mu_{RM}^i$  for any single COA value associated with a particular model i). For example, the COA would have a dense urban membership function value,  $\mu_{DU}^i$ , equal to 0.5. Similar contours would be used to compute values of  $\mu_U^i$ ,  $\mu_S^i$ ,  $\mu_{RP}^i$ , and  $\mu_{RM}^i$ .

Thus, for each COA, there now exists an array or series of membership function values; there are K membership function values (K = number of descriptive terms for the specified environmental factor) for each of M First Order Models. Each COA calculation has associated with it a definitive value for  $\mu_{DU}^i$ ,  $\mu_U^i$ ,  $\mu_S^i$ ,  $\mu_{RP}^i$ , and  $\mu_{RM}^i$ . Taken collectively, the M location hypotheses with membership function values for the K descriptive terms for the particular environmental factor results in a membership function value matrix. Additionally, similar membership function values are computed for each of the N environmental factors, thereby resulting in a corresponding membership function value matrix for each of the N environmental factors.



The Fuzzification Module passes the N membership function value matrices described above to the Rule Base Module along with all of the information it originally received from the COA Calculation Module.

### B.3 Rule Base Module

The Rule Base Module receives from the Fuzzification Module the following information: (1) a geometrical shape associated with each First Order Model, (2) an associated confidence value, (3) an associated COA, and (4) N membership function value matrices. The Rule Base Module uses this information in a manner consistent with typical fuzzy rule bases to determine a set of active or applicable rules. Sample rules were provided in the general discussion of the Context Adjuster. Additionally, references have been supplied that describe the necessary computations. Suffice it to say that the Rule Base Modules employ the information provided by the Fuzzification Module to compute confidence value adjustments for each of the m location hypotheses. Associated with each confidence value adjustment is a minimum membership function value contained in the membership function matrices computed in the Fuzzification Module.

For each location hypothesis, a simple inference engine driving the rule base queries the performance database to determine how well the location hypotheses for the First Order Model providing the current location hypothesis has performed in the past (for a geographic area surrounding the MS location estimate of the current location hypothesis) under the present environmental conditions. For example, the performance database is consulted to determine how well this particular First Order Model has performed in the past in locating an MS for the given time of day, month of year, and area type. Note that the performance value is a value between 0 and 1 wherein a value of 0 indicates that the model is a poor performer, while a value of 1 indicates that the model is always (or substantially always) accurate in determining an MS location under the conditions (and in the area) being considered. These performance values are used to compute values that are attached to the current confidence of the current location hypothesis; i.e., these performance values serve as the "then" sides of the fuzzy rules; the First Order Models that have been effective in the past have their confidence levels incremented by large amounts while First Order Models that have been ineffective in the past have their confidence levels incremented by small amounts. This information is received from the Performance Database in the form of an environmental factor, a First Order Model number, and a performance value. Accordingly, an intermediate value for the adjustment of the confidence value for the current location hypothesis is computed for each environmental condition (used by Context Adjuster) based on the performance value retrieved from the Performance Database. Each of these intermediate adjustment values are computed according to the following equation which is applicable to area information:

$$\text{adjustment}_i^j = Da_i^j = \text{performance\_value}_j * Da_{\text{REGION}}^{\text{MAX}}$$

where a is the confidence value of a particular location hypothesis, performance\_value is the value obtained from the Performance Database,  $Da_{\text{REGION}}^{\text{MAX}}$  is a system parameter that accounts for how important the information is being considered by the context adjuster. Furthermore, this parameter is initially provided by an operator in, for example, a system start-up configuration and a reasonable value for this parameter is believed to be in the range 0.05 to 0.1, the subscript j represents a particular environmental factor, and the superscript i represents a particular First Order Model. However, it is an important aspect of the present invention that this value can be repeatedly altered by an adaptive mechanism such as a genetic algorithm for improving the MS location accuracy of the present invention. In this way, and because the rules are

"written" using current performance information as stored in the Performance Database, the Rule Module is dynamic and becomes more accurate with time.

The Rule Base Module passes the matrix of adjustments to the Defuzzification Module along with the membership function value matrices received from the Fuzzification Module.

#### 5 B.6 Defuzzification Module

The Defuzzification Module receives the matrix of adjustments and the membership function value matrices from the Rule Base Module. The final adjustment to the First Order Model confidence values as computed by the Context Adjuster is computed according to:

$$\Delta \alpha_j^i(k) = \frac{\sum_{j=1}^N \mu_j^i(k) \Delta \alpha_j^i}{\sum_{j=1}^N \mu_j^i(k)}$$

10 such as, but not limited to, time of day, month of year, and base station coverage, there are a number of system start-up configuration parameters that can be adjusted in attempts to improve system performance. These adjustments are, in effect, adjustments computed depending on the previous performance values of each model under similar conditions as being currently considered. These adjustments are summed and forwarded to the blackboard. Thus, the Context Adjuster passes the following information to the blackboard: adjustments in confidence values for each of the First Order Models based on environmental factors and COA values associated with each location hypothesis.

#### Summary

15 The Context Adjuster uses environmental factor information and past performance information for each of i First Order Models to compute adjustments to the current confidence values. It retrieves information from the First Order Models, interacts with the Supervisor and the Performance Database, and computes adjustments to the confidence values. Further, the Context Adjuster employs a genetic algorithm to improve the accuracy of its calculations. The algorithm for the Context Adjuster is included in algorithm BE.B below:

Algorithm BE.B: Pseudocode for the Context Adjuster.

20 `Context_Adjuster (geometries, alpha)`

*/\** This program implements the Context Adjuster. It receives from the First Order Models geometric areas contained in a data structure called geometries, and associated confidence values contained in an array called alpha. The program used environmental information to compute improved numerical values of the confidence values. It places the improved values in the array called alpha, destroying the previous values in the process.

25 *\*/*

*//* pseudo code for the Context Adjuster

*//* assume input from each of i models includes a

*//* geographical area described by a number of points

FOR RELEASE UNDER E.O. 13526

```
// and a confidence value alpha, alpha is such
// that if it is 0.0 then the model is absolutely
// sure that the MS is not in the prescribed area;
// if it is 1.0 then the model is absolutely
5 // sure that the MS is in the prescribed area.
// calculate the center of area for each of the i model areas
for i = 1 to number_of_models
    calculate center of area // termed coa(i) from here on out
// extract information from the "outside world" or the environment
10 find time_of_day
    find month_of_year
    find number_of_BS_available
    find number_of_BS_reporting
// calculate percent coverage of base stations
15 percent_coverage = 100.0 * (number_of_BS_reporting / number_of_BS_available)
// use these j = 4 environmental factors to compute adjustments to the i confidence values
// associated with the i models - alpha(i)
for i = 1 to number_of_models // loop on the number of models
    for j = 1 to number_env_factors // loop on the number of environmental factors
20     for k = 1 to number_of_fuzzy_classes // loop on the number of classes
        // used for each of the environmental
        // factors
// calculate mu values based on membership function definitions
    calculate mu(i,j,k) values
25 // go to the performance database and extract current performance information for each of the i
        //models, in the k fuzzy classes, for the j environmental factors
    fetch performance(i,j,k)
// calculate the actual values for the right hand sides of the fuzzy rules
30
    delta_alpha(i,j,k) = performance(i,j,k) * delta_alpha_max(j)
// delta_alpha_max(j) is a maximum amount each environmental
// factor can alter the confidence value; it is eventually
```



## APPENDIX E: Historical Data Confidence Adjuster Program

`Historical_data_confidence_adjuster(loc_hyp)`

```
5  /* This function adjusts the confidence of location hypothesis, "loc_hyp", according to how well its location signature cluster fits with verified
   location signature clusters in the location signature data base. */
   {
       mesh <-- get_mesh_for(loc_hyp.FOM_ID); // each FOM has a mesh of the Location Center service area
       covering <-- get_mesh_covering_of_MS_estimate_for(loc_hyp); /* get the cells of "mesh" that minimally cover the most
           pertinent target MS estimate in "loc_hyp". */
10  total_per_unit_error <-- 0; // initialization
       for each cell, C, of "covering" do /* determine an error measurement between the location signature cluster of "loc_hyp" and
           the verified location signature clusters in the cell */
           {
               centroid <-- get_centroid(C);
15  error_obj <-- DB_Loc_Sig_Error_Fit(centroid, C, loc_hyp.loc_sig_cluster, "USE ALL LOC SIGS IN
                   DB");
                   /* The above function call computes an error object, "error_obj", providing a
                   measure of how similar the location signature cluster for "loc_hyp" is with the verified
                   location signature clusters in the location signature data base, wherein the verified
                   location signature clusters are in the area represented by the cell, C. See APPENDIX C
20  for details of this function. */
                   total_per_unit_error <-- total_per_unit_error + [error_obj.error * error_obj.confidence / sizeof(C)];
                   /* The above statement computes an "error per unit of cell area" term as:
                   [error_obj.error * error_obj.confidence / sizeof(C)], wherein the error is the term:
                   error_obj.error * error_obj.confidence. Subsequently, this error per unit of cell
25  area term accumulated in "total_relative_error" */
           }
       avg_per_unit_error <-- total_per_unit_error / nbr_cells_in(mesh);
       /* Now get a tunable constant, "tunable_constant", that has been determined by the Adaptation Engine 1382
30  (shown in Figs. 5, 6 and 8), wherein "tunable_constant" may have been adapted to environmental characteristics. */
       tunable_constant <-- get_tunable_constant_for("Historical_Location_Reasoner", loc_hyp);
       /* Now decrement the confidence value of "loc_hyp" by an error amount that is scaled by "tunable_constant"
       */
```

Page 186

```
loc_hyp.confidence --- loc_hyp.confidence - {avg_per_unit_error * size_of_covering} * tunable_constant];  
RETURN(loc_hyp);  
}ENDOF Historical_data_confidence_adjuster
```

5

09770829.012601  
109270.6280260

00770029-012604

What is claimed is:

- 5 I. A method for locating wireless mobile stations using wireless signal measurements of wireless signals transmitted between said wireless mobile stations and a network of base stations, wherein said base stations in the network are cooperatively linked for providing wireless communications with said wireless mobile stations, comprising:
- providing a plurality of mobile station location estimators, wherein said location estimators provide location estimates of said mobile stations when said location estimators are supplied with location information derived from wireless signal measurements of wireless signals transmitted between said mobile stations and the network of base stations;
- 10 generating, by a first and a second of said location estimators, respectively, first and second different initial location estimates of a particular one of said wireless mobile stations, using location information derived from wireless signal measurements of wireless signals transmitted between said particular mobile station and the network of base stations;
- determining:
- (a) first confidence data for a first location hypothesis of said particular mobile station, wherein:
- 15 (i) said first location hypothesis provides one of: said first initial location estimate from said first location estimator, and a first successive location estimate of said particular mobile station, said first successive location estimate derived using said first initial location estimate, and
- (ii) said first confidence data is indicative of a likelihood of said particular mobile station being at a location represented by said first location hypothesis; and
- (b) second confidence data for a second location hypothesis of said particular mobile station, wherein:
- 20 (i) said second location hypothesis provides one of: said second initial location estimate from said second location estimator, and a second successive location estimate of said particular mobile station, said second successive location estimate derived using said second initial location estimate, and
- (ii) said first confidence data is indicative of a likelihood of said particular mobile station being at a location represented by said first location hypothesis;
- 25 deriving a most likelihood location estimate of said particular mobile station, said most likely location estimate being dependent on each of: said location estimates of said first and second location hypotheses, and, values of said first and second confidence data.
- 30 2. A method as claimed in Claim 1, wherein said wireless signal measurements are from wireless signals communicated between said particular mobile station and said network of base stations using an identical communication standard as used when said network of base stations provide wireless communications with said particular mobile station for a purpose different from estimating a location of said particular mobile station.
3. A method as claimed in Claim 2, wherein said different purpose is one of: providing voice communication, and providing visual communication.
4. A method as claimed in Claim 2, wherein said communication standard is for one of CDMA and TDMA.

00770939-019004  
PAGE 10 OF 2386

5. A method as claimed in Claim 1, wherein said wireless signal measurements are from wireless signals communicated between said particular mobile station and said network of base stations using an communication protocol for providing wireless voice communications between said network of base stations and said particular mobile station.

6. A method as claimed in Claim 1, wherein said wireless signal measurements of wireless signals communicated between said particular mobile station and said network of base stations are included in measurements capable of being determined for voice communication with said particular mobile station.

7. A method as claimed in Claim 1, wherein said wireless signal measurements include at least one of: (a) a measurement of a signal strength of wireless signals detected by said particular mobile station and transmitted by one of said base stations, and (b) a measurement of a signal time delay of wireless signals detected by said particular mobile station and transmitted by one of said base stations.

8. A method as claimed in Claim 1, wherein said step of providing includes:

transmitting through a telecommunications network, said first location estimator from a source site to a site having said second location estimator;

operably integrating said first location estimator with said second location estimator for performing said steps of determining and deriving.

9. A method as claimed in Claim 8, wherein said step of transmitting includes sending an encoding of said first location estimator using the Internet.

10. A method as claimed in Claim 1, wherein said step of determining includes retrieving historical location data related to said first initial location estimate and said second initial location estimate, wherein said historical location data includes:

(a) location estimates by said first location estimator for some of said mobile stations at a first plurality of locations, and data identifying said locations of said first plurality of locations;

(b) location estimates by said second location estimator for some of said mobile stations at a second plurality of locations, and data identifying said locations of said second plurality of locations;

wherein said first successive location estimate is determined using said historical location data of (a), and said successive estimate is determined using said historical location data of (b).

11. A method as claimed in Claim 1, wherein said step of determining includes first selecting a first set of one or more location estimates of said mobile stations also output by said first location estimator, wherein said one or more location estimates are determined according to, at least, a proximity of said one or more location estimates to said first initial location estimate.

12. A method as claimed in Claim 11, wherein said step of first selecting includes selecting said first set according to a function of a distance between said first initial location estimate and at least one of said location estimates of said first set.

13. A method as claimed in Claim 11, wherein each location estimate of said first set of location estimates has corresponding location data identifying a location of one of said mobile stations for which said location estimate estimates the mobile station's location, wherein the identified location has been verified.



10570086260

14. A method as claimed in Claim 11, wherein said step of determining includes first obtaining a first collection of one or more previously identified locations, wherein each said previously identified location:

(a) has a corresponding location estimate in said first set, said corresponding location estimate being for a corresponding one of said plurality of mobile stations, and

5 (b) is approximately a location of the corresponding mobile station when said location information, derived from wireless signal measurements of transmissions between the corresponding mobile station and said network, was initially provided to said first location estimator for outputting said corresponding location estimate.

15. A method as claimed in Claim 14, wherein said step of determining includes first calculating said first successive location estimate of said particular mobile station from said first initial location estimate using said one or more previously identified locations.

10 16. A method as claimed in Claim 15, wherein said step of first calculating includes determining said first successive location estimate as a function of a convex hull of said one or more previously identified locations.

17. A method as claimed in Claim 15, wherein said step of determining includes first computing a first value of said first confidence data for said particular mobile station being at a location represented by said first successive location estimate, wherein said first value is a function of at least one of: (a) a value related to a density of said one or more previously identified locations for said first successive location estimate, and (b) a value related to a size of an area for said first successive location estimate.

15 18. A method as claimed in Claim 17, wherein for said second successive location estimate the following steps are performed:

(a) second selecting a second set of one or more location estimates of said mobile stations output by said second location estimator, wherein said location estimates of said second set are determined according to, at least, a proximity of said location estimates in said second set to said second initial location estimate;

20 (b) second obtaining a second collection of one or more previously identified locations, each said previously identified location:

(i) having a corresponding location estimate in said second set for a corresponding one of said plurality of mobile stations, (ii) is approximately a location of the corresponding mobile station when said location information, derived from wireless signal measurements of transmissions between the corresponding mobile station and said network, was initially provided to said second location estimator for outputting said corresponding location estimate;

25 (c) second calculating said second successive estimate of said particular mobile station, wherein said second successive estimate is a function of said one or more previously known locations of said second collection; and

30 (d) second computing a second value of said second confidence data for said particular mobile station being at a location represented by said second successive location estimate, wherein said second value is a function of at least one of: (a) a value related to a density of said one or more previously identified locations of said second collection, and (b) a value related to a size of said second successive location estimate.

19. A method as claimed in Claim 11, wherein said first confidence data includes a data field for a value indicative of said particular mobile station being in an area, wherein said area is determined as a function of said first set of location estimates.

20. A method as claimed in Claim 1, wherein said first confidence data includes a data field for a value indicative of said particular mobile station not being in an area represented by said first location hypothesis.



00770929:049604  
PAGE:00000200

- (b) a trainable location estimator for estimating a location of said particular mobile station by training said trainable estimator to learn an association between each location of a plurality of geographical locations and corresponding instances of said location information related to the wireless signal measurements of wireless transmissions with one of said mobile stations at the location;
  - 5 (c) a triangulation location estimator for estimating a location of said particular mobile station by triangulating on measurements of said location information, wherein said measurements are determined from the wireless signal measurements of wireless transmissions between said particular mobile station and at least three of the base stations of said network;
  - (d) a statistical location estimator for estimating a location of said particular mobile station by applying a statistical regression technique;
  - 10 (e) a mobile base station estimator for estimating a location of said particular mobile station from location information received from a mobile base station detecting wireless transmissions of particular first mobile station;
  - (f) a coverage area location estimator for estimating a location of said particular mobile station by intersecting wireless coverage areas corresponding to each of a plurality of the base stations of said network;
  - 15 (g) a negative logic location estimator for estimating where said particular mobile station is unlikely to be located.
31. A method as claimed in Claim 1, wherein at least said first location estimator includes one of the following:
- (a) an artificial neural network for generating said first initial location estimate by training said artificial neural network to recognize a pattern of characteristics of said location information associated with a location from where said particular mobile station is transmitting;
  - 20 (b) a distance estimator for generating said first initial location estimate by determining one or more distances between said particular mobile station and the base stations, wherein signal timing measurements, obtained from said wireless signal measurements of wireless transmissions between said particular mobile station and one or more base stations of said network, are used for determining said one or more distances;
  - (c) a statistical estimator for generating said first initial location estimate by applying to said location information one of the following statistical techniques: principle decomposition, least squares, partial least squares, and Bollenger Bands.
- 25 32. A method as claimed in Claim 31, wherein said second location estimator includes a different one of said artificial neural network, said distance estimator, and said statistical estimator for generating said second initial location estimate.
33. A method as claimed in Claim 31B, wherein said distance estimator estimates the location of said particular mobile station by one of: a signal time of arrival and a signal time difference of arrival.
- 30 34. A method as claimed in Claim 1, wherein said first location estimator includes an artificial neural network, wherein said artificial neural network is one of: a multilayer perceptron, an adaptive resonance theory model, and radial basis function network.
35. A location system as claimed in Claim 1, wherein said first location estimator includes an artificial neural network with input neurons for receiving location information data related to wireless signal time delay measurements of signal strength for wireless transmissions between said particular mobile station and a first collection of base stations from said network.



09770899-01661  
103210-00000000

43. A method as claimed in Claim 42, wherein said function includes an addition of terms having said first and second likelihood measurements.

44. A method as claimed in Claim 1, wherein said step of deriving includes 0, of said first confidence data, for said particular mobile station being at a location represented by the first location hypothesis;

5        wherein said step of fuzzifying performs a function for distributing a decreased value of said first likelihood measurement to locations outside of a location estimate for said first location hypothesis.

45. A method as claimed in Claim 44, wherein said function includes a sigmoid term.

46. A method as claimed in Claim 1, further including an expert system for activating said first location estimator for outputting said first initial location estimate.

10        47. A method as claimed in Claim 46, wherein said first location estimator is activated by one of: an antecedent of an expert system rule, and a consequent of an expert system rule.

48. A method as claimed in Claim 1, further including a step of determining whether to modify one of: said first location hypothesis, and said first confidence data according to at least one of:

- 15        (a) an expected maximum velocity of said first mobile station;  
      (b) an expected maximum acceleration of said first mobile station;  
      (c) a predicted location of said first mobile station;  
      (d) an expected wireless signal characteristic of an area containing said first location hypothesis; and  
      (e) an expected vehicle route.

20        49. A method as claimed in Claim 48, wherein said step of determining whether to modify includes activating one of an expert system, a fuzzy rule inferencing system and a blackboard daemon.

50. A method as claimed in Claim 1, further including a step of storing historical mobile station location data for access during said step of determining, wherein said step of storing includes the following substeps:

- 25        (a) storing, for each location of a plurality of mobile station locations, a corresponding collection of wireless signal measurements of wireless signals transmitted between one of said mobile stations and the base stations of said network, wherein said one mobile station resides substantially at said location when said wireless signals are transmitted;
- 30        (b) storing, for each location of said plurality of mobile station locations, a corresponding set of location estimates, wherein for each of said mobile station location estimators and each said set of location estimates, there is a location estimate of said set that is generated by said mobile station location estimator; and  
      (b) storing, for each of said stored location estimates, corresponding identification data for identifying a corresponding particular one of said locations of said plurality of mobile station locations, wherein said corresponding identification data accurately identifies said particular location.

51. A method as claimed in Claim 50, wherein for at least a first of said corresponding collections of wireless signal measurements, there is an associated confidence value used for indicating a consistency of the corresponding collection with other of said

105210-2280260

corresponding collections where corresponding particular locations are within a determined proximity to the corresponding particular location for said first corresponding collection.

5 52. A method as claimed in Claim 51 further including a step of changing said associated confidence value when there is a deviation between said first corresponding collection deviates and said other corresponding collections by more than predetermined amount, wherein said deviation is determined using a statistical measurement of deviation.

53. A method as claimed in Claim 52, wherein said statistical measurement of deviation includes a standard deviation measurement.

54. A method as claimed in Claim 52 further including a means for prohibiting said first corresponding collection from use in said step of determining when said associated confidence value is outside of a predetermined range.

10 55. A location system for receiving measurements of wireless signals transmitted between a plurality mobile stations and a network of base stations, wherein said base stations in the network are cooperatively linked for providing wireless communication, the improvement characterized by:

a plurality of different location estimators for estimating locations of said mobile stations, such that when said location estimators are supplied with said measurements of wireless signals transmitted between one of the mobile stations and said network of base stations, said location estimators output corresponding initial location estimates of a geographical location of said one mobile station;

15 an archive for storing a plurality of data item collections, wherein for each location of a plurality geographical locations, there is one of said data item collections having:

- (a1) a representation of the geographical location,
- (a2) a set of said wireless signal measurements corresponding to one of said mobile stations transmitting from approximately the geographical location
- (a3) for each location estimator of said plurality of location estimators, a corresponding initial location estimate generated when said set of said wireless signal measurements is supplied to said location estimator;

20 a means for constructing, for each of said location estimators, corresponding prediction measurements indicative of an historical accuracy of said location estimator, wherein for each said prediction measurement, there is:

- 25 (b1) a corresponding selected group of said data item collections used in determining said prediction measurement,
- (b2) a collection of mappings, wherein each said mapping is an association between: (i) one of said corresponding mobile station initial location estimates generated by said location estimator using said wireless measurements of one of said data item collections in said selected group, and (ii) the geographical location of the data item collection;

30 a means for determining, for an identified one of said mobile stations, a plurality of location hypotheses, wherein for each said location hypothesis:

- (c1) said location hypothesis has a location estimate of said identified mobile station derived using at least one initial location estimate, wherein said initial location estimate is generated by one of said plurality of location

105210-220260

estimator, said one location estimator being supplied with signal measurements of wireless signal transmissions between said identified mobile station and said network of base stations,

(c2) said location hypothesis has a confidence value used for indicating a likelihood of said identified mobile station being at a location represented by said location estimate for said location hypothesis, wherein one of said prediction measurements is used in determining said confidence value;

5

a most likely mobile station location estimator for determining a most likely location estimate of said identified mobile station, said most likely location estimate being derived using location estimates and confidence values from location hypotheses of said plurality of said location hypotheses.

10

56. A method as claimed in Claim 55, wherein said measurements are for wireless signals transmitted in a wireless signal protocol for voice communication between said identified mobile station and said network of base stations.

57. A location system as claimed in Claim 55, wherein said means for constructing includes means for performing a mobile station location simulation using said stored data item collections for determining said prediction measurements.

58. A location system as claimed in Claim 55, wherein said means for determining includes a means for deriving the location estimate of one of said location hypotheses using a time series of location estimates for said identified mobile station.

15

59. A location system as claimed in Claim 55, further including:

a storage means for storing a population of representations for values of a collection of system parameters of said location system, wherein said parameters affect a performance of said location system in locating mobile stations;

an adaptive component for determining one or more of said representations whose values of said collection of system parameters enhance at least one of: a reliability and an accuracy of said location system in locating said mobile stations;

20

wherein said adaptive component uses said plurality of data item collections for providing, for each version of said location system determined by different ones of said representations:

(d1) wireless signal measurements from some of said data item collections as input to said version, and

(d2) for each of said data item collections used as input in (d1), said corresponding geographical location for comparing with the corresponding most likely location estimate location output by said version.

25

60. A location system as claimed in Claim 59, wherein said adaptive component includes a genetic algorithm embodiment.

61. A location system as claimed in Claim 55, wherein for at least a first and second of said plurality of location estimators, each of said first and second location estimators include one of the following:

30

(e1) an artificial neural network for use in generating said corresponding initial location estimates, wherein said artificial neural network is trained to recognize a pattern of characteristics of said signal measurements associated with a location from where one of said mobile stations is transmitting;

(e2) a distance estimator for use in generating said corresponding initial location estimates, wherein said distance estimator determines one or more distances between one of said mobile stations and the base stations, and wherein signal timing measurements, obtained from wireless transmissions between said one mobile station and one or more of the base stations, are used for determining said one or more distances;

(e3) a statistical estimator for use in generating said corresponding initial location estimates, wherein said statistical estimator utilizes a statistical regression technique for correlating characteristics of measurements of wireless signals transmitted between one of said mobile stations and the base stations with a location for said one mobile station.

5 62. A method for locating a mobile station by receiving wireless signal measurements of wireless signals transmitted between a plurality mobile stations and a network of base stations, wherein said base stations in the network are cooperatively linked for providing wireless communication, the improvement characterized by:

providing a mobile station location estimator for estimating locations of said mobile stations, such that when said location estimator is supplied with said measurements of wireless signals transmitted between one of the mobile stations and said network of  
10 base stations, said location estimator generates a initial location estimate of a geographical location of said one mobile station;

storing a plurality of data item collections, wherein for each of a plurality of geographical locations, there is one of said data item collections having: (a1) a representation of the geographical location, and (a2) a representation of measurements of wireless signals transmitted between one of said mobile stations and the base stations when said one mobile station is approximately at the geographical location;

15 determining, from said initial location estimate, a corresponding adjusted location estimate as a function of historical initial location estimates generated by said mobile station location estimator when supplied with said signal measurements for representations of (a2) of said data item collections.

63. A method as claimed in Claim 62, wherein said step of determining includes the steps of:

generating additional initial location estimates when said mobile station location estimator is supplied with said signal  
20 measurements for representations of (a2) for said data item collections;

selecting said additional initial location estimates that are within a determined distance of said initial location estimate; and

25 deriving said corresponding adjusted location estimate using said geographical location representations of (a1) for data item collections of a particular set of said data item collections, wherein said additional initial location estimates selected in said step of selecting were generated from said signal measurements for representations of (a2) for said data item collections of said particular set.

64. A method as claimed in Claim 62, wherein said geographical locations represented in (a1) of said data item collections have been verified.

30 65. A method as claimed in Claim 62, wherein for each data item collection in a set of at least some of said data item collections, there is an associated confidence value used for indicating a consistency of the representation of (a2) for said data item collection with the representation of (a2) for other of said data item collections whose geographical location representations (a1) are within a determined maximum distance of said geographical location representation of (a1) for said data item.

66. A method as claimed in Claim 65 further including:

a step of decreasing a confidence of a first data item collection in said set relative to a confidence for other of said data item collections of said set, when there is a deviation between the measurements of said representation (a2) for said data item collection,





00770939-042904

location estimate, wherein said measurements are used in for determining said corresponding confidence value for said first adjusted location estimate, wherein for each of a plurality geographical locations, there is a corresponding one of said data item collections having a representation of the geographical location and a representation of measurement of wireless signals transmitted between said particular mobile stations and the base stations.

- 5 74. A location system, as claimed in Claim 73, wherein said means for generating includes a means for constructing said measurements, wherein said measurements include values related to a predictiveness of a collection of mappings between: (a) a cluster of initial location estimates, determined by said corresponding location estimator, for one or more of the mobile stations at a plurality of geographical locations, and (b) a corresponding representation of an actual mobile station location for each of the initial location estimates in said cluster.
- 10 75. A location system, as claimed in Claim 74, wherein said cluster of initial location estimates are within a predetermined distance of said first initial location estimate.
76. A location system, as claimed in Claim 74, wherein said measurements are dependent on a density of said corresponding representations of actual mobile station locations for the initial location estimates in said cluster.
77. A location system, as claimed in Claim 74, wherein said measurements are dependent on a size of an area containing said mobile station locations of said corresponding representations of actual mobile station locations for the initial location estimates in said cluster.
- 15 78. A location system, as claimed in Claim 72, wherein said corresponding confidence value for said first adjusted location estimate indicates a likelihood of said particular mobile station being outside of an area for said first adjusted location estimate.
79. A location system, as claimed in Claim 72 further including a means for partitioning a wireless coverage area having said first and second adjusted location estimates into subareas, each subarea having expected similar measurements of wireless signals transmitted between one of said mobile stations in the subarea and the network of base stations.
- 20 80. A location system, as claimed in Claim 72, further including a means for partitioning a wireless coverage area into subareas, wherein each subarea has a corresponding area type characterized by wireless signal transmission characteristics between locations in said subarea and the base stations of said network.
- 25 81. A location system, as claimed in Claim 72, wherein said one or more mobile station location estimators include one or more of: a triangulation mobile station estimator, a trilateration mobile station estimator, a trainable mobile station estimator, a statistical mobile station estimator.
82. A location system, as claimed in Claim 81, wherein said triangulation mobile station estimator triangulates using one of: a signal time of arrival, and a signal strength between the associated mobile station and each of three of said base stations.
- 30 83. A location system for wireless mobile stations, as claimed in Claim 81, wherein said trilateration mobile station estimator trilaterates using a signal time difference of arrival between the associated mobile station and each of three of said base stations.
84. A location system, as claimed in Claim 81, wherein trainable mobile station estimator includes an artificial neural network.
85. A location system, as claimed in Claim 72, wherein said one or more location estimators receives input from a mobile base station.

00770929-012604

86.2 A location system, as claimed in Claim 72, wherein said means for generating includes a simulation means for determining a predictiveness of said location estimator that generates said first initial location estimate.

87. A location system, as claimed in Claim 86, wherein said simulation means includes a statistical simulation for predicting said confidence value said first adjusted location estimate.

5 88. A location system for wireless mobile stations, as claimed in Claim 87, wherein said statistical simulation includes a Monte Carlo simulation.

89. A location system, as claimed in Claim 72, wherein, for deriving said most likely location estimate, said most likely estimator uses a probability density function for fuzzifying at least said confidence value for said first adjusted location estimate over an area outside of said first adjusted location estimate.

10 90. A location system, as claimed in Claim 72, wherein for a first collection of cells of a cell mesh for the wireless coverage area, said most likely estimator includes means for determining a likelihood that said particular mobile station is in each cell of said first collection.

91. A location system for wireless mobile stations, as claimed in Claim 90, wherein boundaries between cells said cell mesh are substantially coincident with boundaries of a wireless signal area type categorization.

15 92. A location system for receiving wireless signal measurements of wireless signals transmitted between a plurality mobile stations and a network of base stations, wherein said base stations in the network are cooperatively linked for providing wireless communication, the improvement characterized by:

an archive for storing a plurality of data item collections, wherein for each location of a plurality geographical locations, there is one of said data item collections having (a1) and (a2):

20 (a1) a representation of the geographical location,

(a2) a set of said wireless signal measurements corresponding to one of said mobile stations transmitting from approximately the geographical location

25 a trainable location estimator for generating a geographical location estimate of one of said mobile stations when said trainable estimator is supplied with said measurements of wireless signals transmitted between one of said mobile stations and the network of base stations, wherein said trainable location estimator learns by associating, for each of at least some of said data item collections, said geographical location representation (a1) of the data item collection with said set of said wireless signal measurements (a2) of the data item collection.

30 93. A location system, as claimed in Claim 92, wherein said trainable location estimator includes a pattern recognition component for recognizing patterns in said wireless signal measurements (a2) for data item collections in an area of a wireless coverage area, wherein said area is determined using said geographical location representations (a1) of said data item collections that have for each of their sets of said wireless signal measurements (a2), wireless signal measurements from a same group of said base stations.

94. A location system, as claimed in Claim 92, wherein said trainable location estimator includes an artificial neural network.

95. A method as claimed in Claim 94, further including a different trainable location estimator utilizing a different artificial neural network for generating a different geographical location estimate of said one mobile station.

FILED: 2020/02/20

96. A method as claimed in Claim 94, wherein said artificial neural is one of: a multilayer perceptron, an adaptive resonance theory model, and radial basis function network.

97. A location system as claimed in Claim 92, wherein said trainable location estimator utilizes an artificial neural network with input neurons for receiving wireless signal time delay measurements of signal strength as said measurements of wireless signal transmissions between said one mobile station and a first collection of base stations from said network.

98. A method as claimed in Claim 97, wherein for each base station in said first collection, said wireless transmissions between the base station and said one mobile station are detected by one of: the base station and said one mobile station.

99. A method as claimed in Claim 92, wherein said trainable location estimator utilizes an artificial neural network with input neurons for receiving data related to wireless transmissions between said one mobile station and a set of one or more of said base stations, wherein for each base station in said set, there is at least one said input neuron for receiving one or more values indicative of at least one of the following conditions:

- (a) the base station is active for wireless communication with said one mobile station and a pilot signal by the base station is detected by the one mobile station;
- (b) the base station is active for wireless communication with said one mobile station and the base station detects wireless transmissions by said one mobile station;
- (c) the base station is active for wireless communication with said one mobile station and the base station does not detect wireless transmissions by said one mobile station;
- (d) the base station is active for wireless communication with said one mobile station and said one mobile station does not detect wireless transmissions by the base station;
- (e) the base station is not active for wireless communication with said one mobile station.

100. A location system, as claimed in Claim 92, wherein for at least some of said data item collections, each data item collection additionally includes at least some of the following:

- (a) at least one of a make and model of a particular mobile station used in obtaining said representation of (a2);
- (b) an identification of at least one of said base stations used in obtaining the representation of (a2);
- (c) a value indicative of whether the representation of (a1) has been verified as an accurate geographical location estimate of the particular mobile station;
- (de) a value indicative of how consistent the representation of (a2) is with the representations of (a2) for other of said data item collections;
- (e) timestamp data indicative of approximately when the measurements of wireless signals for the representation of (a2) were received by one: the network and said location system;
- (f) power level data related to one or more power levels of said at least one of said base stations used in obtaining said measurements for the representation of (a2) for the data item collection;
- (g) power level data related to the power level of the particular mobile station when said wireless signals, for measurements of the representation of (a2) for the data item collection, were transmitted.

09770839-01601  
109210-5580260

101. A location system for receiving wireless signal measurements of wireless signals transmitted between a plurality mobile stations and a network of base stations, wherein said base stations in the network are cooperatively linked for providing wireless communication, the improvement characterized by:

5 a plurality of mobile station location estimators for estimating locations of said mobile stations, such that when said location estimators are supplied with said measurements of wireless signals transmitted between one of the mobile stations and said network of base stations, said location estimators output corresponding initial location estimates of a geographical location of said one mobile station, wherein at least two of said mobile station location estimators of said plurality of mobile station location estimators include a different one of the following (a) through (f):

- 10 (a) a pattern recognition component for estimating a location of said one mobile station from a pattern in the wireless signal measurements of transmissions between the network and said one mobile station;
- (b) a trainable mobile station location estimating component for estimating a location of said one mobile station, wherein said trainable mobile station location estimating component is capable of being trained to associate: (i) each location of a plurality of geographical locations with (ii) corresponding measurements of wireless signals transmitted between a specified one of said mobile stations and the network, wherein said specified mobile station is approximately at the location;
- 15 (c) a triangulation component for estimating a location of said one mobile station, wherein said triangulation component utilizes said measurements of wireless signals between said one mobile station and three of the base stations for triangulating a location estimate of said one mobile station;
- (d) a statistical component utilizing a statistical regression technique for estimating a location of said one mobile station;
- 20 (e) a mobile base station component for estimating a location of said one mobile station, wherein said mobile base station component utilizes location information received from a mobile base station that detects said one mobile station;
- (f) a negative logic component for estimating an area of where said one mobile station is unlikely to be located; and
- 25 a most likely estimator for determining a most likely location estimate of said one mobile station, said most likely location estimate being a function of said plurality of location estimates.

102. A location system, as claimed in Claim 101, wherein at least one of said mobile station location estimators is activated by an expert system.

103. A location system, as claimed in Claim 101, wherein one or more of said mobile station location estimators are capable of being at least one of: added, replaced and deleted by Internet transmissions between said location system and a site remote from location system.

104. A location system for receiving wireless signal measurements of wireless signals transmitted between a plurality mobile stations and a network of base stations, wherein said base stations in the network are cooperatively linked for providing wireless communication, the improvement characterized by:





00770228.01604

constructing a first set of said measurements for said first location estimator, wherein said first set includes values related to a predictiveness of a collection of mappings between: (a) said corresponding mobile station location estimates, and (b) for each said corresponding mobile station location estimate, a corresponding verified mobile station location;

5 generating, by said first location estimator, a first initial location estimate from wireless signal measurements of wireless signals from transmissions between a first of said mobile stations and the base stations, wherein a location of said first mobile station is unknown;

obtaining an adjusted location estimate of said first mobile station, wherein said adjusted location estimate is obtained by using a subcollection of said mappings in a neighborhood of said first initial location estimate;

10 determining a confidence value related to a likelihood of said first mobile station being at a location represented by said adjusted location estimate, wherein said confidence is a function of at least one measurement in said first set of measurements.

117. A method as claimed in Claim 116, wherein said step of constructing includes simulating locating one of said mobile stations using said corresponding mobile station location estimates and said corresponding verified mobile station locations.

118. A method as claimed in Claim 117, wherein said step of simulating includes performing a Monte Carlo simulation.

15 119. A method for locating wireless mobile stations from measurements of wireless signals transmitted between the mobile stations and a network of base stations, wherein for said network, said base stations in the network are cooperatively linked for providing wireless communication, comprising:

20 storing a plurality of data item collections, wherein for each of a plurality locations, there is one of said data item collections having: (a) a representation of the location, and (b) said wireless signal measurements corresponding to one of said mobile stations transmitting from approximately the location, wherein said wireless signal measurements are acceptable as input to a wireless mobile station location system;

determining a collection of parameters of said wireless mobile station location system that affect a performance of said wireless mobile station location system in locating mobile stations;

25 providing a population of representations for values of said collection of parameters to an adaptation component, wherein said adaptation component: (a) generates, for said representations, configurations of said wireless mobile station location system, each said configuration corresponding to the values of one of said representations, and (b) determines, for each of at least some of said configurations, a location predicting performance using said plurality of data items for providing wireless signal measurements as input and said representations of locations for comparing with mobile station location outputs by the configuration;

determining a first of said configurations that an enhanced performance of said wireless mobile station location system;

30 using said first configuration for deriving a location estimate of a first one said mobile station, wherein said first configuration is provides with wireless signal measurements of wireless signals from transmissions between said first mobile station and the base stations, and wherein a location of said first mobile station is unknown.

120. A method as claimed in Claim A9, wherein said adaptation component includes a genetic algorithm embodiment.

121. A method for locating a wireless mobile station, comprising:



determining a plurality of location estimates of a mobile station, wherein: (a) said location estimates are derived from wireless signal measurements of wireless signals transmitted between the mobile station and a network of base stations, wherein for said network, said base stations in the network are cooperatively linked for providing wireless communication, (b) said location estimates are time ordered;

5 obtaining an additional location estimate of said mobile station using additional wireless signal measurements transmitted between said mobile station and the network of base stations;

deriving at least one derived location estimate of said mobile station that is different from said plurality of location estimates, said derived location estimate obtained using one or more measurements of a behavior of said time ordered location estimates;

10 assigning a likelihood value that said mobile station is at location represented by said additional location estimate as a function of a distance between said additional location and said derived location estimate.

122. A method as claimed in Claim 121, wherein said measurements determine at least one of: a speed of said mobile station, a direction of said mobile station, a change in speed of said mobile station, and a change in direction of said mobile station.

123. A method as claimed in Claim 121 further including a step of assigning a likelihood value to said derived location estimate as a function of a characteristic of an environment of an area containing said plurality of location estimates, wherein said characteristic is expected to affect the behavior of said time ordered location estimates.

15 124. A method as claimed in Claim 123, wherein said characteristic is one of: a traffic route, a waterway, an abrupt change in elevation, a weather condition, a density of buildings having a predetermined height.

09720938-0001

ad/A17



## ABSTRACT

5           A location system is disclosed for commercial wireless telecommunication infrastructures. The system is an end-to-end solution  
having one or more location centers for outputting requested locations of commercially available handsets or mobile stations (MS)  
based on, e.g., CDMA, AMPS, NAMPS or TDMA communication standards, for processing both local MS location requests and more  
global MS location requests via, e.g., Internet communication between a distributed network of location centers. The system uses a  
plurality of MS locating technologies including those based on: (1) two-way TOA and TDOA; (2) pattern recognition; (3) distributed  
10 antenna provisioning; and (4) supplemental information from various types of very low cost non-infrastructure base stations for  
communicating via a typical commercial wireless base station infrastructure or a public telephone switching network. Accordingly,  
the traditional MS location difficulties, such as multipath, poor location accuracy and poor coverage are alleviated via such  
technologies in combination with strategies for: (a) automatically adapting and calibrating system performance according to  
environmental and geographical changes; (b) automatically capturing location signal data for continual enhancement of a self-  
maintaining historical data base retaining predictive location signal data; (c) evaluating MS locations according to both heuristics  
and constraints related to, e.g., terrain, MS velocity and MS path extrapolation from tracking and (d) adjusting likely MS locations  
adaptively and statistically so that the system becomes progressively more comprehensive and accurate. Further, the system can be  
modularly configured for use in location signaling environments ranging from urban, dense urban, suburban, rural, mountain to low  
traffic or isolated roadways. Accordingly, the system is useful for 911 emergency calls, tracking, routing, people and animal location  
including applications for confinement to and exclusion from certain areas.

00770930 042004  
10270 02005200  
20

Type a plus sign (+) inside this box

Patent and Trademark Office: U.S. DEPARTMENT OF COMMERCE

DO/PTO Rev. 6/95  <b>DECLARATION FOR UTILITY OR DESIGN PATENT APPLICATION</b>  <input type="checkbox"/> Declaration Submitted with Initial Filing      OR <input type="checkbox"/> Declaration Submitted after Initial Filing	U.S. Department of Commerce Patent and Trademark Office	Attorney Docket Number	1003-PUB	
		First Named Inventor	KARR, Charles L.	
	<i>COMPLETE IF KNOWN</i>			
		Application Number		
		Filing Date		
		Group Art Unit		
		Examiner Name		

As below named inventor, I hereby declare that:

My residence, post office address, and citizenship are as stated below next to my name.

I believe I am the original, first and sole inventor (if only one name is listed below) or an original, first and joint inventor (if plural names are listed below) of the subject matter which is claimed for which a patent is sought on the invention entitled:

**"LOCATION OF A MOBILE STATION"**

*(Title of the Invention)*

the specification of which

is attached hereto

OR

was filed on (MM/DD/YYYY) 08 September 1997 as United States Application Number or PCT International

Application Number PCT/US97/15892 and was amended on (MM/DD/YYYY)   (if applicable)

I hereby state that I have reviewed and understand the contents of the above identified specification, including the claims, as amended by any amendment specifically referred above.

I acknowledge the duty to disclose information which is material to patentability as defined in Title 37 Code of Federal Regulations, § 1.56.

I hereby claim foreign priority benefits under Title 35, United States Code § 119 (a)-(d) or § 365(b) of any foreign application(s) for patent or inventor's certificate, or §365(a) of any PCT International application which designated at least one country other than the United States of America, listed below and have also identified below, by checking the box, any foreign application for patent or inventor's certificate, or of any Pct International application having a filing date before that of the application on which priority is claimed.

Prior Foreign Application Number(s)	Country	Foreign Filing Date (MM/DD/YYYY)	Priority Not Claimed	Certified Copy Attached?	
				Yes	No
			<input type="checkbox"/> <input type="checkbox"/> <input type="checkbox"/> <input type="checkbox"/> <input type="checkbox"/> <input type="checkbox"/>	<input type="checkbox"/> <input type="checkbox"/> <input type="checkbox"/> <input type="checkbox"/> <input type="checkbox"/> <input type="checkbox"/>	<input type="checkbox"/> <input type="checkbox"/> <input type="checkbox"/> <input type="checkbox"/> <input type="checkbox"/> <input type="checkbox"/>

Additional foreign application numbers are listed on a supplemental priority sheet attached hereto.

I hereby claim the benefit under Title 35, United States Code § 118(e) of any United States provisional application(s) listed below

Application Number(s)	Filing Date (MM/DD/YYYY)		
80/025,855	September 9, 1996	<input type="checkbox"/>	Additional provisional application numbers are listed on a supplemental priority sheet.
80/044,821	April 25, 1997		

FROM

(TUE) 11. 17' 98 13:58

13:58/NO. 3561683465 P 3

Type a plus sign (+) inside this box ->

<b>DECLARATION</b>	Page 2
--------------------	--------

I hereby claim the benefit under Title 35, United States Code § 120 of any United States application(s), or § 365(c) of any PCT International application designating the United States of America, listed below and, insofar as the subject matter of each of the claims of this application is not disclosed in the prior United States or PCT International application in the manner provided by the first paragraph of Title 35, United States Code § 112.1 acknowledge the duty to disclose information which is material to patentability as defined in Title 37, Code of Federal Regulations § 1.55 which became available between the filing date of the prior application and the national or PCT International filing date of this application.

U.S. Parent Application Number	PCT Parent Number	Parent Filing Date (MM/DD/YYYY)	Parent Patent Number (if applicable)

Additional U.S. or PCT International application numbers are listed on a supplemental priority sheet attached hereto.

As a named inventor, I hereby appoint the following attorney(s) and/or agent(s) to prosecute this application and to transact all business in the Patent and Trademark Office connected therewith:

Firm Name OR  List attorney(s) and/or agent(s) name and registration number below.

Customer Number or label

Name	Registration Number	Name	Registration Number

Additional attorney(s) and/or agent(s) named on a supplemental sheet attached hereto

Please direct all correspondence to:  Customer Number or label OR  Fill in correspondence address below

Name: DENNIS J. DUPRAY

Address: 222 SOUTH MARION PARKWAY

City: DENVER State: COLORADO Zip: 80208

Country: UNITED STATES OF AMERICA Telephone: (303) 863-9700 Fax: (303) 863-0223

I hereby declare that all statements made herein of my own knowledge are true and that all statements made on information and belief are believed to be true; and further that these statements were made with the knowledge that willful false statements and the falsification made are punishable by fine or imprisonment, or both, under Section 1001 of Title 18 of the United States Code and that such willful false statements may jeopardize the validity of the application or any patent issued thereon.

Name of Sole or First Inventor:  A petition has been filed for this unsigned inventor

Given Name: CHARLES Middle Initial: L Family Name: KARR Suffix: e.g. Jr.

Inventor's Signature: *Charles H. Karr* Date: 11/17/98

Residence City: Tuscaloosa State: Alabama Country: USA Citizenship: USA

Post Office Address: 400 Sandbrook Lane

City: Tuscaloosa State: Alabama

FROM

(TUE) 11. 17' 98 13:58

13:58/NO. 3561683465 P 4

Type 0 Pass Copy (0) Enter into box ->

DECLARATION										Assignment Number(s) Supplemental Check		
Name of Additional Joint Inventor, if any.										<input type="checkbox"/> A petition has been filed for this unassigned inventor		
Given Name	DENNIS			Initial	D.		Family Name	DUPRAY		Suffix O.G. Jr.		
Inventor's Signature	<i>Dennis J. Dupray</i>								Date	Nov. 24, 1998		
Residence City	DENVER			State	COLORADO		Country	USA		Citizenship USA		
Post Office Address	222 SOUTH MARION PARKWAY											
Post Office Address	222											
City	DENVER			State	COLORADO		Zip	80202		Country	USA	
Name of Additional Joint Inventor, if any.										<input type="checkbox"/> A petition has been filed for this unassigned inventor		
Given Name				Initial			Family Name			Suffix O.G. Jr.		
Inventor's Signature									Date			
Residence City				State			Country			Citizenship		
Post Office Address												
Post Office Address												
City				State			Zip			Country		
Name of Additional Joint Inventor, if any.										<input type="checkbox"/> A petition has been filed for this unassigned inventor		
Given Name				Initial			Family Name			Suffix O.G. Jr.		
Inventor's Signature									Date			
Residence City				State			Country			Citizenship		
Post Office Address												
Post Office Address												
City				State			Zip			Country		
Name of Additional Joint Inventor, if any.										<input type="checkbox"/> A petition has been filed for this unassigned inventor		
Given Name				Initial			Family Name			Suffix O.G. Jr.		
Inventor's Signature									Date			
Residence City				State			Country			Citizenship		
Post Office Address												
Post Office Address												
City				State			Zip			Country		

DRS

PATENT APPLICATION SERIAL NO. \_\_\_\_\_

U.S. DEPARTMENT OF COMMERCE  
PATENT AND TRADEMARK OFFICE  
FEE RECORD SHEET

01/31/2001 VYANG1 00000069 09770838

01 FC:201	355.00	OP
02 FC:203	684.00	OP
03 FC:202	80.00	OP

PTO-1556  
(5/87)

\*U.S. GPO: 2000-468-987/39595

**PATENT APPLICATION FEE DETERMINATION RECORD**  
Effective October 1, 2000

Application or Docket Number

09770838

**CLAIMS AS FILED - PART I**

	(Column 1)	(Column 2)
TOTAL CLAIMS	96	
FOR	NUMBER FILED	NUMBER EXTRA
TOTAL CHARGEABLE CLAIMS	96 minus 20 =	* 76
INDEPENDENT CLAIMS	5 minus 3 =	* 2
MULTIPLE DEPENDENT CLAIM PRESENT <input type="checkbox"/>		

**SMALL ENTITY TYPE**  OR

**OTHER THAN SMALL ENTITY**

RATE	FEE
BASIC FEE	355.00
X\$ 9=	684
X40=	80
+135=	
TOTAL	1119

RATE	FEE
BASIC FEE	710.00
X\$18=	
X80=	
+270=	
TOTAL	

\* If the difference in column 1 is less than zero, enter "0" in column 2

**CLAIMS AS AMENDED - PART II**

	(Column 1)	(Column 2)	(Column 3)
<b>AMENDMENT A</b>	CLAIMS REMAINING AFTER AMENDMENT	HIGHEST NUMBER PREVIOUSLY PAID FOR	PRESENT EXTRA
	Total * 75	Minus ** 96	=
	Independent * 11	Minus *** 12	=
FIRST PRESENTATION OF MULTIPLE DEPENDENT CLAIM <input type="checkbox"/>			

**SMALL ENTITY** OR

**OTHER THAN SMALL ENTITY**

RATE	ADDITIONAL FEE
X\$ 9=	
X40=	42.00
+135=	
TOTAL ADDIT. FEE	42.00

RATE	ADDITIONAL FEE
X\$18=	
X80=	
+270=	
TOTAL ADDIT. FEE	

	(Column 1)	(Column 2)	(Column 3)
<b>AMENDMENT B</b>	CLAIMS REMAINING AFTER AMENDMENT	HIGHEST NUMBER PREVIOUSLY PAID FOR	PRESENT EXTRA
	Total * 75	Minus ** 96	=
	Independent * 12	Minus *** 12	=
FIRST PRESENTATION OF MULTIPLE DEPENDENT CLAIM <input type="checkbox"/>			

RATE	ADDITIONAL FEE
X\$ 9=	
X40=	
+135=	
TOTAL ADDIT. FEE	

RATE	ADDITIONAL FEE
X\$18=	
X80=	
+270=	
TOTAL ADDIT. FEE	

	(Column 1)	(Column 2)	(Column 3)
<b>AMENDMENT C</b>	CLAIMS REMAINING AFTER AMENDMENT	HIGHEST NUMBER PREVIOUSLY PAID FOR	PRESENT EXTRA
	Total *	Minus **	=
	Independent *	Minus ***	=
FIRST PRESENTATION OF MULTIPLE DEPENDENT CLAIM <input type="checkbox"/>			

RATE	ADDITIONAL FEE
X\$ 9=	
X40=	
+135=	
TOTAL ADDIT. FEE	

RATE	ADDITIONAL FEE
X\$18=	
X80=	
+270=	
TOTAL ADDIT. FEE	

\* If the entry in column 1 is less than the entry in column 2, write "0" in column 3.  
 \*\* If the "Highest Number Previously Paid For" IN THIS SPACE is less than 20, enter "20".  
 \*\*\* If the "Highest Number Previously Paid For" IN THIS SPACE is less than 3, enter "3".  
 The "Highest Number Previously Paid For" (Total or Independent) is the highest number found in the appropriate box in column 1.

BEST AVAILABLE COPY

MULTIPLE DEPENDENT CLAIM FEE CALCULATION SHEET (FOR USE WITH FORM PTO-875)							SERIAL NO.	FILING DATE				
							APPLICANT(S)					
CLAIMS												
AS FILED		AFTER 1st AMENDMENT		AFTER 2nd AMENDMENT		*		*		*		
IND.	DEP.	IND.	DEP.	IND.	DEP.	IND.	DEP.	IND.	DEP.	IND.	DEP.	
01						51						
02						52						
03						53						
04						54						
05						55						
06						56						
07						57						
08						58						
09						59						
10						60						
11						61						
12						62						
13						63						
14						64						
15						65						
16						66						
17						67						
18						68						
19						69						
20						70						
21						71						
22						72						
23						73						
24						74						
25						75						
26						76						
27						77						
28						78						
29						79						
30						80						
31						81						
32						82						
33						83						
34						84						
35						85						
36						86						
37						87						
38						88						
39						89						
40						90						
41						91						
42						92						
43						93						
44						94						
45						95						
46						96						
47						97						
48						98						
49						99						
50						100						
TOTAL IND.						TOTAL IND.						
TOTAL DEP.						TOTAL DEP.						
TOTAL CLAIMS						TOTAL CLAIMS						

\* MAY BE USED FOR ADDITIONAL CLAIMS OR ADMENDMENTS

FORM PTO-1360 (REV. 3-78)

U.S. DEPARTMENT OF COMMERCE  
Patent and Trademark Office



MULTIPLE DEPENDENT CLAIM FEE CALCULATION SHEET (FOR USE WITH FORM PTO-875)							SERIAL NO.	FILING DATE
							APPLICANT(S)	
CLAIMS								
	AS FILED		AFTER 1st AMENDMENT		AFTER 2nd AMENDMENT		*	
	IND.	DEP.	IND.	DEP.	IND.	DEP.	IND.	DEP.
201		1						
202		1						
203		1						
204		1						
205		1						
206		1						
207	1							
208		1						
209		1						
210		1						
211		1						
212		1						
213	1							
214		1						
215		1						
216		1						
217		1						
218		1						
219		1						
220		1						
221								
22								
23								
24								
25								
26								
27								
28								
29								
30								
31								
32								
33								
34								
35								
36								
37								
38								
39								
40								
41								
42								
43								
44								
45								
46								
47								
48								
49								
50								
TOTAL IND.	5	↓		↓		↓		↓
TOTAL DEP.	91	↓		↓		↓		↓
TOTAL CLAIMS	96							
51								
52								
53								
54								
55								
56								
57								
58								
59								
60								
61								
62								
63								
64								
65								
66								
67								
68								
69								
70								
71								
72								
73								
74								
75								
76								
77								
78								
79								
80								
81								
82								
83								
84								
85								
86								
87								
88								
89								
90								
91								
92								
93								
94								
95								
96								
97								
98								
99								
100								
TOTAL IND.		↓		↓		↓		↓
TOTAL DEP.		↓		↓		↓		↓
TOTAL CLAIMS								

\* MAY BE USED FOR ADDITIONAL CLAIMS OR ADMENDMENTS

FORM PTO-1360 (REV. 3-78) U.S. DEPARTMENT OF COMMERCE  
Patent and Trademark Office

#2  
3-20-02  
DRS  
PreA

PATENT APPLICATION

In Re the Application of:

DUPRAY et al.

Serial No.: Not Yet Assigned

Filed: Filed Herewith

Atty. File No.: 1003-1

For: "LOCATION OF A MOBILE STATION"

Assistant Commissioner for Patents  
Washington, D.C. 20231

Prior Group Art Unit: 3662

Prior Examiner: Dao Phan

PRELIMINARY AMENDMENT

EXPRESS MAIL MAILING LABEL NUMBER:  
DATE OF DEPOSIT: January 26, 2001

I HEREBY CERTIFY THAT THIS PAPER OR FEE IS BEING DEPOSITED WITH THE UNITED STATES POSTAL SERVICE "EXPRESS MAIL POST OFFICE TO ADDRESSEE" SERVICE UNDER 37 CFR 1.10 ON THE DATE INDICATED ABOVE AND IS ADDRESSED TO THE ASSISTANT COMMISSIONER FOR PATENTS, WASHINGTON, D.C. 20231.

TYPED OR PRINTED NAME: Chasity C. Rossum

SIGNATURE: *Chasity C. Rossum*

Dear Sir:

Prior to the initial review of the above-identified patent application by the Examiner, please enter the following Preliminary Amendment. Although Applicants do not believe that any fees are due based upon the filing of this Preliminary Amendment, please charge any such fees to Deposit Account 19-1970.

Please amend the above-identified patent application as follows:

IN THE SPECIFICATION:

Please change the title to WIRELESS LOCATION USING SIGNAL FINGERPRINTING.

A1

Please insert the following paragraph immediately after the title:

A2

The present patent application is a continuation of co-pending U.S. Application No. 09/194,367 filed November 24, 1998, which claims the benefit of International Application No. PCT/US97/15892 filed September 8, 1997, which in turn claims the benefit of the following U.S. Provisional Applications: U.S. Provisional Application No. 60/056,590 filed August 20, 1997; U.S. Provisional Application No. 60/044,821 filed April 25, 1997; and U.S. Provisional Application 60/025,855 filed September 9, 1996. Accordingly, the benefit of each of the above applications are hereby claimed, and each of the above applications are herein fully incorporated by reference.--

On page 11, line 33, please delete "network" and insert network 124 therefor.

189

*A*

A3 On page 12, lines 15, after "PCT patent application" please insert -PCT/US97/15933, filed September 8, 1997 and-.

A4 On page 12, line 16, please replace "; this co-pending PCT patent application" with -which has a corresponding U.S. national patent application filing with the same title and having U.S. Patent Application Serial No. 09/230,109 filed January 22, 1999; these two patent applications--therefor.

A5 On page 15, line 30, after "Gilhausen et al." please insert -filed November 7, 1989;--.

On page 18, line 9, please delete "dead reckoning data" and insert -deadreckoning data--therefor.

On page 18, lines 9 through 10, please delete "dead reckoning devices" and insert -deadreckoning devices--therefor.

On page 19, line 7, please delete "Fig. 8)" and insert -Figs. 8)--therefor.

On page 21, line 13, please start a new paragraph with the sentence beginning with the phrase "Further features and advantages ..." therefore.

On page 22, line 6, please delete "Provider network" and insert -Provider (CMRS) network--therefor.

On page 28, line 18, please delete "MBS 148 of" and insert -MBS 148b-- therefor.

(NE) On page 29, line 21, please start a new paragraph with the sentence beginning with the phrase "Thus, LBSs 152 may be...".

A6 On page 29, line 28, please delete "interface 136 (Fig. 4), or L-API, is" and insert -interface or L-API 14 (see Fig. 30), and which includes L-API-Loc\_APP 135, L-API-MSC 136, and L-API-SCP 137 shown in Fig. 4, is--therefor.

On page 29, line 31, please delete "API should be" and insert -API 14 should be--therefor.

On page 30, line 8, please delete "idintification" and inert -identification--therefor.

✓ On page 30, line 12, please delete "(Fig. 1)" and insert ~~-(Fig. 4)--~~therefor.

✓ On page 30, line 25, please delete "locations area different" and insert ~~-locations are different--~~therefor.

✓ On page 30, line 26, please delete "say less" and insert ~~-of say less--~~ therefor.

✓ On page 30, line 26, please delete "and there multipath" and insert ~~-and their multipath--~~therefor.

✓ On page 31, line 25, please delete "similiarly" and insert ~~-similarly--~~ therefor.

✓ On page 31, line 26, please delete "direction-independent" and insert ~~-direction independent of--~~therefor.

A7 ✓ On page 31, line 26, please delete "is derived which is" and insert ~~-can be derived which can be--~~therefor.

✓ On page 31, line 34, please delete "scenter" and insert ~~-center--~~ therefor.

✓ On page 32, line 3, please delete "to accuracy" and insert ~~-the accuracy--~~ therefor.

✓ On page 32, line 4, please delete "Location center" and insert ~~-location center--~~ therefor.

A8 ✓ On page 32, line 24, please delete "Processing Subsystem" and insert ~~-Processing Subsystem 1220 (also shown in Figs. 5, 6 and 8)--~~ therefor.

✓ On page 33, line 3, please delete "subsystem supports" and insert ~~-subsystem 1220 supports--~~therefor.

✓ On page 33, line 4, please delete "provided bt the location" and insert ~~-provided by the location--~~therefor.

A9 ✓ On page 33, line 4, please delete "programming interface" and insert ~~-programming interface (L-API 14 (Fig. 30)--~~therefor.

✓ On page 33, line 7, please delete "charactersitics. Similiarly, a" and insert ~~-characteristics. Similarly, a--~~therefor.

On page 33, line 11, after the word "messages" but before the word "autonomously", please insert (of L-  
API-SCP interface 137, Fig. 4)--.

A 10

✓ On page 33, line 12, please delete "detemines" and insert --determines-- therefor.

✓ On page 33, line 12, please delete "that the message" and insert --whether such a message--therefor.

✓ On page 33, line 14, please delete "queu 21" and insert --queue 21-- therefor.

(NE) On page 33, line 19, please start a new paragraph with the sentence beginning with the phrase "Output queue(s) 21 are required..." therefor.

✓ On page 33, line 20, please delete "estimate modules" and insert --estimate modules 1224--therefor.

✓ On page 33, line 25, please delete "measurments" and insert --measurements-- therefor.

✓ On page 33, line 26, please delete "internet 168 location" and insert --internet 468 location--therefor.

✓ On page 33, line 26, please delete "Fig. 1" and insert --Fig. 5-- therefor.

✓ On page 33, line 28, please delete "Fig. 1" and insert --Fig. 30--therefor.

✓ On page 33, line 29, please delete "by specifying" and insert --by specifying-- therefor.

✓ On page 34, line 6, please delete "identication" and insert --identification-- therefor.

✓ On page 34, line 7, please delete "communicaiton" and insert --communication--therefor.

✓ On page 34, line 26, please delete "measurements" and insert --measurements-- therefor.

✓ On page 34, line 28, please delete "Fig. 1" and insert --Fig. 4--therefor.

✓ On page 34, line 29, please delete "second case the" and insert --second case, the--therefor.

105210-260260

- ✓ On page 35, line 1, please delete "Fig. 1" and insert -Fig. 4-- therefor.
- ✓ On page 35, line 2, please delete "(L-API)" and insert -(L-API 14)-- therefor.
- ✓ On page 35, line 9, please delete "occurring" and insert -occurring-- therefor.
- ✓ On page 35, line 13, please delete "as wall as" and insert -as well as-- therefor.
- ✓ On page 35, line 23, please delete "The table below establishes" and insert -A table may establish-- therefor.
- ✓ On page 35, line 25, please delete "The MIN" and insert -the MIN-- therefor.
- ✓ On page 36, line 3, please delete "maximum Number" and insert -maximum number-- therefor.
- ✓ On page 36, line 9, please delete "(for example, see Fig. 36)" therefor.
- ✓ On page 36, line 10, please delete "(Fig. 1)" and insert -(Fig. 4)-- therefor.
- ✓ On page 36, line 11, please delete "processning" and insert -processing-- therefor.
- ✓ On page 36, line 12, please delete "table 11. if the data" and insert -table 11. If the data—therefor.
- ✓ On page 36, line 18, please delete "a location" and insert -another location-- therefor.
- ✓ On page 36, line 18, please delete "L-API-CCS 139" and insert -L-API-CCS 239-- therefor.
- ✓ On page 36, line 19, please delete "L-API-CCS 139" and insert -L-API-CCS 239--therefor.
- ✓ On page 36, line 24, please delete "1155b" and insert -155b—therefor.
- ✓ On page 36, line 28, please delete "L-API-CCS" and insert -L-API-CCS 239-- therefor.
- ✓ On page 37, line 15, please delete "arc" and insert -area-- therefor.

*a*

✓ On page 37, line 17, please delete “the” and insert –an-- therefor.

✓ On page 38, line 17, please delete “emsemble” and insert –ensemble-- therefor.

✓ On page 39, line 13, please delete “applications 1232 (Fig. 2.0)” and insert –applications 146 (Fig. 5)-- therefor.

✓ On page 44, line 1, please delete “second deviation” and insert –second standard deviation—therefor.

✓ On page 44, line 2, please delete “second deviation” and insert –second standard deviation-- therefor.

✓ On page 47, line 13, please delete “gardless” and insert –regardless-- therefor.

✓ On page 49, lines 29 through 30, please delete “(as will be described in more detail hereinbelow)”.

✓ On page 52, line 20, please delete “Fig. 8 illustrates another, more detail” and insert  –Figs. 8 illustrates another, more detailed-- therefor.

A11

✓ On page 53, line 12, after “hypotheses” but before “determined”, please insert –that are--.

✓ On page 53, line 29, please delete “be used to both location a target” and insert  –be used to both locate a target-- therefor.

A12

✓ On page 54, line 16, please delete “telephone network” and insert –telephone network 124—therefor.

✓ On page 54, line 19, please delete “telephone network” and insert –telephone network 124--therefor.

✓ On page 54, line 26, please delete “uniform input” and insert –uniform input interface-- therefor.

✓ On page 56, line 1, please delete “an FOM” and insert –a FOM-- therefor.

✓ On page 61, line 14, please delete “network and Internet 1362” and insert  –network 124 and Internet 468-- therefor.

A13

On page 61, line 14, please delete "are due" and insert ~~area due~~ therefor.

On page 61, line 17, please delete "the Internet" and insert ~~the Internet 468~~ therefor.

On page 61, line 21, please delete "Internet location" and insert ~~Internet 468 location~~ therefor.

On page 61, line 25, please delete "Fig. 6 (a) - (b) above" and insert ~~Fig. 6, (a) - (b) above~~ therefor.

On page 61, line 28, please delete "must be provided".

On page 61, line 29, please delete "the particular" and insert ~~a particular~~ therefor.

On page 63, line 8, please delete "Taking CDMA" and insert ~~Taking a CDMA~~ therefor.

On page 63, line 29, please delete "may filtering" and insert ~~by filtering~~ therefor.

On page 65, line 1, please delete "One embodiment," and insert ~~In one embodiment,~~ therefor.

On page 66, line 3, please delete "partial least squares, ".

On page 66, line 17, please delete "for automatically for detecting" and insert ~~for automatically detecting~~ therefor.

On page 66, line 18, please delete "cells of the radio" and insert ~~cells on the radio~~ therefor.

On page 67, line 2, please delete "but addition to" and insert ~~but in addition to~~ therefor.

On page 69, line 14, please delete "delay vs. signal" and insert ~~delay versus signal~~ therefor.

On page 69, line 17, please delete "axes" and insert ~~axes~~ therefor.

On page 70, line 13, please delete "either:" and insert ~~one of~~ therefor.

On page 70, line 15, please delete "for example," and insert ~~for example, a collection B of~~ therefor.



✓ On page 71, line 8, please delete “signature (i.e., 35 inputs” and insert –signature; i.e., 35 inputs— therefor.

✓ On page 71, line 9, please delete “related type of” and insert – related to the type of-- therefor.

✓ On page 71, line 12, please delete “(or less) may be used.,” and insert –(or less) may be used.—therefor.

✓ On page 73, line 14, please delete “Gaussian” and insert –Gaussian-- therefor.

✓ On page 80, line 21, please delete “(b)” and insert –(b1)-- therefor.

✓ On page 85, line 32, please delete “Fig. 243” and insert –Fig. 24-- therefor.

✓ On page 102, line 22, please delete “air planes” and insert –airplanes-- therefor.

✓ On page 104, line 24, please delete “142S” and insert –142-- therefor.

✓ On page 106, line 29, please delete “142. May have multiple” and insert –142. Moreover, also note that there may be multiple-- therefor.

✓ On page 107, line 3, please delete “to appear to perform” and insert –to perform-- therefor.

✓ On page 109, line 32, please delete “dead reckoning” and insert –deadreckoning-- therefor.

✓ On page 111, line 1, please delete “changes direction” and insert –changes in direction-- therefor.

✓ On page 115, line 16, please delete “into the location” and insert –into one of the location--therefor.

✓ On page 120, line 20, please delete “MBS location” and insert –MS location-- therefor.

✓ On page 120, line 23, please delete “MBS moving” and insert –MS moving-- therefor.

✓ On page 124, line 9, please delete “decrease” and insert –decreases-- therefor.

✓ On page 132, line 31, please delete “curr\_est.confidence” and insert –curr\_est.confidence--therefor.

IN THE CLAIMS:

✓ Please cancel Claim 1-124 without prejudice to or disclaimer of the subject matter contained therein, and add the following new claims:

A17

125. A method for estimating, for each mobile station MS of a plurality of mobile stations, a location, L for MS using wireless signal measurements obtained from transmissions between the mobile station MS and a plurality of terrestrial communication stations, wherein each of said communications stations has one or more of each of a transmitter and a receiver for wirelessly communicating with the mobile station MS, comprising:  
5 first receiving a request for locating the mobile station MS;  
second receiving, in response to said step of first receiving, one or more location hypotheses of the mobile station MS, wherein each location hypothesis includes a representation of a location estimate of the mobile station MS, and wherein said one or more location hypotheses are  
10 determined using one or more MS location related outputs from one or more of location information determiners, wherein (A1) – (A2) following hold:

(A1) for determining a corresponding portion of the location related outputs for the mobile station MS, each of said one or more location information determiners is dependent upon (I) and (II) following:

(I) at least some of a plurality of data instances, wherein, for each of a plurality of geographical locations, there is one of the data instances having, (i) and (ii) following:

- (i) a representation of the geographical location, and
- (ii) multipath information of wireless signal data obtained using transmissions between one of the mobile stations and the communication stations, wherein the one mobile station transmits from approximately the geographical location of (i); and

(II) multipath data indicative of wireless signal multipath transmissions between the MS and the communication stations;

(A2) for each representation of a location estimate from said location information determiners, there is a corresponding collection of wireless receivers of the communication stations from which multipath data indicative of wireless signal multipath transmissions between MS and the corresponding collection of receivers are used by the location information determiner for determining its location

10270-8280460

687-A17

FOSEP 880260

related outputs, wherein for at least a first and a second representation of location estimates, their corresponding collections are different; transmitting, to a predetermined destination, via a communications network, resulting information related to the location of the mobile station MS, wherein said resulting information is obtained from said one or more MS location estimates of said location hypotheses.

126. The method of Claim 125, further including, determining the first representation of a location of MS by using, in addition to the multipath data from the corresponding collections of receivers, other wireless signal data indicative of wireless communication between the MS, and one or more of the receivers outside of the corresponding collection for the first representation.

127. The method of Claim 125, wherein the first and second representations are provided by different first and second of the location information determiners.

128. The method of Claim 127, wherein for each of said first and second location information determiners there is a corresponding geographical area wherein substantially throughout the area, the location information determiner is able to determine an instance its portion of the location related outputs, and wherein the corresponding geographical areas for the first and second location information determiners are different.

129. The method of Claim 125, wherein each of the one or more location hypotheses includes one or more of:

- (a) a value indicative of a likelihood of the MS being at the location estimate represented by the location hypothesis;
- (b) an identifier for identifying the MS;
- (c) a representation of a likely point location of the MS;
- (d) a representation of a geographical area containing the MS;
- (e) an identification of one or more cells of a geographical partition, wherein the cells include a location estimate of MS;
- (f) a timestamp indicative of when the wireless signal multipath transmission were received at the communication stations



cont A17

FOR F0620250

138. The method of Claim 125, further including a step of calibrating for at least some of the plurality geographical locations, (A1)(I)(i) with (A1)(I)(ii) using wireless signal transmissions to a GPS receiver substantially co-located with the one mobile station.

139. The method of Claim 125, wherein said step of second receiving includes a step of at least one of the location information determiners determining a value according to a consistency between (B1) and (B2) following:

- 5 (B1) values that are a function of at least one of: a signal strength and a signal time delay of wireless signals between said mobile station MS and the communication stations, and
- (B2) values that are a function of at least one of signal strength and a signal time delay of wireless signals provided by multipath information of (A1)(I)(ii) for at least a collection of some of the data instances;
- 10 wherein an output from the determining step is dependent upon the representations (A1)(I)(i) of the collection of data instances.

140. The method of Claim 125, wherein at least some of said communication stations are substantially co-located with base stations of a commercial mobile radio service provider (CMRS), wherein each of said base stations support two way voice communication with the mobile stations via a plurality antennas at said base station, and the two way voice  
5 communication is provided by one of the following wireless transmission techniques: CDMA, TDMA, GSM, AMPS, and NAMPS.

141. The method of Claim 140, wherein at least some of said communication stations operatively use wireless transceivers at said base stations, wherein said transceivers support the two way voice communication with the mobile stations.

142. The method of Claim 125, wherein said one or more location related outputs are for substantially a same location of the mobile station MS, and further including a step of resolving location ambiguities between different MS location estimates obtained from the one or more location related outputs.

CONFIDENTIAL

109210-2280260

143. The method of Claim 140, wherein said one or more location related outputs are for substantially a same location of the mobile station MS, and further including a step of resolving location ambiguities between different MS location estimates obtained from the one or more location related outputs.

144. The method of Claim 143, wherein said step of resolving includes determining for each of one or more of said location information determiners, one or more of:

- (a) a corresponding likelihood value that said mobile station MS is within one of the location estimates obtained from the one or more location related outputs;
- 5 (b) a condition related to a corresponding velocity or change of velocity of the mobile station MS coinciding with one of the location estimates obtained from the one or more location related outputs;
- (c) a condition related to a corresponding terrain of one of the location estimates obtained from the one or more location related outputs; and
- 10 (d) a consistency with a previous location estimate of the mobile station MS.

145. The method of Claim 125, further including a step of resolving ambiguities between location estimates of the MS by performing a most likely location estimation procedure dependent upon said location estimates.

146. The method of Claim 145, wherein said step of performing a most likely location estimation procedure includes determining for each of one or more cells of a predetermined partitioning of an area containing said one or more location estimates, a value indicative of a likelihood of the mobile station MS being in the cell.

147. The method of Claim 143, wherein said step of resolving includes for at least one of said location information determiners performing a statistical technique for determining a likelihood of the mobile station MS being in an MS location estimate output by the at least one location information determiner.

148. The method of Claim 142, wherein said step of resolving includes detecting a clustering of at least some of said location estimates obtained from the one or more location related outputs for determining a most likely location of the mobile station MS.

cont A17

FOR BEB0260

149. The method of Claim 125, wherein at least one of said location information determiners (LID) uses input identifying of one of:

- (a) additional of said receivers not included in the corresponding receivers for LID that detect the mobile station MS, and
- 5 (b) additional communication station transmitters not included in the corresponding receivers for LID that are detected by the mobile station MS.

150. The method of Claim 125, wherein at least some of said receivers are included in a base station network of a commercial mobile radio service provider, wherein there is a further step of requesting the mobile station MS to raise its transmission power.

151. The method of Claim 125, further including a step of calibrating at least one of said location information determiners using said plurality of data instances.

152. The method of Claim 125, wherein said step of transmitting includes outputting said resulting information using one of a public switched network and the Internet.

153. The method of Claim 125, wherein said step of first receiving includes obtaining the request from the Internet.

154. The method of Claim 125, wherein said step of first receiving includes requesting a location of the mobile station MS for one or more of:

- (1) locating a vehicle;
- (2) locating an emergency caller;
- 5 (3) routing a vehicle;
- (4) locating a child;
- (5) locating livestock;
- (6) tracking a vehicle; and
- (7) locating a parolee.

155. The method of Claim 125, further including a step of determining the resulting information by snapping an intermediate location estimate for the MS, obtained from the MS location estimates, to a vehicle route near the intermediate location estimate.

contA7

FOSEFO-8260260

156. The method of Claim 125, further including the steps of:  
requesting location information for the mobile station MS from one or more mobile station location evaluators, wherein said location evaluators determine information related to one or more location estimates of said mobile station MS when said location estimators are supplied with corresponding input data having values obtained using wireless signals obtained via transmissions between said mobile station MS and the communication stations, wherein the one or more location evaluators perform one or more of the following steps:

- 5 (B1) estimating a location of said mobile station MS using values from a corresponding instance of said input data obtained from timing signals received at the mobile station MS from one or more satellites;
- 10 (B2) determining at least one location area or locus for said mobile station MS using timing measurements from a corresponding instance of said input data, wherein the timing measurements are indicative of one of: a time of arrival of wireless signals, and a time difference of arrival of wireless signals, wherein the wireless signals are transmitted between the mobile station MS and at least one communication station CS<sub>1</sub>, wherein the signals for obtaining the timing measurements are communicated during a plurality of wireless signal transmissions between the mobile station and CS<sub>1</sub>, with at least one of the transmissions being from the mobile station to CS<sub>1</sub>;
- 15 (B3) determining, for at least some one of the communication stations CS<sub>2</sub>, a wireless signal angle of arrival that is indicative of an angular orientation about the communication station CS<sub>2</sub> of a direction of the wireless signal to CS<sub>2</sub> from the mobile station MS;
- 20

obtaining, in response to the step of requesting, at least one output related to a location of the mobile station MS from said one or more location estimators, wherein at least one of the steps (B1) through (B3) is performed;

determining the resulting location information related to the mobile station MS using at least one of: (a) a value obtained from said output related to the location of MS, and (b) said one or more MS location estimates of said location hypotheses.

157. The method of Claim 125, further including the steps of:  
requesting a location information for the mobile station MS from a mobile station location evaluator, wherein said location evaluator determines information related to one or more location estimates of said mobile station MS when said location estimator is supplied with

a



Case 1:10-cv-00260

5 corresponding input data having values obtained by accessing wireless signals from transmissions between said mobile station MS and the communication stations, wherein the location evaluator performs the following step:

determining a statistical correlation for correlating (i) and (ii) following:

- 10 (i) values obtain from the corresponding input data, and
- (ii) information indicative of: a plurality of collections of wireless information between the communication stations and some one of the mobile stations, wherein for each of the collections, the wireless information includes one or more of the following data items:
  - 15 (a) a make and model of the some one mobile station;
  - (b) a representation of a location of the some one mobile station;
  - (c) a value indicative of a consistency of the collection with other collections;
  - (d) a value indicative of a signal strength and signal time delay measurement for wireless signal communications between one of the communication stations and the some mobile station at the location represented in (b);
  - 20 (e) a value indicative of a wireless signal frequency for wireless signal communications between one of the communication stations and the some mobile station at the location represented in (b);
  - (f) one or more wireless signal quality or error measurements of the wireless signal communications between one of the communication stations and the some mobile station at the location represented in (b);
  - 25 (g) a value indicative of a noise ceiling of the wireless signal communications between one of the communication stations and the some mobile station at the location represented in (b);
  - 30 (h) a value indicative of a transmission power level of one or more of the one communication station in (e), and the some one mobile station;

wherein said correlation is used for determining that the mobile station MS is within a corresponding geographic area;

35 obtaining, in response to the step of requesting, at least one output related to a location of the mobile station MS from said one or more location estimators, said determining step is performed;

determining the resulting location information related to the mobile station MS using at least one of: (a) a value obtained from said output related to the location of MS, and (b) said one or more MS location estimates of said location hypotheses.

158. An apparatus for estimating, for each mobile station MS of a plurality of mobile stations, a location, L for MS using wireless signal measurements obtained from transmissions between the mobile station MS and a plurality of terrestrial communication stations, wherein each of said communications stations has one or more of each of a transmitter and a receiver for wirelessly communicating with the mobile station MS, comprising:

one or more data repositories having a plurality of data instances, wherein, for each of a plurality geographical locations, there is one of the data instances having, (i) and (ii) following:

- (i) a representation of the geographical location, and
- (ii) multipath information of wireless signal data obtained using transmissions between one of the mobile stations and the communication stations, wherein the one mobile station transmits from approximately the geographical location of (i);

one or more of location information determiners for determining one or more MS location estimates, wherein (A1) – (A2) following hold:

(A1) for determining a corresponding portion of the location estimates for the mobile station MS, each of said one or more location information determiners is dependent upon (I) and (II) following:

- (I) at least some of a plurality of data instances from the one or more data repositories;
- (II) multipath data indicative of wireless signal multipath transmissions between the MS and the communication stations;

(A2) for each location estimate from said location information determiners, there is a corresponding collection of wireless receivers of the communication stations from which multipath data indicative of wireless signal multipath transmissions between the MS and the corresponding collection of receivers are used by the location information determiner for determining an MS location estimate, wherein for at least a first and a second MS location estimates, their corresponding collections are different;

an output interface operably connected to at least one communications network for transmitting, to a predetermined destination, resulting information related to the location of the

cert ALZ

403270-3E802600

a

sent AT7

FOR THE RECORD

mobile station MS, wherein said resulting information is obtained using said one or more MS location estimates.

159. The apparatus of Claim 158, wherein the first and second MS location estimates are provided by different first and second of the location information determiners.

160. The apparatus of Claim 158, wherein at least one of the location information determiners determines a similarity between (i) and (ii) following: (i) the multipath data of (A1)(II), and (ii) the multipath information of (A1)(I)(ii) for a collection of one or more of the geographical locations.

161. The apparatus of Claim 160, wherein: (a) the mobile station MS is land borne, (b) the communication stations and the mobile station MS communicate using one of: CDMA, TDMA, GSM, AMPS, and NAMPS, and (c) the communications network is one of a public switched telephone network and the Internet.

162. The apparatus of Claim 158, wherein the first and second MS location estimates are for different locations of the MS.

163. The apparatus of Claim 159, wherein the first and second MS location estimates are for the same MS location.

164. The apparatus of Claim 158, further including an ambiguity resolver for resolving MS location ambiguity when there is a plurality of MS location estimates from the location information determiners.

165. The apparatus of Claim 164, wherein the resolver includes a most likelihood estimator for determining a most likely location of the MS obtained from the plurality MS location estimates.

166. The apparatus of Claim 164, wherein for a current instance of locating the MS, the resolver includes an adjuster for providing another MS location estimate that is dependent upon: (a) at least one of the plurality of MS location estimates obtained from a first of the location

CONFIDENTIAL

5 information determiners, and (b) a previous performance of the first location information determiner.

167. The apparatus of Claim 158, further including a storage for storing previously determined MS location estimates so that the MS is able to be tracked.

168. The apparatus of Claim 158, wherein further including an MS location information analyzer for determining an MS location attribute, including one or more of:

- (a) one or more of a velocity and acceleration estimate for the MS;
- (b) one or more extrapolated location estimates for the MS; and
- 5 (c) a path that the MS is travelling.

169. The apparatus of Claim 168, further including a comparison module for comparing the MS location attribute for the first location estimate with the MS location attribute for the second location estimate for reducing an ambiguity in the location of the MS.

170. The apparatus of Claim 158, further including a selector for selecting which of the location information determiners to activate for locating the MS.

171. The apparatus of Claim 158, further including:  
an interface for receiving location information for determining a location of the mobile station MS;

5 one or more additional location information determiners, wherein said additional location information determiners determine information related to one or more location estimates of said mobile station MS when said location estimators are supplied with corresponding input data having values obtained using wireless signals obtained via transmissions between said mobile station MS and the communication stations, wherein the additional location information determiners perform one or more of the following steps:

- 10 (B1) estimating a location of said mobile station MS using values from a corresponding instance of said input data obtained from timing signals received at the mobile station MS from one or more satellites;
- (B2) determining at least one location area or locus for said mobile station MS using timing measurements from a corresponding instance of said input data, wherein
- 15 the timing measurements are indicative of one of: a time of arrival of wireless

cont A17

FOIA b 7 - DATED 02/26/00

20 signals, and a time difference of arrival of wireless signals, wherein the wireless signals are transmitted between the mobile station MS and at least one communication station CS<sub>1</sub>, wherein the signals for obtaining the timing measurements are communicated during a plurality of wireless signal transmissions between the mobile station and CS<sub>1</sub>, with at least one of the transmissions being from the mobile station to CS<sub>1</sub>;

(B3) determining, for at least some one of the communication stations CS<sub>2</sub>, a wireless signal angle of arrival that is indicative of an angular orientation about the communication station CS<sub>2</sub> of a direction of the wireless signal to CS<sub>2</sub> from the mobile station MS;

25 obtaining, in response to the step of requesting, at least one output related to a location of the mobile station MS from said additional location information determiners, wherein at least one of the steps (B1) through (B3) is performed;

30 determining the resulting information related to the mobile station MS using at least one of: (a) a value obtained from said output related to the location of MS, and (b) said one or more MS location estimates.

172. The apparatus of Claim 171, wherein one or more of the location information determiners and the additional location determiners transmit their corresponding location estimates via a TCP/IP network for subsequently determining the resulting information.

173. The apparatus of Claim 158, further including a group of modules for controlling a determining of a location of the MS, wherein one or more of the following are included:

- (a) modules for receiving location requests via the Internet; and
- (b) an access to output requirements for applications requesting location of the MS, wherein the output requirements include one or more of: an accuracy of a location estimate of the MS, and a frequency of determining a location estimate of the MS.

5 174. The apparatus of Claim 158, wherein at least some of said communication stations are substantially co-located with base stations of a commercial mobile radio service provider (CMRS), wherein each of said base stations support two way voice communication with the mobile stations via a plurality antennas at said base station, and the two way voice

cont A17

1092FO: 66602200

5 communication is provided by one of the following wireless transmission techniques: CDMA, TDMA, GSM, AMPS, and NAMPS.

175. The apparatus of Claim 158, further including one or more vehicles, each vehicle having a satellite signal receiving receiver and one of the mobile stations, wherein the satellite signal receiving receiver determines a location of the vehicle, and the mobile station transmits wireless signals to the communication stations so that one or more of the plurality of data instances corresponding to the location of the vehicle and the wireless signals are generated.

176. The apparatus of Claim 158, wherein one or more of the data instances include:
- (a) a make and model of the some one mobile station;
  - (b) a representation of a location of the some one mobile station;
  - (c) a value indicative of a consistency of the collection with other collections;
  - 5 (d) a value indicative of a signal strength and signal time delay measurement for wireless signal communications between one of the communication stations and the some mobile station at the location represented in (b);
  - (e) a value indicative of a wireless signal frequency for wireless signal communications between one of the communication stations and the some mobile station at the location represented in (b);
  - 10 (f) one or more wireless signal quality or error measurements of the wireless signal communications between one of the communication stations and the some mobile station at the location represented in (b);
  - (g) a value indicative of a noise ceiling of the wireless signal communications between one of the communication stations and the some mobile station at the location represented in (b);
  - 15 (h) a value indicative of a transmission power level of one or more of the one communication station in (e), and the some one mobile station.

177. The apparatus of Claim 158, further including a data manager that purges data instances from the one or more data repositories by determining an inconsistency between the data instances for purging and other of the data instances in the data repositories.

a

cont A17

105270-8E802260

178. The apparatus of Claim 158, wherein the first MS location estimate a timestamp associated therewith indicating a time or a date when the wireless signal multipath transmissions between the MS and the communication stations occurred.

179. The apparatus of Claim 158, wherein the predetermined destination uses the resulting information for one or more of:

- (1) locating a vehicle;
- (2) locating an emergency caller;
- (3) routing a vehicle;
- (4) locating a child;
- (5) locating livestock;
- (6) tracking a vehicle; and
- (7) locating a parolee.

180. The apparatus of Claim 158, wherein at least one of the location information determiners is adapts its output location estimates according to changes in said data instances of the data repositories.

181. The apparatus of Claim 158, further including a module for determining a value indicative of the MS being at the first location estimate.

182. The apparatus of Claim 183, further including a module for identifying areas having substantially inhibited wireless communication.

183. The apparatus of Claim 158, further including means for deriving a most likely location estimate of the MS, said most likely estimator uses a probability density function for fuzzifying at least a confidence value for the first location estimate over an area outside of said first location estimate.

184. A method for locating a mobile station MS, of a plurality of mobile stations, using wireless signal data obtained from transmissions between said mobile station MS and a plurality of fixed location receivers, wherein each said receiver is capable of at least wirelessly detecting said mobile stations, comprising :

cond A17

POSTED 02/20/200

5 providing a plurality of data instances, wherein for each of a plurality geographical locations, there is one of said data instances having (a1) and (a2) following:

(a1) a representation of the geographical location,

(a2) corresponding multipath related information of wireless signal data obtained using transmissions between one of said mobile stations and said receivers, wherein the one mobile station transmits from approximately the geographical location of (a1);

10 providing a plurality of location estimators for locating the mobile stations, wherein for a set, C, having at least some of the location estimators, (b1) – (b3) following hold:

(b1) for each said location estimator of C, there is a predetermined corresponding collection of receivers from which the location estimator receives a corresponding input of wireless signal multipath data obtained from one of said mobile stations whose location is to be determined by the location estimator;

(b2) for determining locations of said mobile stations, each said location estimator of C is dependent upon (i) and (ii) following: (i) (a1) and (a2) of at least some of said data instances, and

15 (ii) multipath information from wireless signals communicated between the mobile stations and said predetermined corresponding collection of receivers;

(b3) for at least two of said location estimators of C, their predetermined corresponding collections of receivers are different;

determining, using each of one or more of said location estimators of C, one or more location estimates of the mobile station MS when an occurrence of said wireless signal multipath data is obtained from wireless signals received from the mobile station MS by the corresponding collection of receivers;

25 transmitting, to a predetermined destination, via a communications network, resulting information related to the location of the mobile station MS, wherein said resulting information is obtained from said one or more of said location estimates.

30

185. The method of Claim 184, wherein when determining locations of the mobile stations, each of the location estimators of C change their location estimates when there are changes to the plurality of data instances.

186. The method of Claim 184, wherein at least some of the receivers are co-located, wherein there is a plurality of sites each having a plurality of the receivers co-located therewith.

a



cont A17

105210:8E80Z60

187. The method of Claim 184, wherein said step of providing includes calibrating, for each of the plurality geographical locations, (a1) with (a2) using wireless signal transmissions from having a GPS receiver therein.

188. The method of Claim 184, wherein at least one of the location estimators performs the following step:  
determining one or more likely location estimates for MS by identifying a similarity between (i) and (ii) following: (i) multipath characteristics determined from wireless signals  
5 communicated between the mobile station MS and the receivers, and (ii) the multipath information of (a2) for a collection of one or more of the geographical locations.

189. The method of Claim 184, wherein at least one of the location estimators performs the following step:  
determining a value according to a consistency between (c1) and (c2) following:  
(c1) values that are a function of at least one of: a signal strength and a signal  
5 time delay of wireless signals between said mobile station MS and the receivers,  
and  
(c2) values that are a function of at least one of signal strength and a signal  
time delay of wireless signals provided by (a2) for at least some of the data  
instances;  
10 wherein an output from the correlating step is dependent upon the representations (a1) of the at least some of the data instances.

190. The method of Claim 189, wherein the step of statistically correlating includes performing one of a statistical regression between (a2) for at least some of the data instances, and multipath information from wireless signals received for the mobile station MS

191. The method of Claim 184, wherein at least some of said receivers are substantially co-located with base stations of a commercial mobile radio service provider (CMRS), wherein each of said base stations support two way voice communication with the mobile stations via a plurality antennas at said base station, and the two way voice  
5 communication is provided by one of the following wireless transmission techniques: CDMA, TDMA, GSM, AMPS, and NAMPS.

SECRET

105270-32802600

192. The method of Claim 191, wherein at least some of said receivers are included within transceivers at said base stations, wherein said transceivers support the two way voice communication with the mobile stations.

193. The method of Claim 191, wherein said one or more location estimates are for substantially a same location of the mobile station MS, and further including a step of resolving location ambiguities between said location estimates.

194. The method of Claim 193, wherein said step of resolving includes determining for each of one or more of said location estimates, one or more of:

- (e) a corresponding likelihood value that said mobile station MS is within the location estimate;
- 5 (f) a condition related to a corresponding velocity or change of velocity of the mobile station MS coinciding with the location estimate;
- (g) a condition related to a corresponding terrain of the location estimate; and
- (h) a consistency with a previous instance of locating the mobile station MS.

195. The method of Claim 193, wherein said step of resolving includes performing a most likely location estimation procedure using said location estimates for thereby determining a most likely location of the mobile station MS.

196. The method of Claim 195, wherein for at least some of the location estimators of C, their predetermined corresponding collections of receivers are different from one another, and the mobile station MS is terrestrial.

197. The method of Claim 193, wherein one or more of said location estimators includes a statistical prediction technique.

198. The method of Claim 193, wherein said step of resolving includes detecting a clustering of at least some of said one or more location estimates for determining a most likely location of the mobile station MS.

199. The method of Claim 193, wherein for each of said location estimators of C, said predetermined corresponding collection receivers has at least one of said receivers that is

different from said predetermined corresponding collection of receivers for a different one of said location estimators.

200. The method of Claim 184, wherein said step of determining includes obtaining a location estimate of the mobile station MS from less than all of said location estimators.

201. The method of Claim 200, wherein for each of at least some of said location estimators, the corresponding collection of receivers detects wireless multipath signals from a geographical area different from the predetermined corresponding collection of receivers for said at least some of said location estimators.

202. The method of Claim 201, wherein at least one of said one or more location estimators uses input indicative of additional of said receivers detecting the mobile station MS.

203. The method of Claim 184, wherein at least some of said receivers are included in a base station network of a commercial mobile radio service provider, wherein there is a further step of the commercial mobile radio service provider outputting a request for the mobile station MS to raise its transmission power.

204. The method of Claim 184, further including a step of calibrating at least one of said location estimators using said plurality of data instances.

205. The method of Claim 184 said step of transmitting includes outputting said resulting information using one of a public switched network and the Internet.

206. The method of Claim 205, further including a step of obtaining said resulting information from said one or more of said location estimates, wherein said step of obtaining includes one or more of:

- (c1) snapping a location of the mobile station MS to a vehicle traffic route;
- (c2) detecting a clustering of said one or more location estimates for determining a most likely location of the mobile station MS; and
- (c3) using, for each of said one or more location estimates, a corresponding likelihood value for determining said resulting information.

5

cont 17

109270-82802600

a

CONFIDENTIAL

207. A method for locating a mobile station MS, of a plurality of mobile stations, using wireless signal data obtained from transmissions between said mobile station MS and a plurality of land borne wireless receivers, wherein each said receiver is capable of at least wirelessly detecting said mobile stations, comprising:

5 obtaining data indicative of wireless signal multipath at a plurality of known locations; deriving, for each of at least some of the plurality of known locations, corresponding multipath information indicative of the wireless signal multipath at the known location; storing, for each location L of the known locations, an instance of (a1) and (a2)

following:

10 (a1) a representation of L, and

(a2) said corresponding multipath information, wherein said corresponding multipath information is indicative of the wireless signal multipath at the location L;

activating one or more of a plurality of location estimators for determining one or more of location estimates of the mobile station MS, wherein (b1) – (b3) following:

15 (b1) for each said location estimator, there is a corresponding collection of receivers from which the location estimator receives a corresponding input of wireless signal multipath data when a location estimate of the mobile station MS is determined by the location estimator;

20 (b2) each of the location estimators performs a step of determining one or more likely location estimates for MS by identifying a similarity between (i) and (ii) following: (i) multipath characteristics determined from wireless signals communicated between the mobile station MS and the corresponding collection of receivers, and (ii) the multipath information of (a2) for a collection of one or more of the locations;

25 (b3) for each of said location estimators, the corresponding collection of receivers is different from the corresponding collection of receivers for a different one of said location estimators;

determining, from said one or more location estimates, a most likely location of the mobile station MS;

30 outputting, to a predetermined destination, via a communications network, resulting information related to the location of the mobile station MS, wherein said resulting information is obtained from said one or more of said location estimates.

CONFIDENTIAL

CONFIDENTIAL

208. The method of Claim 207, further including, for each of at least some of said one or more activated location estimators, the step of determining one or more likely location estimates identifies the similarity using at least one: a time value obtained from wireless multipath signals between the MS and the corresponding collection of receivers, a signal strength value obtained from wireless multipath signals between the MS and the corresponding collection of receivers, a value indicative of whether there is a wireless communication between the MS and a receiver not in the corresponding collection of receivers, and a difference in wireless signal data between MS transmissions at different transmission powers.

209. The method of Claim 204, wherein said step of identifying includes recognizing a pattern between (c1) and (c2).

210. The method of Claim 203, further including performing said three steps of obtaining, deriving and storing repeatedly, wherein at least one performance of said three steps occurs prior to said step of activating and another performance occurs after said step of activating.

211. The method of Claim 203, wherein at least some of said receivers are substantially co-located with base stations of a commercial mobile radio service provider (CMRS), wherein each of said base stations support two way voice communication with the mobile stations via a plurality antennas at said base station, and the two way voice communication is provided by one of the following wireless transmission techniques: CDMA, TDMA, GSM, AMPS, and NAMPS.

212. The method of Claim 203, further including a step of receiving a request for locating the mobile station for one or more of:

- (c1) locating a vehicle;
- (c2) locating an emergency caller;
- (c3) routing a vehicle;
- (c4) locating a child;
- (c5) tracking a vehicle; and
- (c6) locating a parolee.

213. An apparatus for locating a mobile station MS, of a plurality of mobile stations, using wireless signal data obtained from transmissions between said mobile station MS and a

2011-08-22  
10:30:00 AM  
10:30:00 AM

plurality of wireless receivers, wherein each said receiver is capable of wirelessly detecting said mobile stations, comprising:

5 a data repository for storing, for each of a plurality of known locations, a plurality of instances of (a1) and (a2) following:

- (a1) a location representation of the known location, and
- (a2) corresponding multipath information, wherein said corresponding multipath information is indicative of the wireless signal multipath at the known location;

10 a plurality of location estimators for determining one or more of location estimates of the mobile station MS, wherein (b1) – (b3) following:

(b1) for each said location estimator, there is a predetermined corresponding collection of one or more of said receivers from which the location estimator receives a corresponding input of wireless signal multipath data obtained from one of said mobile stations whose location is to be determined by the location estimator;

15 (b2) for determining locations of said mobile stations, each said location estimator is dependent upon (i) and (ii) following: (i) (a1) and (a2) of at least some of said instances, and (ii) multipath information from wireless signals communicated between the mobile stations and said predetermined corresponding collection of said receivers;

20 (b3) for each of said location estimators, said predetermined corresponding collection has at least one of said receivers that is different from said predetermined corresponding collection for a different one of said location estimators;

25 a resolver for determining from said one or more location estimates a likely location of the mobile station MS.

214. The apparatus of Claim 213, wherein at least some of said receivers are substantially co-located with base stations of a commercial mobile radio service provider (CMRS), wherein each of said base stations support two way voice communication with the mobile station MS via a plurality antennas at said base station, and the two way voice communication is provided by one of the following wireless transmission techniques: CDMA, TDMA, GSM, AMPS, and NAMPS.

CONFIDENTIAL

CONFIDENTIAL

215. The apparatus of Claim 214, wherein at least some of said receivers are included within transceivers at said base stations, wherein said transceivers are able to support the two way voice communication with the mobile station MS.

216. The apparatus of Claim 215, further including an output gateway for transmitting, on one of a public telephone switching network and the Internet, an output indicative of said likely location to a predetermined destination, wherein said output gateway performs one or more of:

- 5 (a) outputs said output in a format according to said predetermined destination;
- (b) outputs said output according to a frequency for outputting said output; and
- (c) determines said output by snapping said likely location to a transportation route.

217. The apparatus of Claim 215, wherein said resolver includes: a location predictor for predicting a subsequent location of the mobile station MS by accessing data indicative of at least one estimated path for the mobile station MS.

218. The apparatus of Claim 215, wherein said resolver includes: an evaluator for determining one or more of: (i) whether one of said location estimates implies that the mobile station MS has an excessive expected speed, (ii) whether one of said location estimates implies that the mobile station MS has an excessive expected speed for an area having  
5 said one location estimate, (iii) whether one of said location estimates implies that the mobile station MS has an excessive expected change in velocity; (iv) whether one of said location estimates implies that the mobile station MS is travelling a known transportation pathway.

219. The apparatus of Claim 215, wherein said resolver includes: an evaluator for determining a value indicative of a likelihood that the mobile station MS is at a corresponding one of said location estimates, wherein said evaluator determines said value as a function of a past performance of one of said location estimators that determined said  
5 corresponding one of said location estimates.

220. The apparatus of Claim 215, wherein said resolver includes: an evaluator for determining a value indicative of a likelihood that the mobile station MS is at a corresponding one of said location estimates, L, wherein said evaluator determines said value as a function of one of a similarity and a dissimilarity between one or more occurrences of said

2

*Genetic AD*

5 multipath data of (a2), wherein the known locations of (a1) for each occurrence of said multipath data is within an area represented by L or determined to be near L according to a predetermined criteria.

**Remarks**

It is believed that the above claims are patentable above all known prior art. However, should the Examiner determine that there is prior art to the filing date of the co-pending application to which the present application is a continuation, the Examiner is invited to review the documentation related to the above claims in U.S. **Provisional Patent Application No. 60/025,855 filed Sept. 9, 1996** (also denoted herein as the '855 Application) from which the present application claims benefit. In particular, this provisional patent application describes multiple location estimators (e.g., neural network based location estimators) whose mobile station location estimates (denoted as "First Order Models" or "FOMs" therein) are dependent on multipath wireless signals and wherein there is a substantially different set of (base station) receivers from which at least two of the location estimators receive multipath signal data. In particular, the following portions of the '855 Application are noteworthy: page 17, the last paragraph, through page 18, line 12; page 79 from the heading "Neural Net With Genetic Adaptation Model" (line 11) to just before the heading "Coverage Area Determination" (line 31); page 80, lines 27-29; page 81, the first full paragraph; and Fig. NN-9.

If the Examiner has any questions or concerns regarding the '855 Application, please contact the undersigned hereinbelow. It is believed that not fees beyond the filing fee (included herein) are due. However, in the event that there are additional fees due, please contact the undersigned below.

FOIA b 7 - 2002-00000

Respectfully submitted,

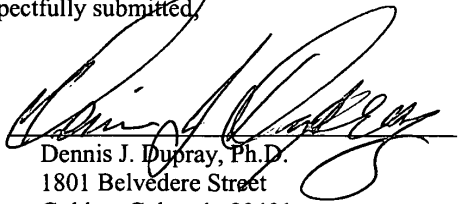
By:   
Dennis J. Dupray, Ph.D.  
1801 Belvedere Street  
Golden, Colorado 80401  
(303) 863-2975

Date: Jan. 26, 2001

*a*



**UNITED STATES PATENT AND TRADEMARK OFFICE**

 COMMISSIONER FOR PATENTS  
 UNITED STATES PATENT AND TRADEMARK OFFICE  
 WASHINGTON, D.C. 20231  
 www.uspto.gov

APPLICATION NUMBER	FILING/RECEIPT DATE	FIRST NAMED APPLICANT	ATTORNEY DOCKET NUMBER
09/770,838	01/26/2001	Charles L. Karr JR.	1003-1

**CONFIRMATION NO. 8410**
**FORMALITIES LETTER**

\*OC00000005940122\*

 Dennis J. Dupray, Ph.D.  
 1801 Belvedere Street  
 Golden, CO 80401

Date Mailed: 04/05/2001

**NOTICE TO FILE CORRECTED APPLICATION PAPERS**
***Filing Date Granted***

This application has been accorded an Application Number and Filing Date. The application, however, is informal since it does not comply with the regulations for the reason(s) indicated below. Applicant is given **TWO MONTHS** from the date of this Notice within which to correct the informalities indicated below. Extensions of time may be obtained by filing a petition accompanied by the extension fee under the provisions of 37 CFR 1.136(a)

The required item(s) identified below must be timely submitted to avoid abandonment:

- o A substitute specification in compliance with 37 CFR 1.52 because:
  - Papers contain improper margins. *Each sheet must have a left margin of at least 2.5 cm (1") and top, bottom and right margins of at least 2.0 cm (3/4")*
- o ~~Substitute drawings in compliance with 37 CFR 1.84 because:~~ *drawings are o.k. per Tom Koontz*
  - ~~drawings contain excessive text. Suitable descriptive legends may be used, or may be required by the Examiner where necessary for understanding of the drawing but should contain as few words as possible ( see 37 CFR 1.84(e)).~~

*A copy of this notice **MUST** be returned with the reply.*

 Customer Service Center  
 Initial Patent Examination Division (703) 308-1202

PART 3 - OFFICE COPY



0300

IN THE UNITED STATES PATENT AND TRADEMARK OFFICE

I am hereby the Application of: )  
 )  
 DUPRAY et al. )  
 )  
 Serial No.: 09/770,838 )  
 )  
 Filed: January 26, 2001 )  
 )  
 Atty. File No.: 1003-1 )  
 )  
 For: "WIRELESS LOCATION USING )  
 SIGNAL FINGERPRINTING" )

Group Art Unit: 3662

Examiner:

RESPONSE TO NOTICE TO FILE  
CORRECTED APPLICATION PAPERS

Assistant Commissioner for Patents  
 Washington, D.C. 20231

<p>CERTIFICATE OF MAILING</p> <p>I HEREBY CERTIFY THAT THIS CORRESPONDENCE IS BEING DEPOSITED WITH THE UNITED STATES POSTAL SERVICE AS FIRST CLASS MAIL IN AN ENVELOPE ADDRESSED TO THE ASSISTANT COMMISSIONER FOR PATENTS, WASHINGTON, DC 20231 ON THIS <u>21<sup>st</sup></u> DAY OF <u>April</u>, 2001.</p> <p style="text-align: center;">SHERIDAN ROSS P.C.</p> <p>BY: <u>Chasity C. Rossum</u> Chasity C. Rossum</p>
--

Dear Sir:

In response to the Notice to File Corrected Application Papers mailed on April 5, 2001, enclosed is a copy of the specification and 62 sheets of formal drawings for the above identified patent application. Also enclosed is a copy of the Notice to File Corrected Application Papers. For Figs. 5 and 6, both a copy with corrections (in red), and a formal copy are provided. The corrections expand some abbreviations originally used into full words, correct spelling errors, and in one case (Fig. 6(2)) adds a small amount of additional text thereto. Note that this additional text was allowed by the Examiner in the parent case to which this is a continuation, and accordingly was incorporated into the formal drawings provided which are provided here. Further, note that in a conversation with Mr. James Washington on April 18, 2001, it was indicated that the present drawings would be permissible in that they are the formal drawings of a pending patent application to which the present application is a continuation. Also note that the new text should be permissible since this text is in the corresponding figure (Fig. 6) of this PCT Application Serial No. PCT/US97/15842 from which the present application claims benefit. Note that the text was inadvertently omitted when the font

size in Fig. 6 of the PCT application was increased. A copy of Fig. 6 of the above-identified PCT patent application is also enclosed herewith with the text requested to be added circled in red.

Applicants believe that no fees are due in connection with the filing of this Response to Notice to File Corrected Application Papers. However, in the event any fee deficiencies, it is requested that the below Applicant be contacted by phone as soon as possible.

Respectfully submitted,

SHERIDAN ROSS P.C.

By: 

Dennis J. Dupray  
Registration No. 46,299  
1560 Broadway, Suite 1200  
Denver, Colorado 80202-5141  
(303) 863-9700

Date: 

patent applications\1003\1\pto\response-01



## UNITED STATES PATENT AND TRADEMARK OFFICE

COMMISSIONER FOR PATENTS  
 UNITED STATES PATENT AND TRADEMARK OFFICE  
 WASHINGTON, D.C. 20231  
 www.uspto.gov

APPLICATION NUMBER	FILING/RECEIPT DATE	FIRST NAMED APPLICANT	ATTORNEY DOCKET NUMBER
09/770,838	01/26/2001	Charles L. Karr JR.	1003-1

CONFIRMATION NO. 8410

## FORMALITIES LETTER



\*OC000000005940122\*

Dennis J. Dupray, Ph.D.  
 1801 Belvedere Street  
 Golden, CO 80401

Date Mailed: 04/05/2001

## NOTICE TO FILE CORRECTED APPLICATION PAPERS

*Filing Date Granted*

This application has been accorded an Application Number and Filing Date. The application, however, is informal since it does not comply with the regulations for the reason(s) indicated below. Applicant is given **TWO MONTHS** from the date of this Notice within which to correct the informalities indicated below. Extensions of time may be obtained by filing a petition accompanied by the extension fee under the provisions of 37 CFR 1.136(a)

The required item(s) identified below must be timely submitted to avoid abandonment:

- o A substitute specification in compliance with 37 CFR 1.52 because:
  - o Papers contain improper margins. *Each sheet must have a left margin of at least 2.5 cm (1") and top, bottom and right margins of at least 2.0 cm (3/4")*
- o Substitute drawings in compliance with 37 CFR 1.84 because:
  - o drawings contain excessive text. Suitable descriptive legends may be used, or may be required by the Examiner where necessary for understanding of the drawing but should contain as few words as possible ( see 37 CFR 1.84(o));

*A copy of this notice **MUST** be returned with the reply.*

Customer Service Center  
 Initial Patent Examination Division (703) 308-1202

PART 2 - COPY TO BE RETURNED WITH RESPONSE

FIG. 1

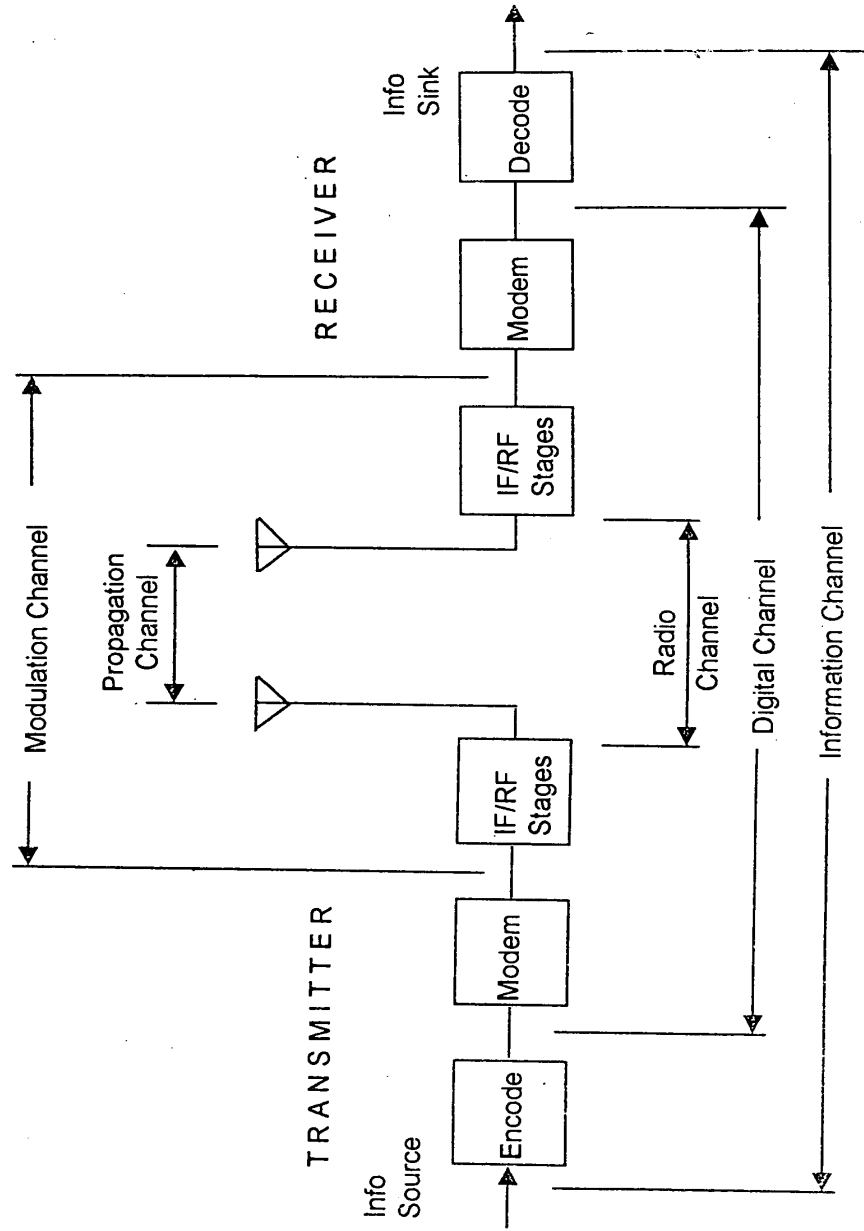

FIG. 1

FIG. 2

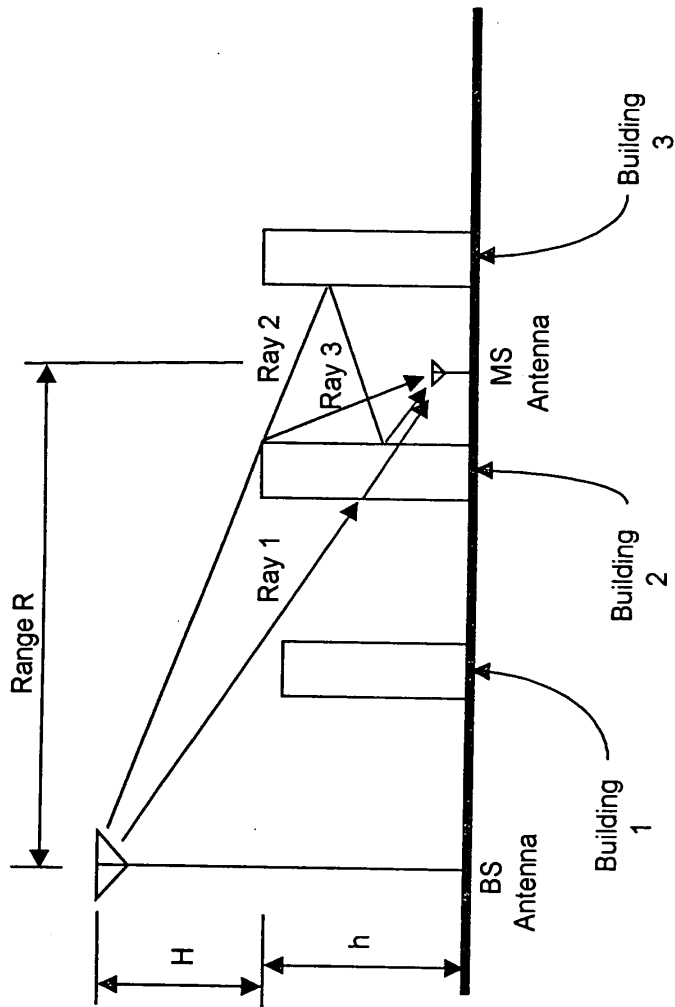

FIG. 2

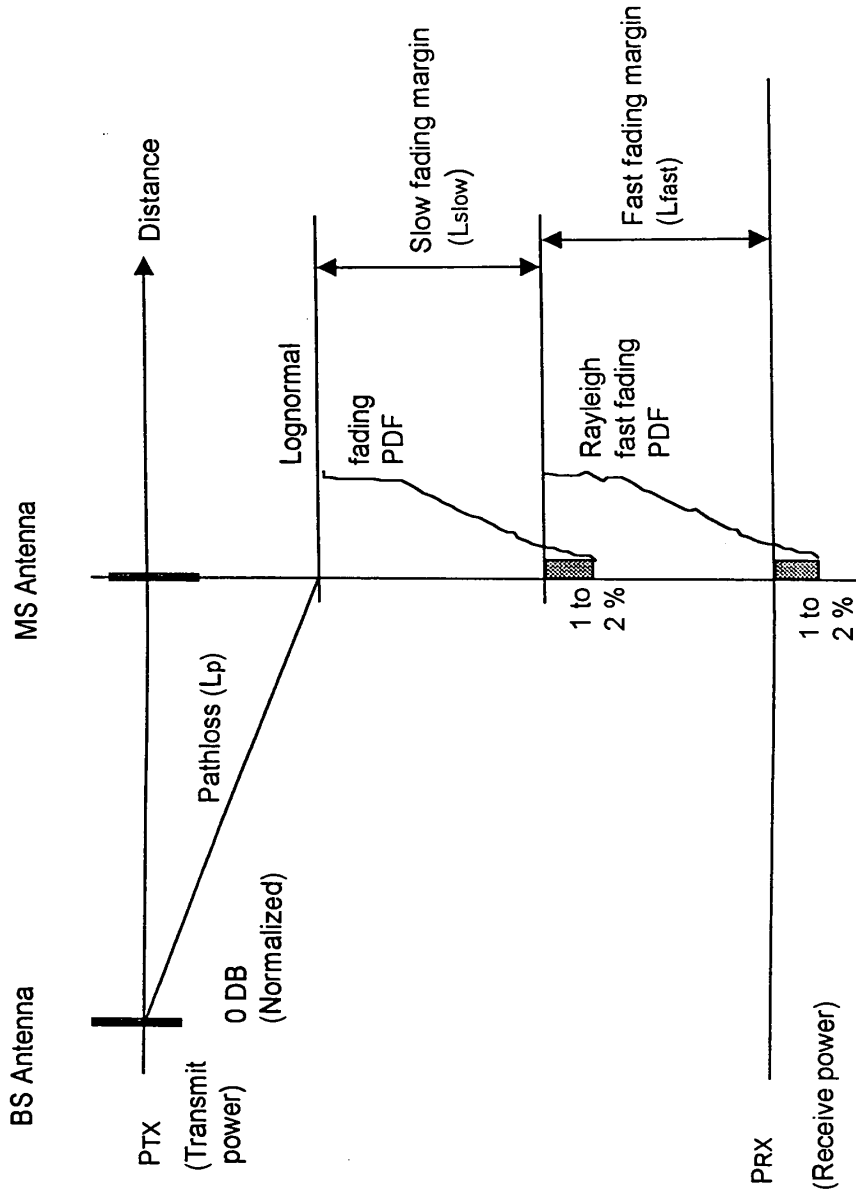

FIG. 3





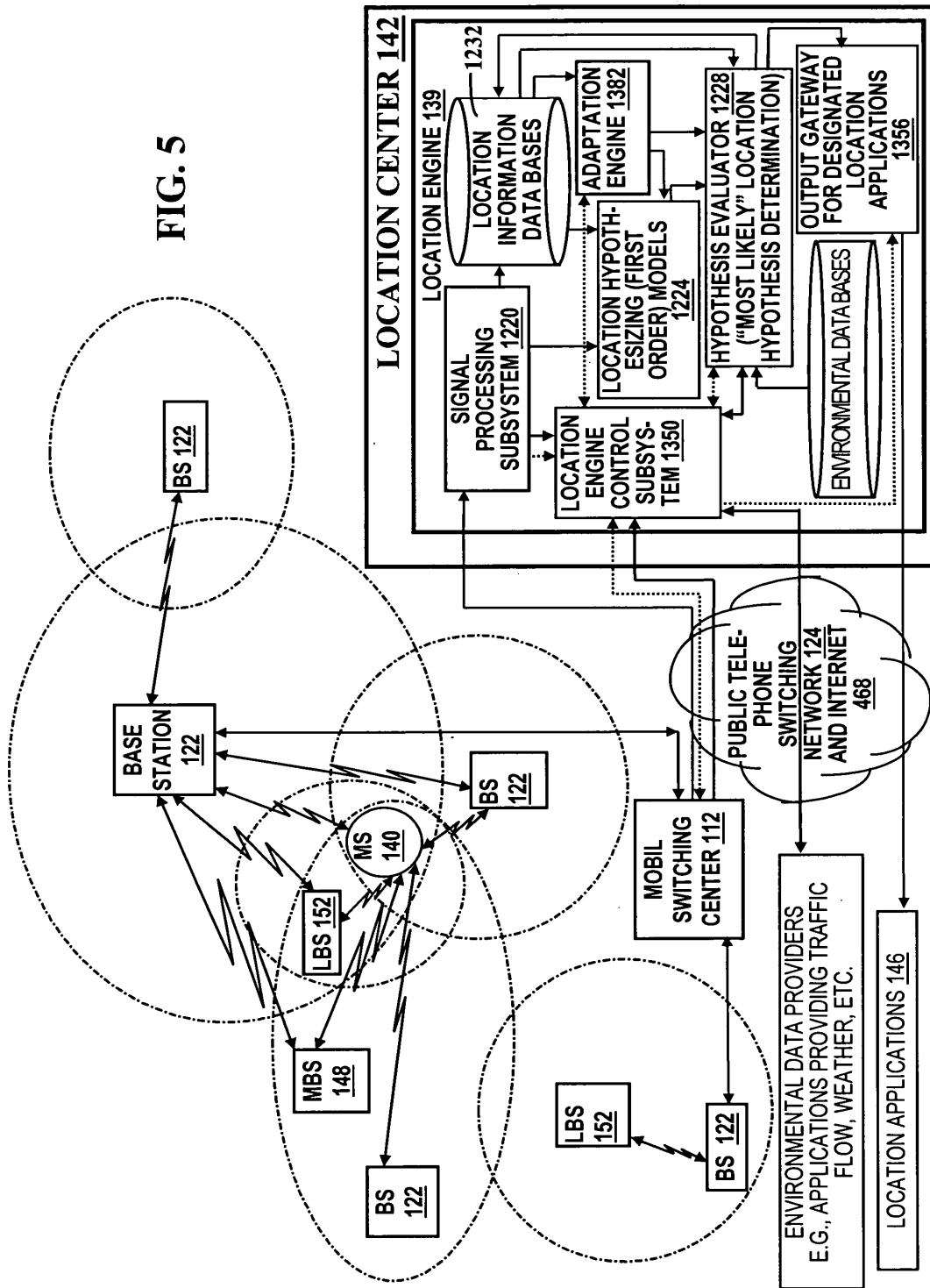

Fig. 6(1)

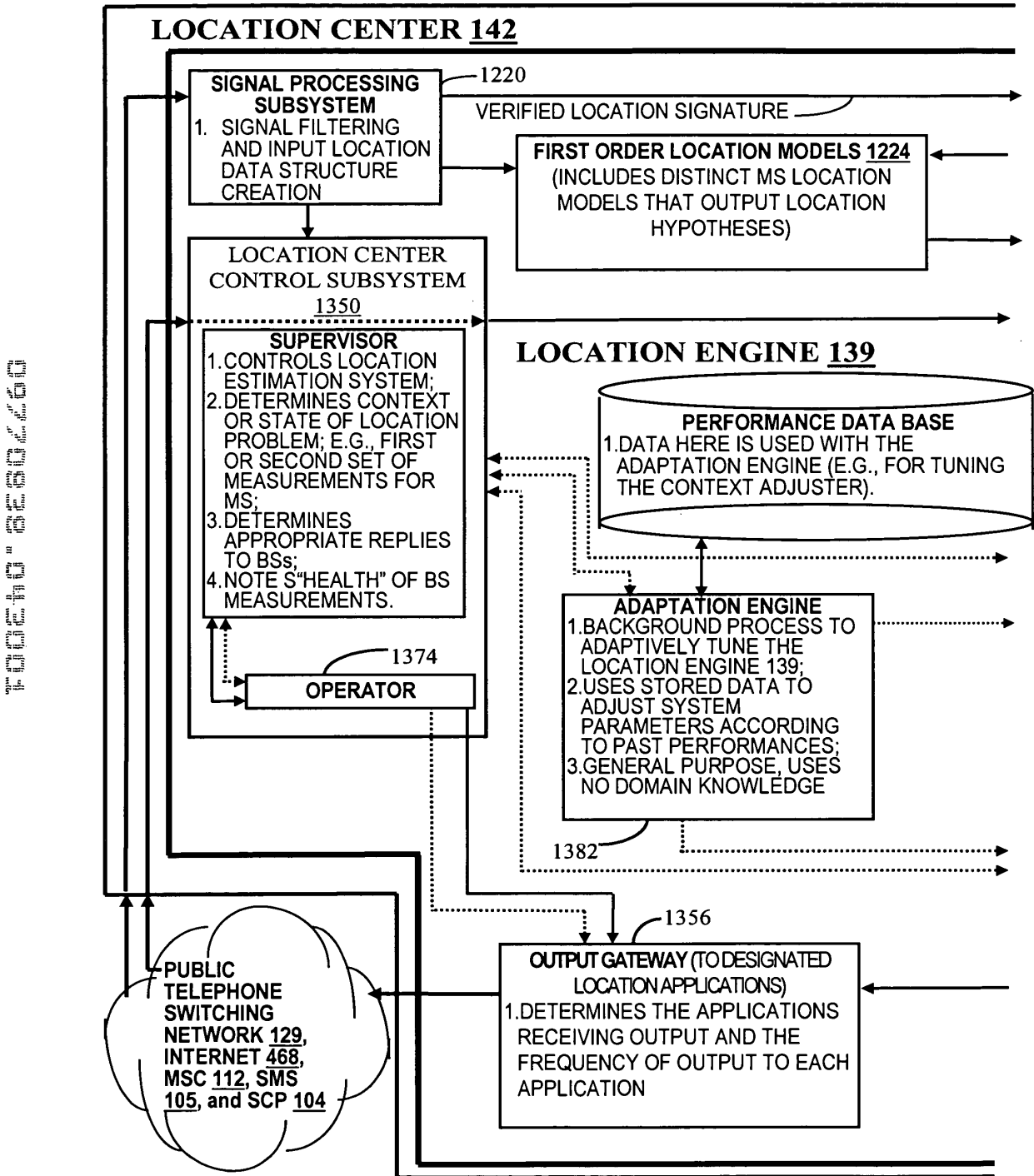
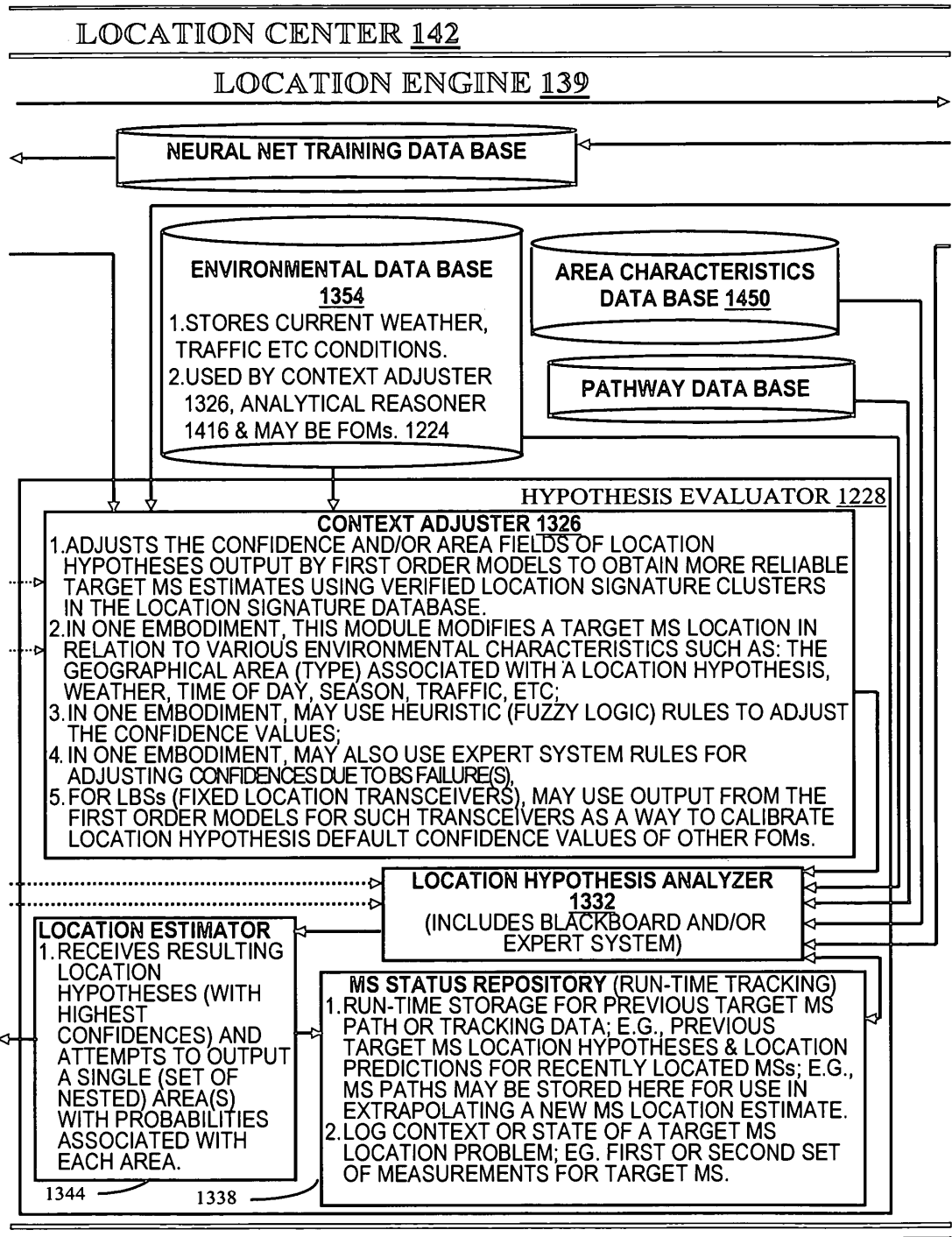
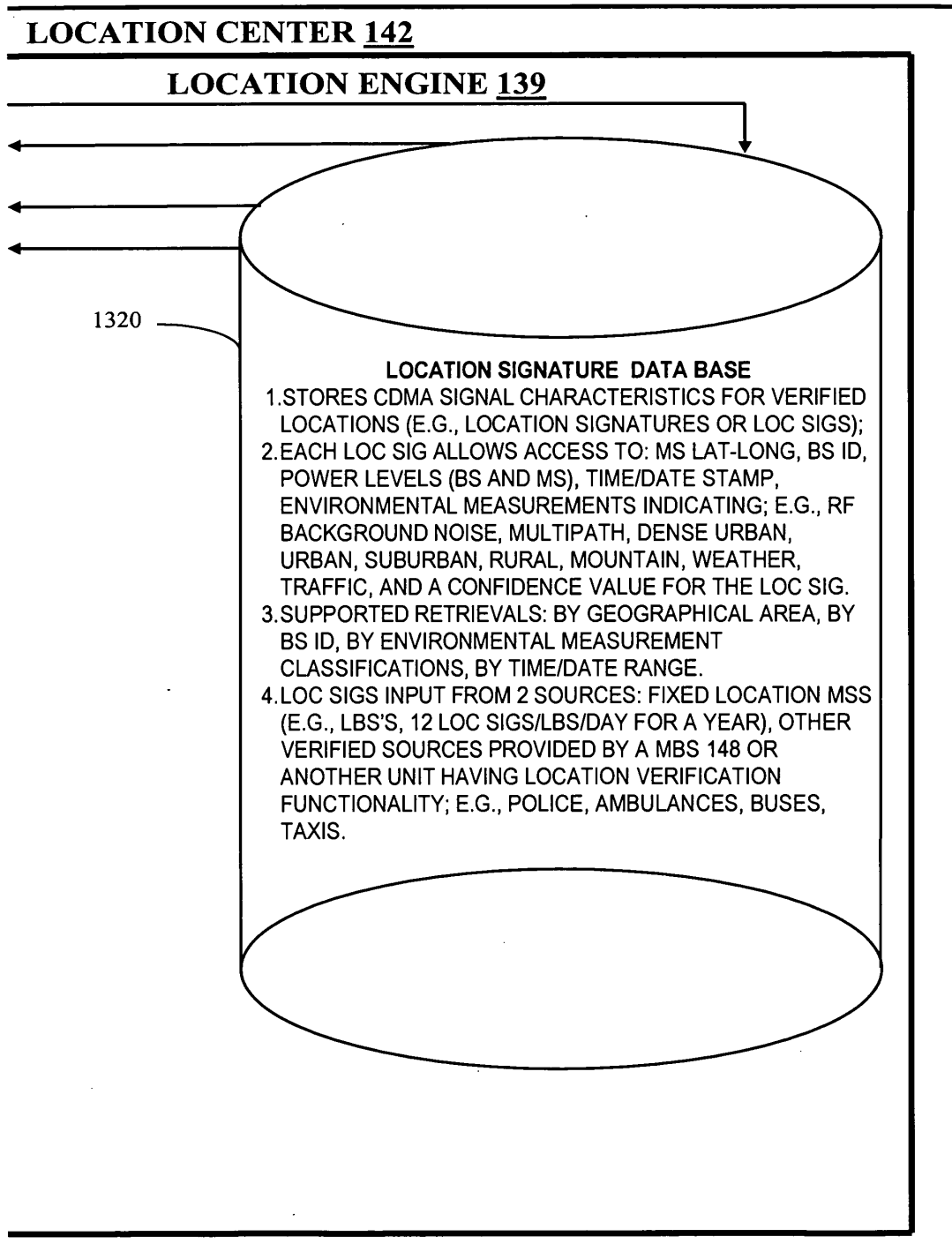

FIG 6(2)



"LOC" SECTOR

**FIG 6(3)**



TracBeam

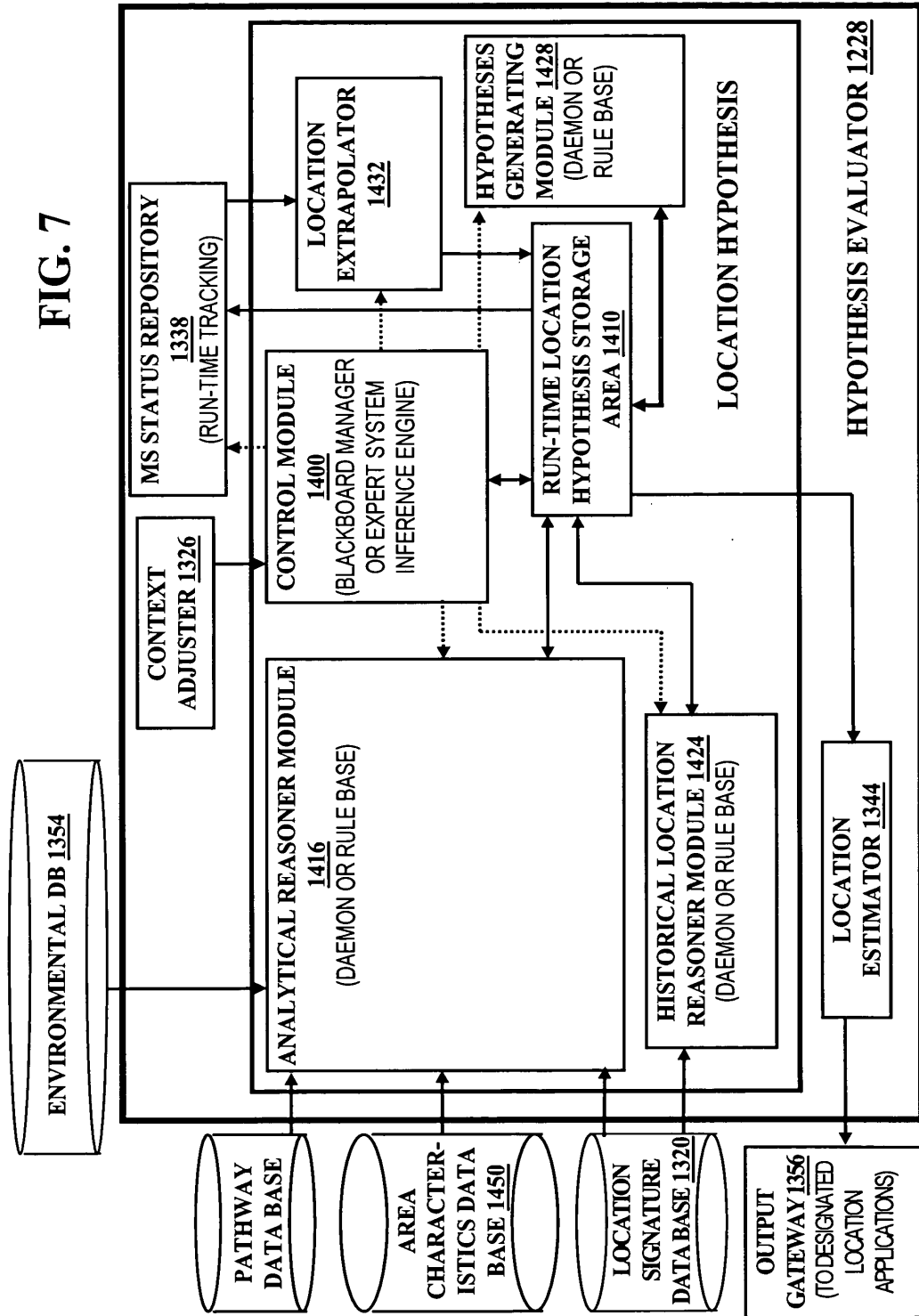

FIG. 7

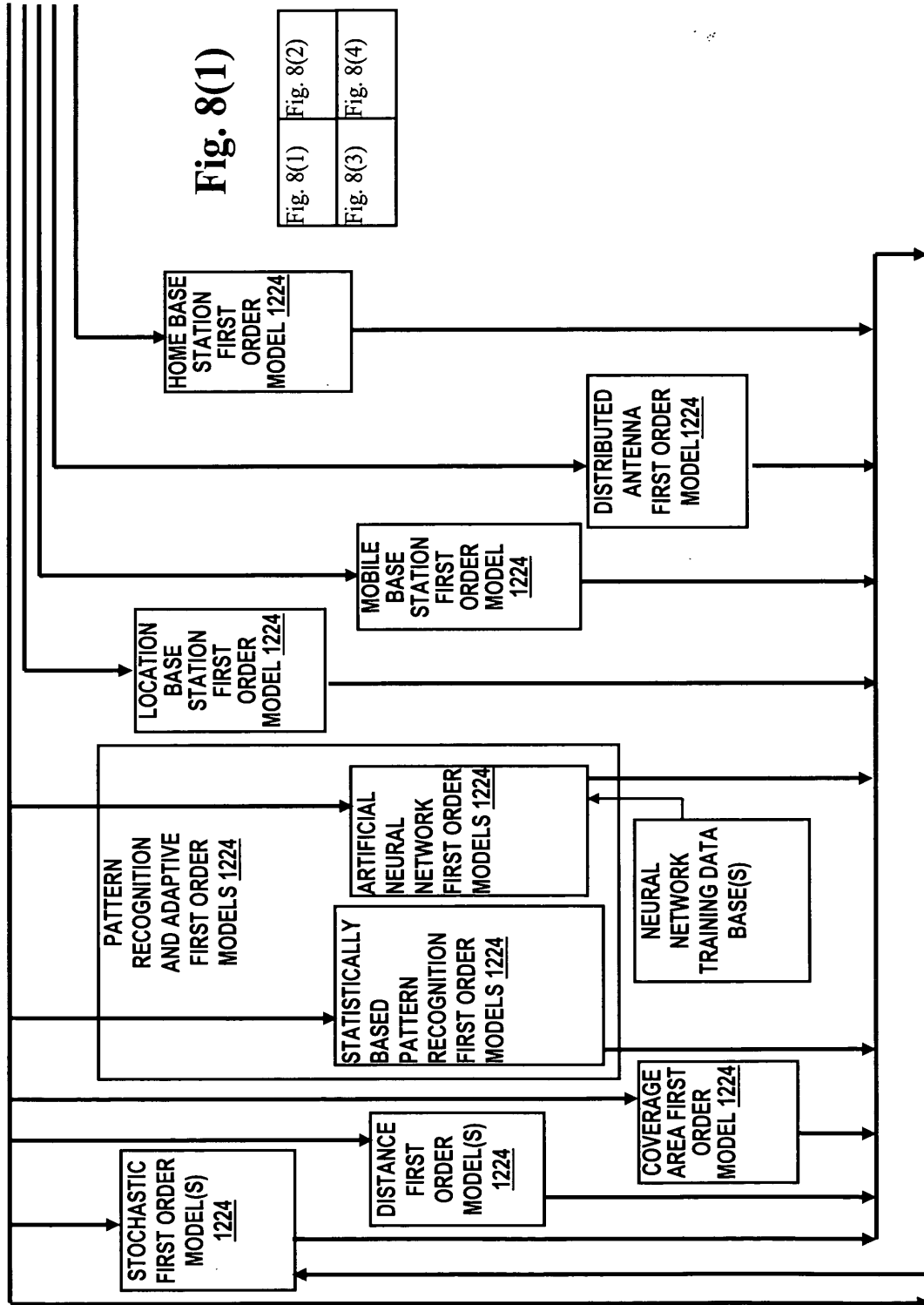

Fig. 8(1)

Fig. 8(1)	Fig. 8(2)
Fig. 8(3)	Fig. 8(4)

FIG. 8(2)

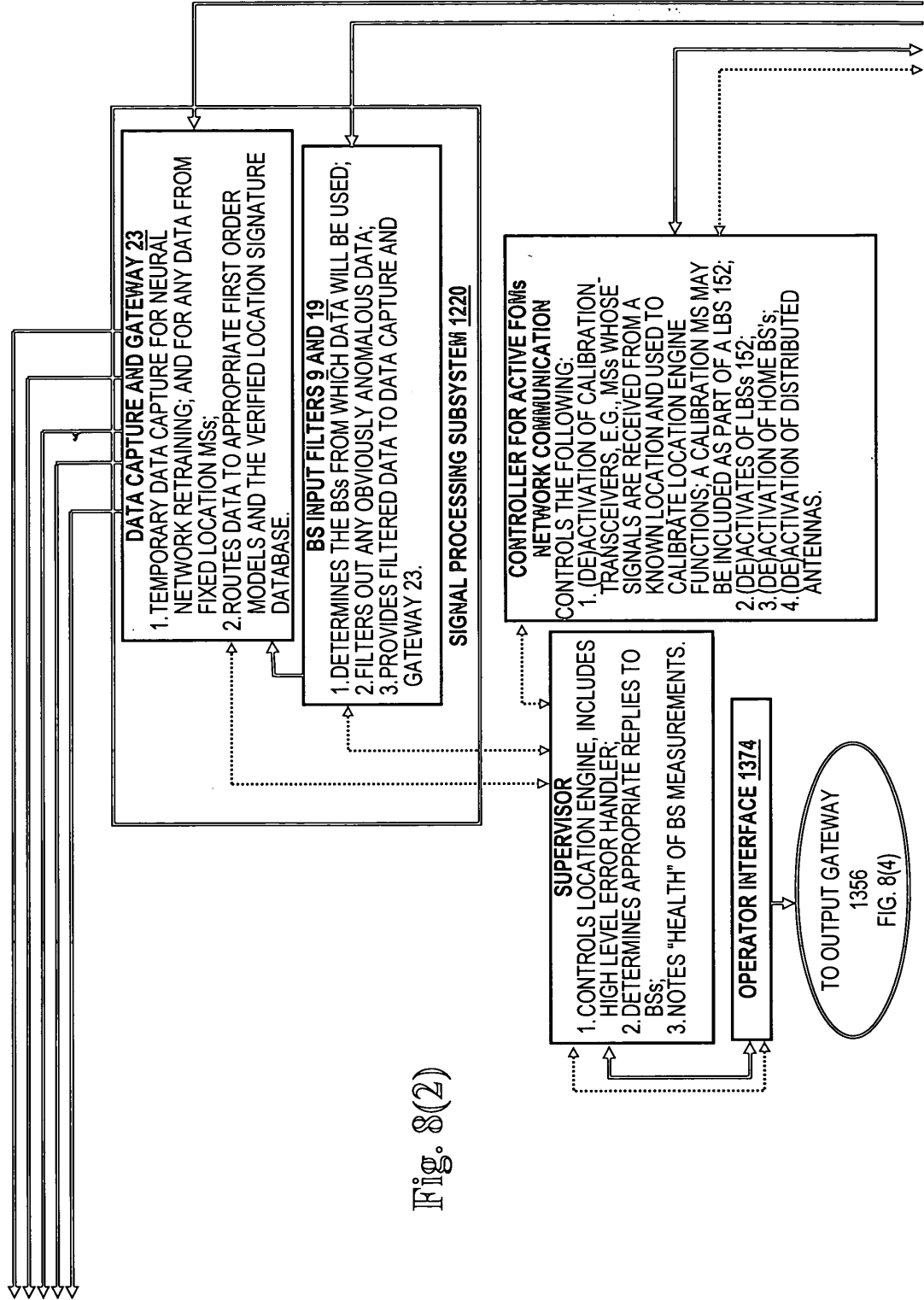

Fig. 8(2)

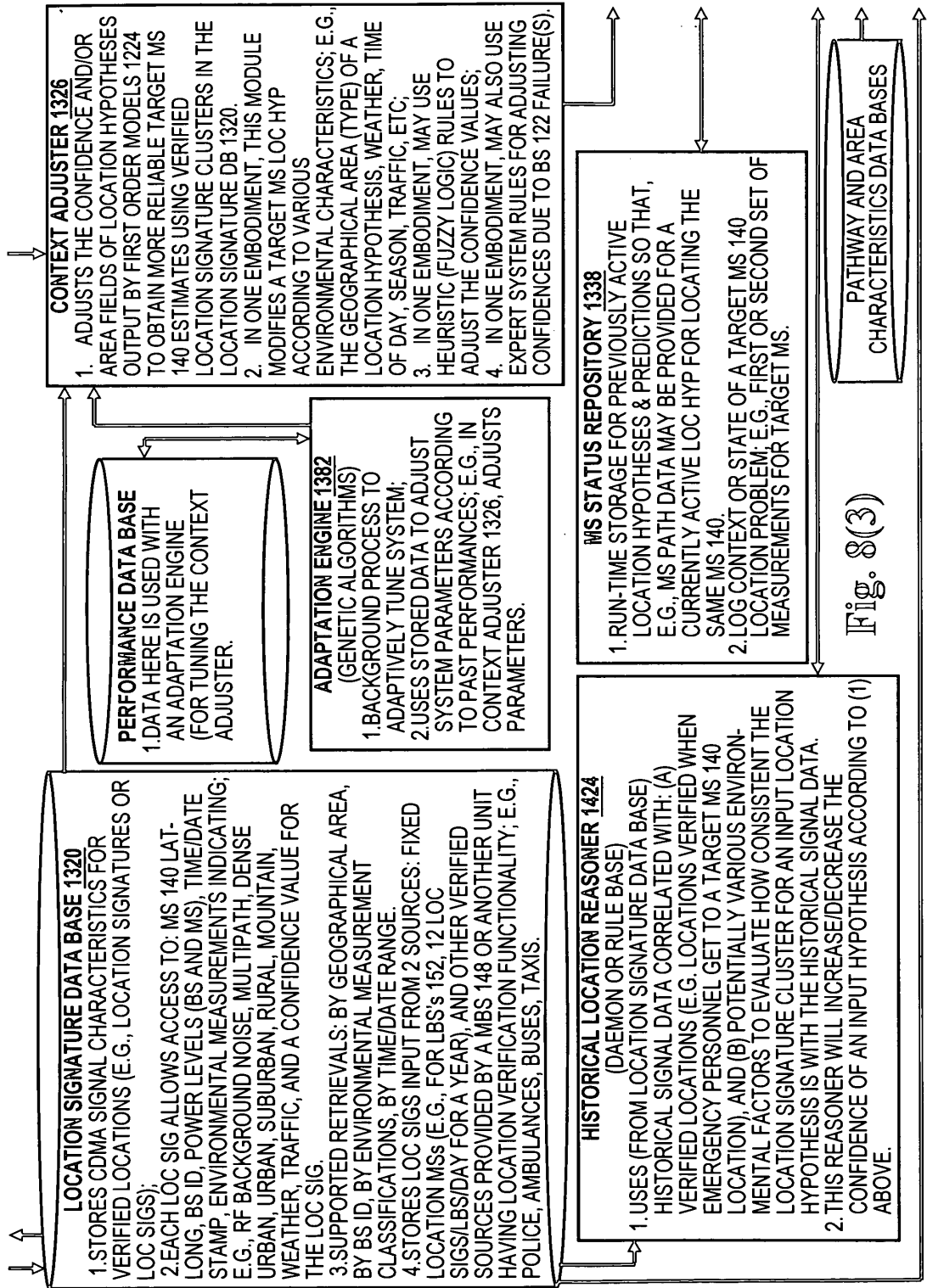

Fig. 8(3)



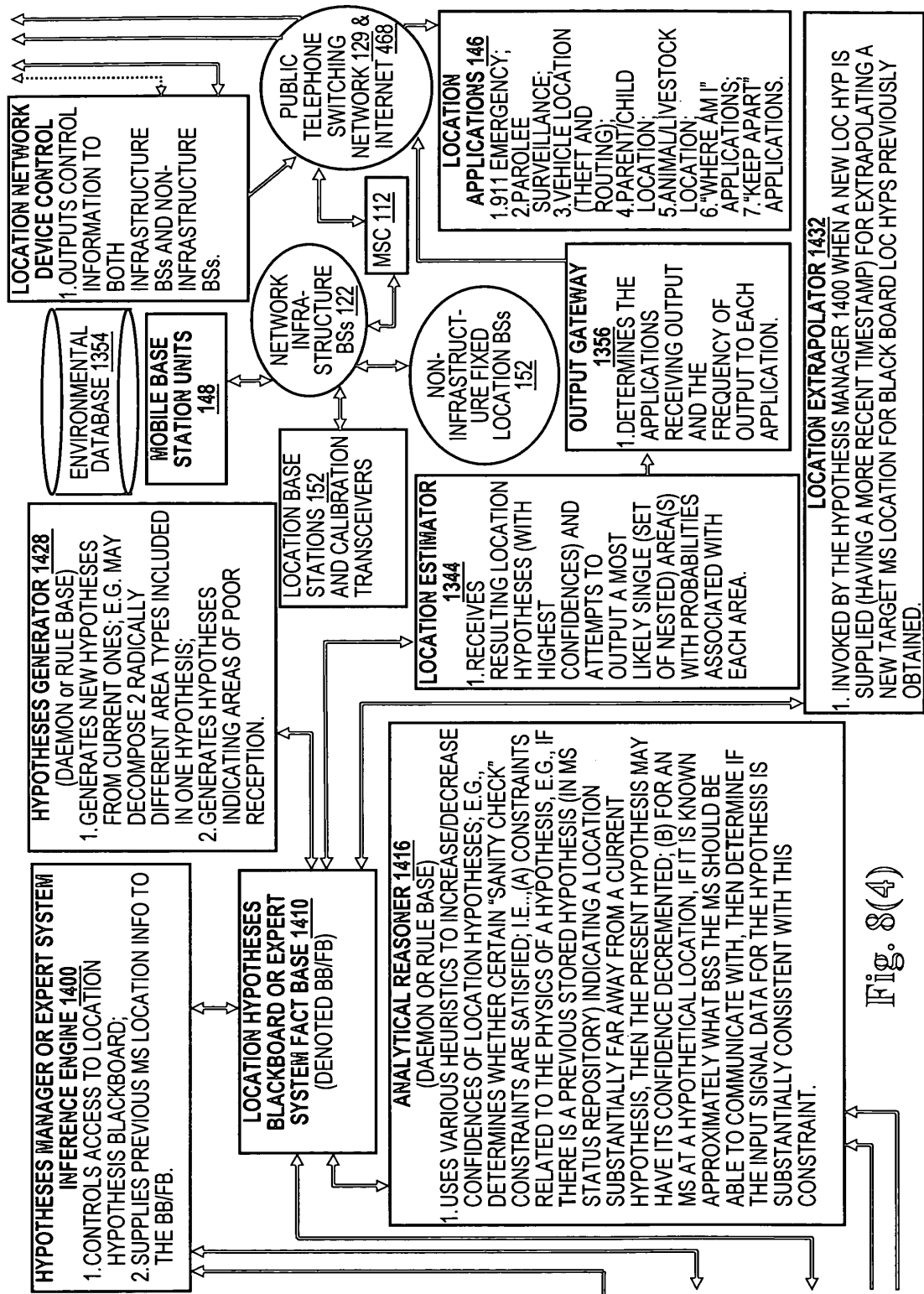

Fig. 8(4)

**FOM\_ID:** First Order Model ID (providing this Location Hypothesis); note, since it is possible for location hypotheses to be generated by other than the FOM's, in general this field identifies the module that generated this location hypothesis.

**MS\_ID:** The identification of the target MS to which this location hypothesis applies.

**pt\_est:** The most likely location point estimate of the target MS

**valid\_pt:** Boolean indicating the validity of "pt\_est"

**area\_est:** Location Area Estimate of the target MS provided by the FOM. This area estimate will be used whenever "image\_area" below is NULL.

**valid\_area:** Boolean indicating the validity of "area\_est" (one of "pt\_est" and "area\_est" must be valid).

**adjust:** Boolean (true iff adjustments to the fields of this location hypothesis are to be performed in the Context Adjuster Module).

**pt\_covering:** reference to a substantially minimal area (e.g., mesh cell) covering of "pt\_est". Note, since this MS may be substantially on a cell boundary, this covering may in some cases include more than one cell.

**image\_area:** reference to an area (e.g., mesh cell) covering of the image cluster set area for "pt\_covering" (see detailed description of the function, "confidence\_adjuster"). Note that if this field is not NULL, then this is the target MS location estimate used by the Location Center instead of "area\_est".

**FIG. 9A**

**extrapolation\_area:** reference to (if non-NULL) an extrapolated MS target estimate area provided by the Location Extrapolator submodule of the Hypothesis Analyzer. That is, this field, if non\_NULL, is an extrapolation of the “image\_area” field if it exists, otherwise this field is an extrapolation of the “area\_est” field. Note other extrapolation fields may also be provided depending on the embodiment of the present invention, such as an extrapolation of the “pt\_covering”.

**confidence:** A real value in the range [-1.0, +1.0] indicating a likelihood that the target MS is in (or out) of a particular area. If positive: if “image\_area” exists, then this is a measure of the likelihood that the target MS is within the area represented by “image\_area,” else if “image\_area” has not been computed (e.g., “adjust” is FALSE), then “area\_est” must be valid and this is a measure of the likelihood that the target MS is within the area represented by “area\_est.” If negative, then “area\_est” must be valid and this is a measure of the likelihood that the target MS is NOT in the area represented by “area\_est”. If it is zero (near zero), then the likelihood is unknown.

**Original\_Timestamp:** Date and time that the location signature cluster for this location hypothesis was received by the CDMA Filter Subsystem,

**Active\_Timestamp:** Run-time field providing the time to which this location hypothesis has had its MS location estimate(s) extrapolated (in the Location Extrapolator of the Hypothesis Analyzer). Note that this field is initialized with the value from the “Original\_Timestamp” field.

**Processing Tags and environmental categorizations:** For indicating particular types of environmental classifications not readily determined by the Original\_Timestamp field (e.g., weather, traffic), and restrictions on location hypothesis processing.

**loc\_sig\_cluster:** Access to location signature signal characteristics provided to the First Order Models by the CDMA Filter Subsystem; i.e., access to the “loc\_sigs” (received at “timestamp” regarding the location of the target MS)

**descriptor:** Optional descriptor (from the First Order Model indicating why/how the Location Area Estimate and Confidence Value were determined).

FIG. 9B

FIG. 10

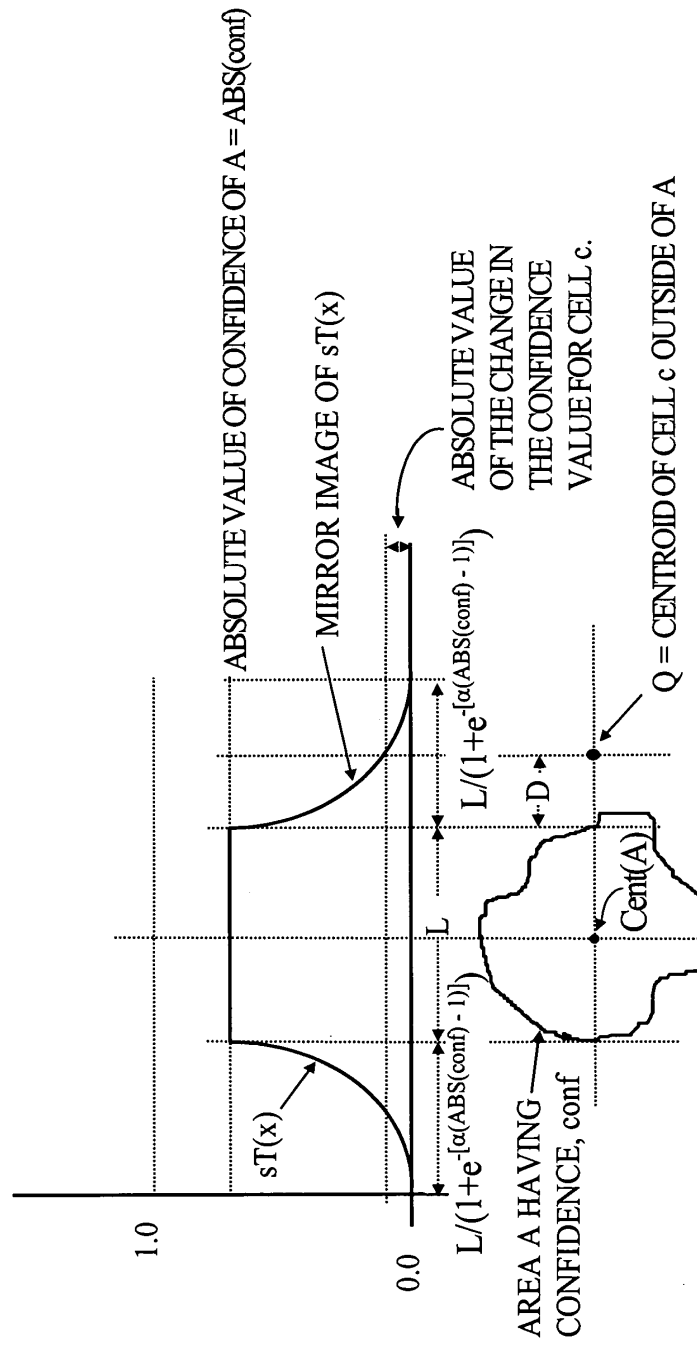



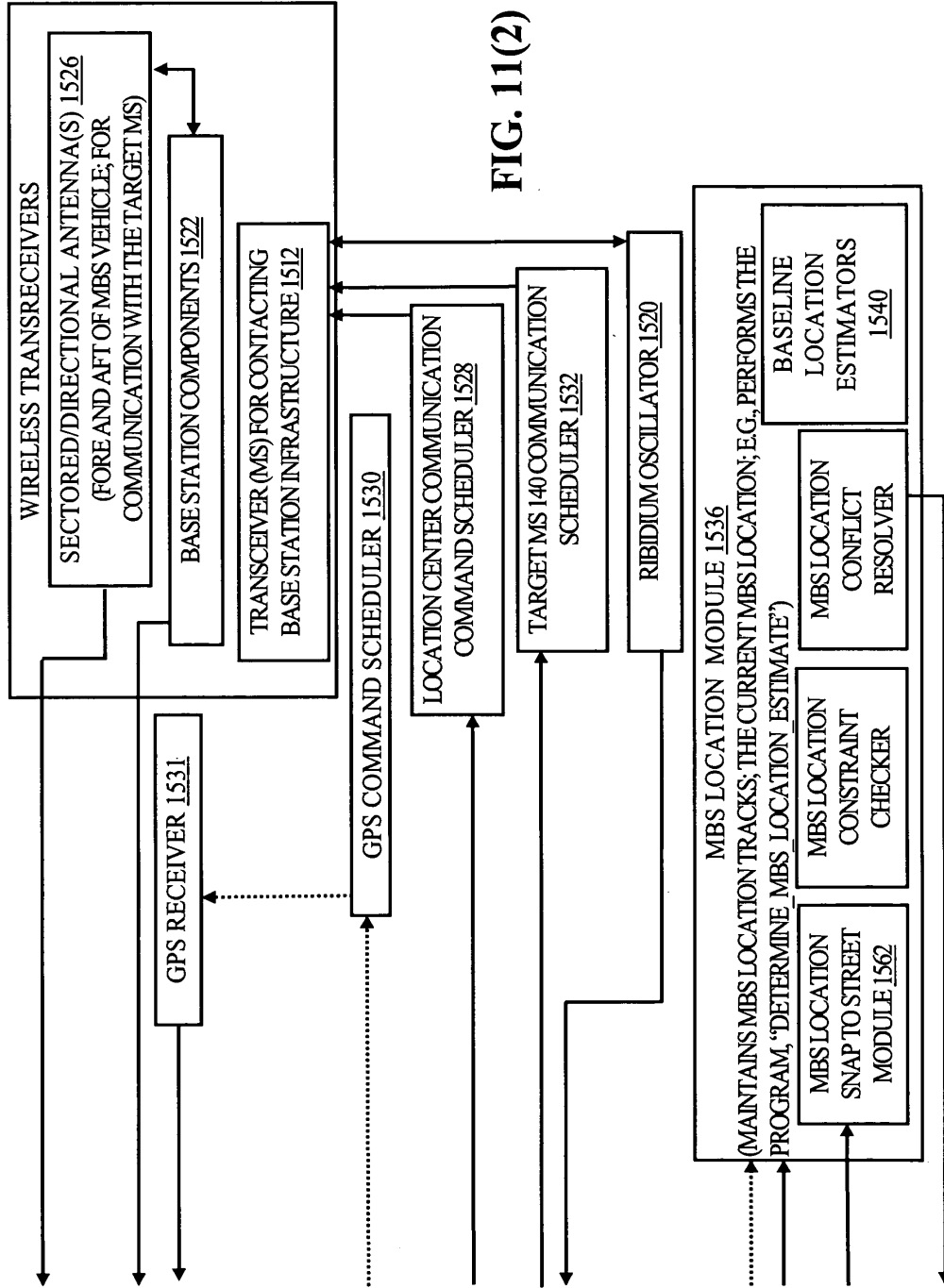

FIG. 11(2)

FIG. 12

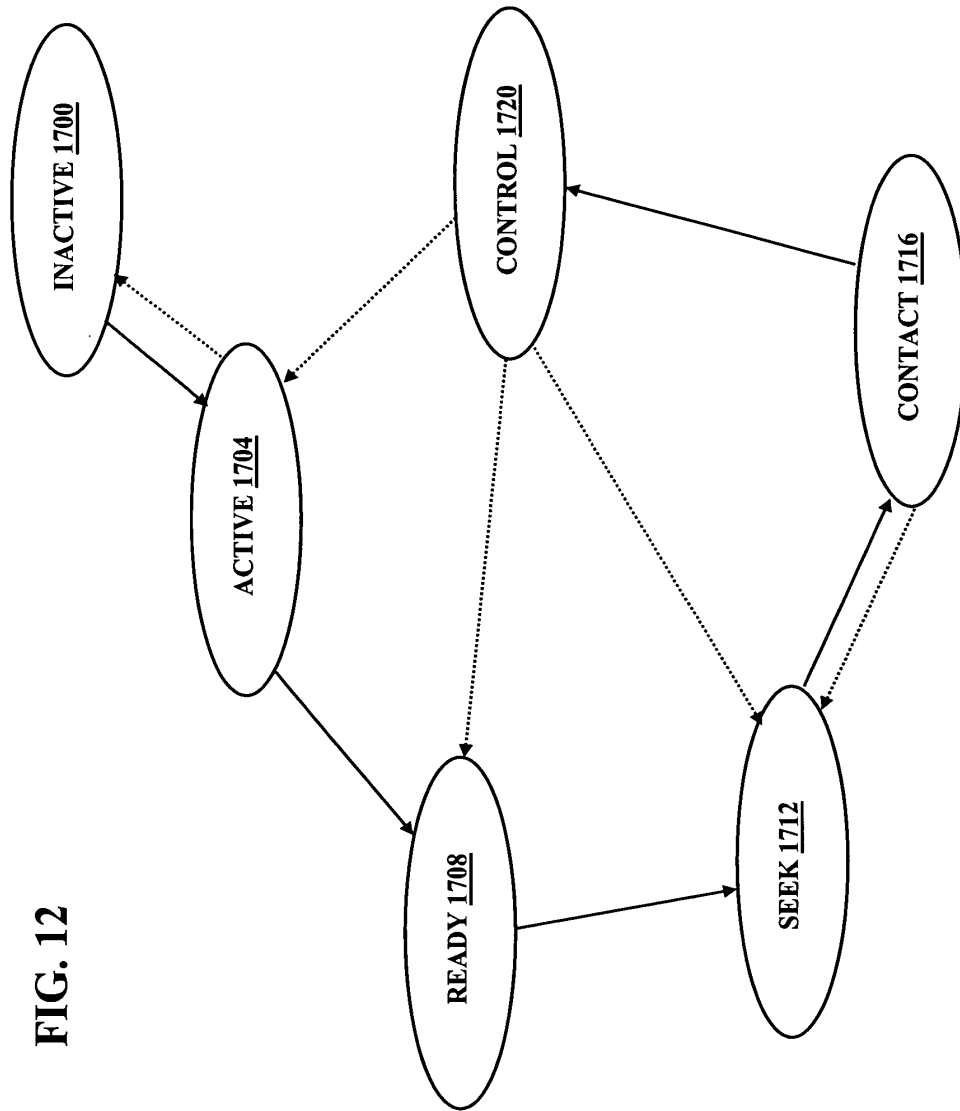

FIG. 12

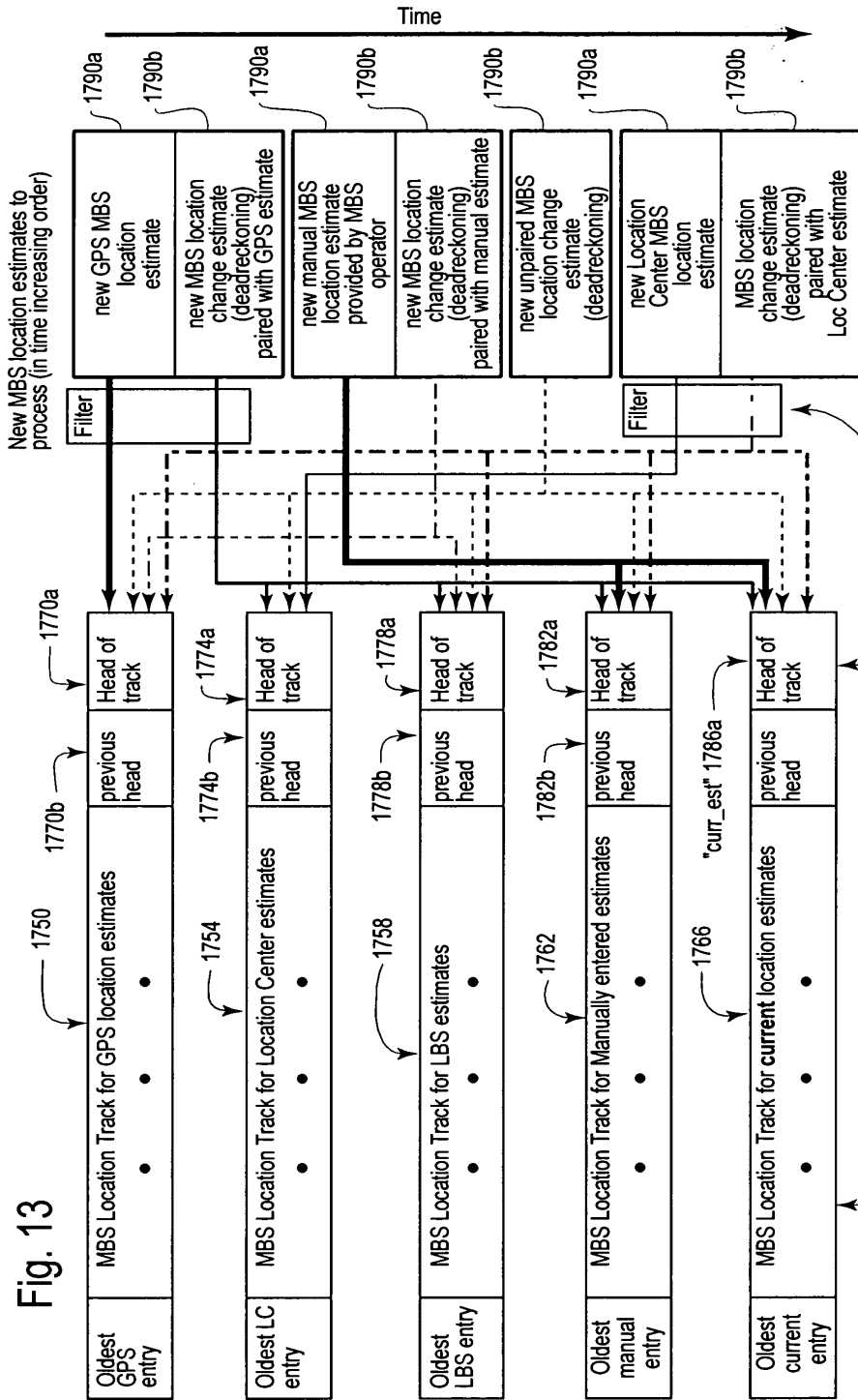

Fig. 13

Filtering mechanism for determining if the new MBS location estimates (other than deadreckoning location change estimates and manual estimates) have a sufficiently high confidence value to qualify them to be inserted into their corresponding MBS location track.

Each entry here is either an extrapolation entry determined using a deadreckoning location change estimate, or a baseline entry derived from a combination of one or more of the other location track heads, or a manual MBS location estimate.



FIG. 14

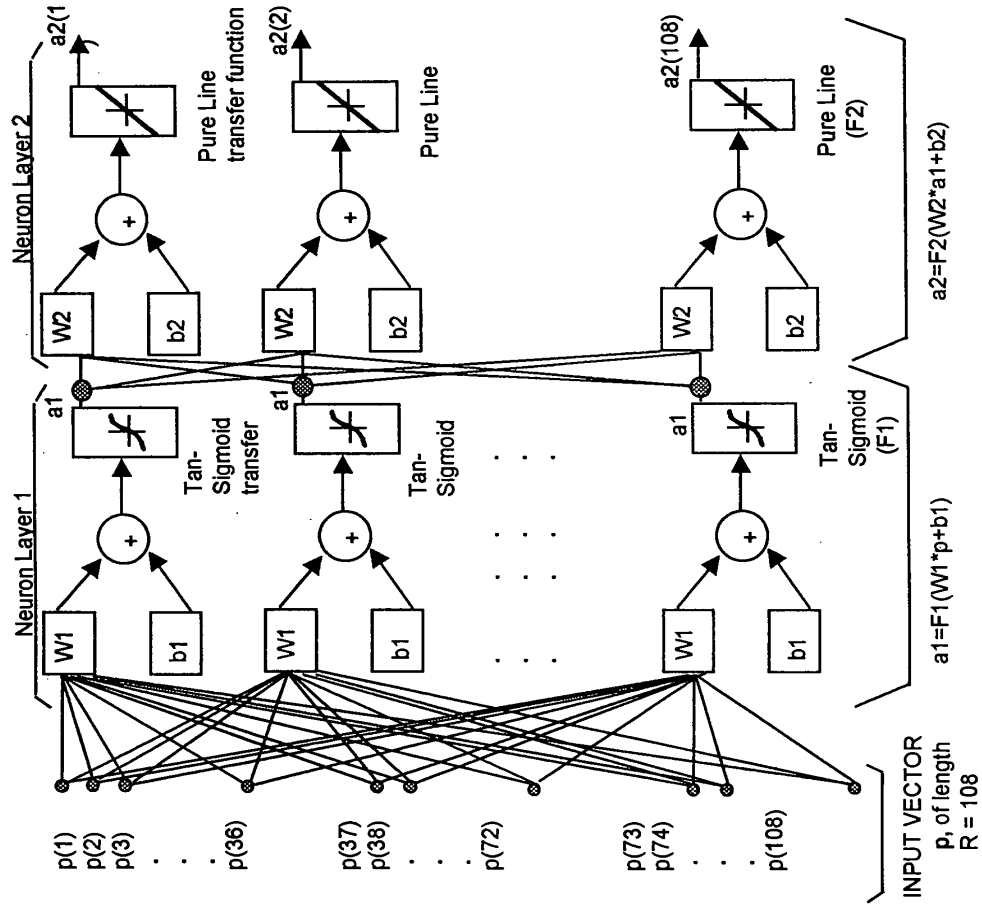
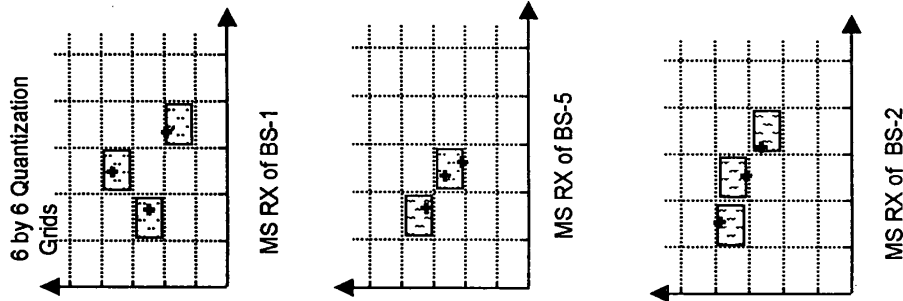

Fig. 14



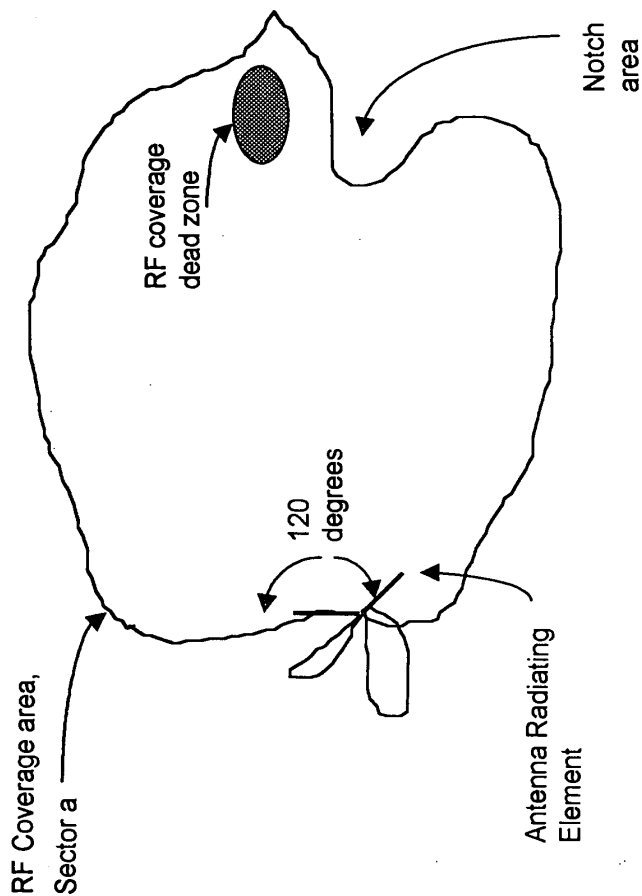

FIG. 15

**Fig. 16a**

**Location Signature Data Type**

- MS\_type:** The make and model of the target MS 140 associated with a location signature instantiation;
  - BS\_id:** An identification of the base station 122 (location base station 152) communicating with the target MS;
  - verified\_flag:** TRUE iff a location of MS\_loc has been verified, FALSE otherwise. Note, if this field is TRUE (i.e., the loc sig is verified), then the base station identified by BS\_id is the current primary base station for the target MS;
  - MS\_loc:** If verified\_flag is TRUE, then this attribute includes an estimated location of the target MS.  
If verified\_flag is FALSE, then this attribute has a value indicating "location unknown".
- Note this attribute may include the following two subfields: an area within which the target MS is presumed to be, and a point location (e.g., a latitude and longitude pair) where the target MS is presumed to be (in one embodiment this is the centroid of the area);
- confidence:** a value indicating how consistent this loc sig is with other loc sigs in the location signature data base 1320; the value for this entry is in the range [0, 1] with 0 corresponding to the lowest (i.e., no) confidence and 1 corresponding to the highest confidence;
  - timestamp:** The time and date when the location signature was received by the base station of BS\_id;

**Fig. 16b**

signal topography characteristics:

Characteristics of a generated surface(s), the surface(s) being generated by the signal filtering subsystem 1220 using signal measurements between the MS and BS associated with the loc sig, wherein the measurements were accumulated over a particular (relatively short) time interval. For example, the dimensions for the generated surface may be signal strength and time delay. By sampling such signal characteristics and tallying the samples in each of a plurality of mesh cells, a mountainous surface can be obtained. Such a surface, is believed, under most circumstances, to provide a contour that is substantially unique to the location of the target MS 140. The attributes of such a surface(s) retained in the signal topography characteristics here include, for example: for each local maximum (of the surface) above a predetermined noise ceiling threshold, the (signal strength, time delay) coordinates of the cell of the local maximum and the corresponding height of the local maximum. Additionally, certain gradients may also be included for characterizing the “steepness” of the surface mountains. Moreover, in some embodiments, a frequency may also be associated with each local maximum. Thus, the data retained for each selected local maximum can include a quadruple of signal strength, time delay, height and frequency;

quality\_obj: This object includes one or more signal quality (or error) measurements (e.g., Eb/No values);

noise\_ceiling: Noise ceiling values used in the initial filtering of noise (by the signal filtering subsystem 1220) from the surface(s) used in generating the signal topography characteristics;

**Fig. 16c**

- power\_level:** The power levels of the associated BS 122 and MS 140 for the signal data used for this loc sig;
- timing\_error:** An estimated (or maximum) timing error between the associated base station (e.g., an infrastructure base station 122 or a location base station 152) detecting the associated target MS 140 and the current primary BS 122 for this target MS. Note that if the BS 122 associated with the loc sig is the primary base station (e.g., when the loc sig is verified), then the value here will be zero;
- cluster\_ptr:** A pointer to the location signature cluster to which this loc sig belongs.

FIG. 17A

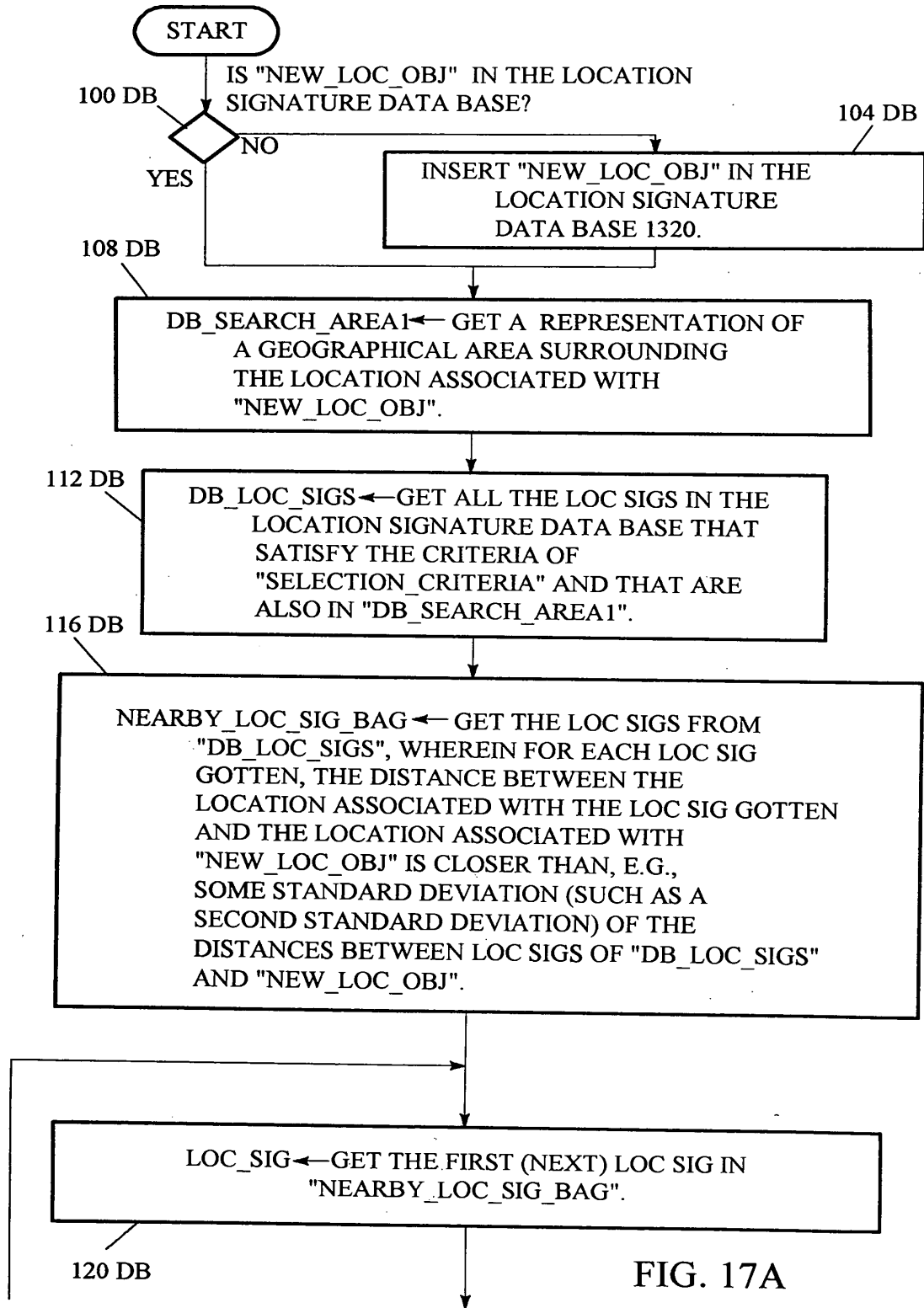

FIG. 17A

FIG. 17B

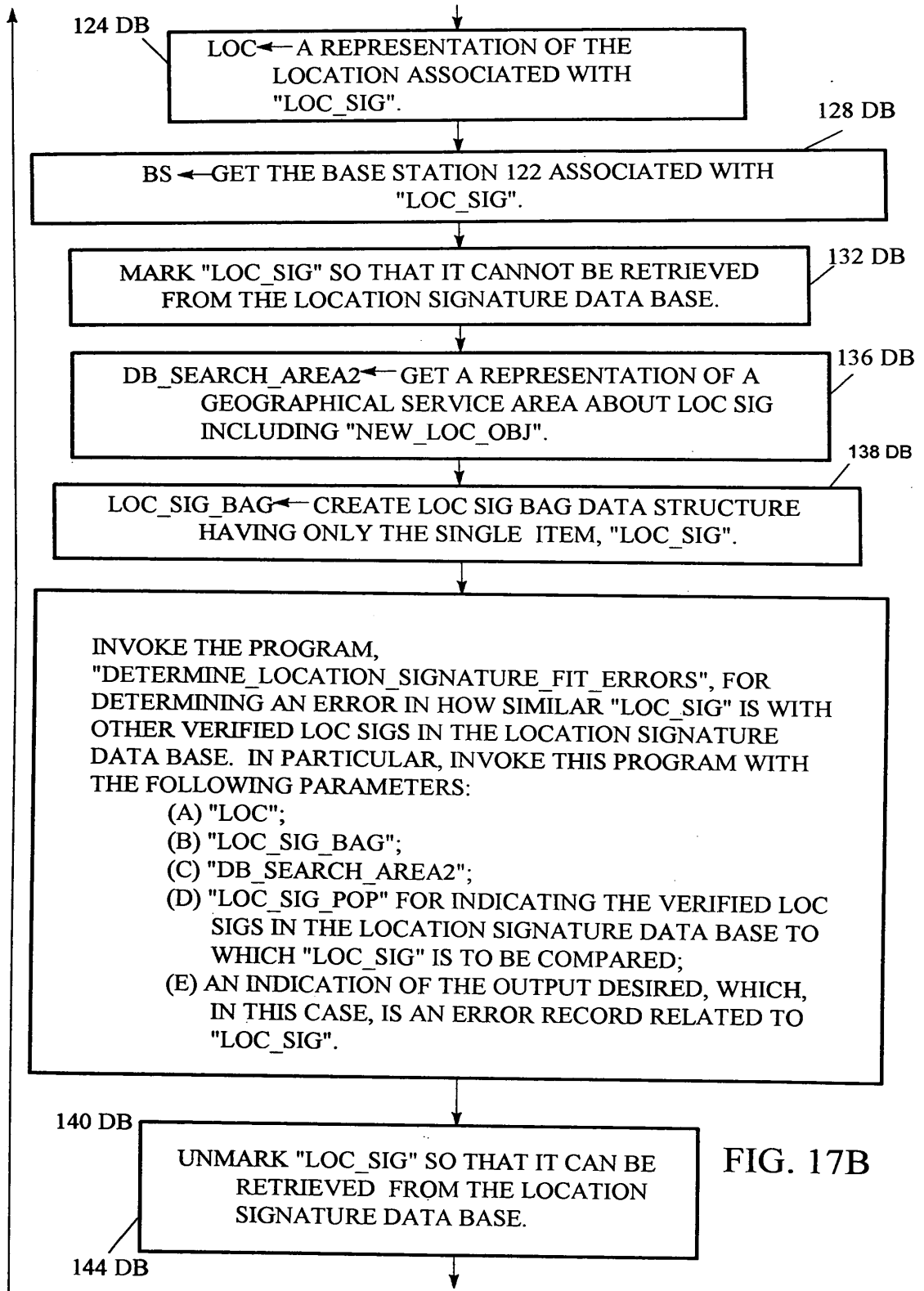

FIG. 17B

FIG. 17C

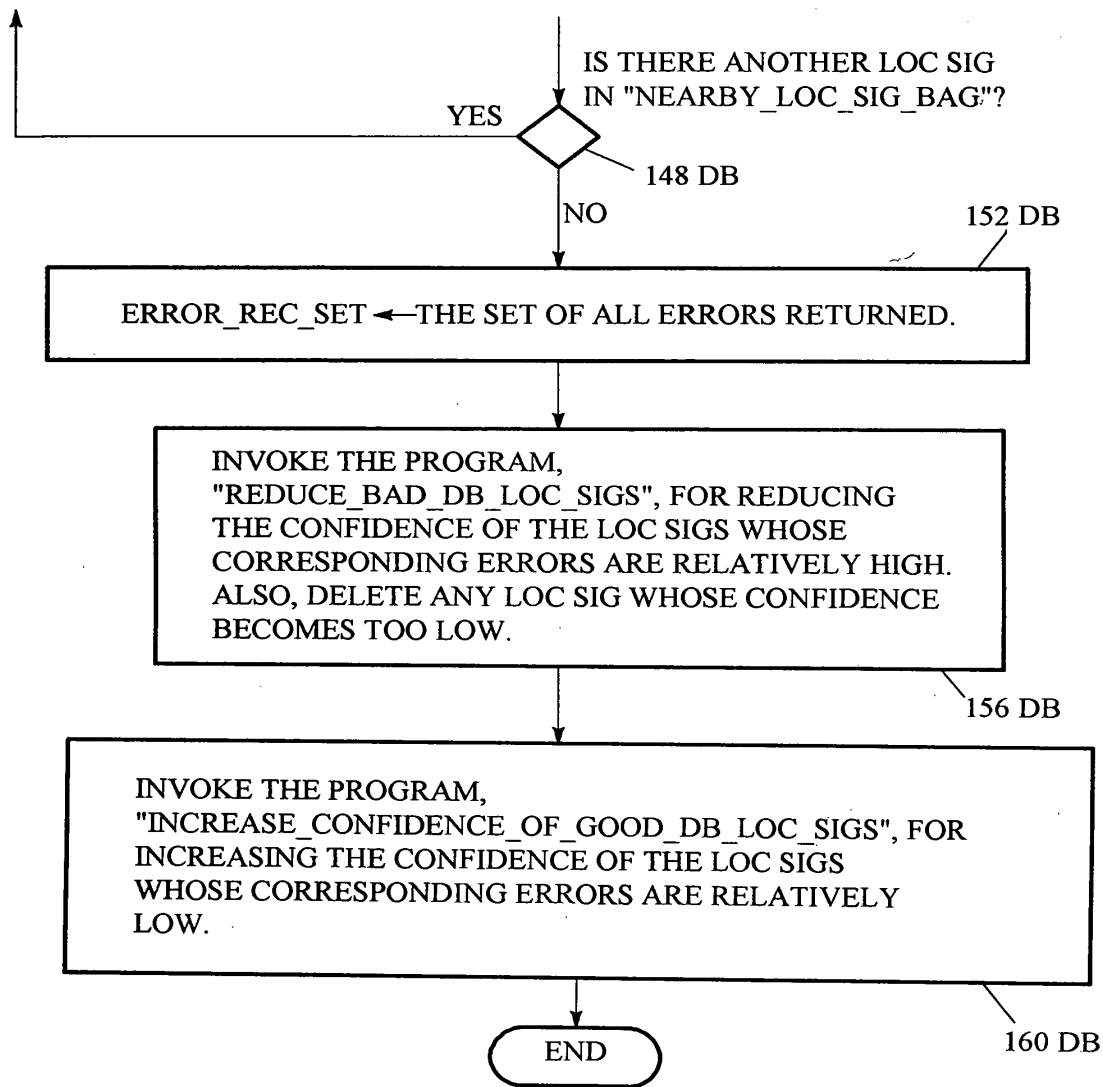

FIG. 17C



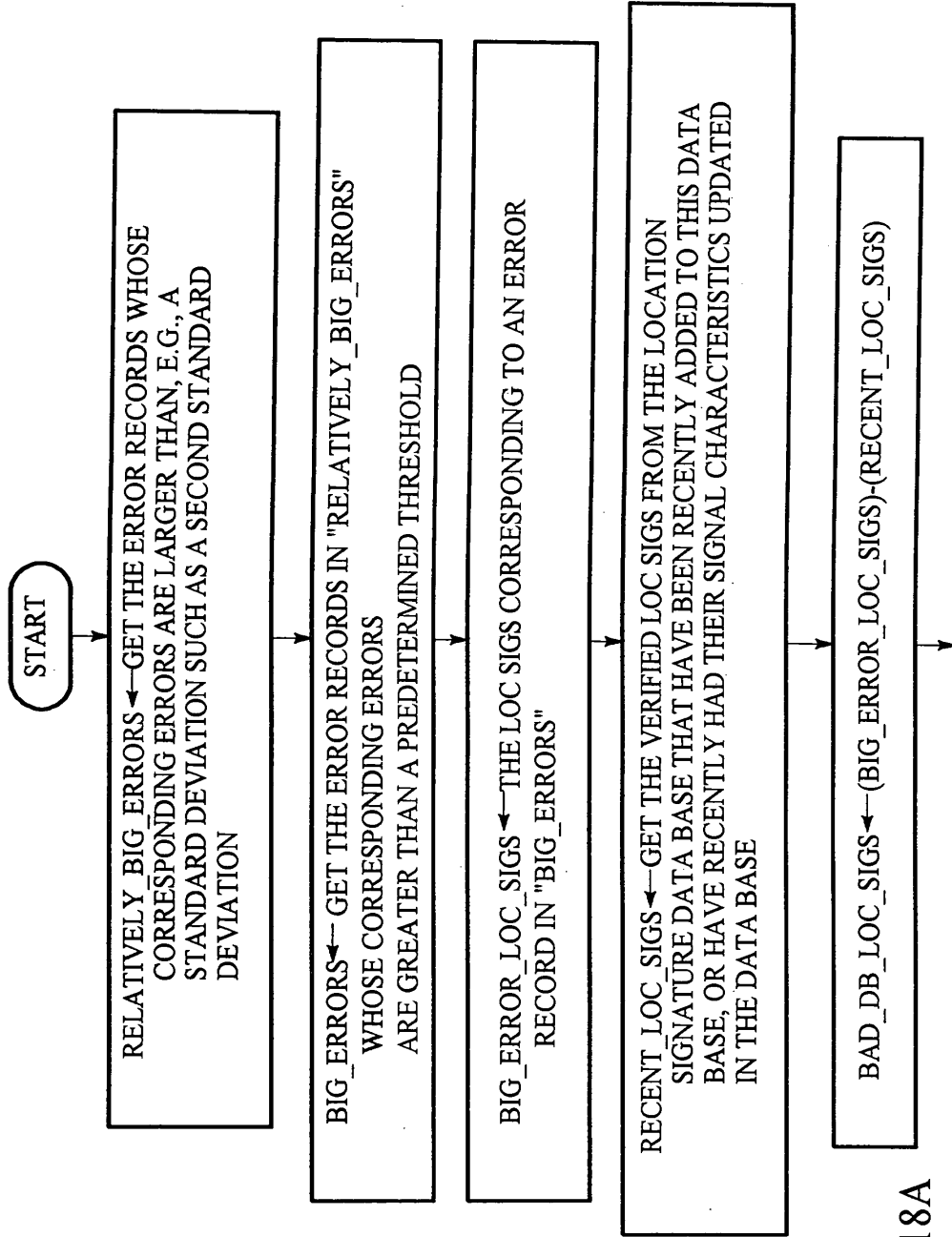

FIG. 18A

"FIG. 18B" 8630260

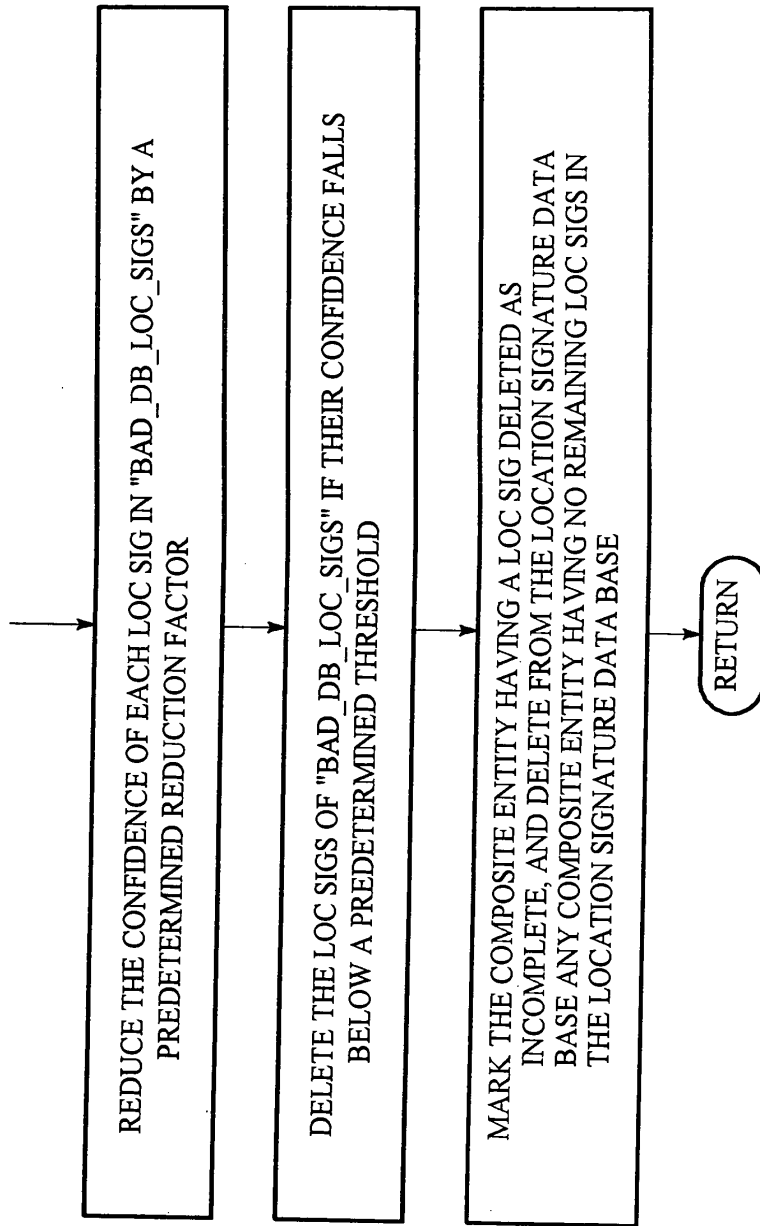

FIG. 18B

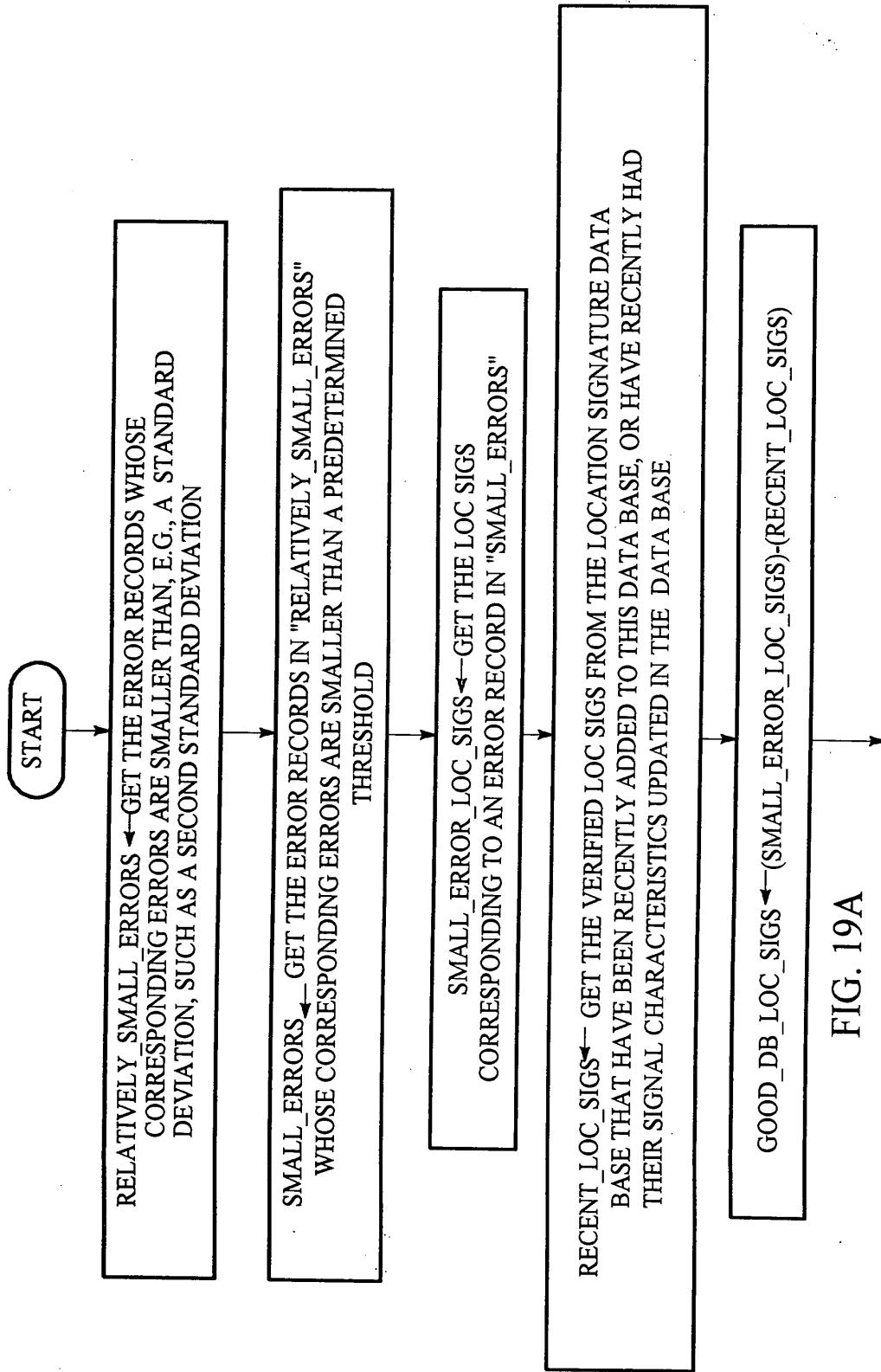

FIG. 19A

"LOC SIG" BEB0400

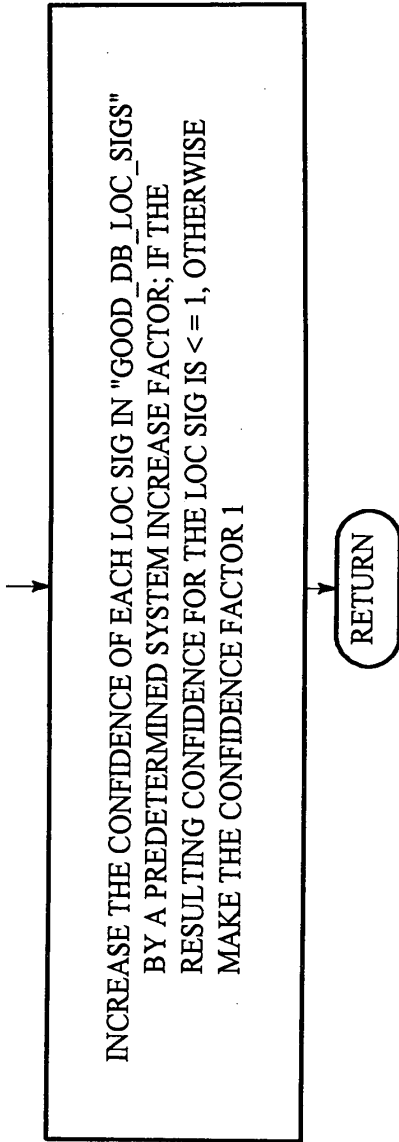
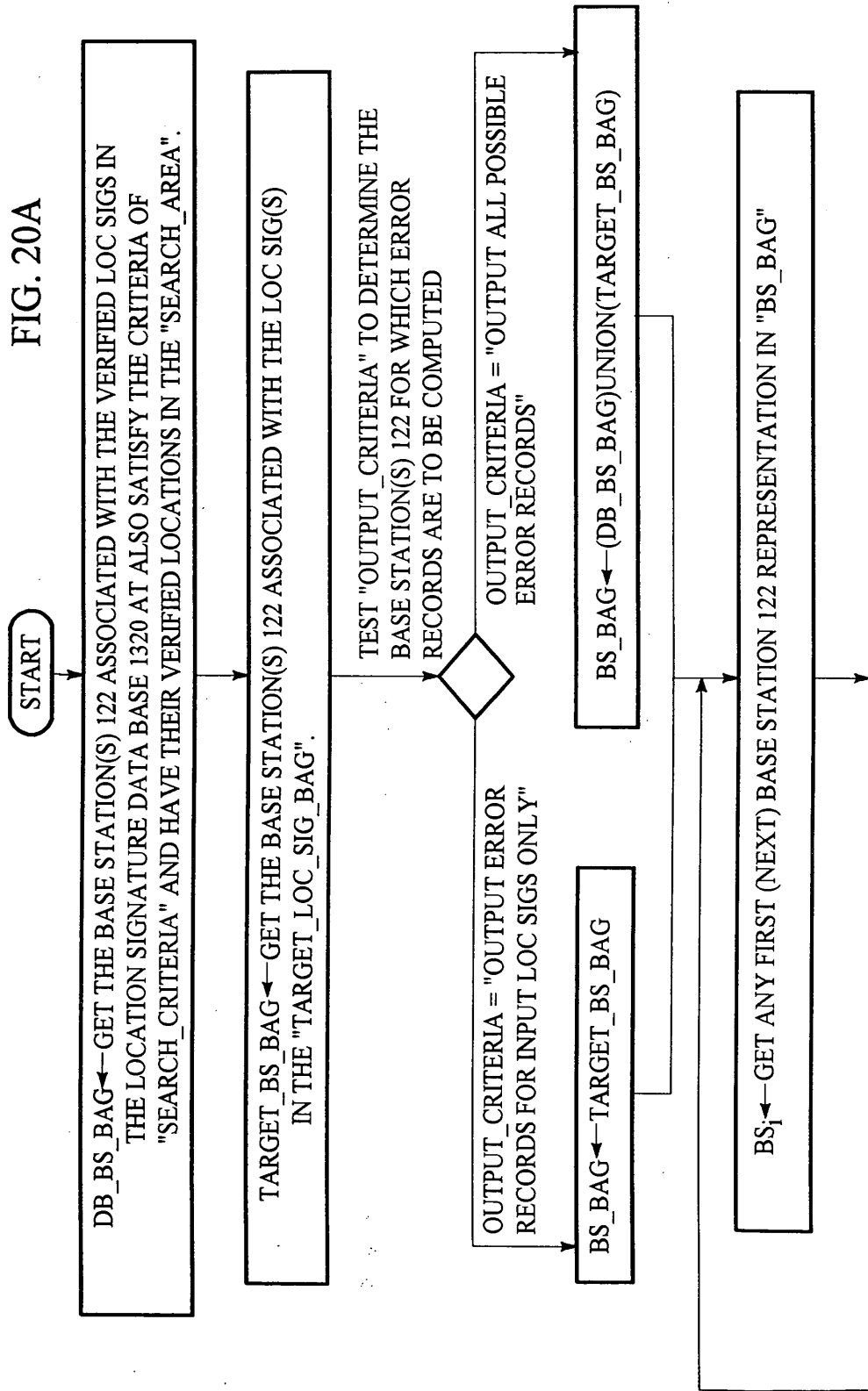
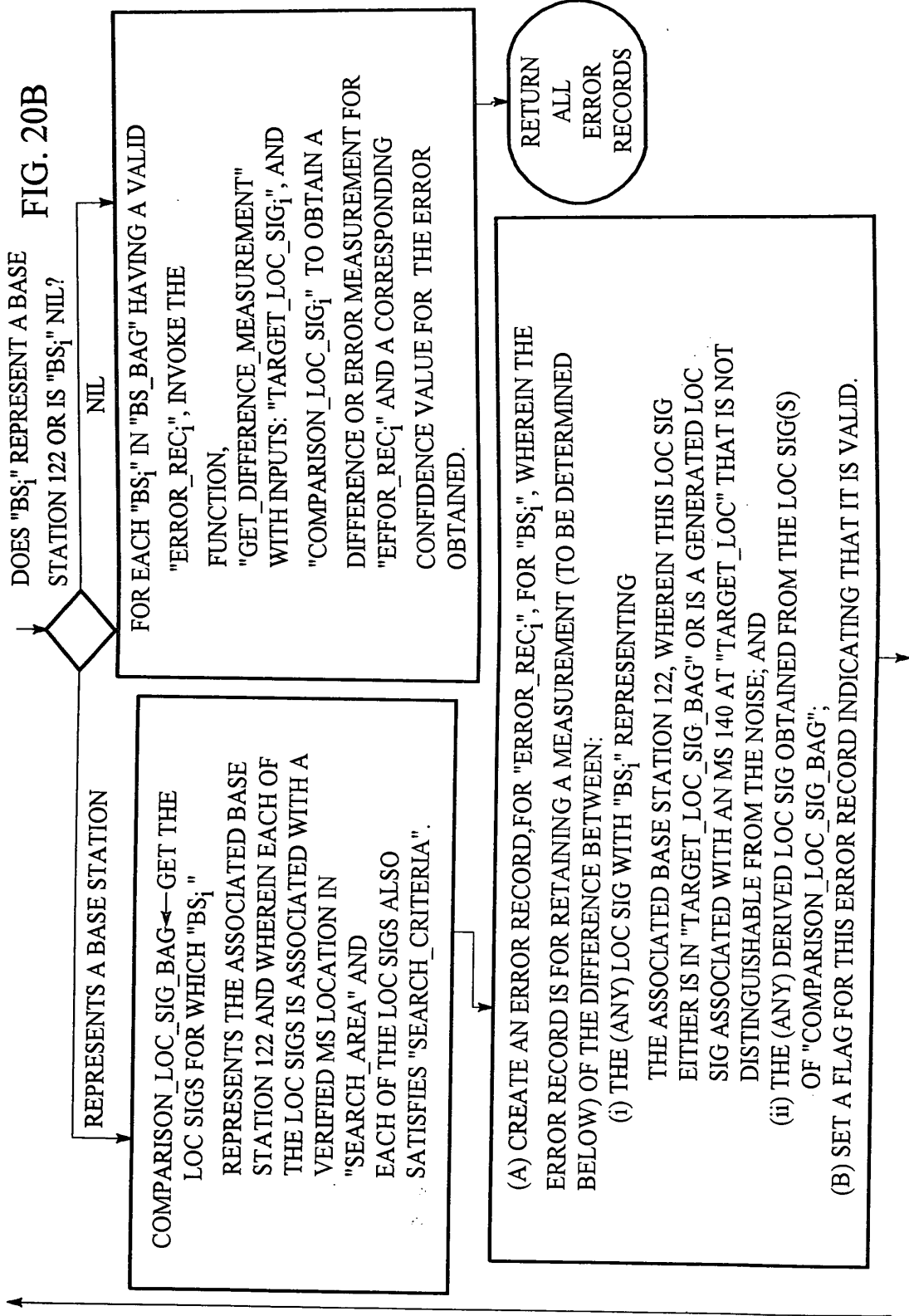

FIG. 19B





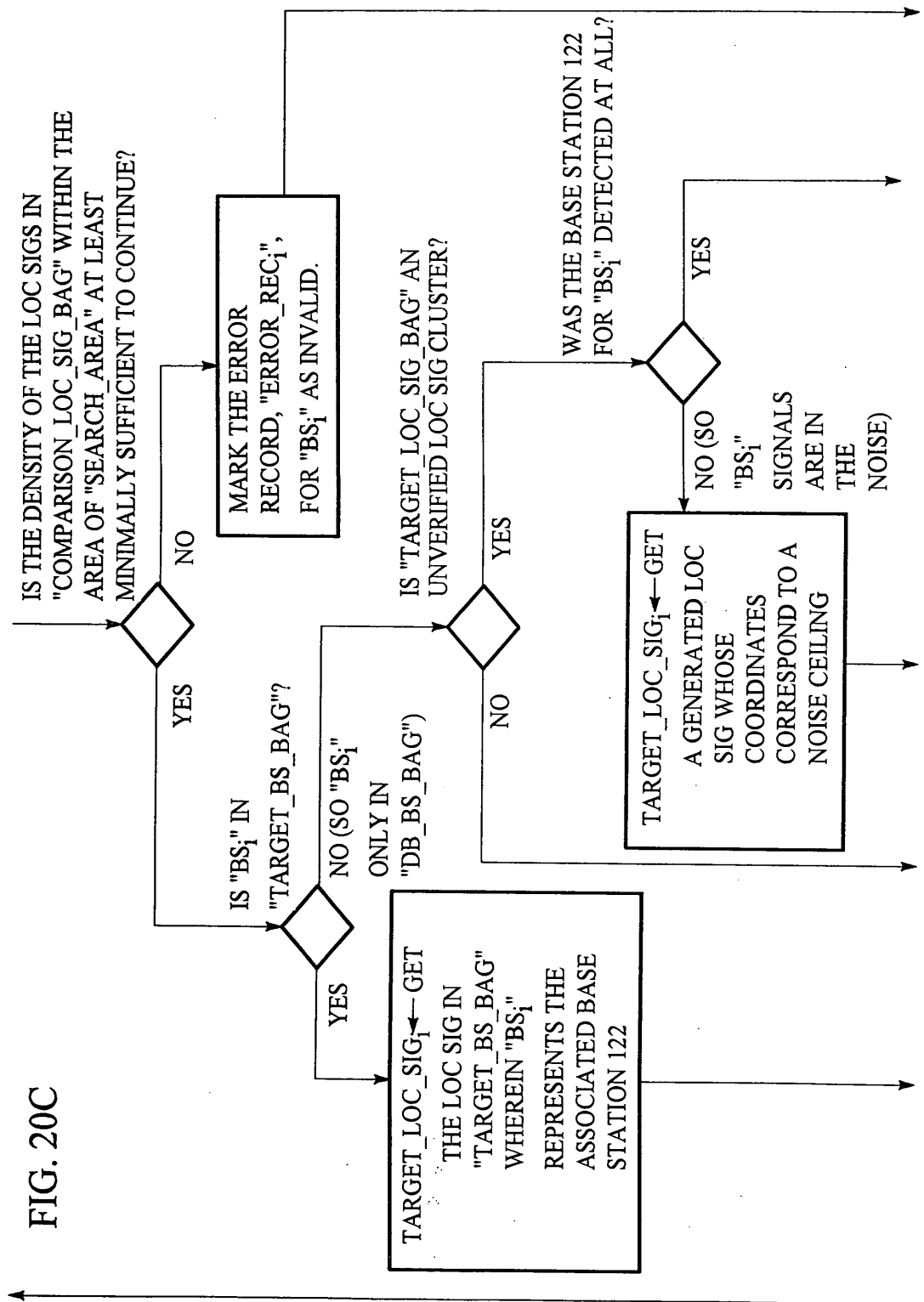

FIG. 20C

FIG. 20D

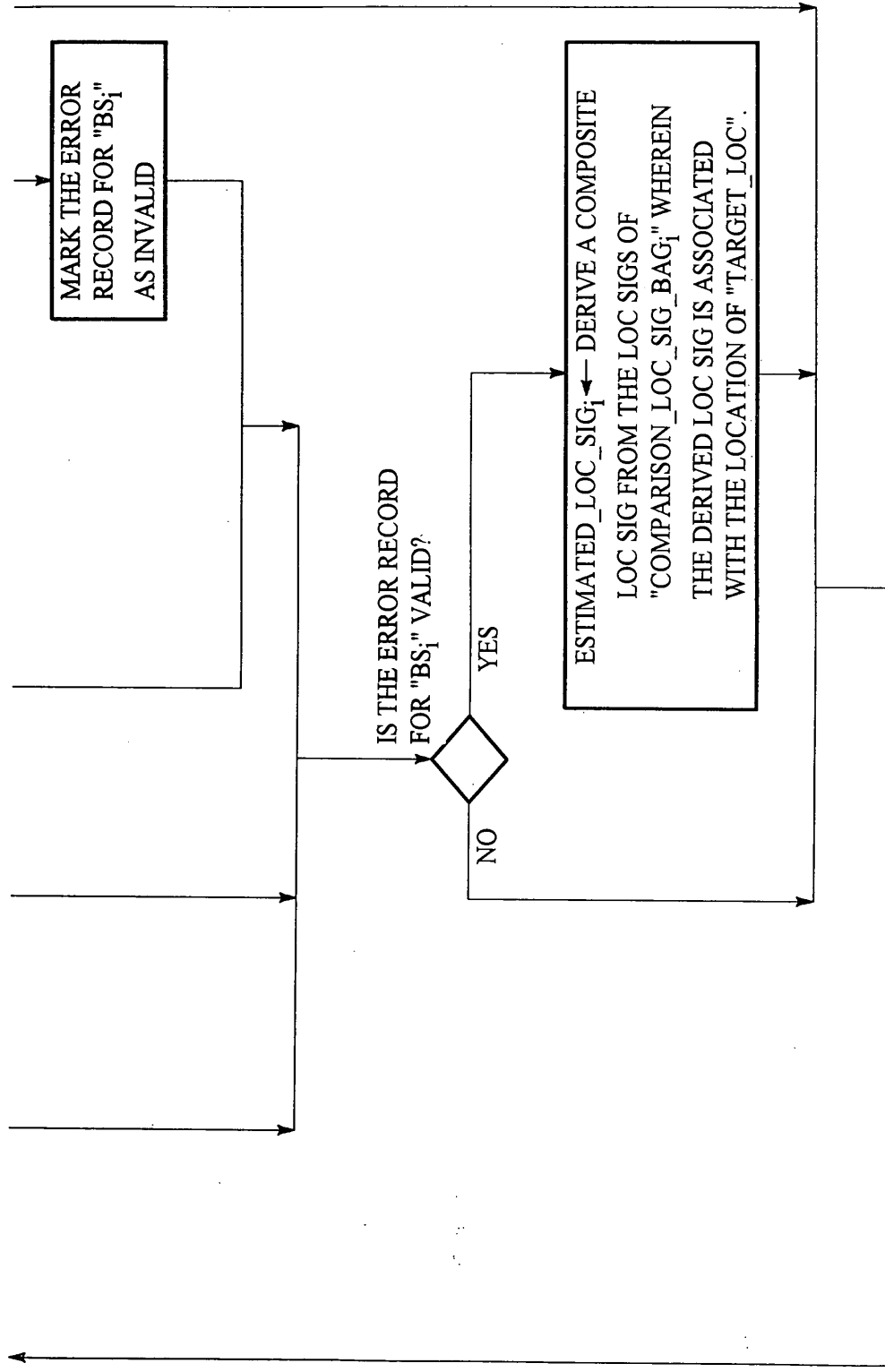

FIG. 20D



FIG. 21

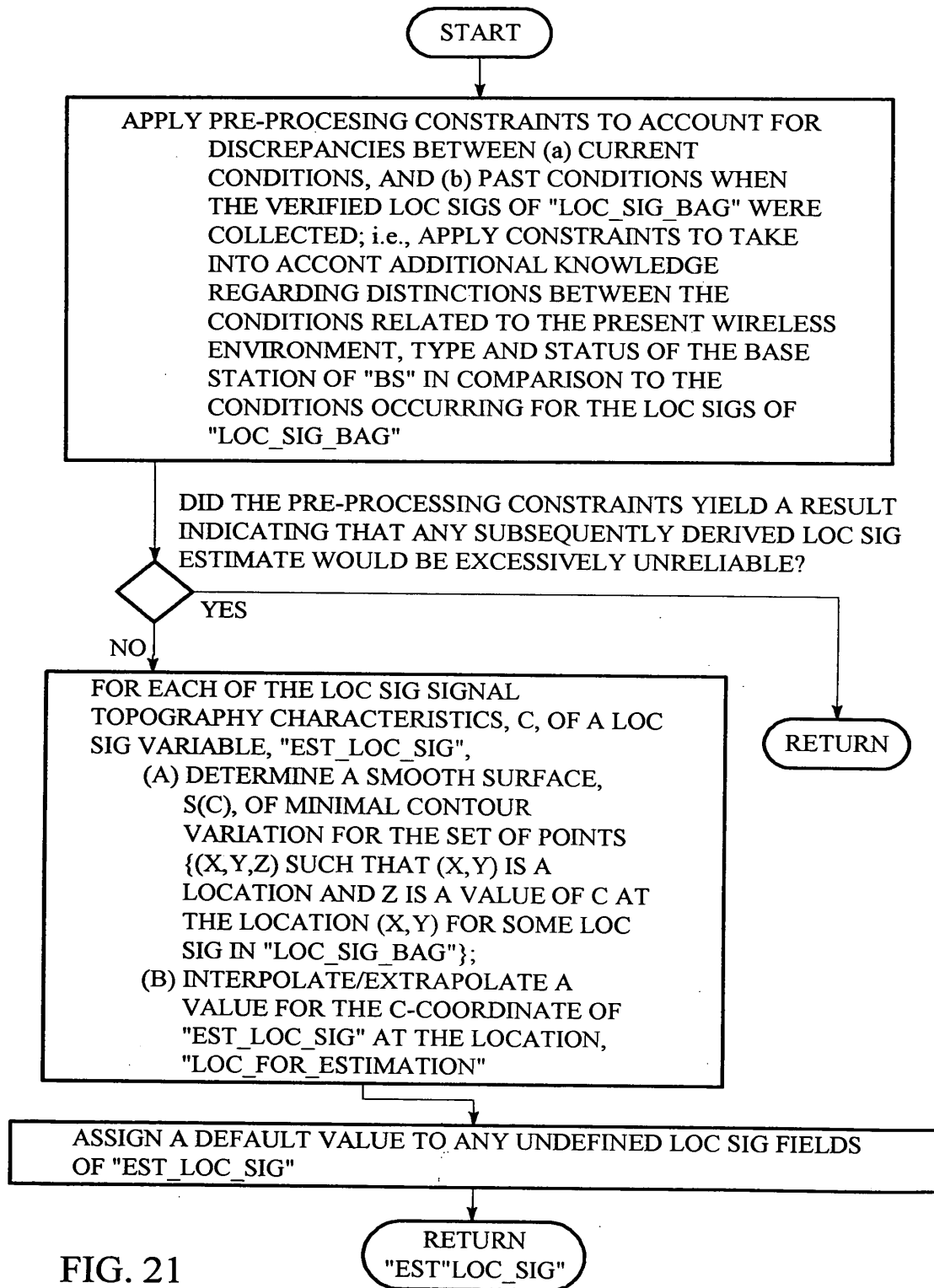

FIG. 21

FIG. 22A

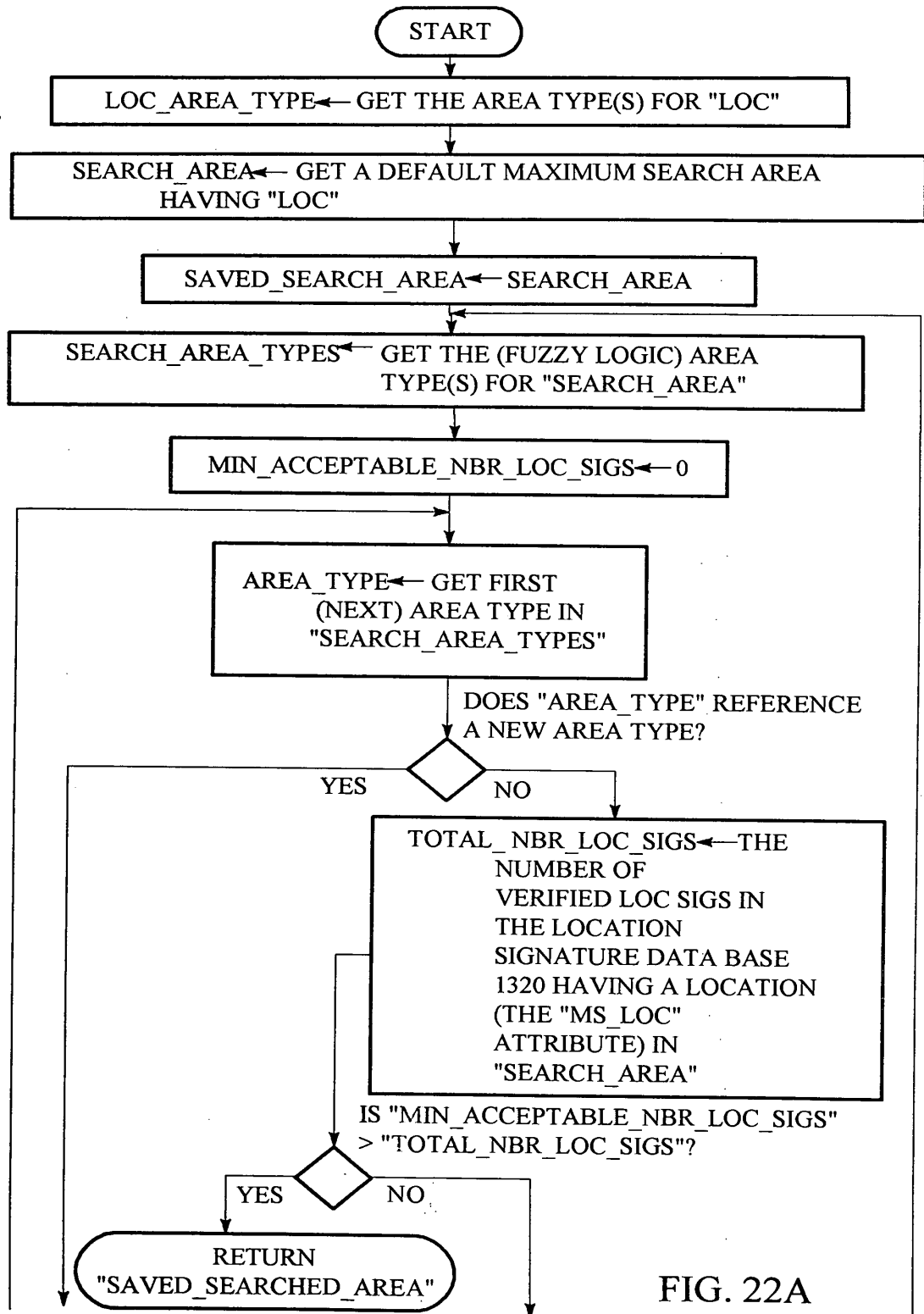

FIG. 22A

FIG. 22B

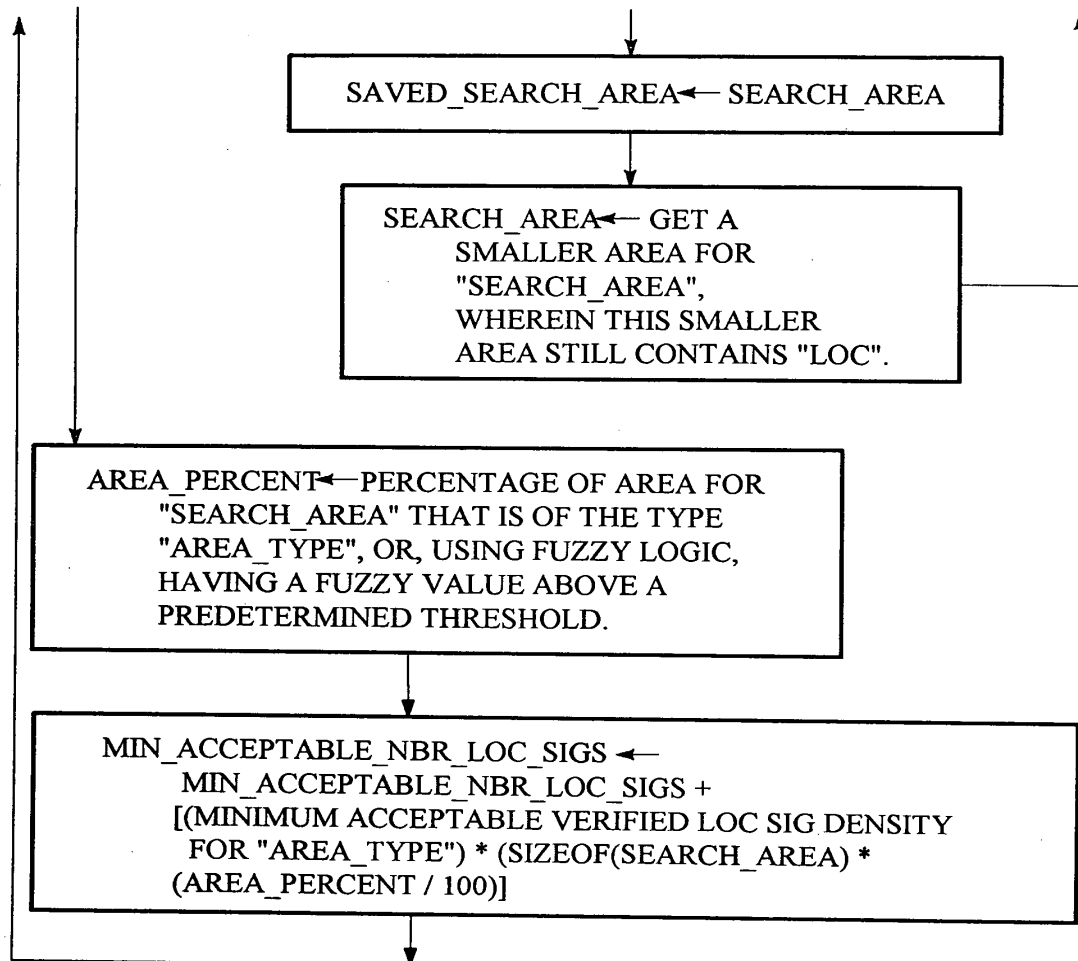

FIG. 22B

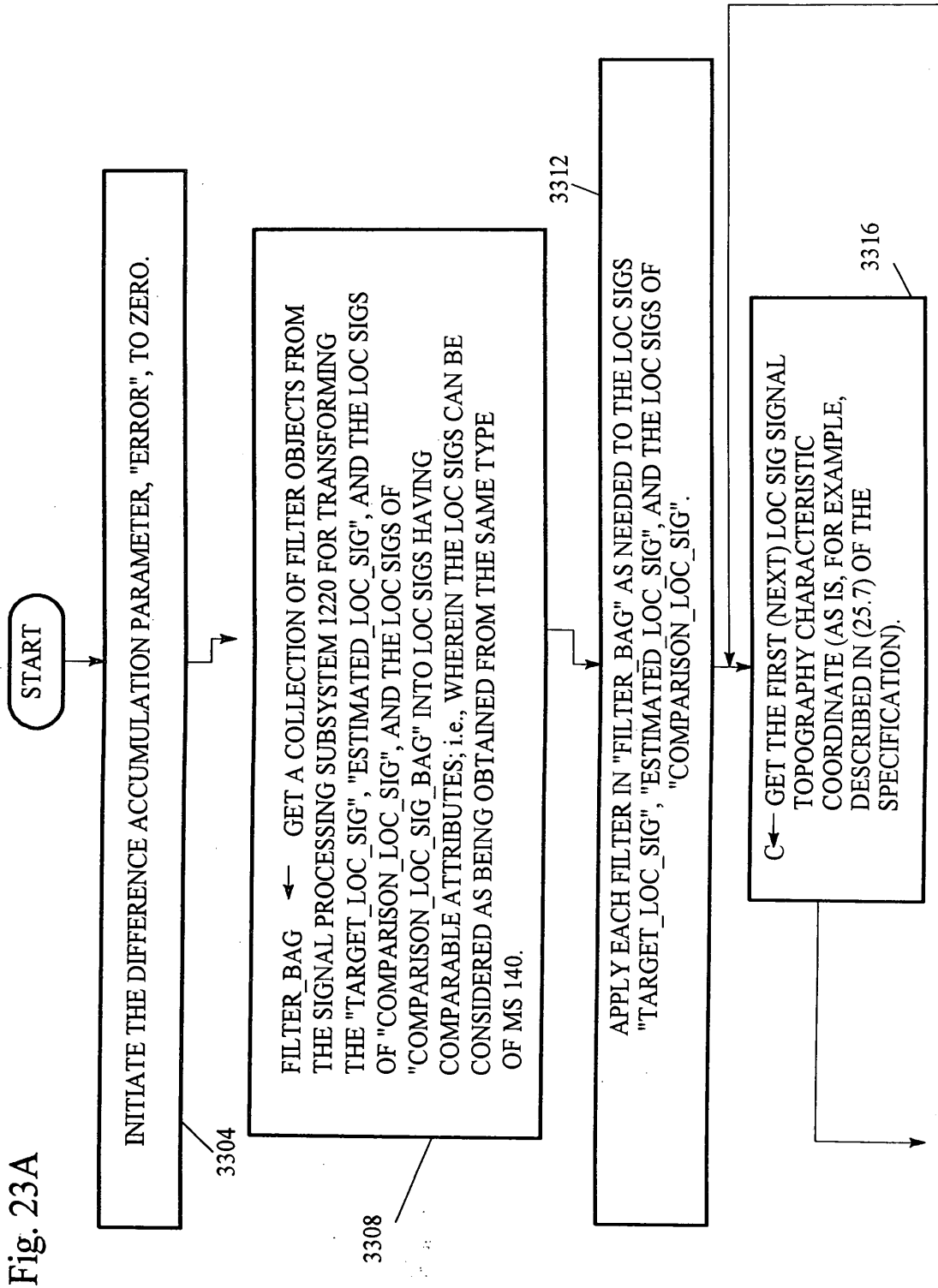

Fig. 23A

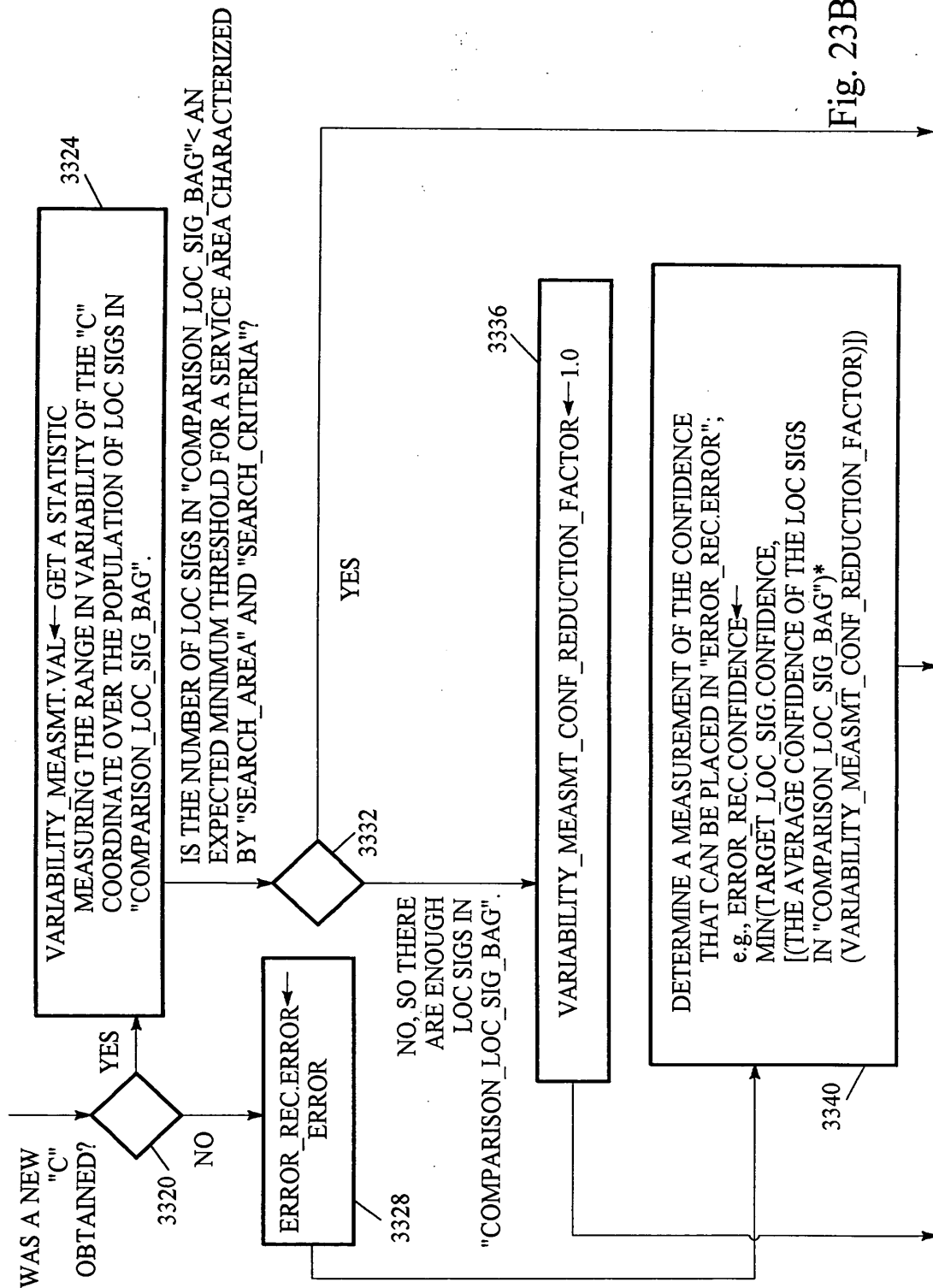

Fig. 23B

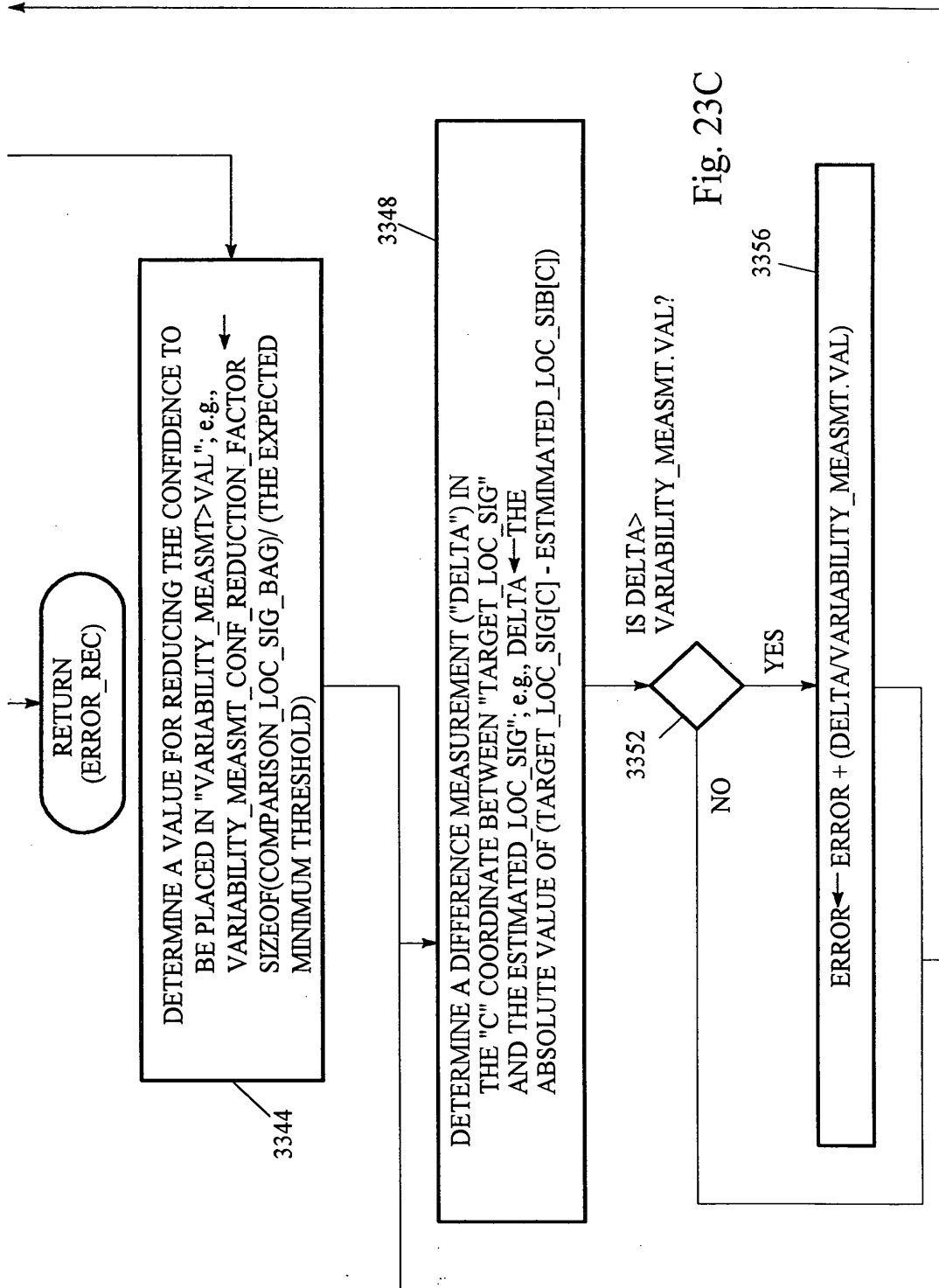

Fig. 23C

▲ = verified MS locations, in the Location Signature Data Base, having corresponding MS estimates (from the FOM identified by "loc\_hyp.FOM\_ID"), wherein the MS estimates are in "loc\_hyp.pt\_covering"

**FIG. 24**

■ = Previous MS location estimates by the present FOM;

"The cluster set" = The set of these FOM MS estimates that are: (a) within "loc\_hyp.pt\_covering", and (b) have corresponding verified MS location in the Location Signature Data Base.

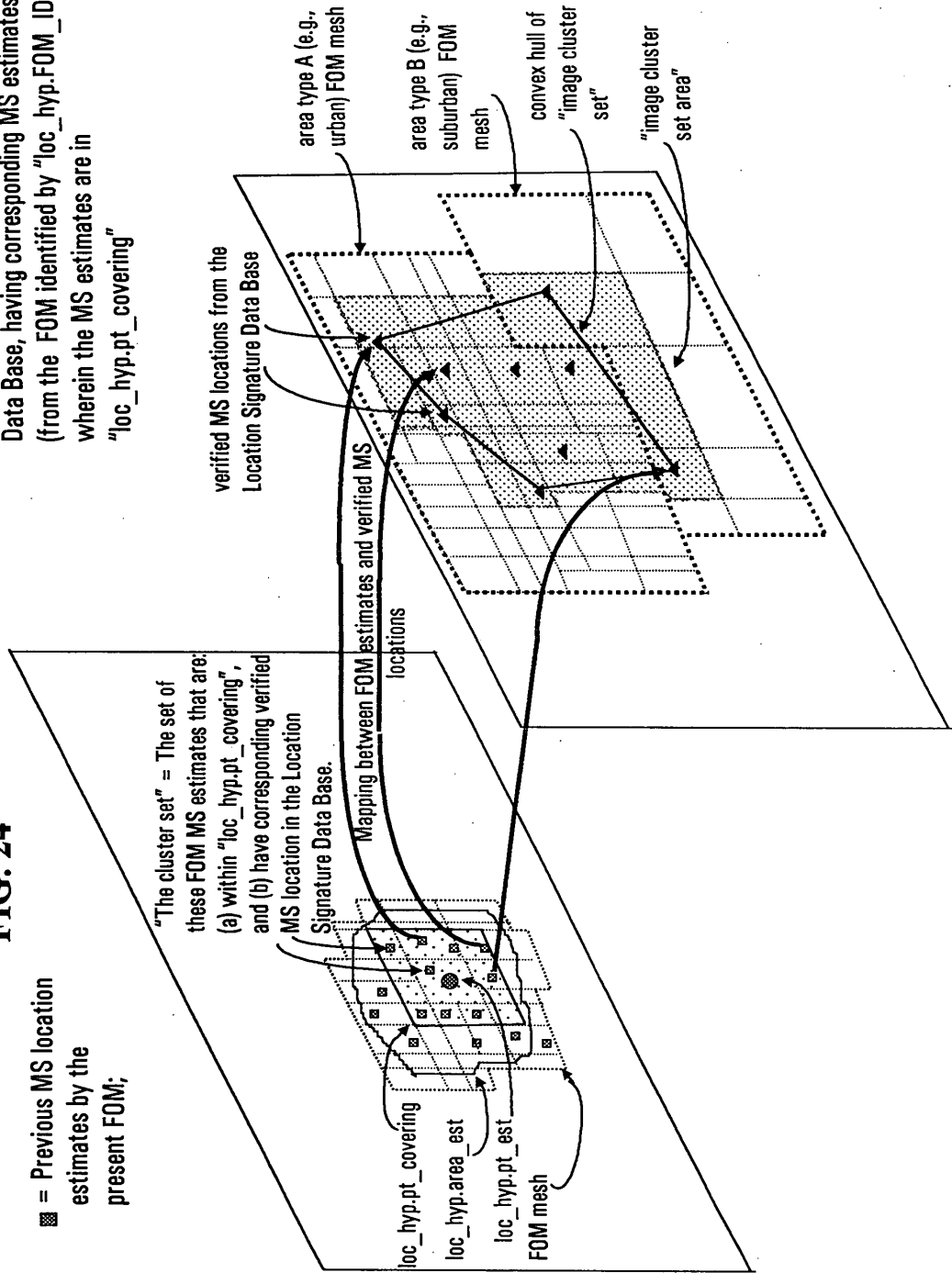

FIG. 25A

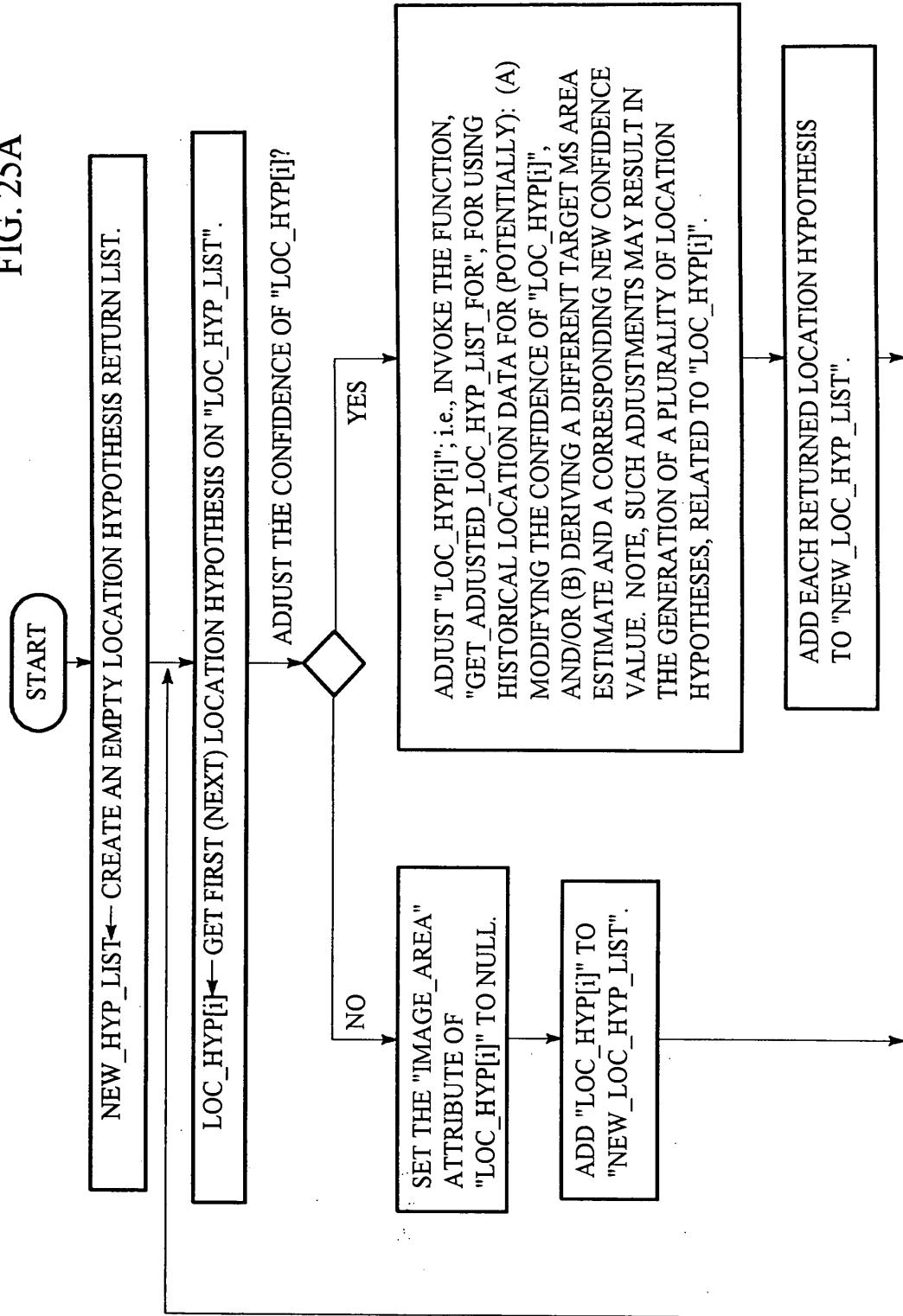



FIG. 25B

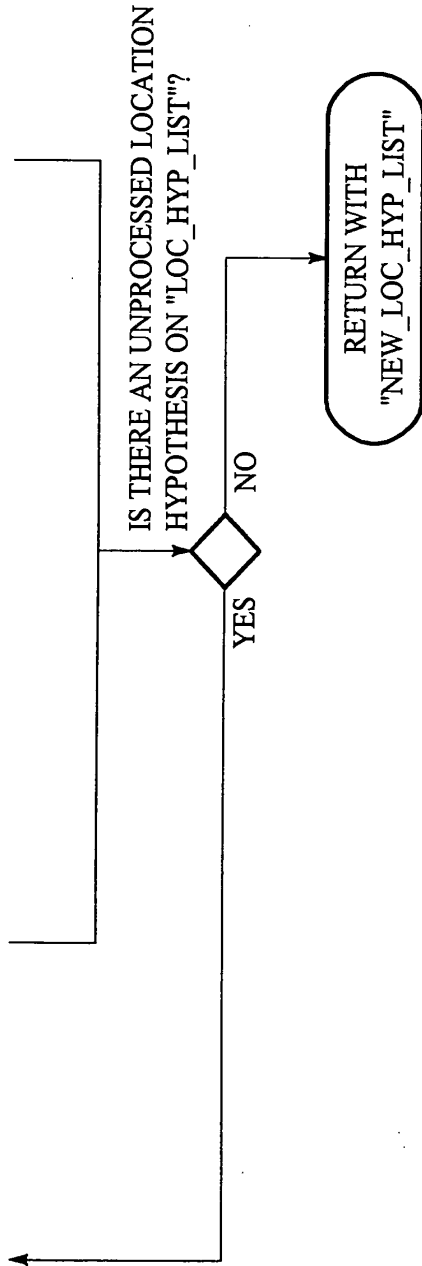
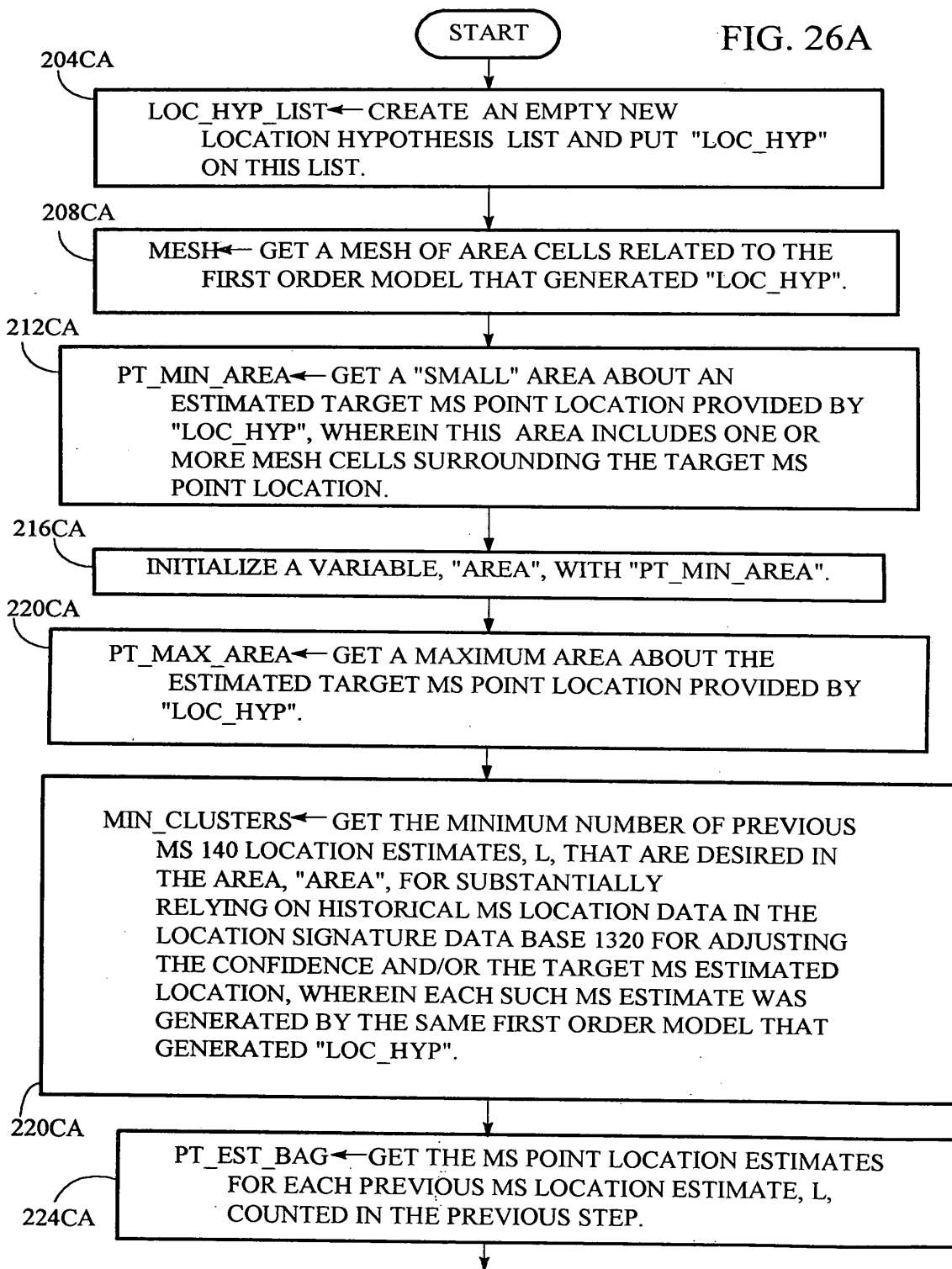

FIG. 25B

FIG. 26A



TOP SECRET

FIG. 26B

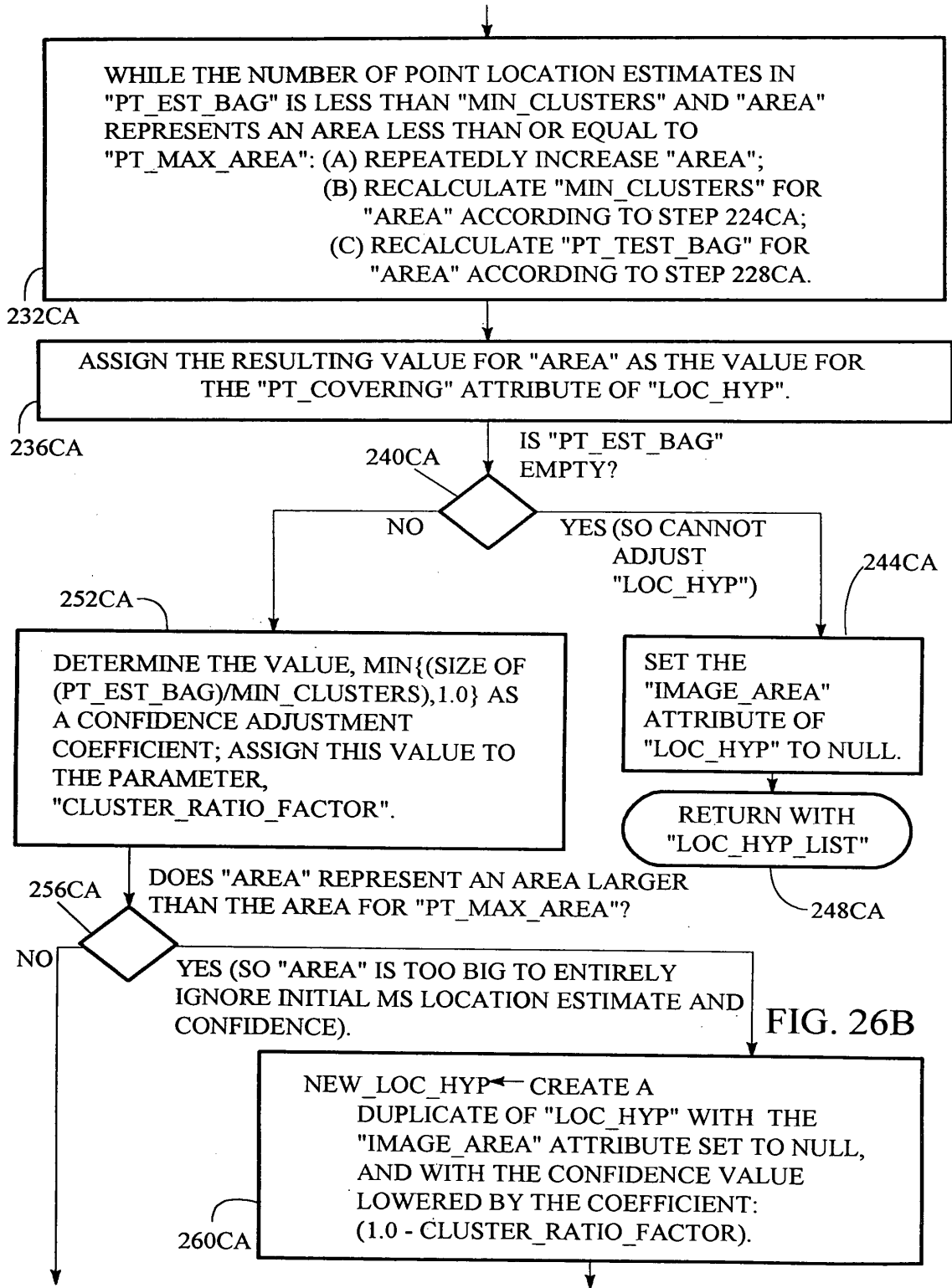

FIG. 26B

FIG. 26C

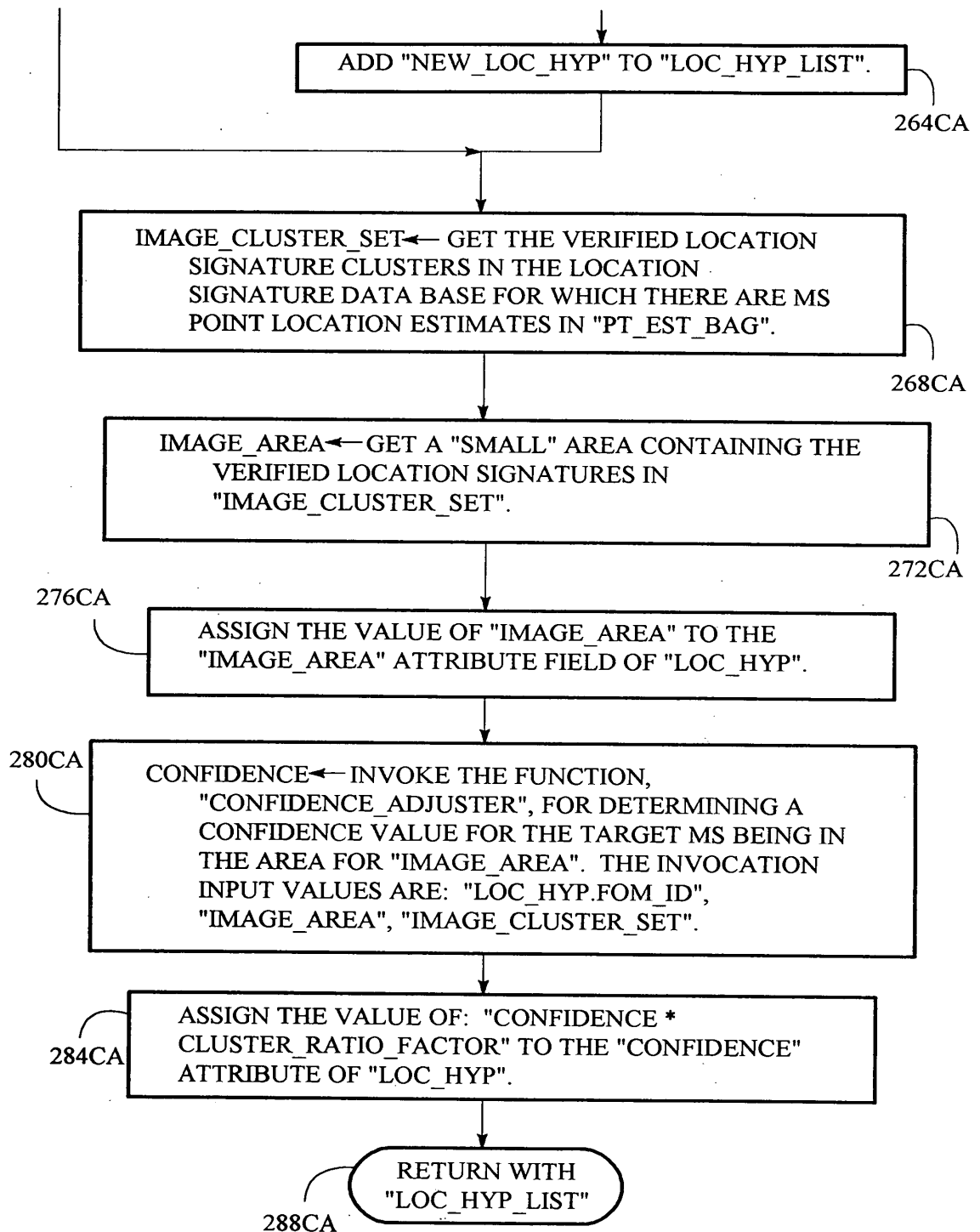

FIG. 26C

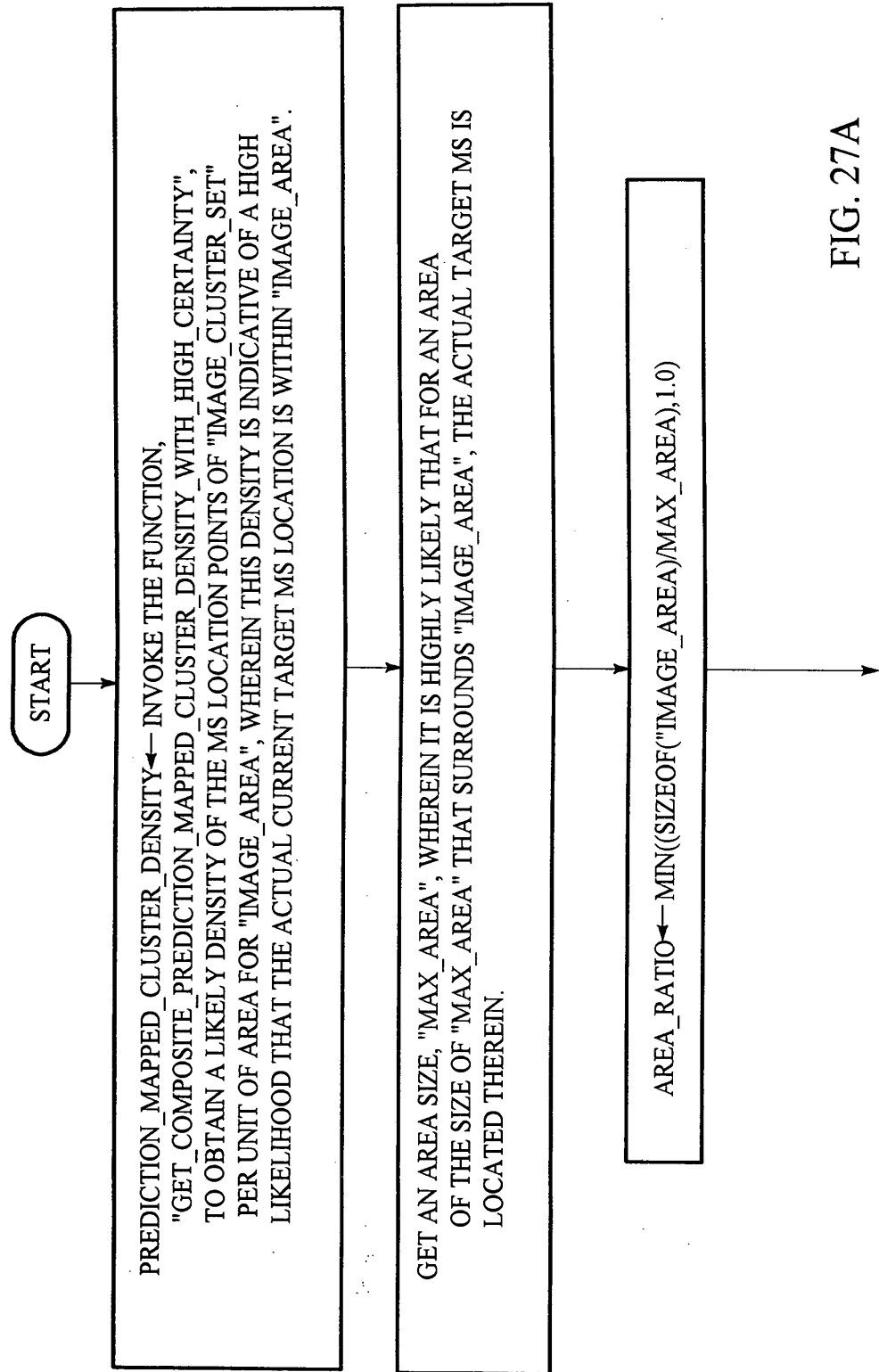

FIG. 27A

"FIG. 27B" 82504460

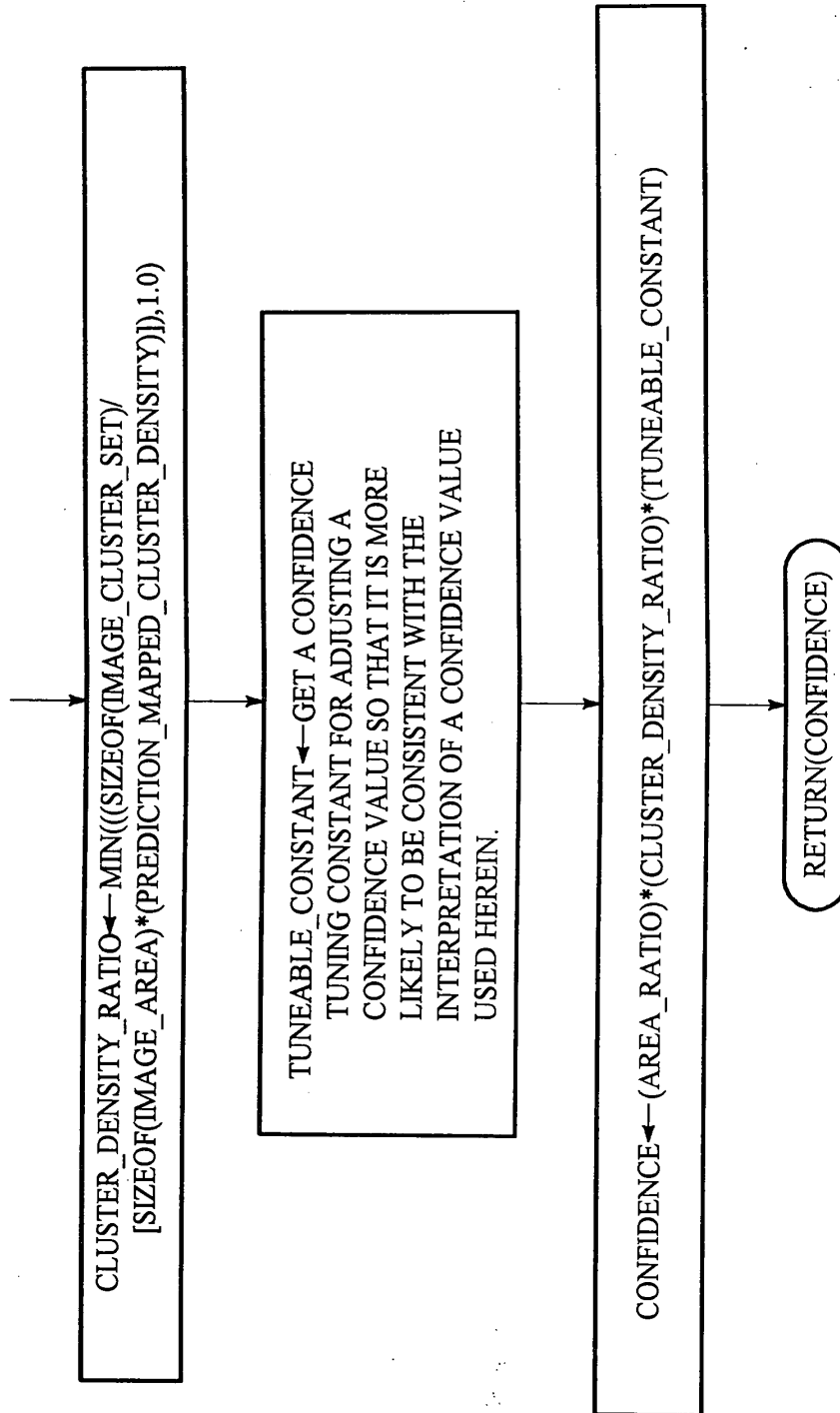

FIG. 27B

FIG. 28A

GET\_COMPOSITE\_PREDICTION\_MAPPED\_CLUSTER\_DENSITY\_WITH\_HIGH\_CERTAINTY  
(FOM\_ID, IMAGE\_AREA)

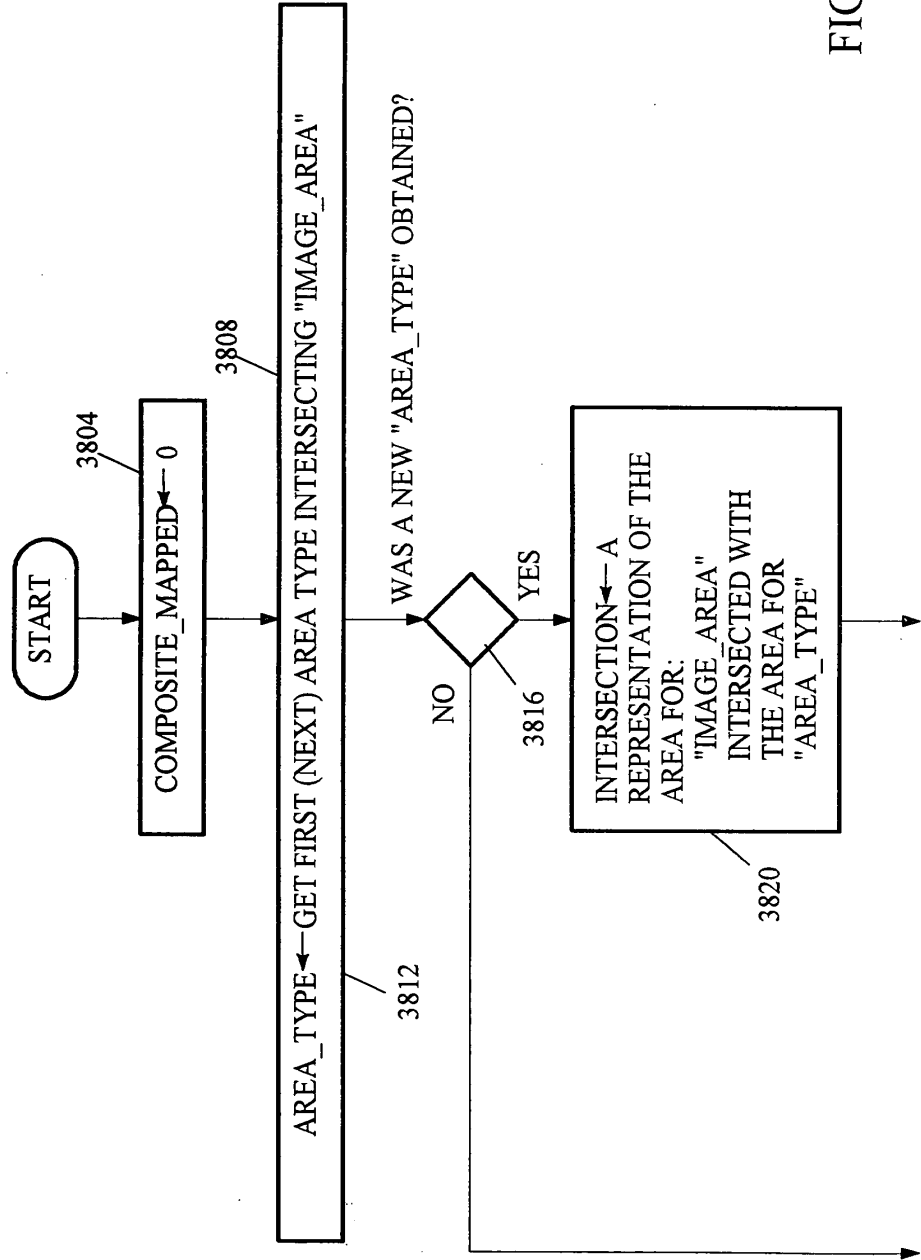

FIG. 28A

FIG. 28B

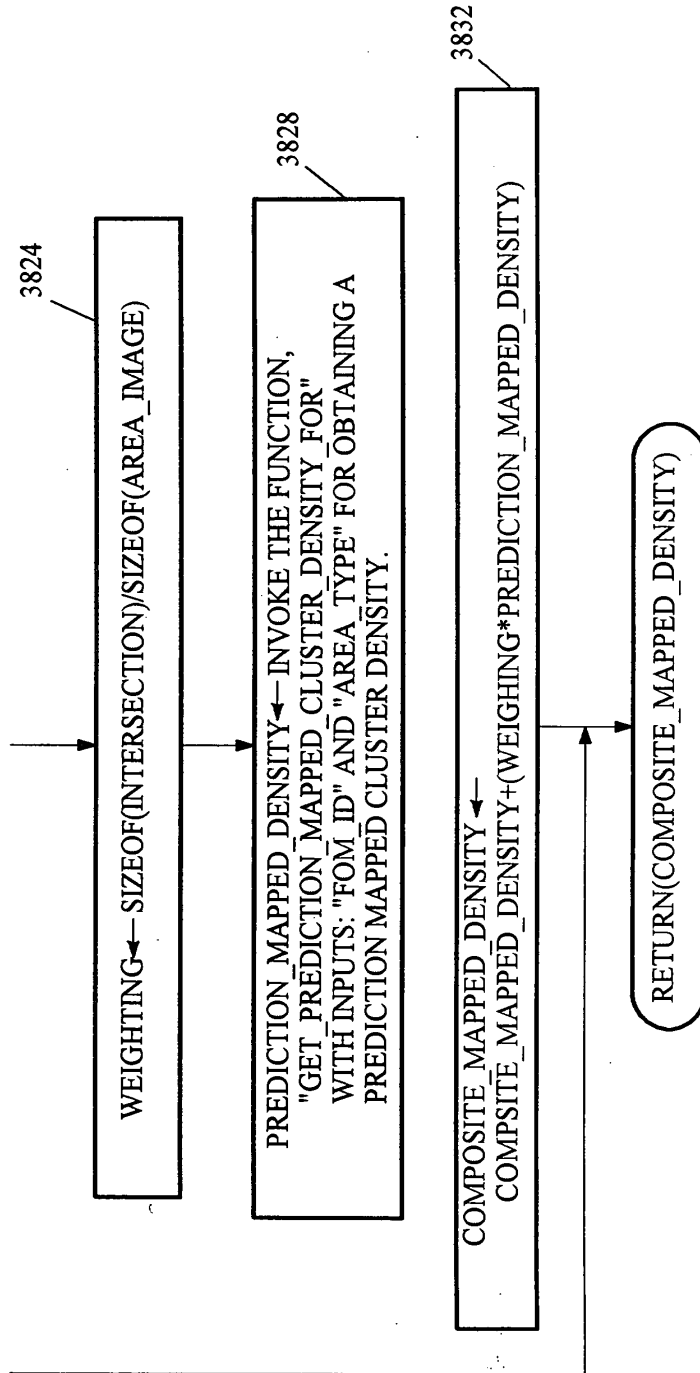

FIG. 28B



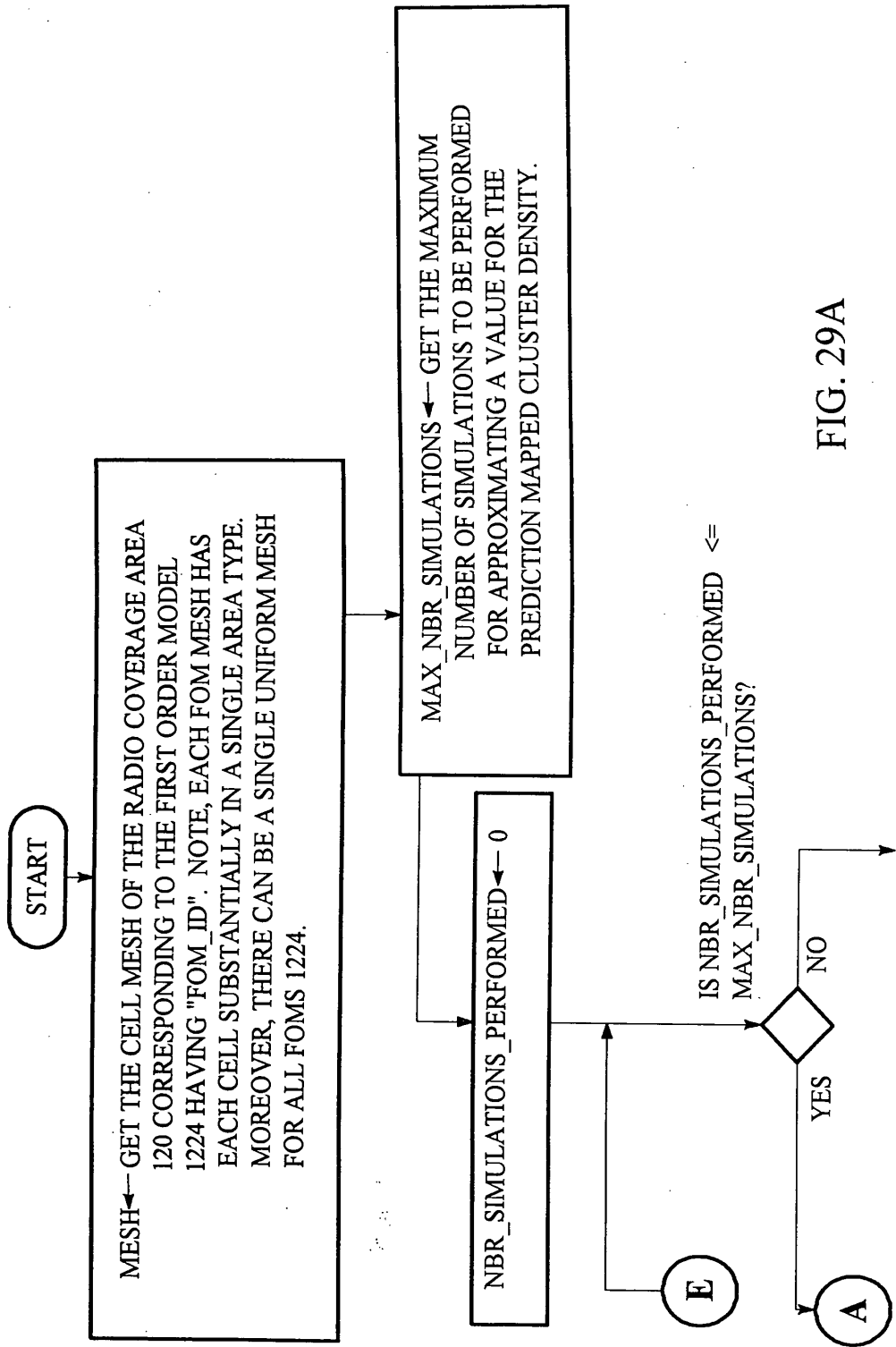

FIG. 29A

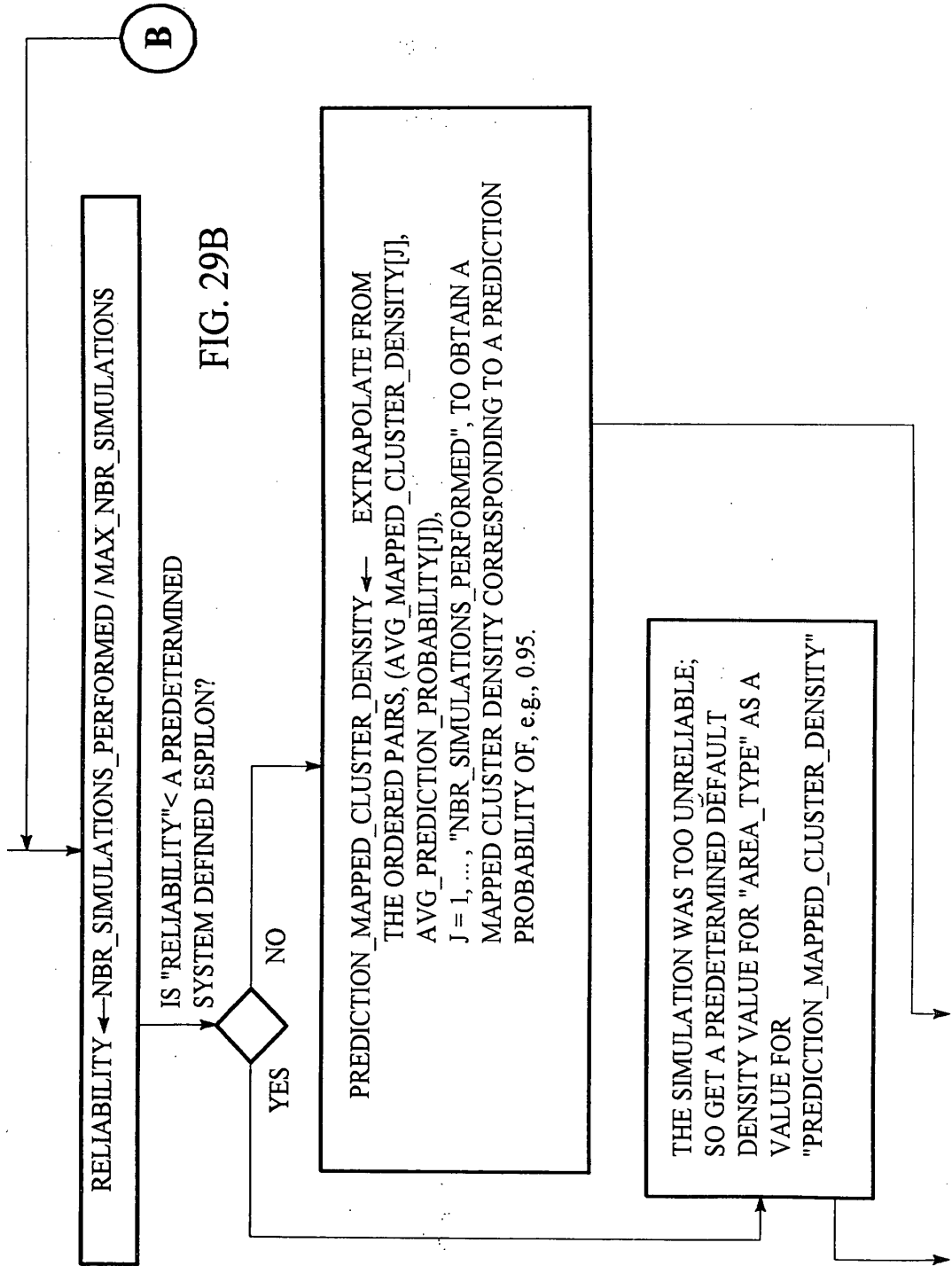

FIG. 29B

"FIG. 29C" 6602/260

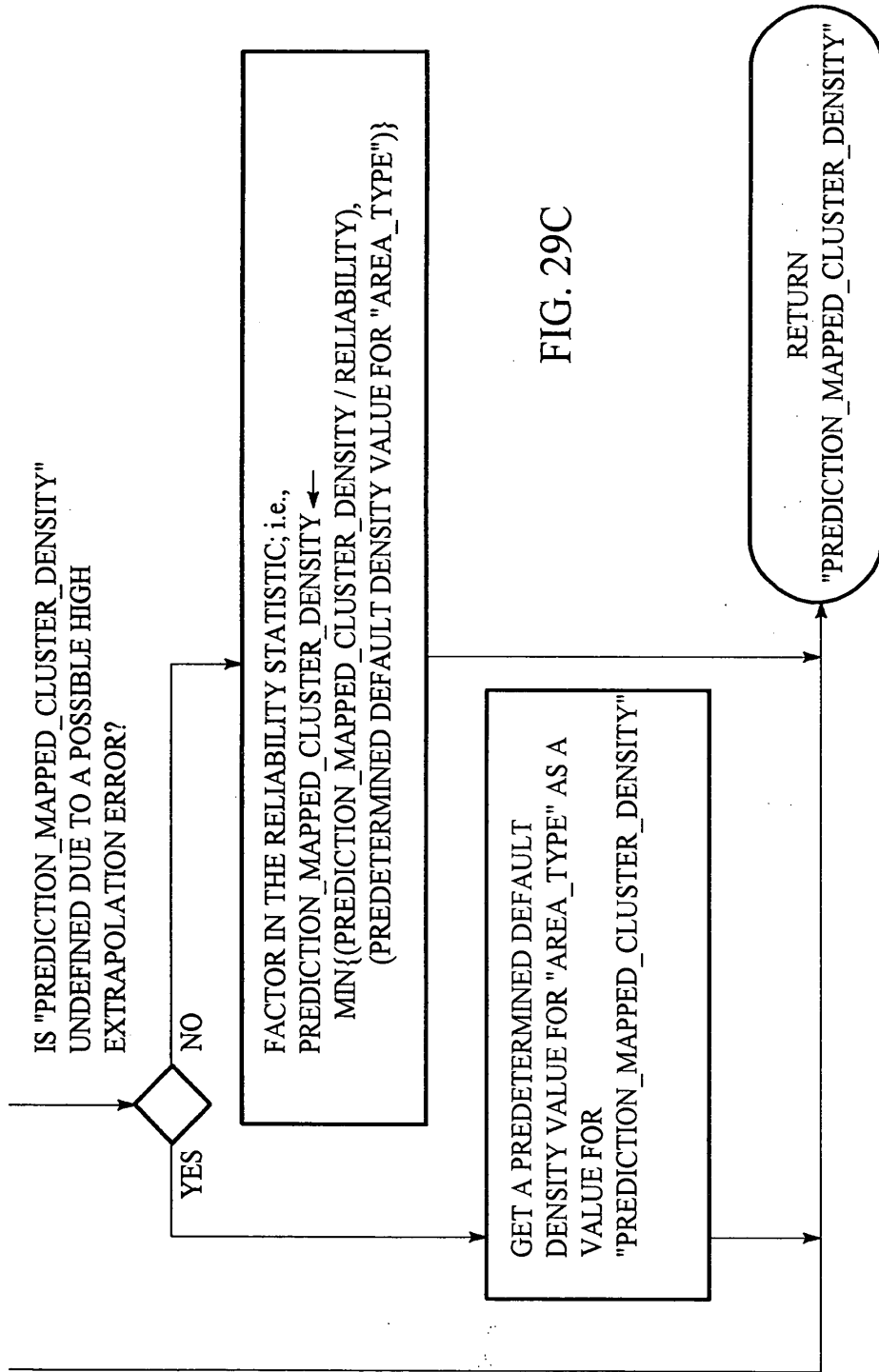

FIG. 29C

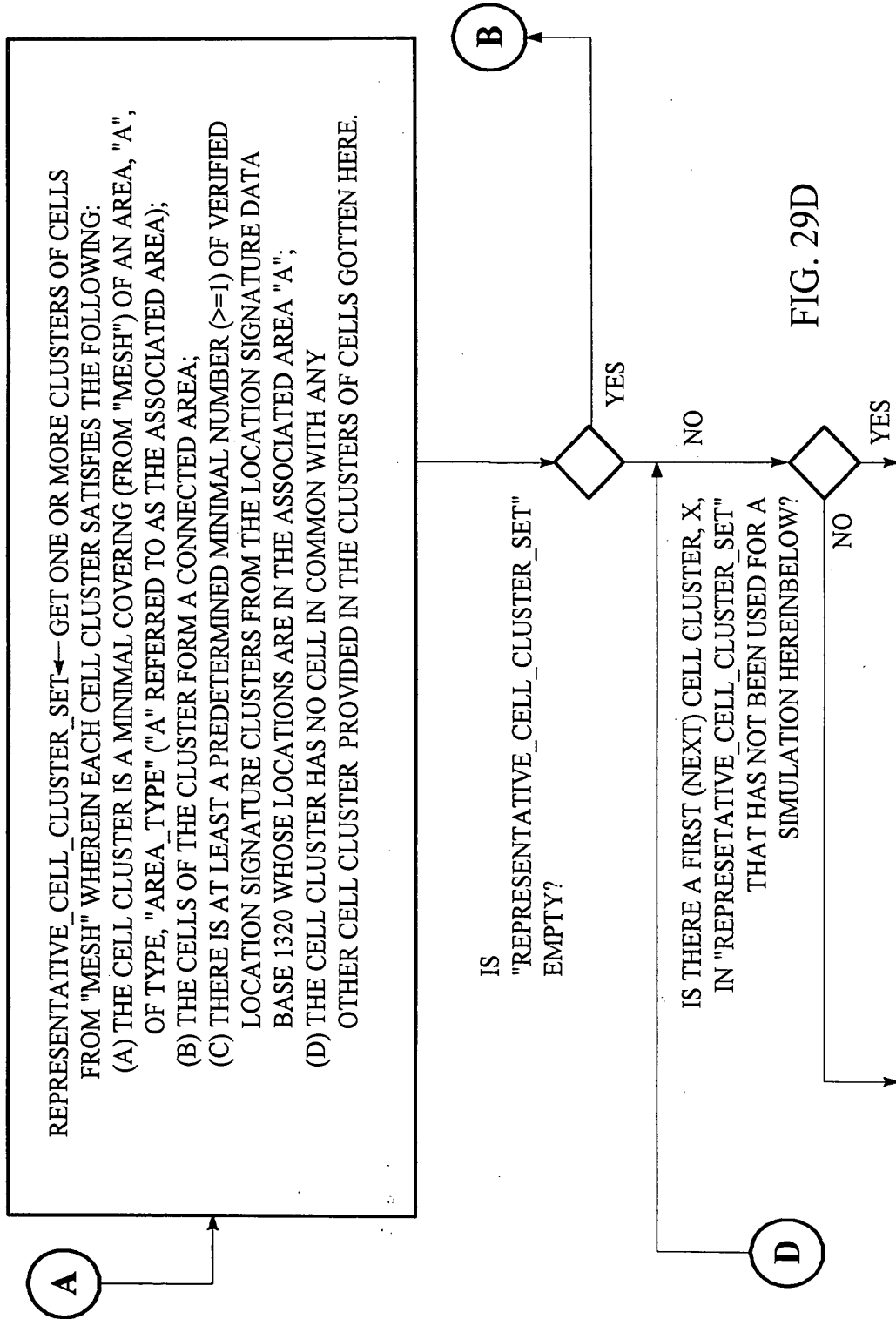
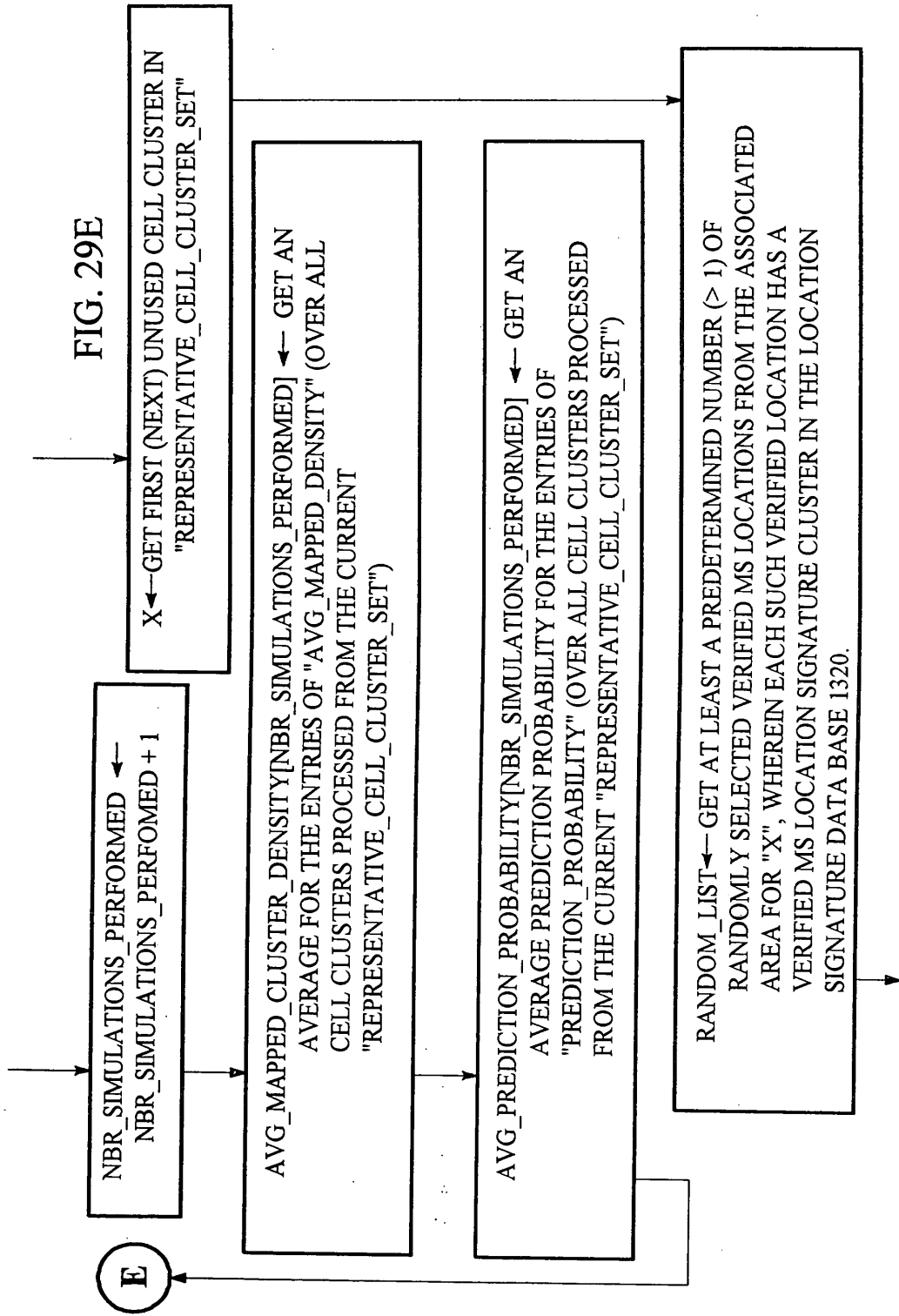
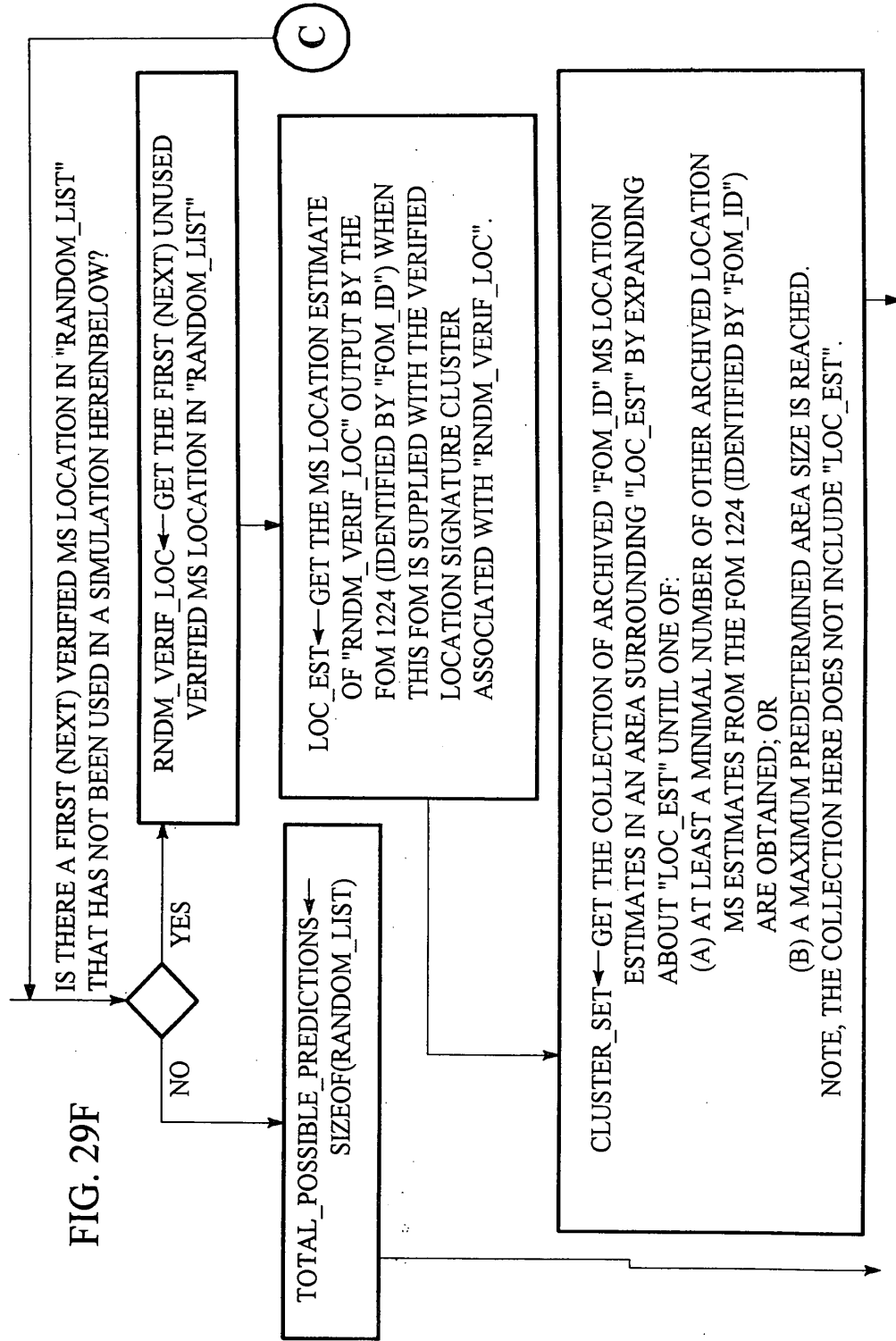

FIG. 29D





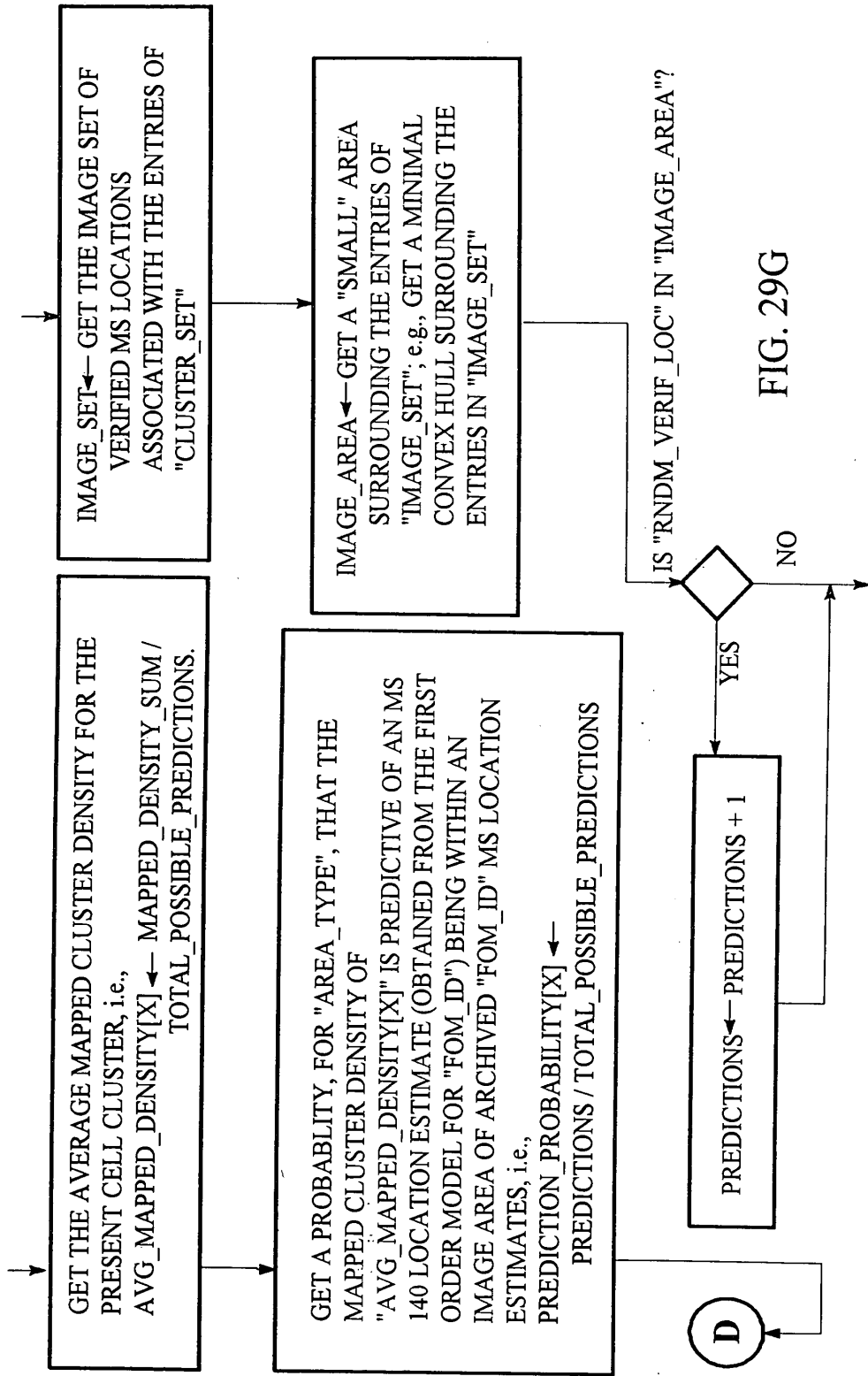

FIG. 29G

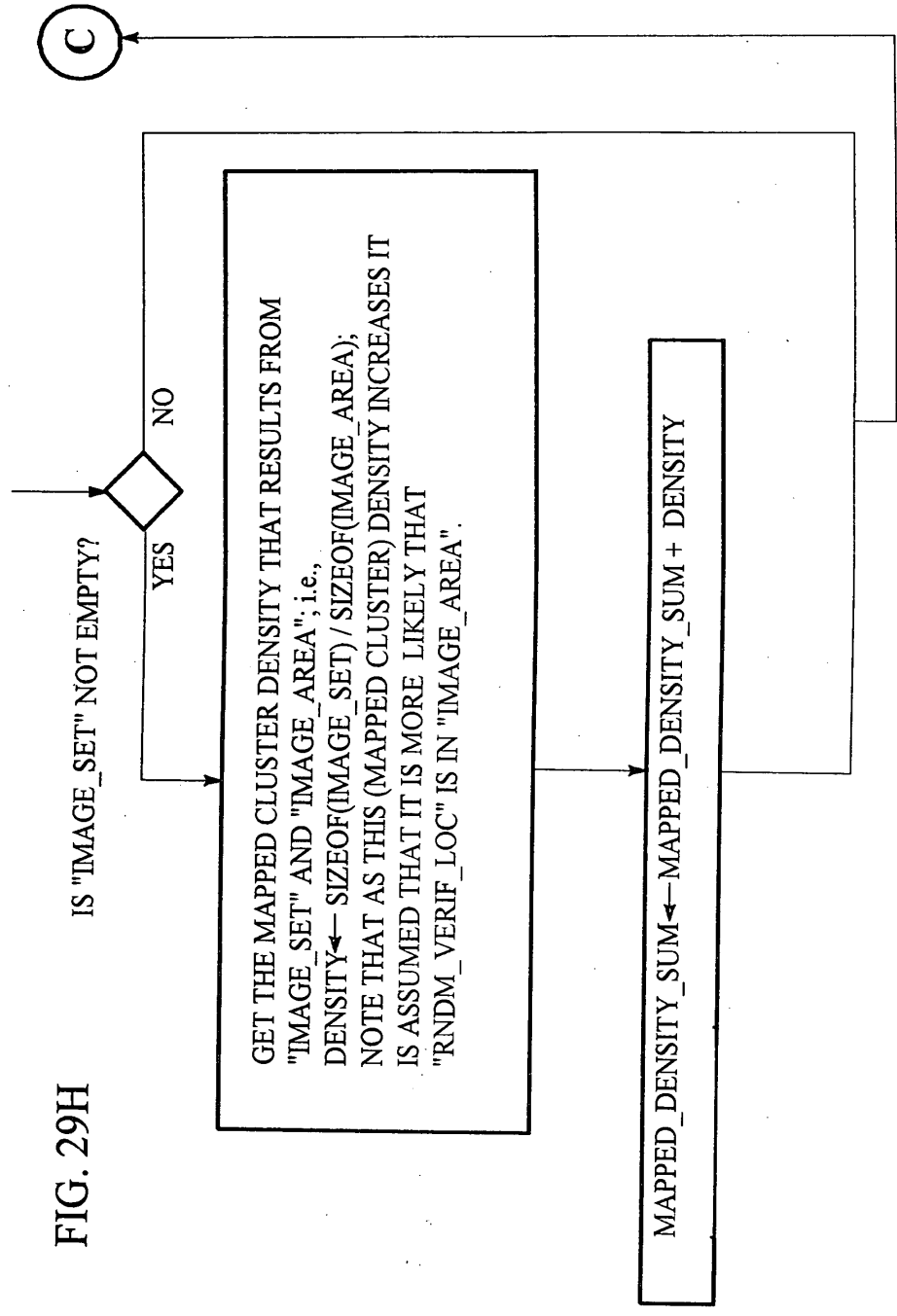

FIG. 29H



FIG. 30

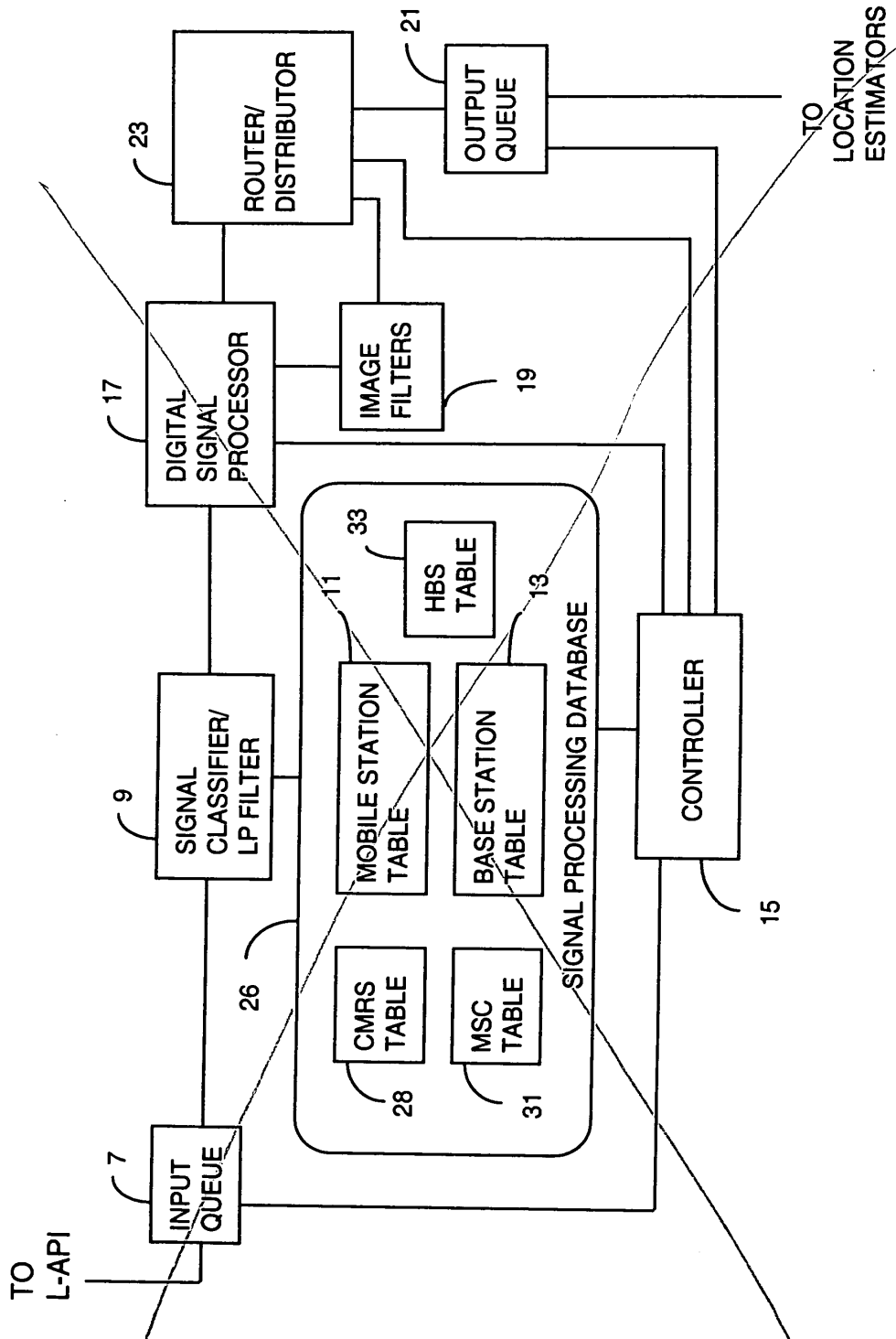

Fig. 30:

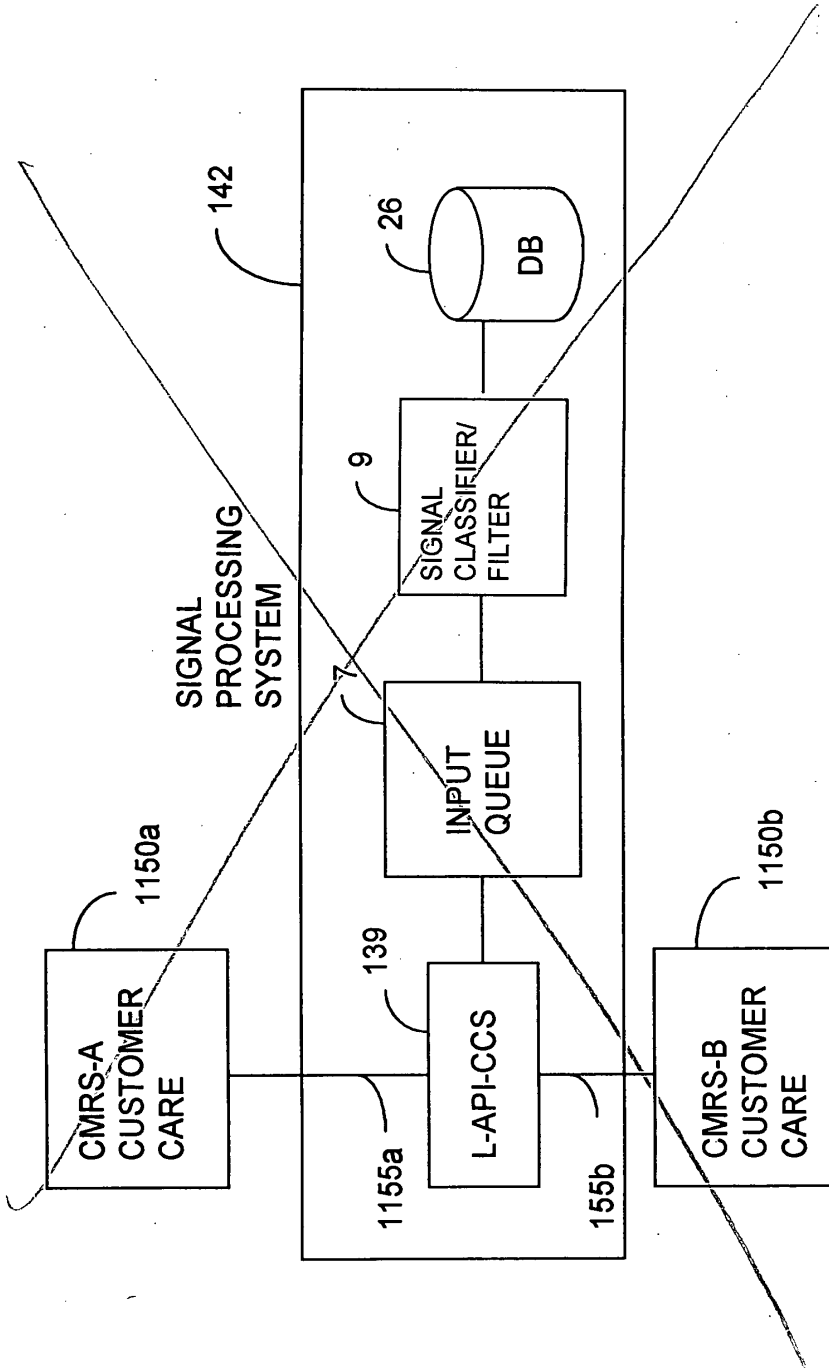

FIG. 31:



IN THE UNITED STATES PATENT AND TRADEMARK OFFICE

CFR Receipt  
E. Brins  
09/17/01  
RECEIVED

Inventor Application of: )  
)  
DUPRAY et al. )  
)  
Serial No.: 09/770,838 )  
)  
Filed: January 26, 2001 )  
)  
Atty. File No.: 1003-1 )  
)  
For: "WIRELESS LOCATION USING )  
SIGNAL FINGERPRINTING" )

Group Art Unit: 3662

Examiner:

SEP 14 2001

REQUEST FOR CORRECTION OF FILING RECEIPT 3600 MAIL ROOM

Office of Initial Patent Examinations  
Customer Service Center  
Commissioner of Patents  
Washington, D.C. 20231

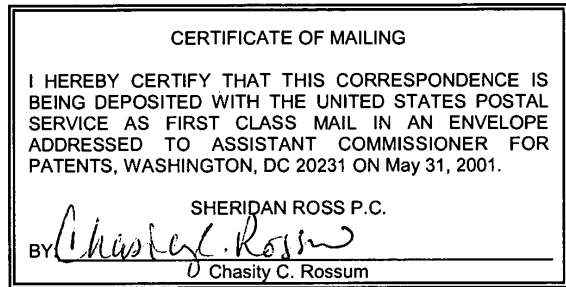

Dear Sir:

The official Filing Receipt for the above-referenced patent application contains the following clerical errors:

1. Please change the order of the listed inventors to list "Dennis J. Dupray" as first named inventor such as that shown on the Utility Continuation Patent Application Transmittal.
2. The name of co-applicant Charles L. Karr is shown as "Charles L. Karr JR." Please delete "JR" from the co-applicant's name to read as Charles L. Karr.
3. The resident for co-applicant Dennis J. Dupray is shown as "Denver, CO." Please change this to read correctly as Golden, CO. (A copy of the Utility Continuation Patent Application Transmittal which was filed with the application on January 26, 2001 is enclosed. Note that a copy of the Oath/Declaration from the pending prior application was filed simultaneously with the present application. Since the execution of the Oath/Declaration by the inventors on November 17, 1998 and November 24, 1998, the address for co-applicant Dennis J. Dupray has changed to that specified on the transmittal.)
4. In the "Domestic Priority Data Claimed by Application" section of the receipt, please delete from the fourth row "said 09/194,367 11/24/1998."

For your reference, a copy of the Filing Receipt is enclosed, with the corrections indicated in red. Please issue a corrected Filing Receipt for this patent application.

Respectfully submitted,

By:

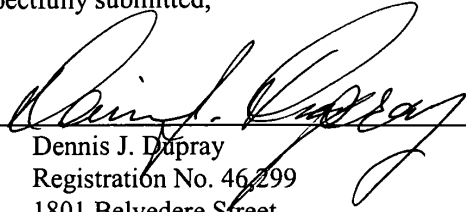
  
Dennis J. Dupray  
Registration No. 46,299  
1801 Belvedere Street  
Golden, Colorado 80401  
(303) 863-9700

Date: MAY 30, 2001  
patent applications\1003-1\pto\request-01

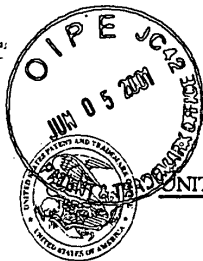

UNITED STATES PATENT AND TRADEMARK OFFICE

COMMISSIONER FOR PATENTS  
 UNITED STATES PATENT AND TRADEMARK OFFICE  
 WASHINGTON, D.C. 20231  
 www.uspto.gov

APPLICATION NUMBER	FILING DATE	GRP ART UNIT	FIL FEE REC'D	ATTY. DOCKET NO	DRAWINGS	TOT CLAIMS	IND CLAIMS
09/770,838 ✓	01/26/2001 ✓	3662	1119 ✓	1003-1	60 ✓	96 ✓	5 ✓

CONFIRMATION NO. 8410

FILING RECEIPT



\*OC00000005940121\*

Dennis J. Dupray, Ph.D.  
 1801 Belvedere Street  
 Golden, CO 80401

Date Mailed: 04/05/2001

Receipt is acknowledged of this nonprovisional Patent Application. It will be considered in its order and you will be notified as to the results of the examination. Be sure to provide the U.S. APPLICATION NUMBER, FILING DATE, NAME OF APPLICANT, and TITLE OF INVENTION when inquiring about this application. Fees transmitted by check or draft are subject to collection. Please verify the accuracy of the data presented on this receipt. If an error is noted on this Filing Receipt, please write to the Office of Initial Patent Examination's Customer Service Center. Please provide a copy of this Filing Receipt with the changes noted thereon. If you received a "Notice to File Missing Parts" for this application, please submit any corrections to this Filing Receipt with your reply to the Notice. When the PTO processes the reply to the Notice, the PTO will generate another Filing Receipt incorporating the requested corrections (if appropriate).

Applicant(s)

Charles L. Karr, Jr., Tuscaloosa, AL;  
 Dennis J. Dupray, Denver, CO;  
 Golden

RECEIVED

Assignment For Published Patent Application

TracBeam LLC;

SEP 14 2001

Domestic Priority data as claimed by applicant

THIS APPLICATION IS A CON OF 09/194,367 11/24/1998  
 WHICH IS A 371 OF PCT/US97/15892 09/08/1997  
 WHICH CLAIMS BENEFIT OF 60/056,590 08/20/1997  
 AND ~~SAID 09/194,367 11/24/1998~~  
 CLAIMS BENEFIT OF 60/044,821 04/25/1997  
 AND CLAIMS BENEFIT OF 60/025,855 09/09/1996

TO 3600-MAIL ROOM

Foreign Applications

If Required, Foreign Filing License Granted 04/04/2001

Projected Publication Date: To Be Determined - pending completion of Corrected Papers

Non-Publication Request: No

Early Publication Request: No



Page 1 of 1  
 CR2 #5  
 E. Busins  
 09/17/01



UNITED STATES PATENT AND TRADEMARK OFFICE

FILE COPY

COMMISSIONER FOR PATENTS  
 UNITED STATES PATENT AND TRADEMARK OFFICE  
 WASHINGTON, D.C. 20231  
 www.uspto.gov



Bib Data Sheet

CONFIRMATION NO. 8410

<b>SERIAL NUMBER</b> 09/770,838	<b>FILING DATE</b> 01/26/2001 <b>RULE</b>	<b>CLASS</b> 342	<b>GROUP ART UNIT</b> 3662	<b>ATTORNEY DOCKET NO.</b> 1003-1	
<b>APPLICANTS</b> Dennis J. Dupray, Golden, CO; Charles L. Karr, Tuscaloosa, AL;					
<b>** CONTINUING DATA *****</b> THIS APPLICATION IS A CON OF 09/194,367 11/24/1998 WHICH IS A 371 OF PCT/US97/15892 09/08/1997 WHICH CLAIMS BENEFIT OF 60/056,590 08/20/1997 AND SAID 09/194,367 11/24/1998 CLAIMS BENEFIT OF 60/025,855 09/09/1996					
<b>** FOREIGN APPLICATIONS *****</b>  <b>IF REQUIRED, FOREIGN FILING LICENSE GRANTED ** 04/04/2001</b>					
Foreign Priority claimed <input type="checkbox"/> yes <input checked="" type="checkbox"/> no 35 USC 119 (a-d) conditions met <input type="checkbox"/> yes <input checked="" type="checkbox"/> no <input type="checkbox"/> Met after Allowance		<b>STATE OR COUNTRY</b> CO	<b>SHEETS DRAWING</b> 62	<b>TOTAL CLAIMS</b> 96	<b>INDEPENDENT CLAIMS</b> 5
Verified and Acknowledged Examiner's Signature: <i>[Signature]</i> Initials:					
<b>ADDRESS</b> Dennis J. Dupray, Ph.D. 1801 Belvedere Street Golden, CO 80401.					
<b>TITLE</b> Wireless location using signal fingerprinting					
<b>FILING FEE RECEIVED</b> 1119	FEES: Authority has been given in Paper No. _____ to charge/credit DEPOSIT ACCOUNT No. _____ for following:		<input type="checkbox"/> All Fees <input type="checkbox"/> 1.16 Fees ( Filing ) <input type="checkbox"/> 1.17 Fees ( Processing Ext. of time ) <input type="checkbox"/> 1.18 Fees ( Issue ) <input type="checkbox"/> Other _____ <input type="checkbox"/> Credit		

RECEIVED  
 SEP 14 2001  
 TO 3600 MAIL ROOM

BEST AVAILABLE COPY

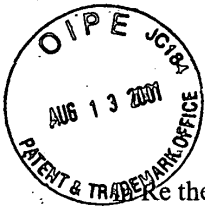

Receipt

IN THE UNITED STATES PATENT AND TRADEMARK OFFICE RECEIVED

OCT 19 2001  
GROUP 3600

Re the Application of: )  
 )  
 DUPRAY et al. )  
 )  
 Serial No.: 09/770,838 )  
 )  
 Filed: January 26, 2001 )  
 )  
 Atty. File No.: 1003-1 )  
 )  
 For: "WIRELESS LOCATION USING )  
 SIGNAL FINGERPRINTING" )

Group Art Unit: 3662  
 Examiner:

SECOND REQUEST FOR  
CORRECTION OF  
FILING RECEIPT

Office of Initial Patent Examinations  
 Customer Service Center  
 Commissioner of Patents  
 Washington, D.C. 20231

<p align="center">CERTIFICATE OF MAILING</p> <p>I HEREBY CERTIFY THAT THIS CORRESPONDENCE IS BEING DEPOSITED WITH THE UNITED STATES POSTAL SERVICE AS FIRST CLASS MAIL IN AN ENVELOPE ADDRESSED TO ASSISTANT COMMISSIONER FOR PATENTS, WASHINGTON, DC 20231 ON THIS <u>8</u> DAY OF <u>August</u>, 2001.</p> <p align="right">SHERIDAN ROSS P.C.</p> <p>BY: <u>Chasity C. Rossum</u>          Chasity C. Rossum</p>
---

Dear Sir:

The official Filing Receipt for the above-referenced patent application contains the following clerical errors:

1. Please change the order of the listed inventors to list "Dennis J. Dupray" as first named inventor such as that shown on the Utility Continuation Patent Application Transmittal.
2. The name of co-applicant Charles L. Karr is shown as "Charles L. Karr JR." Please delete "JR" from the co-applicant's name to read as Charles L. Karr.
3. The resident for co-applicant Dennis J. Dupray is shown as "Denver, CO." Please change this to read correctly as Golden, CO. (A copy of the Utility Continuation Patent Application Transmittal which was filed with the application on January 26, 2001 is enclosed. Note that a copy of the Oath/Declaration from the pending prior application was filed simultaneously with the present application. Since the execution of the Oath/Declaration by the inventors on November 17, 1998 and November 24, 1998, the address for co-applicant Dennis J. Dupray has changed to that specified on the transmittal.)
4. In the "Domestic Priority Data Claimed by Application" section of the receipt, please delete from the fourth row "said 09/194,367 11/24/1998."



For your reference, a copy of the Filing Receipt is enclosed, with the corrections indicated in red. Please issue a corrected Filing Receipt for this patent application.

Respectfully submitted,

By:

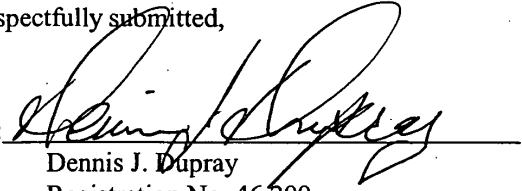

Dennis J. Dupray  
Registration No. 46,299  
1801 Belvedere Street  
Golden, Colorado 80401  
(303) 863-9700

Date: Aug. 8, 2001

patent applications\1003A-1\pt6request-02



## UNITED STATES PATENT AND TRADEMARK OFFICE

COMMISSIONER FOR PATENTS  
 UNITED STATES PATENT AND TRADEMARK OFFICE  
 WASHINGTON, D.C. 20231  
 www.uspto.gov

APPLICATION NUMBER	FILING DATE	GRP ART UNIT	FIL FEE REC'D	ATTY. DOCKET NO.	DRAWINGS	TOT CLAIMS	IND CLAIMS
09/770,838	01/26/2001	3662	1119	1003-1	62	96	5

Dennis J. Dupray, Ph.D.  
 1801 Belvedere Street  
 Golden, CO 80401



CONFIRMATION NO. 8410

## UPDATED FILING RECEIPT



\*OC00000006044568\*

Date Mailed: 05/04/2001

Receipt is acknowledged of this nonprovisional Patent Application. It will be considered in its order and you will be notified as to the results of the examination. Be sure to provide the U.S. APPLICATION NUMBER, FILING DATE, NAME OF APPLICANT, and TITLE OF INVENTION when inquiring about this application. Fees transmitted by check or draft are subject to collection. Please verify the accuracy of the data presented on this receipt. If an error is noted on this Filing Receipt, please write to the Office of Initial Patent Examination's Customer Service Center. Please provide a copy of this Filing Receipt with the changes noted thereon. If you received a "Notice to File Missing Parts" for this application, please submit any corrections to this Filing Receipt with your reply to the Notice. When the USPTO processes the reply to the Notice, the USPTO will generate another Filing Receipt incorporating the requested corrections (if appropriate).

## Applicant(s)

Charles L. Karr, Jr., Tuscaloosa, AL;  
 Dennis J. Dupray, Denver, CO;  
 Golden

## Assignment For Published Patent Application

TracBeam LLC;

## Domestic Priority data as claimed by applicant

THIS APPLICATION IS A CON OF 09/194,367 11/24/1998  
 WHICH IS A 371 OF PCT/US97/15892 09/08/1997  
 WHICH CLAIMS BENEFIT OF 60/056,590 06/20/1997  
 AND SAID 09/194,367 11/24/1998  
 CLAIMS BENEFIT OF 60/044,821 04/25/1997  
 AND CLAIMS BENEFIT OF 60/025,855 09/09/1996

## Foreign Applications

If Required, Foreign Filing License Granted 04/04/2001

Projected Publication Date: 08/16/2001

Non-Publication Request: No

Early Publication Request: No



UNITED STATES PATENT AND TRADEMARK OFFICE

FILE COPY

COMMISSIONER FOR PATENT  
UNITED STATES PATENT AND TRADEMARK OFFICE  
WASHINGTON, D.C. 20231  
www.uspto.gov



Bib Data Sheet

CONFIRMATION NO. 8410

<b>SERIAL NUMBER</b> 09/770,838	<b>FILING DATE</b> 01/26/2001 <b>RULE</b>	<b>CLASS</b> 342	<b>GROUP ART UNIT</b> 3662	<b>ATTORNEY DOCKET NO.</b> 1003-1
------------------------------------	---	---------------------	-------------------------------	--------------------------------------

**APPLICANTS**  
Dennis J. Dupray, Golden, CO;  
Charles L. Karr, Tuscaloosa, AL;

**\*\* CONTINUING DATA \*\*\*\*\***  
THIS APPLICATION IS A CON OF 09/194,367 11/24/1998  
WHICH IS A 371 OF PCT/US97/15892 09/08/1997  
WHICH CLAIMS BENEFIT OF 60/056,590 08/20/1997  
WHICH CLAIMS BENEFIT OF 60/044,821 04/25/1997  
WHICH CLAIMS BENEFIT OF 60/025,855 09/09/1996

**\*\* FOREIGN APPLICATIONS \*\*\*\*\***

**IF REQUIRED, FOREIGN FILING LICENSE GRANTED \*\* SMALL ENTITY \*\***  
**\*\* 04/04/2001**

RECEIVED  
OCT 19 2001  
GROUP 3600

Foreign Priority claimed <input type="checkbox"/> yes <input type="checkbox"/> no	<b>STATE OR COUNTRY</b> CO	<b>SHEETS DRAWING</b> 62	<b>TOTAL CLAIMS</b> 96	<b>INDEPENDENT CLAIMS</b> 5
35 USC 119 (a-d) conditions met <input type="checkbox"/> yes <input type="checkbox"/> no <input type="checkbox"/> Met after Allowance	Verified and Acknowledged Examiner's Signature _____ Initials _____			

**ADDRESS**  
Dennis J. Dupray, Ph.D.  
1801 Belvedere Street  
Golden, CO 80401

**TITLE**  
Wireless location using signal fingerprinting

<b>FILING FEE RECEIVED</b> 1119	FEES: Authority has been given in Paper No. _____ to charge/credit DEPOSITACCOUNT No. _____ for following:	<input type="checkbox"/> All Fees
		<input type="checkbox"/> 1.16 Fees ( Filing )
		<input type="checkbox"/> 1.17 Fees ( Processing Ext. of time )
		<input type="checkbox"/> 1.18 Fees ( Issue )
		<input type="checkbox"/> Other _____
		<input type="checkbox"/> Credit

BEST AVAILABLE COPY



UNITED STATES DEPARTMENT OF COMMERCE  
 Patent and Trademark Office  
 Address: COMMISSIONER OF PATENTS AND TRADEMARKS  
 Washington, D.C. 20231

APPLICATION NO.	FILING DATE	FIRST NAMED INVENTOR	ATTORNEY DOCKET NO.
-----------------	-------------	----------------------	---------------------

09/770,838    01/26/01    DUPRAY    D    1003-1

DENNIS J. DUPRAY, PH.D.  
 1801 BELVEDERE STREET  
 GOLDEN CO 80401

PM82/0830

EXAMINER

PHAN, D  

ART UNIT	PAPER NUMBER
----------	--------------

3662  
 DATE MAILED:

08/30/01

4

Please find below and/or attached an Office communication concerning this application or proceeding.

Commissioner of Patents and Trademarks

Art Unit: 3662

The Preliminary Amendment filed on 1/26/01 can not be entered because the Preliminary Amendment does not match with the specification. For example, on p. 1 of the Preliminary Amendment, the Amendment cited "On p.11, line 33, please deleted "network" ". However, "network" can not be found in the specification on p. 11, line 33. Correction is required.

Any inquiry concerning this communication or earlier communications from the examiner should be directed to Dao Phan whose telephone number is (703) 306-4167.

Any inquiry of a general nature or relating to the status of this application or proceeding should be directed to the receptionist whose telephone number is (703) 306-4187.

  
DAO PHAN  
INVENTOR EXAMINER

EX



UNITED STATES DEPARTMENT OF COMMERCE  
Patent and Trademark Office

Address: COMMISSIONER OF PATENTS AND TRADEMARKS  
Washington, D.C. 20231

MV

APPLICATION NO.	FILING DATE	FIRST NAMED INVENTOR	ATTORNEY DOCKET NO.
-----------------	-------------	----------------------	---------------------

09/770,838 01/26/01 DUPRAY

D 1003-1

PM82/0921

EXAMINER

DENNIS J. DUPRAY, PH.D.  
1801 BELVEDERE STREET  
GOLDEN CO 80401

PHAN, D	
ART UNIT	PAPER NUMBER

3662  
DATE MAILED:

09/21/01

b

Please find below and/or attached an Office communication concerning this application or proceeding.

Commissioner of Patents and Trademarks

BEST AVAILABLE COPY

Office Action Summary

Application No. <b>09/770,838</b>	Applicant(s) <b>Dupray et al</b>
Examiner <b>Dao Phan</b>	Art Unit <b>3662</b>

-- The MAILING DATE of this communication appears on the cover sheet with the correspondence address --

Period for Reply

A SHORTENED STATUTORY PERIOD FOR REPLY IS SET TO EXPIRE 3 MONTH(S) FROM THE MAILING DATE OF THIS COMMUNICATION.

- Extensions of time may be available under the provisions of 37 CFR 1.136 (a). In no event, however, may a reply be timely filed after SIX (6) MONTHS from the mailing date of this communication.
- If the period for reply specified above is less than thirty (30) days, a reply within the statutory minimum of thirty (30) days will be considered timely.
- If NO period for reply is specified above, the maximum statutory period will apply and will expire SIX (6) MONTHS from the mailing date of this communication.
- Failure to reply within the set or extended period for reply will, by statute, cause the application to become ABANDONED (35 U.S.C. § 133).
- Any reply received by the Office later than three months after the mailing date of this communication, even if timely filed, may reduce any earned patent term adjustment. See 37 CFR 1.704(b).

Status

- 1)  Responsive to communication(s) filed on Jan 26, 2001
- 2a)  This action is FINAL.
- 2b)  This action is non-final.
- 3)  Since this application is in condition for allowance except for formal matters, prosecution as to the merits is closed in accordance with the practice under *Ex parte Quayle*, 1935 C.D. 11; 453 O.G. 213.

Disposition of Claims

- 4)  Claim(s) \_\_\_\_\_ is/are pending in the application.
- 4a) Of the above, claim(s) \_\_\_\_\_ is/are withdrawn from consideration.
- 5)  Claim(s) \_\_\_\_\_ is/are allowed.
- 6)  Claim(s) \_\_\_\_\_ is/are rejected.
- 7)  Claim(s) \_\_\_\_\_ is/are objected to.
- 8)  Claims \_\_\_\_\_ are subject to restriction and/or election requirement.

Application Papers

- 9)  The specification is objected to by the Examiner.
- 10)  The drawing(s) filed on \_\_\_\_\_ is/are objected to by the Examiner.
- 11)  The proposed drawing correction filed on \_\_\_\_\_ is: a)  approved b)  disapproved.
- 12)  The oath or declaration is objected to by the Examiner.

Priority under 35 U.S.C. § 119

- 13)  Acknowledgement is made of a claim for foreign priority under 35 U.S.C. § 119(a)-(d).
  - a)  All b)  Some\* c)  None of:
    - 1.  Certified copies of the priority documents have been received.
    - 2.  Certified copies of the priority documents have been received in Application No. \_\_\_\_\_
    - 3.  Copies of the certified copies of the priority documents have been received in this National Stage application from the International Bureau (PCT Rule 17.2(a)).

\*See the attached detailed Office action for a list of the certified copies not received.

- 14)  Acknowledgement is made of a claim for domestic priority under 35 U.S.C. § 119(e).

Attachment(s)

- 15)  Notice of References Cited (PTO-892)
- 16)  Notice of Draftsperson's Patent Drawing Review (PTO-948)
- 17)  Information Disclosure Statement(s) (PTO-1449) Paper No(s). \_\_\_\_\_
- 18)  Interview Summary (PTO-413) Paper No(s). \_\_\_\_\_
- 19)  Notice of Informal Patent Application (PTO-152)
- 20)  Other:

Art Unit: 3662

The Preliminary Amendment filed on 1/26/01 can not be entered because the Preliminary Amendment does not match with the specification. For example, on p. 1 of the Preliminary Amendment, the Amendment cited "On p.11, line 33, please deleted "network" ". However, "network" can not be found in the specification on p. 11, line 33. Correction is required.

Any inquiry concerning this communication or earlier communications from the examiner should be directed to Dao Phan whose telephone number is (703) 306-4167.

Any inquiry of a general nature or relating to the status of this application or proceeding should be directed to the receptionist whose telephone number is (703) 306-4187.

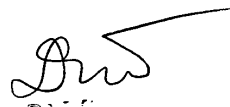
  
PATENT EXAMINER





IN THE UNITED STATES PATENT AND TRADEMARK OFFICE

Receipt  
w/ 236LS/36X1

Re the Application of: )  
DUPRAY et al. )  
Serial No.: 09/770,838 )  
Filed: January 26, 2001 )  
Atty. File No.: 1003-1 )  
For: "WIRELESS LOCATION USING )  
SIGNAL FINGERPRINTING" )

Group Art Unit: 3662

Examiner:

THIRD REQUEST FOR  
CORRECTION OF  
FILING RECEIPT

Office of Initial Patent Examinations  
Customer Service Center  
Commissioner of Patents  
Washington, D.C. 20231

CERTIFICATE OF MAILING  
I HEREBY CERTIFY THAT THIS CORRESPONDENCE IS BEING DEPOSITED WITH THE UNITED STATES POSTAL SERVICE AS FIRST CLASS MAIL IN AN ENVELOPE ADDRESSED TO ASSISTANT COMMISSIONER FOR PATENTS, WASHINGTON, DC 20231 ON THIS 2 DAY OF October, 2001.  
SHERIDAN ROSS P.C.  
BY: Chasity C. Rossum  
Chasity C. Rossum

Dear Sir:

The official Filing Receipt for the above-referenced patent application contains the in the "Domestic Priority Data Claimed by Application" section of the receipt. In particular, the priority claimed in the present application should read as follows:

This application is a con of 09/194,367 11/24/1998  
which is a 371 of PCT/US97/15892 9/8/1997  
which claims the benefit of each of 60/056,590 8/20/1997  
and 60/044,821 4/25/1997  
and 60/025,855 9/9/1996

RECEIVED  
APR 09 2002  
GROUP. 3600

For your reference, a copy of the Filing Receipt is enclosed, with the corrections indicated in red. Please issue a corrected Filing Receipt for this patent application.

Respectfully submitted,

By: Dennis J. Dupray  
Dennis J. Dupray  
Registration No. 46,299  
1801 Belvedere Street  
Golden, Colorado 80401  
(303) 863-9700

Date: Oct. 2, 2001  
patent applications\10031-1\pto\request-02



UNITED STATES PATENT AND TRADEMARK OFFICE

COMMISSIONER FOR PATENTS  
 UNITED STATES PATENT AND TRADEMARK OFFICE  
 WASHINGTON, D.C. 20231  
 www.uspto.gov



APPLICATION NUMBER	FILING DATE	GRP ART UNIT	FIL FEE REC'D	ATTY. DOCKET NO	DRAWINGS	TOT CLAIMS	IND CLAIMS
09/770,838 ✓	01/26/2001 ✓	3662 ✓	1119	1003-1 ✓	62	96	5

CONFIRMATION NO. 8410

CORRECTED FILING RECEIPT



\*OC00000006568645\*

Dennis J. Dupray, Ph.D.  
 1801 Belvedere Street  
 Golden, CO 80401

Date Mailed: 09/18/2001

Receipt is acknowledged of this nonprovisional Patent Application. It will be considered in its order and you will be notified as to the results of the examination. Be sure to provide the U.S. APPLICATION NUMBER, FILING DATE, NAME OF APPLICANT, and TITLE OF INVENTION when inquiring about this application. Fees transmitted by check or draft are subject to collection. Please verify the accuracy of the data presented on this receipt. **If an error is noted on this Filing Receipt, please write to the Office of Initial Patent Examination's Customer Service Center. Please provide a copy of this Filing Receipt with the changes noted thereon. If you received a "Notice to File Missing Parts" for this application, please submit any corrections to this Filing Receipt with your reply to the Notice. When the USPTO processes the reply to the Notice, the USPTO will generate another Filing Receipt incorporating the requested corrections (if appropriate).**

Applicant(s)

Dennis J. Dupray, Golden, CO; ✓  
 Charles L. Karr, Tuscaloosa, AL; ✓

Assignment For Published Patent Application

TracBeam LLC;

Domestic Priority data as claimed by applicant

THIS APPLICATION IS A CON OF 09/194,367 11/24/1998  
 WHICH IS A 371 OF PCT/US97/15892 09/08/1997  
 WHICH CLAIMS BENEFIT OF 60/056,590 08/20/1997 *each of*  
*and* WHICH CLAIMS BENEFIT OF 60/044,821 04/25/1997  
*and* WHICH CLAIMS BENEFIT OF 60/025,855 09/09/1996

RECEIVED  
 APR 09 2002  
 GROUP 3600

Foreign Applications

If Required, Foreign Filing License Granted 04/04/2001 ✓

Projected Publication Date: 08/16/2001 ✓

Non-Publication Request: No ✓

Early Publication Request: No ✓

\*\* SMALL ENTITY \*\* ✓

PMG160C Continuity and Foreign Priority 09770838

File Edit Options Window Help

Insert Continuity Remove Change Disclaim Insert Foreign 2002/7 Pages

### Domestic Continuity

Child Application Number	Continuity Code	Parent Application Number	Parent Patent Number	Parent Status	Parent Filing Date	I N	Seq No.
09770838	CON	09194367		PENDING	11/24/1998	N	1
09194367	NST	PCT/US97/15892			09/08/1997		2
PCT/US97/15892	PRO	60056590		PENDING	08/20/1997	N	3
60056590	PRO	60044821		PENDING	04/25/1997	N	4
60044821	PRO	60025855		PENDING	09/09/1996	N	5

### Foreign Priority

Country Code	Country/Receiving Office Name	Foreign/PCT Application Number	Filing Date	Seq No.

Print Screen itippett 01/15/2002

RECEIVED  
 APR 09 2002  
 GROUP 360C

Change can

RECEIVED  
APR 09 2002  
GROUP 3600

The screenshot displays a software interface for managing patent applications. At the top, there is a menu bar with options like 'File', 'Edit', 'Define', 'Syntax', 'Help', and 'Insert'. Below the menu is a toolbar with various icons. The main area is divided into several sections:

- Table of Applications:** A table with columns for 'Child Application Number', 'Continuity Code', 'Parent Application Number', 'Parent Status', 'Parent Filing Date', and 'Seq. No.'. The table contains several rows of data, including entries for 'COM', 'NST', 'PCT/US97/15892', 'PFI', 'PCT/US97/15892', and 'PFI'.
- Application Details:** A detailed view of a specific application, showing fields for 'Application Type', 'Application Number', 'Continuity Code', 'Parent Application Number', 'Parent Filing Date', 'Parent Status', and 'Seq. No.'. The 'Parent Application Number' field is populated with '60044821'.
- Buttons:** There are several buttons at the bottom of the details section, including 'OK', 'Undo', and 'Cancel'.



IN THE UNITED STATES PATENT AND TRADEMARK OFFICE

*Fig 9 always 3-27-02*

In Re the Application of:

DUPRAY et al.

Serial No.: 09/770,838

Filed: January 26, 2001

Atty. File No.: 1003-1

For: "WIRELESS LOCATION USING SIGNAL FINGERPRINTING"

Assistant Commissioner for Patents  
Washington, D.C. 20231

Dear Sir:

Group Art Unit: 3662

Examiner:

SUBMISSION OF SUBSTITUTE DRAWINGS

<p>CERTIFICATE OF MAILING</p> <p>I HEREBY CERTIFY THAT THIS CORRESPONDENCE IS BEING DEPOSITED WITH THE UNITED STATES POSTAL SERVICE AS FIRST CLASS MAIL IN AN ENVELOPE ADDRESSED TO THE ASSISTANT COMMISSIONER FOR PATENTS, WASHINGTON, DC 20231 ON THIS <u>20</u> DAY OF <u>February</u>, 2002.</p> <p style="text-align: right;">SHERIDAN ROSS P.C.</p> <p>BY: <u>Chasity C. Rossum</u> Chasity C. Rossum</p>
---

Please consider this Submission of Substitute Drawings for Fig. 4, Fig. 30 and Fig. 31 of the above-identified patent application.

Respectfully submitted,

By: Dennis J. Dupray  
 Dennis J. Dupray, Ph.D.  
 Registration No. 46,299  
 1801 Belvedere Street  
 Golden, Colorado 80401  
 (303) 863-2975

Date: Feb 20, 2002  
 L:\tracbeam\patent applications\1003\  
 L:\tracbeam\patent applications\1003\US (1003&continuations)-1\pto\SUB-01-Substitute Drawings.doc

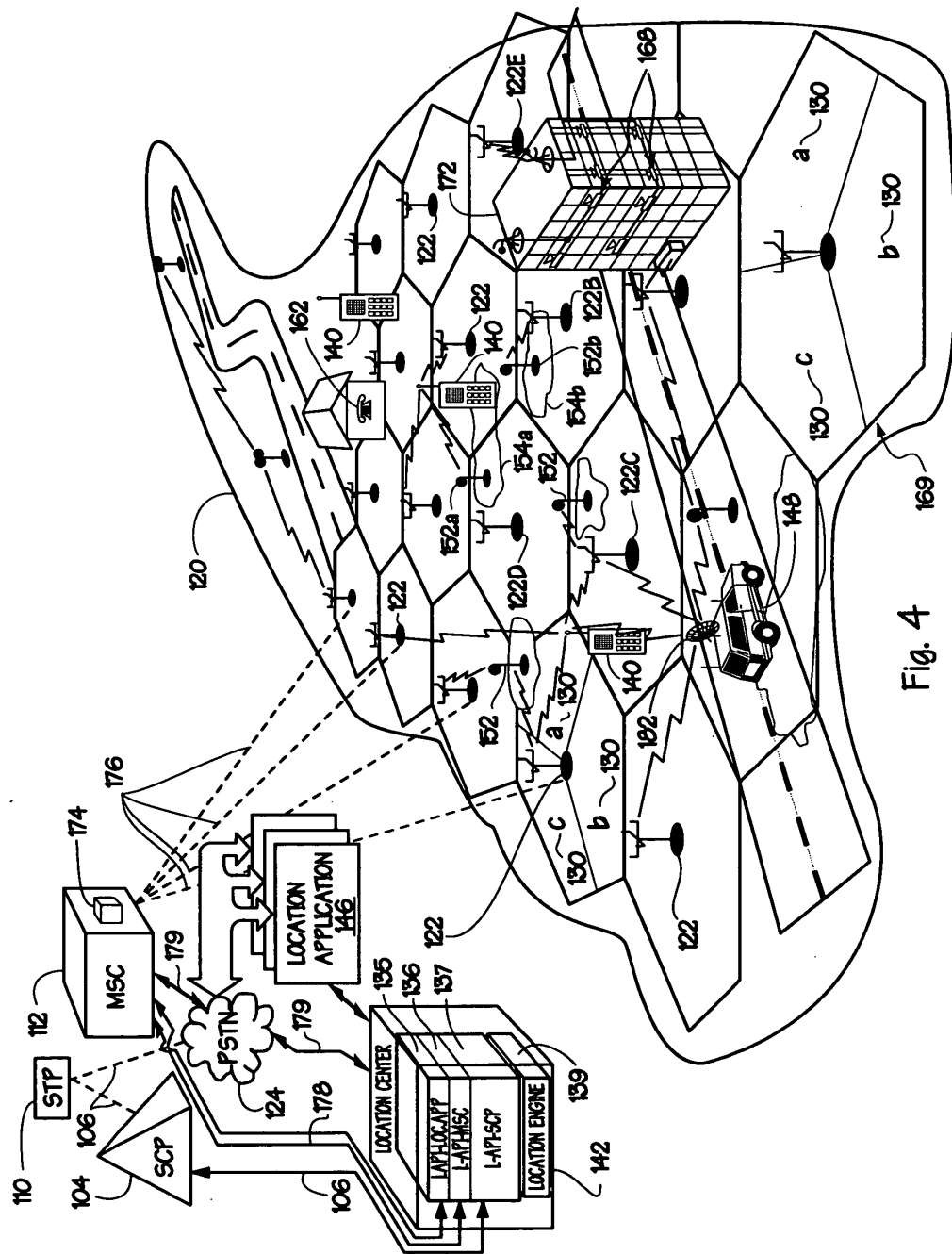

Fig. 4

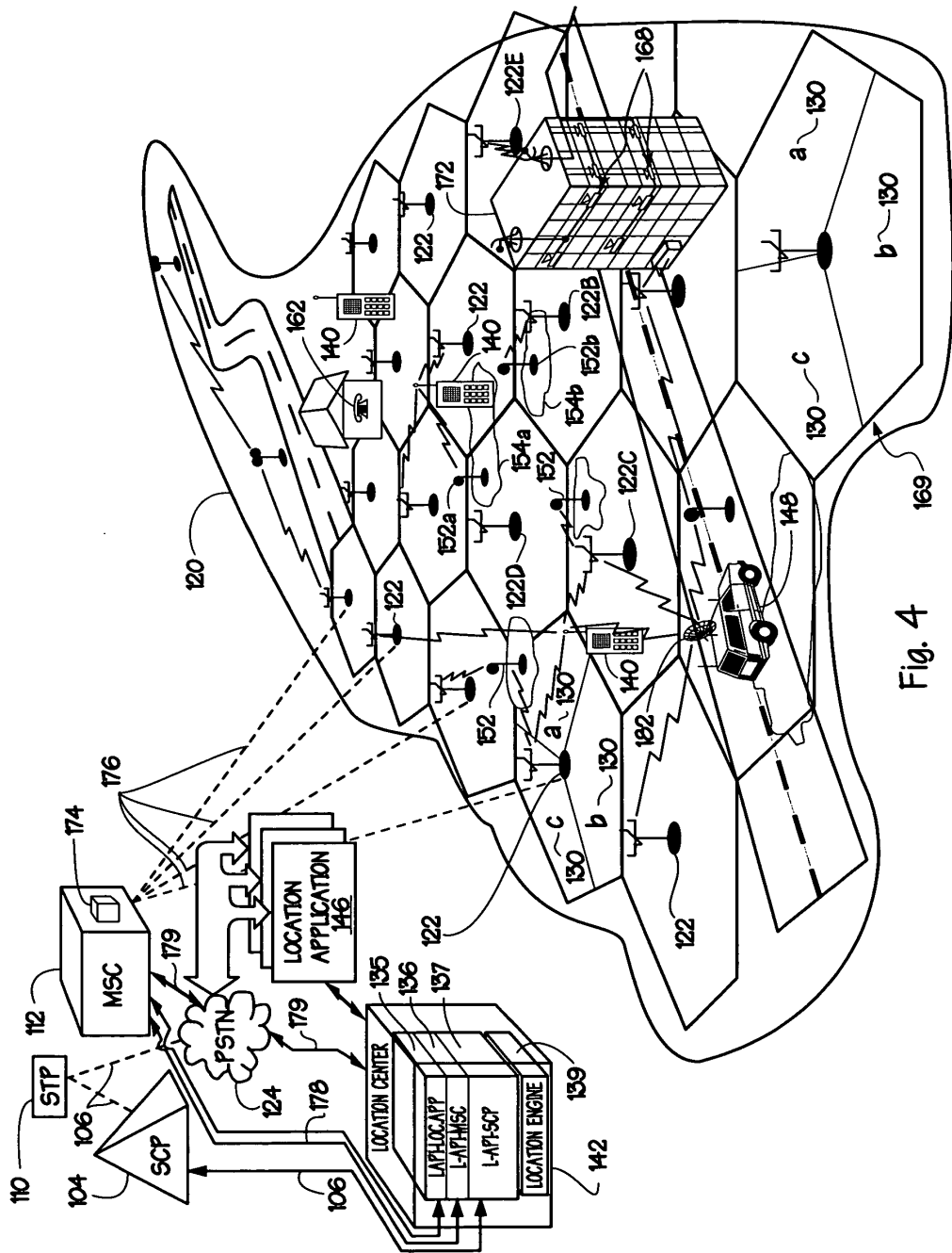

Fig. 4

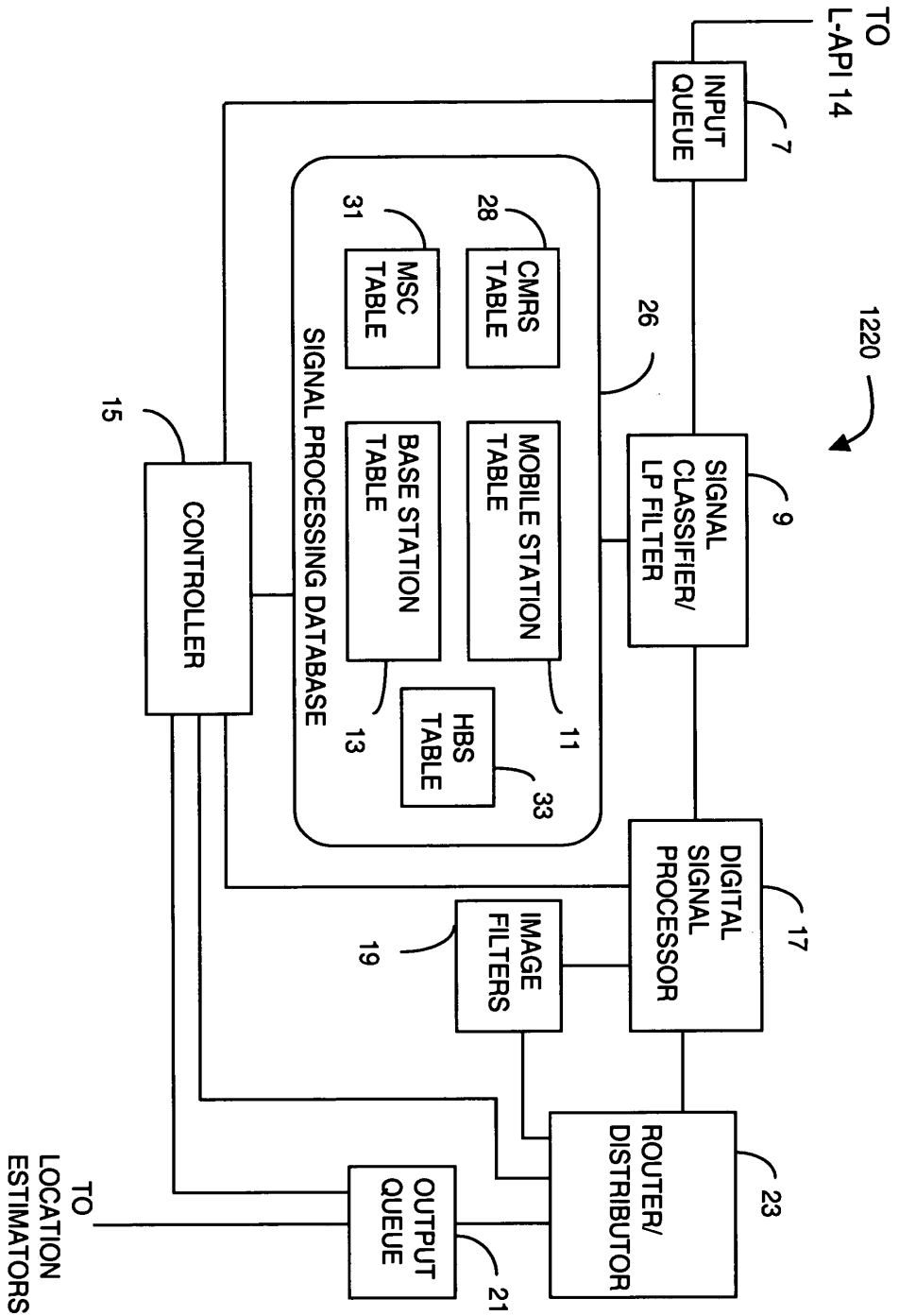

Fig. 30: Signal Processing Subsystem



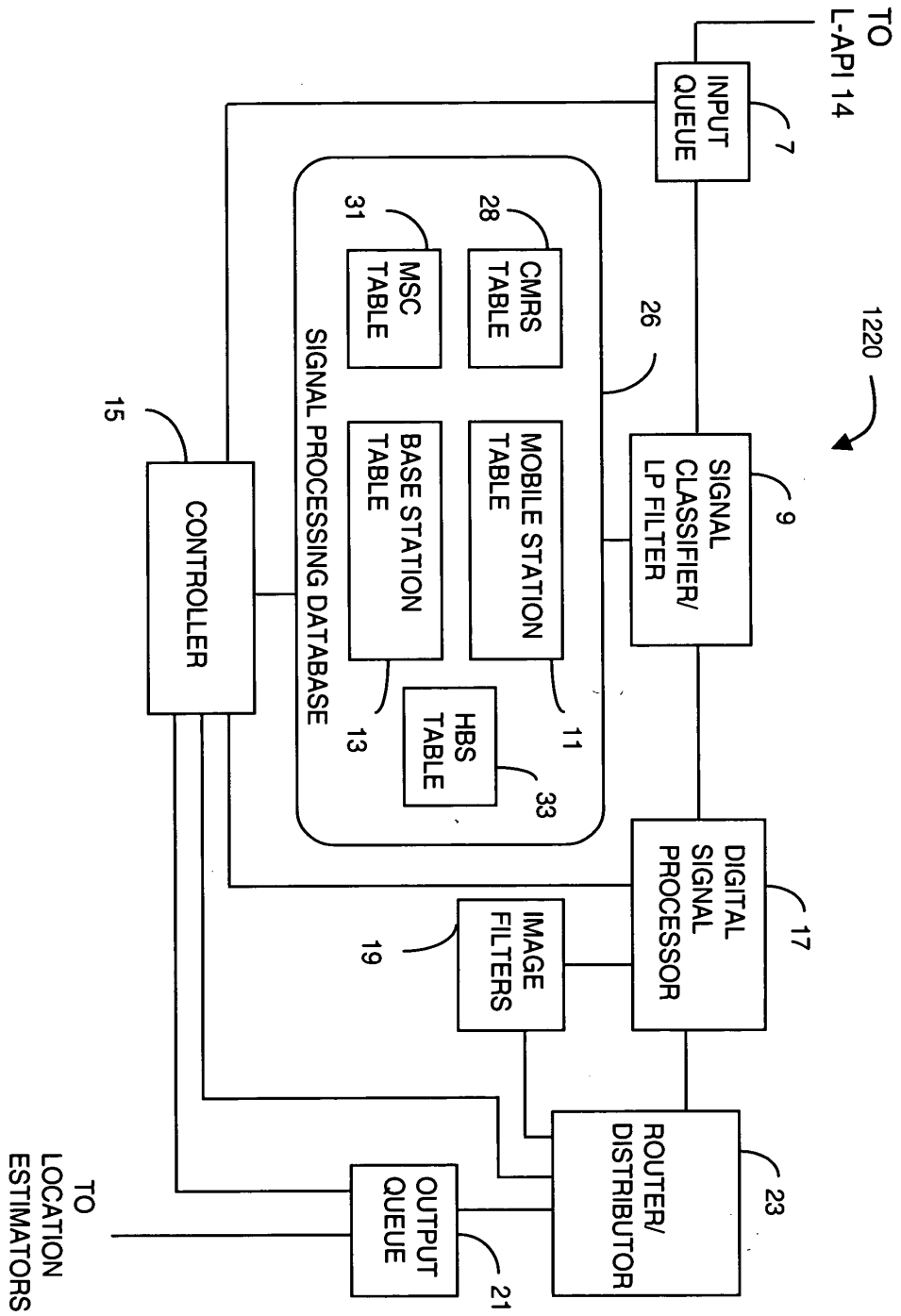
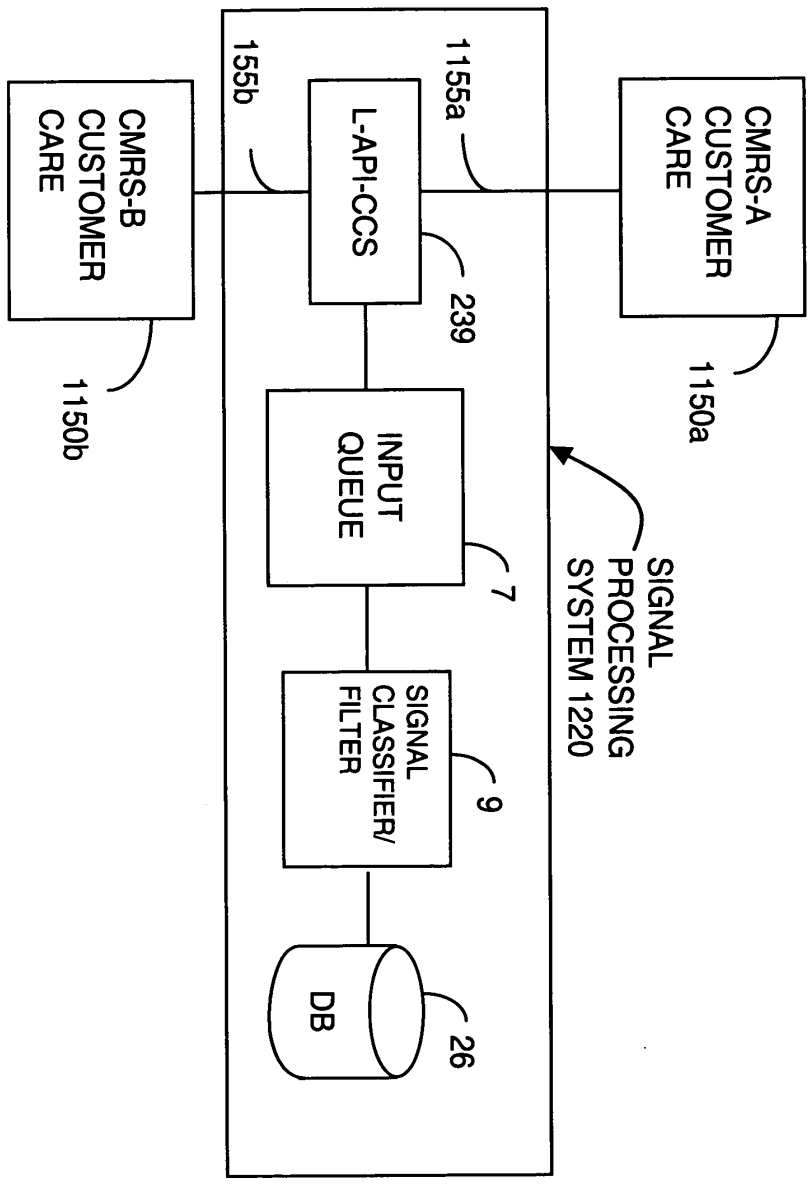

Fig. 30: Signal Processing Subsystem



**FIG. 31: LOCATION PROVISIONING VIA MULTIPLE CMRS**

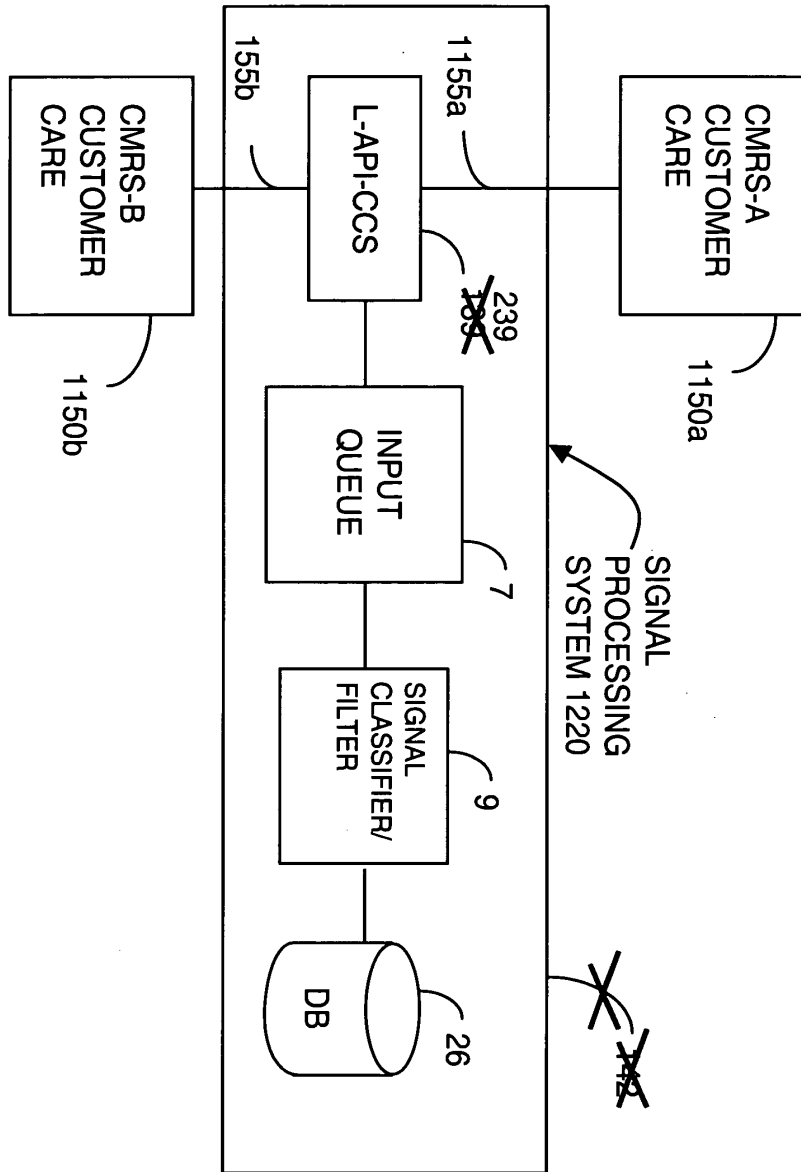

FIG. 31: LOCATION PROVISIONING VIA MULTIPLE CMRS



GP 3662  
PATENT  
LDS  
3-27-02

I hereby certify that this correspondence is being deposited with the United States Postal Service as First Class mail in an envelope addressed to the Assistant Commissioner for Patents, United States Patent and Trademark Office, Washington, D. C. 20231, on February 20, 2002.

By: Christy Kern

IN THE UNITED STATES PATENT AND TRADEMARK OFFICE

In re the application of: )  
DUPRAY et al. )  
Serial No.: 09/770,838 )  
Filed: January 26, 2001 )  
Attorney Docket No.: 1003-1 )  
For: "LOCATION OF A MOBILE )  
STATION" )

Group Art Unit: 3662  
Examiner:

INFORMATION DISCLOSURE STATEMENT

RECEIVED  
MAR 08 2002  
GROUP 3600

Assistant Commissioner for Patents  
Washington, D. C. 20231

Sir:

The references cited on attached Form PTO-1449 are being called to the attention of the Examiner. Copies of the cited references:

- Are enclosed herewith.
- Are not enclosed, in accordance with 37 C.F.R. 1.98(d), because the references were submitted to the U.S. Patent and Trademark Office in prior application Serial No. 09/194,367, titled "WIRELESS LOCATION USING MULTIPLE MOBILE STATION LOCATION TECHNIQUES," and having a filing date of November 24, 1998, which is relied upon for an earlier filing date under 35 U.S.C. 120

To the best of applicants belief, the pertinence of the foreign-language references are believed to be summarized in the attached English abstracts and in the figures, although applicants do not necessarily vouch for the accuracy of the translation.

Examiner's attention is drawn to the following co-pending applications: Serial No. 09/194,367 filed November 24, 1998 and Serial No. 09/820,584 filed March 28, 2001.

Submission of the above information is not intended as an admission that any item is citable under the statutes or rules to support a rejection, that any item disclosed represents analogous art, or that those skilled in the art would refer to or recognize the pertinence of any reference without the benefit of hindsight, nor should an inference be drawn as to the pertinence of the references based on the order in which they are presented. Submission of this statement should not be taken as an indication that a search has been conducted, or that no better art exists.

It is respectfully requested that the cited information be expressly considered during the prosecution of this application and the references made of record therein.

**FEES**

<input checked="" type="checkbox"/>	<p>No fee is believed due in connection with this submission, because the information disclosure statement submitted herewith is being filed:</p> <p><input type="checkbox"/> within three months of the filing date of the continued prosecution application or date of entry into the national stage of an international application or</p> <p><input checked="" type="checkbox"/> before the mailing date of a first Office Action on the merits, whichever occurs last. 37 C.F.R. 1.97(b).</p> <p>Although no fee is believed due, if any fee is deemed due in connection with this submission, please charge such fee to Deposit Account 19-1970.</p>
<input type="checkbox"/>	<p>The information disclosure statement transmitted herewith is being filed after three months of the filing date of this national application or the date of entry of the national stage as set forth in 37 C.F.R. 1.491 in an international application or after the mailing date of the first Office action on the merits, whichever occurred last but before the mailing date of either:</p> <p>(1) a final action under 37 C.F.R. 1.113 or  (2) a notice of allowance under 37 C.F.R. 1.311,  whichever occurs first. This Information Disclosure Statement is accompanied by:</p> <p><input type="checkbox"/> A Certification (below) as specified by 37 C.F.R. 1.97(e). Although no fee is believed due, if any fee is deemed due in connection with this submission, please charge such fee to Deposit Account 19-1970.</p> <p style="text-align: center;">OR</p> <p><input type="checkbox"/> A check in the amount of \$240.00 for the fee set forth in 37 C.F.R. 1.17(p) for submission of an information disclosure statement. Please credit any overpayment or charge any underpayment to Deposit Account No. 19-1970.</p>
<input type="checkbox"/>	<p>This Information Disclosure Statement is being submitted after the mailing date of a final action under §1.113 or a notice of allowance under § 1.311, but before payment of the issue fee.</p> <p><input type="checkbox"/> This information Disclosure Statement includes a Certification (below) as specified by 37 C.F.R. 1.97(e)</p> <p style="text-align: center;">AND</p> <p><input type="checkbox"/> Applicants hereby petition for consideration of the references disclosed herein. Enclosed is a petition fee in the amount of \$130.00 under 37 C.F.R. 1.17(i)(1). Please credit any overpayment or charge any underpayment to Deposit Account No. 19-1970.</p>
<input type="checkbox"/>	<p>Applicant elects to pay the fee set forth in 37 C.F.R. 1.17(p) for submission of an information disclosure statement, and the enclosed check includes \$180.00 for payment of such fee. Please credit any overpayment or charge any underpayment to Deposit Account No. 19-1970. Election to pay the fee should not be taken as an indication that applicant(s) cannot execute a certification.</p>

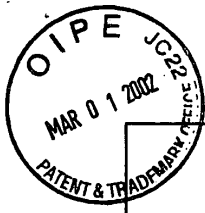

**Certification (37 C.F.R. 1.97(e))**  
(Applicable only if checked)

- The undersigned certifies that:
  - Each item of information contained in this information disclosure statement was cited in a communication from a foreign patent office in a counterpart foreign application not more than three months prior to the filing of this statement. 37 C.F.R. 1.97(e)(1).
  - A copy of the communication from the foreign patent office is enclosed.

OR

- No item of information contained in this information disclosure statement was cited in a communication from a foreign patent office in a counterpart foreign application or to the knowledge of the undersigned after making reasonable inquiry, was known to any individual designated in 37 C.F.R. 1.56(c) more than more than three months prior to the filing of this statement. 37 C.F.R. 1.97(e)(2).

**RECEIVED**  
MAR 08 2002  
**GROUP 3600**

Respectfully submitted,

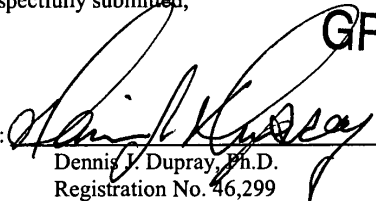
By: 

Dennis K. Dupray, Ph.D.  
Registration No. 46,299  
1801 Belvedere Street  
Golden, Colorado 80401  
303-863-2975  
FAX: 303-863-0223

Date: Feb. 20, 2002  
L:\TracBeam\patent applications\1003\US (1003&continuations)\-1\pto\IDS-02.wpd

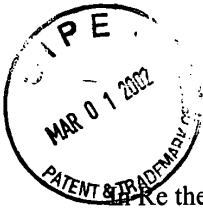

IN THE UNITED STATES PATENT AND TRADEMARK OFFICE

*Reg. Ext. Fee*  
**RECEIVED**

MAR 08 2002

**GROUP 3600**

Re the Application of: )  
DUPRAY et al. )  
Serial No.: 09/770,838 )  
Filed: January 26, 2001 )  
Atty. File No.: 1003-1 )  
For: "WIRELESS LOCATION USING )  
SIGNAL FINGERPRINTING" )

Group Art Unit: 3662

Examiner: Dao Phan

**REQUEST FOR A TWO MONTH**  
**EXTENSION OF TIME**

*Calder*  
*3-27-02*

Commissioner of Patents  
Washington, D.C. 20231

CERTIFICATE OF MAILING
I HEREBY CERTIFY THAT THIS CORRESPONDENCE IS BEING DEPOSITED WITH THE UNITED STATES POSTAL SERVICE AS FIRST CLASS MAIL IN AN ENVELOPE ADDRESSED TO ASSISTANT COMMISSIONER FOR PATENTS, WASHINGTON, DC 20231 ON THIS <u>20</u> DAY OF <u>February</u> , 2002.
SHERIDAN ROSS P.C.
BY: <i>Chasity C. Rossum</i> Chasity C. Rossum

Dear Sir:

Applicants respectfully petition for an extension of time under 37 CFR § 1.136(a) of two (2) months to respond to the Office Action mailed on September 21, 2001, with respect to the above-identified application, thereby extending the period for response from December 21, 2001 to February 21, 2002.

Enclosed is a check in the amount of \$200.00 as payment for the extension fee. Please credit any overpayment or debit any underpayment to Deposit Account No. 19-1970.

03/06/2002 SSITHIB1 00000117 09770838

01 FC:216

200.00 OP

Respectfully submitted,

By: *Dennis J. Dupray*  
Dennis J. Dupray  
Registration No. 46,299  
1801 Belvedere Street  
Golden, Colorado 80401  
(303) 863-2975

Date: Feb. 20, 2002

L:\TracBeam\patent applications\1003\US (1003&continuations)\-1\pto\EXT-01-O.A. of 9-21-01.wpd

04-12-02

3662



PATENT

Handwritten notes: 11 IDS Bates 4/18/02

IN THE UNITED STATES PATENT AND TRADEMARK OFFICE

In re the application of:	)	
DUPRAY et al.	)	Group Art Unit: 3662
Serial No.: 09/770,838	)	Examiner:
Filed: January 26, 2001	)	<b>INFORMATION DISCLOSURE STATEMENT</b>
Attorney Docket No.: 1003-1	)	
For: "LOCATION OF A MOBILE STATION"	)	<b>Express Mail Label No.:</b> EL417660357US

Assistant Commissioner for Patents  
Washington, D. C. 20231

Sir:

The references cited on attached Form PTO-1449 are being called to the attention of the Examiner: Copies of the cited references:

- Are enclosed herewith.
- Are not enclosed, in accordance with 37 C.F.R. 1.98(d), because the references were submitted to the U.S. Patent and Trademark Office in prior application Serial No. 09/194,367, titled "WIRELESS LOCATION USING MULTIPLE MOBILE STATION LOCATION TECHNIQUES," and having a filing date of November 24, 1998, which is relied upon for an earlier filing date under 35 U.S.C. 120

To the best of applicants belief, the pertinence of the foreign-language references are believed to be summarized in the attached English abstracts and in the figures, although applicants do not necessarily vouch for the accuracy of the translation.

Examiner's attention is drawn to the following co-pending applications: Serial No. 09/194,367 filed November 24, 1998 and Serial No. 09/820,584 filed March 28, 2001.



Submission of the above information is not intended as an admission that any item is citable under the statutes or rules to support a rejection, that any item disclosed represents analogous art, or that those skilled in the art would refer to or recognize the pertinence of any reference without the benefit of hindsight, nor should an inference be drawn as to the pertinence of the references based on the order in which they are presented. Submission of this statement should not be taken as an indication that a search has been conducted, or that no better art exists.

It is respectfully requested that the cited information be expressly considered during the prosecution of this application and the references made of record therein.

#### FEES

<input checked="" type="checkbox"/>	<p>No fee is believed due in connection with this submission, because the information disclosure statement submitted herewith is being filed:</p> <p><input type="checkbox"/> within three months of the filing date of the continued prosecution application or date of entry into the national stage of an international application or</p> <p><input checked="" type="checkbox"/> before the mailing date of a first Office Action on the merits, whichever occurs last. 37 C.F.R. 1.97(b).</p> <p>Although no fee is believed due, if any fee is deemed due in connection with this submission, please charge such fee to Deposit Account 19-1970.</p>
<input type="checkbox"/>	<p>The information disclosure statement transmitted herewith is being filed after three months of the filing date of this national application or the date of entry of the national stage as set forth in 37 C.F.R. 1.491 in an international application or after the mailing date of the first Office action on the merits, whichever occurred last but before the mailing date of either:</p> <p>(1) a final action under 37 C.F.R. 1.113 or  (2) a notice of allowance under 37 C.F.R. 1.311,  whichever occurs first. This Information Disclosure Statement is accompanied by:</p> <p><input type="checkbox"/> A Certification (below) as specified by 37 C.F.R. 1.97(e). Although no fee is believed due, if any fee is deemed due in connection with this submission, please charge such fee to Deposit Account 19-1970.</p> <p style="text-align: center;">OR</p> <p><input type="checkbox"/> A check in the amount of \$240.00 for the fee set forth in 37 C.F.R. 1.17(p) for submission of an information disclosure statement. Please credit any overpayment or charge any underpayment to Deposit Account No. 19-1970.</p>
<input type="checkbox"/>	<p>This Information Disclosure Statement is being submitted after the mailing date of a final action under § 1.113 or a notice of allowance under § 1.311, but before payment of the issue fee.</p> <p><input type="checkbox"/> This information Disclosure Statement includes a Certification (below) as specified by 37 C.F.R. 1.97(e)</p> <p style="text-align: center;">AND</p> <p><input type="checkbox"/> Applicants hereby petition for consideration of the references disclosed herein. Enclosed is a petition fee in the amount of \$130.00 under 37 C.F.R. 1.17(i)(1). Please credit any overpayment or charge any underpayment to Deposit Account No. 19-1970.</p>
<input type="checkbox"/>	<p>Applicant elects to pay the fee set forth in 37 C.F.R. 1.17(p) for submission of an information disclosure statement, and the enclosed check includes \$180.00 for payment of such fee. Please credit any overpayment or charge any underpayment to Deposit Account No. 19-1970. Election to pay the fee should not be taken as an indication that applicant(s) cannot execute a certification.</p>



**Certification (37 C.F.R. 1.97(e))**  
(Applicable only if checked)

The undersigned certifies that:

Each item of information contained in this information disclosure statement was cited in a communication from a foreign patent office in a counterpart foreign application not more than three months prior to the filing of this statement. 37 C.F.R. 1.97(e)(1).

A copy of the communication from the foreign patent office is enclosed.

OR

No item of information contained in this information disclosure statement was cited in a communication from a foreign patent office in a counterpart foreign application or to the knowledge of the undersigned after making reasonable inquiry, was known to any individual designated in 37 C.F.R. 1.56(c) more than three months prior to the filing of this statement. 37 C.F.R. 1.97(e)(2).

Respectfully submitted,

By:

Dennis J. Dupray, Ph.D.  
Registration No. 46,299  
1801 Belvedere Street  
Golden, Colorado 80401  
303-863-2975  
FAX: 303-863-0223

Date:

April 10, 2002

L:\TracBeam\patent applications\1003\US (1003&continuations)\-1\pto\IDS-01.wpd

RECEIVED

APR 17 2002

GROUP 3600



4-29-02

EP 3662 # 10/INS  
PATENT  
5/7/02

IN THE UNITED STATES PATENT AND TRADEMARK OFFICE

In re the application of:	)	
DUPRAY et al.	)	Group Art Unit: 3662
Serial No.: 09/770,838	)	Examiner:
Filed: January 26, 2001	)	<b>INFORMATION DISCLOSURE STATEMENT</b>
Attorney Docket No.: 1003-1	)	
For: <b>Old Title:</b> "WIRELESS LOCATION USING SIGNAL FINGERPRINTING"	)	<b>Express Mail Label No.:</b> EL417660269US
<b>New Title:</b> "A GATEWAY AND HYBRID SOLUTIONS FOR WIRELESS LOCATION"	)	

RECEIVED  
MAY 02 2002  
GROUP 3600

Assistant Commissioner for Patents  
Washington, D. C. 20231

Sir:

The references cited on attached Form PTO-1449 are being called to the attention of the Examiner. Copies of the cited references:

- Are enclosed herewith.
- Are not enclosed, in accordance with 37 C.F.R. 1.98(d), because the references were submitted to the U.S. Patent and Trademark Office in prior application Serial No. 09/194,367, titled "WIRELESS LOCATION USING MULTIPLE MOBILE STATION LOCATION TECHNIQUES," and having a filing date of November 24, 1998, which is relied upon for an earlier filing date under 35 U.S.C. 120

To the best of applicants belief, the pertinence of the foreign-language references are believed to be summarized in the attached English abstracts and in the figures, although applicants do not necessarily vouch for the accuracy of the translation.

Examiner's attention is drawn to the following co-pending applications: Serial No. 09/194,367 filed November 24, 1998 and Serial No. 09/820,584 filed March 28, 2001.

Submission of the above information is not intended as an admission that any item is citable under the statutes or rules to support a rejection, that any item disclosed represents analogous art, or that those skilled in the art would refer to or recognize the pertinence of any reference without the benefit of hindsight, nor should an inference

be drawn as to the pertinence of the references based on the order in which they are presented. Submission of this statement should not be taken as an indication that a search has been conducted, or that no better art exists.

It is respectfully requested that the cited information be expressly considered during the prosecution of this application and the references made of record therein.

**FEES**

<input checked="" type="checkbox"/>	<p>No fee is believed due in connection with this submission, because the information disclosure statement submitted herewith is being filed:</p> <p><input type="checkbox"/> within three months of the filing date of the continued prosecution application or date of entry into the national stage of an international application or</p> <p><input checked="" type="checkbox"/> before the mailing date of a first Office Action on the merits, whichever occurs last. 37 C.F.R. 1.97(b).</p> <p>Although no fee is believed due, if any fee is deemed due in connection with this submission, please charge such fee to Deposit Account 19-1970.</p>
<input type="checkbox"/>	<p>The information disclosure statement transmitted herewith is being filed after three months of the filing date of this national application or the date of entry of the national stage as set forth in 37 C.F.R. 1.491 in an international application or after the mailing date of the first Office action on the merits, whichever occurred last but before the mailing date of either:</p> <p>(1) a final action under 37 C.F.R. 1.113 or  (2) a notice of allowance under 37 C.F.R. 1.311,  whichever occurs first. This Information Disclosure Statement is accompanied by:</p> <p><input type="checkbox"/> A Certification (below) as specified by 37 C.F.R. 1.97(e). Although no fee is believed due, if any fee is deemed due in connection with this submission, please charge such fee to Deposit Account 19-1970.</p> <p style="text-align: center;">OR</p> <p><input type="checkbox"/> A check in the amount of \$240.00 for the fee set forth in 37 C.F.R. 1.17(p) for submission of an information disclosure statement. Please credit any overpayment or charge any underpayment to Deposit Account No. 19-1970.</p>
<input type="checkbox"/>	<p>This Information Disclosure Statement is being submitted after the mailing date of a final action under § 1.113 or a notice of allowance under § 1.311, but before payment of the issue fee.</p> <p><input type="checkbox"/> This information Disclosure Statement includes a Certification (below) as specified by 37 C.F.R. 1.97(e)</p> <p style="text-align: center;">AND</p> <p><input type="checkbox"/> Applicants hereby petition for consideration of the references disclosed herein. Enclosed is a petition fee in the amount of \$130.00 under 37 C.F.R. 1.17(i)(1). Please credit any overpayment or charge any underpayment to Deposit Account No. 19-1970.</p>
<input type="checkbox"/>	<p>Applicant elects to pay the fee set forth in 37 C.F.R. 1.17(p) for submission of an information disclosure statement, and the enclosed check includes \$180.00 for payment of such fee. Please credit any overpayment or charge any underpayment to Deposit Account No. 19-1970. Election to pay the fee should not be taken as an indication that applicant(s) cannot execute a certification.</p>

**Certification (37 C.F.R. 1.97(e))**  
(Applicable only if checked)

The undersigned certifies that:

Each item of information contained in this information disclosure statement was cited in a communication from a foreign patent office in a counterpart foreign application not more than three months prior to the filing of this statement. 37 C.F.R. 1.97(e)(1).

A copy of the communication from the foreign patent office is enclosed.

OR

No item of information contained in this information disclosure statement was cited in a communication from a foreign patent office in a counterpart foreign application or to the knowledge of the undersigned after making reasonable inquiry, was known to any individual designated in 37 C.F.R. 1.56(c) more than more than three months prior to the filing of this statement. 37 C.F.R. 1.97(e)(2).

Respectfully submitted,

By: 

Dennis J. Dupray, Ph.D.  
Registration No. 46,299  
1801 Belvedere Street  
Golden, Colorado 80401  
303-863-2975  
FAX: 303-863-0223

Date: April 25, 2002

L:\TracBeam\patent applications\1003\US (1003&continuations)\-1\pto\IDS-03.wpd



UNITED STATES PATENT AND TRADEMARK OFFICE

UNITED STATES DEPARTMENT OF COMMERCE  
United States Patent and Trademark Office  
Address: COMMISSIONER OF PATENTS AND TRADEMARKS  
Washington, D.C. 20231  
www.uspto.gov

APPLICATION NO.	FILING DATE	FIRST NAMED INVENTOR	ATTORNEY DOCKET NO.	CONFIRMATION NO.
09/770,838	01/26/2001	Dennis J. Dupray	1003-1	8410

7590 05/17/2002  
Dennis J. Dupray, Ph.D.  
1801 Belvedere Street  
Golden, CO 80401

EXAMINER

PHAN, DAO LINDA

ART UNIT PAPER NUMBER

3662

DATE MAILED: 05/17/2002

Please find below and/or attached an Office communication concerning this application or proceeding.

Office Action Summary

Application No. <b>09/770,838</b>	Applicant(s) <b>Dupray et al</b>
Examiner <b>Dao L. Phan</b>	Art Unit <b>3662</b>

- The MAILING DATE of this communication appears on the cover sheet with the correspondence address --

Period for Reply

A SHORTENED STATUTORY PERIOD FOR REPLY IS SET TO EXPIRE 3 MONTH(S) FROM THE MAILING DATE OF THIS COMMUNICATION.

- Extensions of time may be available under the provisions of 37 CFR 1.136 (a). In no event, however, may a reply be timely filed after SIX (6) MONTHS from the mailing date of this communication.
- If the period for reply specified above is less than thirty (30) days, a reply within the statutory minimum of thirty (30) days will be considered timely.
- If NO period for reply is specified above, the maximum statutory period will apply and will expire SIX (6) MONTHS from the mailing date of this communication.
- Failure to reply within the set or extended period for reply will, by statute, cause the application to become ABANDONED (35 U.S.C. § 133).
- Any reply received by the Office later than three months after the mailing date of this communication, even if timely filed, may reduce any earned patent term adjustment. See 37 CFR 1.704(b).

Status

- 1)  Responsive to communication(s) filed on Mar 1, 2002
- 2a)  This action is FINAL.
- 2b)  This action is non-final.
- 3)  Since this application is in condition for allowance except for formal matters, prosecution as to the merits is closed in accordance with the practice under *Ex parte Quayle*, 1935 C.D. 11; 453 O.G. 213.

Disposition of Claims

- 4)  Claim(s) \_\_\_\_\_ is/are pending in the application.
- 4a) Of the above, claim(s) \_\_\_\_\_ is/are withdrawn from consideration.
- 5)  Claim(s) \_\_\_\_\_ is/are allowed.
- 6)  Claim(s) \_\_\_\_\_ is/are rejected.
- 7)  Claim(s) \_\_\_\_\_ is/are objected to.
- 8)  Claims \_\_\_\_\_ are subject to restriction and/or election requirement.

Application Papers

- 9)  The specification is objected to by the Examiner.
- 10)  The drawing(s) filed on \_\_\_\_\_ is/are a)  accepted or b)  objected to by the Examiner. Applicant may not request that any objection to the drawing(s) be held in abeyance. See 37 CFR 1.85(a).
- 11)  The proposed drawing correction filed on \_\_\_\_\_ is: a)  approved b)  disapproved by the Examiner. If approved, corrected drawings are required in reply to this Office action.
- 12)  The oath or declaration is objected to by the Examiner.

Priority under 35 U.S.C. §§ 119 and 120

- 13)  Acknowledgement is made of a claim for foreign priority under 35 U.S.C. § 119(a)-(d) or (f).
  - a)  All b)  Some\* c)  None of:
    - 1.  Certified copies of the priority documents have been received.
    - 2.  Certified copies of the priority documents have been received in Application No. \_\_\_\_\_
    - 3.  Copies of the certified copies of the priority documents have been received in this National Stage application from the International Bureau (PCT Rule 17.2(a)).
- \*See the attached detailed Office action for a list of the certified copies not received.
- 14)  Acknowledgement is made of a claim for domestic priority under 35 U.S.C. § 119(e).
  - a)  The translation of the foreign language provisional application has been received.
- 15)  Acknowledgement is made of a claim for domestic priority under 35 U.S.C. §§ 120 and/or 121.

Attachment(s)

- 1)  Notice of References Cited (PTO-892)
- 2)  Notice of Draftsperson's Patent Drawing Review (PTO-948)
- 3)  Information Disclosure Statement(s) (PTO-1449) Paper No(s). \_\_\_\_\_
- 4)  Interview Summary (PTO-413) Paper No(s). \_\_\_\_\_
- 5)  Notice of Informal Patent Application (PTO-152)
- 6)  Other:

Art Unit: 3662

The replaced paragraphs for the specification filed on March 1, 2001 can not be entered. These replaced paragraphs to be entered on p. 2-p.52 do not match with the pages in the original specification. Correction is required.

Any inquiry concerning this communication or earlier communications from the examiner should be directed to Dao Phan whose telephone number is (703) 306-4167.

Any inquiry of a general nature or relating to the status of this application or proceeding should be directed to the receptionist whose telephone number is (703) 306-4187.

  
DAO PHAN  
REGISTERED PATENT ENGINEER





06-28-02

Gp/3662  
#74/IDS  
PATENT (w)  
7/5/02

IN THE UNITED STATES PATENT AND TRADEMARK OFFICE

In Re the Application of:	)	Group Art Unit: 3662
	)	
DUPRAY et a.	)	Examiner: Dao L. Phan
	)	
Serial No.: 09/770,838	)	<b><u>INFORMATION DISCLOSURE</u></b>
	)	<b><u>STATEMENT</u></b>
Filed: January 26, 2001	)	
	)	
Atty. File No.: 1003-1	)	Express Mail Label No.: EL417660723US
	)	
For: "A GATEWAY AND HYBRID SOLUTIONS FOR WIRELESS LOCATION"	)	

RECEIVED  
JUL 03 2002  
GROUP 3600

Assistant Commissioner for Patents  
Washington, D. C. 20231

Sir:

The references cited on attached Form PTO-1449 are being called to the attention of the Examiner.

Copies of the cited references:

- Are enclosed herewith.
- Are not enclosed, in accordance with 37 C.F.R. 1.98(d), because the references were submitted to the U.S. Patent and Trademark Office in prior application Serial No. 09/194,367 filed November 24, 1998, which is relied upon for an earlier filing date under 35 U.S.C. § 120

To the best of applicants' belief, the pertinence of the foreign-language references are believed to be summarized in the attached English abstracts and in the figures, although applicants do not necessarily vouch for the accuracy of the translation.

Examiner's attention is drawn to the following co-pending applications, copies of which have been or are being submitted:

- Serial No. 09/194,367 filed November 24, 1998
- Serial No. 09/820,584 filed March 28, 2001

Submission of the above information is not intended as an admission that any item is citable under the statutes or rules to support a rejection, that any item disclosed represents analogous art, or that those skilled in the art would refer to or recognize the pertinence of any reference without the benefit of hindsight, nor should an inference be drawn as to the pertinence of the references based on the order in which they are presented.

Submission of this statement should not be taken as an indication that a search has been conducted, or that no better art exists.

It is respectfully requested that the cited information be expressly considered during the prosecution of this application and the references made of record therein.

**FEES**

<input type="checkbox"/>	<p><b>37 CFR 1.97(b):</b> No fee is believed due in connection with this submission, because the information disclosure statement submitted herewith is satisfies one of the following conditions ("X" indicates satisfaction):</p> <ul style="list-style-type: none"> <li><input type="checkbox"/> Within three months of the filing date of a national application other than a continued prosecution application under 37 CFR 1.53(d), or</li> <li><input type="checkbox"/> Within three months of the date of entry into the national stage of an international application as set forth in 37 CFR 1.491 or</li> <li><input type="checkbox"/> Before the mailing date of a first Office Action on the merits, or</li> <li><input type="checkbox"/> Before the mailing of a first Office action after the filing of a request for continued examination under 37 CFR 1.114.</li> </ul> <p>Although no fee is believed due, if any fee is deemed due in connection with this submission, please charge such fee to Deposit Account 19-1970.</p>
<input checked="" type="checkbox"/>	<p><b>37 CFR 1.97(c):</b> The information disclosure statement transmitted herewith is being filed after all the above conditions (37 CFR 1.97(b)), but before the mailing date of one of the following conditions:</p> <ul style="list-style-type: none"> <li>(1) a final action under 37 C.F.R. 1.113 or</li> <li>(2) a notice of allowance under 37 C.F.R. 1.311, or</li> <li>(3) an action that otherwise closes prosecution in the application.</li> </ul> <p>This Information Disclosure Statement is accompanied by:</p> <ul style="list-style-type: none"> <li><input checked="" type="checkbox"/> A Certification (below) as specified by 37 C.F.R. 1.97(e). Although no fee is believed due, if any fee is deemed due in connection with this submission, please charge such fee to Deposit Account 19-1970.</li> </ul> <p style="text-align: center;">OR</p> <ul style="list-style-type: none"> <li><input type="checkbox"/> A check in the amount of \$180.00 for the fee set forth in 37 C.F.R. 1.17(p) for submission of an information disclosure statement. Please credit any overpayment or charge any underpayment to Deposit Account No. 19-1970.</li> </ul>
<input type="checkbox"/>	<p><b>37 CFR 1.97(d):</b> This Information Disclosure Statement is being submitted after the period specified in 37 CFR 1.97(c).</p> <ul style="list-style-type: none"> <li><input type="checkbox"/> This information Disclosure Statement includes a Certification (below) as specified by 37 C.F.R. 1.97(e)</li> </ul> <p style="text-align: center;">AND</p> <ul style="list-style-type: none"> <li><input type="checkbox"/> Applicants hereby requests consideration of the reference(s) disclosed herein. Enclosed is the fee in the amount of \$180.00 under 37 C.F.R. 1.17(p). Please credit any overpayment or charge any underpayment to Deposit Account No. 19-1970. Please credit any overpayment or charge any underpayment to Deposit Account No. 19-1970. Election to pay the fee should not be taken as an indication that applicant(s) cannot execute a certification.</li> </ul>

**Certification (37 C.F.R. 1.97(e))**  
(Applicable only if checked)

The undersigned certifies that:

Each item of information contained in this information disclosure statement was first cited in any communication from a foreign patent office in a counterpart foreign application not more than three months prior to the filing of this statement. 37 C.F.R. 1.97(e)(1).

A copy of the communication from the foreign patent office is enclosed.

OR

No item of information contained in this information disclosure statement was cited in a communication from a foreign patent office in a counterpart foreign application, and, to the knowledge of the undersigned after making reasonable inquiry, no item of information contained in this Information Disclosure Statement was known to any individual designated in 37 C.F.R. 1.56(c) more than more than three months prior to the filing of this statement. 37 C.F.R. 1.97(e)(2).

Respectfully submitted,

SHERIDAN ROSS, P.C.

By: 

Dennis J. Dupray  
Registration No. 46,299  
1560 Broadway, Suite 1200  
Denver, CO 80202-5141  
TELEPHONE: 303-863-2975  
FAX: 303-863-0223

Date: June 26, 2002

L:\TracBeam\patent applications\1003\US (1003&continuations)\-1\pto\IDS-04.wpd

OK, to enter DP



#15

Sub. Spec.

Copied 7-17-02

**WIRELESS LOCATION USING MULTIPLE SIMULTANEOUS LOCATION ESTIMATORS**

JWS. A2

**FIELD OF THE INVENTION**

5 The present invention is directed generally to a system and method for locating people or objects, and in particular, to a system and method for locating a wireless mobile station using a plurality of simultaneously activated mobile station location estimators.

RECEIVED  
JUL 11 2002  
GROUP 3600

**BACKGROUND OF THE INVENTION**

**Introduction**

10 Wireless communications systems are becoming increasingly important worldwide. Wireless cellular telecommunications systems are rapidly replacing conventional wire-based telecommunications systems in many applications. Cellular radio telephone networks ("CRT"), and specialized mobile radio and mobile data radio networks are examples. The general principles of wireless cellular telephony have been described variously, for example in U. S. Patent 5,295,180 to Vendetti, et al, which is incorporated herein by reference.

15 There is great interest in using existing infrastructures for wireless communication systems for locating people and/or objects in a cost effective manner. Such a capability would be invaluable in a variety of situations, especially in emergency or crime situations. Due to the substantial benefits of such a location system, several attempts have been made to design and implement such a system.

20 Systems have been proposed that rely upon signal strength and trilateralization techniques to permit location include those disclosed in U.S. Patents 4,818,998 and 4,908,629 to Apsell et al. ("the Apsell patents") and 4,891,650 to Sheffer ("the Sheffer patent"). However, these systems have drawbacks that include high expense in that special purpose electronics are required. Furthermore, the systems are generally only effective in line-of-sight conditions, such as rural settings. Radio wave surface reflections, refractions and ground clutter cause significant distortion, in determining the location of a signal source in most geographical areas that are more than sparsely populated. Moreover, these drawbacks are particularly exacerbated in dense urban  
25 canyon (city) areas, where errors and/or conflicts in location measurements can result in substantial inaccuracies.

Another example of a location system using time of arrival and triangulation for location are satellite-based systems, such as the military and commercial versions of the Global Positioning Satellite system ("GPS"). GPS can provide accurate position determination (i.e., about 100 meters error for the commercial version of GPS) from a time-based signal received simultaneously from at least three satellites. A ground-based GPS receiver at or near the object to be located determines the difference between the  
30 time at which each satellite transmits a time signal and the time at which the signal is received and, based on the time differentials, determines the object's location. However, the GPS is impractical in many applications. The signal power levels from the satellites

2

are low and the GPS receiver requires a clear, line-of-sight path to at least three satellites above a horizon of about 60 degrees for effective operation. Accordingly, inclement weather conditions, such as clouds, terrain features, such as hills and trees, and buildings restrict the ability of the GPS receiver to determine its position. Furthermore, the initial GPS signal detection process for a GPS receiver is relatively long (i.e., several minutes) for determining the receiver's position. Such delays are unacceptable in many applications such as, for example, emergency response and vehicle tracking.

Differential GPS, or DGPS systems offer correction schemes to account for time synchronization drift. Such correction schemes include the transmission of correction signals over a two-way radio link or broadcast via FM radio station subcarriers. These systems have been found to be awkward and have met with limited success.

Additionally, GPS-based location systems have been attempted in which the received GPS signals are transmitted to a central data center for performing location calculations. Such systems have also met with limited success. In brief, each of the various GPS embodiments have the same fundamental problems of limited reception of the satellite signals and added expense and complexity of the electronics required for an inexpensive location mobile station or handset for detecting and receiving the GPS signals from the satellites.

#### Radio Propagation Background

The behavior of a mobile radio signal in the general environment is unique and complicated. Efforts to perform correlations between radio signals and distance between a base station and a mobile station are similarly complex. Repeated attempts to solve this problem in the past have been met with only marginal success. Factors include terrain undulations, fixed and variable clutter, atmospheric conditions, internal radio characteristics of cellular and PCS systems, such as frequencies, antenna configurations, modulation schemes, diversity methods, and the physical geometries of direct, refracted and reflected waves between the base stations and the mobile. Noise, such as man-made external sources (e.g., auto ignitions) and radio system co-channel and adjacent channel interference also affect radio reception and related performance measurements, such as the analog carrier-to-interference ratio (C/I), or digital energy-per-bit/Noise density ratio ( $E_b/N_0$ ) and are particular to various points in time and space domains.

#### RF Propagation in Free Space

Before discussing real world correlations between signals and distance, it is useful to review the theoretical premise, that of radio energy path loss across a pure isotropic vacuum propagation channel, and its dependencies within and among various communications channel types. Fig. 1 illustrates a definition of channel types arising in communications:

Over the last forty years various mathematical expressions have been developed to assist the radio mobile cell designer in establishing the proper balance between base station capital investment and the quality of the radio link, typically using radio energy field-strength, usually measured in microvolts/meter, or decibels.

First consider Hata's single ray model. A simplified radio channel can be described as:

$$G_s = L_p + F + L_t + L_m + L_b - G_t + G_r \quad (\text{Equation 1})$$

where  $G_s$  = system gain in decibels

$L_p$  = free space path loss in dB,

5  $F$  = fade margin in dB,

$L_t$  = transmission line loss from coaxials used to connect radio to antenna, in dB,

$L_m$  = miscellaneous losses such as minor antenna misalignment, coaxial corrosion, increase in the receiver noise figure due to aging, in dB,

10  $L_b$  = branching loss due to filter and circulator used to combine or split transmitter and receiver signals in a single antenna

$G_t$  = gain of transmitting antenna

$G_r$  = gain of receiving antenna

Free space path loss<sup>1</sup>  $L_p$ , as discussed in Mobile Communications Design Fundamentals, William C. Y. Lee, 2nd, Ed across the propagation channel

15 is a function of distance  $d$ , frequency

$f$  (for  $f$  values < 1 GHz, such as the 890-950 MHz cellular band):

T0040

$$\frac{P_{or}}{P_t} = \frac{1}{(4\pi d f c)^2} \quad (\text{equation 2})$$

20 where  $P_{or}$  = received power in free space

$P_t$  = transmitting power

$c$  = speed of light,

25 The difference between two received signal powers in free space,

T0041

$$\Delta_p = (10) \log\left(\frac{P_{or2}}{P_{or1}}\right) = (20) \log\left(\frac{d_1}{d_2}\right) (\text{dB}) \quad (\text{equation 3})$$

4

indicates that the free propagation path loss is 20 dB per decade. Frequencies between 1 GHz and 2GHz experience increased values in the exponent, ranging from 2 to 4, or 20 to 40 dB/decade, which would be predicted for the new PCS 1.8 - 1.9 GHz band.

- 5 This suggests that the free propagation path loss is 20 dB per decade. However, frequencies between 1 GHz and 2 GHz experience increased values in the exponent, ranging from 2 to 4, or 20 to 40 dB/decade, which would be predicted for the new PCS 1.8 - 1.9 GHz band. One consequence from a location perspective is that the effective range of values for higher exponents is an increased at higher frequencies, thus providing improved granularity of ranging correlation.

#### Environmental Clutter and RF Propagation Effects

- 10 Actual data collected in real-world environments uncovered huge variations with respect to the free space path loss equation, giving rise to the creation of many empirical formulas for radio signal coverage prediction. Clutter, either fixed or stationary in geometric relation to the propagation of the radio signals, causes a shadow effect of blocking that perturbs the free space loss effect. Perhaps the best known model set that characterizes the average path loss is Hata's, "Empirical Formula for Propagation Loss in Land Mobile Radio", M. Hata, IEEE Transactions VT-29, pp. 317-325, August 1980, three pathloss models, based  
15 on Okumura's measurements in and around Tokyo, "Field Strength and its Variability in VHF and UHF Land Mobile Service", Y. Okumura, et al, Review of the Electrical Communications laboratory, Vol 16, pp 825-873, Sept. - Oct. 1968.

The typical urban Hata model for  $L_p$  was defined as  $L_p = L_{Hu}$ :

20

$$L_{Hu} = 69.55 + 26.16 \log(f) - 13.82 \log(h_{BS}) - a(h_{MS}) + ((44.9 - 6.55 \log(H_{BS})) \log(d)) [dB]$$

(Equation 4)

where  $L_{Hu}$  = path loss, Hata urban

25

$h_{BS}$  = base station antenna height

$h_{MS}$  = mobile station antenna height

$d$  = distance BS-MS in km

30

$a(h_{MS})$  is a correction factor for small and medium sized cities, found to be:

5

$$1 \log(f - 0.7)h_{MS} - 1.56 \log(f - 0.8) = a(h_{MS})$$

(Equation 5)

For large cities the correction factor was found to be:

5

$$a(h_{MS}) = 3.2 [\log 1.75h_{MS}]^2 - 4.97$$

(Equation 6)

assuming  $f$  is equal to or greater than 400 MHz.

10

The typical suburban model correction was found to be:

70060

$$L_{H_{suburban}} = L_{Hu} - 2 \left[ \log \left( \frac{f}{28} \right)^2 \right] - 5.4 [dB]$$

(Equation 7)

15

The typical rural model modified the urban formula differently, as seen below:

$$L_{Hrural} = L_{Hu} - 4.78 (\log f)^2 + 18.33 \log f - 40.94 [dB]$$

(Equation 8)

20

Although the Hata model was found to be useful for generalized RF wave prediction in frequencies under 1 GHz in certain suburban and rural settings, as either the frequency and/or clutter increased, predictability decreased. In current practice, however, field technicians often have to make a guess for dense urban and suburban areas (applying whatever model seems best), then installing a base stations and begin taking manual measurements. Coverage problems can take up to a year to resolve.

25 Relating Received Signal Strength to Location

Having previously established a relationship between  $d$  and  $P_{or}$ , reference equation 2 above:  $d$  represents the distance between the mobile station (MS) and the base station (BS);  $P_{or}$  represents the received power in free space for a given set of unchanging environmental conditions, it may be possible to dynamically measure  $P_{or}$  and then determine  $d$ .

30 In 1991, U.S. Patent 5,055,851 to Sheffer taught that if three or more relationships have been established in a triangular space of three or more base stations (BSs) with a location database constructed having data related to possible mobile station (MS) locations, then arculation calculations may be performed, which use three distinct  $P_{or}$  measurements to determine an X,Y, two

6 5



dimensional location, which can then be projected onto an area map. The triangulation calculation is based on the fact that the approximate distance of the mobile station (MS) from any base station (BS) cell can be calculated based on the received signal strength. Sheffer acknowledges that terrain variations affect accuracy, although as noted above, Sheffer's disclosure does not account for a sufficient number of variables, such as fixed and variable location shadow fading, which are typical in dense urban areas with moving traffic.

Most field research before about 1988 has focused on characterizing (with the objective of RF coverage prediction) the RF propagation channel (i.e., electromagnetic radio waves) using a single-ray model, although standard fit errors in regressions proved dismal (e.g., 40-80 dB). Later, multi-ray models were proposed, and much later, certain behaviors were studied with radio and digital channels. In 1981, Vogler proposed that radio waves at higher frequencies could be modeled using optics principles. In 1988 Walfisch and Bertoni applied optical methods to develop a two-ray model, which when compared to certain highly specific, controlled field data, provided extremely good regression fit standard errors of within 1.2 dB.

In the Bertoni two ray model it was assumed that most cities would consist of a core of high-rise buildings surrounded by a much larger area having buildings of uniform height spread over regions comprising many square blocks, with street grids organizing buildings into rows that are nearly parallel. Rays penetrating buildings then emanating outside a building were neglected. Fig. 2 provides a basis for the variables.

After a lengthy analysis it was concluded that path loss was a function of three factors: (1) the path loss between antennas in free space; (2) the reduction of rooftop wave fields due to settling; and (3) the effect of diffraction of the rooftop fields down to ground level. The last two factors were summarily termed  $L_{ex}$ , given by:

T0070 20

$$L_{ex} = 57.1 + A + \log(f) + R - ((18 \log(H)) - 18 \log \left[ 1 - \frac{R^2}{17H} \right]) \quad (\text{Equation 9})$$

The influence of building geometry is contained in A:

T0071 25

$$A = 5 \log \left[ \frac{d}{2} \right]^2 - 9 \log d + 20 \log \{ \tan [2(h - H_{MS})]^{-1} \} \quad (\text{Equation 10})$$

However, a substantial difficulty with the two-ray model in practice is that it requires a substantial amount of data regarding building dimensions, geometries, street widths, antenna gain characteristics for every possible ray path, etc. Additionally, it requires an inordinate amount of computational resources and such a model is not easily updated or maintained.

Unfortunately, in practice clutter geometries and building heights are random. Moreover, data of sufficient detail has been extremely difficult to acquire, and regression standard fit errors are poor; i.e., in the general case, these errors were found to be 40-60 dB. Thus the two-ray model approach, although sometimes providing an improvement over single ray techniques, still did not predict RF signal characteristics in the general case to level of accuracy desired (< 10dB).

Work by Greenstein has since developed from the perspective of measurement-based regression models, as opposed to the previous approach of predicting-first, then performing measurement comparisons. Apparently yielding to the fact that low-power, low antenna (e.g., 12-25 feet above ground) height PCS microcell coverage was insufficient in urban buildings, Greenstein, et al, authored "Performance Evaluations for Urban Line-of-sight Microcells Using a Multi-ray Propagation Model", in IEEE Globecom Proceedings, 12/91. This paper proposed the idea of formulating regressions based on field measurements using small PCS microcells in a lineal microcell geometry (i.e., geometries in which there is always a line-of-sight (LOS) path between a subscriber's mobile and its current microsite).

Additionally, Greenstein studied the communication channels variable Bit-Error-Rate (BER) in a spatial domain, which was a departure from previous research that limited field measurements to the RF propagation channel signal strength alone. However, Greenstein based his finding on two suspicious assumptions: 1) he assumed that distance correlation estimates were identical for uplink and downlink transmission paths; and 2) modulation techniques would be transparent in terms of improved distance correlation conclusions. Although some data held very correlations, other data and environments produced poor results. Accordingly, his results appear unreliable for use in general location context.

In 1993 Greenstein, et al, authored "A Measurement-Based Model for Predicting Coverage Areas of Urban Microcells", in the IEEE Journal On Selected Areas in Communications, Vol. 11, No. 7, 9/93. Greenstein reported a generic measurement-based model of RF attenuation in terms of constant-value contours surrounding a given low-power, low antenna microcell environment in a dense, rectilinear neighborhood, such as New York City. However, these contours were for the cellular frequency band. In this case, LOS and non-LOS clutter were considered for a given microcell site. A result of this analysis was that RF propagation losses (or attenuations), when cell antenna heights were relatively low, provided attenuation contours resembling a spline plane curve depicted as an asteroid, aligned with major street grid patterns. Further, Greenstein found that convex diamond-shaped RF propagation loss contours were a common occurrence in field measurements in a rectilinear urban area. The special plane curve asteroid is represented by the formula  $x^{2/3} + y^{2/3} = r^{2/3}$ . However, these results alone have not been sufficiently robust and general to accurately locate an MS, due to the variable nature of urban clutter spatial arrangements..

At Telesis Technology in 1994 Howard Xia, et al, authored "Microcellular Propagation Characteristics for Personal Communications in Urban and Suburban Environments", in IEEE Transactions of Vehicular Technology, Vol. 43, No. 3, 8/94, which performed measurements specifically in the PCS 1.8 to 1.9 GHz frequency band. Xia found corresponding but more variable outcome results in San Francisco, Oakland (urban) and the Sunset and Mission Districts (suburban).

#### Summary of Factors Affecting RF Propagation

The physical radio propagation channel perturbs signal strength, frequency (causing rate changes, phase delay, signal to noise ratios (e.g., C/I for the analog case, or  $E_{b/N_0}$ , RF energy per bit, over average noise density ratio for the digital case) and Doppler-shift. Signal strength is usually characterized by:

- Free Space Path Loss ( $L_p$ )

• Slow fading loss or margin ( $L_{slow}$ )

• Fast fading loss or margin ( $L_{fast}$ )

5 Loss due to slow fading includes shadowing due to clutter blockage (sometimes included in  $L_p$ ). Fast fading is composed of multipath reflections which cause: 1) delay spread; 2) random phase shift or Rayleigh fading; and 3) random frequency modulation due to different Doppler shifts on different paths.

Summing the path loss and the two fading margin loss components from the above yields a total path loss of:

$$L_{total} = L_p + L_{slow} + L_{fast}$$

10 Referring to Fig. 3, the figure illustrates key components of a typical cellular and PCS power budget design process. The cell designer increases the transmitted power  $P_{TX}$  by the shadow fading margin  $L_{slow}$ , which is usually chosen to be within the 1-2 percentile of the slow fading probability density function (PDF) to minimize the probability of unsatisfactorily low received power level  $P_{RX}$  at the receiver. The  $P_{RX}$  level must have enough signal to noise energy level (e.g., 10 dB) to overcome the receiver's internal noise level (e.g., -118dBm in the case of cellular 0.9 GHz), for a minimum voice quality standard. Thus in the example  $P_{RX}$  must never be below -108 dBm, in order to maintain the quality standard.

15 Additionally the short term fast signal fading due to multipath propagation is taken into account by deploying fast fading margin  $L_{fast}$ , which is typically also chosen to be a few percentiles of the fast fading distribution. The 1 to 2 percentiles compliment other network blockage guidelines. For example the cell base station traffic loading capacity and network transport facilities are usually designed for a 1-2 percentile blockage factor as well. However, in the worst-case scenario both fading margins are simultaneously exceeded, thus causing a fading margin overload.

20 In Roy, Steele's, text, Mobile Radio Communications, IEEE Press, 1992, estimates for a GSM system operating in the 1.8 GHz band with a transmitter antenna height of 6.4m and an MS receiver antenna height of 2m, and assumptions regarding total path loss, transmitter power would be calculated as follows:

Table I: GSM Power Budget Example

TO100

Parameter	dBm value	Will require
$L_{slow}$	14	
$L_{fast}$	7	
$L_{path}$	110	
Min. RX pwr required	-104	
		TXpwr = 27 dBm

5

Steele's sample size in a specific urban London area of 80,000 LOS measurements and data reduction found a slow fading variance of

$$\sigma = 7\text{dB}$$

10 assuming lognormal slow fading PDF and allowing for a 1.4% slow fading margin overload, thus

$$L_{slow} = 2\sigma = 14\text{dB}$$

The fast fading margin was determined to be:

15  $L_{fast} = 7\text{dB}$

In contrast, Xia's measurements in urban and suburban California at 1.8 GHz uncovered flat-land shadow fades on the order of 25-30 dB when the mobile station (MS) receiver was traveling from LOS to non-LOS geometries. In hilly terrain fades of +5 to -50 dB were experienced. Thus it is evident that attempts to correlate signal strength with MS ranging distance suggest that error ranges could not be expected to improve below 14 dB, with a high side of 25 to 50 dB. Based on 20 to 40 dB per decade,

20 Corresponding error ranges for the distance variable would then be on the order of 900 feet to several thousand feet, depending upon the particular environmental topology and the transmitter and receiver geometries.

10

9

## SUMMARY OF THE INVENTION

### OBJECTS OF THE INVENTION

It is an objective of the present invention to provide a system and method for to wireless telecommunication systems for accurately locating people and/or objects in a cost effective manner. Additionally, it is an objective of the present invention to provide such location capabilities using the measurements from wireless signals communicated between mobile stations and a network of base stations, wherein the same communication standard or protocol is utilized for location as is used by the network of base stations for providing wireless communications with mobile stations for other purposes such as voice communication and/or visual communication (such as text paging, graphical or video communications). Related objectives for the present invention include providing a system and method that:

- 5
- 10 (1.1) can be readily incorporated into existing commercial wireless telephony systems with few, if any, modifications of a typical telephony wireless infrastructure;
- (1.2) can use the native electronics of typical commercially available telephony wireless mobile stations (e.g., handsets) as location devices;
- (1.3) can be used for effectively locating people and/or objects wherein there are few (if any) line-of-sight wireless receivers for receiving location signals from a mobile station (herein also denoted MS);
- 15 (1.4) can be used not only for decreasing location determining difficulties due to multipath phenomena but in fact uses such multipath for providing more accurate location estimates;
- (1.5) can be used for integrating a wide variety of location techniques in a straight-forward manner; and
- (1.6) can substantially automatically adapt and/or (re)train and/or (re)calibrate itself according to changes in the environment and/or terrain of a geographical area where the present invention is utilized.
- 20

Yet another objective is to provide a low cost location system and method, adaptable to wireless telephony systems, for using simultaneously a plurality of location techniques for synergistically increasing MS location accuracy and consistency. In particular, at least some of the following MS location techniques can be utilized by various embodiments of the present invention:

- (2.1) time-of-arrival wireless signal processing techniques;
- 25 (2.2) time-difference-of-arrival wireless signal processing techniques;
- (2.3) adaptive wireless signal processing techniques having, for example, learning capabilities and including, for instance, artificial neural net and genetic algorithm processing;
- (2.4) signal processing techniques for matching MS location signals with wireless signal characteristics of known areas;
- (2.5) conflict resolution techniques for resolving conflicts in hypotheses for MS location estimates;
- 30 (2.6) enhancement of MS location estimates through the use of both heuristics and historical data associating MS wireless signal characteristics with known locations and/or environmental conditions.

Yet another objective is to provide location estimates in terms of time vectors, which can be used to establish motion, speed, and an extrapolated next location in cases where the MS signal subsequently becomes unavailable.

#### DEFINITIONS

5 The following definitions are provided for convenience. In general, the definitions here are also defined elsewhere in this document as well.

(3.1) The term "wireless" herein is, in general, an abbreviation for "digital wireless", and in particular, "wireless" refers to digital radio signaling using one of standard digital protocols such as CDMA, NAMPS, AMPS, TDMA and GSM, as one skilled in the art will understand.

10 (3.2) As used herein, the term "mobile station" (equivalently, MS) refers to a wireless device that is at least a transmitting device, and in most cases is also a wireless receiving device, such as a portable radio telephony handset. Note that in some contexts herein instead or in addition to MS, the following terms are also used: "personal station" (PS), and "location unit" (LU). In general, these terms may be considered synonymous. However, the later two terms may be used when referring to reduced functionality communication devices in comparison to a typical digital wireless mobile telephone.

*Ins' AC3*

15 (3.3) The term, "infrastructure", denotes the network of telephony communication services, and more particularly, that portion of such a network that receives and processes wireless communications with wireless mobile stations. In particular, this infrastructure includes telephony wireless base stations (BS) such as those for radio mobile communication systems based on CDMA, AMPS, NAMPS, TDMA, and GSM wherein the base stations provide a network of cooperative communication channels with an air interface with the MS, and a conventional telecommunications interface with a Mobile Switch Center (MSC). Thus, an MS user within an area serviced by  
20 the base stations may be provided with wireless communication throughout the area by user transparent communication transfers (i.e., "handoffs") between the user's MS and these base stations in order to maintain effective telephony service. The mobile switch center (MSC) provides communications and control connectivity among base stations and the public telephone network.

(3.4) The phrase, "composite wireless signal characteristic values" denotes the result of aggregating and filtering a collection of measurements of wireless signal samples, wherein these samples are obtained from the wireless communication between an MS to be  
25 located and the base station infrastructure (e.g., a plurality of networked base stations). However, other phrases are also used herein to denote this collection of derived characteristic values depending on the context and the likely orientation of the reader. For example, when viewing these values from a wireless signal processing perspective of radio engineering, as in the descriptions of the subsequent Detailed Description sections concerned with the aspects of the present invention for receiving MS signal measurements from the base station infrastructure, the phrase typically used is: "RF signal measurements". Alternatively, from a data processing  
30 perspective, the phrases: "location signature cluster" and "location signal data" are used to describe signal characteristic values between the MS and the plurality of infrastructure base stations substantially simultaneously detecting MS transmissions. Moreover, since the location communications between an MS and the base station infrastructure typically include simultaneous communications with more than one base station, a related useful notion is that of a "location signature" which is the composite wireless signal

characteristic values for signal samples between an MS to be located and a single base station. Also, in some contexts, the phrases: "signal characteristic values" or "signal characteristic data" are used when either or both a location signature(s) and/or a location signature cluster(s) are intended.

5 SUMMARY DISCUSSION

*Ins. C.1*

The present invention relates to a wireless mobile station location system. In particular, such a wireless mobile station location system may be decomposed into: (i) a first low level wireless signal processing subsystem for receiving, organizing and conditioning low level wireless signal measurements from a network of base stations cooperatively linked for providing wireless communications with mobile stations (MSs); and (ii) a second high level signal processing subsystem for performing high level data processing for providing most likelihood location estimates for mobile stations.

*Ins. C.2*

10 More precisely, the present invention is a novel signal processor that includes at least the functionality for the high signal processing subsystem mentioned hereinabove. Accordingly, assuming an appropriate ensemble of wireless signal measurements characterizing the wireless signal communications between a particular MS and a networked wireless base station infrastructure have been received and appropriately filtered of noise and transitory values (such as by an embodiment of the low level signal processing subsystem disclosed in a copending PCT patent application titled, "Wireless Location Using A Plurality of Commercial Network Infrastructures," by F. W. LeBlanc, and the present applicant(s); this copending patent application being herein incorporated by reference), the present invention uses the output from such a low level signal processing system for determining a most likely location estimate of an MS.

*Ins. C.3*

20 That is, once the following steps are appropriately performed (e.g., by the LeBlanc copending application):

- (4.1) receiving signal data measurements corresponding to wireless communications between an MS to be located (herein also denoted the "target MS") and a wireless telephony infrastructure;
- (4.2) organizing and processing the signal data measurements received from a given target MS and surrounding BSs so that composite wireless signal characteristic values may be obtained from which target MS location estimates may be subsequently derived. In particular, the signal data measurements are ensembles of samples from the wireless signals received from the target MS by the base station infrastructure, wherein these samples are subsequently filtered using analog and digital spectral filtering.

*Ins. C.4*

25 the present invention accomplishes the objectives mentioned above by the following steps:

- (4.3) providing the composite signal characteristic values to one or more MS location hypothesizing computational models (also denoted herein as "first order models" and also "location estimating models"), wherein each such model subsequently determines one or more initial estimates of the location of the target MS based on, for example, the signal processing techniques 2.1 through 2.3 above. Moreover, each of the models output MS location estimates having substantially identical data structures (each such data structure denoted a "location hypothesis"). Additionally, each location hypothesis may also includes a confidence value indicating the likelihood

or probability that the target MS whose location is desired resides in a corresponding location estimate for the target MS;

- (4.4) adjusting or modifying location hypotheses output by the models according to, for example, 2.4 through 2.6 above so that the adjusted location hypotheses provide better target MS location estimates. In particular, such adjustments are performed on both the target MS location estimates of the location hypotheses as well as their corresponding confidences; and
- (4.4) subsequently computing a "most likely" target MS location estimate for outputting to a location requesting application such as 911 emergency, the fire or police departments, taxi services, etc. Note that in computing the most likely target MS location estimate a plurality of location hypotheses may be taken into account. In fact, it is an important aspect of the present invention that the most likely MS location estimate is determined by computationally forming a composite MS location estimate utilizing such a plurality of location hypotheses so that, for example, location estimate similarities between location hypotheses can be effectively utilized.

Referring now to (4.3) above, the filtered and aggregated wireless signal characteristic values are provided to a number of location hypothesizing models (denoted First Order Models, or FOMs), each of which yields a location estimate or location hypothesis related to the location of the target MS. In particular, there are location hypotheses for both providing estimates of where the target MS likely to be and where the target MS is not likely to be. Moreover, it is an aspect of the present invention that confidence values of the location hypotheses are provided as a continuous range of real numbers from, e.g., -1 to 1, wherein the most unlikely areas for locating the target MS are given a confidence value of -1, and the most likely areas for locating the target MS are given a confidence value of 1. That is, confidence values that are larger indicate a higher likelihood that the target MS is in the corresponding MS estimated area, wherein 1 indicates that the target MS is absolutely NOT in the estimated area, 0 indicates a substantially neutral or unknown likelihood of the target MS being in the corresponding estimated area, and 1 indicates that the target MS is absolutely within the corresponding estimated area.

Referring to (4.4) above, it is an aspect of the present invention to provide location hypothesis enhancing and evaluation techniques that can adjust target MS location estimates according to historical MS location data and/or adjust the confidence values of location hypotheses according to how consistent the corresponding target MS location estimate is: (a) with historical MS signal characteristic values, (b) with various physical constraints, and (c) with various heuristics. In particular, the following capabilities are provided by the present invention:

- (5.1) a capability for enhancing the accuracy of an initial location hypothesis, H, generated by a first order model, FOM<sub>n</sub>, by using H as, essentially, a query or index into an historical data base (denoted herein as the location signature data base), wherein this data base includes: (a) a plurality of previously obtained location signature clusters (i.e., composite wireless signal characteristic values) such that for each such cluster there is an associated actual or verified MS locations where an MS communicated with the base station infrastructure for locating the MS, and (b)





previous MS location hypothesis estimates from  $FOM_h$  derived from each of the location signature clusters stored according to (a);

- 5 (5.2) a capability for analyzing composite signal characteristic values of wireless communications between the target MS and the base station infrastructure, wherein such values are compared with composite signal characteristics values of known MS locations (these latter values being archived in the location signature data base). In one instance, the composite signal characteristic values used to generate various location hypotheses for the target MS are compared against wireless signal data of known MS locations stored in the location signature data base for determining the reliability of the location hypothesizing models for particular geographic areas and/or environmental conditions;
- 10 (5.3) a capability for reasoning about the likeliness of a location hypothesis wherein this reasoning capability uses heuristics and constraints based on physics and physical properties of the location geography;
- (5.4) an hypothesis generating capability for generating new location hypotheses from previous hypotheses.

As also mentioned above in (2.3), the present invention utilizes adaptive signal processing techniques. One particularly important utilization of such techniques includes the automatic tuning of the present invention so that, e.g., such tuning can be applied to adjusting the values of location processing system parameters that affect the processing performed by the present invention. For example, such system parameters as those used for determining the size of a geographical area to be specified when retrieving location signal data of known MS locations from the historical (location signature) data base can substantially affect the location processing. In particular, a system parameter specifying a minimum size for such a geographical area may, if too large, cause unnecessary inaccuracies in locating an MS. Accordingly, to accomplish a tuning of such system parameters, an adaptation engine is included in the present invention for automatically adjusting or tuning parameters used by the present invention. Note that in one embodiment, the adaptation engine is based on genetic algorithm techniques.

A novel aspect of the present invention relies on the discovery that in many areas where MS location services are desired, the wireless signal measurements obtained from communications between the target MS and the base station infrastructure are extensive enough to provide sufficiently unique or peculiar values so that the pattern of values alone may identify the location of the target MS. Further, assuming a sufficient amount of such location identifying pattern information is captured in the composite wireless signal characteristic values for a target MS, and that there is a technique for matching such wireless signal patterns to geographical locations, then a FOM based on this technique may generate a reasonably accurate target MS location estimate. Moreover, if the present invention (e.g., the location signature data base) has captured sufficient wireless signal data from location communications between MSs and the base station infrastructure wherein the locations of the MSs are also verified and captured, then this captured data (e.g., location signatures) can be used to train or calibrate such models to associate the location of a target MS with the distinctive signal characteristics between the target MS and one or more base stations. Accordingly, the present invention includes one or more FOMs that may be generally denoted as classification models wherein such FOMs are trained or calibrated to associate particular composite wireless signal characteristic values with a geographical location where a target MS could likely generate the wireless signal samples from which the composite wireless signal characteristic values are derived. Further, the present invention includes the capability for training (calibrating) and retraining (recalibrating) such classification FOMs to automatically

15

maintain the accuracy of these models even though substantial changes to the radio coverage area may occur, such as the construction of a new high rise building or seasonal variations (due to, for example, foliage variations).

Note that such classification FOMs that are trained or calibrated to identify target MS locations by the wireless signal patterns produced constitute a particularly novel aspect of the present invention. It is well known in the wireless telephony art that the phenomenon of signal multipath and shadow fading renders most analytical location computational techniques such as time-of-arrival (TOA) or time-difference-of-arrival (TDOA) substantially useless in urban areas and particularly in dense urban areas. However, this same multipath phenomenon also may produce substantially distinct or peculiar signal measurement patterns, wherein such a pattern coincides with a relatively small geographical area. Thus, the present invention utilizes multipath as an advantage for increasing accuracy where for previous location systems multipath has been a source of substantial inaccuracies. Moreover, it is worthwhile to note that the utilization of classification FOMs in high multipath environments is especially advantageous in that high multipath environments are typically densely populated. Thus, since such environments are also capable of yielding a greater density of MS location signal data from MSs whose actual locations can be obtained, there can be a substantial amount of training or calibration data captured by the present invention for training or calibrating such classification FOMs and for progressively improving the MS location accuracy of such models. Moreover, since it is also a related aspect of the present invention to include a plurality of stationary, low cost, low power "location detection base stations" (LBS), each having both restricted range MS detection capabilities and a built-in MS, a grid of such LBSs can be utilized for providing location signal data (from the built-in MS) for (re)training or (re)calibrating such classification FOMs.

In one embodiment of the present invention, one or more classification FOMs may each include a learning module such as an artificial neural network (ANN) for associating target MS location signal data with a target MS location estimate. Additionally, one or more classification FOMs may be statistical prediction models based on such statistical techniques as, for example, principle decomposition, partial least squares, or other regression techniques.

It is a further aspect of the present invention that the personal communication system (PCS) infrastructures currently being developed by telecommunication providers offer an appropriate localized infrastructure base upon which to build various personal location systems (PLS) employing the present invention and/or utilizing the techniques disclosed herein. In particular, the present invention is especially suitable for the location of people and/or objects using code division multiple access (CDMA) wireless infrastructures, although other wireless infrastructures, such as, time division multiple access (TDMA) infrastructures and GSM are also contemplated. Note that CDMA personal communications systems are described in the Telephone Industries Association standard IS-95, for frequencies below 1 GHz, and in the Wideband Spread-Spectrum Digital Cellular System Dual-Mode Mobile Station-Base Station Compatibility Standard, for frequencies in the 1.8-1.9 GHz frequency bands, both of which are incorporated herein by reference. Furthermore, CDMA general principles have also been described, for example, in U. S. Patent 5,109,390, to Gilhausen, et al, and CDMA Network Engineering Handbook by Qualcomm, Inc., each of which is also incorporated herein by reference.

Notwithstanding the above mentioned CDMA references, a brief introduction of CDMA is given here. Briefly, CDMA is an electromagnetic signal modulation and multiple access scheme based on spread spectrum communication. Each CDMA signal corresponds to an unambiguous pseudorandom binary sequence for modulating the carrier signal throughout a predetermined

spectrum of bandwidth frequencies. Transmissions of individual CDMA signals are selected by correlation processing of a pseudonoise waveform. In particular, the CDMA signals are separately detected in a receiver by using a correlator, which accepts only signal energy from the selected binary sequence and despreads its spectrum. Thus, when a first CDMA signal is transmitted, the transmissions of unrelated CDMA signals correspond to pseudorandom sequences that do not match the first signal. Therefore, these other signals contribute only to the noise and represent a self-interference generated by the personal communications system.

As mentioned in (1.7) and in the discussion of classification FOMs above, the present invention can substantially automatically retrain and/or recalibrate itself to compensate for variations in wireless signal characteristics (e.g., multipath) due to environmental and/or topographic changes to a geographic area serviced by the present invention. For example, in one embodiment, the present invention optionally includes low cost, low power base stations, denoted location base stations (LBS) above, providing, for example, CDMA pilot channels to a very limited area about each such LBS. The location base stations may provide limited voice traffic capabilities, but each is capable of gathering sufficient wireless signal characteristics from an MS within the location base station's range to facilitate locating the MS. Thus, by positioning the location base stations at known locations in a geographic region such as, for instance, on street lamp poles and road signs, additional MS location accuracy can be obtained. That is, due to the low power signal output by such location base stations, for there to be signaling control communication (e.g., pilot signaling and other control signals) between a location base station and a target MS, the MS must be relatively near the location base station. Additionally, for each location base station not in communication with the target MS, it is likely that the MS is not near to this location base station. Thus, by utilizing information received from both location base stations in communication with the target MS and those that are not in communication with the target MS, the present invention can substantially narrow the possible geographic areas within which the target MS is likely to be. Further, by providing each location base station (LBS) with a co-located stationary wireless transceiver (denoted a built-in MS above) having similar functionality to an MS, the following advantages are provided:

- (6.1) assuming that the co-located base station capabilities and the stationary transceiver of an LBS are such that the base station capabilities and the stationary transceiver communicate with one another, the stationary transceiver can be signaled by another component(s) of the present invention to activate or deactivate its associated base station capability, thereby conserving power for the LBS that operate on a restricted power such as solar electrical power;
- (6.2) the stationary transceiver of an LBS can be used for transferring target MS location information obtained by the LBS to a conventional telephony base station;
- (6.3) since the location of each LBS is known and can be used in location processing, the present invention is able to (re)train and/or (re)calibrate itself in geographical areas having such LBSs. That is, by activating each LBS stationary transceiver so that there is signal communication between the stationary transceiver and surrounding base stations within range, wireless signal characteristic values for the location of the stationary transceiver are obtained for each such base station. Accordingly, such characteristic values can then be associated with the known location of the stationary transceiver for training and/or calibrating various of the location processing modules of the present invention such as the classification FOMs discussed above. In particular, such training and/or calibrating may include:

- (i) (re)training and/or (re)calibrating FOMs;

(ii) adjusting the confidence value initially assigned to a location hypothesis according to how accurate the generating FOM is in estimating the location of the stationary transceiver using data obtained from wireless signal characteristics of signals between the stationary transceiver and base stations with which the stationary transceiver is capable of communicating;

(iii) automatically updating the previously mentioned historical data base (i.e., the location signature data base), wherein the stored signal characteristic data for each stationary transceiver can be used for detecting environmental and/or topographical changes (e.g., a newly built high rise or other structures capable of altering the multipath characteristics of a given geographical area); and

(iv) tuning of the location system parameters, wherein the steps of: (a) modifying various system parameters and (b) testing the performance of the modified location system on verified mobile station location data (including the stationary transceiver signal characteristic data), these steps being interleaved and repeatedly performed for obtaining better system location accuracy within useful time constraints.

It is also an aspect of the present invention to automatically (re)calibrate as in (6.3) above with signal characteristics from other known or verified locations. In one embodiment of the present invention, portable location verifying electronics are provided so that when such electronics are sufficiently near a located target MS, the electronics: (i) detect the proximity of the target MS; (ii) determine a highly reliable measurement of the location of the target MS; (iii) provide this measurement to other location determining components of the present invention so that the location measurement can be associated and archived with related signal characteristic data received from the target MS at the location where the location measurement is performed. Thus, the use of such portable location verifying electronics allows the present invention to capture and utilize signal characteristic data from verified, substantially random locations for location system calibration as in (6.3) above. Moreover, it is important to note that such location verifying electronics can verify locations automatically wherein it is unnecessary for manual activation of a location verifying process.

One embodiment of the present invention includes the location verifying electronics as a "mobile (location) base station" (MBS) that can be, for example, incorporated into a vehicle, such as an ambulance, police car, or taxi. Such a vehicle can travel to sites having a transmitting target MS, wherein such sites may be randomly located and the signal characteristic data from the transmitting target MS at such a location can consequently be archived with a verified location measurement performed at the site by the mobile location base station. Moreover, it is important to note that such a mobile location base station as its name implies also includes base station electronics for communicating with mobile stations, though not necessarily in the manner of a conventional infrastructure base station. In particular, a mobile location base station may only monitor signal characteristics, such as MS signal strength, from a target MS without transmitting signals to the target MS. Alternatively, a mobile location base station can periodically be in bi-directional communication with a target MS for determining a signal time-of-arrival (or time-difference-of-arrival) measurement between the mobile location base station and the target MS. Additionally, each such mobile location base station includes components for estimating the location of the mobile location base station, such mobile location base station location estimates being important when the mobile location base station is used for locating a target MS via, for example, time-of-arrival or time-difference-of-arrival measurements as one skilled in the art will appreciate. In particular, a mobile location base station can include:

(7.1) a mobile station (MS) for both communicating with other components of the present invention (such as a location processing center included in the present invention);

(7.2) a GPS receiver for determining a location of the mobile location base station;

(7.3) a gyroscope and other dead reckoning devices; and

5 (7.4) devices for operator manual entry of a mobile location base station location.

Furthermore, a mobile location base station includes modules for integrating or reconciling distinct mobile location base station location estimates that, for example, can be obtained using the components and devices of (7.1) through (7.4) above. That is, location estimates for the mobile location base station may be obtained from: GPS satellite data, mobile location base station data provided by the location processing center, dead reckoning data obtained from the mobile location base station vehicle dead reckoning devices, and location data manually input by an operator of the mobile location base station.

10  
The location estimating system of the present invention offers many advantages over existing location systems. The system of the present invention, for example, is readily adaptable to existing wireless communication systems and can accurately locate people and/or objects in a cost effective manner. In particular, the present invention requires few, if any, modifications to commercial wireless communication systems for implementation. Thus, existing personal communication system infrastructure base stations and other components of, for example, commercial CDMA infrastructures are readily adapted to the present invention. The present invention can be used to locate people and/or objects that are not in the line-of-sight of a wireless receiver or transmitter, can reduce the detrimental effects of multipath on the accuracy of the location estimate, can potentially locate people and/or objects located indoors as well as outdoors, and uses a number of wireless stationary transceivers for location. The present invention employs a number of distinctly different location computational models for location which provides a greater degree of accuracy, robustness and versatility than is possible with existing systems. For instance, the location models provided include not only the radius-radius/TOA and TDOA techniques but also adaptive artificial neural net techniques. Further, the present invention is able to adapt to the topography of an area in which location service is desired. The present invention is also able to adapt to environmental changes substantially as frequently as desired. Thus, the present invention is able to take into account changes in the location topography over time without extensive manual data manipulation. Moreover, the present invention can be utilized with varying amounts of signal measurement inputs. Thus, if a location estimate is desired in a very short time interval (e.g., less than approximately one to two seconds), then the present location estimating system can be used with only as much signal measurement data as is possible to acquire during an initial portion of this time interval. Subsequently, after a greater amount of signal measurement data has been acquired, additional more accurate location estimates may be obtained. Note that this capability can be useful in the context of 911 emergency response in that a first quick course wireless mobile station location estimate can be used to route a 911 call from the mobile station to a 911 emergency response center that has responsibility for the area containing the mobile station and the 911 caller. Subsequently, once the 911 call has been routed according to this first quick location estimate, by continuing to receive additional wireless signal measurements, more reliable and accurate location estimates of the mobile station can be obtained.

20  
25  
30  
Moreover, there are numerous additional advantages of the system of the present invention when applied in CDMA communication systems. The location system of the present invention readily benefits from the distinct advantages of the CDMA

spread spectrum scheme, namely, these advantages include the exploitation of radio frequency spectral efficiency and isolation by (a) monitoring voice activity, (b) management of two-way power control, (c) provisioning of advanced variable-rate modems and error correcting signal encoding, (d) inherent resistance to fading, (e) enhanced privacy, and (f) multiple "rake" digital data receivers and searcher receivers for correlation of signal multipaths.

5  
JWS  
C.H.

At a more general level, it is an aspect of the present invention to demonstrate the utilization of various novel computational paradigms such as:

(8.1) providing a multiple hypothesis computational architecture (as illustrated best in Fig. 8) wherein the hypotheses are:

(8.1.1) generated by modular independent hypothesizing computational models;

(8.1.2) the models are embedded in the computational architecture in a manner wherein the architecture allows for

10 substantial amounts of application specific processing common or generic to a plurality of the models to be straightforwardly incorporated into the computational architecture;

(8.1.3) the computational architecture enhances the hypotheses generated by the models both according to past performance of the models and according to application specific constraints and heuristics without requiring feedback loops for adjusting the models;

15 (8.1.4) the models are relatively easily integrated into, modified and extracted from the computational architecture;

(8.2) providing a computational paradigm for enhancing an initial estimated solution to a problem by using this initial estimated solution as, effectively, a query or index into an historical data base of previous solution estimates and corresponding actual solutions for deriving an enhanced solution estimate based on past performance of the module that generated the initial estimated solution.

20 Note that the multiple hypothesis architecture provided herein is useful in implementing solutions in a wide range of applications. For example, the following additional applications are within the scope of the present invention:

(9.1) document scanning applications for transforming physical documents in to electronic forms of the documents. Note that in many cases the scanning of certain documents (books, publications, etc.) may have a 20% character recognition error rate. Thus, the novel computation architecture of the present invention can be utilized by (i) providing a plurality of document scanning models  
25 as the first order models, (ii) building a character recognition data base for archiving a correspondence between characteristics of actual printed character variations and the intended characters (according to, for example, font types), and additionally archiving a correspondence of performance of each of the models on previously encountered actual printed character variations (note, this is analogous to the Signature Data Base of the MS location application described herein), and (iii) determining any generic constraints and/or heuristics that are desirable to be satisfied by a plurality of the models. Accordingly, by comparing outputs from the first  
30 order document scanning models, a determination can be made as to whether further processing is desirable due to, for example, discrepancies between the output of the models. If further processing is desirable, then an embodiment of the multiple hypothesis architecture provided herein may be utilized to correct such discrepancies. Note that in comparing outputs from the first order document scanning models, these outputs may be compared at various granularities; e.g., character, sentence, paragraph or page;

20

(9.2) diagnosis and monitoring applications such as medical diagnosis/monitoring, communication network diagnosis/monitoring;

(9.3) robotics applications such as scene and/or object recognition;

(9.4) seismic and/or geologic signal processing applications such as for locating oil and gas deposits;

5 (9.5) Additionally, note that this architecture need not have all modules co-located. In particular, it is an additional aspect of the present invention that various modules can be remotely located from one another and communicate with one another via telecommunication transmissions such as telephony technologies and/or the Internet. Accordingly, the present invention is particularly adaptable to such distributed computing environments. For example, some number of the first order models may reside in remote locations and communicate their generated hypotheses via the Internet.

10 For instance, in weather prediction applications it is not uncommon for computational models to require large amounts of computational resources. Thus, such models running at various remote computational facilities can transfer weather prediction hypotheses (e.g., the likely path of a hurricane) to a site that performs hypothesis adjustments according to: (i) past performance of the each model; (ii) particular constraints and/or heuristics, and subsequently outputs a most likely estimate for a particular weather condition.

15 In an alternative embodiment of the present invention, the processing following the generation of location hypotheses (each having an initial location estimate) by the first order models may be such that this processing can be provided on Internet user nodes and the first order models may reside at Internet server sites. In this configuration, an Internet user may request hypotheses from such remote first order models and perform the remaining processing at his/her node.

*Sup. 20*

In other embodiments of the present invention, a fast, albeit less accurate location estimate may be initially performed for very time critical location applications where approximate location information may be required. For example, less than 1 second response for a mobile station location embodiment of the present invention may be desired for 911 emergency response location requests. Subsequently, once a relatively coarse location estimate has been provided, a more accurate most likely location estimate can be performed by repeating the location estimation processing a second time with, e.g., additional with measurements of wireless signals transmitted between a mobile station to be located and a network of base stations with which the mobile station is communicating, thus providing a second, more accurate location estimate of the mobile station.

25 Additionally, note that it is within the scope of the present invention to provide one or more central location development sites that may be networked to, for example, geographically dispersed location centers providing location services according to the present invention, wherein the FOMs may be accessed, substituted, enhanced or removed dynamically via network connections (via, e.g., the Internet) with a central location development site. Thus, a small but rapidly growing municipality in substantially flat low density area might initially be provided with access to, for example, two or three FOMs for generating location hypotheses in the municipality's relatively uncluttered radio signaling environment. However, as the population density increases and the radio signaling environment becomes cluttered by, for example, thermal noise and multipath, additional or alternative FOMs may be transferred via the network to the location center for the municipality.

*21*

Note that in some embodiments of the present invention, since there a lack of sequencing between the FOMs and subsequent processing of location hypotheses, the FOMs can be incorporated into an expert system, if desired. For example, each FOM may be activated from an antecedent of an expert system rule. Thus, the antecedent for such a rule can evaluate to TRUE if the FOM outputs a location hypothesis, and the consequent portion of such a rule may put the output location hypothesis on a list of location hypotheses occurring in a particular time window for subsequent processing by the location center. Alternatively, activation of the FOMs may be in the consequents of such expert system rules. That is, the antecedent of such an expert system rule may determine if the conditions are appropriate for invoking the FOM(s) in the rule's consequent.

Of course, other software architectures may also be used in implementing the processing of the location center without departing from scope of the present invention. In particular, object-oriented architectures are also within the scope of the present invention. For example, the FOMs may be object methods on an MS location estimator object, wherein the estimator object receives substantially all target MS location signal data output by the signal filtering subsystem. Alternatively, software bus architectures are contemplated by the present invention, as one skilled in the art will understand, wherein the software architecture may be modular and facilitate parallel processing. Further features and advantages of the present invention are provided by the figures and detailed description accompanying this invention summary.

JMP  
CLZ

10

15  
JMP  
CLZ

22



## BRIEF DESCRIPTION OF THE DRAWINGS

Fig. 1 illustrates various perspectives of radio propagation opportunities which may be considered in addressing correlation with mobile to base station ranging.

Fig. 2 shows aspects of the two-ray radio propagation model and the effects of urban clutter.

5 (1) Fig. 3 provides a typical example of how the statistical power budget is calculated in design of a Commercial Mobile Radio Service Provider network.

Fig. 4 illustrates an overall view of a wireless radio location network architecture, based on AIN principles.

Fig. 5 is a high level block diagram of an embodiment of the present invention for locating a mobile station (MS) within a radio coverage area for the present invention.

10 Fig. 6 is a high level block diagram of the location center 142.

Fig. 7 is a high level block diagram of the hypothesis evaluator for the location center.

Fig. 8 is a substantially comprehensive high level block diagram illustrating data and control flows between the components of the location center, as well the functionality of the components.

15 (2) Fig. 9 is a high level data structure diagram describing the fields of a location hypothesis object generated by the first order models 1224 of the location center.

Fig. 10 is a graphical illustration of the computation performed by the most likelihood estimator 1344 of the hypothesis evaluator.

Fig. 11 is a high level block diagram of the mobile base station (MBS).

20 Fig. 12 is a high level state transition diagram describing computational states the Mobile Base station enters during operation.

Fig. 13 is a high level diagram illustrating the data structural organization of the Mobile Base station capability for autonomously determining a most likely MBS location from a plurality of potentially conflicting MBS location estimating sources.

Fig. 14 shows one method of modeling CDMA delay spread measurement ensembles and interfacing such signals to a typical artificial neural network based FOM.

25 Fig. 15 illustrates the nature of RF "Dead Zones", notch area, and the importance of including location data signatures from the back side of radiating elements.

Figs. 16a through 16c present a table providing a brief description of the attributes of the location signature data type stored in the location signature data base 1320.

30 Figs. 17a through 17c present a high level flowchart of the steps performed by function, "UPDATE\_LOC\_SIG\_DB," for updating location signatures in the location signature data base 1320; note, this flowchart corresponds to the description of this function in APPENDIX C.

Figs. 18a through 18b present a high level flowchart of the steps performed by function, "REDUCE\_BAD\_DB\_LOC\_SIGS," for updating location signatures in the location signature data base 1320; note, this flowchart corresponds to the description of this function in APPENDIX C.

5 Figs. 19a through 19b present a high level flowchart of the steps performed by function, "INCREASE\_CONFIDENCE\_OF\_GOOD\_DB\_LOC\_SIGS," for updating location signatures in the location signature data base 1320; note, this flowchart corresponds to the description of this function in APPENDIX C.

Figs. 20a through 20d present a high level flowchart of the steps performed by function, "DETERMINE\_LOCATION\_SIGNATURE\_FIT\_ERRORS," for updating location signatures in the location signature data base 1320; note, this flowchart corresponds to the description of this function in APPENDIX C.

10 Fig. 21 presents a high level flowchart of the steps performed by function, "ESTIMATE\_LOC\_SIG\_FROM\_DB," for updating location signatures in the location signature data base 1320; note, this flowchart corresponds to the description of this function in APPENDIX C.

15 Figs. 22a through 22b present a high level flowchart of the steps performed by function, "GET\_AREA\_TO\_SEARCH," for updating location signatures in the location signature data base 1320; note, this flowchart corresponds to the description of this function in APPENDIX C.

Figs. 23a through 23b present a high level flowchart of the steps performed by function, "GET\_DIFFERENCE\_MEASUREMENT," for updating location signatures in the location signature data base 1320; note, this flowchart corresponds to the description of this function in APPENDIX C.

20 Fig. 24 is a high level illustration of context adjuster data structures and their relationship to the radio coverage area for the present invention;

Figs. 25a through 25b present a high level flowchart of the steps performed by the function, "CONTEXT\_ADJUSTER," used in the context adjuster 1326 for adjusting mobile station estimates provided by the first order models 1224; this flowchart corresponds to the description of this function in APPENDIX D.

25 Figs. 26a through 26c present a high level flowchart of the steps performed by the function, "GET\_ADJUSTED\_LOC\_HYP\_LIST\_FOR," used in the context adjuster 1326 for adjusting mobile station estimates provided by the first order models 1224; this flowchart corresponds to the description of this function in APPENDIX D.

Figs. 27a through 27b present a high level flowchart of the steps performed by the function, "CONFIDENCE\_ADJUSTER," used in the context adjuster 1326 for adjusting mobile station estimates provided by the first order models 1224; this flowchart corresponds to the description of this function in APPENDIX D.

30 Fig. 28a and 28b presents a high level flowchart of the steps performed by the function, "GET\_COMPOSITE\_PREDICTION\_MAPPED\_CLUSTER\_DENSITY," used in the context adjuster 1326 for adjusting mobile station estimates provided by the first order models 1224; this flowchart corresponds to the description of this function in APPENDIX D.

Figs. 29a through 29h present a high level flowchart of the steps performed by the function, "GET\_PREDICTION\_MAPPED\_CLUSTER\_DENSITY\_FOR," used in the context adjuster 1326 for adjusting mobile station estimates provided by the first order models 1224; this flowchart corresponds to the description of this function in APPENDIX D.

Fig. 30 illustrates the primary components of the signal processing subsystem.

5 Fig. 31 illustrates how automatic provisioning of mobile station information from multiple CMRS occurs.

25 24

## DETAILED DESCRIPTION

### Detailed Description Introduction

Various digital wireless communication standards have been introduced such as Advanced Mobile Phone Service (AMPS), Narrowband Advanced Mobile Phone Service (NAMPS), code division multiple access (CDMA) and Time Division Multiple Access (TDMA) (e.g., Global Systems Mobile (GSM)). These standards provide numerous enhancements for advancing the quality and communication capacity for wireless applications. Referring to CDMA, this standard is described in the Telephone Industries Association standard IS-95, for frequencies below 1 GHz, and in J-STD-008, the Wideband Spread-Spectrum Digital Cellular System Dual-Mode Mobile Station-Base station Compatibility Standard, for frequencies in the 1.8 - 1.9 GHz frequency bands. Additionally, CDMA general principles have been described, for example, in U.S. Patent 5,109,390, Diversity Receiver in a CDMA Cellular Telephone System by Gilhausen. There are numerous advantages of such digital wireless technologies such as CDMA radio technology. For example, the CDMA spread spectrum scheme exploits radio frequency spectral efficiency and isolation by monitoring voice activity, managing two-way power control, provision of advanced variable-rate modems and error correcting signal design, and includes inherent resistance to fading, enhanced privacy, and provides for multiple "rake" digital data receivers and searcher receivers for correlation of multiple physical propagation paths, resembling maximum likelihood detection, as well as support for multiple base station communication with a mobile station, i.e., soft or softer hand-off capability. When coupled with a location center as described herein, substantial improvements in radio location can be achieved. For example, the CDMA spread spectrum scheme exploits radio frequency spectral efficiency and isolation by monitoring voice activity, managing two-way power control, provision of advanced variable-rate modems and error correcting signal design, and includes inherent resistance to fading, enhanced privacy, and provides for multiple "rake" digital data receivers and searcher receivers for correlation of multiple physical propagation paths, resembling maximum likelihood detection, as well as support for multiple base station communication with a mobile station, i.e., soft hand-off capability. Moreover, this same advanced radio communication infrastructure can also be used for enhanced radio location. As a further example, the capabilities of IS-41 and AIN already provide a broad-granularity of wireless location, as is necessary to, for example, properly direct a terminating call to an MS. Such information, originally intended for call processing usage, can be re-used in conjunction with the location center described herein to provide wireless location in the large (i.e., to determine which country, state and city a particular MS is located) and wireless location in the small (i.e., which location, plus or minus a few hundred feet within one or more base stations a given MS is located).

Fig. 4 is a high level diagram of a wireless digital radiolocation intelligent network architecture for the present invention. Accordingly, this figure illustrates the interconnections between the components, for example, of a typical PCS network configuration and various components that are specific to the present invention. In particular, as one skilled in the art will understand, a typical wireless (PCS) network includes:

- (a) a (large) plurality of conventional wireless mobile stations (MSs) 140 for at least one of voice related communication, visual (e.g., text) related communication, and according to present invention, location related communication;
- (b) a mobile switching center (MSC) 112;

- (c) a plurality of wireless cell sites in a radio coverage area 120, wherein each cell site includes an infrastructure base station such as those labeled 122 (or variations thereof such as 122A - 122D). In particular, the base stations 122 denote the standard high traffic, fixed location base stations used for voice and data communication with a plurality of MSs 140, and, according to the present invention, also used for communication of information related to locating such MSs 140. Additionally, note that the base stations labeled 152 are more directly related to wireless location enablement. For example, as described in greater detail hereinbelow, the base stations 152 may be low cost, low functionality transponders that are used primarily in communicating MS location related information to the location center 142 (via base stations 122 and the MSC 112). Note that unless stated otherwise, the base stations 152 will be referred to hereinafter as "location base station(s) 152" or simply "LBS(s) 152");
- (d) a public switched telephone network (PSTN) 124 (which may include signaling system links 106 having network control components such as: a service control point (SCP) 104, one or more signaling transfer points (STPs) 110.

Added to this wireless network, the present invention provides the following additional components:

- (10.1) a location center 142 which is required for determining a location of a target MS 140 using signal characteristic values for this target MS;
- (10.2) one or more mobile base stations 148 (MBS) which are optional, for physically traveling toward the target MS 140 or tracking the target MS;
- (10.3) a plurality of location base stations 152 (LBS) which are optional, distributed within the radio coverage areas 120, each LBS 152 having a relatively small MS 140 detection area 154;

Since location base stations can be located on potentially each floor of a multi-story building, the wireless location technology described herein can be used to perform location in terms of height as well as by latitude and longitude.

In operation, the MS 140 may utilize one of the wireless technologies, CDMA, TDMA, AMPS, NAMPS or GSM techniques for radio communication with: (a) one or more infrastructure base stations 122, (b) mobile base station(s) 148, (c) an LBS 152.

Referring to Fig. 4 again, additional detail is provided of typical base station coverage areas, sectorization, and high level components within a radio coverage area 120, including the MSC 112. Although base stations may be placed in any configuration, a typical deployment configuration is approximately in a cellular honeycomb pattern, although many practical tradeoffs exist, such as site availability, versus the requirement for maximal terrain coverage area. To illustrate, three such exemplary base stations (BSs) are 122A, 122B and 122C, each of which radiate referencing signals within their area of coverage 169 to facilitate mobile station (MS) 140 radio frequency connectivity, and various timing and synchronization functions. Note that some base stations may contain no sectors 130 (e.g. 122E), thus radiating and receiving signals in a 360 degree omnidirectional coverage area pattern, or the base station may contain "smart antennas" which have specialized coverage area patterns. However, the generally most frequent base stations 122 have three sector 130 coverage area patterns. For example, base station 122A includes sectors 130, additionally labeled a, b and c. Accordingly, each of the sectors 130 radiate and receive signals in an approximate 120 degree arc, from an overhead view. As one skilled in the art will understand, actual base station coverage areas 169 (stylistically represented by hexagons about the base

stations 122) generally are designed to overlap to some extent, thus ensuring seamless coverage in a geographical area. Control electronics within each base station 122 are used to communicate with a mobile stations 140. Information regarding the coverage area for each sector 130, such as its range, area, and "holes" or areas of no coverage (within the radio coverage area 120), may be known and used by the location center 142 to facilitate location determination. Further, during communication with a mobile station 5 140, the identification of each base station 122 communicating with the MS 140 as well, as any sector identification information, may be known and provided to the location center 142.

In the case of the base station types 122, 148, and 152 communication of location information, a base station or mobility controller 174 (BSC) controls, processes and provides an interface between originating and terminating telephone calls from/to mobile station (MS) 140, and the mobile switch center (MSC) 112. The MSC 122, on-the-other-hand, performs various administration 10 functions such as mobile station 140 registration, authentication and the relaying of various system parameters, as one skilled in the art will understand.

The base stations 122 may be coupled by various transport facilities 176 such as leased lines, frame relay, T-Carrier links, optical fiber links or by microwave communication links.

When a mobile station 140 (such as a CDMA, AMPS, NAMPS mobile telephone) is powered on and in the idle state, it constantly 15 monitors the pilot signal transmissions from each of the base stations 122 located at nearby cell sites. Since base station/sector coverage areas may often overlap, such overlapping enables mobile stations 140 to detect, and, in the case of certain wireless technologies, communicate simultaneously along both the forward and reverse paths, with multiple base stations 122 and/or sectors 130. In Fig. 4 the constantly radiating pilot signals from base station sectors 130, such as sectors a, b and c of BS 122A, are detectable by mobile stations 140 within the coverage area 169 for BS 122A. That is, the mobile stations 140 scan for pilot channels, 20 corresponding to a given base station/sector identifiers (IDs), for determining which coverage area 169 (i.e., cell) it is contained. This is performed by comparing signal strengths of pilot signals transmitted from these particular cell-sites.

The mobile station 140 then initiates a registration request with the MSC 112, via the base station controller 174. The MSC 112 determines whether or not the mobile station 140 is allowed to proceed with the registration process (except in the case of a 911 call, wherein no registration process is required). At this point calls may be originated from the mobile station 140 or calls or short 25 message service messages can be received from the network. The MSC 112 communicates as appropriate, with a class 4/5 wireline telephony circuit switch or other central offices, connected to the PSTN 124 network. Such central offices connect to wireline terminals, such as telephones, or any communication device compatible with the line. The PSTN 124 may also provide connections to long distance networks and other networks.

The MSC 112 may also utilize IS/41 data circuits or trunks connecting to signal transfer point 110, which in turn connects 30 to a service control point 104, via Signaling System #7 (SS7) signaling links (e.g., trunks) for intelligent call processing, as one skilled in the art will understand. In the case of wireless AIN services such links are used for call routing instructions of calls interacting with the MSC 112 or any switch capable of providing service switching point functions, and the public switched telephone network (PSTN) 124, with possible termination back to the wireless network.

Referring to Fig. 4 again, the location center (LC) 142 interfaces with the MSC 112 either via dedicated transport facilities 178, using for example, any number of LAN/WAN technologies, such as Ethernet, fast Ethernet, frame relay, virtual private networks, etc., or via the PSTN 124. The LC 142 receives autonomous (e.g., unsolicited) command/response messages regarding, for example: (a) the state of the wireless network of each service provider, (b) MS 140 and BS 122 radio frequency (RF) measurements, (c) any  
5 MBSs 148, (d) location applications requesting MS locations using the location center. Conversely, the LC 142 provides data and control information to each of the above components in (a) - (d). Additionally, the LC 142 may provide location information to an MS 140, via a BS 122. Moreover, in the case of the use of a mobile base station (MBS) 148, several communications paths may exist with the LC 142.

*J.P. 18*

The MBS 148 acts as a low cost, partially-functional, moving base station, and is, in one embodiment, situated in a vehicle where an operator may engage in MS 140 searching and tracking activities. In providing these activities using CDMA, the MBS 148 provides a forward link pilot channel for a target MS 140, and subsequently receives unique BS pilot strength measurements from the MS 140. The MBS 148 also includes a mobile station for data communication with the LC 142, via a BS 122. In particular, such data communication includes telemetering the geographic position of the MBS 148 as well as various RF measurements related to signals  
15 and/or a moveable narrow beam antenna, such as a microwave dish 182. The antennas for such embodiments may have a known orientation in order to further deduce a radio location of the target MS 140 with respect to an estimated current location of the MBS 148. As will be described in more detail herein below, the MBS 148 may further contain a global positioning system (GPS), distance sensors, dead-reckoning electronics, as well as an on-board computing system and display devices for locating both the MBS 148 of itself as well as tracking and locating the target MS 140. The computing and display provides a means for communicating the  
20 position of the target MS 140 on a map display to an operator of the MBS 148.

Each location base station (LBS) 152 is a low cost location device. Each such LBS 152 communicates with one or more of the infrastructure base stations 122 using one or more wireless technology interface standards. In some embodiments, to provide such LBS's cost effectively, each LBS 152 only partially or minimally supports the air-interface standards of the one or more wireless technologies used in communicating with both the BSs 122 and the MSs 140. Each LBS 152, when put in service, is placed at a fixed  
25 location, such as at a traffic signal, lamp post, etc., and wherein the location of the LBS may be determined as accurately as, for example, the accuracy of the locations of the infrastructure BSs 122. Assuming the wireless technology CDMA is used, each BS 122 uses a time offset of the pilot PN sequence to identify a forward CDMA pilot channel. In one embodiment, each LBS 152 emits a unique, time-offset pilot PN sequence channel in accordance with the CDMA standard in the RF spectrum designated for BSs 122, such that the channel does not interfere with neighboring BSs 122 cell site channels, nor would it interfere with neighboring LBSs 152.  
30 However, as one skilled in the art will understand, time offsets, in CDMA chip sizes, may be re-used within a PCS system, thus providing efficient use of pilot time offset chips, thereby achieving spectrum efficiency. Each LBS 152 may also contain multiple wireless receivers in order to monitor transmissions from a target MS 140. Additionally, each LBS 152 contains mobile station 140 electronics, thereby allowing the LBS to both be controlled by the LC 142, and to transmit information to the LC 142, via at least one neighboring BS 122.

*29*

As mentioned above, when the location of a particular target MS 140 is desired, the LC 142 can request location information about the target MS 140 from, for instance, one or more activated LBSs 152 in a geographical area of interest. Accordingly, whenever the target MS 140 is in such an area, or is suspected of being in the area, either upon command from the LC 142, or in a substantially continuous fashion, the LBS's pilot channel appears to the target MS 140 as a potential neighboring base station channel, and consequently, is placed, for example, in the CDMA neighboring set, or the CDMA remaining set, of the target MS 140 (as one familiar with the CDMA standards will understand).

During the normal CDMA pilot search sequence of the mobile station initialization state (in the target MS), the target MS 140 will, if within range of such an activated LBS 152, detect the LBS pilot presence during the CDMA pilot channel acquisition substate. Consequently, the target MS 140 performs RF measurements on the signal from each detected LBS 152. Similarly, an activated LBS 152 can perform RF measurements on the wireless signals from the target MS 140. Accordingly, each LBS 152 detecting the target MS 140 may subsequently telemeter back to the LC 142 measurement results related to signals from/to the target MS 140. Moreover, upon command, the target MS 140 will telemeter back to the LC 142 its own measurements of the detected LBSs 152, and consequently, this new location information, in conjunction with location related information received from the BSs 122, can be used to locate the target MS 140.

It should be noted that an LBS 152 will normally deny hand-off requests, since typically the LBS does not require the added complexity of handling voice or traffic bearer channels, although economics and peak traffic load conditions would dictate preference here. GPS timing information, needed by any CDMA base station, is either achieved via a the inclusion of a local GPS receiver or via a telemetry process from a neighboring conventional BS 122, which contains a GPS receiver and timing information. Since energy requirements are minimal in such an LBS 152, (rechargeable) batteries or solar cells may be used to power the LBS. No expensive terrestrial transport link is typically required since two-way communication is provided by the included MS 140 (or an electronic variation thereof). Thus, LBSs 152 may be placed in numerous locations, such as:

- (a) in dense urban canyon areas (e.g., where signal reception may be poor and/or very noisy);
- (b) in remote areas (e.g., hiking, camping and skiing areas);
- (c) along highways (e.g., for emergency as well as monitoring traffic flow), and their rest stations; or
- (d) in general, wherever more location precision is required than is obtainable using other wireless infrastructure network components.

#### Location Center - Network Elements API Description

A location application programming interface 136 (Fig. 4), or L-API, is required between the location center 142 (LC) and the mobile switch center (MSC) network element type, in order to send and receive various control, signals and data messages. The L-API should be implemented using a preferably high-capacity physical layer communications interface, such as IEEE standard 802.3 (10 baseT Ethernet), although other physical layer interfaces could be used, such as fiber optic ATM, frame relay, etc. Two forms of API implementation are possible. In the first case the signals control and data messages are realized using the MSC 112 vendor's

Imp  
C19

Imp  
C20

30



native operations messages inherent in the product offering, without any special modifications. In the second case the L-API includes a full suite of commands and messaging content specifically optimized for wireless location purposes, which may require some, although minor development on the part of the MSC vendor.

5 Signal Processor Description

*Inv. C21*

Referring to Fig. 30, the signal processing subsystem receives control messages and signal measurements and transmits appropriate control messages to the wireless network via the location applications programming interface referenced earlier, for wireless location purposes. The signal processing subsystem additionally provides various signal identification, conditioning and pre-processing functions, including buffering, signal type classification, signal filtering, message control and routing functions to the location estimate modules.

*Inv. C22*

10

There can be several combinations of Delay Spread/Signal Strength sets of measurements made available to the signal processing subsystem 20. In some cases the mobile station 140 (Fig. 1) may be able to detect up to three or four Pilot Channels representing three to four Base Stations, or as few as one Pilot Channel, depending upon the environment. Similarly, possibly more than one BS 122 can detect a mobile station 140 transmitter signal, as evidenced by the provision of cell diversity or soft hand-off in the CDMA standards, and the fact that multiple CMRS' base station equipment commonly will overlap coverage areas. For each mobile station 140 or BS 122 transmitted signal detected by a receiver group at a station, multiple delayed signals, or "fingers" may be detected and tracked resulting from multipath radio propagation conditions, from a given transmitter.

15

In typical spread spectrum diversity CDMA receiver design, the "first" finger represents the most direct, or least delayed multipath signal. Second or possibly third or fourth fingers may also be detected and tracked, assuming the mobile station contains a sufficient number of data receivers. Although traditional TOA and TDOA methods would discard subsequent fingers related to the same transmitted finger, collection and use of these additional values can prove useful to reduce location ambiguity, and are thus collected by the Signal Processing subsystem in the Location Center 142.

20

*Inv. C23*

From the mobile receiver's perspective, a number of combinations of measurements could be made available to the Location Center. Due to the disperse and near-random nature of CDMA radio signals and propagation characteristics, traditional TOA/TDOA location methods have failed in the past, because the number of signals received in different locations area different. In a particularly small urban area, say less than 500 square feet, the number of RF signals and there multipath components may vary by over 100 percent.

25

Due to the large capital outlay costs associated with providing three or more overlapping base station coverage signals in every possible location, most practical digital PCS deployments result in fewer than three base station pilot channels being reportable in the majority of location areas, thus resulting in a larger, more amorphous location estimate. This consequence requires a family of location estimate location modules, each firing whenever suitable data has been presented to a model, thus providing a location estimate to a backend subsystem which resolves ambiguities.

30

In one embodiment of this invention using backend hypothesis resolution, by utilizing existing knowledge concerning base station coverage area boundaries (such as via the compilation a RF coverage database - either via RF coverage area simulations or

field tests), the location error space is decreased. Negative logic Venn diagrams can be generated which deductively rule out certain location estimate hypotheses.

Although the forward link mobile station's received relative signal strength ( $RRSS_{BS}$ ) of detected nearby base station transmitter signals can be used directly by the location estimate modules, the CDMA base station's reverse link received relative signal strength ( $RRSS_{MS}$ ) of the detected mobile station transmitter signal must be modified prior to location estimate model use, since the mobile station transmitter power level changes nearly continuously, and would thus render relative signal strength useless for location purposes.

One adjustment variable and one factor value are required by the signal processing subsystem in the CDMA air interface case: 1.) instantaneous relative power level in dBm (IRPL) of the mobile station transmitter, and 2.) the mobile station Power Class. By adding the IRPL to the  $RRSS_{MS}$ , a synthetic relative signal strength ( $SRSS_{MS}$ ) of the mobile station I40 signal detected at the BS I22 is derived, which can be used by location estimate model analysis, as shown below:

$$SRSS_{MS} = RRSS_{MS} + IRPL \quad (\text{in dBm})$$

$SRSS_{MS}$ , a corrected indication of the effective path loss in the reverse direction (mobile station to BS), is now comparable with  $RRSS_{BS}$  and can be used to provide a correlation with either distance or shadow fading because it now accounts for the change of the mobile station transmitter's power level. The two signals  $RRSS_{BS}$  and  $SRSS_{MS}$  can now be processed in a variety of ways to achieve a more robust correlation with distance or shadow fading.

Sup.  
C24

Although Rayleigh fading appears as a generally random noise generator, essentially destroying the correlation value of either  $RRSS_{BS}$  or  $SRSS_{MS}$  measurements with distance individually, several mathematical operations or signal processing functions can be performed on each measurement to derive a more robust relative signal strength value, overcoming the adverse Rayleigh fading effects. Examples include averaging, taking the strongest value and weighting the strongest value with a greater coefficient than the weaker value, then averaging the results. This signal processing technique takes advantage of the fact that although a Rayleigh fade may often exist in either the forward or reverse path, it is much less probable that a Rayleigh fade also exists in the reverse or forward path, respectively. A shadow fade however, similarly affects the signal strength in both paths.

Sup.  
C25

At this point a CDMA radio signal direction-independent "net relative signal strength measurement" is derived which is used to establish a correlation with either distance or shadow fading, or both. Although the ambiguity of either shadow fading or distance cannot be determined, other means can be used in conjunction, such as the fingers of the CDMA delay spread measurement, and any other TOA/TDOA calculations from other geographical points. In the case of a mobile station with a certain amount of shadow fading between its BS I22 (Fig. 2), the first finger of a CDMA delay spread signal is most likely to be a relatively shorter duration than the case where the mobile station I40 and BS I22 are separated by a greater distance, since shadow fading does not materially affect the arrival time delay of the radio signal.

Sup.  
C26

By performing a small modification in the control electronics of the CDMA base station and mobile station receiver circuitry, it is possible to provide the signal processing subsystem 20 (reference Fig. 30) within the Location center I42 (Fig. 1) with

data that exceed the one-to-one CDMA delay-spread fingers to data receiver correspondence. Such additional information, in the form of additional CDMA fingers (additional multipath) and all associated detectable pilot channels, provides new information which is used to enhance to accuracy of the Location Center's location estimate location estimate modules.

JAB 7 5

This enhanced capability is provided via a control message, sent from the Location center 142 to the mobile switch center 112, and then to the base station(s) in communication with, or in close proximity with, mobile stations 140 to be located. Two types of location measurement request control messages are needed: one to instruct a target mobile station 140 (i.e., the mobile station to be located) to telemeter its BS pilot channel measurements back to the primary BS 122 and from there to the mobile switch center 112 and then to the location system 42. The second control message is sent from the location system 42 to the mobile switch center 112, then to first the primary BS, instructing the primary BS' searcher receiver to output (i.e., return to the initiating request message source) the detected target mobile station 140 transmitter CDMA pilot channel offset signal and their corresponding delay spread finger (peak) values and related relative signal strengths.

10

The control messages are implemented in standard mobile station 140 and BS 122 CDMA receivers such that all data results from the search receiver and multiplexed results from the associated data receivers are available for transmission back to the Location Center 142. Appropriate value ranges are required regarding mobile station 140 parameters T\_ADD, T\_DROP, and the ranges and values for the Active, Neighboring and Remaining Pilot sets registers, held within the mobile station 140 memory. Further mobile station 140 receiver details have been discussed above.

15

In the normal case without any specific multiplexing means to provide location measurements, exactly how many CDMA pilot channels and delay spread fingers can or should be measured vary according to the number of data receivers contained in each mobile station 140. As a guide, it is preferred that whenever RF characteristics permit, at least three pilot channels and the strongest first three fingers, are collected and processed. From the BS 122 perspective, it is preferred that the strongest first four CDMA delay spread fingers and the mobile station power level be collected and sent to the location system 42, for each of preferably three BSs 122 which can detect the mobile station 140. A much larger combination of measurements is potentially feasible using the extended data collection capability of the CDMA receivers.

20

JAB 25

Fig. 30 illustrates the components of the Signal Processing Subsystem. The main components consist of the input queue(s) 7, signal classifier/filter 9, digital signaling processor 17, imaging filters 19, output queue(s) 21, router/distributor 23, a signal processor database 26 and a signal processing controller 15.

25

Input queues 7 are required in order to stage the rapid acceptance of a significant amount of RF signal measurement data, used for either location estimate purposes or to accept autonomous location data. Each location request using fixed base stations may, in one embodiment, contain from 1 to 128 radio frequency measurements from the mobile station, which translates to approximately 61.44 kilobytes of signal measurement data to be collected within 10 seconds and 128 measurements from each of possibly four base stations, or 245.76 kilobytes for all base stations, for a total of approximately 640 signal measurements from the five sources, or 307.2 kilobytes to arrive per mobile station location request in 10 seconds. An input queue storage space is assigned at the moment a location request begins, in order to establish a formatted data structure in persistent store. Depending upon the

30

53

urgency of the time required to render a location estimate, fewer or more signal measurement samples can be taken and stored in the input queue(s) 7 accordingly.

The signal processing subsystem supports a variety of wireless network signaling measurement capabilities by detecting the capabilities of the mobile and base station through messaging structures provided by the location application programming interface. Detection is accomplished in the signal classifier 9 (Fig. 30) by referencing a mobile station database table within the signal processor database 26, which provides, given a mobile station identification number, mobile station revision code, other mobile station characteristics. Similarly, a mobile switch center table 31 provides MSC characteristics and identifications to the signal classifier/filter 9. The signal classifier/filter adds additional message header information that further classifies the measurement data which allows the digital signal processor and image filter components to select the proper internal processing subcomponents to perform operations on the signal measurement data, for use by the location estimate modules.

Imp' 29

10

Regarding service control point messages autonomously received from the input queue 7, the signal classifier/filter 9 determines via a signal processing database 26 query that the message is to be associated with a home base station module. Thus appropriate header information is added to the message, thus enabling the message to pass through the digital signal processor 17 unaffected to the output queue 21, and then to the router/distributor 23. The router/distributor 23 then routes the message to the HBS first order model. Those skilled in the art will understand that associating location requests from Home Base Station configurations require substantially less data: the mobile identification number and the associated wireline telephone number transmission from the home location register are on the order of less than 32 bytes. Consequentially the home base station message type could be routed without any digital signal processing.

Imp' 30

15

Output queue(s) 21 are required for similar reasons as input queues 7: relatively large amounts of data must be held in a specific format for further location processing by the location estimate modules.

Imp' 31

20

The router and distributor component 23 is responsible to directing specific signal measurement data types and structures to their appropriate modules. For example, the HBS FOM has no use for digital filtering structures, whereas the TDOA module would not be able to process an HBS response message.

Imp' 32

25

The controller 15 is responsible for staging the movement of data among the signal processing subsystem 20 components input queue 7, digital signal processor 17, router/distributor 23 and the output queue 21, and to initiate signal measurements within the wireless network, in response from an internet 168 location request message in Fig. 1, via the location application programming interface.

Imp' 34

Imp' 33

30

In addition the controller 15 receives autonomous messages from the MSC, via the location applications programming interface (Fig. 1) or L-API and the input queue 7 whenever a 9-1-1 wireless call is originated. The mobile switch center provides this autonomous notification to the location system as follows: By specifying the appropriate mobile switch center operations and maintenance commands to surveil calls based on certain digits dialed such as 9-1-1, the location applications programming interface, in communications with the MSCs, receives an autonomous notification whenever a mobile station user dials 9-1-1. Specifically, a bi-directional authorized communications port is configured, usually at the operations and maintenance subsystem of the MSCs, or with their associated network element manager system(s), with a data circuit, such as a DS-1, with the location applications programming

interface in Fig. 1. Next, the "call trace" capability of the mobile switch center is activated for the respective communications port. The exact implementation of the vendor-specific man-machine or Open Systems Interface (OSI) commands(s) and their associated data structures generally vary among MSC vendors, however the trace function is generally available in various forms, and is required in order to comply with Federal Bureau of Investigation authorities for wire tap purposes. After the appropriate surveillance commands are established on the MSC, such 9-1-1 call notifications messages containing the mobile station identification number (MIN) and, in phase E9-1-1 implementations, a pseudo-automatic number identification (a.k.a. pANI) which provides an association with the primary base station in which the 9-1-1 caller is in communication. In cases where the pANI is known from the onset, the signal processing subsystem avoids querying the MSC in question to determine the primary base station identification associated with the 9-1-1 mobile station caller.

JMP  
135

10 After the signal processing controller 15 receives the first message type, the autonomous notification message from the mobile switch center 112 to the location system 42, containing the mobile identification number and optionally the primary base station identification, the controller 15 queries the base station table 13 in the signal processor database 26 to determine the status and availability of any neighboring base stations, including those base stations of other CMRS in the area. The definition of neighboring base stations include not only those within a provisionable "hop" based on the cell design reuse factor, but also includes, in the case of CDMA, results from remaining set information autonomously queried to mobile stations, with results stored in the base station table. Remaining set information indicates that mobile stations can detect other base station (sector) pilot channels which may exceed the "hop" distance, yet are nevertheless candidate base stations (or sectors) for wireless location purposes. Although cellular and digital cell design may vary, "hop" distance is usually one or two cell coverage areas away from the primary base station's cell coverage area.

JMP  
136

20 Having determined a likely set of base stations which may both detect the mobile station's transmitter signal, as well as to determine the set of likely pilot channels (i.e., base stations and their associated physical antenna sectors) detectable by the mobile station in the area surrounding the primary base station (sector), the controller 15 initiates messages to both the mobile station and appropriate base stations (sectors) to perform signal measurements and to return the results of such measurements to the signal processing system regarding the mobile station to be located. This step may be accomplished via several interface means. In a first case the controller 15 utilizes, for a given MSC, predetermined storage information in the MSC table 31 to determine which type of commands, such as man-machine or OSI commands are needed to request such signal measurements for a given MSC. The controller generates the mobile and base station signal measurement commands appropriate for the MSC and passes the commands via the input queue 7 and the locations application programming interface in Fig.1, to the appropriate MSC, using the authorized communications port mentioned earlier. In a second case the controller 15 communicates directly with base stations within having to interface directly with the MSC for signal measurement extraction.

JMP  
137

30 Upon receipt of the signal measurements, the signal classifier 9 in Fig. 30 examines location application programming interface-provided message header information from the source of the location measurement (for example, from a fixed BS 122, a

mobile station 140, a distributed antenna system 168 in Fig. 1 or message location data related to a home base station), provided by the location applications programming interface (L-API) via the input queue 7 in Fig. 30 and determines whether or not device filters 17 or image filters 19 are needed, and assesses a relative priority in processing, such as an emergency versus a background location task, in terms of grouping like data associated with a given location request. In the case where multiple signal measurement requests are outstanding for various base stations, some of which may be associated with a different CMRS network, and additional signal classifier function includes sorting and associating the appropriate incoming signal measurements together such that the digital signal processor 17 processes related measurements in order to build ensemble data sets. Such ensembles allow for a variety of functions such as averaging, outlier removal over a timeperiod, and related filtering functions, and further prevent association errors from occurring in location estimate processing.

Another function of the signal classifier/low pass filter component 9 is to filter information that is not useable, or information that could introduce noise or the effect of noise in the location estimate modules. Consequently low pass matching filters are used to match the in-common signal processing components to the characteristics of the incoming signals. Low pass filters match: Mobile Station, base station, CMRS and MSC characteristics, as well as to classify Home Base Station messages.

The signal processing subsystem contains a base station database table 13 (Fig. 30) which captures the maximum number of CDMA delay spread fingers for a given base station.

The base station identification code, or CLLI or common language level identification code is useful in identifying or relating a human-labeled name descriptor to the Base Station. Latitude, Longitude and elevation values are used by other subsystems in the location system for calibration and estimation purposes. As base stations and/or receiver characteristics are added, deleted, or changed with respect to the network used for location purposes, this database table must be modified to reflect the current network configuration.

Just as an upgraded base station may detect additional CDMA delay spread signals, newer or modified mobile stations may detect additional pilot channels or CDMA delay spread fingers. Additionally different makes and models of mobile stations may acquire improved receiver sensitivities, suggesting a greater coverage capability. The table below establishes the relationships among various mobile station equipment suppliers and certain technical data relevant to this location invention.

Although not strictly necessary, The MIN can be populated in this table from the PCS Service Provider's Customer Care system during subscriber activation and fulfillment, and could be changed at deactivation, or anytime the end-user changes mobile stations. Alternatively, since the MIN, manufacturer, model number, and software revision level information is available during a telephone call, this information could be extracted during the call, and the remaining fields populated dynamically, based on manufacturer's specifications information previously stored in the signal processing subsystem 20. Default values are used in cases where the MIN is not found, or where certain information must be estimated.

A low pass mobile station filter, contained within the signal classifier/low pass filter 9 of the signal processing subsystem 20, uses the above table data to perform the following functions: 1) act as a low pass filter to adjust the nominal assumptions related to the maximum number of CDMA fingers, pilots detectable; and 2) to determine the transmit power class and the receiver thermal noise floor. Given the detected reverse path signal strength, the required value of  $SRSS_{MS}$ , a corrected indication of the effective path

Sup 138  
Sup 139

Sup 140

Sup 141

Sup 142

loss in the reverse direction (mobile station to BS), can be calculated based data contained within the mobile station table 11, stored in the signal processing database 26.

The effects of the maximum Number of CDMA fingers allowed and the maximum number of pilot channels allowed essentially form a low pass filter effect, wherein the least common denominator of characteristics are used to filter the incoming RF signal measurements such that a one for one matching occurs. The effect of the transmit power class and receiver thermal noise floor values is to normalize the characteristics of the incoming RF signals with respect to those RF signals used.

The signal classifier/filter 20 is in communication with both the input queue 7 and the signal processing database 26. In the early stage of a location request the signal processing subsystem 142 in Fig. 4, will receive the initiating location request from either an autonomous 9-1-1 notification message from a given MSC, or from a location application (for example, see Fig. 36), for which mobile station characteristics about the target mobile station 140 (Fig. 1) is required. Referring to Fig. 30, a query is made from the signal processing controller 15 to the signal processing database 26, specifically the mobile station table 11, to determine if the mobile station characteristics associated with the MIN to be located is available in table 11. if the data exists then there is no need for the controller 15 to query the wireless network in order to determine the mobile station characteristics, thus avoiding additional real-time processing which would otherwise be required across the air interface, in order to determine the mobile station MIN characteristics. The resulting mobile station information may be provided either via the signal processing database 26 or alternatively a query may be performed directly from the signal processing subsystem 20 to the MSC in order to determine the mobile station characteristics.

Referring now to Fig. 31, a location application programming interface, L-API-CCS 139 to the appropriate CMRS customer care system provides the mechanism to populate and update the mobile station table 11 within the database 26. The L-API-CCS 139 contains its own set of separate input and output queues or similar implementations and security controls to ensure that provisioning data is not sent to the incorrect CMRS, and that a given CMRS cannot access any other CMRS' data. The interface 1155a to the customer care system for CMRS-A 1150a provides an autonomous or periodic notification and response application layer protocol type, consisting of add, delete, change and verify message functions in order to update the mobile station table 11 within the signal processing database 26, via the controller 15. A similar interface 1155b is used to enable provisioning updates to be received from CMRS-B customer care system 1150b.

Although the L-API-CCS application message set may be any protocol type which supports the autonomous notification message with positive acknowledgment type, the TIMI.5 group within the American National Standards Institute has defined a good starting point in which the L-API-CCS could be implemented, using the robust OSI TMN X-interface at the service management layer. The object model defined in Standards proposal number TIMI.5/96-22R9, Operations Administration, Maintenance, and Provisioning (OAM&P) - Model for Interface Across Jurisdictional Boundaries to Support Electronic Access Service Ordering: Inquiry Function, can be extended to support the L-API-CCS information elements as required and further discussed below. Other choices in which the L-API-CCS application message set may be implemented include ASCII, binary, or any encrypted message set encoding using the Internet protocols, such as TCP/IP, simple network management protocol, http, https, and email protocols.

37

Referring to the digital signal processor (DSP) 17, in communication with the signal classifier/LP filter 9, the DSP 17 provides a time series expansion method to convert non-HBS data from a format of an signal measure data ensemble of time-series based radio frequency data measurements, collected as discrete time-slice samples, to a three dimensional matrix location data value image representation. Other techniques further filter the resultant image in order to furnish a less noisy training and actual data sample to the location estimate modules.

After 128 samples (in one embodiment) of data are collected of the delay spread-relative signal strength RF data measurement sample: mobile station RX for BS-1 and grouped into a quantization matrix, where rows constitute relative signal strength intervals and columns define delay intervals. As each measurement row, column pair (which could be represented as a complex number or Cartesian point pair) is added to their respective values to generate a Z direction of frequency of recurring measurement value pairs or a density recurrence function. By next applying a grid function to each x, y, and z value, a three-dimensional surface grid is generated, which represents a location data value or unique print of that 128-sample measurement.

In the general case where a mobile station is located in an environment with varied clutter patterns, such as terrain undulations, unique man-made structure geometries (thus creating varied multipath signal behaviors), such as a city or suburb, although the first CDMA delay spread finger may be the same value for a fixed distance between the mobile station and BS antennas, as the mobile station moves across such an arc, different finger-data are measured. In the right image for the defined BS antenna sector, location classes, or squares numbered one through seven, are shown across a particular range of line of position (LOP).

A traditional TOA/TDOA ranging method between a given BS and mobile station only provides a range along the arc, thus introducing ambiguity error. However a unique three dimensional image can be used in this method to specifically identify, with recurring probability, a particular unique location class along the same Line Of Position, as long as the multipath is unique by position but generally repeatable, thus establishing a method of not only ranging, but also of complete latitude, longitude location estimation in a Cartesian space. In other words, the unique shape of the "mountain image" enables a correspondence to a given unique location class along a line of position, thereby eliminating traditional ambiguity error.

Although man-made external sources of interference, Rayleigh fades, adjacent and co-channel interference, and variable clutter, such as moving traffic introduce unpredictability (thus no "mountain image" would ever be exactly alike), three basic types of filtering methods can be used to reduce matching/comparison error from a training case to a location request case: 1.) select only the strongest signals from the forward path (BS to mobile station) and reverse path (mobile station to BS), 2.) Convolute the forward path 128 sample image with the reverse path 128 sample image, and 3.) process all image samples through various digital image filters to discard noise components.

In one embodiment, convolution of forward and reverse images is performed to drive out noise. This is one embodiment that essentially nulls noise completely, even if strong and recurring, as long as that same noise characteristic does not occur in the opposite path.

The third embodiment or technique of processing CDMA delay spread profile images through various digital image filters, provides a resultant "image enhancement" in the sense of providing a more stable pattern recognition paradigm to the neural net

Sup.  
C47

Sup.  
C48

50



location estimate model. For example, image histogram equalization can be used to rearrange the images' intensity values, or density recurrence values, so that the image's cumulative histogram is approximately linear.

Other methods which can be used to compensate for a concentrated histogram include: 1) Input Cropping, 2) Output Cropping and 3) Gamma Correction. Equalization and input cropping can provide particularly striking benefits to a CDMA delay spread profile image. Input cropping removes a large percentage of random signal characteristics that are non-recurring.

Other filters and/or filter combinations can be used to help distinguish between stationary and variable clutter affecting multipath signals. For example, it is desirable to reject multipath fingers associated with variable clutter, since over a period of a few minutes such fingers would not likely recur. Further filtering can be used to remove recurring (at least during the sample period), and possibly strong but narrow "pencils" of RF energy. A narrow pencil image component could be represented by a near perfect reflective surface, such as a nearby metal panel truck stopped at a traffic light.

On the other hand, stationary clutter objects, such as concrete and glass building surfaces, adsorb some radiation before continuing with a reflected ray at some delay. Such stationary clutter-affected CDMA fingers are more likely to pass a 4X4 neighbor Median filter as well as a 40 to 50 percent Input Crop filter, and are thus more suited to neural net pattern recognition.. However when subjected to a 4X4 neighbor Median filter and 40 percent clipping, pencil-shaped fingers are deleted. Other combinations include, for example, a 50 percent cropping and 4X4 neighbor median filtering. Other filtering methods include custom linear filtering, adaptive (Weiner) filtering, and custom nonlinear filtering.

*Imp'g  
C49*

The DSP 17 may provide data ensemble results, such as extracting the shortest time delay with a detectable relative signal strength, to the router/distributor 23, or alternatively results may be processed via one or more image filters 19, with subsequent transmission to the router/distributor 23. The router/distributor 23 examines the processed message data from the DSP 17 and stores routing and distribution information in the message header. The router/distributor 23 then forwards the data messages to the output queue 21, for subsequent queuing then transmission to the appropriate location estimator FOMs.

#### LOCATION CENTER HIGH LEVEL FUNCTIONALITY

*Imp'g  
C50*

At a very high level the location center 142 computes location estimates for a wireless Mobile Station 140 (denoted the "target MS" or "MS") by performing the following steps:

- (23.1) receiving signal transmission characteristics of communications communicated between the target MS 140 and one or more wireless infrastructure base stations 122;
- (23.2) filtering the received signal transmission characteristics (by a signal processing subsystem 1220 illustrated in Fig. 5) as needed so that target MS location data can be generated that is uniform and consistent with location data generated from other target MSs 140. In particular, such uniformity and consistency is both in terms of data structures and interpretation of signal characteristic values provided by the MS location data;

*39*

(23.3) inputting the generated target MS location data to one or more MS location-estimating models (denoted First order models or FOMs, and labeled collectively as 1224 in Fig. 5), so that each such model may use the input target MS location data for generating a "location hypothesis" providing an estimate of the location of the target MS 140;

(23.4) providing the generated location hypotheses to an hypothesis evaluation module (denoted the hypothesis evaluator 1228 in Fig. 5):

(a) for adjusting at least one of the target MS location estimates of the generated location hypotheses and related confidence values indicating the confidence given to each location estimate, wherein such adjusting uses archival information related to the accuracy of previously generated location hypotheses,

(b) for evaluating the location hypotheses according to various heuristics related to, for example, the radio coverage area 120 terrain, the laws of physics, characteristics of likely movement of the target MS 140; and

(c) for determining a most likely location area for the target MS 140, wherein the measurement of confidence associated with each input MS location area estimate is used for determining a "most likely location area"; and

(23.5) outputting a most likely target MS location estimate to one or more applications 1232 (Fig. 2.0) requesting an estimate of the location of the target MS 140.

15 Location Hypothesis Data Representation

In order to describe how the steps (23.1) through (23.5) are performed in the sections below, some introductory remarks related to the data denoted above as location hypotheses will be helpful. Additionally, it will also be helpful to provide introductory remarks related to historical location data and the data base management programs associated therewith.

For each target MS location estimate generated and utilized by the present invention, the location estimate is provided in a data structure (or object class) denoted as a "location hypothesis" (illustrated in Table LH-1). Although brief descriptions of the data fields for a location hypothesis is provided in the Table LH-1, many fields require additional explanation. Accordingly, location hypothesis data fields are further described as noted below.

Table LH-1

TO400

FOM_ID	First order model ID (providing this Location Hypothesis); note, since it is possible for location hypotheses to be generated by other than the FOMs 1224, in general, this field identifies the module that generated this location hypothesis.
MS_ID	The identification of the target MS 140 to this location hypothesis applies.
pt_est	The most likely location point estimate of the target MS 140.
valid_pt	Boolean indicating the validity of "pt_est".

area_est	Location Area Estimate of the target MS 140 provided by the FOM. This area estimate will be used whenever "image_area" below is NULL.
valid_area	Boolean indicating the validity of "area_est" (one of "pt_est" and "area_est" must be valid).
adjust	Boolean (true if adjustments to the fields of this location hypothesis are to be performed in the Context adjuster Module).
pt_covering	Reference to a substantially minimal area (e.g., mesh cell) covering of "pt_est". Note, since this MS 140 may be substantially on a cell boundary, this covering may, in some cases, include more than one cell.
image_area	Reference to a substantially minimal area (e.g., mesh cell) covering of "pt_covering" (see detailed description of the function, "confidence_adjuster"). Note that if this field is not NULL, then this is the target MS location estimate used by the location center 142 instead of "area_est".
extrapolation_area	Reference to (if non-NULL) an extrapolated MS target estimate area provided by the location extrapolator submodule 1432 of the hypothesis analyzer 1332. That is, this field, if non-NULL, is an extrapolation of the "image_area" field if it exists, otherwise this field is an extrapolation of the "area_est" field. Note other extrapolation fields may also be provided depending on the embodiment of the present invention, such as an extrapolation of the "pt_covering".
confidence	A real value in the range [-1.0, +1.0] indicating a likelihood that the target MS 140 is in (or out) of a particular area. If positive: if "image_area" exists, then this is a measure of the likelihood that the target MS 140 is within the area represented by "image_area", or if "image_area" has not been computed (e.g., "adjust" is FALSE), then "area_est" must be valid and this is a measure of the likelihood that the target MS 140 is within the area represented by "area_est". If negative, then "area_est" must be valid and this is a measure of the likelihood that the target MS 140 is NOT in the area represented by "area_est". If it is zero (near zero), then the likelihood is unknown.
Original_Timestamp	Date and time that the location signature cluster (defined hereinbelow) for this location hypothesis was received by the signal processing subsystem 1220.
Active_Timestamp	Run-time field providing the time to which this location hypothesis has had its MS location

41

	estimate(s) extrapolated (in the location extrapolator 1432 of the hypothesis analyzer 1332). Note that this field is initialized with the value from the "Original_Timestamp" field.
Processing Tags and environmental categorizations	For indicating particular types of environmental classifications not readily determined by the "Original_Timestamp" field (e.g., weather, traffic), and restrictions on location hypothesis processing.
loc_sig_cluster	Provides access to the collection of location signature signal characteristics derived from communications between the target MS 140 and the base station(s) detected by this MS (discussed in detail hereinbelow); in particular, the location data accessed here is provided to the first order models by the signal processing subsystem 1220; i.e., access to the "loc sigs" (received at "timestamp" regarding the location of the target MS)
descriptor	Original descriptor (from the First order model indicating why/how the Location Area Estimate and Confidence Value were determined).

As can be seen in the Table LH-1, each location hypothesis data structure includes at least one measurement, denoted hereinafter as a confidence value (or simply confidence), that is a measurement of the perceived likelihood that an MS location estimate in the location hypothesis is an accurate location estimate of the target MS 140. Since such confidence values are an important aspect of the present invention, much of the description and use of such confidence values are described below; however, a brief description is provided here. Each such confidence value is in the range -1.0 to 1.0, wherein the larger the value, the greater the perceived likelihood that the target MS 140 is in (or at) a corresponding MS location estimate of the location hypothesis to which the confidence value applies. As an aside, note that a location hypothesis may have more than one MS location estimate (as will be discussed in detail below) and the confidence value will typically only correspond or apply to one of the MS location estimates in the location hypothesis. Further, values for the confidence value field may be interpreted as: (a) -1.0 may be interpreted to mean that the target MS 140 is NOT in such a corresponding MS area estimate of the location hypothesis area, (b) 0 may be interpreted to mean that it is unknown as to the likelihood of whether the MS 140 in the corresponding MS area estimate, and (c) +1.0 may be interpreted to mean that the MS 140 is perceived to positively be in the corresponding MS area estimate.

Additionally, note that it is within the scope of the present invention that the location hypothesis data structure may also include other related "perception" measurements related to a likelihood of the target MS 140 being in a particular MS location area estimate. For example, it is within the scope of the present invention to also utilize measurements such as, (a) "sufficiency factors" for indicating the likelihood that an MS location estimate of a location hypothesis is sufficient for locating the target MS 140; (b) "necessity factors" for indicating the necessity that the target MS be in an particular area estimate. However, to more easily describe the present invention, a single confidence field is used having the interpretation given above.

*AJ* 41

Additionally, in utilizing location hypotheses in, for example, the location evaluator 1228 as in (23.4) above, it is important to keep in mind that each location hypothesis confidence value is a relative measurement. That is, for confidences,  $cf_1$  and  $cf_2$ , if  $cf_1 \leq cf_2$ , then for a location hypotheses  $H_1$  and  $H_2$  having  $cf_1$  and  $cf_2$ , respectively, the target MS 140 is expected to more likely reside in a target MS estimate of  $H_2$  than a target MS estimate of  $H_1$ . Moreover, if an area, A, is such that it is included in a plurality of location hypothesis target MS estimates, then a confidence score,  $CS_A$ , can be assigned to A, wherein the confidence score for such an area is a function of the confidences (both positive and negative) for all the location hypotheses whose (most pertinent) target MS location estimates contain A. That is, in order to determine a most likely target MS location area estimate for outputting from the location center 142, a confidence score is determined for areas within the location center service area. More particularly, if a function, "f", is a function of the confidence(s) of location hypotheses, and f is a monotonic function in its parameters and  $f(cf_1, cf_2, cf_3, \dots, cf_N) = CS_A$  for confidences  $cf_i$  of location hypotheses  $H_i$ ,  $i = 1, 2, \dots, N$ , with  $CS_A$  contained in the area estimate for  $H_i$ , then "f" is denoted a confidence score function. Accordingly, there are many embodiments for a confidence score function f that may be utilized in computing confidence scores with the present invention; e.g.,

(a)  $f(cf_1, cf_2, \dots, cf_N) = S cf_i = CS_A$ ;

(b)  $f(cf_1, cf_2, \dots, cf_N) = S cf_i^n = CS_A$ ,  $n = 1, 3, 5, \dots$ ;

(c)  $f(cf_1, cf_2, \dots, cf_N) = S (K_i * cf_i) = CS_A$ , wherein  $K_i$ ,  $i = 1, 2, \dots$  are positive system (tunable) constants (possibly dependent on environmental characteristics such as topography, time, date, traffic, weather, and/or the type of base station(s) 122 from which location signatures with the target MS 140 are being generated, etc.).

For the present description of the invention, the function f as defined in (c) immediately above is utilized. However, for obtaining a general understanding of the present invention, the simpler confidence score function of (a) may be more useful. It is important to note, though, that it is within the scope of the present invention to use other functions for the confidence score function.

#### Coverage Area: Area Types And Their Determination

The notion of "area type" as related to wireless signal transmission characteristics has been used in many investigations of radio signal transmission characteristics. Some investigators, when investigating such signal characteristics of areas have used somewhat naive area classifications such as urban, suburban, rural, etc. However, it is desirable for the purposes of the present invention to have a more operational definition of area types that is more closely associated with wireless signal transmission behaviors.

To describe embodiments of the an area type scheme used in the present invention, some introductory remarks are first provided. Note that the wireless signal transmission behavior for an area depends on at least the following criteria:

(23.8.1) substantially invariant terrain characteristics (both natural and man-made) of the area; e.g., mountains, buildings, lakes, highways, bridges, building density;

(23.8.2) time varying environmental characteristics (both natural and man-made) of the area; e.g., foliage, traffic, weather, special events such as baseball games;

42

(23.8.3) wireless communication components or infrastructure in the area; e.g., the arrangement and signal communication characteristics of the base stations 122 in the area. Further, the antenna characteristics at the base stations 122 may be important criteria.

Accordingly, a description of wireless signal characteristics for determining area types could potentially include a characterization of wireless signaling attributes as they relate to each of the above criteria. Thus, an area type might be: hilly, treed, suburban, having no buildings above 50 feet, with base stations spaced apart by two miles. However, a categorization of area types is desired that is both more closely tied to the wireless signaling characteristics of the area, and is capable of being computed substantially automatically and repeatedly over time. Moreover, for a wireless location system, the primary wireless signaling characteristics for categorizing areas into at least minimally similar area types are: thermal noise and, more importantly, multipath characteristics (e.g., multipath fade and time delay).

Focusing for the moment on the multipath characteristics, it is believed that (23.8.1) and (23.8.3) immediately above are, in general, more important criteria for accurately locating an MS 140 than (23.8.2). That is, regarding (23.8.1), multipath tends to increase as the density of nearby vertical area changes increases. For example, multipath is particularly problematic where there is a high density of high rise buildings and/or where there are closely spaced geographic undulations. In both cases, the amount of change in vertical area per unit of area in a horizontal plane (for some horizontal reference plane) may be high. Regarding (23.8.3), the greater the density of base stations 122, the less problematic multipath may become in locating an MS 140. Moreover, the arrangement of the base stations 122 in the radio coverage area 120 in Fig. 4 may affect the amount and severity of multipath.

Accordingly, it would be desirable to have a method and system for straightforwardly determining area type classifications related to multipath, and in particular, multipath due to (23.8.1) and (23.8.3). The present invention provides such a determination by utilizing a novel notion of area type, hereinafter denoted "transmission area type" (or, "(transmission) area type" when both a generic area type classification scheme and the transmission area type discussed hereinafter are intended) for classifying "similar" areas, wherein each transmission area type class or category is intended to describe an area having at least minimally similar wireless signal transmission characteristics. That is, the novel transmission area type scheme of the present invention is based on: (a) the terrain area classifications; e.g., the terrain of an area surrounding a target MS 140, (b) the configuration of base stations 122 in the radio coverage area 120, and (c) characterizations of the wireless signal transmission paths between a target MS 140 location and the base stations 122.

JND  
C.52

In one embodiment of a method and system for determining such (transmission) area type approximations, a partition (denoted hereinafter as  $P_0$ ) is imposed upon the radio coverage area 120 for partitioning for radio coverage area into subareas, wherein each subarea is an estimate of an area having included MS 140 locations that are likely to have is at least a minimal amount of similarity in their wireless signaling characteristics. To obtain the partition  $P_0$  of the radio coverage area 120, the following steps are performed:

(23.8.4.1) Partition the radio coverage area 120 into subareas, wherein in each subarea is: (a) connected, (b) variations in the lengths of chords sectioning the subarea through the centroid of the subarea are below a predetermined threshold, (c) the subarea has an area below a predetermined value, and (d) for most locations (e.g., within a first

AA

or second deviation) within the subarea whose wireless signaling characteristics have been verified, it is likely (e.g., within a first or second deviation ) that an MS 140 at one of these locations will detect (forward transmission path) and/or will be detected (reverse transmission path) by a same collection of base stations 122. For example, in a CDMA context, a first such collection may be (for the forward transmission path) the active set of base stations 122, or, the union of the active and candidate sets, or, the union of the active, candidate and/or remaining sets of base stations 122 detected by "most" MSs 140 in . Additionally (or alternatively), a second such collection may be the base stations 122 that are expected to detect MSs 140 at locations within the subarea. Of course, the union or intersection of the first and second collections is also within the scope of the present invention for partitioning the radio coverage area 120 according to (d) above. It is worth noting that it is believed that base station 122 power levels will be substantially constant. However, even if this is not the case, one or more collections for (d) above may be determined empirically and/or by computationally simulating the power output of each base station 122 at a predetermined level. Moreover, it is also worth mentioning that this step is relatively straightforward to implement using the data stored in the location signature data base 1320 (i.e., the verified location signature clusters discussed in detail hereinbelow). Denote the resulting partition here as  $P_1$ .

(23.8.4.2) Partition the radio coverage area 120 into subareas, wherein each subarea appears to have substantially homogeneous terrain characteristics. Note, this may be performed periodically substantially automatically by scanning radio coverage area images obtained from aerial or satellite imaging. For example, EarthWatch Inc. of Longmont, CO can provide geographic with 3 meter resolution from satellite imaging data. Denote the resulting partition here as  $P_2$ .

(23.8.4.3) Overlay both of the above partitions of the radio coverage area 120 to obtain new subareas that are intersections of the subareas from each of the above partitions. This new partition is  $P_0$  (i.e.,  $P_0 = P_1 \text{ intersect } P_2$ ), and the subareas of it are denoted as " $P_0$  subareas".

Now assuming  $P_0$  has been obtained, the subareas of  $P_0$  are provided with a first classification or categorization as follows:

(23.8.4.4) Determine an area type categorization scheme for the subareas of  $P_1$ . For example, a subarea, A, of  $P_1$ , may be categorized or labeled according to the number of base stations 122 in each of the collections used in (23.8.4.1)(d) above for determining subareas of  $P_1$ . Thus, in one such categorization scheme, each category may correspond to a single number x (such as 3), wherein for a subarea, A, of this category, there is a group of x (e.g., three) base stations 122 that are expected to be detected by a most target MSs 140 in the area A. Other embodiments are also possible, such as a categorization scheme wherein each category may correspond to a triple: of numbers such as (5, 2, 1), wherein for a subarea A of this category, there is a common group of 5 base stations 122 with two-way signal detection expected with most locations (e.g., within a first or second deviation) within A, there are 2 base stations that are expected to be detected by a target MS 140 in A but these base stations can not detect the target MS, and there is one base station 122 that is expected to be able to detect a target MS in A but not be detected.

(23.8.4.5) Determine an area type categorization scheme for the subareas of  $P_2$ . Note that the subareas of  $P_2$  may be categorized according to their similarities. In one embodiment, such categories may be somewhat similar to the naive area types mentioned above (e.g., dense urban, urban, suburban, rural, mountain, etc.). However, it is also an aspect of the present invention that more precise categorizations may be used, such as a category for all areas having between 20,000 and 30,000 square feet of vertical area change per 11,000 square feet of horizontal area and also having a high traffic volume (such a category likely corresponding to a “moderately dense urban” area type).

(23.8.4.6) Categorize subareas of  $P_0$  with a categorization scheme denoted the “ $P_0$  categorization,” wherein for each  $P_0$  subarea, A, of  $P_0$  a “ $P_0$  area type” is determined for A according to the following substep(s):

(a) Categorize A by the two categories from (23.8.4.4) and (23.8.5) with which it is identified. Thus, A is categorized (in a corresponding  $P_0$  area type) both according to its terrain and the base station infrastructure configuration in the radio coverage area 120.

(23.8.4.7) For each  $P_0$  subarea, A, of  $P_0$  perform the following step(s):

(a) Determine a centroid,  $C(A)$ , for A;

(b) Determine an approximation to a wireless transmission path between  $C(A)$  and each base station 122 of a predetermined group of base stations expected to be in (one and/or two-way) signal communication with most target MS 140 locations in A. For example, one such approximation is a straight line between  $C(A)$  and each of the base stations 122 in the group. However, other such approximations are within the scope of the present invention, such as, a generally triangular shaped area as the transmission path, wherein a first vertex of this area is at the corresponding base station for the transmission path, and the sides of the generally triangular shaped defining the first vertex have a smallest angle between them that allows A to be completely between these sides.

(c) For each base station 122,  $BS_i$ , in the group mentioned in (b) above, create an empty list,  $BS_i$ -list, and put on this list at least the  $P_0$  area types for the “significant”  $P_0$  subareas crossed by the transmission path between  $C(A)$  and  $BS_i$ . Note that “significant”  $P_0$  subareas may be defined as, for example, the  $P_0$  subareas through which at least a minimal length of the transmission path traverses. Alternatively, such “significant”  $P_0$  subareas may be defined as those  $P_0$  subareas that additionally are know or expected to generate substantial multipath.

(d) Assign as the transmission area type for A as the collection of  $BS_i$ -lists. Thus, any other  $P_0$  subarea having the same (or substantially similar) collection of lists of  $P_0$  area types will be viewed as having approximately the same radio transmission characteristics.

Note that other transmission signal characteristics may be incorporated into the transmission area types. For example, thermal noise characteristics may be included by providing a third radio coverage area 120 partition,  $P_3$ , in addition to the partitions of  $P_1$  and  $P_2$  generated in (23.8.4.1) and (23.8.4.2) respectively. Moreover, the time varying characteristics of (23.8.2) may be



incorporated in the transmission area type frame work by generating multiple versions of the transmission area types such that the transmission area type for a given subarea of  $P_0$  may change depending on the combination of time varying environmental characteristics to be considered in the transmission area types. For instance, to account for seasonality, four versions of the partitions  $P_1$  and  $P_2$  may be generated, one for each of the seasons, and subsequently generate a (potentially) different partition  $P_0$  for each season. Further, the type and/or characteristics of base station I22 antennas may also be included in an embodiment of the transmission area type.

Accordingly, in one embodiment of the present invention, whenever the term "area type" is used hereinbelow, transmission area types as described hereinabove are intended.

#### Location Information Data Bases And Data

##### 10 Location Data Bases Introduction

It is an aspect of the present invention that MS location processing performed by the location center I42 should become increasingly better at locating a target MS I40 both by (a) building an increasingly more detailed model of the signal characteristics of locations in the service area for the present invention, and also (b) by providing capabilities for the location center processing to adapt to environmental changes.

15 One way these aspects of the present invention are realized is by providing one or more data base management systems and data bases for:

(a) storing and associating wireless MS signal characteristics with known locations of MSs I40 used in providing the signal characteristics. Such stored associations may not only provide an increasingly better model of the signal characteristics of the geography of the service area, but also provide an increasingly better model of more changeable signal characteristic affecting environmental factors such as weather, seasons, and/or traffic patterns;

20 (b) adaptively updating the signal characteristic data stored so that it reflects changes in the environment of the service area such as, for example, a new high rise building or a new highway.

Referring again to Fig. 5 of the collective representation of these data bases is the location information data bases I232. Included among these data bases is a data base for providing training and/or calibration data to one or more trainable/calibratable FOMs I224, as well as an archival data base for archiving historical MS location information related to the performance of the FOMs. These data bases will be discussed as necessary hereinbelow. However, a further brief introduction to the archival data base is provided here. Accordingly, the term, "location signature data base" is used hereinafter to denote the archival data base and/or data base management system depending on the context of the discussion. The location signature data base (shown in, for example, Fig. 6 and labeled I320) is a repository for wireless signal characteristic data derived from wireless signal communications between an MS I40 and one or more base stations I22, wherein the corresponding location of the MS I40 is known and also stored in the location signature data base I320. More particularly, the location signature data base I320 associates each such known MS location with the wireless signal characteristic data derived from wireless signal communications between the MS I40 and one or more base stations I22 at this MS location. Accordingly, it is an aspect of the present invention

to utilize such historical MS signal location data for enhancing the correctness and/or confidence of certain location hypotheses as will be described in detail in other sections below.

#### Data Representations for the Location Signature Data Base

There are four fundamental entity types (or object classes in an object oriented programming paradigm) utilized in the location signature data base 1320. Briefly, these data entities are described in the items (24.1) through (24.4) that follow:

(24.1) (verified) location signatures: Each such (verified) location signature describes the wireless signal characteristic measurements between a given base station (e.g., BS 122 or LBS 152) and an MS 140 at a (verified or known) location associated with the (verified) location signature. That is, a verified location signature corresponds to a location whose coordinates such as latitude-longitude coordinates are known, while simply a location signature may have a known or unknown location corresponding with it. Note that the term (verified) location signature is also denoted by the abbreviation, "(verified) loc sig" hereinbelow;

(24.2) (verified) location signature clusters: Each such (verified) location signature cluster includes a collection of (verified) location signatures corresponding to all the location signatures between a target MS 140 at a (possibly verified) presumed substantially stationary location and each BS (e.g., 122 or 152) from which the target MS 140 can detect the BS's pilot channel regardless of the classification of the BS in the target MS (i.e., for CDMA, regardless of whether a BS is in the MS's active, candidate or remaining base station sets, as one skilled in the art will understand). Note that for simplicity here, it is presumed that each location signature cluster has a single fixed primary base station to which the target MS 140 synchronizes or obtains its timing;

(24.3) "composite location objects (or entities)": Each such entity is a more general entity than the verified location signature cluster. An object of this type is a collection of (verified) location signatures that are associated with the same MS 140 at substantially the same location at the same time and each such loc sig is associated with a different base station. However, there is no requirement that a loc sig from each BS 122 for which the MS 140 can detect the BS's pilot channel is included in the "composite location object (or entity)"; and

(24.4) MS location estimation data that includes MS location estimates output by one or more MS location estimating first order models 1224, such MS location estimate data is described in detail hereinbelow.

It is important to note that a loc sig is, in one embodiment, an instance of the data structure containing the signal characteristic measurements output by the signal filtering and normalizing subsystem also denoted as the signal processing subsystem 1220 describing the signals between: (i) a specific base station 122 (BS) and (ii) a mobile station 140 (MS), wherein the BS's location is known and the MS's location is assumed to be substantially constant (during a 2-5 second interval in one embodiment of the present invention), during communication with the MS 140 for obtaining a single instance of loc sig data, although the MS location may or may not be known. Further, for notational purposes, the BS 122 and the MS 140 for a loc sig hereinafter will be denoted the "BS associated with the loc sig", and the "MS associated with the loc sig" respectively. Moreover, the location of the MS 140 at the time the loc sig data is obtained will be denoted the "location associated with the loc sig" (this location possibly being unknown).

In particular, for each (verified) loc sig includes the following:

(25.1) MS\_type: the make and model of the target MS 140 associated with a location signature instantiation; note that the type of MS 140 can also be derived from this entry; e.g., whether MS 140 is a handset MS, car-set MS, or an MS for location only. Note as an aside, for at least CDMA, the type of MS 140 provides information as to the number of fingers that may be measured by the MS., as one skilled in the will appreciate.

Supp. 5.3

Supp. 25.1

40

47

(25.2) BS\_id: an identification of the base station 122 (or, location base station 152) communicating with the target MS;

(25.3) MS\_loc: a representation of a geographic location (e.g., latitude-longitude) or area representing a verified/known MS location where signal characteristics between the associated (location) base station and MS 140 were received. That is, if the "verified\_flag" attribute (discussed below) is TRUE, then this attribute includes an estimated location of the target MS. If verified\_flag is FALSE, then this attribute has a value indicating "location unknown".

Note "MS\_loc" may include the following two subfields: an area within which the target MS is presumed to be, and a point location (e.g., a latitude and longitude pair) where the target MS is presumed to be (in one embodiment this is the centroid of the area);

(25.4) verified\_flag: a flag for determining whether the loc sig has been verified; i.e., the value here is TRUE iff a location of MS\_loc has been verified, FALSE otherwise. Note, if this field is TRUE (i.e., the loc sig is verified), then the base station identified by BS\_id is the current primary base station for the target MS;

(25.5) confidence: a value indicating how consistent this loc sig is with other loc sigs in the location signature data base 1320; the value for this entry is in the range [0, 1] with 0 corresponding to the lowest (i.e., no) confidence and 1 corresponding to the highest confidence. That is, the confidence factor is used for determining how consistent the loc sig is with other "similar" verified loc sigs in the location signature data base 1320, wherein the greater the confidence value, the better the consistency with other loc sigs in the data base. Note that similarity in this context may be operationalized by at least designating a geographic proximity of a loc sig in which to determine if it is similar to other loc sigs in this designated geographic proximity and/or area type (e.g., transmission area type as elsewhere herein). Thus, environmental characteristics may also be used in determining similarities such as: similar time of occurrence (e.g., of day, and/or of month), similar weather (e.g., snowing, raining, etc.). Note, these latter characteristics are different from the notion of geographic proximity since proximity may be only a distance measurement about a location. Note also that a loc sig having a confidence factor value below a predetermined threshold may not be used in evaluating MS location hypotheses generated by the FOMs 1224.

(25.6) timestamp: the time and date the loc sig was received by the associated base station of BS\_id;

(25.7) signal topography characteristics: In one embodiment, the signal topography characteristics retained can be represented as characteristics of at least a two-dimensional generated surface. That is, such a surface is generated by the signal processing subsystem 1220 from signal characteristics accumulated over (a relatively short) time interval. For example, in the two-dimensional surface case, the dimensions for the generated surface may be, for example, signal strength and time delay. That is, the accumulations over a brief time interval of signal characteristic measurements between the BS 122 and the MS 140 (associated with the loc sig) may be classified according to the two signal characteristic dimensions (e.g., signal strength and corresponding time delay). That is, by sampling the signal characteristics and classifying the samples according to a mesh of discrete cells or bins, wherein each cell corresponds to a different range of signal strengths and time delays a tally of the number of samples falling in the range of each cell can be maintained. Accordingly, for each cell, its corresponding tally may be interpreted as height of the cell, so that when the heights of all cells are considered, an undulating or mountainous surface is provided. In particular, for a cell mesh of appropriate fineness, the "mountainous surface", is believed to, under most circumstances, provide a contour that is substantially

JW  
CS 25

unique to the location of the target MS 140. Note that in one embodiment, the signal samples are typically obtained throughout a predetermined signal sampling time interval of 2-5 seconds as is discussed elsewhere in this specification. In particular, the signal topography characteristics retained for a loc sig include certain topographical characteristics of such a generated mountainous surface. For example, each loc sig may include: for each local maximum (of the loc sig surface) above a predetermined noise ceiling threshold, the (signal strength, time delay) coordinates of the cell of the local maximum and the corresponding height of the local maximum. Additionally, certain gradients may also be included for characterizing the "steepness" of the surface mountains. Moreover, note that in some embodiments, a frequency may also be associated with each local maximum. Thus, the data retained for each selected local maximum can include a quadruple of signal strength, time delay, height and frequency. Further note that the data types here may vary. However, for simplicity, in parts of the description of loc sig processing related to the signal characteristics here, it is assumed that the signal characteristic topography data structure here is a vector;

(25.8) quality\_obj: signal quality (or error) measurements, e.g., Eb/No values, as one skilled in the art will understand;

(25.9) noise\_ceiling: noise ceiling values used in the initial filtering of noise from the signal topography characteristics as provided by the signal processing subsystem 1220;

(25.10) power\_level: power levels of the base station (e.g., 122 or 152) and MS 140 for the signal measurements;

(25.11) timing\_error: an estimated (or maximum) timing error between the present (associated) BS (e.g., an infrastructure base station 122 or a location base station 152) detecting the target MS 140 and the current primary BS 122 for the target MS 140. Note that if the BS 122 associated with the loc sig is the primary base station, then the value here will be zero;

(25.12) cluster\_ptr: a pointer to the location signature composite entity to which this loc sig belongs.

(25.13) repeatable: TRUE iff the loc sig is "repeatable" (as described hereinafter), FALSE otherwise. Note that each verified loc sig is designated as either "repeatable" or "random". A loc sig is repeatable if the (verified/known) location associated with the loc sig is such that signal characteristic measurements between the associated BS 122 and this MS can be either replaced at periodic time intervals, or updated substantially on demand by most recent signal characteristic measurements between the associated base station and the associated MS 140 (or a comparable MS) at the verified/known location. Repeatable loc sigs may be, for example, provided by stationary or fixed location MSs 140 (e.g., fixed location transceivers) distributed within certain areas of a geographical region serviced by the location center 142 for providing MS location estimates. That is, it is an aspect of the present invention that each such stationary MS 140 can be contacted by the location center 142 (via the base stations of the wireless infrastructure) at substantially any time for providing a new collection (i.e., cluster) of wireless signal characteristics to be associated with the verified location for the transceiver. Alternatively, repeatable loc sigs may be obtained by, for example, obtaining location signal measurements manually from workers who regularly traverse a predetermined route through some portion of the radio coverage area; i.e., postal workers (as will be described in more detail hereinbelow).

A loc sig is random if the loc sig is not repeatable. Random loc sigs are obtained, for example, from verifying a previously unknown target MS location once the MS 140 has been located. Such verifications may be accomplished by, for example, a vehicle having one or more location verifying devices such as a GPS receiver and/or a manual location input capability becoming sufficiently close to the located target MS 140 so that the location of the vehicle may be associated with the wireless signal characteristics of the MS 140.

Jan 05/16

30

Vehicles having such location detection devices may include: (a) vehicles that travel to locations that are primarily for another purpose than to verify loc sigs, e.g., police cars, ambulances, fire trucks, rescue units, courier services and taxis; and/or (b) vehicles whose primary purpose is to verify loc sigs; e.g., location signal calibration vehicles. Additionally, vehicles having both wireless transceivers and location verifying devices may provide the location center 142 with random loc sigs. Note, a repeatable loc sig may become a random loc sig if an MS 140 at the location associated with the loc sig becomes undetectable such as, for example, when the MS 140 is removed from its verified location and therefore the loc sig for the location can not be readily updated.

Additionally, note that at least in one embodiment of the signal topography characteristics (25.7) above, such a first surface may be generated for the (forward) signals from the base station 122 to the target MS 140 and a second such surface may be generated for (or alternatively, the first surface may be enhanced by increasing its dimensionality with) the signals from the MS 140 to the base station 122 (denoted the reverse signals).

Additionally, in some embodiments the location hypothesis may include an estimated error as a measurement of perceived accuracy in addition to or as a substitute for the confidence field discussed hereinabove. Moreover, location hypotheses may also include a text field for providing a reason for the values of one or more of the location hypothesis fields. For example, this text field may provide a reason as to why the confidence value is low, or provide an indication that the wireless signal measurements used had a low signal to noise ratio.

Loc sigs have the following functions or object methods associated therewith:

(26.1) A "normalization" method for normalizing loc sig data according to the associated MS 140 and/or BS 122 signal processing and generating characteristics. That is, the signal processing subsystem 1220, one embodiment being described in the PCT patent application titled, "Wireless Location Using A Plurality of Commercial Network Infrastructures," by F. W. LeBlanc and the present inventor(s), provides (methods for loc sig objects) for "normalizing" each loc sig so that variations in signal characteristics resulting from variations in (for example) MS signal processing and generating characteristics of different types of MS's may be reduced. In particular, since wireless network designers are typically designing networks for effective use of hand set MS's 140 having a substantially common minimum set of performance characteristics, the normalization methods provided here transform the loc sig data so that it appears as though the loc sig was provided by a common hand set MS 140. However, other methods may also be provided to "normalize" a loc sig so that it may be compared with loc sigs obtained from other types of MS's as well. Note that such normalization techniques include, for example, interpolating and extrapolating according to power levels so that loc sigs may be normalized to the same power level for, e.g., comparison purposes.

Normalization for the BS 122 associated with a loc sig is similar to the normalization for MS signal processing and generating characteristics. Just as with the MS normalization, the signal processing subsystem 1220 provides a loc sig method for "normalizing" loc sigs according to base station signal processing and generating characteristics.

Note, however, loc sigs stored in the location signature data base 1320 are NOT "normalized" according to either MS or BS signal processing and generating characteristics. That is, "raw" values of the wireless signal characteristics are stored with each loc sig in the location signature data base 1320.

Inv. 1057

51

(26.2) A method for determining the "area type" corresponding to the signal transmission characteristics of the area(s) between the associated BS 122 and the associated MS 140 location for the loc sig. Note, such an area type may be designated by, for example, the techniques for determining transmission area types as described hereinabove.

5 (26.3) Other methods are contemplated for determining additional environmental characteristics of the geographical area between the associated BS 122 and the associated MS 140 location for the loc sig; e.g., a noise value indicating the amount of noise likely in such an area.

Referring now to the composite location objects and verified location signature clusters of (24.3) and (24.2) respectively, the following information is contained in these aggregation objects:

10 (27.1.1) an identification of the BS 122 designated as the primary base station for communicating with the target MS 140;

(27.1.2) a reference to each loc sig in the location signature data base 1320 that is for the same MS location at substantially the same time with the primary BS as identified in (27.1);

15 (27.1.3) an identification of each base station (e.g., 122 and 152) that can be detected by the MS 140 at the time the location signal measurements are obtained. Note that in one embodiment, each composite location object includes a bit string having a corresponding bit for each base station, wherein a "1" for such a bit indicates that the corresponding base station was identified by the MS, and a "0" indicates that the base station was not identified. In an alternative embodiment, additional location signal measurements may also be included from other non-primary base stations. For example, the target MS 140 may communicate with other base stations than its primary base station. However, since the timing for the MS 140 is typically derived from its primary base station and since timing synchronization between base stations is not exact (e.g., in the case of CDMA, timing variations may be plus or minus 1 microsecond) at least some of the location signal measurements may be less reliable than the measurements from the primary base station, unless a forced hand-off technique is used to eliminate system timing errors among relevant base stations;

20 (27.1.4) a completeness designation that indicates whether any loc sigs for the composite location object have been removed from (or invalidated in) the location signature data base 1320.

25 Note, a verified composite location object is designated as "incomplete" if a loc sig initially referenced by the verified composite location object is deleted from the location signature data base 1320 (e.g., because of a confidence that is too low). Further note that if all loc sigs for a composite location object are deleted, then the composite object is also deleted from the location signature data base 1320. Also note that common fields between loc sigs referenced by the same composite location object may be provided in the composite location object only (e.g., timestamp, etc.).

30 Accordingly, a composite location object that is complete (i.e., not incomplete) is a verified location signature cluster as described in (24.2).

Location Center Architecture

Overview of Location Center Functional Components

Fig. 5 presents a high level diagram of the location center 142 and the location engine 139 in the context of the infrastructure for the entire location system of the present invention.

It is important to note that the architecture for the location center 142 and the location engine 139 provided by the present invention is designed for extensibility and flexibility so that MS 140 location accuracy and reliability may be enhanced as further location data become available and as enhanced MS location techniques become available. In addressing the design goals of extensibility and flexibility, the high level architecture for generating and processing MS location estimates may be considered as divided into the following high level functional groups described hereinbelow.

Low Level Wireless Signal Processing Subsystem for Receiving and Conditioning Wireless Signal Measurements

A first functional group of location engine 139 modules is for performing signal processing and filtering of MS location signal data received from a conventional wireless (e.g., CDMA) infrastructure, as discussed in the steps (23.1) and (23.2) above. This group is denoted the signal processing subsystem 1220 herein. One embodiment of such a subsystem is described in the PCT patent application titled, "Wireless Location Using A Plurality of Commercial Network Infrastructures," by F. W. LeBlanc and the present inventor(s).

Handwritten signature and number 158.

Initial Location Estimators: First Order Models

A second functional group of location engine 139 modules is for generating various target MS 140 location initial estimates, as described in step (23.3). Accordingly, the modules here use input provided by the signal processing subsystem 1220. This second functional group includes one or more signal analysis modules or models, each hereinafter denoted as a first order model 1224 (FOM), for generating location hypotheses for a target MS 140 to be located. Note that it is intended that each such FOM 1224 use a different technique for determining a location area estimate for the target MS 140. A brief description of some types of first order models is provided immediately below. Note that Fig. 8 illustrates another, more detail view of the location system for the present invention. In particular, this figure illustrates some of the FOMs 1224 contemplated by the present invention, and additionally illustrates the primary communications with other modules of the location system for the present invention. However, it is important to note that the present invention is not limited to the FOMs 1224 shown and discussed herein. That is, it is a primary aspect of the present invention to easily incorporate FOMs using other signal processing and/or computational location estimating techniques than those presented herein. Further, note that each FOM type may have a plurality of its models incorporated into an embodiment of the present invention.

Handwritten signature and number 159.

For example, (as will be described in further detail below), one such type of model or FOM 1224 (hereinafter models of this type are referred to as "distance models") may be based on a range or distance computation and/or on a base station signal reception angle determination between the target MS 140 from each of one or more base stations. Basically, such distance models 1224 determine a location estimate of the target MS 140 by determining a distance offset from each of one or more base stations 122, possibly in a particular direction from each (some of) the base stations, so that an intersection of each area locus defined by the base station offsets may provide an estimate of the location of the target MS. Distance model FOMs 1224 may compute such offsets based on:

- (a) signal timing measurements between the target mobile station 140 and one or more base stations 122; e.g., timing measurements such as time difference of arrival (TDOA), or time of arrival (TOA). Note that both forward and reverse signal path timing measurements may be utilized;
- (b) signal strength measurements (e.g., relative to power control settings of the MS 140 and/or one or more BS 122); and/or
- (c) signal angle of arrival measurements, or ranges thereof, at one or more base stations 122 (such angles and/or angular ranges provided by, e.g., base station antenna sectors having angular ranges of 120° or 60°, or, so called "SMART antennas" with variable angular transmission ranges of 2° to 120°).

Accordingly, a distance model may utilize triangulation or trilateration to compute a location hypothesis having either an area location or a point location for an estimate of the target MS 140. Additionally, in some embodiments location hypothesis may include an estimated error

Another type of FOM 1224 is a statistically based first order model 1224, wherein a statistical technique, such as regression techniques (e.g., least squares, partial least squares, principle decomposition), or e.g., Bollenger Bands (e.g., for computing minimum and maximum base station offsets). In general, models of this type output location hypotheses determined by performing one or more statistical techniques or comparisons between the verified location signatures in location signature data base 1320, and the wireless signal measurements from a target MS. Models of this type are also referred to hereinafter as a "stochastic signal (first order) model" or a "stochastic FOM" or a "statistical model."

Still another type of FOM 1224 is an adaptive learning model, such as an artificial neural net or a genetic algorithm, wherein the FOM may be trained to recognize or associate each of a plurality of locations with a corresponding set of signal characteristics for communications between the target MS 140 (at the location) and the base stations 122. Moreover, typically such a FOM is expected to accurately interpolate/extrapolate target MS 140 location estimates from a set of signal characteristics from an unknown target MS 140 location. Models of this type are also referred to hereinafter variously as "artificial neural net models" or "neural net models" or "trainable models" or "learning models." Note that a related type of FOM 1224 is based on pattern recognition. These FOMs can recognize patterns in the signal characteristics of communications between the target MS 140 (at the location) and the base stations 122 and thereby estimate a location area of the target MS. However, such FOMs may not be trainable.

Yet another type of FOM 1224 can be based on a collection of dispersed low power, low cost fixed location wireless transceivers (also denoted "location base stations 152" hereinabove) that are provided for detecting a target MS 140 in areas where, e.g., there is insufficient base station 122 infrastructure coverage for providing a desired level of MS 140 location accuracy. For example, it may uneconomical to provide high traffic wireless voice coverage of a typical wireless base station 122 in a nature preserve or at a fair ground that is only populated a few days out of the year. However, if such low cost location base stations 152 can be directed to activate and deactivate via the direction of a FOM 1224 of the present type, then these location base stations can be used to both location a target MS 140 and also provide indications of where the target MS is not. For example, if there are location base stations 152 populating an area where the target MS 140 is presumed to be, then by activating these location base stations 152, evidence may be obtained as to whether or not the target MS is actually in the area; e.g., if the target MS 140 is detected by a location base station 152, then a corresponding location hypothesis having a location estimate corresponding to the coverage area of the location base station may have a very high confidence value. Alternatively, if the target MS 140 is not detected by a location base station

Imp. C60

Imp. C61

Imp. C62

Imp. C63

Imp. C64

5A



152, then a corresponding location hypothesis having a location estimate corresponding to the coverage area of the location base station may have a very low confidence value. Models of this type are referred to hereinafter as "location base station models."

Yet another type of FOM 1224 can be based on input from a mobile base station 148, wherein location hypotheses may be generated from target MS 140 location data received from the mobile base station 148.

Still other types of FOM 1224 can be based on various techniques for recognizing wireless signal measurement patterns and associating particular patterns with locations in the coverage area 120. For example, artificial neural networks or other learning models can be used as the basis for various FOMs.

Note that the FOM types mentioned here as well as other FOM types are discussed in detail hereinbelow. Moreover, it is important to keep in mind that a novel aspect of the present invention is the simultaneous use or activation of a potentially large number of such first order models 1224, wherein such FOMs are not limited to those described herein. Thus, the present invention provides a framework for incorporating MS location estimators to be subsequently provided as new FOMs in a straightforward manner. For example, a FOM 1224 based on wireless signal time delay measurements from a distributed antenna system for wireless communication may be incorporated into the present invention for locating a target MS 140 in an enclosed area serviced by the distributed antenna system. Accordingly, by using such a distributed antenna FOM, the present invention may determine the floor of a multi-story building from which a target MS is transmitting. Thus, MSs 140 can be located in three dimensions using such a distributed antenna FOM. Additionally, FOMs for detecting certain registration changes within, for example, a public switched telephone network can also be used for locating a target MS 140. For example, for some MSs 140 there may be an associated or dedicated device for each such MS that allows the MS to function as a cordless phone to a line based telephone network when the device detects that the MS is within signaling range. In one use of such a device (also denoted herein as a "home base station"), the device registers with a home location register of the public switched telephone network when there is a status change such as from not detecting the corresponding MS to detecting the MS, or visa versa, as one skilled in the art will understand. Accordingly, by providing a FOM that accesses the MS status in the home location register, the location engine 139 can determine whether the MS is within signaling range of the home base station or not, and generate location hypotheses accordingly. Moreover, other FOMs based on, for example, chaos theory and/or fractal theory are also within the scope of the present invention.

It is important to note the following aspects of the present invention relating to FOMs 1224:

(28.1) Each such first order model 1224 may be relatively easily incorporated into and/or removed from the present invention. For example, assuming that the signal processing subsystem 1220 provides uniform input to the FOMs, and there is a uniform FOM output interface, it is believed that a large majority (if not substantially all) viable MS location estimation strategies may be accommodated. Thus, it is straightforward to add or delete such FOMs 1224.

(28.2) Each such first order model 1224 may be relatively simple and still provide significant MS 140 locating functionality and predictability. For example, much of what is believed to be common or generic MS location processing has been coalesced into, for example: a location hypothesis evaluation subsystem, denoted the hypotheses evaluator 1228 and described immediately below. Thus, the present invention is modular and extensible such that, for example, (and importantly) different first order models 1224 may be utilized depending on the signal transmission characteristics of the geographic region serviced by an embodiment of the present invention. Thus, a simple configuration of the present invention may have a small number of FOMs 1224 for a simple wireless signal environment (e.g., flat terrain,

Imp's  
C15

Imp's  
C16  
C17

Imp's  
C18

no urban canyons and low population density). Alternatively, for complex wireless signal environments such as in cities like San Francisco, Tokyo or New York, a large number of FOMs 1224 may be simultaneously utilized for generating MS location hypotheses.

#### An Introduction to an Evaluator for Location Hypotheses: Hypothesis Evaluator

5 A third functional group of location engine 139 modules evaluates location hypotheses output by the first order models 1224 and thereby provides a "most likely" target MS location estimate. The modules for this functional group are collectively denoted the hypothesis evaluator 1228.

#### Hypothesis Evaluator Introduction

10 A primary purpose of the hypothesis evaluator 1228 is to mitigate conflicts and ambiguities related to location hypotheses output by the first order models 1224 and thereby output a "most likely" estimate of an MS for which there is a request for it to be located. In providing this capability, there are various related embodiments of the hypothesis evaluator that are within the scope of the present invention. Since each location hypothesis includes both an MS location area estimate and a corresponding confidence value indicating a perceived confidence or likelihood of the target MS being within the corresponding location area estimate, there is a monotonic relationship between MS location area estimates and confidence values. That is, by increasing an MS location area estimate, the corresponding confidence value may also be increased (in an extreme case, the location area estimate could be the entire coverage area 120 and thus the confidence value may likely correspond to the highest level of certainty; i.e., + 1.0). Accordingly, given a target MS location area estimate (of a location hypothesis), an adjustment to its accuracy may be performed by adjusting the MS location area estimate and/or the corresponding confidence value. Thus, if the confidence value is, for example, excessively low then the area estimate may be increased as a technique for increasing the confidence value. Alternatively, if the estimated area is excessively large, and there is flexibility in the corresponding confidence value, then the estimated area may be decreased and the confidence value also decreased. Thus, if at some point in the processing of a location hypothesis, if the location hypothesis is judged to be more (less) accurate than initially determined, then (i) the confidence value of the location hypothesis can be increased (decreased), and/or (ii) the MS location area estimate can be decreased (increased).

20 In a first class of embodiments, the hypothesis evaluator 1228 evaluates location hypotheses and adjusts or modifies only their confidence values for MS location area estimates and subsequently uses these MS location estimates with the adjusted confidence values for determining a "most likely" MS location estimate for outputting. Accordingly, the MS location area estimates are not substantially modified. Alternatively, in a second class of embodiments for the hypothesis evaluator 1228, MS location area estimates can be adjusted while confidence values remain substantially fixed. Of course, hybrids between the first two embodiments can also be provided. Note that the present embodiment provided herein adjusts both the areas and the confidence values.

More particularly, the hypothesis evaluator 1228 may perform any or most of the following tasks:

30 (30.1) it utilizes environmental information to improve and reconcile location hypotheses supplied by the first order models 1224. A basic premise in this context is that the accuracy of the individual first order models may be affected by various environmental factors such as, for example, the season of the year, the time of day, the weather conditions, the presence of buildings, base station failures, etc.;

5  
JMS  
C69

(30.2) it enhances the accuracy of an initial location hypothesis generated by an FOM by using the initial location hypothesis as, essentially, a query or index into the location signature data base 1320 for obtaining a corresponding enhanced location hypothesis, wherein the enhanced location hypothesis has both an adjusted target MS location area estimate and an adjusted confidence based on past performance of the FOM in the location service surrounding the target MS location estimate of the initial location hypothesis;

(30.3) it determines how well the associated signal characteristics used for locating a target MS compare with particular verified loc sigs stored in the location signature data base 1320 (see the location signature data base section for further discussion regarding this aspect of the invention). That is, for a given location hypothesis, verified loc sigs (which were previously obtained from one or more verified locations of one or more MS's) are retrieved for an area corresponding to the location area estimate of the location hypothesis, and the signal characteristics of these verified loc sigs are compared with the signal characteristics used to generate the location hypothesis for determining their similarities and subsequently an adjustment to the confidence of the location hypothesis (and/or the size of the location area estimate);

(30.4) the hypothesis evaluator 1228 determines if (or how well) such location hypotheses are consistent with well known physical constraints such as the laws of physics. For example, if the difference between a previous (most likely) location estimate of a target MS and a location estimate by a current location hypothesis requires the MS to:

- (a) move at an unreasonably high rate of speed (e.g., 200 mph), or
- (b) move at an unreasonably high rate of speed for an area (e.g., 80 mph in a corn patch), or
- (c) make unreasonably sharp velocity changes (e.g., from 60 mph in one direction to 60 mph in the opposite direction in 4 sec), then the confidence in the current Location Hypothesis is likely to be reduced.

Alternatively, if for example, the difference between a previous location estimate of a target MS and a current location hypothesis indicates that the MS is:

- (a2) moving at an appropriate velocity for the area being traversed, or
- (b2) moving along an established path (e.g., a freeway),

then the confidence in the current location hypothesis may be increased.

(30.5) the hypothesis evaluator 1228 determines consistencies and inconsistencies between location hypotheses obtained from different first order models. For example, if two such location hypotheses, for substantially the same timestamp, have estimated location areas where the target MS is likely to be and these areas substantially overlap, then the confidence in both such location hypotheses may be increased. Additionally, note that a velocity of an MS may be determined (via deltas of successive location hypotheses from one or more first order models) even when there is low confidence in the location estimates for the MS, since such deltas may, in some cases, be more reliable than the actual target MS location estimates;

(30.6) the hypothesis evaluator 1228 determines new (more accurate) location hypotheses from other location hypotheses. For example, this module may generate new hypotheses from currently active ones by decomposing a location hypothesis having a target MS

location estimate intersecting two radically different area types. Additionally, this module may generate location hypotheses indicating areas of poor reception; and

(30.7) the hypothesis evaluator 1228 determines and outputs a most likely location hypothesis for a target MS.

Note that the hypothesis evaluator may accomplish the above tasks, (30.1) - (30.7), by employing various data processing tools including, but not limited to, fuzzy mathematics, genetic algorithms, neural networks, expert systems and/or blackboard systems.

Note that, as can be seen in Figs. 6 and 7, the hypothesis evaluator 1228 includes the following four high level modules for processing output location hypotheses from the first order models 1224: a context adjuster 1326, a hypothesis analyzer 1332, an MS status repository 1338 and a most likelihood estimator 1334. These four modules are briefly described hereinbelow.

#### Context Adjuster Introduction.

The context adjuster 1326 module enhances both the comparability and predictability of the location hypotheses output by the first order models 1224. In particular, this module modifies location hypotheses received from the FOMs 1224 so that the resulting location hypotheses output by the context adjuster 1326 may be further processed uniformly and substantially without concern as to differences in accuracy between the first order models from which location hypotheses originate. In providing this capability, the context adjuster 1326 may adjust or modify various fields of the input location hypotheses. In particular, fields giving target MS 140 location estimates and/or confidence values for such estimates may be modified by the context adjuster 1326. Further, this module may determine those factors that are perceived to impact the perceived accuracy (e.g., confidence) of the location hypotheses: (a) differently between FOMs, and/or (b) with substantial effect. For instance, environmental characteristics may be taken into account here, such as time of day, season, month, weather, geographical area categorizations (e.g., dense urban, urban, suburban, rural, mountain, etc.), area subcategorizations (e.g., heavily treed, hilly, high traffic area, etc.). A detailed description of one embodiment of this module is provided in APPENDIX D hereinbelow. Note that, the embodiment described herein is simplified for illustration purposes such that only the geographical area categorizations are utilized in adjusting (i.e., modifying) location hypotheses. But, it is an important aspect of the present invention that various categorizations, such as those mentioned immediately above, may be used for adjusting the location hypotheses. That is, categories such as, for example:

(a) urban, hilly, high traffic at 5pm, or

(b) rural, flat, heavy tree foliage density in summer may be utilized as one skilled in the art will understand from the descriptions

contained hereinbelow.

Accordingly, the present invention is not limited to the factors explicitly mentioned here. That is, it is an aspect of the present invention to be extensible so that other environmental factors of the coverage area 120 affecting the accuracy of location hypotheses may also be incorporated into the context adjuster 1326.

It is also an important and novel aspect of the context adjuster 1326 that the methods for adjusting location hypotheses provided in this module may be generalized and thereby also utilized with multiple hypothesis computational architectures related to various applications wherein a terrain, surface, volume or other "geometric" interpretation (e.g., a metric space of statistical samples) may be placed on a large body of stored application data for relating hypothesized data to verified data. Moreover, it is important to note that various techniques for "visualizing data" may provide such a geometric interpretation. Thus, the methods herein may be utilized in applications such as:

- (a) sonar, radar, x-ray or infrared identification of objects such as occurs in robotic navigation, medical image analysis, geological, and radar imaging.

5 More generally, the novel computational paradigm of the context adjuster 1326 may be utilized in a number of applications wherein there is a large body of archived information providing verified or actual application process data related to the past performance of the application process.

It is worth mentioning that the computational paradigm used in the context adjuster 1326 is a hybrid of a hypothesis adjuster and a data base query mechanism. For example, the context adjuster 1326 uses an input (location) hypothesis both as an hypothesis and as a data base query or index into the location signature data base 1320 for constructing a related but more accurate location hypothesis. Accordingly, 10 substantial advantages are provided by this hybrid architecture, such as the following two advantages.

As a first advantage, the context adjuster 1326 reduces the likelihood that a feedback mechanism is necessary to the initial hypothesis generators (i.e., FOMs 1224) for periodically adjusting default evaluations of the goodness or confidence in the hypotheses generated. That is, since each hypothesis generated is, in effect, an index into a data base or archive of verified application (e.g., location) data, the context adjuster 1326, in turn, generates new corresponding hypotheses based on the actual or verified data retrieved from an archival data base. Thus, 15 as a result, this architecture tends to separate the computations of the initial hypothesis generators (e.g., the FOMs 1224 in the present MS location application) from any further processing and thereby provide a more modular, maintainable and flexible computational system.

As a second advantage, the context adjuster 1326 tends to create hypotheses that are more accurate than the hypotheses generated by the initial hypotheses generators. That is, for each hypothesis, H, provided by one of the initial hypothesis generators, G (e.g., a FOM 1224), a corresponding enhanced hypothesis, provided by the context adjuster 1326, is generated by mapping the past performance of G into the 20 archived verified application data (as will be discussed in detail hereinbelow). In particular, the context adjuster hypothesis generation is based on the archived verified (or known) performance application data that is related to both G and H. For example, in the present wireless location application, if a FOM 1224, G, substantially consistently generates, in a particular geographical area, location hypotheses that are biased approximately 1000 feet north of the actual verified MS 140 location, then the context adjuster 1326 can generate corresponding hypotheses without this bias. Thus, the context adjuster 1326 tends to filter out inaccuracies in the initially generated hypotheses.

25 Therefore in a multiple hypothesis architecture where typically the generated hypotheses may be evaluated and/or combined for providing a "most likely" result, it is believed that a plurality of relatively simple (and possibly inexact) initial hypothesis generators may be used in conjunction with the hybrid computational paradigm represented by the context adjuster 1326 for providing enhanced hypotheses with substantially greater accuracy.

30 Additionally, note that this hybrid paradigm applies to other domains that are not geographically based. For instance, this hybrid paradigm applies to many prediction and/or diagnostic applications for which:

- (a) the application data and the application are dependent on a number of parameters whose values characterize the range of outputs for the application. That is, there is a set of parameters,  $p_1, p_2, p_3, \dots, p_n$  from which a parameter space  $p_1 \times p_2 \times p_3 \times \dots \times p_n$  is derived whose points characterize the actual and estimated (or predicted) outcomes. As examples, in the MS location system,  $p_1 =$  latitude and  $p_2 =$  longitude;

(b) there is historical data from which points for the parameter space,  $p_1 \times p_2 \times p_3 \times \dots \times p_n$  can be obtained, wherein this data relates to (or indicates) the performance of the application, and the points obtained from this data are relatively dense in the space (at least around the likely future actual outcomes that the application is expected to predict or diagnose). For example, such historical data may associate the predicted outcomes of the application with corresponding actual outcomes;

5 (c) there is a metric or distance-like evaluation function that can be applied to the parameter space for indicating relative closeness or accuracy of points in the parameter space, wherein the evaluation function provides a measurement of closeness that is related to the actual performance of the application.

Note that there are numerous applications for which the above criteria are applicable. For instance, computer aided control of chemical processing plants are likely to satisfy the above criteria. Certain robotic applications may also satisfy this criteria.  
10 In fact, it is believed that a wide range of signal processing applications satisfy this criteria.

#### MS Status Repository Introduction

The MS status repository 1338 is a run-time storage manager for storing location hypotheses from previous activations of the location engine 139 (as well as for storing the output "most likely" target MS location estimate(s)) so that a target MS 140 may be tracked using target MS location hypotheses from previous location engine 139 activations to determine, for example, a movement of the target MS 140  
15 between evaluations of the target MS location.

#### Location Hypothesis Analyzer Introduction.

The location hypothesis analyzer 1332, adjusts confidence values of the location hypotheses, according to:

- (a) heuristics and/or statistical methods related to how well the signal characteristics for the generated target MS location hypothesis matches with previously obtained signal characteristics for verified MS locations.
- 20 (b) heuristics related to how consistent the location hypothesis is with physical laws, and/or highly probable reasonableness conditions relating to the location of the target MS and its movement characteristics. For example, such heuristics may utilize knowledge of the geographical terrain in which the MS is estimated to be, and/or, for instance, the MS velocity, acceleration or extrapolation of an MS position, velocity, or acceleration.
- (c) generation of additional location hypotheses whose MS locations are consistent with, for example, previous estimated locations for  
25 the target MS.

As shown in Figs. 6 and 7, the hypothesis analyzer 1332 module receives (potentially) modified location hypotheses from the context adjuster 1326 and performs additional location hypothesis processing that is likely to be common and generic in analyzing most location hypotheses. More specifically, the hypothesis analyzer 1332 may adjust either or both of the target MS 140 estimated location and/or the confidence of a location hypothesis. In brief, the hypothesis analyzer 1332 receives target MS 140 location hypotheses from the context analyzer  
30 1336, and depending on the time stamps of newly received location hypotheses and any previous (i.e., older) target MS location hypotheses that may still be currently available to the hypothesis analyzer 1332, the hypothesis analyzer may:

- (a) update some of the older hypotheses by an extrapolation module,

60

- (b) utilize some of the old hypotheses as previous target MS estimates for use in tracking the target MS 140, and/or
- (c) if sufficiently old, then delete the older location hypotheses.

Note that both the newly received location hypotheses and the previous location hypotheses that are updated (i.e., extrapolated) and still remain in the hypothesis analyzer 1332 will be denoted as "current location hypotheses" or "currently active location hypotheses".

5 The modules within the location hypothesis analyzer 1332 use various types of application specific knowledge likely substantially independent from the computations by the FOMs 1224 when providing the corresponding original location hypotheses. That is, since it is aspect of at least one embodiment of the present invention that the FOMs 1224 be relatively straightforward so that they may be easily modified as well as added or deleted, the processing, for example, in the hypothesis analyzer 1332 (as with the context adjuster 1326) is intended to compensate, when necessary, for this straightforwardness by providing substantially generic MS location processing capabilities that can require  
10 a greater breadth of application understanding related to wireless signal characteristics of the coverage area 120.

Accordingly, the hypothesis analyzer 1332 may apply various heuristics that, for example, change the confidence in a location hypothesis depending on how well the location hypothesis (and/or a series of location hypotheses from e.g., the same FOM 1224): (a) conforms with the laws of physics, (b) conforms with known characteristics of location signature clusters in an area of the location hypothesis MS 140 estimate, and (c) conforms with highly likely heuristic constraint knowledge. In particular, as illustrated best in Fig. 7, the location hypothesis  
15 analyzer 1332 may utilize at least one of a blackboard system and/or an expert system for applying various application specific heuristics to the location hypotheses output by the context adjuster 1326. More precisely, the location hypothesis analyzer 1332 includes, in one embodiment, a blackboard manager for managing processes and data of a blackboard system. Additionally, note that in a second embodiment, where an expert system is utilized instead of a blackboard system, the location hypothesis analyzer provides an expert system inference engine for the expert system. Note that additional detail on these aspects of the invention are provided hereinbelow.

20 Additionally, note that the hypothesis analyzer 1332 may activate one or more extrapolation procedures to extrapolate target MS 140 location hypotheses already processed. Thus, when one or more new location hypotheses are supplied (by the context adjuster 1224) having a substantially more recent timestamp, the hypothesis analyzer may invoke an extrapolation module (i.e., location extrapolator 1432, Fig. 7) for adjusting any previous location hypotheses for the same target MS 140 that are still being used by the location hypothesis analyzer so that all target MS location hypotheses (for the same target MS) being concurrently analyzed are presumed to be for substantially the same time.  
25 Accordingly, such a previous location hypothesis that is, for example, 15 seconds older than a newly supplied location hypothesis (from perhaps a different FOM 1224) may have both: (a) an MS location estimate changed (e.g., to account for a movement of the target MS), and (b) its confidence changed (e.g., to reflect a reduced confidence in the accuracy of the location hypothesis).

It is important to note that the architecture of the present invention is such that the hypothesis analyzer 1332 has an extensible architecture. That is, additional location hypothesis analysis modules may be easily integrated into the hypothesis analyzer 1332 as further  
30 understanding regarding the behavior of wireless signals within the service area 120 becomes available. Conversely, some analysis modules may not be required in areas having relatively predictable signal patterns. Thus, in such service areas, such unnecessary modules may be easily removed or not even developed..

Most Likelihood Estimator Introduction

The most likelihood estimator 1344 is a module for determining a "most likely" location estimate for a target MS being located by the location engine 139. The most likelihood estimator 1344 receives a collection of active or relevant location hypotheses from the hypothesis analyzer 1332 and uses these location hypotheses to determine one or more most likely estimates for the target MS 140. Still referring to the hypothesis evaluator 1228, it is important to note that not all the above mentioned modules are required in all embodiments of the present invention. In particular, for some coverage areas 120, the hypothesis analyzer 1332 may be unnecessary. Accordingly, in such an embodiment, the enhanced location hypothesis output by the context adjuster 1326 are provided directly to the most likelihood estimator 1344.

#### Control and Output Gating Modules

A fourth functional group of location engine 139 modules is the control and output gating modules which includes the location center control subsystem 1350, and the output gateway 1356. The location control subsystem 1350 provides the highest level of control and monitoring of the data processing performed by the location center 142. In particular, this subsystem performs the following functions:

- (a) controls and monitors location estimating processing for each target MS 140. Note that this includes high level exception or error handling functions;
- (b) receives and routes external information as necessary. For instance, this subsystem may receive (via, e.g., the public telephone switching network and Internet 1362) such environmental information as increased signal noise in a particular service area due to increase traffic, a change in weather conditions, a base station 122 (or other infrastructure provisioning), change in operation status (e.g., operational to inactive);
- (c) receives and directs location processing requests from other location centers 142 (via, e.g., the Internet);
- (d) performs accounting and billing procedures;
- (e) interacts with location center operators by, for example, receiving operator commands and providing output indicative of processing resources being utilized and malfunctions;
- (f) provides access to output requirements for various applications requesting location estimates. For example, an Internet location request from a trucking company in Los Angeles to a location center 142 in Denver may only want to know if a particular truck or driver is within the Denver area. Alternatively, a local medical rescue unit is likely to request a precise location estimate as possible.

Note that in Fig. 6 (a) - (d) above are, at least at a high level, performed by utilizing the operator interface 1374.

Referring now to the output gateway 1356, this module routes target MS 140 location estimates to the appropriate location application(s). For instance, upon receiving a location estimate from the most likelihood estimator 1344, the output gateway 1356 may determine that the location estimate is for an automobile being tracked by the police and therefore must be provided according to the particular protocol.

*Imp. C71*

*Imp. C71*

*Imp. C72*

*61*



## System Tuning and Adaptation: The Adaptation Engine

A fifth functional group of location engine 139 modules provides the ability to enhance the MS locating reliability and/or accuracy of the present invention by providing it with the capability to adapt to particular operating configurations, operating conditions and wireless signaling environments without performing intensive manual analysis of the performance of various embodiments of the location engine 139. That is, this functional group automatically enhances the performance of the location engine for locating MSs 140 within a particular coverage area 120 using at least one wireless network infrastructure therein. More precisely, this functional group allows the present invention to adapt by tuning or optimizing certain system parameters according to location engine 139 location estimate accuracy and reliability.

There are a number location engine 139 system parameters whose values affect location estimation, and it is an aspect of the present invention that the MS location processing performed should become increasingly better at locating a target MS 140 not only through building an increasingly more detailed model of the signal characteristics of location in the coverage area 120 such as discussed above regarding the location signature data base 1320, but also by providing automated capabilities for the location center processing to adapt by adjusting or "tuning" the values of such location center system parameters.

Accordingly, the present invention includes a module, denoted herein as an "adaptation engine" 1382, that performs an optimization procedure on the location center 142 system parameters either periodically or concurrently with the operation of the location center in estimating MS locations. That is, the adaptation engine 1382 directs the modifications of the system parameters so that the location engine 139 increases in overall accuracy in locating target MSs 140. In one embodiment, the adaptation engine 1382 includes an embodiment of a genetic algorithm as the mechanism for modifying the system parameters. Genetic algorithms are basically search algorithms based on the mechanics of natural genetics. The genetic algorithm utilized herein is included in the form of pseudo code in APPENDIX B. Note that to apply this genetic algorithm in the context of the location engine 139 architecture only a "coding scheme" and a "fitness function" are required as one skilled in the art will appreciate. Moreover, it is also within the scope of the present invention to use modified or different adaptive and/or tuning mechanisms. For further information regarding such adaptive mechanisms, the following references are incorporated herein by reference: Goldberg, D. E. (1989). Genetic algorithms for search, optimization, and machine learning. Reading, MA: Addison-Wesley Publishing Company; and Holland, J. H. (1975) Adaptation in natural and artificial systems. Ann Arbor, MI: The University of Michigan Press.

### Implementations of First Order Models

Further descriptions of various first order models 1224 are provided in this section.

#### Distance First Order Models (TOA/TDOA)

As discussed in the Location Center Architecture Overview section herein above, distance models determine a presumed direction and/or distance that a target MS 140 is from one or more base stations 122. In some embodiments of distance models, the target MS location estimate(s) generated are obtained using radio signal analysis techniques that are quite general and therefore are not capable of taking into account the peculiarities of the topography of a particular radio coverage area. For example, substantially

62

all radio signal analysis techniques using conventional procedures (or formulas) are based on "signal characteristic measurements" such as:

- (a) signal timing measurements (e.g., TOA and TDOA),
- (b) signal strength measurements, and/or
- (c) signal angle of arrival measurements.

Furthermore, such signal analysis techniques are likely predicated on certain very general assumptions that can not fully account for signal attenuation and multipath due to a particular radio coverage area topography.

Taking CDMA or TDMA base station network as an example, each base station (BS) 122 is required to emit a constant signal-strength pilot channel pseudo-noise (PN) sequence on the forward link channel identified uniquely in the network by a pilot sequence offset and frequency assignment. It is possible to use the pilot channels of the active, candidate, neighboring and remaining sets, maintained in the target MS, for obtaining signal characteristic measurements (e.g., TOA and/or TDOA measurements) between the target MS 140 and the base stations in one or more of these sets.

Based on such signal characteristic measurements and the speed of signal propagation, signal characteristic ranges or range differences related to the location of the target MS 140 can be calculated. Using TOA and/or TDOA ranges as exemplary, these ranges can then be input to either the radius-radius multilateration or the time difference multilateration algorithms along with the known positions of the corresponding base stations 122 to thereby obtain one or more location estimates of the target MS 140. For example, if there are, four base stations 122 in the active set, the target MS 140 may cooperate with each of the base stations in this set to provide signal arrival time measurements. Accordingly, each of the resulting four sets of three of these base stations 122 may be used to provide an estimate of the target MS 140 as one skilled in the art will understand. Thus, potentially (assuming the measurements for each set of three base stations yields a feasible location solution) there are four estimates for the location of the target MS 140. Further, since such measurements and BS 122 positions can be sent either to the network or the target MS 140, location can be determined in either entity.

Since many of the signal measurements utilized by embodiments of distance models are subject to signal attenuation and multipath due to a particular area topography. Many of the sets of base stations from which target MS location estimates are desired may result in either no location estimate, or an inaccurate location estimate.

Accordingly, some embodiments of distance FOMs may attempt to mitigate such ambiguity or inaccuracies by, e.g., identifying discrepancies (or consistencies) between arrival time measurements and other measurements (e.g., signal strength), these discrepancies (or consistencies) may be used to filter out at least those signal measurements and/or generated location estimates that appear less accurate. In particular, such identifying may filtering can be performed by, for example, an expert system residing in the distance FOM.

A second approach for mitigating such ambiguity or conflicting MS location estimates is particularly novel in that each of the target MS location estimates is used to generate a location hypothesis regardless of its apparent accuracy. Accordingly, these location hypotheses are input to an alternative embodiment of the context adjuster 1326 that is substantially (but not identical to) the context adjuster as described in detail in APPENDIX D so that each location hypothesis may be adjusted to enhance its accuracy.

In contradistinction to the embodiment of the context adjuster 1326 of APPENDIX D, where each location hypothesis is adjusted according to past performance of its generating FOM 1224 in an area of the initial location estimate of the location hypothesis (the area, e.g., determined as a function of distance from this initial location estimate), this alternative embodiment adjusts each of the location hypotheses generated by a distance first order model according to a past performance of the model as applied to signal characteristic measurements from the same set of base stations 122 as were used in generating the location hypothesis. That is, instead of only using only an identification of the distance model (i.e., its FOM\_ID) to, for example, retrieve archived location estimates generated by the model in an area of the location hypothesis' estimate (when determining the model's past performance), the retrieval retrieves only the archived location estimates that are, in addition, derived from the signal characteristics measurement obtained from the same collection of base stations 122 as was used in generating the location hypothesis. Thus, the adjustment performed by this embodiment of the context adjuster 1326 adjusts according to the past performance of the distance model and the collection of base stations 122 used.

#### Coverage Area First Order Model

Radio coverage area of individual base stations 122 may be used to generate location estimates of the target MS 140. Although a first order model 1224 based on this notion may be less accurate than other techniques, if a reasonably accurate RF coverage area is known for each (or most) of the base stations 122, then such a FOM (denoted hereinafter as a "coverage area first order model" or simply "coverage area model") may be very reliable. To determine approximate maximum radio frequency (RF) location coverage areas, with respect to BSs 122, antennas and/or sector coverage areas, for a given class (or classes) of (e.g., CDMA or TDMA) mobile station(s) 140, location coverage should be based on an MS's ability to adequately detect the pilot channel, as opposed to adequate signal quality for purposes of carrying user-acceptable traffic in the voice channel. Note that more energy is necessary for traffic channel activity (typically on the order of at least -94 to -104 dBm received signal strength) to support voice, than energy needed to simply detect a pilot channel's presence for location purposes (typically a maximum weakest signal strength range of between -104 to -110 dBm), thus the "Location Coverage Area" will generally be a larger area than that of a typical "Voice Coverage Area", although industry studies have found some occurrences of "no-coverage" areas within a larger covered area. An example of a coverage area including both a "dead zone", i.e., area of no coverage, and a "notch" (of also no coverage) is shown in Fig. 15.

The approximate maximum RF coverage area for a given sector of (more generally angular range about) a base station 122 may be represented as a set of points representing a polygonal area (potentially with, e.g., holes therein to account for dead zones and/or notches). Note that if such polygonal RF coverage area representations can be reliably determined and maintained over time (for one or more BS signal power level settings), then such representations can be used in providing a set theoretic or Venn diagram approach to estimating the location of a target MS 140. Coverage area first order models utilize such an approach.

65

One embodiment, a coverage area model utilizes both the detection and non-detection of base stations 122 by the target MS 140 (conversely, of the MS by one or more base stations 122) to define an area where the target MS 140 may likely be. A relatively straightforward application of this technique is to:

- 5
- (a) find all areas of intersection for base station RF coverage area representations, wherein: (i) the corresponding base stations are on-line for communicating with MSs 140; (ii) the RF coverage area representations are deemed reliable for the power levels of the on-line base stations; (iii) the on-line base stations having reliable coverage area representations can be detected by the target MS; and (iv) each intersection must include a predetermined number of the reliable RF coverage area representations (e.g., 2 or 3); and
  - (b) obtain new location estimates by subtracting from each of the areas of intersection any of the reliable RF coverage area representations for base stations 122 that can not be detected by the target MS.
- 10

Accordingly, the new areas may be used to generate location hypotheses.

#### Location Base Station First Order Model

In the location base station (LBS) model (FOM 1224), a database is accessed which contains electrical, radio propagation and coverage area characteristics of each of the location base stations in the radio coverage area. The LBS model is an active model, in that it can probe or excite one or more particular LBSs 152 in an area for which the target MS 140 to be located is suspected to be placed. Accordingly, the LBS model may receive as input a most likely target MS 140 location estimate previously output by the location engine 139 of the present invention, and use this location estimate to determine which (if any) LBSs 152 to activate and/or deactivate for enhancing a subsequent location estimate of the target MS. Moreover, the feedback from the activated LBSs 152 may be provided to other FOMs 1224, as appropriate, as well as to the LBS model. However, it is an important aspect of the LBS model that when it receives such feedback, it may output location hypotheses having relatively small target MS 140 location area estimates about the active LBSs 152 and each such location hypothesis also has a high confidence value indicative of the target MS 140 positively being in the corresponding location area estimate (e.g., a confidence value of .9 to +1), or having a high confidence value indicative of the target MS 140 not being in the corresponding location area estimate (i.e., a confidence value of -0.9 to -1). Note that in some embodiments of the LBS model, these embodiments may have functionality similar to that of the coverage area first order model described above. Further note that for LBSs within a neighborhood of the target MS wherein there is a reasonable chance that with movement of the target MS may be detected by these LBSs, such LBSs may be requested to periodically activate. (Note, that it is not assumed that such LBSs have an on-line external power source; e.g., some may be solar powered). Moreover, in the case where an LBS 152 includes sufficient electronics to carry voice communication with the target MS 140 and is the primary BS for the target MS (or alternatively, in the active or candidate set), then the LBS model will not deactivate this particular LBS during its procedure of activating and deactivating various LBSs 152.

15

20

25

30

*Handwritten:* Ind. 125

*Handwritten:* 65

Stochastic First Order Model

The stochastic first order models may use statistical prediction techniques such as principle decomposition, partial least squares, partial least squares, or other regression techniques for predicting, for example, expected minimum and maximum distances of the target MS from one or more base stations 122, e.g., Bollenger Bands. Additionally, some embodiments may use Markov processes and Random Walks (predicted incremental MS movement) for determining an expected area within which the target MS 140 is likely to be. That is, such a process measures the incremental time differences of each pilot as the MS moves for predicting a size of a location area estimate using past MS estimates such as the verified location signatures in the location signature data base 1320.

JMP  
076

Pattern Recognition and Adaptive First Order Models

It is a particularly important aspect of the present invention to provide:

- (a) one or more FOMs 1224 that generate target MS 140 location estimates by using pattern recognition or associativity techniques, and/or
- (b) one or more FOMs 1224 that are adaptive or trainable so that such FOMs may generate increasingly more accurate target MS location estimates from additional training.

10

Statistically Based Pattern Recognition First Order Models

Regarding FOMs 1224 using pattern recognition or associativity techniques, there are many such techniques available. For example, there are statistically based systems such as "CART" (acronym for Classification and Regression Trees) by ANGOSS Software International Limited of Toronto, Canada that may be used for automatically for detecting or recognizing patterns in data that were unprovided (and likely previously unknown). Accordingly, by imposing a relatively fine mesh or grid of cells of the radio coverage area, wherein each cell is entirely within a particular area type categorization such as the transmission area types (discussed in the section, "Coverage Area: Area Types And Their Determination" above), the verified location signature clusters within the cells of each area type may be analyzed for signal characteristic patterns. If such patterns are found, then they can be used to identify at least a likely area type in which a target MS is likely to be located. That is, one or more location hypotheses may be generated having target MS 140 location estimates that cover an area having the likely area type wherein the target MS 140 is located. Further note that such statistically based pattern recognition systems as "CART" include software code generators for generating expert system software embodiments for recognizing the patterns detected within a training set (e.g., the verified location signature clusters).

JMP  
077

15

20

25

Accordingly, although an embodiment of a FOM as described here may not be exceedingly accurate, it may be very reliable. Thus, since a fundamental aspect of the present invention is to use a plurality MS location techniques for generating location estimates and to analyze the generated estimates (likely after being adjusted) to detect patterns of convergence or clustering among the estimates, even large MS location area estimates are useful. For example, it can be the case that four different and relatively large MS location estimates, each having very high reliability, have an area of intersection that is acceptably precise and inherits the very high reliability from each of the large MS location estimates from which the intersection area was derived.

30

61

A similar statistically based FOM 1224 to the one above may be provided wherein the radio coverage area is decomposed substantially as above, but addition to using the signal characteristics for detecting useful signal patterns, the specific identifications of the base station 122 providing the signal characteristics may also be used. Thus, assuming there is a sufficient density of verified location signature clusters in some of the mesh cells so that the statistical pattern recognizer can detect patterns in the signal characteristic measurements, an expert system may be generated that outputs a target MS 140 location estimate that may provide both a reliable and accurate location estimate of a target MS 140.

JWD  
1/78

#### Adaptive/Trainable First Order Models

#### Adaptive/Trainable First Order Models

The term adaptive is used to describe a data processing component that can modify its data processing behavior in response to certain inputs that are used to change how subsequent inputs are processed by the component. Accordingly, a data processing component may be "explicitly adaptive" by modifying its behavior according to the input of explicit instructions or control data that is input for changing the component's subsequent behavior in ways that are predictable and expected. That is, the input encodes explicit instructions that are known by a user of the component. Alternatively, a data processing component may be "implicitly adaptive" in that its behavior is modified by other than instructions or control data whose meaning is known by a user of the component. For example, such implicitly adaptive data processors may learn by training on examples, by substantially unguided exploration of a solution space, or other data driven adaptive strategies such as statistically generated decision trees. Accordingly, it is an aspect of the present invention to utilize not only explicitly adaptive MS location estimators within FOMs 1224, but also implicitly adaptive MS location estimators. In particular, artificial neural networks (also denoted neural nets and ANNs herein) are used in some embodiments as implicitly adaptive MS location estimators within FOMs. Thus, in the sections below, neural net architectures and their application to locating an MS is described.

#### Artificial Neural Networks For MS Location

Artificial neural networks may be particularly useful in developing one or more first order models 1224 for locating an MS 140, since, for example, ANNs can be trained for classifying and/or associatively pattern matching of various RF signal measurements such as the location signatures. That is, by training one or more artificial neural nets using RF signal measurements from verified locations so that RF signal transmissions characteristics indicative of particular locations are associated with their corresponding locations, such trained artificial neural nets can be used to provide additional target MS 140 location hypotheses. Moreover, it is an aspect of the present invention that the training of such artificial neural net based FOMs (ANN FOMs) is provided without manual intervention as will be discussed hereinbelow.

LB

#### Artificial Neural Networks That Converge on Near Optimal Solutions

It is as an aspect of the present invention to use an adaptive neural network architecture which has the ability to explore the parameter or matrix weight space corresponding to a ANN for determining new configurations of weights that reduce an objective or error function indicating the error in the output of the ANN over some aggregate set of input data ensembles. Accordingly, in one embodiment, a genetic algorithm is used to provide such an adaptation capability. However, it is also within the scope of the present invention to use other adaptive techniques such as, for example, simulated annealing, cascade correlation with multistarts, gradient descent with multistarts, and truncated Newton's method with multistarts, as one skilled in the art of neural network computing will understand.

#### Artificial Neural Networks as MS Location Estimators for First Order Models

Although there have been substantial advances in artificial neural net computing in both hardware and software, it can be difficult to choose a particular ANN architecture and appropriate training data for yielding high quality results. In choosing a ANN architecture at least the following three criteria are chosen (either implicitly or explicitly):

- (a) a learning paradigm: i.e., does the ANN require supervised training (i.e., being provided with indications of correct and incorrect performance), unsupervised training, or a hybrid of both (sometimes referred to as reinforcement);
- (b) a collection of learning rules for indicating how to update the ANN;
- (c) a learning algorithm for using the learning rules for adjusting the ANN weights.

Furthermore, there are other implementation issues such as:

- (d) how many layers a artificial neural net should have to effectively capture the patterns embedded within the training data. For example, the benefits of using small ANN are many. less costly to implement, faster, and tend to generalize better because they avoid overfitting weights to training patterns. That is, in general, more unknown parameters (weights) induce more local and global minima in the error surface or space. However, the error surface of smaller nets can be very rugged and have few good solutions, making it difficult for a local minimization algorithm to find a good solution from a random starting point as one skilled in the art will understand;
- (e) how many units or neurons to provide per layer;
- (f) how large should the training set be presented to provide effective generalization to non-training data
- (g) what type of transfer functions should be used.

However, the architecture of the present invention allows substantial flexibility in the implementation of ANN for FOMs 1224. In particular, there is no need to choose only one artificial neural net architecture and/or implementation in that a plurality of ANNs may be accommodated by the architecture of the location engine 139. Furthermore, it is important to keep in mind that it may not be necessary to train a ANN for a FOM as rigorously as is done in typical ANN applications since the accuracy and reliability in estimating the location of a target MS 140 with the present invention comes from synergistically utilizing a plurality of different MS location estimators, each of which may be undesirable in terms of accuracy and/or reliability in some areas, but when their estimates

69

68



are synergistically used as in the location engine 139, accurate and reliable location estimates can be attained. Accordingly, one embodiment of the present invention may have a plurality of moderately well trained ANNs having different neural net architectures such as: multilayer perceptrons, adaptive resonance theory models, and radial basis function networks.

5 Additionally, many of the above mentioned ANN architecture and implementation decisions can be addressed substantially automatically by various commercial artificial neural net development systems such as: "NEUROGENETIC OPTIMIZER" by BioComp Systems, wherein genetic algorithms are used to optimize and configure ANNs, and artificial neural network hardware and software products by Accurate Automation Corporation of Chattanooga, Tennessee, such as "ACCURATE AUTOMATION NEURAL NETWORK TOOLS.

#### Artificial Neural Network Input and Output

10  

It is worthwhile to discuss the data representations for the inputs and outputs of a ANN used for generating MS location estimates. Regarding ANN input representations, recall that the signal processing subsystem 1220 may provide various RF signal measurements as input to an ANN (such as the RF signal measurements derived from verified location signatures in the location signature data base 1320). For example, a representation of a histogram of the frequency of occurrence of CDMA fingers in a time delay vs. signal strength 2-dimensional domain may be provided as input to such an ANN. In particular, a 2-dimensional grid of signal strength versus time delay bins may be provided so that received signal measurements are slotted into an appropriate bin of the grid. In one embodiment, such a grid is a six by six array of bins such as illustrated in the left portion of Fig. 14. That is, each of the signal strength and time delay axes are partitioned into six ranges so that both the signal strength and the time delay of RF signal measurements can be slotted into an appropriate range, thus determining the bin.

15 Note that RF signal measurement data (i.e., location signatures) slotted into a grid of bins provides a convenient mechanism for classifying RF measurements received over time so that when each new RF measurement data is assigned to its bin, a counter for the bin can be incremented. Thus in one embodiment, the RF measurements for each bin can be represented pictorially as a histogram. In any case, once the RF measurements have been slotted into a grid, various filters may be applied for filtering outliers and noise prior to inputting bin values to an ANN. Further, various amounts of data from such a grid may be provided to an ANN. In one embodiment, the tally from each bin is provided to an ANN. Thus, as many as 108 values could be input to the ANN (two values defining each bin, and a tally for the bin). However, other representations are also possible. For instance, by ordering the bin tallies linearly, only 36 need be provided as ANN input. Alternatively, only representations of bins having the highest tallies may be provided as ANN input. Thus, for example, if the highest 10 bins and their tallies were provided as ANN input, then only 20 inputs need be provided (i.e., 10 input pairs, each having a single bin identifier and a corresponding tally).

25 In addition, note that the signal processing subsystem 1220 may also obtain the identifications of other base stations 122 (152) for which their pilot channels can be detected by the target MS 140 (i.e., the forward path), or for which the base stations can detect a signal from the target MS (i.e., the reverse path). Thus, in order to effectively utilize substantially all pertinent location RF signal measurements (i.e., from location signature data derived from communications between the target MS 140 and the base station



infrastructure), a technique is provided wherein a plurality of ANNs may be activated using various portions of an ensemble of location signature data obtained. However, before describing this technique, it is worthwhile to note that a naive strategy of providing input to a single ANN for locating target MSs throughout an area having a large number of base stations (e.g., 300) is likely to be undesirable. That is, given that each base station (antenna sector) nearby the target MS is potentially able to provide the ANN with location signature data, the ANN would have to be extremely large and therefore may require inordinate training and retraining. For example, since there may be approximately 30 to 60 ANN inputs per location signature, an ANN for an area having even twenty base stations 122 can require at least 600 input neurons, and potentially as many as 1,420 (i.e., 20 base stations with 70 inputs per base station and one input for every one of possibly 20 additional surrounding base stations in the radio coverage area 120 that might be able to detect, or be detected by, a target MS 140 in the area corresponding to the ANN).

Accordingly, the technique described herein limits the number of input neurons in each ANN constructed and generates a larger number of these smaller ANNs. That is, each ANN is trained on location signature data (or, more precisely, portions of location signature clusters) in an area  $A_{ANN}$  (hereinafter also denoted the "net area"), wherein each input neuron receives a unique input from either:

(A1) location signature data (e.g., signal strength/time delay bin tallies) corresponding to transmissions between an MS 140 and a relatively small number of base stations 122 in the area  $A_{ANN}$ . For instance, location signature data obtained from, for example, four base stations 122 (or antenna sectors) in the area  $A_{ANN}$ . Note, each location signature data cluster includes fields describing the wireless communication devices used; e.g., (i) the make and model of the target MS; (ii) the current and maximum transmission power; (iii) the MS battery power (instantaneous or current); (iv) the base station (sector) current power level; (v) the base station make and model and revision level; (vi) the air interface type and revision level (of, e.g., CDMA, TDMA or AMPS).

(A2) a discrete input corresponding to each base station 122 (or antenna sector 130) in a larger area containing  $A_{ANN}$ , wherein each such input here indicates whether the corresponding base station (sector):

(i) is on-line (i.e., capable of wireless communication with MSs) and at least its pilot channel signal is detected by the target MS 140, but the base station (sector) does not detect the target MS;

(ii) is on-line and the base station (sector) detects a wireless transmission from the target MS, but the target MS does not detect the base station (sector) pilot channel signal;

(iii) is on-line and the base station (sector) detects the target MS and the base station (sector) is detected by the target MS;

(iv) is on-line and the base station (sector) does not detect the target MS, the base station is not detected by the target MS; or

(v) is off-line (i.e., incapable of wireless communication with one or more MSs).

Note that (i)-(v) are hereinafter referred to as the "detection states."

Thus, by generating an ANN for each of a plurality of net areas (potentially overlapping), a local environmental change in the wireless signal characteristics of one net area is unlikely to affect more than a small number of adjacent or overlapping net areas.

Accordingly, such local environmental changes can be reflected in that only the ANNs having net areas affected by the local change need to be retrained. Additionally, note that in cases where RF measurements from a target MS 140 are received across multiple net

Handwritten signature/initials in a triangle shape.

areas, multiple ANNs may be activated, thus providing multiple MS location estimates. Further, multiple ANNs may be activated when a location signature cluster is received for a target MS 140 and location signature cluster includes location signature data corresponding to wireless transmissions between the MS and, e.g., more base stations (antenna sectors) than needed for the collection B described in the previous section. That is, if each collection B identifies four base stations 122 (antenna sectors), and a received location signature cluster includes location signature data corresponding to five base stations (antenna sectors), then there may be up to five ANNs activated to each generate a location estimate.

Moreover, for each of the smaller ANNs, it is likely that the number of input neurons is on the order of 330; (i.e., 70 inputs per each of four location signatures ( i.e., 35 inputs for the forward wireless communications and 35 for the reverse wireless communications), plus 40 additional discrete inputs for an appropriate area surrounding  $A_{ANN}$ , plus 10 inputs related type of MS, power levels, etc. However, it is important to note that the number of base stations (or antenna sectors 130) having corresponding location signature data to be provided to such an ANN may vary. Thus, in some subareas of the coverage area 120, location signature data from five or more base stations (antenna sectors) may be used, whereas in other subareas three (or less) may be used.

Regarding the output from ANNs used in generating MS location estimates, there are also numerous options. In one embodiment, two values corresponding to the latitude and longitude of the target MS are estimated. Alternatively, by applying a mesh to the coverage area 120, such ANN output may be in the form of a row value and a column value of a particular mesh cell (and its corresponding area) where the target MS is estimated to be. Note that the cell sizes of the mesh need not be of a particular shape nor of uniform size. However, simple non-oblong shapes are desirable. Moreover, such cells should be sized so that each cell has an area approximately the size of the maximum degree of location precision desired. Thus, assuming square mesh cells, 250 to 350 feet per cell side in an urban/suburban area, and 500 to 700 feet per cell side in a rural area may be desirable.

#### Artificial Neural Network Training

The following are steps provide one embodiment for training a location estimating ANN according to the present invention.

- (a) Determine a collection, C, of clusters of RF signal measurements (i.e., location signatures) such that each cluster is for RF transmissions between an MS 140 and a common set, B, of base stations 122 (or antenna sectors 130) such the measurements are as described in (A1) above. In one embodiment, the collection C is determined by interrogating the location signature data base 1320 for verified location signature clusters stored therein having such a common set B of base stations (antenna sectors). Alternatively in another embodiment, note that the collection C may be determined from (i) the existing engineering and planning data from service providers who are planning wireless cell sites, or (ii) service provider test data obtained using mobile test sets, access probes or other RF field measuring devices. Note that such a collection B of base stations (antenna sectors) should only be created when the set C of verified location signature clusters is of a sufficient size so that it is expected that the ANN can be effectively trained.
- (b) Determine a collection of base stations (or antenna sectors 130), B', from the common set B, wherein B' is small (e.g., four or five).

- (c) Determine the area,  $A_{ANN}$ , to be associated with collection B' of base stations (antenna sectors). In one embodiment, this area is selected by determining an area containing the set L of locations of all verified location signature clusters determined in step (a) having location signature data from each of the base stations (antenna sectors) in the collection B'. More precisely, the area,  $A_{ANN}$ , may be determined by providing a covering of the locations of L, such as, e.g., by cells of a mesh of appropriately fine mesh size so that each cell is of a size not substantially larger than the maximum MS location accuracy desired.
- (d) Determine an additional collection, b, of base stations that have been previously detected (and/or are likely to be detected) by at least one MS in the area  $A_{ANN}$ .
- (e) Train the ANN on input data related to: (i) signal characteristic measurements of signal transmissions between MSs 140 at verified locations in  $A_{ANN}$ , and the base stations (antenna sectors) in the collection B', and (ii) discrete inputs of detection states from the base stations represented in the collection b. For example, train the ANN on input including: (i) data from verified location signatures from each of the base stations (antenna sectors) in the collection B', wherein each location signature is part of a cluster in the collection C; (ii) a collection of discrete values corresponding to other base stations (antenna sectors) in the area b containing the area,  $A_{ANN}$ .

Regarding (d) immediately above, it is important to note that it is believed that less accuracy is required in training a ANN used for generating a location hypothesis (in a FOM 1224) for the present invention than in most applications of ANNs (or other trainable/adaptive components) since, in most circumstances, when signal measurements are provided for locating a target MS 140, the location engine 139 will activate a plurality location hypothesis generating modules (corresponding to one or more FOMs 1224) for substantially simultaneously generating a plurality of different location estimates (i.e., hypotheses). Thus, instead of training each ANN so that it is expected to be, e.g., 92% or higher in accuracy, it is believed that synergies with MS location estimates from other location hypothesis generating components will effectively compensate for any reduced accuracy in such a ANN (or any other location hypothesis generating component). Accordingly, it is believed that training time for such ANNs may be reduced without substantially impacting the MS locating performance of the location engine 139.

25 Finding Near-Optimal Location Estimating Artificial Neural Networks

*JWP  
C82*

In one traditional artificial neural network training process, a relatively tedious set of trial and error steps may be performed for configuring an ANN so that training produces effective learning. In particular, an ANN may require configuring parameters related to, for example, input data scaling, test/training set classification, detecting and removing unnecessary input variable selection. However, the present invention reduces this tedium. That is, the present invention uses mechanisms such as genetic algorithms or other mechanisms for avoiding non-optimal but locally appealing (i.e., local minimum) solutions, and locating near-optimal solutions instead. In particular, such mechanism may be used to adjust the matrix of weights for the ANNs so that very good, near optimal ANN configurations may be found efficiently. Furthermore, since the signal processing system 1220 uses various

*Q*

types of signal processing filters for filtering the RF measurements received from transmissions between an MS 140 and one or more base stations (antenna sectors 130), such mechanisms for finding near-optimal solutions may be applied to selecting appropriate filters as well. Accordingly, in one embodiment of the present invention, such filters are paired with particular ANNs so that the location signature data supplied to each ANN is filtered according to a corresponding "filter description" for the ANN, wherein the filter description specifies the filters to be used on location signature data prior to inputting this data to the ANN. In particular, the filter description can define a pipeline of filters having a sequence of filters wherein for each two consecutive filters,  $f_1$  and  $f_2$  ( $f_1$  preceding  $f_2$ ), in a filter description, the output of  $f_1$  flows as input to  $f_2$ . Accordingly, by encoding such a filter description together with its corresponding ANN so that the encoding can be provided to a near optimal solution finding mechanism such as a genetic algorithm, it is believed that enhanced ANN locating performance can be obtained. That is, the combined genetic codes of the filter description and the ANN are manipulated by the genetic algorithm in a search for a satisfactory solution (i.e., location error estimates within a desired range). This process and system provides a mechanism for optimizing not only the artificial neural network architecture, but also identifying a near optimal match between the ANN and one or more signal processing filters. Accordingly, the following filters may be used in a filter pipeline of a filter description: Sobel, median, mean, histogram normalization, input cropping, neighbor, Gaussian, Weiner filters.

15 One embodiment for implementing the genetic evolving of filter description and ANN pairs is provided by the following steps that may automatically performed without substantial manual effort:

- 1) Create an initial population of concatenated genotypes, or genetic representations for each pair of an artificial neural networks and corresponding filter description pair. Also, provide seed parameters which guide the scope and characterization of the artificial neural network architectures, filter selection and parameters, genetic parameters and system control parameters.
- 2) Prepare the input or training data, including, for example, any scaling and normalization of the data.
- 3) Build phenotypes, or artificial neural network/filter description combinations based on the genotypes.
- 4) Train and test the artificial neural network/filter description phenotype combinations to determine fitness; e.g., determine an aggregate location error measurement for each network/filter description phenotype.
- 25 5) Compare the fitnesses and/or errors, and retain the best network/filter description phenotypes.
- 6) Select the best networks/filter descriptions in the phenotype population (i.e., the combinations with small errors).
- 7) Repopulate the population of genotypes for the artificial neural networks and the filter descriptions back to a predetermined size using the selected phenotypes.
- 8) Combine the artificial neural network genotypes and filter description genotypes thereby obtaining artificial neural network/filter combination genotypes.
- 30 9) Mate the combination genotypes by exchanging genes or characteristics/features of the network/ filter combinations.
- 10) If system parameter stopping criteria is not satisfied, return to step 3.

74 73

Note that artificial neural network genotypes may be formed by selecting various types of artificial neural network architectures suited to function approximation, such as fast back propagation, as well as characterizing several varieties of candidate transfer/activation functions, such as Tanh, logistic, linear, sigmoid and radial basis. Furthermore, ANNs having complex inputs may be selected (as determined by a filter type in the signal processing subsystem 1220) for the genotypes.

5           Examples of genetic parameters include: (a) maximum population size (typical default: 300), (b) generation limit (typical default: 50), (c) selection criteria, such as a certain percentage to survive (typical default: 0.5) or roulette wheel, (d) population refilling, such as random or cloning (default), (e) mating criteria, such as tail swapping (default) or two cut swapping, (f) rate for a choice of mutation criterion, such as random exchange (default: 0.25) or section reversal, (g) population size of the concatenated artificial neural network/ filter combinations, (h) use of statistical seeding on the initial population to bias the random initialization  
10           toward stronger first order relating variables, and (i) neural node influence factors, e.g., input nodes and hidden nodes. Such parameters can be used as weighting factors that influences the degree the system optimizes for accuracy versus network compactness. For example, an input node factor greater than 0 provides a means to reward artificial neural networks constructed that use fewer input variables (nodes). A reasonable default value is 0.1 for both input and hidden node factors.

              Examples of neural net/filter description system control parameters include: (a) accuracy of modeling parameters, such as  
15           relative accuracy, R-squared, mean squared error, root mean squared error or average absolute error (default), and (b) stopping criteria parameters, such as generations run, elapsed time, best accuracy found and population convergence.

#### Locating a Mobile Station Using Artificial Neural Networks

              When using an artificial neural network for estimating a location of an MS 140, it is important that the artificial neural network be provided with as much accurate RF signal measurement data regarding signal transmissions between the target MS 140  
20           and the base station infrastructure as possible. In particular, assuming ANN inputs as described hereinabove, it is desirable to obtain the detection states of as many surrounding base stations as possible. Thus, whenever the location engine 139 is requested to locate a target MS 140 (and in particular in an emergency context such as an emergency 911 call), the location center 140 automatically transmits a request to the wireless infrastructure to which the target MS is assigned for instructing the MS to raise its transmission power to full power for a short period of time (e.g., 100 milliseconds in a base station infrastructure configuration an optimized for  
25           such requests to 2 seconds in a non-optimized configuration). Note that the request for a change in the transmission power level of the target MS has a further advantage for location requests such as emergency 911 that are initiated from the MS itself in that a first ensemble of RF signal measurements can be provided to the location engine 139 at the initial 911 calling power level and then a second ensemble of RF signal measurements can be provided at a second higher transmission power level. Thus, in one embodiment of the present invention, an artificial neural network can be trained not only on the location signature cluster derived from either the  
30           initial wireless 911 transmissions or the full power transmissions, but also on the differences between these two transmissions. In particular, the difference in the detection states of the discrete ANN inputs between the two transmission power levels may provide useful additional information for more accurately estimating a location of a target MS.

75 74

It is important to note that when gathering RF signal measurements from a wireless base station network for locating MSs, the network should not be overburdened with location related traffic. Accordingly, note that network location data requests for data particularly useful for ANN based FOMs is generally confined to the requests to the base stations in the immediate area of a target MS 140 whose location is desired. For instance, both collections of base stations B' and b discussed in the context of training an ANN are also the same collections of base stations from which MS location data would be requested. Thus, the wireless network MS location data requests are data driven in that the base stations to queried for location data (i.e., the collections B' and b) are determined by previous RF signal measurement characteristics recorded. Accordingly, the selection of the collections B' and b are adaptable to changes in the wireless environmental characteristics of the coverage area 120.

#### LOCATION SIGNATURE DATA BASE

Before proceeding with a description of other levels of the present invention as described in (24.1) through (24.3) above, in this section further detail is provided regarding the location signature data base 1320. Note that a brief description of the location signature data base was provided above indicating that this data base stores MS location data from verified and/or known locations (optionally with additional known environmental characteristic values) for use in enhancing current target MS location hypotheses and for comparing archived location data with location signal data obtained from a current target MS. However, the data base management system functionality incorporated into the location signature data base 1320 is an important aspect of the present invention, and is therefore described in this section. In particular, the data base management functionality described herein addresses a number of difficulties encountered in maintaining a large archive of signal processing data such as MS signal location data. Some of these difficulties can be described as follows:

- (a) in many signal processing contexts, in order to effectively utilize archived signal processing data for enhancing the performance of a related signal processing application, there must be an large amount of signal related data in the archive, and this data must be adequately maintained so that as archived signal data becomes less useful to the corresponding signal processing application (i.e., the data becomes "inapplicable") its impact on the application should be correspondingly reduced. Moreover, as archive data becomes substantially inapplicable, it should be filtered from the archive altogether. However, the size of the data in the archive makes it prohibitive for such a process to be performed manually, and there may be no simple or straightforward techniques for automating such impact reduction or filtering processes for inapplicable signal data;
- (b) it is sometimes difficult to determine the archived data to use in comparing with newly obtained signal processing application data; and
- (c) it is sometimes difficult to determine a useful technique for comparing archived data with newly obtained signal processing application data.

It is an aspect of the present invention that the data base management functionality of the location signature data base 1320 addresses each of the difficulties mentioned immediately above. For example, regarding (a), the location signature data base is "self cleaning" in that by associating a confidence value with each loc sig in the data base and by reducing or increasing the confidences of archived verified loc sigs according to how well their signal characteristic data compares with newly received verified location signature data, the location signature data base 1320 maintains a consistency with newly verified loc sigs.

76 75

The following data base management functional descriptions describe some of the more noteworthy functions of the location signature data base 1320. Note that there are various ways that these functions may be embodied. So as to not overburden the reader here, the details for one embodiment is provided in APPENDIX C. Figs. 16a through 16c present a table providing a brief description of the attributes of the location signature data type stored in the location signature data base 1320.

5 LOCATION SIGNATURE PROGRAM DESCRIPTIONS

The following program updates the random loc sigs in the location signature data base 1320. In one embodiment, this program is invoked primarily by the Signal Processing Subsystem.

Update Location signature Database Program

Update\_Loc\_Sig\_DB(new\_loc\_obj, selection\_criteria, loc\_sig\_pop)

10 /\* This program updates loc sigs in the location signature data base 1320. That is, this program updates, for example, at least the location information for verified random loc sigs residing in this data base. The general strategy here is to use information (i.e., "new\_loc\_obj") received from a newly verified location (that may not yet be entered into the location signature data base) to assist in determining if the previously stored random verified loc sigs are still reasonably valid to use for:

15 (29.1) estimating a location for a given collection (i.e., "bag") of wireless (e.g., CDMA) location related signal characteristics received from an MS,

(29.2) training (for example) adaptive location estimators (and location hypothesizing models), and

(29.3) comparing with wireless signal characteristics used in generating an MS location hypothesis by one of the MS location hypothesizing models (denoted First Order Models, or, FOMs).

20 More precisely, since it is assumed that it is more likely that the newest location information obtained is more indicative of the wireless (CDMA) signal characteristics within some area surrounding a newly verified location than the verified loc sigs (location signatures) previously entered into the Location Signature data base, such verified loc sigs are compared for signal characteristic consistency with the newly verified location information (object) input here for determining whether some of these "older" data base verified loc sigs still appropriately characterize their associated location.

25 In particular, comparisons are iteratively made here between each (target) loc sig "near" "new\_loc\_obj" and a population of loc sigs in the location signature data base 1320 (such population typically including the loc sig for "new\_loc\_obj) for:

30 (29.4) adjusting a confidence factor of the target loc sig. Note that each such confidence factor is in the range [0, 1] with 0 being the lowest and 1 being the highest. Further note that a confidence factor here can be raised as well as lowered depending on how well the target loc sig matches or is consistent with the population of loc sigs to which it is compared. Thus, the confidence in any particular verified loc sig, LS, can fluctuate with

successive invocations of this program if the input to the successive invocations are with location information geographically "near" LS.

(29.5) remove older verified loc sigs from use whose confidence value is below a predetermined threshold. Note, it is intended that such predetermined thresholds be substantially automatically adjustable by periodically testing various confidence factor thresholds in a specified geographic area to determine how well the eligible data base loc sigs (for different thresholds) perform in agreeing with a number of verified loc sigs in a "loc sig test-bed", wherein the test bed may be composed of, for example, repeatable loc sigs and recent random verified loc sigs.

Note that this program may be invoked with a (verified/known) random and/or repeatable loc sig as input. Furthermore, the target loc sigs to be updated may be selected from a particular group of loc sigs such as the random loc sigs or the repeatable loc sigs, such selection being determined according to the input parameter, "selection\_criteria" while the comparison population may be designated with the input parameter, "loc\_sig\_pop". For example, to update confidence factors of certain random loc sigs near "new\_loc\_obj", "selection\_criteria" may be given a value indicating, "USE\_RANDOM\_LOC\_SIGS", and "loc\_sig\_pop" may be given a value indicating, "USE\_REPEATABLE\_LOC\_SIGS". Thus, if in a given geographic area, the repeatable loc sigs (from, e.g., stationary transceivers) in the area have recently been updated, then by successively providing "new\_loc\_obj" with a loc sig for each of these repeatable loc sigs, the stored random loc sigs can have their confidences adjusted.

Alternatively, in one embodiment of the present invention, the present function may be used for determining when it is desirable to update repeatable loc sigs in a particular area (instead of automatically and periodically updating such repeatable loc sigs). For example, by adjusting the confidence factors on repeatable loc sigs here provides a method for determining when repeatable loc sigs for a given area should be updated. That is, for example, when the area's average confidence factor for the repeatable loc sigs drops below a given (potentially high) threshold, then the MSs that provide the repeatable loc sigs can be requested to respond with new loc sigs for updating the data base. Note, however, that the approach presented in this function assumes that the repeatable location information in the location signature data base 1320 is maintained with high confidence by, for example, frequent data base updating. Thus, the random location signature data base verified location information may be effectively compared against the repeatable loc sigs in an area.

INPUT:

new\_loc\_obj: a data representation at least including a loc sig for an associated location about which Location Signature loc sigs are to have their confidences updated.

selection\_criteria: a data representation designating the loc sigs to be selected to have their confidences updated (may be defaulted). The following groups of loc sigs may be selected: "USE\_RANDOM\_LOC\_SIGS" (this is the default), USE\_REPEATABLE\_LOC\_SIGS", "USE\_ALL\_LOC\_SIGS". Note that each of these selections has values for the following values associated with it (although the values may be defaulted):



- (a) a confidence reduction factor for reducing loc sig confidences,
- (b) a big error threshold for determining the errors above which are considered too big to ignore,
- (c) a confidence increase factor for increasing loc sig confidences,
- (d) a small error threshold for determining the errors below which are considered too small (i.e., good) to ignore.
- (e) a recent time for specifying a time period for indicating the loc sigs here considered to be "recent".

5

loc\_sig\_pop: a data representation of the type of loc sig population to which the loc sigs to be updated are compared. The following values may be provided:

- (a) "USE ALL LOC SIGS IN DB",
- (b) "USE ONLY REPEATABLE LOC SIGS" (this is the default),
- (c) "USE ONLY LOC SIGS WITH SIMILAR TIME OF DAY"

10

However, environmental characteristics such as: weather, traffic, season are also contemplated.

**Confidence Aging Program**

The following program reduces the confidence of verified loc sigs in the location signature data base I320 that are likely to be no longer accurate (i.e., in agreement with comparable loc sigs in the data base). If the confidence is reduced low enough, then such loc sigs are removed from the data base. Further, if for a location signature data base verified location composite entity (i.e., a collection of loc sigs for the same location and time), this entity no longer references any valid loc sigs, then it is also removed from the data base. Note that this program is invoked by "Update\_Loc\_Sig\_DB".

15

reduce\_bad\_DB\_loc\_sigs(loc\_sig\_bag , error\_rec\_set, big\_error\_threshold confidence\_reduction\_factor, recent\_time)

20

**Inputs:**

loc\_sig\_bag: A collection or "bag" of loc sigs to be tested for determining if their confidences should be lowered and/or any of these loc sigs removed.

error\_rec\_set: A set of error records (objects), denoted "error\_recs", providing information as to how much each loc sig in "loc\_sig\_bag" disagrees with comparable loc sigs in the data base. That is, there is a "error\_rec" here for each loc sig in "loc\_sig\_bag".

25

big\_error\_threshold: The error threshold above which the errors are considered too big to ignore.

confidence\_reduction\_factor: The factor by which to reduce the confidence of loc sigs.

recent\_time: Time period beyond which loc sigs are no longer considered recent. Note that "recent" loc sigs (i.e., more recent than "recent\_time") are not subject to the confidence reduction and filtering of this actions of this function.

30

### Confidence Enhancement Program

The following program increases the confidence of verified Location Signature loc sigs that are (seemingly) of higher accuracy (i.e., in agreement with comparable loc sigs in the location signature data base 1320). Note that this program is invoked by "Update\_Loc\_Sig\_DB".

5 increase\_confidence\_of\_good\_DB\_loc\_sigs(nearby\_loc\_sig\_bag, error\_rec\_set, small\_error\_threshold, confidence\_increase\_factor, recent\_time);

#### Inputs:

loc\_sig\_bag: A collection or "bag" of to be tested for determining if their confidences should be increased.

error\_rec\_set: A set of error records (objects), denoted "error\_recs", providing information as to how much each loc sig in "loc\_sig\_bag" disagrees with comparable loc sigs in the location signature data base. That is, there is a "error\_rec" here for each loc sig in "loc\_sig\_bag".

small\_error\_threshold: The error threshold below which the errors are considered too small to ignore.

confidence\_increase\_factor: The factor by which to increase the confidence of loc sigs.

recent\_time: Time period beyond which loc sigs are no longer considered recent. Note that "recent" loc sigs (i.e., more recent than "recent\_time") are not subject to the confidence reduction and filtering of this actions of this function.

JAN 33 10

### Location Hypotheses Consistency Program

The following program determines the consistency of location hypotheses with verified location information in the location signature data base 1320. Note that in the one embodiment of the present invention, this program is invoked primarily by a module denoted the historical location reasoner 1424 described sections hereinbelow. Moreover, the detailed description for this program is provided with the description of the historical location reasoner hereinbelow for completeness.

20 DB\_Loc\_Sig\_Error\_Fit(hypothesis, measured\_loc\_sig\_bag, search\_criteria)

/\* This function determines how well the collection of loc sigs in "measured\_loc\_sig\_bag" fit with the loc sigs in the location signature data base 1320 wherein the data base loc sigs must satisfy the criteria of the input parameter "search\_criteria" and are relatively close to the MS location estimate of the location hypothesis, "hypothesis".

Input: hypothesis: MS location hypothesis;

measured\_loc\_sig\_bag: A collection of measured location signatures ("loc sigs" for short) obtained from the MS (the data structure here is an aggregation such as an array or list). Note, it is assumed that there is at most one loc sig here per Base Station in this collection. Additionally, note that the input data structure here may be a location signature cluster such as the "loc\_sig\_cluster" field of a location hypothesis (cf. Fig. 9). Note

JAN 33 10

that variations in input data structures may be accepted here by utilization of flag or tag bits as one skilled in the art will appreciate;

search\_criteria: The criteria for searching the verified location signature data base for various categories of loc sigs. The only limitation on the types of categories that may be provided here is that, to be useful, each category should have meaningful number of loc sigs in the location signature data base. The following categories included here are illustrative, but others are contemplated:

- (a) "USE ALL LOC SIGS IN DB" (the default),
- (b) "USE ONLY REPEATABLE LOC SIGS",
- (c) "USE ONLY LOC SIGS WITH SIMILAR TIME OF DAY".

Further categories of loc sigs close to the MS estimate of "hypothesis" contemplated are: all loc sigs for the same season and same time of day, all loc sigs during a specific weather condition (e.g., snowing) and at the same time of day, as well as other limitations for other environmental conditions such as traffic patterns.

Note, if this parameter is NIL, then (a) is assumed.

Returns: An error object (data type: "error\_object") having: (a) an "error" field with a measurement of the error in the fit of the location signatures from the MS with verified location signatures in the location signature data base 1320; and (b) a "confidence" field with a value indicating the perceived confidence that is to be given to the "error" value. \*/

#### Location Signature Comparison Program

The following program compares: (a1) loc sigs that are contained in (or derived from) the loc sigs in "target\_loc\_sig\_bag" with (b1) loc sigs computed from verified loc sigs in the location signature data base 1320. That is, each loc sig from (a1) is compared with a corresponding loc sig from (b) to obtain a measurement of the discrepancy between the two loc sigs. In particular, assuming each of the loc sigs for "target\_loc\_sig\_bag" correspond to the same target MS location, wherein this location is "target\_loc", this program determines how well the loc sigs in "target\_loc\_sig\_bag" fit with a computed or estimated loc sig for the location, "target\_loc" that is derived from the verified loc sigs in the location signature data base 1320. Thus, this program may be used: (a2) for determining how well the loc sigs in the location signature cluster for a target MS ("target\_loc\_sig\_bag") compares with loc sigs derived from verified location signatures in the location signature data base, and (b2) for determining how consistent a given collection of loc sigs ("target\_loc\_sig\_bag") from the location signature data base is with other loc sigs in the location signature data base. Note that in (b2) each of the one or more loc sigs in "target\_loc\_sig\_bag" have an error computed here that can be used in determining if the loc sig is becoming inapplicable for predicting target MS locations.

Determine\_Location\_Signature\_Fit\_Errors(target\_loc, target\_loc\_sig\_bag, search\_area, search\_criteria, output\_criteria)

/\* Input: target\_loc: An MS location or a location hypothesis for an MS. Note, this can be any of the following:

Jan's  
C85

81

- 5
- (a) An MS location hypothesis, in which case, if the hypothesis is inaccurate, then the loc sigs in “target\_loc\_sig\_bag” are the location signature cluster from which this location hypothesis was derived. Note that if this location is inaccurate, then “target\_loc\_sig\_bag” is unlikely to be similar to the comparable loc sigs derived from the loc sigs of the location signature data base close “target\_loc”; or
  - (b) A previously verified MS location, in which case, the loc sigs of “target\_loc\_sig\_bag” were the loc sigs measurements at the time they were verified. However, these loc sigs may or may not be accurate now.

10 target\_loc\_sig\_bag: Measured location signatures (“loc sigs” for short) obtained from the MS (the data structure here, bag, is an aggregation such as array or list). It is assumed that there is at least one loc sig in the bag. Further, it is assumed that there is at most one loc sig per Base Station;

15 search\_area: The representation of the geographic area surrounding “target\_loc”. This parameter is used for searching the Location Signature data base for verified loc sigs that correspond geographically to the location of an MS in “search\_area”;

search\_criteria: The criteria used in searching the location signature data base. The criteria may include the following:

- (a) “USE ALL LOC SIGS IN DB”,
  - (b) “USE ONLY REPEATABLE LOC SIGS”,
  - (c) “USE ONLY LOC SIGS WITH SIMILAR TIME OF DAY”.
- 20

However, environmental characteristics such as: weather, traffic, season are also contemplated.

output\_criteria: The criteria used in determining the error records to output in “error\_rec\_bag”. The criteria here may include one of:

- (a) “OUTPUT ALL POSSIBLE ERROR\_RECS”;
  - (b) “OUTPUT ERROR\_RECS FOR INPUT LOC SIGS ONLY”.
- 25

Returns: error\_rec\_bag: A bag of error records or objects providing an indication of the similarity between each loc sig in “target\_loc\_sig\_bag” and an estimated loc sig computed for “target\_loc” from stored loc sigs in a surrounding area of “target\_loc”. Thus, each error record/object in “error\_rec\_bag” provides a measurement of how well a loc sig (i.e., wireless signal characteristics) in “target\_loc\_sig\_bag” (for an associated BS and the MS at “target\_loc”) correlates with an estimated loc sig between this BS and MS. Note that the estimated loc sigs are determined using verified location signatures in the Location Signature data base. Note, each error record in “error\_rec\_bag” includes: (a) a BS ID indicating the base station to which the error record corresponds; and (b) a error measurement ( $> = 0$ ), and (c) a confidence value (in  $[0, 1]$ ) indicating the confidence to be placed in the error measurement.

30

#### Computed Location Signature Program

The following program receives a collection of loc sigs and computes a loc sig that is representative of the loc sigs in the collection. That is, given a collection of loc sigs, "loc\_sig\_bag", wherein each loc sig is associated with the same predetermined Base Station, this program uses these loc sigs to compute a representative or estimated loc sig associated with the predetermined Base Station and associated with a predetermined MS location, "loc\_for\_estimation". Thus, if the loc sigs in "loc\_sig\_bag" are from the verified loc sigs of the location signature data base such that each of these loc sigs also has its associated MS location relatively close to "loc\_for\_estimation", then this program can compute and return a reasonable approximation of what a measured loc sig between an MS at "loc\_for\_estimation" and the predetermined Base Station ought to be. This program is invoked by "Determine\_Location\_Signature\_Fit\_Errors".

5  
10 estimate\_loc\_sig\_from\_DB(loc\_for\_estimation, loc\_sig\_bag)

#### Geographic Area Representation Program

The following program determines and returns a representation of a geographic area about a location, "loc", wherein: (a) the geographic area has associated MS locations for an acceptable number (i.e., at least a determined minimal number) of verified loc sigs from the location signature data base, and (b) the geographical area is not too big. However, if there are not enough loc sigs in even a largest acceptable search area about "loc", then this largest search area is returned. "DB\_Loc\_Sig\_Error\_Fit"

15 get\_area\_to\_search(loc)

#### Location signature Comparison Program

This program compares two location signatures, "target\_loc\_sig" and "comparison\_loc\_sig", both associated with the same predetermined Base Station and the same predetermined MS location (or hypothesized location). This program determines a measure of the difference or error between the two loc sigs relative to the variability of the verified location signatures in a collection of loc sigs denoted the "comparison\_loc\_sig\_bag" obtained from the location signature data base. It is assumed that "target\_loc\_sig", "comparison\_loc\_sig" and the loc sigs in "comparison\_loc\_sig\_bag" are all associated with the same base station. This program returns an error record (object), "error\_rec", having an error or difference value and a confidence value for the error value. Note, the signal characteristics of "target\_loc\_sig" and those of "comparison\_loc\_sig" are not assumed to be similarly normalized (e.g., via filters as per the filters of the Signal Processing Subsystem) prior to entering this function. It is further assumed that typically the input loc sigs satisfy the "search\_criteria". This program is invoked by: the program, "Determine\_Location\_Signature\_Fit\_Errors", described above.

20  
25  
30 get\_difference\_measurement(target\_loc\_sig, comparison\_loc\_sig, comparison\_loc\_sig\_bag, search\_area, search\_criteria)

Input:

83

target\_loc\_sig: The loc sig to which the "error\_rec" determined here is to be associated.

comparison\_loc\_sig: The loc sig to compare with the "target\_loc\_sig". Note, if "comparison\_loc\_sig" is NIL, then this parameter has a value that corresponds to a noise level of "target\_loc\_sig".

5 comparison\_loc\_sig\_bag: The universe of loc sigs to use in determining an error measurement between "target\_loc\_sig" and "comparison\_loc\_sig". Note, the loc sigs in this aggregation include all loc sigs for the associated BS that are in the "search\_area".

search\_area: A representation of the geographical area surrounding the location for all input loc sigs. This input is used for determining extra information about the search area in problematic circumstances.

search\_criteria: The criteria used in searching the location signature data base. The criteria may include the following:

- 10 (a) "USE ALL LOC SIGS IN DB",  
(b) "USE ONLY REPEATABLE LOC SIGS",  
(c) "USE ONLY LOC SIGS WITH SIMILAR TIME OF DAY"

However, environmental characteristics such as: weather, traffic, season are also contemplated.

#### Detailed Description of the Hypothesis Evaluator Modules

15 Context Adjuster Embodiments

The context adjuster 1326 performs the first set of potentially many adjustments to at least the confidences of location hypotheses, and in some important embodiments, both the confidences and the target MS location estimates provided by FOMs 1224 may be adjusted according to previous performances of the FOMs. More particularly, as mentioned above, the context adjuster adjusts confidences so that, assuming there is a sufficient density verified location signature clusters captured in the location signature data base 1320, the resulting location hypotheses  
20 output by the context adjuster 1326 may be further processed uniformly and substantially without concern as to differences in accuracy between the first order models from which location hypotheses originate. Accordingly, the context adjuster adjusts location hypotheses both to environmental factors (e.g., terrain, traffic, time of day, etc., as described in 30.1 above), and to how predictable or consistent each first order model (FOM) has been at locating previous target MS's whose locations were subsequently verified.

Of particular importance is the novel computational paradigm utilized herein. That is, if there is a sufficient density of previous verified MS location data stored in the location signature data base 1320, then the FOM location hypotheses are used as an "index" into this data base (i.e., the location signature data base) for constructing new target MS 140 location estimates. A more detailed discussion of this aspect of the present invention is given hereinbelow. Accordingly, only a brief overview is provided here. Thus, since the location signature data base 1320 stores previously captured MS location data including:

- 25 (a) clusters of MS location signature signals (see the location signature data base section for a discussion of these signals) and  
30 (b) a corresponding verified MS location, for each such cluster, from where the MS signals originated,

84

the context adjuster 1326 uses newly created target MS location hypotheses output by the FOM's as indexes or pointers into the location signature data base for identifying other geographical areas where the target MS 140 is likely to be located based on the verified MS location data in the location signature data base.

In particular, at least the following two criteria are addressed by the context adjuster 1326:

- 5 (32.1) Confidence values for location hypotheses are to be comparable regardless of first order models from which the location hypotheses originate. That is, the context adjuster moderates or dampens confidence value assignment distinctions or variations between first order models so that the higher the confidence of a location hypothesis, the more likely (or unlikely, if the location hypothesis indicates an area estimate where the target MS is NOT) the target MS is perceived to be in the estimated area of the location hypothesis regardless of the First Order Model from which the location hypothesis was output;
- 10 (32.2) Confidence values for location hypotheses may be adjusted to account for current environmental characteristics such as month, day (weekday or weekend), time of day, area type (urban, rural, etc.), traffic and/or weather when comparing how accurate the first order models have previously been in determining an MS location according to such environmental characteristics. For example, in one embodiment of the present invention, such
- 15 environmental characteristics are accounted for by utilizing a transmission area type scheme (as discussed in section 5.9 above) when adjusting confidence values of location hypotheses. Details regarding the use of area types for adjusting the confidences of location hypotheses and provided hereinbelow, and in particular, in APPENDIX D.

Note that in satisfying the above two criteria, the context adjuster 1326, at least in one embodiment, may use heuristic (fuzzy logic) rules to adjust the confidence values of location hypotheses from the first order models. Additionally, the context adjuster may also satisfy the following criteria:

20

- (33.1) The context adjuster may adjust location hypothesis confidences due to BS failure(s),
- (33.2) Additionally in one embodiment, the context adjuster may have a calibration mode for at least one of:
- 25 (a) calibrating the confidence values assigned by first order models to their location hypotheses outputs;
- (b) calibrating itself.

A first embodiment of the context adjuster is discussed immediately hereinbelow and in APPENDIX D. However, the present invention also includes other embodiments of the context adjuster. A second embodiment is also described in Appendix D so as to not overburden the reader and thereby chance losing perspective of the overall invention.

A description of the high level functions in an embodiment of the context adjuster 1326 follows. Details regarding the implementation of these functions are provided in APPENDIX D. Also, many of the terms used hereinbelow are defined in APPENDIX D. Accordingly, the program descriptions in this section provide the reader with an overview of this first embodiment of the context adjuster 1326.

30

Context\_adjuster(loc\_hyp\_list)

85 84

This function adjusts the location hypotheses on the list, "loc\_hyp\_list", so that the confidences of the location hypotheses are determined more by empirical data than default values from the First Order Models 1224. That is, for each input location hypothesis, its confidence (and an MS location area estimate) may be exclusively determined here if there are enough verified location signatures available within and/or surrounding the location hypothesis estimate.

5 This function creates a new list of location hypotheses from the input list, "loc\_hyp\_list", wherein the location hypotheses on the new list are modified versions of those on the input list. For each location hypothesis on the input list, one or more corresponding location hypotheses will be on the output list. Such corresponding output location hypotheses will differ from their associated input location hypothesis by one or more of the following: (a) the "image\_area" field (see Fig. 9) may be assigned an area indicative of where the target MS is estimated to be, (b) if "image\_area" is assigned, then the "confidence" field will be the confidence that the target MS is located in the area for "image\_area" (c) if there are not sufficient "nearby" verified location signature clusters in the location signature data base 1320 to entirely rely on a computed confidence using such verified location signature clusters, then two location hypotheses (having reduced confidences) will be returned, one having a reduced computed confidence (for "image\_area") using the verified clusters in the Location Signature data base, and one being substantially the same as the associated input location hypothesis except that the confidence (for the field "area\_est") is reduced to reflect the confidence in its paired location hypothesis having a computed confidence for "image\_area". Note also, in some cases, the location hypotheses on the input list, may have no change to its confidence or the area to which the confidence applies.

15 Get\_adjusted\_loc\_hyp\_list\_for(loc\_hyp)

This function returns a list (or more generally, an aggregation object) of one or more location hypotheses related to the input location hypothesis, "loc\_hyp". In particular, the returned location hypotheses on the list are "adjusted" versions of "loc\_hyp" in that both their target MS location estimates, and confidence placed in such estimates may be adjusted according to archival MS location information in the location signature data base 1320. Note that the steps herein are also provided in flowchart form in Figs. 26a through 26c.

20 RETURNS: loc\_hyp\_list This is a list of one or more location hypotheses related to the input "loc\_hyp". Each location hypothesis on "loc\_hyp\_list" will typically be substantially the same as the input "loc\_hyp" except that there may now be a new target MS estimate in the field, "image\_area", and/or the confidence value may be changed to reflect information of verified location signature clusters in the location signature data base.

30 The function, "get\_adjusted\_loc\_hyp\_list\_for," and functions called by this function presuppose a framework or paradigm that requires some discussion as well as the defining of some terms. Note that some of the terms defined hereinbelow are illustrated in Fig. 243.

Define the term the "the cluster set" to be the set of all MS location point estimates (e.g., the values of the "pt\_est" field of the location hypothesis data type), for the present FOM, such that:



- (a) these estimates are within a predetermined corresponding area (e.g., the "loc\_hyp.pt\_covering" being such a predetermined corresponding area, or more generally, this predetermined corresponding area is determined as a function of the distance from an initial location estimate, e.g., "loc\_hyp.pt\_est", from the FOM), and
- (b) these point estimates have verified location signature clusters in the location signature data base.

5 Note that the predetermined corresponding area above will be denoted as the "cluster set area".

Define the term "image cluster set" (for a given First Order Model identified by "loc\_hyp.FOM\_ID") to mean the set of verified location signature clusters whose MS location point estimates are in "the cluster set".

*JWP's*

Note that an area containing the "image cluster set" will be denoted as the "image cluster set area" or simply the "image area" in some contexts. Further note that the "image cluster set area" will be a "small" area encompassing the "image cluster set". In one embodiment, the image cluster set area will be the smallest covering of cells from the mesh for the present FOM that covers the convex hull of the image cluster set. Note that preferably, each cell of each mesh for each FOM is substantially contained within a single (transmission) area type.

10

Thus, the present FOM provides the correspondences or mapping between elements of the cluster set and elements of the image cluster set.

15

confidence\_adjuster(FOM\_ID, image\_area, image\_cluster\_set)

This function returns a confidence value indicative of the target MS 140 being in the area for "image\_area". Note that the steps for this function are provided in flowchart form in Figs. 27a and 27b.

RETURNS: A confidence value. This is a value indicative of the target MS being located in the area represented by "image\_area" (when it is assumed that for the related "loc\_hyp," the "cluster set area" is the "loc\_hyp.pt\_covering" and "loc\_hyp.FOM\_ID" is "FOM\_ID").

20

The function, "confidence\_adjuster," (and functions called by this function) presuppose a framework or paradigm that requires some discussion as well as the defining of terms.

25

Define the term "mapped cluster density" to be the number of the verified location signature clusters in an "image cluster set" per unit of area in the "image cluster set area".

*JWP's*  
*CS 9*

It is believed that the higher the "mapped cluster density", the greater the confidence can be had that a target MS actually resides in the "image cluster set area" when an estimate for the target MS (by the present FOM) is in the corresponding "the cluster set".

30

Thus, the mapped cluster density becomes an important factor in determining a confidence value for an estimated area of a target MS such as, for example, the area represented by "image\_area". However, the mapped cluster density value requires modification before it can be utilized in the confidence calculation. In particular, confidence values must be in the range [-1, 1] and a mapped cluster density does not have this constraint. Thus, a "relativized mapped cluster density" for an estimated MS area is desired, wherein this relativized measurement is in the range [-1, +1], and in particular, for positive confidences in the

range [0, 1]. Accordingly, to alleviate this difficulty, for the FOM define the term “prediction mapped cluster density” as a mapped cluster density value, MCD, for the FOM and image cluster set area wherein:

(i) MCD is sufficiently high so that it correlates (at least at a predetermined likelihood threshold level) with the actual target MS location being in the “image cluster set area” when a FOM target MS location estimate is in the corresponding “cluster set area”;

That is, for a cluster set area (e.g., “loc\_hyp.pt\_covering”) for the present FOM, if the image cluster set area: has a mapped cluster density greater than the “prediction mapped cluster density”, then there is a high likelihood of the target MS being in the image cluster set area.

It is believed that the prediction mapped cluster density will typically be dependent on one or more area types. In particular, it is assumed that for each area type, there is a likely range of prediction mapped cluster density values that is substantially uniform across the area type. Accordingly, as discussed in detail hereinbelow, to calculate a prediction mapped cluster density for a particular area type, an estimate is made of the correlation between the mapped cluster densities of image areas (from cluster set areas) and the likelihood that if a verified MS location: (a) has a corresponding FOM MS estimate in the cluster set, and (b) is also in the particular area type, then the verified MS location is also in the image area.

Thus, if an area is within a single area type, then such a “relativized mapped cluster density” measurement for the area may be obtained by dividing the mapped cluster density by the prediction mapped cluster density and taking the smaller of: the resulting ratio and 1.0 as the value for the relativized mapped cluster density.

In some (perhaps most) cases, however, an area (e.g., an image cluster set area) may have portions in a number of area types. Accordingly, a “composite prediction mapped cluster density” may be computed, wherein, a weighted sum is computed of the prediction mapped cluster densities for the portions of the area that is in each of the area types. That is, the weighting, for each of the single area type prediction mapped cluster densities, is the fraction of the total area that this area type is. Thus, a “relativized composite mapped cluster density” for the area here may also be computed by dividing the mapped cluster density by the composite prediction mapped cluster density and taking the smaller of: the resulting ratio and 1.0 as the value for the relativized composite mapped cluster density.

Accordingly, note that as such a relativized (composite) mapped cluster density for an image cluster set area increases/decreases, it is assumed that the confidence of the target MS being in the image cluster set area should increase/decrease, respectively.

```
get_composite_prediction_mapped_cluster_density_for_high_certainty(FOM_ID, image_area);
```

The present function determines a composite prediction mapped cluster density by determining a composite prediction mapped cluster density for the area represented by “image\_area” and for the First Order Model identified by “FOM\_ID”.

OUTPUT: composite\_mapped\_density This is a record for the composite prediction mapped cluster density. In particular, there are with two fields:



- (i) a "value" field giving an approximation to the prediction mapped cluster density for the First Order Model having id, FOM\_ID;
- (ii) a "reliability" field giving an indication as to the reliability of the "value" field. The reliability field is in the range [0, 1] with 0 indicating that the "value" field is worthless and the larger the value the more assurance can be put in "value" with maximal assurance indicated when "reliability" is 1.

5

get\_prediction\_mapped\_cluster\_density\_for(FOM\_ID, area\_type)

The present function determines an approximation to a prediction mapped cluster density, D, for an area type such that if an image cluster set area has a mapped cluster density  $\geq D$ , then there is a high expectation that the target MS 140 is in the image cluster set area. Note that there are a number of embodiments that may be utilized for this function. The steps herein are also provided in flowchart form in Figs. 29a through 29h.

10

OUTPUT: prediction\_mapped\_cluster\_density      This is a value giving an approximation to the prediction mapped cluster density for the First Order Model having identity, "FOM\_ID", and for the area type represented by "area\_type" \*/

15

It is important to note that the computation here for the prediction mapped cluster density may be more intense than some other computations but the cluster densities computed here need not be performed in real time target MS location processing. That is, the steps of this function may be performed only periodically (e.g., once a week), for each FOM and each area type thereby precomputing the output for this function. Accordingly, the values obtained here may be stored in a table that is accessed during real time target MS location processing. However, for simplicity, only the periodically performed steps are presented here. However, one skilled in the art will understand that with sufficiently fast computational devices, some related variations of this function may be performed in real-time. In particular, instead of supplying area type as an input to this function, a particular area, A, may be provided such as the image area for a cluster set area, or, the portion of such an image area in a particular area type. Accordingly, wherever "area\_type" is used in a statement of the embodiment of this function below, a comparable statement with "A" can be provided.

20

25

#### Location Hypothesis Analyzer Embodiment

Referring now to Fig. 7, an embodiment of the Hypothesis Analyzer is illustrated. The control component is denoted the control module 1400. Thus, this control module manages or controls access to the run time location hypothesis storage area 1410. The control module 1400 and the run time location hypothesis storage area 1410 may be implemented as a blackboard system and/or an expert system. Accordingly, in the blackboard embodiment, , and the control module 1400 determines when new location hypotheses may be entered onto the

30

blackboard from other processes such as the context adjuster 1326 as well as when location hypotheses may be output to the most likelihood estimator 1344.

The following is a brief description of each submodule included in the location hypothesis analyzer 1332.

- 5 (35.1) A control module 1400 for managing or controlling further processing of location hypotheses received from the context adjuster. This module controls all location hypothesis processing within the location hypothesis analyzer as well as providing the input interface with the context adjuster. There are numerous embodiments that may be utilized for this module, including, but not limited to, expert systems and blackboard managers.
- 10 (35.2) A run-time location hypothesis storage area 1410 for retaining location hypotheses during their processing by the location hypotheses analyzer. This can be, for example, an expert system fact base or a blackboard. Note that in some of the discussion hereinbelow, for simplicity, this module is referred to as a "blackboard". However, it is not intended that such notation be a limitation on the present invention; i.e., the term "blackboard" hereinafter will denote a run-time data repository for a data processing paradigm wherein the flow of control is substantially data-driven.
- 15 (35.3) An analytical reasoner module 1416 for determining if (or how well) location hypotheses are consistent with well known physical or heuristic constraints as, e.g., mentioned in (30.4) above. Note that this module may be a daemon or expert system rule base.
- (35.4) An historical location reasoner module 1424 for adjusting location hypotheses' confidences according to how well the location signature characteristics (i.e., loc sigs) associated with a location hypothesis compare with "nearby" loc sigs in the location signature data base as indicated in (30.3) above. Note that this module may also be a daemon or expert system rule base.
- 20 (35.5) A location extrapolator module 1432 for use in updating previous location estimates for a target MS when a more recent location hypothesis is provided to the location hypothesis analyzer 1332. That is, assume that the control module 1400 receives a new location hypothesis for a target MS for which there are also one or more previous location hypotheses that either have been recently processed (i.e., they reside in the MS status repository 1338, as shown best in Fig. 6), or are currently being processed (i.e., they reside in the run-time location hypothesis storage area 1410). Accordingly, if the active\_timestamp (see Fig. 9 regarding location hypothesis data fields) of the newly received location hypothesis is sufficiently more recent than the active\_timestamp of one of these previous location hypotheses, then an extrapolation may be performed by the location extrapolator module 1432 on such previous location hypotheses so that all target MS location hypotheses being concurrently analyzed are presumed to include target MS location estimates for substantially the same point in time. Thus, initial location estimates generated by the FOMs using different wireless signal measurements, from different signal transmission time intervals, may have their corresponding dependent location hypotheses utilized simultaneously for determining a most likely target MS location estimate. Note that this module may also be daemon or expert system rule base.
- 25 (35.6) hypothesis generating module 1428 for generating additional location hypotheses according to, for example, MS location information not adequately utilized or modeled. Note, location hypotheses may also be decomposed here if, for example it is determined that a location hypothesis includes an MS area estimate that has subareas with radically different characteristics such as an MS area estimate that includes an uninhabited area and a densely populated area. Additionally, the hypothesis generating module 1428 may generate "poor reception" location hypotheses that specify MS location areas of known poor reception that are "near" or intersect currently
- 30

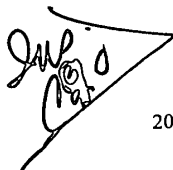

active location hypotheses. Note, that these poor reception location hypotheses may be specially tagged (e.g., with a distinctive FOM\_ID value or specific tag field) so that regardless of substantially any other location hypothesis confidence value overlapping such a poor reception area, such an area will maintain a confidence value of "unknown" (i.e., zero). Note that substantially the only exception to this constraint is location hypotheses generated from mobile base stations 148. Note that this module may also be daemon or expert system rule base.

In the blackboard system embodiment of the location hypothesis analyzer, a blackboard system is the mechanism by which the last adjustments are performed on location hypotheses and by which additional location hypotheses may be generated.. Briefly, a blackboard system can be described as a particular class of software that typically includes at least three basic components. That is:

(36.1) a data base called the "blackboard," whose stored information is commonly available to a collection of programming elements known as "daemons", wherein, in the present invention, the blackboard includes information concerning the current status of the location hypotheses being evaluated to determine a "most likely" MS location estimate. Note that this data base is provided by the run time location hypothesis storage area 1410;

(36.2) one or more active (and typically opportunistic) knowledge sources, denoted conventionally as "daemons," that create and modify the contents of the blackboard. The blackboard system employed requires only that the daemons have application knowledge specific to the MS location problem addressed by the present invention. As shown in Fig. 7, the knowledge sources or daemons in the hypothesis analyzer include the analytical reasoner module 1416, the hypothesis generating module 1428, and the historical location reasoner module 1416;

(36.3) a control module that enables the realization of the behavior in a serial computing environment. The control element orchestrates the flow of control between the various daemons. This control module is provided by the control module 1400.

Note that this blackboard system may be commercial, however, the knowledge sources, i.e., daemons, have been developed specifically for the present invention. For further information regarding such blackboard systems, the following references are incorporated herein by reference: (a) Jagannathan, V., Dodhiawala, R., & Baum, L. S. (1989). Blackboard architectures and applications. Boston, MA: Harcourt Brace Jovanovich Publishers; (b) Engelmores, R., & Morgan, T. (1988). Blackboard systems. Reading, MA: Addison-Wesley Publishing Company.

Alternatively, the control module 1400 and the run-time location hypothesis storage area 1410 may be implemented as an expert system or as a fuzzy rule inferencing system, wherein the control module 1400 activates or "fires" rules related to the knowledge domain (in the present case, rules relating to the accuracy of MS location hypothesis estimates), and wherein the rules provide a computational embodiment of, for example, constraints and heuristics related to the accuracy of MS location estimates. Thus, the control module 1400 for the present embodiment is also used for orchestrating, coordinating and controlling the activity of the individual rule bases of the location hypothesis analyzer (e.g. as shown in Fig. 7, the analytical reasoner module 1416, the hypothesis generating module 1428, the historical location reasoner module 1424, and the location extrapolator module 1432). For further information regarding such expert systems, the following reference is incorporated herein by reference: Waterman, D. A. (1970). A guide to expert systems. Reading, MA: Addison-Wesley Publishing Company.

### MS Status Repository Embodiment

The MS status repository 1338 is a run-time storage manager for storing location hypotheses from previous activations of the location engine 139 (as well as the output target MS location estimate(s)) so that a target MS may be tracked using target MS location hypotheses from previous location engine 139 activations to determine, for example, a movement of the target MS between evaluations of the target MS location. Thus, by retaining a moving window of previous location hypotheses used in evaluating positions of a target MS, measurements of the target MS's velocity, acceleration, and likely next position may be determined by the location hypothesis analyzer 1332. Further, by providing accessibility to recent MS location hypotheses, these hypotheses may be used to resolve conflicts between hypotheses in a current activation for locating the target MS; e.g., MS paths may be stored here for use in extrapolating a new location

### 10 Most Likelihood Estimator Embodiment

The most likelihood estimator 1344 is a module for determining a "most likely" location estimate for a target MS 140 being located (e.g., as in (30.7) above). In one embodiment, the most likelihood estimator performs an integration or summing of all location hypothesis confidence values for any geographic region(s) of interest having at least one location hypothesis that has been provided to the most likelihood estimator, and wherein the location hypothesis has a relatively (or sufficiently) high confidence. That is, the most likelihood estimator 1344 determines the area(s) within each such region having high confidences (or confidences above a threshold) as the most likely target MS 140 location estimates.

In one embodiment of the most likelihood estimator 1344, this module utilizes an area mesh,  $M$ , over which to integrate, wherein the mesh cells of  $M$  are preferably smaller than the greatest location accuracy desired. That is, each cell,  $c$ , of  $M$  is assigned a confidence value indicating a likelihood that the target MS 140 is located in  $c$ , wherein the confidence value for  $c$  is determined by the confidence values of the target MS location estimates provided to the most likelihood estimator 1344. Thus, to obtain the most likely location determination(s) the following steps are performed:

- (a) For each of the active location hypotheses output by, e.g., the hypothesis analyzer 1332 (alternatively, the context adjuster 1326), each corresponding MS location area estimate, LAE, is provided with a smallest covering,  $C_{LEA}$ , of cells  $c$  from  $M$ .
- (b) Subsequently, each of the cells of  $C_{LEA}$  have their confidence values adjusted by adding to it the confidence value for LAE. Accordingly, if the confidence of LEA is positive, then the cells of  $C_{LEA}$  have their confidences increased. Alternatively, if the confidence of LEA is negative, then the cells of  $C_{LEA}$  have their confidences decreased.
- (c) Given that the interval  $[-1.0, +1.0]$  represents the range in confidence values, and that this range has been partitioned into intervals,  $Int$ , having lengths of, e.g., 0.05, for each interval,  $Int$ , perform a cluster analysis function for clustering cells with confidences that are in  $Int$ . Thus, a topographical-type map may be constructed from the resulting cell clusters, wherein higher confidence areas are analogous to representations of areas having higher elevations.
- (d) Output a representation of the resulting clusters for each  $Int$  to the output gateway 1356 for determining the location granularity and representation desired by each location application 146 requesting the location of the target MS 140.

92 91



Of course, variations in the above algorithm also within the scope of the present invention. For example, some embodiments of the most likelihood estimator 1344 may:

5 (e) Perform special processing for areas designated as “poor reception” areas. For example, the most likelihood estimator 1344 may be able to impose a confidence value of zero (i.e., meaning it is unknown as to whether the target MS is in the area) on each such poor reception area regardless of the location estimate confidence values unless there is a location hypothesis from a reliable and unanticipated source. That is, the mesh cells of a poor reception area may have their confidences set to zero unless, e.g., there is a location hypothesis derived from target MS location data provided by a mobile base station 148 that: (a) is near the poor reception area, (b) able to detect that the target MS 140 is in the poor reception area, and (c) can relay target MS location data to the location center 142. In such a case, the confidence of the target MS location estimate from the MBS location hypothesis may take precedence.

10 (f) Additionally, in some embodiments of the most likelihood estimator 1344, cells  $c$  of  $M$  that are “near” or adjacent to a covering  $C_{LEA}$  may also have their confidences adjusted according to how near the cells  $c$  are to the covering. That is, the assigning of confidences to cell meshes may be “fuzzified” in the terms of fuzzy logic so that the confidence value of each location hypothesis utilized by the most likelihood estimator 1344 is provided with a weighting factor depending on its proximity to the target MS location estimate of the location hypothesis. More precisely, it is believed that “nearness,” in the present context, should be monotonic with the “wideness” of the covering; i.e., as the extent of the covering increases (decreases) in a particular direction, the cells  $c$  affected beyond the covering also increases (decreases). Furthermore, in some embodiments of the most likelihood estimator 1344, the greater (lesser) the confidence in the LEA, the more (fewer) cells  $c$  beyond the covering have their confidences affected. To describe this technique in further detail, reference is made to Fig. 10, wherein an area  $A$  is assumed to be a covering  $C_{LEA}$  having a confidence denoted “conf”. Accordingly, to determine a confidence adjustment to add to a cell  $c$  not in  $A$  (and additionally, the centroid of  $A$  not being substantially identical with the centroid of  $c$  which could occur if  $A$  were donut shaped), the following steps may be performed:

- (i) Determine the centroid of  $A$ , denoted  $Cent(A)$ .
- 25 (ii) Determine the centroid of the cell  $c$ , denoted  $Q$ .
- (iii) Determine the extent of  $A$  along the line between  $Cent(A)$  and  $Q$ , denoted  $L$ .
- (iv) For a given type of probability density function,  $P(x)$ , such as a Gaussian function, let  $T$  be the beginning portion of the function that lives on the  $x$ -axis interval  $[0, t]$ , wherein  $P(t) = ABS(conf) =$  the absolute value of the confidence of  $C_{LEA}$ .

30 (v) Stretch  $T$  along the  $x$ -axis so that the stretched function, denoted  $sT(x)$ , has an  $x$ -axis support of  $[0, L/(1 + e^{a(ABS(conf)-1)})]$ , where  $a$  is in range of 3.0 to 10.0; e.g., 5.0. Note that  $sT(x)$  is the function,

$$P(x * (1 + e^{a(ABS(conf)-1)})/L), \text{ on this stretched extent. Further note that for confidences of } +1 \text{ and } -1, \text{ the support of } sT(x) \text{ is } [0, L] \text{ and for confidences at (or near) zero this support. Further, the term,}$$

$$L/(1 + e^{a(ABS(conf)-1)})$$

is monotonically increasing with L and ABS(conf).

- (vi) Determine  $D$  = the minimum distance that Q is outside of A along the line between Cent(A) and Q.
- (vii) Determine the absolute value of the change in the confidence of c as sT(D).
- (viii) Provide the value sT(D) with the same sign as conf, and provide the potentially sign changed value sT(D) as the confidence of the cell c.

5 Additionally, in some embodiments, the most likelihood estimator 1344, upon receiving one or more location hypotheses from the hypothesis analyzer 1332, also performs some or all of the following tasks:

(37.1) Filters out location hypotheses having confidence values near zero whenever such location hypotheses are deemed too unreliable to be utilized in determining a target MS location estimate. For example, location hypotheses having confidence values in the range [-0.02, 0.02] may be filtered here;

(37.2) Determines the area of interest over which to perform the integration. In one embodiment, this area is a convex hull including each of the MS area estimates from the received location hypotheses (wherein such location hypotheses have not been removed from consideration by the filtering process of (37.1));

(37.3) Determines, once the integration is performed, one or more collections of contiguous area mesh cells that may be deemed a "most likely" MS location estimate, wherein each such collection includes one or more area mesh cells having a high confidence value.

#### Detailed Description of the Location Hypothesis Analyzer Submodules

##### Analytical Reasoner Module

The analytical reasoner applies constraint or "sanity" checks to the target MS estimates of the location hypotheses residing in the Run-time Location Hypothesis Storage Area for adjusting the associated confidence values accordingly. In one embodiment, these sanity checks involve "path" information. That is, this module determines if (or how well) location hypotheses are consistent with well known physical constraints such as the laws of physics, in an area in which the MS (associated with the location hypothesis) is estimated to be located. For example, if the difference between a previous (most likely) location estimate of a target MS and an estimate by a current location hypothesis requires the MS to:

- (a) move at an unreasonably high rate of speed (e.g., 200 mph), or
- (b) move at an unreasonably high rate of speed for an area (e.g., 80 mph in a corn patch), or
- (c) make unreasonably sharp velocity changes (e.g., from 60 mph in one direction to 60 mph in the opposite direction in 4 sec),

then the confidence in the current hypothesis is reduced. Such path information may be derived for each time series of location hypotheses resulting from the FOMs by maintaining a window of previous location hypotheses in the MS status repository 1338. Moreover, by additionally retaining the "most likely" target MS location estimates (output by the most likelihood estimator 1344), current location hypotheses may be compared against such most likely MS location estimates.



The following path sanity checks are incorporated into the computations of this module. That is:

- (1) do the predicted MS paths generally follow a known transportation pathway (e.g., in the case of a calculated speed of greater than 50 miles per hour are the target MS location estimates within, for example, .2 miles of a pathway where such speed may be sustained); if so (not), then increase (decrease) the confidence of the location hypotheses not satisfying this criterion;
- 5 (2) are the speeds, velocities and accelerations, determined from the current and past target MS location estimates, reasonable for the region (e.g., speeds should be less than 60 miles per hour in a dense urban area at 9 am); if so (not), then increase (decrease) the confidence of those that are (un)reasonable;
- (3) are the locations, speeds, velocities and/or accelerations similar between target MS tracks produced by different FOMs similar; decrease the confidence of the currently active location hypotheses that are indicated as "outliers" by this criterion;
- 10 (4) are the currently active location hypothesis target MS estimates consistent with previous predictions of where the target MS is predicted to be from a previous (most likely) target MS estimate; if not, then decrease the confidence of at least those location hypothesis estimates that are substantially different from the corresponding predictions. Note, however, that in some cases this may be over ruled. For example, if the prediction is for an area for which there is Location Base Station coverage, and no Location Base Station covering the area subsequently reports communicating with the target MS, then the predictions are
- 15 incorrect and any current location hypothesis from the same FOM should not be decreased here if it is outside of this Location Base Station coverage area.

Notice from Fig. 7 that the analytical reasoner can access location hypotheses currently posted on the Run-time Location Hypothesis Storage Area. Additionally, it interacts with the Pathway Database which contains information concerning the location of natural  
20 transportation pathways in the region (highways, rivers, etc.) and the Area Characteristics Database which contains information concerning, for example, reasonable velocities that can be expected in various regions (for instance, speeds of 80 mph would not be reasonably expected in dense urban areas). Note that both speed and direction can be important constraints; e.g., even though a speed might be appropriate for an area, such as 20 mph in a dense urban area, if the direction indicated by a time series of related location hypotheses is directly through an extensive building complex having no through traffic routes, then a reduction in the confidence of one or more of the location hypotheses may  
25 be appropriate.

One embodiment of the Analytical Reasoner illustrating how such constraints may be implemented is provided in the following section. Note, however, that this embodiment analyzes only location hypotheses having a non-negative confidence value.

Modules of an embodiment of the analytical reasoner module 1416 are provided hereinbelow.

#### Path Comparison Module

- 30 The path comparison module 1454 implements the following strategy: the confidence of a particular location hypothesis is be increased (decreased) if it is (not) predicting a path that lies along a known transportation pathway (and the speed of the target MS is sufficiently high). For instance, if a time series of target MS location hypotheses for a given FOM is predicting a path of the target MS that lies along an interstate

95 94

highway, the confidence of the currently active location hypothesis for this FOM should, in general, be increased. Thus, at a high level the following steps may be performed:

- 5 (a) For each FOM having a currently active location hypothesis in the Run-time Location Hypothesis Storage Area (also denoted "blackboard"), determine a recent "path" obtained from a time series of location hypotheses for the FOM. This computation for the "path" is performed by stringing together successive "center of area" (COA) or centroid values determined from the most pertinent target MS location estimate in each location hypothesis (recall that each location hypothesis may have a plurality of target MS area estimates with one being the most pertinent). The information is stored in, for example, a matrix of values wherein one dimension of the matrix identifies the FOM and the a second dimension of the matrix represents a series of COA path values. Of course, some entries in the matrix may be undefined.
- 10 (b) Compare each path obtained in (a) against known transportation pathways in an area containing the path. A value, `path_match(i)`, representing to what extent the path matches any known transportation pathway is computed. Such values are used later in a computation for adjusting the confidence of each corresponding currently active location hypothesis.

#### Velocity/Acceleration Calculation Module

15 The velocity/acceleration calculation module 1458 computes velocity and/or acceleration estimates for the target MS 140 using currently active location hypotheses and previous location hypothesis estimates of the target MS. In one embodiment, for each FOM 1224 having a currently active location hypothesis (with positive confidences) and a sufficient number of previous (reasonably recent) target MS location hypotheses, a velocity and/or acceleration may be calculated. In an alternative embodiment, such a velocity and/or acceleration may be calculated using the currently active location hypotheses and one or more recent "most likely" locations of the target MS output by the location engine 139. If the estimated velocity and/or acceleration corresponding to a currently active location hypothesis is reasonable for the region, then its confidence value may be incremented; if not, then its confidence may be decremented. The algorithm may be summarized as follows:

- 20 (a) Approximate speed and/or acceleration estimates for currently active target MS location hypotheses may be provided using path information related to the currently active location hypotheses and previous target MS location estimates in a manner similar to the description of the path comparison module 1454. Accordingly, a single confidence adjustment value may be determined for each currently active location hypothesis for indicating the extent to which its corresponding velocity and/or acceleration calculations are reasonable for its particular target MS location estimate. This calculation is performed by retrieving information from the area characteristics data base 1450 (e.g., Figs. 6 and 7). Since each location hypothesis includes timestamp data indicating when the MS location signals were received from the target MS, the velocity and/or acceleration associated with a path for a currently active location hypothesis can be straightforwardly approximated. Accordingly, a confidence adjustment value, `vel_ok(i)`, indicating a likelihood that the velocity calculated for the  $i^{\text{th}}$  currently active location hypothesis (having adequate corresponding path information) may be appropriate is calculated using for the environmental characteristics of the location hypothesis' target MS location estimate. For example, the area characteristics data base 1450 may include expected maximum velocities and/or accelerations for each area type and/or cell of a cell mesh of the coverage area 120. Thus, velocities and/or accelerations above such maximum values may be indicative of anomalies in the MS location estimating process. Accordingly, in one embodiment, the most
- 25
- 30



recent location hypotheses yielding such extreme velocities and/or accelerations may have their confidence values decreased. For example, if the target MS location estimate includes a portion of an interstate highway, then an appropriate velocity might correspond to a speed of up to 100 miles per hour, whereas if the target MS location estimate includes only rural dirt roads and tomato patches, then a likely speed might be no more than 30 miles per hour with an maximum speed of 60 miles per hour (assuming favorable environmental characteristics such as weather). Note that a list of such environmental characteristics may include such factors as: area type, time of day, season. Further note that more unpredictable environmental characteristics such as traffic flow patterns, weather (e.g., clear, raining, snowing, etc.) may also be included, values for these latter characteristics coming from the environmental data base 1354 which receives and maintains information on such unpredictable characteristics (e.g., Figs. 6 and 7). Also note that a similar confidence adjustment value,  $acc\_ok(i)$ , may be provided for currently active location hypotheses, wherein the confidence adjustment is related to the appropriateness of the acceleration estimate of the target MS.

Attribute Comparison Module

The attribute comparison module 1462 compares attribute values for location hypotheses generated from different FOMs, and determines if the confidence of certain of the currently active location hypotheses should be increased due to a similarity in related values for the attribute. That is, for an attribute A, an attribute value for A derived from a set  $S_{FOM[1]}$  of one or more location hypotheses generated by one FOM, FOM[1], is compared with another attribute value for A derived from a set  $S_{FOM[2]}$  of one or more location hypotheses generated by a different FOM, FOM[2] for determining if these attribute values cluster (i.e., are sufficiently close to one another) so that a currently active location hypothesis in  $S_{FOM[1]}$  and a currently active location hypothesis in  $S_{FOM[2]}$  should have their confidences increased. For example, the attribute may be a "target MS path data" attribute, wherein a value for the attribute is an estimated target MS path derived from location hypotheses generated by a fixed FOM over some (recent) time period. Alternatively, the attribute might be, for example, one of a velocity and/or acceleration, wherein a value for the attribute is a velocity and/or acceleration derived from location hypotheses generated by a fixed FOM over some (recent) time period.

In a general context, the attribute comparison module 1462 operates according to the following premise:

(38.1) for each of two or more currently active location hypotheses (with, e.g., positive confidences) if:

- (a) each of these currently active location hypotheses, H, was initially generated by a corresponding different FOM<sub>*ii*</sub>;
- (b) for a given MS estimate attribute and each such currently active location hypothesis, H, there is a corresponding value for the attribute (e.g., the attribute value might be an MS path estimate, or alternatively an MS estimated velocity, or an MS estimated acceleration), wherein the attribute value is derived without using a FOM different from FOM<sub>*ii*</sub>, and;
- (c) the derived attribute values cluster sufficiently well,

then each of these currently active location hypotheses, H, will have their corresponding confidences increased.. That is, these confidences will be increased by a confidence adjustment value or delta.

Note that the phrase "cluster sufficiently well" above may have a number of technical embodiments, including performing various cluster analysis techniques wherein any clusters (according to some statistic) must satisfy a system set threshold for the members of the cluster being

97 96

close enough to one another. Further, upon determining the (any) location hypotheses satisfying (38.1), there are various techniques that may be used in determining a change or delta in confidences to be applied. For example, in one embodiment, an initial default confidence delta that may be utilized is: if "cf" denotes the confidence of such a currently active location hypothesis satisfying (38.1), then an increased confidence that still remains in the interval [0, 1.0] may be:  $cf + [(1 - cf)/(1 + cf)]^2$ , or,  $cf * [1.0 + cf^n]$ ,  $n = > 2$ , or,  $cf * [a \text{ constant having a system tuned parameter as a factor}]$ . That is, the confidence deltas for these examples are:  $[(1 - cf)/(1 + cf)]^2$  (an additive delta), and,  $[1.0 + cf^n]$  (a multiplicative delta), and a constant. Additionally, note that it is within the scope of the present invention to also provide such confidence deltas (additive deltas or multiplicative deltas) with factors related to the number of such location hypotheses in the cluster.

Moreover, note that it is an aspect of the present invention to provide an adaptive mechanism (i.e., the adaptation engine 1382 shown in Figs. 5, 6 and 8) for automatically determining performance enhancing changes in confidence adjustment values such as the confidence deltas for the present module. That is, such changes are determined by applying an adaptive mechanism, such as a genetic algorithm, to a collection of "system parameters" (including parameters specifying confidence adjustment values as well as system parameters of, for example, the context adjuster 1326) in order to enhance performance of the present invention. More particularly, such an adaptive mechanism may repeatedly perform the following steps:

- (a) modify such system parameters;
- (b) consequently activate an instantiation of the location engine 139 (having the modified system parameters) to process, as input, a series of MS signal location data that has been archived together with data corresponding to a verified MS location from which signal location data was transmitted (e.g., such data as is stored in the location signature data base 1320); and
- (c) then determine if the modifications to the system parameters enhanced location engine 139 performance in comparison to previous performances.

Assuming this module adjusts confidences of currently active location hypotheses according to one or more of the attributes: target MS path data, target MS velocity, and target MS acceleration, the computation for this module may be summarized in the following steps:

- (a) Determine if any of the currently active location hypotheses satisfy the premise (38.1) for the attribute. Note that in making this determination, average distances and average standard deviations for the paths (velocities and/or accelerations) corresponding to currently active location hypotheses may be computed..
- (b) For each currently active location hypothesis (wherein "i" uniquely identifies the location hypothesis) selected to have its confidence increased, a confidence adjustment value,  $path\_similar(i)$  (alternatively,  $velocity\_similar(i)$  and/or  $acceleration\_similar(i)$ ), is computed indicating the extent to which the attribute value matches another attribute value being predicted by another FOM.

Note that such confidence adjustment values are used later in the calculation of an aggregate confidence adjustment to particular currently active location hypotheses.

### 30 Analytical Reasoner Controller

Given one or more currently active location hypotheses for the same target MS input to the analytical reasoner controller 1466, this controller activates, for each such input location hypothesis, the other submodules of the analytical reasoner module 1416 (denoted hereinafter as "adjustment submodules") with this location hypothesis. Subsequently, the analytical reasoner controller 1466 receives an output confidence

98

adjustment value computed by each adjustment submodule for adjusting the confidence of this location hypothesis. Note that each adjustment submodule determines:

- (a) whether the adjustment submodule may appropriately compute a confidence adjustment value for the location hypothesis supplied by the controller. (For example, in some cases there may not be a sufficient number of location hypotheses in a time series from a fixed FOM);
- (b) if appropriate, then the adjustment submodule computes a non-zero confidence adjustment value that is returned to the analytical reasoner controller.

Subsequently, the controller uses the output from the adjustment submodules to compute an aggregate confidence adjustment for the corresponding location hypothesis. In one particular embodiment of the present invention, values for the eight types of confidence adjustment values (described in sections above) are output to the present controller for computing an aggregate confidence adjustment value for adjusting the confidence of the currently active location hypothesis presently being analyzed by the analytical reasoner module 1416. As an example of how such confidence adjustment values may be utilized, assuming a currently active location hypothesis is identified by "i", the outputs from the above described adjustment submodules may be more fully described as:

TOP990

15	path_match(i)	1	if there are sufficient previous (and recent) location hypotheses for the same target MS as "i" that have been generated by the same FOM that generated "i", and, the target MS location estimates provided by the location hypothesis "i" and the previous location hypotheses follow a known transportation pathway.
		0	otherwise.
20	vel_ok(i)	1	if the velocity calculated for the i <sup>th</sup> currently active location hypothesis (assuming adequate corresponding path information) is typical for the area (and the current environmental characteristics) of this location hypothesis' target MS location estimate;
		0.2	if the velocity calculated for the i <sup>th</sup> currently active location hypothesis is near a maximum for the area (and the current environmental characteristics) of this location hypothesis' target MS location estimate;
25		0	if the velocity calculated is above the maximum.
	acc_ok(i)	1	if the acceleration calculated for the i <sup>th</sup> currently active location hypothesis (assuming adequate corresponding path information) is typical for the area (and the current environmental characteristics) of this location hypothesis' target MS location estimate;
30		0.2	if the acceleration calculated for the i <sup>th</sup> currently active location hypothesis is near a maximum for the area (and the current environmental characteristics) of this location hypothesis' target MS location estimate;
		0	if the acceleration calculated is above the maximum.
	similar_path(i)	1	if the location hypothesis "i" satisfies (38.1) for the target MS path data attribute; 0 otherwise.
	velocity_similar(i)	1	if the location hypothesis "i" satisfies (38.1) for the target MS velocity attribute; 0 otherwise.

acceleration\_similar(i) | if the location hypothesis "i" satisfies (38.1) for the target MS acceleration attribute; 0 otherwise.  
 extrapolation\_chk(i) | if the location hypothesis "i" is "near" a previously predicted MS location for the target MS; 0 otherwise.

5 Additionally, for each of the above confidence adjustments, there is a corresponding location engine 139 system setable parameter whose value may be determined by repeated activation of the adaptation engine 1382. Accordingly, for each of the confidence adjustment types, T, above, there is a corresponding system setable parameter, "alpha\_T", that is tunable by the adaptation engine 1382. Accordingly, the following high level program segment illustrates the aggregate confidence adjustment value computed by the Analytical Reasoner Controller.

T, 1000

```

10 target_MS_loc_hyps <--- get all currently active location hypotheses, H, identifying the present target ;
    for each currently active location hypothesis, hyp(i), from target_MS_loc_hyps do
    {
        for each of the confidence adjustment submodules, CA, do
            activate CA with hyp(i) as input;
15 /* now compute the aggregate confidence adjustment using the output from the confidence adjustment submodules. */
        aggregate_adjustment(i) <--- alpha_path_match * path_match(i)
            + alpha_velocity * vel_ok(i)
            + alpha_path_similar * path_similar(i)
            + alpha_velocity_similar * velocity_similar(i)
20            + alpha_acceleration_similar * acceleration_similar(i)
            + alpha_extrapolation * extrapolation_chk(i);
        hyp(i).confidence <--- hyp(i).confidence + aggregate_adjustment(i);
    }

```

25 **Historical Location Reasoner**

The historical location reasoner module 1424 may be, for example, a daemon or expert system rule base. The module adjusts the confidences of currently active location hypotheses by using (from location signature data base 1320) historical signal data correlated with: (a) verified MS locations (e.g. locations verified when emergency personnel co-locate with a target MS location), and (b) various environmental factors to evaluate how consistent the location signature cluster for an input location hypothesis agrees with such

30 historical signal data.

This reasoner will increase/decrease the confidence of a currently active location hypothesis depending on how well its associated loc sigs correlate with the loc sigs obtained from data in the location signature data base.

Note that the embodiment hereinbelow is but one of many embodiments that may adjust the confidence of currently active location hypotheses appropriately. Accordingly, it is important to note other embodiments of the historical location reasoner functionality are within the scope of the present invention as one skilled in the art will appreciate upon examining the techniques utilized within this specification. For example, calculations of a confidence adjustment factor may be determined using Monte Carlo techniques as in the context adjuster 1326. Each such embodiment generates a measurement of at least one of the similarity and the discrepancy between the signal characteristics of the verified location signature clusters in the location signature data base and the location signature cluster for an input currently active location hypothesis, "loc\_hyp".

The embodiment hereinbelow provides one example of the functionality that can be provided by the historical location reasoner 1424 (either by activating the following programs as a daemon or by transforming various program segments into the consequents of expert system rules). The present embodiment generates such a confidence adjustment by the following steps:

- (a) comparing, for each cell in a mesh covering of the most relevant MS location estimate in "loc\_hyp", the location signature cluster of the "loc\_hyp" with the verified location signature clusters in the cell so that the following are computed: (i) a discrepancy or error measurement is determined, and (ii) a corresponding measurement indicating a likelihood or confidence of the discrepancy measurement being relatively accurate in comparison to other such error measurements;
- (b) computing an aggregate measurement of both the errors and the confidences determined in (a); and
- (c) using the computed aggregate measurement of (b) to adjust the confidence of "loc\_hyp".

The program illustrated in APPENDIX E provides a more detailed embodiment of the steps immediately above.

#### 20 Location Extrapolator

The location extrapolator 1432 works on the following premise: if for a currently active location hypothesis there is sufficient previous related information regarding estimates of the target MS (e.g., from the same FOM or from using a "most likely" previous target MS estimate output by the location engine 139), then an extrapolation may be performed for predicting future target MS locations that can be compared with new location hypotheses provided to the blackboard. Note that interpolation routines (e.g., conventional algorithms such as Lagrange or Newton polynomials) may be used to determine an equation that approximates a target MS path corresponding to a currently active location hypothesis.

Subsequently, such an extrapolation equation may be used to compute a future target MS location. For further information regarding such interpolation schemes, the following reference is incorporated herein by reference: Mathews, 1992, Numerical methods for mathematics, science, and engineering. Englewood Cliffs, NJ: Prentice Hall.

30 Accordingly, if a new currently active location hypothesis (e.g., supplied by the context adjuster) is received by the blackboard, then the target MS location estimate of the new location hypothesis may be compared with the predicted location. Consequently, a confidence

adjustment value can be determined according to how well if the location hypothesis "i". That is, this confidence adjustment value will be larger as the new MS estimate and the predicted estimate become closer together.

Note that in one embodiment of the present invention, such predictions are based solely on previous target MS location estimates output by location engine 139. Thus, in such an embodiment, substantially every currently active location hypothesis can be provided with a confidence adjustment value by this module once a sufficient number of previous target MS location estimates have been output. Accordingly, a value, `extrapolation_chk(i)`, that represents how accurately the new currently active location hypothesis (identified here by "i") matches the predicted location is determined.

#### Hypothesis Generating Module

The hypothesis generating module 1428 is used for generating additional location hypotheses according to, for example, MS location information not adequately utilized or modeled. Note, location hypotheses may also be decomposed here if, for example it is determined that a location hypothesis includes an MS area estimate that has subareas with radically different characteristics such as an area that includes an uninhabited area and a densely populated area. Additionally, the hypothesis generating module 1428 may generate "poor reception" location hypotheses that specify MS location areas of known poor reception that are "near" or intersect currently active location hypotheses. Note, that these poor reception location hypotheses may be specially tagged (e.g., with a distinctive FOM\_ID value or specific tag field) so that regardless of substantially any other location hypothesis confidence value overlapping such a poor reception area, such an area will maintain a confidence value of "unknown" (i.e., zero). Note that substantially the only exception to this constraint is location hypotheses generated from mobile base stations 148.

102 101



Mobile Base Station Location Subsystem Description

Mobile Base Station Subsystem Introduction

Handwritten initials "JAG" with a checkmark.

5 Any collection of mobile electronics (denoted mobile location unit) that is able to both estimate a location of a target MS 140 and communicate with the base station network may be utilized by the present invention to more accurately locate the target MS. Such mobile location units may provide greater target MS location accuracy by, for example, homing in on the target MS and by transmitting additional MS location information to the location center 142. There are a number of embodiments for such a mobile location unit contemplated by the present invention. For example, in a minimal version, such the electronics of the mobile location unit may be little more than an onboard MS 140, a sectored/directional antenna and a controller for communicating between them. Thus, the onboard MS is used to communicate with the location center 142 and possibly the target MS 140, while the antenna  
10 monitors signals for homing in on the target MS 140. In an enhanced version of the mobile location unit, a GPS receiver may also be incorporated so that the location of the mobile location unit may be determined and consequently an estimate of the location of the target MS may also be determined. However, such a mobile location unit is unlikely to be able to determine substantially more than a direction of the target MS 140 via the sectored/directional antenna without further base station infrastructure cooperation in, for example, determining the transmission power level of the target MS or varying this power level. Thus, if the target MS or the mobile  
15 location unit leaves the coverage area 120 or resides in a poor communication area, it may be difficult to accurately determine where the target MS is located. None-the-less, such mobile location units may be sufficient for many situations, and in fact the present invention contemplates their use. However, in cases where direct communication with the target MS is desired without constant contact with the base station infrastructure, the present invention includes a mobile location unit that is also a scaled down version of a base station 122. Thus, given that such a mobile base station or MBS 148 includes at least an onboard MS 140, a  
20 sectored/directional antenna, a GPS receiver, a scaled down base station 122 and sufficient components (including a controller) for integrating the capabilities of these devices, an enhanced autonomous MS mobile location system can be provided that can be effectively used in, for example, emergency vehicles, air planes and boats. Accordingly, the description that follows below describes an embodiment of an MBS 148 having the above mentioned components and capabilities for use in a vehicle.

25 As a consequence of the MBS 148 being mobile, there are fundamental differences in the operation of an MBS in comparison to other types of BS's 122 (152). In particular, other types of base stations have fixed locations that are precisely determined and known by the location center, whereas a location of an MBS 148 may be known only approximately and thus may require repeated and frequent re-estimating. Secondly, other types of base stations have substantially fixed and stable communication with the location center (via possibly other BS's in the case of LBSs 152) and therefore although these BS's may be more reliable in their in their ability to communicate information related to the location of a target MS with the location center, accuracy can be problematic in poor reception areas. Thus, MBS's may be used in areas (such as wilderness areas) where there may  
30 be no other means for reliably and cost effectively locating a target MS 140 (i.e., there may be insufficient fixed location BS's coverage in an area).



Fig. 11 provides a high level block diagram architecture of one embodiment of the MBS location subsystem 1508. Accordingly, an MBS may include components for communicating with the fixed location BS network infrastructure and the location center 142 via an on-board transceiver 1512 that is effectively an MS 140 integrated into the location subsystem 1508. Thus, if the MBS 148 travels through an area having poor infrastructure signal coverage, then the MBS may not be able to communicate reliably with the location center 142 (e.g., in rural or mountainous areas having reduced wireless telephony coverage). So it is desirable that the MBS 148 must be capable of functioning substantially autonomously from the location center. In one embodiment, this implies that each MBS 148 must be capable of estimating both its own location as well as the location of a target MS 140.

Additionally, many commercial wireless telephony technologies require all BS's in a network to be very accurately time synchronized both for transmitting MS voice communication as well as for other services such as MS location. Accordingly, the MBS 148 will also require such time synchronization. However, since an MBS 148 may not be in constant communication with the fixed location BS network (and indeed may be off-line for substantial periods of time), on-board highly accurate timing device may be necessary. In one embodiment, such a device may be a commercially available rubidium oscillator 1520 as shown in Fig. 11.

Since the MBS 148, includes a scaled down version of a BS 122 (denoted 1522 in Fig. 11), it is capable of performing most typical BS 122 tasks, albeit on a reduced scale. In particular, the base station portion of the MBS 148 can:

- (a) raise/lower its pilot channel signal strength,
- (b) be in a state of soft hand-off with an MS 140, and/or
- (c) be the primary BS 122 for an MS 140, and consequently be in voice communication with the target MS (via the MBS operator telephony interface 1524) if the MS supports voice communication.

Further, the MBS 148 can, if it becomes the primary base station communicating with the MS 140, request the MS to raise/lower its power or, more generally, control the communication with the MS (via the base station components 1522). However, since the MBS 148 will likely have substantially reduced telephony traffic capacity in comparison to a standard infrastructure base station 122, note that the pilot channel for the MBS is preferably a nonstandard pilot channel in that it should not be identified as a conventional telephony traffic bearing BS 122 by MS's seeking normal telephony communication. Thus, a target MS 140 requesting to be located may, depending on its capabilities, either automatically configure itself to scan for certain predetermined MBS pilot channels, or be instructed via the fixed location base station network (equivalently BS infrastructure) to scan for a certain predetermined MBS pilot channel.

Moreover, the MBS 148 has an additional advantage in that it can substantially increase the reliability of communication with a target MS 140 in comparison to the base station infrastructure by being able to move toward or track the target MS 140 even if this MS is in (or moves into) a reduced infrastructure base station network coverage area. Furthermore, an MBS 148 may preferably use a directional or smart antenna 1526 to more accurately locate a direction of signals from a target MS 140. Thus, the sweeping of such a smart antenna 1526 (physically or electronically) provides directional information regarding signals received from the target MS 140. That is, such directional information is determined by the signal propagation delay of signals from the target MS 140 to the angular sectors of one of more directional antennas 1526 on-board the MBS 148.

104

Before proceeding to further details of the MBS location subsystem 1508, an example of the operation of an MBS 148 in the context of responding to a 911 emergency call is given. In particular, this example describes the high level computational states through which the MBS 148 transitions, these states also being illustrated in the state transition diagram of Fig. 12. Note that this figure illustrates the primary state transitions between these MBS 148 states, wherein the solid state transitions are indicative of a typical "ideal" progression when locating or tracking a target MS 140, and the dashed state transitions are the primary state reversions due, for example, to difficulties in locating the target MS 140.

Accordingly, initially the MBS 148 may be in an inactive state 1700, wherein the MBS location subsystem 1508 is effectively available for voice or data communication with the fixed location base station network, but the MS 140 locating capabilities of the MBS are not active. From the inactive state 1700 the MBS (e.g., a police or rescue vehicle) may enter an active state 1704 once an MBS operator has logged onto the MBS location subsystem of the MBS, such logging being for authentication, verification and journaling of MBS 148 events. In the active state 1704, the MBS may be listed by a 911 emergency center and/or the location center 142 as eligible for service in responding to a 911 request. From this state, the MBS 148 may transition to a ready state 1708 signifying that the MBS is ready for use in locating and/or intercepting a target MS 140. That is, the MBS 148 may transition to the ready state 1708 by performing the following steps:

- (1a) Synchronizing the timing of the location subsystem 1508 with that of the base station network infrastructure. In one embodiment, when requesting such time synchronization from the base station infrastructure, the MBS 148 will be at a predetermined or well known location so that the MBS time synchronization may adjust for a known amount of signal propagation delay in the synchronization signal.
- (1b) Establishing the location of the MBS 148. In one embodiment, this may be accomplished by, for example, an MBS operator identifying the predetermined or well known location at which the MBS 148 is located.
- (1c) Communicating with, for example, the 911 emergency center via the fixed location base station infrastructure to identify the MBS 148 as in the ready state.

Thus, while in the ready state 1708, as the MBS 148 moves, it has its location repeatedly (re)-estimated via, for example, GPS signals, location center 142's location estimates from the base stations 122 (and 152), and an on-board deadreckoning subsystem 1527 having an MBS location estimator according to the programs described hereinbelow. However, note that the accuracy of the base station time synchronization (via the rubidium oscillator 1520) and the accuracy of the MBS 148 location may need to both be periodically recalibrated according to (1a) and (1b) above.

Assuming a 911 signal is transmitted by a target MS 140, this signal is transmitted, via the fixed location base station infrastructure, to the 911 emergency center and the location center 142, and assuming the MBS 148 is in the ready state 1708, if a corresponding 911 emergency request is transmitted to the MBS (via the base station infrastructure) from the 911 emergency center or the location center, then the MBS may transition to a seek state 1712 by performing the following steps:

- (2a) Communicating with, for example, the 911 emergency response center via the fixed location base station network to receive the PN code for the target MS to be located (wherein this communication is performed using the MS-like transceiver 1512 and/or the MBS operator telephony interface 1524).

(2b) Obtaining a most recent target MS location estimate from either the 911 emergency center or the location center 142.

(2c) Inputting by the MBS operator an acknowledgment of the target MS to be located, and transmitting this acknowledgment to the 911 emergency response center via the transceiver 1512.

5           Subsequently, when the MBS 148 is in the seek state 1712, the MBS may commence toward the target MS location estimate provided. Note that it is likely that the MBS is not initially in direct signal contact with the target MS. Accordingly, in the seek state 1712 the following steps may be, for example, performed:

10           (3a) The location center 142 or the 911 emergency response center may inform the target MS, via the fixed location base station network, to lower its threshold for soft hand-off and at least periodically boost its location signal strength. Additionally, the target MS may be informed to scan for the pilot channel of the MBS 148. (Note the actions here are not, actions performed by the MBS 148 in the "seek state"; however, these actions are given here for clarity and completeness.)

(3b) Repeatedly, as sufficient new MS location information is available, the location center 142 provides new MS location estimates to the MBS 148 via the fixed location base station network.

15           (3c) The MBS repeatedly provides the MBS operator with new target MS location estimates provided substantially by the location center via the fixed location base station network.

(3d) The MBS 148 repeatedly attempts to detect a signal from the target MS using the PN code for the target MS.

(3e) The MBS 148 repeatedly estimates its own location (as in other states as well), and receives MBS location estimates from the location center.

20           Assuming that the MBS 148 and target MS 140 detect one another (which typically occurs when the two units are within .25 to 3 miles of one another), the MBS enters a contact state 1716 when the target MS 140 enters a soft hand-off state with the MBS. Accordingly, in the contact state 1716, the following steps are, for example, performed:

(4a) The MBS 148 repeatedly estimates its own location.

25           (4b) Repeatedly, the location center 142 provides new target MS 140 and MBS location estimates to the MBS 148 via the fixed location base infrastructure network.

(4c) Since the MBS 148 is at least in soft hand-off with the target MS 140, the MBS can estimate the direction and distance of the target MS itself using, for example, detected target MS signal strength and TOA as well as using any recent location center target MS location estimates.

30           (4d) The MBS 148 repeatedly provides the MBS operator with new target MS location estimates provided using MS location estimates provided by the MBS itself and by the location center via the fixed location base station network.

When the target MS 140 detects that the MBS pilot channel is sufficiently strong, the target MS may switch to using the MBS 148 as its primary base station. When this occurs, the MBS enters a control state 1720, wherein the following steps are, for example, performed:

106 105

(5a) The MBS 148 repeatedly estimates its own location.

(5b) Repeatedly, the location center 142 provides new target MS and MBS location estimates to the MBS 148 via the network of base stations 122 (152).

5 (5c) The MBS 148 estimates the direction and distance of the target MS 140 itself using, for example, detected target MS signal strength and TOA as well as using any recent location center target MS location estimates.

(5d) The MBS 148 repeatedly provides the MBS operator with new target MS location estimates provided using MS location estimates provided by the MBS itself and by the location center 142 via the fixed location base station network.

(5e) The MBS 148 becomes the primary base station for the target MS 140 and therefore controls at least the signal strength output by the target MS.

10 Note, there can be more than one MBS 148 tracking or locating an MS 140. There can also be more than one target MS 140 to be tracked concurrently and each target MS being tracked may be stationary or moving.

#### MBS Subsystem Architecture

An MBS 148 uses MS signal characteristic data for locating the MS 140. The MBS 148 may use such signal characteristic data to facilitate determining whether a given signal from the MS is a "direct shot" or an multipath signal. That is, in one embodiment, the MBS 148 attempts to determine or detect whether an MS signal transmission is received directly, or whether the transmission has been reflected or deflected. For example, the MBS may determine whether the expected signal strength, and TOA agree in distance estimates for the MS signal transmissions. Note, other signal characteristics may also be used, if there are sufficient electronics and processing available to the MBS 148; i.e., determining signal phase and/or polarity as other indications of receiving a "direct shot" from an MS 140.

20 In one embodiment, the MBS 148 (Fig. 11) includes an MBS controller 1533 for controlling the location capabilities of the MBS 148. In particular, the MBS controller 1533 initiates and controls the MBS state changes as described in Fig. 12 above. Additionally, the MBS controller 1533 also communicates with the location controller 1535, wherein this latter controller controls MBS activities related to MBS location and target MS location; e.g., this performs the program, "mobile\_base\_station\_controller" described in APPENDIX A hereinbelow. The location controller 1535 receives data input from an event generator 1537 for generating event records to be provided to the location controller 1535. For example, records may be generated from data input received from: (a) the vehicle movement detector 1539 indicating that the MBS 148 has moved at least a predetermined amount and/or has changed direction by at least a predetermined angle, or (b) the MBS signal processing subsystem 1541 indicating that the additional signal measurement data has been received from either the location center 142 or the target MS 140. Note that the MBS signal processing subsystem 1541, in one embodiment, is similar to the signal processing subsystem 1220 of the location center 142. may have multiple command schedulers. In particular, a scheduler 1528 for commands related to communicating with the location center 142, a scheduler 1530 for commands related to GPS communication (via GPS receiver 1531), a scheduler 1529 for commands related to the frequency and granularity of the reporting of MBS changes in direction and/or position via the MBS dead reckoning subsystem 1527

*JMB/4*

(note that this scheduler is potentially optional and that such commands may be provided directly to the deadreckoning estimator 1544), and a scheduler 1532 for communicating with the target MS(s) 140 being located. Further, it is assumed that there is sufficient hardware and/or software to appear to perform commands in different schedulers substantially concurrently.

In order to display an MBS computed location of a target MS 140, a location of the MBS must be known or determined.

5 Accordingly, each MBS 148 has a plurality of MBS location estimators (or hereinafter also simply referred to as location estimators) for determining the location of the MBS. Each such location estimator computes MBS location information such as MBS location estimates, changes to MBS location estimates, or, an MBS location estimator may be an interface for buffering and/or translating a previously computed MBS location estimate into an appropriate format. In particular, the MBS location module 1536, which determines the location of the MBS, may include the following MBS location estimators 1540 (also denoted baseline location  
10 estimators):

(a) a GPS location estimator 1540a (not individually shown) for computing an MBS location estimate using GPS signals,

(b) a location center location estimator 1540b (not individually shown) for buffering and/or translating an MBS estimate received from the location center 142,

(c) an MBS operator location estimator 1540c (not individually shown) for buffering and/or translating manual MBS location  
15 entries received from an MBS location operator, and

(d) in some MBS embodiments, an LBS location estimator 1540d (not individually shown) for the activating and deactivating of LBS's 152. Note that, in high multipath areas and/or stationary base station marginal coverage areas, such low cost location base stations 152 (LBS) may be provided whose locations are fixed and accurately predetermined and whose signals are substantially only receivable within a relatively small range (e.g., 2000 feet), the range potentially being  
20 variable. Thus, by communicating with the LBS's 152 directly, the MBS 148 may be able to quickly use the location information relating to the location base stations for determining its location by using signal characteristics obtained from the LBSs 152.

Note that each of the MBS baseline location estimators 1540, such as those above, provide an actual MBS location rather than, for example, a change in an MBS location. Further note that it is an aspect of the present invention that additional MBS baseline location  
25 estimators 1540 may be easily integrated into the MBS location subsystem 1508 as such baseline location estimators become available. For example, a baseline location estimator that receives MBS location estimates from reflective codes provided, for example, on streets or street signs can be straightforwardly incorporated into the MBS location subsystem 1508.

Additionally, note that a plurality of MBS location technologies and their corresponding MBS location estimators are utilized due to the fact that there is currently no single location technology available that is both sufficiently fast, accurate and accessible in  
30 substantially all terrains to meet the location needs of an MBS 148. For example, in many terrains GPS technologies may be sufficiently accurate; however, GPS technologies: (a) may require a relatively long time to provide an initial location estimate (e.g., greater than 2 minutes); (b) when GPS communication is disturbed, it may require an equally long time to provide a new location estimate; (c) clouds, buildings and/or mountains can prevent location estimates from being obtained; (d) in some cases signal reflections can substantially skew a location estimate. As another example, an MBS 148 may be able to use triangulation or

107



trilateralization technologies to obtain a location estimate; however, this assumes that there is sufficient (fixed location) infrastructure BS coverage in the area the MBS is located. Further, it is well known that the multipath phenomenon can substantially distort such location estimates. Thus, for an MBS 148 to be highly effective in varied terrains, an MBS is provided with a plurality of location technologies, each supplying an MBS location estimate.

5 In fact, much of the architecture of the location engine 139 could be incorporated into an MBS 148. For example, in some embodiments of the MBS 148, the following FOMs 1224 may have similar location models incorporated into the MBS:

- (a) a variation of the distance FOM 1224 wherein TOA signals from communicating fixed location BS's are received (via the MBS transceiver 1512) by the MBS and used for providing a location estimate;
- (b) a variation of the artificial neural net based FOMs 1224 (or more generally a location learning or a classification model) may be used to provide MBS location estimates via, for example, learned associations between fixed location BS signal characteristics and geographic locations;
- 10 (c) an LBS location FOM 1224 for providing an MBS with the ability to activate and deactivate LBS's to provide (positive) MBS location estimates as well as negative MBS location regions (i.e., regions where the MBS is unlikely to be since one or more LBS's are not detected by the MBS transceiver);
- 15 (d) one or more MBS location reasoning agents and/or a location estimate heuristic agents for resolving MBS location estimate conflicts and providing greater MBS location estimate accuracy. For example, modules similar to the analytical reasoner module 1416 and the historical location reasoner module 1424.

However, for those MBS location models requiring communication with the base station infrastructure, an alternative embodiment is to rely on the location center 142 to perform the computations for at least some of these MBS FOM models. That is, since each of the MBS location models mentioned immediately above require communication with the network of fixed location BS's 122 (152), it may be advantageous to transmit MBS location estimating data to the location center 142 as if the MBS were another MS 140 for the location center to locate, and thereby rely on the location estimation capabilities at the location center rather than duplicate such models in the MBS 148. The advantages of this approach are that:

- (a) an MBS is likely to be able to use less expensive processing power and software than that of the location center;
- 25 (b) an MBS is likely to require substantially less memory, particularly for data bases, than that of the location center.

As will be discussed further below, in one embodiment of the MBS 148, there are confidence values assigned to the locations output by the various location estimators 1540. Thus, the confidence for a manual entry of location data by an MBS operator may be rated the highest and followed by the confidence for (any) GPS location data, followed by the confidence for (any) location center location 142 estimates, followed by the confidence for (any) location estimates using signal characteristic data from LBSs. However, such prioritization may vary depending on, for instance, the radio coverage area 120. In an one embodiment of the present invention, it is an aspect of the present invention that for MBS location data received from the GPS and location center, their confidences may vary according to the area in which the MBS 148 resides. That is, if it is known that for a given area, there is a reasonable probability that a GPS signal may suffer multipath distortions and that the location center has in the past provided reliable location estimates, then the confidences for these two location sources may be reversed.

109

108

In one embodiment of the present invention, MBS operators may be requested to occasionally manually enter the location of the MBS 148 when the MBS is stationary for determining and/or calibrating the accuracy of various MBS location estimators.

There is an additional important source of location information for the MBS 148 that is incorporated into an MBS vehicle (such as a police vehicle) that has no comparable functionality in the network of fixed location BS's. That is, the MBS 148 may use  
5 deadreckoning information provided by a deadreckoning MBS location estimator 1544 whereby the MBS may obtain MBS deadreckoning location change estimates. Accordingly, the deadreckoning MBS location estimator 1544 may use, for example, an on-board gyroscope 1550, a wheel rotation measurement device (e.g., odometer) 1554, and optionally an accelerometer (not shown). Thus, such a deadreckoning MBS location estimator 1544 periodically provides at least MBS distance and directional data related to MBS movements from a most recent MBS location estimate. More precisely, in the absence of any other new MBS location  
10 information, the deadreckoning MBS location estimator 1544 outputs a series of measurements, wherein each such measurement is an estimated change (or delta) in the position of the MBS 148 between a request input timestamp and a closest time prior to the timestamp, wherein a previous deadreckoning terminated. Thus, each deadreckoning location change estimate includes the following fields:

- (a) an "earliest timestamp" field for designating the start time when the deadreckoning location change estimate  
15 commences measuring a change in the location of the MBS;
- (b) a "latest timestamp" field for designating the end time when the deadreckoning location change estimate stops measuring a change in the location of the MBS; and
- (c) an MBS location change vector.

That is, the "latest timestamp" is the timestamp input with a request for deadreckoning location data, and the "earliest timestamp"  
20 is the timestamp of the closest time, T, prior to the latest timestamp, wherein a previous deadreckoning output has its a timestamp at a time equal to T.

Further, the frequency of such measurements provided by the deadreckoning subsystem 1527 may be adaptively provided depending on the velocity of the MBS 148 and/or the elapsed time since the most recent MBS location update. Accordingly, the architecture of at least some embodiments of the MBS location subsystem 1508 must be such that it can utilize such deadreckoning  
25 information for estimating the location of the MBS 148.

In one embodiment of the MBS location subsystem 1508 described in further detail hereinbelow, the outputs from the deadreckoning MBS location estimator 1544 are used to synchronize MBS location estimates from different MBS baseline location estimators. That is, since such a deadreckoning output may be requested for substantially any time from the deadreckoning MBS location estimator, such an output can be requested for substantially the same point in time as the occurrence of the signals from  
30 which a new MBS baseline location estimate is derived. Accordingly, such a deadreckoning output can be used to update other MBS location estimates not using the new MBS baseline location estimate.

It is assumed that the error with dead reckoning increases with deadreckoning distance. Accordingly, it is an aspect of the embodiment of the MBS location subsystem 1508 that when incrementally updating the location of the MBS 148 using deadreckoning and applying deadreckoning location change estimates to a "most likely area" in which the MBS 148 is believed to be, this area is

9/15/05

110 109



incrementally enlarged as well as shifted. The enlargement of the area is used to account for the inaccuracy in the deadreckoning capability. Note, however, that the deadreckoning MBS location estimator is periodically reset so that the error accumulation in its outputs can be decreased. In particular, such resetting occurs when there is a high probability that the location of the MBS is known. For example, the deadreckoning MBS location estimator may be reset when an MBS operator manually enters an MBS location or verifies an MBS location, or a computed MBS location has sufficiently high confidence.

Thus, due to the MBS 148 having less accurate location information (both about itself and a target MS 140), and further that deadreckoning information must be utilized in maintaining MBS location estimates, a first embodiment of the MBS location subsystem architecture is somewhat different from the location engine 139 architecture. That is, the architecture of this first embodiment is simpler than that of the architecture of the location engine 139. However, it important to note that, at a high level, the architecture of the location engine 139 may also be applied for providing a second embodiment of the MBS location subsystem 1508, as one skilled in the art will appreciate after reflecting on the architectures and processing provided at an MBS 148. For example, an MBS location subsystem 1508 architecture may be provided that has one or more first order models 1224 whose output is supplied to, for example, a blackboard or expert system for resolving MBS location estimate conflicts, such an architecture being analogous to one embodiment of the location engine 139 architecture.

Furthermore, it is also an important aspect of the present invention that, at a high level, the MBS location subsystem architecture may also be applied as an alternative architecture for the location engine 139. For example, in one embodiment of the location engine 139, each of the first order models 1224 may provide its MS location hypothesis outputs to a corresponding "location track," analogous to the MBS location tracks described hereinbelow, and subsequently, a most likely MS current location estimate may be developed in a "current location track" (also described hereinbelow) using the most recent location estimates in other location tracks.

Further, note that the ideas and methods discussed here relating to MBS location estimators 1540 and MBS location tracks, and, the related programs hereinbelow are sufficiently general so that these ideas and methods may be applied in a number of contexts related to determining the location of a device capable of movement and wherein the location of the device must be maintained in real time. For example, the present ideas and methods may be used by a robot in a very cluttered environment (e.g., a warehouse), wherein the robot has access: (a) to a plurality of "robot location estimators" that may provide the robot with sporadic location information, and (b) to a deadreckoning location estimator.

Each MBS 148, additionally, has a location display (denoted the MBS operator visual user interface 1558 in Fig. 11) where area maps that may be displayed together with location data. In particular, MS location data may be displayed on this display as a nested collection of areas, each smaller nested area being the most likely area within (any) encompassing area for locating a target MS 140. Note that the MBS controller algorithm below may be adapted to receive location center 142 data for displaying the locations of other MBSs 148 as well as target MSs 140.

Further, the MBS 148 may constrain any location estimates to streets on a street map using the MBS location snap to street module 1562. For example, an estimated MBS location not on a street may be "snapped to" a nearest street location. Note that a nearest street location determiner may use "normal" orientations of vehicles on streets as a constraint on the nearest street location.

Particularly, if an MBS 148 is moving at typical rates of speed and acceleration, and without abrupt changes direction. For example, if the deadreckoning MBS location estimator 1544 indicates that the MBS 148 is moving in a northerly direction, then the street snapped to should be a north-south running street. Moreover, the MBS location snap to street module 1562 may also be used to enhance target MS location estimates when, for example, it is known or suspected that the target MS 140 is in a vehicle and the vehicle is moving at typical rates of speed. Furthermore, the snap to street location module 1562 may also be used in enhancing the location of a target MS 140 by either the MBS 148 or by the location engine 139. In particular, the location estimator 1344 or an additional module between the location estimator 1344 and the output gateway 1356 may utilize an embodiment of the snap to street location module 1562 to enhance the accuracy of target MS 140 location estimates that are known to be in vehicles. Note that this may be especially useful in locating stolen vehicles that have embedded wireless location transceivers (MSs 140), wherein appropriate wireless signal measurements can be provided to the location center 142.

MBS Data Structure Remarks

Assuming the existence of at least some of the location estimators 1540 that were mentioned above, the discussion here refers substantially to the data structures and their organization as illustrated in Fig. 13.

The location estimates (or hypotheses) for an MBS 148 determining its own location each have an error or range estimate associated with the MBS location estimate. That is, each such MBS location estimate includes a "most likely MBS point location" within a "most likely area". The "most likely MBS point location" is assumed herein to be the centroid of the "most likely area." In one embodiment of the MBS location subsystem 1508, a nested series of "most likely areas" may be provided about a most likely MBS point location. However, to simplify the discussion herein each MBS location estimate is assumed to have a single "most likely area". One skilled in the art will understand how to provide such nested "most likely areas" from the description herein. Additionally, it is assumed that such "most likely areas" are not grossly oblong; i.e., area cross sectioning lines through the centroid of the area do not have large differences in their lengths. For example, for any such "most likely area", A, no two such cross sectioning lines of A may have lengths that vary by more than a factor of two.

Each MBS location estimate also has a confidence associated therewith providing a measurement of the perceived accuracy of the MBS being in the "most likely area" of the location estimate.

A (MBS) "location track" is an data structure (or object) having a queue of a predetermined length for maintaining a temporal (timestamp) ordering of "location track entries" such as the location track entries 1770a, 1770b, 1774a, 1774b, 1778a, 1778b, 1782a, 1782b, and 1786a (Fig. 13), wherein each such MBS location track entry is an estimate of the location of the MBS at a particular corresponding time.

JAN 7

There is an MBS location track for storing MBS location entries obtained from MBS location estimation information from each of the MBS baseline location estimators described above (i.e., a GPS location track 1750 for storing MBS location estimations obtained from the GPS location estimator 1540, a location center location track 1754 for storing MBS location estimations obtained from the location estimator 1540 deriving its MBS location estimates from the location center 142, an LBS location track 1758 for storing MBS

location estimations obtained from the location estimator 1540 deriving its MBS location estimates from base stations 122 and/or 152, and a manual location track 1762 for MBS operator entered MBS locations). Additionally, there is one further location track, denoted the "current location track" 1766 whose location track entries may be derived from the entries in the other location tracks (described further hereinbelow). Further, for each location track, there is a location track head that is the head of the queue for the location track. The location track head is the most recent (and presumably the most accurate) MBS location estimate residing in the location track. Thus, for the GPS location track 1750 has location track head 1770; the location center location track 1754 has location track head 1774; the LBS location track 1758 has location track head 1778; the manual location track 1762 has location track head 1782; and the current location track 1766 has location track head 1786. Additionally, for notational convenience, for each location track, the time series of previous MBS location estimations (i.e., location track entries) in the location track will herein be denoted the "path for the location track." Such paths are typically the length of the location track queue containing the path. Note that the length of each such queue may be determined using at least the following considerations:

- (i) In certain circumstances (described hereinbelow), the location track entries are removed from the head of the location track queues so that location adjustments may be made. In such a case, it may be advantageous for the length of such queues to be greater than the number of entries that are expected to be removed;
- (ii) In determining an MBS location estimate, it may be desirable in some embodiments to provide new location estimates based on paths associated with previous MBS location estimates provided in the corresponding location track queue.

Also note that it is within the scope of the present invention that the location track queue lengths may be a length of one.

Regarding location track entries, each location track entry includes:

- (a) a "derived location estimate" for the MBS that is derived using at least one of:
  - (i) at least a most recent previous output from an MBS baseline location estimator 1540 (i.e., the output being an MBS location estimate);
  - (ii) deadreckoning output information from the deadreckoning subsystem 1527.Further note that each output from an MBS location estimator has a "type" field that is used for identifying the MBS location estimator of the output.
- (b) an "earliest timestamp" providing the time/date when the earliest MBS location information upon which the derived location estimate for the MBS depends. Note this will typically be the timestamp of the earliest MBS location estimate (from an MBS baseline location estimator) that supplied MBS location information used in deriving the derived location estimate for the MBS 148.
- (c) a "latest timestamp" providing the time/date when the latest MBS location information upon which the derived location estimate for the MBS depends. Note that earliest timestamp = latest timestamp only for so called "baseline entries" as defined hereinbelow. Further note that this attribute is the one used for maintaining the "temporal (timestamp) ordering" of location track entries.

- (d) A “deadreckoning distance” indicating the total distance (e.g., wheel turns or odometer difference) since the most recently previous baseline entry for the corresponding MBS location estimator for the location track to which the location track entry is assigned.

5 For each MBS location track, there are two categories of MBS location track entries that may be inserted into a MBS location track:

- (a) “baseline” entries, wherein each such baseline entry includes (depending on the location track) a location estimate for the MBS 148 derived from: (i) a most recent previous output either from a corresponding MBS baseline location estimator, or (ii) from the baseline entries of other location tracks (this latter case being the for the “current” location track);
- 10 (b) “extrapolation” entries, wherein each such entry includes an MBS location estimate that has been extrapolated from the (most recent) location track head for the location track (i.e., based on the track head whose “latest timestamp” immediately precedes the latest timestamp of the extrapolation entry). Each such extrapolation entry is computed by using data from a related deadreckoning location change estimate output from the deadreckoning MBS location estimator 1544. Each such deadreckoning location change estimate includes measurements related to changes or
- 15 deltas in the location of the MBS 148. More precisely, for each location track, each extrapolation entry is determined using: (i) a baseline entry, and (ii) a set of one or more (i.e., all later occurring) deadreckoning location change estimates in increasing “latest timestamp” order. Note that for notational convenience this set of one or more deadreckoning location change estimates will be denoted the “deadreckoning location change estimate set” associated with the extrapolation entry resulting from this set.
- 20 (c) Note that for each location track head, it is either a baseline entry or an extrapolation entry. Further, for each extrapolation entry, there is a most recent baseline entry, B, that is earlier than the extrapolation entry and it is this B from which the extrapolation entry was extrapolated. This earlier baseline entry, B, is hereinafter denoted the “baseline entry associated with the extrapolation entry.” More generally, for each location track entry, T, there is a most recent previous baseline entry, B, associated with T, wherein if T is an extrapolation entry, then B is as defined
- 25 above, else if T is a baseline entry itself, then  $T = B$ . Accordingly, note that for each extrapolation entry that is the head of a location track, there is a most recent baseline entry associated with the extrapolation entry.

Further, there are two categories of location tracks:

- (a) “baseline location tracks,” each having baseline entries exclusively from a single predetermined MBS baseline location estimator; and
- 30 (b) a “current” MBS location track having entries that are computed or determined as “most likely” MBS location estimates from entries in the other MBS location tracks.

117

### MBS Location Estimating Strategy

In order to be able to properly compare the track heads to determine the most likely MBS location estimate it is an aspect of the present invention that the track heads of all location tracks include MBS location estimates that are for substantially the same (latest) timestamp. However, the MBS location information from each MBS baseline location estimator is inherently substantially unpredictable and unsynchronized. In fact, the only MBS location information that may be considered predicable and controllable is the deadreckoning location change estimates from the deadreckoning MBS location estimator 1544 in that these estimates may reliably be obtained whenever there is a query from the location controller 1535 for the most recent estimate in the change of the location for the MBS 148. Consequently (referring to Fig. 13), synchronization records 1790 (having at least a 1790b portion, and in some cases also having a 1790a portion) may be provided for updating each location track with a new MBS location estimate as a new track head. In particular, each synchronization record includes a deadreckoning location change estimate to be used in updating all but at most one of the location track heads with a new MBS location estimate by using a deadreckoning location change estimate in conjunction with each MBS location estimate from an MBS baseline location estimator, the location track heads may be synchronized according to timestamp. More precisely, for each MBS location estimate, E, from an MBS baseline location estimator, the present invention also substantially simultaneously queries the deadreckoning MBS location estimator for a corresponding most recent change in the location of the MBS 148. Accordingly, E and the retrieved MBS deadreckoning location change estimate, C, have substantially the same "latest timestamp". Thus, the location estimate E may be used to create a new baseline track head for the location track having the corresponding type for E, and C may be used to create a corresponding extrapolation entry as the head of each of the other location tracks. Accordingly, since for each MBS location estimate, E, there is a MBS deadreckoning location change estimate, C, having substantially the same "latest timestamp", E and C will be hereinafter referred as "paired."

High level descriptions of an embodiment of the location functions performed by an MBS 148 are provided in APPENDIX A hereinbelow.

115

**APPENDIX A: MBS Function Embodiments**

**Mobile Base Station Controller Program**

TT1160

```
5  mobile_base_station_controller()
   {
   wait_for_input_of_first_MBS_location(event); /* "event" is a record (object) with MBS location data */
   WHILE (no MBS operator input to exit) DO
       CASE OF (event): /* determine the type of "event" and process it. */
10      MBS LOCATION DATA RECEIVED FROM GPS:
       MBS LOCATION DATA RECEIVED FROM LBS:
       MBS LOCATION DATA RECEIVED FROM ANY OTHER HIGHLY RELIABLE MBS LOCATION
         SOURCES (EXCEPT LOCATION CENTER):
       {
15      MBS_new_est <--- get_new_MBS_location_using_estimate(event);
         /* Note, whenever a new MBS location estimate is entered as a baseline estimate into the location tracks, the other
         location tracks must be immediately updated with any deadreckoning location change estimates so that all
         location tracks are substantially updated at the same time. */
20      deadreck_est <--- get_deadreckoning_location_change_estimate(event);
       MBS_curr_est <--- DETERMINE_MBS_LOCATION_ESTIMATE(MBS_new_est, deadreck_est);
       if (MBS_curr_est.confidence > a predetermined high confidence threshold) then
         reset_deadreckoning_MBS_location_estimator(event);
         /* deadreckoning starts over from here. */

25      /* Send MBS location information to the Location Center. */
       if ( MBS has not moved since the last MBS location estimate of this type and is not now moving) then
       {
         configure the MBS on-board transceiver (e.g., MBS-MS) to immediately transmit location signals to the fixed
         location BS network as if the MBS were an ordinary location device (MS);

30      communicate with the Location Center via the fixed location BS infrastructure the following:
         (a) a "locate me" signal,
```

Ind. C98

116 115

- (b) MBS\_curr\_est,
- (c) MBS\_new\_est and
- (d) the timestamp for the present event.

5 Additionally, any location signal information between the MBS and the present target MS may be transmitted to the Location Center so that this information may also be used by the Location Center to provide better estimates of where the MBS is. Further, if the MBS determines that it is immediately adjacent to the target MS and also that its own location estimate is highly reliable (e.g., a GPS estimate), then the MBS may also communicate this information to the Location Center so that the Location Center can: (a) associate any target MS location signature cluster data with the fixed base station infrastructure with the location provided by the MBS, and (b) insert this associated data into the location signature data base of the Location Center as a verified cluster of "random loc sigs";

10 /\* note, this transmission preferably continues (i.e., repeats) for at least a predetermined length of time of sufficient length for the Signal Processing Subsystem to collect a sufficient signal characteristic sample size. \*/

15 }

else SCHEDULE an event (if none scheduled) to transmit to the Location Center the following: (a) MBS\_curr\_est, and (b) the GPS location of the MBS and the time of the GPS location estimate;

/\* Now update MBS display with new MBS location; note, MBS operator must request MBS locations on the MBS display; if not requested, then the following call does not do an update. \*/

20 update\_MBS\_operator\_display\_with\_MBS\_est(MBS\_curr\_est);

}

**SINCE LAST MBS LOCATION UPDATE**

**MBS HAS MOVED A THRESHOLD DISTANCE: {**

25 deadreck\_est <--- get\_deadreckoning\_location\_change\_estimate(event);

/\* Obtain from MBS Dead Reckoning Location Estimator a new dead reckoning MBS location estimate having an estimate as to the MBS location change from the location of the last MBS location provided to the MBS. \*/

MBS\_curr\_est <---- DETERMINE\_MBS\_LOCATION\_ESTIMATE(NULL, deadreck\_est);

30 /\* this new MBS estimate will be used in new target MS estimates\*/

update\_MBS\_display\_with\_updated\_MBS\_location(MBS\_curr\_est);

SCHEDULE an event (if none scheduled) to request new GPS location data for MBS;

SCHEDULE an event (if none scheduled) to request communication with Location Center (LC) related to new MBS location data;

SCHEDULE an event (if none scheduled) to request new LBS location communication between the MBS and any LBS's that can detect the MBS;

5           /\* Note, in some embodiments the processing of MBS location data from LBS's may be performed automatically by the Location Center, wherein the Location Center uses signal characteristic data from the LBS's in determining an estimated location of the MBS. \*/

SCHEDULE an event (if none scheduled) to obtain new target MS signal characteristics from MS;   /\* i.e., may get a better target MS location estimate now. \*/

10       }

**TIMER HAS EXPIRED SINCE LAST RELIABLE TARGET MS LOCATION INFORMATION**

**OBTAINED: {**

SCHEDULE an event (if none scheduled) to request location communication with the target MS, the event is at a very high priority;

15       RESET timer for target MS location communication; /\* Try to get target MS location communication again within a predetermined time. Note, timer may dynamically determined according to the perceived velocity of the target MS. \*/

      }

**LOCATION COMMUNICATION FROM TARGET MS RECEIVED: {**

20       MS\_raw\_signal\_data <--- get\_MS\_signal\_characteristic\_raw\_data(event);

          /\* Note, "MS\_raw\_signal\_data" is an object having substantially the unfiltered signal characteristic values for communications between the MBS and the target MS as well as timestamp information. \*/

      Construct a message for sending to the Location Center, wherein the message includes at least "MS\_raw\_signal\_data" and "MBS\_curr\_est" so that the Location Center can also compute an estimated location for the target MS;

25       SCHEDULE an event (if none scheduled) to request communication with Location Center (LC) for sending the constructed message;

          /\* Note, this data does not overwrite any previous data waiting to be sent to the LC. \*/

30       MS\_signal\_data <--- get\_MS\_signal\_characteristic\_data(event);

          /\* Note, the MS signal data obtained above is, in one embodiment, "raw" signal data. However, in a second embodiment, this data is filtered substantially as in the Location Center by the Signal

118 117



Processing Subsystem. For simplicity of discussion here, it is assumed that each MBS includes at least a scaled down version of the Signal Processing Subsystem (see FIG. 11). \*/

```
MS_new_est <---- DETERMINE_MS_MOST_RECENT_ESTIMATE(MBS_curr_est, MS_curr_est,  
MS_signal_data);
```

```
5 /* May use forward and reverse TOA, TDOA, signal power, signal strength, and signal quality  
indicators. Note, "MS_curr_est" includes a timestamp of when the target MS signals were received.  
*/
```

```
if (MS_new_est.confidence > min_MS_confidence) then
```

```
{
```

```
10 mark_MS_est_as_temporary(MS_new_est);
```

```
/* Note, it is assumed that this MS location estimate is "temporary" in the sense that it will be  
replaced by a corresponding MS location estimate received from the Location Center that is based on  
the same target MS raw signal data. That is, if the Location Center responds with a corresponding  
target MS location estimate, E, while "MS_new_est" is a value in a "moving window" of target MS  
15 location estimates (as described hereinbelow), then E will replace the value of "MS_new_est". Note,  
the moving window may dynamically vary in size according to, for example, a perceived velocity of  
the target MS and/or the MBS. */
```

```
MS_moving_window <--- get_MS_moving_window(event);
```

```
/* get moving window of location estimates for this target MS. */
```

```
20
```

```
add_MS_estimate_to_MS_location_window(MS_new_est, MS_moving_window);
```

```
/* Since any given single collection of measurements related to locating the target MS may be  
potentially misleading, a "moving window" of location estimates are used to form a "composite  
location estimate" of the target MS. This composite location estimate is based on some number of the  
25 most recent location estimates determined. Such a composite location estimate may be, for example,  
analogous to a moving average or some other weighting of target MS location estimates. Thus, for  
example, for each location estimate (i.e., at least one MS location area, a most likely single location,  
and, a confidence estimate) a centroid type calculation may be performed to provide the composite  
location estimate. */
```

```
30
```

```
MS_curr_est <---- DETERMINE_MS_LOCATION_ESTIMATE(MS_moving_window);
```

```
/* DETERMINE new target MS location estimate. Note this may an average location or a weighted  
average location. */
```

```
remove_scheduled_events("TARGET_MS_SCHEDULE", event.MS_ID);
```

119

118

```

/* REMOVE ANY OTHER EVENTS SCHEDULED FOR REQUESTING LOCATION COMMUNICATION FROM
TARGET MS */
}
5 else /* target MS location data received but it is not deemed to be reliable (e.g., too much multipath and/or
inconsistent measurements, so SCHEDULE an event (if none scheduled) to request new location
communication with the target MS, the event is at a high priority*/
add_to_scheduled_events("TARGET_MS_SCHEDULE", event.MS_ID);
update_MBS_operator_display_with_MS_est(MS_curr_est);
10 /* The MBS display may use various colors to represent nested location areas overlaid on an area map
wherein, for example, 3 nested areas may be displayed on the map overlay: (a) a largest area having a
relatively high probability that the target MS is in the area (e.g., > 95%); (b) a smaller nested area having
a lower probability that the target MS is in this area (e.g., > 80%); and (c) a smallest area having the
lowest probability that the target MS is in this area (e.g., > 70%). Further, a relatively precise specific
15 location is provided in the smallest area as the most likely single location of the target MS. Note that in one
embodiment, the colors for each region may dynamically change to provide an indication as to how high
their reliability is; e.g., no colored areas shown for reliabilities below, say, 40%; 40-50% is purple; 50-60%
is blue; 60-70% is green; 70-80% is amber; 80-90% is white; and red denotes the most likely single
location of the target MS. Further note the three nested areas may collapse into one or two as the MBS gets
20 closer to the target MS. Moreover, note that the collapsing of these different areas may provide operators in
the MBS with additional visual reassurance that the location of the target MS is being determined with better
accuracy.*/

/* Now RESET timer for target MS location communication to try to get target MS
25 location communication again within a predetermined time. */
reset_timer("TARGET_MS_SCHEDULE", event.MS_ID);
}
COMMUNICATION OF LOCATION DATA TO MBS FROM LOCATION CENTER: {
/* Note, target MS location data may be received from the Location Center in the seek state, contact state and the
30 control state. Such data may be received in response to the MBS sending target MS location signal data to the
Location Center (as may be the case in the contact and control states), or such data may be received from the
Location Center regardless of any previously received target MS location sent by the MBS (as may be the case in
the seek, contact and control states). */

```

120 119

```
if ( (the timestamp of the latest MBS location data sent to the Location Center) <= (the timestamp
returned by this Location Center communication identifying the MBS location data used by the Location Center
for generating the MBS location data of the present event) )
then /* use the LC location data since it is more recent than what is currently being used. */
```

```
5 {
MBS_new_est <--- get_Location_Center_MBS_est(event);
deadreck_est <--- get_deadreckoning_location_change_estimate(event);
MBS_curr_est <----DETERMINE_MBS_LOCATION_ESTIMATE(MBS_new_est, deadreck_est);
if (MBS_curr_est.confidence > a predetermined high confidence threshold) then
10 reset_deadreckoning_MBS_location_estimator(event);
update_MBS_operator_display_with_MBS_est(MBS_curr_est);
}
```

```
if ( (the timestamp of the latest target MS location data sent to the Location Center) <= (the
timestamp returned by this Location Center communication identifying the MS location data used by the
Location Center for generating the target MS location estimate of the present event))
15 then /* use the MS location estimate from the LC since it is more recent than what is currently being used. */
```

Ino. C99

```
20 {
MS_new_est <--- get_Location_Center_MS_est(event);
/* This information includes error or reliability estimates that may be used in subsequent attempts to
determine an MBS location estimate when there is no communication with the LC and no exact (GPS)
location can be obtained. That is, if the reliability of the target MS's location is deemed highly reliable,
then subsequent less reliable location estimates should be used only to the degree that more highly
reliable estimates become less relevant due to the MBS moving to other locations. */
MS_moving_window <--- get_MS_moving_window(event);
25 /* get moving window of location estimates for this target MS. */
```

```
if ( (the Location Center target MS estimate utilized the MS location signature data supplied by the MBS) then
if (a corresponding target MS location estimate marked as "temporary" is still in the moving
window)
30 then /* It is assumed that this new target MS location data is still timely (note the target MS
may be moving); so replace the temporary estimate with the Location Center estimate.
*/
replace the temporary target MS location estimate in the moving window with
"MS_new_est";
```

121 120

```

else      /* there is no corresponding "temporary" target MS location in the moving window; so
           this MS estimate must be too old; so don't use it. */
else /* the Location Center did not use the MS location data from the MBS even though the timestamp of
           the latest MS location data sent to the Location Center is older than the MS location data used by
5           the Location Center to generate the present target MS location estimate. Use the new MS location
           data anyway. Note there isn't a corresponding "temporary" target MS location in the moving
           window. */
           add_MS_estimate_to_MS_location_window(MS_new_est);
}
10 else /* the MS location estimate from the LC is not more recent than the latest MS location data sent to the LC from
           the MBS. */
           if (a corresponding target MS location estimate marked as "temporary" is still in the moving window)
               then /* It is assumed that this new target MS location data is still timely (note the target MS may be
                       moving); so replace the temporary estimate with the Location Center estimate. */
                   replace the temporary target MS location estimate in the moving window with "MS_new_est";
15           else /* there is no corresponding "temporary" target MS location in the moving window; so this MS
                   estimate must be too old; so don't use it. */
MS_curr_est <---- DETERMINE_MS_LOCATION_ESTIMATE(MS_moving_window);
update_MBS_operator_display_with_MS_est(MS_curr_est);
20 reset_timer("LC_COMMUNICATION", event.MS_ID);
}

NO COMMUNICATION FROM LC: {
    /* i.e., too long a time has elapsed since last communication from LC. */
    SCHEDULE an event (if none scheduled) to request location data (MBS and/or target MS) from the Location Center,
25    the event is at a high priority;
    reset_timer("LC_COMMUNICATION", event.MS_ID);
}

REQUEST TO NO LONGER CONTINUE LOCATING THE PRESENT TARGET MS: {
    if (event not from operator) then
30        request MBS operator verification;
    else {
        REMOVE the current target MS from the list of MSs currently being located and/or tracked;
        SCHEDULE an event (if none scheduled) to send communication to the Location Center that the current target MS
        is no longer being tracked;

```

122

PURGE MBS of all data related to current target MS except any exact location data for the target MS that has not been sent to the Location Center for archival purposes;

}  
}

5 **REQUEST FROM LOCATION CENTER TO ADD ANOTHER TARGET MS TO THE LIST OF MSs  
BEING TRACKED: {**

/\* assuming the Location Center sends MBS location data for a new target MS to locate and/or track (e.g., at least a new MS ID and an initial MS location estimate), add this new target MS to the list of MSs to track. Note the MBS will typically be or transitioning to in the seek state.\*/

10 if (event not from operator) then

request MBS operator verification;

else {

INITIALIZE MBS with data received from the Location Center related to the estimated location of the new target MS; /\* e.g., initialize a new moving window for this new target MS; initialize MBS operator interface by graphically indicating where the new target MS is estimated to be. \*/

15

CONFIGURE MBS to respond to any signals received from the new target MS by requesting location data from the new target MS;

INITIALIZE timer for communication from LC; /\* A timer may be set per target MS on list. \*/

20 }  
}

**REQUEST TO MANUALLY ENTER A LOCATION ESTIMATE FOR MBS (FROM AN MBS  
OPERATOR): {**

/\* Note, MBS could be moving or stationary. If stationary, then the estimate for the location of the MBS is given high reliability and a small range (e.g., 20 feet). If the MBS is moving, then the estimate for the location of the MBS is given high reliability but a wider range that may be dependent on the speed of the MBS. In both cases, if the MBS operator indicates a low confidence in the estimate, then the range is widened, or the operator can manually enter a range.\*/

25

MS\_new\_est <--- get\_new\_MBS\_location\_est\_from\_operator(event); /\* The estimate may be obtained, for example, using a light pen on a displayed map \*/

*Ins. C100*

30

if (operator supplies a confidence indication for the input MBS location estimate) then

MBS\_new\_est.confidence <--- get\_MBS\_operator\_confidence\_of\_estimate(event);

else MBS\_new\_est.confidence <--- 1; /\* This is the highest value for a confidence. \*/

deadreck\_est <--- get\_deadreckoning\_location\_change\_estimate(event);

*123*

```

MBS_curr_est <--- DETERMINE_MBS_LOCATION_ESTIMATE(MBS_new_est, deadreck_est);
if (MBS_curr_est.confidence > a predetermined high confidence threshold) then
    reset_deadreckoning_MBS_location_estimator(event);
    update_MBS_operator_display_with_MBS_est(MBS_curr_est);
5
    /* Note, one reason an MBS operator might provide a manual MBS input is that the MBS might be too inaccurate in
    its location. Moreover, such inaccuracies in the MBS location estimates can cause the target MS to be estimated
    inaccurately, since target MS signal characteristic values may be utilized by the MBS to estimate the location of the
    target MS as an offset from where the MBS is. Thus, if there are target MS estimates in the moving window of
    target MS location estimates that are relatively close to the location represented by "MBS_curr_est", then these
10    select few MS location estimates may be updated to reflect a more accurate MBS location estimate. */
    MS_moving_window <--- get_MS_moving_window(event);
    if (MBS has not moved much since the receipt of some previous target MS location that is still being used to location
        the target MS)
    then
15        {
            UPDATE those target MS location estimates in the moving window according to the new MBS location estimate
                here;
            MS_curr_est <---- DETERMINE_MS_LOCATION_ESTIMATE(MS_moving_window);
20            update_MBS_operator_display_with_MS_est(MS_curr_est);
        }
    }
} /* end case statement */

```

25 **Lower Level MBS Function Descriptions**

**/\* PROCEDURE: DETERMINE\_MBS\_LOCATION\_ESTIMATE REMARKS:**

It is assumed that with increasing continuous **dead reckoning** without additional MBS location verification, the potential **error** in the MBS location **increases**.

30 It is assumed that each MBS location estimate includes: (a) a most likely area estimate surrounding a central location and (b) a confidence value of the MBS being in the location estimate.

124

The **confidence value** for each MBS location estimate is a measurement of the likelihood of the MBS location estimate being correct. More precisely, a confidence value for a new MBS location estimate is a measurement that is adjusted according to the following criteria:

- 5 (a) the confidence value increases with the perceived accuracy of the new MBS location estimate (independent of any current MBS location estimate used by the MBS),
- (b) the confidence value decreases as the location discrepancy with the current MBS location increases,
- (c) the confidence value for the current MBS location increases when the new location estimate is contained in the current location estimate,
- 10 (d) the confidence value for the current MBS location decrease when the new location estimate is not contained in the current location estimate, and

Therefore, the **confidence value** is an **MBS location likelihood measurement which takes into account the history of previous MBS location estimates.**

*Sup. 101*

It is assumed that with each MBS location estimate supplied by the Location Center there is a default confidence value supplied which the MBS may change.

15 \*/

#### **DETERMINE\_MBS\_LOCATION\_ESTIMATE(MBS\_new\_est, deadreck\_est)**

**/\* Add the pair, "MBS\_new\_est" and "deadreck\_est" to the location tracks and determine a new current MBS location estimate.**

**Input: MBS\_new\_est A new MBS baseline location estimate to use in determining the location of the MBS, but not a (deadreckoning) location change estimate**

**deadreck\_est The deadreckoning location change estimate paired with "MBS\_new\_est". \*/**

```
25 {
    if (MBS_new_est is not NULL) then /* the "deadreck_est" is paired with "MBS_new_est" */
    {
        if (all MBS location tracks are empty) then
        {
            insert "MBS_new_est" as the head of the location track of type, "MBS_new_est.type";
            insert "MBS_new_est" as the head of the current track; /* so now there is a "MBS_curr_est" MBS location
            estimate to use */
            MBS_curr_est <--- get_curr_est(MBS_new_est.MS_ID); /* from current location track */
        }
    }
}
```

*125*

```

else /* there is at least one non-empty location track in addition to the current location track being non-
empty*/
{
  if (MBS_new_est is of type MANUAL_ENTRY) then
5   { /* MBS operator entered an MBS location estimate for the MBS; so must use
      it */
      MBS_curr_est <--- add_location_entry(MBS_new_est, deadreck_est);
    }
  else /* "MBS_new_est" is not of type MANUAL_ENTRY */
10   if (the MBS location track of type, "MBS_new_est.type", is empty) then
      { /* some other location track is non-empty */
      MBS_curr_est <--- add_location_entry(MBS_new_est, deadreck_est);
      }
    else /* "MBS_new_est.type" location track is non-empty and "MBS_new_est"
15     is not of type MANUAL_ENTRY */
      { /* In the next statement determine if "MBS_new_est" is of at least
          minimal useful quality in comparison to any previous estimates of the
          same type; see program def'n below */
          continue_to_process_new_est <-- FILTER(MBS_new_est);
20         if (continue_to_process_new_est) then /* "MBS_new_est" is of sufficient quality to
            continue processing. */
            {
              MBS_curr_est <--- add_location_entry(MBS_new_est, deadreck_est);
              }/* end "MBS_new_est" not filtered out */
            else /* "MBS_new_est" is filtered out; do nothing */;
25           }/* end else */
          }/* end else at least one non-empty location track */
    }
  else /* MBS_new_est is NULL; thus only a deadreckoning output is to be added to location tracks */
30   {
      extrapolation_entry <--- create_an_extrapolation_entry_from(deadreck_est);
      insert_into_every_location_track(extrapolation_entry); /* including the "current location track" */
      MBS_curr_est <--- get_curr_est(MBS_new_est.MS_ID); /* from current location track */
    }

```

126 125



```

    }
    RETURN(MBS_curr_est);
} END /* DETERMINE_MBS_LOCATION_ESTIMATE */

5  add_location_entry(MBS_new_est, deadreck_est);
    /* This function adds the baseline entry, "MBS_new_est" and its paired deadreckoning location change estimate, "deadreck_est" to
    the location tracks, including the "current location track". Note, however, that this function will roll back and rearrange location
    entries, if necessary, so that the entries are in latest timestamp order.
    Returns:  MBS_curr_est */
10 {
    if (there is a time series of one or more dead reckoning extrapolation entries in the location track of type "MBS_new_est.type"
        wherein the extrapolation entries have a "latest timestamp" more recent than the timestamp of "MBS_new_est") then
    { /* Note, this condition may occur in a number of ways; e.g., (a) an MBS location estimate received from the Location
        Center could be delayed long enough (e.g., 1-4 sec) because of transmission and processing time; (b) the estimation
15 records output from the MBS baseline location estimators are not guaranteed to be always presented to the location
        tracks in the temporal order they are created. */
        roll back all (any) entries on all location tracks, including the "current" track, in "latest timestamp" descending order,
        until a baseline entry, B, is at the head of a location track wherein B is a most recent entry having a "latest
        timestamp" prior to "MBS_new_est"; let "stack" be the stack of a location track entries rolled off the location
20 tracks, wherein an entry in the stack is either a baseline location entry and a paired deadreckoning location change
        estimate, or, an unpaired deadreckoning location change estimate associated with a NULL for the baseline location
        entry;
        insert "MBS_new_est" at the head of the location track of type "MBS_new_est.type" as a new baseline entry;
        insert the extrapolation entry derived from "deadreck_est" in each of the other baseline location tracks except
25 the current track;
        /* It is important to note that "deadreck_est" includes the values for the change in the MBS location substantially for the
        time period between the timestamp, T, of "MS_new_est" and the timestamp of the closest deadreckoning output just
        before T. Further note that if there are any extrapolation entries that were rolled back above, then there is an
        extrapolation entry, E, previously in the location tracks and wherein E has an earliest timestamp equal to the latest
30 timestamp of B above. Thus, all the previous extrapolation entries removed can be put back if E is modified as follows:
        the MBS location change vector of E (denoted herein as E.delta) becomes E.delta - [location change vector of
        "deadreck_est"]. */
        MBS_curr_est <--- UPDATE_CURR_EST(MBS_new_est, deadreck_est);
        if (the extrapolation entry E exists) then /* i.e., "stack" is not empty */

```

127

126

```

{
    modify the extrapolation entry E as per the comment above;
    /* now fix things up by putting all the rolled off location entries back, including
       the "current location track" */
5    do until "stack" is empty
    {
        stack_top <--- pop_stack(stack);
        /* "stack_top" is either a baseline location entry and a paired deadreckoning location change
           estimate, or, an unpaired deadreckoning location change estimate associated with a NULL for the
10        baseline location entry */
        MBS_next_est <--- get_baseline_entry(stack_top);
        deadreck_est <--- get_deadreckoning_entry(stack_top);
        MBS_curr_est <--- DETERMINE_MBS_LOCATION_ESTIMATE(MBS_next_est,
15                deadreck_est);
    }
}
}
else /* there is no deadreckoning extrapolation entries in the location track of type "MBS_new_est.type" wherein the
       extrapolation entries have a "latest timestamp" more recent than the timestamp of "MBS_new_est". So just insert
20    "MBS_new_est" and "deadreck_est".*/
    {
        insert "MBS_new_est" at the head of the location track of type "MBS_new_est.type" as a new baseline entry;
        insert the extrapolation entry derived from "deadreck_est" in each of the other location tracks except the current track;
        MBS_curr_est <--- UPDATE_CURR_EST(MBS_new_est, deadreck_est); /* see prog def'n below */
25    }
    RETURN(MBS_curr_est);
} /* end add_location_entry */

```

#### **FILTER(MBS\_new\_est)**

```

30 /* This function determines whether "MBS_new_est" is of sufficient quality to insert into it's
    corresponding MBS location track. It is assumed that the location track of
    "MBS_new_est.type" is non-empty.

```

120

127

**Input:**     **MBS\_new\_est**     **A new MBS location estimate to use in determining the location of the MBS.**

**Returns:**   **FALSE** if “MBS\_new\_est” was processed here (i.e., filtered out),  
              **TRUE** if processing with “MBS\_new\_est” may be continued . \*/

```
5  {
  continue_to_process_new_est <--TRUE; /* assume “MBS_new_est” will be good enough to use as an MBS location estimate */
  /* see if “MBS_new_est” can be filtered out. */
  if (the confidence in MBS_new_est < a predetermined function of the confidence(s) of previous MBS location estimates of
      type “MBS_new_est.type”)
10     /* e.g., the predetermined function here could be any of a number of functions that provide a minimum threshold on
        what constitutes an acceptable confidence value for continued processing of “MBS_new_est”. The following is an
        example of one such predetermined function:  $K \cdot (\text{confidence of “MBS\_new\_est.type” location track head})$  for
        some  $K$ ,  $0 < K \leq 1.0$ , wherein  $K$  varies with a relative frequency of estimates of type
        “MBS_new_est.type” not filtered; e.g., for a given window of previous MBS location estimates of this type,  $K =$ 
15     (number of MBS location estimates of “MBS_new_est.type” not filtered)/(the total number of estimates of this
        type in the window). Note, such filtering here may be important for known areas where, for example, GPS signals
        may be potentially reflected from an object (i.e., multipath), or, the Location Center provides an MBS location
        estimate of very low confidence. For simplicity, the embodiment here discards any filtered location estimates.
        However, in an alternative embodiment, any such discarded location estimates may be stored separately so that,
20     for example, if no additional better MBS location estimates are received, then the filtered or discarded location
        estimates may be reexamined for possible use in providing a better subsequent MBS location estimate.*/
    then continue_to_process_new_est <-- FALSE;
  else if (an area for “MBS_new_est” > a predetermined function of the corresponding area(s) of entries in the location
      track of type “MBS_new_est.type”)
25     /* e.g., the predetermined function here could be any of a number of functions that provide a maximum threshold
        on what constitutes an acceptable area size for continued processing of “MBS_new_est”. The following are
        examples of such predetermined functions: (a) the identity function on the area of the head of the location track
        of type “MBS_new_est.type”; or, (b)  $K \cdot (\text{the area of the head of the location track of type
        “MBS\_new\_est.type”})$ , for some  $K$ ,  $K \geq 1.0$ , wherein for a given window of previous MBS location estimates of
30     this type,  $K = (\text{the total number of estimates in the window}) / (\text{number of these location estimates not filtered})$ ;
        note, each extrapolation entry increases the area of the head; so areas of entries at the head of each location
        track type grow in area as extrapolation entries are applied. */
    then continue_to_process_new_est <-- FALSE;
```

```
RETURN(continue_to_process_new_est)
}
```

### UPDATE\_CURR\_EST(MBS\_new\_est, deadreck\_est)

```
5  /* This function updates the head of the "current" MBS location track whenever
   /* "MBS_new_est" is perceived as being a more accurate estimate of the location of the
   MBS.
   Input: MBS_new_est A new MBS location estimate to use in determining the location
           of the MBS
10  deadreck_est The deadreckoning MBS location change estimate paired with
           "MBS_new_est".
   Returns a potentially updated "MBS_curr_est" */
{
  if (MBS_new_est is of type MANUAL_ENTRY) then
15  { /* MBS operator entered an MBS location estimate for the MBS; so must use it */
    insert "MBS_new_est" as the head of the "current MBS location track" which is the location track indicating the best
    current approximation of the location of the MBS;
  }
  else /* "MBS_new_est" is not a manual entry */
20  {
    MBS_curr_est <--- get_curr_est(MBS_new_est.MS_ID); /* get the head of the "current location track" */
    adjusted_curr_est <--- apply_deadreckoning_to(MBS_curr_est, deadreck_est);
    /* The above function returns an object of the same type as "MBS_curr_est", but with the most likely MBS
    point and area locations adjusted by "deadreck_est". Accordingly, this function performs the following
25  computations:
       (a) selects,  $A_{MBS}$ , the MBS location area estimate of "MBS_curr_est" (e.g., one of the "most likely"
           nested area(s) provided by "MBS_curr_est" in one embodiment of the present invention);
       (b) applies the deadreckoning translation corresponding to "deadreck_est" to  $A_{MBS}$  to thereby
           translate it (and expand it to at least account for deadreckoning inaccuracies). */
30  if (reasonably_close(MBS_new_est, adjusted_curr_est, MBS_curr_est))
    /* In one embodiment, the function "reasonably_close" here determines whether a most likely MBS point
    location (i.e., centroid) of "MBS_new_est" is contained in the MBS estimated area of
    "adjusted_curr_est"
```

130

Note that the reasoning for this constraint is that if "MBS\_curr\_est" ~~was~~ accurate, then any "most likely MBS point location" of a new MBS baseline estimate that is also accurate ought to be in the MBS estimated area of "adjusted\_curr\_est".

In a second embodiment, the function "reasonably\_close" determines whether the centroid (or most likely MBS point location) of "MBS\_new\_est" is **close enough** to "MBS\_curr\_est" so that **no MBS movement constraints** are (grossly) **violated between the most likely point locations of "MBS\_new\_est" and "MBS\_curr\_est"**; i.e., constraints on (de)acceleration, abruptness of direction change, velocity change, max velocity for the terrain. Note, such constraints are discussed in more detail in the section herein describing the "Analytical Reasoner". Accordingly, it is an aspect of the present invention to provide similar capabilities to that of the Analytical Reasoner as part of the MBS, and in particular, as the functionality of the "MBS LOCATION CONSTRAINT CHECKER" illustrated in Fig. 11. It is assumed hereinafter that the embodiment of the function, "reasonably\_close", performed here is a combination of both the first and second embodiments, wherein the constraints of both the first and second embodiments must be satisfied for the function to return TRUE. \*/

```
15 then
    if (the confidence in MBS_new_est >= the confidence in MBS_curr_est) then
    {
        if (the most likely MBS area of MBS_new_est contains the most likely MBS area of "adjusted_curr_est" as
            computed above) then
20             shrink MBS_new_est uniformly about its centroid (i.e., "most likely MBS point location") until it is
                as small as possible and still contain the MBS estimated area of "adjusted_curr_est".
        insert_into_location_track("current", MBS_new_est);
        /* The program invoked here inserts a location track entry corresponding to the second parameter into the
            location track identified by the first parameter (e.g., "current"). It is important to note that the second
25             parameter for this program may be either of the following data structures: a "location track entry", or an
            "MBS location estimate" and the appropriate location track entry or entries will be put on the location
            track corresponding to the first parameter. The insertion is performed so that a "latest timestamp" order
            is maintained; i.e.,
            (a) any extrapolation entries in the location track, wherein these entries have a more recent
30             "latest timestamp" than the ("earliest" or only) timestamp (depending on the data
                structure) of the second parameter are removed, and
```

131

130

```

                    (b) conceptually at least, the location change estimates output from the deadreckoning MBS
                        location estimator that correspond with the removed extrapolation entries are then
                        reapplied in timestamp order to the head of the target location track. */
                }
5   else /* the centroid of "MBS_new_est", is contained in an area of "MBS_curr_est", but the confidence in
        "MBS_new_est" < confidence in "MBS_curr_est" */
    {
        most_likely_est <-- determine a "most likely MBS location estimate" using the set S = {the MBS
            location estimate centroid(s) of any MBS location track heads contained in the MBS
            estimated area of "adjusted_curr_est", plus, the centroid of "MBS_new_est"};
10        /* Note, in the above statement, the "most likely MBS location estimate" may be determined
            using a number of different techniques depending on what function(s) is used to embody the
            meaning of "most likely". In one embodiment, such a "most likely" function is a function of
            the confidence values of a predetermined population of measurements (e.g., the selected
            location track heads in this case) from which a "most likely" measurement is determined (e.g.,
15        computed or selected). For example, in one embodiment, a "most likely" function may include
            selecting a measurement having the maximum confidence value from among the population of
            measurements. In a second embodiment, a "most likely" function may include a weighting of
            measurements (e.g., location track heads) according to corresponding confidence values of the
            measurements. For example, in the present context (of MBS location track heads) the
20        following steps provide an embodiment of a "most likely" function:
            (a) determine a centroid of area for each of the selected track heads (i.e., the location
                track heads having a point location estimate contained in the MBS estimated area of
                "adjusted_curr_est");
25        (b) determine the "most likely location MBS position" P as a weighted centroid of the
                centroids from step (a), wherein the weighting of each of the centroids from (a) is
                provided by their corresponding confidence values;
            (c) output an area, Ai, as the "most likely MBS location area", wherein the centroid of
                Ai is P and Ai is the largest area within the MBS estimated area of
30        "adjusted_curr_est" satisfying this condition; and
            (d) set a confidence value for Ai as the average confidence value of "MBS_new_est",
                "MBS_curr_est" and the selected location track head used. */
        insert_into_location_track("current", most_likely_est);
    }

```

132

```

else /* "MBS_new_est" is not reasonably close to "adjusted_curr_est" (i.e.,
      "MBS_curr_est" with "deadreck_est" applied to it), so a conflict exists here: e.g.,
      (i) "MBS_new_est" is not a manual entry, and (ii) "MBS_new_est" does not have its centroid contained in the
      MBS estimated area of "adjusted_curr_est", or, there has been a movement constraint violation. Note that it is
5      not advisable to just replace "MBS_curr_est" with "new_est_head" because:
          (a) "MBS_new_est" may be the MBS location estimate that is least accurate, while the previous entries
              of the current location track have been accurate;
          (b) the "MBS_curr_est" may be based on a recent MBS operator manual entry which should not be
              overridden. */
10      {
          MBS_curr_est <--- resolve_conflicts(MBS_new_est, adjusted_curr_est, MBS_curr_est);
      }
} /* end else "MBS_new_est" not a manual entry */
if (MBS is a vehicle) and (not off road) then
15      /* it is assumed that a vehicular MBS is on-road unless explicitly indicated otherwise by MBS operator. */
      MBS_curr_est <--- snap_to_best_fit_street(MBS_curr_est); /* snap to best street location according to location
          estimate, velocity, and/or direction of travel. Note, this is a translation of "MBS_curr_est". */
      RETURN(MBS_curr_est)
} /* END UPDATE(MBS_CURR_EST) */
20
resolve_conflicts(MBS_new_est, adjusted_curr_est, MBS_curr_est)
/* There is a basic conflict here,
   (i) "MBS_new_est" is not a manual entry, and
   (ii) one of the following is true: "MBS_new_est" does not have its centroid contained
25   in the area "adjusted_curr_est", or, using "MBS_new_est" implies an MBS
       movement constraint violation.
Input: MBS_new_est The newest MBS location estimate record.
       adjusted_curr_est The version of "MBS_curr_est" adjusted by the deadreckoning
                           location change estimate paired with "MBS_new_est".
30       MBS_curr_est The location track entry that is the head of the "current" location track. Note
                           that "MBS_new_est.confidence" > "MBS_curr_est.confidence".
Output: An updated "MBS_curr_est". */
{

```

*Imp. C102*

133

132

```

mark that a conflict has arisen between "MBS_curr_est" and "MBS_new_est";
if (the MBS operator desires notification of MBS location estimate conflicts) then
    notify the MBS operator of an MBS location estimate conflict;
if (the MBS operator has configured the MBS location system to ignore new estimates that are not "reasonably
5     close" to adjusted_curr_est) or
    (MBS_curr_est is based on a manual MBS operator location estimate, and the MBS has moved less
    than a predetermined distance (wheel turns) from where the manual estimate was provided) then
    RETURN(adjusted_curr_est);
else /* not required to ignore "MBS_new_est", and there has been no recent manual
10     estimate input*/
    { /* try to use "MBS_new_est" */
        if ((MBS_new_est.confidence - adjusted_curr_est.confidence) > a large predetermined
            threshold) then
                /* Note, the confidence discrepancy is great enough so that "MBS_new_est" should be the most recent baseline
15                 estimate on current MBS location track. Note that the threshold here may be approximately 0.3, wherein
                 confidences are in the range [0, 1].*/
                insert_into_location_track("current", MBS_new_est);
                /* insert "MBS_new_est" into "current" location track (as a baseline entry) in "latest timestamp" order;
                 i.e., remove any extrapolation entries with a more recent "latest timestamp" in this track, and reapply,
20                 in timestamp order, the location change estimates output from the deadreckoning MBS location
                 estimator that correspond with the removed extrapolation entries removed; */
            else /* "MBS_new_est.confidence" is not substantially bigger than
                "adjusted_curr_est.confidence"; so check to see if there are potentially MBS
                location system instabilities */
25         { /* check for instabilities */
            if [ (there has been more than a determined fraction of conflicts between the "MBS_curr_est" and "MBS_new_est"
                within a predetermined number of most recent "MBS_new_est" instantiations) or
                (the path corresponding to the entries of the "current location track" of the MBS has recently violated MBS
                movement constraints more than a predetermined fraction of the number of times there has been new
30                 instantiation of "MBS_curr_est", wherein such movement constraints may be (de)acceleration constraints,
                abrupt change in direction constraints, constraints relating to too high a velocity for a terrain) or
                (there has been an MBS operator indication of lack of confidence in the recently displayed MBS location
                estimates)]

```

13A

133



then /\* the MBS location system is likely unstable and/or inaccurate; check to see if  
this condition has been addressed in the recent past. \*/

{ /\* fix instability \*/

if (fix\_instability\_counter equal to 0) then /\* no instabilities have been addressed here

5                   **within the recent past**; i.e., “fix\_instability\_counter” has the following semantics: if it is 0,  
then no instabilities have been addressed here within the recent past; else if not 0, then a recent  
instability has been attempted to be fixed here. Note, “fix\_instability\_counter” is decremented, if  
not zero, each time a new baseline location entry is inserted into its corresponding **baseline**  
10                   **location track**. Thus, this counter provides a “wait and see” strategy to determine if a previous  
performance of the statements below mitigated the (any) MBS location system instability. \*/

{

most\_likely\_est <-- determine a new “most likely MBS location estimate”; [30.I]

/\* Note, a number of MBS location estimates may be generated and compared here for  
determining the “most\_likely\_est”. For example, various weighted centroid MBS location  
15                   estimates may be determined by a **clustering** of location track head entries in various ways.

In a first embodiment for determining a value (object) for “most\_likely\_est”, a “most  
likely” function may be performed, wherein a weighting of location track heads according to  
their corresponding confidence values is performed. For example, the following steps provide an  
embodiment of a “most likely” function:

- 20                   (a) obtain a set S having: (i) a centroid of area for each of the track heads having a  
corresponding area contained in a determined area surrounding the point  
location of “adjusted\_curr\_est” (e.g., the MBS estimated area of  
“adjusted\_curr\_est”), plus (ii) the centroid of “MBS\_new\_est”;
- 25                   (b) determine the “most likely location MBS *position*” P as a weighted centroid of  
the centroids of the set S from step (a), wherein the weighting of each of the  
centroids from (a) is provided by their corresponding confidence values;
- (c) output an area, A, as the “most likely MBS location *area*” wherein A has P as a  
centroid and A is a “small” area (e.g., a convex hull) containing the  
corresponding the centroids of the set S; and
- 30                   (d) set a **confidence value** for A as the average confidence value of the  
centroids of the set S.

In a second embodiment, “most\_likely\_est” may be determined by expanding (e.g.,  
substantially uniformly in all directions) the MBS location estimate area of “MBS\_new\_est”

BS

```

    until the resulting expanded area contains at least the most likely point location of
    "adjusted_curr_est" as its most likely MBS location area. */
    insert_into_location_track("current", most_likely_est);
    fix_instability_counter <--- a predetermined number, C, corresponding to a number of baseline
5     entries to be put on the baseline location tracks until MBS location system instabilities are to be
    addressed again here; /* when this counter goes to zero and the MBS location system is unstable,
    then the above statements above will be performed again. Note, this counter must be reset to C (or
    higher) if a manual MBS estimate is entered. */
    }
10 } /* fix instability */
    else /* The MBS location system has been reasonably stable, and
    "MBS_curr_est.confidence" is not substantially bigger than
    "adjusted_new_est.confidence" . */
    {
15     most_likely_est <-- determine a most likely MBS location estimate;
    /* The determination in the statement above may be similar or substantially the same as the computation
    discussed in relation to statement [30.1] above. However, since there is both more stability in this case than
    in [30.1] and less confidence in "MBS_new_est", certain MBS movement constraints may be more
    applicable here than in [30.1].
20     Accordingly, note that in any embodiment for determining "most_likely_est" here, reasonable
    movement constraints may also be used such as: (a) unless indicated otherwise, an MBS vehicle will be
    assumed to be on a road, (b) a new MBS location estimate should not imply that the MBS had to travel
    faster than, for example, 120 mph or change direction too abruptly or change velocity too abruptly or
    traverse a roadless region (e.g., corn field or river) at an inappropriate rate of speed.
25     Thus, once a tentative MBS location estimate (e.g., such as in the steps of the first embodiment of
    [30.1]) for "most_likely_est" has been determined, such constraints may be applied to the tentative
    estimate for determining whether it should be pulled back toward the centroid of the "MBS_curr_est" in
    order to satisfy the movement constraints*/
    insert_into_location_track("current", most_likely_est); /* note, the second parameter for this
30     function may be either of the following data structures: a "location track entry", or a "MBS location
    estimate" and the appropriate location track entry or entries will be put on the location track corresponding
    to the first parameter. */
    }

```

136

```
    } /* check for instabilities */  
    MBS_curr_est <--- get_curr_est(MBS_new_est.MS_ID); /* from current location track */  
  } /* try to use "MBS_new_est" */  
  RETURN(MBS_curr_est)  
5 } /* END resolve_conflicts */
```

137 136

**APPENDIX B: Pseudo code for a genetic algorithm**  
**Pseudo code for a genetic algorithm**

T1300

```
5 Genetic_Algorithm (*decode, *fitness_function, parms)
/* This program implements a genetic algorithm for determining efficient
values of parameters for a search problem. The current best values of the parameters are received by the genetic algorithm in a data
structure such as an array. If no such information is available, then the genetic algorithm receives random guesses of the parameter values.
This program also receives as input a pointer to a decode function that provides the genetic algorithm with information about how the
10 parameters are represented by bit strings (see genetic algorithm references). The program also receives a pointer to a fitness function,
"fitness_functions", that provides the genetic algorithm with information about how the quality of potential solutions should be determined.
The program computes new, improved values of parameters and replaces the old values in the array "parms."
*/
// assume that each particular application will have a specific fitness function and decoding
15 // scheme; otherwise, the procedure is the same every time
// generate the initial population
// generate a random population of binary strings containing popsize strings
for i = 1 to popsize
for j = 1 to string_length
20 string(i,j) = random(0,1)
end loop on j
end loop on i
// keep generating new populations until finished
do until finished
25 for i = 1 to popsize
// transform the binary strings into parameters from the problem at hand; requires problem
// specific function
decode (string(i))
// evaluate each string
30 evaluate (string(i))
end loop on i
// perform reproduction
reproduce (population_of_strings)
```

130<sup>137</sup>

```
//perform crossover
crossover (population_of_strings)
//perform mutation
mutate (population_of_strings)
5 // evaluate the new population
for i = 1 to popsize
//transform the binary strings into parameters
//from the problem at hand; requires problem
//specific function
10 decode (string(i))
//evaluate the fitness of each string
evaluate (string(i,j))
end loop on i
if finished then report new results to the calling routine
15 else go back to tip of do-until loop
```

---

139

138

71400

## APPENDIX C: Location Database Maintenance Programs

### DATA BASE PROGRAMS FOR MAINTAINING THE LOCATION SIGNATURE DATA BASE

5 In the algorithms below, external parameter values needed are underlined. Note that in one embodiment of the present invention, such parameters may be adaptively tuned using, for example, a genetic algorithm.

#### EXTERNALLY INVOCABLE PROGRAMS:

#### 10 **Update\_Loc\_Sig\_DB(new\_loc\_obj, selection\_criteria, loc\_sig\_pop)**

/\* This program updates loc sigs in the Location Signature data base. That is, this program updates, for example, at least the location information for verified random loc sigs residing in this data base. Note that the steps herein are also provided in flowchart form in Fig. 17a through FIG. 17C.

#### 15 **Introductory Information Related to the Function, "Update\_Loc\_Sig\_DB"**

The general strategy here is to use information (i.e., "new\_loc\_obj") received from a newly verified location (that may not yet be entered into the Location Signature data base) to assist in determining if the previously stored random verified loc sigs are still reasonably valid to use for:

- 20 (29.1) estimating a location for a given collection (i.e., "bag") of wireless (e.g., CDMA) location related signal characteristics received from an MS,
- (29.2) training (for example) adaptive location estimators (and location hypothesizing models), and
- (29.3) comparing with wireless signal characteristics used in generating an MS location hypothesis by one of the MS location hypothesizing models (denoted First Order Models, or, FOMs).

25 More precisely, since it is assumed that it is more likely that the newest location information obtained is more indicative of the wireless (CDMA) signal characteristics within some area surrounding a newly verified location than the verified loc sigs (location signatures) previously entered into the Location Signature DB, such verified loc sigs are compared for signal characteristic consistency with the newly verified location information (object) input here for determining whether some of these "older" data base verified loc sigs still appropriately characterize their associated location.

30 In particular, comparisons are iteratively made here between each (target) loc sig "near" "new\_loc\_obj" and a population of loc sigs in the location signature data base (such population typically including the loc sig for "new\_loc\_obj) for:

5 (29.4) adjusting a confidence factor of the target loc sig. Note that each such confidence factor is in the range [0, 1] with 0 being the lowest and 1 being the highest. Further note that a confidence factor here can be raised as well as lowered depending on how well the target loc sig matches or is consistent with the population of loc sigs to which it is compared. Thus, the confidence in any particular verified loc sig, LS, can fluctuate with successive invocations of this program if the input to the successive invocations are with location information geographically "near" LS.

10 (29.5) remove older verified loc sigs from use whose confidence value is below a predetermined threshold. Note, it is intended that such predetermined thresholds be substantially automatically adjustable by periodically testing various confidence factor thresholds in a specified geographic area to determine how well the eligible data base loc sigs (for different thresholds) perform in agreeing with a number of verified loc sigs in a "loc sig test-bed", wherein the test bed may be composed of, for example, repeatable loc sigs and recent random verified loc sigs.

Note that this program may be invoked with a (verified/known) random and/or repeatable loc sig as input. Furthermore, the target loc sigs to be updated may be selected from a particular group of loc sigs such as the random loc sigs or the repeatable loc sigs, such selection being determined according to the input parameter, "selection\_criteria" while the comparison population may be designated with the input parameter, "loc\_sig\_pop". For example, to update confidence factors of certain random loc sigs near "new\_loc\_obj", "selection\_criteria" may be given a value indicating, "USE\_RANDOM\_LOC\_SIGS", and "loc\_sig\_pop" may be given a value indicating, "USE\_REPEATABLE\_LOC\_SIGS". Thus, if in a given geographic area, the repeatable loc sigs (from, e.g., stationary transceivers) in the area have recently been updated, then by successively providing "new\_loc\_obj" with a loc sig for each of these repeatable loc sigs, the stored random loc sigs can have their confidences adjusted.

20 Alternatively, in one embodiment of the present invention, the present function may be used for determining when it is desirable to update repeatable loc sigs in a particular area (instead of automatically and periodically updating such repeatable loc sigs). For example, by adjusting the confidence factors on repeatable loc sigs here provides a method for determining when repeatable loc sigs for a given area should be updated. That is, for example, when the area's average confidence factor for the repeatable loc sigs drops below a given (potentially high) threshold, then the MSs that provide the repeatable loc sigs can be requested to respond with new loc sigs for updating the DB. Note, however, that the approach presented in this function assumes that the repeatable location information in the DB is maintained with high confidence by, for example, frequent DB updating. Thus, the random verified DB location information may be effectively compared against the repeatable loc sigs in an area.

30 **INPUT:**

**new\_loc\_obj:** a data representation at least including a loc sig for an associated location about which Location Signature loc sigs are to have their confidences updated.

**selection\_criteria:** a data representation designating the loc sigs to be selected to have their confidences updated (may be defaulted). The following groups of loc sigs may be selected: "USE\_RANDOM\_LOC\_SIGS" (this is the default), USE\_REPEATABLE\_LOC\_SIGS", "USE\_ALL\_LOC\_SIGS". Note that each of these selections has values for the following values associated with it (although the values may be defaulted):

- 5 (a) a confidence reduction factor for reducing loc sig confidences,
- (b) a big\_error\_threshold for determining the errors above which are considered too big to ignore,
- (c) a confidence increase factor for increasing loc sig confidences,
- (d) a small\_error\_threshold for determining the errors below which are considered too small (i.e., good) to ignore.
- 10 (e) a recent\_time for specifying a time period for indicating the loc sigs here considered to be "recent".

**loc\_sig\_pop:** a data representation of the type of loc sig population to which the loc sigs to be updated are compared. The following values may be provided:

- (a) "USE ALL LOC SIGS IN DB",
- (b) "USE ONLY REPEATABLE LOC SIGS" (this is the default),
- 15 (c) "USE ONLY LOC SIGS WITH SIMILAR TIME OF DAY"

However, environmental characteristics such as: weather, traffic, season are also contemplated. \*/

***/\* Make sure "new\_loc\_obj" is in Location DB. \*/***

if (NOT new\_loc\_obj.in\_DB) then /\* this location object is not in the Location Signature DB; note this can be determined by comparing the location and times/datestamp with DB entries \*/

20 DB\_insert\_new\_loc\_sig\_entries(new\_loc\_obj); // stores loc sigs in Location Signature DB

***/\* Determine a geographical area surrounding the location associated with "new\_loc\_obj" for adjusting the confidence factors of loc sigs having associated locations in this area. \*/***

DB\_search\_areal <--- get\_confidence\_adjust\_search\_area\_for\_DB\_random\_loc\_sigs(new\_loc\_obj.location);

25 ***/\* get the loc sigs to have their confidence factors adjusted. \*/***

DB\_loc\_sigs <--- get\_all\_DB\_loc\_sigs\_for(DB\_search\_areal, selection\_criteria);

nearby\_loc\_sig\_bag <--- get loc sigs from "DB\_loc\_sigs" wherein for each loc sig the distance between the location associated with "new\_loc\_obj.location" and the verified location for the loc sig is closer than, for example, some standard deviation (such as the second standard deviation) of these distances for all loc sigs in "DB\_loc\_sigs";

30

***/\* For each "loc sig" having its confidence factor adjusted do \*/***

for each loc\_sig[i] in nearby\_loc\_sig\_bag do // determine a confidence for these random loc sigs

141



```

{
    /* Determine a search area surrounding the location associated with "loc
sig" */
    loc <--- get_verified_location(loc_sig[i]);
5    /* Determine the error corresponding to how well "loc sig" fits with the
portion of the inputted type of loc sig population that is also in the search
area. */
    BS <--- get_BS(loc_sig[i]);
    mark_as_unaccessible(loc_sig[i]); /* mark "loc_sig[i]" in the Location Signature DB so that it isn't retrieved. */
10    DB_search_area2 <--- get_confidence_adjust_search_area_for_DB_loc_sigs(loc.location);
        /* Get search area about "rand_loc". Typically, the "new_loc_obj" would be in this search area */
    loc_sig_bag <--- create_loc_sig_bag(loc_sig[i]); /* create a loc sig bag having a single loc sig, "loc_sig[i]" */
    output_criteria <--- get_criteria_to_input_to "Determine_Location_Signature_Fit_Errors" indicating that the function
        should generate error records in the returned "error_rec_bag" only for the single loc sig in
15    "loc_sig_bag". That is, the output criteria is: "OUTPUT_ERROR_RECS_FOR_INPUT_LOC_SIGS
ONLY".

    error_rec_bag[i] <--- Determine_Location_Signature_Fit_Errors(loc.location, loc_sig_bag,
        DB_search_area2, loc_sig_pop, output_criteria);
    unmark_making_accessible(loc_sig[i]); /* unmark "loc_sig[i]" in the Location Signature DB so that it can now be
20    retrieved. */
}

/* Reduce confidence factors of loc sigs: (a) that are nearby to the location
associated with "new_loc_obj", (b) that have big errors, and (c) that have not
been recently updated/acquired. */
25    error_rec_set <--- make_set_union_of(error_rec_bag[i] for all i);
        /* Now modify confidences of loc sigs in DB and delete loc sigs with very low confidences */
    reduce_bad_DB_loc_sigs(nearby_loc_sig_bag, error_rec_set, selection_criteria.big_error_threshold,
        selection_criteria.confidence_reduction_factor, selection_criteria.recent_time);

/* Increase confidence factors of loc sigs: (a) that are nearby to the location
30    associated with "new_loc_obj", (b) that have small errors, and (c) that have not
been recently updated/acquired. */

```

143

142

```
increase_confidence_of_good_DB_loc_sigs(nearby_loc_sig_bag, error_rec_set,  
                                         selection_criteria.small_error_threshold,  
                                         selection_criteria.confidence_increase_factor,  
                                         selection_criteria.recent_time);
```

5 **END OF Update\_Loc\_Sig\_DB**

**DB\_Loc\_Sig\_Error\_Fit(MS\_loc\_est, DB\_search\_area, measured\_loc\_sig\_bag, search\_criteria)**

/\* This function determines how well the collection of loc sigs in "measured\_loc\_sig\_bag" fit with the loc sigs in the location signature data base wherein the data base loc sigs must satisfy the criteria of the input parameter "search\_criteria" and are relatively close to the MS location estimate of the location hypothesis, "hypothesis". Thus, in one embodiment of the present invention, the present function may be invoked by, for example, the confidence adjuster module to adjust the confidence of a location hypothesis.

Input: **hypothesis**: MS location hypothesis;

**measured\_loc\_sig\_bag**: A collection of measured location signatures ("loc sigs" for short) obtained from the MS (the data structure here is an aggregation such as an array or list). Note, it is assumed that there is at most one loc sig here per Base Station in this collection. Additionally, note that the input data structure here may be a location signature cluster such as the "loc\_sig\_cluster" field of a location hypothesis (cf. Fig. 9). Note that variations in input data structures may be accepted here by utilization of flag or tag bits as one skilled in the art will appreciate;

**search\_criteria**: The criteria for searching the verified location signature data base for various categories of loc sigs. The only limitation on the types of categories that may be provided here is that, to be useful, each category should have meaningful number of loc sigs in the location signature data base. The following categories included here are illustrative, but others are contemplated:

- (a) "USE ALL LOC SIGS IN DB" (the default),
- (b) "USE ONLY REPEATABLE LOC SIGS",
- (c) "USE ONLY LOC SIGS WITH SIMILAR TIME OF DAY".

Further categories of loc sigs close to the MS estimate of "hypothesis" contemplated are: all loc sigs for the same season and same time of day, all loc sigs during a specific weather condition (e.g., snowing) and at the same time of day, as well as other limitations for other environmental conditions such as traffic patterns.

Note, if this parameter is NIL, then (a) is assumed.

Returns: An error object (data type: "error\_object") having: (a) an "error" field with a measurement of the error in the fit of the location signatures from the MS with verified location signatures in the Location Signature data base; and

*Inc  
C/03*

*144* 143

(b) a "confidence" field with a value indicating the perceived confidence that is to be given to the "error" value. \*/

if ("search\_criteria" is NIL) then

search\_criteria <--- "USE ALL LOC SIGS IN DB";

5 **/\* determine a collection of error records wherein there is an error record for each BS that is associated with a loc sig in "measured\_loc\_sig\_bag" and for each BS associated with a loc sig in a geographical area surrounding the hypothesis's location. \*/**

output\_criteria <--- "OUTPUT ALL POSSIBLE ERROR\_RECS";

10 **/\* The program invoked in the following statement is described in the location signature data base section. \*/**

error\_rec\_bag <--- **Determine\_Location\_Signature\_Fit\_Errors**(MS\_loc\_est, measured\_loc\_sig\_bag,  
DB\_search\_area, search\_criteria, output\_criteria);

**/\* Note, "error\_rec\_bag" has "error\_rec's" for each BS having a loc sig in "DB\_search\_area" as well as each BS having a loc sig in "measured\_loc\_sig\_bag". \*/**

15 **/\* determine which error records to ignore \*/**

BS\_errors\_to\_ignore\_bag <--- *get\_BS\_error\_recs\_to\_ignore*(DB\_search\_area, error\_rec\_bag);

**/\* Our general strategy is that with enough BSs having: (a) loc sigs with the target MS, and (b) also having verified locations within an area about the MS location "MS\_loc\_est", some relatively large errors can be tolerated or ignored. For example, if the MS location estimate, "MS\_loc\_est", here is indeed an accurate estimate of the MS's location and if an area surrounding "MS\_loc\_est" has relatively homogeneous environmental characteristics and the area has an adequate number of verified location signature clusters in the location signature data base, then there will be presumably enough comparisons between the measured MS loc sigs of "measured\_loc\_sig\_bag" and the estimated loc sigs, based on verified MS locations in the DB (as determined in "Determine\_Location\_Signature\_Fit\_Errors"), for providing "error\_rec\_bag" with enough small errors that these small errors provide adequate evidence for "MS\_loc\_est" being accurate.**

20 **Accordingly, it is believed that, in most implementations of the present invention, only a relatively small number of loc\_sig comparisons need have small errors for there to be consistency between the loc sigs of "measured\_loc\_sig\_bag" and the verified loc sigs in the location signature data base. That is, a few large errors are assumed, in general, to be less indicative of the MS location hypothesis being incorrect than small errors are**  
25 **indicative of accurate MS locations.** Thus, if there were ten measured and estimated loc sig pairs, each associated with a different BS, then if four pairs have small errors, then that might be enough to have high confidence in  
30

145

144

the MS location hypothesis. However, note that this determination could depend on the types of base stations; e.g., if five full-service base stations had measured and verified loc sigs that match reasonably well but five location BSs in the search area are not detected by the MS (i.e., the measured\_loc\_sig\_bag has no loc sigs for these location BSs), then the confidence is lowered by the mismatches.

5            Thus, for example, the largest x% of the errors in "error\_rec\_bag" may be ignored. Note, that "x" may be: (a) a system parameter that is tunable using, for example, a genetic algorithm; and (b) "x" may be tuned separately for each different set of environmental characteristics that appear most important to accurately accessing discrepancies or errors between loc sigs. Thus, for a first set of environmental characteristics corresponding to: rural, flat terrain, summer, 8 PM and clear weather, it may be the case that no loc sig errors are ignored. Whereas, for a second set of environmental  
10            characteristics corresponding to: dense urban, hilly, fall, 8 PM, heavy traffic, and snowing, all but the three smallest errors may be ignored. \*/

***/\* determine (and return) error object based on the remaining error records \*/***

error\_obj.measmt <--- 0; // initializations

error\_obj.confidence <--- 0;

15    for each error\_rec[i] in (error\_rec\_bag - BS\_errors\_to\_ignore\_bag) do

{

    error\_obj.measmt <--- error\_obj.measmt + (error\_rec[i].error);

    error\_obj.confidence <--- error\_obj.confidence + (error\_rec[i].confidence);

}

20    error\_obj.measmt <--- error\_obj.measmt / SIZEOF(error\_rec\_bag - BS\_errors\_to\_ignore\_bag);

error\_obj.confidence <--- error\_obj.confidence / SIZEOF(error\_rec\_bag - BS\_errors\_to\_ignore\_bag);

RETURN(error\_obj);

**ENDOF DB\_Loc\_Sig\_Error\_Fit**

25    **INTERNAL PROGRAMS:**

**reduce\_bad\_DB\_loc\_sigs(loc\_sig\_bag , error\_rec\_set, big\_error\_threshold**

**confidence\_reduction\_factor, recent\_time)**

*/\* This program reduces the confidence of verified DB loc sigs that are (seemingly) no longer accurate (i.e., in agreement with comparable loc sigs in the DB). If the confidence is reduced low enough, then such loc sigs are removed from the DB. Further, if for a  
30    DB verified location entity (referencing a collection of loc sigs for the same location and time), this entity no longer references any valid loc sigs, then it is also removed from the location signature data base 1320. .Note that the steps herein are also provided in flowchart form in Figs. 18a through 18b.*

Inputs:

146

145

**loc\_sig\_bag:** The loc sigs to be tested for determining if their confidences should be lowered and/or these loc sigs removed.

**error\_rec\_set:** The set of "error\_recs" providing information as to how much each loc sig in "loc\_sig\_bag" disagrees with comparable loc sigs in the DB. That is, there is an "error\_rec" here for each loc sig in "loc\_sig\_bag".

**big\_error\_threshold:** The error threshold above which the errors are considered too big to ignore.

**confidence\_reduction\_factor:** The factor by which to reduce the confidence of loc sigs.

**recent\_time:** Time period beyond which loc sigs are no longer considered recent.

5  
10 ***{ /\* get loc sigs from the Location DB having both big absolute and relative errors (in comparison to other DB nearby loc sigs) \*/***

relatively\_big\_errors\_bag <--- get "error\_recs" in "error\_rec\_set" wherein each "error\_rec.error" has a size larger than, for example, the second standard deviation from the mean (average) of such errors;

big\_errors\_bag <--- get "error\_recs" in "relatively\_big\_errors\_bag" wherein each "error\_rec.error" has a value larger than "big\_error\_threshold";

15 DB\_loc\_sigs\_w\_big\_errors <--- get the loc sigs for "error\_recs" in "big\_errors\_bag" wherein each loc sig gotten here is identified by "error\_rec.loc\_sig\_id";

***/\* get loc sigs from the Location DB that have been recently added or updated \*/***

20 recent\_loc\_sigs <--- *get\_recent\_loc\_sigs*(loc\_sig\_bag, recent\_time); /\* Note, the function, "get\_recent\_loc\_sigs" can have various embodiments, including determining the recent location signatures by comparing their time stamps (or other time related measurements) with one or more threshold values for classifying location signatures into a "recent" category returned here and an a category for "old" or updatable location signatures. Note that these categories can be determined by a (tunable) system time threshold parameter(s) for determining a value for the variable, "recent\_time", and/or, by data driving this categorization by, e.g., classifying the location signatures according to a standard deviation, such as defining the "recent" category as those location signatures more recent than a second standard deviation of the timestamps of the location signatures in "loc\_sig\_bag". \*/

25 ***/\* subtract the recent loc sigs from the loc sigs with big errors to get the bad ones***

***\*/***

bad\_DB\_loc\_sigs <--- (big\_error\_DB\_loc\_sigs) - (recent\_loc\_sigs);

***/\* lower the confidence of the bad loc sigs \*/***

30 for each loc\_sig[i] in bad\_DB\_loc\_sigs do

loc\_sig[i].confidence <--- (loc\_sig[i].confidence) \* (confidence\_reduction\_factor);

147 146

*/\* for each bad loc sig, update it in the DB or remove it from use if its confidence is too low \*/*

*/\* Now delete any loc sigs from the DB whose confidences have become too low. \*/*

for each loc\_sig[i] in bad\_DB\_loc\_sigs do

5 if (loc\_sig[i].confidence < min\_loc\_sig\_confidence) then

{

*REMOVE\_FROM\_USE*(loc\_sig[i]);

*/\* update composite location objects to reflect a removal of a referenced loc sig\*/*

10 verified\_loc\_entity <--- *retrieve\_composite\_location\_entity\_having*(loc\_sig[i]);

*/\* This gets all other (if any) loc sigs for the composite location object that were verified at the same time as "loc\_sig[i]". Note, these other loc sigs may not need to be deleted (i.e., their signal characteristics may have high confidence); however, it must be noted in the DB, that for the DB composite location entity having "loc\_sig[i]", this entity is no longer complete. Thus, this entity may not be useful as, e.g., neural net training data. \*/*

15

mark "verified\_loc\_entity" as incomplete but keep track that a loc sig did exist for the BS associated with "loc\_sig[i]";  
if ("verified\_loc\_entity" now references no loc sigs) then *REMOVE\_FROM\_USE*(verified\_loc\_entity);

}

else *DB\_update\_entry*(loc\_sig[i]); // with its new confidence

20 } **ENDOF** reduce\_bad\_DB\_loc\_sigs

**increase\_confidence\_of\_good\_DB\_loc\_sigs(nearby\_loc\_sig\_bag, error\_rec\_set, small\_error\_threshold, confidence\_increase\_factor, recent\_time);**

*/\* This program increases the confidence of verified DB loc sigs that are (seemingly) of higher accuracy (i.e., in agreement with comparable loc sigs in the DB). Note that the steps herein are also provided in flowchart form in Figs. 19a through 19b.*

25

Inputs:

**loc\_sig\_bag:** The loc sigs to be tested for determining if their confidences should be increased.

**error\_rec\_set:** The set of "error\_recs" providing information as to how much each loc sig in "loc\_sig\_bag" disagrees with comparable loc sigs in the DB. That is, there is an "error\_rec" here for each loc sig in "loc\_sig\_bag".

30

**small\_error\_threshold:** The error threshold below which the errors are considered too small to ignore.

**confidence\_increase\_factor:** The factor by which to increase the confidence of loc sigs.

148

147

**recent\_time:** Time period beyond which loc sigs are no longer considered recent.

***/\* get loc sigs from the Location DB having both small absolute and relative errors (in comparison to other DB nearby loc sigs) \*/***

relatively\_small\_errors\_bag <--- get "error\_rec" in "error\_rec\_set" wherein each "error\_rec.error" has a size smaller than, for  
5 example, the second standard deviation from the mean (average) of such errors;

small\_errors\_bag <--- get "error\_rec" in "relatively\_small\_errors\_bag" wherein each "error\_rec.error" has a size smaller than  
"small\_error\_threshold";

DB\_loc\_sigs\_w\_small\_errors <--- get the loc sigs for "error\_rec" in "small\_errors\_bag" wherein each loc sig gotten here is  
identified by "error\_rec.loc\_sig\_id";

10 ***/\* get loc sigs from the Location DB that have been recently added or updated \*/***

recent\_loc\_sigs <--- *get\_recent\_loc\_sigs*(loc\_sig\_bag, recent\_time);

***/\* subtract the recent loc sigs from the loc sigs with small errors to get the good ones \*/***

good\_DB\_loc\_sigs <--- (small\_error\_DB\_loc\_sigs) - (recent\_loc\_sigs);

15 ***/\* for each good loc sig, update its confidence \*/***

for each loc\_sig[i] in good\_DB\_loc\_sigs do

{

loc\_sig[i].confidence <--- (loc\_sig[i].confidence) \* (confidence\_increase\_factor);

if (loc\_sig[i].confidence > 1.0) then loc\_sig[i] <--- 1.0;

20 }

**ENDOF** increase\_good\_DB\_loc\_sigs

## **DATA BASE PROGRAMS FOR DETERMINING THE CONSISTENCY OF LOCATION**

### **HYPOTHESES WITH VERIFIED LOCATION INFORMATION IN THE LOCATION**

25 **SIGNATURE DATA BASE**

### **LOW LEVEL DATA BASE PROGRAMS FOR LOCATION SIGNATURE DATA BASE**

30 ***/\* The following program compares: (a1) loc sigs that are contained in (or derived from) the loc sigs in "target\_loc\_sig\_bag" with (b1) loc sigs computed from verified loc sigs in the location signature data base. That is, each loc sig from (a1) is compared with a corresponding loc sig from (b1) to obtain a measurement of the discrepancy between the two loc sigs. In particular, assuming each of the loc sigs for "target\_loc\_sig\_bag" correspond to the same target MS location, wherein this location is "target\_loc", this program***

determines how well the loc sigs in "target\_loc\_sig\_bag" fit with a computed or estimated loc sig for the location, "target\_loc" that is derived from the verified loc sigs in the location signature data base. Thus, this program may be used: (a2) for determining how well the loc sigs in the location signature cluster for a target MS ("target\_loc\_sig\_bag") compares with loc sigs derived from verified location signatures in the location signature data base, and (b2) for determining how consistent a given collection of loc sigs ("target\_loc\_sig\_bag") from the location signature data base is with other loc sigs in the location signature data base. Note that in (b2) each of the one or more loc sigs in "target\_loc\_sig\_bag" have an error computed here that can be used in determining if the loc sig is becoming inapplicable for predicting target MS locations Note that the steps herein are also provided in flowchart form in Figs. 20a through 20d.\*/  
5

**Determine\_Location\_Signature\_Fit\_Errors(target\_loc, target\_loc\_sig\_bag,  
10 search\_area, search\_criteria, output\_criteria)**

/\* Input: **target\_loc**: An MS location or a location hypothesis for a particular MS. Note, this can be any of the following:

- (a) An **MS location hypothesis**, in which case, the loc sigs in "target\_loc\_sig\_bag" are included in a location signature cluster from which this location hypothesis was derived. Note that if this location is inaccurate, then "target\_loc\_sig\_bag" is unlikely to be similar to the comparable loc sigs derived from the loc sigs of the location signature data base close "target\_loc"; or
  - (b) A **previously verified MS location**, in which case, the loc sigs of "target\_loc\_sig\_bag" are previously verified loc sigs. However, these loc sigs may or may not be accurate now.
- 15  
20

**target\_loc\_sig\_bag**: Measured location signatures ("loc sigs" for short) obtained from the particular MS (the data structure here, bag, is an aggregation such as array or list). The location signatures here may be verified or unverified. However, *it is assumed that there is at least one loc sig in the bag. Further, it is assumed that there is at most one loc sig per Base Station. It is also assumed that the present parameter includes a "type" field indicating whether the loc sigs here have been individually selected, or, whether this parameter references an entire (verified) loc sig cluster; i.e., the type field may have a value of: "UNVERIFIED LOC SIG CLUSTER" or "VERIFIED LOC SIG CLUSTER";*

25

**search\_area**: The representation of the geographic area surrounding "target\_loc". This parameter is used for searching the Location Signature data base for verified loc sigs that correspond geographically to the location of an MS in "search\_area";

30

150



**search\_criteria:** The criteria used in searching the location signature data base. The criteria may include the following:

- (a) "USE ALL LOC SIGS IN DB",
- (b) "USE ONLY REPEATABLE LOC SIGS",
- (c) "USE ONLY LOC SIGS WITH SIMILAR TIME OF DAY".

However, environmental characteristics such as: weather, traffic, season are also contemplated.

**output\_criteria:** The criteria used in determining the error records to output in "error\_rec". The criteria here may include one of:

- (a) "OUTPUT ALL POSSIBLE ERROR\_RECS";
- (b) "OUTPUT ERROR\_RECS FOR INPUT LOC SIGS ONLY".

Returns: **error\_rec:** A bag of error records or objects providing an indication of the similarity between each loc sig in "target\_loc\_sig\_bag" and an estimated loc sig computed for "target\_loc" from stored loc sigs in a surrounding area of "target\_loc". Thus, each error record/object in "error\_rec" provides a measurement of how well a loc sig (i.e., wireless signal characteristics) in "target\_loc\_sig\_bag" (for an associated BS and the MS at "target\_loc") correlates with an estimated loc sig between this BS and MS. Note that the estimated loc sigs are determined using verified location signatures in the Location Signature DB. Note, each error record in "error\_rec" includes: (a) a BS ID indicating the base station to which the error record corresponds; and (b) an error measurement ( $\geq 0$ ), and (c) a confidence value (in  $[0, 1]$ ) indicating the confidence to be placed in the error measurement. Also note that since "error\_rec" is an aggregate data type (which for many aggregate identifiers in this specification are denoted by the suffix "\_bag" on the identifier), it can be any one of a number data types even though it's members are accessed hereinbelow using array notation. \*/

```
/* get BS's associated with DB loc sigs in "search_area" that satisfy  
"search_criteria" */
```

```
DB_loc_sig_bag <--- retrieve_verified_loc_sigs(search_area, search_criteria);
```

```
// get all verified appropriate location signatures residing in the Location Signature data base.
```

```
// Note, some loc sigs may be blocked from being retrieved.
```

```
DB_BS_bag <--- get_BSs(DB_loc_sig_bag); // get all base stations associated with at least one location
```

```
// signature in DB_loc_sig_bag. Note, some of these BSs may be low power "location
```

```
// BSs".
```

```
/* get BS's associated with loc sigs in "target_loc_sig_bag" */
```

```
target_BS_bag <--- get_BSs(target_loc_sig_bag); // get all base stations associated with at least one
```

```
// location signature in "target_loc_sig_bag".
```

```
/* determine the BS's for which error records are to be computed */
```

case of "output\_criteria" including:

```
"OUTPUT ALL POSSIBLE ERROR_RECS": /* In this case, it is desired to determine a collection of error records wherein there is
an error record for each BS that is associated with a loc sig in "target_loc_sig_bag" and for each BS associated
with a loc in the "search_area" satisfying "search_criteria". */
```

```
5 BS_bag <--- (DB_BS_bag) union (target_BS_bag);
```

```
"OUTPUT ERROR_RECS FOR INPUT LOC SIGS ONLY":
```

```
BS_bag <--- target_BS_bag;
```

```
endcase;"
```

```
10 /* for each BS to have an error record computed, make sure there are two loc sigs
to compare: one loc sig derived from the "BS_bag" loc sig data, and one from
derived from the loc sigs in the Location Signature DB, wherein both loc sigs are
associated with the location, "target_loc". */
```

```
for each BS[i] in "BS_bag" do
```

```
15 { /* determine two (estimated) loc sigs at "target_loc", one derived from "target_loc_sig_bag" (if possible) and one derived
from Location Signature DB loc sigs (if possible) */
```

```
comparison_loc_sig_bag[i] <--- retrieve_verified_loc_sigs_for(BS[i], search_area, search_criteria);
```

```
/* get all loc sigs for which BS[i] is associated and wherein the verified MS location is in
```

```
20 "search_area" (which surrounds the location "target_loc") and wherein the loc
sigs satisfy "search_criteria". */
```

```
/* now determine if there are enough loc sigs in the "comparison_loc_sig_bag" to make
it worthwhile to try to do a comparison. */
```

```
if ((SIZEOF(comparison_loc_sig_bag[i])/(SIZEOF(search_area))) < min_threshold_ratio(area_type(search_area)))
then
```

```
25 /* it is believed that there is not a dense enough number of verified loc sigs to compute a composite
```

```
loc sig associated with a hypothetical MS at "target_loc". */
```

```
error_rec[i].error <--- invalid;
```

```
else /* there are enough loc sigs in "comparison_loc_sig_bag" to continue, and in
particular, an estimated loc sig can be derived from the loc sigs in
```

```
30 "comparison_loc_sig_bag"; however, first see if a target loc sig can be
determined; if so, then make the estimated loc sig (denoted
"estimated_loc_sig[i]"). */
```

```
{
```

152 151

```

if (BS[i] is in target_BS_bag) then
    /* get a loc sig in "target_BS_bag" for BS[i]; assume at most one loc sig per BS in
    "target_loc_sig_bag" */
    target_loc_sig[i] <--- get_loc_sig(BS[i], target_loc_sig_bag);
5
else /* BS[i] is not in "target_BS_bag", accordingly this implies that we are in the
    process of attempting to output all possible error records for all BS's: (a)
    that have previously been detected in the area of "search_area" (satisfying "search_criteria"), union,
    (b) that are associated with a loc sig in "target_loc_sig_bag". Note, the path here is performed when
    the MS at the location for "target_loc" did not detect the BS[i], but BS[i] has previously been detected
10
    in this area. */
    if (target_loc_sig_bag.type == "UNVERIFIED LOC SIG CLUSTER") then
        /* can at least determine if the MS for the cluster detected the BS[i]; i.e., whether BS[i]
        was in the set of BS's detected by the MS even though no loc sig was obtained for BS[i]. */
        if (BS_only_detected(target_loc_sig_bag, BS[i])) then /* detected but no loc sig */
15
            error_rec[i].error <--- invalid; /* can't determine an error if this is all the information
            we have */
        else /* BS[i] was not detected by the MS at "target_loc.location", so the pilot channel for BS[i] was
            in the noise; make an artificial loc sig at the noise ceiling (alternatively, e.g., a mean noise
            value) for the MS location at "target_loc" */
20
            target_loc_sig[i] <--- get_noise_ceiling_loc_sig(target_loc);
        else; /* do nothing; there are no other types for "target_loc_sig_bag.type" that are currently used when
            outputting all possible error records for BS's */
        if (error_rec[i].error NOT invalid) then
            /* we have a "target_loc_sig" for comparing, so get the derived loc sig estimate obtained from the
25
            verified loc sigs in the location signature data base. */
            estimated_loc_sig[i] <--- estimate_loc_sig_from_DB(target_loc.location,
                comparison_loc_sig_bag[i]);
            /* The above call function provides an estimated loc sig for the location of "target_loc" and BS[i]
            using the verified loc sigs of "comparison_loc_sig_bag[i]" */
30
        }

```

*/\* for each BS whose error record has not been marked "invalid", both  
"target\_loc\_sig" and "estimated\_loc\_sig" are now well-defined; so compute an*

153

**error record related to the difference between "target\_loc\_sig" and "estimated\_loc\_sig". \*/**

for each BS[i] in "BS\_bag" with error\_rec[i].error not invalid do /\* determine the error records for these base stations \*/

{

5 /\* Note, the "target\_loc\_sig" here is for an MS at or near the location for the center of area for "target\_loc". \*/  
error\_rec[i] <--- **get\_difference\_measurement**(target\_loc\_sig[i], estimated\_loc\_sig[i],  
comparison\_loc\_sig\_bag[i], search\_area, search\_criteria); /\* get a measurement of the difference  
between these two loc sigs. \*/

error\_rec.loc\_sig\_id <--- target\_loc\_sig[i].id; /\* this is the loc sig with which this error\_rec is associated \*/  
10 error\_rec.comparison\_loc\_sig\_id\_bag <--- comparison\_loc\_sig\_bag[i];

}

RETURN(error\_rec);

**ENDOF Determine\_Location\_Signature\_Fit\_Errors**

15 **estimate\_loc\_sig\_from\_DB(loc\_for\_estimation, loc\_sig\_bag)**

/\* This function uses the verified loc sigs in "loc\_sig\_bag" to determine a single estimated (or "typical") loc sig derived from the loc sigs in the bag. Note, it is assumed that all loc sigs in the "loc\_sig\_bag" are associated with the same BS I22 (denoted the BS associated with the "loc\_sig\_bag") and that the locations associated with these loc sigs are near "loc\_for\_estimation". Further, note *that since the loc sigs are verified, the associated base station was the primary base station when the loc sig signal measurements were sampled.* Thus, the measurements are as precise as the infrastructure allows. Note that the steps herein are also provided in flowchart form in Fig. 21.

**Input:** loc\_for\_estimation A representation of a service area location.

loc\_sig\_bag A collection of verified loc sigs, each associated with the same base station and  
25 each associated with a service area location presumably relatively near to the  
location represented by "loc\_for\_estimation". \*/

est\_loc\_sig <--- extrapolate/interpolate a location signature for the location at "loc\_for\_estimation" based on loc sigs in  
"loc\_sig\_bag";

/\* Note, "est\_loc\_sig" includes a location signature and a confidence measure.

30 The confidence measure (in the range: [0, 1]) is based on: (a) the number of verified loc sigs in the search area; (b) how well they surround the center location of the new\_loc, and (c) the confidence factors of the loc sigs in "loc\_sig\_bag" (e.g., use average confidence value).

154

Note, for the extrapolation/interpolation computation here, there are many such extrapolation/interpolation methods available as one skilled in the art will appreciate. For example, in one embodiment of an extrapolation/interpolation method, the following steps are contemplated:

5 (39.1) Apply any pre-processing constraints that may alter any subsequently computed "est\_loc\_sig" values derived below). For example, if the BS associated with "loc\_sig\_bag" is currently inactive "location BS" (i.e., "active" meaning the BS is on-line to process location information with an MS, "inactive" meaning the not on-line), then, regardless of any values that may be determined hereinbelow, a value or flag is set (for the signal topography characteristics) indicating "no signal" with a confidence value of 1 is provided. Further, additional pre-processing may be performed when the BS associated with "loc\_sig\_bag" is a location BS (LBS) since the  
10 constraint that a pilot channel from such an LBS is likely to be only detectable within a relatively small distance from the BS (e.g., 1000 ft). For example, if the MS location, "loc\_for\_estimation", does not intersect the radius (or area contour) of such a location BS, then, again, a value or flag is set (for the signal topography characteristics) indicating "outside of LBS area" with a confidence value of 1 is provided. Alternatively, if (a) a determined area, A, including the MS location, "loc\_for\_estimation" (which may itself be, and likely is, an  
15 area), intersects (b) the signal detectable area about the location BS, then (c) the confidence factor value may be dependent on the ratio of the area of the intersection to the minimum of the size of the area in which the LBS is detectable and the size of the area of "loc\_for\_estimation", as one skilled in the art will appreciate.

Further, it is noteworthy that such pre-processing constraints as performed in this step may be provided by a constraint processing expert system, wherein system parameters used by such an expert system  
20 are tuned using the adaptation engine 1382.

(39.2) Assuming a value of "no signal" or "outside of LBS area" was not set above (since otherwise no further steps are performed here), for each of the coordinates (records), C, of the signal topography characteristics in the loc sig data structure, generate a smooth surface, S(C), of minimal contour variation for the set of points { (x,y,z) such that (x,y) is a representation of a service area location, and z is a value of C at the location (x,y) for some  
25 loc sig in "loc\_sig\_bag" wherein (x,y) is a point estimate (likely centroid) of the loc sig}. Note that a least squares technique, a partial least squares technique, or averaging on "nearby" (x,y,z) points may be used with points from the above set to generate other points on the surface S(C). Additionally, note that for at least some surfaces characterizing signal energy, the generation process for such a surface may use the radio signal attenuation formulas for urban, suburban, and rural developed by M. Hata in IEEE Trans, VT-29, pgs. 317-325, Aug. 1980, "Empirical Formula For Propagation Loss In Land Mobile Radio" (herein incorporated by reference).  
30 For example, Hata's formulas may be used in:

(39.2.1) Determining portions of the surfaces S(C) where there is a low density of verified loc sigs in "loc\_sig\_bag". In particular, if there is a very low density of verified loc sigs in "loc\_sig\_bag" for the service area surrounding the location of "loc\_for\_estimation", then by determining the area

455

type(s) (e.g., transmission area type as described hereinabove, assuming a correspondence between the transmission area types and the more coarse grained categorization of : urban, suburban, and rural) between this location and the base station associated with "loc\_sig\_bag", and applying Hata's corresponding formula(s), a signal value z may be estimated according to these type(s) and their corresponding area extents between the MS and the BS. Note, however, that this option is considered less optimal to using the verified loc sigs of "loc\_sig\_bag" for determining the values of a surface S(C). Accordingly, a lower confidence value may be assigned the resulting composite loc sig (i.e., "est\_loc\_sig") determined in this manner; and relatedly,

(39.2.2) Determining a surface coordinate  $(x_0, y_0, z_0)$  of S(C) when there are nearby verified loc sigs in "loc\_sig\_bag". For example, by using Hata's formulas, an estimated surface value  $z_i$  at the location  $(x_0, y_0)$  may be derived from estimating a value  $z_i$  at  $(x_i, y_i)$  by adapting Hata's formula's to extrapolate/interpolate the value  $z_i$  from a nearby location  $(x_i, y_i)$  having a verified loc sig in "loc\_sig\_bag". Thus, one or more estimates  $z_i$  may be obtained used in deriving  $z_0$  as one skilled in statistics will appreciate. Note, this technique may be used when there is a moderately low density of verified loc sigs in "loc\_sig\_bag" for the service area surrounding the location of "loc\_for\_estimation". However, since such techniques may be also considered less than optimal to using a higher density of verified loc sigs of "loc\_sig\_bag" for determining the values of a surface S(C) via a least squares or partial least square technique, a lower confidence value may be assigned the resulting composite loc sig (i.e., "est\_loc\_sig") determined in this manner.

Further, recall that the values, z, for each loc sig are obtained from a composite of a plurality of signal measurements with an MS, and, that each value z is the most distinct value that stands out above the noise in measurements for this coordinate, C. So, for example in the CDMA case, for each of the coordinates C representing a finger of signal energy from or to some MS at a verified location, it is believed that S(C) will be a smooth surface without undulations that are not intrinsic to the service area near "loc\_for\_estimation".

(39.3) For each of the coordinates, C, of the signal topography characteristics, extrapolate/interpolate a C-coordinate value on S(C) for an estimated point location of "loc\_for\_estimation".

Further note that to provide more accurate estimates, it is contemplated that Hata's three geographic categories and corresponding formulas may be used in a fuzzy logic framework with adaptive mechanisms such as the adaptation engine 1382 (for adaptively determining the fuzzy logic classifications).

Additionally, it is also within the scope of the present invention to use the techniques of L. E. Vogler as presented in "The Attenuation of Electromagnetic Waves by Multiple Knife Edge Diffraction", US Dept of Commerce, NTIA nos, 81-86 (herein incorporated by reference) in the present context for estimating a loc sig between the base station associated with "loc\_sig\_bag" and the location of "loc\_for\_estimation". \*/

RETURN(est\_loc\_sig)

156

155

## ENDOF estimate\_loc\_sig\_from\_DB

### get\_area\_to\_search(loc)

5 /\* This function determines and returns a representation of a geographic area about a location, "loc", wherein: (a) the geographic area has associated MS locations for an acceptable number (i.e., at least a determined minimal number) of verified loc sigs from the location signature data base, and (b) the geographical area is not too big. However, if there are not enough loc sigs in even a largest acceptable search area about "loc", then this largest search area is returned. Note that the steps herein are also provided in flowchart form in Figs. 22a through 22b. \*/

```
{
10   loc_area_type <--- get_area_type(loc); /* get the area type surrounding "loc"; note this may be
       a vector of fuzzy values associated with a central location of "loc", or, associated with an area having "loc".
       */
   search_area <--- get_default_area_about(loc); /* this is the largest area that will be used */
   saved_search_area <--- search_area; // may need it after "search_area" has been changed
15   search_area_types <--- get_area_types(search_area); // e.g., urban, rural, suburban, mountain, etc.
   loop until RETURN performed:
   {
       min_acceptable_nbr_loc_sigs <--- 0; // initialization
       for each area_type in "search_area_types" do
20       {
           area_percent <--- get_percent_of_area_of(area_type, search_area);
           /* get percentage of area having "area_type" */
           min_acceptable_nbr_loc_sigs <--- min_acceptable_nbr_loc_sigs +
25           [(get_min_acceptable_verified_loc_sig_density_for(area_type)) *
           (SIZEOF(search_area) * area_percentt / 100)];
       }
       /* Now get all verified loc sigs from the location signature data base whose associated MS location is in
       "search_area". */
       total_nbr_loc_sigs <--- get_all_verified_DB_loc_sigs(search_area);
30   if (min_acceptable_nbr_loc_sigs > total_nbr_loc_sigs)
       then /* not enough loc sigs in "search_area"; so return "saved_search_area" */
           RETURN(saved_search_area);
       else /* there is at least enough loc sigs, so see if "search_area" can be decreased */
       { saved_search_area <--- search_area;
```

151

156

```
        search_area <--- decrease_search_area_about(loc, search_area);
    }
}
}
```

5 **ENDOF get\_area\_to\_search**

/\* For processing various types of loc sigs, particular signal processing filters may be required. Accordingly, in one embodiment of the present invention, a "filter\_bag" object class is provided wherein various filters may be methods of this object (in object-oriented terminology) for transforming loc sig signal data so that it is comparable with other loc sig signal data from, for example, an MS of a different classification (e.g., different power classification). It is assumed here that such a "filter\_bag" object includes (or  
10 references) one or more filter objects that correspond to an input filter (from the Signal Filtering Subsystem 1220) so that, given a location signature data object as input to the filter\_bag object,, each such filter object can output loc sig filtered data corresponding to the filter object's filter. Note, such a filter\_bag object may accept raw loc sig data and invoke a corresponding filter on the data. Further, a filter\_bag object may reference filter objects having a wide range of filtering capabilities. For example, adjustments to loc  
15 sig data according to signal strength may be desired for a particular loc sig comparison operator so that the operator can properly compare MS's of different power classes against one another. Thus, a filter may be provided that utilizes, for each BS, a corresponding signal strength change topography map (automatically generated and updated from the verified loc sigs in the location signature data base 1320) yielding signal strength changes detected by the BS for verified MS location's at various distances from the BS, in the radio coverage area. Additionally, there may also be filters on raw signal loc sig data such as quality  
20 characteristics so that loc sigs having different signal quality characteristics may be compared. \*/

**get\_difference\_measurement(target\_loc\_sig, estimated\_loc\_sig,  
comparison\_loc\_sig\_bag, search\_area, search\_criteria)**

/\* Compare two location signatures between a BS and a particular MS location (either a verified or hypothesized location) for  
25 determining a measure of their difference relative to the variability of the verified location signatures in the "comparison\_loc\_sig\_bag" from the location signature data base 1320. **Note, it is assumed that "target\_loc\_sig", "estimated\_loc\_sig" and the loc sigs in "comparison\_loc\_sig\_bag" are all associated with the same BS 122.** Moreover, it is assumed that "target\_loc\_sig" and "estimated\_loc\_sig" are well-defined non-NIL loc sigs, and additionally, that "comparison\_loc\_sig\_bag" is non-NIL. This function returns an error record, "error\_rec", having an error or  
30 difference value and a confidence value for the error value. Note, the signal characteristics of "target\_loc\_sig" and those of "estimated\_loc\_sig" are not assumed to be normalized as described in section (26.1) prior to entering this function so that variations in signal characteristics resulting from variations in (for example) MS signal processing and generating characteristics of different types of MS's may be reduced, as described in the discussion of the loc sig data type hereinabove. It is further assumed

150 157



that typically the input loc sigs satisfy the "search\_criteria". Note that the steps herein are also provided in flowchart form in Figs. 23a through 23c.

5 **target\_loc\_sig:** The loc sig to which the "error\_rec" determined here is to be associated. Note that this loc sig is associated with a location denoted hereinbelow as the "particular location".

**estimated\_loc\_sig:** The loc sig to compare with the "target\_loc\_sig", this loc sig: (a) being for the same MS location as "target\_loc\_sig", and (b) derived from verified loc sigs in the location signature data base whenever possible. However, note that if this loc sig is not derived from the signal characteristics of loc sigs in the location signature data base, then this parameter provides a loc sig that corresponds to a noise level at the particular MS location.

10 **comparison\_loc\_sig\_bag:** The universe of loc sigs to use in determining an error measurement between "target\_loc\_sig" and "estimated\_loc\_sig". Note, the loc sigs in this aggregation include all loc sigs for the associated Base Station 122 that are in the "search\_area" (which surrounds the particular MS location for "target\_loc\_sig") and satisfy the constraints of "search\_criteria". It is assumed that there are sufficient loc sigs in this aggregation to perform at least a minimally effective variability measurement in the loc sigs here.

15 **search\_area:** A representation of the geographical area surrounding the particular MS location for all input loc sigs. This input is used for determining extra information about the search area in problematic circumstances.

**search\_criteria:** The criteria used in searching the location signature data base 1320. The criteria may include the following:

- (a) "USE ALL LOC SIGS IN DB",
- (b) "USE ONLY REPEATABLE LOC SIGS",
- (c) "USE ONLY LOC SIGS WITH SIMILAR TIME OF DAY

However, environmental characteristics such as: weather, traffic, season are also contemplated. \*/

25

```
error <--- 0; // initialization
```

```
/* get identifiers for the filters to be used on the input loc sigs */
```

```
filter_bag <--- get_filter_objects_for_difference_measurement(target_loc_sig, estimated_loc_sig, comparison_loc_sig_bag);
```

30 **/\*** It is assumed here that each entry in "filter\_bag" identifies an input filter to be used in the context of determining a difference measurement between loc sigs. Note, if all loc sigs to be used here are of the same type, then it may be that there is no need for filtering here. Accordingly, "filter\_bag" can be empty. Alternatively, there may be one or more filter objects in "filter\_bag".\*/

159

158

```

/* initializations */

/* for each filter, determine a difference measurement and confidence */
for each filter_obj indicated in filter_bag do
5 {
    /* filter "target_loc_sig", "estimated_loc_sig" and loc sigs in "comparison_loc_sig_bag";
note, each filter_obj can determine when it needs to be applied since each loc sig includes:
(a) a description of the type (e.g., make and model) of the loc sig's associated MS, and (b) a
filter flag(s) indicating filter(s) that have been applied to the loc sig. */
10 target_loc_sig <--- filter_obj(target_loc_sig); /* filter at least the signal topography characteristics */
    estimated_loc_sig <--- filter_obj(estimated_loc_sig); /* filter at least the signal topography characteristics */
    comparison_loc_sig_bag <--- filter_obj(comparison_loc_sig_bag); /* filter loc sigs here too */
}

15 /* determine a difference measurement and confidence for each signal topography
characteristic coordinate */
for each signal topography characteristic coordinate, C, of the loc sig data type do
{
    variability_measmt.val <--- get_variability_range(C, comparison_loc_sig_bag);
20 /* This function provides a range of the variability of the C-coordinate. In one embodiment this measurement is a
range corresponding to a standard deviation. However, other variability measurement definitions are contemplated
such as second, third or fourth standard deviations. */
/* make sure there are enough variability measurements to determine the
variability of values for this coordinate. */
25 if (sizeof(comparison_loc_sig_bag) < expected_BS_loc_sig_threshold(search_area, search_criteria))
        then /* use the data here, but reduce the confidence in the variability measurement. Note that it is expected
that this branch is performed only when "comparison_loc_sig_bag" is minimally big enough to use (since this
is an assumption for performing this function), but not of sufficient size to have full confidence in the values
obtained. Note, a tunable system parameter may also be incorporated as a coefficient in the computation in the
30 statement immediately below. In particular, such a tunable system parameter may be based on "search_area"
or more particularly, area types intersecting "search_area".*/
        {

```

160

159

```

        variability_measmt_conf_reduction_factor <--- SIZEOF(comparison_loc_sig_bag)/
            expected_BS_loc_sig_threshold(search_area, search_criteria);
    }
else /* There is a sufficient number of loc sigs in "comparison_loc_sig_bag" so continue */
5   {
        variability_measmt_conf_reduction_factor <--- 1.0; //i.e., don't reduce confidence
    }
    /* Now determine the C-coord difference measurement between the
        "target_loc_sig" and the "estimated_loc_sig" */
10   delta <--- ABS(target_loc_sig[C] - estimated_loc_sig[C]); // get absolute value of the difference
        if (delta > variability_measmt.val) then
            {
                error <--- error + (delta/variability_measmt.val);
            }
15   } /* end C-coord processing */
    /* construct the error record and return it */
    error_rec.error <--- error;
    /* Get an average confidence value for the loc sigs in "comparison_loc_sig_bag" Note, we use
        this as the confidence of each loc sig coordinate below. */
20   average_confidence <--- AVERAGE(loc_sig.confidence for loc_sig in "comparison_loc_sig_bag");
    error_rec.confidence <--- MIN(target_loc_sig.confidence, estimated_loc_sig.confidence, (average_confidence *
        variability_measmt_conf_reduction_factor)); // presently not used

    RETURN(error_rec);
ENDOF get_difference_measurement

```

25

161

160

## APPENDIX D: Context Adjuster Embodiments

### *A description of the high level functions in a first embodiment of the Context Adjuster*

#### **context\_adjuster(loc\_hyp\_list)**

5 /\* This function adjusts the location hypotheses on the list, "loc\_hyp\_list", so that the confidences of the location hypotheses are determined more by empirical data than default values from the First Order Models 1224. That is, for each input location hypothesis, its confidence (and an MS location area estimate) may be exclusively determined here if there are enough verified location signatures available within and/or surrounding the location hypothesis estimate.

10 This function creates a new list of location hypotheses from the input list, "loc\_hyp\_list", wherein the location hypotheses on the new list are modified versions of those on the input list. For each location hypothesis on the input list, one or more corresponding location hypotheses will be on the output list. Such corresponding output location hypotheses will differ from their associated input location hypothesis by one or more of the following: (a) the "image\_area" field (see Fig. 9) may be assigned an area indicative of where the target MS is estimated to be, (b) if "image\_area" is assigned, then the "confidence" field will be the confidence that the target MS is located in the area for "image\_area", (c) if there are not sufficient "nearby" verified location signature clusters in the location signature data base to entirely rely on a computed confidence using such verified location signature clusters, then two  
15 location hypotheses (having reduced confidences) will be returned, one having a reduced computed confidence (for "image\_area") using the verified clusters in the Location Signature DB, and one being substantially the same as the associated input location hypothesis except that the confidence (for the field "area\_est") is reduced to reflect the confidence in its paired location hypothesis having a computed confidence for "image\_area". Note also, in some cases, the location hypotheses on the input list, may have no  
20 change to its confidence or the area to which the confidence applies. Note that the steps herein are also provided in flowchart form in Figs. 25a and 25b.

\*/

{

new\_loc\_hyp\_list <--- create\_new\_empty\_list();

25 for each loc\_hyp[i] in loc\_hyp\_list do /\* Note, "i" is a First Order Model 1224 indicator, indicating the model that output  
"hyp\_loc[i]" \*/

{

remove\_from\_list(loc\_hyp[i], loc\_hyp\_list);

30 if (NOT loc\_hyp[i].adjust) then /\* no adjustments will be made to the "area\_est" or the "confidence" fields since the  
"adjust" field indicates that there is assurance that these other fields are correct; note that such designations  
indicating that no adjustment are presently contemplated are only for the location hypotheses generated by  
the Home Base Station First Order Model, the Location Base Station First Order Model and the Mobil Base

77620

Ins. C165

Ins. C166

162

Station First Order Model. In particular, location hypotheses from the Home Base Station model will have confidences of 1.0 indicating with highest confidence that the target MS is within the area estimate for the location hypothesis. Alternatively, in the Location Base Station model, generated location hypotheses may have confidences of (substantially) +1.0 (indicating that the target MS is absolutely in the area for "area\_est"), or, -1.0 (indicating that the target MS is NOT in the area estimate for the generated location hypothesis).\*/

5

```
{ loc_hyp[i].image_area <--- NULL; // no adjustment, then no "image_area"  
  add_to_list(new_loc_hyp_list, loc_hyp[i]); // add "loc_hyp[i]" to the new list  
}
```

10

```
else /* the location hypothesis can (and will) be modified; in particular, an "image_area" may be assigned, the  
      "confidence" changed to reflect a confidence for the target MS being in the "image_area". Additionally, in some  
      cases, more than one location hypothesis may be generated from "loc_hyp[i]". See the comments on FIG. 9 and  
      the comments for "get_adjusted_loc_hyp_list_for" for a description of the terms here. */
```

15

```
{  
  temp_list <--- get_adjusted_loc_hyp_list_for(loc_hyp[i]);  
  new_loc_hyp_list <--- combine_lists(new_loc_hyp_list, temp_list);  
}  
RETURN(new_loc_hyp_list);
```

```
}ENDOF
```

20

### get\_adjusted\_loc\_hyp\_list\_for(loc\_hyp)

/\* This function returns a list (or more generally, an aggregation object) of one or more location hypotheses related to the input location hypothesis, "loc\_hyp". In particular, the returned location hypotheses on the list are "adjusted" versions of "loc\_hyp" in that both their target MS 140 location estimates, and confidence placed in such estimates may be adjusted according to archival MS location information in the location signature data base 1320. Note that the steps herein are also provided in flowchart form in Figs. 26a through 26c.

25

**RETURNS:** loc\_hyp\_list This is a list of one or more location hypotheses related to the input "loc\_hyp". Each location hypothesis on "loc\_hyp\_list" will typically be substantially the same as the input "loc\_hyp" except that there may now be a new target MS estimate in the field, "image\_area", and/or the confidence value may be changed to reflect information of verified location signature clusters in the location signature data base.

30

### Introductory Information Related to the Function, "get\_adjusted\_loc\_hyp\_list\_for"

163

162

This function and functions called by this function presuppose a framework or paradigm that requires some discussion as well as the defining of some terms. Note that some of the terms defined hereinbelow are illustrated in Fig. 24.

5 Define the term the “**the cluster set**” to be the set of all MS location point estimates (e.g., the values of the “pt\_est” field of the location hypothesis data type), for the present FOM, such that these estimates are within a predetermined corresponding area (e.g., “loc\_hyp.pt\_covering” being this predetermined corresponding area) and these point estimates have verified location signature clusters in the location signature data base.

Note that the predetermined corresponding area above will be denoted as the “**cluster set area**”.

Define the term “**image cluster set**” (for a given First Order Model identified by “loc\_hyp.FOM\_ID”) to mean the set of verified location signature clusters whose MS location point estimates are in “the cluster set”.

*IMO  
C10 88*

10 Note that an area containing the “image cluster set” will be denoted as the “**image cluster set area**” or simply the “image area” in some contexts. Further note that the “image cluster set area” will be a “small” area encompassing the “image cluster set”. In one embodiment, the image cluster set area will be the smallest covering of cells from the mesh for the present FOM that covers the convex hull of the image cluster set. Note that preferably, each cell of each mesh for each FOM is substantially contained within a single (transmission) area type.

15 Thus, the present FOM provides the correspondences or mapping between elements of the cluster set and elements of the image cluster set. \*/

{

add\_to\_list(loc\_hyp\_list, loc\_hyp); /\* note the fields of “loc\_hyp” may be changed below, but add “loc\_hyp” to the list,  
“loc\_hyp\_list here \*/

20 mesh <--- get\_cell\_mesh\_for\_model(loc\_hyp.FOM\_ID); /\* get the mesh of geographic cells for the First Order Model for this location hypothesis.\*/

pt\_min\_area <--- get\_min\_area\_surrounding\_pt(loc\_hyp, mesh); /\* Get a minimal area about the MS location point,  
“pt\_est” of “loc\_hyp[i]” indicating a point location of the target MS. Note that either the “pt\_est” field must be valid or the “area\_est” field of “loc\_hyp[i]” must be valid. If only the latter field is valid, then the centroid of the  
25 “area\_est” field is determined and assigned to the “pt\_est” field in the function called here. Note that the mesh of the model may be useful in determining an appropriately sized area. In particular, in one embodiment, if “loc\_hyp.pt\_est” is interior to a cell, C, of the mesh, then “pt\_min\_area” may correspond to C. Further note that in at least one embodiment, “pt\_min\_area” may be dependent on the area type within which “loc\_hyp.pt\_est” resides, since sparsely populated flat areas may be provided with larger values for this identifier. Further, this  
30 function may provide values according to an algorithm allowing periodic tuning or adjusting of the values output, via, e.g., a Monte Carlo simulation (more generally, a statistical simulation), a regression or a Genetic Algorithm.

For the present discussion, assume: (i) a cell mesh per FOM 1224; (ii) each cell is contained in substantially a single (transmission) area type; and (iii) “pt\_min\_area” represents an area of at least one cell. \*/  
area <--- pt\_min\_area; // initialization

*164*

pt\_max\_area <--- *get\_max\_area\_surrounding\_pt*(loc\_hyp, mesh); /\* Get the maximum area about "pt\_est" that is deemed worthwhile for examining the behavior of the "loc\_hyp.FOM\_ID" First Order Model (FOM) about "pt\_est". Note that in at least one embodiment, this value of this identifier may also be dependent on the area type within which "loc\_hyp.pt\_est" resides. Further, this function may provide values according to an algorithm allowing periodic tuning or adjusting of the values output, via e.g., a Monte Carlo simulation (more generally, a statistical simulation or regression) or a Genetic Algorithm. In some embodiments of the present invention, the value determined here may be a relatively large proportion of the entire radio coverage area region. However, the tuning process may be used to shrink this value for (for example) various area types as location signature clusters for verified MS location estimates are accumulated in the location signature data base. \*/

10 min\_clusters <--- *get\_min\_nbr\_of\_clusters*(loc\_hyp.FOM\_ID, area); /\* For the area, "area", get the minimum number ("min\_clusters") of archived MS estimates, L, desired in generating a new target MS location estimate and a related confidence, wherein this minimum number is likely to provide a high probability that this new target MS location estimate and a related confidence are meaningful enough to use in subsequent Location Center processing for outputting a target MS location estimate. More precisely, this minimum number, "min\_clusters," is an estimate of the archived MS location estimates, L, required to provide the above mentioned high probability wherein each L satisfies the following conditions: (a) L is in the area for "area"; (b) L is archived in the location signature data base; (c) L has a corresponding verified location signature cluster in the location signature data base; and (d) L is generated by the FOM identified by "loc\_hyp.FOM\_ID". In one embodiment, "min\_clusters" may be a constant; however, in another it may vary according to area type and/or area size (of "area"), in some it may also vary according to the FOM indicated by "loc\_hyp.FOM\_ID". \*/

20 pt\_est\_bag <--- *get\_pt\_estimates\_for\_image\_cluster\_set*(loc\_hyp.FOM\_ID, loc\_hyp.pt\_est, area); /\* Get the MS location point estimates for this FOM wherein for each such estimate: (a) it corresponds to a verified location signature cluster (that may or may not be near its corresponding estimate), and (b) each such MS estimate is in "pt\_min\_area". \*/

/\* Now, if necessary, expand an area initially starting with "pt\_min\_area" until at least "min\_clusters" are obtained, or, until the expanded area gets too big. \*/

25 while ((sizeof(pt\_est\_bag) < min\_clusters) and (sizeof(area) <= pt\_max\_area) do  
{ area <--- *increase*(area);  
min\_clusters <--- *get\_min\_nbr\_of\_clusters*(loc\_hyp.FOM\_ID, area); // update for new "area"  
pt\_est\_bag <--- *get\_pt\_estimates\_for\_image\_cluster\_set*(loc\_hyp.FOM\_ID, loc\_hyp.pt\_est, area);  
30 }

*attach\_to*(loc\_hyp.pt\_covering, area); // Make "area" the "pt\_covering" field

if (sizeof(pt\_est\_bag) == 0) then /\* there aren't any other FOM MS estimates having corresponding verified location signature clusters; so designate "loc\_hyp" as part of the second set as described above and return. \*/

165

```

{
    loc_hyp.image_area <--- NULL; // no image area for this loc_hyp; this indicates second set
    RETURN(loc_hyp_list);
}
5 /* It is now assured that "pt_est_bag" is non-empty and "area" is at least the size of a mesh
cell. */

/* Now determine "image_area" field for "loc_hyp" and a corresponding confidence value
using the verified location signature clusters corresponding to the MS point estimates of
10 "area" (equivalently, in "pt_est_bag"). */

/* There are various strategies that may be used in determining confidences of the "image_area" of a location hypothesis. In
particular, for the MS location estimates (generated by the FOM of loc_hyp.FOM_ID) having corresponding verified location
signature clusters (that may or may not be in "area"), if the number of such MS location estimates in "area" is deemed
sufficiently high (i.e., >= "min_clusters" for "area"), then a confidence value can be computed for the "image_area" that
15 is predictive of the target MS being in "image_area". Accordingly, such a new confidence is used to overwrite any previous
confidence value corresponding with the target MS estimate generated by the FOM. Thus, the initial estimate generated by the
FOM is, in a sense, an index or pointer into the archived location data of the location signature data base for obtaining a new
target MS location estimate (i.e., "image_area") based on previous verified MS locations and a new confidence value for this
new estimate.

20 Alternatively, if the number of archived FOM MS estimates that are in "area," wherein each such MS estimate has a
corresponding verified location signature clusters (in "image_area"), is deemed too small to reliably use for computing a new
confidence value and consequently ignoring the original target MS location estimate and confidence generated by the FOM,
then strategies such as the following may be implemented.

(a) In one embodiment, a determination may be made as to whether there is an alternative area and corresponding
25 "image_area" that is similar to "area" and its corresponding "image_area" (e.g., in area size and type), wherein a
confidence value for the "image_area" of this alternative area can be reliably computed due to there being a sufficient
number of previous FOM MS estimates in the alternative area that have corresponding verified location signature clusters (in
the location signature data base). Thus, in this embodiment, the confidence of the alternative "image_area" is assigned as the
confidence for the "image_area" for of "area".

30 (b) In another embodiment, the area represented by "pt_max_area" may be made substantially identical with the
MS location service region. So that in many cases, there will be, as "area" increases, eventually be enough MS location
estimates in the cluster set so that at least "min_clusters" will be obtained. Note, a drawback here is that "image_area" may
be in become inordinately large and thus be of little use in determining a meaningful target MS location estimate.

```

166

165



(c) In another embodiment, denoted herein as the two tier strategy, both the original FOM MS location estimate and confidence as well as the "image\_area" MS location estimate and a confidence are used. That is, two location hypotheses are provided for the target MS location, one having the FOM MS location estimate and one having the MS location estimate for "image\_area". However, the confidences of each of these location hypotheses maybe reduced to reflect the resulting ambiguity of providing two different location hypotheses derived from the same FOM MS estimate. Thus, the computations for determining the confidence of "image\_area may be performed even though there are less than the minimally required archived FOM estimates nearby to the original FOM target MS estimate. In this embodiment, a weighting(s) may be used to weight the confidence values as, for example, by a function of the size of the "image\_cluster\_set". For example, if an original confidence value from the FOM was 0.76 and "area" contained only two-thirds of the minimally acceptable number, "min\_clusters", then if the computation for a confidence of the corresponding "image\_area" yielded a new confidence of 0.43, then a confidence for the original FOM target MS estimate may be computed as  $[0.76 * (1/3)]$  whereas a confidence for the corresponding "image\_area" may be computed as  $[0.43 * (2/3)]$ . However, it is within the scope of the present invention to use other computations for modifying the confidences used here. For example, tunable system coefficients may also be applied to the above computed confidences. Additionally, note that some embodiments may require at least a minimal number of relevant verified location signature clusters in the location signature data base before a location hypothesis utilizes the "image\_area" as a target MS location estimate.

Although an important aspect of the present invention is that it provides increasingly more accurate MS location estimates as additional verified location signatures are obtained (i.e., added to the location signature data base), it may be the case that for some areas there is substantially no pertinent verified location signature clusters in the location signature data base (e.g., "image\_area" may be undefined). Accordingly, instead of using the original FOM generated location hypotheses in the same manner as the location hypotheses having target MS location estimates corresponding to "image\_areas" in subsequent MS location estimation processing, these two types of location hypotheses may be processed separately. Thus, a strategy is provided, wherein two sets of (one or more) MS location estimates may result:

- (i) one set having the location hypotheses with meaningful "image\_areas" as their target MS location estimates and
- (ii) a second set having the location hypotheses with their confidence values corresponding to the original FOM target MS estimates.

Since the first of these sets is considered, in general, more reliable, the second set may used as a "tie breaker" for determining which of a number of possible MS location estimates determined using the first set to output by the Location Center. Note, however, if there are no location hypotheses in the first set, then the second set may be used to output a Location Center target MS location estimate. Further note that in determining confidences of this second set, the weighting of confidence values as described above is contemplated.

**The steps provided hereinafter reflect a "two tier" strategy as discussed in (c) above.**

\*/

167

```

/* The following factor is analogous to the 2/3's factor discussed in (c) above. */
cluster_ratio_factor <--- min{(sizeof(pt_est_bag) / min_clusters), 1.0};

/* Now use "area" to obtain a new target MS location estimate and confidence based on
5 archived verified loc sigs, but first determine whether "area" is too big to ignore the original
target MS location estimate and confidence generated by the FOM . */
if (sizeof(area) > pt_max_area) then /* create a loc_hyp that is essentially a duplicate of the originally input "loc_hyp"
except the confidence is lowered by "(1.0 - cluster_ratio_factor)". Note that the original "loc_hyp" will have its
confidence computed below. */
10 { new_loc_hyp <--- duplicate(loc_hyp); // get a copy of the "loc_hyp"
new_loc_hyp.image_area <--- NULL; // no image area for this new loc_hyp
/* Now modify the confidence of "loc_hyp"; note, in the one embodiment, a system (i.e., tunable) parameter may also be
used as a coefficient in modifying the confidence here. */
new_loc_hyp.confidence <--- new_loc_hyp.confidence * (1.0 - cluster_ratio_factor);
15 add_to_list(loc_hyp_list, new_loc_hyp);
}

/* Now compute the "image_area" field and a confidence that the target MS is in
"image_area" */
image_cluster_set <--- get_verified_loc_sig_clusters_for(pt_est_bag); /* Note, this statement gets the verified location
20 signature clusters for which the target MS point location estimates (for the First Order Model identified by
"loc_hyp.FOM_ID") in "pt_est_bag" are approximations. Note that the set of MS location point estimates
represented in "pt_est_bag" is defined as a "cluster set" hereinabove.*/
image_area <--- get_area_containing(image_cluster_set); /* Note, in obtaining an area here that contains these verified
location signature clusters, various embodiments are contemplated. In a first embodiment, a (minimal) convex hull
25 containing these clusters may be provided here. In a second embodiment, a minimal covering of cells from the mesh
for the FOM identified by "loc_hyp.FOM_ID" may be used. In a third embodiment, a minimal covering of mesh cells
may be used to cover the convex hull containing the clusters. It is assumed hereinbelow that the first embodiment is
used. Note, that this area is also denoted the "image cluster set area" as is described hereinabove. */
attach_to(loc_hyp.image_area, image_area); /* Make "image_area" the "image_area" field of "loc_hyp". */
30 /* In the following step, determine a confidence value for the target MS being in the area for "image_area". */
confidence <--- confidence_adjuster(loc_hyp.FOM_ID, image_area, image_cluster_set);
/* In the following step, reduce the value of confidence if and only if the number of MS point location estimates in
"pt_est_bag" is smaller than "min_clusters" */

```

160

167

```
loc_hyp.confidence <--- confidence * cluster_ratio_factor;
RETURN(loc_hyp_list);
}ENDOF get_adjusted_loc_hyp_list_for
```

5

**confidence\_adjuster(FOM\_ID, image\_area, image\_cluster\_set)**

/\* This function returns a confidence value indicative of the target MS 140 being in the area for "image\_area". Note that the steps herein are also provided in flowchart form in Figs. 27a and 27b.

**RETURNS: A confidence value.** This is a value indicative of the target MS being located in the area represented by "image\_area" (when it is assumed that for the related "loc\_hyp," the "cluster set area" is the "loc\_hyp.pt\_covering" and "loc\_hyp.FOM\_ID" is "FOM\_ID");

**Introductory Information Related to the Function, "confidence\_adjuster"**

This function (and functions called by this function) presuppose a framework or paradigm that requires some discussion as well as the defining of terms.

Jwd.  
CIII

15

Define the term "**mapped cluster density**" to be the number of the verified location signature clusters in an "image cluster set" per unit of area in the "image cluster set area".

It is believed that the higher the "mapped cluster density", the greater the confidence can be had that a target MS actually resides in the "image cluster set area" when an estimate for the target MS (by the present FOM) is in the corresponding "the cluster set".

20

Thus, the mapped cluster density becomes an important factor in determining a confidence value for an estimated area of a target MS such as, for example, the area represented by "image\_area". However, the mapped cluster density value requires modification before it can be utilized in the confidence calculation. In particular, confidence values must be in the range [-1, 1] and a mapped cluster density does not have this constraint. Thus, a "**relativized mapped cluster density**" for an estimated MS area is desired, wherein this relativized measurement is in the range [-1, +1], and in particular, for positive confidences in the range [0, 1]. Accordingly, to alleviate this difficulty, for the FOM define the term "**prediction mapped cluster density**" as a mapped cluster density value, MCD, for the FOM and image cluster set area wherein:

25

(i) MCD is sufficiently high so that it correlates (at least at a predetermined likelihood threshold level) with the actual target MS location being in the "image cluster set area" when a FOM target MS location estimate is in the corresponding "cluster set area";

30

That is, for a cluster set area (e.g., "loc\_hyp.pt\_covering") for the present FOM, if the image cluster set area: has a mapped cluster density greater than the "prediction mapped cluster density", then there is a high likelihood of the target MS being in the image cluster set area.

169

168

It is believed that the prediction mapped cluster density will typically be dependent on one or more area types. In particular, it is assumed that for each area type, there is a likely range of prediction mapped cluster density values that is substantially uniform across the area type. Accordingly, as discussed in detail hereinbelow, to calculate a prediction mapped cluster density for a particular area type, an estimate is made of the correlation between the mapped cluster densities of image areas (from cluster set areas) and the likelihood that if a verified MS location: (a) has a corresponding FOM MS estimate in the cluster set, and (b) is also in the particular area type, then the verified MS location is also in the image area.

Thus, if an area is within a single area type, then such a "relativized mapped cluster density" measurement for the area may be obtained by dividing the mapped cluster density by the prediction mapped cluster density and taking the smaller of: the resulting ratio and 1.0 as the value for the relativized mapped cluster density.

In some (perhaps most) cases, however, an area (e.g., an image cluster set area) may have portions in a number of area types. Accordingly, a "composite prediction mapped cluster density" may be computed, wherein, a weighted sum is computed of the prediction mapped cluster densities for the portions of the area that is in each of the area types. That is, the weighting, for each of the single area type prediction mapped cluster densities, is the fraction of the total area that this area type is. Thus, a "relativized composite mapped cluster density" for the area here may also be computed by dividing the mapped cluster density by the composite prediction mapped cluster density and taking the smaller of: the resulting ratio and 1.0 as the value for the relativized composite mapped cluster density.

Accordingly, note that as such a relativized (composite) mapped cluster density for an image cluster set area increases/decreases, it is assumed that the confidence of the target MS being in the image cluster set area should increase/decrease, respectively. \*/

```
prediction_mapped_cluster_density <---
```

```
    get_composite_prediction_mapped_cluster_density_with_high_certainty
```

```
        (FOM_ID, image_area);
```

```
    /* The function invoked above provides a "composite prediction cluster density" (i.e., clusters per unit area) that is used in determining the confidence that the target MS is in "image_area". That is, the composite prediction mapped cluster density value provided here is: high enough so that for a computed mapped cluster density greater than or equal to the composite prediction cluster density, and the target MS FOM estimate is in the "cluster set area", there is a high expectation that the actual target MS location is in the "image cluster set area". */
```

```
max_area <--- get_max_area_for_high_certainty(FOM_ID, image_area); /* Get an area size value wherein it is highly likely that for an area of size, "max_area", surrounding "image_area", the actual target MS is located therein. Note, that one skilled in the art will upon contemplation be able to derive various embodiments of this function, some embodiments being similar to the steps described for embodying the function, "get_composite_prediction_mapped_cluster_density_with_high_certainty" invoked above; i.e., performing a Monte Carlo simulation. */
```

170

Imp. 11/2

/\* Given the above two values, a positive confidence value for the area, "image\_area", can be calculated based on empirical data.

There are various embodiments that may be used to determine a confidence for the "image\_area". In general, such a confidence should vary monotonically with (a) and (b) below; that is, the confidence should increase (decrease) with:

- 5 (a) an increase (decrease) in the size of the area, *particularly* if the area is deemed close or relevant to the location of the target MS; and
- (b) an increase (decrease) in the size of the image cluster set (i.e., the number of verified location signature clusters in the area that each have a location estimate, from the FOM identified by "FOM\_ID", in the "cluster set" corresponding to the "image\_cluster\_set;" e.g., the "cluster set" being a "loc\_hyp.pt\_covering").

10 As one skilled in the art will understand, there are many functions for providing confidences that vary monotonically with (a) and (b) above. In particular, for the cluster set area being "loc\_hyp.pt\_covering", one might be inclined to use the (area) size of the image cluster area as the value for (a), and the (cardinality) size of the image cluster set as the value for (b). Then, the following term might be considered for computing the confidence:

$$15 \quad (\text{sizeof}(\text{image cluster set area}) * (\text{sizeof}(\text{image cluster set}))) \text{ which, in the present context, is equal to } (\text{sizeof}(\text{"image\_area"}) * (\text{sizeof}(\text{"image\_cluster\_set"}))).$$

However, since confidences are intended to be in the range [-1,1], a normalization is also desirable for the values corresponding to (a) and (b). Accordingly, in one embodiment, instead of using the above values for (a) and (b), ratios are used. That is, assuming for a "relevant" area, A (e.g., including an image cluster set area of "loc\_hyp.pt\_covering") that there is a very high confidence that the target MS is in A, the following term may be used in place of the term, sizeof("image\_area"), above:

$$20 \quad \min \{ [\text{sizeof}(\text{"image\_area"}) / \text{sizeof}(A)], 1.0 \}. \quad \text{[CAI.1]}$$

Additionally, for the condition (b) above, a similar normalization may be provided. Accordingly, to provide this normalization, note that the term,

$$25 \quad (\text{sizeof}(\text{image\_area}) * \text{prediction\_mapped\_cluster\_density}) \quad \text{[CAI.1.1]}$$

is analogous to sizeof(A) in [CAI.1]. That is, the expression of [CAI.1.1] gives a threshold for the number of verified location signature clusters that are likely to be needed in order to have a high confidence or likelihood that the target MS is in the area represented by "image\_area". Thus, the following term may be used for the condition (b):

$$30 \quad \min \{ (\text{sizeof}(\text{image\_cluster\_set}) / \{ (\text{sizeof}(\text{image\_area}) * \text{prediction\_mapped\_cluster\_density}), 1.0 \} \} \quad \text{[CAI.2]}$$

As an aside, note that

$$\text{sizeof}(\text{image\_cluster\_set}) / [\text{sizeof}(\text{image\_area}) * \text{prediction\_mapped\_cluster\_density}]$$

is equivalent to

$$[\text{sizeof}(\text{image\_cluster\_set}) / \text{sizeof}(\text{image\_area})] / (\text{prediction\_mapped\_cluster\_density})$$

171 170

and this latter term may be interpreted as the ratio of: (i) the mapped cluster density for "image\_area" to (ii) an approximation of a cluster density providing a high expectation that the target MS is contained in "image\_area".

Note that the product of [CA1.1] and [CA1.2] provide the above desired characteristics for calculating the confidence. However, there is no guarantee that the range of resulting values from such products is consistent with the interpretation that has been placed on (positive) confidence values; e.g., that a confidence of near 1.0 has a very high likelihood that the target MS is in the corresponding area. For example, it can be that this product rarely is greater than 0.8, even in the areas of highest confidence. Accordingly, a "tuning" function is contemplated which provides an additional factor for adjusting of the confidence. This factor is, for example, a function of the area types and the size of each area type in "image\_area". Moreover, such a tuning function may be dependent on a "tuning coefficient" per area type. Thus, one such tuning function may be:

$$\min(S_{i=1}^{\text{number of area types}} [t_c * \text{sizeof}(\text{area type, in "image\_area"}) / \text{sizeof}(\text{"image\_area"})], 1.0)$$

where  $t_c$  is a tuning coefficient (determined in background or off-line processing; e.g., by a Genetic Algorithm or Monte Carlo simulation or regression) for the area type indexed by "i".

Note that it is within the scope of the present invention, that other tuning functions may also be used whose values may be dependent on, for example, Monte Carlo techniques or Genetic Algorithms.

It is interesting to note that in the product of [CA1.1] and [CA1.2], the "image\_area" size cancels out. This appears to conflict with the description above of a desirable confidence calculation. However, the resulting (typical) computed value:

$$\frac{\text{sizeof}(\text{image\_cluster\_set})}{[\text{max\_area} * \text{prediction\_mapped\_cluster\_density}]}$$
 [CA1.3]

is strongly dependent on "image\_area" since "image\_cluster\_set" is derived from "image\_area" and "prediction\_mapped\_cluster\_density" also depends on "image\_area". Accordingly, it can be said that the product [CA1.3] above for the confidence does not depend on "raw" area size, but rather depends on a "relevant" area for locating the target MS.

**An embodiment of the confidence computation follows:**

```
*/
area_ratio <--- min((sizeof(image_area) / max_area), 1.0);
cluster_density_ratio <---
min( (sizeof(image_cluster_set) / [sizeof(image_area) * (prediction_mapped_cluster_density)]), 1.0);
tunable_constant <--- get_confidence_tuning_constant(image_area); // as discussed in the comment above
confidence <--- (tunable_constant) * (area_ratio) * (cluster_density_ratio); //This is in the range [0, 1]
RETURN(confidence);
```

Inv. Cl 3

172

171

```
} ENDOF confidence_adjuster
```

### get\_composite\_prediction\_mapped\_cluster\_density\_with\_high\_certainty

5

```
(FOM_ID, image_area);
```

```
/* The present function determines a composite prediction mapped cluster density by determining a composite prediction mapped cluster density for the area represented by "image_area" and for the First Order Model identified by "FOM_ID". The steps herein are also provided in flowchart form in Fig. 28.
```

```
OUTPUT: composite_mapped_density This is a record for the composite prediction
```

10

```
mapped cluster density. In particular, there are with two fields:
```

```
(i) a "value" field giving an approximation to the prediction mapped cluster density for the First Order Model having id, FOM_ID;
```

```
(ii) a "reliability" field giving an indication as to the reliability of the "value" field. The reliability field is in the range [0, 1] with 0 indicating that the "value" field is worthless and the larger the value the more assurance can be put in "value" with maximal assurance indicated when "reliability" is 1.*/
```

15

```
{
```

```
/* Determine a fraction of the area of "image_area" contained in each area type (if there is only one, e.g., dense urban or a particular transmission area type as discussed in the detailed description hereinabove, then there would be a fraction having a value of 1 for this area type and a value of zero for all others). */
```

20

```
composite_mapped_density <--- 0; // initialization
```

```
for each area_type intersecting "image_area" do // "area_type" may be taken from a list of area types .
```

```
{ /* determine a weighting for "area_type" as a fraction of its area in "image_area" */
```

```
intersection <--- intersect(image_area, area_for(area_type));
```

25

```
weighting <--- sizeof(intersection) / sizeof(area_image);
```

```
/* Now compute a prediction cluster density that highly correlates with predicting a location of the target MS for this area type. Then provide this cluster density as a factor of a weighted sum of the prediction cluster densities of each of the area types, wherein the weight for a particular area type's prediction cluster density is the fraction of the total area of "image_area" that is designated this particular area type. Note that the following function call does not utilize information regarding the location of "image_area". Accordingly, this function may access a precomputed table giving prediction mapped cluster densities for (FOM_ID, area_type) pairs. However, in alternative embodiments of the present invention, the prediction mapped cluster densities may be computed specifically for the area of "image_area" intersect "area_type". */
```

30

173

172

```

prediction_mapped_density <--- get_prediction_mapped_cluster_density_for(FOM_ID, area_type);
composite_mapped_density <--- composite_mapped_density +
                               (weighting * prediction_mapped_density);
}
5 RETURN(composite_mapped_density);
} ENDOF get_composite_prediction_mapped_cluster_density_with_high_certainty

```

**get\_prediction\_mapped\_cluster\_density\_for(FOM\_ID, area\_type)**

10 /\* The present function determines an approximation to a prediction mapped cluster density, D, for an area type such that if an image cluster set area has a mapped cluster density  $\geq D$ , then there is a high expectation that the target MS I40 is in the image cluster set area. Note that there are a number of embodiments that may be utilized for this function. The steps herein are also provided in flowchart form in Figs. 29a through 29h.

15 **OUTPUT: prediction\_mapped\_cluster\_density** This is a value giving an approximation to the prediction mapped cluster density for the First Order Model having identity, "FOM\_ID", and for the area type represented by "area\_type" \*/

**Introductory Information Related to the Function,**

**"get\_predication\_mapped\_cluster\_density\_for"**

20 It is important to note that the computation here for the prediction mapped cluster density may be more intense than some other computations but **the cluster densities computed here need not be performed in real time** target MS location processing. That is, the steps of this function may be performed only periodically (e.g., once a week), for each FOM and each area type thereby precomputing the output for this function. Accordingly, the values obtained here may be stored in a table that is accessed during real time target MS location processing. However, for simplicity, only the periodically performed steps are presented here. However, one skilled in the art will understand that with sufficiently fast computational devices, some related variations of this function may be performed in real-time. In particular, instead of supplying area type as an input to this function, a particular area, A, may be provided such as the image area for a cluster set area, or, the portion of such an image area in a particular area type. Accordingly, wherever "area\_type" is used in a statement of the embodiment of this function below, a comparable statement with "A" can be provided.

```

30 {
    mesh <--- get_mesh_for(FOM_ID); /* get the mesh for this First Order Model; preferably each cell of "mesh" is substantially
    in a single area type. */

```

174



```

max_nbr_simulations <--- get_Monte_Carlo_simulation_nbr(FOM_ID, area_type); /* This function outputs a value of the
                                maximum number of simulations to perform for estimating the prediction mapped cluster
                                density. Note that the output here may always be the same value such as 100. */
nbr_simulations_performed <--- 0; // initialization
5  while (nbr_simulations_performed <= max_nbr_simulations) do // determine a value for the "average mapped cluster
                                density" and a likelihood of this value being predictive of an MS location. */
{
    representative_cell_cluster_set <--- get_representative_cell_clusters_for(area_type, mesh); /* Note, each activation
                                of this function should provide a different set of cell clusters from a covering from "mesh" of an (sub)area of
                                type, "area_type". There should ideally be at least enough substantially different sets of representative cell
10   clusters so that there is a distinct sets of cell clusters for each simulation number, j. Further note that, in one
                                embodiment, each of the "representative cell cluster sets" (as used here) may include at least a determined
                                proportion of the number of cells distributed over the area type. Moreover, each cell cluster (within a
                                representative cell cluster set) satisfies the following:
15   A. The cell cluster is a minimal covering (from "mesh") of a non-empty area, A, of type "area_type" ("A"
                                being referred to herein as the associated area for the cell cluster);
                                B. The cells of the cluster form a connected area; note this is not absolutely necessary; however, it is preferred
                                that the associated area "A" of "area_type" covered by the cell cluster have a "small" boundary with other
                                area types since the "image_areas" computed below will be less likely to include large areas of other area
20   types than "area_type;"
                                C. There is at least a predetermined minimal number (>= 1) of verified location signature clusters from the
                                location signature data base whose locations are in the associated area "A".
                                D. The cell cluster has no cell in common with any other cell cluster output as an entry in
                                "representative_cell_cluster_set". */
25   if (representative_cell_cluster_set is NULL) then /* another representative collection of cell clusters could not be found; so
                                cease further simulation processing here, calculate return values and return */
                                break; // jump out of "simulation loop"
                                else /* there is another representative collection of cell clusters to use as a simulation */
{
30   for each cell cluster, C, in "representative_cell_clusters" do /* determine an approximation to the predictiveness of the
                                mappings between: (a) cluster set areas wherein each cluster set area is an area around a (FOM_ID) FOM
                                estimate that has its corresponding verified location in "C," and (b) the corresponding image areas for
                                these cluster set areas. Note, the location signature data base includes at least one (and preferably more)

```

175

location signature clusters having verified locations in each cell cluster C as per the comment at (C) above.

```
*/
{ random_list <--- randomly_select_verified_MS_locs_in(C); /* select one or more verified MS
                    locations from C. */
5 mapped_density_sum <--- 0; // initialization
  for each verified location, "rand_verif_loc", in "random_list" do /* Let X denote the MS I40 estimate by the
                    present FOM of the verified location signature cluster of "rand_verif_loc"; let CS(X) denote
                    the cluster set obtained from the cluster set area (i.e., pt_area) surrounding X; this loop
                    determines whether the associated image area for the set CS(X) - X, (i.e., the image area for
10 CS(X) without "rand_verif_loc") includes "rand_verif_loc"; i.e., try to predict the location
                    area of "rand_verif_loc". */
    { loc_est <--- get_loc_est_for(rand_verif_loc, FOM_ID); /* get the FOM MS location
                    estimate for an MS actually located at "rand_verif_loc". */
      cluster_set <--- get_loc_est_surrounding(loc_est, mesh); /* expand about "loc_est" until a minimal
15 number of other location estimates from this FOM are obtained that are different from
                    "loc_est", or until a maximum area is reached. Note, "cluster_set" could be empty, but
                    hopefully not. Also note that in one embodiment of the function here, the following functions
                    may be invoked: "get_min_area_surrounding," "get_max_area_surrounding" and
                    "get_min_nbr_of_clusters" (as in "get_adjusted_loc_hyp_list_for", the second function
20 of Appendix D): */
      image_set <--- get_image_of(cluster_set); /* "image_set" could be empty, but hopefully not */
      image_area <--- get_image_area(image_est); /* get convex hull of "image_set". Note, "image_area"
                    could be an empty area, but hopefully not. */
      if (rand_verif_loc is in image_area)
25       then /* this is one indication that the mapped cluster density: (sizeof[image_set]/image_area) is
                    sufficiently high to be predictive */
          predictions <--- predictions + 1;
      if (image_set is not empty) then
      {
30 density <--- sizeof(image_set) / sizeof(image_area); /* Get an approximation to the mapped cluster
                    density that results from "image_set" and "image_area." Note, that there is no
                    guarantee that "image_area" is entirely within the area type of "area_type." Also
                    note, it is assumed that as this mapped cluster density increases, it is more likely that
                    "rmdm_verif_loc" is in "image_area". */
```

176

175

```

        mapped_density_sum <--- mapped_density_sum + density;
    }
    } /* end loop for predicting location of a random MS verified location in cell cluster C. */
    total_possible_predictions <--- sizeof(random_list); // One prediction per element on list.
5    /* Now get average mapped density for the cell cluster C. */
    avg_mapped_density[C] <--- mapped_density_sum / total_possible_predictions;
    /* Now get the prediction probability for the cell cluster C. */
    prediction_probability[C] <--- predictions / total_possible_predictions;
    } /* end loop over cell clusters C in "representative_cell_clusters" */
10    nbr_simulations_performed <--- nbr_simulations_performed + 1;
    } // end else

    /* It would be nice to use the set of pairs (avg_mapped_density[C], prediction_probability[C]) for extrapolating a mapped
    density value for the area type that gives a very high prediction probability. However, due to the potentially small
    number of verified MS locations in many cells (and cell clusters), the prediction probabilities may provide a very small
15    number of distinct values such as: 0, 1/2, and 1. Thus, by averaging these pairs over the cell clusters of
    "representative_cell_clusters", the coarseness of the prediction probabilities may be accounted for. */
    avg_mapped_cluster_density[nbr_simulations_performed] <---
        avg_of_cell_mapped_densities(avg_mapped_density);
    avg_prediction_probability[nbr_simulations_performed] <---
20        avg_of_cell_prediction_probabilities(prediction_probability);
    } /* end simulation loop */

    /* Now determine a measure as to how reliable the simulation was. Note that "reliability" computed in the next statement is in
    the range [0, 1]. */
    reliability <--- nbr_simulations_performed / max_nbr_simulations;
25    if (reliability < system_defined_epsilon) then /* simulation too unreliable; so use a default high value for
        "prediction_mapped_cluster_density" */
        prediction_mapped_cluster_density <--- get_default_high_density_value_for(area_type);
    else /* simulation appears to be sufficiently reliable to use the entries of "avg_mapped_cluster_density" and
        "avg_prediction_probability" */
30    {
        /* A more easily discernible pattern between mapped cluster density and prediction probability may be provided by the set
        of pairs:
        S = {(avg_mapped_cluster_density[j], avg_prediction_probability[j])}, so that a mapped cluster density value
        having a high prediction probability (e.g., 0.95) may be extrapolated in the next statement. However, if it is

```

177 176

```

determined (in the function) that the set S does not extrapolate well (due to for example all ordered pairs of S being
clustered in a relatively small region), then a "NULL" value is returned. */
prediction_mapped_cluster_density <--- mapped_cluster_density_extrapolation(avg_mapped_cluster_density,
    avg_prediction_probability, 0.95);
5  if ( (prediction_mapped_cluster_density == NULL) then
    /* set this value to a default "high" value for the present area type*/
    prediction_mapped_cluster_density <--- get_default_high_density_value_for(area_type);
else // So both "prediction_mapped_cluster_density" and it's reliability are minimally OK.
    /* Now take the "reliability" of the "prediction_mapped_cluster_density" into account. Accordingly, as the
10    reliability decreases then the prediction mapped cluster density should be increased. However, there is a system
    defined upper limit on the value to which the prediction mapped cluster density may be increased. The next
    statement is one embodiment that takes all this into account. Of course other embodiments are also possible.
    */
    prediction_mapped_cluster_density <---
15    min {(prediction_mapped_cluster_density / reliability),
        get_default_high_density_value_for(area_type)};
} //end else for simulation appearing reliable
RETURN(prediction_mapped_cluster_density);
}ENDOF get_prediction_mapped_cluster_density_for

```

20

178 177

***A Second Embodiment of the Context Adjuster.***

Note that in this second embodiment of the Context Adjuster, it uses various heuristics to increment/decrement the confidence value of the location hypotheses coming from the First Order Models. These heuristics are implemented using fuzzy mathematics, wherein linguistic, fuzzy "if-then" rules embody the heuristics. That is, each fuzzy rule includes terms in both the "if" and the "then" portions that are substantially described using natural language — like terms to denote various parameter value classifications related to, but not equivalent to, probability density functions. Further note that the Context Adjuster and/or the FOM's may be calibrated using the location information from LBSs (i.e., fixed location BS transceivers), via the Location Base Station Model since such LBS's have well known and accurate predetermined locations.

Regarding the heuristics of the present embodiment of the context adjuster, the following is an example of a fuzzy rule that might appear in this embodiment of the Context Adjuster:

If < the season is Fall > then < the confidence level of Distance Model is increased by 5% >.

In the above sample rule, "Distance Model" denotes a First Order Model utilized by the present invention. To apply this sample rule, the fuzzy system needs a concrete definition of the term "Fall." In traditional expert systems, the term Fall would be described by a particular set of months, for example, September through November, in which traditional set theory is applied. In traditional set theory, an entity, in this case a date, is either in a set or it is not in a set, e.g. its degree of membership in a set is either 0, indicating that the entity is not in a particular set, or 1, indicating that the entity is in the set. However, the traditional set theory employed in expert systems does not lend itself well to entities that fall on set boundaries. For example, a traditional expert system could take dramatically different actions for a date of August 31 than it could for a date of September 1 because August 31 might belong to the set "Summer" while the date September 1 might belong to the set "Fall." This is not a desirable behavior since it is extremely difficult if not impossible to determine such lines of demarcation so accurately. However, fuzzy mathematics allows for the possibility of an entity belonging to multiple sets with varying degrees of confidence ranging from a minimum value of 0 (indicating that the confidence the entity belongs to the particular set is minimum) to 1 (indicating that the confidence the entity belongs to the particular set is maximum). The "fuzzy boundaries" between the various sets are described by fuzzy membership functions which provide a membership function value for each value on the entire range of a variable. As a consequence of allowing entities to belong to multiple sets simultaneously, the fuzzy rule base might have more than one rule that is applicable for any situation. Thus, the actions prescribed by the individual rules are averaged via a weighting scheme where each rule is implemented in proportion to its minimum confidence. For further information regarding such fuzzy heuristics, the following references are incorporated herein by reference: (McNeil and Freiberger, 1993; Cox, 1994; Klir and Folger, 1999; Zimmerman, 1991).

Thus, the rules defined in the fuzzy rule base in conjunction with the membership functions allow the heuristics for adjusting confidence values to be represented in a linguistic form more readily understood by humans than many other heuristic representations and thereby making it easier to maintain and modify the rules. The fuzzy rule base with its membership functions can be thought of as an extension

to a traditional expert system. Thus, since traditional expert systems are subsets of fuzzy systems, an alternative to a fuzzy rule base is a traditional expert system, and it is implicit that anywhere in the description of the current invention that a fuzzy rule base can be replaced with an expert system.

5 Also, these heuristics may evolve over time by employing adaptive mechanisms including, but not limited to, genetic algorithms to adjust or tune various system values in accordance with past experiences and past performance of the Context Adjuster for increasing the accuracy of the adjustments made to location hypothesis confidence values. For example, in the sample rule presented above:

If < the season is Fall > then < the confidence level of Distance Model is increased by 5% >

10 an adaptive mechanism or optimization routine can be used to adjust the percent increase in the confidence level of the Distance Model. For example, by accessing the MS Status Repository, a genetic algorithm is capable of adjusting the fuzzy rules and membership functions such that the location hypotheses are consistent with a majority of the verified MS locations. In this way, the Context Adjuster is able to employ a genetic algorithm to improve its performance over time. For further information regarding such adaptive mechanisms, the following references are incorporated herein by reference: (Goldberg, 1989; Holland, 1975). For further information regarding the tuning of fuzzy systems using such adaptive mechanisms, the following references are incorporated herein by reference: (Karr, 1991a, 1991b).

15 In one embodiment, the Context Adjuster alters the confidence values of location hypotheses according to one or more of the following environmental factors: (1) the type of region (e.g., dense urban, urban, rural, etc.), (2) the month of the year, (3) the time of day, and (4) the operational status of base stations (e.g., on-line or off-line), as well as other environmental factors that may substantially impact the confidence placed in a location hypothesis. Note that in this embodiment, each environmental factor has an associated set of linguistic heuristics and associated membership functions that prescribe changes to be made to the confidence values of the input location hypotheses.

20 The context adjuster begins by receiving location hypotheses and associated confidence levels from the First Order Models. The Context Adjuster takes this information and improves and refines it based on environmental information using the modules described below.

### **B.1 COA Calculation Module**

25 As mentioned above each location hypothesis provides an approximation to the MS position in the form of a geometric shape and an associated confidence value,  $a$ . The COA calculation module determines a center of area (COA) for each of the geometric shapes, if such a COA is not already provided in a location hypothesis. The COA Calculation Module receives the following information from each First Order Model: (1) a geometrical shape and (2) an associated confidence value,  $a$ . The COA calculation is made using traditional geometric computations (numerical algorithms are readily available). Thus, following this step, each location hypothesis includes a COA as a single point that is assumed to represent the most likely approximation of the location of the MS. The COA Calculation Module passes the following information to the fuzzification module: (1) a geometrical shape associated with each first order model 1224, (2) an associated confidence value, and (3) an associated COA.

30

### **B.2 Fuzzification Module**

180 179

A fuzzification module receives the following information from the COA Calculation Module: (1) a geometrical shape associated with each First Order Model, (2) an associated confidence value, and (3) an associated COA. The Fuzzification Module uses this information to compute a membership function value ( $\mu$ ) for each of the M location hypotheses received from the COA calculation module (where the individual models are identified with an i index) for each of the N environmental factors (identified with a j index). In addition to the information received from the COA Calculation Module, the Fuzzification Module receives information from the Location Center Supervisor. The fuzzification module uses current environmental information such as the current time of day, month of year, and information about the base stations on-line for communicating with the MS associated with a location hypothesis currently being processed (this information may include, but is not limited to, the number of base stations of a given type, e.g., location base stations, and regular base stations, that have a previous history of being detected in an area about the COA for a location hypothesis). The base station coverage information is used to compute a percentage of base stations reporting for each location hypothesis.

The fuzzification is achieved in the traditional fashion using fuzzy membership functions for each environmental factor as, for example, is described in the following references incorporated herein by reference: (McNeil and Freiburger, 1993; Cox, 1994; Klir and Folger, 1999; Zimmerman, 1991).

Using the geographical area types for illustration purposes here, the following procedure might be used in the Fuzzification Module. Each value of COA for a location hypothesis is used to compute membership function values ( $\mu$ ) for each of five types of areas: (1) dense urban ( $\mu_{DU}$ ), (2) urban ( $\mu_U$ ), (3) suburban ( $\mu_S$ ), (4) rural plain ( $\mu_{RP}$ ), and (5) rural mountains ( $\mu_{RM}$ ). These membership function values provide the mechanism for representing degrees of membership in the area types, these area types being determined from an area map that has been sectioned off. In accordance with fuzzy theory, there may be geographical locations that include, for example, both dense urban and urban areas; dense urban and rural plane areas; dense urban, urban, and rural plane areas, etc. Thus for a particular MS location area estimate (described by a COA), it may be both dense urban and urban at the same time. The resolution of any apparent conflict in applicable rules is later resolved in the Defuzzification Module using the fuzzy membership function values ( $\mu$ ) computed in the Fuzzification Module.

Any particular value of a COA can land in more than one area type. For example, the COA may be in both dense urban and urban. Further, in some cases a location hypothesis for a particular First Order Model i may have membership functions  $\mu_{DU}^i$ ,  $\mu_U^i$ ,  $\mu_S^i$ ,  $\mu_{RP}^i$ , and  $\mu_{RM}^i$  wherein they all potentially have non-zero values. Additionally, each geographical area is contoured. Note that the membership function contours allow for one distinct value of membership function to be determined for each COA location (i.e., there will be distinct values of  $\mu_{DU}^i$ ,  $\mu_U^i$ ,  $\mu_S^i$ ,  $\mu_{RP}^i$ , and  $\mu_{RM}^i$  for any single COA value associated with a particular model i). For example, the COA would have a dense urban membership function value,  $\mu_{DU}^i$ , equal to 0.5. Similar contours would be used to compute values of  $\mu_U^i$ ,  $\mu_S^i$ ,  $\mu_{RP}^i$ , and  $\mu_{RM}^i$ .

Thus, for each COA, there now exists an array or series of membership function values; there are K membership function values (K = number of descriptive terms for the specified environmental factor) for each of M First Order Models. Each COA calculation has associated with it a definitive value for  $\mu_{DU}^i$ ,  $\mu_U^i$ ,  $\mu_S^i$ ,  $\mu_{RP}^i$ , and  $\mu_{RM}^i$ . Taken collectively, the M location hypotheses with membership function values for the K descriptive terms for the particular environmental factor results in a membership function value matrix. Additionally, similar membership function values are computed for each of the N environmental factors, thereby resulting in a corresponding membership function value matrix for each of the N environmental factors.

The Fuzzification Module passes the N membership function value matrices described above to the Rule Base Module along with all of the information it originally received from the COA Calculation Module.

### B.3 Rule Base Module

The Rule Base Module receives from the Fuzzification Module the following information: (1) a geometrical shape associated with each First Order Model, (2) an associated confidence value, (3) an associated COA, and (4) N membership function value matrices. The Rule Base Module uses this information in a manner consistent with typical fuzzy rule bases to determine a set of active or applicable rules. Sample rules were provided in the general discussion of the Context Adjuster. Additionally, references have been supplied that describe the necessary computations. Suffice it to say that the Rule Base Modules employ the information provided by the Fuzzification Module to compute confidence value adjustments for each of the m location hypotheses. Associated with each confidence value adjustment is a minimum membership function value contained in the membership function matrices computed in the Fuzzification Module.

For each location hypothesis, a simple inference engine driving the rule base queries the performance database to determine how well the location hypotheses for the First Order Model providing the current location hypothesis has performed in the past (for a geographic area surrounding the MS location estimate of the current location hypothesis) under the present environmental conditions. For example, the performance database is consulted to determine how well this particular First Order Model has performed in the past in locating an MS for the given time of day, month of year, and area type. Note that the performance value is a value between 0 and 1 wherein a value of 0 indicates that the model is a poor performer, while a value of 1 indicates that the model is always (or substantially always) accurate in determining an MS location under the conditions (and in the area) being considered. These performance values are used to compute values that are attached to the current confidence of the current location hypothesis; i.e., these performance values serve as the "then" sides of the fuzzy rules; the First Order Models that have been effective in the past have their confidence levels incremented by large amounts while First Order Models that have been ineffective in the past have their confidence levels incremented by small amounts. This information is received from the Performance Database in the form of an environmental factor, a First Order Model number, and a performance value. Accordingly, an intermediate value for the adjustment of the confidence value for the current location hypothesis is computed for each environmental condition (used by Context Adjuster) based on the performance value retrieved from the Performance Database. Each of these intermediate adjustment values are computed according to the following equation which is applicable to area information:

$$\text{adjustment}_i^j = Da_i^j = \text{performance\_value}_j * Da_{\text{REGION}}^{\text{MAX}}$$

where a is the confidence value of a particular location hypothesis, performance\_value is the value obtained from the Performance Database,  $Da_{\text{REGION}}^{\text{MAX}}$  is a system parameter that accounts for how important the information is being considered by the context adjuster. Furthermore, this parameter is initially provided by an operator in, for example, a system start-up configuration and a reasonable value for this parameter is believed to be in the range 0.05 to 0.1, the subscript j represents a particular environmental factor, and the superscript i represents a particular First Order Model. However, it is an important aspect of the present invention that this value can be repeatedly altered by an adaptive mechanism such as a genetic algorithm for improving the MS location accuracy of the present invention. In this way, and because the rules are

182



"written" using current performance information as stored in the Performance Database, the Rule Module is dynamic and becomes more accurate with time.

The Rule Base Module passes the matrix of adjustments to the Defuzzification Module along with the membership function value matrices received from the Fuzzification Module.

## 5 B.6 Defuzzification Module

The Defuzzification Module receives the matrix of adjustments and the membership function value matrices from the Rule Base Module. The final adjustment to the First Order Model confidence values as computed by the Context Adjuster is computed according to:

$$\Delta \alpha_j^i(k) = \frac{\sum_{j=1}^N \mu_j^i(k) \Delta \alpha_j^i}{\sum_{j=1}^N \mu_j^i(k)}$$

T1830

such as, but not limited to, time of day, month of year, and base station coverage, there are a number of system start-up configuration parameters that can be adjusted in attempts to improve system performance. These adjustments are, in effect, adjustments computed depending on the previous performance values of each model under similar conditions as being currently considered. These adjustments are summed and forwarded to the blackboard. Thus, the Context Adjuster passes the following information to the blackboard: adjustments in confidence values for each of the First Order Models based on environmental factors and COA values associated with each location hypothesis.

### Summary

The Context Adjuster uses environmental factor information and past performance information for each of *i* First Order Models to compute adjustments to the current confidence values. It retrieves information from the First Order Models, interacts with the Supervisor and the Performance Database, and computes adjustments to the confidence values. Further, the Context Adjuster employs a genetic algorithm to improve the accuracy of its calculations. The algorithm for the Context Adjuster is included in algorithm BE.B below:

Algorithm BE.B: Pseudocode for the Context Adjuster.

### Context\_Adjuster (geometries, alpha)

20 /\* This program implements the Context Adjuster. It receives from the First Order Models geometric areas contained in a data structure called geometries, and associated confidence values contained in an array called alpha. The program used environmental information to compute improved numerical values of the confidence values. It places the improved values in the array called alpha, destroying the previous values in the process.

T1831

\*/

25 // pseudo code for the Context Adjuster

// assume input from each of *i* models includes a

// geographical area described by a number of points

183 182

```

// and a confidence value alpha(i). alpha is such
// that if it is 0.0 then the model is absolutely
// sure that the MS is not in the prescribed area;
// if it is 1.0 then the model is absolutely
5 // sure that the MS is in the prescribed area.
// calculate the center of area for each of the i model areas
for i = 1 to number_of_models
    calculate center of area // termed coa(i) from here on out
// extract information from the "outside world" or the environment
10 find time_of_day
    find month_of_year
    find number_of_BS_available
    find number_of_BS_reporting
// calculate percent coverage of base stations
15 percent_coverage = 100.0 * (number_of_BS_reporting / number_of_BS_available)
// use these j = 4 environmental factors to compute adjustments to the i confidence values
// associated with the i models - alpha(i)
for i = 1 to number_of_models // loop on the number of models
    for j = 1 to number_env_factors // loop on the number of environmental factors
20     for k = 1 to number_of_fuzzy_classes // loop on the number of classes
        // used for each of the environmental
        // factors
// calculate mu values based on membership function definitions
        calculate mu(i,j,k) values
25 // go to the performance database and extract current performance information for each of the i
// models, in the k fuzzy classes, for the j environmental factors
        fetch performance(i,j,k)

// calculate the actual values for the right hand sides of the fuzzy rules
30
        delta_alpha(i,j,k) = performance(i,j,k) * delta_alpha_max(j)
// delta_alpha_max(j) is a maximum amount each environmental
// factor can alter the confidence value; it is eventually

```

184

183

```

// determined by a genetic algorithm

// compute a weighted average; this is traditional fuzzy mathematics
5  delta_alpha(i,j,k) = sum[mu(i,j,k) * delta_alpha(i,j,k) / sum[mu(i,j,k)]

end loop on k // number of fuzzy classes

// compute final delta_alpha values
10 delta_alpha(i) = sum[delta_alpha(i,j)]
end loop on j // number of environmental factors
alpha(i) += delta_alpha(i)
end loop on i // number of models

15 //send alpha values to blackboard
send delta_alpha(i) to blackboard

// see if it is time to interact with a genetic algorithm
if (in_progress)
20 then continue to calculate alpha adjustments
else
call the genetic algorithm to adjust alpha_max parameters and mu functions

```

185

184

## APPENDIX E: Historical Data Confidence Adjuster Program

### Historical\_data\_confidence\_adjuster(loc\_hyp)

T1860

```
5  /* This function adjusts the confidence of location hypothesis, "loc_hyp", according to how well its location signature cluster fits with verified
   location signature clusters in the location signature data base. */
   {
       mesh <--- get_mesh_for(loc_hyp.FOM_ID); // each FOM has a mesh of the Location Center service area
       covering <--- get_mesh_covering_of_MS_estimate_for(loc_hyp); /* get the cells of "mesh" that minimally cover the most
           pertinent target MS estimate in "loc_hyp". */
10  total_per_unit_error <--- 0; // initialization
       for each cell, C, of "covering" do /* determine an error measurement between the location signature cluster of "loc_hyp" and
           the verified location signature clusters in the cell */
           {
               centroid <--- get_centroid(C);
15  error_obj <--- DB_Loc_Sig_Error_Fit(centroid, C, loc_hyp.loc_sig_cluster, "USE ALL LOC SIGS IN
                   DB");
                   /* The above function call computes an error object, "error_obj", providing a
                   measure of how similar the location signature cluster for "loc_hyp" is with the verified
                   location signature clusters in the location signature data base, wherein the verified
                   location signature clusters are in the area represented by the cell, C. See APPENDIX C
20  for details of this function. */
                   total_per_unit_error <--- total_per_unit_error + [error_obj.error * error_obj.confidence / sizeof(C)];
                   /* The above statement computes an "error per unit of cell area" term as:
                   [error_obj.error * error_obj.confidence / sizeof(C)], wherein the error is the term:
25  error_obj.error * error_obj.confidence. Subsequently, this error per unit of cell
                   area term accumulated in "total_relative_error" */
           }
       avg_per_unit_error <-- total_per_unit_error / nbr_cells_in(mesh);
       /* Now get a tunable constant, "tunable_constant", that has been determined by the Adaptation Engine I382
       (shown in Figs. 5, 6 and B), wherein "tunable_constant" may have been adapted to environmental characteristics. */
30  tunable_constant <--- get_tuneable_constant_for("Historical_Location_Reasoner", loc_hyp);
       /* Now decrement the confidence value of "loc_hyp" by an error amount that is scaled by "tunable_constant"
       */
```

T1860 185

```
loc_hyp.confidence <--- loc_hyp.confidence - [avg_per_unit_error * sizeof(covering) * tunable_constant];  
RETURN(loc_hyp);
```

```
}ENDOF Historical_data_confidence_adjuster
```

5

187

186

**What is claimed is:**

1. A method for locating a wireless mobile station using wireless signal measurements obtained from transmissions between said mobile station and a plurality of base stations capable of wirelessly detecting said mobile station, comprising:

5 providing first and second mobile station location estimators, wherein said location estimators provide location estimates of said mobile station when said location estimators receive wireless signal measurements obtained from transmissions between said mobile station and the base stations, wherein:

(A) said first location estimator is capable of performing one or more of the techniques:

10 (a) a triangulation technique to determine, for each of three or more of the base stations, a distance between the mobile station and the base station using the wireless signal measurements;

(b) a learning technique, wherein said learning technique determines an association for associating: the wireless signal measurements, and data indicative of a location for the mobile station, wherein said association is determined by a training process using a plurality of data pairs, each said pair including: first information indicative of a location of some mobile station, and second information from wireless signal measurements between said some mobile station and one or more of the base stations when said some mobile station is at the location;

15 (c) a stochastic technique, wherein each said stochastic technique uses a statistical correlation for correlating: the wireless signal measurements, and data indicative of a location for the mobile station, wherein said correlation is used for determining a probability that the mobile station is within an area, and

20 (B) for at least a particular one of said techniques performed by said first location estimator, said second location estimator does not perform said particular technique;

first supplying said first location estimator with first data from the wireless signal measurements;

first generating, by said first location estimator, first location related information having at least a first estimate of the mobile station's location;

25 second supplying said second location estimator with second data from the wireless signal measurements;

second generating, by said second location estimator, second location related information having at least a second estimate of the mobile station's location;

determining a resulting location estimate of the mobile station using: (a) a first value obtained from said first location related information, and (b) a second value obtained from said second location related information.

30 2. A method as claimed in Claim 1, further including a step of receiving said measurements during a wireless communication between said mobile station and said plurality of base stations for contacting an emergency response center.

3. A method as claimed in Claim 2, further including a step of transmitting said resulting location estimate to the emergency response center during said wireless communication.

187  
188

4. A method as claimed in Claim 1, wherein said step of providing includes:  
transmitting through a telecommunications network, said first location estimator from a source site to a site having said  
second location estimator;  
operably integrating said first location estimator with said second location estimator for performing at least said step of  
5 determining.

5. A method as claimed in Claim 8, wherein said step of transmitting includes sending an encoding of said first  
location estimator using the Internet.

6. A method as claimed in Claim 1, wherein said step of determining includes retrieving historical location data  
related to said first initial location estimate and said second initial location estimate, wherein said historical location data includes:

10 (a) location estimates by said first location estimator for some of said mobile stations at a first plurality of locations, and  
data identifying said locations of said first plurality of locations;

(b) location estimates by said second location estimator for some of said mobile stations at a second plurality of locations,  
and data identifying said locations of said second plurality of locations;

15 wherein said first successive location estimate is determined using said historical location data of (a), and said successive estimate is  
determined using said historical location data of (b).

7. A method as claimed in Claim 1, further including, for at least one location estimate of said first and second  
estimates, a step of obtaining one of a likelihood value and a probability that a location of said mobile station is in said one location  
estimate, wherein said likelihood value is obtained using historical location estimates generated by the location estimator that  
generated said one location estimate when the location estimator is supplied with wireless signal measurements obtained from  
20 transmissions between one or more mobile stations and said plurality of base stations at a plurality of locations.

8. A method as claimed in Claim 1, wherein said step of providing includes providing some one mobile station  
location estimator, wherein said one mobile station location estimator generates an estimate of where said mobile station is unlikely  
to be located.

9. A method as claimed in Claim 1, wherein said wireless signal measurements are obtained from transmissions  
25 between said mobile station and said plurality of base stations, wherein said transmissions occur within an interval of time wherein  
one of: said mobile station is expected to be in substantially a same location, and said interval is less than a predetermined duration.

10. A method as claimed in Claim 1, wherein one of: said first data includes said second estimate, and said second  
data includes said first estimate.

11. A method as claimed in Claim 1, further including:  
30 performing a first simulation for predicting a likelihood of said mobile station being at said first estimate, wherein said  
simulation uses pairs of location representations, a first member of each pair including a location estimate obtained from said first

location estimator and a second member of the pair including a representation of an independently determined location of a mobile station used for obtaining wireless signal measurements that are obtained from transmissions with said plurality of base stations.

12. A method as claimed in Claim 1, wherein at least one of said first and second location estimators each utilize one of the following:

- 5 (a) a pattern recognition location technique for estimating a location of said mobile station by recognizing a pattern of characteristics of said data obtained from wireless signal measurements;
- (b) a mobile base station estimator for estimating a location of said mobile station from location information received from a mobile base station detecting wireless transmissions of said mobile station;
- (c) a coverage area location technique for estimating a location of said mobile station by intersecting wireless  
10 coverage areas for different sets of one or more of said base stations;
- (d) a negative logic location for estimating where said mobile station is unlikely to be located.

13. A method as claimed in Claim 1, wherein at least one of the following holds:

- 15 (a) said learning technique is capable of providing an artificial neural network for generating a mobile station location estimate by training said artificial neural network to recognize a pattern of characteristics of location information obtained from said wireless signal measurements;
- (b) said triangulation technique is capable of providing the distances between the mobile station and said three or more of the base stations using one or more of: a wireless signal time of arrival, a wireless signal time difference of arrival, a wireless signal strength indication;
- 20 (c) said stochastic technique is capable of providing said statistical correlation using one of: principle decomposition, least squares, partial least squares, and Bollinger Bands.

14. A method as claimed in Claim 1, wherein said first location estimator includes an artificial neural network, wherein said artificial neural network is one of: a multilayer perceptron, an adaptive resonance theory model, and radial basis function network.

15. A method as claimed in Claim 1, wherein said step of determining includes deriving a likelihood measurement that said mobile station is in said resulting location estimate, wherein said likelihood measurement is dependent upon a first likelihood measurement that said mobile station is in said first estimate, and a second likelihood measurement that said mobile station is in said second estimate.

16. A method as claimed in Claim 1, further including a step of deriving one of said first estimate, said second estimate, and said resulting location estimate using one of:

- 30 (a) an expected maximum velocity of said mobile station;
- (b) an expected maximum acceleration of said mobile station;
- (c) an expected route of said mobile station.



17. A location system for locating a mobile station, wherein said mobile station is one of a plurality of mobile stations, and wireless signal measurements are capable of being obtained from wireless transmissions between the plurality of mobile stations and a plurality of base stations, the improvement characterized by:

5 one or more location estimators, each said location estimator for estimating a location for each of one or more individual mobile stations of the plurality of mobile stations, when said location estimator is supplied with data from a set of said wireless signal measurements obtained from wireless transmissions between the individual mobile station and said plurality of base stations;

an archive for storing a plurality of data item collections, wherein for each geographical location of a plurality of geographical locations, there is one of said data item collections having (a1) and (a2):

(a1) a representation of the geographical location, and

10 (a2) a set of said wireless signal measurements corresponding to one of the plurality of mobile stations transmitting from approximately the geographical location of (a1);

a performance estimator for determining, for each one of said location estimators, corresponding one or more performance measurements indicative of a previous performance of said one location estimator in locating one or more of the plurality of mobile stations, wherein said corresponding performance measurements are determined using location estimates generated by said one location estimator when said set of (a2), for some of said data item collections, is supplied to said one location estimator;

15 a controller for activating a group of at least one of said location estimators for generating corresponding location estimates of said mobile station when a first said set of wireless signal measurements is obtained from wireless transmissions between said mobile station and said plurality of base stations, wherein one or more location hypotheses are generated, each said location hypothesis having:

20 (b1) an hypothesized location estimate of said mobile station obtained using the corresponding location estimate generated by a location estimator of said group,

(b2) a likelihood value indicating a likelihood of said mobile station being at a location represented by said hypothesized location estimate of (b1), wherein said corresponding performance measurements for said location estimator providing the location estimate of (b1) are used in determining said likelihood value;

25 a location estimator for determining a resulting location estimate of said mobile station, said resulting location estimate being derived using said hypothesized location estimates and said likelihood values from said one or more location hypotheses.

18. A method as claimed in Claim 55, further including a step of transmitting said resulting location estimate to an emergency response center during a wireless communication wherein said first set of wireless signal measurements is obtained.

30 19. A location system as claimed in Claim 55, further including an hypothesis estimate generator for generating one of said hypothesized location estimates using a time series of location estimates for said mobile station output by said one or more location estimators.

20. A method for locating a mobile station, wherein said mobile station is one of a plurality of mobile stations, and wireless signal measurements are capable of being obtained from wireless transmissions between the plurality mobile stations and a

network of base stations, wherein said base stations in the network are cooperatively linked for providing wireless communication with each of the mobile stations, the improvement characterized by:

providing a mobile station location estimator for estimating locations of one or more individual mobile stations of said plurality of mobile stations when said location estimator is supplied with said wireless signal measurements obtained from wireless transmissions between the individual mobile station and said network of base stations;

storing a plurality of data item collections, wherein for each of a plurality of geographical locations, there is one of said data item collections having:

(a1) a representation of the geographical location, and

(a2) a representation of said wireless signal measurements between one of the mobile stations and the base stations when said one mobile station is approximately at the geographical location of (a1);

generating, from said wireless signal measurements between said mobile and said base stations, an initial location estimate of said mobile;

obtaining a first set of one or more additional location estimates generated by said location estimator, wherein each said additional location estimate is generated from said representations of wireless signal measurements of (a2) for one of said data item collections, and wherein at least a majority of said additional location estimates are within a predetermined distance of said initial location estimate;

deriving an adjusted location estimate from said initial location estimate using a second set of said geographical location representations of (a1) for said data item collections whose representations of wireless signal measurements of (a2) were used to generate one of said additional location estimates of said set.

21. A method as claimed in Claim 20, wherein said step of deriving includes determining an area boundary of said adjusted location estimate as a function of said geographical locations in said second set.

22. A location system for locating mobile stations from received wireless signal measurements obtained from transmissions between said mobile stations and a network of base stations, wherein said base stations in the network are cooperatively linked for providing wireless communication; the improvement characterized by:

one or more location estimators for estimating locations of said mobile stations, such that for each of said mobile stations, when said location estimators are supplied with measurements of wireless signals obtained from transmissions between:

the mobile station, at a corresponding geographical location from which the mobile station is transmitting, and said network of base stations, at least one location estimate is generated;

a location estimate adjuster for deriving a first adjusted location estimate from a first location estimate generated by a first of said location estimators supplied with said wireless signal measurements obtained from transmissions between: (i) a particular one of said mobile stations, at a particular location, and (ii) said base stations, wherein:

(a1) said first adjusted location estimate has a corresponding confidence value indicative of a likelihood of the particular geographical location being a location represented by the first adjusted location estimate,

(a2) said first adjusted location estimate is determined using additional location estimates generated: (i) previously to the generation of said first initial location estimate, and (ii) by said first location estimator;

a most likely estimator for determining a most likely location estimate of the particular geographical location of the particular mobile station, said most likely location estimate being derived using said first adjusted location estimate and its corresponding confidence value.

23. A location system, as claimed in Claim 22, wherein, said location estimate adjuster includes a statistical simulation module for deriving a one or more likelihood values indicative of said first location estimator generating mobile station location estimates that include their corresponding geographical locations.

24. A location system, as claimed in Claim 22, wherein, said location estimate adjuster includes a statistical simulation module for deriving a one or more likelihood values indicative of said first location estimator generating mobile station location estimates that include their corresponding geographical locations.

25. A location system for locating mobile stations from received wireless signal measurements obtained from transmissions between said mobile stations and a network of fixed location transceivers, wherein said transceivers in the network are cooperatively linked for providing wireless communication with said mobile stations; the improvement characterized by:

an archive for storing a plurality of data item collections, wherein for each location of a plurality geographical locations, there is one of said data item collections having (a1) and (a2):

(a1) a representation of the geographical location,

(a2) a set of said wireless signal measurements obtained from transmissions between one of said mobile stations and said fixed location transceivers, wherein the one mobile station transmits from approximately the geographical location;

a plurality of trainable location estimators, each said trainable location estimator for generating a geographical location estimates for said mobile stations, wherein for each said trainable location estimator:

(b1) there is a corresponding group of wireless signal measurement parameters, wherein for said trainable location estimator to generate a location estimate of an individual one of said mobile stations, at least some of said parameters must be instantiated with values obtained from transmissions between said individual mobile station and said fixed location transceivers,

(b2) there is a different corresponding group of wireless signal measurement parameters for another of said trainable location estimators, and

(b3) said trainable location estimator learns by associating, for each of at least some of said data item collections, said geographical location representation (a1) of the data item collection with said set of said wireless signal measurements (a2) of the data item collection;

a location estimator selector for selecting one or more of said plurality of trainable location estimators for generating mobile station location estimates, wherein when each of said selected location estimators has its corresponding group of wireless

signal measurement parameters instantiated with values obtained from transmissions between one of said mobile stations and said fixed location transceivers, said selected location estimator generates a location estimate of the one mobile station;

wherein for locating a particular one of said mobile stations, said location estimator selector selects a particular set of said trainable location estimators whose corresponding group of wireless signal measurement parameters can have at least some said parameters instantiated using wireless signal measurements obtained from transmissions between said particular mobile station and said fixed location transceivers;

a location estimator for determining a resulting location estimate of said particular mobile station, said location estimator receiving location estimates from trainable location estimators of said particular set.

26. A location system, as claimed in Claim 92, wherein at least one of said trainable location estimators includes an artificial neural network.

27. A method as claimed in Claim 94, further including a different trainable location estimator utilizing a different artificial neural network for generating a different geographical location estimate of said one mobile station.

28. A method as claimed in Claim 94, wherein said artificial neural network is one of: a multilayer perceptron, an adaptive resonance theory model, and radial basis function network.

29. A method as claimed in Claim 92, wherein said trainable location estimator utilizes an artificial neural network with an input neuron for receiving a value related to wireless transmissions between said particular mobile station and a particular one of said fixed location transceivers, wherein said value is indicative of at least one of the following conditions:

(a) said particular transceiver is active for wireless communication with said particular mobile station and a pilot signal by said particular transceiver is detected by said particular mobile station;

(b) said particular transceiver is active for wireless communication with said particular mobile station and said particular transceiver detects wireless transmissions by said particular mobile station;

(c) said particular transceiver is active for wireless communication with said particular mobile station and said particular transceiver does not detect wireless transmissions by said particular mobile station;

(d) said particular transceiver is active for wireless communication with said particular mobile station and said particular mobile station does not detect wireless transmissions by said particular transceiver;

(e) said particular transceiver is not active for wireless communication with said particular mobile station.

30. A location system for receiving wireless signal measurements of wireless signals transmitted between a plurality mobile stations and a network of base stations, wherein said base stations in the network are cooperatively linked for providing wireless communication, the improvement characterized by:

a plurality of mobile station location estimators for estimating locations of said mobile stations, such that when said location estimators are supplied with said measurements of wireless signals transmitted between one of the mobile stations and said network of base stations, said location estimators output corresponding initial location estimates of a geographical location of said one mobile station, wherein at least two of said mobile station location estimators of said plurality of mobile station location estimators include a different one of the following (a) through (f):

- 5
- (a) a pattern recognition component for estimating a location of said one mobile station from a pattern in the wireless signal measurements of transmissions between the network and said one mobile station;
  - (b) a trainable mobile station location estimating component for estimating a location of said one mobile station, wherein said trainable mobile station location estimating component is capable of being trained to associate: (i) each location of a plurality of geographical locations with (ii) corresponding measurements of wireless signals transmitted between a specified one of said mobile stations and the network, wherein said specified mobile station is approximately at the location;
  - (c) a triangulation component for estimating a location of said one mobile station, wherein said triangulation component utilizes said measurements of wireless signals between said one mobile station and three of the base stations for triangulating a location estimate of said one mobile station;
  - (d) a statistical component utilizing a statistical regression technique for estimating a location of said one mobile station;
  - (e) a mobile base station component for estimating a location of said one mobile station, wherein said mobile base station component utilizes location information received from a mobile base station that detects said one mobile station;
  - (f) a negative logic component for estimating an area of where said one mobile station is unlikely to be located; and
- 10
- a most likely estimator for determining a most likely location estimate of said one mobile station, said most likely location estimate being a function of said plurality of location estimates.

15

31. A location system, as claimed in Claim 101, wherein one or more of said mobile station location estimators are capable of being at least one of: added, replaced and deleted by Internet transmissions between said location system and a site remote from said location system.

20

32. A location system for receiving wireless signal measurements of wireless signals transmitted between a plurality mobile stations and a network of base stations, wherein said base stations in the network are cooperatively linked for providing wireless communication, the improvement characterized by:

25

- a mobile station location providing means for estimating locations of said mobile stations, such that when said providing means is supplied with said measurements of wireless signals transmitted between a particular one of the mobile stations and said network of base stations, said providing means determines a first collection of one or more location estimates for said particular mobile station;

- an expert system for activating expert system rules for one of: (a) modifying one of said location estimates of said first collection, and (b) obtaining additional location estimates of the particular location;

30

- a most likely estimator for determining a most likely location estimate of the particular location, said most likely location estimate being a function of one or more location estimates provided by said expert system.

33. A location system for locating wireless mobile stations that communicate with a plurality of networked base stations, comprising:

a wireless transceiver means: (a) for at least detecting a direction of wireless signals transmitted from a wireless mobile station, and (b) for communicating with said networked base stations information related to a location of said wireless mobile station;

a means for detecting whether a detected wireless signal from said mobile station has been one of: reflected and deflected;

a means for estimating a location of said mobile station by using wireless signals transmitted from said mobile station that are not detected by said means for detecting as one of: reflected and deflected.

34. A location system as claimed in Claim 106, wherein said means for detecting includes a means for comparing: (a) a distance of said mobile station from said mobile location system using a signal strength of said wireless signals from said mobile station, and (b) a distance of said mobile station from said location system using a signal time delay measurement of wireless signal from said mobile station.

35. A location system as claimed in Claim 106, further including one or more location estimators for estimating a location of said location system, wherein said at least one of said location estimators uses wireless signals transmitted from one of: said networked base stations and a global positioning system.

36. A location system as claimed in Claim 108, further including a deadreckoning means for estimating a change in a location of said location system, wherein said deadreckoning means provides incremental updates to said one or more location estimates of said mobile location system output by said at least one location estimator.

37. A method for locating a particular wireless mobile station using measurements of particular wireless signals, wherein at least one of: said measurements and said particular wireless signals are transmitted between said wireless mobile station and at least one of a plurality of transceivers, wherein said transceivers are capable of at least wireless detection of a plurality of wireless transmitting mobile stations including said particular mobile station, comprising:

providing a first and second mobile station location estimators, wherein each of said location estimators is capable of providing a location estimate for each mobile station of at least some of said mobile stations when said location estimator is supplied with corresponding data obtained from received wireless signal measurements communicated between the mobile station and one or more of said plurality of transceivers, wherein:

said first location estimator performs one or more triangulation techniques, wherein each said triangulation technique determines for each of one or more of said mobile stations, and for each transceiver of a set of three or more of said transceivers, a distance between the mobile station, and said transceiver, each said distance determined from data resulting from received measurements of wireless signals communicated between the mobile station and said transceiver, and said second location estimator does not perform any said triangulation technique;

first supplying said first location estimator with first corresponding data obtained from received wireless signal measurements communicated between said particular mobile station and one or more of said plurality of transceivers;

second supplying said second location estimator with second corresponding data obtained from received wireless signal measurements communicated between said particular mobile station and one or more of said plurality of transceivers;

first generating, by said first location estimator, first location related information having at least a first estimate for the mobile station's location;

second generating, by said second location estimator, second location related information having at least a second estimate for the mobile station's location;

5 determining a resulting location estimate of the mobile station using: (a) a first value obtained from said first location related information, and (b) a second value obtained from said second location related information.

38. A method for locating a particular wireless mobile station using measurements of particular wireless signals, wherein at least one of: said measurements and said particular wireless signals are transmitted between said wireless mobile station and at least one of a plurality of transceivers, wherein said transceivers are capable of at least wireless detection of a plurality of  
10 wireless transmitting mobile stations including said particular mobile station, comprising:

providing a first and second mobile station location estimators, wherein each of said location estimators is capable of providing a location estimate for each mobile station of at least some of said mobile stations when said location estimator is supplied with corresponding data obtained from received wireless signal measurements communicated between the mobile station and one or more of said plurality of transceivers, wherein:

15 said first location estimator performs one or more global positioning techniques, wherein each said global positioning technique determines for each of one or more of said mobile stations, corresponding data resulting from received measurements of wireless signals from one or more global positioning satellites, said corresponding data for determining a location of the mobile station, and said second location estimator does not perform any said global positioning technique;

20 first supplying said first location estimator with first corresponding data obtained from wireless signal measurements communicated between said particular mobile station and one or more of said plurality of transceivers;

second supplying said second location estimator with second corresponding data obtained from wireless signal measurements communicated between said particular mobile station and one or more of said plurality of transceivers;

first generating, by said first location estimator, first location related information having at least a first estimate for said particular mobile station's location;

25 second generating, by said second location estimator, second location related information having at least a second estimate for said particular mobile station's location;

determining a resulting location estimate of said particular mobile station using: (a) a first value obtained from said first location related information, and (b) a second value obtained from said second location related information.

39. A method for locating a particular wireless mobile station using measurements of particular wireless signals, wherein at least one of: said measurements and said particular wireless signals are transmitted between said wireless mobile station and at least one of a plurality of transceivers, wherein said transceivers are capable of at least wireless detection of a plurality of  
30 wireless transmitting mobile stations including said particular mobile station, comprising:

providing a first and second mobile station location estimators, wherein each of said location estimators is capable of providing a location estimate for each mobile station of at least some of said mobile stations when said location estimator is supplied

with corresponding data obtained from received wireless signal measurements communicated between the mobile station and one or more of said plurality of transceivers, wherein:

said first location estimator performs one or more coverage area analysis techniques, wherein each said coverage area analysis technique determines for each of one or more of said mobile stations, an area: (i) included in a corresponding coverage area for each of one or more of said transceivers that detect the mobile station, and (ii) excluded from a corresponding coverage area for each of one or more of said transceivers that can not detect the mobile station, and said second location estimator does not perform any said coverage area analysis technique;

first supplying said first location estimator with first corresponding data obtained from wireless signal measurements communicated between said particular mobile station and one or more of said plurality of transceivers;

second supplying said second location estimator with second corresponding data obtained from wireless signal measurements communicated between said particular mobile station and one or more of said plurality of transceivers;

generating, by said first and a second of said location estimators, respectively, first and second different initial location estimates of said particular mobile station;

determining a location estimate of said particular mobile station as a function of at least one of: (a) said first and second initial location estimates, and (b) a rating of said first and second initial location estimates.

40. A method for locating a wireless mobile station capable of wireless communication with a plurality of base stations, comprising:

providing a plurality of mobile station location estimators, wherein said location estimators provide different location estimates of said mobile station when said location estimators are supplied with location information derived from signal measurements that are transmitted between said mobile station and said plurality of base stations;

receiving measurements of wireless signals transmitted: (a) from one or more global positioning satellites, and (b) between said wireless mobile station and said plurality of base stations;

first generating, by a first of said location estimators, a first time series of one or more location estimates of said mobile station when at least a portion of said measurements are obtained for global positioning satellite signals;

second generating, by a second of said location estimators, a second time series of one or more location estimates of said mobile station when at least a portion of said measurements provide measurements of wireless signals transmitted between said mobile station and at least one of base stations of said plurality of base stations;

determining a resulting time series of one or more resulting location estimates of said mobile station, wherein for each time of said resulting time series when one of said resulting location estimates is derived, said derivation uses at least one location estimate: (a) that is most recently generated by said first location estimator, and (b) that is most recently generated by said second location estimator.

41. A method as claimed in Claim 40, wherein said step of determining includes:

establishing a priority between said first initial location estimate and said second initial location estimate.



42. A method as claimed in Claim 41, wherein said step of establishing includes obtaining a confidence value corresponding to at least one of said first initial location estimate and said second initial location estimate, wherein each said confidence value is indicative of a likelihood of said mobile station being its said corresponding initial location estimate.

43. A method as claimed in Claim 41, wherein said step of establishing includes using a first time value associated with said first initial location estimate, and a second time value associated with said second initial location estimate.

44. A method as claimed in Claim 40, wherein said step of determining includes preferring said first initial location estimate over said second initial location estimate when both are available for substantially a same location of said mobile station.

45. A method as claimed in Claim 40, wherein said step of receiving includes receiving a first portion of said measurements in a first time period and a second portion of said measurements in a second time period different from said first time period, wherein said first portion is obtained from a global positioning satellite, and said second portion is derived from wireless signals transmitted between said mobile station and at least one of base station of said first plurality of base stations.

46. A method as claimed in Claim 40, wherein said mobile station is in a vehicle and said step of determining uses deadreckoning estimates of changes in the location of the vehicle.

47. A method as claimed in Claim 40, wherein said step of determining includes evaluating one or more constraints related to one or more of: a velocity of said mobile station, an acceleration of said mobile station, an estimated location of said mobile station in relation of a terrain of said estimated location.

add  
BT

ABSTRACT

A location system is disclosed for commercial wireless telecommunication infrastructures. The system is an end-to-end solution  
5 having one or more location centers for outputting requested locations of commercially available handsets or mobile stations (MS)  
based on, e.g., CDMA, AMPS, NAMPS or TDMA communication standards, for processing both local MS location requests and more  
global MS location requests via, e.g., Internet communication between a distributed network of location centers. The system uses a  
plurality of MS locating technologies including those based on: (1) two-way TOA and TDOA; (2) pattern recognition; (3) distributed  
antenna provisioning; and (4) supplemental information from various types of very low cost non-infrastructure base stations for  
10 communicating via a typical commercial wireless base station infrastructure or a public telephone switching network. Accordingly,  
the traditional MS location difficulties, such as multipath, poor location accuracy and poor coverage are alleviated via such  
technologies in combination with strategies for: (a) automatically adapting and calibrating system performance according to  
environmental and geographical changes; (b) automatically capturing location signal data for continual enhancement of a self-  
maintaining historical data base retaining predictive location signal data; (c) evaluating MS locations according to both heuristics  
15 and constraints related to, e.g., terrain, MS velocity and MS path extrapolation from tracking and (d) adjusting likely MS locations  
adaptively and statistically so that the system becomes progressively more comprehensive and accurate. Further, the system can be  
modularly configured for use in location signaling environments ranging from urban, dense urban, suburban, rural, mountain to low  
traffic or isolated roadways. Accordingly, the system is useful for 911 emergency calls, tracking, routing, people and animal location  
including applications for confinement to and exclusion from certain areas.

20



UNITED STATES PATENT AND TRADEMARK OFFICE

UNITED STATES DEPARTMENT OF COMMERCE  
United States Patent and Trademark Office  
Address: COMMISSIONER OF PATENTS AND TRADEMARKS  
Washington, D.C. 20231  
www.uspto.gov

APPLICATION NO.	FILING DATE	FIRST NAMED INVENTOR	ATTORNEY DOCKET NO.	CONFIRMATION NO.
09/770,838	01/26/2001	Dennis J. Dupray	1003-1	8410

7590 08/14/2002  
Dennis J. Dupray, Ph.D.  
1801 Belvedere Street  
Golden, CO 80401

EXAMINER

PHAN, DAO LINDA

ART UNIT PAPER NUMBER

3662

DATE MAILED: 08/14/2002

Please find below and/or attached an Office communication concerning this application or proceeding.

2

<b>Office Action Summary</b>	Application No. <b>09/770,838</b>	Applicant(s) <b>Dupray et al</b>	
	Examiner <b>Dao L. Phan</b>	Art Unit <b>3662</b>	

-- The MAILING DATE of this communication appears on the cover sheet with the correspondence address --

**Period for Reply**

A SHORTENED STATUTORY PERIOD FOR REPLY IS SET TO EXPIRE 2 MONTH(S) FROM THE MAILING DATE OF THIS COMMUNICATION.

- Extensions of time may be available under the provisions of 37 CFR 1.136 (a). In no event, however, may a reply be timely filed after SIX (6) MONTHS from the mailing date of this communication.
- If the period for reply specified above is less than thirty (30) days, a reply within the statutory minimum of thirty (30) days will be considered timely.
- If NO period for reply is specified above, the maximum statutory period will apply and will expire SIX (6) MONTHS from the mailing date of this communication.
- Failure to reply within the set or extended period for reply will, by statute, cause the application to become ABANDONED (35 U.S.C. § 133).
- Any reply received by the Office later than three months after the mailing date of this communication, even if timely filed, may reduce any earned patent term adjustment. See 37 CFR 1.704(b).

**Status**

- 1)  Responsive to communication(s) filed on Jul 2, 2002
- 2a)  This action is **FINAL**.                      2b)  This action is non-final.
- 3)  Since this application is in condition for allowance except for formal matters, prosecution as to the merits is closed in accordance with the practice under *Ex parte Quayle*, 1935 C.D. 11; 453 O.G. 213.

**Disposition of Claims**

- 4)  Claim(s) 221-295 is/are pending in the application.
- 4a) Of the above, claim(s) \_\_\_\_\_ is/are withdrawn from consideration.
- 5)  Claim(s) 221-225, 227-242, 244-246, 248, 250-273, and 275-295 is/are allowed.
- 6)  Claim(s) \_\_\_\_\_ is/are rejected.
- 7)  Claim(s) 226, 243, 247, 249, and 274 is/are objected to.
- 8)  Claims \_\_\_\_\_ are subject to restriction and/or election requirement.

**Application Papers**

- 9)  The specification is objected to by the Examiner.
- 10)  The drawing(s) filed on \_\_\_\_\_ is/are a)  accepted or b)  objected to by the Examiner.  
Applicant may not request that any objection to the drawing(s) be held in abeyance. See 37 CFR 1.85(a).
- 11)  The proposed drawing correction filed on \_\_\_\_\_ is: a)  approved b)  disapproved by the Examiner.  
If approved, corrected drawings are required in reply to this Office action.
- 12)  The oath or declaration is objected to by the Examiner.

**Priority under 35 U.S.C. §§ 119 and 120**

- 13)  Acknowledgement is made of a claim for foreign priority under 35 U.S.C. § 119(a)-(d) or (f).  
a)  All b)  Some\* c)  None of:  
1.  Certified copies of the priority documents have been received.  
2.  Certified copies of the priority documents have been received in Application No. \_\_\_\_\_  
3.  Copies of the certified copies of the priority documents have been received in this National Stage application from the International Bureau (PCT Rule 17.2(a)).  
\*See the attached detailed Office action for a list of the certified copies not received.
- 14)  Acknowledgement is made of a claim for domestic priority under 35 U.S.C. § 119(e).  
a)  The translation of the foreign language provisional application has been received.
- 15)  Acknowledgement is made of a claim for domestic priority under 35 U.S.C. §§ 120 and/or 121.

**Attachment(s)**

- |  |   |
|--|---|
| 1) <input type="checkbox"/> Notice of References Cited (PTO-892)   | 4) <input type="checkbox"/> Interview Summary (PTO-413) Paper No(s). _____  |
| 2) <input type="checkbox"/> Notice of Draftsperson's Patent Drawing Review (PTO-948)                     | 5) <input type="checkbox"/> Notice of Informal Patent Application (PTO-152) |
| 3) <input checked="" type="checkbox"/> Information Disclosure Statement(s) (PTO-1449) Paper No(s). _____ | 6) <input type="checkbox"/> Other:  |

Art Unit: 3662

1. Claims 226, 243, 249, and 274 are objected to because of the following informalities:  
there are no period at the end of the claims. Appropriate correction is required.
2. Claim 247 is objected to because the claim appears to be incomplete. Appropriate correction is required.
3. Claims 226, 243, 247, 249, and 274 would be allowable if rewritten or amended to overcome the objections(s).
4. Claims 221-225, 227-242, 244-246, 248, 250-273, 275-295 are allowed.
5. Any inquiry concerning this communication or earlier communications from the examiner should be directed to Dao L. Phan whose telephone number is (703)306-4167.

Any inquiry of a general nature or relating to the status of this application or proceeding should be directed to the receptionist whose telephone number is (703)306-4187.

  
DAO PHAN  
REGISTERED EXAMINER

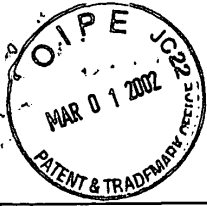

FORM PTO-1449 U.S. DEPARTMENT OF COMMERCE PATENT AND TRADEMARK OFFICE  INFORMATION DISCLOSURE STATEMENT (Use several sheets if necessary)	ATTY. DOCKET NO. 1003-1	SERIAL NO. 09/770,838
	APPLICANT DUPRAY et al.	
	FILING DATE January 26, 2001	GROUP ART 3600

**RECEIVED**  
 MAR 08 2002  
 GROUP 3600

U.S. PATENT DOCUMENTS

*EXAMINER INITIAL		DOCUMENT NUMBER	DATE	NAME	CLASS	SUB CLASS	FILING DATE IF APPROP.
DP ↑ ↓ DP	1.	6,185,427	2/6/2001	Krasner et al.	455	456	
	2.	6,097,958	8/1/2000	Bergen	455	456	
	3.	5,999,126	12/7/1999	Ito	342	357.1	
	4.	5,835,907	11/10/1998	Newman	707	10	
	5.	Re. 35,916	10/6/1998	Dennison et al.	455	456	
	6.	5,815,814	9/29/1998	Dennison et al.	455	456	
	7.	5,754,955	5/19/1998	Ekbatani	455	422	
	8.	5,673,322	9/30/1997	Pepe et al.	380	49	
	9.	5,657,487	8/12/1997	Doner	455	456	
	10.	5,652,570	7/29/1997	Lepkofker	340	573	
	11.	5,625,668	4/29/1997	Loomis et al.	379	58	
	12.	5,592,180	1/7/1997	Yokey et al.	342	450	
	13.	5,546,445	8/13/1996	Dennison et al.	379	60	
	14.	5,515,419	5/7/1996	Sheffer	379	58	
	15.	5,388,147	2/7/1995	Grimes	379	59	
	16.	5,235,633	8/10/1993	Dennison et al.	379	60	
	17.	5,223,844	6/29/1993	Mansell et al.	342	357	
	18.	5,208,756	5/4/1993	Song	364	706	
	19.	5,043,736	8/27/1991	Darnell et al.	342	357	
20.	4,700,374	10/13/1987	Bini	379	60		

EXAMINER <i>Bwt</i>	DATE CONSIDERED <i>8/13/02</i>
*EXAMINER: Initial if reference considered, whether or not citation is in conformance with MPEP 609; Draw line through citation if not in conformance and not considered. Include copy of this form with next communication to applicant.	

L:\TracBeam\patent applications\1003\US (1003&continuations)-1\pto\1449\IDS-02-1449.wpd



FORM P U.S. DEPARTMENT OF COMMERCE PATENT AND TRADEMARK OFFICE INFORMATION DISCLOSURE STATEMENT (Use several sheets if necessary)	ATTY. DOCKET NO. 1003-1	SERIAL NO. 09/770,838
	APPLICANT DUPRAY et al.	
	FILING DATE January 26, 2001	GROUP ART 3662

--	--	--	--	--	--	--	--

FOREIGN PATENT DOCUMENTS

		DOCUMENT NUMBER	DATE	COUNTRY	CLASS	SUB CLASS	TRANSLATION	
							YES	NO

OTHER ART (Including Author, Title, Date, Pertinent Pages, etc.)

DP	21.	Lepkofker; U.S. Patent Application No. 08/246,149 Entitled 'INDIVIDUAL LOCATION SYSTEM'; May 19, 1994
DP	22.	Maloney et al.; U.S. Provisional Patent Application No. 60/017,899 Entitled "ENHANCED TIME-DIFFERENCE LOCALIZATION SYSTEM"; May 17, 1996

EXAMINER <i>Dus</i>	DATE CONSIDERED 8/13/02
*EXAMINER: Initial if reference considered, whether or not citation is in conformance with MPEP 609; Draw line through citation if not in conformance and not considered. Include copy of this form with next communication to applicant.	

L:\TracBeam\patent applications\1003\US (1003&continuations)-1\pto\1449\IDS-02-1449.wpd

FORM PTO-1449 U.S. DEPARTMENT OF COMMERCE PATENT AND TRADEMARK OFFICE INFORMATION DISCLOSURE STATEMENT (Use several sheets if necessary)	ATTY. DOCKET NO. 1003-1	SERIAL NO. Not Yet Assigned
	APPLICANT DUPRAY et al.	
	FILING DATE Filed Herewith	GROUP ART

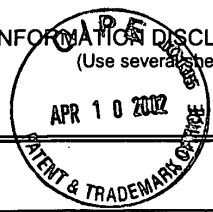

09/770,838

U.S. PATENT DOCUMENTS

*EXAMINER INITIAL		DOCUMENT NUMBER	DATE	NAME	CLASS	SUB CLASS	FILING DATE IF APPROP.
DP	1	6,249,252	6/19/2001	Dupray	342	450	
	2	6,236,365	5/22/01	LeBlanc et al.	342	457	
	3	6,167,274	12/26/2000	Smith	455	456	
	4	6,157,621	12/5/00	Brown et al.	370	310	
	5	6,108,555	8/22/2000	Maloney et al.	455	456	
	6	6,101,391	8/8/00	Ishizuka et al.	455	457	
	7	6,101,390	8/8/00	Jayaraman et al.	455	456	
	8	6,101,178	8/8/00	Beal	370	336	
	9	6,064,942	5/16/00	Johnson et al.	701	213	
	10	6,064,339	5/16/00	Wax et al.	342	417	
	11	6,047,192	4/4/00	Maloney et al.	455	456	
	12	6,046,683	4/4/00	Pidwerbetsky et al.	340	825.54	
	13	6,038,668	3/14/00	Chipman et al.	713	201	
	14	6,031,490	2/29/00	Forssén et al.	342	457	
	15	6,029,161	2/22/00	Lang et al.	707	1	
	16	6,028,551	2/22/00	Schoen et al.	342	357	
	17	6,026,304	2/15/00	Hilsenrath et al.	455	456	
	18	6,014,102	1/11/00	Mitzlaff et al.	342	457	
	19	6,009,334	12/28/99	Grubeck et al.	455	456	
	20	5,999,124	12/7/99	Sheynblat	342	357.09	
	21	5,987,329	11/16/99	Yost et al.	455	456	
	22	5,983,214	11/9/99	Lang et al.	707	1	
	23	5,982,891	11/9/99	Ginter et al.	380	4	
	24	5,982,324	11/9/99	Watters et al.	342	357.06	
	25	5,978,840	11/2/99	Nguyen et al.	709	217	
	26	5,977,913	11/2/99	Christ	342	465	
	27	5,973,643	10/26/99	Hawkes et al.	342	455	
	28	5,963,866	10/5/99	Palamara et al.	455	456	
29	5,952,969	9/14/99	Hagerman et al.	342	457		
DP	30	5,949,815	9/7/99	Pon	375	458	

RECEIVED  
APR 17 2002

GROUP 3600

EXAMINER <i>[Signature]</i>	DATE CONSIDERED 8/13/02
-----------------------------	-------------------------

\*EXAMINER: Initial if reference considered, whether or not citation is in conformance with MPEP 609; Draw line through citation if not in conformance and not considered. Include copy of this form with next communication to applicant.



FORM PTO-1449 U.S. DEPARTMENT OF COMMERCE PATENT AND TRADEMARK OFFICE INFORMATION DISCLOSURE STATEMENT (Use several sheets if necessary)	ATTY. DOCKET NO. 1003-1	SERIAL NO. Not Yet Assigned
	APPLICANT DUPRAY et al.	
	FILING DATE Filed Herewith	GROUP ART

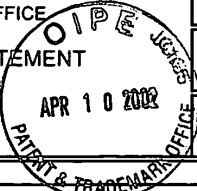

09/17/02, 838

DP	31	5,945,948	8/31/99	Buford et al.	342	457
	32	5,943,014	8/24/99	Gilhousen	342	465
	33	5,936,572	8/10/99	Loomis et al.	342	357
	34	5,933,822	8/3/99	Braden-Harder et al.	707	5
	35	5,933,421	8/3/99	Alamouti et al.	370	330
	36	5,926,133	7/20/99	Green, Jr.	342	363
	37	5,924,090	7/13/99	Krellenstein	707	5
	38	5,920,873	7/6/99	Van Huben et al.	707	202
	39	5,917,866	6/29/99	Pon	375	346
	40	5,917,449	6/29/99	Sanderford et al.	342	457
	41	5,913,170	6/15/99	Wortham	455	457
	42	5,906,655	5/25/99	Fan	701	216
	43	5,905,455	5/18/99	Heger et al.	342	22
	44	5,901,358	5/4/99	Petty et al.	455	456
	45	5,893,091	4/6/99	Hunt et al.	707	3
	46	5,892,441	4/6/99	Woolley et al.	340	539
	47	5,890,068	3/30/99	Fattouche et al.	455	456
	48	5,883,598	3/16/99	Parl et al.	342	457
	49	5,875,401	2/23/99	Rochkind	455	466
	50	5,875,394	2/23/99	Daly et al.	455	411
	51	5,873,076	2/16/99	Barr et al.	707	3
	52	5,873,040	2/16/99	Dunn et al.	455	456
	53	5,872,539	2/16/99	Mullen	342	357
	54	5,870,029	2/9/99	Otto et al.	340	825.36
	55	5,867,799	2/2/99	Lang et al.	707	1
	56	5,867,495	2/2/99	Elliott et al.	370	352
	57	5,845,198	12/1/98	Bamburak et al.	455	31.1
	58	5,844,522	12/1/98	Sheffer et al.	342	457
	59	5,842,130	11/24/1998	Oprescu-Surcobe et al.	455	456
	60	5,838,562	11/17/98	Gudat et al.	364	424.02
	61	5,832,367	11/3/98	Bamburak et al.	455	62
	62	5,822,539	10/13/98	Van Hoff	395	200.66
DP	63	5,819,301	10/6/98	Rowe et al.	707	513

EXAMINER <i>Dw</i>	DATE CONSIDERED 8/13/02
*EXAMINER: Initial if reference considered, whether or not citation is in conformance with MPEP 609; Draw line through citation if not in conformance and not considered. Include copy of this form with next communication to applicant.	

patent applications\1003-1\pto-ids-0001-1449

FORM PTO-1449 U.S. DEPARTMENT OF COMMERCE PATENT AND TRADEMARK OFFICE INFORMATION DISCLOSURE STATEMENT (Use several sheets if necessary)	ATTY. DOCKET NO. 1003-1	SERIAL NO. Not Yet Assigned
	APPLICANT DUPRAY et al.	
	FILING DATE Filed Herewith	GROUP ART



DP	64	5,819,273	10/6/98	Vora et al.	707	10
	65	5,815,538	9/29/98	Grell et al.	375	356
	66	5,805,670	9/8/98	Pons et al.	379	45
	67	5,802,518	9/1/98	Karaev et al.	707	9
	68	5,802,454	9/1/98	Goshay et al.	455	31.2
	69	5,790,953	8/4/98	WANG et al.	455	435
	70	5,786,773	7/28/98	Murphy	340	947
	71	5,774,829	6/30/98	Cisneros et al.	701	213
	72	5,774,802	6/30/98	Tell et al.	455	408
	73	5,737,431	4/7/98	Brandstein et al.	381	92
	74	5,736,964	4/7/98	Ghosh et al.	342	457
	75	5,732,354	3/24/98	MacDonald	455	456
	76	5,724,660	3/3/98	Kauser et al.	455	456
	77	5,724,047	3/3/98	Lioio et al.	342	442
	78	5,719,584	2/17/98	Otto	342	465
	79	5,717,406	2/10/98	Sanderford et al.	342	457
	80	5,710,918	1/20/1998	Lagarde et al.	395	610
	81	5,701,328	12/23/97	Schuchman et al.	375	204
	82	5,686,924	11/11/97	Trimble et al.	342	357
	83	5,675,788	10/7/97	Husick et al.	395	615
	84	5,663,734	9/2/97	Krasner	342	357
	85	5,649,065	7/15/97	Lo et al.	395	23
	86	5,646,630	7/8/97	Sheynblat et al.	342	357
	87	5,640,103	6/17/97	Petsche et al.	324	772
	88	5,638,486	6/10/97	Wang et al.	395	2.45
	89	5,631,469	5/20/97	Carrieri et al.	250	341.5
90	5,629,707	5/13/97	Heuvel et al.	342	357	
91	5,621,848	4/15/97	Wang	395	2.2	
92	5,619,552	4/8/97	Karppanen et al.	379	60	
93	5,614,914	3/25/97	Bolgiano et al.	342	364	
94	5,613,205	3/18/97	Dufour	455	332	
95	5,613,041	3/18/97	Keeler et al.	395	23	
DP	96	5,612,703	3/18/97	Mallinckrodt	342	360

RECEIVED  
 APR 17 2002  
 GROUP 3600

EXAMINER 	DATE CONSIDERED 8/13/02
--------------	----------------------------

\*EXAMINER: Initial if reference considered, whether or not citation is in conformance with MPEP 609; Draw line through citation if not in conformance and not considered. Include copy of this form with next communication to applicant.

FORM PTO-1449 U.S. DEPARTMENT OF COMMERCE PATENT AND TRADEMARK OFFICE <b>INFORMATION DISCLOSURE STATEMENT</b> (Use several sheets if necessary)	ATTY. DOCKET NO. 1003-1	SERIAL NO. Not Yet Assigned
	APPLICANT DUPRAY et al.	
	FILING DATE Filed Herewith	GROUP ART



DP ↑	97	5,610,972	3/11/97	Emery et al.	379	58
	98	5,608,410	3/4/97	Stilp et al.	342	387
	99	5,604,765	2/18/97	Bruno et al.	375	200
	100	5,602,903	2/11/97	LeBlanc et al.	379	60
	101	5,600,706	2/4/1997	Dunn et al.	379	59
	102	5,596,625	1/21/97	LeBlanc	379	60
	103	5,583,517	12/10/96	Yokey et al.	342	457
	104	5,583,513	12/10/96	Cohen	342	357
	105	5,581,596	12/3/96	Hogan	379	59
	106	5,577,169	11/19/96	Prezioso	395	61
	107	5,574,648	11/12/96	Pilley	364	439
	108	5,572,218	11/5/96	Cohen et al.	342	357
	109	5,570,412	10/29/96	LeBlanc	379	58
	110	5,564,079	10/8/96	Olsson	455	54.1
	111	5,563,611	10/8/96	McGann et al.	342	389
	112	5,537,460	7/16/96	Holliday, Jr. et al.	379	59
	113	5,526,466	6/11/96	Takizawa	395	2.62
	114	5,526,357	6/11/96	Jandrell	370	95.2
	115	5,526,001	6/11/96	Rose et al.	342	442
	116	5,519,760	5/21/96	Borkowski et al.	379	59
	117	5,517,667	5/14/96	Wang	395	24
	118	5,512,908	4/30/96	Herrick	342	387
	119	5,508,708	4/16/96	Ghosh et al.	342	457
	120	5,508,707	4/16/96	LeBlanc et al.	342	457
	121	5,506,864	4/9/96	Schilling	375	205
	122	5,485,163	1/16/96	Singer	342	457
	123	5,479,482	12/26/95	Grimes	379	59
	124	5,479,397	12/26/95	Lee	370	18
	125	5,457,736	10/10/95	Cain et al.	379	60
126	5,448,754	9/5/95	Ho et al.	455	34.1	
127	5,444,451	8/22/95	Johnson et al.	342	453	
128	5,438,644	8/1/95	Fu	395	22	
DP ↓	129	5,434,927	7/18/95	Brady et al.	382	104

EXAMINER 	DATE CONSIDERED 8/13/02
--------------	----------------------------

\*EXAMINER: Initial if reference considered, whether or not citation is in conformance with MPEP 609; Draw line through citation if not in conformance and not considered. Include copy of this form with next communication to applicant.

patent applications\1003-1\pto-ids-0001-1449

FORM PTO-1449 U.S. DEPARTMENT OF COMMERCE PATENT AND TRADEMARK OFFICE INFORMATION DISCLOSURE STATEMENT (Use several sheets if necessary)	ATTY. DOCKET NO. 1003-1	SERIAL NO. Not Yet Assigned
	APPLICANT DUPRAY et al.	
	FILING DATE Filed Herewith	GROUP ART

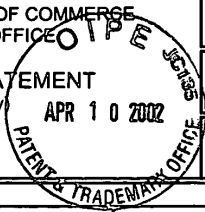

DP	130	5,426,745	7/20/95	Baji et al.	395	375
	131	5,422,813	6/6/95	Schuchman et al.	364	449
	132	5,420,914	5/30/95	Blumhardt	379	114
	133	5,410,737	4/25/95	Jones	455	56.1
	134	5,408,588	4/18/95	Ulug	395	23
	135	5,408,586	4/18/95	Skeirik	395	23
	136	5,402,520	3/28/95	Schnitta	395	22
	137	5,398,302	3/14/95	Thrift	395	23
	138	5,394,435	2/28/95	Weerackody	375	206
	139	5,394,185	2/28/95	Chia	342	457
	140	5,390,339	2/14/95	Bruckert et al.	455	33.2
	141	5,389,934	2/14/95	Kass	342	357
	142	5,388,259	2/7/95	Fleischman et al.	395	600
	143	5,379,224	1/3/95	Brown et al.	364	449
	144	5,365,544	11/15/94	Schilling	375	1
	145	5,365,516	11/15/94	Jandrell	370	18
	146	5,365,450	11/15/94	Schuchman et al.	364	449
	147	5,365,447	11/15/94	Dennis	364	449
	148	5,363,110	11/8/94	Inamiya	342	357
	149	5,359,521	10/25/94	Kyrtsos et al.	364	449
	150	5,349,631	9/20/94	Lee	379	59
	151	5,331,550	7/19/94	Stafford et al.	364	413.02
	152	5,327,144	7/5/94	Stiip et al.	342	387
	153	5,325,419	6/28/94	Connolly et al.	379	60
	154	5,319,374	6/7/94	Desai et al.	342	387
	155	5,317,323	5/31/94	Kennedy et al.	342	457
	156	5,311,195	5/10/94	Mathis et al.	342	357
	157	5,295,180	3/15/94	Vendetti et al.	379	59
	158	5,293,645	3/8/1994	Sood	455	54.1
	159	5,293,642	3/8/94	Lo	455	33.1
	160	5,282,261	1/25/94	Skeirik	395	22
	161	5,280,472	1/18/94	Gilhousen et al.	370	18
DP	162	5,280,295	1/18/94	Kelley et al.	342	463

EXAMINER <i>Duo</i>	DATE CONSIDERED 8/13/02
---------------------	-------------------------

\*EXAMINER: Initial if reference considered, whether or not citation is in conformance with MPEP 609; Draw line through citation if not in conformance and not considered. Include copy of this form with next communication to applicant.

patent applications\1003-1\pto-ids-0001-1449

FORM PTO-1449 U.S. DEPARTMENT OF COMMERCE PATENT AND TRADEMARK OFFICE INFORMATION DISCLOSURE STATEMENT (Use several sheets if necessary)	ATTY. DOCKET NO. 1003-1	SERIAL NO. Not Yet Assigned
	APPLICANT DUPRAY et al.	
	FILING DATE Filed Herewith	GROUP ART

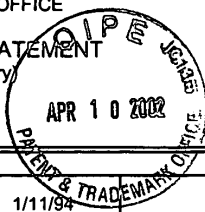

DP	163	5,278,892	1/11/94	Bolliger et al.	379	60
	164	5,260,711	11/9/93	Sterzer	342	375
	165	5,251,273	10/5/93	Betts et al.	382	57
	166	5,243,530	9/7/93	Stanifer et al.	364	452
	167	5,225,842	7/6/93	Brown et al.	342	357
	168	5,218,716	6/8/93	Comroe et al.	455	33
	169	5,218,618	6/8/93	Sagey	375	001
	170	5,218,367	6/8/93	Sheffer et al.	342	457
	171	5,214,789	5/25/93	George	455	33.2
	172	5,212,804	5/18/93	Choate	455	33.1
	173	5,212,765	5/18/93	Skeirik	395	11
	174	5,191,342	3/2/93	Alsup et al.	342	465
	175	5,184,347	2/2/93	Farwell et al.	370	94.1
	176	5,177,489	1/5/93	Hatch	342	357
	177	5,166,694	11/24/92	Russell et al.	342	457
	178	5,163,004	11/10/92	Rentz	364	460
	179	5,155,490	10/13/92	Spradley et al.	342	357
	180	5,142,590	8/25/92	Carpenter et al.	382	14
	181	5,136,686	8/4/92	Koza	395	13
182	5,119,102	6/2/92	Barnard	342	357	
183	5,099,245	3/24/92	Sagey	342	357	
184	5,092,343	3/3/92	Spitzer et al.	128	733	
185	5,055,851	10/8/91	Sheffer	342	457	
186	5,034,898	7/23/91	Lu et al.	364	513	
187	5,017,926	5/21/91	Ames et al.	342	353	
188	5,008,679	4/16/91	Efland et al.	342	353	
189	5,003,317	3/26/91	Gray et al.	342	457	
190	4,992,796	2/12/91	Apostolos	342	156	
191	4,990,922	2/5/91	Young et al.	342	52	
192	4,952,772	8/28/90	Zana	219	124.34	
193	4,914,689	4/3/90	Quade et al.	379	142	
194	4,888,593	12/19/89	Friedman et al.	342	387	
DP	195	4,879,713	11/7/89	Ichiyoshi	370	75

EXAMINER <i>DWD</i>	DATE CONSIDERED 8/13/02
*EXAMINER: Initial if reference considered, whether or not citation is in conformance with MPEP 609; Draw line through citation if not in conformance and not considered. Include copy of this form with next communication to applicant.	

patent applications\1003-1\pto-ids-0001-1449

FORM PTO-1449 U.S. DEPARTMENT OF COMMERCE PATENT AND TRADEMARK OFFICE INFORMATION DISCLOSURE STATEMENT (Use several sheets if necessary)	ATTY. DOCKET NO. 1003-1	SERIAL NO. Not Yet Assigned
	APPLICANT DUPRAY et al.	
	FILING DATE Filed Herewith	GROUP ART 1

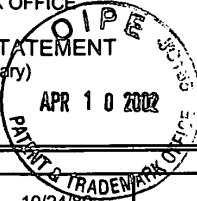

DP ↑	196	4,876,550	10/24/89	Kelly	342	451	
	197	4,864,313	9/5/89	Konneker	342	457	
	198	4,860,352	8/22/89	Laurance et al.	380	23	
	199	4,857,840	8/15/89	Lanchais	324	207	
	200	4,799,062	1/17/89	Sanderford, Jr. et al.	342	450	
	201	4,742,357	5/3/88	Rackley	342	457	
	202	4,740,792	4/26/88	Sagey et al.	342	457	
	203	4,670,758	6/2/87	Campbell	342	458	
	204	4,651,157	3/17/87	Gray et al.	342	457	
	205	4,636,795	1/13/87	Dano	342	387	
	206	4,630,057	12/16/86	Martin	342	358	
	207	Re. 31,962	7/30/85	Brodeur	343	389	
	208	4,475,010	10/2/84	Huensch et al.	179	2 EB	
	209	4,438,439	3/20/84	Shreve	343	449	
	210	4,347,618	8/31/82	Kavouras et al.	375	37	
	211	4,232,313	11/4/80	Fleishman	343	6 R	
	212	4,023,176	5/10/77	Currie et al.	343	113 R	
DP ↓	213	3,886,553	5/27/75	Bates	343	112 R	

FOREIGN PATENT DOCUMENTS

	DOCUMENT NUMBER	DATE	COUNTRY	CLASS	SUB CLASS	TRANSLATION	
						YES	NO
DP ↑	214	EP 0 689 369 A1	12/27/95	Europe	—	—	
	215	WO 94/27161	4/28/94	PCT	—	—	
	216	EP 0 546 758 A2	6/16/93	Europe	—	—	
	217	WO 93/04453	3/4/93	PCT	—	—	
	218	EP 0 177 203 A2	9/9/85	Europe	—	—	
	219	GB 2 155 720 A	3/8/84	Great Britain	—	—	
	220	GB 1 605 207	6/17/75	Great Britain	—	—	8485
DP ↓	221	PCT/US01/17957	6/4/01	PCT	—	—	

EXAMINER 	DATE CONSIDERED 8/13/02
--------------	----------------------------

\*EXAMINER: Initial if reference considered, whether or not citation is in conformance with MPEP 609; Draw line through citation if not in conformance and not considered. Include copy of this form with next communication to applicant.

patent applications\1003-1\pto-ids-0001-1449

FORM PTO-1449 U.S. DEPARTMENT OF COMMERCE PATENT AND TRADEMARK OFFICE INFORMATION DISCLOSURE STATEMENT (Use several sheets if necessary)	ATTY. DOCKET NO. 1003-1	SERIAL NO. Not Yet Assigned
	APPLICANT DUPRAY et al.	
	FILING DATE Filed Herewith	GROUP ART.

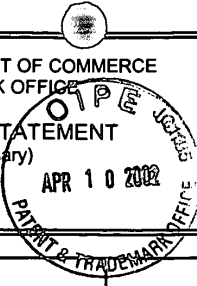

OTHER ART (Including Author, Title, Date, Pertinent Pages, etc.)

DP	222	DUPRAY et al.; U.S. Patent Application Serial No. 09/820,584 Entitled "Location Of A Mobile Station Using A Plurality Of Commercial Wireless Infrastructures" filed March 28, 2001
↑	223	CC Docket No. 94-102, Before the Federal Communications Commission, in the Matter of Revision of the Commission's Rules to Ensure Compatibility with Enhanced 911 Emergency Calling Systems; "Comments of Harris Government Communication Systems Division A Division of Harris Corporation", filed September 25, 1996
	224	CC Docket No. 94-102, Before the Federal Communications Commission, in the Matter of Revision of the Commission's Rules to Ensure Compatibility with Enhanced 911 Emergency Calling Systems; "Reply Comments of KSI Inc. and MULIC Inc." filed October 25, 1996
	225	CC Docket No. 94-102, Before the Federal Communications Commission, in the Matter of Revision of the Commission's Rules to Ensure Compatibility with Enhanced 911 Emergency Calling Systems; <u>ex parte</u> communication from Cambridge Positioning Systems Ltd. received April 14, 1997 by the Commission
	226	CC Docket No. 94-102, Before the Federal Communications Commission, in the Matter of Revision of the Commission's Rules to Ensure Compatibility with Enhanced 911 Emergency Calling Systems; <u>ex parte</u> communication from GeoTek Communications, Inc. received April 14, 1997 by the Commission
	227	CC Docket No. 94-102, Before the Federal Communications Commission, in the Matter of Revision of the Commission's Rules to Ensure Compatibility with Enhanced 911 Emergency Calling Systems; <u>ex parte</u> communication from XYPOINT Corporation, Inc. received July 28, 1997 by the Commission
	228	CC Docket No. 94-102, Before the Federal Communications Commission, in the Matter of Revision of the Commission's Rules to Ensure Compatibility with Enhanced 911 Emergency Calling Systems; <u>ex parte</u> communication from National Strategies, Inc., regarding enhanced 911 system trial by TruePosition, Inc. and New Jersey Office of Emergency Telecommunications Services, received August 8, 1997 by the Commission
	229	CC Docket No. 94-102, Before the Federal Communications Commission, in the Matter of Revision of the Commission's Rules to Ensure Compatibility with Enhanced 911 Emergency Calling Systems; <u>ex parte</u> communication from SnapTrack, Inc., received June 27, 1997 by the Commission
	230	from <a href="http://www.uswcorp.com/labv.htm">http://www.uswcorp.com/labv.htm</a> , Release concerning RadioCamera™, printed 9/14/98
	231	Wylie et al., "The Non-Line of Sight Problem in Mobile Location Estimation"
	232	Evans, 1998, "New Satellites for Personal Communications," <i>Scientific American</i> , 278(4):70-77
	233	Hills, 1998, "Terrestrial Wireless Networks," <i>Scientific American</i> , 278(4):86-91
	234	Pelton, 1998, "Telecommunications for the 21 <sup>st</sup> Century," <i>Scientific American</i> , 278(4):80-85
	235	Stutzmann et al., 1998, "Moving Beyond Wireless Voice Systems," <i>Scientific American</i> , 278(4):92-93
	236	* Driscoll, "Wireless Caller Location Systems", 1998, <i>GSP World Advanstar Communications, Inc.</i> , <a href="http://www.gpsworld.com/1198/1198driscol.html">www.gpsworld.com/1198/1198driscol.html</a> , pgs. 1-8
	237	* Junius et al., "New Methods for Processing GSM Radio Measurement Data: Applications for Locating, Handover, and Network Management", 1994, <i>Communication Network, Aachen University of Technology</i> , pgs. 338-342
	238	* Low, "Comparison of Urban Propagation Models with CW-Measurements", 1992, <i>IEEE Deutsche Bundespost Telekom</i> , pgs. 936-942
	239	* "Location Systems and Technologies", 1994, <i>Wireless Emergency Services JEM Report</i> , Annex A pgs. 42-46 and Appendix A pgs. 1-2
✓	240	* Fechner et al., "A Hybrid Neural Network Architecture for Automatic Object Recognition", 1994, <i>IEEE</i> , pgs. 187-194
DP	241	* Kosko, "Fuzzy Systems as Universal Approximators", 1994, <i>IEEE</i> , pgs. 1329-1333

EXAMINER <i>DWS</i>	DATE CONSIDERED 8/13/02
---------------------	-------------------------

\*EXAMINER: Initial if reference considered, whether or not citation is in conformance with MPEP 609; Draw line through citation if not in conformance and not considered. Include copy of this form with next communication to applicant.







FORM PTO-1449 U.S. DEPARTMENT OF COMMERCE PATENT AND TRADEMARK OFFICE  INFORMATION DISCLOSURE STATEMENT (Use several sheets if necessary)	ATTY. DOCKET NO. 1003-1	SERIAL NO. 09/770,838
	APPLICANT DUPRAY et al.	
	FILING DATE January 26, 2001	GROUP ART 3662

U.S. PATENT DOCUMENTS

*EXAMINER INITIAL		DOCUMENT NUMBER	DATE	NAME	CLASS	SUB CLASS	FILING DATE IF APPROP.
DP	1.	5,513,246	4/30/1996	JONSSON et al.	379	60	

FOREIGN PATENT DOCUMENTS

		DOCUMENT NUMBER	DATE	COUNTRY	CLASS	SUB CLASS	TRANSLATION	
							YES	NO

OTHER ART (Including Author, Title, Date, Pertinent Pages, etc.)

DP	2.	Christ, U.S. Provisional Patent Application Serial No. 60/038,037 Entitled "METHOD AND APPARATUS FOR TRACKING AND LOCATING PERSONNEL" filed February 7, 1997
↑	3.	Maloney; U.S. Provisional Patent Application Serial No. 60/035,691 Entitled "ROBUST, EFFICIENT, LOCALIZATION SYSTEM" filed January 16, 1997
	4.	Maloney; U.S. Provisional Patent Application Serial No. 60/017,269 Entitled "EFFICIENT, DISTRIBUTED, TIME DIFFERENCE LOCALIZATION SYSTEM" filed May 13, 1996
↓	5.	U.S. Patent Application Serial No. 08/355,901 Entitled "MICR-MINIATURE EMERGENCY GEO-LOCATION BEACON SYSTEM FOR PERSONAL SECURITY", filed December 13, 1994
	6.	Communication from U.S. Patent and Trademark Office Re: U.S. Patent Application No. 08/355,901 Paper from Examiner M. Blum of Group Art Unit 2202
DP	7.	Ergon Proprietary; "Performance Analyses Brief: Microminiature Emergency Locator Systems (MELS)"; May 1996;

EXAMINER <i>DW</i>	DATE CONSIDERED <i>8/13/02</i>
*EXAMINER: Initial if reference considered, whether or not citation is in conformance with MPEP 609; Draw line through citation if not in conformance and not considered. Include copy of this form with next communication to applicant.	

L:\TracBeam\patent applications\1003\US (1003&continuations)-1\pto\1449\IDS-03-1449.wpd





RECEIVED

JUL 03 2002

GROUP 3600

SHEET 1 OF 2

FORM PTO-1449 DEPARTMENT OF COMMERCE PATENT AND TRADEMARK OFFICE  INFORMATION DISCLOSURE STATEMENT (Use several sheets if necessary)	ATTY. DOCKET NO. 1003-1	SERIAL NO. 09/770,838
	APPLICANT DUPRAY et al.	
	FILING DATE January 26, 2001	GROUP ART 3662

U.S. PATENT DOCUMENTS

*EXAMINER INITIAL		DOCUMENT NUMBER	DATE	NAME	CLASS	SUB CLASS	FILING DATE IF APPROP.
DP	1	6,308,072	10/23/2001	Labeledz et al.	455	448	
↑	2	6,061,064	5/9/2000	Reichlen	345	418	
	3	5,914,675	6/22/1999	Tognazzini	340	989	
	4	5,835,857	11/10/1998	Otten	455	410	
	5	5,790,974	8/4/1998	Tognazzini	701	204	
	6	5,729,549	3/17/1998	Kostreski et al.	370	522	
	7	5,727,057	3/10/1998	Emery et al.	379	211	
	8	5,594,740	1/14/1997	LaDue	379	59	
	9	5,561,704	10/1/1996	Salimando	379	58	
	DP	10	5,515,378	5/7/1996	Roy, III et al.	370	95.1

FOREIGN PATENT DOCUMENTS

		DOCUMENT NUMBER	DATE	COUNTRY	CLASS	SUB CLASS	TRANSLATION	
							YES	NO
DP	11	EP 0 870 203 B1	Dec. 9, 1996	Europe	G01S	5/04		
↑	12	WO 98/00982	Jan. 8, 1998	PCT	H04Q			
	13	WO 97/38540	Oct. 16, 1997	PCT	H04Q	7/22		
	14	WO 97/26750	Jul. 24, 1997	PCT	H04M	11/00		
	15	WO 97/24010	Jul. 3, 1997	PCT	H04Q	7/38		
DP	16	WO 97/22888	Jun. 26, 1997	PCT	G01S	5/04		

EXAMINER <i>DPW</i>	DATE CONSIDERED <i>8/13/02</i>
*EXAMINER: Initial if reference considered, whether or not citation is in conformance with MPEP 609; Draw line through citation if not in conformance and not considered. Include copy of this form with next communication to applicant.	

L:\TracBeam\patent applications\1003\US (1003&continuations)\1\pto\1449\IDS-04-1449.wpd

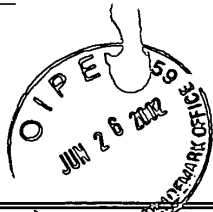

FORM PTO-1449 U.S. DEPARTMENT OF COMMERCE PATENT AND TRADEMARK OFFICE  <b>INFORMATION DISCLOSURE STATEMENT</b> (Use several sheets if necessary)	ATTY. DOCKET NO. 1003-1	SERIAL NO. 09/770,838
	APPLICANT DUPRAY et al.	
	FILING DATE January 26, 2001	GROUP ART 3662

OTHER ART (Including Author, Title, Date, Pertinent Pages, etc.)

RECEIVED  
 JUL 03 2002  
 GROUP 3600

EXAMINER	DATE CONSIDERED
*EXAMINER: Initial if reference considered, whether or not citation is in conformance with MPEP 609; Draw line through citation if not in conformance and not considered. Include copy of this form with next communication to applicant.	

L:\TracBeam\patent applications\1003\US (1003&continuations)-1\pto\1449\IDS-04-1449.wpd

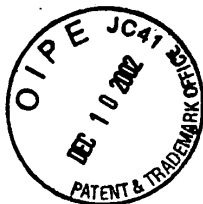

12/12/02

3662

PATENT

Enl. Paper #18 IDS 1-1-02

IN THE UNITED STATES PATENT AND TRADEMARK OFFICE

In Re the Application of:	)	Group Art Unit: 3662
DUPRAY et al.	)	Examiner: Dao L. Phan
Serial No.: 09/770,838	)	<b><u>INFORMATION DISCLOSURE</u></b>
Filed: January 26, 2001	)	<b><u>STATEMENT</u></b>
Atty. File No.: 1003-1	)	Express Mail Label No.: EV190613761US
For: "A GATEWAY AND HYBRID SOLUTIONS FOR WIRELESS LOCATION"	)	

RECEIVED  
DEC 16 2002  
GROUP 3600

Assistant Commissioner for Patents  
Washington, D. C. 20231

Sir:

The references cited on attached Form PTO-1449 are being called to the attention of the Examiner.

Copies of the cited references:

- Are enclosed herewith.
- Are not enclosed, in accordance with 37 C.F.R. 1.98(d), because the references were submitted to the U.S. Patent and Trademark Office in prior application Serial No. 09/194,367 filed November 24, 1998, which is relied upon for an earlier filing date under 35 U.S.C. § 120

To the best of applicants' belief, the pertinence of the foreign-language references are believed to be summarized in the attached English abstracts and in the figures, although applicants do not necessarily vouch for the accuracy of the translation.

Examiner's attention is drawn to the following co-pending applications, copies of which have been or are being submitted:

- Serial No. 09/820,584 filed March 28, 2001
- Serial No. 10/262,413 filed September 30, 2002
- Serial No. 10/262/338 filed September 30, 2002
- Serial No. 09/176,587 filed October 21, 1998

Submission of the above information is not intended as an admission that any item is citable under the statutes or rules to support a rejection, that any item disclosed represents analogous art, or that those skilled in

12/13/2002 11:02:05 00000021 09770838  
01 FC:1806 180.00 DP

the art would refer to or recognize the pertinence of any reference without the benefit of hindsight, nor should an inference be drawn as to the pertinence of the references based on the order in which they are presented. Submission of this statement should not be taken as an indication that a search has been conducted, or that no better art exists.

It is respectfully requested that the cited information be expressly considered during the prosecution of this application and the references made of record therein.

**FEEES**

<input type="checkbox"/>	<p><b>37 CFR 1.97(b):</b> No fee is believed due in connection with this submission, because the information disclosure statement submitted herewith is satisfies one of the following conditions ("X" indicates satisfaction):</p> <ul style="list-style-type: none"> <li><input type="checkbox"/> Within three months of the filing date of a national application other than a continued prosecution application under 37 CFR 1.53(d), or</li> <li><input type="checkbox"/> Within three months of the date of entry into the national stage of an international application as set forth in 37 CFR 1.491 or</li> <li><input type="checkbox"/> Before the mailing date of a first Office Action on the merits, or</li> <li><input type="checkbox"/> Before the mailing of a first Office action after the filing of a request for continued examination under 37 CFR 1.114.</li> </ul> <p>Although no fee is believed due, if any fee is deemed due in connection with this submission, please charge such fee to Deposit Account 19-1970.</p>
<input checked="" type="checkbox"/>	<p><b>37 CFR 1.97(c):</b> The information disclosure statement transmitted herewith is being filed after all the above conditions (37 CFR 1.97(b)), but before the mailing date of one of the following conditions:</p> <ul style="list-style-type: none"> <li>(1) a final action under 37 C.F.R. 1.113 or</li> <li>(2) a notice of allowance under 37 C.F.R. 1.311, or</li> <li>(3) an action that otherwise closes prosecution in the application.</li> </ul> <p>This Information Disclosure Statement is accompanied by:</p> <ul style="list-style-type: none"> <li><input type="checkbox"/> A Certification (below) as specified by 37 C.F.R. 1.97(e). Although no fee is believed due, if any fee is deemed due in connection with this submission, please charge such fee to Deposit Account 19-1970.</li> </ul> <p style="text-align: center;">OR</p> <ul style="list-style-type: none"> <li><input checked="" type="checkbox"/> A check in the amount of \$180.00 for the fee set forth in 37 C.F.R. 1.17(p) for submission of an information disclosure statement. Please credit any overpayment or charge any underpayment to Deposit Account No. 19-1970.</li> </ul>
<input type="checkbox"/>	<p><b>37 CFR 1.97(d):</b> This Information Disclosure Statement is being submitted after the period specified in 37 CFR 1.97(c).</p> <ul style="list-style-type: none"> <li><input type="checkbox"/> This information Disclosure Statement includes a Certification (below) as specified by 37 C.F.R. 1.97(e)</li> </ul> <p style="text-align: center;">AND</p> <ul style="list-style-type: none"> <li><input type="checkbox"/> Applicants hereby requests consideration of the reference(s) disclosed herein. Enclosed is the fee in the amount of \$180.00 under 37 C.F.R. 1.17(p). Please credit any overpayment or charge any underpayment to Deposit Account No. 19-1970. Please credit any overpayment or charge any underpayment to Deposit Account No. 19-1970. Election to pay the fee should not be taken as an indication that applicant(s) cannot execute a certification.</li> </ul>

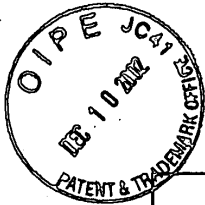

**Certification (37 C.F.R. 1.97(e))**  
(Applicable only if checked)

- The undersigned certifies that:
    - Each item of information contained in this information disclosure statement was first cited in any communication from a foreign patent office in a counterpart foreign application not more than three months prior to the filing of this statement. 37 C.F.R. 1.97(e)(1).
      - A copy of the communication from the foreign patent office is enclosed.
- OR
- No item of information contained in this information disclosure statement was cited in a communication from a foreign patent office in a counterpart foreign application, and, to the knowledge of the undersigned after making reasonable inquiry, no item of information contained in this Information Disclosure Statement was known to any individual designated in 37 C.F.R. 1.56(c) more than more than three months prior to the filing of this statement. 37 C.F.R. 1.97(e)(2).

Respectfully submitted,

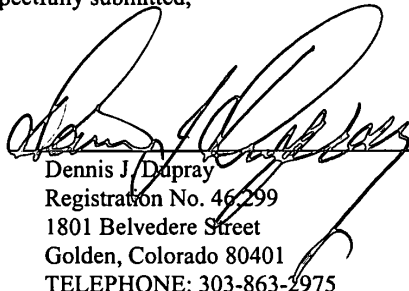
By:   
 Dennis J. Dupray  
 Registration No. 46,299  
 1801 Belvedere Street  
 Golden, Colorado 80401  
 TELEPHONE: 303-863-2975  
 FAX: 303-863-0223

Date: Dec. 10, 2002  
 E:\TRACBEAM\patent applications\1003\US (1003&continuations)\-1\pto\IDS-05.wpd

RECEIVED  
 DEC 16 2002  
 GROUP 3600

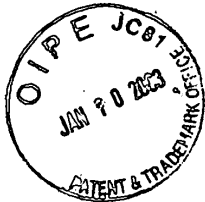

PATENT

IN THE UNITED STATES PATENT AND TRADEMARK OFFICE

In Re the Application of: )  
 )  
 DUPRAY et al. )  
 )  
 Serial No.: 09/770,838 )  
 )  
 Filed: January 26, 2001 )  
 )  
 Atty. File No.: 1003-1 )  
 )  
 For: A GATEWAY AND HYBRID )  
 SOLUTIONS FOR WIRELESS )  
 LOCATION )

Group Art Unit: 3662  
 Examiner: Dao L. Phan

#20 / Amndt D  
 ROSS  
 1-27-03

AMENDMENT AND RESPONSE

Express Mail Label No.: EL923664816US

RECEIVED  
 JAN 17 2003  
 GROUP 3600

Assistant Commissioner for Patents  
 Washington, D. C. 20231

Dear Sir:

This Amendment and Response is filed in response to the Office Action mailed on August 14, 2002. A request for a three-month extension of time is enclosed, to extend the time for response from October 14, 2002 to January 14, 2003.

The information disclosure statements (IDSs) filed on the following dates apparently have not been considered (or at least Applicants do not have confirmation of such consideration): June 26, 2002; April 25, 2002; April 10, 2002; February 20, 2002. Accordingly, it is respectfully requested that the Examiner consider these IDSs if not already considered, and additionally provide the undersigned Applicant with acknowledgement of such consideration.

IN THE SPECIFICATION:

A request for a change in the title to the application's current title (above) was previously entered. However, applicant's want to make sure that the title is as identified above. Accordingly, if the above title for the present application is not recorded as "A GATEWAY AND HYBRID SOLUTIONS FOR WIRELESS LOCATION," then please change the title of



the present application to "A GATEWAY AND HYBRID SOLUTIONS FOR WIRELESS LOCATION."

IN THE CLAIMS:

D1  
15226. (Once Amended) The method of Claim 221, wherein said step of providing includes representing each of said first and second location inputs in a common data representation having a plurality of location attributes, including a common representation A<sub>1</sub> for representing a geographical position for the first mobile station, and one or more attributes related to one of: an error in data for A<sub>1</sub>, a likelihood of the first mobile station being in the geographical extent represented by A<sub>1</sub>, a timestamp related to the first mobile station being in the geographical extent represented by A<sub>1</sub>, and descriptor information related to location processing performed by one of said resources in obtaining an instance of said location information for M.

D2  
243. (Once Amended) A method as set forth in claim 221, wherein said first location finding technology involves a first location finding controller for receiving first location data from a first source and determining, using said first data, one or more geometric extents for a location of the first mobile station and a value related to an uncertainty of said one or more geometric extents to provide said first location input, and said second location finding technology involves obtaining second location data from a second source and determining, using said second data, one or more geometric extents for a location of the first mobile station and a value related to an uncertainty of said one or more geometric extents to provide said second location input, and said step of combining comprises obtaining said first data from said first source, obtaining said second data from said second source, and said step of combining further comprises using one of said first data and said second data to obtain derived location information.

D3  
247. (Once Amended) A method for locating mobile stations at one or more unknown terrestrial locations using wireless signal measurements obtained from transmissions between said mobile stations and a plurality of terrestrial or non-terrestrial communication stations, wherein each of said communications stations includes one or

D

*D's Cont*

more of a transmitter and a receiver for wirelessly communicating with said mobile stations, comprising:

receiving, from a plurality of location requesting sources, a plurality of input requests for locations of the mobile stations, wherein for each of the input requests there is a corresponding destination for a responsive output;

for a first of the input requests, first providing one or more location requests for location information, related to a location of a first of said mobile stations, to one or more mobile station location determining sources for activating a first set of one or more wireless location techniques;

first obtaining, in response to a first of the location requests received from a first of the requesting sources, at least first location information of a first location of a first of said mobile stations, said first location information determined using the first set of one or more wireless location techniques;

where the first obtaining step results from an activation of at least two different wireless location techniques, each using measurements from one of: (i) first wireless signals for communication between a first set of one or more of the communication stations and the first mobile station, wherein first mobile station is in two-way communication with the first set of communication stations, and (ii) second wireless signals broadcast from a second set of one or more of the communications stations and received by the first mobile station, wherein the first mobile station does not transmit a wireless signal that is used by the second set of communication stations for communicating with the first mobile station;

first determining, using said first location information, first output location data according to a first output criteria for the corresponding destination for the first request, said first output location data including a representation identifying a first geographical range of the first location;

for a second of the input requests, second providing one or more second location requests for location information, related to a location of a second of said mobile stations,

*262<sup>3</sup>*

to one or more mobile station location determining sources for activating a second set of one or more wireless location techniques;

second obtaining, in response to a second of the location requests received from a second of the requesting sources, at least second location information of a second location of a second of said mobile stations, said second location information determined using the second set of one or more wireless location techniques, wherein the second set determines the second location information by activating at least one technique (T) of the second set for locating the second mobile station that does not provide a result that substantively effects said first output location data;

second determining, using said second location information, second output location data according to a second output criteria for the corresponding destination for the second request, said second output location data including a representation identifying a geographical range of the second location;

wherein said second output location data is substantively dependent upon a result from said technique T;

wherein for at least one of said first and second output criteria, there is an output criteria for another of the location requests that is different from said at least one output criteria;

first transmitting said first output location data to its corresponding destination via a communications network; and

second transmitting said second output location data to its corresponding destination via a communications network, the first and second locations being different locations.

---

<sup>247</sup> 249. (Once Amended) The method of Claim <sup>247</sup> 247, wherein said steps of first and second determining use at least one common mobile station location related component for determining, respectively, said first output location data and said second output location data.

---

D3 cont

D4

263 4

D

D5

~~54~~ 74. (Once Amended) The method of Claim ~~53~~ 73, wherein said first location technique includes a step of using information dependent upon a wireless coverage area of the at least one transceiver for improving said first location information.

HA 5

D

REMARKS

The information disclosure statements (IDSs) filed on the following dates apparently have not been considered (or at least Applicants do not have confirmation of such consideration): June 26, 2002; April 25, 2002; April 10, 2002; February 20, 2002. Accordingly, it is respectfully requested that the Examiner consider these IDSs if not already considered, and additionally provide the undersigned Applicant with acknowledgement of such consideration.

Regarding Claims 226, 243, 249, and 274, a period has been inserted at the end of each of these claims as requested by the Examiner. The Examiner's attention to such details is appreciated.

Regarding Claim 247, the claim has been amended and is believed to be allowable.

It is respectfully requested that the application now be reconsidered.

No fees are believed due with this response beyond the fees for a 3 month extension of time. If there are additional fees due, please contact the undersigned so that such fees can be promptly paid.

Attached hereto is a marked up version of the changes made to the specification and claims by this Amendment. The attached page is captioned "Version With Markings to Show Changes Made."

*Jan. 10, 2003*

Respectfully submitted,

By: 

Dennis J. Dupray  
Registration No. 46,299  
1801 Belvedere Street  
Golden, Colorado 80401  
TELEPHONE: 303-863-2975  
FAX: 303-863-0223

*D*

Version with Markings to Show Changes Made

In the specification:

The title of the application has been changed to “A GATEWAY AND HYBRID SOLUTIONS FOR WIRELESS LOCATION.”

In the claims:

226. (Once Amended) The method of Claim 221, wherein said step of providing includes representing each of said first and second location inputs in a common data representation having a plurality of location attributes, including a common representation  $A_1$  for representing a geographical position for the first mobile station, and one or more attributes related to one of: an error in data for  $A_1$ , a likelihood of the first mobile station being in the geographical extent represented by  $A_1$ , a timestamp related to the first mobile station being in the geographical extent represented by  $A_1$ , and descriptor information related to location processing performed by one of said resources in obtaining an instance of said location information for  $M_1$ .

243. (Once Amended) A method as set forth in claim 239, wherein said first location finding technology involves a first location finding controller for receiving first location data from a first source and determining, using said first data, one or more geometric extents for a location of the first mobile station and a value related to an uncertainty of said one or more geometric extents to provide said first location input, and said second location finding technology involves obtaining second location data from a second source and determining, using said second data, one or more geometric extents for a location of the first mobile station and a value related to an uncertainty of said one or more geometric extents to provide said second location input, and said step of combining comprises obtaining said first data from said first source, obtaining said second data from said second source, and said step of combining further comprises using one of said first data and said second data to obtain derived location information.

247. (Once Amended) A method for locating mobile stations at one or more unknown terrestrial locations using wireless signal measurements obtained from

transmissions between said mobile stations and a plurality of [fixed location] terrestrial or non-terrestrial communication stations, wherein each of said communications stations includes one or more of a transmitter and a receiver for wirelessly communicating with said mobile stations, comprising:

receiving, from a plurality of location requesting sources, a plurality of input requests for locations of the mobile stations, wherein for each of the input requests there is a corresponding destination for a responsive output;

for a first [each] of the input requests, first providing one or more location requests for location information, related to a location of a first [one] of said mobile stations, to one or more mobile station location determining sources for activating a first set of one or more wireless location techniques;

first obtaining, in response to a first of the location requests received from a first of the requesting sources, at least first location information of a first location of a first of said mobile stations, said first location information determined using the [a] first set of one or more wireless location techniques;

where the first obtaining step results from an activation of at least two different wireless location techniques, each using measurements from one of: (i) first wireless signals for communication between a first set of one or more of the communication stations and the first mobile station, wherein first mobile station is in two-way communication with the first set of communication stations, and (ii) second wireless signals broadcast from a second set of one or more of the communications stations and received by the first mobile station, wherein the first mobile station does not transmit a wireless signal that is used by the second set of communication stations for communicating with the first mobile station;

first determining, using said first location information, first output location data according to a first output criteria for the corresponding destination for the first request, said first output location data including a representation identifying a first geographical range of the first location;

for a second of the input requests, second providing one or more second location requests for location information, related to a location of a second of said mobile stations, to one or more mobile station location determining sources for activating a second set of one or more wireless location techniques;

second obtaining, in response to a second of the location requests received from a second of the requesting sources, at least second location information of a second location of a second of said mobile stations, said second location information determined using the [a] second set of one or more wireless location techniques, wherein the second set determines the second location information by activating at least one technique (T) of the second set [computational module] for locating the second mobile station that does not provide a result that substantively effects said first output location data [is not activated for determining the first location information];

second determining, using said second location information, second output location data according to a second output criteria for the corresponding destination for the second request, said second output location data including a representation identifying a geographical range of the second location;

wherein said second output location data is substantively dependent upon a result from said technique T;

wherein for at least one of said first and second output criteria, there is an output criteria for another of the location requests that is different from said at least one output criteria;

first transmitting said first output location data to its corresponding destination via a communications network; and

second transmitting said second output location data to its corresponding destination via a communications network, the first and second locations being different locations

249. (Once Amended) The method of Claim 247, wherein said steps of first and second determining use at least one common mobile station location related component



for determining, respectively, said first output location data and said second output location data.

274. (Once Amended) The method of Claim 273, wherein said first location technique includes a step of using information dependent upon a wireless coverage area of the at least one transceiver for improving said first location information.





01 - 13 - 03

# 3662  
Request for Extension  
#19 1-27-03

IN THE UNITED STATES PATENT AND TRADEMARK OFFICE

RECEIVED  
JAN 17 2003  
GROUP 3600

In Re the Application of: )  
 )  
DUPRAY et al. )  
 )  
Serial No.: 09/770,838 )  
 )  
Filed: January 26, 2001 )  
 )  
Atty. File No.: 1003-1 )  
 )  
For: "WIRELESS LOCATION USING )  
SIGNAL FINGERPRINTING" )

Group Art Unit: 3662

Examiner:

REQUEST FOR EXTENSION OF TIME

"EXPRESS MAIL" LABEL NUMBER: EL923664816 US  
DATE OF DEPOSIT: JANUARY 10, 2003

I HEREBY CERTIFY THAT THIS PAPER OR FEE IS BEING DEPOSITED WITH THE UNITED STATES POSTAL SERVICE "EXPRESS MAIL POST OFFICE TO ADDRESSEE" SERVICE UNDER 37 CFR 1.10 ON THE DATE INDICATED ABOVE AND IS ADDRESSED TO THE COMMISSIONER OF PATENTS, WASHINGTON, D.C. 20231.

Assistant Commissioner for Patents  
Washington, D.C. 20231

TYPED OR PRINTED NAME: CONSTANCE ROBBETT  
SIGNATURE: [Signature]

Dear Sir:

Applicants attorneys, respectfully petition for an extension of time under 37 CFR § 1.136(a) of three (3) months to respond to the Office Action mailed on August 14, 2002, with respect to the above-identified application, thereby extending the period for response from October 14, 2002, to January 14, 2003.

Enclosed is a check in the amount of \$465.00 as payment for the extension fee. Please credit any overpayment or debit any underpayment to Deposit Account No. 19-1970.

01/14/2003 H:ARZ11 00000011 09770838  
01 FC:2253 465.00 OP

Respectfully submitted,

By: [Signature]

Dennis J. Dupray  
Registration No. 46,299  
1801 Belvedere Street  
Golden, Colorado 80401  
TELEPHONE: 303-863-2975  
FAX: 303-863-0223

Date: Jan. 10, 2003



UNITED STATES PATENT AND TRADEMARK OFFICE

UNITED STATES DEPARTMENT OF COMMERCE
United States Patent and Trademark Office
Address: COMMISSIONER OF PATENTS AND TRADEMARKS
Washington, D.C. 20231
www.uspto.gov

NOTICE OF ALLOWANCE AND FEE(S) DUE

7590 03/11/2003
Dennis J. Dupray, Ph.D.
1801 Belvedere Street
Golden, CO 80401

EXAMINER
PHAN, DAO LINDA
ART UNIT 3662 CLASS-SUBCLASS 342-450000

DATE MAILED: 03/11/2003

Table with 5 columns: APPLICATION NO., FILING DATE, FIRST NAMED INVENTOR, ATTORNEY DOCKET NO., CONFIRMATION NO.

TITLE OF INVENTION: A GATEWAY AND HYBRID SOLUTIONS FOR WIRELESS LOCATION

Table with 6 columns: APPLN. TYPE, SMALL ENTITY, ISSUE FEE, PUBLICATION FEE, TOTAL FEE(S) DUE, DATE DUE

THE APPLICATION IDENTIFIED ABOVE HAS BEEN EXAMINED AND IS ALLOWED FOR ISSUANCE AS A PATENT. PROSECUTION ON THE MERITS IS CLOSED. THIS NOTICE OF ALLOWANCE IS NOT A GRANT OF PATENT RIGHTS. THIS APPLICATION IS SUBJECT TO WITHDRAWAL FROM ISSUE AT THE INITIATIVE OF THE OFFICE OR UPON PETITION BY THE APPLICANT. SEE 37 CFR 1.313 AND MPEP 1308.

THE ISSUE FEE AND PUBLICATION FEE (IF REQUIRED) MUST BE PAID WITHIN THREE MONTHS FROM THE MAILING DATE OF THIS NOTICE OR THIS APPLICATION SHALL BE REGARDED AS ABANDONED. THIS STATUTORY PERIOD CANNOT BE EXTENDED. SEE 35 U.S.C. 151. THE ISSUE FEE DUE INDICATED ABOVE REFLECTS A CREDIT FOR ANY PREVIOUSLY PAID ISSUE FEE APPLIED IN THIS APPLICATION. THE PTOL-85B (OR AN EQUIVALENT) MUST BE RETURNED WITHIN THIS PERIOD EVEN IF NO FEE IS DUE OR THE APPLICATION WILL BE REGARDED AS ABANDONED.

HOW TO REPLY TO THIS NOTICE:

I. Review the SMALL ENTITY status shown above.

If the SMALL ENTITY is shown as YES, verify your current SMALL ENTITY status:

- A. If the status is the same, pay the TOTAL FEE(S) DUE shown above.
B. If the status is changed, pay the PUBLICATION FEE (if required) and twice the amount of the ISSUE FEE shown above and notify the United States Patent and Trademark Office of the change in status, or

If the SMALL ENTITY is shown as NO:

- A. Pay TOTAL FEE(S) DUE shown above, or
B. If applicant claimed SMALL ENTITY status before, or is now claiming SMALL ENTITY status, check the box below and enclose the PUBLICATION FEE and 1/2 the ISSUE FEE shown above.
[ ] Applicant claims SMALL ENTITY status. See 37 CFR 1.27.

II. PART B - FEE(S) TRANSMITTAL should be completed and returned to the United States Patent and Trademark Office (USPTO) with your ISSUE FEE and PUBLICATION FEE (if required). Even if the fee(s) have already been paid, Part B - Fee(s) Transmittal should be completed and returned. If you are charging the fee(s) to your deposit account, section "4b" of Part B - Fee(s) Transmittal should be completed and an extra copy of the form should be submitted.

III. All communications regarding this application must give the application number. Please direct all communications prior to issuance to Box ISSUE FEE unless advised to the contrary.

IMPORTANT REMINDER: Utility patents issuing on applications filed on or after Dec. 12, 1980 may require payment of maintenance fees. It is patentee's responsibility to ensure timely payment of maintenance fees when due.

**PART B - FEE(S) TRANSMITTAL**

**Complete and send this form, together with applicable fee(s), to: Mail **Box ISSUE FEE**  
**Commissioner for Patents**  
**Washington, D.C. 20231**  
Fax **(703)746-4000****

**INSTRUCTIONS:** This form should be used for transmitting the **ISSUE FEE** and **PUBLICATION FEE** (if required). Blocks 1 through 4 should be completed where appropriate. All further correspondence including the Patent, advance orders and notification of maintenance fees will be mailed to the current correspondence address as indicated unless corrected below or directed otherwise in Block 1, by (a) specifying a new correspondence address; and/or (b) indicating a separate "FEE ADDRESS" for maintenance fee notifications.

**CURRENT CORRESPONDENCE ADDRESS** (Note: Legibly mark-up with any corrections or use Block 1)  
 7590 03/11/2003

Dennis J. Dupray, Ph.D.  
 1801 Belvedere Street  
 Golden, CO 80401

Note: A certificate of mailing can only be used for domestic mailings of the Fee(s) Transmittal. This certificate cannot be used for any other accompanying papers. Each additional paper, such as an assignment or formal drawing, must have its own certificate of mailing or transmission.

**Certificate of Mailing or Transmission**

I hereby certify that this Fee(s) Transmittal is being deposited with the United States Postal Service with sufficient postage for first class mail in an envelope addressed to the Box Issue Fee address above, or being facsimile transmitted to the USPTO, on the date indicated below.

(Depositor's name)
(Signature)
(Date)

APPLICATION NO.	FILING DATE	FIRST NAMED INVENTOR	ATTORNEY DOCKET NO.	CONFIRMATION NO.
09/770,838	01/26/2001	Dennis J. Dupray	1003-1	8410

TITLE OF INVENTION: A GATEWAY AND HYBRID SOLUTIONS FOR WIRELESS LOCATION

APPLN. TYPE	SMALL ENTITY	ISSUE FEE	PUBLICATION FEE	TOTAL FEE(S) DUE	DATE DUE
nonprovisional	YES	\$650	\$300	\$950	06/11/2003

EXAMINER	ART UNIT	CLASS-SUBCLASS
PHAN, DAO LINDA	3662	342-450000

<p>1. Change of correspondence address or indication of "Fee Address" (37 CFR 1.363).</p> <p><input type="checkbox"/> Change of correspondence address (or Change of Correspondence Address form PTO/SB/122) attached.</p> <p><input type="checkbox"/> "Fee Address" indication (or "Fee Address" Indication form PTO/SB/47; Rev 03-02 or more recent) attached. <b>Use of a Customer Number is required.</b></p>	<p>2. For printing on the patent front page, list (1) the names of up to 3 registered patent attorneys or agents OR, alternatively, (2) the name of a single firm (having as a member a registered attorney or agent) and the names of up to 2 registered patent attorneys or agents. If no name is listed, no name will be printed.</p> <p>1 _____</p> <p>2 _____</p> <p>3 _____</p>
---	---

3. ASSIGNEE NAME AND RESIDENCE DATA TO BE PRINTED ON THE PATENT (print or type)

PLEASE NOTE: Unless an assignee is identified below, no assignee data will appear on the patent. Inclusion of assignee data is only appropriate when an assignment has been previously submitted to the USPTO or is being submitted under separate cover. Completion of this form is NOT a substitute for filing an assignment.

(A) NAME OF ASSIGNEE \_\_\_\_\_ (B) RESIDENCE: (CITY and STATE OR COUNTRY) \_\_\_\_\_

Please check the appropriate assignee category or categories (will not be printed on the patent)  individual  corporation or other private group entity  government

4a. The following fee(s) are enclosed:

Issue Fee

Publication Fee

Advance Order - # of Copies \_\_\_\_\_

4b. Payment of Fee(s):

A check in the amount of the fee(s) is enclosed.

Payment by credit card. Form PTO-2038 is attached.

The Commissioner is hereby authorized by charge the required fee(s), or credit any overpayment, to Deposit Account Number \_\_\_\_\_ (enclose an extra copy of this form).

Commissioner for Patents is requested to apply the Issue Fee and Publication Fee (if any) or to re-apply any previously paid issue fee to the application identified above.

<p>(Authorized Signature) _____</p> <p>(Date) _____</p> <p>NOTE: The Issue Fee and Publication Fee (if required) will not be accepted from anyone other than the applicant, a registered attorney or agent, or the assignee or other party in interest as shown by the records of the United States Patent and Trademark Office.</p> <p>This collection of information is required by 37 CFR 1.311. The information is required to obtain or retain a benefit by the public which is to file (and by the USPTO to process) an application. Confidentiality is governed by 35 U.S.C. 122 and 37 CFR 1.14. This collection is estimated to take 12 minutes to complete, including gathering, preparing, and submitting the completed application form to the USPTO. Time will vary depending upon the individual case. Any comments on the amount of time you require to complete this form and/or suggestions for reducing this burden, should be sent to the Chief Information Officer, U.S. Patent and Trademark Office, U.S. Department of Commerce, Washington, D.C. 20231. <b>DO NOT SEND FEES OR COMPLETED FORMS TO THIS ADDRESS. SEND TO: Commissioner for Patents, Washington, DC 20231.</b></p> <p>Under the Paperwork Reduction Act of 1995, no persons are required to respond to a collection of information unless it displays a valid OMB control number.</p>	
--	--



UNITED STATES PATENT AND TRADEMARK OFFICE

UNITED STATES DEPARTMENT OF COMMERCE  
United States Patent and Trademark Office  
Address: COMMISSIONER OF PATENTS AND TRADEMARKS  
Washington, D.C. 20231  
www.uspto.gov

APPLICATION NO.	FILING DATE	FIRST NAMED INVENTOR	ATTORNEY DOCKET NO.	CONFIRMATION NO.
09/770,838	01/26/2001	Dennis J. Dupray	1003-1	8410
	7590 03/11/2003		EXAMINER	
Dennis J. Dupray, Ph.D. 1801 Belvedere Street Golden, CO 80401			PHAN, DAO LINDA	
			ART UNIT	PAPER NUMBER
			3662	

DATE MAILED: 03/11/2003

**Determination of Patent Term Adjustment under 35 U.S.C. 154 (b)**  
(application filed on or after May 29, 2000)

The patent term adjustment to date is 0 days. If the issue fee is paid on the date that is three months after the mailing date of this notice and the patent issues on the Tuesday before the date that is 28 weeks (six and a half months) after the mailing date of this notice, the term adjustment will be 0 days.

If a continued prosecution application (CPA) was filed in the above-identified application, the filing date that determines patent term adjustment is the filing date of the most recent CPA.

Applicant will be able to obtain more detailed information by accessing the Patent Application Information Retrieval (PAIR) system. (<http://pair.uspto.gov>)

Any questions regarding the patent term extension or adjustment determination should be directed to the Office of Patent Legal Administration at (703)305-1383.



UNITED STATES PATENT AND TRADEMARK OFFICE

UNITED STATES DEPARTMENT OF COMMERCE  
United States Patent and Trademark Office  
Address: COMMISSIONER OF PATENTS AND TRADEMARKS  
Washington, D.C. 20231  
www.uspto.gov

APPLICATION NO.	FILING DATE	FIRST NAMED INVENTOR	ATTORNEY DOCKET NO.	CONFIRMATION NO.
09/770,838	01/26/2001	Dennis J. Dupray	1003-1	8410
	7590 03/11/2003		EXAMINER	
Dennis J. Dupray, Ph.D. 1801 Belvedere Street Golden, CO 80401 UNITED STATES			PHAN, DAO LINDA	
			ART UNIT	PAPER NUMBER
			3662	

DATE MAILED: 03/11/2003

**Notice of Fee Increase on January 1, 2003**

If a reply to a "Notice of Allowance and Fee(s) Due" is filed in the Office on or after January 1, 2003, then the amount due will be higher than that set forth in the "Notice of Allowance and Fee(s) Due" since there will be an increase in fees effective on January 1, 2003. See Revision of Patent and Trademark Fees for Fiscal Year 2003; Final Rule, 67 Fed. Reg. 70847, 70849 (November 27, 2002).

The current fee schedule is accessible from: <http://www.uspto.gov/main/howtofees.htm>.

If the issue fee paid is the amount shown on the "Notice of Allowance and Fee(s) Due," but not the correct amount in view of the fee increase, a "Notice to Pay Balance of Issue Fee" will be mailed to applicant. In order to avoid processing delays associated with mailing of a "Notice to Pay Balance of Issue Fee," if the response to the Notice of Allowance and Fee(s) due form is to be filed on or after January 1, 2003 (or mailed with a certificate of mailing on or after January 1, 2003), the issue fee paid should be the fee that is required at the time the fee is paid. If the issue fee was previously paid, and the response to the "Notice of Allowance and Fee(s) Due" includes a request to apply a previously-paid issue fee to the issue fee now due, then the difference between the issue fee amount at the time the response is filed and the previously paid issue fee should be paid. See Manual of Patent Examining Procedure, Section 1308.01 (Eighth Edition, August 2001).

Questions relating to issue and publication fee payments should be directed to the Customer Service Center of the Office of Patent Publication at (703) 305-8283.

<b>Notice of Allowability</b>	Application No. <b>09/770,838</b>	Applicant(s) <b>Dupray et al</b>
	Examiner <b>Dao L. Phan</b>	Art Unit <b>3662</b>

**--The MAILING DATE of this communication appears on the cover sheet with the correspondence address--**

All claims being allowable, PROSECUTION ON THE MERITS IS (OR REMAINS) CLOSED in this application. If not included herewith (or previously mailed), a Notice of Allowance (PTOL-85) or other appropriate communication will be mailed in due course. **THIS NOTICE OF ALLOWABILITY IS NOT A GRANT OF PATENT RIGHTS.** This application is subject to withdrawal from issue at the initiative of the Office or upon petition by the applicant. See 37 CFR 1.313 and MPEP 1308.

- 1.  This communication is responsive to 1/10/03.
- 2.  The allowed claim(s) is/are 221-295 (renumbered 1-75).
- 3.  The drawings filed on 1/26/01 and 3/1/02 are accepted by the Examiner.
- 4.  Acknowledgement is made of a claim for foreign priority under 35 U.S.C. § 119(a)-(d).
  - a)  All    b)  Some\*    c)  None    of the:
    - 1.  Certified copies of the priority documents have been received.
    - 2.  Certified copies of the priority documents have been received in Application No. \_\_\_\_\_.
    - 3.  Copies of the certified copies of the priority documents have been received in this national stage application from the International Bureau (PCT Rule 17.2(a)).
- \*Certified copies not received: \_\_\_\_\_.
- 5.  Acknowledgement is made of a claim for domestic priority under 35 U.S.C. § 119(e) (to a provisional application).
  - (a)  The translation of the foreign language provisional application has been received.
- 6.  Acknowledgement is made of a claim for domestic priority under 35 U.S.C. §§ 120 and/or 121.

Applicant has THREE MONTHS FROM THE "MAILING DATE" of this communication to file a reply complying with the requirements noted below. Failure to timely comply will result in ABANDONMENT of this application. **THIS THREE-MONTH PERIOD IS NOT EXTENDABLE.**

- 7.  A SUBSTITUTE OATH OR DECLARATION must be submitted. Note the attached EXAMINER'S AMENDMENT or NOTICE OF INFORMAL PATENT APPLICATION (PTO-152) which gives reason(s) why the oath or declaration is deficient.
- 8.  CORRECTED DRAWINGS must be submitted.
  - (a)  including changes required by the Notice of Draftsperson's Patent Drawing Review (PTO-948) attached
    - 1)  hereto or 2)  to Paper No. \_\_\_\_\_.
  - (b)  including changes required by the proposed drawing correction filed \_\_\_\_\_, which has been approved by the examiner.
  - (c)  including changes required by the attached Examiner's Amendment/Comment or in the Office action of Paper No. \_\_\_\_\_.

Identifying indicia such as the application number (see 37 CFR 1.84(c)) should be written on the drawings in the top margin (not the back) of each sheet. The drawings should be filed as a separate paper with a transmittal letter addressed to the Official Draftsperson.

- 9.  DEPOSIT OF and/or INFORMATION about the deposit of BIOLOGICAL MATERIAL must be submitted. Note the attached Examiner's comment regarding REQUIREMENT FOR THE DEPOSIT OF BIOLOGICAL MATERIAL.

**Attachment(s)**

- 1  Notice of References Cited (PTO-892)
- 2  Notice of Informal Patent Application (PTO-152)
- 3  Notice of Draftsperson's Patent Drawing Review (PTO-948)
- 4  Interview Summary (PTO-413), Paper No. \_\_\_\_\_
- 5  Information Disclosure Statement(s) (PTO-1449), Paper No(s). \_\_\_\_\_
- 6  Examiner's Amendment/Comment
- 7  Examiner's Comment Regarding Requirement for Deposit of Biological Material
- 8  Examiner's Statement of Reasons for Allowance
- 9  Other

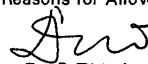
  
 DAO PHAN  
 PATENT EXAMINER

Application Number: 09/770838

Art Unit: 3662

The following is an examiner's statement of reasons for allowance: the examiner found no teaching in the prior art that would render obvious the claimed mobile station location system and method for use in a wireless network including the steps of “wherein the first location estimating source employs a first location finding technology, wherein the steps of first and second obtaining includes a step of providing the first and second location inputs in a common standardized format, and third obtaining the requested location information by selectively using portions of the data from the memory”, claim 221, “initialing a plurality of requests for information related to the location of the mobile station M”, claim 245, “where the first obtaining steps results from an activation of at least two different wireless location technique, first determining, using the first location information, first output location data according to a first output criteria, second obtaining, in response to a second of the location requests received from a second of the requesting sources, at least second location information of a second location of a second of the mobile stations, and second determining, using the second location information, second output location data according to a second output criteria”, claim 247, “providing access to first and second different mobile station location technique, wherein there is at least on predetermined common location related component activated for determining the resulting location information, and providing the resulting location information for each of the first and second mobile stations for presentation”, claim 268, “repeatedly performing the following steps (A1) through (A3) for tracking the mobile station as claimed”, claim 269, “receiving, from each of at least first and second mobile station location estimators”, claim 276, “providing access to a plurality of mobile



station location estimating techniques”, claim 278, “determining additional location information of the mobile station”, claim 285, “generating one or more messages, for information related to a location of the first mobile station”, claim 290, “determining a second location estimate of the mobile station by activating an accessible second of the location techniques, wherein when the mobile is at a first location, an instance of at least the first location estimate is used in obtaining step for obtaining a first corresponding instance of the resulting location information”, claim 291, “a gating module for communicating with two or more mobile station location estimating sources for determining corresponding geographic extents for locations of a plurality of mobile stations, and a resulting estimator for determining a likely location estimate of the location L of the mobile station M”, claim 292, “wherein for a first of the mobile station location estimating sources, when estimating a location of one of the mobile station, and a resulting estimator for determining a likely location estimate of a location L of the mobile station M”, claim 295.

Any comments considered necessary by applicant must be submitted no later than the payment of the issue fee and, to avoid processing delays, should preferably accompany the issue fee. Such submissions should be clearly labeled "Comments on Statement of Reasons for Allowance."

Any inquiry concerning this communication or earlier communications from the examiner should be directed to Dao L. Phan whose telephone number is (703)306-4167.

  
DAO PHAN  
PATENT EXAMINER



UNITED STATES DEPARTMENT OF COMMERCE  
 Patent and Trademark Office  
 COMMISSIONER OF PATENTS AND TRADEMARKS  
 Washington, D.C. 20231

SERIAL NUMBER	FILING DATE	FIRST NAMED APPLICANT	ATTORNEY DOCKET NO.
			EXAMINER
		ART UNIT	PAPER NUMBER

DATE MAILED:

This is a communication from the examiner in charge of your application  
 COMMISSIONER OF PATENTS AND TRADEMARKS

The petition filed January 10, 2003 under 37 CFR §1.97(d)(2)(ii) for consideration of an information disclosure statement filed after allowance has been:

GRANTED.

DENIED.

The petition lacks:

The required fee under 37 CFR §§1.97(d)(2)(iii) and 1.17(i)(1).

A proper certification as specified in 37 CFR §§1.97(d)(2)(i) and 1.97(e)

The information disclosure statement has been placed of record in the file but will not be considered by the examiner.

Thomas H. Tarca  
 SPE Art Unit 3662

*Notice of References Cited*

Application/Control No. <b>09/770,838</b>	Applicant(s)/Patent Under Reexam <b>Dupray et al</b>	
Examiner <b>Dao L. Phan</b>	Art Unit <b>3662</b>	Page 1 of 1

**U.S. PATENT DOCUMENTS**

	Document Number Country Code-Number-Kind Code	Date MM-YYYY <sup>1</sup>	Name	Classification <sup>2</sup>
A				
B				
C				
D				
E				
F				
G				
H				
I				
J				
K				
L				
M				

*None*

**FOREIGN PATENT DOCUMENTS**

	Document Number Country Code-Number-Kind Code	Date MM-YYYY <sup>1</sup>	Country	Name	Classification <sup>2</sup>
N					
O					
P					
Q					
R					
S					
T					

**NON-PATENT DOCUMENTS**

	Include, as applicable: Author, Title, Date, Publisher, Edition or Volume, Pertinent Pages
U	
V	
W	
X	

\* A copy of this reference is not being furnished with this Office action. See MPEP § 707.05(a). <sup>1</sup> Dates in MM-YYYY format are publication dates. <sup>2</sup> Classifications may be U.S. or foreign.



#18

SHEET 1 OF 2

FORM PTO-1449 U.S. DEPARTMENT OF COMMERCE PATENT AND TRADEMARK OFFICE  INFORMATION DISCLOSURE STATEMENT (Use several sheets if necessary)	ATTY. DOCKET NO. 1003-1	SERIAL NO. 09/770,838
	APPLICANT DUPRAY et al.	
	FILING DATE January 26, 2001	GROUP ART 3662

U.S. PATENT DOCUMENTS

*EXAMINER INITIAL		DOCUMENT NUMBER	DATE	NAME	CLASS	SUB CLASS	FILING DATE IF APPROP.
DP ↑	1	6,324,404	11/27/2001	Dennison et al.	455	456	
	2	6,321,092	11/20/2001	Fitch et al.	455	456	
	3	6,249,245	6/19/2001	Watters et al.	342	357.03	
	4	6,034,635	3/7/2000	Gilhousen	342	457	
	5	5,966,658	10/12/1999	Kennedy, III et al.	455	426	
	6	5,903,844	5/11/1999	Bruckert et al.	455	456	
	7	5,864,755	1/26/1999	King et al.	455	404	
	8	5,774,869	6/30/1998	Toader	705	10	
	9	5,732,074	3/24/1998	Spaur et al.	370	313	
	10	5,710,758	1/20/1998	Soliman et al.	370	241	
	11	5,675,344	10/7/1997	Tong et al.	342	457	
	12	5,611,704	3/18/1997	Kamizono et al.	439	164	
	13	5,600,705	2/4/1997	Maenpaa	379	58	
	14	5,555,257	9/10/1996	Dent	370	95.1	
	15	5,395,366	3/7/1995	D'Andrea et al.	604	890.1	
DP	16	5,111,209	5/5/1992	Toriyama	342	357	

RECEIVED  
 DEC 16 2002  
 GROUP 3600

EXAMINER <i>Duo</i>	DATE CONSIDERED <i>3/6/03</i>
*EXAMINER: Initial if reference considered, whether or not citation is in conformance with MPEP 609; Draw line through citation if not in conformance and not considered. Include copy of this form with next communication to applicant.	

E:\TRACBEAM\patent applications\1003\US (1003&continuations)\1\pto\1449\IDS-05-1449.wpd



FORM PTO-1449 U.S. DEPARTMENT OF COMMERCE PATENT AND TRADEMARK OFFICE  INFORMATION DISCLOSURE STATEMENT (Use several sheets if necessary)	ATTY. DOCKET NO. 1003-1	SERIAL NO. 09/770,838
	APPLICANT DUPRAY et al.	
	FILING DATE January 26, 2001	GROUP ART 3662

FOREIGN PATENT DOCUMENTS

		DOCUMENT NUMBER	DATE	COUNTRY	CLASS	SUB CLASS	TRANSLATION	
							YES	NO
DP	17	WO 01/95642	Dec. 13, 2001	PCT	H04Q	—		
DP	18	WO 98/10307	Mar. 12, 1998	PCT	G01S	3/02		
DP	19	WO 97/01228	Jan. 9, 1997	PCT	H04B	7/28		
DP	20	WO 96/14588	17/5/1996	PCT	G01S	5/02		

OTHER ART (Including Author, Title, Date, Pertinent Pages, etc.)

DP	21	Rizzo et al.; "Integration of Location Services in the Open Distributed Office"; <i>Technical Report 14-94, Computing Laboratory, University of Kent, Canterbury, United Kingdom</i> ; August 1994; pgs. 1-14
↑	22	Caffery, J. and Stüüber, G. L., "Vehicle Location and Tracking for IVHS in CDMA Microcells," <i>International Symposium on Personal, Indoor, and Mobile Radio Communications</i> , pp. 1227-1231, September 1994.
↑	23	Caffery et al.; "Radio Location in Urban CDMA Microcells"; <i>International Symposium on Personal, Indoor, and Mobil Radio Communications</i> , September 1995; 5 pgs.
↑	24	Beck et al.; "Simulation Results on the Downlink of a Qualcomm-like DS-CDMA-System Over Multipath fading channels"; September 1994 pgs. 1-7
↑	25	Pop et al.; "Site Engineering for Indoor Wireless Spread Spectrum Communications"; June 2001; 3 pgs.
↑	26	Caffery et al.; "Overview of Radiolocation in CDMA Cellular Systems"; <i>IEEE Communications Magazine</i> ; April 1998; pgs. 38-45
↑	27	Salcic; "AGPCS - An Automatic GSM-based Positioning and Communication System" <i>Proceedings of GeoComputation 1997 &amp; SIRC 1997</i> ; August, 1997; pgs. 15-22
DP	28	Ramanathan et al.; "A Survey of Routing Techniques for Mobile Communications Networks"; <i>Mobile Networks and Applications</i> ; October 1996; Vol. 1(2); pgs. 1-31

EXAMINER <i>DW</i>	DATE CONSIDERED <i>3/6/03</i>
*EXAMINER: Initial if reference considered, whether or not citation is in conformance with MPEP 609; Draw line through citation if not in conformance and not considered. Include copy of this form with next communication to applicant.	

E:\TRACBEAM\patent applications\1003\US (1003&continuations)\1\pto\1449\DS-05-1449.wpd

RECEIVED  
 DEC 16 2002  
 GROUP 3600



26-05-07  
 REQUEST FOR CONTINUED EXAMINATION (RCE) TRANSMITTAL  
 Address to:  
 Commissioner for Patents  
 Mail Stop RCE  
 P.O. Box 1450  
 Alexandria, VA 22313-1450

Receipts  
 copy of paper #24

Application Number	09/770,838
Filing Date	January 26, 2001
First Named Inventor	Dupray
Examiner Name	Dao L. Phan
Attorney Docket Number	1003-1

This is a Request for Continued Examination (RCE) under 37 C.F.R. §1.114 of the above-identified application.

1. Submission required under 37 C.F.R. § 1.114

- a.  Previously submitted:
  - i.  Consider the amendment(s)/reply under 37 C.F.R. § 1.116 previously filed on \_\_\_\_\_ (Any unentered amendment(s) referred to above will be entered).
  - ii.  Consider the arguments in the Appeal Brief or Reply Brief previously filed on \_\_\_\_\_.
  - iii.  Other \_\_\_\_\_
- b.  Enclosed:
  - i.  Amendment/Reply
  - ii.  Affidavit(s)/Declaration(s)
  - iii.  Information Disclosure statement (IDS)
  - iv.  Other \_\_\_\_\_

**RECEIVED**  
 JUN 11 2003  
 GROUP 3600

2. Miscellaneous

- a.  Suspension of action on the above-identified application is requested under 37 C.F.R. § 1.103(c) for a period of \_\_\_\_\_ months. (Period of suspension shall not exceed 3 months; Fee under 37 C.F.R. § 1.17(l) required).
- b.  Other \_\_\_\_\_

3. Fees

- a.  The Director is hereby authorized to charge the following fees, or credit any overpayments, to Deposit Account No. \_\_\_\_\_
  - i.  RCE fee required under 37 C.F.R. § 1.17(e)
  - ii.  Extension of time fee (37 C.F.R. §§ 1.138 and 1.17)
  - iii.  Other \_\_\_\_\_
- b.  Check in the amount of \$375.00 enclosed
- c.  Payment by credit card (Form PTO-2038 enclosed).

"EXPRESS MAIL" MAILING LABEL NUMBER: EV331283733US  
 DATE OF DEPOSIT: June 6, 2003

RESPECTFULLY SUBMITTED,

SHERIDAN ROSS P.C.

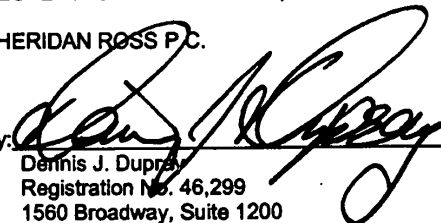
By:   
 Dennis J. Dupray  
 Registration No. 46,299  
 1560 Broadway, Suite 1200  
 Denver, Colorado 80202-5141  
 Phone: (303) 863-9700  
 Facsimile: (303) 863-0223

I HEREBY CERTIFY THAT THIS PAPER OR FEE IS BEING DEPOSITED WITH THE UNITED STATES POSTAL SERVICE "EXPRESS MAIL POST OFFICE TO ADDRESSEE" SERVICE UNDER 37 CFR 1.10 ON THE DATE INDICATED ABOVE AND IS ADDRESSED TO THE COMMISSIONER FOR PATENTS, P.O. BOX 1450, ALEXANDRIA, VIRGINIA 22313-1450.

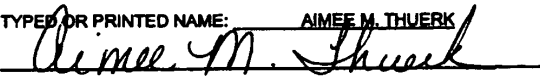
TYPE OR PRINTED NAME: AIMEE M. THUERK  

**Match and Return**

06/09/2003 CNSUYEN 00000152 09770838  
 01 FC:2801 375.00 DP



IN THE UNITED STATES PATENT AND TRADEMARK OFFICE

3600  
23  
HDS  
Bates  
7/22

In Re the Application of:

Dupray et al.

Serial No.: 09/770,838

Filed: January 26, 2001

Atty. File No.: 1003-1

For: A GATEWAY AND HYBRID  
SOLUTIONS FOR WIRELESS  
LOCATION

) Group Art Unit: 3662

) Examiner: Dao L. Phan

) INFORMATION DISCLOSURE STATEMENT

) "EXPRESS MAIL" MAILING LABEL NUMBER: EV331283733US  
) DATE OF DEPOSIT: June 3, 2003

) I HEREBY CERTIFY THAT THIS PAPER OR FEE IS BEING DEPOSITED  
) WITH THE UNITED STATES POSTAL SERVICE "EXPRESS MAIL POST  
) OFFICE TO ADDRESSEE" SERVICE UNDER 37 CFR 1.10 ON THE DATE  
) INDICATED ABOVE AND IS ADDRESSED TO THE COMMISSIONER  
) FOR PATENTS, P.O. BOX 1450, ALEXANDRIA, VIRGINIA 22313-1450.

) TYPED OR PRINTED NAME: AIMEE M. THUERK

) SIGNATURE: Aimee M. Thuerk

Commissioner for Patents  
P.O. Box 1450  
Alexandria, Virginia 22313-1450

Dear Sir:

The references cited on attached Form PTO-1449 are being called to the attention of the Examiner. Copies of the cited references:

- Are enclosed herewith.
- Are not enclosed, in accordance with 37 C.F.R. 1.98(d), because the references

were submitted to the U.S. Patent and Trademark Office in prior application Serial No. 09/194,367 filed November 24, 1998, which is relied upon for an earlier filing date under 35 U.S.C. § 120.

To the best of applicants' belief, the pertinence of the foreign-language references is believed to be summarized in the attached English abstracts and in the figures, although applicants do not necessarily vouch for the accuracy of the translation.

Examiner's attention is drawn to the following co-pending applications, copies of which have been or are being submitted:

- Serial No. 09/194,367 filed November 24, 1998
- Serial No. 09/770,838 filed January 26, 2001
- Serial No. 10/262,413 filed September 30, 2002
- Serial No. 10/262,338 filed September 30, 2002
- Serial No. 09/176,587 filed October 21, 1998

Other: \_\_\_\_\_

RECEIVED  
JUN 11 2003  
GROUP 3600

Match & Return

03-03

Submission of the above information is not intended as an admission that any item is citable under the statutes or rules to support a rejection, that any item disclosed represents analogous art, or that those skilled in the art would refer to or recognize the pertinence of any reference without the benefit of hindsight, nor should an inference be drawn as to the pertinence of the references based on the order in which they are presented. Submission of this statement should not be taken as an indication that a search has been conducted, or that no better art exists.

It is respectfully requested that the cited information be expressly considered during the prosecution of this application and the references made of record therein.

FEEs

<input checked="" type="checkbox"/>	<p>37 CFR 1.97(b): No fee is believed due in connection with this submission, because the information disclosure statement submitted herewith is satisfies one of the following conditions ("X" indicates satisfaction):</p> <ul style="list-style-type: none"> <li><input type="checkbox"/> Within three months of the filing date of a national application other than a continued prosecution application under 37 CFR 1.53(d), or</li> <li><input type="checkbox"/> Within three months of the date of entry into the national stage of an international application as set forth in 37 CFR 1.491 or</li> <li><input type="checkbox"/> Before the mailing date of a first Office Action on the merits, or</li> <li><input checked="" type="checkbox"/> Before the mailing of a first Office action after the filing of a request for continued examination under 37 CFR 1.114.</li> </ul> <p>Although no fee is believed due, if any fee is deemed due in connection with this submission, please charge such fee to Deposit Account 19-1970.</p>
<input type="checkbox"/>	<p>37 CFR 1.97(c): The information disclosure statement transmitted herewith is being filed after all the above conditions (37 CFR 1.97(b)), but before the mailing date of one of the following conditions:</p> <ul style="list-style-type: none"> <li>(1) a final action under 37 C.F.R. 1.113 or</li> <li>(2) a notice of allowance under 37 C.F.R. 1.311, or</li> <li>(3) an action that otherwise closes prosecution in the application.</li> </ul> <p>This Information Disclosure Statement is accompanied by:</p> <ul style="list-style-type: none"> <li><input type="checkbox"/> A Certification (below) as specified by 37 C.F.R. 1.97(e). Although no fee is believed due, if any fee is deemed due in connection with this submission, please charge such fee to Deposit Account 19-1970.</li> </ul> <p style="text-align: center;">OR</p> <ul style="list-style-type: none"> <li><input type="checkbox"/> A check in the amount of \$180.00 for the fee set forth in 37 C.F.R. 1.17(p) for submission of an information disclosure statement. Please credit any overpayment or charge any underpayment to Deposit Account No. 19-1970. Election to pay the fee should not be taken as an indication that applicant(s) cannot execute a certification.</li> </ul>
<input type="checkbox"/>	<p>37 CFR 1.97(d): This Information Disclosure Statement is being submitted after the period specified in 37 CFR 1.97(c).</p> <ul style="list-style-type: none"> <li><input type="checkbox"/> This information Disclosure Statement includes a Certification (below) as specified by 37 C.F.R. 1.97(e)</li> </ul> <p style="text-align: center;">AND</p> <ul style="list-style-type: none"> <li><input type="checkbox"/> Applicants hereby requests consideration of the reference(s) disclosed herein. Enclosed is the fee in the amount of \$180.00 under 37 C.F.R. 1.17(p). Please credit any overpayment or charge any underpayment to Deposit Account No. 19-1970.</li> </ul>



**Certification (37 C.F.R. 1.97(e))**  
(Applicable only if checked)

The undersigned certifies that:

Each item of information contained in this information disclosure statement was first cited in any communication from a foreign patent office in a counterpart foreign application not more than three months prior to the filing of this statement. 37 C.F.R. 1.97(e)(1).

A copy of the communication from the foreign patent office is enclosed.

OR

No item of information contained in this information disclosure statement was cited in a communication from a foreign patent office in a counterpart foreign application, and, to the knowledge of the undersigned after making reasonable inquiry, no item of information contained in this Information Disclosure Statement was known to any individual designated in 37 C.F.R. 1.56(c) more than more than three months prior to the filing of this statement. 37 C.F.R. 1.97(e)(2).

Respectfully submitted,

SHERIDAN ROSS P.C.

By: 

Dennis J. Dupray  
Registration No. 46,299  
1560 Broadway, Suite 1200  
Denver, Colorado 80202-5141  
(303) 863-9700

Date: June 6, 2003



175 Match & Return 6-19-03

GP 3662  
re

IN THE UNITED STATES PATENT AND TRADEMARK OFFICE

In Re the Application of:

Dupray et al.

Serial No.: 09/770,838

Filed: January 26, 2001

Atty. File No.: 1003-1

For: A GATEWAY AND HYBRID  
SOLUTIONS FOR WIRELESS  
LOCATION

) Group Art Unit: 3662

) Examiner: Dao L. Phan

) INFORMATION DISCLOSURE STATEMENT

) "EXPRESS MAIL" MAILING LABEL NUMBER: EV331284946US  
) DATE OF DEPOSIT: June 17, 2003

) I HEREBY CERTIFY THAT THIS PAPER OR FEE IS BEING DEPOSITED  
) WITH THE UNITED STATES POSTAL SERVICE "EXPRESS MAIL POST  
) OFFICE TO ADDRESSEE" SERVICE UNDER 37 CFR 1.10 ON THE DATE  
) INDICATED ABOVE AND IS ADDRESSED TO THE COMMISSIONER  
) FOR PATENTS, P.O. BOX 1450, ALEXANDRIA, VIRGINIA 22313-1450.

) TYPED OR PRINTED NAME: AIMEE M. THUERK

SIGNATURE: *Aimee M Thuerk*

Commissioner for Patents  
P.O. Box 1450  
Alexandria, Virginia 22313-1450

Dear Sir:

The references cited on attached Form PTO-1449 are being called to the attention of the Examiner. Copies of the cited references:

Are enclosed herewith.

Are not enclosed, in accordance with 37 C.F.R. 1.98(d), because the references were submitted to the U.S. Patent and Trademark Office in prior application Serial No. 09/194,367 filed November 24, 1998, which is relied upon for an earlier filing date under 35 U.S.C. § 120.

To the best of applicants' belief, the pertinence of the foreign-language references is believed to be summarized in the attached English abstracts and in the figures, although applicants do not necessarily vouch for the accuracy of the translation.

Examiner's attention is drawn to the following co-pending applications, copies of which have been or are being submitted:

- Serial No. 09/194,367 filed November 24, 1998
- Serial No. 10/262,413 filed September 30, 2002
- Serial No. 10/262,338 filed September 30, 2002
- Serial No. 09/176,587 filed October 21, 1998
- Serial No. 10/297,449 filed December 5, 2002
- Serial No. 10/337,807 filed January 6, 2003

**RECEIVED**  
JUN 20 2003  
**GROUP 3600**

Submission of the above information is not intended as an admission that any item is citable under the statutes or rules to support a rejection, that any item disclosed represents analogous art, or that those skilled in the art would refer to or recognize the pertinence of any reference without the benefit of hindsight, nor should an inference be drawn as to the pertinence of the references based on the order in which they are presented. Submission of this statement should not be taken as an indication that a search has been conducted, or that no better art exists.

It is respectfully requested that the cited information be expressly considered during the prosecution of this application and the references made of record therein.

**FEES**

<input checked="" type="checkbox"/>	<p><b>37 CFR 1.97(b):</b> No fee is believed due in connection with this submission, because the information disclosure statement submitted herewith is satisfies one of the following conditions ("X" indicates satisfaction):</p> <ul style="list-style-type: none"> <li><input type="checkbox"/> Within three months of the filing date of a national application other than a continued prosecution application under 37 CFR 1.53(d), or</li> <li><input type="checkbox"/> Within three months of the date of entry into the national stage of an international application as set forth in 37 CFR 1.491 or</li> <li><input type="checkbox"/> Before the mailing date of a first Office Action on the merits, or</li> <li><input checked="" type="checkbox"/> Before the mailing of a first Office action after the filing of a request for continued examination under 37 CFR 1.114.</li> </ul> <p>Although no fee is believed due, if any fee is deemed due in connection with this submission, please charge such fee to Deposit Account 19-1970.</p>
<input type="checkbox"/>	<p><b>37 CFR 1.97(c):</b> The information disclosure statement transmitted herewith is being filed after all the above conditions (37 CFR 1.97(b)), but before the mailing date of one of the following conditions:</p> <ul style="list-style-type: none"> <li>(1) a final action under 37 C.F.R. 1.113 or</li> <li>(2) a notice of allowance under 37 C.F.R. 1.311, or</li> <li>(3) an action that otherwise closes prosecution in the application.</li> </ul> <p>This Information Disclosure Statement is accompanied by:</p> <ul style="list-style-type: none"> <li><input type="checkbox"/> A Certification (below) as specified by 37 C.F.R. 1.97(e). Although no fee is believed due, if any fee is deemed due in connection with this submission, please charge such fee to Deposit Account 19-1970.</li> </ul> <p style="text-align: center;">OR</p> <ul style="list-style-type: none"> <li><input type="checkbox"/> A check in the amount of \$180.00 for the fee set forth in 37 C.F.R. 1.17(p) for submission of an information disclosure statement. Please credit any overpayment or charge any underpayment to Deposit Account No. 19-1970. Election to pay the fee should not be taken as an indication that applicant(s) cannot execute a certification.</li> </ul>
<input type="checkbox"/>	<p><b>37 CFR 1.97(d):</b> This Information Disclosure Statement is being submitted after the period specified in 37 CFR 1.97(c).</p> <ul style="list-style-type: none"> <li><input type="checkbox"/> This information Disclosure Statement includes a Certification (below) as specified by 37 C.F.R. 1.97(e)</li> </ul> <p style="text-align: center;">AND</p> <ul style="list-style-type: none"> <li><input type="checkbox"/> Applicants hereby requests consideration of the reference(s) disclosed herein. Enclosed is the fee in the amount of \$180.00 under 37 C.F.R. 1.17(p). Please credit any overpayment or charge any underpayment to Deposit Account No. 19-1970.</li> </ul>



Certification (37 C.F.R. 1.97(e))  
(Applicable only if checked)

The undersigned certifies that:

Each item of information contained in this information disclosure statement was first cited in any communication from a foreign patent office in a counterpart foreign application not more than three months prior to the filing of this statement. 37 C.F.R. 1.97(e)(1).

A copy of the communication from the foreign patent office is enclosed.

OR

No item of information contained in this information disclosure statement was cited in a communication from a foreign patent office in a counterpart foreign application, and, to the knowledge of the undersigned after making reasonable inquiry, no item of information contained in this Information Disclosure Statement was known to any individual designated in 37 C.F.R. 1.56(c) more than more than three months prior to the filing of this statement. 37 C.F.R. 1.97(e)(2).

Respectfully submitted,

SHERIDAN ROSS P.C.

By: 

Dennis J. Depray  
Registration No. 46,299  
1560 Broadway, Suite 1200  
Denver, Colorado 80202-5141  
(303) 863-9700

Date: 

RECEIVED  
JUN 20 2003  
GROUP 3600

3714

24  
RCE

DAVID F. ZINGER  
TODD P. BLAKELY  
GARY J. CONNELL  
SABRINA C. STAVISH  
JOSEPH B. KOVARIK  
SUSAN FRYOR WILLSON  
LEWIS D. HANSEN  
ROBERT R. BRUNELLI  
DOUGLAS W. SWARTZ  
BRUCE A. KUGLER  
BRENT P. JOHNSON  
DANA HARTIG CARDWELL  
BENJAMIN B. LIEB  
BRADLEY M. KNEPPER  
MELIAM DRICKMAN TRUDELL  
SCOTT R. BIALECKI  
KENNETH C. WINTERTON  
ROBERT D. TRAYER, Ph.D.  
CHRISTOPHER J. HUSSIN  
MARK L. YASKANIN

**SHERIDAN ROSS**  
*A Professional Corporation*  
ATTORNEYS AND COUNSELORS AT LAW

1560 BROADWAY  
SUITE 1200  
DENVER, COLORADO 80202-5141

TELEPHONE (303) 863-9700  
FACSIMILE (303) 863-0223  
E-MAIL [srtr@sheridanross.com](mailto:srtr@sheridanross.com)

PATENTS  
TRADEMARKS  
COPYRIGHTS

KERMIT F. ROSS  
1910-1986

OF COUNSEL  
PHILIP H. SHERIDAN  
CHAO C. GROSETH

TECHNICAL SPECIALISTS  
DENNIS J. DUFFRAY, Ph.D.  
ANGELA E. DALLAS, Ph.D.  
CRAIG W. MUELLER

July 28, 2003

FACSIMILE COVER SHEET

Please deliver the following page(s) to:

Name: Thomas Tarza  
U.S. Patent and Trademark Office

Facsimile Number: (703) 305-7658

Our File No. 1003-1

Serial No.: 09/770,838 ✓

Total Number of Pages, including this cover page: 3

Sender's Name: Dennis J. Dupray

Comments:

PLEASE CONFIRM RECEIPT

If you do not receive all the pages. please call Aimee at (303) 863-9700

THIS FACSIMILE MESSAGE IS CONFIDENTIAL AND MAY CONTAIN ATTORNEY PRIVILEGED INFORMATION INTENDED ONLY FOR THE USE OF THE INDIVIDUAL OR COMPANY NAMED ABOVE. If the reader is not the intended recipient, or the employee or agent responsible to deliver it to the intended recipient, you are hereby notified that any dissemination, distribution or copying of this communication is strictly prohibited. If you have received this communication in error, please immediately notify us by telephone, so that we may arrange for the return of the original message to us. Thank you.

OFFICIAL  
FAX RECEIVED  
JUL 31 2003  
GROUP 3600

(MON) 07.28.03 11:55/ST. 11:55/NO. 3561683903 P 1

FROM

REQUEST FOR CONTINUED EXAMINATION (RCE) TRANSMITTAL

Address to:  
 Commissioner for Patents  
 Mail Stop RCE  
 P.O. Box 1450  
 Alexandria, VA 22313-1450

Application Number	09/770,838
Filing Date	January 26, 2001
First Named Inventor	Dupray
Examiner Name	Dao L. Phan
Attorney Docket Number	1003-1

This is a Request for Continued Examination (RCE) under 37 C.F.R. §1.114 of the above-identified application.

1. Submission required under 37 C.F.R. § 1.114

- a.  Previously submitted:
  - i.  Consider the amendment(s)/reply under 37 C.F.R. § 1.116 previously filed on \_\_\_\_\_ (Any unentered amendment(s) referred to above will be entered).
  - ii.  Consider the arguments in the Appeal Brief or Reply Brief previously filed on \_\_\_\_\_.
  - iii.  Other \_\_\_\_\_
- b.  Enclosed:
  - i.  Amendment/Reply
  - ii.  Affidavit(s)/Declaration(s)
  - iii.  Information Disclosure statement (IDS)
  - iv.  Other \_\_\_\_\_

2. Miscellaneous

- a.  Suspension of action on the above-identified application is requested under 37 C.F.R. § 1.103(c) for a period of \_\_\_\_\_ months. (Period of suspension shall not exceed 3 months; Fee under 37 C.F.R. § 1.17(l) required).
- b.  Other \_\_\_\_\_

3. Fees

- a.  The Director is hereby authorized to charge the following fees, or credit any overpayments, to Deposit Account No. \_\_\_\_\_
  - i.  RCE fee required under 37 C.F.R. § 1.17(e)
  - ii.  Extension of time fee (37 C.F.R. §§ 1.136 and 1.17)
  - iii.  Other \_\_\_\_\_
- b.  Check in the amount of \$375.00 enclosed
- c.  Payment by credit card (Form PTO-2038 enclosed).

"EXPRESS MAIL" MAILING LABEL NUMBER: EV331283/33US  
 DATE OF DEPOSIT: June 6, 2003

RESPECTFULLY SUBMITTED,

SHERIDAN ROSS P.C.

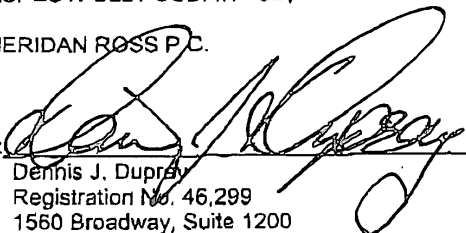
By:   
 Dennis J. Dupray  
 Registration No. 46,299  
 1560 Broadway, Suite 1200  
 Denver, Colorado 80202-5141  
 Phone: (303) 863-9700  
 Facsimile: (303) 863-0223

I HEREBY CERTIFY THAT THIS PAPER OR FEE IS BEING DEPOSITED WITH THE UNITED STATES POSTAL SERVICE "EXPRESS MAIL POST OFFICE TO ADDRESSEE" SERVICE UNDER 37 CFR 1.10 ON THE DATE INDICATED ABOVE AND IS ADDRESSED TO THE COMMISSIONER FOR PATENTS, P.O. BOX 1450, ALEXANDRIA, VIRGINIA 22313-1450.

TYPED OR PRINTED NAME: AIMEE M. THUERK

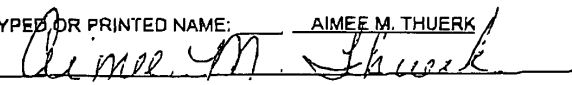

FAX RECEIVED

JUL 31 2003

GROUP 3600

(MON) 07.28.03 11:56/ST. 11:55/NO. 35616889903 P 2

FROM

Initial: AMT

Date: June 6, 2003

PTO Stamp indicates receipt of:

Patent Matter  Trademark Matter

Application Docket No.: 1003-1

Applicant: DUPRAY

Title or Mark: A GATEWAY AND HYBRID SOLUTIONS FOR WIRELESS LOCATION

Filing Date: January 26, 2001

Serial No.: 09/770,838

Certificate of Mailing

Express Mail No.: EV331283733



\_\_\_\_ No. of Pages in Specification

\_\_\_\_ No. of Pages in Claims

\_\_\_\_ No. of Sheets of Drawings

Check \$375.00

LIST ALL DOCUMENTS BEING SENT TO TRADEMARK OFFICE:

REQUEST FOR CONTINUED EXAMINATION; INFORMATION DISCLOSURE STATEMENT; PTO FORM 1449

JUN 16 2003

SHERIDAN, ROSS



Customer Copy Label 71-F June 2002

Post Office To Addressee

ORIGIN (POSTAL USE ONLY)				DELIVERY (POSTAL USE ONLY)			
PO ZIP Code 80302	Day of Delivery 8/1/03	Flat Rate Envelope <input type="checkbox"/> None <input checked="" type="checkbox"/> Standard		Delivery Attempt	Time <input type="checkbox"/> AM <input type="checkbox"/> PM	Employee Signature	
Date In 6-6-03	Mo. Day Year 6 6 03	Postage \$ 136.5	Return Receipt Fee	Delivery Attempt	Time <input type="checkbox"/> AM <input type="checkbox"/> PM	Employee Signature	
Time In 14:55	Military <input type="checkbox"/> 1st Day <input type="checkbox"/> 2nd Day <input type="checkbox"/> 3rd Day	Int'l Alpha Country Code	COO Fee Insurance Fee	Mo. Day 6 6	Time <input type="checkbox"/> AM <input type="checkbox"/> PM	Employee Signature	
Weight 3 lbs 7oz	Acceptance Clerk Initials [Signature]	Total Postage & Fees \$ 136.5		<input type="checkbox"/> DELIVERED <input type="checkbox"/> NOT DELIVERED <input type="checkbox"/> RETURN TO SENDER <input type="checkbox"/> OTHER			
CUSTOMER USE ONLY METHOD OF PAYMENT Express Mail Collection Acct. No.				Federal Agency Acct. No. of Postal Service Acct. No.			
FROM: (PLEASE PRINT) PHONE: _____ SHERIDAN, ROSS PC 1500 BROADWAY STE 1200 DENVER, CO 80202-3145				TO: (PLEASE PRINT) PHONE: _____ COMMISSIONER FOR PATENTS P.O. BOX 400 ALEXANDRIA VA 22304-0400			
1003-1 (AMT)							

(MON) 07.28.03 11:55/ST. 11:55/NO. 3561683903 P 3

FROM



UNITED STATES PATENT AND TRADEMARK OFFICE

UNITED STATES DEPARTMENT OF COMMERCE
United States Patent and Trademark Office
Address: COMMISSIONER FOR PATENTS
P.O. Box 1450
Alexandria, Virginia 22313-1450
www.uspto.gov

NOTICE OF ALLOWANCE AND FEE(S) DUE

7590 08/27/2003
Dennis J. Dupray, Ph.D.
1801 Belvedere Street
Golden, CO 80401

EXAMINER

PHAN, DAO LINDA

ART UNIT CLASS-SUBCLASS

3662 342-450000

DATE MAILED: 08/27/2003

Table with 5 columns: APPLICATION NO., FILING DATE, FIRST NAMED INVENTOR, ATTORNEY DOCKET NO., CONFIRMATION NO.
09/770,838 01/26/2001 Dennis J. Dupray 1003-1 8410

TITLE OF INVENTION: A GATEWAY AND HYBRID SOLUTIONS FOR WIRELESS LOCATION

Table with 6 columns: APPLN. TYPE, SMALL ENTITY, ISSUE FEE, PUBLICATION FEE, TOTAL FEE(S) DUE, DATE DUE
nonprovisional YES \$650 \$300 \$950 11/28/2003

THE APPLICATION IDENTIFIED ABOVE HAS BEEN EXAMINED AND IS ALLOWED FOR ISSUANCE AS A PATENT. PROSECUTION ON THE MERITS IS CLOSED. THIS NOTICE OF ALLOWANCE IS NOT A GRANT OF PATENT RIGHTS. THIS APPLICATION IS SUBJECT TO WITHDRAWAL FROM ISSUE AT THE INITIATIVE OF THE OFFICE OR UPON PETITION BY THE APPLICANT. SEE 37 CFR 1.313 AND MPEP 1308.

THE ISSUE FEE AND PUBLICATION FEE (IF REQUIRED) MUST BE PAID WITHIN THREE MONTHS FROM THE MAILING DATE OF THIS NOTICE OR THIS APPLICATION SHALL BE REGARDED AS ABANDONED. THIS STATUTORY PERIOD CANNOT BE EXTENDED. SEE 35 U.S.C. 151. THE ISSUE FEE DUE INDICATED ABOVE REFLECTS A CREDIT FOR ANY PREVIOUSLY PAID ISSUE FEE APPLIED IN THIS APPLICATION. THE PTOL-85B (OR AN EQUIVALENT) MUST BE RETURNED WITHIN THIS PERIOD EVEN IF NO FEE IS DUE OR THE APPLICATION WILL BE REGARDED AS ABANDONED.

HOW TO REPLY TO THIS NOTICE:

I. Review the SMALL ENTITY status shown above.

If the SMALL ENTITY is shown as YES, verify your current SMALL ENTITY status:

A. If the status is the same, pay the TOTAL FEE(S) DUE shown above.

B. If the status is changed, pay the PUBLICATION FEE (if required) and twice the amount of the ISSUE FEE shown above and notify the United States Patent and Trademark Office of the change in status, or

If the SMALL ENTITY is shown as NO:

A. Pay TOTAL FEE(S) DUE shown above, or

B. If applicant claimed SMALL ENTITY status before, or is now claiming SMALL ENTITY status, check the box below and enclose the PUBLICATION FEE and 1/2 the ISSUE FEE shown above.

[ ] Applicant claims SMALL ENTITY status. See 37 CFR 1.27.

II. PART B - FEE(S) TRANSMITTAL should be completed and returned to the United States Patent and Trademark Office (USPTO) with your ISSUE FEE and PUBLICATION FEE (if required). Even if the fee(s) have already been paid, Part B - Fee(s) Transmittal should be completed and returned. If you are charging the fee(s) to your deposit account, section "4b" of Part B - Fee(s) Transmittal should be completed and an extra copy of the form should be submitted.

III. All communications regarding this application must give the application number. Please direct all communications prior to issuance to Mail Stop ISSUE FEE unless advised to the contrary.

IMPORTANT REMINDER: Utility patents issuing on applications filed on or after Dec. 12, 1980 may require payment of maintenance fees. It is patentee's responsibility to ensure timely payment of maintenance fees when due.



**PART B - FEE(S) TRANSMITTAL**

**Complete and send this form, together with applicable fee(s), to: Mail Mail Stop ISSUE FEE  
Commissioner for Patents  
Alexandria, Virginia 22313-1450  
or Fax (703) 746-4000**

**INSTRUCTIONS:** This form should be used for transmitting the ISSUE FEE and PUBLICATION FEE (if required). Blocks 1 through 4 should be completed where appropriate. All further correspondence including the Patent, advance orders and notification of maintenance fees will be mailed to the current correspondence address as indicated unless corrected below or directed otherwise in Block 1, by (a) specifying a new correspondence address; and/or (b) indicating a separate "FEE ADDRESS" for maintenance fee notifications.

CURRENT CORRESPONDENCE ADDRESS (Note: Legibly mark-up with any corrections or use Block 1)  
7590 08/27/2003

Dennis J. Dupray, Ph.D.  
1801 Belvedere Street  
Golden, CO 80401

Note: A certificate of mailing can only be used for domestic mailings of the Fee(s) Transmittal. This certificate cannot be used for any other accompanying papers. Each additional paper, such as an assignment or formal drawing, must have its own certificate of mailing or transmission.

**Certificate of Mailing or Transmission**

I hereby certify that this Fee(s) Transmittal is being deposited with the United States Postal Service with sufficient postage for first class mail in an envelope addressed to the Mail Stop ISSUE FEE address above, or being facsimile transmitted to the USPTO, on the date indicated below.

_____ (Depositor's name)
_____ (Signature)
_____ (Date)

APPLICATION NO.	FILING DATE	FIRST NAMED INVENTOR	ATTORNEY DOCKET NO.	CONFIRMATION NO.
09/770,838	01/26/2001	Dennis J. Dupray	1003-1	8410

TITLE OF INVENTION: A GATEWAY AND HYBRID SOLUTIONS FOR WIRELESS LOCATION

APPLN. TYPE	SMALL ENTITY	ISSUE FEE	PUBLICATION FEE	TOTAL FEE(S) DUE	DATE DUE
nonprovisional	YES	\$650	\$300	\$950	11/28/2003

EXAMINER	ART UNIT	CLASS-SUBCLASS
PHAN, DAO LINDA	3662	342-450000

1. Change of correspondence address or indication of "Fee Address" (37 CFR 1.363).

Change of correspondence address (or Change of Correspondence Address form PTO/SB/122) attached.

"Fee Address" indication (or "Fee Address" Indication form PTO/SB/47; Rev 03-02 or more recent) attached. Use of a Customer Number is required.

2. For printing on the patent front page, list (1) the names of up to 3 registered patent attorneys or agents OR, alternatively, (2) the name of a single firm (having as a member a registered attorney or agent) and the names of up to 2 registered patent attorneys or agents. If no name is listed, no name will be printed.

1 \_\_\_\_\_

2 \_\_\_\_\_

3 \_\_\_\_\_

3. ASSIGNEE NAME AND RESIDENCE DATA TO BE PRINTED ON THE PATENT (print or type)

PLEASE NOTE: Unless an assignee is identified below, no assignee data will appear on the patent. Inclusion of assignee data is only appropriate when an assignment has been previously submitted to the USPTO or is being submitted under separate cover. Completion of this form is NOT a substitute for filing an assignment.

(A) NAME OF ASSIGNEE \_\_\_\_\_ (B) RESIDENCE: (CITY and STATE OR COUNTRY) \_\_\_\_\_

Please check the appropriate assignee category or categories (will not be printed on the patent);  individual  corporation or other private group entity  government

4a. The following fee(s) are enclosed:

Issue Fee

Publication Fee

Advance Order - # of Copies \_\_\_\_\_

4b. Payment of Fee(s):

A check in the amount of the fee(s) is enclosed.

Payment by credit card. Form PTO-2038 is attached.

The Director is hereby authorized by charge the required fee(s), or credit any overpayment, to Deposit Account Number \_\_\_\_\_ (enclose an extra copy of this form).

Director for Patents is requested to apply the Issue Fee and Publication Fee (if any) or to re-apply any previously paid issue fee to the application identified above.

(Authorized Signature) \_\_\_\_\_ (Date) \_\_\_\_\_

NOTE: The Issue Fee and Publication Fee (if required) will not be accepted from anyone other than the applicant; a registered attorney or agent; or the assignee or other party in interest as shown by the records of the United States Patent and Trademark Office.

This collection of information is required by 37 CFR 1.311. The information is required to obtain or retain a benefit by the public which is to file (and by the USPTO to process) an application. Confidentiality is governed by 35 U.S.C. 122 and 37 CFR 1.14. This collection is estimated to take 12 minutes to complete, including gathering, preparing, and submitting the completed application form to the USPTO. Time will vary depending upon the individual case. Any comments on the amount of time you require to complete this form and/or suggestions for reducing this burden, should be sent to the Chief Information Officer, U.S. Patent and Trademark Office, U.S. Department of Commerce, Alexandria, Virginia 22313-1450. DO NOT SEND FEES OR COMPLETED FORMS TO THIS ADDRESS. SEND TO: Commissioner for Patents, Alexandria, Virginia 22313-1450.

Under the Paperwork Reduction Act of 1995, no persons are required to respond to a collection of information unless it displays a valid OMB control number.

TRANSMIT THIS FORM WITH FEE(S)



UNITED STATES PATENT AND TRADEMARK OFFICE

UNITED STATES DEPARTMENT OF COMMERCE
United States Patent and Trademark Office
Address: COMMISSIONER FOR PATENTS
P.O. Box 1450
Alexandria, Virginia 22313-1450
www.uspto.gov

Table with columns: APPLICATION NO., FILING DATE, FIRST NAMED INVENTOR, ATTORNEY DOCKET NO., CONFIRMATION NO.
09/770,838 01/26/2001 Dennis J. Dupray 1003-1 8410
7590 08/27/2003
Dennis J. Dupray, Ph.D.
1801 Belvedere Street
Golden, CO 80401
EXAMINER
PHAN, DAO LINDA
ART UNIT PAPER NUMBER
3662
DATE MAILED: 08/27/2003

Determination of Patent Term Adjustment under 35 U.S.C. 154 (b)
(application filed on or after May 29, 2000)

The Patent Term Adjustment to date is 0 day(s). If the issue fee is paid on the date that is three months after the mailing date of this notice and the patent issues on the Tuesday before the date that is 28 weeks (six and a half months) after the mailing date of this notice, the Patent Term Adjustment will be 0 day(s).

If a Continued Prosecution Application (CPA) was filed in the above-identified application, the filing date that determines Patent Term Adjustment is the filing date of the most recent CPA.

Applicant will be able to obtain more detailed information by accessing the Patent Application Information Retrieval (PAIR) system (http://pair.uspto.gov).

Any questions regarding the Patent Term Extension or Adjustment determination should be directed to the Office of Patent Legal Administration at (703) 305-1383. Questions relating to issue and publication fee payments should be directed to the Customer Service Center of the Office of Patent Publication at (703) 305-8283.



UNITED STATES PATENT AND TRADEMARK OFFICE

UNITED STATES DEPARTMENT OF COMMERCE
United States Patent and Trademark Office
Address: COMMISSIONER FOR PATENTS
P.O. Box 1450
Alexandria, Virginia 22313-1450
www.uspto.gov

Table with columns: APPLICATION NO., FILING DATE, FIRST NAMED INVENTOR, ATTORNEY DOCKET NO., CONFIRMATION NO., EXAMINER, ART UNIT, PAPER NUMBER. Includes details for Dennis J. Dupray, Ph.D. and PHAN, DAO LINDA.

Notice of Fee Increase on October 1, 2003

If a reply to a "Notice of Allowance and Fee(s) Due" is filed in the Office on or after October 1, 2003, then the amount due will be higher than that set forth in the "Notice of Allowance and Fee(s) Due" since there will be an increase in fees effective on October 1, 2003.

The current fee schedule is accessible from (http://www.uspto.gov/main/howtofees.htm).

If the fee paid is the amount shown on the "Notice of Allowance and Fee(s) Due" but not the correct amount in view of the fee increase, a "Notice of Pay Balance of Issue Fee" will be mailed to applicant.

Effective October 1, 2003, 37 CFR 1.18 is amended by revising paragraphs (a) through (c) to read as set forth below.

Section 1.18 Patent post allowance (including issue) fees.

- (a) Issue fee for issuing each original or reissue patent, except a design or plant patent: By a small entity (Sec. 1.27(a))..... \$665.00 By other than a small entity..... \$1,330.00
(b) Issue fee for issuing a design patent: By a small entity (Sec. 1.27(a))..... \$240.00 By other than a small entity..... \$480.00
(c) Issue fee for issuing a plant patent: By a small entity (Sec. 1.27(a))..... \$320.00 By other than a small entity..... \$640.00

Questions relating to issue and publication fee payments should be directed to the Customer Service Center of the Office of Patent Publication at (703) 305-8283.

<b>Notice of Allowability</b>	Application No. <b>09/770,838</b>	Applicant(s) <b>Dupray et al</b>
	Examiner <b>Dao L. Phan</b>	Art Unit <b>3662</b>

**--The MAILING DATE of this communication appears on the cover sheet with the correspondence address--**

All claims being allowable, PROSECUTION ON THE MERITS IS (OR REMAINS) CLOSED in this application. If not included herewith (or previously mailed), a Notice of Allowance (PTOL-85) or other appropriate communication will be mailed in due course. **THIS NOTICE OF ALLOWABILITY IS NOT A GRANT OF PATENT RIGHTS.** This application is subject to withdrawal from issue at the initiative of the Office or upon petition by the applicant. See 37 CFR 1.313 and MPEP 1308.

1.  This communication is responsive to 6/6/03 & 6/17/03.
2.  The allowed claim(s) is/are 221-295 (renumbered 1-75).
3.  The drawings filed on 1/26/01 and 3/1/02 are accepted by the Examiner.
4.  Acknowledgement is made of a claim for foreign priority under 35 U.S.C. § 119(a)-(d).
  - a)  All    b)  Some\*    c)  None    of the:
    1.  Certified copies of the priority documents have been received.
    2.  Certified copies of the priority documents have been received in Application No. \_\_\_\_\_.
    3.  Copies of the certified copies of the priority documents have been received in this national stage application from the International Bureau (PCT Rule 17.2(a)).

\*Certified copies not received: \_\_\_\_\_

5.  Acknowledgement is made of a claim for domestic priority under 35 U.S.C. § 119(e) (to a provisional application).
  - (a)  The translation of the foreign language provisional application has been received.
6.  Acknowledgement is made of a claim for domestic priority under 35 U.S.C. §§ 120 and/or 121.

Applicant has THREE MONTHS FROM THE "MAILING DATE" of this communication to file a reply complying with the requirements noted below. Failure to timely comply will result in ABANDONMENT of this application. **THIS THREE-MONTH PERIOD IS NOT EXTENDABLE.**

7.  A SUBSTITUTE OATH OR DECLARATION must be submitted. Note the attached EXAMINER'S AMENDMENT or NOTICE OF INFORMAL PATENT APPLICATION (PTO-152) which gives reason(s) why the oath or declaration is deficient.
8.  CORRECTED DRAWINGS must be submitted.
  - (a)  including changes required by the Notice of Draftsperson's Patent Drawing Review (PTO-948) attached
    - 1)  hereto or 2)  to Paper No. \_\_\_\_\_.
  - (b)  including changes required by the proposed drawing correction filed \_\_\_\_\_, which has been approved by the examiner.
  - (c)  including changes required by the attached Examiner's Amendment/Comment or in the Office action of Paper No. \_\_\_\_\_.

Identifying indicia such as the application number (see 37 CFR 1.84(c)) should be written on the drawings in the top margin (not the back) of each sheet. The drawings should be filed as a separate paper with a transmittal letter addressed to the Official Draftsperson.

9.  DEPOSIT OF and/or INFORMATION about the deposit of BIOLOGICAL MATERIAL must be submitted. Note the attached Examiner's comment regarding REQUIREMENT FOR THE DEPOSIT OF BIOLOGICAL MATERIAL.

**Attachment(s)**

- |  |  |
|--|--|
| 1 <input type="checkbox"/> Notice of References Cited (PTO-892)  | 2 <input type="checkbox"/> Notice of Informal Patent Application (PTO-152) |
| 3 <input type="checkbox"/> Notice of Draftsperson's Patent Drawing Review (PTO-948)                      | 4 <input type="checkbox"/> Interview Summary (PTO-413), Paper No. _____    |
| 5 <input checked="" type="checkbox"/> Information Disclosure Statement(s) (PTO-1449), Paper No(s). _____ | 6 <input type="checkbox"/> Examiner's Amendment/Comment                    |
| 7 <input type="checkbox"/> Examiner's Comment Regarding Requirement for Deposit of Biological Material   | 8 <input type="checkbox"/> Examiner's Statement of Reasons for Allowance   |
| 9 <input type="checkbox"/> Other   |  |

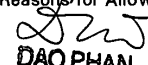
  
**DAO PHAN**  
**PATENT EXAMINER**



FORM PTO-1449 U.S. DEPARTMENT OF COMMERCE PATENT AND TRADEMARK OFFICE  INFORMATION DISCLOSURE STATEMENT (Use several sheets if necessary)	ATTY. DOCKET NO. 1003-1	SERIAL NO. 09/770,838
	APPLICANT DUPRAY, Dennis J.	
	FILING DATE January 26, 2001	GROUP ART 3662

U.S. PATENT DOCUMENTS

*EXAMINER INITIAL		DOCUMENT NUMBER	DATE	NAME	CLASS	SUB CLASS	FILING DATE IF APPROP.
DP ↑ ↓ DP	AA	5,845,267	12/1/98	Ronen	705	40	
	AB	5,809,415	9/15/98	Rossmann	455	422	
	AC	5,799,016	8/25/98	Onweller	370	401	
	AD	5,764,756	6/9/98	Onweller	379	242	
	AE	5,742,905	4/21/98	Pepe et al.	455	461	
	AF	5,742,509	4/21/98	Goldberg et al.	364	449.5	
	AG	5,610,815	3/11/97	Gudat et al.	364	424.027	
	AH	5,563,931	10/8/96	Bishop et al.	379	59	
	AI	5,473,602	12/5/95	McKenna et al.	370	60	
	AJ	5,392,052	2/21/95	Eberwine	342	357	
	AK	4,721,958	1/26/88	Jenkin	342	13	
	AL	3,646,580	2/29/72	Fuller et al.	325	53	
	AM	U.S. Patent App. No. 08/191,984	—	Loomis	—	—	2/4/94

RECEIVED

JUN 11 2003

GROUP 3600

EXAMINER <i>DP</i>	DATE CONSIDERED <i>8/22/03</i>
*EXAMINER: Initial if reference considered, whether or not citation is in conformance with MPEP 609; Draw line through citation if not in conformance and not considered. Include copy of this form with next communication to applicant.	



FORM PTO-1449 U.S. DEPARTMENT OF COMMERCE PATENT AND TRADEMARK OFFICE  INFORMATION DISCLOSURE STATEMENT (Use several sheets if necessary)	ATTY. DOCKET NO. 1003-1	SERIAL NO. 09/770,838
	APPLICANT DUPRAY, Dennis J.	
	FILING DATE January 26, 2001	GROUP ART 3662

FOREIGN PATENT DOCUMENTS

		DOCUMENT NUMBER	DATE	COUNTRY	CLASS	SUB CLASS	TRANSLATION	
							YES	NO
DP	AN	WO 97/50002	12/31/97	PCT	G01S 3	02		
DP	AO	WO 97/41654	11/6/97	PCT	H04H 1	00		
DP	AP	WO 94/11853	5/26/94	PCT	G08G 1	0968		

OTHER ART (Including Author, Title, Date, Pertinent Pages, etc.)

DP	AQ	Smith, et al., "Passive Location of Mobile Cellular Telephone Terminals," pp. 221-225, IEEE, 1991.

RECEIVED  
 JUN 11 2003  
 GROUP 3600

EXAMINER <i>Duo</i>	DATE CONSIDERED <i>8/22/03</i>
*EXAMINER: Initial if reference considered, whether or not citation is in conformance with MPEP 609; Draw line through citation if not in conformance and not considered. Include copy of this form with next communication to applicant.	



FORM PTO-1449 U.S. DEPARTMENT OF COMMERCE PATENT AND TRADEMARK OFFICE  <b>INFORMATION DISCLOSURE STATEMENT</b> (Use several sheets if necessary)	ATTY. DOCKET NO. 1003-1	SERIAL NO. 09/770,838
	APPLICANT DUPRAY, Dennis J.	
	FILING DATE January 26, 2001	GROUP ART 3662

U.S. PATENT DOCUMENTS

*EXAMINER INITIAL	DOCUMENT NUMBER	DATE	NAME	CLASS	SUB CLASS	FILING DATE IF APPROP.

FOREIGN PATENT DOCUMENTS

DOCUMENT NUMBER	DATE	COUNTRY	CLASS	SUB CLASS	TRANSLATION	
					YES	NO

OTHER ART (Including Author, Title, Date, Pertinent Pages, etc.)

DP	AA	Schopp, Michael, "User Modelling and Performance Evaluation of Distributed Location Management for Personal Communications Services," Proceedings of the 15 <sup>th</sup> International Teletraffic Congress (ITC) 15, Washington, D.C., 1997, S. 23-34.
DP	AB	Kennemann, Olrik, "Continuous Location of Moving GSM Mobile Stations by Pattern Recognition Techniques," Fifth IEEE International Symposium on Personal, Indoor and Mobile Radio Communications (PIMRC '94), pp. 630-634, IEEE, Sept. 1994.

**RECEIVED**  
 JUN 20 2003  
**GROUP 3600**

EXAMINER <i>DPW</i>	DATE CONSIDERED <i>8/22/03</i>
*EXAMINER: Initial if reference considered, whether or not citation is in conformance with MPEP 609; Draw line through citation if not in conformance and not considered. Include copy of this form with next communication to applicant.	

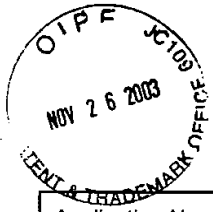

11-28-03

RCE/3662/B

REQUEST FOR CONTINUED EXAMINATION (RCE) TRANSMITTAL

Address to:  
Commissioner for Patents  
Mail Stop RCE  
P.O. Box 1450  
Alexandria, VA 22313-1450

Application Number	09/770,838
Filing Date	January 26, 2001
First Named Inventor	Dupray
Examiner Name	Dao L. Phan
Attorney Docket Number	1003-1

This is a Request for Continued Examination (RCE) under 37 C.F.R. §1.114 of the above-identified application.

1. Submission required under 37 C.F.R. § 1.114

- a.  Previously submitted:
  - i.  Consider the amendment(s)/reply under 37 C.F.R. § 1.116 previously filed on \_\_\_\_\_ (Any unentered amendment(s) referred to above will be entered).
  - ii.  Consider the arguments in the Appeal Brief or Reply Brief previously filed on \_\_\_\_\_.
  - iii.  Other \_\_\_\_\_
- b.  Enclosed:
  - i.  Amendment/Reply
  - ii.  Affidavit(s)/Declaration(s)
  - iii.  Information Disclosure statement (IDS)
  - iv.  Other \_\_\_\_\_

RECEIVED  
DEC 04 2003  
GROUP 3600

2. Miscellaneous

- a.  Suspension of action on the above-identified application is requested under 37 C.F.R. § 1.103(c) for a period of \_\_\_\_\_ months. (Period of suspension shall not exceed 3 months; Fee under 37 C.F.R. § 1.17(i) required).
- b.  Other \_\_\_\_\_

3. Fees

- a.  The Director is hereby authorized to charge the following fees, or credit any overpayments, to Deposit Account No. \_\_\_\_\_
  - i.  RCE fee required under 37 C.F.R. § 1.17(e)
  - ii.  Extension of time fee (37 C.F.R. §§ 1.136 and 1.17)
  - iii.  Other \_\_\_\_\_
- b.  Check in the amount of \$385.00 enclosed
- c.  Payment by credit card (Form PTO-2038 enclosed).

"EXPRESS MAIL" MAILING LABEL NUMBER: EV331283849US  
DATE OF DEPOSIT: November 26, 2003

RESPECTFULLY SUBMITTED,

SHERIDAN ROSS P.C.

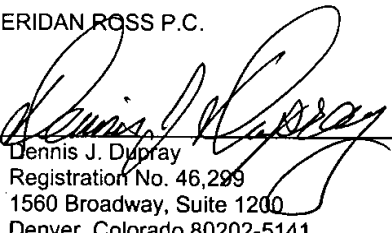
By:   
 Dennis J. Dupray  
 Registration No. 46,299  
 1560 Broadway, Suite 1200  
 Denver, Colorado 80202-5141  
 Phone: (303) 863-9700  
 Facsimile: (303) 863-0223

I HEREBY CERTIFY THAT THIS PAPER OR FEE IS BEING DEPOSITED WITH THE UNITED STATES POSTAL SERVICE "EXPRESS MAIL POST OFFICE TO ADDRESSEE" SERVICE UNDER 37 CFR 1.10 ON THE DATE INDICATED ABOVE AND IS ADDRESSED TO THE COMMISSIONER FOR PATENTS, P.O. BOX 1450, ALEXANDRIA, VIRGINIA 22313-1450.

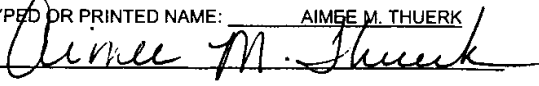
TYPED OR PRINTED NAME: AIMEE M. THUERK  

12/02/2003 SZEWDIE1 00000018 09770838  
01 FC:2801 385.00 0P





IN THE UNITED STATES PATENT AND TRADEMARK OFFICE

RECEIVED  
DEC 04 2003  
GROUP 3600

In Re the Application of:	) Group Art Unit: 3662
Dupray et al.	)
Serial No.: 09/770,838	) Examiner: Dao L. Phan
Filed: January 26, 2001	)
Atty. File No.: 1003-1	) <u>INFORMATION DISCLOSURE STATEMENT</u>
For: A GATEWAY AND HYBRID SOLUTIONS FOR WIRELESS LOCATION	)

"EXPRESS MAIL" MAILING LABEL NUMBER: EV331283849US  
DATE OF DEPOSIT: NOVEMBER 26, 2003

I HEREBY CERTIFY THAT THIS PAPER OR FEE IS BEING DEPOSITED WITH THE UNITED STATES POSTAL SERVICE "EXPRESS MAIL POST OFFICE TO ADDRESSEE" SERVICE UNDER 37 CFR 1.10 ON THE DATE INDICATED ABOVE AND IS ADDRESSED TO THE COMMISSIONER FOR PATENTS, P.O. BOX 1450, ALEXANDRIA, VIRGINIA 22313-1450.

TYPED OR PRINTED NAME:           AIMEE M. THUERK          

SIGNATURE: *Aimee M. Thuerk*

Commissioner for Patents  
P.O. Box 1450  
Alexandria, Virginia 22313-1450

Dear Sir:

The references cited on attached Form PTO-1449 are being called to the attention of the Examiner.

Copies of the references marked with an asterisk are enclosed herewith.

The remaining references are not enclosed, in accordance with 37 C.F.R. 1.98(d), because the references were submitted to the U.S. Patent and Trademark Office in prior application Serial No. 09/194,367 filed November 24, 1998, which is relied upon for an earlier filing date under 35 U.S.C. § 120.

To the best of applicants' belief, the pertinence of the foreign-language references is believed to be summarized in the attached English abstracts and in the figures, although applicants do not necessarily vouch for the accuracy of the translation.

Examiner's attention is drawn to the following co-pending applications, and for at least such applications to which the present application does not claim priority, copies have been or are being submitted:

- Serial No. 09/194,367 filed November 24, 1998
- Serial No. 09/820,584 filed March 28, 2001
- Serial No. 10/262,413 filed September 30, 2002
- Serial No. 10/262,338 filed September 30, 2002
- Serial No. 09/176,587 filed October 21, 1998

Serial No. 10/297,449 filed December 5, 2002

Serial No. 10/337,807 filed January 6, 2003

Submission of the above information is not intended as an admission that any item is citable under the statutes or rules to support a rejection, that any item disclosed represents analogous art, or that those skilled in the art would refer to or recognize the pertinence of any reference without the benefit of hindsight, nor should an inference be drawn as to the pertinence of the references based on the order in which they are presented. Submission of this statement should not be taken as an indication that a search has been conducted, or that no better art exists.

It is respectfully requested that the cited information be expressly considered during the prosecution of this application and the references made of record therein.

### FEES

<input checked="" type="checkbox"/>	<p>37 CFR 1.97(b): No fee is believed due in connection with this submission, because the information disclosure statement submitted herewith is satisfies one of the following conditions ("X" indicates satisfaction):</p> <ul style="list-style-type: none"><li><input type="checkbox"/> Within three months of the filing date of a national application other than a continued prosecution application under 37 CFR 1.53(d), or</li><li><input type="checkbox"/> Within three months of the date of entry into the national stage of an international application as set forth in 37 CFR 1.491 or</li><li><input type="checkbox"/> Before the mailing date of a first Office Action on the merits, or</li><li><input checked="" type="checkbox"/> Before the mailing of a first Office action after the filing of a request for continued examination under 37 CFR 1.114.</li></ul> <p>Although no fee is believed due, if any fee is deemed due in connection with this submission, please charge such fee to Deposit Account 19-1970.</p>
<input type="checkbox"/>	<p>37 CFR 1.97(c): The information disclosure statement transmitted herewith is being filed after all the above conditions (37 CFR 1.97(b)), but before the mailing date of one of the following conditions:</p> <ul style="list-style-type: none"><li>(1) a final action under 37 C.F.R. 1.113 or</li><li>(2) a notice of allowance under 37 C.F.R. 1.311, or</li><li>(3) an action that otherwise closes prosecution in the application.</li></ul> <p>This Information Disclosure Statement is accompanied by:</p> <ul style="list-style-type: none"><li><input type="checkbox"/> A Certification (below) as specified by 37 C.F.R. 1.97(e). Although no fee is believed due, if any fee is deemed due in connection with this submission, please charge such fee to Deposit Account 19-1970.</li></ul> <p style="text-align: center;">OR</p> <ul style="list-style-type: none"><li><input type="checkbox"/> A check in the amount of \$180.00 for the fee set forth in 37 C.F.R. 1.17(p) for submission of an information disclosure statement. Please credit any overpayment or charge any underpayment to Deposit Account No. 19-1970. Election to pay the fee should not be taken as an indication that applicant(s) cannot execute a certification.</li></ul>
<input type="checkbox"/>	<p>37 CFR 1.97(d): This Information Disclosure Statement is being submitted after the period specified in 37 CFR 1.97(c).</p> <ul style="list-style-type: none"><li><input type="checkbox"/> This information Disclosure Statement includes a Certification (below) as specified by 37 C.F.R. 1.97(e)</li></ul> <p style="text-align: center;">AND</p> <ul style="list-style-type: none"><li><input type="checkbox"/> Applicants hereby requests consideration of the reference(s) disclosed herein. Enclosed is the fee in the amount of \$180.00 under 37 C.F.R. 1.17(p). Please credit any overpayment or charge any underpayment to Deposit Account No. 19-1970.</li></ul>

**Certification (37 C.F.R. 1.97(e))**  
(Applicable only if checked)

The undersigned certifies that:

Each item of information contained in this information disclosure statement was first cited in any communication from a foreign patent office in a counterpart foreign application not more than three months prior to the filing of this statement. 37 C.F.R. 1.97(e)(1).

A copy of the communication from the foreign patent office is enclosed.

OR

No item of information contained in this information disclosure statement was cited in a communication from a foreign patent office in a counterpart foreign application, and, to the knowledge of the undersigned after making reasonable inquiry, no item of information contained in this Information Disclosure Statement was known to any individual designated in 37 C.F.R. 1.56(c) more than more than three months prior to the filing of this statement. 37 C.F.R. 1.97(e)(2).

Respectfully submitted,

SHERIDAN ROSS P.C.

By: 

Dennis J. Dupray  
Registration No. 46,299  
1560 Broadway, Suite 1200  
Denver, Colorado 80202-5141  
(303) 863-9700

Date: Nov. 26, 2003

FORM PTO-1449 U.S. DEPARTMENT OF COMMERCE PATENT AND TRADEMARK OFFICE  INFORMATION DISCLOSURE STATEMENT (Use several sheets if necessary)	ATTY. DOCKET NO. 1003-1	SERIAL NO. 09/770,838
	APPLICANT DUPRAY, Dennis J.	
	FILING DATE January 26, 2001	GROUP ART 3662

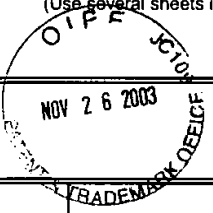

U.S. PATENT DOCUMENTS

*EXAMINER INITIAL	DOCUMENT NUMBER	DATE	NAME	CLASS	SUB CLASS	FILING DATE IF APPROP.
AA*	6,549,130	4/15/03	Joao	340	539	
AB	6,381,464	4/30/02	Vannucci	455	456	
AC	6,330,452	12/11/01	Fattouche et al.	455	456	
AD	6,243,587	6/5/01	Dent et al.	455	456	
AE*	5,917,405	6/29/99	Joao	340	426	
AF	5,594,425	1/14/97	Ladner et al.	340	825.06	
AG	4,542,744	9/24/85	Barnes et al.	128	660	
AH*	Application No. 10/337,807		Dupray			1/6/03
AI*	Application No. 10/297,449		Dupray			12/6/02
AJ*	Application No. 09/176,587		Dupray			10/21/98

FOREIGN PATENT DOCUMENTS

	DOCUMENT NUMBER	DATE	COUNTRY	CLASS	SUB CLASS	TRANSLATION	
						YES	NO

OTHER ART (Including Author, Title, Date, Pertinent Pages, etc.)

**RECEIVED**  
DEC 04 2003

EXAMINER	DATE CONSIDERED
*EXAMINER: Initial if reference considered, whether or not citation is in conformance with MPEP 609; Draw line through citation if not in conformance and not considered. Include copy of this form with next communication to applicant.	

**GROUP 3600**



SHEET 2 OF 2

FORM PTO-1449 U.S. DEPARTMENT OF COMMERCE PATENT AND TRADEMARK OFFICE  INFORMATION DISCLOSURE STATEMENT (Use several sheets if necessary)	ATTY. DOCKET NO. 1003-1	SERIAL NO. 09/770,838
	APPLICANT DUPRAY, Dennis J.	
	FILING DATE January 26, 2001	GROUP ART 3662

	AK	Smith, Jr., "Passive Location of Mobile Cellular Telephone Terminals," IEEE, CH3031-2/91/0000-0221, 1991 pp. 221-225

**RECEIVED**  
DEC 04 2003  
**GROUP 3600**

EXAMINER	DATE CONSIDERED
*EXAMINER: Initial if reference considered, whether or not citation is in conformance with MPEP 609; Draw line through citation if not in conformance and not considered. Include copy of this form with next communication to applicant.	



#### A WIRELESS LOCATION GATEWAY AND APPLICATIONS THEREFOR

##### FIELD OF THE INVENTION

The present invention is directed generally to a system and method for locating people or objects, and in particular, to a system and method for locating a wireless mobile station using a plurality of simultaneously activated mobile station location estimators.

##### FIELD OF THE INVENTION

The present invention is directed generally to a system and method for locating people or objects, and in particular, to a system and method for locating a wireless mobile station using a plurality of mobile station location estimators. More generally, the present invention is directed to a computational system and method for calibrating the relative performance of multiple models, wherein each such model is capable of being activated for generating hypotheses (e.g., estimates and/or predictions) of an unknown condition such as the location of wireless mobile station. Additionally, the present invention is directed to a computational system and method for generating enhanced hypotheses of the unknown condition, wherein the model generated hypotheses are used as queries into an archive that associates: (a) historical model generated hypotheses, (b) model input data used in generating the model hypotheses, and (c) verified hypotheses to which the model input data is known to correspond.

##### BACKGROUND OF THE INVENTION

There is great interest in providing existing infrastructures for wireless communication systems with the capability for locating people and/or objects in a cost effective manner. Such a capability would be invaluable in a variety of situations, especially in emergency, crime situations and mobile commerce. There are numerous competing wireless location technologies that purport to effectively locate wireless mobile stations (as used herein this term includes, e.g., mobile phones, short message devices (SMS), electronic container tracking tags, micro-transceivers for personal location and/or emergency). These technologies can be generally classified as:

- (a) handset centric wherein a portion of the location processing is performed at the mobile stations, and in particular, each such mobile station (MS) includes specialized electronics specifically for performing location. In most cases, such specialized electronics are for detecting and receiving satellite (or more generally, non-terrestrial) signals that can then be used in determining a location of the MS.
- (b) network centric wherein the wireless communication network(s) with which the MS is in contact handle substantially all location specific processing. As one skilled in the art will understand, there are various wireless location technologies that are available such as time difference of arrival (TDOA), time of arrival (TOA), timing advance (TA) techniques, angle of arrival (AOA), multipath pattern matching techniques, and
- (c) hybrid systems wherein there are specialized location electronics at the handset, but a substantial amount of the location processing is performed at a network site rather than at the MS. An example of such a hybrid system is what is

RECEIVED

DEC 04 2003

GROUP 3600

known as network assisted GPS systems, wherein GPS signals are obtained at the MS (with the assistance network received information) and GPS timing information is transmitted from the MS to the network for performing MS location computations.

The wide variety of wireless location techniques can provide, under appropriate circumstances, the following advantages:

- 5 (a) if the techniques are used in combination, a more reliable and accurate wireless location capability can be provided. In particular, when an embodiment of one wireless location technique is known to be less than satisfactory in a particular geographic area, an alternative embodiment (or alternative technique) can be used to obtain an MS's location(s). Additionally, two different embodiments and/or techniques can be applied substantially simultaneously for locating an MS. In this latter case, a location resolver is likely needed to determine a "most likely" resulting MS location estimate. Note, that wireless location systems for combining wireless location techniques is described in the following international and U.S. patent applications which are each incorporated fully by reference herein:
1. U.S. Provisional Application No. 60/075,355 filed September 9, 1996
  2. U.S. Provisional Application No. 60/044,821, filed April 25, 1997;
  3. U.S. Provisional Application No. 60/056,598, filed August 20, 1997;
  - 15 4. International Application No. PCT/US97/35933 filed September 8, 1997 entitled "LOCATION OF A MOBILE STATION USING A PLURALITY OF COMMERCIAL WIRELESS INFRASTRUCTURES"
  5. International Application No. PCT/US97/35842 filed September 8, 1997; entitled "LOCATION OF A MOBILE STATION";
  6. U.S. Application No. 09/194,367 filed Nov. 24, 1999 entitled "Location Of A Mobile Station";
  - 20 7. U.S. Application No. 09/176,587 filed Dec. 23, 1998 entitled "Wireless Location System For Calibrating Multiple Location Estimators";
  8. U.S. Patent No. 6,236,385 filed Jan. 22, 1999 entitled "Location of a Mobile Station Using A Plurality Of Commercial Infrastructures";
  9. U.S. Application No. 09/299,175 filed April 23, 1999 entitled "WIRELESS LOCATION USING MULTIPLE SIMULTANEOUS LOCATION ESTIMATORS"; and
  - 25 (b) if a primary wireless location technique fails (e.g., due to an electronics malfunction), then assuming an alternative technique is available that does not use, e.g., the malfunctioning electronics of the primary technique, then the alternative technique can be used for MS location.

However, the variety of wireless location techniques available is also problematic for at least the following reasons:

- 30 (a) a request for an MS location can require either the requester to know the wireless location service provider of the geographical area where the MS is likely to be, or to contract a location broker that is able to, e.g., determine a communication network covering the geographical area within which the MS is currently residing and activate

(directly or through the MS's wireless service provider) an appropriate wireless location service. In the art, the technology enabling such a location broker capability has been referred to as a "wireless location gateway". An embodiment of such a gateway is described in the PCT/US97/15892 reference identified above;

- (b) for communication networks relying on handset centric and/or hybrid systems for MS location, MSs roaming from networks using only network centric location capabilities will likely not have the specialized electronics needed for being located and accordingly many location related network services will not be available such as emergency services (e.g., E911 in the U.S.).
- (c) different location techniques have different reliability and accuracy characteristics.

Accordingly, it would be desirable to integrate into a single wireless location broker or wireless location gateway as many location techniques as possible so that location requests can be fulfilled without the requester needing to know what location technique is used. It would be further desirable for roaming MSs to be able to be located in coverage areas where a wireless location technique is different from the one (or more) techniques supported in the primary subscription area for the MS. Additionally, it would be desirable to provide new applications for which MS location information can be applied via, e.g., a wireless location gateway.

#### OBJECTS OF THE INVENTION RELATING TO WIRELESS LOCATION

It is an objective of the present invention to provide a system and method for accurately locating people and/or objects in a cost effective manner wherein a location requester can obtain an MS location without needing to provide location technique specific information with the request.

It is a further object the present invention to provide wireless location without the requester knowing the particulars of communication network with which the MS may be in contact, e.g., the commercial radio service provider (CRS), the wireless communication protocol, etc.

Yet another objective is to provide a low cost location system and method, adaptable to wireless telephony/internet systems, for using a plurality of location techniques for increasing MS location accuracy and consistency. In particular, the plurality of location techniques (embodied in "location estimators" also denoted "first order models" or FOMs herein) may be activated according to any one or more of a number of activation strategies such as concurrent activation (e.g., for obtaining two location estimates of an MS location), data-driven activation (e.g., activated when appropriate input data is available), priority activation (e.g., an attempt to activate a preferred FOM is first performed, and if unsuccessful, or a result unsatisfactory, then an attempt at activating a second FOM is performed).

Yet another object is to (or be able to) integrate into a wireless location gateway a large number of MS location techniques such as:

- (2.1) time-of-arrival wireless signal processing techniques;
- (2.2) timing advance techniques;
- (2.2) time-difference-of-arrival wireless signal processing techniques;



- (2.3) adaptive wireless signal processing techniques having, for example, learning capabilities and including, for instance, artificial neural net and genetic algorithm processing;
- (2.4) signal processing techniques for matching MS location signals with wireless signal characteristics of known areas;
- (2.5) conflict resolution techniques for resolving conflicts in hypotheses for MS location estimates;
- (2.6) techniques for enhancing MS location estimates through the use of both heuristics and historical data associating MS wireless signal characteristics with known locations and/or environmental conditions;
- (2.7) angle of arrival techniques (also denoted direction of arrival) for estimating an angle and/or direction of wireless signals transmitted from an MS;
- (2.8) location techniques that use satellite signals such as GPS signals received at the MS;
- (2.9) hybrid wireless location techniques that combine a two or more of the above location techniques (2.1) – (2.2) or other wireless location techniques.
- (2.10) Wireless location techniques that use Doppler, phase coherency, and other signal characteristics for determining MS location, MS velocity and MS direction of movement.

5  
10

A related object is to integrate handset centric, network centric and hybrid systems so that the problems identified hereinabove are mitigated.

15

Note that it is an objective of the present invention to provide a "plug and play" capability for new wireless location estimators, wherein new location estimators can be easily incorporated into an embodiment of the present invention. That is, provide an interface that allows substantially automatic integration of new TDMs.

20

Yet another object is to provide novel applications for wireless location that benefits from an integration of different location techniques.

DEFINITIONS

The following definitions are provided for convenience. In general, the definitions here are also defined elsewhere in this document as well.

25

(3.1) The term "wireless" herein is, in general, an abbreviation for "digital wireless", and in particular, "wireless" refers to digital radio signaling using one of standard digital protocols such as Advanced Mobile Phone Service (AMPS), Narrowband Advanced Mobile Phone Service (NAMPS), code division multiple access (CDMA) and Time Division Multiple Access (TDMA), Global Systems Mobile (GSM), and time division multiple access (TDMA) as one skilled in the art will understand.

30

(3.2) As used herein, the term "mobile station" (equivalently, MS) refers to a wireless device that is at least a transmitting device, and in most cases is also a wireless receiving device, such as a portable radio telephony handset. Note that in some contexts herein instead or in addition to MS, the following terms are also used: "personal station" (PS), and "location unit" (LU). In general, these terms may be considered synonymous. Note that examples of various MSs are identified in the Background section above.

(3.3) The term, "wireless infrastructure" (or simply "infrastructure"), denotes one or more of: (a) a network for one or more of telephony communication services, (b) a collection of commonly controlled transceivers for providing wireless communication with a plurality of MSs, (c) the wireless Internet, (d) that portion of communications network that receives and processes wireless communications with wireless mobile stations. In particular, this infrastructure includes telephony wireless base stations (BS) such as those for radio mobile communication systems based on CDMA, AMPS, NAMPS, TDMA, and GSM wherein the base stations provide a network of cooperative communication channels with an air interface to the MS, and a conventional telecommunications interface with a Mobile Switch Center (MSC). Thus, an MS user within an area serviced by the base stations may be provided with wireless communication throughout the area by user transparent communication transfers (i.e., "handoffs") between the user's MS and these base stations in order to maintain effective telephony service. The mobile switch center (MSC) provides communication and control connectivity among base stations and the public telephone network.

(3.4) The phrase, "composite wireless signal characteristic values" denotes the result of aggregating and filtering a collection of measurements of wireless signal samples, wherein these samples are obtained from the wireless communication between an MS to be located and the base station infrastructure (e.g., a plurality of networked base stations). However, other phrases are also used herein to denote this collection of derived characteristic values depending on the context and the likely orientation of the reader. For example, when viewing these values from a wireless signal processing perspective of radio engineering, as in the descriptions of the subsequent Detailed Description sections concerned with the aspects of the present invention for receiving MS signal measurements from the base station infrastructure, the phrase typically used is: "RF signal measurements". Alternatively, from a data processing perspective, the phrases: "location signature cluster" and "location signal data" are used to describe signal characteristic values between the MS and the plurality of infrastructure base stations substantially simultaneously detecting MS transmissions. Moreover, since the location communications between an MS and the base station infrastructure typically include simultaneous communications with more than one base station, a related useful notion is that of a "location signature" (also denoted "loc sig" herein) which is the composite wireless signal characteristic values for signal samples between an MS to be located and a single base station. Also, in some contexts, the phrases: "signal characteristic values" or "signal characteristic data" are used when either or both a location signature(s) and/or a location signature cluster(s) are intended.

#### SUMMARY DISCUSSION

The present invention relates to a method and system for performing wireless mobile station location. In particular, the present invention is a wireless mobile station location computing method and system that utilizes multiple wireless location computational estimators (these estimators also denoted herein as MS location hypothesizing computational models, "first order models", FOMs, and/or "location estimating models"), for providing location estimates of a target mobile station MS, wherein ambiguities and/or conflicts between the location estimates may be effectively and straightforwardly resolved. More particularly, the present invention provides a technique for calibrating the performance of each of the location estimators so that a confidence value (e.g., a probability) can be assigned to each generated location estimate. Additionally, the present invention provides a straightforward technique for using the confidence values (probabilities) for deriving a resulting most likely location estimate of a target wireless mobile station.

More generally, the present invention relates to a novel computational method and architecture for synergistically combining the results of a plurality of computational models in a straightforward way that allows the models to be calibrated relative to one another so that differences in results generated by the models can be readily resolved. Accordingly, the computational method and architecture of the present invention may be applied to wide range applications where synergies between multiple models is expected to be enhance performance.

For a particular application having a plurality of computational models (each generating a hypothetical estimate of a desired result(s) in a space of hypothesis results), the present invention may be described, at a high level, as any method or system that performs the following steps:

- (4.1.1) A step of determining a classification scheme for determining an input class for each input data set supplied to the plurality of computational models (COMs), wherein for each range,  $R$ , of a plurality of ranges of desired results in the hypothesis space, there is an input class, and the input data sets of this input class are expected to have their corresponding desired result(s) in the range  $R$ . Some examples will be illustrative. For a wireless location system, the present step determines geographical subareas of a wireless network coverage area that have "similar" wireless signal characteristics. Such subareas may be relatively easy to determine, and there may be no constraint on the size of the subareas. The intention is to determine: (a) such a subarea as only a general area where a target MS must reside, and (b) the subarea should be relatively homogeneous in its wireless signaling characteristics. Accordingly, (a) and (b) are believed to be substantially satisfied by grouping together into the same input class the wireless signal data sets (i.e., input data sets) from corresponding target MS locations wherein at each of the target MS locations: (i) the set of base stations detected by the target MS (at the location) is substantially the same, and/or (ii) the set of base stations detecting the target MS is substantially the same set of base stations.

Note that there are numerous techniques and commercial packages for determining such a classification scheme. In particular, the statistically based system, "CART" (acronym for Classification and Regression Trees) by AMGOS Software International Limited of Toronto, Canada is one such package. Further, note that this step is intended to provide reliable but not necessarily highly accurate ranges  $R$  for the desired results. Also note that in some applications there may be only a single input class, thus assuring high reliability (albeit, likely low accuracy). Accordingly, in this latter case the present step may be omitted.

- (4.1.2) A step of calibrating each of the plurality of computational models (COMs) so that each subsequent hypothesis generated by one of the models has a confidence value (e.g., probability) associated therewith that is indicative of the likelihood of the hypothesis being correct. The calibrating of this step is performed using the input classification scheme determined in the above step (4.1.1). In one embodiment of this step, each model is supplied with inputs from a given fixed input class, wherein each of these inputs have corresponding known results that constitute a correct hypothesis (i.e., a desired result). Subsequently, the performance of each model is determined for the input class and a confidence value is assigned to the model for inputs received from the input class. Note that this procedure is repeated with each input class available from

the input classification scheme. In performing this procedure, an application domain specific criteria is used to determine whether the hypotheses generated by the models identify the desired results in the hypothesis space. Accordingly, for each of the models, when supplied with an input data set from a fixed input class, the hypothesis generated by the model will be given the confidence value determined for this input class as an indication of the likelihood of the generated hypothesis being correct (i.e., the desired result). Note that the confidence value for each generated hypothesis may be computed as a probability that the hypothesis is correct.

Note that for a wireless location application, the criteria (in one embodiment) is whether a location hypothesis contains the actual location where the MS was when the corresponding input data set (wireless signal measurements) were communicated between this MS and the wireless network.

For applications related to the diagnosis of electronic systems, this criteria may be whether an hypothesis identifies a proper functional unit such as a circuit board or chip.

For economic forecasting applications, this criteria may be whether an hypothesis is within a particular range of the correct hypothesis. For example, if an application according to the present invention predicts the U.S. gross national product (GNP) six months into the future according to certain inputs (defining input data sets), then hypotheses generated from historical data that has associated therewith the actual corresponding GNP (six months later), may be used for calibrating each of the plurality of economic forecasting models (EFMs). Thus, the application specific criteria for this case may be that a generated hypothesis is within, say, 70% of the actual corresponding six month GNP prediction.

For identifying a known object such as an air or space borne, terrestrial vehicle, or watercraft, the criteria may be whether an hypothesis actually identifies the object.

For geophysical analysis applications (e.g., for identifying and/or classifying and/or mapping mineral deposits, oil, aquifers or seismic faults), the criteria may be whether an hypothesis provides a correct analysis.

Note that the applications described herein are illustrative, but not comprehensive of the scope of the present invention. Further note that this step typically is performed at least once prior to inputting input data sets whose resulting hypotheses are to be used to determine the desired or correct results. Additionally, once an initial calibration has been performed, this step may also be performed: (a) intermittently between the generation of hypotheses, and/or (b) substantially continuously and in parallel with the generation of hypotheses by the models.

(4.1.3) A step of providing one or more input data sets to the models (EFMs) for generating a plurality of hypotheses, wherein the result(s) desired to be hypothesized are unknown. Moreover, note that the generated hypotheses are preferred to have a same data structure definition.

For example, for a wireless location system, the present step provides an input data set including the composite signal characteristic values to one or more MS location hypothesizing computational models, wherein each such model subsequently determines one or more initial estimates (also denoted location hypotheses) of the location of the

target MS. Note that one or more of these models may be based on, for example, the signal processing techniques 2.1 through 2.3, above.

(4.1.4) A step of adjusting or modifying the generated hypotheses output by the models, wherein for such an hypothesis, adjustments may be performed on one or both of its hypothesized result H.R. and its confidence value for further enhancing the performance of the present invention. In one embodiment of this step, H.H. is used as an index to retrieve other results from an archival database, wherein this database associates hypothesized results with their corresponding desired or correct results. Thus, H.H. may be used to identify data from other archived hypothesized results that are "nearby" to H.R. and subsequently use the nearby data to retrieve the corresponding desired results. Thus, the set of retrieved desired results may be used to define a new "adjusted" hypothesis.

For example, for a wireless location system utilizing the present invention, each location hypothesis, H, identifies an area for a target MS, and H can used to identify additional related locations included in archived hypotheses generated by the same FDM as generated H. For instance, such related locations may be the area centroids of the archived hypotheses, wherein these centroids reside within the area hypothesized by H. Accordingly, such centroids may be used to retrieve the corresponding actual verified MS locations (i.e., the corresponding desired results), and these retrieved verified locations may be used to generate a new adjusted area that is likely to be more accurate than H. In particular, a convex hull of the verified locations may be used as a basis for determining a new location hypothesis of the target MS. Moreover, this aspect of the invention may include the preprocessing of such adjustments throughout a wireless coverage area to produce a geolocation vector gradient field, wherein for each archived hypothesis H (having  $L_a$  as an MS location estimate) for a designated FDM, throughout the coverage area, a corresponding verified location version  $M_a$  is determined. Subsequently, the adjustment vector  $AV_a = (M_a - L_a)$  is determined as one of the adjustment vectors of the vector gradient field. Thus,  $L_a$  and  $AV_a$  are associated in the data archive as a record of the vector gradient field. Accordingly, when a location hypothesis  $H_0$  for a target MS at an unknown location is generated (the hypothesis  $H_0$  having  $L_0$  as the target MS location estimate), records within the vector gradient field having their corresponding location  $L_a$  "near"  $L_0$ , (e.g., within area of a predetermined distance about  $L_0$  or a "neighborhood" of  $L_0$ ) can be retrieved. Accordingly, an adjustment to  $L_0$  can be determined as a function of the  $L_a$  and  $AV_a$  values of the retrieved records. Note that an adjustment to  $L_0$  may be simply an average of these  $AV_a$  vectors for the retrieved records. Alternatively, the  $AV_a$  values may be weighted such that the  $AV_a$  having  $L_a$  closer to  $L_0$  are more influential in the resulting derived location for the target MS. More generally, the adjustment technique includes a method for interpolating an adjustment at  $L_0$  from the verified adjustments at locations about  $L_0$ . Enhancements on such adjustment/interpolation techniques are also within the scope of the present invention. For example, the weightings (or other terms of an such an interpolation technique) may be combined with other known wireless signal characteristics of the area such as an identification of: (a) a known sharp change in the geolocation gradient vector field, and/or (b) a

subarea having reduced wireless transmission capabilities, and/or (3) a subarea wherein the retrieved records for the subarea have their estimates  $L_n$  widely spaced apart, and/or (4) a subarea wherein there is an insufficient number of retrieved records.

For other application domains, the present step requires a first technique to determine both "nearby" archived data from previously archived hypotheses, and a second technique to determine an "adjusted" hypothesis from the retrieved desired results. In general, such techniques can be relatively straightforward to provide when the hypothesized results reside in a vector space, and more particularly, in a Cartesian product of the real numbers. Accordingly, there are numerous applications that can be configured to generate hypothesized results in a vector space (or Cartesian product of the real numbers). For instance, economic financial forecasting applications typically result in numeric predictions where the first and second techniques can be, e.g., substantially identical to the centroid and convex hull techniques for the wireless location application; and

(4.1.5) A step of subsequently computing a "most likely" target MS location estimate is computed, for outputting to a location requesting application such as an emergency, the fire or police departments, taxi services, etc. Note that in computing the most likely target MS location estimate a plurality of location hypotheses may be taken into account. In fact, it is an important aspect of the present invention that the most likely MS location estimate is determined by computationally forming a composite MS location estimate utilizing such a plurality of location hypotheses so that, for example, location estimate similarities between location hypotheses can be effectively utilized.

Referring to (4.1.3) there may be hypotheses for estimating not only desired result(s), but also hypotheses may be generated that indicate where the desired result(s) is not. Thus, if the confidence values are probabilities, an hypothesis may be generated that has a very low (near zero) probability of having the desired result. As an aside, note that in general, for each generated hypothesis,  $H$ , having a probability,  $P$ , there is a dual hypothesis  $H^c$  that may be generated, wherein the  $H^c$  represents the complementary hypothesis that the desired result is in the space of hypothesized results outside of  $H$ . Thus, the probability that the desired result(s) is outside of the result hypothesized by  $H$  is  $1-P$ . Accordingly, with each location hypothesis having a probability favorably indicating where a desired result may be (i.e.,  $P >= 0.5$ ), there is a corresponding probability for the complement hypothesis that indicates where the desired result(s) is unlikely to be. Thus, applying this reasoning to a wireless location application utilizing the present invention, then for an hypothesis  $H$  indicating that the target MS is in a geographical area  $A$ , there is a dual location estimate  $H^c$  that may be generated, wherein the  $H^c$  represents the area outside of  $A$  and the probability that the target MS is outside of  $A$  is  $1-P$ . Thus, with each location hypothesis having a probability favorably indicating where a target MS may be (i.e.,  $P >= 0.5$ ), there is a corresponding probability for the complement area not represented by the location hypothesis that does not favor the target MS being in this complement area. Further, note that similar dual hypotheses can be used in other applications using the multiple model architecture of the present invention when probabilities are assigned to hypotheses generated by the models of the application.

Referring to (4.1.3) as it relates to a wireless location system provided by the present invention, note that, it is an aspect of the present invention to provide location hypothesis enhancing and evaluation techniques that can adjust target MS location estimates according to

historical MS location data and/or adjust the confidence values of location hypotheses according to how consistent the corresponding target MS location estimate is: (a) with historical MS signal characteristic values, (b) with various physical constraints, and (c) with various heuristics. In particular, the following capabilities are provided by the present invention:

- 5 (5.1) a capability for enhancing the accuracy of an initial location hypothesis,  $H_i$ , generated by a first order model,  $FOM_i$ , by using  $H_i$  as, essentially, a query or index into an historical data base (denoted herein as the location signature data base). Note, this data base may include: (a) a plurality of previously obtained location signature clusters (i.e., composite wireless signal characteristic values) such that for each such cluster there is an associated actual or verified MS location where an MS communicated with the base station infrastructure for locating the MS, and (b) previous MS location hypothesis estimates from  $FOM_i$  derived from each of the location signature clusters scored according to (a). Alternatively this data base include a location error gradient field for the known location errors for  $FOM_i$ ;
- 10 (5.2) a capability for analyzing composite signal characteristic values of wireless communications between the target MS and the base station infrastructure, wherein such values are compared with composite signal characteristics values of known MS locations (these latter values being archived in the location signature data base). In one instance, the composite signal characteristic values used to generate various location hypotheses for the target MS are compared against wireless signal data of known MS locations stored in the location signature data base for determining the reliability of the location hypothesizing models for particular geographic areas and/or environmental conditions;
- 15 (5.3) a capability for reasoning about the likelihood of a location hypothesis wherein this reasoning capability uses heuristics and constraints based on physics and physical properties of the location geography;
- (5.4) an hypothesis generating capability for generating new location hypotheses from previous hypotheses.

20 As also mentioned above in (2.3), the present invention may utilize adaptive signal processing techniques. One particularly important utilization of such techniques includes the automatic tuning of the present invention so that, e.g., such tuning can be applied to adjusting the values of location processing system parameters that affect the processing performed by the present invention. For example, such system parameters as those used for determining the size of a geographical area to be specified when retrieving location signal data of known MS locations from the historical (location signature) data base can substantially affect the location processing. In particular, a system parameter specifying a minimum size for such a geographical area may, if too large, cause unnecessary inaccuracies in locating an MS. Accordingly, to accomplish a tuning of such system parameters, an adaptation engine is included in the present invention for automatically adjusting or tuning parameters used by the present invention. Note that in one embodiment, the adaptation engine is based on genetic algorithm techniques.

The present invention may include one or more FOMs that may be generally denoted as classification models wherein such FOMs are trained or calibrated to associate particular composite wireless signal characteristic values with a geographical location where a target MS could likely generate the wireless signal samples from which the composite wireless signal characteristic values are derived. Further, the present invention may include the capability for training and retraining such classification FOMs to automatically maintain the accuracy of these models even though substantial changes to the radio coverage area may occur, such as the construction of a new high rise building or seasonal variations

30

(due to, for example, foliage variations). As used herein, "training" refers to iteratively presenting "training data" to a computational module for changing the behavior of the module so that the module may perform progressively better as it learns appropriate behavioral responses to the training data. Accordingly, training may include, for example, the repeated input of training data to an artificial neural network, or repeated statistical regression analyses on different and/or enhanced training data (e.g., statistical sample data sets). Note that other embodiments of a trained pattern matching FOMs for wireless location are disclosed in U.S. Patent 6,028,304, titled "Radio Transmitter Location Finding for Wireless Communication Network Services and Management," filed Jan. 8, 1997 and issued Feb. 15, 2000, having Kishenrath and Max as inventors, this patent being incorporated herein fully by reference.

It is well known in the wireless telephony art that the phenomenon of signal multipath and shadow fading renders most analytical location computational techniques such as time-of-arrival (TOA) or time-difference-of-arrival (TDOA) substantially error prone in urban areas and particularly in dense urban areas without further statistical correlation processing such as such super resolution as disclosed in U.S. patent 5,890,068 by Fawcotte et. al. issued on Mar. 30, 1999 and incorporated fully herein by reference. Moreover, it may be the case that even though such additional processing is performed, the multipath phenomenon may still be problematic. However, this same multipath phenomenon also may produce substantially distinct or peculiar signal measurement patterns, wherein such a pattern coincides with a relatively small geographical area. Thus, the present invention may include a FOM(s) utilize multipath as an advantage for increasing accuracy. Moreover, it is worthwhile to note that the utilization of classification FOMs in high multipath environments is especially advantageous in that high multipath environments are typically densely populated. Thus, since such environments are also capable of yielding a greater density of MS location signal data from MSs whose actual locations can be obtained, there can be a substantial amount of training or calibration data captured by the present invention for training or calibrating such classification FOMs and for progressively improving the MS location accuracy of such models.

It is also an aspect of the present invention that classification FOMs may be utilized that determine target MS locations by correlating and/or associating network anomalous behavior with geographic locations where such behavior occurs. That is, network behaviors that are problematic for voice and/or data communication may be used advantageously for locating a target MS. For example, it is well known that wireless networks typically have within their coverage areas persistent subareas where voice quality is problematic due to, e.g., measurements related to high total error, a high error rate, or change in error rate. In particular, such measurements may be related to frame error rates, redundancy errors, co-channel interference, excessive handoffs between base stations, and/or other call quality measurements. Additionally, measurements may be used that are related to subareas where wireless communication between the network and a target MS is not sufficient to maintain a call (i.e., "deadzones"). Thus, information about such so called problematic behaviors may be used by, e.g., a location estimator (FOM) to generate a more accurate estimate of a target MS. For example, such network behavioral measurements may be provided for training an artificial neural network and/or for providing to a statistical regression analysis technique and/or statistical prediction models (e.g., using principle decomposition, partial least squares, or other regression techniques) for associating or correlating such measurements with the geographic area for which they likely derive. Moreover, note that such network behavioral measurements can also be used to reduce the likelihood of a target MS being in an area if such measurements are not what would be expected for the area.



It is also an aspect of the present invention that FOMs themselves may be hybrid combinations of MS location techniques. For example, an embodiment of the present invention may include a FOM that uses a combination of Time Difference of Arrival (TDOA) and Timing Advance (TA) location measurement techniques for locating the target MS, wherein such a technique may require only minor modifications to the wireless infrastructure. In particular, such a FOM may provide reduced MS location errors and reduced resolution of ambiguities than are present when these techniques are used separately. One embodiment of such a FOM (also denoted the Yost Model or FOM herein) is disclosed in U.S. Patent 5,987,329 filed July 30, 1997 and issued Nov. 16, 1999 having Yost and Panchapakesan as inventors, this patent being fully incorporated herein by reference.

Additionally, note that FOMs related to the Yost Model may also be incorporated into embodiments of the present invention wherein an elliptical search restriction location technique may also be utilized. In particular, such a technique is disclosed in U.S. patent application, having U.S. Serial No. 08/903,551, and entitled "System and Method Using Elliptical Search Area Coverage in Determining the Location of a Mobile Terminal", filed Jul. 30, 1997, which is also incorporated by reference herein.

It is also a related aspect of the present invention to include a plurality of stationary, low cost, low power "location detection base stations" (LBS), each such LBS having both restricted range MS detection capabilities, and a built-in MS. Accordingly, a grid of such LBSs can be utilized for providing wireless signaling characteristic data (from their built-in MSs) for: (a) (re)training such classification FOMs, and (b) calibrating the FOMs so that each generated location hypothesis has a reliable confidence value (probability) indicative of the likelihood of the target MS being in an area represented by the location hypothesis.

It is a further aspect of the present invention that the personal communication system (PCS) infrastructures currently being developed by telecommunication providers offer an appropriate localized infrastructure base upon which to build various personal location systems (PLS) employing the present invention and/or utilizing the techniques disclosed herein. In particular, the present invention is especially suitable for the location of people and/or objects using code division multiple access (CDMA) wireless infrastructures, although other wireless infrastructures, such as, time division multiple access (TDMA) infrastructures and GSM are also contemplated. CDMA general principles are described, for example, in U.S. Patent 5,109,390, to Gilman, et al, which is also incorporated herein by reference.

As mentioned in (2.7) and in the discussion of classification FOMs above, embodiments of the present invention may include components (e.g., FOMs) that can substantially automatically retrain themselves to compensate for variations in wireless signal characteristics (e.g., multipath) due to environmental and/or topographic changes to a geographic area serviced by the present invention. For example, in one embodiment, the present invention optionally includes low cost, low power base stations, denoted location base stations (LBS) above, providing, for example, CDMA pilot channels to a very limited area about each such LBS. The location base stations may provide limited voice traffic capabilities, but each is capable of gathering sufficient wireless signal characteristics from an MS within the location base station's range to facilitate locating the MS. Thus, by positioning the location base stations at known locations in a geographic region such as, for instance, on street lamp poles and road signs, additional MS location accuracy can be obtained. That is, due to the low power signal output by such location base stations, there to be signaling control communication (e.g., pilot signaling and other control signals) between a location base station and a

target MS, the MS must be relatively near the location base station. Additionally, for each location base station not in communication with the target MS, it is likely that the MS is not near to this location base station. Thus, by utilizing information received from both location base stations in communication with the target MS and those that are not in communication with the target MS, the present invention may substantially narrow the possible geographic areas within which the target MS is likely to be. Further, by providing each location base station (LBS) with a co-located stationary wireless transceiver (denoted a built-in MS above) having similar functionality to an MS, the following advantages are provided:

(6.1) assuming that the co-located base station capabilities and the stationary transceiver of an LBS are such that the base station capabilities and the stationary transceiver communicate with one another, the stationary transceiver can be signaled by another component(s) of the present invention to activate or deactivate its associated base station capability, thereby conserving power for the LBS that operate on a restricted power such as solar electrical power;

(6.2) the stationary transceiver of an LBS can be used for transferring target MS location information obtained by the LBS to a conventional telephony base station;

(6.3) since the location of each LBS is known and can be used in location processing, the present invention is able to (re)train itself in geographical areas having such LBSs. That is, by activating each LBS stationary transceiver so that there is signal communication between the stationary transceivers and surrounding base stations within range, wireless signal characteristic values for the location of the stationary transceiver are obtained for each such base station. Accordingly, such characteristic values can then be associated with the known location of the stationary transceiver for training various of the location processing modules of the present invention such as the classification FDMs discussed above. In particular, such training and/or calibrating may include:

(i) (re)training FDMs;

(ii) adjusting the confidence value initially assigned to a location hypothesis according to how accurate the generating FDM is in estimating the location of the stationary transceiver using data obtained from wireless signal characteristics of signals between the stationary transceiver and base stations with which the stationary transceiver is capable of communicating;

(iii) automatically updating the previously mentioned historical data base (i.e., the location signature data base), wherein the stored signal characteristic data for each stationary transceiver can be used for detecting environmental and/or topographical changes (e.g., a newly built high rise or other structures capable of altering the multipath characteristics of a given geographical area); and

(iv) tuning of the location system parameters, wherein the steps of: (a) modifying various system parameters and (b) testing the performance of the modified location system on verified mobile station location data (including the stationary transceiver signal characteristic data), these steps being interleaved and repeatedly performed for obtaining better system location accuracy within useful time constraints.

One embodiment of the present invention utilizes a mobile (location) base station (MBS) that can be, for example, incorporated into a vehicle, such as an ambulance, police car, or taxi. Such a vehicle can travel to sites having a transmitting target MS, wherein such sites may be randomly located and the signal characteristic data from the transmitting target MS at such a location can consequently be archived with a verified location measurement performed at the site by the mobile location base station. Moreover, it is important to note that such a mobile location base station as its name implies also includes base station electronics for communicating with mobile stations, though not necessarily in

the manner of a conventional infrastructure base station. In particular, a mobile location base station may (in one embodiment) only monitor signal characteristics, such as MS signal strength, from a target MS without transmitting signals to the target MS. Alternatively, a mobile location base station can periodically be in bi-directional communication with a target MS for determining a signal time-of-arrival (or time-difference-of-arrival) measurement between the mobile location base station and the target MS. Additionally, each such mobile location base station includes components for estimating the location of the mobile location base station, such mobile location base station location estimates being important when the mobile location base station is used for locating a target MS via, for example, time-of-arrival or time-difference-of-arrival measurements as one skilled in the art will appreciate. In particular, a mobile location base station can include:

- (7.1) a mobile station (MS) for both communicating with other components of the present invention (such as a location processing center included in the present invention);
- (7.2) a GPS receiver for determining a location of the mobile location base station;
- (7.3) a gyroscope and other dead reckoning devices; and
- (7.4) devices for operator manual entry of a mobile location base station location.

Furthermore, a mobile location base station includes modules for integrating or reconciling distinct mobile location base station location estimates that, for example, can be obtained using the components and devices of (7.1) through (7.4) above. That is, location estimates for the mobile location base station may be obtained from: GPS satellite data, mobile location base station data provided by the location processing center, dead reckoning data obtained from the mobile location base station vehicle dead reckoning devices, and location data manually input by an operator of the mobile location base station.

The location estimating system of the present invention offers many advantages over existing location systems. The present invention employs a number of distinctly different location estimators which provide a greater degree of accuracy and/or reliability than is possible with existing wireless location systems. For instance, the location models provided may include not only the radius-radius/TOA and TDOA techniques but also adaptive techniques such as artificial neural net techniques and the techniques disclosed in the U.S. Patent 6,026,304 by Hilsenrath et. al. incorporated by reference herein, and angle or direction of arrival techniques as well as substantially any other wireless location technique wherein appropriate input data can be obtained.

- (a) Note that hybrid location estimators based on combinations of such techniques (such as the location technique of U.S. Patent 5,987,329 by Yost et. al.) may also be provided by the present invention.

It is also an aspect of the present invention that various embodiments may provide various strategies for activating, within a single MS location instance, one or more location estimators (TOEs), wherein each such activated location estimator is provided with sufficient wireless signal data input for the activation. In one embodiment, one such strategy may be called "greedy" in that substantially as many location estimators may be activated as there is sufficient input (additionally, time and resources as well) for activation. Note that some wireless location techniques are dependent on specialized location related devices being operational such as fixed or network based receivers, antennas, transceivers, and/or signal processing equipment. Additionally note that some location techniques also require particular functionality to be operable in the MS; e.g., functionality for detecting one or more location related signals from satellites (more generally non-terrestrial transmitting stations).

For example, the signals may be GPS signals. Accordingly, certain wireless location techniques may have their activations dependent upon whether such location related devices and/or MS functionality are available and operable for each instance of determining an MS location. Thus, for each MS wireless location instance, location estimators may be activated according to the operable features present during an MS location instance for providing input activation data.

5 The present invention may be able to adapt to environmental changes substantially as frequently as desired. Thus, the present invention may be able to take into account changes in the location topography over time without extensive manual data manipulation. Moreover, the present invention can be utilized with varying amounts of signal measurement inputs. Thus, if a location estimate is desired in a very short time interval (e.g., less than approximately one to two seconds), then the present invention can be used with only as much signal measurement data as is possible to acquire during an initial portion of this time interval. Subsequently, after a greater amount of signal measurement data has been acquired, additional more accurate location estimates may be obtained. Note that this capability can be useful in the context of 911 emergency response in that a first quick coarse wireless mobile station location estimate can be used to route a 911 call from the mobile station to a 911 emergency response center that has responsibility for the area containing the mobile station and the 911 caller. Subsequently, once the 911 call has been routed according to this first quick location estimate, by continuing to receive additional wireless signal measurements, more reliable and accurate location estimates of the mobile station can be obtained.

15 Moreover, there are numerous additional advantages of the system of the present invention when applied in communication systems using, e.g., CDMA. The location system of the present invention readily benefits from the distinct advantages of the CDMA spread spectrum scheme. Namely, these advantages include the exploitation of radio frequency spectral efficiency and isolation by (a) monitoring voice activity, (b) management of two-way power control, (c) provisioning of advanced variable-rate modems and error correcting signal encoding, (d) inherent resistance to fading, (e) enhanced privacy, and (f) multiple "rake" digital data receivers and searcher receivers for correlation of signal multipaths.

20 At a more general level, it is an aspect of the present invention to demonstrate the utilization of various novel computational paradigms such as:

(8.1) providing a multiple FOM computational architecture (as illustrated in Fig. 8) wherein:

- 25 (8.1.1) the hypotheses may be generated by modular independent hypothesizing computational models (FOMs), wherein the FOMs have been calibrated to thereby output confidence values (probabilities) related to the likelihood of correspondingly generated hypotheses being correct;
- (8.1.2) the location hypotheses from the FOMs may be further processed using additional amounts of application specific processing common or generic to a plurality of the FOMs;
- 30 (8.1.3) the computational architecture may enhance the hypotheses generated by the FOMs both according to past performance of the models and according to application specific constraints and benefits without requiring complex feedback loops for recalibrating one or more of the FOMs;
- (8.1.4) the FOMs are relatively easily integrated into, modified and extracted from the computational architecture;

(8.2) providing a computational paradigm for enhancing an initial estimated solution to a problem by using this initial estimated solution as, effectively, a query or index into an historical data base of previous solution estimates and corresponding actual solutions for deriving an enhanced solution estimate based on past performance of the module that generated the initial estimated solution.

The multiple FOM architecture provided herein is useful in implementing solutions in a wide range of applications. In fact, most of the Detailed Description hereinbelow can be immediately translated into other application areas, as one skilled in the art of computer application architectures will come to appreciate. For example, the following additional applications are within the scope of the present invention:

(9.1) document scanning applications;

(9.2) diagnosis and monitoring applications such as medical diagnosis/monitoring, communication network diagnosis/monitoring. Note that in many cases, the domain wherein a diagnosis is to be performed has a canonical hierarchical order among the components within the domain. For example, in automobile diagnosis, the components of an auto may be hierarchically ordered according to ease of replacement in combination within function. Thus, within an auto's electrical system (function), there may be a fuse box, and within the fuse box there will be fuses. Thus, these components may be ordered as follows (highest to lowest): auto, electrical system, fuse box, fuses. Thus, if different diagnostic FOMs provided different hypotheses as to a problem with an auto, the confidence values for each component and its subcomponents may be summed together to provide a likelihood value that the problem within the component. Accordingly, the lowest component having, for example, at least a minimum threshold of summed confidences can be selected as the most likely component for either further analysis and/or replacement. Note that such summed confidences may be normalized by dividing by the number of hypotheses generated from the same input so that the highest summed confidence is one and the lowest is zero. Further note that this example is merely representative of a number of different diagnosis and/or prediction applications to which the present invention is applicable, wherein there are components that have canonical hierarchical decompositions. For example, a technique similar to the auto illustration above may be provided for the diagnosis of computer systems, networks (LANs, WANs, Internet and telephony networks), medical diagnosis from, e.g., x-rays, MRIs, sonograms, etc;

(9.3) robotics applications such as scene and/or object recognition. That is, various FOMs may process visual image input differently, and it may be that for expediency, an object is recognized if the summed confidence values for the object being recognized is above a certain threshold;

(9.4) seismic and/or geologic signal processing applications such as for locating oil and gas deposits;

(9.5) recognition of terrestrial and/or airborne objects from satellites, wherein there may be various spectral bands monitored.

(9.6) Additionally, note that this architecture need not have all modules co-located. In particular, it is an additional aspect of the present invention that various modules can be remotely located from one another and communicate with one another via telecommunication transmissions such as telephony technologies and/or the Internet. Accordingly, the present invention is particularly adaptable to such distributed computing environments. For example, some number of the first order models may reside in remote locations and communicate their generated hypotheses via the Internet.

In an alternative embodiment of the present invention, the processing following the generation of location hypotheses (each having an initial location estimate) by the first order models may be such that this processing can be provided on Internet user nodes and the first order models may reside at Internet server sites. In this configuration, an Internet user may request hypotheses from such remote first order models and perform the remaining processing at his/her node.

5 Additionally, note that it is within the scope of the present invention to provide one or more central location development sites that may be networked to, for example, geographically dispersed location centers providing location services according to the present invention, wherein the FOMs may be accessed, substituted, enhanced or removed dynamically via network connections (via, e.g., the Internet) with a central location development site. Thus, a small but rapidly growing municipality in substantially flat low density area might initially be provided with access to, for example, two or three FOMs for generating location hypotheses in the municipality's relatively uncluttered radio signaling  
10 environment. However, as the population density increases and the radio signaling environment becomes cluttered by, for example, thermal noise and multipath, additional or alternative FOMs may be transferred via the network to the location center for the municipality.

Note that in some embodiments of the present invention, since there is a lack of sequencing between the FOMs and subsequent processing of hypotheses (e.g., location hypotheses, or other application specific hypotheses), the FOMs can be incorporated into an expert system, if desired. For example, each FOM may be activated from an antecedent of an expert system rule. Thus, the antecedent for such a rule can  
15 evaluate to TRUE if the FOM outputs a location hypothesis, and the consequent portion of such a rule may put the output location hypothesis on a list of location hypotheses occurring in a particular time window for subsequent processing by the location center. Alternatively, activation of the FOMs may be in the consequents of such expert system rules. That is, the antecedent of such an expert system rule may determine if the conditions are appropriate for invoking the FOM(s) in the rule's consequent.

The present invention may also be configured as a blackboard system with intelligent agents (FOMs). In this embodiment, each of the  
20 intelligent agents is calibrated using archived data so that for each of the input data sets provided either directly to the intelligent agents or to the blackboard, each hypothesis generated and placed on the blackboard by the intelligent agents has a corresponding confidence value indicative of an expected validity of the hypothesis.

Of course, other software architectures may also be used in implementing the processing of the location center without departing from scope of the present invention. In particular, object-oriented architectures are also within the scope of the present invention. For example, the FOMs may be object methods on an MS location estimator object, wherein the estimator object receives substantially all target MS location  
25 signal data output by the signal filtering subsystem. Alternatively, software bus architectures are contemplated by the present invention, as one skilled in the art will understand, wherein the software architecture may be modular and facilitate parallel processing.

Further features and advantages of the present invention are provided by the figures and detailed description accompanying this invention summary.

30 BRIEF DESCRIPTION OF THE DRAWINGS

Fig. 1 illustrates various perspectives of radio propagation opportunities which may be considered in addressing correlation with mobile to base station ranging.

Fig. 2 shows aspects of the two-ray radio propagation model and the effects of urban clutter.

Fig. 3 provides a typical example of how the statistical power budget is calculated in design of a Commercial Mobile Radio Service

5 Provider network.

Fig. 4 illustrates an overall view of a wireless radio location network architecture, based on advanced intelligent network (AIN) principles.

Fig. 5 is a high level block diagram of an embodiment of the present invention for locating a mobile station (MS) within a radio coverage area for the present invention.

10 Fig. 6 is a high level block diagram of the location center 142.

Fig. 7 is a high level block diagram of the hypothesis evaluator for the location center.

Fig. 8 is a substantially comprehensive high level block diagram illustrating data and control flows between the components of (and/or accessed by) the location center/gateway 142, as well the functionality of these components.

15 Fig. 9A and 9B are a high level data structure diagram describing the fields of a location hypothesis object generated by the first order models 122A of the location center.

Fig. 10 is a graphical illustration of the computation performed by the most likelihood estimator 134A of the hypothesis evaluator.

Fig. 11 is a high level block diagram of the mobile base station (MBS).

Fig. 12 is a high level state transition diagram describing computational states the Mobile Base station enters during operation.

20 Fig. 13 is a high level diagram illustrating the data structural organization of the Mobile Base station capability for autonomously determining a most likely MBS location from a plurality of potentially conflicting MBS location estimating sources.

Fig. 14 illustrates the primary components of the signal processing subsystem.

Fig. 15 illustrates how automatic provisioning of mobile station information from multiple CMRS occurs.

25 Fig. 16 illustrates another embodiment of the location engine 134, wherein the context adjuster 132B (denoted in this figure as "location hypothesis adjuster modules") includes a module (143B) that is capable of adjusting location hypotheses for reliability, and another module (144B) that is capable of adjusting location hypotheses for accuracy.

Fig. 17 illustrates the primary components of the signal processing subsystem.

Fig. 18 is a block diagram further illustrating the present invention as a wireless location gateway.

Fig. 19 is a block diagram of an electronic networked yellow pages for providing intelligent advertising services, wherein wireless location services may be utilized.

30 DETAILED DESCRIPTION

Detailed Description Introduction

When performing wireless location as described herein, substantial improvements in radio location can be achieved since CDMA and other advanced radio communication infrastructures can be used for enhancing radio location. For example, the capabilities of IS-41 and advanced intelligent network (AIN) already provide a coarse-granularity of wireless location, as is necessary to, for example, properly direct a terminating call to an MS. Such information, originally intended for call processing usage, can be re-used in conjunction with the wireless location processing described herein to provide wireless location in the large (i.e., to determine which country, state and city a particular MS is located), and wireless location in the small (i.e., which location, plus or minus a few hundred feet a given MS is located).

Fig. 4 is a high level diagram of one embodiment of a wireless radiolocation architecture for the present invention. Accordingly, this figure illustrates the interconnections between the components of a wireless cellular communication network, such as, a typical PCS network configuration and various components that are specific to the present invention. In particular, as one skilled in the art will understand, a typical wireless (PCS) network includes:

- (a) a (large) plurality of wireless mobile stations (MSs) 140 for at least one of voice related communication, textual (e.g., text such as is provided by a short message service) related communication, and according to present invention, location related communication. Note that some of the MSs 140 may include the electronics and corresponding software to detect and process signals from non-terrestrial transmission stations such as GPS and/or GLONASS satellites. Moreover, note that such non-terrestrial transmission stations can also be high altitude aircraft which, e.g., can hover over a metropolitan area thereby facilitating wireless communication;
- (b) a mobile switching center (MSC) 172;
- (c) a plurality of wireless cell sites in a radio coverage area 120, wherein each cell site includes an infrastructure base station such as those labeled 122 (or variations thereof such as 122A - 122B). In particular, the base stations 122 denote the standard high traffic, fixed location base stations used for voice and data communication with a plurality of MSs 140, and, according to the present invention, also used for communication of information related to locating such MSs 140. Additionally, note that the base stations labeled 152 are more directly related to wireless location enablement. For example, as described in greater detail hereinafter, the base stations 152 may be low cost, low functionality transponders that are used primarily in communicating MS location related information to the location center 142 (via base stations 122 and the MSC 172). Note that unless stated otherwise, the base stations 152 will be referred to hereinafter as location base station(s) 152 or simply LBS(s) 152;
- (d) a public switched telephone network (PSTN) 174 (which may include signaling system links 106 having network control components such as: a service control point (SCP) 104, one or more signaling transfer points (STPs) 110.

In addition, the present invention provides one or more location centers/gateways 142. Such gateways may be described at a high level as follows.

#### 30 Location Center/Gateway 142 Description



A location center/gateway 142, (also be referred to as a location center/gateway, or simply gateway), in response to a location request received at the location center, can request activation of one or more of a plurality of wireless location techniques in order to locate an MS 140.

Various embodiments are provided herein of the location center/gateway 142. In particular, Fig. 18 is block diagram illustrating another embodiment of the location center/gateway 142 of the present invention. Note that the wireless location gateway activation requests may be dependent upon, e.g.,

- (a) a wireless network with which the MS 140 may be in contact, such a network may be:
  - (i) a commercial mobile radio network supporting telephony functionality,
  - (ii) a short messaging service or paging network;
  - (iii) a wireless network of beacons for providing location related information such as GPS and LORAN C,
  - (iv) wireless carrier independent networks for performing wireless location such as the wireless location network provided by Times Three, Suite #220, Franklin Airpark, 2015 5th Avenue N.E., Calgary, AB T2A 6T8,
  - (v) a wireless broadcasting network for use in activating an MS 140 of, e.g., a stolen vehicle such as is provided by LuJack Corporation, 333 Elm Street, Dedham, MA 02026, and/or
  - (vi) a hybrid network including portions of wireless networks each network providing different types of signal measurements for performing wireless location);
- (b) the location signal measurement obtaining capabilities of the wireless network with which the MS may be in contact. For example, such a network may only support a network centric location technique;
- (c) the functionality of the MS 140 such as: the type(s) of wireless signals which can be detected and processed by the MS such as:
  - (i) non-terrestrial signals such as GPS signals,
  - (ii) signals from wireless beaconing/broadcasting systems such as for LORAN C signals or stolen vehicle broadcast networks for activating an MS 140 attached to the stolen vehicle, or
  - (iii) wireless telephony protocols like CDMA, TDMA, and/or GSM,
- (d) a likely location of the target MS 140. For example, if the target MS 140 is likely to be in Japan rather than the United States, then the location service provider contacted by the gateway 142 may be different from the location service provider if the MS is likely to be in the U.S.

Moreover, regarding the plurality of wireless location techniques (embodiments thereof also denoted herein as "location estimators") for which activation may be requested by the gateway, these techniques may be co-located with the gateway, accessible via a network including: (i) local area networks, and (ii) wide area networks such as a telephony (wired or wireless) network, the Internet or a cable network. The gateway 142 may supply to one or more of the location estimators, measurements of communications between the MS 140 and one or more

networks for determining a location of the MS 140. Alternatively, instead of supplying such measurements (locally or remotely, and, via a network or otherwise), the gateway 142 may provide, with the location activation request, an identification of where the measurements may be obtained (e.g., one or more network addresses). In yet another alternative, such a gateway 142 may also send request(s) to the network(s) having such MS communication measurements to forward them to particular location estimators. Note, that in performing these tasks, the gateway 142 may receive with a location request (or may retrieve in response thereto) information regarding the functionality of the target MS 140, e.g., as discussed above. Accordingly, such information may be used in selecting the location estimator to which an activation request is provided. Thus, the gateway 142 may be the intermediary between location requesting applications and the location estimators, thereby providing a simple, uniform application programming interface (API) for such applications substantially independently of the location estimators that are activated to fulfill such location requests. Moreover, the gateway 142 (or embodiments thereof) can substantially ease the burden on geolocation service providers by providing a substantially uniform method for obtaining target MS/network signal data for use in locating the target MS. Then, by interfacing to the gateway 142, a location service provider may substantially reduce the number and complexity of its data exchange interfaces with the wireless networks for obtaining target MS/network signal data. Similarly, the networks capturing such signal data may also reduce the complexity and number of their interfaces for providing such signal data to location service providers. Additionally, note that the gateway may also fulfill location requests wherein the location is for a stationary and/or wireline handset instead of a mobile station 140. Accordingly, the gateway 142 may request access to, e.g., phone location information stored in a carrier's database of premise provisioning equipment as one skilled in the art will understand.

In some embodiments of the gateway 142, it may also facilitate in the providing of certain location related services in addition to providing, e.g., MS 140 locations. In particular, one or more of the following location related services may be facilitated by the gateway 142 or may be made operative via the wireless location capabilities of the gateway 142. However, note that the following location related services can, in general, be provided without use of a gateway 142, albeit, e.g., in a likely more restricted context wherein not all available wireless location estimating techniques are utilized, and/or by multiplying the number of interfaces to geolocation service providers (e.g., distinct wireless location interfaces provided directly to each wireless location service provider utilized). Further note that at some of these applications are described in greater detail in later sections herein:

- (10.1) Routing instructions for directing a vehicle or person to get to a desired destination. Note, that there are various forms of utilizing MS location capabilities to determine an appropriate route, and related teachings are provided in copending U.S. patent application titled, "Wireless Location Using A Plurality of Commercial Network Infrastructures," by F. W. LeBlanc, Dupray and Karr filed Jan. 22, 1999 and having US Patent No. 6,326,366 issued May 22, 2001 which is fully incorporated herein by reference, and by the following two copending U.S. patent applications which are also incorporated herein by reference: (i) "Location Of A Mobile Station" filed Nov. 24, 1999 having Application No. 09/194,367 whose inventors are Dupray and Karr, and (ii) "A Wireless Location System For Calibrating Multiple Location Estimators" filed October 21, 1998 having Application No. 09/176,387 whose inventor is Dupray. Additionally, other routing services may also be provided by the gateway 142 (or by service providers in cooperation with the gateway). For example, the gateway 142 may cooperate

with an automated speech recognition interpretation and synthesis unit for providing substantially automated interactive communication with an MS 149 for providing spoken directions. Note that such directions may be provided in terms of street names and/or descriptions of the terrain (e.g., "the glass high rise on the left having pink tinted glass").

(10.2) Advertising may be directed to an MS 149 according to its location. In at least some studies it appears that MS 149 users do not respond well to unsolicited wireless advertisement whether location based or otherwise. However, in response to certain user queries for locally available merchandise, certain advertisements may be viewed in a more friendly light. Thus, by allowing an MS user to contact, e.g., a wireless advertising portal by voice or via wireless Internet, and describe certain merchandise desired (e.g., via interacting with an automated speech interaction unit) the user may be able to describe and receive (at his/her MS 149) visual displays of merchandise that may satisfy such a user's request. For example, an MS user may provide a spoken request such as: "I need a shirt, who has specials near here?".

(10.3) Applications that combine routing with safety for assisting MS users with requests such as "How do I get back to the hotel safely?".

(10.4) Applications that combine routing with sight seeing guided tour where routing is interactive and depending on feedback from users regarding, e.g., user interests;

(10.5) Applications using Internet picture capture with real time voice capture and MS location (e.g., sightseeing, security, and law enforcement).

(10.6) Intelligent transportation (e.g., voice commanded vehicles)

(10.7) Applications that monitor whether or not a person or object (e.g., a vehicle) is within a predetermined boundary. Note that such an application may automatically provide speech output to the MS user (or other authorized user) when the person or object is beyond the predetermined boundary;

(10.8) Applications that route to an event and automatically determine parking availability and where to park;

(10.9) Traffic/weather condition routing

Further note that various architectures for the location center/location gateway are within the scope of the invention including a distributed architecture wherein in addition to the FQDN being possibly remotely accessed (e.g., via a communications network such as the Internet), the gateway itself may be distributed throughout one or more communication networks. Thus, a location request received at a first location gateway portion may be routed to a second location gateway portion (e.g., via the Internet). Such a distributed gateway may be considered a "meta-gateway" and in fact such gateway portions may be fully functioning gateways in their own right. Thus, such routing therebetween may be due to contractual arrangements between the two gateways (each fulfilling location requests for a different network, wireless carrier, and/or geographical region). For example, for locating a stolen vehicle, it is not uncommon for the stolen vehicle to be transported rapidly beyond the coverage area of a local or regional wireless vehicle locating service. Moreover, a given location gateway may provide location information for only certain areas corresponding, e.g., to contractual arrangements with the wireless carriers with which the location gateway is affiliated. Thus, a first location gateway may provide vehicle location for a first collection of one or more wireless networks,

and a second location gateway may provide vehicle locations for a second collection of one or more wireless networks. Accordingly, for an MS 140 built into a vehicle which can be detected by one or more wireless networks (or portions thereof) in each of the first and second collections, then if the vehicle is stolen, the first gateway may be initially contacted for determining whether the vehicle can be located via communications with the first collection of one or more wireless networks, and if the vehicle can not be located, the first gateway may provide a location request to the second gateway for thereby locating the stolen vehicle via wireless communications with one or more wireless networks of the second collection. Furthermore, the first gateway may provide location requests for the stolen vehicle to other location gateways.

The present invention provides the following additional components:

- (n1.1) one or more mobile base stations 148 (MBS) which are optional, for physically traveling toward the target MS 140 or tracking the target MS;
- (n1.2) a plurality of location base stations 152 (LBS) which are optional, distributed within the radio coverage areas 720, each LBS 152 having a relatively small MS 140 detection area 154. Note that such LBSs 152 may also support Internet and/or TCP/IP transmissions for transmitting visual location related information (e.g., graphical, or pictorial) related to an MS location request.

Since location base stations 152 can be located on, e.g., each floor of a multi-story building, the wireless location technology described herein can be used to perform location in terms of height as well as by latitude and longitude.

In operation, an MS 140 may utilize one or more of the wireless technologies, CDMA, TDMA, AMPS, HAPPS or GSM for wireless communication with: (a) one or more infrastructure base stations 722, (b) mobile base station(s) 148, or (c) an LBS 152. Additionally, note that in some embodiments of the invention, there may be MS to MS communication.

Referring to Fig. 4 again, additional detail is provided of typical base station coverage areas, sectorization, and high level components within a radio coverage area 720, including the MSC 712. Three exemplary base stations (BSs) are 722A, 722B and 722C, each of which radiate referencing signals within their area of coverage 164 to facilitate mobile station (MS) 140 radio frequency connectivity, and various timing and synchronization functions. Note that some base stations may contain no sectors 130 (e.g. 722E), thus radiating and receiving signals in a 360 degree omnidirectional coverage area pattern, or the base station may contain "smart antennas" which have specialized coverage area patterns. However, the generally most frequent base stations 722 have three sector 130 coverage area patterns. For example, base station 722A includes sectors 130, additionally labeled a, b and c. Accordingly, each of the sectors 130 radiate and receive signals in an approximate 120 degree arc, from an overhead view. As one skilled in the art will understand, actual base station coverage areas 164 (stylistically represented by hexagons about the base stations 722) generally are designed to overlap to some extent, thus ensuring seamless coverage in a geographical area. Control electronics within each base station 722 are used to communicate with a mobile stations 140. Information regarding the coverage area for each sector 130, such as its range, area, and "holes" or areas of no coverage (within the radio coverage area 720), may be known and used by the location center 142 to facilitate location determination. Further, during communication with a mobile station 140, the identification of each base station 722 communicating with the MS 140 as well, as any sector identification information, may be known and provided to the location center 142.

In the case of the base station types 122, 148, and 152 communicating location information, a base station or mobility controller 174 (BSC) controls, processes and provides an interface between originating and terminating telephone calls from/to mobile station (MS) 140, and the mobile switch center (MSC) 112. The MSC 112, on-the-other-hand, performs various administration functions such as mobile station 140 registration, authentication and the relaying of various system parameters, as one skilled in the art will understand.

The base stations 122 may be coupled by various transport facilities 176 such as leased lines, frame relay, T-carrier links, optical fiber links or by microwave communication links.

When an MS 140 is powered on and in the idle state, it constantly monitors the pilot signal transmissions from each of the base stations 122 located at nearby cell sites. Since base station/sector coverage areas may often overlap, such overlapping enables an MS 140 to detect, and, in the case of certain wireless technologies, communicate simultaneously along both the forward and reverse paths, with multiple base stations 122 and/or sectors 130. In Fig. 4, the constantly radiating pilot signals from base station sectors 130, such as sectors a, b and c of BS 122A, are detectable by MSs 140 within the coverage area 104 for BS 122A. That is, the mobile station 140 scans for pilot channels, corresponding to a given base station/sector identifier (ID), for determining in which coverage area 104 (i.e., cell) it is contained. This is performed by comparing signal strengths of pilot signals transmitted from these particular cell-sites.

The mobile station 140 then initiates a registration request with the MSC 112, via the base station controller 174. The MSC 112 determines whether or not the mobile station 140 is allowed to proceed with the registration process (except, e.g., in the case of a 911 call, wherein no registration process is required). Once any required registration is complete, calls may be originated from the mobile station 140 or calls or short message service messages can be received from the network. Note that the MSC 112 communicates as appropriate, with a class 4/5 wireline telephony circuit switch or other central offices, connected to the PSTN 124 network. Such central offices connect to wireline terminals, such as telephones, or any communication device compatible with a wireline. The PSTN 124 may also provide connections to long distance networks and other networks.

The MSC 112 may also utilize IS-41 data circuits or trunks connecting to signal transfer point 110, which in turn connects to a service control point 104, via Signaling System #7 (SS7) signaling links (e.g., trunks) for intelligent call processing, as one skilled in the art will understand. In the case of wireless AIN services such links are used for call routing instructions of calls interacting with the MSC 112 or any switch capable of providing service switching point functions, and the public switched telephone network (PSTN) 124, with possible termination back to the wireless network.

Referring still to Fig. 4, the location center/gateway (LC) 142 interfaces with the MSC 112 either via dedicated transport facilities 176, using, e.g., any number of LAN/WAN technologies, such as Ethernet, Fast Ethernet, frame relay, virtual private networks, etc., or via the PSTN 124. The gateway 142 may receive autonomous (e.g., unsolicited) commands/response messages regarding, for example: (a) the state of the wireless network of each commercial radio service provider utilizing the LC 142 for wireless location services, (b) MS 140 and BS 122 radio frequency (RF) measurements, (c) communications with any MBSs 148A, and (d) location applications requesting MS location using the location center/gateway 142. Conversely, the LC 142 may provide data and control information to each of the above components in (a)-(d). Additionally, the LC 142

may provide location information to an MS 140, via a BS 122. Moreover, in the case of the use of a mobile base station (MBS) 148, several communications paths may exist with the LC 142.

The MBS 148 may act as a low cost, partially-functional, moving base station, and is, in one embodiment, situated in a vehicle (e.g., land, water or aircraft) where an operator may engage in MS 140 searching and tracking activities. In providing these activities using CDMA, the MBS 148 provides a forward link pilot channel for a target MS 140, and subsequently receives unique BS pilot strength measurements from the MS 140. The MBS 148 also includes a mobile station 140 for data communication with the gateway 142, via a BS 122. In particular, such data communication includes telemetering at least the geographic position (or estimates thereof) of the MBS 148, various RF measurements related to signals received from the target MS 140, and in some embodiments, MBS 148 estimates of the location of the target MS 140. In some embodiments, the MBS 148 may utilize multiple-beam fixed antenna array elements and/or a moveable narrow beam antenna, such as a microwave dish 182. The antennas for such embodiments may have a known orientation in order to further define a radio location of the target MS 140 with respect to an estimated current location of the MBS 148. As will be described in more detail herein below, the MBS 148 may further contain a satellite (e.g., Global Positioning System (GPS)) receiver (or other receiver for non-terrestrial wireless signals) for determining the location of the MBS 148 and/or providing wireless location assistance a target MS 140, e.g., providing GPS information to the MS to assist the MS in determining its location. Additionally, the MBS 148 may include distance sensors, dead-reckoning electronics, as well as an on-board computing system and display devices for locating both the MBS 148 itself as well as tracking and locating the target MS 140. The computing and display provides a means for communicating the position of the target MS 140 on a map display to an operator of the MBS 148. It is important to note that in one embodiment, an MBS 148 may determine its location substantially independent of the communication network(s) with which the MBS communicates.

Each location base station (LBS) 152 is a low cost location device. In some embodiments, to provide such LBS's cost effectively, each LBS 152 only partially or minimally supports the air-interface standards of the one or more wireless technologies used in communicating with both the BS 122 and the MS 140. Each LBS 152, when put in service, is placed at a fixed location, such as at a traffic signal, lamp post, etc., wherein the location of the LBS may be determined as accurately as, for example, the accuracy of the locations of the infrastructure BS 122. Assuming the wireless technology, CDMA, is used, each BS 122 uses a time offset of the pilot PN sequence to identify a forward CDMA pilot channel. In one embodiment, each LBS 152 emits a unique, time-offset pilot PN sequence channel in accordance with the CDMA standard in the RF spectrum designated for BS 122, such that the channel does not interfere with neighboring BS 122 cell site channels, and does not interfere with neighboring LBS 152. Each LBS 152 may also contain multiple wireless receivers in order to monitor transmissions from a target MS 140. Additionally, each LBS 152 contains mobile station 140 electronics, thereby allowing the LBS to both be controlled by, e.g., the gateway 142 or the wireless carrier(s) for the LBS, and to transmit information to, e.g., the gateway 142 (via, e.g., at least one neighboring BS 122), or to another wireless location service provider such as one providing one or more FOMs.

As mentioned above, when the location of a particular target MS 140 is desired, the gateway 142 may request location information about the target MS 140 from, for instance, one or more activated LBS 152 in a geographical area of interest. Accordingly, whenever the target MS 140 is in an LBS coverage area, or is suspected of being in the coverage area, either upon command from the gateway 142 (or other location

service provider), or in a substantially continuous (or periodic) fashion, the LBS's pilot channel appears to the target MS 140 as a potential neighboring base station channel, and consequently, is placed, for example, in the CDMA neighboring set, or the CDMA remaining set of the target MS 140 (as one familiar with the CDMA standards will understand).

During the normal CDMA pilot search sequence of the mobile station initialization state (in the target MS), the target MS 140 will, if within range of such an activated LBS 152, detect the LBS pilot presence during the CDMA pilot channel acquisition substrate. Consequently, the target MS 140 performs RF measurements on the signal from each detected LBS 152. Similarly, an activated LBS 152 can perform RF measurements on the wireless signals from the target MS 140. Accordingly, each LBS 152 detecting the target MS 140 may subsequently telemeter back to the LC 142 measurement results related to signals from/to the target MS 140. Moreover, upon command, the target MS 140 may telemeter back to the gateway 142 its own measurements of the detected LBSs 152, and consequently, this new location information, in conjunction with location related information received from the BSs 122, can be used to locate the target MS 140.

It should be noted that an LBS 152 will normally deny hand-off requests, since typically the LBS does not require the added complexity of handling voice or traffic bearer channels, although economic and peak traffic load conditions may dictate preference here. Note that GPS timing information, needed by any CDMA base station, is either achieved via a the inclusion of a local GPS receiver or via a telemetry process from a neighboring conventional BS 122, which contain a GPS receiver and timing information. Since energy requirements are minimal in such an LBS 152, (rechargeable) batteries or solar cells may be used to power the LBSs. Further, no expensive terrestrial transport link is typically required since two-way communication is provided by an included MS 140 (or an electronic variation thereof) within each LBS. Thus, LBSs 152 may be placed in numerous locations, such as:

- (a) in dense urban canyon areas (e.g., where signal reception may be poor and/or very noisy);
- (b) in remote areas (e.g., hiking, camping and skiing areas);
- (c) along highways (e.g., for emergency as well as monitoring traffic flow), and their rest stations; or
- (d) in general, wherever more location precision is required than is obtainable using other wireless infrastructure network components.

#### Location Center - Network Elements API Description

A location application programming interface 136 (Fig. 4), denoted L-API, is may be provided between the location center/gateway 142 (LC) and the mobile switch center (MSC) network element type, in order to send and receive various control, signals and data messages. The L-API may be implemented using a preferably high-capacity physical layer communications interface, such as IEEE standard 802.3 (no base! Ethernet), although other physical layer interfaces could be used, such as fiber optic ATM, frame relay, etc. At least two forms of L-API implementation are possible. In a first case, the signal control and data messages are provided using the MSC 132 vendor's native operations messages inherent in the product offering, without any special modifications. In a second case, the L-API includes a full suite of commands and messaging content specifically optimized for wireless location purposes, which may require some, although minor development on the part of an MSC vendor.

## Signal Processor Description

Referring to Fig. 17, a signal processing subsystem (labeled 720 in other figures) may be provided (or accessed) by the gateway 102. Such a signal processing subsystem may: (a) receive control messages and signal measurements from one or more wireless service providers networks, and (b) transmit appropriate control messages to such wireless networks via the location applications programming interface 730 referenced earlier, for wireless location purposes. The signal processing subsystem 720 additionally provides various signal identification, conditioning and pre-processing functions, including buffering, signal type classification, signal filtering, message control and routing functions to the location estimating modules or FDM.

There can be several combinations of Delay Spread/Signal Strength sets of measurements made available to the signal processing subsystem 720. In some cases a mobile station 140 (Fig. 1) may be able to detect up to three or four pilot channels representing three to four base stations, or as few as one pilot channel, depending upon the environment and wireless network configuration. Similarly, possibly more than one BS 722 can detect a mobile station 140 transmitter signal, and the fact that multiple (MBS) base station equipment commonly will overlap coverage areas.

For each mobile station 140 or BS 722 transmitted signal that is detected by a receiver group at a base or mobile station, respectively, multiple delayed signals, or "fingers" may be detected (e.g., in CDMA) and tracked resulting from multipath radio propagation conditions from a given transmitter. In typical spread spectrum diversity CDMA receiver design, the "first" finger represents the most direct, or least delayed multipath signal. Second or possibly third or fourth fingers may also be detected and tracked, assuming the detecting base station and/or mobile station 140 contain a sufficient number of data receivers for doing so. The signal processing subsystem may utilize various wireless signal measurements of transmissions between a target mobile station 140 and a network of base stations 722, 152 and/or 148. Such measurements can be important in effectively estimating the location of mobile stations 140 in that it is well known that measurements of wireless signal propagation characteristics, such as signal strength (e.g., RSSI), time delay, angle of arrival, and any number other measurements, can individually lead to gross errors in MS 140 location estimates.

Accordingly, one aspect of the present invention is directed to utilizing a larger number of wireless signal measurements, and utilizing a plurality of MS 140 estimation techniques to compensate for location estimation errors generated by some such techniques. For example, due to the large capital outlay costs associated with providing three or more overlapping base station coverage signals in every possible location, most practical digital PCS deployments result in fewer than three base station pilot channels being reportable in the majority of location areas, thus resulting in a larger, more amorphous location estimates by terrestrial triangulation systems. Thus, by utilizing wireless signal measurements from a variety of sources substantially simultaneously and/or "greedily" (i.e., use whatever signal measurements can be obtained from any of the signal sources as they are obtained), additional location enhancements can be obtained. For example, by enhancing a mobile station 140 with electronics for detecting satellite transmissions (as done with mobile base stations 148 and which also can be viewed as such an enhanced mobile station 140) additional location related signals may be obtained from:

- (a) the GPS satellite system,
- (b) the Global Navigation Satellite System (GLONASS) satellite system, a Russian counterpart to the U.S. GPS system, and/or



(c) the numerous low earth orbit satellite systems (LEOs) and medium earth orbit satellite systems (MEOs) such as the IRISSIM system being developed by Motorola Corp., the GLOBALSTAR system by Loral and Qualcomm, and the IEO satellite system by IC Global Communications.

Thus, by combining even insufficient wireless location measurements from different wireless communication systems, accurate location of an MS 140 is possible. For example, by if only two GPS satellites are detectable, but there is an additional reliable wireless signal measurement from, e.g., a terrestrial base station 122, then by triangulating using wireless signal measurements derived from transmissions from each of these three sources, a potentially reliable and accurate MS location can be obtained.

Moreover, the transmissions from the MS 140 used for determining the MS's location need not be transmitted to terrestrial base stations (e.g., 122). It is within the scope of the present invention that a target MS 140 may transmit location related information to satellites as well. For example, if a target MS 140 detects two GPS satellite transmissions and is able to subsequently transmit the GPS signal measurements (e.g., timing measurements) to an additional satellite capable of determining additional MS location measurements according to the signals received, then by performing a triangulation process at the location center/gateway 142 (which may be co-located with the additional satellite, or at a remote terrestrial site), a potentially reliable and accurate MS location can be obtained. Accordingly, the present invention is capable of resolving wireless location ambiguities due to a lack of location related information of one type by utilizing supplemental location related information of a different type. Note that by "type" as used here it is intended to be interpreted broadly as, e.g.,

- (a) a data type of location information, and/or
- (b) communications from a particular commercial wireless system as opposed to an alternative system, each such system having distinct groups of known or registered MS users.

Moreover, it can be that different FDNs are provided for at least some wireless location computational models utilizing different types of location related information. For example, in certain contexts wireless networks based on different wireless signaling technologies may be used to locate an MS 140 during the time period of a single emergency call such as 911. Moreover, in other contexts it may be possible for the target MS 140 to use one or more of a plurality of wireless communication networks, possibly based on different wireless communication technologies, depending on availability of the technology in the coverage area. In particular, since so called "dual mode" or "tri-mode" mobile stations 140 are available, wherein such mobile stations are capable of wireless communication in a plurality of wireless communication technologies, such as digital (e.g., CDMA, and/or TDMA) as well as analog or AMPS/IS-136, such mobile stations may utilize a first (likely a default) wireless communication technology whenever possible, but switch to another wireless communication technology when, e.g., coverage of the first wireless technology becomes poor. Moreover, such different technologies are typically provided by different wireless networks (wherein the term "network" is understood to include a network of communication supporting nodes geographically spaced apart that provide a communications infrastructure having access to information regarding subscribers to the network prior to a request to access the network by the subscribers). Accordingly, the present invention may include (or access) FDNs for providing mobile station location estimates wherein the target MS 140 communicates with various networks using different wireless communication technologies. Moreover, such FDNs may be activated according to the wireless signal measurements received from various wireless networks and/or wireless technologies supported by a target MS 140 and to which

there is a capability of communicating measurements of such varied wireless signals to the FOM(s). Thus, in one embodiment of the present invention, there may be a triangulation (or trilateration) based FOM for each of CDMA, TDMA and AMF/HANPS which may be singly, serially, or concurrently for obtaining a particular location of an MS 140 at a particular time (e.g., for an E911 call). Thus, when locating a target MS 140, the MS may, if there is overlapping coverage of two wireless communication technologies and the MS supports communications with both, repeatedly switch back and forth between the two thereby providing additional wireless signal measurements for use in locating the target MS 140.

In one embodiment of the present invention, wherein multiple FOMs may be activated substantially simultaneously (or alternatively, whenever appropriate input is received that allow particular FOMs to be activated). Note that at least some of the FOMs may provide "inverse" estimates of where a target MS 140 is not instead of where it is. Such inverse analysis can be very useful in combination with location estimates indicating where the target MS is in that the accuracy of a resulting MS location estimate may be substantially decreased in size when such inverse estimates are utilized to rule out areas that otherwise appear to be likely possibilities for containing the target MS 140. Note that one embodiment of a FOM that can provide such reverse analysis is a location computational model that generates target MS location estimates based on archived knowledge of base station coverage areas (such an archive being the result of, e.g., the compilation a BS coverage database - either via RF coverage area simulations or field tests). In particular, such a model may provide target MS location inverse estimates having a high confidence or likelihood that the target MS 140 is not in an area since either a base station 122 (or 152) can not detect the target MS 140, or the target MS can not detect a particular base station. Accordingly, the confidences or likelihoods on such estimates may be used by diminishing a likelihood that the target MS is in an area for the estimate, or alternatively the confidence or likelihood of all areas of interest outside of the estimate can increased.

Note that in some embodiments of the present invention, both measurements of forward wireless signals to a target MS 140, and measurements of reverse wireless signals transmitted from the target MS to a base station can be utilized by various FOMs. In some embodiments, the received relative signal strength (RRSS<sub>ms</sub>) of detected nearby base station transmitter signals along the forward link to the target mobile station can be more readily used by the location estimate modules (FOMs) since the transmission power of the base stations 122 typically changes little during a communication with a mobile station. However, the relative signal strength (RRSS<sub>ms</sub>) of target mobile station transmissions received by the base stations on the reverse link may require more adjustment prior to location estimate model use, since the mobile station transmitter power level changes nearly continuously.

#### LOCATION CENTER HIGH LEVEL FUNCTIONALITY

At a very high level the location center/gateway 142 computes (or requests computation of) location estimates for a wireless mobile station 140 by performing at least some of the following steps:

(22.0) receiving an MS location request;

- (23.1) receiving measurements of signal transmission characteristics of communications communicated between the target MS 140 and one or more wireless infrastructure base station 122. Note, this step may only be performed if the gateway provides such measurements to a FOM (e.g., a FOM co-located therewith);
- (23.2) filtering the received signal transmission characteristics (by a signal processing subsystem 1220 illustrated in, e.g., Figs. 5 and 30) as needed so that target MS location data can be generated that is uniform and consistent with location data generated from other target MS 140. In particular, such uniformity and consistency is both in terms of data structures and interpretation of signal characteristic values provided by the MS location data, as will be described hereinafter. Note, this step may also only be performed if the gateway provides such measurements to a FOM. Otherwise, such FOM is likely to perform such filtering;
- (23.3) inputting the generated target MS location data to one or more MS location estimating models (FOMs, labeled collectively as 1224 in Fig. 5), so that each such FOM may use the input target MS location data for generating a "location hypothesis" providing an estimate of the location of the target MS 140. Note, this step may also only be performed if the gateway provides such measurements to a FOM;
- (23.4) receiving the resulting location hypotheses from the activated FOMs, and providing the generated location hypotheses to a hypothesis evaluation module (denoted the hypothesis evaluator 1228 in Fig. 5) for:
- (a) (optionally) adjusting the target MS location estimates of the generated location hypotheses and/or adjusting confidence values of the location hypotheses, wherein for each location hypothesis, its confidence value indicates the confidence or likelihood that the target MS is located in the location estimate of the location hypothesis. Moreover, note that such adjusting uses archival information related to the accuracy and/or reliability of previously generated location hypotheses;
  - (b) (optionally) evaluating the location hypotheses according to various heuristics related to, for example, the radio coverage area 120 terrain, the laws of physics, characteristics of likely movement of the target MS 140; and
  - (c) (necessarily) determining a most likely location area for the target MS 140, wherein the measurement of confidence associated with each input MS location area estimate may be used for determining a "most likely location area"; and
- (23.5) outputting a most likely target MS location estimate to one or more applications 140 (Fig. 5) requesting an estimate of the location of the target MS 140.

#### Location Hypothesis Data Representation

In order to describe how the steps (23.1) through (23.5) are performed in the sections below, some introductory remarks related to the data denoted above as location hypotheses will be helpful. Additionally, it will also be helpful to provide introductory remarks related to historical location data and the data base management programs associated therewith.

For each target MS location estimate generated and utilized by the present invention, the location estimate is provided in a data structure (or object class) denoted as a "location hypothesis" (illustrated in Table UH-1). Brief descriptions of the data fields for a location hypothesis is provided in the Table UH-1.

Table UH-1

FOH_ID	First order model ID (providing this Location Hypothesis); note, since it is possible for location hypotheses to be generated by other than the FOHs 1224, in general, this field identifies the module that generated this location hypothesis.
MS_ID	The identification of the target MS 140 to this location hypothesis applies.
pt_est	The most likely location point estimate of the target MS 140.
valid_pt	Boolean indicating the validity of "pt_est".
area_est	Location Area Estimate of the target MS 140 provided by the FOH. This area estimate will be used whenever "image_area" below is NULL.
valid_area	Boolean indicating the validity of "area_est" (one of "pt_est" and "area_est" must be valid).
adjust	Boolean (true if adjustments to the fields of this location hypothesis are to be performed in the Context Adjuster Module).
pt_covering	Reference to a substantially minimal area (e.g., mesh cell) covering of "pt_est". Note, since this MS 140 may be substantially on a cell boundary, this covering may, in some cases, include more than one cell.
image_area	Reference to a substantially minimal area (e.g., mesh cell) covering of "pt_covering" (see detailed description of the function, "confidence_adjuster"). Note that if this field is not NULL, then this is the target MS location estimate used by the location center 142 instead of "area_est".
extrapolation_area	Reference to (if non-NULL) an extrapolated MS target estimate area provided by the location extrapolator submodule 1432 of the hypothesis analyzer 1332. That is, this field, if non-NULL, is an extrapolation of the "image_area" field if it exists, otherwise this field is an extrapolation of the "area_est" field. Note other extrapolation fields may also be provided depending on the

	embodiment of the present invention, such as an extrapolation of the "pt_covering".
confidence	In one embodiment, this is a probability indicating a likelihood that the target MS 140 is in (or out) of a particular area. If "image_area" exists, then this is a measure of the likelihood that the target MS 140 is within the area represented by "image_area", or if "image_area" has not been computed (e.g., "adjust" is FALSE), then "area_est" must be valid and this is a measure of the likelihood that the target MS 140 is within the area represented by "area_est". Other embodiments, are also within the scope of the present invention that are not probabilities; e.g., translations and/or expansions of the [0, 1] probability range as one skilled in the art will understand.
Original_Timestamp	Date and time that the location signature cluster (defined hereinafter) for this location hypothesis was received by the signal processing subsystem 1220.
Active_Timestamp	Run-time field providing the time to which this location hypothesis has had its MS location estimate(s) extrapolated (in the location extrapolator 1432 of the hypothesis analyzer 1332). Note that this field is initialized with the value from the "Original_Timestamp" field.
Processing_Tags_and_environmental_categorizations	For indicating particular types of environmental classifications not readily determined by the "Original_Timestamp" field (e.g., weather, traffic), and restrictions on location hypothesis processing.
loc_sig_cluster	Provides access to the collection of location signature signal characteristics derived from communications between the target MS 140 and the base station(s) detected by this MS (discussed in detail hereinafter); in particular, the location data accessed here is provided to the first order models by the signal processing subsystem 1220; i.e., access to the "loc_sigs" (received at "timestamp" regarding the location of the target MS)
descriptor	Original descriptor (from the First order model indicating why/how the

	Location Area Estimate and Confidence Value were determined).
--	---

As can be seen in the Table LH-3, each location hypothesis data structure includes at least one measurement, denoted hereinafter as a confidence value (or simply confidence), that is a measurement of the perceived likelihood that an MS location estimate in the location hypothesis is an accurate location estimate of the target MS 140. Since, in some embodiments of the invention, such confidence values are an important aspect, much of the description and use of such confidence values are described below, however, a brief description is provided here.

In one embodiment, each confidence value is a probability indicative of a likelihood that the target MS 140 resides within an geographic area represented by the hypothesis to which the confidence value applies. Accordingly, each such confidence value is in the range [0, 1]. Moreover, for clarity of discussion, it is assumed that unless stated otherwise that the probabilistic definition provided here is to be used when confidence values are discussed.

Note, however, other definitions of confidence values are within the scope of the present invention that may be more general than probabilities, and/or that have different ranges other than [0, 1]. For example, one such alternative is that each such confidence value is in the range -1.0 to 1.0, wherein the larger the value, the greater the perceived likelihood that the target MS 140 is in (or at) a corresponding MS location estimate of the location hypothesis to which the confidence value applies. As an aside, note that a location hypothesis may have more than one MS location estimate (as will be discussed in detail below) and the confidence value will typically only correspond or apply to one of the MS location estimates in the location hypothesis. Further, values for the confidence value field may be interpreted as: (a) -1.0 means that the target MS 140 is NOT in such a corresponding MS area estimate of the location hypothesis area, (b) 0 means that it is unknown as to the likelihood of whether the MS 140 is in the corresponding MS area estimate, and (c) +1.0 means that the MS 140 is perceived to positively be in the corresponding MS area estimate.

Additionally, in utilizing location hypotheses in, for example, the location evaluator 322.8 as in (23.4) above, it is important to keep in mind that for confidences,  $c_1$  and  $c_2$ , if  $c_1 < c_2$ , then for a location hypotheses  $H_1$  and  $H_2$  having  $c_1$  and  $c_2$ , respectively, the target MS 140 is expected to more likely reside in a target MS estimate of  $H_2$  than a target MS estimate of  $H_1$ . Moreover, if an area,  $A$ , is such that it is included in a plurality of location hypothesis target MS estimates, then a confidence score,  $CS_A$ , can be assigned to  $A$ , wherein the confidence score for such an area is a function of the confidences for all the location hypotheses whose (most pertinent) target MS location estimates contain  $A$ . That is, in order to determine a most likely target MS location area estimate for outputting from the location center/gateway 142, a confidence score is determined for areas within the location center/gateway service area.

Coverage Area: Area Types And Their Determination

The notion of "area type" as related to wireless signal transmission characteristics has been used in many investigations of radio signal transmission characteristics. Some investigators, when investigating such signal characteristics of areas have used somewhat naive area classifications such as urban, suburban, rural, etc. However, it is desirable for the purposes of the present invention to have a more operational definition of area types that is more closely associated with wireless signal transmission behaviors.

To describe embodiments of the an area type scheme that may be used in the present invention, some introductory remarks are first provided. Note that the wireless signal transmission behavior for an area depends on at least the following criteria:

- (23.8.1) substantially invariant certain characteristics (both natural and man-made) of the area; e.g., mountains, buildings, lakes, highways, bridges, building density;
- (23.8.2) time varying environmental characteristics (both natural and man-made) of the area; e.g., foliage, traffic, weather, special events such as baseball games;
- (23.8.3) wireless communication components of infrastructure in the area; e.g., the arrangement and signal communication characteristics of the base stations 122 in the area (e.g., base station antenna down tilt). Further, the antenna characteristics at the base stations 122 may be important criteria.

Accordingly, a description of wireless signal characteristics for determining area types could potentially include a characterization of wireless signalling attributes as they relate to each of the above criteria. Thus, an area type might be: hilly, treed, suburban, having no buildings above 50 feet, with base stations spaced apart by two miles. However, a categorization of area types is desired that is both more closely tied to the wireless signalling characteristics of the area, and is capable of being computed substantially automatically and repeatedly over time. Moreover, for a wireless location system, the primary wireless signaling characteristics for categorizing areas into at least minimally similar area types are: thermal noise and, more importantly, multipath characteristics (e.g., multipath fade and time delay).

Focusing for the moment on the multipath characteristics, it is believed that (23.8.1) and (23.8.3) immediately above are, in general, more important criteria for accurately locating an MS 140 than (23.8.2). That is, regarding (23.8.1), multipath tends to increase as the density of nearby vertical area changes increases. For example, multipath is particularly problematic where there is a high density of high rise buildings and/or where there are closely spaced geographic undulations. In both cases, the amount of change in vertical area per unit of area in a horizontal plane (for some horizontal reference plane) may be high. Regarding (23.8.3), the greater the density of base stations 122, the less problematic multipath may become in locating an MS 140. Moreover, the arrangement of the base stations 122 in the radio coverage area 120 in Fig. 4 may affect the amount and severity of multipath.

Accordingly, it would be desirable to have a method and system for straightforwardly determining area type classifications related to multipath, and in particular, multipath due to (23.8.1) and (23.8.3). The present invention provides such a

determination by utilizing a novel notion of area type, hereinafter denoted "transmission area type" (or, "area type" when both a generic area type classification scheme and the transmission area type discussed hereinafter are intended) for classifying "similar" areas, wherein each transmission area type class or category is intended to describe an area having at least minimally similar wireless signal transmission characteristics. That is, the novel transmission area type scheme of the present invention is based on:

5 (a) the terrain area classifications; e.g., the terrain of an area surrounding a target MS 140, (b) the configuration of base stations 122 in the radio coverage area 120, and (c) characterizations of the wireless signal transmission paths between a target MS 140 location and the base stations 122.

In one embodiment of a method and system for determining such (transmission) area type approximations, a partition (denoted hereinafter as  $P_r$ ) is imposed upon the radio coverage area 120 for partitioning for radio coverage area into subareas, wherein each subarea is an estimate of an area having included MS 140 locations that are likely to have in at least a minimal amount of similarity in their wireless signaling characteristics. To obtain the partition  $P_r$  of the radio coverage area 120, the following steps are performed:

- (23.8.4.1) Partition the radio coverage area 120 into subareas, wherein in each subarea is: (a) connected, (b) the subarea is not too oblong, e.g., the variations in the lengths of chords sectioning the subarea through the centroid of the subarea are below a predetermined threshold, (c) the size of the subarea is below a predetermined value, and (d) for most locations (e.g., within a first or second deviation) within the subarea whose wireless signaling characteristics have been verified, it is likely (e.g., within a first or second deviation) that an MS 140 at one of these locations will detect (forward transmission path) and/or will be detected (reverse transmission path) by a same collection of base stations 122. For example, in a CDMA context, a first such collection may be (for the forward transmission path) the active set of base stations 122, or, the union of the active and candidate sets, or, the union of the active, candidate and/or remaining sets of base stations 122 detected by "most" MSs 140 in . . . Additionally (or alternatively), a second such collection may be the base station 122 that are expected to detect MSs 140 at locations within the subarea. Of course, the union or intersection of the first and second collections is also within the scope of the present invention for partitioning the radio coverage area 120 according to (d) above. It is worth noting that it is believed that base station 122 power levels will be substantially constant. However, even if this is not the case, one or more collections for (d) above may be determined empirically and/or by computationally simulating the power output of each base station 122 at a predetermined level. Moreover, it is also worth mentioning that this step is relatively straightforward to implement using the data stored in the location signature data base 1320 (i.e., the verified location signature clusters discussed in detail hereinafter). Denote the resulting partition here as  $P_r$ .
- (23.8.4.2) Partition the radio coverage area 120 into subareas, wherein each subarea appears to have substantially homogeneous terrain characteristics. Note, this may be performed periodically substantially automatically by



scanning radio coverage area images obtained from aerial or satellite imaging. For example, EarthWatch Inc. of Longmont, CO can provide geographic with 3 meter resolution from satellite imaging data. Denote the resulting partition here as  $P_1$ .

(23.8.4.3) Overlay both of the above partitions,  $P_1$  and  $P_2$ , of the radio coverage area 720 to obtain new subareas that are intersections of the subareas from each of the above partitions. This new partition is  $P_3$  (i.e.,  $P_3 = P_1 \cap P_2$ ), and the subareas of it are denoted as " $P_3$  subareas".

Now assuming  $P_3$  has been obtained, the subareas of  $P_3$  are provided with a first classification or categorization as follows:

(23.8.4.4) Determine an area type categorization scheme for the subareas of  $P_3$ . For example, a subarea,  $A$ , of  $P_3$  may be categorized or labeled according to the number of base stations 722 in each of the collections used in (23.8.4.1)-(4) above for determining subareas of  $P_3$ . Thus, in one such categorization scheme, each category may correspond to a single number  $x$  (such as 3), wherein for a subarea,  $A$ , of this category, there is a group of  $x$  (e.g., three) base stations 722 that are expected to be detected by a most target MS 140 in the area  $A$ . Other embodiments are also possible, such as a categorization scheme wherein each category may correspond to a triple of numbers such as  $(x, y, z)$ , wherein for a subarea  $A$  of this category, there is a common group of  $z$  base stations 722 with two-way signal detection expected with most locations (e.g., within a first or second deviation) within  $A$ , there are  $y$  base stations that are expected to be detected by a target MS 140 in  $A$  but these base stations can not detect the target MS, and there is one base station 722 that is expected to be able to detect a target MS in  $A$  but not be detected.

(23.8.4.5) Determine an area type categorization scheme for the subareas of  $P_3$ . Note that the subareas of  $P_3$  may be categorized according to their similarities. In one embodiment, such categories may be somewhat similar to the naive area types mentioned above (e.g., dense urban, urban, suburban, rural, mountain, etc.). However, it is also an aspect of the present invention that more precise categorizations may be used, such as a category for all areas having between 20,000 and 30,000 square feet of vertical area change per 11,000 square feet of horizontal area and also having a high traffic volume (such a category likely corresponding to a "moderately dense urban" area type).

(23.8.4.6) Categorize subareas of  $P_3$  with a categorization scheme denoted the " $P_3$  categorization," wherein for each  $P_3$  subarea,  $A$ , a " $P_3$  area type" is determined for  $A$  according to the following substep(s):

(a) Categorize  $A$  by the two categories from (23.8.4.4) and (23.8.5) with which it is identified. Thus,  $A$  is categorized (in a corresponding  $P_3$  area type) both according to its terrain and the base station infrastructure configuration in the radio coverage area 720.

(23.8.4.7) For each  $P_3$  subarea,  $A$ , of  $P_3$ , perform the following step(s):

(a) Determine a centroid,  $C(A)$ , for  $A$ .

(b) Determine an approximation to a wireless transmission path between  $C(A)$  and each base station 122 of a predetermined group of base stations expected to be in (one and/or two-way) signal communication with most target MS 140 locations in  $A$ . For example, one such approximation is a straight line between  $C(A)$  and each of the base stations 122 in the group. However, other such approximations are within the scope of the present invention, such as, a generally triangular shaped area as the transmission path, wherein a first vertex of this area is at the corresponding base station for the transmission path, and the sides of the generally triangular shaped defining the first vertex have a smallest angle between them that allows  $A$  to be completely between these sides.

(c) For each base station 122,  $BS_k$ , in the group mentioned in (b) above, create an empty list,  $BS_k$ -list, and put on this list at least the  $P_i$  area types for the "significant"  $P_i$  subareas crossed by the transmission path between  $C(A)$  and  $BS_k$ . Note that "significant"  $P_i$  subareas may be defined as, for example, the  $P_i$  subareas through which at least a minimal length of the transmission path traverses. Alternatively, such "significant"  $P_i$  subareas may be defined as those  $P_i$  subareas that additionally are known or expected to generate substantial multipath.

(d) Assign as the transmission area type for  $A$  as the collection of  $BS_k$ -list. Thus, any other  $P_i$  subarea having the same (or substantially similar) collection of lists of  $P_i$  area types will be viewed as having approximately the same radio transmission characteristic.

Note that other transmission signal characteristics may be incorporated into the transmission area types. For example, thermal noise characteristics may be included by providing a third radio coverage area 720 partition,  $P_3$ , in addition to the partitions of  $P_1$  and  $P_2$  generated in (23.8.4.1) and (23.8.4.2) respectively. Moreover, the time varying characteristics of (23.8.2) may be incorporated in the transmission area type framework by generating multiple versions of the transmission area types such that the transmission area type for a given subarea of  $P_i$  may change depending on the combination of time varying environmental characteristics to be considered in the transmission area types. For instance, to account for seasonality, four versions of the partitions  $P_1$  and  $P_2$  may be generated, one for each of the seasons, and subsequently generate a (potentially) different partition  $P_3$  for each season. Further, the type and/or characteristics of base station 122 antennas may also be included in an embodiment of the transmission area type.

Other embodiments of area types are also within the scope of the present invention. As mentioned above, each of the first order models 7224 have default confidence values associated therewith, and these confidence values may be probabilities. More precisely, with probability confidence values can be determined as follows. Assume there is a partition of the coverage area into subareas, each subarea being denoted a "partition area." For each partition area, activate each first order model 7224 with

historical location data in the Location Signature Data Base 1320 (Fig. 6), wherein the historical location data has been obtained from corresponding known mobile station locations in the partition area. For each first order model, determine a probability of the first order model generating a location hypothesis whose location estimate contains the corresponding known mobile station location. To accomplish this, assume the coverage area is partitioned into partition areas A, wherein each partition area A is specified as the collection of coverage area locations such that for each location, the detected wireless transmissions between the network base stations and a target mobile station at the location can be straightforwardly equated with other locations of area A. For example, one such partition,  $P_n$ , can be defined wherein each partition area A is specified in terms of three sets of base station identifiers, namely, (a) the base station identifiers of the base stations that can be ~~not~~ detected at each location of A and can detect a target mobile station at each location, (b) the identifiers for base stations that can detect a target mobile station at each location of A, but can not be detected by the target mobile station, and (c) the identifiers for base stations that can be detected by a target mobile station at each location of A, but these base stations can not detect the target mobile station. That is, two locations, L and L', are identified as being in A if and only if the three sets of (a), (b), and (c) for L, respectively, identical to the three sets of (a), (b), and (c) for L'.

Accordingly, assuming the partition  $P_n$  is used, a description can be given as to how probabilities may be assigned as the confidence values of location hypotheses generated by the first order models 1224. For each partition area A, a first order model 1224 is supplied with wireless measurements of archived location data in the Location Signature Data Base associated with corresponding verified mobile station locations. Thus, a probability can be determined as to how likely the first order model is to generate a location hypothesis having a location estimate containing the corresponding verified mobile station location. Accordingly, a table of partition area probabilities can be determined for each first order model 1224. Thus, when a location hypothesis is generated and identified as belonging to one of the partition areas, the corresponding probability for that partition area may be assigned as the confidence value for the location hypothesis. The advantages to using actual probabilities here is that, as will be discussed below, the most likelihood estimator 1344 can compute a straightforward probability for each distinct intersection of the multiple location hypotheses generated by the multiple first order models, such that each such probability indicates a likelihood that the target mobile station is in the corresponding intersection.

#### 25 Location Information Data Bases And Data

##### Location Data Bases Introduction

It is an aspect of the present invention that MS location processing performed by the location center/gateway 142 should become increasingly better at locating a target MS 140 both by (a) building an increasingly more detailed model of the signal characteristics of locations in the service area for the present invention, and also (b) by providing capabilities for the location center processing to adapt to environmental changes.

30 One way these aspects of the present invention are realized is by providing one or more data base management systems and data bases for:

(a) storing and associating wireless MS signal characteristics with known locations of MS 140 used in providing the signal characteristic. Such stored associations may not only provide an increasingly better model of the signal characteristics of the geography of the service area, but also provide an increasingly better model of more changeable signal characteristic affecting environmental factors such as weather, season, and/or traffic patterns;

(b) adaptively updating the signal characteristic data stored so that it reflects changes in the environment of the service area such as, for example, a new high rise building or a new highway.

Referring again to Fig. 5 of the collective representation of these data bases is the location information data base 122. Included among these data bases is a data base for providing training and/or calibration data to one or more trainable/calibratable FOMs 122A, as well as an archival data base for archiving historical MS location information related to the performance of the FOM. These data bases will be discussed as necessary hereinbelow. However, a further brief introduction to the archival data base is provided here. Accordingly, the term, "location signature data base" is used hereinafter to denote the archival data base and/or data base management system depending on the context of the discussion. The location signature data base (shown in, for example, Fig. 6 and labeled 1220) is a repository for wireless signal characteristic data derived from wireless signal communications between an MS 140 and one or more base stations 122, wherein the corresponding location of the MS 140 is known and also stored in the location signature data base 1220. More particularly, the location signature data base 1220 associates each such known MS location with the wireless signal characteristic data derived from wireless signal communications between the MS 140 and one or more base stations 122 at this MS location. Accordingly, it is an aspect of the present invention to utilize such historical MS signal location data for enhancing the correctness and/or confidence of certain location hypotheses as will be described in detail in other sections below.

#### Data Representation for the Location Signature Data Base

In one embodiment, there are four fundamental entity types (or object classes in an object oriented programming paradigm) utilized in the location signature data base 1220. Briefly, these data entities are described in the items (2.4.1) through (2.4.4) that follow:

(2.4.1) (verified) location signatures: Each such (verified) location signature describes the wireless signal characteristic measurements between a given base station (e.g., BS 122 or BS 152) and an MS 140 at a (verified or known) location associated with the (verified) location signature. That is, a verified location signature corresponds to a location whose coordinates such as latitude-longitude coordinates are known, while simply a location signature may have a known or unknown location corresponding with it. Note that the term (verified) location signature is also denoted by the abbreviation, "(verified) loc sig" hereinbelow.

(2.4.2) (verified) location signature clusters: Each such (verified) location signature cluster includes a collection of (verified) location signatures corresponding to all the location signatures between a target MS 140 at a (possibly verified) presumed substantially stationary location and each BS (e.g., 122 or 152) from which the target MS 140 can detect the BS's pilot channel regardless of the classification of the BS in the target MS (i.e., for CPM, regardless of whether a BS is in the MS's active, candidate or remaining base station sets, as one skilled in the art will understand). Note that for simplicity here, it is presumed that each location signature cluster has a single fixed primary base station to which the target MS 140 synchronizes or obtains its timing.

(2.4.3) "composite location objects (or entities)": Each such entity is a more general entity than the verified location signature cluster. An object of this type is a collection of (verified) location signatures that are associated with the same MS 140 at substantially the same location at the same time and each such loc sig is associated with a different base station. However, there is no requirement that a loc sig from each BS 122 for which the MS 140 can detect the BS's pilot channel is included in the "composite location object (or entity)"; and

5 (2.4.4) MS location estimation data that includes MS location estimates output by one or more MS location estimating first order models 122, such MS location estimate data is described in detail hereinafter.

It is important to note that a loc sig is, in one embodiment, an instance of the data structure containing the signal characteristic measurements output by the signal filtering and normalizing subsystem also denoted as the signal processing subsystem 120 describing the signals between: (i) a specific base station 122 (BS) and (ii) a mobile station 140 (MS), wherein the BS's location is known and the MS's location is assumed to be substantially constant (during a 2-5 second interval in one embodiment of the present invention), during communication with the MS 140 for obtaining a single instance of loc sig data, although the MS location may or may not be known. Further, for notational purposes, the BS 122 and the MS 140 for a loc sig hereinafter will be denoted the "BS associated with the loc sig", and the "MS associated with the loc sig" respectively. Moreover, the location of the MS 140 at the time the loc sig data is obtained will be denoted the "location associated with the loc sig" (this location possibly being unknown).

15 Note that additional description of this aspect of the present invention can be found in one of the following two copending U.S. patent applications which are incorporated herein by reference: (a) "Location Of A Mobile Station" filed Nov. 24, 1999 having Application No. 09/194,367 whose inventors are D. J. Dopyay and C. L. Karr, and (b) "A Wireless Location System For Calibrating Multiple Location Estimators" filed October 23, 1998 having Application No. 09/176,567 whose inventor is D. J. Dopyay, wherein these copending patent applications may have essential material for the present specification. In particular, these copending patent applications may have essential material relating to the location signature data base 130.

#### Location Center Architecture

##### Overview of Location Center/Gateway Functional Components

Fig. 5 presents a high level diagram of an embodiment of the location center/gateway 102 and the location engine 139 in the context of the infrastructure for the entire location system of the present invention.

25 It is important to note that the architecture for the location center/gateway 102 and the location engine 139 provided by the present invention is designed for extensibility and flexibility so that MS 140 location accuracy and reliability may be enhanced as further location data become available and as enhanced MS location techniques become available. In addressing the design goals of extensibility and flexibility, the high level architecture for generating and processing MS location estimates may be considered as divided into the following high level functional groups described hereinafter.

Low Level Wireless Signal Processing Subsystem for Receiving and Conditioning Wireless Signal Measurements

A first functional group of location engine 139 modules is for performing signal processing and filtering of MS location signal data received from a conventional wireless (e.g., CDMA) infrastructure, as discussed in the steps (23.1) and (23.2) above. This group is denoted the signal processing subsystem 1220 herein. One embodiment of such a subsystem is described in the U.S. copending parent application titled, "Wireless Location Using A Plurality of Commercial Network Infrastructures," by F. W. Zellmer, Dupray and Karr filed Jan. 22, 1999 and having U.S. Patent No. 6,236,365. Note that this copending parent application is incorporated herein entirely by reference since it may contain essential material for the present invention. In particular, regarding the signal processing subsystem 20. Note, however, that the signal processing subsystem may be unnecessary for the gateway 142 unless the gateway supplies wireless location signal data to one or more FDMs.

Initial Location Estimators: First Order Models

A second functional group of modules at least accessible by the location engine 139 are the FDM 1224 for generating various target MS 140 location initial estimates, as described in step (23.3). A brief description of some types of first order models is provided immediately below. Note that Fig. 8 illustrates another, more detail view of an embodiment of the location center/gateway 142 for the present invention. In particular, this figure illustrates some of the FDMs 1224 at least accessible (but not necessarily co-located with the other location center/gateway modules shown in this figure), and additionally illustrates the primary communications with other modules of the gateway. However, it is important to note that the present invention is not limited to the FDMs 1224 shown and discussed herein. That is, it is a primary aspect of the present invention to easily incorporate FDMs using other signal processing and/or computational location estimating techniques than those presented herein. Further, note that each FDM type may have a plurality of its MS location estimating models (at least) accessible by the gateway 142.

For example, (as will be described in further detail below), one such type of model or FDM 1224 (hereinafter models of this type are referred to as "terrestrial communication station offset (TCO) models" or "terrestrial communication station offset (TCO) first order models", or "terrestrial communication station offset (TCO) FDMs") may be based on a range, offset, and/or distance computation such as on a base station signal reception angle determination between the target MS 140 from each of one or more base stations. Basically, such TCO models 1224 determine a location estimate of the target MS 140 by determining an offset from each of one or more base stations 122, possibly in a particular direction from each (some of) the base stations, so that, e.g., an intersection of each area locus defined by the base station offsets may provide an estimate of the location of the target MS. TCO FDMs 1224 may compute such offsets based on, e.g.:

- (a) signal timing measurements between the target mobile station 140 and one or more base stations 122, e.g., timing measurements such as time difference of arrival (TDOA), or time of arrival (TOA). Note that both forward and reverse signal path timing measurements may be utilized;
- (b) signal strength measurements (e.g., relative to power control settings of the MS 140 and/or one or more BS 122); and/or

(i) signal angle of arrival measurement, or ranges thereof, at one or more base stations 122 (such angles and/or angular ranges provided by, e.g., base station antenna sectors having angular ranges of 72° or 60°, or so called "SMART antennas" with variable angular transmission ranges of 2° to 72°).

Accordingly, a terrestrial communication station offset (TCO) model may utilize, e.g., triangulation or trilateration to compute a location hypothesis having either an area location or a point location for an estimate of the target MS 140. Additionally, in some embodiments location hypothesis may include an estimated error.

Another type of FOM 1224 is a statistically based first order model 1224, wherein a statistical technique, such as regression techniques (e.g., least squares, partial least squares, principle decomposition), or e.g., Bellenger Bands (e.g., for computing minimum and maximum base station offsets). In general, models of this type output location hypotheses determined by performing one or more statistical techniques or comparisons between the verified location signatures in location signature data base 1320, and the wireless signal measurements from a target MS. Models of this type are also referred to hereinafter as a "stochastic signal (first order) model" or a "stochastic FOM" or a "statistical model." Of course, statistically based FOMs may be a hybrid combination with another type of FOM such as a TCO FOM.

Still another type of FOM 1224 is an adaptive learning model, such as an artificial neural net or a genetic algorithm, wherein the FOM may be trained to recognize or associate each of a plurality of locations with a corresponding set of signal characteristics for communications between the target MS 140 (at the location) and the base stations 122. Moreover, typically such a FOM is expected to accurately interpolate/extrapolate target MS 140 location estimates from a set of signal characteristics from an unknown target MS 140 location. Models of this type are also referred to hereinafter variously as "artificial neural net models" or "neural net models" or "trainable models" or "learning models." Note that a related type of FOM 1224 is based on pattern recognition. These FOMs can recognize patterns in the signal characteristics of communications between the target MS 140 (at the location) and the base stations 122 and thereby estimate a location area of the target MS. However, such FOMs may not be trainable.

Yet another type of FOM 1224 can be based on a collection of dispersed low power, low cost fixed location wireless transceivers (also denoted "location base stations 152" hereinafter) that are provided for detecting a target MS 140 in areas where, e.g., there is insufficient base station 122 infrastructure coverage for providing a desired level of MS 140 location accuracy. For example, it may be uneconomical to provide high traffic wireless voice coverage of a typical wireless base station 122 in a nature preserve or at a fair ground that is only populated a few days out of the year. However, if such low cost location base stations 152 can be directed to activate and deactivate via the direction of a FOM 1224 of the present type, then these location base stations can be used to both locate a target MS 140 and also provide indications of where the target MS is not. For example, if there are location base stations 152 populating an area where the target MS 140 is presumed to be, then by activating these location base stations 152, evidence may be obtained as to whether or not the target MS is actually in the area; e.g., if the target MS 140 is detected by a location base station 152, then a corresponding location hypothesis having a location estimate corresponding to the coverage area of the location base station may have a very high confidence value. Alternatively, if the target MS 140 is not detected by a location base station 152, then a corresponding location hypothesis having a location estimate corresponding to the coverage area of the location base station may have a very low confidence value. Models of this type are referred to hereinafter as "location base station model."

Yet another type of FOM 1224 can be based on input from a mobile base station 148, wherein location hypotheses may be generated from target MS 140 location data received from the mobile base station 148.

Still other types of FOM 1224 can be based on various techniques for recognizing wireless signal measurement patterns and associating particular patterns with locations in the coverage area 120. For example, artificial neural networks or other learning models can used as the basis for various FOMs.

Note that the FOM types mentioned here as well as other FOM types are discussed in detail hereinbelow. Moreover, it is important to keep in mind that in one embodiment of the present invention, the substantially simultaneous use or activation of a potentially large number of such first order models 1224, may be able to enhance both the reliability of location estimates and the accuracy of such estimates. Additionally, note that in some embodiments of the present invention, the first order models 1224 can be activated when appropriate signal measurements are obtained. For example, a TDOA FOM may be activated when only a single signal time delay measurement is obtained from some plurality of base station 122. However, if, for instance, additional time delay values are obtained (and assuming such additional values are necessary), then one or more wireless signal pattern matching FOM may also be activated in conjunction with the TDOA FOM. Additionally, a FOM using satellite signals (e.g., GPS) to perform a triangulation may be activated whenever appropriate measurements are received regardless of whether additional FOMs are capable of being substantially simultaneously activated or not. Accordingly, since such satellite signal FOMs are generally more accurate, output from such a FOM may dominate any other previous or simultaneous estimates unless there is evidence to the contrary.

Moreover, the present invention provides a framework for incorporating MS location estimators to be subsequently provided as new FOMs in a straightforward manner. For example, a FOM 1224 based on wireless signal time delay measurements from a distributed antenna system for wireless communication may be incorporated into the present invention for thereby locating a target MS 140 in an enclosed area serviced by the distributed antenna system. Accordingly, by using such a distributed antenna FOM, the present invention may determine the floor of a multi-story building from which a target MS is transmitting. Thus, MS 140 can be located in three dimensions using such a distributed antenna FOM. Additionally, FOMs for detecting certain registration changes within, for example, a public switched telephone network can also be used for locating a target MS 140. For example, for some MSs 140 there may be an associated or dedicated device for each MS that allows the MS to function as a cordless phone to a line based telephone network when the device detects that the MS is within signaling range. In one use of such a device (also denoted herein as a "home base station"), the device registers with a home location register of the public switched telephone network when there is a status change such as from not detecting the corresponding MS to detecting the MS, or vice versa, as one skilled in the art will understand. Accordingly, by providing a FOM that accesses the MS status in the home location register, the location engine 130 can determine whether the MS is within signaling range of the home base station or not, and generate location hypotheses accordingly. Moreover, other FOMs based on, for example, chaos theory and/or fractal theory are also within the scope of the present invention.

It is important to note the following aspects of the present invention relating to FOMs 1224:

(A.1) Each such first order model 1224 may be relatively easily incorporated into and/or removed from the present invention. For example, assuming that the signal processing subsystem 1220 provides uniform input to the FOMs, and there is a uniform FOM output interface (e.g., API), it is



believed that a large majority (if not substantially all) viable MS location estimation strategies may be accommodated. Thus, it is straightforward to add or delete such FOMs 1224.

(2.1.2) First order models 1224 may be relatively simple and still provide significant MS 140 locating functionality and predictability. For example, much of what is believed to be common or generic MS location processing has been coalesced into, for example, a location hypothesis evaluation subsystem, denoted the hypotheses evaluator 1228 and described immediately below. Thus, the present invention is modular and extensible such that, for example, (and importantly) different first order models 1224 may be utilized depending on the signal transmission characteristics of the geographic region serviced by an embodiment of the present invention. Thus, a simple configuration of the present invention may have (or access) a small number of FOMs 1224 for a simple wireless signal environment (e.g., flat terrain, no urban canyons and low population density). Alternatively, for complex wireless signal environments such as in cities like San Francisco, Tokyo or New York, a large number of FOMs 1224 may be simultaneously utilized for generating MS location hypotheses.

#### An Introduction to an Evaluator for Location Hypotheses: Hypothesis Evaluator

A third functional group of location engine 139 modules evaluates location hypotheses output by the first order models 1224 and thereby provides a "most likely" target MS location estimate. The modules for this functional group are collectively denoted the hypothesis evaluator 1228.

#### Hypothesis Evaluator

A primary purpose of the hypothesis evaluator 1228 is to mitigate conflicts and ambiguities related to location hypotheses output by the first order models 1224 and thereby output a "most likely" estimate of an MS for which there is a request for it to be located. In providing this capability, there are various related embodiments of the hypothesis evaluator that are within the scope of the present invention. Since each location hypothesis includes both an MS location area estimate and a corresponding confidence value indicating a perceived confidence or likelihood of the target MS being within the corresponding location area estimate, there is a monotonic relationship between MS location area estimates and confidence values. That is, by increasing an MS location area estimate, the corresponding confidence value may also be increased (in an extreme case, the location area estimate could be the entire coverage area 120 and thus the confidence value may likely correspond to the highest level of certainty, i.e., +1.0). Accordingly, given a target MS location area estimate (of a location hypothesis), an adjustment to its accuracy may be performed by adjusting the MS location area estimate and/or the corresponding confidence value. Thus, if the confidence value is, for example, excessively low then the area estimate may be increased as a technique for increasing the confidence value. Alternatively, if the estimated area is excessively large, and there is flexibility in the corresponding confidence value, then the estimated area may be decreased and the confidence value also decreased. Thus, if at some point in the processing of a location hypothesis, if the location hypothesis is judged to be more (less) accurate than initially determined, then (i) the confidence value of the location hypothesis may be increased (decreased), and/or (ii) the MS location area estimate can be decreased (increased). Moreover, note that when the confidence values are probabilities, such adjustments are may require the reactivation of one or more FOMs 1224 with respects to generate location hypotheses having location estimates of different sizes. Alternatively, adjuster modules 1436 and/or 1440 (Fig. 16 discussed hereinbelow) may be invoked for generating location hypotheses having area estimates of different sizes. Moreover, the confidence value on such an

adjusted location hypothesis (actually a new location hypothesis corresponding to the originally generated hypothesis) may also be a probability in that combination of FOMs 1224 and adjuster modules 1438 and 1440 can also be calibrated for thereby yielding probabilities as confidence values to the resulting location hypotheses.

In a first class of embodiments (typically wherein the confidence values are not maintained as probabilities), the hypothesis evaluator 1228 evaluates location hypotheses and adjusts or modifies only their confidence values for MS location area estimates and subsequently uses these MS location estimates with the adjusted confidence values for determining a "most likely" MS location estimate for outputting. Alternatively, in a second class of embodiments for the hypothesis evaluator 1228 (also typically wherein the confidence values are not maintained as probabilities), MS location area estimates can be adjusted while confidence values remain substantially fixed. However, in one preferred embodiment of the present embodiment, both location hypothesis area estimates and confidence values are modified.

The hypothesis evaluator 1228 may perform any or most of the following tasks depending on the embodiment of the hypothesis evaluator. That is,

(30.1) it may enhance the accuracy of an initial location hypothesis generated by an FOM by using the initial location hypothesis as, essentially, a query or index into the location signature data base 1320 for obtaining one or more corresponding enhanced location hypotheses,

wherein the enhanced location hypotheses have both an adjusted target MS location area estimates and an adjusted confidence based on past performance of the FOM in the location service surrounding the target MS location estimate of the initial location hypothesis;

Additionally, for embodiments of the hypothesis evaluator 1228 wherein the confidence values for location hypotheses are not maintained as probabilities, the following additional tasks (30.2) through (30.7) may be performed:

(30.2) the hypothesis evaluator 1228 may utilize environmental information to improve and reconcile location hypotheses supplied by the first order models 1224. A basic premise in this context is that the accuracy of the individual first order models may be affected by various

environmental factors such as, for example, the season of the year, the time of day, the weather conditions, the presence of buildings, base station failures, etc.;

(30.3) the hypothesis evaluator 1228 may determine how well the associated signal characteristics used for locating a target MS compare with particular verified loc sigs stored in the location signature data base 1320 (see the location signature data base section for further discussion regarding this aspect of the invention). That is, for a given location hypothesis, verified loc sigs (which were previously obtained from one or more verified locations of one or more MS's) are retrieved for an area corresponding to the location area estimate of the location hypothesis, and the signal characteristics of these verified loc sigs are compared with the signal characteristics used to generate the location hypothesis for determining their similarities and subsequently an adjustment to the confidence of the location hypothesis (and/or the size of the location area estimate);

(30.4) the hypothesis evaluator 1228 may determine if (or how well) such location hypotheses are consistent with well known physical constraints such as the laws of physics. For example, if the difference between a previous (most likely) location estimate of a target MS and a location estimate by a current location hypothesis requires the MS to:

(a) move at an unreasonably high rate of speed (e.g., 200 mph), or

- (b) move at an unreasonably high rate of speed for an area (e.g., 80 mph in a corn patch), or
  - (c) make unreasonably sharp velocity changes (e.g., from 60 mph in one direction to 60 mph in the opposite direction in 4 sec),
- then the confidence in the current Location Hypothesis is likely to be reduced.

Alternatively, if for example, the difference between a previous location estimate of a target MS and a current location hypothesis indicates that the MS is:

- (a) moving at an appropriate velocity for the area being traversed, or
- (b) moving along an established path (e.g., a freeway),

then the confidence in the current location hypothesis may be increased.

(30.5) the hypothesis evaluator 122.8 may determine consistencies and inconsistencies between location hypotheses obtained from different first order models. For example, if two such location hypotheses, for substantially the same timestamp, have estimated location areas where the target MS is likely to be and these areas substantially overlap, then the confidence in both such location hypotheses may be increased. Additionally, note that a velocity of an MS may be determined (via deltas of successive location hypotheses from one or more first order models) even when there is low confidence in the location estimates for the MS, since such deltas may, in some cases, be more reliable than the actual target MS location estimates;

(30.6) the hypothesis evaluator 122.8 determines new (more accurate) location hypotheses from other location hypotheses. For example, this module may generate new hypotheses from currently active ones by decomposing a location hypothesis having a target MS location estimate intersecting two radically different wireless signaling area types. Additionally, this module may generate location hypotheses indicating areas of poor reception; and

(30.7) the hypothesis evaluator 122.8 determines and outputs a most likely location hypothesis for a target MS.

Here that additional description of the hypothesis evaluator 122.8 can be found in one of the following two co-pending U.S. patent applications which are incorporated herein by reference: (a) "Location Of A Mobile Station" filed Nov. 24, 1999 having Application No. 09/194,367 whose inventors are B. J. Dupray and C. L. Karr, and (b) "A Wireless Location System For Calibrating Multiple Location Estimators" filed October 21, 1998 having Application No. 09/176,587 whose inventor is B. J. Dupray, wherein these co-pending patent applications may have essential material for the present specification. In particular, these co-pending patent applications may have essential material relating to their descriptions of the hypothesis evaluator.

#### Context Adjuster Introduction.

The context adjuster (alternatively denoted "location adjuster modules") 132.6 module enhances both the comparability and predictability of the location hypotheses output by the first order models 122.4. In one embodiment (typically where confidence values of location hypotheses are not maintained as probabilities), this module modifies location hypotheses received from the FOMs 122.4 so that the resulting location hypotheses output by the context adjuster 132.6 may be further processed uniformly and substantially without concern as to differences in accuracy between the first order models from which location hypotheses originate. Further, embodiments of the context adjuster may determine those factors that are

perceived to impact the perceived accuracy (e.g., confidence) of the location hypotheses. For instance, environmental characteristics may be taken into account here, such as time of day, season, month, weather, geographical area categorization (e.g., dense urban, urban, suburban, rural, mountain, etc.), area subcategorizations (e.g., heavily treed, hilly, high traffic area, etc.).

In Fig. 16, two such adjuster modules are shown, namely, an adjuster for enhancing reliability 1436 and an adjuster for enhancing accuracy 1440. Both of these adjusters perform their location hypothesis adjustments in the manner described above. The difference between these two adjuster modules 1436 and 1440 is primarily the size of the localized area "nearby" the newly generated location estimate. In particular, since it is believed that the larger (smaller) the localized nearby area is, the more likely (less likely) the corresponding adjusted image is to contain the target mobile station location, the adjuster for enhancing reliability 1436 may determine its localized area "nearby" a newly generated location estimate as, for example, having a 40% larger diameter (alternatively, area) than the location area estimate generated by a first order model 1224. Alternatively, the adjuster for enhancing accuracy 1444 may determine its localized area "nearby" a newly generated location estimate as, for example, having a 30% smaller diameter (alternatively, area) than the location area estimate generated by a first order model 1224. Thus, each newly generated location hypothesis can potentially be used to derive at least two additional adjusted location hypotheses with some of these adjusted location hypotheses being more reliable and some being more accurate than the location hypotheses generated directly from the first order models 1224.

Note that additional description of context adjuster aspects of the present invention can be found in the following two pending U.S. patent applications which are incorporated herein by reference: (a) "Location Of A Mobile Station" filed Nov. 24, 1999 having Application No. 09/194,361 whose inventors are D. J. Dupray and C. L. Karr, and (b) "A Wireless Location System for Calibrating Multiple Location Estimators" filed December 21, 1998 having Application No. 09/176,687 whose inventor is D. J. Dupray, wherein these pending patent applications may have essential material for the present specification. In particular, these pending patent applications may have essential material relating to the context adjuster 1326.

#### MS Status Repository Introduction

The MS status repository 1338 is a run-time storage manager for storing location hypotheses from previous activations of the location engine 134 (as well as for storing the output "most likely" target MS location estimate(s)) so that a target MS 140 may be tracked using target MS location hypotheses from previous location engine 134 activations to determine, for example, a movement of the target MS 140 between evaluations of the target MS location.

#### Location Hypothesis Analyzer Introduction

The location hypothesis analyzer 1332, may adjust confidence values of the location hypotheses, according to:

- (a) heuristics and/or statistical methods related to how well the signal characteristics for the generated target MS location hypothesis matches with previously obtained signal characteristics for verified MS locations.

(b) heuristics related to how consistent the location hypothesis is with physical laws, and/or highly probable reasonableness conditions relating to the location of the target MS and its movement characteristics. For example, such heuristics may utilize knowledge of the geographical terrain in which the MS is estimated to be, and/or, for instance, the MS velocity, acceleration or extrapolation of an MS position, velocity, or acceleration.

5 (c) generation of additional location hypotheses whose MS locations are consistent with, for example, previous estimated locations for the target MS.

Note that additional description of this aspect of the present invention can be found in one of the following pending U.S. patent application which is incorporated herein by reference: "Location Of A Mobile Station" filed Nov. 24, 1999 having Application No. 09/194,367 whose inventors are D. J. Rupray and C. L. Karr.

#### 10 Most Likelihood Estimator

The most likelihood estimator 1344 is a module for determining a "most likely" location estimate for a target MS being located by the location engine 139. The most likelihood estimator 1344 receives a collection of active or relevant location hypotheses from the hypothesis analyzer 1332 and uses these location hypotheses to determine one or more most likely estimates for the target MS 140.

15 There are various embodiments of the most likelihood estimator 1344 that may be utilized with the present invention. One such embodiment will now be described. At a high level, an area of interest is first determined which contains the target MS 140 whose location is desired. This can be straightforwardly determined by identifying the base stations 122 that can be detected by the target MS 140 and/or the base station 140 that can detect the target MS. Subsequently, assuming that this area of interest has been previously partitioned into "cells" (e.g., small rectangular areas of, for example, 50 to 200 feet per side) and that the resulting location hypotheses for estimating the location of the target MS 140 each have a likelihood probability associated therewith, then for each such location hypothesis, a probability (more generally confidence value) is capable of being assigned to each cell intersecting and/or included in the associated target MS location estimate. In particular, for each location hypothesis, a portion of the probability value, P, for the associated location estimate, A, can be assigned to each cell, C, intersecting the estimate. One simple way to perform this is to divide P by the number of cells C, and increment, for each cell C, a corresponding probability indicative of the target MS 140 being in C with the result from the division. One skilled in the art will readily recognize numerous other ways of incrementing such cell probabilities, including providing a Gaussian or other probabilistic distribution of probability values according to, e.g., the distance of the cell from the centroid of the location estimate. Accordingly, assuming all such probability increments have been assigned to all such cells C from all location hypotheses generated for locating the target MS 140, then the following is one embodiment of a program for determining one or more most likely locations of the target MS.

```

20 desired_rel ← get the desired reliability for the resulting location estimate;
    max_size ← get the desired maximum extent for the resulting location estimate;
    binned_cells ← sort the cells of the area of interest by their probabilities into bins where each successive bin includes those cells whose
30 confidence values are within a smaller (non-overlapping) range from that of any preceding bin. Further, assume

```

there are, e.g., 100 bins  $B_i$  wherein  $B_1$  has cells with confidences within the range  $[0, 0.1]$ , and  $B_2$  has cells with confidences within the range  $[(i-1) * 0.01, i * 0.01]$ .

```

Result ← nil;
Curr_ref ← 0; /* current likelihood of target MS 140 being in the area represented by "Result" */
5 Done ← FALSE;
Repeat
  Cell_bin ← get first (next) bin of cells from Binned_cells;
  While (there are cells in Cell_bin) do
    Curr_cell ← get a next cell from Cell_bin that is closest to the centroid of "Result";
    Result ← Result + Curr_cell;
10    /* now determine a new reliability value corresponding to adding "Curr_cell" to the most likely location
    estimate being built in "Result" */
    Curr_ref ← Curr_ref + confidence_of_MS_in(Curr_cell);
    If (Curr_ref > Desired_ref) then
15      Done ← TRUE;
  Until Done;
  /* reliability that the target MS is in "Result" is sufficient */
  Curr_size ← current maximum geographic extent (i.e. dimensions) of the area represented by "Result";
  If (Curr_size ≤ Max_size) then output(Result);
20 Else Determine whether "Result" has one or more outlying cells that can be replaced by other cells closer to the centroid of "Result" and
  still have a reliability ≥ "Desired_ref";
  If (there are replaceable outlier cells) then
    replace them in Result and output(Result);
  Else output(Result);
25 Note that numerous similar embodiments of the above program maybe used, as one skilled in the art will understand. For instance, instead
of "building" Result as provided in the above program, Result can be "whittled" from the area of interest. Accordingly, Result would be initialized to
the entire area of interest, and cells would be selected for removal from Result. Additionally, note that the above program determines a fast
approximation to the optimal most likely area containing the target MS 140 having at least a particular desired confidence. However, a similar
program may be readily provided where a most likely area having less than a desired extent or dimension is output; e.g., such a program would could
30 be used to provide an answer to the question: "What city block is the target MS most likely in?"

```

Additionally, note that a center of gravity type of computation for obtaining the most likely location estimate of the target MS 140 may be used as described in U.S. patent 5,293,642 (642 patent) filed Dec. 19, 1990 having an issue date of Mar. 8, 1994 with inventor Lo which is incorporated by reference herein and may contain essential material for the present invention.

5 Still referring to the hypothesis evaluator 122, it is important to note that not all the above mentioned modules are required in all embodiments of the present invention. In particular, the hypothesis analyzer 132 may be unnecessary. Accordingly, in such an embodiment, the enhanced location hypotheses output by the context adjuster 132b are provided directly to the most likelihood estimator 134.

#### Control and Output Gating Modules

A fourth functional group of location engine 134 modules is the control and output gating modules which includes the location control subsystem 135a, and the output gateway 135b. The location control subsystem 135a provides the highest level of control and monitoring of the data processing performed by the location center 142. In particular, this subsystem performs the following functions:

- 10 (a) controls and monitors location estimating processing for each target MS 140. Note that this includes high level exception or error handling functions;
- (b) receives and routes external information as necessary. For instance, this subsystem may receive (via, e.g., the public telephone switching network and Internet 464) such environmental information as increased signal noise in a particular service area due to increase traffic, a change in weather conditions, a base station 122 (or other infrastructure provisioning), change in operation status (e.g., operational to inactive);
- 15 (c) receives and directs location processing requests from other location centers 142 (via, e.g., the Internet);
- (d) performs accounting and billing procedures such as billing according to MS location accuracy and the frequency with which an MS is located;
- 20 (e) interacts with location center operators by, for example, receiving operator commands and providing output indicative of processing resources being utilized and malfunctions;
- (f) provides access to output requirements for various applications requesting location estimates. For example, an Internet location request from a trucking company in Los Angeles to a location center 142 in Denver may only want to know if a particular truck or driver is within the Denver area. Alternatively, a local medical rescue unit is likely to request a precise location estimate as possible.

25 Note that in Fig. 6, (a) - (f) above are, at least at a high level, performed by utilizing the operator interface 137a.

Referring now to the output gateway 135b, this module routes target MS 140 location estimates to the appropriate location application(s). For instance, upon receiving a location estimate from the most likelihood estimator 134a, the output gateway 135b may determine that the location estimate is for an automobile being tracked by the police and therefore must be provided according to the particular protocol.

#### System Tuning and Adaptation: The Adaptation Engine

A fifth functional group of location engine 139 modules provides the ability to enhance the MS locating reliability and/or accuracy of the present invention by providing it with the capability to adapt to particular operating configurations, operating conditions and wireless signaling environments without performing intensive manual analysis of the performance of various embodiments of the location engine 139. That is, this functional group automatically enhances the performance of the location engine for locating MS 140 within a particular coverage area 120 using at least one wireless network infrastructure therein. More precisely, this functional group allows the present invention to adapt by tuning or optimizing certain system parameters according to location engine 139 location estimate accuracy and reliability.

There are a number location engine 139 system parameters whose values affect location estimation, and it is an aspect of the present invention that the MS location processing performed should become increasingly better at locating a target MS 140 not only through building an increasingly more detailed model of the signal characteristics of location in the coverage area 120 such as discussed above regarding the location signature data base 132a, but also by providing automated capabilities for the location center processing to adapt by adjusting or "tuning" the values of such location center system parameters.

Accordingly, the present invention may include a module, denoted herein as an "adaptation engine" 132b, that performs an optimization procedure on the location center 142 system parameters either periodically or concurrently with the operation of the location center in estimating MS locations. That is, the adaptation engine 132b directs the modifications of the system parameters so that the location engine 139 increases in overall accuracy in locating target MS 140. In one embodiment, the adaptation engine 132b includes an embodiment of a genetic algorithm as the mechanism for modifying the system parameters. Genetic algorithms are basically search algorithms based on the mechanics of natural genetics.

Note that additional description of this aspect of the present invention can be found in one of the following two copending U.S. patent applications which are incorporated herein by reference: (a) "Location Of A Mobile Station" filed Nov. 24, 1999 having Application No. 09/194,267 whose inventors are D. J. Dwyer and C. L. Karr, and (b) "A Wireless Location System For Calibrating Multiple Location Estimators" filed October 21, 1998 having Application No. 09/176,587 whose inventor is D. J. Dwyer, wherein these copending patent applications may have essential material for the present specification. In particular, these copending patent applications may have essential material relating to the use of genetic algorithm implementations for adaptively tuning system parameters of a particular embodiment of the present invention.

#### Implementations of First Order Models

Further descriptions of various first order models 122a are provided in this section. However, it is important to note that these are merely representative embodiments of location estimators that are within the scope of the present invention. In particular, two or more of the wireless location technologies described hereinafter may be combined to create additional First Order Models. For example, various triangulation techniques between a target MS 140 and the base station infrastructure (e.g., time difference of arrival (TDOA) or time of arrival (TOA)), may be combined with an angle of arrival (AOA) technique. For instance, if a single direct line of sight angle measurement and a single direct line of sight distance measurement determined by, e.g., TDOA or TOA can effectively location the target MS 140. In such cases, the resulting



First Order Models may be more complex. However, location hypotheses may generated from such models where individually the triangulation techniques and the AOA techniques would be unable to generate effective location estimates.

Terrestrial Communication Station Offset (TCSO) First Order Models (e.g., TOA/TDOA/AOA)

As discussed in the Location Center Architecture Overview section herein above, TCSO models determine a presumed direction and/or distance (more generally, an offset) that a target MS 140 is from one or more base stations 722. In some embodiments of TCSO models, the target MS location estimate(s) generated are obtained using radio signal analysis techniques that are quite general and therefore are not capable of taking into account the peculiarities of the topography of a particular radio coverage area. For example, substantially all radio signal analysis techniques using conventional procedures (or formulas) are based on "signal characteristic measurements" such as:

- (a) signal timing measurements (e.g., TOA and TDOA), and/or
- (b) signal strength measurements.

Furthermore, such signal analysis techniques are likely predicated on certain very general assumptions that can not fully account for signal attenuation and multipath due to a particular radio coverage area topography.

Taking CDMA or TDMA base station network as an example, each base station (BS) 722 is required to emit a constant signal-strength pilot channel pseudo-noise (PN) sequence on the forward link channel identified uniquely in the network by a pilot sequence offset and frequency assignment. It is possible to use the pilot channels of the active, candidate, neighboring and remaining sets, maintained in the target MS, for obtaining signal characteristic measurements (e.g., TOA and/or TDOA measurements) between the target MS 140 and the base stations in one or more of these sets.

Based on such signal characteristic measurements and the speed of signal propagation, signal characteristic ranges or range differences related to the location of the target MS 140 can be calculated. Using TOA and/or TDOA ranges as exemplary, these ranges can then be input to either the radius-radius multilateration or the time difference multilateration algorithms along with the known positions of the corresponding base stations 722 to thereby obtain one or more location estimates of the target MS 140. For example, if there are four base stations 722 in the active set, the target MS 140 may cooperate with each of the base stations in this set to provide signal arrival time measurements. Accordingly, each of the resulting four sets of three of these base stations 722 may be used to provide an estimate of the target MS 140 as one skilled in the art will understand. Thus, potentially (assuming the measurements for each set of three base stations yields a feasible location solution) there are four estimates for the location of the target MS 140. Further, since such measurements and BS 722 positions can be sent either to the network or the target MS 140, location can be determined in either entity.

Since many of the signal measurements utilized by embodiments of TCSO models are subject to signal attenuation and multipath due to a particular area topography. Many of the sets of base stations from which target MS location estimates are desired may result in either no location estimate, or an inaccurate location estimate.

Accordingly, some embodiments of TCSO FOMs may attempt to mitigate such ambiguity or inaccuracies by, e.g., identifying discrepancies (or consistencies) between arrival time measurements and other measurements (e.g., signal strength), these discrepancies (or

consistencies) may be used to filter out at least those signal measurements and/or generated location estimates that appear less accurate. In particular, such identifying and filtering may be performed by, for example, an expert system residing in the FQO FOM.

Another approach for enhancing certain location techniques such as TDOA or angle of arrival (AOA) is that of super resolution as disclosed in U.S. patent 5,890,668 filed on Oct. 3, 1996 having an issue date of Mar. 30, 1999 with inventors Farnouche et. al. which is incorporated by reference herein and which may contain essential material for the present invention. In particular, the following portions of the '668 patent are particularly important: the Summary section, the Detailed Description portion regarding Figs. 12-17, and the section titled "Description Of The Preferred Embodiments Of The Invention."

Another approach, regardless of the FOM utilized, for mitigating such ambiguity or conflicting MS location estimates is particularly novel in that each of the target MS location estimates is used to generate a location hypothesis regardless of its apparent accuracy. Accordingly, these location hypotheses are input to an embodiment of the context adjuster 132b. In particular, in one context adjuster 132b embodiment each location hypothesis is adjusted according to past performance of its generating FOM 122a in an area of the initial location estimate of the location hypothesis (the area, e.g., determined as a function of distance from this initial location estimate), this alternative embodiment adjusts each of the location hypotheses generated by a first order model according to a past performance of the model as applied to signal characteristic measurements from the same set of base stations 122 as were used in generating the location hypothesis. That is, instead of only using only an identification of the first order model (i.e., its FOM\_ID) to, for example, retrieve archived location estimates generated by the model in an area of the location hypothesis' estimate (when determining the model's past performance), the retrieval retrieves the archived location estimates that are, in addition, derived from the signal characteristics measurement obtained from the same collection of base stations 122 as was used in generating the location hypothesis. Thus, the adjustment performed by this embodiment of the context adjuster 132b adjusts according to the past performance of the distance model and the collection of base stations 122 used.

Note in one embodiment, such adjustments can also be implemented using a precomputed vector location error gradient field. Thus, each of the location error vectors (as determined by past performance for the FOM) of the gradient field has its starting location at a location previously generated by the FOM, and its vector head at a corresponding verified location where the target MS 140 actually was. Accordingly, for a location hypothesis of an unknown location, this embodiment determines or selects the location error vectors having starting locations within a small area (e.g., possibly of a predetermined size, but alternatively, dependent on the density of the location error vector starting locations nearby to the location hypothesis) of the location hypothesis. Additionally, the determination or selection may also be based upon a similarity of signal characteristics also obtained from the target MS 140 being located with signal characteristics corresponding to the starting locations of location error vectors of the gradient field. For example, such signal characteristics may be, e.g., time delay/signal strength multipath characteristics.

#### *Angle Of Arrival First Order Model*

Various mobile station location estimating models can be based on the angle of arrival (AOA) of wireless signals transmitted from a target MS 140 to the base station infrastructure as one skilled in the art will understand. Such AOA models (sometimes also referred to as

direction of arrival or DOA models) typically require precise angular measurements of the wireless signals, and accordingly utilize specialized antennas at the base stations 122. The determined signal transmission angles are subject to multipath aberrations. Therefore, ADA is most effective when there is an unimpeded line of sight simultaneous transmission between the target MS 140 and at least two base stations 122.

*TCO (Grubeck) FOM with Increased Accuracy Via Multiple MS Transmissions*

5 Another TCO first order model 722A, denoted the Grubeck model (FOM) herein, is disclosed in U.S. Patent 6,009,334 filed Nov. 26, 1997 and filed Dec. 28, 1999 having Grubeck, Fischer, and Lundqvist as inventors, this patent being fully incorporated herein by reference. The Grubeck model includes a location estimator for determining more accurately the distance between a wireless receiver at (RX), e.g., a CHRS fixed location communication station (such as a BS 122) and a target MS 140, wherein wireless signals are repeatedly transmitted from the target MS 140 and may be subject to multipath. An embodiment of the Grubeck model may be applied to TDA, TDA, and/or ADA wireless measurements.

10 For the TDA case, the following steps are performed:

- (a) transmitting "M" samples  $s_i$ ,  $1 < i <= M$  of the same wireless signal from, e.g., the target MS 140 to the RX. Preferably M is on the order of 50 to 100 (e.g., 70) wireless signal bursts, wherein each such burst contains a portion having an identical known contents of bits (denoted a training sequence). However, note that a different embodiment can use (e.g., 70) received bursts containing different (non-identical) information, but information still known to the RX;
- (b) receiving the "M" signal samples  $s_i$  along with multipath components and noise at, e.g., RX;
- (c) for each of the received "M" samples  $s_i$ , determining at the RX an estimated channel power profile (CPP). Each CPP is determined by first determining, via a processor at the RX, a combined correlation response ("Channel Impulse Response" or CIR) of a small number of the bursts (e.g., 5) by correlating each burst with its known contents. Accordingly, the squared absolute value of the CIR is the "estimated channel power profile" or CPP;
- (d) (randomly) selecting "N" (e.g., 10) out of the "M" received samples;
- (e) performing incoherent integration of the CPP for the "N" samples selected, which results in an integrated signal, i.e., one integrated channel power profile  $KPP(N)$ ;
- (f) determining if the signal-to-noise quality of the  $KPP(N)$  is greater than or equal to a predetermined threshold value, and if not, improving the signal-to-noise quality of  $KPP(N)$  as required, by redoing the incoherent integration with successively one additional received sample CPP until the signal-to-noise quality of the  $KPP(N)$  is greater than or equal to the predetermined threshold value;
- (g) determining the TOA(t), including the case of determining TOA(t) from the maximum signal amplitude;
- (h) entering the determined TOA(t) value into a diagram that shows a frequency of occurrence as a function of TOA(t);
- (i) repeating the whole procedure "X" times by selecting a new combination of "N" out of "M" samples, which results in "X" additional points in the frequency of occurrence diagram;

- (j) reading the minimum value TOA(min) as the time value having "z" of all occurrences with higher TOA(t) values and "z+1" of all occurrences with lower TOA(t) values, where  $z > 0.7$ .

As mentioned above, an embodiment of the Grubbeck FDM may also be provided for TDOA and/or AOA wireless location techniques, wherein a similar incoherent integration may be performed.

- 5 Note that a Grubbeck FDM may be particularly useful for locating a target MS 140 in a GSM wireless network.

*TCO (Part) FDM Using Different Tones and Multiple Antennas at BS 122*

A first order model 1224, denoted the Part model herein, is substantially disclosed in U.S. Patent 5,823,598 (denoted the '598 Patent herein) filed Dec. 15, 1995 and issued Mar. 16, 1999 having Parl, Deuzang, Weitzen and Zagami as inventors, this patent being fully incorporated herein by reference. The Part FDM includes a system for receiving representative signals (denoted also "locating signal(s)") from the target MS 140 via, e.g., base stations 122 and subsequently combines information regarding the amplitude and phase of the MS transmitted signals received at the base stations to determine the position of the target MS 140. In one embodiment, the Part model uses input from a locating signal having two or more single-frequency tones, as one skilled in the art will understand. Moreover, at least some of the base stations 122 preferably includes at least two antennas spaced from each other by a distance between a quarter wavelength and several wavelengths of the wireless locating signals received from the target MS 140. Optionally, another antenna vertically above or below the two or more antennas also spaced by a distance of between a quarter wavelength and several wavelengths can be used where elevation is also being estimated. The base stations 122 sample locating signals from the target MS 140. The locating signals include tones that can be at different frequencies. The tones can also be transmitted at different times, or, in an alternative embodiment, they can be transmitted simultaneously. Because, in one embodiment, only single-frequency tones are used as the locating signal instead of modulated signals, substantial transmission circuitry may be eliminated. The Part FDM extracts information from each representative signal received from a target MS 140, wherein at least some of the extracted information is related to the amplitude and phase of the received signal.

In one embodiment of a Part FDM, related to the disclosure in the '598 Patent, when the locations of the BSs 122 are known, and the direction from any two of the BSs 122 to the target MS 140, the MS's location can be initially (roughly) determined by signal direction finding techniques. For example, an estimate of the phase difference between the signals at a pair of antennas at any BS 122 (having two such antennas) can lead to the determination of the angle from the base station to the target MS 140, and then, the determination of the target MS direction. Subsequently, an enhanced location of the target MS 140 is computed directly from received target MS signal data using an ambiguity function  $A(x,y)$  described in the '598 Patent, wherein for each point at  $x,y$ , the ambiguity function  $A(x,y)$  depends upon the probability that the MS is located at the geolocation represented by  $(x,y)$ . Essentially the Part FDM combines angle of arrival related data and TDOA related data for obtaining an optimized estimate of the target MS 140. However, it appears that independent AOA and TDOA MS locations are not used in determining a resulting target MS location (e.g., without the need for projecting lines at angles of arrival or computing the intersection of hyperbolas defined by pairs of base stations). Instead, the Part FDM estimates the target MS's location by minimizing a joint probability of location related errors. In particular, such minimization may use the mean square error, and the location  $(x,y)$  at which minimization occurs is taken as

the estimate of the target MS 140. In particular, the ambiguity function  $A(x,y)$  defines the error involved in a position determination for each point in a geolocation Cartesian coordinate system. The Parl model optimizes the ambiguity function to select a point  $x,y$  at which the associated error is minimized. The resulting location for  $(x,y)$  is taken as the estimate of the location of the target MS 140. Any of several different optimization procedures can be used to optimize the ambiguity function  $A(x,y)$ . E.g., a first rough estimate of the target MS's location may be obtained by direction finding (as discussed above). Next, six points  $x,y$  may be selected that are in close proximity to the estimated point. The ambiguity function  $A(x,y)$  is solved for each of the  $x,y$  points to obtain six values. The six computed values are then used to define a parabolic surface. The point  $x,y$  at which the maximum value of the parabolic surface occurs is then taken as the estimate of the target MS 140. However, other optimization techniques may also be used. For example, a standard technique such as an iterative progression through trial and error to converge to the maximum can be used. Also, gradient search can be used to optimize the ambiguity function. In the case of three-dimensional location, the two-dimensional ambiguity function  $A(x,y)$  is extended to a three-dimensional function  $A(x,y,z)$ . As in the two-dimensional case, the ambiguity function may be optimized to select a point  $x,y,z$  as the best estimate of the target MS's location in three dimensions. Again, any of several known optimization procedures, such as iterative progression through trial and error, gradient search, etc., can be used to optimize the ambiguity function.

*TCO FOM Using TDOA/DOA Measurements from an MBS 148 and/or an LBS 152*

It is believed clear from the location center/gateway 142 architecture and from the architecture of the mobile station location subsystem (described in a separate section hereinafter) that target MS 140 location related information can be obtained from an MBS 148 and/or one or more LBSs 152. Moreover, such location related information can be supplied to any FOM 122.4 that is able to accept such information as input. Thus, pattern recognition and adaptive FOMs may accept such information. However, to provide an alternative description of how MS location related information from an MBS and/or LBS may be used, reference is made to U.S. Patent 6,031,490 (denoted the '490 Patent herein) filed Dec. 23, 1997 and issued Feb. 29, 2000 having Forsen, Berg and Ghisler as inventors, this patent being fully incorporated herein fully by reference. A TCO FOM (denoted the FORSEN FOM herein) using TDOA/DOA is disclosed in the '490 Patent.

The FORSEN FOM includes a location estimator for determining the Time Difference of Arrival (TDOA) of the position of a target MS 140, which is based on Time of Arrival (TOA) and/or DOA measurements. This FOM uses data received from "measuring devices" provided within a wireless telecommunications network. The measuring devices measure TOA on demand and (optionally) Direction of Arrival (DOA), on a digital uplink time slot or on digital information on an analog uplink traffic channel in one of more radio base stations. The TOA and DOA information and the traffic channel number are reported to a Mobile Services Switching Center (MSC), which obtains the identity of the target MS 140 from the traffic channel number and sends the terminal identity and TOA and DOA measurement information to a Service Node (e.g., location center 142) of the network. The Service Node calculates the position of the target MS 140 using the TOA information (supplemented by the DOA information when available). Note, that the TLFM model may utilize data from a second mobile radio terminal is collocated on a mobile platform (auto, emergency vehicle, etc.) with one of the radio base stations (e.g., MBS 148), which can be moved into relatively close proximity with the

target MS 140. Consequently, by moving one of the radio base stations (RBSs) close to the region of interest (near the target MS 140), the position determination accuracy is significantly improved.

Here that the '490 Patent also discloses techniques for rising the target MS's transmission power for thereby allowing wireless signals from the target MS to be better detected by distant BSs 122.

#### 5 Coverage Area First Order Model

Radio coverage area of individual base stations 122 may be used to generate location estimates of the target MS 140. Although a first order model 122a based on this notion may be less accurate than other techniques, if a reasonably accurate RF coverage area is known for each (or most) of the base stations 122, then such a FOM (denoted hereinafter as a "coverage area first order model" or simply "coverage area model") may be very reliable. To determine approximate maximum radio frequency (RF) location coverage areas, with respect to BSs 122, antennas and/or sector coverage areas, for a given class (or classes) of (e.g., CDMA or TDMA) mobile station(s) 140, location coverage should be based on an MS's ability to adequately detect the pilot channel, as opposed to adequate signal quality for purposes of carrying user-acceptable traffic in the voice channel. Note that more energy is necessary for traffic channel activity (typically on the order of at least -94 to -104 dBm received signal strength) to support voice, than energy needed to simply detect a pilot channel's presence for location purposes (typically a maximum weakest signal strength range of between -104 to -110 dBm), thus the "Location Coverage Area" will generally be a larger area than that of a typical "Voice Coverage Area", although industry studies have found some occurrences of "no-coverage" areas within a larger covered area.

The approximate maximum RF coverage area for a given sector of (more generally angular range about) a base station 122 may be represented as a set of points representing a polygonal area (potentially with, e.g., holes therein to account for dead zones and/or notches). Note that if such polygonal RF coverage area representations can be reliably determined and maintained over time (for one or more BS signal power level settings), then such representations can be used in providing a set theoretic or Venn diagram approach to estimating the location of a target MS 140. Coverage area first order models utilize such an approach.

One embodiment, a coverage area model utilizes both the detection and non-detection of base stations 122 by the target MS 140 (conversely, of the MS by one or more base stations 122) to define an area where the target MS 140 may likely be. A relatively straightforward application of this technique is to:

- (a) find all areas of intersection for base station RF coverage area representations, wherein: (i) the corresponding base stations are on-line for communicating with MSs 140; (ii) the RF coverage area representation are deemed reliable for the power levels of the on-line base stations; (iii) the on-line base stations having reliable coverage area representations can be detected by the target MS; and (iv) each intersection must include a predetermined number of the reliable RF coverage area representations (e.g., 2 or 3); and
- (b) obtain new location estimates by subtracting from each of the areas of intersection any of the reliable RF coverage area representations for base stations 122 that can not be detected by the target MS.

Accordingly, the new areas may be used to generate location hypotheses.

#### Satellite Signal Triangulation First Order Model

As mentioned hereinabove, there are various satellite systems that may be used to provide location estimates of a target MS 140 (e.g., GPS, GLONASS, LEOs, and MEOs). In many cases, such location estimates can be very accurate, and accordingly such accuracy would be reflected in the present invention by relatively high confidence values for the location hypotheses generated from such models in comparison to other FOMs. However, it may be difficult for the target MS 140 to detect and/or lock onto such satellite signals sufficiently well to provide a location estimate. For example, it may be very unlikely that such satellite signals can be detected by the MS 140 in the middle of high rise concrete buildings or parking structures having very reduced exposure to the sky.

#### Hybrid Satellite and TSO FOMs

A first order model 722a, denoted the MATTERS FOM herein, is disclosed in U.S. Patent 5,982,324 filed May 14, 1998 and issued Nov. 9, 1999 having Matters, Strawczynski, and Steer as inventors, this patent being fully incorporated herein by reference. The MATTERS FOM includes a location estimator for determining the location of a target MS 140 using satellite signals to the target MS 140 as well as delay in wireless signals communicated between the target MS and base stations 722. For example, aspects of global positioning system (GPS) technology and cellular technology are combined in order to locate a target MS 140. The MATTERS FOM may be used to determine target MS location in a wireless network, wherein the network is utilized to collect differential GPS error correction data, which is forwarded to the target MS 140 via the wireless network. The target MS 140 (which includes a receiver R for receiving non-terrestrial wireless signals from, e.g., GPS, or other satellites, or even airborne craft) receives this data, along with GPS pseudoranges using its receiver R, and calculates its position using this information. However, when the requisite number of satellites are not in view of the MS 140, then a pseudosatellite signal, broadcast from a BS 722 of the wireless network, is received by the target MS 140 and processed as a substitute for the missing satellite signal. Additionally, in at least some circumstances, when the requisite number of satellites (more generally, non-terrestrial wireless transmitters) are not detected by the receiver R, then the target MS's location is calculated using the wireless network infrastructure via TDOA/TOA with the BSs 722 of the network. When the requisite number of satellites (more generally, non-terrestrial wireless transmitters) are again detected by the receiver R, then the target MS is again calculated using wireless signals from the non-terrestrial wireless transmitters. Additionally, the MATTERS FOM may use wireless signals already being transmitted from base stations 722 to the target MS 140 in wireless network to calculate a round trip time delay, from which a distance calculation between the base station and the target MS can be made. This distance calculation substitutes for a missing non-terrestrial transmission signal.

#### Location Base Station First Order Model

In the location base station (LBS) model (FOM 722a), a database is accessed which contain electrical, radio propagation and coverage area characteristics of each of the location base stations in the radio coverage area. The LBS model is an active model, in that it can probe or excite one or more particular LBSs 722 in an area for which the target MS 140 to be located is suspected to be placed. Accordingly, the LBS model

may receive as input a most likely target MS 140 location estimate previously output by the location engine 139 of the present invention, and use this location estimate to determine which (if any) LBSs 152 to activate and/or deactivate for enhancing a subsequent location estimate of the target MS. Moreover, the feedback from the activated LBSs 152 may be provided to other FOMs 1224, as appropriate, as well as to the LBS model. However, it is an important aspect of the LBS model that when it receives such feedback, it may output location hypotheses having relatively small target MS 140 location area estimates about the active LBSs 152 and each such location hypothesis also has a high confidence value indicative of the target MS 140 positively being in the corresponding location area estimate (e.g., a confidence value of  $q$  to  $+1$ ), or having a high confidence value indicative of the target MS 140 not being in the corresponding location area estimate (i.e., a confidence value of  $-q$  to  $-1$ ). Note that in some embodiments of the LBS model, these embodiments may have functionality similar to that of the coverage area first order model described above. Further note that for LBSs within a neighborhood of the target MS wherein there is a reasonable chance that with movement of the target MS may be detected by these LBSs, such LBSs may be requested to periodically activate. (Note, that it is not assumed that such LBSs have an on-line external power source, e.g., some may be solar powered). Moreover, in the case where an LBS 152 includes sufficient electronics to carry voice communication with the target MS 140 and is the primary BS for the target MS (or alternatively, in the active or candidate set), then the LBS model will not deactivate this particular LBS during its procedure of activating and deactivating various LBSs 152.

#### Stochastic First Order Model

The stochastic first order models may use statistical prediction techniques such as principle decomposition, partial least squares, partial least squares, or other regression techniques for predicting, for example, expected minimum and maximum distances of the target MS from one or more base stations 122, e.g., Bollinger Bands. Additionally, some embodiments may use Markov processes and Random Walks (predicted incremental MS movement) for determining an expected area within which the target MS 140 is likely to be. That is, such a process measures the incremental time differences of each pilot as the MS moves for predicting a size of a location area estimate using past MS estimates such as the verified location signatures in the location signature data base 132a.

#### Pattern Recognition and Adaptive First Order Models

It is a particularly important aspect of the present invention to provide:

- (a) one or more FOMs 1224 that generate target MS 140 location estimates by using pattern recognition or associativity techniques, and/or
- (b) one or more FOMs 1224 that are adaptive or trainable so that such FOMs may generate increasingly more accurate target MS location estimates from additional training.



## Statistically Based Pattern Recognition First Order Models

Regarding FOMs 7224 using pattern recognition or associativity techniques, there are many such techniques available. For example, there are statistically based systems such as "CART" (acronym for Classification and Regression Trees) by ANSOFT Software International Limited of Toronto, Canada that may be used for automatically detecting or recognizing patterns in data that were not provided (and likely previously unknown). Accordingly, by imposing a relatively fine mesh or grid of cells of the radio coverage area, wherein each cell is entirely within a particular area type categorization, such as the transmission area types (discussed in the section, "Coverage Area: Area Types And Their Determination" above), the verified location signature clusters within the cells of each area type may be analyzed for signal characteristic patterns. Accordingly, if such a characteristic pattern is found, then it can be used to identify one or more of the cells in which a target MS is likely to be located. That is, one or more location hypotheses may be generated having target MS 140 location estimates that cover an area having the identified cells wherein the target MS 140 is likely to be located. Further note that such statistically based pattern recognition systems as "CART" include software code generators for generating expert system software embodiments for recognizing the patterns detected within a training set (e.g., the verified location signature clusters).

A related statistical pattern recognition FOM 7224 is also disclosed in U.S. Patent 6,026,304, filed Jan. 8, 1997 and issued Feb. 15, 2000, having Hilsenrath and Wax as inventors, this patent (denoted the Hilsenrath patent herein) being incorporated herein fully by reference. An embodiment of a FOM 7224 based on the disclosure of the Hilsenrath patent is referred to herein as the Hilsenrath FOM. The Hilsenrath FOM includes a wireless location estimator that locates a target MS 140 using measurements of multipath signals in order to accurately determine the location of the target MS 140. More particularly, to locate the target MS 140, the Hilsenrath FOM uses wireless measurements of both a direct signal transmission path and multipath transmission signals from the MS 140 to a base station 722 receiver. The wireless signals from the target MS 140 arrive at and are detected by an antenna array of the receiver at the BS 722, wherein the antenna array includes a plurality of antennas. A signal signature (e.g., an embodiment of a location signature herein) for this FOM may be derived from any combination of amplitude, phase, delay, direction, and polarization information of the wireless signals transmitted from the target MS 140 to the base station 722 receiver. The Hilsenrath FOM 7224 determines a signal signature from a signal subspace of a covariance matrix. In particular, for  $p$  antennas included in the base station receiver, these antennas are used to receive complex signal envelopes  $x_1(t), x_2(t), \dots, x_p(t)$ , respectively, which are conventionally grouped together to form a  $p$ -dimensional array vector  $x(t) = [x_1(t), x_2(t), \dots, x_p(t)]^T$ . The signal subspace may be determined from a collection of  $M$  such array vectors  $x(t)$  by several techniques. In one such technique, the outer products of the  $M$  vectors are added together to form a  $p \times p$  signal covariance matrix,  $R = 1/M [x_1(t)x_1^H(t) + \dots + x_M(t)x_M^H(t)]$ . The eigenvalues of  $R$  whose magnitudes exceed a predetermined threshold determine a set of dominant eigenvectors. The signal subspace is the space spanned by these dominant eigenvectors. The signal signature is compared to a database of calibrated signal signatures and corresponding locations (e.g., an embodiment of the location signature data base 1320), wherein the signal signatures in the database include representations of the signal subspaces (such as the dominant eigenvectors of the covariance matrices). Accordingly, a location whose calibrated signature best matches the signal signature of the target MS 140 is selected as the most likely location of the target MS 140. Note that the database of calibrated signal signatures and corresponding verified locations is

generated by a calibration procedure to which a calibrating MS 140 transmits location data derived from a co-located GPS receiver to the base station 122. Thus, for each of a plurality of locations distributed through a service area, the location has associated therewith: the (GPS or verified) location information and the corresponding signal signature of the calibrating MS 140.

Accordingly, the location of a target MS 140 in the service area may be determined as follows. Signals originating from the target MS 140 at an unknown location are received at a base station 122. A signal processor, e.g., at the base station 122, then determines the signal signature as described above. The signal signature is then compared with the calibrated signal signatures stored in the above described embodiment of the location signature database 1320 during the calibration procedure. Using a measure of difference between subspaces (e.g., an angle between subspaces), a set of likely locations is selected from this location signature database embodiment. These selected likely locations are those locations whose associated calibrated signal signatures differ by less than a minimum threshold value from the target MS 140 signal signature. The difference measure is further used to provide a corresponding measure of the probability that each of the selected likely locations is the actual target MS location. Moreover, for one or more of the selected likely location, the corresponding measure may be output as the confidence value for a corresponding location hypothesis output by a filterbank FOM 1224.

Thus, an embodiment of the present invention using such a filterbank FOM 1224 performs the following steps (a) – (d):

- (a) receiving at an antenna array provided at one of the base stations 122, signals originating from the target MS 140, wherein the signals comprise  $p$ -dimensional array vectors sampled from  $p$  antennas of the array;
- (b) determining from the received signals, a signal signature, wherein the signal signature comprises a measured subspace, wherein the array vectors  $\mathbf{x}(t)$  are approximately confined to the measured subspace;
- (c) comparing the signal signature to previously obtained (and similarly computed) signal signatures, wherein each of the previously obtained signal signatures,  $S_i$ , has associated therewith corresponding location data verifying the location where  $S_i$  was obtained, wherein this step of comparing comprises substep of calculating differences between: (i) the measured subspace, and (ii) a similarly determined subspace for each of a plurality of the previously obtained signal signatures; and
- (d) selecting from the previously obtained signal signatures a most likely signal signature and a corresponding most likely location of the target MS 140 by using the calculated differences;

Note that regardless of the reliability some FOMs as described here may not be exceedingly accurate, but may be very reliable. Thus, since an aspect of at least some embodiments of the present invention is to use a plurality of MS location techniques (FOMs) for generating location estimates and to analyze the generated estimates (likely after being adjusted) to detect patterns of convergence or clustering among the estimates, even large MS location area estimates may be useful. For example, it can be the case that four different and relatively large MS location estimates, each having very high reliability, have an area of intersection that is acceptably precise and inherits the very high reliability from each of the large MS location estimates from which the intersection area was derived.

Note, that another statistically based FOM 1224 may be provided wherein the radio coverage area is decomposed substantially as above, but in addition to using the signal characteristics for detecting useful signal patterns, the specific identifications of the base station 122 providing the signal characteristics may also be used. Thus, assuming there is a sufficient density of verified location signature clusters in some of

the mesh cells so that the statistical pattern recognizer can detect patterns in the signal characteristic measurements, an expert system may be generated that outputs a target MS 140 location estimate that may provide both a reliable and accurate location estimate of a target MS 140.

#### Adaptive/Trainable First Order Models

#### Adaptive/Trainable First Order Models

5           The term adaptive is used to describe a data processing component that can modify its data processing behavior in response to certain inputs that are used to change how subsequent inputs are processed by the component. Accordingly, a data processing component may be "explicitly adaptive" by modifying its behavior according to the input of explicit instructions or control data that is input for changing the component's subsequent behavior in ways that are predictable and expected. That is, the input encodes explicit instructions that are known by a user of the component. Alternatively, a data processing component may be "implicitly adaptive" in that its behavior is modified by other than  
10 instructions or control data whose meaning is known by a user of the component. For example, such implicitly adaptive data processors may learn by training on examples, by substantially unguided exploration of a solution space, or other data driven adaptive strategies such as statistically generated decision trees. Accordingly, it is an aspect of the present invention to utilize not only explicitly adaptive MS location estimators within FOMs 1224, but also implicitly adaptive MS location estimators. In particular, artificial neural networks (also denoted neural nets and ANNs herein) are used in some embodiments as implicitly adaptive MS location estimators within FOMs. Thus, in the sections below,  
15 neural net architectures and their application to locating an MS is described.

#### Artificial Neural Networks For MS Location

Artificial neural networks may be particularly useful in developing one or more first order models 1224 for locating an MS 140, since, for example, ANNs can be trained for classifying and/or associatively pattern matching of various RF signal measurements such as the location signatures. That is, by training one or more artificial neural nets using RF signal measurements from verified locations so that RF signal  
20 transmissions characteristic of particular locations are associated with their corresponding locations, such trained artificial neural nets can be used to provide additional target MS 140 location hypotheses. Moreover, it is an aspect of the present invention that the training of such artificial neural net based FOMs (ANN FOMs) is provided without manual intervention as will be discussed hereinafter. Additional description of this aspect of the present invention can be found in the copending U.S. patent application titled "Location Of A Mobile Station" filed Nov. 24, 1999 having Application No. 09/144,367 whose inventors are D. J. Buhray and C. L. Karr, which is incorporated herein by reference and wherein this  
25 copending patent application may have essential material for the present invention. In particular, this copending patent application may have essential material relating to the use of ANNs as mobile station location estimators 1224.

## Other First Order Models

U.S. patent 5,390,339 ('339 patent) filed Oct. 23, 1991 having an issue date of Feb. 14, 1995 with inventor being Brockert et. al. provides number of embodiments of wireless location estimators for estimating the location of a "remote unit." In particular, various location estimator embodiments are described in relation to Figs. 18 and 28 therein. The location estimators in the '339 patent are, in general, directed to determining weighted or adjusted distances of the "remote unit" (e.g., MS 140) from one or more "transceivers" (e.g., base stations 122). The distances are determined using signal strength measurements of wireless signals transmitted between the "remote unit" and the "transceivers." However, adjustments are in the signal strengths according to various signal transmission anomalies (e.g., co-channel interference), impairments and/or errors. Additionally, a signal RF propagation model may be utilized, and a likelihood of the "remote unit" being in the designated coverage areas (cells) of particular transceivers (e.g., base stations 122) is determined using probabilistic techniques such as posteriori probabilities. Accordingly, the Brockert '339 patent is fully incorporated by reference herein and may contain essential material for the present invention.

U.S. patent 5,570,472 ('472 patent) filed Sept. 28, 1994 having an issue date of Oct. 29, 1996 with inventors LeBlanc et. al. provide further embodiments of wireless location estimators that may be used as First Order Models 1224. The location estimating techniques of the LeBlanc '472 patent are described with reference to Fig. 8 and succeeding figures therein. At a high level, wireless location techniques of the '472 patent can be characterized by the following quote therefrom:

"The location processing of the present invention focuses on the ability to predict and model RF contours using actual RF measurements, then performing data reduction techniques such as curve fitting technique, Bollinger Bands, and Genetic Algorithms, in order to locate a mobile unit and disseminate its location."

Accordingly, the LeBlanc '472 patent is fully incorporated by reference herein and may contain essential material for the present invention.

U.S. patent 5,293,645 ('645 patent) filed Dec. 4, 1991 having an issue date of March 8, 1994 with inventor Sood, provide further embodiments of wireless location estimators that may be used as First Order Models 1224. In particular, the '645 patent describes wireless location estimating techniques using triangulations or other geographical intersection techniques. Further, one such technique is described in column 6, line 42 through column 7, line 7. Accordingly, the Sood '645 patent is fully incorporated by reference herein and may contain essential material for the present invention.

U.S. patent 5,293,642 ('642 patent) filed Dec. 19, 1990 having an issue date of Mar. 8, 1994 with inventors Lo provide further embodiments of wireless location estimators that may be used as First Order Models 1224. In particular, the '642 patent determines a corresponding probability density function (pdf) about each of a plurality of base stations in communication with the target MS 140. That is, upon receiving wireless signal measurements from the transmissions between the target MS 140 and base stations 122, for each BS 122, a corresponding pdf is obtained from prior measurements of a particular wireless signal characteristic at locations around the base station. Subsequently, a most likely location estimation is determined from a joint probability density function of the individual base station probability density functions.

Further description can be found in the Description Of The Preferred Embodiment section of the '642 patent. Accordingly, the Co '642 patent is incorporated by reference herein and may contain essential material for the present invention.

#### Hybrid First Order Models

##### *Time Difference of Arrival and Timing Advance FOM*

5 A first order model 722.4 denoted the Yost model herein. The Yost model includes a location estimator that uses a combination of Time Difference of Arrival (TDOA) and Timing Advance (TA) location determining techniques for determining the location of a target MS 140, wherein there are minor modifications to a telecommunication network such as a CNRS. The hybrid wireless location technique utilized by this location estimator uses TDOA measurements and TA measurements to obtain substantially independent location estimates of the target MS 140, wherein the TDOA measurements determine hyperbolic MS loci about base stations 722 (communicating (uni or bi-directionally) with the target MS, and the TA measurements determine circles about the base stations 722. Accordingly, an enhanced location estimate of the MS 140 can be obtained by using a least squares (or other statistical technique), wherein the least-squares technique determines a location for the MS between the various curves (hyperbolae and circles) that best approximates a point of intersection. Note that TA is used in all Time Division Multiple Access (TDMA) systems as one skilled in the art will understand, and measurements of TA can provide a measurement of the distance of the MS from a TDMA communication station in communication with the target MS 140. The Yost model is disclosed in U.S. Patent 5,987,329 (329 Patent) filed July 30, 1997 and issued Nov. 16, 1999 having Yost and Panthapakesan as inventors, this patent being fully incorporated herein fully by reference to thereby further describe the Yost model. The following quote from the '329 Patent describes an important aspect of the Yost model:

15  
20  
25  
Furthermore, the combination of TA and TDOA allows resolution of common ambiguities suffered by either technique separately. For example, in FIG. 5 a situation involving three base stations 24 (A, B and C as described, the latter being visible in the figure) is represented along with the resultant two hyperbolas AB and AC (and redundant hyperbola BC) for a TDOA position determination of the mobile M. FIG. 5 is a magnified view of the mobile terminal M location showing the nearby base stations and the nearby portions at the curves. It should be understood that, in this case, using TDOA alone, there are two possible solutions, where the hyperbolae cross. The addition of the TA circles (dashed curves) will allow the ambiguous solutions, which lie at different TA from all three base stations, to be clearly resolved without the need for additional base station 24 measurements."

As an aside note that a timing advance (TA) first order model may be provided as a separate FOM independent from the TDOA portion of the Yost model. Thus, if an embodiment of the present invention includes both a TA FOM and a TDOA FOM, then the multiple location estimator architecture of the present invention may substantially include the Yost model whenever both the TA FOM and TDOA FOM are both activated for a same location instance of a target MS 140. However, it is an aspect of the present invention to also activate such a TA FOM and a TDOA FOM asynchronously from one another.

*Satellite and Terrestrial Base Station Hybrid FOM*

A first order model 1224, denoted the Sheynblat model (FOM) herein, is disclosed in U.S. Patent 5,999,724 (denoted the '724 Patent herein) filed April 22, 1998 and issued Dec. 7, 1999 having Sheynblat as the inventor, this patent being fully incorporated herein by reference. The Sheynblat FOM provides a location estimator for processing target MS 140 location related information obtained from: (a) satellite signals of a satellite positioning system (denoted SPS in the '724 Patent) (e.g., GPS or GLOPASS, LEO positioning satellites, and/or MEO positioning satellites), and (b) communication signals transmitted in the terrestrial wireless cellular network of BSs 122 for a radio coverage area, e.g., coverage area 120 (Fig. 4), wherein there is two-way wireless communication between the target MS 140 and the BSs. In one embodiment of the Sheynblat FOM, the location related information obtained from the satellite signals includes a representation of a time of travel of SPS satellite signals from a SPS satellite to a corresponding SPS receiver operatively coupled to (and co-located with) the target MS 140 (such "time of travel" is referred to as a pseudorange to the SPS satellite). Additionally for this embodiment, the location related information obtained from the communication signals in the wireless cellular network includes time of travel related information for a message in the communication signals between a BS 122 transceiver and the target MS 140 (this second "time of travel" related information is referred to as a cellular pseudorange). Accordingly, various combinations of pseudoranges to SPS satellites, and cellular pseudoranges can be used to determine a likely location of the target MS 140. As an example, if the target MS 140 (enhanced with a SPS receiver) can receive SPS satellite signals from one satellite, and additionally, the target MS is also in wireless communication (or can be in wireless communication) with two BSs 122, then three pseudoranges may be obtained and used to determine the position of the target MS by, e.g., triangulation. Of course, other combinations are possible for determining a location of the target MS 140, e.g., pseudoranges to two SPS satellites and one cellular pseudorange. Additionally, various techniques may be used to mitigate the effects of multipath on these pseudoranges. For example, since it is typical for the target MS 140 to detect (or be detected by) a plurality of BSs 122, a corresponding plurality of cellular pseudoranges may be obtained, wherein such cellular pseudoranges may be used in a cluster analysis technique to disambiguate MS locations identified by the satellite pseudoranges. Moreover, the determination of a location hypothesis is performed, in at least one embodiment, at a site remote from the target MS 140, such as the location center/gateway 142, or another site that communicates with the location center/gateway for supplying a resulting MS location to the gateway. Alternatively, the target MS 140 may perform the calculations to determine its own location. Note that this alternative technique may be particularly useful when the target MS 140 is a mobile base station 144.

25 MS Status Repository Embodiment

The MS status repository 1338 is a run-time storage manager for storing location hypotheses from previous activations of the location engine 139 (as well as the output target MS location estimate(s)) so that a target MS may be tracked using target MS location hypotheses from previous location engine 139 activations to determine, for example, a movement of the target MS between evaluations of the target MS location. Thus, by retaining a moving window of previous location hypotheses used in evaluating positions of a target MS, measurements of the target MS's velocity, acceleration, and likely next position may be determined by the location hypothesis analyzer 1332. Further, by providing accessibility to

recent MS location hypotheses, these hypotheses may be used to resolve conflicts between hypotheses in a current activation for locating the target MS; e.g., MS paths may be stored here for use in extrapolating a new location

#### Mobile Base Station Location Subsystem Description

##### Mobile Base Station Subsystem Introduction

5 Any collection of mobile electronics (denoted mobile location unit) that is able to both estimate a location of a target MS 140 and communicate with the base station network may be utilized by the present invention to more accurately locate the target MS. Such mobile location units may provide greater target MS location accuracy by, for example, homing in on the target MS and by transmitting additional MS location information to the location center 142. There are a number of embodiments for such a mobile location unit contemplated by the present invention. For example, in a minimal version, such the electronics of the mobile location unit may be little more than an onboard MS 140, a 10 sector/directional antenna and a controller for communicating between them. Thus, the onboard MS is used to communicate with the location center 142 and possibly the target MS 140, while the antenna monitors signals for homing in on the target MS 140. In an enhanced version of the mobile location unit, a GPS receiver may also be incorporated so that the location of the mobile location unit may be determined and consequently an estimate of the location of the target MS may also be determined. However, such a mobile location unit is unlikely to be able to determine substantially more than a direction of the target MS 140 via the sector/directional antenna without further base station 15 infrastructure cooperation in, for example, determining the transmission power level of the target MS or varying this power level. Thus, if the target MS or the mobile location unit leaves the coverage area 120 or resides in a poor communication area, it may be difficult to accurately determine where the target MS is located. None-the-less, such mobile location units may be sufficient for many situations, and in fact the present invention contemplates their use. However, in cases where direct communication with the target MS is desired without constant contact with the base station infrastructure, the present invention includes a mobile location unit that is also a scaled down version of a base station 122. Thus, 20 given that such a mobile base station or MBS 148 includes at least an onboard MS 140, a sector/directional antenna, a GPS receiver, a scaled down base station 122 and sufficient components (including a controller) for integrating the capabilities of these devices, an enhanced autonomous MS mobile location system can be provided that can be effectively used in, for example, emergency vehicles, air planes and boats. Accordingly, the description that follows below describes an embodiment of an MBS 148 having the above mentioned components and capabilities for use in a vehicle.

25 As a consequence of the MBS 148 being mobile, there are fundamental differences in the operation of an MBS in comparison to other types of BS's 152. In particular, other types of base stations have fixed locations that are precisely determined and known by the location center, whereas a location of an MBS 148 may be known only approximately and thus may require repeated and frequent re-estimating. Secondly, other types of base stations have substantially fixed and stable communication with the location center (via possibly other BS's in the case of BS's 152) and therefore although these BS's may be more reliable in their ability to communicate information related to the 30 location of a target MS with the location center, accuracy can be problematic in poor reception areas. Thus, MBS's may be used in areas (such as

wilderness areas) where there may be no other means for reliably and cost effectively locating a target MS 140 (i.e., there may be insufficient fixed location BS's coverage in an area).

Fig. 11 provides a high level block diagram architecture of one embodiment of the MBS location subsystem 1508. Accordingly, an MBS may include components for communicating with the fixed location BS network infrastructure and the location center 142 via an on-board transceiver 1521 that is effectively an MS 140 integrated into the location subsystem 1508. Thus, if the MBS 148 travels through an area having poor infrastructure signal coverage, then the MBS may not be able to communicate reliably with the location center 142 (e.g., in rural or mountainous areas having reduced wireless telephony coverage). So it is desirable that the MBS 148 must be capable of functioning substantially autonomously from the location center. In one embodiment, this implies that each MBS 148 must be capable of estimating both its own location as well as the location of a target MS 140.

Additionally, many commercial wireless telephony technologies require all BS's in a network to be very accurately time synchronized both for transmitting MS voice communication as well as for other services such as MS location. Accordingly, the MBS 148 will also require such time synchronization. However, since an MBS 148 may not be in constant communication with the fixed location BS network (and indeed may be off-line for substantial periods of time), on-board highly accurate timing device may be necessary. In one embodiment, such a device may be a commercially available rubidium oscillator 1520 as shown in Fig. 11.

Since the MBS 148 includes a scaled down version of a BS 122 (denoted 1522 in Fig. 11), it is capable of performing most typical BS 122 tasks, albeit on a reduced scale. In particular, the base station portion of the MBS 148 can:

- (a) raise/lowers its pilot channel signal strength,
- (b) be in a state of soft hand-off with an MS 140, and/or
- (c) be the primary BS 122 for an MS 140, and consequently be in voice communication with the target MS (via the MBS operator telephony interface 1524) if the MS supports voice communication.

Further, the MBS 148 can, if it becomes the primary base station communicating with the MS 140, request the MS to raise/lowers its power or, more generally, control the communication with the MS (via the base station components 1522). However, since the MBS 148 will likely have substantially reduced telephony traffic capacity in comparison to a standard infrastructure base station 122, note that the pilot channel for the MBS is preferably a nonstandard pilot channel in that it should not be identified as a conventional telephony traffic bearing BS 122 by MS's seeking normal telephony communication. Thus, a target MS 140 requesting to be located may, depending on its capabilities, either automatically configure itself to scan for certain predetermined MBS pilot channel, or be instructed via the fixed location base station network (equivalently BS infrastructure) to scan for a certain predetermined MBS pilot channel.

Moreover, the MBS 148 has an additional advantage in that it can substantially increase the reliability of communication with a target MS 140 in comparison to the base station infrastructure by being able to move toward or track the target MS 140 even if this MS is in (or moves into) a reduced infrastructure base station network coverage area. Furthermore, an MBS 148 may preferably use a directional or smart antenna 1526 to more accurately locate a direction of signals from a target MS 140. Thus, the sweeping of such a smart antenna 1526 (physically or electronically) provides directional information regarding signals received from the target MS 140. That is, such directional information is



determined by the signal propagation delay of signals from the target MS 140 to the angular sectors of one of more directional antennas 152b on-board the MBS 148.

Before proceeding to further details of the MBS location subsystem 1508, an example of the operation of an MBS 148 in the context of responding to a 911 emergency call is given. In particular, this example describes the high level computational states through which the MBS 148 transitions, these states also being illustrated in the state transition diagram of Fig. 12. Note that this figure illustrates the primary state transitions between these MBS 148 states, wherein the solid state transitions are indicative of a typical "ideal" progression when locating or tracking a target MS 140, and the dashed state transitions are the primary state reversions due, for example, to difficulties in locating the target MS 140.

Accordingly, initially the MBS 148 may be in an inactive state 1700, wherein the MBS location subsystem 1508 is effectively available for voice or data communication with the fixed location base station network, but the MS 140 locating capabilities of the MBS are not active. From the inactive state 1700 the MBS (e.g., a police or rescue vehicle) may enter an active state 1704 once an MBS operator has logged onto the MBS location subsystem of the MBS, such logging being for authentication, verification and journaling of MBS 148 events. In the active state 1704, the MBS may be listed by a 911 emergency center and/or the location center 142 as eligible for service in responding to a 911 request. From this state, the MBS 148 may transition to a ready state 1708 signifying that the MBS is ready for use in locating and/or intercepting a target MS 140. That is, the MBS 148 may transition to the ready state 1708 by performing the following steps:

- (1a) Synchronizing the timing of the location subsystem 1508 with that of the base station network infrastructure. In one embodiment, when requesting such time synchronization from the base station infrastructure, the MBS 148 will be at a predetermined or well known location so that the MBS time synchronization may adjust for a known amount of signal propagation delay in the synchronization signal.
- (1b) Establishing the location of the MBS 148. In one embodiment, this may be accomplished by, for example, an MBS operator identifying the predetermined or well known location at which the MBS 148 is located.
- (1c) Communicating with, for example, the 911 emergency center via the fixed location base station infrastructure to identify the MBS 148 as in the ready state.

Thus, while in the ready state 1708, as the MBS 148 moves, its location is repeatedly (re)-estimated via, for example, GPS signals, location center 142 location estimates from the base stations 122 (and 152), and an on-board deadreckoning subsystem 152) having an MBS location estimator according to the programs described hereinbelow. However, note that the accuracy of the base station time synchronization (via the rubidium oscillator 152a) and the accuracy of the MBS 148 location may need to both be periodically recalibrated according to (1a) and (1b) above.

Assuming a 911 signal is transmitted by a target MS 140, this signal is transmitted, via the fixed location base station infrastructure, to the 911 emergency center and the location center 142, and assuming the MBS 148 is in the ready state 1708, if a corresponding 911 emergency request is transmitted to the MBS (via the base station infrastructure) from the 911 emergency center or the location center, then the MBS may transition to a seek state 1712 by performing the following steps:

(2a) Communicating with, for example, the 911 emergency response center via the fixed location base station network to receive the PIN code for the target MS to be located (wherein this communication is performed using the MS-like transceiver 1572 and/or the MBS operator telephony interface 1524).

(2b) Obtaining a most recent target MS location estimate from either the 911 emergency center or the location center 142.

5 (2c) Inputting by the MBS operator an acknowledgment of the target MS to be located, and transmitting this acknowledgment to the 911 emergency response center via the transceiver 1572.

Subsequently, when the MBS 148 is in the seek state 1772, the MBS may commence toward the target MS location estimate provided. Note that it is likely that the MBS is not initially in direct signal contact with the target MS. Accordingly, in the seek state 1772, the following steps may be, for example, performed:

10 (3a) The location center 142 or the 911 emergency response center may inform the target MS, via the fixed location base station network, to lower its threshold for soft hand-off and at least periodically boost its location signal strength. Additionally, the target MS may be informed to scan for the pilot channel of the MBS 148. (Note the actions here are not, actions performed by the MBS 148 in the "seek state"; however, these actions are given here for clarity and completeness.)

15 (3b) Repeatedly, as sufficient new MS location information is available, the location center 142 provides new MS location estimates to the MBS 148 via the fixed location base station network.

(3c) The MBS repeatedly provides the MBS operator with new target MS location estimates provided substantially by the location center via the fixed location base station network.

(3d) The MBS 148 repeatedly attempts to detect a signal from the target MS using the PIN code for the target MS.

20 (3e) The MBS 148 repeatedly estimates its own location (as in other states as well), and receives MBS location estimates from the location center.

Assuming that the MBS 148 and target MS 140 detect one another (which typically occurs when the two units are within .25 to 3 miles of one another), the MBS enters a contact state 1716 when the target MS 140 enters a soft hand-off state with the MBS. Accordingly, in the contact state 1716, the following steps are, for example, performed:

25 (4a) The MBS 148 repeatedly estimates its own location.

(4b) Repeatedly, the location center 142 provides new target MS 140 and MBS location estimates to the MBS 148 via the fixed location base infrastructure network.

(4c) Since the MBS 148 is at least in soft hand-off with the target MS 140, the MBS can estimate the direction and distance of the target MS itself using, for example, detected target MS signal strength and TOA as well as using any recent location center target MS location estimates.

30 (4d) The MBS 148 repeatedly provides the MBS operator with new target MS location estimates provided using MS location estimates provided by the MBS itself and by the location center via the fixed location base station network.

When the target MS 140 detects that the MBS pilot channel is sufficiently strong, the target MS may switch to using the MBS 148 as its primary base station. When this occurs, the MBS enters a control state 1720, wherein the following steps are, for example, performed:

(5a) The MBS 148 repeatedly estimates its own location.

(5b) Repeatedly, the location center 142 provides new target MS and MBS location estimates to the MBS 148 via the network of base stations 122 (152).

(5c) The MBS 148 estimates the direction and distance of the target MS 140 itself using, for example, detected target MS signal strength and TOA as well as using any recent location center target MS location estimates.

(5d) The MBS 148 repeatedly provides the MBS operator with new target MS location estimates provided using MS location estimates provided by the MBS itself and by the location center 142 via the fixed location base station network.

(5e) The MBS 148 becomes the primary base station for the target MS 140 and therefore controls at least the signal strength output by the target MS.

Note, there can be more than one MBS 148 tracking or locating an MS 140. There can also be more than one target MS 140 to be tracked concurrently and each target MS being tracked may be stationary or moving.

#### MBS Subsystem Architecture

An MBS 148 uses MS signal characteristic data for locating the MS 140. The MBS 148 may use such signal characteristic data to facilitate determining whether a given signal from the MS is a "direct shot" or a multipath signal. That is, in one embodiment, the MBS 148 attempts to determine or detect whether an MS signal transmission is received directly, or whether the transmission has been reflected or deflected. For example, the MBS may determine whether the expected signal strength, and TOA agree in distance estimates for the MS signal transmissions. Note, other signal characteristics may also be used, if there are sufficient electronics and processing available to the MBS 148, i.e., determining signal phase and/or polarity as other indications of receiving a "direct shot" from an MS 140.

In one embodiment, the MBS 148 (Fig. 11) includes an MBS controller 1533 for controlling the location capabilities of the MBS 148. In particular, the MBS controller 1533 initiates and controls the MBS state changes as described in Fig. 12. Additionally, the MBS controller 1533 also communicates with the location controller 1535, wherein this latter controller controls MBS activities related to MBS location and target MS location. The location controller 1535 receives data input from an event generator 1537 for generating event records to be provided to the location controller 1535. For example, records may be generated from data input received from: (a) the vehicle movement detector 1539 indicating that the MBS 148 has moved at least a predetermined amount and/or has changed direction by at least a predetermined angle, or (b) the MBS signal processing subsystem 1541 indicating that the additional signal measurement data has been received from either the location center 142 or the target MS 140. Note that the MBS signal processing subsystem 1541, in one embodiment, is similar to the signal processing subsystem 1220 of the location center 142. may have multiple command schedulers. In particular, a scheduler 1528 for commands related to communicating with the location center 142, a scheduler 1530 for commands related to GPS communication (via GPS receiver 1531), a scheduler 1529 for commands related to the frequency and granularity of the reporting of MBS changes in direction and/or position via the MBS dead

reckoning subsystem 1527 (note that this scheduler is potentially optional and that such commands may be provided directly to the deadreckoning estimator 1544), and a scheduler 1532 for communicating with the target M(s) 140 being located. Further, it is assumed that there is sufficient hardware and/or software to appear to perform commands in different schedulers substantially concurrently.

In order to display an MBS computed location of a target M 140, a location of the MBS must be known or determined. Accordingly, each MBS 148 has a plurality of MBS location estimators (or hereinafter also simply referred to as location estimators) for determining the location of the MBS. Each such location estimator computes MBS location information such as MBS location estimates, changes to MBS location estimates, or, an MBS location estimator may be an interface for buffering and/or translating a previously computed MBS location estimate into an appropriate format. In particular, the MBS location module 1536, which determines the location of the MBS, may include the following MBS location estimators 1540 (also denoted baseline location estimators):

- (a) a GPS location estimator 1540a (not individually shown) for computing an MBS location estimate using GPS signals,
- (b) a location center location estimator 1540b (not individually shown) for buffering and/or translating an MBS estimate received from the location center 142,
- (c) an MBS operator location estimator 1540c (not individually shown) for buffering and/or translating manual MBS location entries received from an MBS location operator, and
- (d) in some MBS embodiments, an LBS location estimator 1540d (not individually shown) for the activating and deactivating of LBS's 152.

Note that, in high multipath areas and/or stationary base station marginal coverage areas, such low cost location base stations 152 (LBS) may be provided whose locations are fixed and accurately predetermined and whose signals are substantially only receivable within a relatively small range (e.g., 2000 feet), the range potentially being variable. Thus, by communicating with the LBS's 152 directly, the MBS 148 may be able to quickly use the location information relating to the location base stations for determining its location by using signal characteristics obtained from the LBS's 152.

Note that each of the MBS baseline location estimators 1540, such as those above, provide an actual MBS location rather than, for example, a change in an MBS location. Further note that it is an aspect of the present invention that additional MBS baseline location estimators 1540 may be easily integrated into the MBS location subsystem 1508 as such baseline location estimators become available. For example, a baseline location estimator that receives MBS location estimates from reflective codes provided, for example, on streets or street signs can be straightforwardly incorporated into the MBS location subsystem 1508.

Additionally, note that a plurality of MBS location technologies and their corresponding MBS location estimators are utilized due to the fact that there is currently no single location technology available that is both sufficiently fast, accurate and accessible in substantially all terrains to meet the location needs of an MBS 148. For example, in many terrains GPS technologies may be sufficiently accurate, however, GPS technologies: (a) may require a relatively long time to provide an initial location estimate (e.g., greater than 2 minutes); (b) when GPS communication is disturbed, it may require an equally long time to provide a new location estimate; (c) clouds, buildings and/or mountain can prevent location estimates from being obtained; (d) in some cases signal reflections can substantially skew a location estimate. As another example, an MBS 148 may be able to use triangulation or trilateration technologies to obtain a location estimate, however, this assumes that

there is sufficient (fixed location) infrastructure BS coverage in the area the MBS is located. Further, it is well known that the multipath phenomenon can substantially distort such location estimates. Thus, for an MBS 148 to be highly effective in varied terrain, an MBS is provided with a plurality of location technologies, each supplying an MBS location estimate.

In fact, much of the architecture of the location engine 134 could be incorporated into an MBS 148. For example, in some embodiments of the MBS 148, the following FOMs 1224 may have similar location models incorporated into the MBS:

- (a) a variation of the TDOA FOM 1224 wherein TOA signals from communicating fixed location BS's are received (via the MBS transceiver 1512) by the MBS and used for providing a location estimate;
- (b) a variation of the artificial neural net based FOMs 1224 (or more generally a location learning or a classification model) may be used to provide MBS location estimates via, for example, learned association between fixed location BS signal characteristics and geographic locations;
- (c) an LBS location FOM 1224 for providing an MBS with the ability to activate and deactivate LBS's to provide (positive) MBS location estimates as well as negative MBS location regions (i.e., regions where the MBS is unlikely to be since one or more LBS's are not detected by the MBS transceiver);
- (d) one or more MBS location reasoning agents and/or a location estimate heuristic agents for resolving MBS location estimate conflicts and providing greater MBS location estimate accuracy. For example, modules similar to the analytical reasoner module 1416 and the historical location reasoner module 1424.

However, for those MBS location models requiring communication with the base station infrastructure, an alternative embodiment is to rely on the location center 142 to perform the computations for at least some of these MBS FOM models. That is, since each of the MBS location models mentioned immediately above require communication with the network of fixed location BS's 122 (152), it may be advantageous to transmit MBS location estimating data to the location center 142 as if the MBS were another MS 140 for the location center to locate, and thereby rely on the location estimation capabilities at the location center rather than duplicate such models in the MBS 148. The advantages of this approach are that:

- (a) an MBS is likely to be able to use less expensive processing power and software than that of the location center;
- (b) an MBS is likely to require substantially less memory, particularly for data bases, than that of the location center.

As will be discussed further below, in one embodiment of the MBS 148, there are confidence values assigned to the locations output by the various location estimators 1540. Thus, the confidence for a manual entry of location data by an MBS operator may be rated the highest and followed by the confidence for (any) GPS location data, followed by the confidence for (any) location center location 142 estimates, followed by the confidence for (any) location estimates using signal characteristic data from LBS's. However, such prioritization may vary depending on, for instance, the radio coverage area 120. In one embodiment of the present invention, it is an aspect of the present invention that for MBS location data received from the GPS and location center, their confidences may vary according to the area in which the MBS 148 resides. That is, if it is known that for a given area, there is a reasonable probability that a GPS signal may suffer multipath distortions and that the location center has in the past provided reliable location estimates, then the confidences for these two location sources may be reversed.

In one embodiment of the present invention, MBS operators may be requested to occasionally manually enter the location of the MBS 148 when the MBS is stationary for determining and/or calibrating the accuracy of various MBS location estimators.

There is an additional important source of location information for the MBS 148 that is incorporated into an MBS vehicle (such as a police vehicle) that has no comparable functionality in the network of fixed location BS's. That is, the MBS 148 may use deadreckoning information provided by a deadreckoning MBS location estimator 1544 whereby the MBS may obtain MBS deadreckoning location change estimates. Accordingly, the deadreckoning MBS location estimator 1544 may use, for example, an on-board gyroscope 1550, a wheel rotation measurement device (e.g., odometer) 1554, and optionally an accelerometer (not shown). Thus, such a deadreckoning MBS location estimator 1544 periodically provides at least MBS distance and directional data related to MBS movements from a most recent MBS location estimate. More precisely, in the absence of any other new MBS location information, the deadreckoning MBS location estimator 1544 outputs a series of measurements, wherein each such measurement is an estimated change (or delta) in the position of the MBS 148 between a request input timestamp and a closest time prior to the timestamp, wherein a previous deadreckoning terminated. Thus, each deadreckoning location change estimate includes the following fields:

- (a) an "earliest timestamp" field for designating the start time when the deadreckoning location change estimate commences measuring a change in the location of the MBS;
- (b) a "latest timestamp" field for designating the end time when the deadreckoning location change estimate stops measuring a change in the location of the MBS; and
- (c) an MBS location change vector.

That is, the "latest timestamp" is the timestamp input with a request for deadreckoning location data, and the "earliest timestamp" is the timestamp of the closest time, T, prior to the latest timestamp, wherein a previous deadreckoning output has its a timestamp at a time equal to T.

Further, the frequency of such measurements provided by the deadreckoning subsystem 1527 may be adaptively provided depending on the velocity of the MBS 148 and/or the elapsed time since the most recent MBS location update. Accordingly, the architecture of at least some embodiments of the MBS location subsystem 1508 must be such that it can utilize such deadreckoning information for estimating the location of the MBS 148.

In one embodiment of the MBS location subsystem 1508 described in further detail hereinbelow, the outputs from the deadreckoning MBS location estimator 1544 are used to synchronize MBS location estimates from different MBS baseline location estimators. That is, since such a deadreckoning output may be requested for substantially any time from the deadreckoning MBS location estimator, such an output can be requested for substantially the same point in time as the occurrence of the signals from which a new MBS baseline location estimate is derived. Accordingly, such a deadreckoning output can be used to update other MBS location estimates not using the new MBS baseline location estimate.

It is assumed that the error with dead reckoning increases with deadreckoning distance. Accordingly, it is an aspect of the embodiment of the MBS location subsystem 1508 that when incrementally updating the location of the MBS 148 using deadreckoning and applying deadreckoning location change estimates to a "most likely area" in which the MBS 148 is believed to be, this area is incrementally enlarged as well as shifted.

The enlargement of the area is used to account for the inaccuracy in the deadreckoning capability. Note, however, that the deadreckoning MBS location estimator is periodically reset so that the error accumulation in its outputs can be decreased. In particular, such resetting occurs when there is a high probability that the location of the MBS is known. For example, the deadreckoning MBS location estimator may be reset when an MBS operator manually enters an MBS location or verifies an MBS location, or a computed MBS location has sufficiently high confidence.

Thus, due to the MBS 148 having less accurate location information (both about itself and a target MS 149), and further that deadreckoning information must be utilized in maintaining MBS location estimates, a first embodiment of the MBS location subsystem architecture is somewhat different from the location engine 139 architecture. That is, the architecture of this first embodiment is simpler than that of the architecture of the location engine 139. However, it is important to note that, at a high level, the architecture of the location engine 139 may also be applied for providing a second embodiment of the MBS location subsystem 1508, as one skilled in the art will appreciate after reflecting on the architectures and processing provided at an MBS 148. For example, an MBS location subsystem 1508 architecture may be provided that has one or more first order models 1224 whose output is supplied to, for example, a blackboard or expert system for resolving MBS location estimate conflicts, such an architecture being analogous to one embodiment of the location engine 139 architecture.

Furthermore, it is also an important aspect of the present invention that, at a high level, the MBS location subsystem architecture may also be applied as an alternative architecture for the location engine 139. For example, in one embodiment of the location engine 139, each of the first order models 1224 may provide its MS location hypothesis outputs to a corresponding "location track," analogous to the MBS location tracks described hereinbelow, and subsequently, a most likely MS current location estimate may be developed in a "current location track" (also described hereinbelow) using the most recent location estimates in other location tracks. Thus, the location estimating models of the location center 139 and those of the MBS 148 are may be interchanged depending on where it is deemed most appropriate for such each such model to reside. Additionally, note that in different embodiments of the present invention, various combinations of the location center location architecture and the mobile station architecture may be utilized at either the location center or the MBS 148. Thus, by providing substantially all location estimating computational models at the location center 142, the models described here for locating the MBS 148 (and equivalently, its incorporated MS 149) can be used for locating other MS 149 that are capable of supporting transmission of wireless signal measurements that relate to models requiring the additional electronics available at the MBS 149 (e.g., GPS or other satellite signals used for location).

Further, note that the ideas and methods discussed here relating to MBS location estimators 1540 and MBS location tracks, and, the related programs hereinbelow are sufficiently general so that these ideas and methods may be applied in a number of contexts related to determining the location of a device capable of movement and wherein the location of the device must be maintained in real time. For example, the present ideas and methods may be used by a robot in a very cluttered environment (e.g., a warehouse), wherein the robot has access: (a) to a plurality of "robot location estimators" that may provide the robot with sporadic location information, and (b) to a deadreckoning location estimator.

Each MBS 148, additionally, has a location display (denoted the MBS operator visual user interface 1558 in Fig. 11) where area maps that may be displayed together with location data. In particular, MS location data may be displayed on this display as a nested collection of areas, each smaller nested area being the most likely area within (any) encompassing area for locating a target MS 149. Note that the MBS controller algorithm below may be adapted to receive location center 141 data for displaying the locations of other MBSs 148 as well as target MSs 149.

Further, the MBS 148 may constrain any location estimates to streets on a street map using the MBS location map to street module 156. For example, an estimated MBS location not on a street may be "snapped to" a nearest street location. Note that a nearest street location determiner may use "normal" orientations of vehicles on streets as a constraint on the nearest street location. Particularly, if an MBS 148 is moving at typical rates of speed and acceleration, and without abrupt changes in direction. For example, if the deadreckoning MBS location estimator 1544 indicates that the MBS 148 is moving in a northerly direction, then the street snapped to should be a north-south running street. Moreover, the MBS location map to street module 156 may also be used to enhance target MBS location estimates when, for example, it is known or suspected that the target MBS 140 is in a vehicle and the vehicle is moving at typical rates of speed. Furthermore, the map to street location module 156 may also be used in enhancing the location of a target MBS 140 by either the MBS 148 or by the location engine 134. In particular, the location estimator 1344 or an additional module between the location estimator 1344 and the output gateway 1356 may utilize an embodiment of the map to street location module 156 to enhance the accuracy of target MBS 140 location estimates that are known to be in vehicles. Note that this may be especially useful in locating stolen vehicles that have embedded wireless location transceivers (MBS 140), wherein appropriate wireless signal measurements can be provided to the location center 142.

#### MBS Data Structure Remarks

Assuming the existence of at least some of the location estimators 1540 that were mentioned above, the discussion here refers substantially to the data structures and their organization as illustrated in Fig. 13.

The location estimates (or hypotheses) for an MBS 148 determining its own location each have an error or range estimate associated with the MBS location estimate. That is, each such MBS location estimate includes a "most likely MBS point location" within a "most likely area". The "most likely MBS point location" is assumed herein to be the centroid of the "most likely area". In one embodiment of the MBS location subsystem 1508, a nested series of "most likely areas" may be provided about a most likely MBS point location. However, to simplify the discussion herein each MBS location estimate is assumed to have a single "most likely area". One skilled in the art will understand how to provide such nested "most likely areas" from the description herein. Additionally, it is assumed that such "most likely areas" are not grossly oblong, i.e., area cross sectioning lines through the centroid of the area do not have large differences in their lengths. For example, for any such "most likely area",  $A$ , no two such cross sectioning lines of  $A$  through the centroid thereof may have lengths that vary by more than a factor of five.

Each MBS location estimate also has a confidence associated therewith providing a measurement of the perceived accuracy of the MBS being in the "most likely area" of the location estimate.

A (MBS) "location track" is a data structure (or object) having a queue of a predetermined length for maintaining a temporal (timestamp) ordering of "location track entries" such as the location track entries 1770a, 1770b, 1774a, 1774b, 1778a, 1778b, 1782a, 1782b, and 1786a (Fig. 11), wherein each such MBS location track entry is an estimate of the location of the MBS at a particular corresponding time.

There is an MBS location track for storing MBS location entries obtained from MBS location estimation information from each of the MBS baseline location estimators described above (i.e., a GPS location track 1750 for storing MBS location estimations obtained from the GPS location estimator 1540, a location center location track 1754 for storing MBS location estimations obtained from the location estimator 1540 deriving its



MBS location estimates from the location center 142, an LBS location track 1768 for storing MBS location estimations obtained from the location estimator 1540 deriving its MBS location estimates from base stations 122 and/or 152, and a manual location track 1762 for MBS operator entered MBS location). Additionally, there is one further location track, denoted the "current location track" 1766 whose location track entries may be derived from the entries in the other location tracks (described further hereinafter). Further, for each location track, there is a location track head that is the head of the queue for the location track. The location track head is the most recent (and presumably the most accurate) MBS location estimate residing in the location track. Thus, for the GPS location track 1750 has location track head 1770, the location center location track 1764 has location track head 1774, the LBS location track 1768 has location track head 1778, the manual location track 1762 has location track head 1782, and the current location track 1766 has location track head 1786. Additionally, for notational convenience, for each location track, the time series of previous MBS location estimations (i.e., location track entries) in the location track will herein be denoted the "path for the location track." Such paths are typically the length of the location track queue containing the path. Note that the length of each such queue may be determined using at least the following considerations:

- (i) In certain circumstances (described hereinafter), the location track entries are removed from the head of the location track queues so that location adjustments may be made. In such a case, it may be advantageous for the length of such queues to be greater than the number of entries that are expected to be removed;
- (ii) In determining an MBS location estimate, it may be desirable in some embodiments to provide new location estimates based on paths associated with previous MBS location estimates provided in the corresponding location track queue.

Also note that it is within the scope of the present invention that the location track queue lengths may be a length of one.

Regarding location track entries, each location track entry includes:

- (a) a "derived location estimate" for the MBS that is derived using at least one of:
  - (i) at least a most recent previous output from an MBS baseline location estimator 1540 (i.e., the output being an MBS location estimate);
  - (ii) deadreckoning output information from the deadreckoning subsystem 152.

Further note that each output from an MBS location estimator has a "type" field that is used for identifying the MBS location estimator of the output.
- (b) an "earliest timestamp" providing the time/date when the earliest MBS location information upon which the derived location estimate for the MBS depends. Note this will typically be the timestamp of the earliest MBS location estimate (from an MBS baseline location estimator) that supplied MBS location information used in deriving the derived location estimate for the MBS 148.
- (c) a "latest timestamp" providing the time/date when the latest MBS location information upon which the derived location estimate for the MBS depends. Note that earliest timestamp = latest timestamp only for so called "baseline entries" as defined hereinafter. Further note that this attribute is the one used for maintaining the "temporal (timestamp) ordering" of location track entries.

(d) A "deadreckoning distance" indicating the total distance (e.g., wheel turns or odometer difference) since the most recently previous baseline entry for the corresponding MBS location estimator for the location track to which the location track entry is assigned.

For each MBS location track, there are two categories of MBS location track entries that may be inserted into a MBS location track:

(a) "baseline" entries, wherein each such baseline entry includes (depending on the location track) a location estimate for the MBS 14A derived from: (i) a most recent previous output either from a corresponding MBS baseline location estimator, or (ii) from the baseline entries of other location tracks (this latter case being for the "current" location track);

(b) "extrapolation" entries, wherein each such entry includes an MBS location estimate that has been extrapolated from the (most recent) location track head for the location track (i.e., based on the track head whose "latest timestamp" immediately precedes the latest timestamp of the extrapolation entry). Each such extrapolation entry is computed by using data from a related deadreckoning location change estimate output from the deadreckoning MBS location estimator 154A. Each such deadreckoning location change estimate includes measurements related to changes or deltas in the location of the MBS 14A. More precisely, for each location track, each extrapolation entry is determined using: (i) a baseline entry, and (ii) a set of one or more (i.e., all later occurring) deadreckoning location change estimates in increasing "latest timestamp" order. Note that for notational convenience this set of one or more deadreckoning location change estimates will be denoted the "deadreckoning location change estimate set" associated with the extrapolation entry resulting from this set.

(c) Note that for each location track head, it is either a baseline entry or an extrapolation entry. Further, for each extrapolation entry, there is a most recent baseline entry, B, that is earlier than the extrapolation entry and it is this B from which the extrapolation entry was extrapolated. This earlier baseline entry, B, is hereinafter denoted the "baseline entry associated with the extrapolation entry." More generally, for each location track entry, T, there is a most recent previous baseline entry, B, associated with T, wherein if T is an extrapolation entry, then B is as defined above, else if T is a baseline entry itself, then T = B. Accordingly, note that for each extrapolation entry that is the head of a location track, there is a most recent baseline entry associated with the extrapolation entry.

Further, there are two categories of location tracks:

(a) "baseline location tracks," each having baseline entries exclusively from a single predetermined MBS baseline location estimator; and

(b) a "current" MBS location track having entries that are computed or determined as "most likely" MBS location estimates from entries in the other MBS location tracks.

#### MBS Location Estimating Strategy

In order to be able to properly compare the track heads to determine the most likely MBS location estimate it is an aspect of the present invention that the track heads of all location tracks include MBS location estimates that are for substantially the same (latest) timestamp.

However, the MBS location information from each MBS baseline location estimator is inherently substantially unpredictable and unsynchronized. In fact, the only MBS location information that may be considered predictable and controllable is the deadreckoning location change estimates from the deadreckoning MBS location estimator 1344. In that these estimates may reliably be obtained whenever there is a query from the location controller 1335 for the most recent estimate in the change of the location for the MBS 148. Consequently (referring to Fig. 13), synchronization records 1790 (having at least a 1790b portion, and in some cases also having a 1790a portion) may be provided for updating each location track with a new MBS location estimate as a new track head. In particular, each synchronization record includes a deadreckoning location change estimate to be used in updating all but at most one of the location track heads with a new MBS location estimate by using a deadreckoning location change estimate in conjunction with each MBS location estimate from an MBS baseline location estimator, the location track heads may be synchronized according to timestamp. More precisely, for each MBS location estimate, E, from an MBS baseline location estimator, the present invention also substantially simultaneously queries the deadreckoning MBS location estimator for a corresponding most recent change in the location of the MBS 148. Accordingly, E and the retrieved MBS deadreckoning location change estimate, C, have substantially the same "latest timestamp". Thus, the location estimate E may be used to create a new baseline track head for the location track having the corresponding type for E, and C may be used to create a corresponding extrapolation entry as the head of each of the other location tracks. Accordingly, since for each MBS location estimate, E, there is a MBS deadreckoning location change estimate, C, having substantially the same "latest timestamp", E and C will be hereinafter referred as "paired."

#### Wireless Location Applications

Such wireless location applications as were briefly described above in reference to the gateway 142 will now be described in further detail. Note that the following location related services are considered within the scope of the invention, and such services can, in general, be provided without use of a gateway 142, albeit, e.g., in a likely more restricted context wherein not all available wireless location estimating techniques are utilized, and/or by multiplying the number of interfaces to geolocation service providers (e.g., distinct wireless location interfaces are provided directly to each wireless location service provider utilized).

#### Routing Applications

In one noteworthy routing application, hotels and other personal service providers, such as auto rental agencies, hotels, resorts and cruise ships may provide an inexpensive MS 140 that can be used substantially only for contacting: (i) the personal service, (ii) emergency services, and/or (iii) receiving directions to return to the personal service. Accordingly, the MS 140 may be wirelessly located during operations (i) and (ii) via wireless communications between the MS 140 and a local commercial wireless service provider wherein a request to locate the MS 140 is provided to, e.g., the gateway 142, and the resulting MS location estimate is provided to a public safety emergency center (e.g., E911) for dispatching emergency services, or provided to a mapping and routing system such as provided by MapInfo or disclosed in the LeBlanc et. al. patent application filed Jan. 22, 1999 and having U.S. Patent No. 6,236,365 (which is fully incorporated herein by reference) so that the MS 140 user may be routed safely and expeditiously to a predetermined location of the personal service. Note that data representing the location of the

personal service can be associated with an identification of the MS 140 so that MS activation for (ii) above results in one or more audio and/or visual presentation of directions for directing the user to return to the personal service.

The MS 140 and the MS location providing wireless network (e.g., a CMB, a PSTN 124 or the Internet 448) may also provide the MS user with the ability to explicitly request to be substantially continuously tracked, wherein the MS tracked locations are stored for access by those having permission (e.g., the user, parents and/or associates of the user). Additionally, the velocity and/or expected time of arrival at a predetermined destination may be derived from such tracking and may be provided to the user or his/her associates (e.g., employer, friends, and/or family). Further, note that this tracking and notification of information obtained therefrom may be provided via a commercial telephony or Internet enabled mobile station, or a mobile station in operable communication with a short messaging service. For example, the MS registered owner may provide permissions for those able to access such MS tracking information so that such information can be automatically provided to certain associates and/or provided on request to certain associates. Additionally, note that the MS 140 and the MS location providing wireless network may also allow the MS user to deactivate such MS tracking functionality. In one embodiment, an MS user may activate such tracking for his/her MS 140 during working hours and deactivate such tracking during non-working hours. Accordingly, an employer can then track employee's whereabouts during work hours, while the employee is able to retain his/her location privacy when not working although the employer may be still able to contact the employee in case of an emergency during the employee's non-working time. Note that this location capability and method of obtaining location information about an MS user while assuring privacy at other times may be useful for appropriately monitoring in personnel in the military, hospital, transportation services (e.g., for couriers, bus and taxi drivers), telecommunications personnel, emergency rescue and correctional institution personnel. Further, note that this selective MS location capability may be performed in a number of ways. For example, the MS 140 may activate and deactivate such tracking by dialing a predetermined number (e.g., by manually or speed dialing the number) for switching between activation of a process that periodically requests a wireless location of the MS 140 from, e.g., the location gateway 142. Note that the resulting MS location information may be made available to other users at a predetermined phone number, Internet address or having sufficient validation information (e.g., a password). Alternatively, the MS location providing wireless network may automatically activate such MS tracking for predetermined times of the day and for predetermined days of the week. Note that this latter embodiment may be particularly useful for both tracking employees, e.g., at large construction sites, and, e.g., determining when each employee is at his/her work site. Thus, in this embodiment, the MS location providing wireless network may provide database storage of times and days of the week for activation and deactivation of this selective MS tracking capability that is accessible via, e.g., a network service control point 104 (or other telephony network control points as one skilled in the art will understand), wherein triggers may be provided within the database for generating a network message (to, e.g., the gateway 142) requesting the commencement of tracking the MS 140 or the deactivation of such tracking. Accordingly, the resulting MS location information may be provided to an employer's tracking and payroll system so that the employer is able to determine the actual time an employee arrives at and leaves a work location site.

In another routing related application of the present invention, an MS 140 and the MS location providing wireless network may provide the MS user with functionality to register certain locations so that data representing such locations can be easily accessed for use at a later time. For example, the MS 140 user may be staying at a hotel in an unfamiliar area. Accordingly, using the present capability of the invention,

the user can request, via his/her MS 140, that his/her location at the hotel be determined and registered so that it is available at a later time for routing the user back to the hotel. In fact, the user may have personal location registrations of a plurality of locations in various cities and countries so that when traveling the user has wireless access to directions to preferred locations such as his/her hotel, preferred restaurants, shopping areas, scenic areas, rendezvous points, theaters, athletic events, churches, entertainment establishments, location of acquaintances, etc.

5 More, that such personal location registration information may reside primarily on the user's subscriber network, but upon the MS user's request, his/her personal location registrations may be transmitted to another network from which the user is receiving wireless services as a roamer. Moreover, any new location registrations (or deletions) may be duplicated in the user's personal registration of the user's subscriber network. However, in some instances an MS user may wish to retain such registered locations only temporarily while the user is in a particular area; e.g., a predetermined network coverage area. Accordingly, the MS user may indicate (or such may be the default) that a new personal location registration be retained for a particular length of time, and/or until a location of the user is outside the area to which such new location registration appear to be applicable. However, prior to deleting any such registrations, the MS user may be queried to confirm such deletion. For example, if the MS user has new location registrations for the Dallas, Texas area, and the MS user subsequently travels to London, then upon the first wireless location performed by the MS user for location registration services, the MS user may be queried as whether to save the new Dallas, Texas location registrations permanently, for an particular length of time (e.g. 30 days), or delete all or selected portions thereof.

15 Other routing related applications of the present invention are for security (e.g., tracking how do I get back to my hotel safely), and, e.g., sight seeing guided tour where the is interactive depending on feedback from users

#### *Advertising Application*

Advertising may be directed to an MS 140 according to its location. In at least some studies it is believed that MS 140 users do not respond well to unsolicited wireless advertisement whether location based or otherwise. However, in response to certain user queries for locally available merchandise, certain advertisements may be viewed as more friendly. Thus, by allowing an MS user to contact, e.g., a wireless advertising portal by voice or via wireless Internet, and describe certain products or services desired (e.g., via interacting with an automated speech interaction unit), the user may be able to describe and receive (at his/her MS 140) audio and/or visual presentations of such products or services that may satisfy such a user's request. For example, a user may enter a request: "I need a Hawaiian shirt, who has such shirts near here?"

25 In the area of advertising, the present invention has advantages both for the MS user (as well as the wireless user), and for product and service providers that are nearby to the MS user. For instance, an MS user may be provided with (or request) a default set of advertisements for an area when the MS user enters the area, registers with a hotel in the area, or makes a purchase in the area, and/or requests information about a particular product or service in the area. Moreover, there may be different collections of advertisements for MS users that are believed to have different demographic profiles and/or purposes for being in the area. Accordingly, an MS whose location is being determined periodically may be monitored by an advertisement wizard such that this wizard may maintain a collection the MS user's preferences, and needs so that when the MS user comes near a business that can satisfy such a preference or need, then an advertisement relating to the fulfillment of the preference

or need may be presented to the MS user. However, it is an aspect of the invention that such potential advertising presentations be intelligently selected using as much information about the user as is available. In particular, in one embodiment of the invention MS user preferences and needs may be ordered according to importance. Moreover, such user preferences and needs may be categorized by temporal importance (i.e., must be satisfied within a particular time frame, e.g., immediately, today, or next month) and by situational importance wherein user preferences and needs in this category are less time critical (e.g., do not have to be satisfied immediately, and/or within a specified time period), but if certain criteria are met the user will consider satisfying such a preference or need. Thus, finding a Chinese restaurant for dinner may be in the temporal importance category while purchasing a bicycle and a new pair of athletic shoes may be ordered as listed here in the situational category. Accordingly, advertisements for Chinese restaurants may be provided to the user at least partially dependent upon the user's location. Thus, once such a restaurant is selected and routing directions are determined, then the advertising wizard may examine advertisements (or other available product inventories and/or services that are within a predetermined distance of the route to the restaurant for determining whether there is product or service along the route that could potentially satisfy one of the user's preferences or needs from the situational importance category. If so, then the MS user may be provided with the option of examining such product or service information and registering the location of user selected businesses providing such products or services. Accordingly, the route to the restaurant may be modified to incorporate detours to one or more of these selected businesses. Of course, an MS user's situationally categorized preferences and needs may allow the MS user to receive unrequested advertising during other situations as well. Thus, whenever an MS user is moving such an advertisement wizard (e.g., if activated by the user) may attempt to satisfy the MS user's preferences and needs by presenting to the user advertisements of nearby merchants that appear to be directed to such user preferences and needs.

Accordingly, for MS user preferences and needs, the wizard will attempt to present information (e.g., advertisements, coupon, discounts, product price and quality comparisons) related to products and/or services that may satisfy the user's corresponding preference or need: (a) within the time frame designated by the MS user when identified as having a temporal constraint, and/or (b) consistent with situational criteria provided by the MS user (e.g., item on sale, item is less than a specified amount, within a predetermined traveling distance and/or time) when identified as having a situational constraint. Moreover, such information may be dependent on the geolocation of both the user and a merchant(s) having such products and/or services. Additionally, such information may be dependent on a proposed or expected user route (e.g., a route to work, a trip route). Thus, items in the temporal category are ordered according to how urgent must a preference or need must be satisfied, while items in the situational category may be substantially unordered and/or ordered according to desirability (e.g., an MS user might want a motorcycle of a particular make and maximum price, want a new car more). However, since items in the situational category may be fulfilled substantially irrespective of circumstances detected by the wizard, various orderings or no ordering may be used. Thus, e.g., if the MS user travels from one commercial area to another, the wizard may compare a new collection of merchant products and/or services against the items on an MS user's temporal and situational lists, and at least alerting the MS user that there may be new information available about a user desired service or product which is within a predetermined traveling time from where the user is. Note that such alerts may be visual (e.g., textual, or iconic) displays, or audio presentations using, e.g., synthesized speech (such as "Discounted motorcycles ahead three blocks at cycles cycles").

Note that the advertising aspects of the present invention may be utilized by an intelligent electronic yellow pages which can utilize the MS user's location (and/or anticipated locations, e.g., due to roadway being traversed) together with user preferences and needs (as well as other constraints) to both intelligently respond to user requests as well as intelligently anticipate user preferences and needs. A block diagram showing the high level components of an electronic yellow pages according to this aspect of the present invention is shown in Fig. 19. Accordingly, in one aspect of the present invention advertising is user driven in that the MS user is able to select advertising based on attributes such as: merchant proximity, traffic/parking conditions, the product/service desired, quality ratings, price, user merchant preferences, product/service availability, coupons and/or discounts. That is, the MS user may be able to determine an ordering of advertisements presented based on, e.g., his/her selection inputs for categorizing such attributes. For example, the MS user may request advertisements athletic shoes be ordered according to the following values: (a) within 20 minutes travel time of the MS user's current location, (b) midrange in price, (c) currently in stock, and (d) no preferred merchants. Note that in providing advertisements according to the MS user's criteria, the electronic yellow pages may have to make certain assumptions such as if the MS user does not specify a time for being at the merchant, the electronic yellow pages may default the time to a range of times somewhat longer than the travel time thereby going on the assumption that MS user will likely be traveling to an advertised merchant relatively soon. Accordingly, the electronic yellow pages may also check stored data on the merchant to assure that the MS user can access the merchant once the MS user arrives at the merchant's location (e.g., that the merchant is open for business). Accordingly, the MS user may dynamically, and in real time, vary such advertising selection parameters for thereby substantially immediately changing the advertising being provided to the user's MS. For example, the MS display may provide an area for entering an identification of a product/service name wherein the network determines a list of related or complementary products/services. Accordingly, if an MS user desires to purchase a wedding gift, and knows that the couple to be wed are planning a trip to Australia, then upon the MS user providing input in response to activating a "related products/services" feature, and then inputting, e.g., "trip to Australia" (as well as any other voluntary information indicating that the purchase is for: a gift, for a wedding, and/or a price of less than \$100.00), then the intelligent yellow pages may be able to respond with advertisements for related products/services such as portable electric power converter for personal appliances that is available from a merchant local (and/or non-local) to the MS user. Moreover, such related products/services (and/or "suggestion") functionality may be interactive with the MS user. For example, there may be a network response to the MS user's above gift inquiry such as "type of gift: conventional or unconventional?". Moreover, the network may inquire as to the maximum travel time (or distance) the MS user is willing to devote to finding a desired product/service, and/or the maximum travel time (or distance) the MS user is willing to devote to visiting any one merchant. Note that in one embodiment of the electronic yellow pages, priorities may be provided by the MS user as to a presentation ordering of advertisements, wherein such ordering may be by: price

Note that various aspects of such an electronic yellow pages described herein are not constrained to using the MS user's location. In general, the MS user's location is but one attribute that can be intelligently used for providing users with targeted advertising, and importantly, advertising that is perceived as informative and/or addresses current user preferences and needs. Accordingly, such electronic yellow page aspects of the present invention in are not related to a change in the MS user's location over time also apply to stationary communication stations such home computers wherein, e.g., such electronic yellow pages are accessed via the Internet. Additionally, the MS user may be able to adjust, e.g.,

via icon selection switches (e.g., buttons or toggles) and icon range specifiers (e.g., slider bars) the relevancy and a corresponding range for various purchasing criteria. In particular, once a parameter is indicated as relevant (e.g., via activating a toggle switch), a slider bar may be used for indicating a relative or absolute value for the parameter. Thus, parameter values may be for: product/service quality ratings (e.g., display given to highest quality), price (low comparable price to high comparable price), travel time (maximum estimated time to get to merchant), parking conditions.

Accordingly, such electronic yellow pages may include the following functionality:

- (a) dynamically change as the user travels from one commercial area to another when the MS user's location periodically determined such that local merchant's are given preference;
- (b) routing instructions are provided to the MS user when a merchant is selected;
- (c) provide dynamically generated advertising that is related to an MS user's preferences or needs. For example, if an MS user wishes to purchase a new dining room set, then such an electronic yellow pages may dynamically generate advertisements with dining room sets therein for merchants that sell them. Note that this aspect of the present invention can be accomplished by having, e.g., a predetermined collection of advertising templates that are assigned to particular areas of an MS user's display wherein the advertising information selected according to the item(s) that the MS user has expressed a preference or desire to purchase, and additionally, according to the user's location, the user's preferred merchants, and/or the item's price, quality, as well as coupons, and/or discounts that may be provided. Thus, such displays may have a plurality of small advertisements that may be selected for hyper-linking to more detailed advertising information related to a product or service the MS user desires. Note that this aspect of the present invention may, in one embodiment, provide displays (and/or corresponding audio information) that is similar to Internet page displays. However, such advertising may dynamically change with the MS user's location such that MS user preferences and needs for a items (including services) having higher priority are given advertisement preference on the MS display when the MS user comes within a determined proximity of the merchant offering the item. Moreover, the MS user may be able dynamically reprioritize the advertising displayed and/or change a proximity constraint so that different advertisements are displayed. Furthermore, the MS user may be able to request advertising information on a specified number of nearest merchants that provide a particular category of products or services. For example, an MS user may be able to request advertising on the three nearest Chinese restaurants that have a particular quality rating. Note, that such dynamically generated advertising
- (d) information about MS user's preferences and needs may be supplied to yellow page merchants regarding MS user's reside and/or travel nearby yellow subscriber merchant locations as described hereinabove.

The following is a high level description of some of the components shown in Fig. 19 of an illustrative embodiment of the electronic yellow pages of the present invention.

- a. Electronic yellow pages center: Assists both the users and the merchants in providing more useful advertising for enhancing business transactions. The electronic yellow pages center may be a regional centers within the carrier, or



(as shown) an enterprise separate from the carrier. The center receives input from users regarding preferences and needs which first received by the user interface.

- b. User interface: Receives input from a user that validates the user via password, voice identification, or other biometric capability for identifying the user. Note that the identification of user's communication device (e.g., phone number) is also provided. For a user contact, the user interface does one of: (a) validates the user thereby allowing user access to further electronic yellow page services, (b) requests additional validation information from the user, or (c) invalidates the user and rejects access to electronic yellow pages. Note that the user interface retrieves user identification information from the user profile database (described hereinafter), and allows a validated user to add, delete, and/or modify such user identification information.
- c. User ad advisor: Provides user interface and interactions with the user. Receives an identification/description of the user's communication device for determining an appropriate user communication technique. Note that the user ad advisor may also query (any) user profile available (using the user's identity) for determining a preferred user communication technique supported by the user's communication device. For example, if the user's communication device supports visual presentations, then the user ad advisor defaults to visual presentations unless there are additional constraints that preclude providing such visual presentations. In particular, the user may request only audio ad presentations, or merely graphical pages without video. Additionally, if the user's communication device supports speech recognition, then the user ad advisor may interact with user solely via verbal interactions. Note that such purely verbal interactions may be preferable in some circumstances such as when the user can not safely view a visual presentation; e.g., when driving. Further note that the user's communication device may sense when it is electronically connected to a vehicle and provide such sensor information to the user ad advisor so that this module will then default to only a verbal presentation unless the user requests otherwise. Accordingly, the user ad advisor includes a speech recognition unit (not shown) as well as a presentation manager (not shown) for outputting ads in a form compatible both with the functional capabilities of the user's communication device and with the user's interaction preference.

Note that the user ad advisor communicates: (a) with the user ad selection engine for selecting advertisements to be presented to the user, (b) with the user profile database for inputting thereto substantially persistent user personal information that can be used by the user ad selection engine, and for retrieving user preferences such as media preference(s) for presentations of advertisements, and (c) with the user preference and needs satisfaction agents for instantiating intelligent agents (e.g., database triggers, initiating merchant requests for a product/service to satisfy a user preference or need).

Also note that in some embodiments of the present invention, the user ad advisor may also interact with a user for obtaining feedback regarding: (a) whether the advertisements presented, the merchants represented,

and/or the products/services offered are deemed appropriate by the user, and (b) the satisfaction with a merchant with which the user has interactions. In particular, such feedback may be initiated and/or controlled substantially by the user preference and needs satisfaction agent management system (described hereinafter).

4. User profile database: A database management system for accessing and retaining user identification information, user personal information, and identification of the user's communication device (e.g., make, model, and/or software version(s) being used). Note that the user profile database may contain information about the user that is substantially persistent; e.g., preferences for language (e.g., English, Spanish, etc.), ad presentation media (e.g., spoken, textual, graphical, and/or video), maximum traveling time/distance for user preferences and needs of temporal importance (e.g., what is considered "near" to the user), user demographic information (e.g., purchasing history, income, residential address, age, sex, ethnicity, marital status, family statistics such as number of child and their ages), and merchant preferences/predictions (e.g., user prefers one restaurant chain over another, or the user wants no advertisements from a particular merchant).
5. User ad selection engine: This module selects advertisements that are deemed appropriate to the user's preferences and needs. In particular, this module determines the categories and presentation order of advertisements to be presented to the user. To perform this task, the user ad selection engine uses a user's profile information (from the user profile database), a current user request (via the user ad advisor), and/or the user's current geolocation (via the interface to the location gateway 142). Thus, for a user requesting the location of an Italian restaurant within 1/2 mile of the user's current location, in a midrange price range, and accepting out of town checks, the user ad selection engine identifies the ad criteria within the user's request, and determines the advertising categories (and/or values thereof) from which advertisements are desired. In one embodiment,

Note that the user ad selection engine can suggest advertisement categories and/or values thereof to the user if requested to do so.

When an MS 140 appears to be traveling an extended distance through a plurality of areas (as determined, e.g., by recent MS locations along an interstate that traverse a plurality of areas), then upon entering each new area having a new collection of location registrations (and possibly a new location registration wizard) may be provided. For example, a new default set of local location registrations may become available to the user. Accordingly, the user may be notified that new temporary location registrations are available for the MS user to access if desired. For example, such notification may be a color change on a video display indicating that new temporary registrations are available. Moreover, if the MS user has a personal profile that also is accessible by a location registration wizard, then the wizard may provide advertising for local businesses and services that are expected to better meet the MS user's tastes and needs. Thus, if such wizard knows that the MS user prefers fine Italian food but does not want to travel more than 20 minutes by auto from his/her hotel to reach a restaurant, then advertisements for restaurants satisfying such criteria will become available to the user however, MS users may also remain anonymous to such wizards, wherein the

Note, that by retaining MS user preferences and needs, if permission is provided, e.g., for anonymously capturing such user information, this information could be provided to merchants. Thus, merchants can get an understanding of what nearby MS user's would like to purchase (and under what conditions, e.g., an electric fan for less than \$10). Note such user's may be traveling through the area, or user's may live nearby. Accordingly, it is a feature of the present invention to provide merchant's with MS user preferences and needs according to whether the MS user is a passerby or lives nearby so that the merchant can better target his/hes advertising.

In one embodiment, a single wizard may be used over the coverage area of a CMS and the database of local businesses and services changes as the MS user travels from one location registration area to another. Moreover, such a wizard may determine the frequency and when requests for MS locations are provided to the gateway 12. For example, such databases of local businesses and services may be coincident with LATA boundaries. Additionally, the wizard may take into account the direction and roadway the MS 140 is traveling so that, e.g., only businesses within a predetermined area and preferably in the direction of travel of the MS 140 are candidates to have advertising displayed to the MS user.

#### *Points of Interest Applications*

The invention can used for sight seeing guided tours where the invention is interactive depending on feedback from users. Such interactivity being both verbal descriptions and directions to points of interest.

#### *Security Applications*

The invention may provide Internet picture capture with real time voice capture and location information for righteering, and/or security.

The foregoing description of preferred embodiments of the present invention has been provided for the purposes of illustration and description. It is not intended to be exhaustive or to limit the invention to the precise forms disclosed herein. Modifications and variations commensurate with the description herein will be apparent those skilled in the art, and are intended to be within the scope of the present invention to the extent permitted by the relevant art. The embodiments provided are for enabling others skilled in the art to understand the invention, its various embodiments and modifications as are suited for uses contemplated. It is intended that the scope of the invention be defined by the following claims and their equivalents.

What is claimed is:

1. A method for locating a mobile station using wireless signal measurements obtained from transmissions between said mobile station and a plurality of fixed location communication stations, wherein each of said communication stations includes one or more of a transmitter and a receiver for wirelessly communicating with said mobile station, comprising:

5 providing first and second mobile station location evaluators, wherein said location evaluators determine information related to one or more location estimates of said mobile station when said location estimators are supplied with data having values obtained from wireless signal measurements obtained via transmissions between said mobile station and the communication stations, wherein:

(A) said first location evaluator performs one or more of the following techniques (i), (ii), (iii), (iv) when supplied with a corresponding instance of said data:

10 (i) a first technique for determining, for at least one of the communication stations, one of: a distance, and a time difference of arrival between the mobile station and the communication station, wherein said first technique estimates a time of arrival (TOA) of a received signal relative to a time reference at each one of a plurality of wireless signal monitoring stations using an inverse transform whose resolution is greater than Rayleigh resolution;

15 (ii) a second technique for estimating a location of said mobile station, using values from a corresponding instance of said data obtained from signals received by the mobile station from one or more satellites;

(iii) a third technique for recognizing a pattern of characteristics of a corresponding instance of said data, wherein said pattern of characteristics is indicative of a plurality of wireless signal transmission paths between the mobile station and each of one or more of the communication stations; and

20 (iv) a fourth technique for estimating a location of said mobile station using a DSM model, wherein the following steps (a) - (d) are performed:

a) receiving at an antenna array provided at one of the communication stations, signals originating from the mobile station, wherein the signals comprise p-dimensional array vectors sampled from p antennas of the array;

b) determining from the received signals, a signal signature, wherein the signal signature comprises a measured subspace, wherein the array vectors are approximately confined to the measured subspace;

25 c) comparing the signal signature to a database comprising calibrated signal signatures and corresponding location data, wherein the comparing comprises calculating differences between the measured subspace and calibrated subspaces; and

d) selecting from the database a most likely calibrated signal signature and a corresponding most likely location of the mobile station by using the calculated differences;

30 (v) a fifth technique for estimating a location of said mobile station using an E model, wherein the following steps (a) - (e) are performed:

a) receiving, at a multiplicity of the communication stations, a signal transmitted by the mobile station;

- b. forwarding, by each of a multiplicity of the communication stations, said received signal and timing information to a central processing center;
- c. calculating, within said central processing center, a time difference of arrival (TDOA) location estimate of said mobile station based upon said timing information;
- 5 d. calculating, within said central processing center, a timing advance (TA) location estimate of said mobile station based upon said timing information; and
- e. determining said position of said mobile station using said TDOA and TA location estimates;
- (vi) a sixth technique for estimating a location of said mobile station using an ST model, wherein the following steps (a) - (e) are performed:
- 10 a. receiving, in a GPS receiver co-located with the mobile station, GPS signals from at least one GPS satellite;
- b. transmitting cell based communication signals between a communication system having a first of the communication stations coupled to said GPS receiver, and a second of the communication stations which is remotely positioned relative to said mobile station, wherein said cell based communication signals are wireless;
- 15 c. determining a first time measurement which represents a time of travel of a message in said cell based communication signals in a cell based communication system having at least some of the communication stations which comprises said second communication station and said communication system;
- d. determining a second time measurement which represents a time of travel of said GPS signals;
- e. determining a position of said mobile station from at least said first time measurement and said second time measurement, wherein said cell based communication signals are capable of communicating data messages in a two-way direction between said first cell based transceiver and said communication system;
- 20
- (vii) a seventh technique for estimating a location of said mobile station using an TE model, wherein the following steps (a) - (f) are performed:
- a. transmitting from said mobile station M samples of a signal;
- b. receiving at one of the communication stations, said M samples together with multipath components and noise;
- 25 c. determining an estimated channel power profile for each of said M samples;
- d. selecting a first set of N samples from said M samples;
- 30

- e. performing incoherent integration for said estimated channel power profiles for said first set of  $M$  samples to form a first integrated signal;
- f. if a quality level of said first integrated signal with respect to signal to noise is less than a predetermined threshold, selecting another sample from said  $M$  samples;
- 5 g. performing incoherent integration for said estimated channel power profiles for said first set of  $M$  samples and said another sample to form a second integrated signal;
- h. if a quality level of said second integrated signal with respect to signal to noise is greater than or equal to said predetermined threshold, determining a time-of-arrival of a maximum level of said second integrated signal;
- 10 i. entering said time-of-arrival into a time-of-arrival versus frequency of occurrence array;
- j. selecting a second set of  $N$  samples from said  $M$  samples;
- k. repeating all of said performing through said entering steps for said second set of  $N$  samples; and
- l. determining a minimum value estimated time-of-arrival from said array;
- (vii) an eighth technique for estimating a location of said mobile station using an SDF model, wherein the following steps (a) - (c) are performed:
- 15 a. within the mobile station, transmitting a locating signal composed of at least two tone components;
- b. within each of a plurality of the communication stations, receiving the locating signal at one or more antennas, and within at least one of the communication stations, receiving the locating signal with at least two antennas;
- 20 c. coupling each antenna to a receiver;
- d. within each receiver, generating amplitude and phase values from the locating signal as received by the antenna, the values indicative of amplitude and phase of at least two tone components of the locating signal, as received at the corresponding antenna and measured at defined times; and
- 25 e. combining the values indicative of amplitude and phase for the tone components from a plurality of the receivers to determine the position of the mobile station;
- (ix) a ninth technique for estimating a location of said mobile station using a TDM model, wherein the following steps (a) - (h) are performed therefor in a mobile radio system providing at least some of the communication stations, said mobile radio system including a network controller and at least three of the communication stations, each of said at least three communication stations including an uplink TOA measuring unit operable to communicate with said network controller, a control unit, and a time reference unit operable to provide timing reference signals to said uplink TOA measuring unit, at least one of said at least three communication stations co-located with and connected to a second
- 30

mobile station, said second mobile station coupled to said network controller via a radio interface, and a service node operable to store known positions of at least two of said at least three communication stations:

- a. receiving a request in said mobile radio system to determine the geographical position of said mobile station;
  - b. determining and reporting the position of said second mobile station to said service node;
  - c. directing said mobile station to transmit digital signals uplink on a traffic channel when said mobile station is not transmitting or transmitting only analog signals;
  - d. measuring in each uplink TDA measuring unit an uplink TDA of the digital signals transmitted by the mobile station;
  - e. receiving in said network controller said uplink TDA measurements from said at least three communication stations and a traffic channel number to said traffic channel;
  - f. translating said traffic channel number to an identity of said mobile station;
  - g. conveying said uplink TDA measurements and said mobile station identity to said service node; and
  - h. calculating in said service node the position of said mobile station using said known positions of said at least three communication stations and said uplink TDA measurements;
- (x) a tenth technique for estimating a location of said mobile station using an N model, wherein the following steps (a) - (f) are performed:
- a. receiving global positioning system satellite (GPS) signals from a plurality of global positioning system satellites;
  - b. receiving a plurality of cellular position signals that do not contain data in a GPS-like format;
  - c. calculating the geographic position of the mobile station using said received global positioning system satellite signals when a requisite number of the plurality of global positioning system satellites are in view of a global positioning system receiver; and
  - d. calculating the geographic position of the mobile station using both said received plurality of cellular position signals and substantially all of said received global positioning system satellite signals when the requisite number of the plurality of global positioning system satellites are not in view of the global positioning system receiver;
- (y) for at least a particular one of said techniques performed by said first location estimator, said second location evaluator performs a different one of said techniques when supplied with a corresponding instance of said data for the different technique;

first generating, by said first location estimator, first location related information that is dependent upon an availability of a first corresponding instance of said data;

second generating, by said second location evaluator, second location related information that is dependent upon an availability of a second corresponding instance of said data;

5 determining a resulting location estimate of the mobile station dependent upon at least one of: (a) a first value obtained from said first location related information, and (b) a second value obtained from said second location related information.

2. A method as claimed in Claim 1, wherein said steps of Claim 1 are performed for a single emergency response request.

3. A method as claimed in Claim 1, further including a step of outputting, to an emergency response center, said resulting location estimate of said mobile station in response to said emergency response request.

4. A method for locating a mobile station using wireless signal measurements obtained from transmissions between said mobile station and a plurality of fixed location communication stations, wherein each of said communication stations includes one or more of a transmitter and a receiver for wirelessly communicating with said mobile station, comprising:

providing first and second mobile station location evaluators, wherein said location evaluators determine information related to one or more location estimates of said mobile station when said location estimators are supplied with data having values obtained from wireless signal measurements obtained via transmissions between said mobile station and the communication stations, wherein:

(A) said first location evaluator performs one or more of the following techniques (i), (ii) and (iii) when supplied with a corresponding instance of said data:

(i) a first technique for determining, for at least one of the communication stations, one of: a distance, and a time difference of arrival between the mobile station and the communication station, wherein said first technique estimates a time of arrival (TOA) of a received signal relative to a time reference at each one of a plurality of wireless signal monitoring stations using an inverse transform whose resolution is greater than Rayleigh resolution;

(ii) a second technique for estimating a location of said mobile station, using values from a corresponding instance of said data obtained from signals received by the mobile station from one or more satellites;

(iii) a third technique for recognizing a pattern of characteristics of a corresponding instance of said data, wherein said pattern of characteristics is indicative of a plurality of wireless signal transmission paths between the mobile station and each of one or more of the communication stations; and

(B) for at least a particular one of said techniques performed by said first location estimator, said second location evaluator performs a different one of said techniques when supplied with a corresponding instance of said data for the different technique;



first generating, by said first location estimator, first location related information using an available first corresponding instance of said data;

second generating, by said second location evaluator, second location related information using an available second corresponding instance of said data;

5 determining a resulting location estimate of the mobile station dependent upon at least one of: (a) a first value obtained from said first location related information, and (b) a second value obtained from said second location related information.

5 The method as claimed in Claim 4, wherein one or more of said mobile station location evaluators generates a location estimate of said mobile station.

10

6. The method as claimed in Claim 4, wherein said mobile station is co-located with a processor for activating at least one of said location estimators.

## ABSTRACT

5 A location system is disclosed for commercial wireless telecommunication infrastructures. The system is an end-to-end solution having one or more location centers for outputting requested locations of commercially available handsets or mobile stations (MS) based on, e.g., CDMA, AMPS, ISMPS or TDMA communication standards, for processing both local MS location requests and more global MS location requests via, e.g., Internet communication between a distributed network of location centers. The system uses a plurality of MS locating technologies including those based on: (1) two-way TOA and TDOA; (2) pattern recognition; (3) distributed antenna provisioning; (4) GPS signals; (5) angle of arrival; (7) super resolution enhancements, and (8) supplemental information from various types of very low cost non-infrastructure base stations for  
10 communicating via a typical commercial wireless base station infrastructure or a public telephone switching network. Accordingly, the traditional MS location difficulties, such as multipath, poor location accuracy and poor coverage are alleviated via such technologies in combination with strategies for: (a) automatically adapting and calibrating system performance according to environmental and geographical changes; (b) automatically capturing location signal data for continual enhancement of a self-maintaining historical data base retaining predictive location  
15 signal data; (c) evaluating MS locations according to both heuristics and constraints related to, e.g., terrain, MS velocity and MS path extrapolation from tracking and (d) adjusting likely MS locations adaptively and statistically so that the system becomes progressively more comprehensive and accurate. Further, the system can be modularly configured for use in location signaling environments ranging from urban, dense urban, suburban, rural, mountain to low traffic or isolated roadways. Accordingly, the system is useful for 911 emergency calls, tracking, routing, people and animal location including applications for confinement to and exclusion from certain areas.

20

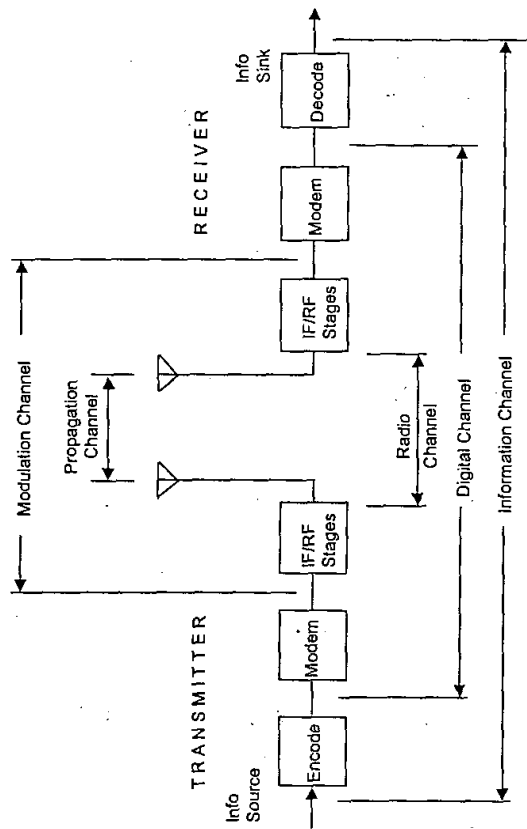

FIG. 1

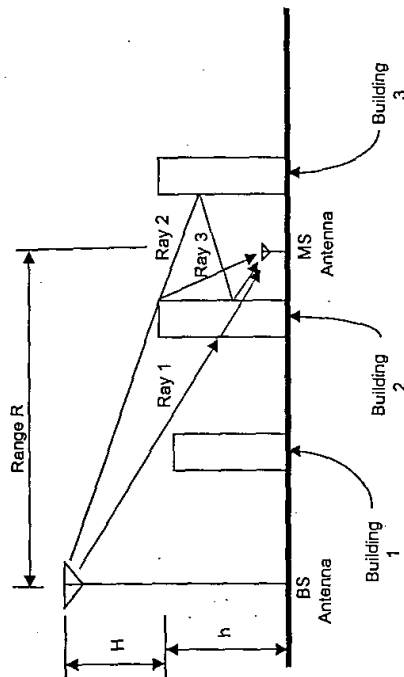

FIG. 2

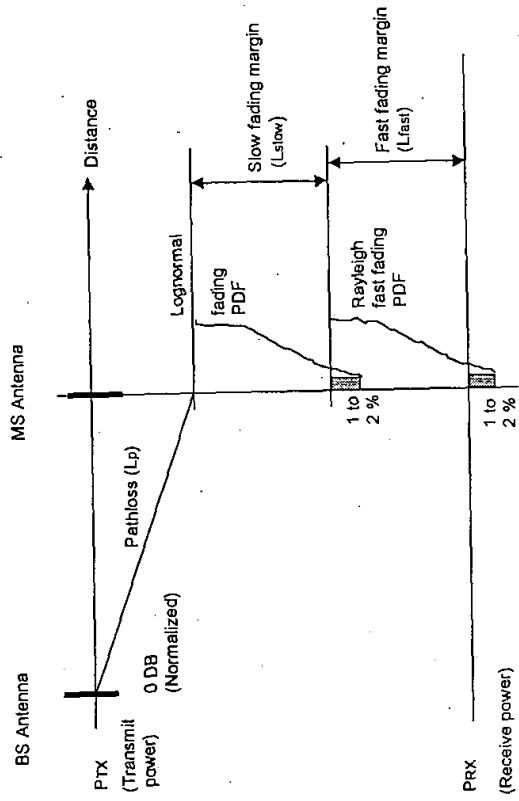

FIG. 3

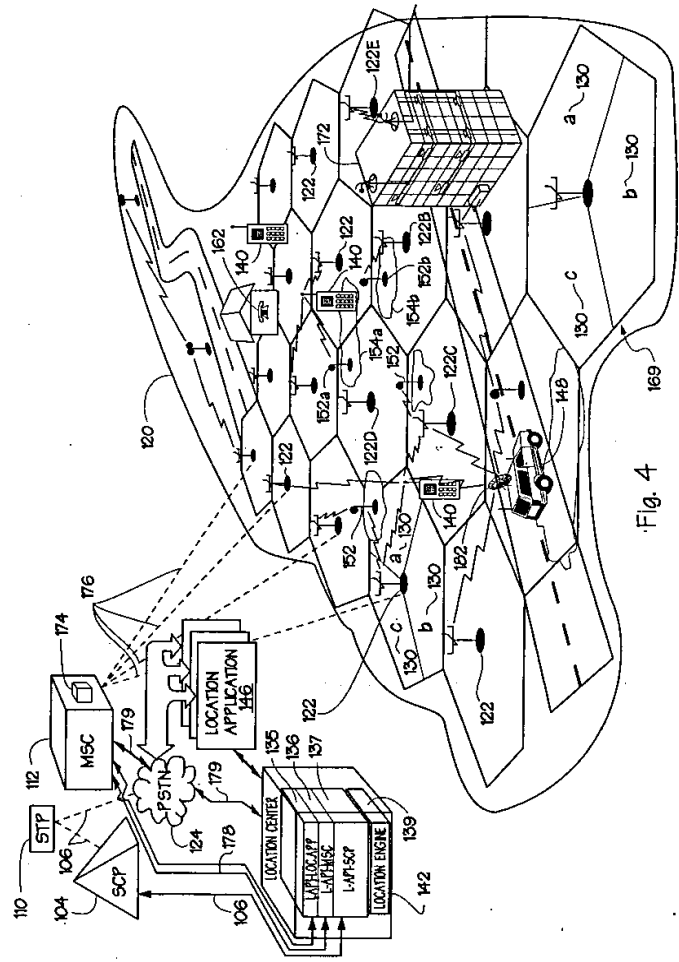

Fig. 4

FIG. 5

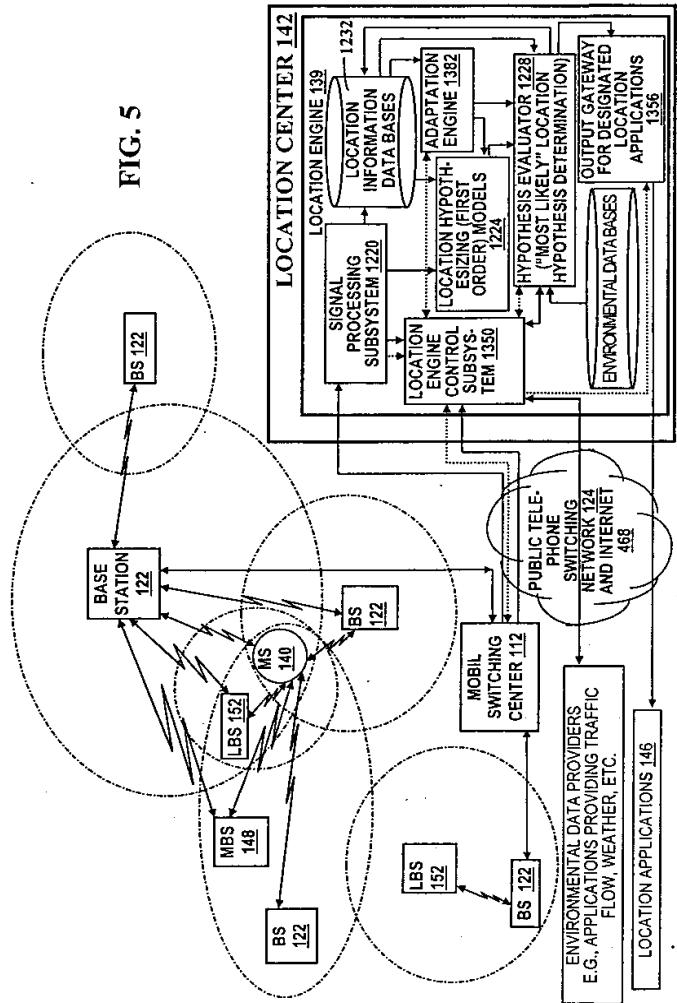

Fig. 6(1)

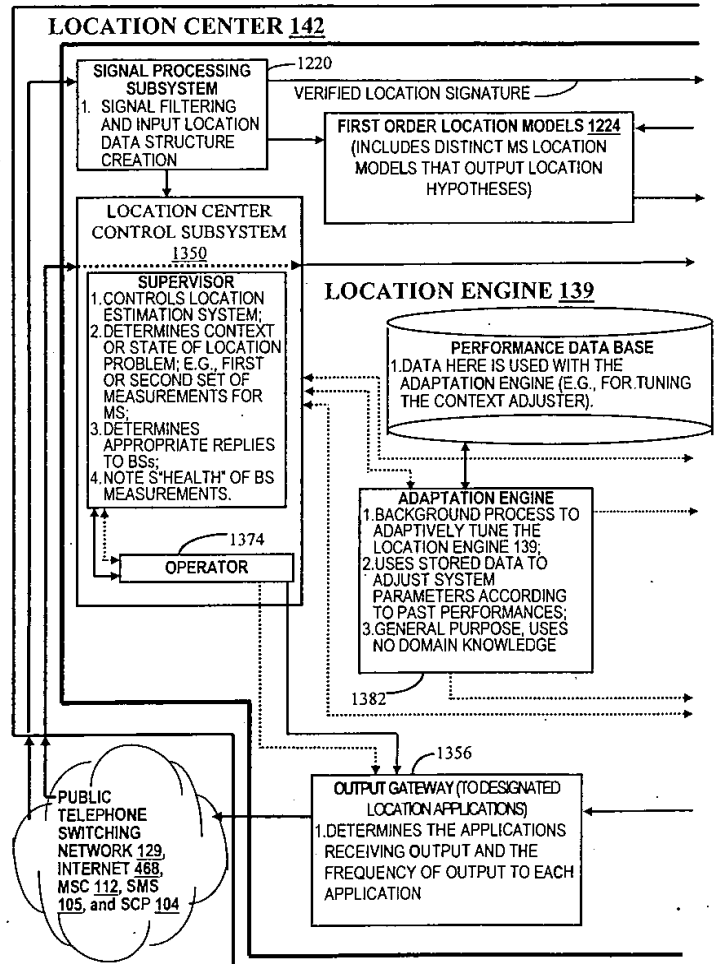



FIG 6(2)

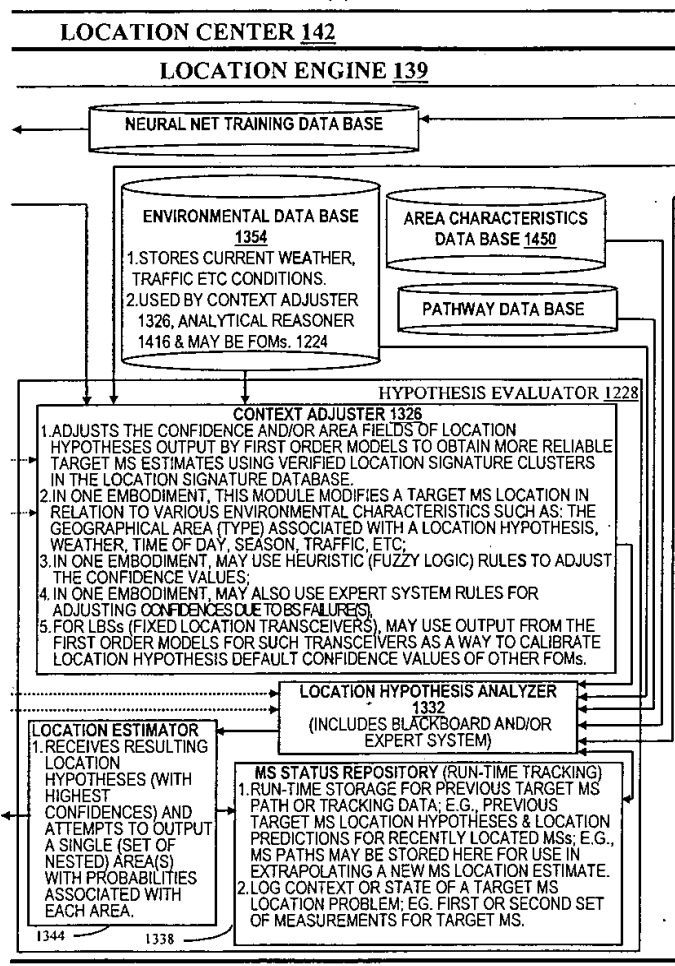
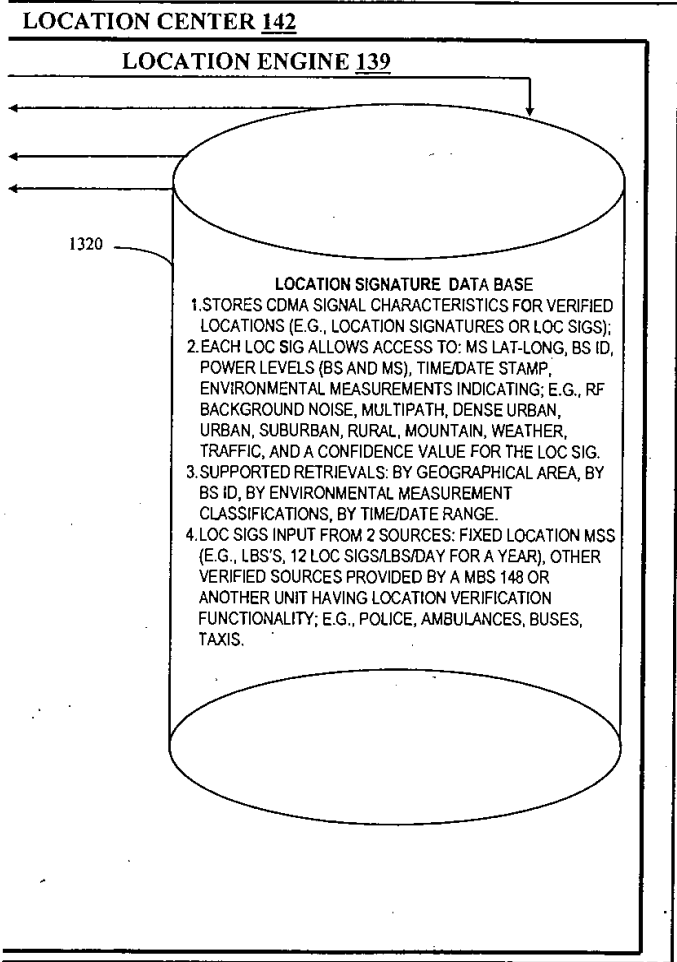

FIG 6(3)



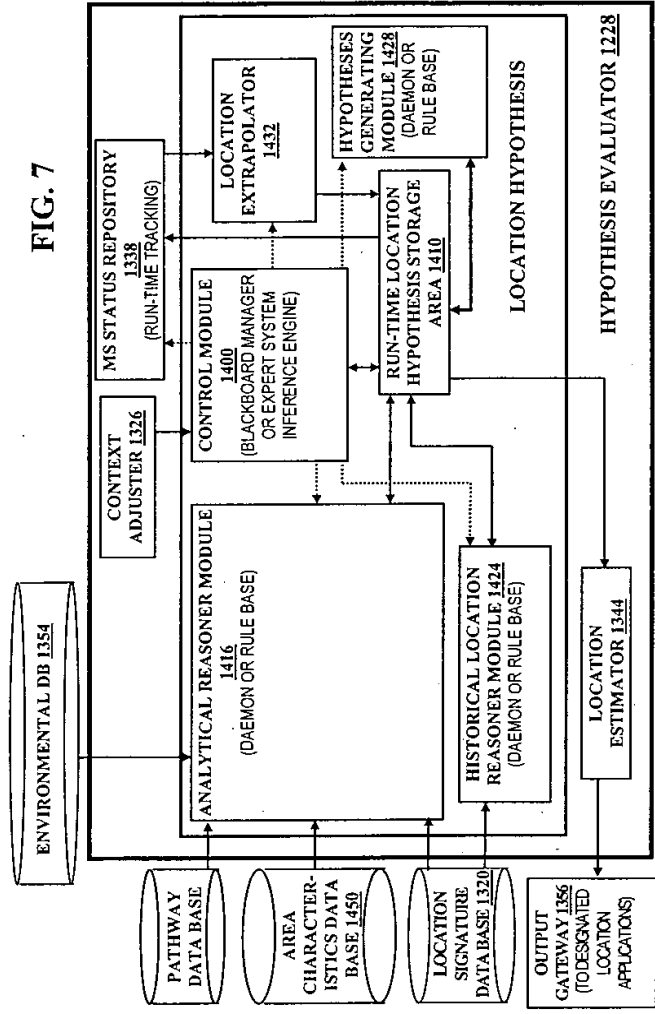
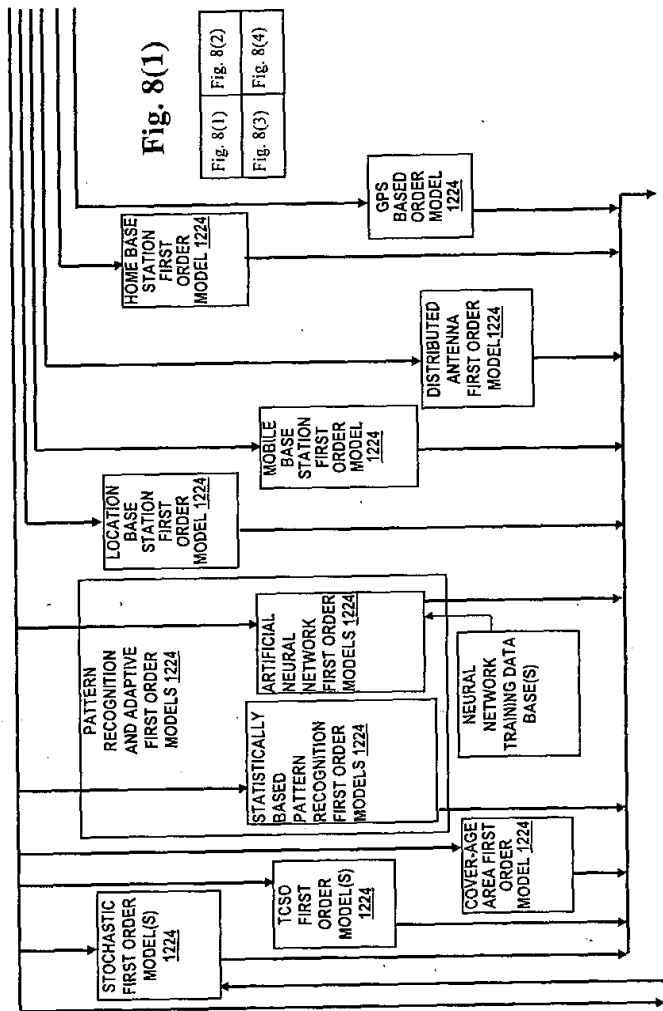

FIG. 7



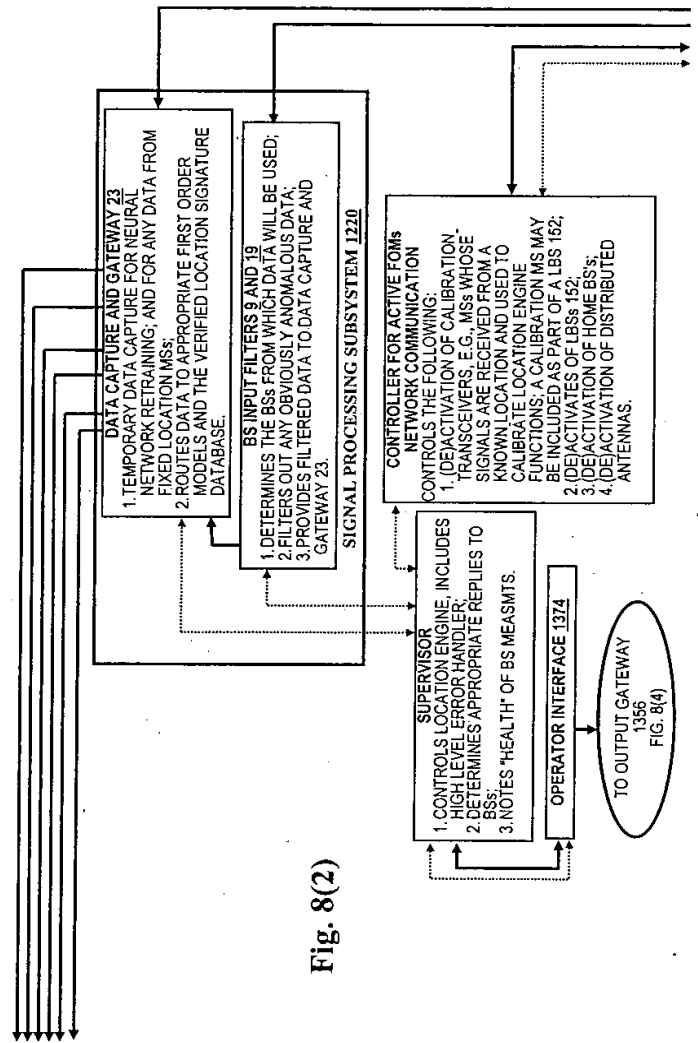
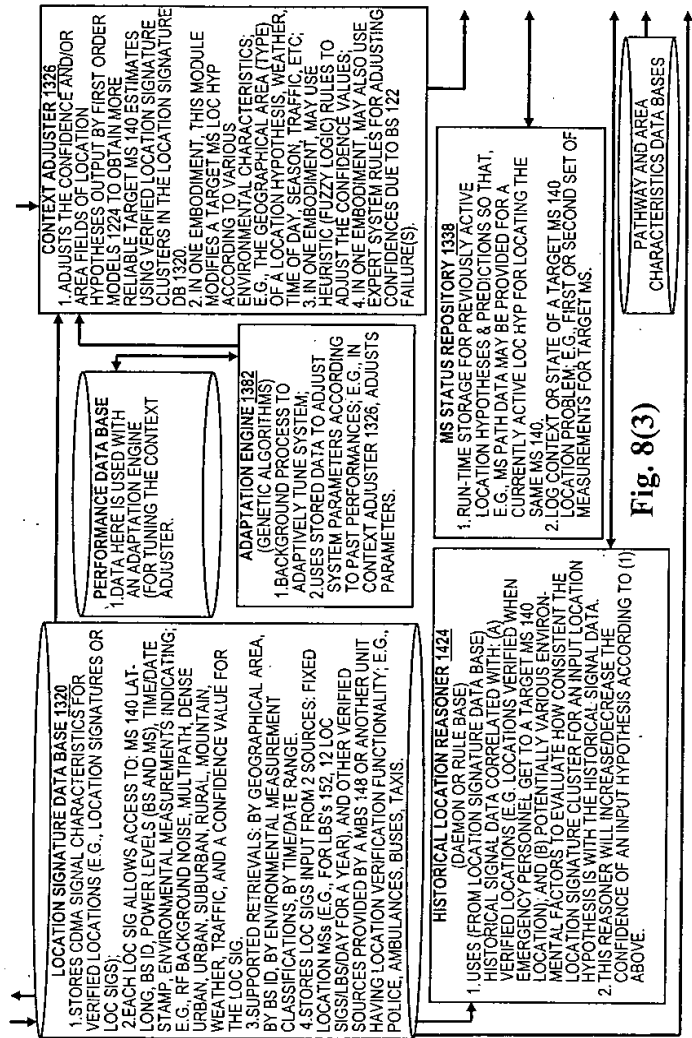

Fig. 8(2)



**Fig. 8(3)**

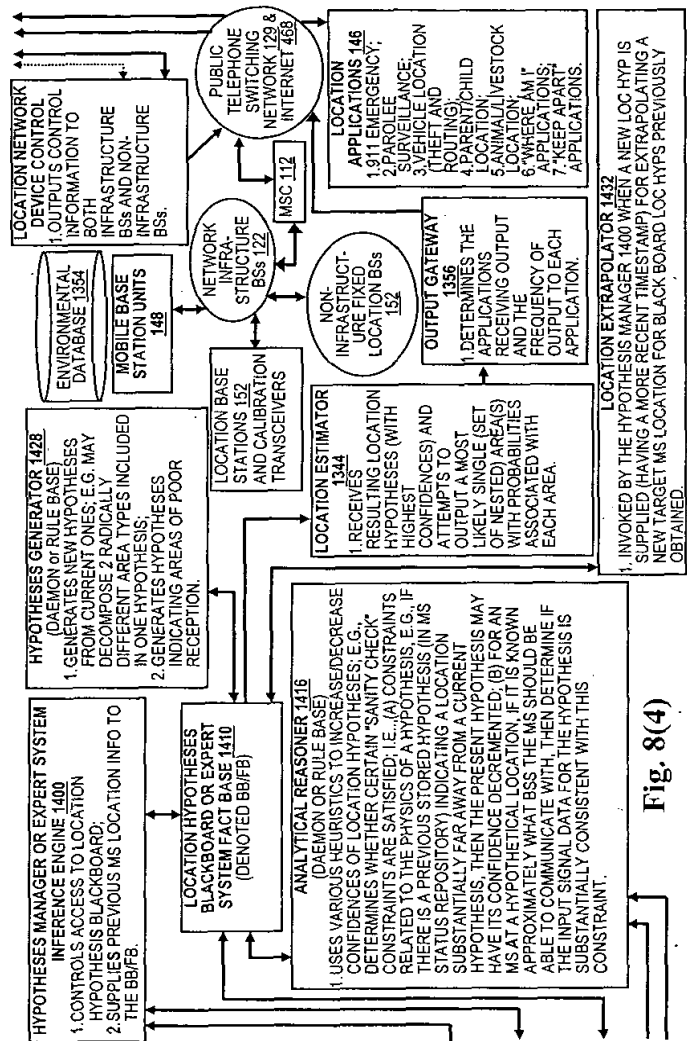

Fig. 8(4)

**FOM\_ID:** First Order Model ID (providing this Location Hypothesis); note, since it is possible for location hypotheses to be generated by other than the FOM's, in general this field identifies the module that generated this location hypothesis.

**MS\_ID:** The identification of the target MS to which this location hypothesis applies.

**pt\_est:** The most likely location point estimate of the target MS

**valid\_pt:** Boolean indicating the validity of "pt\_est"

**area\_est:** Location Area Estimate of the target MS provided by the FOM. This area estimate will be used whenever "image\_area" below is NULL.

**valid\_area:** Boolean indicating the validity of "area\_est" (one of "pt\_est" and "area\_est" must be valid).

**adjust:** Boolean (true iff adjustments to the fields of this location hypothesis are to be performed in the Context Adjuster Module).

**pt\_covering:** reference to a substantially minimal area (e.g., mesh cell) covering of "pt\_est". Note, since this MS may be substantially on a cell boundary, this covering may in some cases include more than one cell.

**image\_area:** reference to an area (e.g., mesh cell) covering of the image cluster set area for "pt\_covering" (see detailed description of the function, "confidence\_adjuster"). Note that if this field is not NULL, then this is the target MS location estimate used by the Location Center instead of "area\_est".

FIG. 9A



**extrapolation\_area:** reference to (if non-NULL) an extrapolated MS target estimate area provided by the Location Extrapolator submodule of the Hypothesis Analyzer. That is, this field, if non\_NULL, is an extrapolation of the "image\_area" field if it exists, otherwise this field is an extrapolation of the "area\_est" field. Note other extrapolation fields may also be provided depending on the embodiment of the present invention, such as an extrapolation of the "pt\_covering".

**confidence:** A real value in the range [0, +1.0] indicating a likelihood (e.g., probability) that the target MS is in (or out) of a particular area. If positive: if "image\_area" exists, then this is a measure of the likelihood that the target MS is within the area represented by "image\_area," else if "image\_area" has not been computed (e.g., "adjust" is FALSE), then "area\_est" must be valid and this is a measure of the likelihood that the target MS is within the area represented by "area\_est." If negative, then "area\_est" must be valid and this is a measure of the likelihood that the target MS is NOT in the area represented by "area\_est". If it is zero (near zero), then the likelihood is unknown.

**Original\_Timestamp:** Date and time that the location signature cluster for this location hypothesis was received by the CDMA Filter Subsystem.

**Active\_Timestamp:** Run-time field providing the time to which this location hypothesis has had its MS location estimate(s) extrapolated (in the Location Extrapolator of the Hypothesis Analyzer). Note that this field is initialized with the value from the "Original\_Timestamp" field.

**Processing Tags and environmental categorizations:** For indicating particular types of environmental classifications not readily determined by the Original\_Timestamp field (e.g., weather, traffic), and restrictions on location hypothesis processing.

**loc\_sig\_cluster:** Access to location signature signal characteristics provided to the First Order Models by the CDMA Filter Subsystem; i.e., access to the "loc sigs" (received at "timestamp" regarding the location of the target MS)

**descriptor:** Optional descriptor (from the First Order Model indicating why/how the Location Area Estimate and Confidence Value were determined).

FIG. 9B

FIG. 10

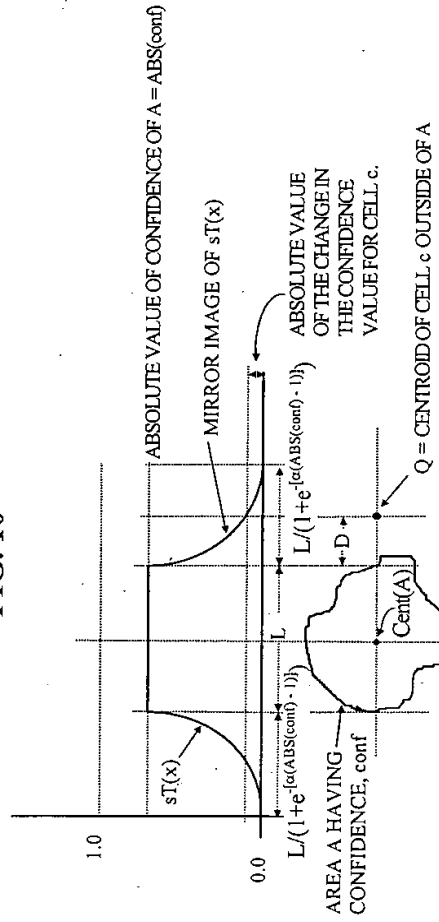

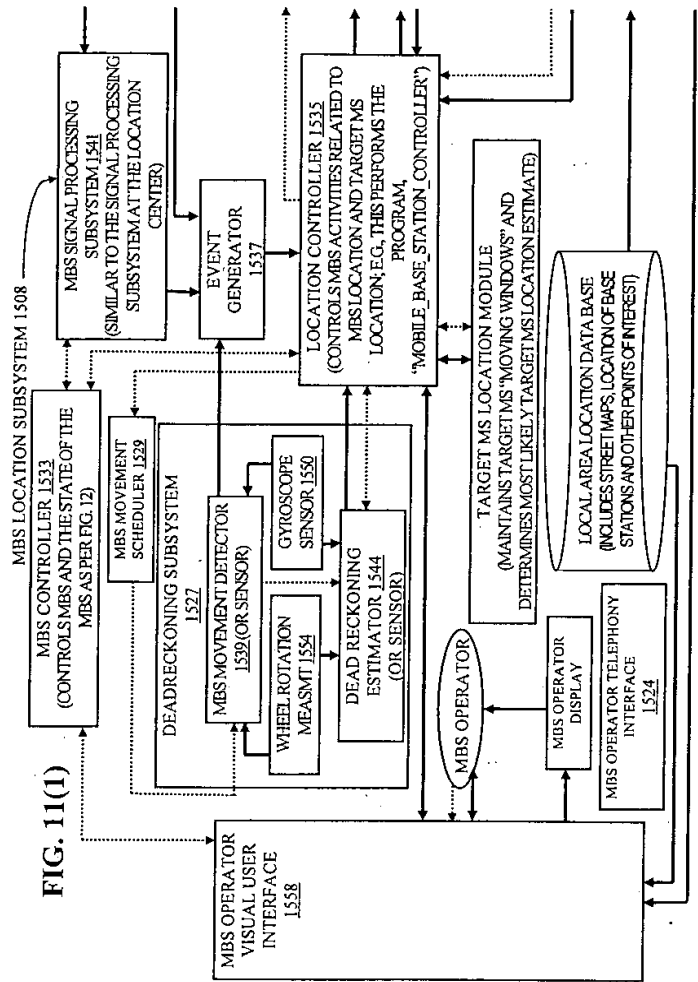

FIG. 11(1)

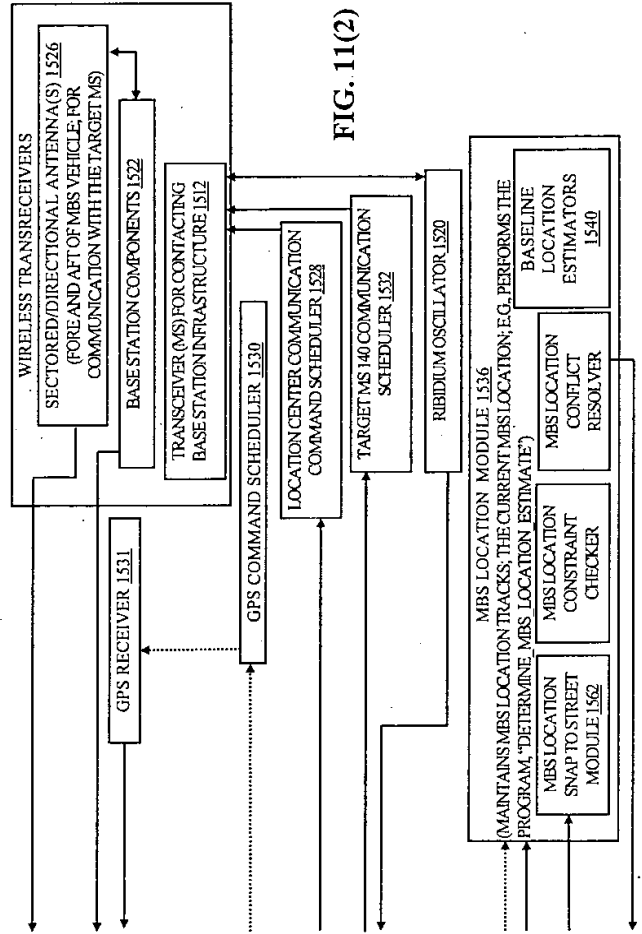

FIG. 11(2)

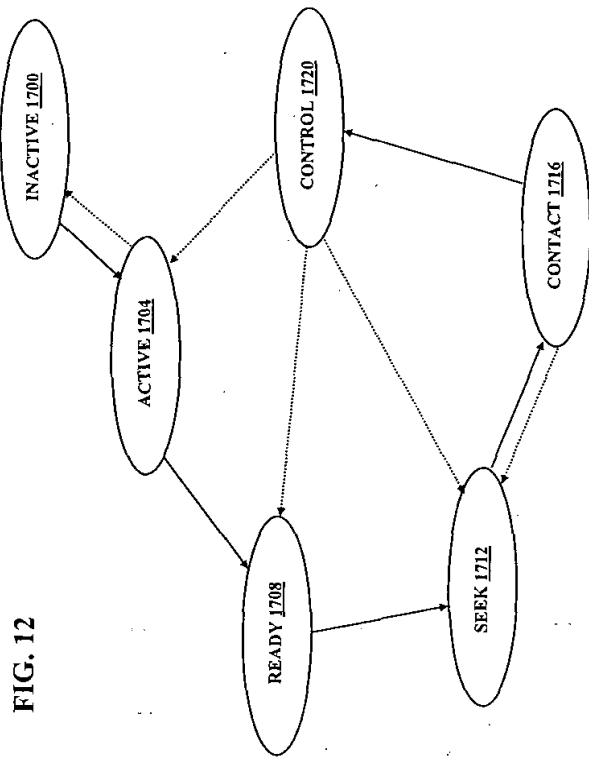
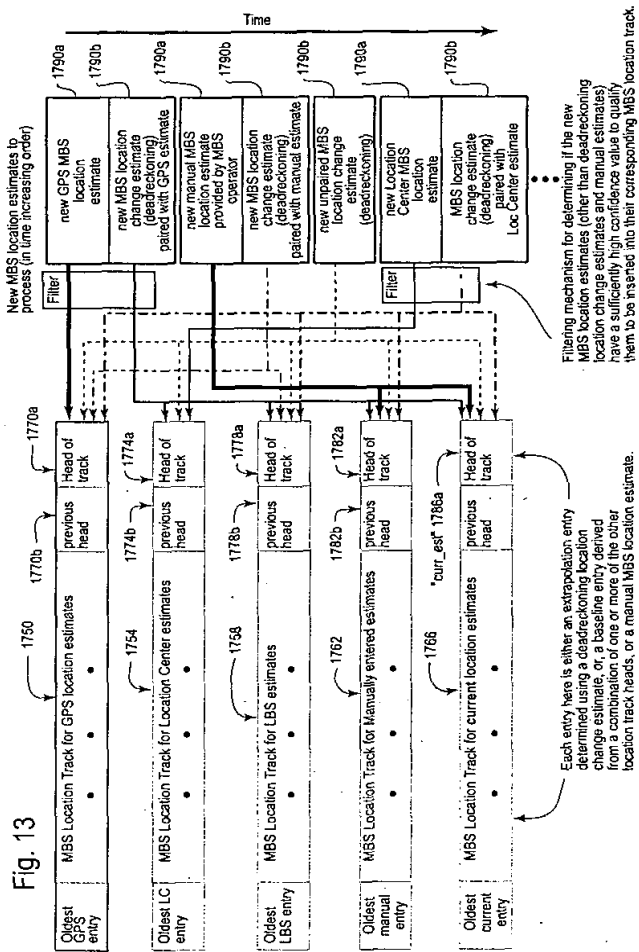
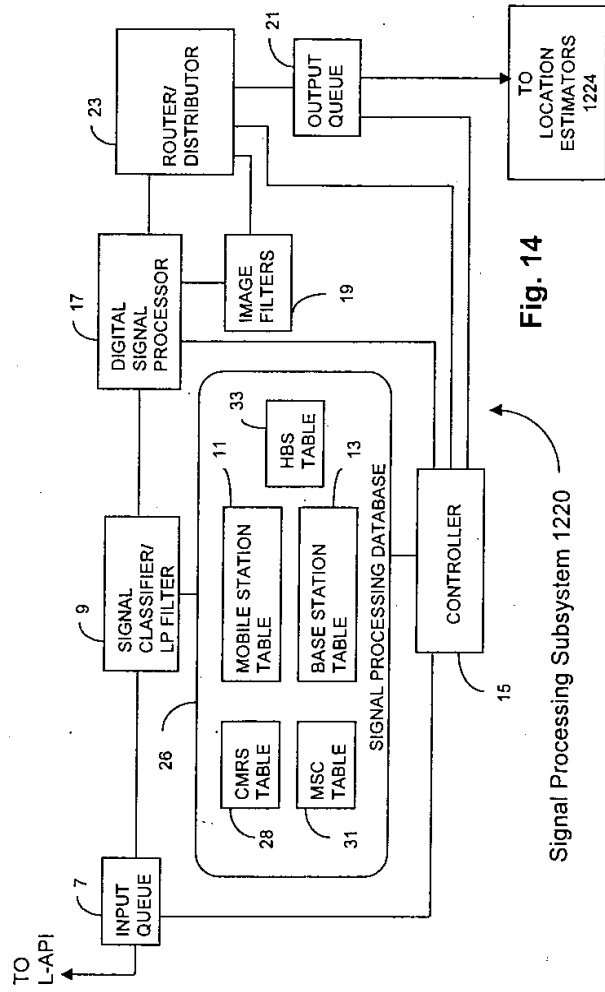

FIG. 12





**Fig. 14**

Signal Processing Subsystem 1220

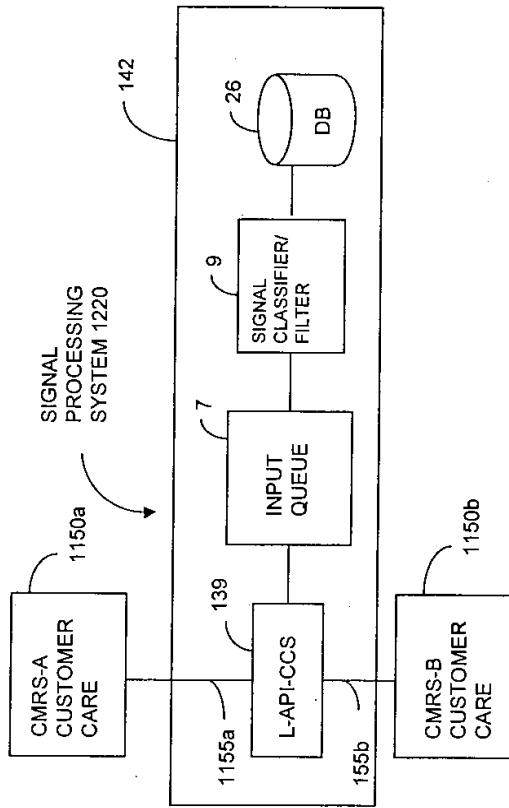

FIG. 15: LOCATION PROVISIONING VIA MULTIPLE CMRS



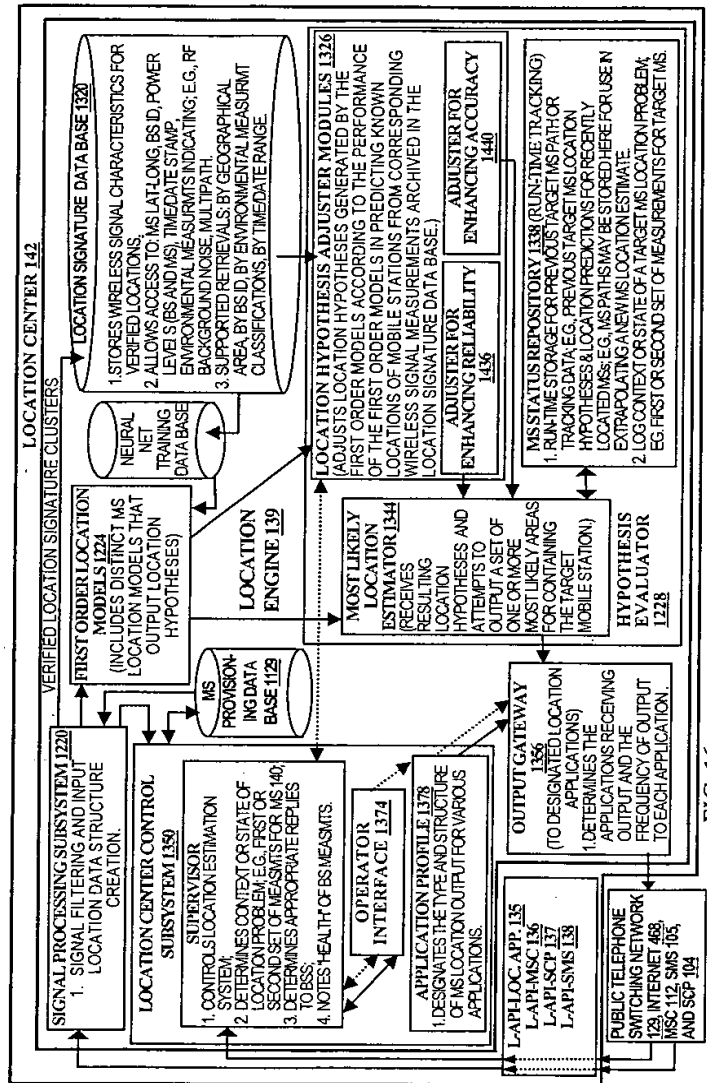
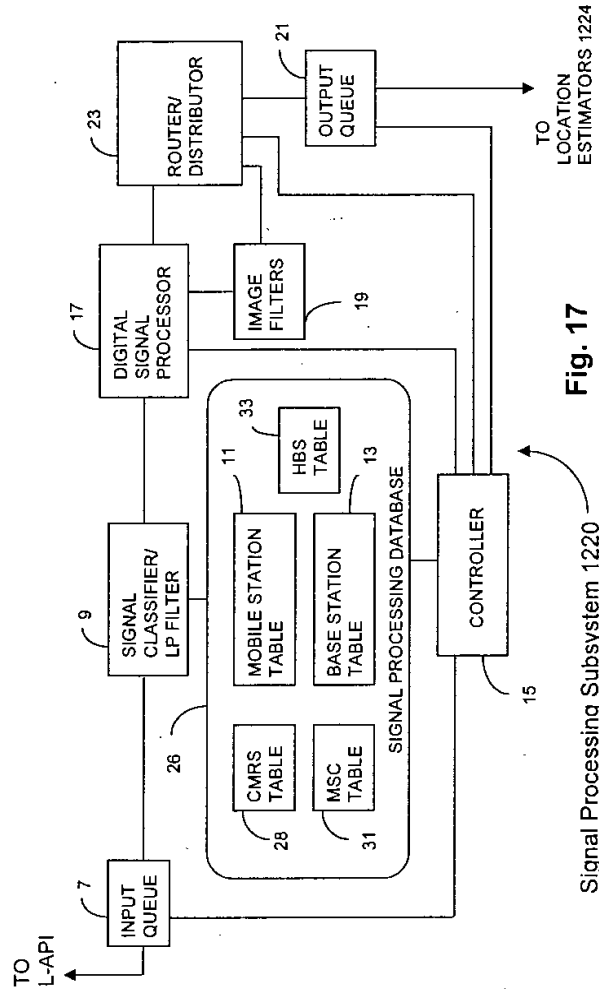

FIG. 16



**Fig. 17**

Signal Processing Subsystem 1220

Fig. 18

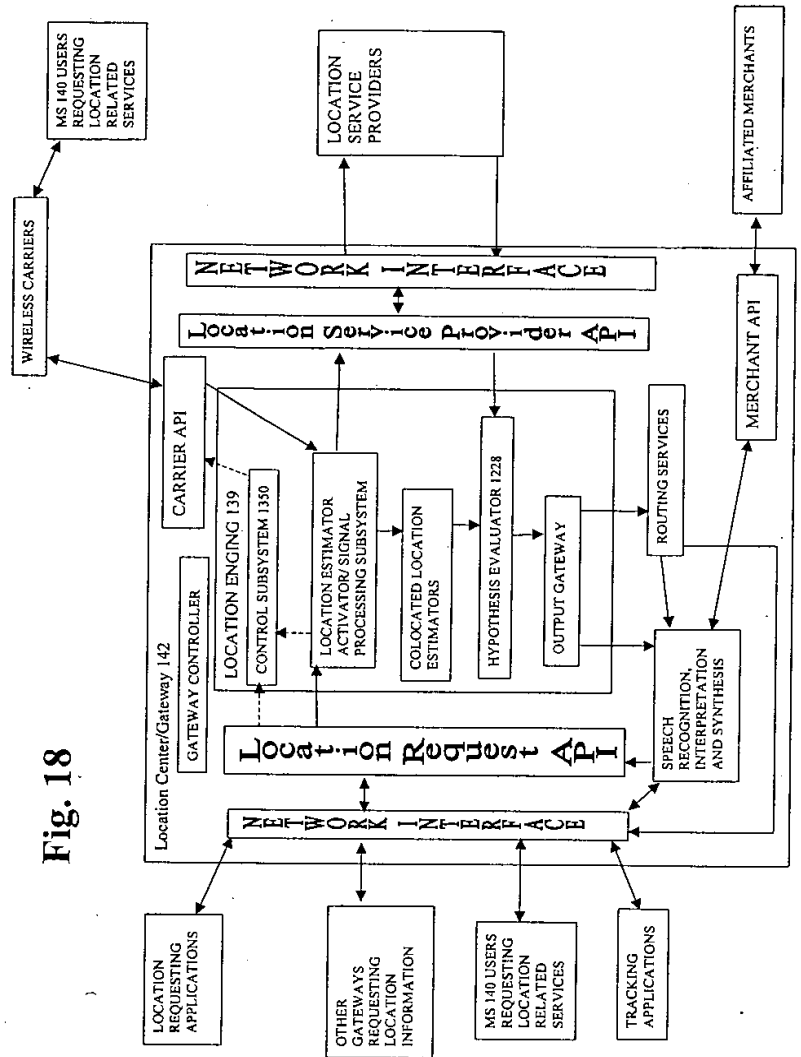

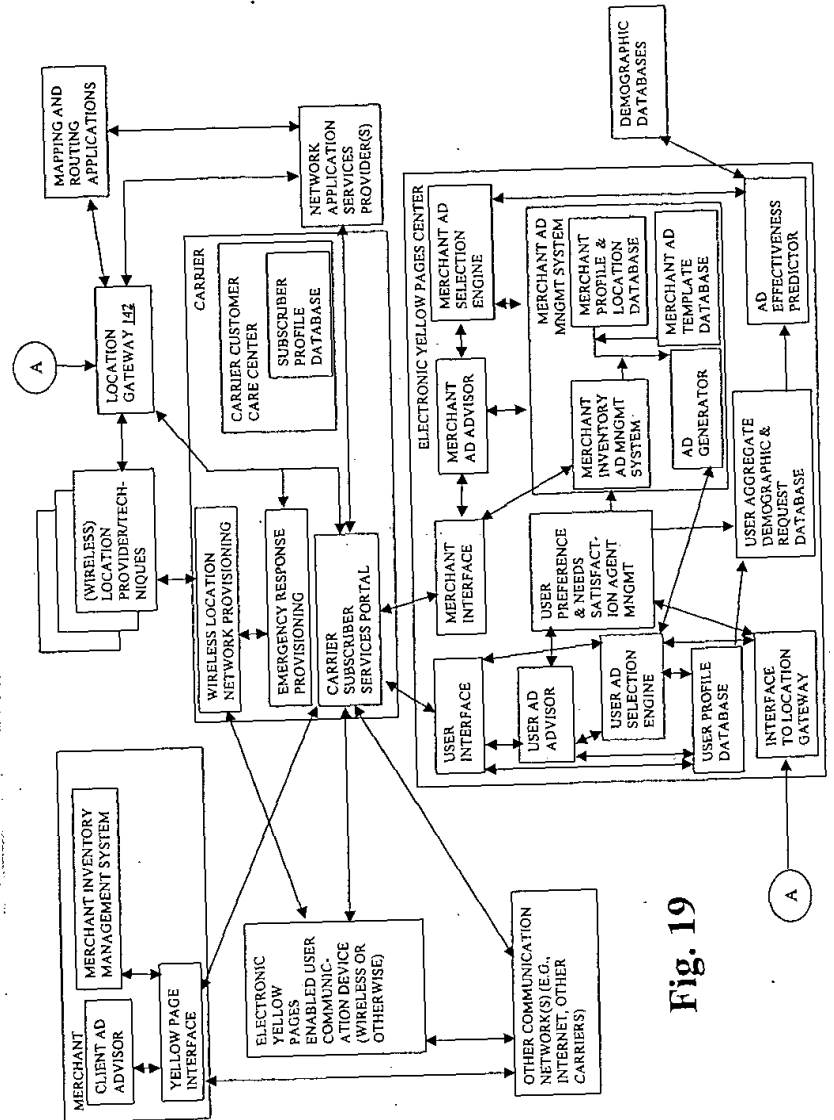

Fig. 19

## APPLICATIONS FOR A WIRELESS LOCATION GATEWAY

### RELATED APPLICATIONS

The present application claims the benefit of U.S. Provisional Patent Application Serial No. 60/349,100 filed January 4, 2002. The entire disclosure of the above-identified provisional application is incorporated by reference herein.

### FIELD OF THE INVENTION

The present invention is directed generally to a system and method for providing complex network services requiring interactions between various network accessible applications and/or services, and in particular where such complex services utilize or require the location of a wireless mobile station. Additionally, the present invention is directed to a platform for enabling such complex services, and to identifying such novel services that may be provided by such a platform. Thus, the present invention is directed to complex network services such as location based services for locating people or objects, and in particular, to a system and method for locating wireless mobile stations. The present invention is further directed to using a plurality of mobile station location estimators such as is provided by a wireless location gateway.

### BACKGROUND OF THE INVENTION

There is great interest in providing existing infrastructures for wireless communication systems with the capability for locating people and/or objects in a cost effective manner. Such a capability would be invaluable in a variety of situations, especially in emergency, crime situations and mobile commerce. There are numerous competing wireless location technologies that purport to effectively locate wireless mobile stations (as used herein this term includes, e.g., mobile phones, short message devices (SMS), electronic container tracking tags, micro-transceivers for personal location and/or emergency, and mobile transmitters such as can be used on battlefield or military reconnaissance, surveillance or tracking; additionally, in a more general

context, this term includes vehicles, and other mobile units such as railroad cars, watercraft, and aircraft containing a device that can be located wirelessly). These technologies can be generally classified as:

- 5 (a) handset centric wherein a portion of the location processing is performed at the mobile stations, and in particular, each such mobile station (MS) includes specialized electronics specifically for performing location. In most cases, such specialized electronics are for detecting and receiving satellite (or more generally, non-terrestrial transmitters and/or transceivers) signals that can then be used in  
10 determining a location of the MS;
- (b) network centric wherein the wireless communication network(s) with which the MS is in contact handle substantially all location specific processing. As one skilled in the art will understand, there are  
15 various wireless location technologies that are available such as location technologies based on time difference of arrival (TDOA), time of arrival (TOA), timing advance (TA) techniques, angle of arrival (AOA), multipath pattern matching techniques; and
- (c) hybrid systems wherein there are specialized location electronics at the handset ("handset" being used herein as an equivalent to mobile  
20 station unless stated otherwise), but a non-trivial amount of the location processing is performed at a network site rather at the MS. An example of such a hybrid system is what is known as network assisted GPS systems, wherein GPS signals are obtained at the MS (with the assistance network received information) and GPS timing  
25 information is transmitted from the MS to the network for performing MS location computations.

The wide variety of wireless location techniques can provide, under appropriate circumstances, the following advantages:

- 30 (a) if the techniques are used in combination, a more reliable and accurate wireless location capability can be provided. In particular,

when an embodiment of one wireless location technique is known to be less than satisfactory in a particular geographic area, an alternative embodiment (or alternative technique) can be used to obtain an MS's location(s). Additionally, two different embodiments and/or techniques can be applied substantially simultaneously for locating an MS. In this latter case, a location resolver is likely needed to determine a "most likely" resulting MS location estimate. Note, that wireless location systems for combining wireless location techniques is described in the following international and U.S. patent applications which are each incorporated fully by reference herein:

- i. U.S. Provisional Patent Application No. 60/025,855 filed September 9, 1996;
- ii. U.S. Provisional Patent Application No. 60/044,821, filed April 25, 1997;
- iii. U.S. Provisional Application No. 60/056,590, filed August 20, 1997;
- iv. International Patent Application No. PCT/US97/15933 filed September 8, 1997 entitled "LOCATION OF A MOBILE STATION USING A PLURALITY OF COMMERCIAL WIRELESS INFRASTRUCTURES" by LeBlanc, Dupray, and Karr;
- v. International Patent Application No. PCT/US97/15892 filed September 8, 1997; entitled "LOCATION OF A MOBILE STATION" by Dupray, and Karr
- vi. U.S. Patent Application No. 09/194,367 filed Nov. 24, 1999 entitled "Location Of A Mobile Station" by Dupray, and Karr;
- vii. U.S. Patent Application No. 09/176,587 filed Oct. 21, 1998 entitled "Wireless Location System For Calibrating Multiple Location Estimators" by Dupray;

viii. U.S. Patent No. 6,236,365 filed Jan. 22, 1999 entitled "Location of a Mobile Station Using A Plurality Of Commercial Infrastructures" by LeBlanc, Dupray and Karr;

ix. U.S. Patent No. 6,235,365 filed: April 23, 1999 entitled "WIRELESS LOCATION USING MULTIPLE LOCATION ESTIMATORS" by Dupray; and

x. International Patent Application No. PCT/US01/17957 filed June 4, 2001 entitled "A Wireless Location Gateway And Applications Therefor" by Dupray; and

(b) if a primary wireless location technique fails (e.g., due to an electronics malfunction), then assuming an alternative technique is available that does not use, e.g., the malfunctioning electronics of the primary technique, then the alternative technique can be used for MS location.

However, the variety of wireless location techniques available is also problematic for at least the following reasons:

(a) a request for an MS location can require either the requester to know the wireless location service provider of the geographical area where the MS is likely to be, or to contact a location broker that is able to, e.g., determine a communication network covering the geographical area within which the MS is currently residing and activate (directly or through the MS's wireless service provider) an appropriate wireless location service. In the art, the technology enabling such a location broker capability has been referred to as a "wireless location gateway". An embodiment of such a gateway is described in the PCT/US97/15892 reference identified above;

(b) for communication networks relying on handset centric and/or hybrid systems for MS location, MSs roaming from networks using only network centric location capabilities will likely not have the specialized electronics needed for being located, and accordingly



many location related network services will not be available such as emergency services (e.g., E911 in the U.S.).

- 5 (c) different location techniques have different reliability and accuracy characteristics. Thus, the wireless location technology may need to be selected according to the requirements of the location requesting application. For example, location requesting applications that require relatively precise location information are emergency rescue, and certain military related applications (e.g., battlefield data fusion, battlefield maneuvers and/or military command, control and
- 10 communication (C3)).

Accordingly, it would be desirable to integrate into a single wireless location broker or wireless location gateway as many location techniques as possible (or commercially feasible) so that location requests can be fulfilled without the requester needing to know what location technique is used. It would be further desirable for

15 roaming MSs to be able to be located in coverage areas where a wireless location technique is different from the one (or more) techniques supported in the primary subscription area for the MS. Additionally, it would be desirable to provide new applications for which MS location information can be applied via, e.g., a wireless location gateway.

20 OBJECTS OF THE INVENTION RELATING TO WIRELESS LOCATION

It is an objective of the present invention to provide a system and method for accurately locating people and/or objects in a cost effective manner wherein a location requester can obtain an MS location without needing to provide location technique specific information with the request.

25 It is a further object the present invention to provide wireless location without the requester knowing the particulars of a communication network with which the MS may be in contact, e.g., the commercial radio service provider (CMRS), the wireless communications protocol, etc. Furthermore, wireless location may be determined in two or three spacial dimensions depending upon, e.g., the requirements of the location

requesting application and the wireless location technologies available in the area where the MS resides.

Yet another objective is to provide a low cost location system and method, adaptable to wireless telephony/Internet systems, for using a plurality of location techniques for increasing MS location accuracy and consistency. In particular, the plurality of location techniques (embodied in "location estimators" also denoted "first order models" or FOMs herein) may be: activated according to any one or more of a number of activation strategies such as: (i) concurrent activation (e.g., for obtaining two location estimates of an MS location), (ii) data-driven activation (e.g., activated when appropriate input data is available), (iii) priority activation (e.g., an attempt to activate a preferred FOM is first performed, and if unsuccessful, or a result unsatisfactory, then an attempt at activating a different second FOM is performed), (iv) "most recent location" (e.g., for obtaining the most recently determined MS location).

Yet another objective of the present invention is to provide, in combination with MS wireless location estimates, one or more of:

- i. dimensional information such as an indication as to whether the location is in two dimensions (e.g., generally corresponding to a location on a two dimensional representation of a geographical area) or three dimensions (e.g., additionally having an elevation component corresponding to a floor in a high rise building above or below the surrounding terrestrial surface),
- ii. timing information such as a timestamp indicative of when the MS is presumed to have been at a corresponding estimated location (e.g., generally, when corresponding wireless signal measurements were first obtained),
- iii. MS movement information such as velocity, direction of movement, acceleration,
- iv. performance information indicating, e.g., a likely accuracy and/or reliability of the corresponding location estimate, and/or likely variance in the location estimate (such variance may be different along different

dimensions, particularly elevation), and/or status information indicative of success or failure in locating the MS,

- v. billing information indicating, e.g., a cost for the location information and/or who is to be billed and/or itemizations of discounts, taxes or tariffs for the wireless location service performed,
- vi. descriptive information as to who requested the location of the MS,
- vii. use permissions indicating who can access the MS location estimate, e.g., there may two MS location requests pending for the same MS, once a location estimate is determined one of the pending requests may be eligible for receiving the estimate while the other is not , network statistics,
- viii. descriptive information as to whether location enhancement techniques were used such as snap an estimated MS location to a nearest likely roadway (e.g., given an MS direction of travel, speed and previous location estimates), and/or
- ix. additional descriptive information such as identifying the location techniques used, the priority given to determining the MS location, the identity of location service provider(s) used in determining the MS location.

Yet another object is to (or be able to) integrate into a wireless location gateway a large number of MS location techniques such as:

- (2.1) time-of-arrival wireless signal processing techniques;
- (2.2) timing advance techniques (e.g., as provided in the GSM wireless standard);
- (2.2) time-difference-of-arrival wireless signal processing techniques;
- (2.3) adaptive wireless signal processing techniques having, for example, learning capabilities and including, for instance, artificial neural net and/or genetic algorithm processing;
- (2.4) signal processing techniques for matching MS location signals with wireless signal characteristics of known areas;

- 5
- (2.5) conflict resolution techniques for resolving conflicts in hypotheses for MS location estimates;
  - (2.6) techniques for enhancing MS location estimates through the use of both heuristics and historical data associating MS wireless signal characteristics with known locations and/or environmental conditions;
  - (2.7) angle of arrival techniques (also denoted direction of arrival) for estimating an angle and/or direction of wireless signals transmitted from an MS;
  - 10 (2.8) location techniques that use satellite signals such as GPS signals received at the MS; e.g., network assisted GPS location techniques, or non-network assisted GPS location techniques;
  - (2.9) wireless location techniques that use Doppler, phase coherency, and other signal characteristics for determining MS location, MS velocity and MS direction of movement;
  - 15 (2.10) calibration techniques that utilize wireless signal measurement survey data (e.g., signal measurements at verified geographical locations) for adjusting or calibrating a wireless location technique according to such survey data of a coverage area;
  - 20 (2.11) hybrid wireless location techniques that combine two or more of the above location techniques (2.1) – (2.10) or other wireless location techniques.

A related object is to integrate handset centric, network centric and hybrid systems so that the problems identified hereinabove are mitigated.

25 Note that it is a further objective of the present invention to provide a “plug and play” capability for new wireless location estimators and wireless location requesting application, wherein new location estimators and/or application can be easily incorporated into an embodiment of the present invention. For example, such plug and play capability may include providing an interface that allows substantially  
30 automatic integration of new FOMs, wherein such integration maybe at a central site

or at a mobile unit such as an MS. Regarding integration into a mobile unit, such a plug and play capability may be particularly important in military contexts where data fusion may be required. For example, in a battlefield context it may be desirable to have a relatively small number of command units (mobile or otherwise) that are in  
5 contact with a higher level chain of command and/or provide battlefield analysis applications. However, if one or more of the command units (e.g., soldiers, tanks, helicopters, etc.) are disabled or otherwise are unable to properly communicate it may that software embodiments of wireless location technologies and/or certain applications requiring wireless locations must be able to migrate between the  
10 command units to thereby maintain appropriate battlefield communications and/or combat coordination. More particularly, military applications that, once provided with locations of friendly and enemy units, analyze a global or overall view of a battlefield may be computationally intensive enough so that it is not be practical to have such applications reside on every mobile unit, even though it may be necessary for such  
15 applications to migrate between mobile units according to casualties and other computational tasks and/or security constraints that can dynamically arise.

Yet another object is to provide novel applications for wireless location that benefit from an integration of different location techniques.

Yet another object of the present invention is to provide a wireless platform  
20 that may be used substantially uniformly across a large number of wireless applications, and in particular, wireless applications that utilize wireless location.

#### DEFINITIONS

The following definitions are provided for convenience. In general, the definitions here are also defined elsewhere in this document as well.

25 (3.1) The term “**wireless**” herein is, in general, an abbreviation for “digital wireless”, and in particular, “wireless” refers to digital radio signaling using one of standard digital protocols such as Advanced Mobile Phone Service (AMPS), Narrowband Advanced Mobile Phone Service (NAMPS), code division multiple access (CDMA) and Time Division Multiple Access (TDMA), Global Systems Mobile (GSM), and

time division multiple access (TDMA) as one skilled in the art will understand.

However, other wireless protocols are also within the scope of the present invention in that the invention is not dependent upon a particular wireless signaling convention.

Additionally, it is intended that the scope of the invention also encompass analog

5 signal transmissions to the extent permissible, and in some contexts may also include signals in bandwidths other than radio such as optical and infrared.

(3.2) As used herein, the term “**mobile station**” (equivalently, MS) refers to a

wireless device that is at least a transmitting device, and in most cases is also a

wireless receiving device, such as a portable radio telephony handset. Note that in

10 some contexts herein instead of, or in addition to, MS, the following terms are also

used: “personal station” (PS), and “location unit” (LU) or mobile unit. In general,

these terms may be considered synonymous. Note that examples of various MSs are identified in the Background section above.

(3.3) The terms, “**wireless infrastructure**” (or simply “infrastructure”), denotes one

15 or more of: (a) a network for one or more of telephony communication services, (b) a

collection of commonly controlled transceivers for providing wireless communication

with a plurality of MSs, (c) the wireless Internet or portions thereof, (d) that portion of

communications network that receives and processes wireless communications with

wireless mobile stations. In particular, this infrastructure may in one embodiment

20 include: (i) telephony wireless base stations (BS) such as those for radio mobile

communication systems based on CDMA, AMPS, NAMPS, TDMA, and GSM

wherein the base stations provide a network of cooperative communication channels

with an air interface to the MS, and (ii) a conventional telecommunications interface

with a Mobile Switch Center (MSC). Thus, an MS user within an area serviced by the

25 base stations may be provided with wireless communication throughout the area by

user transparent communication transfers (i.e., “handoffs”) between the user’s MS and

these base stations in order to maintain effective telephony service. The mobile switch

center (MSC) provides communications and control connectivity among base stations

and the public telephone network. Note that in some contexts (e.g., military and/or

emergency) at least some of the MSs may also provide base station capabilities such as receiving and transmitting communications between two other MSs, e.g., wherein these two other MSs may be out of range for communicating directly with one another.

(3.4) The phrase, “**composite wireless signal characteristic values**” denotes the result of aggregating and filtering a collection of measurements of wireless signal samples, wherein these samples are obtained from the wireless communication between an MS to be located and the base station infrastructure (e.g., a plurality of networked base stations). However, other phrases are also used herein to denote this collection of derived characteristic values depending on the context and the likely orientation of the reader. For example, when viewing these values from a wireless signal processing perspective of radio engineering, as in the descriptions of the subsequent Detailed Description sections concerned with the aspects of the present invention for receiving MS signal measurements from the base station infrastructure, the phrase typically used is: “**RF signal measurements**”. Alternatively, from a data processing perspective, the phrases: “location signature cluster” and “location signal data” are used to describe signal characteristic values between the MS and the plurality of infrastructure base stations substantially simultaneously detecting MS transmissions. Moreover, since the location communications between an MS and the base station infrastructure typically include simultaneous communications with more than one base station, a related useful notion is that of a “**location signature**” (also denoted “**loc sig**” herein) which is the composite wireless signal characteristic values for signal samples between an MS (e.g., to be located) and a single base station. Also, in some contexts, the phrases: “**signal characteristic values**” or “**signal characteristic data**” are used when either or both a location signature(s) and/or a location signature cluster(s) are intended.

(3.5) The phrases “profile”, “subscriber profile”, and “user profile”, in general, will be used interchangeably. These phrases denote network a collection of information residing on a network to which the user subscribes or is registered to receive network services. In most cases, it is believed that a user will have such a network profile,

wherein it may include substantially any user information that is required to allow or prohibit access, activation, or fulfillment of one or more network services by the user, or by another user where the requested service by the other user requires accessing information about the user that is identified as being confidential or private.

## 5 SUMMARY DISCUSSION

The present invention relates to a method and system for performing wireless mobile station location and using resulting locations in services provided to wireless subscribers. In one aspect, the present invention is a wireless mobile station location computing method and system that utilizes multiple wireless location computational  
10 estimators (these estimators also denoted herein as MS location hypothesizing computational models, “first order models”, FOMs, and/or “location estimating models”), for providing location estimates of a target mobile station MS. Moreover, in the event that ambiguities and/or conflicts between the location estimates arise, such ambiguities and/or conflicts may be effectively and straightforwardly resolved.  
15 Moreover, the present invention provides a technique for calibrating the performance of each of the location estimators so that a confidence value (e.g., a probability) can be assigned to each generated location estimate. Additionally, the present invention provides a straightforward technique for using the confidence values (e.g., probabilities) for deriving a resulting most likely location estimate of a target wireless  
20 mobile station.

In one aspect, the present invention relates to a novel computational method and architecture for synergistically combining the results of a plurality of computational models in a straightforward way that allows the models to be calibrated relative to one another so that differences in results generated by the models can be  
25 readily resolved. Accordingly, the computational method and architecture of the present invention may be applied to a wide range applications where synergies between multiple models is expected to be enhance performance.

In another more general aspect of the present invention, its multiple model gateway architecture may used for other application domains beyond wireless location.



For example, application domains related to evaluating, diagnosing, monitoring and/or predicting a condition or state of affairs in the application domain. For example, such application domains can be in the areas of medical, electronic, and/or network evaluation, diagnosis, monitoring and/or prediction. However, other application domains are within the scope of the invention.

To further elaborate, for a particular application domain and a corresponding particular application having access to a plurality of computational models (each generating a hypothetical estimate or evaluation of a desired result(s) from/in a space of hypothesis results), the present invention may be described, at a high level, as any method or system that performs the following steps:

(4.1.1) A step of determining a classification scheme for determining an input class (C) for each input data set obtained for a condition or state of affairs to be evaluated by the particular application, wherein this input data set (or portions thereof) are to be supplied to the plurality of computational models (FOMs). For determining each input class, there is a range,  $R_C$ , of a plurality of ranges, from a space (the hypothesis space) of possible resulting hypotheses (or evaluations) that could be output by the FOMs. The the input data sets of this input class C are identified as those input data sets that are expected to have their corresponding desired result(s), generated by the particular application, in the range R.

Some examples will be illustrative. For a wireless location system as the "particular application", the present step, in one embodiment, determines geographical subareas of a wireless network coverage area that have "similar" wireless signal characteristics. Such subareas may be relatively easy to determine, and there may be no constraint on the size of the subareas. The intention is to determine: (a) such a subarea as only a general area where a target MS to be located must reside, and (b) the subarea should be relatively homogeneous

regarding at least one wireless signaling characteristic. Accordingly, in one embodiment of the present step, (a) and (b) are believed to be substantially satisfied by grouping together into the same input class the wireless signal data sets (i.e., input data sets) from corresponding target MS locations wherein at each of the target MS locations: (i) the set of base stations detected by the target MS (at the location) is substantially the same, and/or (b) the set of base stations detecting the target MS is substantially the same set of base stations.

Classification schemes in other application domains are also within the scope of the present step. For example, in diagnosis applications (e.g., medical, electronic, network, electromechanical), symptoms (e.g., input data sets) are generally classified according to their corresponding diagnoses. Also, in automated or electronic scene, object or image recognition such classification schemes may be used.

In some application domains, the present step may be viewed as a pre-filter or pre-selection capability for reducing subsequent computational overhead, e.g., so that only appropriate FOMs are activated (such appropriateness may be as much a function of economics and/or contractual agreements as it is the input data set available and the FOMs that are available).

Note that more complex classifications, there are numerous techniques and commercial packages for determining such a classification scheme. In particular, the statistically based system, "CART" (acronym for Classification and Regression Trees) by ANGOSS Software International Limited of Toronto, Canada is one such package. Further, note that this step is intended to provide reliable but not necessarily highly accurate ranges R for the desired results. Also note that in some applications there may be only a single input class. Accordingly, in this latter case the present step may be omitted entirely.

(4.1.2) A step of calibrating each of the plurality of computational models (FOMs) so that each subsequent hypothesis generated by one of the models has a confidence value (e.g., probability or other measurement) associated therewith that is indicative of the likeliness of the hypothesis being correct. The calibrating of this step is performed using the classes of the input classification scheme determined in the above step (4.1.1). Note that there may be only a single class (such as if step (4.1.1) were omitted). In one embodiment of present step, each FOM is supplied with inputs from a given fixed input class, wherein each of these inputs are for a known condition (or state of affairs) and/or a condition that can be verified as to its identity. In particular, the identity of the known condition constitutes a "correct" hypothesis (i.e., a desired result) with which outputs from FOMs can be compared and/or further processed. Subsequently, the performance of each model is determined for the input class and a confidence value is assigned to the model for inputs received from the input class. Note that this procedure is repeated with each input class available from the input classification scheme. In performing this procedure, an application domain specific criteria is used to determine whether the hypotheses generated by the models identify the desired results in the hypothesis space. Accordingly, for each of the models, when supplied with an input data set from a fixed input class, the hypothesis generated by the model will be given the confidence value determined for this input class as an indication of the likelihood of the generated hypothesis being correct (i.e., the desired result). Note that the confidence value for each generated hypothesis may be computed as a probability that the hypothesis is correct.

Note that for a wireless location application, the criteria (in one embodiment) is whether a location hypothesis contains the actual location where the MS was when the corresponding input data set

(wireless signal measurements) were communicated between this MS and the wireless network.

For applications related to the diagnosis of electronic systems, this criteria may be whether an hypothesis identifies a proper functional unit such as a circuit board or chip.

For economic forecasting applications, this criteria may be whether an hypothesis is within a particular range of the correct hypothesis. For example, if an application according to the present invention predicts the U.S. gross national product (GNP) six months into the future according to certain inputs (defining input data sets), then hypotheses generated from historical data that has associated therewith the actual corresponding GNP (six months later), may be used for calibrating each of the plurality of economic forecasting models (FOMs). Thus, the application specific criteria for this case may be that a generated hypothesis is within, say, 10% of the actual corresponding six month GNP prediction.

For identifying a known object such as an air or space borne, terrestrial vehicle, or watercraft, the criteria may be whether an hypothesis actually identifies the object.

For geophysical analysis applications (e.g., for identifying and/or classifying and/or mapping mineral deposits, oil, aquifers or seismic faults), the criteria may be whether an hypothesis provides a correct analysis.

Note that the applications described herein are illustrative, but not comprehensive of the scope of the present invention. Further note that this step typically is performed at least once prior to inputting input data sets whose resulting hypotheses are to be used to determine the desired or correct results. Additionally, once an initial calibration has been performed, this step may also be performed: (a) intermittently between the generation of hypotheses, and/or (b) substantially

continuously and in parallel with the generation of hypotheses by the models.

(4.1.3) A step of providing one or more input data sets to the models (FOMs) for generating a plurality of hypotheses, wherein the result(s) desired to be hypothesized are unknown. Moreover, note that the generated hypotheses are preferred to have a same data structure definition.

For example, for a wireless location system, the present step provides an input data set including the composite signal characteristic values to one or more MS location hypothesizing computational models, wherein each such model subsequently determines one or more initial estimates (also denoted location hypotheses) of the location of the target MS. Note that one or more of these model may be based on, for example, the signal processing techniques 2.1 through 2.3 above.

(4.1.4) A step of adjusting or modifying the generated hypotheses output by the models, wherein for such an hypothesis, adjustments may be performed on one or both of its hypothesized result H.R, and its confidence value for further enhancing the performance of the present invention. In one embodiment of this step, H.R is used as an index to retrieve other results from an archival database, wherein this database associates hypothesized results with their corresponding desired or correct results. Thus, H.R may be used to identify data from other archived hypothesized results that are “nearby” to H.R, and subsequently use the nearby data to retrieve the corresponding desired results. Thus, the set of retrieved desired results may be used to define a new “adjusted” hypothesis.

For example, for a wireless location system utilizing the present invention, each location hypothesis, H, identifies an area for a target MS, and H can be used to identify additional related locations included in archived hypotheses generated by the same FOM as generated H. For instance, such related locations may be the area centroids of the

archived hypotheses, wherein these centroids reside within the area hypothesized by H. Accordingly, such centroids may be used to retrieve the corresponding actual verified MS locations (i.e., the corresponding desired results), and these retrieved verified locations may be used to generate a new adjusted area that is likely to be more accurate than H. In particular, a convex hull of the verified locations may be used as a basis for determining a new location hypothesis of the target MS. Moreover, this aspect of the invention may include the preprocessing of such adjustments throughout a wireless coverage area to produce a geolocation vector gradient field, wherein for each archived hypotheses H (having  $L_H$  as an MS location estimate) for a designated FOM, throughout the coverage area, a corresponding verified location version  $VL_H$  is determined. Subsequently, the adjustment vector  $AV_H = (VL_H - L_H)$  is determined as one of the adjustment vectors of the vector gradient field. Thus,  $L_H$  and  $AV_H$  are associated in the data archive as a record of the vector gradient field. Accordingly, when a location hypothesis  $H_0$  for a target MS at an unknown location is generated (the hypothesis  $H_0$  having  $L_0$  as the target MS location estimate), records within the vector gradient field having their corresponding location  $L_H$  "near"  $L_0$ , (e.g., within area of a predetermined distance about  $L_0$  or a "neighborhood" of  $L_0$ ) can be retrieved. Accordingly, an adjustment to  $L_0$  can be determined as a function of the  $L_H$  and  $AV_H$  values of the retrieved records. Note that an adjustment to  $L_0$  may be simply an average of these  $AV_H$  vectors for the retrieved records. Alternatively, the  $AV_H$  values may be weighted such that the  $AV_H$  having  $L_H$  closer to  $L_0$  are more influential in the resulting derived location for the target MS. More generally, the adjustment technique includes a method for interpolating an adjustment at  $L_0$  from the verified adjustments at locations about  $L_0$ . Enhancements on such adjustment/interpolation techniques are also

within the scope of the present invention. For example, the weightings (or other terms of an such an interpolation technique) may be combined with other known wireless signal characteristics of the area such as an identification of: (a) a known sharp change in the geolocation gradient vector field, and/or (b) a subarea having reduced wireless transmission capabilities, and/or (c) a subarea wherein the retrieved records for the subarea have their estimates  $L_H$  widely spaced apart, and/or (d) a subarea wherein there is an insufficient number of retrieved records.

For other application domains, the present step requires a first technique to determine both “nearby” archived data from previously archived hypotheses, and a second technique to determine an “adjusted” hypothesis from the retrieved desired results. In general, such techniques can be relatively straightforward to provide when the hypothesized results reside in a vector space, and more particularly, in a Cartesian product of the real numbers. Accordingly, there are numerous applications that can be configured to generate hypothesized results in a vector space (or Cartesian product of the real numbers). For instance, economic financial forecasting applications typically result in numeric predictions where the first and second techniques can be, e.g., substantially identical to the centroid and convex hull techniques for the wireless location application.; and

(4.1.5) A step of subsequently computing a “most likely” target MS location estimate is computed. for outputting to a location requesting application such as 911 emergency, the fire or police departments, taxi services, etc. Note that in computing the most likely target MS location estimate a plurality of location hypotheses may be taken into account. In fact, it is an important aspect of the present invention that the most likely MS location estimate is determined by computationally forming a composite MS location estimate utilizing such a plurality of location

hypotheses so that, for example, location estimate similarities between location hypotheses can be effectively utilized.

Referring to (4.1.3) there may be hypotheses for estimating not only desired result(s), but also hypotheses may be generated that indicate where the desired result(s) is not. Thus, if the confidence values are probabilities, an hypothesis may be generated that has a very low (near zero) probability of having the desired result. As an aside, note that in general, for each generated hypothesis, H, having a probability, P, there is a dual hypothesis  $H^c$  that may be generated, wherein the  $H^c$  represents the complementary hypothesis that the desired result is in the space of hypothesized results outside of H. Thus, the probability that the desired result(s) is outside of the result hypothesized by H is 1-P. Accordingly, with each location hypothesis having a probability favorably indicating where a desired result may be (i.e.,  $P \geq 0.5$ ), there is a corresponding probability for the complement hypothesis that indicates where the desired result(s) is unlikely to be. Thus, applying this reasoning to a wireless location application utilizing the present invention, then for an hypothesis H indicating that the target MS is in a geographical area A, there is a dual location estimate  $H^c$  that may be generated, wherein the  $H^c$  represents the area outside of A and the probability that the target MS is outside of A is 1-P. Thus, with each location hypothesis having a probability favorably indicating where a target MS may be (i.e.,  $P \geq 0.5$ ), there is a corresponding probability for the complement area not represented by the location hypothesis that does not favor the target MS being in this complement area. Further, note that similar dual hypotheses can be used in other applications using the multiple model architecture of the present invention when probabilities are assigned to hypotheses generated by the models of the application.

Referring to (4.1.3) as it relates to a wireless location system provided by the present invention, note that, it is an aspect of the present invention to provide location hypothesis enhancing and evaluation techniques that can adjust target MS location estimates according to historical MS location data and/or adjust the confidence values of location hypotheses according to how consistent the corresponding target MS location estimate is: (a) with historical MS signal characteristic values, (b) with



various physical constraints, and (c) with various heuristics. In particular, the following capabilities are provided by the present invention:

- 5 (5.1) a capability for enhancing the accuracy of an initial location hypothesis,  $H$ , generated by a first order model,  $FOM_H$ , by using  $H$  as, essentially, a query or index into an historical data base (denoted herein as the location signature data base). Note, this data base may include: (a) a plurality of previously obtained location signature clusters (i.e., composite wireless signal characteristic values) such that for each such cluster there is an associated actual or verified MS locations where an MS communicated with the base station infrastructure for locating the MS, and (b) previous MS location hypothesis estimates from  $FOM_H$  derived from each of the location signature clusters stored according to (a). Alternatively this data base include a location error gradient field for the know location errors for  $FOM_H$ ;
- 10
- 15 (5.2) a capability for analyzing composite signal characteristic values of wireless communications between the target MS and the base station infrastructure, wherein such values are compared with composite signal characteristics values of known MS locations (these latter values being archived in the location signature data base). In one instance, the composite signal characteristic values used to generate various location hypotheses for the target MS are compared against wireless signal data of known MS locations stored in the location signature data base for determining the reliability of the location hypothesizing models for particular geographic areas and/or environmental conditions;
- 20
- 25 (5.3) a capability for reasoning about the likeliness of a location hypothesis wherein this reasoning capability uses heuristics and constraints based on physics and physical properties of the location geography;
- (5.4) an hypothesis generating capability for generating new location hypotheses from previous hypotheses.

As also mentioned above in (2.3), the present invention may utilize adaptive signal processing techniques. One particularly important utilization of such techniques includes the automatic tuning of the present invention so that, e.g., such tuning can be applied to adjusting the values of location processing system parameters that affect the processing performed by the present invention. For example, such system parameters as those used for determining the size of a geographical area to be specified when retrieving location signal data of known MS locations from the historical (location signature) data base can substantially affect the location processing. In particular, a system parameter specifying a minimum size for such a geographical area may, if too large, cause unnecessary inaccuracies in locating an MS. Accordingly, to accomplish a tuning of such system parameters, an adaptation engine is included in the present invention for automatically adjusting or tuning parameters used by the present invention. Note that in one embodiment, the adaptation engine is based on genetic algorithm techniques.

The present invention may include one or more FOMs that may be generally denoted as classification models wherein such FOMs are trained or calibrated to associate particular composite wireless signal characteristic values with a geographical location where a target MS could likely generate the wireless signal samples from which the composite wireless signal characteristic values are derived. Further, the present invention may include the capability for training and retraining such classification FOMs to automatically maintain the accuracy of these models even though substantial changes to the radio coverage area may occur, such as the construction of a new high rise building or seasonal variations (due to, for example, foliage variations). As used herein, "training" refers to iteratively presenting "training data" to a computational module for changing the behavior of the module so that the module may perform progressively better as it learns appropriate behavioral responses to the training data. Accordingly, training may include, for example, the repeated input of training data to an artificial neural network, or repeated statistical regression analyses on different and/or enhanced training data (e.g., statistical sample data sets). Note that other embodiments of a trained pattern matching FOMs for wireless location

are disclosed in U.S. Patent 6,026,304, titled "Radio Transmitter Location Finding for Wireless Communication Network Services and Management," filed Jan. 8, 1997 and issued Feb. 15, 2000, having Hilsenrath and Wax as inventors, this patent being incorporated herein fully by reference.

5           It is well known in the wireless telephony art that the phenomenon of signal multipath and shadow fading renders most analytical location computational techniques such as time-of-arrival (TOA) or time-difference-of-arrival (TDOA) substantially error prone in urban areas and particularly in dense urban areas without further statistical correlation processing such as such super resolution as disclosed in  
10 U.S. patent 5,890,068 by Fattouche et. al. issued on Mar. 30, 1999 and incorporated fully herein by reference. Moreover, it may be the case that even though such additional processing is performed, the multipath phenomenon may still be problematic. However, this same multipath phenomenon also may produce substantially distinct or peculiar signal measurement patterns, wherein such a pattern  
15 coincides with a relatively small geographical area. Thus, the present invention may include a FOM(s) utilize multipath as an advantage for increasing accuracy. Moreover, it is worthwhile to note that the utilization of classification FOMs in high multipath environments is especially advantageous in that high multipath environments are typically densely populated. Thus, since such environments are also  
20 capable of yielding a greater density of MS location signal data from MSs whose actual locations can be obtained, there can be a substantial amount of training or calibration data captured by the present invention for training or calibrating such classification FOMs and for progressively improving the MS location accuracy of such models.

25           It is also an aspect of the present invention that classification FOMs may be utilized that determine target MS locations by correlating and/or associating network anomalous behavior with geographic locations where such behavior occurs. That is, network behaviors that are problematic for voice and/or data communication may be used advantageously for locating a target MS. For example, it is well known that  
30 wireless networks typically have within their coverage areas persistent subareas where

voice quality is problematic due to, e.g., measurements related to high total errors, a high error rate, or change in error rate. In particular, such measurements may be related to frame error rates, redundancy errors, co-channel interference, excessive handoffs between base stations, and/or other call quality measurements. Additionally, measurements may be used that are related to subareas where wireless communication between the network and a target MS is not sufficient to maintain a call (i.e., “deadzones”). Thus, information about such so called problematic behaviors may be used by, e.g., a location estimator (FOM) to generate a more accurate estimate of a target MS. For example, such network behavioral measurements may be provided for training an artificial neural network and/or for providing to a statistical regression analysis technique and/or statistical prediction models (e.g., using principle decomposition, partial least squares, or other regression techniques) for associating or correlating such measurements with the geographic area for which they likely derive. Moreover, note that such network behavioral measurements can also be used to reduce the likelihood of a target MS being in an area if such measurements are not what would be expected for the area.

It is also an aspect of the present invention that FOMs themselves may be hybrid combinations of MS location techniques. For example, an embodiment of the present invention may include a FOM that uses a combination of Time Difference of Arrival (TDOA) and Timing Advance (TA) location measurement techniques for locating the target MS, wherein such a technique may require only minor modifications to the wireless infrastructure. In particular, such a FOM may provide reduced MS location errors and reduced resolution of ambiguities than are present when these techniques are used separately. One embodiment of such a FOM (also denoted the Yost Model or FOM herein) is disclosed in U.S. Patent 5,987,329 filed July 30, 1997 and issued Nov. 16, 1999 titled: “System and Method for Mobile Telephone Location Measurement Using a Hybrid Technique” having Yost and Panchapakesan as inventors, this patent being fully incorporated herein by reference.

Additionally, note that FOMs related to the Yost Model may also be incorporated into embodiments of the present invention wherein an elliptical search restriction location technique may also be utilized. In particular, such a technique is disclosed in U.S. patent application, having U.S. PatentNo. 5,930,717, and titled:  
5 "System and Method Using Elliptical Search Area Coverage in Determining the Location of a Mobile Terminal", filed Jul. 30, 1997, by Yost et. al. which is also fully incorporated by reference herein.

It is also a related aspect of the present invention to include a plurality of stationary, low cost, low power "location detection base stations" (LBS), each such  
10 LBS having both restricted range MS detection capabilities, and a built-in MS. Accordingly, a grid of such LBSs can be utilized for providing wireless signaling characteristic data (from their built-in MSs) for: (a) (re)training such classification FOMs, and (b) calibrating the FOMs so that each generated location hypothesis has a reliable confidence value (e.g., probability) indicative of the likeliness of the target MS  
15 being in an area represented by the location hypothesis.

It is a further aspect of the present invention that the personal communication system (PCS) infrastructures currently being developed by telecommunication providers offer an appropriate localized infrastructure base upon which to build various personal location systems (PLS) employing the present invention and/or  
20 utilizing the techniques disclosed herein. In particular, the present invention is especially suitable for the location of people and/or objects using code division multiple access (CDMA) wireless infrastructures, although other wireless infrastructures, such as, time division multiple access (TDMA) infrastructures and GSM are also contemplated. CDMA general principles are described, for example, in  
25 U. S. Patent 5,109,390, to Gilhausen, et al, which is also incorporated herein by reference.

As mentioned in (1.7) and in the discussion of classification FOMs above, embodiments of the present invention may include components (e.g., FOMs) that can substantially automatically retrain themselves to compensate for variations in wireless

signal characteristics (e.g., multipath) due to environmental and/or topographic changes to a geographic area serviced by the present invention. For example, in one embodiment, the present invention optionally includes low cost, low power base stations, denoted location base stations (LBS) above, providing, for example, CDMA pilot channels to a very limited area about each such LBS. The location base stations may provide limited voice traffic capabilities, but each is capable of gathering sufficient wireless signal characteristics from an MS within the location base station's range to facilitate locating the MS. Thus, by positioning the location base stations at known locations in a geographic region such as, for instance, on street lamp poles and road signs, additional MS location accuracy can be obtained. That is, due to the low power signal output by such location base stations, for there to be signaling control communication (e.g., pilot signaling and other control signals) between a location base station and a target MS, the MS must be relatively near the location base station. Additionally, for each location base station not in communication with the target MS, it is likely that the MS is not near to this location base station. Thus, by utilizing information received from both location base stations in communication with the target MS and those that are not in communication with the target MS, the present invention may substantially narrow the possible geographic areas within which the target MS is likely to be. Further, by providing each location base station (LBS) with a co-located stationary wireless transceiver (denoted a built-in MS above) having similar functionality to an MS, the following advantages are provided:

(6.1) assuming that the co-located base station capabilities and the stationary transceiver of an LBS are such that the base station capabilities and the stationary transceiver communicate with one another, the stationary transceiver can be signaled by another component(s) of the present invention to activate or deactivate its associated base station capability, thereby conserving power for the LBS that operate on a restricted power such as solar electrical power;

(6.2) the stationary transceiver of an LBS can be used for transferring target MS location information obtained by the LBS to a conventional telephony base station;

(6.3) since the location of each LBS is known and can be used in location processing, the present invention is able to (re)train itself in geographical areas having such LBSs. That is, by activating each LBS stationary transceiver so that there is signal communication between the stationary transceiver and surrounding base stations within range, wireless signal characteristic values for the location of the stationary transceiver are obtained for each such base station. Accordingly, such characteristic values can then be associated with the known location of the stationary transceiver for training various of the location processing modules of the present invention such as the classification FOMs discussed above. In particular, such training and/or calibrating may include:

- (i) (re)training FOMs;
- (ii) adjusting the confidence value initially assigned to a location hypothesis according to how accurate the generating FOM is in estimating the location of the stationary transceiver using data obtained from wireless signal characteristics of signals between the stationary transceiver and base stations with which the stationary transceiver is capable of communicating;
- (iii) automatically updating the previously mentioned historical data base (i.e., the location signature data base), wherein the stored signal characteristic data for each stationary transceiver can be used for detecting environmental and/or topographical changes (e.g., a newly built high rise or other structures capable of altering the multipath characteristics of a given geographical area); and
- (iv) tuning of the location system parameters, wherein the steps of: (a) modifying various system parameters and (b) testing the performance of the modified location system on verified mobile station location data (including the stationary transceiver signal characteristic data), these steps being interleaved and repeatedly performed for obtaining better system location accuracy within useful time constraints.

One embodiment of the present invention utilizes a mobile (location) base station (MBS) that can be, for example, incorporated into a vehicle, such as an ambulance, police car, or taxi. Such a vehicle can travel to sites having a transmitting

target MS, wherein such sites may be randomly located and the signal characteristic data from the transmitting target MS at such a location can consequently be archived with a verified location measurement performed at the site by the mobile location base station. Moreover, it is important to note that such a mobile location base station as its name implies also includes base station electronics for communicating with mobile stations, though not necessarily in the manner of a conventional infrastructure base station. In particular, a mobile location base station may (in one embodiment) only monitor signal characteristics, such as MS signal strength, from a target MS without transmitting signals to the target MS. Alternatively, a mobile location base station can periodically be in bi-directional communication with a target MS for determining a signal time-of-arrival (or time-difference-of-arrival) measurement between the mobile location base station and the target MS. Additionally, each such mobile location base station includes components for estimating the location of the mobile location base station, such mobile location base station location estimates being important when the mobile location base station is used for locating a target MS via, for example, time-of-arrival or time-difference-of-arrival measurements as one skilled in the art will appreciate. In particular, a mobile location base station can include:

- (7.1) a mobile station (MS) for both communicating with other components of the present invention (such as a location processing center included in the present invention);
- (7.2) a GPS receiver for determining a location of the mobile location base station;
- (7.3) a gyroscope and other dead reckoning devices; and
- (7.4) devices for operator manual entry of a mobile location base station location.

Furthermore, a mobile location base station includes modules for integrating or reconciling distinct mobile location base station location estimates that, for example, can be obtained using the components and devices of (7.1) through (7.4) above. That is, location estimates for the mobile location base station may be obtained from: GPS satellite data, mobile location base station data provided by the location processing center, dead reckoning data obtained from the mobile location base station vehicle



dead reckoning devices, and location data manually input by an operator of the mobile location base station.

The location estimating system of the present invention offers many advantages over existing location systems. The present invention employs a number of distinctly different location estimators which provide a greater degree of accuracy and/or reliability than is possible with existing wireless location systems. For instance, the location models provided may include not only the radius-radius/TOA and TDOA techniques but also adaptive techniques such as artificial neural net techniques and the techniques disclosed in the U.S. Patent 6,026,304 by Hilsenrath et al. incorporated fully by reference herein, and angle or direction of arrival techniques as well as substantially any other wireless location technique wherein appropriate input data can be obtained. Note that hybrid location estimators based on combinations of such techniques (such as the location technique of U.S. Patent 5,987,329 by Yost et al.) may also be provided by the present invention.

It is also an aspect of the present invention that various embodiments may provide various strategies for activating, within a single MS location instance, one or more location estimators (FOMs), wherein each such activated location estimator is provided with sufficient wireless signal data input for the activation. In one embodiment, one such strategy may be called "greedy" in that substantially as many location estimators may be activated as there is sufficient input (additionally, time and resources as well) for activation. Note that some wireless location techniques are dependent on specialized location related devices being operational such as fixed or network based receivers, antennas, transceivers, and/or signal processing equipment. Additionally note that some location techniques also require particular functionality to be operable in the MS; e.g., functionality for detecting one or more location related signals from satellites (more generally non-terrestrial transmitting stations). For example, the signals may be GPS signals. Accordingly, certain wireless location techniques may have their activations dependent upon whether such location related devices and/or MS functionality are available and operable for each instance of determining an MS location. Thus, for each MS wireless location instance, location

estimators may be activated according to the operable features present during an MS location instance for providing input activation data.

The present invention may be able to adapt to environmental changes substantially as frequently as desired. Thus, the present invention may be able to take  
5 into account changes in the location topography over time without extensive manual data manipulation. Moreover, the present invention can be utilized with varying amounts of signal measurement inputs. Thus, if a location estimate is desired in a very short time interval (e.g., less than approximately one to two seconds), then the present invention can be used with only as much signal measurement data as is possible to  
10 acquire during an initial portion of this time interval. Subsequently, after a greater amount of signal measurement data has been acquired, additional more accurate location estimates may be obtained. Note that this capability can be useful in the context of 911 emergency response in that a first quick coarse wireless mobile station location estimate can be used to route a 911 call from the mobile station to a 911  
15 emergency response center that has responsibility for the area containing the mobile station and the 911 caller. Subsequently, once the 911 call has been routed according to this first quick location estimate, by continuing to receive additional wireless signal measurements, more reliable and accurate location estimates of the mobile station can be obtained.

20 Moreover, there are numerous additional advantages of the system of the present invention when applied in communication systems using, e.g., CDMA. The location system of the present invention readily benefits from the distinct advantages of the CDMA spread spectrum scheme. Namely, these advantages include the exploitation of radio frequency spectral efficiency and isolation by (a) monitoring  
25 voice activity, (b) management of two-way power control, (c) provisioning of advanced variable-rate modems and error correcting signal encoding, (d) inherent resistance to fading, (e) enhanced privacy, and (f) multiple "rake" digital data receivers and searcher receivers for correlation of signal multipaths.

At a more general level, it is an aspect of the present invention to demonstrate  
30 the utilization of various novel computational paradigms such as:

(8.1) providing a multiple FOM computational architecture (as illustrated in Fig. 8) wherein:

(8.1.1) the hypotheses may be generated by modular independent hypothesizing computational models (FOMs), wherein the FOMs have been calibrated to thereby output confidence values (probabilities) related to the likelihood of correspondingly generated hypotheses being correct;

(8.1.2) the location hypotheses from the FOMs may be further processed using additional amounts of application specific processing common or generic to a plurality of the FOMs;

(8.1.3) the computational architecture may enhance the hypotheses generated by the FOMs both according to past performance of the models and according to application specific constraints and heuristics without requiring complex feedback loops for recalibrating one or more of the FOMs;

(8.1.4) the FOMs are relatively easily integrated into, modified and extracted from the computational architecture; and

(8.2) providing a computational paradigm for enhancing an initial estimated solution to a problem by using this initial estimated solution as, effectively, a query or index into an historical data base of previous solution estimates and corresponding actual solutions for deriving an enhanced solution estimate based on past performance of the module that generated the initial estimated solution.

The multiple FOM architecture provided herein is useful in implementing solutions in a wide range of applications. In fact, most of the Detailed Description hereinbelow can be immediately translated into other application areas, as one skilled in the art of computer application architectures will come to appreciate. For example, the following additional applications are within the scope of the present invention:

(9.1) document scanning applications;

(9.2) diagnosis and monitoring applications such as medical diagnosis/monitoring, communication network diagnosis/monitoring. Note that in many cases, the domain wherein a diagnosis is to be performed has a canonical hierarchical order among the components within the domain. For example, in automobile diagnosis, the components of an auto may be hierarchically ordered according to ease of replacement in combination within function. Thus, within an auto's electrical system (function), there may be a fuse box, and within the fuse box there will be fuses. Thus, these components may be ordered as follows (highest to lowest): auto, electrical system, fuse box, fuses. Thus, if different diagnostic FOMs provided different hypotheses as to a problem with an auto, the confidence values for each component and its subcomponents may be summed together to provide a likelihood value that the problem within the component. Accordingly, the lowest component having, for example, at least a minimum threshold of summed confidences can be selected as the most likely component for either further analysis and/or replacement. Note that such summed confidences may be normalized by dividing by the number of hypotheses generated from the same input so that the highest summed confidence is one and the lowest is zero. Further note that this example is merely representative of a number of different diagnosis and/or prediction applications to which the present invention is applicable, wherein there are components that have canonical hierarchical decompositions. For example, a technique similar to the auto illustration above may be provided for the diagnosis of computer systems, networks (LANs, WANs, Internet and telephony networks), medical diagnosis from, e.g., x-rays, MRIs, sonograms, etc;

(9.3) robotics applications such as scene and/or object recognition. That is, various FOMs may process visual image input differently, and it may be that for expediency, an object is recognized if the summed confidence values for the object being recognized is above a certain threshold ;

(9.4) seismic and/or geologic signal processing applications such as for locating oil and gas deposits;

(9.5) recognition of terrestrial and/or airborne objects from satellites, wherein there may be various spectral bands monitored.

5 (9.6) modeling of physical phenomena such as for assessing models of motion of physical phenomena through a fluid, wherein such motion causes an acoustic signal that traverses an uncertain path which received by sensors with uncertain biases, in the presence of noise. An example of such modeling using a multiple hypothesis architecture is disclosed in U.S. Patent No. 6,304,833, filed April  
10 27, 1999 by Ferkinhoff, et al. and incorporated fully herein by reference.

(9.7) Additionally, note that this architecture need not have all modules co-located. In particular, it is an additional aspect of the present invention that various modules can be remotely located from one another and communicate with one another via telecommunication transmissions such as telephony technologies  
15 (ISDN, virtual private networks, POTS, DSL, etc.) and/or the Internet. Accordingly, the present invention is particularly adaptable to such distributed computing environments. For example, some number of the first order models may reside in remote locations and communicate their generated hypotheses via the Internet.

20 In an alternative embodiment of the present invention, the processing following the generation of location hypotheses (each having an initial location estimate) by the first order models may be such that this processing can be provided on Internet user nodes and the first order models may reside at various Internet server sites. In this configuration, an Internet user may request hypotheses from such remote first order  
25 models and perform the remaining processing at his/her node. Moreover, embodiments of the present invention may access FOMs at sites distributed on other communication networks such as a local area network in a hotel, or an ad hoc network in a battlefield, military or emergency scenario.

30 Additionally, note that it is within the scope of the present invention to provide one or more central location development or repository sites that may be networked to,

for example, geographically dispersed location centers providing location services according to the present invention, wherein the FOMs may be accessed, substituted, enhanced or removed dynamically via network connections (via, e.g., the Internet or other network) with a central location development or repository site. Thus, a small but rapidly growing municipality in substantially flat low density area might initially be provided with access to, for example, two or three FOMs for generating location hypotheses in the municipality's relatively uncluttered radio signaling environment. However, as the population density increases and the radio signaling environment becomes cluttered by, for example, thermal noise and multipath, additional or alternative FOMs may be transferred via the network to the location center for the municipality.

Note that in some embodiments of the present invention, since there may be a lack of sequencing between the FOMs and subsequent processing of hypotheses (e.g., location hypotheses, or other application specific hypotheses), the FOMs can be incorporated into an expert system, or another computational architecture for performing "intelligent" processing if desired. For example, for an expert system architecture, each FOM may be activated from an antecedent of an expert system rule. Thus, the antecedent for such a rule can evaluate to TRUE if the FOM outputs a location hypothesis, and the consequent portion of such a rule may put the output location hypothesis on a list of location hypotheses occurring in a particular time window for subsequent processing by the location center. Alternatively, activation of the FOMs may be in the consequents of such expert system rules. That is, the antecedent of such an expert system rule may determine if the conditions are appropriate for invoking the FOM(s) in the rule's consequent.

The present invention may also be configured as a blackboard system with intelligent agents (FOMs). In this embodiment, each of the intelligent agents is calibrated using archived data so that for each of the input data sets provided either directly to the intelligent agents or to the blackboard, each hypothesis generated and placed on the blackboard by the intelligent agents has a corresponding confidence value indicative of an expected validity of the hypothesis.

Of course, other software architectures may also be used in implementing the processing of the location center without departing from scope of the present invention. In particular, object-oriented architectures are also within the scope of the present invention. For example, the FOMs may be object methods on an MS location estimator object, wherein the estimator object receives substantially all target MS location signal data output by the signal filtering subsystem. Alternatively, software bus architectures are contemplated by the present invention, as one skilled in the art will understand, wherein the software architecture may be modular and facilitate parallel processing.

#### 10 **Wireless Application Platform Services and Architecture**

It is yet another aspect of the present invention to provide a platform or architecture for providing wireless application services to wireless subscribers. In particular, the present invention includes a service providing platform that is substantially uniform over a plurality of different wireless application services, and in particular wireless location based services, and/or, short and/or instant messaging services, and in particular in combination with Internet access for such services as mobile commerce (also known as "mcommerce"), personal communications with friends and family, wireless games, wireless assessment of an emergency situation (e.g., where voice data, picture data, e.g., from camera phones, as well as data transmissions from on-site emergency assessment and/or analysis equipment such as chemical analyzers, radiation analyzers, biochemical hazard analyzers, etc. Accordingly, this platform may be considered as a wireless location application hub, wherein a single instance (or substantially duplicate copies) of the platform can provide a plurality of different wireless services to wireless subscribers. In particular, such a platform can provide robust generic wireless data communication capabilities that are required or desirable by a wide variety of wireless application services, and particularly services using wireless location capabilities. For example, such data communication capabilities provided by such a platform can include:

- 5
- (a) **user profile processing:** E.g., (i) using user profile information for identifying and/or predicting information that is likely to be of interest to the user; (ii) gathering user profile information from not only receiving such profile information from the user, but also performing data mining operations on various public data sources for obtaining further user profile information about specific users as well as more general demographic profile information, and (iii) maintaining limitations or constraints on the content and/or types of information that can be stored in the user's profile.
- 10
- (b) **data encryption processing:** E.g., encryption/decryption of a user's personal profile, encryption/decryption of a user's location (e.g., such user location encryption may be particularly advantageous in a user in a witness protection program).
- 15
- (c) **data privacy processing:** E.g., there may be only certain individuals or designated agents that can view and/or modify a user's profile; additionally, there may be certain portions of a user's profile that can not be accessed without appropriate permissions (e.g., financial information, home address, social security number, etc.). Thus, various profile data items can be grouped together, wherein each such
- 20
- group may be provided with corresponding access permissions and/or restrictions. For example, there may be a first group of data items that can be accessed with substantially all access privileges of the user. Individuals and/or designated agents having this access may include: parents (e.g., where the user is under the age of say, 15),
- 25
- children of elderly parents. Optionally, a second smaller group of profile data items may include, e.g., some financial information, social security number, and other user identifications, wherein individuals and/or designated agents having access to this second group may include a spouse and/or close family members.



Optionally, a third group of profile data items may include:  
professional and/or some personal information that would be useful  
for a designated corporate agent that is, e.g., subsidizing the use of the  
mobile station. Such a corporate agent may be, e.g., the user's  
5 employer. Accordingly, the user's employer may be allowed to view  
mobile station use records, as well as modify restrictions on the  
services that can be accessed via the mobile station (e.g., Internet  
transmission of full length movies or other pay per view services).  
Other grouping of profile data items are, of course, possible such as a  
10 fourth grouping of user profile information related to personal or  
professional commercial transactions that the user may desire to  
perform, e.g., buy/sell a car, bicycle, or pair of shoes, buy/sell tickets  
to a particular event (sports event or other entertainment), buy/sell  
travel accommodations. Note that the fourth group may be only  
15 viewed by pre-authorized or pre-qualified agents, such as those  
identified individually and/or aggregately by the user or a user  
designated agent (such as an agent for an electronic yellow pages  
enterprise, an Internet search service, and/or an Internet product  
discounter). Optionally, another grouping of profile data items may  
20 be for an organization to which the user is affiliated such as a  
professional organization (e.g., American Medical Association,  
American Bar Association, or other professional organization). There  
may other profile data groups for religious, personal, and/or political  
organization user affiliations with correspond access privileges and  
25 restrictions.

- (d) **data exposure processing:** E.g., for various inquiries for information  
about a user, the user may provide criteria about what information  
may be exposed. Thus, for an anonymous inquiry received due to,  
e.g., the location of the user, the user may provide criteria for  
30 exposing certain interests such as interests in cars, types of music, etc.

Note the processing here may be similar to that of the data privacy above, and in some embodiments may be substantially identical therewith. However, if sophisticated profile capabilities are accessible to mobile station users, inconsistencies can occur within such a profile wherein the user wishes to leave his/her profile groups unaltered, but still exercise additional control such as exclude all accesses from a particular person, and/or exclude all accesses for a particular period of time, and/or provide access to particular profile data items for a particular time period or when the user is in a particular geographical location and/or when the accessing agent is in a particular geographical location or relationship to the user's geographical location. Thus, in one embodiment, the data exposure processing contemplated here may be a more dynamic version of the data privacy processing above, wherein, e.g., user location, time periods, and/or accessing agent location may be taken into account. Additionally and/or alternatively, the data exposure processing contemplated here may function as a profile access supervisor or controller that can override (temporarily or until countermanding input is provided) more stable long term profile access criteria such as the profile data groups and their corresponding access privileges and/or restrictions described above.

Note that in one embodiment of the present invention, a network service provider or other authorized agent may provide predetermined groups of profile data together with corresponding access permissions/restrictions that allow the user to easily construct profile data groups (with their corresponding access permissions/restrictions) and assign individuals and/or categories of entities to such groups. Thus, the user may provide network input to create the first, second and fourth data profile groups described above. Subsequently, the user may be able to exclude all profile

access by a particular organization, individual or business without the user modifying the profile groupings.

It is important to note here that in the term "access" as used regarding profile data not only encompasses the discovery of such information network agents that may actively search user profiles for particular types of information, but also encompasses the active exposure of such profile data to selected enterprises, organizations, and/or individuals. In particular, a network service provider or other authorized agent may be granted permission to distribute portions of the user's profile to certain entities. For example, a user may request that his/her profile include information that he/she wishes to purchase a various brand names of expensive clothing, but only when these brands are on sale. Thus, such profile information may be actively distributed to selected businesses.

- 15 (e) **constraint checking and rule activation processing:** E.g., evaluating application specific conditions in a substantially uniform manner across a plurality of different application according to, e.g., data stored in a constraint database(s), a rule base(s), and/or a user profile database(s),
- 20 (f) **transaction processing:** for certain wireless applications transaction based user interactions are most appropriate wherein there is the ability to initiate, commit, and roll back or undo a series of data communications as one skilled in the art will understand. Moreover, it is desirable that such a transaction processing capability provide for
- 25 multilevel transactions wherein one instance of a transaction can be within another,
- (g) **data synchronization:** e.g., providing a duplicate copy of a collection of data from one point on a communications network to another point on the network,

- (h) **event or transaction logging:** e.g., for some wireless applications the interactions with users are sufficiently important to warrant storing a trace of such interactions,
- (i) **common interfaces:** e.g., substantially uniform interfaces between an embodiment of the wireless application platform of the present invention and both a plurality of wireless applications as well as users of such applications,
- (j) **wireless location request triggering mechanisms:** e.g., (i) for requesting the information related to users of nearby wireless mobiles when the requesting user is at a particular location or area (e.g., at a ski resort, walking through a downtown area), or at a particular time of day; or (ii) for requesting periodic locations of persons (e.g., employees, salespersons, friends, relatives, etc) or assets (e.g., a furniture shipment), or sensitive materials (e.g., toxic wastes being transported across country), or (iii) providing wireless advertising or purchasing incentives.

Moreover, an application platform according to the present invention may support such service functions as (a)-(j) immediately above via standard telephony and/or network functionality including WAP, BlueTooth, and other wireless (and wired) application protocols. It is important to note that the term WAP is being used generically to refer to any wireless Internet protocol, including HDML and any future wireless Internet protocols that may be developed. The following examples are provided of some competing technologies that for the purposes of the present description will be referred to generically as WAP. For instance, Web content may be delivered as existing HTML. Internet content may be provided wirelessly as proposed by Spyglass' Prism technology or i-mode which is popular in Japan. As a further example, Internet content can be processed through a template model that reads existing HTML content and fits the data to a template optimized for various types of wireless mobile stations such as the system proposed by Everypath.com. As another

example, the data content can be delivered to a Palm Pilot or other PDA or handheld device that uses a proprietary protocol. Thus it is an aspect of the present invention to provide an inventive wireless application platform wherein applications can be substantially implemented by providing application specific data which can be used to drive the application processing performed by, e.g., the above listed functions.

It is important to note that platform of the present invention is particularly useful for cost effectively and quickly making "complex" network services available to subscribers; e.g., network services that require far more additional network coordination and communication between various network components (of one or more different networks) than services such as voice and data communication, and various enhancements to these basic services. For example, for wireless location based services, at least the following network services and components must communicate appropriately for performing at least some of the following functions: (i) wireless signal measurements related to the target MS must be captured and routed to a wireless location entity for determining a location estimate of the target mobile station; (ii) a component such as a wireless location gateway, must determine what wireless location technology to activate to determine the target mobile station's location; moreover, such a determination is likely dependent upon the capabilities of the target mobile station, capabilities of wireless network (e.g., the wireless carrier with which the target mobile station is currently communicating) to support particular wireless location technologies, and/or the ability of the wireless carrier to communicate with particular wireless location service provider; (iii) billing for determining the location estimate must be determined; (iv) a location request may be received from various sources; (v) privacy and/or security issues must be resolved; (vi) location data representations may need to be resolved between a wireless location providing service and a location based application; (vii) a capability for iteratively frequently performing such a wireless location may be required, and appropriate network provisioning allocated thereto such as in tracking a mobile station; (viii) wireless locations may require a verification capability such as a callback mechanism

as described in International Patent Application PCT/US00/40989 titled  
“Geographically Constrained Network Services”, filed Sept. 25, 2000 by Goldberg and  
Dupray and having International Publication No. WO 02/003, this reference being  
fully incorporated herein by reference; (ix) the location based application’s output be  
5 may media rich in the sense that graphical and/or image representations may need to  
communicated to the user and/or to another network destination; thus, network  
congestion may occur due to increased network bandwidth required; (x) a wireless  
location based application may be only an intermediate step in enabling another  
application; e.g., in the International Patent Application by Goldberg and Dupray cited  
10 above, a wireless location verification application may be performed prior to a  
wireless network financial transaction such as a wireless gaming wager to assure that  
the subscriber is in a location that allows such, or a download of a geographically  
restricted software product (e.g., a software product that can only be downloaded  
and/or utilized in a particular geographical region or country such as the U.S. or  
15 Canada due to, for instance, national security concerns and/or patent possible or other  
legal violations on the use of the software outside of the particular area); (xi) location  
based games are popular in some areas, and such games may also utilize short  
messaging services (SMS); thus, coordination and communication between the game  
application, a wireless location service provider, and the SMS provider must be  
20 performed; (xii) it is generally perceived that location based advertising is viewed with  
distain by subscribers since such advertising has been not much more than a location  
based broadcast vehicle for advertising; accordingly, what is believed desired is an  
“intelligent” location based advertising capability such as is disclosed herein and in  
International Patent Application No. PCT/US01/17957 filed June 4, 2001 entitled “A  
25 Wireless Location Gateway And Applications Therefor” by Dupray incorporated  
herein fully by reference; however, such intelligence may likely require additional  
complexity such as accessing subscriber profiles, activating network triggering  
mechanisms or network daemons or intelligent subscriber network software agents to

determine when and/or where a subscriber request is satisfied such as a request for obtaining tickets to a local sporting event that is sold out.

It has been suggested that the most commercially viable location based services have yet to be determined, and that in order to determine such services, numerous location based applications will have to be developed and marketed to gain experience in what services subscribers will pay for and to provide subscribers with experience in using such services. However, due to the complexity of developing applications for such services, if a generic or uniform platform such as is provided by the present invention is not utilized, the overhead and financial risk in developing such services may be beyond the financial risk tolerance as well as the technical expertise of wireless carriers and/or third party network service developers to surmount. Various examples of complex network services have been developed and/or described in the relevant art. For example, U.S. Patent 5,742,905 by Peppe et. al. filed Sept. 19, 1994, titled "Personal Communications Internetworking" fully incorporated herein by reference discloses:

"a personal communications internetwork providing a network subscriber with the ability to remotely control the receipt and delivery of wireless and wireline voice and text messages. The network operates as an interface between various wireless and wireline networks, and also performs media translation, where necessary. The subscriber's message receipt and delivery options are maintained in a database which the subscriber may access by wireless or wireline communications to update the options programmed in the database. The subscriber may be provided with CallCommand service which provides real-time control of voice calls while using a wireless data terminal or PDA."

As a further example, International Patent Application PCT/IB00/01995 Jhanji having International Publication No. WO 144998 and titled "IMPROVED SYSTEMS FOR COMMUNICATING CURRENT AND FUTURE ACTIVITY INFORMATION AMONG MOBILE INTERNET USERS AND METHODS THEREFOR" is fully incorporated herein by reference, wherein this application discloses:

“there is provided a search facility wherein a user may search among all users and/or posted information (or at least users and/or information to which the searcher has access privilege) for postings or users based on some search criteria. Since substantially all user profiles and posted information are kept in the database subsystem,, such data is available to those, having the proper access privilege. By way of example, a certain user may perform a search among selected ones of her friends for those currently engaged in shopping activities or planning to go shopping. As another example, a certain user may perform a search to check oh the status, location, or activity pertaining to a specific other user. As another example, a given user may wish to search for anyone in the public who is interested in a particular activity, who may be in a particular location, or who may have a certain profile characteristic of interest. Since many of the items of information pertaining to user activities are time-sensitive, searches preferably take into account the time component whenever appropriate (e.g., for activity currently taking place or proposed in the future). Along with user profile and activity, the invention permits users to find one another based on location and time, as well as having a degree of control over the privacy of their user profile and posted information.”

However, it is believed that most commercially viable complex network services have yet to be developed, and the present invention is directed to both such novel new network services, and a method and system for rapidly providing such services to subscribers, wherein the applications providing such services use various combinations of, e.g., SMS, MS location services/applications, email services/applications, voice and data transmission services/applications, Internet access, Internet accessible applications, and/or voice over IP services/applications.

Moreover, note that the network services platform of the present invention may also be utilized to expedite providing other subscriber services, complex or otherwise. For example, “intelligent” electronic yellow page capabilities may require capabilities such as (xii) immediately above regardless of whether such capabilities include a location based component.



It is believed that there are two general types of wireless services that can be easily supported by the present invention: (i) services (denoted "called services" herein) where the wireless subscriber initiates an activation substantially by placing a telephony call for service activation (e.g., services similar to E911), and (ii) services (denoted "connection services" herein) that are activated by a subscriber navigating a previously established network (e.g., Internet) connection where the establishment of the network connection provides virtually no information about what subsequent network services that may be activated by the subscriber. Such called services may interface directly with an embodiment of the platform of the present invention, wherein the embodiment may be for a single wireless carrier or may provide such services for multiple carriers. Moreover, for connection services, such services may be of two types:

- (1) connection services that make use of the capabilities of an embodiment of the platform of the present invention; e.g., "platform aware" application for providing such a connection service might inspect a network (e.g., Internet) path by which an activation was received by a subscriber, wherein the inspection would determine whether there is a platform embodiment by which the platform aware application can communicate for receiving appropriate additional information such as subscriber location, type of mobile device, subscriber profile attributes (e.g., authorizations for billing a profile designated entity), and/or for transmitting information to the platform for billing for and/or logging the activated connection service (e.g., an electronic yellow pages subsidiary of a wireless carrier may be activated, via the Internet, by a merchant for advertising an eminent sale and the expense incurred is automatically incorporated into the merchant's bill with the carrier, or, e.g., providing a corporation with an integrated billing, auditing and employee wireless profile management system for telecommunications and Internet services wherein a platform embodiment acts as a common interface for both managing employee profiles for access to network

services, and billing the corporation for employee network accesses to billable network services whose enabling applications are “platform aware”; and

- 5 (2) connection services that do not make use of the capabilities of the platform of the present invention. However, even for these services the platform of the present invention may provide substantial benefits. It is believed that in many (if not most cases) wherein connection services are accessed via a platform of the present invention, that the entity providing the connection to the network (e.g., an Internet service provider) for such connection services will be “platform aware”.  
10 Accordingly, information from a subscriber’s profile can be requested and/or “pushed” to the network connection providing entity so that, e.g., this entity can prohibit access to certain network information, can push corporate specific information to an employee for incorporation in  
15 to the employee’s network connection device (e.g., MS) such as an updated preferred vendor list, a download of a new customer record management system, periodically automatically changing a corporate employee address book.

Note, that the functionality of (2) immediately above may be, of course,  
20 available to the “platform aware” applications as well.

Thus, it is an aspect of the platform of the present invention to provide for the distribution and use of subscriber or user profile information over a plurality of different types of communication networks (e.g., networks having different transmission characteristics such as network bandwidth, the data types that can be  
25 effectively presented to users, reliability or quality of service of network transmissions, transmission protocols and/or services provided). For example, networks that can be classified as different are: different wireless telephony networks (CDMA, TDMA, GSM), wireline telephony networks (PSTNs), the Internet or other packet switched networks (e.g., networks using WAP), wherein there is profile information provided  
30 for the communication capabilities of individual ones of the communication networks

and/or the services offered on individual ones of the communication networks, and, wherein the platform coordinates fulfillment of complex service requests that may require the fulfillment of a plurality of subordinate service requests on potentially different ones of these communication networks according to, e.g., information in a user profile that is accessed by the platform for controlling at least portions of the fulfillment of the complex service request.

Furthermore, it is a particular aspect of the platform of the present invention to enable easy implementation of wireless location related applications. For example, embodiments of the platform of the present invention have “plug and play” interfaces so that applications for fulfilling service requests need only identify to the platform their requirements and the platform coordinates the activation and routing of results from other applications operatively attached to the platform.

Examples of wireless location applications enabled by the present invention follow. Wireless applications related to intelligent advertising (e.g., personalized advertising driven by information disclosed by a subscriber or user) may be provided by an embodiment of the invention, wherein the user’s location is used in determining the advertising provided. Alternatively, wireless applications for providing games and gaming may also be provided by an embodiment of the inventive platform. Moreover, for gaming, the inventive platform may support wireless Internet gaming wherein the geographic location of a wireless player is taken into account for determining any legal restrictions that must be obeyed in order to conform with gaming laws where the user is located. Additional wireless services or applications expeditiously enabled by the present invention include: introductions of wireless users with likely or stated shared interests (possibly based on location proximity), labor management and tracking, asset management and tracking, and sightseeing. Other applications are provided in the Detailed Description hereinbelow.

It is a particular aspect of the present invention that for at least some wireless applications, a geographical proximity subsystem or engine is accessed for determining when the application invoking (or location monitored) user or a tracked asset is in proximity to a particular entity (e.g., a location, person, or moving object)

that the proximity engine outputs a message to the corresponding invoked application. Conversely, the proximity engine may be used for determining when two or more entities become further apart than some predetermined distance (e.g., hikers, or children from their home).

5           It is a further aspect of the present invention that a wireless services platform according to the invention provide such wireless applications to wireless users in an “always on” or “always accessible” capability much like broadcast television wherein the user has access to a predetermined number of wireless services/applications, and the user can selectively activate/deactivate such services/applications depending upon  
10 the user’s input. However, it is also an aspect of the present invention to go beyond the broadcast television paradigm in that: (i) a plurality of such applications can be concurrently active, and (ii) such applications can be activated/deactivated according to various criteria such as user location, time of day, proximity to/from a particular location or entity. Moreover, this “always accessible” capability may be presented at  
15 the user’s wireless mobile station via a graphical user interface such that a proactive intelligent collection of applications wherein such applications may function as, e.g., electronic agents or extensions of a user so that such an agent can, e.g., (i) alert the user of location based circumstances to which the user would not otherwise be aware, (ii) arrange or facilitate communications between users that are in proximity to one  
20 another when it is determined that such communication is likely desired by both parties wherein these users may have no a priori knowledge of one another and/or their common interests. Moreover, the present invention is intended to support “intelligent” wireless communication between a user and a plurality of different wireless applications via (at least in one embodiment) substantially the same wireless services  
25 platform wherein such applications may be, e.g., considered as intelligent agents of the user for providing the user with information about products, services, people, objects, and/or locations about which the user may have an interest but which the user has both insufficient knowledge, and an insufficient knowledge to prearrange the obtaining of such information. For example, a user may input user profile information to the  
30 wireless services platform indicating that the user should be alerted when any other

user that is presumed to be walking (or stationary), and is nearby (e.g., within 200 feet), and has a profile indicating that he/she is receptive to contact, and is interested in purchasing early Asian art. In particular, such alerts may be very useful if, e.g., a user is a seller of such art and is attending a well attended art auction or museum displaying Asian art. As another example, if a user is on an airplane, the user may be alerted to other users on the airplane wherein it may likely that communication between the two users would be a mutually beneficial based on the (personal or professional) profiles of the users.

Moreover, the present invention is novel in that it provides a user with a mobile station interface that allows the user to have a plurality of such intelligent location sensitive agents/applications active simultaneously wherein the user is wirelessly notified when any one or more of these agents/applications detect a condition or circumstance that may be of interest to the user. Thus, the user may have one or more business related agents/applications active (e.g., for contacting potential nearby buyers or sellers of products or services ), in combination with one or more personal needs related agents/applications (e.g., for meeting a possible nearby compatible mate, or someone interested in East European folk dancing, or for purchasing a nearby bicycle below a particular price), in combination with one or more agents/applications related to nearby entertainment. Moreover such agents/applications may be explicitly turned on or off by the user at any time (e.g., the user may manually request an immediate one time query of other users within a specified proximity), as well as the user may provide criteria for activating and deactivating such agents/applications according to time schedules, and/or the user's location. Thus, the user may request automatic deactivation of personal agents while at work, and activation of such agents when the user is detected as being away from work. Moreover, the present invention may offer a plurality generic agents/applications which the user can then customize. For example, a first sales representative for a particular company may request wireless downloads of current prices for a first collection of products or services while a second sales representative may request wireless downloads of current prices for a second different collection of

products or services. More generally, the present invention supports wireless synchronization between a corporate enterprise wide data repository and various corporate subentities such as subsidiaries, salespersons or other employees, wherein access to the data repository and wireless data synchronization with a particular view  
5 or subset of the data repository is dependent upon the subentities access permissions as provided by the corporation.

Additionally, the wireless platform may provide services so that applications/agents can perform data mining of various network accessible databases to provide verification of data of interest to a user. For example, a user that travels  
10 frequently may request that a wireless application perform data mining via, e.g., Internet search engines for currently available nearby movies, concerts, lectures, and special events whenever the user activates the application. As other examples, a user may request data mining be performed to determine information such as: the legal description or owner of a particular property given the property's address, or the  
15 average income of households within one mile of the user's location. As other examples, a user may request data mining to be performed for automatically entering information into the user's profile and/or validating information in his/her profile and another user's profile.

Additionally, it is an aspect of the present invention that requests for location  
20 information by a user and/or applications activated by the user are coordinated so that there is efficient use of wireless location network capabilities. For example, a first wireless application may be activated by a user for requesting information related to nearby users that have an interest in health products (e.g., the user may be an owner of a health food store). Additionally, the user may have another wireless  
25 agent/application active for requesting information about nearby individuals that appear to be compatible with the user. Accordingly, the frequency of receiving information on nearby users, and the sharing of results between the two active agents/applications can provide better utilization of network resources.

It is another aspect of the present invention that when a request for user  
30 information is received such as due to location based proximity query, there is a

sequence of steps and interactions between the requesting user and the queried user which can lead from substantial anonymity to (if desired by both parties) personal contact in a non-threatening and comfortable manner. In particular, as an intermediate step from substantial anonymity to possibly meeting face-to-face, it is an aspect of the present invention to provide an instant messaging type service between the requesting user and a queried user wherein the two users can converse without the identity of the other user being automatically provided by the network.

Further features and advantages of the present invention are provided by the figures and detailed description accompanying this invention summary.

#### 10 BRIEF DESCRIPTION OF THE DRAWINGS

Fig. 1 illustrates various perspectives of radio propagation opportunities which may be considered in addressing correlation with mobile to base station ranging.

Fig. 2 shows aspects of the two-ray radio propagation model and the effects of urban clutter.

15 Fig. 3 provides a typical example of how the statistical power budget is calculated in design of a Commercial Mobile Radio Service Provider network.

Fig. 4 illustrates an overall view of a wireless radio location network architecture, based on advanced intelligent network (AIN) principles.

Fig. 5 is a high level block diagram of an embodiment of the present invention for locating a mobile station (MS) within a radio coverage area for the present invention.

Fig. 6 is a high level block diagram of the location center 142.

Fig. 7 is a high level block diagram of the hypothesis evaluator for the location center.

25 Fig. 8 is a substantially comprehensive high level block diagram illustrating data and control flows between the components of (and/or accessed by) the location center/gateway 142, as well the functionality of these components.

Figs. 9A and 9B are a high level data structure diagram describing the fields of a location hypothesis object generated by the first order models 1224 of the location center.

5 Fig. 10 is a graphical illustration of the computation performed by the most likelihood estimator 1344 of the hypothesis evaluator.

Fig. 11 is a high level block diagram of the mobile base station (MBS).

Fig. 12 is a high level state transition diagram describing computational states the Mobile Base station enters during operation.

10 Fig. 13 is a high level diagram illustrating the data structural organization of the Mobile Base station capability for autonomously determining a most likely MBS location from a plurality of potentially conflicting MBS location estimating sources.

Fig. 14 illustrates the primary components of the signal processing subsystem.

Fig. 15 illustrates how automatic provisioning of mobile station information from multiple CMRS occurs.

15 Fig. 16 illustrates another embodiment of the location engine 139, wherein the context adjuster 1326 (denoted in this figure as "location hypothesis adjuster modules") includes a module (1436) that is capable of adjusting location hypotheses for reliability, and another module (1440) that is capable of adjusting location hypotheses for accuracy.

20 Fig. 17 illustrates the primary components of the signal processing subsystem.

Fig. 18 is a block diagram further illustrating the present invention as a wireless location gateway.

25 Fig. 19 is a block diagram of an electronic networked yellow pages for providing intelligent advertising services, wherein wireless location services may be utilized.

Fig. 20 is a high level block diagram illustrating the wireless application platform of the present invention.

Fig. 21 is a more detailed block diagram illustrating the wireless application platform of the present invention.



Fig. 22 is a high level flowchart of the operation of the wireless application platform of the present invention.

## DETAILED DESCRIPTION

### Detailed Description Introduction

5           When performing wireless location as described herein, substantial improvements in radio location can be achieved since CDMA and other advanced radio communication infrastructures can be used for enhancing radio location. For example, the capabilities of IS-41 and advanced intelligent network (AIN) already provide a coarse-granularity of wireless location, as is necessary to, for example,  
10           properly direct a terminating call to an MS. Such information, originally intended for call processing usage, can be re-used in conjunction with the wireless location processing described herein to provide wireless location in the large (i.e., to determine which country, state and city a particular MS is located), and wireless location in the small (i.e., which location, plus or minus a few hundred feet a given MS is located).

15           Fig. 4 is a high level diagram of one embodiment of a wireless radiolocation architecture for the present invention. Accordingly, this figure illustrates the interconnections between the components of a wireless cellular communication network, such as, a typical PCS network configuration and various components that are specific to the present invention. In particular, as one skilled in the art will  
20           understand, a typical wireless (PCS) network includes:

(a) a (large) plurality of wireless mobile stations (MSs) 140 for at least one of voice related communication, visual (e.g., text such as is provided by a short message service) related communication, and according to present invention, location related communication. Note that some of the MSs 140  
25           may include the electronics and corresponding software to detect and process signals from non-terrestrial transmission stations such as GPS and/or GLONASS satellites. Moreover, note that such non-terrestrial transmission stations can also be high attitude aircraft which, e.g., can

hover over a metropolitan area thereby facilitating wireless communications;

(b) a mobile switching center (MSC) 112;

(c) a plurality of wireless cell sites in a radio coverage area 120, wherein each

5 cell site includes an infrastructure base station such as those labeled 122 (or variations thereof such as 122A - 122D). In particular, the base stations 122 denote the standard high traffic, fixed location base stations used for voice and data communication with a plurality of MSs 140, and, according to the present invention, also used for communication of information  
10 related to locating such MSs 140. Additionally, note that the base stations labeled 152 are more directly related to wireless location enablement. For example, as described in greater detail hereinbelow, the base stations 152 may be low cost, low functionality transponders that are used primarily in communicating MS location related information to the location center 142  
15 (via base stations 122 and the MSC 112). Note that unless stated otherwise, the base stations 152 will be referred to hereinafter as location base station(s) 152 or simply LBS(s) 152;

(d) a public switched telephone network (PSTN) 124 (which may include signaling system links 106 having network control components such as: a  
20 service control point (SCP) 104 , one or more signaling transfer points (STPs) 110.

In addition, the present invention provides one or more location centers/gateways 142. Such gateways may be described at a high level as follows.

*Location Center/Gateway 142 Description*

25 A location center/gateway 142, (also be referred to as a location center/gateway, or simply gateway) , in response to a location request received at the location center, can request activation of one or more of a plurality of wireless location techniques in order to locate an MS 140.

Various embodiments are provided herein of the location center/gateway 142. In particular, Fig. 18 is block diagram illustrating another embodiment of the location center/gateway 142 of the present invention. Note that the wireless location gateway activation requests may be dependent upon, e.g.,

- 5 (a) a wireless network with which the MS 140 may be in contact, such a network may be:
  - (i) a commercial mobile radio network supporting telephony functionality,
  - (ii) a short messaging service or paging network;
  - 10 (iii) a wireless network of beacons for providing location related information such as GPS and LORAN C,
  - (iv) wireless carrier independent networks for performing wireless location such as the wireless location network provided by Times Three, Suite #220, Franklin Atrium, 3015 5th Avenue  
15 N.E., Calgary, AB T2A 6TB,
  - (v) a wireless broadcasting network for use in activating an MS 140 of, e.g., a stolen vehicle such as is provided by LoJack Corporation, 333 Elm Street, Dedham, MA 02026, and/or
  - (vi) a hybrid network including portions of wireless networks each  
20 network providing different types of signal measurements for performing wireless location);
- (b) the location signal measurement obtaining capabilities of the wireless network with which the MS may be in contact. For example, such a network may only support a network centric location technique;
- 25 (c) the functionality of the MS 140 such as: the type(s) of wireless signals which can be detected and processed by the MS such as:
  - (i) non-terrestrial signals such as GPS signals,
  - (ii) signals from wireless beaconing/broadcasting systems such as for LORAN C signals or stolen vehicle broadcast networks for  
30 activating an MS 140 attached to the stolen vehicle, or

(iii) wireless telephony protocols like CDMA, TDMA, and/or GSM,

(d) a likely location of the target MS 140. For example, if the target MS 140 is likely to be in Japan rather than the United States, then the location service provider contacted by the gateway 142 may be different from the location service provider if the MS is likely to be in the U.S.

Moreover, regarding the plurality of wireless location techniques (embodiments thereof also denoted herein as "location estimators") for which activation may be requested by the gateway, these techniques may be co-located with the gateway, accessible via a network including: (i) local area networks, and (ii) wide area networks such as a telephony (wired or wireless) network, the Internet or a cable network. The gateway 142 may supply to one or more of the location estimators, measurements of communications between the MS 140 and one or more networks for determining a location of the MS 140. Alternatively, instead of supplying such measurements (locally or remotely, and, via a network or otherwise), the gateway 142 may provide, with the location activation request, an identification of where the measurements may be obtained (e.g., one or more network addresses). In yet another alternative, such a gateway 142 may also send request(s) to the network(s) having such MS communication measurements to forward them to particular location estimators.

Note, that in performing these tasks, the gateway 142 may receive with a location request (or may retrieve in response thereto) information regarding the functionality of the target MS 140, e.g., as discussed above. Accordingly, such information may be used in selecting the location estimator to which an activation request is provided. Thus, the gateway 142 may be the intermediary between location requesting applications and the location estimators, thereby providing a simple, uniform application programming interface (API) for such applications substantially independently of the location estimators that are activated to fulfill such location requests. Moreover, the gateway 142 (or embodiments thereof) can substantially ease the burden on geolocation service providers by providing a substantially uniform method for obtaining target MS/network signal data for use in locating the target MS.

Thus, by interfacing to the gateway 142, a location service provider may substantially reduce the number and complexity of its data exchange interfaces with the wireless networks for obtaining target MS/network signal data. Similarly, the networks capturing such signal data may also reduce the complexity and number of their  
5 interfaces for providing such signal data to location service providers. Additionally, note that the gateway may also fulfill location requests wherein the location is for a stationary and/or wireline handset instead of a mobile station 140. Accordingly, the gateway 142 may request access to, e.g., phone location information stored in a carrier's database of premise provisioning equipment as one skilled in the art will  
10 understand.

In some embodiments of the gateway 142, it may also facilitate in the providing of certain location related services in addition to providing, e.g., MS 140 locations. In particular, one or more of the following location related services may be facilitated by the gateway 142 or may be made operative via the wireless location  
15 capabilities of the gateway 142. However, note that the following location related services can, in general, be provided without use of a gateway 142, albeit, e.g., in a likely more restricted context wherein not all available wireless location estimating techniques are utilized, and/or by multiplying the number of interfaces to geolocation service providers (e.g., distinct wireless location interfaces provided directly to each  
20 wireless location service provider utilized). Further note that at some of these applications are described in greater detail in later sections herein:

- (10.1) Routing instructions for directing a vehicle or person to get to a desired destination. Note, that there are various forms of utilizing MS location capabilities to determine an appropriate route, and related teachings are  
25 provided in copending U.S. patent application titled, "Wireless Location Using A Plurality of Commercial Network Infrastructures," by F. W. LeBlanc, Dupray and Karr filed Jan. 22, 1999 and having US Patent No. 6,236,365 issued May 22, 2001 which is fully incorporated herein by reference, and by the following two copending U.S. patent applications  
30 which are also incorporated herein by reference: (i) "Location Of A

Mobile Station” filed Nov. 24, 1999 having Application No. 09/194,367 whose inventors are Dupray and Karr, and (ii) “A Wireless Location System For Calibrating Multiple Location Estimators” filed October 21, 1998 having Application No. 09/176,587 whose inventor is Dupray. Additionally, other routing services may also be provided by the gateway 142 (or by service providers in cooperation with the gateway). For example, the gateway 142 may cooperate with an automated speech recognition interpretation and synthesis unit for providing substantially automated interactive communication with an MS 140 for providing spoken directions. Note that such directions may be provided in terms of street names and/or descriptions of the terrain (e.g., “the glass high rise on the left having pink tinted glass”).

(10.2) Advertising may be directed to an MS 140 according to its location. In at least some studies it appears that MS 140 users do not respond well to unsolicited wireless advertisement whether location based or otherwise. However, in response to certain user queries for locally available merchandise, certain advertisements may be viewed in a more friendly light. Thus, by allowing an MS user to contact, e.g., a wireless advertising portal by voice or via wireless Internet, and describe certain merchandise desired (e.g., via interacting with an automated speech interaction unit) the user may be able to describe and receive (at his/her MS 140) visual displays of merchandise that may satisfy such a user’s request. For example, an MS user may provide a spoken request such as: “I need a shirt, who has specials near here?”.

(10.3) Applications that combine routing with safety for assisting MS users with requests such as “How do I get back to the hotel safely?”;

(10.4) Applications that combine routing with sight seeing guided tour where routing is interactive and depending on feedback from users regarding, e.g., user interests;

- (10.5) Applications using Internet picture capture with real time voice capture and MS location (e.g., sightseeing, security, and law enforcement),
- (10.6) Intelligent transportation (e.g., voice commanded vehicles)
- (10.7) Applications that monitor whether or not a person or object (e.g., a vehicle) is within a predetermined boundary. Note, that such as application may automatically provide speech output to the MS user (or other authorized user) when the person or object is beyond the predetermined boundary;
- (10.8) Applications that route to an event and automatically determine parking availability and where to park;
- (10.9) Traffic/weather condition routing

Further note that various architectures for the location center/location gateway are within the scope of the invention including a distributed architecture wherein in addition to the FOMs being possibly remotely accessed (e.g., via a communications network such as the Internet), the gateway itself may be distributed throughout one or more communication networks. Thus, a location request received at a first location gateway portion may be routed to a second location gateway portion (e.g., via the Internet). Such a distributed gateway may be considered a “meta-gateway” and in fact such gateway portions may be fully functioning gateways in their own right. Thus, such routing therebetween may be due to contractual arrangements between the two gateways (each fulfilling location requests for a different network, wireless carrier, and/or geographical region). For example, for locating a stolen vehicle, it is not uncommon for the stolen vehicle to be transported rapidly beyond the coverage area of a local or regional wireless vehicle locating service. Moreover, a given location gateway may provide location information for only certain areas corresponding, e.g., to contractual arrangements with the wireless carriers with which the location gateway is affiliated. Thus, a first location gateway may provide vehicle locations for a first collection of one or more wireless networks, and a second location gateway may provide vehicle locations for a second collection of one or more wireless networks. Accordingly, for an MS 140 built into a vehicle which can be detected by one or more

wireless networks (or portions thereof) in each of the first and second collections, then if the vehicle is stolen, the first gateway may be initially contacted for determining whether the vehicle can be located via communications with the first collection of one or more wireless networks, and if the vehicle can not be located, the first gateway may  
5 provide a location request to the second gateway for thereby locating the stolen vehicle via wireless communications with one or more wireless networks of the second collection. Furthermore, the first gateway may provide location requests for the stolen vehicle to other location gateways.

The present invention provides the following additional components:

- 10 (11.1) one or more mobile base stations 148 (MBS) which are optional, for physically traveling toward the target MS 140 or tracking the target MS;
- (11.2) a plurality of location base stations 152 (LBS) which are optional, distributed within the radio coverage areas 120, each LBS 152 having a  
15 relatively small MS 140 detection area 154. Note that such LBSs 152 may also support Internet and/or TCP/IP transmissions for transmitting visual location related information (e.g., graphical, or pictorial) related to an MS location request.

Since location base stations 152 can be located on, e.g., each floor of a multi-  
20 story building, the wireless location technology described herein can be used to perform location in terms of height as well as by latitude and longitude.

In operation, an MS 140 may utilize one or more of the wireless technologies, CDMA, TDMA, AMPS, NAMPS or GSM for wireless communication with: (a) one or more infrastructure base stations 122, (b) mobile base station(s) 148, or (c) an LBS  
25 152. Additionally, note that in some embodiments of the invention, there may be MS to MS communication.

Referring to Fig. 4 again, additional detail is provided of typical base station coverage areas, sectorization, and high level components within a radio coverage area 120, including the MSC 112. Three exemplary base stations (BSs) are 122A, 122B  
30 and 122C, each of which radiate referencing signals within their area of coverage 169



to facilitate mobile station (MS) 140 radio frequency connectivity, and various timing and synchronization functions. Note that some base stations may contain no sectors 130 (e.g. 122E), thus radiating and receiving signals in a 360 degree omnidirectional coverage area pattern, or the base station may contain "smart antennas" which have specialized coverage area patterns. However, the generally most frequent base stations 122 have three sector 130 coverage area patterns. For example, base station 122A includes sectors 130, additionally labeled a, b and c. Accordingly, each of the sectors 130 radiate and receive signals in an approximate 120 degree arc, from an overhead view. As one skilled in the art will understand, actual base station coverage areas 169 (stylistically represented by hexagons about the base stations 122) generally are designed to overlap to some extent, thus ensuring seamless coverage in a geographical area. Control electronics within each base station 122 are used to communicate with a mobile stations 140. Information regarding the coverage area for each sector 130, such as its range, area, and "holes" or areas of no coverage (within the radio coverage area 120), may be known and used by the location center 142 to facilitate location determination. Further, during communication with a mobile station 140, the identification of each base station 122 communicating with the MS 140 as well, as any sector identification information, may be known and provided to the location center 142.

In the case of the base station types 122, 148, and 152 communicating location information, a base station or mobility controller 174 (BSC) controls, processes and provides an interface between originating and terminating telephone calls from/to mobile station (MS) 140, and the mobile switch center (MSC) 112. The MSC 122, on-the-other-hand, performs various administration functions such as mobile station 140 registration, authentication and the relaying of various system parameters, as one skilled in the art will understand.

The base stations 122 may be coupled by various transport facilities 176 such as leased lines, frame relay, T-Carrier links, optical fiber links or by microwave communication links.

When an MS 140 is powered on and in the idle state, it constantly monitors the pilot signal transmissions from each of the base stations 122 located at nearby cell sites. Since base station/sector coverage areas may often overlap, such overlapping enables an MS 140 to detect, and, in the case of certain wireless technologies, communicate simultaneously along both the forward and reverse paths, with multiple base stations 122 and/or sectors 130. In Fig. 4, the constantly radiating pilot signals from base station sectors 130, such as sectors a, b and c of BS 122A, are detectable by MSs 140 within the coverage area 169 for BS 122A. That is, the mobile stations 140 scan for pilot channels, corresponding to a given base station/sector identifiers (IDs), for determining in which coverage area 169 (i.e., cell) it is contained. This is performed by comparing signal strengths of pilot signals transmitted from these particular cell-sites.

The mobile station 140 then initiates a registration request with the MSC 112, via the base station controller 174. The MSC 112 determines whether or not the mobile station 140 is allowed to proceed with the registration process (except, e.g., in the case of a 911 call, wherein no registration process is required). Once any required registration is complete, calls may be originated from the mobile station 140 or calls or short message service messages can be received from the network. Note that the MSC 112 communicates as appropriate, with a class 4/5 wireline telephony circuit switch or other central offices, connected to the PSTN 124 network. Such central offices connect to wireline terminals, such as telephones, or any communication device compatible with a wireline. The PSTN 124 may also provide connections to long distance networks and other networks.

The MSC 112 may also utilize IS/41 data circuits or trunks connecting to signal transfer point 110, which in turn connects to a service control point 104, via Signaling System #7 (SS7) signaling links (e.g., trunks) for intelligent call processing, as one skilled in the art will understand. In the case of wireless AIN services such links are used for call routing instructions of calls interacting with the MSC 112 or any switch capable of providing service switching point functions, and the public switched

telephone network (PSTN) 124, with possible termination back to the wireless network.

Referring still to Fig. 4, the location center/gateway (LC) 142 interfaces with the MSC 112 either via dedicated transport facilities 178, using, e.g., any number of LAN/WAN technologies, such as Ethernet, fast Ethernet, frame relay, virtual private networks, etc., or via the PSTN 124. The gateway 142 may receive autonomous (e.g., unsolicited) command/response messages regarding, for example: (a) the state of the wireless network of each commercial radio service provider utilizing the LC 142 for wireless location services, (b) MS 140 and BS 122 radio frequency (RF) measurements, (c) communications with any MBSs 148, and (d) location applications requesting MS locations using the location center/gateway 142. Conversely, the LC 142 may provide data and control information to each of the above components in (a) - (d). Additionally, the LC 142 may provide location information to an MS 140, via a BS 122. Moreover, in the case of the use of a mobile base station (MBS) 148, several communications paths may exist with the LC 142.

The MBS 148 may act as a low cost, partially-functional, moving base station, and is, in one embodiment, situated in a vehicle (e.g., land, water or aircraft) where an operator may engage in MS 140 searching and tracking activities. In providing these activities using CDMA, the MBS 148 provides a forward link pilot channel for a target MS 140, and subsequently receives unique BS pilot strength measurements from the MS 140. The MBS 148 also includes a mobile station 140 for data communication with the gateway 142, via a BS 122. In particular, such data communication includes telemetering at least the geographic position (or estimates thereof) of the MBS 148, various RF measurements related to signals received from the target MS 140, and in some embodiments, MBS 148 estimates of the location of the target MS 140. In some embodiments, the MBS 148 may utilize multiple-beam fixed antenna array elements and/or a moveable narrow beam antenna, such as a microwave dish 182. The antennas for such embodiments may have a known orientation in order to further deduce a radio location of the target MS 140 with respect to an estimated current location of the MBS 148. As will be described in more detail herein below, the MBS 148 may further

contain a satellite (e.g., global positioning system (GPS)) receiver (or other receiver for non-terrestrial wireless signals) for determining the location of the MBS 148 and/or providing wireless location assistance a target MS 140, e.g., providing GPS information to the MS to assist the MS in determining its location. Additionally, the MBS 148 may include distance sensors, dead-reckoning electronics, as well as an on-board computing system and display devices for locating both the MBS 148 itself as well as tracking and locating the target MS 140. The computing and display provides a means for communicating the position of the target MS 140 on a map display to an operator of the MBS 148. It is important to note that in one embodiment, an MBS 148 may determine its location substantially independent of the communications network(s) with which the MBS communicates.

Each location base station (LBS) 152 is a low cost location device. In some embodiments, to provide such LBS's cost effectively, each LBS 152 only partially or minimally supports the air-interface standards of the one or more wireless technologies used in communicating with both the BSs 122 and the MSs 140. Each LBS 152, when put in service, is placed at a fixed location, such as at a traffic signal, lamp post, etc., wherein the location of the LBS may be determined as accurately as, for example, the accuracy of the locations of the infrastructure BSs 122. Assuming the wireless technology, CDMA, is used, each BS 122 uses a time offset of the pilot PN sequence to identify a forward CDMA pilot channel. In one embodiment, each LBS 152 emits a unique, time-offset pilot PN sequence channel in accordance with the CDMA standard in the RF spectrum designated for BSs 122, such that the channel does not interfere with neighboring BSs 122 cell site channels, and does not interfere with neighboring LBSs 152. Each LBS 152 may also contain multiple wireless receivers in order to monitor transmissions from a target MS 140. Additionally, each LBS 152 contains mobile station 140 electronics, thereby allowing the LBS to both be controlled by, e.g., the gateway 142 or the wireless carrier(s) for the LBS, and to transmit information to, e.g., the gateway 142 (via, e.g., at least one neighboring BS 122), or to another wireless location service provider such as one providing one or more FOMs.

As mentioned above, when the location of a particular target MS 140 is desired, the gateway 142 may request location information about the target MS 140 from, for instance, one or more activated LBSs 152 in a geographical area of interest. Accordingly, whenever the target MS 140 is in an LBS coverage area, or is suspected of being in the coverage area, either upon command from the gateway 142 (or other location service provider), or in a substantially continuous (or periodic) fashion, the LBS's pilot channel appears to the target MS 140 as a potential neighboring base station channel, and consequently, is placed, for example, in the CDMA neighboring set, or the CDMA remaining set of the target MS 140 (as one familiar with the CDMA standards will understand).

During the normal CDMA pilot search sequence of the mobile station initialization state (in the target MS), the target MS 140 will, if within range of such an activated LBS 152, detect the LBS pilot presence during the CDMA pilot channel acquisition substate. Consequently, the target MS 140 performs RF measurements on the signal from each detected LBS 152. Similarly, an activated LBS 152 can perform RF measurements on the wireless signals from the target MS 140. Accordingly, each LBS 152 detecting the target MS 140 may subsequently telemeter back to the LC 142 measurement results related to signals from/to the target MS 140. Moreover, upon command, the target MS 140 may telemeter back to the gateway 142 its own measurements of the detected LBSs 152, and consequently, this new location information, in conjunction with location related information received from the BSs 122, can be used to locate the target MS 140.

It should be noted that an LBS 152 will normally deny hand-off requests, since typically the LBS does not require the added complexity of handling voice or traffic bearer channels, although economics and peak traffic load conditions may dictate preference here. Note that GPS timing information, needed by any CDMA base station, is either achieved via a the inclusion of a local GPS receiver or via a telemetry process from a neighboring conventional BS 122, which contains a GPS receiver and timing information. Since energy requirements are minimal in such an LBS 152, (rechargeable) batteries or solar cells may be used to power the LBSs. Further, no

expensive terrestrial transport link is typically required since two-way communication is provided by an included MS 140 (or an electronic variation thereof) within each LBS. Thus, LBSs 152 may be placed in numerous locations, such as:

- 5 (a) in dense urban canyon areas (e.g., where signal reception may be poor and/or very noisy);
- (b) in remote areas (e.g., hiking, camping and skiing areas);
- (c) along highways (e.g., for emergency as well as monitoring traffic flow), and their rest stations; or
- 10 (d) in general, wherever more location precision is required than is obtainable using other wireless infrastructure network components.

#### Location Center - Network Elements API Description

A location application programming interface 136 (Fig. 4), denoted L-API, is may be provided between the location center/gateway 142 (LC) and the mobile switch center (MSC) network element type, in order to send and receive various control, signals and data messages. The L-API may be implemented using a preferably high-capacity physical layer communications interface, such as IEEE standard 802.3 (10 baseT Ethernet), although other physical layer interfaces could be used, such as fiber optic ATM, frame relay, etc. At least two forms of L-API implementation are possible. In a first case, the signal control and data messages are provided using the MSC 112 vendor's native operations messages inherent in the product offering, without any special modifications. In a second case, the L-API includes a full suite of commands and messaging content specifically optimized for wireless location purposes, which may require some, although minor development on the part of an MSC vendor.

#### 25 Signal Processor Description

Referring to Fig. 17, a signal processing subsystem (labeled 1220 in other figures) may be provided (or accessed) by the gateway 142. Such a signal processing subsystem may: (a) receive control messages and signal measurements from one or more wireless service provider networks, and (b) transmit appropriate control

messages to such wireless networks via the location applications programming interface 136 referenced earlier, for wireless location purposes. The signal processing subsystem 1220 additionally provides various signal identification, conditioning and pre-processing functions, including buffering, signal type classification, signal  
5 filtering, message control and routing functions to the location estimating modules or FOMs .

There can be several combinations of Delay Spread/Signal Strength sets of measurements made available to the signal processing subsystem 1220. In some cases a mobile station 140 (Fig. 1) may be able to detect up to three or four pilot channels  
10 representing three to four base stations, or as few as one pilot channel, depending upon the environment and wireless network configuration. Similarly, possibly more than one BS 122 can detect a mobile station 140 transmitter signal, and the fact that multiple CMRS' base station equipment commonly will overlap coverage areas.

For each mobile station 140 or BS 122 transmitted signal that is detected by a  
15 receiver group at a base or mobile station, respectively, multiple delayed signals, or "fingers" may be detected (e.g., in CDMA) and tracked resulting from multipath radio propagation conditions from a given transmitter. In typical spread spectrum diversity CDMA receiver design, the "first" finger represents the most direct, or least delayed multipath signal. Second or possibly third or fourth fingers may also be detected and  
20 tracked, assuming the detecting base station and/or mobile station 140 contains a sufficient number of data receivers for doing so. The signal processing subsystem may utilize various wireless signal measurements of transmissions between a target mobile station 140 and a network of base stations 122, 152 and/or 148. Such measurements can be important in effectively estimating the location of mobile stations 140 in that it  
25 is well known that measurements of wireless signal propagation characteristics, such as signal strength (e.g., RSSI), time delay, angle of arrival, and any number other measurements, can individually lead to gross errors in MS 140 location estimates.

Accordingly, one aspect of the present invention is directed to utilizing a larger number of wireless signal measurements, and utilizing a plurality of MS 140  
30 estimation techniques to compensate for location estimation errors generated by some

such techniques. For example, due to the large capital outlay costs associated with providing three or more overlapping base station coverage signals in every possible location, most practical digital PCS deployments result in fewer than three base station pilot channels being reportable in the majority of location areas, thus resulting in a larger, more amorphous location estimates by terrestrial triangulation systems. Thus, by utilizing wireless signal measurements from a variety of sources substantially simultaneously and/or "greedily" (i.e., use whatever signal measurements can be obtained from any of the signal sources as they are obtained), additional location enhancements can be obtained. For example, by enhancing a mobile station T40 with electronics for detecting satellite transmissions (as done with mobile base stations 148 and which also can be viewed as such an enhanced mobile station 140) additional location related signals maybe obtained from:

- (a) the GPS satellite system,
- (b) the Global Navigation Satellite System (GLONASS) satellite system, a Russian counterpart to the U.S. GPS system, and/or
- (c) the numerous low earth orbit satellite systems (LEOs) and medium earth orbit satellite systems (MEOs) such as the IRIDIUM system being developed by Motorola Corp., the GLOBALSTAR system by Loral and Qualcomm, and the ICO satellite system by ICO Global Communications.

Thus, by combining even insufficient wireless location measurements from different wireless communication systems, accurate location of an MS 140 is possible. For example, by if only two GPS satellites are detectable, but there is an additional reliable wireless signal measurement from, e.g., a terrestrial base station 122, then by triangulating using wireless signal measurements derived from transmissions from each of these three sources, a potentially reliable and accurate MS location can be obtained.

Moreover, the transmissions from the MS 140 used for determining the MS's location need not be transmitted to terrestrial base stations (e.g., 122). It is within the scope of the present invention that a target MS 140 may transmit location related information to satellites as well. For example, if a target MS 140 detects two GPS



satellite transmissions and is able to subsequently transmit the GPS signal measurements (e.g., timing measurements) to an additional satellite capable of determining additional MS location measurements according to the signals received, then by performing a triangulation process at the location center/gateway 142 (which  
5 may be co-located with the additional satellite, or at a remote terrestrial site), a potentially reliable and accurate MS location can be obtained. Accordingly, the present invention is capable of resolving wireless location ambiguities due to a lack of location related information of one type by utilizing supplemental location related information of a different type. Note that by “type” as used here it is intended to be  
10 interpreted broadly as, e.g.,

- (a) a data type of location information, and/or
- (b) communications from a particular commercial wireless system as opposed to an alternative system, each such system having distinct groups of known or registered MS users.

15 Moreover, it can be that different FOMs are provided for at least some wireless location computational models utilizing different types of location related information. For example, in certain contexts wireless networks based on different wireless signaling technologies may be used to locate an MS 140 during the time period of a single emergency call such as E911. Moreover, in other contexts it may be possible  
20 for the target MS 140 to use one or more of a plurality of wireless communication networks, possibly based on different wireless communication technologies, depending on availability the of technology in the coverage area. In particular, since so called “dual mode” or “tri-mode” mobile stations 140 are available, wherein such mobile stations are capable of wireless communication in a plurality of wireless  
25 communication technologies, such as digital (e.g., CDMA, and/or TDMA) as well as analog or AMP/NAMPS, such mobile stations may utilize a first (likely a default) wireless communication technology whenever possible, but switch to another wireless communication technology when, e.g., coverage of the first wireless technology becomes poor. Moreover, such different technologies are typically provided by  
30 different wireless networks (wherein the term “network” is understood to include a

network of communication supporting nodes geographically spaced apart that provide a communications infrastructure having access to information regarding subscribers to the network prior to a request to access the network by the subscribers). Accordingly, the present invention may include (or access) FOMs for providing mobile station  
5 location estimates wherein the target MS 140 communicates with various networks using different wireless communication technologies. Moreover, such FOMs may be activated according to the wireless signal measurements received from various wireless networks and/or wireless technologies supported by a target MS 140 and to which there is a capability of communicating measurements of such varied wireless  
10 signals to the FOM(s). Thus, in one embodiment of the present invention, there may be a triangulation (or trilateration) based FOM for each of CDMA, TDMA and AMP/NAMPS which may be singly, serially, or concurrently for obtaining a particular location of an MS 140 at a particular time (e.g., for an E911 call). Thus, when locating a target MS 140, the MS may, if there is overlapping coverage of two wireless  
15 communication technologies and the MS supports communications with both, repeatedly switch back and forth between the two thereby providing additional wireless signal measurements for use in locating the target MS 140.

In one embodiment of the present invention, wherein multiple FOMs may be activated substantially simultaneously (or alternatively, wherever appropriate input is  
20 received that allow particular FOMs to be activated). Note that at least some of the FOMs may provide "inverse" estimates of where a target MS 140 is not instead of where it is. Such inverse analysis can be very useful in combination with location estimates indicating where the target MS is in that the accuracy of a resulting MS location estimate may be substantially decreased in size when such inverse estimates  
25 are utilized to rule out areas that otherwise appear to be likely possibilities for containing the target MS 140. Note that one embodiment of a FOM that can provide such reverse analysis is a location computational model that generates target MS location estimates based on archived knowledge of base station coverage areas (such an archive being the result of, e.g., the compilation a RF coverage database - either via  
30 RF coverage area simulations or field tests). In particular, such a model may provide

target MS location inverse estimates having a high confidence or likelihood that that the target MS 140 is not in an area since either a base station 122 (or 152) can not detect the target MS 140, or the target MS can not detect a particular base station. Accordingly, the confidences or likelihoods on such estimates may be used by  
5 diminishing a likelihood that the target MS is in an area for the estimate, or alternatively the confidence or likelihood of all areas of interest outside of the estimate can increased.

Note that in some embodiments of the present invention, both measurements of forward wireless signals to a target MS 140, and measurements of reverse wireless  
10 signals transmitted from the target MS to a base station can be utilized by various FOMs. In some embodiments, the received relative signal strength ( $RRSS_{BS}$ ) of detected nearby base station transmitter signals along the forward link to the target mobile station can be more readily used by the location estimate modules (FOMs) since the transmission power of the base stations 122 typically changes little during a  
15 communication with a mobile station. However, the relative signal strength ( $RRSS_{MS}$ ) of target mobile station transmissions received by the base stations on the reverse link may require more adjustment prior to location estimate model use, since the mobile station transmitter power level changes nearly continuously.

#### LOCATION CENTER HIGH LEVEL FUNCTIONALITY

20 At a very high level the location center/gateway 142 computes (or requests computation of) location estimates for a wireless mobile station 140 by performing at least some of the following steps:  
(23.0) receiving an MS location request;  
(23.1) receiving measurements of signal transmission characteristics of  
25 communications communicated between the target MS 140 and one or more wireless infrastructure base stations 122. Note, this step may only be performed if the gateway provides such measurements to a FOM (e.g., a FOM co-located therewith);  
(23.2) filtering the received signal transmission characteristics (by a signal processing subsystem 1220 illustrated in, e.g., Figs. 5 and 30) as needed so that target MS location

data can be generated that is uniform and consistent with location data generated from other target MSs 140. In particular, such uniformity and consistency is both in terms of data structures and interpretation of signal characteristic values provided by the MS location data, as will be described hereinbelow. Note, this step may also only be performed if the gateway provides such measurements to a FOM. Otherwise, such FOM is likely to perform such filtering;

(23.3) inputting the generated target MS location data to one or more MS location estimating models (FOMs, labeled collectively as 1224 in Fig. 5), so that each such FOM may use the input target MS location data for generating a "location hypothesis" providing an estimate of the location of the target MS 140. Note, this step may also only be performed if the gateway provides such measurements to a FOM;

(23.4) receiving the resulting location hypotheses from the activated FOMs, and providing the generated location hypotheses to an hypothesis evaluation module (denoted the hypothesis evaluator 1228 in Fig. 5) for:

(a) (optionally) adjusting the target MS location estimates of the generated location hypotheses and/or adjusting confidence values of the location hypotheses, wherein for each location hypothesis, its confidence value indicates the confidence or likelihood that the target MS is located in the location estimate of the location hypothesis. Moreover, note that such adjusting uses archival information related to the accuracy and/or reliability of previously generated location hypotheses;

(b) (optionally) evaluating the location hypotheses according to various heuristics related to, for example, the radio coverage area 120 terrain, the laws of physics, characteristics of likely movement of the target MS 140; and

(c) (necessarily) determining a most likely location area for the target MS 140, wherein the measurement of confidence associated with each input MS location area estimate may be used for determining a "most likely location area"; and

(23.5) outputting a most likely target MS location estimate to one or more applications 146 (Fig. 5) requesting an estimate of the location of the target MS 140.

Location Hypothesis Data Representation

In order to describe how the steps (23.1) through (23.5) are performed in the sections below, some introductory remarks related to the data denoted above as location hypotheses will be helpful. Additionally, it will also be helpful to provide introductory remarks related to historical location data and the data base management programs associated therewith.

For each target MS location estimate generated and utilized by the present invention, the location estimate is provided in a data structure (or object class) denoted as a "location hypothesis" (illustrated in Table LH-1).

Brief descriptions of the data fields for a location hypothesis is provided in the

Table LH-1.

Table LH-1

FOM_ID	First order model ID (providing this Location Hypothesis); note, since it is possible for location hypotheses to be generated by other than the FOMs 1224, in general, this field identifies the module that generated this location hypothesis.
MS_ID	The identification of the target MS 140 to this location hypothesis applies.
pt_est	The most likely location point estimate of the target MS 140.
valid_pt	Boolean indicating the validity of "pt_est".
area_est	Location Area Estimate of the target MS 140 provided by the FOM. This area estimate will be used whenever "image_area" below is NULL.
valid_area	Boolean indicating the validity of "area_est" (one of "pt_est" and "area_est" must be valid).
adjust	Boolean (true if adjustments to the fields of this location hypothesis are to be performed in the Context adjuster Module).

pt_covering	Reference to a substantially minimal area (e.g., mesh cell) covering of "pt_est". Note, since this MS 140 may be substantially on a cell boundary, this covering may, in some cases, include more than one cell.
image_area	Reference to a substantially minimal area (e.g., mesh cell) covering of "pt_covering" (see detailed description of the function, "confidence_adjuster"). Note that if this field is not NULL, then this is the target MS location estimate used by the location center 142 instead of "area_est".
extrapolation_area	Reference to (if non-NULL) an extrapolated MS target estimate area provided by the location extrapolator submodule 1432 of the hypothesis analyzer 1332. That is, this field, if non-NULL, is an extrapolation of the "image_area" field if it exists, otherwise this field is an extrapolation of the "area_est" field. Note other extrapolation fields may also be provided depending on the embodiment of the present invention, such as an extrapolation of the "pt_covering".
Confidence	In one embodiment, this is a probability indicating a likelihood that the target MS 140 is in (or out) of a particular area. If "image_area" exists, then this is a measure of the likelihood that the target MS 140 is within the area represented by "image_area", or if "image_area" has not been computed (e.g., "adjust" is FALSE), then "area_est" must be valid and this is a measure of the likelihood that the target MS 140 is within the area represented by "area_est". Other embodiments, are also within the scope of the present invention that are not probabilities; e.g., translations and/or expansions of the [0, 1] probability range as one skilled in the art will understand.
Original_Timestamp	Date and time that the location signature cluster (defined hereinbelow) for this location

	hypothesis was received by the signal processing subsystem 1220.
Active_Timestamp	Run-time field providing the time to which this location hypothesis has had its MS location estimate(s) extrapolated (in the location extrapolator 1432 of the hypothesis analyzer 1332). Note that this field is initialized with the value from the "Original_Timestamp" field.
Processing Tags and environmental categorizations	For indicating particular types of environmental classifications not readily determined by the "Original_Timestamp" field (e.g., weather, traffic), and restrictions on location hypothesis processing.
loc_sig_cluster	Provides access to the collection of location signature signal characteristics derived from communications between the target MS 140 and the base station(s) detected by this MS (discussed in detail hereinbelow); in particular, the location data accessed here is provided to the first order models by the signal processing subsystem 1220; i.e., access to the "loc sigs" (received at "timestamp" regarding the location of the target MS)
descriptor	Original descriptor (from the First order model indicating why/how the Location Area Estimate and Confidence Value were determined).

As can be seen in the Table LH-1, each location hypothesis data structure includes at least one measurement, denoted hereinafter as a confidence value (or simply confidence), that is a measurement of the perceived likelihood that an MS location estimate in the location hypothesis is an accurate location estimate of the target MS 140. Since, in some embodiments of the invention, such confidence values are an important aspect, much of the description and use of such confidence values are described below; however, a brief description is provided here.

In one embodiment, each confidence value is a probability indicative of a likeliness that the target MS 140 resides within an geographic area represented by the hypothesis to which the confidence value applies. Accordingly, each such confidence value is in the range [0, 1]. Moreover, for clarity of discussion, it is assumed that unless stated otherwise that the probabilistic definition provided here is to be used when confidence values are discussed.

Note, however, other definitions of confidence values are within the scope of the present invention that may be more general than probabilities, and/or that have different ranges other than [0, 1]. For example, one such alternative is that each such confidence value is in the range -1.0 to 1.0, wherein the larger the value, the greater the perceived likelihood that the target MS 140 is in (or at) a corresponding MS location estimate of the location hypothesis to which the confidence value applies. As an aside, note that a location hypothesis may have more than one MS location estimate (as will be discussed in detail below) and the confidence value will typically only correspond or apply to one of the MS location estimates in the location hypothesis. Further, values for the confidence value field may be interpreted as: (a) -1.0 means that the target MS 140 is NOT in such a corresponding MS area estimate of the location hypothesis area, (b) 0 means that it is unknown as to the likelihood of whether the MS 140 in the corresponding MS area estimate, and (c) +1.0 means that the MS 140 is perceived to positively be in the corresponding MS area estimate.

Additionally, in utilizing location hypotheses in, for example, the location evaluator 1228 as in (23.4) above, it is important to keep in mind that for confidences,  $cf_1$  and  $cf_2$ , if  $cf_1 \leq cf_2$ , then for a location hypotheses  $H_1$  and  $H_2$  having  $cf_1$  and  $cf_2$ , respectively, the target MS 140 is expected to more likely reside in a target MS estimate of  $H_2$  than a target MS estimate of  $H_1$ . Moreover, if an area, A, is such that it is included in a plurality of location hypothesis target MS estimates, then a confidence score,  $CS_A$ , can be assigned



to A, wherein the confidence score for such an area is a function of the confidences for all the location hypotheses whose (most pertinent) target MS location estimates contain A. That is, in order to determine a most likely target MS location area estimate for outputting from the location center/gateway 142, a confidence score is determined for areas within the location center/gateway service area.

#### Coverage Area: Area Types And Their Determination

The notion of "area type" as related to wireless signal transmission characteristics has been used in many investigations of radio signal transmission characteristics. Some investigators, when investigating such signal characteristics of areas have used somewhat naive area classifications such as urban, suburban, rural, etc. However, it is desirable for the purposes of the present invention to have a more operational definition of area types that is more closely associated with wireless signal transmission behaviors.

To describe embodiments of the an area type scheme that may be used in the present invention, some introductory remarks are first provided. Note that the wireless signal transmission behavior for an area depends on at least the following criteria:

(23.8.1) substantially invariant terrain characteristics (both natural and man-made) of the area; e.g., mountains, buildings, lakes, highways, bridges, building density;

(23.8.2) time varying environmental characteristics (both natural and man-made) of the area; e.g., foliage, traffic, weather, special events such as baseball games;

(23.8.3) wireless communication components or infrastructure in the area; e.g., the arrangement and signal communication characteristics of the base stations 122 in the area (e.g., base station antenna downtilt). Further, the antenna characteristics at the base stations 122 may be important criteria.

Accordingly, a description of wireless signal characteristics for determining area types could potentially include a characterization of wireless signaling attributes as they relate to each of the above criteria. Thus, an area type might be: hilly, treed, suburban, having no buildings above 50 feet, with base stations spaced apart by two miles. However, a categorization of area types is desired that is both more closely tied to the wireless signaling characteristics of the area, and is capable of being computed substantially automatically and repeatedly over time. Moreover, for a wireless location system, the primary wireless signaling characteristics for categorizing areas into at least minimally similar area types are: thermal noise and, more importantly, multipath characteristics (e.g., multipath fade and time delay).

Focusing for the moment on the multipath characteristics, it is believed that (23.8.1) and (23.8.3) immediately above are, in general, more important criteria for accurately locating an MS 140 than (23.8.2). That is, regarding (23.8.1), multipath tends to increase as the density of nearby vertical area changes increases. For example, multipath is particularly problematic where there is a high density of high rise buildings and/or where there are closely spaced geographic undulations. In both cases, the amount of change in vertical area per unit of area in a horizontal plane (for some horizontal reference plane) may be high. Regarding (23.8.3), the greater the density of base stations 122, the less problematic multipath may become in locating an MS 140. Moreover, the arrangement of the base stations 122 in the radio coverage area 120 in Fig. 4 may affect the amount and severity of multipath.

Accordingly, it would be desirable to have a method and system for straightforwardly determining area type classifications related to multipath, and in particular, multipath due to (23.8.1) and (23.8.3). The present invention provides such a determination by utilizing a novel notion of area type, hereinafter denoted "transmission area type" (or, "area type" when both a generic area type classification scheme and the transmission area type discussed hereinafter are intended) for classifying "similar" areas, wherein

each transmission area type class or category is intended to describe an area having at least minimally similar wireless signal transmission characteristics. That is, the novel transmission area type scheme of the present invention is based on: (a) the terrain area classifications; e.g., the terrain of an area  
5 surrounding a target MS 140, (b) the configuration of base stations 122 in the radio coverage area 120, and (c) characterizations of the wireless signal transmission paths between a target MS 140 location and the base stations 122.

In one embodiment of a method and system for determining such  
10 (transmission) area type approximations, a partition (denoted hereinafter as  $P_0$ ) is imposed upon the radio coverage area 120 for partitioning for radio coverage area into subareas, wherein each subarea is an estimate of an area having included MS 140 locations that are likely to have is at least a minimal amount of similarity in their wireless signaling characteristics. To obtain the  
15 partition  $P_0$  of the radio coverage area 120, the following steps are performed:

(23.8.4.1) Partition the radio coverage area 120 into subareas, wherein  
in each subarea is: (a) connected, (b) the subarea is not too  
oblong, e.g., the variations in the lengths of chords sectioning the  
subarea through the centroid of the subarea are below a  
20 predetermined threshold, (c) the size of the subarea is below a  
predetermined value, and (d) for most locations (e.g., within a  
first or second deviation) within the subarea whose wireless  
signaling characteristics have been verified, it is likely (e.g.,  
within a first or second deviation ) that an MS 140 at one of these  
25 locations will detect (forward transmission path) and/or will be  
detected (reverse transmission path) by a same collection of base  
stations 122. For example, in a CDMA context, a first such  
collection may be (for the forward transmission path) the active  
set of base stations 122, or, the union of the active and candidate  
30 sets, or, the union of the active, candidate and/or remaining sets

of base stations 122 detected by “most” MSs 140 in .

Additionally (or alternatively), a second such collection may be the base stations 122 that are expected to detect MSs 140 at locations within the subarea. Of course, the union or intersection of the first and second collections is also within the scope of the present invention for partitioning the radio coverage area 120 according to (d) above. It is worth noting that it is believed that base station 122 power levels will be substantially constant.

However, even if this is not the case, one or more collections for (d) above may be determined empirically and/or by

computationally simulating the power output of each base station 122 at a predetermined level. Moreover, it is also worth

mentioning that this step is relatively straightforward to

implement using the data stored in the location signature data

base 1320 (i.e., the verified location signature clusters discussed in detail hereinbelow). Denote the resulting partition here as  $P_1$ .

(23.8.4.2) Partition the radio coverage area 120 into subareas, wherein

each subarea appears to have substantially homogeneous terrain

characteristics. Note, this may be performed periodically

substantially automatically by scanning radio coverage area

images obtained from aerial or satellite imaging. For example,

EarthWatch Inc. of Longmont, CO can provide geographic with

3 meter resolution from satellite imaging data. Denote the

resulting partition here as  $P_2$ .

(23.8.4.3) Overlay both of the above partitions,  $P_1$  and  $P_2$  of the radio

coverage area 120 to obtain new subareas that are intersections of

the subareas from each of the above partitions. This new

partition is  $P_0$  (i.e.,  $P_0 = P_1 \text{ intersect } P_2$ ), and the subareas of it are

denoted as “ $P_0$  subareas”.

Now assuming  $P_0$  has been obtained, the subareas of  $P_0$  are provided with a first classification or categorization as follows:

(23.8.4.4) Determine an area type categorization scheme for the subareas of  $P_1$ . For example, a subarea, A, of  $P_1$ , may be categorized or labeled according to the number of base stations 122 in each of the collections used in (23.8.4.1)(d) above for determining subareas of  $P_1$ . Thus, in one such categorization scheme, each category may correspond to a single number  $x$  (such as 3), wherein for a subarea, A, of this category, there is a group of  $x$  (e.g., three) base stations 122 that are expected to be detected by a most target MSs 140 in the area A. Other embodiments are also possible, such as a categorization scheme wherein each category may correspond to a triple: of numbers such as (5, 2, 1), wherein for a subarea A of this category, there is a common group of 5 base stations 122 with two-way signal detection expected with most locations (e.g., within a first or second deviation) within A, there are 2 base stations that are expected to be detected by a target MS 140 in A but these base stations can not detect the target MS, and there is one base station 122 that is expected to be able to detect a target MS in A but not be detected.

(23.8.4.5) Determine an area type categorization scheme for the subareas of  $P_2$ . Note that the subareas of  $P_2$  may be categorized according to their similarities. In one embodiment, such categories may be somewhat similar to the naive area types mentioned above (e.g., dense urban, urban, suburban, rural, mountain, etc.). However, it is also an aspect of the present invention that more precise categorizations may be used, such as a category for all areas having between 20,000 and 30,000 square feet of vertical area change per 11,000 square feet of horizontal

area and also having a high traffic volume (such a category likely corresponding to a “moderately dense urban” area type).

(23.8.4.6) Categorize subareas of  $P_0$  with a categorization scheme denoted the “ $P_0$  categorization,” wherein for each  $P_0$  subarea,  $A$ , a “ $P_0$  area type” is determined for  $A$  according to the following substep(s):

(a) Categorize  $A$  by the two categories from (23.8.4.4) and (23.8.5) with which it is identified. Thus,  $A$  is categorized (in a corresponding  $P_0$  area type) both according to its terrain and the base station infrastructure configuration in the radio coverage area 120.

(23.8.4.7) For each  $P_0$  subarea,  $A$ , of  $P_0$  perform the following step(s):

(a) Determine a centroid,  $C(A)$ , for  $A$ ;

(b) Determine an approximation to a wireless transmission path between  $C(A)$  and each base station 122 of a predetermined group of base stations expected to be in (one and/or two-way) signal communication with most target MS 140 locations in  $A$ . For example, one such approximation is a straight line between  $C(A)$  and each of the base stations 122 in the group. However, other such approximations are within the scope of the present invention, such as, a generally triangular shaped area as the transmission path, wherein a first vertex of this area is at the corresponding base station for the transmission path, and the sides of the generally triangular shaped defining the first vertex have a smallest angle between them that allows  $A$  to be completely between these sides.

(c) For each base station 122,  $BS_i$ , in the group mentioned in (b) above, create an empty list,  $BS_i$ -list, and put on this list at least the  $P_0$  area types for the "significant"  $P_0$  subareas crossed by the transmission path between

5  $C(A)$  and  $BS_i$ . Note that "significant"  $P_0$  subareas may be defined as, for example, the  $P_0$  subareas through which at least a minimal length of the transmission path traverses. Alternatively, such "significant"  $P_0$  subareas may be defined as those  $P_0$  subareas that additionally

10 are known or expected to generate substantial multipath.

(d) Assign as the transmission area type for  $A$  as the collection of  $BS_i$ -lists. Thus, any other  $P_0$  subarea having the same (or substantially similar) collection of lists of  $P_0$  area types will be viewed as having

15 approximately the same radio transmission characteristics.

Note that other transmission signal characteristics may be incorporated into the transmission area types. For example, thermal noise characteristics may be included by providing a third radio coverage area 120 partition,  $P_3$ , in

20 addition to the partitions of  $P_1$  and  $P_2$  generated in (23.8.4.1) and (23.8.4.2) respectively. Moreover, the time varying characteristics of (23.8.2) may be incorporated in the transmission area type framework by generating multiple versions of the transmission area types such that the transmission area type for a given subarea of  $P_0$  may change depending on the combination of time

25 varying environmental characteristics to be considered in the transmission area types. For instance, to account for seasonality, four versions of the partitions  $P_1$  and  $P_2$  may be generated, one for each of the seasons, and subsequently generate a (potentially) different partition  $P_0$  for each season. Further, the type and/or characteristics of base station 122 antennas may also

30 be included in an embodiment of the transmission area type.

Other embodiments of area types are also within the scope of the present invention. As mentioned above, each of the first order models 1224 have default confidence values associated therewith, and these confidence values may be probabilities. More precisely, such probability confidence values can be determined as follows. Assume there is a partition of the coverage area into subareas, each subarea being denoted a "partition area." For each partition area, activate each first order model 1224 with historical location data in the Location Signature Data Base 1320 (Fig. 6), wherein the historical location data has been obtained from corresponding known mobile station locations in the partition area. For each first order model, determine a probability of the first order model generating a location hypothesis whose location estimate contains the corresponding known mobile station location. To accomplish this, assume the coverage area is partitioned into partition areas A, wherein each partition area A is specified as the collection of coverage area locations such that for each location, the detected wireless transmissions between the network base stations and a target mobile station at the location can be straightforwardly equated with other locations of area A. For example, one such partition,  $P_0$ , can be defined wherein each partition area A is specified in terms of three sets of base station identifiers, namely, (a) the base station identifiers of the base stations that can be *both* detected at each location of A and can detect a target mobile station at each location, (b) the identifiers for base stations that can detect a target mobile station at each location of A, but can not be detected by the target mobile station, and (c) the identifiers for base stations that can be detected by a target mobile station at each location of A, but these base stations can not detect the target mobile station. That is, two locations,  $l_1$  and  $l_2$ , are identified as being in A if and only if the three sets of (a), (b), and (c) for  $l_1$  are, respectively, identical to the three sets of (a), (b), and (c) for  $l_2$ .

Accordingly, assuming the partition  $P_0$  is used, a description can be given as to how probabilities may be assigned as the confidence values of



location hypotheses generated by the first order models 1224. For each partition area A, a first order model 1224 is supplied with wireless measurements of archived location data in the Location Signature Data Base associated with corresponding verified mobile station locations. Thus, a probability can be determined as to how likely the first order model is to generate a location hypothesis having a location estimate containing the corresponding verified mobile station location. Accordingly, a table of partition area probabilities can be determined for each first order model 1224. Thus, when a location hypothesis is generated and identified as belonging to one of the partition areas, the corresponding probability for that partition area may be assigned as the confidence value for the location hypothesis. The advantages to using actual probabilities here is that, as will be discussed below, the most likelihood estimator 1344 can compute a straightforward probability for each distinct intersection of the multiple location hypotheses generated by the multiple first order models, such that each such probability indicates a likelihood that the target mobile station is in the corresponding intersection.

#### Location Information Data Bases And Data

#### Location Data Bases Introduction

It is an aspect of the present invention that MS location processing performed by the location center/gateway 142 should become increasingly better at locating a target MS 140 both by (a) building an increasingly more detailed model of the signal characteristics of locations in the service area for the present invention, and also (b) by providing capabilities for the location center processing to adapt to environmental changes.

One way these aspects of the present invention are realized is by providing one or more data base management systems and data bases for:

(a) storing and associating wireless MS signal characteristics with known locations of MSs 140 used in providing the signal characteristics. Such stored associations may not only provide an increasingly better model of the signal characteristics of the geography of the service area, but also provide an increasingly better model of more changeable signal characteristic affecting environmental factors such as weather, seasons, and/or traffic patterns;

(b) adaptively updating the signal characteristic data stored so that it reflects changes in the environment of the service area such as, for example, a new high rise building or a new highway.

10 Referring again to Fig. 5 of the collective representation of these data bases is the location information data bases 1232. Included among these data bases is a data base for providing training and/or calibration data to one or more trainable/calibratable FOMs 1224, as well as an archival data base for archiving historical MS location information related to the performance of the FOMs. These data bases will be discussed as necessary  
15 hereinbelow. However, a further brief introduction to the archival data base is provided here. Accordingly, the term, "location signature data base" is used hereinafter to denote the archival data base and/or data base management system depending on the context of the discussion. The location signature data base (shown in, for example, Fig. 6 and labeled 1320) is a repository for wireless signal characteristic data derived from wireless  
20 signal communications between an MS 140 and one or more base stations 122, wherein the corresponding location of the MS 140 is known and also stored in the location signature data base 1320. More particularly, the location signature data base 1320 associates each such known MS location with the wireless signal characteristic data derived from wireless signal communications between the MS 140 and one or more base  
25 stations 122 at this MS location. Accordingly, it is an aspect of the present invention to utilize such historical MS signal location data for enhancing the correctness and/or confidence of certain location hypotheses as will be described in detail in other sections below.

Data Representations for the Location Signature Data Base

In one embodiment, there are four fundamental entity types (or object classes in an object oriented programming paradigm) utilized in the location signature data base 1320. Briefly, these data entities are described in the items (24.1) through (24.4) that follow:

- 5 (24.1) (verified) location signatures: Each such (verified) location signature describes the wireless signal characteristic measurements between a given base station (e.g., BS 122 or LBS 152) and an MS 140 at a (verified or known) location associated with the (verified) location signature. That is, a verified location signature corresponds to a location whose coordinates such as latitude-longitude coordinates are known, while  
10 simply a location signature may have a known or unknown location corresponding with it. Note that the term (verified) location signature is also denoted by the abbreviation, “(verified) loc sig” hereinbelow;
- (24.2) (verified) location signature clusters: Each such (verified) location signature cluster includes a collection of (verified) location signatures corresponding to all the  
15 location signatures between a target MS 140 at a (possibly verified) presumed substantially stationary location and each BS (e.g., 122 or 152) from which the target MS 140 can detect the BS’s pilot channel regardless of the classification of the BS in the target MS (i.e., for CDMA, regardless of whether a BS is in the MS’s active, candidate or remaining base station sets, as one skilled in the art will understand). Note that for  
20 simplicity here, it is presumed that each location signature cluster has a single fixed primary base station to which the target MS 140 synchronizes or obtains its timing;
- (24.3) “composite location objects (or entities)”: Each such entity is a more general entity than the verified location signature cluster. An object of this type is a collection of  
25 (verified) location signatures that are associated with the same MS 140 at substantially the same location at the same time and each such loc sig is associated with a different base station. However, there is no requirement that a loc sig from each BS 122 for which the MS 140 can detect the BS’s pilot channel is included in the “composite location object (or entity)”; and

(24.4) MS location estimation data that includes MS location estimates output by one or more MS location estimating first order models 1224, such MS location estimate data is described in detail hereinbelow.

5 It is important to note that a loc sig is, in one embodiment, an instance of the data structure containing the signal characteristic measurements output by the signal filtering and normalizing subsystem also denoted as the signal processing subsystem 1220 describing the signals between: (i) a specific base station 122 (BS) and (ii) a mobile station 140 (MS), wherein the BS's location is known and the MS's location is assumed to be substantially constant (during a 2-5 second interval in one embodiment  
10 of the present invention), during communication with the MS 140 for obtaining a single instance of loc sig data, although the MS location may or may not be known. Further, for notational purposes, the BS 122 and the MS 140 for a loc sig hereinafter will be denoted the "BS associated with the loc sig", and the "MS associated with the loc sig" respectively. Moreover, the location of the MS 140 at the time the loc sig  
15 data is obtained will be denoted the "location associated with the loc sig" (this location possibly being unknown).

Note that additional description of this aspect of the present invention can be found in one of the following two copending U.S. patent applications which are incorporated herein by reference: (a) "Location Of A Mobile Station" filed Nov. 24,  
20 1999 having Application No. 09/194,367 whose inventors are D. J. Dupray and C. L. Karr, and (b) "A Wireless Location System For Calibrating Multiple Location Estimators" filed October 21, 1998 having Application No. 09/176,587 whose inventor is D. J. Dupray, wherein these copending patent applications may have essential material for the present specification. In particular, these copending patent  
25 applications may have essential material relating to the location signature data base 1320.

Location Center Architecture

## Overview of Location Center/Gateway Functional Components

Fig. 5 presents a high level diagram of an embodiment of the location center/gateway 142 and the location engine 139 in the context of the infrastructure for the entire location system of the present invention.

5 It is important to note that the architecture for the location center/gateway 142 and the location engine 139 provided by the present invention is designed for extensibility and flexibility so that MS 140 location accuracy and reliability may be enhanced as further location data become available and as enhanced MS location techniques become available. In addressing the design goals of extensibility and  
10 flexibility, the high level architecture for generating and processing MS location estimates may be considered as divided into the following high level functional groups described hereinbelow.

### Low Level Wireless Signal Processing Subsystem for Receiving and Conditioning Wireless Signal Measurements

15 A first functional group of location engine 139 modules is for performing signal processing and filtering of MS location signal data received from a conventional wireless (e.g., CDMA) infrastructure, as discussed in the steps (23.1) and (23.2) above. This group is denoted the signal processing subsystem 1220 herein. One embodiment of such a subsystem is described in the U.S. copending patent application titled, "Wireless  
20 Location Using A Plurality of Commercial Network Infrastructures," by F. W. LeBlanc, Dupray and Karr filed Jan. 22, 1999 and having U.S. Patent No. 6,236,365. Note that this copending patent application is incorporated herein entirely by reference since it may contain essential material for the present invention.. In particular, regarding the signal processing subsystem 20. Note, however, that the signal processing subsystem may be  
25 unnecessary for the gateway 142 unless the gateway supplies wireless location signal data to one or more FOMs.

## Initial Location Estimators: First Order Models

A second functional group of modules at least accessible by the location engine 139 are the FOM 1224 for generating various target MS 140 location initial estimates, as described in step (23.3). A brief description of some types of first order models is provided immediately below. Note that Fig. 8 illustrates another, more detail view of an embodiment of the location center/gateway 142 for the present invention. In particular, this figure illustrates some of the FOMs 1224 at least accessible (but not necessarily co-located with the other location center/gateway modules shown in this figure), and additionally illustrates the primary communications with other modules of the gateway. However, it is important to note that the present invention is not limited to the FOMs 1224 shown and discussed herein. That is, it is a primary aspect of the present invention to easily incorporate FOMs using other signal processing and/or computational location estimating techniques than those presented herein. Further, note that each FOM type may have a plurality of its MS location estimating models (at least) accessible by the gateway 142.

For example, (as will be described in further detail below), one such type of model or FOM 1224 (hereinafter models of this type are referred to as “terrestrial communication station offset (TCSO) models” or “terrestrial communication station offset (TCSO) first order models”, or “terrestrial communication station offset (TCSO) FOMs”) may be based on a range, offset, and/or distance computation such as on a base station signal reception angle determination between the target MS 140 from each of one or more base stations. Basically, such TCSO models 1224 determine a location estimate of the target MS 140 by determining an offset from each of one or more base stations 122, possibly in a particular direction from each (some of) the base stations, so that, e.g., an intersection of each area locus defined by the base station offsets may provide an estimate of the location of the target MS. TCSO FOMs 1224 may compute such offsets based on, e.g.:

- (a) signal timing measurements between the target mobile station 140 and one or more base stations 122; e.g., timing measurements such as time difference of

arrival (TDOA), or time of arrival (TOA). Note that both forward and reverse signal path timing measurements may be utilized;

(b) signal strength measurements (e.g., relative to power control settings of the MS 140 and/or one or more BS 122); and/or

5 (c) signal angle of arrival measurements, or ranges thereof, at one or more base stations 122 (such angles and/or angular ranges provided by, e.g., base station antenna sectors having angular ranges of  $120^{\circ}$  or  $60^{\circ}$ , or, so called "SMART antennas" with variable angular transmission ranges of  $2^{\circ}$  to  $120^{\circ}$ ).

Accordingly, a terrestrial communication station offset (TCSO) model may utilize, e.g.,  
10 triangulation or trilateration to compute a location hypothesis having either an area location or a point location for an estimate of the target MS 140. Additionally, in some embodiments location hypothesis may include an estimated error.

Another type of FOM 1224 is a statistically based first order model 1224, wherein a statistical technique, such as regression techniques (e.g., least squares, partial  
15 least squares, principle decomposition), or e.g., Bollenger Bands (e.g., for computing minimum and maximum base station offsets). In general, models of this type output location hypotheses determined by performing one or more statistical techniques or comparisons between the verified location signatures in location signature data base 1320, and the wireless signal measurements from a target MS. Models of this type are  
20 also referred to hereinafter as a "stochastic signal (first order) model" or a "stochastic FOM" or a "statistical model." Of course, statistically based FOMs may be a hybrid combination with another type of FOM such as a TCSO FOM.

Still another type of FOM 1224 is an adaptive learning model, such as an artificial neural net or a genetic algorithm, wherein the FOM may be trained to recognize  
25 or associate each of a plurality of locations with a corresponding set of signal characteristics for communications between the target MS 140 (at the location) and the base stations 122. Moreover, typically such a FOM is expected to accurately interpolate/extrapolate target MS 140 location estimates from a set of signal characteristics from an unknown target MS 140 location. Models of this type are also  
30 referred to hereinafter variously as "artificial neural net models" or "neural net models"

or “trainable models” or “learning models.” Note that a related type of FOM 1224 is based on pattern recognition. These FOMs can recognize patterns in the signal characteristics of communications between the target MS 140 (at the location) and the base stations 122 and thereby estimate a location area of the target MS. However, such  
5 FOMs may not be trainable.

Yet another type of FOM 1224 can be based on a collection of dispersed low power, low cost fixed location wireless transceivers (also denoted “location base stations 152” hereinabove) that are provided for detecting a target MS 140 in areas where, e.g., there is insufficient base station 122 infrastructure coverage for providing a desired level  
10 of MS 140 location accuracy. For example, it may be uneconomical to provide high traffic wireless voice coverage of a typical wireless base station 122 in a nature preserve or at a fair ground that is only populated a few days out of the year. However, if such low cost location base stations 152 can be directed to activate and deactivate via the direction of a FOM 1224 of the present type, then these location base stations can be used to both  
15 location a target MS 140 and also provide indications of where the target MS is not. For example, if there are location base stations 152 populating an area where the target MS 140 is presumed to be, then by activating these location base stations 152, evidence may be obtained as to whether or not the target MS is actually in the area; e.g., if the target MS 140 is detected by a location base station 152, then a corresponding location  
20 hypothesis having a location estimate corresponding to the coverage area of the location base station may have a very high confidence value. Alternatively, if the target MS 140 is not detected by a location base station 152, then a corresponding location hypothesis having a location estimate corresponding to the coverage area of the location base station may have a very low confidence value. Models of this type are referred to hereinafter as  
25 “location base station models.”

Yet another type of FOM 1224 can be based on input from a mobile base station 148, wherein location hypotheses may be generated from target MS 140 location data received from the mobile base station 148.

Still other types of FOM 1224 can be based on various techniques for  
30 recognizing wireless signal measurement patterns and associating particular patterns



with locations in the coverage area 120. For example, artificial neural networks or other learning models can be used as the basis for various FOMs.

Note that the FOM types mentioned here as well as other FOM types are discussed in detail hereinbelow. Moreover, it is important to keep in mind that in one embodiment of the present invention, the substantially simultaneous use or activation of a potentially large number of such first order models 1224, may be able to enhance both the reliability of location estimates and the accuracy of such estimates. Additionally, note that in some embodiments of the present invention, the first order models 1224 can be activated when appropriate signal measurements are obtained. For example, a TDOA FOM may be activated when only a single signal time delay measurement is obtained from some plurality of base station 122. However, if, for instance, additional time delay values are obtained (and assuming such additional values are necessary), then one or more wireless signal pattern matching FOM may also be activated in conjunction with the TDOA FOM. Additionally, a FOM using satellite signals (e.g., GPS) to perform a triangulation may be activated whenever appropriate measurements are received regardless of whether additional FOMs are capable of being substantially simultaneously activated or not. Accordingly, since such satellite signal FOMs are generally more accurate, output from such a FOM may dominate any other previous or simultaneous estimates unless there is evidence to the contrary.

Moreover, the present invention provides a framework for incorporating MS location estimators to be subsequently provided as new FOMs in a straightforward manner. For example, a FOM 1224 based on wireless signal time delay measurements from a distributed antenna system for wireless communication may be incorporated into the present invention for thereby locating a target MS 140 in an enclosed area serviced by the distributed antenna system. Accordingly, by using such a distributed antenna FOM, the present invention may determine the floor of a multi-story building from which a target MS is transmitting. Thus, MSs 140 can be located in three dimensions using such a distributed antenna FOM. Additionally, FOMs for detecting certain registration changes within, for example, a public switched telephone network can also be used for locating a target MS 140. For example, for some MSs 140 there may be an

associated or dedicated device for each such MS that allows the MS to function as a cordless phone to a line based telephone network when the device detects that the MS is within signaling range. In one use of such a device (also denoted herein as a "home base station"), the device registers with a home location register of the public switched  
5 telephone network when there is a status change such as from not detecting the corresponding MS to detecting the MS, or visa versa, as one skilled in the art will understand. Accordingly, by providing a FOM that accesses the MS status in the home location register, the location engine 139 can determine whether the MS is within signaling range of the home base station or not, and generate location hypotheses  
10 accordingly. Moreover, other FOMs based on, for example, chaos theory and/or fractal theory are also within the scope of the present invention.

It is important to note the following aspects of the present invention relating to FOMs 1224:

- (28.1) Each such first order model 1224 may be relatively easily incorporated into and/or  
15 removed from the present invention. For example, assuming that the signal processing subsystem 1220 provides uniform input to the FOMs, and there is a uniform FOM output interface (e.g., API), it is believed that a large majority (if not substantially all) viable MS location estimation strategies may be accommodated. Thus, it is straightforward to add or delete such FOMs 1224.
- 20 (28.2) First order models 1224 may be relatively simple and still provide significant MS  
- 140 locating functionality and predictability. For example, much of what is believed to be common or generic MS location processing has been coalesced into, for example: a location hypothesis evaluation subsystem, denoted the hypotheses evaluator 1228 and described immediately below. Thus, the present invention is  
25 modular and extensible such that, for example, (and importantly) different first order models 1224 may be utilized depending on the signal transmission characteristics of the geographic region serviced by an embodiment of the present invention. Thus, a simple configuration of the present invention may have (or access) a small number of  
FOMs 1224 for a simple wireless signal environment (e.g., flat terrain, no urban  
30 canyons and low population density). Alternatively, for complex wireless signal

environments such as in cities like San Francisco, Tokyo or New York, a large number of FOMs 1224 may be simultaneously utilized for generating MS location hypotheses.

#### An Introduction to an Evaluator for Location Hypotheses: Hypothesis Evaluator

5 A third functional group of location engine 139 modules evaluates location hypotheses output by the first order models 1224 and thereby provides a “most likely” target MS location estimate. The modules for this functional group are collectively denoted the hypothesis evaluator 1228.

#### Hypothesis Evaluator

10 A primary purpose of the hypothesis evaluator 1228 is to mitigate conflicts and ambiguities related to location hypotheses output by the first order models 1224 and thereby output a “most likely” estimate of an MS for which there is a request for it to be located. In providing this capability, there are various related embodiments of the hypothesis evaluator that are within the scope of the present invention. Since each  
15 location hypothesis includes both an MS location area estimate and a corresponding confidence value indicating a perceived confidence or likelihood of the target MS being within the corresponding location area estimate, there is a monotonic relationship between MS location area estimates and confidence values. That is, by increasing an MS location area estimate, the corresponding confidence value may also be increased (in an  
20 extreme case, the location area estimate could be the entire coverage area 120 and thus the confidence value may likely correspond to the highest level of certainty; i.e., +1.0). Accordingly, given a target MS location area estimate (of a location hypothesis), an adjustment to its accuracy may be performed by adjusting the MS location area estimate and/or the corresponding confidence value. Thus, if the confidence value is, for  
25 example, excessively low then the area estimate may be increased as a technique for increasing the confidence value. Alternatively, if the estimated area is excessively large, and there is flexibility in the corresponding confidence value, then the estimated area may be decreased and the confidence value also decreased. Thus, if at some point in the

processing of a location hypothesis, if the location hypothesis is judged to be more (less) accurate than initially determined, then (i) the confidence value of the location hypothesis may be increased (decreased), and/or (ii) the MS location area estimate can be decreased (increased). Moreover, note that when the confidence values are probabilities, such adjustments are may require the reactivation of one or more FOMs 1224 with requests to generate location hypotheses having location estimates of different sizes. Alternatively, adjuster modules 1436 and/or 1440 (Fig. 16 discussed hereinbelow) may be invoked for generating location hypotheses having area estimates of different sizes. Moreover, the confidence value on such an adjusted location hypothesis (actually a new location hypothesis corresponding to the originally generated hypothesis) may also be a probability in that combinations of FOMs 1224 and adjuster modules 1436 and 1440 can also be calibrated for thereby yielding probabilities as confidence values to the resulting location hypotheses.

In a first class of embodiments (typically wherein the confidence values are not maintained as probabilities), the hypothesis evaluator 1228 evaluates location hypotheses and adjusts or modifies only their confidence values for MS location area estimates and subsequently uses these MS location estimates with the adjusted confidence values for determining a “most likely” MS location estimate for outputting. Alternatively, in a second class of embodiments for the hypothesis evaluator 1228 (also typically wherein the confidence values are not maintained as probabilities), MS location area estimates can be adjusted while confidence values remain substantially fixed. However, in one preferred embodiment of the present embodiment, both location hypothesis area estimates and confidence values are modified.

The hypothesis evaluator 1228 may perform any or most of the following tasks depending on the embodiment of the hypothesis evaluator. That is, (30.1) it may enhance the accuracy of an initial location hypothesis generated by an FOM by using the initial location hypothesis as, essentially, a query or index into the location signature data base 1320 for obtaining one or more corresponding enhanced location hypotheses, wherein the enhanced location hypotheses have both an adjusted target MS location area estimates and an

adjusted confidences based on past performance of the FOM in the location service surrounding the target MS location estimate of the initial location hypothesis;

Additionally, for embodiments of the hypothesis evaluator 1228 wherein the confidence values for location hypotheses are not maintained as probabilities, the following additional tasks (30.2) through (30.7) may be performed:

(30.2) the hypothesis evaluator 1228 may utilize environmental information to improve and reconcile location hypotheses supplied by the first order models 1224. A basic premise in this context is that the accuracy of the individual first order models may be affected by various environmental factors such as, for example, the season of the year, the time of day, the weather conditions, the presence of buildings, base station failures, etc.;

(30.3) the hypothesis evaluator 1228 may determine how well the associated signal characteristics used for locating a target MS compare with particular verified loc sigs stored in the location signature data base 1320 (see the location signature data base section for further discussion regarding this aspect of the invention). That is, for a given location hypothesis, verified loc sigs (which were previously obtained from one or more verified locations of one or more MS's) are retrieved for an area corresponding to the location area estimate of the location hypothesis, and the signal characteristics of these verified loc sigs are compared with the signal characteristics used to generate the location hypothesis for determining their similarities and subsequently an adjustment to the confidence of the location hypothesis (and/or the size of the location area estimate);

(30.4) the hypothesis evaluator 1228 may determine if (or how well) such location hypotheses are consistent with well known physical constraints such as the laws of physics. For example, if the difference between a previous (most likely) location estimate of a target MS and a location estimate by a current location hypothesis requires the MS to:

(a1) move at an unreasonably high rate of speed (e.g., 200 mph), or

(b1) move at an unreasonably high rate of speed for an area (e.g., 80 mph in a corn patch), or

(c1) make unreasonably sharp velocity changes (e.g., from 60 mph in one direction to 60 mph in the opposite direction in 4 sec), then the

5 confidence in the current Location Hypothesis is likely to be reduced.

Alternatively, if for example, the difference between a previous location estimate of a target MS and a current location hypothesis indicates that the MS is:

(a2) moving at an appropriate velocity for the area being traversed, or

(b2) moving along an established path (e.g., a freeway),

10 then the confidence in the current location hypothesis may be increased.

(30.5) the hypothesis evaluator 1228 may determine consistencies and inconsistencies between location hypotheses obtained from different first order models. For example, if two such location hypotheses, for substantially the same timestamp, have estimated location areas where the target MS is likely to be and these areas substantially overlap, then the confidence in both such location hypotheses may be increased. Additionally, note that a velocity of an MS may be determined (via deltas of successive location hypotheses from one or more first order models) even when there is low confidence in the location estimates for the MS, since such deltas may, in some cases, be more reliable than the actual target MS location estimates;

15  
20 (30.6) the hypothesis evaluator 1228 determines new (more accurate) location hypotheses from other location hypotheses. For example, this module may generate new hypotheses from currently active ones by decomposing a location hypothesis having a target MS location estimate intersecting two radically different wireless signaling area types. Additionally, this module may generate location hypotheses indicating areas of poor reception; and

25 (30.7) the hypothesis evaluator 1228 determines and outputs a most likely location hypothesis for a target MS.

Note that additional description of the hypothesis evaluator 1228 can be found  
30 in one of the following two copending U.S. patent applications which are incorporated

herein by reference: (a) "Location Of A Mobile Station" filed Nov. 24, 1999 having Application No. 09/194,367 whose inventors are D. J. Dupray and C. L. Karr, and (b) "A Wireless Location System For Calibrating Multiple Location Estimators" filed October 21, 1998 having Application No. 09/176,587 whose inventor is D. J. Dupray, wherein these copending patent applications may have essential material for the present specification. In particular, these copending patent applications may have essential material relating to their descriptions of the hypothesis evaluator.

#### Context Adjuster Introduction.

The context adjuster (alternatively denoted "location adjuster modules)-1326 module enhances both the comparability and predictability of the location hypotheses output by the first order models 1224. In one embodiment (typically where confidence values of location hypotheses are not maintained as probabilities), this module modifies location hypotheses received from the FOMs 1224 so that the resulting location hypotheses output by the context adjuster 1326 may be further processed uniformly and substantially without concern as to differences in accuracy between the first order models from which location hypotheses originate. Further, embodiments of the context adjuster may determine those factors that are perceived to impact the perceived accuracy (e.g., confidence) of the location hypotheses. For instance, environmental characteristics may be taken into account here, such as time of day, season, month, weather, geographical area categorizations (e.g., dense urban, urban, suburban, rural, mountain, etc.), area subcategorizations (e.g., heavily treed, hilly, high traffic area, etc.).

In Fig. 16, two such adjuster modules are shown, namely, an adjuster for enhancing reliability 1436 and an adjuster for enhancing accuracy 1440. Both of these adjusters perform their location hypothesis adjustments in the manner described above.

The difference between these two adjuster modules 1436 and 1440 is primarily the size of the localized area "nearby" the newly generated location estimate. In particular, since it is believed that the larger (smaller) the localized nearby area is, the more likely (less likely) the corresponding adjusted image is to contain the target mobile station location, the adjuster for enhancing reliability 1436 may determine its

localized areas “nearby” a newly generated location estimate as, for example, having a 40% larger diameter (alternatively, area) than the location area estimate generated by a first order model 1224. Alternatively, the adjuster for enhancing accuracy 1444 may determine its localized areas “nearby” a newly generated location estimate as, for  
5 example, having a 30% smaller diameter (alternatively, area) than the location area estimate generated by a first order model 1224. Thus, each newly generated location hypothesis can potentially be used to derive at least two additional adjusted location hypotheses with some of these adjusted location hypotheses being more reliable and some being more accurate than the location hypotheses generated directly from the  
10 first order models 1224.

Note that additional description of context adjuster aspects of the present invention can be found in the following two copending U.S. patent applications which are incorporated herein by reference: (a) “Location Of A Mobile Station” filed Nov. 24, 1999 having Application No. 09/194,367 whose inventors are D. J. Dupray and C.  
15 L. Karr, and (b) “A Wireless Location System For Calibrating Multiple Location Estimators” filed October 21, 1998 having Application No. 09/176,587 whose inventor is D. J. Dupray, wherein these copending patent applications may have essential material for the present specification. In particular, these copending patent applications may have essential material relating to the context adjuster 1326.

#### 20 MS Status Repository Introduction

The MS status repository 1338 is a run-time storage manager for storing location hypotheses from previous activations of the location engine 139 (as well as for storing the output “most likely” target MS location estimate(s)) so that a target MS 140 may be tracked using target MS location hypotheses from previous location engine 139  
25 activations to determine, for example, a movement of the target MS 140 between evaluations of the target MS location.

Location Hypothesis Analyzer Introduction.



The location hypothesis analyzer 1332, may adjust confidence values of the location hypotheses, according to:

- 5 (a) heuristics and/or statistical methods related to how well the signal characteristics for the generated target MS location hypothesis matches with previously obtained signal characteristics for verified MS locations.
- (b) heuristics related to how consistent the location hypothesis is with physical laws, and/or highly probable reasonableness conditions relating to the location of the target MS and its movement characteristics. For example, such heuristics may utilize knowledge of the geographical terrain in which the MS is  
10 estimated to be, and/or, for instance, the MS velocity, acceleration or extrapolation of an MS position, velocity, or acceleration.
- (c) generation of additional location hypotheses whose MS locations are consistent with, for example, previous estimated locations for the target MS.

Note that additional description of this aspect of the present invention can be  
15 found in one of the following copending U.S. patent application which is incorporated herein by reference: "Location Of A Mobile Station" filed Nov. 24, 1999 having Application No. 09/194,367 whose inventors are D. J. Dupray and C. L. Karr..

#### Most Likelihood Estimator

The most likelihood estimator 1344 is a module for determining a "most likely"  
20 location estimate for a target MS being located by the location engine 139. The most likelihood estimator 1344 receives a collection of active or relevant location hypotheses from the hypothesis analyzer 1332 and uses these location hypotheses to determine one or more most likely estimates for the target MS 140.

There are various embodiments of the most likelihood estimator 1344 that may  
25 be utilized with the present invention. One such embodiment will now be described. At a high level, an area of interest is first determined which contains the target MS 140 whose location is desired. This can be straightforwardly determined by identifying the base stations 122 that can be detected by the target MS 140 and/or the base stations 140 that can detect the target MS. Subsequently, assuming that this area of interest has been

previously partitioned into "cells" (e.g., small rectangular areas of, for example, 50 to 200 feet per side) and that the resulting location hypotheses for estimating the location of the target MS 140 each have a likelihood probability associated therewith, then for each such location hypothesis, a probability (more generally confidence value) is capable of  
5 being assigned to each cell intersecting and/or included in the associated target MS location estimate. In particular, for each location hypothesis, a portion of the probability value, P, for the associated location estimate, A, can be assigned to each cell, C, intersecting the estimate. One simple way to perform this is to divide P by the number of cells C, and increment, for each cell C, a corresponding probability indicative of the  
10 target MS 140 being in C with the result from the division. One skilled in the art will readily recognize numerous other ways of incrementing such cell probabilities, including: providing a Gaussian or other probabilistic distribution of probability values according to, e.g., the distance of the cell from the centroid of the location estimate. Accordingly, assuming all such probability increments have been assigned to all such  
15 cells C from all location hypotheses generated for locating the target MS 140, then the following is one embodiment of a program for determining one or more most likely locations of the target MS.

```
Desired_rel ← get the desired reliability for the resulting location estimate;  
Max_size ← get the desired maximum extent for the resulting location estimate;  
20 Binned_cells ← sort the cells of the area of interest by their probabilities into  
bins where each successive bin includes those cells whose  
confidence values are within a smaller (non-overlapping) range  
from that of any preceding bin . Further, assume there are, e.g.,  
100 bins Bi wherein B1 has cells with confidences within the  
25 range [0, 0.1], and Bi has cells with confidences within the range [  
(i - 1) * 0.01, i * 0.01].  
Result ← nil;  
Curr_rel ← 0; /* current likelihood of target MS 140 being in the area  
represented by "Result" */  
30 Done ← FALSE;
```

```

Repeat
    Cell_bin ← get first (next) bin of cells from Binned_cells;
    While (there are cells in Cell_bin) do
        Curr_cell ← get a next cell from Cell_bin that is closest to the
5         centroid of "Result";
        Result ← Result + Curr_cell;
        /* now determine a new reliability value corresponding to adding
         "Curr_cell" to the most likely location estimate being built in
         "Result" */
10        Curr_rel ← Curr_rel + confidence_of_MS_in(Curr_cell);
        If (Curr_rel > Desired_rel) then
            Done ← TRUE;

    Until Done;
    /* reliability that the target MS is in "Result" is sufficient */
15    Curr_size ← current maximum geographic extent (i.e., dimension) of the area
        represented by "Result";
    If (Curr_size <= Max_size) then output(Result);
    Else Determine whether "Result" has one or more outlying cells that can be
        replaced by other cells closer to the centroid of "Result" and still have a
20        reliability >= "Desired_rel";
        If (there are replaceable outlier cells) then
            replace them in Result and output(Result);
        Else output(Result);

```

Note that numerous similar embodiments of the above program maybe used, as
 25 one skilled in the art will understand. For instance, instead of "building" Result as
 provided in the above program, Result can be "whittled" from the area of interest.
 Accordingly, Result would be initialized to the entire area of interest, and cells would be
 selected for removal from Result. Additionally, note that the above program determines
 a fast approximation to the optimal most likely area containing the target MS 140 having
 30 at least a particular desired confidence. However, a similar program may be readily

provided where a most likely area having less than a desired extent or dimension is output; e.g., such a program would could be used to provide an answer to the question: "What city block is the target MS most likely in?"

5 Additionally, note that a center of gravity type of computation for obtaining the most likely location estimate of the target MS 140 may be used as described in U.S. patent 5,293,642 ('642 patent) filed Dec. 19, 1990 having an issue date of Mar. 8, 1994 with inventor Lo which is incorporated by reference herein and may contain essential material for the present invention.

10 Still referring to the hypothesis evaluator 1228, it is important to note that not all the above mentioned modules are required in all embodiments of the present invention. In particular, the hypothesis analyzer 1332 may be unnecessary. Accordingly, in such an embodiment, the enhanced location hypotheses output by the context adjuster 1326 are provided directly to the most likelihood estimator 1344.

#### Control and Output Gating Modules

15 A fourth functional group of location engine 139 modules is the control and output gating modules which includes the location center control subsystem 1350, and the output gateway 1356. The location control subsystem 1350 provides the highest level of control and monitoring of the data processing performed by the location center 142. In particular, this subsystem performs the following functions:

20 (a) controls and monitors location estimating processing for each target MS 140.

Note that this includes high level exception or error handling functions;

(b) receives and routes external information as necessary. For instance, this subsystem may receive (via, e.g., the public telephone switching network and Internet 468) such environmental information as increased signal noise in a particular service area due to increase traffic, a change in weather conditions, a base station 122 (or other infrastructure provisioning), change in operation status (e.g., operational to inactive);

25

(c) receives and directs location processing requests from other location centers 142 (via, e.g., the Internet);

(d) performs accounting and billing procedures such as billing according to MS location accuracy and the frequency with which an MS is located;

5 (e) interacts with location center operators by, for example, receiving operator commands and providing output indicative of processing resources being utilized and malfunctions;

(f) provides access to output requirements for various applications requesting location estimates. For example, an Internet location request from a trucking 10 company in Los Angeles to a location center 142 in Denver may only want to know if a particular truck or driver is within the Denver area. Alternatively, a local medical rescue unit is likely to request a precise a location estimate as possible.

Note that in Fig. 6, (a) - (d) above are, at least at a high level, performed by 15 utilizing the operator interface 1374.

Referring now to the output gateway 1356, this module routes target MS 140 location estimates to the appropriate location application(s). For instance, upon receiving a location estimate from the most likelihood estimator 1344, the output gateway 1356 may determine that the location estimate is for an automobile being 20 tracked by the police and therefore must be provided according to the particular protocol.

#### System Tuning and Adaptation: The Adaptation Engine

A fifth functional group of location engine 139 modules provides the ability to enhance the MS locating reliability and/or accuracy of the present invention by providing 25 it with the capability to adapt to particular operating configurations, operating conditions and wireless signaling environments without performing intensive manual analysis of the performance of various embodiments of the location engine 139. That is, this functional group automatically enhances the performance of the location engine for locating MSs

140 within a particular coverage area 120 using at least one wireless network infrastructure therein. More precisely, this functional group allows the present invention to adapt by tuning or optimizing certain system parameters according to location engine 139 location estimate accuracy and reliability.

5           There are a number location engine 139 system parameters whose values affect location estimation, and it is an aspect of the present invention that the MS location processing performed should become increasingly better at locating a target MS 140 not only through building an increasingly more detailed model of the signal characteristics of location in the coverage area 120 such as discussed above regarding the location  
10       signature data base 1320, but also by providing automated capabilities for the location center processing to adapt by adjusting or “tuning” the values of such location center system parameters.

          Accordingly, the present invention may include a module, denoted herein as an “adaptation engine” 1382, that performs an optimization procedure on the location center  
15       142 system parameters either periodically or concurrently with the operation of the location center in estimating MS locations. That is, the adaptation engine 1382 directs the modifications of the system parameters so that the location engine 139 increases in overall accuracy in locating target MSs 140. In one embodiment, the adaptation engine 1382 includes an embodiment of a genetic algorithm as the mechanism for modifying the  
20       system parameters. Genetic algorithms are basically search algorithms based on the mechanics of natural genetics.

          Note that additional description of this aspect of the present invention can be found in one of the following two copending U.S. patent applications which are incorporated herein by reference: (a) “Location Of A Mobile Station” filed Nov. 24,  
25       1999 having Application No. 09/194,367 whose inventors are D. J. Dupray and C. L. Karr, and (b) “A Wireless Location System For Calibrating Multiple Location Estimators” filed October 21, 1998 having Application No. 09/176,587 whose inventor is D. J. Dupray, wherein these copending patent applications may have essential material for the present specification. In particular, these copending patent  
30       applications may have essential material relating to the use of genetic algorithm

implementations for adaptively tuning system parameters of a particular embodiment of the present invention.

#### Implementations of First Order Models

Further descriptions of various first order models 1224 are provided in this section. However, it is important to note that these are merely representative 5 embodiments of location estimators that are within the scope of the present invention. In particular, two or more of the wireless location technologies described hereinbelow may be combined to create additional First Order Models. For example, various triangulation techniques between a target MS 140 and the base station infrastructure 10 (e.g., time difference of arrival (TDOA) or time of arrival (TOA)), may be combined with an angle of arrival (AOA) technique. For instance, if a single direct line of sight angle measurement and a single direct line of sight distance measurement determined by, e.g., TDOA or TOA can effectively locate the target MS 140. In such cases, the resulting First Order Models may be more complex. However, location hypotheses 15 may be generated from such models where individually the triangulation techniques and the AOA techniques would be unable to generate effective location estimates.

#### Terrestrial Communication Station Offset (TCSO) First Order Models (e.g., TOA/TDOA/AOA)

As discussed in the Location Center Architecture Overview section herein 20 above, TCSO models determine a presumed direction and/or distance (more generally, an offset) that a target MS 140 is from one or more base stations 122. In some embodiments of TCSO models, the target MS location estimate(s) generated are obtained using radio signal analysis techniques that are quite general and therefore are not capable of taking into account the peculiarities of the topography of a particular 25 radio coverage area. For example, substantially all radio signal analysis techniques using conventional procedures (or formulas) are based on "signal characteristic measurements" such as:

- (a) signal timing measurements (e.g., TOA and TDOA), and/or

(b) signal strength measurements.

Furthermore, such signal analysis techniques are likely predicated on certain very general assumptions that can not fully account for signal attenuation and multipath due to a particular radio coverage area topography.

5           Taking CDMA or TDMA base station network as an example, each base station (BS) 122 is required to emit a constant signal-strength pilot channel pseudo-noise (PN) sequence on the forward link channel identified uniquely in the network by a pilot sequence offset and frequency assignment. It is possible to use the pilot channels of the active, candidate, neighboring and remaining sets, maintained in the  
10 target MS, for obtaining signal characteristic measurements (e.g., TOA and/or TDOA measurements) between the target MS 140 and the base stations in one or more of these sets.

          Based on such signal characteristic measurements and the speed of signal propagation, signal characteristic ranges or range differences related to the location of  
15 the target MS 140 can be calculated. Using TOA and/or TDOA ranges as exemplary, these ranges can then be input to either the radius-radius multilateration or the time difference multilateration algorithms along with the known positions of the corresponding base stations 122 to thereby obtain one or more location estimates of the target MS 140. For example, if there are, four base stations 122 in the active set,  
20 the target MS 140 may cooperate with each of the base stations in this set to provide signal arrival time measurements. Accordingly, each of the resulting four sets of three of these base stations 122 may be used to provide an estimate of the target MS 140 as one skilled in the art will understand. Thus, potentially (assuming the measurements for each set of three base stations yields a feasible location solution) there are four  
25 estimates for the location of the target MS 140. Further, since such measurements and BS 122 positions can be sent either to the network or the target MS 140, location can be determined in either entity.

          Since many of the signal measurements utilized by embodiments of TCSO models are subject to signal attenuation and multipath due to a particular area  
30 topography. Many of the sets of base stations from which target MS location



estimates are desired may result in either no location estimate, or an inaccurate location estimate.

Accordingly, some embodiments of TCSO FOMs may attempt to mitigate such ambiguity or inaccuracies by, e.g., identifying discrepancies (or consistencies) between arrival time measurements and other measurements (e.g., signal strength), these discrepancies (or consistencies) may be used to filter out at least those signal measurements and/or generated location estimates that appear less accurate. In particular, such identifying and filtering may be performed by, for example, an expert system residing in the TCSO FOM.

Another approach for enhancing certain location techniques such as TDOA or angle or arrival (AOA) is that of super resolution as disclosed in U.S. patent 5,890,068 filed on Oct 3, 1996 having an issue date of Mar. 30, 1999 with inventors Fattouche et al. which is incorporated by reference herein and which may contain essential material for the present invention. In particular, the following portions of the '068 patent are particularly important: the Summary section, the Detailed Description portion regarding Figs. 12-17, and the section titled "Description Of The Preferred Embodiments Of The Invention."

Another approach, regardless of the FOM utilized, for mitigating such ambiguity or conflicting MS location estimates is particularly novel in that each of the target MS location estimates is used to generate a location hypothesis regardless of its apparent accuracy. Accordingly, these location hypotheses are input to an embodiment of the context adjuster 1326. In particular, in one context adjuster 1326 embodiment each location hypothesis is adjusted according to past performance of its generating FOM 1224 in an area of the initial location estimate of the location hypothesis (the area, e.g., determined as a function of distance from this initial location estimate), this alternative embodiment adjusts each of the location hypotheses generated by a first order model according to a past performance of the model as applied to signal characteristic measurements from the same set of base stations 122 as were used in generating the location hypothesis. That is, instead of only using only an identification of the first order model (i.e., its FOM\_ID) to, for example, retrieve

archived location estimates generated by the model in an area of the location hypothesis' estimate (when determining the model's past performance), the retrieval retrieves the archived location estimates that are, in addition, derived from the signal characteristics measurement obtained from the same collection of base stations 122 as  
5 was used in generating the location hypothesis. Thus, the adjustment performed by this embodiment of the context adjuster 1326 adjusts according to the past performance of the distance model and the collection of base stations 122 used.

Note in one embodiment, such adjustments can also be implemented using a precomputed vector location error gradient field. Thus, each of the location error  
10 vectors (as determined by past performance for the FOM) of the gradient field has its starting location at a location previously generated by the FOM, and its vector head at a corresponding verified location where the target MS 140 actually was. Accordingly, for a location hypothesis of an unknown location, this embodiment determines or selects the location error vectors having starting locations within a small area (e.g.,  
15 possibly of a predetermined size, but alternatively, dependent on the density of the location error vector starting locations nearby to the location hypothesis) of the location hypothesis. Additionally, the determination or selection may also be based upon a similarity of signal characteristics also obtained from the target MS 140 being located with signal characteristics corresponding to the starting locations of location  
20 error vectors of the gradient field. For example, such sign characteristics may be, e.g., time delay/signal strength multipath characteristics.

#### *Angle Of Arrival First Order Model*

Various mobile station location estimating models can be based on the angle of arrival (AOA) of wireless signals transmitted from a target MS 140 to the base station  
25 infrastructure as one skilled in the art will understand. Such AOA models (sometimes also referred to as direction of arrival or DOA models) typically require precise angular measurements of the wireless signals, and accordingly utilize specialized antennas at the base stations 122. The determined signal transmission angles are

subject to multipath aberrations. Therefore, AOA is most effective when there is an unimpeded line-of-sight simultaneous transmission between the target MS 140 and at least two base stations 122.

*TCSO (Grubeck) FOM with Increased Accuracy Via Multiple MS Transmissions*

5 Another TCSO first order model 1224, denoted the Grubeck model (FOM) herein, is disclosed in U.S. Patent 6,009,334 filed Nov. 26, 1997 and issued Dec. 28, 1999 having Grubeck, Fischer, and Lundqvist as inventors, this patent being fully incorporated herein by reference. The Grubeck model includes a location estimator for determining more accurately the distance between a wireless receiver at (RX), e.g., a  
10 CMRS fixed location communication station (such as a BS 122) and a target MS 140, wherein wireless signals are repeatedly transmitted from the target MS 140 and may be subject to multipath. An embodiment of the Grubeck model may be applied to TOA, TDOA, and/or AOA wireless measurements. For the TOA case, the following steps are performed:

- 15 (a) transmitting "M" samples  $s_i$ ,  $1 \leq i \leq M$  of the same wireless signal from, e.g., the target MS 140 to the RX. Preferably M is on the order of 50 to 100 (e.g., 70) wireless signal bursts, wherein each such burst contains a portion having an identical known contents of bits (denoted a training sequence). However, note that a different embodiment can use (e.g.,  
20 70) received bursts containing different (non-identical) information, but information still known to the RX.;
- (b) receiving the "M" signal samples  $s_i$  along with multipath components and noise at, e.g., RX;
- (c) for each of the received "M" samples  $s_i$ , determining at the RX an  
25 estimated channel power profile (CPP<sub>i</sub>). Each CPP<sub>i</sub> is determined by first determining, via a processor at the RX, a combined correlation response ("Channel Impulse Response" or CIR<sub>i</sub>) of a small number of the bursts (e.g., 5) by correlating each burst with its known contents.

Accordingly; the squared absolute value of the CIR<sub>i</sub> is the "estimated channel power profile" or CPP<sub>i</sub>;

- (d) (randomly) selecting "N" (e.g., 10) out of the "M" received samples;
- (e) performing incoherent integration of the CPP<sub>i</sub> for the "N" samples selected, which results in an integrated signal, i.e., one integrated channel power profile\_ICPP(N<sub>i</sub>);
- (f) determining if the signal-to-noise quality of the ICPP(N<sub>i</sub>) is greater than or equal to a predetermined threshold value, and if not, improving the signal-to-noise quality of ICPP(N<sub>i</sub>) as required, by redoing the incoherent integration with successively one additional received sample CPP<sub>i</sub> until the signal-to-noise quality of the ICPP(N<sub>i</sub>) is greater than or equal to the predetermined threshold value;
- (g) determining the TOA(i), including the case of determining TOA(i) from the maximum signal amplitude;
- (h) entering the determined TOA(i) value into a diagram that shows a frequency of occurrence as a function of TOA(i);
- (i) repeating the whole procedure "X" times by selecting a new combination of "N" out of "M" samples, which results in "X" additional points in the frequency of occurrence diagram;
- (j) reading the minimum value TOA(min) as the time value having "z" of all occurrences with higher TOA(i) values and "1-z" of all occurrences with lower TOA(i) values, where  $z > 0.7$ .

As mentioned above, an embodiment of the Grubeck FOM may also be provides for TDOA and/or AOA wireless location techniques, wherein a similar incoherent integration may be performed.

Note that a Grubeck FOM may be particularly useful for locating a target MS 140 in a GSM wireless network.

*TCSO (Parl) FOM Using Different Tones and Multiple Antennas at BSs 122*

A first order model 1224, denoted the Parl model herein, is substantially disclosed in U.S. Patent 5,883,598 (denoted the '598 Patent herein) filed Dec. 15, 1995 and issued Mar. 16, 1999 having Parl, Bussgang, Weitzen and Zagami as  
5 inventors, this patent being fully incorporated herein by reference. The Parl FOM includes a system for receiving representative signals (denoted also "locating signal(s)") from the target MS 140 via, e.g., base stations 122 and subsequently combines information regarding the amplitude and phase of the MS transmitted signals received at the base stations to determine the position of the target MS 140. In one  
10 embodiment, the Parl model uses input from a locating signal having two or more single-frequency tones, as one skilled in the art will understand. Moreover, at least some of the base stations 122 preferably includes at least two antennas spaced from each other by a distance between a quarter wavelength and several wavelengths of the wireless locating signals received from the target MS 140. Optionally, another antenna  
15 vertically above or below the two or more antennas also spaced by a distance of between a quarter wavelength and several wavelengths can be used where elevation is also being estimated. The base stations 122 sample locating signals from the target MS 140. The locating signals include tones that can be at different frequencies. The tones can also be transmitted at different times, or, in an alternative embodiment, they  
20 can be transmitted simultaneously. Because, in one embodiment, only single-frequency tones are used as the locating signal instead of modulated signals, substantial transmission circuitry may be eliminated. The Parl FOM extracts information from each representative signal received from a target MS 144, wherein at least some of the extracted information is related to the amplitude and phase of the  
25 received signal.

In one embodiment of a Parly FOM, related to the disclosure in the '598 Patent, when the locations of the BSs 122 are known, and the direction from any two of the BSs 122 to the target MS 140, the MS's location can be initially (roughly) determined by signal direction finding techniques. For example, an estimate of the

phase difference between the signals at a pair of antennas at any BS 122 (having two such antennas) can lead to the determination of the angle from the base station to the target MS 140, and thus, the determination of the target MS direction. Subsequently, an enhanced location of the target MS 140 is computed directly from received target MS signal data using an ambiguity function  $A(x,y)$  described in the '598 Patent, wherein for each point at  $x,y$ , the ambiguity function  $A(x,y)$  depends upon the probability that the MS is located at the geolocation represented by  $(x,y)$ . Essentially the Parl FOM combines angle of arrival related data and TDOA related data for obtaining an optimized estimate of the target MS 140. However, it appears that independent AOA and TDOA MS locations are not used in determining a resulting target MS location (e.g., without the need for projecting lines at angles of arrival or computing the intersection of hyperbolas defined by pairs of base stations). Instead, the Parl FOM estimates the target MS's location by minimizing a joint probability of location related errors. In particular, such minimization may use the mean square error, and the location  $(x, y)$  at which minimization occurs is taken as the estimate of the target MS 140. In particular, the ambiguity function  $A(x,y)$  defines the error involved in a position determination for each point in a geolocation Cartesian coordinate system. The Parl model optimizes the ambiguity function to select a point  $x,y$  at which the associated error is minimized. The resulting location for  $(x, y)$  is taken as the estimate of the location of the target MS 140. Any of several different optimization procedures can be used to optimize the ambiguity function  $A(x,y)$ . E.g., a first rough estimate of the target MS's location may be obtained by direction finding (as discussed above). Next, six points  $x,y$  may be selected that are in close proximity to the estimated point. The ambiguity function  $A(x,y)$  is solved for each of the  $x,y$  points to obtain six values. The six computed values are then used to define a parabolic surface. The point  $x,y$  at which the maximum value of the parabolic surface occurs is then taken as the estimate of the target MS 140. However, other optimization techniques may also be used. For example, a standard technique such as an iterative progression through trial and error to converge to the maximum can be used. Also, gradient search can be used to optimize the ambiguity function. In the

case of three-dimensional location, the two-dimensional ambiguity function  $A(x,y)$  is extended to a three-dimensional function  $A(x,y,z)$ . As in the two-dimensional case, the ambiguity function may be optimized to select a point  $x,y,z$  as the best estimate of the target MS's location in three dimensions. Again, any of several known  
5 optimization procedures, such as iterative progression through trial and error, gradient search, etc., can be used to optimize the ambiguity function.

*TCSO FOM Using TDOA/AOA Measurements From an MBS 148 and/or an LBS 152*

It is believed clear from the location center/gateway 142 architecture and from the architecture of the mobile station location subsystem (described in a separate  
10 section hereinbelow) that target MS 140 location related information can be obtained from an MBS 148 and/or one or more LBSs 152. Moreover, such location related information can be supplied to any FOM 1224 that is able to accept such information as input. Thus, pattern recognition and adaptive FOMs may accept such information. However, to provide an alternative description of how MS location related information  
15 from an MBS and/or LBS may be used, reference is made to U.S. Patent 6,031,490 (denoted the '490 Patent herein) filed Dec. 23, 1997 and issued Feb. 29, 2000 having Forssen, Berg and Ghisler as inventors, this patent being fully incorporated herein fully by reference. A TCSO FOM (denoted the FORSSEN FOM herein) using TDOA/AOA is disclosed in the '490 Patent.

20 The FORSSEN FOM includes a location estimator for determining the Time Difference of Arrival (TDOA) of the position of a target MS 140, which is based on Time of Arrival (TOA) and/or AOA measurements. This FOM uses data received from "measuring devices" provided within a wireless telecommunications network. The measuring devices measure TOA on demand and (optionally) Direction of Arrival  
25 (DOA), on a digital uplink time slot or on digital information on an analog uplink traffic channel in one or more radio base stations. The TOA and DOA information and the traffic channel number are reported to a Mobile Services Switching Center (MSC), which obtains the identity of the target MS 140 from the traffic channel number and

sends the terminal identity and TOA and DOA measurement information to a Service Node (e.g., location center 142) of the network. The Service Node calculates the position of the target MS 140 using the TOA information (supplemented by the DOA information when available). Note, that the TLME model may utilize data from a second mobile radio terminal is colocated on a mobile platform (auto, emergency vehicle, etc.) with one of the radio base stations (e.g., MBS 148), which can be moved into relatively close proximity with the target MS 140. Consequently, by moving one of the radio base stations (MBSs) close to the region of interest (near the target MS 140), the position determination accuracy is significantly improved.

Note that the '490 Patent also discloses techniques for rising the target MS's transmission power for thereby allowing wireless signals from the target MS to be better detected by distant BSs 122.

#### Coverage Area First Order Model

Radio coverage area of individual base stations 122 may be used to generate location estimates of the target MS 140. Although a first order model 1224 based on this notion may be less accurate than other techniques, if a reasonably accurate RF coverage area is known for each (or most) of the base stations 122, then such a FOM (denoted hereinafter as a "coverage area first order model" or simply "coverage area model") may be very reliable. To determine approximate maximum radio frequency (RF) location coverage areas, with respect to BSs 122, antennas and/or sector coverage areas, for a given class (or classes) of (e.g., CDMA or TDMA) mobile station(s) 140, location coverage should be based on an MS's ability to adequately detect the pilot channel, as opposed to adequate signal quality for purposes of carrying user-acceptable traffic in the voice channel. Note that more energy is necessary for traffic channel activity (typically on the order of at least -94 to -104 dBm received signal strength) to support voice, than energy needed to simply detect a pilot channel's presence for location purposes (typically a maximum weakest signal strength range of between -104 to -110 dBm), thus the "Location Coverage Area" will generally be a larger area than



that of a typical "Voice Coverage Area", although industry studies have found some occurrences of "no-coverage" areas within a larger covered area

The approximate maximum RF coverage area for a given sector of (more generally angular range about) a base station 122 may be represented as a set of points representing a polygonal area (potentially with, e.g., holes therein to account for dead zones and/or notches). Note that if such polygonal RF coverage area representations can be reliably determined and maintained over time (for one or more BS signal power level settings), then such representations can be used in providing a set theoretic or Venn diagram approach to estimating the location of a target MS 140. Coverage area first order models utilize such an approach.

One embodiment, a coverage area model utilizes both the detection and non-detection of base stations 122 by the target MS 140 (conversely, of the MS by one or more base stations 122) to define an area where the target MS 140 may likely be. A relatively straightforward application of this technique is to:

- (a) find all areas of intersection for base station RF coverage area representations, wherein: (i) the corresponding base stations are on-line for communicating with MSs 140; (ii) the RF coverage area representations are deemed reliable for the power levels of the on-line base stations; (iii) the on-line base stations having reliable coverage area representations can be detected by the target MS; and (iv) each intersection must include a predetermined number of the reliable RF coverage area representations (e.g., 2 or 3); and
- (b) obtain new location estimates by subtracting from each of the areas of intersection any of the reliable RF coverage area representations for base stations 122 that can not be detected by the target MS.

Accordingly, the new areas may be used to generate location hypotheses.

### Satellite Signal Triangulation First Order Models

As mentioned hereinabove, there are various satellite systems that may be used to provide location estimates of a target MS 140 (e.g., GPS, GLONASS, LEOs, and MEOs). In many cases, such location estimates can be very accurate, and accordingly  
5 such accuracy would be reflected in the present invention by relatively high confidence values for the location hypotheses generated from such models in comparison to other FOMs. However, it may be difficult for the target MS 140 to detect and/or lock onto such satellite signals sufficiently well to provide a location estimate. For example, it may be very unlikely that such satellite signals can be detected by the MS 140 in the  
10 middle of high rise concrete buildings or parking structures having very reduced exposure to the sky.

### Hybrid Satellite and TCSO FOMs

A first order model 1224, denoted the WATTERS FOM herein, is disclosed in U.S. Patent 5,982,324 filed May 14, 1998 and issued Nov. 9, 1999 having Watters,  
15 Strawczynski, and Steer as inventors, this patent being fully incorporated herein by reference. The WATTERS FOM includes a location estimator for determining the location of a target MS 140 using satellite signals to the target MS 140 as well as delay in wireless signals communicated between the target MS and base stations 122. For example, aspects of global positioning system (GPS) technology and cellular  
20 technology are combined in order to locate a target MS 140. The WATTERS FOM may be used to determine target MS location in a wireless network, wherein the network is utilized to collect differential GPS error correction data, which is forwarded to the target MS 140 via the wireless network. The target MS 140 (which includes a receiver R for receiving non-terrestrial wireless signals from, e.g., GPS, or other  
25 satellites, or even airborne craft) receives this data, along with GPS pseudoranges using its receiver R, and calculates its position using this information. However, when the requisite number of satellites are not in view of the MS 140, then a pseudosatellite signal, broadcast from a BS 122 of the wireless network, is received by the target MS

140 and processed as a substitute for the missing satellite signal. Additionally, in at least some circumstances, when the requisite number of satellites (more generally, non-terrestrial wireless transmitters) are not detected by the receiver R, then the target MS's location is calculated using the wireless network infrastructure via TDOA/TOA with the BSs 122 of the network. When the requisite number of satellites (more generally, non-terrestrial wireless transmitters) are again detected by the receiver R, then the target MS is again calculated using wireless signals from the non-terrestrial wireless transmitters. Additionally, the WATTERS FOM may use wireless signals already being transmitted from base stations 122 to the target MS 140 in wireless network to calculate a round trip time delay, from which a distance calculation between the base station and the target MS can be made. This distance calculation substitutes for a missing non-terrestrial transmission signal.

#### Location Base Station First Order Model

In the location base station (LBS) model (FOM 1224), a database is accessed which contains electrical, radio propagation and coverage area characteristics of each of the location base stations in the radio coverage area. The LBS model is an active model, in that it can probe or excite one or more particular LBSs 152 in an area for which the target MS 140 to be located is suspected to be placed. Accordingly, the LBS model may receive as input a most likely target MS 140 location estimate previously output by the location engine 139 of the present invention, and use this location estimate to determine which (if any) LBSs 152 to activate and/or deactivate for enhancing a subsequent location estimate of the target MS. Moreover, the feedback from the activated LBSs 152 may be provided to other FOMs 1224, as appropriate, as well as to the LBS model. However, it is an important aspect of the LBS model that when it receives such feedback, it may output location hypotheses having relatively small target MS 140 location area estimates about the active LBSs 152 and each such location hypothesis also has a high confidence value indicative of the target MS 140 positively being in the corresponding location area estimate (e.g., a

confidence value of .9 to +1), or having a high confidence value indicative of the target MS 140 not being in the corresponding location area estimate (i.e., a confidence value of -0.9 to -1). Note that in some embodiments of the LBS model, these embodiments may have functionality similar to that of the coverage area first order model described above. Further note that for LBSs within a neighborhood of the target MS wherein there is a reasonable chance that with movement of the target MS may be detected by these LBSs, such LBSs may be requested to periodically activate. (Note, that it is not assumed that such LBSs have an on-line external power source; e.g., some may be solar powered). Moreover, in the case where an LBS 152 includes sufficient electronics to carry voice communication with the target MS 140 and is the primary BS for the target MS (or alternatively, in the active or candidate set), then the LBS model will not deactivate this particular LBS during its procedure of activating and deactivating various LBSs 152.

#### Stochastic First Order Model

The stochastic first order models may use statistical prediction techniques such as principle decomposition, partial least squares, partial least squares, or other regression techniques for predicting, for example, expected minimum and maximum distances of the target MS from one or more base stations 122, e.g., Bollenger Bands. Additionally, some embodiments may use Markov processes and Random Walks (predicted incremental MS movement) for determining an expected area within which the target MS 140 is likely to be. That is, such a process measures the incremental time differences of each pilot as the MS moves for predicting a size of a location area estimate using past MS estimates such as the verified location signatures in the location signature data base 1320.

#### Pattern Recognition and Adaptive First Order Models

It is a particularly important aspect of the present invention to provide:

(a) one or more FOMs 1224 that generate target MS 140 location estimates by using pattern recognition or associativity techniques, and/or

(b) one or more FOMs 1224 that are adaptive or trainable so that such FOMs may generate increasingly more accurate target MS location estimates from additional training.

5

#### Statistically Based Pattern Recognition First Order Models

Regarding FOMs 1224 using pattern recognition or associativity techniques, there are many such techniques available. For example, there are statistically based systems such as "CART" (acronym for Classification and Regression Trees) by  
10 ANGOSS Software International Limited of Toronto, Canada that may be used for automatically for detecting or recognizing patterns in data that were not provided (and likely previously unknown). Accordingly, by imposing a relatively fine mesh or grid of cells of the radio coverage area, wherein each cell is entirely within a particular area type categorization, such as the transmission area types (discussed in the section,  
15 "Coverage Area: Area Types And Their Determination" above), the verified location signature clusters within the cells of each area type may be analyzed for signal characteristic patterns. Accordingly, if such a characteristic pattern is found, then it can be used to identify one or more of the cells in which a target MS is likely to be located. That is, one or more location hypotheses may be generated having target MS  
20 MS 140 location estimates that cover an area having the identified cells wherein the target MS 140 is likely to be located. Further note that such statistically based pattern recognition systems as "CART" include software code generators for generating expert system software embodiments for recognizing the patterns detected within a training set (e.g., the verified location signature clusters).

25 A related statistical pattern recognition FOM 1224 is also disclosed in U.S. Patent 6,026,304, filed Jan. 8, 1997 and issued Feb. 15, 2000, having Hilsenrath and Wax as inventors, this patent (denoted the Hilsenrath patent herein) being incorporated herein fully by reference. An embodiment of a FOM 1224 based on the disclosure of

the Hilsenrath patent is referred to herein as the Hilsenrath FOM. The Hilsenrath FOM includes a wireless location estimator that locates a target MS 140 using measurements of multipath signals in order to accurately determine the location of the target MS 140. More particularly, to locate the target MS 140, the Hilsenrath FOM uses wireless measurements of both a direct signal transmission path and multipath transmission signals from the MS 140 to a base station 122 receiver. The wireless signals from the target MS 140 arrive at and are detected by an antenna array of the receiver at the BS 122, wherein the antenna array includes a plurality of antennas. A signal signature (e.g., an embodiment of a location signature herein) for this FOM may be derived from any combination of amplitude, phase, delay, direction, and polarization information of the wireless signals transmitted from the target MS 140 to the base station 122 receiver. The Hilsenrath FOM 1224 determines a signal signature from a signal subspace of a covariance matrix. In particular, for  $p$  antennas included in the base station receiver, these antennas are used to receive complex signal envelopes  $x_1(t), x_2(t), \dots, x_p(t)$ , respectively, which are conventionally grouped together to form a  $p$ -dimensional array vector  $x(t)=[x_1(t), x_2(t), \dots, x_p(t)]^T$ . The signal subspace may be determined from a collection of  $M$  such array vectors  $x(t)$  by several techniques. In one such technique, the outer products of the  $M$  vectors are added together to form a  $p \times p$  signal covariance matrix,  $R=1/M [x(t_1)x(t_1)^H + \dots + x(t_M)x(t_M)^H]$ . The eigenvalues of  $R$  whose magnitudes exceed a predetermined threshold determine a set of dominant eigenvectors. The signal subspace is the space spanned by these dominant eigenvectors. The signal signature is compared to a database of calibrated signal signatures and corresponding locations (e.g., an embodiment of the location signature data base 1320), wherein the signal signatures in the database include representations of the signal subspaces (such as the dominant eigenvectors of the covariance matrices. Accordingly, a location whose calibrated signature best matches the signal signature of the target MS 140 is selected as the most likely location of the target MS 140. Note that the database of calibrated signal signatures and corresponding verified locations is generated by a calibration procedure in which a calibrating MS 140 transmits location data derived from a co-located GPS

receiver to the base stations 122. Thus, for each of a plurality of locations distributed through a service area, the location has associated therewith: the (GPS or verified) location information and the corresponding signal signature of the calibrating MS 140.

Accordingly, the location of a target MS 140 in the service area may be  
5 determined as follows. Signals originating from the target MS 140 at an unknown location are received at a base station 122. A signal processor, e.g., at the base station 122, then determines the signal signature as described above. The signal signature is then compared with the calibrated signal signatures stored in the above described embodiment of the location signature database 1320 during the calibration procedure.  
10 Using a measure of difference between subspaces (e.g., an angle between subspaces), a set of likely locations is selected from this location signature database embodiment. These selected likely locations are those locations whose associated calibrated signal signatures differ by less than a minimum threshold value from the target MS 140 signal signature. The difference measure is further used to provide a corresponding  
15 measure of the probability that each of the selected likely locations is the actual target MS location. Moreover, for one or more of the selected likely location, the corresponding measure may be output as the confidence value for a corresponding location hypothesis output by a Hilsenrath FOM 1224.

Thus, an embodiment of the present invention using such a Hilsenrath FOM  
20 1224 performs the following steps (a) – (d):

- (a) receiving at an antenna array provided at one of the base stations 122, signals originating from the target MS 140, wherein the signals comprise p-dimensional array vectors sampled from p antennas of the array;
- (b) determining from the received signals, a signal signature, wherein the  
25 signal signature comprises a measured subspace, wherein the array vectors  $x(t)$  are approximately confined to the measured subspace;
- (c) comparing the signal signature to previously obtained (and similarly computed) signal signatures, wherein each of the previously obtained signal signatures, SS, has associated therewith corresponding location data  
30 verifying the location where SS was obtained, wherein this step of

comparing comprises substep of calculating differences between: (i) the measured subspace, and (ii) a similarly determined subspace for each of a plurality of the previously obtained signal signatures; and

(d) selecting from the previously obtained signal signatures a most likely signal signature and a corresponding most likely location of the target MS 140 by using the calculated differences;

Note that regardless of the reliability some FOMs as described here may not be exceedingly accurate, but may be very reliable. Thus, since an aspect of at least some embodiments of the present invention is to use a plurality of MS location techniques (FOMs) for generating location estimates and to analyze the generated estimates (likely after being adjusted) to detect patterns of convergence or clustering among the estimates, even large MS location area estimates may be useful. For example, it can be the case that four different and relatively large MS location estimates, each having very high reliability, have an area of intersection that is acceptably precise and inherits the very high reliability from each of the large MS location estimates from which the intersection area was derived.

Note, that another statistically based FOM 1224 may be provided wherein the radio coverage area is decomposed substantially as above, but in addition to using the signal characteristics for detecting useful signal patterns, the specific identifications of the base station 122 providing the signal characteristics may also be used. Thus, assuming there is a sufficient density of verified location signature clusters in some of the mesh cells so that the statistical pattern recognizer can detect patterns in the signal characteristic measurements, an expert system may be generated that outputs a target MS 140 location estimate that may provide both a reliable and accurate location estimate of a target MS 140.

#### Adaptive/Trainable First Order Models

The term adaptive is used to describe a data processing component that can modify its data processing behavior in response to certain inputs that are used to



change how subsequent inputs are processed by the component. Accordingly, a data processing component may be “explicitly adaptive” by modifying its behavior according to the input of explicit instructions or control data that is input for changing the component’s subsequent behavior in ways that are predictable and expected. That is, the input encodes explicit instructions that are known by a user of the component. Alternatively, a data processing component may be “implicitly adaptive” in that its behavior is modified by other than instructions or control data whose meaning is known by a user of the component. For example, such implicitly adaptive data processors may learn by training on examples, by substantially unguided exploration of a solution space, or other data driven adaptive strategies such as statistically generated decision trees. Accordingly, it is an aspect of the present invention to utilize not only explicitly adaptive MS location estimators within FOMs 1224, but also implicitly adaptive MS location estimators. In particular, artificial neural networks (also denoted neural nets and ANNs herein) are used in some embodiments as implicitly adaptive MS location estimators within FOMs. Thus, in the sections below, neural net architectures and their application to locating an MS is described.

#### Artificial Neural Networks For MS Location

Artificial neural networks may be particularly useful in developing one or more first order models 1224 for locating an MS 140, since, for example, ANNs can be trained for classifying and/or associatively pattern matching of various RF signal measurements such as the location signatures. That is, by training one or more artificial neural nets using RF signal measurements from verified locations so that RF signal transmissions characteristics indicative of particular locations are associated with their corresponding locations, such trained artificial neural nets can be used to provide additional target MS 140 location hypotheses. Moreover, it is an aspect of the present invention that the training of such artificial neural net based FOMs (ANN FOMs) is provided without manual intervention as will be discussed hereinbelow. Additional description of this aspect of the present invention can be found in the

copending U.S. patent application titled "Location Of A Mobile Station" filed Nov. 24, 1999 having Application No. 09/194,367 whose inventors are D. J. Dupray and C. L. Karr, which is incorporated herein by reference and wherein this copending patent application may have essential material for the present invention. In particular, this  
5 copending patent application may have essential material relating to the use of ANNs as mobile station location estimators 1224.

#### Other First Order Models

U.S. patent 5,390,339 ('339 patent) filed Oct. 23, 1991 having an issue date of Feb. 14, 1995 with inventor being Bruckert et. al. provides number of embodiments of  
10 wireless location estimators for estimating the location of a "remote unit." In particular, various location estimator embodiments are described in relation to Figs. 1B and 2B therein. The location estimators in the '339 patent are, in general, directed to determining weighted or adjusted distances of the "remote unit" (e.g., MS 140) from one or more "transceivers" (e.g., base stations 122). The distances are  
15 determined using signal strength measurements of wireless signals transmitted between the "remote unit" and the "transceivers." However, adjustments are in the signal strengths according to various signal transmission anomalies (e.g., co-channel interference), impairments and/or errors. Additionally, a signal RF propagation model may be utilized, and a likelihood of the "remote unit" being in the designated coverage  
20 areas (cells) of particular transceivers (e.g., base stations 122) is determined using probabilistic techniques such as posteriori probabilities. Accordingly, the Bruckert '339 patent is fully incorporated by reference herein and may contain essential material for the present invention.

U.S. patent 5,570,412 ('412 patent) filed Sept. 28, 1994 having an issue date of  
25 Oct. 29, 1996 with inventors LeBlanc et. al. provide further embodiments of wireless location estimators that may be used as First Order Models 1224. The location estimating techniques of the LeBlanc '412 patent are described with reference to Fig. 8

and succeeding figures therein. At a high level, wireless location techniques of the '412 patent can be characterized by the following quote therefrom:

5           “The location processing of the present invention focuses on the ability to predict and model RF contours using actual RF measurements, then performing data reduction techniques such as curve fitting technique, Bollinger Bands, and Genetic Algorithms, in order to locate a mobile unit and disseminate its location.”

Accordingly, the LeBlanc '412 patent is fully incorporated by reference herein and may contain essential material for the present invention.

10           U.S. patent 5,293,645 ('645 patent) filed Oct. 4, 1991 having an issue date of March 8, 1994 with inventor Sood. provide further embodiments of wireless location estimators that may be used as First Order Models 1224. In particular, the '645 patent describes wireless location estimating techniques using triangulations or other geographical intersection techniques. Further, one such technique is described in  
15           column 6, line 42 through column 7, line 7. Accordingly, the Sood '645 patent is fully incorporated by reference herein and may contain essential material for the present invention.

            U.S. patent 5,293,642 ('642 patent) filed Dec. 19, 1990 having an issue data of Mar. 8, 1994 with inventor Lo provide further embodiments of wireless location  
20           estimators that may be used as First Order Models 1224. In particular, the '642 patent determines a corresponding probability density function (pdf) about each of a plurality of base stations in communication with the target MS 140. That is, upon receiving wireless signal measurements from the transmissions between the target MS 140 and base stations 122, for each BS 122, a corresponding pdf is obtained from prior  
25           measurements of a particular wireless signal characteristic at locations around the base station. Subsequently, a most likely location estimation is determined from a joint probability density function of the individual base station probability density functions. Further description can be found in the Description Of The Preferred Embodiment section of the '642 patent. Accordingly, the Lo '642 patent is incorporated by  
30           reference herein and may contain essential material for the present invention.

## Hybrid First Order Models

### *Time Difference of Arrival and Timing Advance FOM*

A first order model 1224 denoted the Yost model herein. The Yost model includes a location estimator that uses a combination of Time Difference of Arrival (TDOA) and Timing Advance (TA) location determining techniques for determining the location of a target MS 140, wherein there are minor modifications to a telecommunication network such as a CMRS. The hybrid wireless location technique utilized by this location estimator uses TDOA measurements and TA measurements to obtain substantially independent location estimates of the target MS 140, wherein the TDOA measurements determine hyperbolae MS loci, about base stations 122 communicating (uni or bi-directionally) with the target MS, and the TA measurements determine circles about the base stations 122. Accordingly, an enhanced location estimate of the MS 140 can be obtained by using a least squares (or other statistical technique), wherein the least-squares technique determines a location for the MS between the various curves (hyperbolae and circles) that best approximates a point of intersection.. Note that TA is used in all Time Division Multiple Access (TDMA) systems as one skilled in the art will understand, and measurements of TA can provide a measurement of the distance of the MS from a TDMA communication station in communication with the target MS 140. The Yost model is disclosed in U.S. Patent 5,987,329 ('329 Patent) filed July 30, 1997 and issued Nov. 16, 1999 having Yost and Panchapakesan as inventors, this patent being fully incorporated herein fully by reference to thereby further describe the Yost model. The following quote from the '329 Patent describes an important aspect of the Yost model:

“Furthermore, the combination of TA and TDOA allows resolution of common ambiguities suffered by either technique separately. For example, in FIG. 5 a situation involving three base stations 24 (A, B and C as described, the latter being visible in the figure) is represented along with the resultant two hyperbolas AB and AC (and redundant hyperbola BC) for a TDOA position

determination of the mobile M. FIG. 5 is a magnified view of the mobile terminal M location showing the nearby base stations and the nearby portions at the curves. It should be understood that, in this case, using TDOA alone, there are two possible solutions, where the hyperbolae cross. The addition of the TA circles (dashed curves) will allow the ambiguous solutions, which lie at different TA from all three base stations, to be clearly resolved without the need for additional base station 24 measurements.”

As an aside note that a timing advance (TA) first order model may be provided as a separate FOM independent from the TDOA portion of the Yost model. Thus, if an embodiment of the present invention includes both a TA FOM and a TDOA FOM, then the multiple location estimator architecture of the present invention may substantially include the Yost model whenever both the TA FOM and TDOA FOM are both activated for a same location instance of a target MS 140. However, it is an aspect of the present invention to also activate such a TA FOM and a TDOA FOM asynchronously from one another.

#### *Satellite and Terrestrial Base Station Hybrid FOM*

A first order model 1224, denoted the Sheynblat model (FOM) herein, is disclosed in U.S. Patent 5,999,124 (denoted the ‘124 Patent herein) filed April 22, 1998 and issued Dec. 7, 1999 having Sheynblat as the inventor, this patent being fully incorporated herein by reference. The Sheynblat FOM provides a location estimator for processing target MS 140 location related information obtained from: (a) satellite signals of a satellite positioning system (denoted SPS in the ‘124 Patent) (e.g., GPS or GLONASS, LEO positioning satellites, and/or MEO positioning satellites), and (b) communication signals transmitted in the terrestrial wireless cellular network of BSs 122 for a radio coverage area, e.g., coverage area 120 (Fig. 4), wherein there is two-way wireless communication between the target MS 140 and the BSs. In one embodiment of the Sheynblat FOM, the location related information obtained from the satellite signals includes a representation of a time of travel of SPS satellite signals

from a SPS satellite to a corresponding SPS receiver operatively coupled to (and co-located with) the target MS 140 (such “time of travel” is referred to as a pseudorange to the SPS satellite). Additionally for this embodiment, the location related information obtained from the communication signals in the wireless cellular network includes time of travel related information for a message in the communication signals between a BS 122 transceiver and the target MS 140 (this second “time of travel” related information is referred to as a cellular pseudorange). Accordingly, various combinations of pseudoranges to SPS satellites, and cellular pseudoranges can be used to determine a likely location of the target MS 140. As an example, if the target MS 140 (enhanced with a SPS receiver) can receive SPS satellite signals from one satellite, and additionally, the target MS is also in wireless communication (or can be in wireless communication) with two BSs 122, then three pseudoranges may be obtained and used to determine the position of the target MS by, e.g., triangulation. Of course, other combinations are possible for determining a location of the target MS 140, e.g., pseudoranges to two SPS satellites and one cellular pseudorange. Additionally, various techniques may be used to mitigate the effects of multipath on these pseudoranges. For example, since it is typical for the target MS 140 to detect (or be detected by) a plurality of BSs 122, a corresponding plurality of cellular pseudoranges may be obtained, wherein such cellular pseudoranges may be used in a cluster analysis technique to disambiguate MS locations identified by the satellite pseudoranges. Moreover, the determination of a location hypothesis is performed, in at least one embodiment, at a site remote from the target MS 140, such as the location center/gateway 142, or another site that communicates with the location center/gateway for supplying a resulting MS location to the gateway. Alternatively, the target MS 140 may perform the calculations to determine its own location. Note that this alternative technique may be particularly useful when the target MS 140 is a mobile base station 148.

## MS Status Repository Embodiment

The MS status repository 1338 is a run-time storage manager for storing location hypotheses from previous activations of the location engine 139 (as well as the output target MS location estimate(s)) so that a target MS may be tracked using target MS location hypotheses from previous location engine 139 activations to determine, for example, a movement of the target MS between evaluations of the target MS location. Thus, by retaining a moving window of previous location hypotheses used in evaluating positions of a target MS, measurements of the target MS's velocity, acceleration, and likely next position may be determined by the location hypothesis analyzer 1332. Further, by providing accessibility to recent MS location hypotheses, these hypotheses may be used to resolve conflicts between hypotheses in a current activation for locating the target MS; e.g., MS paths may be stored here for use in extrapolating a new location

## Mobile Base Station Location Subsystem Description

### 15 Mobile Base Station Subsystem Introduction

Any collection of mobile electronics (denoted mobile location unit) that is able to both estimate a location of a target MS 140 and communicate with the base station network may be utilized by the present invention to more accurately locate the target MS. Such mobile location units may provide greater target MS location accuracy by, for example, homing in on the target MS and by transmitting additional MS location information to the location center 142. There are a number of embodiments for such a mobile location unit contemplated by the present invention. For example, in a minimal version, such the electronics of the mobile location unit may be little more than an onboard MS 140, a sectored/directional antenna and a controller for communicating between them. Thus, the onboard MS is used to communicate with the location center 142 and possibly the target MS 140, while the antenna monitors signals for homing in on the target MS 140. In an enhanced version of the mobile location unit, a GPS receiver may also be incorporated so that the location of the

mobile location unit may be determined and consequently an estimate of the location of the target MS may also be determined. However, such a mobile location unit is unlikely to be able to determine substantially more than a direction of the target MS 140 via the sectored/directional antenna without further base station infrastructure cooperation in, for example, determining the transmission power level of the target MS or varying this power level. Thus, if the target MS or the mobile location unit leaves the coverage area 120 or resides in a poor communication area, it may be difficult to accurately determine where the target MS is located. None-the-less, such mobile location units may be sufficient for many situations, and in fact the present invention contemplates their use. However, in cases where direct communication with the target MS is desired without constant contact with the base station infrastructure, the present invention includes a mobile location unit that is also a scaled down version of a base station 122. Thus, given that such a mobile base station or MBS 148 includes at least an onboard MS 140, a sectored/directional antenna, a GPS receiver, a scaled down base station 122 and sufficient components (including a controller) for integrating the capabilities of these devices, an enhanced autonomous MS mobile location system can be provided that can be effectively used in, for example, emergency vehicles, air planes and boats. Accordingly, the description that follows below describes an embodiment of an MBS 148 having the above mentioned components and capabilities for use in a vehicle.

As a consequence of the MBS 148 being mobile, there are fundamental differences in the operation of an MBS in comparison to other types of BS's 122 (152). In particular, other types of base stations have fixed locations that are precisely determined and known by the location center, whereas a location of an MBS 148 may be known only approximately and thus may require repeated and frequent re-estimating. Secondly, other types of base stations have substantially fixed and stable communication with the location center (via possibly other BS's in the case of LBSs 152) and therefore although these BS's may be more reliable in their in their ability to communicate information related to the location of a target MS with the location center, accuracy can be problematic in poor reception areas. Thus, MBSs may be used



in areas (such as wilderness areas) where there may be no other means for reliably and cost effectively locating a target MS 140 (i.e., there may be insufficient fixed location BS's coverage in an area).

Fig. 11 provides a high level block diagram architecture of one embodiment of the MBS location subsystem 1508. Accordingly, an MBS may include components for communicating with the fixed location BS network infrastructure and the location center 142 via an on-board transceiver 1512 that is effectively an MS 140 integrated into the location subsystem 1508. Thus, if the MBS 148 travels through an area having poor infrastructure signal coverage, then the MBS may not be able to communicate reliably with the location center 142 (e.g., in rural or mountainous areas having reduced wireless telephony coverage). So it is desirable that the MBS 148 must be capable of functioning substantially autonomously from the location center. In one embodiment, this implies that each MBS 148 must be capable of estimating both its own location as well as the location of a target MS 140.

Additionally, many commercial wireless telephony technologies require all BS's in a network to be very accurately time synchronized both for transmitting MS voice communication as well as for other services such as MS location. Accordingly, the MBS 148 will also require such time synchronization. However, since an MBS 148 may not be in constant communication with the fixed location BS network (and indeed may be off-line for substantial periods of time), on-board highly accurate timing device may be necessary. In one embodiment, such a device may be a commercially available rubidium oscillator 1520 as shown in Fig. 11.

Since the MBS 148, includes a scaled down version of a BS 122 (denoted 1522 in Fig. 11), it is capable of performing most typical BS 122 tasks, albeit on a reduced scale. In particular, the base station portion of the MBS 148 can:

- (a) raise/lower its pilot channel signal strength,
- (b) be in a state of soft hand-off with an MS 140, and/or
- (c) be the primary BS 122 for an MS 140, and consequently be in voice communication with the target MS (via the MBS operator telephony interface 1524) if the MS supports voice communication.

Further, the MBS 148 can, if it becomes the primary base station communicating with the MS 140, request the MS to raise/lower its power or, more generally, control the communication with the MS (via the base station components 1522). However, since the MBS 148 will likely have substantially reduced telephony traffic capacity in comparison to a standard infrastructure base station 122, note that the pilot channel for the MBS is preferably a nonstandard pilot channel in that it should not be identified as a conventional telephony traffic bearing BS 122 by MS's seeking normal telephony communication. Thus, a target MS 140 requesting to be located may, depending on its capabilities, either automatically configure itself to scan for certain predetermined MBS pilot channels, or be instructed via the fixed location base station network (equivalently BS infrastructure) to scan for a certain predetermined MBS pilot channel.

Moreover, the MBS 148 has an additional advantage in that it can substantially increase the reliability of communication with a target MS 140 in comparison to the base station infrastructure by being able to move toward or track the target MS 140 even if this MS is in (or moves into) a reduced infrastructure base station network coverage area. Furthermore, an MBS 148 may preferably use a directional or smart antenna 1526 to more accurately locate a direction of signals from a target MS 140. Thus, the sweeping of such a smart antenna 1526 (physically or electronically) provides directional information regarding signals received from the target MS 140. That is, such directional information is determined by the signal propagation delay of signals from the target MS 140 to the angular sectors of one of more directional antennas 1526 on-board the MBS 148.

Before proceeding to further details of the MBS location subsystem 1508, an example of the operation of an MBS 148 in the context of responding to a 911 emergency call is given. In particular, this example describes the high level computational states through which the MBS 148 transitions, these states also being illustrated in the state transition diagram of Fig. 12. Note that this figure illustrates the primary state transitions between these MBS 148 states, wherein the solid state transitions are indicative of a typical "ideal" progression when locating or tracking a

target MS 140, and the dashed state transitions are the primary state reversions due, for example, to difficulties in locating the target MS 140.

Accordingly, initially the MBS 148 may be in an inactive state 1700, wherein the MBS location subsystem 1508 is effectively available for voice or data

5 communication with the fixed location base station network, but the MS 140 locating capabilities of the MBS are not active. From the inactive state 1700 the MBS (e.g., a police or rescue vehicle) may enter an active state 1704 once an MBS operator has logged onto the MBS location subsystem of the MBS, such logging being for

authentication, verification and journaling of MBS 148 events. In the active state

10 1704, the MBS may be listed by a 911 emergency center and/or the location center 142 as eligible for service in responding to a 911 request. From this state, the MBS

148 may transition to a ready state 1708 signifying that the MBS is ready for use in locating and/or intercepting a target MS 140. That is, the MBS 148 may transition to the ready state 1708 by performing the following steps:

15 (1a) Synchronizing the timing of the location subsystem 1508 with that of the base station network infrastructure. In one embodiment, when requesting such time synchronization from the base station infrastructure, the MBS 148 will be at a predetermined or well known location so that the MBS time synchronization may adjust for a known amount of signal propagation delay in the synchronization signal.

(1b) Establishing the location of the MBS 148. In one embodiment, this may be accomplished by, for example, an MBS operator identifying the predetermined or well known location at which the MBS 148 is located.

25 (1c) Communicating with, for example, the 911 emergency center via the fixed location base station infrastructure to identify the MBS 148 as in the ready state.

Thus, while in the ready state 1708, as the MBS 148 moves, it has its location repeatedly (re)-estimated via, for example, GPS signals, location center 142S location estimates from the base stations 122 (and 152), and an on-board deadreckoning

30 subsystem 1527 having an MBS location estimator according to the programs

described hereinbelow. However, note that the accuracy of the base station time synchronization (via the rubidium oscillator 1520) and the accuracy of the MBS 148 location may need to both be periodically recalibrated according to (1a) and (1b) above.

5            Assuming a 911 signal is transmitted by a target MS 140, this signal is transmitted, via the fixed location base station infrastructure, to the 911 emergency center and the location center 142, and assuming the MBS 148 is in the ready state 1708, if a corresponding 911 emergency request is transmitted to the MBS (via the base station infrastructure) from the 911 emergency center or the location center, then  
10          the MBS may transition to a seek state 1712 by performing the following steps:

(2a) Communicating with, for example, the 911 emergency response center via the fixed location base station network to receive the PN code for the target MS to be located (wherein this communication is performed using the MS-like transceiver 1512 and/or the MBS operator telephony interface 1524).

15          (2b) Obtaining a most recent target MS location estimate from either the 911 emergency center or the location center 142.

(2c) Inputting by the MBS operator an acknowledgment of the target MS to be located, and transmitting this acknowledgment to the 911 emergency response center via the transceiver 1512.

20            Subsequently, when the MBS 148 is in the seek state 1712, the MBS may commence toward the target MS location estimate provided. Note that it is likely that the MBS is not initially in direct signal contact with the target MS. Accordingly, in the seek state 1712 the following steps may be, for example, performed:

(3a) The location center 142 or the 911 emergency response center may inform the  
25            target MS, via the fixed location base station network, to lower its threshold for soft hand-off and at least periodically boost its location signal strength. Additionally, the target MS may be informed to scan for the pilot channel of the MBS 148. (Note the actions here are not, actions performed by the MBS 148 in the "seek state"; however, these actions are given here for clarity and  
30            completeness.)

- (3b) Repeatedly, as sufficient new MS location information is available, the location center 142 provides new MS location estimates to the MBS 148 via the fixed location base station network.
- 5 (3c) The MBS repeatedly provides the MBS operator with new target MS location estimates provided substantially by the location center via the fixed location base station network.
- (3d) The MBS 148 repeatedly attempts to detect a signal from the target MS using the PN code for the target MS.
- 10 (3e) The MBS 148 repeatedly estimates its own location (as in other states as well), and receives MBS location estimates from the location center.
- Assuming that the MBS 148 and target MS 140 detect one another (which typically occurs when the two units are within .25 to 3 miles of one another), the MBS enters a contact state 1716 when the target MS 140 enters a soft hand-off state with the MBS. Accordingly, in the contact state 1716, the following steps are, for example,
- 15 performed:
- (4a) The MBS 148 repeatedly estimates its own location.
- (4b) Repeatedly, the location center 142 provides new target MS 140 and MBS location estimates to the MBS 148 via the fixed location base infrastructure network.
- 20 (4c) Since the MBS 148 is at least in soft hand-off with the target MS 140, the MBS can estimate the direction and distance of the target MS itself using, for example, detected target MS signal strength and TOA as well as using any recent location center target MS location estimates.
- (4d) The MBS 148 repeatedly provides the MBS operator with new target MS
- 25 location estimates provided using MS location estimates provided by the MBS itself and by the location center via the fixed location base station network.

When the target MS 140 detects that the MBS pilot channel is sufficiently strong, the target MS may switch to using the MBS 148 as its primary base station.

When this occurs, the MBS enters a control state 1720, wherein the following steps are, for example, performed:

- (5a) The MBS 148 repeatedly estimates its own location.
  - (5b) Repeatedly, the location center 142 provides new target MS and MBS  
5 location estimates to the MBS 148 via the network of base stations 122 (152).
  - (5c) The MBS 148 estimates the direction and distance of the target MS 140 itself using, for example, detected target MS signal strength and TOA as well as using any recent location center target MS location estimates.
  - (5d) The MBS 148 repeatedly provides the MBS operator with new target MS  
10 location estimates provided using MS location estimates provided by the MBS itself and by the location center 142 via the fixed location base station network.
  - (5e) The MBS 148 becomes the primary base station for the target MS 140 and therefore controls at least the signal strength output by the target MS.
- 15 Note, there can be more than one MBS 148 tracking or locating an MS 140. There can also be more than one target MS 140 to be tracked concurrently and each target MS being tracked may be stationary or moving.

#### MBS Subsystem Architecture

An MBS 148 uses MS signal characteristic data for locating the MS 140. The  
20 MBS 148 may use such signal characteristic data to facilitate determining whether a given signal from the MS is a “direct shot” or an multipath signal. That is, in one embodiment, the MBS 148 attempts to determine or detect whether an MS signal transmission is received directly, or whether the transmission has been reflected or deflected. For example, the MBS may determine whether the expected signal strength,  
25 and TOA agree in distance estimates for the MS signal transmissions. Note, other signal characteristics may also be used, if there are sufficient electronics and processing available to the MBS 148; i.e., determining signal phase and/or polarity as other indications of receiving a “direct shot” from an MS 140.

In one embodiment, the MBS 148 (Fig. 11) includes an MBS controller 1533 for controlling the location capabilities of the MBS 148. In particular, the MBS controller 1533 initiates and controls the MBS state changes as described in Fig. 12. Additionally, the MBS controller 1533 also communicates with the location controller 5 1535, wherein this latter controller controls MBS activities related to MBS location and target MS location. The location controller 1535 receives data input from an event generator 1537 for generating event records to be provided to the location controller 1535. For example, records may be generated from data input received from: (a) the vehicle movement detector 1539 indicating that the MBS 148 has moved 10 at least a predetermined amount and/or has changed direction by at least a predetermined angle, or (b) the MBS signal processing subsystem 1541 indicating that the additional signal measurement data has been received from either the location center 142 or the target MS 140. Note that the MBS signal processing subsystem 1541, in one embodiment, is similar to the signal processing subsystem 15 1541 of the location center 142. The MBS 148 may have multiple command schedulers. In particular, a scheduler 1528 for commands related to communicating with the location center 142, a scheduler 1530 for commands related to GPS communication (via GPS receiver 1531), a scheduler 1529 for commands related to the frequency and granularity of the reporting of MBS changes in direction and/or position via the MBS dead reckoning 20 subsystem 1527 (note that this scheduler is potentially optional and that such commands may be provided directly to the deadreckoning estimator 1544), and a scheduler 1532 for communicating with the target MS(s) 140 being located. Further, it is assumed that there is sufficient hardware and/or software to appear to perform commands in different schedulers substantially concurrently.

25 In order to display an MBS computed location of a target MS 140, a location of the MBS must be known or determined. Accordingly, each MBS 148 has a plurality of MBS location estimators (or hereinafter also simply referred to as location estimators) for determining the location of the MBS. Each such location estimator computes MBS location information such as MBS location estimates, changes to MBS location 30 estimates, or, an MBS location estimator may be an interface for buffering and/or

translating a previously computed MBS location estimate into an appropriate format. In particular, the MBS location module 1536, which determines the location of the MBS, may include the following MBS location estimators 1540 (also denoted baseline location estimators):

- 5 (a) a GPS location estimator 1540a (not individually shown) for computing an MBS location estimate using GPS signals,
- (b) a location center location estimator 1540b (not individually shown) for buffering and/or translating an MBS estimate received from the location center 142,
- 10 (c) an MBS operator location estimator 1540c (not individually shown) for buffering and/or translating manual MBS location entries received from an MBS location operator, and
- (d) in some MBS embodiments, an LBS location estimator 1540d (not individually shown) for the activating and deactivating of LBS's 152. Note  
15 that, in high multipath areas and/or stationary base station marginal coverage areas, such low cost location base stations 152 (LBS) may be provided whose locations are fixed and accurately predetermined and whose signals are substantially only receivable within a relatively small range (e.g., 2000 feet), the range potentially being variable. Thus, by communicating with the LBS's  
20 152 directly, the MBS 148 may be able to quickly use the location information relating to the location base stations for determining its location by using signal characteristics obtained from the LBSs 152.

Note that each of the MBS baseline location estimators 1540, such as those above, provide an actual MBS location rather than, for example, a change in an MBS  
25 location. Further note that it is an aspect of the present invention that additional MBS baseline location estimators 1540 may be easily integrated into the MBS location subsystem 1508 as such baseline location estimators become available. For example, a baseline location estimator that receives MBS location estimates from reflective codes provided, for example, on streets or street signs can be straightforwardly  
30 incorporated into the MBS location subsystem 1508.



Additionally, note that a plurality of MBS location technologies and their corresponding MBS location estimators are utilized due to the fact that there is currently no single location technology available that is both sufficiently fast, accurate and accessible in substantially all terrains to meet the location needs of an MBS 148.

5 For example, in many terrains GPS technologies may be sufficiently accurate; however, GPS technologies: (a) may require a relatively long time to provide an initial location estimate (e.g., greater than 2 minutes); (b) when GPS communication is disturbed, it may require an equally long time to provide a new location estimate; (c) clouds, buildings and/or mountains can prevent location estimates from being  
10 obtained; (d) in some cases signal reflections can substantially skew a location estimate. As another example, an MBS 148 may be able to use triangulation or trilateration technologies to obtain a location estimate; however, this assumes that there is sufficient (fixed location) infrastructure BS coverage in the area the MBS is located. Further, it is well known that the multipath phenomenon can substantially  
15 distort such location estimates. Thus, for an MBS 148 to be highly effective in varied terrains, an MBS is provided with a plurality of location technologies, each supplying an MBS location estimate.

In fact, much of the architecture of the location engine 139 could be incorporated into an MBS 148. For example, in some embodiments of the MBS 148,  
20 the following FOMs 1224 may have similar location models incorporated into the MBS:

- (a) a variation of the TCSO FOM 1224 wherein TOA signals from communicating fixed location BS's are received (via the MBS transceiver 1512) by the MBS and used for providing a location  
25 estimate;
- (b) a variation of the artificial neural net based FOMs 1224 (or more generally a location learning or a classification model) may be used to provide MBS location estimates via, for example, learned associations between fixed location BS signal characteristics and geographic  
30 locations;

- 5 (c) an LBS location FOM 1224 for providing an MBS with the ability to activate and deactivate LBS's to provide (positive) MBS location estimates as well as negative MBS location regions (i.e., regions where the MBS is unlikely to be since one or more LBS's are not detected by the MBS transceiver);
- (d) one or more MBS location reasoning agents and/or a location estimate heuristic agents for resolving MBS location estimate conflicts and providing greater MBS location estimate accuracy. For example, modules similar to the analytical reasoner module 1416 and the historical location reasoner module 1424.
- 10

However, for those MBS location models requiring communication with the base station infrastructure, an alternative embodiment is to rely on the location center 142 to perform the computations for at least some of these MBS FOM models. That is, since each of the MBS location models mentioned immediately above require

15 communication with the network of fixed location BS's 122 (152), it may be advantageous to transmit MBS location estimating data to the location center 142 as if the MBS were another MS 140 for the location center to locate, and thereby rely on the location estimation capabilities at the location center rather than duplicate such models in the MBS 148. The advantages of this approach are that:

- 20 (a) an MBS is likely to be able to use less expensive processing power and software than that of the location center;
- (b) an MBS is likely to require substantially less memory, particularly for data bases, than that of the location center.

As will be discussed further below, in one embodiment of the MBS 148, there are

25 confidence values assigned to the locations output by the various location estimators 1540. Thus, the confidence for a manual entry of location data by an MBS operator may be rated the highest and followed by the confidence for (any) GPS location data, followed by the confidence for (any) location center location 142 estimates, followed by the confidence for (any) location estimates using signal characteristic data from

30 LBSs. However, such prioritization may vary depending on, for instance, the radio

coverage area 120. In an one embodiment of the present invention, it is an aspect of the present invention that for MBS location data received from the GPS and location center, their confidences may vary according to the area in which the MBS 148 resides. That is, if it is known that for a given area, there is a reasonable probability that a GPS signal may suffer multipath distortions and that the location center has in the past provided reliable location estimates, then the confidences for these two location sources may be reversed.

In one embodiment of the present invention, MBS operators may be requested to occasionally manually enter the location of the MBS 148 when the MBS is stationary for determining and/or calibrating the accuracy of various MBS location estimators.

There is an additional important source of location information for the MBS 148 that is incorporated into an MBS vehicle (such as a police vehicle) that has no comparable functionality in the network of fixed location BS's. That is, the MBS 148 may use deadreckoning information provided by a deadreckoning MBS location estimator 1544 whereby the MBS may obtain MBS deadreckoning location change estimates. Accordingly, the deadreckoning MBS location estimator 1544 may use, for example, an on-board gyroscope 1550, a wheel rotation measurement device (e.g., odometer) 1554, and optionally an accelerometer (not shown). Thus, such a deadreckoning MBS location estimator 1544 periodically provides at least MBS distance and directional data related to MBS movements from a most recent MBS location estimate. More precisely, in the absence of any other new MBS location information, the deadreckoning MBS location estimator 1544 outputs a series of measurements, wherein each such measurement is an estimated change (or delta) in the position of the MBS 148 between a request input timestamp and a closest time prior to the timestamp, wherein a previous deadreckoning terminated. Thus, each deadreckoning location change estimate includes the following fields:

- (a) an "earliest timestamp" field for designating the start time when the deadreckoning location change estimate commences measuring a change in the location of the MBS;

(b) a “latest timestamp” field for designating the end time when the deadreckoning location change estimate stops measuring a change in the location of the MBS; and

(c) an MBS location change vector.

5 That is, the “latest timestamp” is the timestamp input with a request for deadreckoning location data, and the “earliest timestamp” is the timestamp of the closest time, T, prior to the latest timestamp, wherein a previous deadreckoning output has its a timestamp at a time equal to T.

Further, the frequency of such measurements provided by the deadreckoning subsystem 1527 may be adaptively provided depending on the velocity of the MBS 148 and/or the elapsed time since the most recent MBS location update. Accordingly, the architecture of at least some embodiments of the MBS location subsystem 1508 must be such that it can utilize such deadreckoning information for estimating the location of the MBS 148.

15 In one embodiment of the MBS location subsystem 1508 described in further detail hereinbelow, the outputs from the deadreckoning MBS location estimator 1544 are used to synchronize MBS location estimates from different MBS baseline location estimators. That is, since such a deadreckoning output may be requested for substantially any time from the deadreckoning MBS location estimator, such an output  
20 can be requested for substantially the same point in time as the occurrence of the signals from which a new MBS baseline location estimate is derived. Accordingly, such a deadreckoning output can be used to update other MBS location estimates not using the new MBS baseline location estimate.

It is assumed that the error with dead reckoning increases with deadreckoning  
25 distance. Accordingly, it is an aspect of the embodiment of the MBS location subsystem 1508 that when incrementally updating the location of the MBS 148 using deadreckoning and applying deadreckoning location change estimates to a “most likely area” in which the MBS 148 is believed to be, this area is incrementally enlarged as well as shifted. The enlargement of the area is used to account for the inaccuracy in  
30 the deadreckoning capability. Note, however, that the deadreckoning MBS location

estimator is periodically reset so that the error accumulation in its outputs can be decreased. In particular, such resetting occurs when there is a high probability that the location of the MBS is known. For example, the deadreckoning MBS location estimator may be reset when an MBS operator manually enters an MBS location or  
5 verifies an MBS location, or a computed MBS location has sufficiently high confidence.

Thus, due to the MBS 148 having less accurate location information (both about itself and a target MS 140), and further that deadreckoning information must be utilized in maintaining MBS location estimates, a first embodiment of the MBS  
10 location subsystem architecture is somewhat different from the location engine 139 architecture. That is, the architecture of this first embodiment is simpler than that of the architecture of the location engine 139. However, it important to note that, at a high level, the architecture of the location engine 139 may also be applied for providing a second embodiment of the MBS location subsystem 1508, as one skilled  
15 in the art will appreciate after reflecting on the architectures and processing provided at an MBS 148. For example, an MBS location subsystem 1508 architecture may be provided that has one or more first order models 1224 whose output is supplied to, for example, a blackboard or expert system for resolving MBS location estimate conflicts, such an architecture being analogous to one embodiment of the location  
20 engine 139 architecture.

Furthermore, it is also an important aspect of the present invention that, at a high level, the MBS location subsystem architecture may also be applied as an alternative architecture for the location engine 139. For example, in one embodiment of the location engine 139, each of the first order models 1224 may provide its MS location  
25 hypothesis outputs to a corresponding "location track," analogous to the MBS location tracks described hereinbelow, and subsequently, a most likely MS current location estimate may be developed in a "current location track" (also described hereinbelow) using the most recent location estimates in other location tracks. Thus, the location estimating models of the location center 139 and those of the MBS 148 are may be  
30 interchanged depending on the where it is deemed most appropriate for such each such

model to reside. Additionally, note that in different embodiments of the present invention, various combinations of the location center location architecture and the mobile station architecture may be utilized at either the location center or the MBS 148. Thus, by providing substantially all location estimating computational models at the location center 142, the models described here for locating the MBS 148 (and equivalently, its incorporated MS 140) can be used for locating other MSs 140 that are capable of supporting transmission of wireless signal measurements that relate to models requiring the additional electronics available at the MBS 140 (e.g., GPS or other satellite signals used for location).

Further, note that the ideas and methods discussed here relating to MBS location estimators 1540 and MBS location tracks, and, the related programs hereinbelow are sufficiently general so that these ideas and methods may be applied in a number of contexts related to determining the location of a device capable of movement and wherein the location of the device must be maintained in real time. For example, the present ideas and methods may be used by a robot in a very cluttered environment (e.g., a warehouse), wherein the robot has access: (a) to a plurality of "robot location estimators" that may provide the robot with sporadic location information, and (b) to a deadreckoning location estimator.

Each MBS 148, additionally, has a location display (denoted the MBS operator visual user interface 1558 in Fig. 11) where area maps that may be displayed together with location data. In particular, MS location data may be displayed on this display as a nested collection of areas, each smaller nested area being the most likely area within (any) encompassing area for locating a target MS 140. Note that the MBS controller algorithm below may be adapted to receive location center 142 data for displaying the locations of other MBSs 148 as well as target MSs 140.

Further, the MBS 148 may constrain any location estimates to streets on a street map using the MBS location snap to street module 1562. For example, an estimated MBS location not on a street may be "snapped to" a nearest street location. Note that a nearest street location determiner may use "normal" orientations of vehicles on streets as a constraint on the nearest street location. Particularly, if an MBS 148 is moving at

typical rates of speed and acceleration, and without abrupt changes direction. For example, if the deadreckoning MBS location estimator 1544 indicates that the MBS 148 is moving in a northerly direction, then the street snapped to should be a north-south running street. Moreover, the MBS location snap to street module 1562 may also be used to enhance target MS location estimates when, for example, it is known or suspected that the target MS 140 is in a vehicle and the vehicle is moving at typical rates of speed. Furthermore, the snap to street location module 1562 may also be used in enhancing the location of a target MS 140 by either the MBS 148 or by the location engine 139. In particular, the location estimator 1344 or an additional module between the location estimator 1344 and the output gateway 1356 may utilize an embodiment of the snap to street location module 1562 to enhance the accuracy of target MS 140 location estimates that are known to be in vehicles. Note that this may be especially useful in locating stolen vehicles that have embedded wireless location transceivers (MSs 140), wherein appropriate wireless signal measurements can be provided to the location center 142.

#### MBS Data Structure Remarks

Assuming the existence of at least some of the location estimators 1540 that were mentioned above, the discussion here refers substantially to the data structures and their organization as illustrated in Fig. 13.

The location estimates (or hypotheses) for an MBS 148 determining its own location each have an error or range estimate associated with the MBS location estimate. That is, each such MBS location estimate includes a "most likely MBS point location" within a "most likely area". The "most likely MBS point location" is assumed herein to be the centroid of the "most likely area." In one embodiment of the MBS location subsystem 1508, a nested series of "most likely areas" may be provided about a most likely MBS point location. However, to simplify the discussion herein each MBS location estimate is assumed to have a single "most likely area". One skilled in the art will understand how to provide such nested "most likely areas" from

the description herein. Additionally, it is assumed that such “most likely areas” are not grossly oblong; i.e., area cross sectioning lines through the centroid of the area do not have large differences in their lengths. For example, for any such “most likely area”, A, no two such cross sectioning lines of A through the centroid thereof may have  
5 lengths that vary by more than a factor of five.

Each MBS location estimate also has a confidence associated therewith providing a measurement of the perceived accuracy of the MBS being in the “most likely area” of the location estimate.

A (MBS) “location track” is a data structure (or object) having a queue of a  
10 predetermined length for maintaining a temporal (timestamp) ordering of “location track entries” such as the location track entries 1770a, 1770b, 1774a, 1774b, 1778a, 1778b, 1782a, 1782b, and 1786a (Fig. 13), wherein each such MBS location track entry is an estimate of the location of the MBS at a particular corresponding time.

There is an MBS location track for storing MBS location entries obtained from  
15 MBS location estimation information from each of the MBS baseline location estimators described above (i.e., a GPS location track 1750 for storing MBS location estimations obtained from the GPS location estimator 1540, a location center location track 1754 for storing MBS location estimations obtained from the location estimator 1540 deriving its MBS location estimates from the location center 142, an LBS  
20 location track 1758 for storing MBS location estimations obtained from the location estimator 1540 deriving its MBS location estimates from base stations 122 and/or 152, and a manual location track 1762 for MBS operator entered MBS locations).  
Additionally, there is one further location track, denoted the “current location track” 1766 whose location track entries may be derived from the entries in the other location  
25 tracks (described further hereinbelow). Further, for each location track, there is a location track head that is the head of the queue for the location track. The location track head is the most recent (and presumably the most accurate) MBS location estimate residing in the location track. Thus, for the GPS location track 1750 has location track head 1770; the location center location track 1754 has location track  
30 head 1774; the LBS location track 1758 has location track head 1778; the manual



location track 1762 has location track head 1782; and the current location track 1766 has location track head 1786. Additionally, for notational convenience, for each location track, the time series of previous MBS location estimations (i.e., location track entries) in the location track will herein be denoted the “path for the location track.” Such paths are typically the length of the location track queue containing the path. Note that the length of each such queue may be determined using at least the following considerations:

- (i) In certain circumstances (described hereinbelow), the location track entries are removed from the head of the location track queues so that location adjustments may be made. In such a case, it may be advantageous for the length of such queues to be greater than the number of entries that are expected to be removed;
- (ii) In determining an MBS location estimate, it may be desirable in some embodiments to provide new location estimates based on paths associated with previous MBS location estimates provided in the corresponding location track queue.

Also note that it is within the scope of the present invention that the location track queue lengths may be a length of one.

Regarding location track entries, each location track entry includes:

- (a) a “derived location estimate” for the MBS that is derived using at least one of:
    - (i) at least a most recent previous output from an MBS baseline location estimator 1540 (i.e., the output being an MBS location estimate);
    - (ii) deadreckoning output information from the deadreckoning subsystem 1527.
- Further note that each output from an MBS location estimator has a “type” field that is used for identifying the MBS location estimator of the output.
- (b) an “earliest timestamp” providing the time/date when the earliest MBS location information upon which the derived location estimate for the MBS depends. Note this will typically be the timestamp of the earliest

MBS location estimate (from an MBS baseline location estimator) that supplied MBS location information used in deriving the derived location estimate for the MBS 148.

- 5 (c) a “latest timestamp” providing the time/date when the latest MBS location information upon which the derived location estimate for the MBS depends. Note that earliest timestamp = latest timestamp only for so called “baseline entries” as defined hereinbelow. Further note that this attribute is the one used for maintaining the “temporal (timestamp) ordering” of location track entries.
- 10 (d) A “deadreckoning distance” indicating the total distance (e.g., wheel turns or odometer difference) since the most recently previous baseline entry for the corresponding MBS location estimator for the location track to which the location track entry is assigned.

15 For each MBS location track, there are two categories of MBS location track entries that may be inserted into a MBS location track:

- (a) “baseline” entries, wherein each such baseline entry includes (depending on the location track) a location estimate for the MBS 148 derived from:
- (i) a most recent previous output either from a corresponding MBS baseline location estimator, or (ii) from the baseline entries of other location tracks (this latter case being the for the “current” location track);
- 20 (b) “extrapolation” entries, wherein each such entry includes an MBS location estimate that has been extrapolated from the (most recent) location track head for the location track (i.e., based on the track head whose “latest timestamp” immediately precedes the latest timestamp of the extrapolation entry). Each such extrapolation entry is computed by
- 25 using data from a related deadreckoning location change estimate output from the deadreckoning MBS location estimator 1544. Each such deadreckoning location change estimate includes measurements related to changes or deltas in the location of the MBS 148. More precisely, for
- 30 each location track, each extrapolation entry is determined using: (i) a

baseline entry, and (ii) a set of one or more (i.e., all later occurring) deadreckoning location change estimates in increasing “latest timestamp” order. Note that for notational convenience this set of one or more deadreckoning location change estimates will be denoted the “deadreckoning location change estimate set” associated with the extrapolation entry resulting from this set.

(c) Note that for each location track head, it is either a baseline entry or an extrapolation entry. Further, for each extrapolation entry, there is a most recent baseline entry, B, that is earlier than the extrapolation entry and it is this B from which the extrapolation entry was extrapolated. This earlier baseline entry, B, is hereinafter denoted the “baseline entry associated with the extrapolation entry.” More generally, for each location track entry, T, there is a most recent previous baseline entry, B, associated with T, wherein if T is an extrapolation entry, then B is as defined above, else if T is a baseline entry itself, then  $T=B$ . Accordingly, note that for each extrapolation entry that is the head of a location track, there is a most recent baseline entry associated with the extrapolation entry.

Further, there are two categories of location tracks:

- (a) “baseline location tracks,” each having baseline entries exclusively from a single predetermined MBS baseline location estimator; and
- (b) a “current” MBS location track having entries that are computed or determined as “most likely” MBS location estimates from entries in the other MBS location tracks.

#### MBS Location Estimating Strategy

In order to be able to properly compare the track heads to determine the most likely MBS location estimate it is an aspect of the present invention that the track heads of all location tracks include MBS location estimates that are for substantially the same (latest) timestamp. However, the MBS location information from each MBS baseline

location estimator is inherently substantially unpredictable and unsynchronized. In fact, the only MBS location information that may be considered predicable and controllable is the deadreckoning location change estimates from the deadreckoning MBS location estimator 1544 in that these estimates may reliably be obtained

5 whenever there is a query from the location controller 1535 for the most recent estimate in the change of the location for the MBS 148. Consequently (referring to Fig. 13), synchronization records 1790 (having at least a 1790b portion, and in some cases also having a 1790a portion) may be provided for updating each location track with a new MBS location estimate as a new track head. In particular, each

10 synchronization record includes a deadreckoning location change estimate to be used in updating all but at most one of the location track heads with a new MBS location estimate by using a deadreckoning location change estimate in conjunction with each MBS location estimate from an MBS baseline location estimator, the location track heads may be synchronized according to timestamp. More precisely, for each MBS

15 location estimate, E, from an MBS baseline location estimator, the present invention also substantially simultaneously queries the deadreckoning MBS location estimator for a corresponding most recent change in the location of the MBS 148. Accordingly, E and the retrieved MBS deadreckoning location change estimate, C, have substantially the same "latest timestamp". Thus, the location estimate E may be used

20 to create a new baseline track head for the location track having the corresponding type for E, and C may be used to create a corresponding extrapolation entry as the head of each of the other location tracks. Accordingly, since for each MBS location estimate, E, there is a MBS deadreckoning location change estimate, C, having substantially the same "latest timestamp", E and C will be hereinafter referred as "paired."

## 25 High Level Description Of A Wireless Platform

Fig. 20 is a high level block diagram illustrating the wireless application platform 2004 of the present invention in combination with various services and network components with which the platform communicates. In particular, the embodiment of Fig. 20 is illustrative of how the platform 2004 communicates with,

e.g., the subscribers (e.g., users 2008), applications (e.g., applications 2016, 2020, 2024, 2028, and 2032 which may or may not receive wireless location related information from the wireless location gateway 142), and network accessible components (e.g., wireless equipment) for a single commercial wireless carrier. The platform 2004 communicates with subscribers or users 2008 of the wireless carrier via, e.g., a mobile station 140 in communication with various provisioning equipment and communication services of the wireless carrier, collectively this equipment and communication services are identified as carrier network provisioning 2012, and may include e.g.:

- 10 1. wireless voice and/or wireless data (local and/or long distance) services;
2. Internet access;
3. high speed data and/or Internet services such as (3G, cable, DSL, ISDN, satellite communications, etc.);
4. telephony specific services (e.g., call forwarding, call back busy, Caller ID, Do  
15 Not Disturb, prepaid calling card services, etc.);
5. PBX and/or business network installation and maintenance services;
6. teleconferencing provisioning and services; and/or
7. short messaging services (SMS).

More particularly, users 2008 can communicate various requests to the platform 2004  
20 for various wireless location related services such as:

- PR 1. Requests for routing the user from his/her location to a desired location;
- PR 2. Requests for information about products, services, places and/or persons that are geographically related to a location of the user 2008;
- PR 3. Requests for displaying and/or modifying, e.g., user profile information  
25 to thereby change access permissions, and/or profile visibility;
- PR 4. Requests for activating or deactivating services wireless services such as hotel concierge wireless location and routing services offered by hotel, such services capable of, e.g., being attached and detached from a user's profile as a unit;

PR 5. Requests for procuring products and/or services (location related or otherwise); and/or

PR 6. Standard telephony, Internet and data services.

It is worth noting that embodiments of related wireless platforms have been  
5 described in the art. In particular, International Patent Application PCT/US01/02526,  
filed January 26, 2001 by McDowell et. al. titled: "Method and Apparatus For Sharing  
Mobile User Event Information Between Wireless Between Wireless and Fixed IP  
Networks" incorporated herein fully by reference, and, International Patent  
Application PCT/US02/04533, filed February 15, 2002 by McDowell et. al. titled:  
10 "Use Of Presence And Location Information Concerning Wireless Subscribers For  
Instant Messaging And Mobile Commerce" also incorporated herein fully by  
reference. However, these platforms appear directed to short messaging service  
applications and ecommerce (i.e., merchant advertising), and do not appear to address  
issues related to the easy incorporation of entirely new complex network services, and  
15 in particular, network services wherein there is a uniform architecture for  
communications between the platform and new network service applications. Instead,  
the PCT/US02/04533 application is directed to: "the integration of presence  
determination, location determination, Instant Messaging, and mobile commerce into a  
functionally seamless system" wherein such presence determination "determines  
20 whether a mobile device is ON or OFF in real-time." So that this system "may then  
share the revenue generated through the sale of subscriber information with the  
participating wireless carriers that host the subscribers.", and "determines both Internet  
presence and wireless network presence, and makes this information available to  
entities on both networks." However, the above-identified McDowell et. al. PCT  
25 patent applications do provide appropriate supportive and enabling information for the  
present invention, and in particular, the platform 2004.

Fig. 22 shows an embodiment of the high level steps performed that can be  
performed by the platform 2004. Descriptions of these steps follows:

Step 2204: The subscriber interfaces 2104 (Fig. 21) receives a service request  
30 from a user 2008, via the carrier network provisioning 2012 (Fig. 20).

Note that such service requests may be from users 2008 where such users include not only persons, but also entities such as businesses, employers, other telecommunication carriers, government agencies (e.g., command, control, and communications centers), law enforcement, etc. In at least some circumstances, the actual payload of the data describing the service request and/or related data in the request may be encrypted. Thus, the present step determines whether one or portions of the service request is encrypted, and if so, activates the encryption and decryption component 2108 (Fig. 21) for decrypting the service request. Encryption/decryption cyphers are well known in the art, and accordingly will not be discussed at length here. However, the encryption and decryption component 2108 may support a substantial number encryption/decryption cyphers (e.g., RC4 and RSA, by Security Inc, Belford, Massachusetts, USA) as well as such general encryption techniques as public/private key cryptographic technique such Diffie-Hellman.

Note that the present step may identify, e.g., at least some of the following data items:

- (i) the identity of the requestor;
- (ii) the identity of an entity (or entities) to whom an action of the request is directed, e.g., (a) the identity of the person or MS 140 whose wireless location is requested (this may be the mobile identification number (MIN) as one skilled in the art will understand), or (b) the identity of a package whose whereabouts is being tracked, (c) the location of an MS 140 which to be identified (e.g., in a battlefield context to determine if the location of the MS corresponds to friend or foe);
- (iii) any additional data that may be needed by an application activated to fulfill the request, e.g., for an MS 140 location request, this may include the last known location of the MS;

- (iv) any timing constraints that the service requesting application should be aware of;
- (v) any authorization code needed for granting access to any generated information about the entity (e.g., for determining a subscriber's location, a code indicating that permission has been obtained to locate the subscriber, or a code indicating that location of the subscriber is at the request of the government agency responsible for national security or crime prevention);
- (vi) any encryption parameters needed for a resulting response to the request;
- (vii) the identity of any specific application to be activated to fulfill the request;
- (viii) any billing code required in order to bill for fulfilling the service request;
- (ix) a priority for fulfilling the service request (note, emergency 911 and other time critical life threatening or emergency services will have highest priority and may pre-empt other service requests being processed by the platform 2004);
- (x) identity of all destinations, entities and/or persons to which the results from the fulfillment (and/or activation) of the service request is to be transmitted;
- (xi) any authorization code or protocol to be used in identifying the appropriate person or entity prior to presenting information related to the results of the service request.

Further note, however, that it is not intended that the user 2008 be required to enter all of the items identified in this step. In particular, many of these items may be automatically filled in with default values residing on the user's service requesting device.

Step 2208: With any decryption completed, the service request is now readable and accordingly may be logged in the user request & response log



management database 2112 so that, e.g., (i) audits can be performed for verifying what service requests have been received, (ii) analyzing platform 2004 performance, diagnosing errors in service request processing, and/or statistical analysis of service request volume may be performed, and (iii) tracking or identifying criminal behavior and/or misuse of a service offered by the platform 2004.

Regarding the request & response log management database 2112, this database may capture and store at least most of the following information related to a service request received by the platform 2004:

- (a) The identity of the party initiating the service request, e.g., a user ID or log in name;
- (b) The time of receipt of the service request;
- (c) The identity of the service requested;
- (d) The priority of the service request (if any provided);
- (e) Any time constraints that the service request is imposing (e.g., a response within 30 seconds);
- (f) Information related to the source of the request, e.g., the MIN (or other identification) of an MS 140 requesting service, or an Internet address of a service requestor;
- (g) Any authorization code for permitting the service request to be performed; and
- (h) Any billing code identifying who is to be charged.

Step 2212: Subsequently, a readable version of the service request is provided to the subscriber identification & application authorization subsystem 2116 (Fig. 21), wherein the identification of both the requestor and the application to be activated to fulfill the service request is determined. The subsystem 2116 may access various user identification repositories, such as user profile repositories collectively labeled 2120 (Fig. 21), including customer care data

management systems that are maintained by, e.g., a wireless carrier responsible for the operation of the platform 2004, such repositories being, e.g., home location registers (HLRs) and Visitor Location Registers (VLRs). Additionally, some of the repositories 2120 may be accessed only via another network carrier not affiliated or responsible for the operation of the platform 2004. Such repositories may be accessed for obtaining, e.g., (i) additional user information that may not have been provided with the service request, and/or (ii) an identification of the carrier network (if any) to which the user is a subscriber. In particular, such additional information may relate to an authorization to activate, e.g., a wireless location based application, and receive a response therefrom. Note that such authorization may include two processes: a determination of whether the user is eligible to make the request (e.g., such eligibility may be substantially determined according to, e.g., the service package to which the user 2008 has subscribed and whether the user's subscription remains active), and a determination as to whether the current service request can be honored given privacy, security, and/or legal constraints that must satisfied for fulfilling the service request, e.g., location based network services where a person different from the user 2008 is to be located.

In one embodiment, if the user 2004 is a roamer (civilian or military), the network carrier operably responsible for the platform 2004 may initiate, via the subsystem 2116, a request for user profile information to be transmitted from the user's subscriber network or other central profile repository. Various embodiments of such profiles and/or data within them are provided throughout this description. Thus, a user profile may include substantially any user information that is required to allow or prohibit access, activation, or fulfillment of a network service by the user, or, by another user where

the requested service, by the other user, requires accessing information about the user that is identified as being confidential or private. However, in one preferred embodiment such user profiles may be automatically requested when the roamer activates his/her MS 140 for out of network service. Moreover, it may be the case that when fulfillment of the service request requires the location or other personal information (e.g., financial information) of another user or entity, at least a portion of the profile for this other user or entity must be queried or accessed for determining whether such a location activity is permissible and/or legal. That and such information may be substantially only accessible from the carrier network to which the user is a subscriber.

In order to identify the service being requested, the subsystem 2116 can access the user assessable & authorized services database 2124 (Fig. 21) for determining the services that are currently accessible from via the platform 2004, e.g., as called services or platform aware connection services as described in the Summary section hereinabove. Additionally, the database 2124 may be accessed by the subsystem 2116 for retrieving information related to who is authorized to access certain services. For example, certain network services may be available for only a particular time period(s). For example, a particular network based game may extend for a predetermined time period such as three weeks, or may be only played on non-holiday weekends when there is less network traffic. In such a case, it may more expedient to associate game activation authorization data with information identifying the game in the database 2124 than iteratively modifying, e.g., user 2008 profiles of game players for indicating when the game can be accessed as a network service. Additionally, note that a network service that is malfunctioning may be easily prevented from being accessed if such

authorizations are associated with network service identifications.

Furthermore, it may be the case, that an alternative service provider may be utilized for fulfilling the service. Thus, the preferred (now malfunctioning) service provider may be effectively disconnected from being accessed by users 2008, and a second less preferred backup network service activated for the providing substantially the same service in a manner that is transparent to the users 2008.

Examples where such backup service providers may be desirable are:

(i) when wireless location requests must be fulfilled (e.g., E911 requests) and the primary wireless location service provider is experiencing operational difficulties, then a second less desirable backup wireless location service provider may be easily activated (assuming all communication and data flow paths with the second location service provider have been previously established) by merely changing the value of the activation information for each of the primary and secondary wireless location service providers in the database 2124, (ii) when a service provider for an Internet service 2128 (Fig. 21) such as service provider for an Internet connection, or some other Internet accessible service such as a search engine or a battlefield command and control Internet site becomes inoperative, then users 2004 may be transparently (or substantially so) switched to a corresponding backup service provider for the Internet service.

Thus, the database 2124 may allow for providing a simple and effective technique for providing the platform 2004 with a measure of fail safeness to network services that are accessible via the platform 2004.

Note that the services & applications 2016 (Fig. 20) are representative examples of some of the services that may be requested as called services. However, these services may also be connection services, e.g., the 911 may be a voice over IP connection which also

provides the FCC mandated information to the 911 center. The services identified in 2016 will now be briefly described:

- i. Yellow page services related to the purchase of products and/or services, and in particular electronic networked yellow page services as described more fully under the section Wireless Location Applications hereinbelow;
- ii. Emergency services such as E-911 in the USA (note that emergency services are typically routed through substantially dedicated channels; however, it is believed that with increasing network bandwidth and robustness, such dedicated channels can be substantially dispensed with and, instead, such emergency services can be appropriately and timely performed by using the platform 2004 of the present invention. Moreover, by utilizing the platform 2004, emergency services may be significantly enhanced by, e.g., accessing the emergency callers profile and thereby alerting friends, relatives, neighbors, and/or appropriate passersby. Additionally, caller medical information may be provided in the caller's profile such as type of medical insurance, caller medical conditions, and/or medical personal to be alerted;
- iii. 411 information services, and in particular, location based information services, and more particularly "intelligent" location based information services such as the location based routing services described hereinbelow in the section titled Routing Applications, and the section titled Point of Interest Applications hereinbelow;
- iv. Roaming services such as wireless concierge services that may be offered to travelers by, e.g., hotels as described more fully in the section titled Roaming Services hereinbelow.

Note, however, that for different application domains very different network services may be available. For example, in a military or battlefield context there may be analogous services to some of the items (i) through (iv) immediately above; however, certainly additional network services are likely such as network services for real time control over robotic or surveillance battlefield devices.

5  
Step 2216: Subsequently, a determination is made by the subscriber identification & application authorization subsystem 2116 as to whether the network service request is an emergency such as an E911 request.

10  
Step 2220: If the results from Step 2216 is positive, then the subsystem 2116 activates an emergency protocol for communicating with one or more emergency response service providers 2132 (represented in Fig. 21 by the 911 processing block 2132), whereby, e.g., a predetermined series of emergency tasks or steps are performed for: (i) locating the emergency, (ii) identifying the type of emergency, and (iii) directing assistance to the emergency or directing persons out of the emergency. When the platform 2004 is used for accessing network services within a U.S. commercial mobile radio provider network (CMRS), the U.S. Federal Communications Commission (FCC) provides guidelines and mandates regarding how and what emergency tasks are performed. Such emergency protocols are well known in the art and are not elaborated on here. However, note that such emergency protocols may be different when the platform 2004 is utilized in a military or battlefield context, or in the context of a major disaster such as damage from a hurricane or a biological terrorist attack in that there may be many requests for emergency services within a relatively short timeframe (e.g., 1 minute to 12 hours or longer). However, whether the platform 2004 is utilized in a civilian or military context, a high rate of emergency service requests

15  
20  
25  
30

can be problematic for the communications network to appropriately handle. In one embodiment, of the platform 2004, the subsystem 2116 detects high rates of emergency requests, and alerts a platform controller 2136 (Fig. 21) which, e.g., allocates computational resources within the platform 2004, and handles error or exceptional event processing. The controller 2136 may in one embodiment, modify the database 2124 so that when the subsystem 2116 subsequently accesses this database for determining an emergency response service provider to service emergency requests, the database 2124 commences to distribute the output identifications of emergency response service over a plurality of such service providers. Thus, two successive requests for a emergency response service provider by the subsystem 2116 may result in different in identifications of two different service providers, whereas without the controller 2136 database modification, the same emergency response service provider would have been provided to the subsystem 2116. Note that the database 2124 may use a static or fixed allocation scheme for allocating emergency service requests among a plurality of emergency response service providers 2132 operatively connected to the platform 2004. Alternatively, a dynamic scheme may be used wherein there is feedback to the platform 2004 (and more particularly, the controller 2136) from each (or at least some) of the emergency response service providers 2132 providing data indicative of the emergency processing loads they are experiencing. For example, such feedback from an emergency response service provider may include one or more of: (i) a measurement related to the number of emergency requests that are queued and not currently being processed (e.g., the current number or the average over some time period); (ii) a measurement related to the rate at which emergency requests are being processed (e.g., an average number of emergency requests fully processed in a particular

time period); (iii) one or more measurements related to the time to process a specified number of emergency requests (e.g., an average time for fully processing a moving window of 10 emergency requests, a percentage of the number of emergency requests being currently processed that are identified as likely to require very lengthy or an indeterminate amount of time to process; (iv) a measurement related to the overall emergency response processing load (e.g., this measurement identified as high whenever a measurement for (i) is above a predetermined threshold, or a measurement for (iii) above is above a predetermined threshold).

Thus, upon receiving such feedback, the controller 2136 may be able to adjust the distribution of emergency requests among the emergency response service providers to thereby balance the loads on these service providers, or provide a higher emergency response completion rate, or provide a lower average time for providing an initial response to emergency requests.

Moreover, the present step also includes providing what is known as "reverse 911" protocols, wherein persons in a given area are alerted to an eminent or likely emergency situation or event which may be dangerous to them, e.g., an impending flood, an enemy aircraft that is nearby, a change in the direction of a forest fire or hurricane, etc. Thus, for such reverse 911 service requests, the requestor is likely to be a governmental agency or designated agent (e.g., a field observer), and location information, e.g., indicating the area to likely be affected by the imminent threat is provided with the service request. Accordingly, subscribers (and others that can be contacted) whose location is identified as being in designated area are notified of the danger. Thus, it is aspect of the platform 2004 to push certain types of information to users' MSs 140 such as reverse 911 information.



Step 2224: If the result from step 2216 indicates that the service request is not for an emergency, then in step 2224 the subsystem 2116 may access a billing system 2140 (Fig. 21) for determining whether the request by a user 2008 should be honored. Note such access to the billing system 2140 may be desirable for the present invention since an important aspect of the platform 2004 is the ability to provide common network services (and in particular complex network services, and more particularly, wireless location base network services) to a large and potentially varying number of network services. That is, it may be the case that a user 2008 is denied further access to a particular network service due to a delinquent payment or disputed charges, but is given access to other network services. Additionally, the present step accesses the database 2120 for retrieving profile information for the user 2008 requesting the service, and/or the user profile information related to the service or application being requested.

Step 2228: In the present step a determination is made by the subsystem 2116 as to whether the application being requested is known to the platform 2004. Note that for roaming MS 140 users, they may request services that are not available in a network in which they are roaming.

Step 2232: If the result from step 2228 is negative, then in one embodiment of the present step an applications controller 2144 and more particularly application access initialization 2148 attempts to obtain data for initializing access to the requested service and providing the billing system 2140 with sufficient information for billing for the service request. If the application access initialization 2148 is successful, then in these two substeps, then retrieved application request description data may be in the application requirements database management system 2152. However, in another alternative embodiment of the present step, the application access initialization 2148 outputs a request failure code, and this code is provided to the

subscriber interfaces component 2104, wherein an appropriate representation of this failure is presented to the user 2008 by accessing the presentation engine 2156 for generating a presentation that is presentable at the user's network device such as an MS 140.

5 Subsequently, in this embodiment, the process of Fig. 22 terminates relative to the service request being processed.

Step 2236: If the result from step 2228 is positive, then in one embodiment the subsystem 2116 determines whether there is authorization for activating an application for fulfilling the service request.

10 Step 2240: If the result of step 2236 is negative, then in a similar manner to the alternative embodiment of step 2232 a failure indication is output to the user.

Step 2244: If the result of step 2236 is positive, then the applications controller 2144 performs the following steps: (a) it parses the service request for identifying service request specific data; (b) it prioritizes the service request according to, e.g., desired performance requirements for fulfilling the service request and priority; and (c) if needed, determines network access paths for accessing the application that can fulfill the service request, and/or activates the request provisioning system 2160 for determining/allocating network resources such as equipment and bandwidth (e.g., virtual private communication channels or allocating bandwidth for a user requested movie to be streamed to his/her MS 140).

20  
25  
30 Step 2248: In the present step, the applications controller 2144 in combination with the request provisioning system 2160: (a) accesses the applications requirements data management system 2152 to determine what activations of other network services are required by the current service request being processed by the applications controller 2144, and (b) determines how such additional network service output are to be provided to the current service request being

processed; e.g., output format, output timing restrictions, accuracy  
restrictions, etc. Note that the applications requirements data  
management system 2152 may include scripts or other interpretative  
or executable code that identifies a series of intermediate service  
5 requests that must be performed to fulfill the user's input service  
request. Moreover, in some embodiments, the user's input service  
request may substantially identify such intermediate steps and thereby  
over ride any default intermediate service requests in the data  
management system 2152. In particular, the user service request  
10 input may be declarative in nature, wherein the user identifies what is  
to be performed in as much detail as desired and the system 2152  
determines the mapping between a desired output and the one or more  
service requests the need to be fulfilled in order to fulfill the user's  
request. Thus, for each service request for which the platform 2004 is  
15 responsible for processing the request, the system 2152 includes, e.g.,  
a script, schema or other data structure indicating the services to be  
activated, any sequencing of those services. Note that by providing  
such data structures (e.g., service request scripts) so that they are  
accessible by the platform 2004, then following advantages are  
20 obtained: (1) any backup or alternative services that can be used may  
be performed as necessary without the users 2004 having to specify  
such alternatives; (2) network and/or service request enhancements  
may be more easily utilized in fulfilling service requests certain  
service requests; e.g., certain location based service requests may  
25 require a particular location accuracy and such accuracy may require  
activating more than one location service provider. Typically, the  
wireless location gateway or location center 142 would provide such  
functionality. However, certain networks utilize such a gateway and  
the platform 2004 may assume such responsibility. Accordingly,  
30 such scripts for location based services that require a predetermined

accuracy may be modified without the need to change to user service requests input to the platform 2004. Thus, a location based dating service may require location based information of mobile stations 140 that are within 20 meters of one another, and it may be determined (e.g., through user complaints) that the accuracy currently being provided is insufficient. Thus, the corresponding script for fulfilling an activation of the dating service request may be changed to use additional location service providers and/or a location gateway 142 entirely transparent to the users 2008. In another example, if the platform 2004 offers a service request to obtain estimates for obtaining discounted hotel rooms for users 2008 seeking immediate occupancy in a relatively local geographical area (e.g., a city or within 5 miles of the user), the script for such a service may change frequently according to season, occupancy rates, hotels opting in or out of such a service.

- 15
- Step 2252: A determination is made by the applications controller 2144 as to whether there are currently sufficient network resources available to appropriately fulfill the service request currently being processed (more precisely, attempting to be processed).
- 20
- Step 2256: If the result from step 2252 is negative, then in one embodiment of the present step, the applications controller 2144 requeues the current service for examining at a later time and commences processing another service request as the current request. Additionally, the applications controller 2144 may issue an allocation request to the request provisioning system 2160 to reserve certain network resources (e.g., reserve a high bandwidth data channel) if such is needed by the previous "current" service that has been requeued. If the requeued service request is not processed within a request specific amount of time, then as in the alternative embodiment of step 2232, the user 2008 is informed of the failure of the service request.
- 25
- 30

However, in one alternative embodiment, instead of notifying the user 2008 of failure, the user may be notified that there is a delay in fulfilling the service request and the user may be provided with the option of canceling the service request or waiting for its fulfillment.

5 Step 2260: The applications controller 2144 activates one or more applications for fulfilling the service request currently being processed since all the network resources it requires are available as well as the application(s) for fulfillment of the request. Note that the service request data processed by the applications controller 2144 may be in  
10 form of script that the controller 2144 interprets.

Step 2264: In some circumstance service requests are automatically activated as, e.g., intermediate steps in fulfilling another service request. Accordingly, the present step illustrates the performance of such automatically activated service requests.

15 The above high level description of the processing performed by the platform 2004 is not fully descriptive of the entire processing capabilities that various embodiments of the present invention may include nor of other features and benefits of the components that communicate with the platform 2004. Accordingly, additional description of component provided by or in communication with an embodiment of  
20 the platform 2004 will now be described:

(a) billing system 2140: Note that in one embodiment of the platform 2004 the billing system 2140 (or an enhancement thereto) is the billing system of the wireless carrier with whom the user 2008 subscribes for wireless services. It is contemplated that for various wireless  
25 applications, and particularly location based applications, such applications can be more quickly make available to subscribers 2008 if the already existing network infrastructure and support services (such as billing) are used. Thus, assuming an appropriate and preferably uniform interface between service request fulfillment application  
30 management processes (not shown) and the billing system 2104,

business rules, charges for existing, new and removed application services maybe communicated to the billing system 2104. Furthermore, such a central billing system 2104 makes it easier for network services, and in particular, complex network services such as location based services to be bundled or packaged together and potentially provided under the trademarks or servicemarks of the wireless carrier even though such "private label" applications (identified in Fig. 20 by the components labeled 2020 and 2024) are owned and operated by third parties. Moreover, such a central billing system 2140 also has the advantage of providing fewer individual bills to the subscribers 2008 in that charges for such services may be incorporated into the bill provided by the subscriber's wireless carrier;

- (b) data exposure engine: This component provides the functionality described in the Wireless Application Platform Services and Architecture section of the Summary.

#### Wireless Location Applications

Such wireless location applications as were briefly described above in reference to the gateway 142 will now be described in further detail. Note that the following location related services are considered within the scope of the invention, and such services can, in general, be provided without use of a gateway 142, albeit, e.g., in a likely more restricted context wherein not all available wireless location estimating techniques are utilized, and/or by multiplying the number of interfaces to geolocation service providers (e.g., distinct wireless location interfaces are provided directly to each wireless location service provider utilized).

#### *Routing Applications*

In one noteworthy routing application, hotels and other personal service providers, such as auto rental agencies, resorts and cruise ships may provide

inexpensive or free wireless concierge services to their customers, wherein an inexpensive MS 140 can offered to customers that can be used substantially only for contacting: (i) the personal service, (ii) emergency services, (iii) receiving directions to return to the personal service, and/or (iv) routing or directing customers predetermined locations such as historic sites, shopping areas, and/or entertainment. In a similar fashion, instead of providing such a dedicated MS 140, the person service could in an alternative embodiment, could allow customers access such information from their own personal mobile stations 140. In one embodiment, this may be accomplished by allowing a user to attach such information to their user profiles and thereby obtain at least temporary access to a wireless concierge providing one or more of the location based services (i) – (iv) immediately above. Accordingly, the MS 140 may be wirelessly located during operations (ii) and (iii) via wireless communications between the MS 140 and a local commercial wireless service provider wherein a request to locate the MS 140 is provided to, e.g., the gateway 142, and the resulting MS location estimate is: provided to a public safety emergency center (e.g., E911) for dispatching emergency services, or provided to a mapping and routing system such as provided by MapInfo or disclosed in the LeBlanc et. al. patent application filed Jan. 22, 1999 and having U.S. Patent No. 6,236,365 (which is fully incorporated herein by reference) so that the MS 140 user may be routed safely and expeditiously to a predetermined location of the personal service. Note that data representing the location of the personal service can be associated with an identification of the MS 140 so that MS activation for (iii) above results in one or more audio and/or visual presentations of directions for directing the user to return to the personal service.

Additionally, directions to such personal services may be made available to the personal MS 140 of a user, wherein upon calling a number (or accessing a website via the MS), the directions to a desired destination may be transmitted to the MS and presented to the user. Moreover, such directions may be dependent upon how the MS user is traveling. For example, if it is known (or presumed) that the user is in a vehicle such as an auto, the user may be directed first to a parking garage rather than to the front door of a government agency building. Alternatively, if it is known (or

presumed) that the user is on foot, then the MS user may indeed be directed to the front door of the government agency building. Similarly, if the MS 140 is determined to be on a train, bicycle, watercraft, etc. such modes of conveyance may be used in determining an appropriate route to present to the MS user. In one embodiment of the invention, traffic congestion may also be used to determine an appropriate route to present to the MS user.

Moreover, it is an aspect of the present invention that the MS 140 user may be tracked by, e.g., periodic MS location determinations, until the MS user is substantially at the personal service. Note that if the MS 140 user does not correctly follow the directions received, then for a predetermined deviation (e.g., dependent upon whether it is perceived that the user is on foot or in a vehicle, which may be determined according to the user's velocity) the MS user may be alerted to the deviation and a new route determined dependent upon, e.g., the user's new location, the direction that the user is traveling, and/or the mode of transportation. For example, if the MS 140 user got on an subway train, then after one or more locations of the MS user have been performed, if such locations are sufficiently accurate, it can be determined whether the user is proceeding along a route consistent with directions provided, and that the user is on the subway. In the case where the MS user got onto the wrong subway train, the user can be alerted of this fact and given the opportunity to have a new route determined which takes into account not only the user's location, but where the user can exit the subway train, and likely the subway train schedules for expeditiously getting the MS user to his/her destination.

The MS 140 and the MS location providing wireless network (e.g., a CMRS, a PSTN 124 or the Internet 468) may also provide the MS user with the ability to explicitly request to be substantially continuously tracked, wherein the MS tracked locations are stored for access by those having permission (e.g., the user, parents and/or associates of the user). Additionally, the velocity and/or expected time of arrival at a predetermined destination may be derived from such tracking and may be provided to the user or his/her associates (e.g., employer, friends, and/or family). Further, note that this tracking and notification of information obtained therefrom may



be provided via a commercial telephony or Internet enabled mobile station, or a mobile station in operable communication with a short messaging service. For example, the MS registered owner may provide permissions for those able to access such MS tracking information so that such information can be automatically provided to certain associates and/or provided on request to certain associates. Additionally, note that the MS 140 and the MS location providing wireless network may also allow the MS user to deactivate such MS tracking functionality. In one embodiment, an MS user may activate such tracking for his/her MS 140 during working hours and deactivate such tracking during non-working hours. Accordingly, an employer can then track employee's whereabouts during work hours, while the employee is able to retain his/her location privacy when not working although the employer may be still able to contact the employee in case of an emergency during the employee's non-working time. Note, that this location capability and method of obtaining location information about an MS user while assuring privacy at other times may be useful for appropriately monitoring in personnel in the military, hospitals, transportation services (e.g., for couriers, bus and taxis drivers), telecommunications personnel, emergency rescue and correctional institution personnel. Further, note that this selective MS location capability may be performed in a number of ways. For example, the MS 140 may activate and deactivate such tracking by dialing a predetermined number (e.g., by manually or speed dialing the number) for switching between activation of a process that periodically requests a wireless location of the MS 140 from, e.g., the location gateway 142. Note that the resulting MS location information may be made available to other users at a predetermined phone number, Internet address or having sufficient validation information (e.g., a password). Alternatively, the MS location providing wireless network may automatically activate such MS tracking for predetermined times of the day and for predetermined days of the week. Note that this latter embodiment may be particularly useful for both tracking employees, e.g., at large construction sites, and, e.g., determining when each employee is at his/her work site. Thus, in this embodiment, the MS location providing wireless network may provide database storage of times and days of the week for activation and deactivation of this

selective MS tracking capability that is accessible via, e.g., a network service control point 104 (or other telephony network control points as one skilled in the art will understand), wherein triggers may be provided within the database for generating a network message (to, e.g., the gateway 142) requesting the commencement of tracking  
5 the MS 140 or the deactivation of such tracking. Accordingly, the resulting MS location information may be provided to an employer's tracking and payroll system so that the employer is able to determine the actual time an employee arrives at and leaves a work location site.

In another routing related application of the present invention, an MS 140 and  
10 the MS location providing wireless network may provide the MS user with functionality to register certain locations so that data representing such locations can be easily accessed for use at a later time. For example, the MS 140 user may be staying at a hotel in an unfamiliar area. Accordingly, using the present capability of the invention, the user can request, via his/her MS 140, that his/her location at the  
15 hotel be determined and registered so that it is available at a later time for routing the user back to the hotel. In fact, the user may have personal location registrations of a plurality of locations in various cities and countries so that when traveling the user has wireless access to directions to preferred locations such as his/her hotel, preferred restaurants, shopping areas, scenic areas, rendezvous points, theatres, athletic events,  
20 churches, entertainment establishments, locations of acquaintances, etc. Note, that such personal location registration information may reside primarily on the user's subscriber network, but upon the MS user's request, his/her personal location registrations may be transmitted to another network from which the user is receiving wireless services as a roamer. Moreover, any new location registrations (or deletions)  
25 may be duplicated in the user's personal registration of the user's subscriber network. However, in some instances an MS user may wish to retain such registered locations only temporarily while the user is in a particular area; e.g., a predetermined network coverage area. Accordingly, the MS user may indicate (or such may be the default) that a new personal location registration be retained for a particular length of time,  
30 and/or until a location of the user is outside the area to which such new location

registrations appear to be applicable. However, prior to deleting any such registrations, the MS user may be queried to confirm such deletions. For example, if the MS user has new location registrations for the Dallas, Texas area, and the MS user subsequently travels to London, then upon the first wireless location performed by the MS user for location registration services, the MS user may be queried as to whether to save the new Dallas, Texas location registrations permanently, for an particular length of time (e.g. 30 days), or delete all or selected portions thereof.

Other routing related applications of the present invention are for security (e.g., tracking how do I get back to my hotel safely), and, e.g., sight seeing guided tour where the is interactive depending on feedback from users

#### *Roaming Services*

Roaming services such as wireless concierge services that may offered to travelers by, e.g., hotels, resorts, theme parks, and/or ski areas. Additionally and/or alternatively, a user 2008 may be able to store and associate a location with a user input description (and possibly a picture if the user's MS 140 supports such) and store such information so that it is available at a later time, e.g., when the user is once again in the same geographical area.

There may also be roaming services wherein the various portions of the user's profile and/or attachments thereto may become active depending on the geographical location of the user. For example, a hotel chain may offer regional and/or global wireless concierge services wherein local location based information, such as pre-selected restaurants, shopping areas, points of interest, entertainment, exercise areas, travel routes, bus (train or boat) schedules, parking areas (e.g., where may be subsidized by the hotel chain), sports equipment rentals, emergency services (police, fire, etc.), that is in a geographical area (such as a metropolitan area, a resort area, a theme park or other relatively local area) where the user is located is automatically activated as the "current" set of locations to receive priority when the user enters a request that can be satisfied by entities identified in such local location based information. Note that a potentially simple embodiment of this aspect of the present

invention may be for the hotel chain to have an Internet website having for each of their hotels; corresponding web pages dedicated to local location based information in geographic areas surrounding the hotel. Such web pages may provide searching and routing capabilities related to the local location base information for relatively local geographical areas surrounding the hotel and these web pages may be made the default wireless concierge service capability. In one embodiment, a user's profile (or specific portions thereof) maintained, e.g., (i) by a network service, such as a wireless carrier, (ii) by the user himself (i.e., on the user's MS 140, assuming the user's MS 140 has sufficient storage capacity), (iii) by an electronic yellow pages entity, (iv) by an Internet search engine, may be made available (at least temporarily) to the hotel's Internet wireless concierge capabilities so that user service requests can be easily customized to the user's preferences. Moreover, such Internet access may provide access (at least while the user is staying at the hotel) to discounts, coupons, and/or free access to various local facilities.

15.

#### *Advertising Applications*

Advertising may be directed to an MS 140 according to its location. In at least some studies it is believed that MS 140 users do not respond well to unsolicited wireless advertisement whether location based or otherwise. However, in response to certain user queries for locally available merchandise, certain advertisements may be viewed as more friendly. Thus, by allowing an MS user to contact, e.g., a wireless advertising portal by voice or via wireless Internet, and describe certain products or services desired (e.g., via interacting with an automated speech interaction unit), the user may be able to describe and receive (at his/her MS 140) audio and/or visual presentations of such products or services that may satisfy such a user's request. For example, a user may enter a request: "I need a Hawaiian shirt, who has such shirts near here?"

In the area of advertising, the present invention has advantages both for the MS user (as well as the wireline user), and for product and service providers that are

nearby to the MS user. For instance, an MS user may be provided with (or request) a default set of advertisements for an area when the MS user enters the area, registers with a hotel in the area, or makes a purchase in the area, and/or requests information about a particular product or service in the area. Moreover, there may be different collections of advertisements for MS users that are believed to have different demographic profiles and/or purposes for being in the area. Accordingly, an MS whose location is being determined periodically may be monitored by an advertisement wizard such that this wizard may maintain a collection the MS user's preferences, and needs so that when the MS user comes near a business that can satisfy such a preference or need, then an advertisement relating to the fulfillment of the preference or need may be presented to the MS user. However, it is an aspect of the invention that such potential advertising presentations be intelligently selected using as much information about the user as is available. In particular, in one embodiment of the invention MS user preferences and needs may be ordered according to importance. Moreover, such user preferences and needs may be categorized by temporal importance (i.e., must be satisfied within a particular time frame, e.g., immediately, today, or next month) and by situational importance wherein user preferences and needs in this category are less time critical (e.g., do not have to be satisfied immediately, and/or within a specified time period), but if certain criteria are met the user will consider satisfying such a preference or need. Thus, finding a Chinese restaurant for dinner may be in the temporal importance category while purchasing a bicycle and a new pair of athletic shoes may be ordered as listed here in the situational category. Accordingly, advertisements for Chinese restaurants may be provided to the user at least partially dependent upon the user's location. Thus, once such a restaurant is selected and routing directions are determined, then the advertising wizard may examine advertisements (or other available product inventories and/or services that are within a predetermined distance of the route to the restaurant for determining whether there is product or service along the route that could potentially satisfy one of the user's preferences or needs from the situational importance category. If so, then the MS user may be provided with the option of examining such product or service

information and registering the locations of user selected businesses providing such products or services. Accordingly, the route to the restaurant may be modified to incorporate detours to one or more of these selected businesses. Of course, an MS user's situationally categorized preferences and needs may allow the MS user to receive unrequested advertising during other situations as well. Thus, whenever an MS user is moving such an advertisement wizard (e.g., if activated by the user) may attempt to satisfy the MS user's preferences and needs by presenting to the user advertisements of nearby merchants that appear to be directed to such user preferences and needs.

10           Accordingly, for MS user preferences and needs, the wizard will attempt to present information (e.g., advertisements, coupons, discounts, product price and quality comparisons) related to products and/or services that may satisfy the user's corresponding preference or need: (a) within the time frame designated by the MS user when identified as having a temporal constraint, and/or (b) consistent with situational  
15           criteria provided by the MS user (e.g., item on sale, item is less than a specified amount, within a predetermined traveling distance and/or time) when identified as having a situational constraint. Moreover, such information may be dependent on the geolocation of both the user and a merchant(s) having such products and/or services. Additionally, such information may be dependent on a proposed or expected user route  
20           (e.g., a route to work, a trip route). Thus, items in the temporal category are ordered according how urgent must a preference or need must be satisfied, while items in the situational category may be substantially unordered and/or ordered according to desirableness (e.g., an MS user might want a motorcycle of a particular make and maximum price, want a new car more). However, since items in the situational  
25           category may be fulfilled substantially serendipitous circumstances detected by the wizard, various orderings or no ordering may be used. Thus, e.g., if the MS user travels from one commercial area to another, the wizard may compare a new collection of merchant products and/or services against the items on an MS user's temporal and situational lists, and at least alerting the MS user that there may be new information  
30           available about a user desired service or product which is within a predetermined

traveling time from where the user is. Note that such alerts may be visual (e.g., textual, or iconic) displays, or audio presentations using, e.g., synthesized speech (such as “Discounted motorcycles ahead three blocks at Cydes Cycles”).

Note that the advertising aspects of the present invention may be utilized by an intelligent electronic yellow pages which can utilize the MS user’s location (and/or anticipated locations; e.g., due to roadways being traversed) together with user preferences and needs (as well as other constraints) to both intelligently respond to user requests as well as intelligently anticipate user preferences and needs. A block diagram showing the high level components of an electronic yellow pages according to this aspect of the present invention is shown in Fig. 19. Accordingly, in one aspect of the present invention advertising is user driven in that the MS user is able to select advertising based on attributes such as: merchant proximity, traffic/parking conditions, the product/service desired, quality ratings, price, user merchant preferences, product/service availability, coupons and/or discounts. That is, the MS user may be able to determine an ordering of advertisements presented based on, e.g., his/her selection inputs for categorizing such attributes. For example, the MS user may request advertisements athletic shoes be ordered according to the following values: (a) within 20 minutes travel time of the MS user’s current location, (b) midrange in price, (c) currently in stock, and (d) no preferred merchants. Note that in providing advertisements according to the MS user’s criteria, the electronic yellow pages may have to make certain assumptions such if the MS user does not specify a time for being at the merchant, the electronic yellow pages may default the time to a range of times somewhat longer than the travel time thereby going on the assumption that MS user will likely be traveling to an advertised merchant relatively soon. Accordingly, the electronic yellow pages may also check stored data on the merchant to assure that the MS user can access the merchant once the MS user arrives at the merchant’s location (e.g., that the merchant is open for business). Accordingly, the MS user may dynamically, and in real time, vary such advertising selection parameters for thereby substantially immediately changing the advertising being provided to the user’s MS. For example, the MS display may provide an area for entering an identification of a

product/service name wherein the network determines a list of related or complementary products/services. Accordingly, if an MS user desires to purchase a wedding gift, and knows that the couple to be wed are planning a trip to Australia, then upon the MS user providing input in response to activating a “related products/services” feature, and then inputting, e.g., “trip to Australia” (as well as any other voluntary information indicating that the purchase is for: a gift, for a wedding, and/or a price of less than \$100.00), then the intelligent yellow pages may be able to respond with advertisements for related products/services such as portable electric power converter for personal appliances that is available from a merchant local (and/or non-local) to the MS user. Moreover, such related products/services (and/or “suggestion”) functionality may be interactive with the MS user. For example, there may be a network response to the MS user’s above gift inquiry such as “type of gift: conventional or unconventional?”. Moreover, the network may inquire as to the maximum travel time (or distance) the MS user is willing to devote to finding a desired product/service, and/or the maximum travel time (or distance) the MS user is willing to devote to visiting any one merchant. Note that in one embodiment of the electronic yellow pages, priorities may be provided by the MS user as to a presentation ordering of advertisements, wherein such ordering may be by: price

Note that various aspects of such an electronic yellow pages described herein are not constrained to using the MS user’s location. In general, the MS user’s location is but one attribute that can be intelligently used for providing users with targeted advertising, and importantly, advertising that is perceived as informative and/or addresses current user preferences and needs. Accordingly, such electronic yellow page aspects of the present invention in are not related to a change in the MS user’s location over time also apply to stationary communication stations such home computers wherein, e.g., such electronic yellow pages are accessed via the Internet. Additionally, the MS user may be able to adjust, e.g., via iconic selection switches (e.g., buttons or toggles) and icon range specifiers (e.g., slider bars) the relevancy and a corresponding range for various purchasing criteria. In particular, once a parameter is indicated as relevant (e.g., via activating a toggle switch), a slider bar may be used



for indicating a relative or absolute value for the parameter. Thus, parameter values may be for:: product/service quality ratings (e.g., display given to highest quality), price (low comparable price to high comparable price), travel time (maximum estimated time to get to merchant), parking conditions.

5 Accordingly, such electronic yellow pages may include the following functionality:

- (a) dynamically change as the user travels from one commercial area to another when the MS user's location periodically determined such that local merchant's are given preference;
- 10 (b) routing instructions are provided to the MS user when a merchant is selected;
- (c) provide dynamically generated advertising that is related to an MS user's preferences or needs. For example, if an MS user wishes to purchase a new dining room set, then such an electronic yellow pages may dynamically  
15 generate advertisements with dining room sets therein for merchants that sell them. Note that this aspect of the present invention is can be accomplished by having, e.g., a predetermined collection of advertising templates that are assigned to particular areas of an MS user's display wherein the advertising information selected according to the item(s) that  
20 the MS user has expressed a preferences or desire to purchase, and additionally, according to the user's location, the user's preferred merchants, and/or the item's price, quality, as well as coupons, and/or discounts that may be provided. Thus, such displays may have a plurality of small advertisements that may be selected for hyperlinking to more  
25 detailed advertising information related to a product or service the MS user desires. Note that this aspect of the present invention may, in one embodiment, provide displays (and/or corresponding audio information) that is similar to Internet page displays. However, such advertising may dynamically change with the MS user's location such that MS user  
30 preferences and needs for a items (including services) having higher

priority are given advertisement preference on the MS display when the MS user comes within a determined proximity of the merchant offering the item. Moreover, the MS user may be able dynamically reprioritize the advertising displayed and/or change a proximity constraint so that different advertisements are displayed. Furthermore, the MS user may be able to request advertising information on a specified number of nearest merchants that provide a particular category of products or services. For example, an MS user may be able to request advertising on the three nearest Chinese restaurants that have a particular quality rating. Note, that such dynamically generated advertising

(d) information about MS user's preferences and needs may be supplied to yellow page merchants regarding MS user's reside and/or travel nearby yellow subscriber merchant locations as described hereinabove

The following is a high level description of some of the components shown in Fig. 19 of an illustrative embodiment of the electronic yellow pages of the present invention.

- a. **Electronic yellow pages center:** Assists both the users and the merchants in providing more useful advertising for enhancing business transactions. The electronic yellow pages center may be a regional center within the carrier, or (as shown) an enterprise separate from the carrier. The center receives input from users regarding preferences and needs which first received by the user interface.
- b. **User interface:** Receives input from a user that validates the user via password, voice identification, or other biometric capability for identifying the user. Note that the that the identification of user's communication device (e.g., phone number) is also provided. For a user contact, the user interface does one of: (a) validates the user thereby allowing user access to further electronic yellow page

services, (b) requests additional validation information from the user, or (c) invalidates the user and rejects access to electronic yellow pages. Note that the user interface retrieves user identification information from the user profile database (described hereinbelow), and allows a validated user to add, delete, and/or modify such user identification information.

5  
10  
15  
20  
25  
30

c. **User ad advisor:** Provides user interface and interactions with the user. Receives an identification/description of the user's communication device for determining an appropriate user communication technique. Note that the user ad advisor may also query (any) user profile available (using the user's identity) for determining a preferred user communication technique supported by the user's communication device. For example, if the user's communication device supports visual presentations, then the user ad advisor defaults to visual presentations unless there are additional constraints that preclude providing such visual presentations. In particular, the user may request only audio ad presentations, or merely graphical pages without video. Additionally, if the user's communication supports speech recognition, then the user ad advisor may interact with user solely via verbal interactions. Note that such purely verbal interactions may be preferable in some circumstances such as when the user can not safely view a visual presentation; e.g., when driving. Further note that the user's communication device may sense when it is electronically connected to a vehicle and provide such sensor information to the user ad advisor so that this module will then default to only a verbal presentation unless the user requests otherwise. Accordingly, the user ad advisor includes a speech recognition unit (not shown) as well as a presentation manager (not shown) for outputting ads in a form compatible both with the

functional capabilities of the user's communication device and with the user's interaction preference.

Note that the user ad advisor communicates: (a) with the user ad selection engine for selecting advertisements to be presented to the user, (b) with the user profile database for inputting thereto substantially persistent user personal information that can be used by the user ad selection engine, and for retrieving user preferences such as media preference(s) for presentations of advertisements, and (c) with the user preference and needs satisfaction agents for instantiating intelligent agents (e.g., database triggers, initiating merchant requests for a product/service to satisfy a user preference or need).

Also note that in some embodiments of the present invention, the user ad advisor may also interact with a user for obtaining feedback regarding: (a) whether the advertisements presented, the merchants represented, and/or the products/services offered are deemed appropriate by the user, and (b) the satisfaction with a merchant with which the user has interactions. In particular, such feedback may be initiated and/or controlled substantially by the user preference and needs satisfaction agent management system (described hereinbelow).

d. **User profile database:** A database management system for accessing and retaining user identification information, user personal information, and identification of the user's communication device (e.g., make, model, and/or software version(s) being used). Note that the user profile database may contain information about the user that is substantially persistent; e.g., preferences for: language (e.g., English, Spanish, etc.), ad presentation media (e.g., spoken, textual, graphical, and/or video), maximum traveling time/distance for user preferences and needs of

temporal importance (e.g., what is considered “near” to the user), user demographic information (e.g., purchasing history, income, residential address, age, sex, ethnicity, marital status, family statistics such as number of child and their ages), and merchant preferences/preclusions (e.g., user prefers one restaurant chain over another, or the user wants no advertisements from a particular merchant).

- 5
- e. **User ad selection engine:** This module selects advertisements that are deemed appropriate to the user’s preferences and needs. In particular, this module determines the categories and presentation order of advertisements to be presented to the user. To perform this task, the user ad selection engine uses a user’s profile information (from the user profile database), a current user request (via the user ad advisor), and/or the user’s current geolocation (via the interface to the location gateway 142). Thus, for a user requesting the location of an Italian restaurant within ½ mile of the user’s current location, in a medium price range, and accepting out of town checks, the user ad selection engine identifies the ad criteria within the user’s request, and determines the advertising categories (and/or values thereof) from which advertisements are desired. In one embodiment,
- 10
- 15
- 20

Note that the user ad selection engine can suggest advertisement categories and/or values thereto to the user if requested to do so.

When an MS 140 appears to be traveling an extended distance through a plurality of areas (as determined, e.g., by recent MS locations along an interstate that traverse a plurality of areas), then upon entering each new area having a new collection of location registrations (and possibly a new location registration wizard) may be provided. For example, a new default set of local location registrations may become available to the user. Accordingly, the user may be notified that new temporary location registrations are available for the MS user to access if desired. For example,

25

30

such notification may be a color change on a video display indicating that new temporary registrations are available. Moreover, if the MS user has a personal profile that also is accessible by a location registration wizard, then the wizard may provide advertising for local businesses and services that are expected to better meet the MS user's tastes and needs. Thus, if such wizard knows that the MS user prefers fine Italian food but does not want to travel more than 20 minutes by auto from his/her hotel to reach a restaurant, then advertisements for restaurants satisfying such criteria will become available to the user. However, MS users may also remain anonymous to such wizards, wherein the

Note, that by retaining MS user preferences and needs, if permission is provided, e.g., for anonymously capturing such user information, this information could be provided to merchants. Thus, merchants can get an understanding of what nearby MS user's would like to purchase (and under what conditions, e.g., an electric fan for less than \$10). Note such user's may be traveling through the area, or user's may live nearby. Accordingly, it is a feature of the present invention to provide merchant's with MS user preferences and needs according to whether the MS user is a passerby or lives nearby so that the merchant can better target his/her advertising.

In one embodiment, a single wizard may be used over the coverage area of a CMRS and the database of local businesses and services changes as the MS user travels from one location registration area to another. Moreover, such a wizard may determine the frequency and when requests for MS locations are provided to the gateway 142. For example, such databases of local businesses and services may be coincident with LATA boundaries. Additionally, the wizard may take into account the direction and roadway the MS 140 is traveling so that, e.g., only businesses within a predetermined area and preferably in the direction of travel of the MS 140 are candidates to have advertising displayed to the MS user.

#### *Points of Interest Applications*

The invention can be used for sight seeing guided tours where the invention is interactive depending on feedback from users. Such interactivity being both verbal descriptions and directions to points of interest.

*Security Applications*

5       The invention may provide Internet picture capture with real time voice capture and location information for sightseeing, and/or security.

The foregoing description of preferred embodiments of the present invention has been provided for the purposes of illustration and description. It is not intended to be exhaustive or to limit the invention to the precise forms disclosed herein.

10       Modifications and variations commensurate with the description herein will be apparent to those skilled in the art and are intended to be within the scope of the present invention to the extent permitted by the relevant art. The embodiments provided are for enabling others skilled in the art to understand the invention, its various  
embodiments and modifications as are suited for uses contemplated. It is intended  
15       that the scope of the invention be defined by the following claims and their equivalents.

What is claimed is:

1. A method for locating a mobile station using wireless signal measurements obtained from transmissions between said mobile station and a plurality of fixed location communication stations, wherein each of said communications stations includes one or more of a transmitter and a receiver for wirelessly communicating with said mobile station, comprising:

providing first and second mobile station location evaluators, wherein said location evaluators determine information related to one or more location estimates of said mobile station when said location estimators are supplied with data having values obtained from wireless signal measurements obtained via transmissions between said mobile station and the communication stations, wherein:

(A) said first location evaluator performs one or more of the following techniques (i), (ii) and (iii) when supplied with a corresponding instance of said data:

(i) a first technique for determining, for at least one of the communication stations, one of: a distance, and a time difference of arrival between the mobile station and the communication station, wherein said first technique estimates a time of arrival (TOA) of a received signal relative to a time reference at each one of a plurality of wireless signal monitoring stations using an inverse transform whose resolution is greater than Rayleigh resolution;

(ii) a second technique for estimating a location of said mobile station, using values from a corresponding instance of said data obtained from signals received by the mobile station from one or more satellites;

(iii) a third technique for recognizing a pattern of characteristics of a corresponding instance of said data, wherein said pattern of characteristics is indicative of a plurality of wireless signal transmission paths between the mobile station and each of one or more of the communication stations; and



(iv) a fourth technique for estimating a location of said mobile station using a USW model, wherein the following steps (a) – (d) are performed:

5 (e) receiving at an antenna array provided at one of the communication stations, signals originating from the mobile station, wherein the signals comprise p-dimensional array vectors sampled from p antennas of the array;

(f) determining from the received signals, a signal signature, wherein the signal signature comprises a measured subspace, wherein the array vectors are approximately confined to the measured subspace;

10 (g) comparing the signal signature to a database comprising calibrated signal signatures and corresponding location data, wherein the comparing comprises calculating differences between the measured subspace and calibrated subspaces; and

15 (h) selecting from the database a most likely calibrated signal signature and a corresponding most likely location of the mobile station by using the calculated differences;

(v) a fifth technique for estimating a location of said mobile station using an E model, wherein the following steps (a) – (e) are performed:

20 a. receiving, at a multiplicity of the communication stations, a signal transmitted by the mobile station;

b. forwarding, by each of a multiplicity of the communication stations, said received signal and timing information to a central processing center;

25 c. calculating, within said central processing center, a time difference of arrival (TDOA) location estimate of said mobile station based upon said timing information;

30 d. calculating, within said central processing center, a timing advance (TA) location estimate of said mobile station based upon said timing information; and

- e. determining said position of said mobile station using said TDOA and TA location estimates;
- (vi) a sixth technique for estimating a location of said mobile station using an ST model, wherein the following steps (a) – (e) are performed:
- a. receiving, in a SPS receiver co-located with the mobile station, SPS signals from at least one SPS satellite;
  - b. transmitting cell based communication signals between:
    - a communications system having a first of the communication stations coupled to said SPS receiver,
    - and a second of the communication stations which is remotely positioned relative to said mobile station, wherein said cell based communication signals are wireless;
  - c. determining a first time measurement which represents a time of travel of a message in said cell based communication signals in a cell based communication system having at least some of the communication stations which comprises said second communication station and said communication system;
  - d. determining a second time measurement which represents a time of travel of said SPS signals;
  - e. determining a position of said mobile station from at least said first time measurement and said second time measurement, wherein said cell based communication signals are capable of communicating data messages in a two-way direction between said first cell based transceiver and said communication system;

(vii) a seventh technique for estimating a location of said mobile station using an TE model, wherein the following steps (a) – (l) are performed:

- 5 a. transmitting from said mobile station M samples of a signal;
- b. receiving at one of the communication stations, said M samples together with multipath components and noise;
- c. determining an estimated channel power profile for each of said M samples;
- 10 d. selecting a first set of N samples from said M samples;
- e. performing incoherent integration for said estimated channel power profiles for said first set of N samples to form a first integrated signal;
- 15 f. if a quality level of said first integrated signal with respect to signal to noise is less than a predetermined threshold, selecting another sample from said M samples;
- g. performing incoherent integration for said estimated channel power profiles for said first set of N samples and said another sample to form a second integrated signal;
- 20 h. if a quality level of said second integrated signal with respect to signal to noise is greater than or equal to said predetermined threshold, determining a time-of-arrival of a maximum level of said second integrated signal;
- 25 i. entering said time-of-arrival into a time-of-arrival versus frequency of occurrence array;
- j. selecting a second set of N samples from said M samples;

k. repeating all of said performing through said entering steps for said second set of N samples; and

l. determining a minimum value estimated time-of-arrival from said array;

5 (viii) an eighth technique for estimating a location of said mobile station using an SigT model, wherein the following steps (a) – (e) are performed:

a. within the mobile station, transmitting a locating signal composed of at least two tone components;

10 b. within each of a plurality of the communication stations, receiving the locating signal at one or more antennas, and within at least one of the communication stations, receiving the locating signal with at least two antennas;

c. coupling each antenna to a receiver;

15 d. within each receiver, generating amplitude and phase values from the locating signal as received by the antenna, the values indicative of amplitude and phase of at least two tone components of the locating signal, as received at the corresponding antenna and measured at defined times; and

20 e. combining the values indicative of amplitude and phase for the tone components from a plurality of the receivers to determine the position of the mobile station;

(ix) an ninth technique for estimating a location of said mobile station using a TLME model, wherein the following steps (a) – (h) are performed therefor in a mobile radio system providing at least some of the communication stations, said mobile radio system including a network controller and at least three of the communication stations, each of said at least three communication stations including an uplink TOA measuring unit operable to communicate with said network

30

controller, a control unit, and a time reference unit operable to provide timing reference signals to said uplink TOA measuring unit, at least one of said at least three communication stations co-located with and connected to a second mobile station, said second mobile station coupled to said network controller via a radio interface, and a service node operable to store known positions of at least two of said at least three communication stations:

5

10

15

20

25

30

- a. receiving a request in said mobile radio system to determine the geographical position of said mobile station;
- b. determining and reporting the position of said second mobile station to said service node;
- c. directing said mobile station to transmit digital signals uplink on a traffic channel when said mobile station is not transmitting or transmitting only analog signals;
- d. measuring in each uplink TOA measuring unit an uplink TOA of the digital signals transmitted by the mobile station;
- e. receiving in said network controller said uplink TOA measurements from said at least three communication stations and a traffic channel number to said traffic channel;
- f. translating said traffic channel number to an identity of said mobile station;
- g. conveying said uplink TOA measurements and said mobile station identity to said service node; and
- h. calculating in said service node the position of said mobile station using said known positions of said at least three communication stations and said uplink TOA measurements;

(x) a tenth technique for estimating a location of said mobile station using an N model, wherein the following steps (a) – (d) are performed:

a. receiving global positioning system satellite (GPS) signals from a plurality of global positioning system satellites;

b. receiving a plurality of cellular position signals that do not contain data in a GPS-like format;

c. calculating the geographic position of the mobile station using said received global positioning system satellite signals when a requisite number of the plurality of global positioning system satellites are in view of a global positioning system receiver; and

d. calculating the geographic position of the mobile station using both said received plurality of cellular position signals and substantially all of said received global positioning system satellite signals when the requisite number of the plurality of global positioning system satellites are not in view of the global positioning system receiver;

(B) for at least a particular one of said techniques performed by said first location estimator, said second location evaluator performs a different one of said techniques when supplied with a corresponding instance of said data for the different technique;

first generating, by said first location estimator, first location related information that is dependent upon an availability of a first corresponding instance of said data;

second generating, by said second location evaluator, second location related information that is dependent upon an availability of a second corresponding instance of said data;

determining a resulting location estimate of the mobile station dependent upon at least one of: (a) a first value obtained from said first location related information, and (b) a second value obtained from said second location related information.

5

2. A method as claimed in Claim 1, wherein said steps of Claim 1 are performed for a single emergency response request.

3. A method as claimed in Claim 1, further including a step of outputting, to an emergency response center, said resulting location estimate of said mobile station in response to said emergency response request.

4. A method for locating a mobile station using wireless signal measurements obtained from transmissions between said mobile station and a plurality of fixed location communication stations, wherein each of said communications stations includes one or more of a transmitter and a receiver for wirelessly communicating with said mobile station, comprising:

providing first and second mobile station location evaluators, wherein said location evaluators determine information related to one or more location estimates of said mobile station when said location estimators are supplied with data having values obtained from wireless signal measurements obtained via transmissions between said mobile station and the communication stations, wherein:

(A) said first location evaluator performs one or more of the following techniques (i), (ii) and (iii) when supplied with a corresponding instance of said data:

(i) a first technique for determining, for at least one of the communication stations, one of: a distance, and a time difference of arrival between the mobile station and the communication station, wherein said first technique estimates a time of arrival (TOA) of a received signal relative to a time reference at each one of a plurality of

30

wireless signal monitoring stations using an inverse transform whose resolution is greater than Rayleigh resolution;

(ii) a second technique for estimating a location of said mobile station, using values from a corresponding instance of said data obtained from signals received by the mobile station from one or more satellites;

(iii) a third technique for recognizing a pattern of characteristics of a corresponding instance of said data, wherein said pattern of characteristics is indicative of a plurality of wireless signal transmission paths between the mobile station and each of one or more of the communication stations; and

(B) for at least a particular one of said techniques performed by said first location estimator, said second location evaluator performs a different one of said techniques when supplied with a corresponding instance of said data for the different technique;

first generating, by said first location estimator, first location related information using an available first corresponding instance of said data;

second generating, by said second location evaluator, second location related information using an available second corresponding instance of said data;

determining a resulting location estimate of the mobile station dependent upon at least one of: (a) a first value obtained from said first location related information, and (b) a second value obtained from said second location related information.

5. The method as claimed in Claim 4, wherein one or more of said mobile station location evaluators generates a location estimate of said mobile station.

6. The method as claimed in Claim 4, wherein said mobile station is co-located with a processor for activating at least one of said location estimators.



## ABSTRACT

A location system is disclosed for commercial wireless telecommunication infrastructures. The system is an end-to-end solution having one or more location centers for outputting requested locations of commercially available handsets or mobile stations (MS) based on, e.g., CDMA, AMPS, NAMPS or TDMA communication standards, for processing both local MS location requests and more global MS location requests via, e.g., Internet communication between a distributed network of location centers. The system uses a plurality of MS locating technologies including those based on: (1) two-way TOA and TDOA; (2) pattern recognition; (3) distributed antenna provisioning; (5) GPS signals, (6) angle of arrival, (7) super resolution enhancements, and (8) supplemental information from various types of very low cost non-infrastructure base stations for communicating via a typical commercial wireless base station infrastructure or a public telephone switching network.

Accordingly, the traditional MS location difficulties, such as multipath, poor location accuracy and poor coverage are alleviated via such technologies in combination with strategies for: (a) automatically adapting and calibrating system performance according to environmental and geographical changes; (b) automatically capturing location signal data for continual enhancement of a self-maintaining historical data base retaining predictive location signal data; (c) evaluating MS locations according to both heuristics and constraints related to, e.g., terrain, MS velocity and MS path extrapolation from tracking and (d) adjusting likely MS locations adaptively and statistically so that the system becomes progressively more comprehensive and accurate. Further, the system can be modularly configured for use in location signaling environments ranging from urban, dense urban, suburban, rural, mountain to low traffic or isolated roadways. Accordingly, the system is useful for 911 emergency calls, tracking, routing, people and animal location including applications for confinement to and exclusion from certain areas.

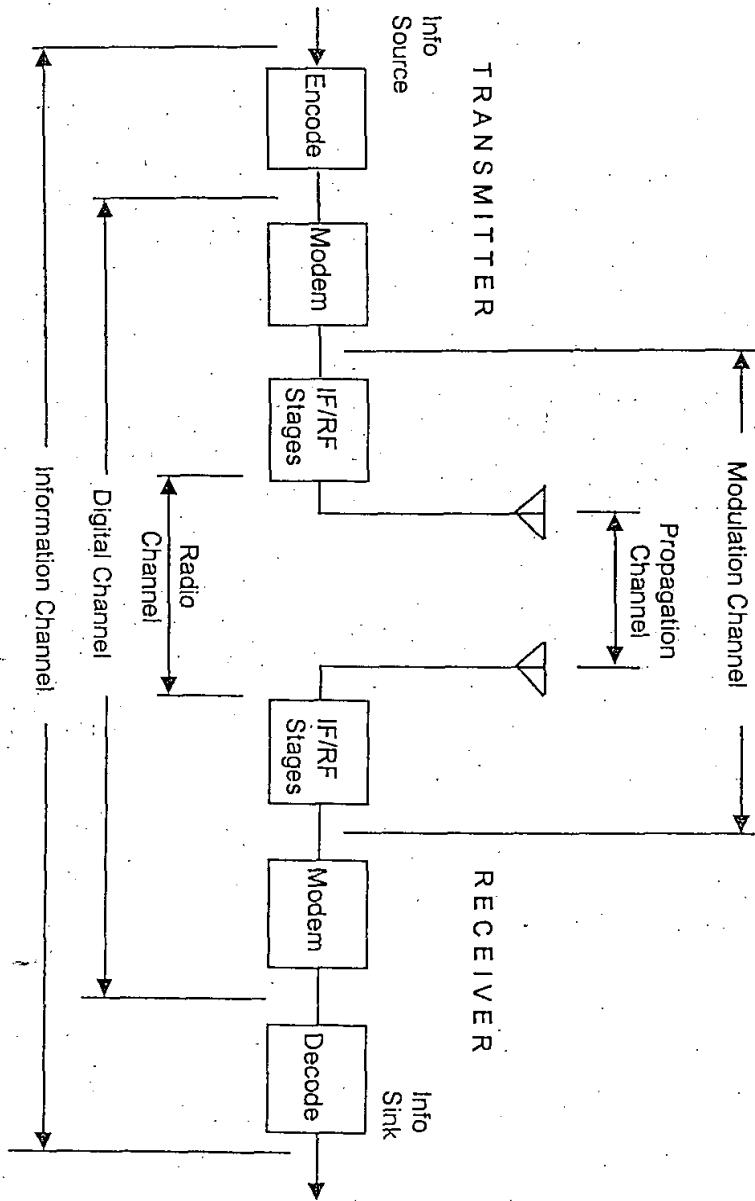

FIG. 1

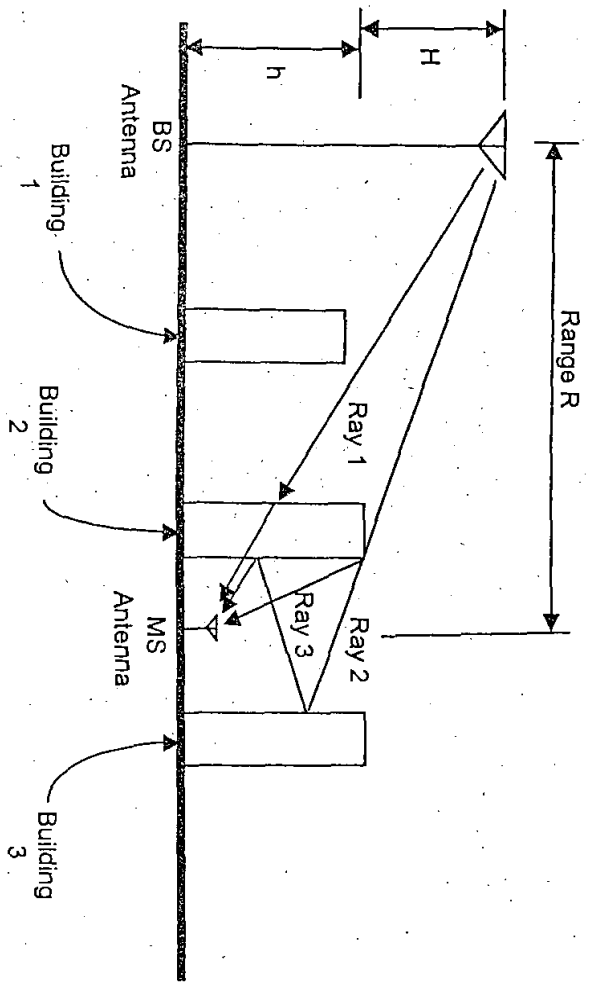

FIG. 2

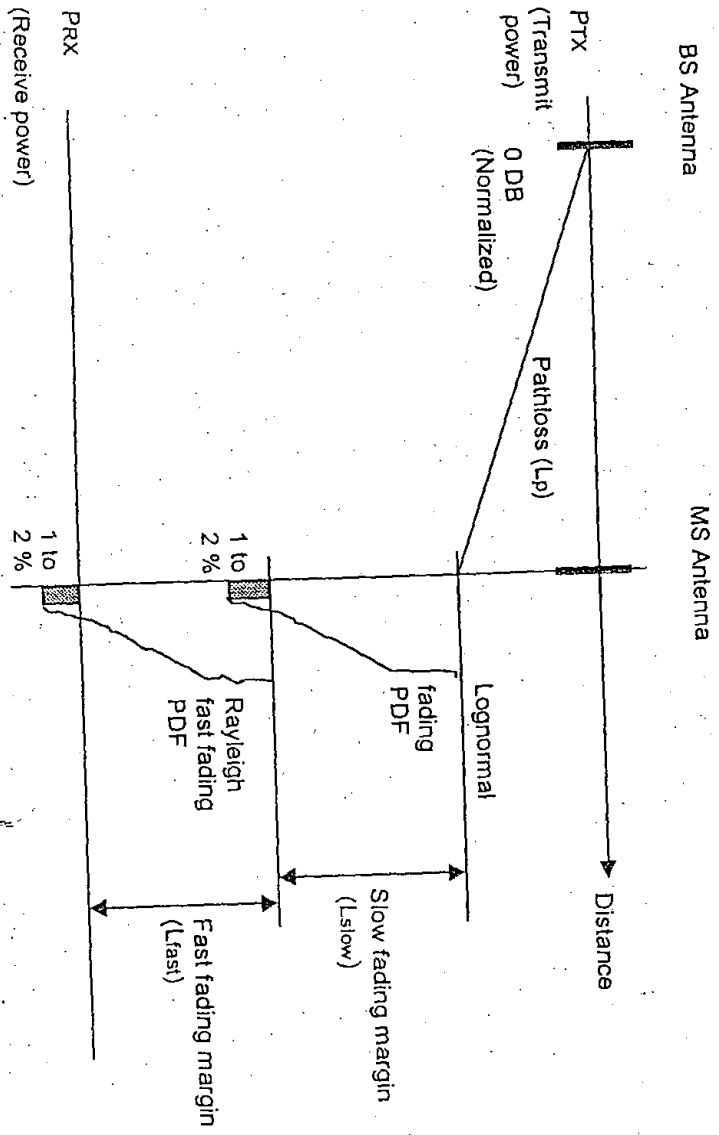

FIG. 3

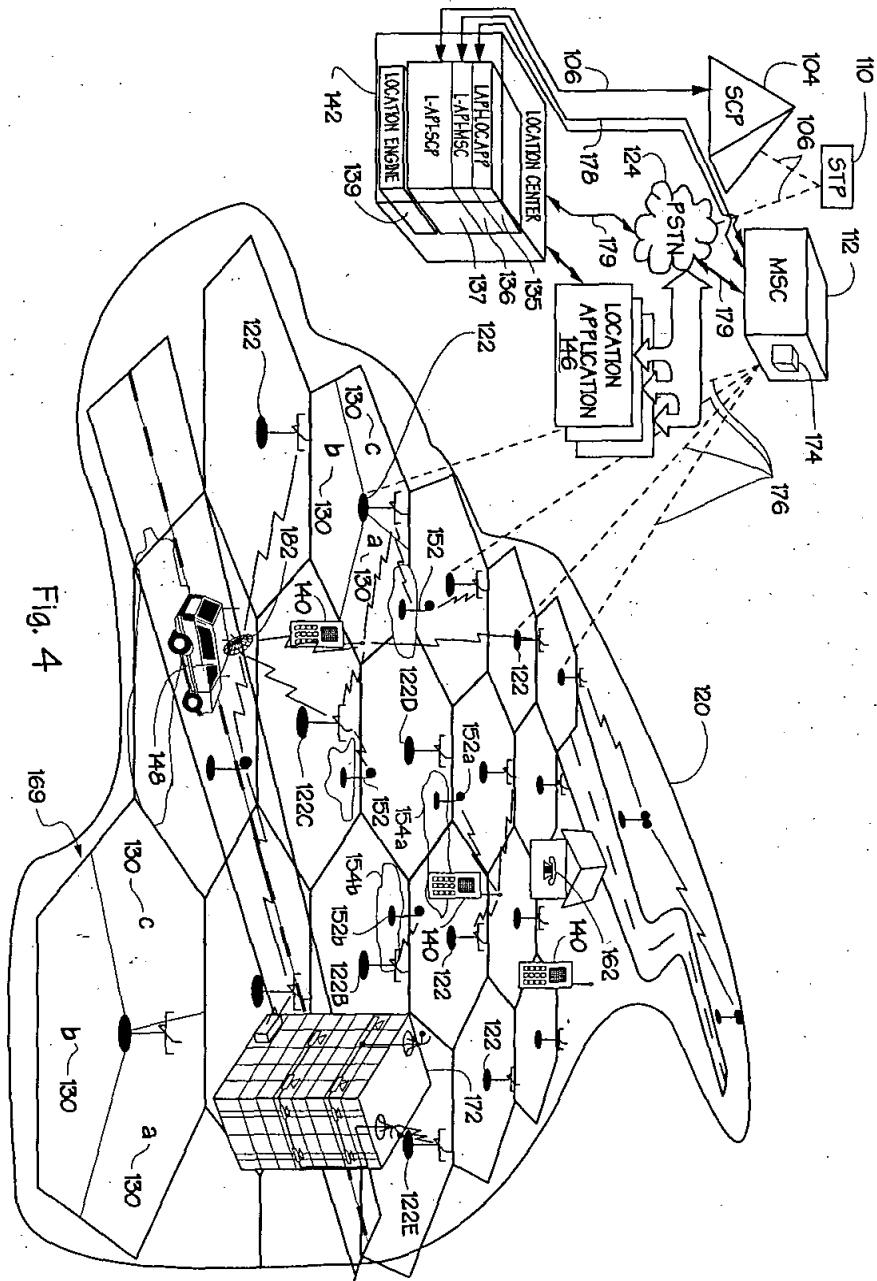

FIG. 4

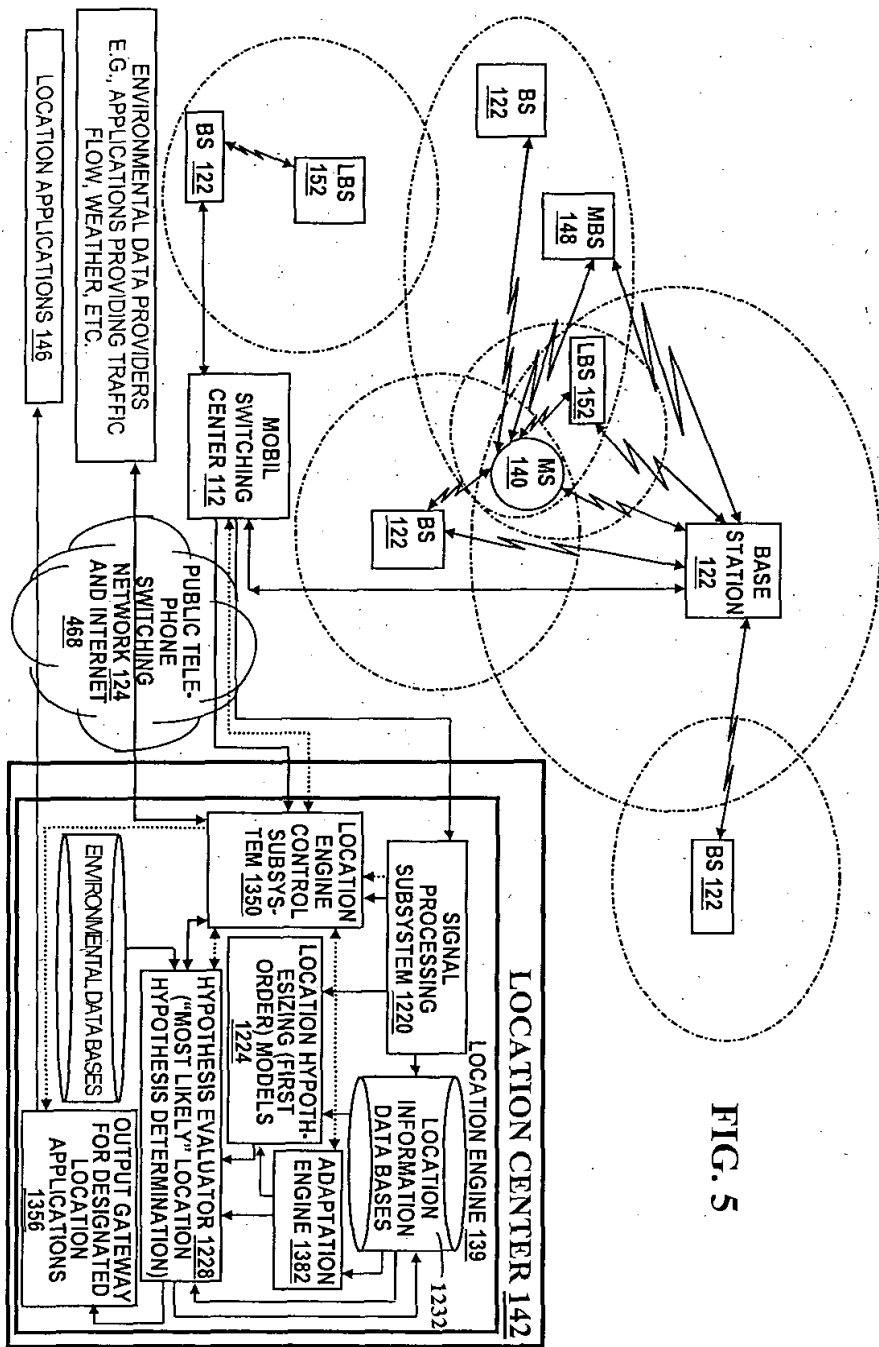

FIG. 5

Fig. 6(1)

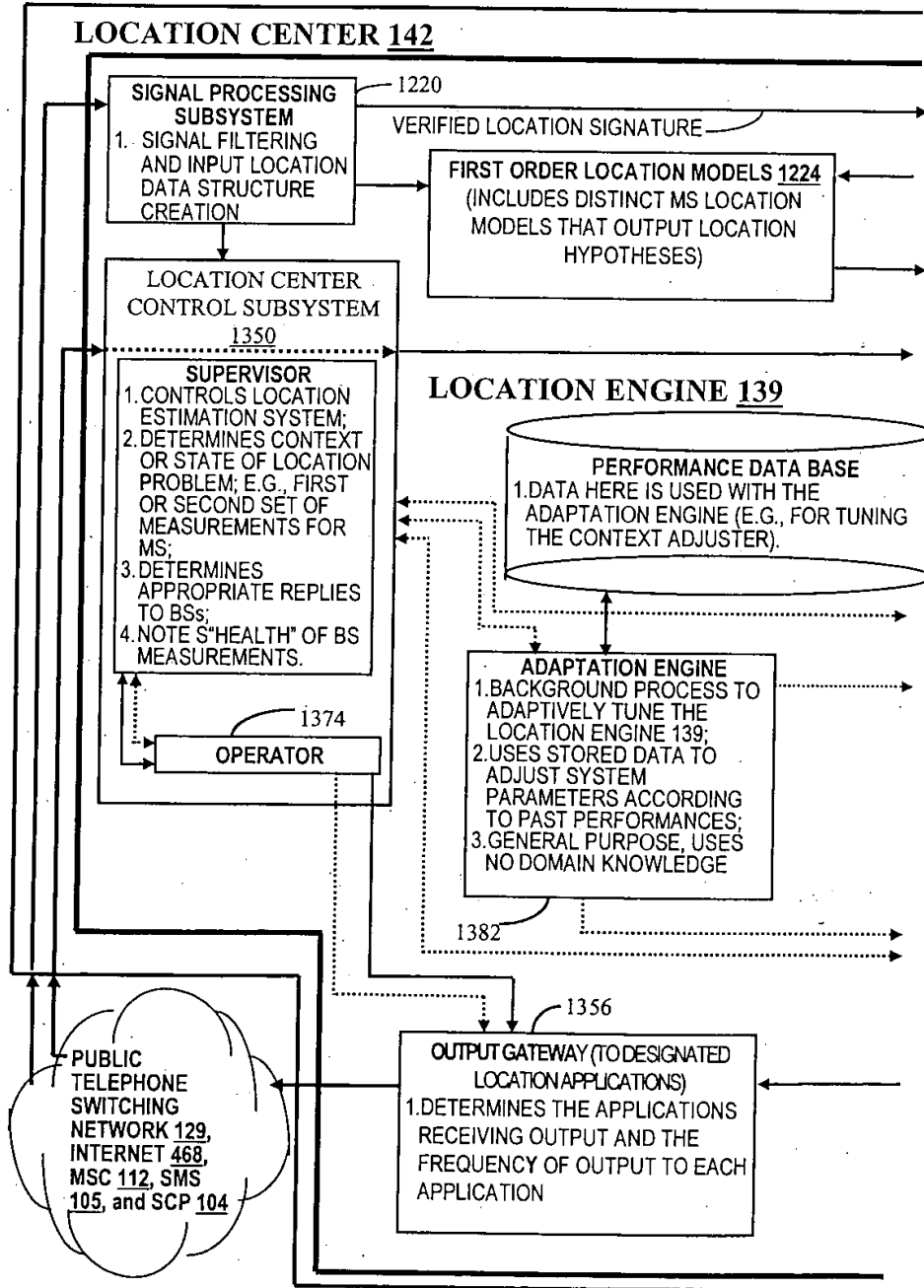

FIG 6(2)

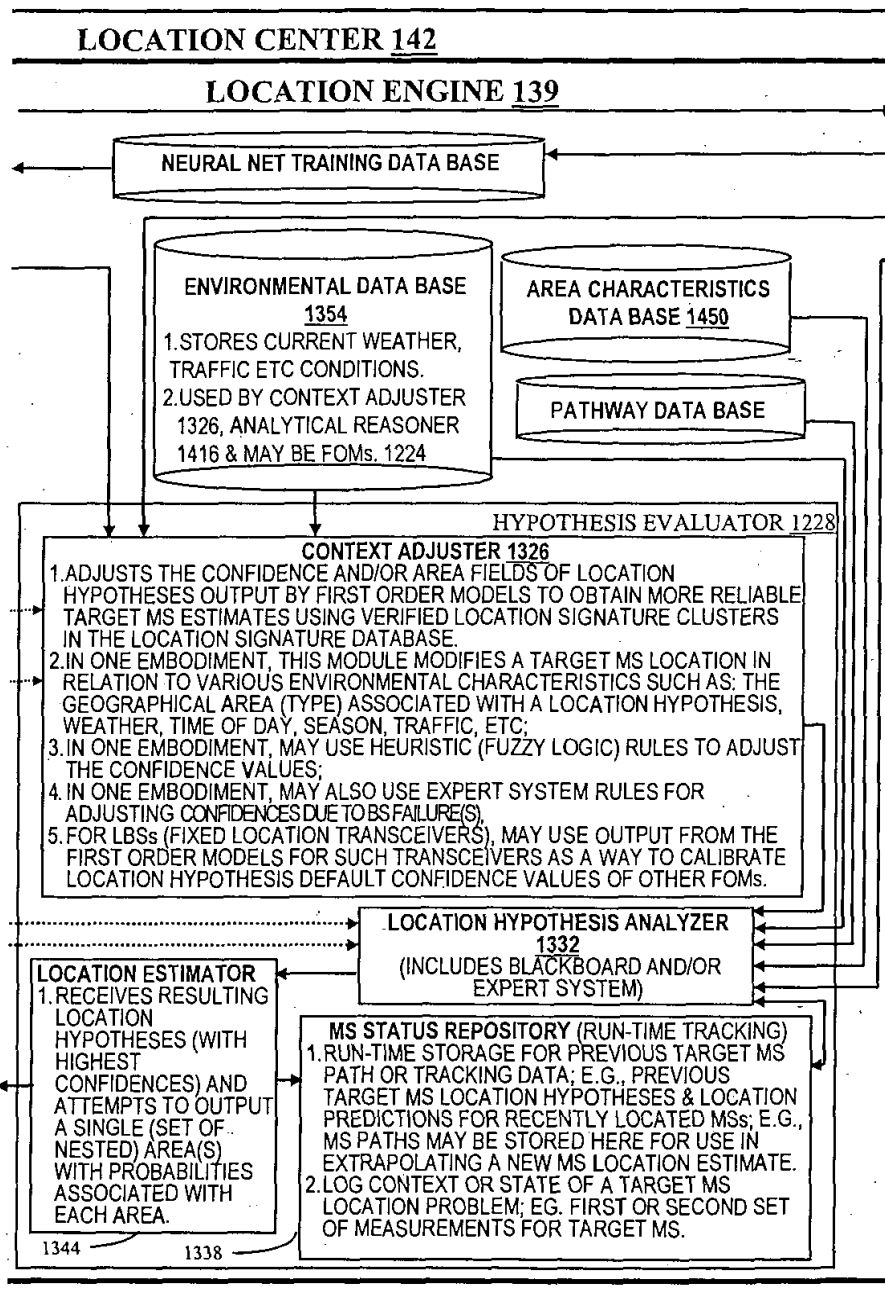



FIG 6(3)

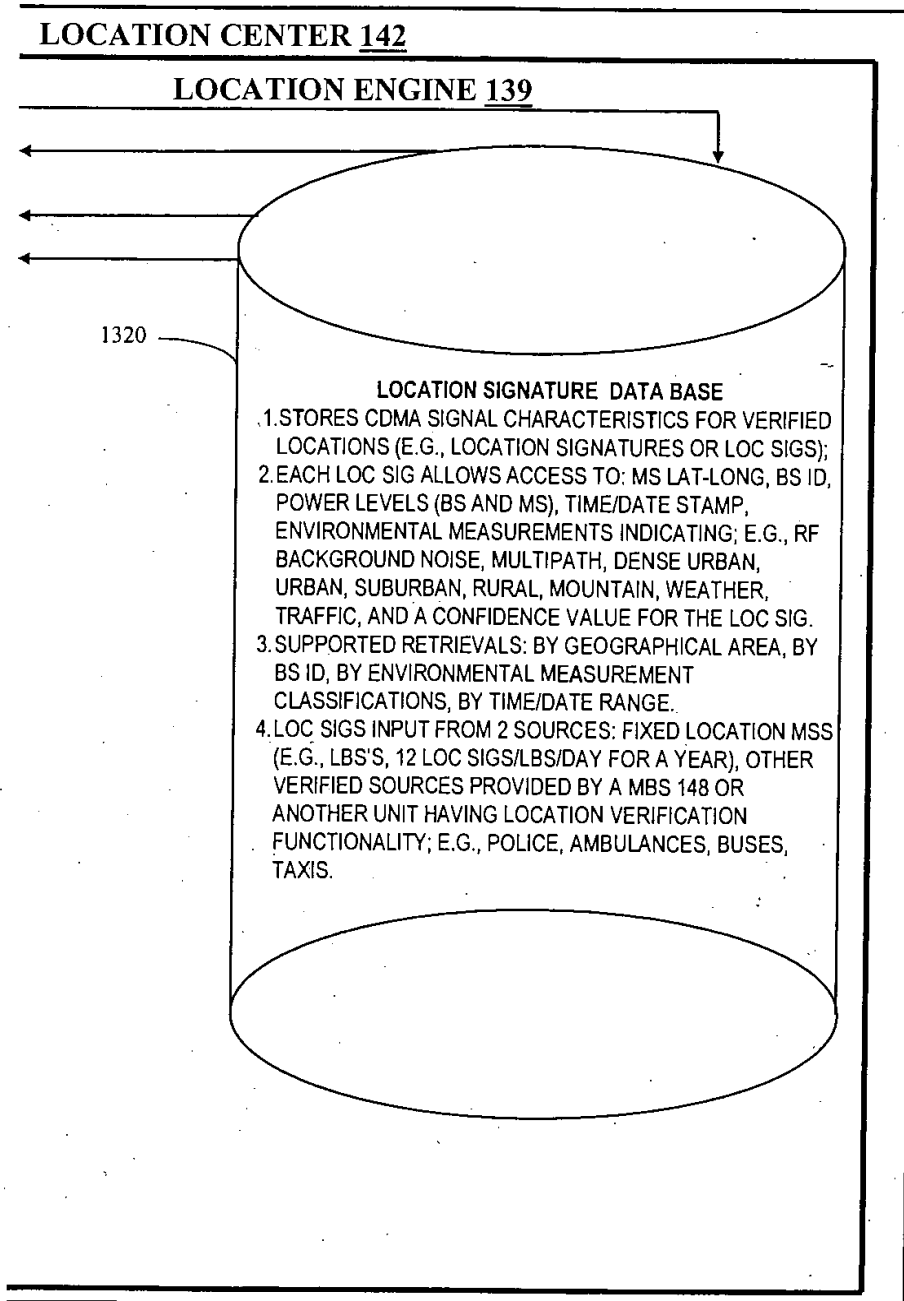
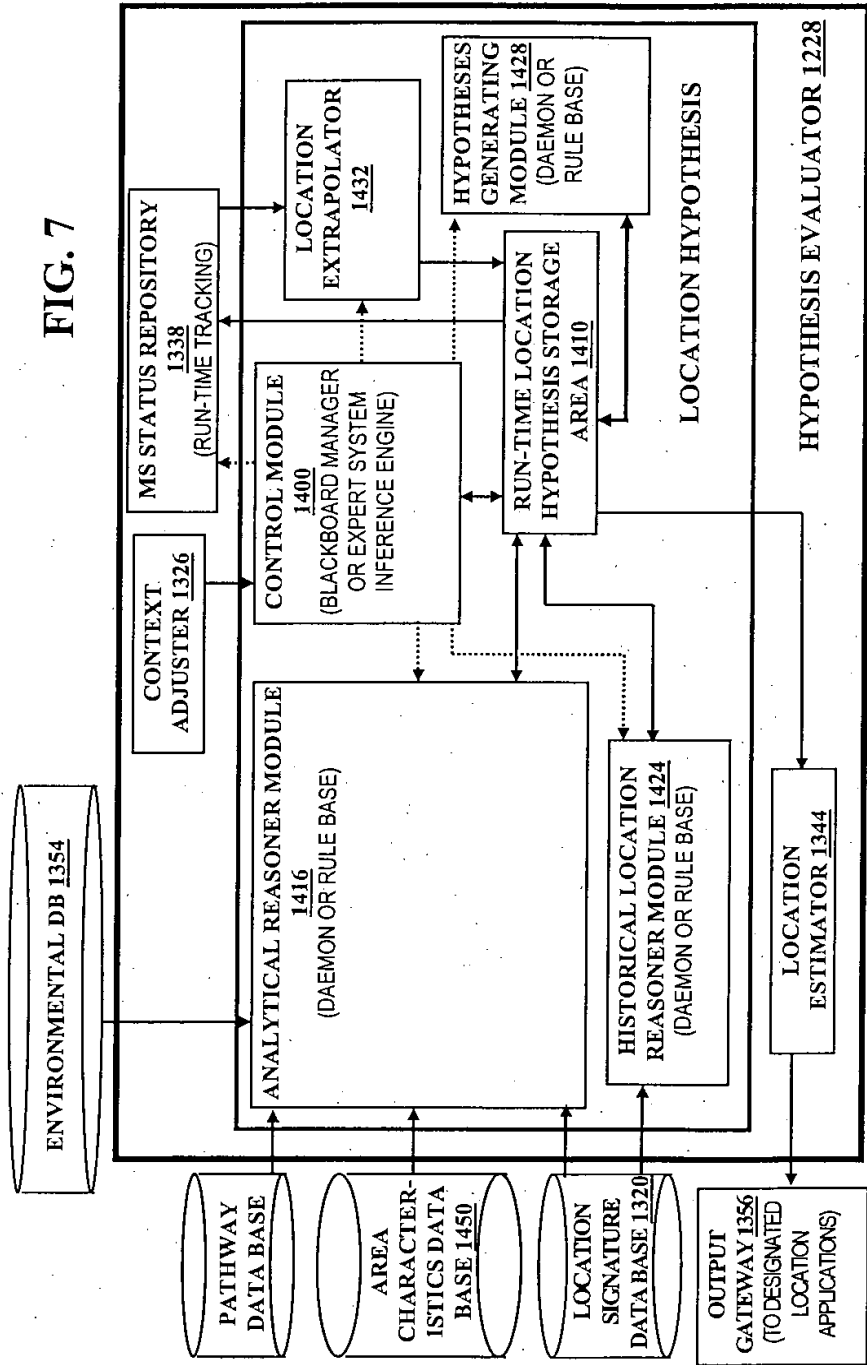
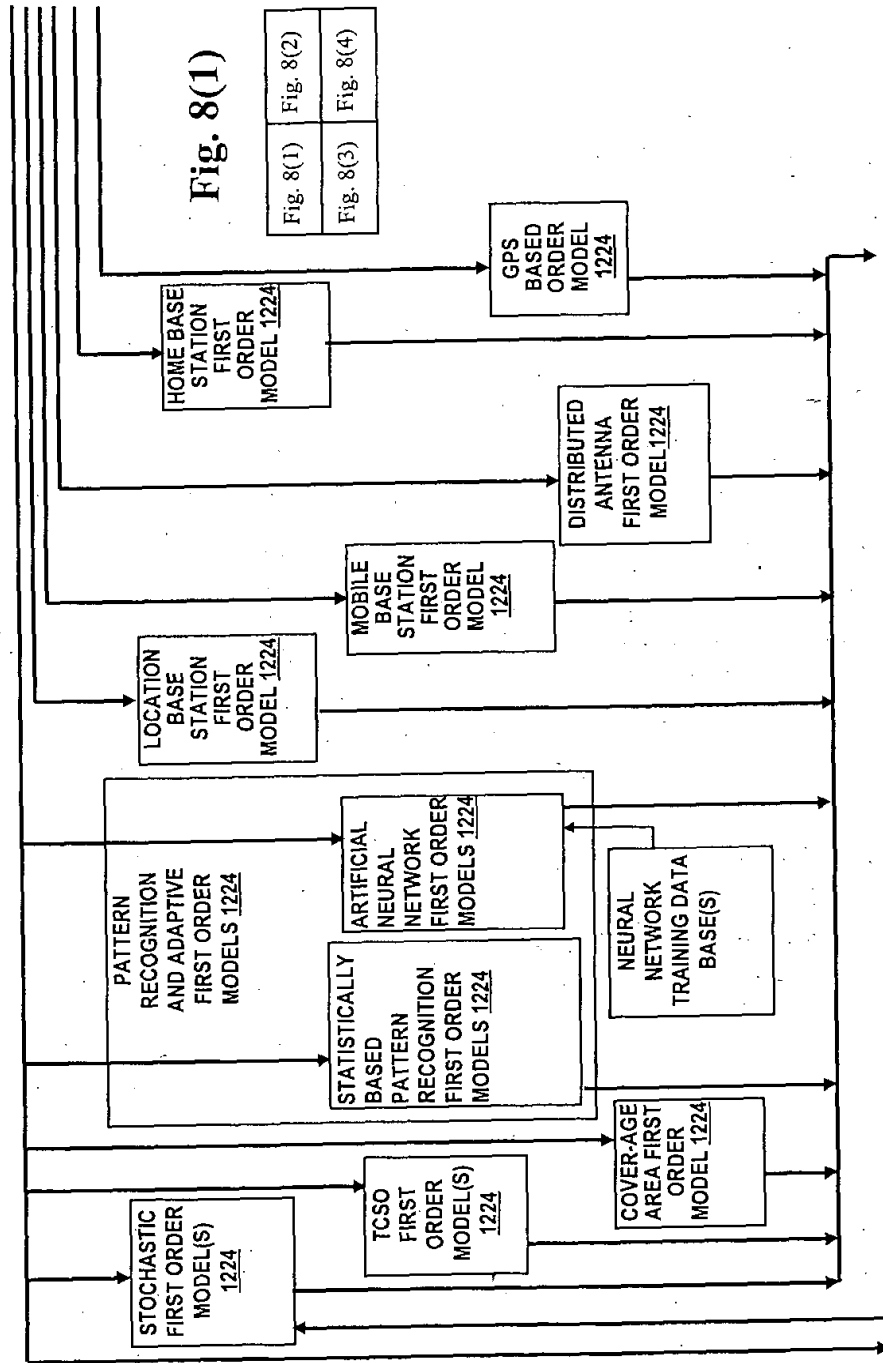

FIG. 7





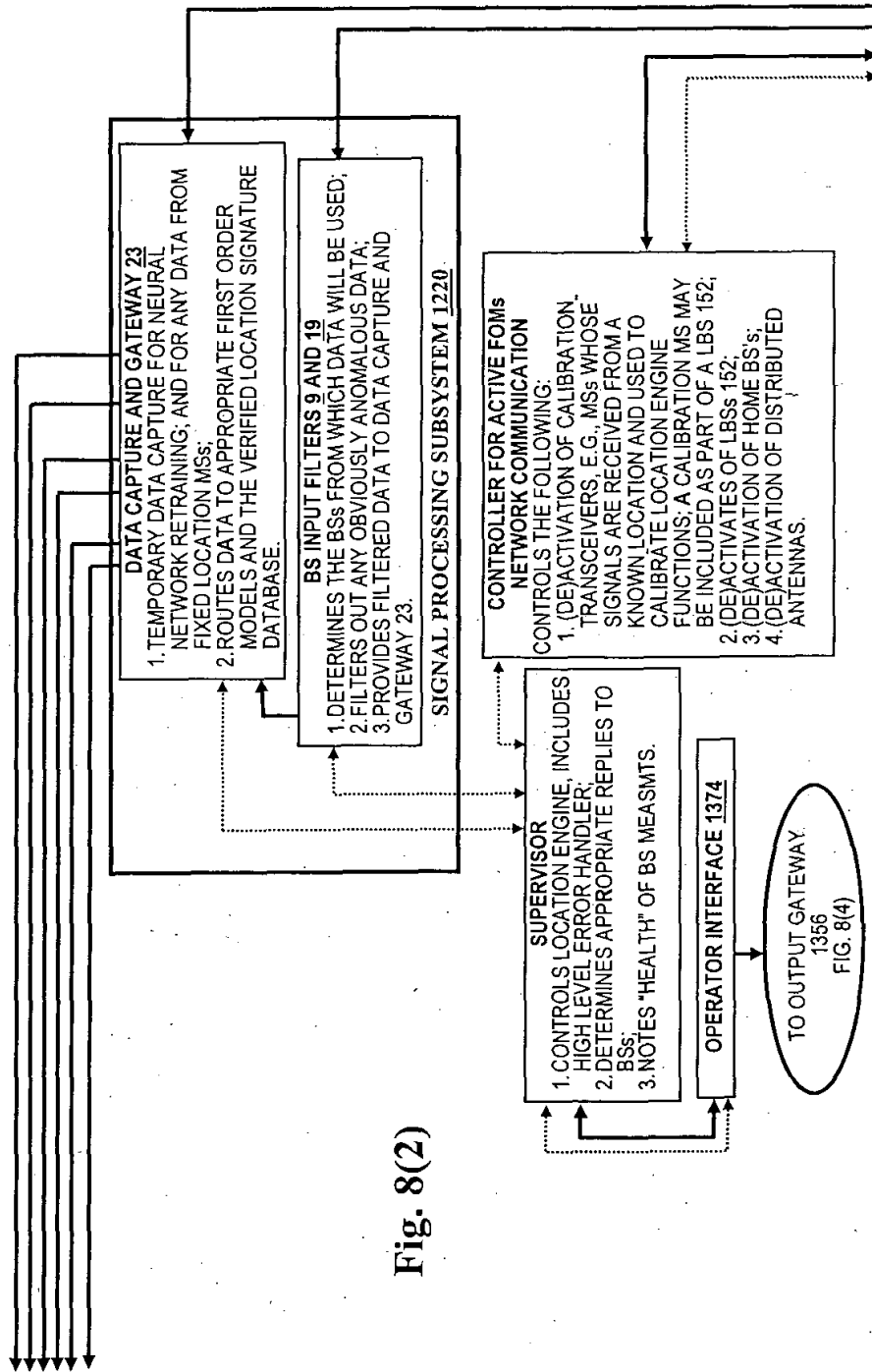

Fig. 8(2)

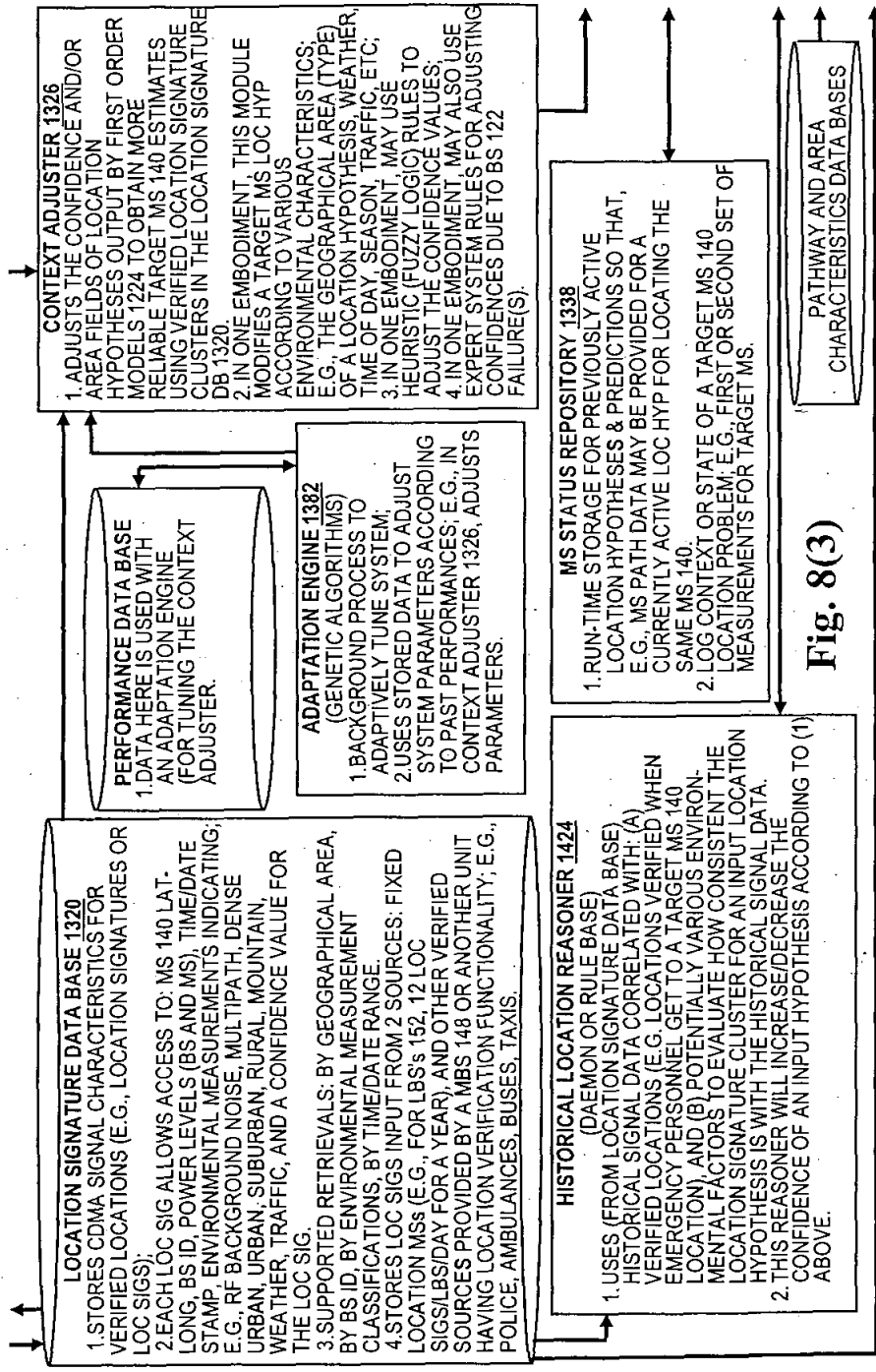
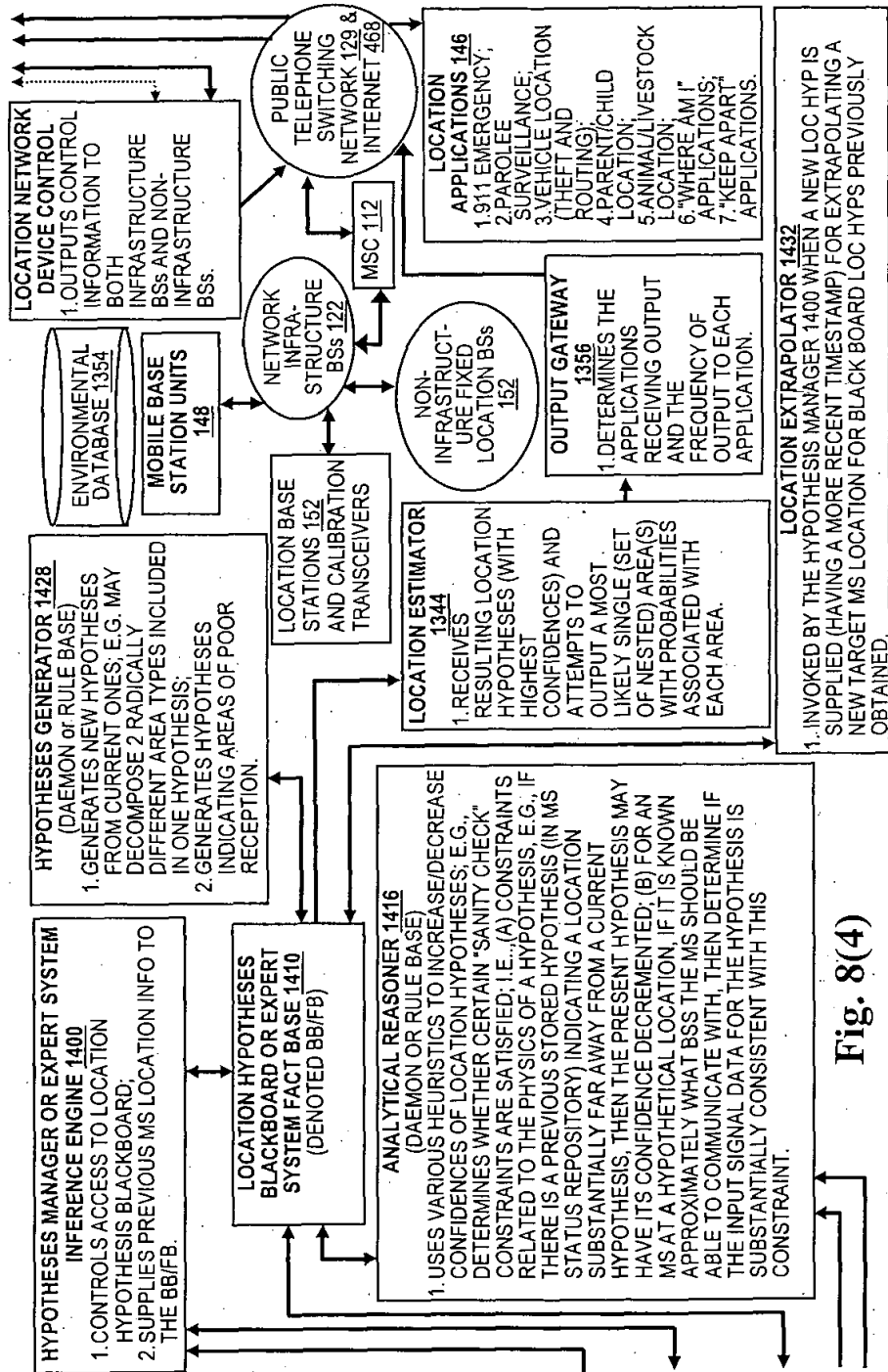

Fig. 8(3)



**Fig. 8(4)**

**FOM\_ID:** First Order Model ID (providing this Location Hypothesis); note, since it is possible for location hypotheses to be generated by other than the FOM's, in general this field identifies the module that generated this location hypothesis.

**MS\_ID:** The identification of the target MS to which this location hypothesis applies.

**pt\_est:** The most likely location point estimate of the target MS

**valid\_pt:** Boolean indicating the validity of "pt\_est"

**area\_est:** Location Area Estimate of the target MS provided by the FOM. This area estimate will be used whenever "image\_area" below is NULL.

**valid\_area:** Boolean indicating the validity of "area\_est" (one of "pt\_est" and "area\_est" must be valid).

**adjust:** Boolean (true iff adjustments to the fields of this location hypothesis are to be performed in the Context Adjuster Module).

**pt\_covering:** reference to a substantially minimal area (e.g., mesh cell) covering of "pt\_est". Note, since this MS may be substantially on a cell boundary, this covering may in some cases include more than one cell.

**image\_area:** reference to an area (e.g., mesh cell) covering of the image cluster set area for "pt\_covering" (see detailed description of the function, "confidence\_adjuster"). Note that if this field is not NULL, then this is the target MS location estimate used by the Location Center instead of "area\_est".

**FIG. 9A**

**extrapolation\_area:** reference to (if non-NULL) an extrapolated MS target estimate area provided by the Location Extrapolator submodule of the Hypothesis Analyzer. That is, this field, if non\_NULL, is an extrapolation of the "image\_area" field if it exists, otherwise this field is an extrapolation of the "area\_est" field. Note other extrapolation fields may also be provided depending on the embodiment of the present invention, such as an extrapolation of the "pt\_covering".

**confidence:** A real value in the range [0, +1.0] indicating a likelihood (e.g., probability) that the target MS is in (or out) of a particular area. If positive: if "image\_area" exists, then this is a measure of the likelihood that the target MS is within the area represented by "image\_area," else if "image\_area" has not been computed (e.g., "adjust" is FALSE), then "area\_est" must be valid and this is a measure of the likelihood that the target MS is within the area represented by "area\_est." If negative, then "area\_est" must be valid and this is a measure of the likelihood that the target MS is NOT in the area represented by "area\_est". If it is zero (near zero), then the likelihood is unknown.

**Original\_Timestamp:** Date and time that the location signature cluster for this location hypothesis was received by the CDMA Filter Subsystem,

**Active\_Timestamp:** Run-time field providing the time to which this location hypothesis has had its MS location estimate(s) extrapolated (in the Location Extrapolator of the Hypothesis Analyzer). Note that this field is initialized with the value from the "Original\_Timestamp" field.

**Processing Tags and environmental categorizations:** For indicating particular types of environmental classifications not readily determined by the Original\_Timestamp field (e.g., weather, traffic), and restrictions on location hypothesis processing.

**loc\_sig\_cluster:** Access to location signature signal characteristics provided to the First Order Models by the CDMA Filter Subsystem; i.e., access to the "loc sigs" (received at "timestamp" regarding the location of the target MS)

**descriptor:** Optional descriptor (from the First Order Model indicating why/how the Location Area Estimate and Confidence Value were determined).

**FIG. 9B**



**FIG. 10**

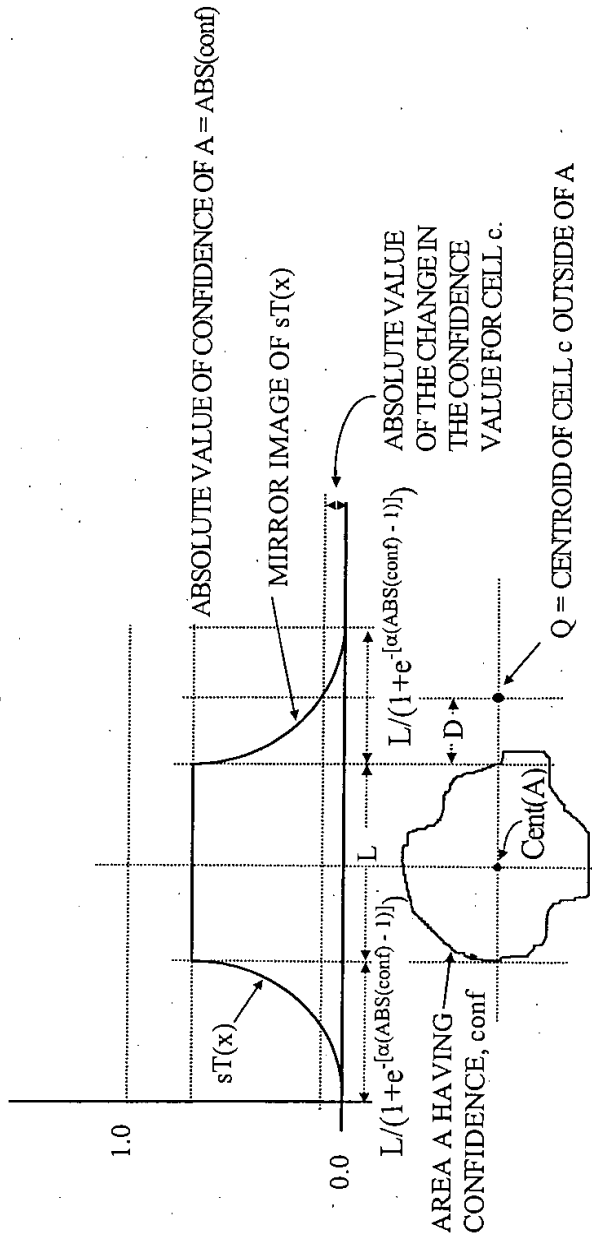

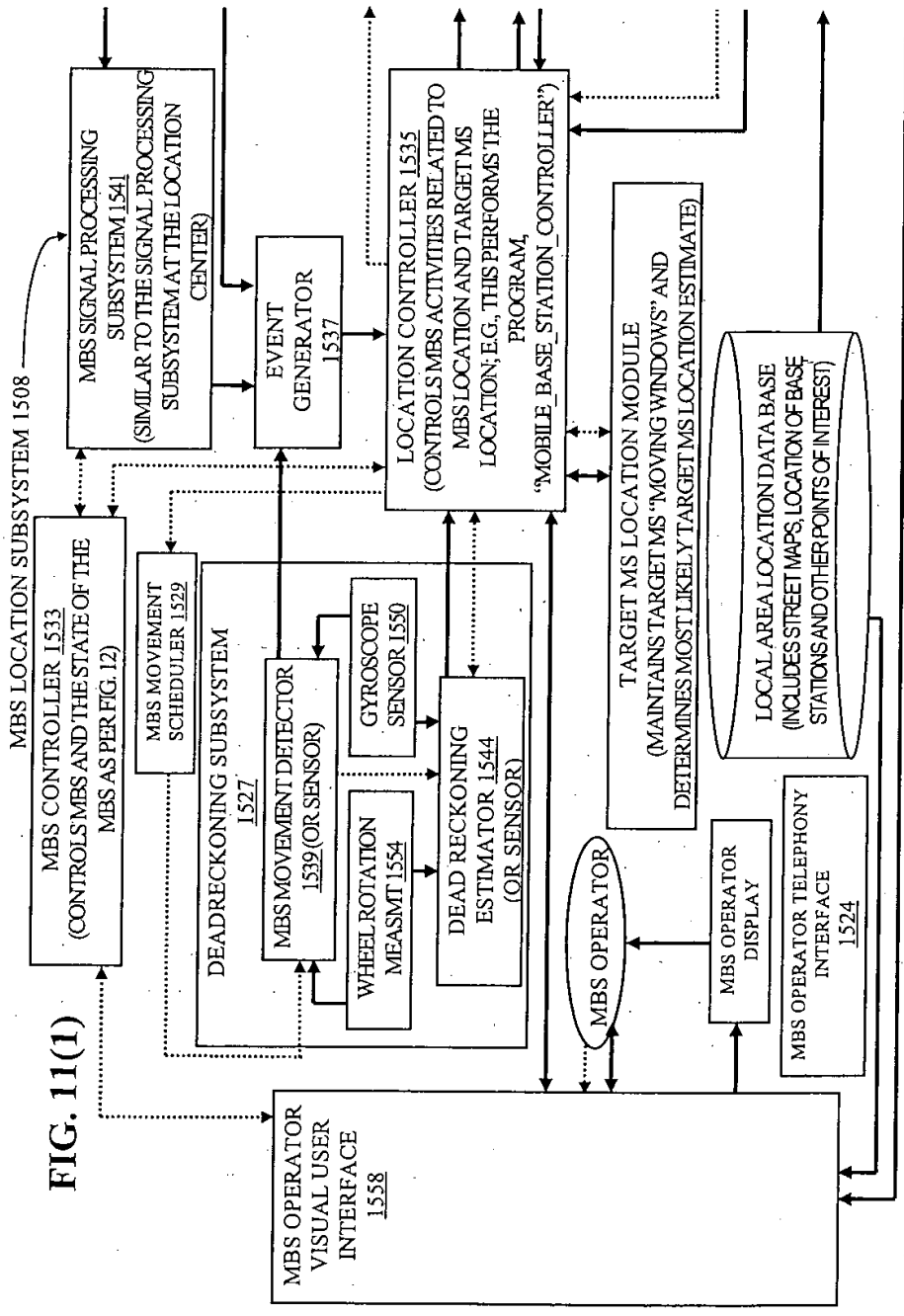

FIG. 11(1)

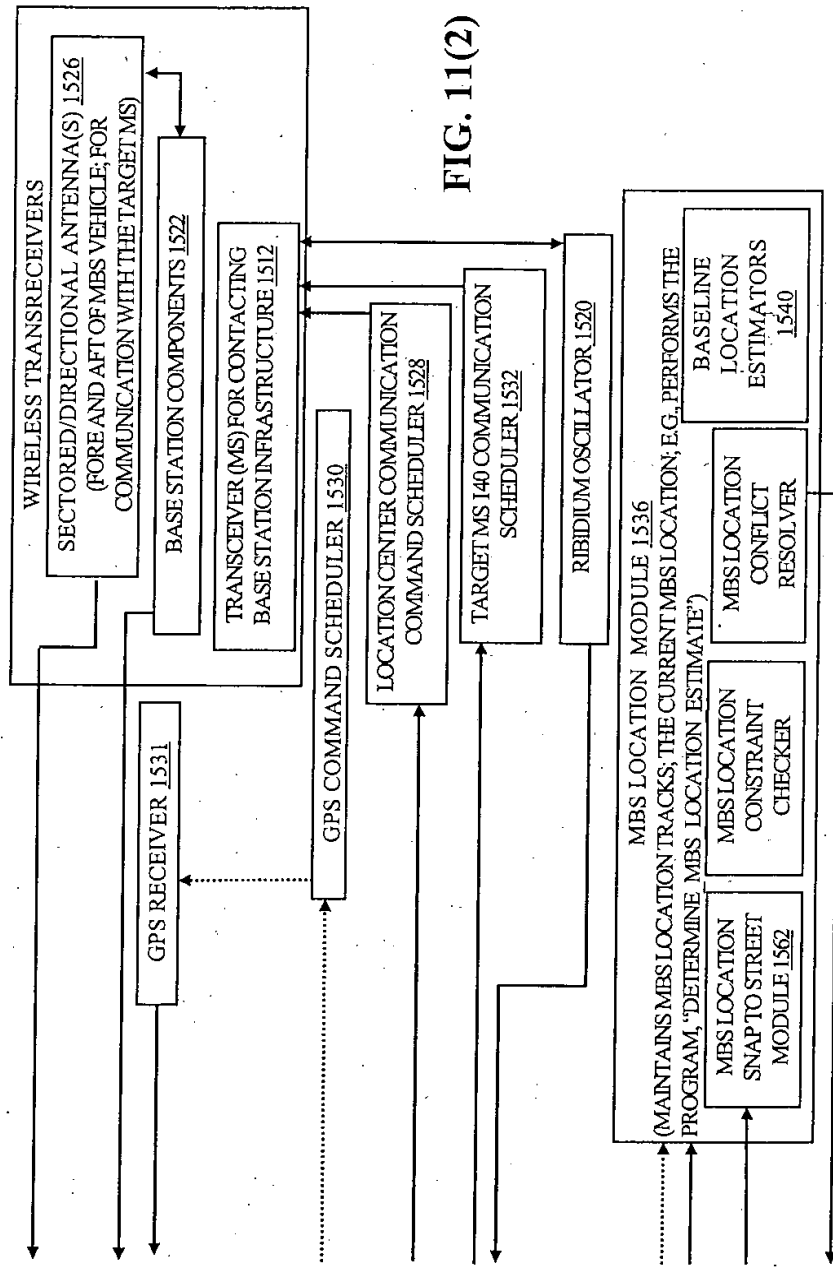
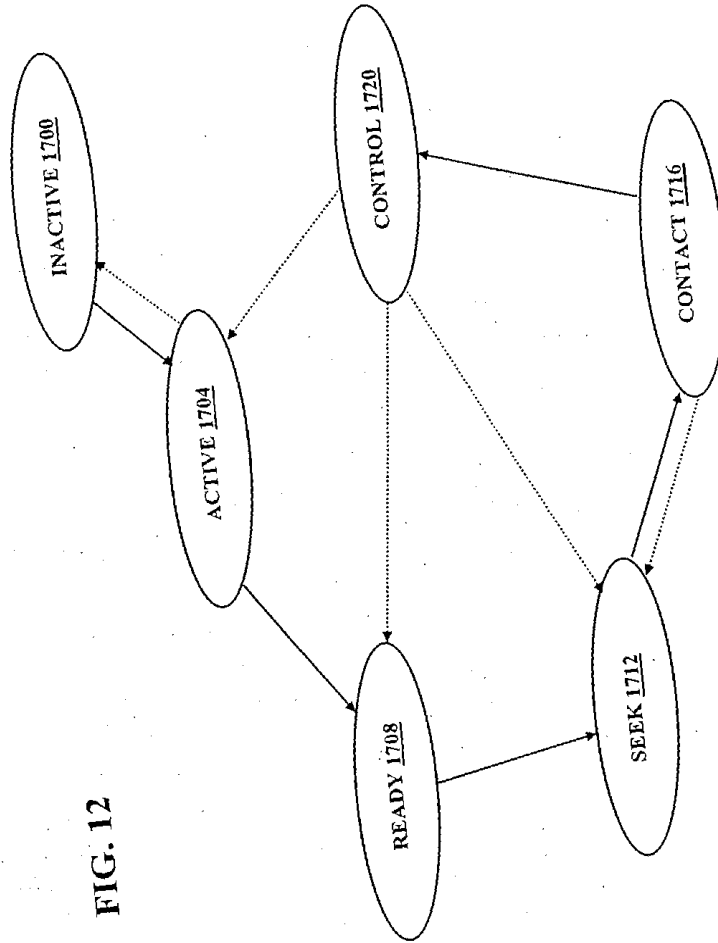

FIG. 11(2)

FIG. 12



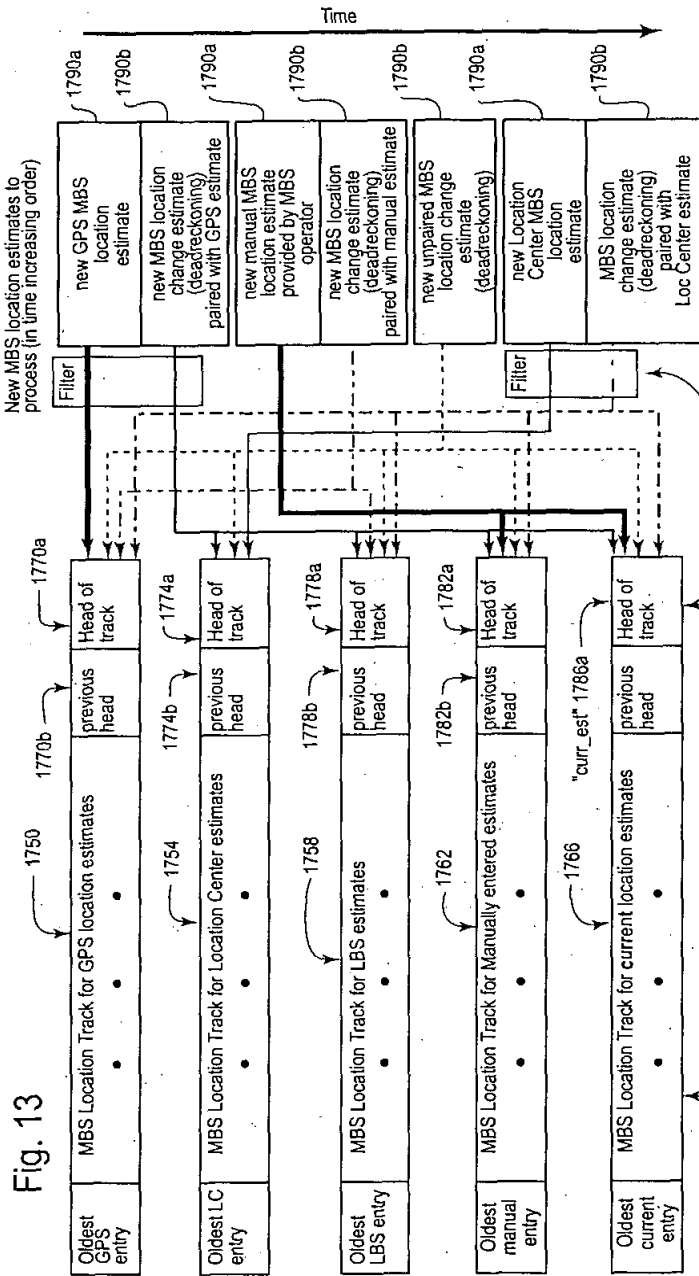

Fig. 13

Filtering mechanism for determining if the new MBS location estimates (other than deadreckoning location change estimates and manual estimates) have a sufficiently high confidence value to qualify them to be inserted into their corresponding MBS location track.

Each entry here is either an extrapolation entry determined using a deadreckoning location change estimate, or a baseline entry derived from a combination of one or more of the other location track heads, or a manual MBS location estimate.

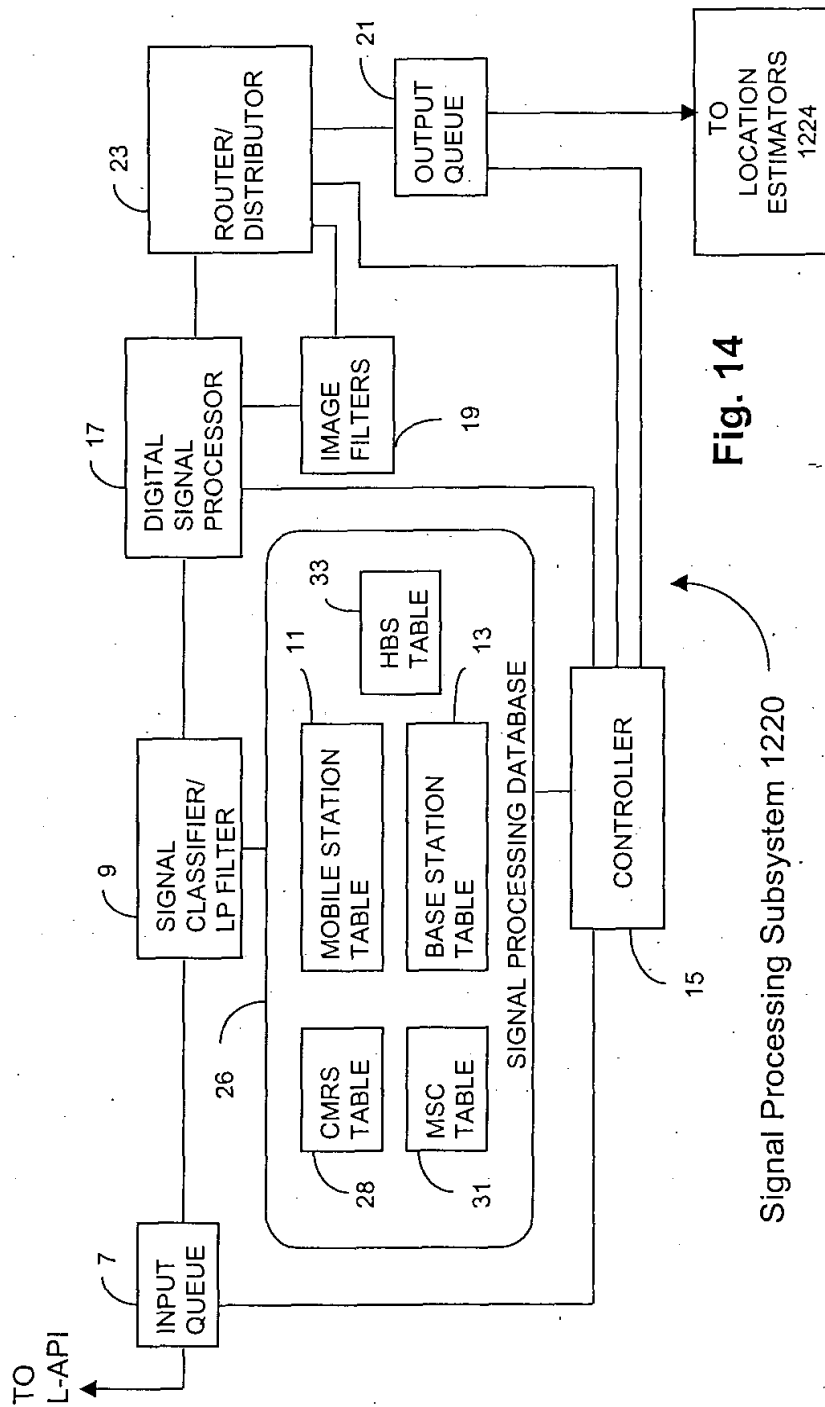

Fig. 14

Signal Processing Subsystem 1220

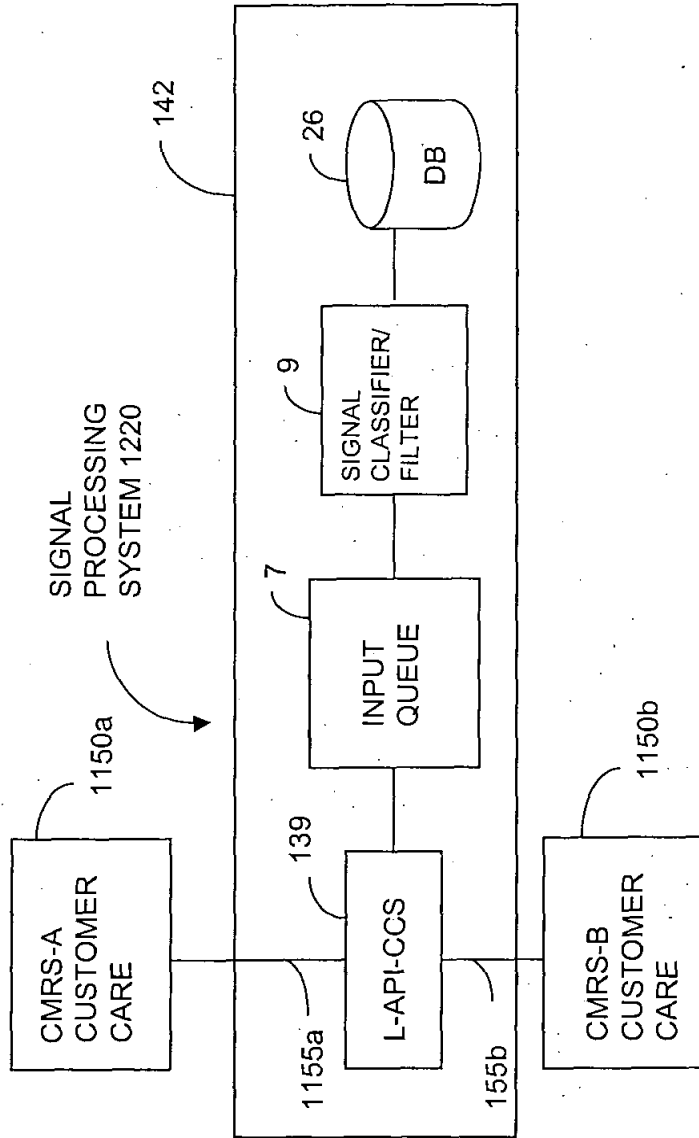

FIG. 15: LOCATION PROVISIONING VIA MULTIPLE CMRS

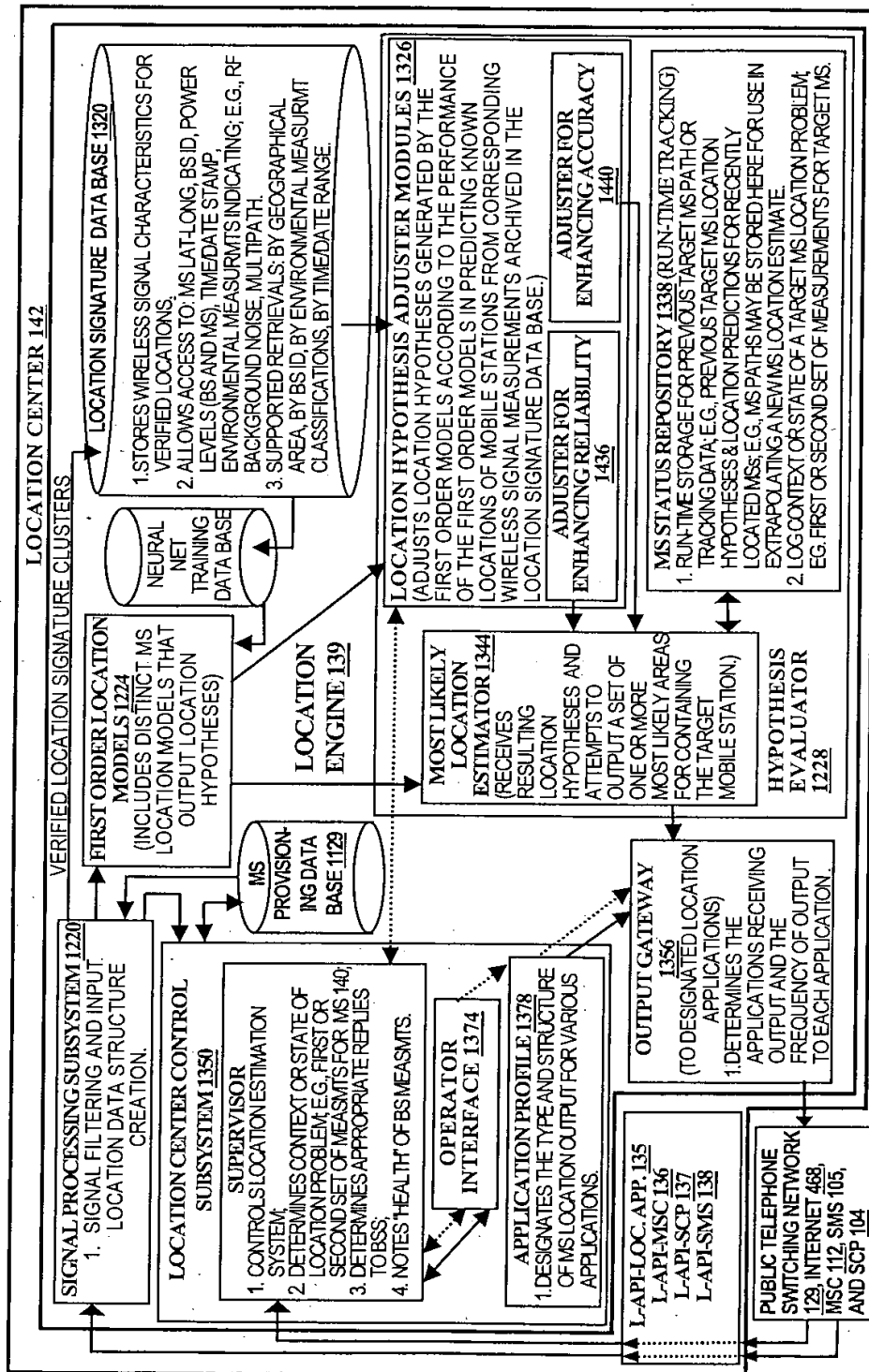

FIG. 16





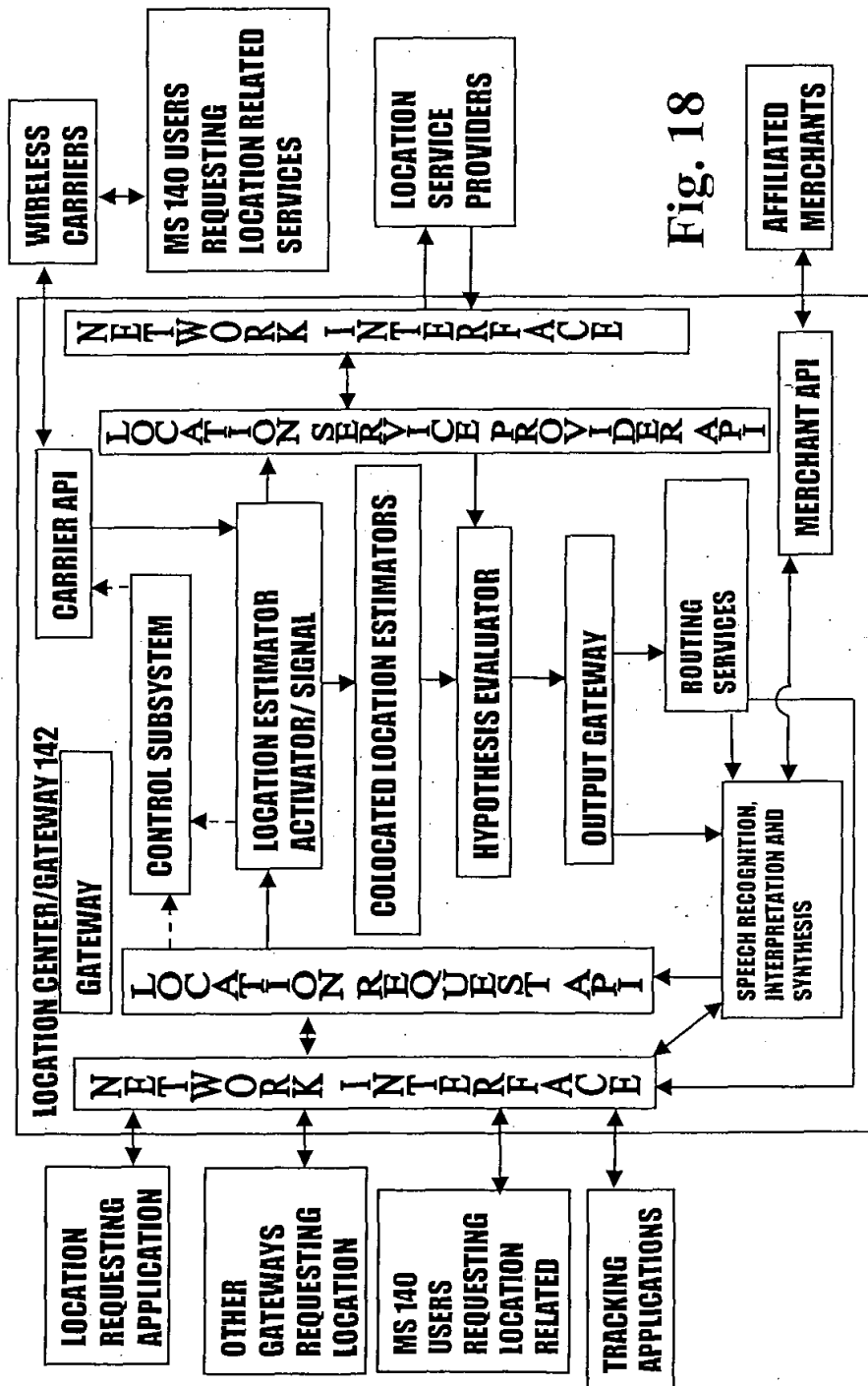
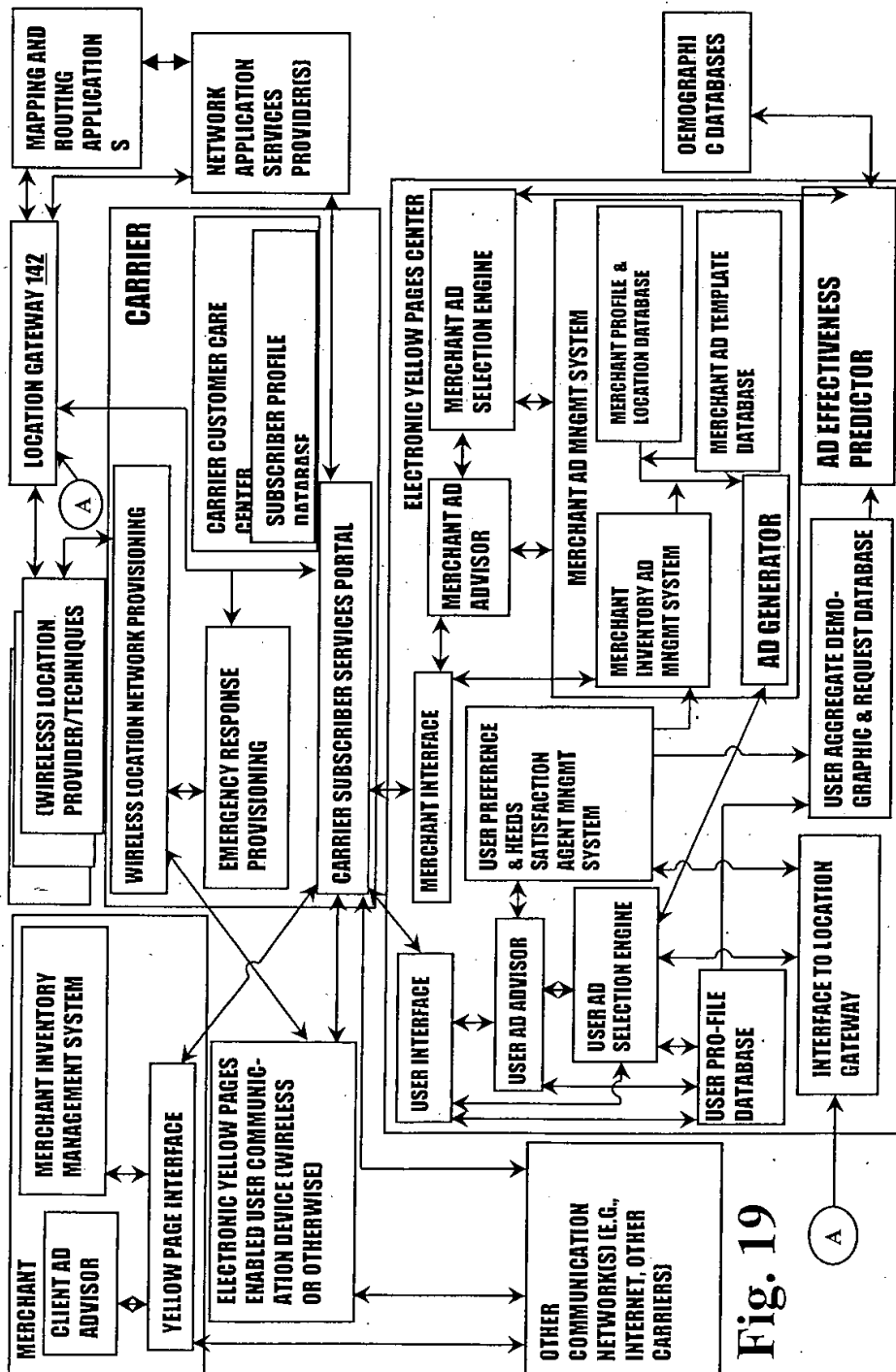
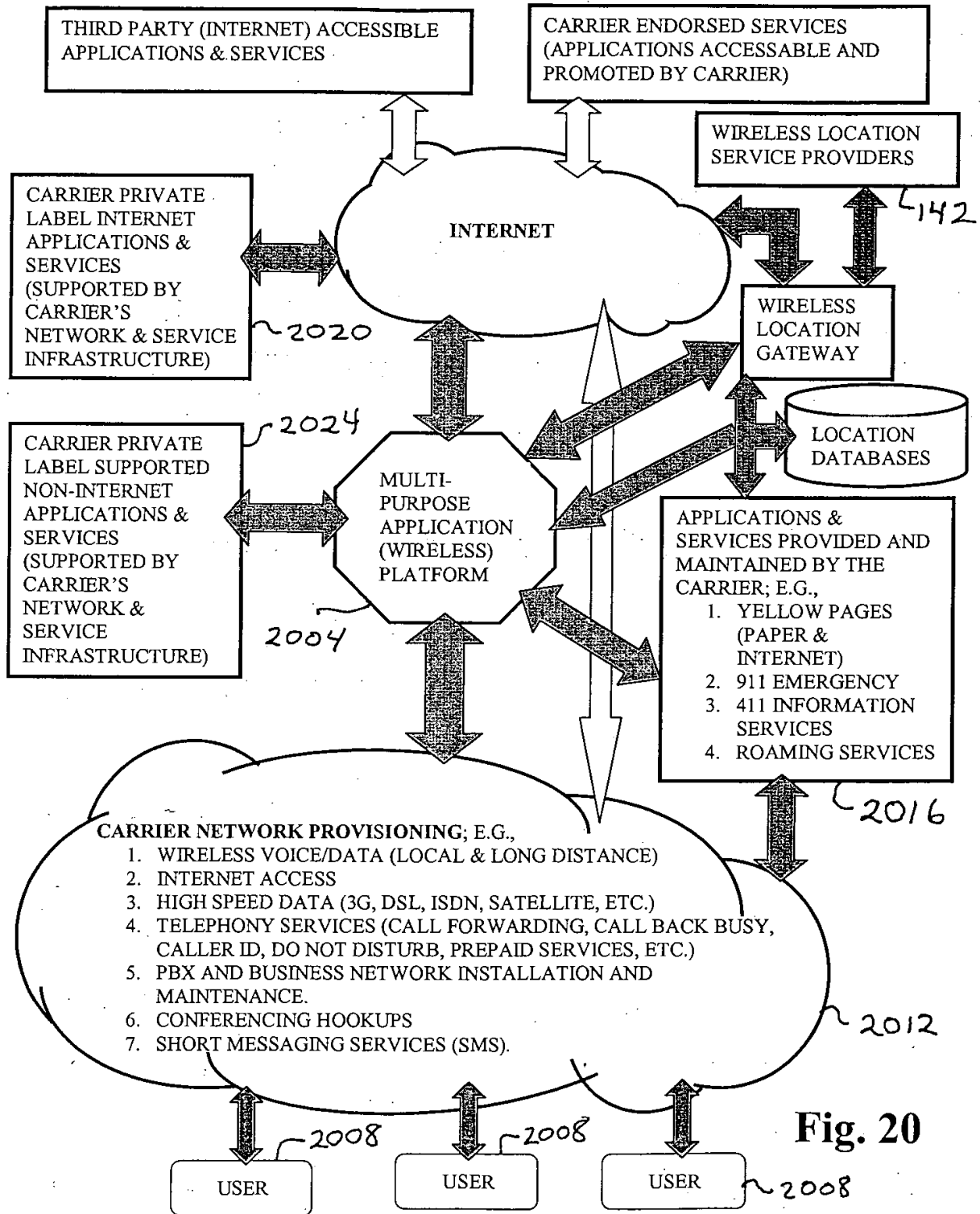

Fig. 18



**Fig. 19**



**Fig. 20**



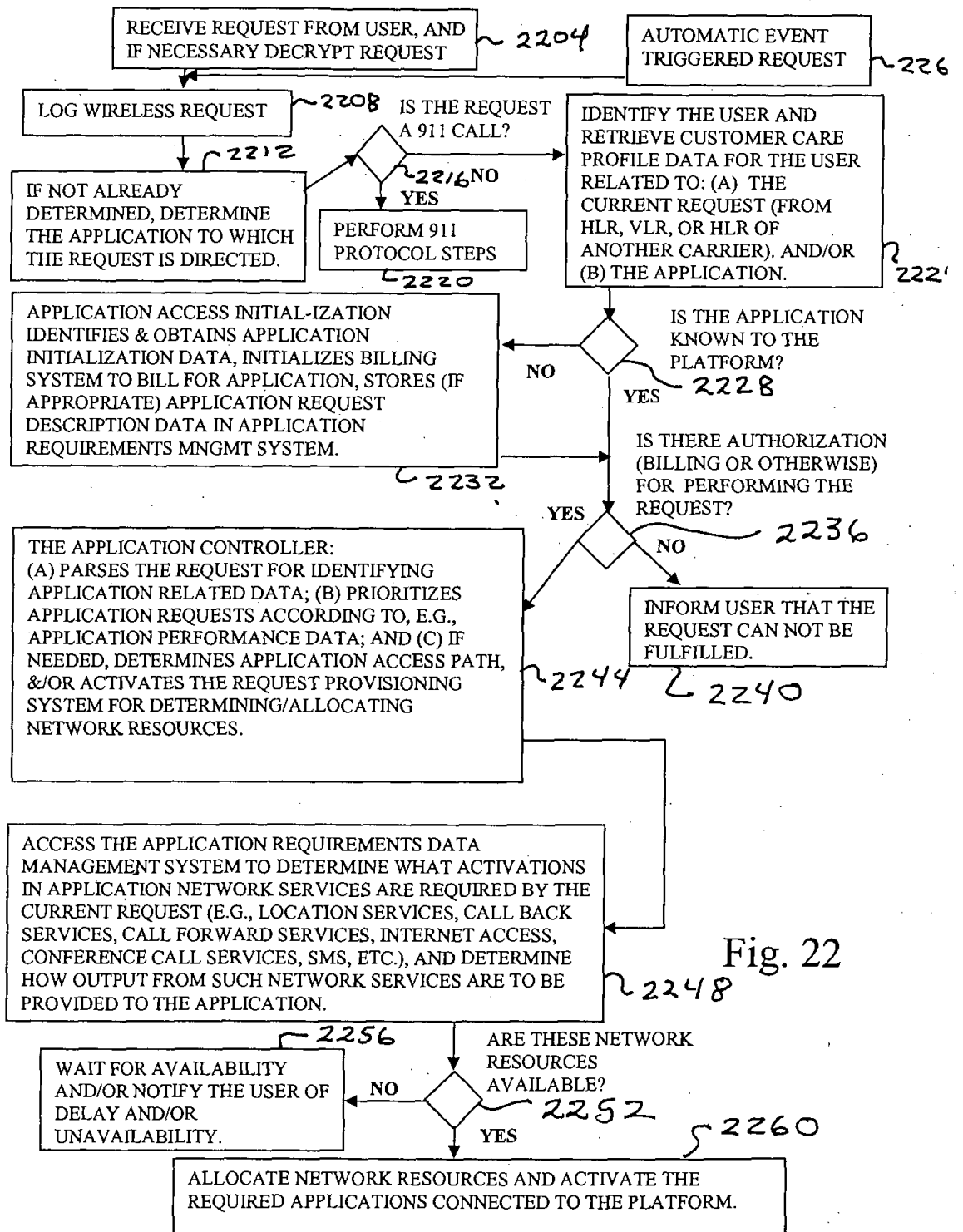

Fig. 22



12-29-03

3662  
B

IN THE UNITED STATES PATENT AND TRADEMARK OFFICE

In Re the Application of:

Dupray et al.

Serial No.: 09/770,838

Filed: January 26, 2001

Atty. File No.: 1003-1

For: A GATEWAY AND HYBRID  
SOLUTIONS FOR WIRELESS  
LOCATION

) Group Art Unit: 3662

) Examiner: Dao L. Phan

) INFORMATION DISCLOSURE STATEMENT

) "EXPRESS MAIL" MAILING LABEL NUMBER: EV331284521US  
) DATE OF DEPOSIT: December 23, 2003

) I HEREBY CERTIFY THAT THIS PAPER OR FEE IS BEING DEPOSITED  
) WITH THE UNITED STATES POSTAL SERVICE "EXPRESS MAIL POST  
) OFFICE TO ADDRESSEE" SERVICE UNDER 37 CFR 1.10 ON THE DATE  
) INDICATED ABOVE AND IS ADDRESSED TO THE COMMISSIONER  
) FOR PATENTS, P.O. BOX 1450, ALEXANDRIA, VIRGINIA 22313-1450.

) TYPED OR PRINTED NAME: AIMEE M. THUERK

SIGNATURE: Aimee M Thuerk

Commissioner for Patents  
P.O. Box 1450  
Alexandria, Virginia 22313-1450

Dear Sir:

The references cited on attached Form PTO-1449 are being called to the attention of the Examiner.

Are enclosed herewith.

Are not enclosed, in accordance with 37 C.F.R. 1.98(d), because the references were submitted to the U.S. Patent and Trademark Office in prior application Serial No. 09/194,367 filed November 24, 1998, which is relied upon for an earlier filing date under 35 U.S.C. § 120.

To the best of applicants' belief, the pertinence of the foreign-language references is believed to be summarized in the attached English abstracts and in the figures, although applicants do not necessarily vouch for the accuracy of the translation.

Examiner's attention is drawn to the following co-pending applications, and for at least such applications to which the present application does not claim priority, copies have been or are being submitted:

- Serial No.09/194,367 filed Nov. 24, 1998 (docket no. 1003-PUS)
- Serial No.10/262,413 filed Sept. 30, 2002 (docket no. 1003-2)
- Serial No. 10/262,338 filed Sept. 30, 2002 (docket no. 1003-3)
- Serial No. 09/820,584 filed March 29, 2001 (docket no. 1004-1)
- Serial No.09/176,587 filed Oct. 21, 1998 (docket no. 1005-DJD)

Serial No. 10/297,449 filed Dec. 5, 2002 (docket no. 1010-PUS)  
 Serial No. 10/337,807 filed Jan. 6, 2003 (docket no. 1011)

Submission of the above information is not intended as an admission that any item is citable under the statutes or rules to support a rejection, that any item disclosed represents analogous art, or that those skilled in the art would refer to or recognize the pertinence of any reference without the benefit of hindsight, nor should an inference be drawn as to the pertinence of the references based on the order in which they are presented. Submission of this statement should not be taken as an indication that a search has been conducted, or that no better art exists.

It is respectfully requested that the cited information be expressly considered during the prosecution of this application and the references made of record therein.

**FEES**

<input checked="" type="checkbox"/>	<p><b>37 CFR 1.97(b):</b> No fee is believed due in connection with this submission, because the information disclosure statement submitted herewith is satisfies one of the following conditions ("X" indicates satisfaction):</p> <ul style="list-style-type: none"> <li><input type="checkbox"/> Within three months of the filing date of a national application other than a continued prosecution application under 37 CFR 1.53(d), or</li> <li><input type="checkbox"/> Within three months of the date of entry into the national stage of an international application as set forth in 37 CFR 1.491 or</li> <li><input type="checkbox"/> Before the mailing date of a first Office Action on the merits, or</li> <li><input checked="" type="checkbox"/> Before the mailing of a first Office action after the filing of a request for continued examination under 37 CFR 1.114.</li> </ul> <p>Although no fee is believed due, if any fee is deemed due in connection with this submission, please charge such fee to Deposit Account 19-1970.</p>
<input type="checkbox"/>	<p><b>37 CFR 1.97(c):</b> The information disclosure statement transmitted herewith is being filed after all the above conditions (37 CFR 1.97(b)), but before the mailing date of one of the following conditions:</p> <ul style="list-style-type: none"> <li>(1) a final action under 37 C.F.R. 1.113 or</li> <li>(2) a notice of allowance under 37 C.F.R. 1.311, or</li> <li>(3) an action that otherwise closes prosecution in the application.</li> </ul> <p>This Information Disclosure Statement is accompanied by:</p> <ul style="list-style-type: none"> <li><input type="checkbox"/> A Certification (below) as specified by 37 C.F.R. 1.97(e). Although no fee is believed due, if any fee is deemed due in connection with this submission, please charge such fee to Deposit Account 19-1970.</li> </ul> <p style="text-align: center;">OR</p> <ul style="list-style-type: none"> <li><input type="checkbox"/> A check in the amount of \$180.00 for the fee set forth in 37 C.F.R. 1.17(p) for submission of an information disclosure statement. Please credit any overpayment or charge any underpayment to Deposit Account No. 19-1970. Election to pay the fee should not be taken as an indication that applicant(s) cannot execute a certification.</li> </ul>
<input type="checkbox"/>	<p><b>37 CFR 1.97(d):</b> This Information Disclosure Statement is being submitted after the period specified in 37 CFR 1.97(c).</p> <ul style="list-style-type: none"> <li><input type="checkbox"/> This information Disclosure Statement includes a Certification (below) as specified by 37 C.F.R. 1.97(e)</li> </ul> <p style="text-align: center;">AND</p> <ul style="list-style-type: none"> <li><input type="checkbox"/> Applicants hereby requests consideration of the reference(s) disclosed herein. Enclosed is the fee in the amount of \$180.00 under 37 C.F.R. 1.17(p). Please credit any overpayment or charge any underpayment to Deposit Account No. 19-1970.</li> </ul>



**Certification (37 C.F.R. 1.97(e))**  
(Applicable only if checked)

The undersigned certifies that:

Each item of information contained in this information disclosure statement was first cited in any communication from a foreign patent office in a counterpart foreign application not more than three months prior to the filing of this statement. 37 C.F.R. 1.97(e)(1).

A copy of the communication from the foreign patent office is enclosed.

OR

No item of information contained in this information disclosure statement was cited in a communication from a foreign patent office in a counterpart foreign application, and, to the knowledge of the undersigned after making reasonable inquiry, no item of information contained in this Information Disclosure Statement was known to any individual designated in 37 C.F.R. 1.56(c) more than more than three months prior to the filing of this statement. 37 C.F.R. 1.97(e)(2).

Respectfully submitted,

SHERIDAN ROSS P.C.

By: 

Dennis J. Dupray  
Registration No. 46,299  
1560 Broadway, Suite 1200  
Denver, Colorado 80202-5141  
(303) 863-9700

Date: 

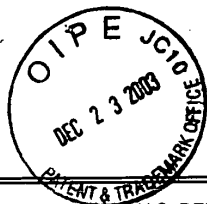

FORM PTO-1449 U.S. DEPARTMENT OF COMMERCE PATENT AND TRADEMARK OFFICE  INFORMATION DISCLOSURE STATEMENT (Use several sheets if necessary)	ATTY. DOCKET NO. 1003-1	SERIAL NO. 09/770,838
	APPLICANT DUPRAY, Dennis J.	
	FILING DATE January 26, 2001	GROUP ART 3662

U.S. PATENT DOCUMENTS

*EXAMINER INITIAL		DOCUMENT NUMBER	DATE	NAME	CLASS	SUB CLASS	FILING DATE IF APPROP.
	AA	5,588,038	12/24/96	Snyder	379	57	
	AB	5,119,104	6/2/92	Heller	342	450	

FOREIGN PATENT DOCUMENTS

		DOCUMENT NUMBER	DATE	COUNTRY	CLASS	SUB CLASS	TRANSLATION	
							YES	NO
	AC	WO 94/15412	July 7, 1994	PCT	H04B 7	185		

OTHER ART (Including Author, Title, Date, Pertinent Pages, etc.)

EXAMINER	DATE CONSIDERED
*EXAMINER: Initial if reference considered, whether or not citation is in conformance with MPEP 609; Draw line through citation if not in conformance and not considered. Include copy of this form with next communication to applicant.	

This Page Is Inserted by IFW Operations  
and is not a part of the Official Record

## **BEST AVAILABLE IMAGES**

Defective images within this document are accurate representations of the original documents submitted by the applicant.

Defects in the images may include (but are not limited to):

- BLACK BORDERS
- TEXT CUT OFF AT TOP, BOTTOM OR SIDES
- FADED TEXT
- ILLEGIBLE TEXT
- SKEWED/SLANTED IMAGES
- COLORED PHOTOS
- BLACK OR VERY BLACK AND WHITE DARK PHOTOS
- GRAY SCALE DOCUMENTS

**IMAGES ARE BEST AVAILABLE COPY.**

**As rescanning documents *will not* correct images,  
please do not report the images to the  
Image Problem Mailbox.**



INTERNATIONAL APPLICATION PUBLISHED UNDER THE PATENT COOPERATION TREATY (PCT)

(51) International Patent Classification <sup>5</sup> : H04B 7/185, G01S 5/02, H04L 27/30		A1	(11) International Publication Number: WO 94/15412
(21) International Application Number: PCT/US93/12179			(43) International Publication Date: 7 July 1994 (07.07.94)
(22) International Filing Date: 17 December 1993 (17.12.93)			
(30) Priority Data: 07/992,892 17 December 1992 (17.12.92) US 08/079,810 22 June 1993 (22.06.93) US 08/115,087 2 September 1993 (02.09.93) US			(US). BRUNO, Ronald [US/US]; 3202 North 4th Street, Arlington, VA 22203 (US). RENNARD, Robert [US/US]; 12825 Stevens Court, San Martin, CA (US). MOSES, Charles [US/US]; 105 Rosewood Avenue, Catonsville, MD 21228 (US). WEINBERG, Aaron [US/US]; 12219 Doublewood Drive, Potomac, MD 20854 (US). ENGELBRECHT, Lloyd [US/US]; 1405 Newport Spring Court, Reston, VA 22094 (US).
(60) Parent Applications or Grants (63) Related by Continuation US 07/992,892 (CIP) Filed on 17 December 1992 (17.12.92) US 08/079,810 (CIP) Filed on 22 June 1993 (22.06.93) US 08/115,087 (CIP) Filed on 2 September 1993 (02.09.93)			(74) Agent: ZEGEER, Jim; 801 North Pitt Street, #108, Alexandria, VA 22314 (US).
(71) Applicant (for all designated States except US): STANFORD TELECOMMUNICATIONS, INC. [US/US]; 1761 Business Center Drive, Reston, VA 22090 (US).			(81) Designated States: AU, BR, CA, JP, KR, US, European patent (AT, BE, CH, DE, DK, ES, FR, GB, GR, IE, IT, LU, MC, NL, PT, SE).
(72) Inventors; and (75) Inventors/Applicants (for US only): SCHUCHMAN, Leonard [US/US]; 11054 Seven Hill Lane, Potomac, MD 20854			Published With international search report. Before the expiration of the time limit for amending the claims and to be republished in the event of the receipt of amendments.

(54) Title: HYBRID GPS/DATA AND MULTI-SERVICE LINK UNIT

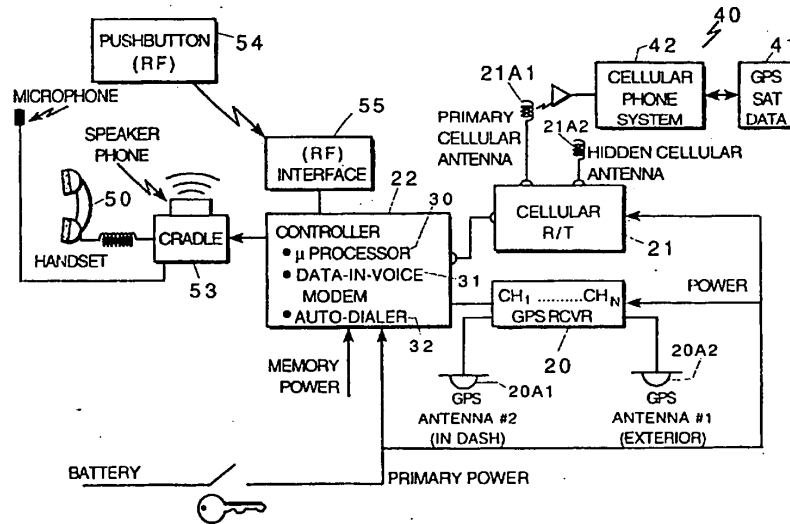

(57) Abstract

A global positioning system (GPS) (20) in which a plurality earth orbiting satellites transmit position information to mobile radio stations on earth, is provided with a separate source satellite position data broadcast digital channels and one or more dial-up service separate communication channels (selected from a data link supported by terrestrial cellular telephone (42) and other radio packet data services (54)) for assisting the mobile radio station to access position information from the satellites. A controller (22) is coupled to the mobile radio station (55) for connecting to the separate communication channel for extricating the satellite position data via separate communication channel. The controller (22) includes a microprocessor (30) for processing the satellite position data to enable the mobile radio station to rapidly locate and access position information from said earth orbiting satellite.

FOR THE PURPOSES OF INFORMATION ONLY

Codes used to identify States party to the PCT on the front pages of pamphlets publishing international applications under the PCT.

AT	Austria	GB	United Kingdom	MR	Mauritania
AU	Australia	GE	Georgia	MW	Malawi
BB	Barbados	GN	Guinea	NE	Niger
BE	Belgium	GR	Greece	NL	Netherlands
BF	Burkina Faso	HU	Hungary	NO	Norway
BG	Bulgaria	IE	Ireland	NZ	New Zealand
BJ	Benin	IT	Italy	PL	Poland
BR	Brazil	JP	Japan	PT	Portugal
BY	Belarus	KE	Kenya	RO	Romania
CA	Canada	KG	Kyrgyzstan	RU	Russian Federation
CF	Central African Republic	KP	Democratic People's Republic of Korea	SD	Sudan
CG	Congo	KR	Republic of Korea	SE	Sweden
CH	Switzerland	KZ	Kazakhstan	SI	Slovenia
CI	Côte d'Ivoire	LI	Liechtenstein	SK	Slovakia
CM	Cameroon	LK	Sri Lanka	SN	Senegal
CN	China	LU	Luxembourg	TD	Chad
CS	Czechoslovakia	LV	Latvia	TG	Togo
CZ	Czech Republic	MC	Monaco	TJ	Tajikistan
DE	Germany	MD	Republic of Moldova	TT	Trinidad and Tobago
DK	Denmark	MG	Madagascar	UA	Ukraine
ES	Spain	ML	Mali	US	United States of America
FI	Finland	MN	Mongolia	UZ	Uzbekistan
FR	France			VN	Viet Nam
GA	Gabon				

## HYBRID GPS/DATA AND MULTI-SERVICE LINK UNIT

This invention relates to method and apparatus for enabling rapid and accurate measurement of vehicle position, and more particularly to the global positioning system (GPS) for achieving precise position location in the urban canyon and other line of sight obstructed environments. It further relates to supplying the required data link over a cellular phone or other channel in order to support the measurement of GPS position, and to relay the resulting position measurements over the phone system to service providers that need to know vehicle position in order to provide services, such as:

1. A Emergency Roadside Assistance (ERA) service which will provide subscribers with the ability to request roadside services using their cellular phone without having to leave their car or know their exact location. Typical roadside services would include delivery of fuel, repairing a flat tire, jump-start the automobile, or towing to a service station.

2. A Personal Emergency Response (PER) service which will provide subscribers with the ability to request emergency equipment and personnel immediately upon request from their vehicle without knowing their exact location. Examples of scenarios where this service is envisioned to be useful include sudden extreme illness of the subscriber (requiring an ambulance), automobile fire (requiring a fire extinguisher), or an accident (requiring police assistance). In addition, a panic button allows a user to call for police in cases where a user feels endangered in or near the automobile.

3. A Vehicle Tracking Assistance (VTA) service which will be designed to maintain the most up-to-date, accurate location of the automobile, and truck, possible without the aid of the driver. The primary application of the VTA service is in the theft/automobile security arena. When a subscriber's automobile is stolen or car-jacked, maintaining the current location of the automobile is critical to recovery, and could be of great

assistance to the police. It can be used to track trucks carrying commercial cargos, taxis, etc.

4. A Traveler Information Assistance (TIA) service which will enable subscribers to acquire information on a variety of destinations from the comfort of their automobile. The types of destinations about which information such as name, address, and phone number will be provided include banks, ATMs, restaurants, service stations, and hotels/motels. The subscriber will receive assistance in selecting the optimal destination, and also can be given detailed directions from the current automobile location to the selected destination.

5. A traffic Incident Management (TIM) service which will assist subscribers in reaching their destinations as quickly as possible and alert travelers to traffic conditions in the area they are traveling or typically travel. Such a capability will be provided by devising a route based on the time of day, day of the week, and the current traffic conditions, including both static and dynamic conditions. These three factors can affect the traffic volume on a road, the turn restrictions to/from a road, the speed limit on a road, and the direction of traffic (one-way or two-way) permitted on the road. In addition, weather, as it affects traffic and driving conditions will be utilized in providing TIM service.

**BACKGROUND AND BRIEF DESCRIPTION OF THE INVENTION:**

The current cellular telephone system provides a means for people to gain access to a variety of services (described above) that can be obtained via the public switched telephone system. However, the ability to provide service to people in this system is severely limited by the fact that a mobile user does not have a fixed address which enables a service provider to locate the customer and supply the requested service. The critical missing element that is lacking is the automatic determination of the geographical position (in latitude and longitude) of a mobile user that serves as the address of the mobile. This element is integrated into the invention via a novel technique for rapidly

deriving precise position estimates via the GPS system in obstructed environments. In addition, the invention described herein also provides for the automatic relay of the derived position estimate to a service provider whenever a person calls and connects with a service provider that has communications equipment compatible with the mobile. Such equipment, described herein, supports the simultaneous transmission of voice and data over a single telephone channel in the cellular telephone network.

Most modern GPS receivers employ the GPS satellite almanac and rough information on current time and position to attempt to acquire signals of visible GPS satellites by searching in a limited number of frequency bins over a time uncertainty hypothesis of one millisecond, the repetition interval of the GPS C/A codes. The terms "frequency bin" or "frequency cell" (used interchangeably herein), mean a narrow frequency range or spectrum, each frequency bin or cell having a characteristic center frequency and a predefined width or band of frequencies. In general, the entire sequence of events for arriving at a estimate of position location is in accordance with the following sequence of events:

1. Detection of a satellite PN code in a frequency bin,
2. Acquisition and tracking of the carrier frequency,
3. Acquisition and tracking of the data transitions and data frame boundary,
4. Reading broadcast data for the satellite ephemeris and time model (the 900 bit Satellite Data Message),
5. Completing steps 1-4 (serially or in parallel) for all in-view satellites,
6. Making pseudorange measurements on these signals in parallel, and
7. Computation of position using the pseudorange measurements and satellite data.

The time required to accomplish these steps in a conventional GPS receiver will vary depending upon the assumed



starting point of the GPS receiver. It is useful to define three reference starting points for a GPS receiver. These are as follows:

**Cold Start:** Where the receiver has no GPS almanac.

5 The GPS almanac is a 15,000 bit block of coarse ephemeris and time model data for the entire GPS constellation. Without an almanac, the GPS receiver must conduct the widest possible frequency search to acquire a satellite signal. In this case, signal  
10 acquisition can take several minutes to accomplish because a large number of frequency cells must be searched that takes into account the large uncertainties in satellite Doppler as well as GPS receiver oscillator offset. In addition, acquisition  
15 of the GPS almanac will take at least 12-1/2 minutes of listening to the broadcast of a single GPS satellite.

**Warm Start:** Where the receiver has a GPS almanac to aid the acquisition of satellite signals by greatly reducing the uncertainty in satellite Doppler and  
20 therefore number of frequency cells that must be searched. In this case, the number of frequency cells that must be searched is determined by the accuracy of the GPS local oscillator. For a typical oscillator accuracy of one ppm, the frequency search can be  
25 accomplished in less than 10 seconds. In this case, the major time bottleneck for generating a position fix is the time required to acquire the 900 bits of the Satellite Data Message for each GPS satellite that is to be used in computing the receiver position. This  
30 Message is broadcast every 30 seconds at 50 bps. For parallel GPS receiver channels, the time requirement to obtain the 900 bit Message from each in-view satellite is roughly 30 seconds.

35

Hot Start: Where the receiver already has the Satellite Data Messages for all the in-view GPS satellites (7200 bits for eight satellites). In this case, the major time bottleneck is the acquisition of multiple satellite signals and generating pseudorange measurements from them (steps 6 and 7 above). The condition of a GPS receiver is "hot" if it recently (minutes) traversed the steps 1 - 5 above, or if it received the Satellite Data Messages from an alternate source. From a hot start, position determination begins at steps 6 and 7. This can be accomplished quite rapidly if a pseudorange measurement is utilized to calibrate out the frequency uncertainty of the GPS receiver oscillator, thereby enabling the rapid acquisition of subsequent satellite signals with a search over only a single frequency cell. Thus, from a hot start, it is possible to achieve a position fix very rapidly (in less than one second) if a search algorithm is used that minimizes the required frequency search band for signal acquisition.

This invention merges GPS position location and wireless data communication technologies to achieve a precise position location via GPS in the urban canyon and other line-of-sight obstructed environments. A multi-channel GPS receiver with the capability to simultaneously track (and make pseudorange measurements with) all in-view GPS satellites is used in conjunction with an algorithm that makes maximum use of all a priori information about the GPS receiver (its oscillator bias, its location, its knowledge of time) and the ephemeris and time models of the GPS constellation received by a wireless data communication channel or link to enable rapid acquisition of the GPS signal.

As shown above, currently, there are two time bottlenecks in estimating accurate position via GPS. One of these is due to the

oscillator bias of the GPS receiver which is a driver for a time consuming search over many frequency cells.

According to the invention, the search over frequency is required only for the acquisition of the first GPS satellite. The frequency measurement from tracking that one satellite is then used to calibrate out the frequency bias of the GPS local oscillator. Thus, the subsequent acquisition of other GPS satellite signals can be accomplished very rapidly because the number of frequency cells that must be searched is reduced to one.

The second time bottleneck in determining precise position location is the necessity to read the 900 bit GPS Satellite Data Message block containing the ephemeris and satellite clock models of the GPS satellites. This data message must be extracted for each satellite that is used for the GPS position solution. Extracting this needed information for determining position will take 30 seconds in a clear environment; in an obstructed environment, extracting this information may take far longer, and in the worst case, may not be possible at all.

According to the invention, this is supplied to the GPS receiver with the needed ephemeris and satellite clock information via an independent wireless data channel such as can be supported by an RDS FM broadcast or a cellular telephone channel. With a cellular telephone, the needed data can be supplied by calling (or receiving a call from) a service center and establishing a data link via a modem in the cellular phone, and a modem to a service center. The required GPS satellite information is then supplied via the established data link. At typical modem speeds (300 bps to 19.6 Kbps), this information is supplied in only several seconds to less than one second, depending upon the modem speed. In this manner, the GPS is assisted in rapid signal acquisition and rapid determination of position, even in obstructed environments.

In addition to an improved algorithm for rapidly determining position via GPS in an obstructed environment, this invention

also solves the problem of establishing the required data link with the GPS receiver. The primary method discussed herein utilizes a mobile cellular phone channel to support a data and a voice channel at the same time. According to the invention, this is accomplished by taking a frequency notch (say 600 Hz, for example) out of the audio band and embedding a data channel in this notch. A 300 bps half-duplex channel can be achieved via a frequency shift keyed (FSK) system with two tones in the frequency notch. With the appropriate notch filter, the participants in the voice conversation hear no modem tones associated with the transfer of data. Preferably, the notch filtering is digitally implemented. There is of course some degradation to the voice quality, depending upon the size and shape of the frequency notch, and its center location. For example, with a notch placed between 1500 Hz and 2100 Hz, voice intelligibility is excellent, and voice recognition is good. With such a frequency notch, a 300 bps "data-in-voice" modem with FSK tones at 1650 Hz and 1959 Hz can be implemented.

A further embodiment of the invention incorporates a recliner for monitoring local radio stations and determining position from the signalling geometries of a plurality of local stations, and a circuit detects GPS outages or black-outs and enable the use of local radio broadcasts for position determination or finding. In a preferred embodiment, local AM radio broadcasts are used with the data channel in the cellular phone being used.

#### DESCRIPTION OF THE DRAWINGS:

The above and other objects advantages and features of the invention will become more apparent when considered with the following specifications and accompanying drawings wherein:

Figure 1 is a chart illustrating prior and warm start sequence of events in a GPS system,

Figure 2 is a chart illustrating the warm start sequence according to the invention,

Figure 3 is a schematic illustration of how a priori knowledge of position resolves the ambiguity in time-position,

Figure 4 is a flow chart of signal processing according to the invention,

5 Figure 5 is a block diagram of GPS receiver combined with a cellular telephone and a controller according to the invention,

Figure 6 is a block diagram of the data-in-voice modem according to the invention,

10 Figure 7a is a block diagram of a configuration for the invention that interfaces with existing cellular phone equipment that may already be installed in the vehicle, and FIG. 7b illustrates how this can be done with a wireless connection,

Figure 8 is a block diagram of the enhanced cellular telephone services provided by the invention,

15 Figure 9 is a block diagram of the customer service center disclosed in Fig. 8,

Figure 10 is a block diagram of a system modification incorporating position determination using the position geometries of commercial radio broadcasting stations in conjunction with a local reference station, and

20 Figure 11 is a block diagram of a receiver for deriving signals used in the microprocessor for this alternate position finding.

#### DETAILED DESCRIPTION OF THE INVENTION

25 Figure 1 illustrates the sequence of events and the time requirements to estimate the position via a typical GPS receiver from a warm start. From a warm start, the first step in the process is the reading the GPS Satellite Data Messages contained in the broadcast signals of each satellite. This proceeds with  
30 the acquisition of the signals from all in-view satellites (which may take up to 10 seconds). Acquisition begins with PN code acquisition and proceeds to move through the processes of detection confirmation, PN tracking, frequency locked loop pull-in, conversion to phase lock for data demodulation, followed by  
35 bit and frame synchronization. Within 40 seconds after a warm

start, the receiver will typically have extracted the necessary satellite ephemeris and clock data in the Satellite Data Message of each satellite (i.e., if no obstructions are presented). For a receiver that is presented with obstructions, the time required to collect the necessary data can be quite long. GPS data is transmitted in 1500 bit frames at 50 bits per second. Thus, each frame is transmitted in 30 seconds. The 1500 bit frame of each broadcast is composed of five subframes of 300 bits length. The first three subframes of a broadcast signal (900 bits) comprise the Satellite Data Message for the broadcasting satellite. The Satellite Data Message contains precise ephemeris and time model information for that satellite. The first three subframes are identically repeated in each 1500 bit frame, except that the information is updated periodically. The fourth and fifth subframe contain a part of the almanac which contains coarse ephemeris and time model information for the entire GPS constellation. The contents of the fourth and fifth subframes change until the entire almanac is sent. The repetition period of the fourth and fifth subframes is 12-1/2 minutes and so the entire GPS almanac is contained in 15,000 bits. The subframes are composed of 10 words of 30 bits length with Hamming (32, 26) parity concatenation across words. This means that the last two bits of the previous word are part of the 26 bits used to compute a six bit syndrome. Therefore, it is necessary to receive all 32 bits of each word without interruption.

The invention removes the two greatest time bottlenecks discussed above in determining position via the GPS system. One bottleneck is eliminated by providing the GPS receiver with the needed Satellite Data Messages of the GPS constellation via an external data link supported by the cellular channel. The Satellite Data Messages for eight in-view satellite will be contained in 7200 bits or less; thus, with an external link at data rates from 300 bps up to 19.2 Kbps, the time required to transfer the needed Satellite Data Messages will take from several seconds to only a fraction of a second. The second

bottleneck that the invention eliminates is the time required to acquire the signal from subsequent satellites after the first satellite is acquired. It accomplishes this by an algorithm that optimally using GPS ephemeris and time model data together with  
5 the Doppler measurement on a single satellite signal to calibrate the GPS receiver frequency reference and thereby reduce the frequency uncertainty (and therefore the time required) for acquisition of subsequent satellite signals.

Figure 2 illustrate the general strategy and algorithm for a  
10 GPS receiver capable of rapid acquisition. While the embodiment discussed herein assumes an eight-channel receiver capable of simultaneously tracking all "in-view" GPS satellites, it is clear that more satellites could be used. The start of any position determination via GPS is normally the acquisition of the signal  
15 from the "in-view" GPS satellites in order to read the Satellite Data Messages. However, in this case, the current Satellite Data Message of the GPS constellation are first requested and received via an independent link such as a data link supported by the cellular telephone system. As soon as the first satellite is  
20 acquired, the pseudorange and Doppler are measured. Using the Doppler information from this measurement allows subsequent satellites to be rapidly and reliably acquired and reacquired as the mobile host vehicle progresses through obstructed fields of view.

25 According to the invention, at the acquisition from a warm start-up, the receiver's oscillator offset is the dominant factor in determining the frequency error of uncertainly ( $f_e$ ) of a broadcast GPS satellite signal. The GPS receiver has either a user-entered, or integral timing function, which is accurate to  
30  $t_e$ . Using this local time value, the receiver employs a GPS satellite almanac which was previously collected, or was injected via a data port to estimate which GPS satellite is most directly overhead. This computation produces an estimate of the line-of-sight Doppler offset of the GPS L1 carrier frequency relative at

the fixed at the location of the GPS receiver. The frequency search aperture is the sum of error in this line-of-sight Doppler offset estimate, the Doppler offset due to motion of the user vehicle, and the offset of the GPS receiver local oscillator scaled to the L1 carrier frequency. For a  $t$  of one minute, the error in the estimated offset will typically be about 60 Hz. If the user velocity is assumed to be less than 30 meters per second, this will produce an additional 76 Hz frequency uncertainty. (With the velocity vector principally in the local tangent plane, its contribution to the search aperture is 150 Hz times the cosine of the elevation angle to the satellite which presumably is above 60 degrees, thus reducing the offset by half.) The crystal oscillator is presumed to have a one ppm accuracy, giving an offset of  $\pm 1580$  Hz when scaled to the L1 frequency. This results in a total frequency uncertainty of roughly  $\pm 1700$  Hz around the computed Doppler offset.

The C/A code can be searched at a rate of 1000 chip timing hypotheses per second per correlator per channel for a detection probability of 0.95 and a false alarm probability of 0.01 assuming a 40 dB-Hz C/kT. Typically, triple correlator (early, punctual, and late) spacing is 1.5 chips or less. Thus a specific C/A signal can be searched in one Doppler bin of 500 Hz width in one second or less. There are seven bins in the 3500 Hz frequency uncertainty band (each 500 Hz wide) thereby requiring a total search time of seven seconds to acquire the first signal. However, if an eight-channel receiver is used to acquire a chosen overhead GPS satellite, all frequency cells can be searched simultaneously and the satellite signal can be acquired in one second. Upon acquisition of the signal, the signal is tracked, and a measurement of pseudorange and Doppler is obtained. This convergence requires less than 4 seconds.

This Doppler measurement is then used to collapse the frequency uncertainty in acquisition of subsequent satellite signals by calibrating the GPS local oscillator against the Doppler measurement. The acquisition frequency uncertainty band



is then reduced to the sum of the uncertainties of the ephemeris data and the vehicle Doppler, or less than a few hundred Hz. Consequently, subsequent satellite signal acquisitions can be accomplished in only one second via a search over only a single  
5 500 Hz frequency cell. Thus, with an eight-channel receiver, all in-view satellites can be acquired in parallel in only one second, and pseudorange measurements can be generated in an additional 1/2 second. Until the data frames from at least one  
10 GPS satellite are read, the above measurements contain a time-range ambiguity equal to the period of the PN code (1 msec-300 km). If time framing for only one satellite signal is established, this time-position ambiguity is resolved. As mentioned above, reading the required data frames on the broadcast signal will require roughly 30 seconds. However, this  
15 time bottleneck can be avoided as long the a priori position uncertainty is sufficiently small to resolve the ambiguity. The requirement will, in general, depend upon the GDOP of the in-view GPS constellation, but it is clear that the assumed a priori assumption of 10 km will be more than sufficient to resolve the  
20 ambiguity. Thus, position location is possible without ever taking the time to read the GPS data. In summation, with the invention that starts with providing the GPS receiver with the needed Satellite Data Messages via an external data link, the position may be determined in less than three seconds.

25 Figure 3 illustrates how the a priori knowledge of position resolves the ambiguity in time-position. It pictures a cylindrical start-up position uncertainty volume of height  $2v_e$  and radius  $r_e$ . Here,  $v_e$  denotes a bound on the uncertainty in altitude relative to the WGS-84 geoid and  $r_e$  denotes a bound on  
30 the radial uncertainty in position from a known point in the plane tangent to the geoid. At start-up, the receiver is somewhere within this uncertainty cylinder, and the receiver's software assumes that it is located at the center of the cylinder. The uncertainty cylinder determines the ability of the

a priori position knowledge to resolve the time-position ambiguity of the GPS receiver. In the worst case situation, the uncertainty cylinder will result in an uncertainty corresponding to a distance of  $v_e^2 + r_e^2$ . If one assumes a value of 10 km for this quantity, the resulting local clock uncertainty will be about 30 microseconds. In general, based upon pseudorange measurements with the in-view satellites, there will be a number of GPS receiver time-position pairs that are consistent with these pseudorange measurements). However, only those solutions contained inside the position uncertainty cylinder and the time uncertainty window (one minute assumed) can be real solutions. And it is clear that as long as the uncertainty cylinder is not large, there will only be one time-position pair in this region so that the solution is unique and the ambiguity is resolved.

Subsequent to resolving the time ambiguity of the GPS receiver, acquiring satellites can be further aided by the reduced time as well as frequency uncertainties. With a one ppm GPS receiver clock drift, time can be maintained to better than 60 microseconds, even with the receiver outages lasting up to one minute. Thus, the required PN search to acquire a satellite can be reduced to a search over less than 100 C/A code chip positions. The frequency uncertainty is still much less than a 500 Hz cell. Thus, it should be possible to acquire subsequent satellite signals in 0.1 seconds by searching 100 code chip phases in a single frequency bin. A measurement of pseudorange using code phase under condition of frequency lock can be made in an additional 0.5 seconds. Thus, once the GPS receiver time and frequency are calibrated, it is possible to acquire and generate pseudorange measurements from multiple satellite signals in parallel in less than one second. Thus, in this reacquisition mode, the time required for position location is indeed quite short. In situations where signals are obstructed by tall structures except at the crossroads, this is the only way that a GPS position fix can be generated. The search process for

multiple satellite signals is repeated endlessly, and acquisition of multiple satellite signals will occur whenever the view to multiple satellites is unobstructed. The detailed logic of the algorithm for rapid GPS signal acquisition is illustrated in Figure 4.

Figure 5 illustrates a preferred embodiment or configuration which includes a GPS receiver 20 combined with a cellular telephone 21, having a primary cellular antenna 21A1 and a hidden parallel cellular antenna 21A2 that is capable of supporting the rapid acquisition capability of the GPS signals, and rapid determination of position. The GPS receiver 20 has an in-dash antenna 20A1 and a roof or exterior antenna 20A2 and a plurality of parallel channels CH...CHn for independent attempts at acquiring multiple (sight in this embodiment) satellites simultaneously. This is required since it is important that the acquisition process for the first satellite can search the entire frequency uncertainty region in parallel. Given that the state-of-the-art oscillators for GPS receivers have a frequency accuracy of about one ppm, this requires at least seven parallel channels to encompass the frequency uncertainty band. When oscillator frequency accuracy improves, then the preferred number of parallel channels can be reduced. The eight-channel receiver is also important for rapid acquisition in parallel of all in-view satellites. With an eight-channel receiver, all in-view satellite signals will be searched for; thus as long as the line-of-sight to a given in-view satellite is not blocked, its signal will be typically acquired in less than one second with a rapid acquisition receiver. The GPS receiver 20 is under the control of the controller element 22 shown in Figure 5, which includes a microprocessor controller 30, "data-in-voice" modem 31 (see Fig. 6), and autodialer 32.

The first step in using the unit to determine the position via GPS would be for the controller to acquire the Satellite Data Messages for the in-view GPS satellites. In one embodiment, this is provided by intercepting a broadcast signal such as the RDS in

the FM radio band, or by calling a service center 40 and establishing data link with a compatible modem. The current ephemeris and time models of the GPS satellite constellation stored in the GPS satellite almanac database 41 would then be provided to the unit via that data link - the cellular telephone system 42. This link would also provide GPS correction parameters that support much improved GPS position accuracy when the GPS is in the search and acquisition mode. The controller 22 would thus obtain the Satellite Data Messages of in-view Satellites, and route this data to the GPS receiver 20 where it would be used to support the acquisition of the first overhead satellite, support the subsequent acquisition of all in-view satellites, and calculate the position of the receiver, based upon subsequent pseudorange measurements with these satellites. A memory power is supplied to controller 22 to maintain data stored therein.

The system shown in Fig. 5 also includes a cellular telephone handset 50, a cradle, and an RF pushbutton device 54 for theft alarm enable/disable initiation, and the RF interface 55 for that device to controller 22. The handset has all the controls (not shown) needed to initiate and receive calls from the telephone system, but the installed unit in the vehicle acts as relay station to the cellular system 42. The handset 50 serves as the interface for voice input and audio output for the vehicle user. The controller 22 mediates the transmission of voice and data over the common cellular telephone channel. The RF pushbutton device 54 is used to enable/disable a theft reporting function of the vehicle unit. This function is to autonomously initiate a call when a defined theft condition is realized and to accurately relay the vehicle position as determined by the GPS receiver 21.

One example of such condition is whenever the system receives battery power with the theft reporting function in the enabled state. The pushbutton device 54 (which may be called a "panic button") is packaged in a small keychain type unit similar

to those for alarm enable/disable of current vehicle theft alarm equipment. The panic button 54 may also be a two-way communication device that will operate as follows: the user, upon pressing the panic button will send an RF signal that will be received at the vehicle receiver interface 53; the receiver 55 will then send an acknowledgement to the user-held panic button 54 via an RF signal; the user will be informed that an acknowledgement is sent via an inaudible vibration 54IB of the panic button 54 when an acknowledgement is received.

In addition to an improved algorithm for rapidly determining position via GPS in an obstructed environment, the present invention also solves the problem of establishing the required data link with the GPS receiver. The primary method of this embodiment utilizes a mobile cellular phone channel to support a data and a voice channel at the same time. This is accomplished by taking a 600 Hz frequency notch out of the audio band and embedding a data channel in this notch. A 300 bps half-duplex channel can be achieved via a frequency shift keyed (FSK) system with two tones in the frequency notch. With the appropriate notch filter, the participants in the voice conversation hear no modem tones associated with the transfer of data. Degradation to the voice quality is low, depending upon the size and shape of the frequency notch, and its center location. It has been found that with a 600 Hz notch placed between 1500 Hz and 2100 Hz, voice intelligibility is excellent, and voice recognition is good. With such a frequency notch, a 300 bps "data-in-voice" modem with FSK tones at 1650 Hz and 1959 Hz can be implemented.

Figure 6 illustrates the block diagram for the data-in-voice modem contained in controller 22. A digital implementation of this algorithm using a commercially available digital signal processing (DSP) chip is within the scope of this invention. In Fig. 6 note that processing and filtering is implemented on both the transmit and receive channels.

The transmit channel 100 includes filter delay line 101 feeding bandstop filter 102 so that a notch (600 Hz, for example)

is subtracted from the voice or audio band and a tone generator 103 inserts the two FSK tones (1650 Hz and 1959 Hz, for example), of the data channel into this notch via summer 104. The receiver channel 105 is similarly filtered by filter delay line 106 and  
5 bandstop filter 107 creating separate outputs 108 and 109-H and 109-L of the filtered voice, the high tone bandpass 110, and the low tone bandpass 111. A comparison and smoothing operation on the bandpass signals in the data decisions circuit 114 results in the received data stream 115. In addition to the processing of  
10 the transmit and receive channels, the "data-in-voice" modem has two digital inputs 112 and 113 from microprocessor 30 (Fig. 5) for mode control: one enables/disables the channel filtering, and the other toggles the modem between its transmit and receive modes.

15 In addition to combining data and voice on a single audio channel, the data-in-voice modem 311 (Fig. 6) also samples and compares the incoming and outgoing voice power during hands free operation. In hands-free mode (microphone/speaker phone in Fig. 5), incoming voice is broadcast from the cradle speaker and  
20 outgoing voice is picked up by the microphone. One way of avoiding feedback and echoes in this configuration is to severely attenuate one of the voice signals (i.e. the weaker) so that the voice conversation is half duplex. It is important to do this attenuation on the audio signals before the transmit data has  
25 been put on (for the outgoing audio), and after the receive data has been stripped off for the incoming audio. By implementing the processing in this manner the data-in-voice modem is fully compatible with hands-free operation of the cellular telephone: that is, data transfer will not be affected by the voice  
30 conversation, and neither will the voice conversation be affected by data transfer.

This system for combining data and voice on the same cellular telephone channel is advantageous in that there is (1) blanking of the voice channel, (2) no audible tones to the users  
35 involved in a voice conversation, and (3) little degradation to

speech quality.

Configurations for retrofitting existing cellular phones with the invention are shown in Figs. 7a and 7b. As diagrammatically illustrated in Figs. 7a and 7b, a trunk mounted cellular phone transceiver unit and controller, model and GPS unit is coupled to the existing cellular phone components by a RJ cable, whereas in Fig. 7b, they are coupled by an RF link. The retrofit configuration shown in Fig. 7b requires a conventional wireless add link between the trunk mounted components and the existing cellular phone components (cradle and handset) in the passenger compartment of the vehicle.

This invention provides the most rapid and robust position location system possible via the GPS constellation. Novel aspects of the above system include the use of an external data link to the GPS receiver to rapidly provide the Satellite Data Messages, and the efficient system and method that optimally uses this information to rapidly acquire all in-view satellites.

An embodiment of a Position-Enhanced Cellular Service Systems (PECS) system is shown in Fig. 8. The two main PECS elements are the Vehicular Applique Unit 120 and the customer Service Centers 121. The elements are shown in this diagram as "applique" features to the existing Cellular Service which require no modification to or interference with the existing Cellular System: the Vehicular Applique Unit (VAU) 120 replaces the existing vehicle cellular phone, and the Customer Service Center 121 connects with the Cellular System 123 via the existing switched telephone system 122. Because of the present implementation of this "applique" concept, the enhanced services can be provided on any Cellular System, making the system "portable" to other service areas. Furthermore, because of the "open architecture" concept, other services can be accommodated, thereby providing an enormous potential for a variety of revenue-generating specialized commercial services. Functionally, VAU 120 may be packaged in a hand-held device and include a key pad (not shown) for programming. In addition, a digital recorder

chip for recording voice digitally in VAU 120 and playing back to the user of the cellular telephone can be easily incorporated in the unit. The system offers a number of unique and attractive features such as:

- 5           1. Vehicle position updates as often as every 2 seconds to support real-time routing.
2. Novel data-in-voice modem that simultaneously supports a 300 bps continuous positioning data channel and a voice channel via a single cellular telephone call.
- 10          3. Exterior Primary cellular and GPS antennas for robust performance in all environments.
4. Switched Failover to hidden cellular and GPS antennas for Vehicle Tracking (in case a thief disables the primary antennas).
- 15          5. Fleet management is a further application of the invention whereby an operator of a fleet of maintenance vehicles or taxis can keep track of the position of all vehicles in the fleet in order to optimally assign the vehicles to tasks at a given location.

20           A key value-added feature of the PECS concept that differentiates it from other systems is the ability to accurately determine the vehicle's ephemeris data (position, heading, and speed). The system incorporates the use of the Global Positioning System's NAVSTAR Satellite constellation to provide  
25           the most accurate, freely-available, and worldwide navigation data distribution system. An eight-channel GPS receiver (capable of differential operation) is preferably used in the baseline Vehicular Applique Unit in order to provide a consistent accuracy that can unambiguously identify vehicle location by street  
30           address and determine on which side of a major highway the vehicle is positioned.

          Figure 9 illustrates the configuration of a Customer Service Centers (CSC) 130, 131, 132... 13n for the Positioned-Enhanced Cellular Services System shown in Fig. 8. Each CSC 130, 131,  
35           132...13n is comprised of four subsystems which allow it to



perform its activities. Those subsystems are the Communication and Switching Subsystem 133, the Administration and Maintenance (A&M) Subsystem 134, the Position Processing Subsystem 135, and the Service Provisioning Subsystem 136.

5           The Communication and Switching Subsystem 133 includes the hardware and software required to interface the CSC with the public switched telephone system 122 for the receipt of incoming calls and the transmission of outgoing voice and data to the subscriber and the subscriber's vehicle. The Communication and  
10       Switching Subsystem also interacts with the A&M Subsystem to ensure that a subscriber's voice and data links are routed to the same service representative position (SRP) within the Service Provisioning Subsystem 136.

15           The A&M Subsystem 134 performs all CSC tasks related to system administration and maintenance. An example of an administrative task executed by the A&M Subsystem is the assignment of an incoming call to the optimal SRP, based on criteria such as SRP loading and service representative profiles. An instance of a maintenance task would be the near-real-time  
20       maintenance of mapping and Yellow Pages databases.

          The Positioning Subsystem 135 has the responsibility of interfacing with an on-site or remote GPS reference station 137 for the purpose of receiving differential correction coefficients. The differential correction coefficients  
25       ultimately will be passed to the VAU in a subscriber's vehicle. The delivery of the differential correction coefficients to the vehicle allows the position of the vehicle to be determined to a high degree of accuracy (to within ten meters).

30           The Service Provisioning Subsystem 136 allows service representative to speak directly with subscribers to determine the exact nature of service requirements. The Service Provisioning Subsystem is comprised of the hardware and software via which the service representatives can access mapping, routing, Yellow Pages, and user profile data in order to provide  
35       responses to the subscriber as quickly and accurately as

possible.

Another embodiment and feature of the invention is that it can include receiver means for monitoring local AM radio stations to augment GPS signals when receipt of GPS signals is impaired or rendered unreliable by the urban environment. Referring to Fig. 10, AM receiver 220 has antenna 221 for receiving the AM signals broadcast by stations AM1, AM2...AMN and provide the phase measurements for which are used to determine position, as described later herein in connection with Fig. 11. AM receiver 220 provides phase measurements to microprocessor 223, which is coupled to digital data storage base 224, which has stored therein the frequency and physical location of all of the AM radio stations of interest for the area. Any drift in these AM station frequencies is corrected in microprocessor 223 by data received from the local reference station 211 via the customer service center 213, cellular network 216, and the cellular telephone 225.

In order to resolve any ambiguities in the AM radio positions, and accommodate the lack of synchronization among the AM stations, the most recent accurate GPS position data from GPS receiver 226 is provided to microprocessor 223 for storage in storage 224.

Outside of urban canyon areas positioning via GPS will almost always suffice. Within urban canyons (e.g., downtown Manhattan) considerable blockage from tall buildings TB can dramatically reduce GPS satellite visibility. Within these same urban canyons, however, a significant number (e.g., 5-10) of strong AM signals will be simultaneously available; furthermore, these signals can "surround" the vehicle 210, thereby yielding excellent signaling geometries for positioning. Within the framework of Fig. 10, the invention may be described as follows:

1. Outside the urban canyon, GPS 226 provides the vehicle with regular, accurate position updates, as described earlier.
2. The local Reference Station 211 shown regularly receives signals from all local AM stations of interest and measures key

parameters (e.g., frequency and wavelength variation), that are provided to customer service centers 215 and then to vehicles via the cellular network and serve as differential corrections. AM signals are passively received -- i.e. asynchronously, and with  
5 no coordination with the AM Stations. With proper site selection, and utilization of a suitable, low-cost clock reference (e.g., 1 part in  $10^{10}$ ), this Reference Station 211 can be established and maintained very cost-effectively; for example, they do not have to be mounted on an expensive tower. The  
10 reference station also collects data from the GPS satellites in order to generate GPS differential data. This data is also provided to the vehicles via the customer service centers and the cellular phone link described earlier.

3. As the vehicle approaches the urban canyon TB, the  
15 vehicle receives local AM signals from stations AM1, AM2, AM3...AMN, and associated differential corrections from the Reference Station 211. The vehicle contains a digital database 224 that includes the frequencies and locations of all local AM stations of interest. In this embodiment, AM signals are not  
20 used for positioning as long as GPS is providing reliable position.

4. The vehicle 210 continues its positioning process via GPS until a GPS blockage or outage is detected by detector 227. At the onset of a GPS outage, the vehicle's positioning system  
25 contains an accurate GPS position estimate that serves as the starting point for the AM positioning process. The accuracy of this initial position estimate is on the order of 100'. Since this is a fraction of an AM wavelength, it can serve as the basis for an unambiguous pseudorange estimate for each AM signal that  
30 is being received. The AM wavelength is a critical and highly attractive ingredient of this aspect of the invention, given its amenability to a priori ambiguity resolution and its subsequent amenability to highly accurate tone ranging (see below).

5. The AM positioning process involves incremental, differential range measurements via tone ranging of the AM carriers. The process, illustrated in Fig. 11, includes the following:

- 5 a. At least three, and preferably four or more AM signals ( $F_1, F_2, F_3$  and  $F_4$ ) are simultaneously received, split by power splitter 230, and sampled in each AM RF processor 235-1, 235-2, 235-3, and 235-4 at 0.5 second (TBR) intervals. This sampling interval is selected because even at a speed of 100 ft/sec (>60mph), the incremental distance the vehicle travels is a small fraction of an AM wavelength. This is important to ensure that no AM wavelengths are "skipped" from one sampling interval to the next. Also, while a minimum of three simultaneous AM signals are required, more than three can be used to enhance accuracy and/or ensure that the strongest, highest quality AM signals are being employed.
- 10 b. The incremental phase of each AM carrier -- relative to the previous measurement -- is measured, and corrected for phenomena such as carrier frequency drift via the corrections provided by the Reference Station, via the cellular telephone network.
- 15
- 20

The measurement process sequence is as follows:

- 25
- The incremental Phase =  $\phi_{12} - \phi_{11}$  (Radians)
    - Incremental Range =  $\lambda_1[(\phi_{12} - \phi_{11})/2\pi] = \Delta R$
    - Estimate of New Range at  $t_2, R_{12} = R_{11} + \Delta R$
- 30
- Simultaneous Computations for 3 other AM signals Yield New Range Values:  
 $R_{22}, R_{32}, R_{42} \dots R_{N2}$

- Differenced Ranges Formed:  $R_{22} - R_{12}; R_{32} - R_{12} \dots R_{N2} - R_{12}$   
- Differencing Eliminates Vehicle's Local Clock Error
- Set of Differenced Ranges Processed to Yield Updated  
5 Position
- Process Repeats Every 0.5 sec (TBR)

10 This phase measurement process reflects the high-accuracy  
tone ranging process that is uniquely accommodated by the  
judicious wavelength of the AM waveform. In particular, for a  
representative 1 MHz AM carrier and a corresponding ~1000'  
wavelength, a phase measurement accuracy on the order 1 degree -2  
degrees yields a corresponding range accuracy of 3' - 6'. An  
15 exemplary embodiment of a robust implementation approach for this  
phase measurement process is described later herein.

- c. As indicated above, each incremental phase is  
normalized and multiplied by its respective wavelength  
to yield an incremental range value, which is then  
20 added to the previous value of total range to yield an  
updated estimate of total range.
- d. The resulting set of at least four range values are  
used to form a set of at least three corresponding  
differential range values. This differencing process  
25 effectively eliminates the vehicle's clock as an error  
source in the positioning process.
- e. Based on the above, at each 0.5 second interval, the  
set of differential range values are used to compute a  
new position estimate.
- 30 6. Throughout the above process, the vehicle's GPS receiver  
continues to operate and to ascertain the quality of the received  
GPS signals. Once GPS quality is resumed, handover from AM -  
to - GPS positioning takes place. Furthermore, while the above  
process addresses AM processing only, the invention contemplates

and encompasses hybrid approach of processing both AM and GPS signals simultaneously. This should enhance the urban canyon positioning process, since even in the urban canyon at least one GPS signals should always be available with high probability.

5 DESCRIPTION OF AM SIGNAL PROCESSING APPROACH:

Implementation of the invention depends on a robust, low-complexity approach to measuring the incremental phases of several AM signals simultaneously. In one embodiment, signal processing that accomplishes the above is illustrated in Fig. 11  
10 This processing approach is employed by each vehicle, and also by the Reference Station to accurately measure reference values for transmission to each vehicle. The following is noted:

1. Because of its low frequency, each AM signal may be sampled and A/D converted in A/D converter 241 directly at RF  
15 without downconversion. As illustrated, the sampling and phase measurement process employed is "open-loop". This has the distinct advantage of not being susceptible to short-lived channel transients -- such as impulsive noise arising during a thunderstorm. Thus, in contrast to a closed-loop process, which  
20 may lose lock during such an impulsive transient, the embodiment of Fig. 11 would only yield a phase measurement "glitch" due to the transient, which is easily recognizable, and can be discarded; crucial, however, is that the integrity of the sampling and phase measurement process would be maintained.

25 2. The sampler 240 has the sampling rate shown -- i.e., at 4 times the carrier frequency -- and is selected so that successive samples are precisely 90 degrees apart, which are thus effectively in-phase (I) and quadrature (Q) samples of the AM carrier sine wave. As has been discussed earlier, the AM  
30 frequencies of interest are resident in the vehicle's digital memory 224, and precise frequency information is available via corrections provided by the Reference Station 211. Also high sampling accuracy -- to a small fraction of a Hz -- is readily achievable via low-cost, existing digital frequency synthesis  
35 technology. In fact, the multi-channel digital processor shown

in Fig. 11 is readily amenable to miniaturization in an Application Specific Integrated Circuit (ASIC).

3. The multiplicative sequencer 242 shown after the A/D converter 241 appropriately rectifies the negative-going I and Q samples, so that the two-stage accumulator 243 that follows can filter out all other AM signals and yield averaged, SNR-enhanced I and Q samples 244. This sampling and averaging takes place for ~ 1 ms every 0.5 seconds. For the strong AM signals of interest, this 1 ms interval will be more than adequate for SNR enhancement. Furthermore, in 1 ms the AM carrier phase will vary negligibly due to vehicle motion (e.g., <0.05 degrees) for a 1 MHz AM carrier and a vehicle moving at 100 ft/sec.

4. The averaged I and Q samples,  $\bar{I}$  and  $\bar{Q}$ , are then used as shown to measure phase via the arctangent function 246 or an equivalent. Note that the ratio of  $\bar{Q}/\bar{I}$  automatically cancels any AM fluctuations superimposed on the desired sinusoidal waveform.

A summary of mathematical considerations is as follows:

#### MATHEMATICAL DESCRIPTION

- $a(t)$  Represents AM Information;  $w$  is AM Carrier Radian Frequency; (Reflects Reference Station Corrections);  $wt_1$  is Odd Multiple of  $\pi/2$
- I - Samples:  $A[1 + a(t_1)] \cos [wt_1 + \phi] \sim A[1 + a(t_1)] \cos \phi$
- Q - Samples:  $A[1 + a(t_1 + \delta)] \sin [wt_1 + \phi] \sim A[1 + a(t_1)] \sin \phi; a(t_1 + \delta) \sim a(t_1)$  for  $\delta \sim 1\mu s$
- $\bar{I} \sim A \sum [1 + a(t_1)] \cos \phi; \bar{Q} \sim A \sum [1 + a(t_1)] \sin \phi$

Note:  $\phi$  Varies Negligibly Over Averaging Interval (~1 ms)

$$\Rightarrow \phi = \text{TAN}^{-1}(\bar{Q}/\bar{I})$$

This aspect of the invention introduces new capabilities, for truly global positioning, that are neither in existence nor currently planned. Further unique features of the invention include the following:

1. Global, international positioning capability (~30m,  $3\sigma$ ):

- a. Via GPS or differential GPS outside of urban canyons, where GPS is unobstructed.
  - b. Via AM radio signals (or a combination of GPS and AM) within urban canyon areas, where GPS obstruction occurs and local AM signals are strongest.
- 5
2. Passive reception of GPS and AM signals:
    - a. Each vehicle contains database that stores all relevant AM station locations and frequencies.
    - b. No interaction, coordination, synchronization with GPS or AM stations.
- 10
3. A low cost Reference Station 211 is located within each required urban canyon area:
    - a. Measures key AM station parameters.
    - b. Transmits parameters to vehicles via low rate data link that employs the cellular telephone network.
- 15
4. Key operations concept ingredients:
    - a. Vehicle uses GPS-derived position data as unambiguous position reference prior to initiation of AM signal processing (accomplished prior to entry into urban canyon).
- 20
5. Key features/advantages of AM signal utilization:
    - a. The AM signal structure is simple and universal.
    - b. GPS a priori position accuracy is a fraction of the AM wavelength.
    - c. Even at high-speeds (e.g., 100 ft/sec) a vehicle's incremental position changes by a small fraction of an AM wavelength in-between position updates; this prevents large errors from occurring that may arise from "cycle skips".
    - d. The AM waveform includes a residual carrier that easily lends itself to highly accurate tone ranging.
- 25
- 30
- 35



- 5 e. Straightforward tone ranging processing, using sampling and high SNR phase estimation, yields range estimate accuracies on the order of 5'; this is a direct result of the AM wavelength that varies between ~600' and 2000'.
- f. The low AM frequency permits a very simplified receiver/processor, with sampling and A/D conversion directly at the incoming RF, without downconversion required.
- 10 g. Open loop processing and a reasonable update rate yield robustness against impulsive noise (e.g., lightning).
- h. The relatively long AM wavelength yields a degree of robustness against multipath.

15 While preferred embodiments of the invention have been shown and described, it will be appreciated that various other embodiments and adaptations of the invention will be readily apparent to those skilled in the art.

20 **WHAT IS CLAIMED IS:**

25

30

35

## CLAIMS

1. In a global positioning system (GPS) in which a plurality earth orbiting GPS satellites transmit position information to mobile radio stations on earth including a Satellite Data Message block, characterized by:

an earth based source of satellite data for all in-view GPS satellites including said Satellite Data Message blocks for each in-view satellite for assisting said mobile radio station to access position information from said satellites, and an earth based communication means coupled to said source,

means coupled to said mobile radio station for connecting to said earth based communication means to said earth-based source for extricating said satellite position data via said non-satellite earth based communication means, and

means at said mobile for processing said Satellite Data message blocks from said earth-based source to enable said mobile radio station to rapidly locate and access position information from said earth orbiting satellite.

2. In a GPS satellite positioning system in which a plurality of earth orbiting GPS satellites each transmit Satellite Data Messages, including ephemeris data and time models, said Satellite Data Messages being transmitted in a frequency uncertainty band, the method of optimally and rapidly acquiring all in view satellites, characterized by:

providing a receiver for said GPS satellite having a local oscillator,

performing a parallel search over the entire frequency uncertainty band to acquire an overhead GPS satellite,

calibrating said receiver local oscillator to reduce the frequency band for the acquisition of subsequent in-view satellites, and

performing a further parallel search for all in-view satellites using a single frequency search cell per in-view satellite.

3. In a method for determining the position of a user of a GPS receiver for receiving GPS satellite signals containing GPS broadcast data, bit sync signals and frame sync signals, characterized by, providing an independent source of a priori  
5 knowledge of receiver position to resolve ambiguity in the time position of the GPS solution.

4. In a GPS satellite positioning system for use in obstructed environments where much of the time, the line of site to most satellites is blocked and occasionally is clear, as on  
10 roads and urban areas or in heavily forested regions, characterized by, providing a GPS receiver having a calibratable local oscillator and capable of performing parallel search for acquisition of all in-view satellites, comprising:

performing a parallel search for all in-view satellites, and  
15 reducing the frequency uncertainty band for signal reacquisition to one frequency cell by calibrating the GPS local receiver oscillator on the basis of a pseudo-range measurement of one overhead satellite.

5. The invention defined in claim 1 wherein said earth-based source includes one or more dial-up service channels selected from a data link supported by terrestrial cellular telephone and other radio packet data services, and means  
20 accessing said earth-based source via one of said dial-up service channels to supply said Satellite Data Messages for all in-view satellites and said GPS receiver.

6. The invention defined in claim 5 in which said Satellite Data Message block contains ephemeris data and time models for each in-view satellite, said mobile radio station including a receiver local oscillator and means for performing a parallel  
30 search over an entire frequency uncertainty band to acquire a GPS satellite overhead and calibrating said receiver local oscillator to reduce the frequency band for the acquisition of subsequent in-view satellites, and performing a further parallel search for all in-view satellites using a single frequency search cell per  
35 satellite.

7. The invention defined in claim 5 including a basestation for a cordless cellular telephone handset, an RF control means for remote control of said handset, an RF interface means connected to said handset to said RF control means, said handset being coupled to said GPS receiver, and modem means located in the mobile unit, whereby access to said handset provides access to the full range of capabilities, including, generation and relay of position, supported by the mobile unit.

8. In a GPS system wherein a plurality of GPS satellites transmit their respective time and location data including a Satellite Data Message block having ephemeris and time modes over radio frequency signals which enable a mobile GPS receiver on the ground receive said radio frequency signal to determine its position, characterized by: a source of satellite data message block containing the ephemeris and time modes of the GPS satellites, which is independent of said satellite, an independent wireless data channel for accessing said satellite data message block, and a controller means connecting said satellite data message block to said mobile GPS receiver.

9. The invention defined in claim 8 further characterized by said cellular telephone includes a cordless handset and further including a basestation relay means for said cordless handset for allowing remote use of said handset via said basestation relay means.

10. The invention defined in claim 8 further characterized by a pushbutton controlled RF control signal source, means for coupling control signals to said controller means to cause said mobile GPS receiver to determine its position and transmit, via said cellular telephone, the determined position to a predetermined location.

11. The global position system (GPS) defined in claim 1, further characterized by said earth based source of satellite data message block containing the ephemeris and time modes of the GPS satellites and being independent of said satellite, said mobile radio station being an independent cellular telephone

channel having a voice channel, a digital notch filter means in said voice channel for inserting and retrieving data in and from, respectively, said notch for accessing said satellite data message block and controller means connecting said satellite message data block to said mobile GPS receiver.

12. The GPS system defined in claim 11 wherein said data inserted in said notch is frequency shift keyed (FSK) data.

13. The GPS system defined in claim 11 wherein said data inserted in said notch is a plurality of discrete FSK tones.

14. In a GPS system wherein a plurality of satellites transmit time and location data over radio frequency signals to enable a mobile GPS receiver station on the ground to determine its position, and a cellular telephone carried with said mobile GPS receiver, and a plurality of conventional ground based amplitude modulated (AM) transmitters for transmitting AM signals, characterized by:

1) each mobile GPS receiver station including phase detection means for (1) simultaneously receiving a predetermined number of said AM signals, and (2) measuring the changes in phase of each of said AM signals as said mobile GPS receiver travels, and deriving therefrom an AM position signal,

2) a reference station for receiving said GPS and AM signals and providing a correction signals and a cellular telephone network for receiving and transmitting said correction signals to said mobile receiver station, and

3) means for using said GPS position signal for resolving any ambiguities in said AM radio position signal and to accommodate the lack of synchronization in said AM transmitters.

15. The invention defined in claim 14 wherein said reference station measures the frequency and wavelength variations in said AM signals and conveys same to said mobile station by said cellular telephone.

16. The invention defined in claim 14 including means for detecting outages or blockages in said GPS signal and including said means for receiving.

17. The invention defined in claim 14 including means for storing the frequency and geographic positions of said plurality of AM transmitters and means for selecting therefrom said predetermined number.

5 18. The invention defined in any one of claims 1-17 including a user service center accessible via said cellular phone to provide user services selected from one or more of the following: emergency roadside assistance, personal emergency  
10 response, vehicle tracking assistance, traveler information assistance, traffic management assistance, and fleet management.

15

20

25

30

35

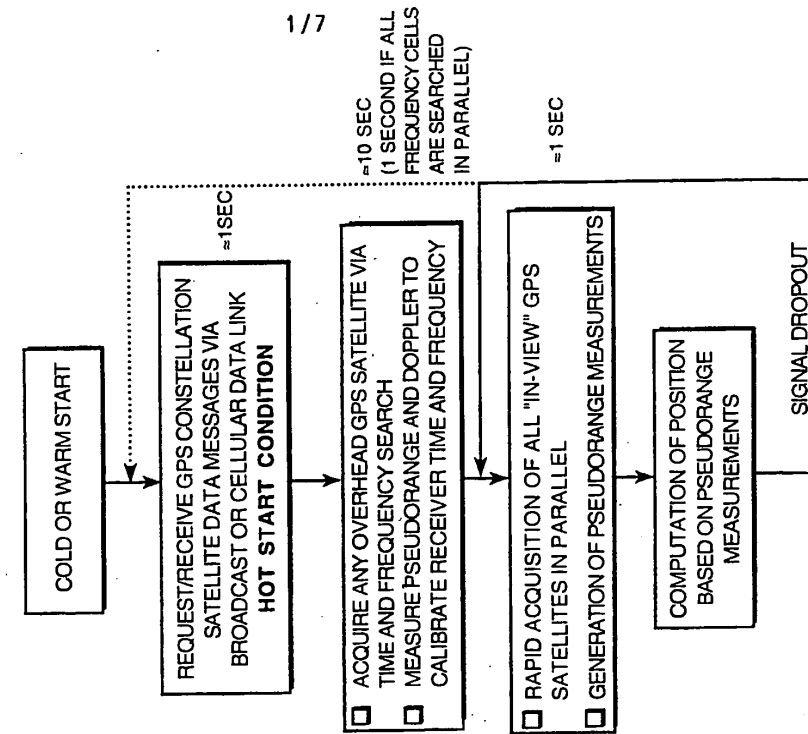

FIG. 1 (PRIOR ART)

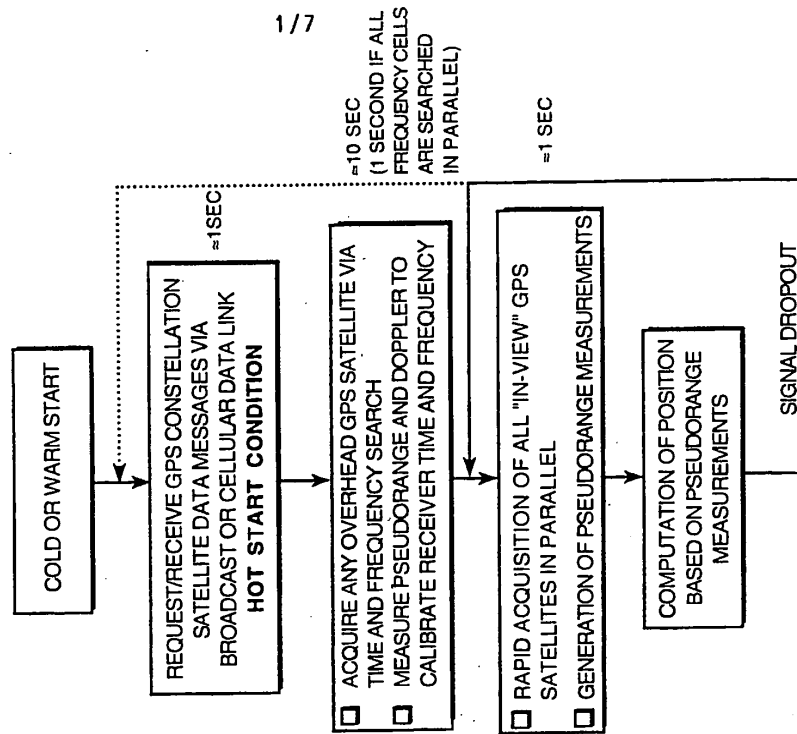

FIG. 2

SUBSTITUTE SHEET (RULE 26)

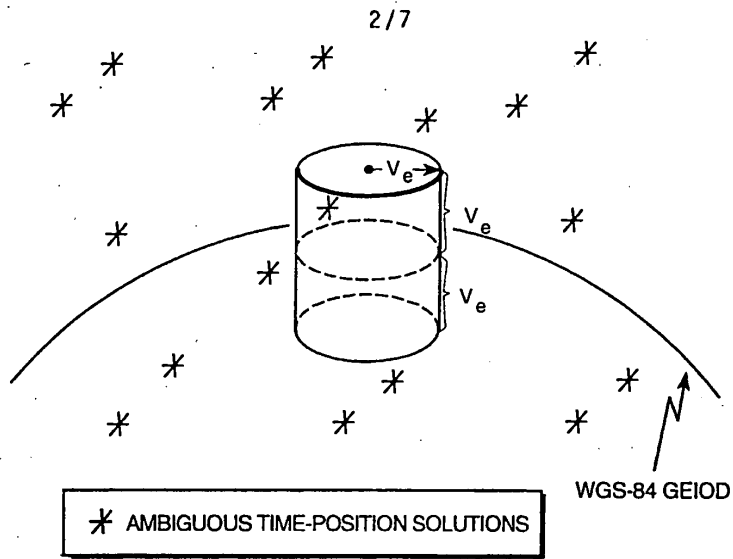

FIG. 3

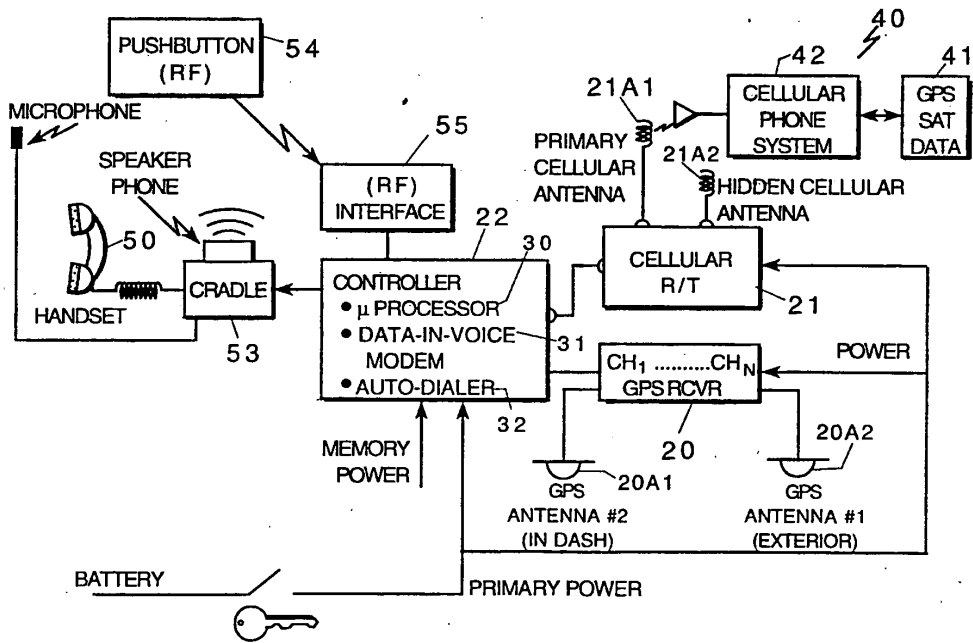

FIG. 5

SUBSTITUTE SHEET (RULE 26)



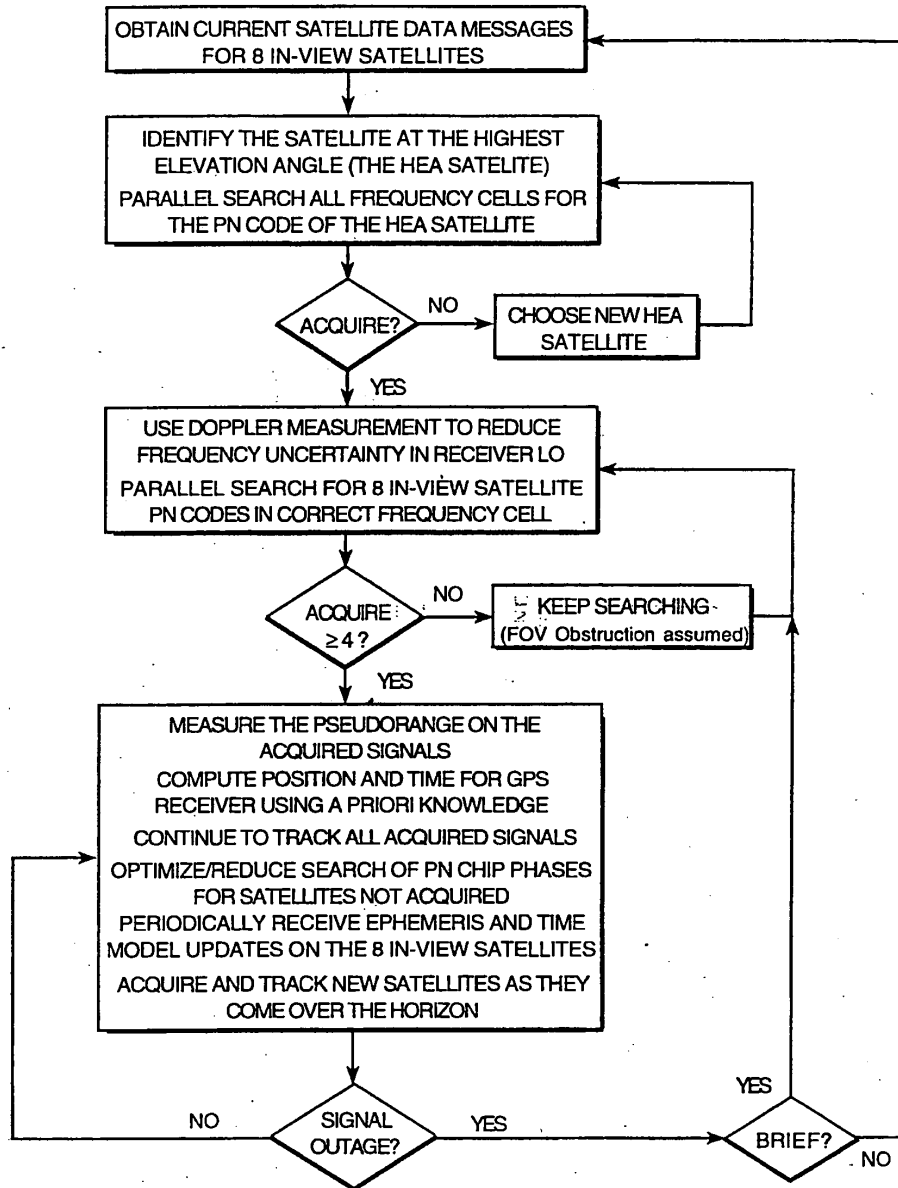

FIG. 4

SUBSTITUTE SHEET (RULE 26)

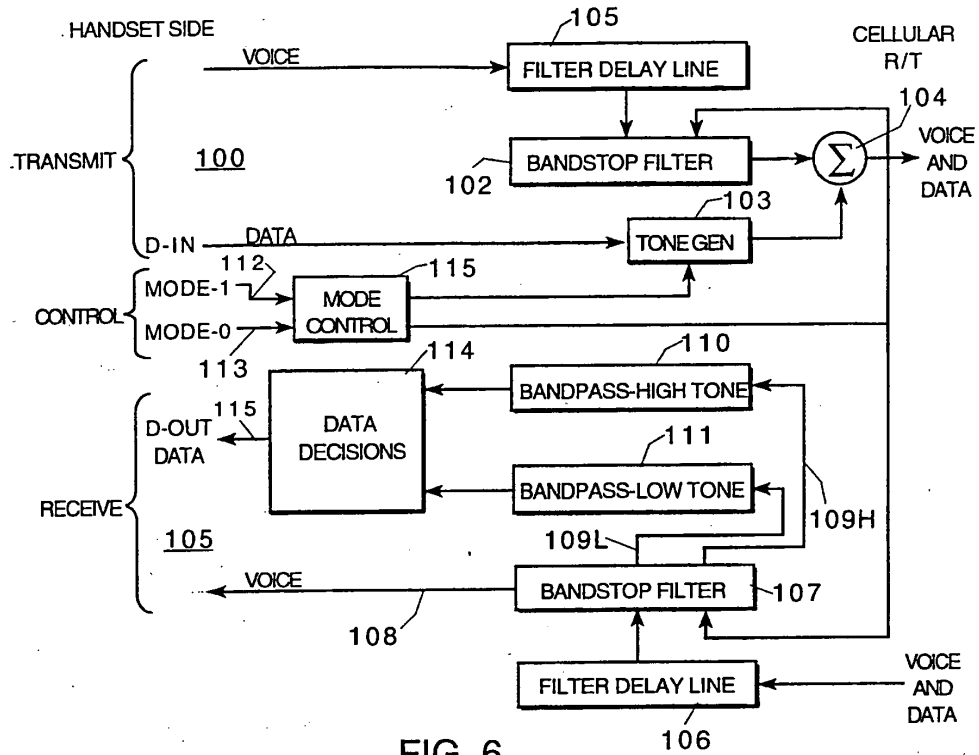

FIG. 6

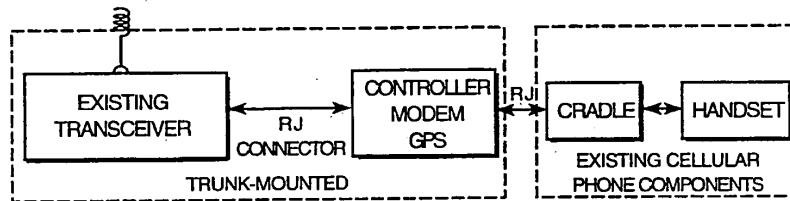

FIG. 7a

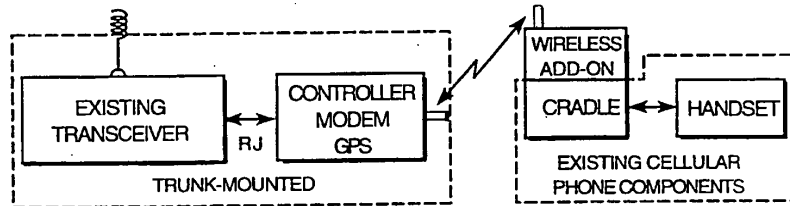

FIG. 7b

SUBSTITUTE SHEET (RULE 26)

5/7

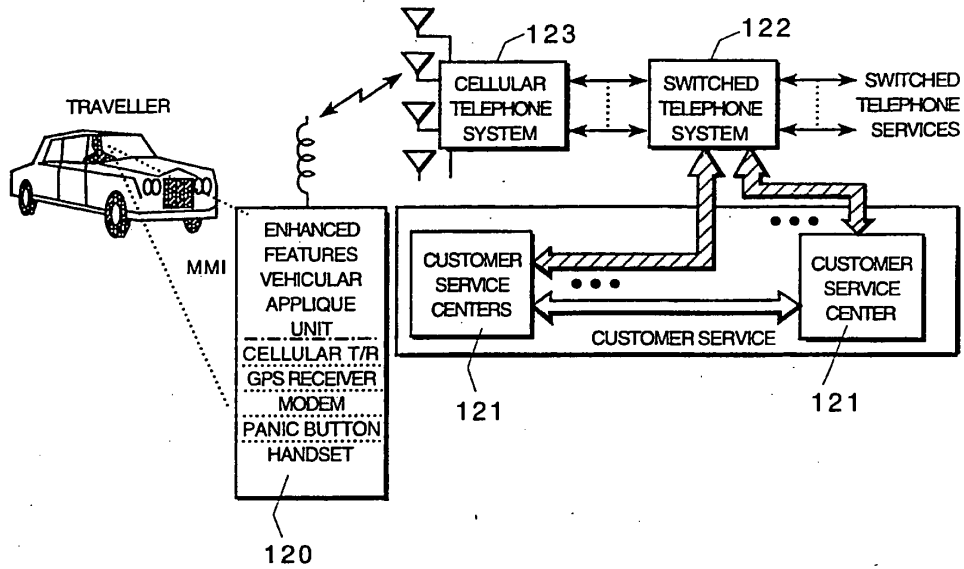

FIG. 8

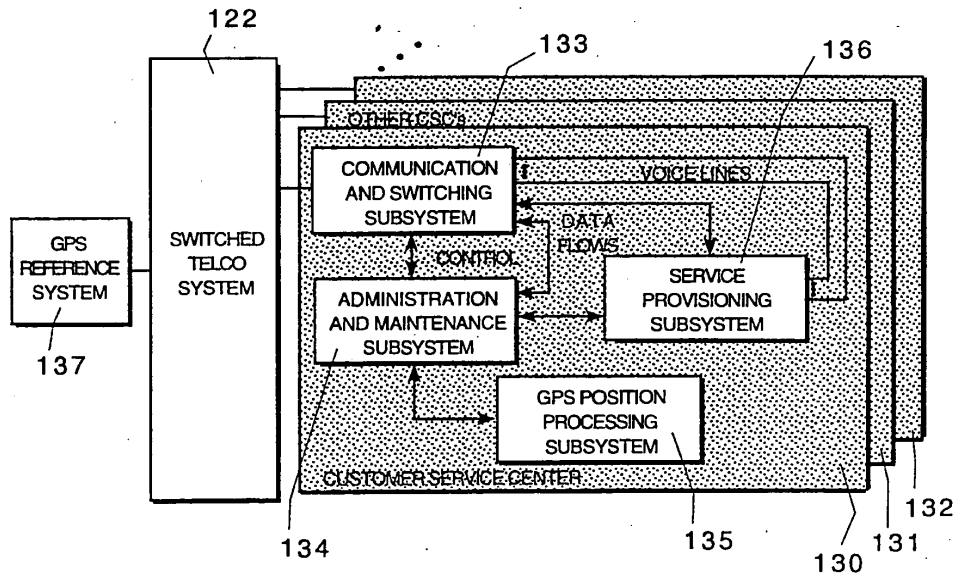

FIG. 9

SUBSTITUTE SHEET (RULE 26)

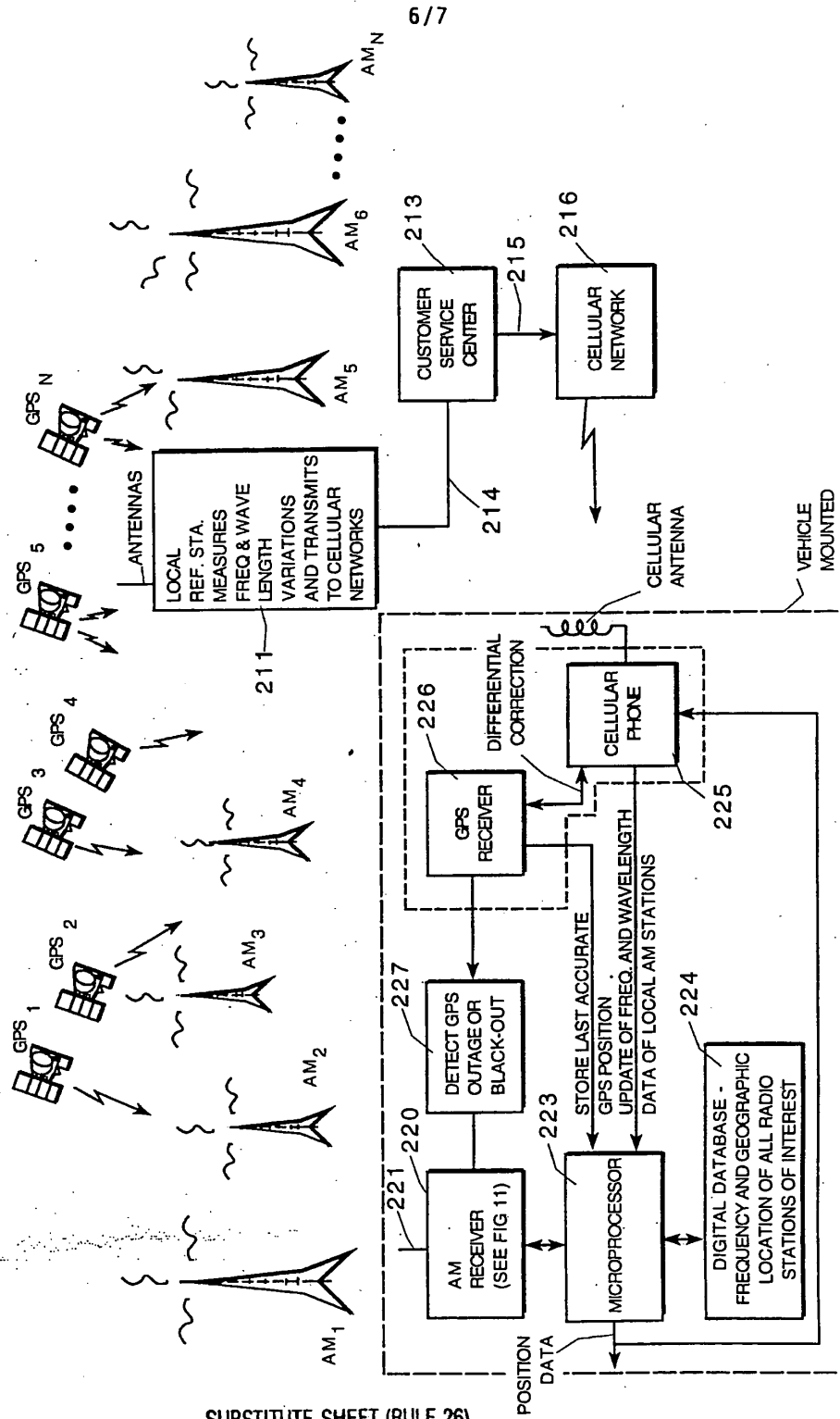
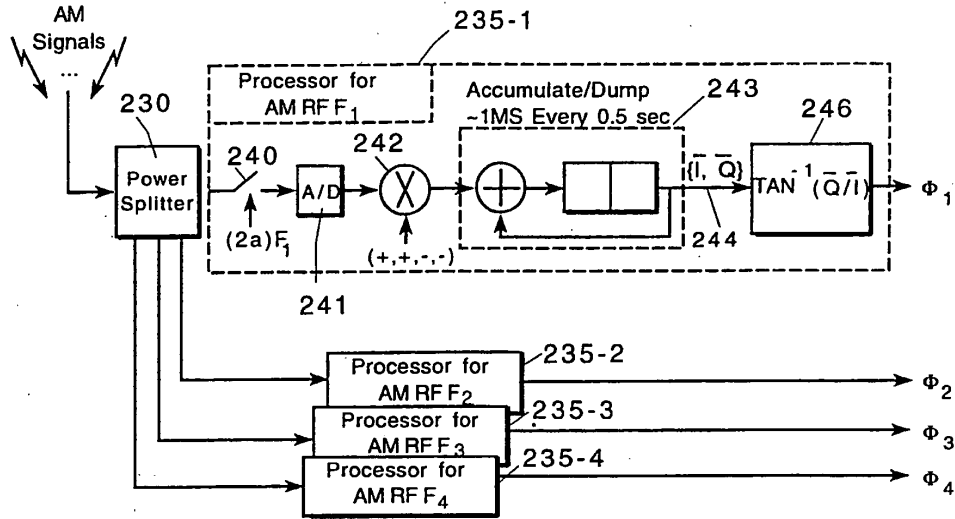

FIG. 10

SUBSTITUTE SHEET (RULE 26)



**MATHEMATICAL DESCRIPTION**

- $a(t)$  Represents AM Information;  $w$  is AM Carrier Radian Frequency; (Reflects Reference Station Corrections);  $wt_i$  is Odd Multiple of  $\pi/2$
- I-Samples:  $A[1+a(t_i)] \cos [wt_i + \Phi] \sim A[1+a(t_i)] \cos \Phi$
- Q-Samples:  $A[1+a(t_i + \delta)] \sin [wt_i + \Phi] \sim A[1+a(t_i)] \sin \Phi; a(t_i + \delta) \sim a(t_i)$  for  $\delta \sim 1\mu s$
- $\bar{I} \sim A \sum_i [1+a(t_i)] \cos \Phi; \bar{Q} \sim A \sum_i [1+a(t_i)] \sin \Phi$

Note:  $\Phi$  Varies Negligibly Over Averaging Interval ( $\sim 1$  ms)

$$\Rightarrow \Phi = \text{TAN}^{-1} (\bar{Q}/\bar{I})$$

FIG. 11

SUBSTITUTE SHEET (RULE 26)

INTERNATIONAL SEARCH REPORT

International Application No.  
PCT/US93/12179

<b>A. CLASSIFICATION OF SUBJECT MATTER</b>																				
IPC(5) : Please See Extra Sheet. US CL : 364/449, 452,443; 342/457,450 According to International Patent Classification (IPC) or to both national classification and IPC																				
<b>B. FIELDS SEARCHED</b>																				
Minimum documentation searched (classification system followed by classification symbols) U.S. : 364/449, 452,443, 460 ; 342/457,450,451,463																				
Documentation searched other than minimum documentation to the extent that such documents are included in the fields searched Please See Extra Sheet.																				
Electronic data base consulted during the international search (name of data base and, where practicable, search terms used)																				
<b>C. DOCUMENTS CONSIDERED TO BE RELEVANT</b>																				
Category*	Citation of document, with indication, where appropriate, of the relevant passages	Relevant to claim No.																		
Y,P	US,A, 5,223,844 (Mansell et al) 29 June 1993 see columns 2,5-10, and 14	1,5-10, 11-13, 14-18																		
Y,P	US,A, 5,218,618 (Sagey) 8 June 1993 See abstract; col. 1, lines 55-66; col.2, lines 5-15; col. 2,lines 32-48.	11-13																		
X	US,A, 4,785,463 (Janc et al) 15 November 1988 see col.3, lines 56-60; columns 5,19,and 20	2,3																		
A		4																		
Y,P	US,A, 5,173,710 (Kelley et al) 22 December 1992 see abstract; columns 1,2; col. 4, lines 9-25; col. 5, lines 18-21; col. 5, lines 46-68; col. 6, lines 43-68	14-18																		
<input type="checkbox"/> Further documents are listed in the continuation of Box C. <input type="checkbox"/> See patent family annex.																				
<table border="0"> <tr> <td>* Special categories of cited documents:</td> <td>"T"</td> <td>later document published after the international filing date or priority date and not in conflict with the application but cited to understand the principle or theory underlying the invention</td> </tr> <tr> <td>"A" document defining the general state of the art which is not considered to be part of particular relevance</td> <td>"X"</td> <td>document of particular relevance; the claimed invention cannot be considered novel or cannot be considered to involve an inventive step when the document is taken alone</td> </tr> <tr> <td>"E" earlier document published on or after the international filing date</td> <td>"Y"</td> <td>document of particular relevance; the claimed invention cannot be considered to involve an inventive step when the document is combined with one or more other such documents, such combination being obvious to a person skilled in the art</td> </tr> <tr> <td>"L" document which may throw doubts on priority claim(s) or which is cited to establish the publication date of another citation or other special reason (as specified)</td> <td>"Z"</td> <td>document member of the same patent family</td> </tr> <tr> <td>"O" document referring to an oral disclosure, use, exhibition or other means</td> <td></td> <td></td> </tr> <tr> <td>"P" document published prior to the international filing date but later than the priority date claimed</td> <td></td> <td></td> </tr> </table>			* Special categories of cited documents:	"T"	later document published after the international filing date or priority date and not in conflict with the application but cited to understand the principle or theory underlying the invention	"A" document defining the general state of the art which is not considered to be part of particular relevance	"X"	document of particular relevance; the claimed invention cannot be considered novel or cannot be considered to involve an inventive step when the document is taken alone	"E" earlier document published on or after the international filing date	"Y"	document of particular relevance; the claimed invention cannot be considered to involve an inventive step when the document is combined with one or more other such documents, such combination being obvious to a person skilled in the art	"L" document which may throw doubts on priority claim(s) or which is cited to establish the publication date of another citation or other special reason (as specified)	"Z"	document member of the same patent family	"O" document referring to an oral disclosure, use, exhibition or other means			"P" document published prior to the international filing date but later than the priority date claimed		
* Special categories of cited documents:	"T"	later document published after the international filing date or priority date and not in conflict with the application but cited to understand the principle or theory underlying the invention																		
"A" document defining the general state of the art which is not considered to be part of particular relevance	"X"	document of particular relevance; the claimed invention cannot be considered novel or cannot be considered to involve an inventive step when the document is taken alone																		
"E" earlier document published on or after the international filing date	"Y"	document of particular relevance; the claimed invention cannot be considered to involve an inventive step when the document is combined with one or more other such documents, such combination being obvious to a person skilled in the art																		
"L" document which may throw doubts on priority claim(s) or which is cited to establish the publication date of another citation or other special reason (as specified)	"Z"	document member of the same patent family																		
"O" document referring to an oral disclosure, use, exhibition or other means																				
"P" document published prior to the international filing date but later than the priority date claimed																				
Date of the actual completion of the international search 02 MAY 1994		Date of mailing of the international search report 01 JUN 1994																		
Name and mailing address of the ISA/US Commissioner of Patents and Trademarks Box PCT Washington, D.C. 20231 Facsimile No. (703) 305-9564		Authorized officer <i>B. Hardi</i> Tom Black Telephone No. (703) 305-9758																		

Form PCT/ISA/210 (second sheet)(July 1992)\*

**INTERNATIONAL SEARCH REPORT**

International application No.  
PCT/US93/12179

**A. CLASSIFICATION OF SUBJECT MATTER:**  
IPC (5):

H04B 7/185; G01S 5/02; H04L 27/30

**B. FIELDS SEARCHED**

Documentation other than minimum documentation that are included in the fields searched:

APS search: GPS and cellular telephone  
GPS and AM  
GPS and oscillator and calibrat?

Form PCT/ISA/210 (extra sheet)(July 1992)\*



03-29-04  
71

6P3662

IN THE UNITED STATES PATENT AND TRADEMARK OFFICE

In Re the Application of: ) Group Art Unit: 3662  
 Dupray et al. ) Examiner: Dao L. Phan  
 Serial No.: 09/770,838 ) INFORMATION DISCLOSURE STATEMENT  
 Filed: January 26, 2001 )  
 Atty. File No.: 1003-1 )  
 For: A GATEWAY AND HYBRID )  
 SOLUTIONS FOR WIRELESS )  
 LOCATION )

"EXPRESS MAIL" MAILING LABEL NUMBER: EV331284115US  
DATE OF DEPOSIT: MARCH 26, 2004

I HEREBY CERTIFY THAT THIS PAPER OR FEE IS BEING DEPOSITED WITH THE UNITED STATES POSTAL SERVICE "EXPRESS MAIL POST OFFICE TO ADDRESSEE" SERVICE UNDER 37 CFR 1.10 ON THE DATE INDICATED ABOVE AND IS ADDRESSED TO THE COMMISSIONER FOR PATENTS, P.O. BOX 1450, ALEXANDRIA, VIRGINIA 22313-1450.

TYPED OR PRINTED NAME: Aimee Thuerk  
SIGNATURE: Aimee Thuerk

Commissioner for Patents  
P.O. Box 1450  
Alexandria, Virginia 22313-1450

RECEIVED

MAR 30 2004

GROUP 3600

Dear Sir:

The references cited on attached Form PTO-1449 are being called to the attention of the Examiner.

Are enclosed herewith.

Are not enclosed, in accordance with 37 C.F.R. 1.98(d), because the references were submitted to the U.S. Patent and Trademark Office in prior application Serial No. 09/194,367 filed November 24, 1998, which is relied upon for an earlier filing date under 35 U.S.C. § 120.

To the best of applicants' belief, the pertinence of the foreign-language references is believed to be summarized in the attached English abstracts and in the figures, although applicants do not necessarily vouch for the accuracy of the translation.

Examiner's attention is drawn to the following co-pending applications, and for at least such applications to which the present application does not claim priority, copies have been or are being submitted:

- Serial No.09/194,367 filed Nov. 24, 1998 (docket no. 1003-PUS)
- Serial No.10/262,413 filed Sept. 30, 2002 (docket no. 1003-2)
- Serial No. 10/262,338 filed Sept. 30, 2002 (docket no. 1003-3)
- Serial No. 09/820,584 filed March 29, 2001 (docket no. 1004-1)
- Serial No.09/176,587 filed Oct. 21, 1998 (docket no. 1005-DJD)



Serial No. 10/297,449 filed Dec. 5, 2002 (docket no. 1010-PUS)  
 Serial No. 10/337,807 filed Jan. 6, 2003 (docket no. 1011)

Submission of the above information is not intended as an admission that any item is citable under the statutes or rules to support a rejection, that any item disclosed represents analogous art, or that those skilled in the art would refer to or recognize the pertinence of any reference without the benefit of hindsight, nor should an inference be drawn as to the pertinence of the references based on the order in which they are presented. Submission of this statement should not be taken as an indication that a search has been conducted, or that no better art exists.

It is respectfully requested that the cited information be expressly considered during the prosecution of this application and the references made of record therein.

**FEEES**

<input checked="" type="checkbox"/>	<p><b>37 CFR 1.97(b):</b> No fee is believed due in connection with this submission, because the information disclosure statement submitted herewith is satisfies one of the following conditions ("X" indicates satisfaction):</p> <ul style="list-style-type: none"> <li><input type="checkbox"/> Within three months of the filing date of a national application other than a continued prosecution application under 37 CFR 1.53(d), or</li> <li><input type="checkbox"/> Within three months of the date of entry into the national stage of an international application as set forth in 37 CFR 1.491 or</li> <li><input type="checkbox"/> Before the mailing date of a first Office Action on the merits, or</li> <li><input checked="" type="checkbox"/> Before the mailing of a first Office action after the filing of a request for continued examination under 37 CFR 1.114.</li> </ul> <p>Although no fee is believed due, if any fee is deemed due in connection with this submission, please charge such fee to Deposit Account 19-1970.</p>
<input type="checkbox"/>	<p><b>37 CFR 1.97(c):</b> The information disclosure statement transmitted herewith is being filed after all the above conditions (37 CFR 1.97(b)), but before the mailing date of one of the following conditions:</p> <ul style="list-style-type: none"> <li>(1) a final action under 37 C.F.R. 1.113 or</li> <li>(2) a notice of allowance under 37 C.F.R. 1.311, or</li> <li>(3) an action that otherwise closes prosecution in the application.</li> </ul> <p>This Information Disclosure Statement is accompanied by:</p> <ul style="list-style-type: none"> <li><input type="checkbox"/> A Certification (below) as specified by 37 C.F.R. 1.97(e). Although no fee is believed due, if any fee is deemed due in connection with this submission, please charge such fee to Deposit Account 19-1970.</li> </ul> <p style="text-align: center;">OR</p> <ul style="list-style-type: none"> <li><input type="checkbox"/> A check in the amount of \$180.00 for the fee set forth in 37 C.F.R. 1.17(p) for submission of an information disclosure statement. Please credit any overpayment or charge any underpayment to Deposit Account No. 19-1970. Election to pay the fee should not be taken as an indication that applicant(s) cannot execute a certification.</li> </ul>
<input type="checkbox"/>	<p><b>37 CFR 1.97(d):</b> This Information Disclosure Statement is being submitted after the period specified in 37 CFR 1.97(c).</p> <ul style="list-style-type: none"> <li><input type="checkbox"/> This information Disclosure Statement includes a Certification (below) as specified by 37 C.F.R. 1.97(e)</li> </ul> <p style="text-align: center;">AND</p> <ul style="list-style-type: none"> <li><input type="checkbox"/> Applicants hereby requests consideration of the reference(s) disclosed herein. Enclosed is the fee in the amount of \$180.00 under 37 C.F.R. 1.17(p). Please credit any overpayment or charge any underpayment to Deposit Account No. 19-1970.</li> </ul>

**Certification (37 C.F.R. 1.97(e))**  
(Applicable only if checked)

The undersigned certifies that:

Each item of information contained in this information disclosure statement was first cited in any communication from a foreign patent office in a counterpart foreign application not more than three months prior to the filing of this statement. 37 C.F.R. 1.97(e)(1).

A copy of the communication from the foreign patent office is enclosed.

OR

No item of information contained in this information disclosure statement was cited in a communication from a foreign patent office in a counterpart foreign application, and, to the knowledge of the undersigned after making reasonable inquiry, no item of information contained in this Information Disclosure Statement was known to any individual designated in 37 C.F.R. 1.56(c) more than more than three months prior to the filing of this statement. 37 C.F.R. 1.97(e)(2).

Respectfully submitted,

SHERIDAN ROSS P.C.

By: 

Dennis J. Dupray

Registration No. 46,299

1560 Broadway, Suite 1200

Denver, Colorado 80202-5141

(303) 863-9700

Date: MAR CH 25, 2004



FORM PTO-1449 U.S. DEPARTMENT OF COMMERCE PATENT AND TRADEMARK OFFICE  <b>INFORMATION DISCLOSURE STATEMENT</b> (Use several sheets if necessary)	ATTY. DOCKET NO. 1003-1	SERIAL NO. 09/770,838
	APPLICANT DUPRAY, Dennis J.	
	FILING DATE January 26, 2001	GROUP ART 3662

U.S. PATENT DOCUMENTS

*EXAMINER INITIAL		DOCUMENT NUMBER	DATE	NAME	CLASS	SUB CLASS	FILING DATE IF APPROP.
	1.	5,857,181	1/5/99	AUGENBRAUN	707	2	
	2.	5,787,235	7/28/98	SMITH et al.	395	50	
	3.	5,625,748	4/29/97	McDONOUGH et al.	395	2.6	
	4.	5,581,490	12/3/96	FERKINHOFF et al.	364	578	
	5.	5,563,931	10/8/96	BISHOP et al.	379	59	
	6.	5,402,524	3/28/95	BAUMAN et al.	395	50	
	7.	5,373,456	12/13/94	FERKINHOFF et al.	364	574	
	8.	5,233,541	8/3/93	CORWIN et al.	364	516	
	9.	5,045,852	9/3/91	MITCHELL et al.	341	51	
	10.	4,542,744	9/24/85	BARNES et al.	128	660	

FOREIGN PATENT DOCUMENTS

	DOCUMENT NUMBER	DATE	COUNTRY	CLASS	SUB CLASS	TRANSLATION	
						YES	NO

RECEIVED  
MAR 30 2004

GROUP 3600

EXAMINER	DATE CONSIDERED
<small>*EXAMINER: Initial if reference considered, whether or not citation is in conformance with MPEP 609; Draw line through citation if not in conformance and not considered. Include copy of this form with next communication to applicant.</small>	



FORM PTO-1449 U.S. DEPARTMENT OF COMMERCE PATENT AND TRADEMARK OFFICE  <b>INFORMATION DISCLOSURE STATEMENT</b> (Use several sheets if necessary)	ATTY. DOCKET NO. 1003-1	SERIAL NO. 09/770,838
	APPLICANT DUPRAY, Dennis J.	
	FILING DATE January 26, 2001	GROUP ART 3662

OTHER ART (Including Author, Title, Date, Pertinent Pages, etc.)

11.	Miller, RT, et al., "Protein fold recognition by sequence threading: tools and assessment techniques," Journal Announcement, Department of Biochemistry and Molecular Biology, University College, London, United Kingdom, January 1996
12.	Dailey, D.J., "Demonstration of an Advanced Public Transportation System in the Context of an IVHS Regional Architecture," paper presented at the First World Congress on Applications of Transport Telematics and Intelligent Vehicle-Highway Systems, Nov. 30-Dec. 3, 1994
13.	Dailey, D.J., et al., "ITS Data Fusion," Final Research Report, Research Project T9903, Task 9, ATIS/ATMS Regional IVHS Demonstration, University of Washington, April, 1996
14.	Dartmouth College, "Soldiers, Agents and Wireless Networks: A Report on a Military Application," PAAM 2000.
15.	Bass, Tim, "Intrusion Detection Systems & Multisensor Data Fusion: Creating Cyberspace Situational Awareness," Communications of the ACM, date unknown.

RECEIVED  
 MAR 30 2004  
 GROUP 3600

EXAMINER	DATE CONSIDERED
*EXAMINER: Initial if reference considered, whether or not citation is in conformance with MPEP 609; Draw line through citation if not in conformance and not considered. Include copy of this form with next communication to applicant.	



UNITED STATES PATENT AND TRADEMARK OFFICE

UNITED STATES DEPARTMENT OF COMMERCE
United States Patent and Trademark Office
Address: COMMISSIONER FOR PATENTS
P.O. Box 1450
Alexandria, Virginia 22313-1450
www.uspto.gov

NOTICE OF ALLOWANCE AND FEE(S) DUE

7590 04/20/2004
Dennis J. Dupray, Ph.D.
1801 Belvedere Street
Golden, CO 80401

EXAMINER PHAN, DAO LINDA
ART UNIT PAPER NUMBER
3662

DATE MAILED: 04/20/2004

Table with 5 columns: APPLICATION NO., FILING DATE, FIRST NAMED INVENTOR, ATTORNEY DOCKET NO., CONFIRMATION NO.
09/770,838 01/26/2001 Dennis J. Dupray 1003-1 8410

TITLE OF INVENTION: A GATEWAY AND HYBRID SOLUTIONS FOR WIRELESS LOCATION

Table with 6 columns: APPLN. TYPE, SMALL ENTITY, ISSUE FEE, PUBLICATION FEE, TOTAL FEE(S) DUE, DATE DUE
nonprovisional YES \$665 \$300 \$965 07/20/2004

THE APPLICATION IDENTIFIED ABOVE HAS BEEN EXAMINED AND IS ALLOWED FOR ISSUANCE AS A PATENT. PROSECUTION ON THE MERITS IS CLOSED. THIS NOTICE OF ALLOWANCE IS NOT A GRANT OF PATENT RIGHTS. THIS APPLICATION IS SUBJECT TO WITHDRAWAL FROM ISSUE AT THE INITIATIVE OF THE OFFICE OR UPON PETITION BY THE APPLICANT. SEE 37 CFR 1.313 AND MPEP 1308.

THE ISSUE FEE AND PUBLICATION FEE (IF REQUIRED) MUST BE PAID WITHIN THREE MONTHS FROM THE MAILING DATE OF THIS NOTICE OR THIS APPLICATION SHALL BE REGARDED AS ABANDONED. THIS STATUTORY PERIOD CANNOT BE EXTENDED. SEE 35 U.S.C. 151. THE ISSUE FEE DUE INDICATED ABOVE REFLECTS A CREDIT FOR ANY PREVIOUSLY PAID ISSUE FEE APPLIED IN THIS APPLICATION. THE PTOL-85B (OR AN EQUIVALENT) MUST BE RETURNED WITHIN THIS PERIOD EVEN IF NO FEE IS DUE OR THE APPLICATION WILL BE REGARDED AS ABANDONED.

HOW TO REPLY TO THIS NOTICE:

I. Review the SMALL ENTITY status shown above.

If the SMALL ENTITY is shown as YES, verify your current SMALL ENTITY status:

A. If the status is the same, pay the TOTAL FEE(S) DUE shown above.

B. If the status is changed, pay the PUBLICATION FEE (if required) and twice the amount of the ISSUE FEE shown above and notify the United States Patent and Trademark Office of the change in status, or

If the SMALL ENTITY is shown as NO:

A. Pay TOTAL FEE(S) DUE shown above, or

B. If applicant claimed SMALL ENTITY status before, or is now claiming SMALL ENTITY status, check the box below and enclose the PUBLICATION FEE and 1/2 the ISSUE FEE shown above.

[ ] Applicant claims SMALL ENTITY status. See 37 CFR 1.27.

II. PART B - FEE(S) TRANSMITTAL should be completed and returned to the United States Patent and Trademark Office (USPTO) with your ISSUE FEE and PUBLICATION FEE (if required). Even if the fee(s) have already been paid, Part B - Fee(s) Transmittal should be completed and returned. If you are charging the fee(s) to your deposit account, section "4b" of Part B - Fee(s) Transmittal should be completed and an extra copy of the form should be submitted.

III. All communications regarding this application must give the application number. Please direct all communications prior to issuance to Mail Stop ISSUE FEE unless advised to the contrary.

IMPORTANT REMINDER: Utility patents issuing on applications filed on or after Dec. 12, 1980 may require payment of maintenance fees. It is patentee's responsibility to ensure timely payment of maintenance fees when due.

**PART B - FEE(S) TRANSMITTAL**

Complete and send this form, together with applicable fee(s), to: **Mail** **Mail Stop ISSUE FEE**  
**Commissioner for Patents**  
**P.O. Box 1450**  
**Alexandria, Virginia 22313-1450**  
**or Fax (703) 746-4000**

**INSTRUCTIONS:** This form should be used for transmitting the ISSUE FEE and PUBLICATION FEE (if required). Blocks 1 through 4 should be completed where appropriate. All further correspondence including the Patent, advance orders and notification of maintenance fees will be mailed to the current correspondence address as indicated unless corrected below or directed otherwise in Block 1, by (a) specifying a new correspondence address; and/or (b) indicating a separate "FEE ADDRESS" for maintenance fee notifications.

CURRENT CORRESPONDENCE ADDRESS (Note: Legibly mark-up with any corrections or use Block 1)

Note: A certificate of mailing can only be used for domestic mailings of the Fee(s) Transmittal. This certificate cannot be used for any other accompanying papers. Each additional paper, such as an assignment or formal drawing, must have its own certificate of mailing or transmission.

7590 04/20/2004  
**Dennis J. Dupray, Ph.D.**  
 1801 Belvedere Street  
 Golden, CO 80401

**Certificate of Mailing or Transmission**  
 I hereby certify that this Fee(s) Transmittal is being deposited with the United States Postal Service with sufficient postage for first class mail in an envelope addressed to the Mail Stop ISSUE FEE address above, or being facsimile transmitted to the USPTO, on the date indicated below.

_____ (Depositor's name)
_____ (Signature)
_____ (Date)

APPLICATION NO.	FILING DATE	FIRST NAMED INVENTOR	ATTORNEY DOCKET NO.	CONFIRMATION NO.
09/770,838	01/26/2001	Dennis J. Dupray	1003-1	8410

TITLE OF INVENTION: A GATEWAY AND HYBRID SOLUTIONS FOR WIRELESS LOCATION

APPLN. TYPE	SMALL ENTITY	ISSUE FEE	PUBLICATION FEE	TOTAL FEE(S) DUE	DATE DUE
nonprovisional	YES	\$665	\$300	\$965	07/20/2004

EXAMINER	ART UNIT	CLASS-SUBCLASS
PHAN, DAO LINDA	3662	342-450000

1. Change of correspondence address or indication of "Fee Address" (37 CFR 1.363).  
 Change of correspondence address (or Change of Correspondence Address form PTO/SB/122) attached.  
 "Fee Address" indication (or "Fee Address" Indication form PTO/SB/47; Rev 03-02 or more recent) attached. Use of a Customer Number is required.

2. For printing on the patent front page, list (1) the names of up to 3 registered patent attorneys or agents OR, alternatively, (2) the name of a single firm (having as a member a registered attorney or agent) and the names of up to 2 registered patent attorneys or agents. If no name is listed, no name will be printed.  
 1 \_\_\_\_\_  
 2 \_\_\_\_\_  
 3 \_\_\_\_\_

**3. ASSIGNEE NAME AND RESIDENCE DATA TO BE PRINTED ON THE PATENT (print or type)**

PLEASE NOTE: Unless an assignee is identified below, no assignee data will appear on the patent. Inclusion of assignee data is only appropriate when an assignment has been previously submitted to the USPTO or is being submitted under separate cover. Completion of this form is NOT a substitute for filing an assignment.  
 (A) NAME OF ASSIGNEE  
 (B) RESIDENCE: (CITY and STATE OR COUNTRY)

Please check the appropriate assignee category or categories (will not be printed on the patent);  individual  corporation or other private group entity  government

4a. The following fee(s) are enclosed:  
 Issue Fee  
 Publication Fee  
 Advance Order - # of Copies \_\_\_\_\_

4b. Payment of Fee(s):  
 A check in the amount of the fee(s) is enclosed.  
 Payment by credit card. Form PTO-2038 is attached.  
 The Director is hereby authorized by charge the required fee(s), or credit any overpayment, to Deposit Account Number \_\_\_\_\_ (enclose an extra copy of this form).

Director for Patents is requested to apply the Issue Fee and Publication Fee (if any) or to re-apply any previously paid issue fee to the application identified above.

(Authorized Signature) \_\_\_\_\_ (Date) \_\_\_\_\_

NOTE: The Issue Fee and Publication Fee (if required) will not be accepted from anyone other than the applicant; a registered attorney or agent; or the assignee or other party in interest as shown by the records of the United States Patent and Trademark Office.

This collection of information is required by 37 CFR 1.311. The information is required to obtain or retain a benefit by the public which is to file (and by the USPTO to process) an application. Confidentiality is governed by 35 U.S.C. 122 and 37 CFR 1.14. This collection is estimated to take 12 minutes to complete, including gathering, preparing, and submitting the completed application form to the USPTO. Time will vary depending upon the individual case. Any comments on the amount of time you require to complete this form and/or suggestions for reducing this burden, should be sent to the Chief Information Officer, U.S. Patent and Trademark Office, U.S. Department of Commerce, Alexandria, Virginia 22313-1450. DO NOT SEND FEES OR COMPLETED FORMS TO THIS ADDRESS. SEND TO: Commissioner for Patents, Alexandria, Virginia 22313-1450.

Under the Paperwork Reduction Act of 1995, no persons are required to respond to a collection of information unless it displays a valid OMB control number.

TRANSMIT THIS FORM WITH FEE(S)



UNITED STATES PATENT AND TRADEMARK OFFICE

UNITED STATES DEPARTMENT OF COMMERCE  
United States Patent and Trademark Office  
Address: COMMISSIONER FOR PATENTS  
P.O. Box 1450  
Alexandria, Virginia 22313-1450  
www.uspto.gov

APPLICATION NO.	FILING DATE	FIRST NAMED INVENTOR	ATTORNEY DOCKET NO.	CONFIRMATION NO.
09/770,838	01/26/2001	Dennis J. Dupray	1003-1	8410
	7590 04/20/2004		EXAMINER PHAN, DAO LINDA	
Dennis J. Dupray, Ph.D. 1801 Belvedere Street Golden, CO 80401			ART UNIT      PAPER NUMBER	
			3662	

DATE MAILED: 04/20/2004

**Determination of Patent Term Adjustment under 35 U.S.C. 154 (b)**  
(application filed on or after May 29, 2000)

The Patent Term Adjustment to date is 0 day(s). If the issue fee is paid on the date that is three months after the mailing date of this notice and the patent issues on the Tuesday before the date that is 28 weeks (six and a half months) after the mailing date of this notice, the Patent Term Adjustment will be 0 day(s).

If a Continued Prosecution Application (CPA) was filed in the above-identified application, the filing date that determines Patent Term Adjustment is the filing date of the most recent CPA.

Applicant will be able to obtain more detailed information by accessing the Patent Application Information Retrieval (PAIR) system (<http://pair.uspto.gov>).

Any questions regarding the Patent Term Extension or Adjustment determination should be directed to the Office of Patent Legal Administration at (703) 305-1383. Questions relating to issue and publication fee payments should be directed to the Customer Service Center of the Office of Patent Publication at (703) 305-8283.

<b>Notice of Allowability</b>	<b>Application No.</b>	<b>Applicant(s)</b>	
	09/770,838	DUPRAY ET AL.	
	<b>Examiner</b>	<b>Art Unit</b>	
	Dao L. Phan	3662	

**-- The MAILING DATE of this communication appears on the cover sheet with the correspondence address--**

All claims being allowable, PROSECUTION ON THE MERITS IS (OR REMAINS) CLOSED in this application. If not included herewith (or previously mailed), a Notice of Allowance (PTOL-85) or other appropriate communication will be mailed in due course. **THIS NOTICE OF ALLOWABILITY IS NOT A GRANT OF PATENT RIGHTS.** This application is subject to withdrawal from issue at the initiative of the Office or upon petition by the applicant. See 37 CFR 1.313 and MPEP 1308.

1.  This communication is responsive to 11/26/03 & 12/23/03.
2.  The allowed claim(s) is/are 221-295 (renumbered 1-75).
3.  The drawings filed on 1/26/01 & 3/1/02 are accepted by the Examiner.
4.  Acknowledgment is made of a claim for foreign priority under 35 U.S.C. § 119(a)-(d) or (f).
  - a)  All    b)  Some\*    c)  None    of the:
    1.  Certified copies of the priority documents have been received.
    2.  Certified copies of the priority documents have been received in Application No. \_\_\_\_\_.
    3.  Copies of the certified copies of the priority documents have been received in this national stage application from the International Bureau (PCT Rule 17.2(a)).

\* Certified copies not received: \_\_\_\_\_.

Applicant has THREE MONTHS FROM THE "MAILING DATE" of this communication to file a reply complying with the requirements noted below. Failure to timely comply will result in ABANDONMENT of this application.  
**THIS THREE-MONTH PERIOD IS NOT EXTENDABLE.**

5.  A SUBSTITUTE OATH OR DECLARATION must be submitted. Note the attached EXAMINER'S AMENDMENT or NOTICE OF INFORMAL PATENT APPLICATION (PTO-152) which gives reason(s) why the oath or declaration is deficient.
6.  CORRECTED DRAWINGS ( as "replacement sheets") must be submitted.
  - (a)  including changes required by the Notice of Draftsperson's Patent Drawing Review ( PTO-948) attached
    - 1)  hereto or 2)  to Paper No./Mail Date \_\_\_\_\_.
  - (b)  including changes required by the attached Examiner's Amendment / Comment or in the Office action of Paper No./Mail Date \_\_\_\_\_.

Identifying indicia such as the application number (see 37 CFR 1.84(c)) should be written on the drawings in the front (not the back) of each sheet. Replacement sheet(s) should be labeled as such in the header according to 37 CFR 1.121(d).
7.  DEPOSIT OF and/or INFORMATION about the deposit of BIOLOGICAL MATERIAL must be submitted. Note the attached Examiner's comment regarding REQUIREMENT FOR THE DEPOSIT OF BIOLOGICAL MATERIAL.

**Attachment(s)**

- |  |  |
|--|--|
| 1. <input type="checkbox"/> Notice of References Cited (PTO-892)   | 5. <input type="checkbox"/> Notice of Informal Patent Application (PTO-152)            |
| 2. <input type="checkbox"/> Notice of Draftsperson's Patent Drawing Review (PTO-948)   | 6. <input type="checkbox"/> Interview Summary (PTO-413),<br>Paper No./Mail Date _____. |
| 3. <input checked="" type="checkbox"/> Information Disclosure Statements (PTO-1449 or PTO/SB/08),<br>Paper No./Mail Date _____ | 7. <input type="checkbox"/> Examiner's Amendment/Comment                               |
| 4. <input type="checkbox"/> Examiner's Comment Regarding Requirement for Deposit<br>of Biological Material                     | 8. <input type="checkbox"/> Examiner's Statement of Reasons for Allowance              |
|  | 9. <input type="checkbox"/> Other _____.   |

  
**DAO PHAN**  
**PATENT EXAMINER**





FORM PTO-1449 U.S. DEPARTMENT OF COMMERCE PATENT AND TRADEMARK OFFICE  INFORMATION DISCLOSURE STATEMENT (Use several sheets if necessary)	ATTY. DOCKET NO. 1003-1	SERIAL NO. 09/770.838
	APPLICANT DUPRAY, Dennis J.	
	FILING DATE January 26, 2001	GROUP ART 3662

U.S. PATENT DOCUMENTS

*EXAMINER INITIAL		DOCUMENT NUMBER	DATE	NAME	CLASS	SUB CLASS	FILING DATE IF APPROP.
DP	AA	5,588,038	12/24/96	Snyder	379	57	
DP	AB	5,119,104	6/2/92	Heller	342	450	

FOREIGN PATENT DOCUMENTS

		DOCUMENT NUMBER	DATE	COUNTRY	CLASS	SUB CLASS	TRANSLATION	
							YES	NO
DP	AC	WO 94/15412	July 7, 1994	PCT	H04B 7	185		

OTHER ART (Including Author, Title, Date, Pertinent Pages, etc.)

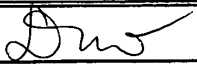
EXAMINER 	DATE CONSIDERED 4/13/04
*EXAMINER: Initial if reference considered, whether or not citation is in conformance with MPEP 609; Draw line through citation if not in conformance and not considered. Include copy of this form with next communication to applicant.	

92

APR 23 2004

3662  
B

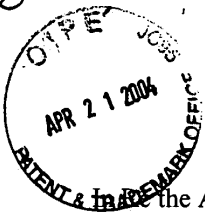

IN THE UNITED STATES PATENT AND TRADEMARK OFFICE

the Application of:  
Dupray et al.  
Serial No.: 09/770,838  
Filed: January 26, 2001  
Atty. File No.: 1003-1  
For: A GATEWAY AND HYBRID  
SOLUTIONS FOR WIRELESS  
LOCATION

) Group Art Unit: 3662  
)  
) Examiner: Dao L. Phan  
)  
) INFORMATION DISCLOSURE STATEMENT  
)

"EXPRESS MAIL" MAILING LABEL NUMBER: EV331284331US  
DATE OF DEPOSIT: April 21, 2004

I HEREBY CERTIFY THAT THIS PAPER OR FEE IS BEING DEPOSITED WITH THE UNITED STATES POSTAL SERVICE "EXPRESS MAIL POST OFFICE TO ADDRESSEE" SERVICE UNDER 37 CFR 1.10 ON THE DATE INDICATED ABOVE AND IS ADDRESSED TO THE COMMISSIONER FOR PATENTS, P.O. BOX 1450, ALEXANDRIA, VIRGINIA 22313-1450.

TYPED OR PRINTED NAME: Aimee Thueck  
SIGNATURE: Aimee Thueck

Commissioner for Patents  
P.O. Box 1450  
Alexandria, Virginia 22313-1450

Dear Sir:

The references cited on attached Form PTO-1449 are being called to the attention of the Examiner.

Are enclosed herewith.

Are not enclosed, in accordance with 37 C.F.R. 1.98(d), because the references were submitted to the U.S. Patent and Trademark Office in prior application Serial No. 09/194,367 filed November 24, 1998, which is relied upon for an earlier filing date under 35 U.S.C. § 120.

To the best of applicants' belief, the pertinence of the foreign-language references is believed to be summarized in the attached English abstracts and in the figures, although applicants do not necessarily vouch for the accuracy of the translation.

Examiner's attention is drawn to the following co-pending applications, and for at least such applications to which the present application does not claim priority, copies have been or are being submitted:

Serial No.09/194,367	filed	Nov. 24, 1998 (docket no. 1003-PUS)
Serial No.10/262,413	filed	Sept. 30, 2002 (docket no. 1003-2)
Serial No. 10/262,338	filed	Sept. 30, 2002 (docket no. 1003-3)
Serial No. 09/820,584	filed	March 29, 2001 (docket no. 1004-1)
Serial No.09/176,587	filed	Oct. 21, 1998 (docket no. 1005-DJD)

Serial No. 10/297,449 filed Dec. 5, 2002 (docket no. 1010-PUS)  
 Serial No. 10/337,807 filed Jan. 6, 2003 (docket no. 1011)

Submission of the above information is not intended as an admission that any item is citable under the statutes or rules to support a rejection, that any item disclosed represents analogous art, or that those skilled in the art would refer to or recognize the pertinence of any reference without the benefit of hindsight, nor should an inference be drawn as to the pertinence of the references based on the order in which they are presented. Submission of this statement should not be taken as an indication that a search has been conducted, or that no better art exists.

It is respectfully requested that the cited information be expressly considered during the prosecution of this application and the references made of record therein.

**FEES**

<input checked="" type="checkbox"/>	<p><b>37 CFR 1.97(b):</b> No fee is believed due in connection with this submission, because the information disclosure statement submitted herewith is satisfies one of the following conditions ("X" indicates satisfaction):</p> <ul style="list-style-type: none"> <li><input type="checkbox"/> Within three months of the filing date of a national application other than a continued prosecution application under 37 CFR 1.53(d), or</li> <li><input type="checkbox"/> Within three months of the date of entry into the national stage of an international application as set forth in 37 CFR 1.491 or</li> <li><input type="checkbox"/> Before the mailing date of a first Office Action on the merits, or</li> <li><input checked="" type="checkbox"/> Before the mailing of a first Office action after the filing of a request for continued examination under 37 CFR 1.114.</li> </ul> <p>Although no fee is believed due, if any fee is deemed due in connection with this submission, please charge such fee to Deposit Account 19-1970.</p>
<input type="checkbox"/>	<p><b>37 CFR 1.97(c):</b> The information disclosure statement transmitted herewith is being filed after all the above conditions (37 CFR 1.97(b)), but before the mailing date of one of the following conditions:</p> <ul style="list-style-type: none"> <li>(1) a final action under 37 C.F.R. 1.113 or</li> <li>(2) a notice of allowance under 37 C.F.R. 1.311, or</li> <li>(3) an action that otherwise closes prosecution in the application.</li> </ul> <p>This Information Disclosure Statement is accompanied by:</p> <ul style="list-style-type: none"> <li><input type="checkbox"/> A Certification (below) as specified by 37 C.F.R. 1.97(e). Although no fee is believed due, if any fee is deemed due in connection with this submission, please charge such fee to Deposit Account 19-1970.</li> </ul> <p style="text-align: center;">OR</p> <ul style="list-style-type: none"> <li><input type="checkbox"/> A check in the amount of \$180.00 for the fee set forth in 37 C.F.R. 1.17(p) for submission of an information disclosure statement. Please credit any overpayment or charge any underpayment to Deposit Account No. 19-1970. Election to pay the fee should not be taken as an indication that applicant(s) cannot execute a certification.</li> </ul>
<input type="checkbox"/>	<p><b>37 CFR 1.97(d):</b> This Information Disclosure Statement is being submitted after the period specified in 37 CFR 1.97(c).</p> <ul style="list-style-type: none"> <li><input type="checkbox"/> This information Disclosure Statement includes a Certification (below) as specified by 37 C.F.R. 1.97(e)</li> </ul> <p style="text-align: center;">AND</p> <ul style="list-style-type: none"> <li><input type="checkbox"/> Applicants hereby requests consideration of the reference(s) disclosed herein. Enclosed is the fee in the amount of \$180.00 under 37 C.F.R. 1.17(p). Please credit any overpayment or charge any underpayment to Deposit Account No. 19-1970.</li> </ul>

**Certification (37 C.F.R. 1.97(e))**  
(Applicable only if checked)

The undersigned certifies that:

Each item of information contained in this information disclosure statement was first cited in any communication from a foreign patent office in a counterpart foreign application not more than three months prior to the filing of this statement. 37 C.F.R. 1.97(e)(1).

A copy of the communication from the foreign patent office is enclosed.

OR

No item of information contained in this information disclosure statement was cited in a communication from a foreign patent office in a counterpart foreign application, and, to the knowledge of the undersigned after making reasonable inquiry, no item of information contained in this Information Disclosure Statement was known to any individual designated in 37 C.F.R. 1.56(c) more than more than three months prior to the filing of this statement. 37 C.F.R. 1.97(e)(2).

Respectfully submitted,

SHERIDAN ROSS P.C.

By: 

Dennis J. Dupray  
Registration No. 46,299  
1560 Broadway, Suite 1200  
Denver, Colorado 80202-5141  
(303) 863-9700

Date: April 21, 2004



FORM PTO-1449 U.S. DEPARTMENT OF COMMERCE PATENT AND TRADEMARK OFFICE  <b>INFORMATION DISCLOSURE STATEMENT</b> (Use several sheets if necessary)	ATTY. DOCKET NO. 1003-1	SERIAL NO. 09/770,838
	APPLICANT DUPRAY, Dennis J.	
	FILING DATE January 26, 2001	GROUP ART 3662

U.S. PATENT DOCUMENTS

*EXAMINER INITIAL	DOCUMENT NUMBER	DATE	NAME	CLASS	SUB CLASS	FILING DATE IF APPROP.
AA*	6,240,285	5/29/01	BLUM et al.	455	404	
AB*	5,959,568	9/28/99	Woolley	342	42	
AC*	5,787,354	7/28/98	GRAY et al.	455	456	
AD*	5,774,805	6/30/98	ZICKER	455	426	
AE*	5,724,648	3/3/98	SHAUGHNESSY et al.	455	56.1	
AF*	5,594,782	1/14/97	ZICKER et al.	379	63	
AG*	5,513,243	4/30/96	KAGE	379	58	
AH*	5,193,110	3/9/93	JONES et al.	379	94	

FOREIGN PATENT DOCUMENTS

	DOCUMENT NUMBER	DATE	COUNTRY	CLASS	SUB CLASS	TRANSLATION	
						YES	NO
AI*	EP 0 811 296 B1	9/25/02	EPO	H04Q 7	38		
AJ*	WO 02/065250 A2	8/22/02	WIPO	G06F			
AK*	WO 01/44998 A2	6/21/01	WIPO	G06F 17	60		

OTHER ART (Including Author, Title, Date, Pertinent Pages, etc.)

EXAMINER	DATE CONSIDERED
*EXAMINER: Initial if reference considered, whether or not citation is in conformance with MPEP 609; Draw line through citation if not in conformance and not considered. Include copy of this form with next communication to applicant.	

93

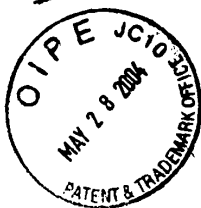

06-01-04

REQUEST FOR CONTINUED EXAMINATION (RCE) TRANSMITTAL

Address to:  
Commissioner for Patents  
Mail Stop RCE  
P.O. Box 1450  
Alexandria, VA 22313-1450

RCE \$  
3662

Application Number	09/770,838
Filing Date	January 26, 2001
First Named Inventor	Dupray
Examiner Name	Dao L. Phan
Attorney Docket Number	1003-1

This is a Request for Continued Examination (RCE) under 37 C.F.R. §1.114 of the above-identified application.

1. Submission required under 37 C.F.R. § 1.114

a.  Previously submitted:

- i.  Consider the amendment(s)/reply under 37 C.F.R. § 1.116 previously filed on \_\_\_\_\_ (Any unentered amendment(s) referred to above will be entered).
- ii.  Consider the arguments in the Appeal Brief or Reply Brief previously filed on \_\_\_\_\_.
- iii.  Other: Consider the Information Disclosure Statements filed November 26, 2003, March 26, 2004 and April 21, 2004, copies of which are enclosed herewith.

b.  Enclosed:

- i.  Amendment/Reply
- ii.  Affidavit(s)/Declaration(s)
- iii.  Information Disclosure statement (IDS)
- iv.  Other: Request for Consideration of Information Disclosure Statements

2. Miscellaneous

- a.  Suspension of action on the above-identified application is requested under 37 C.F.R. § 1.103(c) for a period of \_\_\_\_\_ months. (Period of suspension shall not exceed 3 months; Fee under 37 C.F.R. § 1.17(i) required).
- b.  Other \_\_\_\_\_

3. Fees

- a.  The Director is hereby authorized to charge the following fees, or credit any overpayments, to Deposit Account No. \_\_\_\_\_
  - i.  RCE fee required under 37 C.F.R. § 1.17(e)
  - ii.  Extension of time fee (37 C.F.R. §§ 1.136 and 1.17)
  - iii.  Other \_\_\_\_\_
- b.  Check in the amount of \$385.00 enclosed
- c.  Payment by credit card (Form PTO-2038 enclosed).

"EXPRESS MAIL" MAILING LABEL NUMBER: EV331284169US  
DATE OF DEPOSIT: May 28, 2004

RESPECTFULLY SUBMITTED,

SHERIDAN ROSS P.C.

By:

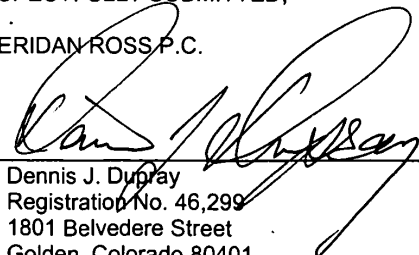
  
 Dennis J. Dupray  
 Registration No. 46,299  
 1801 Belvedere Street  
 Golden, Colorado 80401  
 303-863-2975  
 Facsimile: (303) 863-0223

I HEREBY CERTIFY THAT THIS PAPER OR FEE IS BEING DEPOSITED WITH THE UNITED STATES POSTAL SERVICE "EXPRESS MAIL POST OFFICE TO ADDRESSEE" SERVICE UNDER 37 CFR 1.10 ON THE DATE INDICATED ABOVE AND IS ADDRESSED TO THE COMMISSIONER FOR PATENTS, P.O. BOX 1450, ALEXANDRIA, VIRGINIA 22313-1450.

TYPED OR PRINTED NAME: AIMEE M. THUERK



06/02/2004 MAHME1 00000026 09770838

01 FC:2801

385.00 DP



IN THE UNITED STATES PATENT AND TRADEMARK OFFICE

In Re the Application of: )  
 )  
 ) DUPRAY et al. )  
 )  
 ) Serial No.: 09/770,838 )  
 )  
 ) Filed: January 26, 2001 )  
 )  
 ) Atty. File No.: 1003-1 )  
 )  
 ) For: A GATEWAY AND HYBRID )  
 ) SOLUTIONS FOR WIRELESS )  
 ) LOCATION )

Group Art Unit: 3662  
Examiner: Dao L. Phan

REQUEST FOR CONSIDERATION OF  
INFORMATION DISCLOSURE  
STATEMENTS

"EXPRESS MAIL" MAILING LABEL NUMBER: EV331284169US  
DATE OF DEPOSIT: May 28, 2004

I HEREBY CERTIFY THAT THIS PAPER OR FEE IS BEING DEPOSITED WITH THE UNITED STATES POSTAL SERVICE "EXPRESS MAIL POST OFFICE TO ADDRESSEE" SERVICE UNDER 37 CFR 1.10 ON THE DATE INDICATED ABOVE AND IS ADDRESSED TO THE COMMISSIONER FOR PATENTS, P.O. BOX 1450, ALEXANDRIA, VIRGINIA 22313-1450.

Assistant Commissioner for Patents  
Washington, D.C. 20231

TYPED OR PRINTED NAME: AMEE M. THUERK

Dear Sir:

Applicants respectfully request consideration of the Information Disclosure Statements filed November 26, 2003, March 26, 2004 and April 21, 2004, copies of which are enclosed.

Respectfully submitted,

By:

Dennis J. Dupray  
Registration No. 46,299  
1801 Belvedere Street  
Golden, Colorado 80401

TELEPHONE: 303-863-2975

FAX: 303-863-0223

Date: MAY 28, 2004

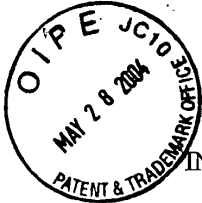

IN THE UNITED STATES PATENT AND TRADEMARK OFFICE

In Re the Application of:  
Dupray et al.  
Serial No.: 09/770,838  
Filed: January 26, 2001  
Atty. File No.: 1003-1  
For: A GATEWAY AND HYBRID  
SOLUTIONS FOR WIRELESS  
LOCATION

) Group Art Unit: 3662  
)  
) Examiner: Dao L. Phan  
)  
) INFORMATION DISCLOSURE STATEMENT

"EXPRESS MAIL" MAILING LABEL NUMBER: EV331284311US  
DATE OF DEPOSIT: April 21, 2004

I HEREBY CERTIFY THAT THIS PAPER OR FEE IS BEING DEPOSITED WITH THE UNITED STATES POSTAL SERVICE "EXPRESS MAIL POST OFFICE TO ADDRESSEE" SERVICE UNDER 37 CFR 1.10 ON THE DATE INDICATED ABOVE AND IS ADDRESSED TO THE COMMISSIONER FOR PATENTS, P.O. BOX 1450, ALEXANDRIA, VIRGINIA 22313-1450.

TYPED OR PRINTED NAME: Aimee Thuerk  
SIGNATURE: Aimee Thuerk

Commissioner for Patents  
P.O. Box 1450  
Alexandria, Virginia 22313-1450

Dear Sir:

The references cited on attached Form PTO-1449 are being called to the attention of the Examiner.

Are enclosed herewith.

Are not enclosed, in accordance with 37 C.F.R. 1.98(d), because the references were submitted to the U.S. Patent and Trademark Office in prior application Serial No. 09/194,367 filed November 24, 1998, which is relied upon for an earlier filing date under 35 U.S.C. § 120.

To the best of applicants' belief, the pertinence of the foreign-language references is believed to be summarized in the attached English abstracts and in the figures, although applicants do not necessarily vouch for the accuracy of the translation.

Examiner's attention is drawn to the following co-pending applications, and for at least such applications to which the present application does not claim priority, copies have been or are being submitted:

- Serial No.09/194,367 filed Nov. 24, 1998 (docket no. 1003-PUS)
- Serial No.10/262,413 filed Sept. 30, 2002 (docket no. 1003-2)
- Serial No. 10/262,338 filed Sept. 30, 2002 (docket no. 1003-3)
- Serial No. 09/820,584 filed March 29, 2001 (docket no. 1004-1)
- Serial No.09/176,587 filed Oct. 21, 1998 (docket no. 1005-DJD)



Serial No. 10/297,449  
Serial No. 10/337,807

filed Dec. 5, 2002 (docket no. 1010-PUS)  
filed Jan. 6, 2003 (docket no. 1011)

Submission of the above information is not intended as an admission that any item is citable under the statutes or rules to support a rejection, that any item disclosed represents analogous art, or that those skilled in the art would refer to or recognize the pertinence of any reference without the benefit of hindsight, nor should an inference be drawn as to the pertinence of the references based on the order in which they are presented. Submission of this statement should not be taken as an indication that a search has been conducted, or that no better art exists.

It is respectfully requested that the cited information be expressly considered during the prosecution of this application and the references made of record therein.

### FEES

<input checked="" type="checkbox"/>	<p>37 CFR 1.97(b): No fee is believed due in connection with this submission, because the information disclosure statement submitted herewith is satisfies one of the following conditions ("X" indicates satisfaction):</p> <ul style="list-style-type: none"><li><input type="checkbox"/> Within three months of the filing date of a national application other than a continued prosecution application under 37 CFR 1.53(d), or</li><li><input type="checkbox"/> Within three months of the date of entry into the national stage of an international application as set forth in 37 CFR 1.491 or</li><li><input type="checkbox"/> Before the mailing date of a first Office Action on the merits, or</li><li><input checked="" type="checkbox"/> Before the mailing of a first Office action after the filing of a request for continued examination under 37 CFR 1.114.</li></ul> <p>Although no fee is believed due, if any fee is deemed due in connection with this submission, please charge such fee to Deposit Account 19-1970.</p>
<input type="checkbox"/>	<p>37 CFR 1.97(c): The information disclosure statement transmitted herewith is being filed after all the above conditions (37 CFR 1.97(b)), but before the mailing date of one of the following conditions:</p> <ul style="list-style-type: none"><li>(1) a final action under 37 C.F.R. 1.113 or</li><li>(2) a notice of allowance under 37 C.F.R. 1.311, or</li><li>(3) an action that otherwise closes prosecution in the application.</li></ul> <p>This Information Disclosure Statement is accompanied by:</p> <ul style="list-style-type: none"><li><input type="checkbox"/> A Certification (below) as specified by 37 C.F.R. 1.97(e). Although no fee is believed due, if any fee is deemed due in connection with this submission, please charge such fee to Deposit Account 19-1970.</li></ul> <p style="text-align: center;">OR</p> <ul style="list-style-type: none"><li><input type="checkbox"/> A check in the amount of \$180.00 for the fee set forth in 37 C.F.R. 1.17(p) for submission of an information disclosure statement. Please credit any overpayment or charge any underpayment to Deposit Account No. 19-1970. Election to pay the fee should not be taken as an indication that applicant(s) cannot execute a certification.</li></ul>
<input type="checkbox"/>	<p>37 CFR 1.97(d): This Information Disclosure Statement is being submitted after the period specified in 37 CFR 1.97(c).</p> <ul style="list-style-type: none"><li><input type="checkbox"/> This information Disclosure Statement includes a Certification (below) as specified by 37 C.F.R. 1.97(e)</li></ul> <p style="text-align: center;">AND</p> <ul style="list-style-type: none"><li><input type="checkbox"/> Applicants hereby requests consideration of the reference(s) disclosed herein. Enclosed is the fee in the amount of \$180.00 under 37 C.F.R. 1.17(p). Please credit any overpayment or charge any underpayment to Deposit Account No. 19-1970.</li></ul>

**Certification (37 C.F.R. 1.97(e))**  
(Applicable only if checked)

The undersigned certifies that:

Each item of information contained in this information disclosure statement was first cited in any communication from a foreign patent office in a counterpart foreign application not more than three months prior to the filing of this statement. 37 C.F.R. 1.97(e)(1).

A copy of the communication from the foreign patent office is enclosed.

OR

No item of information contained in this information disclosure statement was cited in a communication from a foreign patent office in a counterpart foreign application, and, to the knowledge of the undersigned after making reasonable inquiry, no item of information contained in this Information Disclosure Statement was known to any individual designated in 37 C.F.R. 1.56(c) more than more than three months prior to the filing of this statement. 37 C.F.R. 1.97(e)(2).

Respectfully submitted,

SHERIDAN ROSS P.C.

By: 

Dennis J. Dupray  
Registration No. 46,299  
1560 Broadway, Suite 1200  
Denver, Colorado 80202-5141  
(303) 863-9700

Date: April 21, 2004



FORM PTO-1449 U.S. DEPARTMENT OF COMMERCE PATENT AND TRADEMARK OFFICE  <b>INFORMATION DISCLOSURE STATEMENT</b> (Use several sheets if necessary)	ATTY. DOCKET NO. 1003-1	SERIAL NO. 09/770,838
	APPLICANT DUPRAY, Dennis J.	
	FILING DATE January 26, 2001	GROUP ART 3662

U.S. PATENT DOCUMENTS

*EXAMINER INITIAL		DOCUMENT NUMBER	DATE	NAME	CLASS	SUB CLASS	FILING DATE IF APPROP.
	AA*	6,240,285	5/29/01	BLUM et al.	455	404	
	AB*	5,959,568	9/28/99	Woolley	342	42	
	AC*	5,787,354	7/28/98	GRAY et al.	455	456	
	AD*	5,774,805	6/30/98	ZICKER	455	426	
	AE*	5,724,648	3/3/98	SHAUGHNESSY et al.	455	56.1	
	AF*	5,594,782	1/14/97	ZICKER et al.	379	63	
	AG*	5,513,243	4/30/96	KAGE	379	58	
	AH*	5,193,110	3/9/93	JONES et al.	379	94	

FOREIGN PATENT DOCUMENTS

		DOCUMENT NUMBER	DATE	COUNTRY	CLASS	SUB CLASS	TRANSLATION	
							YES	NO
	AI*	EP 0 811 296 B1	9/25/02	EPO	H04Q 7	38		-
	AJ*	WO 02/065250 A2	8/22/02	WIPO	G06F			
	AK*	WO 01/44998 A2	6/21/01	WIPO	G06F 17	60		

OTHER ART (Including Author, Title, Date, Pertinent Pages, etc.)

--	--	--

EXAMINER	DATE CONSIDERED
*EXAMINER: Initial if reference considered, whether or not citation is in conformance with MPEP 609; Draw line through citation if not in conformance and not considered. Include copy of this form with next communication to applicant.	



IN THE UNITED STATES PATENT AND TRADEMARK OFFICE

In Re the Application of: ) Group Art Unit: 3662  
 Dupray et al. ) Examiner: Dao L. Phan  
 Serial No.: 09/770,838 )  
 Filed: January 26, 2001 )  
 Atty. File No.: 1003-1 )  
 For: A GATEWAY AND HYBRID )  
 SOLUTIONS FOR WIRELESS )  
 LOCATION )

INFORMATION DISCLOSURE STATEMENT

"EXPRESS MAIL" MAILING LABEL NUMBER: EV331283849US  
DATE OF DEPOSIT: NOVEMBER 26, 2003

I HEREBY CERTIFY THAT THIS PAPER OR FEE IS BEING DEPOSITED WITH THE UNITED STATES POSTAL SERVICE "EXPRESS MAIL POST OFFICE TO ADDRESSEE" SERVICE UNDER 37 CFR 1.10 ON THE DATE INDICATED ABOVE AND IS ADDRESSED TO THE COMMISSIONER FOR PATENTS, P.O. BOX 1450, ALEXANDRIA, VIRGINIA 22313-1450.

TYPED OR PRINTED NAME: AMEE M. THUERK

SIGNATURE: *Aimee M. Thuerk*

Commissioner for Patents  
P.O. Box 1450  
Alexandria, Virginia 22313-1450

Dear Sir:

The references cited on attached Form PTO-1449 are being called to the attention of the Examiner.

- Copies of the references marked with an asterisk are enclosed herewith.
- The remaining references are not enclosed, in accordance with 37 C.F.R. 1.98(d), because the references were submitted to the U.S. Patent and Trademark Office in prior application Serial No. 09/194,367 filed November 24, 1998, which is relied upon for an earlier filing date under 35 U.S.C. § 120.

To the best of applicants' belief, the pertinence of the foreign-language references is believed to be summarized in the attached English abstracts and in the figures, although applicants do not necessarily vouch for the accuracy of the translation.

Examiner's attention is drawn to the following co-pending applications, and for at least such applications to which the present application does not claim priority, copies have been or are being submitted:

- Serial No. 09/194,367 filed November 24, 1998
- Serial No. 09/820,584 filed March 28, 2001
- Serial No. 10/262,413 filed September 30, 2002
- Serial No. 10/262,338 filed September 30, 2002
- Serial No. 09/176,587 filed October 21, 1998

Serial No. 10/297,449 filed December 5, 2002

Serial No. 10/337,807 filed January 6, 2003

Submission of the above information is not intended as an admission that any item is citable under the statutes or rules to support a rejection, that any item disclosed represents analogous art, or that those skilled in the art would refer to or recognize the pertinence of any reference without the benefit of hindsight, nor should an inference be drawn as to the pertinence of the references based on the order in which they are presented. Submission of this statement should not be taken as an indication that a search has been conducted, or that no better art exists.

It is respectfully requested that the cited information be expressly considered during the prosecution of this application and the references made of record therein.

### FEES

<input checked="" type="checkbox"/>	<p>37 CFR 1.97(b): No fee is believed due in connection with this submission, because the information disclosure statement submitted herewith satisfies one of the following conditions ("X" indicates satisfaction):</p> <ul style="list-style-type: none"><li><input type="checkbox"/> Within three months of the filing date of a national application other than a continued prosecution application under 37 CFR 1.53(d), or</li><li><input type="checkbox"/> Within three months of the date of entry into the national stage of an international application as set forth in 37 CFR 1.491 or</li><li><input type="checkbox"/> Before the mailing date of a first Office Action on the merits, or</li><li><input checked="" type="checkbox"/> Before the mailing of a first Office action after the filing of a request for continued examination under 37 CFR 1.114.</li></ul> <p>Although no fee is believed due, if any fee is deemed due in connection with this submission, please charge such fee to Deposit Account 19-1970.</p>
<input type="checkbox"/>	<p>37 CFR 1.97(c): The information disclosure statement transmitted herewith is being filed after all the above conditions (37 CFR 1.97(b)), but before the mailing date of one of the following conditions:</p> <ul style="list-style-type: none"><li>(1) a final action under 37 C.F.R. 1.113 or</li><li>(2) a notice of allowance under 37 C.F.R. 1.311, or</li><li>(3) an action that otherwise closes prosecution in the application.</li></ul> <p>This Information Disclosure Statement is accompanied by:</p> <ul style="list-style-type: none"><li><input type="checkbox"/> A Certification (below) as specified by 37 C.F.R. 1.97(e). Although no fee is believed due, if any fee is deemed due in connection with this submission, please charge such fee to Deposit Account 19-1970.</li></ul> <p style="text-align: center;">OR</p> <ul style="list-style-type: none"><li><input type="checkbox"/> A check in the amount of \$180.00 for the fee set forth in 37 C.F.R. 1.17(p) for submission of an information disclosure statement. Please credit any overpayment or charge any underpayment to Deposit Account No. 19-1970. Election to pay the fee should not be taken as an indication that applicant(s) cannot execute a certification.</li></ul>
<input type="checkbox"/>	<p>37 CFR 1.97(d): This Information Disclosure Statement is being submitted after the period specified in 37 CFR 1.97(c).</p> <ul style="list-style-type: none"><li><input type="checkbox"/> This information Disclosure Statement includes a Certification (below) as specified by 37 C.F.R. 1.97(e)</li></ul> <p style="text-align: center;">AND</p> <ul style="list-style-type: none"><li><input type="checkbox"/> Applicants hereby requests consideration of the reference(s) disclosed herein. Enclosed is the fee in the amount of \$180.00 under 37 C.F.R. 1.17(p). Please credit any overpayment or charge any underpayment to Deposit Account No. 19-1970.</li></ul>

**Certification (37 C.F.R. 1.97(e))**  
(Applicable only if checked)

The undersigned certifies that:

Each item of information contained in this information disclosure statement was first cited in any communication from a foreign patent office in a counterpart foreign application not more than three months prior to the filing of this statement. 37 C.F.R. 1.97(e)(1).

A copy of the communication from the foreign patent office is enclosed.

OR

No item of information contained in this information disclosure statement was cited in a communication from a foreign patent office in a counterpart foreign application, and, to the knowledge of the undersigned after making reasonable inquiry, no item of information contained in this Information Disclosure Statement was known to any individual designated in 37 C.F.R. 1.56(c) more than more than three months prior to the filing of this statement. 37 C.F.R. 1.97(e)(2).

Respectfully submitted,

SHERIDAN ROSS P.C.

By: 

Dennis J. Dupray  
Registration No. 46,299  
1560 Broadway, Suite 1200  
Denver, Colorado 80202-5141  
(303) 863-9700

Date: Nov. 26, 2003



FORM PTO-1449 DEPARTMENT OF COMMERCE PATENT AND TRADEMARK OFFICE  INFORMATION DISCLOSURE STATEMENT (Use several sheets if necessary)	ATTY. DOCKET NO. 1003-1	SERIAL NO. 09/770,838
	APPLICANT DUPRAY, Dennis J.	
	FILING DATE January 26, 2001	GROUP ART 3662

U.S. PATENT DOCUMENTS

*EXAMINER INITIAL		DOCUMENT NUMBER	DATE	NAME	CLASS	SUB CLASS	FILING DATE IF APPROP.
	AA*	6,549,130	4/15/03	Joao	340	539	
	AB	6,381,464	4/30/02	Vannucci	455	456	
	AC	6,330,452	12/11/01	Fattouche et al.	455	456	
	AD	6,243,587	6/5/01	Dent et al.	455	456	
	AE*	5,917,405	6/29/99	Joao	340	426	
	AF	5,594,425	1/14/97	Ladner et al.	340	825.06	
	AG	4,542,744	9/24/85	Barnes et al.	128	660	
	AH*	Application No. 10/337,807		Dupray			1/6/03
	AI*	Application No. 10/297,449		Dupray			12/6/02
	AJ*	Application No. 09/176,587		Dupray			10/21/98

FOREIGN PATENT DOCUMENTS

		DOCUMENT NUMBER	DATE	COUNTRY	CLASS	SUB CLASS	TRANSLATION	
							YES	NO

OTHER ART (Including Author, Title, Date, Pertinent Pages, etc.)

EXAMINER	DATE CONSIDERED
*EXAMINER: Initial if reference considered, whether or not citation is in conformance with MPEP 609; Draw line through citation if not in conformance and not considered. Include copy of this form with next communication to applicant.	

FORM PTO-1449 U.S. DEPARTMENT OF COMMERCE PATENT AND TRADEMARK OFFICE  INFORMATION DISCLOSURE STATEMENT (Use several sheets if necessary)	ATTY. DOCKET NO. 1003-1	SERIAL NO. 09/770,838
	APPLICANT DUPRAY, Dennis J.	
	FILING DATE January 26, 2001	GROUP ART 3662

	AK	Smith, Jr., "Passive Location of Mobile Cellular Telephone Terminals," IEEE, CH3031-2/91/0000-0221, 1991 pp. 221-225

EXAMINER	DATE CONSIDERED
*EXAMINER: Initial if reference considered, whether or not citation is in conformance with MPEP 609; Draw line through citation if not in conformance and not considered. Include copy of this form with next communication to applicant.	





IN THE UNITED STATES PATENT AND TRADEMARK OFFICE

the Application of:  
Dupray et al.  
Serial No.: 09/770,838  
Filed: January 26, 2001  
Atty. File No.: 1003-1  
For: A GATEWAY AND HYBRID  
SOLUTIONS FOR WIRELESS  
LOCATION

) Group Art Unit: 3662  
)  
) Examiner: Dao L. Phan  
)  
) INFORMATION DISCLOSURE STATEMENT  
)

"EXPRESS MAIL" MAILING LABEL NUMBER: EV331284115US  
DATE OF DEPOSIT: MARCH 26, 2004

I HEREBY CERTIFY THAT THIS PAPER OR FEE IS BEING DEPOSITED WITH THE UNITED STATES POSTAL SERVICE "EXPRESS MAIL POST OFFICE TO ADDRESSEE" SERVICE UNDER 37 CFR 1.10 ON THE DATE INDICATED ABOVE AND IS ADDRESSED TO THE COMMISSIONER FOR PATENTS, P.O. BOX 1450, ALEXANDRIA, VIRGINIA 22313-1450.

TYPED OR PRINTED NAME: Aimee Thuerk  
SIGNATURE: Aimee Thuerk

Commissioner for Patents  
P.O. Box 1450  
Alexandria, Virginia 22313-1450

Dear Sir:

The references cited on attached Form PTO-1449 are being called to the attention of the Examiner.

Are enclosed herewith.

Are not enclosed, in accordance with 37 C.F.R. 1.98(d), because the references were submitted to the U.S. Patent and Trademark Office in prior application Serial No. 09/194,367 filed November 24, 1998, which is relied upon for an earlier filing date under 35 U.S.C. § 120.

To the best of applicants' belief, the pertinence of the foreign-language references is believed to be summarized in the attached English abstracts and in the figures, although applicants do not necessarily vouch for the accuracy of the translation.

Examiner's attention is drawn to the following co-pending applications, and for at least such applications to which the present application does not claim priority, copies have been or are being submitted:

- Serial No.09/194,367 filed Nov. 24, 1998 (docket no. 1003-PUS)
- Serial No.10/262,413 filed Sept. 30, 2002 (docket no. 1003-2)
- Serial No. 10/262,338 filed Sept. 30, 2002 (docket no. 1003-3)
- Serial No. 09/820,584 filed March 29, 2001 (docket no. 1004-1)
- Serial No.09/176,587 filed Oct. 21, 1998 (docket no. 1005-DJD)

Serial No. 10/297,449

filed Dec. 5, 2002 (docket no. 1010-PUS)

Serial No. 10/337,807

filed Jan. 6, 2003 (docket no. 1011)

Submission of the above information is not intended as an admission that any item is citable under the statutes or rules to support a rejection, that any item disclosed represents analogous art, or that those skilled in the art would refer to or recognize the pertinence of any reference without the benefit of hindsight, nor should an inference be drawn as to the pertinence of the references based on the order in which they are presented. Submission of this statement should not be taken as an indication that a search has been conducted, or that no better art exists.

It is respectfully requested that the cited information be expressly considered during the prosecution of this application and the references made of record therein.

FEES

<input checked="" type="checkbox"/>	<p>37 CFR 1.97(b): No fee is believed due in connection with this submission, because the information disclosure statement submitted herewith is satisfies one of the following conditions ("X" indicates satisfaction):</p> <ul style="list-style-type: none"> <li><input type="checkbox"/> Within three months of the filing date of a national application other than a continued prosecution application under 37 CFR 1.53(d), or</li> <li><input type="checkbox"/> Within three months of the date of entry into the national stage of an international application as set forth in 37 CFR 1.491 or</li> <li><input type="checkbox"/> Before the mailing date of a first Office Action on the merits, or</li> <li><input checked="" type="checkbox"/> Before the mailing of a first Office action after the filing of a request for continued examination under 37 CFR 1.114.</li> </ul> <p>Although no fee is believed due, if any fee is deemed due in connection with this submission, please charge such fee to Deposit Account 19-1970.</p>
<input type="checkbox"/>	<p>37 CFR 1.97(c): The information disclosure statement transmitted herewith is being filed after all the above conditions (37 CFR 1.97(b)), but before the mailing date of one of the following conditions:</p> <ul style="list-style-type: none"> <li>(1) a final action under 37 C.F.R. 1.113 or</li> <li>(2) a notice of allowance under 37 C.F.R. 1.311, or</li> <li>(3) an action that otherwise closes prosecution in the application.</li> </ul> <p>This Information Disclosure Statement is accompanied by:</p> <ul style="list-style-type: none"> <li><input type="checkbox"/> A Certification (below) as specified by 37 C.F.R. 1.97(e). Although no fee is believed due, if any fee is deemed due in connection with this submission, please charge such fee to Deposit Account 19-1970.</li> </ul> <p style="text-align: center;">OR</p> <ul style="list-style-type: none"> <li><input type="checkbox"/> A check in the amount of \$180.00 for the fee set forth in 37 C.F.R. 1.17(p) for submission of an information disclosure statement. Please credit any overpayment or charge any underpayment to Deposit Account No. 19-1970. Election to pay the fee should not be taken as an indication that applicant(s) cannot execute a certification.</li> </ul>
<input type="checkbox"/>	<p>37 CFR 1.97(d): This Information Disclosure Statement is being submitted after the period specified in 37 CFR 1.97(c).</p> <ul style="list-style-type: none"> <li><input type="checkbox"/> This information Disclosure Statement includes a Certification (below) as specified by 37 C.F.R. 1.97(e)</li> </ul> <p style="text-align: center;">AND</p> <ul style="list-style-type: none"> <li><input type="checkbox"/> Applicants hereby requests consideration of the reference(s) disclosed herein. Enclosed is the fee in the amount of \$180.00 under 37 C.F.R. 1.17(p). Please credit any overpayment or charge any underpayment to Deposit Account No. 19-1970.</li> </ul>

**Certification (37 C.F.R. 1.97(e))**  
(Applicable only if checked)

The undersigned certifies that:

Each item of information contained in this information disclosure statement was first cited in any communication from a foreign patent office in a counterpart foreign application not more than three months prior to the filing of this statement. 37 C.F.R. 1.97(e)(1).

A copy of the communication from the foreign patent office is enclosed.

OR

No item of information contained in this information disclosure statement was cited in a communication from a foreign patent office in a counterpart foreign application, and, to the knowledge of the undersigned after making reasonable inquiry, no item of information contained in this Information Disclosure Statement was known to any individual designated in 37 C.F.R. 1.56(c) more than more than three months prior to the filing of this statement. 37 C.F.R. 1.97(e)(2).

Respectfully submitted,

SHERIDAN ROSS P.C.

By: 

Dennis J. Dupray  
Registration No. 46,299  
1560 Broadway, Suite 1200  
Denver, Colorado 80202-5141  
(303) 863-9700

Date: MARCH 25, 2004

FORM PTO-1449 U.S. DEPARTMENT OF COMMERCE PATENT AND TRADEMARK OFFICE INFORMATION DISCLOSURE STATEMENT (Use several sheets if necessary)	ATTY. DOCKET NO. 1003-1	SERIAL NO. 09/770,838
	APPLICANT DUPRAY, Dennis J.	
	FILING DATE January 26, 2001	GROUP ART 3662



U.S. PATENT DOCUMENTS

*EXAMINER INITIAL		DOCUMENT NUMBER	DATE	NAME	CLASS	SUB CLASS	FILING DATE IF APPROP.
	1.	5,857,181	1/5/99	AUGENBRAUN	707	2	
	2.	5,787,235	7/28/98	SMITH et al.	395	50	
	3.	5,625,748	4/29/97	McDONOUGH et al.	395	2.6	
	4.	5,581,490	12/3/96	FERKINHOFF et al.	364	578	
	5.	5,563,931	10/8/96	BISHOP et al.	379	59	
	6.	5,402,524	3/28/95	BAUMAN et al.	395	50	
	7.	5,373,456	12/13/94	FERKINHOFF et al.	364	574	
	8.	5,233,541	8/3/93	CORWIN et al.	364	516	
	9.	5,045,852	9/3/91	MITCHELL et al.	341	51	
	10.	4,542,744	9/24/85	BARNES et al.	128	660	

FOREIGN PATENT DOCUMENTS

		DOCUMENT NUMBER	DATE	COUNTRY	CLASS	SUB CLASS	TRANSLATION	
							YES	NO

EXAMINER	DATE CONSIDERED
*EXAMINER: Initial if reference considered, whether or not citation is in conformance with MPEP 609; Draw line through citation if not in conformance and not considered. Include copy of this form with next communication to applicant.	

FORM PTO-1449 U.S. DEPARTMENT OF COMMERCE PATENT AND TRADEMARK OFFICE  <b>INFORMATION DISCLOSURE STATEMENT</b> (Use several sheets if necessary)	ATTY. DOCKET NO. 1003-1	SERIAL NO. 09/770,838
	APPLICANT DUPRAY, Dennis J.	
	FILING DATE January 26, 2001	GROUP ART 3662

OTHER ART (Including Author, Title, Date, Pertinent Pages, etc.)

11.	Miller, RT, et al., "Protein fold recognition by sequence threading: tools and assessment techniques," Journal Announcement, Department of Biochemistry and Molecular Biology, University College, London, United Kingdom, January 1996
12.	Dailey, D.J., "Demonstration of an Advanced Public Transportation System in the Context of an IVHS Regional Architecture," paper presented at the First World Congress on Applications of Transport Telematics and Intelligent Vehicle-Highway Systems, Nov. 30-Dec. 3, 1994
13.	Dailey, D.J., et al., "ITS Data Fusion," Final Research Report, Research Project T9903, Task 9, ATIS/ATMS Regional IVHS Demonstration, University of Washington, April, 1996
14.	Dartmouth College, "Soldiers, Agents and Wireless Networks: A Report on a Military Application," PAAM 2000.
15.	Bass, Tim, "Intrusion Detection Systems & Multisensor Data Fusion: Creating Cyberspace Situational Awareness," Communications of the ACM, date unknown.

EXAMINER	DATE CONSIDERED
*EXAMINER: Initial if reference considered, whether or not citation is in conformance with MPEP 609; Draw line through citation if not in conformance and not considered. Include copy of this form with next communication to applicant.	



2-16-05

3662  
JRW

PATENT

IN THE UNITED STATES PATENT AND TRADEMARK OFFICE

In Re the Application of:

DUPRAY et al.

Serial No.: 09/770,838

Filed: January 26, 2001

Atty. File No.: 1003-1

For: "A GATEWAY AND HYBRID SOLUTIONS FOR WIRELESS LOCATION

Commissioner for Patents  
P.O. Box 1450  
Alexandria, VA 22313

Prior Group Art Unit: 3662

Prior Examiner: Dao L. Phan

SUPPLEMENTAL AMENDMENT

"EXPRESS MAIL" MAILING LABEL NUMBER: EV493476569US  
DATE OF DEPOSIT: FEB. 14, 2005

I HEREBY CERTIFY THAT THIS PAPER OR FEE IS BEING DEPOSITED WITH THE UNITED STATES POSTAL SERVICE "EXPRESS MAIL POST OFFICE TO ADDRESSEE" SERVICE UNDER 37 CFR 1.10 ON THE DATE INDICATED ABOVE AND IS ADDRESSED TO THE COMMISSIONER FOR PATENTS, P.O. BOX 1450, ALEXANDRIA, VA 22313-1450

TYPED OR PRINTED NAME: Aimee Thuerk

SIGNATURE:

Dear Sir:

To better phrase the priority claims for the present application according to the priority claiming conventions put in place on Nov. 29, 2000, it is requested that the first sentence of the specification following the title be amended as indicated hereinbelow. Since no priority claims are being changed with this amendment, it is believed that no fees are due. However, if there are fees due for this request, please contact the undersigned Applicant.

**IN THE SPECIFICATION:**

Please replace the sentence following the title with following sentence.

The present application is a continuation of Application No. 09/194,367, filed on Nov. 24, 1998 which is the National Stage of International Application No. PCT/US97/15892 filed September 8, 1997; International Application No. PCT/US97/15892 claims the benefit of the following three provisional applications: U.S.

Application Serial No. 09/770,838  
"SUPPLEMENTAL AMENDMENT"

Provisional Application No. 60/056,590 filed August 20, 1997; U.S. Provisional  
Application No. 60/044,821 filed April 25, 1997; and U.S. Provisional Application No.  
60/025,855 filed September 9, 1996.

Respectfully submitted,

*Feb. 14, 2005*

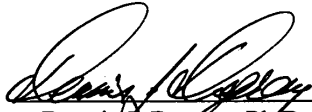
By:   
Dennis J. Dupray, Ph.D.  
1801 Belvedere Street  
Golden, Colorado 80401  
(303) 863-2975

5-20-05

B/ 3662  
ERW



IN THE UNITED STATES PATENT AND TRADEMARK OFFICE

Re the Application of:  
  
Dupray et al.  
  
Serial No.: 09/770,838  
  
Filed: January 26, 2001  
  
Atty. File No.: 1003-1  
  
For: A GATEWAY AND HYBRID  
SOLUTIONS FOR WIRELESS  
LOCATION

) Group Art Unit: 3662  
)  
) Examiner: Dao L. Phan  
)  
) INFORMATION DISCLOSURE STATEMENT  
)  
) \*EXPRESS MAIL\* MAILING LABEL NUMBER: EV556789543US  
) DATE OF DEPOSIT: May 18, 2005  
)  
) I HEREBY CERTIFY THAT THIS PAPER OR FEE IS BEING DEPOSITED  
) WITH THE UNITED STATES POSTAL SERVICE \*EXPRESS MAIL POST  
) OFFICE TO ADDRESSEE\* SERVICE UNDER 37 CFR 1.10 ON THE DATE  
) INDICATED ABOVE AND IS ADDRESSED TO THE COMMISSIONER  
) FOR PATENTS, P.O. BOX 1450, ALEXANDRIA, VIRGINIA 22313-1450.  
)  
) TYPED OR PRINTED NAME: Aimee M. Thuerk  
)  
) SIGNATURE: Aimee M Thuerk

Commissioner for Patents  
P.O. Box 1450  
Alexandria, Virginia 22313-1450

Dear Sir:

The references cited on attached Form PTO-1449 are being called to the attention of the Examiner.

- Copies of the cited non-patent and/or foreign references are enclosed herewith.
- Copies of the cited U.S. patents and/or patent applications are enclosed herewith.
- Copies of the cited U.S. patents/patent application publications are not enclosed in accordance with the waiver dated July 11, 2003, whereby patent applications filed after June 30, 2003 and international applications that have entered the national stage under 35 U.S.C. § 371 after June 30, 2003 need not submit copies of U.S. patents and U.S. patent application publications.
- Copies of the cited references are not enclosed, in accordance with 37 C.F.R. 1.98(d), because the references were cited by or submitted to the U.S. Patent and Trademark Office in prior application Serial No. \_\_\_\_\_ filed \_\_\_\_\_, which is relied upon for an earlier filing date under 35 U.S.C. § 120.
- To the best of applicants' belief, the pertinence of the foreign-language references are believed to be summarized in the attached English abstracts and in the figures, although applicants do not necessarily vouch for the accuracy of the translation.



Examiner's attention is drawn to the following co-pending applications, and for at least such applications to which the present application does not claim priority, copies have been or are being submitted:

Serial No.09/194,367 filed Nov. 24, 1998 (docket no. 1003-PUS)  
 Serial No.10/262,413 filed Sept. 30, 2002 (docket no. 1003-2)  
 Serial No. 10/262,338 filed Sept. 30, 2002 (docket no. 1003-3)  
 Serial No. 09/820,584 filed March 29, 2001 (docket no. 1004-1)  
 Serial No.09/176,587 filed Oct. 21, 1998 (docket no. 1005-DJD)  
 Serial No. 10/297,449 filed Dec. 5, 2002 (docket no. 1010-PUS)  
 Serial No. 10/337,807 filed Jan. 6, 2003 (docket no. 1011)

Submission of the above information is not intended as an admission that any item is citable under the statutes or rules to support a rejection, that any item disclosed represents analogous art, or that those skilled in the art would refer to or recognize the pertinence of any reference without the benefit of hindsight, nor should an inference be drawn as to the pertinence of the references based on the order in which they are presented. Submission of this statement should not be taken as an indication that a search has been conducted, or that no better art exists.

It is respectfully requested that the cited information be expressly considered during the prosecution of this application and the references made of record therein.

**FEEs**

<input checked="" type="checkbox"/>	<p><b>37 CFR 1.97(b):</b> No fee is believed due in connection with this submission, because the information disclosure statement submitted herewith is satisfies one of the following conditions ("X" indicates satisfaction):</p> <p><input type="checkbox"/> Within three months of the filing date of a national application other than a continued prosecution application under 37 CFR 1.53(d), or</p> <p><input type="checkbox"/> Within three months of the date of entry into the national stage of an international application as set forth in 37 CFR 1.491 or</p> <p><input type="checkbox"/> Before the mailing date of a first Office Action on the merits, or</p> <p><input checked="" type="checkbox"/> Before the mailing of a first Office action after the filing of a request for continued examination under 37 CFR 1.114.</p> <p>Although no fee is believed due, if any fee is deemed due in connection with this submission, please charge such fee to Deposit Account 19-1970.</p>
<input type="checkbox"/>	<p><b>37 CFR 1.97(e):</b> The information disclosure statement transmitted herewith is being filed after all the above conditions (37 CFR 1.97(b)), but before the mailing date of one of the following conditions:</p> <p>(1) a final action under 37 C.F.R. 1.113 or</p> <p>(2) a notice of allowance under 37 C.F.R. 1.311, or</p> <p>(3) an action that otherwise closes prosecution in the application.</p> <p>This Information Disclosure Statement is accompanied by:</p> <p><input type="checkbox"/> A Certification (below) as specified by 37 C.F.R. 1.97(e). Although no fee is believed due, if any fee is deemed due in connection with this submission, please charge such fee to Deposit Account 19-1970.</p> <p style="text-align: center;">OR</p> <p><input type="checkbox"/> A check in the amount of \$180.00 for the fee set forth in 37 C.F.R. 1.17(p) for submission of an information disclosure statement. Please credit any overpayment or charge any underpayment to Deposit Account No. 19-1970. Election to pay the fee should not be taken as an indication that applicant(s) cannot execute a certification.</p>

<input type="checkbox"/>	<p>37 CFR 1.97(d): This Information Disclosure Statement is being submitted after the period specified in 37 CFR 1.97(c).</p> <p><input type="checkbox"/> This information Disclosure Statement includes a Certification (below) as specified by 37 C.F.R. 1.97(e)</p> <p>AND</p> <p><input type="checkbox"/> Applicants hereby requests consideration of the reference(s) disclosed herein. Enclosed is the fee in the amount of \$180.00 under 37 C.F.R. 1.17(p). Please credit any overpayment or charge any underpayment to Deposit Account No. 19-1970.</p>
--------------------------	--

Respectfully submitted,

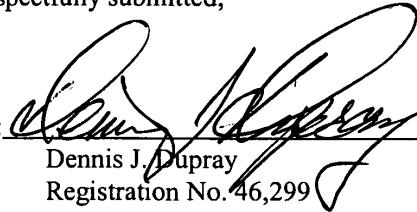
By:   
Dennis J. Dupray  
Registration No. 46,299  
1801 Belvedere Street  
Golden, Colorado 80401  
(303) 863-9700

Date: MAY 18, 2005



FORM PTO-1449 U.S. DEPARTMENT OF COMMERCE PATENT AND TRADEMARK OFFICE  INFORMATION DISCLOSURE STATEMENT (Use several sheets if necessary)	ATTY. DOCKET NO. 1003-1	SERIAL NO. 09/770,838
	APPLICANT DUPRAY, Dennis J.	
	FILING DATE January 26, 2001	GROUP ART 3662

U.S. PATENT DOCUMENTS

*EXAMINER INITIAL		DOCUMENT NUMBER	DATE	NAME	CLASS	SUB CLASS	FILING DATE IF APPROP.
	1.	6,438,380	8/20/02	BI et al.	455	456	
	2.	5,740,048	4/14/98	ABEL et al.	364	443	
	3.	5,634,051	5/27/97	THOMSON	395	605	
	4.	5,617,565	4/1/97	AUGENBRAUM et al.	395	604	
	5.	5,216,611	6/1/93	McELREATH	364	454	

FOREIGN PATENT DOCUMENTS

		DOCUMENT NUMBER	DATE	COUNTRY	CLASS	SUB CLASS	TRANSLATION	
							YES	NO
	6.	EP 0 923 817	5/2/02	Europe	H04B 7	26		
	7.	WO 98/14018	4/2/98	Europe	H04Q 7	20		
	8.	WO 94/01978	1/20/94	Europe	H04Q 7	04		

OTHER ART (Including Author, Title, Date, Pertinent Pages, etc.)

9.	Callan, James P., et al., "SEARCHING DISTRIBUTED COLLECTIONS WITH INFERENCE NETWORKS," 18th Annual International ACM SIGIR Conference on Research and Development in Information Retrieval, 1995
10.	Orphanoudakis, C.E., et al., "I <sup>2</sup> Cnet: Content-Based Similarity Search in Geographically Distributed Repositories of Medical Images," vol. 20(4), pp. 193-207, <i>Computerized Medical Imaging and Graphics</i> , 1996

EXAMINER	DATE CONSIDERED
*EXAMINER: Initial if reference considered, whether or not citation is in conformance with MPEP 609; Draw line through citation if not in conformance and not considered. Include copy of this form with next communication to applicant.	

PCT

WORLD INTELLECTUAL PROPERTY ORGANIZATION  
International Bureau



INTERNATIONAL APPLICATION PUBLISHED UNDER THE PATENT COOPERATION TREATY (PCT)

(51) International Patent Classification <sup>6</sup> : <b>H04Q 7/20</b>	<b>A1</b>	(11) International Publication Number: <b>WO 98/14018</b>
		(43) International Publication Date: 2 April 1998 (02.04.98)
<p>(21) International Application Number: PCT/US97/17786</p> <p>(22) International Filing Date: 29 September 1997 (29.09.97)</p> <p>(30) Priority Data: 60/027,453 27 September 1996 (27.09.96) US</p> <p>(71) Applicant: RUTGERS UNIVERSITY [US/US]; Office of Corporate Liaison &amp; Technology Transfer, Administrative Services Building, Annex II, Piscataway, NJ 08854-1179 (US).</p> <p>(72) Inventors: WYLIE, Marilyn, P.; 1621 North Robinson Road, Philadelphia, PA 19151 (US). HOLTZMAN, Jack, M.; Apartment 2A, 10 West Court, Westfield, NJ 07090 (US).</p> <p>(74) Agent: McKAY, Diane, Dunn; Mathews, Collins, Shepherd &amp; Gould, Suite 306, 100 Thanet Circle, Princeton, NJ 08540 (US).</p>	<p>(81) Designated States: AL, AM, AT, AU, AZ, BA, BB, BG, BR, BY, CA, CH, CN, CU, CZ, DE, DK, EE, ES, FI, GB, GE, GH, HU, ID, IL, IS, JP, KE, KG, KP, KR, KZ, LC, LK, LR, LS, LT, LU, LV, MD, MG, MK, MN, MW, MX, NO, NZ, PL, PT, RO, RU, SD, SE, SG, SI, SK, SL, TJ, TM, TR, TT, UA, UG, UZ, VN, YU, ZW, ARIPO patent (GH, KE, LS, MW, SD, SZ, UG, ZW), European patent (AT, BE, CH, DE, DK, ES, FI, FR, GB, GR, IE, IT, LU, MC, NL, PT, SE), OAPI patent (BF, BJ, CF, CG, CI, CM, GA, GN, ML, MR, NE, SN, TD, TG).</p> <p>Published <i>With international search report. Before the expiration of the time limit for amending the claims and to be republished in the event of the receipt of amendments.</i></p>	

(54) Title: METHOD AND SYSTEM FOR MOBILE LOCATION ESTIMATION

(57) Abstract

The present invention relates to a method and system for mobile location estimation in which range measurements between the mobile station and a base station are discriminated as being either from a base station which is line of sight with the mobile station or a base station that is non-line of sight with the mobile station (22). Non-line of sight error present in range measurements from base stations that are non-line of sight with the mobile station is corrected (24). A reconstructed line of sight range measurement is established from the correction of the non-line of sight error. The reconstructed line of sight range measurements can be used with range measurements of base stations determined to be line of sight for accurately locating the mobile station (26).

20

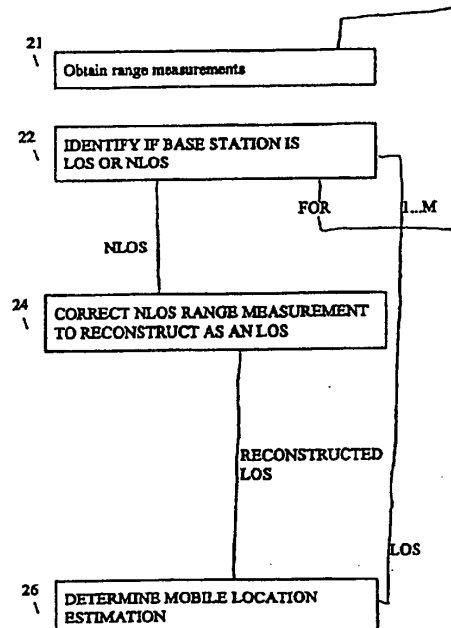

BEST AVAILABLE COPY

**FOR THE PURPOSES OF INFORMATION ONLY**

Codes used to identify States party to the PCT on the front pages of pamphlets publishing international applications under the PCT.

AL	Albania	ES	Spain	LS	Lesotho	SI	Slovenia
AM	Armenia	FI	Finland	LT	Lithuania	SK	Slovakia
AT	Austria	FR	France	LU	Luxembourg	SN	Senegal
AU	Australia	GA	Gabon	LV	Latvia	SZ	Swaziland
AZ	Azerbaijan	GB	United Kingdom	MC	Monaco	TD	Chad
BA	Bosnia and Herzegovina	GE	Georgia	MD	Republic of Moldova	TG	Togo
BB	Barbados	GH	Ghana	MG	Madagascar	TJ	Tajikistan
BE	Belgium	GN	Guinea	MK	The former Yugoslav Republic of Macedonia	TM	Turkmenistan
BF	Burkina Faso	GR	Greece	ML	Mali	TR	Turkey
BG	Bulgaria	HU	Hungary	MN	Mongolia	TT	Trinidad and Tobago
BJ	Benin	IE	Ireland	MR	Mauritania	UA	Ukraine
BR	Brazil	IL	Israel	MW	Malawi	UG	Uganda
BY	Belarus	IS	Iceland	MX	Mexico	US	United States of America
CA	Canada	IT	Italy	NE	Niger	UZ	Uzbekistan
CF	Central African Republic	JP	Japan	NL	Netherlands	YN	Yucatan
CG	Congo	KE	Kenya	NO	Norway	YU	Yugoslavia
CH	Switzerland	KG	Kyrgyzstan	NZ	New Zealand	ZW	Zimbabwe
CI	Côte d'Ivoire	KP	Democratic People's Republic of Korea	PL	Poland		
CM	Cameroon	KR	Republic of Korea	PT	Portugal		
CN	China	KZ	Kazakhstan	RO	Romania		
CU	Cuba	LC	Saint Lucia	RU	Russian Federation		
CZ	Czech Republic	LI	Liechtenstein	SD	Sudan		
DE	Germany	LK	Sri Lanka	SE	Sweden		
DK	Denmark	LR	Liberia	SG	Singapore		
EE	Estonia						

5

## METHOD AND SYSTEM FOR MOBILE LOCATION ESTIMATION

10

This application claims the benefit of U.S. Provisional Application No. 60/027,453 entitled Non-Line Of Sight Problem in Mobile Location Estimation filed by Applicants on September 27, 1996 hereby incorporated by reference into this application.

15

Background of the Invention1. Field of the Invention:

The present invention relates to a method and system for mobile station location estimation in which base stations that are in line of sight of the mobile station and base stations that are not in the line of sight of the base station can be determined. Errors in base station signals generated from determined non-line of sight base stations are reduced for providing improved mobile station location estimation.

20

2. Description of the Related Art

Mobile location estimation determines a geographical estimate of the location of a mobile station. Mobile location estimation is useful in management of fleets of mobile stations, location dependent information services, location dependent billing services and Emergency 911 location of a mobile station. Enhanced 911 is designed to automatically forward the number of a caller to a public safety answering point (PSAP). In implementing enhanced 911 in a wireless network, wireless service providers provide two dimensional location of the vehicle to the public safety answering point (PSAP). The Federal Communications Commission (FCC) has regulated by the year 2001 that wireless service

30

5 providers have the capability of locating callers in two dimensions within 125 meters 67% of the time.

One conventional method for locating a mobile station in two dimensions would use the measurement of the line of sight distance between the mobile station and at least three base stations. U.S. Patent No. 5,365,516 describes a method for determining the location of a  
10 transponder unit in which a radio signal is sent by the mobile station. The arrival time of the radio signal is measured at each of three base stations. Each distance measurement between the mobile station and one of the base stations can be used to generate a circle which is centered at the measuring base station. The circle has a radius which is equal to the distance  
15 for each of the base stations. In the absence of any measurement error of the distance between the base stations and the mobile station, the intersection of the three circles unambiguously determines the location of the mobile station. This method has the drawback that the distance measurements can be corrupted by noise resulting in errors in determining the location of the mobile station.

20 A conventional solution for providing more accurate position estimates is to reduce the error due to noise with a least squares analysis. Accordingly, the least squares analysis provides a more accurate position estimate. This solution has the limitation of not accounting for the possibility of a lack of a direct path between the base station and the mobile station. For example, in an urban environment, a building or buildings may be in the path between the  
25 mobile station and the base station. A propagating signal between the mobile station and the base station can be reflected and defracted by the object in the path of the mobile station to the base station resulting in the signal traveling excess path lengths. The excess path lengths can be on the order of a hundred meters.

5           The lack of direct path between the mobile station and the base station can be defined  
as a non-line of sight (NLOS). The importance of detecting and reducing the NLOS  
measurements between a mobile station and a base station is recognized in M.I. Silventoinen,  
et al., "Mobile Station Locating in GSM", IEEE Wireless Communication System Symposium,  
Long Island NY, November 1995 and J.L. Caffrey et al., "Radio Location in Urban CDMA  
10   Microcells", Proceedings of the Personal, Indoor and Mobile Radio Environment, 1995.

U.S. Patent No. 5,365,516 ('516 patent) describes an embodiment of a transceiver  
locating system operating in an environment susceptible to multipath interference. The system  
includes a transponder which is operable within a prescribed coverage area to transmit a burst  
of data symbols in a coded carrier pulse. Each base station includes a receiver for detecting  
15   and responding to the data symbol at a given time, interrupting the data symbol and rejecting  
echoes resulting from multipath interference. A comparison circuit responds to the receiver  
for comparing respectively identified given times and decorrelating the time difference to  
improve data quality. Although the '516 patent addresses multipath interference, it does not  
attempt to detect base stations for reducing multipath NLOS with mobile stations.

20           It is desirable to provide a method and system for providing improved mobile location  
estimation which is robust to NLOS error.

#### Summary of the Invention

Briefly described, the present invention relates to a method and a system for mobile  
location estimation in which base stations are identified to be either line of sight (LOS) or non-  
25   line of sight (NLOS) with a mobile station. A range measurement is determined as the distance  
between the base station and the mobile station. NLOS ranging error is corrected for base  
stations identified to be NLOS with the mobile station by reconstructing the LOS



5 measurement. From the range measurements of base stations identified as LOS and the reconstructed LOS range measurements the location of the mobile station is estimated.

The base station can be identified as being NLOS by comparing the standard deviation of standard measurement noise from the environment to the standard deviation of a smoothed range measurement obtained from the range measurements between the base station and  
10 mobile station. The smoothed range measurement can be obtained using an  $N^{\text{th}}$  order polynomial fit. It has been found that when the standard deviation of the smoothed range measurement is on the order of the standard deviation of the standard measurement noise, the base station corresponds to an LOS environment and when the standard deviation of the smoothed range measurement is greater than the standard deviation due to standard  
15 measurement noise, the base station corresponds to an NLOS environment. Alternatively, the residuals from a least squares analysis can be used to determine the presence of NLOS range measurements.

NLOS error can be corrected when the standard measurement noise dominates the NLOS error and there is predetermined identification of the approximate support of the  
20 standard measurement noise over the real axis. A reconstructed LOS range measurement can be determined by graphing a curve of the smoothed range measurements. The point of maximum deviation of the smoothed range measurement below the curve is determined. The curve is displaced downwards to pass through the point of maximum deviation. Thereafter, the curve is displaced upwards by the value of the maximum standard measurement noise  
25 deviation from an LOS measurement with negligible noise, thereby providing a reconstructed range measurement.

The mobile location estimation can be determined using at least three range measurements between LOS base stations and the mobile station or reconstructed LOS range

5 measurements in a multilateration analysis. In this analysis, a circle is generated from each range measurement. The circle is centered at the base station and the range measurement is the radius of the circle. The estimated intersection of the three circles determines the location of the mobile station. Alternatively, two range measurements and information directed to the position angle of the mobile station can be used for estimating the location of the mobile  
10 station.

The present invention has the advantages of accurately determining the location of a mobile station by reducing NLOS error. In addition, the present invention can provide confidence in an LOS environment that all base stations are LOS with the mobile station. Results indicate that position range bias due to NLOS error can be reduced several orders of  
15 magnitude with the method of the present invention.

The present invention will be more fully described by reference to the following drawings.

#### Brief Description of the Drawings

20 Fig. 1A is a schematic diagram of an environment in which there is an unobstructed line of sight radio signal path between a mobile station and a base station.

Fig. 1B is a schematic diagram of an environment in which there is a non-line sight radio signal path between a mobile station and a base station.

Fig. 2 is a flow diagram of the system and method for mobile location estimation in  
25 accordance with the teachings of the present invention.

Fig. 3 is a schematic diagram of distance measurements of a reconstructed line of sight base station and determined line of sight base stations.

5            Fig. 4 is a flow diagram of a method for identifying non-line of sight base stations of the present invention.

             Fig. 5 is a flow diagram of an alternate method for identifying non-line of sight base stations.

             Fig. 6 is a flow diagram of a method for reconstructing a line of sight base station for  
10 non-line of sight measurements.

             Fig. 7 is a graph of a comparison of NLOS measurements and reconstructed LOS measurements.

             Fig. 8 is a schematic diagram of a system for implementing the method of the present invention.

15            Fig. 9 is a schematic diagram of positioning of base stations used in examples of performance of the method of the present invention.

             Fig. 10A is a graph of two dimensional tracking without non line of sight error detection and correction.

             Fig. 10B is a graph of two dimensional tracking with non line of sight error detection  
20 and correction.

             Fig. 11A is a graph of two dimensional tracking without non line of sight error detection and correction.

             Fig. 11B is a graph of two dimensional tracking with non line of sight error detection and correction.

25            Fig. 12 is a graph of the fraction of time a base station was declared NLOS using the residual rank analysis method.

5

Detailed Description of the Present Invention

During the course of this description like numbers will be used to identify like elements according to the different figures which illustrate the invention.

Fig. 1A illustrates a schematic diagram of a line of sight (LOS) path 10 between a base station 12 and mobile station 14. Signal 13 can be transmitted from base station 12 to mobile station 14 and returned from mobile station 14 to base station 12. Fig. 1B illustrates a schematic non-line of sight (NLOS) path 11 between base station 12 and mobile station 14. Building 15 is positioned between base station 12 and mobile station 14 resulting in reflection of signal 16. For example, signal 13 and signal 16 can be a radio signal.

A range measurement for measuring the distance between base station 12 and mobile station 14 can be measured as the time it takes a signal sent between base station 12 and mobile station 14:

$$r = cT \quad (1)$$

in which the mobile station to base station range measurement is represented by  $r$ ,  $c$  represents the speed of light which is the same speed as the propagation of radio waves and  $T$  represents the one-way travel time of the signal. A range measurement of the distance between mobile station 14 and base station 12 in Fig. 1A and 1B can be determined using equation (1) based on travel time of signal 13 and signal 16, respectively, between base station 12 and mobile station 14. The value of  $r$  generated from signal 16 is greater than the value of  $r$  generated for signal 13.

Fig. 2 is a flow diagram of the system and method of the present invention for mobile location estimation 20. In block 21, a range measurement is obtained between mobile station 14 and base station 12 using equation (1). In block 22, base station 12 is identified as being in line of sight (LOS) or non-line of sight (NLOS) with mobile station 14. Block 22 is repeated

5 for a plurality of base stations 12 positioned at different locations from mobile station 14. If  
base station 12 is identified to be LOS in block 22, the range measurement obtained from  
block 21 is forwarded to block 26. If base station 12 is identified to be NLOS in block 22,  
block 24 is implemented for reducing the error of the range measurement between base station  
12 and mobile station 14, thereby rendering the range measurement between base station 12  
10 and mobile station 14 as a reconstructed LOS base station 13, as shown in Fig. 3.

In Fig. 3, base station 12 labeled BS1 has a range measurement labeled LOS RANGE  
1 determined to be LOS. Base station 12 labeled BS2 has a range measurement labeled LOS  
RANGE 2 determined to be LOS. Base station 13 labeled BS3 has a range measurement  
labeled NLOS RANGE 3 determined to be NLOS. A range measurement for the  
15 reconstructed LOS base station labeled RECONSTRUCTED RANGE 3 is forwarded to block  
26. Range measurements from determined LOS base stations from block 22 labeled LOS  
RANGE 1, and LOS RANGE 2 are also forwarded to block 26. From the range  
measurements of the reconstructed LOS base stations or the determined LOS base stations, or  
a combination of range measurements of the reconstructed LOS the mobile location estimation  
20 can be identified using a conventional multilateration technique, such as described in U.S.  
Patent No. 5,365,516, hereby incorporated by reference into this application. Alternatively,  
the mobile location estimation can be determined from time difference of arrival time  
measurements as the difference of propagation delays between the mobile station 14 and pairs  
of base stations 12. In this case, the position estimate is at the intersection of hyperbolas. The  
25 number of base stations can be reduced below three if there is also angle of arrival information.  
These methods are described in T.S. Rappaport et al., "Position Location Using Wireless  
Communication On Highways Of the Future", IEEE Communications Magazine, October  
1996.

5 One method for identifying if a base station is LOS or NLOS in block 22 is illustrated in Fig. 4. In this method, the time history of range measurements between base station 12 and mobile station 14 is combined with predetermined standard deviation from conventional measurement noise in a radio signal environment.

The arrival time of signals sent from base station 12 to a mobile station 14 and  
10 transponded back to the base station 12 can be converted to a range measurement, in block 30. The range measurement at the  $m^{\text{th}}$  base station at time  $t_i$  can be represented as:

$$r_m(t_i) = L_m(t_i) + n_m(t_i) + NLOS_m(t_i) \quad (2)$$

15 for  $m = 1, \dots, M$   $i = 0, \dots, K-1$ , wherein

$L_m(t_i)$  is the LOS distance between a mobile station and the  $m^{\text{th}}$  base station in two dimensions which is given by:

$$L_m(t_i) = |\mathbf{x}(t_i) + j * \mathbf{y}(t_i) - \mathbf{x}_m - j * \mathbf{y}_m|; \quad (3)$$

20  $\mathbf{x}(t_i)$ ,  $\mathbf{y}(t_i)$  and  $(\mathbf{x}_m, \mathbf{y}_m)$  are respectively the coordinates of the mobile station at time,  $t_i$ , and those of the  $m^{\text{th}}$  base station;  $n_m(t_i)$  represents conventional measurement noise such as additive white Gaussian measurement noise and  $NLOS_m(t_i)$  represents NLOS measurement error at time  $t_i$ ; and  $M$  is the total number of base stations; and  $K$  is the total number of time samples.

25 In block 30, an LOS range measurement with negligible noise is obtained for base station 12 in LOS with mobile station 14. The LOS range measurement can be obtained by physically measuring a range between base station 12 and mobile station 14 or can be obtained as a range measurement determined by equation (1) in a negligible noise environment. In block 31, a noisy range measurement is determined as a range measurement which is LOS  
30 with a base station taken in a noisy environment. In block 32, the standard deviation of the noisy range measurement from the LOS measurement without noise is determined. Blocks 30,

5 31 and 32 can be predetermined before identifying base station 12 as either LOS or NLOS in block 22. The standard deviation due to noise  $n_m(t)$  can be represented by  $\sigma_m$ .

In block 32, the range measurement obtained from block 21 is smoothed by modeling

$$r_m(t_i) = \sum_{n=0}^{N-1} a_m(n) t_i^n \quad (4)$$

and solving for the unknown coefficients,  $\{a_m(n)\}_{n=0}^{N-1}$  with a least squares technique. The smoothed range measurement can be represented as:

$$s_m(t_i) = \sum_{n=0}^{N-1} \hat{a}_m(n) t_i^n \quad (5)$$

In block 34, the standard deviation of the smoothed range measurement from a noisy range measurement (i.e., the residual) is determined. The standard deviation of the residual from block 34 can be represented as  $\hat{\sigma}_m$  since  $\sigma_m^2 = E\{n_m^2(t)\}$ . The smoothed range measurements along with the noisy range measurement can be used to determine standard deviation  $\hat{\sigma}_m$  with the formulation of:

$$\hat{\sigma}_m = \sqrt{\frac{1}{K} \sum_{i=0}^{K-1} (s_m(t_i) - r_m(t_i))^2} \quad (6)$$

From the value of the standard deviation,  $\hat{\sigma}_m$  and the standard deviation  $\sigma_m$ , the range measurement can be determined as either the result of base station 12 being LOS or NLOS, in block 36. When the range measurement has NLOS error, the value of the standard deviation  $\hat{\sigma}_m$  is significantly larger than the value of the standard deviation  $\sigma_m$ . Accordingly, range measurement for base station 12 that is NLOS with mobile station 14 is determined when the  $\hat{\sigma}_m$  is greater than the standard deviation  $\sigma_m$ . A range measurement of base station 12 that is LOS with mobile station 14 is determined when the standard deviation  $\hat{\sigma}_m$  is on the order of the standard deviation  $\sigma_m$ .

5 Alternatively, a residual analysis ranking method can be used to identify a range measurement as being from a base station 13 NLOS with mobile station 14. Range measurements between mobile station 12 and base station 14 which have been obtained in block 21 are inputted to block 41. At each instance of time  $t_i$ , estimated coordinates  $\hat{x}_{LS}(t_i), \hat{y}_{LS}(t_i)$  of mobile station 14 are determined as least squares estimates in block 41.

10 The estimated coordinates

$\hat{x}_{LS}(t_i), \hat{y}_{LS}(t_i)$  are selected to minimize the formulation:

$$F_i = \sum_{m=1}^M (r_m(t_i) - \hat{L}_m(t_i))^2 \quad (7)$$

where  $\hat{L}_m(t_i) = | \hat{x}(t_i) - x_m + j * \hat{y}(t_i) - j * y_m |$ .

In block 41, a calculated range measurement is determined from the estimated  
15 coordinates. In block 42, a residual difference of the range measurement between mobile station 12 and base station 14 with the calculated range measurement is determined. The residual difference can be represented as:

$$e_m(t_i) = r_m(t_i) - \hat{L}_m(t_i) \quad (8)$$

In block 44, the number of times the residual difference of a range measurement to a  
20 base station 12 has the largest value in comparison to the residual difference determined for range measurements at other base stations is counted for each time instant  $t_i$ . It has been found that base stations having a range measurement between a base station NLOS with a mobile station have a significantly larger number of greatest absolute residual differences than the number of greatest absolute residual differences from other base stations. From the value  
25 of the counted number of residual differences, base station 14 can be defined as a base station 12 that is a LOS or a base station 12 that is NLOS with mobile station 14.



5 Fig. 6 illustrates a method for correction of range measurements between a base station 12 that has been determined NLOS with mobile station 14 to reconstruct a LOS range measurement. Data related to the range measurements from block 21 are smoothed using an  $N^{\text{th}}$  order polynomial fit described in block 32. The smooth range measurements are inputted to block 52. The maximum deviation below the smoothed curve due to NLOS error in  
 10 determined in block 56. It has been found that NLOS error is a non-negative random variable which can be approximately represented in a real axis as follows:

$$0 \leq \text{NLOS}_m(t_i) \leq \beta_m$$

in which  $\beta_m$  is the maximum value of NLOS error. The standard measurement noise,  $n_m(t_i)$  can be represented as a zero-mean random variable which can be approximately represented in  
 15 a real axis as follows:  $-\alpha_m \leq n_m(t_i) \leq \alpha_m$ , so that in a range measurement in which there is also an NLOS error, the total noise component can be approximated represented over the real axis as follows:

$$-\alpha_m \leq n_m(t_i) + \text{NLOS}_m(t_i) \leq \beta_m - \alpha_m.$$

It has been found that the point of maximum deviation of the measured range below  
 20 the smoothed curve is about  $\alpha_m$  below the LOS function represented as  $L_m(t_i)$ . In block 58, the smoothed curve is displaced mathematically downward to the point of maximum deviation. The smoothed curve is displaced mathematically upward by a value of the noise deviation  $\alpha_m$  in block 60 to provide a reconstructed curve representing a reconstructed LOS base station.

Fig. 7 represents a graph of a comparison of simulated range measurements. Curve 90  
 25 represents the true time range measurement between a base station 12 which is LOS with a mobile station 14. Curve 91 represents determined range measurements having NLOS error. Curve 92 represents a smoothed range measurement of block station 12 and mobile station 14

5 determined from block 30 of Fig. 4. Curve 93 represents base station 12 which is reconstructed LOS with the mobile station 14 from block 60 of Fig. 6.

Fig. 8 is a schematic diagram of a system 80 for implementing the method for mobile location estimation. System 80 includes base station server 81. Base station server 81 can be a computer located at base station 12 or networked thereto. Base station server 81  
 10 communicates with base station 12 for requesting and receiving data related to range measurements of mobile station 14 and base station 12. Base station server 81 also collects information on range measurements between mobile station 14 and each of base stations 81A-81N. The information is reported to base station server 81 either by mobile station 14 or base station servers 81A-81N. The functions of modules shown in Figs. 4-6 which are coded with a  
 15 standard programming language, such as C++ programming language. The coded modules can be executed by base station server 81.

Results for examples of mobile location estimates with system 80 are shown in Tables I - IV and Fig. 9 through Fig. 12. In all of the examples, the vehicle's position in the x-y plane at any is given by:

$$20 \quad \begin{aligned} x(t) &= x_0 + v_x t \\ y(t) &= y_0 + v_y t \end{aligned}$$

$x(t)$  represents the  $x$  - coordinate in  $x$  -  $y$  plane at time instant,  $t$ ,

$y(t)$  represents the  $y$  - coordinate in  $x$  -  $y$  plane at time instant,  $t$ ,

$x_0$  represents the initial  $x$  - coordinate,

25  $y_0$  represents the initial  $y$  - coordinate,

$v_x$  represents the speed in  $x$  - direction,

$v_y$  represents the speed in  $y$  - direction.

5 The sampling period was chosen to be 0.5s and 200 samples were taken. The velocity remained constant at  $v_x = 9.7$  m/s and  $v_y = 16.8$  m/s. Base stations 12 were assigned to have NLOS or LOS range measurements. Standard deviation of the standard measurement noise was represented as a  $\sigma_m$  was 150m and  $B_m$  was chosen as 1300m. In each example three base stations 101, 102, 103 were used uniformly spaced around a circle of 5 kilometers and a fourth  
 10 base station 104 was located at the center of the circle, as shown in Fig. 9.

In a first example, base station 101 and base station 102 provide NLOS range measurements and base stations 103 and base station 104 provide LOS range measurements. The standard deviation  $\hat{\sigma}_m$  (m) of the smoothed curve determined in Fig. 4 is shown in Table  
 1.

15

TABLE 1  
 STANDARD DEVIATION OF MEASUREMENTS FROM SMOOTHED  
 CURVE FOR 2 NLOS MEASUREMENTS

Base	NLOS	$\hat{\sigma}_m$ (m)
101	Yes	467.3
102	Yes	447.6
103	No	163.1
104	No	142.1

20

The results indicate base stations 101 and 102 have NLOS range measurements with a significantly larger standard deviation than base station 103 and base station 104 having a LOS range measurement.

Fig. 10A shows two-dimensional tracking error without NLOS identification and  
 25 correction Fig. 10B shows two dimensional tracking error after the method of mobile location

5 estimation of the present invention is performed. The results indicate improvement of estimated vehicle trajectory after NLOS identification and correction.

In a second example, base stations 101, 102, 103 and 104 have NLOS range measurements. The standard deviation  $\hat{\sigma}_m$  (m) of the smoothed curve determined in Fig. 4 is shown in Table 2.

10

15  
 TABLE 2  
 STANDARD DEVIATION OF MEASUREMENTS FROM SMOOTHED  
 CURVE FOR FOUR NLOS MEASUREMENTS

Base	NLOS	$\hat{\sigma}_m$ (m)
101	Yes	440.2
102	Yes	444.4
103	Yes	463.6
104	Yes	450.2

The results indicate a similar standard deviation  $\hat{\sigma}_m$  for all four base stations 101, 102, 103 and 104 having NLOS.

20 In a third example, three results were determined using  $x_0 = -118.3m$   $y_0 = -3.7m$  with the residual analysis tracking method shown in Fig. 5. In test 1, base station 104 was NLOS. In test 2, base station 103 and base station 104 are NLOS. In test 3, base station 102, base station 103 and base station 104 were non-line of sight. The number of times each base station had the largest absolute residual difference is shown in Table 3.

5

TABLE 3  
 PERCENTAGE OF TIME BS HAD LARGEST RESIDUAL

TEST		BS101	BS102	BS103	BS104
1	LOS	10	11	18.5	
	NLOS				60
2	LOS	18.5	15		
	NLOS			26.5	40
3	LOS	12.5			
	NLOS		20	40.5	27

The results indicate NLOS base stations having larger percentages of residual  
 10 differences.

In a fourth example, results of the method for location estimation at the present  
 invention were compared with a conventional least square analysis, a least square analysis with  
 all range measurements are line of sight and a conventional Cramer Rao Lower Bound  
 analysis. The Cramer Rao Lower Bound represents a lower bound on the rms error of any  
 15 unbiased estimator. Table 4 represents the present method shown in column 2, the  
 conventional least squares analysis shown in column 1, a least square analysis with all  
 measurements LOS in column 3 and the conventional Cramer Rao Lower Bound analysis  
 shown in column 4. The location and speed errors in each coordinates were measured in  
 meters and meters/second respectively.

20

5

$\mu_{x_0}$  = mean error in estimating  $x_0$                        $\sigma_{x_0}$  = standard deviation of  $\hat{x}_0$   
 $\mu_{y_0}$  = mean error in estimating  $y_0$                        $\sigma_{y_0}$  = standard deviation of  $\hat{y}_0$   
 $\mu_{v_x}$  = mean error in estimating  $v_x$                        $\sigma_{v_x}$  = standard deviation of  $\hat{v}_x$   
 $\mu_{v_y}$  = mean error in estimating  $v_y$                        $\sigma_{v_y}$  = standard deviation of  $\hat{v}_y$

10

TABLE 4  
 COMPARISON OF ESTIMATOR PERFORMANCE

	LEAST SQUARES PRIOR ART METHOD	METHOD OF PRESENT INVENTION	LOS	$\sqrt{CRLB}$
$\mu_{x_0}$	297.8	-3.98	0.17	--
$\sigma_{x_0}$	32.9	28.30	16.42	15.88
$\mu_{y_0}$	-306.1	-2.36	0.54	--
$\sigma_{y_0}$	55.5	45.13	14.15	14.18
$\mu_{v_x}$	0.18	-0.09	-0.005	--
$\sigma_{v_x}$	0.55	0.49	0.27	0.27
$\mu_{v_y}$	4.49	-.01	-0.005	--
$\sigma_{v_y}$	0.84	0.64	0.25	0.25

The results indicate that the mobile location estimation method of the present invention significantly reduced the estimation bias as compared to results without NLOS error correction.

Fig. 12 is a comparison of the probability of detecting an NLOS range measurement. The sampling period was 0.5 seconds. The number of samples varied between 5 and 150.  $x_0$  was 200m and  $y_0$  was 100m. Base station 101 and base station 104 were LOS. Base station 102 and base station 103 were NLOS. The results indicate NLOS can be detected with high probability for a small number of samples.

5           It is to be understood that the above-described embodiments are illustrative of only a few of the many possible specific embodiments which can represent applications of the principles of the invention. Numerous and varied other arrangements can be readily devised in accordance with these principles by those skilled in the art without departing from the spirit and scope of the invention.

We claim:

1. A method for mobile station location estimation comprising the steps of:
  - a. obtaining range measurements between said mobile station and a base station;
  - b. identifying whether said base station is line of sight with said mobile station or non-line of sight with said mobile station at the time at which a mobile location estimate is made;
  - c. correcting non-line of sight range measurements for a base station identified as non-line of sight with said mobile station in step b to determine reconstructed line of sight range measurements;
  - d. repeating steps a through c for a predetermined number of said base stations;  
and
  - e. determining said mobile station location estimation from said reconstructed line of sight range measurements determined in step c or said range measurements determined in step a for an identified line of sight base station in step b, or the combination of said reconstructed line of sight range measurements determined in step c, and said range measurements determined in step a for an identified line of sight base station in step b.
2. The method of claim 1 wherein step b comprises the steps of:
  - obtaining line of sight range measurements between said mobile station and a base station without noise;
  - obtaining noisy line of sight range measurements between said mobile station and said base station;



predetermining a first standard deviation of the difference of said line of sight range measurements with said noisy line of sight range measurements,  
smoothing said range measurements determined in step a,  
determining a second standard deviation of the difference between said smoothed range measurements and said noisy line of sight range measurements; and  
discriminating between said base station being line of sight or said base station being non-line of sight from said first standard deviation and said second standard deviation, wherein said base station is determined to be non-line of sight when said second standard deviation is greater than said first standard deviation and line of sight when said second standard deviation is on the order of said first standard deviation.

3. The method of claim 1 wherein the range measurement obtained in step a is represented by:

$$r_m(t_i) = L_m(t_i) + n_m(t_i) + NLOS_m(t_i)$$

for  $m = 1, \dots, M$   $i = 0, \dots, K-1$ , wherein

$L_m(t_i)$  is the LOS distance between a mobile station and the  $m^{\text{th}}$  base station in two dimensions which is given by:

$$L_m(t_i) = |x(t_i) + j * y(t_i) - x_m - j * y_m|;$$

$j = \sqrt{-1}$ ,  $| |$  is absolute value,

$x(t_i)$ ,  $y(t_i)$  and  $(x_m, y_m)$  are respectively the coordinates of the mobile station at time,  $t_i$ , and those of the  $m^{\text{th}}$  base station;  $n_m(t_i)$  represents conventional measurement noise such as additive white Gaussian measurement noise and  $NLOS_m(t_i)$  represents NLOS measurement error at time  $t_i$ ; and  $M$  is the total number of base stations; and  $K$  is the total number of time samples.

4. The method of claim 3 where the range measurement is smoothed by modeling:

$$r_m(t_i) = \sum_{n=0}^{N-1} a_m(n) t_i^n$$

and solving for the unknown coefficients,  $\{a_m(n)\}_{n=0}^{N-1}$  with a least squares technique.

5. The method of claim 4 wherein the second standard deviation is represented by

$$\hat{\sigma}_m = \sqrt{\frac{1}{K} \sum_{i=0}^{K-1} (s_m(t_i) - r_m(t_i))^2}$$

wherein

$$s_m(t_i) = \sum_{n=0}^{N-1} \hat{a}_m(n) t_i^n.$$

6. The method of claim 1 wherein step b comprises the steps of:

estimating coordinates of said mobile station from said range measurement

obtained in step a over time;

calculating a range measurement from said estimated coordinates;

determining a residual from the difference of said range measurement obtained in step a and said calculated range measurement;

counting the number of times the residual is the greatest at each base station for each time instant; and

defining said base station as non-line of sight from the base station which has the greatest value of the number of times the greatest residual was counted.

7. The method of claim 6 wherein said estimated coordinates are represented by  $\hat{x}_{LS}(t_i), \hat{y}_{LS}(t_i)$  at each instance of time  $t_i$ , said estimated coordinates are determined as least

squares estimates to 
$$F_i = \sum_{m=1}^M (r_m(t_i) - \hat{L}_m(t_i))^2$$

where  $\hat{L}_m(t_i) = | \hat{x}(t_i) - x_m + j^* \hat{y}(t_i) - j^* y_m |$ .

8. The method of claim 1 wherein step c comprises the steps of:

determining a value of maximum noise deviation and standard deviation from said range measurements obtained in step a and a predetermined line of sight range measurement with negligible noise;

smoothing said range measurements obtained from step a;

graphing a curve of said smoothed range measurements;

determining a point of maximum deviation of said range measurement below said curve;

displacing said curve downwards to pass through said point of maximum deviation; and

displacing said curve upwards by said value of said maximum noise deviation, thereby providing said reconstructed range measurement.

9. The method of claim 1 wherein said steps a through c are repeated for at least two base stations and further comprising the step of determining angle arrival information, wherein said mobile station location is estimated from range measurements or reconstructed line of sight range measurements of said two base stations and said angle arrival information.

10. The method of claim 1 wherein steps a through c are repeated for three base stations.

11. A system for mobile station location estimation comprising:  
means for obtaining range measurements between said mobile station and a plurality of base stations;  
identifying means for identifying whether each of said base stations is line of sight with said mobile station as a line of sight base station or non-line of sight with said mobile station as a non-line of sight base station;  
correcting means for correcting said range measurement for each of said non-line of sight base stations to determine a reconstructed line of sight range measurement; and  
estimating means for determining said mobile station location estimation from said reconstructed line of sight range measurements or said range measurements for said line of sight base station, or the combination of said reconstructed line of sight range measurements, and said range measurements for said line of sight base stations.

12. The system of claim 11 wherein said identifying means comprises:

means for obtaining a line of sight range measurement without noise between said mobile station and each of said base station;

means for obtaining a noisy line of sight range measurement between said mobile station and each of said base station;

means for predetermining a first standard deviation of the difference of said line of sight range measurement with said noisy line of sight range measurements,

means for smoothing said range measurements;

means for determining a second standard deviation of the difference between said smoothed range measurements and said noisy line of sight range measurement; and

means for discriminating each of said base stations as being line of sight or being non-line of sight from said first standard deviation and said second standard deviation, wherein said base station is determined to be non-line of sight when said second standard deviation is significantly greater than said first standard deviation and line of sight when said second standard deviation is on the order of said first standard deviation.

13. The system of claim 12 wherein the range measurement is represented by:

$$r_m(t_i) = L_m(t_i) + n_m(t_i) + NLOS_m(t_i)$$

for  $m = 1, \dots, M$   $i = 0, \dots, K-1$ , wherein

$L_m(t_i)$  is the LOS distance between a mobile station and the  $m^{\text{th}}$  base station in two dimensions which is given by:

$$L_m(t_i) = |x(t_i) + j * y(t_i) - x_m - j * y_m|;$$

$j = \sqrt{-1}$ ,  $||$  is absolute value,

$x(t_i), y(t_i)$  and  $(x_m, y_m)$  are respectively the coordinates of the mobile station at time,  $t_i$ , and those of the  $m^{\text{th}}$  base station;  $n_m(t_i)$  represents conventional measurement noise such as additive white Gaussian measurement noise and  $\text{NLOS}_m(t_i)$  represents NLOS measurement error at time  $t_i$ ; and  $M$  is the total number of base stations; and  $K$  is the total number of time samples.

14. The system of claim 13 where the range measurement is smoothed by modeling:

$$r_m(t_i) = \sum_{n=0}^{N-1} a_m(n) t_i^n$$

and solving for the unknown coefficients,  $\{a_m(n)\}_{n=0}^{N-1}$  with a least squares technique.

15. The system of claim 14 wherein the second standard deviation is represented by

$$\hat{\sigma}_m = \sqrt{\frac{1}{K} \sum_{i=0}^{K-1} (s_m(t_i) - r_m(t_i))^2}$$

wherein

$$s_m(t_i) = \sum_{n=0}^{N-1} \hat{a}_m(n) t_i^n.$$

16. The system of claim 12 wherein said identifying means comprises:

means for estimating coordinates of said mobile station from said range measurements from a plurality of base stations received over time;

means for calculating a calculated range measurement from said estimated coordinates;

means for determining a residual from the difference of said range measurements and said calculated range measurement;

means for counting the number of times the residual is the greatest at each base station for each time instant; and

means for defining said base station as non-line of sight from the base station which has the greatest value of the number of times the greatest residual was counted.

17. The system of claim 14 wherein said estimated coordinates are represented by  $\hat{x}_{LS}(t_i), \hat{y}_{LS}(t_i)$  at each instance of time  $t_i$ , said estimated coordinates are determined as least

squares estimates to

$$F_i = \sum_{m=1}^M (r_m(t_i) - \hat{L}_m(t_i))^2$$

where  $\hat{L}_m(t_i) = |\hat{x}(t_i) - x_m + j \hat{y}(t_i) - j y_m|$ .

18. The system of claim 12 wherein said estimating means comprises:

means for determining a value of maximum noise deviation and standard deviation for each of said range measurements and a predetermined line of sight range measurement with negligible noise;

means for smoothing said range measurements;

means for graphing a curve of said smoothed range measurements;

means for determining a point of maximum deviation of said range measurements below said curve;

means for displacing said curve downwards to pass through said point of maximum deviation; and

means for displacing said curve upwards by said value of said maximum noise deviation, thereby providing said reconstructed range measurement.

19. The system of claim 12 further comprises means for obtaining angle arrival information wherein said mobile station location is estimated from range measurements or reconstructed line of sight range measurement of said base stations and said angle arrival information.



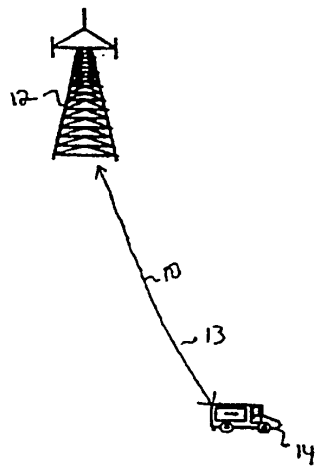

FIG 1A

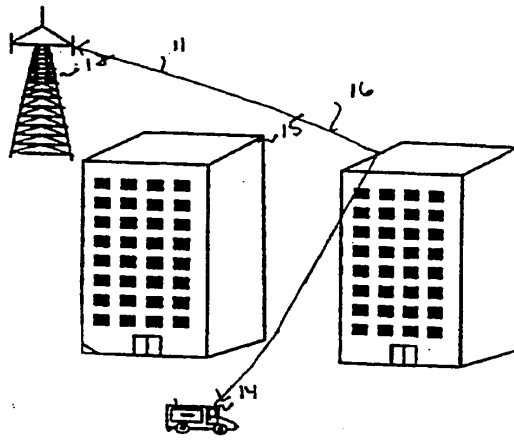

FIG 1B

20

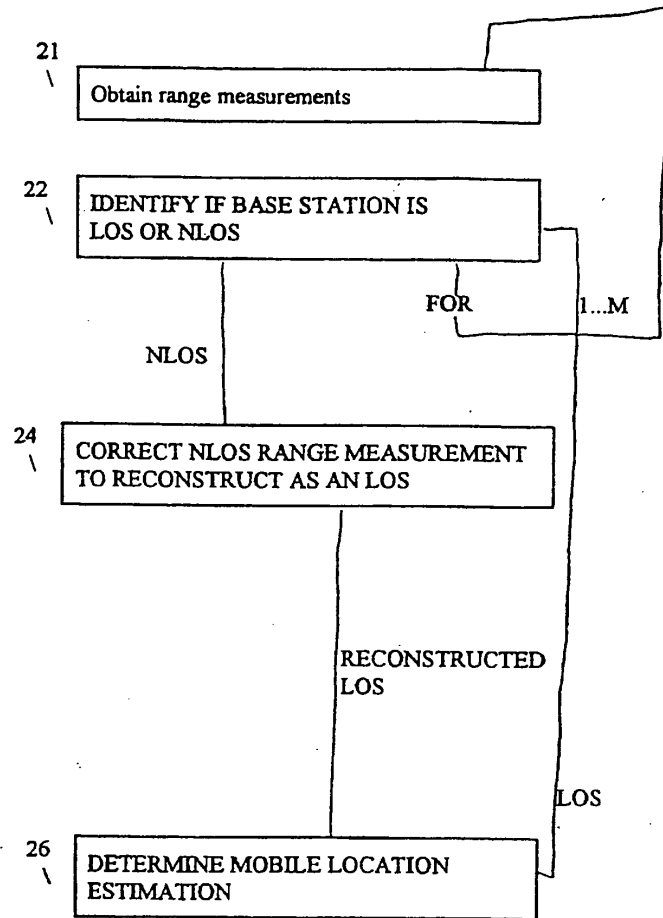

FIG. 2

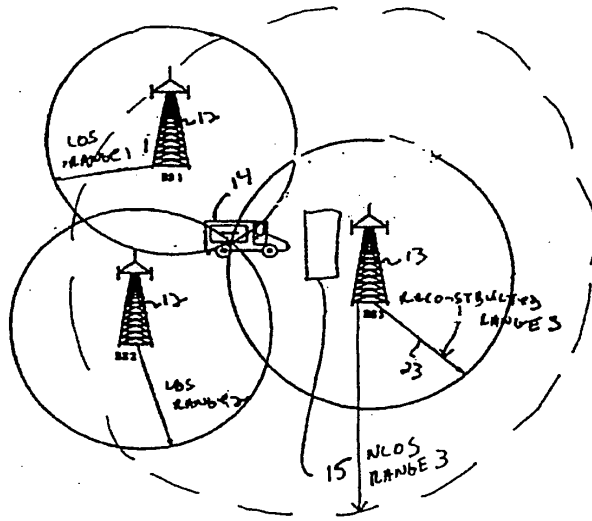

FIG 3

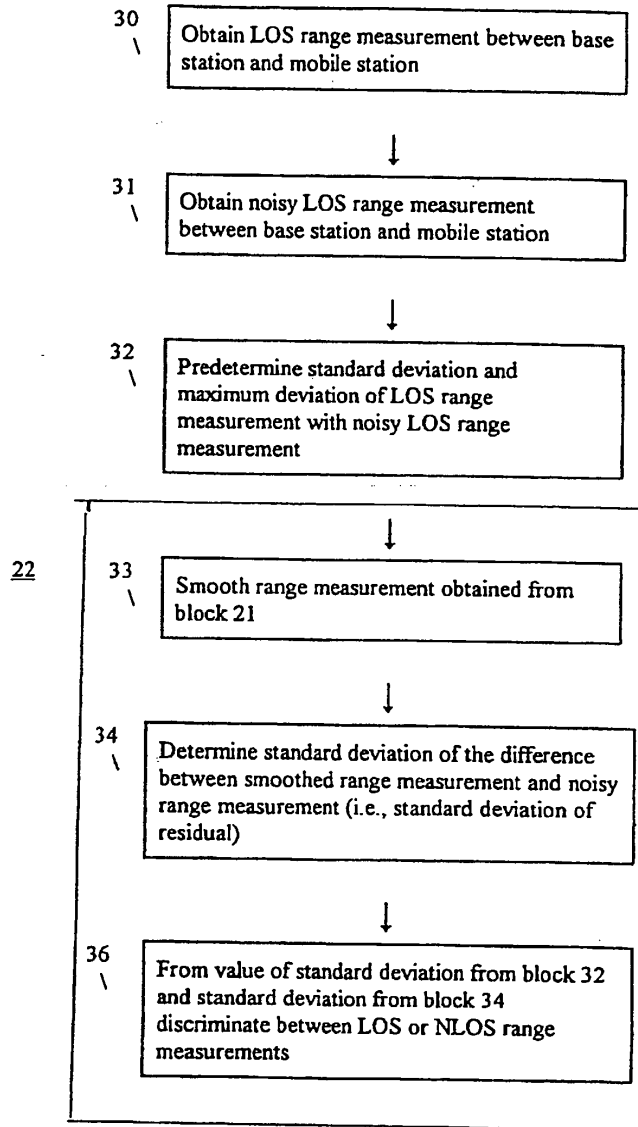

FIG. 4

22

FIG. 5

6/13

24

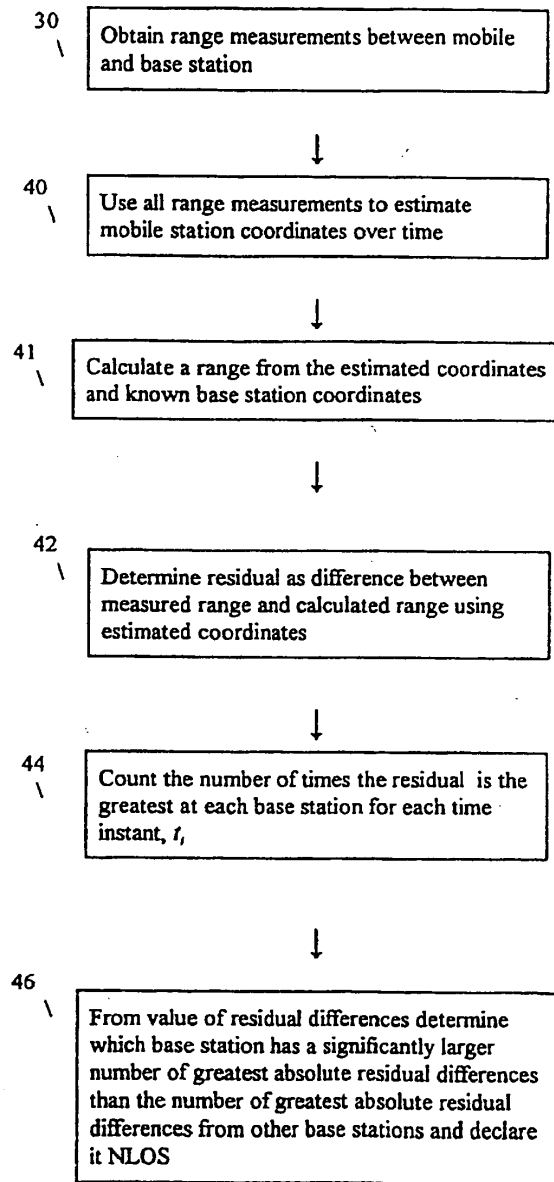
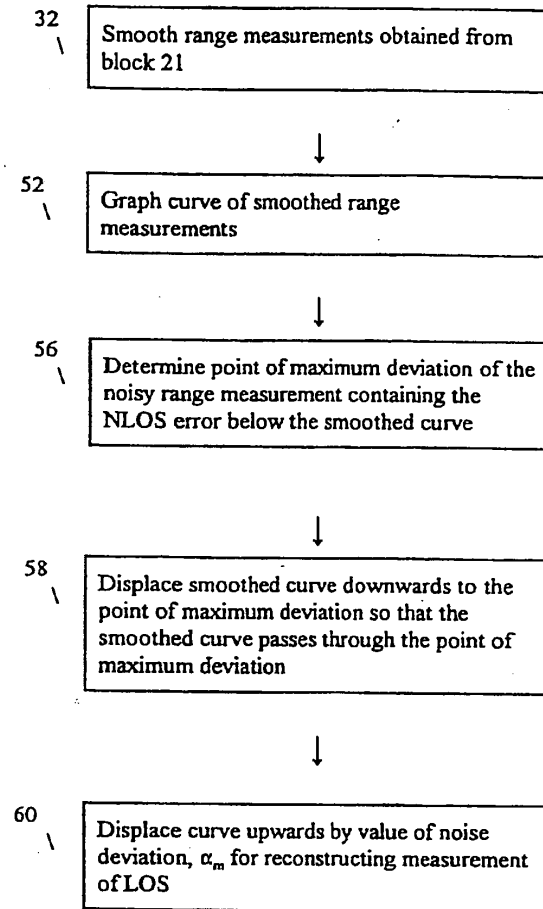

FIG. 6

7/13

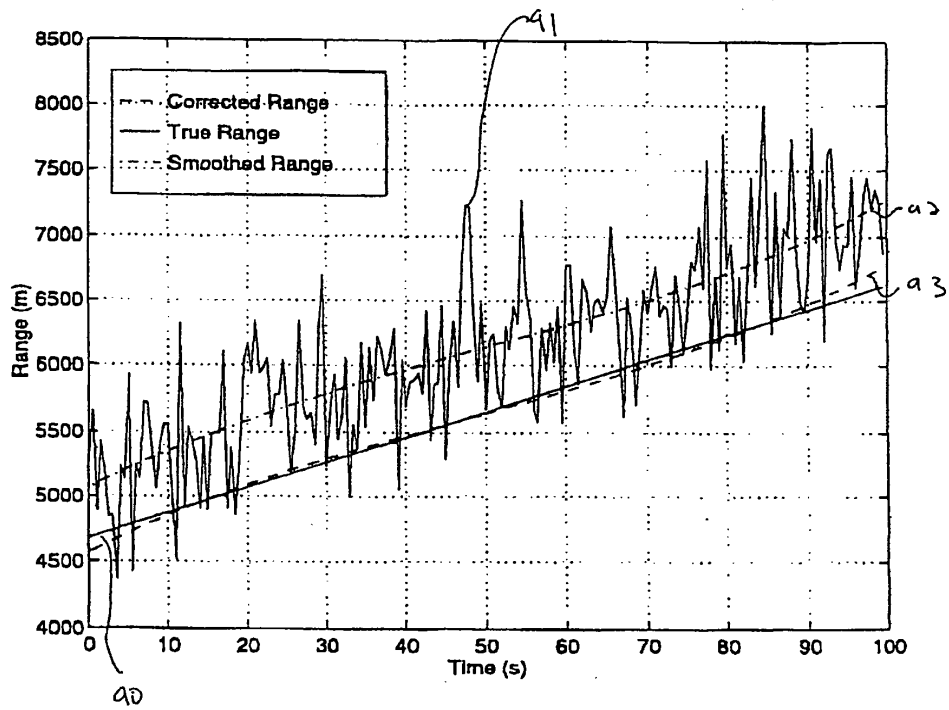

FIG 7



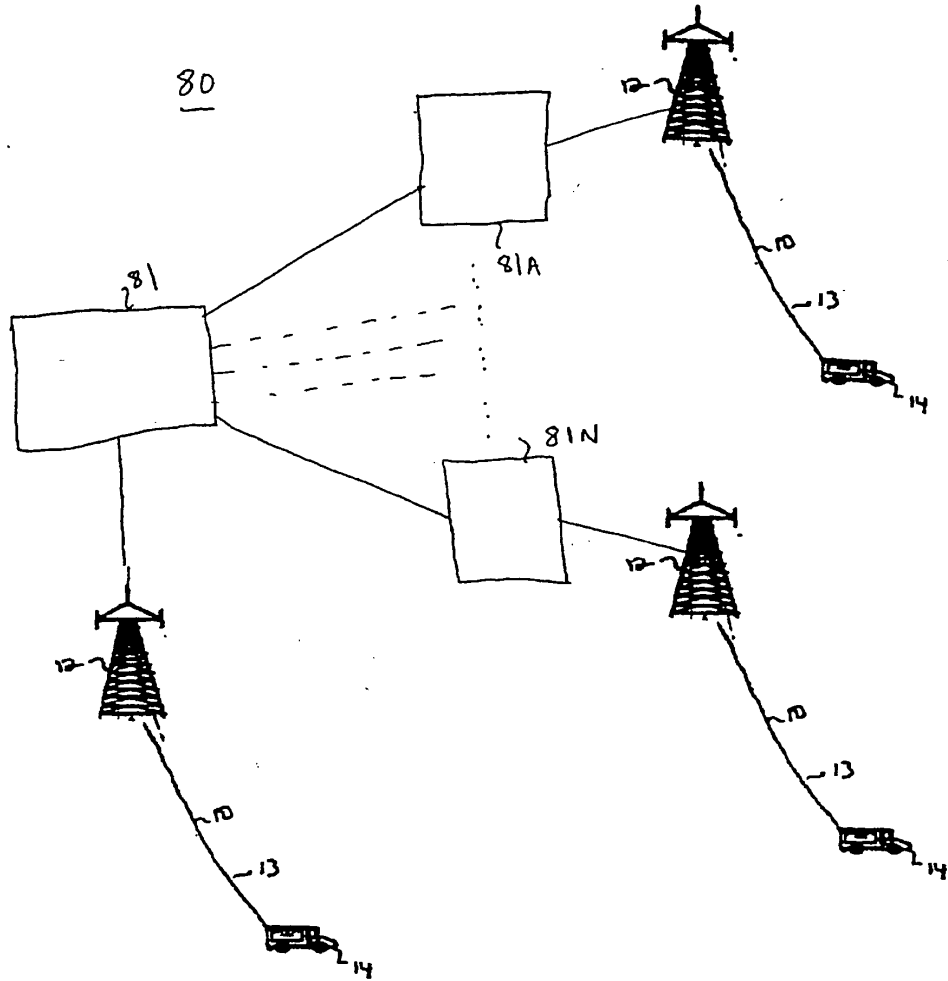

FIG 8

9/13

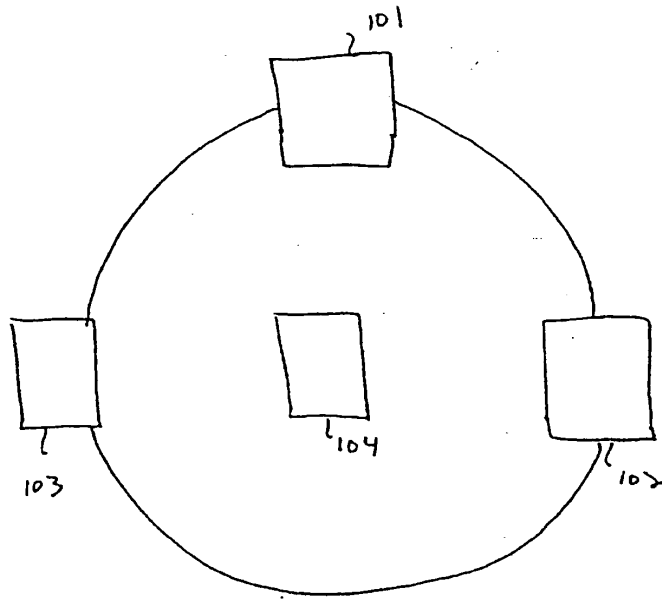

FIG 9

FIG 10 A

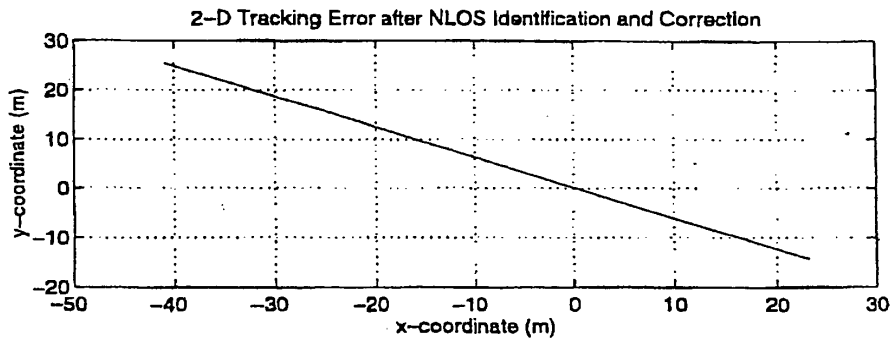
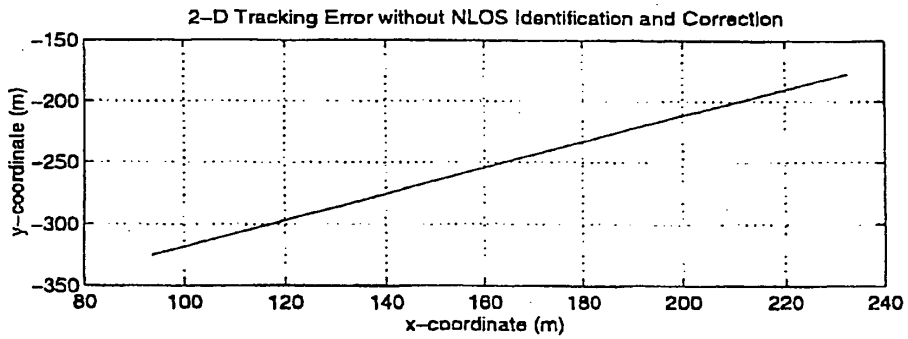

FIG 10 B

**This Page is Inserted by IFW Indexing and Scanning  
Operations and is not part of the Official Record**

**BEST AVAILABLE IMAGES**

Defective images within this document are accurate representations of the original documents submitted by the applicant.

Defects in the images include but are not limited to the items checked:

- BLACK BORDERS
- IMAGE CUT OFF AT TOP, BOTTOM OR SIDES
- FADED TEXT OR DRAWING
- BLURRED OR ILLEGIBLE TEXT OR DRAWING
- SKEWED/SLANTED IMAGES
- COLOR OR BLACK AND WHITE PHOTOGRAPHS
- GRAY SCALE DOCUMENTS
- LINES OR MARKS ON ORIGINAL DOCUMENT
- REFERENCE(S) OR EXHIBIT(S) SUBMITTED ARE POOR QUALITY
- OTHER: \_\_\_\_\_

**IMAGES ARE BEST AVAILABLE COPY.**

**As rescanning these documents will not correct the image problems checked, please do not report these problems to the IFW Image Problem Mailbox.**



(12) **EUROPEAN PATENT SPECIFICATION**

- (45) Date of publication and mention of the grant of the patent:  
02.05.2002 Bulletin 2002/18
- (51) Int Cl.7: **H04B 7/26**
- (21) Application number: 97938230.6
- (86) International application number:  
PCT/US97/14085
- (22) Date of filing: 12.08.1997
- (87) International publication number:  
WO 98/10537 (12.03.1998 Gazette 1998/10)

(54) **COMBINED SUBTRACTIVE INTERFERENCE CANCELLATION AND SPACE DIVERSITY SIGNAL PROCESSING IN A CELLULAR CDMA COMMUNICATIONS SYSTEM**

KOMBINIERTE SUBTRAKTIVE STÖRUNGSUNTERDRÜCKUNGS- UND RAUMDIVERSITYSIGNALVERARBEITUNG IN EINEM ZELLULAREN CDMA-NACHRICHTENÜBERTRAGUNGSSYSTEM

ELIMINATION D'UNE INTERFERENCE PAR SOUSTRACTION COMBINEE A UN TRAITEMENT DE SIGNAUX DE DIVERSITE D'ESPACE DANS UN SYSTEME CELLULAIRE DE COMMUNICATIONS AMCR

- |   |   |
|---|---|
| <p>(84) Designated Contracting States:<br/>DE FR GB SE</p> <p>(30) Priority: 04.09.1996 US 706493</p> <p>(43) Date of publication of application:<br/>23.06.1999 Bulletin 1999/25</p> <p>(73) Proprietor: ERICSSON INC.<br/>Research Triangle Park, NC 27709 (US)</p> <p>(72) Inventor: DENT, Paul, W.<br/>Pittsboro, NC 27312 (US)</p> <p>(74) Representative: HOFFMANN - EITLE<br/>Patent- und Rechtsanwälte<br/>Arabellastrasse 4<br/>81925 München (DE)</p> | <p>(56) References cited:<br/>EP-A- 0 491 668 WO-A-95/19078<br/>US-A- 5 151 919</p> <p>• LIU T -C: "The modular covariance adjustment adaptive array for CDMA wireless communications" ICASSP-93. 1993 IEEE INTERNATIONAL CONFERENCE ON ACOUSTICS, SPEECH, AND SIGNAL PROCESSING (CAT. NO.92CH3252-4), ICASSP '93. IEEE INTERNATIONAL CONFERENCE ON ACOUSTICS, SPEECH AND SIGNAL PROCESSING, MINNEAPOLIS, MN, USA, 27-30 APRIL 1993, ISBN 0-7803-0946-4, 1993, NEW YORK, NY, USA, IEEE, USA, pages 180-183 vol.4, XP000437039</p> |
|---|---|

Note: Within nine months from the publication of the mention of the grant of the European patent, any person may give notice to the European Patent Office of opposition to the European patent granted. Notice of opposition shall be filed in a written reasoned statement. It shall not be deemed to have been filed until the opposition fee has been paid. (Art. 99(1) European Patent Convention).

## Description

Field of the Invention

5 [0001] The invention relates to a communication system and provides improved capacity in cellular wireless telephone systems using Code Division Multiple Access methods together with base station receiving systems employing antenna arrays.

Background of the Invention

10 [0002] The cellular telephone industry has made phenomenal strides in commercial operations in the United States and throughout the rest of the world. Growth in major metropolitan areas has far exceeded expectations and is outpacing system capacity. If this trend continues, the effects of rapid growth will soon even reach the smallest markets. Innovative solutions are required to meet these increasing capacity needs as well as maintain high quality service and avoid rising prices.

15 [0003] Currently, channel access is achieved using Frequency Division Multiple Access (FDMA), Time Division Multiple Access (TDMA) and Code Division Multiple Access (CDMA) methods. With FDMA or TDMA systems or hybrid FDMA/TDMA systems, the goal is to insure that two potentially interfering signals do not occupy the same frequency at the same time. In contrast, CDMA allows signals to overlap in both time and frequency. Thus, all CDMA signals share the same frequency spectrum. In either the frequency or the time domain, the multiple access signals appear to be on top of each other. In principle, the informational data stream to be transmitted is impressed upon a much higher bit rate data stream generated by a pseudo-random code generator. The informational data stream and the high bit rate data stream are combined by multiplying the two bit streams together. This combination of the higher bit rate signal with the lower bit rate data stream is called coding or spreading the informational data stream signal. Each informational data stream or channel is allocated a unique spreading code. A plurality of coded information signals are transmitted on radio frequency carrier waves and jointly received as a composite signal at the receiver. Each of the coded signals overlaps all of the other coded signals, as well as noise-related signals, in both frequency and time. By correlating the composite signal with one of the unique codes, the corresponding information signal is isolated and decoded.

30 [0004] There are a number of advantages associated with CDMA communication techniques. The capacity limits of CDMA-based cellular systems are projected to be up to twenty times that of existing analog technology as a result of the properties of a wide band CDMA system, such as improved coding gain modulation density, voice activity gating, sectorization and reuse of the same spectrum in every cell. CDMA is virtually immune to multi-path interference, and eliminates fading and static to enhance performance in urban areas. CDMA transmission of voice by a high bit rate decoder insures superior, realistic voice quality. CDMA also provides for variable data rates allowing many different grades of voice quality to be offered. The scrambled signal format of CDMA completely eliminates cross talk and makes it very difficult and costly to eavesdrop or track calls, insuring greater privacy for callers and greater immunity from air time fraud.

40 [0005] U.S. Patent No. 5,151,919 describes a Code Division Multiple Access system in which overlapping signals coded using different access codes are received at a receiving system and decoded in order of decreasing signal strength, subtracting stronger signals after they are decoded and before attempting decoding of weaker signals. The patent discloses a preferred method of subtraction involving transforming the received signal to a symbol-space domain to identify the symbol most likely transmitted, and then setting to zero the value identified with the symbol in the symbol-space domain, thus removing that signal. An inverse transform returns the residual values to the original domain for iterative processing by performing a transform to the symbol-space of the next signal to be decoded, and so on.

45 [0006] U.S. Patent No. 5,353,352 discloses how to form access codes suitable for discriminating different mobile transmissions on the same frequency, suitable for use with subtractive demodulation.

[0007] U.S. Patent No. 5,218,619 describes an improved method of subtractive demodulation wherein a second subtraction of a previously subtracted signal is performed after subtracting other intervening signals, in order to cancel residual errors left from the first subtraction caused by the original presence of the intervening signals.

50 [0008] Neither of the above-incorporated patents discloses performing a two-dimensional transform from an antenna-space/time domain to a symbol-space/direction-of-arrival domain. The above-incorporated patents are relied upon to provide background art to the technique subtraction demodulation of coded signals and for performing signal subtraction by nulling in a transform domain.

55 [0009] U.S. patent No. 5,619,503 discloses various ways of employing an antenna array for receiving multiple signals from different directions using the same frequency bandwidth. Mathematical transforms involving matrix operations are disclosed, whereby a signal received from a given direction may be discriminated while simultaneously nulling interfering signals received from other directions. Thus, several signal transmissions may share the same frequency

bandwidth provided that the transmitters' directions relative to the receiving antenna are sufficiently different. When the directions of two transmitters almost coincide, the matrix solution becomes undefined and the transmitters can not be discriminated. An alternate method is disclosed for such cases, whereby, instead of attempting to separate signals by matrix-combining the signals from the antenna elements, a symbol received from each transmitter is hypothesized, and the expected corresponding received signals at each antenna element are computed using direction of arrival estimates. The sum of signals expected at each antenna element is compared with the actual value at each antenna element and the squared differences used to form a metric indicative of the probability that the symbol hypotheses are correct. A maximum likelihood processor then identifies that hypothesis that has highest probability of being correct. The complexity of such a maximum likelihood processor is proportional to two-to-the-power of N, where N is the number of overlapping signals.

[0010] U.S. patent No. 5,790,606 discloses using an array of antenna elements to receive signals from a plurality of transmitters using the same frequency with a maximum likelihood processor operating sequentially along a spatial dimension, being the dimension along which antenna elements are spaced, the maximum likelihood processor complexity being much less than proportional to  $2^N$  and proportional instead to  $2^M$ , where M is only as large as the subset of antenna elements that receive significant signals strengths from the same transmitter. Thus, the antenna element signals are not transformed into directly received signals corresponding to different transmitter directions, but rather different transmitter signals are transformed into expected antenna element signals.

[0011] The above mentioned patents are relied upon to supply background on the state of the art using antenna arrays for improved reception of multiple signals using the same frequency channel.

#### Summary of the Invention

[0012] The object of the invention is to provide a communications system and a method which provide greater communications capacity or quality. This object is solved by a communications system according to claim 1 or by a method according to claim 33. Further advantageous embodiments and improvements are listed in the dependent claims.

[0013] The invention to be described below in accordance with one aspect is an improvement upon the above prior art when utilizing subtractive demodulation of coded signals simultaneously with the use of antenna arrays to provide directive discrimination. The invention differs from using prior art antenna arrays to provide directive beams and then processing the signal from a directive beam using subtractive demodulation. Such a combination is considered anticipated in the incorporated references. In the invention, when a signal is decoded and subtracted, it is subtracted from all antenna element signals and therefore vanishes not only from the directive beam it is received in, but also vanishes from all other beams formed using the same antenna elements, even when those other beams have substantial spatial overlap with the signal's beam.

[0014] Mobile phones transmit coded signals to at least one base station. The base station in accordance with the invention is equipped with an antenna array for receiving signals from a plurality of mobile stations lying in different directions, the signals transmitted by the mobile stations comprising information symbols chosen from an orthogonal alphabet, further scrambled using an access code.

[0015] Signals from the antenna array elements comprising weighted sums of the signals transmitted by different mobile stations are amplified, downconverted filtered and digitized to form corresponding streams of numerical samples that are fed to a processor including means for storing numerical samples and means for performing arithmetic operations on stored samples. The processor arranges samples received sequentially in time from different antenna elements in a two-dimensional array, one dimension corresponding to the different antenna elements and the other dimension corresponding to time, i.e. sequence of reception, hereinafter referred to as the space/time domain.

[0016] The numerical samples are unscrambled using the access code of a first mobile transmitter and the processor then computes a two-dimensional transform of the two-dimensional array of unscrambled samples to produce a two-dimensional array of result-bins, wherein bins along one dimension correspond to the symbols in the alphabet and bins in the other dimension correspond to combinations of samples received via different antenna elements thus providing directive receiving beams in different directions, the result-bins hereinafter referred to as the code/space domain.

[0017] The processor identifies the result-bin containing the greatest value and thereby identifies a symbol received from the first mobile and a direction of reception. The value of the bin is then set to zero and an inverse two dimensional transform is performed to transform the residual bin values back to the space/time domain, the just-identified signal having been subtracted out. The samples are then rescrumbled using the first mobile's access code.

[0018] The process then repeats starting with descrambling using a second mobile's access code, and so forth, until a symbol has been decoded from all mobile transmitters. The entire process then repeats for sequential symbol periods to construct a sequence of received symbols from each mobile transmitter.

[0019] The access codes of the first mobile, second mobile etc. preferably belong to mobiles selected in order of decreasing signal strength such that the strongest mobile signals are decoded and subtracted out before decoding weaker mobile signals, thereby providing improved discrimination of overlapping signals by both access code and

direction of arrival, and thus allowing a greater number of transmissions to share the same frequency bandwidth.

[0020] According to another aspect of the present invention, a communications system is disclosed comprising a plurality of mobile stations and an improved base station for receiving signals from said mobile stations and decoding information-bearing signals transmitted therefrom. An antenna means comprising antenna elements disposed around a support structure receives signals transmitted from said plurality of mobile stations and generates output signals from each antenna element. Conversion means amplify, filter and convert signals from each of said antenna elements into a corresponding number of converted signals for processing. Storage means temporarily store a number of samples of said converted signals. Processing means iteratively process and reprocess said stored samples successively to decode said information from each of said mobile stations in turn. The processing provided by said processing means identifies from said stored samples an information symbol transmitted by one of said mobile stations thereby decoding said information-bearing signal, and subtracts values dependent on said identified information symbol from said stored samples thereby reducing interference between the just-decoded signal and the signal to be decoded at a subsequent iteration.

[0021] According to yet another aspect of the present invention, a communications system is disclosed comprising a plurality of mobile stations and an improved base station for receiving signals transmitted from said mobile stations each with the aid of an assigned access code and for decoding information symbols belonging to an allowed alphabet of symbols encoded in said transmissions. Antenna means comprising antenna elements disposed around a support structure receive signals transmitted from said plurality of mobile stations and generate output signals from each antenna element. Conversion means amplify, filter and convert signals from each of said antenna elements into a corresponding number of converted signals for processing. Storage means temporarily store a number of samples of said signals converted from each of said antenna elements at successive instants in time. Two-dimensional numerical transform means process said stored samples using one of said access codes assigned to a first one of said mobile stations to produce a two-dimensional array of transformed samples, said transformed samples lying along one dimension of said two-dimensional array corresponding to different possible directions of arrival of signals at said base station transmitted by said first mobile station and transformed samples lying along the other dimension of said two-dimensional array corresponding to correlations with different ones of said information symbols in an allowed alphabet of symbols.

[0022] According to still another aspect of the present invention, a communications system is disclosed comprising a plurality of mobile stations and an improved base station for receiving signals transmitted from said mobile stations each with the aid of an assigned access code and for decoding information symbols belonging to an allowed alphabet of symbols encoded in said transmissions. Antenna means comprising antenna elements disposed around a support structure receive signals transmitted from said plurality of mobile stations and generate output signals from each antenna element. Conversion means amplify, filter and convert signals from each of said antenna elements into a corresponding number of converted signals for processing. Storage means temporarily store a number of samples of said signals converted from each of said antenna elements at successive instants in time. Two-dimensional numerical transform means process said stored samples using one of said access codes assigned to a first one of said mobile stations to produce a two-dimensional array of transformed samples, said transformed samples lying along one dimension of said two-dimensional array corresponding to different possible directions of arrival of signals at said base station transmitted by said first mobile station and transformed samples lying along the other dimension of said two-dimensional array corresponding to correlating samples with different ones of said information symbols in an allowed alphabet of symbols using a prescribed time-shift between the samples correlated and said information symbols. Means repeat said two-dimensional transform for a plurality of said time-shifts corresponding to delayed reception of signals from said first mobile station corresponding to delayed echoes of said signals caused by signals reflection from objects in the propagation path.

#### Brief Description of the Drawings

[0023] These and other features and advantages of the invention will be readily apparent to one skilled in the art from the following written description, used in conjunction with the drawings, in which:

Figure 1 illustrates a prior art transmitter for use with the present invention;

Figure 2 illustrates an array antenna for use with the present invention;

Figure 3 illustrates a space/code processor according to one embodiment of the present invention;

Figure 4 illustrates ray processing for time-of-arrival and direction-of-arrival combinations according to one embodiment of the present invention; and

Figure 5 illustrates Butler Matrix/Fourier Transform formulation of beamforming according to one embodiment of the present invention.



Detailed Description

[0024] Figure 1 illustrates a simplified block diagram of the type of mobile transmitter the current invention is designed to decode. The transmitter is a prior art transmitter of the same form disclosed in the incorporated documents.

5 [0025] A speech signal from a microphone 10 is digitized and compressed using a speech coding algorithm in a speech encoder 11 to produce a digital bitstream representative of the speech signal. Existing digital cellular systems have compressed the speech signal to bitrates of 13KB/s (GSM) and 7KB/s (IS54) respectively, and at the state of the art acceptable speech quality can be maintained even with speech coders that reduce the bitrate to 3.6KB/s.

10 [0026] The bitrate from the speech encoder may be increased again by the use of error correction encoding. Most redundancy is added to protect the most perceptually important bits while the least perceptually important bits may not be coded at all. Such coding, if any, is considered to be part of block 11 in Figure 1. The resulting encoded digital speech from block 11 is formed into multi-bit symbols for spread-spectrum encoding in block 13. For example, 7-bit blocks can be formed and each of the 128 possible 7-bit patterns is represented by one of 128 orthogonal Walsh-Hadamard codes, thus expanding the bitrate further by a factor of 128/7. When such block-orthogonal spread-spectrum symbol coding is employed, a preferred form of error correction coding within speech encoder 11 is Reed-Solomon coding, which is adapted to code multi-bit symbols. The combination of Reed-Solomon coding and Walsh-Hadamard coding can be done in a variety of ways to produce unequal coding for the most and least perceptually significant bits. For example, a Reed-Solomon code constructed on a  $GF(2^7)$  can code a block of 7-bit important symbols to produce an RS-coded block containing a greater number of symbols. A "Galois Field or GF is the set of all integers from 0 to some maximum that is a closed set under some modulo combinatorial operations. A  $GF(2^7)$  (two to the power of seven or  $GF(2^7)$ ) means all integers from 0 to 127, i.e., all 7-bit binary codes. If two of these are combined by 7-bit wide XOR (modulo-2 addition) an other 7-bit value in the set results, so the set is "closed" under the combinatorial operation "XOR". The remaining less important symbols can be formed into 7-bit blocks but not RS coded. The RS-coded and the non-RS-coded 7-bit symbols are then output from the encoder 11 to the Walsh-Hadamard encoder 13, the bit-to-symbol formation 12 having already been performed inside the encoder 11 in this case, at least for the RS-coded symbols.

15 [0027] An alternative unequal coding method is to form important bits into, for example, 5-bit symbols which are then RS-coded on a  $GF(2^5)$  to form a larger block of RS-coded 5-bit symbols. Two bits of lesser importance are then added to each 5-bit RS symbol to obtain 7-bit symbols which are then submitted to Walsh-Hadamard coder 13 to obtain 128-bit codewords.

20 [0028] To provide privacy for individual conversations, encryption can be added either in block 11 or in block 12 as described in U.S. Patent No. 5,353,352.

25 [0029] Different mobiles produce Walsh-Hadamard codes from the symbol encoder 13 belonging to the same set of 128 codes, and thus to aid discrimination between different mobiles, an access code is bitwise modulo-2 combined with the codewords at block 14, as described in U.S. Patent No. 5,353,352. The access codes are preferably chosen such that an access-coded codeword of one mobile transmitter is maximally different from all 128 possible access-coded codewords produced by any other mobile transmitter.

30 [0030] For simplicity, details that are not material to the current application are omitted from Figure 1, such as addition of signalling information to speech information, source of encryption keys, and overall control of the transmitter by a control processor is not shown.

35 [0031] The access-coder 14 produces 128 bits out that are converted to a serial stream if necessary for modulating the radio-frequency carrier by a serializer 15. The bit stream is applied to a modulator 16 to produce a modulated RF signal which is then amplified to a transmit power level in a power amplifier 17 for transmission using an antenna 18. For simplicity, the corresponding mobile receiver circuits that use the same antenna for receiving are not shown.

40 [0032] Figure 2 illustrates the connection of a cylindrical antenna array 21, such as is described in U.S. Patent No. 5,619,503 to the inventive processor 60 of the current invention.

45 [0033] Antenna elements 22 are arranged in collinear columns 20 and the columns 20 are disposed around a cylinder 21 atop an antenna mast at a cellular base station site. The elements of a column are coupled so as to form column signals 23 and each such collinear column exhibits directivity in the vertical elevation plane but a broad beamwidth in the horizontal (azimuth) plane. Each column signal is processed by a receiving channel 31 forming a bank of channels 30. Each channel 31 comprises for example a first RF filter 310; a low noise amplifier 311; a second RF filter 312; a downconverter 313 using a common local oscillator 32; an Intermediate Frequency (IF) filter 314; an IF amplifier 315 and a complex AtoD convertor 316 to generate a stream of complex numerical samples 36 representative of the RF signal from each collinear column of elements.

50 [0034] The AtoD convertor can comprise quadrature downconversion using I,Q mixers and I,Q AtoD convertors, or alternatively can employ the logpolar digitization technique described in U.S. Patent No. 5,048,059.

55 [0035] The complex digital outputs 36 are then fed to the processor 60 which includes a space/code processor 40 to discriminate and output separate symbol streams received from each mobile transmitter (Figure 1) and a bank 50

of individual traffic channel processor units to process the symbol streams for each traffic channel to regenerate speech signals, signalling and control information or user data such as fax or computer data signals.

[0036] Figure 3 illustrates part of space/code processor 40 comprising a two-dimensional numerical transform. Signals received from the set of antenna columns at the same time ( $t_1$ ) form a row of input signals to a beamforming matrix 70 for  $t_1$ . The set of antenna signals received at successive time instants  $t_2, t_3, \dots, t_{128}$  are fed to a corresponding number of identical beamforming matrices 70. It shall be understood that all signals processed by the two-dimensional transform are complex numbers, having a real part and imaginary part each represented as fixed or floating point binary values. In general, fixed point representations are preferable as the hardware required to process fixed point numbers is less expensive.

[0037] The beamforming matrices compute a set of output signals each corresponding to having formed a directive beam in a particular direction in azimuth. The number of beams computed for each sampling instant  $t(i)$  is typically equal to the number of antenna columns, such that the beamforming matrix corresponds to a multiplication of a row of input values by a square matrix of complex beamforming coefficients. Numerical beamforming and efficient methods therefor are described in U.S. patent No 5,909,460 entitled "Efficient Apparatus For Simultaneous Modulation and Digital Beamforming For an Antenna Array".

[0038] Through the beamforming matrix, a signal arriving from a particular direction corresponding to a beam direction is enhanced relative to signals arriving from other directions. The beamformer computes beams covering the ensemble of directions and so all signals are enhanced in one or another of the beams. As will be discussed below, the beamformer does not necessarily however compute beams for all signals at the same time, as it preferably makes fine beam direction adjustments individually for each mobile signal.

[0039] The beam signals for beam direction 1 computed for successive time instants  $t_1, t_2, \dots, t_{128}$  form a 128-complex-valued input vector to Fast Walsh Hadamard Transform (FWT) processor 71 for beam 1 and likewise the set of signals for beam 128 computed for successive sampling instants  $t_1 \dots t_{128}$  form the input vector to FWT processor 71 for beam N. The FWT processors for all other beams are also performed, yielding an array of  $128 \times N$  two-dimensionally transformed results, the first dimension of the transform being antenna-element/beam-space and the second dimension being time/code-space. Each FWT processor transforms 128 input values to 128 output values and can be constructed using fully parallel logic to operate extremely rapidly, as described in U.S. Patent No. 5,357,454 to applicant, which is hereby incorporated by reference in its entirety herein.

[0040] In Figure 3, for simplicity, it is assumed that the operation of descrambling the set of 128 input values using an access code assigned to a particular mobile signal is included as the first step inside FWT processor 71. This step undoes the step performed by the corresponding scrambler 14 of Figure 1. The access code is chosen first to be that assigned to a mobile transmitter previously identified with the strongest signal received at the base station. A symbol transmitted by that transmitter will result in a corresponding one of 128 FWT processor outputs from one of the N beam-associated FWT processors 71 being the largest output. The beam in question should not change rapidly between one symbol and the next, a period of typically a fraction of a millisecond, because the mobile transmitter does not circulate around the antenna array with such a huge angular velocity. Therefore the beam to use for identifying a transmitted symbol may be predicted from previous results, and after identification of the transmitted symbol, the value in the same symbol bin in other beams can be examined to determine if the signal is growing in another direction-bin; at some point, if the mobile transmitter is moving, the signal in another beam/direction-bin would become larger and then the beam for decoding that mobile would be changed. In an intermediate phase, when the mobile straddles two beams and thus produces similar results from two neighboring sets of 128 outputs, the weighted sum of the two sets of 128 outputs may be used for decoding the symbol.

[0041] Decoding a symbol comprises identifying the index of the largest of the 128 values of the above-mentioned sum, or of 128 FWT processor outputs of a single beam. This may be done extremely rapidly using fully parallel logic, as described in U.S. Patent No. 5,187,675.

[0042] Having identified the index of the largest value, that value is set to zero in the 128-value array for the beam (or beams, if more than one are summed) used for decoding. Thus, out of the  $128 \times 8$  space/code domain values computed by the space/code processor, one value (or perhaps two) are set to zero. The remaining values are then inverse transformed using Figure 3 in reverse, namely an inverse FWT is performed on columns of values, they are resampled using the same access code, and then rows of values are multiplied by a matrix inverse of the beamforming matrix to obtain  $128 \times N$  values once more in the space/time domain.

[0043] Because the beam from which the signal was decoded was predicted in advance, it will be realized that beamforming matrices 70 did not need to compute beam signals for all the beams, but only for that in which the signal is predicted to be received strongest plus perhaps the beams lying on either side, in order to monitor for the signal crossing to an adjacent beam due to transmitter movement. The FWT processors 71 do not then have to be performed for the beam signals that are not computed. However, in order to be able to reverse the beamforming process 70, the number of output values computed must be equal to the number of input values, i.e. the beamforming matrix must be square and therefore information-lossless. However, it may be possible to simplify the matrix multiplication by using a

matrix containing many zeros in rows corresponding to uncomputed beams, as long as the inverse of the matrix still exists and rows corresponding to the needed beams comprise the correct beamforming coefficients. Since completely different matrices and inverses would then need to be precomputed and stored for each signal direction, it may be better to use a single matrix and to not be concerned about the wasted effort in computing unneeded beams. The unneeded FWTs are still saved if the corresponding beams are not needed to decode a signal.

5 [0044] Now, the signals received from different mobile transmitters do not necessarily have their 128-sample symbol periods exactly aligned. Moreover, the signal sampling performed in the AtoD converters 316 is not necessarily synchronous with the center or an optimum sampling point of every symbol. Indeed the signal from any particular mobile transmitter may be received with time-smear due to the phenomenon known as multipath propagation whereby reflections  
10 of the signal from tall buildings, hillsides and such are received with different delays that can be many sample-periods delayed, each delayed version of the signal being called a "ray". Sample timing misalignment, whereby sampling occurs between two code chips, also gives rise to ray-splitting, whereby a correlation is observed for the two chip-shifts straddling the correct sampling point. The aforementioned references explain how to handle all these effects by computing FWTs also for 128-sample vectors that are shifted in time to account for the delay of a particular echo. FWT  
15 vectors for each shift are added with complex weights accounting for the phase shift and attenuation of each path to obtain a combined signal for decoding. The chip-shifts that are selected for combining using complex weighted addition are called "RAKE taps", and the coefficients are called "RAKE coefficients". The combining of FWTs with complex weights may be simplified by restricting the RAKE coefficients to comprise real and imaginary parts that are inverse powers of two, which involves an acceptable loss compared to using exact complex weighting values. Multiplications  
20 by inverse powers of two are simple to implement by time-delaying bit-serially presented binary values, as described in U.S. Patent No. 5,305,349 entitled "Rake Receiver with Quantized Coefficients".

[0045] Figure 4 illustrates the arrangement for carrying out 2-dimensional transforms on different chip-shifts (RAKE taps) and also how unneeded FWTs may be omitted. The input buffers 72 receive AtoD converted sample streams from each antenna channel 31 and clock the samples into 128+L storage locations for each channel. The extra "L"  
25 locations corresponds to the amount of timing spread expected, expressed in chip periods, between the timing alignment of 128 chips of the latest Walsh code to be received relative to the earliest, the spread being either between two different mobile transmitters located at different distances from the base station or between two different rays that have propagated over different length paths. Corresponding ones of the 128+L buffered sample values from N antenna channel, are connected to an N-input, N-output beamforming matrix and transformed to produce N beam values. The  
30 128+L values output from the beam in which a particular ray of a particular signal is expected to lie are then subject to a selection of those 128 that correspond to a particular timing alignment for a 128-chip Walsh code. The prediction of the beam and the timing of a particular ray is made by a channel tracker 73 which keeps track of the values of maximum correlations for beam directions on either side of the nominal direction of arrival as well as correlations with time shifts on either side, i.e. one chip early and one chip late, of the nominal expected time of arrival. The channel  
35 tracker 73 also keeps track of the mean complex value of maximum correlations averaged from one Walsh-Hadamard symbol period to the next, which yield the RAKE coefficient weights for combining different rays. The 128-point Walsh spectrum output from each FWT for a ray of a particular signal is weighted with the complex conjugate of the expected value produced by the channel tracker 73 and added with 128-point weighted vectors for all other rays for the same signal. Each ray has its own timing and may lie in a different beam from other rays of the same signal. Thus, the RAKE  
40 combining can combine a set of Walsh correlations for a direct ray received from the South with another set received L chips later from the North, being for example a signal reflection from a large building or mountainside. The channel tracker determines which of the times-of-arrival combined with which directions-of-arrival contain the most energy and combines these signals using for example the aforementioned inventive RAKE combiner having quantized coefficients. The combined signal, due to the complex conjugate weightings, should have its resulting values rotated into the real  
45 plane and thus the maximum of the 128 results' real parts is determined by a maximum search circuit 74. In Figure 4, block 74 also comprises accumulation of the 128-Walsh spectra for all rays using the weighting coefficient supplied by the channel tracker 73. When the largest value has been found, its value is returned to the channel tracker to update the coefficient in time for the next symbol period. The channel tracker will also determine whether that ray shall be used next time or whether another ray has become larger. Implicitly, the circuit of Figure 4 computes FWTs also for  
50 time-of-arrivals and direction-of-arrivals that are not presently significant and therefore do not contribute to the weighted sum, but which are computed in order to determine when or if one of them grows to become greater than one previously contributing to the sum, at which point the larger one will replace the smaller one.

[0046] Figure 4 shows the connections for selecting the RAKE tap or time-of-arrival represented by buffered samples L+1 to 128+L, i.e. the latest possible time-of-arrival. All 128+L time-of-arrivals are shown connected to beamforming matrices, although it is possible to omit beamforming matrices for the time-of-arrivals not used, i.e. for samples 1 to L.  
55 Only outputs from beamformers L+1 to 128+L are subjected to an FWT. In this case, the ray of time-of-arrival L+1 is anticipated to be received from direction "k", so only outputs "k" from beamformers L+1 to 128+L are connected to the 128-input FWT 71 to produce a 128-point Walsh spectrum output. This is accumulated in 128 bins in block 74 with the

Walsh spectra for all other significant rays, using a weighting coefficient from channel tracker 73. When all rays have been processed, block 74 determines the largest accumulated value and outputs its index as the decoded symbol, and returns the value to the channel tracker. The sequence of 2-dimensional transforms corresponding to each ray is then repeated, to reproduce the FWT values that were accumulated, and after each FWT is reproduced, the value corresponding to the decoded symbol index is set to zero and the inverse FWT performed on the residual values. Then the inverse of the beamforming matrices are applied to return the modified values to input buffers 72 once more. After the just decoded signal has been removed from the buffered values for all significant rays (each defined by a direction-of-arrival plus a time-of-arrival) that signal has vanished from the picture and thus does not interfere with signals subsequently decoded.

[0047] In the incorporated references, a preferred way to select the 128-samples from an input buffer 72 corresponding to a particular time-of-arrival is disclosed to be by use of a barrel shifter. A barrel shifter is an efficient way to shift a set of 128 taps up or down across a  $128+L$  set of available tap selections. The desired shift "j" between 0 and L is expressed as a binary integer

$$j_0 + 2j_1 + 4j_2 + 8j_3$$

as an example where the maximum value L is 15.

[0048] A first stage of the barrel shifter selects 135 taps to comprise either the sample values 1 to 135 or 9 to 143 according as the value of binary digit  $j_3$  is 0 or 1. The 135 selected values are then subjected to further selection of 131 values to be either previously selected values 1 to 131 or 5 to 135 according as the value of  $j_2$  is 0 or 1. Then those 131 values are subjected to a further selection of 129 values to be either previously selected values 1-129 or 3-131 according to  $j_1$ . Finally,  $j_0$  determines whether previously selected value numbers 1 to 128 or 2 to 129 are selected. The advantage of this approach is that the total number of switch positions is approximately  $2^{128} \log_2(L)$  compared with  $128L$  for 128, L-pole switches, a reduction of approximately 2:1 in complexity for  $L=15$  and greater savings for larger values of L.

[0049] It has thus been described how a first signal is decoded and subtracted. After each iteration, a symbol is decoded for a particular mobile and then the access code is changed to be that of the next strongest mobile signal and a new iteration performed. After decoding each signal, the largest value indicative of the symbol is saved. Its complex value is a measure of the phase and amplitude of that signal, and the complex value is averaged in a channel tracker as described in the incorporated references in order to determine in which plane the signal phase lies, and thus to be able to effect coherent detection of the symbol. The magnitude of the tracked value can also be used to predict the signal strength order for the next 128-sample symbol interval and thus to effect re-adaptation of the order of processing to account for different fading on different signals, such that decoding in descending signal strength order is maintained.

[0050] The index of the largest FWT component identified after combining all RAKE taps provides the index of the FWT component to be set to zero on the signal subtraction cycle. The machine of Figures 3 and 4 thus preferably comprises at least the two distinct phases of:

Detection phase: Calculate FWTs for the time-of-arrival and direction-of-arrivals of rays predicted by the channel tracker from past history to contain significant energy, accumulating the FWTs in 128 bins using channel-tracker-supplied weighting coefficients. Then determine the index of the largest accumulated value.

Subtraction phase: Recalculate the same FWTs as above, in descending order of ray strength, and set to zero the component of each with the above index before inverse 2-dimensional transforming the residual values to obtain modified values for performing the next 2-dimensional transform for the ray of next lowest ray strength.

In addition, a third phase which may be termed "search phase" comprises:

Search phase: Perform a 2-dimensional transform for at least one other time-of-arrival and or direction-of-arrival not used in the detection and subtraction phases in order to detect the imminent growth of rays which should in the future be used in detection and subtraction.

In the incorporated references, it is also taught that a fourth phase, termed "reorthogonalization," can be desirable, in which, after processing other signals through phases of detection, subtraction and search, a previous signal-access code is re-used and a new subtraction phase is performed for the previous signal using an already determined index. In other words, the detection phase is omitted because the index of the current symbol is already known. The purpose

of the reorthogonalization phase is to reduce residual errors left from a previous signal subtraction phase due to errors in the amount subtracted caused by the presence of other signals. Those errors are proportional to the strengths of the other signals, but correlated with the first signal. After removing the other signals causing the error and therefore originally making it, the error can be detected by performing a new correlation using an FWT. A new subtraction phase then removes the error.

[0051] A preferred formulation of the beamforming operation will now be described. A signal incident on the array of ray strength  $s$  will result in a vector  $\underline{V}$  of antenna column signals 23 of

$$\underline{V} = \begin{bmatrix} s \cdot a1 \\ s \cdot a2 \\ \cdot \\ s \cdot a(n) \end{bmatrix} = \begin{bmatrix} a1 \\ a2 \\ \cdot \\ a(n) \end{bmatrix} \cdot s = \underline{A} \cdot s$$

where  $\underline{A}$  is a column vector of the complex values  $a(i)$ .

[0052] How much of the column signal is attributed to  $s$  and how much is attributed to the antenna channel gain factors  $a(i)$  is somewhat arbitrary, so for reasons that will become clear it is chosen to normalize the values of  $a1...a(n)$  such that

$$|a1|^2 + |a2|^2 + \dots + |a(n)|^2 = 1$$

To produce a beam that optimally combines the energy from each element to produce maximum directivity towards the signals source of  $S$ , the combining weighting coefficients should be equal to the complex conjugates of  $a(i)$ , that is the combined signal should be

$$[a1^*, a2^*, a3^* \dots a(n)] \cdot \begin{bmatrix} a1 \\ a2 \\ \cdot \\ a(n) \end{bmatrix} \cdot s = \underline{A}^{\#} \cdot \underline{A} s$$

where  $*$  signifies complex conjugate and  $\#$  signifies conjugate transpose. But

$$\underline{A}^{\#} \cdot \underline{A} = |a1|^2 + |a2|^2 + \dots + |a(n)|^2$$

which has been set equal to 1 above. Therefore the result is simply  $s$ , indicating that  $s$  can be equated with the total signal energy intercepted by the array.

[0053] The beam forming matrix  $B$  must therefore contain a row equal to  $\underline{A}^{\#}$  for the beam needed for receiving  $S$ . As yet, the other rows of  $B$  are not-defined, but will become so shortly after we impose the additional requirement that, after setting to zero the component in  $S$ 's beam and multiplying by the inverse of  $B$ , the signal  $S$  shall have vanished from all antenna element values.

[0054] Thus multiplying the vector of received signals  $\underline{V}$  by the beamforming matrix  $B$  yields

$$B \cdot \underline{V} = \begin{bmatrix} s1 \\ s2 \\ \cdot \\ s \\ \cdot \end{bmatrix}$$

where "s" is the desired signal ray and s1,s2 correspond to other signals or mixtures thereof. Setting to zero the output corresponding to S is the same as subtracting the vector

5

$$\underline{S} = \begin{bmatrix} 0 \\ 0 \\ \cdot \\ \cdot \\ s \\ \cdot \\ \cdot \\ 0 \end{bmatrix} \text{ from the result.}$$

10

After multiplying by the inverse of B, we then get

15

$$B^{-1} \cdot ((B \cdot \underline{V}) - \underline{S}) = \underline{V} - B^{-1} \cdot \underline{S}$$

which should be equal to zero if  $B^{-1} \cdot \underline{S}$  cancels the components of S at all antenna elements.

20 [0055] Therefore

25

$$B^{-1} \cdot \begin{bmatrix} 0 \\ 0 \\ \cdot \\ s \\ \cdot \\ \cdot \\ \cdot \end{bmatrix} = \begin{bmatrix} a1 \\ a2 \\ a3 \\ a(i) \\ \cdot \\ a(n) \end{bmatrix} \cdot s \quad \text{or} \quad B^{-1} \cdot \begin{bmatrix} 0 \\ 0 \\ \cdot \\ 1 \\ \cdot \\ 0 \end{bmatrix} = \begin{bmatrix} a1 \\ a2 \\ a3 \\ \cdot \\ a(n) \end{bmatrix}$$

30

[0056] The above shows that the column of  $B^{-1}$  corresponding to the beam of signal S is equal to the vector of coefficients a(i).

[0057] Since  $B \cdot B^{-1} = I$ , the NxN unit matrix by definition of the inverse, this is consistent with the row of  $B = (a1, a2, a3, \dots, a(n))$  times the column of B being equal to  $|a1|^2 + |a2|^2 + \dots + |a(n)|^2 = 1$ , giving a "1" on the diagonal, but other rows of B times the same column of the inverse must give zeros, as the off-diagonal elements of the unit matrix I are zero. All other rows of B must therefore be orthogonal to the column of  $B^{-1}$  formed by the a(i) values. Denoting any other row of B by (r1, r2, ..., r(n)) we must therefore have

35

40

$$r1.a1 + r2.a2 + r3.a3 + \dots + r(n).a(n) = 0$$

It can also arbitrarily be required that  $r1^2 + r2^2 + r(n)^2 = 1$ .

[0058] Such a matrix constructed with one row equal to a given vector, all other rows being orthogonal to it and the sum of the moduli squared of any row being equal to unity is called an orthonormal matrix, and may be constructed by the known process of Gram-Schmidt orthonormalization. There are some degrees of freedom in assigning values to the other rows, and if desired as indicated above, this may be done in such a way as to maximize the total number of zeros in the matrix.

45

[0059] Therefore, it has been shown that the beamforming matrix can be constructed by setting one row equal to the conjugates of the received signal gains and phases at the N antenna element columns, the other N-1 rows being constructed by Gram-Schmidt orthonormalization.

50

[0060] Another formulation of the beamformer may be made using Butler matrices or their numerical counterparts, discrete Fourier transforms. A set of signals from the N antenna element columns 20 disposed around the cylinder 21 in a regular fashion is connected to a Butler matrix 80. The Butler matrix 80 produces N transformed signal outputs which are related to the N input signals by an NxN discrete Fourier transform matrix which has the Orthonormal property. When a signal impinges on the array from a direction THETA which is slowly changing, the signal pattern received at the elements slowly moves around the array, becoming identical with the pattern a value  $2\pi/N$  of THETA earlier merely shifted by one element. The Butler-matrix transformed values become equal in amplitude to the values at an earlier value of THETA,  $THETA - 2\pi/N$  likewise, while the phase shifts of the transformed values are changed by multiples of

55

2Pi/N. In fact, the amplitudes of the transformed values are very nearly the same for all values of THETA, while only the phase changes by multiples of THETA. Therefore, the desired weighting of the element signals can, to a sufficient accuracy, be provided by means of a constant amplitude shaping performed by applying different gains or attenuation factors  $c_1, c_2, \dots, c(n)$  in an amplitude shaping unit 81, which also may insert fixed phase changes if necessary for transformed components 1 to N, while a phasing unit 82 changes the phase of each transformed and amplitude-shaped value by multiples of the direction of arrival angle THETA.

[0061] Finally, if the phasing unit 82 is chosen to provide the phases necessary for N beams simultaneously that are spaced by multiples of  $2\pi/N$ , then the phasing unit 82 is an inverse Butler matrix (or inverse Fourier transform in the numerical domain).

[0062] In Figure 5 it is shown that the input buffers have been transferred to the outputs of the Butler Matrix unit 80 and the amplitude shaper 81. This is possible because functions performed by the Butler Matrix unit 80 and the amplitude shaper 81 are neither direction-of-arrival nor time-of-arrival dependent and may be performed on a sample-by-sample basis, and the results held in the buffers 72. The barrel shifters (not shown) as described above then select 128 of the  $128+L$  locations of each of the N buffers to form the N inputs to 128 phasing units 82 that complete the beamforming for a ray with a particular time-of-arrival and direction-of-arrival. After signal detection and subtraction, the residual signal need only be inverse transformed as far as input buffers 72 and need not be transformed back through the amplitude shaping unit 81 nor through the Butler matrix 80.

[0063] The advantage of performing the fixed transformation of the Butler matrix 80 and the amplitude shaping 81 prior to entering the input buffers illustrated in Figure 4 is that the beamforming units 70 become simply phasing units 82 that only change the phases of the signals prior to combining them and do not weight the amplitudes. The phasing units 82 may moreover be efficiently implemented using an Fast Fourier Transform (FFT). The FFT produces beams with spacing  $2\pi/N$  from a starting angle THETA that is implemented by applying a fixed phase slope to the input values given by the factors

$$1, \text{EXP}(\text{THETA}), \text{EXP}(2 \cdot \text{THETA}), \text{EXP}(3 \cdot \text{THETA}) \dots$$

where THETA is between 0 and  $\pi/N$ , or between  $-\pi/N$  and  $+\pi/N$ . THETA in this case represents a fine direction-of-arrival resolution to accuracies of less than  $2\pi/N$  while the FFT resolves the beams in steps of  $2\pi/N$ .

[0064] Figure 5 when combined with Figure 4 exhibits a cascade of FFT processors operating in one dimension of a 2-dimensional array of numbers with FWT processors operating in the second dimension. FWTs and FFTs are both in the family of Walsh-Fourier transforms, that differ only in their application of steps known as "Twiddling". A Fast Walsh-Fourier transform comprises stages for combing pairs of values called "Butterflies" that compute a sum and a difference interspersed with stages for rotating the phases of the complex sum and differences by fixed amounts, called "Twiddling". A pure Fourier transform has twiddling between every two successive Butterfly stages, while a pure Fast Walsh Transform has no Twiddling stages. A hybrid Walsh-Fourier transform has some Twiddling stages; a two dimensional Fourier Transform is one example and omits one twiddling stage. A Fourier transform on a 3-dimensional array of numbers is structured the same as a 1D Fourier transform operating on all the numbers arranged in one big vector, but omits two twiddling stages, and so on, that is M-1 twiddling stages are omitted in performing an M-dimensional Fourier Transform. For the phasing units 82 of Figure 5 and the FWT processors 71 of Figure 4, the combined transform may be performed very efficiently by using one large 1-dimensional transform of all  $128 \times N$  values arranged in a single vector, just omitting 6 twiddling stages corresponding to the 128-point FWT portions, which are equivalent to a seven-dimensional Fourier transform having two data values in each dimension, and omitting a further stage of twiddling corresponding to the 2-dimensional cascade of the FFT with the FWT portion.

[0065] An example will make this clearer: Fast Walsh-Fourier transforms may be constructed most efficiently when the total data array comprises a number of values equal to a power of two. Thus, if the number of beams N is chosen to be a power of two, for example 32, since the FWT portion of size 128 is already a power of two, then the total number of data values will be  $32 \times 128$  or 4096, which is  $2^{12}$ .

[0066] A  $2^{12}$  FFT would normally comprise 12 Butterfly stages with 11 Twiddling stages between them. In the present application however, the required transform is an 8-dimensional transform of an 8-dimensional array of values of size

$$32 \times 2 \times 2 \times 2 \times 2 \times 2 \times 2 \times 2 = 4096 \text{ values in total.}$$

[0067] Accordingly, the number of twiddling stages is reduced by  $8-1 = 7$ , leaving only 4 out of the 11 which a 4096-point FWT can accommodate. The four remaining correspond to those lying between the first 5 Butterfly stages of the 32-point FFT portions.

[0068] Thus it has been shown above that the cascade of FFT beamformers 82 in one data plane with FWT decoders 71 in a second data plane may be performed using a generalised single-dimensional Fast Walsh-Fourier transform programmed to delete appropriate stages of twiddling. If such a device is constructed sufficiently, efficiently and economically, it may become uninteresting to omit computation of unused FWTs or beams and simpler to compute the

whole set for every ray.

[0069] A further variation is to note that the exact beam direction for a ray, formed by customizing the value of THETA in Figure 5 for each ray independently, is only of relevance in obtaining accurate signal subtraction. Accurate signal detection in the detection phase can be performed by computing only sets of beams using THETA-0, in which case a particular signal happening to have a direction-of-arrival midway between two beams will show up in those two adjacent beams, appearing as two rays. As long as the channel trackers 73 supply appropriate coefficients for the two adjacent beams however, correct detection will result. The subtraction phase however preferably uses the correct value of THETA to cause the signal to appear in only one of the computed beams, from which it is nulled out. The value of THETA required may be determined by the channel tracker from the RAKE coefficients for the two adjacent beams used for detection.

[0070] Still other variations comprise, instead of setting a transform component to zero, after updating the channel tracker for the just-detected symbol value to predict the next value, the updated predicted value is subtracted from the transform component before performing the inverse transform.

[0071] It is beyond the scope of this application to provide a detailed analysis of all the pro's and con's for one variation or another, the selection of which depends on the exact parameters of a particular implementation, e.g. number of antenna columns, size of Walsh-Hadamard codewords, signal bandwidth, traffic capacity and whether the implementation of computations is by means of programmable signal processors, hardwired logic or Applications-Specific Integrated Circuits (ASIC) the capabilities of which are ever-increasing due to rapid advance in silicon integration technology.

[0072] All such variations incorporating the inventive principle of subtractive demodulation of signals in both a signal (or code) space and a spatial dimension (or antenna beam space) that may be made by a person skilled in the art are considered to lie within the scope of the following claims.

25 **Claims**

1. A communications system comprising a plurality of mobile stations and an improved base station for receiving signals from said mobile stations and decoding information-bearing signals transmitted therefrom, the base station comprising:

30 a) antenna means (20-22) comprising antenna elements (22) disposed around a support structure (21) for receiving signals transmitted from said plurality of mobile stations and generating output signals (23) from each antenna element (22);

35 b) conversion means (30, 31) for amplifying (311, 315), filtering (310, 312, 314), and converting (316) signals from each of said antenna elements (22) into a corresponding number of converted signals (36), for processing;

c) storage means for temporarily storing a number of samples of said converted signals (36) at successive instants in time; and

40 d) processing means (70, 71) for iteratively processing and reprocessing said stored samples successively to decode said information from each of said mobile stations in turn, wherein the processing provided by said processing means identifies from said stored samples an information symbol transmitted by one of said mobile stations thereby decoding said information-bearing signal and subtracts values dependent on said identified - information symbol from said stored samples of all antenna element signals thereby reducing interference between the just-decoded signal and the signal to be decoded at a subsequent iteration.

2. The communications system of claim 1, wherein at least some of said mobile stations transmit said information using the same radio frequency channel at the same time.

3. The communications system of claim 1, wherein at least some of said mobile stations transmit Code Division Multiple Access signals.

4. A communications system according to claim 1, wherein said processing means further comprises:

55 means for combining corresponding ones of said stored samples converted from respective antenna elements to enhance signals received from a particular direction, wherein a particular one of said mobile stations lies.



5. The communications system of claim 1, wherein said successively decoded signals are selected in descending order of received signal strength.
6. The communications system of claim 4, wherein said means for combining computes a weighted sum of the combined values using as the weights a set of complex beamforming coefficients.
7. The communications system of claim 6, wherein said beamforming coefficients are adapted at each iteration to enhance the signal being decoded at that iteration.
8. The communications system of claim 1, wherein said processing means comprises:
- beamforming means for combining groups of said stored samples comprising a signal sample converted by said conversion means from each antenna at the same instant in time to produce beam samples for signals received from a plurality of directions of arrival at a corresponding instant in time.
9. The communications system of claim 8, further comprising: CDMA despreading means for processing said beam samples received at successive instants in time from the same one of said plurality of directions of arrival in order to identify said identified symbol transmitted from one of said mobile station and received at said improved base station from said direction of arrival.
10. The communications system of claim 9, wherein said CDMA despreading means comprises computing a Walsh-Hadamard transform to obtain a number of Walsh spectrum components each corresponding to one of an allowed alphabet of information symbols.
11. The communications system of claim 10, wherein said identified symbol is identified by determining the largest of said Walsh spectrum components and thus the corresponding symbol from said allowed alphabet of symbols.
12. The communications system of claim 11, wherein said largest Walsh spectrum component is set to zero after being determined to be the largest.
13. The communications system of claim 12, wherein said Walsh spectrum after having said largest component set to zero is inverse Walsh-Hadamard transformed to obtain modified beam samples.
14. The communications system of claim 13, wherein said modified beam samples are combined using an inverse beamforming means to obtain modified stored samples which replace the original ones of said stored samples prior to performing a subsequent iteration to decode a symbol from a different mobile transmitter.
15. A communications system according to claim 1, wherein said improved base station is adapted for receiving said signals transmitted from said mobile stations each with the aid of an assigned access code (14), wherein said processing means is adapted for arranging said samples received sequentially in time from said antenna elements in a two-dimensional space/time array, one dimension thereof corresponding to the different antenna elements and the other dimension corresponding to time of reception, and for unscrambling the stored numerical samples using one of said access codes assigned to a first one of said mobile stations, and comprises: two-dimensional numerical transform means (71) for processing said unscrambled stored samples to produce a two-dimensional space/code array of transformed samples, the space dimension of said two-dimensional space/code array corresponding to different possible directions of arrival of signals at said base station transmitted by said first mobile station and the code dimension of said two-dimensional array corresponding to the information symbols in an allowed alphabet of symbols, wherein the transformed samples for a fixed arrival direction value of the space dimension indicate the correlations with the different information symbols along the code dimension.
16. The communications system of claim 1, wherein said access code used is chosen to be that assigned to the mobile station that is received with greatest signal strength at said base station.
17. The communications system of claim 15, characterized by decoding means for decoding of one of said information symbols, comprising a determining means for determining the largest of said transformed samples and thereby identifying a symbol belonging to said allowed alphabet of symbols and also a direction of arrival of the signal, wherein said information symbol was encoded.

- 5
18. The communications system of claim 15, characterized by decoding means for said decoding of one of said information symbols, comprising a combining means for combining said transformed samples that lie adjacent along the direction-of-arrival dimension using a set of combining coefficients to produce a combined value for each position in the other dimension of said two dimensional array of transformed samples.
- 10
19. The communications system of claim 18, characterized by a determining means for determining the largest of said combined values and thereby identifying said decoded information symbol.
20. The communications system of claim 17, wherein the largest of said transformed samples is set to zero after identifying said symbol.
- 15
21. The communications system of claim 20, further comprising: inverse two-dimensional transform means (71) for transforming said transformed samples having one sample set to zero to obtain modified stored samples stored in said storage means (70).
22. The communications system of claim 21, characterized by means (71) for processing said modified stored samples using said two-dimensional transform means with the access code assigned to a second mobile station and thereby identifying a symbol transmitted by said second mobile station.
- 20
23. The communications system of claim 22, wherein after identifying the symbol transmitted by said second mobile station, a corresponding transform component is set to zero and then performing said inverse two-dimensional transform is performed to produce further modified stored samples.
- 25
24. The communications system according to claim 23, wherein said further modified samples are iteratively processed using successively selected access codes to identify successively symbols transmitted from mobile stations assigned said access codes and after identifying each symbol to further modify said stored samples by setting to zero a transformed component and performing an inverse transform.
- 30
25. The communications system of claim 24, wherein said successively selected access codes are assigned to mobile stations received at said base station in successively descending signal strength order.
- 35
26. A communications system according to claim 15, characterized in that said two-dimensional numerical transform means (71) performs said processing of said stored samples using a prescribed time-shift numerical transform means (71) are provided for between the samples correlated and said information symbols; said two-dimensional repeating said two-dimensional transform for a plurality of said time-shifts corresponding to delayed reception of signals from said first mobile station corresponding to delayed echoes of said signals caused by signals reflection from objects in the propagation path.
- 40
27. The communications system of claim 26, characterized by means (73) to predict the direction of arrival and corresponding time-of-arrival of each of said echoes of significant strength and to adapt thereto said possible different directions of arrival assumed by said two-dimensional numerical transform means and said prescribed time-shifts used for correlation.
- 45
28. The communications system of claim 27, characterized by combining means (74) for combining using a set of weighting coefficients transformed components corresponding to said predicted directions and times of arrival to obtain a set of combined values corresponding to correlation with each symbol in said allowed alphabet of symbols.
- 50
29. The communications system of claim 28, characterized by one of said combined values that has the largest magnitude is determined and thereby identifies a symbol transmitted by said first station.
- 55
30. The communications system of claim 29, characterized by means (74) for setting to zero two-dimensionally transformed components corresponding to said identified symbol and corresponding to said predicted directions and times of arrival and inverse transforming said transformed components after setting said symbol, time and direction-corresponding component to zero to obtain modified stored sample values.
31. The communications system of claim 30, characterized by means (74) for iteratively reprocessing said modified stored samples using successively selected access codes to identify in turn a symbol transmitted by the mobile station assigned the selected access code and after each iteration generating further modified stored samples for

processing in the next iteration.

- 5
32. The communications system of claim 31, characterized in that said access codes are selected in descending order of received signal strength of the corresponding mobile station to which the access code is assigned.
- 10
33. A method for receiving signals transmitted from a plurality of mobile stations, in a communication system comprising said mobile stations and an improved base station, each signal received with the aid of a respectively assigned access code (14) and said access code used for decoding information symbols belonging to an allowed alphabet of symbols encoded in said transmissions, comprising the steps of:
- 15
- a) receiving signals transmitted from said plurality of mobile stations at antenna means (20-22) with antenna elements (22) disposed around a support structure (21) and generating output signals (23) from each antenna element (22);
- b) amplifying (311, 315), filtering (310, 312, 314) and converting (316) signals from each of said antenna elements (22) into a corresponding number of converted signals (36) for processing;
- 20
- c) temporarily storing a number of samples (36) of said signals converted from each of said antenna elements (22) at successive instants in time (t1 ... t128);
- d) processing means (70, 71) for iteratively processing and reprocessing said stored samples successively to decode said information from each of said mobile stations in turn, wherein the processing provided by said processing means identifies from said stored samples an information symbol transmitted by one of said mobile stations thereby decoding said information-bearing signal and subtracts values dependent on said identified information symbol from said stored samples of all antenna element signals thereby reducing interference between the just-decoded signal and the signal to be decoded at a subsequent iteration.
- 25
34. A method according to claim 33, wherein said improved base station is adapted for receiving said signals transmitted from said mobile stations each with the aid of an assigned access code (14), further comprising the steps of arranging (71) said samples received sequentially in time from said antenna elements in a two-dimensional space/time array, one dimension thereof corresponding to the different antenna elements and the other dimension corresponding to time of reception, unscrambling (71) the stored numerical samples using one of said access codes assigned to a first one of said mobile stations, and processing (71) said unscrambled stored samples to produce a two-dimensional space/code array of transformed samples, the space dimension of said two-dimensional space/code array corresponding to different possible directions of arrival of signals at said base station transmitted by said first mobile station and the code dimension of said two-dimensional array corresponding to the information symbols in an allowed alphabet of symbols, wherein the transformed samples for a fixed arrival direction value of the space dimension indicate the correlations with the different information symbols along the code dimension.
- 30
35. A method according to claim 34, characterized in that said processing (71) is performed by using a prescribed time-shift between the samples correlated and said information symbols; and
- 35
- repeating said two-dimensional transform for a plurality of said time-shifts corresponding to delayed reception of signals from said first mobile station corresponding to delayed echoes of said signals caused by signals reflection from objects in the propagation path.
- 40
36. The method according to claim 35, further comprising the steps of: predicting (73) the direction of arrival and corresponding time-of-arrival of each of said echoes of significant strength and to adapt thereto said possible different directions of arrival assumed by said two-dimensional numerical transform means and said prescribed time-shifts used for correlation.
- 45
37. The method according to claim 36, further comprising the steps of: combining (74) using a set of weighting coefficients transformed components corresponding to said predicted directions and times of arrival to obtain a set of combined values corresponding to correlation with each symbol in said allowed alphabet of symbols.
- 50
38. The method according to claim 37, wherein one of said combined values that has the largest magnitude is determined and thereby identifies a symbol transmitted by said first station.
- 55
39. The method according to claim 38, further comprising the steps of: setting to zero two-dimensionally transformed components corresponding to said identified symbol and corresponding to said predicted directions and times of arrival and inverse transforming said transformed components after setting said symbol, time and direction-corre-

sponding component to zero to obtain modified stored sample values.

- 5 40. The method according to claim 39, further comprising the steps of: iteratively reprocessing said modified stored samples using successively selected access codes to identify in turn a symbol transmitted by the mobile station assigned the selected access code and after each iteration generating further modified stored samples for processing in the next iteration.
- 10 41. The method according to claim 40, wherein said access codes are selected in descending order of received signal strength of the corresponding mobile station to which the access code is assigned.

Patentansprüche

- 15 1. Kommunikationssystem, umfassend eine Vielzahl von Mobilstationen und eine verbesserte Basisstation zum Empfangen von Signalen von den Mobilstationen und Dekodieren von Informations-tragenden Signalen, die davon gesendet werden, wobei die Basisstation umfasst:
- 20 a) eine Antenneneinrichtung (20-22), die Antennenelemente (22) umfasst, die um einen Halterungsaufbau (21) herum angeordnet sind, zum Empfangen von Signalen, die von der Vielzahl von Mobilstationen gesendet werden, und Erzeugen von Ausgangssignalen (23) von jedem Antennenelement (22);
- 25 b) eine Umwandlungseinrichtung (30, 31) zum Verstärken (311, 315), Filtern (310, 312, 314) und Umwandeln (316) von Signalen von jedem der Antennenelemente (22) in eine entsprechende Anzahl von umgewandelten Signalen (36), für eine Verarbeitung;
- 30 c) eine Speichereinrichtung zum vorübergehenden Speichern einer Anzahl von Abtastwerten der umgewandelten Signale (36) bei sukzessiven Zeitaugenblicken; und
- 35 d) eine Verarbeitungseinrichtung (70, 71) zum iterativen Verarbeiten und Neuverarbeiten der gespeicherten Abtastwerte sukzessive, um wiederum die Information von jeder der Mobilstationen zu dekodieren, wobei die Verarbeitung, die von der Verarbeitungseinrichtung bereitgestellt wird, aus den gespeicherten Abtastwerten ein Informationssymbol identifiziert, das von einer der Mobilstationen gesendet wird, wodurch das Informations-tragende Signal dekodiert wird, und Werte in Abhängigkeit von dem identifizierten Informationssymbol aus den gespeicherten Abtastwerten von sämtlichen Antennenelementensignalen subtrahiert, wodurch eine Störung zwischen dem eben dekodierten Signal und dem bei einer nachfolgenden Iteration zu dekodierenden Signal verringert wird.
- 40 2. Kommunikationssystem nach Anspruch 1, wobei wenigstens einige der Mobilstationen die Information unter Verwendung des gleichen Funkfrequenzkanals gleichzeitig senden.
3. Kommunikationssystem nach Anspruch 1, wobei wenigstens einige der Mobilstationen Codevielfachzugriff-Signale senden.
- 45 4. Kommunikationssystem nach Anspruch 1, wobei die Verarbeitungseinrichtung ferner umfasst:
- eine Einrichtung zum Kombinieren von entsprechenden der gespeicherten Abtastwerte, die von jeweiligen Antennenelementen umgewandelt sind, um Signale zu verbessern, die aus einer bestimmten Richtung empfangen werden, in der eine bestimmte der Mobilstationen liegt.
- 50 5. Kommunikationssystem nach Anspruch 1, wobei die sukzessiv dekodierten Signale in einer abfallenden Reihenfolge der empfangenen Signalstärke gewählt werden.
- 55 6. Kommunikationssystem nach Anspruch 4, wobei die Einrichtung zum Kombinieren eine gewichtete Summe der kombinierten Werte unter Verwendung eines Satzes von komplexen strahlbildenden Koeffizienten als die Gewichte berechnet.
7. Kommunikationssystem nach Anspruch 6, wobei die strahlbildenden Koeffizienten dafür ausgelegt sind, um bei jeder Iteration das Signal zu verbessern, welches bei dieser Iteration dekodiert wird.

8. Kommunikationssystem nach Anspruch 1, wobei die Verarbeitungseinrichtung umfasst:
- 5 eine Strahlbildungseinrichtung zum Kombinieren von Gruppen der gespeicherten Abtastwerte, umfassend einen Signalabtastwert, der von der Umwandlungseinrichtung von jeder Antenne zu dem gleichen Zeit Augenblick umgewandelt wird, um Strahlabtastwerte für Signale zu erzeugen, die von einer Vielzahl von Ankunftsrichtungen zu einem entsprechenden Zeit Augenblick empfangen werden.
9. Kommunikationssystem nach Anspruch 8, ferner umfassend:
- 10 eine CDMA Entspreizungseinrichtung zum Verarbeiten der Strahlabtastwerte, die zu sukzessiven Zeit Augenblicken von der gleichen der Vielzahl von Ankunftsrichtungen empfangen werden, um das identifizierte Symbol zu identifizieren, das von einer der Mobilstationen gesendet und an der verbesserten Basisstation aus der Ankunftsrichtung empfangen wird.
- 15 10. Kommunikationssystem nach Anspruch 9, wobei die CDMA Entspreizungseinrichtung die Berechnung einer Walsh-Hadamard Transformation umfasst, um eine Anzahl von Walsh Spektrumkomponenten zu ermitteln, die jeweils einem eines zugelassenen Alphabets von Informationssymbolen entsprechen.
- 20 11. Kommunikationssystem nach Anspruch 10, wobei das identifizierte Symbol durch Bestimmen der größten der Walsh Spektrumkomponenten und somit des entsprechenden Symbols aus dem zugelassenen Alphabet von Symbolen identifiziert wird.
- 25 12. Kommunikationssystem nach Anspruch 11, wobei die größte Walsh Spektrumkomponente auf Null gesetzt wird, nachdem bestimmt wird, dass sie die größte ist.
- 30 13. Kommunikationssystem nach Anspruch 12, wobei das Walsh Spektrum, nachdem die größte Komponente auf Null gesetzt worden ist, eine inverse Walsh-Hadamard Transformation durchläuft, um modifizierte Strahlabtastwerte zu ermitteln.
- 35 14. Kommunikationssystem nach Anspruch 13, wobei die modifizierten Strahlabtastwerte unter Verwendung einer inversen Strahlformungseinrichtung kombiniert werden, um modifizierte gespeicherte Abtastwerte zu ermitteln, die die ursprünglichen der gespeicherten Abtastwerte ersetzen, vor einer Ausführung einer nachfolgenden Iteration, um ein Symbol von einem anderen mobilen Sender zu dekodieren.
- 40 15. Kommunikationssystem nach Anspruch 1, wobei die verbesserte Basisstation dafür ausgelegt ist, um die von den Mobilstationen gesendeten Signale jeweils mit Hilfe eines zugewiesenen Zugriffscode (14) zu empfangen, wobei die Verarbeitungseinrichtung dafür ausgelegt ist, um die sequentiell zeitlich von den Antennenelementen empfangenen Abtastwerte in einem zweidimensionalen Raum/Zeit-Feld anzuordnen, wobei eine Dimension davon den verschiedenen Antennenelementen entspricht und die andere Dimension einer Empfangszeit entspricht, und zum Entscrambeln der gespeicherten numerischen Abtastwerte unter Verwendung von einem der Zugriffscode, der einer ersten der Mobilstationen zugewiesen ist, und umfasst: eine zweidimensionale numerische Transformationseinrichtung (71) zum Verarbeiten der entscrambelten gespeicherten Abtastwerte, um ein zweidimensionales Raum/Code-Feld von transformierten Abtastwerten zu erzeugen, wobei die Raumdimension des zweidimensionalen Raum/Code-Felds verschiedenen möglichen Ankunftsrichtungen von Signalen an der Basisstation, die von der Mobilstation gesendet werden, entspricht und die Code-Dimension des zweidimensionalen Felds den Informationssymbolen in einem zugelassenen Alphabet von Symbolen entspricht, wobei die transformierten Abtastwerte für einen festen Ankunftsrichtungswert der Raumdimension die Korrelationen mit den verschiedenen Informationssymbolen entlang der Code-Dimension anzeigen.
- 45 50 16. Kommunikationssystem nach Anspruch 1, wobei der verwendete Zugriffscode gewählt wird, um derjenige zu sein, der der Mobilstation zugewiesen ist, die mit der größten Signalstärke an der Basisstation empfangen wird.
- 55 17. Kommunikationssystem nach Anspruch 15, gekennzeichnet durch eine Dekodierungseinrichtung zum Dekodieren von einem der Informationssymbole, umfassend eine Bestimmungseinrichtung zum Bestimmen des größten der transformierten Abtastwerte und dadurch zum Identifizieren eines Symbols, das zu dem zugelassenen Alphabet von Symbolen und auch einer Ankunftsrichtung des Signals gehört, aus der das Informationssymbol kodiert wurde.

18. Kommunikationssystem nach Anspruch 15, **gekennzeichnet durch eine Dekodierungseinrichtung für die Dekodierung von einem der Informationssymbole, umfassend eine Kombiniereinrichtung zum Kombinieren der transformierten Abtastwerte, die benachbart entlang der Ankunftsrichtungsdimension liegen, unter Verwendung eines Satzes von Kombinierkoeffizienten, um einen kombinierten Wert für jede Position in der anderen Dimension des zweidimensionalen Felds von transformierten Abtastwerten zu erzeugen.**
19. Kommunikationssystem nach Anspruch 18, **gekennzeichnet durch eine Bestimmungseinrichtung zum Bestimmen des größten der kombinierten Werte und dadurch zum Identifizieren des dekodierten Informationssymbols.**
20. Kommunikationssystem nach Anspruch 17, wobei der größte der transformierten Abtastwerte auf Null nach einem Identifizieren des Symbols gesetzt wird.
21. Kommunikationssystem nach Anspruch 20, ferner umfassend eine inverse zweidimensionale Transformationseinrichtung (71) zum Transformieren der transformierten Abtastwerte, bei denen ein Abtastwert auf Null gesetzt ist, um modifizierte gespeicherte Abtastwerte zu ermitteln, die in der Speichereinrichtung (70) gespeichert werden.
22. Kommunikationssystem nach Anspruch 21, **gekennzeichnet durch eine Einrichtung (71) zum Verarbeiten der modifizierten gespeicherte Abtastwerte unter Verwendung der zweidimensionalen Transformationseinrichtung mit dem einer zweiten Mobilstation zugewiesenen Zugriffscode und dadurch zum Identifizieren eines Symbols, das von der zweiten Mobilstation gesendet wird.**
23. Kommunikationssystem nach Anspruch 22, wobei nach einem Identifizieren des Symbols, das von der zweiten Mobilstation gesendet wird, eine entsprechende Transformationskomponente auf Null gesetzt wird und dann eine Ausführung der inversen zweidimensionalen Transformation ausgeführt wird, um weitere modifizierte gespeicherte Abtastwerte zu erzeugen.
24. Kommunikationssystem nach Anspruch 23, wobei die weiter modifizierten Abtastwerte iterativ unter Verwendung von sukzessive gewählten Zugriffs-codes verarbeitet werden, um sukzessive Symbole, die von Mobilstationen gesendet werden, denen die Zugriffs-codes zugewiesen sind, zu identifizieren und um nach einem Identifizieren jedes Symbols die gespeicherten Abtastwerte weiter zu modifizieren, indem eine Transformationskomponente auf Null gesetzt wird und eine inverse Transformation ausgeführt wird.
25. Kommunikationssystem nach Anspruch 24, wobei die sukzessive gewählten Zugriffs-codes Mobilstationen, die an der Basisstation empfangen werden, in eine sukzessive abnehmenden Signalstärkereihenfolge zugewiesen werden.
26. Kommunikationssystem nach Anspruch 15, **dadurch gekennzeichnet, dass die zweidimensionale numerische Transformationseinrichtung (71) die Verarbeitung der gespeicherten Abtastwerte unter Verwendung einer vorgeschriebenen numerischen Zeitverschiebungs-Transformationseinrichtung (71) zwischen den korrelierten Abtastwerten und den Informationssymbolen ausführt, wobei das zweidimensionale Wiederholen der zweidimensionalen Transformation für eine Vielzahl der Zeitverschiebungen einem verzögerten Empfang von Signalen von der ersten Mobilstation entsprechend zu verzögerten Echos der Signale, verursacht durch Signalreflexionen von Objekten in dem Ausbreitungspfad, entspricht.**
27. Kommunikationssystem nach Anspruch 26, **gekennzeichnet durch eine Einrichtung (73) zur Vorhersage der Ankunftsrichtung und einer entsprechenden Ankunftszeit von jedem der Echos einer signifikanten Stärke und zum Anpassen der möglichen verschiedenen Ankunftsrichtungen, die von der zweidimensionalen numerischen Transformationseinrichtung angenommen werden, und der vorgeschriebenen Zeitverschiebungen, die für eine Korrelation verwendet werden, darauf.**
28. Kommunikationssystem nach Anspruch 27, **gekennzeichnet durch eine Kombiniereinrichtung (74) zum Kombinieren unter Verwendung eines Satzes von Gewichtungskoeffizienten-transformierten Komponenten entsprechend zu den vorgegebenen Ankunfts-Richtungen und -zeiten, um einen Satz von kombinierten Werten entsprechend zu einer Korrelation mit jedem Symbol in dem zugelassenen Alphabet von Symbolen zu ermitteln.**
29. Kommunikationssystem nach Anspruch 28, **dadurch gekennzeichnet, dass**

einer der kombinierten Werte, der die größte Größe aufweist, bestimmt wird und dadurch ein Symbol identifiziert, das von der ersten Station gesendet wird.

- 5 30. Kommunikationssystem nach Anspruch 29, gekennzeichnet durch eine Einrichtung (74) zum Einstellen auf Null von zweidimensionalen Transformationskomponenten, die dem identifizierten Symbol entsprechen und den vorgegebenen Ankunfts-Richtungen und -zeiten entsprechen, und inversen Transformieren der transformierten Komponenten nach Setzen des Symbols, der Zeit und der Richtungs-entsprechenden Komponente auf Null, um modifizierte gespeicherte Abtastwerte zu ermitteln.
- 10 31. Kommunikationssystem nach Anspruch 30, gekennzeichnet durch eine Einrichtung (84) zum iterativen Neuverarbeiten der modifizierten gespeicherten Abtastwerte unter Verwendung von sukzessive gewählten Zugriffscodes, um wiederum ein Symbol zu identifizieren, das von der Mobilstation gesendet wird, der der gewählte Zugriffscodes zugewiesen ist, und nach jeder Iteration zum Erzeugen von weiter modifizierten gespeicherten Abtastwerten für eine Verarbeitung in der nächsten Iteration.
- 15 32. Kommunikationssystem nach Anspruch 31, dadurch gekennzeichnet, dass die Zugriffscodes in einer abfallende Reihenfolge der empfangenen Signalstärke der entsprechende Mobilstation, der der Zugriffscodes zugewiesen ist, gewählt werden.
- 20 33. Verfahren zum Empfangen von Signalen, die von einer Vielzahl von Mobilstationen gesendet werden, in einem Kommunikationssystem, welches die Mobilstationen und eine verbesserte Basisstation umfasst, wobei jedes Signal mit Hilfe eines jeweils zugewiesenen Zugriffscodes (14) empfangen wird und der Zugriffscodes zum Dekodieren von Informationssymbolen verwendet wird, die zu einem zugelassenen Alphabet von Symbolen gehören, die in die Aussendungen kodiert sind, umfassend die folgenden Schritte:
- 25 a) Empfangen von Signalen die von der Vielzahl von Mobilstationen gesendet werden, an einer Antenneneinrichtung (20-22) mit Antennenelementen (22), die um einen Halterungsaufbau (21) herum angeordnet sind, und zum Erzeugen von Ausgangssignalen (23) für jedes Antennenelement (22);
- 30 b) Verstärken (311, 315), Filtern (310, 312, 314), und Umwandeln (316) von Signalen von jedem der Antennenelemente (22) in eine entsprechende Anzahl von umgewandelten Signalen (36) für eine Verarbeitung;
- c) vorübergehendes Speichern einer Anzahl von Abtastwerten (36) der Signale, die von jedem der Antennenelemente (22) bei sukzessiven Zeitaugenblicken ( $t_1 \dots t_{128}$ ) umgewandelt werden;
- 35 d) eine Verarbeitungseinrichtung (70, 71) zum iterativen Verarbeiten und Neuverarbeiten der gespeicherten Abtastwerte sukzessive, um wiederum die Information von jeder der Mobilstationen zu dekodieren, wobei die Verarbeitung, die von der Verarbeitungseinrichtung bereitgestellt wird, aus den gespeicherten Abtastwerten ein Informationssymbol identifiziert, das von einer der Mobilstationen gesendet wird, wodurch das Informationstragende Signal dekodiert wird und Werte in Abhängigkeit von dem identifizierten Informationssymbol von den gespeicherten Abtastwerten von sämtlichen Antennenelementensignalen subtrahiert, wodurch eine Störung zwischen dem eben dekodierten Signal und dem bei einer nachfolgenden Iteration zu dekodierendem Signal verringert wird.
- 40 34. Verfahren nach Anspruch 33, wobei die verbesserte Basisstation ausgelegt ist zum Empfangen der Signale, die von den Mobilstationen gesendet werden, jeweils mit Hilfe eines zugewiesenen Zugriffscodes (14), ferner umfassend die Schritte zum Anordnen (71) der Abtastwerte, die zeitlich sequentiell von den Antennenelementen empfangen werden, in einem zweidimensionalen Raum/Zeit-Feld, wobei eine Dimension davon den verschiedenen Antennenelementen entspricht und wobei die andere Dimension der Empfangszeit entspricht, Entscrambeln (71) der gespeicherten numerischen Abtastwerte unter Verwendung von einem der Zugriffscodes, der eine ersten der Mobilstationen zugewiesen ist, und Verarbeiten (71) der entscrambelten gespeicherten Abtastwerte zum Erzeugen eines zweidimensionalen Raum/Code-Felds von transformierten Abtastwerten, wobei die Raumdimensionen des zweidimensionalen Raum/Code-Felds verschiedenen möglichen Ankunftsrichtungen von Signalen an der Basisstation, die von der Mobilstation gesendet werden, entspricht und die Code-Dimension des zweidimensionalen Felds den Informationssymbolen in einem zugelassen Alphabet von Symbolen entspricht, wobei die transformierten Abtastwerte für einen festen Ankunftsrichtungswert der Raumdimension die Korrelationen mit den verschiedenen Informationssymbolen entlang der Code-Dimension anzeigen.
- 45 50 55

35. Verfahren nach Anspruch 34, dadurch gekennzeichnet, dass die Verarbeitung (71) durch Verwenden einer vorgeschriebenen Zeitverschiebung zwischen den korrelierten Abtastwerten und den Informationssymbolen ausgeführt wird; und
- 5 Wiederholen der zweidimensionalen Transformation für eine Vielzahl der Zeitverschiebungen entsprechend zu einem verzögerten Empfang von Signalen von der ersten Mobilstation entsprechend zu verzögerten Echos der Signale, die von einer Signalreflexion von Objekten in dem Ausbreitungspfad verursacht werden.
36. Verfahren nach Anspruch 35, umfassend die folgenden Schritte: Vorhersagen (73) der Ankunftsrichtung und einer entsprechenden Ankunftszeit von jedem der Echos einer signifikanten Stärke und um darauf die möglichen verschiedenen Ankunftsrichtungen, die von der zweidimensionalen numerischen Transformationseinrichtung angenommen werden, und die vorgeschriebenen Zeitverschiebungen, die für eine Korrelation verwendet werden, anzupassen.
- 10 37. Verfahren nach Anspruch 36, ferner umfassend die folgenden Schritte: Kombinieren (74) unter Verwendung eines Satzes von Gewichtungskoeffizienten-transformierten Komponenten entsprechend zu den vorgeschriebenen Richtungen und Ankunftszeiten, um einen Satz von kombinierten Werten entsprechend zu einer Korrelation mit jedem Symbol in dem zugelassenen Alphabet von Symbolen zu ermitteln.
- 20 38. Verfahren nach Anspruch 37, wobei einer der kombinierten Werte, der die größte Größe aufweise, bestimmt wird und dadurch ein Symbol identifiziert, das von der ersten Station gesendet wird.
39. Verfahren nach Anspruch 38, ferner umfassend die folgenden Schritte: Einstellen von zweidimensional transformierten Komponenten entsprechend zu dem identifizierten Symbol und entsprechend zu vorgeschriebenen Ankunfts-Richtungen und -zeiten auf Null und inverses Transformieren der transformierten Komponenten nach Setzen des Symbols, der Zeit und Richtungs-entsprechenden Komponente auf Null, um modifizierte gespeicherte Abtastwerte zu ermitteln.
- 25 40. Verfahren nach Anspruch 39, ferner umfassend die folgenden Schritte: iteratives Neuverarbeiten der modifizierten gespeicherten Abtastwerte unter Verwendung von sukzessive gewählten Zugriffscode, um wiederum ein Symbol zu identifizieren, das von der Mobilstation gesendet wird, der der gewählte Zugriffscode zugewiesen ist, und nach jeder Iteration Erzeugen von weiter modifizierten gespeicherten Abtastwerten zur Verarbeitung in der nächsten Iteration.
- 30 41. Verfahren nach Anspruch 40, wobei die Zugriffscode in einer abfallenden Reihenfolge einer empfangenen Signalstärke der entsprechenden Mobilstation, der der Zugriffscode zugewiesen ist, gewählt werden.

#### Revendications

- 40 1. Système de communication comprenant une pluralité de stations mobiles et une station de base améliorée pour recevoir des signaux depuis lesdites stations mobiles et décoder des signaux portant des informations émis à partir de celles-ci, la station de base comprenant :
- 45 a) des moyens formant antenne (20 à 22) comprenant des éléments d'antenne (22) disposés autour d'une structure de support (21) pour recevoir des signaux émis depuis ladite pluralité de stations mobiles et générer des signaux de sortie (23) à partir de chaque élément d'antenne (22) ;
- b) des moyens de conversion (30, 31) pour amplifier (311, 315), filtrer (310, 312, 314), et convertir (316) des signaux venant de chacun desdits éléments d'antenne (22) en un nombre correspondant de signaux convertis (36), pour le traitement ;
- 50 c) des moyens de mémorisation pour mémoriser temporairement un certain nombre d'échantillons desdits signaux convertis (36) à des instants successifs dans le temps ; et
- d) des moyens de traitement (70, 71) pour traiter et retraiter successivement de façon itérative lesdits échantillons mémorisés afin de décoder ladite information venant de chacune desdites stations mobiles tour à tour, dans lequel le traitement assuré par lesdits moyens de traitement identifie à partir desdits échantillons mémorisés un symbole d'information émis par l'une desdites stations mobiles, de façon à décoder par conséquent ledit signal portant une information, et soustrait des valeurs en fonction dudit symbole d'information identifié venant desdits échantillons mémorisés de tous les signaux d'éléments d'antenne, de façon à réduire par con-
- 55



séquent l'interférence entre le signal qui vient d'être décodé et le signal devant être décodé lors d'une itération suivante.

2. Système de communication selon la revendication 1, dans lequel au moins certaines des stations mobiles émettent ladite information en utilisant le même canal de fréquence radio au même moment.
3. Système de communication selon la revendication 1, dans lequel au moins certaines desdites stations mobiles émettent des signaux d'accès multiple à division de code.
4. Système de communication selon la revendication 1, dans lequel lesdits moyens de traitement comprennent de plus :
  - des moyens pour combiner des échantillons correspondants parmi lesdits échantillons mémorisés convertis à partir d'éléments d'antenne respectifs afin de renforcer les signaux reçus depuis une direction particulière, dans laquelle se trouve une station particulière parmi lesdites stations mobiles.
5. Système de communication selon la revendication 1, dans lequel lesdits signaux décodés successivement sont sélectionnés dans l'ordre descendant de force de signal reçu.
6. Système de communication selon la revendication 4, dans lequel lesdits moyens pour la combinaison calculent une somme pondérée des valeurs combinées en utilisant comme poids un jeu de coefficients de formation de faisceau complexes.
7. Système de communication selon la revendication 6, dans lequel lesdits coefficients de formation de faisceau sont adaptés lors de chaque itération pour renforcer le signal qui est décodé lors de cette itération.
8. Système de communication selon la revendication 1, dans lequel lesdits moyens de traitement comprennent :
  - des moyens de formation de faisceau pour combiner des groupes desdits échantillons mémorisés comprenant un échantillon de signal converti par lesdits moyens de conversion à partir de chaque antenne au même instant dans le temps afin de produire des échantillons de faisceaux pour des signaux reçus depuis une pluralité de directions d'arrivée à un instant correspondant dans le temps.
9. Système de communication selon la revendication 8, comprenant de plus : des moyens de dé-étalement d'accès multiple à division de code pour traiter lesdits échantillons de faisceaux reçus à des instants successifs dans le temps à partir de la même direction parmi ladite pluralité de directions d'arrivée dans l'ordre afin d'identifier ledit symbole identifié émis à partir de l'une desdites stations mobiles et reçu sur ladite station de base améliorée depuis ladite direction d'arrivée.
10. Système de communication selon la revendication 9, dans lequel lesdits moyens de dé-étalement d'accès multiple à division de code comprennent le calcul d'une transformation de Walsh-Hadamard afin d'obtenir un certain nombre de composantes de spectre de Walsh, correspondant chacune à l'un d'un alphabet de symboles d'information autorisé.
11. Système de communication selon la revendication 10, dans lequel ledit symbole identifié est identifié en déterminant la plus grande desdites composantes de spectre de Walsh, et, par conséquent le symbole correspondant, parmi ledit alphabet de symboles autorisé.
12. Système de communication selon la revendication 11, dans lequel ladite composante de spectre de Walsh la plus grande est établie à zéro après qu'il a été déterminé qu'elle était la plus grande.
13. Système de communication selon la revendication 12, dans lequel ledit spectre de Walsh après que ladite composante la plus grande a été établie à zéro est transformé selon une transformation de Walsh-Hadamard inverse afin d'obtenir des échantillons de faisceaux modifiés.
14. Système de communication selon la revendication 13, dans lequel lesdits échantillons de faisceaux modifiés sont combinés à l'aide de moyens de formation de faisceau inverses afin d'obtenir des échantillons mémorisés modifiés qui remplacent les échantillons originaux parmi lesdits échantillons mémorisés avant d'effectuer une itération sui-

vante pour décoder un symbole à partir d'un émetteur mobile différent.

- 5 15. Système de communication selon la revendication 1, dans lequel ladite station de base améliorée est adaptée pour recevoir lesdits signaux émis à partir desdites stations mobiles, chacun à l'aide d'un code d'accès assigné (14), dans lequel lesdits moyens de traitement sont adaptés pour agencer lesdits échantillons reçus en séquence dans le temps depuis lesdits éléments d'antenne dans un groupement espace/temps à deux dimensions, une dimension de celui-ci correspondant aux différents éléments d'antenne et l'autre dimension correspondant au temps de réception, et pour décrypter les échantillons numériques mémorisés à l'aide de l'un desdits codes d'accès assignés à une première desdites stations mobiles, et comprend : des moyens de transformation numérique à 10 deux dimensions (71) pour traiter lesdits échantillons mémorisés décryptés afin de produire un groupement espace/code à deux dimensions d'échantillons transformés, la dimension d'espace dudit groupement espace/code à deux dimensions correspondant aux différentes directions d'arrivée possibles de signaux sur ladite station de base, émis par ladite première station mobile, et la dimension de code dudit groupement à deux dimensions correspondant aux symboles d'information dans un alphabet de symboles autorisé, dans lequel les échantillons transformés pour une valeur de direction d'arrivée fixe de la dimension d'espace indiquent les corrélations avec les différents symboles d'information le long de la dimension de code.
- 20 16. Système de communication selon la revendication 1, dans lequel ledit code d'accès utilisé est choisi de façon à être celui assigné à la station mobile qui est reçue avec la plus grande force de signal sur ladite station de base.
- 25 17. Système de communication selon la revendication 15, caractérisé par des moyens de décodage pour le décodage de l'un desdits symboles d'information, comprenant des moyens de détermination pour déterminer le plus grand desdits échantillons transformés et identifier par conséquent un symbole appartenant audit alphabet de symboles autorisé, ainsi qu'une direction d'arrivée du signal, dans lequel ledit symbole d'information a été codé.
- 30 18. Système de communication selon la revendication 15, caractérisé par des moyens de décodage pour ledit décodage de l'un desdits symboles d'information, comprenant des moyens de combinaison pour combiner lesdits échantillons transformés qui se trouvent au voisinage de la dimension de direction d'arrivée à l'aide d'un jeu de coefficients de combinaison afin de produire une valeur combinée pour chaque position dans l'autre dimension dudit groupement à deux dimensions d'échantillons transformés.
- 35 19. Système de communication selon la revendication 18, caractérisé par des moyens de détermination pour déterminer la plus grande desdites valeurs combinées et identifier par conséquent ledit symbole d'information décodé.
- 40 20. Système de communication selon la revendication 17, dans lequel le plus grand desdits échantillons transformés est établi à zéro après l'identification dudit symbole.
- 45 21. Système de communication selon la revendication 20, comprenant de plus : des moyens de transformation à deux dimensions inverses (71) pour transformer lesdits échantillons transformés comportant un échantillon établi à zéro afin d'obtenir des échantillons mémorisés modifiés mémorisés dans lesdits moyens de mémorisation (70).
- 50 22. Système de communication selon la revendication 21, caractérisé par des moyens (71) pour traiter lesdits échantillons mémorisés modifiés à l'aide desdits moyens de transformation à deux dimensions avec le code d'accès assigné à une deuxième station mobile, et identifier par conséquent un symbole émis par ladite deuxième station mobile.
- 55 23. Système de communication selon la revendication 22, dans lequel, après l'identification du symbole émis par ladite deuxième station mobile, une composante de transformation correspondante est établie à zéro, après quoi la réalisation de ladite transformation à deux dimensions inverse est effectuée afin de produire d'autres échantillons mémorisés modifiés.
24. Système de communication selon la revendication 23, dans lequel lesdits autres échantillons modifiés sont traités de façon itérative à l'aide de codes d'accès sélectionnés successivement afin d'identifier successivement des symboles émis par des stations mobiles auxquelles sont assignés lesdits codes d'accès, et, après l'identification de chaque symbole, afin de modifier à nouveau lesdits échantillons mémorisés en établissant à zéro une composante transformée et en réalisant une transformation inverse.
25. Système de communication selon la revendication 24, dans lequel lesdits codes d'accès sélectionnés successi-

vement sont assignés à des stations mobiles reçues sur ladite station de base dans un ordre de force de signal successivement descendant.

26. Système de communication selon la revendication 15, caractérisé en ce que  
 5 lesdits moyens de transformation numérique à deux dimensions (71) effectuent ledit traitement desdits échantillons mémorisés à l'aide de moyens de transformation numérique à décalage dans le temps prescrit (71) qui sont présents entre les échantillons corrélés et lesdits symboles d'information ; ladite répétition de ladite transformation à deux dimensions pour une pluralité desdits décalages dans le temps correspondant à la réception retardée de signaux depuis ladite première station mobile, correspondant à des échos retardés desdits signaux  
 10 provoqués par la réflexion de signaux à partir d'objets dans le trajet de propagation.
27. Système de communication selon la revendication 26, caractérisé par des moyens (73) pour prédire la direction d'arrivée et le temps d'arrivée correspondant de chacun desdits échos de force significative et pour adapter à  
 15 ceux-ci lesdites différentes directions d'arrivée possibles prises par lesdits moyens de transformation numérique à deux dimensions et lesdits décalages dans le temps prescrits utilisés pour la corrélation.
28. Système de communication selon la revendication 27, caractérisé par des moyens de combinaison (74) pour combiner l'utilisation d'un jeu de composantes transformées par des coefficients de pondération correspondant  
 20 auxdites directions et auxdits temps d'arrivée prédits afin d'obtenir un jeu de valeurs combinées correspondant à la corrélation avec chaque symbole dans ledit alphabet de symboles autorisé.
29. Système de communication selon la revendication 28, caractérisé par le fait que l'une desdites valeurs combinées qui a la plus grande valeur est déterminée, et identifie par conséquent un symbole émis par ladite première station.
- 25 30. Système de communication selon la revendication 29, caractérisé par des moyens (74) pour établir à zéro des composantes transformées à deux dimensions correspondant audit symbole identifié et correspondant auxdites directions et auxdits temps d'arrivée prédits, et transformer par une transformation inverse lesdites composantes transformées après l'établissement à zéro de ladite composante correspondant au symbole, au temps et à la direction afin d'obtenir des valeurs d'échantillons mémorisées modifiées.
- 30 31. Système de communication selon la revendication 30, caractérisé par des moyens (74) pour retraiter de façon itérative lesdits échantillons mémorisés modifiés à l'aide de codes d'accès sélectionnés successivement pour identifier tour à tour un symbole émis par la station mobile à laquelle a été assigné le code d'accès sélectionné, et, après chaque itération, pour générer d'autres échantillons mémorisés encore modifiés pour le traitement dans  
 35 l'itération suivante.
32. Système de communication selon la revendication 31, caractérisé en ce que lesdits codes d'accès sont sélectionnés dans un ordre descendant de force de signal reçu de la station mobile correspondante à laquelle est assigné le code d'accès.  
 40
33. Procédé pour recevoir des signaux émis à partir d'une pluralité de stations mobiles, dans un système de communication comprenant lesdites stations mobiles et une station de base améliorée, chaque signal étant reçu à l'aide d'un code d'accès respectivement assigné (14) et dudit code d'accès utilisé pour décoder des symboles d'information appartenant à un alphabet de symboles autorisé codé dans lesdites émissions, comprenant les étapes  
 45 suivantes :
- a) la réception de signaux émis depuis ladite pluralité de stations mobiles sur des moyens formant antenne (20 à 22) avec des éléments d'antenne (22) disposés autour d'une structure de support (21) et la génération de signaux de sortie (23) à partir de chaque élément d'antenne (22) ;
  - 50 b) l'amplification (311, 315), le filtrage (310, 312, 314), et la conversion (316) de signaux venant de chacun desdits éléments d'antenne (22) en un nombre correspondant de signaux convertis (36) pour le traitement ;
  - c) la mémorisation temporaire d'un certain nombre d'échantillons (36) desdits signaux convertis à partir de chacun desdits éléments d'antenne (22) à des instants successifs dans le temps (t1, ..., t128) ;
  - 55 d) le traitement par des moyens (70, 71), pour effectuer un traitement et un retraitement itératifs successifs, desdits échantillons mémorisés afin de décoder ladite information venant de chacune desdites stations mobiles tour à tour, dans lequel le traitement assuré par lesdits moyens de traitement identifie à partir desdits échantillons mémorisés un symbole d'information émis par l'une desdites stations mobiles, de façon à décoder par conséquent ledit signal portant une information, et soustrait des valeurs dépendant dudit symbole d'infor-

mation identifié desdits échantillons mémorisés de tous les signaux d'éléments d'antenne, de façon à réduire par conséquent l'interférence entre le signal qui vient d'être décodé et le signal qui doit être décodé lors d'une itération suivante.

- 5 34. Procédé selon la revendication 33, dans lequel ladite station de base améliorée est adaptée pour recevoir lesdits signaux émis à partir desdites stations mobiles, chacun à l'aide d'un code d'accès assigné (14), comprenant de plus les étapes d'agencement (71) desdits échantillons reçus en séquence dans le temps à partir desdits éléments d'antenne dans un groupement espace/temps à deux dimensions, une dimension de celui-ci correspondant aux différents éléments d'antenne et l'autre dimension correspondant au temps de réception, de décryptage (71) des échantillons numériques mémorisés à l'aide de l'un desdits codes d'accès assignés à une première station parmi lesdites stations mobiles, et de traitement (71) desdits échantillons mémorisés décryptés afin de produire un groupement espace/code à deux dimensions d'échantillons transformés, la dimension d'espace dudit groupement espace/code à deux dimensions correspondant à différentes directions d'arrivée possibles de signaux sur ladite station de base, émis par ladite première station mobile, et la dimension de code dudit groupement à deux dimensions correspondant aux symboles d'information dans un alphabet de symboles autorisé, dans lequel les échantillons transformés pour une valeur de direction d'arrivée fixe de la dimension d'espace indiquent les corrélations avec les différents symboles d'information le long de la dimension de code.
- 10
- 15
- 20 35. Procédé selon la revendication 34, caractérisé en ce que ledit traitement (71) est effectué en utilisant un décalage dans le temps prescrit entre les échantillons corrélés et lesdits symboles d'information ; et en répétant ladite transformation à deux dimensions pour une pluralité desdits décalages dans le temps correspondant à une réception retardée de signaux depuis ladite première station mobile correspondant à des échos retardés desdits signaux provoqués par la réflexion de signaux à partir d'objets dans le trajet de propagation.
- 25 36. Procédé selon la revendication 35, comprenant de plus les étapes suivantes : la prédiction (73) de la direction d'arrivée et du temps d'arrivée correspondant de chacun desdits échos de force significative et pour adapter à ceux-ci lesdites différentes directions d'arrivée possibles assumées par lesdits moyens de transformation numérique à deux dimensions et lesdits décalages dans le temps prescrits utilisés pour la corrélation.
- 30 37. Procédé selon la revendication 36, comprenant de plus les étapes suivantes : la combinaison (74), à l'aide d'un jeu de composantes transformées par des coefficients de pondération correspondant auxdites directions et auxdits temps d'arrivée prédits, afin d'obtenir un jeu de valeurs combinées correspondant à une corrélation avec chaque symbole dans ledit alphabet de symboles autorisé.
- 35 38. Procédé selon la revendication 37, dans lequel l'une desdites valeurs combinées qui a la plus grande valeur est déterminée, et identifie par conséquent un symbole émis par ladite première station.
- 40 39. Procédé selon la revendication 38, comprenant de plus les étapes suivantes : l'établissement à zéro de composantes transformées à deux dimensions correspondant audit symbole identifié et correspondant auxdites directions et auxdits temps d'arrivée prédits et la transformation par une transformation inverse desdites composantes transformées après l'établissement à zéro de ladite composante correspondant à un symbole, à un temps et à une direction afin d'obtenir des valeurs d'échantillons mémorisées modifiées.
- 45 40. Procédé selon la revendication 39, comprenant de plus les étapes suivantes : le retraitement itératif desdits échantillons mémorisés modifiés à l'aide de codes d'accès sélectionnés successivement afin d'identifier tour à tour un symbole émis par la station mobile à laquelle est assigné le code d'accès sélectionné, et, après chaque itération, la génération d'autres échantillons mémorisés modifiés pour le traitement lors de l'itération suivante.
- 50 41. Procédé selon la revendication 40, dans lequel lesdits codes d'accès sont sélectionnés dans l'ordre descendant de force de signal reçu de la station mobile correspondante à laquelle est assigné le code d'accès.

55

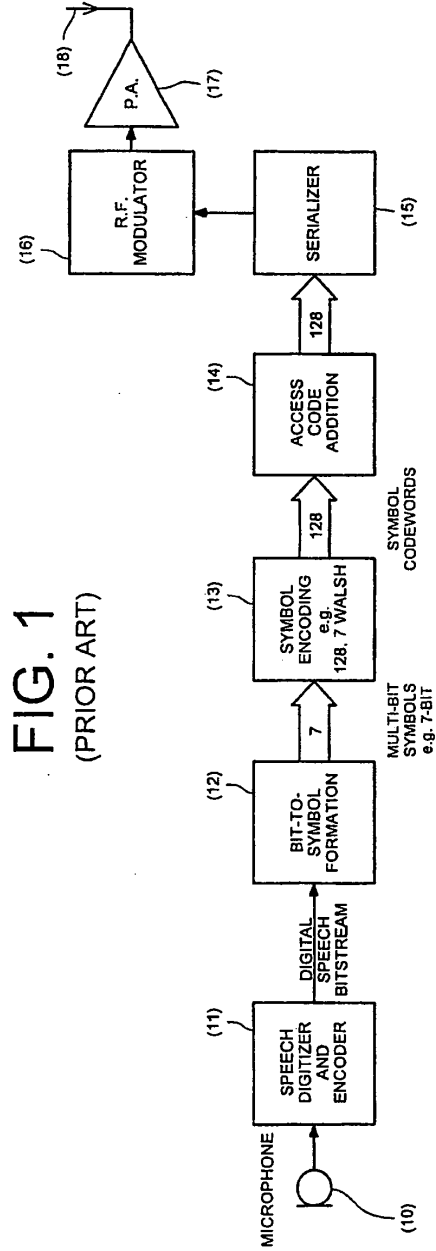

**FIG. 1**  
(PRIOR ART)

FIG. 2

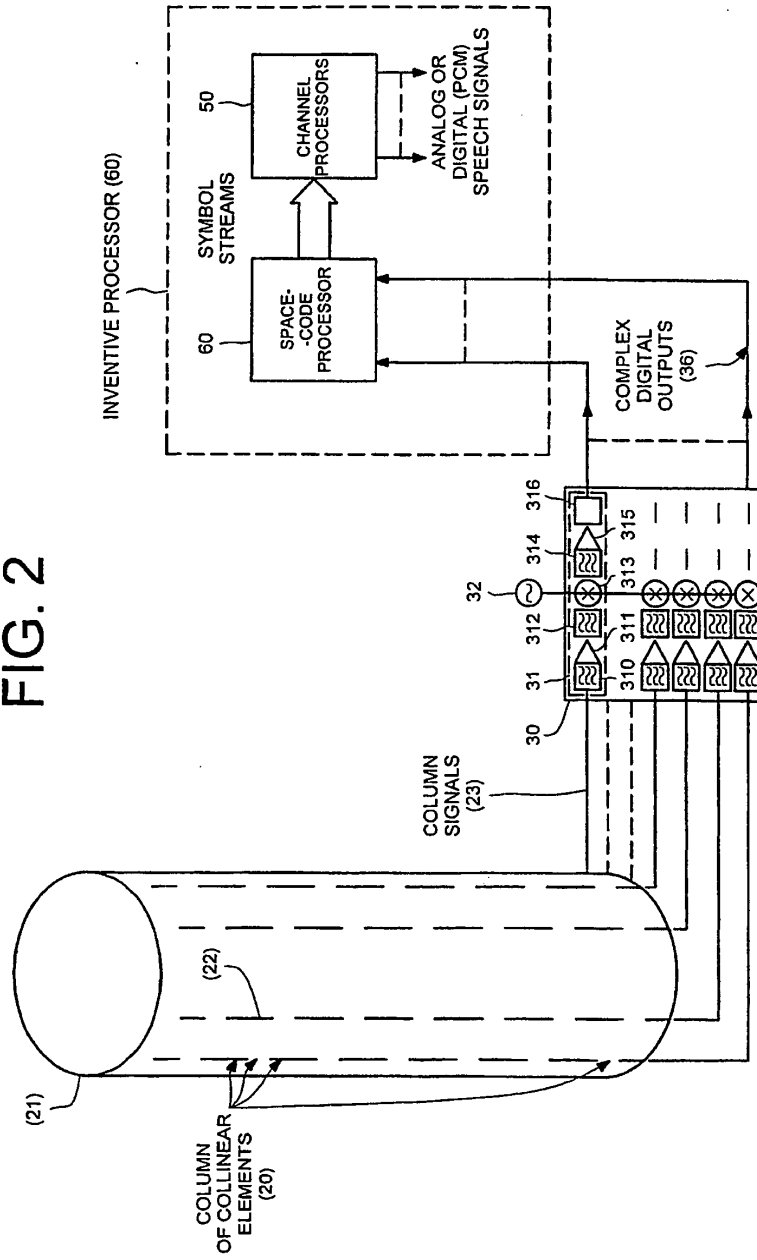

FIG. 3

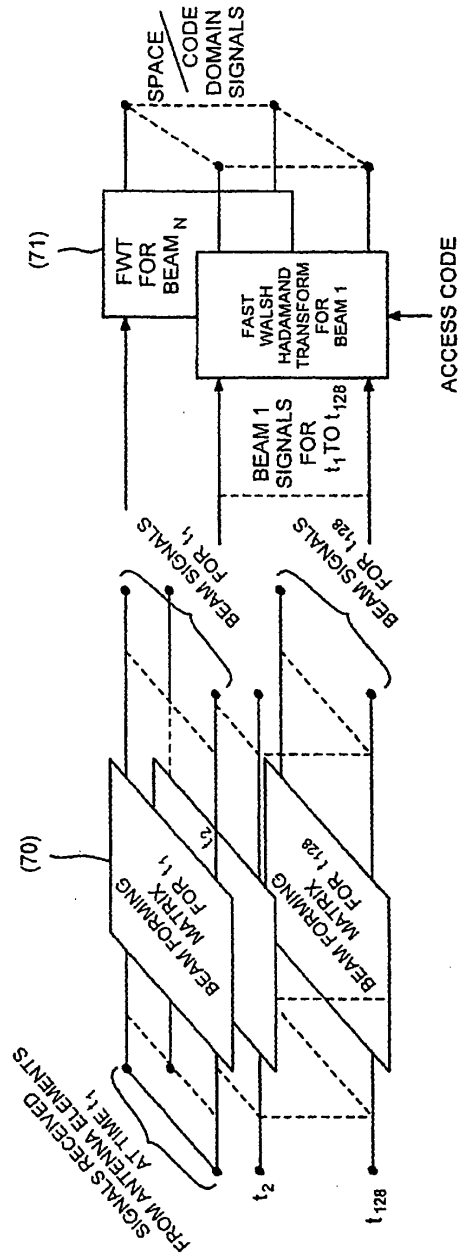

FIG. 4

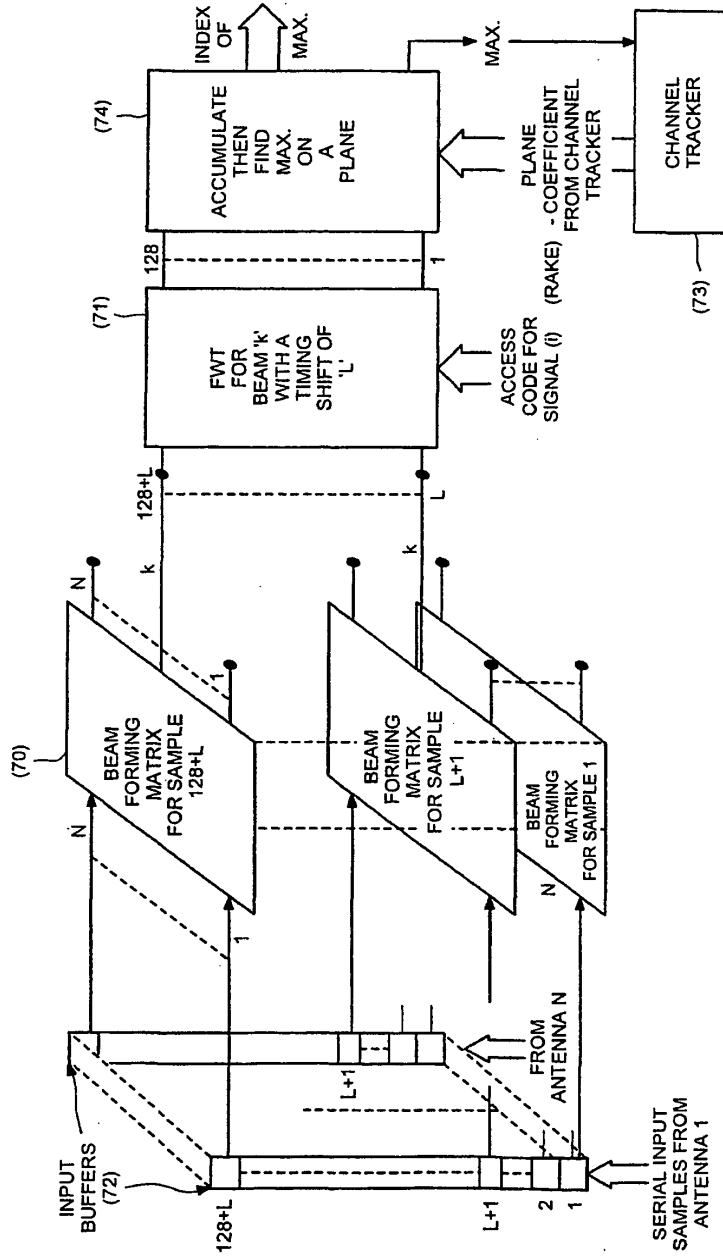
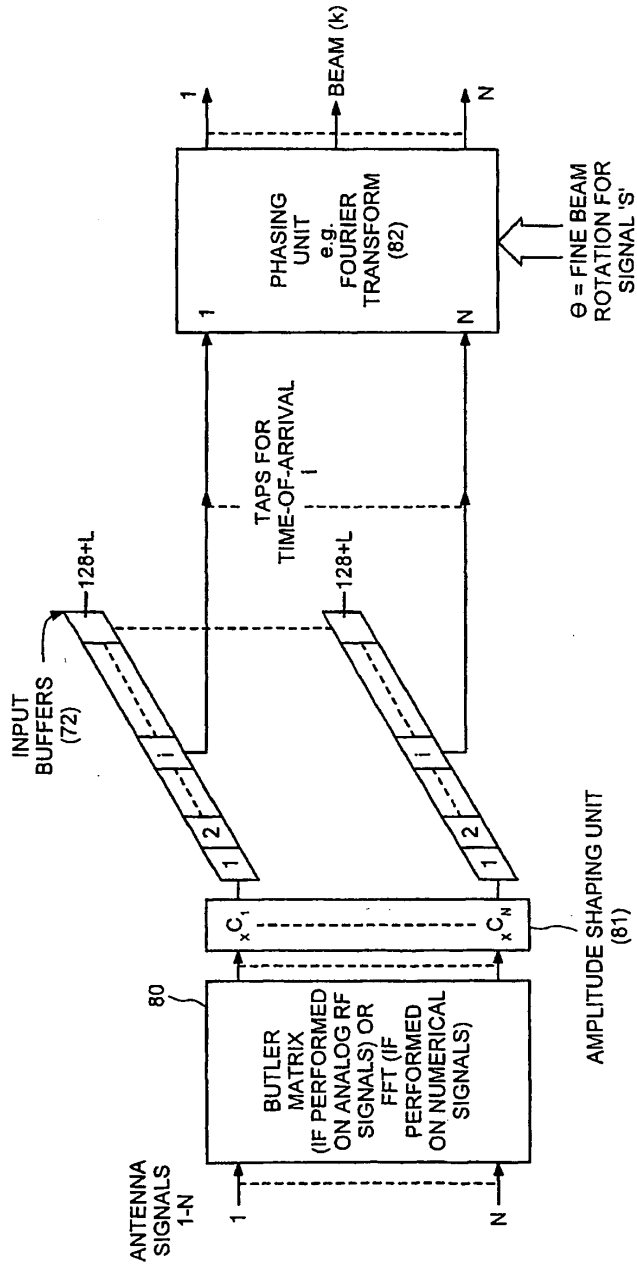



FIG. 5





INTERNATIONAL APPLICATION PUBLISHED UNDER THE PATENT COOPERATION TREATY (PCT)

<p>(51) International Patent Classification 5 : H04Q 7/04, H04B 7/26</p>	<p>A1</p>	<p>(11) International Publication Number: WO 94/01978 (43) International Publication Date: 20 January 1994 (20.01.94)</p>
<p>(21) International Application Number: PCT/US93/06531 (22) International Filing Date: 12 July 1993 (12.07.93) (30) Priority data: 07/911,971 10 July 1992 (10.07.92) US (71)(72) Applicants and Inventors: RIMER, Neil, Alexander [CH/CH]; 9, avenue Jacques-Martin, CH-1224 Geneva (CH). GUTIERREZ, Peter [GB/GB]; 29 Athens Gardens, Elgin Avenue, London W9 3RS (GB). FIORENTINO, Marco, Alberto [IT/US]; 931 Massachusetts Avenue, #203, Cambridge, MA 02139 (US). (74) Agent: LOGINOV, William, A.; Wolf, Greenfield &amp; Sacks, Federal Reserve Plaza, 600 Atlantic Avenue, Boston, MA 02210 (US).</p>	<p>(81) Designated States: CA, European patent (AT, BE, CH, DE, DK, ES, FR, GB, GR, IE, IT, LU, MC, NL, PT, SE).  Published <i>With international search report. Before the expiration of the time limit for amending the claims and to be republished in the event of the receipt of amendments.</i></p>	

(54) Title: SYSTEM FOR LOCATING AND COMMUNICATING WITH MOBILE VEHICLES

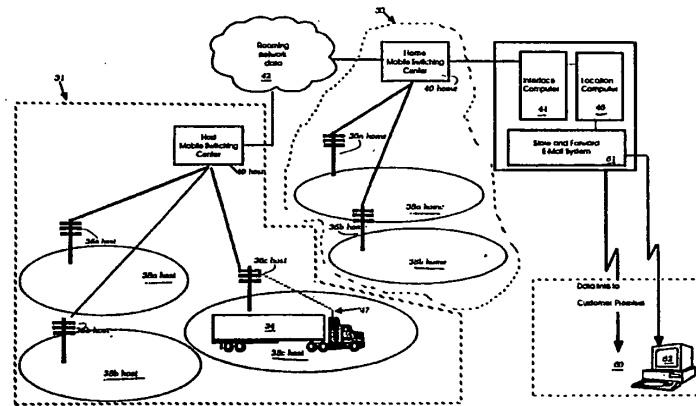

(57) Abstract

A vehicle location system which provides a plurality of cellular systems that each includes a memory for identifying the cellular subscriber stations that are based in the particular system and visiting cellular subscriber stations based in another of the systems. The plurality of cellular systems include a roaming network that interconnects and transfers data in the memory relative to the presence of home and visiting cellular subscriber stations in the systems. An interface computer is provided to interconnect with at least one of the plurality of cellular systems. The interface computer accesses data in the roaming network relative to predetermined cellular subscriber stations. A location computer interconnects with the interface computer and translates the interface computer data relative to these predetermined cellular subscriber stations into location data that indicates the position of each cellular subscriber stations based upon the known position of the particular cellular system in which the subscriber station is currently registered. A user interface, that may include messaging systems and an electronic mail system, interconnect between a user and the location computer and allows access to location and related data relative to specified fleets of subscriber stations.

BEST AVAILABLE COPY

**FOR THE PURPOSES OF INFORMATION ONLY**

Codes used to identify States party to the PCT on the front pages of pamphlets publishing international applications under the PCT.

AT	Austria	FR	France	MR	Mauritania
AU	Australia	GA	Gabon	MW	Malawi
BB	Barbados	GB	United Kingdom	NE	Niger
BE	Belgium	GN	Guinea	NL	Netherlands
BF	Burkina Faso	GR	Greece	NO	Norway
BG	Bulgaria	HU	Hungary	NZ	New Zealand
BJ	Benin	IE	Ireland	PL	Poland
BR	Brazil	IT	Italy	PT	Portugal
BY	Belarus	JP	Japan	RO	Romania
CA	Canada	KP	Democratic People's Republic of Korea	RU	Russian Federation
CF	Central African Republic	KR	Republic of Korea	SD	Sudan
CG	Congo	KZ	Kazakhstan	SE	Sweden
CH	Switzerland	LJ	Liechtenstein	SI	Slovenia
CJ	Côte d'Ivoire	LK	Sri Lanka	SK	Slovak Republic
CM	Cameroon	LJ	Luxembourg	SN	Senegal
CN	China	LV	Latvia	TD	Chad
CS	Czechoslovakia	MC	Monaco	TC	Togo
CZ	Czech Republic	MG	Madagascar	UA	Ukraine
DE	Germany	ML	Mali	US	United States of America
DK	Denmark	MN	Mongolia	UZ	Uzbekistan
ES	Spain			VN	Viet Nam
FI	Finland				

SYSTEM FOR LOCATING AND COMMUNICATING  
WITH MOBILE VEHICLES

Field of the Invention

This invention relates to the field of mobile vehicle location determination and corresponding messaging systems and, more particularly, to a system that allows relatively low-cost fleet management of vehicles over a wide geographical area.

Background of the Invention

Demand for mobile vehicle positioning and messaging is growing very rapidly. A typical application for such a mobile vehicle positioning and messaging system is in the field of truck fleet management whereby a central dispatch office of a trucking company may obtain the location of each truck in a widely dispersed geographical area upon demand. Using such a system, the dispatch office can track the location and progress of each vehicle, thus updating the vehicle's arrival time for customers. Some systems currently available also allow the transmission of messages between the truck and dispatch office while enroute; this facilitates diversion of the truck to additional pick-up sites, for example.

One class of available system that allows the sending and receiving of messages is provided by Qualcomm. The system, named Omnitrac<sup>SM</sup>, uses satellites to determine vehicle position via triangulation. A dish antenna which tracks the satellites is mounted within each vehicle in a pod placed, generally, upon the vehicle roof. The dish must continuously track the location of the satellite as the vehicle moves. Messages to and from the vehicle are limited to pager style alpha-numeric readouts. Voice and facsimile

- 2 -

messages are also unavailable due to the limited bandwidth of satellite transmission. However, the most significant disadvantage to the Qualcomm system is cost. The vehicle-borne base unit and the satellites are rather expensive to maintain. Additionally, the dish mechanism may be prone to breakage since it is an electromechanical link that must maintain fairly precise alignment while subjected to extreme vibration and jarring in the normal highway environment.

Another class of available vehicle location systems are systems such as Motorola's CoveragePLUS™ system based upon the Specialized Mobile Radio (SMR) system. In these systems vehicles carry conventional 2-way SMR units for mobile radio communication. These units communicate with one of a number of dedicated and proprietary fixed earth stations that have been installed or converted expressly for vehicle location use. The system determines which earth station is within range of the mobile unit, thereby obtaining the approximate vehicle location. The location determination is based largely upon signal strength. A major disadvantage of the CoveragePLUS™ system is the large investment necessary to deploy the required dedicated earth stations. Since accuracy of the CoveragePLUS™ system is inversely related to the range of each earth station, a large number of stations is required to provide adequate coverage. In order to cover the continental United States, therefore, CoveragePLUS™ requires over 1,200 dedicated earth stations. Even using existing radio towers, the cost of equipment would be quite substantial and on the order of tens of millions of dollars. Higher accuracy may be obtained by equipping the vehicle with an outside positioning system such as LORAN C, and transmitting the LORAN C longitude and latitude data over the radio link. This higher accuracy comes at the cost of equipping each vehicle with a LORAN C receiver, which at the time of this application involves about \$700 per vehicle.

- 3 -

Another class of vehicle location system utilizing a somewhat unconventional antenna medium is the meteor-burst system. Vehicles are equipped with a LORAN C device or equivalent triangulation system that establishes each vehicle's position using government-operated transmitters. The position data from these LORAN C units is then transmitted from the vehicle to the base station via reflections off of the ionized "tails" of micro-meteorites entering the earth's atmosphere. Signals in the range of 37 Mhz to 70 Mhz are reflected by these tails. Thus, short packets of radio signals may be transmitted from the vehicle to the base station during meteor bursts. These bursts may also carry rather short data/text messages to and from the vehicle. A great disadvantage to this system is that a number of base stations (100 or more) must be dedicated to receiving transmissions from meteor bursts. Since meteor bursts are intermittent and unpredictable in time and location, in order to insure the receipt of a signal from one of the bursts, a very large number of costly base stations would be required. Continuous signals carrying the same data would be repeated until the correctly positioned "burst" appeared, allowing transmission to one of the base stations. Clearly, this system also requires somewhat costly vehicle-borne transceivers for utilizing the meteor bursts.

Yet another class of system that has been proposed would utilize a cellular telephone network to determine the approximate position of a vehicle. Such a system is proposed in U.S. Patent No. 4,891,650 to Sheffer for locating stolen vehicles. The system fixes upon the position of a stolen vehicle by triangulating the signal strength of the vehicle's cellular transmissions between three or more base station transmitters, or "cells" in a given cellular system. To do so, the vehicle must first register a signal to its transmitter that is activated via a signal indicating that the vehicle carrying it is being stolen. The transmitter then places a dialed call over the cellular network to a base

- 4 -

unit which then searches through the system to determine which cells the vehicle is currently near. This information may be utilized to locate the vehicle. Clearly, one disadvantage to the Sheffer system is that it requires placing a call over the cellular network, which actively engages the voice channels on the cellular network. While this form of direct transmission is perfectly acceptable in the somewhat infrequent occurrence of a vehicle theft, it would prove rather costly, and wasteful of cellular voice channels, when utilized to track an entire fleet of vehicles. Basically, it would require a continuous placement of expensive long distance cellular phone calls to continuously update vehicle location.

Additionally, the coverage of the Sheffer system is limited to only one cellular system having been modified to implement it. This would necessarily limit such a system's operation to an area such as a single city. To provide wider coverage, all switches (groupings of cells) of a particular system must be modified. This would prove very costly and require approval of all the cellular operators serving the area of interest. All the cells in each of the switches to be tapped must be similarly modified, and the interconnections between these switches must also be modified in order to provide the requisite wide coverage. Even if one were to provide a LORAN C or similar positioning unit and merely make a phone call to report the data, the cost of cellular telephone-based vehicle location would remain high since the calls themselves are expensive and continuously occupy a large number of scarce voice channels.

A vehicle location system that, unlike the above-described systems, is based entirely upon existing and established system hardware is highly desirable since implementation costs would be minimized. As such, the growing cellular telephone network currently being implemented throughout the nation, and the world, provides a likely candidate for a vehicle location system. As noted

- 5 -

above with reference to the Sheffer system, however, a system that requires placement of costly telephone calls is wasteful and expensive to operate.

A basic cellular telephone system 32 is depicted in FIG. 1. The concept of a cellular system involves utilization of a number of base stations 36a-f each having a transceiver that covers a particular transmission area known as a "cell" 38a-f. There are usually a number of cells, and an equal number of corresponding "base stations" within a particular cellular system. Often, such a system covers a given metropolitan area or highway stretch between metropolitan areas. In this example each cell 38a-f has coverage boundaries 35 that are schematically depicted as defining a hexagon. In reality, boundaries will tend to be circular and overlap each other, and may vary in dimensions based upon such factors as terrain and obstructions. Base stations are generally positioned so that a given system area is fully served in transmission and reception. The outer boundaries 41 of the system 32 are generally defined by the outermost cells therein. The base stations 32a-f are all interlinked to a particular "switch" or mobile switching center (MSC) 37. There may be more than one MSC within any given cellular system. The system 32 of FIG. 3 depicts one MSC 37 for simplicity. The MSCs are connected to the public switched telephone network (PSTN) 39 which is more commonly known as the local telephone company. The telephone company interlinks the various subscribers each having a hard wired conventional telephone set, shown schematically as the single handset 43.

Each vehicle 34a-d in communication with a particular base station includes its own on-board transceiver more commonly termed a cellular telephone or cellular subscriber station (CSS). The transceiver allows communication with a particular base station. Base stations throughout a cellular system, and throughout the country, utilize a standard communication protocol, thus, CSSs moving from one "cell" to



- 6 -

another are equipped to continue to communicate with other cells in the system.

Communication of CSSs traveling between cells in a system is coordinated by means of a communication protocol carried out between the CSSs and the switching center (MSC) via the base station covering the area in which the CSS is currently located. Thus, as a vehicle 34a moves from cell 38a to cell 38c (as shown in FIG. 1A), while engaged in a call, CSS communication from base station 36a is transferred, in an uninterrupted manner to base station 36c. The link between the vehicle CSS and a given cell is maintained because the MSC 37 is constantly updated as to the particular position of the vehicle. The MSC 37 tracks the CSS even if it is not engaged in a call because each CSS transmits, at a predetermined time, a so-called "self-registration" signal over a control radio channel. This signal comprises data representing a unique identification number (Mobile Serial Number (MSN)) identifying the particular CSS. It is transmitted on both a time-dependent periodic basis and each time the CSS sends or receives a call. The Mobile Serial Number matches a number registered in the MSC for that CSS. Note that the MSC is programmed with the CSS's Mobile Serial Number, because the CSS user is a subscriber to that particular cellular system and, thus, the user's CSS is registered with the system. Thus, when a particular cell receives the self-registration signal from a CSS, the MSC is alerted that the recognized CSS is now within that particular cell.

Until recently, the automatic updating of vehicle location occurred only on a system-wide basis (e.g., only between cells in a single system). It was generally not possible to move to an adjacent cellular system and maintain uninterrupted cellular service (particularly reception) since the new system did not recognize the presence of the "foreign" CSS's transmitted MSN number automatically. However, large groups of systems in various geographical

- 7 -

areas are now implementing a so-called "roaming" network whereby suitably equipped cellular systems are alerted to the presence of foreign (unregistered) CSSs within their system. Each switch in the roaming network is connected to the others, usually by land lines carrying telephone calls and/or data. Data is passed between the systems relative to CSSs currently present in their coverage areas on certain of these lines. The network is a system for controlling the direction of the data. As such, uninterrupted communication (roaming) is possible for CSSs traveling between systems.

It is important to note that each cellular system is identified by a unique 15 bit System Identification Number (SID) that is assigned by the FCC. Each CSS is registered only with a single cellular system, termed the "home" system as described above to which its user subscribes. In general, a CSS's home system is a cellular system that covers the area in which the CSS's user lives or travels most of the time. The SID number of the home system is stored in the CSS's internal memory (usually set by the system operator when the user's subscription begins) and is transmitted as part of the self-registration process.

This basic vehicle and host/home system identification information is carried on the roaming network in order to keep track of the various CSSs traveling within the network.

It is, therefore, an object of the present invention to provide a system for locating vehicles utilizing existing cellular telephone hardware and software for implementing a roaming standard in an unintended manner that allows location of vehicles over a widely dispersed geographical area without the need of complex, specialized and costly vehicle-borne hardware and without the need to modify the cellular network equipment.

#### Summary of the Invention

The objects of this invention are achieved by tapping roaming network information through which one can derive the

- 8 -

location of particular vehicles without actually placing costly telephone calls. Thus, an inexpensive system for tracking vehicles over a wide geographical area is possible. Additionally, there is no need to alter existing base station or switch hardware or software to tap the data, thus lowering location system implementation costs. In fact, access to only one switch that is part of a given roaming network allows access of all CSS data relative to all switches in the network since all the roaming data is shared by all the switches in the network. Using the tapped data it is possible to develop a data base of vehicle locations. To locate any vehicle it need only carry a basic cellular telephone transceiver.

In addition, using a cellular system, one is not limited to obtaining location data only. Rather, since the cellular system is designed to carry large volume voice information, one may also transmit various data and facsimile information to vehicles having cellular transceivers. Thus, location and messaging services are possible via the cellular roaming network.

A vehicle location system according to a preferred embodiment of the present invention provides an interface computer that is connected to a roaming network that joins a number of individual cellular systems. Each of the cellular systems stores data relative to and identifies cellular subscriber stations that are based within that particular system and also identifies visiting cellular subscriber stations from other cellular systems that are currently within the given system. The roaming network transfers identification data between each of these cellular systems so that each cellular subscriber station's home system may keep track of the cellular subscriber station and transfer calls to and from the station while the station is situated in another cellular system.

The interface computer accesses roaming network data via a given cellular system and scans that data for predetermined

cellular subscriber station identification numbers that correspond to particular stations of interest to a user. These stations, which may comprise a fleet of vehicles, generally carry the tapped cellular system as their registered "home" system. That user may be a fleet operator or other mobile vehicle management entity.

In order to interpret the tapped interface data relative to predetermined subscriber stations, a location computer taps, on demand of a user or at predetermined intervals of time, into the interface computer data. The location computer then interprets, cellular system identification data corresponding to each predetermined vehicle. Location data is particularly derived by comparing system identifications to known geographical locations for those particular systems. This data is then correlated to each vehicle and formatted so that a user may easily review the location of various subscriber stations. Such review may include electronic display maps, charts, graphs and textual formats.

This system may be adapted to tap multiple roaming networks, where more than one network is in place, by determining the probable location of moving vehicles from one roaming network to another. This may entail predicting vehicle location using previous vehicle position, speed and approximate direction. Such data would be stored within the memory of the location computer for each vehicle and would be transferred to an appropriate interface computer interconnected with each roaming network through a given cellular system attached thereto.

#### Brief Description of the Drawings

The foregoing and other objects and advantages of the invention will become clearer by referring to the following detailed description and the drawing, in which:

FIGS. 1 and 1A are schematic diagrams of a simplified cellular system as utilized by the vehicle location system

- 10 -

according to this invention with vehicles moving between different system cells at first and second times;

FIG. 2 is a schematic diagram of an overview of the vehicle location system according to this invention;

FIG. 3 is more detailed schematic diagram of the peripheral transmission and data display elements of the vehicle location system of FIG. 1;

FIG. 4 is a schematic diagram of a roaming network for joining a plurality of cellular systems utilized in the vehicle location system according to this invention;

FIG. 5 is a schematic diagram of a basic location system implementation according to this invention;

FIG. 6 is a flow diagram of an interface procedure for use by the interface computer of FIG. 5;

FIG. 6A is a schematic diagram of memory locations for a typical interface computer according to this invention;

FIG. 7 is a flow diagram of a procedure for use by the location computer of FIG. 5;

FIG. 8 is a flow diagram of the location update procedure for use by the location computer based upon reported changes from the interface computer of FIG. 5;

FIG. 9 is a schematic diagram of a typical mobile vehicle cellular telephone configurator including data and facsimile peripherals according to this invention;

FIG. 10 is a schematic diagram of the mobile vehicle cellular configuration of FIG. 9 including LORAN C for more accurate location determination according to this invention;

FIG. 11 is a schematic diagram of a vehicle location system according to an alternative embodiment of this invention in which multiple roaming networks are accessed;

FIG. 12 is a flow diagram of the main procedure for a location computer interfaced with multiple roaming network systems according to the FIG. 11 embodiment of this invention;

FIG. 13 is a flow diagram of a procedure for use in computing and updating location information by the location computer of FIG. 12;

- 11 -

FIG. 14 is a flow diagram of a procedure for expanding and restricting the search for a vehicle based upon its last known location, for use in the multiple roaming embodiment of FIG. 12; and

FIG. 15 is a schematic diagram of a typical system implementing the European GSM roaming standard.

#### Detailed Description of Preferred Embodiments

An overview of the cellular vehicular location system according to this invention is depicted in FIG. 2. A vehicle 34 (similar to the multiple vehicles 34a-d of FIG. 1) having an on-board cellular subscriber station (CSS) 47 is served by base station 36c<sub>HOST</sub> of cell 38c<sub>HOST</sub> of one of a plurality of cellular systems. The systems depicted include the vehicle's "home" system 33 and a remote "host" system 31. Each system includes one corresponding switch, 40<sub>HOME</sub> and 40<sub>HOST</sub> respectively, interconnecting various base stations 36a-b<sub>HOME</sub> and 36a-c<sub>HOST</sub> in cells 38a-b<sub>HOME</sub> and 38a-c<sub>HOST</sub>. It is assumed that the cellular systems described herein implement a protocol defined in ELECTRONIC INDUSTRIES ASSOCIATION/TELECOMMUNICATIONS INDUSTRIES ASSOCIATION (EIA/TIA) Standard for Mobile Station-Land Station Compatibility, Specification EIA/TIA-553 (September 1989 publication) which is incorporated by reference herein. As previously discussed, according to this standard, each vehicle which carries a CSS is assigned a unique 32 bit Mobile Serial Number (MSN) that is permanently stored in its security memory (not shown). The vehicle 34 in this figure is traveling in a system 31 other than its own registered "home" cellular system 33. The remote "host" system 31 within which the vehicle 24 is traveling may recognize the vehicle by means of its 32 bit MSN which is transmitted at regular time intervals by the vehicle Cellular Subscriber Station (CSS) 47. By "registering" or, in the case of automatic signalling "self-registering" with the host system 31, the vehicle 34 CSS makes its presence known to the host.

- 12 -

It is assumed, for the purposes of this description, that the vehicle's host system 31 and home system 33 are joined together by a network 42 adhering to the standards set forth in EIA/TIA-553 and also to the so called "roaming" standard currently being instituted under ELECTRONIC INDUSTRIES ASSOCIATION/TELECOMMUNICATIONS INDUSTRIES ASSOCIATION (EIA/TIA) IS.41 Interim Standard for Cellular Radio Telecommunications Intersystem Operations, Specification (January, 1991). This standard should be deemed to be incorporated herein by reference. As previously discussed, this roaming standard allows a vehicle to be located and to communicate with another cellular system via a link referred to as the "roaming network". Thus, as a vehicle 34 moves from the area serviced by one cellular system to the area serviced by another, the roaming network 42 informs the vehicle's home system 33 of this new location, allowing the home system to route calls to the CSS vehicle 34, wherever it may be in the network 42, as a result of which callers can reach the CSS 35 of the vehicle 34, and vice versa.

As discussed above, minimum communication linkage via a roaming network is maintained, particularly by means of the self-registration process carried out by the CSS. According to this process an identification signal (MSN) is sent by the vehicle, and received by the host MSC, at a predetermined time interval or when the CSS user makes and receives calls. The self-registration process, thus, acts as a tracking "beacon" that is received by the closest base station in the system in which the CSS is currently present. The roaming network allows the base station and, hence, the system to identify the CSS. Therefore, means for tracking a vehicle as it travels has been developed by us, using this network. Data received by the home system 33 from the host system 31 through the roaming network 42 is utilized by depicted interface and location computers 44 and 46, respectively, according to this invention, to determine the current

- 13 -

location of each vehicle carrying a CSS. The vehicle location is thus known to within the geographic area of a single cell and/or the geographic area served by the MSC serving that cell. The particular mechanics involved in interfacing with the roaming network will be described further below.

Vehicle and user peripherals for use with the vehicle location system are illustrated in FIG. 3. The system implementation includes the mobile equipment 48 of a vehicle CSS's 34' which includes a standard cellular telephone 50 and may include peripherals such as a modem 52 to interconnect a text terminal and/or on-board computer and a facsimile machine 56. The mobile equipment is joined by a standard cellular radio link, which transmits both voice line and self-registration signals, to the cellular network which includes the various cellular systems joined by the roaming network which allows conventional calls or facsimile messages to be transferred to and from the vehicle from the vehicle's home base 60. According to this invention, information from the cellular network 58 (systems joined by a roaming capability) is utilized by the interface computer 44 and location computer 46, to determine and transmit the vehicle's location data to a home base terminal or computer system 62 adapted to receive external communications via an electronic mail system 61 to which the interface and location computers 44, 46 are linked. This customer may have its own voice unit (e.g., telephone) 63 and facsimile unit 65, as well. Note that, according to this invention, it is equally possible to transmit and display location information to the customer premises through a variety of other links, such as direct transmission without an electronic mail link.

FIGS. 2 and 3, thus, generally depict the vehicle location system according to this invention and should be referred to generally throughout the following detailed description.



- 14 -

As noted, a CSS operating outside the area served by its home system may be referred to as "roaming". While roaming, a CSS is thus being served by a non-home "host" system. Absent agreed protocols, the host has no way of recognizing the identity of the CSS and no data exchange necessary for communication as be carried out by the host. Thus, an agreed, standardized (and preprogrammed) protocol, via the roaming network, is necessary in order to allow each cellular system to recognize other systems' roaming registered CSSs.

To provide "seamless" roaming capability to users (i.e., without interruption in service when traveling from one cellular system to another) while traveling over geographical areas served by several cellular systems, roaming under EIA/TIA IS.41 standard is being implemented. This standard specifies how individual cellular systems are interconnected to form a "roaming network". All relevant portions of EIA/TIA IS.41 are hereby incorporated herein by reference.

#### Detailed Operation of The Roaming Network and System Implementation

The "mechanics" of the roaming network are further detailed in FIG. 4. Each of cellular systems I, II and III, 64, 66 and 68 respectively, maintains a group of data bases (registers) that include the Home Location Register (HLR) 70<sub>I</sub>, 70<sub>II</sub> and 70<sub>III</sub> and the Visitor Location Register (VLR) 72<sub>I</sub>, 72<sub>II</sub>, and 72<sub>III</sub> that are part of each switch (MSC) in the system. The HLR 70<sub>I-III</sub> store specified information relating to each CSS registered with that specific cellular system. In other words, each HLR 70<sub>I-III</sub> stores information relating to those CSSs whose home is specified as being that HLR's particular cellular system. Records of all registered CSSs are maintained even when CSSs roam outside the region served by their home cellular system. Conversely, the VLRs 72<sub>I-III</sub> store specified information relating only to CSSs currently roaming within the area served by the particular cellular system in which

- 15 -

the VLR is located. HLRs and VLRs are usually located within Mobile Switching Centers (MSCs) 40<sub>I-III</sub> but may be implemented in separate units.

According to the EIA/TIA IS.41 standard, when an MSC determines, from information received over the roaming network 42, that a roaming Cellular Subscriber Station (CSS) has entered its service area, it initiates a Registration Notification Procedure. Part of the procedure calls for transmitting a Registration Notification message to the HLR of the CSS's home system over the roaming network 42. The transfer is performed by network landlines that interconnect all systems therein. The data passed to the home HLR 70<sub>HOME</sub> by the host MSC, as detailed by the HLR registers 74, 76 and 78 in FIG. 5, includes:

- 1) the unique Mobile Serial Number (register 74) (MSN) of the CSS;
- 2) the Mobile Switching Center Identification 76 (MSC ID or SID) number (register 76) of the host system now serving the CSS;
- 3) the Switch ID (register 78)(SWID), which is defined as the Identification (ID) number of the switch (SW) and MSC within the host system serving the CSS.

The SID (System Identification Number) and SWID (Switch ID) of the host switch serving the roaming CSS are stored in the home HLR so that telephone calls bound for the CSS from the Public Switched Telephone Network (PSTN) 39 or the cellular network 58 may be forwarded to the called CSS's current host system. These procedures insure that the home system HLR is always updated with the SID and SWID of the switch (MSC) serving the CSS while it is roaming. If the CSS is not roaming, but rather, is still within its home system, the HLR simply contains the Identification Number (SWID) of the home system switch serving the CSS. In order to initiate a registration notification, first an autonomous registration signal (self-registration) by the CSS must be transmitted to the base station. As noted previously, this can also be

- 16 -

triggered by a call origination, a call termination (i.e., a page response) or a service order. While call origination, call termination or service orders may require action by the user (using scarce voice channel capacity), a calling party or a system operator, autonomous self-registration occurs automatically at regular time intervals as described above and does not use voice channels. The frequency of this autonomous registration is a function of a number of parameters set forth by the system operator and defined in EIA/TIAV553. In general, the parameters are set so that CSSs self-register each 30 minutes or less.

The implementation of a basic system for locating vehicles through the roaming network 42 is depicted in FIG. 5. This system is interfaced with a particular MSC 40<sub>HOME</sub> interconnected with the roaming network 42. At least one interface computer is interconnected with the switch 40<sub>HOME</sub> and receives information on CSS registration from the switch. In this example, three interface computers IC I (44<sub>I</sub>), IC II (44<sub>II</sub>) and IC III (44<sub>III</sub>), are assigned to the MSC 40<sub>HOME</sub> in order to lighten the processing load. The switch selected for connection to the interface computer(s) according to this invention may be considered the home switch in the home system for the purposes of CSS registration. In other words, each CSS to be located will carry a registration number (MSN) that identifies that CSS as belonging to the depicted home MSC 40<sub>HOME</sub>. Each switch is connected with CSSs that are registered to it. These CSSs are in their respective "home" switch/system. Each switch may also at any time be connected with a number of CSSs that are registered to a different switch or system. These CSSs, therefore have a different "home" switch than that in which they are currently present. The non-home switch is, therefore considered to be a "host" switch and system. The roaming network 42 allows the MSC 40<sub>HOME</sub> to record periodically the location (i.e., the particular host cellular system) of each home-registered CSS

- 17 -

even if it is visiting in another host system. The home registered CSS registration data (stored in HLR registers MSN 74, SID 76 and SWID 78), termed HLR data, is read from the home MSC 40<sub>HOME</sub> by one of the interface computers 44<sub>I</sub>, 44<sub>II</sub> and 44<sub>III</sub>. These computers store the information in an internal data base for subsequent transmission to a central location computer 46 of this embodiment. This computer concentrates and coordinates all data received from the various interface computers 44<sub>I-II</sub> connected to the switch (MSC) 40<sub>HOME</sub>. The location computer 46, according to this invention, then processes the HLR data from the interface computers 40<sub>I-II</sub> and determines the cellular system location of each CSS registered to this home MSC 40<sub>I-III</sub>. This information is then forwarded to the electronic mailbox system 61 that, in turn, transfers the location information to the customer site 60. The customer, which is generally connected by modem to the electronic mail system, maintains a terminal or computer 62 for receiving the data in a readable format (e.g., terminal 62 of FIGS. 2 and 3). As will be described further below, the interface and location computers 44 and 46 are adapted to provide to a particular customer only data relative to that customer's vehicle fleets. As such, the customer only receives data indicating the location of its own vehicles; thus, not only is privacy maintained, but also the customer is relieved of the burden of culling wanted data from unwanted data.

With specific reference to the interface computers IC<sub>I</sub>, IC<sub>II</sub> and IC<sub>III</sub> as depicted in FIG. 5, several different methods of allowing the computers 44<sub>I-III</sub> to access HLR data may be employed. The home MSC 40<sub>HOME</sub> respectively, can be programmed to transmit to a port, or alternatively, store in a file, data relating to changes occurring in HLR entries from the tracked CSSs. Changes in HLR entries for home-registered vehicles are brought about by the registration signals received from the roaming network 42. The roaming network 42, itself receives the signals from

- 18 -

the various host systems in which CSSs are located. The interface computers can then read and decipher this information. Alternatively, the interface computer(s) 44<sub>I-III</sub> can be disposed directly between the IS.41-based roaming network 42 and the home MSC 40<sub>HOME</sub>. The interface computers 60, 62, 64 allow the information to pass through to the MSC 56 unaffected, but would capture the messages carrying the new data bound for the home MSC's HLR 70<sub>HOME</sub>.

Yet another method of reading data involves reliance upon a feature that is proposed for the next revision of the IS.41 standard (IS.41-B), that allows switches to read each other's HLR registered data. The interface computer or computers could then be adapted to read HLR data by simulating a switch-to-switch call for accessing each switch's HLR register. In the depicted embodiment, the HLR information is obtained by the interface computers 44<sub>I-III</sub> by accessing the MSC's operations and maintenance port (not shown). The interface computers 44<sub>I-III</sub> then query the HLR database 70<sub>HOME</sub>, 74, 76 and 78 using the man-machine command interface built into the MSC 40<sub>HOME</sub> operating software. The implementation of this method, of course, varies from switch to switch.

With particular reference to Northern Telecom switches (DMS/MTX switch family), the interface computer logs into the Operations Administration and Maintenance System over a local serial connection or a Dial-in I/O port. The interface computer then issues commands over the system's generic database access language (the BCS software system) to retrieve the necessary HLR information. Alternatively, on a Motorola switch (the EMX family), the interface computer logs into the Service Order Port normally used by CAMP terminals. The interface computer then uses the CAMP man-machine command interface to read the HLR fields of data from the subscriber database.

Interface Computer Procedure

FIG. 6 illustrates a procedure executed by the interface computer(s) (44<sub>I-III</sub> throughout this description) according to one embodiment of this invention. It should be noted that the interface computer(s) continually receives messages sent from the location computer 46 and queues them in a register termed QUEUE\_MSG\_IN. The messages are loaded from the location computer through a standard file transfer protocol such as Kermit.

The procedure depicted in FIG. 6 allows communication between each interface computer(s) 44<sub>I-III</sub> and the location computer 46, and between the interface computer and the tapped system MSC 40<sub>HOME</sub> (FIG. 5), alternatively. The registers utilized in the procedure are defined briefly in Table 1 shown below.

The main registers are shown again in figure 6a. These include the message transfer file memories for QUEUE\_MSG\_OUT 77 and QUEUE\_MSG\_IN 79, which are the buffers that store messages received from the location computer or bound to the location computer. The other main memory locations are: STATUS(VN) 89 which indicates whether particular vehicle is found, not found, or should not be looked for; MSN(VN) 81, which relates vehicle number VN to the serial number of the vehicle's CSS; SID(VN) 83 and SWNO(VN) 85, which contain the latest MSN information on vehicle VN; LOCATION\_TIME(VN) 87 which indicates the last time at which SWNO(VN) and SID(VN) were last updated for vehicle VN.

Table 2 shows the messages passed between the Interface and Location Computers. In general, the Location Computer sends messages to the Interface Computer(s) to initiate or discontinue the search for particular vehicle(s), under control of a user. The Location Computer may also send commands to monitor the operations of the Interface Computers. On the other hand, the Interface Computer(s) send messages to the Location Computer to relay any new information obtained regarding vehicles that they were

- 20 -

previously instructed to track, or to signal technical problems.

Messages sent by the location computer 46 may be received by the interface computer(s) at any time, and are stored in QUEUE\_MSG\_IN until processed by the procedure depicted in figure 6. Messages sent by the interface computer to the location computer 46 are stored in QUE\_MSG\_OUT before transmission. This file comprises all location messages received in the latest round of CSS location processing. The actual transmission is performed in this embodiment at step 87 of procedure 79 shown in figure 6. However, the transmission of QUEUE\_MSG\_OUT may occur at any time subsequent to the receipt of new location data by the computer and may, in fact, occur by direct transmission of the data to the location computer without the use of storage file.

TABLE 1 -- DATA STRUCTURE FOR INTERFACE COMPUTER

Variable_Name	Type	Purpose
VN_MAX	Integer	Arbitrary number equal to the maximum number of vehicles tracked by the system
TIME_NOW	Integer	Number of seconds elapsed from arbitrary point in time such as 12:00 am, January 1, 1991
MSN(1..VN_MAX)	Array of integers	Unique serial number of the phone on-board vehicle VN
SID(1..VN_MAX)	Array of integers	Identification number of the system that last served vehicle VN
SMNO(1..VN_MAX)	Array of integers	Identification number of the switch that last served vehicle VN
LOCATION_TIME(1..VN_MAX)	Array of integers	Time of last successful retrieval of SID and SMNO from Home Location Register (HLR)
STATUS(1..VN_MAX)	Array of integers	Status of VN within the interface computer where 0 = look for 1 = found 2 = do not look for
QUEUE_MSG_OUT	ASCII file	Queue of messages bound for the Location Computer
QUEUE_MSG_IN	ASCII file	Queue of messages inbound from the Location Computer
INT_COMP_ID	Integer	Unique number assigned to each Interface Computer
ROAM_NET_ID	Integer	Unique number of the roaming network to which the INT COMP HLR belongs
VN	Integer	Vehicle number
SID	Integer	Identification number of a system
41WNO	Integer	Identification number of a switch
MSH	Integer	Unique mobile serial number of the phone on-board a vehicle
T1	Integer	Time storage variable
DELAY	Integer	Amount of time in seconds between HLR queries



TABLE 2 - LIST OF MESSAGES PASSED BETWEEN INTERFACE AND LOCATION COMPUTERS

<u>Msg_ID</u>	<u>From</u>	<u>To</u>	<u>Parameters_Passed</u>	<u>Description</u>
1	Interface Computer	Location Computer	1, VN, SID, SMO, TIME, INT_COMP_ID, ROAM_NET_ID	*Lost vehicle is found and located
2	Interface Computer	Location Computer	2, VN, SID, SMO, TIME	Vehicle has moved to a new location
3	Interface Computer	Location Computer	3, VN, TIME	Vehicle has been found in the same location as previously
4	Interface Computer	Location Computer	4, VN, INT_COMP_ID, ROAM_NET_ID, TIME	Vehicle not found
5	Location Computer	Interface Computer	5, VN, MSN	Look for vehicle VN
6	Location Computer	Interface Computer	6, VN	Do not look for vehicle VN
7	Location Computer	Interface Computer	7, VN	Service call, read all data fields associated with VN
8	Location Computer	Interface Computer	8, VN, MSN, SID, SMO	Service call, modify data stored for VN
9	Location Computer	Interface Computer	9, RESTART	Service call, enter the re-initiation procedure
10	Interface Computer	Location Computer	10, INT_COMP_ID, ROAM_NET_ID, TIME	Failure to log on to switch

- 23 -

Procedure 79 of FIG 6. begins by initializing variables in step 80. A variable, VN\_MAX, is set to the maximum number of vehicles to be tracked by the system. A variable, INT COMP\_ID, is then set to a unique identification number assigned to the interface computer. A variable, DELAY, is set to an arbitrary number of seconds (typically less than 5). Another variable, ROAM\_NET\_ID, is then set to 1 and all STATUS(1..VN\_MAX) flags are set to 2, indicating that the system should search for no vehicles. Other associated variables are reset to 0 according to this embodiment.

The interface computer subsequently attempts to log in to the MSC (40<sub>HOME</sub> throughout this description) to access the HLR 50<sub>HOME</sub> database, step 82, by following a predetermined communications script. This script varies according to the log-in procedure of the specific switch (MSC) to be tapped. If the log-in procedure fails, the interface computer 44<sub>I-III</sub> branches to step 84 and transmits a Log-in Failure message to the location computer, indicating a Log-in failure, and then returns control to Log-in step 82 again. Once Log-in is achieved, the interface computer sets a time storage variable T1 to the current system clock time, TIME\_NOW, in step 86. Once the time is registered, the interface computer searches a register QUEUE MSG\_IN in step 88 for messages sent from the location computer. As noted before, the location computer may send messages to the interface computer at any time during the procedure. A typical message may relay to the Interface Computer the identifications of CSSs (vehicles) to be located in the roaming network. These vehicles are usually all or part of a particular customer's fleet. These messages are processed in step 88. After interpreting the messages read from QUEUE\_MSG\_IN in step 88 the interface computer enters a loop 90 that counts through all of the vehicle numbers (an arbitrary number VN) in the fleet from 1 to VN\_MAX. If no messages were received from the location computer since start-up, then the interface computer would be looking for no

- 24 -

vehicles as all STATUS(VN) 89 registers would still be equal to 2. Given this condition, loop 90 would be completed without querying the HLR of the MSC because the decision step 98 would always branch back to step 92, without ever executing steps 100 through 130.

When the interface computer(s) receive a message via QUEUE\_MSG\_IN to Locate Vehicle VN, the interface computer receives both the identifier VN of the vehicle and the MSN of the vehicle's CSS. A procedure (not shown) interprets these messages. When a Locate Vehicle VN message is received, the MSN that is associated with the vehicle's CCS (vehicle VN) is stored in a register termed MSN(VN). Additionally, the variable STATUS(VN) for the vehicle VN is set to 0 at this time, indicating that the interface computer must search for vehicle VN.

As before, loop 90 counts through each vehicle VN to the maximum number of vehicles, indicated by the variable VN\_MAX, for a particular fleet to be located. The counting begins in increments of one in the step 92. If the maximum (VN\_MAX) number of vehicles has been exceeded by step 92 (e.g., VN > VN\_MAX) then the variable VN is reset to 1 in step 94. The loop proceeds to decision step 96 wherein if VN equals VN\_MAX and if the flag STATUS(VN) for the vehicle VN equals 2 (which is always the case for VN=VN\_MAX) then the procedure returns via branch 97 to the main routine step 86.

From decision step 96, if conditions for return are not met as described above, the procedure continues to decision step 98. If the STATUS(VN) flag for vehicle VN equals 2, then the procedure returns via branch 99 to loop counting step 92 since the vehicle VN is to be ignored (based upon STATUS(VN) = 2, indicating that the vehicle should not be looked for). If, however, STATUS(VN) is not equal to 2 the procedure enters a decision step 100 which loops via branch 101 until a delay time represented by the variable DELAY is reached. The procedure then enters the HLR access step 102

- 25 -

and attempts to access the home switch 40<sub>HOME</sub> to ascertain the switch and system in which vehicle VN is located.

The interface computer(s) 44<sub>I-III</sub> issue a database command to the MSC in step 102 querying its HLR register (84) for the SID and SWNO (also known as SWID) that is associated with the MSN of the vehicle's CSS, an MSN number corresponding to the variable MSN(VN). A particular communication script would be employed to accomplish the querying procedure. This script, of course, would vary according to the particular switch to be tapped. If the interface computer fails to contact the MSC, control is immediately transferred to the Log-in procedure 82, via branch 104, and the Log-in procedure 82 attempts to re-establish communications with the MSC.

Assuming that the interface computer successfully contacts the MSC, it branches to decision step 106. In decision step 106 the interface computer procedure determines whether an associated SID and SWNO has been read from the HLR for the particular vehicle VN. If not, the vehicle is not found and the procedure branches to decision step 108. If vehicle VN was previously not found, as indicated by STATUS(VN) equal to 0 (e.g., STATUS(VN) not equal to 1), then the decision step 108 branches down branch 110 to step 112, which sets the flag STATUS(VN) to 0. The procedure then branches down branch 114 back to step 86, where the time variable T1 is reset. The procedure then reenters step 88, searching for a new message from the location computer. Execution of the main loop then continues.

If, at decision step 106, the interface computer does successfully contact the MSC and retrieves an SID and the SWNO for vehicle VN then the vehicle has been found; the procedure continues from step 106 to step 116. If the vehicle were previously not found, as indicated by STATUS(VN) equal to 0, then decision step 116 branches to step 118, which relays to the location computer (via the file QUEUE\_MSG OUT) a message indicating that vehicle VN, previously not

- 26 -

found, is now found. The message indicates the vehicle's VN, the newly determined SID and SWNO, the current time, the ID of the interface computer INT\_COMP\_ID, and the id of the roaming network ROAM\_NET\_ID. Next, step 120 stores the SID and SWNO information obtained from the MSC in SID(VN) and SWNO(VN) registers respectively. In addition, the variable LOCATION\_TIME(VN) is set to the value of variable TIME\_NOW to record the time when vehicle VN has been found. The flag STATUS(VN) is set to 1 in step 122, that follows step 120, to indicate that the vehicle VN has been found. Note that the data transferred by the Vehicle Found message to the location computer (e.g., variables VN, SID(VN), SWNO(VN), LOCATION\_TIME(VN), INT\_COMP\_ID(VN), ROAM\_NET\_ID(VN)) in step 118 makes possible the determination by the location computer the position of the vehicle at a point in time as well as a determination of which interface computer, 44<sub>I</sub>, 44<sub>II</sub> or 44<sub>III</sub>, has detected the vehicle.

If the vehicle has already been found by the interface computer such as described hereinabove, and, in a subsequent loop by the interface computer, the MSC is again queried, via loop 90, in step 102, for the vehicle's SID and SWNO numbers then the interface computer will undertake one of the following actions:

If an entry for MSN(VN) is found in the HLR of the MSC in step 102, the procedure branches from decision step 106 to decision step 116. Since the variable STATUS(VN) equals 1, decision step 116 then branches to decision step 124. If the SID and SWNO numbers correspond to the previously stored SID(VN) and SWNO(VN) for that particular vehicle VN, then the vehicle has not moved from the previous location and the procedure branches to step 126. A same location message is sent to the location computer via the file QUEUE\_MSG\_OUT in step 126 indicating that the vehicle has not

- 27 -

moved. The time that the vehicle is detected represented by the variable LOCATION\_TIME(VN) is also sent to the location computer from the interface computer in subsequent step 128 to update the location computer record on vehicle VN.

If, as before, an entry for MSN(VN) is found in the HLR of the MSC in step 102, but decision step 124 determines that the SID and SWNO numbers do not correspond to the previously stored SID(VN) and SWNO(VN) for that particular vehicle VN, then the vehicle has moved from the previous location. Decision step 124 then branches to step 130, which sends a moved vehicle message to the location computer via the file QUEUE\_MSG\_OUT, indicating that the vehicle has moved. The new SID and SWNO obtained from the MSC are sent to the location computer, along with the time when the vehicle is detected (represented by LOCATION\_TIME(VN)). Step 130 then branches to step 120, which updates the SID(VN), SWNO(VN) and the LOCATION\_TIME(VN) registers with the newly acquired up-to date information. Next, the main loop is reentered via steps 122 and 86, described before.

If no entry for the variable MSN(VN) is found in the HLR of the MSC for vehicle VN is step 102, then the previously located vehicle has now been lost by the interface computer. Decision step 106 thus branches to decision step 108. Since the variable STATUS(VN) equals 1, decision step 108 branches to step 128, which appends a vehicle not found message (including the vehicle's VN, the ID of the interface computer INT\_COMP\_ID, the id of the roaming network ROAM\_NET\_ID and the current time) to QUEUE\_MSG\_OUT, the queue of messages bound for

- 28 -

the location computer. The procedure then branches to step 110 and resets the flag STATUS(VN) to 0 in step 112, to indicate that the vehicle is not found. The procedure then branches down branch 114 back to step 86, where the time variable T1 is reset and the loop main is continued.

The location computer 46 can prevent the interface computer(s) 44<sub>I-III</sub> from searching for a specific vehicle for any of a variety of reasons. To prevent the search, the location computer sends a Do Not Search For Vehicle VN message to the interface computer. This message indicates the VN of the vehicle to be ignored. The Process QUEUE\_MSG IN subroutine (not shown) responds to the message by setting the variable STATUS(VN) for vehicle VN to equal 2. This assures that the MSC will not be queried for the SID and SWNO of the ignored vehicle identified by MSN(VN).

The location computer 46 may also transmit certain additional commands to the interface computer(s) 44<sub>I-III</sub> to remotely start its (their) operation. A Restart message will accomplish this function. The location computer may also remotely change certain variables using a Modify Data message and may remotely read certain variables using a Read Data Associated With VN message. The implementation of these service routines may be accomplished by a variety of procedures.

In summary, the procedure described above allows the location computer 46 to instruct each interface computer 44<sub>I</sub>, 44<sub>II</sub> and 44<sub>III</sub> to initiate and complete searches for certain vehicles, receive from the interface computer(s) 44<sub>I-III</sub> transmitted changes in HLR data relative to each vehicle, and receive and display an alarm message if an interface computer(s) fails to gain access to its interconnected MSC.

Reference is now made to the location computer 46. The main function of the location computer 46 is to coordinate

- 29 -

the interface computers, to concentrate all HLR data from the interface computer(s) 44<sub>I-III</sub>, to compute the position of the vehicles, and forward this information to the appropriate mailboxes in the electronic mail system 61. The electronic mail system 61, in turn, forwards this information to the customer site(s) 60.

#### Location Computer Procedure

The location computer 46 executes the main procedure shown in FIG. 7. Table 3 below defines the corresponding variables for the associated location computer data structure. The location computer begins execution of this routine by initializing all variables in step 132. In the initialization step, the variable INT\_COMP\_MAX is set to equal the number of interface computers in the system, the variable VN\_MAX is then set to equal the maximum number of vehicles tracked by the system and the variable SID\_MAX is set to the highest SID number for all cellular systems in the roaming network. Additionally, all STATUS(1..VN\_MAX) flags are set to equal 2, indicating that the system should search for no vehicles. All other variables are reset to 0. If the system is initialized for the first time, all interface computers 44<sub>I-III</sub> are reset by sending a Restart message to each of them.

The location computer main procedure subsequently verifies whether the operator is not attempting to gain manual control of the system in decision step 134. If so, then the location computer procedure branches to step 136 and receives any operator instructions, such as search requests and parameters. If no access by an operator is attempted, then the location computer enters a loop 138 in which, in step 140, it first reads all messages received from the interface computer(s), which are queued in the file QUEUE\_MSG IN. These messages are placed into a PROCESS\_MSGS file in which they can be acted upon. This procedure is described further below. The location computer procedure then, in step



TABLE 3 - DATA STRUCTURE FOR LOCATION COMPUTER (Single Roaming Network)

Variable Name	Type	Purpose
SHND_MAX	Integer	Highest number of switches in any given cellular system covered
INT_COMP_MAX	Integer	Number of interface computers tapping each roaming network
VN_MAX system	Integer	Arbitrary number equal to the number of vehicles tracked by the
SID_MAX	Integer	Highest SID number of this cellular system covered
TIME_NOW	Integer	Number of seconds elapsed from arbitrary point in time such as 12:00 am, January 1, 1991
MSN(1..VN_MAX)	Array of integers	Matches on-board phone serial numbers with particular vehicles
SID(1..VN_MAX)	Array of integers	Identification number of the system that last served vehicle VN
SHND(1..VN_MAX) VN	Array of integers	Identification number of the switch that last served the vehicle
LOCATION_TIME(1..VN_MAX) location	Array of integers	Time of last successful retrieval of SID and SHND from home register (HLR)
STATUS(1..VN_MAX)	Array of integers	Status of VN within the location computer where 0 = look for 1 = found 2 = do not look for
LAST_LOCATION(1..VN_MAX)	Array of strings	Tells where vehicle VN was last located
MAILBOX(1..VN_MAX) mailboxes	Array of list of strings	Matches vehicle with the list of the dispatcher's electronic
LOAD(1..INT_COMP_MAX)	Array of integers	Number of vehicles assigned to interface computer INT_COMP_ID in roaming network ROADNET
LOCATION(1..SID_MAX, 1..SHND_MAX)	Array of strings	Tells where vehicle VN was last located
QUEUE-MSG_IN	ASCII file	Queue of messages inbound from the interface computer
QUEUE-MSG_OUT	ASCII file	Queue of messages bound for the interface computer
MIN	Integer	Temporary holder of minimum load

- 31 -

142, computes, based upon the data in the PROCESS\_MSGS file, the new location for the associated vehicles and then forwards the information to the Store and Forward system 61 mailboxes corresponding to the home offices (customer site) 60 of the vehicles. If no messages are received from the interface computers, then no action is taken by the location computer.

Control of the location computer begins when the operator instructs the location computer to search for one or more vehicles. The operator enters each vehicle's VN number and the MSN of its associated CSS. The operator also enters a list of mailboxes to which location information should be forwarded corresponding generally to customer sites. These parameters are stored in the variables VN, MSN(VN) and MAILBOX(VN) respectively. The location computer procedure then determines (not shown) which interface computer is handling the least number of vehicles, and then assigns the new vehicle(s) to the least occupied interface computer by sending a Search For Vehicle VN message. Thus STATUS(VN) flag for each new vehicle VN is set to 0, indicating that the new vehicles having numbers VN are not yet found.

As discussed above, the interface computer(s) 44<sub>I-III</sub> report changes in the HLR data associated with each vehicle VN to the location computer 46. These messages are read from the new QUEUE\_MSG\_IN register into the temporary file PROCESS\_MSGS and processed in sequence by the COMPUTE AND UPDATE LOCATION procedure 144 shown in FIG. 8. The following is a description of the various messages from the interface computer processed by the location computer in this procedure as it reads the PROCESS\_MSGS file in step 144, also described in step 140 of the main procedure in FIG. 7. These messages are listed generally in Table 2.

A Log-in Failure message, indicating that the interface computer is unable to log-in to its MSC, causes the location computer procedure to branch from initial decision step 146 to read values for variables INT\_COMP\_ID, ROAMNET\_ID and TIME

- 32 -

in step 148 and to display in step 150 an alarm message to the operator indicating the identifier (the ID) of the specific interface computer experiencing Log-in failure. The message is then deleted from the PROCESS\_MSGS file in step 152 and the procedure returns via step 154 to read the next message in PROCESS\_MSGS at step 144.

Any message read from the PROCESS\_MSGS file other than Log-in Failure causes the decision step 146 to branch 156. A Found Vehicle message, indicating that a previously unlocated vehicle is now located, causes the location computer procedure in decision step 158 to branch to step 160 in which the values for variables VN, SID, SWNO, TIME, INT\_COMP\_ID and ROAMNET\_ID transmitted with the message are read. This information is stored by the location computer in registers SID(VN), SWNO(VN), LOCATION\_TIME(VN), INT\_COMP\_ID(VN) and ROAMNET\_ID(VN) respectively for the particular VN in step 162. STATUS(VN) is also set to 1, indicating that vehicle VN is now located. Variables SID(VN), SWNO(VN) and LOCATION TIME(VN) are then set equal to the read associated values for vehicle VN in step 164. The location computer procedure 144 then calls in step 166 a COMPUTE LOCATION subroutine (not shown but described below) to determine the new position of the vehicle. This subroutine involves comparison of a list of known geographical locations with associated switch and system identification numbers (SWNO(VN) and SID(VN) respectively) for the corresponding vehicle VN. The location of the vehicle is stored in a data string LOCATION(VN) via the subroutine COMPUTE LOCATION. The vehicle's position is then forwarded to the mailbox(es) (as identified by the variable MAILBOX(VN)) corresponding to the vehicle's home base(s) in step 168 along with the time in which vehicle VN was found. The message subsequently is deleted from PROCESS\_MSGS in step 152 and the next message is then read by the location computer 46 in step 144.

A Moved Vehicle message indicating that a previously found vehicle has moved, causes the location computer

- 33 -

procedure to branch from decision step 158 to decision step 170 wherein a Moved Vehicle message causes the procedure to branch to step 172. Values for the variables VN, SID, SWNO and TIME included with the message are read in step 172 and the procedure branches to step 164 to store this information in the registers SID(VN), SWNO(VN) and LOCATION\_TIME(VN) for vehicle VN respectively. The location computer then again calls COMPUTE LOCATION subroutine in step 166 to determine the new position of the vehicle and stores this position value in the data string LOCATION(VN). The vehicle's position and time is then forwarded to the mailbox(es) corresponding to the vehicle's home base in step 168, the message is deleted in step 152 and the next message is read by the location computer in step 144.

A Same Location message, indicating that a previously located vehicle has not moved, causes the location computer to branch through decision steps 158 and 170. The message results in branching from step 174 to step 176 wherein the procedure reads the values for the variables VN and TIME transmitted with the message. The location computer then stores the time of location in the register LOCATION\_TIME(VN) to update the currentness of the search in step 178. The vehicle's position is then forwarded to the mailbox(es) corresponding to the vehicle's home base(s) in step 168 in a manner described above for a Found Vehicle message. Similarly, the next message is then read by the location computer procedure in step 144.

Finally, a Vehicle Not Found message, read from PROCESS\_MSGS, indicating that a previously located vehicle is no longer located, causes the location computer procedure to branch via branch 180 to step 182. In step 182 the procedure reads values for VN, INT\_COMP\_ID and ROAMNET\_ID and stores a value of 0 for the variable STATUS(VN). This 0 value indicates that the vehicle has been lost and causes the transmittal of a message to that effect to the mailbox(es) corresponding to the vehicle's home base(s). The procedure

- 34 -

branches via branch 184 to step 152 wherein again, the message is deleted and the next message is then read by the location computer procedure in step 144.

The above-described process continues until all messages stored in the file PROCESS\_MSGS are processed. Following completion of the reading of all messages, the procedure returns in step 183 to the main procedure wherein the location computer main procedure verifies whether the operator is attempting to gain control of the system per step 134 of FIG. 7. If so, the operator instructions are read. If not, then the next batch of inbound messages is then read from the QUEUE\_MSG\_IN file into the temporary file PROCESS\_MSGS, and the loop 138 continues.

As discussed above, Found Vehicle and Moved Vehicle messages cause the location computer procedure 144 to call a subroutine COMPUTE LOCATION, in step 166 of FIG. 8, which determines the vehicle's current location. In particular, this subroutine reads the latest HLR data for the particular vehicle VN from the corresponding values stored for variables SID(VN) and SWNO(VN). The subroutine then determines the location of the vehicle by reading the entry corresponding to the variables SID(VN) and SWNO(VN) in a variable matrix LOCATION(1..SID\_MAX, 1..SWNO\_MAX) or an equivalent data structure. This procedure essentially involves a table look-up. Each entry in this matrix comprises the location of the area served by a switch number SWNO in the cellular system number SID. This information may be stored in ordinary descriptive text, geographic area form or in any other form that indicates location. The contents of this matrix may be derived directly by gathering coverage information from the FCC and/or various cellular operators. Similarly, the information may be derived empirically by locating one or more CSSs at various known positions, and then recording the SID and HLR readings reported by the system for each of these positions. Once the vehicle's

- 35 -

position is determined, it may be stored in the register LAST LOCATION(VN)(See Table 3 below).

#### Hardware Requirements

As shown in FIGS. 2 and 3 generally, the information obtained by the interface and location computers, 44 and 46 respectively, is transmitted to the electronic mail system 61 for transfer to terminals 62 and other output/display devices at the customer site(s) 60. At the site 60, the customer may manipulate, or otherwise utilize, data to track the location of its fleet of vehicles. The main purpose of the Store and Forward electronic mailbox system 61 is to relay position data from the location computer to the customer's site(s) and to relay text and data messages between the vehicles and the customer's site(s). Store and Forward hardware and software is readily available in today's market. An example of such a system that could be implemented on a Tandem fault-tolerant (OLTP) computer is the Easy Mail™ software sold by TelcoSolutions, Inc. The Dial-in I/O ports of the Store and Forward system may employ standard modems with a data rate of at least 300 baud, and preferably higher, and should implement an error correction standard such as MNP 4 or better.

Electronic mail Store and Forward systems particularly provide a number of mailboxes acting as storage areas for messages bound for user. Messages are sent to and read from the system by logging on to a communication port and then issuing appropriate commands. In this embodiment, each vehicle is assigned a mailbox for outbound messages (messages sent from the home base to the vehicles), and each home base is assigned a mailbox for inbound messages (messages sent by the location computer 46 and/or the vehicle CSS 35 to the home base(s)60).

According to the location computer procedures depicted in FIGS. 7 and 8, messages comprising the latest location of each vehicle are transmitted to the mailboxes corresponding

- 36 -

to the home base(s) 60 of each vehicle. Inbound text and data messages are sent from the vehicle CSS to the appropriate mailboxes via the cellular telephone voice line network using normal placement of calls in a manner described further below.

As important as any other single piece of equipment according to this embodiment, the on-board cellular telephone system (CSS) carried by each vehicle is essential to allow the location of that particular vehicle. In its most basic form, the mobile equipment required by the system according to this embodiment comprises only a basic cellular telephone transceiver unit. The vehicle tracking system of this embodiment does not entail the placement of calls to and from the CSS. However, the system does retain the ability to exchange messages. For example, an answering machine can be attached to this cellular telephone to store an incoming call when the telephone is unattended. However, such a configuration restricts messaging capabilities to voice telephone calls only.

Messaging is a useful part of the vehicle location system according to this invention. The capability to transfer messages to and from the vehicle allows a fleet operator to change the driver's dispatch orders and receive news of vehicle progress from the driver on an ongoing basis. In order to minimize cellular telephone usage, users may opt to exchange messages in data form over the cellular link. By employing this method, a typical message of a few hundred characters may be sent in less than 10 seconds.

Fig. 9 depicts a possible configuration of the mobile equipment according to this embodiment including the required communication links. The cellular telephone 186 having an antenna 188 is linked using an RJ11 communication interface to a Cellular Telephone Interface 190 (such as the CHI™ unit made by Cellars of Canoga Park, California or the Celjack™ unit distributed by Cellular Solutions, Boulder, Colorado). The telephone interface 190 allows standard

- 37 -

line-linked telephone equipment to be connected to the cellular telephone. The Telephone Interface is connected to an optional Call Router 192 unit (such as the ASAP TF 555™ unit made by Command Communications Inc. in Aurora, Colorado), which distinguishes incoming data calls from incoming voice calls and fax calls, and routes the calls to a voice and/or data telephone port 194 and 196 respectively on a unit (handset 197, text terminal 200 and facsimile machine 202) corresponding to that call type.

One of the Call Router ports in this embodiment is connected by an RJ11 data line to a standard auto-answer data modem 198 compatible with Store and Forward electronic mail modems and implementing the same error correction standard. The modem 198 is interconnected to a text terminal 200, composed of a keyboard, display, one or more serial/parallel ports in programmable computer. The text terminal may be implemented on a Tandy 102™ unit, and Atari Portfolio™ unit or other readily available terminal units.

In order to transmit an inbound text/message, the vehicle's operator enters a data/message in the text terminal 200. The text terminal 200 then automatically inserts a header into the message that indicates the identification numbers of the Store and Forward electronic mailbox(es) (not shown) corresponding to the vehicle's home base(s). The cellular telephone subsequently dials the telephone number corresponding to the DIAL-IN I/O port of the Store and Forward electronic mail system 61. With some Telephone Interface units, such as Celjack™ the dialing command may be issued directly by a computer that is part of the text terminal 200 through the modem 198. With other units, the vehicle's operator must manually instruct the cellular telephone 186 to dial the number which may be preprogrammed in the cellular and accessed via a speed dial feature. The actual call may be delayed until the cellular telephone is within range of a cellular system.



- 38 -

After a cellular connection is established between the vehicle and the electronic mail Store and Forward system 61, the text terminal 200 logs on to the Store and Forward system 61, identifying itself and downloading the data/message(s) into the electronic mailbox system. The mailbox system then forwards a copy of the transmission to each of the mailboxes indicated in the header. The electronic mail system 61 then determines whether the mailbox corresponding to the calling vehicle has any messages to be delivered, and if so, the system uploads these messages to the vehicle's terminal 200. The telephone call is then terminated subsequent to the two-way data transfer.

In order to transmit an outbound message to one or more vehicles, the computer terminal 62 at the vehicle's home base 60 logs onto the Store and Forward system 61 and then downloads the message with a header indicating the vehicle(s) to which the message should be delivered. The Store and Forward system 61 then stores the messages in the mailboxes corresponding to the vehicles and then delivers the messages by dialing the telephone numbers corresponding the cellular telephones in the vehicles until a connection is established. When the vehicle cellular telephone 186 receives a call from the Store and Forward electronic mail system 61, the Telephone Interface unit 190 "picks up" the phone and passes the received information to the Call Router 192, which identifies the transmission as a data call and then forwards it to the data modem 198. The data modem 198 automatically answers the call and instructs the text terminal 200 to store the incoming data/message for later display. Following message receipt, the text terminal 200 may transmit a confirmation message to the Store and Forward system 61 which is subsequently forwarded to the vehicle's home office 60.

In order to receive an inbound facsimile message, the cellular telephone calls the recipients number. With some Telephone Interface units, such as Celjack™, the dialing

- 39 -

command may be issued directly by the facsimile unit 202. With other units, the vehicle operator must manually instruct the cellular telephone to dial the number which, again, may be preprogrammed in the cellular telephone and is accessible by means of a speed-dial command.

In order to transmit an outbound facsimile message to a vehicle, the originating facsimile machine 65 repeatedly dials the number of the vehicle's cellular telephone until a connection is established. Once a cellular telephone call from the facsimile machine 65 is received, the Telephone Interface unit 190 again "picks up" the line and passes the transmission to the Call Router 192. The Call Router 192 identifies it as a facsimile call and forwards it to the on-board facsimile machine 202, which automatically activates to receive the facsimile message.

It should be noted that the above described embodiment for implementing based vehicle messaging is only one possible embodiment. Many of the systems described may be substituted with a cellular modem such as the Cellmodem 2400+™ made by Cellars. Additionally, data/text messaging bound for the vehicle need not be delivered over the cellular network, but, rather, could be implemented by means of an alpha numeric paging system which may or may not be interfaced with the mobile equipment described above and depicted generally in FIG. 9.

To avoid line charges incurred in the exchange of data/text messages with vehicles, information could be transmitted and received through a cellular control channel rather than a voice channel. This would necessarily require the modification of the cellular telephone firmware, as well as software on the host and home switches to exchange messages. Clearly, such an approach would increase initial system implementation costs and require the cooperation of a number of system operators. It should be again noted that all messaging systems are an option according to this embodiment and that a primary goal of this invention is the

- 40 -

implementation of low cost vehicle location utilizing preexisting cellular control channels that does not require placement of calls in order to track vehicles. In doing so, vehicle location may be pinpointed to a particular switch coverage area.

#### Location Accuracy Improvements

As discussed above, the accuracy of the basic location system according to this invention is a function of the size of the area served by each cellular switch (MSC). The size of this area may range from a single section of an urban area to a rural area having a radius of more than 60 miles. Of course, it is generally more critical to accurately pinpoint the location of a vehicle in an urban area where a local delivery may be problematic than in a larger rural area in which the vehicles are generally in high speed transit such that accurate pinpointing of location is neither possible nor desirable.

Position accuracy according to an alternative embodiment of this invention may be improved to better than +/- ten miles by configuring the system to gather not only SID and SWNO data but to also gather cell site number (Base Station) data for the particular cell in which the vehicle CSS is currently located. For example, the IS.41 software in the "host" switches may be modified to communicate to the home system HLR not only the host SID number and switch number (SWNO), but also the cell number through which the cellular telephone's self-registration is processed. The interface computers 44<sub>I-III</sub> gather and store this additional information, and pass it as an additional parameter to the location computer 46 through Found Vehicle and Moved Vehicle messages. The more accurate position information would then be transmitted to the vehicle's home base(s) 60 using the same mechanism employed by the above-described basic embodiment according to this invention.

- 41 -

The COMPUTE LOCATION procedure, V as discussed with reference to step 166 at FIG. 8, that is implemented in the location computer 46 would be modified to manage the additional information provided by cell numbers. This procedure would read the SID, SWNO and cell number data and then determine the location of a vehicle by reading the entry corresponding to the variables SID(VN), SWNO(VN) and cell number in a three dimensional variable matrix such as LOCATION(1..SID\_MAX,1..SWNO\_MAX, 1..CELL\_NUMBER\_MAX) or an equivalent data structure. In this example, the variable CELL\_NUMBER\_MAX represents the highest possible identification number for a cellular cell. Each entry in this matrix would contain the location of the area served by the cell the variable CELL\_NUMBER of switch number SWNO in the cellular system number SID. This information may be stored in normal textual form in geographic area form or in any other form indicating location. As with other location information, the cell number information could be converted to location information either using FCC and/or cellular operator data or empirically. This more accurate position information could be transmitted to the vehicles home base or bases utilizing the same mechanism employed by the basic embodiment according to this invention.

Of course, the more accurate version of the location system according to this embodiment need not be applied to all cellular systems in the roaming network. Rather, it may be utilized on a selective basis to locate vehicles in areas where greater accuracy is desired by the customer or location system operator. If a cellular system were not modified to relay cell information, then the interface computers 44<sub>I-III</sub> could relay a known value for CELL\_NUMBER to the location computer 46. This would cause the location computer to default to a two dimensional version of the LOCATION matrix to determine the vehicle's position.

Even better accuracy may be obtained according to another alternative embodiment of this system utilizing an

outside positioning system in conjunction with the location system according to this invention. For example, a LORAN C receiver or Global Positioning System (GPS) unit or another equivalent receiver may be included in the vehicles on-board equipment. FIG. 10 depicts a mobile vehicle equipment configuration including a LORAN C system 206 interfaced to the text terminal 200 using an RS232 standard data line.

Such a system would operate only on an occasional basis to obtain a higher accuracy fix on vehicle position. The home base could send a position query data message to the vehicle by calling the vehicle's text terminal directly via the vehicle's cellular telephone 186. Alternatively, a position query data message could be sent to the vehicle's mailbox in the Store and Forward system 61 which would then call the mobile telephone 186 and forward the message at an appropriate time. Upon receiving the call, the Call Router 192 identifies the data call and forwards it to the text terminal modem 198, which automatically answers the call. On reading the location query message, the vehicle text terminal 200 reads from the positioning receiver (LORAN C, GPS, etc) the latest position fix and transmits this fix in data form back to the home base 60 or to an appropriate mailbox in the Store and Forward system 61.

In order to avoid line charges occurred in placing a telephone call over the cellular system, the location data gathered from the positioning receiver could be passed to the host cellular switch and then on to the home switch by encoding it in self-registration transmissions sent from the vehicle CSS. Of course, this system would require modifications to the cellular telephone firmware in the vehicle as well as the software in the host and home switches. Such modifications may also be implemented for the cell identification embodiments described above.

In some applications it may also be desirable to incorporate certain sensors into the text terminal or other vehicle telephone interfaces. Such a configuration is

- 43 -

depicted for the sensors 204 at FIGS. 9 and 10. The cellular system on board the vehicle would be programmed to automatically forward readings of these sensors to the home base. A typical application would be remote sensing of the temperature of a refrigerator container or the sensing of the opening and closing of cargo doors upon the vehicle. These messages could be encoded and sent through the text terminal which could be programmed to initiate a call if certain conditions were met by the sensors or if certain other events occur.

#### Multiple Independent Roaming Networks

In all of the above-described embodiments, it is assumed that one roaming network 42 joins all cellular systems utilized to locate vehicles according to this invention. In other words, all systems in which vehicles are to be found are interconnected via the roaming network 42 to the tapped "home" system and its MSC 40 HOME to which the interface computers 44<sub>I-III</sub> and the location computer 46 are connected (FIG. 5). Since a unified roaming network has not and may not join all cellular systems within a given geographical area such as the United States, it may be necessary to interconnect the interface and location computers of the tapped home system with more than one roaming network in order to obtain adequate location coverage. Such a system is shown generally in FIG. 11. Typically, each individual roaming network 42A, 42B and 42C in such a multiple-network environment could have home system switches 40<sub>HOME a</sub>, 40<sub>HOME b</sub> and 40<sub>HOME c</sub> that are each tapped by one or more corresponding interface computers 42A, 42B and 42C each linked to a single cellular system switch, 42A, 42B and 42C respectively, in that network which would act as the network's "home system". The various interface computers 44A-C from each network could then be joined to one or more central location computers 46 that determine vehicle location and send this information on to the Store and

- 44 -

Forward electronic mail system 61. A number of modifications to the overall system operating software are then required to determine which roaming network to tap to locate a particular vehicle and when to tap new roaming networks to continue location of a moving vehicle.

As discussed above, a CSS self-registration triggers the transmission of registration notification data to the vehicle home system's HLR. This data includes the SID and SWNO numbers of the host system that now serves the vehicle CSS. As discussed, home systems require this information to forward calls bound for the roaming vehicle to the systems in which they may be reached. IS.41 standard-compatible systems route this information to the CSS's (vehicle's) home system by reading the contents of the CSS's home SID register which is transmitted from the CSS to the host system during the self-registration process. If, however, multiple IS.41 roaming networks exist, the proposed system must insure that the registration notification messages are forwarded to the one cellular system within each roaming network that is tapped.

In one embodiment, the home SID register of each cellular telephone installed on the client's vehicles is set so that all SID numbers are the same. One cellular system in each roaming network is assigned this SID number as well. Thus, each roaming network would, necessarily, contain one cellular system having the same SID number and this number would be assigned to all mobile telephones installed in vehicles to be tracked by the location system. The IS.41 message routing software could then automatically forward the registration notification data to the tapped cellular systems because the SID of each CSS and one switch in the system would match. As pairs of separate roaming networks are joined by IS.41 communication links, one of the two systems with the same SID number would be eliminated, thus insuring that no two cellular systems in the same cellular roaming network would have the same SID number.

- 45 -

An alternative embodiment would involve modifying the cellular telephone firmware to change the contents of the home SID register to match the SID number of the cellular system tapped in the roaming network in which the cellular telephone is currently located. According to the IS.41 standard, the routing software would then automatically forward the registration notification data to the system whose SID number matches that transmitted by the cellular telephone as part of its self-registration procedure. In one implementation, the cellular telephone would determine the desired SID number by reading the SID number of its current host system. As noted, this number is continuously received over the control channel of the cellular system. The telephone would then look up the desired SID number in a table that associates the host system SID to the SID of the system tapped by interface computers in the roaming network of the host system.

Yet another alternative embodiment would require the modification of the software that directs data exchange between various cellular telephone systems. In one implementation, the routing software reads the MSN of each CSS (vehicle) whose data is being sent to the home system. If the MSN matches that of a CSS which is part of a fleet using the location system according to this invention, then the call would not be forwarded to the CSSs home system but, instead, would be routed to the cellular system that is tapped for that particular roaming network by the interface computer.

In all of the above-described alternative embodiments, it is assumed that the home systems of the roaming CSSs are constantly updated with information indicating the identity of the host switch serving the roaming CSSs. Home systems require this information to forward calls bound for roaming CSSs to the systems currently serving them. This function may be achieved through the mechanisms specified in the IS.41 standard, or other mechanisms that the cellular telephone



- 46 -

industry, individual service providers, switch manufacturers or other entities may adopt in the U.S. and abroad. In Europe, for example, the mechanism for roaming is dictated by the GSM rather than the IS.41 standard. Regardless of the actual implementation employed, the system according to this invention reads the information maintained by cellular systems to track which part of the system or systems are currently serving a particular CSS. Since the IS.41 standard is at this time the mechanism currently implemented in the U.S., it is assumed that the multiple roaming network implementation described further below relates to systems all utilizing the IS.41 standard.

In the multiple network roaming embodiments described above, the function and operation of the interface computers is essentially the same as that of the basic single roaming network embodiment. One or more interface computers are assigned to at least one cellular system within each cellular network. The main procedure of the interface computer as depicted in FIG. 6 and as described in Tables 1 and 2 is, thus, applicable to this embodiment. The primary difference in the operation of the interface computers 44A-C according to this multiple roaming network embodiment is that the value of the variable ROAMNET\_ID, as used throughout the preceding discussion, is not set equal to 1. Rather, it is set to a unique identification (ID) number of the roaming network which the particular interface computer taps. The value for the resulting variable ROAMNET\_ID is transmitted to the location computer 46 by a Found Vehicle message to indicate in which roaming network a vehicle numbered VN is traveling. If a value for the variable ROAMNET\_ID is, alternatively, transmitted to location computer in a Vehicle Not Found message the interface computer is indicating which roaming network (identified by the variable ROAMNET-ID) is no longer capable of locating the vehicle. Similarly a Log-in Failure message indicates which interface computer is no longer able to access the HLR data from the associated switch (MSC).

- 47 -

The basic function of the location computer 46 in the multiple roaming network embodiment is also similar to that shown for the basic single roaming network embodiment. However, this location computer must also track which vehicles are found in each specific roaming network. It must schedule the search for vehicles across different roaming networks in doing so. In order to minimize the number of HLR queries issued to tapped cellular systems, the location computer 46 limits the search for a vehicle to the smallest possible set of roaming networks. If no location information is available for the particular vehicle in the set of roaming networks accessed, then the search is extended to include all roaming networks. When the vehicle is found, the location computer 46 constricts further searches to the roaming network in which the vehicle is found, and to neighboring networks. If the vehicle is not found for an extended time period, then the search is extended to those roaming networks that could have been reached by the vehicle from its last known position given the time interval since the last position fix.

As in the basic single roaming network embodiment, the location computer 46 forwards to the store-and-forward electronic mail system 61, the location information for each vehicle. An additional parameter passed through the store-and-forward system 61 is the identification number (the variable ROAMNET\_ID) of the particular roaming network in which the vehicle is located. This information is used by the store-and-forward system 61 and/or by the home base 60 to reach the CSS of the vehicle in order to send each of data, text, fax and voice messages to it. As in the single roaming network embodiment, the location computer 46 executes a continuous procedure that receives messages from the interface computers and queues them in the register QUEUE\_MSG IN. Loading of the messages employs standard transfer protocols described above.

- 48 -

For multiple roaming networks, the location computer executes a main procedure as shown in FIG. 12. Table 4 below, similarly, depicts the associated internal data structure for variables utilized in the procedure of FIG. 12. The particular variables added to implement a multiple roaming network embodiment are marked with an asterisk "\*".

According to the procedure of FIG. 12, the location computer 46 in step 208 initiates operation by initializing all variables as described in the basic single roaming network embodiment procedure discussed above for FIG. 7. However, the Table 3 variable INT\_COMP\_MAX is now also set to the number of interface computers of the roaming network that is tapped by the largest number of interface computers. The variable ROAMNET\_MAX is set to the number of roaming networks tapped by the system. the variable matrix INT\_COMP MAX(1..ROAMNET\_MAX) is set to the number of interface computers tapping each roaming network. The variable SID\_MAX is set to the highest SID number for all cellular systems in all the roaming networks encompassed in the overall system. Since movement of vehicles between roaming networks may be a factor in this embodiment, the speed of vehicles is taken into account, thus, a variable called SPEED\_CLASS\_MAX is set to the maximum number of vehicle speed classes (i.e., specific increments of average vehicle speed which may vary based upon vehicle weight, size, ets.) that are recognized by the system. Each vehicle, in particular, is classified according to its maximum predicted travel speed, which influences the rate at which searches are extended when a vehicle is not found. Similarly, the MIN\_TRAVEL\_TIME(1..SID MAX, 1..ROAMNET\_MAX, 1..SPEED\_CLASS\_MAX) matrixes are each set to the minimum time required for a vehicle having a given value for the variable SPEED\_CLASS to reach a particular roaming network (identified by the variable ROAMNET) starting from the geographical area corresponding to a known cellular system. Variable entries for geographically adjacent or

TABLE 4 - DATA STRUCTURE FOR INTERFACE COMPUTER (MULTIPLE ROAMING NETWORKS)

Var/Label Name	Type	Purpose
ROAMNET_MAX*	Integer	Number of roaming networks tapped
SHNO_MAX	Integer	Highest number of switches in any given cellular system covered
INT_COMP_MAX_MAX*	Integer	Highest number of interface computers serving any one network of systems
INT_COMP_MAX(1..ROAMNET_MAX)*	Integer	Number of interface computers serving any one network of systems
VN_MAX	Integer	Arbitrary number equal to the number of vehicles tracked by the system
SID_MAX	Integer	Highest SID number of the cellular system covered
SPEED_CLASS_MAX*	Integer	Number of vehicle classes recognized by the system
TIME_NOW	Integer	Number of seconds elapsed from arbitrary point in time such as 12:00 am, January 1, 1991
MSM(1..VN_MAX)	Array of integers	Matches on-board phone serial numbers with particular vehicles
SID(1..VN_MAX)	Array of integers	Identification number of the system that last served vehicle VN
SHNO(1..VN_MAX)	Array of integers	Identification number of the switch that last served the vehicle VN
LOCATION/TIME(1..VN_MAX)	Array of integers	Time of last successful retrieval of SID and SHNO from home location register (HLR)
ROAMNET_ID(1..VN_MAX)*	Array of integers	Tells which roaming network vehicle VN was last in
INT_COMP_ID(1..VN_MAX,1..ROAMNET_MAX)*	Array of integers	Tells which interface computer in which roaming network last processed VN
STATUS(1..VN_MAX)	Array of integers	Status of VN within the location computer where 0 = look for 1 = found 2 = do not look for
LAST_LOCATION(1..VN_MAX)	Array of strings	Tells where vehicle VN was last located
MAILBOX(1..VN_MAX)	Array of list of	Matches vehicle with the list of the dispatcher's electronic strings mailboxes
SPEED_CLASS(1..VN_MAX)*	Array of integers	Speed class of each vehicle
LOOK_ROAMNET(1..VN_MAX,1..ROAMNET_MAX)	Matrix of 1-bit flags	Indicates in which roaming networks vehicles must be "looked for"

- 50 -

overlapping systems and roaming networks (identified by variables SID and ROAMNET\_ID) are set to zero regardless of speed class. Variable entries for non-adjacent and non-overlapping systems and roaming networks are set proportionally to travel distance and inversely proportionally to the maximum travel speed associated with the vehicle's speed classification (identified by the variable SPEED\_CLASS). All other variables and registers are set to zero. If the system is initiated for the first time, then all interface computers in the location system are reset using an appropriate message from the location computer 46.

The location computer main procedure of FIG. 12 subsequently verifies in decision step 210 whether the operator is attempting to gain manual control of the location computer. If so, the procedure allows such access in step 212 wherein the operator can transmit specific instructions to the location computer 46. Otherwise, the location computer 46 then enters a loop 214 in which it first reads all messages received from the interface computers 44A-C in step 216 into the temporary storage file PROCESS\_MSGS from the file QUEUE\_MSG\_IN. The location computer 46 then computes the new location for specific vehicles to be found in step 218 and also updates a matrix indicating the earliest possible of arrival of particular vehicles into each roaming network. The location computer 46 then forwards this information to mailboxes corresponding to the home offices of the particular vehicles located. The location computer in step 220 then reschedules the search for all vehicles that are to be tracked. After appropriate rescheduling commands are sent to the interface computers in subsequent step 222 via the file QUEUE\_MSG\_OUT, the location computer main procedure loop 214 described above repeats.

Operations of the system according to this embodiment begin when the operator instructs the location computer 46 to search for one or more vehicles identified by the variable VN. The operator enters each vehicle's vehicle

- 51 -

identification number VN, and speed class (identified by the variable SPEED\_CLASS) and the MSN of its associated CSS. A list of mailboxes to which the location information should be forwarded is also entered. The location computer 46 then determines which interface computer is handling the least number of vehicles and assigns to that interface computer the new vehicles by sending a search for Vehicle VN to the chosen interface computer message. The STATUS(VN) flag for each new, still unsearched and unlocated, vehicle VN is set to zero to indicate that these new vehicles are not yet located.

As described above, the interface computers (44A-C in the FIG. 11 embodiment) report changes in the HLR information associated with each vehicle to the location computer 46. These messages are read from the file QUEUE\_MSG\_IN into the temporary PROCESS\_MSGS file (step 216 in FIG. 12) and these messages are then processed in sequence by the COMPUTE AND UPDATE LOCATION procedure 224 outlined in FIG. 13. This procedure is basically similar to that described in a single roaming network embodiment at FIG. 8 and corresponding reference numerals are employed wherein procedure step 5 are similar, except for the following differences:

1. When a Found Vehicle message is processed in steps 158 and 160, the variable matrix FOUND\_ROAMNET\_ID(VN, ROAMNET\_ID) is set equal to 1 to indicate that the vehicle VN is now detected in the roaming network identified by the variable ROAMNET\_ID at subsequent step 226.
2. When a Vehicle Not Found message is processed in steps 180 and 182, the variable matrix FOUND\_ROAMNET\_ID(VN, ROAMNET\_ID) is set equal to 0 to indicate that the vehicle VN is not now detected in the roaming network identified by the variable ROAMNET\_ID in subsequent step 228.
3. As in the single roaming network embodiment of FIG. 8, Found Vehicle, Moved Vehicle and Same Location messages instruct the location computer 46 to forward

- 52 -

the vehicle's position data to the mailboxes corresponding to the vehicles home base(s) 60 at step 168. However, the messages now also include the identification number indicated by the variable ROAMNET(VN) of the roaming network in which the associated vehicle VN was last detected.

4. Found Vehicle, Moved Vehicle and Same Location messages also trigger a call to the RESET\_ROAM TIMERS(VN,SID) procedure shown below in Routine 1 in step 230.

ROUTINE 1

```

RESET_ROAM_TIMERS(VN,SID)
FOR ROAMNET=1 TO MAX_ROAMNET
    ETA_MIN(VN,ROAMNET)=LOCATION_TIME(VN)+MIN_TRAVEL_
TIME(SID,ROAMNET,SPEED_CLASS(VN))
NEXT ROAMNET

```

This routine (Routine 1) determines the earliest possible time of arrival to all roaming networks of a vehicle VN, given the SID of the MSC that last detected it. This time value is derived from adding the time in which the vehicle was detected to the value for the variable MIN\_TRAVEL TIME(SID,ROAMNET, SPEED\_CLASS(VN)) which is defined as the minimum travel time required by a vehicle having a speed classification of SPEED\_CLASS(VN) to move from the area served by an MSC having a number SID to the roaming network having a number ROAMNET. The earliest possible time of arrival of vehicle VN to all roaming networks is stored in the register ETA\_MIN(VN,1..MAX\_ROAMNET). The value stored in the ETA\_MIN for roaming networks that are geographically overlapping or adjacent to the area corresponding to the MSC that last detected the CSS (vehicle) would be less than the current time which indicates that the vehicle may already have arrived in these roaming networks. Conversely, the ETA\_MIN would be greater than the current time for roaming networks that are distant from the area corresponding to the

- 53 -

MSC that last detected the CSS. The COMPUTE AND UPDATE LOCATION procedure 224 (FIG. 13) terminates when all messages queried in the file PROCESS\_MSGS are processed and this register is emptied.

After returning from the COMPUTE AND UPDATE LOCATION procedure 224 to the main procedure via step 183, the main loop 214 (FIG. 12) of the main location computer procedure continues with the entry into the SCHEDULE SEARCH procedure in step 220. This procedure 232 is further described in FIG. 14. This procedure loops through each identified vehicle VN and expands and restricts the search for each active vehicle VN to roaming networks in which the vehicle could be reached based upon its last known position. The procedure 232 counts in step 234 from a VN value of one through the maximum value (VN\_MAX) for the variable VN. The procedure, for each VN determines in decision step 236 whether the value of the variable STATUS(VN) for the associated vehicle VN is equal to 2. If so, this vehicle is not to be located and the procedure branches to step 238 which causes a direct return via branch 240 to the VN count in step 234. If the vehicle however is to be searched for (e.g., STATUS(VN) is not equal to 2), then step 236 branches to a series of subroutine calls that expand (step 242) or restrict (step 244) the search and then determine if the vehicle VN is found (step 246). When all vehicles have been looped through. The procedure in step 248 returns to the main COMPUTE AND UPDATE LOCATION procedure 224 in FIG. 13.

The subroutine EXPAND SEARCH 242 is shown in Routine 2 below and determines whether the vehicle could have arrived in the roaming network numbered ROAMNET by determining if the value for the variable ETA\_MIN(VN,ROAMNET) is less than the current time and also by verifying whether the system is not already searching for the vehicle VN in the roaming network ROAMNET. If these conditions are met, then the EXPAND SEARCH routine 242 (FIG. 14 and Routine 2) calls the corresponding



- 54 -

subroutine entitled ASSIGN\_INT\_COMP(ROAMNET,VN) shown in Routine 6 below.

ROUTINE 2

```
EXPAND SEARCH(VN)
FOR ROAMNET=1 to MAX_ROAMNET
  IF ETA_MIN(VN), ROAMNET)>TIME_NOW
  AND LOOK_ROAMNET(VN, ROAMNET)=0
  THEN
    ASSIGN INT_COMP(ROAMNET,VN)
    LOOK_ROAMNET(VN,ROAMNET)=1
NEXT ROAMNET
RETURN
```

The ASSIGN\_INT\_COMP subroutine (Routine 6) determines which interface computer in the roaming network ROAMNET has the least number of vehicles assigned to it. The subroutine then instructs this interface computer to search for vehicle VN by appending a Search For Vehicle VN message to the file QUEUE MSG\_OUT.

Similarly, the subroutine RESTRICT SEARCH 244 (FIG. 14 and Routine 3 below) determines whether the vehicle VN can no longer be

ROUTINE 3

```
RESTRICT SEARCH(VN)
FOR ROAMNET=1 to MAX_ROAMNET
  IF ETA_MIN(VN, ROAMNET)<TIME_NOW
  AND LOOK_ROAMNET(VN, ROAMNET)=1
  THEN
    DEASSIGN INT_COMP(ROAMNET, VN)
    LOOK_ROAMNET(VN,ROAMNET)=0
NEXT ROAMNET
RETURN
```

- 55 -

located determines whether the vehicle VN can no longer be located in a given roaming network by determining if the value for the variable ETA\_MIN(VN,ROAMNET) is greater than the current time and also by checking whether the system is already searching for the vehicle in the given roaming network (identified by the variable ROAMNET). If these conditions are met, then the RESTRICT SEARCH subroutine calls the corresponding subroutine DEASSIGN\_INT\_COMP(ROAMNET,VN) of Routine 4 below.

ROUTINE 4

```
DEASSIGN_INT_COMP(ROAMNET,VN)
DEASSIGN=INT_COMP_ID(VN, ROAMNET)
APPEND(ROAMNET,ASSIGN,"Do Not Search VN",VN) TO QUEUE_MSG_OUT
LOAD(ROAMNET, DEASSIGN)=LOAD(ROAMNET, DEASSIGN)-1
INT_COMP_ID(VN, ROAMNET)=0
```

This subroutine determines which interface computer in the roaming network identified by the variable ROAMNET is currently serving vehicle VN and then instructs this interface computer to no longer search for vehicle VN by appending a Do Not Search For Vehicle VN message to the file QUEUE\_MSG\_OUT.

After expanding and restricting the search for vehicle VN as appropriate, the SCHEDULE SEARCH subroutine (step 232 of FIG. 14) calls the subroutine DETERMINE IF FOUND(VN) 246 (See Routine 5 below) to determine if vehicle VN has been found in at least one roaming network of the system. This routine may be modified so that a "Vehicle Not Found" message is sent to the mailboxes corresponding to the home base vehicle VN in the event that a previously found vehicle is now no longer found.

ROUTINE 5

```
DETERMINE IF FOUND(VN)
STATUS(VN)=0
```

- 56 -

```

FOR ROAMNET=1 to MAX_ROAMNET
  IF FOUND_ROAMNET=1 THEN STATUS(VN)=1
NEXT ROAMNET
RETURN STATUS(VN)

```

Following completion of the SCHEDULE SEARCH procedure, the location computer 46 transmits messages appended to the QUEUE MSG\_OUT register by the subroutine, ASSIGN\_INT\_COMP (See Routine 6) and DEASSIGN\_INT\_COMP (see Routine 4), to the appropriate interface computers.

ROUTINE 6

```

ASSIGN_INT_COMP(ROAMNET,VN)
ASSIGN=1
MIN=LOAD(ROAMNET,1)
FOR INT_COMP_ID=2 TO INT_COMP_MAX(ROAMNET)
  IF LOAD(ROAMNET,INT_COMP_ID)<MIN
  THEN
    ASSIGN=INT_COMP_ID
    MIN=LOAD(ROAMNET,INT_COMP_ID)
NEXT INT_COMP_ID
APPEND(ROAMNET, ASSIGN,"Search For VN",VN,MSN(VN)TO QUEUE_MSG
OUT
LOAD(ROAMNET, ASSIGN)=LOAD(ROAMNET, ASSIGN)+1
INT_COMP_ID(VN, ROAMNET)=ASSIGN

```

The location computer 46 may facilitate this task by first sorting all messages by roaming network and interface computer identification number, so that all messages bound for a specific interface computer may be transmitted in a single packet. After these messages are transmitted, the location computer verifies whether the operator is attempting to gain control of the system and then initiates the main procedure loop 214 (FIG. 12) by reading the next batch of inbound messages from the file QUEUE\_MSG\_IN to the file PROCESS\_MSGS.

- 57 -

In multiple roaming network embodiment described above, the mobile equipment required for each vehicle is the same as that described for the basic single roaming network embodiment. In order to transmit an outbound message to one or more vehicles, it is necessary for the originating equipment to first determine which roaming network currently serves the particular vehicles. This information is automatically passed to the home base by the location computer 46 and, thus, may be used for message transmission.

#### Improvement with GSM

The purpose of this section is to describe the specific variations that can be applied to the above embodiments, when the area in which mobile units are to be located is served by cellular systems that adhere the GSM standard. This standard is specified by ETSI (e European based standards setting body) in the Recommendation GSM document. The current revision number is 3. This standard should be deemed to be incorporated herein by reference.

GSM is the cellular telephone standard selected by a number of telephone operators in Europe. Because the standard incorporates the specifications to interface individual cellular systems to each other in order to implement roaming, GSM systems will soon offer service on a pan-European basis. GSM based roaming networks are therefore the prime candidates to implement the proposed system in Europe as the goal of the invention is to track the location of vehicles over the widest possible area.

There are significant similarities among the IS.41 and the GSM roaming standards. As with the IS.41 standard, each GSM Mobile Subscriber MS, is identified by a unique number, the IMSI (International Mobile Subscriber Data) which also identifies the home GSM network of the MS.

As in IS.41 systems, minimum communication linkage with a roaming network is maintained, particularly by means of a self-registration process which occurs at predetermined

- 58 -

intervals, and also when the MS enters a new Location Area or when certain other conditions occur (see Recommendation GSM 03.12 Location Registration Procedures in ETSI/TC GSM released by ETSI/PT 12, June 1991, and section 4.4.1 in Recommendation GSM 04.08 v. 3.13.0 in ETSI/TC GSM).

As in IS.41, the registration process acts as a tracking "beacon" that is received by the closest base station in the system in which the MS is present. The roaming network allows the base station, and therefore the system, to identify the MS. Each system includes one or more HLR and VLR registers (see attached FIG. 15 from Recommendation GSM 01.02 General Description of a GSM PLMN from ETSI/TC GSM released by ETSI/PT 12, March 1990). The HLR stores information about MSs belonging to the system which might be roaming in other systems, while the VLR stores information regarding MSs belonging to other systems but roaming in the area of coverage of the particular system. As with IS.41, the GSM standard specifies that whenever an MS registers in a system other than its home, the "guest" system must automatically convey to the HLR of the home system information so that the home system may reach the MS, for example to deliver calls. (see again GSM Recommendation 03/12 and also Recommendation GSM 09.02 Mobile Application Part Specification, v. 3.8.0, January 1991).

Table 5 (from GSM Recommendation 03.08 Organization of Subscriber Data) illustrates the data that is stored in the HLR and VLR. In particular, when a roaming MS registers with the system serving the area where it is present, this system sends to the home HLR register location information, which could be a combination of MSC number, VLR number, MS RoamingID and local mobile station identity. In addition, the Local Area ID corresponding to the location of the MS is stored both in the MSs non-volatile memory and in the VLR of the local system (for an explanation of this procedure, see GSM 03/12 and GSM 09.02 v. 3.8.0 section 5.2.1.2.2. For an explanation of parameters passed, see GSM 03.08 and GSM

TABLE 5  
Overview of data stored in location registers

PARAMETER	SECTION	HLR	VLR	TYPE
IMSI	2.1.1	M	M	P
International MS ISDN number	2.1.2	M	M	P
TMSI	2.1.3	-	C	T
LMSI	2.1.4	C	C	T
Mobile Station Category	2.2.1	C	C	P
Authentication key	2.3.1	C	C	P
RAND/SRES and Kc	2.3.2	M	M	T
Cipher Key Sequence Number	2.3.3	-	M	T
MS roamingnumber, (Note 1)	2.4.1	C	M	T
Location area id	2.4.2	-	M	T
VLR number	2.4.3	M	-	T
MSC number	2.4.4	C	C	T
Roaming restriction	2.4.5	M	-	T
HLR number	2.4.6	-	C	T
Provision of bearer service	2.5.1	M	M	P
Provision of teleservice	2.5.2	M	M	P
BC allocation	2.5.3	C	C	P
Subscription restriction	2.5.4	C	C	P
Provision of suppl.serv.	2.6.1.1	M	M	P
CUG Interlock code	2.6.1.2	C	C	P
CUG index	2.6.1.3	C	C	P
Per call basis subscription	2.6.2.1	C	C	P
Notification to calling party	2.6.2.4	C	C	P
User-to-user signalling service ind.	2.6.2.8	C	C	P
CUG facility	2.6.2.9	C	C	P
Preferential CUG facility	2.6.2.10	C	C	P
Barring incoming calls within CUG	2.6.2.11	C	-	P
Barring outgoing calls within CUG	2.6.2.12	C	C	P
Maximum number of conferees	2.6.2.13	C	C	P
Control of barring services	2.6.2.14	C	C	P
Hunt group access selection order	2.6.2.15	FS	FS	FS
Forwarded-to number	2.6.3.1	C	C	T
Registration status	2.6.3.2	C	C	T
No reply condition timer	2.6.3.3	C	C	T
Call barring password	2.6.3.4	C	-	T
Activation status	2.6.4.1	C	C	T
IMSI detached flag	2.7.1	-	C	T
Radio Confirmation Indicator	2.7.2.1	-	M	T
HLR Confirmation Indicator	2.7.2.2	-	M	T
MSRN flag	2.7.2.3	-	C	T
Check Suppl. Services flag	2.7.2.4	M	-	T
Access priority class	2.8.1	C	C	P
Handover Number	2.9.1	-	C	T
Messages Waiting Data	2.10.1	C	-	T
Messages Waiting Flag	2.10.2	-	M	T

Note 1. See section 2.4.1

See section 3 for explanation of M,C,T and P in table.

- 60 -

03.03). In addition, the Local Area ID corresponding to the location of the MS is stored both in the MS's non-volatile memory and in the VLR of the local system (See GSM 04.08 v. 3.13.0 section 4.4.4.5). As we shall see later, Local Area ID data may be tapped to gather more accurate position information than in the basic embodiment.

Some of the possible means through which this data is extracted from the home system, converted to location information and distributed to users are the same as the ones described in FIG. 5, which shows the implementation of a basic system for locating vehicles through the roaming network 42. In this embodiment the roaming network abides to the GSM than the IS.41 standard. This system is interfaced with a particular MSC 40<sub>HOME</sub> interconnected with the roaming network 42 according to the GSM standard. At least one interface computer is interconnected with the switch 40<sub>HOME</sub> and receives information on MS registration from the switch. In this example, three interface computers IC I (44<sub>I</sub>), IC II (44<sub>II</sub>) and IC III (44<sub>III</sub>), are assigned to the MSC 40<sub>HOME</sub> in order to lighten the processing load. The switch selected for connection to the interface computer(s) according to this invention may be considered the home switch in the home system for the purposes of MS registration. In other words, each MS to be located will carry an International Mobile Service Identification (IMSI) that identifies that MS as belonging to the depicted home MSC 40<sub>HOME</sub>.

The roaming network 42 allows the MSC 40<sub>HOME</sub> to record periodically the location (i.e., the particular host MSC and VLR number) of each home-registered MS even if it is visiting in another host system. The home registered MS registration data (stored in the HLR register shown in Table 1), termed HLR data, is read from the home MSC 40<sub>HOME</sub> by one of the interface computers 44<sub>I</sub>, 44<sub>II</sub> and 44<sub>III</sub>. These computers store the information in an internal data base for subsequent transmission to a central location computer 46 of

- 61 -

this embodiment. This computer concentrates the coordinates all data received from the various interface computers 44<sub>I-II</sub> connected to the switch (MSC) 40<sub>HOME</sub>. The location computer 46, according to this invention, then processes the HLR data from the interface computers 40<sub>I-II</sub> and determines the cellular system location of each MS registered to this home MSC 40<sub>I-III</sub> on the basis of database correlating MSC and VLR numbers to geographic position. This information is then forwarded to the electronic mailbox system 61 that, in turn, transfers the location information to the customer site 60. The customer, which is generally connected by modem to the electronic mail data line, maintains a terminal or computer 62 for receiving the data in a readable format (e.g., terminal 62 of FIGS. 2 and 3).

With specific reference to the interface computers IC I, IC II and IC III as depicted in FIG. 5, several different methods of allowing the computers 44<sub>I-III</sub> to access HLR data may be employed. The home MSC 40<sub>HOME</sub> respectively, can be programmed to transmit to a port, or alternatively, store in a file, data relating to changes occurring in HLR entries from the tracked MSs. Changes in HLR entries for home-registered vehicles are brought about by the registration signals received from the roaming network 42. The roaming network 42, itself receives the signals from the various host systems in which MSs are located. The interface computers can then read and decipher this information. Alternatively, the interface computer(s) 44<sub>I-III</sub> can be disposed directly between the GSM-based roaming network 42 and the home MSC 40<sub>HOME</sub>. The interface computers 60, 62, 64 allow the information to pass through the MSC 56 unaffected, but would capture the messages carrying the new data bound for the home MSC's HLR 70<sub>HOME</sub>.

Yet another method of reading data involves reliance upon a feature that may be built into future version of the GSM standard, which would allow switches to read the VLR



- 62 -

registers of other systems. The interface computer(s) could then be adapted to read the VLR data relating to the MSs to be tracked directly from the VLRs of the MSCs serving the MSs of interest. This may require reading the MSC, VLR and MS Roaming Number from the HLR in order to properly query the correct entry in the remote VLR. This would make available the Location Area Identification register, (not available with the IS.41 standard), which is stored in the remote VLR, and which can be converted to more accurate geographic information than MSC or VLR data. This field provides one higher level of geographic detail as it indicates the MS registered from within a specific region of an MSC area (see section 4.1 in Recommendation GSM 03.03 Numbering, Addressing and Identification in ETSI/TC GSM released by ETSI/PT 12, January 1991). The interface computer(s) could access this data by reading the VLR, MSC and MR Roaming number from the MS's entry in the HLR, then calling the indicated VLR in the indicated HLR, and then Querying that VLR for the Location Area ID of the indicated MS Roaming Number. Alternatively, the Interface Computer could delegate this task to the home MSC, which would then relay this data to the Interface Computer(s).

In another possible embodiment, this same information could be obtained by calling the Update Location Area operation specified in section 6 of GSM Recommendation 9.02 Mobile Part Specification. This routine automatically returns the Local Area ID of the MS.

In yet another possible implementation, the Local Area Identification Field, and possibly the Cell Identification Field can be sent to the Interface Computer or the Home system from the MS using the Short Message feature specified in the GSM standard (see GSM 01.02), or other GSM features allowing for data transfer from the MS to the MSCs, PSTN/ISDN terminals or other message senders/recipients. Whenever an MS re-registers, it acquires and stores the Local Area Identification Field (and possibly the Cell Identification

- 63 -

fields) corresponding to the area of its current location. This information can be relayed to the Interface computer either automatically or at its request, and relayed to the Location Computer for conversion to geographic position. This implementation may require modifying the software in MS units that implements Location Updating (as specified in GSM 03.12) so that a message containing the Local Area Identification Field and/or the Cell Identification field is sent to an address corresponding to the Interface computer automatically (for example, whenever the MS re-registers), or when a particular message is received by the MS by way of the Short Message Mobile Terminated GSM feature (also outlined in GSM section 01.02).

In the depicted embodiment, the HLR information is obtained by the interface computers 44<sub>I-III</sub> by accessing the MSC's operations and maintenance port (not shown). The interface computers 44<sub>I-III</sub> then query the HLR database 70<sub>HOME</sub>, 74, 76 and 78 using a man-machine command interface built into the MSC 40<sub>HOME</sub> operating software. All other details of this embodiment are equivalent to those specified for IS.41 based systems. Of course, the front-end of the actual routine that reads the MSC, VLR and possibly the Location ID data from the HLR would have to be modified to interface with the specific equipment utilized by the home cellular operator to implement the MSC and HLR. As before, location is determined over the entire region covered by the roaming network without modifying the systems covering areas outside the reach of the home system.

Another improvement over the IS.41 based system is the elimination of some of the equipment that had to be coupled to the MS in the IS.41 embodiment in order to implement the messaging functions between the mobile vehicle and stationary correspondents. Since the GSM standard allows for the direct exchange of digital data between the MS unit and other PSTN/ISDN terminals with several protocols, including synchronous, asynchronous and G3 Fax, the Cellular Telephone

- 64 -

Interface 190, Call Router 191 and Modem 198 shown in FIG. 9 are no longer necessary as the MS already provides all the necessary interfaces.

#### Further System Options and Improvements

Having described herein above embodiments detailing the vehicle location system according to this invention having one or multiple roaming networks, it is possible to implement further modifications and optional implementations to both of these systems. For example, limited dial-in and dial-out capability may be afforded to mobile vehicle telephones to prevent unauthorized use by using restricted outgoing facilities offered by some cellular carriers, such as the Pulsar series, and by limiting the ability of the home switch to forward calls so that only predefined telephone numbers may do so.

Additionally, it may be desirable to program the text terminal of each vehicle to transmit predefined messages to the home base. A typical application would be a "panic" button that could be utilized by the vehicle's driver to signal distress or other important situations. The text terminal would send these messages to the Store and Forward electronic mail system. These messages would be predefined, rather than manually entered.

The following has been a detailed description of the preferred embodiments various modifications and alterations to these embodiments that are possible according to the spirit and scope of this invention. This detailed description should be taken only by way of example and is meant only to describe the preferred embodiments and should not be taken to limit the invention. Rather, the invention should only be limited by the following claims.

What is claimed is:

- 65 -

CLAIMS

1. A vehicle location system for tracking predetermined cellular subscriber stations over a wide geographical area that includes a plurality of cellular telephone systems, each of the cellular telephone systems including a memory for holding data that (1) identifies cellular subscriber stations based in that telephone system, (2) identifies visiting cellular subscriber stations based in other cellular telephone systems and (3) identifies that cellular telephone system, a roaming network for interconnecting and transferring the data in the memory between cellular telephone systems in the network, the data enabling a cellular telephone system receiving the data to at least one of establish a telephone connection and maintain a telephone connection with cellular subscriber stations based in that cellular telephone system that are visiting other cellular telephone systems in the network, the vehicle location system comprising:

interface means interconnected to the memory of at least one of the plurality of cellular telephone systems in the network, the interface means including means for accessing the data relative to predetermined cellular subscriber stations, and means for reading the data identifying the cellular telephone systems in the network in which each of the predetermined cellular subscriber stations is currently present; and

location means, interconnected with the interface means, for translating the data relative to the predetermined cellular subscriber stations into location data indicative of the geographical position of each of the predetermined cellular subscriber stations based upon the position of the system in which each of the cellular subscriber stations is present.

- 66 -

2. The vehicle location system of claim 1 further comprising user interface means, interconnected with the location means, for receiving and displaying the location data.

3. The vehicle location system of claim 2 wherein the user interface means further comprises means for transmitting data to the location means that identifies the predetermined cellular subscriber stations to be located.

4. The vehicle location system of claim 3 wherein the location computer includes instruction means interconnected to the interface means for instructing the interface means to access data related to the predetermined cellular subscriber stations.

5. The vehicle location system of claim 1 wherein the interface means includes means for continuously updating location data related to predetermined cellular subscriber stations, the means for updating including database means for storing data relative to an identity of a cellular telephone system in which each of the predetermined cellular subscriber stations is positioned.

6. The vehicle location system of claim 1 wherein at least one of the plurality of cellular telephone systems includes a plurality of cellular telephone switches and the interface means include means for identifying predetermined cellular subscriber stations positioned within a cellular telephone switch.

7. The vehicle location system of any one of claims 1-6 wherein the roaming network is based upon EIA/TIA Standard IS.41.

- 67 -

8. The vehicle location system of any one of claims 2-4 wherein the user interface means includes a store-and-forward electronic mail system.

9. The vehicle location system of claim 8 wherein the user interface means includes means for transmitting messages through the store-and-forward electronic mail system to an from a predetermined cellular subscriber station.

10. The vehicle location system of claim 1 further comprising a plurality of independent roaming networks interconnecting predetermined of the plurality of cellular telephone systems, the interface computer means including roaming network update means for tracking positions of predetermined cellular subscriber stations passing between the independent roaming networks.

11. The vehicle location system of claim 10 wherein the roaming network update means includes means for expanding and restricting a search for a cellular subscriber station moving between the independent roaming networks including means for predicting probable locations of a cellular subscriber stations in an adjoining roaming network based upon a movement speed and a passed movement pattern of the cellular subscriber station.

12. The vehicle location system of claim 1 wherein at least one of the cellular subscriber stations comprises a mobile cellular telephone positioned in a respective vehicle.

13. The vehicle location system of any one of claims 1-6 wherein the roaming network is based upon the GSM standard.

14. The vehicle location system as set forth in claim 13 wherein the cellular subscriber stations include registers

- 68 -

for storing information representative of a local area of a predetermined cellular telephone system and wherein the means for reading reads the information representative of the local area.

15. A method for tracking cellular subscriber stations for a wide geographical area that includes a plurality of cellular telephone systems, each of the cellular telephone systems including a memory controlling data that (1) identifies those subscriber stations based in that telephone system, (2) identifies visiting cellular subscriber stations based in other cellular telephone systems and (3) identifies that cellular telephone system, a roaming network for interconnecting and transferring the data in the memory between cellular telephone systems in the network, the data enabling a cellular telephone system receiving the data to at least one of establish a telephone connection and maintain a telephone connection with cellular subscriber stations based in that cellular telephone system that are visiting other cellular telephone systems in the network, the method comprising:

interfacing to the memory of at least one of the plurality of cellular telephone systems in the network, the step of interfacing including accessing the data relative to predetermined cellular subscriber stations and reading the data identifying the cellular telephone systems in the network in which each of the predetermined cellular subscriber stations is currently present; and

translating, in response to the step of interfacing, the data relative to the predetermined cellular subscriber stations into location data indicative of the geographical position of each of the predetermined cellular subscriber stations based upon the position of the system in which each of the predetermined cellular subscriber stations is currently present.

- 69 -

16. The method as set forth in claim 15 wherein each of the cellular telephone systems adheres to the GSM standard.

17. The method as set forth in claim 16 wherein at least one of the predetermined cellular subscriber stations comprises a mobile cellular telephone positioned in a respective vehicle.

18. The method as set forth in any one of claims 15 or 16 wherein at least one of the plurality of cellular telephone systems includes a plurality of cellular telephone switches and wherein the step of interfacing includes identifying predetermined cellular subscriber stations positioned within a cellular telephone switch.

19. The method as set forth in claim 18 wherein the step of interfacing includes updating location data related to predetermined cellular subscriber stations, the step of updating including storing data relative to an identity of a cellular telephone system in which each of the predetermined cellular subscriber stations is positioned.



Fig. 1

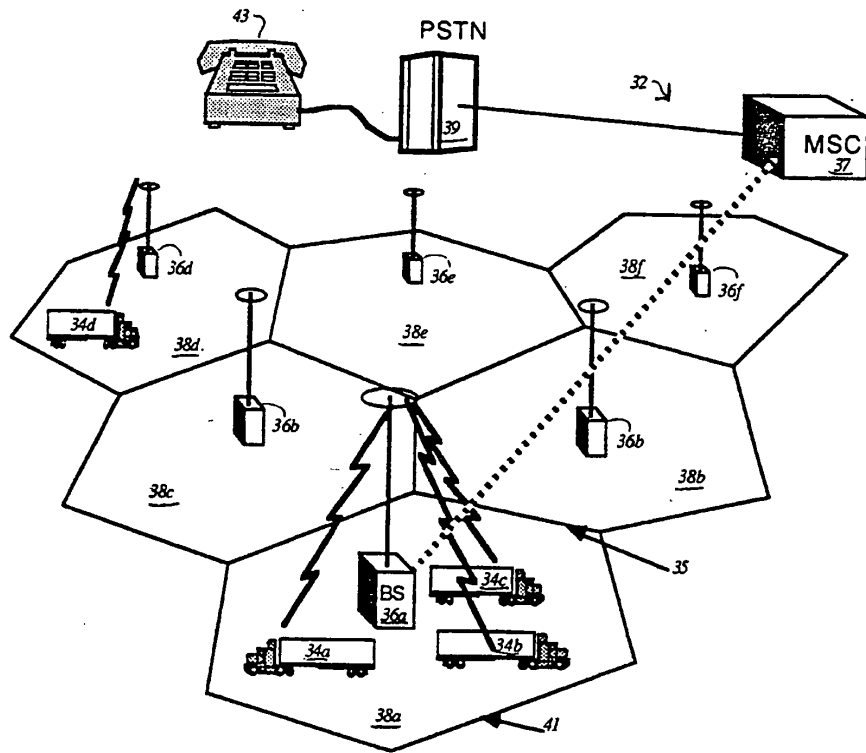
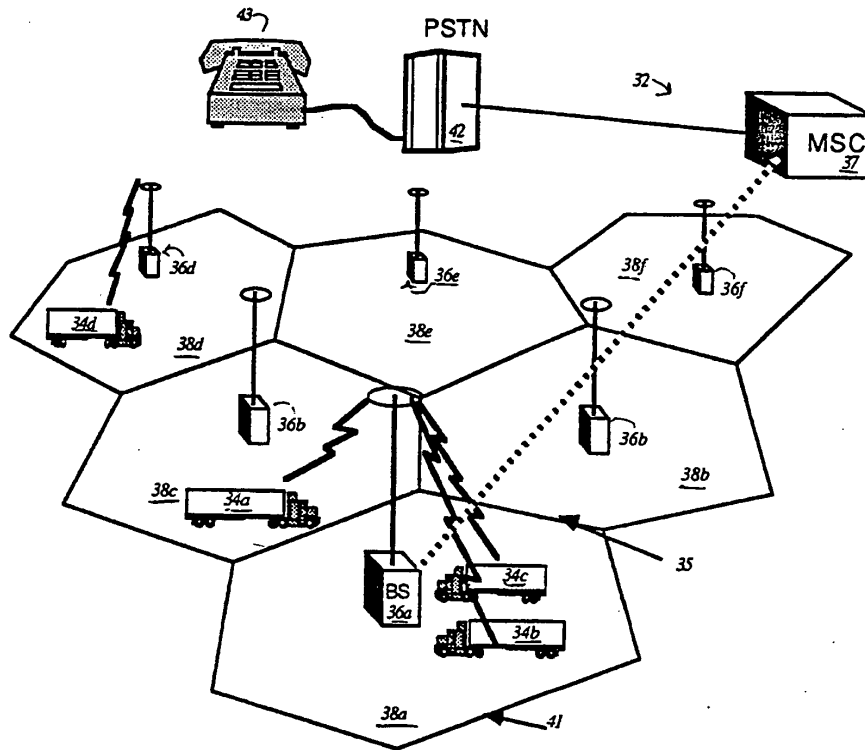

Fig. 1A



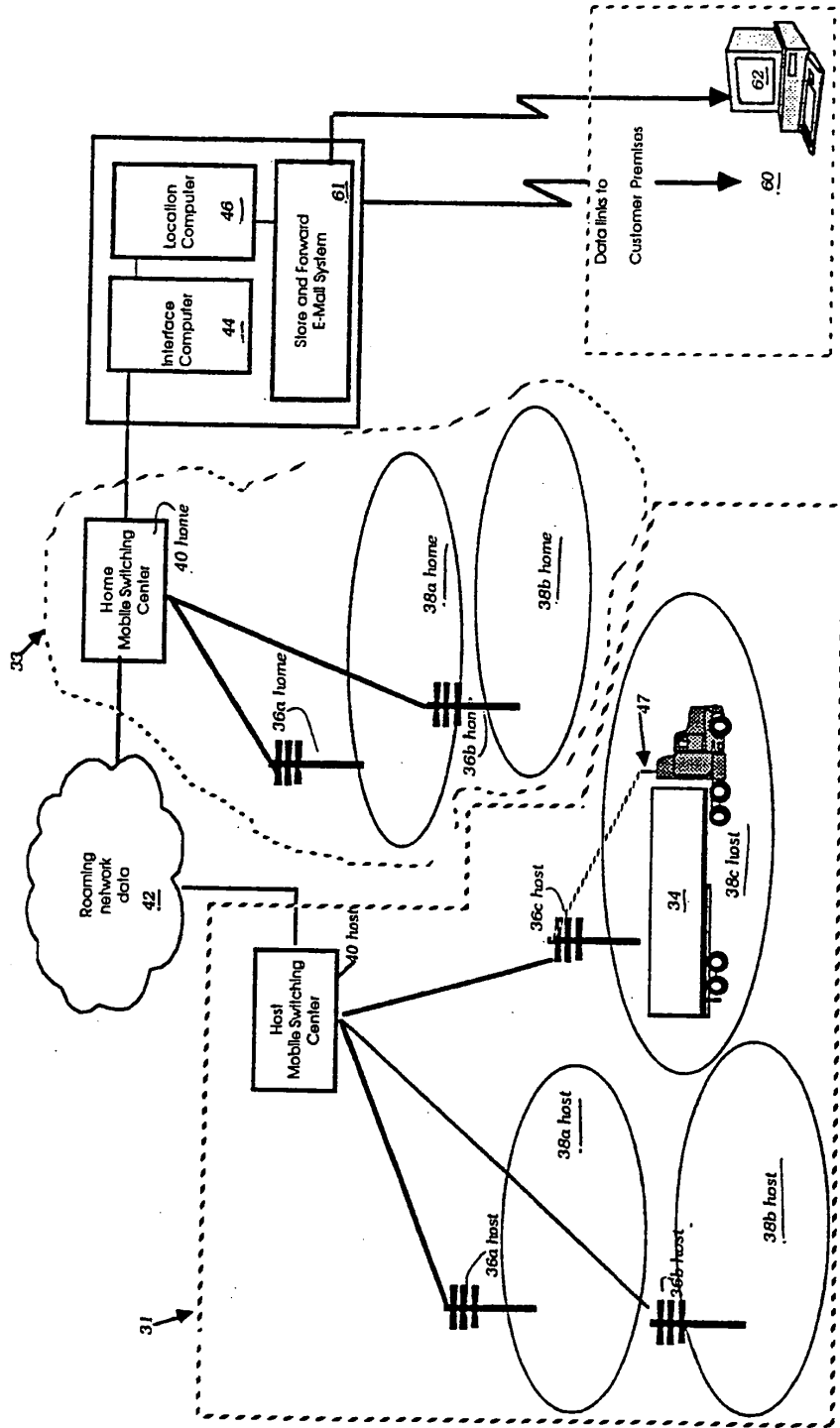

Fig. 2

4/17

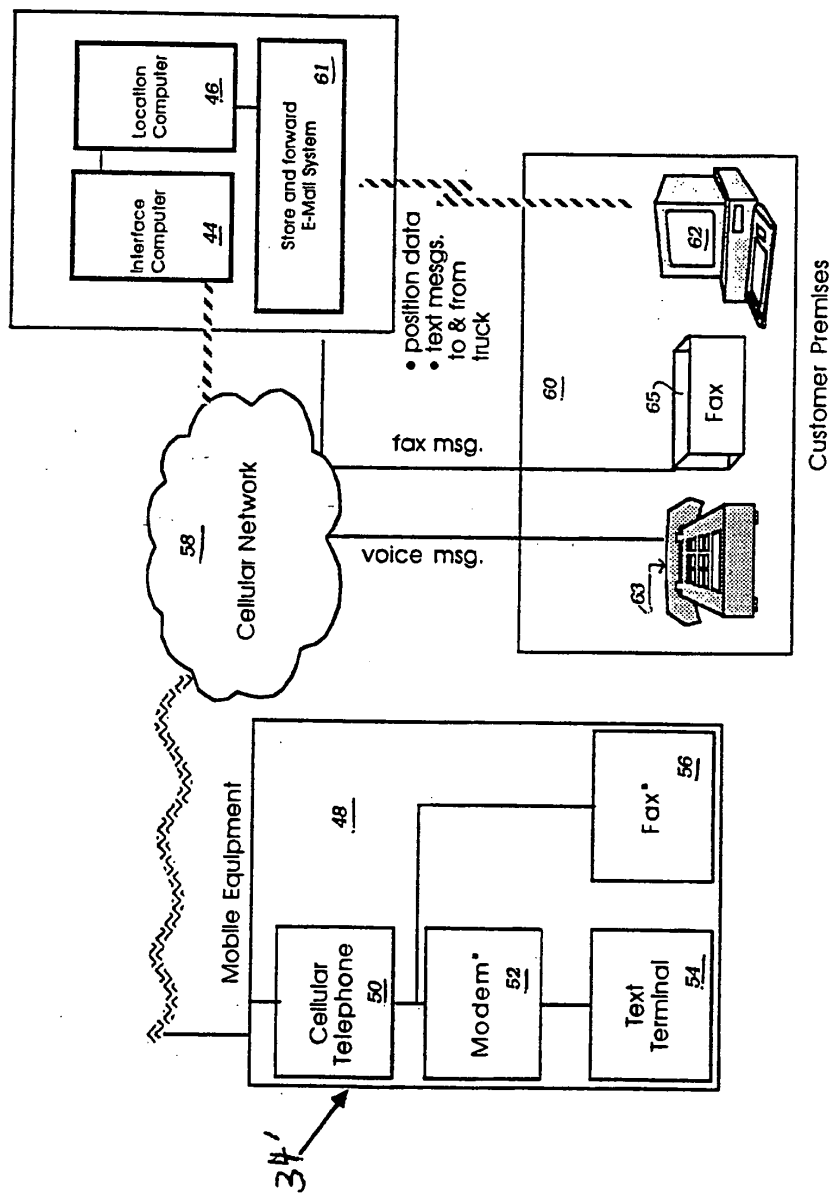

Fig. 3

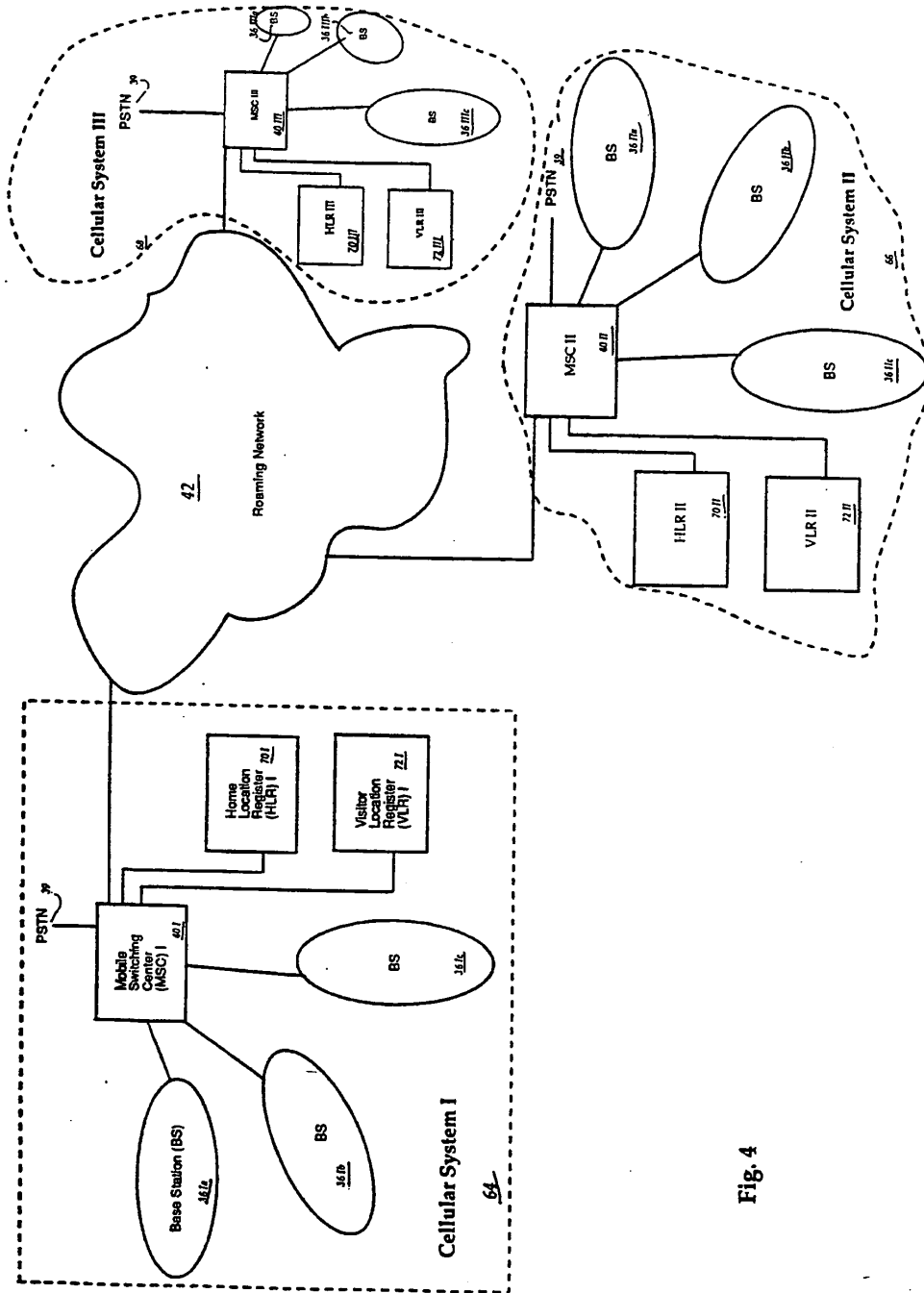

Fig. 4

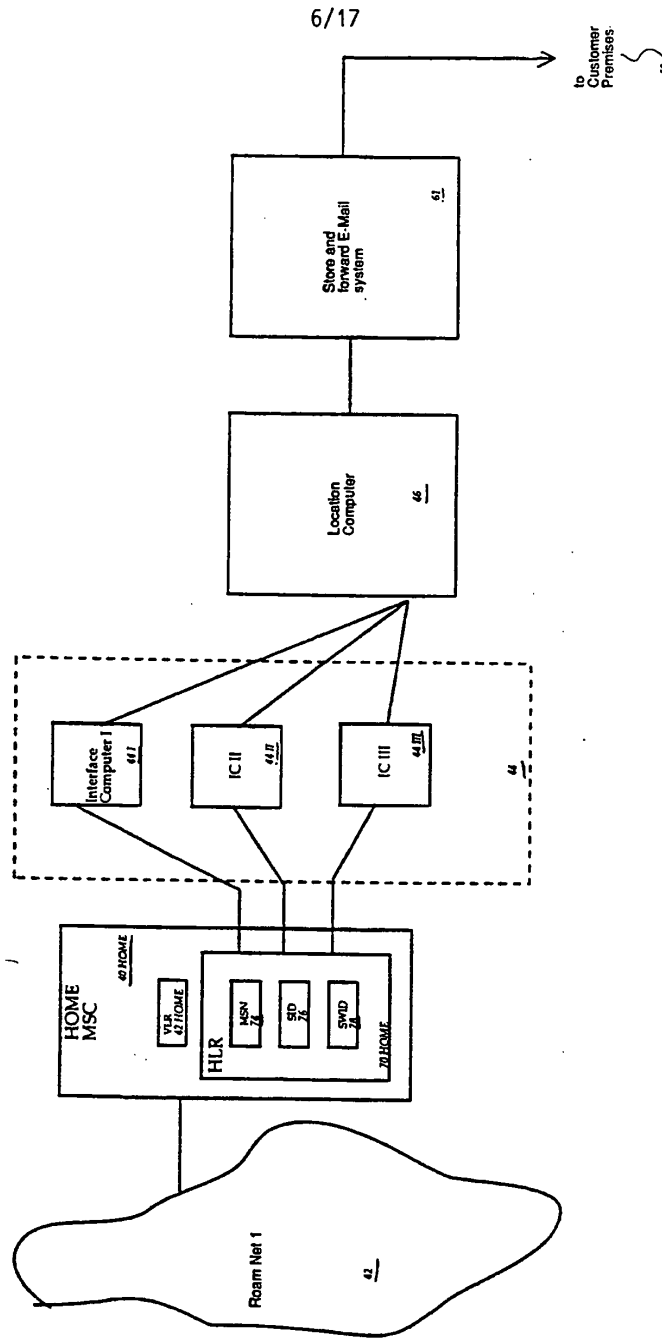

Fig. 5

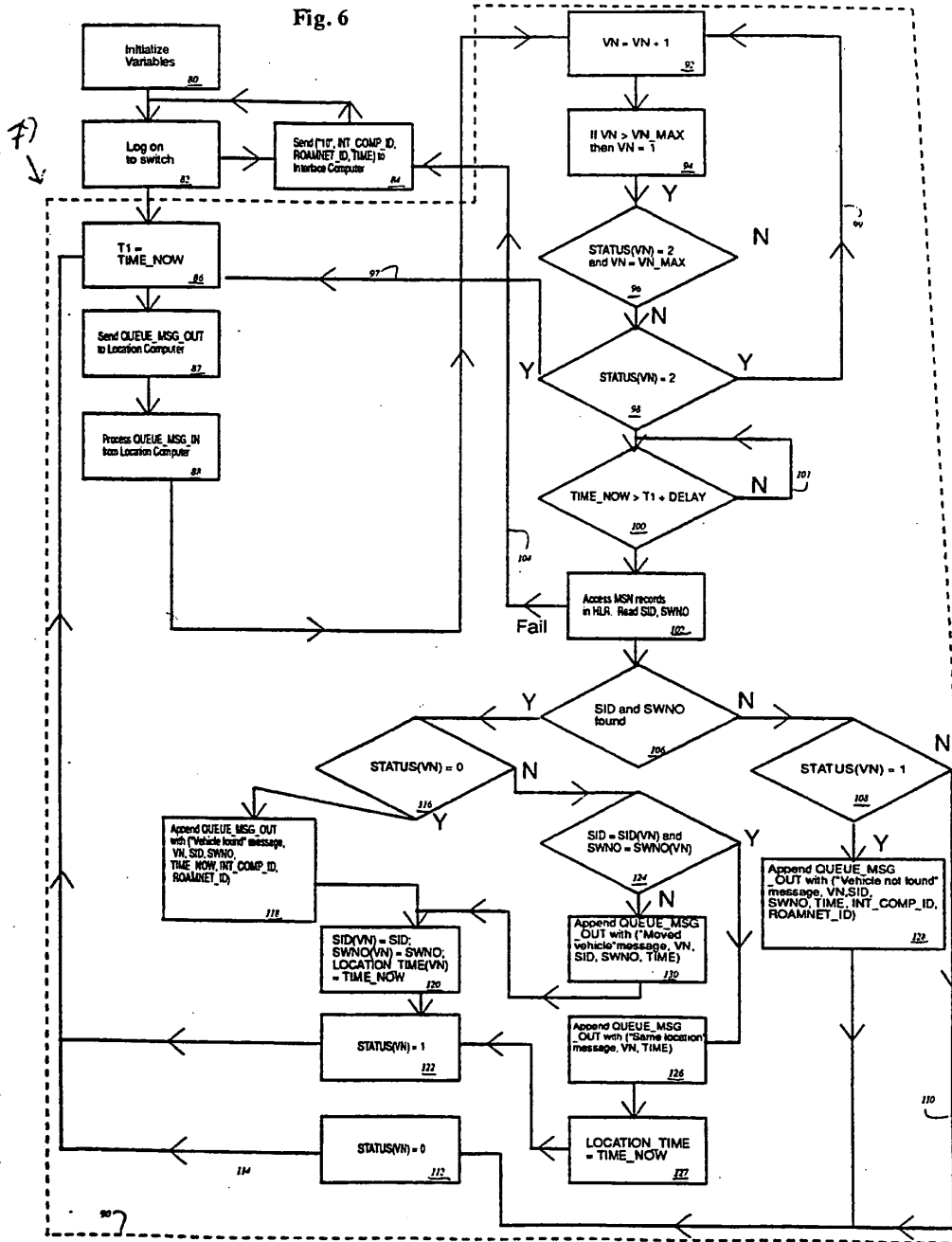

Fig. 6A

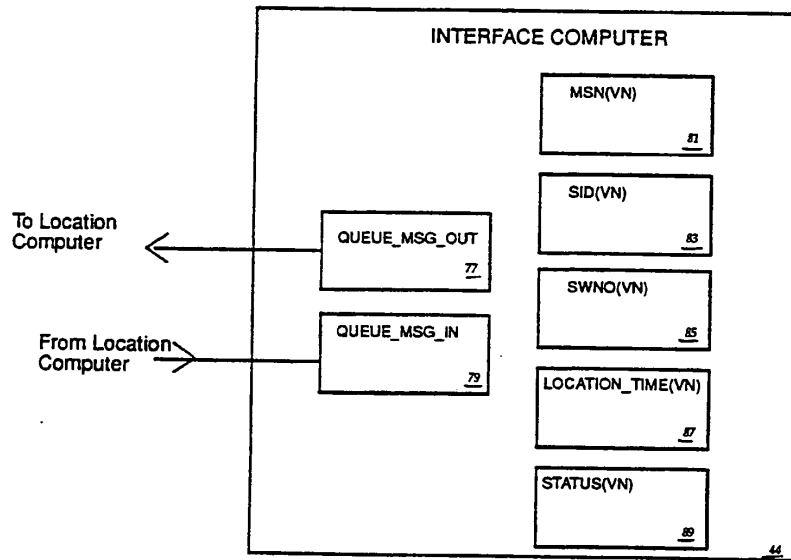
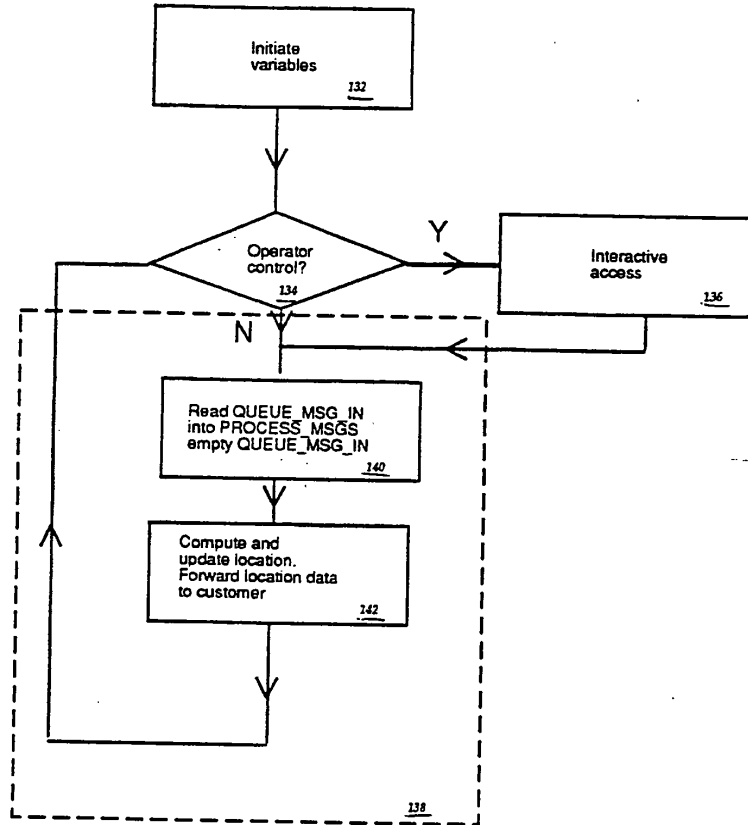



Fig. 7



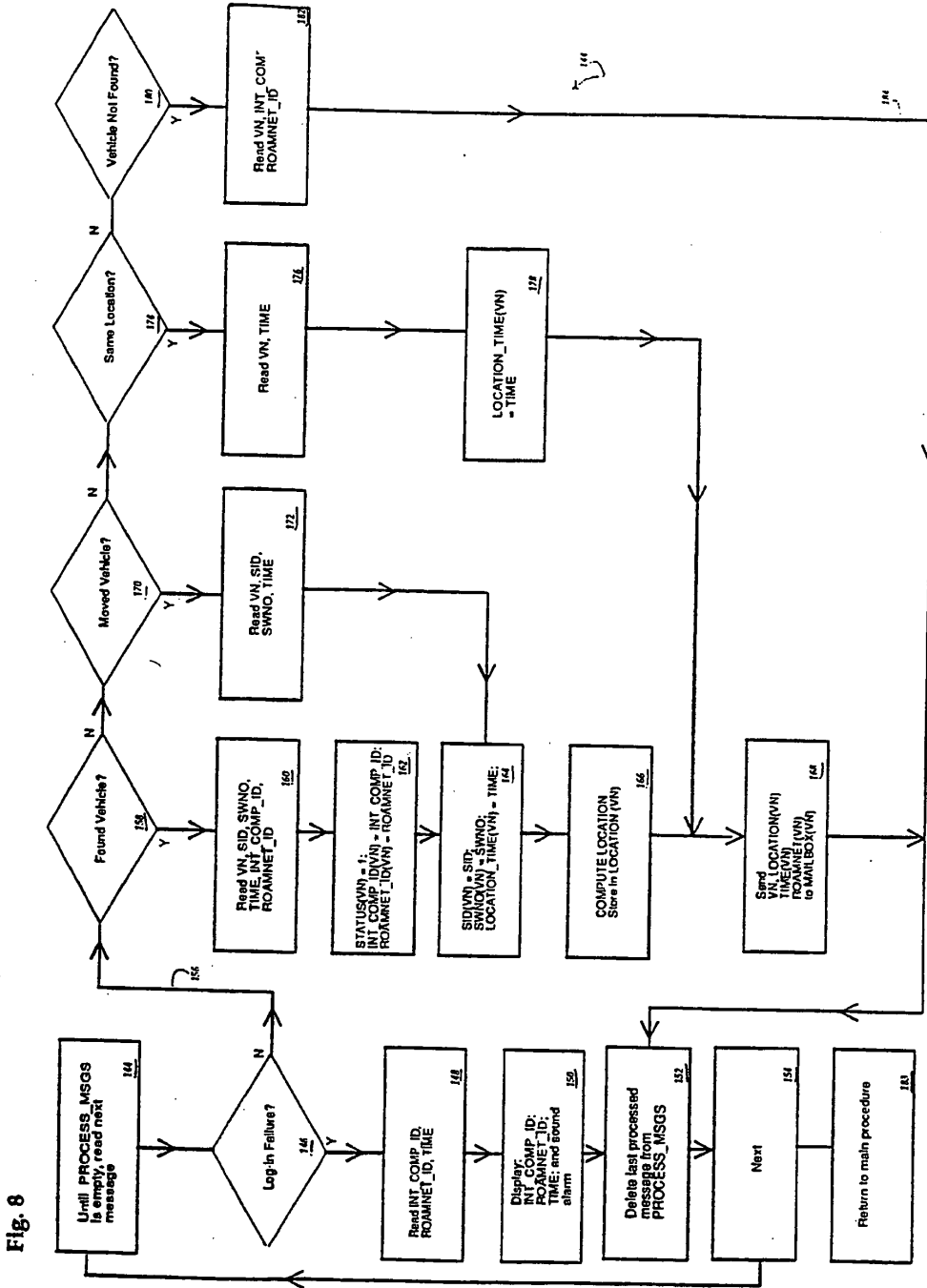

Fig. 8

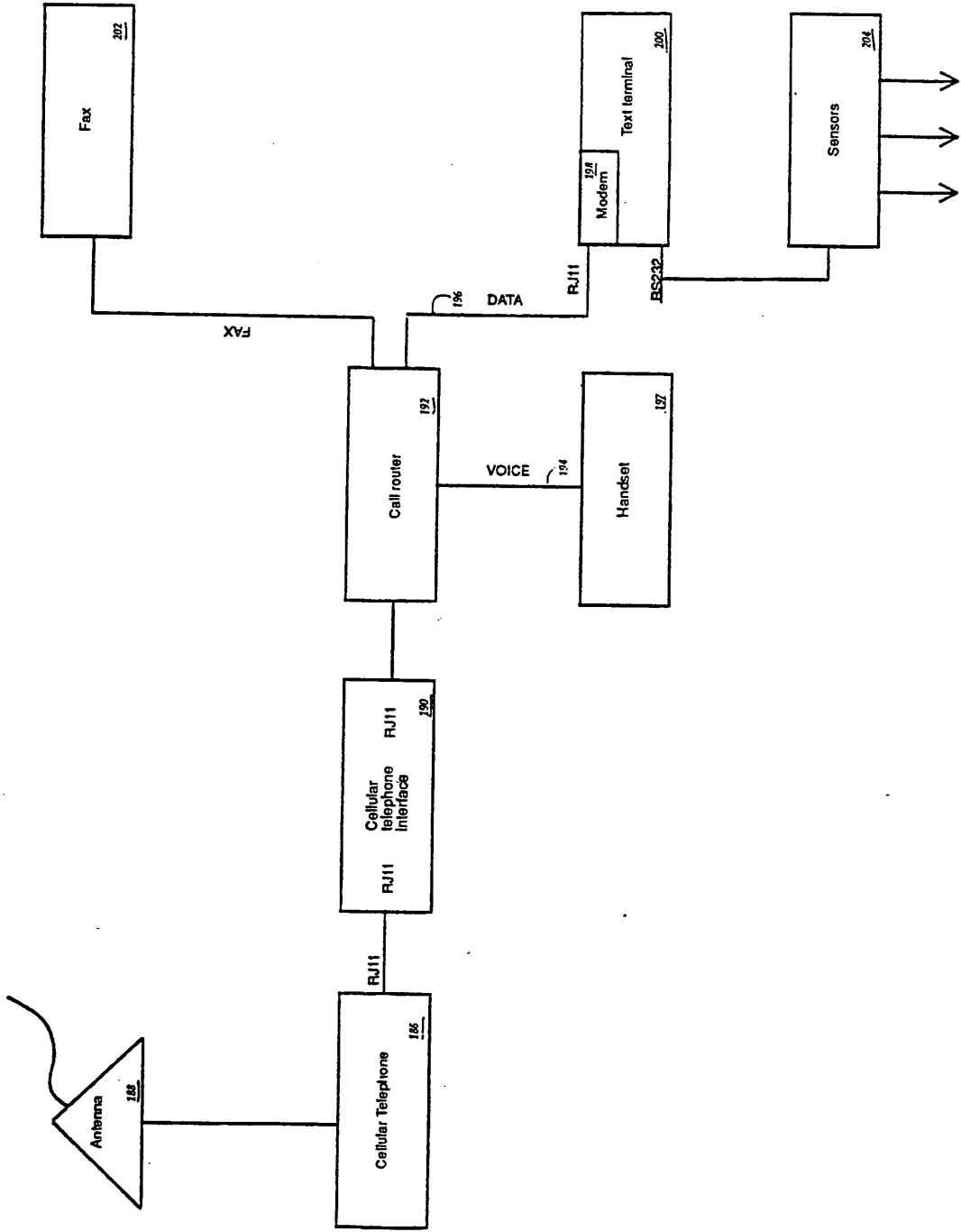

Fig. 9

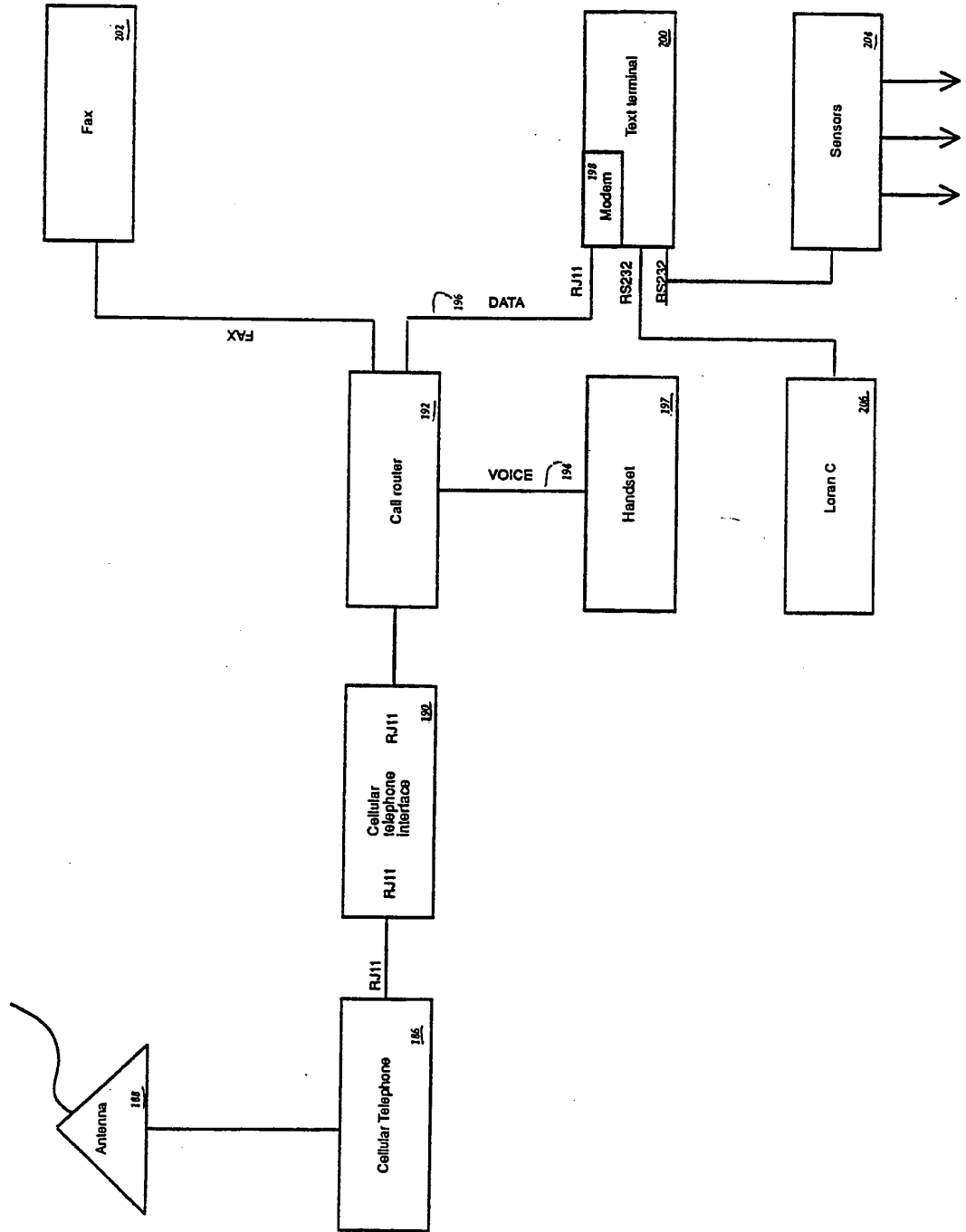

Fig. 10

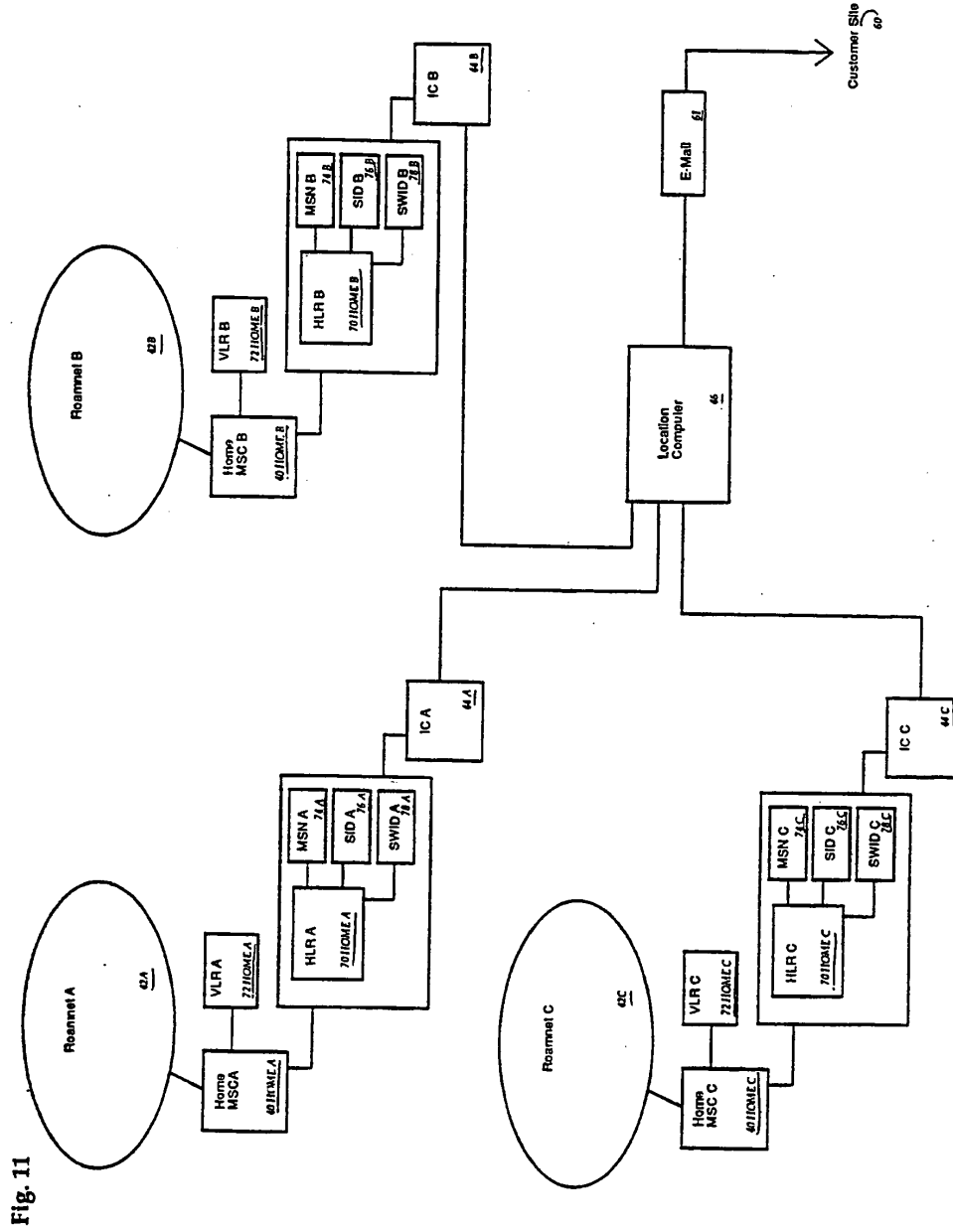
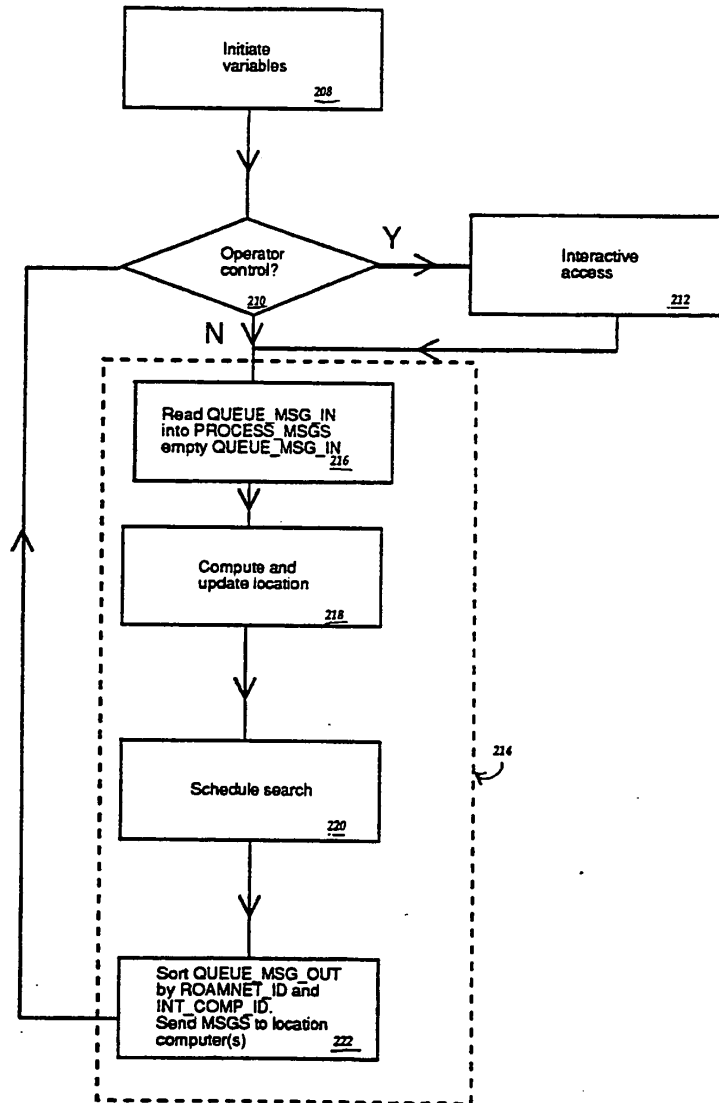

Fig. 11

Fig. 12



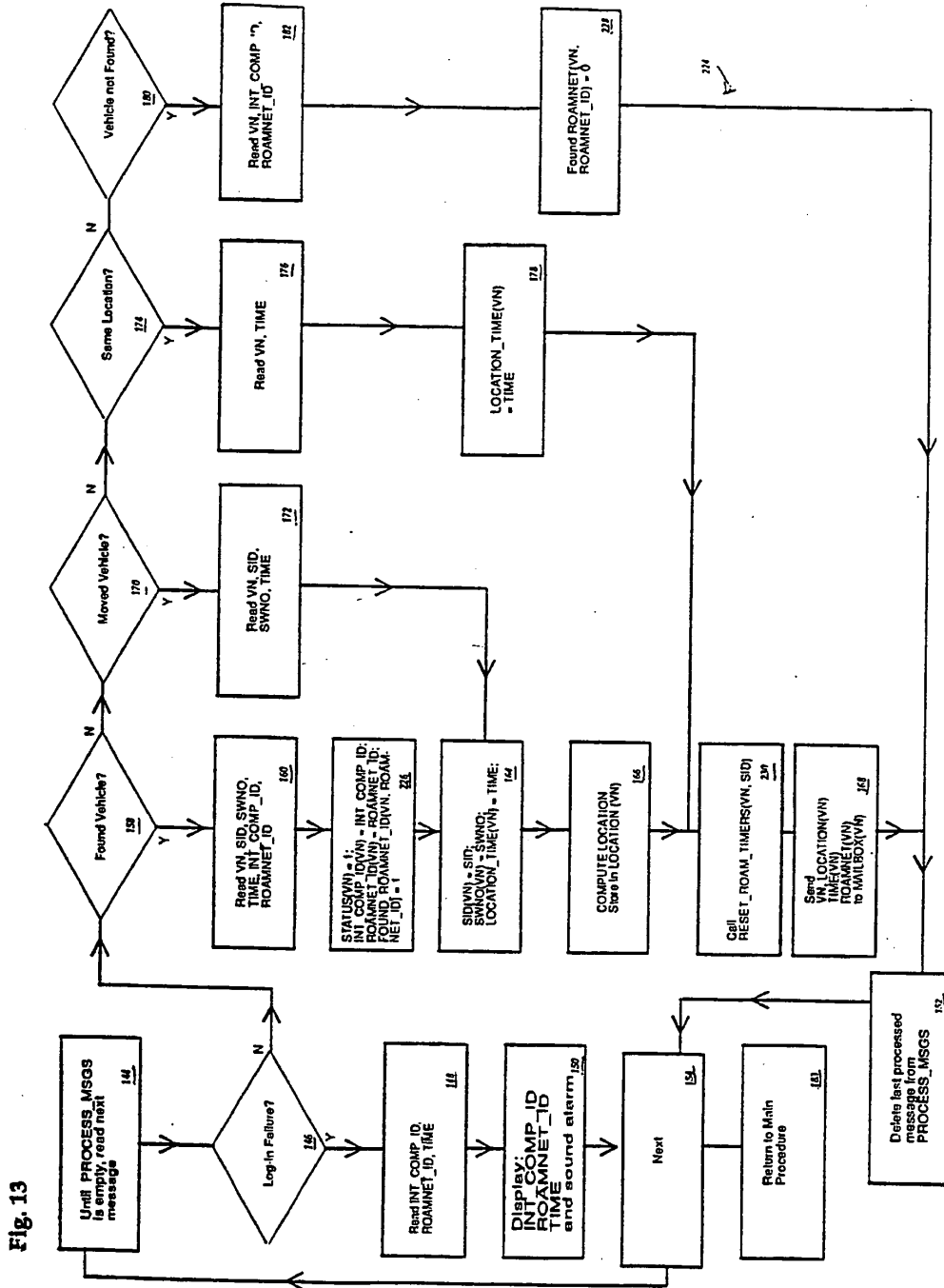
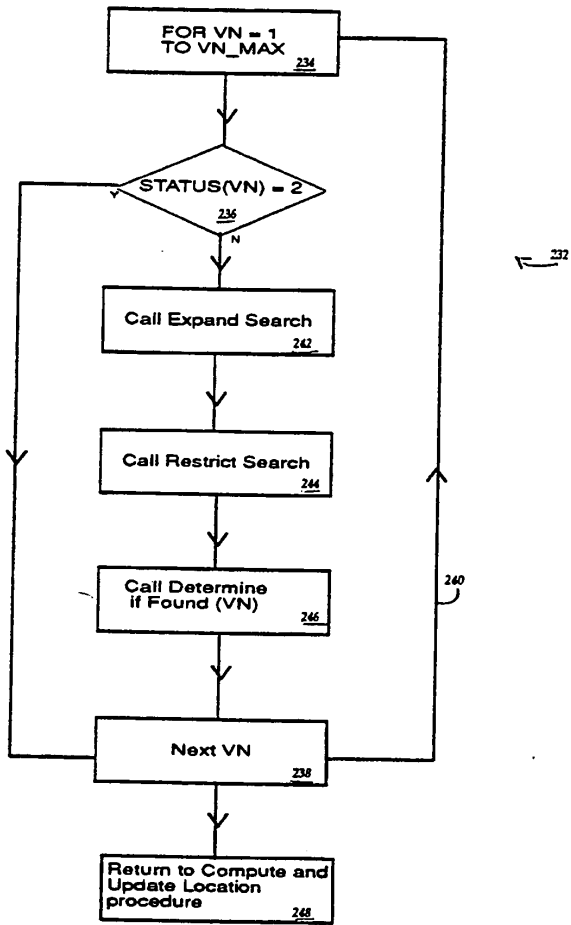

Fig. 13

Fig. 14





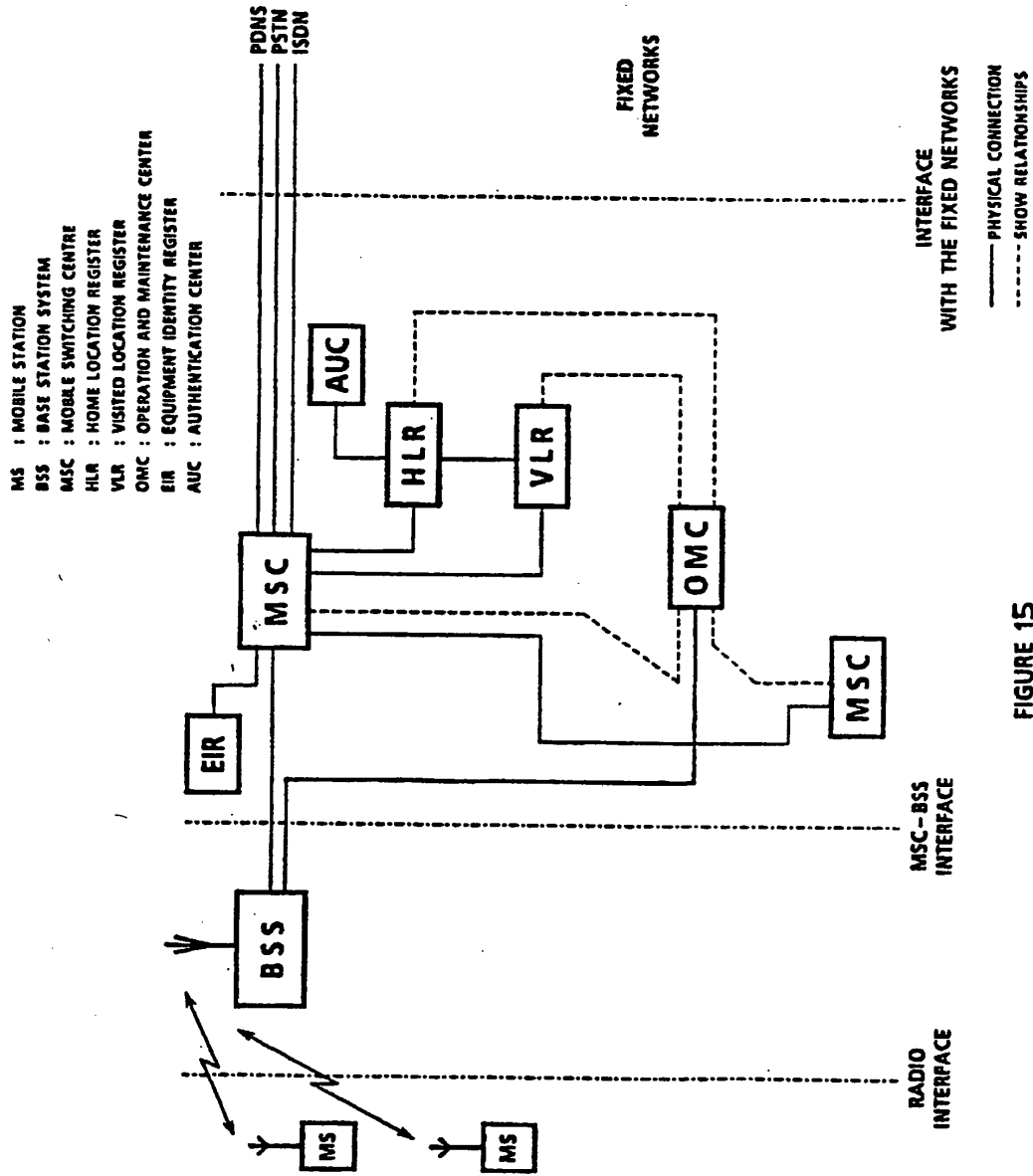

FIGURE 15

## INTERNATIONAL SEARCH REPORT

International Application No

PCT/US 93/06531

A. CLASSIFICATION OF SUBJECT MATTER  
 IPC 5 H04Q7/04 H04B7/26

According to International Patent Classification (IPC) or to both national classification and IPC

## B. FIELDS SEARCHED

Minimum documentation searched (classification system followed by classification symbols)

IPC 5 H04Q

Documentation searched other than minimum documentation to the extent that such documents are included in the fields searched

Electronic data base consulted during the international search (name of data base and, where practical, search terms used)

## C. DOCUMENTS CONSIDERED TO BE RELEVANT

Category*	Citation of document, with indication, where appropriate, of the relevant passages	Relevant to claim No.
A	WO,A,91 05429 (MOTOROLA INC.) 18 April 1991 see page 3, line 11 - page 5, line 19 ---	1, 5, 6, 10, 12, 15, 18, 19
A,P	EP,A,0 501 058 (BY-WORD TECHNOLOGIES INC) 2 September 1992 see column 8, line 55 - column 11, line 9 & NO,A,9 102 516 20 January 1992 ---	1-3, 5, 6, 8-10, 12, 15
A	EP,A,0 290 725 (ROBERT BOSCH GMBH) 17 November 1988 see column 2, line 24 - column 3, line 7 ---	1, 6, 12, 15, 18, 19
	-/--	

Further documents are listed in the continuation of box C.

Patent family members are listed in annex.

## \* Special categories of cited documents :

- \*A\* document defining the general state of the art which is not considered to be of particular relevance
- \*E\* earlier document but published on or after the international filing date
- \*L\* document which may throw doubts on priority claim(s) or which is cited to establish the publication date of another citation or other special reason (as specified)
- \*O\* document referring to an oral disclosure, use, exhibition or other means
- \*P\* document published prior to the international filing date but later than the priority date claimed

- \*T\* later document published after the international filing date or priority date and not in conflict with the application but cited to understand the principle or theory underlying the invention
- \*X\* document of particular relevance; the claimed invention cannot be considered novel or cannot be considered to involve an inventive step when the document is taken alone
- \*Y\* document of particular relevance; the claimed invention cannot be considered to involve an inventive step when the document is combined with one or more other such documents, such combination being obvious to a person skilled in the art.
- \*Z\* document member of the same patent family

Date of the actual completion of the international search

15 November 1993

Date of mailing of the international search report

26. 11. 93

Name and mailing address of the ISA

European Patent Office, P.B. 5818 Patentlaan 2  
 NL - 2280 HV Rijswijk  
 Tel. (+ 31-70) 340-2040, Tx. 31 651 epo nl,  
 Fac (+ 31-70) 340-3016

Authorized officer

BEHRINGER, L

Form PCT/ISA/210 (second sheet) (July 1992)

page 1 of 2

INTERNATIONAL SEARCH REPORT

International Application No  
PCT/US 93/06531

C.(Continuation) DOCUMENTS CONSIDERED TO BE RELEVANT		
Category *	Citation of document, with indication, where appropriate, of the relevant passages	Relevant to claim No.
A	39TH IEEE VEHICULAR TECHNOLOGY CONFERENCE vol. 1 , 1 May 1989 , SAN FRANCISCO, CALIFORNIA, US pages 1 - 6 XP292031 K.W.KACZMAREK 'Cellular Networking: A Carrier's Perspective' -----	

1

Form PCT/ISA/210 (continuation of second sheet) (July 1992)

**INTERNATIONAL SEARCH REPORT**  
 Information on patent family members

Int. .onal Application No  
**PCT/US 93/06531**

Patent document cited in search report	Publication date	Patent family member(s)	Publication date
WO-A-9105429	18-04-91	AU-A- 6277790 CN-A- 1050964	28-04-91 24-04-91
EP-A-0501058	02-09-92	US-A- 5155689	13-10-92
NO-A-9102516		NONE	
EP-A-0290725	17-11-88	DE-A- 3716320 DE-A- 3883062	24-11-88 16-09-93

Form PCT/ISA/210 (patent family annex) (July 1992)

**This Page is Inserted by IFW Indexing and Scanning  
Operations and is not part of the Official Record**

**BEST AVAILABLE IMAGES**

Defective images within this document are accurate representations of the original documents submitted by the applicant.

Defects in the images include but are not limited to the items checked:

- BLACK BORDERS
- IMAGE CUT OFF AT TOP, BOTTOM OR SIDES
- FADED TEXT OR DRAWING
- BLURRED OR ILLEGIBLE TEXT OR DRAWING
- SKEWED/SLANTED IMAGES
- COLOR OR BLACK AND WHITE PHOTOGRAPHS
- GRAY SCALE DOCUMENTS
- LINES OR MARKS ON ORIGINAL DOCUMENT
- REFERENCE(S) OR EXHIBIT(S) SUBMITTED ARE POOR QUALITY
- OTHER: \_\_\_\_\_

**IMAGES ARE BEST AVAILABLE COPY.**

**As rescanning these documents will not correct the image problems checked, please do not report these problems to the IFW Image Problem Mailbox.**

**● PRINTER RUSH ●**  
(PTO ASSISTANCE)

Application : <u>09/770838</u>	Examiner : <u>Phan</u>	GAU : <u>3662</u>
From : <u>J. Black</u>	Location : <u>(IDC) FMF FDC</u>	Date : <u>5/24/05</u>
Tracking # : <u>06057210</u>		Week Date : <u>12/27/04</u>

DOC CODE	DOC DATE	MISCELLANEOUS
<input type="checkbox"/> 1449	_____	<input type="checkbox"/> Continuing Data
<input checked="" type="checkbox"/> IDS	<u>3/26/04</u>	<input type="checkbox"/> Foreign Priority
<input checked="" type="checkbox"/> CLM	<u>11/26/03</u>	<input type="checkbox"/> Document Legibility
<input type="checkbox"/> IIFW	_____	<input type="checkbox"/> Fees
<input type="checkbox"/> SRFW	_____	<input type="checkbox"/> Other
<input type="checkbox"/> DRW	_____	
<input type="checkbox"/> OATH	_____	
<input type="checkbox"/> 312	_____	
<input checked="" type="checkbox"/> SPEC	<u>1/26/01</u>	

[RUSH] MESSAGE: ① Please initial line through citations.  
 ② Amendment C (Applied to SPEC dated 7/20/02) can not be found in file.  
 ③ Original claims 221-225, 227-242, 244-246, 248, 290-273 and 275-295 can not be found in file.  
 ④ Amtt A (SPEC 1/26/01) can not be applied to specification does not match specification. Please review

[XRUSH] RESPONSE: \_\_\_\_\_

\_\_\_\_\_

\_\_\_\_\_

\_\_\_\_\_

**INITIALS:**

NOTE: This form will be included as part of the official USPTO record, with the Response document coded as XRUSH.  
 REV 10/04



UNITED STATES PATENT AND TRADEMARK OFFICE

UNITED STATES DEPARTMENT OF COMMERCE  
United States Patent and Trademark Office  
Address: COMMISSIONER FOR PATENTS  
P.O. Box 1450  
Alexandria, Virginia 22313-1450  
www.uspto.gov

APPLICATION NO.	FILING DATE	FIRST NAMED INVENTOR	ATTORNEY DOCKET NO.	CONFIRMATION NO.
09/770,838	01/26/2001	Dennis J. Dupray	1003-1	8410
	7590 07/12/2005		EXAMINER PHAN, DAO LINDA	
Dennis J. Dupray, Ph.D. 1801 Belvedere Street Golden, CO 80401			ART UNIT 3662	PAPER NUMBER
DATE MAILED: 07/12/2005				

Please find below and/or attached an Office communication concerning this application or proceeding.

<b>Office Action Summary</b>	<b>Application No.</b> 09/770,838	<b>Applicant(s)</b> DUPRAY ET AL.	
	<b>Examiner</b> Dao L. Phan	<b>Art Unit</b> 3662	

-- The MAILING DATE of this communication appears on the cover sheet with the correspondence address --

**Period for Reply**

A SHORTENED STATUTORY PERIOD FOR REPLY IS SET TO EXPIRE 3 MONTH(S) FROM THE MAILING DATE OF THIS COMMUNICATION.

- Extensions of time may be available under the provisions of 37 CFR 1.136(a). In no event, however, may a reply be timely filed after SIX (6) MONTHS from the mailing date of this communication.
- If the period for reply specified above is less than thirty (30) days, a reply within the statutory minimum of thirty (30) days will be considered timely.
- If NO period for reply is specified above, the maximum statutory period will apply and will expire SIX (6) MONTHS from the mailing date of this communication.
- Failure to reply within the set or extended period for reply will, by statute, cause the application to become ABANDONED (35 U.S.C. § 133). Any reply received by the Office later than three months after the mailing date of this communication, even if timely filed, may reduce any earned patent term adjustment. See 37 CFR 1.704(b).

**Status**

- 1)  Responsive to communication(s) filed on 5/28/04.
- 2a)  This action is FINAL.
- 2b)  This action is non-final.
- 3)  Since this application is in condition for allowance except for formal matters, prosecution as to the merits is closed in accordance with the practice under *Ex parte Quayle*, 1935 C.D. 11, 453 O.G. 213.

**Disposition of Claims**

- 4)  Claim(s) \_\_\_\_\_ is/are pending in the application.
  - 4a) Of the above claim(s) \_\_\_\_\_ is/are withdrawn from consideration.
- 5)  Claim(s) \_\_\_\_\_ is/are allowed.
- 6)  Claim(s) \_\_\_\_\_ is/are rejected.
- 7)  Claim(s) \_\_\_\_\_ is/are objected to.
- 8)  Claim(s) \_\_\_\_\_ are subject to restriction and/or election requirement.

**Application Papers**

- 9)  The specification is objected to by the Examiner.
- 10)  The drawing(s) filed on \_\_\_\_\_ is/are: a)  accepted or b)  objected to by the Examiner.
  - Applicant may not request that any objection to the drawing(s) be held in abeyance. See 37 CFR 1.85(a).
  - Replacement drawing sheet(s) including the correction is required if the drawing(s) is objected to. See 37 CFR 1.121(d).
- 11)  The oath or declaration is objected to by the Examiner. Note the attached Office Action or form PTO-152.

**Priority under 35 U.S.C. § 119**

- 12)  Acknowledgment is made of a claim for foreign priority under 35 U.S.C. § 119(a)-(d) or (f).
    - a)  All    b)  Some \*    c)  None of:
      - 1.  Certified copies of the priority documents have been received.
      - 2.  Certified copies of the priority documents have been received in Application No. \_\_\_\_\_.
      - 3.  Copies of the certified copies of the priority documents have been received in this National Stage application from the International Bureau (PCT Rule 17.2(a)).
- \* See the attached detailed Office action for a list of the certified copies not received.

**Attachment(s)**

- 1)  Notice of References Cited (PTO-892)
- 2)  Notice of Draftsperson's Patent Drawing Review (PTO-948)
- 3)  Information Disclosure Statement(s) (PTO-1449 or PTO/SB/08)  
Paper No(s)/Mail Date \_\_\_\_\_
- 4)  Interview Summary (PTO-413)  
Paper No(s)/Mail Date. \_\_\_\_\_
- 5)  Notice of Informal Patent Application (PTO-152)
- 6)  Other: \_\_\_\_\_



1. Previously presented specification and the claims of the instant application have been lost. New sets of the previously presented claims and the specification are requested for examination.

2. Any inquiry concerning this communication or earlier communications from the examiner should be directed to Dao L. Phan whose telephone number is (571)272-6976. The examiner can normally be reached on M-F 9:00-5:30.

If attempts to reach the examiner by telephone are unsuccessful, the examiner's supervisor, Dao Phan can be reached on (571)272-6979. The fax phone number for the organization where this application or proceeding is assigned is 703-872-9306.

3. Information regarding the status of an application may be obtained from the Patent Application Information Retrieval (PAIR) system. Status information for published applications may be obtained from either Private PAIR or Public PAIR. Status information for unpublished applications is available through Private PAIR only. For more information about the PAIR system, see <http://pair-direct.uspto.gov>. Should you have questions on access to the Private PAIR system, contact the Electronic Business Center (EBC) at 866-217-9197 (toll-free).

  
DAO PHAN  
PATENT EXAMINER

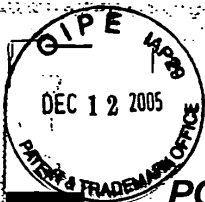

POST OFFICE TO ADDRESSEE



EL417660635US

ORIGIN (POSTAL USE ONLY)		DELIVERY (POSTAL USE ONLY)	
PO ZIP Code	Day of Delivery	Delivery Attempt	Time
	<input type="checkbox"/> Next <input type="checkbox"/> Second		Employee Signature

POST OFFICE TO ADDRESSEE



EL417660635US

ORIGIN (POSTAL USE ONLY)		
PO ZIP Code	Day of Delivery	Flat Rate Envelope
80202	<input type="checkbox"/> Next <input checked="" type="checkbox"/> Second	<input type="checkbox"/>
Date In	Time In	Postage
Mo 7 2 02	<input checked="" type="checkbox"/> 12 Noon <input type="checkbox"/> 3 PM	\$ 24.20
Time In	Military	Return Receipt Fee
1919	<input type="checkbox"/> 2nd Day <input type="checkbox"/> 3rd Day	
Weight	Int'l Alpha Country Code	COD Fee
3 lbs. 11 ozs.		
No Delivery	Acceptance Clerk Initials	Total Postage & Fees
<input type="checkbox"/> Weekend <input type="checkbox"/> Holiday	8	\$ 24.20

SEE REVERSE SIDE FOR SERVICE GUARANTEE AND LIMITS ON INSURANCE COVERAGE

CUSTOMER USE ONLY	
METHOD OF PAYMENT:	<input type="checkbox"/> WAIVER OF SIGNATURE (Domestic Only): Additional merchandise insurance coverage of signature is required. I wish delivery to be made without obtaining signature of addressee or addressee's agent (if delivery employee, that article can be left in secure location) and I authorize that delivery employee's signature constitutes valid proof of delivery.
Express Mail Corporate Acct. No.	<input type="checkbox"/> NO DELIVERY: <input type="checkbox"/> Weekend <input type="checkbox"/> Holiday
Federal Agency Acct. No. or Postal Service Acct. No.	Customer Signature

FROM: (PLEASE PRINT) PHONE ( )

SHERIDAN ROSS PC  
1560 BROADWAY STE 1200  
DENVER CO 80202-5145

1063-1 (COR)

TO: (PLEASE PRINT) PHONE ( )

COMMISSIONER OF PATENTS AND TRADEMARKS  
WASHINGTON DC 20231-00

**PRESS HARD.** You are making 3 copies. **FOR PICKUP OR TRACKING CALL 1-800-222-1811** [www.usps.gov](http://www.usps.gov)

BEST AVAILABLE COPY

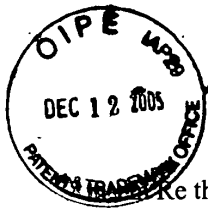

12-14-05

3662  
AP  
JFW

IN THE UNITED STATES PATENT AND TRADEMARK OFFICE

Re the Application of:  
Dupray et al.  
Serial No.: 09/770,838  
Filed: January 26, 2001  
Atty. File No.: 1003-1  
For: A GATEWAY AND HYBRID  
SOLUTIONS FOR WIRELESS  
LOCATION

) Group Art Unit: 3662  
)  
) Examiner: Dao L. Phan  
)

RESPONSE TO OFFICE ACTION  
DATED JULY 12, 2005

\*EXPRESS MAIL\* MAILING LABEL NUMBER: EV737752064US

DATE OF DEPOSIT: Dec 12, 2005

I HEREBY CERTIFY THAT THIS PAPER OR FEE IS BEING DEPOSITED WITH THE UNITED STATES POSTAL SERVICE \*EXPRESS MAIL POST OFFICE TO ADDRESSEE\* SERVICE UNDER 37 CFR 1.10 ON THE DATE INDICATED ABOVE AND IS ADDRESSED TO THE COMMISSIONER FOR PATENTS, P.O. BOX 1450, ALEXANDRIA, VIRGINIA 22313-1450.

TYPED OR PRINTED NAME: AIMEE THUERK

SIGNATURE: Aimee Thuerk

Commissioner for Patents  
P.O. Box 1450  
Alexandria, Virginia 22313-1450

Dear Madam:

In response to the Office Action dated July 12, 2005, enclosed please find a copy of Response to Office Action filed July 2, 2002, along with a copy of the substitute specification filed with the Response.

A request for a two month extension of time is enclosed, along with a check in the amount of \$225.00. Although no additional fees are believed due, the Examiner is invited to contact the undersigned if additional fees are due.

Respectfully submitted,

By: Dennis A. Dupray  
Dennis A. Dupray  
Registration No. 46,299  
1801 Belvedere Street  
Golden, Colorado 80401  
(303) 863-9700

Date: Dec. 12, 2005



PATENT APPLICATION

In Re the Application of:

DUPRAY et al.

Serial No.: 09/770,838

Filed: January 26, 2001

Atty. File No.: 1003-1

For: "A GATEWAY AND HYBRID  
SOLUTIONS FOR WIRELESS  
LOCATION"

Prior Group Art Unit: 3662

Prior Examiner: Dao I. Phan

**RESPONSE TO OFFICE ACTION**

**DATED MAY 17, 2002**

**Express Mail Label: EL417660635US**

**EL417660635US**

Assistant Commissioner for Patents  
Washington, D.C. 20231

Dear Sir:

Applicants herewith submit an amendment and response to the Office Action dated May 17, 2002. In particular, as per a conversation with the Examiner on June 25, 2002, Applicants are submitting a substitute specification which is a copy of U.S. Patent Application Serial No. 09/194,367 ('367 Patent Application) filed November 24, 1998, to which the present application is a continuation. Note that since the present patent application is a continuation of the '367 Patent, which in turn, is the U.S. National Phase of PCT/US97/15892 filed Sept. 8, 1997, the substitute specification provided herewith is a copy of the original PCT patent application PCT/US97/15892 filed Sept. 8, 1997 with the same formatting (font and pagination) as this PCT. However, the substitute specification also includes the claims that were pending when the '367 Patent was filed.

Additionally, filed herewith is a revised copy of all requested amendments to the specification, wherein these specification amendments correspond with the page and line numbers of the substitute specification. Accordingly, all previously requested amendments to the specification are requested to be cancelled with the exception of the claim for the priority benefits of previous patent applications which was filed on October 31, 2000.

It is believed that the substitute specification and the corresponding specification amendments provided herewith address all the Examiner's concerns. Accordingly, reconsideration of the claims of

**the present application is requested, wherein these claims were provided in the previous response to the Office Action of September 21, 2001. Note that this previous response was filed with the U.S. Patent and Trademark Office on February 20, 2002 (and was inadvertently identified as a "Preliminary Amendment").**

If there are any questions regarding the present Amendment and Response, it is requested that the named Applicant hereinbelow (Dennis Dupray) be contacted at 303-863-2975.

**IN THE SPECIFICATION:**

Applicants have provided herein a replacement set of amendments to the specification. The amendments to the specification herein are to replace all previous specification amendments with the exception of the change in the title and the claim for priority filed which were provided in a transmittal to the USPTO filed on October 31, 2000. Accordingly, it is requested that all previous amendments to the specification, except for the change in title and the claim for priority, be replaced with the specification amendments provided herein following.

**Please replace the paragraph beginning on page 8, line 3 with the following paragraph:**

Loss due to slow fading includes shadowing due to clutter blockage (sometimes included in Lp). Fast fading is composed of multipath reflections which cause: 1) delay spread; 2) random phase shift or Rayleigh fading; and 3) random frequency modulation due to different Doppler shifts on different paths.

**Please replace the paragraph beginning on page 10, line 3 through page 10, line 20 with the following paragraphs:**

It is an objective of the present invention to provide a system and method for to wireless telecommunication systems for accurately locating people and/or objects in a cost effective manner. Additionally, it is an objective of the present invention to provide such location capabilities using the measurements from wireless signals communicated between mobile stations and a network of base stations, wherein the same communication standard or protocol is utilized for location as is used by the network of base stations for providing wireless communications with mobile stations for other purposes such as voice communication and/or visual communication (such as text paging, graphical or video communications). Related objectives for various embodiments of the present invention include providing a system and method that:

(1.1) can be readily incorporated into existing commercial wireless telephony systems with few, if any, modifications of a typical telephony wireless infrastructure;

- (1.2) can use the native electronics of typical commercially available, or likely to be available, telephony wireless mobile stations (e.g., handsets) as location devices;
- (1.3) can be used for effectively locating people and/or objects wherein there are few (if any) line-of-sight wireless receivers for receiving location signals from a mobile station (herein also denoted MS);
- (1.4) can be used not only for decreasing location determining difficulties due to multipath phenomena but in fact uses such multipath for providing more accurate location estimates;
- (1.5) can be used for integrating a wide variety of location techniques in a straight-forward manner;
- (1.6) can substantially automatically adapt and/or (re)train and/or (re)calibrate itself according to changes in the environment and/or terrain of a geographical area where the present invention is utilized;
- (1.7) can utilize a plurality of wireless location estimators based on different wireless location technologies (e.g., GPS location techniques, terrestrial base station signal timing techniques for triangulation and/or trilateration, wireless signal angle of arrival location techniques, techniques for determining a wireless location within a building, techniques for determining a mobile station location using wireless location data collected from the wireless coverage area for, e.g., location techniques using base station signal coverage areas, signal pattern matching location techniques and/or stochastic techniques), wherein each such estimator may be activated independently of one another, whenever suitable data is provided thereto and/or certain conditions, e.g., specific to the estimator are met;
- (1.8) can provide a common interface module from which a plurality of the location estimators can be activated and/or provided with input;
- (1.9) provides resulting mobile station location estimates to location requesting applications (e.g., for 911 emergency, the fire or police departments, taxi services, vehicle location, etc.) via an output gateway, wherein this gateway:
  - (a) routes the mobile station location estimates to the appropriate location application(s) via a communications network such as a wireless network, a public switched telephone network, a short messaging service (SMS), and the Internet,
  - (b) determines the location granularity and representation desired by each location application requesting a location of a mobile station, and/or
  - (c) enhances the received location estimates by, e.g., performing additional processing such as "snap to street" functions for mobile stations known to reside in a vehicle.

**Please replace the paragraph beginning on page 11, line 15 with the following paragraph:**

- (3.3) The term, "infrastructure", denotes the network of telephony communication services, and more particularly, that portion of such a network that receives and processes wireless communications with wireless mobile stations. In particular, this infrastructure includes telephony wireless base stations (BS)

such as those for radio mobile communication systems based on CDMA, AMPS, NAMPS, TDMA, and GSM wherein the base stations provide a network of cooperative communication channels with an air interface with the MS, and a conventional telecommunications interface with a Mobile Switch Center (MSC). Thus, an MS user within an area serviced by the base stations may be provided with wireless communication throughout the area by user transparent communication transfers (i.e., "handoffs") between the user's MS and these base stations in order to maintain effective telephony service. The mobile switch center (MSC) provides communications and control connectivity among base stations and the public telephone network 124.

**Please replace the paragraph beginning on page 12, line 6 with the following paragraphs:**

The present invention relates to a wireless mobile station location system, and in particular, various subsystems related thereto such as a wireless location gateway, and the combining or hybridizing of a plurality of wireless location techniques.

Regarding a wireless location gateway, this term refers to a communications network node whereat a plurality of location requests are received for locating various mobile stations from various sources (e.g., for E911 requests, for stolen vehicle location, for tracking of vehicles traveling cross country, etc.), and for each such request and the corresponding mobile station to be located, this node: (a) activates one or more wireless location estimators for locating the mobile station, (b) receives one or more location estimates of the mobile station from the location estimators, and (c) transmits a resulting location estimate(s) to, e.g., an application which made the request. Moreover, such a gateway typically will likely activate location estimators according to the particulars of each individual wireless location request, e.g., the availability of input data needed by particular location estimators. Additionally, such a gateway will typically have sufficiently well defined uniform interfaces so that such location estimators can be added and/or deleted to, e.g., provide different location estimators for performing wireless location different coverage areas.

The present invention encompasses such wireless location gateways. Thus, for locating an identified mobile station, the location gateway embodiments of the present invention may activate one or more of a plurality of location estimators depending on, e.g., (a) the availability of particular types of wireless location data for locating the mobile station, and (b) the location estimators accessible by the location gateway. Moreover, a plurality of location estimators may be activated for locating the mobile station in a single location, or different ones of such location estimators may be activated to locate the mobile station at different locations. Moreover, the location gateway of the present invention may have incorporated therein one or more of the location estimators, and/or may access geographically distributed location estimators via requests through a communications network such as the Internet.

In particular, the location gateway of the present invention may access, in various instances of locating mobile stations, various location estimators that utilize one or more of the following wireless location techniques:

- (a) A GPS location technique such as, e.g., one of the GPS location techniques as described in the Background section hereinabove;
- (b) A technique for computing a mobile station location that is dependent upon geographical offsets of the mobile station from one or more terrestrial transceivers (e.g., base stations of a commercial radio service provider). Such offsets may be determined from signal time delays between such transceivers and the mobile station, such as by time of arrival (TOA) and/or time difference of arrival (TDOA) techniques as is discussed further hereinbelow. Moreover, such offsets may be determined using both the forward and reverse wireless signal timing measurements of transmissions between the mobile station and such terrestrial transceivers. Additionally, such offsets may be directional offsets, wherein a direction is determined from such a transceiver to the mobile station;
- (c) Various wireless signal pattern matching, associative, and/or stochastic techniques for performing comparisons and/or using a learned association between:
  - (i) characteristics of wireless signals communicated between a mobile station to be located and a network of wireless transceivers (e.g., base stations), and
  - (ii) previously obtained sets of characteristics of wireless signals (from each of a plurality of locations), wherein each set was communicated, e.g., between a network of transceivers (e.g., the fixed location base stations of a commercial radio service provider), and, some one of the mobile stations available for communicating with the network;
- (d) Indoor location techniques using a distributed antenna system;
- (e) Techniques for locating a mobile station, wherein, e.g., wireless coverage areas of individual fixed location transceivers (e.g., fixed location base stations) are utilized for determining the mobile station's location (e.g., intersecting such coverage areas for determining a location);
- (f) Location techniques that use communications from low power, low functionality base stations (denoted "location base stations"); and



- (g) Any other location techniques that may be deemed worthwhile to incorporate into an embodiment of the present invention.

Accordingly, some embodiments of the present invention may be viewed as platforms for integrating wireless location techniques in that wireless location computational models (denoted "first order models" or "FOMs" hereinbelow) may be added and/or deleted from such embodiments of the invention without changing the interface to further downstream processes. That is, one aspect of the invention is the specification of a common data interface between such computational models and subsequent location processing such as processes for combining of location estimates, tracking mobile stations, and/or outputting location estimates to location requesting applications.

Moreover, it should be noted that the present invention also encompasses various hybrid approaches to wireless location, wherein various combinations of two or more of the location techniques (a) through (g) immediately above may be used in locating a mobile station at substantially a single location. Thus, location information may be obtained from a plurality of the above location techniques for locating a mobile station, and the output from such techniques can be synergistically used for deriving therefrom an enhanced location estimate of the mobile station.

It is a further aspect of the present invention that it may be used to wirelessly locate a mobile station: (a) from which a 911 emergency call is performed, (b) for tracking a mobile station (e.g., a truck traveling across country), (c) for routing a mobile station, and (d) locating people and/or animals, including applications for confinement to (and/or exclusion from) certain areas.

It is a further aspect of the present invention that it may be decomposed into: (i) a first low level wireless signal processing subsystem for receiving, organizing and conditioning low level wireless signal measurements from a network of base stations cooperatively linked for providing wireless communications with mobile stations (MSs); and (ii) a second high level signal processing subsystem for performing high level data processing for providing most likelihood location estimates for mobile stations.

**Please replace the paragraph beginning on page 12, line 11 with the following paragraph:**

Thus, the present invention may be considered as a novel signal processor that includes at least the functionality for the high signal processing subsystem mentioned hereinabove. Accordingly, assuming an appropriate ensemble of wireless signal measurements characterizing the wireless signal communications between a particular MS and a networked wireless base station infrastructure have been received and appropriately filtered of noise and transitory values (such as by an embodiment of the low level signal processing subsystem disclosed in a copending PCT patent application PCT/US97/15933

titled, "Wireless Location Using A Plurality of Commercial Network Infrastructures," by F. W. LeBlanc et al., filed September 8, 1997 from which U.S. Patent 6,236,365, filed July 8, 1999 is the U.S. national counterpart; these two references being herein fully incorporated by reference), the present invention uses the output from such a low level signal processing system for determining a most likely location estimate of an MS.

**Please replace the paragraph beginning on page 12, line 19 (and ending on this same line 19) with the following paragraph:**

That is, once the following steps are appropriately performed (e.g., by the LeBlanc U.S. Patent 6,236,365):

**Please replace the paragraph beginning on page 12, line 28 has been replaced with the following paragraph:**

(4.3) providing the composite signal characteristic values to one or more MS location hypothesizing computational models (also denoted herein as "first order models" and also "location estimating models"), wherein each such model subsequently determines one or more initial estimates of the location of the target MS based on, for example, the signal processing techniques 2.1 through 2.3 above. Moreover, each of the models output MS location estimates having substantially identical data structures (each such data structure denoted a "location hypothesis"). Additionally, each location hypothesis may also include a confidence value indicating the likelihood or probability that the target MS whose location is desired resides in a corresponding location estimate for the target MS;

**Please replace the paragraph beginning on page 13, line 14 with the following paragraph:**

Referring now to (4.3) above, the filtered and aggregated wireless signal characteristic values are provided to a number of location hypothesizing models (denoted First Order Models, or FOMs), each of which yields a location estimate or location hypothesis related to the location of the target MS. In particular, there are location hypotheses for both providing estimates of where the target MS is likely to be and where the target MS is not likely to be. Moreover, it is an aspect of the present invention that confidence values of the location hypotheses are provided as a continuous range of real numbers from, e.g., -1 to 1, wherein the most unlikely areas for locating the target MS are given a confidence value of -1, and the most likely areas for locating the target MS are given a confidence value of 1. That is, confidence values that are larger indicate a higher likelihood that the target MS is in the corresponding MS estimated area, wherein -1 indicates that the target MS is absolutely NOT in the estimated area, 0 indicates a

substantially neutral or unknown likelihood of the target MS being in the corresponding estimated area, and 1 indicates that the target MS is absolutely within the corresponding estimated area.

**Please replace the paragraph beginning on page 15, line 22 with the following paragraph:**

It is a further aspect of the present invention that the personal communication system (PCS) infrastructures currently being developed by telecommunication providers offer an appropriate localized infrastructure base upon which to build various personal location systems (PLS) employing the present invention and/or utilizing the techniques disclosed herein. In particular, the present invention is especially suitable for the location of people and/or objects using code division multiple access (CDMA) wireless infrastructures, although other wireless infrastructures, such as, time division multiple access (TDMA) infrastructures and GSM are also contemplated. Note that CDMA personal communications systems are described in the Telephone Industries Association standard IS-95, for frequencies below 1 GHz, and in the Wideband Spread-Spectrum Digital Cellular System Dual-Mode Mobile Station-Base Station Compatibility Standard, for frequencies in the 1.8-1.9 GHz frequency bands, both of which are incorporated herein by reference. Furthermore, CDMA general principles have also been described, for example, in U. S. Patent 5,109,390, to Gilhausen, et al, filed November 7, 1989, and CDMA Network Engineering Handbook by Qualcomm, Inc., each of which is also incorporated herein by reference.

**The paragraph beginning on page 16, line 6 has been replaced with the following paragraph:**

As mentioned in the discussion of classification FOMs above, the present invention can substantially automatically retrain and/or recalibrate itself to compensate for variations in wireless signal characteristics (e.g., multipath) due to environmental and/or topographic changes to a geographic area serviced by the present invention. For example, in one embodiment, the present invention optionally includes low cost, low power base stations, denoted location base stations (LBS) above, providing, for example, CDMA pilot channels to a very limited area about each such LBS. The location base stations may provide limited voice traffic capabilities, but each is capable of gathering sufficient wireless signal characteristics from an MS within the location base station's range to facilitate locating the MS. Thus, by positioning the location base stations at known locations in a geographic region such as, for instance, on street lamp poles and road signs, additional MS location accuracy can be obtained. That is, due to the low power signal output by such location base stations, for there to be signaling control communication (e.g., pilot signaling and other control signals) between a location base station and a target MS, the MS must be relatively near the location base station. Additionally, for each location base station not in communication with the target MS, it is likely that the MS is not near to this location base station. Thus, by utilizing information received from both location base stations in communication with the target MS

and those that are not in communication with the target MS, the present invention can substantially narrow the possible geographic areas within which the target MS is likely to be. Further, by providing each location base station (LBS) with a co-located stationary wireless transceiver (denoted a built-in MS above) having similar functionality to an MS, the following advantages are provided:

**Please replace the paragraph beginning on page 17, line 12 with the following paragraph:**

It is also an aspect of the present invention to automatically (re)calibrate as in (6.3) above with signal characteristics from other known or verified locations. In one embodiment of the present invention, portable location verifying electronics are provided so that when such electronics are sufficiently near a located target MS, the electronics: (i) detect the proximity of the target MS; (ii) determine a highly reliable measurement of the location of the target MS; (iii) provide this measurement to other location determining components of the present invention so that the location measurement can be associated and archived with related signal characteristic data received from the target MS at the location where the location measurement is performed. Thus, the use of such portable location verifying electronics allows the present invention to capture and utilize signal characteristic data from verified, substantially random locations for location system calibration as in (6.3) above. Moreover, it is important to note that such location verifying electronics can verify locations automatically wherein it is unnecessary for manual activation of a location verifying process.

**Please replace the paragraph beginning on page 18, line 6 with the following paragraph:**

Furthermore, a mobile location base station includes modules for integrating or reconciling distinct mobile location base station location estimates that, for example, can be obtained using the components and devices of (7.1) through (7.4) above. That is, location estimates for the mobile location base station may be obtained from: GPS satellite data, mobile location base station data provided by the location processing center, deadreckoning data obtained from the mobile location base station vehicle deadreckoning devices, and location data manually input by an operator of the mobile location base station.

**Please replace the paragraph beginning on page 18, line 11 with the following paragraph:**

The location estimating system of the present invention offers many advantages over existing location systems. The system of the present invention, for example, is readily adaptable to existing wireless communication systems and can accurately locate people and/or objects in a cost effective manner. In particular, the present invention requires few, if any, modifications to commercial wireless

communication systems for implementation. Thus, existing personal communication system infrastructure base stations and other components of, for example, commercial CDMA infrastructures are readily adapted to the present invention. The present invention can be used to locate people and/or objects that are not in the line-of-sight of a wireless receiver or transmitter, can reduce the detrimental effects of multipath on the accuracy of the location estimate, can potentially locate people and/or objects located indoors as well as outdoors, and uses a number of wireless stationary transceivers for location. The present invention employs a number of distinctly different location computational models for location which provides a greater degree of accuracy, robustness and versatility than is possible with existing systems. For instance, the location models provided include not only the radius-radius/TOA and TDOA techniques but also adaptive artificial neural net techniques. Further, the present invention is able to adapt to the topography of an area in which location service is desired. The present invention is also able to adapt to environmental changes substantially as frequently as desired. Thus, the present invention is able to take into account changes in the location topography over time without extensive manual data manipulation. Moreover, the present invention can be utilized with varying amounts of signal measurement inputs. Thus, if a location estimate is desired in a very short time interval (e.g., less than approximately one to two seconds), then the present location estimating system can be used with only as much signal measurement data as is possible to acquire during an initial portion of this time interval. Subsequently, after a greater amount of signal measurement data has been acquired, additional more accurate location estimates may be obtained. Note that this capability can be useful in the context of 911 emergency response in that a first quick coarse wireless mobile station location estimate can be used to route a 911 call from the mobile station to a 911 emergency response center that has responsibility for the area containing the mobile station and the 911 caller. Subsequently, once the 911 call has been routed according to this first quick location estimate, by continuing to receive additional wireless signal measurements, more reliable and accurate location estimates of the mobile station can be obtained.

**Please replace the paragraph beginning on page 19, line 5 through page 19, line 19 with the following paragraph:**

At a more general level, it is an aspect of the present invention to demonstrate the utilization of various novel computational paradigms such as:

(8.1) providing a multiple hypothesis computational architecture (as illustrated best in Figs. 8) wherein the hypotheses are:

(8.1.1) generated by modular independent hypothesizing computational models;

(8.1.2) the models are embedded in the computational architecture in a manner wherein the architecture allows for substantial amounts of application specific processing common or generic to a plurality of the models to be straightforwardly incorporated into the computational architecture;

(8.1.3) the computational architecture enhances the hypotheses generated by the models both according to past performance of the models and according to application specific constraints and heuristics without requiring feedback loops for adjusting the models;

(8.1.4) the models are relatively easily integrated into, modified and extracted from the computational architecture;

(8.2) providing a computational paradigm for enhancing an initial estimated solution to a problem by using this initial estimated solution as, effectively, a query or index into an historical data base of previous solution estimates and corresponding actual solutions for deriving an enhanced solution estimate based on past performance of the module that generated the initial estimated solution.

**Please replace the paragraph beginning on page 20, line 19 with the following paragraph:**

In other embodiments of the present invention, a fast, albeit less accurate location estimate may be initially performed for very time critical location applications where approximate location information may be required. For example, less than 1 second response for a mobile station location embodiment of the present invention may be desired for 911 emergency response location requests. Subsequently, once a relatively coarse location estimate has been provided, a more accurate most likely location estimate can be performed by repeating the location estimation processing a second time with, e.g., additional with measurements of wireless signals transmitted between a mobile station to be located and a network of base stations with which the mobile station is communicating, thus providing a second, more accurate location estimate of the mobile station.

**Please replace the paragraph beginning on page 21, line 1 with the following paragraph:**

Note that in some embodiments of the present invention, since there is a lack of sequencing between the FOMs and subsequent processing of location hypotheses, the FOMs can be incorporated into an expert system, if desired. For example, each FOM may be activated from an antecedent of an expert system rule. Thus, the antecedent for such a rule can evaluate to TRUE if the FOM outputs a location hypothesis, and the consequent portion of such a rule may put the output location hypothesis on a list of location hypotheses occurring in a particular time window for subsequent processing by the location center. Alternatively, activation of the FOMs may be in the consequents of such expert system rules. That is, the antecedent of such an expert system rule may determine if the conditions are appropriate for invoking the FOM(s) in the rule's consequent.

**Please replace the paragraph beginning on page 21, line 8 with the following two paragraphs. Note that the only difference here is the commencement of a new paragraph at –Further features and advantages–.**

Of course, other software architectures may also be used in implementing the processing of the location center without departing from scope of the present invention. In particular, object-oriented architectures are also within the scope of the present invention. For example, the FOMs may be object methods on an MS location estimator object, wherein the estimator object receives substantially all target MS location signal data output by the signal filtering subsystem. Alternatively, software bus architectures are contemplated by the present invention, as one skilled in the art will understand, wherein the software architecture may be modular and facilitate parallel processing.

Further features and advantages of the present invention are provided by the figures and detailed description accompanying this invention summary.

**Please replace the paragraph beginning on page 22, line 5 with the following paragraph:**

Fig. 3 provides a typical example of how the statistical power budget is calculated in design of a Commercial Mobile Radio Service Provider (CMRS) network.

**Please replace the paragraph beginning on page 22, line 14 with the following paragraph:**

Figs. 9A and 9B is a high level data structure diagram describing the fields of a location hypothesis object generated by the first order models 1224 of the location center.

**Please replace the paragraph beginning on page 23, line 16 with the following paragraph:**

Figs. 23A through 23C present a high level flowchart of the steps performed by function, "GET\_DIFFERENCE\_MEASUREMENT," for updating location signatures in the location signature data base 1320; note, this flowchart corresponds to the description of this function in APPENDIX C.

**Please replace the paragraph beginning on page 28, line 9 with the following paragraph:**

The MBS 148 acts as a low cost, partially-functional, moving base station, and is, in one embodiment, situated in a vehicle where an operator may engage in MS 140 searching and tracking activities. In providing these activities using CDMA, the MBS 148 provides a forward link pilot channel for a target MS 140, and subsequently receives unique BS pilot strength measurements from the MS 140. The MBS 148 also includes a mobile station for data communication with the LC 142, via a BS 122. In

particular, such data communication includes telemetering the geographic position of the MBS 148 as well as various RF measurements related to signals received from the target MS 140. In some embodiments, the MBS 148 may also utilize multiple-beam fixed antenna array elements and/or a moveable narrow beam antenna, such as a microwave dish 182. The antennas for such embodiments may have a known orientation in order to further deduce a radio location of the target MS 140 with respect to an estimated current location of the MBS 148. As will be described in more detail herein below, the MBS 148 may further contain a global positioning system (GPS), distance sensors, deadreckoning electronics, as well as an on-board computing system and display devices for locating both the MBS 148 itself as well as tracking and locating the target MS 140. The computing and display provides a means for communicating the position of the target MS 140 on a map display to an operator of the MBS 148.

**Please replace the paragraph beginning on page 29, line 15 with the following two paragraphs. Note that the only difference here is the commencement of a new paragraph at –Thus, LBSs 152–.**

It should be noted that an LBS 152 will normally deny hand-off requests, since typically the LBS does not require the added complexity of handling voice or traffic bearer channels, although economics and peak traffic load conditions would dictate preference here. GPS timing information, needed by any CDMA base station, is either achieved via the inclusion of a local GPS receiver or via a telemetry process from a neighboring conventional BS 122, which contains a GPS receiver and timing information. Since energy requirements are minimal in such an LBS 152, (rechargeable) batteries or solar cells may be used to power the LBS. No expensive terrestrial transport link is typically required since two-way communication is provided by the included MS 140 (or an electronic variation thereof).

Thus, LBSs 152 may be placed in numerous locations, such as:

- (a) in dense urban canyon areas (e.g., where signal reception may be poor and/or very noisy);
- (b) in remote areas (e.g., hiking, camping and skiing areas);
- (c) along highways (e.g., for emergency as well as monitoring traffic flow), and their rest stations;
- or
- (d) in general, wherever more location precision is required than is obtainable using other wireless infrastructure network components.

**Please replace the paragraph beginning on page 29, line 29 with the following paragraph:**

A location application programming interface or L-API 14 (see Fig. 30, and including L-API-Loc\_APP 135, L-API-MSC 136, and L-API-SCP 137 shown in Fig. 4), is required between the location center 142 (LC) and the mobile switch center (MSC) network element type, in order to send and receive various control, signals and data messages. The L-API 14 should be implemented using a preferably high-



capacity physical layer communications interface, such as IEEE standard 802.3 (10 baseT Ethernet), although other physical layer interfaces could be used, such as fiber optic ATM, frame relay, etc. Two forms of API implementation are possible. In the first case the signals control and data messages are realized using the MSC 112 vendor's native operations messages inherent in the product offering, without any special modifications. In the second case the L-API includes a full suite of commands and messaging content specifically optimized for wireless location purposes, which may require some, although minor development on the part of the MSC vendor.

**Please replace the paragraph beginning on page 30, line 6 with the following paragraph:**

Referring to Fig. 30, the signal processing subsystem 1220 receives control messages and signal measurements and transmits appropriate control messages to the wireless network via the location applications programming interface referenced earlier, for wireless location purposes. The signal processing subsystem additionally provides various signal identification, conditioning and pre-processing functions, including buffering, signal type classification, signal filtering, message control and routing functions to the location estimate modules.

**Please replace the paragraph beginning on page 30, line 11 with the following paragraph:**

There can be several combinations of Delay Spread/Signal Strength sets of measurements made available to the signal processing subsystem 1220. In some cases the mobile station 140 (Fig. 4) may be able to detect up to three or four Pilot Channels representing three to four Base Stations, or as few as one Pilot Channel, depending upon the environment. Similarly, possibly more than one BS 122 can detect a mobile station 140 transmitter signal, as evidenced by the provision of cell diversity or soft hand-off in the CDMA standards, and the fact that multiple CMRS' base station equipment commonly will overlap coverage areas. For each mobile station 140 or BS 122 transmitted signal detected by a receiver group at a station, multiple delayed signals, or "fingers" may be detected and tracked resulting from multipath radio propagation conditions, from a given transmitter.

**Please replace the paragraph beginning on page 30, line 23 with the following paragraph:**

From the mobile receiver's perspective, a number of combinations of measurements could be made available to the Location Center. Due to the disperse and near-random nature of CDMA radio signals and propagation characteristics, traditional TOA/TDOA location methods have failed in the past, because the number of signals received in different locations are different. In a particularly small urban

area, of say less than 500 square feet, the number of RF signals and their multipath components may vary by over 100 percent.

**Please replace the paragraph beginning on page 31, line 19 with the following paragraph:**

Although Rayleigh fading appears as a generally random noise generator, essentially destroying the correlation value of either  $RRSS_{BS}$  or  $SRSS_{MS}$  measurements with distance individually, several mathematical operations or signal processing functions can be performed on each measurement to derive a more robust relative signal strength value, overcoming the adverse Rayleigh fading effects. Examples include averaging, taking the strongest value and weighting the strongest value with a greater coefficient than the weaker value, then averaging the results. This signal processing technique takes advantage of the fact that although a Rayleigh fade may often exist in either the forward or reverse path, it is much less probable that a Rayleigh fade also exists in the reverse or forward path, respectively. A shadow fade however, similarly affects the signal strength in both paths.

**Please replace the paragraph beginning on page 31, line 26 with the following paragraph:**

At this point a CDMA radio signal direction independent of "net relative signal strength measurement" can be derived which can be used to establish a correlation with either distance or shadow fading, or both. Although the ambiguity of either shadow fading or distance cannot be determined, other means can be used in conjunction, such as the fingers of the CDMA delay spread measurement, and any other TOA/TDOA calculations from other geographical points. In the case of a mobile station with a certain amount of shadow fading between its BS 122 (Fig. 2), the first finger of a CDMA delay spread signal is most likely to be a relatively shorter duration than the case where the mobile station 140 and BS 122 are separated by a greater distance, since shadow fading does not materially affect the arrival time delay of the radio signal.

**Please replace the paragraph beginning on page 31, line 33 with the following paragraph:**

By performing a small modification in the control electronics of the CDMA base station and mobile station receiver circuitry, it is possible to provide the signal processing subsystem 1220 (reference Fig. 30) within the location center 142 (Fig. 1) with data that exceed the one-to-one CDMA delay-spread fingers to data receiver correspondence. Such additional information, in the form of additional CDMA fingers (additional multipath) and all associated detectable pilot channels, provides new information which is used to enhance the accuracy of the location center's location estimators.

**Please replace the paragraph beginning on page 32, line 4 with the following paragraph:**

This enhanced capability is provided via a control message, sent from the location center 142 to the mobile switch center 12, and then to the base station(s) in communication with, or in close proximity with, mobile stations 140 to be located. Two types of location measurement request control messages are needed: one to instruct a target mobile station 140 (i.e., the mobile station to be located) to telemeter its BS pilot channel measurements back to the primary BS 122 and from there to the mobile switch center 112 and then to the location system 42. The second control message is sent from the location system 42 to the mobile switch center 112, then to first the primary BS, instructing the primary BS' searcher receiver to output (i.e., return to the initiating request message source) the detected target mobile station 140 transmitter CDMA pilot channel offset signal and their corresponding delay spread finger (peak) values and related relative signal strengths.

**Please replace the paragraph beginning on page 32, line 24 with the following paragraph:**

Fig. 30 illustrates the components of the Signal Processing Subsystem 1220 (also shown in Figs. 5, 6 and 8). The main components consist of the input queue(s) 7, signal classifier/filter 9, digital signaling processor 17, imaging filters 19, output queue(s) 21, router/distributor 23, (also denoted as the "Data Capture And Gateway" in Fig. 8(2)), a signal processor database 26 and a signal processing controller 15.

**Please replace the paragraph beginning on page 33, line 3 with the following paragraph:**

The signal processing subsystem 1220 supports a variety of wireless network signaling measurement capabilities by detecting the capabilities of the mobile and base station through messaging structures provided by the location application programming interface (L-API 14, Fig. 30). Detection is accomplished in the signal classifier 9 (Fig. 30) by referencing a mobile station database table within the signal processor database 26, which provides, given a mobile station identification number, mobile station revision code, other mobile station characteristics. Similarly, a mobile switch center table 31 provides MSC characteristics and identifications to the signal classifier/filter 9. The signal classifier/filter adds additional message header information that further classifies the measurement data which allows the digital signal processor and image filter components to select the proper internal processing subcomponents to perform operations on the signal measurement data, for use by the location estimate modules.

**Please replace the paragraph beginning on page 33, line 11 and ending at page 33, line 18 with the following paragraph.**

Regarding service control point messages (of L-API-SCP interface 137, Fig. 4) autonomously received from the input queue 7 (Figs. 30 and 31), the signal classifier/filter 9 determines via a signal processing database 26 query whether such a message is to be associated with a home base station module. Thus appropriate header information is added to the message, thus enabling the message to pass through the digital signal processor 17 unaffected to the output queue 21, and then to the router/distributor 23. The router/distributor 23 then routes the message to the HBS first order model. Those skilled in the art will understand that associating location requests from Home Base Station configurations require substantially less data: the mobile identification number and the associated wireline telephone number transmission from the home location register are on the order of less than 32 bytes. Consequentially the home base station message type could be routed without any digital signal processing.

**The paragraph beginning on page 33, line 19 has been replaced with the following paragraph:**

Output queue(s) 21 (Fig. 30) are required for similar reasons as input queues 7: relatively large amounts of data must be held in a specific format for further location processing by the location estimate modules 1224.

**Please replace the paragraph beginning on page 33, line 21 through page 33, line 23 with the following paragraph.**

The router and distributor component 23 (Fig. 30) is responsible for directing specific signal measurement data types and structures to their appropriate modules. For example, the HBS FOM has no use for digital filtering structures, whereas the TDOA module would not be able to process an HBS response message.

**Please replace the paragraph beginning on page 33, line 27 with the following paragraph:**

In addition the controller 15 receives autonomous messages from the MSC, via the location applications programming interface or L-API 14 (Fig. 30) and the input queue 7, whenever a 9-1-1 wireless call is originated. The mobile switch center provides this autonomous notification to the location system as follows: by specifying the appropriate mobile switch center operations and maintenance commands to surveil calls based on certain digits dialed such as 9-1-1, the location applications programming interface 14, in communications with the MSCs, receives an autonomous notification whenever a mobile station user dials 9-1-1. Specifically, a bi-directional authorized communications port is configured, usually at the operations and maintenance subsystem of the MSCs, or with their associated network element manager system(s), with a data circuit, such as a DS-1, with the location applications

programming interface 14. Next, the "call trace" capability of the mobile switch center is activated for the respective communications port. The exact implementation of the vendor-specific man-machine or Open Systems Interface (OSI) command(s) and their associated data structures generally vary among MSC vendors. However, the trace function is generally available in various forms, and is required in order to comply with Federal Bureau of Investigation authorities for wire tap purposes. After the appropriate surveillance commands are established on the MSC, such 9-1-1 call notifications messages containing the mobile station identification number (MIN) and, in U.S. FCC phase 1 E9-1-1 implementations, a pseudo-automatic number identification (a.k.a. pANI) which provides an association with the primary base station in which the 9-1-1 caller is in communication. In cases where the pANI is known from the onset, the signal processing subsystem 1220 avoids querying the MSC in question to determine the primary base station identification associated with the 9-1-1 mobile station caller.

**The paragraph beginning on page 33, line 34 has been replaced with the following paragraph:**

The controller 15 (Fig. 30) is responsible for staging the movement of data among the signal processing subsystem 1220 components input queue 7, digital signal processor 17, router/distributor 23 and the output queue 21, and to initiate signal measurements within the wireless network, in response from an internet 468 location request message in Fig. 5, via the location application programming interface.

**The paragraph beginning on page 34, line 10 has been replaced with the following paragraph:**

After the signal processing controller 15 receives the first message type, the autonomous notification message from the mobile switch center 112 to the location system 142, containing the mobile identification number and optionally the primary base station identification, the controller 15 queries the base station table 13 (Fig. 30) in the signal processor database 26 to determine the status and availability of any neighboring base stations, including those base stations of other CMRS in the area. The definition of neighboring base stations include not only those within a provisionable "hop" based on the cell design reuse factor, but also includes, in the case of CDMA, results from remaining set information autonomously queried to mobile stations, with results stored in the base station table. Remaining set information indicates that mobile stations can detect other base station (sector) pilot channels which may exceed the "hop" distance, yet are nevertheless candidate base stations (or sectors) for wireless location purposes. Although cellular and digital cell design may vary, "hop" distance is usually one or two cell coverage areas away from the primary base station's cell coverage area.

**Please replace the paragraph beginning on page 34, line 20 with the following paragraph:**

Having determined a likely set of base stations which may both detect the mobile station's transmitter signal, as well as to determine the set of likely pilot channels (i.e., base stations and their associated physical antenna sectors) detectable by the mobile station in the area surrounding the primary base station (sector), the controller 15 initiates messages to both the mobile station and appropriate base stations (sectors) to perform signal measurements and to return the results of such measurements to the signal processing system regarding the mobile station to be located. This step may be accomplished via several interface means. In a first case the controller 15 utilizes, for a given MSC, predetermined storage information in the MSC table 31 to determine which type of commands, such as man-machine or OSI commands are needed to request such signal measurements for a given MSC. The controller generates the mobile and base station signal measurement commands appropriate for the MSC and passes the commands via the input queue 7 and the locations application programming interface 14 in Fig. 30, to the appropriate MSC, using the authorized communications port mentioned earlier. In a second case, the controller 15 communicates directly with base stations within having to interface directly with the MSC for signal measurement extraction.

**Please replace the paragraph beginning on page 34, line 31 with the following paragraph:**

Upon receipt of the signal measurements, the signal classifier 9 in Fig. 30 examines location application programming interface-provided message header information from the source of the location measurement (for example, from a fixed BS 122, a mobile station 140, a distributed antenna system 168 in Fig. 4 or message location data related to a home base station), provided by the location applications programming interface (L-API 14) via the input queue 7 in Fig. 30 and determines whether or not device filters 17 or image filters 19 are needed, and assesses a relative priority in processing, such as an emergency versus a background location task, in terms of grouping like data associated with a given location request. In the case where multiple signal measurement requests are outstanding for various base stations, some of which may be associated with a different CMRS network, and additional signal classifier function includes sorting and associating the appropriate incoming signal measurements together such that the digital signal processor 17 processes related measurements in order to build ensemble data sets. Such ensembles allow for a variety of functions such as averaging, outlier removal over a time period, and related filtering functions, and further prevent association errors from occurring in location estimate processing.

**Please replace the paragraph beginning on page 35, line 10 with the following paragraph:**

Another function of the signal classifier/low pass filter component 9 is to filter information that is not useable, or information that could introduce noise or the effect of noise in the location estimate

modules. Consequently low pass matching filters are used to match the in-common signal processing components to the characteristics of the incoming signals. Low pass filters match: Mobile Station, base station, CMRS and MSC characteristics, as well as to classify Home Base Station messages.

**Please replace the paragraph beginning on page 35, line 14 with the following paragraph:**

The signal processing subsystem 1220 contains a base station database table 13 (Fig. 30) which captures the maximum number of CDMA delay spread fingers for a given base station.

**Please replace the paragraph beginning on page 35, line 21 with the following paragraph:**

Just as an upgraded base station may detect additional CDMA delay spread signals, newer or modified mobile stations may detect additional pilot channels or CDMA delay spread fingers. Additionally different makes and models of mobile stations may acquire improved receiver sensitivities, suggesting a greater coverage capability. A table may establish the relationships among various mobile station equipment suppliers and certain technical data relevant to this location invention.

**Please replace the paragraph beginning on page 35, line 25 with the following paragraph:**

Although not strictly necessary, the MIN can be populated in this table from the PCS Service Provider's Customer Care system during subscriber activation and fulfillment, and could be changed at deactivation, or anytime the end-user changes mobile stations. Alternatively, since the MIN, manufacturer, model number, and software revision level information is available during a telephone call, this information could be extracted during the call, and the remaining fields populated dynamically, based on manufacturer's specifications information previously stored in the signal processing subsystem 1220. Default values are used in cases where the MIN is not found, or where certain information must be estimated.

**Please replace the paragraph beginning on page 35, line 31 with the following paragraph:**

A low pass mobile station filter, contained within the signal classifier/low pass filter 9 of the signal processing subsystem 1220, uses the above table data to perform the following functions: 1) act as a low pass filter to adjust the nominal assumptions related to the maximum number of CDMA fingers, pilots detectable; and 2) to determine the transmit power class and the receiver thermal noise floor. Given the detected reverse path signal strength, the required value of  $SRSS_{MS}$ , a corrected indication of the effective path loss in the reverse direction (mobile station to BS), can be calculated based on data contained within the mobile station table 11, stored in the signal processing database 26.

**Please replace the paragraph beginning on page 36, line 3 with the following paragraph:**

The effects of the maximum number of CDMA fingers allowed and the maximum number of pilot channels allowed essentially form a low pass filter effect, wherein the least common denominator of characteristics are used to filter the incoming RF signal measurements such that a one for one matching occurs. The effect of the transmit power class and receiver thermal noise floor values is to normalize the characteristics of the incoming RF signals with respect to those RF signals used.

**Please replace the paragraph beginning on page 36, line 7 with the following paragraph:**

The signal classifier/filter 9 (Fig. 30) is in communication with both the input queue 7 and the signal processing database 26. In the early stage of a location request the signal processing subsystem 1220 shown in, e.g., Figs. 5, 30 and 31, will receive the initiating location request from either an autonomous 9-1-1 notification message from a given MSC, or from a location application, for which mobile station characteristics about the target mobile station 140 (Fig. 4) is required. Referring to Fig. 30, a query is made from the signal processing controller 15 to the signal processing database 26, specifically the mobile station table 11, to determine if the mobile station characteristics associated with the MIN to be located is available in table 11. If the data exists then there is no need for the controller 15 to query the wireless network in order to determine the mobile station characteristics, thus avoiding additional real-time processing which would otherwise be required across the air interface, in order to determine the mobile station MIN characteristics. The resulting mobile station information may be provided either via the signal processing database 26 or alternatively a query may be performed directly from the signal processing subsystem 1220 to the MSC in order to determine the mobile station characteristics.

**Please replace the paragraph beginning on page 36, line 18 with the following paragraph. Note that a new Fig. 31 is provided with the label "139" changed to -239-. This is being done since the label "139" is already being used to denote the "location engine."**

Referring now to Fig. 31, another location application programming interface, L-API-CCS 239 to the appropriate CMRS customer care system provides the mechanism to populate and update the mobile station table 11 within the database 26. The L-API-CCS 239 contains its own set of separate input and output queues or similar implementations and security controls to ensure that provisioning data is not sent to the incorrect CMRS, and that a given CMRS cannot access any other CMRS' data. The interface 1155a to the customer care system for CMRS-A 1150a provides an autonomous or periodic notification and response application layer protocol type, consisting of add, delete, change and verify message functions in



order to update the mobile station table 11 within the signal processing database 26, via the controller 15. A similar interface 155b is used to enable provisioning updates to be received from CMRS-B customer care system 1150b.

**Please replace the paragraph beginning on page 36, line 26 with the following paragraph:**

Although the L-API-CCS application message set may be any protocol type which supports the autonomous notification message with positive acknowledgment type, the T1M1.5 group within the American National Standards Institute has defined a good starting point in which the L-API-CCS 239 could be implemented, using the robust OSI TMN X-interface at the service management layer. The object model defined in Standards proposal number T1M1.5/96-22R9, Operations Administration, Maintenance, and Provisioning (OAM&P) - Model for Interface Across Jurisdictional Boundaries to Support Electronic Access Service Ordering: Inquiry Function, can be extended to support the L-API-CCS information elements as required and further discussed below. Other choices in which the L-API-CCS application message set may be implemented include ASCII, binary, or any encrypted message set encoding using the Internet protocols, such as TCP/IP, simple network management protocol, http, https, and email protocols.

**Please replace the paragraph beginning on page 37, line 12 with the following paragraph:**

In the general case where a mobile station is located in an environment with varied clutter patterns, such as terrain undulations, unique man-made structure geometries (thus creating varied multipath signal behaviors), such as a city or suburb, although the first CDMA delay spread finger may be the same value for a fixed distance between the mobile station and BS antennas, as the mobile station moves across such an area, different finger-data are measured. In the right image for the defined BS antenna sector, location classes, or squares numbered one through seven, are shown across a particular range of line of position (LOP).

**Please replace the paragraph beginning on page 37, line 17 with the following paragraph:**

A traditional TOA/TDOA ranging method between a given BS and mobile station only provides a range along an arc, thus introducing ambiguity error. However a unique three dimensional image can be used in this method to specifically identify, with recurring probability, a particular unique location class along the same Line Of Position, as long as the multipath is unique by position but generally repeatable, thus establishing a method of not only ranging, but also of complete latitude, longitude location estimation in a Cartesian space. In other words, the unique shape of the "mountain image" enables a

correspondence to a given unique location class along a line of position, thereby eliminating traditional ambiguity error.

**Please replace the paragraph beginning on page 38, line 17 with the following paragraph:**

The DSP 17 may provide data ensemble results, such as extracting the shortest time delay with a detectable relative signal strength, to the router/distributor 23, or alternatively results may be processed via one or more image filters 19, with subsequent transmission to the router/distributor 23. The router/distributor 23 examines the processed message data from the DSP 17 and stores routing and distribution information in the message header. The router/distributor 23 then forwards the data messages to the output queue 21, for subsequent queuing then transmission to the appropriate location estimator FOMs.

**Please replace the paragraph beginning on page 38, line 24 and ending at page 39, line 14 with the following paragraph:**

At a very high level the location center 142 computes location estimates for a wireless Mobile Station 140 (denoted the "target MS" or "MS") by performing the following steps:

- (23.1) receiving signal transmission characteristics of communications communicated between the target MS 140 and one or more wireless infrastructure base stations 122;
- (23.2) filtering the received signal transmission characteristics (by a signal processing subsystem 1220 illustrated in Fig. 5) as needed so that target MS location data can be generated that is uniform and consistent with location data generated from other target MSs 140. In particular, such uniformity and consistency is both in terms of data structures and interpretation of signal characteristic values provided by the MS location data;
- (23.3) inputting the generated target MS location data to one or more MS location estimating models (denoted First order models or FOMs, and labeled collectively as 1224 in Fig. 5), so that each such model may use the input target MS location data for generating a "location hypothesis" providing an estimate of the location of the target MS 140;
- (23.4) providing the generated location hypotheses to an hypothesis evaluation module (denoted the hypothesis evaluator 1228 in Fig. 5):
  - (a) for adjusting at least one of the target MS location estimates of the generated location hypotheses and related confidence values indicating the confidence given to each location estimate, wherein such adjusting uses archival information related to the accuracy of previously generated location hypotheses,

- (b) for evaluating the location hypotheses according to various heuristics related to, for example, the radio coverage area 120 terrain, the laws of physics, characteristics of likely movement of the target MS 140; and
- (c) for determining a most likely location area for the target MS 140, wherein the measurement of confidence associated with each input MS location area estimate is used for determining a "most likely location area"; and
- (23.5) outputting a most likely target MS location estimate to one or more applications 146 (Fig. 5) requesting an estimate of the location of the target MS 140.

**Please replace the paragraph beginning on page 42, line 1 with the following paragraph:**

Additionally, in utilizing location hypotheses in, for example, the location evaluator 1228 as in (23.4) above, it is important to keep in mind that each location hypothesis confidence value is a relative measurement. That is, for confidences,  $cf_1$  and  $cf_2$ , if  $cf_1 \leq cf_2$ , then for a location hypotheses  $H_1$  and  $H_2$  having  $cf_1$  and  $cf_2$ , respectively, the target MS 140 is expected to more likely reside in a target MS estimate of  $H_2$  than a target MS estimate of  $H_1$ . Moreover, if an area,  $A$ , is such that it is included in a plurality of location hypothesis target MS estimates, then a confidence score,  $CS_A$ , can be assigned to  $A$ , wherein the confidence score for such an area is a function of the confidences (both positive and negative) for all the location hypotheses whose (most pertinent) target MS location estimates contain  $A$ . That is, in order to determine a most likely target MS location area estimate for outputting from the location center 142, a confidence score is determined for areas within the location center service area. More particularly, if a function, " $f$ ", is a function of the confidence(s) of location hypotheses, and  $f$  is a monotonic function in its parameters and  $f(cf_1, cf_2, cf_3, \dots, cf_N) = CS_A$  for confidences  $cf_i$  of location hypotheses  $H_i$ ,  $i=1,2,\dots,N$ , with  $CS_A$  contained in the area estimate for  $H_i$ , then " $f$ " is denoted a confidence score function. Accordingly, there are many embodiments for a confidence score function  $f$  that may be utilized in computing confidence scores with the present invention; e.g.,

(a)  $f(cf_1, cf_2, \dots, cf_N) = \sum cf_i = CS_A$ ;

(b)  $f(cf_1, cf_2, \dots, cf_N) = \sum cf_i^n = CS_A$ ,  $n = 1, 3, 5, \dots$ ;

(c)  $f(cf_1, cf_2, \dots, cf_N) = \sum (K_i * cf_i) = CS_A$ , wherein  $K_i$ ,  $i = 1, 2, \dots$  are positive system (tunable) constants (possibly dependent on environmental characteristics such as topography, time, date, traffic, weather, and/or the type of base station(s) 122 from which location signatures with the target MS 140 are being generated, etc.).

**Please replace the paragraph beginning on page 43, line 27 and ending on page 44, line 23 with the following paragraph:**

In one embodiment of a method and system for determining such (transmission) area type approximations, a partition (denoted hereinafter as  $P_0$ ) is imposed upon the radio coverage area 120 for partitioning for radio coverage area into subareas, wherein each subarea is an estimate of an area having included MS 140 locations that are likely to have is at least a minimal amount of similarity in their wireless signaling characteristics. To obtain the partition  $P_0$  of the radio coverage area 120, the following steps are performed:

- (23.8.4.1) Partition the radio coverage area 120 into subareas, wherein in each subarea is: (a) connected, (b) variations in the lengths of chords sectioning the subarea through the centroid of the subarea are below a predetermined threshold, (c) the subarea has an area below a predetermined value, and (d) for most locations (e.g., within a first or second standard deviation) within the subarea whose wireless signaling characteristics have been verified, it is likely (e.g., within a first or second standard deviation ) that an MS 140 at one of these locations will detect (forward transmission path) and/or will be detected (reverse transmission path) by a same collection of base stations 122. For example, in a CDMA context, a first such collection may be (for the forward transmission path) the active set of base stations 122, or, the union of the active and candidate sets, or, the union of the active, candidate and/or remaining sets of base stations 122 detected by "most" MSs 140 in the subarea. Additionally (or alternatively), a second such collection may be the base stations 122 that are expected to detect MSs 140 at locations within the subarea. Of course, the union or intersection of the first and second collections is also within the scope of the present invention for partitioning the radio coverage area 120 according to (d) above. It is worth noting that it is believed that base station 122 power levels will be substantially constant. However, even if this is not the case, one or more collections for (d) above may be determined empirically and/or by computationally simulating the power output of each base station 122 at a predetermined level. Moreover, it is also worth mentioning that this step is relatively straightforward to implement using the data stored in the location signature data base 1320 (i.e., the verified location signature clusters discussed in detail hereinbelow). Denote the resulting partition here as  $P_1$ .
- (23.8.4.2) Partition the radio coverage area 120 into subareas, wherein each subarea appears to have substantially homogeneous terrain characteristics. Note, this may be performed periodically substantially automatically by scanning radio coverage area images obtained from aerial or satellite imaging. For example, EarthWatch Inc. of Longmont, CO can

provide geographic with 3 meter resolution from satellite imaging data. Denote the resulting partition here as  $P_2$ .

(23.8.4.3) Overlay both of the above partitions of the radio coverage area 120 to obtain new subareas that are intersections of the subareas from each of the above partitions. This new partition is  $P_0$  (i.e.,  $P_0 = P_1 \text{ intersect } P_2$ ), and the subareas of it are denoted as " $P_0$  subareas".

**Please replace the paragraph beginning on page 47, line 4 and ending at page 47, line 22 with the following paragraph:**

There are four fundamental entity types (or object classes in an object oriented programming paradigm) utilized in the location signature data base 1320. Briefly, these data entities are described in the items (24.1) through (24.4) that follow:

- (24.1) (verified) location signatures: Each such (verified) location signature describes the wireless signal characteristic measurements between a given base station (e.g., BS 122 or LBS 152) and an MS 140 at a (verified or known) location associated with the (verified) location signature. That is, a verified location signature corresponds to a location whose coordinates such as latitude-longitude coordinates are known, while simply a location signature may have a known or unknown location corresponding with it. Note that the term (verified) location signature is also denoted by the abbreviation, "(verified) loc sig" hereinbelow;
- (24.2) (verified) location signature clusters: Each such (verified) location signature cluster includes a collection of (verified) location signatures corresponding to all the location signatures between a target MS 140 at a (possibly verified) presumed substantially stationary location and each BS (e.g., 122 or 152) from which the target MS 140 can detect the BS's pilot channel regardless of the classification of the BS in the target MS (i.e., for CDMA, regardless of whether a BS is in the MS's active, candidate or remaining base station sets, as one skilled in the art will understand). Note that for simplicity here, it is presumed that each location signature cluster has a single fixed primary base station to which the target MS 140 synchronizes or obtains its timing;
- (24.3) "composite location objects (or entities)": Each such entity is a more general entity than the verified location signature cluster. An object of this type is a collection of (verified) location signatures that are associated with the same MS 140 at substantially the same location at the same time and each such loc sig is associated with a different base station. However, there is no requirement that a loc sig from each BS 122 for which the MS 140 can detect the BS's pilot channel is included in the "composite location object (or entity)"; and
- (24.4) MS location estimation data that includes MS location estimates output by one or more MS location estimating first order models 1224, such MS location estimate data is described in detail hereinbelow.

**Please replace the paragraph beginning on page 47, line 30 with the following paragraph:**

In particular, for each (verified) loc sig includes the following:

- (25.1) MS\_type: the make and model of the target MS 140 associated with a location signature instantiation; note that the type of MS 140 can also be derived from this entry; e.g., whether MS 140 is a handset MS, car-set MS, or an MS for location only. Note as an aside, for at least CDMA, the type of MS 140 provides information as to the number of fingers that may be measured by the MS, as one skilled in the will appreciate.

**Please replace the paragraph beginning on page 48, line 24 with the following paragraph:**

- (25.7) signal topography characteristics: In one embodiment, the signal topography characteristics retained can be represented as characteristics of at least a two-dimensional generated surface. That is, such a surface is generated by the signal processing subsystem 1220 from signal characteristics accumulated over (a relatively short) time interval. For example, in the two-dimensional surface case, the dimensions for the generated surface may be, for example, signal strength and time delay. That is, the accumulations over a brief time interval of signal characteristic measurements between the BS 122 and the MS 140 (associated with the loc sig) may be classified according to the two signal characteristic dimensions (e.g., signal strength and corresponding time delay). That is, by sampling the signal characteristics and classifying the samples according to a mesh of discrete cells or bins, wherein each cell corresponds to a different range of signal strengths and time delays a tally of the number of samples falling in the range of each cell can be maintained. Accordingly, for each cell, its corresponding tally may be interpreted as height of the cell, so that when the heights of all cells are considered, an undulating or mountainous surface is provided. In particular, for a cell mesh of appropriate fineness, the "mountainous surface", is believed to, under most circumstances, provide a contour that is substantially unique to the location of the target MS 140. Note that in one embodiment, the signal samples are typically obtained throughout a predetermined signal sampling time interval of 2-5 seconds as is discussed elsewhere in this specification. In particular, the signal topography characteristics retained for a loc sig include certain topographical characteristics of such a generated mountainous surface. For example, each loc sig may include: for each local maximum (of the loc sig surface) above a predetermined noise ceiling threshold, the (signal strength, time delay) coordinates of the cell of the local maximum and the corresponding height of the local maximum. Additionally, certain gradients may also be included for characterizing the "steepness" of the surface mountains. Moreover, note that in some embodiments, a frequency may also be associated with each local maximum. Thus, the data retained for each selected local maximum can

include a quadruple of signal strength, time delay, height and frequency. Further note that the data types here may vary. However, for simplicity, in parts of the description of loc sig processing related to the signal characteristics here, it is assumed that the signal characteristic topography data structure here is a vector;

**Please replace the paragraph beginning on page 49, line 19 with the following paragraph:**

(25.13) repeatable: TRUE iff the loc sig is "repeatable" (as described hereinafter), FALSE otherwise. Note that each verified loc sig is designated as either "repeatable" or "random". A loc sig is repeatable if the (verified/known) location associated with the loc sig is such that signal characteristic measurements between the associated BS 122 and this MS can be either replaced at periodic time intervals, or updated substantially on demand by most recent signal characteristic measurements between the associated base station and the associated MS 140 (or a comparable MS) at the verified/known location. Repeatable loc sigs may be, for example, provided by stationary or fixed location MSs 140 (e.g., fixed location transceivers) distributed within certain areas of a geographical region serviced by the location center 142 for providing MS location estimates. That is, it is an aspect of the present invention that each such stationary MS 140 can be contacted by the location center 142 (via the base stations of the wireless infrastructure) at substantially any time for providing a new collection (i.e., cluster) of wireless signal characteristics to be associated with the verified location for the transceiver. Alternatively, repeatable loc sigs may be obtained by, for example, obtaining location signal measurements manually from workers who regularly traverse a predetermined route through some portion of the radio coverage area; i.e., postal workers.

**Please replace the paragraph beginning on page 50, line 17 with the following paragraph:**

(26.1) A "normalization" method for normalizing loc sig data according to the associated MS 140 and/or BS 122 signal processing and generating characteristics. That is, the signal processing subsystem 1220, one embodiment being described in the PCT patent application PCT/US97/15933, titled, "Wireless Location Using A Plurality of Commercial Network Infrastructures," by F. W. LeBlanc and the present inventors, filed September 8, 1997 (which has a U.S. national filing that is now U.S. Patent No. 6,236,365, filed July 8, 1999, note, both PCT/US97/15933 and U.S. Patent No. 6,236,365 are incorporated fully by reference herein) provides (methods for loc sig objects) for "normalizing" each loc sig so that variations in signal characteristics resulting from variations in (for example) MS signal processing and generating characteristics of different types of MS's may be reduced. In particular, since wireless network designers are typically designing networks for effective use of hand set MS's 140 having a substantially common minimum set of performance characteristics, the normalization

methods provided here transform the loc sig data so that it appears as though the loc sig was provided by a common hand set MS 140. However, other methods may also be provided to "normalize" a loc sig so that it may be compared with loc sigs obtained from other types of MS's as well. Note that such normalization techniques include, for example, interpolating and extrapolating according to power levels so that loc sigs may be normalized to the same power level for, e.g., comparison purposes.

Normalization for the BS 122 associated with a loc sig is similar to the normalization for MS signal processing and generating characteristics. Just as with the MS normalization, the signal processing subsystem 1220 provides a loc sig method for "normalizing" loc sigs according to base station signal processing and generating characteristics.

**Please replace the paragraph beginning on page 52, line 10 with the following paragraph:**

A first functional group of location engine 139 modules is for performing signal processing and filtering of MS location signal data received from a conventional wireless (e.g., CDMA) infrastructure, as discussed in the steps (23.1) and (23.2) above. This group is denoted the signal processing subsystem 1220 herein. One embodiment of such a subsystem is described in the PCT patent application titled, "Wireless Location Using A Plurality of Commercial Network Infrastructures," by F. W. LeBlanc and the present inventors.

**Please replace the paragraph beginning on page 52, line 15 with the following paragraph:**

A second functional group of location engine 139 modules is for generating various target MS 140 location initial estimates, as described in step (23.3). Accordingly, the modules here use input provided by the signal processing subsystem 1220. This second functional group includes one or more signal analysis modules or models, each hereinafter denoted as a first order model 1224 (FOM), for generating location hypotheses for a target MS 140 to be located. Note that it is intended that each such FOM 1224 use a different technique for determining a location area estimate for the target MS 140. A brief description of some types of first order models is provided immediately below. Note that Figs. 8 illustrates another, more detailed view of the location system for the present invention. In particular, this figure illustrates some of the FOMs 1224 contemplated by the present invention, and additionally illustrates the primary communications with other modules of the location system for the present invention. However, it is important to note that the present invention is not limited to the FOMs 1224 shown and discussed herein. That is, it is a primary aspect of the present invention to easily incorporate FOMs using other signal processing and/or computational location estimating techniques than those presented herein. Further, note that each FOM type may have a plurality of its models incorporated into an embodiment of the present invention.



Please insert the following paragraph immediately before the paragraph beginning on page 53, line 10:

In one embodiment, such a distance model may perform the following steps:

- (a) Determines a minimum distance between the target MS and each BS using TOA, TDOA, signal strength on both forward and reverse paths;
- (b) Generates an estimated error;
- (c) Outputs a location hypothesis for estimating a location of a MS: each such hypothesis having: (i) one or more (nested) location area estimates for the MS, each location estimate having a confidence value (e.g., provided using the estimated error) indicating a perceived accuracy, and (ii) a reason for both the location estimate (e.g., substantial multipath, etc) and the confidence.

Please replace the paragraph beginning on page 53, line 10 with the following paragraph:

Another type of FOM 1224 is a statistically based first order model 1224, wherein a statistical technique, such as regression techniques (e.g., least squares, partial least squares, principle decomposition), or e.g., Bollinger Bands (e.g., for computing minimum and maximum base station offsets). In general, models of this type output location hypotheses that are determined by performing one or more statistical techniques or comparisons between the verified location signatures in location signature data base 1320, and the wireless signal measurements from a target MS. Models of this type are also referred to hereinafter as a "stochastic signal (first order) model" or a "stochastic FOM" or a "statistical model."

Please insert the following paragraph immediately before the paragraph beginning on page 53, line 16:

In one embodiment, such a stochastic signal model may output location hypotheses determined by one or more statistical comparisons with loc sigs in the Location Signature database 1320 (e.g., comparing MS location signals with verified signal characteristics for predetermined geographical areas).

Please insert the following paragraph immediately before the paragraph beginning on page 53, line 24:

In one embodiment, an adaptive learning model such as a model based on an artificial neural network may determine an MS 140 location estimate using base station IDs, data on signal-to-noise, other signal data (e.g., a number of signal characteristics including, e.g., all CDMA fingers). Moreover, the output from

such a model may include: a latitude and longitude for a center of a circle having radius R (R may be an input to such an artificial neural network), and is in the output format of the distance model(s).

**Please replace the paragraph beginning on page 53, line 24 with the following paragraph:**

Yet another type of FOM 1224 can be based on a collection of dispersed low power, low cost fixed location wireless transceivers (also denoted "location base stations 152" hereinabove) that are provided for detecting a target MS 140 in areas where, e.g., there is insufficient base station 122 infrastructure coverage for providing a desired level of MS 140 location accuracy. For example, it may be uneconomical to provide high traffic wireless voice coverage of a typical wireless base station 122 in a nature preserve or at a fair ground that is only populated a few days out of the year. However, if such low cost location base stations 152 can be directed to activate and deactivate via the direction of a FOM 1224 of the present type, then these location base stations can be used to both locate a target MS 140 and also provide indications of where the target MS is not. For example, if there are location base stations 152 populating an area where the target MS 140 is presumed to be, then by activating these location base stations 152, evidence may be obtained as to whether or not the target MS is actually in the area; e.g., if the target MS 140 is detected by a location base station 152, then a corresponding location hypothesis having a location estimate corresponding to the coverage area of the location base station may have a very high confidence value. Alternatively, if the target MS 140 is not detected by a location base station 152, then a corresponding location hypothesis having a location estimate corresponding to the coverage area of the location base station may have a very low confidence value. Models of this type are referred to hereinafter as "location base station models."

**Please insert the following paragraph immediately before the paragraph beginning on page 54, line 3:**

In one embodiment, such a location base station model may perform the following steps:

- (a) If an input is received then the target MS 140 is detected by a location base station 152 (i.e., a LBS being a unit having a reduced power BS and a MS).
- (b) If an input is obtained, then the output is a hypothesis data structure having a small area of the highest confidence.
- (c) If no input is received from a LBS then a hypothesis having an area with highest negative confidence is output.

**Please replace the paragraph beginning on page 54, line 3 with the following paragraph:**

Yet another type of FOM 1224 can be based on input from a mobile base station 148, wherein location hypotheses may be generated from target MS 140 location data received from the mobile base station 148. In one embodiment, such a mobile base station model may provide output similar to the distance FOM 1224 described hereinabove.

**Please replace the paragraph beginning on page 54, line 8 and ending on page 54, line 23 with the following paragraphs. Note the commencement of two new paragraphs inserted at ~~–Additionally, FOMS 1224—~~, and at ~~–Moreover, other FOMs—~~.**

Note that the FOM types mentioned here as well as other FOM types are discussed in detail hereinbelow. Moreover, it is important to keep in mind that a novel aspect of the present invention is the simultaneous use or activation of a potentially large number of such first order models 1224, wherein such FOMs are not limited to those described herein. Thus, the present invention provides a framework for incorporating MS location estimators to be subsequently provided as new FOMs in a straightforward manner. For example, a FOM 1224 based on wireless signal time delay measurements from a distributed antenna system 168 for wireless communication may be incorporated into the present invention for locating a target MS 140 in an enclosed area serviced by the distributed antenna system (such a FOM is more fully described in the U.S. Patent 6,236,365 filed July 8, 1999 which is incorporated fully by reference herein). Accordingly, by using such a distributed antenna FOM 1224 (Fig. 8(1)), the present invention may determine the floor of a multi-story building from which a target MS is transmitting. Thus, MSs 140 can be located in three dimensions using such a distributed antenna FOM 1224.

In one embodiment, such a distributed antenna model may perform the following steps:

- (a) Receives input only from a distributed antenna system.
- (b) If an input is received, then the output includes a lat-long and height of highest confidence.

Additionally, FOMs 1224 for detecting certain registration changes within, for example, a public switched telephone network 124 can also be used for locating a target MS 140. For example, for some MSs 140 there may be an associated or dedicated device for each such MS that allows the MS to function as a cordless phone to a line based telephone network when the device detects that the MS is within signaling range. In one use of such a device (also denoted herein as a "home base station"), the device registers with a home location register of the public switched telephone network 124 when there is a status change such as from not detecting the corresponding MS to detecting the MS, or visa versa, as one skilled in the art will understand. Accordingly, by providing a FOM 1224 (denoted the "Home Base Station First Order Model" in Fig. 8(1)) that accesses the MS status in the home location register, the location engine 139 can determine whether the MS is within signaling range of the home base station or not, and generate location hypotheses accordingly.

In one embodiment, such a home base station model may perform the following steps:

- (a) Receives an input only from the Public Telephone Switching Network.
- (b) If an input is received then the target MS 140 is detected by a home base station associated with the target MS.
- (c) If an input is obtained, then the output is a hypothesis data structure having a small area of the highest confidence.
- (d) If no input and there is a home base station then a hypothesis having a negative area is of highest confidence is output.

Moreover, other FOMs based on, for example, chaos theory and/or fractal theory are also within the scope of the present invention.

**Please replace the paragraph beginning on page 54, line 24 with the following paragraph:**

It is important to note the following aspects of the present invention relating to FOMs 1224:

- (28.1) Each such first order model 1224 may be relatively easily incorporated into and/or removed from the present invention. For example, assuming that the signal processing subsystem 1220 provides uniform input interface to the FOMs, and there is a uniform FOM output interface, it is believed that a large majority (if not substantially all) viable MS location estimation strategies may be accommodated. Thus, it is straightforward to add or delete such FOMs 1224.

**Please replace the paragraph beginning on page 56, line 1 with the following paragraph:**

- (30.2) it enhances the accuracy of an initial location hypothesis generated by a FOM by using the initial location hypothesis as, essentially, a query or index into the location signature data base 1320 for obtaining a corresponding enhanced location hypothesis, wherein the enhanced location hypothesis has both an adjusted target MS location area estimate and an adjusted confidence based on past performance of the FOM in the location service surrounding the target MS location estimate of the initial location hypothesis;

**Please replace the paragraph beginning on page 61, line 8 and ending on page 6, line 24 with the following paragraph:**

A fourth functional group of location engine 139 modules is the control and output gating modules which includes the location center control subsystem 1350, and the output gateway 1356. The location control subsystem 1350 provides the highest level of control and monitoring of the data processing performed by the location center 142. In particular, this subsystem performs the following functions:

- (a) controls and monitors location estimating processing for each target MS 140. Note that this includes high level exception or error handling functions;
- (b) receives and routes external information as necessary. For instance, this subsystem may receive (via, e.g., the public telephone switching network 124 and Internet 468) such environmental information as increased signal noise in a particular service area due to increase traffic, a change in weather conditions, a base station 122 (or other infrastructure provisioning), change in operation status (e.g., operational to inactive);
- (c) receives and directs location processing requests from other location centers 142 (via, e.g., the Internet 468);
- (d) performs accounting and billing procedures;
- (e) interacts with location center operators by, for example, receiving operator commands and providing output indicative of processing resources being utilized and malfunctions;
- (f) provides access to output requirements for various applications requesting location estimates. For example, an Internet 468 location request from a trucking company in Los Angeles to a location center 142 in Denver may only want to know if a particular truck or driver is within the Denver area. Alternatively, a local medical rescue unit is likely to request a precise a location estimate as possible.

**Please replace the paragraph beginning on page 61, line 25 with the following paragraph:**

Note that in Fig. 6, (a) - (d) above are, at least at a high level, performed by utilizing the operator interface 1374.

**Please replace the paragraph beginning on page 61, line 26 with the following paragraph:**

Referring now to the output gateway 1356, this module routes target MS 140 location estimates to the appropriate location application(s). For instance, upon receiving a location estimate from the most likelihood estimator 1344, the output gateway 1356 may determine that the location estimate is for an automobile being tracked by the police and therefore must be provided according to a particular protocol.

**Please replace the paragraph beginning on page 63, line 8 with the following paragraph:**

Taking a CDMA or TDMA base station network as an example, each base station (BS) 122 is required to emit a constant signal-strength pilot channel pseudo-noise (PN) sequence on the forward link channel identified uniquely in the network by a pilot sequence offset and frequency assignment. It is possible to use the pilot channels of the active, candidate, neighboring and remaining sets, maintained in

the target MS, for obtaining signal characteristic measurements (e.g., TOA and/or TDOA measurements) between the target MS 140 and the base stations in one or more of these sets.

**Please replace the paragraph beginning on page 63, line 26 with the following paragraph:**

Accordingly, some embodiments of distance FOMs may attempt to mitigate such ambiguity or inaccuracies by, e.g., identifying discrepancies (or consistencies) between arrival time measurements and other measurements (e.g., signal strength), these discrepancies (or consistencies) may be used to filter out at least those signal measurements and/or generated location estimates that appear less accurate. In particular, such identifying by filtering can be performed by, for example, an expert system residing in the distance FOM.

**Please replace the paragraph beginning on page 65, line 1 with the following paragraph:**

In one embodiment, a coverage area model utilizes both the detection and non-detection of base stations 122 by the target MS 140 (conversely, of the MS by one or more base stations 122) to define an area where the target MS 140 may likely be. A relatively straightforward application of this technique is to:

- (a) find all areas of intersection for base station RF coverage area representations, wherein: (i) the corresponding base stations are on-line for communicating with MSs 140; (ii) the RF coverage area representations are deemed reliable for the power levels of the on-line base stations; (iii) the on-line base stations having reliable coverage area representations can be detected by the target MS; and (iv) each intersection must include a predetermined number of the reliable RF coverage area representations (e.g., 2 or 3); and
- (b) obtain new location estimates by subtracting from each of the areas of intersection any of the reliable RF coverage area representations for base stations 122 that can not be detected by the target MS.

**Please replace the paragraph beginning on page 66, line 2 with the following paragraph:**

The stochastic first order models may use statistical prediction techniques such as principle decomposition, partial least squares, or other regression techniques for predicting, for example, expected minimum and maximum distances of the target MS from one or more base stations 122, e.g., Bollenger Bands. Additionally, some embodiments may use Markov processes and Random Walks (predicted incremental MS movement) for determining an expected area within which the target MS 140 is likely to be. That is, such a process measures the incremental time differences of each pilot as the MS moves for

predicting a size of a location area estimate using past MS estimates such as the verified location signatures in the location signature data base 1320.

**Please replace the paragraph beginning on page 66, line 15 with the following paragraph:**

Regarding FOMs 1224 using pattern recognition or associativity techniques, there are many such techniques available. For example, there are statistically based systems such as "CART" (an acronym for Classification and Regression Trees) by ANGOSS Software International Limited of Toronto, Canada that may be used for automatically detecting or recognizing patterns in data that were unprovided (and likely previously unknown). Accordingly, by imposing a relatively fine mesh or grid of cells on the radio coverage area, wherein each cell is entirely within a particular area type categorization such as the transmission area types (discussed in the section, "Coverage Area: Area Types And Their Determination" above), the verified location signature clusters within the cells of each area type may be analyzed for signal characteristic patterns. If such patterns are found, then they can be used to identify at least a likely area type in which a target MS is likely to be located. That is, one or more location hypotheses may be generated having target MS 140 location estimates that cover an area having the likely area type wherein the target MS 140 is located. Further note that such statistically based pattern recognition systems as "CART" include software code generators for generating expert system software embodiments for recognizing the patterns detected within a training set (e.g., the verified location signature clusters).

**Please replace the paragraph beginning on page 67, line 1 with the following paragraph:**

A similar statistically based FOM 1224 to the one above may be provided wherein the radio coverage area is decomposed substantially as above, but in addition to using the signal characteristics for detecting useful signal patterns, the specific identifications of the base station 122 providing the signal characteristics may also be used. Thus, assuming there is a sufficient density of verified location signature clusters in some of the mesh cells so that the statistical pattern recognizer can detect patterns in the signal characteristic measurements, an expert system may be generated that outputs a target MS 140 location estimate that may provide both a reliable and accurate location estimate of a target MS 140.

**Please replace the paragraph beginning on page 69, line 10 with the following paragraph:**

It is worthwhile to discuss the data representations for the inputs and outputs of a ANN used for generating MS location estimates. Regarding ANN input representations, recall that the signal processing subsystem 1220 may provide various RF signal measurements as input to an ANN (such as the RF signal measurements derived from verified location signatures in the location signature data base 1320). For

example, a representation of a histogram of the frequency of occurrence of CDMA fingers in a time delay versus signal strength 2-dimensional domain may be provided as input to such an ANN. In particular, a 2-dimensional grid of signal strength versus time delay bins may be provided so that received signal measurements are slotted into an appropriate bin of the grid. In one embodiment, such a grid is a six by six array of bins such as illustrated in the left portion of Fig. 14. That is, each of the signal strength and time delay axes are partitioned into six ranges so that both the signal strength and the time delay of RF signal measurements can be slotted into an appropriate range, thus determining the bin.

**Please replace the paragraph beginning on page 70, line 10 with the following paragraph:**

Accordingly, the technique described herein limits the number of input neurons in each ANN constructed and generates a larger number of these smaller ANNs. That is, each ANN is trained on location signature data (or, more precisely, portions of location signature clusters) in an area  $A_{ANN}$  (hereinafter also denoted the "net area"), wherein each input neuron receives a unique input from one of: (A1) location signature data (e.g., signal strength/time delay bin tallies) corresponding to transmissions between an MS 140 and a relatively small number of base stations 122 in the area  $A_{ANN}$ . For instance, location signature data obtained from, for example, a collection B of four base stations 122 (or antenna sectors) in the area  $A_{ANN}$ . Note, each location signature data cluster includes fields describing the wireless communication devices used; e.g., (i) the make and model of the target MS; (ii) the current and maximum transmission power; (iii) the MS battery power (instantaneous or current); (iv) the base station (sector) current power level; (v) the base station make and model and revision level; (vi) the air interface type and revision level (of, e.g., CDMA, TDMA or AMPS).

**Please replace the paragraph beginning on page 71, line 7 with the following paragraph:**

Moreover, for each of the smaller ANNs, it is likely that the number of input neurons is on the order of 330; (i.e., 70 inputs per each of four location signatures ( i.e., 35 inputs for the forward wireless communications and 35 for the reverse wireless communications), plus 40 additional discrete inputs for an appropriate area surrounding  $A_{ANN}$ , plus 10 inputs related to: the type of MS, power levels, etc.). However, it is important to note that the number of base stations (or antenna sectors 130) having corresponding location signature data to be provided to such an ANN may vary. Thus, in some subareas of the coverage area 120, location signature data from five or more base stations (antenna sectors) may be used, whereas in other subareas three (or less) may be used.

**Please replace the paragraph beginning on page 72, line 26 with the following paragraph:**



In one traditional artificial neural network training process, a relatively tedious set of trial and error steps may be performed for configuring an ANN so that training produces effective learning. In particular, an ANN may require configuring parameters related to, for example, input data scaling, test/training set classification, detecting and removing unnecessary input variable selection. However, the present invention reduces this tedium. That is, the present invention uses mechanisms such as genetic algorithms or other mechanisms for avoiding non-optimal but locally appealing (i.e., local minimum) solutions, and locating near-optimal solutions instead. In particular, such mechanism may be used to adjust the matrix of weights for the ANNs so that very good, near optimal ANN configurations may be found efficiently. Furthermore, since the signal processing system 1220 uses various types of signal processing filters for filtering the RF measurements received from transmissions between an MS 140 and one or more base stations (antenna sectors 130), such mechanisms for finding near-optimal solutions may be applied to selecting appropriate filters as well. Accordingly, in one embodiment of the present invention, such filters are paired with particular ANNs so that the location signature data supplied to each ANN is filtered according to a corresponding "filter description" for the ANN, wherein the filter description specifies the filters to be used on location signature data prior to inputting this data to the ANN. In particular, the filter description can define a pipeline of filters having a sequence of filters wherein for each two consecutive filters,  $f_1$  and  $f_2$  ( $f_1$  preceding  $f_2$ ), in a filter description, the output of  $f_1$  flows as input to  $f_2$ . Accordingly, by encoding such a filter description together with its corresponding ANN so that the encoding can be provided to a near optimal solution finding mechanism such as a genetic algorithm, it is believed that enhanced ANN locating performance can be obtained. That is, the combined genetic codes of the filter description and the ANN are manipulated by the genetic algorithm in a search for a satisfactory solution (i.e., location error estimates within a desired range). This process and system provides a mechanism for optimizing not only the artificial neural network architecture, but also identifying a near optimal match between the ANN and one or more signal processing filters. Accordingly, the following filters may be used in a filter pipeline of a filter description: Sobel, median, mean, histogram normalization, input cropping, neighbor, Gaussian, Weiner filters.

**Please replace the paragraph beginning on page 79, line 9 with the following paragraph. Note the only change herein is the removal of the underlining of the phrase 'there is a "error\_rec" here for each loc sig in "loc\_sig\_bag".'**

**error\_rec\_set:** A set of error records (objects), denoted "error\_recs", providing information as to how much each loc sig in "loc\_sig\_bag" disagrees with comparable loc sigs in the location signature data base. That is, there is a "error\_rec" here for each loc sig in "loc\_sig\_bag".

Please replace the paragraph beginning on page 79, line 22 and ending on page 80, line 9 has been replaced with the following paragraph:

DB\_Loc\_Sig\_Error\_Fit(hypothesis, measured\_loc\_sig\_bag, search\_criteria)

/\* This function determines how well the collection of loc sigs in "measured\_loc\_sig\_bag" fit with the loc sigs in the location signature data base 1320 wherein the data base loc sigs must satisfy the criteria of the input parameter "search\_criteria" and are relatively close to the MS location estimate of the location hypothesis, "hypothesis".

Input: hypothesis: MS location hypothesis;

measured\_loc\_sig\_bag: A collection of measured location signatures ("loc sigs" for short) obtained from the MS (the data structure here is an aggregation such as an array or list).

Note, it is assumed that there is at most one loc sig here per Base Station in this collection. Additionally, note that the input data structure here may be a location signature cluster such as the "loc\_sig\_cluster" field of a location hypothesis (cf. Figs. 9A and 9B). Note that variations in input data structures may be accepted here by utilization of flag or tag bits as one skilled in the art will appreciate;

search\_criteria: The criteria for searching the verified location signature data base for various categories of loc sigs. The only limitation on the types of categories that may be provided here is that, to be useful, each category should have meaningful number of loc sigs in the location signature data base. The following categories included here are illustrative, but others are contemplated:

- (a) "USE ALL LOC SIGS IN DB" (the default),
- (b) "USE ONLY REPEATABLE LOC SIGS",
- (c) "USE ONLY LOC SIGS WITH SIMILAR TIME OF DAY".

Please replace the paragraph beginning on page 80, line 19 with the following paragraph:

The following program compares: (a1) loc sigs that are contained in (or derived from) the loc sigs in "target\_loc\_sig\_bag" with (b1) loc sigs computed from verified loc sigs in the location signature data base 1320. That is, each loc sig from (a1) is compared with a corresponding loc sig from (b1) to obtain a measurement of the discrepancy between the two loc sigs. In particular, assuming each of the loc sigs for "target\_loc\_sig\_bag" correspond to the same target MS location, wherein this location is "target\_loc", this program determines how well the loc sigs in "target\_loc\_sig\_bag" fit with a computed or estimated loc sig for the location, "target\_loc" that is derived from the verified loc sigs in the location signature data base 1320. Thus, this program may be used: (a2) for determining how well the loc sigs in the location

signature cluster for a target MS ("target\_loc\_sig\_bag") compares with loc sigs derived from verified location signatures in the location signature data base, and (b2) for determining how consistent a given collection of loc sigs ("target\_loc\_sig\_bag") from the location signature data base is with other loc sigs in the location signature data base. Note that in (b2) each of the one or more loc sigs in "target\_loc\_sig\_bag" have an error computed here that can be used in determining if the loc sig is becoming inapplicable for predicting target MS locations.

**Please replace the paragraph beginning on page 85, line 5 with the following paragraph:**

This function creates a new list of location hypotheses from the input list, "loc\_hyp\_list", wherein the location hypotheses on the new list are modified versions of those on the input list. For each location hypothesis on the input list, one or more corresponding location hypotheses will be on the output list. Such corresponding output location hypotheses will differ from their associated input location hypothesis by one or more of the following: (a) the "image\_area" field (see Figs. 9A and 9B) may be assigned an area indicative of where the target MS is estimated to be, (b) if "image\_area" is assigned, then the "confidence" field will be the confidence that the target MS is located in the area for "image\_area", (c) if there are not sufficient "nearby" verified location signature clusters in the location signature data base 1320 to entirely rely on a computed confidence using such verified location signature clusters, then two location hypotheses (having reduced confidences) will be returned, one having a reduced computed confidence (for "image\_area") using the verified clusters in the Location Signature data base, and one being substantially the same as the associated input location hypothesis except that the confidence (for the field "area\_est") is reduced to reflect the confidence in its paired location hypothesis having a computed confidence for "image\_area". Note also, in some cases, the location hypotheses on the input list, may have no change to its confidence or the area to which the confidence applies.

Get\_adjusted\_loc\_hyp\_list\_for(loc\_hyp)

**Please replace the paragraph beginning on page 85, line 30 with the following paragraph:**

The function, "get\_adjusted\_loc\_hyp\_list\_for," and functions called by this function presuppose a framework or paradigm that requires some discussion as well as the defining of some terms. Note that some of the terms defined hereinbelow are illustrated in Fig. 24.

**Please replace the paragraph beginning on page 86, line 6 with the following paragraph. Note the only change here is the removal of the underlining of the word 'verified.'**

Define the term "image cluster set" (for a given First Order Model identified by "loc\_hyp.FOM\_ID") to mean the set of verified location signature clusters whose MS location point estimates are in "the cluster set".

**Please replace the paragraph beginning on page 86, line 25 with the following paragraph. Note the removal of the underlining in the phrase 'per unit of area.'**

Define the term "mapped cluster density" to be the number of the verified location signature clusters in an "image cluster set" per unit of area in the "image cluster set area".

**Please replace the paragraph beginning on page 89, line 18 has been replaced with the following paragraph:**

(35.5) A location extrapolator module 1432 for use in updating previous location estimates for a target MS when a more recent location hypothesis is provided to the location hypothesis analyzer 1332. That is, assume that the control module 1400 receives a new location hypothesis for a target MS for which there are also one or more previous location hypotheses that either have been recently processed (i.e., they reside in the MS status repository 1338, as shown best in Fig. 6), or are currently being processed (i.e., they reside in the run-time location hypothesis storage area 1410). Accordingly, if the active\_timestamp (see Figs. 9A and 9B regarding location hypothesis data fields) of the newly received location hypothesis is sufficiently more recent than the active\_timestamp of one of these previous location hypotheses, then an extrapolation may be performed by the location extrapolator module 1432 on such previous location hypotheses so that all target MS location hypotheses being concurrently analyzed are presumed to include target MS location estimates for substantially the same point in time. Thus, initial location estimates generated by the FOMs using different wireless signal measurements, from different signal transmission time intervals, may have their corresponding dependent location hypotheses utilized simultaneously for determining a most likely target MS location estimate. Note that this module may also be daemon or expert system rule base.

**Please replace the paragraph beginning on page 100, line 30 through page 101, line 2 with the following paragraph:**

Accordingly, if a new currently active location hypothesis (e.g., supplied by the context adjuster) is received by the blackboard, then the target MS location estimate of the new location hypothesis may be compared with the predicted location. Consequently, a confidence adjustment value can be determined according to how well the new location hypothesis "i" fits with the predicted location. That is, this

confidence adjustment value will be larger as the new MS estimate and the predicted estimate become closer together.

**Please replace the paragraph beginning on page 102, line 3 with the following paragraph:**

Any collection of mobile electronics (denoted mobile location unit) that is able to both estimate a location of a target MS 140 and communicate with the base station network may be utilized by the present invention to more accurately locate the target MS. Such mobile location units may provide greater target MS location accuracy by, for example, homing in on the target MS and by transmitting additional MS location information to the location center 142. There are a number of embodiments for such a mobile location unit contemplated by the present invention. For example, in a minimal version, such the electronics of the mobile location unit may be little more than an onboard MS 140, a sectored/directional antenna and a controller for communicating between them. Thus, the onboard MS is used to communicate with the location center 142 and possibly the target MS 140, while the antenna monitors signals for homing in on the target MS 140. In an enhanced version of the mobile location unit, a GPS receiver may also be incorporated so that the location of the mobile location unit may be determined and consequently an estimate of the location of the target MS may also be determined. However, such a mobile location unit is unlikely to be able to determine substantially more than a direction of the target MS 140 via the sectored/directional antenna without further base station infrastructure cooperation in, for example, determining the transmission power level of the target MS or varying this power level. Thus, if the target MS or the mobile location unit leaves the coverage area 120 or resides in a poor communication area, it may be difficult to accurately determine where the target MS is located. None-the-less, such mobile location units may be sufficient for many situations, and in fact the present invention contemplates their use. However, in cases where direct communication with the target MS is desired without constant contact with the base station infrastructure, the present invention includes a mobile location unit that is also a scaled down version of a base station 122. Thus, given that such a mobile base station or MBS 148 includes at least an onboard MS 140, a sectored/directional antenna, a GPS receiver, a scaled down base station 122 and sufficient components (including a controller) for integrating the capabilities of these devices, an enhanced autonomous MS mobile location system can be provided that can be effectively used in, for example, emergency vehicles, airplanes and boats. Accordingly, the description that follows below describes an embodiment of an MBS 148 having the above mentioned components and capabilities for use in a vehicle.

**Please replace the paragraph beginning on page 104, line 23 with the following paragraph:**

Thus, while in the ready state 1708, as the MBS 148 moves, it has its location repeatedly (re)-estimated via, for example, GPS signals, location center 142 location estimates from the base stations 122 (and 152), and an on-board deadreckoning subsystem 1527 having an MBS location estimator according to the programs described hereinbelow. However, note that the accuracy of the base station time synchronization (via the rubidium oscillator 1520) and the accuracy of the MBS 148 location may need to both be periodically recalibrated according to (1a) and (1b) above.

**Please replace the paragraph beginning on page 106, line 20 with the following paragraph:**

In one embodiment, the MBS 148 (Fig. 11) includes an MBS controller 1533 for controlling the location capabilities of the MBS 148. In particular, the MBS controller 1533 initiates and controls the MBS state changes as described in Fig. 12 above. Additionally, the MBS controller 1533 also communicates with the location controller 1535, wherein this latter controller controls MBS activities related to MBS location and target MS location; e.g., this performs the program, "mobile\_base\_station\_controller" described in APPENDIX A hereinbelow. The location controller 1535 receives data input from an event generator 1537 for generating event records to be provided to the location controller 1535. For example, records may be generated from data input received from: (a) the vehicle movement detector 1539 indicating that the MBS 148 has moved at least a predetermined amount and/or has changed direction by at least a predetermined angle, or (b) the MBS signal processing subsystem 1541 indicating that the additional signal measurement data has been received from either the location center 142 or the target MS 140. Note that the MBS signal processing subsystem 1541, in one embodiment, is similar to the signal processing subsystem 1220 of the location center 142. Moreover, also note that there may be multiple command schedulers. In particular, a scheduler 1528 for commands related to communicating with the location center 142, a scheduler 1530 for commands related to GPS communication (via GPS receiver 1531), a scheduler 1529 for commands related to the frequency and granularity of the reporting of MBS changes in direction and/or position via the MBS deadreckoning subsystem 1527 (note that this scheduler is potentially optional and that such commands may be provided directly to the deadreckoning estimator 1544), and a scheduler 1532 for communicating with the target MS(s) 140 being located. Further, it is assumed that there is sufficient hardware and/or software to perform commands in different schedulers substantially concurrently.

**Please replace the paragraph beginning on page 109, line 32 with the following paragraph:**

It is assumed that the error with deadreckoning increases with deadreckoning distance. Accordingly, it is an aspect of the embodiment of the MBS location subsystem 1508 that when incrementally updating the location of the MBS 148 using deadreckoning and applying deadreckoning location change estimates

to a "most likely area" in which the MBS 148 is believed to be, this area is incrementally enlarged as well as shifted. The enlargement of the area is used to account for the inaccuracy in the deadreckoning capability. Note, however, that the deadreckoning MBS location estimator is periodically reset so that the error accumulation in its outputs can be decreased. In particular, such resetting occurs when there is a high probability that the location of the MBS is known. For example, the deadreckoning MBS location estimator may be reset when an MBS operator manually enters an MBS location or verifies an MBS location, or a computed MBS location has sufficiently high confidence.

**Please replace the paragraph beginning on page 110, line 32 with the following paragraph:**

Further, the MBS 148 may constrain any location estimates to streets on a street map using the MBS location snap to street module 1562. For example, an estimated MBS location not on a street may be "snapped to" a nearest street location. Note that a nearest street location determiner may use "normal" orientations of vehicles on streets as a constraint on the nearest street location, particularly, if an MBS 148 is moving at typical rates of speed and acceleration, and without abrupt changes in direction. For example, if the deadreckoning MBS location estimator 1544 indicates that the MBS 148 is moving in a northerly direction, then the street snapped to should be a north-south running street. Moreover, the MBS location snap to street module 1562 may also be used to enhance target MS location estimates when, for example, it is known or suspected that the target MS 140 is in a vehicle and the vehicle is moving at typical rates of speed. Furthermore, the snap to street location module 1562 may also be used in enhancing the location of a target MS 140 by either the MBS 148 or by the location engine 139. In particular, the location estimator 1344 or an additional module between the location estimator 1344 and the output gateway 1356 may utilize an embodiment of the snap to street location module 1562 to enhance the accuracy of target MS 140 location estimates that are known to be in vehicles. Note that this may be especially useful in locating stolen vehicles that have embedded wireless location transceivers (MSs 140), wherein appropriate wireless signal measurements can be provided to the location center 142.

**Please replace the paragraph beginning on page 111, line 29 with the following paragraph:**

There is an MBS location track for storing MBS location entries obtained from MBS location estimation information from each of the MBS baseline location estimators described above (i.e., a GPS location track 1750 for storing MBS location estimations obtained from the GPS location estimator 1540, a location center location track 1754 for storing MBS location estimations obtained from the location estimator 1540 deriving its MBS location estimates from the location center 142, an LBS location track 1758 for storing MBS location estimations obtained from the location estimator 1540 deriving its MBS location estimates from base stations 122 and/or 152, and a manual location track 1762 for MBS operator

entered MBS locations). Additionally, there is one further location track, denoted the "current location track" 1766 whose location track entries may be derived from the entries in the other location tracks (described further hereinbelow). Further, for each location track, there is a location track head that is the head of the queue for the location track. The location track head is the most recent (and presumably the most accurate) MBS location estimate residing in the location track. Thus, the GPS location track 1750 has location track head 1770; the location center location track 1754 has location track head 1774; the LBS location track 1758 has location track head 1778; the manual location track 1762 has location track head 1782; and the current location track 1766 has location track head 1786. Additionally, for notational convenience, for each location track, the time series of previous MBS location estimations (i.e., location track entries) in the location track will herein be denoted the "path for the location track." Such paths are typically the length of the location track queue containing the path. Note that the length of each such queue may be determined using at least the following considerations:

**Please replace the paragraph beginning on page 115, line 15 and ending on page 115, line 18 with the following paragraph:**

```
MBS_new_est <--- get_new_MBS_location_using_estimate(event);  
/* Note, whenever a new MBS location estimate is entered as a baseline estimate into one  
of the location tracks, the other location tracks must be immediately updated with any  
deadreckoning location change estimates so that all location tracks are substantially  
updated at the same time. */
```

**Please replace the paragraph beginning on page 120, line 19 with the following paragraph:**

```
/* This information includes error or reliability estimates that may be used in  
subsequent attempts to determine an MS location estimate when there is no  
communication with the LC and no exact (GPS) location can be obtained. That is,  
if the reliability of the target MS's location is deemed highly reliable, then  
subsequent less reliable location estimates should be used only to the degree that  
more highly reliable estimates become less relevant due to the MS moving to other  
locations. */
```

**Please replace the paragraph beginning on page 122, line 28 with the following paragraph. Note the only change here is the insertion of —) immediately after "event."**

```
MBS_new_est <--- get_new_MBS_location_est_from_operator(event); /* The estimate may  
be obtained, for example, using a light pen on a displayed map */
```



Please replace the paragraph beginning on page 124, line 1 and ending on page 124, line 12 with the following paragraph:

The confidence value for each MBS location estimate is a measurement of the likelihood of the MBS location estimate being correct. More precisely, a confidence value for a new MBS location estimate is a measurement that is adjusted according to the following criteria:

- (a) the confidence value increases with the perceived accuracy of the new MBS location estimate (independent of any current MBS location estimate used by the MBS),
- (b) the confidence value decreases as the location discrepancy with the current MBS location increases,
- (c) the confidence value for the current MBS location increases when the new location estimate is contained in the current location estimate,
- (d) the confidence value for the current MBS location decreases when the new location estimate is not contained in the current location estimate, and

Therefore, the confidence value is an MBS location likelihood measurement which takes into account the history of previous MBS location estimates.

Please replace the paragraph beginning on page 132, line 27 and ending on page 132, line 131 with the following paragraph:

**Input: MBS\_new\_est** The newest MBS location estimate record.

**adjusted\_curr\_est** The version of "MBS\_curr\_est" adjusted by the deadreckoning location change estimate paired with "MBS\_new\_est".

**MBS\_curr\_est** The location track entry that is the head of the "current" location track.  
Note that "MBS\_new\_est.confidence" > "MBS\_curr\_est.confidence".

Please replace the paragraph beginning on page 143, line 14 and ending on page 143, line 19 with the following paragraph:

**measured\_loc\_sig\_bag**: A collection of measured location signatures ("loc sigs" for short) obtained from the MS (the data structure here is an aggregation such as an array or list). Note, it is assumed that there is at most one loc sig here per Base Station in this collection. Additionally, note that the input data structure here may be a location signature cluster such as the "loc\_sig\_cluster" field of a location hypothesis (cf. Figs.

9A and 9B). Note that variations in input data structures may be accepted here by utilization of flag or tag bits as one skilled in the art will appreciate;

**Please replace the paragraph beginning on page 147, line 28 with the following paragraph. Note the only change herein is the removal of the underlining of the phrase 'there is an "error\_rec" here for each loc sig in "loc\_sig\_bag".'**

**error\_rec\_set:** The set of "error\_recs" providing information as to how much each loc sig in "loc\_sig\_bag" disagrees with comparable loc sigs in the DB. That is, *there is an "error\_rec" here for each loc sig in "loc\_sig\_bag"*.

**Please replace the paragraph beginning on page 161, line 9 with the following paragraph.**

This function creates a new list of location hypotheses from the input list, "loc\_hyp\_list", wherein the location hypotheses on the new list are modified versions of those on the input list. For each location hypothesis on the input list, one or more corresponding location hypotheses will be on the output list. Such corresponding output location hypotheses will differ from their associated input location hypothesis by one or more of the following: (a) the "image\_area" field (see Figs. 9A and 9B) may be assigned an area indicative of where the target MS is estimated to be, (b) if "image\_area" is assigned, then the "confidence" field will be the confidence that the target MS is located in the area for "image\_area", (c) if there are not sufficient "nearby" verified location signature clusters in the location signature data base to entirely rely on a computed confidence using such verified location signature clusters, then two location hypotheses (having reduced confidences) will be returned, one having a reduced computed confidence (for "image\_area") using the verified clusters in the Location Signature DB, and one being substantially the same as the associated input location hypothesis except that the confidence (for the field "area\_est") is reduced to reflect the confidence in its paired location hypothesis having a computed confidence for "image\_area". Note also, in some cases, the location hypotheses on the input list, may have no change to its confidence or the area to which the confidence applies. Note that the steps herein are also provided in flowchart form in Figs. 25a and 25b.

**Please replace the paragraph beginning on page 161, line 29 and ending on page 162, line 6 with the following paragraph:**

if (NOT loc\_hyp[i].adjust) then /\* no adjustments will be made to the "area\_est" or the "confidence" fields since the "adjust" field indicates that there is assurance that these other fields are correct; note that such designations indicating that no adjustment are

presently contemplated are only for the location hypotheses generated by the Home Base Station First Order Model, the Location Base Station First Order Model and the Mobile Base Station First Order Model. In particular, location hypotheses from the Home Base Station model will have confidences of 1.0 indicating with highest confidence that the target MS is within the area estimate for the location hypothesis. Alternatively, in the Location Base Station model, generated location hypotheses may have confidences of (substantially) +1.0 (indicating that the target MS is absolutely in the area for "area\_est"), or, -1.0 (indicating that the target MS is NOT in the area estimate for the generated location hypothesis).\*/

**Please replace the paragraph beginning on page 162, line 10 with the following paragraph:**

else /\* the location hypothesis can (and will) be modified; in particular, an "image\_area" may be assigned, the "confidence" changed to reflect a confidence in the target MS being in the "image\_area". Additionally, in some cases, more than one location hypothesis may be generated from "loc\_hyp[i]". See the comments on Figs. 9A and 9B and the comments for "get\_adjusted\_loc\_hyp\_list\_for" for a description of the terms here. \*/

**Please replace the paragraph beginning on page 163, line 8 with the following paragraph. Please note that the only change is the removal of underlining of text.**

Define the term "image cluster set" (for a given First Order Model identified by "loc\_hyp.FOM\_ID") to mean the set of verified location signature clusters whose MS location point estimates are in "the cluster set".

**Please replace the paragraph beginning on page 164, line 1 with the following paragraph. Note the only change herein is the removal of the underlining in the phrase 'identifier may also be dependent on the area type.'**

pt\_max\_area <-- get\_max\_area\_surrounding\_pt(loc\_hyp, mesh); /\* Get the maximum area about "pt\_est" that is deemed worthwhile for examining the behavior of the "loc\_hyp.FOM\_ID" First Order Model (FOM) about "pt\_est". Note that in at least one embodiment, this value of this identifier may also be dependent on the area type within which "loc\_hyp.pt\_est" resides. Further, this function may provide values according to an algorithm allowing periodic tuning or adjusting of the values output, via, e.g., a Monte Carlo simulation (more generally, a statistical simulation or regression) or a Genetic Algorithm. In some embodiments of the

present invention, the value determined here may be a relatively large proportion of the entire radio coverage area region. However, the tuning process may be used to shrink this value for (for example) various area types as location signature clusters for verified MS location estimates are accumulated in the location signature data base. \*/

Please replace the paragraph beginning on page 164, line 10 with the following paragraph: Note the removal of the underlining in the phrase 'vary according to area type and/or area size (of "area")'.

min\_clusters <--- get\_min\_nbr\_of\_clusters(loc\_hyp.FOM\_ID, area); /\* For the area, "area", get the minimum number ("min\_clusters") of archived MS estimates, L, desired in generating a new target MS location estimate and a related confidence, wherein this minimum number is likely to provide a high probability that this new target MS location estimate and a related confidence are meaningful enough to use in subsequent Location Center processing for outputting a target MS location estimate. More precisely, this minimum number, "min\_clusters," is an estimate of the archived MS location estimates, L, required to provide the above mentioned high probability wherein each L satisfies the following conditions: (a) L is in the area for "area"; (b) L is archived in the location signature data base; (c) L has a corresponding verified location signature cluster in the location signature data base; and (d) L is generated by the FOM identified by "loc\_hyp.FOM\_ID". In one embodiment, "min\_clusters" may be a constant; however, in another it may vary according to area type and/or area size (of "area"), in some it may also vary according to the FOM indicated by "loc\_hyp.FOM\_ID". \*/

The paragraph beginning on page 168, line 15 has been replaced with the following paragraph. Note the removal of underlining of text.

Define the term "mapped cluster density" to be the number of the verified location signature clusters in an "image cluster set" per unit of area in the "image cluster set area".

The paragraph beginning on page 170, line 1 has been replaced with the following paragraph. Note the only change herein is the removal of the underlining in the phrase '*positive confidence*'.

/\* Given the above two values, a *positive confidence* value for the area, "image\_area", can be calculated based on empirical data.

The paragraph beginning on page 171, line 3 has been replaced with the following paragraph:

Note that the product of [CA1.1] and [CA1.2] provide the above desired characteristics for calculating the confidence. However, there is no guarantee that the range of resulting values from such products is consistent with the interpretation that has been placed on (positive) confidence values; e.g., that a confidence of near 1.0 has a very high likelihood that the target MS is in the corresponding area. For example, it can be that this product rarely is greater than 0.8, even in the areas of highest confidence. Accordingly, a "tuning" function is contemplated which provides an additional factor for adjusting of the confidence. This factor is, for example, a function of the area types and the size of each area type in "image\_area". Moreover, such a tuning function may be dependent on a "tuning coefficient" per area type. Thus, one such tuning function may be:

$$\min(\sum_{i=1}^{\text{number of area types}} [tc_i * \text{sizeof}(\text{area type}_i \text{ in "image\_area"}) / \text{sizeof}(\text{"image\_area"})], 1.0)$$

where  $tc_i$  is a tuning coefficient (determined in background or off-line processing; e.g., by a Genetic Algorithm or Monte Carlo simulation or regression) for the area type indexed by "i".

## Remarks

### Amendments To The Specification:

The amendments to the specification which the Applicants request entry herewith are primarily to correct obvious errors, and/or to provide consistency between annotations for identifying the same item in different drawings. However, an additional amount of descriptive text is also requested to be entered into the SUMMARY section of the specification on page 10, line 3 and page 12, line 6. This additional text merely summarizes subject matter from other portions of the originally filed specification so that the SUMMARY section better reflects the aspects of the invention for which patent protection is being requested. This additional summarizing text introduces no new matter to the specification. However, it is believed important to provide this additional descriptive text in that, for such a lengthy specification as the present application has, a more easily located description for better understanding the claims is in the public interest.

### Specification Amendments For Adding Text That Was In The U.S. Provisional From Which The Present Application Claims Priority:

Additional amendments to the specification include the following paragraphs which were in the U.S. Provisional Patent Application No. 60/025,855 filed Sept. 9, 1996 from which the present application claims priority. In particular, the text for which entry is requested is in a figure (Fig. 4) of this provisional, the text was removed when preparing drawings for the PCT application from which the present application is the U.S. national filing (Fig. 4 of the provisional corresponds to Fig. 8 in the present application). Moreover, the removed text was not placed in the PCT specification, and accordingly is not in the present application. It is requested that this text now be incorporated into the specification. The paragraphs referred to here are duplicated hereinbelow. For the Examiner's convenience, a copy of Fig. 4 from the above-identified U.S. Provisional Patent Application was previously supplied with the previous response to the Office Action of September 21, 2001. Note that this previous response was filed with the U.S. Patent and Trademark Office on February 20, 2002 (and was inadvertently identified as a "Preliminary Amendment").

#### First requested new text from Provisional Fig. 4 (added on page 53, line 10):

"In one embodiment, such a distance model may perform the following steps:

- (a) Determine a minimum distance between the target MS and each BS using TOA, TDOA, signal strength on both forward and reverse paths;
- (b) Generates an estimated error;
- (c) Outputs a location hypothesis for estimating a location of a MS: each such hypothesis having: (a) one or more (nested) location area estimates for the MS, each location estimate having a confidence value (e.g., provided using the estimated error) indicating a perceived accuracy and (b) a reason for both the location estimate (e.g., substantial multipath, etc) and the confidence."

**Second requested new text from Provisional Fig. 4 (added on page 53, line 16):**

"In one embodiment, such a stochastic signal model may outputs location hypotheses determined by one or more statistical comparisons with loc sigs in the Location Signature database 1320 (e.g., comparing MS location signals with verified signal characteristics for predetermined geographical areas)."

**Third requested new text from Provisional Fig. 4 (added on page 53, line 24):**

"In one embodiment, an adaptive learning model such as a model based on an artificial neural network may determine an MS 140 location estimate using base station IDs, data on signal-to-noise, other signal data (e.g., a number of signal characteristics including, e.g., all CDMA fingers). Moreover, the output from such a model may include: a latitude and longitude for a center of a circle having radius R (R may be an input to such an artificial neural network), and is in the output format of the distance model(s)."

**Fourth requested new text from Provisional Fig. 4 (added on page 54, line 3):**

"In one embodiment, such a location base station model may perform the following steps:

- (a) If an input is received then the target MS 140 is detected by a location base station 152 (i.e., a LBS being a unit having a reduced power BS and a MS).
- (b) If an input is obtained, then the output is a hypothesis data structure having a small area of the highest confidence.

- (c) If no input is received from a LBS then a hypothesis having an area with highest negative confidence is output."

**Fifth requested new text from Provisional Fig. 4 (added as second paragraph in the new text starting on page 54, line 8):**

"In one embodiment, such a distributed antenna model may perform the following steps:

- (a) Receives input only from a distributed antenna system.
- (b) If an input is received, then the output is a lat-long and height of highest confidence."

**Sixth requested new text from Provisional Fig. 4 (added as the fourth paragraph of the new text on page 54, line 8):**

"In one embodiment, such a home base station model may perform the following steps:

- (a) Receives an input only from the Public Telephone Switching Network.
- (b) If an input is received then the target MS 140 is detected by a home base station associated with the target MS.
- (c) If an input is obtained, then the output is a hypothesis data structure having a small area of the highest confidence.
- (d) If no input and there is a home base station then a hypothesis having a negative area is of highest confidence is output."

**Seventh requested new text from Provisional Fig. 4 (added as the last sentence of the text starting on page 54, line 3):**

"In one embodiment, such a mobile base station model may provide output similar to the distance FOM 1224 described hereinabove."



Application Serial No.: 09/770,838  
Document: "Response to Office Action Dated May 17, 2002"

No new fees are believed due with this Amendment and Response. However, if additional fees are due, then the Applicant respectfully requests notification of the Applicant named below so that any additional fees can be timely paid.

Respectfully submitted,

By:

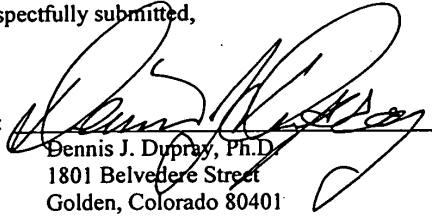
  
Dennis J. Dupray, Ph.D.  
1801 Belvedere Street  
Golden, Colorado 80401  
(303) 863-2975

Date:

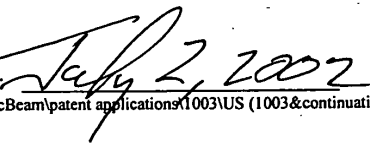

L:\TracBeam\patent applications\1003\US (1003&continuations)\-1\pto\RSP-01-O.A. dated 5-17-02 (copy of AMD-08v10).doc

**VERSION WITH MARKINGS TO SHOW CHANGES MADE**

**IN THE SPECIFICATION:**

The paragraph beginning on page 8, line 3 has been replaced with the following paragraph. Note that the only change here is the insertion of a space before the sentence beginning with the phrase "Fast fading...":

Loss due to slow fading includes shadowing due to clutter blockage (sometimes included in Lp). Fast fading is composed of multipath reflections which cause: 1) delay spread; 2) random phase shift or Rayleigh fading; and 3) random frequency modulation due to different Doppler shifts on different paths.

The paragraph beginning on page 10, line 3 through page 10, line 20 has been replaced with the following paragraphs:

It is an objective of the present invention to provide a system and method for to wireless telecommunication systems for accurately locating people and/or objects in a cost effective manner. Additionally, it is an objective of the present invention to provide such location capabilities using the measurements from wireless signals communicated between mobile stations and a network of base stations, wherein the same communication standard or protocol is utilized for location as is used by the network of base stations for providing wireless communications with mobile stations for other purposes such as voice communication and/or visual communication (such as text paging, graphical or video communications). Related objectives for various embodiments of the present invention include providing a system and method that:

- (1.1) can be readily incorporated into existing commercial wireless telephony systems with few, if any, modifications of a typical telephony wireless infrastructure;
- (1.2) can use the native electronics of typical commercially available, or likely to be available, telephony wireless mobile stations (e.g., handsets) as location devices;
- (1.3) can be used for effectively locating people and/or objects wherein there are few (if any) line-of-sight wireless receivers for receiving location signals from a mobile station (herein also denoted MS);
- (1.4) can be used not only for decreasing location determining difficulties due to multipath phenomena but in fact uses such multipath for providing more accurate location estimates;

- (1.5) can be used for integrating a wide variety of location techniques in a straight-forward manner; [and]
- (1.6) can substantially automatically adapt and/or (re)train and/or (re)calibrate itself according to changes in the environment and/or terrain of a geographical area where the present invention is utilized;
- (1.7) can utilize a plurality of wireless location estimators based on different wireless location technologies (e.g., GPS location techniques, terrestrial base station signal timing techniques for triangulation and/or trilateration, wireless signal angle of arrival location techniques, techniques for determining a wireless location within a building, techniques for determining a mobile station location using wireless location data collected from the wireless coverage area for, e.g., location techniques using base station signal coverage areas, signal pattern matching location techniques and/or stochastic techniques), wherein each such estimator may be activated independently of one another, whenever suitable data is provided thereto and/or certain conditions, e.g., specific to the estimator are met;
- (1.8) can provide a common interface module from which a plurality of the location estimators can be activated and/or provided with input;
- (1.9) provides resulting mobile station location estimates to location requesting applications (e.g., for 911 emergency, the fire or police departments, taxi services, vehicle location, etc.) via an output gateway, wherein this gateway:
- (a) routes the mobile station location estimates to the appropriate location application(s) via a communications network such as a wireless network, a public switched telephone network, a short messaging service (SMS), and the Internet;
  - (b) determines the location granularity and representation desired by each location application requesting a location of a mobile station, and/or
  - (c) enhances the received location estimates by, e.g., performing additional processing such as "snap to street" functions for mobile stations known to reside in a vehicle.

The paragraph beginning on page 11, line 15 has been replaced with the following paragraph:

- (3.3) The term, "infrastructure", denotes the network of telephony communication services, and more particularly, that portion of such a network that receives and processes wireless communications with

wireless mobile stations. In particular, this infrastructure includes telephony wireless base stations (BS) such as those for radio mobile communication systems based on CDMA, AMPS, NAMPS, TDMA, and GSM wherein the base stations provide a network of cooperative communication channels with an air interface with the MS, and a conventional telecommunications interface with a Mobile Switch Center (MSC). Thus, an MS user within an area serviced by the base stations may be provided with wireless communication throughout the area by user transparent communication transfers (i.e., "handoffs") between the user's MS and these base stations in order to maintain effective telephony service. The mobile switch center (MSC) provides communications and control connectivity among base stations and the public telephone network 124.

The paragraph beginning on page 12, line 6 has been replaced with the following paragraphs:

The present invention relates to a wireless mobile station location system, and in particular, various subsystems related thereto such as a wireless location gateway, and the combining or hybriding of a plurality of wireless location techniques.

Regarding a wireless location gateway, this term refers to a communications network node whereat a plurality of location requests are received for locating various mobile stations from various sources (e.g., for E911 requests, for stolen vehicle location, for tracking of vehicles traveling cross country, etc.), and for each such request and the corresponding mobile station to be located, this node: (a) activates one or more wireless location estimators for locating the mobile station, (b) receives one or more location estimates of the mobile station from the location estimators, and (c) transmits a resulting location estimate(s) to, e.g., an application which made the request. Moreover, such a gateway typically will likely activate location estimators according to the particulars of each individual wireless location request, e.g., the availability of input data needed by particular location estimators. Additionally, such a gateway will typically have sufficiently well defined uniform interfaces so that such location estimators can be added and/or deleted to, e.g., provide different location estimators for performing wireless location different coverage areas.

The present invention encompasses such wireless location gateways. Thus, for locating an identified mobile station, the location gateway embodiments of the present invention may activate one or more of a plurality of location estimators depending on, e.g., (a) the availability of particular types of wireless location data for locating the mobile station, and (b) the location estimators accessible by the location gateway. Moreover, a plurality of location estimators may

be activated for locating the mobile station in a single location, or different ones of such location estimators may be activated to locate the mobile station at different locations. Moreover, the location gateway of the present invention may have incorporated therein one or more of the location estimators, and/or may access geographically distributed location estimators via requests through a communications network such as the Internet.

In particular, the location gateway of the present invention may access, in various instances of locating mobile stations, various location estimators that utilize one or more of the following wireless location techniques:

- (a) A GPS location technique such as, e.g., one of the GPS location techniques as described in the Background section hereinabove;
- (b) A technique for computing a mobile station location that is dependent upon geographical offsets of the mobile station from one or more terrestrial transceivers (e.g., base stations of a commercial radio service provider). Such offsets may be determined from signal time delays between such transceivers and the mobile station, such as by time of arrival (TOA) and/or time difference of arrival (TDOA) techniques as is discussed further hereinbelow. Moreover, such offsets may be determined using both the forward and reverse wireless signal timing measurements of transmissions between the mobile station and such terrestrial transceivers. Additionally, such offsets may be directional offsets, wherein a direction is determined from such a transceiver to the mobile station;
- (c) Various wireless signal pattern matching, associative, and/or stochastic techniques for performing comparisons and/or using a learned association between:
  - (i) characteristics of wireless signals communicated between a mobile station to be located and a network of wireless transceivers (e.g., base stations), and
  - (ii) previously obtained sets of characteristics of wireless signals (from each of a plurality of locations), wherein each set was communicated, e.g., between a network of transceivers (e.g., the fixed location base stations of a commercial radio service

provider), and, some one of the mobile stations available for communicating with the network;

- (d) Indoor location techniques using a distributed antenna system;
- (e) Techniques for locating a mobile station, wherein, e.g., wireless coverage areas of individual fixed location transceivers (e.g., fixed location base stations) are utilized for determining the mobile station's location (e.g., intersecting such coverage areas for determining a location);
- (f) Location techniques that use communications from low power, low functionality base stations (denoted "location base stations"); and
- (g) Any other location techniques that may be deemed worthwhile to incorporate into an embodiment of the present invention.

Accordingly, some embodiments of the present invention may be viewed as platforms for integrating wireless location techniques in that wireless location computational models (denoted "first order models" or "FOMs" hereinbelow) may be added and/or deleted from such embodiments of the invention without changing the interface to further downstream processes. That is, one aspect of the invention is the specification of a common data interface between such computational models and subsequent location processing such as processes for combining of location estimates, tracking mobile stations, and/or outputting location estimates to location requesting applications.

Moreover, it should be noted that the present invention also encompasses various hybrid approaches to wireless location, wherein various combinations of two or more of the location techniques (a) through (g) immediately above may be used in locating a mobile station at substantially a single location. Thus, location information may be obtained from a plurality of the above location techniques for locating a mobile station, and the output from such techniques can be synergistically used for deriving therefrom an enhanced location estimate of the mobile station.

It is a further aspect of the present invention that it may be used to wirelessly locate a mobile station: (a) from which a 911 emergency call is performed, (b) for tracking a mobile station (e.g., a truck traveling across country), (c) for routing a mobile station, and (d) locating people and/or animals, including applications for confinement to (and/or exclusion from) certain areas.

It is a further aspect of the present invention that it [In particular, such a wireless mobile station location system] may be decomposed into: (i) a first low level wireless signal processing subsystem for receiving, organizing and conditioning low level wireless signal measurements from a network of base stations cooperatively linked for providing wireless communications with mobile stations (MSs); and (ii) a second high level signal processing subsystem for performing high level data processing for providing most likelihood location estimates for mobile stations.

**The paragraph beginning on page 12, line 11 has been replaced with the following paragraph:**

Thus[More precisely], the present invention may be considered as [is] a novel signal processor that includes at least the functionality for the high signal processing subsystem mentioned hereinabove. Accordingly, assuming an appropriate ensemble of wireless signal measurements characterizing the wireless signal communications between a particular MS and a networked wireless base station infrastructure have been received and appropriately filtered of noise and transitory values (such as by an embodiment of the low level signal processing subsystem disclosed in a copending PCT patent application PCT/US97/15933 titled, "Wireless Location Using A Plurality of Commercial Network Infrastructures," by F. W. LeBlanc et al., [ and the present applicant(s); this copending patent application] filed September 8, 1997 from which U.S. Patent 6,236,365, filed July 8, 1999 is the U.S. national counterpart; these two references being herein fully incorporated by reference), the present invention uses the output from such a low level signal processing system for determining a most likely location estimate of an MS.

**The paragraph beginning on page 12, line 19 (and ending on this same line 19) has been replaced with the following paragraph:**

That is, once the following steps are appropriately performed (e.g., by the LeBlanc [copending application] U.S. Patent 6,236,365):

**The paragraph beginning on page 12, line 28 has been replaced with the following paragraph:**

(4.3) providing the composite signal characteristic values to one or more MS location hypothesizing computational models (also denoted herein as "first order models" and also "location estimating models"), wherein each such model subsequently determines one or more initial estimates of the location of the target MS based on, for example, the signal processing techniques 2.1 through 2.3 above.

Moreover, each of the models output MS location estimates having substantially identical data structures (each such data structure denoted a "location hypothesis"). Additionally, each location hypothesis may also include[s] a confidence value indicating the likelihood or probability that the target MS whose location is desired resides in a corresponding location estimate for the target MS;

**The paragraph beginning on page 13, line 14 has been replaced with the following paragraph:**

Referring now to (4.3) above, the filtered and aggregated wireless signal characteristic values are provided to a number of location hypothesizing models (denoted First Order Models, or FOMs), each of which yields a location estimate or location hypothesis related to the location of the target MS. In particular, there are location hypotheses for both providing estimates of where the target MS is likely to be and where the target MS is not likely to be. Moreover, it is an aspect of the present invention that confidence values of the location hypotheses are provided as a continuous range of real numbers from, e.g., -1 to 1, wherein the most unlikely areas for locating the target MS are given a confidence value of -1, and the most likely areas for locating the target MS are given a confidence value of 1. That is, confidence values that are larger indicate a higher likelihood that the target MS is in the corresponding MS estimated area, wherein [1] -1 indicates that the target MS is absolutely NOT in the estimated area, 0 indicates a substantially neutral or unknown likelihood of the target MS being in the corresponding estimated area, and 1 indicates that the target MS is absolutely within the corresponding estimated area.

**The paragraph beginning on page 15, line 22 has been replaced with the following paragraph:**

It is a further aspect of the present invention that the personal communication system (PCS) infrastructures currently being developed by telecommunication providers offer an appropriate localized infrastructure base upon which to build various personal location systems (PLS) employing the present invention and/or utilizing the techniques disclosed herein. In particular, the present invention is especially suitable for the location of people and/or objects using code division multiple access (CDMA) wireless infrastructures, although other wireless infrastructures, such as, time division multiple access (TDMA) infrastructures and GSM are also contemplated. Note that CDMA personal communications systems are described in the Telephone Industries Association standard IS-95, for frequencies below 1 GHz, and in the Wideband Spread- Spectrum Digital Cellular System Dual-Mode Mobile Station-Base Station Compatibility Standard, for frequencies in the 1.8-1.9 GHz frequency bands, both of which are incorporated herein by reference. Furthermore, CDMA general principles have also been described, for



example, in U. S. Patent 5,109,390, to Gilhausen, et al, filed November 7, 1989, and CDMA Network Engineering Handbook by Qualcomm, Inc., [ ] each of which is also incorporated herein by reference.

**The paragraph beginning on page 16, line 6 has been replaced with the following paragraph:**

As mentioned [in (1.7) and ]in the discussion of classification FOMs above, the present invention can substantially automatically retrain and/or recalibrate itself to compensate for variations in wireless signal characteristics (e.g., multipath) due to environmental and/or topographic changes to a geographic area serviced by the present invention. For example, in one embodiment, the present invention optionally includes low cost, low power base stations, denoted location base stations (LBS) above, providing, for example, CDMA pilot channels to a very limited area about each such LBS. The location base stations may provide limited voice traffic capabilities, but each is capable of gathering sufficient wireless signal characteristics from an MS within the location base station's range to facilitate locating the MS. Thus, by positioning the location base stations at known locations in a geographic region such as, for instance, on street lamp poles and road signs, additional MS location accuracy can be obtained. That is, due to the low power signal output by such location base stations, for there to be signaling control communication (e.g., pilot signaling and other control signals) between a location base station and a target MS, the MS must be relatively near the location base station. Additionally, for each location base station not in communication with the target MS, it is likely that the MS is not near to this location base station. Thus, by utilizing information received from both location base stations in communication with the target MS and those that are not in communication with the target MS, the present invention can substantially narrow the possible geographic areas within which the target MS is likely to be. Further, by providing each location base station (LBS) with a co-located stationary wireless transceiver (denoted a built-in MS above) having similar functionality to an MS, the following advantages are provided:

**The paragraph beginning on page 17, line 12 has been replaced with the following paragraph:**

It is also an aspect of the present invention to automatically (re)calibrate as in (6.3) above with signal characteristics from other known or verified locations. In one embodiment of the present invention, portable location verifying electronics are provided so that when such electronics are sufficiently near a located target MS, the electronics: (i)[(I)] detect the proximity of the target MS; (ii) determine a highly reliable measurement of the location of the target MS; (iii) provide this measurement to other location determining components of the present invention so that the location measurement can be associated and archived with related signal characteristic data received from the target MS at the location where the

location measurement is performed. Thus, the use of such portable location verifying electronics allows the present invention to capture and utilize signal characteristic data from verified, substantially random locations for location system calibration as in (6.3) above. Moreover, it is important to note that such location verifying electronics can verify locations automatically wherein it is unnecessary for manual activation of a location verifying process.

**The paragraph beginning on page 18, line 6 has been replaced with the following paragraph:**

Furthermore, a mobile location base station includes modules for integrating or reconciling distinct mobile location base station location estimates that, for example, can be obtained using the components and devices of (7.1) through (7.4) above. That is, location estimates for the mobile location base station may be obtained from: GPS satellite data, mobile location base station data provided by the location processing center, [dead reckoning] deadreckoning data obtained from the mobile location base station vehicle [dead reckoning] deadreckoning devices, and location data manually input by an operator of the mobile location base station.

**The paragraph beginning on page 18, line 11 has been replaced with the following paragraph:**

[ ]The location estimating system of the present invention offers many advantages over existing location systems. The system of the present invention, for example, is readily adaptable to existing wireless communication systems and can accurately locate people and/or objects in a cost effective manner. In particular, the present invention requires few, if any, modifications to commercial wireless communication systems for implementation. Thus, existing personal communication system infrastructure base stations and other components of, for example, commercial CDMA infrastructures are readily adapted to the present invention. The present invention can be used to locate people and/or objects that are not in the line-of-sight of a wireless receiver or transmitter, can reduce the detrimental effects of multipath on the accuracy of the location estimate, can potentially locate people and/or objects located indoors as well as outdoors, and uses a number of wireless stationary transceivers for location. The present invention employs a number of distinctly different location computational models for location which provides a greater degree of accuracy, robustness and versatility than is possible with existing systems. For instance, the location models provided include not only the radius-radius/TOA and TDOA techniques but also adaptive artificial neural net techniques. Further, the present invention is able to adapt to the topography of an area in which location service is desired. The present invention is also able to adapt to environmental changes substantially as frequently as desired. Thus, the present invention

is able to take into account changes in the location topography over time without extensive manual data manipulation. Moreover, the present invention can be utilized with varying amounts of signal measurement inputs. Thus, if a location estimate is desired in a very short time interval (e.g., less than approximately one to two seconds), then the present location estimating system can be used with only as much signal measurement data as is possible to acquire during an initial portion of this time interval. Subsequently, after a greater amount of signal measurement data has been acquired, additional more accurate location estimates may be obtained. Note that this capability can be useful in the context of 911 emergency response in that a first quick [course ]coarse wireless mobile station location estimate can be used to route a 911 call from the mobile station to a 911 emergency response center that has responsibility for the area containing the mobile station and the 911 caller. Subsequently, once the 911 call has been routed according to this first quick location estimate, by continuing to receive additional wireless signal measurements, more reliable and accurate location estimates of the mobile station can be obtained.

**The paragraph beginning on page 19, line 5 through page 19, line 19 has been replaced with the following paragraph:**

At a more general level, it is an aspect of the present invention to demonstrate the utilization of various novel computational paradigms such as:

(8.1) providing a multiple hypothesis computational architecture (as illustrated best in [Fig. 8] Figs. 8) wherein the hypotheses are:

(8.1.1) generated by modular independent hypothesizing computational models;

(8.1.2) the models are embedded in the computational architecture in a manner wherein the architecture allows for substantial amounts of application specific processing common or generic to a plurality of the models to be straightforwardly incorporated into the computational architecture;

(8.1.3) the computational architecture enhances the hypotheses generated by the models both according to past performance of the models and according to application specific constraints and heuristics without requiring feedback loops for adjusting the models;

(8.1.4) the models are relatively easily integrated into, modified and extracted from the computational architecture;

(8.2) providing a computational paradigm for enhancing an initial estimated solution to a problem by using this initial estimated solution as, effectively, a query or index into an historical data base of

previous solution estimates and corresponding actual solutions for deriving an enhanced solution estimate based on past performance of the module that generated the initial estimated solution.

**The paragraph beginning on page 20, line 19 has been replaced with the following paragraph:**

In other embodiments of the present invention, a fast, [a]beit [a]lbeit less accurate location estimate may be initially performed for very time critical location applications where approximate location information may be required. For example, less than 1 second response for a mobile station location embodiment of the present invention may be desired for 911 emergency response location requests. Subsequently, once a relatively [co]arse location estimate has been provided, a more accurate most likely location estimate can be performed by repeating the location estimation processing a second time with, e.g., additional with measurements of wireless signals transmitted between a mobile station to be located and a network of base stations with which the mobile station is communicating, thus providing a second, more accurate location estimate of the mobile station.

**The paragraph beginning on page 21, line 1 has been replaced with the following paragraph:**

Note that in some embodiments of the present invention, since there is a lack of sequencing between the FOMs and subsequent processing of location hypotheses, the FOMs can be incorporated into an expert system, if desired. For example, each FOM may be activated from an antecedent of an expert system rule. Thus, the antecedent for such a rule can evaluate to TRUE if the FOM outputs a location hypothesis, and the consequent portion of such a rule may put the output location hypothesis on a list of location hypotheses occurring in a particular time window for subsequent processing by the location center. Alternatively, activation of the FOMs may be in the consequents of such expert system rules. That is, the antecedent of such an expert system rule may determine if the conditions are appropriate for invoking the FOM(s) in the rule's consequent.

**The paragraph beginning on page 21, line 8 has been replaced with the following two paragraphs. Note that the only difference here is the commencement of a new paragraph at --Further features and advantages--.**

Of course, other software architectures may also be used in implementing the processing of the location center without departing from the scope of the present invention. In particular, object-oriented architectures are also within the scope of the present invention. For example, the FOMs may be object methods on an MS location estimator object, wherein the estimator object receives substantially all target MS location signal data output by the signal filtering subsystem. Alternatively, software bus architectures are contemplated by the present invention, as one skilled in the art will understand, wherein the software architecture may be modular and facilitate parallel processing.

Further features and advantages of the present invention are provided by the figures and detailed description accompanying this invention summary.

**The paragraph beginning on page 22, line 5 has been replaced with the following paragraph:**

Fig. 3 provides a typical example of how the statistical power budget is calculated in design of a Commercial Mobile Radio Service Provider (CMRS) network.

**The paragraph beginning on page 22, line 14 has been replaced with the following paragraph:**

Figs. 9A and 9A is a high level data structure diagram describing the fields of a location hypothesis object generated by the first order models 1224 of the location center.

**The paragraph beginning on page 23, line 16 has been replaced with the following paragraph:**

Figs. 23[a]A through 23[b]C present a high level flowchart of the steps performed by function, "GET\_DIFFERENCE\_MEASUREMENT," for updating location signatures in the location signature data base 1320; note, this flowchart corresponds to the description of this function in APPENDIX C.

**The paragraph beginning on page 28, line 9 has been replaced with the following paragraph:**

The MBS 148 acts as a low cost, partially-functional, moving base station, and is, in one embodiment, situated in a vehicle where an operator may engage in MS 140 searching and tracking activities. In providing these activities using CDMA, the MBS 148 provides a forward link pilot channel for a target MS 140, and subsequently receives unique BS pilot strength measurements from the MS 140.

The MBS 148 also includes a mobile station for data communication with the LC 142, via a BS 122. In particular, such data communication includes telemetering the geographic position of the MBS 148 as well as various RF measurements related to signals received from the target MS 140. In some embodiments, the MBS 148 may also utilize multiple-beam fixed antenna array elements and/or a moveable narrow beam antenna [ ], such as a microwave dish 182. The antennas for such embodiments may have a known orientation in order to further deduce a radio location of the target MS 140 with respect to an estimated current location of the MBS 148. As will be described in more detail herein below, the MBS 148 may further contain a global positioning system (GPS), distance sensors, [dead-reckoning] deadreckoning electronics, as well as an on-board computing system and display devices for locating both the MBS 148 [of] itself as well as tracking and locating the target MS 140. The computing and display provides a means for communicating the position of the target MS 140 on a map display to an operator of the MBS 148.

**The paragraph beginning on page 29, line 15 has been replaced with the following two paragraphs. Note that the only difference here is the commencement of a new paragraph at --Thus, LBSs 152--.**

It should be noted that an LBS 152 will normally deny hand-off requests, since typically the LBS does not require the added complexity of handling voice or traffic bearer channels, although economics and peak traffic load conditions would dictate preference here. GPS timing information, needed by any CDMA base station, is either achieved via a the inclusion of a local GPS receiver or via a telemetry process from a neighboring conventional BS 122, which contains a GPS receiver and timing information. Since energy requirements are minimal in such an LBS 152, (rechargeable) batteries or solar cells may be used to power the LBS. No expensive terrestrial transport link is typically required since two-way communication is provided by the included MS 140 (or an electronic variation thereof).

Thus, LBSs 152 may be placed in numerous locations, such as:

- (a) in dense urban canyon areas (e.g., where signal reception may be poor and/or very noisy);
- (b) in remote areas (e.g., hiking, camping and skiing areas);
- (c) along highways (e.g., for emergency as well as monitoring traffic flow), and their rest stations; or
- (d) in general, wherever more location precision is required than is obtainable using other wireless [infrastructure] infrastructure network components.

**The paragraph beginning on page 29, line 29 has been replaced with the following paragraph:**

A location application programming interface [136 (Fig. 4); ]or L-API 14 (see Fig. 30, and including L-API-Loc APP 135, L-API-MS 136, and L-API-SCP 137 shown in Fig. 4), is required between the location center 142 (LC) and the mobile switch center (MSC) network element type, in order to send and receive various control, signals and data messages. The L-API 14 should be implemented using a preferably high-capacity physical layer communications interface, such as IEEE standard 802.3 (10 baseT Ethernet), although other physical layer interfaces could be used, such as fiber optic ATM, frame relay, etc. Two forms of API implementation are possible. In the first case the signals control and data messages are realized using the MSC 112 vendor's native operations messages inherent in the product offering, without any special modifications. In the second case the L-API includes a full suite of commands and messaging content specifically optimized for wireless location purposes, which may require some, although minor development on the part of the MSC vendor.

**The paragraph beginning on page 30, line 6 has been replaced with the following paragraph:**

Referring to Fig. 30, the signal processing subsystem 1220 receives control messages and signal measurements and transmits appropriate control messages to the wireless network via the location applications programming interface referenced earlier, for wireless location purposes. The signal processing subsystem additionally provides various signal [identification]identification, conditioning and pre-processing functions, including buffering, signal type classification, signal filtering, message control and routing functions to the location estimate modules.

**The paragraph beginning on page 30, line 11 has been replaced with the following paragraph:**

There can be several combinations of Delay Spread/Signal Strength sets of measurements made available to the signal processing subsystem [20]1220. In some cases the mobile station 140 ([Fig. 1]Fig. 4) may be able to detect up to three or four Pilot Channels representing three to four Base Stations, or as few as one Pilot Channel, depending upon the environment. Similarly, possibly more than one BS 122 can detect a mobile station 140 transmitter signal, as evidenced by the provision of cell diversity or soft hand-off in the CDMA standards, and the fact that multiple CMRS' base station equipment commonly will overlap coverage areas. For each mobile station 140 or BS 122 transmitted signal detected by a

receiver group at a station, multiple delayed signals, or "fingers" may be detected and tracked resulting from multipath radio propagation conditions, from a given transmitter.

**The paragraph beginning on page 30, line 23 has been replaced with the following paragraph:**

From the mobile receiver's perspective, a number of combinations of measurements could be made available to the Location Center. Due to the disperse and near-random nature of CDMA radio signals and propagation characteristics, traditional TOA/TDOA location methods have failed in the past, because the number of signals received in different locations [area ]are different. In a particularly small urban area, of say less than 500 square feet, the number of RF signals and [there ]their multipath components may vary by over 100 percent.

**The paragraph beginning on page 31, line 19 has been replaced with the following paragraph:**

Although Rayleigh fading appears as a generally random noise generator, essentially destroying the correlation value of either  $RRSS_{BS}$  or  $SRSS_{MS}$  measurements with distance individually, several mathematical operations or signal processing functions can be performed on each measurement to derive a more robust relative signal strength value, overcoming the adverse Rayleigh fading effects. Examples include averaging, taking the strongest value and weighting the strongest value with a greater coefficient than the weaker value, then averaging the results. This signal processing technique takes advantage of the fact that although a Rayleigh fade may often exist in either the forward or reverse path, it is much less probable that a Rayleigh fade also exists in the reverse or forward path, respectively. A shadow fade however, [similarly ]similarly affects the signal strength in both paths.

**The paragraph beginning on page 31, line 26 has been replaced with the following paragraph:**

At this point a CDMA radio signal [direction-independent "]direction independent of "net relative signal strength measurement" [is ]can be derived which [is ]can be used to establish a correlation with either distance or shadow fading, or both. Although the ambiguity of either shadow fading or distance cannot be determined, other means can be used in conjunction, such as the fingers of the CDMA delay spread measurement, and any other TOA/TDOA calculations from other geographical points. In the case of a mobile station with a certain amount of shadow fading between its BS 122 (Fig. 2), the first finger of



a CDMA delay spread signal is most likely to be a relatively shorter duration than the case where the mobile station 140 and BS 122 are separated by a greater distance, since shadow fading does not materially affect the arrival time delay of the radio signal.

**The paragraph beginning on page 31, line 33 has been replaced with the following paragraph:**

By performing a small modification in the control electronics of the CDMA base station and mobile station receiver circuitry, it is possible to provide the signal processing subsystem [20]1220 (reference Fig. 30) within the [L]location [scenter ]center 142 (Fig. 1) with data that exceed the one-to-one CDMA delay-spread fingers to data receiver correspondence. Such additional information, in the form of additional CDMA fingers (additional multipath) and all associated detectable pilot channels, provides new information which is used to enhance [to ]the accuracy of the [L]location [C]center's location estimators [estimate location estimate modules].

**The paragraph beginning on page 32, line 4 has been replaced with the following paragraph:**

This enhanced capability is provided via a control message, sent from the [Location ]location center 142 to the mobile switch center 12, and then to the base station(s) in communication with, or in close proximity with, mobile stations 140 to be located. Two types of location measurement request control messages are needed: one to instruct a target mobile station 140 (i.e., the mobile station to be located) to telemeter its BS pilot channel measurements back to the primary BS 122 and from there to the mobile switch center 112 and then to the location system 42. The second control message is sent from the location system 42 to the mobile switch center 112, then to first the primary BS, instructing the primary BS' searcher receiver to output (i.e., return to the initiating request message source) the detected target mobile station 140 transmitter CDMA pilot channel offset signal and their corresponding delay spread finger (peak) values and related relative signal strengths.

**The paragraph beginning on page 32, line 24 has been replaced with the following paragraph:**

Fig. 30 illustrates the components of the Signal Processing Subsystem 1220 (also shown in Figs. 5, 6 and 8). The main components consist of the input queue(s) 7, signal classifier/filter 9, digital signaling processor 17, imaging filters 19, output queue(s) 21, router/distributor 23, (also denoted as the

"Data Capture And Gateway" in Fig. 8(2), a signal processor database 26 and a signal processing controller 15.

**The paragraph beginning on page 33, line 3 has been replaced with the following paragraph:**

The signal processing subsystem 1220 supports a variety of wireless network signaling measurement capabilities by detecting the capabilities of the mobile and base station through messaging structures provided [bt ]by the location application programming interface (L-API 14, Fig. 30). Detection is accomplished in the signal classifier 9 (Fig. 30) by referencing a mobile station database table within the signal processor database 26, which provides, given a mobile station identification number, mobile station revision code, other mobile station [characteristics]characteristics. [Similiarly ] Similarly, a mobile switch center table 31 provides MSC characteristics and identifications to the signal classifier/filter 9. The signal classifier/filter adds additional message header information that further classifies the measurement data which allows the digital signal processor and image filter components to select the proper internal processing subcomponents to perform operations on the signal measurement data, for use by the location estimate modules.

**The paragraph beginning on page 33, line 11 and ending on page 33, line 18 has been replaced with the following paragraph.**

Regarding service control point messages (of L-API-SCP interface 137, Fig. 4) autonomously received from the input queue 7 (Figs. 30 and 31), the signal classifier/filter 9 [determines ] determines via a signal processing database 26 query [that the ] whether such a message is to be associated with a home base station module. Thus appropriate header information is added to the message, thus enabling the message to pass through the digital signal processor 17 unaffected to the output [queu ] queue 21, and then to the router/distributor 23. The router/distributor 23 then routes the message to the HBS first order model. Those skilled in the art will understand that associating location requests from Home Base Station configurations require substantially less data: the mobile identification number and the associated wireline telephone number transmission from the home location register are on the order of less than 32 bytes. Consequentially the home base station message type could be routed without any digital signal processing.

**The paragraph beginning on page 33, line 19 has been replaced with the following paragraph:**

\_\_\_\_\_ Output queue(s) 21 (Fig. 30) are required for similar reasons as input queues 7: relatively large amounts of data must be held in a specific format for further location processing by the location estimate modules 1224.

**The paragraph beginning on page 33, line 21 through page 33, line 23 has been replaced with the following paragraph:**

The router and distributor component 23 (Fig. 30) is responsible [to ]for directing specific signal measurement data types and structures to their appropriate modules. For example, the HBS FOM has no use for digital filtering structures, whereas the TDOA module would not be able to process an HBS response message.

**The paragraph beginning on page 33, line 24 has been replaced with the following paragraph:**

\_\_\_\_\_ The controller 15 (Fig. 30) is responsible for staging the movement of data among the signal processing subsystem [20]1220 components input queue 7, digital signal processor 17, router/distributor 23 and the output queue 21, and to initiate signal [measurements ]measurements within the wireless network, in response from an internet [168 ]468 location request message in Fig. [1]5, via the location application programming interface.

**The paragraph beginning on page 33, line 27 has been replaced with the following paragraph:**

In addition the controller 15 receives autonomous messages from the MSC[ ], via the location applications programming interface [ (Fig. 1) ]or L-API 14 (Fig. 30) and the input queue 7, whenever a 9-1-1 wireless call is originated. The mobile switch center provides this autonomous notification to the location system as follows: [By specifying ]by specifying the appropriate mobile switch center operations and maintenance commands to surveil calls based on certain digits dialed such as 9-1-1, the location applications programming interface 14, in communications with the MSCs, receives an autonomous notification whenever a mobile station user dials 9-1-1. Specifically, a bi-directional authorized communications port is configured, usually at the operations and maintenance subsystem of the MSCs, or with their associated network element manager system(s), with a data circuit, such as a DS-

1, with the location applications programming interface [ in Fig. 1]14. Next, the "call trace" capability of the mobile switch center is activated for the respective communications port. The exact implementation of the vendor-specific man-machine or Open Systems Interface (OSI) command[s](s) and their associated data structures generally vary among MSC vendors,[, however] However, the trace function is generally available in various forms, and is required in order to comply with Federal Bureau of Investigation authorities for wire tap purposes. After the appropriate surveillance commands are established on the MSC, such 9-1-1 call notifications messages containing the mobile station identification number (MIN) and, in U.S. FCC phase 1 E9-1-1 implementations, a pseudo-automatic number [identification]identification (a.k.a. pANI) which provides an association with the primary base station in which the 9-1-1 caller is in [communicaiton]communication. In cases where the pANI is known from the onset, the signal processing subsystem 1220 avoids querying the MSC in question to determine the primary base station identification associated with the 9-1-1 mobile station caller.

**The paragraph beginning on page 34, line 10 has been replaced with the following paragraph:**

After the signal processing controller 15 receives the first message type, the autonomous notification message from the mobile switch center 112 to the location system 142[42], containing the mobile identification number and optionally the primary base station identification, the controller 15 queries the base station table 13 (Fig. 30) in the signal processor database 26 to determine the status and availability of any neighboring base stations, including those base stations of other CMRS in the area. The definition of neighboring base stations include not only those within a provisionable "hop" based on the cell design reuse factor, but also includes, in the case of CDMA, results from remaining set information autonomously queried to mobile stations, with results stored in the base station table. Remaining set information indicates that mobile stations can detect other base station (sector) pilot channels which may exceed the "hop" distance, yet are nevertheless candidate base stations (or sectors) for wireless location purposes. Although cellular and digital cell design may vary, "hop" distance is usually one or two cell coverage areas away from the primary base station's cell coverage area.

**The paragraph beginning on page 34, line 20 has been replaced with the following paragraph:**

Having determined a likely set of base stations which may both detect the mobile station's transmitter signal, as well as to determine the set of likely pilot channels (i.e., base stations and their associated physical antenna sectors) detectable by the mobile station in the area surrounding the primary

base station (sector), the controller 15 initiates messages to both the mobile station and appropriate base stations (sectors) to perform signal measurements and to return the results of such measurements to the signal processing system regarding the mobile station to be located. This step may be accomplished via several interface means. In a first case the controller 15 utilizes, for a given MSC, predetermined storage information in the MSC table 31 to determine which type of commands, such as man-machine or OSI commands are needed to request such signal [measurements]measurements for a given MSC. The controller generates the mobile and base station signal measurement commands appropriate for the MSC and passes the commands via the input queue 7 and the locations application programming interface 14 in Fig. 30[ in Fig.1], to the appropriate MSC, using the authorized communications port mentioned earlier. In a second case, the controller 15 communicates directly with base stations within having to interface directly with the MSC for signal measurement extraction.

**The paragraph beginning on page 34, line 31 has been replaced with the following paragraph:**

Upon receipt of the signal measurements, the signal classifier 9 in Fig. 30 examines location application programming interface-provided message header information from the source of the location measurement (for example, from a fixed BS 122, a mobile station 140, a distributed antenna system 168 in Fig. [1]4 or message location data related to a home base station), provided by the location applications programming interface (L-API 14) via the input queue 7 in Fig. 30 and determines whether or not device filters 17 or image filters 19 are needed, and assesses a relative priority in processing, such as an emergency versus a background location task, in terms of grouping like data associated with a given location request. In the case where multiple signal measurement requests are outstanding for various base stations, some of which may be associated with a different CMRS network, and additional signal classifier function includes sorting and associating the appropriate incoming signal measurements together such that the digital signal processor 17 processes related measurements in order to build ensemble data sets. Such ensembles allow for a variety of functions such as averaging, outlier removal over a time period, and related filtering functions, and further prevent association errors from [occurring]occurring in location estimate processing.

**The paragraph beginning on page 35, line 10 has been replaced with the following paragraph:**

Another function of the signal classifier/low pass filter component 9 is to filter information that is not useable, or information that could introduce noise or the effect of noise in the location estimate

modules. Consequently low pass matching filters are used to match the in-common signal processing components to the characteristics of the incoming signals. Low pass filters match: Mobile Station, base station, CMRS and MSC characteristics, as [wall]well as to classify Home Base Station messages.

**The paragraph beginning on page 35, line 14 has been replaced with the following paragraph:**

The signal processing subsystem 1220 contains a base station database table [ ]13 (Fig. 30) which captures the maximum number of CDMA delay spread fingers for a given base station.

**The paragraph beginning on page 35, line 21 has been replaced with the following paragraph:**

Just as an upgraded base station may detect additional CDMA delay spread signals, newer or modified mobile stations may detect additional pilot channels or CDMA delay spread fingers. Additionally different makes and models of mobile stations may acquire improved receiver sensitivities, suggesting a greater coverage capability. [The] A table [below establishes]may establish the relationships among various mobile station equipment suppliers and certain technical data relevant to this location invention.

**The paragraph beginning on page 35, line 25 has been replaced with the following paragraph:**

Although not strictly necessary, [The]the MIN can be populated in this table from the PCS Service Provider's Customer Care system during subscriber activation and fulfillment, and could be changed at deactivation, or anytime the end-user changes mobile stations. Alternatively, since the MIN, manufacturer, model number, and software revision level information is available during a telephone call, this information could be extracted during the call, and the remaining fields populated dynamically, based on manufacturer's specifications information previously stored in the signal processing subsystem [20]1220. Default values are used in cases where the MIN is not found, or where certain information must be estimated.

**The paragraph beginning on page 35, line 31 has been replaced with the following paragraph:**

A low pass mobile station filter, contained within the signal classifier/low pass filter 9 of the signal processing subsystem [20]1220, uses the above table data to perform the following functions: 1) act as a low pass filter to adjust the nominal assumptions related to the maximum number of CDMA

fingers, pilots detectable; and 2) [ ] to determine the transmit power class and the receiver thermal noise floor. Given the detected reverse path signal strength, the required value of  $SRSS_{MS,1}$  a corrected indication of the effective path loss in the reverse direction (mobile station to BS), can be calculated based on data contained within the mobile station table 11, stored in the signal processing database 26.

**The paragraph beginning on page 36, line 3 has been replaced with the following paragraph:**

The effects of the maximum [Number]number of CDMA fingers allowed and the maximum number of pilot channels allowed essentially form a low pass filter effect, wherein the least common denominator of characteristics are used to filter the incoming RF signal measurements such that a one for one matching occurs. The effect of the transmit power class and receiver thermal noise floor values is to normalize the characteristics of the incoming RF signals with respect to those RF signals used.

**The paragraph beginning on page 36, line 7 has been replaced with the following paragraph:**

The signal classifier/filter [20]9 (Fig. 30) is in communication with both the input queue 7 and the signal processing database 26. In the early stage of a location request the signal processing subsystem [142]1220 shown in, e.g., [in] Figs. [4]5, 30 and 31, will receive the initiating location request from either an autonomous 9-1-1 notification message from a given MSC, or from a location application[ (for example, see Fig. 36)], for which mobile station characteristics about the target mobile station 140 (Fig. [1]4) is required. Referring to Fig. 30, a query is made from the signal processing controller 15 to the signal [processing]processing database 26, specifically the mobile station table 11, to determine if the mobile station characteristics associated with the MIN to be located is available in table 11. [if] If the data exists then there is no need for the controller 15 to query the wireless network in order to determine the mobile station characteristics, thus avoiding additional real-time processing which would otherwise be required across the air interface, in order to determine the mobile station MIN characteristics. The resulting mobile station information may be provided either via the signal processing database 26 or alternatively a query may be performed directly from the signal processing subsystem [20]1220 to the MSC in order to determine the mobile station characteristics.

**The paragraph beginning on page 36, line 18 has been replaced with the following paragraph. Note that a new Fig. 31 is provided with the label "139" changed to -239-. This is being done since the label "139" is already being used to denote the "location engine."**

Referring now to Fig. 31, [a]nother location application programming interface, L-API-CCS [139]239 to the appropriate CMRS customer care system provides the mechanism to populate and update the mobile station table 11 within the database 26. The L-API-CCS [139]239 contains its own set of separate input and output queues or similar implementations and security controls to ensure that provisioning data is not sent to the incorrect CMRS, and that a given CMRS cannot access any other CMRS' data. The interface 1155a to the customer care system for CMRS-A 1150a provides an autonomous or periodic notification and response application layer protocol type, consisting of add, delete, change and verify message functions in order to update the mobile station table 11 within the signal processing database 26, via the controller 15. A similar interface [1155b]155b is used to enable provisioning updates to be received from CMRS-B customer care system 1150b.

**The paragraph beginning on page 36, line 26 has been replaced with the following paragraph:**

Although the L-API-CCS application message set may be any protocol type which supports the autonomous notification message with positive acknowledgment type, the TIM1.5 group within the American National Standards Institute has defined a good starting point in which the L-API-CCS 239 could be implemented, using the robust OSI TMN X-interface at the service management layer. The object model defined in Standards proposal number TIM1.5/96-22R9, Operations Administration, Maintenance, and Provisioning (OAM&P) - Model for Interface Across Jurisdictional Boundaries to Support Electronic Access Service Ordering: Inquiry Function, can be extended to support the L-API-CCS information elements as required and further discussed below. Other choices in which the L-API-CCS application message set may be implemented include ASCII, binary, or any encrypted message set encoding using the Internet protocols, such as TCP/IP, simple network management protocol, http, https, and email protocols.

**The paragraph beginning on page 37, line 12 has been replaced with the following paragraph:**

In the general case where a mobile station is located in an environment with varied clutter patterns, such as terrain undulations, unique man-made structure geometries (thus creating varied multipath signal behaviors), such as a city or suburb, although the first CDMA delay spread finger may be the same value for a fixed distance between the mobile station and BS antennas, as the mobile station moves across such an [arc]area, different finger-data are measured. In the right image for the defined BS



antenna sector, location classes, or squares numbered one through seven, are shown across a particular range of line of position (LOP).

**The paragraph beginning on page 37, line 17 has been replaced with the following paragraph:**

A traditional TOA/TDOA ranging method between a given BS and mobile station only provides a range along [the] arc, thus introducing ambiguity error. However a unique three dimensional image can be used in this method to specifically identify, with recurring probability, a particular unique location class along the same Line Of Position, as long as the multipath is unique by position but generally repeatable, thus establishing a method of not only ranging, but also of complete latitude, longitude location estimation in a Cartesian space. In other words, the unique shape of the "mountain image" enables a correspondence to a given unique location class along a line of position, thereby eliminating traditional ambiguity error.

**The paragraph beginning on page 38, line 17 has been replaced with the following paragraph:**

The DSP 17 may provide data [ensemble]ensemble results, such as extracting the shortest time delay with a detectable relative signal strength, to the router/distributor 23, or alternatively results may be processed via one or more image filters 19, with subsequent transmission to the router/distributor 23. The router/distributor 23 examines the processed message data from the DSP 17 and stores routing and distribution information in the message header. The router/distributor 23 then forwards the data messages to the output queue 21, for subsequent queuing then transmission to the appropriate location estimator FOMs.

**The paragraph beginning on page 38, line 24 and ending on page 39, line 14 has been replaced with the following paragraph:**

At a very high level the location center [ ]142 computes location estimates for a wireless Mobile Station 140 (denoted the "target MS" or "MS") by performing the following steps:

- (23.1) receiving signal transmission characteristics of communications communicated between the target MS 140 and one or more wireless infrastructure base stations 122;
- (23.2) filtering the received signal transmission characteristics (by a signal processing subsystem 1220 illustrated in Fig. 5) as needed so that target MS location data can be generated that is uniform and

consistent with location data generated from other target MSs 140. In particular, such uniformity and consistency is both in terms of data structures and interpretation of signal characteristic values provided by the MS location data;

(23.3) inputting the generated target MS location data to one or more MS location estimating models (denoted First order models or FOMs, and labeled collectively as 1224 in Fig. 5), so that each such model may use the input target MS location data for generating a "location hypothesis" providing an estimate of the location of the target MS 140;

(23.4) providing the generated location hypotheses to an hypothesis evaluation module (denoted the hypothesis evaluator 1228 in Fig. 5):

(a) for adjusting at least one of the target MS location estimates of the generated location hypotheses and related confidence values indicating the confidence given to each location estimate, wherein such adjusting uses archival information related to the accuracy of previously generated location hypotheses,

(b) for evaluating the location hypotheses according to various heuristics related to, for example, the radio coverage area 120 terrain, the laws of physics, characteristics of likely movement of the target MS 140; and

(c) for determining a most likely location area for the target MS 140, wherein the measurement of confidence associated with each input MS location area estimate is used for determining a "most likely location area"; and

(23.5) outputting a most likely target MS location estimate to one or more applications [1232]146 (Fig. [2.0]5) requesting an estimate of the location of the target MS 140.

**The paragraph beginning on page 42, line 1 has been replaced with the following paragraph:**

Additionally, in utilizing location hypotheses in, for example, the location evaluator 1228 as in (23.4) above, it is important to keep in mind that each location hypothesis confidence value is a relative measurement. That is, for confidences,  $cf_1$  and  $cf_2$ , if  $cf_1 \leq cf_2$ , then for a location hypotheses  $H_1$  and  $H_2$  having  $cf_1$  and  $cf_2$ , respectively, the target MS 140 is expected to more likely reside in a target MS estimate of  $H_2$  than a target MS estimate of  $H_1$ . Moreover, if an area, A, is such that it is included in a plurality of location hypothesis target MS estimates, then a confidence score,  $CS_A$ , can be assigned to A, wherein the confidence score for such an area is a function of the confidences (both positive and negative) for all the location hypotheses whose (most pertinent) target MS location estimates contain A. That is, in order to determine a most likely target MS location area estimate for outputting from the location center