

UNITED STATES PATENT AND TRADEMARK OFFICE

BEFORE THE PATENT TRIAL AND APPEAL BOARD

MYLAN PHARMACEUTICALS INC.,
Petitioner,

v.

SANOFI-AVENTIS DEUTSCHLAND GMBH,
Patent Owner

Case No. IPR2018-01670
Case No. IPR2018-01675
Case No. IPR2018-01676
Case No. IPR2018-01678
Case No. IPR2018-01679
Case No. IPR2018-01680
Case No. IPR2018-01682
Case No. IPR2018-01684
Case No. IPR2019-00122
U.S. Patent No. 8,603,044
U.S. Patent No. 8,679,069
U.S. Patent No. 8,992,486
U.S. Patent No. 9,526,844
U.S. Patent No. 9,604,008

**DECLARATION OF ALEXANDER SLOCUM, PH.D. IN SUPPORT OF
PATENT OWNER RESPONSES**

TABLE OF CONTENTS

	PAGES
I. INTRODUCTION	1
II. QUALIFICATIONS	1
III. MATERIALS CONSIDERED	6
IV. LEGAL STANDARDS	6
V. BACKGROUND OF THE TECHNOLOGY	8
A. Insulin Pen Injectors	9
B. Screw and Nut Physics	11
1. Overview	11
2. Reactive Forces in Screw-Nut Systems	13
3. Friction in Screw-Nut Systems	14
4. Screw-Nut Systems in Pen Injector Design	16
C. Injector Pen Design Considerations for Diabetic Patients	18
1. Diabetic Hand and Wrist Conditions	20
2. Design Considerations for Diabetic Patients	27
VI. OVERVIEW OF THE CHALLENGED PATENTS	32
A. The Disclosure of the Challenged Patents	33
1. The First Depicted Embodiment	34
2. The Second Depicted Embodiment	39
3. The Third Embodiment	40
B. The Challenged Claims of the Challenged Patents	45
C. The Priority Date of the Challenged Patents	51
VII. LEVEL OF ORDINARY SKILL IN THE ART	59
VIII. CLAIM CONSTRUCTION	61
A. “main housing”	68
B. “tubular clutch”	73
C. “an interior of a flange”	74

IX.	OVERVIEW OF THE PRIOR ART IDENTIFIED IN THE GROUNDS	83
A.	Burroughs	83
B.	Steenfeldt-Jensen	89
1.	Steenfeldt-Jensen’s First Embodiment	91
2.	Steenfeldt-Jensen’s Second Embodiment.....	92
3.	Steenfeldt-Jensen’s Fifth Embodiment.....	96
C.	Møller	100
D.	Giambattista.....	105
E.	Klitgaard.....	110
X.	OVERVIEW OF THE GROUNDS.....	110
XI.	THE ASSERTED GROUNDS DO NOT TEACH OR RENDER OBVIOUS CERTAIN CLAIMS OF THE CHALLENGED PATENTS	113
A.	Burroughs Does Not Render Obvious The Challenged Claims of the ’069, ’044, or ’486 Patents [IPR2018-01670 Ground 1, IPR2018-01675 Ground 1, IPR2019-00122 Ground 1].....	113
1.	Burroughs Does Not Disclose Or Render Obvious A “Helical Groove Provided Along An Outer Surface Of Said Dose Dial Sleeve” [’069 Patent Claim 1; ’044 Patent Claim 11] or A “Dose Dial Sleeve Comprising A Helical Groove Configured To Engage A Threading Provided By Said Main Housing” [’486 Patent Claim 1].....	114
2.	Burroughs Does Not Disclose Or Render Obvious That The “Helical Groove Of The Dose Dial Sleeve Has A First Lead And Said Internal Threading Of Said Drive Sleeve Has A Second Lead, And Wherein Said First Lead And Said Second Lead Are Different” [’044 Patent Claim 11].....	132
3.	Burroughs Does Not Disclose Or Render Obvious A “Tubular Clutch Located Adjacent A Distal End Of Said Dose [Dial Sleeve]/[Knob], Said Tubular Clutch Operatively Coupled To Said Dose [Dial Sleeve]/[Knob]” [069 patent Claim 1; 044 Patent Claim 11; 486 Patent Claim 1]	137

B.	Steenfeldt-Jensen Alone, or in Combination with Klitgaard, Does Not Render Obvious the Challenged Claims of the 069, 044, 486, or 844 Patents [IPR2018-01670 (069) Ground 2, IPR2018-01676 (044-B) Ground 1, IPR2018-01678 (486-A2) Ground 1, 2018-01682 (844-B) Grounds 1 and 2].....	142
1.	Steenfeldt-Jensen Does Not Teach or Render Obvious “a drive sleeve comprising an internal threading” [IPR2018-01670 (069), IPR2018-01676 (044-B)], a “driver comprising an internal threading” [IPR2018-01678 (486-A2)], or a “driving member comprising a third thread” [IPR2018-01682 (844-B)].....	143
2.	Steenfeldt-Jensen Does Not Teach or Render Obvious a Dose Dial Sleeve That “comprises at least one radial stop, said radial stop positioned near an end of said helical groove” [IPR2018-01678 (486-A2) Claims 30 and 32]	172
3.	Steenfeldt-Jensen Does Not Teach or Render Obvious “where the piston rod has a circular cross-section” [IPR2018-01682 (844-B) Claim 22].....	181
4.	Steenfeldt-Jensen Combined with Klitgaard Does Not Teach or Render Obvious “a nut that tracks each set dose of medicament delivered” [IPR2018-01682 (844-B) Claim 30].....	183
C.	The Combination of Møller and Steenfeldt-Jensen’s Fifth Embodiment Does Not Render Obvious the Challenged Claims of the 069, 044, or 486 Patents [IPR2018-01670 (069) Ground 3, IPR2018-01676 (044-B) Ground 2, IPR2018-01678 (486-A2) Ground 2]	183
1.	The Combination of Møller and Steenfeldt-Jensen Does Not Teach or Render Obvious “a drive sleeve extending along a portion of said piston rod” [069 Patent Claim 1; 044 Patent Claim 11]	184
2.	A POSA Would Not Have Been Motivated to Combine Møller With Steenfeldt-Jensen [069 Patent Claim 1; 044 Patent Claim 11; 486 Patent Claim 1]	194
3.	The Combination of Møller and Steenfeldt-Jensen Does Not Teach or Render Obvious “said dose dial sleeve	

	comprising a helical groove configured to engage a threading provided by said main housing” [069 Patent Claim 1; 044 Patent Claim 11; 486 Patent Claim 1] and “said helical groove provided along an outer surface of said dose dial sleeve” [069 Patent Claim 1; 044 Patent Claim 11].....	202
4.	Møller Does Not Disclose a Dose Dial Sleeve That Engages a Threading of a “Main Housing”	205
5.	A POSA Would Not Have Been Motivated to Modify Møller’s Internally-Threaded Dose Dial Sleeve to Be Externally-Threaded.....	209
6.	The Combination of Møller and Steinfeldt-Jensen Does Not Teach or Render Obvious “at least one flexible arm ... and at least one spline ... to provide said audible feedback” [044 Patent Claim 15]	212
7.	The Combination of Møller and Steinfeldt-Jensen Does Not Teach or Render Obvious “wherein said main housing further comprises a helical rib ... adapted to be seated in said helical groove provided along said outer surface of said dose dial sleeve” [044 Patent Claim 19]	214
8.	Møller Does Not Teach or Render Obvious “a helical rib provided on an inner surface of said outer housing” [486 Patent Claim 4].....	215
9.	Møller Does Not Teach or Render Obvious a Driver Comprising “a cylindrical shape” [486 Patent Claim 5]	216
10.	Møller Does Not Teach or Render Obvious a Clicker Comprising “at least one flexible [extending] arm” [486 Patent Claims 18 and 20]	217
11.	Møller Does Not Teach or Render Obvious a Dose Dial Sleeve That Is “radially inward of said main housing” [486 Patent Claim 26]	218
12.	Møller Combined With Steinfeldt-Jensen Does Not Teach or Render Obvious a “radial stop positioned near an end of [a] helical groove” or “near a distal end of said helical groove” [486 Patent Claims 30 and 32]	221

D.	Neither Møller nor Steinfeldt-Jensen Teaches or Renders Obvious Claim 56 of the 486 Patent [IPR2018-01679 (486-B) Grounds 3, 4, and 6]	222
1.	Steenfeldt-Jensen Does Not Teach Claim 56 [IPR2018-01679 (486-B) Ground 3]	223
2.	Steenfeldt-Jensen Does Not Render Obvious Claim 56 [IPR2018-01679 (486-B) Ground 4]	227
3.	Møller Does Not Teach Claim 56 [IPR2018-01679 (486-B) Ground 6]	228
E.	The Combination of Møller and Steinfeldt-Jensen’s Second Embodiment Does Not Render Obvious the Challenged Claims of the 008 Patent [IPR2018-01684 (008) Claims 1, 3, 7-8, 11, and 17]	231
1.	A POSA Would Not Have Been Motivated to Combine the Teachings of Møller and Steinfeldt-Jensen as Petitioner Contend.....	231
F.	Giambattista, Whether Alone in Combination with Steinfeldt-Jensen or Klitgaard Do Not Render Challenged Claims 21-30 of the 844 Patent Unpatentable [IPR2018-01680 (844-A) Grounds 1, 2, 3]	256
1.	Giambattista Is Not Prior Art.....	256
2.	Giambattista Does Not Disclose a Piston Rod With a Circular Cross Section	257
3.	Giambattista in combination with Klitgaard Does Not Render Claim 30 Obvious.....	260
XII.	OBJECTIVE INDICIA.....	267
A.	The SoloSTAR Practices the Challenged Claims	267
1.	SoloSTAR Components.....	267
2.	SoloSTAR Operation	277
3.	The ’069 Patent SoloSTAR® Analysis	280
4.	The ’486 Patent SoloSTAR® Analysis	297
5.	The ’844 Patent SoloSTAR® Analysis	311
6.	The ’008 Patent SoloSTAR® Analysis	331

B. The OptiClik Does Not Practice the Challenged Claims.....343
C. Benefits of the Claims of the Challenged Patents.....345
XIII. CONCLUSION AND JURAT346

I, Alexander Slocum, declare as follows:

I. INTRODUCTION

1. I have been retained by Weil, Gotshal & Manges LLP, counsel for Patent Owner Sanofi-Aventis Deutschland GmbH, to submit declarations in connection with the *Inter Partes* Reviews that have been instituted on Sanofi's U.S. Patent Nos. 8,603,044 (the "044 Patent"), 8,679,069 (the "069 Patent"), 8,992,486 (the "486 Patent"), 9,526,844 (the "844 Patent"), and 9,604,008 (the "008 Patent") (collectively, the "challenged patents").

II. QUALIFICATIONS

2. I have summarized in this section my educational background, career history, awards, publications, and other relevant qualifications. My Curriculum Vitae (CV), which includes my qualifications as well as my publications is attached as Exhibit 2108.

3. My principal field of experience is mechanical engineering with a focus on precision engineering, and precision machine design. I have written two books on machine design, as well as a section of another book, and approximately 170 papers published in refereed journals and in proceedings of refereed conferences. I have taught courses on mechanical design, including precision machine design, continuously since 1991. I have also taught courses on medical device design continuously since 2001. I also regularly consult for companies to assist them with various types of design challenges.

4. I graduated from the Massachusetts Institute of Technology in 1982 with a Bachelors of Science degree in Mechanical Engineering. I received my Master of Science in Mechanical Engineering from MIT in 1983, and my Doctor of Philosophy degree from MIT in 1985. My doctoral thesis was entitled “Sensor System Design to Determine Position and Orientation of Articulated Structures.” While working on my Doctoral Thesis, I was a full-time employee of the US National Bureau of Standards (now NIST) where I was in charge of multiple projects related to precision instruments and automated systems that led to many awards, patents and publications.

5. After receiving my Doctorate in 1985, I came to MIT as an Assistant Professor in Civil Engineering to do research on automating construction processes and to teach courses in civil engineering (construction automation), and precision machine design. From 1989 to 1990, I accepted a Royal Society Fellowship and an Oak Ridge National Laboratory Optics Fellowship to enable me to become a Visiting Professor at the Cranfield Institute of Technology in Cranfield, United Kingdom where my focus was on precision machines in support of creating optics for the “Star Wars” missile defense system program.

6. I returned to MIT in 1991 as an Assistant Professor in the Mechanical Engineering Department. I continued to do research in and teach courses on precision machine design. I became a Chaired Associate Professor in 1992, a

Chaired Tenured Associate Professor in 1995, and a Chaired full Professor in 1998. I am currently the Walter M. May and A. Hazel May Professor of Mechanical Engineering.

7. In 2001, I co-taught a course in “Medical Innovation” and ever since have taught courses with multiple term projects on medical device design, including course number 2.75 titled “Design of Medical Devices”.

8. I have served on numerous advisory and review panels and professional committees, as set forth in my CV. *See* Ex. 2108.

9. I am an inventor on approximately 133 United States patents, many of which relate to machine elements, tools, and medical devices, and these are listed in my CV. My earliest patents on mechanisms issued over thirty years ago, including patents on leadscrew and nut arrangements. *See* Ex. 2108 at 4 (US4685661, “Method And Mechanism For Fixturing Objects”, 8/11/1987; US4765668, “Robot End Effector”, 8/23/1988; US4836042, “System To Convert Rotary Motion To Linear Motion”, 6/6/1989), 6 (US5839769 “Expanding Gripper With Elastically Variable Pitch Screw”, 11/24/1998). I also have patents on telescoping or collapsing robotic tube structures having an arrangement of concentric structures containing precision mechanisms including nested concentric leadscrews. *See* 2108 at 5 (US5733096, “Multi-Stage Telescoping Structure”, 3/31/1998). With regard to syringes and low forces, for example, I have a patent

on a pressure measuring syringe. *See* 2108 at 8 (US8291768 “ Pressure Measuring Syringe”, 10/23/2012).

10. In 1986 I was awarded the US Dept. of Commerce Bronze Medal Award for Superior Federal Service (precision machine design for the Automated Manufacturing Research Facility). In 1994, I received the American Society of Civil Engineers Thomas Fitch Rowland Prize. In 1997, I was awarded an NSF Presidential Young Investigator Award and the Society of Mechanical Engineers Frederick W. Taylor Research Medal. In 1999, I received the Martin Luther King Jr. Leadership Award and in 2000 the Massachusetts Professor of the Year Award, In 2004 I received the American Society of Mechanical Engineers Leonardo da Vinci Award, the ASME Machine Design Award in 2008, and the ASME Thar Energy Award in 2014. In 2014, I received the Association of Manufacturing Technology Charlie Carter Award.

11. In addition, I have helped products win 11 R&D 100 Awards for Best New Scientific and Technical Products as determined by R&D Magazine. A full list of my awards is provided in my Curriculum Vitae.

12. My CV also lists all of the publications authored by me. Some of these publications describe my work on medical devices, including, among other things, my work on teaching medical device design, on ultrasound devices in 1993 and on endoscopic mechanisms in the 2000s. *See* Ex. 2108 at 13 (“The Design of

a Precision Bilaminar Resonating Transducer Assembly Tool”, Jou. Int. Soc. of Precision Engineering and Nanotechnology, October 1993), 18 (“Classroom to Clinic: Merging Education and Research to Efficiently Prototype Medical Devices,” IEEE Journal of Translational Engineering in Health and Medicine, August 15, 2013, *available at* <https://www.ncbi.nlm.nih.gov/pmc/articles/PMC4847477/>), 24 (“A Needle Guidance System For Percutaneous Lung Biopsy” ASME 2005 International Design Engineering Technical Conferences & Computers and Information in Engineering Conference, September 24-28 2005).

13. Since 1983 (starting at NBS), my R&D work for industry and government agencies has included extensive studies of fluid systems from hydraulic valves and actuators to pressurized liquid bearings, as well as medical devices. In 2010, I served on Energy Secretary Chu’s special DoE Science Team working on the Gulf Oil Spill, and in 2013 I served in the Office of Science and Technology Policy in the Executive Office of the President as the Assistant Director for Advanced Manufacturing. I was elected to the National Academy of Engineering in 2017 for my work on precision machine design, manufacturing, and teaching.

14. I am being compensated for the time I am spending on this case at my normal consulting rate of \$700 per hour. My compensation is not based on either the content of my opinions or the outcome of the case.

III. MATERIALS CONSIDERED

15. In connection with my work on this matter, I have reviewed and considered the materials listed in the table of Appendix G to my declaration.

16. In addition to the documents identified in the table of Appendix G, my opinions herein are based on my personal experience, knowledge, skill, and expertise, and any other materials cited herein.

IV. LEGAL STANDARDS

17. I am not a lawyer, and I offer no legal opinions in this declaration. I have been informed by counsel as to various legal standards that apply to the technical issues I address in this declaration, and I have applied those standards in arriving at my conclusions.

18. I understand that a Petitioner in an *inter partes* review proceeding must prove invalidity of the challenged claims by a preponderance of the evidence.

19. I have been informed that, when determining whether the challenged claims of a Patent are invalid as anticipated, one must determine whether each and every claim limitation as arranged in a claim is found in a single prior art reference, expressly or inherently. I have been informed that a claim limitation is

inherent only when a prior art reference necessarily includes the unstated limitation.

20. I have been informed that a prior art reference does not anticipate a claim if it is missing even one claim limitation. I also understand that a prior art reference does not anticipate if it is not enabling. A prior art reference is enabling if it enables persons of ordinary skill to make the invention without undue experimentation.

21. I have been informed that, when analyzing whether the challenged claims of the challenged patents are invalid as obvious, one must determine whether the invention in each challenged claim as a whole would have been obvious to a person of ordinary skill in the art, taking into account 1) the scope and content of the prior art; 2) the differences between the prior art and the claimed invention; 3) the level of ordinary skill in the art; and 4) any secondary considerations of nonobviousness. I understand that a determination of whether a patent claim is invalid as obvious requires consideration of all four of these factors, and it is error to reach a conclusion of obviousness until all those factors are considered.

22. I have been informed that a determination of obviousness requires that a person of ordinary skill in the art would have had a reason to modify or combine prior art references to achieve the claimed invention. I understand that this reason

to modify or combine is not based on whether a person of ordinary skill in the art could combine prior art references, but whether a person of ordinary skill in the art would have been motivated to do that at the time of the invention.

23. I have also been informed that a determination of obviousness requires that a person of ordinary skill have a reasonable expectation of success in combining the prior art references to achieve the claimed invention.

24. I have been informed that secondary considerations may show that the claimed subject matter is not obvious. These secondary considerations can include, for example, commercial success (evidence of commercial success that can be attributed to the merits of the invention), failure of others (evidence that others have tried and failed to solve the problem or satisfy the need resolved by the claimed invention), and skepticism (evidence that those of skill in the art were skeptical as to the merits of the invention, or even taught away from the invention). I understand that secondary considerations play an important role as a guard against prohibited hindsight reasoning in the obviousness analysis.

V. BACKGROUND OF THE TECHNOLOGY

25. I have been asked to provide a background of the relevant technology and design principles, which I describe below.

A. Insulin Pen Injectors

26. Pen injectors come in reusable and prefilled varieties. Reusable injection pens allow the user to reset the drive mechanism and replace the medicament cartridge after the remaining dose is expelled. Ex. 2123 at 2. Prefilled pens (or disposable pens) are intended to be discarded after the contents of the prefilled cartridge runs out. Ex. 2123 at 2. Because prefilled pens are typically smaller, lighter, and simpler to use, patients typically prefer them over the reusable variety. Ex. 2123 at 4; *see also* Ex. 2113 at 7. Usually, prefilled pens are also less expensive since the components can be manufactured using plastics and cheaper materials. *See e.g.*, Ex. 2120 at 2; Reusable pens, on the other hand, include additional components necessary to reset the drive mechanism and are constructed of more rugged and durable materials since a single reusable device may be used for several years. Ex. 2113 at 6, 7.

27. Reusable pens were the first to enter the market in 1985 when Novo introduced the NovoPen®. Ex. 2137 at 25, 65; Ex. 2160 at 1. The NovoPen® measured and administered two units of insulin, corresponding to two clicks per depression. Ex. 2144 at 4. In 1986, Nordisk introduced its own reusable insulin pen, called Insuject®. Ex. 2137 at 25. Three years later, in 1989, Novo introduced the NovoLet®, the world's first prefilled insulin pen. *Id.*

28. In 2001, Novo introduced the FlexPen, a prefilled disposable injector, “designed for easy and discrete use.” Ex. 2137 at 53, 66; Ex. 2136 at 22. Based on my review of the FlexPen, it has two modes of operation – dose setting and dose injection. To set a dose, the user dials a dose by rotating a dose knob to select the amount of medicament to be dispensed. To inject a dose, the user applied force to the dose button and causing the dose knob to rotate back into the housing.

29. While the FlexPen was considered a leading pen at the time, it had many drawbacks. Notably, the FlexPen had high injection force, long dial extension, and only permitted a user to select 60 units of insulin. Ex. 2144 at 8; Ex. 2100 at 3. Based on my analysis of the FlexPen, it is my opinion that main contributing factor to the FlexPen’s high injection force resulted from having to overcome the ratchet mechanism between the driver tube and the housing. It was not until 2008 (7 years after the launch of the FlexPen) that Novo introduced the New Generation FlexPen (NGFP), which included redesigned components in order to reduce the injection force. Ex. 2136 at 71. I understand from my discussions with Rob Veasey (an inventor of the challenged patents), and my own analysis, that Steinfeld-Jensen’s fifth embodiment closely corresponds to the disposable FlexPen.

B. Screw and Nut Physics

1. Overview

30. Many pen injector designs, including those covered by the challenged patents, operate using screw and nut mechanisms. When evaluating such pen injectors, the physics of a “screw” working in concert with a “nut” needs to be considered carefully. For the purposes of describing the physics of operation, consider the case where the “screw” is a shaft with external threads and the “nut” is a component with internal threads that mate with the screw’s external threads. Relative rotation between a screw and a nut is required to have axial motion between the two. This axial motion can occur by causing the screw or the nut to rotate while the other is prevented from rotating and, similarly, by preventing one of the two components from translating (*i.e.*, moving axially). In all cases, there will be relative rotation and translation of the sliding contact interface between the screw’s threads and the nut’s threads.

31. Newton’s 3rd law tells us that for every action there is an equal and opposite reaction. In the case of the thread interface between the screw and nut, because the threads are helical, which means they are in effect ramps or wedges, they convert rotational motion to axial motion, or vice versa. Most people have experience with wedges and know that they can use a wedge to generate much larger forces on an object than they could if they pushed directly on the object. For

example, a wedge can be driven between two objects to lift one away from the other or driven into an object, as is the case with an axe and a log, to separate it. Most people also know that the distance the wedge moves in is less than the distance it makes the object move up. This is a result of the conservation of energy: the product of an applied force with the distance over which it is applied (times the efficiency of the system, which is governed by friction) will equal the product of the resulting output force over the distance which it acts. The wedge is a simple transmission that makes life easier for people by helping them amplify the small forces they create with their body in order to do useful work. The same is true with screws and nuts, which are essentially rotary wedges.

32. As mentioned above, in a screw-nut system the application of torque to either a screw or a nut can cause one of the two to move axially, depending on which component is axially fixed and which is rotationally fixed. The application of axial force to one of the components, however, may or may not impart rotation to the other component depending on the circumstances. For example, most people know that if they were to push down on the nut instead of rotating it, the nut will not move. This is because of a small thread angle and high friction. In this case, the threads act as self-locking wedges, and, which is the case where if the wedge angle is small, typically less than 15 degrees, the wedge will not dislodge itself once the user stops applying force to push it in to pry apart objects.

33. Conversely, if the thread angle is large enough and the coefficient of friction small enough, applying strictly axial force to either the screw or the nut can cause relative rotation and axial motion between the two. Such a system is referred to as being “backdriveable” and the term “backdrive” or “backdriving” is used to describe applying an axial force to screw or nut element and causing helical movement thereof. Ex. 2214.

2. Reactive Forces in Screw-Nut Systems

34. Newton’s 3rd law tells us that any external axial force applied to the screw will be resisted by an equal and opposite force applied to the screw by the nut’s threads. This also means that there must be an external force acting on the nut to act against the force on the nut threads by the screw. This external force on the nut would be supplied by another element connected to or supporting the nut. Ultimately, there must be structural elements connecting the equal and opposite forces acting on the screw and the nut. This loop of forces through elements is called the “structural loop”.

35. In the case of an injector pen, a person can hold the injector pen in the air with one hand and push the button and fluid will flow out of the needle. The body of the pen is held in the palm of the person’s hand with their fingers wrapped around the body squeezing it. The person’s thumb placed over the end of the pen pushes down on the button to cause the pen’s internal mechanisms to function to

push a plunger that causes the fluid to flow from the needle. The structural loop of the pen mechanism is thus completed from the thumb, through the pen, and back into the user's hand. If a user did not have a firm grip on the pen—either because of having greasy hands or weak grip, rather than the button being pushed into the pen, the pen might slide through the person's grip when the user pushed down on the button to create the injection force because of internal friction in the pen. Alternatively, if the user's thumb was weak and finger grip strong, the button might not be pushed into the pen.

36. Hence designers of injection pens have sought to minimize the injection force that the user needs to apply to the injector button, particularly for insulin injector pens intended for use by diabetics. There will of course be tradeoffs between cost and injection force, but in general a POSA would not have been motivated to increase both cost (*e.g.*, by adding complexity) and, given industry trends and needs of diabetics as I explain below (*see also* Ex. 2101 at 5-6), injection force.

3. Friction in Screw-Nut Systems

37. All physical systems have friction between moving components in contact with each other, and friction at a moving interface means energy (units of Joules) is being dissipated, which means a loss of efficiency. A frictional force (F_f) resisting motion at an interface is created by the product of the coefficient of

friction (μ) between the moving interface elements and the axial force (N) between the elements:

$$F_f = \mu N$$

The product of the friction force (units of Newtons) and the relative distance travelled (units of meters) between elements equals the energy dissipated. While the motion is occurring, the power (units of Watts) dissipated is the product of the friction force (Newtons) and the relative motion velocity (meters per second) between elements.

38. Newton's first law states that a body at rest or in motion will not change its state unless a force is applied. In the case of rotating elements, a torque, which is created by a force applied at a distance from the axis of rotation causes rotation, or in the case of friction resists rotation. And recall the axial force passing through the screw/nut system is what leads to the frictional force. The efficiency of an injector pen system is thus found by considering which element is rotating and how the rotation is enabled. Rotation is key because the frictional force at a rotating interface resists the torque that is causing the rotation to occur. Force being transmitted through elements must pass through the rotational interfaces, but the larger the radius of contact of the rotational interface, the larger the radius the frictional force acts to resist the rotation.

39. Hence a key fundamental goal for injector pens is to keep the axial forces passing through rotating elements as close to the central longitudinal axis of the pen as possible to minimize frictional torques and maximize efficiency.

4. Screw-Nut Systems in Pen Injector Design

40. Back to the principle of conservation of energy: The amount of insulin injected is very small and so the piston that moves in the ampoule must only move a short distance. *See, e.g.*, Ex. 1015, ¶ 0004. However, the needle must slip easily into the skin and with minimal pain so it needs to be a very small diameter. *See, e.g.*, Ex. 1015, ¶ 0005. The resistance to fluid flow through the needle is proportional to the needle's internal diameter to the fourth power; hence very large forces must be applied to the piston, albeit for a very short distance, to quickly force out the medicament. Because the user can only apply a comparatively modest force, injector pen designers must create a transmission inside the pen to amplify the user's applied force (*i.e.*, a gearing to create a mechanical advantage), which means the user must apply the force over a greater distance than the piston moves as it pushes out the fluid from the ampoule.

41. Due to the nature of their disease process, diabetics have been found to have decreased grip and pinch strength, and are also at risk for development of compression neuropathies that further affect grip strength and hand function (*i.e.*

carpal tunnel syndrome). *See* Ex. 2173; Ex. 2174; Ex. 2177; Ex. 2176; Ex. 2178; Ex. 2179. These hand and wrist conditions are discussed in greater detail below.

42. Furthermore, for an injector pen, the only externally applied motion is the axial force created by the thumb pressing down towards the curled fingers gripping the pen, within the pen. If the design is limited to the use of screws, nuts, and structures to constrain them (*e.g.*, a spline prevents an element from rotating but allows translation through it), then at least one screw/nut interface must be backdrivable (*i.e.*, the thread angle exceeds the angle of friction) to convert the axial motion of the user's thumb to rotational motion. The rotation of either a screw or a nut then causes translation of a component to push the piston and eject the insulin from the ampoule.

43. There are many different combinations of screws and nuts with which to accomplish this overall design goal, and the cleverness of how to implement a screw-nut system having minimal cost while maximizing efficiency (*e.g.*, reducing the distance from the pen's axis to the axial forces transmitted between relative rotating components) and ease of use from the patient's perspective (*e.g.*, having an acceptable dial stroke extension so that the patient can comfortably use the pen injector with one hand) is what has led to many patents.

C. Injector Pen Design Considerations for Diabetic Patients

44. A person of ordinary skill in the art would have understood that in order to design a device for human use, it is fundamental to understand the use cases and needs of the intended users—*i.e.*, to understand the human factors that impact device design. In the pen injector context, those who use the device include diabetics. Thus, a person of ordinary skill in the art would have understood that the design of a pen injector must account for any needs or limitations imposed on the diabetic population by the circumstances of their condition. Consideration of human factors is particularly relevant for pen injectors, since diabetic patients will have a large role in self-management of their disease and often self-administer insulin with the pen injector. Moreover, because insulin injections are often seen as inconvenient, painful, and/or traumatic for some patients, it can be critical to a patient's health that the pen injector is simple and easy to use; a pen injector that is too difficult presents another barrier to enabling patients to control and self-manage their disease, rather than being a tool with which patients can take care of themselves. *See, e.g.*, Ex. 2175 at 2, Ex. 2113 at 6, 10; Ex. 2135 at 7; Ex. 2111 at ¶ 14.

45. Whatever the cause, studies have found that diabetics generally have reduced hand strength relative to the general population. *See* Ex. 2176 (discussing both pinching and gripping hand strength); Ex. 2159. Hand dexterity and flexibility

impairments are also common in the diabetic population, as discussed below. The prevalence and significance of limited hand function, and the potential for certain conditions (*e.g.*, carpal tunnel syndrome) to have significant negative impact on a diabetic's use of, and comfort with, operating a pen injector, would have been of critical importance to guide a person of ordinary skill in the art's decisions on the design of, or modifications made to, a pen injector. *See* Ex. 2163 at 74:4-12 (agreeing that it is important to consider the needs and use cases of diabetics when designing insulin injector pens).

46. A person of ordinary skill in the art would have educated themselves on any hand and wrist conditions affecting diabetics to understand the design considerations that go into a pen injector and to achieve a general idea as to the magnitude of average decrease in grip strength seen among diabetics. *See* Ex. 2176; *see also, e.g.*, Ex. 2163 at 75:3-76:8. I understand that Petitioner's expert, Mr. Leinsing, did not specifically consult any materials or personnel to understand these design considerations, but instead relies solely on his recollection from designing isolated components of pen injectors, much of which was from 20 years ago. *See* Ex. 2163 at 36:10-20 (explaining his work on a pen injector occurred during the 1990s), 74:21-75:2 (incorrectly guessing how peripheral neuropathy, a common condition affecting diabetics as discussed below, affects a diabetic's ability to successfully use a pen injector), 76:9-77:25 (explaining that he is only

relying on his recollection from his work on pen injectors). In forming my opinions in this declaration, I sought to avoid the bias of hindsight. I spoke with Robert Veasey, who was developing pen injectors during the relevant period (2003), about the important design considerations for pen injectors in the early 2000s. I also consulted ISO 11608-1 (1st ed. Dec. 15, 2000), which is a design standards document for pen-injectors that was developed by the International Standards Organization. *See* Ex. 2131. Another method I used to avoid this bias, which I note Mr. Leinsing did not do, was to review materials on the hand and wrist conditions affecting diabetic patients so as to ensure that I at least had an understanding of the medical considerations that should guide pen injector design. A summary of these conditions is described in the following sections.

1. Diabetic Hand and Wrist Conditions

47. There are a number of hand and wrist conditions that affect diabetics more commonly than the general population. These conditions, which a person of ordinary skill in the art would have kept in mind when designing a pen injector, limit hand strength and can also affect joint mobility; these include peripheral neuropathy, carpal tunnel syndrome, cheiroarthropathy (or limited joint mobility (LJM)), Dupuytren's contracture, arthritis (which can affect all of the small joints of the hand and wrist), stiff hand syndrome, and stenosing tenosynovitis.

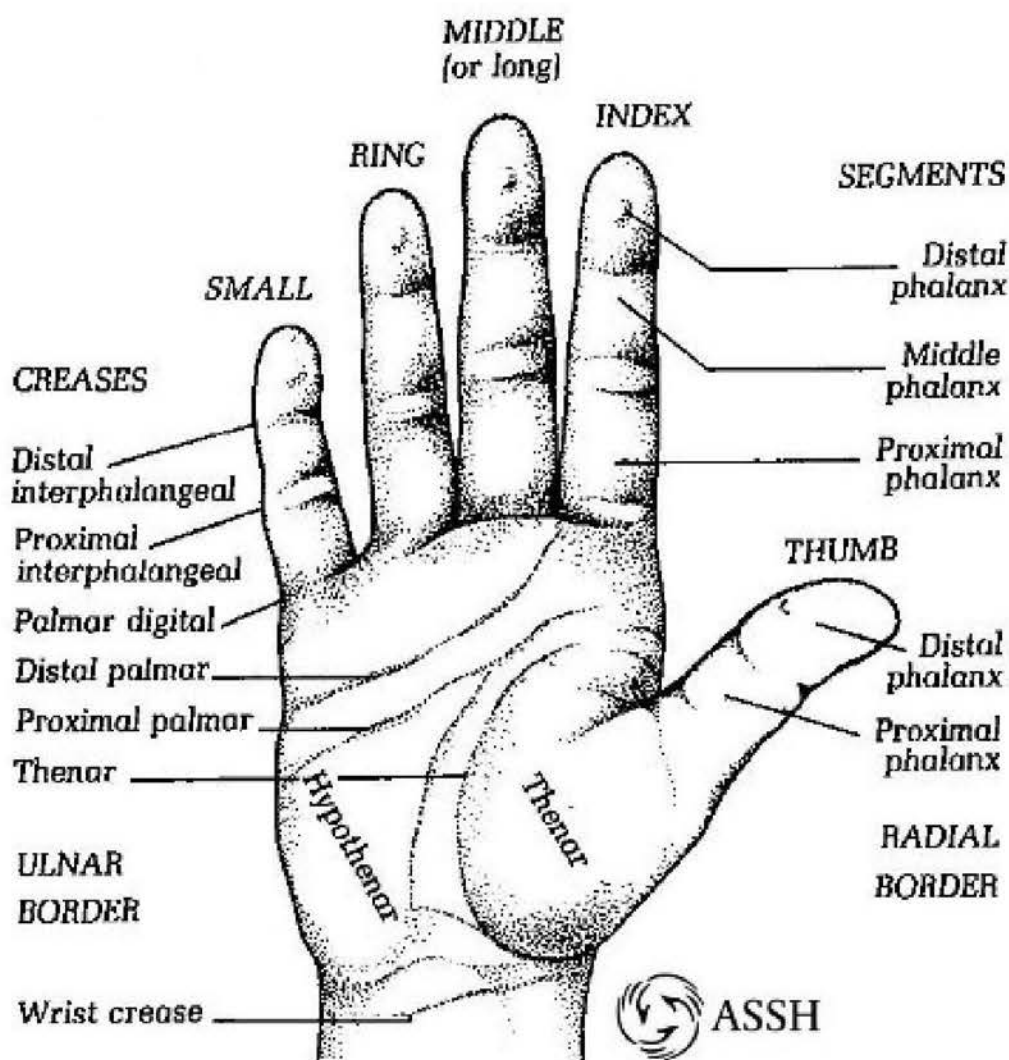

Source: <https://www.assh.org/handcare/hand-arm-anatomy>.

a. Peripheral Neuropathy

48. A condition that affects a large proportion of diabetics, peripheral neuropathy, results from, simply put, the increased concentration of sugar in diabetics that causes, over time, overall swelling of the nerve fibers and subsequent nerve injury and decreased function. The effects are felt first in the most distal nerve endings, most commonly the hands and feet. *See Ex. 2183, Ex. 2158 at 2.*

The symptoms can include decreased tactile sensation, paresthesias (burning, tingling), pain, and in latter stages when motor nerves are affected, muscles are denervated, resulting in physical weakness. *Id.* Carpal tunnel syndrome, discussed below, is one type of neuropathy (*i.e.*, damage to the median nerve), but is caused by compression of the median nerve in the carpal tunnel; peripheral neuropathy in diabetics is caused by increased pressure on the nerve, but due to an intrinsic processes related to high blood sugar. *Id.* Neuropathy is reported to affect the ulnar nerve in in 2% of diabetic patients. *See Ex. 2138 at 4.*

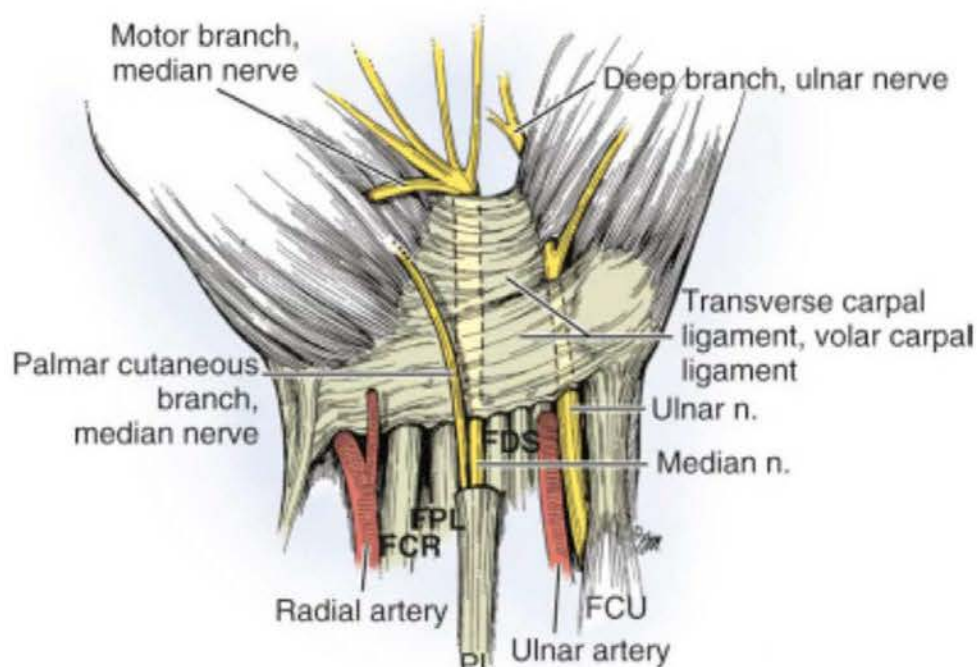

Source: Mackinnon SE, Novak CB, “Compression Neuropathies”, Chapter 23 in Green’s Operative Hand Surgery, 2017, Wolfe SE et al, Elsevier 2017.

b. Cheiroarthropathy (or Limited Joint Mobility (LJM))

49. This condition is symptomatic of the diabetic population and affects a significant proportion of diabetics. *See* Ex. 2158 at 2. The condition is characterized by the thickening of skin around the fingers that limited joint mobility. *See* Ex. 2134 at 3, 6; Ex. 2182. Specifically, those with the condition are typically unable to fully extend their fingers (as depicted below), but there is no pain or muscular weakness associated with this condition. *See* Ex. 2134 at 3-4, 6.

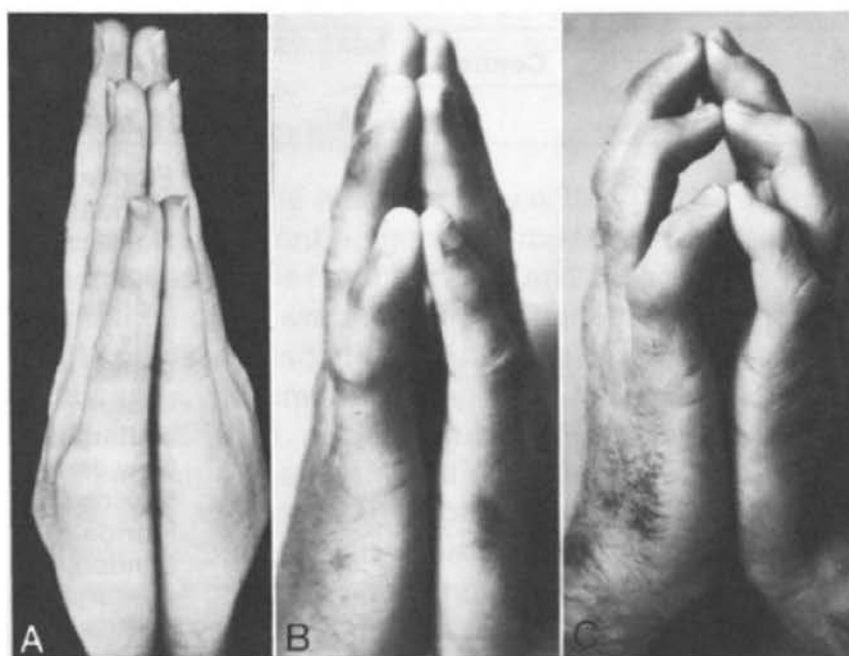

Ex. 2134 at 4 (progressively showing severity of cheiroarthropathy)

c. Dupuytren's Disease

50. Dupuytren's contracture is the result of fibrosis (*i.e.*, the formation of excess connective tissue by myofibroblasts) in the hand, resulting in fixed contractures of the MCP and PIP joints (and rarely, the DIP joints); this often limits extension of the fingers. *See* Ex. 2134 at 1-2, 6. This disease is more

common in the diabetic population than the non-diabetic population, with estimates being that approximately 40% of middle-aged diabetics have this condition. *See* Ex. 2134 at 1-2, 6. It may be associated with pain, and it is not reported to result in reduced finger strength, but the fixed contractures can severely limit hand function to the point where an individual with Dupuytren's contracture would be unable to effectively use an injector pen. *See* Ex. 2134 at 6; Ex. 2182.

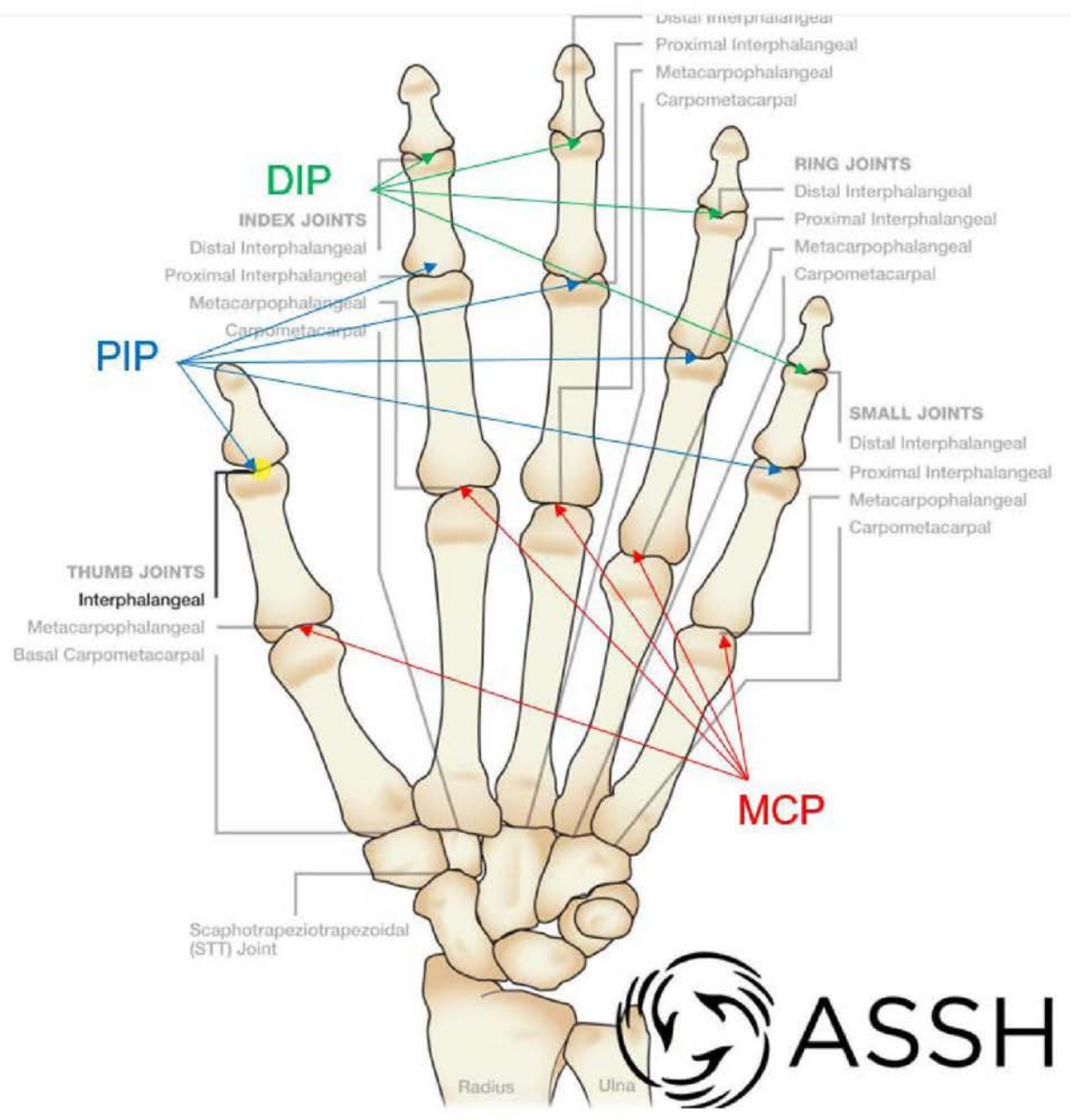

Source: <https://www.assh.org/handcare/Anatomy/Joints>

d. Stiff Hand Syndrome

51. Stiff hand syndrome, which is a less common condition in diabetics, results from the stiffening of subcutaneous tissue in the fingers and palms of

patients. *See* Ex. 2134 at 2, 6. This disorder limits the mobility of an afflicted person's fingers and can be accompanied by tingling or pain. *See id.*

e. Carpal Tunnel Syndrome

52. Carpal Tunnel Syndrome is the most common compressive neuropathy in the general population; the incidence is much higher in diabetics, however, in the range of 30% (1 in 3). In both diabetics and non-diabetics, carpal tunnel syndrome results from compression of the median nerve. Studies have shown that morbidity of carpal tunnel syndrome is higher in diabetics due to injury to both of the major nerves, which control intrinsic hand muscle function, namely the median and ulnar nerves. *See* Ex. 2134 at 2, 6. Over a long period, the muscles at the base of the thumb (termed the thenar eminence) may atrophy, and in diabetics, the extent of muscular atrophy can affect a larger portion of the hand. *See* Ex. 2134 at 2, 6. One study showed that diabetics accounted for 5 – 16% of cases with severe carpal tunnel syndrome and muscular weakness. *See* Ex. 2134 at 2.

f. Stenosing Tenosynovitis

53. Commonly known as “trigger finger,” this condition results from inflammation in the tendon sheath at the level of the flexor pulleys, most commonly the A1 pulley, and can affect any finger, including the thumb. *See* Ex. 2181. Symptoms include pain when bending or straightening the finger, a catching

or popping sensation during movement, and in some cases, the finger may become locked in bent position and needs to be forcibly extended by the patient. *See* Ex. 2181. Some estimates attribute a third of all cases to diabetes. *See* Ex. 2134 at 2.

2. Design Considerations for Diabetic Patients

54. A person of ordinary skill in the art would have taken into account these diabetic conditions when designing a pen injector or determining what modifications to make to a pen injector. A person of ordinary skill in the art would have understood that design objectives for an insulin pen injector include having a lower injection force (*i.e.*, the force exerted by the user to dispense insulin) to accommodate those with reduced grip or thumb strength, a narrower body to facilitate grip, a limited dial extension (or dial stroke) so that the user can comfortably reach the injection button with the thumb while gripping the body of the pen, and ease of use in terms of operability so that the user readily understands how to correctly self-administer (*i.e.*, setting the dose, correcting the dose, and injecting the dose). *See* Ex. 2144 at 8 (“From the patients’ perspective, the simplicity of use of a specific device is an important factor when deciding on which pen to use on a day-to-day basis”). Dosage accuracy and audible clicks corresponding dose setting and injection were (and still are) important considerations as well, and indeed the ISO standards specified (and continue to specify) threshold requirements in this regard. *See* Ex. 2131 at 10-11, 18-19.

Larger dose numbers may also be preferable for patients having vision impairments.

55. Designing a pen injector, or modifying one, is not as simple as selecting or substituting components. In the design of any mechanical device, including a pen injector, each component that plays a role in the operation of the device will have an effect on other components and the overall design of the device. There can be tradeoffs in selecting or substituting components such that trying to achieve one objective with a component, or components, may compromise another objective and/or increase the overall cost to manufacture. For example, one might be tempted to improve the mechanical advantage of a pen injector by increasing the dose dial stroke length relative to the cartridge piston stroke length, but the thumb can only extend so far, as there are limits to comfortable reach. Thus, a person of ordinary skill in the art will weigh pros and cons and not make a change that would result in an overall inferior, and less desirable pen.

56. In terms of highly important design objectives for an insulin pen injector, many articles and studies highlight the importance and desirability of low injection force. *See* Ex. 2100 at 1-2, 5; Ex. 2144 at 5, 9; Ex. 2175 at 3 (noting that the manufacturer of the FlexPen received complaints about high injection force and that the “Next Generation FlexPen” was introduced to overcome this problem), 5

(noting that lower injection force “contributed to three out of four patients finding [the pen with lower injection force] ‘simpler and more comfortable’ to use.”), Ex. 2159 at 4 (noting the grip and pinch strength for diabetics is significantly lower than for non-diabetics), Ex. 2116 at 4, 7; Ex. 2135 at 4 (“In a study comparing usability and patient preference for different pen injectors, patients preferred the pen with the lowest injection force.”), Ex. 2123 at 2 (“Injection force is also a key element in the design of an insulin pen,[] as lower injection forces are associated with simpler operation, more comfortable use,[] and less injection-site pain.”). Having a lower injection force, including a smoother injection force profile, is perceived by diabetics as being easier to use. It puts less strain on the user, thus making less daunting a task that diabetics have to perform on a regular basis. Further, the likelihood of needle movement at the injection site, which can cause discomfort and inadvertent insulin waste, diminishes with lower injection force and a smoother injection profile. *See* Ex. 2144 at 10; Ex. 2180 at 2 (“The plungers/buttons of some pens are difficult to push down, making it easy to accidentally lift the needle out of the skin when delivering the insulin, thus leaving a ‘wet spot.’”); *see also* <https://www.youtube.com/watch?v=6dKOD74EQN4> (video showing difficulty to inject FlexPen). I note that Petitioner’s expert, Mr. Leinsing, agrees that reducing injection force is an important consideration in pen

injector design. *See* Ex. at 2163 at 80:17-81:5 (“[T]here’s a lot of focus in pen injectors to reduce the force of injection.”).

57. The SoloSTAR pen, for example, was widely documented as an advantageous pen injector preferred by many patients due to the reduced injection force required to dispense a dose relative to the other commercial pens on the market at its release. *See* Ex. 2100; Ex. 2144 at 5; Ex. 2116 at 7-8; Ex. 2123 at 4-6, Ex. 2126 at 3. Relatedly, the SoloSTAR was noted to have a smoother injection profile, as opposed to, for example, the jolting injection profile of the FlexPen (which was due to a stiff one-way ratchet mechanism). *See* Ex. 2144 at 5 (“Lower injection force means the user can *steadily* apply pressure to the end of the pen”) (emphasis added).

58. A shorter dial extension (*i.e.*, the maximum distance the dose dial extends axially out of the housing) is another important consideration to accommodate those patients with limited joint flexibility. *See* Ex. 2144 at 5 (“Limited joint mobility of the hand, also referred to as cheiroarthropathy, is a significant problem for patients with diabetes and may affect daily life It has been estimated that up to 58% of patients with diabetes have limited joint mobility of the hand”), Ex. 2116 at 4. As explained in one of the references I reviewed, “a short dial extension will facilitate easier grip during injection and easier depression off the injection button” to overcome limited joint flexibility. Ex. 2144

at 5; *see also* Ex. 2100 at 5 (“The shorter push-button travel as the result of the shorter dial stroke extension is likely to be preferable for patients with impaired dexterity[] as well as unimpaired patients.”). Petitioner’s expert, Mr. Leinsing, agrees with me in this regard. *See* Ex. 2163 at 103:13-105:5. The desire of a shorter injection dial extension, however, must be balanced with other resulting changes to the system. There is a fundamental issue of transmission ratio involved in the design decision: the product of the pen’s mechanical efficiency, thumb force, and stroke of the user’s thumb as it presses from an extended state to approach the index finger while gripping the pen, will be equal to the product of the force applied to the piston in the ampule and the distance the piston moves. In other words, conservation of energy applies to these systems (as it does to all systems) and a careful accounting of all the forces and motions of elements in the structural loop is what a skilled POSA would do in order to assess the viability of a design concept.

59. A slimmer pen injector is also an important consideration from a patient’s perspective, particularly those patients having limited manual flexibility and strength. *See* Ex. 2113 at 2 (“Pen devices are also more compact, portable and easier to grip, which may benefit those with impairments in manual dexterity.”). Generally, a narrower pen injector will be easier to grip during dose injection, and also more portable and discreet. Mr. Leinsing, Petitioner’s expert, indicated that a

pen injector should not be widened to a large extent and that generally it is better if the pen remains smaller. *See* Ex. 2163 at 169:12-171:3.

60. It is also important to design a pen injector that accounts for poor vision and lack of manual dexterity. *See* Ex. 2158 at 4 (“Accuracy and reliability of the dose setting are also important criteria for patients with visual impairment.”). Design considerations to address these human factors include single-unit increments on the dosing mechanism (*e.g.*, a dial sleeve), audible clicks to signify unit increments, a large dose selector, and a dosing mechanism that clearly shows the selected dosage with large printed numbers. *See, e.g.*, Ex. 2113 at 3-5.

61. I applied all of these considerations in the analysis contained in this declaration and in forming my opinions.

VI. OVERVIEW OF THE CHALLENGED PATENTS

62. Across IPR2018-01670, IPR2018-01675, IPR2018-01676, IPR2018-01678, IPR2018-01679, IPR2018-01680, IPR2018-01682, IPR2018-01684, and IPR2019-00122, Petitioner Mylan challenges U.S. Patent Nos. 8,603,044 (the “044 Patent”), 8,679,069 (the “069 Patent”), 8,992,486 (the “486 Patent”), 9,526,844 (the “844 Patent”), and 9,604,008 (the “008 Patent”). The 044 Patent, 069 Patent, 486 Patent, and the 844 Patent share substantially the same specification and figures. The 008 Patent contains the same figures and much of the same written

description, but it includes additional figures and written description for two additional depicted embodiments, as well as a lengthier summary of the invention. The 008 Patent also contains express definitions for certain claim terms, as I discuss further in the claim construction section of my declaration. All five of the challenged patents claim priority back to the same Great Britain patent application—GB 0304822.0 (Ex. 1026)—that was filed on March 3, 2003.

63. Below I provide an overview of these patents. When discussing subject matter common to all five of the challenged patents below, I will cite to the 044 Patent. When discussing subject matter only expressly disclosed in the 008 Patent, for example the second and third depicted embodiments, I will cite the relevant disclosures in the 008 Patent.

A. The Disclosure of the Challenged Patents

64. The challenged patents relate to pen injector devices that are used to dispense medications. Ex. 1002, 1:20-24. Diabetic patients, who manage their diabetes by self-treatment without formal medical training, frequently use pen injectors to administer doses of diabetes medication, such as insulin or insulin glargine. *Id.*, 1:25-29. Because of this, the challenged patents teach that pen injectors should be designed with several usability criteria in mind, including robustness of construction, and ease of use and understanding by the user. *Id.*, 1:30-35. Usability is especially important among diabetic populations, who may

be physically infirm and have impaired vision in many cases. *Id.* The challenged patents disclose improved designs for pen injectors that meet the criteria described above.

1. The First Depicted Embodiment

65. The first depicted embodiment is illustrated in Figures 1 through 16 of all of the challenged patents. This embodiment, shown below in Figures 1 and 2, is an example of an improved pen injector that satisfies the objectives identified in the paragraph above. I have reviewed an animation of this embodiment, which is Exhibit 2117, and in my opinion it fairly and accurately shows an embodiment described in the challenged patents.

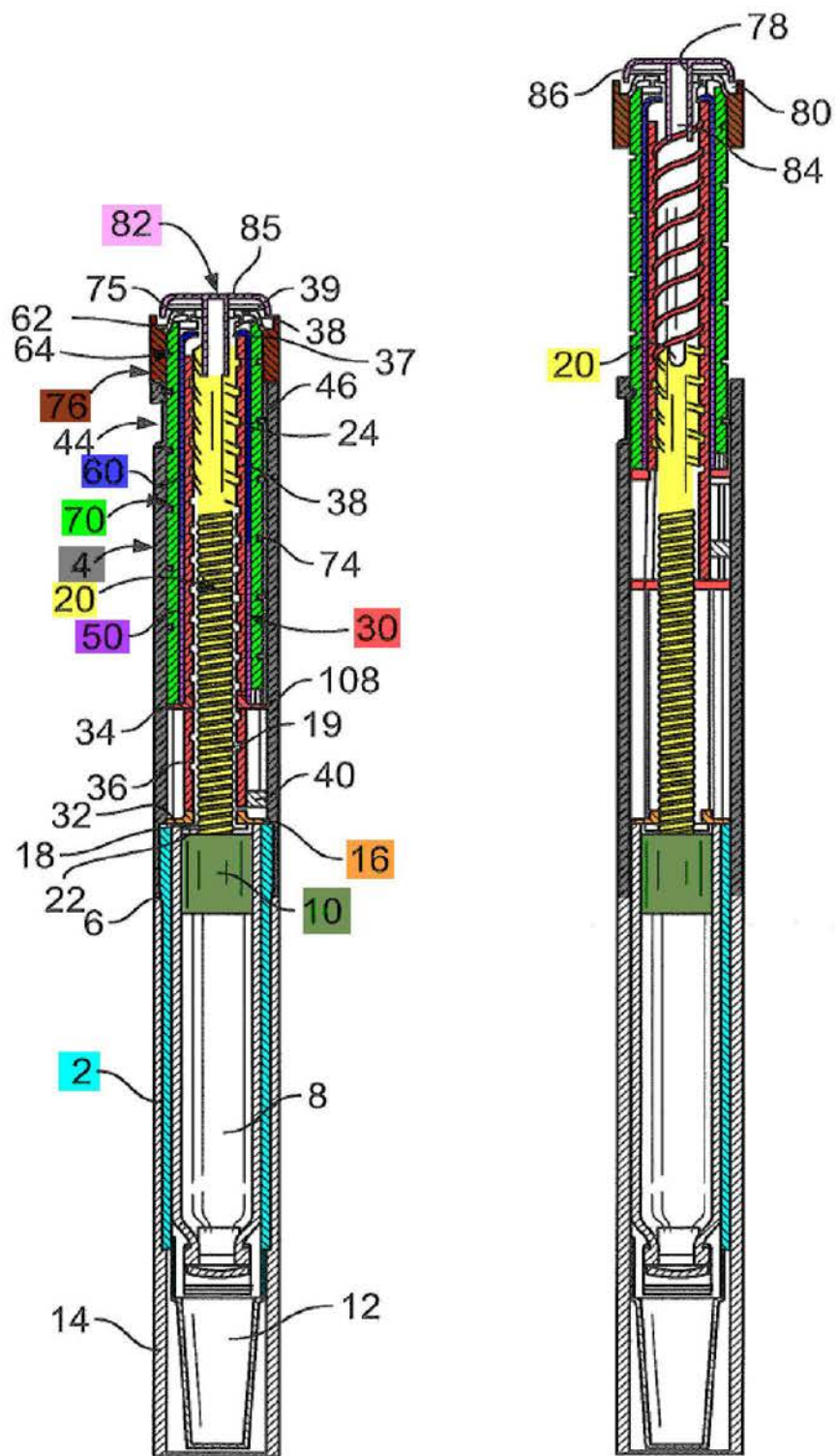

FIG. 1

FIG. 2

Ex. 1002, Figs. 1 and 2 (annotated)

66. As shown by the color coding in the figures above, this pen injector embodiment includes a cartridge retaining part 2 (light blue), a main housing 4 with internal threading (grey), a cartridge 8 for medication (yellow), a drive sleeve 30 (red), a clicker 50 (purple), a clutch 60 (dark blue), a dose dial sleeve 70 with an external helical groove (light green), a dose dial grip 76 (brown), and an injection button 82 (pink). The pen injector also has a window 44 in the main housing 4, which is used to indicate the amount of dosage that has been dialed.

67. A user selects a dose value in this embodiment by rotating the dose dial grip 76 (brown), which causes the dose dial sleeve 70 (light green) to wind out of the main housing 4 (grey) along a helical path defined by the engagement between the helical groove on the outer surface of the dose dial sleeve 70 and a helical rib 46, which is located on the interior of the main housing 4. Ex. 1002, 5:50-6:3; Figs. 9-10. The operation of this mechanism is shown below in Figures 9 and 10.

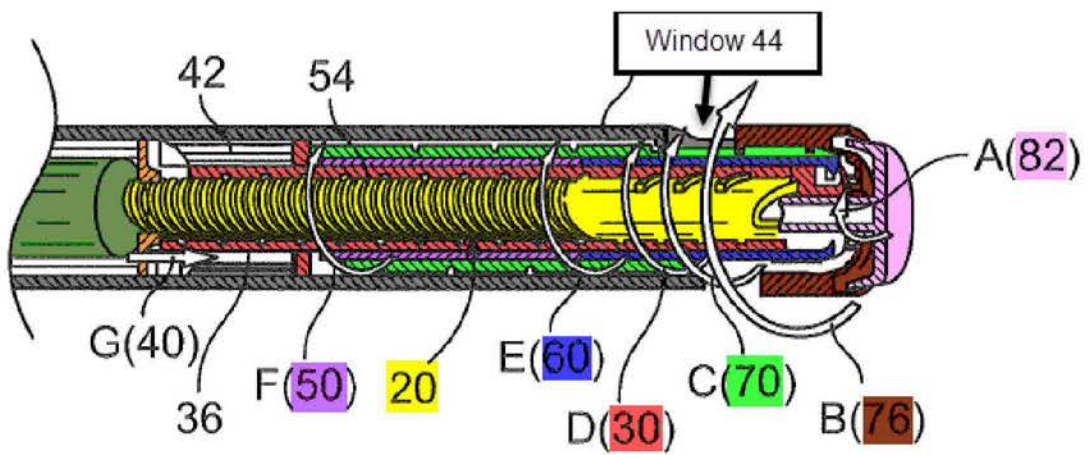

FIG. 9

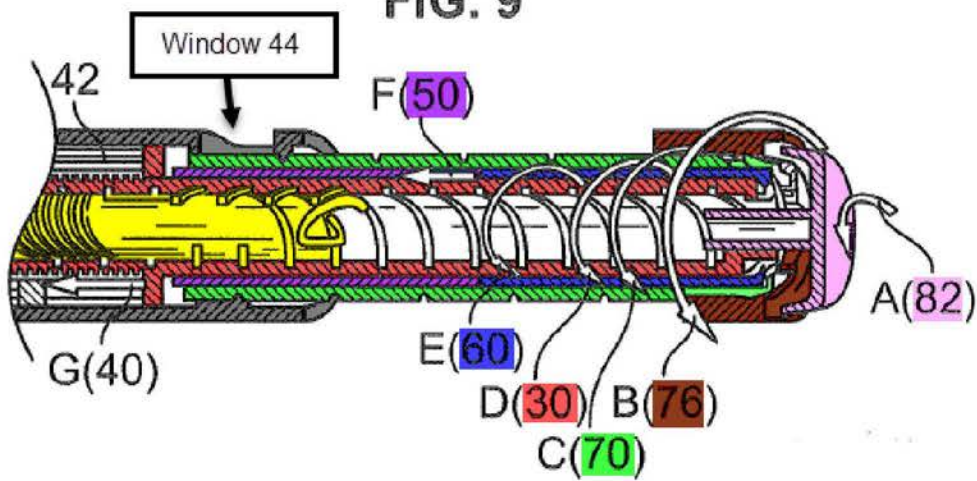

FIG. 10

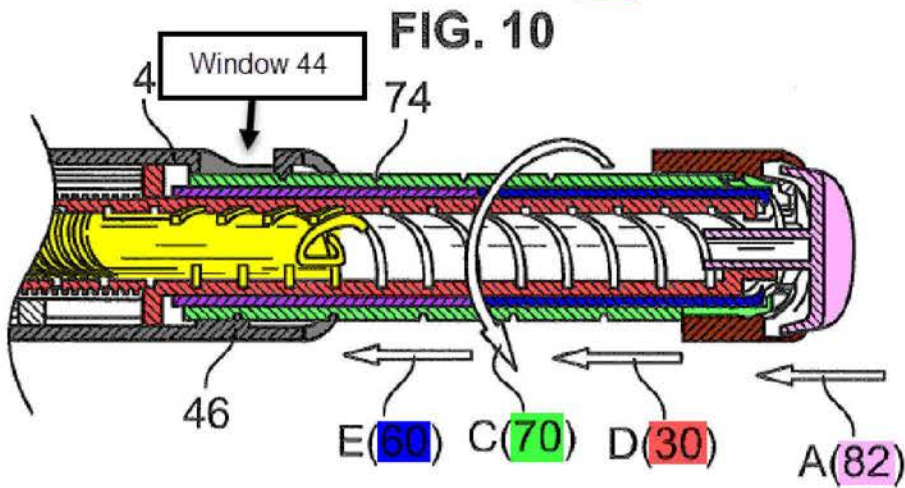

FIG. 11

Ex. 1002, Figs. 9-11 (annotated)

68. Dose marking numbers are printed on the external surface of the dose dial sleeve 70 to indicate the dialed dosage. *Id.*, 5:17-21. These numbers are visible to the user through the window 44, which is indicated in the figures above. *Id.* Additionally, in this embodiment, the pen has a clicker 50 that interacts with splines on the dose dial sleeve to provide audible feedback at each fixed dosage unit (for example, a click for every fixed unit of dosage that is dialed) to assist the user in understanding how much medication has been selected. *Id.*, 4:33-44, 5:54-60.

69. Figure 11, above, shows the operation of the device once the user has selected a dose and is ready to inject the medication. The user dispenses the dose by pressing the dose button 82 (pink) with their finger or thumb, as indicated by the arrow labeled A(82). *Id.*, 6:27-28. This causes the dose dial sleeve to advance into the housing and move the drive sleeve 30 (red) toward the distal end of the pen, as shown by arrow D(30). This causes piston rod 20 (yellow) to move piston 10 (dark green in Figs. 1 and 2) into the cartridge to force the stored medication out through the needle. *Id.*, 6:44-46.

70. During this injection process, the button 82 (pink) and drive sleeve (30) become rotationally decoupled (by a clutch) from the dose dial sleeve 70 (light green). This allows the dose dial sleeve 70 (light green) to rotate back into the housing along the helical path defined by the groove in the outer surface of the

dose dial sleeve, which is indicated by Arrow C(70) in Figure 11. In contrast, the dose button 82 (pink) and drive sleeve (30) travel along an axial, non-rotating path, shown by arrows A(82) and D(30). *Id.*, 6:27-34; Fig. 11.

71. After injection is complete, the dose dial sleeve 70 (light green) reaches the “starting” or “zero dose” position, at which point it is prevented from rotating further into the pen injector. *Id.*, 6:47-51. The user can then release the injection button, and the spring action of the clicker re-engages a clutch thus returning the device mechanism to the dose dialing state. When it is time for another injection, the pen is ready for the user to rotate the dose dial grip to dial a new dose. *Id.*, 6:39-43.

2. The Second Depicted Embodiment

72. The 008 Patent illustrates a second embodiment, which shares many of the same general parts as the first depicted embodiment and operates similarly. As shown below in Figure 17 of the 008 patent, these parts include those identified as a main housing 4' (dark grey), an insert 16' (orange) secured to the main housing, a piston rod 20' (yellow), a drive sleeve 30' (red), a nut 40' to track the total dosage of a cartridge dialed, a clicker 50' (purple), a clutch 60' (dark blue), a dose dial sleeve 70' (light green), a dose dial grip 76' (brown), and a button 82' (pink). *See Ex. 1005, 10:48-12:45.*

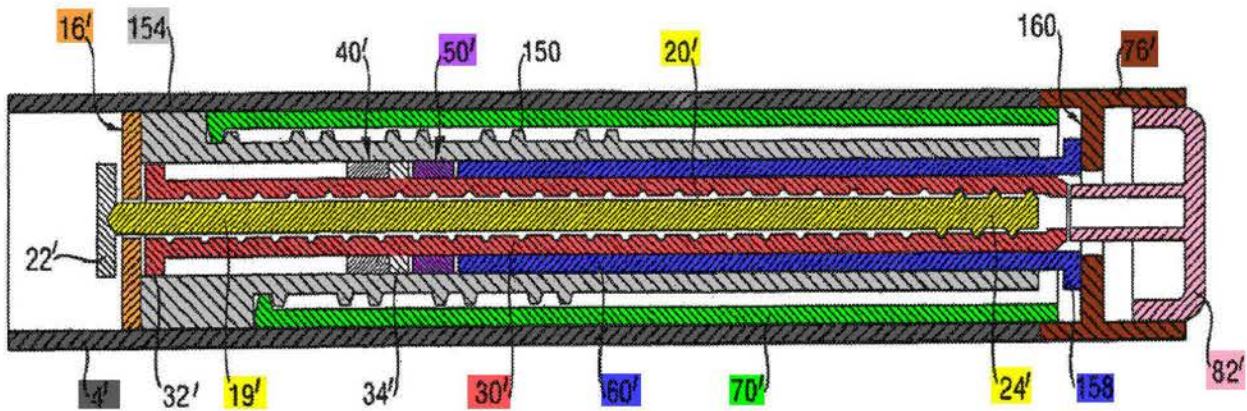

Ex. 1005, Fig. 17.

73. Relative to the first embodiment, the second embodiment includes a separate new part—internal housing 154 (light grey)—that is secured to the main housing 4'. *See Ex. 1005, 10:65-11:7.* Instead of the main housing 4' (dark grey) having an internal thread that engages with an exterior thread of the dose dial sleeve 70' (light green), as in the first embodiment, here the dose dial sleeve 70' (light green) has an interior thread that engages with the exterior thread 150 of the internal housing 154 (light grey). *See Ex. 1005, 10:65-11:7, 12:7-10.* Other than this threaded engagement between the dose dial sleeve 70' and the internal housing 154, the dose dialing, cancelling, and dispensing operations of the second embodiment are generally the same as with the first embodiment.

3. The Third Embodiment

74. The 008 Patent illustrates a third depicted embodiment in Figures 18 through 24. From a patient perspective, the dose dialing, dose cancelling, and dose dispensing steps work the same way as the first two embodiments, but the internal

drive mechanism is different. As shown in figures 18, 23 and 24, below, the pen injector of the third embodiment includes a housing 2'' having a second part 10'' (dark grey), a rack 6'' (purple) that is axially and rotationally fixed to the housing 2'', and a drive sleeve 18'' (red) with internal helical threads that engages helically-shaped teeth of a gear 22'' (dark green). *See Ex. 1005, 14:3-45.* This gear 22'' (green) is mounted on the end of a piston rod 32'' (yellow) that is rotationally-fixed with respect to the housing 2'' (dark grey). *See id., 14:53-59.* This embodiment also includes a dose dial sleeve 36'' (light green) with internal threads that engage the external threads of an internal sleeve portion 44'' (light grey). *See id., 14:60-15:15.* The threads between the internal sleeve portion 44'' (light grey) and dose dial sleeve 36'' (light green) have the same lead as the internal threading on the drive sleeve 18'' (red). *See id., 14:39-42, 15:12-13.* This embodiment also includes a button 56'' (pink), which is permanently locked with respect to rotation with the drive sleeve 18'' (red). *See id., 15:21-28, 15:46-47.* The button 56'' (pink) is held against end wall 50'' (light green) of the dose dial sleeve 36'' (green) by a U-shaped locking spring 68'' (dark blue), such that the interface between button 56'' (pink) and end wall 50'' (light green) acts as a clutch during dose dialing and dose cancellation. *See id., 15:41-47, 16:5-11.*

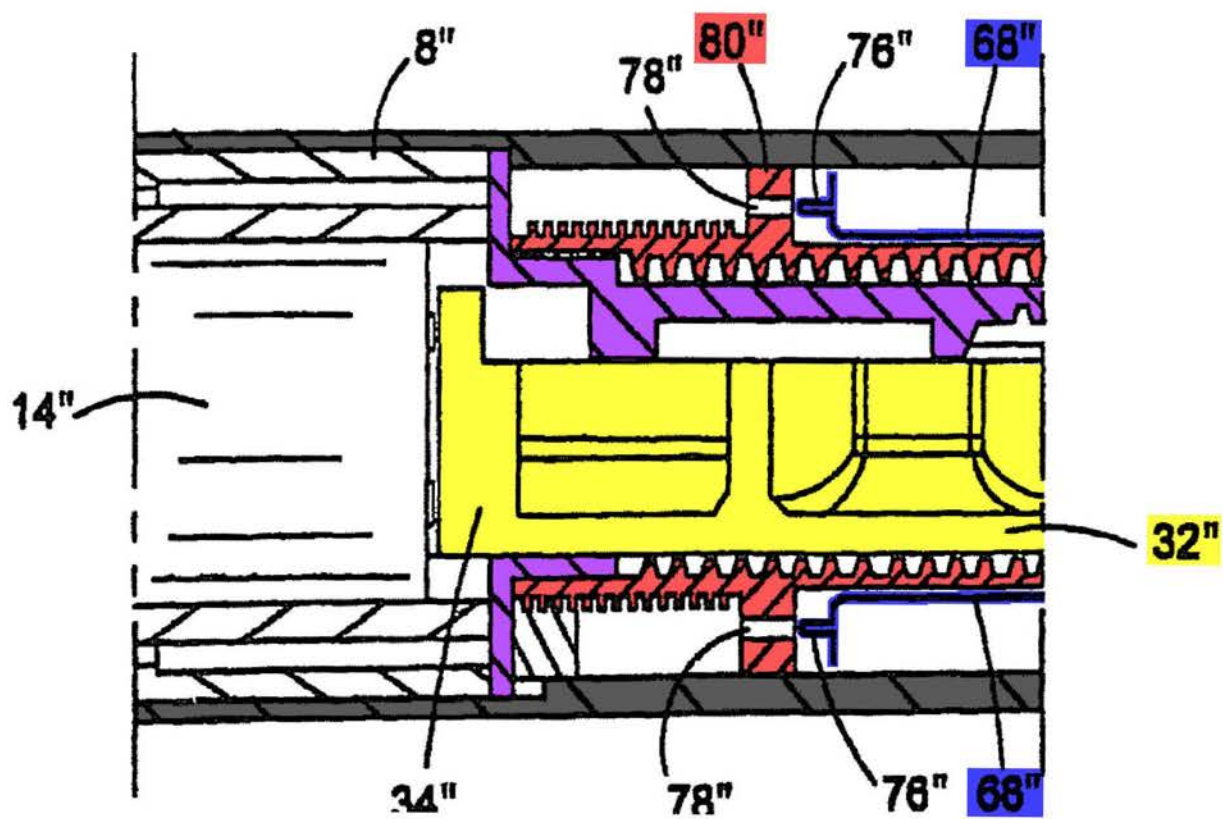
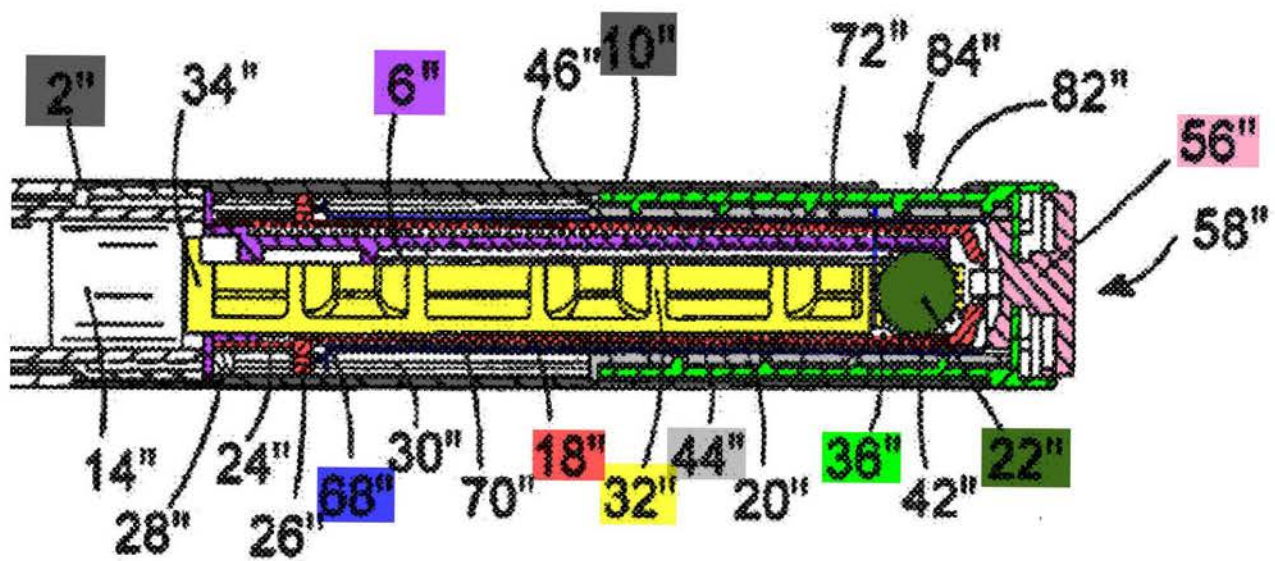

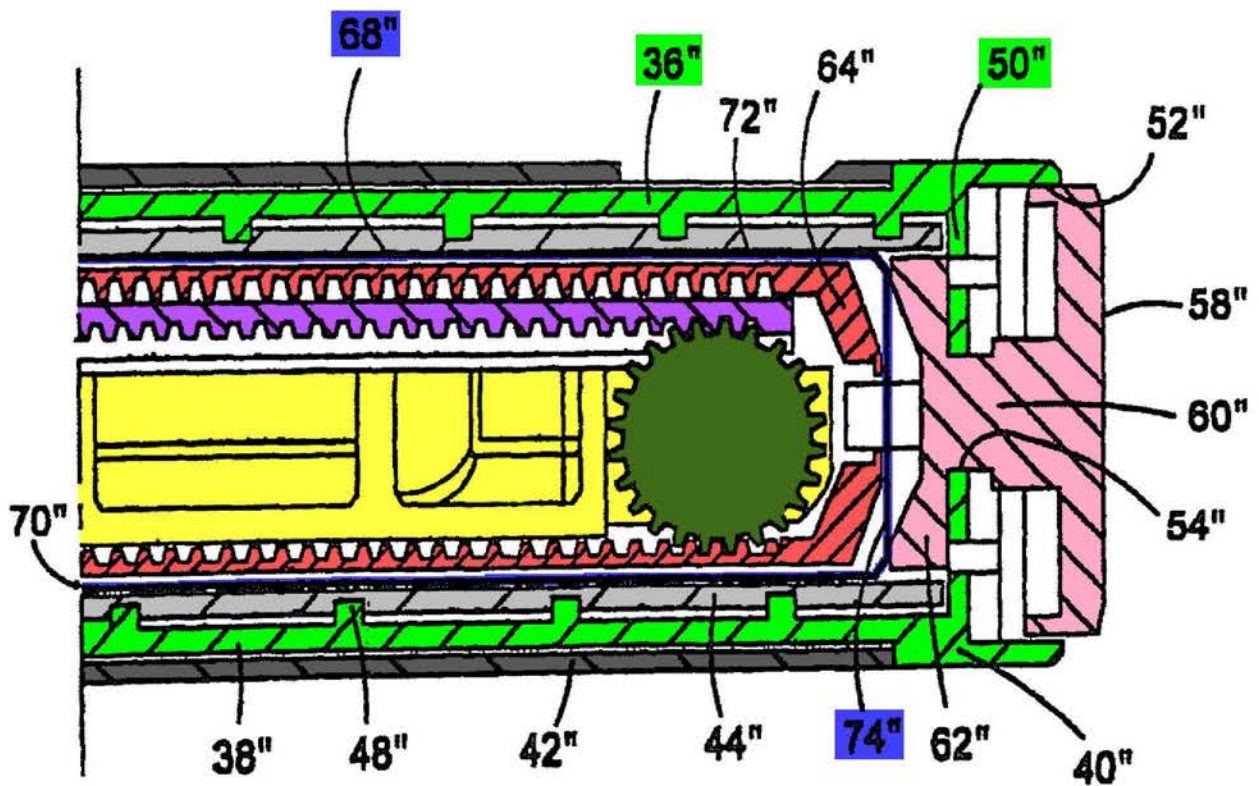

Ex. 1005, Figs. 18 (partial), 23 and 24

75. Because the U-shaped spring 68'' biases the button 56'' into a clutching engagement with end wall 50'' of dose dial sleeve 36'' (light green), and because the dose button 56'' is permanently rotationally locked with the drive sleeve 18'' (red), during dose dialing and dose cancelling the dose dial sleeve 36'' (light green), button 56'' (pink) and drive sleeve 18'' (red) all rotate out of and in to the housing 2'' (dark grey). *See id.*, 16:1-24. During dose dialing and cancelling, the drive sleeve 18'' (red) rotates around the rack 6'' (purple), piston rod 32'' (yellow), and toothed gear 22'' (dark green) without moving them. The drive sleeve 18'' (red) includes two clicker projections 80'' (red) that click past

splines 30'' in the housing 2'' (dark grey) during dose dialing as the drive sleeve 18'' (red) is rotated.

76. During dose injection, the button 56'' (pink) is pressed, which pushes against U-shaped locking spring 68'' (dark blue) and disengages the button 56'' from the clutch interface with end wall 50'' (light green). *See id.*, 16:25-30. The button 56'' (pink) and drive sleeve 18'' (red) move axially back into the housing 2'' (dark grey) without spinning while the dose dial sleeve 36'' (light green) rotates back into the housing 2'' (dark grey). *See id.*, 16:30-42. This relative movement between the drive sleeve 18'' (red) and rack 6'' (purple) cause the toothed gear 22'' (dark green) to rotate and, together with the piston rod 32'' (yellow) move axially toward the cartridge. *See id.*, 16:42-60.

77. This third embodiment also includes a nut 28'' to track the total dosage of the cartridge that has been dialed. *See id.*, 16:19-24, 16:65-17:15. There is also a maximum dial end stop, which prevents the dose dial sleeve 36'' from rotating out of the housing beyond the maximum dose that can be injected at once. *See id.*, 17:16-26.

B. The Challenged Claims of the Challenged Patents

78. I understand that Petitioner has challenged the validity of the following claims:¹

- 044 Patent: claims 11, 14-15, 18-19
- 069 Patent: claim 1
- 486 Patent: claims 1-6, 12-18, 20, 23, 26-30, 32-33, 36, 38-40, 51-57
- 844 Patent: claims 21-30
- 008 Patent: claims 1, 3, 7-8, 11, and 17

79. Independent claim 11 of the 044 Patent, independent claim 1 of the 069 Patent, and independent claim 1 of the 486 Patent recite many of the same limitations, but there are differences. I have noted the differences between these three independent claims below with underlining.

044 Patent, claim 11	069 Patent, claim 1	486 Patent, claim 1
A housing part for a medication dispensing apparatus, said housing part comprising:	A housing part for a medication dispensing apparatus, said housing part comprising:	A housing part for a medication dispensing apparatus, said housing part comprising:
a main housing, said	a main housing, said main	a main housing, said

¹ In Section X, below, I provide an overview of the grounds.

main housing extending from a distal end to a proximal end;	housing extending from a distal end to a proximal end;	main housing extending from a distal end to a proximal end;
a dose dial sleeve positioned within said housing, said dose dial sleeve comprising a helical groove configured to engage a threading provided by said main housing, <u>said helical groove provided along an outer surface of said dose dial sleeve;</u>	a dose dial sleeve positioned within said housing, said dose dial sleeve comprising a helical groove configured to engage a threading provided by said main housing, <u>said helical groove provided along an outer surface of said dose dial sleeve;</u>	a dose dial sleeve positioned within said housing, said dose dial sleeve comprising a helical groove configured to engage a threading provided by said main housing;
a <u>dose dial grip</u> disposed near a proximal end of said dose dial sleeve;	a <u>dose dial grip</u> disposed near a proximal end of said dose dial sleeve;	a <u>dose knob</u> disposed near a proximal end of said dose dial sleeve;
a piston rod provided within said housing, said piston rod is non-rotatable during a dose setting step relative to said main housing;	a piston rod provided within said housing, said piston rod is non-rotatable during a dose setting step relative to said main housing;	a piston rod provided within said housing, said piston rod is non-rotatable during a dose setting step relative to said main housing;

<p>a <u>drive sleeve</u> extending along a portion of said piston rod, said <u>drive sleeve</u> comprising an internal threading near a distal portion of said <u>drive sleeve</u>, said internal threading adapted to engage an external thread of said piston rod; and,</p>	<p>a <u>drive sleeve</u> extending along a portion of said piston rod, said <u>drive sleeve</u> comprising an internal threading near a distal portion of said <u>drive sleeve</u>, said internal threading adapted to engage an external thread of said piston rod; and,</p>	<p>a <u>driver</u> extending along a portion of said piston rod, said <u>driver</u> comprising an internal threading near a distal portion of said <u>driver</u>, said internal threading adapted to engage an external thread of said piston rod; and,</p>
<p>a tubular clutch located adjacent a distal end of said <u>dose dial grip</u>, said tubular clutch operatively coupled to said <u>dose dial grip</u>, wherein said dose dial sleeve extends circumferentially around at least a portion of said tubular clutch, and wherein said helical groove of the dose dial sleeve has a</p>	<p>a tubular clutch located adjacent a distal end of said <u>dose dial grip</u>, said tubular clutch operatively coupled to said <u>dose dial grip</u>, wherein said dose dial sleeve extends circumferentially around at least a portion of said tubular clutch.</p>	<p>a tubular clutch located adjacent a distal end of said <u>dose knob</u>, said tubular clutch operatively coupled to said <u>dose knob</u>, wherein said dose dial sleeve extends circumferentially around at least a portion of said tubular clutch.</p>

<p>first lead and said internal threading of said drive sleeve has a second lead, and wherein said first lead and said second lead are different.</p>		
---	--	--

80. Because of the overlapping language between these claims, Mr. Leinsing analyzed these claims together in his declaration. *See, e.g.*, Ex. 1011, ¶¶ 258-285.

81. Petitioner also challenges the validity of independent claim 51 of the 486 Patent, which states:

51. A clutch for use within a pen type drug delivery device, said clutch comprising
a tubular body, said tubular body extending from a distal end to a proximal end; and said distal end of said tubular body having a diameter sized such that said distal end of said tubular body may be positioned within a proximal end of a dial member.

82. The challenged claims of the 844 Patent include independent claim 21, which recites:

21. A drug delivery device comprising:
a housing comprising a dose dispensing end and a first thread;

a dose indicator comprising a second thread that engages with the first thread;

a driving member comprising a third thread;

a sleeve that is (i) disposed between the dose indicator and the driving member and (ii) releasably connected to the dose indicator;

a piston rod comprising either an internal or an external fourth thread that is engaged with the third thread;

a piston rod holder that is rotatably fixed relative to the housing and configured to (i) prevent the piston rod from rotating during dose setting and (ii) permit the piston rod to traverse axially towards the distal end during dose dispensing;

wherein:

the housing is disposed at an outermost position of the drug delivery device;

the dose indicator is disposed between the housing and the sleeve and is configured to (i) rotate and traverse axially away from the dose dispensing end during dose setting and (ii) rotate and traverse axially towards the dose dispensing end during dose dispensing;

the driving member is configured to rotate relative to the piston rod;

the sleeve is rotatably fixed relative to the driving member and configured to traverse axially with the dose indicator; and

the piston rod and the driving member are configured to rotate relative to one another during dose dispensing;

and the piston rod is configured to traverse axially towards the dose dispensing end during dose dispensing.

83. The challenged claims of the 008 Patent include independent claim 1, which recites:

1. A drive mechanism for use in a drug delivery device comprising:
 - a housing comprising a helical thread;
 - a dose dial sleeve having a threaded surface that is engaged with the helical thread of the housing,
 - an insert provided in the housing, where the insert has a threaded circular opening;
 - a drive sleeve releasably connected to the dose dial sleeve and having an internal helical thread;
 - a piston rod having a first thread and a second thread, wherein the first thread is engaged with the threaded circular opening of the insert and the second thread is engaged with the internal helical thread of the drive sleeve; and
 - a clutch located between the dose dial sleeve and the drive sleeve, wherein the clutch is located (i) radially outward of the drive sleeve and (ii) radially inward of the dose dial sleeve.

84. The dependent claims challenged by Petitioner across the nine IPRs additionally recite clicking mechanisms (044 Patent, claims 14-15; 486 Patent, claims 14-18, 20; 844 Patent, claims 24-25, 29), maximum dose dial stops (486 Patent, claims 30, 32), last-dose nuts (844 Patent, claim 30), interior housing (486

Patent, claims 38-40; 008 Patent, claim 3), disposability of the pen injector (486 Patent, claim 36), and otherwise recite different geometries, positions, and features of previously recited components (044 Patent, claims 18-19; 486 Patent, claims 2-6, 12-13, 23-29, 33, 52-57; 844 Patent, claims 22, 26-27; 008 Patent, claims 7-8, 11, 17).

C. The Priority Date of the Challenged Patents

85. Each of the challenged patents issued from an application that claims priority to the filing dates of earlier-filed parent applications. The ultimate parent application to which all of the challenged patents claim priority is GB 0304822.0, a Great Britain application filed on March 3, 2003. I understand then that each of the claims of the challenged patents are entitled to a March 3, 2003 priority date. For purposes of my analysis and opinions in this report, I have thus assumed that March 3, 2003 is the priority date of each of the challenged patents. Note, my opinions below regarding validity do not change if it is determined that one or more challenged patents are not entitled to the March 3, 2003 date.

86. I understand that Petitioner and its expert, Mr. Leinsing contend that claims 21-30 of the 844 Patent are not entitled to this March 3, 2003 priority date because the GB Application does not specifically disclose, “‘a piston rod’ comprising an internal fourth thread that is engaged with a third thread of a ‘driving member.’” Petition at 16. Therefore, according to Petitioner, the GB

Application provides no written description support for this limitation of claim 21 (and claims 22-30, which depend from claim 21) of the 844 patent. Petition at 16.

87. I understand that the test for written description is whether the disclosure of the application relied upon reasonably conveys to those skilled in the art that the inventor had possession of the claimed subject matter as of the filing date.

88. In evaluating written description, I understand that a claim does not lack written description simply because the embodiments of the specification do not contain examples explicitly covering the full scope of the claim language. This is because the patent specification is written for a person of skill in the art, and such a person comes to the patent with the knowledge of what has come before. Placed in that context, it is unnecessary to spell out every detail of the invention in the specification.

89. I understand that the disclosure needed to satisfy written description varies with the nature and scope of the invention, with the scientific and technologic knowledge already in existence.

90. I further understand that because written description is applied to each invention in view of the state of relevant knowledge, the application of written description will vary with differences in the state of knowledge in the field and differences in the predictability of the science.

91. Under this standard, in my opinion, the 844 Patent can claim priority to the GB Application because the GB Application provides adequate written description support to a POSA for the limitation of “‘a piston rod’ comprising an internal fourth thread that is engaged with a third thread of a ‘driving member.’” I therefore disagree with Petitioner and Mr. Leinsing on this issue.

92. In my opinion, the GB Application broadly discloses a piston rod with threads engaged to a drive sleeve with threads. As I discuss below, a POSA would understand that there are two ways to implement this threaded engagement: (1) the piston rod has external threads that engage internal threads of a drive sleeve; or (2) the piston rod has internal threads that engage external threads of a drive sleeve. Both drive mechanisms were conventional at the time the GB Application was filed. So in my opinion the broad disclosure in the GB application is sufficient to reasonably convey possession of an internally threaded piston rod with an externally threaded drive tube and vice versa. Below is the language from the GB application that I am referring to as the broad disclosure.

- 25 According to a first aspect of the present invention, a pen-type injector comprises
a housing;
a piston rod adapted to operate through the housing;
a dose dial sleeve located between the housing and the piston rod, the dose dial
sleeve having a helical thread of first lead;
- 30 a drive sleeve located between the dose dial sleeve and the piston rod, the drive
sleeve having a helical groove of second lead;
characterised in that the first lead of the helical thread and the second lead of the
helical groove are the same.
- Preferably, the piston rod has a first threaded portion at a first end and a second
threaded portion at a second end;
an insert or radially inwardly extending flange is located in the housing and
- 5 through which the first threaded portion of the piston rod may rotate;
the dose dial sleeve being rotatable with respect to the housing and the insert;
the drive sleeve being releasably connected to the dose dial sleeve and
connected to the piston rod for rotation with respect thereto along the second
threaded portion of the piston rod;

Ex. 1026 at 0007-0008 (highlighting added). According to Mr. Leinsing, the GB Application “exclusively describes an injector device that has a piston rod having external threading adapted to engage internal threading of a drive sleeve and insert.” Ex. 1011 at ¶ 101. But nowhere in the broad disclosure above does it say that the piston rod has external threads or that the drive sleeve has internal threads. Instead, it broadly describes a threaded engagement between a piston rod and drive sleeve without specifying whether threading is internal or external on these components.

93. Mr. Leinsing appears to testify that because the dose dial sleeve described in the embodiment is located between the housing and the piston rod, the GB Application’s broad disclosure is limited to an externally threaded piston rod.

This argument restricts the use of “between” to the radial direction. In my opinion, this interpretation does not appreciate the full scope of the GB Application since the GB Application also uses “between” when referring to the relationship of components in the axial direction. For example, the GB Application talks about an intermediate thread 36 “extending between the first flange 32 and the second flange 34.”. Ex. 1026 at 12 (6:8-12). As shown in FIG. 2, the figure below illustrates the difference between the axial and radial directions:

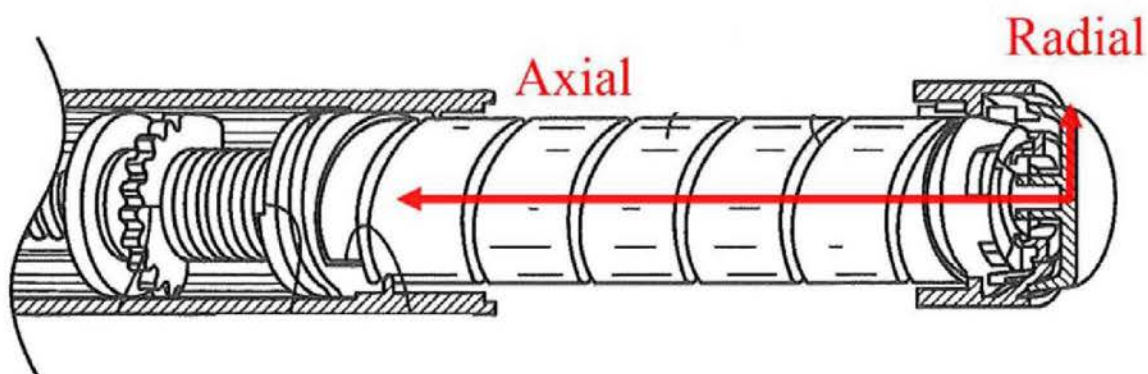

94. A POSA, reading the GB Application, would have understood that “between” includes either of axial and radial directions. This is the plain and ordinary meaning for “between” which means one must encounter B as one goes from A to C: “between” by itself does not imply direction. Thus, where the passage above states that “a drive sleeve located between the dose dial sleeve and the piston rod”, this includes the situation where the drive sleeve is located *axially*

between the dose dial sleeve and the piston rod. Accordingly, this arrangement *does not foreclose* an internally threaded piston rod.

95. At the time the GB Application was filed, driving mechanisms where an internally threaded piston rod is driven by externally threaded driver were well known to a POSA. As an example, U.S. Patent No. 4,648,872 (“872 Patent”), which was filed on November 15, 1983, discloses a medical infusion pump where the medicine delivery means comprises an externally threaded drive screw 14 that drives an internally threaded piston member 12. Ex. 2169 (4,648,872), 1:6-10; 2:55-61. Below, left, is FIG. 1B from the 872 Patent showing the arrangement and operation of the pump, and below to the right is FIG. 3A, showing a cross-sectional view of the piston member 12 showing internal threads 31:

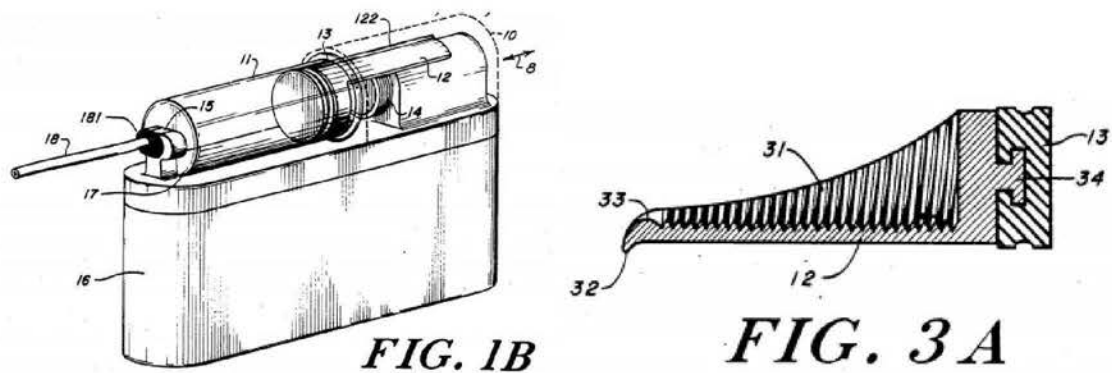

96. Other patents before the GB Application disclosed a driving mechanism whereby an internally threaded piston rod is driven by an externally threaded driver. U.S. Patent No. 4,747,824, which was filed on May 30, 1986, is directed to a hypodermic anesthetic injection method disclosed an axially slidable

“piston rod [that] is internally threaded to receive a drive screw 23.” Ex. 2170 (4,747,824), 6:33-41, FIG. 5.

97. These patents demonstrate that at the time the GB Application was filed, a driving mechanism where an internally threaded piston rod was driven by an externally threaded driver was well known to a POSA. In fact, by the late 1990s, years before the GB Application was filed, this mechanism was described in the art as a “conventional lead-screw drive mechanism.” *See* Ex. 2171 at Cover (showing 1999 filing date), 5:17-21, FIGS. 3a, 3b. Because this mechanism was conventional, in my opinion, a POSA did not need to explicitly show the arrangement of an internally threaded piston rod engaged to an externally threaded drive sleeve, when the GB Application explicitly disclosed a threaded piston rod engaged to a drive sleeve.

98. My conclusion is further supported by the underlying physics that a POSA would have understood (*see* ¶¶ 31-33 above). Regardless of the overall arrangement of components (*i.e.*, internally threaded piston rod engaged to externally threaded piston rod and vice versa), in the end, physics does not care which element has the internal thread and which element has the external thread. What physics does care about is the flow of force from the user’s thumb through the mechanism and into the ampoule piston. This flow of force for these types of mechanisms will be: (1) The thumb force is applied and flows into a threaded shaft

that reacts against a mating thread so relative rotation occurs between the two. This is the backdriven thread portion of the pen injector, where user thumb force (injection force) is transformed into rotary motion and torque. (2) The rotation generated in the drive sleeve is applied to a threaded interface between it and the proximal threaded region of the piston rod. Unlike all other prior art, the piston rod is not constrained rotational or axially, rather it has another thread at its distal region that engages with a threaded body that is essentially fixed to the housing which the user holds in their hand. Again, Newton's third law comes into play where the torque between the drive sleeve and the piston results in a torque in the piston that causes it to want to rotate and in so doing the piston rotates in the threaded body that is fixed to the housing causing the piston rod to advance through the threaded body to exert.

99. Note that it does not matter which thread (whether on the piston rod or drive sleeve) is internal or external, the analysis is the same all throughout the flow of energy from the motion of the user's finger through the mechanism and into the ampoule to cause the medicament to flow out of the needle. A POSA would thus have understood that, at the time of the GB Application, providing an externally threaded piston rod engaged with an internally threaded driver was interchangeable with an internally threaded piston rod engaged with an externally threaded driver. In my opinion, therefore, disclosure of a threaded piston rod connected to a drive

sleeve was adequate disclosure for a POSA to understand the inventors to be in possession of an internally threaded piston rod engaged to an externally threaded driver.

100. In my opinion, the GB Application provides written description support for “‘a piston rod’ comprising an internal fourth thread that is engaged with a third thread of a ‘driving member.’” Since the GB Application was filed earlier than Giambattista, Giambattista is not prior art and cannot anticipate or render the challenged claims 21-30 of the 844 patent unpatentable.

VII. LEVEL OF ORDINARY SKILL IN THE ART

101. I have been informed that a person of ordinary skill in the art is a hypothetical person who, as of the relevant timeframe, would have the capability of understanding the scientific and engineering principles applicable to the pertinent art. I have been informed by counsel that factors that may be considered in determining the level of ordinary skill in the art may include: (A) the “type of problems encountered in the art”; (B) “prior art solutions to those problems”; (C) the “rapidity with which innovations are made”; (D) the “sophistication of the technology”; and (E) the “educational level of active workers in the field.” I also understand that every factor may not be present for a given case, and one or more factors may predominate.

102. Based on my review of the challenged patents (*i.e.*, U.S. Patent Nos. 8,603,044, 8,679,069, 8,992,486, 9,526,844, and 9,604,008), related prior art, and my professional experience, it is my opinion that the correct level of ordinary skill is defined by a person who understands the mechanical elements (*e.g.*, lead screws, clutches, gears) used in drug injection delivery devices as well as the principles governing the interactions of such mechanical elements, and further understands the basics of device design and manufacturing. That person will have a bachelor's degree in mechanical engineering or an equivalent degree. This level of ordinary skill reflects the educational level of workers in the field and the sophistication of the technology.

103. I understand that the level of ordinary skill in the art proposed by Petitioner is inconsistent across the different IPRs for the patents in this family. For example, in IPR2018-01684, IPR2018-01682, IPR2018-01680, and IPR2018-01670 Petitioner's proposed level of ordinary skill does not require any years of experience, whereas in other petitions, Petitioner states that a POSA would have had "design experience," "approximately three years of experience in medical-device design," or "three-year's experience" depending on the petition. *See* IPR2018-01675, Paper 2 at 14; IPR2018-01676, Paper 2 at 14, IPR2018-01679, Paper 2 at 12. Petitioner has not provided any reasoning for this inconsistency. Moreover, Mr. Leinsing testified that three years of experience is not required.

Regardless, the slight differences between Petitioner's level of ordinary skill and my opinion on the level of ordinary skill do not affect the opinions I offer in this declaration.

104. Due to my education, experience, knowledge, and skill, I am familiar with the level of skill in the art during the relevant timeframe and was a person of ordinary skill in the art.

VIII. CLAIM CONSTRUCTION

105. I have been informed by counsel that in these IPRs, the claims of the challenged patents must be given their broadest reasonable interpretation consistent with the specification. I understand that this standard does not mean the broadest possible interpretation. Instead, the meaning ascribed to a claim term must be consistent with its ordinary and customary meaning and consistent with the specification and drawings as understood from the perspective of a person of ordinary skill in the art. I have also been informed that when construing a claim term, it is not proper to import into the meaning any limitations that are not part of the claim. I have been informed, however, that there are exceptions to these rules. For example, I have been informed that if the specification of a patent clearly sets forth a definition of a claim term, as opposed to a preferred embodiment, then that definition will apply over the ordinary and customary meaning given to the term by a person of ordinary skill in the art. I have also been informed that the same claim

term across related patents (*i.e.*, patents that claim the benefit of a common parent or ancestor application’s earlier filing date) is presumed to have the same meaning.

I have followed these principles in the analysis in this declaration.

106. I am aware that in a co-pending district court litigation (*Sanofi-Aventis U.S. LLC et al. v. Mylan GmbH et al.*, Civil Action No. 17-9105 (SRC)) (“Mylan DNJ Case”) Sanofi has proposed the following constructions for the following terms (*see* Ex. 1019 at 19-33):

Term	Sanofi’s Proposed Construction in the Mylan DNJ Case
“drive sleeve”	“an essentially tubular component of essentially circular cross-section releasably connected to the dose dial sleeve that drives the piston during dose dispensing”
“driver” / “driving member”	“a component releasably connected to the dose dial sleeve that drives the piston during dose dispensing”
“main housing”	“an exterior unitary or multipart component configured to house, fix, protect, guide, and/or engage with one or more inner components”
“piston rod”	“a rod that engages with the drive sleeve/driver/driving member to advance the piston during dose dispensing”

Term	Sanofi's Proposed Construction in the Mylan DNJ Case
"the piston rod and the driving member are configured to rotate relative to one another during dose dispensing"	Plain and ordinary meaning, which a person of ordinary skill in the art would understand to be "during dose dispensing, the piston rod rotates while the driving member does not rotate, the driving member rotates while the piston rod does not rotate, or both rotate at different rates and/or directions"
"thread" / "threaded" / "threading" ²	"a rib or groove on a first structure that engages a corresponding groove or rib on a second structure"
"tubular clutch"	"a tubular structure that couples and decouples a moveable component from another component"
"clutch"	"a structure that couples and decouples a moveable component from another component"
"clicker"	"a structure that provides audible and/or tactile feedback when the dose knob is rotated"
"insert"	Plain and ordinary meaning, which a person of ordinary skill in the art would understand to be "an internal structure" as defined in each of the claims in which it appears ³

² I understand that Sanofi dropped the proposed constructions for these terms and did not submit any arguments in support.

³ I note that Mr. Leinsing attempts to identify Sanofi's proposed construction for "insert" in the Mylan DNJ Case on page 58 of his declaration, but the construction he lists differs from Sanofi's proposed construction in Ex. 1019 (Plaintiffs'

Term	Sanofi's Proposed Construction in the Mylan DNJ Case
"holder" ⁴	Plain and ordinary meaning, which a person of ordinary skill in the art would understand to be "a structure that holds a referenced structure" (e.g., a piston rod holder holds a piston rod) ⁵

107. With the exception of the terms "main housing" and "tubular clutch," I have not been asked to form any opinion on the above-listed proposed constructions and have not formed any opinion on the above-listed proposed constructions.

Preliminary Claim Constructions), to which Mr. Leinsing cites. *See* Ex. 1011 at p. 59.

⁴ On page 58 of his declaration, Mr. Leinsing also cites Ex. 1019 (Plaintiffs' Preliminary Claim Constructions) in support of his contention that Sanofi proposed a construction for "piston rod holder," but the Sanofi's proposed construction in Ex. 1019 is for "holder." *See* Ex. 1011 at p. 59.

⁵ As with the proposed construction for "insert," Mr. Leinsing's identification of Sanofi's construction here is different than the construction in Ex. 1019 (Plaintiffs' Preliminary Claim Constructions), to which Mr. Leinsing cites. *See* Ex. 1011 at p. 59.

108. I also understand that in the Mylan DNJ Case, Mylan proposed that the terms “tubular clutch,” “clutch,” “clicker,” “insert,” and “holder” are means-plus-function terms having the following constructions:

Term	Sanofi’s Proposed Construction in the Mylan DNJ Case
“tubular clutch” / “clutch”	<p>Structure:</p> <p>Figures 1, 5-11, item 60</p> <p>Function:</p> <p>“clutching, i.e., coupling and decoupling a moveable component from another component”</p> <p>or</p> <p>“a tubular component that, during dose setting, operates to reversibly lock two components in rotation”</p>
“clicker”	<p>Structure:</p> <p>Figures 6-8, item 50</p> <p>Function:</p> <p>“providing at least an audible feedback to a user when said dose dial grip is rotated”</p>
“insert” / “holder”	<p>Structure:</p> <p>Figures 1, 3-5, item 16</p> <p>Function:</p> <p>“prevent the piston rod from rotating during dose setting and permit the</p>

Term	Sanofi's Proposed Construction in the Mylan DNJ Case
	piston rod to traverse axially towards the distal end during dose dispensing"

109. I have not been asked to form any opinion on the above-listed proposed constructions, or on any of Mylan's proposed construction from the Mylan DNJ Case, and have not formed any opinion on such proposed constructions.

110. I further understand that the Court in the Mylan DNJ Case issued a claim construction order. The constructions adopted by the Court are as follows (*see* Ex. 2165 at 7-25):

Term	Sanofi's Proposed Construction in the Mylan DNJ Case
"drive sleeve"	Ordinary meaning, which is "an essentially tubular component configured to transfer force to the piston rod"
"driver" / "driving member"	Ordinary meaning, which is "a component configured to transfer force to the piston rod"
"main housing"	Ordinary meaning, no construction is necessary.
"piston rod"	Ordinary meaning, which is "a rod that can advance the piston"
"the piston rod and the driving member are configured to rotate relative to one another during dose dispensing"	"[T]he ordinary meaning of the requirements that two components rotate relative to one another means that an observer situated on one component would observe the other component in rotation. Both components do not need to rotate to

Term	Sanofi's Proposed Construction in the Mylan DNJ Case
	produce this outcome”
“thread” / “threaded” / “threading” ⁶	“a rib or groove on a first structure that engages a corresponding groove or rib on a second structure and that allows rotational and axial movement between the first and second structures”
“clutch”	Not means-plus-function. Ordinary meaning, which is “a component that can operate to reversibly lock two components in rotation”
“tubular clutch”	Construed in conformity with the construction for “clutch”
“clicker”	Not means-plus-function. Ordinary meaning, which is “a component that clicks”
“insert”	Not means-plus-function. Ordinary meaning, no construction necessary.
“holder”	Not means-plus-function. Ordinary meaning, no construction necessary.

111. With the exception of the terms “main housing” and “tubular clutch,” I have not been asked to form any opinion on the above-listed proposed constructions and have not formed any opinion on the above-listed proposed constructions.

112. As explained below, I do not disagree with the Court’s interpretation of “main housing” in the Mylan DNJ Action. However, it is my opinion that a

⁶ I understand that Sanofi dropped the proposed constructions for these terms and did not submit any arguments in support.

POSA would not understand the ordinary meaning of “main housing” to mean simply “housing,” which would encompass both external and internal housing. I do not disagree with the Court’s interpretation of “tubular clutch” or “clutch” (in conformity with which “tubular clutch” is to be construed).

A. “main housing”

113. As set forth in the table above, I understand that Sanofi proposed that a “main housing” should be construed to mean “an exterior unitary or multipart component configured to house, fix, protect, guide, and/or engage with one or more inner components.” Based on my review of the challenged patents, including the claims, specification, figures, and file histories, it is my opinion, as explained below that this is a fair meaning for the term “main housing” under the broadest reasonable interpretation consistent with the specifications of the challenged patents. In particular, it is my opinion that, under the broadest reasonable interpretation consistent with the specifications, a POSA would have understood that a “main housing” is a type of exterior housing that does not encompass separate or integrally-formed interior housings.

114. As also noted in a table above, I understand that the Court in the Mylan DNJ Action held that the term “main housing” should be given its ordinary meaning and that therefore no express construction is required. In the case between Sanofi and Merck Sharp & Dohme Corp., however, I understand that the

District Court adopted Sanofi's construction of "main housing," as recited above. See Ex. 2166 at 7-9.

115. In my opinion, Sanofi's proposed construction is consistent with the ordinary meaning of the term "main housing" as it would have been understood by a person of ordinary skill in the art in the context of the challenged patents. Again, it is my opinion that a POSA would have understood that the ordinary meaning of the term "main housing" as used in the challenged patents specifies a type of exterior housing, even if comprised of multiple exterior housing pieces (*e.g.*, an external window that snaps into an external body), that does not encompass separate or integrally-formed interior housings.

116. As I mentioned above, I understand that the same claim term across related patents are presumed to have the same meaning. And by virtue of all of the challenged patents claiming priority to GB 0304822 (Ex. 1026), I understand that all of the challenged patents are related. The 008 Patent includes a description of "main housing" not expressly included in the other four challenged patents, and I based on my understanding of the law I understand that this description applies to the term "main housing" in all of the challenged patents. This description states:

The term "housing" according to instant invention shall preferably mean any exterior housing ("main housing", "body", "shell") or interior housing ("insert", "inner body") having a helical thread. The housing may be designed to enable the safe, correct, and comfortable

handling of the drug delivery device or any of its mechanism. Usually, it is designed to house, fix, protect, guide, and/or engage with any of the inner components of the drug delivery device (e.g., the drive mechanism, cartridge, plunger, piston rod) by limiting the exposure to contaminants, such as liquid, dust, dirt etc. In general, the housing may be unitary or a multipart component of tubular or non-tubular shape. Usually, the exterior housing serves to house a cartridge from which a number of doses of a medicinal product may be dispensed.

Ex. 1005, 2:66-3:12. As can be seen above, the paragraph provides a description of “housing” and begins by classifying it into two types: exterior housing and interior housing. It also includes descriptions of housing that are consistent with the construction proposed by Sanofi in the Mylan DNJ Case.

117. A POSA would have understood that the first sentence of the above excerpt specifies that a “main housing” *is* an exterior housing. The term “main housing” is recited in parenthesis following the words “exterior housing” along with other words that are synonyms for exterior housing (*i.e.*, body and shell). Notably, the 008 Patent does not say that exterior housing preferably includes a “main housing.” This makes perfect sense, as a person of ordinary skill in the art would have understood that the purpose of a housing is to enclose interior components, and the word “main” signifies that it would be the most important housing—*i.e.*, the outermost housing. After all, the pen injectors described in the challenged patents all require an outermost housing.

118. A POSA also would have understood that the term “main housing” does not encompass an interior housing. For the term interior housing, the first sentence of the paragraph excerpted above from the 008 Patent recites the words “interior housing” and then immediately lists in parenthesis synonyms of internal housing structure—*i.e.* an insert and an inner body. This list does not include the term “main housing” or otherwise indicate that it could fall into the category of interior housing. Instead, by juxtaposing the terms exterior housing and interior housing, and placing “main housing” into the former category, a POSA would have understood that the term “main housing” belongs to the former category and not the latter.

119. Further evidence that would inform the understanding of a POSA that a “main housing” is an exterior housing and does not encompass interior housing is found in the challenged patents. In the embodiment depicted in all of the challenged patents, a “main housing 4” is identified. *See, e.g.*, Ex. 1002, 3:27-33, Ex. 1005, 7:11-13 (identifying a “main (exterior) housing part 4”). This component is radially the outermost component of the device, and, although it itself has small features such as threading formed on its interior surface, it is treated separately and distinctly from inner components. For example, the description of this depicted embodiment identifies “an insert 16 provided at a first end of the main housing 4.” Ex. 1003, 3:49-50. The insert 16 (orange, below),

which is identified as a type of interior housing distinct from exterior housing in the 008 Patent at column 2, line 66 through column 3, line 2, is not part of the main housing 4 (grey, below), and the main housing 4 is not part of the insert 16.

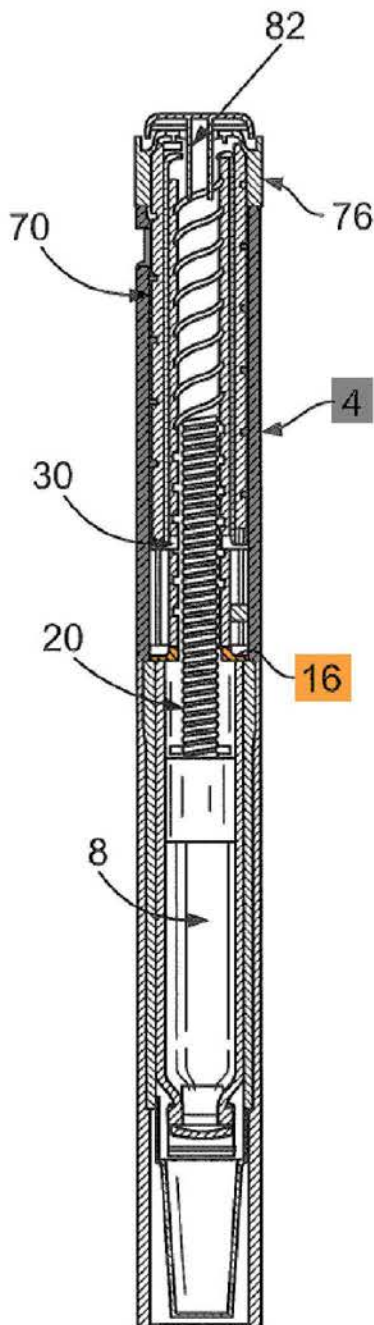

Ex. 1002, Fig. 3 (annotated).

120. The challenged patents even specify that the insert and main housing are distinct components when formed integrally: “Alternatively, the insert may be formed integrally with the main housing 4 the form of a radially inwardly directed flange having an internal thread.” Ex. 1003, 3:53-55. Note, the sentence here does *not* say that the *insert may be replaced* by an inwardly directed flange of the main housing, but rather that the *insert may be integrally formed with* the main housing in the form of a inwardly directed housing. Thus, a POSA would have understood that even when the main housing and insert are integrally formed, the patents still treat the main housing (*i.e.*, an exterior housing) distinct from the insert (*i.e.*, an interior housing). This view is entirely consistent with the disclosures in the challenged patents.

B. “tubular clutch”

121. As set forth in the table above, I understand that the Court in the Mylan DNJ Action construed “clutch” according to its ordinary meaning, which is “a component that can operate to reversibly lock two components in rotation.” I agree with the Court that this is the ordinary meaning of “clutch.”

122. I further understand that the parties to the Mylan DNJ Action agreed that “tubular clutch” should be construed in conformity with the construction for “clutch.” I agree with this as well. In view of the Court’s construction of “clutch,” a person of ordinary skill in the art would have understood “tubular clutch” to

mean “a tubular component that can operate to reversibly lock two components in rotation.”

C. “an interior of a flange”

123. I have been asked to opine on the broadest reasonable interpretation consistent with the specifications of the term “an interior of a flange,” which is recited in claim 56 of the 486 Patent (“The clutch of claim 51, further comprising a plurality of axially extending teeth formed in an interior of a flange of said clutch.”). I have also been asked to assume that the “flange” recited in this term refers to a disk-shaped flange.⁷ It is my opinion that the broadest reasonable interpretation consistent with the specifications for the term “an interior of a flange” means “at the inner diameter of a flange,” as I explain below.

⁷ Note, in my opinion a POSA would have understood that the ordinary meaning of a disk-shaped flange is a protrusion that extends outwardly and/or inwardly from the surface of a cylinder. These types of flanges can be used to connect two cylindrical structures, to provide support or bearing for another structure, and to provide strength and stability for the structure it is formed on. A common example is a pipe with an external flange at one end that serves to facilitate connection with another pipe having an external flange.

124. In my opinion, a POSA would have understood that the 486 Patent describes an example of claim 56, including “an interior of a flange,” in its depicted embodiment. Specifically, the 486 Patent describes a clutch means 60 (blue) that includes, at its “second end 64” (or button-end), a “radially inwardly directed flange 62” (yellow). See Ex. 1003, 4:54-55.

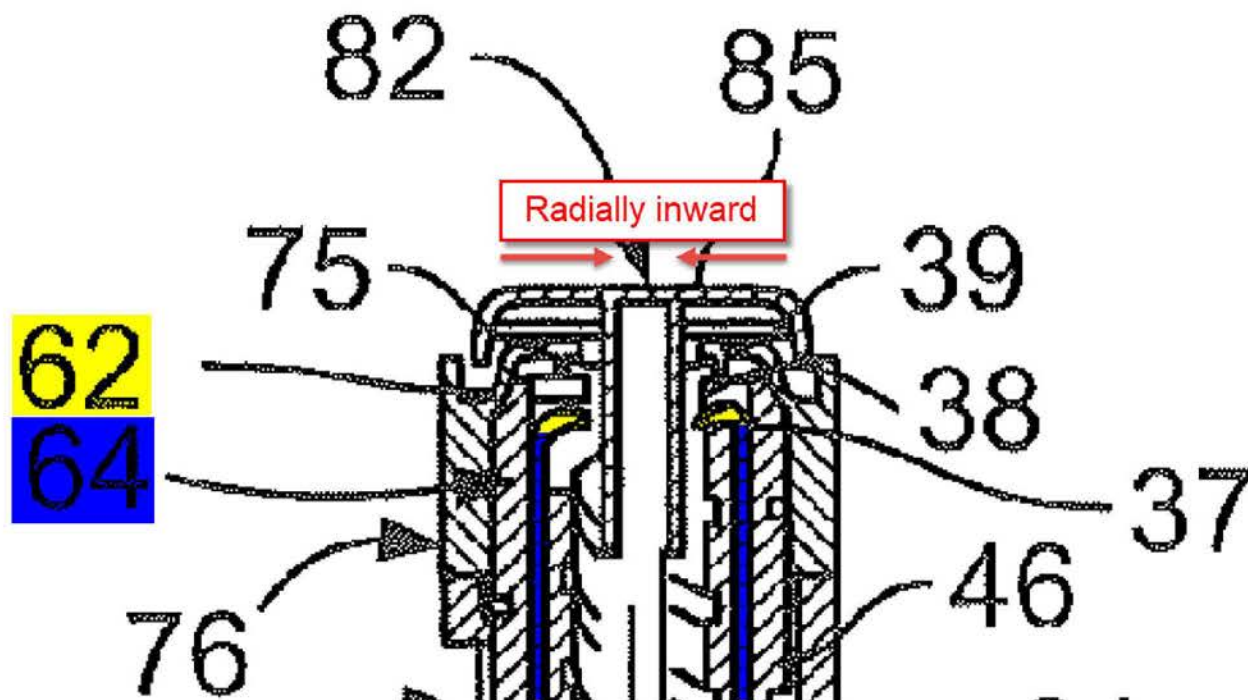

Ex. 1003, Fig. 1 (annotated)

With respect to another figure (Figure 8) illustrating the depicted embodiment, which also shows more detail,⁸ the 486 Patent describes that a series of dog teeth

⁸ We know that both figures 5 and 8 are depicting the same embodiment. See, e.g., Ex. 1003, 2:58-59 (“FIG. 3 shows a sectional view of the pen-type injector of FIG.

(light green) are formed along the inner circumference of this inwardly directed flange 62 (yellow) of the clutch means 60 (blue). *See Ex. 1003, 4:58-60.*

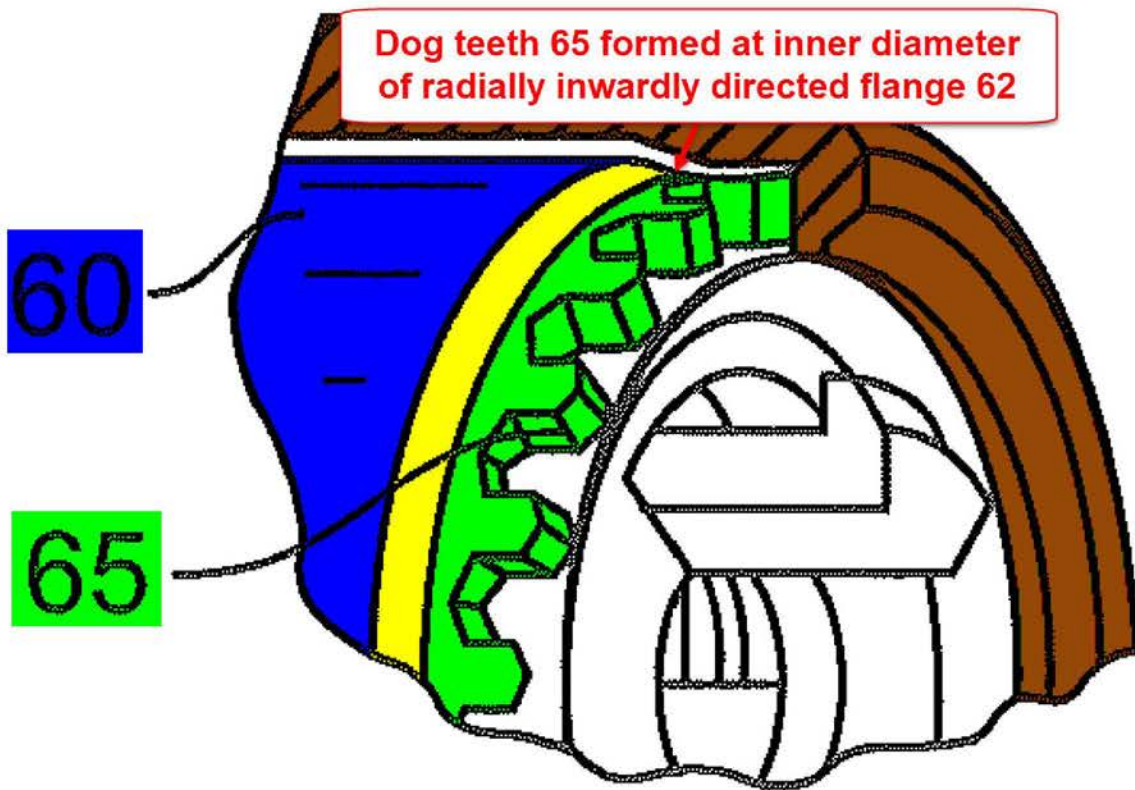

Ex. 1003, Fig. 8 (annotated)

As shown above, the dog teeth 65 (light green) are formed at the inner diameter, or along the inner circumference, of inwardly directed flange 62 (yellow).

1 in a third, first maximum first dose dispensed position.”), 2:62-63 (“FIG. 5 shows a sectional view of the pen-type injector of FIG. 1 in a fifth, final dose dispensed, position.”), 3:1-2 (“FIG. 8 shows a partially cut-away view of a third detail of the pen-type injector of FIG. 1”).

125. Moreover, a POSA would have understood “interior of a flange” to refer to the inner diameter of a flange because the 486 Patent uses synonyms for “interior” in a radially inward sense. Specifically, the 486 Patent uses the words “internal,” “inner,” “inward,” and “interior” all to refer to the features or components located toward the radial center of a circular or tubular component. For example, akin to the teeth “formed in an interior of a flange” (as recited by claim 56), the 486 Patent also describes an insert as a disk-shaped flange (orange) having a thread formed in its interior (red): “the insert may be formed integrally with the main housing 4 the form of a *radially inwardly* directed flange having an *internal* thread.” Ex. 1003, 3:53-55.

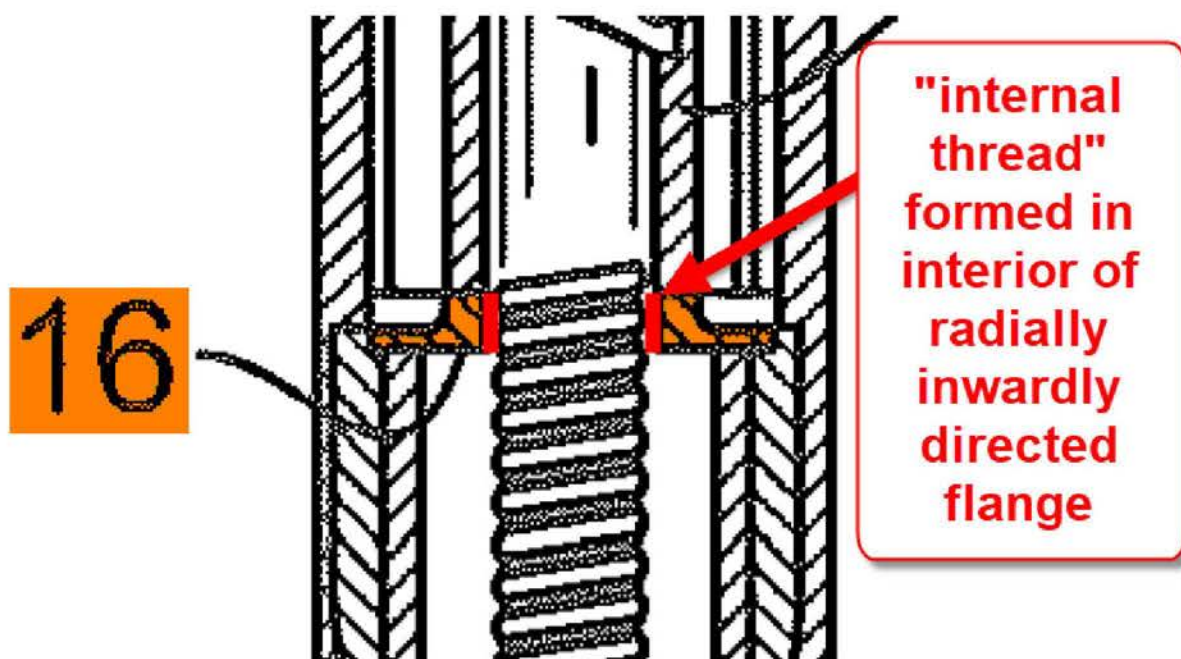

Ex. 1003, Fig. 5 (annotated)

Petitioner's expert, Mr. Leinsing, in his deposition agreed that this thread is formed in the interior (or at the inner diameter) of this flange: "A. So the thread is on the inside or inner diameter". Ex. 2163 at 148:18-19; *see also id.* at 149:20-25 ("it's on the inner hole or diameter portion of that insert."). Other examples in the 486 Patent of "internal" meaning the inner diameter side of a component include a "helical groove 38 [that] extends along the *internal* surface of the drive sleeve 30" (Ex. 1003, 4:12-13) and a "nut 40 [that] has an *internal* thread matching the intermediate thread 36" (Ex. 1003, 4:20-21). The helical groove 38 is shown as being on the radial interior of drive sleeve 30 in Figure 1, and the threads on the radial interior of nut 40 are shown to mate with the exterior thread 36 on the drive sleeve in Figure 1. Accordingly, a POSA would have understood that an "interior of a flange" means, for a disk-shape flange, "at the inner diameter of a flange."

126. In my opinion, for a disk-shaped flange a POSA would not have understood that "an interior of a flange" encompasses the outer diameter of a flange (*i.e.*, the exterior of a flange), the distal side of a flange (*i.e.*, the needle-side of a flange), or the proximal side of a flange (*i.e.*, the button-side of a flange). In the figures below, the disk-shaped flange 83 of Steinfeldt-Jensen's bushing 82 (blue) has been isolated from Figures 16 and 17 and the interior, exterior, proximal, and distal sides identified in Figure 16 in accordance with how a POSA's understanding.

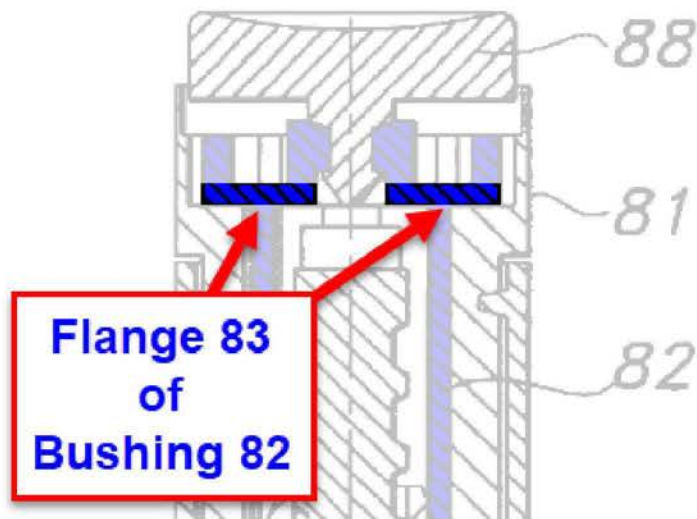

Ex. 1014, Fig. 16 (annotated)

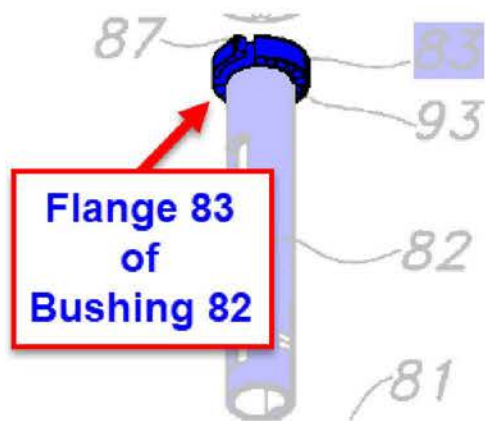

Ex. 1014, Fig. 17 (annotated)

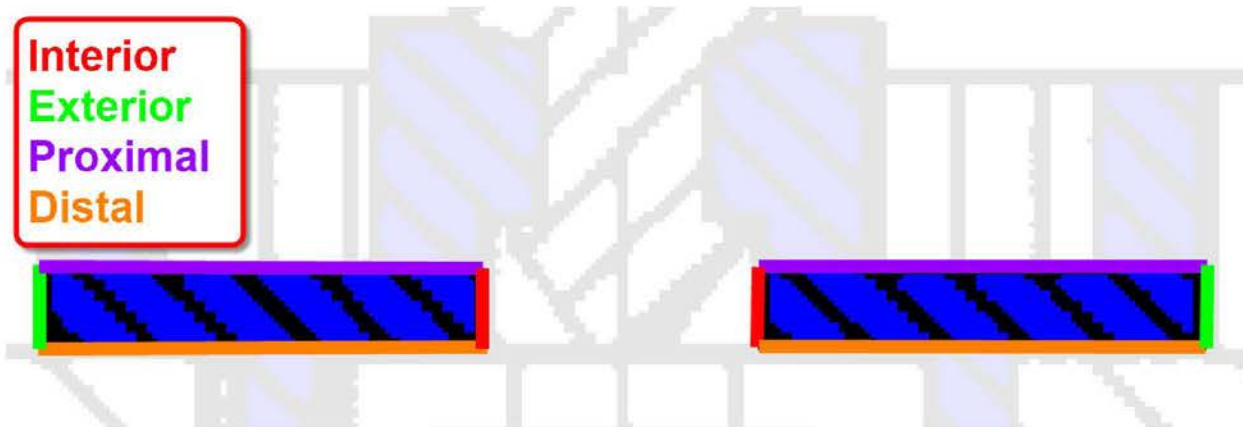

Ex. 1014, Fig. 16 (annotated).

127. I note that Petitioner's expert, Mr. Leinsing, does not appear to dispute this interpretation. As I noted above, at his deposition Mr. Leinsing was asked about a thread formed on the interior of an inwardly directed flange and Mr. Leinsing agreed that "the thread is on the inside or inner diameter." Ex. 2163 at 148:18-19. Further, Mr. Leinsing was asked to identify the sides of the disk-shaped flanges drawn in Exhibit 2102, below. *See* Ex. 2163 at 151:18-159:6.

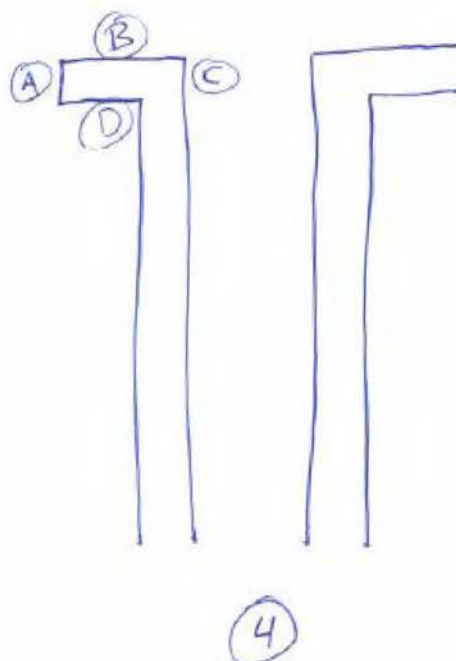
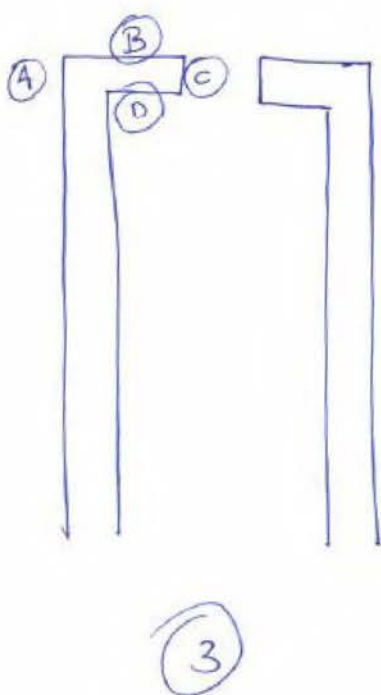
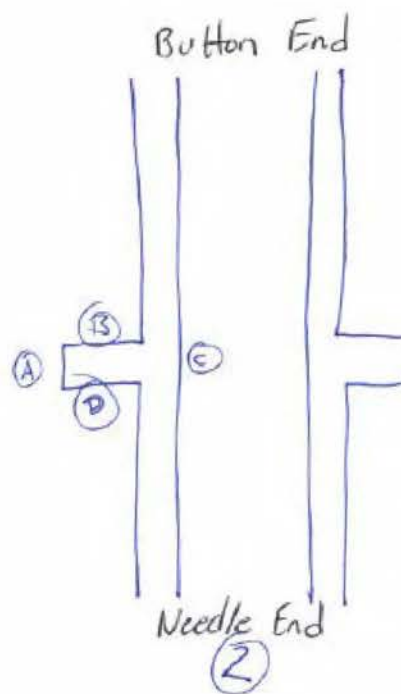
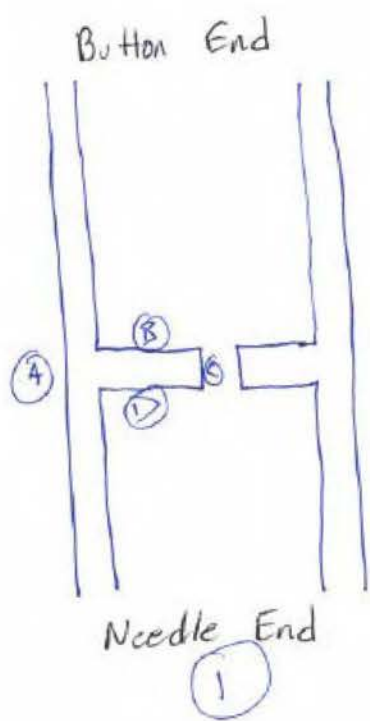

Ex. 2102

For all four of these figures, Mr. Leinsing testified that the side labeled (B) is the proximal, or button-end, surface of the disk-shaped flange, and the side labeled (D) is the distal, or needle-end, surface of the flange. *See* Ex. 2163 at 153:4-14, 154:24-155:9, 158:4-21. For figures 1 and 3, Mr. Leinsing testified that side (C) is the interior of the disk-shaped flange and that for figures 2 and 4 that side (C) could be considered the interior of the flange. *See* Ex. 2163 at 151:18-153:19 (“Yeah. C would be the interior surface in Figure 1 of Exhibit 2102”), 155:13-18, 158:4-21. For figures 1 and 3, Mr. Leinsing testified that he did not think there was an exterior of the flange and that for figures 2 and 4, side (A) is the exterior of the flange. *See* Ex. 2163 at 153:20-154:23, 155:10-11, 158:4-21. In short, Mr. Leinsing agrees that the inner diameter of a circular flange would be the interior of the flange, and that the proximal, distal, and exterior sides of the flange are different.

128. Therefore, it is my opinion that a POSA would have understood that the broadest reasonable interpretation of “an interior of a flange” for a disk-shaped flange that is consistent with the specification of the 486 Patent is “at the inner diameter of a flange” and does not include the proximal end (*i.e.*, the button-end), distal end (*i.e.*, the needle-end), or exterior of a disk-shaped flange.

IX. OVERVIEW OF THE PRIOR ART IDENTIFIED IN THE GROUNDS

A. Burroughs

129. Burroughs describes a multi-use injector pen design. Burroughs at Abstract. According to Burroughs' specification, injector pens were developed to provide diabetic patients with an alternative to conventional syringes, which were difficult for patients to control when setting the quantity of medication to inject and during the actual injection process. Ex. 1013 at 1:18-29.

130. Figure 2 of Burroughs shows the main components of Burroughs' injector pen:

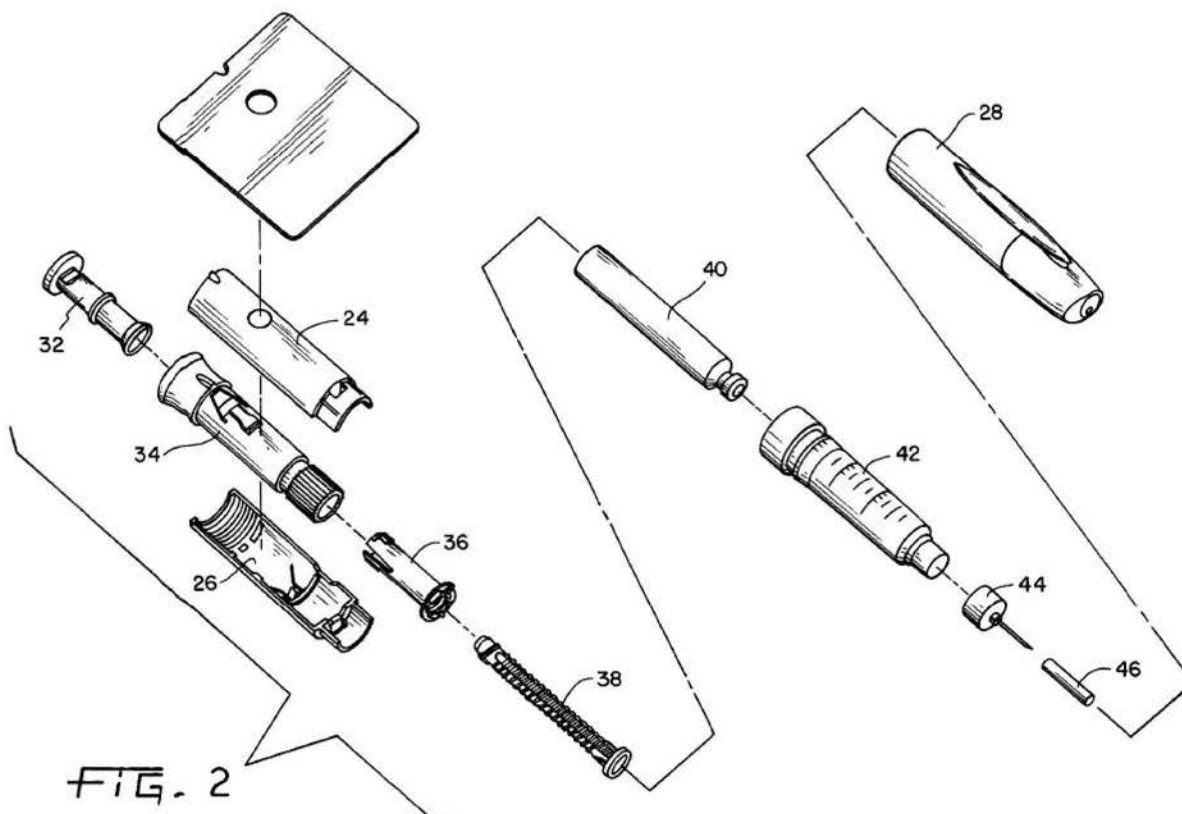

Ex. 1013, Figure 2

131. As shown in Figure 2, Burroughs' injector pen has a main housing that is made up of a first part 24 and a second part 26. Ex. 1013 at 7:16-26. The housing contains the dial mechanism 34. Ex. 1013 at 7:31-33. An injection button 32 is inserted in the proximal end of the dial mechanism 34. *Id.* At the distal end, dial mechanism 34 attaches to a nut 36. *Id.* Leadscrew 38, which acts as a drive stem, inserts into the dial mechanism 34 through the nut 36. *Id.* A distal body 42, which Burroughs also refers to as a "cartridge retainer" or "cartridge body," is permanently attached to the housing parts 24 and 26, and contains the medication cartridge 40. *Id.*, 7:34-35, 9:34-36. A needle assembly comprised of needle 44 and needle cover 46 attach to the distal end of distal body 42, and a cap 28 attaches to the distal body 42 to cover the needle when the pen is not in use. *Id.* at 7:34-35, 9:40-46.

132. A user dials a dose on Burroughs' injector pen by initially turning the dial mechanism 34 to what Burroughs calls the "zero position," which is indicated by a clicking sound and tangible vibration that are created by splines 152 of the dial mechanism 34 engaging with finger 170 of the second housing part 26. Ex. 1013 at 9:47-64. The splines 152 are illustrated in Burroughs' Figure 8 (below in green), and the finger 170 is shown in Burroughs' Figure 5 (below in orange). The injector pen also provides a visual indicator of the zero position, by way of protrusion 153 on the first housing part 24 and protrusion 88 of the dial mechanism

34, which align when the dial is in the zero position. *Id.* at 9:66-10:4. The protrusion 88 of the dial mechanism 34 is shown in Figure 7 (below in purple).

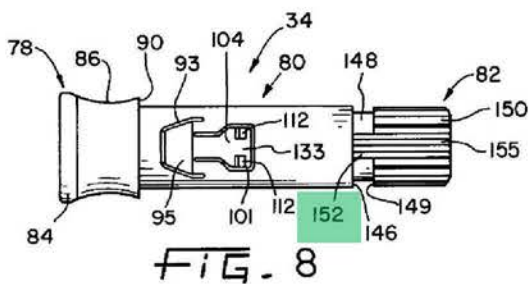
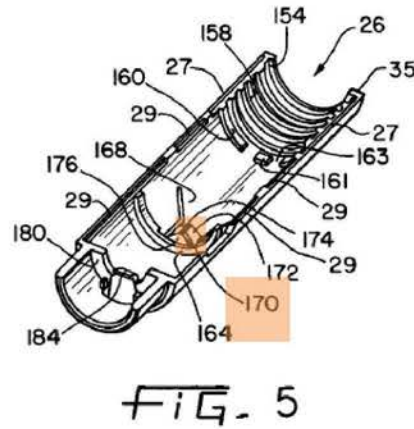
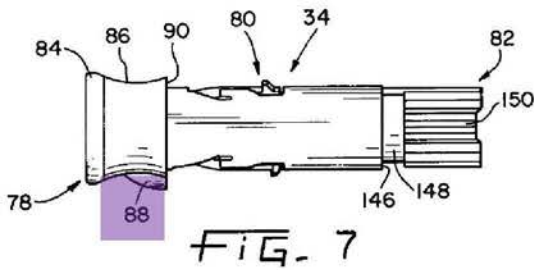

Ex. 1013, Figs. 5, 7, and 8

133. Once in the zero position, the user can place the dial mechanism 34 into the dose-setting position by retracting it slightly from the housing. *Burroughs*, 10:15-18. From the dose-setting position, the user can set the desired dosage by rotating the dial mechanism. *Id.*, 10:42-52. Dial mechanism 34 has threads 110 and 112 on its outer surface, which engage with a groove 158 on the inner surface of housing parts 24 and 26. *Burroughs* at 10:28-38, 10:60-63. This engagement guides the rotation and movement of the dial mechanism 34 when the user is

dialing a dose. A ledge at the end of groove 158 prevents the user from dialing a dose greater than a predetermined maximum dosage. *Id.* at 10:65-11:1.

134. Once the user sets the desired dosage as described above, the user can inject the dose by pressing button 32. As button 32 moves forward, its enlarged diameter portion 54 (below in blue) contacts ramped surfaces 96 (below in yellow) on the inside of the dial mechanism 34. Burroughs at 8:15-20, 11:6-12.

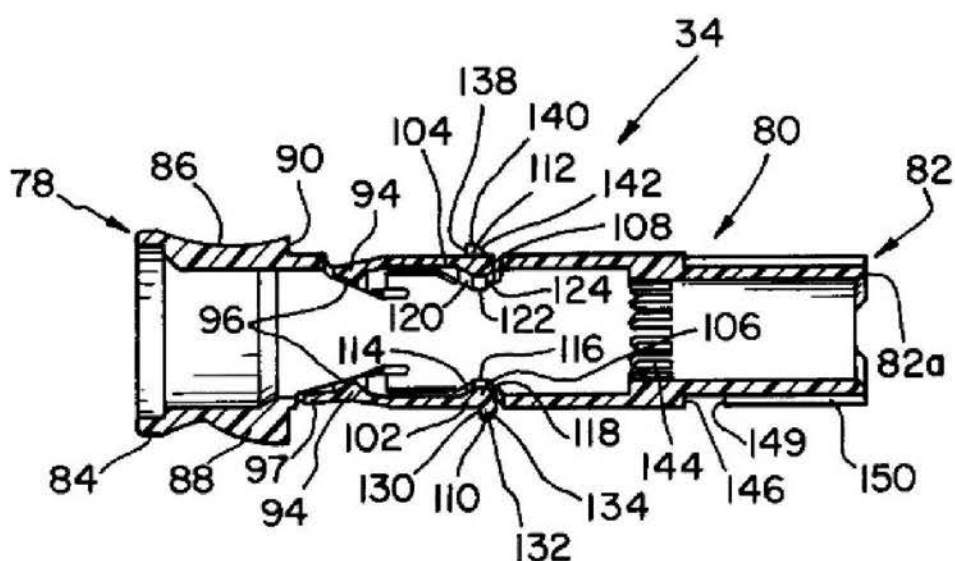

FIG. 9

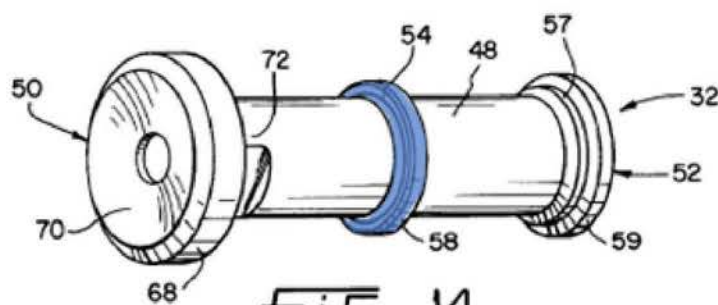
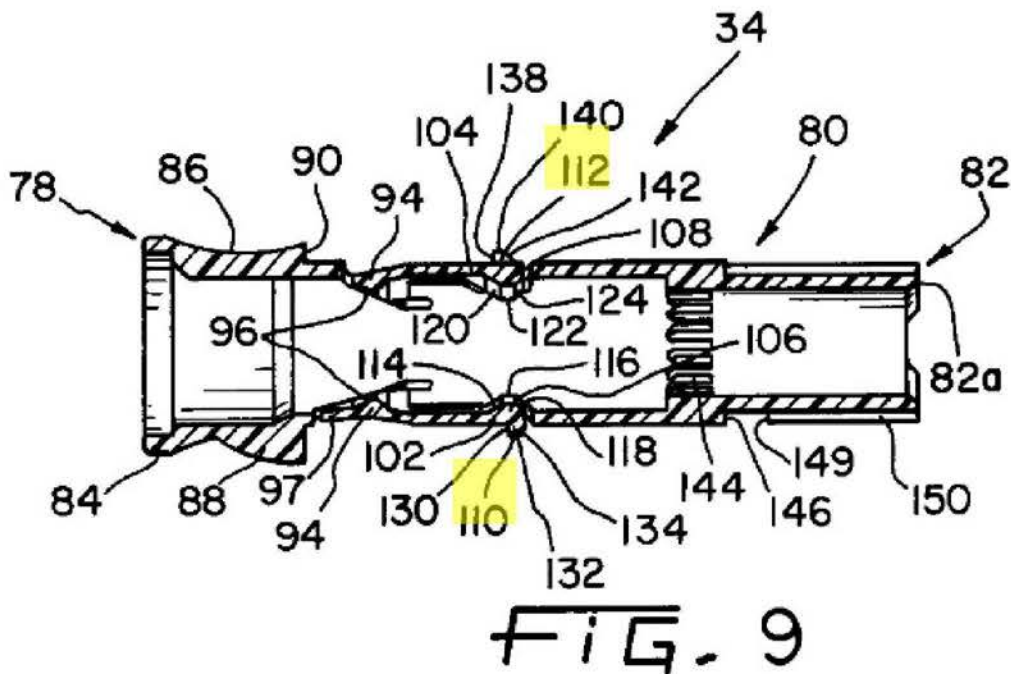

FIG. 14

Burroughs, Figs. 9 and 14 (highlighted).

135. The ramped surfaces 96 are part of legs 102 and 104, such that when the ramped surfaces 96 contact enlarged diameter portion 54 of the button, the legs 102 and 104 are forced inward. *Id.* This allows threads 110 and 112, which are formed on the ends of legs 102 and 104, to disengage from groove 158. *Id.* Burroughs describes that this mechanism provides a “dosage lockout mechanism” that prevents inadvertent delivery of medication during dose-setting by ensuring that the dial mechanism 34 can only move axially forward when the injection button is pressed. *Id.* 4:39-31, 11:1-6.



Burroughs, Fig. 9 (highlighted)

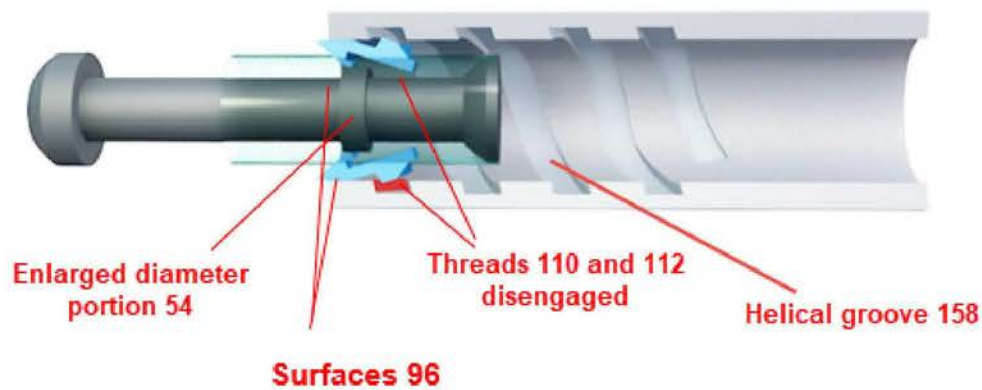

136. Once the threads 110 and 122 disengage from groove 158, the dial mechanism 34 is able to move axially forward toward the cartridge 40 until the dial mechanism reaches the “end-of-injection” position. Burroughs at 11:13-23. An audible “click” provided by the engagement between click finger 97 on the surface of dial mechanism 34 and groove 154 on the inner surface of housing parts 24 and 26 signals that the entire dosage has been injected. *Id.* at 11:23-26. Raised surfaces 199 (shown in red, below) on the nut 36 engage with ledges 178 and 180 (shown in blue, below) in the housing parts 24 and 26 to prevent the dial mechanism 34 and nut 36 from moving past the end-of-injection position.

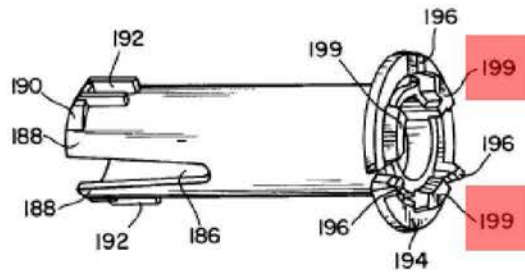

FIG. 10

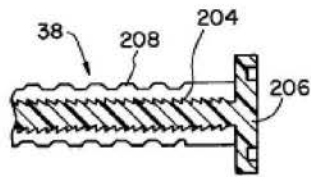

FIG. 13

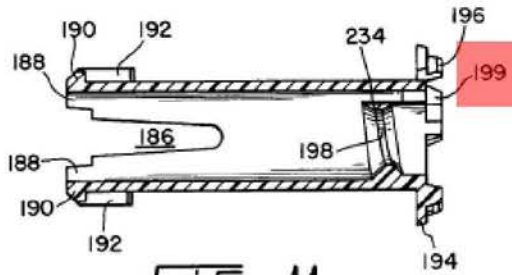

FIG. 11

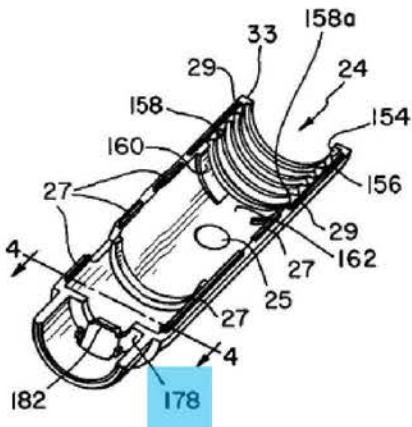

FIG. 3

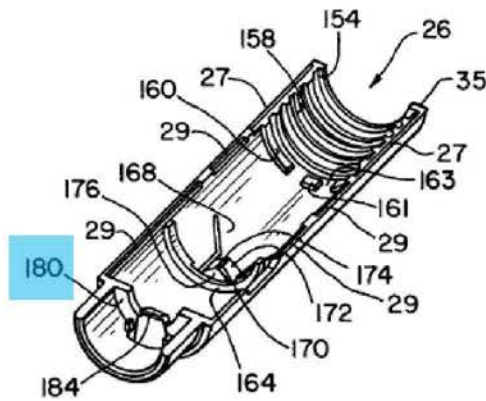
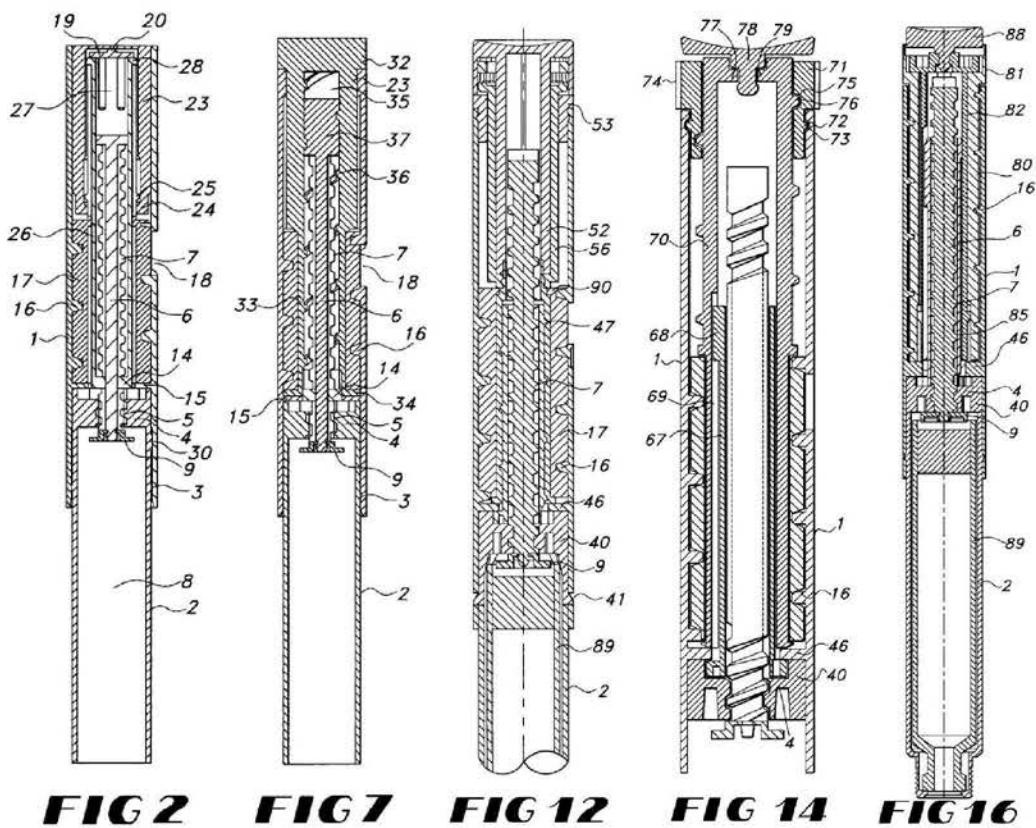

FIG. 5

B. Steinfeldt-Jensen

137. Steinfeldt-Jensen discloses five distinct pen injector embodiments. See Ex. 1014, Figs. 1-17. The first embodiment is depicted in figures 1-5, the second embodiment is depicted in figures 6-10, the third embodiment is depicted in figures 11-13, the fourth embodiment is depicted in figure 14, and the fifth

embodiment is depicted in figures 15-17. I have reviewed several animations of embodiments from Steinfeldt-Jensen that, in my opinion, accurately show the components and operation of these embodiments (i.e., how they work to dial a dose and how they work to dispense a dose). Specifically, Ex. 2148 shows the components and operation of Steinfeldt-Jensen's first embodiment. Ex. 2149 shows the components and operation of Steinfeldt-Jensen's second embodiment. Ex. 2147 shows the components and operation of Steinfeldt-Jensen's fifth embodiment. Each of the five embodiments of Steinfeldt-Jensen are shown below:



Ex. 1014, Figs. 2, 7, 12, 14, and 16.

1. Steinfeldt-Jensen's First Embodiment

138. Unlike the fifth embodiment, in Steinfeldt-Jensen's first embodiment (which I have shown below), the piston rod 6 (yellow) directly engages the ampoule holder 2 (light blue). As shown below, the ampoule holder 2 includes a wall 4 having a central bore with an internal thread 5, and the piston rod 6 has external thread 7 that mates with the thread 5. Ex. 1014, 5:55-58. To dial a dose, the user grasps the ampoule holder and rotates it counter-clockwise relative to housing 1. *See id.*, 6:42-43. When the ampoule holder is rotated, the piston rod rotates along with the ampoule holder, which in turn rotates with the piston rod guide 14 (the piston rod is inserted into the piston rod guide), with torque then transmitted to the driver tube 26. *Id.*, 6:54-59, 7:1-3. As a result, due to hooks 28 at the proximal end of the driver tube engaging slots 22 in the dose scale drum extension 21, the dose scale drum 17 will be rotated and screwed upwards. *Id.*, 7:3-6.

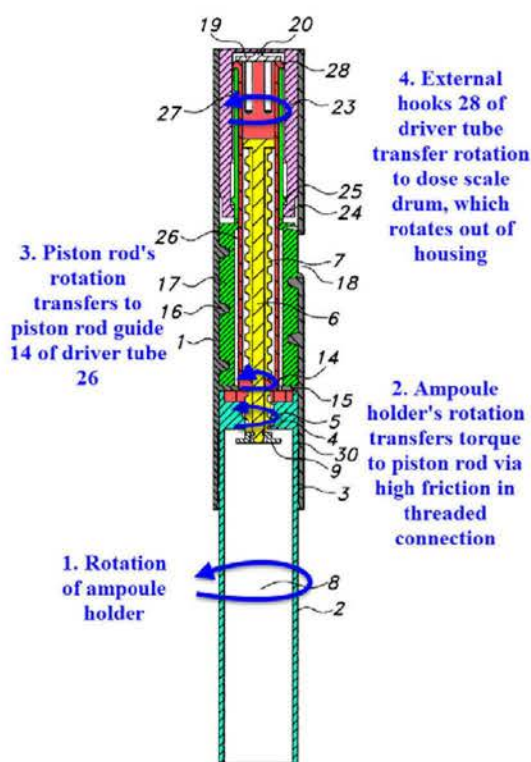

FIG 2

Ex. 1014, Fig. 2 (annotated)

139. To inject a dose, injection button 23 is pressed into the housing 1. Ex. 1014, 7:17-18. This applies a torque on the dose scale drum 17 causing it to rotate in the clockwise direction due to the threaded connection between the dose scale drum and the housing. *Id.*, 7:18-21. The torque is transmitted via the slots 22 in the drum extension 21 and the hooks 28 at the end of the driver tube 26. *Id.*, 7:21-24. The torque is then transmitted to the piston rod guide 14. *Id.*

2. Steinfeldt-Jensen's Second Embodiment

140. Steinfeldt-Jensen's second embodiment is shown and described at column 7, line 48, through column 8, line 33, and Figures 6-10. This is an

embodiment that Petitioner relies upon in the IPR2018-01684 (008) Petition. The second embodiment, which I show below, comprises an ampoule holder 2 (turquoise), a housing 1 (grey), a unidirectional coupling comprising a pawl 13 and piston rod guide 14 (both red), a piston rod 6 (yellow), a dose scale drum 17 (green), and an injection button 23 (pink).

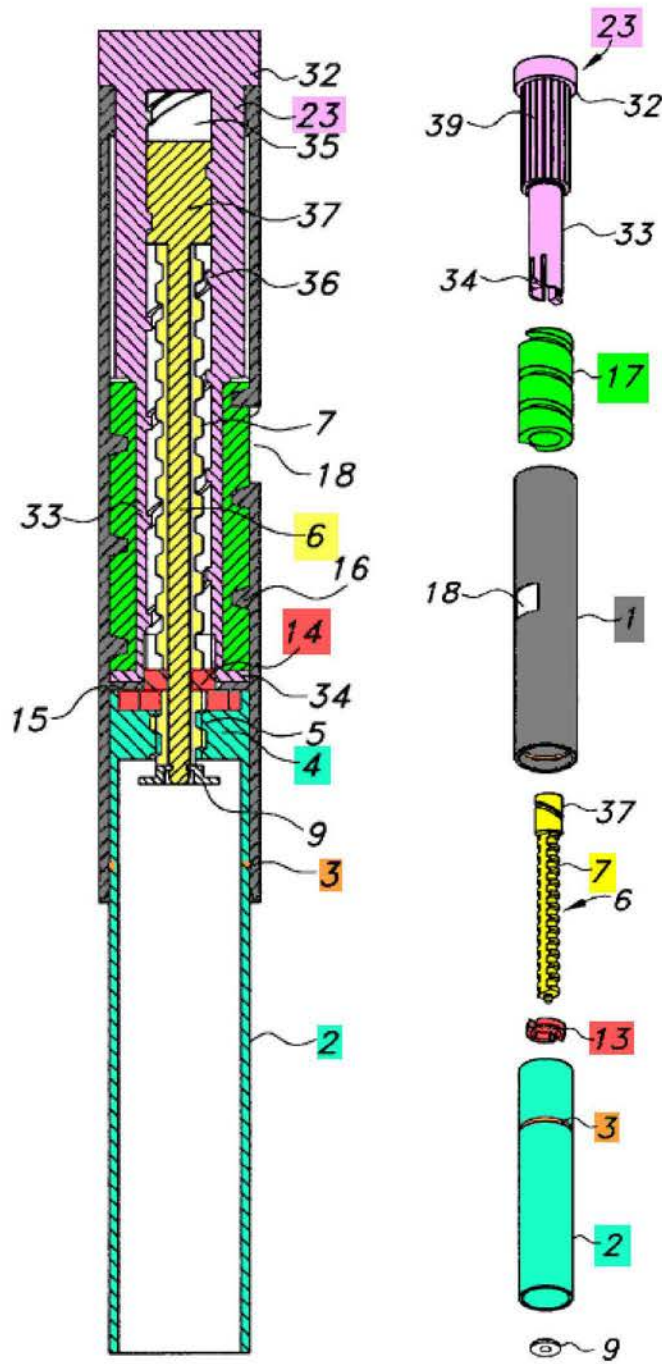

Ex. 1014, Figs. 7, 8 (annotated)

141. The ampoule holder 2 (turquoise) is rotatable relative to the housing 1 (grey) and includes a ring-shaped bead 3 (orange) that can be snapped into

connection with a circumferential groove (also orange) in the housing 1. Steinfeldt-Jensen explains that “[b]y this snap connection the ampoule holder 2 is secured in the housing 1 so that it can be rotated but not axially displaced relative to this housing.” Ex. 1014, 5:44-46 (emphasis added). This rotatable ampoule holder 2 includes an end wall 4 (turquoise) that has a threaded connection to piston rod 6 (yellow). A unidirectional coupling comprising a piston rod guide 14 and pawl 13 (both red) can prevent rotation of the piston rod 6 relative to the ampoule holder 2. See Ex. 1014, 8:1-8, 8:25-33. This unidirectional coupling (red) does not prevent rotation of the piston rod 6 relative to the housing 1 (grey) because the ampoule holder 2 (turquoise) can rotate relative to the housing 1 via snap connection of the ring-shaped bead 3 (orange).

142. The operation of Steinfeldt-Jensen’s second embodiment does not require a clutch as I explain below. The user dials a dose by rotating injection button 23, which screws the injection button and dose scale drum 17 outward from the housing along the threaded connection between the injection button and enlargement 37 of piston rod 6. See Ex. 1014, 7:60-8:12. The injection button 23 includes grooves 39 that engage protrusions 38 on the inner wall of the housing 1 to produce a clicks as the injection button is rotated. *Id.*, 8:16-24. To inject the dose, a user simply presses down vertically on the injection button, and protrusions 38 on the inner wall of the housing 1 help guide the injection button in the axial

direction without rotation. *Id.*, 8:25-33. There is no actuation of a clutch. The axial movement of the injection button causes the piston rod 6 to rotate in order to dispense a dose. *See also* Ex. 2149 (animation depicting dose dialing and injection).

3. Steinfeldt-Jensen's Fifth Embodiment

143. In many Petitions, Petitioner primarily relies on the fifth embodiment (Ex. 1014 at 11:6-12:16, Figs. 15-17) to argue that Steinfeldt-Jensen discloses or renders obvious the challenged claims. *See* Petition at 26-71. The fifth embodiment, depicted in an exploded view below, comprises an ampoule holder 2 (turquoise), an ampoule (or cartridge) 89 (dark blue), pressure foot 9, member 40 (orange), driver tube 85 (red), piston rod 6 (yellow), housing 1 (grey), scale drum 80 (light green), bushing 82 (light blue), and injection button 88 (purple).

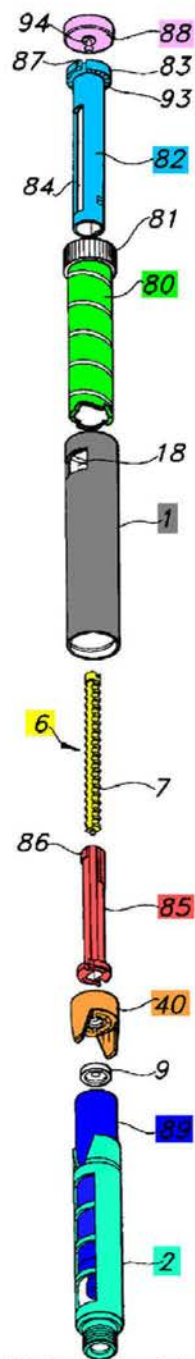
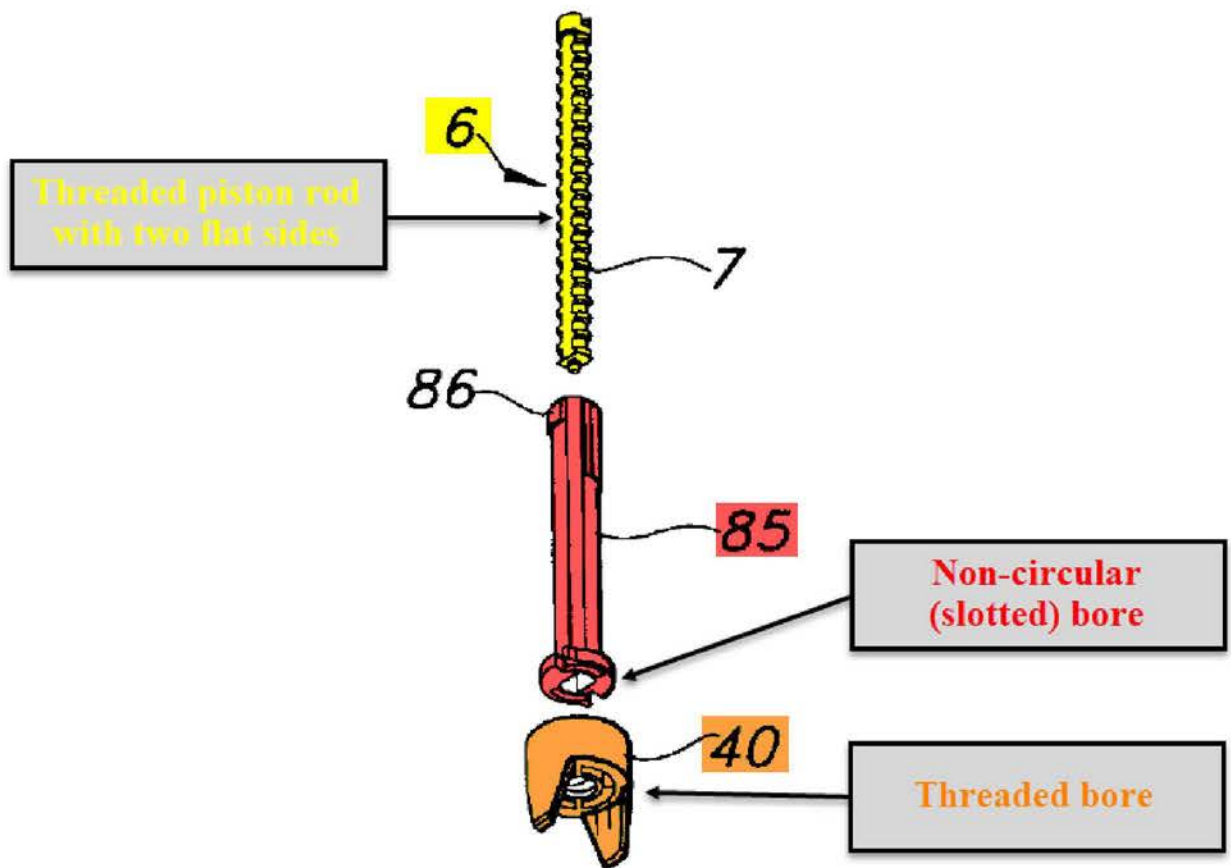

FIG 17

Ex. 1014, Fig. 17.

144. Steinfeldt-Jensen's fifth embodiment includes non-threaded driver tube 85 and a threaded piston rod 6 having two flat sides—*i.e.*, a non-circular

threaded piston. Ex. 1014 at 11:15-19 (“The piston rod has a not round cross-section and fits through the driver tube bore which has a corresponding not round cross-section.”). This non-circular shape is important in the fifth embodiment because the piston rod 6 (yellow) rotates with driver tube 85 (red). The non-circular shape of the piston rod 6 (yellow) fits within the same non-circular bore of the driver tube 85 (red), thus rotationally coupling the components while allowing them to move axially relative to one another.



Ex. 1014, Fig. 17 (cropped and annotated).

145. Piston rod 6 extends from driver tube 85 and the threading of piston rod 6 interfaces with the threaded bore of member 40, which is fixed relative to housing 1. When the driver tube is rotated (during the dose dispensing phase), the piston rod 6 also rotates, causing it to screw into member 40. Cross-sections from two different angles of the fifth embodiment are depicted below. Ex. 2150 accurately depicts the threaded opening of member 40 and the slotted opening of driver tube 85.

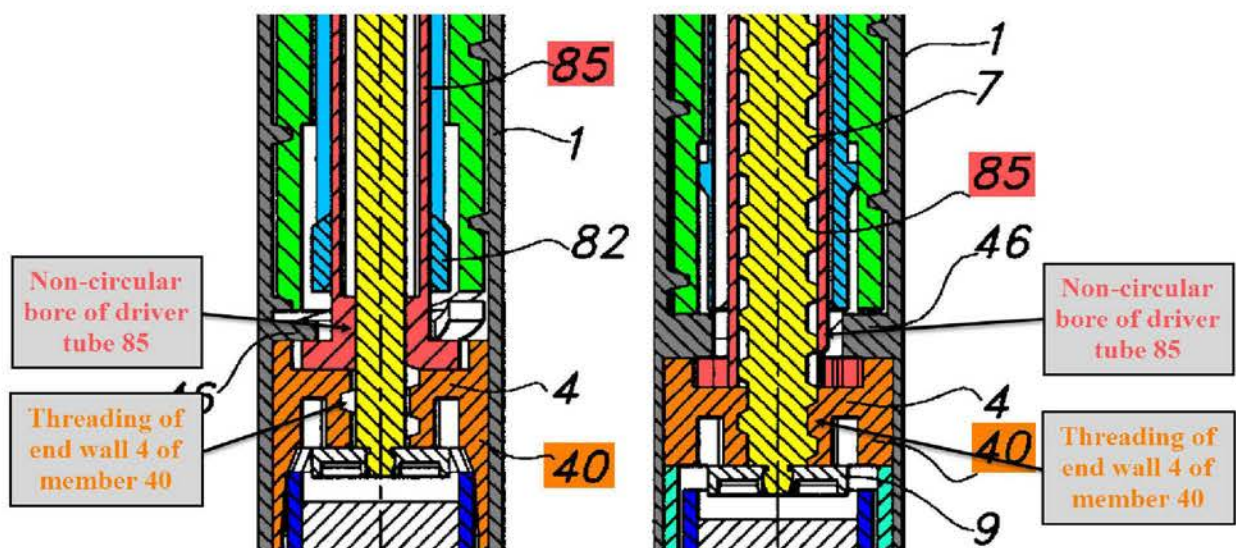

Ex. 1014, Figs. 15 and 16 (cropped and annotated).

146. To set a dose, the user rotates the dose setting button 81 on the proximal end of scale drum 80 in the clockwise direction (viewed from the proximal end). This causes the scale drum 80 to screw out of the housing. Ex. 1014, 11:43-49. The bushing 82, driver tube 85, and piston rod 6 remain stationary during the clockwise rotation of dose setting because the pawls on the distal end of

the driver tube 85 engage with the teeth in the member 40 and prevent movement in that direction, and also because the hooks 86 on the driver tube engage with the longitudinal slots 84 on the bushing. *Id.*, 11:52-67.

147. Once the dose is set, the dose is dispensed by pressing the injection button 88, whereby the rosette of teeth 93 on flange 83 of bushing 82 and corresponding rosette in dose setting button 81 are “pressed into engagement so that the bushing 82 will follow the anticlockwise rotation of the dose setting button 81 which is induced by the thread engagement between the helical track of the scale drum 80 and the rib 16 in the housing when the scale drum 80 is pressed back into said housing.” Ex. 1014, 12:5-10. The bushing 82 and the driver tube 85 are rotationally, but not axially, coupled to each other by the driver tube 85’s outer wall hooks 86 that fit into bushing 82’s longitudinal slots 84. *Id.*, 11:26-33. “The piston rod has a not round cross-section and fits through the driver tube bore which has a corresponding not round cross-section. This way rotation is transmitted [from the driver tube to the piston rod] whereas the piston rod is allowed to move longitudinally through the driver tube.” *Id.*, 11:15-19.

C. Møller

148. Møller is aimed at providing an injection pen where the mechanism providing a mechanical advantage (*i.e.*, “gearing”) between an injection button and an ampoule piston comprises a rack and gear wheel. *See* Ex. 1015, ¶¶ 0006.

Møller states that this gearing reduces the force necessary to deliver an injection—*i.e.*, injection force—to help users who have reduced finger strength. *Id.*

149. The use of a gear wheel and gear rack to achieve a mechanical advantage is key to Møller. In the background section of the reference, he discusses other prior patent publications and notes their advantages and disadvantages. For example, Møller cites WO 99/38554 (Ex. 2153), which includes the same teachings of an externally-grooved dose setting drum as Steinfeldt-Jensen. I am informed that WO 99/38554 is a foreign related patent application. Specifically, Møller states:

A similar gearing is provided in WO 99/38554 [Steenfeldt-Jensen's foreign related patent application] wherein the thread with the high pitch is cut in the outer surface of a dose setting drum and is engaged by a mating thread on the inner side of the cylindrical housing.

However, by this kind of gearing relative large surfaces are sliding over each other so that most of the transformed force is lost due to friction between the sliding surfaces. Therefore a traditional gearing using mutual engaging gear wheels and racks is preferred.

Ex. 1015, ¶ 0008 (emphasis added). Møller then goes on to say:

It is an objective of the invention to provide an injection device, which combines the advantages of the devices according to the prior art ***without adopting their disadvantages*** and to provide a device wherein is established a direct gearing, *i.e.*, ***a gearing by which more transformations of rotational movement to linear movement and***

linear movement to rotational movement are avoided, between the injection button and the piston rod.

Id., ¶ 0011 (emphasis added). A POSA reading this would have understood that the “disadvantages” referred to here include the specific threaded dose setting drum taught by Steinfeldt-Jensen that Møller expressly notes as being disadvantageous in paragraph 8. Indeed, Steinfeldt-Jensen teaches a gearing by which there are, in Møller’s words, “more transformations of rotational movement to linear movement and linear movement to rotational movement ... between the injection button and piston rod” than there would be with a direct gearing that uses gear wheels and gear racks, and thus a POSA would have understood that Møller is saying to avoid Steinfeldt-Jensen’s teachings.

150. Petitioner primarily relies upon Møller’s first embodiment, but also cites to Møller’s second embodiment. To aid in understanding the operation and components of the first and second embodiments, I cite two animations that I understand are being submitted with this response. I have reviewed both of these animations and in my opinion they accurately describe Møller’s first and second embodiments. Ex. 2206 is an animation that accurately depicts the first embodiment, and identifies components in this embodiment as well as shows how the pen operates during dose dialing and dose dispensing. Ex. 2207 is an animation that accurately depicts the second embodiment again showing the

components of this embodiment and its operation during dose dialing and dispensing.

151. To set a dose using the first embodiment, Møller states that “the dose setting button 18 is rotated to screw the dose-setting drum 17 up along the thread 6. Due to the coupling 21 the cup shaped element will follow the rotation of the dose-setting drum 17 and will be lifted with this drum up from the end of the housing 1.” Ex. 1015, ¶ 0029. “When the dose setting drum is screwed up along the thread 6 on the tubular element 5 the ring 25 will follow the dose setting drum in its axial movement as the spring 26 is supported on the shoulder 27.” *Id.* “The spring will keep the V-shaped teeth of the ring 25 and the cup shaped element in engagement and maintain in engagement the coupling 21, which may comprise Δ -shaped protrusions 32 on the cup shaped element engaging Δ -shaped recesses in an inner ring 33 in the dose setting button 18.” *Id.*

152. The “ Δ -shaped protrusions 32” (purple) are depicted as being formed on a cup shaped element, as depicted below. Note that Møller includes no

discussion of whether the Δ -shaped protrusions 32 are formed on a flange.

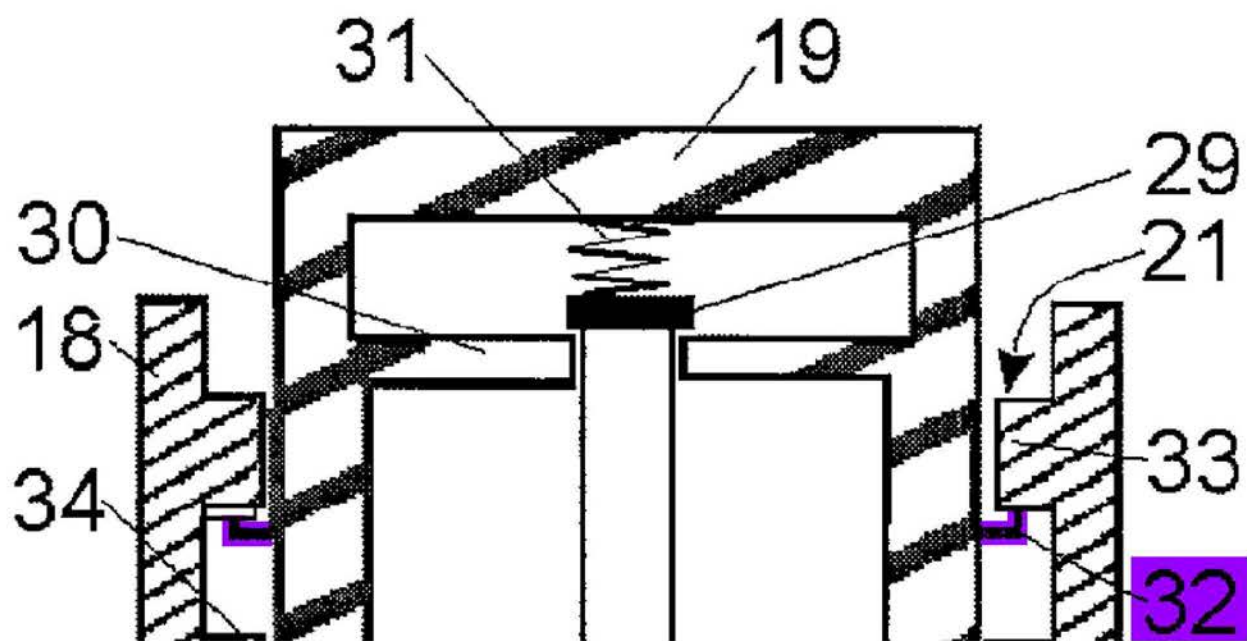

Ex. 1015, Fig. 1 (partial and annotated)

153. In Møller's second embodiment, the Petition references a tubular element 120 having teeth 132 formed around its exterior surface, which are shown in purple, below.

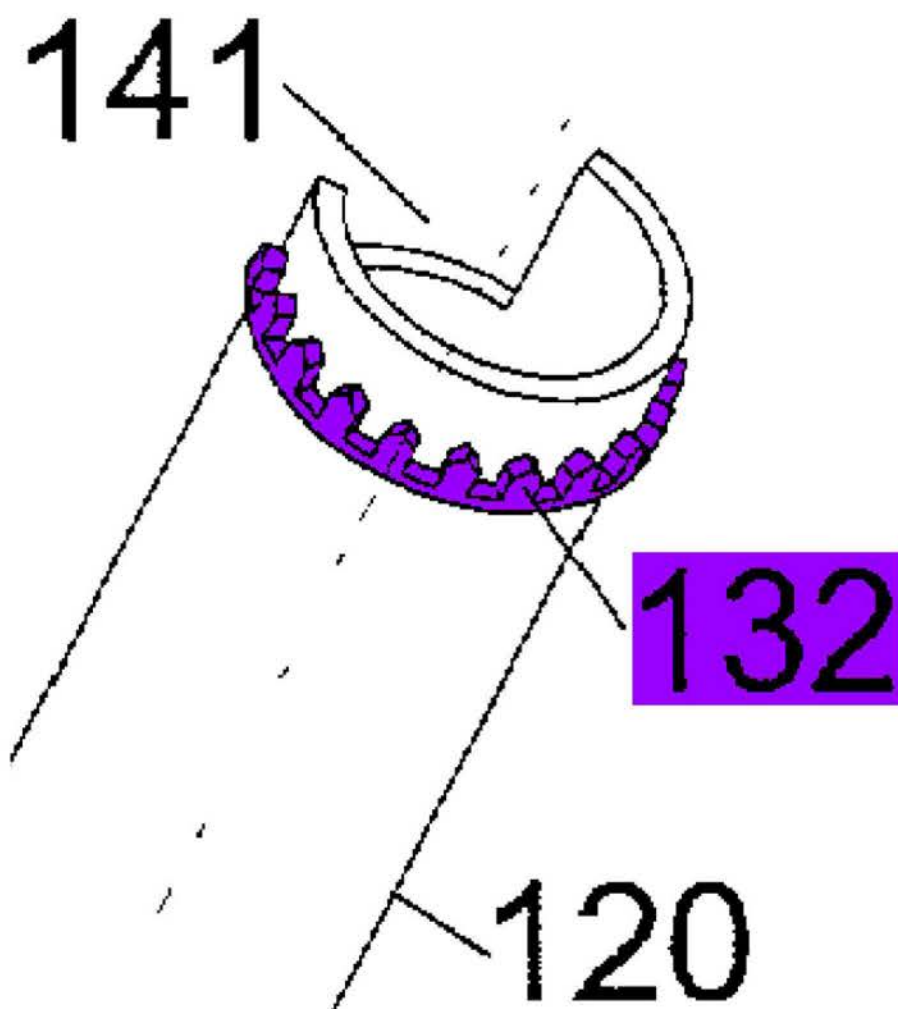

Ex. 1015, Fig. 5 (partial and annotated)

D. Giambattista

154. Giambattista describes an injector pen where a user can dial back a dose without dispensing medicament or resetting the device. According to Giambattista, in existing medication delivery pens, if a user dials a dose beyond the desired dose, “a waste of time or medication results in correcting to the desired amount.” Ex. 1016, 1:22-23. For example, dialing back the dose will result in

wasteful expulsion of medicine or will reset the pen, which results in additional time required to dial the desired dose. *Id.*, 1:28-37.

155. Giambattista states that it solves this problem by providing a pen having a dose knob that “can be dialed freely in both directions, without causing medicine to be administered, particularly upon ‘dialing back’” and without resetting the device. *Id.* at 1:56-60. Figure 2 of Giambattista is an exploded view of its medication delivery pen:

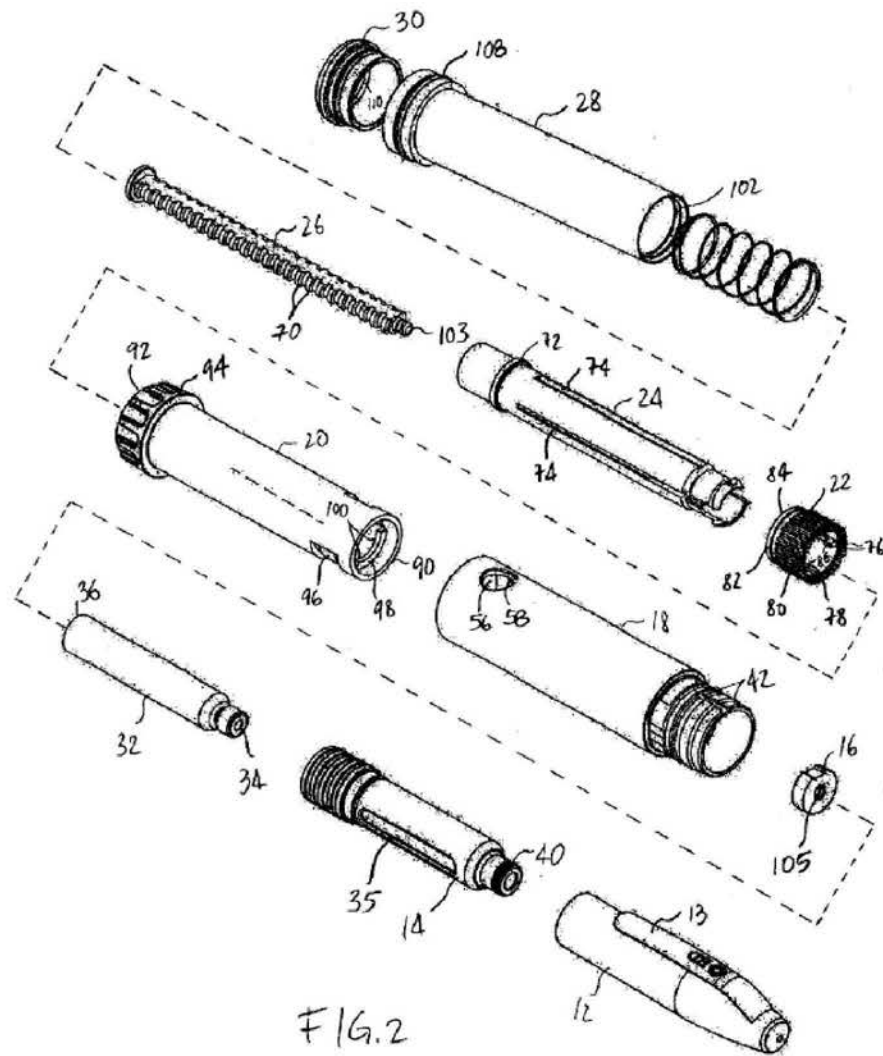

156. Giambattista's pen 10 includes a cap 12, a cartridge holder 14, a spinner 16, a body 18, a dose knob 20, a dosing ring 22, a driver 24, a leadscrew 16, a dosing ring adaptor 28, and a thumb button 30. Ex. 1016, 2:35-40. The cartridge holder 14 accommodates a drug cartridge 32, and the spinner 16 is configured to engage a plunger 38 (shown in figure 7) to expel drug from the drug cartridge 32. *Id.*, 2:45-50. The body 18 has threads or detents 42 onto which the cartridge holder 14 is mounted. Ex. 1016, 2:66-3:3. A bulkhead 44 extends across the interior of the body 18 through which an aperture 46 is formed. *Id.*, 3:1-3.

157. The driver 24 includes a proximal end 60 where a snap ring 64 is formed. Ex. 1016, 3:16-18. The snap ring 64 passes through a channel 50 of the body 18 and locks onto the wall 48 in the recess 53. *Id.* at 3:18-20. This engagement causes the driver 24 to be fixed axially relative to the body 18, but allows relative rotation between the driver 24 and the body 18. *Id.* at 3:19-21. The proximal end of the driver also includes ratchet fingers 66 that cooperate with ratchet teeth 52 that extend from wall 48. *Id.* at 3:33-37. The ratchet teeth 52 and ratchet fingers 66 allow the driver 24 to rotate in one direction relative to the body 18 by providing "a measure" of protection against unwanted rearward movements of the leadscrew 26. *Id.* The driver 24 also includes internal threads 68 that engage threads 70 of the leadscrew 26. *Id.* at 3:21-22.

158. Dosing ring 22 includes grooves 76 at a proximal end 78, longitudinal ribs 80, snap ring 82 in proximity to a distal end 84, and inwardly extending splines 86 formed and located to be disposed in keyways 74 of the driver 24. *Id.* at 3:39-43. As assembled, the dosing ring 22 is mounted onto the driver 24 with the splines 86 extending into the keyways 74; meaning that the dosing ring 22 cannot be rotated relative to the driver 24. *Id.* at 3:44-47. The splines 86 allow the dosing ring 22 to move axially along the keyways 74 of the driver 24. *Id.* at 3:47-49.

159. Dose knob 20 is used to set the pen to a desired dosage amount and includes proximal and distal ends 90 and 92. *Id.* at 3:56-60. Giambattista explains that the dose knob 20 is rotated in body 18, which results in translation of that rotation to the axial displacement of the dose knob 20 relative to the body 18. *Id.* at 3:63-66. The dose knob 20 is coaxially disposed about the dosing ring 22 and includes ratchet arms 96 are aligned with the ribs 80 of the dosing ring 22 such that the arms 96 act on the ribs 80 in a ratcheting manner giving the user an audible signal when the dose knob 20 rotates. *Id.* at 4:2-8.

160. The dosing ring 22 is mounted onto the dosing ring adaptor 28 with a snap ring 82 of the dosing ring 22 snapping into locking channel 102 of the dosing ring adaptor 28. *Id.* at 4:21-24. Dosing ring 22 and dosing ring adaptor 28 move together axially but can rotate relative to one another rotationally. *Id.* at 4:24-25,

4:51-53. Giambattista states that “[i]n an alternative embodiment, the dosing ring adaptor 28 and the dosing ring 22 may be formed unitarily.” *Id.* at 4:25-27.

161. During dialing of a dose, the dose knob 20 can be rotated without rotating the dosing ring 22. *Id.* at 4:51-53. This allows, according to Giambattista, a user to rotate the dose knob freely and set to a desired dose, including the ability to dial back if a desired dose is inadvertently exceeded. *Id.* at 4:51-53. During dose dialing, the dosing ring adaptor 28 and dose ring 22 move axially, with the dose ring 22 sliding axially along the driver 24 as a dose is being selected. *Id.* at 4:56-61. The ratchet arms 96 provide holding force to maintain the desired radial position of the dose knob 20 relative to the dosing ring 22 and thus the driver 24. *Id.* at 4:65-5:2. Dose knob 20 cannot rotate without overcoming this holding force. *Id.* at 5:2-3.

162. To dispense a dose, thumb button 30 is depressed, which causes the engagement of the grooves 76 of the dosing ring 22 with teeth 100 of the dose knob 20. *Id.* at 5:6-16. This engagement causes the dosing ring 22 to rotate with the dose knob 20, which in turn causes the driver 24 to rotate with the dosing ring 22 due to the engagement of the keyways 74 of the driver 24 and the splines 86 of the dosing ring 22. *Id.* at 5:14-18. The threads 68 of the driver 24 rotate about the threads 70 of the leadscrew 26. *Id.* at 5:18-19. The leadscrew 26, which is designed with two flat sides to correspond to a rectangular aperture, cannot rotate

because of its rotationally fixed positioning in the rectangular aperture 46, and therefore, the leadscrew 26 axially translates in a proximal direction to ultimately expel medication from the cartridge 32. *Id.* at 5:20-24.

E. Klitgaard

163. Klitgaard is titled “Dose Setting Limiter” and Petitioner relies on its third figure which discloses an embodiment showing a dose setting member 30 surrounding a driver 31. Ex. 1017, 4:16-17, FIG. 3. Between the dose setting member 30 and the driver 31 is a nut member 32 that when rotated relative to the driver 31, moves axially along the driver on a helical track 33. *Id.* at 4:26-28. During setting of a dose, the nut member 32 is rotated with the dose setting member 30 relative to the driver 31 so that the position of the nut member 32 on the driver 31 reflects the dose set. *Id.* at 4:33-37. Klitgaard states that during the delivery of the dose, the driver 31 is forced to be rotated with the dose setting member 30 and during this rotation the nut member 32 will maintain its position on the driver 31. *Id.* at 4:49-52.

X. OVERVIEW OF THE GROUNDS

164. Below is an overview of the grounds asserted by Petitioner and Mr. Leinsing across the nine IPRs. For consistency, I have used the same short-hand reference for each IPR that Mr. Leinsing adopts in his declaration.

Reference	IPR No.	Patent	Grounds
069	IPR2018-	069	Ground 1: Obvious over Burroughs

Reference	IPR No.	Patent	Grounds
	01670		<ul style="list-style-type: none"> • Claim 1 <p>Ground 2: Obvious over Steinfeldt-Jensen</p> <ul style="list-style-type: none"> • Claim 1 <p>Ground 3: Obvious over Møller in combination with Steinfeldt-Jensen</p> <ul style="list-style-type: none"> • Claim 1
044-A	IPR2018-01675	044	<p>Ground 1: Obvious over Burroughs</p> <ul style="list-style-type: none"> • Claims 11, 14-15, 18-19
044-B	IPR2018-01675	044	<p>Ground 1: Obvious over Steinfeldt-Jensen</p> <ul style="list-style-type: none"> • Claims 11, 14-15, 18-19 <p>Ground 2: Obvious over Møller in combination with Steinfeldt-Jensen</p> <ul style="list-style-type: none"> • Claims 11, 14-15, 18-19
486-A1	IPR2019-00122	486	<p>Ground 1: Obvious over Burroughs</p> <ul style="list-style-type: none"> • Claims 1-6, 12-18, 20, 23, 26-30, 32-33, 36, 38-40
486-A2	IPR2018-01678	486	<p>Ground 1: Obvious over Steinfeldt-Jensen</p> <ul style="list-style-type: none"> • Claims 1-6, 12-18, 20, 23, 26-30, 32-33, 36, 38-40 <p>Ground 2: Obvious over Møller in combination with Steinfeldt-Jensen</p> <ul style="list-style-type: none"> • Claims 1-6, 12-18, 20, 23, 26-30, 32-33, 36, 38-40

Reference	IPR No.	Patent	Grounds
486-B ⁹	IPR2018-01679	486	<p>Ground 1: Anticipated by Burroughs</p> <ul style="list-style-type: none"> • Claims 51-55 and 57 <p>Ground 2: Obvious over Burroughs</p> <ul style="list-style-type: none"> • Claims 54-55 <p>Ground 3: Anticipated by Steinfeldt-Jensen</p> <ul style="list-style-type: none"> • Claims 51-53, 56-57 <p>Ground 4: Obvious over Steinfeldt-Jensen</p> <ul style="list-style-type: none"> • Claim 56 <p>Ground 5: Obvious over Steinfeldt-Jensen in combination with Burroughs</p> <ul style="list-style-type: none"> • Claims 54-55 <p>Ground 6: Anticipated by Møller</p> <ul style="list-style-type: none"> • Claims 51-53, 56-57 <p>Ground 7: Obvious over Møller in combination with Burroughs</p> <ul style="list-style-type: none"> • Claims 54-55
844-A	IPR2018-01680	844	<p>Ground 1: Anticipated by Giambattista</p> <ul style="list-style-type: none"> • Claims 21-29 <p>Ground 2: Obvious over Giambattista in combination with Steinfeldt-Jensen</p> <ul style="list-style-type: none"> • Claims 24-29 <p>Ground 3: Obvious over Giambattista in combination with Klitgaard</p>

⁹ Note that Patent Owner only asked me to consider Grounds 1, 2, 5, and 7 in the context of amendments. I have not considered the validity of these claims outside of the amendments.

Reference	IPR No.	Patent	Grounds
			<ul style="list-style-type: none"> • Claim 30
844-B	IPR2018-01682	844	Ground 1: Obvious over Steinfeldt-Jensen <ul style="list-style-type: none"> • Claims 21-29 Ground 2: Obvious over Steinfeldt-Jensen in combination with Klitgaard <ul style="list-style-type: none"> • Claim 30
008	IPR2018-01684	008	Ground 1: Obvious over Møller in combination with Steinfeldt-Jensen <ul style="list-style-type: none"> • Claims 1, 3, 7-8, 11, and 17

165. In Section XI below, I respond to the arguments made by Petitioner and Mr. Leinsing in each of the nine IPRs. As explained below, it is my opinion that the following challenged claims are patentable: claim 1 of the 069 Patent; claims 11, 14-15, and 18-19 of the 044 Patent; claims 1-6, 12-18, 20, 23, 26-30, 32-33, 36, 38-40, and 56 of the 486 Patent; claims 21-30 of the 844 Patent; and claims 1, 3, 7-8, 11, and 17 of the 008 Patent. I have not been asked to form an opinion regarding the patentability of the remaining claims are valid.

XI. THE ASSERTED GROUNDS DO NOT TEACH OR RENDER OBVIOUS CERTAIN CLAIMS OF THE CHALLENGED PATENTS

A. Burroughs Does Not Render Obvious The Challenged Claims of the '069, '044, or '486 Patents [IPR2018-01670 Ground 1, IPR2018-01675 Ground 1, IPR2019-00122 Ground 1]

166. I understand that Petitioner and Mr. Leinsing have asserted that Burroughs renders obvious claim 1 of the 069 Patent, claims 11, 14, and 18-19 of

the 044 Patent, and claims 1-6, 12-18, 20, 23, 26-30, 32-33, 36, and 38-40 of the 486 Patent. I disagree. For the reasons discussed below, it is my opinion that a person of ordinary skill in the art would not have found these challenged claims to be obvious over Burroughs.

1. Burroughs Does Not Disclose Or Render Obvious A “Helical Groove Provided Along An Outer Surface Of Said Dose Dial Sleeve” [‘069 Patent Claim 1; ‘044 Patent Claim 11] or A “Dose Dial Sleeve Comprising A Helical Groove Configured To Engage A Threading Provided By Said Main Housing” [‘486 Patent Claim 1]

167. Each challenged claim of the ’069 and ’044 Patents requires a helical groove provided along an outer surface of a dose dial sleeve. Each challenged claim of the ’486 Patent requires that the dose dial sleeve comprise a helical groove configured to engage a threading provided by a main housing. Burroughs does not disclose or render obvious such a helical groove, and therefore does not invalidate any of the challenged claims.

a. Burroughs Does Not Disclose The Required Helical Groove

168. As I discussed in the overview of Burroughs, Burroughs’ dial mechanism 34 does not have a helical groove that engages with a threading provided by a main housing or a helical groove along its outer surface. Instead, Burroughs’ dial mechanism 34 has protruding threads 110 and 112 that engage with a helical groove 158 on the inner surface of the housing. Thus, Burroughs does not

disclose the helical groove required by the claims. Mr. Leinsing agrees. Ex. 1011, ¶ 166 (“Thus, Burroughs teaches a ‘dose dial sleeve’ in the form of a dial mechanism 34 that is ‘positioned within’ the mechanism housing 22, *and includes a ‘helical rib,’ rather than a ‘helical groove,’* that is ‘provided along an outer surface of’ the dial mechanism 34...”).

b. Burroughs Does Not Render Obvious The Required Helical Groove

169. Because Burroughs does not disclose the helical groove recited in the challenged claims, Petitioner and Mr. Leinsing propose various modifications to Burroughs in order to argue obviousness.

170. As I discuss below, the Petitions in IPR2018-01675 and IPR2019-00122 propose cutting a groove into Burroughs’ threads 110 and 112 into “u-shaped” or “grooved” threads, and argue that the resulting threads constitute a “helical groove.” IPR2018-01675 Petition at 41-42 (“... helical threads 110 and 112 were provided as u-shaped”; “protruding, grooved threads 110 and 112”); IPR2019-00122 Petition at 39 (referring to “protruding helical grooves,” “grooved threading,” and “protruding u-shaped groove”). I have illustrated this modification in the figures below, which are cutaways from Figures 7 and 8 of Burroughs. The dashed red lines indicate where the u-shaped grooves would be cut in the threads.

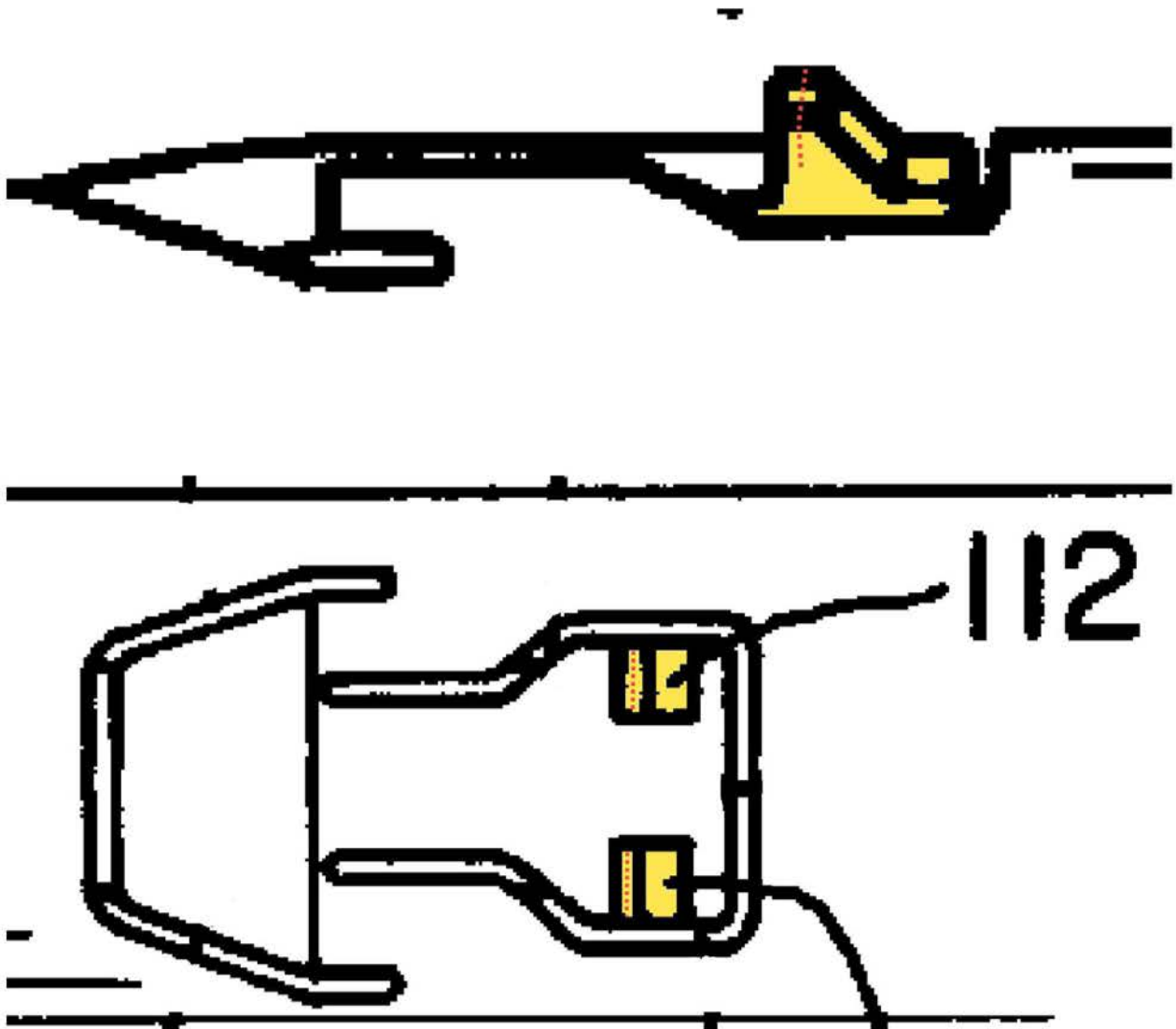

Ex. 1013, Figs. 7 and 8 (excerpted and annotated)

171. Additionally, Mr. Leinsing and the Petition in IPR2018-01670 propose a *different* modification, which involves adding a second set of threads behind the existing threads 110 and 112 to form a “helical groove” in the space between the threads. Ex. 1011, ¶ 166 (“... a person of ordinary skill would have found it obvious to add another helical rib next to the existing one, such that the threads 110, 112 form a ‘helical groove’ that engages a threading provided by the

housing.”). I have illustrated a mock-up of this modification below using a cutaway of Burroughs’ Figures 7, and also provide Mr. Leinsing’s annotations of Burroughs’ Figures 6-8 showing the proposed modification.

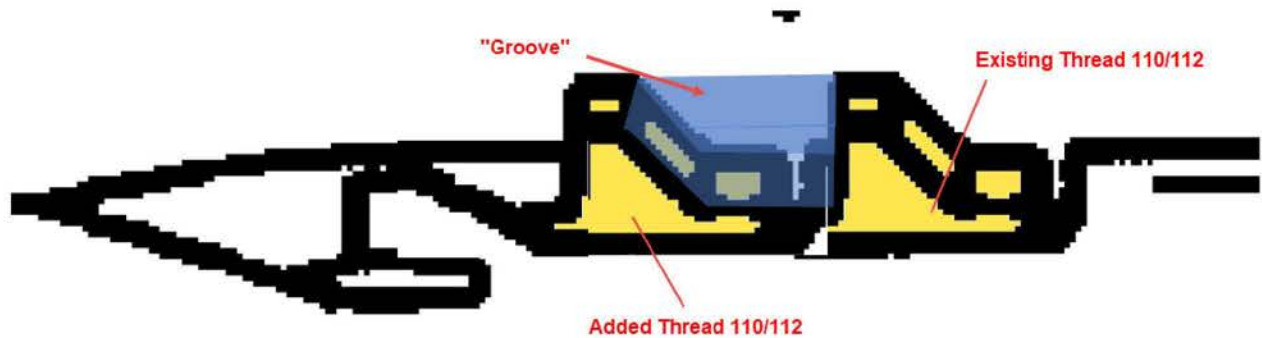

Ex. 1013, Fig. 7 (modified and annotated)

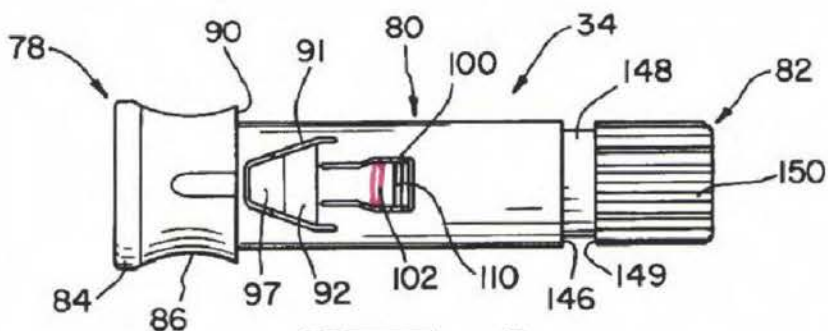

FIG. 6

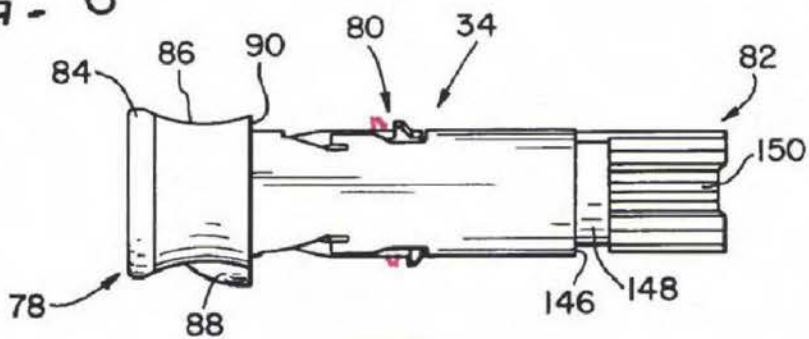

FIG. 7

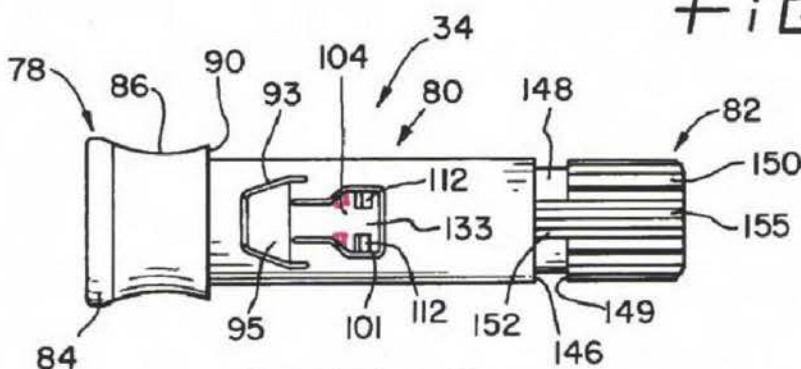

FIG. 8

138 140 34

Ex. 1013, Figs. 6-8 (annotated by Mr. Leinsing and excerpted); Ex. 2103

(excerpted)

172. I further note that neither of these proposed modifications involves a simple reversal or swapping of the positions of the threads 110, 112 on the dial mechanism 34 and the helical groove 158 in the housing. Simply switching the places of threads 110, 112 and helical groove 158 would not work because, as I

discussed in my overview of Burroughs, Burroughs' threads 110, 112 are seated on legs 102 and 104, which pivot downward when the enlarged diameter portion 54 of Burroughs' injection button presses against the ramped surfaces 96 of the legs 102, 104 during injection. Ex. 1013, 8:15-20, 11:6-12. This downward pivoting of the legs 102 and 104 is what disengages threads 110, 112 from the helical groove 158, allowing the dial mechanism to advance axially within the housing as part of the injection process. *Id.* If the threads and helical groove were simply "swapped" so that the threads were attached to the housing and the helical groove ran along the outer surface of the dial, then the downward pivot of the legs during dose injection would disengage the threads and the groove. However, the downward projecting threads would interfere with the structure of the dial adjacent to the legs and would therefore prevent the injection process from successfully completing.

173. It is my opinion that neither of the proposed modifications offered by Petitioner and Mr. Leinsing would have rendered the claimed helical groove obvious to a person of ordinary skill in the art, because a person of ordinary skill in the art would not have been motivated to attempt either modification for the reasons discussed below.

c. A Person of Ordinary Skill In The Art Would Not Have Been Motivated To Create U-Shaped, Grooved Threads [IPR2018-01675 and IPR2019-00122 Petition Modification]

174. A person of ordinary skill in the art would not have been motivated to convert Burroughs' threads 110 and 112 into "u-shaped," "grooved" threads, as proposed by the Petitions in IPR2018-01675 and IPR2019-00122, for several reasons.

175. As an initial matter, a person of ordinary skill in the art would have recognized that "u-shaped" threads on the dial mechanism must mate with a protruding thread on the inner surface of the housing. This requires either using the existing "wall" of groove 158, or replacing groove 158 with a new protruding thread. A person of ordinary skill in the art would not have been motivated to do either of these.

176. A person of ordinary skill in the art would not have been motivated to mate u-shaped threads 110 and 112 with the existing "wall" of groove 158 because it would have been clear that such an interface would not work. Burroughs' threads 110 and 112 are sized to engage with helical groove 158. Any u-shaped groove added to threads 110 and 112 would therefore necessarily be narrower than the threads 110 and 112 themselves, and therefore would be too narrow to mate with the "wall" of groove 158. The Petitions in IPR2018-01675 and IPR2019-00122 make no mention of resizing threads 110 and 112 to allow for an adequately

sized u-shape groove to be cut into each thread, but a person of ordinary skill in the art would also have recognized that enlarging threads 110 and 112 would likewise be insufficient, because it would require a “domino effect” of changes to the rest of the injector pen, such as resizing helical groove 158 to accommodate the newly resized threads, and further modifying the legs 102 and 104 on the dial mechanism to allow sufficient downward deflection for the newly resized threads 110, 112 to disengage from the resized helical groove 158 during injection. In essence, attempting to mate u-shaped, grooved threads 110 and 112 with the existing “wall” of helical groove 158 would require a significant redesign of the internals of Burroughs’ pen injector.

177. Similarly, a person of ordinary skill in the art would not have been motivated to provide a *new* protruding thread on the inner surface of the housing to mate with u-shaped, grooved threads 110 and 112 because doing so would have greatly complicated the manufacturing for the injector and introduced additional points of failure. A person of ordinary skill in the art would have recognized, for example, that Burroughs’ threads 110 and 112 are very small components in a pen-sized form factor, with a thickness on the order of millimeters. This means that any u-shaped groove added to these threads would be even narrower than the threads themselves, and thus an appropriately sized thread in the housing to engage with the groove would have to be equally narrow. The current configuration

centers around minimizing the size of components. Taking a thread of a certain width and cutting a groove into it to create two threads would drastically increase the amount of stress. Such a narrow thread would be extremely fragile, and therefore highly likely to bend or break during normal use. This greatly increases the likelihood that the thread would unintentionally disengage from the groove, either from breakage or by “skipping” out of the groove during movement of the parts, which would cause the pen injector to malfunction. This could lead to improper injection or inaccurate dose setting, both of which are highly undesirable and potentially dangerous to the user.

178. The Petition does not provide any actual detail to address the fundamental engineering issue discussed above with respect to with Ex. 1013, Fig. 7 and 8, and thus I can only conclude that the proposed modification was made without any design considerations an actual POSA would do. This is in accordance with the face the Petition does not identify a problem with Burroughs’ device that would have been solved by this proposed modification, nor any other benefit arising from the proposed modification that would have offset the disadvantages and additional points of failure that the modification would have introduced into the pen injector. Burroughs likewise does not identify any shortcomings with its injection pen that would have been addressed by the proposed modification, and a person of ordinary skill in the art would not have understood the proposed

modification to provide any additional benefits or advantages. Indeed, even the Petitions admit that the modification would perform the *same function* as the existing threads 110 and 112 that are already present in Burroughs. IPR2018-01675, Petition at 42; IPR2019-00122, Petition at 39.

179. Indeed, my analysis above is corroborated by Petitioner's own expert. I understand that during his deposition, Mr. Leinsing testified that a person of ordinary skill in the art would not have cut grooves into threads 110 and 112, because "based on proportions, you would have nothing left." Ex. 2163, 193:22-194:11. This is consistent with my opinion in the preceding paragraph that because the threads 110 and 112 are already small components to begin with, cutting a groove into them would require an extremely narrow cut to avoid removing the threads altogether. The fact that Petitioner's own expert did not believe this modification would have been practical further confirms my opinion that it would not have been obvious.

d. A Person of Ordinary Skill In The Art Would Not Have Been Motivated To Add A Second Set Of Threads Behind The Existing Threads 110, 112 [IPR2018-01670 Petition and Mr. Leinsing's Modification]

180. A person of ordinary skill in the art also would not have been motivated to provide an additional set of protruding threads behind Burroughs'

threads 110 and 112, as proposed by Mr. Leinsing and the Petition in IPR2018-01670.

181. First, a person of ordinary skill in the art would not have been motivated to attempt this modification because it would significantly increase the amount of stress experienced by legs 102 and 104 of the dial mechanism 34 during injection, which increases the likelihood of breakage and decreases the useful life of the pen injector.

182. Specifically, as I noted above, Mr. Leinsing proposes adding a second thread to each of the legs 102 and 104 (which I also refer to as “flexure beams”) that hold only a single thread in Burroughs’ design. While Mr. Leinsing sketched his proposed modification in figures during his deposition, he provided no engineering basis to show that this modification is workable. Because a person of ordinary skill in the art would not be motivated to undertake an unworkable modification, I performed an analytical assessment of Mr. Leinsing’s proposed modification. The results of that assessment are incorporated in Appendices D and F, with my written notes (including the scaling law equations I developed) supporting the results provided as Appendix D. Additionally, a CAD model and finite element analysis of Mr. Leinsing’s proposed modification, which were developed under my instruction and supervision, are included as Appendix F. The results of my assessment confirm my opinion that Mr. Leinsing’s modification

would not have been obvious to a person of ordinary skill in the art, as the modifications proposed by Mr. Leinsing are not feasible.

183. In performing the assessment summarized in Appendices D and F, I assumed regions 92 and 95 remained the stress flexible regions, and that the overall length of the legs 102, 104 and flexible sections 92, 95 combined must remain the same. In other words, my analysis only changed the proportions of the legs 102, 104 and flexible sections 92, 95, and the size of the new “groove” formed between the existing threads 110, 112 and the newly added threads.

184. Because Mr. Leinsing proposes adding an additional thread behind each existing thread 110, 112, the legs 102 and 104 must pivot downward to a greater degree – specifically, a 30 to 40 percent increase in downward deflection – during dose injection to allow both sets of threads to disengage from the helical groove 158. Likewise, the corresponding flexible sections 92 and 95 must pivot upward to a greater degree. If no change were made to the amount of downward deflection or pivot of legs 102 and 104 during injection, Mr. Leinsing’s modification would cause the pen injector to seize up during injection because the added proximal threads would not clear the walls of the helical groove 158, and therefore would halt the forward axial movement of the injection button 32 and dial mechanism 34. Alternatively, the stress against the added threads would continue to accumulate until the threads either broke, or “skipped” out of

engagement with the helical groove. This would be highly undesirable and potentially dangerous during the injection process, because it could cause the user's grip on the injector to slip, or the needle of the injector could be inadvertently driven deeper into the injection site. Even if the user could successfully deliver the full dose under these conditions, this would not be an acceptable manner of operation.

185. Mr. Leinsing testified in his deposition that he did not believe any other modifications to the injector would be required and that his proposed modification would not have any negative impacts on the force required to disengage the new set of parallel threads from the helical groove, but I disagree.

186. As shown in the calculations below I developed and incorporated into a spreadsheet (which includes the scaling law equations I developed and are included in Appendices D and F), if no changes are made to Burroughs' device other than the addition of the new threads and providing sufficient downward deflection of the legs for the new thread to clear the helical groove 158 during injection, the force and stress experienced by the legs increases by approximately 30 to 40 percent.

Design requirement: keep the force at end of beam and stress in beam the same, just change relative lengths of beam elements to enable new proposed tooth to be moved to clear engaging thread

Note, dimensions relative to drawing (so unitless)

Original distances

distance to new tooth, X_1	0.55
distance to original tooth, X_2	0.72
X_2/X_1	1.309

Increase in force and stress IF no change is done to beam lengths and new tooth is to clear	31%
---	-----

Distance of force (displacement) application, L_1	0.4
Length of beam segment A, L_2	0.29
constant C = L_1+L_2 initial	0.69
Constant C_3 for quadratic	0.207

From the quadratic equation, terms a, b, c

aq	1
bq	-1.38
cq	0.414

New L_2 diemnsion required:

solution 1	0.94
solution 2	0.44

Modified dimensions

L_2 new	0.44
L_1 new	0.25
Check: $(L_2^2/2+L_1*L_2)$ new/old = X_2/X_1, ?	TRUE
L_2 new / L_2 original	1.52
L_1 new / L_1 original	0.62

Change in deflection at end of beam (L_1) to get the tooth deflection

New design deflection/original design deflection	1.08
--	------

NOTE the force and stress is the same (original design criteria)

2nd order effects

height of tooth relative to length scale, Htooth	0.14
Slope at deflection (degrees)	14.58
cosine error ignoring tilt when calculating required slope (but this counters the fact deflection ignored and only slope used for lever calcs, see notes)	3.2%

IF < 5%, ignoring tilt insignificant?	TRUE
---------------------------------------	------

Appendix F, Analysis for Thread 110

Design requirement: keep the force at end of beam and stress in beam the same, just change relative lengths of beam elements to enable new proposed tooth to be moved to clear engaging thread

Note, dimensions relative to drawing (so unitless)

Original distances

distance to new tooth, X_1 0.46

distance to original tooth, X_2 0.65

X_2/X_1 1.413

Increase in force and stress IF no change is done to beam lengths and new tooth is to clear 41%

Distance of force (displacement) application, L_1 0.4

Length of beam segment A, L_2 0.29

constant C = L_1+L_2 initial 0.69

Constant C_3 for quadratic 0.223

From the quadratic equation, terms a, b, c

aq 1

bq -1.38

cq 0.447

New L_2 dimension required:

solution 1 0.86

solution 2 0.52

Modified dimensions

L_2 new 0.52

L_1 new 0.17

Check: $(L_2^2/2+L_1*L_2)$ new/old = X_2/X_1, ? TRUE

L_2 new / L_2 original 1.79

L_1 new / L_1 original 0.43

Change in deflection at end of beam (L_1) to get the tooth deflection

New design deflection/original design deflection 1.10

NOTE the force and stress is the same (original design criteria)

2nd order effects

height of tooth relative to length scale, Htooth 0.14

Slope at deflection (degrees) 17.44

cosine error ignoring tilt when calculating required slope (but this counters the fact deflection ignored and only slope used for lever calcs, see notes) 4.6%

IF < 5%, ignoring tilt insignificant? TRUE

Appendix F, Analysis for Thread 112

187. The analysis above is also confirmed by the finite element analysis included in Appendix F, which shows that for leg 104, a force increase of 32% is required in order to generate the vertical displacement needed for Mr. Leinsing's proposed second tooth to clear the groove 158 during injection.

188. A person of ordinary skill in the art would have recognized that this is clearly detrimental to the device, because it increases fatigue on the legs during usage and would result in a decrease in useful life. In view of the fact that Burroughs expressly intends for its injector to be a "multi-use," *i.e.*, reusable, injector, an increase of this magnitude in the stress experienced by a moving part that is critical to the operation of the device would have been a strong deterrent against modifying the device as proposed by Mr. Leinsing.

189. Although Mr. Leinsing maintained at his deposition that no modification other than adding the parallel threads was necessary, I further note that a person of ordinary skill in the art also would have recognized that changing the dimensions of the legs 102 and 104 to offset the 30-40% increase in stress during injection likewise would not have been viable, and therefore also would not have been motivated to pursue such a design.

190. Specifically, a person of ordinary skill in the art would have recognized that because the legs 102 and 104 pivot inwardly toward the radial center of the injector during does injection, the device itself must have a

sufficiently sized radius to accommodate the pivoted legs *and* the other internal components of the device (*e.g.*, injection button 32) during dose injection. As shown in the calculations above (taken from Appendices D and F), the length of the distal portion of the legs 102 and 104 (which I labeled L_2) must increase significantly, by between 40 and 80 percent.

191. To accommodate this increased length when the legs pivot inward, the internal diameter of the pen injector must also increase by at least 10 percent, resulting in a thicker device. Increasing the thickness of the injector is undesirable, however, because a larger device is more difficult for users to grasp and manipulate, especially when the thumb is used to press the injection button. Additionally, as I discussed in my overview of injector pen design considerations for diabetic populations, diabetic patients often suffer from a variety of hand and wrist conditions that make it more difficult for them to grip and operate injection devices, and those difficulties are exacerbated when the device is larger and therefore more difficult to grasp.

192. Additionally, regardless of whether the dimensions of legs 102 and 104 are changed, a person of ordinary skill in the art would have recognized that because a greater amount of downward pivot is required to disengage the additional set of threads that Mr. Leinsing proposes to add, the amount of force that the user must exert to inject the dose also increase by around 15 percent. This

is because the amount of axial displacement of the injector button that the user can generate is fixed, both by the length of the user's thumb and the overall dimensions of the injector pen. Thus, during injection the injection button has a fixed amount of travel that must both engage the ramped surfaces 96 to cause the legs 102 and 104 to pivot, and drive the leadscrew 38 to inject the dialed dose. Because Mr. Leinsing's modification requires a greater downward pivot of the legs 102 and 104, more of the injection button's travel is spent pivoting the legs in comparison to the unmodified Burroughs injector. This leaves less travel available for driving the leadscrew to inject the dose, meaning that the user must apply more force per unit of distance traveled over the remaining travel of the button to inject the same dosage. As I discussed in the background sections of this declaration, design changes that increase the required injection force are highly undesirable for pen injectors, because of the many hand and wrist conditions experienced by diabetics that greatly limit patients' ability to generate sufficient injection force with their thumbs. A person of ordinary skill in the art therefore would have been deterred from attempting to modify Burroughs as proposed by Mr. Leinsing, because the resulting injector would require a significantly higher injection force to dispense the same amount of medication.

193. Neither Petitioner nor Mr. Leinsing discuss any benefits that would have resulted from the proposed modification that would warrant introducing the

disadvantages discussed above into Burroughs' injector. Thus, a person of ordinary skill in the art would not have been motivated to modify Burroughs as proposed by Mr. Leinsing and the IPR2018-01670 Petition.

2. Burroughs Does Not Disclose Or Render Obvious That The “Helical Groove Of The Dose Dial Sleeve Has A First Lead And Said Internal Threading Of Said Drive Sleeve Has A Second Lead, And Wherein Said First Lead And Said Second Lead Are Different” [’044 Patent Claim 11]

194. Each challenged claim of the ’044 Patent also requires that the “helical groove of the dose dial sleeve has a first lead and said internal threading of said drive sleeve has a second lead, and wherein said first lead and said second lead are different.” In my opinion, Burroughs does not disclose or render obvious this limitation, and therefore does not render the challenged claims obvious, for several reasons.

195. First, the helical groove in this limitation is the “helical groove provided along an outer surface of said dose dial sleeve” that I discussed in the previous section. Because Burroughs does not disclose or render obvious this required helical groove, it also cannot disclose or render obvious that the helical groove has a lead that is different than the lead of the internal threading of the drive sleeve.

196. Second, even if Burroughs did disclose or render obvious the required helical groove, it does not disclose that the lead of the groove is different from the

lead of the threading on the drive sleeve. The Petitioner and Mr. Leinsing agree with me in this regard. IPR2018-01675 (044-A) Petition at 39 (“Burroughs does not specifically address the lead on threads 110 and 112, nor for helical thread 198.”); Ex. 1011, ¶ 192 (“Burroughs does not explicitly disclose numerical values for the leads contained on the dial mechanism 34 and the nut 36. It also does not explicitly disclose whether the leads for the dial mechanism 34 and the nut 36 are the same or different.”).

197. Third, it would not have been obvious to a person of ordinary skill in the art to make the lead of the helical groove different from the lead of the internal threading on the drive sleeve, because a person of ordinary skill in the art would not have had a reason to make this modification. Mr. Leinsing relies on Møller to argue that having different leads would allow a user to better perceive small movements of the dial mechanism, correlating to small changes in dose, during the dose setting process. Ex. 1011, ¶ 195. In my opinion, however, Mr. Leinsing’s position is based on a misreading of Møller, and a person of ordinary skill in the art would not have shared Mr. Leinsing’s view.

198. Specifically, Mr. Leinsing cites Møller at “1:33-57.” Ex. 1011, ¶ 195. I note that Møller does not include column and line numbers, but counting the lines in the first column of Møller shows that this citation roughly correlates to paragraphs [0005] through [0007] of Møller. Ex. 1015, ¶¶ 0005-0007. These

passages, however, relate to issues concerning the movement of the *injection button* on a pen injector *during dose injection*, not with the movement of the dose dial during dose setting. In these paragraphs, Møller explains that previous work in this field, which halved the distance that the piston of prior art pen injectors is required to move in order to dispense a single unit of medicament, was disadvantageous for patients with reduced finger strength, because it became difficult for patients to feel whether the injection button had moved at all when injecting small amounts of medication. *Id.*, ¶ 0005. Specifically, Møller explained that to inject one unit of medication from a 3mL ampoule, the injection button on a prior art injector need only move approximately 0.1mm. Møller further explained that one solution to this concern was to provide gearing between the injection button and the piston, with the gearing coupled to components having two different thread pitches to ensure that a greater travel of the injection button is required in comparison with a non-g geared injector in order to produce an equivalent movement of the piston. *Id.*, ¶¶ 0006-0007. Thus, these paragraphs of Møller have *nothing* to do with sensing movement of the dose dial during dose setting.

199. Because the paragraphs that Mr. Leinsing cited do not relate to sensing movement of the dose dial during dose setting, a person of ordinary skill in the art would not have found a reason in these paragraphs to modify Burroughs as Mr. Leinsing proposes. Nothing in these paragraphs provides any hint of a

suggestion that there was a problem in prior art pen injectors with users being unable to sense movement of the dose dial during dose setting. Nor does Burroughs itself suggest any such problem with its pen injector.

200. Likewise, a person of ordinary skill in the art certainly would not have inferred from Møller's discussion regarding the injection button that a similar issue existed with respect to the dose dial, because the operation of the injection button during injection is completely different from the operation of the dose dial during dose setting. For example, as discussed in my overview of Burroughs, during dose setting the dose dial of Burroughs' injector rotates within the housing, winding out along the helical groove 158 on the inner surface of the housing. This movement is produced by the user grasping the exposed portion of the dial mechanism and turning it. By contrast, during injection, the injection button is pushed by the user and moves axially toward the needle end of the device. During injection, the dose dial similarly moves axially without rotating, because the threads 110 and 112 have been disengaged from the helical groove 158 by the movement of the button. Because dose setting and injection involve different body mechanics on the part of the user, a person of ordinary skill in the art would not have understood the difficulties that users may have in performing the injection process to be applicable to the dose setting process.

201. Furthermore, Burroughs discloses numerous *existing* features of its pen injector that would have led a person of ordinary skill in the art to conclude that a user would not have had any difficulty sensing movements of the dose dial during dose setting or otherwise understanding how much dosage had been dialed. For example, Burroughs discloses that the dial 34 includes splines 150 that engage with a finger 170 in the housing when the dial is rotated to generate an audible “click” and a tangible vibration in the device, with each click indicating one unit of dosage. Ex. 1013, 10:38-47. Burroughs also provides a lens 25 through which a user can see a numeral indicating the amount of dosage that has been selected. *Id.*, 10:5-14, 10:48-49. Thus, Burroughs already provides audible, tactile, and visual feedback to indicate to the user when the dose dial has moved (*i.e.*, when an additional unit of dosage has been dialed), eliminating any need for the user to directly perceive through touch whether the dose dial has undergone a small movement. Neither the Petition nor Mr. Leinsing identifies any shortcomings or problems with these mechanisms that would have motivated a person of ordinary skill in the art to experiment with changing the leads of the dose dial or drive sleeve. To the contrary, a person of ordinary skill in the art would have considered these mechanisms to provide far more precise and desirable indicators of the dialed dosage compared to requiring users to estimate whether the correct dosage has

been dialed by sensing whether the dose dial has undergone an appropriate amount of rotation.

202. Thus, for the reasons discussed above, it is my opinion that a person of ordinary skill in the art would not have been motivated to modify Burroughs such that the “helical groove of the dose dial sleeve has a first lead and said internal threading of said drive sleeve has a second lead, and wherein said first lead and said second lead are different.”

**3. Burroughs Does Not Disclose Or Render Obvious A
“Tubular Clutch Located Adjacent A Distal End Of Said
Dose [Dial Sleeve]/[Knob], Said Tubular Clutch Operatively
Coupled To Said Dose [Dial Sleeve]/[Knob]” [069 patent
Claim 1; 044 Patent Claim 11; 486 Patent Claim 1]**

203. Each challenged claim of the 069 and 044 Patents requires a “tubular clutch located adjacent a distal end of said dose dial grip, said tubular clutch operatively coupled to said dose dial grip.” Each challenged claim of the 486 Patent requires a “tubular clutch located adjacent a distal end of said dose knob, said tubular clutch operatively coupled to said dose knob.”

204. As can be seen by comparing the language in the preceding paragraph, these limitations are identical except that the 069 and 044 Patents refer to a “dose dial grip,” whereas the 486 Patent refers to a “dose knob.” The Petitions and Mr. Leinsing analyze the “dose dial grip” as being the same as the “dose knob,” identifying the proximal portion 78 of Burroughs’ dial mechanism 34 for both the

dose dial grip and the dose knob. Ex. 1011, ¶¶ 173-175. Thus, my analysis for these limitations is also the same, notwithstanding this slight difference in the language.

205. As I noted in the claim construction section, the proper construction of the term “tubular clutch” is “a tubular component that can operate to reversibly lock two components in rotation.”

206. Mr. Leinsing and the Petitions identify the injection button 32 of Burroughs as being the “tubular clutch” recited in the challenged claims. Ex. 1011, ¶ 183. Mr. Leinsing offers two different ways in which the button 32 purportedly operates as a clutch. First, Mr. Leinsing opines that the button 32 disengages the dial mechanism 34 from the housing 22. *Id.* Second, Mr. Leinsing opines that the button 32 disengages the dial mechanism 34 from the nut 36. *Id.* For the reasons discussed below, however, a person of ordinary skill in the art would not have understood the button 32 to constitute a “tubular clutch,” as properly construed, under either of these theories.

207. With respect to the engagement between the dial mechanism 34 and the housing 22, the button 32 is not a tubular clutch, as properly construed, because it cannot operate to reversibly lock two components (*i.e.*, the dial 34 and the housing 22) *in rotation*. As I discussed in my overview of Burroughs, dial 34 is coupled to the housing 22 during dose setting by threads 110 and 112, which are

formed on the dial and engage with the helical groove 158 in the inner surface of the housing. Even assuming that this engagement constitutes “reversibly locking” the dial to the housing and that it is attributable to the operation of the button 32, the dial 34 and housing 22 are not reversibly locked *in rotation* because the engagement between threads 110, 112 and helical groove 158 is specifically designed to allow the dial 34 to rotate *relative to* the housing. Burroughs explains this by stating that “[u]pon rotation of dial 34, threads 110, 112 move within housing groove 158 in the proximal direction *as dial mechanism 34 retracts from housing 22....*” Ex. 1013, 10:34-37. In other words, when the user rotates dial 34, the housing 22 remains motionless relative to the dial, while the dial retracts from the housing by winding out along the path created by helical groove 158. Thus, rather than being locked in rotation, which would require that the housing rotates when the dial rotates and vice versa, the dial rotates while the housing remains still. This would result in a non-operative device. Accordingly, with respect to dial 34 and housing 22, the button 32 is not “a tubular component that can operate to reversibly lock two components in rotation.”

208. With respect to the engagement between dial 34 and nut 36, button 32 is not a “tubular clutch” because it cannot operate to reversibly lock dial 34 and nut 36 at all. Mr. Leinsing opines that the axial movement of the button 32 during injection “causes the dial mechanism’s splines 144 to move out of its alignment

with the nut's splines 192, which rotationally decouples the component prior to any axial movement of the nut.” Ex. 1011, ¶ 183. But a person of ordinary skill in the art would not have understood this to show that the button 32 reversibly *locks* dial 34 and nut 36. Rather, as Mr. Leinsing's own opinion makes clear, the locking is provided by splines 144 and splines 192, which engage with one another to reversibly lock the dial to the nut. Moreover, Burroughs makes it clear that the operation of button 32 is not what causes these splines to engage with one another. As Burroughs explains, the splines 144 and splines 192 are brought into engagement with each other by the user retracting the dial from the zero-dose position during dose setting:

In its zero-dose position, *dial mechanism 34 may be axially retracted a predetermined distance, e.g. 3 to 5mm, to engage the clutch mechanism.* This places dial mechanism 34 into the dose-setting position. As dial mechanism 34 is retracted, ledge 149 is moved past housing finger 10 resulting in housing finger 170 being in engagement with splines 150. In addition, *splines 144 of dial mechanism 34 are moved into engagement with splines 192 of nut 36* so that the adjacent lateral surfaces of the splines 144 and 196 will engage with each other (FIGS. 4 and 11). *When the surfaces are engaged, rotation of the dial mechanism 34 causes corresponding rotation of nut 36.*

Ex. 1013, 10:15-26 (emphasis added).

Referring to FIG. 9, there are shown a plurality of splines 144 extending circumferentially about the interior surface of intermediate portion 80 of dial mechanism 34. *Splines 144* extend 360° about the inner circumference of intermediate portion 80 and *engage with teeth 192* (FIGS. 10, 11) *provided on nut 36 when the clutch is engaged to set a dosage.*

Id., 8:42-48 (emphasis added). Thus, a person of ordinary skill in the art would not have understood the button 32 to operate as a clutch in connection with dial 34 and nut 36, because it is the splines 144 and splines/teeth 192, not the button 32, that “reversibly lock” the dial to the nut.

209. While the passages cited above from Burroughs refer to a “clutch” or “clutch mechanism,” Burroughs makes clear that its clutch is the combination of splines 144 and teeth 192, *not* the injection button 32:

The clutching device *comprises a series of splines on the inner cylindrical surface of the dial mechanism which axially engage corresponding splines on the outer surface of the nut.* The splines are engaged with one another by retracting the dial mechanism with respect to the nut after the dial mechanism has been rotated to its zero-dose position.

Ex. 1013, 2:59-65 (emphasis added). Burroughs’ “clutching device” is not a “tubular clutch,” however, because the splines 144 and teeth 192 are not tubular. Additionally, Burroughs’ “clutching device” is not a “tubular clutch located adjacent a distal end of said dose [dial grip/knob]” because the splines 144 and

teeth 192 are not adjacent to either end of the proximal portion 78 of the dial mechanism -- as I noted above, Mr. Leinsing and Petitioner have taken the position that proximal portion 78 in Burroughs is the dose dial grip or dose knob. The fact that Burroughs expressly discloses a clutch that is *not* the button 32 further supports my opinion that a person of ordinary skill in the art would not have understood button 32 to constitute the claimed “tubular clutch.”

210. For all of the reasons discussed above, Burroughs does not disclose or render obvious a “tubular clutch located adjacent a distal end of said dose dial grip” or a “tubular clutch located adjacent a distal end of said dose knob,” as required by the challenged claims.

B. Steinfeldt-Jensen Alone, or in Combination with Klitgaard, Does Not Render Obvious the Challenged Claims of the 069, 044, 486, or 844 Patents [IPR2018-01670 (069) Ground 2, IPR2018-01676 (044-B) Ground 1, IPR2018-01678 (486-A2) Ground 1, 2018-01682 (844-B) Grounds 1 and 2]

211. I understand that Petitioner and Mr. Leinsing assert that Steinfeldt-Jensen’s fifth embodiment renders obvious claim 1 of the 069 Patent, claims 11, 14-15, and 18-19 of the 044 Patent, claims 1-16, 12-18, 20, 23, 26-30, 32-33, 36, and 38-40 of the 486 Patent, and claims 21-29 of the 844 Patent. I further understand that Petitioner and Mr. Leinsing propose combining Steinfeldt-Jensen with Klitgaard to argue obviousness of claim 30 of the 844 Patent, which additionally recites “a nut that tracks each set dose of medicament delivered.” I

disagree. For the reasons discussed below, it is my opinion that a person of ordinary skill in the art would not have found the challenged claims obvious over Steinfeldt-Jensen alone, or the combination of Steinfeldt-Jensen Klitgaard.

1. Steinfeldt-Jensen Does Not Teach or Render Obvious “a drive sleeve comprising an internal threading” [IPR2018-01670 (069), IPR2018-01676 (044-B)], a “driver comprising an internal threading” [IPR2018-01678 (486-A2)], or a “driving member comprising a third thread” [IPR2018-01682 (844-B)]

212. Each of the challenged claims I identify in the paragraph above require either a drive sleeve, driver, or driving member with an internal thread. In my opinion, Steinfeldt-Jensen does not disclose a drive sleeve, driver, or driving member with an internal thread. Petitioner and Mr. Leinsing even concede this. *See, e.g.*, IPR2018-01682 (844-B) Petition at 53; Ex. 1011, ¶ 621.

213. Nonetheless, to argue that these claim limitations are obvious, Petitioner and Mr. Leinsing argue that a POSA would have known to modify Steinfeldt-Jensen to have an internally-threaded drive sleeve/driver/driving member. Specifically, Petitioner and Mr. Leinsing propose a modification whereby the driver tube 85 in Steinfeldt-Jensen’s fifth embodiment is internally threaded, instead of slotted, and the member 40 is slotted, instead of internally threaded. *See, e.g.*, IPR2018-01678 (486-A2) Petition at 36; IPR2018-01682 (844-B) Petition at 55; Ex. 1011, ¶¶ 277, 624. For the reasons I explain below, it is my

opinion that a POSA would not have been motivated to make the modification proposed by Petitioner and Mr. Leinsing for the reasons I explain, below.

a. Steinfeldt-Jensen Does Not Disclose or Suggest an Internally-Threaded Driver Tube

214. According to Petitioner and Mr. Leinsing, Steinfeldt-Jensen “suggests an alternative embodiment in which ... driver tuber 85 does have such [internal] threading.” *See* IPR2018-01682 (844-B) Petition at 55; Ex. 1011, ¶ 624. I disagree.

215. A POSA would not have understood that the disclosures in Steinfeldt-Jensen, including the four disclosures that Petitioner identifies, discloses or suggests a driver tube that is internally threaded. Instead, the disclosures cited by Petitioner, which I identify below, only disclose an internally threaded “nut member” or “nut element,” which is *rotated by* a driver tube. In other words, the disclosures only say that the “nut member” or “nut element” is internally threaded, not the driver tube.

216. The first disclosure that Petitioner and Mr. Leinsing identify is:

This is obtained by an-injection syringes for apportioning set doses of a medicine from a cartridge containing an amount of medicine sufficient for the preparation of a number of therapeutic doses, comprising
a housing
a piston rod having a not circular cross-section and an outer thread
a piston rod drive comprising two elements
a) a piston rod guide in relation to which the piston rod is axially

displaceable but not rotatable, and
b) a nut member which is rotatable but not axially displaceable in the housing and which has an inner thread mating the thread of the piston rod to form a self locking thread connection,

Ex. 1014, 2:40-53. This first passage does not identify a driver tube or refer to any figures depicting a driver tube. It also does not identify or describe an internally-threaded driver tube. It instead identifies (1) a piston rod guide that can move axially, but not rotatably, relative to a piston rod and (2) a nut member that is rotatable, but not axially displaceable, relative to the housing. The only threaded component described above is a “nut 6member,” not a driver tube.

The next two disclosures that Petitioner and Mr. Leinsing identify are:

When the injection button is pressed the movement of this button is transformed into a rotation of the piston rod (or the nut member) relative to the nut member (or the piston rod). When the button is pressed hard enough the initial reluctans [*sic*] is overcome so that the two elements, the piston rod and the nut member, are rotated relative to each other.

Ex. 1014, 3:15-20.

The thread connection by which the injection button is screwed out from the housing by setting a dose may be the thread connection between the dose scale drum and the housing. In this case the dose scale drum must be coupled to a driver rotating the piston rod (or the nut member) relative to the nut member (or the piston rod) when the injection button is pressed.

Ex. 1014, 3:41-47.

217. Petitioner argues that these passages teach “alternative ways to drive the piston rod.” IPR2028-01682 (844-B) Petition at 54; Ex. 1011, ¶ 622. These passages, however, only state that in order for a piston rod to traverse axially through a nut member, there must be relative rotation between it and the nut member. This is simply a recognition of a basic principles of screw-nut physics, as I explained in my overview of the technology, above, in Section V.B.

218. The four disclosures that Petitioner and Mr. Leinsing rely on as alleged support for their proposed modification is:

In the shown embodiment the end wall 4 with its threaded bore forms a nut member relative to which the piston rod is rotated by the piston rod guide 14 and the driver tube 26. Embodiments may be imagined wherein the piston rod guide is provided in the wall 4 and a nut element is rotated by the driver tube and such embodiment will not be beyond the scope of the invention.

Ex. 1014, 7:41-47.

219. [reserved]

220. This disclosure does not disclose putting an internal thread in a driver tube 26, and a POSA would not have understood this disclosure as stating such. Instead, this passage teaches an internally threaded “nut member” that may be rotated by a “driver tube.”

221. I also note that Steinfeldt-Jensen describes nut members and driver tubes as being different with respect to the depicted embodiments. In the third embodiment, element 48 (light green, below) in Figure 13 is identified as a “nut member” and element 45 (red, below), which is an entirely different component, is separately identified as a “driver tube.” See Ex. 1014, 10:2-10 (“The coupling between the tubular part 52 and the nut member 48 makes this nut member inrotatable relative to the housing so an axial movement of said nut member in a distal direction will [*sic*] due to the not self locking thread coupling between this nut element and the driver tube 45 make this driver tube 45 rotate in a clockwise direction and due to the key/groove coupling between the driver tube 45 and the piston rod 6 said piston rod will be screwed through the end wall 4 further into the ampoule holder compartment.”).

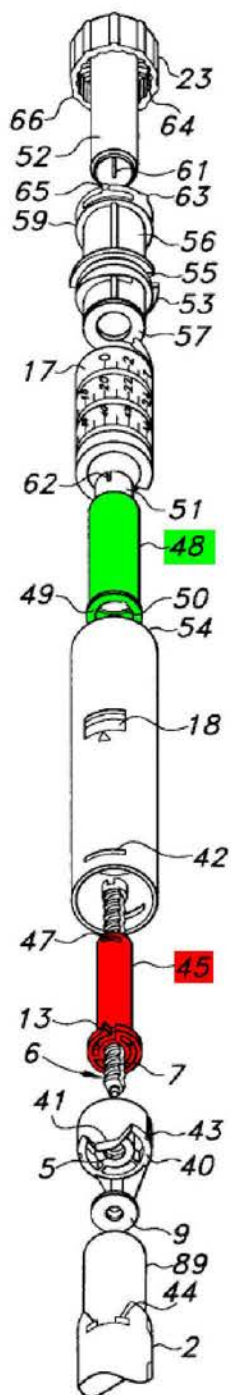

Ex. 1014, Fig. 13 (annotated)

222. Therefore, none of the disclosures above discloses a threaded driver tube. Instead they discuss a threaded nut member or nut element, which is not

described as the driver tube. Instead, as the fourth passage explains, the nut member is rotated by the driver tube.

b. Steinfeldt-Jensen's Disclosure at Column 7, Lines 41-47, Is Made for the First Embodiment

223. Of the four disclosures Petitioner and Mr. Leinsing rely on, as I noted above, three are made in the background and summary section of Steinfeldt-Jensen, and one is made in the description of the first embodiment. The disclosure made for the first embodiment says:

In the shown embodiment [i.e., the first embodiment] the end wall 4 with its threaded bore forms a nut member relative to which the piston rod is rotated by the piston rod guide 14 and the driver tube 26. Embodiments may be imagined wherein the piston rod guide is provided in the wall 4 and a nut element is rotated by the driver tube and such embodiment will not be beyond the scope of the invention.

Ex. 1014, 7:41-47.

224. This disclosure is made at the end of the first embodiment, the description of which begins at column 5, line 33. Petitioner seems to suggest that this disclosure applies to the fifth embodiment. In my opinion, a POSA would not have understood that this disclosure is made for anything other than the first embodiment or that it has general applicability to the other embodiments.

225. It would have been clear to a POSA that this passage is made for and applies specifically to the first embodiment. Immediately after describing the first

embodiment and before describing the second embodiment at column 7, line 48, the introductory sentence of this paragraph references the “shown embodiment.” This statement is not repeated for any other embodiment, including the fifth embodiment. The paragraph also references components specifically shown and described for the first embodiment—i.e., piston rod guide 14 and driver tube 26. Furthermore, this exact passage first appeared in Steinfeldt-Jensen’s provisional application, which included descriptions and figures for the first embodiment but not the fifth embodiment, but when the fifth embodiment was later added to the Steinfeldt-Jensen disclosure, similar language was not added for the fifth embodiment. This clearly demonstrates that this passage is specific to the first embodiment and not applicable to the fifth embodiment.

226. A POSA would have understood that this passage does not provide a general teaching having applicability to all of Steinfeldt-Jensen’s embodiments. For example, with respect to Steinfeldt-Jensen’s second embodiment, if a “piston rod guide” is provided in wall 4 and a nut member is provided in pawl wheel 13, then the pen injector of the second embodiment would not work. Specifically, a user would be able to dial a dose but not dispense one. This is because the threads from wall 4 are self-locking and now the piston rod 6 must move axially through piston rod guide in the ampoule holder wall, whereas in the depicted embodiment it screws through wall 4. *See* Ex. 2149 (showing a fair representation of

Steenfeldt-Jensen's second embodiment in operation). The piston rod 6 in this modified embodiment cannot move axially, however, because the threaded pawl wheel would have to rotate around piston rod during injection. But due to the self-locking nature of these threads, the pawl wheel 13 would not be able to rotate as would be required to have the piston rod move axially through it. Thus, the user would be unable to depress the button to inject the dose. A POSA would have recognized this and understand that the disclosure at column 7, lines 41-47, could not have had general applicability.

227. Moreover, it is my opinion that even if this statement at column 7, lines 41-47, were somehow seen as being applicable to the fifth embodiment, it does not teach the modification that Petitioner and Mr. Leinsing propose. As I discussed above, the passage says embodiments "may be imagined" with respect to the first embodiment where a piston rod guide is placed in an end wall 4 and a nut is rotated by a driver tube. The passage does not suggest forming a driver tube with an internal thread. Nonetheless, Petitioner argues that this statement suggests to a POSA to modify Steenfeldt-Jensen's driver tube 85 (in the fifth embodiment) to have an internal helical thread and to modify Steenfeldt-Jensen's member 40 (in the fifth embodiment) to have a slotted opening instead of its helical thread. I will refer to this modification to Steenfeldt-Jensen's fifth embodiment as Petitioner's proposed modification. I note that Mr. Leinsing, when asked about this in his

deposition, confirmed that putting a threaded opening in the driver tube 85 and a slotted opening in member 40 is the extent of the modification. *See* Ex. 2164 at 219:18-220:11.

228. As I explain below, a POSA would not have been motivated to make Petitioner's proposed modification because it would lead to an inferior pen injector.

c. Petitioner's Proposed Modification to the Fifth Embodiment Results in an Inferior Pen Injector

229. In my opinion, a POSA would not have had a reason to make Petitioner's proposed modification to the Steinfeldt-Jensen's fifth embodiment, because, as I explain below, it would result in a pen injector that at best would have a much lower mechanical efficiency and would require prohibitively more force from the user to inject medication ("injection force"). A POSA would not have been motivated to make a pen injector that was harder for diabetics to use.

230. As I explained in section V.C., pursuing a design choice that had no apparent benefit while also increasing injection force (*i.e.*, Petitioner's proposed modification to Steinfeldt-Jensen's fifth embodiment) would have gone against the prevailing design incentives for pen injectors during the relevant time period. Specifically, at the time, there was intense focus to reduce injection force, not increase it. *See, e.g.*, Ex. 2163 at 20:24-81:1 ("So there's a lot of focus in pen injectors to reduce the force of injection."); Ex. 2100 at 1-2; Ex. 2144 at 5, 9; Ex.

2175 at 3; Ex. 2159 at 4; Ex. 2116 at 4, 7; Ex. 2136 at 4. Lower injection force is not just a design incentive driven by patient preference; having a pen injector that is easy to use correlates with patients adhering to their dosing regimens and thus healthier lifestyles. *See, e.g.*, Ex. 2111 at ¶ 26.

231. Here, Petitioner's proposed modification results in a pen injector that suffers from higher injection forces due to the introduction of "collar friction"—which is essentially a disc brake being applied to Steinfeldt-Jensen's system during dose injection.

i. Explanation for Why Petitioner's Modification Results in Higher Friction

232. To explain, during dose injection the pen injector is able to expel medicament by advancing a piston into an ampoule. A piston in an ampoule should resist movement so as not to inadvertently expel medication when the pen injector is not in use. Movement of the ampoule piston thus requires enough force to overcome the tendency of the piston to stay at rest inside the ampoule and the additional force needed to force the liquid medicament through the small capillary diameter of the hypodermic needle. In Steinfeldt-Jensen, the piston rod 6 moves axially toward the needle-end of the device to push on the ampoule piston for ejecting medicament.

233. According to Newton's third law, the ampoule piston will exert a reactive force back on the piston rod during dose dispensing—*i.e.*, when the lead

screw is being rotated through member 40. As shown below, this reactive force pushes up on the piston rod, which then pushes the piston rod up against the threads of member 40, conveying the reactive forces (shown in black arrows below) to the housing and back into the user's hand and thumb to close the structural loop.

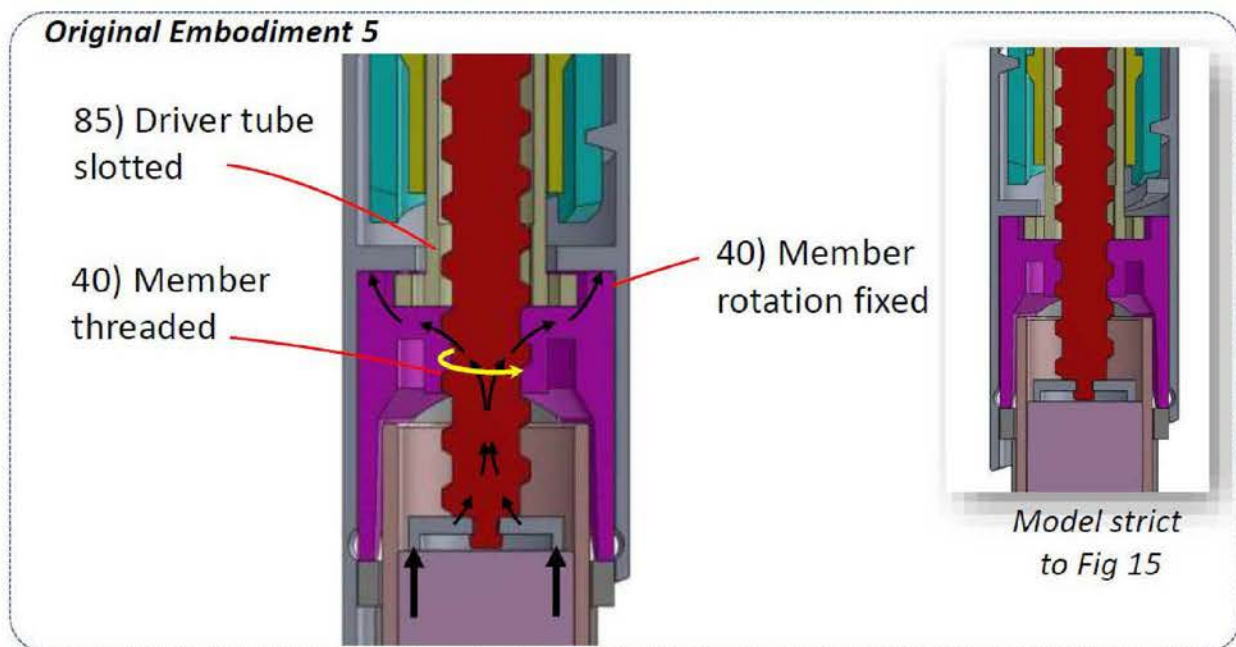

Appendix C

234. Notably, frictional losses will result from the piston rod being forced up against the threads in member 40 while the piston rod rotates. These forces exert a drag force at the radius of the threads ($\tau = r \times F$), which must be overcome to screw the piston rod through member 40 and advance the piston rod. Some of the force exerted by the user to inject medicament from the pen injector is used to

overcome the drag force caused by this thread friction. This drag can be considered a “parasitic force”.

235. In the modification proposed by Petitioner and Mr. Leinsing, however, the amount of force the user must expend to inject medicine is greater because the proposed modification creates greater drag force from friction. In the proposed modification, the threads that engage the piston rod are no longer in member 40, which is fixed relative to the housing. Instead, the threads are in the rotatable driver tube that has an outwardly extending flange (or collar) comprising flexures. The driver tube and its collar rotate during dose injection between the ring-shaped wall 46 and member 40.

236. Just as the ampoule piston exerted a force on the piston rod during dose injection in Steinfeldt-Jensen’s fifth embodiment, in Petitioner’s proposed modification it will do the same. However, instead of the reactive forces pushing the piston rod threads up against the threads in member 40 (which is now slotted), the forces push the piston rod threads up against the threads in the driver tube, which pushes the driver tube up against ring-shaped wall 46. Thus, the reactive forces are conveyed to ring-shaped wall, to the housing, and back to the user’s hand to close the structural loop.

237. In Petitioner’s proposed modification, there is still drag force at the interface of the piston rod threads, but now there is an additional drag force at a

much larger radius that did not exist before: the interface of the driver tube collar and ring-shaped wall 46. Because the driver tube is forced up against ring-shaped wall 46 while the driver tube is rotating, the friction forces are applied via surfaces in relative motion to each other at a much greater radius (as shown below) than the leadscrew threads, means there is an increase in drag force ($\tau = r \times F$) that the user will have to overcome—*i.e.*, much higher injection force will have to be applied to get the same net force on the ampoule. I have also included an animation at Exhibit 2152 that illustrates this concept.

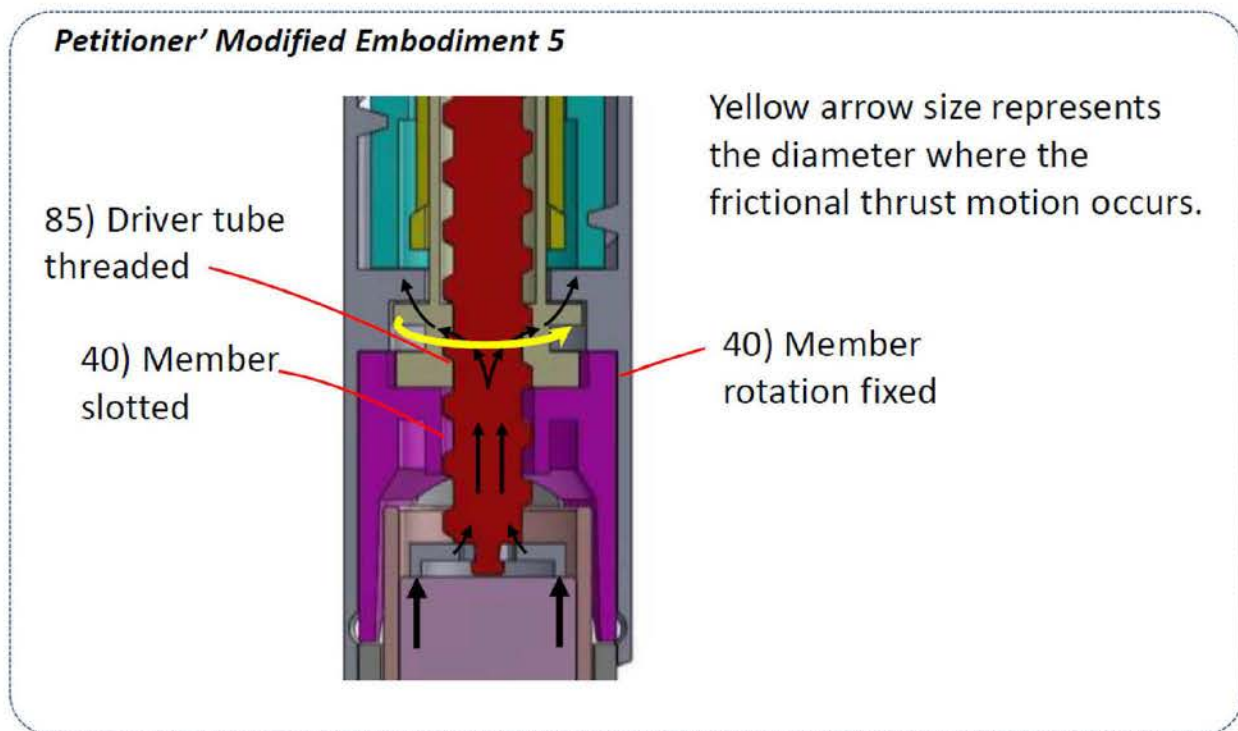

Appendix C

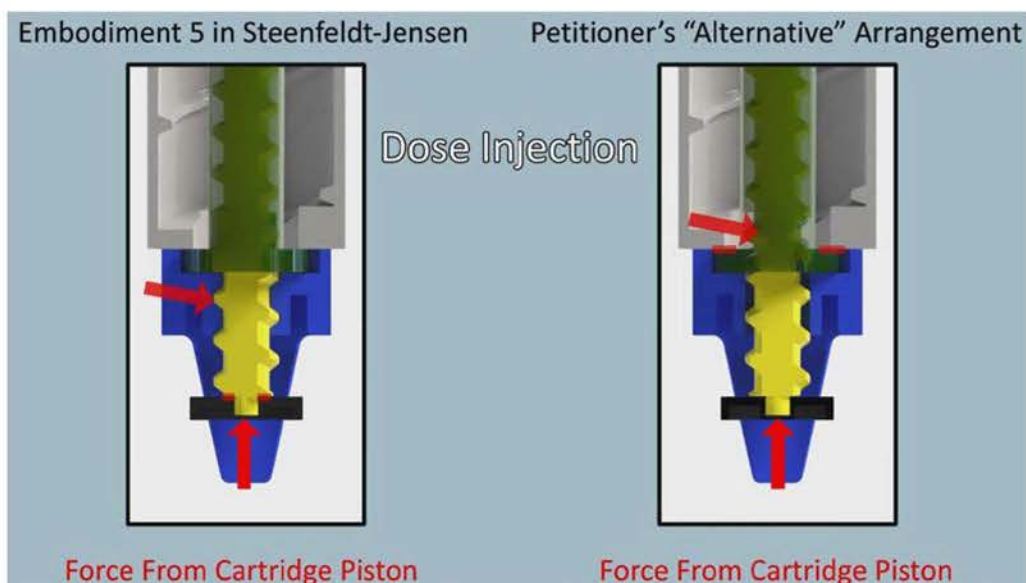

Ex. 2152 (screenshot from animation)

238. By pushing the surface of the rotating collar of the driver tube up against the ring-shaped wall 46 (via reactive forces from the ampoule piston transmitted to the driver tube threads), the driver tube in the Petitioner’s proposed modification essentially acts like a disc brake that one would expect to see to slow or stop a spinning wheel.

239. I note that having the driver tube’s collar act like a disc brake is a problem with Petitioner’s proposed modification. The driver tube collar includes small flexures that serve as ratchet teeth, and these flexures are also forced up against ring-shaped wall 46 during dose injection when, according to Petitioner’s proposed modification, threads are placed on the rotating driver tube. There are three possible bad outcomes relating to these flexures, but none of these possible outcomes would have motivated a POSA to try Petitioner’s proposed modification.

First, due to compression with ring-shaped wall 56 the flexures could get stuck so that they do not detente and allow uncoupling between the driver tube and the pawl of member 40. The potential result here is a pen injector that would not dispense a dose. Second, because there is an opening in the ring-shaped wall (identified below with a blue box), the flexures could be pressed into the opening, thereby jamming the driver tube or causing the flexures to pass above the ring-shaped wall such that the driver tube moved proximally into the housing.

240. And third, the flexures could break due to the stresses of rotating against ring shaped wall 46 while under an axial load. In my early attempts to demonstrate Petitioner's modified pen, described below, the flexures did indeed break under these stresses.

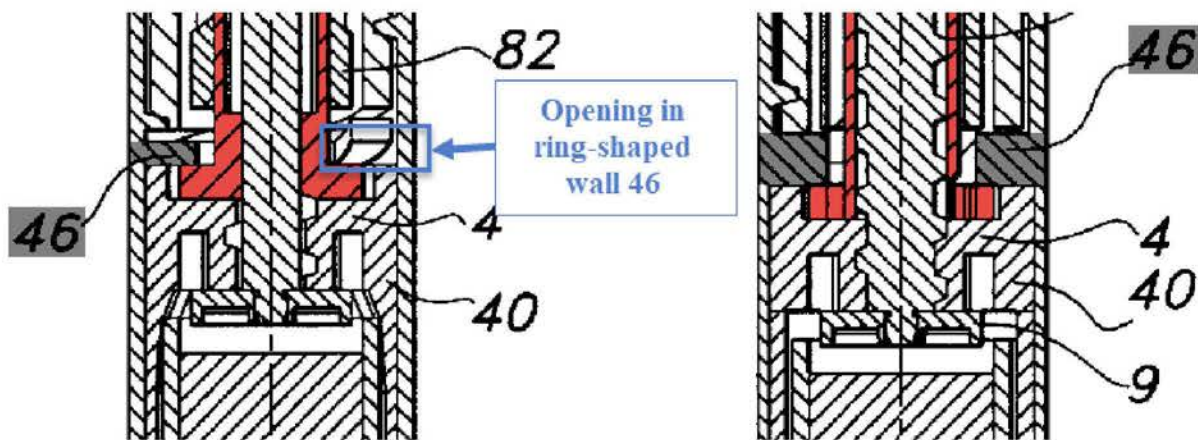

Ex. 1014, Figs. 15 and 16 (cropped and annotated)

241. Given that there is no beneficial scenario when implementing Petitioner's proposed modification, a POSA never would have been motivated to modify Steinfeldt-Jensen's fifth embodiment to add this detrimental frictional

interface. A POSA would have recognized the flaw in Petitioner's proposed modification without formal analysis, but nevertheless I have developed analytical and physical models as described below to confirm the extent of impairment that Petitioner's proposed modification would cause.

ii. Analytical Model

242. To evaluate the degree to which Petitioner's proposed modification would worsen Steinfeldt-Jensen's fifth embodiment, I built a spreadsheet that mathematically analyzes the impact of the modification on the forces a user would need to exert to inject a dose. I have excerpted these calculations, below, which is also appended to my declaration as Appendix A. An explanation of my calculations is appended as Appendix B.

Screwthread_Analysis.xls				
To determine forces and torques in Steinfeldt-Jensen pen injector				
By Alex Slocum, 6/20/2019				
Enter numbers in BOLD, results in RED				
Be consistent with units! (in, lb or N, m or N, mm)				
Stage 1: User applies force to button creating torque input to actuate threaded piston rod				
User thumb force input	10	Fuser	N	
Thread to be backdriven to create rotation				
Pitch diameter	12.0	Dpbd	mm	
Root diameter	11.5	Drbd	mm	
Lead (distance traveled with one complete rotation)	11.0	Leadbd	mm	
Reference: Helix angle (degrees, radians)	16.3	0.284		
Flank angle alpha, cos(alpha)	6	0.995	cosalphabd	degrees
Friction properties of backdriven thread				
Coefficient of friction between backdriven screw threads	0.1	mutbd		
Actual Beta	1.09	betabd		
Actual screwthread efficiency (Slocum PMD page 709 Eq. 10.8.18)	72%	etabd		
Reference: efficiency for lowering a load (>100% if backdriveable)	157%	etaLL		
Backdriveable?	YES			
Resulting torque generated that gets applied to piston rod thread	12.64	Torquepr	N-mm	
Stage 2: Torque generated is input to actuate actuate threaded piston rod				
Thrust surface between rotating drive thread and housing (for Petitioner's modified 5th embodiment, not present in 5th)				
Outside Diameter	9.4	ODpr	mm	
Inside Diameter	5.7	IDpr	mm	
Average diameter for torque calculation	7.70	Dtbavg	mm	
Non-circular piston rod sliding drive spline (for 5th embodiment, not present in modified 5th)				
% reduction in root diameter to form flats	20%	wof		
Width of flat	1.98	wofmm		
Distance between flats	2.64	Dfpr	mm	
Force couple magnitude	6.38	Fcspline		
Coefficient of friction of between spline components	0.1	muspline		
Drag force from the force couple	1.28	Fdragspline		
Piston Rod Thread				
Pitch diameter	3.9	Dppr	mm	
Root diameter	3.3	Drpr	mm	
Lead (distance traveled with one complete rotation)	3.98	Leadpr	mm	
Reference: Helix angle (degrees, radians)	17.9	0.313		
Flank angle alpha, cos(alpha)	6	0.995	cosalphapr	degrees
Friction properties				
Coefficient of friction between moving thrust surfaces (if present, else enter 0)	0.1	mutbpr		
Coefficient of friction of piston rod screw threads	0.1	mutpr		
Actual Beta	0.98	betapr		
Actual screwthread efficiency	74%	etapr		
Backdriveable?	YES			
Resulting ampoule piston force				
<i>With spline and without rotating thrust surface (e.g., Steinfeldt-Jensen 5th Embodiment)</i>				
Ampoule piston force (output)	13.4	Finwtb	N	
Amplification of user thumb force (Force user pushes/resulting ampoule piston force)	134%	Awtb		
Ideal amplification based only on thread pitch ratio	276%			
<i>With spline and rotating thrust surface (i.e., Steinfeldt-Jensen's 5th as Modified by Petitioner)</i>				
Ampoule piston force (output)	8.9	Finrtb	N	
Amplification of user thumb force (Force user pushes/resulting ampoule piston force)	89%	Artb		
Percent increase in injection force for modified 5th embodiment	51%			
Leadscrew stresses and buckling load				
Length	30.0	Lpr		
Material	Delrin			
Young's Modulus	2800	Epr	MPa	
Yield stress	69	sigmaxpr	MPa	

Root diameter area for full round shaft	8.55		Ardpr	mm ²
Root diameter area for shaft with flats	7.66		Ardprwf	mm ²
Itwist for full round shaft	11.64		lppr	mm ⁴
Itwist for shaft with flats	9.58		lpprwf	mm ⁴
Ibuckle for full round shaft	5.82		lpr	mm ⁴
Ibuckle for shaft with flats	3.93		lprwf	mm ⁴
<i>Maximum allowable ampoule piston force to not buckle piston rod (assume fixed-free)</i>				
Full round shaft	49		Finmax	N
Shaft with flats	33		Finmaxwf	N
<i>Load induced stresses</i>				
Full round shaft				
Torsional shear stress	2.1		taupr	MPa
Axial stress	1.6		sigpr	MPa
Von Mises equivalent stress	4.0		sigeqpr	MPa
Shaft with flats				
Torsional shear stress	2.6		tauprwf	MPa
Axial stress	1.8		sigprwf	MPa
Von Mises equivalent stress	4.8		sigeqprwf	MPa
<i>Safety Factors</i>				
Stress Safety Factor				
Full round shaft	17.2			
Shaft with flats	14.3			
<i>Buckling Load Safety Factor</i>			Buckle?	
Shaft with flats	2.5	NO		
Shaft without flats	3.6	NO		

Appendix A

243. Using this model, we are able to hold all variables constant (*e.g.*, friction coefficients, manufacturing quality, etc.) other than the specific modifications that Petitioner proposes. This model demonstrates applying Petitioner's modification would increase the force that the user would need to input into the pen injector by 51%.

244. It is clear then, that Petitioner's proposed modification is a flawed design that a POSA would not have wanted to implement.

iii. Collar Friction Model

245. I understand that in a prior case involving Sanofi and Merck, a rig was designed to demonstrate the principle of collar friction, and how it can be introduced simply by switching thread and slot elements between a fixed member

and a rotating collar when driving a screw. A similar model was created for these IPRs, which I have carefully reviewed, analyzed, and tested. It is my opinion that this rig, which I will refer to as the “Collar Friction Model,” accurately represents the principle underlying the flaw in Petitioner’s proposed modification. Below I discuss how it is used, how it correlates both to Steinfeldt-Jensen’s fifth embodiment and Petitioner’s modified embodiment, and the data I gathered to show that adding an internal thread to a rotating driving element introduces greater frictional losses through this collar friction interface.

246. Below is an image of the Collar Friction Model that I analyzed and tested, as well as a cross-sectional illustration of the Collar Friction Model having a certain configuration, which I describe below. Exhibit 2211 is an animation that accurately and fairly explains and shows the correspondence between the collar friction model, Steinfeldt-Jensen’s 5th embodiment, and Petitioner’s proposed modification.



Collar Friction Model Setup

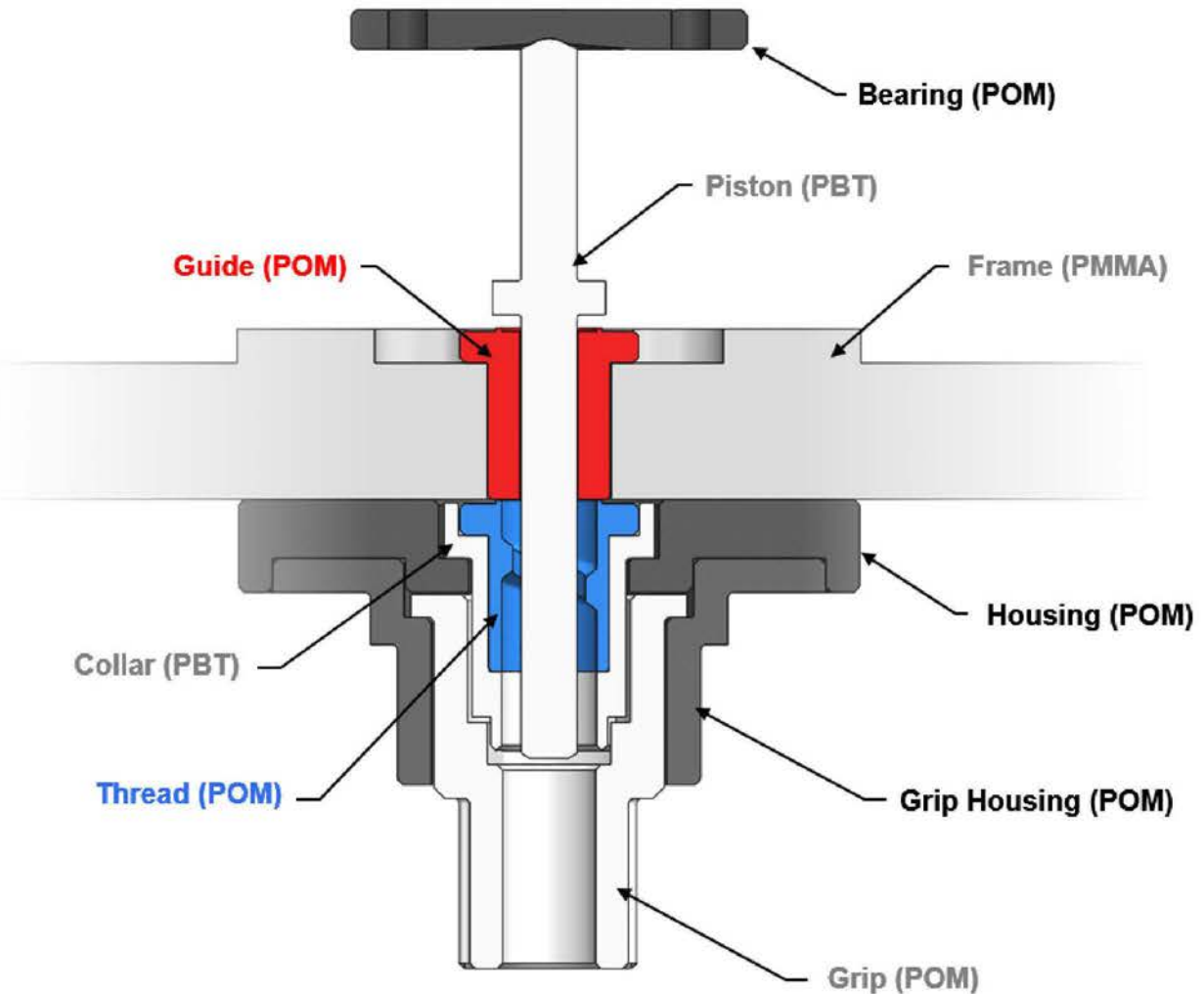

Illustration of a Cross-Section of One Side of Collar Friction Model

247. The Collar Friction Model comprises a number of components:

- **Housing:** This component is a fixed component that represents the housing 1 of Steinfeldt-Jensen’s fifth embodiment.
- **Collar:** This component can be fitted with either the red slotted insert shown above (the “Guide”) to represent driver tube 85 in Steinfeldt-Jensen’s fifth embodiment, or the blue threaded insert shown above

(“Thread Insert”) to represent a threaded driver tube according to Petitioner’s proposed modification. The configuration shown immediately above is for Petitioner’s proposed modification.

- **Frame:** The frame is a fixed component that can be fitted wither with the blue Thread Insert to represent the member 40 in Steinfeldt-Jensen’s fifth embodiment, or the red Guide to represent Petitioner’s proposed modification.
- **Piston:** This component represents the piston rod 6 in Steinfeldt-Jensen’s fifth embodiment. It is a non-circular piston rod.
- **Bearing:** This component can slide freely up and down and support a 2 kilogram weight. With the weight, it represents the reactive force experience by Steinfeldt-Jensen’s piston rod 6 when it presses on the ampoule piston during dose injection.
- **Grip:** This component is a rotatable component splined to the Collar, and it can be turned by the operator to turn the Collar.

248. Below is a figure from Steinfeldt-Jensen’s fifth embodiment that has been flipped upside down and annotated to show the correlation between it and the Collar Friction Model, including its orientation. I have also included below two additional cross-sections of the Collar Friction Model. The cross-section on the left corresponds to Steinfeldt-Jensen’s fifth embodiment (where the Guide is

rotatable in the Collar and the Thread Insert is fixed to the Frame) and the cross-section on the right corresponds to Petitioner's proposed modification (where the Thread Insert is rotatable in the Collar and the Guide is fixed to the Frame).

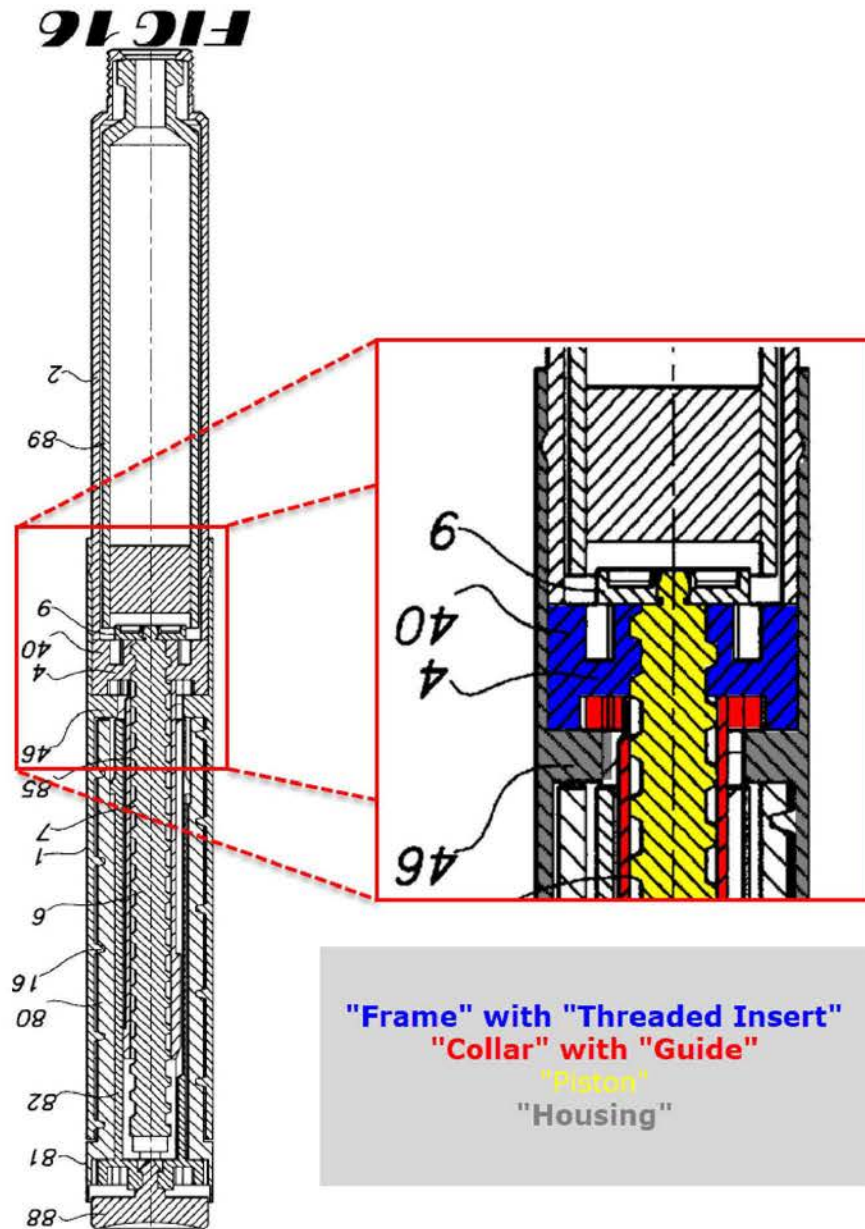

Ex. 1014, Fig. 16 (flipped and annotated)

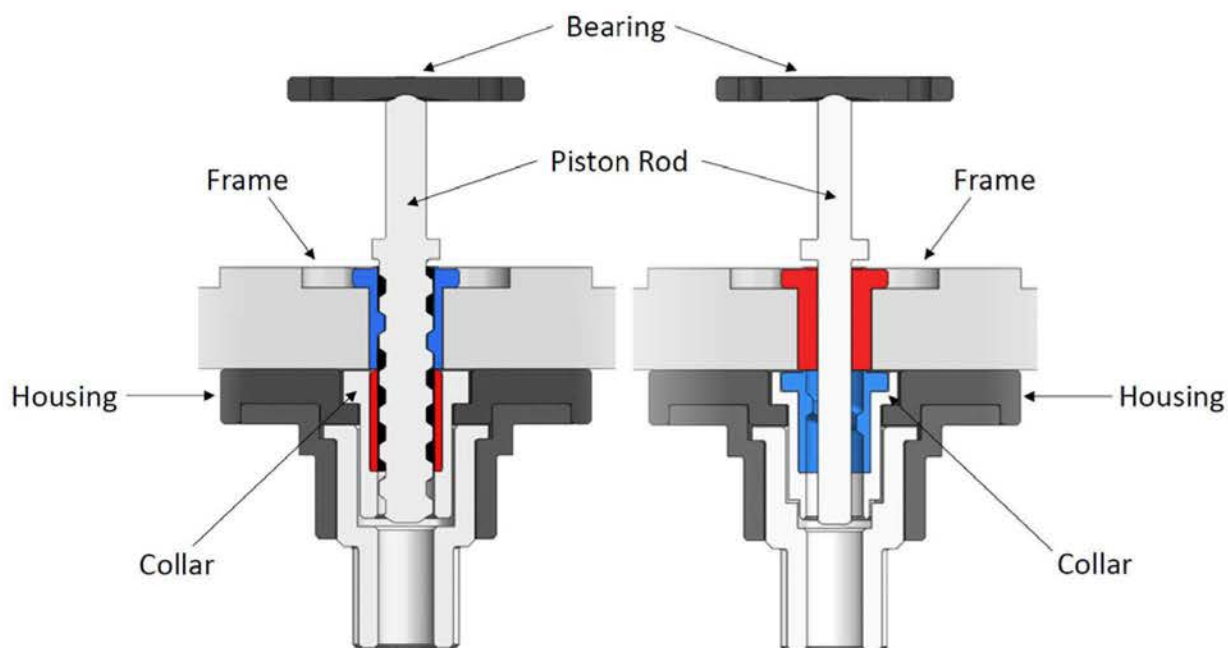

Cross-Sections of Collar Friction Model Configured to Demonstrate Steenfeldt-Jensen's Fifth Embodiment (left) and Petitioner's Proposed Modification (right)

249. Exhibit 2215 is a video I created to demonstrate how to assemble the Collar Friction Model. First, I place the Thread Insert onto the Piston first, then I slot the Guide onto the Piston. I next load the Piston with the Thread Insert and Guide into the model so that it is configured as shown in the cross-section above on the left. This represents Steenfeldt-Jensen's fifth embodiment. Second, on the right, I slot the Guide onto the Piston first, and then I screw the Thread Insert on next. When loaded into the apparatus, it represents Petitioner's proposed modification as shown in the cross-section image above on the right. Note that the two red Guide elements used here are materially the same, as are the two blue Thread Inserts. The important difference is which of the Guide and Thread Insert

is rotating in the Collar and which is fixed to the housing—*i.e.*, the difference between Steinfeldt-Jensen’s fifth embodiment and Petitioner’s proposed modification.

250. Exhibit 2216 is a video I created to demonstrate how to operate the Collar Friction Model, which shows the impact of Petitioners’ proposed modification—*i.e.*, simply swapping a threaded opening for a slotted opening. I load the Bearing on each side with a 2kg weight to represent the reactive force of the ampoule piston during dose injection. Once loaded, I apply torque to the Collar by turning the Grip. Because the thread on the Piston has a high pitch, it is backdrivable. For the configuration on the left, which again represents Steinfeldt-Jensen’s fifth embodiment, the Piston *backdrives* when the Grip is released. For the configuration on the right, which represents Petitioner’s proposed modification, the Piston *does not backdrive* when the Grip is released. This is because the Piston’s threads are pressing on the blue Thread Insert in the Collar and forcing the interface of the Collar’s outward flange against the Housing. Due to this new friction interface—*i.e.*, collar friction—the Collar is prevented from rotating on its own, thereby preventing the Piston from being backdriven. The flange of the Collar for the configuration on the right essentially acts like a disc brake by pressing against the Housing to prevent rotation. I have marked this interface in orange, below.

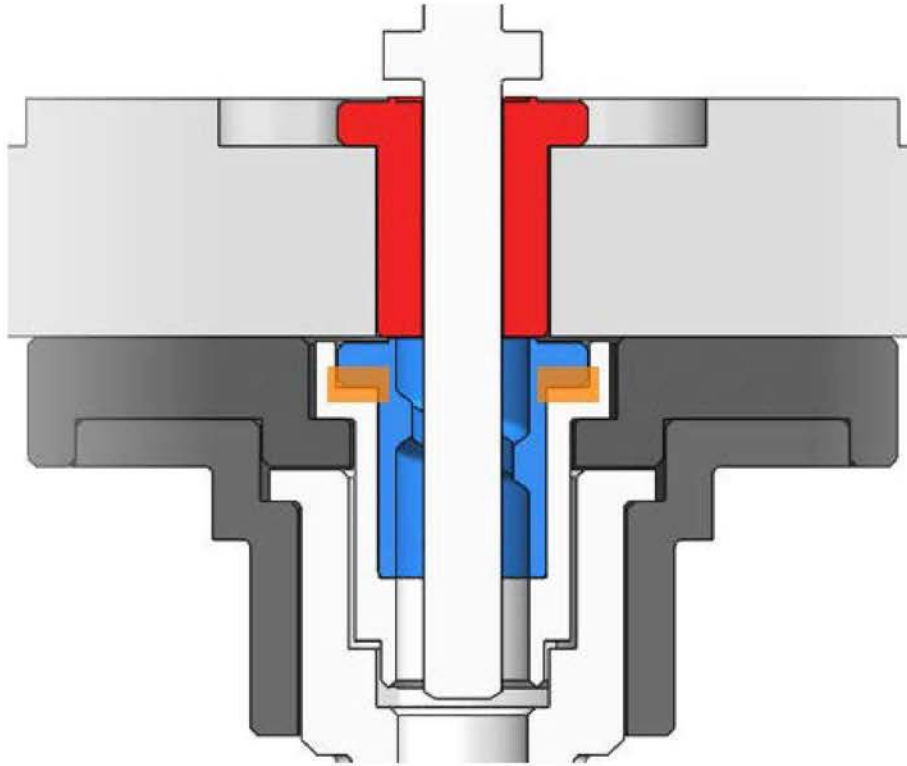

Collar Friction Model Configured to Represent Petitioner's Proposed Modification with Orange Shading to Show Area of Collar Friction

251. Exhibit 2217 is a third video I made to show that this same difference between Steinfeldt-Jensen's fifth embodiment and Petitioner's proposed modification can be shown with the same exact pieces and materials. In other words, there is no bias in the mechanisms used. Specifically, the video shows how the configuration for Petitioner's proposed modification does not allow the Piston to be backdriven, and then but simply reversing the order of the Thread Insert and Guide using the exact same pieces we now represent Steinfeldt-Jensen's fifth embodiment again. Once loaded into the apparatus, we now see that the collar

friction has disappeared and that the Piston is now backdriveable once again after rotating the Grip and then releasing it.

252. Although I have been discussing how Petitioner's proposed modification introduces collar friction when the Grip is released and the Piston does not backdrive, this collar friction exists anytime the Collar fitted with the blue Thread Insert is rotating to drive a Piston against the Bearing. Due to this collar friction, additional force is needed to rotate the Grip and drive the Piston in Petitioner's proposed modification relative to Steinfeldt-Jensen's fifth embodiment.

253. To test the additional force needed to drive the Piston using the configuration representing Petitioner's proposed modification, I mounted a Sauter FC-50 force gauge on a low-friction linear guide to precisely control its movement relative to the Grip of the Collar Friction Model. Then, by fixing an arm to the Grip and placing the stinger of the force gauge at a ninety-degree angle relative to the Grip arm, I moved the force gauge along the linear guide. The stinger of the force gauge pressed on the Grip arm to rotate the Grip, and thus the Collar, to drive the Piston. In doing so, the force gauge would register the force of that interaction. I performed these steps repeatedly for each configuration—*i.e.*, for both the configuration representing Steinfeldt-Jensen's embodiment and the

configuration representing Petitioner’s proposed modification. The result of my testing is below, which is also found at Appendix E.

Data analysis for DCA tests
Alex Slocum 6/21/2019

Left side rig	Force (N)	
	Static	Dynamic
Modified 5th element/5th element	154%	142%
Additional torque required by modified 5th element	54%	42%

Config. A: 5th embodiement modified (rotating nut)

test #	Force (N)	
	static	dynamic
1	2.29	2
2	2.18	1.95
3	2.22	1.95
4	2.27	1.9
5	2.14	1.84
6	2.35	1.87
7	2.27	1.85
8	2.32	1.9
9	2.18	1.87
10	2.37	1.88
Average	2.26	1.90
standard deviation	0.070	0.046
Ratio static to dynamic	1.19	

Config. B: 5th embodiement (rotating spline)

test #	Force (N)	
	static	dynamic
1	1.42	1.31
2	1.44	1.36
3	1.56	1.35
4	1.51	1.35
5	1.44	1.31
6	1.5	1.36
7	1.52	1.31
8	1.49	1.36
9	1.39	1.33
10	1.43	1.33
Average	1.47	1.34
standard deviation	0.048	0.020
Ratio static to dynamic	1.10	

Right side rig	Force (N)	
	Static	Dynamic
Modified 5th element/5th element	150%	152%
Additional torque required by modified 5th element	50%	52%

Config. A: 5th embodiement modified (rotating nut)

test #	Force (N)	
	static	dynamic
1	2	1.75
2	2.18	1.76
3	1.98	1.83
4	2.08	1.72
5	1.94	1.74
6	2.07	1.8
7	1.92	1.72
8	2.05	1.75
9	2.02	1.7
10	1.92	1.71
Average	2.02	1.75
standard deviation	0.078	0.039
Ratio static to dynamic	1.15	

Config. B: 5th embodiement (rotating spline)

test #	Force (N)	
	static	dynamic
1	1.4	1.15
2	1.34	1.14
3	1.35	1.14
4	1.36	1.14
5	1.34	1.15
6	1.33	1.11
7	1.36	1.14
8	1.33	1.15
9	1.34	1.17
10	1.3	1.19
Average	1.35	1.15
standard deviation	0.025	0.020
Ratio static to dynamic	1.17	

Appendix E

254. Based on the data collected, as shown above, on average the force required to rotate the Grip and drive the Piston was 50% to 54% higher during static testing, and 42% to 52% higher for dynamic testing, for the configuration representing Petitioner's proposed modification (*i.e.*, the one with collar friction) than for the configuration representing Steinfeldt-Jensen's fifth embodiment.¹⁰

255. It is my opinion that the increase in force required to drive the Piston is due the flange on the Collar becoming a rotating large diameter bearing surface when the Collar is fitted with the Thread Insert. In other words, like Petitioner's proposed modification, swapping the location of a slotted opening (*e.g.*, the Guide) with a threaded opening (*e.g.*, the Thread Insert) introduces collar friction and significantly reduces the efficiency of the system. A POSA would have recognized Petitioner's proposed design modification and would not been motivated to modify Steinfeldt-Jensen's fifth embodiment to implement it.

2. Steinfeldt-Jensen Does Not Teach or Render Obvious a Dose Dial Sleeve That “comprises at least one radial stop, said radial stop positioned near an end of said helical groove” [IPR2018-01678 (486-A2) Claims 30 and 32]

256. Claim 30 of the 486 Patent, which depends on claim 1, requires “said dose dial sleeve comprising at least one radial stop, said radial stop positioned near

¹⁰ The range represents testing for both sets of Guides, Thread Inserts, and Pistons.

an end of said helical groove.” Claim 32, which depends on claim 30, further requires “said radial stop is positioned near a distal end of said helical groove.”

257. Petitioner and Mr. Leinsing acknowledge that Steinfeldt-Jensen’s fifth embodiment does not teach or render obvious a dose dial sleeve comprising a radial stop, and they argue instead that it would have been obvious to modify Steinfeldt-Jensen’s *fifth embodiment* based on a teaching from Steinfeldt-Jensen’s *third embodiment*. IPR2018-01678 (486-A2) Petition at 51-53; Ex. 1011, ¶¶ 326-332. Specifically, Petitioner argues that it would have been obvious to take a “saw tooth 91” from the proximal end of dose scale drum 18 in the third embodiment and modify the dose scale drum 80 of the fifth embodiment to include a radial stop—not necessarily saw tooth 91—at the distal end. I disagree.

258. First, a POSA would not have found it obvious to modify the dose scale drum of Steinfeldt-Jensen’s fifth embodiment to include a radial stop because Steinfeldt-Jensen already includes a mechanism on driver tube 85 that serves the alleged purpose of a radial stop. Mr. Leinsing alleges that the purpose of a radial stop is “to prevent further movement of the dose scale drum during dose setting when the maximum dose for a single injection has been reached.” Ex. 1011, ¶ 327. This further movement is prevented in Steinfeldt-Jensen’s fifth embodiment by outer wall hooks 86 (shown in yellow below) of driver tube 85 (shown in red) that abut against the needle-end of longitudinal slot 84 (shown in

orange) of bushing 82 (shown in light blue) when the dose scale drum 80 (shown in light green) is fully dialed out. In other words, the user will be prevented from dialing out the dose further once the ends of hooks 86 and slot 84 meet. I note that Mr. Leinsing admits this: “The hooks 86 may serve as a stop by engaging the end of slots 84 when the bushing 82 axially by its maximum length during dose setting, which would similarly indicate that the maximum dose has been set.” *See* Ex. 1011, ¶ 330.

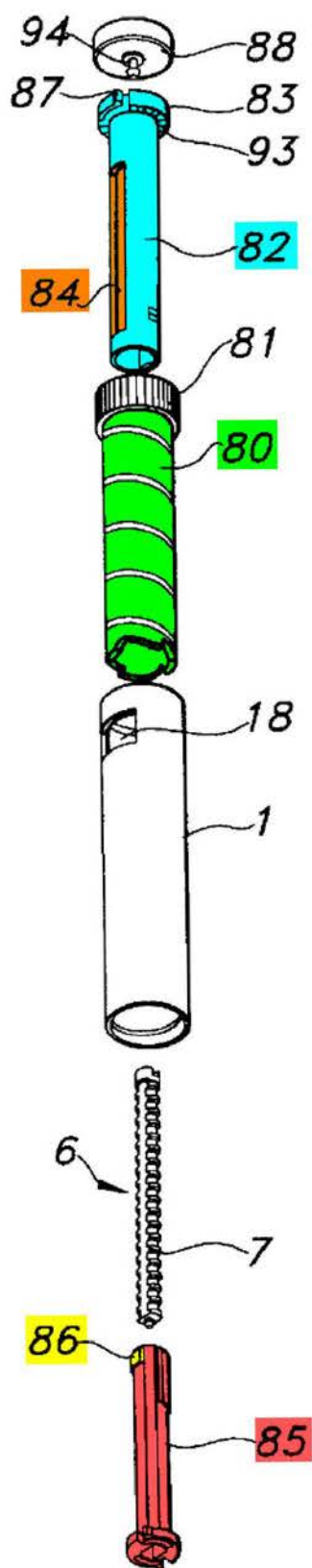

Ex. 1014, Fig. 17 (cropped and annotated)

259. Given that Steinfeldt-Jensen already has an allegedly functional radial stop, a POSA would not have been motivated to add more material to Steinfeldt-Jensen's dose scale drum to form another radial stop. Doing so would not serve any purpose and may cause mechanical interference with other components unless other modifications were made. As I explain below, neither Petitioner nor Mr. Leinsing actually explain how the modification would have been made. Thus, a POSA would not have had a reason to make the proposed modification.

260. I note further that to the extent Mr. Leinsing implies that a POSA would have recognized that hooks 86 and a radial stop on the dose scale drum 80 are interchangeable, I disagree. *See* Ex. 1011, ¶ 330. A POSA would not have understood the two to be structurally and functionally equivalent, because the hooks 85 and slot 84 serve the necessary purpose of rotationally coupling the bushing and driver tube while allowing relative longitudinal motion. These hooks and slots also can serve the additional purpose of the stop. Substituting a radial stop to place on the dose dial sleeve, however, seems to serve no other purpose and would operate in a different way.

261. Second, Petitioner and Mr. Leinsing have not explained how a POSA would have been able to implement a radial stop, particularly the saw tooth 91 taught by Steinfeldt-Jensen's third embodiment, on the distal end of the fifth embodiment's dose scale drum 80. The depiction of Steinfeldt-Jensen's fifth

embodiment (shown below with the dose scale drum 80 in light green and the housing 1 in grey) does not appear to have room for a protruding tooth unless one increased the size of the pen injector, which would run counter to pen injector design principles. *See* Ex. 2163 at 169:12-170:20.

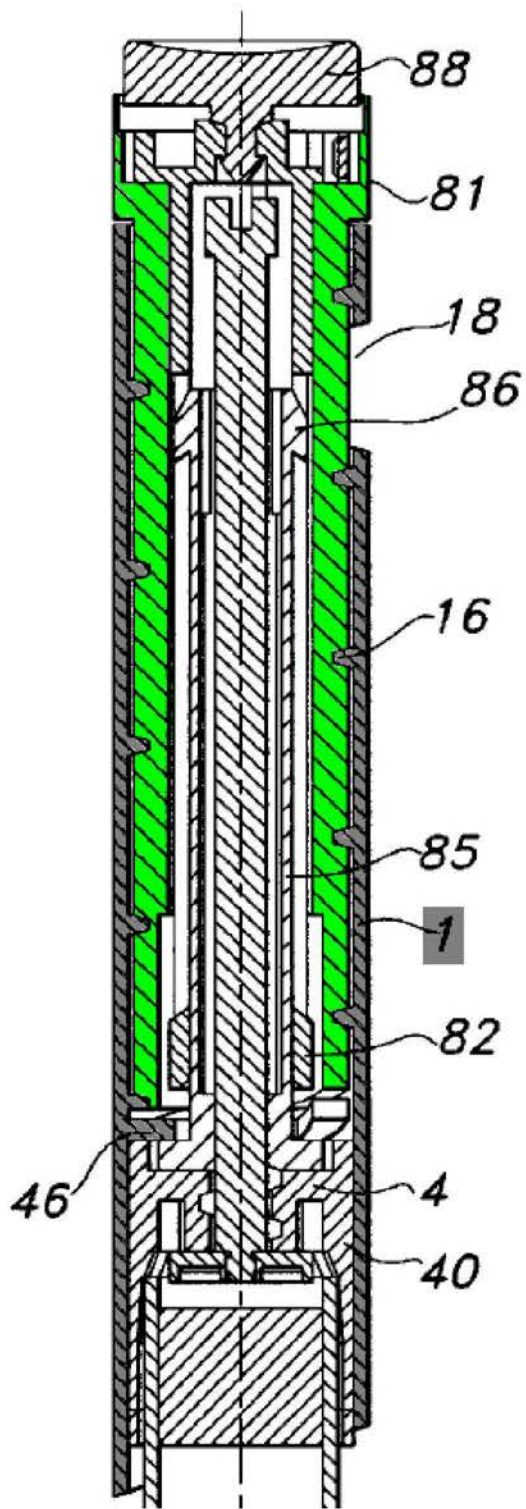

Ex. 1014, Fig. 15 (cropped and annotated)

262. Third, it is my opinion that a POSA would not add “a corresponding stop provided on the housing 1 near the button-end of its helical rib 16” to engage a radial stop near the needle-end of the dose scale drum 80, as Mr. Leinsing alleges (Ex. 1011, ¶ 329), because doing so would mean that the dose scale drum 80 (and all of the dosage indications printed thereon) would screw out past the window 18 of the housing—*i.e.*, well past its maximum dosage. I have highlighted in red the two ends Mr. Leinsing is discussing in the image below, and you can see how when the two red features meet the dose scale drum would be screwed out past the window in the housing.

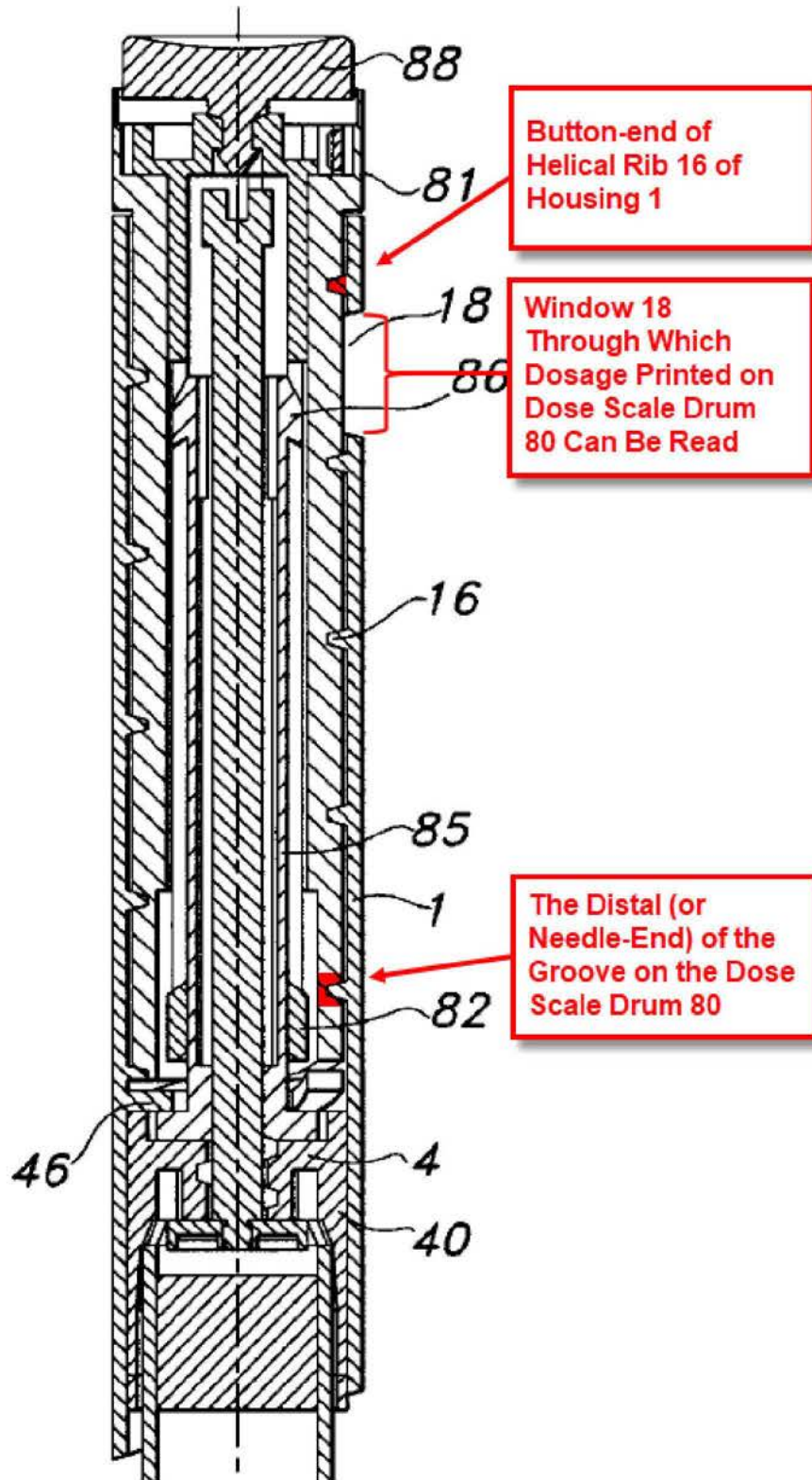

Ex. 1014, Fig. 15 (cropped and annotated)

263. Therefore it is my opinion my opinion that a POSA would not have been motivated to add a radial stop to Steinfeldt-Jensen's fifth embodiment. Thus, it is my opinion that Steinfeldt-Jensen does not teach or render obvious claims 30 and 32.

**3. Steinfeldt-Jensen Does Not Teach or Render Obvious
“where the piston rod has a circular cross-section”
[IPR2018-01682 (844-B) Claim 22]**

264. Mr. Leinsing argues that Steinfeldt-Jensen's piston rod 6 is a piston rod that has a circular cross section as required by claim 22. I disagree. Piston rod 6 cannot satisfy claim 22 because it has two flat sides, and therefore, has a non-circular cross-section.

265. My opinion is consistent with Steinfeldt-Jensen, which specifically characterizes the cross-section of piston rod 6 as having a “not round cross-section” and a “non-circular cross section.” Ex. 1014, 11:15-17 (“The piston rod has a not round cross-section and fits through the driver tube bore which has a corresponding not round cross-section.”), Abstract (“a piston rod with a non-circular cross-section having an outer thread”). Mr. Leinsing also testified that the cross-section of piston rod 6 is non-circular. *See, e.g.*, Ex. 1011, ¶ 317 (“piston rod 6 contains a ‘not round cross-section’ due to flattened portions for engaging a not-round bore”).

266. Despite Steinfeldt-Jensen's characterization that the cross-section of the piston rod is non-circular, Mr. Leinsing relies on the ends of Steinfeldt-Jensen's piston rod to argue that the limitation is satisfied. But this interpretation of the claim is unreasonable. The claim requires that "the piston rod has a circular cross-section," and nowhere in the claim or specification is it suggested that the cross-section of the piston rod is defined by the very ends (e.g., the head) of the piston rod.

267. In fact, the 844 Patent specification shows that a piston rod with a circular cross-section over its length because it is adapted to engage with and move rotationally and axially relative to the circular bore in the drive sleeve. *See* Ex. 1004, 3:65-66, 4:13-14, 6:55-58, Figs. 9-11.

268. Mr. Leinsing's characterization of Steinfeldt-Jensen's piston rod as having a circular cross-section is wrong. A POSA would understand that the cross-section of the piston rod in Steinfeldt-Jensen is non-circular so that it can slot through and is rotationally constrained to the non-circular bore of driver tube 85. That is why Steinfeldt-Jensen itself explicitly characterizes the piston rod as having "non-circular" or "not round" cross-section. Ex. 1014, 11:15-17, Abstract.

269. To a POSA, a circular cross-sectioned piston rod is mechanically different than one with a non-circular cross-section. The former has a substantially

lower buckling force, which is important when it comes to minimizing lead screw diameter in order to maximize mechanism efficiency.

4. Steinfeldt-Jensen Combined with Klitgaard Does Not Teach or Render Obvious “a nut that tracks each set dose of medicament delivered” [IPR2018-01682 (844-B) Claim 30]

270. I understand that Ground 2 challenges only claim 30, which itself depends on claim 21. Because it is my opinion that Steinfeldt-Jensen alone does not render obvious claim 21, and because neither Petitioner nor Mr. Leinsing assert that Klitgaard teaches or renders obvious a driver tube with an internal thread as required by claim 21, it is my opinion that Steinfeldt-Jensen combined with Klitgaard fails to teach or render obvious claim 30.

C. The Combination of Møller and Steinfeldt-Jensen’s Fifth Embodiment Does Not Render Obvious the Challenged Claims of the 069, 044, or 486 Patents [IPR2018-01670 (069) Ground 3, IPR2018-01676 (044-B) Ground 2, IPR2018-01678 (486-A2) Ground 2]

271. I understand that Petitioner and Mr. Leinsing assert that Møller in combination with Steinfeldt-Jensen’s fifth embodiment renders obvious claim 1 of the 069 Patent, claims 11, 14, and 18-19 of the 044 Patent, and claims 1-6, 12-18, 20, 23, 26-30, 32-33, 36, and 38-40 of the 486 Patent. I disagree. For the reasons discussed below, it is my opinion that a person of ordinary skill in the art would not have found the challenged claims obvious over the combination of Møller and Steinfeldt-Jensen.

1. The Combination of Møller and Steinfeldt-Jensen Does Not Teach or Render Obvious “a drive sleeve extending along a portion of said piston rod” [069 Patent Claim 1; 044 Patent Claim 11]

272. Claim 1 of the 069 Patent and claim 11 of the 044 Patent each require “a drive *sleeve* extending a long a portion of said piston rod, said drive *sleeve* comprising an internal threading near a distal portion of said drive *sleeve*, said internal threading adapted to engage an external thread of said piston rod.” To satisfy this claim limitation, Petitioner identifies Møller’s connection bars 12 and nut 13 as the claimed “drive sleeve.” IPR2018-01670 (069) Petition at 74-77; IPR2018-01676 (044-B) Petition at 60-63. For the reasons I explain below, in my opinion, Møller’s connection bars 12 and nut 13 are not a sleeve and thus do not teach the “drive sleeve” according to these claims.

273. Below I have included Figures 1 and 2 from Møller with red shading to indicate the elements that Petitioner and Mr. Leinsing identify as the claimed “drive *sleeve*.” In my opinion a POSA would not have understood these structures as forming a sleeve. Rather, what is shown and described in Møller are two parallel bars with a nut at the end.

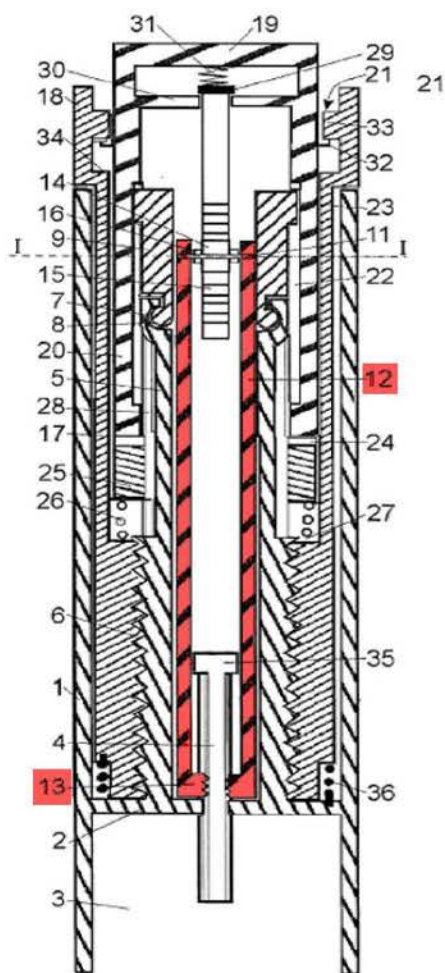

Fig. 1

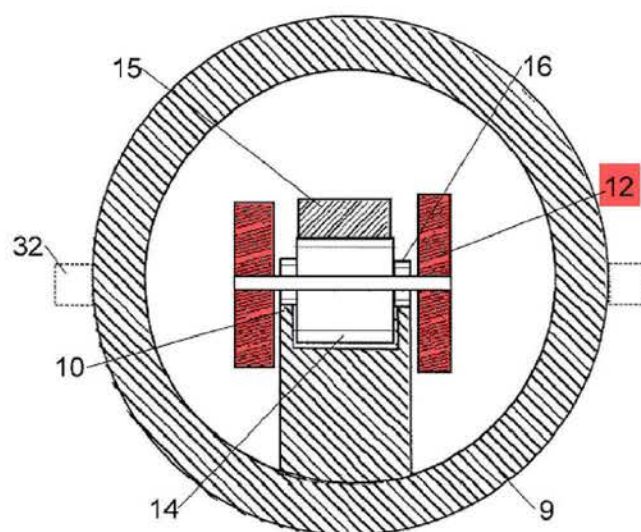

Fig. 2

Ex. 1015, Figs. 1 and 2 (red shading added).

274. That a POSA would not have considered bars 12 and nut 13 to be a “sleeve” is supported by Sanofi’s, Mylan’s, and the Court’s view on this term in the Mylan DNJ Case. Specifically, I understand that in the co-pending Mylan DNJ Case Sanofi, Mylan, and the Court all agreed that a drive *sleeve* means at least “an essentially tubular component.” In my opinion, connection bars 12 and nut 13 are not essentially tubular. A “tube” is a hollow cylindrical body, and two parallel bars and a nut would not have been understood as cylindrical or essentially

cylindrical. That is because, as can be seen from the top view (Fig. 2), the two parallel bars do not resemble a circle or essentially a circle. They do not even enclose the components inside as a tube or sleeve would. Instead, they form two parallel bars.

275. Thus, in my opinion Møller does not disclose a drive sleeve.

276. Petitioner and Mr. Leinsing appear to make a second argument. Specifically, the Petitioner states that “[t]o the extent connection bars 12 with nut 13 are not a ‘sleeve,’” then a POSA would have understood that tubular connection element 112 with nut 113 from Møller’s *second* embodiment are “structurally and functionally equivalent” to bars 12 and nut 13 from Møller’s *first* embodiment. Petitioner concludes that a “POSA ... would have expected connection bars 12 with nut 13 could readily be formed as a tubular structure that encompasses piston rod 4, without affecting the device’s operation.” IPR2018-01670 (069) Petition at 77; IPR2018-01676 Petition at 63; *see also* Ex. 1011, ¶¶ 370-371. For the reasons I explain below, I disagree.

a. A POSA Would Not Have Considered Connection Bars 12 and Nut 13 to Be Functionally and Structurally Equivalent to Connection Element 112 and Nut 113

277. Petitioner and Mr. Leinsing both argue that the connection bars 12 and nut 13 from Møller’s first embodiment are “essentially equivalent, in both structure

and function” to tubular element 112 and nut 113 from Møller’s second embodiment. I disagree.

278. Below I have included annotated images from Møller’s first and second embodiments. The highlighted elements include bars 12 and nut 13 (red), gear wheel 14 (light green), gear wheels 16 (dark blue), and gear rack 15 (purple) from Møller’s first embodiment, and tubular element 112 and nut 113 (red), gear wheels 114 (light green), a gearbox part 109 that carries rack 110 (purple), and a shell that carries rack 115 (purple). *See* Ex. 1015, ¶¶ 0024, 0039.

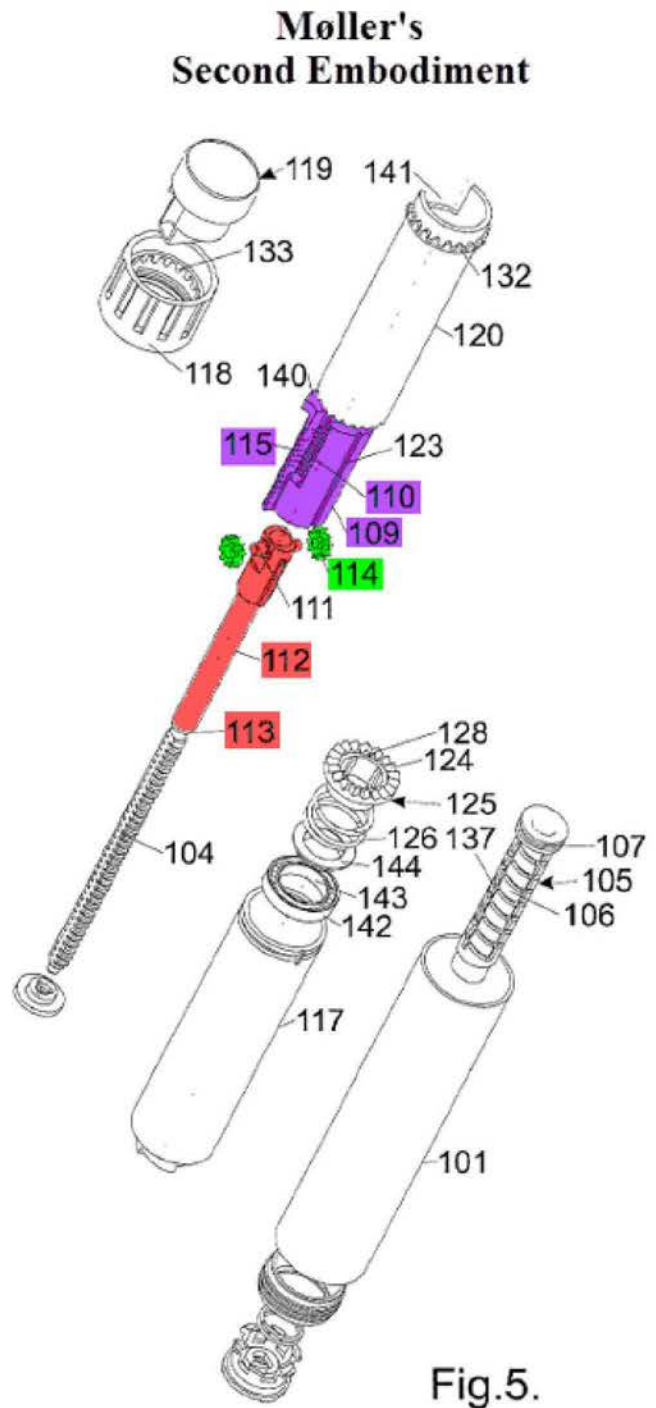
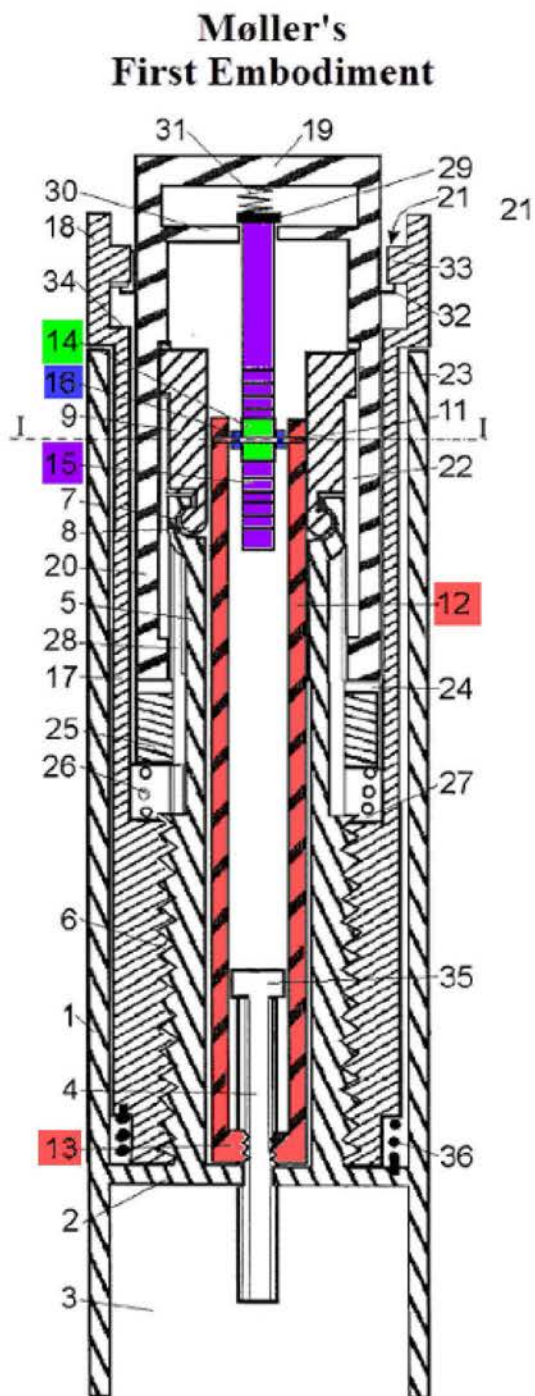

Ex. 1015, Figs. 1, 5 (annotated).

279. As would have been immediately apparent to a POSA, the connection bars 12 and connection element 112 are not structurally and functionally equivalent because they have different shapes, engage with different components in significantly different ways, and operate in different manners. The connection bars 12 are parallel rectangular structures rather than a tubular structure because they need to be able to accommodate internal structures that must engage with structures external to the connection bars. Two rectangles would have *two orders of magnitude less torsional stiffness* than a circumscribed circle (tube), because they cannot effectively transmit torsional shear (which requires a closed circular section). Specifically, as shown below, the parallel connection bars have in their interior a gear wheel 14 (green) that must engage a rack 15 (purple). On the other side, a pair of internal gear wheels 16 (blue) must engage with a rack 10 (yellow) connected to the exterior gearbox 9. Also, the connection bars 12 do not need to carry a high torsional load during injection (the bars apply axial force to the piston rod, not a torque so while rectangular cross sections are efficient axial force transmitters, they are not at all appropriate for transmitting torque), so a POSA would have understood that they do not need to be formed as a sleeve. *See Ex. 1015, ¶¶ 0024, 0032.*

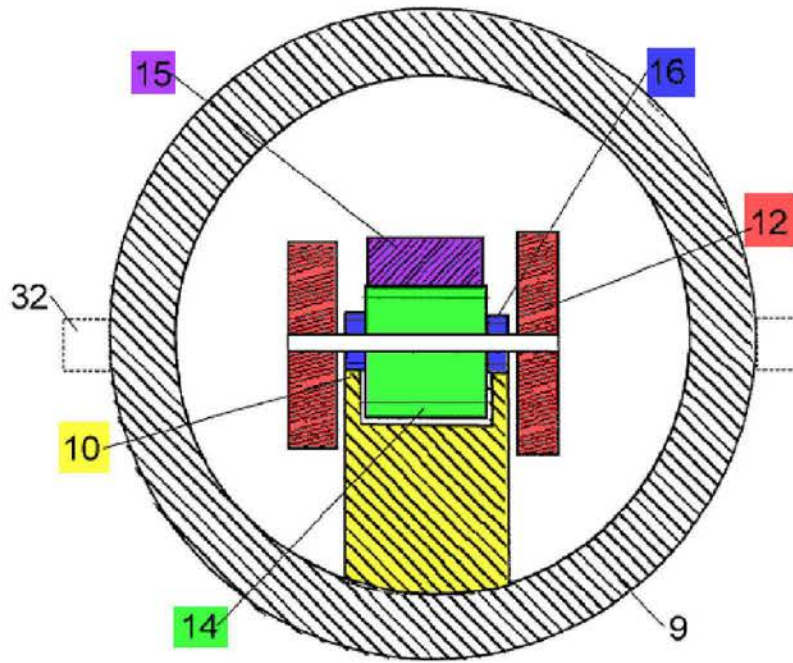

Fig. 2

Ex. 1015, Fig. 2 (annotated).

280. By contrast, the connection element 112 in Møller's second embodiment has a closed tubular shape with gear wheels 114 (green) that are engaged with the racks 110 and 115 (both purple), *all* of which is *exterior* to the connection element 112. See Ex. 1015, ¶¶ 0039-0040.

**Møller's
Second Embodiment**

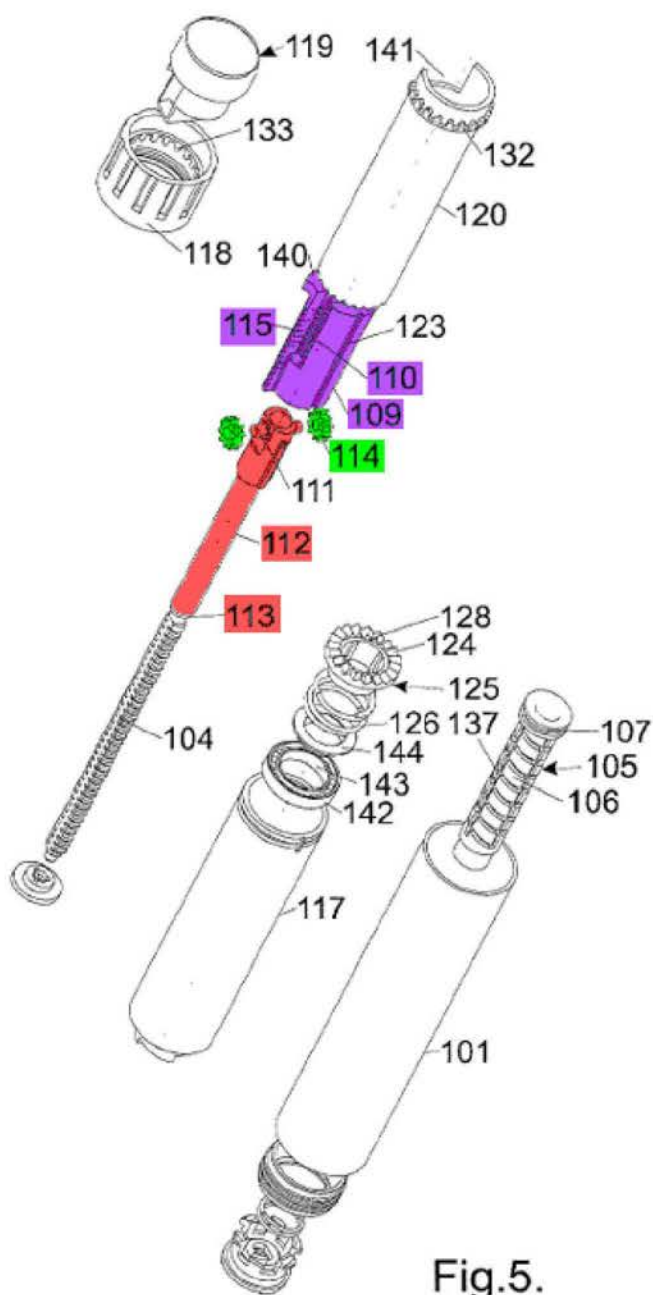

Fig.5.

Ex. 1015, Fig. 5 (annotated).

281. Thus, a POSA would not have understood connection bars 12 and nut 13 to be structurally and functionally equivalent to connection element 112 and nut 113 because the former allows for internal gear wheels and gear racks (or internal gear wheels that can engage with internal gear racks) and the latter does not. With the open configuration of connection bars 12 in the first embodiment, Møller's first embodiment can achieve a range of gearing ratios with differently-sized gear wheels and racks.

b. A POSA Would Not Have Expected Connection Bars 12 With Nut 13 Could be Formed as a Tubular Structure That Encompasses Piston Rod 4 Without Affecting the Device's Operation

282. Both Petitioner and Mr. Leinsing allege that a POSA "would have expected connection bars 12 with nut 13 could readily be formed as a tubular structure that encompasses piston rod 4, without affecting the device's operation." IPR2018-01670 (069) Petition at 77; IPR2018-01676 Petition at 63; *see also* Ex. 1011, ¶ 371. In my opinion, neither Petitioner nor Mr. Leinsing have explained how this tubular structure would be formed in Møller's first embodiment or why a POSA would have modified Møller's connection bars 12 to be a sleeve. As I explained above, Møller's connection bars 12 in the first embodiment do not carry a high torsional load during injection and also need to be open at opposing ends to accommodate internal gear wheels 14 and 16 that engage with internal/external gear racks 10 and 15.

283. If a POSA were to form connection bars 12 along its entire length as a tubular element like connection element 112 in Møller's second embodiment, a POSA would have had to redesign other elements of Møller's first embodiment. The gear wheels 14 and 16 would have to be moved to the exterior of the now tubular element to engage with external gear racks 10 and 15. Whereas connection element 112 in the second embodiment has a pair of same-size gear wheels on opposing sides, here to maintain the gearing ratio of the first embodiment a POSA implementing connection bars 12 as the connection element 112 would have added two pairs of gear wheels (*i.e.*, a pair of gear wheels 14 and a pair of gear wheels 16), which results in four externally-mounted gear wheels that would engage four gear racks (two of rack 10 and two of rack 15). Looking at Figure 1 of Møller, these modifications would require increasing the diameter of the pen injector, which as I explained in Section V.C. is something a POSA would not want to do without good reason.

284. In my view, neither Petitioner nor Mr. Leinsing has provided a reason to modify Møller's first embodiment to form parallel connection bars 12 as a sleeve, let alone as the connection element 112 of Møller's second embodiment.

2. A POSA Would Not Have Been Motivated to Combine Møller With Steinfeldt-Jensen [069 Patent Claim 1; 044 Patent Claim 11; 486 Patent Claim 1]

285. Claim 1 of the 069 Patent, claim 11 of the 044 Patent, and claim 1 of the 486 Patent each require a “dose dial sleeve positioned within said housing, said dose dial sleeve comprising a helical groove configured to engage a threading provided by said main housing.” Claim 1 of the 069 Patent and Claim 11 of the 044 Patent additionally require “said helical groove provided along an outer surface of said dose dial sleeve.”¹¹

286. For these claims of the 069, 044, and 486 Patent, Petitioner and Mr. Leinsing point to the dose-setting drum 17 from Møller’s first embodiment as the claimed “dose dial sleeve” and argue that it would have been obvious to combine it with the groove on the dose setting drum 80 from Steinfeldt-Jensen’s fifth embodiment. IPR2018-01670 (069) Petition at 68-71; IPR2018-01676 (044-B) Petition at 54-57; IPR2018-01678 (486-A2) Petition at 62-66; Ex. 1011, ¶¶ 347-

¹¹ I note that while claim 1 of the 486 Patent does not include this additional limitation whereby the helical groove is provided on an outer surface of the dose dial sleeve, dependent claim 4 of the 486 Patent recites a similar limitation whereby the main housing has “a helical rib provided on an inner surface,” which I address in a separate section, below.

361. Below I have included Figure 1 of Møller's first embodiment showing this dose-setting drum 17 (in green) and also Figure 16 of Steinfeldt-Jensen's fifth embodiment showing the dose scale drum 80 (also in green). Unlike Steinfeldt-Jensen's fifth embodiment, Møller's first embodiment includes an interior housing (tubular element 5). As a result, Møller is able to implement, and does implement, the threads of its dose-setting drum 17 such that they are internal. Steinfeldt-Jensen's fifth embodiment does not have an interior housing extending axially along its dose-scale drum 80, and so the threads of its dose-scale drum 80 are external.

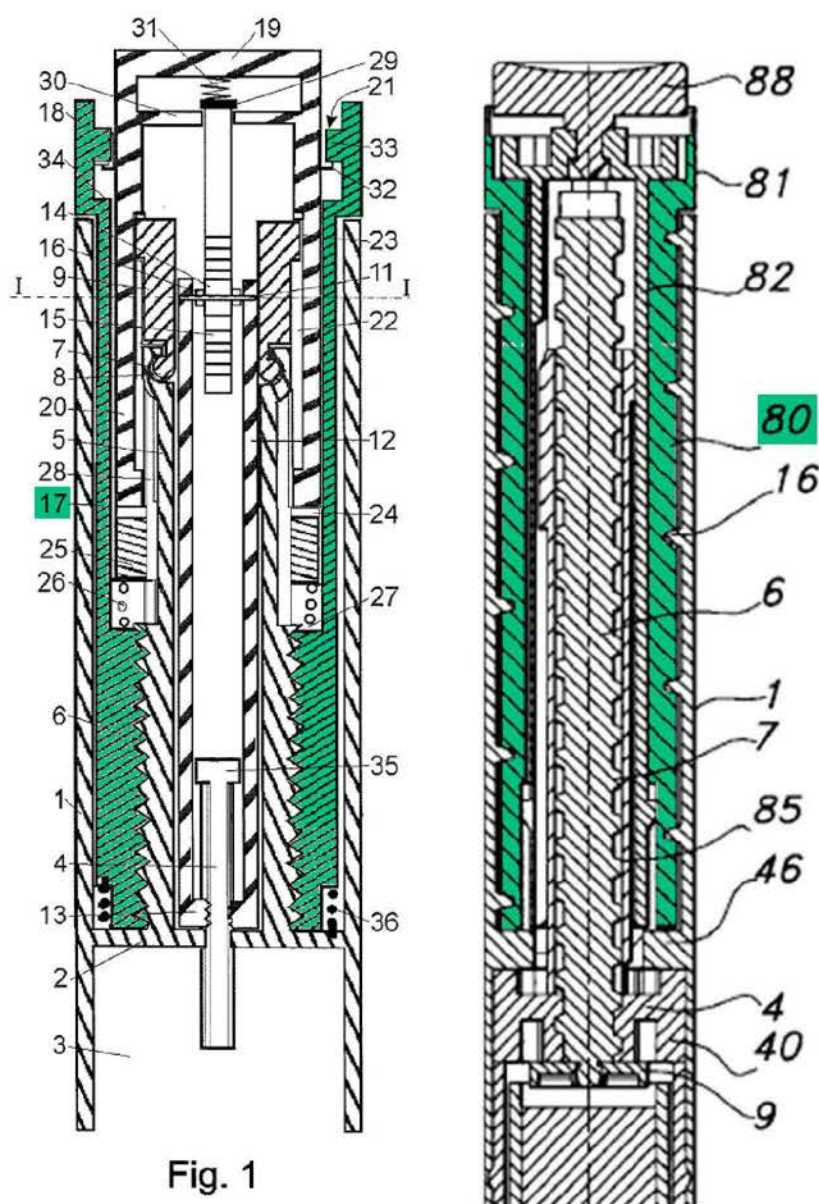

Fig. 1

Ex. 1014, Fig. 1 (left) (annotated), Ex. 1015, Fig. 16 (right) (annotated)

287. Petitioner’s and Mr. Leinsing’s reasons for combining Møller with the groove of Steinfeldt-Jensen’s dose scale drum 80 are as follows. For claim 1 of the 486 Patent, Petitioner argues that to the extent Møller doesn’t disclose a dose dial sleeve comprising a helical *groove*, “a POSA would have known to implement thread 6 [on Møller’s dose-setting drum 17] as a groove from Steinfeldt-Jensen’s