

Under the Paperwork Reduction Act of 1995, no persons are required to respond to a collection of information unless it displays a valid OMB control number.

**STATEMENT UNDER 37 CFR 3.73(c)**

Applicant/Patent Owner: Robert Frederick VEASEY, et al.

Application No./Patent No.: \_\_\_\_\_ Filed/Issue Date: \_\_\_\_\_

Titled: DRIVE MECHANISMS SUITABLE FOR USE IN DRUG DELIVERY DEVICES

SANOFI AVENTIS DEUTSCHLAND GMBH, a Corporation

(Name of Assignee) (Type of Assignee, e.g., corporation, partnership, university, government agency, etc.)

states that, for the patent application/patent identified above, it is (choose **one** of options 1, 2, 3 or 4 below):

- 1.  The assignee of the entire right, title, and interest.
- 2.  An assignee of less than the entire right, title, and interest (check applicable box):
  - The extent (by percentage) of its ownership interest is \_\_\_\_\_%. Additional Statement(s) by the owners holding the balance of the interest must be submitted to account for 100% of the ownership interest.
  - There are unspecified percentages of ownership. The other parties, including inventors, who together own the entire right, title and interest are:

[Empty box for additional statement]

Additional Statement(s) by the owner(s) holding the balance of the interest must be submitted to account for the entire right, title, and interest.

- 3.  The assignee of an undivided interest in the entirety (a complete assignment from one of the joint inventors was made). The other parties, including inventors, who together own the entire right, title, and interest are:

[Empty box for additional statement]

Additional Statement(s) by the owner(s) holding the balance of the interest must be submitted to account for the entire right, title, and interest.

- 4.  The recipient, via a court proceeding or the like (e.g., bankruptcy, probate), of an undivided interest in the entirety (a complete transfer of ownership interest was made). The certified document(s) showing the transfer is attached.

The interest identified in option 1, 2 or 3 above (not option 4) is evidenced by either (choose **one** of options A or B below):

- A.  An assignment from the inventor(s) of the patent application/patent identified above. The assignment was recorded in the United States Patent and Trademark Office at Reel 026978, Frame 0938, or for which a copy thereof is attached.
- B.  A chain of title from the inventor(s), of the patent application/patent identified above, to the current assignee as follows:

1. From: \_\_\_\_\_ To: \_\_\_\_\_

The document was recorded in the United States Patent and Trademark Office at Reel \_\_\_\_\_, Frame \_\_\_\_\_, or for which a copy thereof is attached.

2. From: \_\_\_\_\_ To: \_\_\_\_\_

The document was recorded in the United States Patent and Trademark Office at Reel \_\_\_\_\_, Frame \_\_\_\_\_, or for which a copy thereof is attached.

This collection of information is required by 37 CFR 3.73(b). The information is required to obtain or retain a benefit by the public which is to file (and by the USPTO to process) an application. Confidentiality is governed by 35 U.S.C. 122 and 37 CFR 1.11 and 1.14. This collection is estimated to take 12 minutes to complete, including gathering, preparing, and submitting the completed application form to the USPTO. Time will vary depending upon the individual case. Any comments on the amount of time you require to complete this form and/or suggestions for reducing this burden, should be sent to the Chief Information Officer, U.S. Patent and Trademark Office, U.S. Department of Commerce, P.O. Box 1450, Alexandria, VA 22313-1450. DO NOT SEND FEES OR COMPLETED FORMS TO THIS ADDRESS. **SEND TO: Commissioner for Patents, P.O. Box 1450, Alexandria, VA 22313-1450**

If you need assistance in completing the form, call 1-800-PTO-9199 and select option 2.

Under the Paperwork Reduction Act of 1995, no persons are required to respond to a collection of information unless it displays a valid OMB control number.

**STATEMENT UNDER 37 CFR 3.73(c)**

3. From: \_\_\_\_\_ To: \_\_\_\_\_

The document was recorded in the United States Patent and Trademark Office at  
Reel \_\_\_\_\_, Frame \_\_\_\_\_, or for which a copy thereof is attached.

4. From: \_\_\_\_\_ To: \_\_\_\_\_

The document was recorded in the United States Patent and Trademark Office at  
Reel \_\_\_\_\_, Frame \_\_\_\_\_, or for which a copy thereof is attached.

5. From: \_\_\_\_\_ To: \_\_\_\_\_

The document was recorded in the United States Patent and Trademark Office at  
Reel \_\_\_\_\_, Frame \_\_\_\_\_, or for which a copy thereof is attached.

6. From: \_\_\_\_\_ To: \_\_\_\_\_

The document was recorded in the United States Patent and Trademark Office at  
Reel \_\_\_\_\_, Frame \_\_\_\_\_, or for which a copy thereof is attached. Additional documents in the chain of title are listed on a supplemental sheet(s). As required by 37 CFR 3.73(c)(1)(i), the documentary evidence of the chain of title from the original owner to the assignee was, or concurrently is being, submitted for recordation pursuant to 37 CFR 3.11.

[NOTE: A separate copy (i.e., a true copy of the original assignment document(s)) must be submitted to Assignment Division in accordance with 37 CFR Part 3, to record the assignment in the records of the USPTO. See MPEP 302.08]

The undersigned (whose title is supplied below) is authorized to act on behalf of the assignee.

/David M. Frischkorn/

June 30, 2014

Signature

Date

David M. Frischkorn

32,833

Printed or Typed Name

Title or Registration Number

[Page 2 of 2]

## Privacy Act Statement

The **Privacy Act of 1974 (P.L. 93-579)** requires that you be given certain information in connection with your submission of the attached form related to a patent application or patent. Accordingly, pursuant to the requirements of the Act, please be advised that: (1) the general authority for the collection of this information is 35 U.S.C. 2(b)(2); (2) furnishing of the information solicited is voluntary; and (3) the principal purpose for which the information is used by the U.S. Patent and Trademark Office is to process and/or examine your submission related to a patent application or patent. If you do not furnish the requested information, the U.S. Patent and Trademark Office may not be able to process and/or examine your submission, which may result in termination of proceedings or abandonment of the application or expiration of the patent.

The information provided by you in this form will be subject to the following routine uses:

1. The information on this form will be treated confidentially to the extent allowed under the Freedom of Information Act (5 U.S.C. 552) and the Privacy Act (5 U.S.C. 552a). Records from this system of records may be disclosed to the Department of Justice to determine whether disclosure of these records is required by the Freedom of Information Act.
2. A record from this system of records may be disclosed, as a routine use, in the course of presenting evidence to a court, magistrate, or administrative tribunal, including disclosures to opposing counsel in the course of settlement negotiations.
3. A record in this system of records may be disclosed, as a routine use, to a Member of Congress submitting a request involving an individual, to whom the record pertains, when the individual has requested assistance from the Member with respect to the subject matter of the record.
4. A record in this system of records may be disclosed, as a routine use, to a contractor of the Agency having need for the information in order to perform a contract. Recipients of information shall be required to comply with the requirements of the Privacy Act of 1974, as amended, pursuant to 5 U.S.C. 552a(m).
5. A record related to an International Application filed under the Patent Cooperation Treaty in this system of records may be disclosed, as a routine use, to the International Bureau of the World Intellectual Property Organization, pursuant to the Patent Cooperation Treaty.
6. A record in this system of records may be disclosed, as a routine use, to another federal agency for purposes of National Security review (35 U.S.C. 181) and for review pursuant to the Atomic Energy Act (42 U.S.C. 218(c)).
7. A record from this system of records may be disclosed, as a routine use, to the Administrator, General Services, or his/her designee, during an inspection of records conducted by GSA as part of that agency's responsibility to recommend improvements in records management practices and programs, under authority of 44 U.S.C. 2904 and 2906. Such disclosure shall be made in accordance with the GSA regulations governing inspection of records for this purpose, and any other relevant (*i.e.*, GSA or Commerce) directive. Such disclosure shall not be used to make determinations about individuals.
8. A record from this system of records may be disclosed, as a routine use, to the public after either publication of the application pursuant to 35 U.S.C. 122(b) or issuance of a patent pursuant to 35 U.S.C. 151. Further, a record may be disclosed, subject to the limitations of 37 CFR 1.14, as a routine use, to the public if the record was filed in an application which became abandoned or in which the proceedings were terminated and which application is referenced by either a published application, an application open to public inspection or an issued patent.
9. A record from this system of records may be disclosed, as a routine use, to a Federal, State, or local law enforcement agency, if the USPTO becomes aware of a violation or potential violation of law or regulation.

Under the Paperwork Reduction Act of 1995, no persons are required to respond to a collection of information unless it displays a valid OMB control number.

**POWER OF ATTORNEY TO PROSECUTE APPLICATIONS BEFORE THE USPTO**

I hereby revoke all previous powers of attorney given in the application identified in the attached statement under 37 CFR 3.73(c).

I hereby appoint:

Practitioners associated with Customer Number: 98548

**OR**

Practitioner(s) named below (if more than ten patent practitioners are to be named, then a customer number must be used):

Name	Registration Number	Name	Registration Number

As attorney(s) or agent(s) to represent the undersigned before the United States Patent and Trademark Office (USPTO) in connection with any and all patent applications assigned only to the undersigned according to the USPTO assignment records or assignments documents attached to this form in accordance with 37 CFR 3.73(c).

Please change the correspondence address for the application identified in the attached statement under 37 CFR 3.73(c) to:

The address associated with Customer Number: 98548


**OR**

<input type="checkbox"/>	Firm or Individual Name		
	Address		
	City		
	Country		
	Telephone		Email

Assignee Name and Address: **Sanofi-Aventis Deutschland GmbH**  
 Brüningstrasse 50, D65929 Frankfurt am Main, Germany

**A copy of this form, together with a statement under 37 CFR 3.73(c) (Form PTO/SB/96 or equivalent) is required to be Filed in each application in which this form is used. The statement under 37 CFR 3.73(c) may be completed by one of The practitioners appointed in this form, and must identify the application in which this Power of Attorney is to be filed.**

**SIGNATURE of Assignee of Record**  
 The individual whose signature and title is supplied below is authorized to act on behalf of the assignee

Signature		Date <b>September 24, 2012</b>
Name	<b>Dr. Michael Bankmann     Dieter Breuer</b>	Telephone 0049-69-305-5794
Title	<b>Prokurist                     Authorized Signatory</b>	

This collection of information is required by 37 CFR 1.31, 1.32 and 1.33. The information is required to obtain or retain a benefit by the public which is to file (and by the USPTO to process) an application. Confidentiality is governed by 35 U.S.C. 122 and 37 CFR 1.11 and 1.14. This collection is estimated to take 3 minutes to complete, including gathering, preparing, and submitting the completed application form to the USPTO. Time will vary depending upon the individual case. Any comments on the amount of time you require to complete this form and/or suggestions for reducing this burden, should be sent to the Chief Information Officer, U.S. Patent and Trademark Office, U.S. Department of Commerce, P.O. Box 1450, Alexandria, VA 22313-1450. DO NOT SEND FEES OR COMPLETED FORMS TO THIS ADDRESS. SEND TO: Commissioner for Patents, P.O. Box 1450, Alexandria, VA 22313-1450.

If you need assistance in completing the form, call 1-800-PTO-9199 and select option 2.

**IN THE UNITED STATES PATENT AND TRADEMARK OFFICE**  
(Attorney Docket No.: 10-015-US-CON9)

Applicant: Robert Frederick Veasey, *et al.*  
Appl. No.: Unassigned  
Filed: June 30, 2014  
Title: IMPROVEMENTS IN AND RELATING TO DRIVE MECHANISMS  
SUITABLE FOR USE IN DRUG DELIVERY DEVICES  
TC/A.U.: Unassigned  
Confirmation No.: Unassigned  
Examiner: Unassigned

**INFORMATION DISCLOSURE STATEMENT**  
**TRANSMITTAL LETTER**

**Mail Stop: AMENDMENT**

Commissioner for Patents  
P.O. Box 1450  
Alexandria, VA 22313-1450

Dear Examiner,

In accordance with the duty of candor provisions set forth under 37 C.F.R. §1.56, submitted herewith on Form PTO/SB/08 is a listing of documents that Applicant wishes to make of record in the above-identified application.

In compliance with the provisions set forth under 37 C.F.R. §1.98(d), a copy of any reference that was previously submitted and/or provided by the Examiner in the parent application for the above-identified Continuation application are not being resubmitted herewith. For the Examiner's convenience, the parent application serial numbers to which the above-identified parent application claims priority to under 35 U.S.C. §120 are 12/941,702; 12/320,189; 11/520,598 and 10/790,866.

The submission of any document herewith is not intended as an admission that such document constitutes prior art against the claims of the present application or that such document is considered material to patentability as defined in 37 C.F.R. § 1.56(b). Applicant does not waive any rights to take any action which would be appropriate to antedate or otherwise remove as a competent reference any document which is determined to be a *prima facie* art reference against the claims of the present application.

In compliance with 37 C.F.R. §1.97(b), the listed documents are being submitted concurrently with the filing of the present application.

Applicant respectfully requests that the listed document(s) be considered by the Examiner and be made of record in the present application, and that a copy of Form PTO/SB/08 be returned in accordance with M.P.E.P. §609.

Respectfully submitted,  
**McDonnell Boehnen Hulbert & Berghoff LLP**

Dated: June 30, 2014

By: /David M. Frischkorn/  
David M. Frischkorn  
Registration No. 32,833

McDonnell Boehnen  
Hulbert & Berghoff LLP  
300 South Wacker Drive  
Chicago, IL 60606  
Tel: 312-913-0001

<b>INFORMATION DISCLOSURE STATEMENT BY APPLICANT</b> ( Not for submission under 37 CFR 1.99)	Application Number		
	Filing Date		2014-06-30
	First Named Inventor	Robert Frederick Veasey et al.	
	Art Unit		
	Examiner Name		
	Attorney Docket Number	10-015-US-CON9	

U.S.PATENTS						Remove
Examiner Initial*	Cite No	Patent Number	Kind Code <sup>1</sup>	Issue Date	Name of Patentee or Applicant of cited Document	Pages,Columns,Lines where Relevant Passages or Relevant Figures Appear
	1	5938642		1999-08-17	Burroughs et al.	
	2	6221046		2001-04-05	Burroughs et al.	
	3	5284480		1994-02-08	Porter et al.	
	4	6379339		2002-04-20	Klitgaard et al.	
	5	5685864		1997-11-11	Shanely et al.	
	6	5308340		1994-05-03	Harris	
	7	5827232		1998-10-27	Chanoch	
	8	6086567		2000-07-11	Kirchhofer et al.	

**INFORMATION DISCLOSURE  
STATEMENT BY APPLICANT**  
( Not for submission under 37 CFR 1.99)

Application Number		
Filing Date		2014-06-30
First Named Inventor	Robert Frederick Veasey et al.	
Art Unit		
Examiner Name		
Attorney Docket Number	10-015-US-CON9	

	9	6096010		2000-08-01	Walters	
	10	6048336		2000-04-11	Gabriel	
	11	5584815		1996-12-17	Pawelka	
	12	5549574		1996-08-27	Townsend	
	13	6663602		2003-12-16	Moller	
	14	7133329		2006-11-07	Skyggebjerg et al.	
	15	6899699		2005-05-31	Enggaard	
	16	6893415		2005-05-17	Madsen et al.	
	17	6796970		2004-09-28	Klitmose et al.	
	18	6726661		2004-04-27	Munk et al.	
	19	6716198		2004-04-06	Larsen	



**INFORMATION DISCLOSURE  
STATEMENT BY APPLICANT**  
( Not for submission under 37 CFR 1.99)

Application Number		
Filing Date		2014-06-30
First Named Inventor	Robert Frederick Veasey et al.	
Art Unit		
Examiner Name		
Attorney Docket Number	10-015-US-CON9	

	20	6692472		2004-02-17	Hansen et al.	
	21	5331954		1994-07-26	Rex et al.	
	22	6613019		2003-09-02	Munk	
	23	6605067		2003-08-12	Larsen	
	24	6547764		2003-04-15	Larsen et al.	
	25	6547763		2003-04-15	Steenfeldt-Jensen et al.	
	26	6514230		2003-02-04	Munk et al.	
	27	7090662		2006-08-15	Wimpenny et al.	
	28	7094221		2006-08-22	Veasey et al.	
	29	5716990		1998-02-10	Bagshawe et al.	
	30	4994033		1991-02-19	Shockey et al.	

**INFORMATION DISCLOSURE  
STATEMENT BY APPLICANT**  
( Not for submission under 37 CFR 1.99)

Application Number		
Filing Date		2014-06-30
First Named Inventor	Robert Frederick Veasey et al.	
Art Unit		
Examiner Name		
Attorney Docket Number		10-015-US-CON9

	31	5440976		1995-08-15	Guiliano et al.	
	32	5447150		1995-09-05	Bacon	
	33	5546932		1996-08-20	Galli	
	34	6281225		2001-08-28	Hearst et al.	
	35	6283941		2001-09-04	Schoenfeld et al.	
	36	6770288		2004-08-03	Duirs	
	37	5271527		1993-12-21	Haber et al.	
	38	5584815		1996-12-17	Pawelka et al.	
	39	5279585		1994-01-18	Balkwill	
	40	5279586		1994-01-18	Balkwill	
	41	5281198		1994-01-25	Haber et al.	

**INFORMATION DISCLOSURE  
STATEMENT BY APPLICANT**  
( Not for submission under 37 CFR 1.99)

Application Number		
Filing Date		2014-06-30
First Named Inventor	Robert Frederick Veasey et al.	
Art Unit		
Examiner Name		
Attorney Docket Number		10-015-US-CON9

	42	5320609		1994-01-17	Haber et al.	
	43	5383865		1995-01-24	Michel	
	44	5681285		1997-10-28	Ford et al.	
	45	4568335		1986-02-04	Updike et al.	
	46	5257987		1993-11-02	Athayde et al.	
	47	5318540		1994-06-07	Athayde et al.	
	48	4833379		1989-05-23	Kaibel et al.	
	49	4919596		1990-04-24	Slate et al.	
	50	5207752		1993-05-04	Sorenson et al.	
	51	5246417		1993-09-21	Haak et al.	
	52	5445606		1995-08-29	Haak et al.	

**INFORMATION DISCLOSURE  
STATEMENT BY APPLICANT**  
( Not for submission under 37 CFR 1.99)

Application Number		
Filing Date		2014-06-30
First Named Inventor	Robert Frederick Veasey et al.	
Art Unit		
Examiner Name		
Attorney Docket Number	10-015-US-CON9	

	53	5492534		1996-02-20	Athayde et al.	
	54	5645052		1997-07-08	Kersey	
	55	5755692		1998-05-26	Manicom	
	56	6258062		2001-07-10	Thielen et al.	
	57	6269340		2001-07-31	Ford et al.	
	58	6287283		2001-09-11	Ljunggreen	
	59	6277097		2001-08-21	Mikkelsen et al.	
	60	6235004		2001-05-22	Steenfeldt-Jensen et al.	
	61	6231540		2001-05-15	Smedegaard	
	62	6110149		2000-08-29	Klitgaard et al.	
	63	6074372		2000-06-13	Hansen	

**INFORMATION DISCLOSURE  
STATEMENT BY APPLICANT**  
( Not for submission under 37 CFR 1.99)

Application Number		
Filing Date		2014-06-30
First Named Inventor	Robert Frederick Veasey et al.	
Art Unit		
Examiner Name		
Attorney Docket Number		10-015-US-CON9

	64	6010485		2000-01-04	Buch-Rasmussen et al.	
	65	6004297		1999-12-21	Steenfeldt-Jensen et al.	
	66	5984900		1999-11-16	Mikkelsen	
	67	5980491		1999-11-09	Hansen	
	68	5961496		1999-10-05	Nielsen et al.	
	69	5954689		1999-09-21	Poulsen	
	70	5951530		1999-09-14	Steengaard et al.	
	71	5947934		1999-10-07	Hanjen et al.	
	72	5898028		1999-04-27	Jensen et al.	
	73	5882718		1999-03-16	Pommer et al.	
	74	5626566		1997-05-06	Peterson et al.	

**INFORMATION DISCLOSURE  
STATEMENT BY APPLICANT**  
( Not for submission under 37 CFR 1.99)

Application Number		
Filing Date		2014-06-30
First Named Inventor	Robert Frederick Veasey et al.	
Art Unit		
Examiner Name		
Attorney Docket Number		10-015-US-CON9

	75	5611783		1997-03-18	Mikkelson	
	76	5314412		1994-05-24	Rex	
	77	5843036		1998-12-01	Olive et al.	
	78	5709662		1998-01-20	Olive et al.	
	79	5478316		1995-12-26	Bitdinger et al.	
	80	4936833		1990-06-26	Sams	
	81	4865591		1989-09-12	Sams	
	82	7104972		2006-09-12	Moller et al.	
	83	7008399		2006-03-07	Larsen et al.	
	84	6945961		2005-09-20	Miller et al.	
	85	6569126		2003-05-27	Poulsen et al.	

**INFORMATION DISCLOSURE  
STATEMENT BY APPLICANT**  
( Not for submission under 37 CFR 1.99)

Application Number		
Filing Date		2014-06-30
First Named Inventor	Robert Frederick Veasey et al.	
Art Unit		
Examiner Name		
Attorney Docket Number	10-015-US-CON9	

	86	6562011		2003-05-13	Buch Rasmussen et al.	
	87	6340357		2002-01-22	Poulsen et al.	
	88	6312413		2001-11-06	Jensen et al.	
	89	6302869		2001-10-16	Klitgaard	
	90	6277098		2001-08-21	Klitmose et al.	
	91	6277097		2001-08-21	Mikkelsen et al.	
	92	6248090		2001-06-19	Jensen et al.	
	93	6003376		2000-03-07	Rockley	
	94	6033377		2000-03-07	Rasmussen et al.	
	95	5928201		1997-07-27	Poulsen et al.	
	96	5626566		1997-05-06	Peterson et al.	

**INFORMATION DISCLOSURE  
STATEMENT BY APPLICANT**  
( Not for submission under 37 CFR 1.99)

Application Number		
Filing Date		2014-06-30
First Named Inventor	Robert Frederick Veasey et al.	
Art Unit		
Examiner Name		
Attorney Docket Number		10-015-US-CON9

	97	6899698		2005-05-31	Sams	
	98	6083197		2000-07-04	Umbaugh	
	99	5921966		1999-07-13	Bendek et al.	
	100	6146361		2000-11-14	DiBiasi et al.	
	101	5370629		1994-12-06	Michel et al.	
	102	5823998		1998-10-20	Yamagata	
	103	5591136		1997-01-07	Gabriel	
	104	5599314		1997-02-04	Neill	
	105	5304152		1994-04-19	Sams	
	106	5688251		1997-11-18	Chanoch	
	107	5671204		1997-10-07	Chanoch	



**INFORMATION DISCLOSURE  
STATEMENT BY APPLICANT**  
( Not for submission under 37 CFR 1.99)

Application Number		
Filing Date		2014-06-30
First Named Inventor	Robert Frederick Veasey et al.	
Art Unit		
Examiner Name		
Attorney Docket Number		10-015-US-CON9

	108	7175055		2007-02-13	Hansen et al.	
	109	6129080		2000-10-10	Pitcher et al.	
	110	6899699		2005-05-31	Enggaard	
	111	4470317		1984-09-11	Sabloewski et al.	
	112	4585439		1986-04-29	Michel	
	113	6074372		2000-06-13	Hansen	
	114	5743889		1998-04-28	Sams	
	115	4883472		1989-11-28	Michel	
	116	6003736		1999-12-21	Ljunggren	
	117	5112317		1992-05-12	Michel	
	118	6221053		2001-04-24	Walters et al.	

**INFORMATION DISCLOSURE  
STATEMENT BY APPLICANT  
( Not for submission under 37 CFR 1.99)**

Application Number		
Filing Date		2014-06-30
First Named Inventor	Robert Frederick Veasey et al.	
Art Unit		
Examiner Name		
Attorney Docket Number	10-015-US-CON9	

	119	5626566		1997-05-06	Petersen et al.	
	120	4498904		1985-02-12	Turner et al.	
	121	6004297		1999-12-21	Steenfeldt-Jensen et al.	
	122	5304152		1994-04-19	Sams	
	123	6193698		2001-02-27	Kirchhofer et al.	
	124	6248095		2001-06-19	Giambattista et al.	
	125	5505704		1996-04-09	Pawelka et al.	
	126	5480387		1996-01-02	Gabriel et al.	
	127	6582404		2003-06-24	Klitgaard et al.	
	128	6221046		2001-04-24	Burroughs	
	129	5308340		1994-05-03	Harris	

**INFORMATION DISCLOSURE  
STATEMENT BY APPLICANT**  
( Not for submission under 37 CFR 1.99)

Application Number		
Filing Date		2014-06-30
First Named Inventor	Robert Frederick Veasey et al.	
Art Unit		
Examiner Name		
Attorney Docket Number		10-015-US-CON9

	130	6899698		2005-05-31	Sams	
	131	4973318		1990-11-27	Holm	
	132	4865591		1989-09-12	Sams	
	133	4936833		1990-06-26	Sams	
	134	5549575		1996-08-27	Giambattista	
	135	5226895		1993-07-13	Harris	
	136	5674204		1997-10-07	Chanoch	
	137	6221053		2001-04-24	Walters et al.	
	138	5017190		1991-05-21	Simon et al.	
	139	5304152		1994-04-19	Sams	
	140	5679111		1997-10-21	Hjertman et al.	

**INFORMATION DISCLOSURE  
STATEMENT BY APPLICANT**  
( Not for submission under 37 CFR 1.99)

Application Number		
Filing Date		2014-06-30
First Named Inventor	Robert Frederick Veasey et al.	
Art Unit		
Examiner Name		
Attorney Docket Number		10-015-US-CON9

	141	5599314		1997-02-04	Neill	
	142	5725508		1998-03-10	Chanoch et al.	
	143	5383865		1995-01-24	Michel	
	144	2444570		1948-07-05	H.J. Lawrence et al.	
	145	5545147		1996-08-13	Harris	
	146	5693027		1997-12-02	Hansen et al.	
	147	5380297		1995-01-10	Wadman et al.	
	148	7316670		2008-01-08	Graf et al.	
	149	7553299		2009-06-30	Veasey et al.	
	150	6932794		2005-08-23	Giambattista et al.	
	151	7169132		2007-01-30	Bendek et al.	

**INFORMATION DISCLOSURE  
STATEMENT BY APPLICANT**  
( Not for submission under 37 CFR 1.99)

Application Number		
Filing Date		2014-06-30
First Named Inventor	Robert Frederick Veasey et al.	
Art Unit		
Examiner Name		
Attorney Docket Number		10-015-US-CON9

	152	7291132		2007-11-06	DeRuntz et al.	
	153	7241278		2007-07-10	Moller	
	154	6547764		2003-04-15	Larsen et al.	
	155	5304152		1994-04-19	Sams	
	156	5320609		1994-06-14	Gabriel et al.	
	157	5480387		1996-01-02	Gabriel et al.	
	158	5505704		1996-04-09	Pawelka et al.	
	159	6193698		2001-02-27	Kirchhofer et al.	
	160	6248095		2001-06-19	Giambattista et al.	
	161	7241278		2007-07-10	Moller	

If you wish to add additional U.S. Patent citation information please click the Add button. [Add](#)

**U.S.PATENT APPLICATION PUBLICATIONS** [Remove](#)

**INFORMATION DISCLOSURE  
STATEMENT BY APPLICANT**  
( Not for submission under 37 CFR 1.99)

Application Number		
Filing Date		2014-06-30
First Named Inventor	Robert Frederick Veasey et al.	
Art Unit		
Examiner Name		
Attorney Docket Number	10-015-US-CON9	

Examiner Initial*	Cite No	Publication Number	Kind Code <sup>1</sup>	Publication Date	Name of Patentee or Applicant of cited Document	Pages, Columns, Lines where Relevant Passages or Relevant Figures Appear
	1	20020007154		2002-01-17	Hansen et al.	
	2	20070093761		2007-04-26	Veasey	
	3	20040249348		2004-12-09	Wimpenny et al.	
	4	20040260247		2004-12-23	Veasey et al.	
	5	20040267207		2004-12-30	Veasey et al.	
	6	20050004529		2005-01-06	Veasey et al.	
	7	20050033244		2005-02-10	Veasey et al.	
	8	20030039679		2003-02-27	Duirs	
	9	20040236282		2004-11-25	Braithwaite	
	10	20050019400		2005-01-27	Deveney et al.	

**INFORMATION DISCLOSURE  
STATEMENT BY APPLICANT**  
( Not for submission under 37 CFR 1.99)

Application Number		
Filing Date		2014-06-30
First Named Inventor	Robert Frederick Veasey et al.	
Art Unit		
Examiner Name		
Attorney Docket Number		10-015-US-CON9

11	20050268915		2005-12-08	Wassenaar et al.	
12	20040186431		2004-09-23	Graf et al.	
13	20040210199		2004-10-21	Atterbury et al.	
14	20020077852		2002-06-20	Ford et al.	
15	20030172924		2003-09-18	Staniforth et al.	
16	20050205083		2005-09-22	Staniforth et al.	
17	20050055011		2005-03-10	Enggaanrd	
18	20020052578		2002-05-02	Moller	
19	20040059299		2004-03-25	Moller	
20	20020120235		2002-08-29	Enggaard	
21	20040127858		2004-07-01	Bendek et al.	

**INFORMATION DISCLOSURE  
STATEMENT BY APPLICANT**  
( Not for submission under 37 CFR 1.99)

Application Number		
Filing Date		2014-06-30
First Named Inventor	Robert Frederick Veasey et al.	
Art Unit		
Examiner Name		
Attorney Docket Number		10-015-US-CON9

	22	20060206057		2006-09-14	DeRuntz et al.	
	23	20060264839		2006-11-23	Veasey et al.	
	24	20050209570		2005-09-22	Moller	
	25	20050113765		2005-05-26	Veasey et al.	
	26	20040267208		2004-12-30	Veasey et al.	

If you wish to add additional U.S. Published Application citation information please click the Add button. [Add](#)

**FOREIGN PATENT DOCUMENTS**

[Remove](#)

Examiner Initial*	Cite No	Foreign Document Number <sup>3</sup>	Country Code <sup>2</sup> i	Kind Code <sup>4</sup>	Publication Date	Name of Patentee or Applicant of cited Document	Pages, Columns, Lines where Relevant Passages or Relevant Figures Appear	T <sup>5</sup>
	1	1570876	EP	A2	2005-07-09	Novo Nordisk A/S		<input type="checkbox"/>
	2	1250167	EP	B1	2005-07-20	Novo Nordisk A/S		<input type="checkbox"/>
	3	702970	EP		1996-03-27	Becton, Dickinson & Co.		<input type="checkbox"/>
	4	554996	EP		1993-08-11	Becton Dickinson & Co.		<input type="checkbox"/>



**INFORMATION DISCLOSURE  
STATEMENT BY APPLICANT**  
( Not for submission under 37 CFR 1.99)

Application Number		
Filing Date		2014-06-30
First Named Inventor	Robert Frederick Veasey et al.	
Art Unit		
Examiner Name		
Attorney Docket Number	10-015-US-CON9	

5	295075	EP		1988-12-14	Hypoguard (UK) Limited	<input type="checkbox"/>
6	879610	EP		1998-11-25	Eli Lilly & Co.	<input type="checkbox"/>
7	498737	EP		1992-08-12	Terumo Kabushiki	<input type="checkbox"/>
8	594349	EP		1994-04-27	Eli Lilly & Co.	<input type="checkbox"/>
9	8907463	WO		1989-08-24	D.C.P. AF	<input type="checkbox"/>
10	9810813	WO		1998-03-19	Novo Nordisk A/S	<input type="checkbox"/>
11	9856436	WO		1998-12-17	Novo Nordisk A/S	<input type="checkbox"/>
12	9736626	WO		1997-10-09	Kirchhofer et al.	<input type="checkbox"/>
13	9938554	WO		1999-08-05	Novo Nordisk A/S	<input type="checkbox"/>
14	9638190	WO		1996-12-05	Novo Nordisk A/S	<input type="checkbox"/>
15	0119434	WO		2001-03-22	Novo Nordisk A/S	<input type="checkbox"/>

**INFORMATION DISCLOSURE  
STATEMENT BY APPLICANT**  
( Not for submission under 37 CFR 1.99)

Application Number		
Filing Date		2014-06-30
First Named Inventor	Robert Frederick Veasey et al.	
Art Unit		
Examiner Name		
Attorney Docket Number	10-015-US-CON9	

16	9626754	WO		1996-09-06	Sams		<input type="checkbox"/>
17	9916487	WO		1999-04-08	Becton Dickinson & Co.		<input type="checkbox"/>
18	0937476	EP		1999-08-25	Becton Dickinson & Co.		<input type="checkbox"/>
19	9114467	WO		1991-10-03	Sams		<input type="checkbox"/>
20	0937471	EP		1999-08-25	Becton Dickinson & Co.		<input type="checkbox"/>
21	0673482	EP		1998-04-29	Sams		<input type="checkbox"/>
22	2767479	FR		1999-02-26	Laboratoire Agneltant Societe Anonyme		<input type="checkbox"/>
23	9938554	WO		1999-08-05	Novo Nordisk A/S		<input type="checkbox"/>
24	3609555	DE		1987-09-24	Pomer		<input type="checkbox"/>
25	2583291	FR		1986-12-19	Hazon Bernard		<input type="checkbox"/>
26	9857688	WO		1998-12-23	Novo Nordisk A/S		<input type="checkbox"/>

**INFORMATION DISCLOSURE  
STATEMENT BY APPLICANT**  
( Not for submission under 37 CFR 1.99)

Application Number		
Filing Date		2014-06-30
First Named Inventor	Robert Frederick Veasey et al.	
Art Unit		
Examiner Name		
Attorney Docket Number	10-015-US-CON9	

	27	9626754	WO		1996-09-06	Sams		<input type="checkbox"/>
	28	9114467	WO		1991-10-03	Sams		<input type="checkbox"/>
	29	2111019	RU		1998-05-20	Khvorostov Sergej Aleksandrovi		<input type="checkbox"/>
	30	9110460	WO		1991-07-25	Novo Nordisk A/S		<input type="checkbox"/>
	31	9009202	WO		1990-08-23	Novo Nordisk A/S		<input type="checkbox"/>
	32	327910	EP		1989-08-16	DCP AF 1988 AS		<input type="checkbox"/>
	33	450905	EP		1991-10-09	Eli Lilly & Co.		<input type="checkbox"/>
	34	608343	EP	B1	1994-08-03	Novo Nordisk A/S		<input type="checkbox"/>
	35	359070	EP	B1	1990-03-21	Graesslin KG		<input type="checkbox"/>
	36	1232899	GB		1971-05-19			<input type="checkbox"/>
	37	2141799	GB		1985-01-03	Diehl GmbH & Co.		<input type="checkbox"/>

<b>INFORMATION DISCLOSURE STATEMENT BY APPLICANT</b> ( Not for submission under 37 CFR 1.99)	Application Number		
	Filing Date		2014-06-30
	First Named Inventor	Robert Frederick Veasey et al.	
	Art Unit		
	Examiner Name		
	Attorney Docket Number		10-015-US-CON9

38	9307922	WO		1993-04-29	Novo Nordisk A/S		<input type="checkbox"/>
39	9419034	WO		1994-09-01	Medicorp Holding		<input type="checkbox"/>
40	735443	GB		1955-08-24	English Numbering Machines		<input type="checkbox"/>
41	06296691	JP		1994-10-25	Michel et al.		<input type="checkbox"/>
42	05337179	JP		1993-12-21	Balkwill		<input type="checkbox"/>
43	1294418	EP		2005-07-09	Moller		<input type="checkbox"/>
44	99/38554	WO		1999-08-05	Novo Nordisk A/S		<input type="checkbox"/>

If you wish to add additional Foreign Patent Document citation information please click the Add button **Add**

**NON-PATENT LITERATURE DOCUMENTS**

**Remove**

Examiner Initials*	Cite No	Include name of the author (in CAPITAL LETTERS), title of the article (when appropriate), title of the item (book, magazine, journal, serial, symposium, catalog, etc), date, pages(s), volume-issue number(s), publisher, city and/or country where published.	T <sup>5</sup>
	1	U.S. Reissue Patent Application No. 10/442,855, "Injection Syringe", Filed May 21, 2003, including copies of as-filed specification, drawings, abstract, and claims, as well as the reissue declaration and a copy of list of documents found in image file wrapper in PAIR as of March 3, 2011.	<input type="checkbox"/>
	2	U.S. Reissue Patent Application No. 10/960,900, "Injection Syringe", Filed October 7, 2004, including copies of as-filed specification, drawings, abstract, and claims, as well as the reissue declaration and a copy of list of documents found in image file wrapper in PAIR as of March 3, 2011.	<input type="checkbox"/>

<b>INFORMATION DISCLOSURE STATEMENT BY APPLICANT</b> ( Not for submission under 37 CFR 1.99)	Application Number			
	Filing Date		2014-06-30	
	First Named Inventor	Robert Frederick Veasey et al.		
	Art Unit			
	Examiner Name			
	Attorney Docket Number		10-015-US-CON9	

3	U.S. Reissue Patent Application No. 11/121,331, "Injection Syringe", Filed December 18, 2006, including copies of as-filed specification, drawings, abstract, and claims, as well as the reissue declaration and a copy of list of documents found in image file wrapper in PAIR as of March 3, 2011.	<input type="checkbox"/>
4	U.S. Reissue Patent Application No. 11/640,610, "Injection Syringe", Filed May 3, 2005, including copies of as-filed specification, drawings, abstract, and claims, as well as the reissue declaration and a copy of list of documents found in image file wrapper in PAIR as of March 3, 2011.	<input type="checkbox"/>
5	US Office Action mailed March 14, 2006 in U.S. Application No. 10/790,866	<input type="checkbox"/>
6	US Office Action mailed December 18, 2008 in U.S. Application No. 10/960,600	<input type="checkbox"/>
7	US Office Action mailed April 17, 2009 in U.S. Application No. 11/121,331.	<input type="checkbox"/>
8	US Office Action mailed April 17, 2009 in U.S. Application No. 11/640,610.	<input type="checkbox"/>

If you wish to add additional non-patent literature document citation information please click the Add button **Add**

**EXAMINER SIGNATURE**

Examiner Signature		Date Considered	
--------------------	--	-----------------	--

\*EXAMINER: Initial if reference considered, whether or not citation is in conformance with MPEP 609. Draw line through a citation if not in conformance and not considered. Include copy of this form with next communication to applicant.

<sup>1</sup> See Kind Codes of USPTO Patent Documents at [www.USPTO.GOV](http://www.USPTO.GOV) or MPEP 901.04. <sup>2</sup> Enter office that issued the document, by the two-letter code (WIPO Standard ST.3). <sup>3</sup> For Japanese patent documents, the indication of the year of the reign of the Emperor must precede the serial number of the patent document. <sup>4</sup> Kind of document by the appropriate symbols as indicated on the document under WIPO Standard ST.16 if possible. <sup>5</sup> Applicant is to place a check mark here if English language translation is attached.

<b>INFORMATION DISCLOSURE STATEMENT BY APPLICANT</b> ( Not for submission under 37 CFR 1.99)	Application Number		
	Filing Date		2014-06-30
	First Named Inventor	Robert Frederick Veasey et al.	
	Art Unit		
	Examiner Name		
	Attorney Docket Number		10-015-US-CON9

**CERTIFICATION STATEMENT**

Please see 37 CFR 1.97 and 1.98 to make the appropriate selection(s):

That each item of information contained in the information disclosure statement was first cited in any communication from a foreign patent office in a counterpart foreign application not more than three months prior to the filing of the information disclosure statement. See 37 CFR 1.97(e)(1).

**OR**

That no item of information contained in the information disclosure statement was cited in a communication from a foreign patent office in a counterpart foreign application, and, to the knowledge of the person signing the certification after making reasonable inquiry, no item of information contained in the information disclosure statement was known to any individual designated in 37 CFR 1.56(c) more than three months prior to the filing of the information disclosure statement. See 37 CFR 1.97(e)(2).

See attached certification statement.

Fee set forth in 37 CFR 1.17 (p) has been submitted herewith.

None

**SIGNATURE**

A signature of the applicant or representative is required in accordance with CFR 1.33, 10.18. Please see CFR 1.4(d) for the form of the signature.

Signature	/David M. Frischkorn/	Date (YYYY-MM-DD)	2014-06-30
Name/Print	David M. Frischkorn	Registration Number	32833

This collection of information is required by 37 CFR 1.97 and 1.98. The information is required to obtain or retain a benefit by the public which is to file (and by the USPTO to process) an application. Confidentiality is governed by 35 U.S.C. 122 and 37 CFR 1.14. This collection is estimated to take 1 hour to complete, including gathering, preparing and submitting the completed application form to the USPTO. Time will vary depending upon the individual case. Any comments on the amount of time you require to complete this form and/or suggestions for reducing this burden, should be sent to the Chief Information Officer, U.S. Patent and Trademark Office, U.S. Department of Commerce, P.O. Box 1450, Alexandria, VA 22313-1450. **DO NOT SEND FEES OR COMPLETED FORMS TO THIS ADDRESS. SEND TO: Commissioner for Patents, P.O. Box 1450, Alexandria, VA 22313-1450.**

## Privacy Act Statement

The Privacy Act of 1974 (P.L. 93-579) requires that you be given certain information in connection with your submission of the attached form related to a patent application or patent. Accordingly, pursuant to the requirements of the Act, please be advised that: (1) the general authority for the collection of this information is 35 U.S.C. 2(b)(2); (2) furnishing of the information solicited is voluntary; and (3) the principal purpose for which the information is used by the U.S. Patent and Trademark Office is to process and/or examine your submission related to a patent application or patent. If you do not furnish the requested information, the U.S. Patent and Trademark Office may not be able to process and/or examine your submission, which may result in termination of proceedings or abandonment of the application or expiration of the patent.

The information provided by you in this form will be subject to the following routine uses:

1. The information on this form will be treated confidentially to the extent allowed under the Freedom of Information Act (5 U.S.C. 552) and the Privacy Act (5 U.S.C. 552a). Records from this system of records may be disclosed to the Department of Justice to determine whether the Freedom of Information Act requires disclosure of these records.
2. A record from this system of records may be disclosed, as a routine use, in the course of presenting evidence to a court, magistrate, or administrative tribunal, including disclosures to opposing counsel in the course of settlement negotiations.
3. A record in this system of records may be disclosed, as a routine use, to a Member of Congress submitting a request involving an individual, to whom the record pertains, when the individual has requested assistance from the Member with respect to the subject matter of the record.
4. A record in this system of records may be disclosed, as a routine use, to a contractor of the Agency having need for the information in order to perform a contract. Recipients of information shall be required to comply with the requirements of the Privacy Act of 1974, as amended, pursuant to 5 U.S.C. 552a(m).
5. A record related to an International Application filed under the Patent Cooperation Treaty in this system of records may be disclosed, as a routine use, to the International Bureau of the World Intellectual Property Organization, pursuant to the Patent Cooperation Treaty.
6. A record in this system of records may be disclosed, as a routine use, to another federal agency for purposes of National Security review (35 U.S.C. 181) and for review pursuant to the Atomic Energy Act (42 U.S.C. 218(c)).
7. A record from this system of records may be disclosed, as a routine use, to the Administrator, General Services, or his/her designee, during an inspection of records conducted by GSA as part of that agency's responsibility to recommend improvements in records management practices and programs, under authority of 44 U.S.C. 2904 and 2906. Such disclosure shall be made in accordance with the GSA regulations governing inspection of records for this purpose, and any other relevant (i.e., GSA or Commerce) directive. Such disclosure shall not be used to make determinations about individuals.
8. A record from this system of records may be disclosed, as a routine use, to the public after either publication of the application pursuant to 35 U.S.C. 122(b) or issuance of a patent pursuant to 35 U.S.C. 151. Further, a record may be disclosed, subject to the limitations of 37 CFR 1.14, as a routine use, to the public if the record was filed in an application which became abandoned or in which the proceedings were terminated and which application is referenced by either a published application, an application open to public inspections or an issued patent.
9. A record from this system of records may be disclosed, as a routine use, to a Federal, State, or local law enforcement agency, if the USPTO becomes aware of a violation or potential violation of law or regulation.

## Electronic Patent Application Fee Transmittal

<b>Application Number:</b>				
<b>Filing Date:</b>				
<b>Title of Invention:</b>	IMPROVEMENTS IN AND RELATING TO DRIVE MECHANISMS SUITABLE FOR USE IN DRUG DELIVERY DEVICES			
<b>First Named Inventor/Applicant Name:</b>	Robert Frederick Veasey			
<b>Filer:</b>	David M. Frischkorn			
<b>Attorney Docket Number:</b>	10-015-US-CON9			
Filed as Large Entity				
<b>Utility under 35 USC 111(a) Filing Fees</b>				
<b>Description</b>	<b>Fee Code</b>	<b>Quantity</b>	<b>Amount</b>	<b>Sub-Total in USD(\$)</b>
<b>Basic Filing:</b>				
Utility application filing	1011	1	280	280
Utility Search Fee	1111	1	600	600
Utility Examination Fee	1311	1	720	720
<b>Pages:</b>				
<b>Claims:</b>				
<b>Miscellaneous-Filing:</b>				
<b>Petition:</b>				
<b>Patent-Appeals-and-Interference:</b>				



Description	Fee Code	Quantity	Amount	Sub-Total in USD(\$)
<b>Post-Allowance-and-Post-Issuance:</b>				
<b>Extension-of-Time:</b>				
<b>Miscellaneous:</b>				
<b>Total in USD (\$)</b>				<b>1600</b>

## Electronic Acknowledgement Receipt

<b>EFS ID:</b>	19453262
<b>Application Number:</b>	14319388
<b>International Application Number:</b>	
<b>Confirmation Number:</b>	6141
<b>Title of Invention:</b>	IMPROVEMENTS IN AND RELATING TO DRIVE MECHANISMS SUITABLE FOR USE IN DRUG DELIVERY DEVICES
<b>First Named Inventor/Applicant Name:</b>	Robert Frederick Veasey
<b>Customer Number:</b>	98548
<b>Filer:</b>	David M. Frischkorn
<b>Filer Authorized By:</b>	
<b>Attorney Docket Number:</b>	10-015-US-CON9
<b>Receipt Date:</b>	30-JUN-2014
<b>Filing Date:</b>	
<b>Time Stamp:</b>	15:32:33
<b>Application Type:</b>	Utility under 35 USC 111(a)

### Payment information:

Submitted with Payment	yes
Payment Type	Deposit Account
Payment was successfully received in RAM	\$1600
RAM confirmation Number	2464
Deposit Account	132490
Authorized User	

The Director of the USPTO is hereby authorized to charge indicated fees and credit any overpayment as follows:

Charge any Additional Fees required under 37 C.F.R. Section 1.17 (Patent application and reexamination processing fees)

Charge any Additional Fees required under 37 C.F.R. Section 1.21 (Miscellaneous fees and charges)

0034

Mylan Exhibit - 1010

Mylan v. Sanofi

<b>File Listing:</b>					
<b>Document Number</b>	<b>Document Description</b>	<b>File Name</b>	<b>File Size(Bytes)/ Message Digest</b>	<b>Multi Part /.zip</b>	<b>Pages (if appl.)</b>
1	Application Data Sheet	10-015-US-CON9_ADS.PDF	1561916 7591a1b5f301031171097e5f5d159eeb5b61cab3	no	8
<b>Warnings:</b>					
<b>Information:</b>					
2		10-015-US-CON9_Spec.pdf	151057 0eede36f20aa7c02e2d714ad5cb92760447c13a	yes	29
	<b>Multipart Description/PDF files in .zip description</b>				
	<b>Document Description</b>		<b>Start</b>	<b>End</b>	
	Specification		1	25	
	Claims		26	28	
Abstract		29	29		
<b>Warnings:</b>					
<b>Information:</b>					
3	Drawings-other than black and white line drawings	10-015-US-CON9_Drawings.pdf	9774794 9cba1e005f3d5c15d8783f620b3c43078b6701d4	no	21
<b>Warnings:</b>					
<b>Information:</b>					
4	Oath or Declaration filed	10-015-US-CON9_Declaration.pdf	157318 6177578578898b032ddcb3804b7e01a377cd5c06	no	2
<b>Warnings:</b>					
<b>Information:</b>					
5	Power of Attorney	10-015-US-CON9_POA.pdf	462778 4ed041f78223ca711232558203b40ac34171746b	no	4
<b>Warnings:</b>					
<b>Information:</b>					
6	Transmittal Letter	10-015-US-CON9_IDS_Transmittal.pdf	86612 ab268f57ebc3b8f71050bc2eadd0f6cf048dfc6d	no	2
<b>Warnings:</b>					
<b>Information:</b>					
7	Information Disclosure Statement (IDS) Form (SB08)	10-015-US-CON9_IDS.PDF	618303 20f6e046a741b44bf3e3d64e741947126b04b95	no	25

<b>Warnings:</b>					
<b>Information:</b>					
8	Fee Worksheet (SB06)	fee-info.pdf	33349	no	2
			73ca305038649d59b96615ca37f218b2adf074ca		
<b>Warnings:</b>					
<b>Information:</b>					
<b>Total Files Size (in bytes):</b>				12846127	
<p><b>This Acknowledgement Receipt evidences receipt on the noted date by the USPTO of the indicated documents, characterized by the applicant, and including page counts, where applicable. It serves as evidence of receipt similar to a Post Card, as described in MPEP 503.</b></p> <p><b><u>New Applications Under 35 U.S.C. 111</u></b>  <b>If a new application is being filed and the application includes the necessary components for a filing date (see 37 CFR 1.53(b)-(d) and MPEP 506), a Filing Receipt (37 CFR 1.54) will be issued in due course and the date shown on this Acknowledgement Receipt will establish the filing date of the application.</b></p> <p><b><u>National Stage of an International Application under 35 U.S.C. 371</u></b>  <b>If a timely submission to enter the national stage of an international application is compliant with the conditions of 35 U.S.C. 371 and other applicable requirements a Form PCT/DO/EO/903 indicating acceptance of the application as a national stage submission under 35 U.S.C. 371 will be issued in addition to the Filing Receipt, in due course.</b></p> <p><b><u>New International Application Filed with the USPTO as a Receiving Office</u></b>  <b>If a new international application is being filed and the international application includes the necessary components for an international filing date (see PCT Article 11 and MPEP 1810), a Notification of the International Application Number and of the International Filing Date (Form PCT/RO/105) will be issued in due course, subject to prescriptions concerning national security, and the date shown on this Acknowledgement Receipt will establish the international filing date of the application.</b></p>					

## Electronic Acknowledgement Receipt

<b>EFS ID:</b>	19453262
<b>Application Number:</b>	14319388
<b>International Application Number:</b>	
<b>Confirmation Number:</b>	6141
<b>Title of Invention:</b>	IMPROVEMENTS IN AND RELATING TO DRIVE MECHANISMS SUITABLE FOR USE IN DRUG DELIVERY DEVICES
<b>First Named Inventor/Applicant Name:</b>	Robert Frederick Veasey
<b>Customer Number:</b>	98548
<b>Filer:</b>	David M. Frischkorn
<b>Filer Authorized By:</b>	
<b>Attorney Docket Number:</b>	10-015-US-CON9
<b>Receipt Date:</b>	30-JUN-2014
<b>Filing Date:</b>	
<b>Time Stamp:</b>	15:32:33
<b>Application Type:</b>	Utility under 35 USC 111(a)

### Payment information:

Submitted with Payment	yes
Payment Type	Deposit Account
Payment was successfully received in RAM	\$1600
RAM confirmation Number	2464
Deposit Account	132490
Authorized User	

The Director of the USPTO is hereby authorized to charge indicated fees and credit any overpayment as follows:

Charge any Additional Fees required under 37 C.F.R. Section 1.17 (Patent application and reexamination processing fees)

Charge any Additional Fees required under 37 C.F.R. Section 1.21 (Miscellaneous fees and charges)

0037

Mylan Exhibit - 1010

Mylan v. Sanofi

<b>File Listing:</b>					
<b>Document Number</b>	<b>Document Description</b>	<b>File Name</b>	<b>File Size(Bytes)/ Message Digest</b>	<b>Multi Part /.zip</b>	<b>Pages (if appl.)</b>
1	Application Data Sheet	10-015-US-CON9_ADS.PDF	1561916 7591a1b5f301031171097e5f5d159eeb5b61cab3	no	8
<b>Warnings:</b>					
<b>Information:</b>					
2		10-015-US-CON9_Spec.pdf	151057 0eede36f20aa7c02e2d714ad5cb92760447c13a	yes	29
	<b>Multipart Description/PDF files in .zip description</b>				
	<b>Document Description</b>		<b>Start</b>	<b>End</b>	
	Specification		1	25	
	Claims		26	28	
	Abstract		29	29	
<b>Warnings:</b>					
<b>Information:</b>					
3	Drawings-other than black and white line drawings	10-015-US-CON9_Drawings.pdf	9774794 9cba1e005f3d5c15d8783f620b3c43078b6701d4	no	21
<b>Warnings:</b>					
<b>Information:</b>					
4	Oath or Declaration filed	10-015-US-CON9_Declaration.pdf	157318 6177578578898b032ddcb3804b7e01a377cd5c06	no	2
<b>Warnings:</b>					
<b>Information:</b>					
5	Power of Attorney	10-015-US-CON9_POA.pdf	462778 4ed041f78223ca711232558203b40ac34171746b	no	4
<b>Warnings:</b>					
<b>Information:</b>					
6	Transmittal Letter	10-015-US-CON9_IDS_Transmittal.pdf	86612 ab268f57ebc3b8f71050bc2eadd0f6cf048dfc6d	no	2
<b>Warnings:</b>					
<b>Information:</b>					
7	Information Disclosure Statement (IDS) Form (SB08)	10-015-US-CON9_IDS.PDF	618303 20f6e046a741b44bf3e3d64e741947126b04b95	no	25

<b>Warnings:</b>					
<b>Information:</b>					
8	Fee Worksheet (SB06)	fee-info.pdf	33349	no	2
			73ca305038649d59b96615ca37f218b2adf074ca		
<b>Warnings:</b>					
<b>Information:</b>					
<b>Total Files Size (in bytes):</b>				12846127	
<p><b>This Acknowledgement Receipt evidences receipt on the noted date by the USPTO of the indicated documents, characterized by the applicant, and including page counts, where applicable. It serves as evidence of receipt similar to a Post Card, as described in MPEP 503.</b></p> <p><b><u>New Applications Under 35 U.S.C. 111</u></b>  <b>If a new application is being filed and the application includes the necessary components for a filing date (see 37 CFR 1.53(b)-(d) and MPEP 506), a Filing Receipt (37 CFR 1.54) will be issued in due course and the date shown on this Acknowledgement Receipt will establish the filing date of the application.</b></p> <p><b><u>National Stage of an International Application under 35 U.S.C. 371</u></b>  <b>If a timely submission to enter the national stage of an international application is compliant with the conditions of 35 U.S.C. 371 and other applicable requirements a Form PCT/DO/EO/903 indicating acceptance of the application as a national stage submission under 35 U.S.C. 371 will be issued in addition to the Filing Receipt, in due course.</b></p> <p><b><u>New International Application Filed with the USPTO as a Receiving Office</u></b>  <b>If a new international application is being filed and the international application includes the necessary components for an international filing date (see PCT Article 11 and MPEP 1810), a Notification of the International Application Number and of the International Filing Date (Form PCT/RO/105) will be issued in due course, subject to prescriptions concerning national security, and the date shown on this Acknowledgement Receipt will establish the international filing date of the application.</b></p>					

Under the Paperwork Reduction Act of 1995, no persons are required to respond to a collection of information unless it contains a valid OMB control number.

<b>Application Data Sheet 37 CFR 1.76</b>		Attorney Docket Number	10-015-US-CON9
		Application Number	
Title of Invention	IMPROVEMENTS IN AND RELATING TO DRIVE MECHANISMS SUITABLE FOR USE IN DRUG DELIVERY DEVICES		
<p>The application data sheet is part of the provisional or nonprovisional application for which it is being submitted. The following form contains the bibliographic data arranged in a format specified by the United States Patent and Trademark Office as outlined in 37 CFR 1.76. This document may be completed electronically and submitted to the Office in electronic format using the Electronic Filing System (EFS) or the document may be printed and included in a paper filed application.</p>			

**Secrecy Order 37 CFR 5.2**

<input type="checkbox"/>	Portions or all of the application associated with this Application Data Sheet may fall under a Secrecy Order pursuant to 37 CFR 5.2 (Paper filers only. Applications that fall under Secrecy Order may not be filed electronically.)
--------------------------	---

**Inventor Information:**

<b>Inventor 1</b>					<input type="button" value="Remove"/>
<b>Legal Name</b>					
<b>Prefix</b>	<b>Given Name</b>	<b>Middle Name</b>	<b>Family Name</b>	<b>Suffix</b>	
	Robert	Frederick	Veasey		
<b>Residence Information (Select One)</b> <input type="radio"/> US Residency <input checked="" type="radio"/> Non US Residency <input type="radio"/> Active US Military Service					
<b>City</b>	Warwickshire	<b>Country of Residence i</b>	GB		
<b>Mailing Address of Inventor:</b>					
<b>Address 1</b>	35 Hitchman Road, Leamington Spa				
<b>Address 2</b>					
<b>City</b>	Warwickshire	<b>State/Province</b>			
<b>Postal Code</b>		<b>Country i</b>	GB		
<b>Inventor 2</b>					<input type="button" value="Remove"/>
<b>Legal Name</b>					
<b>Prefix</b>	<b>Given Name</b>	<b>Middle Name</b>	<b>Family Name</b>	<b>Suffix</b>	
	Robert		Perkins		
<b>Residence Information (Select One)</b> <input type="radio"/> US Residency <input checked="" type="radio"/> Non US Residency <input type="radio"/> Active US Military Service					
<b>City</b>	Warwickshire	<b>Country of Residence i</b>	GB		
<b>Mailing Address of Inventor:</b>					
<b>Address 1</b>	67 Erica Drive, Leamington Spa				
<b>Address 2</b>					
<b>City</b>	Warwickshire	<b>State/Province</b>			
<b>Postal Code</b>		<b>Country i</b>	GB		
<b>Inventor 3</b>					<input type="button" value="Remove"/>
<b>Legal Name</b>					



Under the Paperwork Reduction Act of 1995, no persons are required to respond to a collection of information unless it contains a valid OMB control number.

<b>Application Data Sheet 37 CFR 1.76</b>		Attorney Docket Number	10-015-US-CON9
		Application Number	
Title of Invention	IMPROVEMENTS IN AND RELATING TO DRIVE MECHANISMS SUITABLE FOR USE IN DRUG DELIVERY DEVICES		

Prefix	Given Name	Middle Name	Family Name	Suffix
	David	Aubrey	Plumptre	
<b>Residence Information (Select One)</b> <input type="radio"/> US Residency <input checked="" type="radio"/> Non US Residency <input type="radio"/> Active US Military Service				
City	Worcestershire	Country of Residence i	GB	

<b>Mailing Address of Inventor:</b>				
Address 1	36 Shire Way, Droitwich			
Address 2				
City	Worcestershire	State/Province		
Postal Code		Country i	GB	
All Inventors Must Be Listed - Additional Inventor Information blocks may be generated within this form by selecting the <b>Add</b> button.				<input type="button" value="Add"/>

**Correspondence Information:**

Enter either Customer Number or complete the Correspondence Information section below. For further information see 37 CFR 1.33(a).			
<input type="checkbox"/> An Address is being provided for the correspondence information of this application.			
Customer Number	98548		
Email Address	DOCKETING@MBHB.COM	<input type="button" value="Add Email"/>	<input type="button" value="Remove Email"/>

**Application Information:**

Title of the Invention	IMPROVEMENTS IN AND RELATING TO DRIVE MECHANISMS SUITABLE FOR USE IN DRUG DELIVERY DEVICES		
Attorney Docket Number	10-015-US-CON9	Small Entity Status Claimed	<input type="checkbox"/>
Application Type	Nonprovisional		
Subject Matter	Utility		
Total Number of Drawing Sheets (if any)	21	Suggested Figure for Publication (if any)	

**Filing By Reference :**

Only complete this section when filing an application by reference under 35 U.S.C. 111(c) and 37 CFR 1.57(a). Do not complete this section if application papers including a specification and any drawings are being filed. Any domestic benefit or foreign priority information must be provided in the appropriate section(s) below (i.e., "Domestic Benefit/National Stage Information" and "Foreign Priority Information").

For the purposes of a filing date under 37 CFR 1.53(b), the description and any drawings of the present application are replaced by this reference to the previously filed application, subject to conditions and requirements of 37 CFR 1.57(a).

Application number of the previously filed application	Filing date (YYYY-MM-DD)	Intellectual Property Authority or Country i

<b>Application Data Sheet 37 CFR 1.76</b>	Attorney Docket Number	10-015-US-CON9
	Application Number	
Title of Invention	IMPROVEMENTS IN AND RELATING TO DRIVE MECHANISMS SUITABLE FOR USE IN DRUG DELIVERY DEVICES	

**Publication Information:**
 Request Early Publication (Fee required at time of Request 37 CFR 1.219)

 **Request Not to Publish.** I hereby request that the attached application not be published under 35 U.S.C. 122(b) and certify that the invention disclosed in the attached application **has not and will not** be the subject of an application filed in another country, or under a multilateral international agreement, that requires publication at eighteen months after filing.
**Representative Information:**

Representative information should be provided for all practitioners having a power of attorney in the application. Providing this information in the Application Data Sheet does not constitute a power of attorney in the application (see 37 CFR 1.32). Either enter Customer Number or complete the Representative Name section below. If both sections are completed the customer Number will be used for the Representative Information during processing.

Please Select One:	<input checked="" type="radio"/> Customer Number	<input type="radio"/> US Patent Practitioner	<input type="radio"/> Limited Recognition (37 CFR 11.9)
Customer Number	98548		

**Domestic Benefit/National Stage Information:**

This section allows for the applicant to either claim benefit under 35 U.S.C. 119(e), 120, 121, or 365(c) or indicate National Stage entry from a PCT application. Providing this information in the application data sheet constitutes the specific reference required by 35 U.S.C. 119(e) or 120, and 37 CFR 1.78.

When referring to the current application, please leave the application number blank.

Prior Application Status	Pending		<a href="#">Remove</a>		
Application Number	Continuity Type	Prior Application Number	Filing Date (YYYY-MM-DD)		
	Continuation of	12941702	2010-11-08		
Prior Application Status	Patented		<a href="#">Remove</a>		
Application Number	Continuity Type	Prior Application Number	Filing Date (YYYY-MM-DD)	Patent Number	Issue Date (YYYY-MM-DD)
12941702	Continuation of	12320189	2009-01-21	7850662	2010-12-14
Prior Application Status	Patented		<a href="#">Remove</a>		
Application Number	Continuity Type	Prior Application Number	Filing Date (YYYY-MM-DD)	Patent Number	Issue Date (YYYY-MM-DD)
12320189	Continuation of	11520598	2006-09-14	7935088	2011-05-03
Prior Application Status	Abandoned		<a href="#">Remove</a>		
Application Number	Continuity Type	Prior Application Number	Filing Date (YYYY-MM-DD)		
11520598	Continuation of	10790866	2004-03-03		
Additional Domestic Benefit/National Stage Data may be generated within this form by selecting the <b>Add</b> button.					<a href="#">Add</a>

<b>Application Data Sheet 37 CFR 1.76</b>	Attorney Docket Number	10-015-US-CON9
	Application Number	
Title of Invention	IMPROVEMENTS IN AND RELATING TO DRIVE MECHANISMS SUITABLE FOR USE IN DRUG DELIVERY DEVICES	

### Foreign Priority Information:

This section allows for the applicant to claim priority to a foreign application. Providing this information in the application data sheet constitutes the claim for priority as required by 35 U.S.C. 119(b) and 37 CFR 1.55(d). When priority is claimed to a foreign application that is eligible for retrieval under the priority document exchange program (PDX) the information will be used by the Office to automatically attempt retrieval pursuant to 37 CFR 1.55(h)(1) and (2). Under the PDX program, applicant bears the ultimate responsibility for ensuring that a copy of the foreign application is received by the Office from the participating foreign intellectual property office, or a certified copy of the foreign priority application is filed, within the time period specified in 37 CFR 1.55(g)(1).

<input type="button" value="Remove"/>			
Application Number	Country <sup>i</sup>	Filing Date (YYYY-MM-DD)	Access Code <sup>i</sup> (if applicable)
0304822.0	gb	2003-03-03	
Additional Foreign Priority Data may be generated within this form by selecting the <b>Add</b> button.			<input type="button" value="Add"/>

### Statement under 37 CFR 1.55 or 1.78 for AIA (First Inventor to File) Transition Applications

This application (1) claims priority to or the benefit of an application filed before March 16, 2013 and (2) also contains, or contained at any time, a claim to a claimed invention that has an effective filing date on or after March 16, 2013.

NOTE: By providing this statement under 37 CFR 1.55 or 1.78, this application, with a filing date on or after March 16, 2013, will be examined under the first inventor to file provisions of the AIA.

### Authorization to Permit Access:

Authorization to Permit Access to the Instant Application by the Participating Offices

Under the Paperwork Reduction Act of 1995, no persons are required to respond to a collection of information unless it contains a valid OMB control number.

<b>Application Data Sheet 37 CFR 1.76</b>	Attorney Docket Number	10-015-US-CON9
	Application Number	
Title of Invention	IMPROVEMENTS IN AND RELATING TO DRIVE MECHANISMS SUITABLE FOR USE IN DRUG DELIVERY DEVICES	

If checked, the undersigned hereby grants the USPTO authority to provide the European Patent Office (EPO), the Japan Patent Office (JPO), the Korean Intellectual Property Office (KIPO), the World Intellectual Property Office (WIPO), and any other intellectual property offices in which a foreign application claiming priority to the instant patent application is filed access to the instant patent application. See 37 CFR 1.14(c) and (h). This box should not be checked if the applicant does not wish the EPO, JPO, KIPO, WIPO, or other intellectual property office in which a foreign application claiming priority to the instant patent application is filed to have access to the instant patent application.

In accordance with 37 CFR 1.14(h)(3), access will be provided to a copy of the instant patent application with respect to: 1) the instant patent application-as-filed; 2) any foreign application to which the instant patent application claims priority under 35 U.S.C. 119(a)-(d) if a copy of the foreign application that satisfies the certified copy requirement of 37 CFR 1.55 has been filed in the instant patent application; and 3) any U.S. application-as-filed from which benefit is sought in the instant patent application.

In accordance with 37 CFR 1.14(c), access may be provided to information concerning the date of filing this Authorization.

## Applicant Information:

Providing assignment information in this section does not substitute for compliance with any requirement of part 3 of Title 37 of CFR to have an assignment recorded by the Office.			
<b>Applicant 1</b>			<input type="button" value="Remove"/>
If the applicant is the inventor (or the remaining joint inventor or inventors under 37 CFR 1.45), this section should not be completed. The information to be provided in this section is the name and address of the legal representative who is the applicant under 37 CFR 1.43; or the name and address of the assignee, person to whom the inventor is under an obligation to assign the invention, or person who otherwise shows sufficient proprietary interest in the matter who is the applicant under 37 CFR 1.46. If the applicant is an applicant under 37 CFR 1.46 (assignee, person to whom the inventor is obligated to assign, or person who otherwise shows sufficient proprietary interest) together with one or more joint inventors, then the joint inventor or inventors who are also the applicant should be identified in this section.			
<input type="button" value="Clear"/>			
<input checked="" type="radio"/> Assignee	<input type="radio"/> Legal Representative under 35 U.S.C. 117	<input type="radio"/> Joint Inventor	
<input type="radio"/> Person to whom the inventor is obligated to assign.		<input type="radio"/> Person who shows sufficient proprietary interest	
If applicant is the legal representative, indicate the authority to file the patent application, the inventor is:			
Name of the Deceased or Legally Incapacitated Inventor : <input type="text"/>			
If the Applicant is an Organization check here. <input checked="" type="checkbox"/>			
Organization Name	SANOFI-AVENTIS DEUTSCHLAND GMBH		
<b>Mailing Address Information:</b>			
Address 1	BRUNINGSTRASSE 50, 65929		
Address 2			
City	FRANKFURT AM MAIN	State/Province	
Country <sup>i</sup>	DE	Postal Code	
Phone Number		Fax Number	

Under the Paperwork Reduction Act of 1995, no persons are required to respond to a collection of information unless it contains a valid OMB control number.

<b>Application Data Sheet 37 CFR 1.76</b>		Attorney Docket Number	10-015-US-CON9
		Application Number	
Title of Invention	IMPROVEMENTS IN AND RELATING TO DRIVE MECHANISMS SUITABLE FOR USE IN DRUG DELIVERY DEVICES		
Email Address			
Additional Applicant Data may be generated within this form by selecting the Add button.			<input type="button" value="Add"/>

## Assignee Information including Non-Applicant Assignee Information:

Providing assignment information in this section does not substitute for compliance with any requirement of part 3 of Title 37 of CFR to have an assignment recorded by the Office.

<b>Assignee 1</b>				
Complete this section if assignee information, including non-applicant assignee information, is desired to be included on the patent application publication. An assignee-applicant identified in the "Applicant Information" section will appear on the patent application publication as an applicant. For an assignee-applicant, complete this section only if identification as an assignee is also desired on the patent application publication.				
				<input type="button" value="Remove"/>
If the Assignee or Non-Applicant Assignee is an Organization check here.				<input type="checkbox"/>
Prefix	Given Name	Middle Name	Family Name	Suffix
<b>Mailing Address Information For Assignee including Non-Applicant Assignee:</b>				
Address 1				
Address 2				
City		State/Province		
Country i	Postal Code			
Phone Number		Fax Number		
Email Address				
Additional Assignee or Non-Applicant Assignee Data may be generated within this form by selecting the Add button.				<input type="button" value="Add"/>

## Signature:

NOTE: This form must be signed in accordance with 37 CFR 1.33. See 37 CFR 1.4 for signature requirements and certifications				
Signature	/David M. Frischkorn/		Date (YYYY-MM-DD)	2014-06-30
First Name	David M.	Last Name	Frischkorn	Registration Number
				32833
Additional Signature may be generated within this form by selecting the Add button.				<input type="button" value="Add"/>

Under the Paperwork Reduction Act of 1995, no persons are required to respond to a collection of information unless it contains a valid OMB control number.

<b>Application Data Sheet 37 CFR 1.76</b>	Attorney Docket Number	10-015-US-CON9
	Application Number	
Title of Invention	IMPROVEMENTS IN AND RELATING TO DRIVE MECHANISMS SUITABLE FOR USE IN DRUG DELIVERY DEVICES	

This collection of information is required by 37 CFR 1.76. The information is required to obtain or retain a benefit by the public which is to file (and by the USPTO to process) an application. Confidentiality is governed by 35 U.S.C. 122 and 37 CFR 1.14. This collection is estimated to take 23 minutes to complete, including gathering, preparing, and submitting the completed application data sheet form to the USPTO. Time will vary depending upon the individual case. Any comments on the amount of time you require to complete this form and/or suggestions for reducing this burden, should be sent to the Chief Information Officer, U.S. Patent and Trademark Office, U.S. Department of Commerce, P.O. Box 1450, Alexandria, VA 22313-1450. DO NOT SEND FEES OR COMPLETED FORMS TO THIS ADDRESS. **SEND TO: Commissioner for Patents, P.O. Box 1450, Alexandria, VA 22313-1450.**

## Privacy Act Statement

The Privacy Act of 1974 (P.L. 93-579) requires that you be given certain information in connection with your submission of the attached form related to a patent application or patent. Accordingly, pursuant to the requirements of the Act, please be advised that: (1) the general authority for the collection of this information is 35 U.S.C. 2(b)(2); (2) furnishing of the information solicited is voluntary; and (3) the principal purpose for which the information is used by the U.S. Patent and Trademark Office is to process and/or examine your submission related to a patent application or patent. If you do not furnish the requested information, the U.S. Patent and Trademark Office may not be able to process and/or examine your submission, which may result in termination of proceedings or abandonment of the application or expiration of the patent.

The information provided by you in this form will be subject to the following routine uses:

1. The information on this form will be treated confidentially to the extent allowed under the Freedom of Information Act (5 U.S.C. 552) and the Privacy Act (5 U.S.C. 552a). Records from this system of records may be disclosed to the Department of Justice to determine whether the Freedom of Information Act requires disclosure of these records.
2. A record from this system of records may be disclosed, as a routine use, in the course of presenting evidence to a court, magistrate, or administrative tribunal, including disclosures to opposing counsel in the course of settlement negotiations.
3. A record in this system of records may be disclosed, as a routine use, to a Member of Congress submitting a request involving an individual, to whom the record pertains, when the individual has requested assistance from the Member with respect to the subject matter of the record.
4. A record in this system of records may be disclosed, as a routine use, to a contractor of the Agency having need for the information in order to perform a contract. Recipients of information shall be required to comply with the requirements of the Privacy Act of 1974, as amended, pursuant to 5 U.S.C. 552a(m).
5. A record related to an International Application filed under the Patent Cooperation Treaty in this system of records may be disclosed, as a routine use, to the International Bureau of the World Intellectual Property Organization, pursuant to the Patent Cooperation Treaty.
6. A record in this system of records may be disclosed, as a routine use, to another federal agency for purposes of National Security review (35 U.S.C. 181) and for review pursuant to the Atomic Energy Act (42 U.S.C. 218(c)).
7. A record from this system of records may be disclosed, as a routine use, to the Administrator, General Services, or his/her designee, during an inspection of records conducted by GSA as part of that agency's responsibility to recommend improvements in records management practices and programs, under authority of 44 U.S.C. 2904 and 2906. Such disclosure shall be made in accordance with the GSA regulations governing inspection of records for this purpose, and any other relevant (i.e., GSA or Commerce) directive. Such disclosure shall not be used to make determinations about individuals.
8. A record from this system of records may be disclosed, as a routine use, to the public after either publication of the application pursuant to 35 U.S.C. 122(b) or issuance of a patent pursuant to 35 U.S.C. 151. Further, a record may be disclosed, subject to the limitations of 37 CFR 1.14, as a routine use, to the public if the record was filed in an application which became abandoned or in which the proceedings were terminated and which application is referenced by either a published application, an application open to public inspections or an issued patent.
9. A record from this system of records may be disclosed, as a routine use, to a Federal, State, or local law enforcement agency, if the USPTO becomes aware of a violation or potential violation of law or regulation.

## SPECIFICATION

### TITLE

# **IMPROVEMENTS IN AND RELATING TO DRIVE MECHANISMS SUITABLE FOR USE IN DRUG DELIVERY DEVICES**

### CROSS REFERENCE TO RELATED APPLICATIONS

[0001] The present application is a continuation application of U.S. Patent Application No. 12/941,702, filed November 8, 2010, currently pending, which is a continuation application of U.S. Patent Application No. 12/320,189, filed January 21, 2009, now U.S. Pat. No. 7,850,662, which is a continuation application of U.S. Patent Application No. 11/520,598, filed September 14, 2006, now U.S. Pat. No. 7,935,088, which is a continuation application of U.S. Patent Application No. 10/790,866, filed March 3, 2004, abandoned, and claims priority to GB Patent Application No. 0304822.0, filed March 3, 2003, the entire contents of each of which are incorporated herein by reference.

### TECHNICAL FIELD

[0002] The present invention relates to drive mechanisms suitable for use in drug delivery devices, in particular pen-type injectors, having dosage setting means, enabling the administration of medicinal products from a multi-dose cartridge. In particular, the present invention relates to such drug delivery devices where a user may set the dose.

### BACKGROUND

[0003] Such drug delivery devices have application where regular injection by persons without formal medical training occurs, i.e., patients. This is increasingly common amongst those having diabetes where self-treatment enables such persons to conduct effective management of their diabetes.

[0004] These circumstances set a number of requirements for drug delivery devices of this kind. The device must be robust in construction, yet easy to use in terms of the manipulation of the parts, understanding by a user of its operation and the delivery of the required dose of medicament. Dose setting must be easy and unambiguous. In the case of those with diabetes, many users will be physically infirm and may also have impaired vision requiring the drive



mechanism to have low dispensing force and an easy to read dose setting display. Where the device is to be disposable rather than reusable, the device should be cheap to manufacture and easy to dispose of (preferably being suitable for recycling). To meet these requirements the number of parts required to assemble the device and the number of material types the device is made from need to be kept to a minimum.

[0005] User operated drug delivery devices are well known within the medical field.

[0006] In US 5304152 a dispensing device is disclosed which has a body length to plunger length ratio of about 1:1 in order to allow the dispensing of relatively large doses. Whilst this device provides many improvements over the prior art the easy correction of a set overdose remains unresolved without either dispensing the set amount of fluid or dismantling the cartridge.

[0007] WO 9938554 A2 teaches an injection syringe for apportioning set doses of a medicine from a cartridge wherein a drive mechanism comprising a unidirectional coupling (i.e., a ratchet) is disclosed which allows correction of a set overdose without dispensing the set amount of fluid or requiring the dismantling of the cartridge.

[0008] Surprisingly it was found that the drive mechanism according to instant invention without having a unidirectional coupling provides a valuable technical alternative for drive mechanisms, wherein reduced force is needed to actuate the mechanism. This is achieved by the introduction of a clutch means as defined by instant invention. The drive mechanism according to instant invention further provides the advantage of intuitive and easy to use correction of a set dose.

#### SUMMARY

[0009] According to a first aspect of the present invention, a drive mechanism for use in a drug delivery device is provided comprising:

a housing having a helical thread;

a dose dial sleeve having a helical thread engaged with the helical thread of the said housing;

a drive sleeve releasibly connected to the said dose dial sleeve;

and a clutch means located between the dose dial sleeve and the drive sleeve;

characterized in that,

a) when the dose dial sleeve and the drive sleeve are coupled, the dose dial sleeve and the drive sleeve are allowed to rotate with respect to the housing; and

b) when the dose dial sleeve and the drive sleeve are de-coupled, rotation of the dose dial sleeve with respect to the housing is allowed, whilst rotation of the drive sleeve with respect to the housing is not allowed, whereby axial movement of the drive sleeve is allowed so that a force is transferred in the longitudinal direction to the proximal end of the drug delivery device.

[0010] In a preferred embodiment of the drive mechanism of instant invention the said drive mechanism further comprises a piston rod adapted to operate through the housing and transfer the said force in the said longitudinal direction to the proximal end of the drug delivery device.

[0011] In another preferred embodiment of the drive mechanism of instant invention the said dose dial sleeve further comprises a helical thread, which has the same lead as the lead of the helical thread of the said drive sleeve.

[0012] In a more specific embodiment of instant invention, the drive mechanism further comprises a nut, which is rotatable with respect to the drive sleeve and axially displaceable but not rotatable with respect to the housing.

[0013] The term "drug delivery device" according to instant invention shall mean a single-dose or multi-dose, or re-useable device designed to dispense a selected dose of a medicinal product, preferably multiple selected doses, e.g. insulin, growth hormones, low molecular weight heparins, and their analogues and/or derivatives etc. Said device may be of any shape, e.g. compact or pen-type. Dose delivery may be provided through a mechanical (optionally manual) or electrical drive mechanism or stored energy drive mechanism, such as a spring, etc. Dose selection may be provided through a manual mechanism or electronic mechanism. Additionally, said device may contain components designed to monitor physiological properties such as blood glucose levels, etc.. Furthermore, the said device may comprise a needle or may be needle-free. In particular, the term "drug delivery device" shall mean a disposable multi-dose pen-type device having mechanical and manual dose delivery and dose selection mechanisms, which is designed for regular use by persons without formal medical training such as patients. Preferably, the drug delivery device is of the injector-type.

[0014] The term "housing" according to instant invention shall preferably mean any exterior housing ("main housing", "body", "shell") or interior housing ("insert", "inner body") having a helical thread. The housing may be designed to enable the safe, correct, and comfortable handling of the drug delivery device or any of its mechanism. Usually, it is designed to house, fix, protect, guide, and/or engage with any of the inner components of the drug delivery device (e.g., the drive mechanism, cartridge, plunger, piston rod) by limiting the exposure to contaminants, such as liquid, dust, dirt etc. In general, the housing may be unitary or a multipart component of tubular or non-tubular shape. Usually, the exterior housing serves to house a cartridge from which a number of doses of a medicinal product may be dispensed.

[0015] In a more specific embodiment of instant invention, the exterior housing is provided with a plurality of maximum dose stops adapted to be abutted by a radial stop provided on the dose dial sleeve. Preferably, at least one of the maximum dose stops comprises a radial stop located between a helical thread and spline means provided at a second end of the housing. Alternatively; at least one of the maximum dose stops comprises a part of a raised window portion provided at a second end of the housing.

[0016] The term "engaged" according to instant invention shall particularly mean the interlocking of two or more components of the drive mechanism/drug delivery device, e.g. a spline, thread; or meshed teeth connection, preferably the interlocking of helical threads of components ("threadedly engaged").

[0017] The term "helical thread" according to instant invention shall preferably mean a full or part thread, e.g., a cylindrical spiral rib/groove, located on the internal and/or external surface of a component of the drug delivery device, having an essentially triangular or square or rounded section designed to allow continuous free rotational and/or axial movement between components. Optionally, a thread may be further designed to prevent rotational or axial movement of certain components in one direction.

[0018] The term "dose dial sleeve" according to instant invention shall mean an essentially tubular component of essentially circular cross-section having either:

- a) both an internal and external thread, or
- b) an internal thread, or
- c) an external thread.

[0019] Preferably, the dose dial sleeve according to instant invention comprises a helical thread having a lead, which is similar to, preferably the same as the lead of the helical thread of the drive sleeve. In yet another preferred embodiment the dose dial sleeve is designed to indicate a selected dose of a dispensable product. This may be achieved by use of markings, symbols, numerals, etc., e.g. printed on the external surface of the dose dial sleeve or an odometer, or the like.

[0020] In a more specific embodiment of instant invention, the dose dial sleeve is provided with a plurality of radially extending members adapted to abut a corresponding plurality of radial stops provided at a second end of the housing.

[0021] The term "lead" according to instant invention shall preferably mean the axial distance a nut would advance in one complete revolution; preferably "lead" shall mean the axial distance through which a component having a helical thread, i.e. dose dial sleeve, drive sleeve, piston rod, etc., of the drive mechanism travels during one rotation. Therefore lead is a function of the pitch of the thread of the relevant component.

[0022] The term "pitch" according to instant invention shall preferably mean the distance between consecutive contours on a helical thread, measured parallel to the axis of the helical thread.

[0023] The term "drive sleeve" according to instant invention shall mean any essentially tubular component of essentially circular cross-section and which is further releasibly connected to the dose dial sleeve. In a preferred embodiment the drive sleeve is further engaged with the piston rod.

[0024] In a more particular embodiment of instant invention, the drive sleeve is provided at a first end with first and second flanges with an intermediate helical thread between the first and second flanges, having a nut disposed between the first and second flanges and keyed to the housing by spline means. Optionally, a first radial stop may be provided on a second face of the nut and a second radial stop may be provided on a first face of the second flange.

[0025] The term "releasibly connected" according to instant invention shall preferably mean that two components of instant mechanism or device are reversibly joined to each other, which allows coupling and decoupling, e.g. by means of a clutch.

[0026] The term "piston rod" according to instant invention shall mean a component adapted to operate through/within the housing, designed to translate axial movement

through/within the drug delivery device, preferably from the drive sleeve to the piston, for the purpose of discharging/dispensing an injectable product. Said piston rod may be flexible or not. It may be a simple rod, a lead-screw, a rack and pinion system, a worm gear system, or the like. The "piston rod" shall further mean a component having a circular or non-circular cross-section. It may be made of any suitable material known by a person skilled in the art.

[0027] In a preferred embodiment, the piston rod comprises at least one, more preferably two, external and/or internal helical threads. In another preferred embodiment of the piston rod according to instant invention, a first helical thread is located at a first end and a second helical thread is located at a second end of the said piston rod, whereby the said threads may have the same or, preferably, opposite dispositions. In another preferred embodiment the piston rod of instant invention comprises threads having the same leads at the first and the second end.

[0028] In yet another preferred embodiment of instant invention the lead of the first helical thread of the piston rod shall be greater than the lead of the second helical thread. More preferred, the ratio of the leads of the helical threads of the said first and the second helical threads is 1:1, 01 to 1:20, even more preferred 1:1, 1 to 1:10. Preferably, one of the said threads is designed to engage with the drive sleeve.

[0029] Alternatively, in another preferred embodiment of the piston rod of instant invention, the piston rod is designed to have attached, optionally by means of a journal bearing, a toothed gear, and wherein said toothed gear is designed to mesh with the threads of the drive sleeve and the teeth of a toothed rack, whereby said toothed rack is fixed to the housing.

[0030] The term "first end" according to instant invention shall mean the proximal end. The proximal end of the device or a component of the device shall mean the end, which is closest to the dispensing end of the device.

[0031] The term "second end" according to instant invention shall mean the distal end. The distal end of the device or a component of the device shall mean the end, which is furthest away from the dispensing end of the device.

[0032] The term "clutch means" according to instant invention shall mean any means, which releasibly connects the dose dial sleeve and the drive sleeve and which is designed to allow rotation of the dose dial sleeve and the drive sleeve with respect to the housing when the dose dial sleeve and the drive sleeve are coupled and, when both are de-coupled, allows rotation of the dose dial sleeve with respect to the housing, but does not allow rotation of the drive sleeve

with respect to the housing and allows axial movement of the drive sleeve. Preferably, the clutch means releasibly connects the drive sleeve to the housing. Accordingly, the term clutch means is any clutch engaging for the purpose of reversibly locking two components in rotation, e.g., by use of axial forces to engage a set of face teeth (saw teeth, dog teeth, crown teeth) or any other suitable frictional faces.

[0033] In a more specific embodiment of instant invention, a second end of the clutch means is provided with a plurality of dog teeth adapted to engage with a second end of the dose dial sleeve.

[0034] In an alternative embodiment, the clutch means of instant invention is a locking spring, operable, e.g., by means of a dose dial button, between a first, relaxed position, in which the dose dial sleeve is locked with respect to rotation with the drive sleeve and a second, deformed position, in which the dose dial sleeve is locked with respect to rotation with the housing.

[0035] In still another embodiment of instant invention, the drive mechanism further comprises a clicker means, optionally disposed between the clutch means and spline means provided on the housing.

[0036] Optionally, the clicker means comprises a sleeve provided at a first end with a helically extending arm, a free end of the arm having a toothed member; and at a second end with a plurality of circumferentially directed saw teeth adapted to engage a corresponding plurality of circumferentially saw teeth provided on the clutch means. Alternatively, the clicker means comprises a sleeve provided at a first end with at least one helically extending arm and at least one spring member, a free end of the arm having a toothed member, and at a second end with a plurality of circumferentially directed saw teeth adapted to engage corresponding plurality of circumferentially directed saw teeth provided on the clutch means.

[0037] In still another embodiment of the drive mechanism of the invention, the drive mechanism is provided with a first stop means, preferably in the form of an external flange on the dose dial sleeve, adapted to engage limiting means associated with the housing, preferably in the form of an internal flange in the housing, to limit the maximum dose which can be dialed. In yet another embodiment of the drive mechanism of the invention, the drive mechanism is further provided with a second stop means, preferably in the form of an external flange on the drive sleeve, adapted to engage limiting means, preferably in the form of a limiting nut keyed to the

housing and mounted for rotation on an external threaded section of the drive sleeve, to provide an end of life stop.

[0038] A second aspect of instant invention provides an assembly for use in a drug delivery device comprising the drive mechanism according to instant invention.

[0039] A third aspect of the present invention provides a drug delivery device comprising the drive mechanism or the assembly according to instant invention.

[0040] A fourth aspect of the present invention provides a method of assembling a drug delivery device comprising the step of providing a drive mechanism or an assembly according to instant invention.

[0041] A fifth aspect of instant invention is the use of a drug delivery device according to instant invention for dispensing a medicinal product preferably dispensing a pharmaceutical formulation (e.g. solution, suspension etc.) comprising an active compound selected from the group consisting of insulin, growth hormone, low molecular weight heparin, their analogues and their derivatives.

#### BRIEF DESCRIPTION OF THE FIGURES

[0042] Without any limitation, the instant invention will be explained in greater detail below in connection with a preferred embodiment and with reference to the drawings in which:

[0043] Figure 1 shows a sectional view of a first embodiment of the drug delivery device in accordance with the present invention in a first, cartridge full, position;

[0044] Figure 2 shows a sectional view of the drug delivery device of Figure 1 in a second, maximum first dose dialed, position;

[0045] Figure 3 shows a sectional view of the drug delivery device of Figure 1 in a third, maximum first dose dispensed, position;

[0046] Figure 4 shows a sectional view of the drug delivery device of Figure 1 in a fourth, final dose dialed, position;

[0047] Figure 5 shows a sectional view of the drug delivery device of Figure 1 in a fifth, final dose dispensed, position;

[0048] Figure 6 shows a cut-away view of a first detail of the drug delivery device of Figure 1;

[0049] Figure 7 shows a partially cut-away view of a second detail of the drug delivery device of Figure 1;

[0050] Figure 8 shows a partially cut-away view of a third detail of the drug delivery device of Figure 1;

[0051] Figure 9 shows the relative movement of parts of the drug delivery device shown in Figure 1 during dialing up of a dose;

[0052] Figure 10 shows the relative movement of parts of the drug delivery device shown in Figure 1 during dialing down of a dose;

[0053] Figure 11 shows the relative movement of parts of the drug delivery device shown in Figure 1 during dispensing of a dose;

[0054] Figure 12 shows a partially cut-away view of the drug delivery device of Figure 1 in the second, maximum first dose dialed, position;

[0055] Figure 13 shows a partially cut-away view of the drug delivery device of Figure 1 in the fourth, final dose dialed, position;

[0056] Figure 14 shows a partially cut-away view of the drug delivery device of Figure 1 in one of the first, third or fifth positions;

[0057] Figure 15 shows a cut-away view of a first part of a main housing of the drug delivery device of Figure 1; and

[0058] Figure 16 shows a cut-away view of a second part of the main housing of the drug delivery device of Figure 1;

[0059] Figure 17 shows a sectional view of a second embodiment of the drive mechanism according to instant invention in a first, cartridge full, position.

[0060] Figure 18 shows a sectional side view of a third embodiment of the drug delivery device in accordance with the present invention in a first, cartridge full, position; Figure 19 shows a sectional side view of the drug delivery device of Figure 18 in a second, maximum first dose dialed, position;

[0061] Figure 20 shows a sectional side view of the drug delivery device of Figure 18 in a third, maximum first dose dispensed, position;

[0062] Figure 21 shows a sectional side view of the drug delivery device of Figure 18 in a fourth, final dose dialed, position;

[0063] Figure 22 shows a sectional side view of the drug delivery device of Figure 18 in a fifth final dose dispensed, position;



[0064] Figure 23 shows a fragment of the drug delivery device of Figure 18 in a larger scale;

[0065] Figure 24 shows a further fragment of the drug delivery device of Figure 18 in a larger scale;

[0066] Figure 25 shows an exploded perspective view of the drive mechanism of the drug delivery device of Figure 1;

[0067] Figure 26 shows a perspective view of the drive member of the drive mechanism of the drug delivery device of Figure 1;

[0068] Figure 27 shows a perspective view of the clutch of the drive mechanism of the drug delivery device of Figure 1;

[0069] Figure 28 shows a perspective view of the dose dial grip and button of the drive mechanism of the drug delivery device of Figure 1;

[0070] Figure 29 shows a close-up perspective view of the piston rod of the drive mechanism of the drug delivery device of Figure 1;

[0071] Figure 30 shows a close-up perspective view of the dose dial sleeve and the window of the drive mechanism of the drug delivery device of Figure 1;

[0072] Figure 31 shows a close-up perspective view of a portion of the drive mechanism of the drug delivery device of Figure 1;

[0073] Figure 32 shows a close-up perspective view of the insert in the housing of the drive mechanism of the drug delivery device of Figure 1.

## DETAILED DESCRIPTION

### **Example 1**

[0074] Referring first to Figures 1 to 5, there is shown a drug delivery device in accordance with the present invention in a number of positions.

[0075] The drug delivery device comprises a housing having a first cartridge retaining part 2, and second main (exterior) housing part 4. A first end of the cartridge retaining means 2 and a second end of the main housing 4 are secured together by retaining features 6. In the illustrated embodiment, the cartridge retaining means 2 is secured within the second end of the main housing 4.

[0076] A cartridge 8 from which a number of doses of a medicinal product may be dispensed is provided in the cartridge retaining part 2. A piston 10 is retained in a first end of the cartridge 8.

[0077] A removable cap 12 is releasably retained over a second end of the cartridge retaining part 2. In use the removable cap 12 can be replaced by a user with a suitable needle unit (not shown). A replaceable cap 14 is used to cover the cartridge retaining part 2 extending from the main housing 4. Preferably, the outer dimensions of the replaceable cap 14 are similar or identical to the outer dimensions of the main housing 4 to provide the impression of a unitary whole when the replaceable cap 14 is in position covering the cartridge retaining part 2.

[0078] In the illustrated embodiment, an insert 16 is provided at a first end of the main housing 4. (see Fig. 32). The insert 16 is secured against rotational or longitudinal motion. The insert 16 is provided with a threaded circular opening 18 extending there through. Alternatively, the insert may be formed integrally with the main housing 4 having the form of a radially inwardly directed flange having an internal thread.

[0079] A first thread 19 extends from a first end of a piston rod 20. The piston rod 20 is of generally circular section. The first end of the piston rod 20 extends through the threaded opening 18 in the insert 16. A pressure foot 22 is located at the first end of the piston rod 20. The pressure foot 22 is disposed to abut a second end of the cartridge piston 10. A second thread 24 extends from a second end of the piston rod 20. In the illustrated embodiment the second thread 24 comprises a series of part threads rather than a complete thread. The illustrated embodiment is easier to manufacture and helps to reduce the overall force required for a user to actuate the device when dispensing the medicinal product.

[0080] The first thread 19 and the second thread 24 are oppositely disposed. The second end of the piston rod 20 is provided with a receiving recess 26.

[0081] A drive sleeve 30 extends about the piston rod 20. The drive sleeve 30 is generally cylindrical. The drive sleeve 30 is provided at a first end with a first radially extending flange 32. A second radially extending flange 34 is provided spaced distance along the drive sleeve 30 from the first flange 32. An intermediate thread 36 is provided on an outer part of the drive sleeve 30 extending between the first flange 32 and the second flange 34. A helical groove (thread) 38 extends along the internal surface of the drive sleeve 30. The second thread 24 of the piston rod 20 is adapted to work within the helical groove 38.

[0082] A first end of the first flange 32 is adapted to conform to a second side of the insert 16.

[0083] A nut 40 is located between the drive sleeve 30 and the main housing 2, disposed between the first flange 32 and the second flange 34. In the illustrated embodiment the nut 40 is a half-nut. This assists in the assembly of the device. The nut 40 has an internal thread 240 matching the intermediate thread 36. (see Fig. 31). The outer surface of the nut 40 and an internal surface of the main housing 4 are keyed together by splines 42 (Figures 10, 11, 15 and 16) to prevent relative rotation between the nut 40 and the main housing 4, while allowing relative longitudinal movement there between.

[0084] A shoulder 37 is formed between a second end of the drive sleeve 30 an extension 47 provided at the second end of the drive sleeve 30. The extension 47 has reduced inner and outer diameters in comparison to the remainder of the drive sleeve 30. A second end of the extension 47 is provided with a radially outwardly directed flange 39.

[0085] A clicker 50 and a clutch 60 are disposed about the drive sleeve 30, between the drive sleeve 30 and a dose dial sleeve 70 (described below).

[0086] The clicker 50 is located adjacent the second flange 34 of the drive sleeve 30. The clicker 50 is generally cylindrical and is provided at a first end with a flexible helically extending arm 52 (Figure 6). A free end of the arm 52 is provided with a radially directed toothed member 54. A second end of the clicker 50 is provided with a series of circumferentially directed saw teeth 56 (Figure 7). Each saw tooth comprises a longitudinally directed surface and an inclined surface.

[0087] Fig. 25 illustrates the various components of the drive mechanism, including at least one biasing element depicted as spring member 200 in Fig. 25. The at least one spring member 200 assists in the resetting of the clutch 60 following dispense and can form part of clicker 50.

[0088] The clutch 60 is located adjacent the second end of the drive sleeve 30. The clutch 60 is generally cylindrical and is provided at a first end with a series of circumferentially directed saw teeth 66 (Figure 7). Each saw tooth comprises a longitudinally directed surface and an inclined surface. Towards the second end 64 of the clutch 60 there is located a radially inwardly directed flange 62. The flange 62 of the clutch 60 is disposed between the shoulder 37 of the drive sleeve 30 and the radially outwardly directed flange 39 of the extension 47 (see Fig. 26).

The second end of the clutch 60 is provided with a plurality of dog teeth 65 (Figure 8). The clutch 60 is keyed to the drive sleeve 30 by way of splines 266 (see Fig. 27) to prevent relative rotation between the clutch 60 and the drive sleeve 30.

[0089] In the illustrated embodiment, the clicker 50 and the clutch 60 each extend approximately half the length of the drive sleeve 30. However, it will be understood that other arrangements regarding the relative lengths of these parts are possible.

[0090] The clicker 50 and the clutch 60 are engaged as shown in Figure 7.

[0091] A dose dial sleeve 70 is provided outside of the clicker 50 and clutch 60 and radially inward of the main housing 4. A helical groove 74 is provided about an outer surface of the dose dial sleeve 70.

[0092] The main housing 4 is provided with a window 44 through which a part of the outer surface of the dose dial sleeve may be seen. The main housing 4 is further provided with a helical rib (thread) 46, adapted to be seated in the helical groove (thread) 74 on the outer surface of the dose dial sleeve 70. The helical rib 46 extends for a single sweep of the inner surface of the main housing 4. A first stop 100 is provided between the splines 42 and the helical rib 46 (Figure 15). A second stop 102, disposed at an angle of 180° to the first stop 100 is formed by a frame surrounding the window 44 in the main housing 4 (Figures 16). Window 44 has a raised portion 244. (see Figure 30).

[0093] Conveniently, a visual indication of the dose that may be dialed, for example reference numerals (not shown), is provided on the outer surface of the dose dial sleeve 70. The window 44 conveniently only allows to be viewed a visual indication of the dose currently dialed.

[0094] A second end of the dose dial sleeve 70 is provided with an inwardly directed flange in the form of a number of radially extending members 75. A dose dial grip 76 is disposed about an outer surface of the second end of the dose dial sleeve 70. An outer diameter of the dose dial grip 76 preferably corresponds to the outer diameter of the main housing 4. The dose dial grip 76 is secured to the dose dial sleeve 70 to prevent relative movement therebetween. The dose dial grip 76 is provided with a central opening 78. An annular recess 80 located in the second end of the dose dial grip 76 extends around the opening 78.

[0095] A button 82 of generally "T" section is provided at a second end of the device. (see Fig. 28) A stem 84 of the button 82 may extend through the opening 78 in the dose dial grip

76, through the inner diameter of the extension 47 of the drive sleeve 30 and into the receiving recess 26 of the piston rod 20. The stem 84 is retained for limited axial movement in the drive sleeve 30 and against rotation with respect thereto. A head 85 of the button 82 is generally circular. A skirt 86 depends from a periphery of the head 85. The skirt 86 is adapted to be seated in the annular recess 80 of the dose dial grip 76.

[0096] Operation of the drug delivery device in accordance with the present invention will now be described. In Figures 9, 10 and 11 arrows A, B, C, D, E, F and G represent the respective movements of the button 82, the dose dial grip 76, the dose dial sleeve 70, the drive sleeve 30, the clutch 60, the clicker 50 and the nut 40.

[0097] To dial a dose (Figure 9) a user rotates the dose dial grip 76 (arrow B). With the clicker 50 and clutch 60 engaged, the drive sleeve 30, the clicker 50, the clutch 60 and the dose dial sleeve 70 rotate with the dose dial grip 76.

[0098] Audible and tactile feedback of the dose being dialed is provided by the clicker 50 and the clutch 60. Torque is transmitted through the saw teeth 56, 66 between the clicker 50 and the clutch 60. The flexible arm 52 deforms and drags the toothed member 54 over the splines 42 to produce a click. Preferably, the splines 42 are disposed such that each click corresponds to a conventional unit dose, or the like.

[0099] The helical groove 74 on the dose dial sleeve 70 and the helical groove 38 in the drive sleeve 30 have the same lead. This allows the dose dial sleeve 70 (arrow C) to extend from the main housing 4 and the drive sleeve 30 (arrow D) to climb the piston rod 20 at the same rate. At the limit of travel, a radial stop 104 (Figures 12 and 30) on the dose dial sleeve 70 engages either the first stop 100 or the second stop 102 provided on the main housing 4 to prevent further movement. Rotation of the piston rod 20 is prevented due to the opposing directions of the overhauled and driven threads on the piston rod 20.

[00100] The nut 40, keyed to the main housing 4, is advanced along the intermediate thread 36 by the rotation of the drive sleeve 30 (arrow D). When the final dose dispensed position (Figures 4, 5 and 13) is reached, a radial stop 106 formed on a second surface of the nut 40 abuts a radial stop 108 on a first surface of the second flange 34 of the drive sleeve 30, preventing both the nut 40 and the drive sleeve 30 from rotating further (see Fig. 31).

[00101] In an alternative embodiment a first surface of the nut 40 is provided with a radial stop 231 for abutment with a radial stop 230 provided on a second surface of the first

flange 32. This aids location of the nut 40 at the cartridge full position during assembly of the drug delivery device.

[00102] Should a user inadvertently dial beyond the desired dosage, the drug delivery device allows the dosage to be dialed down without dispense of medicinal product from the cartridge (Figure 10). The dose dial grip 76 is counter rotated (arrow B). This causes the system to act in reverse. The flexible arm 52 preventing the clicker 50 from rotating. The torque transmitted through the clutch 60 causes the saw teeth 56, 66 to ride over one another to create the clicks corresponding to dialed dose reduction. Preferably the saw teeth 56, 66 are so disposed that the circumferential extent of each saw tooth corresponds to a unit dose.

[00103] When the desired dose has been dialed, the user may then dispense this dose by depressing the button 82 (Figure 11). This displaces the clutch 60 axially with respect to the dose dial sleeve 70 causing the dog teeth 65 to disengage. However the clutch 60 remains keyed in rotation to the drive sleeve 30. The dose dial sleeve 70 and associated dose dial grip 76 are now free to rotate (guided by the helical rib 46 located in helical groove 74).

[00104] The axial movement deforms the flexible arm 52 of the clicker 50 to ensure the saw teeth 56, 66 cannot be overhauled during dispense. This prevents the drive sleeve 30 from rotating with respect to the main housing 4 though it is still free to move axially with respect thereto. This deformation is subsequently used to urge the clicker 50, and the clutch 60, back along the drive sleeve 30 to restore the connection between the clutch 60 and the dose dial sleeve 70 when pressure is removed from the button 82

[00105] The longitudinal axial movement of the drive sleeve 30 causes the piston rod 20 to rotate through the opening 18 in the insert 16, thereby to advance the piston 10 in the cartridge 8. Once the dialed dose has been dispensed, the dose dial sleeve 70 is prevented from further rotation by contact of a plurality of members 110 (Figure 14) extending from the dose dial grip 76 with a corresponding plurality of stops 112 formed in the main housing 4 (Figures 15 and 16). In the illustrated embodiment, the members 110 extend axially from the dose dial grip 76 and have an inclined end surface. The zero dose position is determined by the abutment of one of the axially extending edges of the members 110 with a corresponding stop 112 (see Fig. 31).

## Example2

[00106] In another embodiment of the invention (Figure 17) there is seen a drive mechanism comprising a second main housing 4' having a first end and a second end. A cartridge, containing medicinal product, can be mounted to the first end of the second main housing 4' and retained by any suitable means. The cartridge and its retaining means are not shown in the illustrated embodiment. The cartridge may contain a number of doses of a medicinal product and also typically contains a displaceable piston. Displacement of the piston causes the medicinal product to be expelled from the cartridge via a needle (also not shown).

[00107] In the illustrated embodiment, an insert 16' is provided within the main housing 4'. The insert 16' is secured against rotational and axial motion with respect to the second main housing 4'. The insert 16' is provided with a threaded circular opening extending therethrough. Alternatively, the insert may be formed integrally with the second main housing 4'.

[0100] An internal housing 154 is also provided within the second main housing 4'. The internal housing 154 is secured against rotational and axial motion with respect to the second main housing 4'. The internal housing 154 is provided with a circular opening extending through its length in which a series of longitudinally directed splines are formed. A helical thread 150 extends along the outer cylindrical surface of the internal housing 154. Alternatively, the internal housing may be formed integrally with the second main housing 4' and/or with the insert 16'.

[0101] A first thread 19' extends from a first end of a piston rod 20'. The piston rod 20' is of generally circular section. The first end of the piston rod 20' extends through the threaded opening in the insert 16' and the first thread 19' of the piston rod 20' is engaged with the thread of the insert 16'. A pressure foot 22' is located at the first end of the piston rod 20'. The pressure foot 22' is disposed to abut a cartridge piston (not shown). A second thread 24' extends from a second end of the piston rod 20'. The first thread 19' and the second thread 24' are oppositely disposed.

[0102] A drive sleeve 30' extends about the piston rod 20'. The drive sleeve 30' is generally cylindrical. The drive sleeve 30' is provided at a first end with a first radially extending flange 32'. A second radially extending flange 34' is provided, spaced a distance along the drive sleeve 30' from the first flange 32'. An external helical thread (not shown) is provided on the outer part of the drive sleeve 30' extending between the first flange 32' and the second

flange 34'. An internal helical thread extends along the internal surface of the drive sleeve 30'. The second thread 24' of the piston rod 20' is engaged with the internal helical thread of the drive sleeve 30'.

[0103] A nut 40' is located between the drive sleeve 30' and the internal housing 154, disposed between the first flange 32' and the second flange 34' of the drive sleeve 30'. The nut 40' can be either a 'half-nut' or a 'full-nut'. The nut 40' has an internal thread that is engaged with the external helical thread of the drive sleeve 30'. The outer surface of the nut 40' and an internal surface of the internal housing 154 are keyed together by means of longitudinally directed splines to prevent relative rotation between the nut 40' and the internal housing 154, while allowing relative longitudinal movement there between.

[0104] A clicker 50' and a clutch 60' are disposed about the drive sleeve 30', between the drive sleeve 30' and the internal housing 154.

[0105] The clicker 50' is located adjacent the second flange 34' of the drive sleeve 30'. The clicker 50' includes at least one spring member (not shown). The clicker 50' also includes a set of teeth (not shown) having a triangular profile disposed towards the second end of the drive mechanism. When compressed, the at least one spring member of the clicker 50' applies an axial force between the flange 34' of the drive sleeve 30' and the clutch 60'. The outer surface of the clicker 50' and an internal surface of the internal housing 154 are keyed together by means of longitudinally directed splines to prevent relative rotation between the clicker 50' and the internal housing 154, while allowing relative longitudinal movement there between.

[0106] The clutch 60' is located adjacent the second end of the drive sleeve 30'. The clutch 60' is generally cylindrical and is provided at its' first end with a plurality of teeth of triangular profile disposed about the circumference (not shown), that act upon the teeth of the clicker 50'. Towards the second end of the clutch 60' there is located a shoulder 158. The shoulder 158 of the clutch 60' is disposed between the internal housing 154 and a radially inwardly directed flange of the dose dial grip 76' (described below). The shoulder 158 of the clutch 60' is provided with a plurality of dog teeth (not shown) extending in the direction of the second end of the drive mechanism. The clutch 60' is keyed to the drive sleeve 30' by way of splines (not shown) to prevent relative rotation between the clutch 60' and the drive sleeve 30'.

[0107] A dose dial sleeve 70' is provided outside of the internal housing 154 and radially inward from the second main housing 4'. A helical thread is provided on an inner surface of the



dose dial sleeve 70'. The helical thread of the dose dial sleeve 70' is engaged with the helical thread 150 of the internal housing 154.

[0108] The second main housing 4' is provided with a window (not shown) through which part of the outer surface of the dose dial sleeve 70' may be viewed. Conveniently, a visual indication of the dose that may be dialed, for example reference numerals (not shown), is provided on the outer surface of the dose dial sleeve 70'. Conveniently, the window of the second main housing 4' allows only the dose that is currently dialed to be viewed.

[0109] A dose dial grip 76' is located towards the second end of the drive mechanism. The dose dial grip 76' is secured against rotational and axial motion within respect to the dose dial sleeve 70'. The dose dial grip 76' is provided with a radially inwardly directed flange 160. The radially inwardly directed flange 160 of the dose dial grip 76' is provided with a plurality of dog teeth (not shown) extending in the direction of the first end of the drive mechanism to abut the dog teeth of the clutch 60'. Coupling and decoupling of the dog teeth of the dose dial grip 76' with the dog teeth of the clutch 60' provides a releasable clutch between the dose dial grip 76' and the clutch 60'.

[0110] A button 82' of generally "T" shaped cross-section is provided at a second end of the drive mechanism. A cylindrical feature of the button 82' extends towards the first end of the drive mechanism, through an opening in the dose dial grip 76' and into a recess in the drive sleeve 30'. The cylindrical feature of the button 82' is retained for limited axial movement in the drive sleeve 30' and against rotation with respect thereto. The cylindrical feature of the button 82' has lugs extending radially (not shown) that abut the second surface of the shoulder 158 of the clutch 60'. The second end of the button 82' is generally circular and has a cylindrical skirt about its periphery that descends towards the first end of the drive mechanism. The skirt of the button 82' is located radially inward from the dose dial grip 76'.

[0111] Operation of the drive mechanism in accordance with the present invention will now be described.

[0112] To dial a dose, a user rotates the dose dial grip 76'. The spring member of the clicker 50' applies an axial force to the clutch 60' in the direction of the second end of the drive mechanism. The force exerted by the spring member of the clicker 50' couples the dog teeth of the clutch 60' to the dog teeth of the dose dial grip 76' for rotation. As the dose dial grip 76' is

rotated, the associated dose dial sleeve 70', the drive sleeve 30' and the clutch 60' all rotate in unison.

[0113] Audible and tactile feedback of the dose being dialed is provided by the clicker 50' and the clutch 60'. As the clutch 60' is rotated, torque is transmitted from the teeth at the first end of the clutch 60' and the teeth of the clicker 50'. The clicker 50' cannot rotate with respect to the internal housing 154, so the at least one spring member of the clicker 50' deforms allowing the teeth of the clutch 60' to jump over the teeth of the clicker 50' producing an audible and tactile 'click'. Preferably; the teeth of the clicker 50' and the teeth of the clutch 60' are disposed such that each 'click' corresponds to a conventional unit of the medicinal product, or the like.

[0114] The helical thread of the dose dial sleeve 70' and the internal helical thread of the drive sleeve 30' have the same lead. This allows the dose dial sleeve 70' to advance along the thread 150 of the internal housing 154 at the same rate as the drive sleeve 30' advances along the second thread 24' of the piston rod 20'. Rotation of the piston rod 20' is prevented due to the opposing direction of the first thread 19' and the second thread 24' of the piston rod 20'. The first thread 19' of the piston rod 20' is engaged with the thread of the insert 16' and so the piston rod 20' does not move with respect to the second main housing 4' while a dose is dialed.

[0115] The nut 40', keyed to the internal housing 154, is advanced along the external thread of the drive sleeve 30' by the rotation of the drive sleeve 30'. When a user has dialed a quantity of medicinal product that is equivalent to the deliverable volume of the cartridge, the nut 40' reaches a position where it abuts the second flange 34' of the drive sleeve 30'. A radial stop formed on the second surface of the nut 40' contacts a radial stop on the first surface of the second flange 34' of the drive sleeve 30', preventing both the nut 40' and the drive sleeve 30' from being rotated further.

[0116] Should a user inadvertently dial a quantity greater than the desired dosage, the drive mechanism allows the dosage to be corrected without dispense of medicinal product from the cartridge. The dose dial grip 76' is counter-rotated. This causes the system to act in reverse. The torque transmitted through the clutch 60' causes the teeth at the first end of the clutch 60' to ride over the teeth of the clicker 50' to create the clicks corresponding to the dialed dose reduction.

[0117] When the desired dose has been dialed, the user may then dispense this dose by depressing the button 82' in the direction of the first end of the drive mechanism. The lugs of the button 82' apply pressure to the second surface of the shoulder 158 of the clutch 60', displacing the clutch 60' axially with respect to the dose dial grip 76'. This causes the dog teeth on the shoulder 158 of the clutch 60' to disengage from the dog teeth of the dose dial grip 76'. However, the clutch 60' remains keyed in rotation to the drive sleeve 30'. The dose dial grip 76' and associated dose dial sleeve 70' are now free to rotate (guided by the helical thread 150 of the internal housing 154).

[0118] The axial movement of the clutch 60' deforms the spring member of the clicker 50' and couples the teeth at the first end of the clutch 60' to the teeth of the clicker 50' preventing relative rotation there between. This prevents the drive sleeve 30' from rotating with respect to the internal housing 154, though it is still free to move axially with respect thereto.

[0119] Pressure applied to the button 82' thus causes the dose dial grip 76' and the associated dose dial sleeve 70' to rotate into the second main housing 4'. Under this pressure the clutch 60', the clicker 50' and the drive sleeve 30' are moved axially in the direction of the first end of the drive mechanism, but they do not rotate. The axial movement of the drive sleeve 30' causes the piston rod 20' to rotate through the threaded opening in the insert 16', thereby to advance the pressure foot 22'. This applies force to the piston, causing the medicinal product to be expelled from the cartridge. The selected dose is delivered when the dose dial grip 76' returns to a position where it abuts the second main housing 4'.

[0120] When pressure is removed from the button 82', the deformation of the spring member of the clicker 50' is used to urge the clutch 60' back along the drive sleeve 30' to re-couple the dog teeth on the shoulder 158 of the clutch 60' with the dog teeth on the dose dial grip 76'. The drive mechanism is thus reset in preparation to dial a subsequent dose.

### **Example 3**

[0121] Referring to Figures 18 to 22 there may be seen a drug delivery device in accordance with the present invention. The drug delivery device comprises a two-part housing 2" within which are located a cartridge 4" containing a medicinal product, means for setting or selecting the dose of medicinal product to be expelled and means for expelling the selected

dose of medicinal product. The housing 2" is generally cylindrical in shape and houses a rack 6" to be described in more detail below. The cartridge 4" is located within a first part 8" of the housing 2". The dose setting means and the means for expelling the selected dose of medicinal product are retained, that is held, within a second part 10" of the housing 2". The first part 8" of the housing 2" and the second part 10" of the housing 2" may be secured together by any suitable means

[0122] The cartridge 4" may be secured in position in the first part 8" of the housing 2" by any suitable means. A needle unit may be secured to a first end of the cartridge 4". A temporary covering 12" is shown in this position in the Figures. The cartridge 4" further comprises a displaceable piston 14". Advancing the piston 10" towards the first end of the cartridge 4" causes the medicinal product to be expelled from the cartridge 4" through the needle unit. A cap 16" is provided to cover the needle unit when the drug delivery device is not in use. The cap 16" may be releasably secured to the housing 2" by any suitable means.

[0123] The dose setting means and the means for expelling the selected dose of medicinal product will now be described in more detail. The rack 6" is located within a drive sleeve 18" located within the housing 2" and is fixed both axially and rotationally with respect to the housing 2" by any suitable means. The drive sleeve 18" comprises an internally threaded portion 20", which extends along substantially the entire internal surface of the sleeve. An internal toothed gear 22" is located within the drive sleeve 18" and has helical teeth which match the pitch of the internal thread of the drive sleeve 18". The internal thread of the drive sleeve 18" is a multi-start thread with a lead which is the same as the lead of the helical thread of the dose dial sleeve, which will be described later. The drive sleeve 18" terminates in an externally threaded section 24" which extends from an end of the sleeve as far as an external circumferential flange 26" which projects from the drive sleeve 18". A limiting nut 28" is mounted for rotation on the externally threaded section 24" of the sleeve 18". The limiting nut 28" is keyed to the housing 2" by means of a plurality of longitudinally extending splines 30" which extend along the internal surface of the first portion 8" of the housing 2". In the Illustrated embodiment, the limiting nut 28" is shown as a half-nut, but a full nut could be used.

[0124] A piston rod 32" is provided extending along the length of the rack 6" and through a hole in the end of the rack 6". The piston rod 32" is generally elongate and is

provided with a pressure foot 34". In use the pressure foot 34" is disposed to abut the cartridge piston 14". The toothed gear 22" is mounted on the end of the piston rod 32" remote from the pressure foot 34" in a journal bearing (not shown).

[0125] A dose dial sleeve 36" of generally cylindrical form comprises a first section 38" of first diameter and a second section 40" of larger second diameter: The first section is located within the housing 2".

[0126] The second section 40" of the dose dial sleeve 36" is preferably of the same outer diameter as the housing 2". The second part 10" of the housing 2" comprises an external sleeve portion 42" surrounding a coaxial internal sleeve portion 44". The external sleeve portion 42" is closed to the internal sleeve portion 44" at a circular internal flange portion 46". The first section 38" of the dose dial sleeve 36" is located within the second part 10" of the housing 2", between the external sleeve portion 42" and the internal sleeve portion 44". An inner surface of the first section 38" and the outer surface of the internal sleeve portion 44" are provided with inter-engaging features to provide a helical thread 48" between the internal sleeve portion 44" of the second part 10" of the housing 2" and the dose dial sleeve 36". This helical thread 48" has the same lead as the internal thread of the drive sleeve 18", as noted above. Within the helical track, a helical rib provided on the inner surface of the dose dial sleeve 36" may run. This enables the dose dial sleeve 36" to rotate about and along the housing 2".

[0127] The second section 40" of the dose dial sleeve 36" is provided with an end wall 50" adjacent its free end, which defines a central receiving area 52" between the end wall 50" and the free end of the dose dial sleeve 36". A through hole 54" is provided in the end wall 50". A dose button 56" of generally "T" shaped configuration is provided, the head 58" of which is retained within the receiving area 52" and the stem 60" of which is sized to pass through the through hole 54". The stem 60" of the button 56" is provided with a plurality of fingers 62" that are deformable to pass through the through hole 54" of the end wall 50" only in the direction away from the free end of the dose dial sleeve 36".

[0128] The drive sleeve 18" is closed at its end remote from the externally threaded section 24" by an apertured end wall 64" from which a plurality of engagement features 66" project external to the drive sleeve 18".

[0129] A substantially U-shaped locking spring 68" comprising first and second legs 70", 72" joined by a link portion 74" is provided for longitudinal mounting on the exterior of the drive sleeve 18". The link portion 74" is of a length which is substantially equal to the external diameter of the drive sleeve 18". Each of the legs 70", 72" of the locking spring 68" terminates in a latch portion 76", the function of which will be described later.

[0130] When the device is assembled, the locking spring 68" urges the dose button 56" axially away from the piston rod 32" and drive sleeve 18", towards the inside of the end wall 50" of the dose dial sleeve 36". In this position, the dose button 56" is locked with respect to rotation with the dose dial sleeve 36". The dose button 56" is also permanently locked with respect to rotation with the drive sleeve 18".

[0131] An outer surface of the first section of the dose dial sleeve 36" is provided with graphics 82". The graphics are typically a sequence of reference numerals. The housing 2" is provided with an aperture or window 84" through which a portion of the graphics, representing a dosage value selected by the user, may be viewed.

[0132] The graphics 82" may be applied to the dose dial sleeve 36" by any suitable means. The graphics 82" may be printed directly on the dose dial sleeve 36" or may be provided in the form of a printed label encircling the dose dial sleeve 36". Alternatively the graphics may take the form of a marked sleeve clipped to the dose dial sleeve 36". The graphics may be marked in any suitable manner, for example by laser marking.

[0133] The external circumferential flange 26" which projects from the drive sleeve 18" is provided with a pair of diametrically opposed through apertures 78" sized to receive the corresponding latch portions 76" of the locking spring 68". A clicker projection 80" from the outer edge of the flange 26" is associated with each through aperture 78".

[0134] In Figure 18, the drug delivery device is provided with a filled cartridge 4". To operate the drug delivery device a user must first select a dose. To set a dose the dose dial sleeve 36" is rotated with respect to the housing 2" until the desired dose value is visible through the window 84". The drive sleeve 18" is linked to the dose dial sleeve 36" and spirals out at the same rate during dialing. During the dialing of a dose, the locking spring 68 is straight and urges the dose button 56" axially away from the piston rod 32" and drive sleeve 18", towards the inside of the end wall 50" of the dose dial sleeve 36", thereby providing a clutch mechanism. The drive sleeve 18" therefore rotates over the toothed gear 22" that is

located inside it. The relative rotation between the drive sleeve 18" and the housing 2" causes an audible confirmation of the dose being dialed by engagement of the two clicker projections 80" with the splines 30" which extend along the internal surface of the first portion 8" of the housing 2".

[0135] The limiting nut 28" climbs up the drive sleeve 18" in proportion to the dose dialed. The position of the limiting nut 28", which only moves along the external thread of the drive sleeve 18" when there is relative rotation between the drive sleeve 18" and the housing 2", corresponds to the amount of medicinal product remaining in the cartridge 4".

[0136] Once a desired dose has been set (as shown for example in Figure 19), to deliver the dose the user depresses the dose button 56" to urge the button 56" against the locking spring 68". As the dose button 56" pushes down on the spring 68", the clutch between the dose button 56" and the dose dial sleeve 36" is disengaged. The axial force applied from the dose button 56" onto the dose dial sleeve 36" causes the dose dial sleeve 36" to spin into the housing 2" on the helical thread between the dose dial sleeve 36" and the housing 2". The locking spring 68" deforms and the legs of the spring move axially down the drive sleeve 18". The latch portions 76" of the locking spring 68" engage in the through apertures 78" on the external flange 26" which projects from the drive sleeve 18" and maintain engagement between the clicker projections 80" of the flange 26" with the grooves between the splines 30", locking the drive sleeve to the housing 2" and preventing the drive sleeve 18" from rotation relative to the housing 2" during dispensing of the dose. The drive sleeve 18" is thus prevented from spinning and moves axially in, causing the toothed gear 22" to rotate against the fixed rack 6". The toothed gear 22", together with the piston rod 32" on which it is mounted, move along the rack 6" a distance corresponding to one half of the distance by which the drive sleeve 18" moves axially, creating a 2:1 mechanical advantage. This has the two-fold benefit of allowing the display on the dose dial sleeve 36" to be larger for a given amount of travel of the piston 14" within the cartridge 4", that is for a given amount of medicament to be dispensed and secondly of halving the force required to dispense the dose.

[0137] The piston rod 32" is driven through the drive sleeve 18" towards the first end of the drug delivery device, thereby to advance the cartridge piston 14" and expel the desired dose of medicinal product. The piston rod 32" continues to advance until the drive sleeve 18" and dose dial sleeve 36" have returned to their initial positions (Figure 20).

[0138] It can be seen that the dose selecting means and the dose expelling means extend beyond a second end of the housing 2'' as the dose is selected and are returned within the housing 2'' as the selected dose is expelled.

[0139] Further dosages may be delivered as required. Figure 21 shows an example of a subsequently selected dosage. As noted above, the position of the limiting nut 28'' along the external thread of the drive sleeve 18'' corresponds to the amount of medicinal product remaining in the cartridge 4''; such that when the nut 28'' reaches the external flange 26'' and can rotate no further this corresponds to no medicinal product remaining in the cartridge 4''. It will be seen that if a user seeks to select a quantity of medical product greater than that remaining in the cartridge 4'', this cannot be done since when the nut 28'' stops rotating against the drive sleeve 18'', the drive sleeve 18'' and the housing 2'' will become locked together preventing rotation of the drive sleeve 18'' and hence the dose dial sleeve 36''. This prevents the setting of a larger dose than the amount of medical product remaining within the cartridge 4''. Figure 22 shows a drug delivery device according to the present invention in which the entire medicinal product within the cartridge 4'' has been expelled.

[0140] The illustrated embodiment of the device according to the invention further comprises a maximum dosage dial end stop. When the dose dial sleeve 36'' is dialed fully out, the external flange 26'' on the drive sleeve 18'' engages the internal flange 46'' in the housing 2''. It will be seen that if the user tries to dial beyond the maximum dosage, this cannot be done. When the drive sleeve 18'' stops rotating against the housing 2'', the dose dial sleeve is also prevented from rotating. The reaction between the external flange 44'' and the internal flange 86'' indicates to the user that the maximum dose has been dialed.



## CLAIMS

1. A drive mechanism for use in a drug delivery device comprising:
  - a housing comprising a helical thread;
  - a dose dial sleeve having a threaded surface that is engaged with the helical thread of the housing,
  - an insert provided in the housing, where the insert has a threaded circular opening;
  - a drive sleeve releasably connected to the dose dial sleeve and having an internal helical thread;
  - a piston rod having a first thread and a second thread , wherein the first thread is engaged with the threaded circular opening of the insert and the second thread is engaged with the internal helical thread of the drive sleeve; and
  - a clutch located between the dose dial sleeve and the drive sleeve,
  
2. The drive mechanism of claim 1, wherein the drive sleeve comprises a threaded outer surface, the drive mechanism further comprising a limiting nut being threadedly engaged with the threaded outer surface of drive sleeve, where the limiting nut is rotationally fixed and slidable relative to the housing.
  
3. The drive mechanism of claim 1, wherein the insert is secured in the housing against rotational and longitudinal motion.
  
4. The drive mechanism of claim 1, wherein the limiting nut translates distally along the threaded outer surface relative to the two radially extending flanges as the drive sleeve is rotated during dose setting;
  
5. The drive mechanism of claim 1, wherein the threaded outer surface of the drive sleeve is located between two radially extending flanges.

6. The drive mechanism of claim 1, wherein the housing comprises a window insert at a distal end of the housing, where the distal end of the housing has the helical thread, where the window insert is rotationally fixed relative to the housing;
7. The drive mechanism of claim 1, wherein the threaded outer surface of the dose dial sleeve has a first lead.
8. The drive mechanism of claim 7, wherein the first thread of the piston rod has a second lead.
9. The drive mechanism of claim 8, wherein the internal drive sleeve thread has a lead equal to the first lead.
10. The drive mechanism of claim 1, where the clutch is rotationally fixed to the drive sleeve and dose dial sleeve during dose setting.
11. The drive mechanism of claim 1, wherein the helical thread of the housing is an internal helical thread and the dose dial sleeve has a threaded outer surface that is engaged with the internal helical thread of the housing.
12. The drive mechanism of claim 1 where the piston rod rotates and translates axially in a proximal direction relative to and through the threaded circular opening during dose delivery.
13. The drive mechanism of claim 6 where the window insert comprises a frame having a stop that is configured to engage a stop on the dose dial sleeve when a predetermined maximum dose is set by rotation of the dose dial sleeve.
14. The drive mechanism of claim 9 where the ratio of leads of the first thread of the piston rod to the second thread of the piston rod is in the range from about 1:1.01 to 1:20.

15. The drive mechanism of claim 9 where the ratio of leads of the first thread of the piston rod to the second thread of the piston rod is in the range from about 1:1.1 to 1:10.
16. The drive mechanism of claim 1 where the second thread of the piston rod is a part thread.
17. The drive mechanism of claim 1 where the first and second threads of the piston rod are oppositely disposed.
18. The drive mechanism of claim 1 where the first thread and the second thread of the piston rod are configured such that the piston rod is prevented from rotating during dose setting.
19. The drive mechanism of claim 1 where the drive sleeve is configured to rotate and climb the piston rod at a rate equal to a rate of rotation of the dose dial sleeve when the dose dial sleeve is rotated to set a dose.

## ABSTRACT

A drive mechanism suitable for use in drug delivery devices is disclosed. The drive mechanism may be used with injector-type drug delivery devices, such as those permitting a user to set the delivery dose. The drive mechanism may include a housing, a dose dial sleeve, and a drive sleeve. A clutch is configured to permit rotation of the drive sleeve and the dose dial sleeve with respect to the housing when the dose dial sleeve and drive sleeve are coupled through the clutch. Conversely, when the dose dial sleeve and drive sleeve are in a de-coupled state, rotation of the dose dial sleeve with respect to the housing is permitted and rotation of the drive sleeve with respect to the housing is prevented. In the de-coupled state, axial movement of the drive sleeve transfers force in a longitudinal direction for actuation of a drug delivery device.

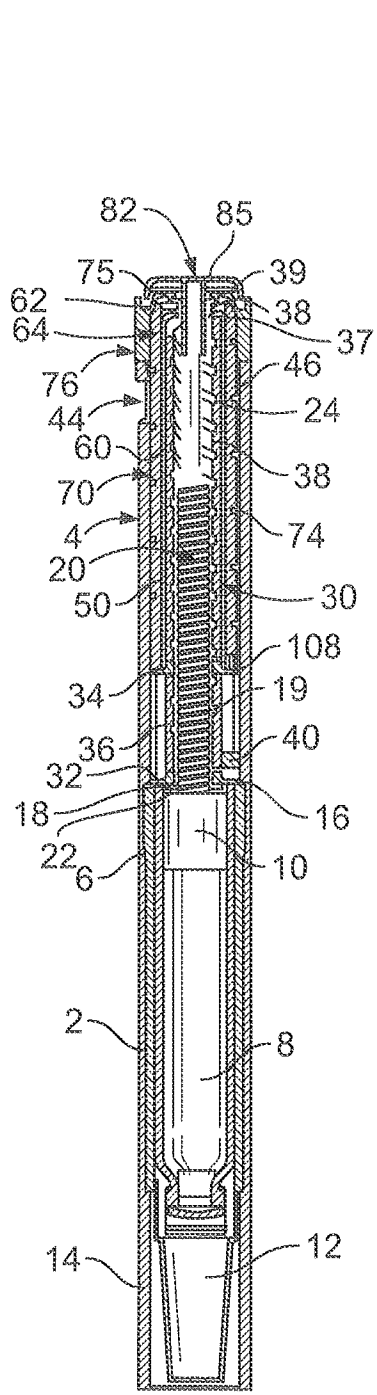


FIG. 1

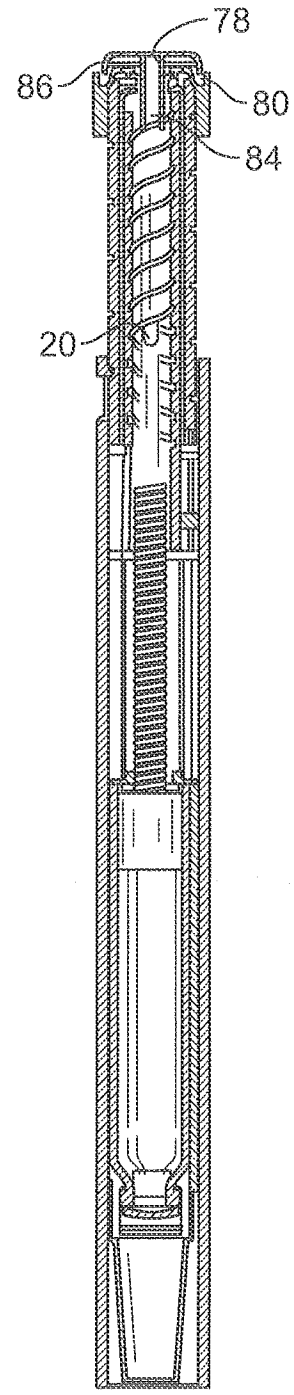


FIG. 2

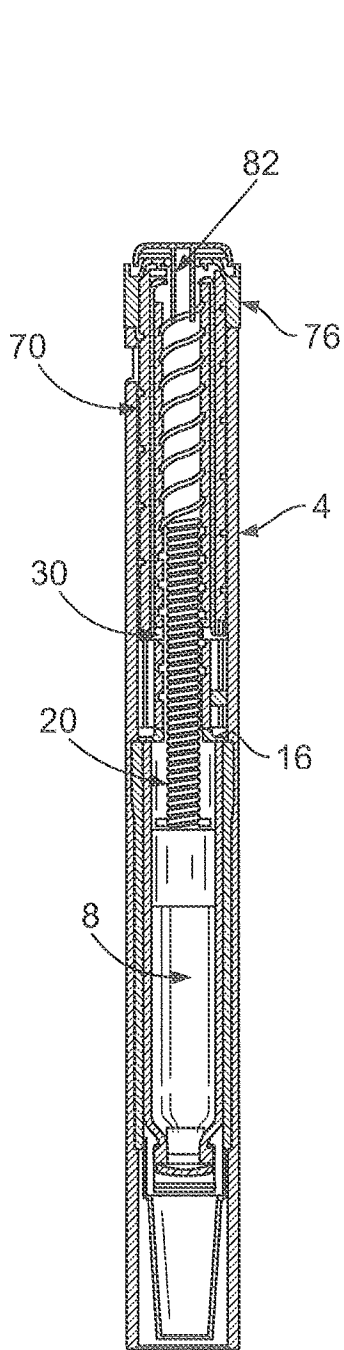


FIG. 3

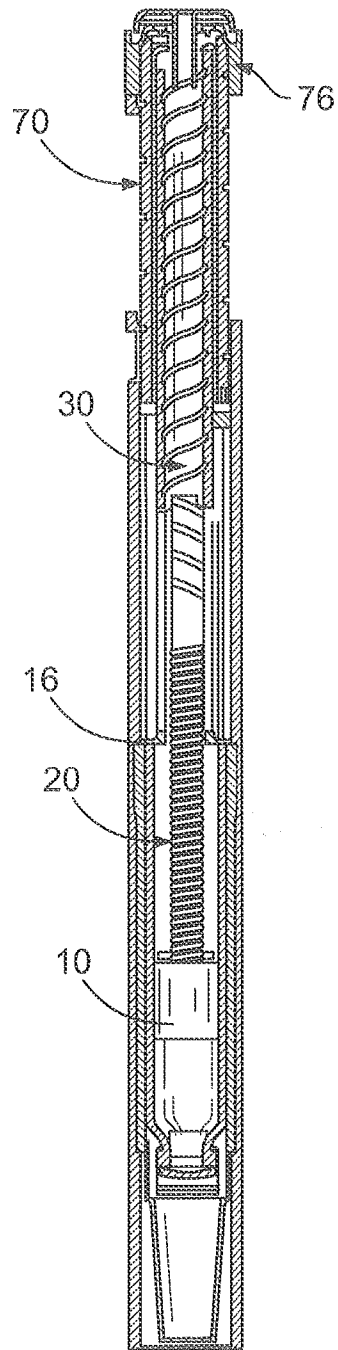


FIG. 4

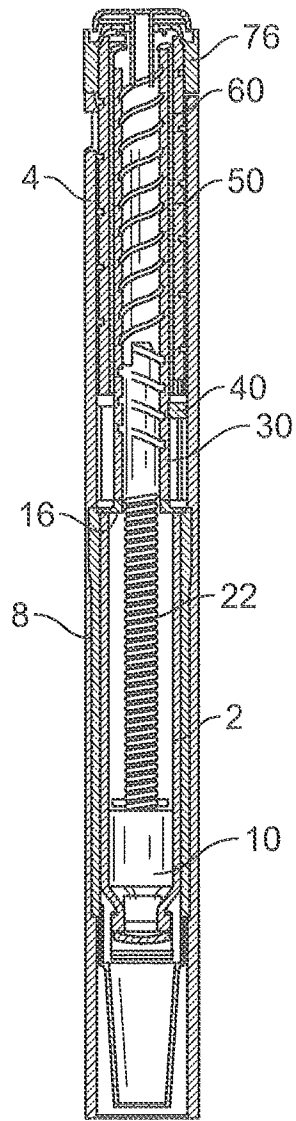


FIG. 5

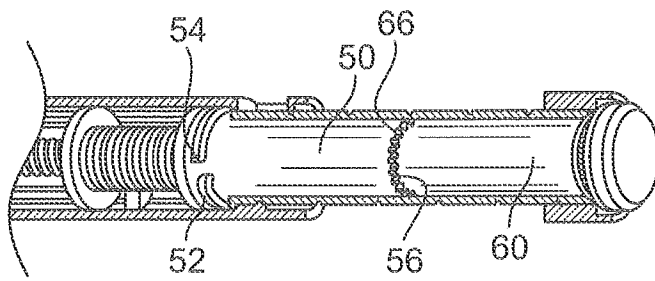


FIG. 6

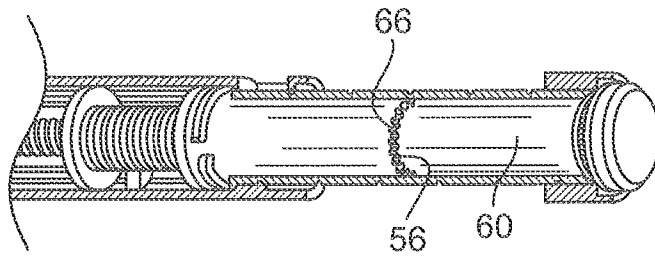


FIG. 7

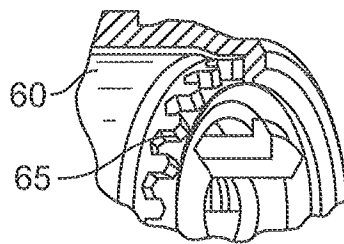


FIG. 8



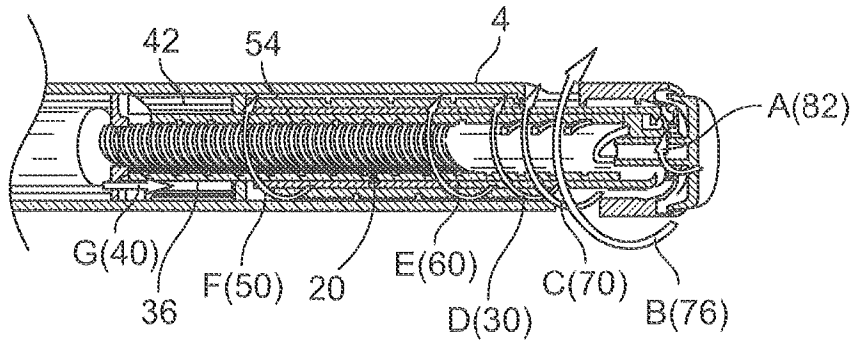


FIG. 9

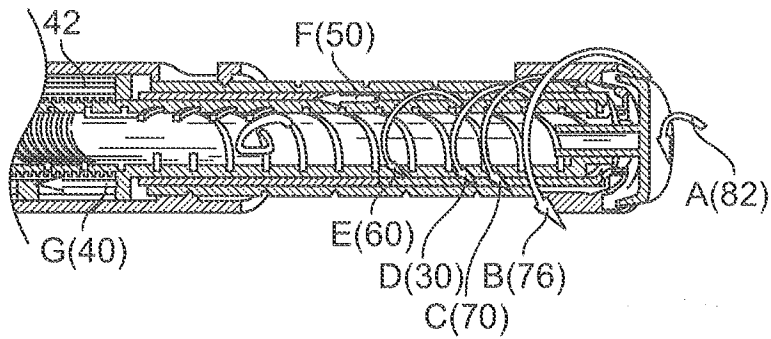


FIG. 10

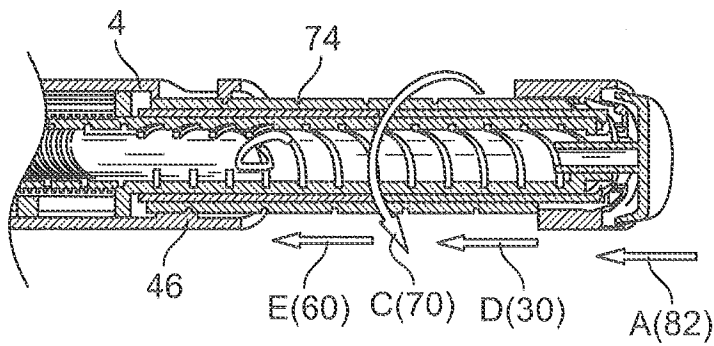


FIG. 11

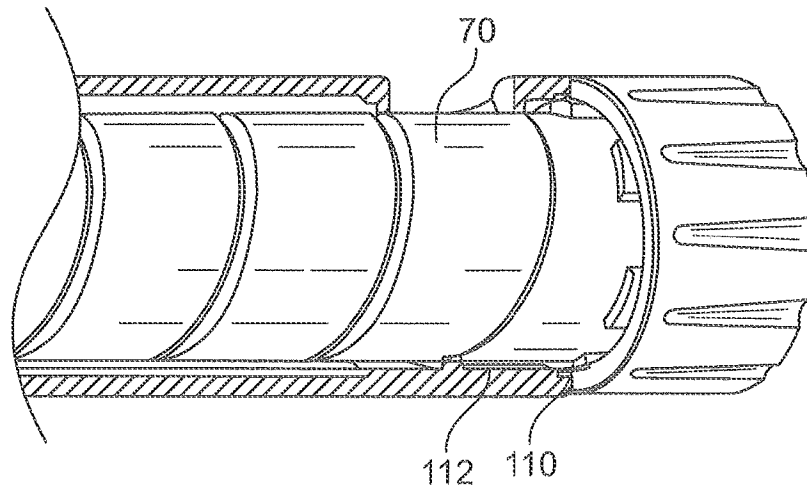
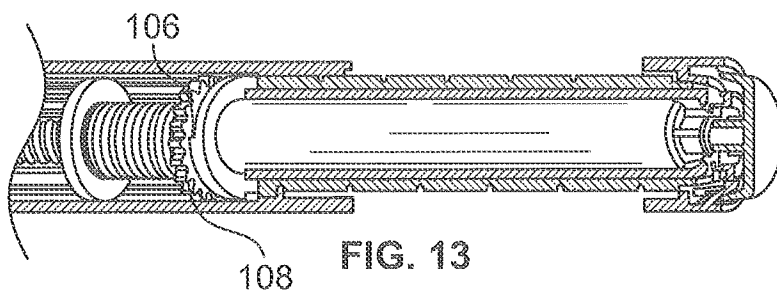
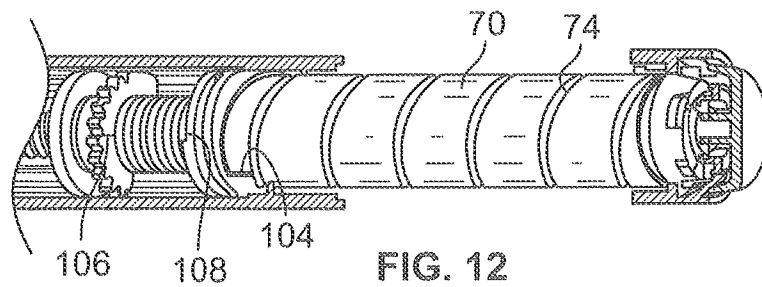
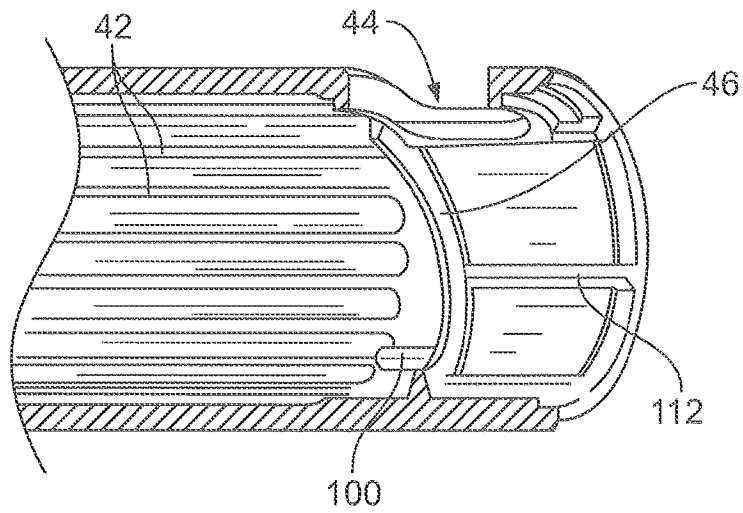
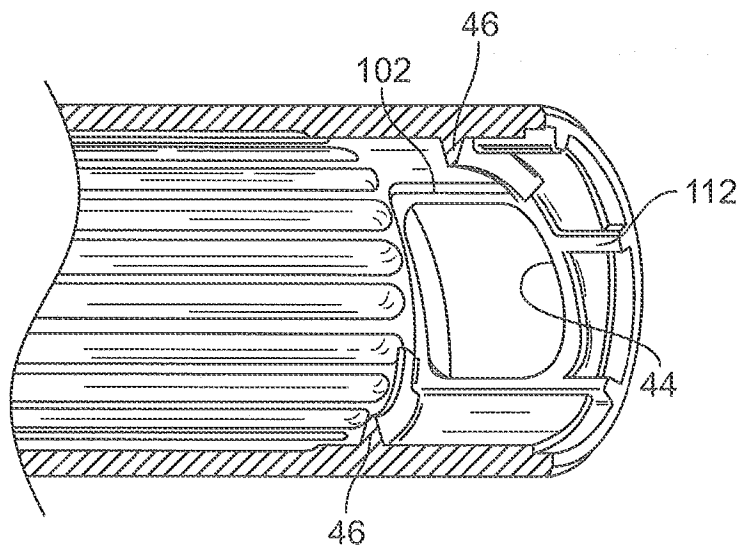


FIG. 14



**FIG. 15**



**FIG. 16**

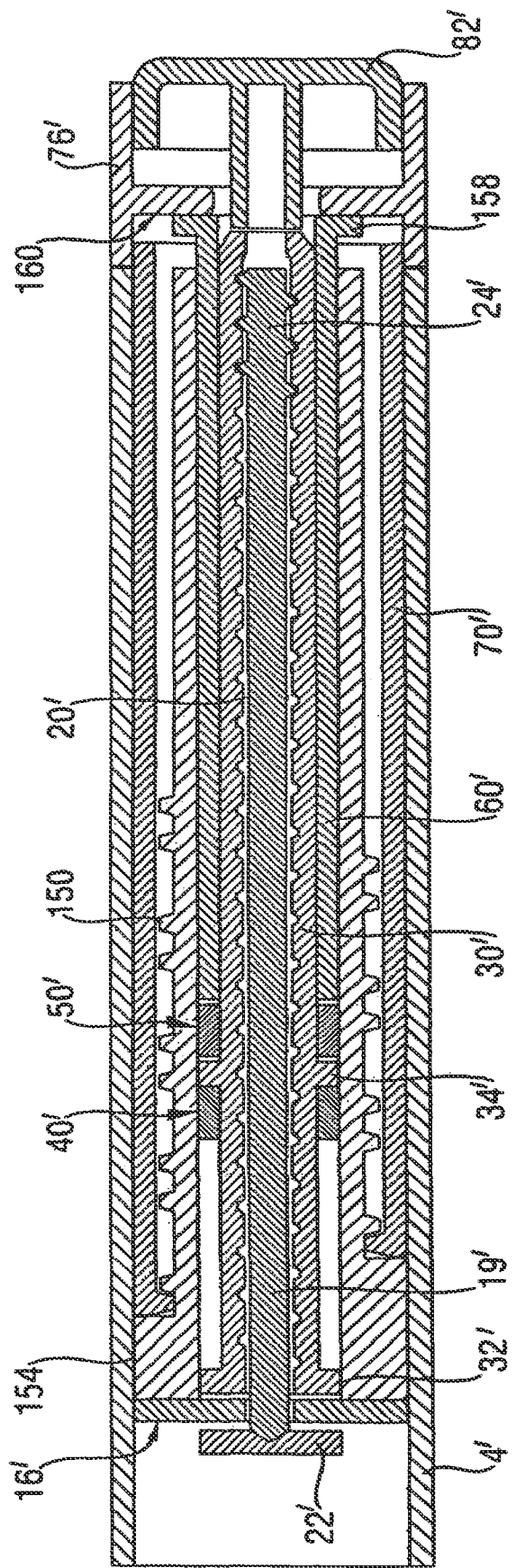


Fig. 17

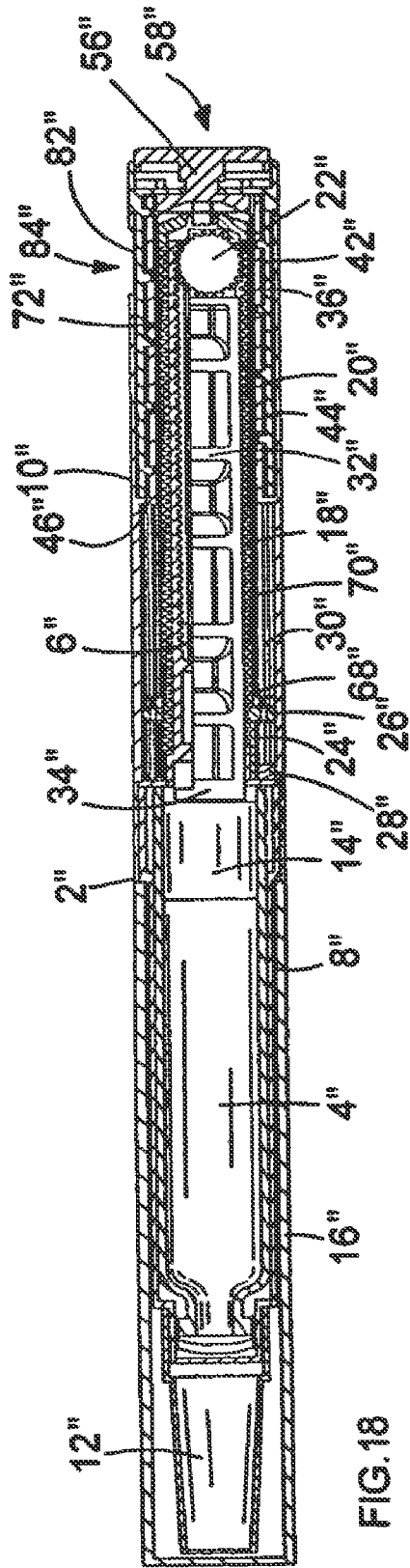


FIG. 18

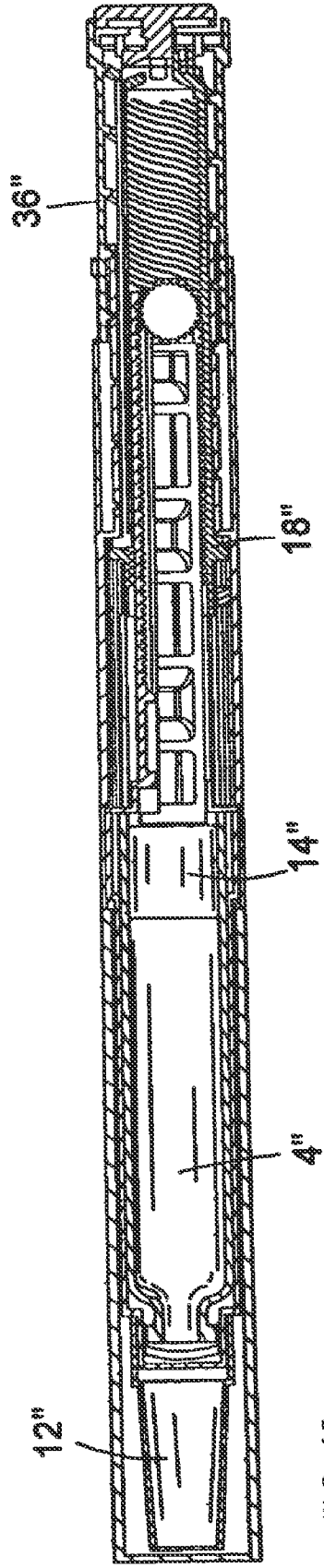


FIG. 19

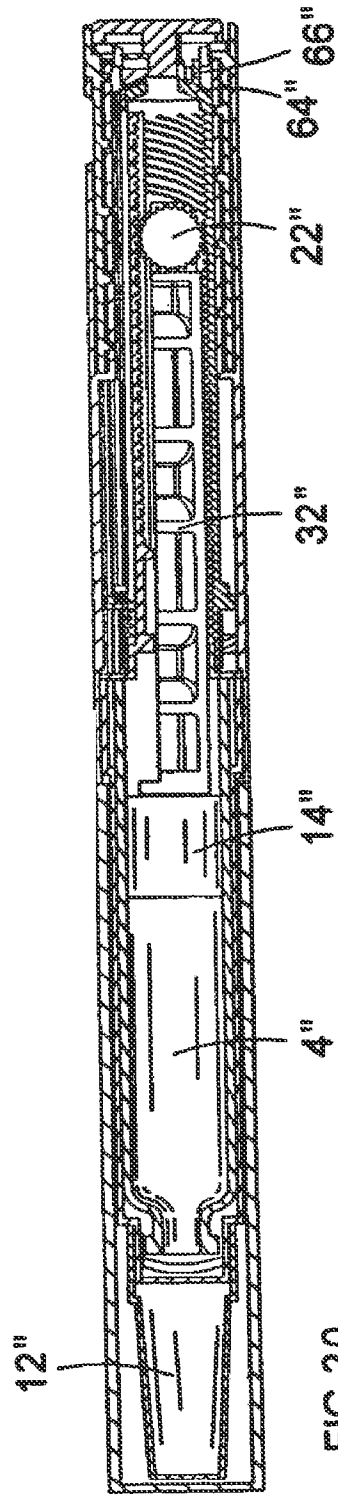


FIG. 20

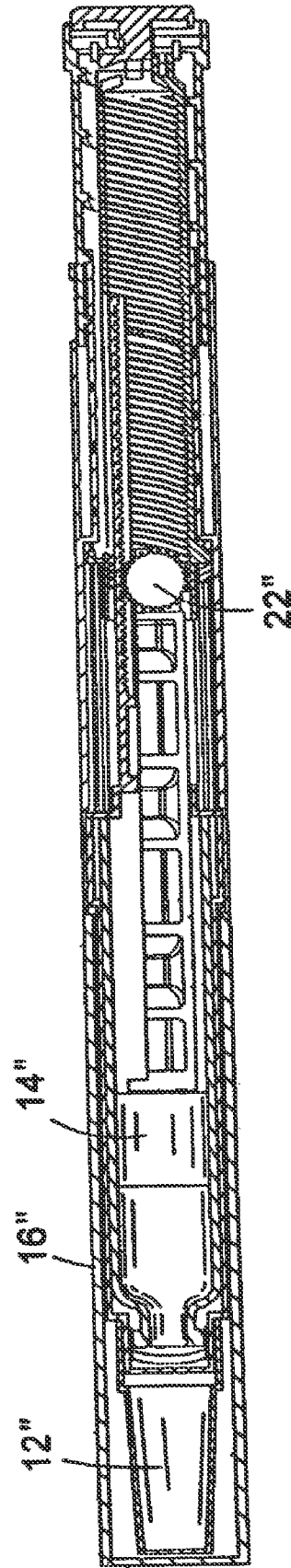


FIG. 21

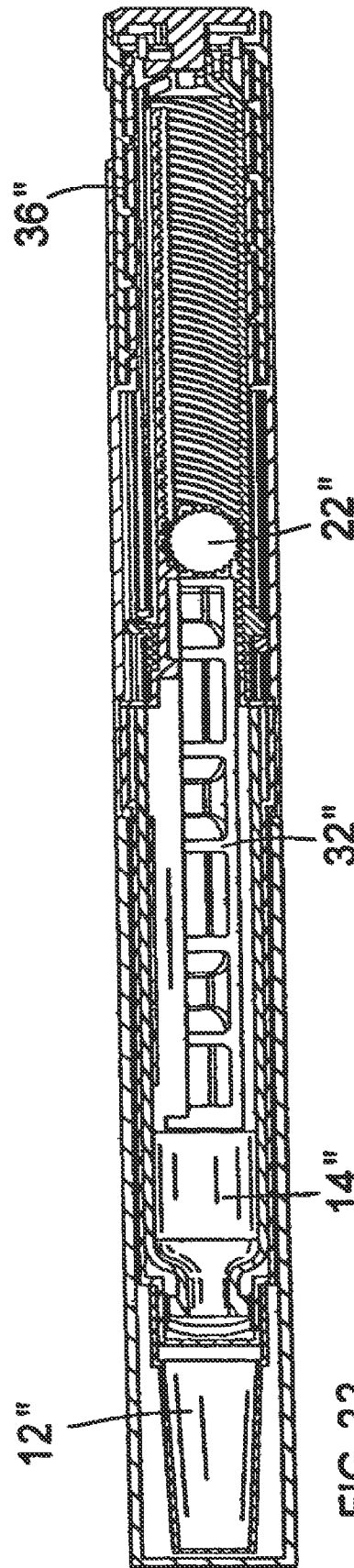


FIG. 22

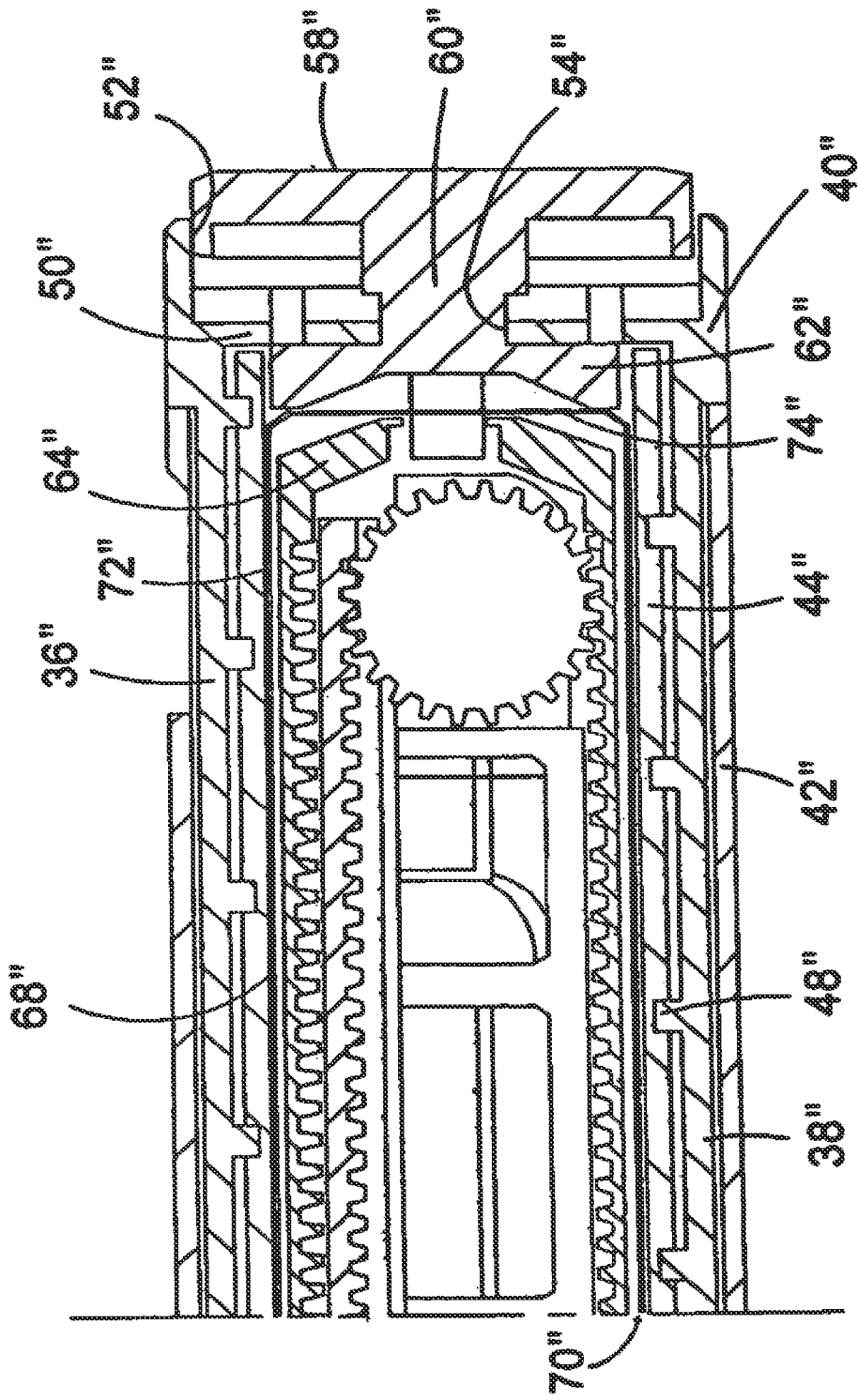


FIG.23



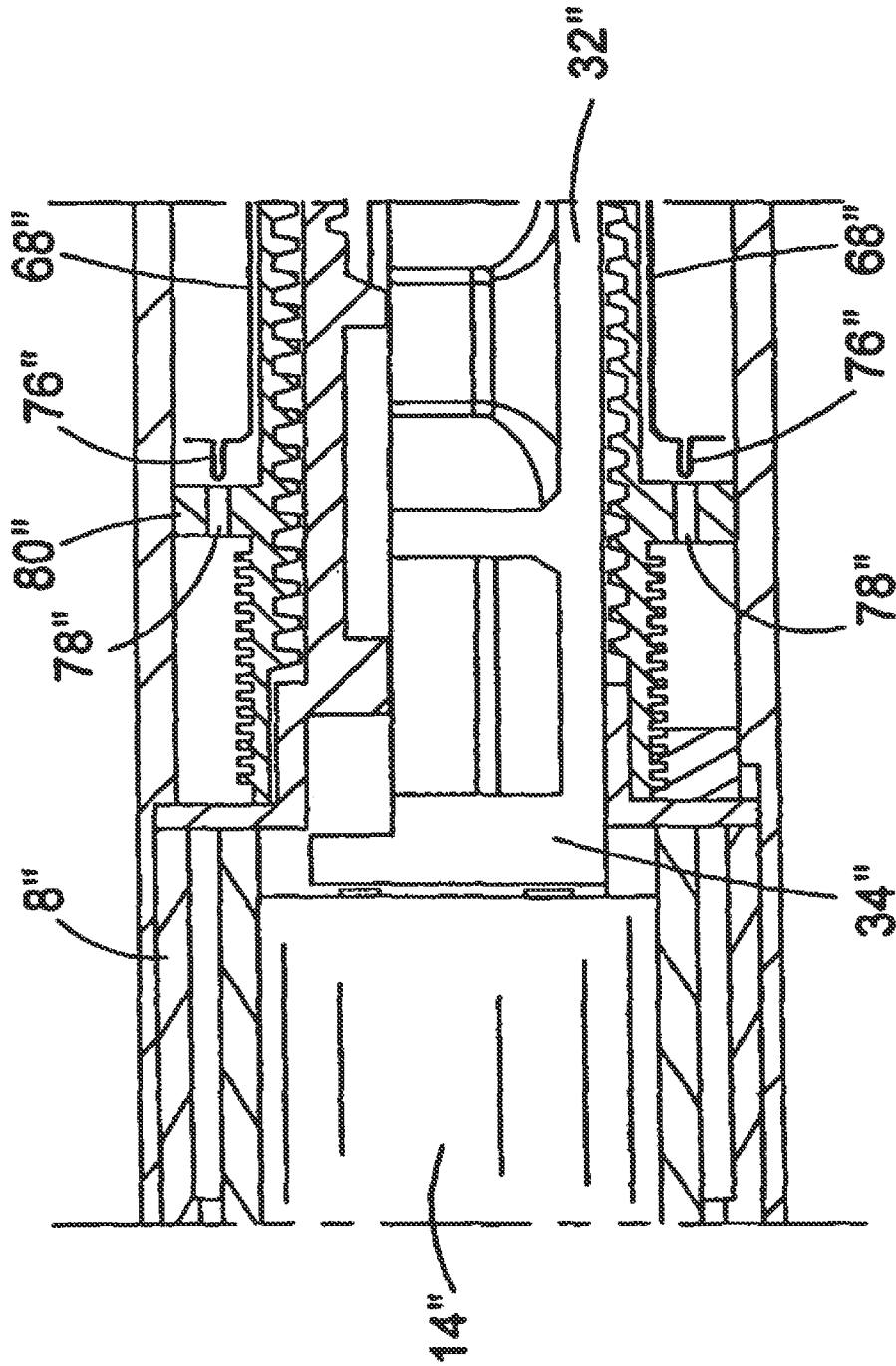


FIG.24

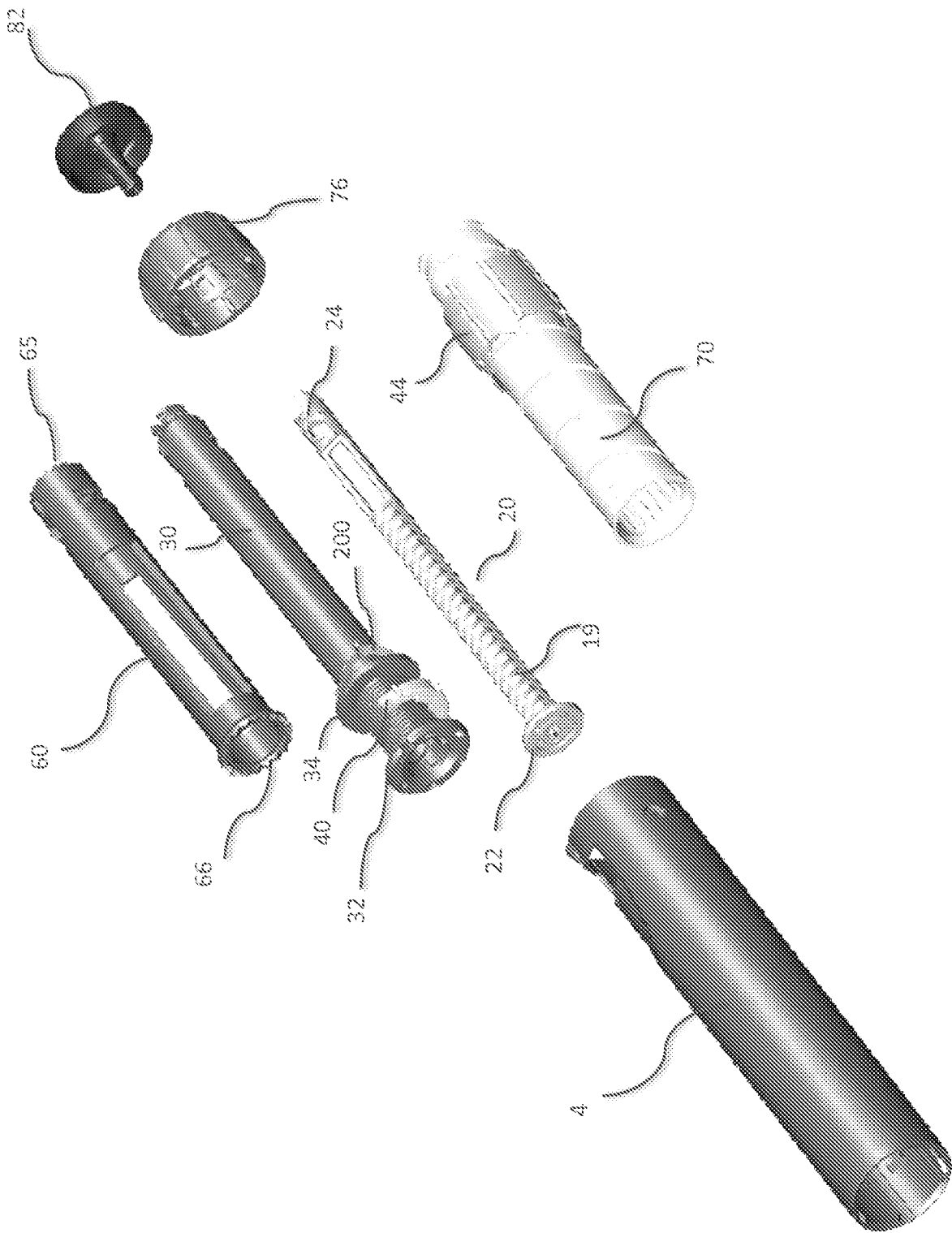


Fig. 25

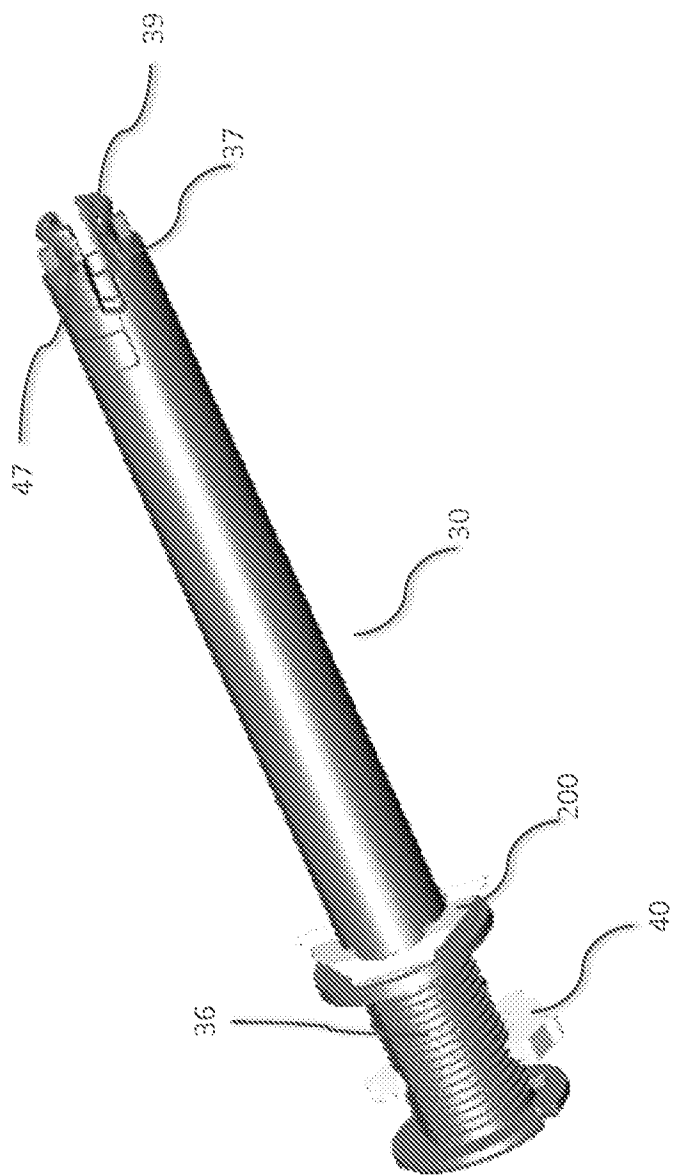


Fig. 26

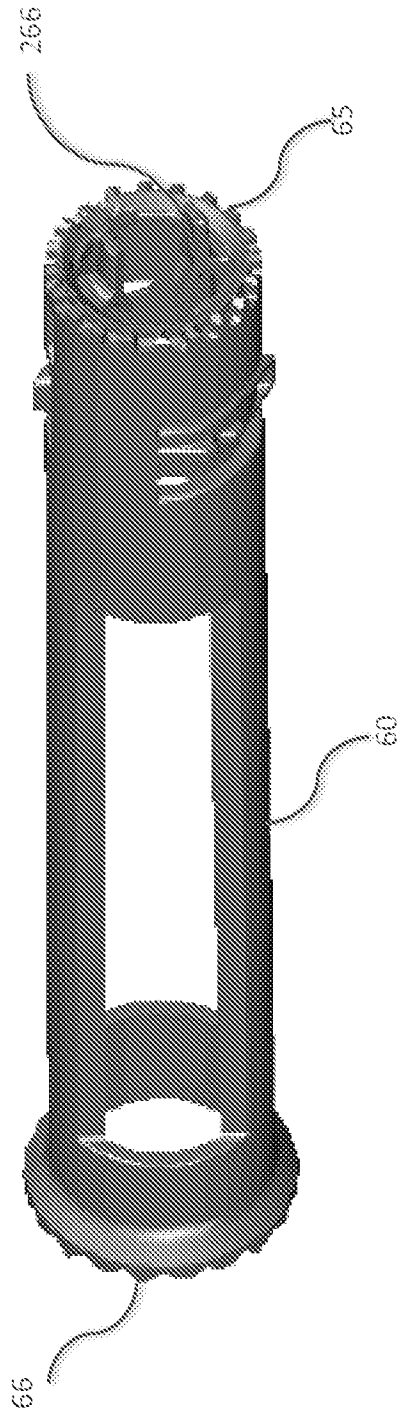


Fig. 27

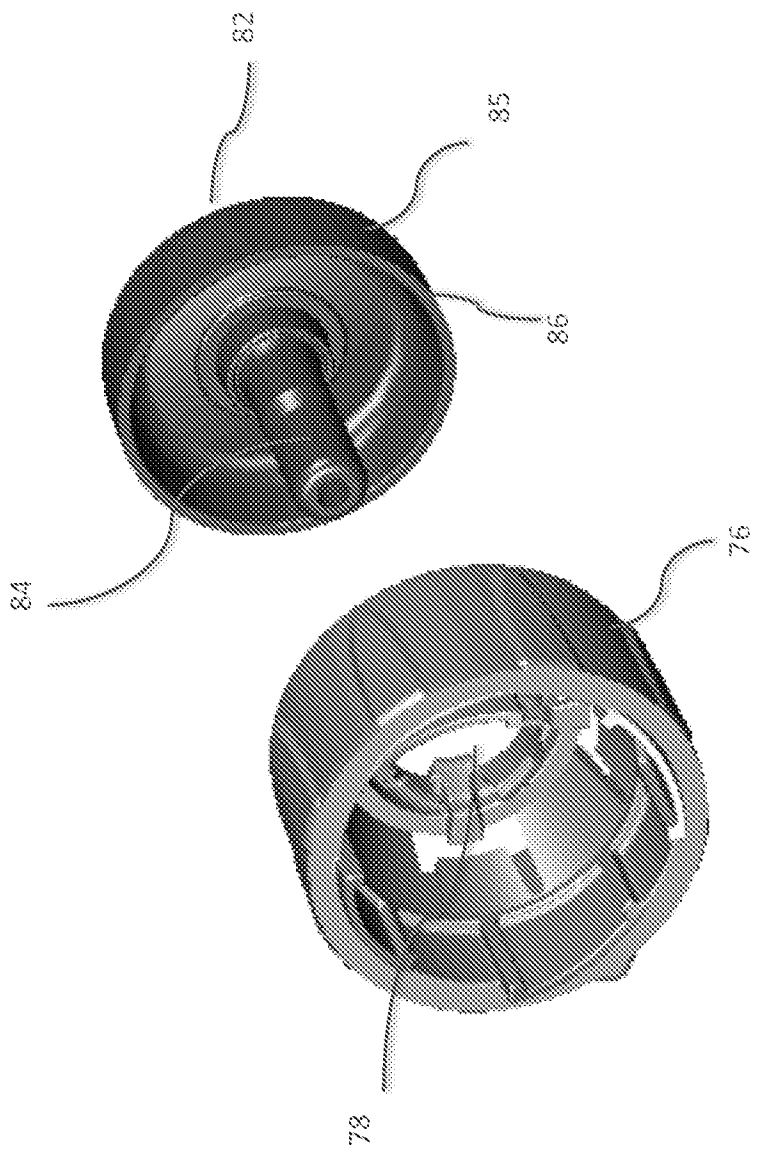


Fig. 28

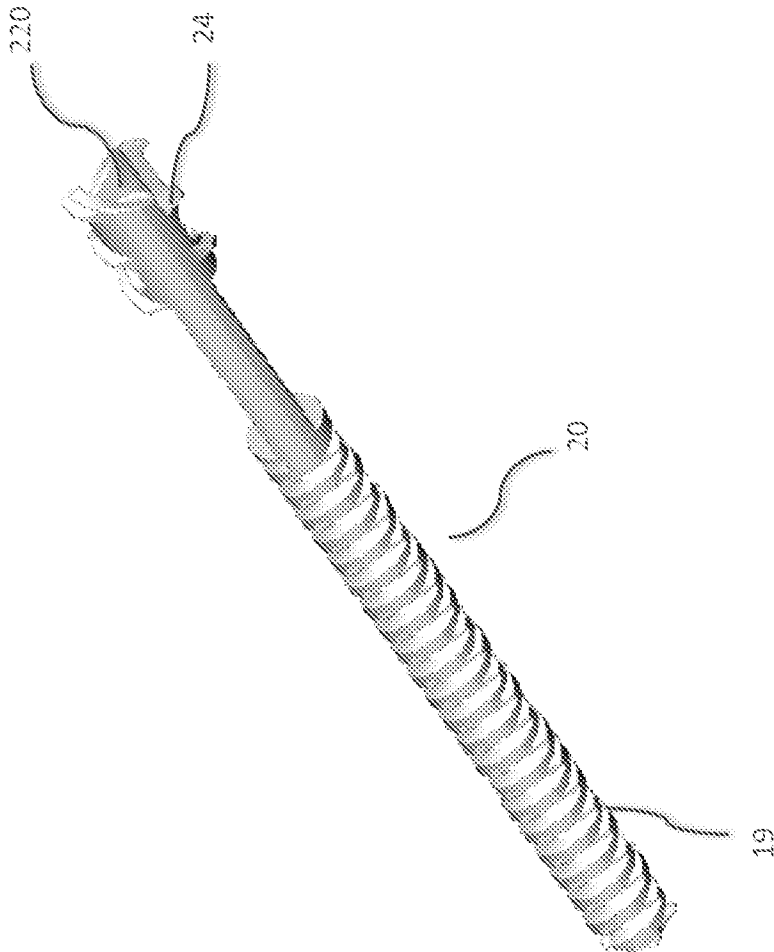


Fig. 29

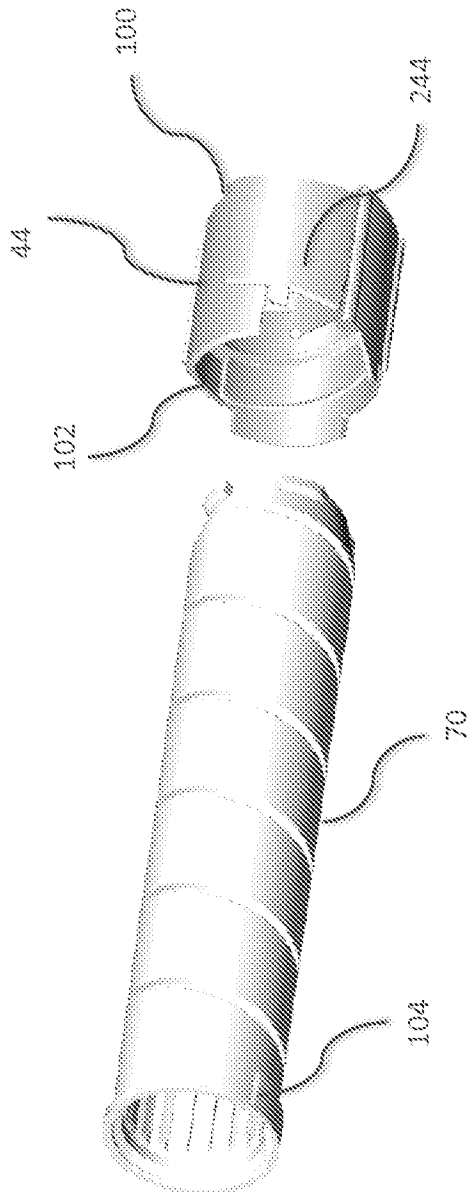


Fig. 30

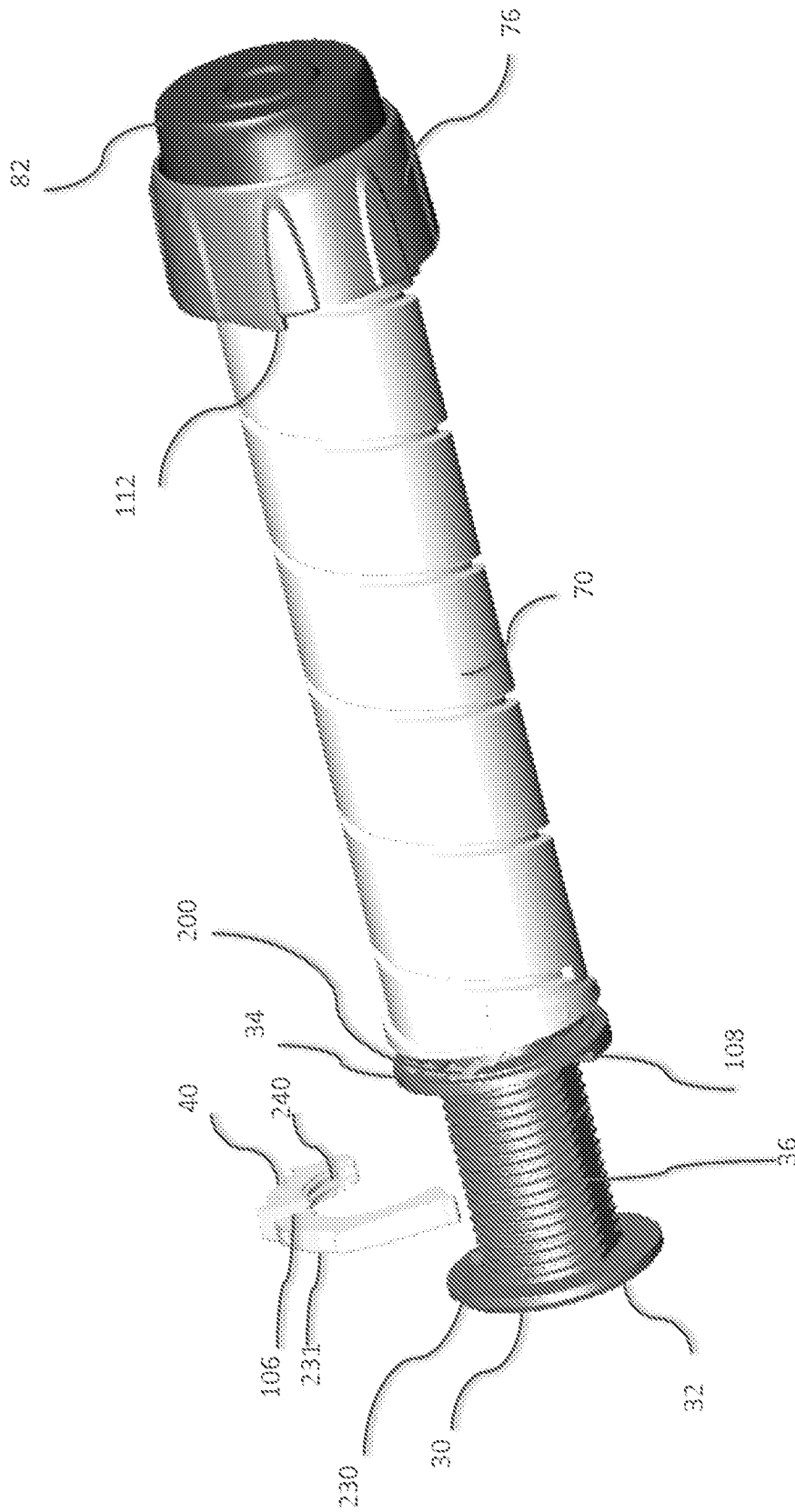


Fig. 31



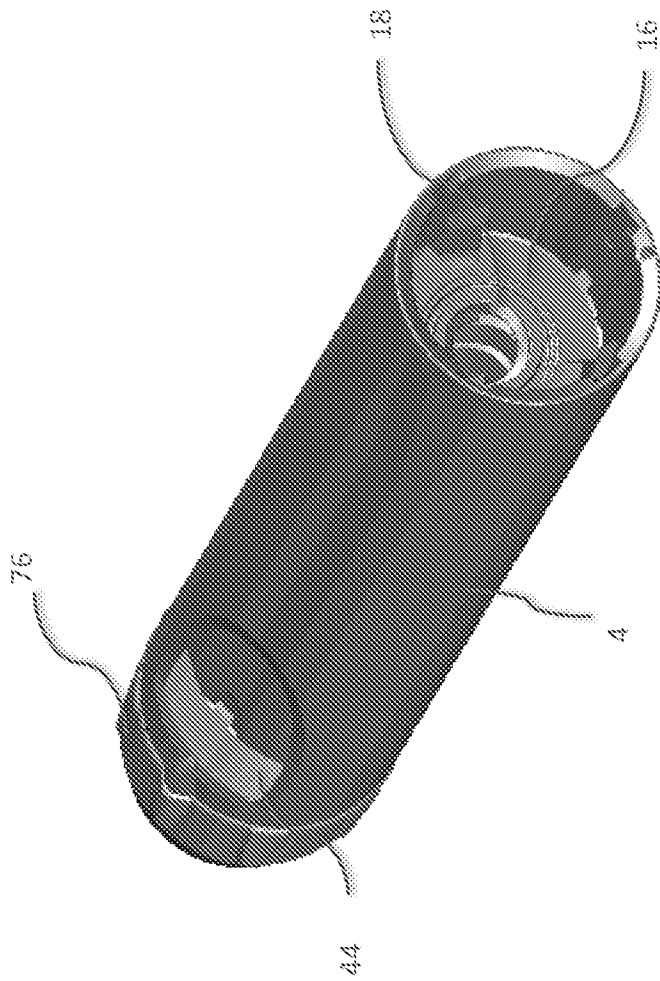


Fig. 32

DECLARATION AND POWER OF ATTORNEY

As a below named inventor, I hereby declare that: my residence, post office address and citizenship are as stated below next to my name; I believe I am the original, first, and sole inventor (if only one name is listed below) or an original, first, and joint inventor (if plural names are listed below) of the subject matter which is claimed and for which a patent is sought on the invention entitled:

IMPROVEMENTS IN AND RELATING TO DRIVE MECHANISMS SUITABLE FOR USE IN DRUG DELIVERY DEVICES

the specification of which

- is attached and/or
- was filed on March 3, 2004 as United States Application Serial No. 10/790,866 and/or
- was filed on \_\_\_\_\_ as PCT International Application No. \_\_\_\_\_ and
- was amended on \_\_\_\_\_ (if applicable).

I hereby state that I have reviewed and understand the contents of the above-identified specification, including the claims, as amended by any amendment referred to above. I acknowledge the duty to disclose information which is material to patentability as defined in 37 CFR § 1.56.

I hereby claim foreign priority benefits under 35 U.S.C. § 119(a)-(d) or § 365(b) of any foreign application(s) for patent or inventor's certificate or § 365(a) of any PCT international application(s) designating at least one country other than the United States, listed below and have also identified below, any foreign application(s) for patent or inventor's certificate, or any PCT International application(s) having a filing date before that of the application(s) of which priority is claimed:

Country	Application Number	Date of Filing	Priority Claimed Under 35 U.S.C. 119
Great Britain	0304822.0	March 3, 2003	<input checked="" type="checkbox"/> YES <input type="checkbox"/> NO
			<input type="checkbox"/> YES <input type="checkbox"/> NO

I hereby claim the benefit under 35 U.S.C. § 119(e) of any United States provisional application(s) listed below:

Application Number	Date of Filing

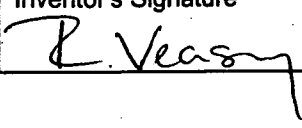

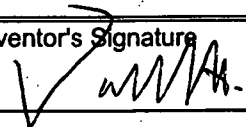
I hereby claim the benefit under 35 U.S.C. § 120 of any United States application(s) or § 365(c) of any PCT International application(s) designating the United States, listed below and, insofar as the subject matter of each of the claims of this application is not disclosed in the prior United States or PCT International application(s) in the manner provided by the first paragraph of 35 U.S.C. § 112, I acknowledge the duty to disclose information which is material to patentability as defined in 37 CFR § 1.56 which became available between the filing date of the prior application(s) and the national or PCT International filing date of this application:

Application Number	Date of Filing	Status (Patented, Pending, Abandoned)

I hereby appoint the following attorney and/or agent(s) to prosecute this application and transact all business in the Patent and Trademark Office connected therewith. **FINNEGAN, HENDERSON, FARABOW, GARRETT & DUNNER, L.L.P., CUSTOMER NUMBER 22,852**, Douglas B. Henderson, Reg. No. 20,291; Ford F. Farabow, Jr., Reg. No. 20,630; Arthur S. Garrett, Reg. No. 20,338; Donald R. Dunner, Reg. No. 19,073; Brian G. Brunsvold, Reg. No. 22,593; Tipton D. Jennings, IV, Reg. No. 20,645; Jerry D. Voight, Reg. No. 23,020; Laurence R. Hefter, Reg. No. 20,827; Kenneth E. Payne, Reg. No. 23,098; Herbert H. Mintz, Reg. No. 26,691; C. Larry O'Rourke, Reg. No. 26,014; Albert J. Santorelli, Reg. No. 22,610; Michael C. Elmer, Reg. No. 25,857; Richard H. Smith, Reg. No. 20,609; Stephen L. Peterson, Reg. No. 26,325; John M. Romary, Reg. No. 26,331; Bruce C. Zotter, Reg. No. 27,680; Dennis P. O'Reilly, Reg. No. 27,932; Allen M. Sokal, Reg. No. 26,695; Robert D. Bajefsky, Reg. No. 25,387; Richard L. Stroup, Reg. No. 28,478; David W. Hill, Reg. No. 28,220; Thomas L. Irving, Reg. No. 28,619; Charles E. Lipsey, Reg. No. 28,165; Thomas W. Winland, Reg. No. 27,605; Basil J. Lewis, Reg. No. 28,818; Martin I. Fuchs, Reg. No. 28,508; E. Robert Yoches, Reg. No. 30,120; Barry W. Graham, Reg. No. 29,924; Susan Haberman Griffen, Reg. No. 30,907; Richard B. Racine, Reg. No. 30,415; Thomas H. Jenkins, Reg. No. 30,857; Robert E. Converse, Jr., Reg. No. 27,432; Clair X. Mullen, Jr., Reg. No. 20,348; Christopher P. Foley, Reg. No. 31,354; John C. Paul, Reg. No. 30,413; Roger D. Taylor, Reg. No. 28,992; David M. Kelly, Reg. No. 30,953; Kenneth J. Meyers, Reg. No. 25,146; Carol P. Einaudi, Reg. No. 32,220; Steven M. Anzalone, Reg. No. 32,095; Jean B. Fordis, Reg. No. 32,984; Barbara C.

McCurdy, Reg. No. 32,120; James K. Hammond, Reg. No. 31,964; Richard V. Burgujian, Reg. No. 31,744; J. Michael Jakes, Reg. No. 32,824; Thomas W. Banks, Reg. No. 32,719; Christopher P. Isaac, Reg. No. 32,616; Bryan C. Diner, Reg. No. 32,409; M. Paul Barker, Reg. No. 32,013; Andrew Chanho Sonu, Reg. No. 33,457; David S. Forman, Reg. No. 33,694; Vincent P. Kovalick, Reg. No. 32,867; James W. Edmondson, Reg. No. 33,871; Michael R. McGurk, Reg. No. 32,045; Joann M. Neth, Reg. No. 36,363; Gerson S. Panitch, Reg. No. 33,751; Cheri M. Taylor, Reg. No. 33,216; Charles E. Van Horn, Reg. No. 40,266; Linda A. Wadler, Reg. No. 33,218; Jeffrey A. Berkowitz, Reg. No. 36,743; Michael R. Kelly, Reg. No. 33,921; James B. Monroe, Reg. No. 33,971; Doris Johnson Hines, Reg. No. 34,629; Lori Ann Johnson, Reg. No. 34,498; R. Bruce Bower, Reg. No. 37,099; John Rissman, Reg. No. 33,764; Therese A. Hendricks, Reg. No. 30,389; Leslie I. Bookoff, Reg. No. 38,084; Michele C. Bosch, Reg. No. 40,524; Michael J. Flibbert, Reg. No. 33,234; Scott A. Herbst, Reg. No. 35,189; Leslie A. McDonell, Reg. No. 34,872; Thalia V. Wamement, Reg. No. 39,064; Ronald A. Bleeker, Reg. No. 27,773; Kathleen A. Daley, Reg. No. 36,116; C. Gregory Gramenopoulos, Reg. No. 36,532; Anthony M. Gutowski, Reg. No. 38,742; Yitai Hu, Reg. No. 40,653; Lionel M. Lavenue, Reg. No. 46,859; and Christine E. Lehman, Reg. No. 38,535; and . Please address all correspondence to **FINNEGAN, HENDERSON, FARABOW, GARRETT & DUNNER, L.L.P.**, 1300 I Street, N.W., Washington, D.C. 20005, Telephone No. (202) 408-4000.

I hereby declare that all statements made herein of my own knowledge are true and that all statements made on information and belief are believed to be true; and further that these statements were made with the knowledge that willful false statements and the like so made are punishable by fine or imprisonment, or both, under section 1001 of Title 18 of the United States Code, and that such willful false statements may jeopardize the validity of the application or any patent issuing thereon.

Full Name of First Inventor Robert Frederick VEASEY	Inventor's Signature 	Date 26/5/04
Residence Leamington Spa, Warwickshire, Great Britain		Citizenship Great Britain
Post Office Address 35 Hitchman Road Leamington Spa Warwickshire, Great Britain		
Full Name of Second Inventor Robert PERKINS	Inventor's Signature 	Date 26 MAY 04
Residence Leamington Spa, Warwickshire, Great Britain		Citizenship Great Britain
Post Office Address 67 Erica Drive Leamington Spa Warwickshire, Great Britain		
Full Name of Third Inventor David Aubrey PLUMPTRE	Inventor's Signature 	Date 26/May/04
Residence Droitwich, Worcestershire, Great Britain		Citizenship Great Britain
Post Office Address 36 Shire Way Droitwich Worcestershire, Great Britain		
Full Name of Fourth Inventor	Inventor's Signature	Date
Residence		Citizenship
Post Office Address		

## SCORE Placeholder Sheet for IFW Content

Application Number: 14319388

Document Date: 06/30/2014

The presence of this form in the IFW record indicates that the following document type was received in electronic format on the date identified above. This content is stored in the SCORE database.

Since this was an electronic submission, there is no physical artifact folder, no artifact folder is recorded in PALM, and no paper documents or physical media exist. The TIFF images in the IFW record were created from the original documents that are stored in SCORE.

- Drawing

At the time of document entry (noted above):

- USPTO employees may access SCORE content via eDAN using the Supplemental Content tab, or via the SCORE web page.
- External customers may access SCORE content via PAIR using the Supplemental Content tab.

**IN THE UNITED STATES PATENT AND TRADEMARK OFFICE**

(Attorney Docket No. 10-015-US-CON9)

Applicant: Robert Frederick Veasey, *et al.*  
Appl. No.: 14/319,388  
Filed: June 30, 2014  
Title: IMPROVEMENTS IN AND RELATING TO DRIVE MECHANISMS  
SUITABLE FOR USE IN DRUG DELIVERY DEVICES  
TC/A.U.: 3763  
Confirmation No.: 6141  
Examiner: TBD  
Mail Stop Issue Fee  
Commissioner for Patents  
P.O. Box 1450  
Alexandria, VA 22313-1450

**SUBMISSION OF FORMAL DRAWINGS**

Dear Sir:

The drawing sheets containing Figures 25-32 have been amended. Please replace the drawing sheet containing Figure 25-32 with the replacement drawings that are being concurrently filed. No new matter is introduced.

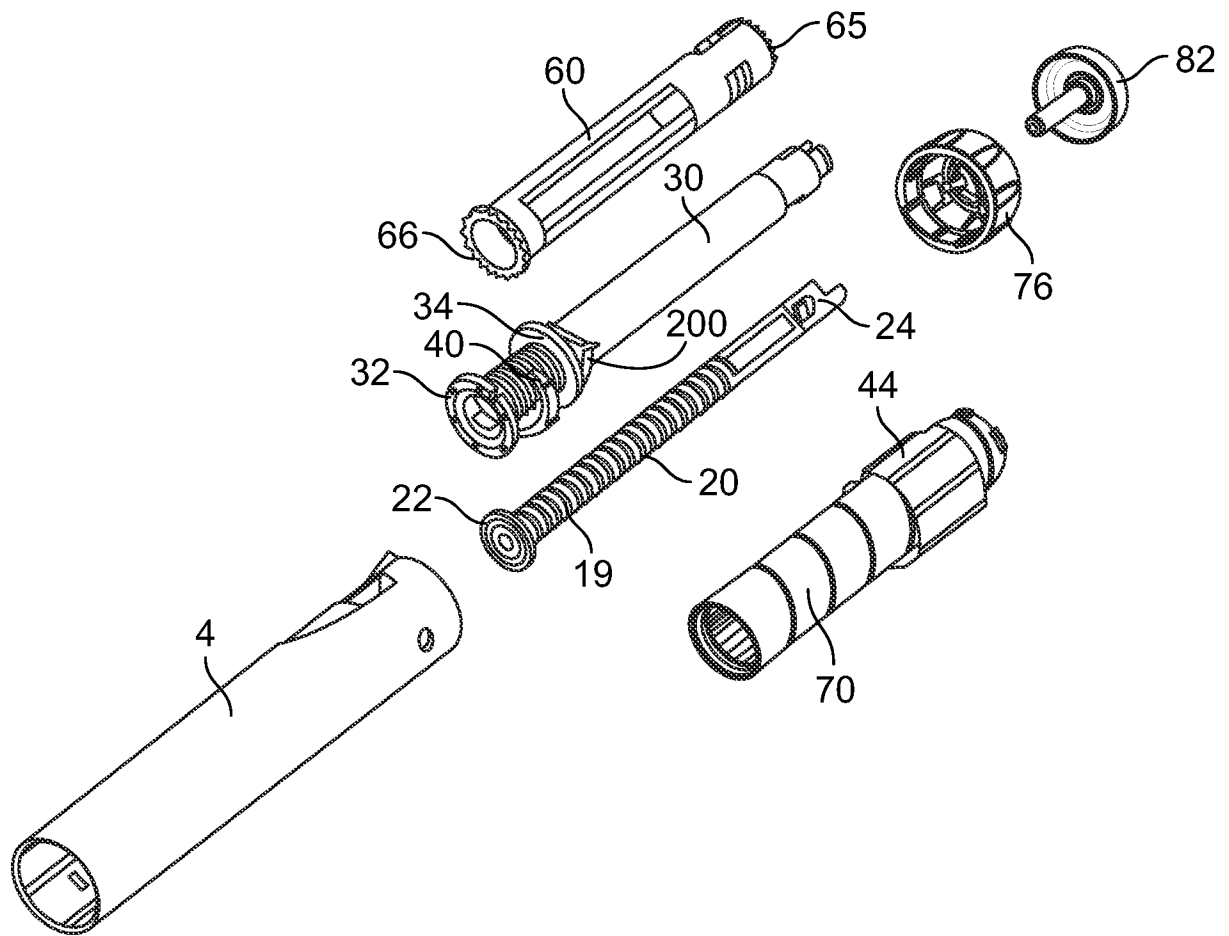
No fees are believed to be due at this time. However, if the Commissioner believes a fee is due, the Commissioner is hereby authorized to charge any fees or credit any overpayment to Deposit Account No. 13-2490.

Respectfully submitted,  
**McDonnell Boehnen Hulbert & Berghoff LLP**

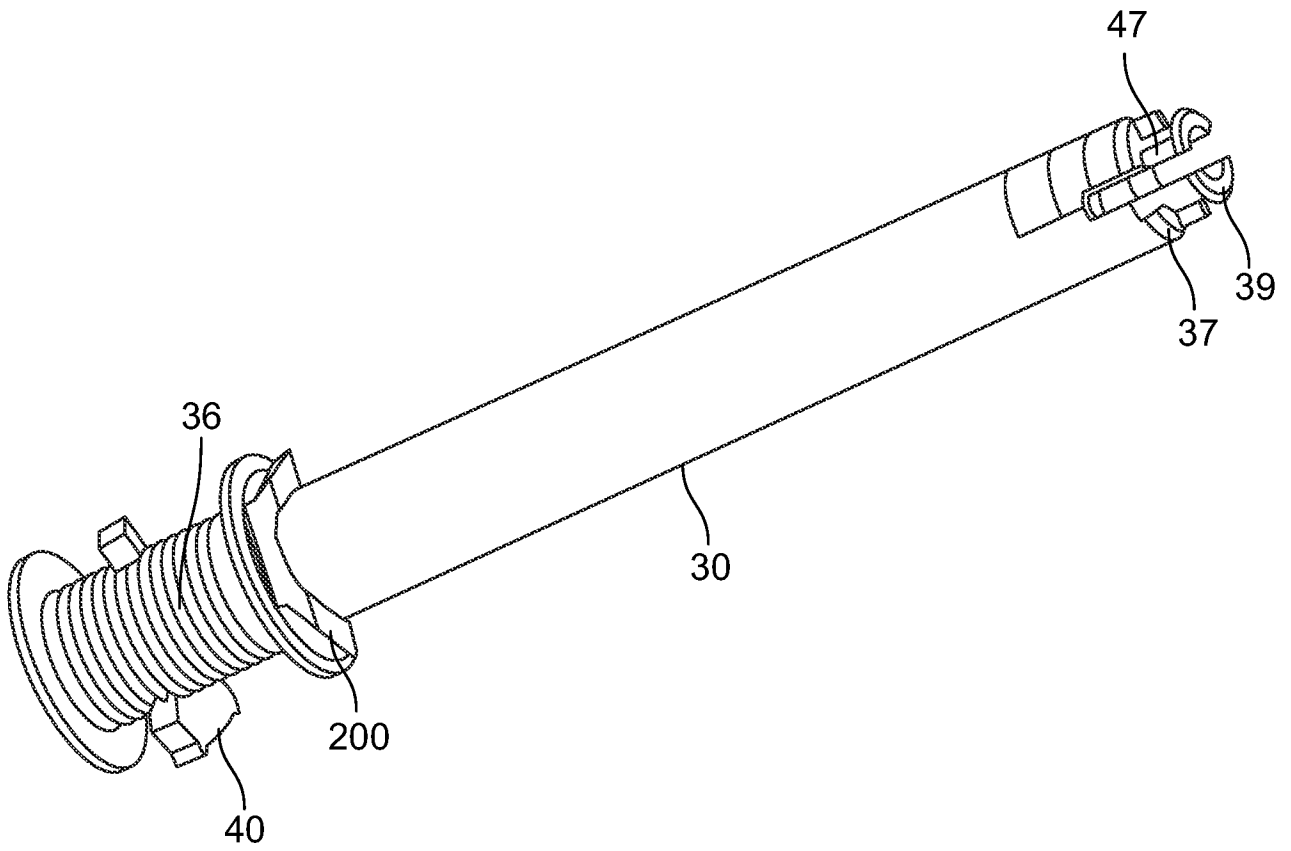
Dated: July 10, 2014

By: / David M. Frischkorn /  
David M. Frischkorn  
Registration No. 32,833

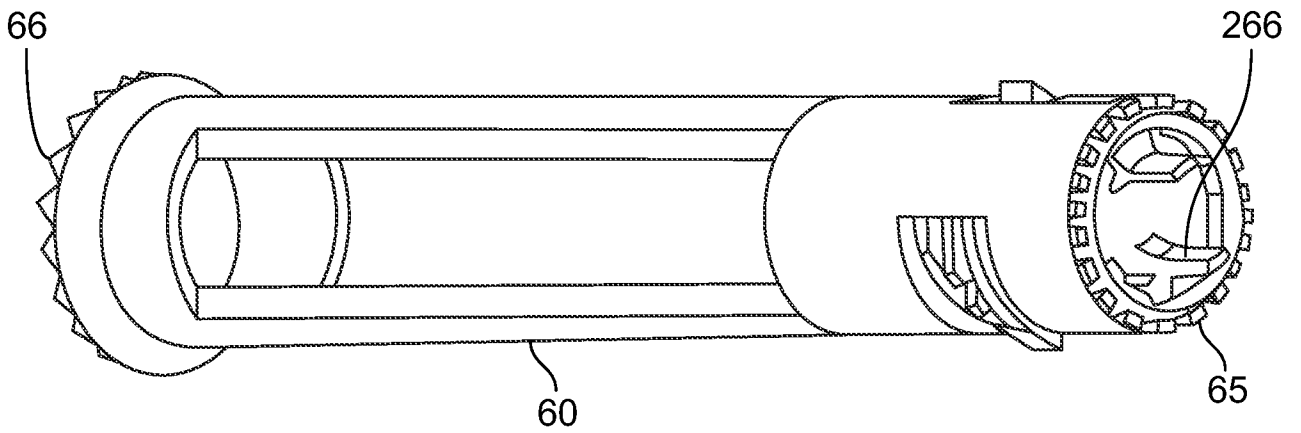
McDonnell Boehnen  
Hulbert & Berghoff LLP  
300 South Wacker Drive  
Chicago, IL 60606  
Tel: 312-913-0001



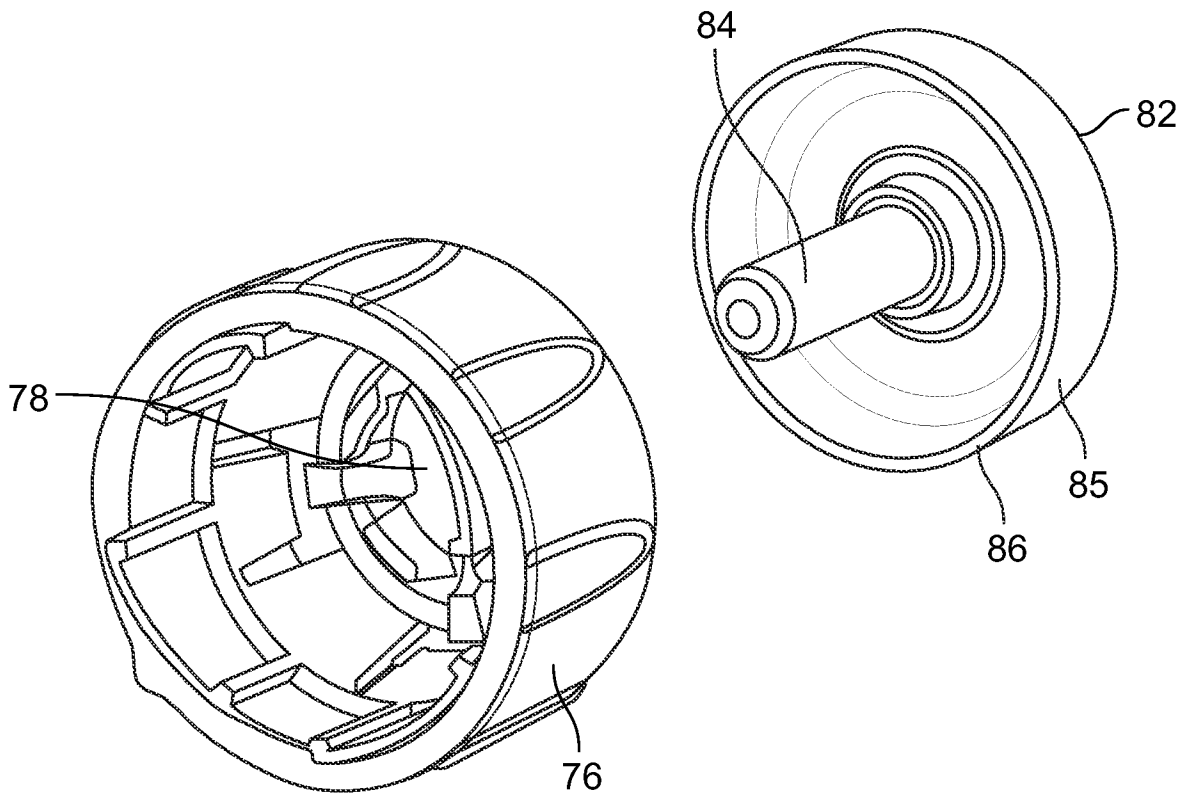
**FIG. 25**



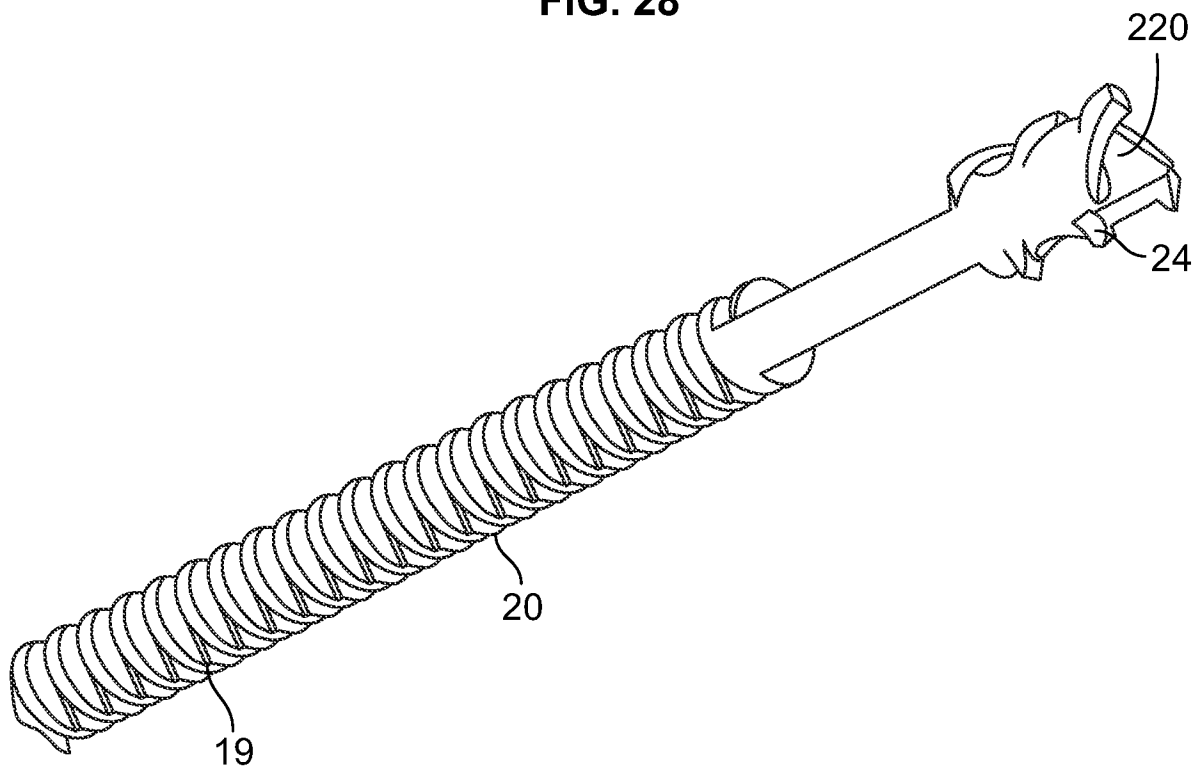
**FIG. 26**



**FIG. 27**

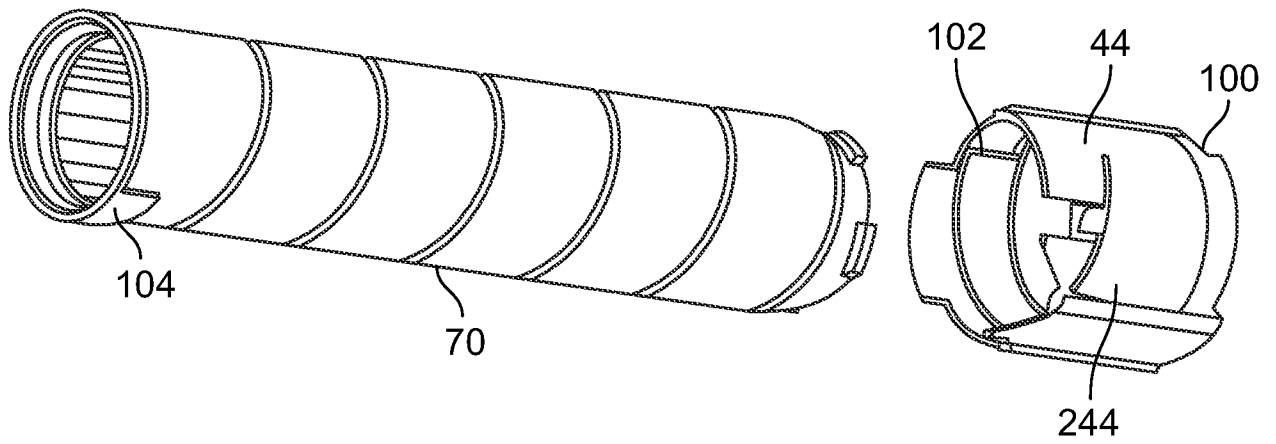


**FIG. 28**



**FIG. 29**





**FIG. 30**

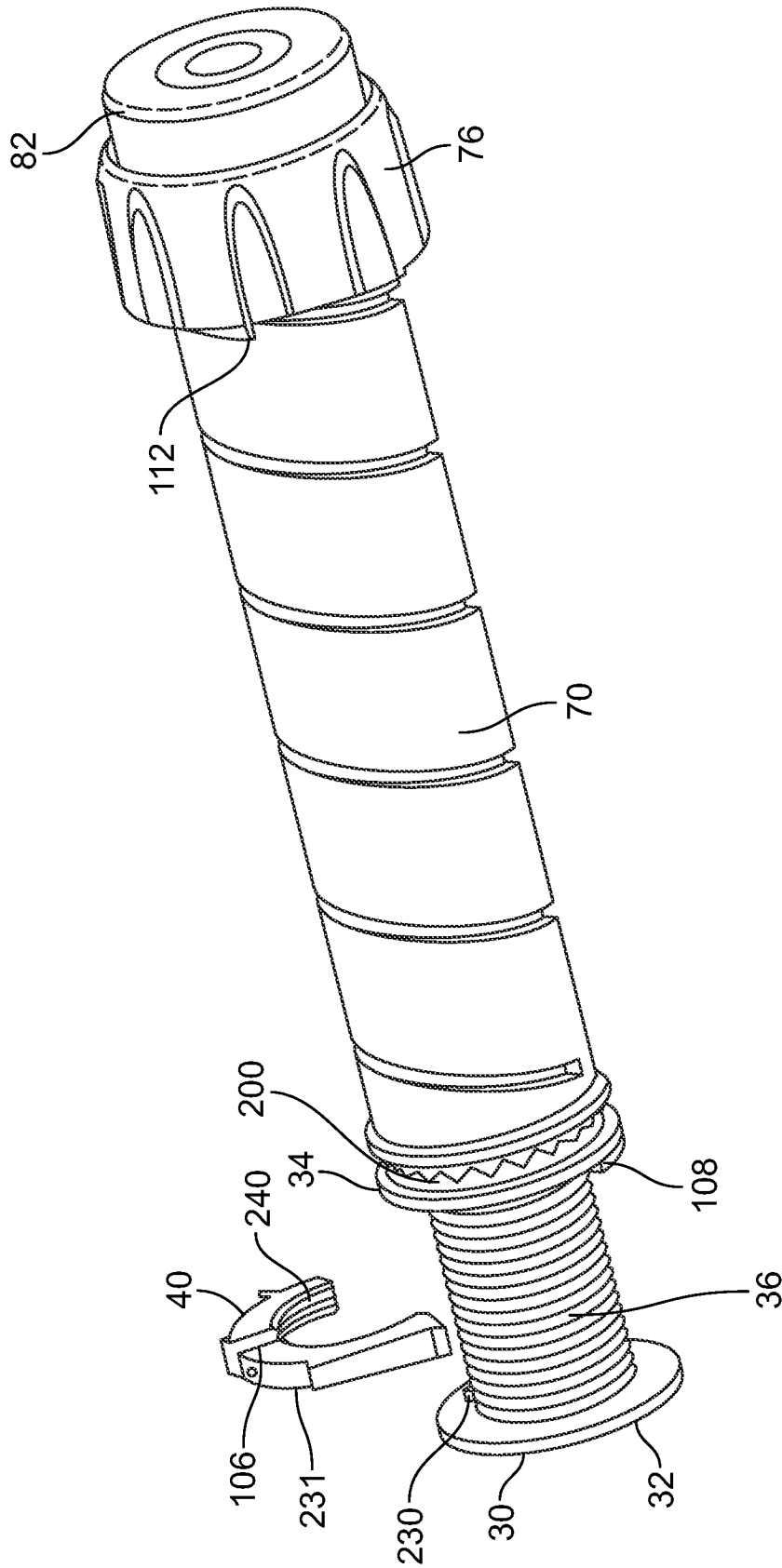
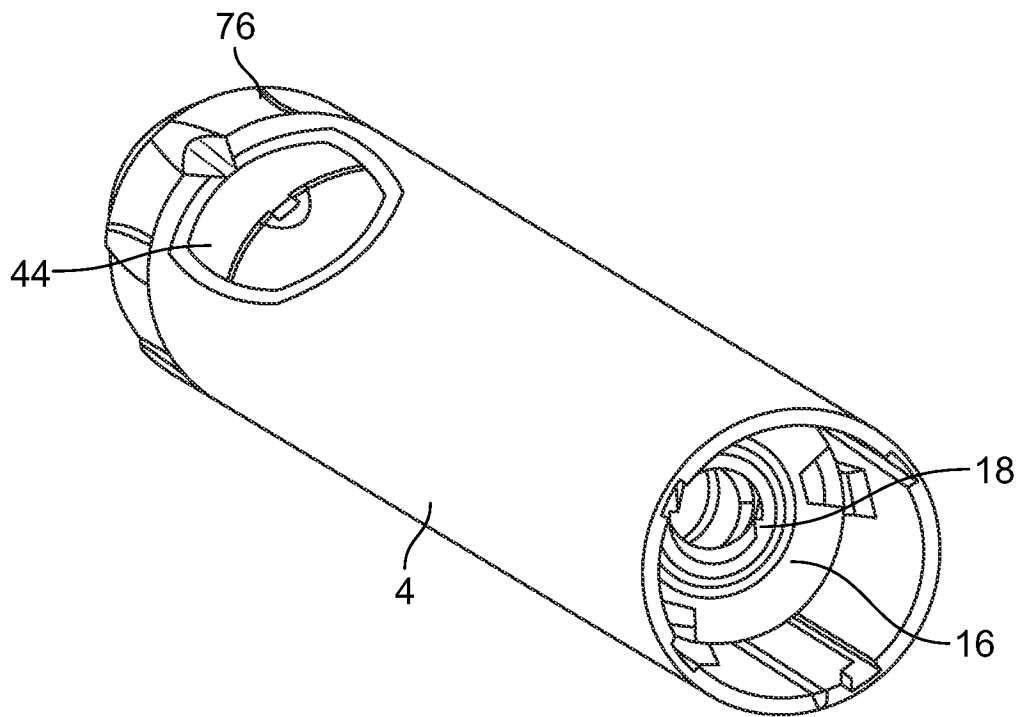


FIG. 31



**FIG. 32**

## Electronic Acknowledgement Receipt

<b>EFS ID:</b>	19541295
<b>Application Number:</b>	14319388
<b>International Application Number:</b>	
<b>Confirmation Number:</b>	6141
<b>Title of Invention:</b>	IMPROVEMENTS IN AND RELATING TO DRIVE MECHANISMS SUITABLE FOR USE IN DRUG DELIVERY DEVICES
<b>First Named Inventor/Applicant Name:</b>	Robert Frederick Veasey
<b>Customer Number:</b>	98548
<b>Filer:</b>	David M. Frischkorn
<b>Filer Authorized By:</b>	
<b>Attorney Docket Number:</b>	10-015-US-CON9
<b>Receipt Date:</b>	10-JUL-2014
<b>Filing Date:</b>	
<b>Time Stamp:</b>	13:17:07
<b>Application Type:</b>	Utility under 35 USC 111(a)

### Payment information:

Submitted with Payment	no
------------------------	----

### File Listing:

Document Number	Document Description	File Name	File Size(Bytes)/ Message Digest	Multi Part /.zip	Pages (if appl.)
1	Miscellaneous Incoming Letter	10-015-US-CON9_Submission. pdf	81340 <small>297c4d77c5503e1f324abc450bfb56c4a110b5d8</small>	no	1

### Warnings:

### Information:

2	Drawings-only black and white line drawings	10-015-US- CON9_New_Drawings.pdf	80173  2eda2c1726a5f1fedadee796fab501ff7e26e ece	no	6
---	---	-------------------------------------	---	----	---

**Warnings:**

**Information:**

<b>Total Files Size (in bytes):</b>	161513
-------------------------------------	--------

**This Acknowledgement Receipt evidences receipt on the noted date by the USPTO of the indicated documents, characterized by the applicant, and including page counts, where applicable. It serves as evidence of receipt similar to a Post Card, as described in MPEP 503.**

**New Applications Under 35 U.S.C. 111**

**If a new application is being filed and the application includes the necessary components for a filing date (see 37 CFR 1.53(b)-(d) and MPEP 506), a Filing Receipt (37 CFR 1.54) will be issued in due course and the date shown on this Acknowledgement Receipt will establish the filing date of the application.**

**National Stage of an International Application under 35 U.S.C. 371**

**If a timely submission to enter the national stage of an international application is compliant with the conditions of 35 U.S.C. 371 and other applicable requirements a Form PCT/DO/EO/903 indicating acceptance of the application as a national stage submission under 35 U.S.C. 371 will be issued in addition to the Filing Receipt, in due course.**

**New International Application Filed with the USPTO as a Receiving Office**

**If a new international application is being filed and the international application includes the necessary components for an international filing date (see PCT Article 11 and MPEP 1810), a Notification of the International Application Number and of the International Filing Date (Form PCT/RO/105) will be issued in due course, subject to prescriptions concerning national security, and the date shown on this Acknowledgement Receipt will establish the international filing date of the application.**



UNITED STATES PATENT AND TRADEMARK OFFICE

UNITED STATES DEPARTMENT OF COMMERCE
United States Patent and Trademark Office
Address: COMMISSIONER FOR PATENTS
P.O. Box 1450
Alexandria, Virginia 22313-1450
www.uspto.gov

Table with 4 columns: APPLICATION NUMBER (14/319,388), FILING OR 371(C) DATE (06/30/2014), FIRST NAMED APPLICANT (Robert Frederick Veasey), ATTY. DOCKET NO./TITLE (10-015-US-CON9)

CONFIRMATION NO. 6141

98548
McDonnell Boehnen Hulbert & Berghoff LLP
Sanofi - Aventis
300 South Wacker Drive
Chicago, IL 60606

NOTICE



Date Mailed: 07/14/2014

INFORMATIONAL NOTICE TO APPLICANT

Applicant is notified that the above-identified application contains the deficiencies noted below. No period for reply is set forth in this notice for correction of these deficiencies. However, if a deficiency relates to the inventor's oath or declaration, the applicant must file an oath or declaration in compliance with 37 CFR 1.63, or a substitute statement in compliance with 37 CFR 1.64, executed by or with respect to each actual inventor no later than the expiration of the time period set in the "Notice of Allowability" to avoid abandonment. See 37 CFR 1.53(f).

The item(s) indicated below are also required and should be submitted with any reply to this notice to avoid further processing delays.

A new inventor's oath or declaration that identifies this application (e.g., by Application Number and filing date) is required. The inventor's oath or declaration does not comply with 37 CFR 1.63 in that it:

- does not state that the above-identified application was made or authorized to be made by the person executing the oath or declaration.

Robert Frederick Veasey
Robert Perkins
David Aubrey Plumptre



UNITED STATES PATENT AND TRADEMARK OFFICE

UNITED STATES DEPARTMENT OF COMMERCE
United States Patent and Trademark Office
Address: COMMISSIONER FOR PATENTS
P.O. Box 1450
Alexandria, Virginia 22313-1450
www.uspto.gov

Table with 7 columns: APPLICATION NUMBER, FILING or 371(c) DATE, GRP ART UNIT, FIL FEE REC'D, ATTY. DOCKET NO, TOT CLAIMS, IND CLAIMS. Row 1: 14/319,388, 06/30/2014, 3763, 1600, 10-015-US-CON9, 19, 1

CONFIRMATION NO. 6141

FILING RECEIPT

98548
McDonnell Boehnen Hulbert & Berghoff LLP
Sanofi - Aventis
300 South Wacker Drive
Chicago, IL 60606



Date Mailed: 07/14/2014

Receipt is acknowledged of this non-provisional patent application. The application will be taken up for examination in due course. Applicant will be notified as to the results of the examination. Any correspondence concerning the application must include the following identification information: the U.S. APPLICATION NUMBER, FILING DATE, NAME OF APPLICANT, and TITLE OF INVENTION. Fees transmitted by check or draft are subject to collection. Please verify the accuracy of the data presented on this receipt. If an error is noted on this Filing Receipt, please submit a written request for a Filing Receipt Correction. Please provide a copy of this Filing Receipt with the changes noted thereon. If you received a "Notice to File Missing Parts" for this application, please submit any corrections to this Filing Receipt with your reply to the Notice. When the USPTO processes the reply to the Notice, the USPTO will generate another Filing Receipt incorporating the requested corrections

Inventor(s)

Robert Frederick Veasey, Warwickshire, UNITED KINGDOM;
Robert Perkins, Warwickshire, UNITED KINGDOM;
David Aubrey Plumptre, Worcestershire, UNITED KINGDOM;

Applicant(s)

SANOFI-AVENTIS DEUTSCHLAND GMBH, FRANKFURT AM MAIN, GERMANY

Power of Attorney: The patent practitioners associated with Customer Number 98548

Domestic Priority data as claimed by applicant

This application is a CON of 12/941,702 11/08/2010
which is a CON of 12/320,189 01/21/2009 PAT 7850662
which is a CON of 11/520,598 09/14/2006 PAT 7935088
which is a CON of 10/790,866 03/03/2004 ABN

Foreign Applications (You may be eligible to benefit from the Patent Prosecution Highway program at the USPTO. Please see http://www.uspto.gov for more information.)

UNITED KINGDOM 0304822.0 03/03/2003 No Access Code Provided

Permission to Access - A proper Authorization to Permit Access to Application by Participating Offices (PTO/SB/39 or its equivalent) has been received by the USPTO.

If Required, Foreign Filing License Granted: 07/11/2014

The country code and number of your priority application, to be used for filing abroad under the Paris Convention, is US 14/319,388

Projected Publication Date: 10/23/2014

**Non-Publication Request:** No

**Early Publication Request:** No

**Title**

DRIVE MECHANISMS SUITABLE FOR USE IN DRUG DELIVERY DEVICES

**Preliminary Class**

604

**Statement under 37 CFR 1.55 or 1.78 for AIA (First Inventor to File) Transition Applications:** No

## **PROTECTING YOUR INVENTION OUTSIDE THE UNITED STATES**

Since the rights granted by a U.S. patent extend only throughout the territory of the United States and have no effect in a foreign country, an inventor who wishes patent protection in another country must apply for a patent in a specific country or in regional patent offices. Applicants may wish to consider the filing of an international application under the Patent Cooperation Treaty (PCT). An international (PCT) application generally has the same effect as a regular national patent application in each PCT-member country. The PCT process **simplifies** the filing of patent applications on the same invention in member countries, but **does not result** in a grant of "an international patent" and does not eliminate the need of applicants to file additional documents and fees in countries where patent protection is desired.

Almost every country has its own patent law, and a person desiring a patent in a particular country must make an application for patent in that country in accordance with its particular laws. Since the laws of many countries differ in various respects from the patent law of the United States, applicants are advised to seek guidance from specific foreign countries to ensure that patent rights are not lost prematurely.

Applicants also are advised that in the case of inventions made in the United States, the Director of the USPTO must issue a license before applicants can apply for a patent in a foreign country. The filing of a U.S. patent application serves as a request for a foreign filing license. The application's filing receipt contains further information and guidance as to the status of applicant's license for foreign filing.

Applicants may wish to consult the USPTO booklet, "General Information Concerning Patents" (specifically, the section entitled "Treaties and Foreign Patents") for more information on timeframes and deadlines for filing foreign patent applications. The guide is available either by contacting the USPTO Contact Center at 800-786-9199, or it can be viewed on the USPTO website at <http://www.uspto.gov/web/offices/pac/doc/general/index.html>.

For information on preventing theft of your intellectual property (patents, trademarks and copyrights), you may wish to consult the U.S. Government website, <http://www.stopfakes.gov>. Part of a Department of Commerce initiative, this website includes self-help "toolkits" giving innovators guidance on how to protect intellectual property in specific countries such as China, Korea and Mexico. For questions regarding patent enforcement issues, applicants may call the U.S. Government hotline at 1-866-999-HALT (1-866-999-4258).



**LICENSE FOR FOREIGN FILING UNDER**  
**Title 35, United States Code, Section 184**  
**Title 37, Code of Federal Regulations, 5.11 & 5.15**

**GRANTED**

The applicant has been granted a license under 35 U.S.C. 184, if the phrase "IF REQUIRED, FOREIGN FILING LICENSE GRANTED" followed by a date appears on this form. Such licenses are issued in all applications where the conditions for issuance of a license have been met, regardless of whether or not a license may be required as set forth in 37 CFR 5.15. The scope and limitations of this license are set forth in 37 CFR 5.15(a) unless an earlier license has been issued under 37 CFR 5.15(b). The license is subject to revocation upon written notification. The date indicated is the effective date of the license, unless an earlier license of similar scope has been granted under 37 CFR 5.13 or 5.14.

This license is to be retained by the licensee and may be used at any time on or after the effective date thereof unless it is revoked. This license is automatically transferred to any related applications(s) filed under 37 CFR 1.53(d). This license is not retroactive.

The grant of a license does not in any way lessen the responsibility of a licensee for the security of the subject matter as imposed by any Government contract or the provisions of existing laws relating to espionage and the national security or the export of technical data. Licensees should apprise themselves of current regulations especially with respect to certain countries, of other agencies, particularly the Office of Defense Trade Controls, Department of State (with respect to Arms, Munitions and Implements of War (22 CFR 121-128)); the Bureau of Industry and Security, Department of Commerce (15 CFR parts 730-774); the Office of Foreign Assets Control, Department of Treasury (31 CFR Parts 500+) and the Department of Energy.

**NOT GRANTED**

No license under 35 U.S.C. 184 has been granted at this time, if the phrase "IF REQUIRED, FOREIGN FILING LICENSE GRANTED" DOES NOT appear on this form. Applicant may still petition for a license under 37 CFR 5.12, if a license is desired before the expiration of 6 months from the filing date of the application. If 6 months has lapsed from the filing date of this application and the licensee has not received any indication of a secrecy order under 35 U.S.C. 181, the licensee may foreign file the application pursuant to 37 CFR 5.15(b).

---

***SelectUSA***

The United States represents the largest, most dynamic marketplace in the world and is an unparalleled location for business investment, innovation, and commercialization of new technologies. The U.S. offers tremendous resources and advantages for those who invest and manufacture goods here. Through SelectUSA, our nation works to promote and facilitate business investment. SelectUSA provides information assistance to the international investor community; serves as an ombudsman for existing and potential investors; advocates on behalf of U.S. cities, states, and regions competing for global investment; and counsels U.S. economic development organizations on investment attraction best practices. To learn more about why the United States is the best country in the world to develop technology, manufacture products, deliver services, and grow your business, visit <http://www.SelectUSA.gov> or call +1-202-482-6800.

**PATENT APPLICATION FEE DETERMINATION RECORD**

Substitute for Form PTO-875

Application or Docket Number  
14/319,388

**APPLICATION AS FILED - PART I**

(Column 1) (Column 2)

FOR	NUMBER FILED	NUMBER EXTRA
BASIC FEE (37 CFR 1.16(a), (b), or (c))	N/A	N/A
SEARCH FEE (37 CFR 1.16(k), (l), or (m))	N/A	N/A
EXAMINATION FEE (37 CFR 1.16(o), (p), or (q))	N/A	N/A
TOTAL CLAIMS (37 CFR 1.16(j))	19	minus 20 = *
INDEPENDENT CLAIMS (37 CFR 1.16(h))	1	minus 3 = *
APPLICATION SIZE FEE (37 CFR 1.16(s))	If the specification and drawings exceed 100 sheets of paper, the application size fee due is \$310 (\$155 for small entity) for each additional 50 sheets or fraction thereof. See 35 U.S.C. 41(a)(1)(G) and 37 CFR 1.16(s).	
MULTIPLE DEPENDENT CLAIM PRESENT (37 CFR 1.16(j))		

**SMALL ENTITY**

RATE(\$)	FEE(\$)
N/A	
N/A	
N/A	
TOTAL	

**OR OTHER THAN SMALL ENTITY**

RATE(\$)	FEE(\$)
N/A	280
N/A	600
N/A	720
x 80 =	0.00
x 420 =	0.00
	0.00
	0.00
TOTAL	1600

\* If the difference in column 1 is less than zero, enter "0" in column 2.

**APPLICATION AS AMENDED - PART II**

(Column 1) (Column 2) (Column 3)

AMENDMENT A		CLAIMS REMAINING AFTER AMENDMENT		HIGHEST NUMBER PREVIOUSLY PAID FOR	PRESENT EXTRA
	Total (37 CFR 1.16(j))	*	Minus	**	=
	Independent (37 CFR 1.16(h))	*	Minus	***	=
	Application Size Fee (37 CFR 1.16(s))				
FIRST PRESENTATION OF MULTIPLE DEPENDENT CLAIM (37 CFR 1.16(j))					

**SMALL ENTITY**

RATE(\$)	ADDITIONAL FEE(\$)
x =	
x =	
TOTAL ADD'L FEE	

**OR OTHER THAN SMALL ENTITY**

RATE(\$)	ADDITIONAL FEE(\$)
x =	
x =	
TOTAL ADD'L FEE	

(Column 1) (Column 2) (Column 3)

AMENDMENT B		CLAIMS REMAINING AFTER AMENDMENT		HIGHEST NUMBER PREVIOUSLY PAID FOR	PRESENT EXTRA
	Total (37 CFR 1.16(j))	*	Minus	**	=
	Independent (37 CFR 1.16(h))	*	Minus	***	=
	Application Size Fee (37 CFR 1.16(s))				
FIRST PRESENTATION OF MULTIPLE DEPENDENT CLAIM (37 CFR 1.16(j))					

**SMALL ENTITY**

RATE(\$)	ADDITIONAL FEE(\$)
x =	
x =	
TOTAL ADD'L FEE	

**OR OTHER THAN SMALL ENTITY**

RATE(\$)	ADDITIONAL FEE(\$)
x =	
x =	
TOTAL ADD'L FEE	

\* If the entry in column 1 is less than the entry in column 2, write "0" in column 3.

\*\* If the "Highest Number Previously Paid For" IN THIS SPACE is less than 20, enter "20".

\*\*\* If the "Highest Number Previously Paid For" IN THIS SPACE is less than 3, enter "3".

The "Highest Number Previously Paid For" (Total or Independent) is the highest found in the appropriate box in column 1.

**IN THE UNITED STATES PATENT AND TRADEMARK OFFICE**

(Attorney Docket No. 10-015-US-CON9)

Applicant: Robert Frederick Veasey, *et al.*  
Appl. No.: 14/319,388  
Filed: June 30, 2014  
Title: DRIVE MECHANISMS SUITABLE FOR USE IN DRUG DELIVERY  
DEVICES  
TC/A.U.: 3763  
Confirmation No.: 6141  
Examiner: TBD  
Mail Stop Missing Parts  
Commissioner for Patents  
P.O. Box 1450  
Alexandria, VA 22313-1450

**RESPONSE TO INFORMATIONAL NOTICE TO APPLICANT**

Dear Sir:

In response to the Informational Notice to Applicant mailed July 14, 2014, Applicants submit herewith a newly executed Oath for the application.

No fees are believed to be due at this time. However, if the Commissioner believes a fee is due, the Commissioner is hereby authorized to charge any fees or credit any overpayment to Deposit Account No. 13-2490.

Respectfully submitted,  
**McDonnell Boehnen Hulbert & Berghoff LLP**

Dated: July 23, 2014

By: /David M. Frischkorn/  
David M. Frischkorn  
Registration No. 32,833

McDonnell Boehnen  
Hulbert & Berghoff LLP  
300 South Wacker Drive  
Chicago, IL 60606  
Tel: 312-913-0001

Under the Paperwork Reduction Act of 1995, no persons are required to respond to a collection of information unless it displays a valid OMB control number.

**DECLARATION (37 CFR 1.63) FOR UTILITY OR DESIGN APPLICATION USING AN APPLICATION DATA SHEET (37 CFR 1.76)**

Title of Invention

IMPROVEMENTS IN AND RELATING TO DRIVE MECHANISMS SUITABLE FOR USE IN DRUG DELIVERY DEVICES

As the below named inventor, I hereby declare that:

This declaration is directed to:

The attached application, or

United States application or PCT international application number 14/319,388

filed on June 30, 2014

The above-identified application was made or authorized to be made by me.

I believe that I am the original inventor or an original joint inventor of a claimed invention in the application.

I hereby acknowledge that any willful false statement made in this declaration is punishable under 18 U.S.C. 1001 by fine or imprisonment of not more than five (5) years, or both.

**WARNING:**

Petitioner/applicant is cautioned to avoid submitting personal information in documents filed in a patent application that may contribute to identity theft. Personal information such as social security numbers, bank account numbers, or credit card numbers (other than a check or credit card authorization form PTO-2038 submitted for payment purposes) is never required by the USPTO to support a petition or an application. If this type of personal information is included in documents submitted to the USPTO, petitioners/applicants should consider redacting such personal information from the documents before submitting them to the USPTO. Petitioner/applicant is advised that the record of a patent application is available to the public after publication of the application (unless a non-publication request in compliance with 37 CFR 1.213(a) is made in the application) or issuance of a patent. Furthermore, the record from an abandoned application may also be available to the public if the application is referenced in a published application or an issued patent (see 37 CFR 1.14). Checks and credit card authorization forms PTO-2038 submitted for payment purposes are not retained in the application file and therefore are not publicly available.

LEGAL NAME OF INVENTOR

Inventor: Robert Frederick Veasey

Date (Optional): 7/7/2014

Signature: R. Veasey

Note: An application data sheet (PTO/SB/14 or equivalent), including naming the entire inventive entity, must accompany this form or must have been previously filed. Use an additional PTO/AIA/01 form for each additional inventor.

This collection of information is required by 35 U.S.C. 115 and 37 CFR 1.63. The information is required to obtain or retain a benefit by the public which is to file (and by the USPTO to process) an application. Confidentiality is governed by 35 U.S.C. 122 and 37 CFR 1.11 and 1.14. This collection is estimated to take 1 minute to complete, including gathering, preparing, and submitting the completed application form to the USPTO. Time will vary depending upon the individual case. Any comments on the amount of time you require to complete this form and/or suggestions for reducing this burden, should be sent to the Chief Information Officer, U.S. Patent and Trademark Office, U.S. Department of Commerce, P.O. Box 1455, Alexandria, VA 22313-1455. DO NOT SEND FEES OR COMPLETED FORMS TO THIS ADDRESS. SEND TO: Commissioner for Patents, P.O. Box 1455, Alexandria, VA 22313-1455.

If you need assistance in completing the form, call 1-800-PTO-9199 and select option 2.

Under the Paperwork Reduction Act of 1995, no persons are required to respond to a collection of information unless it displays a valid OMB control number.

**DECLARATION (37 CFR 1.63) FOR UTILITY OR DESIGN APPLICATION USING AN APPLICATION DATA SHEET (37 CFR 1.76)**

Title of Invention	IMPROVEMENTS IN AND RELATING TO DRIVE MECHANISMS SUITABLE FOR USE IN DRUG DELIVERY DEVICES
--------------------	--

As the below named inventor, I hereby declare that:

This declaration is directed to:  The attached application, or  United States application or PCT international application number 14/319,388  
filed on June 30, 2014

The above-identified application was made or authorized to be made by me.

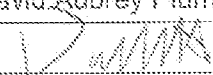
I believe that I am the original inventor or an original joint inventor of a claimed invention in the application.

I hereby acknowledge that any willful false statement made in this declaration is punishable under 18 U.S.C. 1001 by fine or imprisonment of not more than five (5) years, or both.

**WARNING:**

Petitioner/applicant is cautioned to avoid submitting personal information in documents filed in a patent application that may contribute to identify theft. Personal information such as social security numbers, bank account numbers, or credit card numbers (other than a check or credit card authorization form PTO-2038 submitted for payment purposes) is never required by the USPTO to support a petition or an application. If this type of personal information is included in documents submitted to the USPTO, petitioners/applicants should consider redacting such personal information from the documents before submitting them to the USPTO. Petitioner/applicant is advised that the record of a patent application is available to the public after publication of the application (unless a non-publication request in compliance with 37 CFR 1.213(a) is made in the application) or issuance of a patent. Furthermore, the record from an abandoned application may also be available to the public if the application is referenced in a published application or an issued patent (see 37 CFR 1.14). Checks and credit card authorization forms PTO-2038 submitted for payment purposes are not retained in the application file and therefore are not publicly available.

**LEGAL NAME OF INVENTOR**

Inventor: David Aubrey Plumptre Date (Optional): \_\_\_\_\_  
Signature: 

Note: An application data sheet (PTO/SB/14 or equivalent), including naming the entire inventive entity, must accompany this form or must have been previously filed. Use an additional PTO/AIA/01 form for each additional inventor.

This collection of information is required by 35 U.S.C. 115 and 37 CFR 1.63. The information is required to obtain or retain a benefit by the public which is to file (and by the USPTO to process) an application. Confidentiality is governed by 35 U.S.C. 120 and 37 CFR 1.11 and 1.14. This collection is estimated to take 1 minute to complete, including gathering, preparing, and submitting the completed application form to the USPTO. Time will vary depending upon the individual case. Any comments on the amount of time you require to complete this form and/or suggestions for reducing this burden, should be sent to the Chief Information Officer, U.S. Patent and Trademark Office, U.S. Department of Commerce, P.O. Box 1450, Alexandria, VA 22313-1450. DO NOT SEND FEES OR COMPLETED FORMS TO THIS ADDRESS. SEND TO: Commissioner for Patents, P.O. Box 1450, Alexandria, VA 22313-1450.

If you need assistance in completing this form, call 1-800-PTO-9199 and select option 2.

## DECLARATION (37 CFR 1.63) FOR UTILITY OR DESIGN APPLICATION USING AN APPLICATION DATA SHEET (37 CFR 1.76)

Title of Invention: **IMPROVEMENTS IN AND RELATING TO DRIVE MECHANISMS SUITABLE FOR USE IN DRUG DELIVERY DEVICES**

As the below named inventor, I hereby declare that:

This declaration is directed to:  The attached application, or  
 United States application or PCT international application number 14/319,388  
 filed on June 30, 2014

The above-identified application was made or authorized to be made by me.

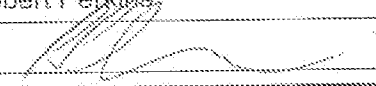
I believe that I am the original inventor or an original joint inventor of a claimed invention in the application.

I hereby acknowledge that any willful false statement made in this declaration is punishable under 18 U.S.C. 1001 by fine or imprisonment of not more than five (5) years, or both.

### WARNING:

Petitioner/applicant is cautioned to avoid submitting personal information in documents filed in a patent application that may contribute to identity theft. Personal information such as social security numbers, bank account numbers, or credit card numbers (other than a check or credit card authorization form PTO-2038 submitted for payment purposes) is never required by the USPTO to support a petition or an application. If this type of personal information is included in documents submitted to the USPTO, petitioners/applicants should consider redacting such personal information from the documents before submitting them to the USPTO. Petitioner/applicant is advised that the record of a patent application is available to the public after publication of the application (unless a non-publication request in compliance with 37 CFR 1.213(a) is made in the application) or issuance of a patent. Furthermore, the record from an abandoned application may also be available to the public if the application is referenced in a published application or an issued patent (see 37 CFR 1.14). Checks and credit card authorization forms PTO-2038 submitted for payment purposes are not retained in the application file and therefore are not publicly available.

### LEGAL NAME OF INVENTOR

Inventor: Robert Perkins Date (Optional): 08/30/2014  
 Signature: 

Note: An application data sheet (PTO/SB/14 or equivalent), including naming the entire inventive entity, must accompany this form or must have been previously filed. Use an additional PTO/AIA/01 form for each additional inventor.

This collection of information is required by 35 U.S.C. 115 and 37 CFR 1.63. The information is required to obtain or retain a benefit by the public which is to file (and by the USPTO to process) an application. Confidentiality is governed by 35 U.S.C. 122 and 37 CFR 1.11 and 1.14. This collection is estimated to take 1 minute to complete, including gathering, preparing, and submitting the completed application form to the USPTO. Time will vary depending upon the individual case. Any comments on the amount of time you require to complete this form and/or suggestions for reducing this burden, should be sent to the Chief Information Officer, U.S. Patent and Trademark Office, U.S. Department of Commerce, P.O. Box 1450, Alexandria, VA 22313-1450. DO NOT SEND FEES OR COMPLETED FORMS TO THIS ADDRESS. SEND TO: Commissioner for Patents, P.O. Box 1450, Alexandria, VA 22313-1450.

If you need assistance in completing this form, call 1-800-PTO-9199 and select option 2.

## Electronic Acknowledgement Receipt

<b>EFS ID:</b>	19657040
<b>Application Number:</b>	14319388
<b>International Application Number:</b>	
<b>Confirmation Number:</b>	6141
<b>Title of Invention:</b>	DRIVE MECHANISMS SUITABLE FOR USE IN DRUG DELIVERY DEVICES
<b>First Named Inventor/Applicant Name:</b>	Robert Frederick Veasey
<b>Customer Number:</b>	98548
<b>Filer:</b>	David M. Frischkorn
<b>Filer Authorized By:</b>	
<b>Attorney Docket Number:</b>	10-015-US-CON9
<b>Receipt Date:</b>	23-JUL-2014
<b>Filing Date:</b>	30-JUN-2014
<b>Time Stamp:</b>	15:05:08
<b>Application Type:</b>	Utility under 35 USC 111(a)

### Payment information:

Submitted with Payment	no
------------------------	----

### File Listing:

Document Number	Document Description	File Name	File Size(Bytes)/ Message Digest	Multi Part /.zip	Pages (if appl.)
1	Applicant Response to Pre-Exam Formalities Notice	10-015-US-CON9_Response.pdf	80336 <small>dc4faa89e090ee7640becde1a5da37c343e8d163</small>	no	1

### Warnings:

### Information:

2	Oath or Declaration filed	10-015-US-CON9_Declarations.pdf	2034108 e16b1165ea8b69c19e3184196c19801f96af5ea9	no	3
---	---------------------------	---------------------------------	---	----	---

**Warnings:**

**Information:**

<b>Total Files Size (in bytes):</b>	2114444
-------------------------------------	---------

**This Acknowledgement Receipt evidences receipt on the noted date by the USPTO of the indicated documents, characterized by the applicant, and including page counts, where applicable. It serves as evidence of receipt similar to a Post Card, as described in MPEP 503.**

**New Applications Under 35 U.S.C. 111**

**If a new application is being filed and the application includes the necessary components for a filing date (see 37 CFR 1.53(b)-(d) and MPEP 506), a Filing Receipt (37 CFR 1.54) will be issued in due course and the date shown on this Acknowledgement Receipt will establish the filing date of the application.**

**National Stage of an International Application under 35 U.S.C. 371**

**If a timely submission to enter the national stage of an international application is compliant with the conditions of 35 U.S.C. 371 and other applicable requirements a Form PCT/DO/EO/903 indicating acceptance of the application as a national stage submission under 35 U.S.C. 371 will be issued in addition to the Filing Receipt, in due course.**

**New International Application Filed with the USPTO as a Receiving Office**

**If a new international application is being filed and the international application includes the necessary components for an international filing date (see PCT Article 11 and MPEP 1810), a Notification of the International Application Number and of the International Filing Date (Form PCT/RO/105) will be issued in due course, subject to prescriptions concerning national security, and the date shown on this Acknowledgement Receipt will establish the international filing date of the application.**





UNITED STATES PATENT AND TRADEMARK OFFICE

UNITED STATES DEPARTMENT OF COMMERCE
United States Patent and Trademark Office
Address: COMMISSIONER FOR PATENTS
P.O. Box 1450
Alexandria, Virginia 22313-1450
www.uspto.gov

Table with 4 columns: APPLICATION NUMBER (14/319,388), FILING OR 371(C) DATE (06/30/2014), FIRST NAMED APPLICANT (Robert Frederick Veasey), ATTY. DOCKET NO./TITLE (10-015-US-CON9)

CONFIRMATION NO. 6141

PUBLICATION NOTICE



98548
McDonnell Boehnen Hulbert & Berghoff LLP
Sanofi - Aventis
300 South Wacker Drive
Chicago, IL 60606

Title:DRIVE MECHANISMS SUITABLE FOR USE IN DRUG DELIVERY DEVICES

Publication No.US-2014-0316348-A1
Publication Date:10/23/2014

NOTICE OF PUBLICATION OF APPLICATION

The above-identified application will be electronically published as a patent application publication pursuant to 37 CFR 1.211, et seq. The patent application publication number and publication date are set forth above.

The publication may be accessed through the USPTO's publically available Searchable Databases via the Internet at www.uspto.gov. The direct link to access the publication is currently http://www.uspto.gov/patft/.

The publication process established by the Office does not provide for mailing a copy of the publication to applicant. A copy of the publication may be obtained from the Office upon payment of the appropriate fee set forth in 37 CFR 1.19(a)(1). Orders for copies of patent application publications are handled by the USPTO's Office of Public Records. The Office of Public Records can be reached by telephone at (703) 308-9726 or (800) 972-6382, by facsimile at (703) 305-8759, by mail addressed to the United States Patent and Trademark Office, Office of Public Records, Alexandria, VA 22313-1450 or via the Internet.

In addition, information on the status of the application, including the mailing date of Office actions and the dates of receipt of correspondence filed in the Office, may also be accessed via the Internet through the Patent Electronic Business Center at www.uspto.gov using the public side of the Patent Application Information and Retrieval (PAIR) system. The direct link to access this status information is currently http://pair.uspto.gov/. Prior to publication, such status information is confidential and may only be obtained by applicant using the private side of PAIR.

Further assistance in electronically accessing the publication, or about PAIR, is available by calling the Patent Electronic Business Center at 1-866-217-9197.

Office of Data Management, Application Assistance Unit (571) 272-4000, or (571) 272-4200, or 1-888-786-0101



UNITED STATES PATENT AND TRADEMARK OFFICE

UNITED STATES DEPARTMENT OF COMMERCE
United States Patent and Trademark Office
Address: COMMISSIONER FOR PATENTS
P.O. Box 1450
Alexandria, Virginia 22313-1450
www.uspto.gov

Table with 5 columns: APPLICATION NO., FILING DATE, FIRST NAMED INVENTOR, ATTORNEY DOCKET NO., CONFIRMATION NO.
14/319,388 06/30/2014 Robert Frederick Veasey 10-015-US-CON9 6141

98548 7590 02/24/2016
McDonnell Boehnen Hulbert & Berghoff LLP
Sanofi - Aventis
300 South Wacker Drive
Chicago, IL 60606

EXAMINER

GILBERT, ANDREW M

ART UNIT PAPER NUMBER

3763

MAIL DATE DELIVERY MODE

02/24/2016

PAPER

Please find below and/or attached an Office communication concerning this application or proceeding.

The time period for reply, if any, is set in the attached communication.



## DETAILED ACTION

### ***Notice of Pre-AIA or AIA Status***

1. The present application is being examined under the pre-AIA first to invent provisions.

### ***Acknowledgments***

2. The present application, filed on 6/30/2014, is a continuation of USPN 9028454, which is a continuation of USPN 7850662, which is a continuation of USPN 7935088, which is a continuation of US App. No. 10/790866 (abandoned), filed on 3/3/2004, which claims foreign priority to GB0304822.0 filed on 3/3/2003.

3. ***The applicant is advised to update the continuity data in ¶0001 of the Specification.***

4. Claims 1-19 are pending for examination.

### ***Priority***

5. The examiner notes that the present application appears to include new drawings and description not previously disclosed in the prior filed applications, application No. 12941702 (USPN 9028454), 12320189 (USPN 7850662), 11520598 (USPN 7935088), 10/790866 (abandoned), and GB 0304822.0.

6. For example, Figs 25-32 are new and while Figs 25-32 are disclosed as being perspective and exploded views of the embodiment of Fig 1 and the examiner appreciates the additional clarity provided by the drawings, the examiner finds several differences, including, for example, the embodiment of Fig 1 including a clicker 50, while

Art Unit: 3763

Fig 25 does not have a clicker at all and instead has a spring 200 which contacts proximally facing teeth 66.

7. However, ***as presently claimed***, the claimed subject matter is properly supported by Fig 1-16 and the accompanying disclosure and prior-filed applications.

8. For example, GB 0304822.0 discloses identical Figures 1-16 to present Figures 1-16, and discloses an insert 16 with a threaded circular opening 18, a drive sleeve 30 with an internal thread 38, and a piston rod 20 having 1<sup>st</sup> thread 19 and second thread 24 (pg 5, lns 25-31; pg 6, lns 6-14) and appears to support the subject matter of claims 1-13, 17-19.

9. However, claims 14-15 are not properly supported in GB 0304822.0, which does not disclose the claimed ratios. US App. No. 10/790,866 discloses in ¶37 of the PGPUB US 20050033244 A1 the ratios being about 1:1.01 to 1:2 or 1:1.1 to 1:10.

**10. Thus, the effective filing date of claims 1-13, 17-19 is 3/3/2003 and claims 14-15 is 3/4/2004.**

#### ***Information Disclosure Statement***

11. The information disclosure statement (IDS) submitted on 6/30/2014 is in compliance with the provisions of 37 CFR 1.97. Accordingly, the information disclosure statement is being considered by the examiner.

#### ***Drawings***

12. The drawings are objected to as failing to comply with 37 CFR 1.84(p)(4) because reference character "38" has been used to designate both a helical groove and a radially outwardly directly flange (i.e. the examiner believes should be reference

Art Unit: 3763

number 39 instead of 38 – see ¶94 of PGPub US 2014/0316348 A1). Corrected drawing sheets in compliance with 37 CFR 1.121(d) are required in reply to the Office action to avoid abandonment of the application. Any amended replacement drawing sheet should include all of the figures appearing on the immediate prior version of the sheet, even if only one figure is being amended. Each drawing sheet submitted after the filing date of an application must be labeled in the top margin as either “Replacement Sheet” or “New Sheet” pursuant to 37 CFR 1.121(d). If the changes are not accepted by the examiner, the applicant will be notified and informed of any required corrective action in the next Office action. The objection to the drawings will not be held in abeyance.

***Claim Rejections - 35 USC § 112***

13. The following is a quotation of 35 U.S.C. 112(b):  
(b) CONCLUSION.—The specification shall conclude with one or more claims particularly pointing out and distinctly claiming the subject matter which the inventor or a joint inventor regards as the invention.

The following is a quotation of 35 U.S.C. 112 (pre-AIA), second paragraph:  
The specification shall conclude with one or more claims particularly pointing out and distinctly claiming the subject matter which the applicant regards as his invention.

14. Claims 1-19 are rejected under 35 U.S.C. 112(b) or 35 U.S.C. 112 (pre-AIA), second paragraph, as being indefinite for failing to particularly point out and distinctly claim the subject matter which the inventor or a joint inventor, or for pre-AIA the applicant regards as the invention.
15. Claim 1, In 12 recites “*a clutch located between the dose dial sleeve and the drive sleeve,*” and includes a comma rather than a period at the end of the claim. The examiner is unsure whether there is a claim phrase missing or whether the applicant

Art Unit: 3763

intended to end the claim with a period instead of a comma (i.e. see 112 rejection below to claim 4 which appears to be referencing subject matter that may have intended to be included in claim 1, but was not, so it now lacks proper antecedent basis). Claims 2-19 are rejected by virtue of depending on claim 1. **Appropriate correction is required.**

16. Claim 4 recites the limitation "the threaded outer surface" in ln 1-2. There is insufficient antecedent basis for this limitation in the claim.

17. Claim 4 recites the limitation "the two radially extending flanges" in 2. There is insufficient antecedent basis for this limitation in the claim.

18. Claim 4 also ends the claim with a ";" instead of a period, so again, as discussed above in claim 1, the examiner is unsure on the intended scope of the claim and whether there is subject matter missing in the claim.

19. Claim 5 recites the limitation "the threaded outer surface" in ln 1. There is insufficient antecedent basis for this limitation in the claim.

20. Claim 6 also ends the claim with a ";" instead of a period, so again, as discussed above in claim 1, the examiner is unsure on the intended scope of the claim and whether there is subject matter missing in the claim.

21. Claim 7 recites the limitation "the threaded outer surface" in ln 1. There is insufficient antecedent basis for this limitation in the claim.

***Claim Rejections - 35 USC § 102***

22. The following is a quotation of the appropriate paragraphs of pre-AIA 35 U.S.C. 102 that form the basis for the rejections under this section made in this Office action:

A person shall be entitled to a patent unless –

Art Unit: 3763

(b) the invention was patented or described in a printed publication in this or a foreign country or in public use or on sale in this country, more than one year prior to the date of application for patent in the United States.

23. Claims 1, 3, 7-8, 10-12, 17, 18 are rejected under pre-AIA 35 U.S.C. 102(b) as being anticipated by Steinfeldt-Jensen et al (6004297). See 112 discussion above.

24. Steinfeldt-Jensen et al discloses a drive mechanism (Figs 6-10) for use in a drug delivery device comprising: a housing (1, 2) comprising a helical thread (16); a dose dial sleeve (17) having a threaded surface (Fig 8) that is engaged with the helical thread of the housing, an insert (4) provided in the housing, where the insert has a threaded circular opening (5); a drive sleeve (23) releasably connected to the dose dial sleeve (Fig 6-8) and having an internal helical thread (36); a piston rod (6) having a first thread (7) and a second thread (37), wherein the first thread is engaged with the threaded circular opening of the insert (Fig 7) and the second thread is engaged with the internal helical thread of the drive sleeve (Fig 7); and a clutch (34) located between the dose dial sleeve and the drive sleeve (col 7, lns 54-57; the examiner suggests further definition of the structure and function of the clutch to clarify the applicant's claimed invention).

25. Regarding claim 3, where insert (4) is secured in the housing against rotational and longitudinal motion (col 5, lns 52-55).

26. Regarding claims 7-8, where the threaded outer surface of the dose dial sleeve (17) has a first lead (Fig 7-8), the first thread (7) of the piston rod has a second lead (Fig 7-8).



Art Unit: 3763

27. Regarding claim 10, the clutch (34) is rotationally fixed to the drive sleeve (23) and the dose dial sleeve (17) during dose setting (col 7, lns 54-57; col 7, lns 65-col 8, lns 6).
28. Regarding claim 11, see Figs 7-8, helical housing thread 16 and corresponding threaded outer surface on 17.
29. Regarding claim 12, see Figs 7-8 and col 5, lns 53-58.
30. Regarding claim 17, see 37 and 7 in Fig 7, 8 which appear oppositely disposed.
31. Regarding claim 18, see Figs 7-8 and col 7, lns 65-col 8, lns 9 where piston rod 6 will not rotate during dose setting.

***Claim Rejections - 35 USC § 103***

32. The following is a quotation of pre-AIA 35 U.S.C. 103(a) which forms the basis for all obviousness rejections set forth in this Office action:

(a) A patent may not be obtained though the invention is not identically disclosed or described as set forth in section 102 of this title, if the differences between the subject matter sought to be patented and the prior art are such that the subject matter as a whole would have been obvious at the time the invention was made to a person having ordinary skill in the art to which said subject matter pertains. Patentability shall not be negated by the manner in which the invention was made.

33. Claim 2 is rejected under pre-AIA 35 U.S.C. 103(a) as being unpatentable over Steinfeldt-Jensen et al, as applied to claim 1 above, in view of Klitgaard et al (6582404). Steinfeldt-Jensen et al discloses the invention substantially as claimed except for expressly disclosing the drive sleeve comprising a threaded outer surface, and a limiting nut threaded engaged therewith and rotationally fixed and slidable relative to the housing. Klitgaard et al teaches that it is known to have the drive sleeve (31) comprising a threaded outer surface (33), and a limiting nut (32) threaded engaged

Art Unit: 3763

therewith and rotationally fixed and slidable relative to the housing (col 4, Ins 29-37) for the purpose of tracking the dosage delivered to stop a setting of a dose that is larger than the amount remaining in the cartridge (col 4, Ins 54-58). It would have been obvious to one having ordinary skill in the art at the time the invention was made to modify the drive mechanism as taught by Steinfeldt-Jensen et al with the thread and limiting nut as taught by Klitgaard et al for the purpose of tracking the dosage delivered to stop a setting of a dose that is larger than the amount remaining in the cartridge (col 4, Ins 54-58).

34. Claim 6, 13 are rejected under pre-AIA 35 U.S.C. 103(a) as being unpatentable over Steinfeldt-Jensen et al, as applied to claim 1 above, in view of Chanoch (5582598). Steinfeldt-Jensen et al discloses the invention substantially as claimed except for expressly disclosing the housing comprising a window insert at a distal end of the housing and rotationally fixed thereto, the insert comprising a frame having a stop that is configured to engage a stop on the dose dial sleeve when a predetermined maximum dose is set by rotation of the dose dial sleeve. Chanoch teaches that it is known to have the housing comprising a window insert (78) at a distal end of the housing (22) and rotationally fixed thereto, the insert comprising a frame (80) having a stop (protrusion 86) that is configured to engage a stop (end wall of groove 70, i.e. in groove portion 194) in on the dose dial sleeve when a predetermined maximum dose is set by rotation of the dose dial sleeve (58) for the purpose of allowing a dosage to be set between a maximum and minimum dosage. It would have been obvious to one having ordinary skill in the art at the time the invention was made to modify the drive

Art Unit: 3763

mechanism as taught by Steinfeldt-Jensen et al with window and maximum dose limiter as taught by Chanoch for the purpose of allowing a dosage to be set between a maximum and minimum dosage.

35. Claims 9, 14-17, 19 are rejected under pre-AIA 35 U.S.C. 103(a) as being unpatentable over Steinfeldt-Jensen et al, as applied to claim 1 above. Steinfeldt-Jensen et al discloses the invention substantially as claimed, including a piston rod having first and second threads of different lead (see discussion above in claim 1), except for expressly disclosing the ratio between the leads being 1:1.01 to 1:20 or 1:1.1 to 1:10, the internal drive sleeve thread and first lead being equal, the threads being oppositely disposed, the second thread of the piston rod being a part thread, or the rotation rate of the drive sleeve and dose dial sleeve being equal. At the time the invention was made, it would have been an obvious matter of design choice to a person of ordinary skill in the art to have the claimed lead ratios, being oppositely disposed, the second thread of the piston rod being a part thread, or the rotation rate of the drive sleeve and dose dial sleeve being equal because the Applicant has not disclosed that having the claim lead ratios, the internal drive sleeve thread and first lead being equal, being oppositely disposed, or the second thread of the piston rod being a part thread, provides an advantage, is used for a particular purpose, or solves a stated problem. Furthermore, one of ordinary skill in the art would have expected the Applicants invention to perform equally well with the threads with different leads of Steinfeldt-Jensen because they perform substantially the same function in substantially the same manner. Therefore, it would have been an obvious matter of design choice to modify

Art Unit: 3763

Steenfeldt-Jensen to obtain the invention as specified in claim 9, 14-17, 19. Further, where the general conditions of a claim are disclosed in the prior art, it is not inventive to discover the optimum or workable ranges by routine experimentation.

### ***Double Patenting***

36. The nonstatutory double patenting rejection is based on a judicially created doctrine grounded in public policy (a policy reflected in the statute) so as to prevent the unjustified or improper timewise extension of the “right to exclude” granted by a patent and to prevent possible harassment by multiple assignees. A nonstatutory double patenting rejection is appropriate where the claims at issue are not identical, but at least one examined application claim is not patentably distinct from the reference claim(s) because the examined application claim is either anticipated by, or would have been obvious over, the reference claim(s). See, e.g., *In re Berg*, 140 F.3d 1428, 46 USPQ2d 1226 (Fed. Cir. 1998); *In re Goodman*, 11 F.3d 1046, 29 USPQ2d 2010 (Fed. Cir. 1993); *In re Longi*, 759 F.2d 887, 225 USPQ 645 (Fed. Cir. 1985); *In re Van Ornum*, 686 F.2d 937, 214 USPQ 761 (CCPA 1982); *In re Vogel*, 422 F.2d 438, 164 USPQ 619 (CCPA 1970); and *In re Thorington*, 418 F.2d 528, 163 USPQ 644 (CCPA 1969).

A timely filed terminal disclaimer in compliance with 37 CFR 1.321(c) or 1.321(d) may be used to overcome an actual or provisional rejection based on a nonstatutory double patenting ground provided the reference application or patent either is shown to be commonly owned with this application, or claims an invention made as a result of activities undertaken within the scope of a joint research agreement. See MPEP § 717.02 for applications subject to examination under the first inventor to file provisions

of the AIA as explained in MPEP § 2159. See MPEP §§ 706.02(l)(1) - 706.02(l)(3) for applications not subject to examination under the first inventor to file provisions of the AIA. A terminal disclaimer must be signed in compliance with 37 CFR 1.321(b).

The USPTO Internet website contains terminal disclaimer forms which may be used. Please visit [www.uspto.gov/forms/](http://www.uspto.gov/forms/). The filing date of the application in which the form is filed determines what form (e.g., PTO/SB/25, PTO/SB/26, PTO/AIA/25, or PTO/AIA/26) should be used. A web-based eTerminal Disclaimer may be filled out completely online using web-screens. An eTerminal Disclaimer that meets all requirements is auto-processed and approved immediately upon submission. For more information about eTerminal Disclaimers, refer to <http://www.uspto.gov/patents/process/file/efs/guidance/eTD-info-I.jsp>.

37. Claims 1, 3, 5-12, 17-19 rejected on the ground of nonstatutory double patenting as being unpatentable over claims 8-10 of U.S. Patent No. 8,556,864. Although the claims at issue are not identical, they are not patentably distinct from each other because the present claims are merely broader than the related patent and cover similar subject matter including a drive mechanism having a housing with a helical thread, insert, drive sleeve, piston rod having two threads, and clutch.

38. Claim 4 is rejected on the ground of nonstatutory double patenting as being unpatentable over claims 8-10 of U.S. Patent No. 8556864, as set forth above, in view of claims 1-8 of U.S. Patent No. 9,233,211. *See 112 rejection above.*

39. '864 claims the subject matter, except for the limiting nut translating along a threaded outer surface between two radially extending flanges of the drive sleeve,

Art Unit: 3763

which is claimed in '211 along with other similar elements, such as the insert. It would have been obvious to one of ordinary skill in the art to modify the claimed invention of '864 with the claimed invention of the threaded outer surface and two radially extending flanges of '211 for the purpose of providing a threaded length with proximal/distal stops for the nut to travel along that corresponds to the set and delivered dosage.

### ***Conclusion***

40. The prior art made of record and not relied upon is considered pertinent to applicant's disclosure. *See PTO 892 Form.*

41. *To expedite prosecution in the event the applicant has any questions or proposed claim amendments to discuss the applicant is invited to contact the examiner at the telephone number listed below.*

Any inquiry concerning this communication or earlier communications from the examiner should be directed to ANDREW GILBERT whose telephone number is (571)272-7216. The examiner can normally be reached on 8:30 am to 5:00 pm Monday through Friday.

If attempts to reach the examiner by telephone are unsuccessful, the examiner's supervisor, Kevin Sirmons can be reached on (571)272-4965. The fax phone number for the organization where this application or proceeding is assigned is 571-273-8300.

Art Unit: 3763

Information regarding the status of an application may be obtained from the Patent Application Information Retrieval (PAIR) system. Status information for published applications may be obtained from either Private PAIR or Public PAIR. Status information for unpublished applications is available through Private PAIR only. For more information about the PAIR system, see <http://pair-direct.uspto.gov>. Should you have questions on access to the Private PAIR system, contact the Electronic Business Center (EBC) at 866-217-9197 (toll-free). If you would like assistance from a USPTO Customer Service Representative or access to the automated information system, call 800-786-9199 (IN USA OR CANADA) or 571-272-1000.

/ANDREW GILBERT/  
Primary Examiner, Art Unit 3763

<b>Notice of References Cited</b>	Application/Control No. 14/319,388	Applicant(s)/Patent Under Reexamination VEASEY ET AL.	
	Examiner ANDREW GILBERT	Art Unit 3763	Page 1 of 2

**U.S. PATENT DOCUMENTS**

*		Document Number Country Code-Number-Kind Code	Date MM-YYYY	Name	CPC Classification	US Classification
*	A	US-5,545,147 A	08-1996	Harris; Dale C.	A61M5/31551	604/208
*	B	US-5,626,566 A	05-1997	Petersen; Lars P. K.	A61M5/31551	222/309
*	C	US-5,679,111 A	10-1997	Hjertman; Birger	A61M5/20	604/135
*	D	US-6,004,297 A	12-1999	Steenfeldt-Jensen; S.o slashed.ren	A61M5/31551	604/207
*	E	US-6,221,053 B1	04-2001	Walters; Daniel A.	A61M5/31551	604/208
*	F	US-6,248,095 B1	06-2001	Giambattista; Lucio	A61M5/31551	604/207
*	G	US-2002/0120235 A1	08-2002	Enggaard, Christian	A61M5/20	604/135
*	H	US-6,582,404 B1	06-2003	Klitgaard; Peter Christian	A61M5/31525	604/181
*	I	US-6,936,032 B1	08-2005	Bush, Jr.; Charles L.	A61M5/31551	604/187
*	J	US-7,195,616 B2	03-2007	Diller; Mark Gerard	A61M5/31566	604/207
*	K	US-7,241,278 B2	07-2007	Moller; Claus Schmidt	A61M5/24	604/211
*	L	US-7,361,161 B2	04-2008	Bainton; Michael Cameron	A61M5/31551	604/207
*	M	US-7,736,343 B2	06-2010	Marshall; Jeremy	A61M5/31525	604/207

**FOREIGN PATENT DOCUMENTS**

*		Document Number Country Code-Number-Kind Code	Date MM-YYYY	Country	Name	CPC Classification
	N					
	O					
	P					
	Q					
	R					
	S					
	T					

**NON-PATENT DOCUMENTS**

*		Include as applicable: Author, Title Date, Publisher, Edition or Volume, Pertinent Pages)
	U	
	V	
	W	
	X	

\*A copy of this reference is not being furnished with this Office action. (See MPEP § 707.05(a).)  
Dates in MM-YYYY format are publication dates. Classifications may be US or foreign.



<b>Notice of References Cited</b>	Application/Control No. 14/319,388	Applicant(s)/Patent Under Reexamination VEASEY ET AL.	
	Examiner ANDREW GILBERT	Art Unit 3763	Page 2 of 2

**U.S. PATENT DOCUMENTS**

*		Document Number Country Code-Number-Kind Code	Date MM-YYYY	Name	CPC Classification	US Classification
*	A	US-7,850,662 B2	12-2010	Veasey; Robert Frederick	A61M5/31546	604/207
*	B	US-7,905,867 B2	03-2011	Veasey; Robert Frederick	A61M5/24	604/207
*	C	US-7,935,088 B2	05-2011	Veasey; Robert Frederick	A61M5/31546	604/207
*	D	US-8,021,345 B2	09-2011	Veasey; Robert Frederick	A61M5/24	604/207
*	E	US-8,556,864 B2	10-2013	Veasey; Robert Frederick	A61M5/31546	604/207
*	F	US-8,888,750 B2	11-2014	Veasey; Robert Frederick	A61M5/24	604/207
*	G	US-9,028,454 B2	05-2015	Veasey; Robert Frederick	A61M5/31546	604/211
*	H	US-5,582,598 A	12-1996	Chanoch; Lawrence H.	A61M5/31551	222/309
*	I	US-9,233,211 B2	01-2016	Veasey; Robert Frederick	A61M5/31535	1/1
	J	US-				
	K	US-				
	L	US-				
	M	US-				


**FOREIGN PATENT DOCUMENTS**

*		Document Number Country Code-Number-Kind Code	Date MM-YYYY	Country	Name	Classification
	N					
	O					
	P					
	Q					
	R					
	S					
	T					

**NON-PATENT DOCUMENTS**

*		Include as applicable: Author, Title Date, Publisher, Edition or Volume, Pertinent Pages)
	U	
	V	
	W	
	X	

\*A copy of this reference is not being furnished with this Office action. (See MPEP § 707.05(a).)  
Dates in MM-YYYY format are publication dates. Classifications may be US or foreign.

<b>Search Notes</b>  	<b>Application/Control No.</b>  14319388	<b>Applicant(s)/Patent Under Reexamination</b>  VEASEY ET AL.
	<b>Examiner</b>  ANDREW GILBERT	<b>Art Unit</b>  3763

CPC- SEARCHED		
Symbol	Date	Examiner
A61M5/24,31533,31535,31536,31541,31551,31565,31578	2/21/2016	AG

CPC COMBINATION SETS - SEARCHED		
Symbol	Date	Examiner

US CLASSIFICATION SEARCHED			
Class	Subclass	Date	Examiner

SEARCH NOTES		
Search Notes	Date	Examiner
Searched EAST CPC class/subclass and keyword search - see attached sheets	2/21/2016	AG
Inventor Name search	2/21/2016	AG
Forward/backward citation searches	2/21/2016	AG
Updated search in related cases USPN 7935088, 7850662, 9028454 and US App No 14319371, 14319379, 14319381, and 14319384	2/21/2016	AG

INTERFERENCE SEARCH			
US Class/ CPC Symbol	US Subclass / CPC Group	Date	Examiner


	/ANDREW GILBERT/ Primary Examiner.Art Unit 3763
--	--


**UNITED STATES PATENT AND TRADEMARK OFFICE**

UNITED STATES DEPARTMENT OF COMMERCE  
**United States Patent and Trademark Office**  
 Address: COMMISSIONER FOR PATENTS  
 P.O. Box 1450  
 Alexandria, Virginia 22313-1450  
 www.uspto.gov

**BIB DATA SHEET**
**CONFIRMATION NO. 6141**

SERIAL NUMBER	FILING or 371(c) DATE RULE	CLASS	GROUP ART UNIT	ATTORNEY DOCKET NO.	
14/319,388	06/30/2014	604	3763	10-015-US-CON9	
<b>APPLICANTS</b> SANOFI-AVENTIS DEUTSCHLAND GMBH, FRANKFURT AM MAIN, GERMANY;					
<b>INVENTORS</b> Robert Frederick Veasey, Warwickshire, UNITED KINGDOM; Robert Perkins, Warwickshire, UNITED KINGDOM; David Aubrey Plumtre, Worcestershire, UNITED KINGDOM;					
<b>** CONTINUING DATA *****</b> This application is a CON of 12/941,702 11/08/2010 PAT 9028454 which is a CON of 12/320,189 01/21/2009 PAT 7850662 which is a CON of 11/520,598 09/14/2006 PAT 7935088 which is a CON of 10/790,866 03/03/2004 ABN					
<b>** FOREIGN APPLICATIONS *****</b> UNITED KINGDOM 0304822.0 03/03/2003					
<b>** IF REQUIRED, FOREIGN FILING LICENSE GRANTED **</b> 07/11/2014					
Foreign Priority claimed <input checked="" type="checkbox"/> Yes <input type="checkbox"/> No 35 USC 119(a-d) conditions met <input checked="" type="checkbox"/> Yes <input type="checkbox"/> No Verified and /ANDREW M GILBERT/ Acknowledged Examiner's Signature	<input type="checkbox"/> Met after Allowance Initials	<b>STATE OR COUNTRY</b>  UNITED KINGDOM	<b>SHEETS DRAWINGS</b>  21	<b>TOTAL CLAIMS</b>  19	<b>INDEPENDENT CLAIMS</b>  1
<b>ADDRESS</b>  McDonnell Boehnen Hulbert & Berghoff LLP Sanofi - Aventis 300 South Wacker Drive Chicago, IL 60606 UNITED STATES					
<b>TITLE</b>  DRIVE MECHANISMS SUITABLE FOR USE IN DRUG DELIVERY DEVICES					
<b>FILING FEE RECEIVED</b>  1600	FEES: Authority has been given in Paper No. _____ to charge/credit DEPOSIT ACCOUNT No. _____ for following:		<input type="checkbox"/> All Fees <input type="checkbox"/> 1.16 Fees (Filing) <input type="checkbox"/> 1.17 Fees (Processing Ext. of time) <input type="checkbox"/> 1.18 Fees (Issue) <input type="checkbox"/> Other _____ <input type="checkbox"/> Credit		

<b>Index of Claims</b>  	<b>Application/Control No.</b> 14319388	<b>Applicant(s)/Patent Under Reexamination</b> VEASEY ET AL.
	<b>Examiner</b> ANDREW GILBERT	<b>Art Unit</b> 3763

✓	<b>Rejected</b>
=	<b>Allowed</b>

-	<b>Cancelled</b>
÷	<b>Restricted</b>

N	<b>Non-Elected</b>
I	<b>Interference</b>

A	<b>Appeal</b>
O	<b>Objected</b>

Claims renumbered in the same order as presented by applicant
  CPA
  T.D.
  R.1.47

CLAIM		DATE							
Final	Original	02/21/2016							
	1	✓							
	2	✓							
	3	✓							
	4	✓							
	5	✓							
	6	✓							
	7	✓							
	8	✓							
	9	✓							
	10	✓							
	11	✓							
	12	✓							
	13	✓							
	14	✓							
	15	✓							
	16	✓							
	17	✓							
	18	✓							
	19	✓							

Under the Paperwork Reduction Act of 1995, no persons are required to respond to a collection of information unless it displays a valid OMB control number.

<b>TRANSMITTAL FORM</b>  <i>(to be used for all correspondence after initial filing)</i>	Application Number	14/319,388
	Filing Date	June 30, 2014
	First Named Inventor	Robert Frederick Veasey
	Art Unit	3763
	Examiner Name	Gilbert, Andrew M.
Total Number of Pages in This Submission		Attorney Docket Number 10-015-US-CON9

<b>ENCLOSURES (Check all that apply)</b>		
<input type="checkbox"/> Fee Transmittal Form <input type="checkbox"/> Fee Attached <input checked="" type="checkbox"/> Amendment/Reply <input type="checkbox"/> After Final <input type="checkbox"/> Affidavits/declaration(s) <input checked="" type="checkbox"/> Extension of Time Request <input type="checkbox"/> Express Abandonment Request <input type="checkbox"/> Information Disclosure Statement  <input type="checkbox"/> Certified Copy of Priority Document(s) <input type="checkbox"/> Reply to Missing Parts/ Incomplete Application <input type="checkbox"/> Reply to Missing Parts under 37 CFR 1.52 or 1.53	<input type="checkbox"/> Drawing(s) <input type="checkbox"/> Licensing-related Papers <input type="checkbox"/> Petition <input type="checkbox"/> Petition to Convert to a Provisional Application <input type="checkbox"/> Power of Attorney, Revocation Change of Correspondence Address <input type="checkbox"/> Terminal Disclaimer <input type="checkbox"/> Request for Refund <input type="checkbox"/> CD, Number of CD(s) ___ <input type="checkbox"/> Landscape Table on CD	<input type="checkbox"/> After Allowance Communication to TC <input type="checkbox"/> Appeal Communication to Board of Appeals and Interferences <input type="checkbox"/> Appeal Communication to TC (Appeal Notice, Brief, Reply Brief) <input type="checkbox"/> Proprietary Information <input type="checkbox"/> Status Letter <input checked="" type="checkbox"/> Other Enclosure(s) (please identify below): <b>General Authorization</b>
<div style="border: 1px solid black; padding: 2px; display: inline-block;">Remarks</div>		

**SIGNATURE OF APPLICANT, ATTORNEY, OR AGENT**

Firm Name	McDonnell Boehnen Hulbert & Berghoff LLP		
Signature	/Thomas E. Wettermann/		
Printed name	Thomas E. Wettermann		
Date	June 7, 2016	Reg. No.	41,523

**CERTIFICATE OF TRANSMISSION/MAILING**

I hereby certify that this correspondence is being electronically transmitted to the USPTO or deposited with the United States Postal Service with sufficient postage as first class mail in an envelope addressed to: Commissioner for Patents, P.O. Box 1450, Alexandria, VA 22313-1450 on the date shown below:			
Signature	/Thomas E. Wettermann/		
Typed or printed name	Thomas E. Wettermann	Date	June 7, 2016

This collection of information is required by 37 CFR 1.5. The information is required to obtain or retain a benefit by the public which is to file (and by the USPTO to process) an application. Confidentiality is governed by 35 U.S.C. 122 and 37 CFR 1.11 and 1.14. This collection is estimated to 2 hours to complete, including gathering, preparing, and submitting the completed application form to the USPTO. Time will vary depending upon the individual case. Any comments on the amount of time you require to complete this form and/or suggestions for reducing this burden, should be sent to the Chief Information Officer, U.S. Patent and Trademark Office, U.S. Department of Commerce, P.O. Box 1450, Alexandria, VA 22313-1450. DO NOT SEND FEES OR COMPLETED FORMS TO THIS ADDRESS. SEND TO: **Commissioner for Patents, P.O. Box 1450, Alexandria, VA 22313-1450.**

*If you need assistance in completing the form, call 1-800-PTO-9199 and select option 2.*

IN THE UNITED STATES PATENT AND TRADEMARK OFFICE  
(MBHB Case No.: 10-015-US-CON9)

In the Application of:	)	
	)	
Robert Frederick Veasey et al.	)	Examiner: Gilbert, Andrew M.
	)	
Serial No. 14/319,388	)	Group Art Unit: 3763
	)	
Filed: June 30, 2014	)	Confirmation No.: 6141
	)	
For: Drive Mechanisms Suitable for Use in Drug	)	
Delivery Devices	)	

Commissioner for Patents  
P.O. Box 1450  
Alexandria, Virginia 22313-1450

**RESPONSE TO THE OFFICE ACTION MAILED FEBRUARY 24, 2016**

Dear Sir:

This paper is submitted in response to the Office Action mailed February 24, 2016. Please enter the following remarks and amendments into the record for this application. Also enclosed is a Petition for Extension of Time under 37 C.F.R. § 1.136(a) (1 Month), along with requisite fees.

**Amendments to the Claims** are reflected in the listing of claims that begins on page 2 of this paper.

**Remarks/Arguments** begin on page 6 of this paper.

Please charge any underpayment or credit any overpayment to Deposit Account No. 132490. Further, Applicant generally authorizes the Office to treat any filing in this matter that requires an extension of time as incorporating a request for such an extension.

## AMENDMENTS

### IN THE SPECIFICATION:

**Please amend the first paragraph on page 1 of the specification (spanning lines 6-13) as follows:**

[0001] The present application is a continuation application of U.S. Patent Application No. 12/941,702, filed November 8, 2010, ~~currently pending,~~ now U.S. Patent No. 9,028,454, which is a continuation application of U.S. Patent Application No. 12/320,189, filed January 21, 2009, now U.S. Pat. No. 7,850,662, which is a continuation application of U.S. Patent Application No. 11/520,598, filed September 14, 2006, now U.S. Pat. No. 7,935,088, which is a continuation application of U.S. Patent Application No. 10/790,866, filed March 3, 2004, abandoned, and claims priority to GB Patent Application No. 0304822.0, filed March 3, 2003, the entire contents of each of which are incorporated herein by reference.

**IN THE FIGURES:**

**Please enter the replacement sheet for Figures 1-2 that is filed herewith.**

The replacement sheet, attached as Tab A, for Figures 1-2 contain the following amendment: In Figure 1, the reference numeral identifying the extension provided at the second end of the drive sleeve 30 has been changed from “38” to -- 47 -- .



**IN THE CLAIMS**

1. (currently amended) A drive mechanism for use in a drug delivery device comprising:
  - a housing comprising a helical thread;
  - a dose dial sleeve having a threaded surface that is engaged with the helical thread of the housing,
  - an insert provided in the housing, where the insert has a threaded circular opening;
  - a drive sleeve releasably connected to the dose dial sleeve and having an internal helical thread;
  - a piston rod having a first thread and a second thread , wherein the first thread is engaged with the threaded circular opening of the insert and the second thread is engaged with the internal helical thread of the drive sleeve; and
  - a clutch located between the dose dial sleeve and the drive sleeve\_[[,]]
  
2. (original) The drive mechanism of claim 1, wherein the drive sleeve comprises a threaded outer surface, the drive mechanism further comprising a limiting nut being threadedly engaged with the threaded outer surface of drive sleeve, where the limiting nut is rotationally fixed and slidable relative to the housing.
  
3. (original) The drive mechanism of claim 1, wherein the insert is secured in the housing against rotational and longitudinal motion.

4. (currently amended) The drive mechanism of claim [[1]]2, wherein the limiting nut translates distally along the threaded outer surface relative to [[the]] two radially extending flanges as the drive sleeve is rotated during dose setting.[:;]

5. (currently amended) The drive mechanism of claim [[1]]2, wherein the threaded outer surface of the drive sleeve is located between two radially extending flanges.

6. (currently amended) The drive mechanism of claim 1, wherein the housing comprises a window insert at a distal end of the housing, where the distal end of the housing has the helical thread, where the window insert is rotationally fixed relative to the housing.[:;]

7. (currently amended) The drive mechanism of claim 1, wherein the threaded ~~outer~~ surface of the dose dial sleeve has a first lead.

8. (original) The drive mechanism of claim 7, wherein the first thread of the piston rod has a second lead.

9. (original) The drive mechanism of claim 8, wherein the internal drive sleeve thread has a lead equal to the first lead.

10. (original) The drive mechanism of claim 1, where the clutch is rotationally fixed to the drive sleeve and dose dial sleeve during dose setting.

11. (original) The drive mechanism of claim 1, wherein the helical thread of the housing is an internal helical thread and the dose dial sleeve has a threaded outer surface that is engaged with the internal helical thread of the housing.

12. (original) The drive mechanism of claim 1 where the piston rod rotates and translates axially in a proximal direction relative to and through the threaded circular opening during dose delivery.

13. (original) The drive mechanism of claim 6 where the window insert comprises a frame having a stop that is configured to engage a stop on the dose dial sleeve when a predetermined maximum dose is set by rotation of the dose dial sleeve.

14. (original) The drive mechanism of claim 9 where the ratio of leads of the first thread of the piston rod to the second thread of the piston rod is in the range from about 1:1.01 to 1:20.

15. (original) The drive mechanism of claim 9 where the ratio of leads of the first thread of the piston rod to the second thread of the piston rod is in the range from about 1:1.1 to 1:10.

16. (original) The drive mechanism of claim 1 where the second thread of the piston rod is a part thread.

17. (original) The drive mechanism of claim 1 where the first and second threads of the piston rod are oppositely disposed.

18. (original) The drive mechanism of claim 1 where the first thread and the second thread of the piston rod are configured such that the piston rod is prevented from rotating during dose setting.

19. (original) The drive mechanism of claim 1 where the drive sleeve is configured to rotate and climb the piston rod at a rate equal to a rate of rotation of the dose dial sleeve when the dose dial sleeve is rotated to set a dose.

## REMARKS

In the Office Action mailed February 24, 2016 claims 1-19 are currently pending.

In this Office Action, the Examiner stated that the effective filing date of claims 1-13 and 17-19 is March 3, 2003 and the effective filing date of claims 14-15 is March 4, 2004. Further, the Examiner objected to the drawings, and the Examiner rejected claims 1-19 under 35 U.S.C. § 112, second paragraph as being allegedly indefinite. Still further, the Examiner rejected claims 1, 3, 7-8, 10-12, and 17-18 under 35 U.S.C. § 102(b) as being allegedly anticipated by U.S. Patent No. 6,004,297 (Steenfeldt-Jensen), and the Examiner rejected claim 2 under 35 U.S.C. § 103(a) as being allegedly obvious over Steenfeldt-Jensen in view of U.S. Patent No. 6,582,404 (Klitgaard). Yet still further, the Examiner rejected claims 6 and 13 under 35 U.S.C. § 103(a) as being allegedly obvious over Steenfeldt-Jensen in view of U.S. Patent No. 5,582,598 (Chanoch), and the Examiner rejected claims 9, 14-17, and 19 under 35 U.S.C. § 103(a) as being allegedly obvious over Steenfeldt-Jensen.

And yet still further, the Examiner rejected claims 1, 3, 5-12, and 17-19 on the ground of nonstatutory double patenting as being unpatentable over claims 8-10 of U.S. Patent No. 8,556,864 (the '864 patent), and the Examiner rejected claim 4 on the ground of nonstatutory double patenting as being unpatentable over claims 8-10 of the '864 patent in view of claims 1-8 of U.S. Patent No. 9,233,211 (the '211 patent).

Claims 1-19 are currently pending in the application, of which claim 1 is independent and the remainder are dependent.

Applicants respectively traverse. After a careful review of the Office Action and the cited references, Applicants respectively request reconsideration in view of the following remarks.

As an initial matter, Applicant has amended the specification to update the Cross Reference to Related Applications paragraph.

As noted herein, the Examiner objected to the drawings. (Office action, pages 2-3.) In particular, the Examiner objected to the drawings as failing to comply with 37 CFR 1.84(p)(4) because reference character “38” has allegedly been used to designate both a helical groove and a radially outwardly directed flange. (Office action, page 3.)

Applicant has amended Figure 1 so that the reference numeral identifying the extension provided at the second end of the drive sleeve 30 has been changed from “38” to -- 47 -- . In view of the replacement sheet, Applicant believes that the objection to the drawings is moot. Therefore, Applicant respectfully requests that the Examiner withdraw the objection to the drawings.

In response to the rejection of claims 1-19 under 35 U.S.C. § 112, second paragraph as being allegedly indefinite, Applicant has amended claims 1 and 4-7. Applicant amended these claims to address the Examiner’s concerns. In view of these amendments, the rejection under 35 U.S.C. § 112, second paragraph is moot. Accordingly, Applicant respectfully requests that the Examiner withdraw the rejection.

As mentioned herein, the Examiner rejected claims 1, 3, 5-12, and 17-19 on grounds of obvious-type double-patenting as being unpatentable over claims 8-10 of the ‘864 patent, and the Examiner rejected claim 4 on the ground of nonstatutory double patenting as being unpatentable over claims 8-10 of the ‘864 patent in view of claims 1-8 of the ‘211 patent. Applicant submits herewith a terminal disclaimer, thus rendering the obviousness type double-patenting rejection of claims 1, 3-12, and 17-19 moot.

By submitting this terminal disclaimer, Applicant does not acquiesce in (i) the Examiner's conclusion that claims 1, 3, 5-12, and 17-19 of the present application are obvious over claims 8-10 of the '864 patent or (ii) the Examiner's conclusion that claim 4 of the present application is obvious over claims 8-10 of the '864 patent in view of claims 1-8 in the '211 patent.

As indicated herein, the Examiner rejected independent claim 1 as being anticipated by Steinfeldt-Jensen. Applicant respectfully traverses.

In the Office Action, the Examiner stated that “Steenfeldt-Jensen et al discloses . . . a dose dial sleeve (17) . . . a drive sleeve (23) releasably connected to the dose dial sleeve (Fig 6-8) . . . and a clutch (34) located between the dose dial sleeve and the drive sleeve (col 7, Ins 54-57[)].” (Office Action, page 6.) Therefore, the Examiner appears to treat dose scale drum 17 as the purported dose dial sleeve, cup shaped cap 23 as the purported drive sleeve, and hooks 34 as the purported clutch. However, as can clearly be seen in Figures 7 and 8, hooks 34 are not located between the dose scale drum 17 and the cap 23. Therefore, Steinfeldt-Jensen fails to disclose “a clutch located between the dose dial sleeve and the drive sleeve.”

Further, the claims require that the drive sleeve be releasably connected to the dose dial sleeve, but what the Examiner has identified as the drive sleeve (23) and dose dial sleeve (17) in Steinfeldt-Jensen are not releasably connected. Steinfeldt-Jensen notes that “the extension 33 serves as a journal for the dose scale drum 17 which is free to rotate on this journal but bound to follow axial movements of the injection button 23 due to hooks 34 at the end of the extension 33.” Steinfeldt-Jensen 7:54-57. As a result, the drive sleeve (23) and dose dial sleeve (17) are either fully connected or are not connected at all. Nothing happens during the operation of the device that causes a change in the state of connectivity between these two parts. Therefore, what

the examiner has identified as the drive sleeve (23) and dose dial sleeve (17) in Steinfeldt-Jensen are not releasably connected.

For at least these reasons, Steinfeldt-Jensen fails to teach the presently pending claim 1. Consequently, Applicant submits that claim 1 is allowable. Furthermore, Applicant submits that claims 2-19 are allowable as well for at least the reason that they depend from allowable claim 1.

Applicants respectfully submit that, in view of the remarks above, the present application is in condition for allowance and solicit action to that end.

If there are any matters that may be resolved or clarified through a telephone interview, the Examiner is respectfully requested to contact Applicants' undersigned representative at (312) 913-2138.

Respectfully submitted,

**McDonnell Boehnen Hulbert & Berghoff LLP**

Date: June 7, 2016

By: /Thomas E. Wettermann/  
Thomas E. Wettermann  
Reg. No. 41,523



# TAB A

# REPLACEMENT SHEET

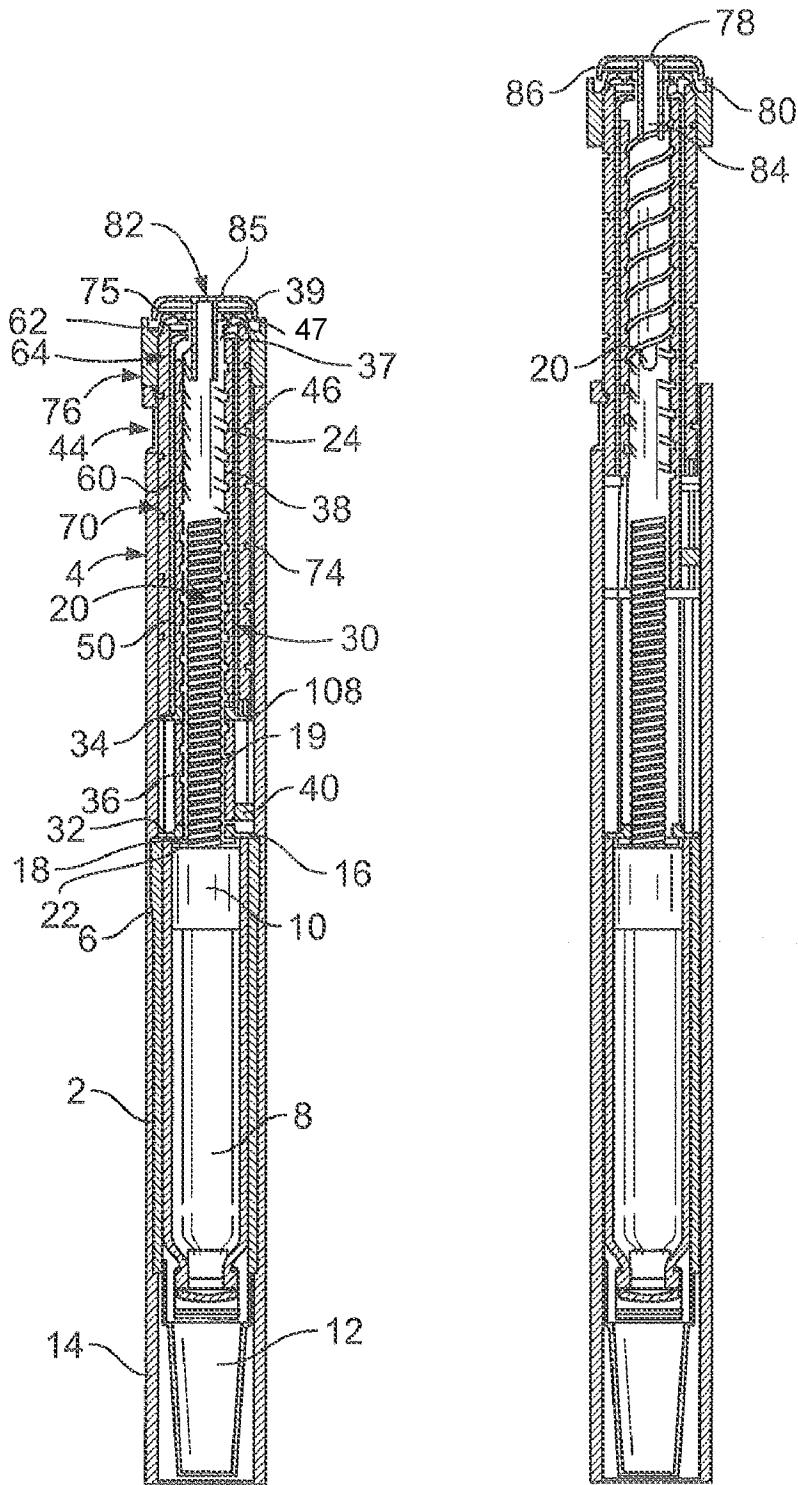


FIG. 1

FIG. 2

Under the Paperwork Reduction Act of 1995, no persons are required to respond to a collection of information unless it displays a valid OMB control number.

<b>PETITION FOR EXTENSION OF TIME UNDER 37 CFR 1.136(a)</b>		Docket Number (Optional) 10-015-US-CON9
Application Number 14/319,388	Filed June 30, 2014	
For Drive Mechanisms Suitable for Use in Drug Delivery Devices		
Art Unit 3763	Examiner Gilbert, Andrew M.	

This is a request under the provisions of 37 CFR 1.136(a) to extend the period for filing a reply in the above-identified application.

The requested extension and fee are as follows (check time period desired and enter the appropriate fee below):

	Fee	Small Entity Fee	Micro Entity Fee	
<input checked="" type="checkbox"/> One month (37 CFR 1.17(a)(1))	\$200	\$100	\$50	\$ 200.00
<input type="checkbox"/> Two months (37 CFR 1.17(a)(2))	\$600	\$300	\$150	\$ _____
<input type="checkbox"/> Three months (37 CFR 1.17(a)(3))	\$1,400	\$700	\$350	\$ _____
<input type="checkbox"/> Four months (37 CFR 1.17(a)(4))	\$2,200	\$1,100	\$550	\$ _____
<input type="checkbox"/> Five months (37 CFR 1.17(a)(5))	\$3,000	\$1,500	\$750	\$ _____

Applicant asserts small entity status. See 37 CFR 1.27.

Applicant certifies micro entity status. See 37 CFR 1.29.  
Form PTO/SB/15A or B or equivalent must either be enclosed or have been submitted previously.

A check in the amount of the fee is enclosed.

Payment by credit card. Form PTO-2038 is attached.

The Director has already been authorized to charge fees in this application to a Deposit Account.

The Director is hereby authorized to charge any fees which may be required, or credit any overpayment, to  
Deposit Account Number 13-2490.

Payment made via EFS-Web.

**WARNING: Information on this form may become public. Credit card information should not be included on this form. Provide credit card information and authorization on PTO-2038.**

I am the

applicant.

attorney or agent of record. Registration number 41,523.

attorney or agent acting under 37 CFR 1.34. Registration number \_\_\_\_\_.

/Thomas E. Wettermann/  
Signature

June 7, 2016  
Date

Thomas E. Wettermann  
Typed or printed name

312-913-2138  
Telephone Number

**NOTE:** This form must be signed in accordance with 37 CFR 1.33. See 37 CFR 1.4 for signature requirements and certifications. Submit multiple forms if more than one signature is required, see below\*.

\* Total of 1 forms are submitted.

This collection of information is required by 37 CFR 1.136(a). The information is required to obtain or retain a benefit by the public, which is to file (and by the USPTO to process) an application. Confidentiality is governed by 35 U.S.C. 122 and 37 CFR 1.11 and 1.14. This collection is estimated to take 6 minutes to complete, including gathering, preparing, and submitting the completed application form to the USPTO. Time will vary depending upon the individual case. Any comments on the amount of time you require to complete this form and/or suggestions for reducing this burden should be sent to the Chief Information Officer, U.S. Patent and Trademark Office, U.S. Department of Commerce, P.O. Box 1450, Alexandria, VA 22313-1450. DO NOT SEND FEES OR COMPLETED FORMS TO THIS ADDRESS. SEND TO: Mail Stop PCT, Commissioner for Patents, P.O. Box 1450, Alexandria, VA 22313-1450.

## Privacy Act Statement

The **Privacy Act of 1974 (P.L. 93-579)** requires that you be given certain information in connection with your submission of the attached form related to a patent application or patent. Accordingly, pursuant to the requirements of the Act, please be advised that: (1) the general authority for the collection of this information is 35 U.S.C. 2(b)(2); (2) furnishing of the information solicited is voluntary; and (3) the principal purpose for which the information is used by the U.S. Patent and Trademark Office is to process and/or examine your submission related to a patent application or patent. If you do not furnish the requested information, the U.S. Patent and Trademark Office may not be able to process and/or examine your submission, which may result in termination of proceedings or abandonment of the application or expiration of the patent.

The information provided by you in this form will be subject to the following routine uses:

1. The information on this form will be treated confidentially to the extent allowed under the Freedom of Information Act (5 U.S.C. 552) and the Privacy Act (5 U.S.C. 552a). Records from this system of records may be disclosed to the Department of Justice to determine whether disclosure of these records is required by the Freedom of Information Act.
2. A record from this system of records may be disclosed, as a routine use, in the course of presenting evidence to a court, magistrate, or administrative tribunal, including disclosures to opposing counsel in the course of settlement negotiations.
3. A record in this system of records may be disclosed, as a routine use, to a Member of Congress submitting a request involving an individual, to whom the record pertains, when the individual has requested assistance from the Member with respect to the subject matter of the record.
4. A record in this system of records may be disclosed, as a routine use, to a contractor of the Agency having need for the information in order to perform a contract. Recipients of information shall be required to comply with the requirements of the Privacy Act of 1974, as amended, pursuant to 5 U.S.C. 552a(m).
5. A record related to an International Application filed under the Patent Cooperation Treaty in this system of records may be disclosed, as a routine use, to the International Bureau of the World Intellectual Property Organization, pursuant to the Patent Cooperation Treaty.
6. A record in this system of records may be disclosed, as a routine use, to another federal agency for purposes of National Security review (35 U.S.C. 181) and for review pursuant to the Atomic Energy Act (42 U.S.C. 218(c)).
7. A record from this system of records may be disclosed, as a routine use, to the Administrator, General Services, or his/her designee, during an inspection of records conducted by GSA as part of that agency's responsibility to recommend improvements in records management practices and programs, under authority of 44 U.S.C. 2904 and 2906. Such disclosure shall be made in accordance with the GSA regulations governing inspection of records for this purpose, and any other relevant (*i.e.*, GSA or Commerce) directive. Such disclosure shall not be used to make determinations about individuals.
8. A record from this system of records may be disclosed, as a routine use, to the public after either publication of the application pursuant to 35 U.S.C. 122(b) or issuance of a patent pursuant to 35 U.S.C. 151. Further, a record may be disclosed, subject to the limitations of 37 CFR 1.14, as a routine use, to the public if the record was filed in an application which became abandoned or in which the proceedings were terminated and which application is referenced by either a published application, an application open to public inspection or an issued patent.
9. A record from this system of records may be disclosed, as a routine use, to a Federal, State, or local law enforcement agency, if the USPTO becomes aware of a violation or potential violation of law or regulation.

IN THE UNITED STATES PATENT AND TRADEMARK OFFICE  
(MBHB Case No. 10-015-US-CON9)

In re Application of:	)	
	)	
Robert Frederick Veasey et al.	)	
	)	Examiner: Gilbert, Andrew M.
Serial No.: 14/319,388	)	
	)	Group Art Unit: 3763
Filed: June 30, 2014	)	
	)	Confirmation No.: 6141
For: Drive Mechanisms Suitable for Use in Drug	)	
Delivery Devices	)	

Commissioner for Patents  
P.O. Box 1450  
Alexandria, VA 22313-1450

**GENERAL AUTHORIZATION UNDER 37 C.F.R. § 1.136(a)(3)**

Sir:

The Commissioner is hereby generally authorized under 37 C.F.R. § 1.136(a)(3) to treat the present and any future related filings in this or any related application filed pursuant to 37 C.F.R. § 1.53 requiring an extension of time as incorporating a request therefore, and the Commissioner is hereby specifically authorized to charge Deposit Account No. 13-2490 for any fee that may be due in connection with such a request for an extension of time.

Respectfully submitted,  
**McDonnell Boehnen Hulbert & Berghoff LLP**

Date: June 7, 2016

By: /Thomas E. Wettermann/  
Thomas E. Wettermann  
Reg. No. 41,523

## Electronic Patent Application Fee Transmittal

<b>Application Number:</b>	14319388
<b>Filing Date:</b>	30-Jun-2014
<b>Title of Invention:</b>	DRIVE MECHANISMS SUITABLE FOR USE IN DRUG DELIVERY DEVICES
<b>First Named Inventor/Applicant Name:</b>	Robert Frederick Veasey
<b>Filer:</b>	Thomas E. Wettermann
<b>Attorney Docket Number:</b>	10-015-US-CON9

Filed as Large Entity

**Filing Fees for Utility under 35 USC 111(a)**

Description	Fee Code	Quantity	Amount	Sub-Total in USD(\$)
<b>Basic Filing:</b>				
<b>Pages:</b>				
<b>Claims:</b>				
<b>Miscellaneous-Filing:</b>				
<b>Petition:</b>				
<b>Patent-Appeals-and-Interference:</b>				
<b>Post-Allowance-and-Post-Issuance:</b>				
<b>Extension-of-Time:</b>				

Description	Fee Code	Quantity	Amount	Sub-Total in USD(\$)
Extension - 1 month with \$0 paid	1251	1	200	200
<b>Miscellaneous:</b>				
<b>Total in USD (\$)</b>				<b>200</b>

## Electronic Acknowledgement Receipt

<b>EFS ID:</b>	25993334
<b>Application Number:</b>	14319388
<b>International Application Number:</b>	
<b>Confirmation Number:</b>	6141
<b>Title of Invention:</b>	DRIVE MECHANISMS SUITABLE FOR USE IN DRUG DELIVERY DEVICES
<b>First Named Inventor/Applicant Name:</b>	Robert Frederick Veasey
<b>Customer Number:</b>	98548
<b>Filer:</b>	Thomas E. Wettermann
<b>Filer Authorized By:</b>	
<b>Attorney Docket Number:</b>	10-015-US-CON9
<b>Receipt Date:</b>	08-JUN-2016
<b>Filing Date:</b>	30-JUN-2014
<b>Time Stamp:</b>	13:17:24
<b>Application Type:</b>	Utility under 35 USC 111(a)

### Payment information:

Submitted with Payment	yes
Payment Type	Deposit Account
Payment was successfully received in RAM	\$200
RAM confirmation Number	9612
Deposit Account	132490
Authorized User	WETTERMANN, THOMAS E.

The Director of the USPTO is hereby authorized to charge indicated fees and credit any overpayment as follows:



Charge any Additional Fees required under 37 CFR 1.19 (Document supply fees)  
 Charge any Additional Fees required under 37 CFR 1.20 (Post Issuance fees)  
 Charge any Additional Fees required under 37 CFR 1.21 (Miscellaneous fees and charges)

**File Listing:**

Document Number	Document Description	File Name	File Size(Bytes)/ Message Digest	Multi Part /.zip	Pages (if appl.)
1	Transmittal Letter	10_015_US_CON9_OA_Transmittal_2016_06_07.pdf	158751	no	1
			514b90673a9e5591a163f070ecbf94473b335157		
<b>Warnings:</b>					
<b>Information:</b>					
2	Applicant Arguments/Remarks Made in an Amendment	10_015_US_CON9_OA_Response_2016_06_07.pdf	245696	no	13
			7eba5973e318098e5471a2e7d2a1e153ec4406af		
<b>Warnings:</b>					
<b>Information:</b>					
3	Extension of Time	10_015_US_CON9_1Mo_Extension_2016_06_07.pdf	163553	no	2
			57ef1296c8d926354e66ca815f121deb5ca4ac5e		
<b>Warnings:</b>					
<b>Information:</b>					
4	Authorization for Extension of Time all replies	10_015_US_CON9_General_Authorization_2016_06_07.pdf	59414	no	1
			a30af9acb2daf0547dafb32e8b9fa1b8ad1f9c		
<b>Warnings:</b>					
<b>Information:</b>					
5	Fee Worksheet (SB06)	fee-info.pdf	31055	no	2
			dbcd0a2bfad69de352018b0d14d98fb218abded0		
<b>Warnings:</b>					
<b>Information:</b>					
<b>Total Files Size (in bytes):</b>			658469		

**This Acknowledgement Receipt evidences receipt on the noted date by the USPTO of the indicated documents, characterized by the applicant, and including page counts, where applicable. It serves as evidence of receipt similar to a Post Card, as described in MPEP 503.**

**New Applications Under 35 U.S.C. 111**

**If a new application is being filed and the application includes the necessary components for a filing date (see 37 CFR 1.53(b)-(d) and MPEP 506), a Filing Receipt (37 CFR 1.54) will be issued in due course and the date shown on this Acknowledgement Receipt will establish the filing date of the application.**

**National Stage of an International Application under 35 U.S.C. 371**

**If a timely submission to enter the national stage of an international application is compliant with the conditions of 35 U.S.C. 371 and other applicable requirements a Form PCT/DO/EO/903 indicating acceptance of the application as a national stage submission under 35 U.S.C. 371 will be issued in addition to the Filing Receipt, in due course.**

**New International Application Filed with the USPTO as a Receiving Office**

**If a new international application is being filed and the international application includes the necessary components for an international filing date (see PCT Article 11 and MPEP 1810), a Notification of the International Application Number and of the International Filing Date (Form PCT/RO/105) will be issued in due course, subject to prescriptions concerning national security, and the date shown on this Acknowledgement Receipt will establish the international filing date of the application.**

Under the Paperwork Reduction Act of 1995, no persons are required to respond to a collection of information unless it displays a valid OMB control number.

<b>PATENT APPLICATION FEE DETERMINATION RECORD</b> Substitute for Form PTO-875	Application or Docket Number <b>14/319,388</b>	Filing Date <b>06/30/2014</b>	<input type="checkbox"/> To be Mailed
---	---	----------------------------------	---------------------------------------

ENTITY:  LARGE  SMALL  MICRO

**APPLICATION AS FILED – PART I**

FOR	NUMBER FILED	NUMBER EXTRA	RATE (\$)	FEE (\$)
<input type="checkbox"/> BASIC FEE <small>(37 CFR 1.16(a), (b), or (c))</small>	N/A	N/A	N/A	
<input type="checkbox"/> SEARCH FEE <small>(37 CFR 1.16(k), (l), or (m))</small>	N/A	N/A	N/A	
<input type="checkbox"/> EXAMINATION FEE <small>(37 CFR 1.16(o), (p), or (q))</small>	N/A	N/A	N/A	
TOTAL CLAIMS <small>(37 CFR 1.16(i))</small>	minus 20 =	*	X \$ =	
INDEPENDENT CLAIMS <small>(37 CFR 1.16(h))</small>	minus 3 =	*	X \$ =	
<input type="checkbox"/> APPLICATION SIZE FEE <small>(37 CFR 1.16(s))</small>	If the specification and drawings exceed 100 sheets of paper, the application size fee due is \$310 (\$155 for small entity) for each additional 50 sheets or fraction thereof. See 35 U.S.C. 41(a)(1)(G) and 37 CFR 1.16(s).			
<input type="checkbox"/> MULTIPLE DEPENDENT CLAIM PRESENT <small>(37 CFR 1.16(j))</small>				
<small>* If the difference in column 1 is less than zero, enter "0" in column 2.</small>			TOTAL	

**APPLICATION AS AMENDED – PART II**

	(Column 1)	(Column 2)	(Column 3)	PRESENT EXTRA	RATE (\$)	ADDITIONAL FEE (\$)
<b>AMENDMENT</b>	<b>06/08/2016</b>	CLAIMS REMAINING AFTER AMENDMENT	HIGHEST NUMBER PREVIOUSLY PAID FOR			
	Total <small>(37 CFR 1.16(i))</small>	* 19	Minus	** 20	= 0	X \$80 = 0
	Independent <small>(37 CFR 1.16(h))</small>	* 1	Minus	***3	= 0	X \$420 = 0
	<input type="checkbox"/> Application Size Fee <small>(37 CFR 1.16(s))</small>					
	<input type="checkbox"/> FIRST PRESENTATION OF MULTIPLE DEPENDENT CLAIM <small>(37 CFR 1.16(j))</small>					
					TOTAL ADD'L FEE	<b>0</b>

	(Column 1)	(Column 2)	(Column 3)	PRESENT EXTRA	RATE (\$)	ADDITIONAL FEE (\$)
<b>AMENDMENT</b>		CLAIMS REMAINING AFTER AMENDMENT	HIGHEST NUMBER PREVIOUSLY PAID FOR			
	Total <small>(37 CFR 1.16(i))</small>	*	Minus	**	=	X \$ =
	Independent <small>(37 CFR 1.16(h))</small>	*	Minus	***	=	X \$ =
	<input type="checkbox"/> Application Size Fee <small>(37 CFR 1.16(s))</small>					
	<input type="checkbox"/> FIRST PRESENTATION OF MULTIPLE DEPENDENT CLAIM <small>(37 CFR 1.16(j))</small>					
					TOTAL ADD'L FEE	

\* If the entry in column 1 is less than the entry in column 2, write "0" in column 3.  
 \*\* If the "Highest Number Previously Paid For" IN THIS SPACE is less than 20, enter "20".  
 \*\*\* If the "Highest Number Previously Paid For" IN THIS SPACE is less than 3, enter "3".  
 The "Highest Number Previously Paid For" (Total or Independent) is the highest number found in the appropriate box in column 1.

LIE  
/THERESA LINDSAY/

This collection of information is required by 37 CFR 1.16. The information is required to obtain or retain a benefit by the public which is to file (and by the USPTO to process) an application. Confidentiality is governed by 35 U.S.C. 122 and 37 CFR 1.14. This collection is estimated to take 12 minutes to complete, including gathering, preparing, and submitting the completed application form to the USPTO. Time will vary depending upon the individual case. Any comments on the amount of time you require to complete this form and/or suggestions for reducing this burden, should be sent to the Chief Information Officer, U.S. Patent and Trademark Office, U.S. Department of Commerce, P.O. Box 1450, Alexandria, VA 22313-1450. DO NOT SEND FEES OR COMPLETED FORMS TO THIS ADDRESS. **SEND TO: Commissioner for Patents, P.O. Box 1450, Alexandria, VA 22313-1450.**

*If you need assistance in completing the form, call 1-800-PTO-9199 and select option 2.*



UNITED STATES PATENT AND TRADEMARK OFFICE

UNITED STATES DEPARTMENT OF COMMERCE
United States Patent and Trademark Office
Address: COMMISSIONER FOR PATENTS
P.O. Box 1450
Alexandria, Virginia 22313-1450
www.uspto.gov

Table with 5 columns: APPLICATION NO., FILING DATE, FIRST NAMED INVENTOR, ATTORNEY DOCKET NO., CONFIRMATION NO.
14/319,388 06/30/2014 Robert Frederick Veasey 10-015-US-CON9 6141

98548 7590 08/19/2016
McDonnell Boehnen Hulbert & Berghoff LLP
Sanofi - Aventis
300 South Wacker Drive
Chicago, IL 60606

EXAMINER

GILBERT, ANDREW M

ART UNIT PAPER NUMBER

3763

MAIL DATE DELIVERY MODE

08/19/2016

PAPER

Please find below and/or attached an Office communication concerning this application or proceeding.

The time period for reply, if any, is set in the attached communication.



## **DETAILED ACTION**

### ***Notice of Pre-AIA or AIA Status***

1. The present application is being examined under the pre-AIA first to invent provisions.

### ***Acknowledgments***

2. This office action is in response to the reply filed on 6/8/2016.

3. In the reply, the applicant amended claims 1, 4-7 and filed a replacement drawing sheet, which is accepted.

4. Thus, claims 1-19 are pending for examination.

### ***Response to Arguments***

5. Applicant's arguments filed 6/8/2016 have been fully considered but they are not persuasive.

6. First, no terminal disclaimer has been received. The applicant agreed to file the terminal disclaimer in the interview (see attached summary), however, as of the writing of this action, no terminal disclaimer has been received. The applicant is advised to file the terminal disclaimer and, as always, is always welcome to contact the examiner by telephone if the applicant has any questions to expedite prosecution. The double patenting rejections are maintained.

7. The examiner notes that the applicant failed to comment or take any action regarding the priority issue and presence of new claims and subject matter not present in prior applications to which the applicant claims benefit as a continuation. Thus, the issue remains outstanding as set forth below in the Priority section.

Art Unit: 3763

8. Last, the applicant argues that Steinfeldt-Jensen et al ("SJ") does not teach suggest the claimed invention because SJ does not teach or suggest a clutch located between the dose dial sleeve and the drive sleeve since hooks 34 are not located between dose scale drum 17 and cap 23.

9. The applicant's arguments are recognized but not persuasive. The examiner notes that the present recitation does not require the clutch to be in physical contact with either the dose dial sleeve or drive sleeve or recite the relative positional manner in which the clutch is located between each element, i.e. the clutch being located radially outward relative to the drive sleeve and radially inward of a dose dial sleeve. *Such a recitation reciting the relative positions with respect to one another is strongly advised.*

10. Here, SJ discloses a clutch (34) located between the dose dial sleeve (17) and the drive sleeve (23) as shown in Fig 7-8 because as shown in Fig 7-8 and col 7, Ins 445-64 the clutch 34 serves as the connection between the dose dial sleeve (17) and the drive sleeve (23) (i.e. extension 33 and hooks/clutch 34 are located between 23 and the dose scale drum). The applicant is strongly advised to recite the clutch being located radially outward relative to the drive sleeve and radially inward of a dose dial sleeve to distinguish the applicant's claimed invention. The rejection is maintained.

11. Additionally, the applicant argues that SJ does not teach or suggest the drive sleeve (23) being releasably connected to the dose dial sleeve (17) as they are "either fully connected or not connected at all. Nothing happens during the operation of the device that causes a change in the state of connectivity between these two parts".

Art Unit: 3763

12. The applicant's arguments are recognized but not persuasive. The applicant has not provided a special definition of "releasably connected" in the original disclosure.

Thus, the broadest reasonable interpretation of "releasably connected" will be given to the claims. Webster's dictionary defines "releasably" as "to be able to be set free from restraint" and "connected" as "joined or linked together". Thus, "releasably connected" means "to be able to be set free from being linked together".

13. Here, the applicant appears to be arguing that "releasably connected" requires a physical separation of the drive sleeve from the dose dial sleeve. This is narrower than the broadest reasonable interpretation of the claims. Rather, "a drive sleeve releasably connected to the dose dial sleeve" means "a drive sleeve that is able to be set from being linked together with the dose dial sleeve". A "link" is defined as "a relationship between two things". Thus, the drive sleeve and dose dial sleeve being linked together can be a relationship between each element, such as a rotational and axial movement relationship.

14. Here, SJ discloses the drive sleeve (23) releasably connected to the dose dial sleeve (17) via the extension (33) and hooks/clutch (34) (col 7, Ins 49-58). The extension (33) and hooks/clutch (34) are attached to the drive sleeve. The dose dial sleeve (17) is free to rotate on the extension and thus free to rotate relative to the drive sleeve (23). However, due to the hooks/clutch (34) the dose dial sleeve must follow the axial movements of the drive sleeve (23). The result is a releasable connection where the dose dial sleeve is releasably connected to the drive sleeve such that they are released for rotation, i.e. free to rotate with respect to another, but connected for axial



Art Unit: 3763

movements, i.e. connected to follow each other axially. The present recitation of "releasably connected" allows for this interpretation. The rejection is maintained.

15. *The applicant is strongly advised to further define the releasable connection to clarify the applicant's claimed invention, i.e. recite that in the releasable connection results in a complete physical disengagement therebetween.*

16. *To expedite prosecution in the event the applicant has any questions or proposed claim amendments to discuss the applicant is invited to contact the examiner at the telephone number listed below.*

#### ***Priority***

Applicant states that this application is a continuation or divisional application of the prior-filed application. **A continuation or divisional application cannot include new matter.** Applicant is required to delete the benefit claim ***or change the relationship (continuation or divisional application) to continuation-in-part*** because this application contains the following matter not disclosed in the prior-filed application: **Figs 25-32 and all accompanying disclosure.**

17. The examiner notes that if the applicant deletes any benefit claim that changes the effective filing date of the claims the notice of allowability will be thereby vacated as the notice of allowability is dependent upon the effective filing dates stated in this office action.

18. The examiner also believes that the applicant may also keep the current designation as a continuation application if the applicant cancels **all** the new subject matter not disclosed in the prior-filed applications.

### ***Claim Objections***

19. Claims 1-19 are objected to because of the following informalities:
20. In claim 1, In 9 the phrase “a second thread ,” should have the space deleted between the word “thread” and the comma. Claims 2-19 are objected to by virtue of depending on claim 1. Appropriate correction is required.

### ***Double Patenting***

21. The nonstatutory double patenting rejection is based on a judicially created doctrine grounded in public policy (a policy reflected in the statute) so as to prevent the unjustified or improper timewise extension of the “right to exclude” granted by a patent and to prevent possible harassment by multiple assignees. A nonstatutory double patenting rejection is appropriate where the claims at issue are not identical, but at least one examined application claim is not patentably distinct from the reference claim(s) because the examined application claim is either anticipated by, or would have been obvious over, the reference claim(s). See, e.g., *In re Berg*, 140 F.3d 1428, 46 USPQ2d 1226 (Fed. Cir. 1998); *In re Goodman*, 11 F.3d 1046, 29 USPQ2d 2010 (Fed. Cir. 1993); *In re Longi*, 759 F.2d 887, 225 USPQ 645 (Fed. Cir. 1985); *In re Van Ornum*, 686 F.2d 937, 214 USPQ 761 (CCPA 1982); *In re Vogel*, 422 F.2d 438, 164 USPQ 619 (CCPA 1970); and *In re Thorington*, 418 F.2d 528, 163 USPQ 644 (CCPA 1969).

A timely filed terminal disclaimer in compliance with 37 CFR 1.321(c) or 1.321(d) may be used to overcome an actual or provisional rejection based on a nonstatutory double patenting ground provided the reference application or patent either is shown to be commonly owned with this application, or claims an invention made as a result of

Art Unit: 3763

activities undertaken within the scope of a joint research agreement. See MPEP § 717.02 for applications subject to examination under the first inventor to file provisions of the AIA as explained in MPEP § 2159. See MPEP §§ 706.02(l)(1) - 706.02(l)(3) for applications not subject to examination under the first inventor to file provisions of the AIA. A terminal disclaimer must be signed in compliance with 37 CFR 1.321(b).

The USPTO Internet website contains terminal disclaimer forms which may be used. Please visit [www.uspto.gov/forms/](http://www.uspto.gov/forms/). The filing date of the application in which the form is filed determines what form (e.g., PTO/SB/25, PTO/SB/26, PTO/AIA/25, or PTO/AIA/26) should be used. A web-based eTerminal Disclaimer may be filled out completely online using web-screens. An eTerminal Disclaimer that meets all requirements is auto-processed and approved immediately upon submission. For more information about eTerminal Disclaimers, refer to <http://www.uspto.gov/patents/process/file/efs/guidance/eTD-info-l.jsp>.

22. Claims 1, 3, 5-12, 17-19 rejected on the ground of nonstatutory double patenting as being unpatentable over claims 8-10 of U.S. Patent No. 8,556,864. Although the claims at issue are not identical, they are not patentably distinct from each other because the present claims are merely broader than the related patent and cover similar subject matter including a drive mechanism having a housing with a helical thread, insert, drive sleeve, piston rod having two threads, and clutch.

23. Claim 4 is rejected on the ground of nonstatutory double patenting as being unpatentable over claims 8-10 of U.S. Patent No. 8556864, as set forth above, in view of claims 1-8 of U.S. Patent No. 9,233,211.

Art Unit: 3763

24. '864 claims the subject matter, except for the limiting nut translating along a threaded outer surface between two radially extending flanges of the drive sleeve, which is claimed in '211 along with other similar elements, such as the insert. It would have been obvious to one of ordinary skill in the art to modify the claimed invention of '864 with the claimed invention of the threaded outer surface and two radially extending flanges of '211 for the purpose of providing a threaded length with proximal/distal stops for the nut to travel along that corresponds to the set and delivered dosage.

***Claim Rejections - 35 USC § 102***

25. The following is a quotation of the appropriate paragraphs of pre-AIA 35 U.S.C. 102 that form the basis for the rejections under this section made in this Office action:

A person shall be entitled to a patent unless –

(b) the invention was patented or described in a printed publication in this or a foreign country or in public use or on sale in this country, more than one year prior to the date of application for patent in the United States.

26. Claims 1, 3, 7-8, 10-12, 17, 18 are rejected under pre-AIA 35 U.S.C. 102(b) as being anticipated by Steinfeldt-Jensen et al (6004297). ***See response to arguments above incorporated herein by reference.***

27. Steinfeldt-Jensen et al discloses a drive mechanism (Figs 6-10) for use in a drug delivery device comprising: a housing (1, 2) comprising a helical thread (16); a dose dial sleeve (17) having a threaded surface (Fig 8) that is engaged with the helical thread of the housing, an insert (4) provided in the housing, where the insert has a threaded circular opening (5); a drive sleeve (23) releasably connected to the dose dial sleeve (Fig 6-8) and having an internal helical thread (36); a piston rod (6) having a first thread (7) and a second thread (37), wherein the first thread is engaged with the threaded

Art Unit: 3763

circular opening of the insert (Fig 7) and the second thread is engaged with the internal helical thread of the drive sleeve (Fig 7); and a clutch (34) located between the dose dial sleeve and the drive sleeve (col 7, lns 54-57; the examiner suggests further definition of the structure and function of the clutch to clarify the applicant's claimed invention).

28. Regarding claim 3, where insert (4) is secured in the housing against rotational and longitudinal motion (col 5, lns 52-55).

29. Regarding claims 7-8, where the threaded outer surface of the dose dial sleeve (17) has a first lead (Fig 7-8), the first thread (7) of the piston rod has a second lead (Fig 7-8).

30. Regarding claim 10, the clutch (34) is rotationally fixed to the drive sleeve (23) and the dose dial sleeve (17) during dose setting (col 7, lns 54-57; col 7, lns 65-col 8, lns 6).

31. Regarding claim 11, see Figs 7-8, helical housing thread 16 and corresponding threaded outer surface on 17.

32. Regarding claim 12, see Figs 7-8 and col 5, lns 53-58.

33. Regarding claim 17, see 37 and 7 in Fig 7, 8 which appear oppositely disposed.

34. Regarding claim 18, see Figs 7-8 and col 7, lns 65-col 8, lns 9 where piston rod 6 will not rotate during dose setting.

***Claim Rejections - 35 USC § 103***

35. The following is a quotation of pre-AIA 35 U.S.C. 103(a) which forms the basis for all obviousness rejections set forth in this Office action:

Art Unit: 3763

(a) A patent may not be obtained though the invention is not identically disclosed or described as set forth in section 102 of this title, if the differences between the subject matter sought to be patented and the prior art are such that the subject matter as a whole would have been obvious at the time the invention was made to a person having ordinary skill in the art to which said subject matter pertains. Patentability shall not be negated by the manner in which the invention was made.

36. Claim 2 is rejected under pre-AIA 35 U.S.C. 103(a) as being unpatentable over Steinfeldt-Jensen et al, as applied to claim 1 above, in view of Klitgaard et al (6582404). Steinfeldt-Jensen et al discloses the invention substantially as claimed except for expressly disclosing the drive sleeve comprising a threaded outer surface, and a limiting nut threaded engaged therewith and rotationally fixed and slidable relative to the housing. Klitgaard et al teaches that it is known to have the drive sleeve (31) comprising a threaded outer surface (33), and a limiting nut (32) threaded engaged therewith and rotationally fixed and slidable relative to the housing (col 4, lns 29-37) for the purpose of tracking the dosage delivered to stop a setting of a dose that is larger than the amount remaining in the cartridge (col 4, lns 54-58). It would have been obvious to one having ordinary skill in the art at the time the invention was made to modify the drive mechanism as taught by Steinfeldt-Jensen et al with the thread and limiting nut as taught by Klitgaard et al for the purpose of tracking the dosage delivered to stop a setting of a dose that is larger than the amount remaining in the cartridge (col 4, lns 54-58).

37. Claim 6, 13 are rejected under pre-AIA 35 U.S.C. 103(a) as being unpatentable over Steinfeldt-Jensen et al, as applied to claim 1 above, in view of Chanoch (5582598). Steinfeldt-Jensen et al discloses the invention substantially as claimed except for expressly disclosing the housing comprising a window insert at a distal end of

Art Unit: 3763

the housing and rotationally fixed thereto, the insert comprising a frame having a stop that is configured to engage a stop on the dose dial sleeve when a predetermined maximum dose is set by rotation of the dose dial sleeve. Chanoch teaches that it is known to have the housing comprising a window insert (78) at a distal end of the housing (22) and rotationally fixed thereto, the insert comprising a frame (80) having a stop (protrusion 86) that is configured to engage a stop (end wall of groove 70, i.e. in groove portion 194) in on the dose dial sleeve when a predetermined maximum dose is set by rotation of the dose dial sleeve (58) for the purpose of allowing a dosage to be set between a maximum and minimum dosage. It would have been obvious to one having ordinary skill in the art at the time the invention was made to modify the drive mechanism as taught by Steinfeldt-Jensen et al with window and maximum dose limiter as taught by Chanoch for the purpose of allowing a dosage to be set between a maximum and minimum dosage.

38. Claims 9, 14-17, 19 are rejected under pre-AIA 35 U.S.C. 103(a) as being unpatentable over Steinfeldt-Jensen et al, as applied to claim 1 above. Steinfeldt-Jensen et al discloses the invention substantially as claimed, including a piston rod having first and second threads of different lead (see discussion above in claim 1), except for expressly disclosing the ratio between the leads being 1:1.01 to 1:20 or 1:1.1 to 1:10, the internal drive sleeve thread and first lead being equal, the threads being oppositely disposed, the second thread of the piston rod being a part thread, or the rotation rate of the drive sleeve and dose dial sleeve being equal. At the time the invention was made, it would have been an obvious matter of design choice to a person

Art Unit: 3763

of ordinary skill in the art to have the claimed lead ratios, being oppositely disposed, the second thread of the piston rod being a part thread, or the rotation rate of the drive sleeve and dose dial sleeve being equal because the Applicant has not disclosed that having the claim lead ratios, the internal drive sleeve thread and first lead being equal, being oppositely disposed, or the second thread of the piston rod being a part thread, provides an advantage, is used for a particular purpose, or solves a stated problem. Furthermore, one of ordinary skill in the art would have expected the Applicants invention to perform equally well with the threads with different leads of Steinfeldt-Jensen because they perform substantially the same function in substantially the same manner. Therefore, it would have been an obvious matter of design choice to modify Steinfeldt-Jensen to obtain the invention as specified in claim 9, 14-17, 19. Further, where the general conditions of a claim are disclosed in the prior art, it is not inventive to discover the optimum or workable ranges by routine experimentation.

### ***Conclusion***

39. **THIS ACTION IS MADE FINAL.** Applicant is reminded of the extension of time policy as set forth in 37 CFR 1.136(a).

A shortened statutory period for reply to this final action is set to expire THREE MONTHS from the mailing date of this action. In the event a first reply is filed within TWO MONTHS of the mailing date of this final action and the advisory action is not mailed until after the end of the THREE-MONTH shortened statutory period, then the shortened statutory period will expire on the date the advisory action is mailed, and any extension fee pursuant to 37 CFR 1.136(a) will be calculated from the mailing date of



Art Unit: 3763

the advisory action. In no event, however, will the statutory period for reply expire later than SIX MONTHS from the mailing date of this final action.

Any inquiry concerning this communication or earlier communications from the examiner should be directed to ANDREW GILBERT whose telephone number is (571)272-7216. The examiner can normally be reached on 8:30 am to 5:00 pm Monday through Friday.

If attempts to reach the examiner by telephone are unsuccessful, the examiner's supervisor, Kevin Sirmons can be reached on (571)272-4965. The fax phone number for the organization where this application or proceeding is assigned is 571-273-8300.

Information regarding the status of an application may be obtained from the Patent Application Information Retrieval (PAIR) system. Status information for published applications may be obtained from either Private PAIR or Public PAIR. Status information for unpublished applications is available through Private PAIR only. For more information about the PAIR system, see <http://pair-direct.uspto.gov>. Should you have questions on access to the Private PAIR system, contact the Electronic Business Center (EBC) at 866-217-9197 (toll-free). If you would like assistance from a USPTO Customer Service Representative or access to the automated information system, call 800-786-9199 (IN USA OR CANADA) or 571-272-1000.

/ANDREW GILBERT/  
Primary Examiner, Art Unit 3763

<b>Examiner-Initiated Interview Summary</b>	<b>Application No.</b> 14/319,388	<b>Applicant(s)</b> VEASEY ET AL.	
	<b>Examiner</b> ANDREW GILBERT	<b>Art Unit</b> 3763	

All participants (applicant, applicant's representative, PTO personnel):

- (1) ANDREW GILBERT. (3)\_\_\_\_\_.
- (2) Thomas Wettermann. (4)\_\_\_\_\_.

Date of Interview: 09 August 2016.

Type:  Telephonic  Video Conference  
 Personal [copy given to:  applicant  applicant's representative]

Exhibit shown or demonstration conducted:  Yes  No.  
If Yes, brief description: \_\_\_\_\_.

Issues Discussed 101 112 102 103 Others  
(For each of the checked box(es) above, please describe below the issue and detailed description of the discussion)

Claim(s) discussed: 1-19.

Identification of prior art discussed: USPNs 8556864, and applicant's original disclosure.

**Substance of Interview**

(For each issue discussed, provide a detailed description and indicate if agreement was reached. Some topics may include: identification or clarification of a reference or a portion thereof, claim interpretation, proposed amendments, arguments of any applied references etc...)

See Continuation Sheet.

**Applicant recordation instructions:** It is not necessary for applicant to provide a separate record of the substance of interview.


**Examiner recordation instructions:** Examiners must summarize the substance of any interview of record. A complete and proper recordation of the substance of an interview should include the items listed in MPEP 713.04 for complete and proper recordation including the identification of the general thrust of each argument or issue discussed, a general indication of any other pertinent matters discussed regarding patentability and the general results or outcome of the interview, to include an indication as to whether or not agreement was reached on the issues raised.

Attachment

/ANDREW GILBERT/  
Primary Examiner, Art Unit 3763

Continuation of Substance of Interview including description of the general nature of what was agreed to if an agreement was reached, or any other comments: The applicant and examiner discussed how the present application is stated as a continuation of the prior-filed applications. However, a continuation or divisional application cannot include new matter (see MPEP 211, 211.05 and form paragraph 2-10-01). The examiner discussed how the applicant is required to delete the benefit claim or change the relationship (continuation or divisional application) to continuation-in-part because this application contains the following matter not disclosed in the prior-filed application (i.e. see Figures 25-32 and related additional description disclosure not present in prior applications). The applicant decided that such a requirement may take time to resolve and thus declined an examiner's amendment or other appropriate correction at this time.

The examiner additionally discussed how the Remarks filed on 6/8/2016 stated a Terminal Disclaimer to '864 would be filed with the reply, however no terminal disclaimer was received. The applicant agreed to file the Terminal Disclaimer, however as of the writing of this office action, no terminal disclaimer has been received. The applicant is advised to file the terminal disclaimer and, as always, contact the examiner to expedite prosecution if the applicant has any questions or concerns.

<b>Search Notes</b>  	<b>Application/Control No.</b>  14319388	<b>Applicant(s)/Patent Under Reexamination</b>  VEASEY ET AL.
	<b>Examiner</b>  ANDREW GILBERT	<b>Art Unit</b>  3763

CPC- SEARCHED		
Symbol	Date	Examiner
A61M5/24,31533,31535,31536,31541,31551,31565,31578	8/17/2016	AG


CPC COMBINATION SETS - SEARCHED		
Symbol	Date	Examiner

US CLASSIFICATION SEARCHED			
Class	Subclass	Date	Examiner

SEARCH NOTES		
Search Notes	Date	Examiner
Searched EAST CPC class/subclass and keyword search done on 2/21/2016 - see attached sheets	8/17/2016	AG
Inventor Name search	8/17/2016	AG
Forward/backward citation searches	8/17/2016	AG
Updated search in related cases USPN 7935088, 7850662, 9028454 and US App No 14319371, 14319379, 14319381, and 14319384	8/17/2016	AG

INTERFERENCE SEARCH			
US Class/ CPC Symbol	US Subclass / CPC Group	Date	Examiner

	/ANDREW GILBERT/ Primary Examiner.Art Unit 3763
--	--

<b>Index of Claims</b>  	<b>Application/Control No.</b> 14319388	<b>Applicant(s)/Patent Under Reexamination</b> VEASEY ET AL.
	<b>Examiner</b> ANDREW GILBERT	<b>Art Unit</b> 3763

✓	<b>Rejected</b>
=	<b>Allowed</b>

-	<b>Cancelled</b>
÷	<b>Restricted</b>

N	<b>Non-Elected</b>
I	<b>Interference</b>

A	<b>Appeal</b>
O	<b>Objected</b>

Claims renumbered in the same order as presented by applicant
  CPA
  T.D.
  R.1.47

CLAIM		DATE							
Final	Original	02/21/2016	08/17/2016						
	1	✓	✓						
	2	✓	✓						
	3	✓	✓						
	4	✓	✓						
	5	✓	✓						
	6	✓	✓						
	7	✓	✓						
	8	✓	✓						
	9	✓	✓						
	10	✓	✓						
	11	✓	✓						
	12	✓	✓						
	13	✓	✓						
	14	✓	✓						
	15	✓	✓						
	16	✓	✓						
	17	✓	✓						
	18	✓	✓						
	19	✓	✓						

Electronic Petition Request	<b>TERMINAL DISCLAIMER TO OBVIATE A DOUBLE PATENTING REJECTION OVER A "PRIOR" PATENT</b>
Application Number	14319388
Filing Date	30-Jun-2014
First Named Inventor	Robert Veasey
Attorney Docket Number	10-015-US-CON9
Title of Invention	DRIVE MECHANISMS SUITABLE FOR USE IN DRUG DELIVERY DEVICES

- Filing of terminal disclaimer does not obviate requirement for response under 37 CFR 1.111 to outstanding Office Action
- This electronic Terminal Disclaimer is not being used for a Joint Research Agreement.

Owner	Percent Interest
Sanofi-Aventis Deutschland GmbH	100%

The owner(s) with percent interest listed above in the instant application hereby disclaims, except as provided below, the terminal part of the statutory term of any patent granted on the instant application which would extend beyond the expiration date of the full statutory term of prior patent number(s)

9233211  
8556864

as the term of said prior patent is presently shortened by any terminal disclaimer. The owner hereby agrees that any patent so granted on the instant application shall be enforceable only for and during such period that it and the prior patent are commonly owned. This agreement runs with any patent granted on the instant application and is binding upon the grantee, its successors or assigns.

In making the above disclaimer, the owner does not disclaim the terminal part of the term of any patent granted on the instant application that would extend to the expiration date of the full statutory term of the prior patent, "as the term of said prior patent is presently shortened by any terminal disclaimer," in the event that said prior patent later:

- expires for failure to pay a maintenance fee;
- is held unenforceable;
- is found invalid by a court of competent jurisdiction;
- is statutorily disclaimed in whole or terminally disclaimed under 37 CFR 1.321;
- has all claims canceled by a reexamination certificate;
- is reissued; or
- is in any manner terminated prior to the expiration of its full statutory term as presently shortened by any terminal disclaimer.

Terminal disclaimer fee under 37 CFR 1.20(d) is included with Electronic Terminal Disclaimer request.

I certify, in accordance with 37 CFR 1.4(d)(4), that the terminal disclaimer fee under 37 CFR 1.20(d) required for this terminal disclaimer has already been paid in the above-identified application.

Applicant claims the following fee status:

Small Entity

Micro Entity

Regular Undiscounted

I hereby declare that all statements made herein of my own knowledge are true and that all statements made on information and belief are believed to be true; and further that these statements were made with the knowledge that willful false statements and the like so made are punishable by fine or imprisonment, or both, under Section 1001 of Title 18 of the United States Code and that such willful false statements may jeopardize the validity of the application or any patent issued thereon.

THIS PORTION MUST BE COMPLETED BY THE SIGNATORY OR SIGNATORIES

I certify, in accordance with 37 CFR 1.4(d)(4) that I am:

An attorney or agent registered to practice before the Patent and Trademark Office who is of record in this application

Registration Number 41523

A sole inventor

A joint inventor; I certify that I am authorized to sign this submission on behalf of all of the inventors as evidenced by the power of attorney in the application

A joint inventor; all of whom are signing this request

Signature	/Thomas E. Wettermann/
Name	Thomas E. Wettermann

\*Statement under 37 CFR 3.73(b) is required if terminal disclaimer is signed by the assignee (owner).  
Form PTO/SB/96 may be used for making this certification. See MPEP § 324.

## Electronic Patent Application Fee Transmittal

<b>Application Number:</b>	14319388			
<b>Filing Date:</b>	30-Jun-2014			
<b>Title of Invention:</b>	DRIVE MECHANISMS SUITABLE FOR USE IN DRUG DELIVERY DEVICES			
<b>First Named Inventor/Applicant Name:</b>	Robert Frederick Veasey			
<b>Filer:</b>	Thomas E. Wettermann			
<b>Attorney Docket Number:</b>	10-015-US-CON9			
Filed as Large Entity				
<b>Filing Fees for Utility under 35 USC 111(a)</b>				
<b>Description</b>	<b>Fee Code</b>	<b>Quantity</b>	<b>Amount</b>	<b>Sub-Total in USD(\$)</b>
<b>Basic Filing:</b>				
STATUTORY OR TERMINAL DISCLAIMER	1814	1	160	160
<b>Pages:</b>				
<b>Claims:</b>				
<b>Miscellaneous-Filing:</b>				
<b>Petition:</b>				
<b>Patent-Appeals-and-Interference:</b>				
<b>Post-Allowance-and-Post-Issuance:</b>				



Description	Fee Code	Quantity	Amount	Sub-Total in USD(\$)
<b>Extension-of-Time:</b>				
<b>Miscellaneous:</b>				
<b>Total in USD (\$)</b>				<b>160</b>

Doc Code: DISQ.E.FILE

Document Description: Electronic Terminal Disclaimer – Approved

Application No.: 14319388

Filing Date: 30-Jun-2014

Applicant/Patent under Reexamination: Veasey et al.

Electronic Terminal Disclaimer filed on October 24, 2016

APPROVED

**This patent is subject to a terminal disclaimer**

DISAPPROVED

Approved/Disapproved by: Electronic Terminal Disclaimer automatically approved by EFS-Web

U.S. Patent and Trademark Office

## Electronic Acknowledgement Receipt

<b>EFS ID:</b>	27298099
<b>Application Number:</b>	14319388
<b>International Application Number:</b>	
<b>Confirmation Number:</b>	6141
<b>Title of Invention:</b>	DRIVE MECHANISMS SUITABLE FOR USE IN DRUG DELIVERY DEVICES
<b>First Named Inventor/Applicant Name:</b>	Robert Frederick Veasey
<b>Customer Number:</b>	98548
<b>Filer:</b>	Thomas E. Wettermann
<b>Filer Authorized By:</b>	
<b>Attorney Docket Number:</b>	10-015-US-CON9
<b>Receipt Date:</b>	24-OCT-2016
<b>Filing Date:</b>	30-JUN-2014
<b>Time Stamp:</b>	14:28:36
<b>Application Type:</b>	Utility under 35 USC 111(a)

### Payment information:

Submitted with Payment	yes
Payment Type	DA
Payment was successfully received in RAM	\$160
RAM confirmation Number	102516INTEFSW00000744132490
Deposit Account	132490
Authorized User	thomas wettermann

The Director of the USPTO is hereby authorized to charge indicated fees and credit any overpayment as follows:

37 CFR 1.16 (National application filing, search, and examination fees)

37 CFR 1.17 (Patent application and reexamination processing fees)

Mylan Exhibit - 1010

Mylan v. Sanofi

0187

37 CFR 1.19 (Document supply fees)  
 37 CFR 1.20 (Post Issuance fees)  
 37 CFR 1.21 (Miscellaneous fees and charges)

**File Listing:**

Document Number	Document Description	File Name	File Size(Bytes)/ Message Digest	Multi Part /.zip	Pages (if appl.)
1	Electronic Terminal Disclaimer-Filed	eTerminal-Disclaimer.pdf	33602 f6556eca6db72d1ee7b82cfb26ba2554769d2cae	no	2

**Warnings:**

**Information:**

2	Fee Worksheet (SB06)	fee-info.pdf	30751 a35cd60a280605049b3943f37739d4445d5a1b17	no	2
---	----------------------	--------------	---	----	---

**Warnings:**

**Information:**

**Total Files Size (in bytes):** 64353

**This Acknowledgement Receipt evidences receipt on the noted date by the USPTO of the indicated documents, characterized by the applicant, and including page counts, where applicable. It serves as evidence of receipt similar to a Post Card, as described in MPEP 503.**

**New Applications Under 35 U.S.C. 111**

**If a new application is being filed and the application includes the necessary components for a filing date (see 37 CFR 1.53(b)-(d) and MPEP 506), a Filing Receipt (37 CFR 1.54) will be issued in due course and the date shown on this Acknowledgement Receipt will establish the filing date of the application.**

**National Stage of an International Application under 35 U.S.C. 371**

**If a timely submission to enter the national stage of an international application is compliant with the conditions of 35 U.S.C. 371 and other applicable requirements a Form PCT/DO/EO/903 indicating acceptance of the application as a national stage submission under 35 U.S.C. 371 will be issued in addition to the Filing Receipt, in due course.**

**New International Application Filed with the USPTO as a Receiving Office**

**If a new international application is being filed and the international application includes the necessary components for an international filing date (see PCT Article 11 and MPEP 1810), a Notification of the International Application Number and of the International Filing Date (Form PCT/RO/105) will be issued in due course, subject to prescriptions concerning national security, and the date shown on this Acknowledgement Receipt will establish the international filing date of the application.**

**REQUEST FOR CONTINUED EXAMINATION(RCE)TRANSMITTAL  
(Submitted Only via EFS-Web)**

Application Number	14319388	Filing Date	2014-06-30	Docket Number (if applicable)	10-015-US-CON9	Art Unit	3763
First Named Inventor	Robert Frederick Veasey			Examiner Name	Andrew M. Gilbert		

**This is a Request for Continued Examination (RCE) under 37 CFR 1.114 of the above-identified application.** Request for Continued Examination (RCE) practice under 37 CFR 1.114 does not apply to any utility or plant application filed prior to June 8, 1995, to any international application that does not comply with the requirements of 35 U.S.C. 371, or to any design application. The Instruction Sheet for this form is located at WWW.USPTO.GOV.

**SUBMISSION REQUIRED UNDER 37 CFR 1.114**

Note: If the RCE is proper, any previously filed unentered amendments and amendments enclosed with the RCE will be entered in the order in which they were filed unless applicant instructs otherwise. If applicant does not wish to have any previously filed unentered amendment(s) entered, applicant must request non-entry of such amendment(s).

Previously submitted. If a final Office action is outstanding, any amendments filed after the final Office action may be considered as a submission even if this box is not checked.

Consider the arguments in the Appeal Brief or Reply Brief previously filed on \_\_\_\_\_

Other \_\_\_\_\_

Enclosed

Amendment/Reply

Information Disclosure Statement (IDS)

Affidavit(s)/ Declaration(s)

Other \_\_\_\_\_

**MISCELLANEOUS**

Suspension of action on the above-identified application is requested under 37 CFR 1.103(c) for a period of months \_\_\_\_\_ (Period of suspension shall not exceed 3 months; Fee under 37 CFR 1.17(i) required)

Other

**FEES**

**The RCE fee under 37 CFR 1.17(e) is required by 37 CFR 1.114 when the RCE is filed.**

The Director is hereby authorized to charge any underpayment of fees, or credit any overpayments, to Deposit Account No

**SIGNATURE OF APPLICANT, ATTORNEY, OR AGENT REQUIRED**

<input checked="" type="checkbox"/> Patent Practitioner Signature
<input type="checkbox"/> Applicant Signature

Signature of Registered U.S. Patent Practitioner			
Signature	Thomas E. Wettermann/	Date (YYYY-MM-DD)	2016-10-24
Name	Thomas E. Wettermann	Registration Number	41523

This collection of information is required by 37 CFR 1.114. The information is required to obtain or retain a benefit by the public which is to file (and by the USPTO to process) an application. Confidentiality is governed by 35 U.S.C. 122 and 37 CFR 1.11 and 1.14. This collection is estimated to take 12 minutes to complete, including gathering, preparing, and submitting the completed application form to the USPTO. Time will vary depending upon the individual case. Any comments on the amount of time you require to complete this form and/or suggestions for reducing this burden, should be sent to the Chief Information Officer, U.S. Patent and Trademark Office, U.S. Department of Commerce, P.O. Box 1450, Alexandria, VA 22313-1450.

*If you need assistance in completing the form, call 1-800-PTO-9199 and select option 2.*

## Privacy Act Statement

The Privacy Act of 1974 (P.L. 93-579) requires that you be given certain information in connection with your submission of the attached form related to a patent application or patent. Accordingly, pursuant to the requirements of the Act, please be advised that: (1) the general authority for the collection of this information is 35 U.S.C. 2(b)(2); (2) furnishing of the information solicited is voluntary; and (3) the principal purpose for which the information is used by the U.S. Patent and Trademark Office is to process and/or examine your submission related to a patent application or patent. If you do not furnish the requested information, the U.S. Patent and Trademark Office may not be able to process and/or examine your submission, which may result in termination of proceedings or abandonment of the application or expiration of the patent.

The information provided by you in this form will be subject to the following routine uses:

1. The information on this form will be treated confidentially to the extent allowed under the Freedom of Information Act (5 U.S.C. 552) and the Privacy Act (5 U.S.C. 552a). Records from this system of records may be disclosed to the Department of Justice to determine whether the Freedom of Information Act requires disclosure of these records.
2. A record from this system of records may be disclosed, as a routine use, in the course of presenting evidence to a court, magistrate, or administrative tribunal, including disclosures to opposing counsel in the course of settlement negotiations.
3. A record in this system of records may be disclosed, as a routine use, to a Member of Congress submitting a request involving an individual, to whom the record pertains, when the individual has requested assistance from the Member with respect to the subject matter of the record.
4. A record in this system of records may be disclosed, as a routine use, to a contractor of the Agency having need for the information in order to perform a contract. Recipients of information shall be required to comply with the requirements of the Privacy Act of 1974, as amended, pursuant to 5 U.S.C. 552a(m).
5. A record related to an International Application filed under the Patent Cooperation Treaty in this system of records may be disclosed, as a routine use, to the International Bureau of the World Intellectual Property Organization, pursuant to the Patent Cooperation Treaty.
6. A record in this system of records may be disclosed, as a routine use, to another federal agency for purposes of National Security review (35 U.S.C. 181) and for review pursuant to the Atomic Energy Act (42 U.S.C. 218(c)).
7. A record from this system of records may be disclosed, as a routine use, to the Administrator, General Services, or his/her designee, during an inspection of records conducted by GSA as part of that agency's responsibility to recommend improvements in records management practices and programs, under authority of 44 U.S.C. 2904 and 2906. Such disclosure shall be made in accordance with the GSA regulations governing inspection of records for this purpose, and any other relevant (i.e., GSA or Commerce) directive. Such disclosure shall not be used to make determinations about individuals.
8. A record from this system of records may be disclosed, as a routine use, to the public after either publication of the application pursuant to 35 U.S.C. 122(b) or issuance of a patent pursuant to 35 U.S.C. 151. Further, a record may be disclosed, subject to the limitations of 37 CFR 1.14, as a routine use, to the public if the record was filed in an application which became abandoned or in which the proceedings were terminated and which application is referenced by either a published application, an application open to public inspections or an issued patent.
9. A record from this system of records may be disclosed, as a routine use, to a Federal, State, or local law enforcement agency, if the USPTO becomes aware of a violation or potential violation of law or regulation.

IN THE UNITED STATES PATENT AND TRADEMARK OFFICE  
(MBHB Case No.: 10-015-US-CON9)

In the Application of:	)	
	)	
Robert Frederick Veasey et al.	)	Examiner: Gilbert, Andrew M.
	)	
Serial No.    14/319,388	)	Group Art Unit: 3763
	)	
Filed:        June 30, 2014	)	Confirmation No.: 6141
	)	
For:    Drive Mechanisms Suitable for Use in Drug	)	
Delivery Devices	)	

Mail Stop RCE  
Commissioner for Patents  
P.O. Box 1450  
Alexandria, Virginia 22313-1450

**REQUEST FOR CONTINUED EXAMINATION**

Please consider the following Request for Continued Examination, amendments, and remarks in response to the Final Office Action mailed August 19, 2016.

**Amendments to the Specification** begin on page 2 of this paper.

**Amendments to the Drawings** begin on page 7 of this paper.

**Amendments to the Claims** begin on page 8 of this paper.

**Remarks/Arguments** begin on page 12 of this paper.

Please charge any underpayment or credit any overpayment to Deposit Account No. 132490. Further, Applicant generally authorizes the Office to treat any filing in this matter that requires an extension of time as incorporating a request for such an extension.



## AMENDMENTS TO THE SPECIFICATION

**Please amend paragraph [0064] on page 10 of the specification (spanning lines 1-2)**

**as follows:**

[0064] Figure 23 shows a fragment of the drug delivery device of Figure 18 in a larger scale; and

**Please amend paragraph [0065] on page 10 of the specification (spanning lines 3-4)**

**as follows:**

[0065] Figure 24 shows a further fragment of the drug delivery device of Figure 18 in a larger scale. [;]

**Please delete paragraphs [0066]-[0073] of the specification (spanning lines 5-20).**

**Please amend paragraph [0078] on page 11 of the specification (spanning lines 10-**

**14) as follows:**

[0078] In the illustrated embodiment, an insert 16 is provided at a first end of the main housing 4. ~~(see Fig. 32).~~ The insert 16 is secured against rotational or longitudinal motion. The insert 16 is provided with a threaded circular opening 18 extending therethrough. Alternatively, the insert may be formed integrally with the main housing 4 having the form of a radially inwardly directed flange having an internal thread.

**Please amend paragraph [0083] on page 12 of the specification (spanning lines 3-9)**

**as follows:**

[0083] A nut 40 is located between the drive sleeve 30 and the main housing 2, disposed between the first flange 32 and the second flange 34. In the illustrated embodiment the nut 40 is a half-nut. This assists in the assembly of the device. The nut 40 has an internal thread 240 matching the intermediate thread 36. ~~(see Fig. 31).~~ The outer surface of the nut 40 and an internal surface of the main housing 4 are keyed together by splines 42 (Figures 10, 11, 15 and 16) to prevent relative rotation between the nut 40 and the main housing 4, while allowing relative longitudinal movement therebetween.

**Please amend paragraph [0087] on page 12 of the specification (spanning lines 22-**

**25) as follows:**

[0087] ~~Fig. 25 illustrates the various components of the drive mechanism, including~~ In an alternative embodiment (not shown) the clicker further includes at least one ~~biasing element depicted as spring member 200 in Fig. 25.~~ The at least one spring member 200 assists in the resetting of the clutch 60 following dispense ~~and can form part of clicker 50.~~

**Please amend paragraph [0088] starting on page 12 of the specification (spanning page 12, line 26 – page 13, line 3) as follows:**

[0088] The clutch 60 is located adjacent the second end of the drive sleeve 30. The clutch 60 is generally cylindrical and is provided at a first end with a series of circumferentially directed

saw teeth 66 (Figure 7). Each saw tooth comprises a longitudinally directed surface and an inclined surface. Towards the second end 64 of the clutch 60 there is located a radially inwardly directed flange 62. The flange 62 of the clutch 60 is disposed between the shoulder 37 of the drive sleeve 30 and the radially outwardly directed flange 39 of the extension 47 ~~(see Fig. 26)~~38. The second end of the clutch 60 is provided with a plurality of dog teeth 65 (Figure 8). The clutch 60 is keyed to the drive sleeve 30 by way of splines ~~266 (see Fig. 27)~~(not shown) to prevent relative rotation between the clutch 60 and the drive sleeve 30.

**Please amend paragraph [0092] on page 13 of the specification (spanning lines 11-18) as follows:**

[0092] The main housing 4 is provided with a window 44 through which a part of the outer surface of the dose dial sleeve may be seen. The main housing 4 is further provided with a helical rib (thread) 46, adapted to be seated in the helical groove (thread) 74 on the outer surface of the dose dial sleeve 70. The helical rib 46 extends for a single sweep of the inner surface of the main housing 4. A first stop 100 is provided between the splines 42 and the helical rib 46 (Figure 15). A second stop 102, disposed at an angle of 180° to the first stop 100 is formed by a frame surrounding the window 44 in the main housing 4 (Figure[[s]] 16). ~~Window 44 has a raised portion 244. (see Figure 30).~~

**Please amend paragraph [0095] starting on page 13 of the specification (spanning page 13, line 30 – page 14, line 5) as follows:**

[0095] A button 82 of generally “T” section is provided at a second end of the device. ~~(see Fig. 28)~~ A stem 84 of the button 82 may extend through the opening 78 in the dose dial grip

76, through the inner diameter of the extension 47 of the drive sleeve 30 and into the receiving recess 26 of the piston rod 20. The stem 84 is retained for limited axial movement in the drive sleeve 30 and against rotation with respect thereto. A head 85 of the button 82 is generally circular. A skirt 86 depends from a periphery of the head 85. The skirt 86 is adapted to be seated in the annular recess 80 of the dose dial grip 76.

**Please amend paragraph [0099] on page 14 of the specification (spanning lines 18-24) as follows:**

[0099] The helical groove<sup>74</sup> on the dose dial sleeve 70 and the helical groove 38 in the drive sleeve 30 have the same lead. This allows the dose dial sleeve 70 (arrow C) to extend from the main housing 4 and the drive sleeve 30 (arrow D) to climb the piston rod 20 at the same rate. At the limit of travel, a radial stop 104 (Figure<sup>[[s]]</sup> 12 ~~and 30~~) on the dose dial sleeve 70 engages either the first stop 100 or the second stop 102 provided on the main housing 4 to prevent further movement. Rotation of the piston rod 20 is prevented due to the opposing directions of the overhauled and driven threads on the piston rod 20.

**Please amend paragraph [00100] on page 14 of the specification (spanning lines 25-29) as follows:**

[00100] The nut 40, keyed to the main housing 4, is advanced along the intermediate thread 36 by the rotation of the drive sleeve 30 (arrow D). When the final dose dispensed position (Figures 4, 5 and 13) is reached, a radial stop 106 formed on a second surface of the nut 40 abuts a radial stop 108 on a first surface of the second flange 34 of the drive sleeve 30, preventing both the nut 40 and the drive sleeve 30 from rotating further (~~see Fig. 31~~).

**Please amend paragraph [00101] starting on page 14 of the specification (spanning page 14, line 30 – page 15, line 2) as follows:**

[00101] In an alternative embodiment (not shown) a first surface of the nut 40 is provided with a radial stop ~~231~~ for abutment with a radial stop ~~230~~ provided on a second surface of the first flange 32. This aids location of the nut 40 at the cartridge full position during assembly of the drug delivery device.

**Please amend paragraph [00105] on page 15 of the specification (spanning lines 21-29) as follows:**

[00105] The longitudinal axial movement of the drive sleeve 30 causes the piston rod 20 to rotate through the opening 18 in the insert 16, thereby to advance the piston 10 in the cartridge 8. Once the dialed dose has been dispensed, the dose dial sleeve 70 is prevented from further rotation by contact of a plurality of members 110 (Figure 14) extending from the dose dial grip 76 with a corresponding plurality of stops 112 formed in the main housing 4 (Figures 15 and 16). In the illustrated embodiment, the members 110 extend axially from the dose dial grip 76 and have an inclined end surface. The zero dose position is determined by the abutment of one of the axially extending edges of the members 110 with a corresponding stop 112 (~~see Fig. 31~~).

**AMENDMENTS TO THE DRAWINGS**

**Please delete Figures 25-32.**

## AMENDMENTS TO THE CLAIMS

1. (currently amended) A drive mechanism for use in a drug delivery device comprising:
  - a housing comprising a helical thread;
  - a dose dial sleeve having a threaded surface that is engaged with the helical thread of the housing,
  - an insert provided in the housing, where the insert has a threaded circular opening;
  - a drive sleeve releasably connected to the dose dial sleeve and having an internal helical thread;
  - a piston rod having a first thread and a second thread[[ ]], wherein the first thread is engaged with the threaded circular opening of the insert and the second thread is engaged with the internal helical thread of the drive sleeve; and
  - a clutch located between the dose dial sleeve and the drive sleeve, wherein the clutch is located (i) radially outward of the drive sleeve and (ii) radially inward of the dose dial sleeve.
  
2. (original) The drive mechanism of claim 1, wherein the drive sleeve comprises a threaded outer surface, the drive mechanism further comprising a limiting nut being threadedly engaged with the threaded outer surface of drive sleeve, where the limiting nut is rotationally fixed and slidable relative to the housing.
  
3. (original) The drive mechanism of claim 1, wherein the insert is secured in the housing against rotational and longitudinal motion.

4. (previously presented) The drive mechanism of claim 2, wherein the limiting nut translates distally along the threaded outer surface relative to two radially extending flanges as the drive sleeve is rotated during dose setting.

5. (previously presented) The drive mechanism of claim 2, wherein the threaded outer surface of the drive sleeve is located between two radially extending flanges.

6. (previously presented) The drive mechanism of claim 1, wherein the housing comprises a window insert at a distal end of the housing, where the distal end of the housing has the helical thread, where the window insert is rotationally fixed relative to the housing.

7. (previously presented) The drive mechanism of claim 1, wherein the threaded surface of the dose dial sleeve has a first lead.

8. (original) The drive mechanism of claim 7, wherein the first thread of the piston rod has a second lead.

9. (original) The drive mechanism of claim 8, wherein the internal drive sleeve thread has a lead equal to the first lead.



10. (original) The drive mechanism of claim 1, where the clutch is rotationally fixed to the drive sleeve and dose dial sleeve during dose setting.

11. (original) The drive mechanism of claim 1, wherein the helical thread of the housing is an internal helical thread and the dose dial sleeve has a threaded outer surface that is engaged with the internal helical thread of the housing.

12. (original) The drive mechanism of claim 1 where the piston rod rotates and translates axially in a proximal direction relative to and through the threaded circular opening during dose delivery.

13. (original) The drive mechanism of claim 6 where the window insert comprises a frame having a stop that is configured to engage a stop on the dose dial sleeve when a predetermined maximum dose is set by rotation of the dose dial sleeve.

14. (original) The drive mechanism of claim 9 where the ratio of leads of the first thread of the piston rod to the second thread of the piston rod is in the range from about 1:1.01 to 1:20.

15. (original) The drive mechanism of claim 9 where the ratio of leads of the first thread of the piston rod to the second thread of the piston rod is in the range from about 1:1.1 to 1:10.

16. (original) The drive mechanism of claim 1 where the second thread of the piston rod is a part thread.

17. (original) The drive mechanism of claim 1 where the first and second threads of the piston rod are oppositely disposed.

18. (original) The drive mechanism of claim 1 where the first thread and the second thread of the piston rod are configured such that the piston rod is prevented from rotating during dose setting.

19. (original) The drive mechanism of claim 1 where the drive sleeve is configured to rotate and climb the piston rod at a rate equal to a rate of rotation of the dose dial sleeve when the dose dial sleeve is rotated to set a dose.

## REMARKS

### 1. Summary of Office Action

In the Office Action mailed August 19, 2016, the Examiner stated that Figures 25-32 and the accompanying disclosure discussing those figures is matter not disclosed in the prior filed application. Further, the Examiner objected to claims 1-19. Still further, the Examiner rejected claims 1, 3, 5-12, and 17-19 on the ground of nonstatutory double patenting as being unpatentable over claims 8-10 of U.S. Patent No. 8,556,864 (the '864 patent), and the Examiner rejected claim 4 on the ground of nonstatutory double patenting as being unpatentable over claims 8-10 of the '864 patent in view of claims 1-8 of U.S. Patent No. 9,233,211 (the '211 patent).

Yet still further, the Examiner rejected claims 1, 3, 7-8, 10-12, and 17-18 under 35 U.S.C. § 102(b) as being allegedly anticipated by U.S. Patent No. 6,004,297 (Steenfeldt-Jensen), and the Examiner rejected claim 2 under 35 U.S.C. § 103(a) as being allegedly obvious over Steinfeldt-Jensen in view of U.S. Patent No. 6,582,404 (Klitgaard). And yet still further, the Examiner rejected claims 6 and 13 under 35 U.S.C. § 103(a) as being allegedly obvious over Steinfeldt-Jensen in view of U.S. Patent No. 5,582,598 (Chanoch), and the Examiner rejected claims 9, 14-17, and 19 under 35 U.S.C. § 103(a) as being allegedly obvious over Steinfeldt-Jensen.

### 2. Status of Claims

Claims 1-19 are currently pending in the application, of which claim 1 is independent and the remainder are dependent. Applicant has amended claim 1 to clarify that the clutch is located (i) radially outward of the drive sleeve and (ii) radially inward of the dose dial sleeve. Support for this amendment is found throughout the specification as filed including, for instance, at pages 10-15 and Figures 1-11.

Applicant reserves the right to pursue in a continuation application the subject matter of any of the claims without the present amendments, and any other subject matter disclosed by this application.

**3. Summary of Examiner Interview**

Applicant thanks Examiner Gilbert for the telephone interview conducted on August 9, 2016. Applicant generally agrees with the Substance of the Interview provided by the Examiner in the Examiner-Initiated Interview Summary mailed August 19, 2016.

**4. Response to Objections to Claims**

In response to the objection of claims 1-19, Applicant has amended claim 1 to delete the space between “a second thread” and the comma. In view of this amendment, the objection to claims 1-19 is moot. Accordingly, Applicant respectfully requests that the Examiner withdraw the objection.

**5. Response to Double-Patenting Rejection**

As mentioned herein, the Examiner rejected claims 1, 3, 5-12, and 17-19 on grounds of obvious-type double-patenting as being unpatentable over claims 8-10 of the ‘864 patent, and the Examiner rejected claim 4 on the ground of nonstatutory double patenting as being unpatentable over claims 8-10 of the ‘864 patent in view of claims 1-8 of the ‘211 patent. Along with this response, Applicant is filing an electronic terminal disclaimer, thus rendering the obviousness type double-patenting rejection of claims 1, 3-12, and 17-19 moot.

By submitting this terminal disclaimer, Applicant does not acquiesce in (i) the Examiner's conclusion that claims 1, 3, 5-12, and 17-19 of the present application are obvious over claims 8-10 of the ‘864 patent or (ii) the Examiner's conclusion that claim 4 of the present application is obvious over claims 8-10 of the ‘864 patent in view of claims 1-8 in the ‘211 patent.

## 6. Response to Examiner's Comments Regarding Priority

In the Office Action, the Examiner stated:

Applicant states that this application is a continuation or divisional application of the prior-filed application. *A continuation or divisional application cannot include new matter.* Applicant is required to delete the benefit claim *or change the relationship (continuation or divisional application) to continuation-in-part* because this application contains the following matter not disclosed in the prior-filed application: **Figs 25-32 and all accompanying disclosure.**

(Office action, page 5; emphasis original.)

Applicant does not acquiesce in the Examiner's assertions regarding priority. Nonetheless, Applicant has amended the specification to address the Examiner's comments. In particular, Applicant has deleted Figures 25-32 and the accompanying disclosure discussing Figures 25-32. Further, Applicant has amended the specification so that the brief description of the figures and the detailed description are the same as the brief description of the figures and the detailed description of the parent application. As a result, the disclosure presented in the present continuation application clearly does not include any subject matter which would constitute new matter if submitted as an amendment to the parent application. Further, the Examiner stated that "[t]he examiner also believes that the applicant may also keep the current designation as a continuation application if the applicant cancels all the new subject matter not disclosed the prior-filed applications." (Office action, page 5; emphasis original.)

In light of the above, Applicant respectfully submits that the continuation designation is proper.

**7. Response to Rejections under 35 U.S.C. §§ 102 and 103**

As mentioned above, claims 1-19 are currently amended. Of these claims, claim 1 is independent. The Examiner rejected independent claim 1 as being allegedly anticipated by Steinfeldt-Jensen.

Applicant has amended claim 1 to clarify that the clutch is located (i) radially outward of the drive sleeve and (ii) radially inward of the dose dial sleeve. Applicant submits that Steinfeldt-Jensen does not anticipate independent claim 1, because Steinfeldt-Jensen does not disclose the combination of elements recited by this claim. In particular, Steinfeldt-Jensen does not disclose “a clutch located between the dose dial sleeve and the drive sleeve, wherein the clutch is located (i) radially outward of the drive sleeve and (ii) radially inward of the dose dial sleeve.”

In the “Response to Arguments” section of the office action and in response to Applicant’s previous arguments that Steinfeldt-Jensen fails to disclose “a clutch located between the dose dial sleeve and the drive sleeve,” the Examiner stated that “[t]he applicant is strongly advised to recite the clutch being located radially outward relative to the drive sleeve and radially inward of a dose dial sleeve to distinguish the applicant's claimed invention.” (Office Action, page 3.) The present amendments clarify “located between the dose dial sleeve and the drive sleeve” and distinguish the presently-claimed invention from Steinfeldt-Jensen.

In the Office Action, the Examiner stated that “Steenfeldt-Jensen et al discloses . . . a dose dial sleeve (17) . . . a drive sleeve (23) releasably connected to the dose dial sleeve (Fig 6-8) . . . and a clutch (34) located between the dose dial sleeve and the drive sleeve (col 7, Ins 54-57[]).” (Office Action, pages 8-9.) Therefore, the Examiner appears to treat dose scale drum 17 as the purported dose dial sleeve, cup shaped cap 23 as the purported drive sleeve, and hooks 34

as the purported clutch. However, as can clearly be seen in Figures 7 and 8, hooks 34 are not located (i) radially outward of the cup shaped cap 23 and (ii) radially inward of the dose scale drum 17. Therefore, Steinfeldt-Jensen fails to disclose “a clutch located between the dose dial sleeve and the drive sleeve, wherein the clutch is located (i) radially outward of the drive sleeve and (ii) radially inward of the dose dial sleeve.”

For at least this reason, Steinfeldt-Jensen fails to teach the presently-claimed invention of claim 1. Consequently, Applicant submits that claim 1 is allowable. Furthermore, Applicant submits that claims 2-19 are allowable as well for at least the reason that they depend from allowable claim 1.

As indicated above, the Examiner rejected claim 2 as being allegedly obvious over Steinfeldt-Jensen in view of Klitgaard, the Examiner rejected claims 6 and 13 as being allegedly obvious over Steinfeldt-Jensen in view of Chanoch, and the Examiner rejected claims 9, 14-17, and 19 as being allegedly obvious over Steinfeldt-Jensen. However, Klitgaard and Chanoch fail to overcome the deficiency of Steinfeldt-Jensen. Further, claims 2, 6, 9, 13-17, and 19 are dependent from claim 1. Applicant submits that claims 2, 6, 9, 13-17, and 19 are allowable for at least the reason that they each depend from allowable independent claim 1.

## **8. Conclusion**

For the foregoing reasons, Applicant submits that the pending claims are allowable. Therefore, Applicant requests favorable action.

Applicant does not acquiesce in any assertion in the office action that is not expressly addressed by these remarks.

Should the Examiner wish to discuss this case with the undersigned, the Examiner is invited to call the undersigned at (312) 913-2138.

Respectfully submitted,

**McDonnell Boehnen Hulbert & Berghoff LLP**

Date: October 24, 2016

By: /Thomas E. Wettermann/

Thomas E. Wettermann

Reg. No. 41,523



<b>INFORMATION DISCLOSURE STATEMENT BY APPLICANT</b> ( Not for submission under 37 CFR 1.99)	Application Number	14319388
	Filing Date	2014-06-30
	First Named Inventor	Robert Frederick Veasey
	Art Unit	3763
	Examiner Name	Andrew M. Gilbert
	Attorney Docket Number	10-015-US-CON9

U.S.PATENTS						Remove
Examiner Initial*	Cite No	Patent Number	Kind Code <sup>1</sup>	Issue Date	Name of Patentee or Applicant of cited Document	Pages,Columns,Lines where Relevant Passages or Relevant Figures Appear
	1	6936032	B1	2005-08-30	Bush, Jr. et al.	
	2	5582598	A	1996-12-10	Chanoch	
	3	0533575		1895-02-05	J.D. Wilkens	
	4	5961495	A	1999-10-05	Walters et al.	
	5	2717597		1955-09-13	G.N. Hein, Jr.	
	6	2722931		1955-11-08	E.A. May	
	7	3815785		1974-06-11	Gilmont	
	8	4592745		1986-06-03	Rex et al.	

**INFORMATION DISCLOSURE  
STATEMENT BY APPLICANT**  
( Not for submission under 37 CFR 1.99)

Application Number		14319388
Filing Date		2014-06-30
First Named Inventor	Robert Frederick Veasey	
Art Unit		3763
Examiner Name	Andrew M. Gilbert	
Attorney Docket Number		10-015-US-CON9

9	4863072		1989-09-05	Perler
10	5030209		1991-07-09	Wanderer et al.
11	5328486	A	1994-07-12	Woodruff
12	5547131	A	1996-08-20	Brace
13	5582598	A	1996-12-10	Chanoch
14	5728074	A	1998-03-17	Castellano et al.
15	5728075	A	1998-03-17	Levander
16	5957896	A	1999-09-28	Bendek et al.
17	6001089	A	1999-12-14	Burroughs et al.
18	6059755	A	2000-05-09	Michel
19	6277099	B1	2001-08-21	Strowe et al.

**INFORMATION DISCLOSURE  
STATEMENT BY APPLICANT**  
( Not for submission under 37 CFR 1.99)

Application Number		14319388
Filing Date		2014-06-30
First Named Inventor	Robert Frederick Veasey	
Art Unit		3763
Examiner Name	Andrew M. Gilbert	
Attorney Docket Number		10-015-US-CON9

20	6277101	B1	2001-08-21	Kirchhofer et al.
21	6383167	B2	2002-05-07	Kirchhofer et al.
22	7771400	B2	2010-08-10	Nielsen
23	7850662	B2	2010-12-14	Veasey et al.
24	7905867	B2	2011-03-15	Veasey et al.
25	7918833	B2	2011-04-05	Veasey et al.
26	7935088	B2	2011-05-03	Veasey et al.
27	8021345	B2	2011-09-20	Veasey et al.
28	8512297	B2	2013-08-20	Veasey et al.
29	8608709	B2	2013-12-17	Moller et al.
30	8679069	B2	2014-03-25	Veasey et al.

**INFORMATION DISCLOSURE  
STATEMENT BY APPLICANT**  
( Not for submission under 37 CFR 1.99)

Application Number	14319388
Filing Date	2014-06-30
First Named Inventor	Robert Frederick Veasey
Art Unit	3763
Examiner Name	Andrew M. Gilbert
Attorney Docket Number	10-015-US-CON9

31	9028454	B2	2015-05-12	Veasey et al.
32	9233211	B2	2016-01-12	Veasey et al.

If you wish to add additional U.S. Patent citation information please click the Add button.

Add

**U.S.PATENT APPLICATION PUBLICATIONS**

Remove

Examiner Initial*	Cite No	Publication Number	Kind Code <sup>1</sup>	Publication Date	Name of Patentee or Applicant of cited Document	Pages, Columns, Lines where Relevant Passages or Relevant Figures Appear
	1	20010034507	A1	2001-10-25	Kirchhofer et al.	
	2	20020165499	A1	2002-11-07	Slate et al.	
	3	20030050609	A1	2003-03-13	Sams	
	4	20070123829	A1	2007-05-31	Atterbury et al.	
	5	20090275916	A1	2009-11-05	Harms et al.	
	6	20100042054	A1	2010-02-18	Elahi et al.	
	7	20120053528	A1	2012-03-01	Bollenbach et al.	

If you wish to add additional U.S. Published Application citation information please click the Add button.

Add

**INFORMATION DISCLOSURE  
STATEMENT BY APPLICANT**  
( Not for submission under 37 CFR 1.99)

Application Number	14319388
Filing Date	2014-06-30
First Named Inventor	Robert Frederick Veasey
Art Unit	3763
Examiner Name	Andrew M. Gilbert
Attorney Docket Number	10-015-US-CON9

FOREIGN PATENT DOCUMENTS								Remove
Examiner Initial*	Cite No	Foreign Document Number <sup>3</sup>	Country Code <sup>2</sup> i	Kind Code <sup>4</sup>	Publication Date	Name of Patentee or Applicant of cited Document	Pages, Columns, Lines where Relevant Passages or Relevant Figures Appear	T <sup>5</sup>
	1	2001010484	WO	A1	2001-02-15	Becton, Dickinson and Company		
	2	0937477	EP	A2	1999-08-25	Becton, Dickinson and Company		
	3	1855743	EP	B1	2008-12-17	Novo Nordisk A/S		
	4	1996025965	WO	A1	1996-08-29	Smith et al.		
	5	2002053214	WO	A1	2002-07-11	Novo Nordisk A/S		
	6	2002092153	WO	A2	2002-11-21	Eli Lilly and Company		
	7	2003080160	WO	A1	2003-10-02	Eli Lilly and Company		
	8	2011051366	WO	A2	2011-05-05	Sanofi-Aventis Deutschland GmbH		

If you wish to add additional Foreign Patent Document citation information please click the Add button

NON-PATENT LITERATURE DOCUMENTS								Remove
Examiner Initials*	Cite No	Include name of the author (in CAPITAL LETTERS), title of the article (when appropriate), title of the item (book, magazine, journal, serial, symposium, catalog, etc), date, pages(s), volume-issue number(s), publisher, city and/or country where published.						T <sup>5</sup>

<b>INFORMATION DISCLOSURE STATEMENT BY APPLICANT</b> ( Not for submission under 37 CFR 1.99)	Application Number	14319388
	Filing Date	2014-06-30
	First Named Inventor	Robert Frederick Veasey
	Art Unit	3763
	Examiner Name	Andrew M. Gilbert
	Attorney Docket Number	10-015-US-CON9

1	
---	--

If you wish to add additional non-patent literature document citation information please click the Add button

**EXAMINER SIGNATURE**

Examiner Signature		Date Considered	
--------------------	--	-----------------	--

\*EXAMINER: Initial if reference considered, whether or not citation is in conformance with MPEP 609. Draw line through a citation if not in conformance and not considered. Include copy of this form with next communication to applicant.

<sup>1</sup> See Kind Codes of USPTO Patent Documents at [www.USPTO.GOV](http://www.USPTO.GOV) or MPEP 901.04. <sup>2</sup> Enter office that issued the document, by the two-letter code (WIPO Standard ST.3). <sup>3</sup> For Japanese patent documents, the indication of the year of the reign of the Emperor must precede the serial number of the patent document. <sup>4</sup> Kind of document by the appropriate symbols as indicated on the document under WIPO Standard ST.16 if possible. <sup>5</sup> Applicant is to place a check mark here if English language translation is attached.

<b>INFORMATION DISCLOSURE STATEMENT BY APPLICANT</b> ( Not for submission under 37 CFR 1.99)	Application Number	14319388
	Filing Date	2014-06-30
	First Named Inventor	Robert Frederick Veasey
	Art Unit	3763
	Examiner Name	Andrew M. Gilbert
	Attorney Docket Number	10-015-US-CON9

**CERTIFICATION STATEMENT**

Please see 37 CFR 1.97 and 1.98 to make the appropriate selection(s):

That each item of information contained in the information disclosure statement was first cited in any communication from a foreign patent office in a counterpart foreign application not more than three months prior to the filing of the information disclosure statement. See 37 CFR 1.97(e)(1).

**OR**

That no item of information contained in the information disclosure statement was cited in a communication from a foreign patent office in a counterpart foreign application, and, to the knowledge of the person signing the certification after making reasonable inquiry, no item of information contained in the information disclosure statement was known to any individual designated in 37 CFR 1.56(c) more than three months prior to the filing of the information disclosure statement. See 37 CFR 1.97(e)(2).

See attached certification statement.

- The fee set forth in 37 CFR 1.17 (p) has been submitted herewith.
- A certification statement is not submitted herewith.

**SIGNATURE**

A signature of the applicant or representative is required in accordance with CFR 1.33, 10.18. Please see CFR 1.4(d) for the form of the signature.

Signature	/Thomas E. Wettermann/	Date (YYYY-MM-DD)	2016-10-24
Name/Print	Thomas E. Wettermann	Registration Number	41,523

This collection of information is required by 37 CFR 1.97 and 1.98. The information is required to obtain or retain a benefit by the public which is to file (and by the USPTO to process) an application. Confidentiality is governed by 35 U.S.C. 122 and 37 CFR 1.14. This collection is estimated to take 1 hour to complete, including gathering, preparing and submitting the completed application form to the USPTO. Time will vary depending upon the individual case. Any comments on the amount of time you require to complete this form and/or suggestions for reducing this burden, should be sent to the Chief Information Officer, U.S. Patent and Trademark Office, U.S. Department of Commerce, P.O. Box 1450, Alexandria, VA 22313-1450. **DO NOT SEND FEES OR COMPLETED FORMS TO THIS ADDRESS. SEND TO: Commissioner for Patents, P.O. Box 1450, Alexandria, VA 22313-1450.**

## Privacy Act Statement

The Privacy Act of 1974 (P.L. 93-579) requires that you be given certain information in connection with your submission of the attached form related to a patent application or patent. Accordingly, pursuant to the requirements of the Act, please be advised that: (1) the general authority for the collection of this information is 35 U.S.C. 2(b)(2); (2) furnishing of the information solicited is voluntary; and (3) the principal purpose for which the information is used by the U.S. Patent and Trademark Office is to process and/or examine your submission related to a patent application or patent. If you do not furnish the requested information, the U.S. Patent and Trademark Office may not be able to process and/or examine your submission, which may result in termination of proceedings or abandonment of the application or expiration of the patent.

The information provided by you in this form will be subject to the following routine uses:

1. The information on this form will be treated confidentially to the extent allowed under the Freedom of Information Act (5 U.S.C. 552) and the Privacy Act (5 U.S.C. 552a). Records from this system of records may be disclosed to the Department of Justice to determine whether the Freedom of Information Act requires disclosure of these records.
2. A record from this system of records may be disclosed, as a routine use, in the course of presenting evidence to a court, magistrate, or administrative tribunal, including disclosures to opposing counsel in the course of settlement negotiations.
3. A record in this system of records may be disclosed, as a routine use, to a Member of Congress submitting a request involving an individual, to whom the record pertains, when the individual has requested assistance from the Member with respect to the subject matter of the record.
4. A record in this system of records may be disclosed, as a routine use, to a contractor of the Agency having need for the information in order to perform a contract. Recipients of information shall be required to comply with the requirements of the Privacy Act of 1974, as amended, pursuant to 5 U.S.C. 552a(m).
5. A record related to an International Application filed under the Patent Cooperation Treaty in this system of records may be disclosed, as a routine use, to the International Bureau of the World Intellectual Property Organization, pursuant to the Patent Cooperation Treaty.
6. A record in this system of records may be disclosed, as a routine use, to another federal agency for purposes of National Security review (35 U.S.C. 181) and for review pursuant to the Atomic Energy Act (42 U.S.C. 218(c)).
7. A record from this system of records may be disclosed, as a routine use, to the Administrator, General Services, or his/her designee, during an inspection of records conducted by GSA as part of that agency's responsibility to recommend improvements in records management practices and programs, under authority of 44 U.S.C. 2904 and 2906. Such disclosure shall be made in accordance with the GSA regulations governing inspection of records for this purpose, and any other relevant (i.e., GSA or Commerce) directive. Such disclosure shall not be used to make determinations about individuals.
8. A record from this system of records may be disclosed, as a routine use, to the public after either publication of the application pursuant to 35 U.S.C. 122(b) or issuance of a patent pursuant to 35 U.S.C. 151. Further, a record may be disclosed, subject to the limitations of 37 CFR 1.14, as a routine use, to the public if the record was filed in an application which became abandoned or in which the proceedings were terminated and which application is referenced by either a published application, an application open to public inspections or an issued patent.
9. A record from this system of records may be disclosed, as a routine use, to a Federal, State, or local law enforcement agency, if the USPTO becomes aware of a violation or potential violation of law or regulation.



IN THE UNITED STATES PATENT AND TRADEMARK OFFICE  
(MBHB Case No. 10-015-US-CON9)

In re Application of:	)	
	)	
Robert Frederick Veasey et al.	)	
	)	Examiner: Gilbert, Andrew M.
Serial No.: 14/319,388	)	
	)	Group Art Unit: 3763
Filed: June 30, 2014	)	
	)	Confirmation No.: 6141
For: Drive Mechanisms Suitable for Use in Drug	)	
Delivery Devices	)	

Commissioner for Patents  
P.O. Box 1450  
Alexandria, VA 22313-1450

**GENERAL AUTHORIZATION UNDER 37 C.F.R. § 1.136(a)(3)**

Sir:

The Commissioner is hereby generally authorized under 37 C.F.R. § 1.136(a)(3) to treat the present and any future related filings in this or any related application filed pursuant to 37 C.F.R. § 1.53 requiring an extension of time as incorporating a request therefore, and the Commissioner is hereby specifically authorized to charge Deposit Account No. 13-2490 for any fee that may be due in connection with such a request for an extension of time.

Respectfully submitted,  
**McDonnell Boehnen Hulbert & Berghoff LLP**

Date: October 24, 2016

By: /Thomas E. Wettermann/  
Thomas E. Wettermann  
Reg. No. 41,523

## Electronic Patent Application Fee Transmittal

<b>Application Number:</b>	14319388
<b>Filing Date:</b>	30-Jun-2014
<b>Title of Invention:</b>	DRIVE MECHANISMS SUITABLE FOR USE IN DRUG DELIVERY DEVICES
<b>First Named Inventor/Applicant Name:</b>	Robert Frederick Veasey
<b>Filer:</b>	Thomas E. Wettermann
<b>Attorney Docket Number:</b>	10-015-US-CON9

Filed as Large Entity

**Filing Fees for Utility under 35 USC 111(a)**

Description	Fee Code	Quantity	Amount	Sub-Total in USD(\$)
<b>Basic Filing:</b>				
<b>Pages:</b>				
<b>Claims:</b>				
<b>Miscellaneous-Filing:</b>				
<b>Petition:</b>				
<b>Patent-Appeals-and-Interference:</b>				
<b>Post-Allowance-and-Post-Issuance:</b>				
<b>Extension-of-Time:</b>				

Description	Fee Code	Quantity	Amount	Sub-Total in USD(\$)
<b>Miscellaneous:</b>				
RCE- 1st Request	1801	1	1200	1200
Submission- Information Disclosure Stmt	1806	1	180	180
<b>Total in USD (\$)</b>				<b>1380</b>

## Electronic Acknowledgement Receipt

<b>EFS ID:</b>	27299014
<b>Application Number:</b>	14319388
<b>International Application Number:</b>	
<b>Confirmation Number:</b>	6141
<b>Title of Invention:</b>	DRIVE MECHANISMS SUITABLE FOR USE IN DRUG DELIVERY DEVICES
<b>First Named Inventor/Applicant Name:</b>	Robert Frederick Veasey
<b>Customer Number:</b>	98548
<b>Filer:</b>	Thomas E. Wettermann
<b>Filer Authorized By:</b>	
<b>Attorney Docket Number:</b>	10-015-US-CON9
<b>Receipt Date:</b>	24-OCT-2016
<b>Filing Date:</b>	30-JUN-2014
<b>Time Stamp:</b>	14:30:08
<b>Application Type:</b>	Utility under 35 USC 111(a)

### Payment information:

Submitted with Payment	yes
Payment Type	DA
Payment was successfully received in RAM	\$1380
RAM confirmation Number	102516INTEFSW00000771132490
Deposit Account	132490
Authorized User	thomas wettermann

The Director of the USPTO is hereby authorized to charge indicated fees and credit any overpayment as follows:

37 CFR 1.16 (National application filing, search, and examination fees)

37 CFR 1.17 (Patent application and reexamination processing fees)

Mylan Exhibit - 1010

0220

Mylan v. Sanofi

37 CFR 1.19 (Document supply fees)  
 37 CFR 1.20 (Post Issuance fees)  
 37 CFR 1.21 (Miscellaneous fees and charges)

**File Listing:**

Document Number	Document Description	File Name	File Size(Bytes)/ Message Digest	Multi Part /.zip	Pages (if appl.)
1	Request for Continued Examination (RCE)	10_015_US_CON9_RCE_Transmittal_2016_10_24.pdf	1350098	no	3
			7225f82c44e794918e07c85860148ff2dad9e6dd		
<b>Warnings:</b>					
<b>Information:</b>					
2	Amendment Submitted/Entered with Filing of CPA/RCE	10_015_US_CON9_RCE_Response_2016_10_24.pdf	149936	no	17
			c3f716ecb28a74df3005d746a9edcf07d91573b2		
<b>Warnings:</b>					
<b>Information:</b>					
3	Information Disclosure Statement (IDS) Form (SB08)	10_015_US_CON9_Supplemental_IDS_2016_10_24.pdf	1036794	no	8
			2e42daf31df51febd9a6fd2f8a10f4630d54714f		
<b>Warnings:</b>					
<b>Information:</b>					
4	Foreign Reference	10_015_US_CON9_Foreign_Reference_1.pdf	717922	no	22
			c2b2c47ad6c44aa35f22266e6baef6e86d0c3740a		
<b>Warnings:</b>					
<b>Information:</b>					
5	Foreign Reference	10_015_US_CON9_Foreign_Reference_2.pdf	1028929	no	22
			3b9cdb65d4f364373a016ed98a05c573e230fecf		
<b>Warnings:</b>					
<b>Information:</b>					
6	Foreign Reference	10_015_US_CON9_Foreign_Reference_3.pdf	586785	no	14
			60c45c21854e186ce5625818f0a1f913a56ff321		
<b>Warnings:</b>					
<b>Information:</b>					

7	Foreign Reference	10_015_US_CON9_Foreign_Ref_4.pdf	1214700 bba27a4a73badac314d6a07f0ddae0e039d8466f	no	33
<b>Warnings:</b>					
<b>Information:</b>					
8	Foreign Reference	10_015_US_CON9_Foreign_Ref_5.pdf	1755177 1cf9ed25501d12e85e4f5d45065fbef26df1a570	no	45
<b>Warnings:</b>					
<b>Information:</b>					
9	Foreign Reference	10_015_US_CON9_Foreign_Ref_6.pdf	4797970 2fe425949fd7c281847c9dbaefc46c9501b06bbad	no	98
<b>Warnings:</b>					
<b>Information:</b>					
10	Foreign Reference	10_015_US_CON9_Foreign_Ref_7.pdf	2570827 46f7e92f241647d92ed80d0e345467056d814af6	no	59
<b>Warnings:</b>					
<b>Information:</b>					
11	Foreign Reference	10_015_US_CON9_Foreign_Ref_8.pdf	1566976 a90ee90627433fe39371497ece0d1e3b7863ab4a	no	42
<b>Warnings:</b>					
<b>Information:</b>					
12	Authorization for Extension of Time all replies	10_015_US_CON9_General_Au thorization_2016_10_24.pdf	59416 50f33c2019e7a1499ac47735f63f44d9b1465a08	no	1
<b>Warnings:</b>					
<b>Information:</b>					
13	Fee Worksheet (SB06)	fee-info.pdf	32397 b1fc90ac903fc1830005e7e03a4c41b95e01def0	no	2
<b>Warnings:</b>					
<b>Information:</b>					
<b>Total Files Size (in bytes):</b>			16867927		

**This Acknowledgement Receipt evidences receipt on the noted date by the USPTO of the indicated documents, characterized by the applicant, and including page counts, where applicable. It serves as evidence of receipt similar to a Post Card, as described in MPEP 503.**

**New Applications Under 35 U.S.C. 111**

**If a new application is being filed and the application includes the necessary components for a filing date (see 37 CFR 1.53(b)-(d) and MPEP 506), a Filing Receipt (37 CFR 1.54) will be issued in due course and the date shown on this Acknowledgement Receipt will establish the filing date of the application.**

**National Stage of an International Application under 35 U.S.C. 371**

**If a timely submission to enter the national stage of an international application is compliant with the conditions of 35 U.S.C. 371 and other applicable requirements a Form PCT/DO/EO/903 indicating acceptance of the application as a national stage submission under 35 U.S.C. 371 will be issued in addition to the Filing Receipt, in due course.**

**New International Application Filed with the USPTO as a Receiving Office**

**If a new international application is being filed and the international application includes the necessary components for an international filing date (see PCT Article 11 and MPEP 1810), a Notification of the International Application Number and of the International Filing Date (Form PCT/RO/105) will be issued in due course, subject to prescriptions concerning national security, and the date shown on this Acknowledgement Receipt will establish the international filing date of the application.**

Under the Paperwork Reduction Act of 1995, no persons are required to respond to a collection of information unless it displays a valid OMB control number.

<b>PATENT APPLICATION FEE DETERMINATION RECORD</b> Substitute for Form PTO-875	Application or Docket Number <b>14/319,388</b>	Filing Date <b>06/30/2014</b>	<input type="checkbox"/> To be Mailed
---	---	----------------------------------	---------------------------------------

ENTITY:  LARGE  SMALL  MICRO

**APPLICATION AS FILED – PART I**

FOR	NUMBER FILED	NUMBER EXTRA	RATE (\$)	FEE (\$)
<input type="checkbox"/> BASIC FEE (37 CFR 1.16(a), (b), or (c))	N/A	N/A	N/A	
<input type="checkbox"/> SEARCH FEE (37 CFR 1.16(k), (l), or (m))	N/A	N/A	N/A	
<input type="checkbox"/> EXAMINATION FEE (37 CFR 1.16(o), (p), or (q))	N/A	N/A	N/A	
TOTAL CLAIMS (37 CFR 1.16(i))	minus 20 =	*	X \$ =	
INDEPENDENT CLAIMS (37 CFR 1.16(h))	minus 3 =	*	X \$ =	
<input type="checkbox"/> APPLICATION SIZE FEE (37 CFR 1.16(s))	If the specification and drawings exceed 100 sheets of paper, the application size fee due is \$310 (\$155 for small entity) for each additional 50 sheets or fraction thereof. See 35 U.S.C. 41(a)(1)(G) and 37 CFR 1.16(s).			
<input type="checkbox"/> MULTIPLE DEPENDENT CLAIM PRESENT (37 CFR 1.16(j))				
* If the difference in column 1 is less than zero, enter "0" in column 2.			TOTAL	

**APPLICATION AS AMENDED – PART II**

	(Column 1)	(Column 2)	(Column 3)	PRESENT EXTRA	RATE (\$)	ADDITIONAL FEE (\$)
<b>AMENDMENT</b>	<b>10/24/2016</b>	CLAIMS REMAINING AFTER AMENDMENT	HIGHEST NUMBER PREVIOUSLY PAID FOR			
	Total (37 CFR 1.16(i))	* 19	Minus	** 20	= 0	X \$80 = 0
	Independent (37 CFR 1.16(h))	* 1	Minus	***3	= 0	X \$420 = 0
	<input type="checkbox"/> Application Size Fee (37 CFR 1.16(s))					
<input type="checkbox"/> FIRST PRESENTATION OF MULTIPLE DEPENDENT CLAIM (37 CFR 1.16(j))						
					TOTAL ADD'L FEE	<b>0</b>

	(Column 1)	(Column 2)	(Column 3)	PRESENT EXTRA	RATE (\$)	ADDITIONAL FEE (\$)
<b>AMENDMENT</b>		CLAIMS REMAINING AFTER AMENDMENT	HIGHEST NUMBER PREVIOUSLY PAID FOR			
	Total (37 CFR 1.16(i))	*	Minus	**	=	X \$ =
	Independent (37 CFR 1.16(h))	*	Minus	***	=	X \$ =
	<input type="checkbox"/> Application Size Fee (37 CFR 1.16(s))					
<input type="checkbox"/> FIRST PRESENTATION OF MULTIPLE DEPENDENT CLAIM (37 CFR 1.16(j))						
					TOTAL ADD'L FEE	

\* If the entry in column 1 is less than the entry in column 2, write "0" in column 3.  
 \*\* If the "Highest Number Previously Paid For" IN THIS SPACE is less than 20, enter "20".  
 \*\*\* If the "Highest Number Previously Paid For" IN THIS SPACE is less than 3, enter "3".

The "Highest Number Previously Paid For" (Total or Independent) is the highest number found in the appropriate box in column 1.

LIE  
THUY TA

This collection of information is required by 37 CFR 1.16. The information is required to obtain or retain a benefit by the public which is to file (and by the USPTO to process) an application. Confidentiality is governed by 35 U.S.C. 122 and 37 CFR 1.14. This collection is estimated to take 12 minutes to complete, including gathering, preparing, and submitting the completed application form to the USPTO. Time will vary depending upon the individual case. Any comments on the amount of time you require to complete this form and/or suggestions for reducing this burden, should be sent to the Chief Information Officer, U.S. Patent and Trademark Office, U.S. Department of Commerce, P.O. Box 1450, Alexandria, VA 22313-1450. DO NOT SEND FEES OR COMPLETED FORMS TO THIS ADDRESS. **SEND TO: Commissioner for Patents, P.O. Box 1450, Alexandria, VA 22313-1450.**

If you need assistance in completing the form, call 1-800-PTO-9199 and select option 2.





NOTICE OF ALLOWANCE AND FEE(S) DUE

98548 7590 11/15/2016
McDonnell Boehnen Hulbert & Berghoff LLP
Sanofi - Aventis
300 South Wacker Drive
Chicago, IL 60606

Table with 2 columns: EXAMINER (GILBERT, ANDREW M), ART UNIT (3763), PAPER NUMBER

DATE MAILED: 11/15/2016

Table with 5 columns: APPLICATION NO., FILING DATE, FIRST NAMED INVENTOR, ATTORNEY DOCKET NO., CONFIRMATION NO.

TITLE OF INVENTION: DRIVE MECHANISMS SUITABLE FOR USE IN DRUG DELIVERY DEVICES

Table with 7 columns: APPLN. TYPE, ENTITY STATUS, ISSUE FEE DUE, PUBLICATION FEE DUE, PREV. PAID ISSUE FEE, TOTAL FEE(S) DUE, DATE DUE

THE APPLICATION IDENTIFIED ABOVE HAS BEEN EXAMINED AND IS ALLOWED FOR ISSUANCE AS A PATENT. PROSECUTION ON THE MERITS IS CLOSED. THIS NOTICE OF ALLOWANCE IS NOT A GRANT OF PATENT RIGHTS. THIS APPLICATION IS SUBJECT TO WITHDRAWAL FROM ISSUE AT THE INITIATIVE OF THE OFFICE OR UPON PETITION BY THE APPLICANT. SEE 37 CFR 1.313 AND MPEP 1308.

THE ISSUE FEE AND PUBLICATION FEE (IF REQUIRED) MUST BE PAID WITHIN THREE MONTHS FROM THE MAILING DATE OF THIS NOTICE OR THIS APPLICATION SHALL BE REGARDED AS ABANDONED. THIS STATUTORY PERIOD CANNOT BE EXTENDED. SEE 35 U.S.C. 151. THE ISSUE FEE DUE INDICATED ABOVE DOES NOT REFLECT A CREDIT FOR ANY PREVIOUSLY PAID ISSUE FEE IN THIS APPLICATION. IF AN ISSUE FEE HAS PREVIOUSLY BEEN PAID IN THIS APPLICATION (AS SHOWN ABOVE), THE RETURN OF PART B OF THIS FORM WILL BE CONSIDERED A REQUEST TO REAPPLY THE PREVIOUSLY PAID ISSUE FEE TOWARD THE ISSUE FEE NOW DUE.

HOW TO REPLY TO THIS NOTICE:

I. Review the ENTITY STATUS shown above. If the ENTITY STATUS is shown as SMALL or MICRO, verify whether entitlement to that entity status still applies. If the ENTITY STATUS is the same as shown above, pay the TOTAL FEE(S) DUE shown above. If the ENTITY STATUS is changed from that shown above, on PART B - FEE(S) TRANSMITTAL, complete section number 5 titled "Change in Entity Status (from status indicated above)". For purposes of this notice, small entity fees are 1/2 the amount of undiscounted fees, and micro entity fees are 1/2 the amount of small entity fees.

II. PART B - FEE(S) TRANSMITTAL, or its equivalent, must be completed and returned to the United States Patent and Trademark Office (USPTO) with your ISSUE FEE and PUBLICATION FEE (if required). If you are charging the fee(s) to your deposit account, section "4b" of Part B - Fee(s) Transmittal should be completed and an extra copy of the form should be submitted. If an equivalent of Part B is filed, a request to reapply a previously paid issue fee must be clearly made, and delays in processing may occur due to the difficulty in recognizing the paper as an equivalent of Part B.

III. All communications regarding this application must give the application number. Please direct all communications prior to issuance to Mail Stop ISSUE FEE unless advised to the contrary.

IMPORTANT REMINDER: Utility patents issuing on applications filed on or after Dec. 12, 1980 may require payment of maintenance fees. It is patentee's responsibility to ensure timely payment of maintenance fees when due.

**PART B - FEE(S) TRANSMITTAL**

**Complete and send this form, together with applicable fee(s), to: Mail Mail Stop ISSUE FEE  
 Commissioner for Patents  
 P.O. Box 1450  
 Alexandria, Virginia 22313-1450  
 or Fax (571)-273-2885**

**INSTRUCTIONS:** This form should be used for transmitting the ISSUE FEE and PUBLICATION FEE (if required). Blocks 1 through 5 should be completed where appropriate. All further correspondence including the Patent, advance orders and notification of maintenance fees will be mailed to the current correspondence address as indicated unless corrected below or directed otherwise in Block 1, by (a) specifying a new correspondence address; and/or (b) indicating a separate "FEE ADDRESS" for maintenance fee notifications.

CURRENT CORRESPONDENCE ADDRESS (Note: Use Block 1 for any change of address)

Note: A certificate of mailing can only be used for domestic mailings of the Fee(s) Transmittal. This certificate cannot be used for any other accompanying papers. Each additional paper, such as an assignment or formal drawing, must have its own certificate of mailing or transmission.

98548                      7590                      11/15/2016  
**McDonnell Boehnen Hulbert & Berghoff LLP**  
 Sanofi - Aventis  
 300 South Wacker Drive  
 Chicago, IL 60606

**Certificate of Mailing or Transmission**

I hereby certify that this Fee(s) Transmittal is being deposited with the United States Postal Service with sufficient postage for first class mail in an envelope addressed to the Mail Stop ISSUE FEE address above, or being facsimile transmitted to the USPTO (571) 273-2885, on the date indicated below.

(Depositor's name)
(Signature)
(Date)

APPLICATION NO.	FILING DATE	FIRST NAMED INVENTOR	ATTORNEY DOCKET NO.	CONFIRMATION NO.
14/319,388	06/30/2014	Robert Frederick Veasey	10-015-US-CON9	6141

TITLE OF INVENTION: DRIVE MECHANISMS SUITABLE FOR USE IN DRUG DELIVERY DEVICES

APPLN. TYPE	ENTITY STATUS	ISSUE FEE DUE	PUBLICATION FEE DUE	PREV. PAID ISSUE FEE	TOTAL FEE(S) DUE	DATE DUE
nonprovisional	UNDISCOUNTED	\$960	\$0	\$0	\$960	02/15/2017

EXAMINER	ART UNIT	CLASS-SUBCLASS
GILBERT, ANDREW M	3763	604-211000

<p>1. Change of correspondence address or indication of "Fee Address" (37 CFR 1.363).</p> <p><input type="checkbox"/> Change of correspondence address (or Change of Correspondence Address form PTO/SB/122) attached.</p> <p><input type="checkbox"/> "Fee Address" indication (or "Fee Address" Indication form PTO/SB/47; Rev 03-02 or more recent) attached. <b>Use of a Customer Number is required.</b></p>	<p>2. For printing on the patent front page, list</p> <p>(1) The names of up to 3 registered patent attorneys or agents OR, alternatively, _____ 1</p> <p>(2) The name of a single firm (having as a member a registered attorney or agent) and the names of up to 2 registered patent attorneys or agents. If no name is listed, no name will be printed. _____ 2</p> <p>_____ 3</p>
---	---

3. ASSIGNEE NAME AND RESIDENCE DATA TO BE PRINTED ON THE PATENT (print or type)

PLEASE NOTE: Unless an assignee is identified below, no assignee data will appear on the patent. If an assignee is identified below, the document has been filed for recordation as set forth in 37 CFR 3.11. Completion of this form is NOT a substitute for filing an assignment.

(A) NAME OF ASSIGNEE \_\_\_\_\_ (B) RESIDENCE: (CITY and STATE OR COUNTRY) \_\_\_\_\_

Please check the appropriate assignee category or categories (will not be printed on the patent) :  Individual  Corporation or other private group entity  Government

<p>4a. The following fee(s) are submitted:</p> <p><input type="checkbox"/> Issue Fee</p> <p><input type="checkbox"/> Publication Fee (No small entity discount permitted)</p> <p><input type="checkbox"/> Advance Order - # of Copies _____</p>	<p>4b. Payment of Fee(s): (<b>Please first reapply any previously paid issue fee shown above</b>)</p> <p><input type="checkbox"/> A check is enclosed.</p> <p><input type="checkbox"/> Payment by credit card. Form PTO-2038 is attached.</p> <p><input type="checkbox"/> The director is hereby authorized to charge the required fee(s), any deficiency, or credits any overpayment, to Deposit Account Number _____ (enclose an extra copy of this form).</p>
---	--

5. **Change in Entity Status** (from status indicated above)

Applicant certifying micro entity status. See 37 CFR 1.29

Applicant asserting small entity status. See 37 CFR 1.27

Applicant changing to regular undiscounted fee status.

**NOTE:** Absent a valid certification of Micro Entity Status (see forms PTO/SB/15A and 15B), issue fee payment in the micro entity amount will not be accepted at the risk of application abandonment.

**NOTE:** If the application was previously under micro entity status, checking this box will be taken to be a notification of loss of entitlement to micro entity status.

**NOTE:** Checking this box will be taken to be a notification of loss of entitlement to small or micro entity status, as applicable.

**NOTE:** This form must be signed in accordance with 37 CFR 1.31 and 1.33. See 37 CFR 1.4 for signature requirements and certifications.

Authorized Signature \_\_\_\_\_ Date \_\_\_\_\_

Typed or printed name \_\_\_\_\_ Registration No. \_\_\_\_\_



UNITED STATES DEPARTMENT OF COMMERCE
United States Patent and Trademark Office
Address: COMMISSIONER FOR PATENTS
P.O. Box 1450
Alexandria, Virginia 22313-1450
www.uspto.gov

Table with 5 columns: APPLICATION NO., FILING DATE, FIRST NAMED INVENTOR, ATTORNEY DOCKET NO., CONFIRMATION NO.
14/319,388 06/30/2014 Robert Frederick Veasey 10-015-US-CON9 6141

98548 7590 11/15/2016
McDonnell Boehnen Hulbert & Berghoff LLP
Sanofi - Aventis
300 South Wacker Drive
Chicago, IL 60606

Table with 2 columns: EXAMINER, ART UNIT, PAPER NUMBER
EXAMINER: GILBERT, ANDREW M
ART UNIT: 3763

DATE MAILED: 11/15/2016

Determination of Patent Term Adjustment under 35 U.S.C. 154 (b)

(Applications filed on or after May 29, 2000)

The Office has discontinued providing a Patent Term Adjustment (PTA) calculation with the Notice of Allowance.

Section 1(h)(2) of the AIA Technical Corrections Act amended 35 U.S.C. 154(b)(3)(B)(i) to eliminate the requirement that the Office provide a patent term adjustment determination with the notice of allowance. See Revisions to Patent Term Adjustment, 78 Fed. Reg. 19416, 19417 (Apr. 1, 2013). Therefore, the Office is no longer providing an initial patent term adjustment determination with the notice of allowance. The Office will continue to provide a patent term adjustment determination with the Issue Notification Letter that is mailed to applicant approximately three weeks prior to the issue date of the patent, and will include the patent term adjustment on the patent. Any request for reconsideration of the patent term adjustment determination (or reinstatement of patent term adjustment) should follow the process outlined in 37 CFR 1.705.

Any questions regarding the Patent Term Extension or Adjustment determination should be directed to the Office of Patent Legal Administration at (571)-272-7702. Questions relating to issue and publication fee payments should be directed to the Customer Service Center of the Office of Patent Publication at 1-(888)-786-0101 or (571)-272-4200.

## OMB Clearance and PRA Burden Statement for PTOL-85 Part B

The Paperwork Reduction Act (PRA) of 1995 requires Federal agencies to obtain Office of Management and Budget approval before requesting most types of information from the public. When OMB approves an agency request to collect information from the public, OMB (i) provides a valid OMB Control Number and expiration date for the agency to display on the instrument that will be used to collect the information and (ii) requires the agency to inform the public about the OMB Control Number's legal significance in accordance with 5 CFR 1320.5(b).

The information collected by PTOL-85 Part B is required by 37 CFR 1.311. The information is required to obtain or retain a benefit by the public which is to file (and by the USPTO to process) an application. Confidentiality is governed by 35 U.S.C. 122 and 37 CFR 1.14. This collection is estimated to take 12 minutes to complete, including gathering, preparing, and submitting the completed application form to the USPTO. Time will vary depending upon the individual case. Any comments on the amount of time you require to complete this form and/or suggestions for reducing this burden, should be sent to the Chief Information Officer, U.S. Patent and Trademark Office, U.S. Department of Commerce, P.O. Box 1450, Alexandria, Virginia 22313-1450. DO NOT SEND FEES OR COMPLETED FORMS TO THIS ADDRESS. SEND TO: Commissioner for Patents, P.O. Box 1450, Alexandria, Virginia 22313-1450. Under the Paperwork Reduction Act of 1995, no persons are required to respond to a collection of information unless it displays a valid OMB control number.

### Privacy Act Statement

**The Privacy Act of 1974 (P.L. 93-579)** requires that you be given certain information in connection with your submission of the attached form related to a patent application or patent. Accordingly, pursuant to the requirements of the Act, please be advised that: (1) the general authority for the collection of this information is 35 U.S.C. 2(b)(2); (2) furnishing of the information solicited is voluntary; and (3) the principal purpose for which the information is used by the U.S. Patent and Trademark Office is to process and/or examine your submission related to a patent application or patent. If you do not furnish the requested information, the U.S. Patent and Trademark Office may not be able to process and/or examine your submission, which may result in termination of proceedings or abandonment of the application or expiration of the patent.

The information provided by you in this form will be subject to the following routine uses:

1. The information on this form will be treated confidentially to the extent allowed under the Freedom of Information Act (5 U.S.C. 552) and the Privacy Act (5 U.S.C. 552a). Records from this system of records may be disclosed to the Department of Justice to determine whether disclosure of these records is required by the Freedom of Information Act.
2. A record from this system of records may be disclosed, as a routine use, in the course of presenting evidence to a court, magistrate, or administrative tribunal, including disclosures to opposing counsel in the course of settlement negotiations.
3. A record in this system of records may be disclosed, as a routine use, to a Member of Congress submitting a request involving an individual, to whom the record pertains, when the individual has requested assistance from the Member with respect to the subject matter of the record.
4. A record in this system of records may be disclosed, as a routine use, to a contractor of the Agency having need for the information in order to perform a contract. Recipients of information shall be required to comply with the requirements of the Privacy Act of 1974, as amended, pursuant to 5 U.S.C. 552a(m).
5. A record related to an International Application filed under the Patent Cooperation Treaty in this system of records may be disclosed, as a routine use, to the International Bureau of the World Intellectual Property Organization, pursuant to the Patent Cooperation Treaty.
6. A record in this system of records may be disclosed, as a routine use, to another federal agency for purposes of National Security review (35 U.S.C. 181) and for review pursuant to the Atomic Energy Act (42 U.S.C. 218(c)).
7. A record from this system of records may be disclosed, as a routine use, to the Administrator, General Services, or his/her designee, during an inspection of records conducted by GSA as part of that agency's responsibility to recommend improvements in records management practices and programs, under authority of 44 U.S.C. 2904 and 2906. Such disclosure shall be made in accordance with the GSA regulations governing inspection of records for this purpose, and any other relevant (i.e., GSA or Commerce) directive. Such disclosure shall not be used to make determinations about individuals.
8. A record from this system of records may be disclosed, as a routine use, to the public after either publication of the application pursuant to 35 U.S.C. 122(b) or issuance of a patent pursuant to 35 U.S.C. 151. Further, a record may be disclosed, subject to the limitations of 37 CFR 1.14, as a routine use, to the public if the record was filed in an application which became abandoned or in which the proceedings were terminated and which application is referenced by either a published application, an application open to public inspection or an issued patent.
9. A record from this system of records may be disclosed, as a routine use, to a Federal, State, or local law enforcement agency, if the USPTO becomes aware of a violation or potential violation of law or regulation.

<b>Notice of Allowability</b>	<b>Application No.</b> 14/319,388	<b>Applicant(s)</b> VEASEY ET AL.	
	<b>Examiner</b> ANDREW GILBERT	<b>Art Unit</b> 3763	<b>AIA (First Inventor to File) Status</b> No

**-- The MAILING DATE of this communication appears on the cover sheet with the correspondence address--**

All claims being allowable, PROSECUTION ON THE MERITS IS (OR REMAINS) CLOSED in this application. If not included herewith (or previously mailed), a Notice of Allowance (PTOL-85) or other appropriate communication will be mailed in due course. **THIS NOTICE OF ALLOWABILITY IS NOT A GRANT OF PATENT RIGHTS.** This application is subject to withdrawal from issue at the initiative of the Office or upon petition by the applicant. See 37 CFR 1.313 and MPEP 1308.

1.  This communication is responsive to the request for continued examination filed on 10/24/2016.  
 A declaration(s)/affidavit(s) under **37 CFR 1.130(b)** was/were filed on \_\_\_\_\_.
2.  An election was made by the applicant in response to a restriction requirement set forth during the interview on \_\_\_\_\_; the restriction requirement and election have been incorporated into this action.
3.  The allowed claim(s) is/are 1-19. As a result of the allowed claim(s), you may be eligible to benefit from the **Patent Prosecution Highway** program at a participating intellectual property office for the corresponding application. For more information, please see [http://www.uspto.gov/patents/init\\_events/pph/index.jsp](http://www.uspto.gov/patents/init_events/pph/index.jsp) or send an inquiry to [PPHfeedback@uspto.gov](mailto:PPHfeedback@uspto.gov).
4.  Acknowledgment is made of a claim for foreign priority under 35 U.S.C. § 119(a)-(d) or (f).

**Certified copies:**

- a)  All    b)  Some    \*c)  None of the:
1.  Certified copies of the priority documents have been received.
  2.  Certified copies of the priority documents have been received in Application No. 10/790,866.
  3.  Copies of the certified copies of the priority documents have been received in this national stage application from the International Bureau (PCT Rule 17.2(a)).

\* Certified copies not received: \_\_\_\_\_.

Applicant has THREE MONTHS FROM THE "MAILING DATE" of this communication to file a reply complying with the requirements noted below. Failure to timely comply will result in ABANDONMENT of this application.

**THIS THREE-MONTH PERIOD IS NOT EXTENDABLE.**

5.  CORRECTED DRAWINGS ( as "replacement sheets") must be submitted.  
 including changes required by the attached Examiner's Amendment / Comment or in the Office action of Paper No./Mail Date \_\_\_\_\_.  
**Identifying indicia such as the application number (see 37 CFR 1.84(c)) should be written on the drawings in the front (not the back) of each sheet. Replacement sheet(s) should be labeled as such in the header according to 37 CFR 1.121(d).**
6.  DEPOSIT OF and/or INFORMATION about the deposit of BIOLOGICAL MATERIAL must be submitted. Note the attached Examiner's comment regarding REQUIREMENT FOR THE DEPOSIT OF BIOLOGICAL MATERIAL.

**Attachment(s)**

- |  |  |
|--|--|
| 1. <input type="checkbox"/> Notice of References Cited (PTO-892)   | 5. <input checked="" type="checkbox"/> Examiner's Amendment/Comment                  |
| 2. <input checked="" type="checkbox"/> Information Disclosure Statements (PTO/SB/08),<br>Paper No./Mail Date _____ | 6. <input checked="" type="checkbox"/> Examiner's Statement of Reasons for Allowance |
| 3. <input type="checkbox"/> Examiner's Comment Regarding Requirement for Deposit<br>of Biological Material         | 7. <input type="checkbox"/> Other _____.   |
| 4. <input type="checkbox"/> Interview Summary (PTO-413),<br>Paper No./Mail Date _____ .                            |  |

/ANDREW GILBERT/  
Primary Examiner, Art Unit 3763

## **DETAILED ACTION**

### ***Notice of Pre-AIA or AIA Status***

1. The present application is being examined under the pre-AIA first to invent provisions.

### ***Continued Examination Under 37 CFR 1.114***

2. A request for continued examination under 37 CFR 1.114, including the fee set forth in 37 CFR 1.17(e), was filed in this application after allowance or after an Office action under *Ex Parte Quayle*, 25 USPQ 74, 453 O.G. 213 (Comm'r Pat. 1935). Since this application is eligible for continued examination under 37 CFR 1.114, and the fee set forth in 37 CFR 1.17(e) has been timely paid, prosecution in this application has been reopened pursuant to 37 CFR 1.114. Applicant's submission filed on 10/24/2016 has been entered.

### ***Acknowledgments***

3. This office action is in response to the reply filed on 10/24/2016.
4. In the reply, the applicant amended claim 1 and made amendments to the specification and drawings. Both submissions are accepted.
5. Thus, claims 1-19 are pending for examination.

### ***Information Disclosure Statement***

6. The information disclosure statement (IDS) submitted on 10/24/2016 is in compliance with the provisions of 37 CFR 1.97. Accordingly, the information disclosure statement is being considered by the examiner.

***Terminal Disclaimer***

7. The terminal disclaimer filed on 10/24/2016 disclaiming the terminal portion of any patent granted on this application which would extend beyond the expiration date of USPNs 9233211 and 8556864 has been reviewed and is accepted. The terminal disclaimer has been recorded.

***Response to Arguments***

8. Applicant's arguments, see Remarks, filed 10/24/2016 along with the amendments to the Specification and Drawings, with respect to the issue of Priority (see discussion in Final Rejection mailed on 8/19/2016) have been fully considered and are persuasive. The applicant has deleted all new subject matter not disclosed in the prior-filed applications such that the present application is properly a continuation of the prior filed cases. Thus, requirement do delete or change the benefit claim has been withdrawn.

***ALLOWANCE***

9. Claims 1-19 are allowed.

10. The following is an examiner's statement of reasons for allowance:

11. The subject matter of the independent claim could either not be found or was not suggested in the prior art of record. The prior art does not disclose or render obvious the combination as claimed specifically including a drive mechanism for use in a drug delivery device having a clutch located between the dose dial sleeve and the drive sleeve, wherein the clutch is located (i) radially outward of the drive sleeve and (ii)

Art Unit: 3763

radially inward of the dose dial sleeve in combination with the other elements of the claims.

12. The closest prior art related to the claimed elements of the drive mechanism is Steinfeldt-Jensen (USPN 6004297) as set forth in the Final Rejection mailed on 8/19/2016. However, the examiner agrees with the applicant's Remarks filed on 10/24/2016 that Steinfeldt-Jensen does not teach or suggest a clutch located (i) radially outward of the drive sleeve and (ii) radially inward of the dose dial sleeve as now claimed.

Any comments considered necessary by applicant must be submitted no later than the payment of the issue fee and, to avoid processing delays, should preferably accompany the issue fee. Such submissions should be clearly labeled "Comments on Statement of Reasons for Allowance."

Any inquiry concerning this communication or earlier communications from the examiner should be directed to ANDREW GILBERT whose telephone number is (571)272-7216. The examiner can normally be reached on 8:30 am to 5:00 pm Monday through Friday.

If attempts to reach the examiner by telephone are unsuccessful, the examiner's supervisor, Kevin Sirmons can be reached on (571)272-4965. The fax phone number for the organization where this application or proceeding is assigned is 571-273-8300.



Art Unit: 3763

Information regarding the status of an application may be obtained from the Patent Application Information Retrieval (PAIR) system. Status information for published applications may be obtained from either Private PAIR or Public PAIR. Status information for unpublished applications is available through Private PAIR only. For more information about the PAIR system, see <http://pair-direct.uspto.gov>. Should you have questions on access to the Private PAIR system, contact the Electronic Business Center (EBC) at 866-217-9197 (toll-free). If you would like assistance from a USPTO Customer Service Representative or access to the automated information system, call 800-786-9199 (IN USA OR CANADA) or 571-272-1000.

/ANDREW GILBERT/  
Primary Examiner, Art Unit 3763

Doc code: IDS

PTO/SB/08a (03-15)

Doc description: Information Disclosure Statement (IDS) Filed

Approved for use through 07/31/2016. OMB 0651-0031  
U.S. Patent and Trademark Office; U.S. DEPARTMENT OF COMMERCE

Under the Paperwork Reduction Act of 1995, no persons are required to respond to a collection of information unless it contains a valid OMB control number.

<b>INFORMATION DISCLOSURE STATEMENT BY APPLICANT</b> ( Not for submission under 37 CFR 1.99)	Application Number	14319388
	Filing Date	2014-06-30
	First Named Inventor	Robert Frederick Veasey
	Art Unit	3763
	Examiner Name	Andrew M. Gilbert
	Attorney Docket Number	10-015-US-CON9

U.S.PATENTS						Remove
Examiner Initial*	Cite No	Patent Number	Kind Code <sup>1</sup>	Issue Date	Name of Patentee or Applicant of cited Document	Pages,Columns,Lines where Relevant Passages or Relevant Figures Appear
	1	6936032	B1	2005-08-30	Bush, Jr. et al.	
	2	5582598	A	1996-12-10	Chanoch	
	3	0533575		1895-02-05	J.D. Wilkens	
	4	5961495	A	1999-10-05	Walters et al.	
	5	2717597		1955-09-13	G.N. Hein, Jr.	
	6	2722931		1955-11-08	E.A. May	
	7	3815785		1974-06-11	Gilmont	
	8	4592745		1986-06-03	Rex et al.	

**INFORMATION DISCLOSURE  
STATEMENT BY APPLICANT**  
( Not for submission under 37 CFR 1.99)

Application Number	14319388
Filing Date	2014-06-30
First Named Inventor	Robert Frederick Veasey
Art Unit	3763
Examiner Name	Andrew M. Gilbert
Attorney Docket Number	10-015-US-CON9

9	4863072		1989-09-05	Perler
10	5030209		1991-07-09	Wanderer et al.
11	5328486	A	1994-07-12	Woodruff
12	5547131	A	1996-08-20	Brace
13	5582598	A	1996-12-10	Chanoch
14	5728074	A	1998-03-17	Castellano et al.
15	5728075	A	1998-03-17	Levander
16	5957896	A	1999-09-28	Bendek et al.
17	6001089	A	1999-12-14	Burroughs et al.
18	6059755	A	2000-05-09	Michel
19	6277099	B1	2001-08-21	Strowe et al.

**INFORMATION DISCLOSURE  
STATEMENT BY APPLICANT**  
( Not for submission under 37 CFR 1.99)

Application Number		14319388
Filing Date		2014-06-30
First Named Inventor	Robert Frederick Veasey	
Art Unit		3763
Examiner Name	Andrew M. Gilbert	
Attorney Docket Number		10-015-US-CON9

20	6277101	B1	2001-08-21	Kirchhofer et al.
21	6383167	B2	2002-05-07	Kirchhofer et al.
22	7771400	B2	2010-08-10	Nielsen
23	7850662	B2	2010-12-14	Veasey et al.
24	7905867	B2	2011-03-15	Veasey et al.
25	7918833	B2	2011-04-05	Veasey et al.
26	7935088	B2	2011-05-03	Veasey et al.
27	8021345	B2	2011-09-20	Veasey et al.
28	8512297	B2	2013-08-20	Veasey et al.
29	8608709	B2	2013-12-17	Moller et al.
30	8679069	B2	2014-03-25	Veasey et al.

**INFORMATION DISCLOSURE  
STATEMENT BY APPLICANT**  
( Not for submission under 37 CFR 1.99)

Application Number	14319388
Filing Date	2014-06-30
First Named Inventor	Robert Frederick Veasey
Art Unit	3763
Examiner Name	Andrew M. Gilbert
Attorney Docket Number	10-015-US-CON9

31	9028454	B2	2015-05-12	Veasey et al.
32	9233211	B2	2016-01-12	Veasey et al.

If you wish to add additional U.S. Patent citation information please click the Add button.

**U.S.PATENT APPLICATION PUBLICATIONS**

Examiner Initial*	Cite No	Publication Number	Kind Code <sup>1</sup>	Publication Date	Name of Patentee or Applicant of cited Document	Pages, Columns, Lines where Relevant Passages or Relevant Figures Appear
	1	20010034507	A1	2001-10-25	Kirchhofer et al.	
	2	20020165499	A1	2002-11-07	Slate et al.	
	3	20030050609	A1	2003-03-13	Sams	
	4	20070123829	A1	2007-05-31	Atterbury et al.	
	5	20090275916	A1	2009-11-05	Harms et al.	
	6	20100042054	A1	2010-02-18	Elahi et al.	
	7	20120053528	A1	2012-03-01	Bollenbach et al.	

If you wish to add additional U.S. Published Application citation information please click the Add button.

**INFORMATION DISCLOSURE  
STATEMENT BY APPLICANT**  
( Not for submission under 37 CFR 1.99)

Application Number	14319388
Filing Date	2014-06-30
First Named Inventor	Robert Frederick Veasey
Art Unit	3763
Examiner Name	Andrew M. Gilbert
Attorney Docket Number	10-015-US-CON9

**FOREIGN PATENT DOCUMENTS** [Remove](#)

Examiner Initial*	Cite No	Foreign Document Number <sup>3</sup>	Country Code <sup>2</sup> i	Kind Code <sup>4</sup>	Publication Date	Name of Patentee or Applicant of cited Document	Pages, Columns, Lines where Relevant Passages or Relevant Figures Appear	T <sup>5</sup>
	1	2001010484	WO	A1	2001-02-15	Becton, Dickinson and Company		
	2	0937477	EP	A2	1999-08-25	Becton, Dickinson and Company		
	3	1855743	EP	B1	2008-12-17	Novo Nordisk A/S		
	4	1996025965	WO	A1	1996-08-29	Smith et al.		
	5	2002053214	WO	A1	2002-07-11	Novo Nordisk A/S		
	6	2002092153	WO	A2	2002-11-21	Eli Lilly and Company		
	7	2003080160	WO	A1	2003-10-02	Eli Lilly and Company		
	8	2011051366	WO	A2	2011-05-05	Sanofi-Aventis Deutschland GmbH		

If you wish to add additional Foreign Patent Document citation information please click the Add button [Add](#)

**NON-PATENT LITERATURE DOCUMENTS** [Remove](#)

Examiner Initials*	Cite No	Include name of the author (in CAPITAL LETTERS), title of the article (when appropriate), title of the item (book, magazine, journal, serial, symposium, catalog, etc), date, pages(s), volume-issue number(s), publisher, city and/or country where published.	T <sup>5</sup>

**INFORMATION DISCLOSURE  
STATEMENT BY APPLICANT**  
( Not for submission under 37 CFR 1.99)

Application Number		14319388
Filing Date		2014-06-30
First Named Inventor	Robert Frederick Veasey	
Art Unit		3763
Examiner Name	Andrew M. Gilbert	
Attorney Docket Number		10-015-US-CON9

1	
---	--

If you wish to add additional non-patent literature document citation information please click the Add button

**EXAMINER SIGNATURE**

Examiner Signature	/ANDREW M GILBERT/	Date Considered	11/10/2016
--------------------	--------------------	-----------------	------------

\*EXAMINER: Initial if reference considered, whether or not citation is in conformance with MPEP 609. Draw line through a citation if not in conformance and not considered. Include copy of this form with next communication to applicant.

<sup>1</sup> See Kind Codes of USPTO Patent Documents at [www.USPTO.GOV](http://www.USPTO.GOV) or MPEP 901.04. <sup>2</sup> Enter office that issued the document, by the two-letter code (WIPO Standard ST.3). <sup>3</sup> For Japanese patent documents, the indication of the year of the reign of the Emperor must precede the serial number of the patent document. <sup>4</sup> Kind of document by the appropriate symbols as indicated on the document under WIPO Standard ST.16 if possible. <sup>5</sup> Applicant is to place a check mark here if English language translation is attached.

**INFORMATION DISCLOSURE  
STATEMENT BY APPLICANT**  
( Not for submission under 37 CFR 1.99)

Application Number	14319388
Filing Date	2014-06-30
First Named Inventor	Robert Frederick Veasey
Art Unit	3763
Examiner Name	Andrew M. Gilbert
Attorney Docket Number	10-015-US-CON9

**CERTIFICATION STATEMENT**

Please see 37 CFR 1.97 and 1.98 to make the appropriate selection(s):

That each item of information contained in the information disclosure statement was first cited in any communication from a foreign patent office in a counterpart foreign application not more than three months prior to the filing of the information disclosure statement. See 37 CFR 1.97(e)(1).

**OR**

That no item of information contained in the information disclosure statement was cited in a communication from a foreign patent office in a counterpart foreign application, and, to the knowledge of the person signing the certification after making reasonable inquiry, no item of information contained in the information disclosure statement was known to any individual designated in 37 CFR 1.56(c) more than three months prior to the filing of the information disclosure statement. See 37 CFR 1.97(e)(2).

See attached certification statement.

- The fee set forth in 37 CFR 1.17 (p) has been submitted herewith.  
 A certification statement is not submitted herewith.

**SIGNATURE**

A signature of the applicant or representative is required in accordance with CFR 1.33, 10.18. Please see CFR 1.4(d) for the form of the signature.

Signature	/Thomas E. Wettermann/	Date (YYYY-MM-DD)	2016-10-24
Name/Print	Thomas E. Wettermann	Registration Number	41,523

This collection of information is required by 37 CFR 1.97 and 1.98. The information is required to obtain or retain a benefit by the public which is to file (and by the USPTO to process) an application. Confidentiality is governed by 35 U.S.C. 122 and 37 CFR 1.14. This collection is estimated to take 1 hour to complete, including gathering, preparing and submitting the completed application form to the USPTO. Time will vary depending upon the individual case. Any comments on the amount of time you require to complete this form and/or suggestions for reducing this burden, should be sent to the Chief Information Officer, U.S. Patent and Trademark Office, U.S. Department of Commerce, P.O. Box 1450, Alexandria, VA 22313-1450. **DO NOT SEND FEES OR COMPLETED FORMS TO THIS ADDRESS. SEND TO: Commissioner for Patents, P.O. Box 1450, Alexandria, VA 22313-1450.**




## Privacy Act Statement

The Privacy Act of 1974 (P.L. 93-579) requires that you be given certain information in connection with your submission of the attached form related to a patent application or patent. Accordingly, pursuant to the requirements of the Act, please be advised that: (1) the general authority for the collection of this information is 35 U.S.C. 2(b)(2); (2) furnishing of the information solicited is voluntary; and (3) the principal purpose for which the information is used by the U.S. Patent and Trademark Office is to process and/or examine your submission related to a patent application or patent. If you do not furnish the requested information, the U.S. Patent and Trademark Office may not be able to process and/or examine your submission, which may result in termination of proceedings or abandonment of the application or expiration of the patent.

The information provided by you in this form will be subject to the following routine uses:

1. The information on this form will be treated confidentially to the extent allowed under the Freedom of Information Act (5 U.S.C. 552) and the Privacy Act (5 U.S.C. 552a). Records from this system of records may be disclosed to the Department of Justice to determine whether the Freedom of Information Act requires disclosure of these records.
2. A record from this system of records may be disclosed, as a routine use, in the course of presenting evidence to a court, magistrate, or administrative tribunal, including disclosures to opposing counsel in the course of settlement negotiations.
3. A record in this system of records may be disclosed, as a routine use, to a Member of Congress submitting a request involving an individual, to whom the record pertains, when the individual has requested assistance from the Member with respect to the subject matter of the record.
4. A record in this system of records may be disclosed, as a routine use, to a contractor of the Agency having need for the information in order to perform a contract. Recipients of information shall be required to comply with the requirements of the Privacy Act of 1974, as amended, pursuant to 5 U.S.C. 552a(m).
5. A record related to an International Application filed under the Patent Cooperation Treaty in this system of records may be disclosed, as a routine use, to the International Bureau of the World Intellectual Property Organization, pursuant to the Patent Cooperation Treaty.
6. A record in this system of records may be disclosed, as a routine use, to another federal agency for purposes of National Security review (35 U.S.C. 181) and for review pursuant to the Atomic Energy Act (42 U.S.C. 218(c)).
7. A record from this system of records may be disclosed, as a routine use, to the Administrator, General Services, or his/her designee, during an inspection of records conducted by GSA as part of that agency's responsibility to recommend improvements in records management practices and programs, under authority of 44 U.S.C. 2904 and 2906. Such disclosure shall be made in accordance with the GSA regulations governing inspection of records for this purpose, and any other relevant (i.e., GSA or Commerce) directive. Such disclosure shall not be used to make determinations about individuals.
8. A record from this system of records may be disclosed, as a routine use, to the public after either publication of the application pursuant to 35 U.S.C. 122(b) or issuance of a patent pursuant to 35 U.S.C. 151. Further, a record may be disclosed, subject to the limitations of 37 CFR 1.14, as a routine use, to the public if the record was filed in an application which became abandoned or in which the proceedings were terminated and which application is referenced by either a published application, an application open to public inspections or an issued patent.
9. A record from this system of records may be disclosed, as a routine use, to a Federal, State, or local law enforcement agency, if the USPTO becomes aware of a violation or potential violation of law or regulation.

<b>Issue Classification</b> 	<b>Application/Control No.</b> 14319388	<b>Applicant(s)/Patent Under Reexamination</b> VEASEY ET AL.
	<b>Examiner</b> ANDREW GILBERT	<b>Art Unit</b> 3763

CPC						
Symbol					Type	Version
A61M		5		31551	F	2013-01-01
A61M		5		31565	A	2013-01-01
A61M		5		31578	A	2013-01-01
A61M		5		24	I	2013-01-01
A61M		5		31535	I	2013-01-01
A61M		5		31541	I	2013-01-01
A61M		5		3156	A	2013-01-01
A61M		5		31575	A	2013-01-01
A61M		5		31585	I	2013-01-01
A61M		2005		2407	A	2013-01-01
A61M		2205		581	A	2013-01-01
A61M		2205		582	A	2013-01-01
A61M		5		31533	I	2013-01-01
A61M		5		31536	I	2013-01-01
A61M		5		31546	I	2013-01-01
A61M		5		31528	I	2013-01-01
A61M		5		31563	I	2013-01-01
A61M		5		31568	I	2013-01-01
A61M		5		3157	I	2013-01-01
A61M		5		31593	I	2013-01-01
A61M		5		32	I	2013-01-01
A61M		2005		3126	A	2013-01-01

CPC Combination Sets				
Symbol	Type	Set	Ranking	Version

NONE		<b>Total Claims Allowed:</b>	
(Assistant Examiner)	(Date)	19	
/ANDREW GILBERT/ Primary Examiner.Art Unit 3763	11/11/2016	O.G. Print Claim(s)	O.G. Print Figure
(Primary Examiner)	(Date)	1	1, 2







IN THE UNITED STATES PATENT AND TRADEMARK OFFICE  
(MBHB Case No.: 10-015-US-CON9)

In re Application of:	)	
	)	
Robert Frederick Veasey	)	
	)	Group Art Unit: 3763
Serial No.: 14/319,388	)	
	)	Examiner: Gilbert, Andrew M.
Filed: June 30, 2014	)	
	)	Confirmation No.: 6141
For: Drive Mechanisms Suitable for Use in	)	
Drug Delivery Devices	)	

Mail Stop Issue Fee  
Commissioner for Patents  
P.O. Box 1450  
Alexandria, VA 22313-1450

**COMMENTS ON STATEMENT OF REASONS FOR ALLOWANCE**

Dear Commissioner:

Responsive to the Notice of Allowance mailed November 15, 2016, Applicant express appreciation for the allowance of the present application. The Applicant notes the Examiner’s reasons for allowance, but further comment that the art of record, alone and in combination, fails to show, teach or suggest the entirety of each combination of steps and/or structure recited by each of the allowed claims of the present invention. Applicant understands that the Examiner has thoroughly examined the claims and prior art of record and has concluded that the art of record, whether considered alone or in combination, fails to disclose or suggest the entirety of each combination of steps and/or structure recited by each of the allowed claims, that the Examiner has found each claim as a whole to patentably distinguish over the art of record, and that patentability of the claims does not necessarily rest on only any aspect that the Examiner listed in the statement of reasons for allowance.

Applicant takes no position regarding the Reasons for Allowance presented by the Examiner other than the positions Applicant may have previously taken during prosecution.

Therefore, the Examiner's Reasons for Allowance should not be attributed to Applicant as a sole indication of the basis for Applicant's belief that the claims are patentable. Furthermore, Applicant respectfully asserts that there may also be additional reasons for patentability of the claimed subject matter not explicitly stated in this record and Applicant does not waive its rights to such arguments by not further addressing such reasons herein.

Respectfully submitted,  
**McDonnell Boehnen Hulbert & Berghoff LLP**

Date: February 13, 2017

By: /Thomas E. Wettermann/  
Thomas E. Wettermann  
Reg. No. 41,523

IN THE UNITED STATES PATENT AND TRADEMARK OFFICE  
(MBHB Case No. 10-015-US-CON9)

In re Application of:	)	
	)	
Robert Frederick Veasey et al.	)	Examiner: Gilbert, Andrew M.
	)	
Serial No.: 14/319,388	)	Group Art Unit: 3763
	)	
Filed: June 30, 2014	)	Confirmation No.: 6141
	)	
For: Drive Mechanisms Suitable for Use in Drug	)	
Delivery Devices	)	

Commissioner for Patents  
P.O. Box 1450  
Alexandria, VA 22313-1450

**GENERAL AUTHORIZATION UNDER 37 C.F.R. § 1.136(a)(3)**

Sir:

The Commissioner is hereby generally authorized under 37 C.F.R. § 1.136(a)(3) to treat the present and any future related filings in this or any related application filed pursuant to 37 C.F.R. § 1.53 requiring an extension of time or any other required filing fee as incorporating a request therefore, and the Commissioner is hereby specifically authorized to charge Deposit Account No. 13-2490 for any fee that may be due in connection with such a request for an extension of time.

Respectfully submitted,  
**McDonnell Boehnen Hulbert & Berghoff LLP**

Date: February 13, 2017

By: /Thomas E. Wettermann/  
Thomas E. Wettermann  
Reg. No. 41,523



## Electronic Patent Application Fee Transmittal

<b>Application Number:</b>	14319388
<b>Filing Date:</b>	30-Jun-2014
<b>Title of Invention:</b>	DRIVE MECHANISMS SUITABLE FOR USE IN DRUG DELIVERY DEVICES
<b>First Named Inventor/Applicant Name:</b>	Robert Frederick Veasey
<b>Filer:</b>	Thomas E. Wettermann
<b>Attorney Docket Number:</b>	10-015-US-CON9

Filed as Large Entity

**Filing Fees for Utility under 35 USC 111(a)**

Description	Fee Code	Quantity	Amount	Sub-Total in USD(\$)
<b>Basic Filing:</b>				
<b>Pages:</b>				
<b>Claims:</b>				
<b>Miscellaneous-Filing:</b>				
<b>Petition:</b>				
<b>Patent-Appeals-and-Interference:</b>				
<b>Post-Allowance-and-Post-Issuance:</b>				
UTILITY APPL ISSUE FEE	1501	1	960	960

Description	Fee Code	Quantity	Amount	Sub-Total in USD(\$)
<b>Extension-of-Time:</b>				
<b>Miscellaneous:</b>				
<b>Total in USD (\$)</b>				<b>960</b>

## Electronic Acknowledgement Receipt

<b>EFS ID:</b>	28341536
<b>Application Number:</b>	14319388
<b>International Application Number:</b>	
<b>Confirmation Number:</b>	6141
<b>Title of Invention:</b>	DRIVE MECHANISMS SUITABLE FOR USE IN DRUG DELIVERY DEVICES
<b>First Named Inventor/Applicant Name:</b>	Robert Frederick Veasey
<b>Customer Number:</b>	98548
<b>Filer:</b>	Thomas E. Wettermann
<b>Filer Authorized By:</b>	
<b>Attorney Docket Number:</b>	10-015-US-CON9
<b>Receipt Date:</b>	13-FEB-2017
<b>Filing Date:</b>	30-JUN-2014
<b>Time Stamp:</b>	17:05:27
<b>Application Type:</b>	Utility under 35 USC 111(a)

### Payment information:

Submitted with Payment	yes
Payment Type	DA
Payment was successfully received in RAM	\$960
RAM confirmation Number	021417INTEFSW00004319132490
Deposit Account	132490
Authorized User	thomas wettermann

The Director of the USPTO is hereby authorized to charge indicated fees and credit any overpayment as follows:

37 CFR 1.16 (National application filing, search, and examination fees)

37 CFR 1.17 (Patent application and reexamination processing fees)

0251

Mylan Exhibit - 1010

Mylan v. Sanofi

37 CFR 1.19 (Document supply fees)  
 37 CFR 1.20 (Post Issuance fees)  
 37 CFR 1.21 (Miscellaneous fees and charges)

**File Listing:**

Document Number	Document Description	File Name	File Size(Bytes)/ Message Digest	Multi Part /.zip	Pages (if appl.)
1	Transmittal Letter	10_015_US_CON9_Issue_Fee_Transmittal_2017_02_13.pdf	158831 aa7cc8dbd95a2074c0416b81d77d68edb7727451	no	1
<b>Warnings:</b>					
<b>Information:</b>					
2	Issue Fee Payment (PTO-85B)	10_015_US_CON9_Issue_Fee_2017_02_13.pdf	90697 cace2ed5189764b4319a8d7ff5c79e221f6a607a	no	1
<b>Warnings:</b>					
<b>Information:</b>					
3	Post Allowance Communication - Incoming	10_015_US_CON9_Comments_Statement_Reasons_Allowance_2017_02_13.pdf	59134 fad8c4e7cfe3ce37d12fdb5c4686078003430ef1	no	2
<b>Warnings:</b>					
<b>Information:</b>					
4	Authorization for Extension of Time all replies	10_015_US_CON9_General_Authorization_2017_02_13.pdf	59436 5d07a79795a96fcaef78720c4db4eb305b9c658a	no	1
<b>Warnings:</b>					
<b>Information:</b>					
5	Fee Worksheet (SB06)	fee-info.pdf	30949 6742df5c2e0a941d4fba4ee1980eec2a2cdaa1ec	no	2
<b>Warnings:</b>					
<b>Information:</b>					
<b>Total Files Size (in bytes):</b>			399047		

**This Acknowledgement Receipt evidences receipt on the noted date by the USPTO of the indicated documents, characterized by the applicant, and including page counts, where applicable. It serves as evidence of receipt similar to a Post Card, as described in MPEP 503.**

**New Applications Under 35 U.S.C. 111**

**If a new application is being filed and the application includes the necessary components for a filing date (see 37 CFR 1.53(b)-(d) and MPEP 506), a Filing Receipt (37 CFR 1.54) will be issued in due course and the date shown on this Acknowledgement Receipt will establish the filing date of the application.**

**National Stage of an International Application under 35 U.S.C. 371**

**If a timely submission to enter the national stage of an international application is compliant with the conditions of 35 U.S.C. 371 and other applicable requirements a Form PCT/DO/EO/903 indicating acceptance of the application as a national stage submission under 35 U.S.C. 371 will be issued in addition to the Filing Receipt, in due course.**

**New International Application Filed with the USPTO as a Receiving Office**

**If a new international application is being filed and the international application includes the necessary components for an international filing date (see PCT Article 11 and MPEP 1810), a Notification of the International Application Number and of the International Filing Date (Form PCT/RO/105) will be issued in due course, subject to prescriptions concerning national security, and the date shown on this Acknowledgement Receipt will establish the international filing date of the application.**

Under the Paperwork Reduction Act of 1995, no persons are required to respond to a collection of information unless it displays a valid OMB control number.

<b>TRANSMITTAL FORM</b>  <i>(to be used for all correspondence after initial filing)</i>	Application Number	14/319,388	
	Filing Date	June 30, 2014	
	First Named Inventor	Robert Frederick Veasey	
	Art Unit	3763	
	Examiner Name	Gilbert, Andrew M.	
Total Number of Pages in This Submission		Attorney Docket Number	10-015-US-CON9

<b>ENCLOSURES (Check all that apply)</b>		
<input type="checkbox"/> Fee Transmittal Form <input type="checkbox"/> Fee Attached <input type="checkbox"/> Amendment/Reply <input type="checkbox"/> After Final <input type="checkbox"/> Affidavits/declaration(s) <input type="checkbox"/> Extension of Time Request <input type="checkbox"/> Express Abandonment Request <input type="checkbox"/> Information Disclosure Statement <input type="checkbox"/> Certified Copy of Priority Document(s) <input type="checkbox"/> Reply to Missing Parts/ Incomplete Application <input type="checkbox"/> Reply to Missing Parts under 37 CFR 1.52 or 1.53	<input type="checkbox"/> Drawing(s) <input type="checkbox"/> Licensing-related Papers <input type="checkbox"/> Petition <input type="checkbox"/> Petition to Convert to a Provisional Application <input type="checkbox"/> Power of Attorney, Revocation Change of Correspondence Address <input type="checkbox"/> Terminal Disclaimer <input type="checkbox"/> Request for Refund <input type="checkbox"/> CD, Number of CD(s) ___ <input type="checkbox"/> Landscape Table on CD	<input type="checkbox"/> After Allowance Communication to TC <input type="checkbox"/> Appeal Communication to Board of Appeals and Interferences <input type="checkbox"/> Appeal Communication to TC (Appeal Notice, Brief, Reply Brief) <input type="checkbox"/> Proprietary Information <input type="checkbox"/> Status Letter <input checked="" type="checkbox"/> Other Enclosure(s) (please identify below): Issue Fee Transmittal, Comments on Statement of Reasons for Allowance and General Authorization
<div style="border: 1px solid black; padding: 2px; display: inline-block;">Remarks</div>		

**SIGNATURE OF APPLICANT, ATTORNEY, OR AGENT**

Firm Name	McDonnell Boehnen Hulbert & Berghoff LLP		
Signature	/Thomas E. Wettermann/		
Printed name	Thomas E. Wettermann		
Date	February 13, 2017	Reg. No.	41,523

**CERTIFICATE OF TRANSMISSION/MAILING**

I hereby certify that this correspondence is being electronically transmitted to the USPTO or deposited with the United States Postal Service with sufficient postage as first class mail in an envelope addressed to: Commissioner for Patents, P.O. Box 1450, Alexandria, VA 22313-1450 on the date shown below:			
Signature	/Thomas E. Wettermann/		
Typed or printed name	Thomas E. Wettermann	Date	February 13, 2017

This collection of information is required by 37 CFR 1.5. The information is required to obtain or retain a benefit by the public which is to file (and by the USPTO to process) an application. Confidentiality is governed by 35 U.S.C. 122 and 37 CFR 1.11 and 1.14. This collection is estimated to 2 hours to complete, including gathering, preparing, and submitting the completed application form to the USPTO. Time will vary depending upon the individual case. Any comments on the amount of time you require to complete this form and/or suggestions for reducing this burden, should be sent to the Chief Information Officer, U.S. Patent and Trademark Office, U.S. Department of Commerce, P.O. Box 1450, Alexandria, VA 22313-1450. DO NOT SEND FEES OR COMPLETED FORMS TO THIS ADDRESS. SEND TO: **Commissioner for Patents, P.O. Box 1450, Alexandria, VA 22313-1450.**

*If you need assistance in completing the form, call 1-800-PTO-9199 and select option 2.*

**INFORMATION DISCLOSURE  
STATEMENT BY APPLICANT**  
( Not for submission under 37 CFR 1.99)

Application Number		14319388 - GAU: 3763
Filing Date		2014-06-30
First Named Inventor	Robert Frederick Veasey et al.	
Art Unit		
Examiner Name		
Attorney Docket Number		10-015-US-CON9

	152	7291132		2007-11-06	DeRuntz et al.	
	153	7241278		2007-07-10	Moller	
	154	6547764		2003-04-15	Larsen et al.	
	155	5304152		1994-04-19	Sams	
Change(s) applied to document, /K.D./ 11/29/2016	156	5320609		1994-06-14	Gabriel et al. Haber, et al.	
	157	5480387		1996-01-02	Gabriel et al.	
	158	5505704		1996-04-09	Pawelka et al.	
	159	6193698		2001-02-27	Kirchhofer et al.	
	160	6248095		2001-06-19	Giambattista et al.	
	161	7241278		2007-07-10	Moller	

If you wish to add additional U.S. Patent citation information please click the Add button.

Add

**U.S.PATENT APPLICATION PUBLICATIONS**

Remove

**INFORMATION DISCLOSURE  
STATEMENT BY APPLICANT**  
( Not for submission under 37 CFR 1.99)

Application Number		14319388 - GAU: 3763
Filing Date		2014-06-30
First Named Inventor	Robert Frederick Veasey et al.	
Art Unit		
Examiner Name		
Attorney Docket Number	10-015-US-CON9	

	97	6899698		2005-05-31	Sams	
	98	6083197		2000-07-04	Umbaugh	
	99	5921966		1999-07-13	Bendek et al.	
	100	6146361		2000-11-14	DiBiasi et al.	
	101	5370629		1994-12-06	Michel et al.	
	102	5823998		1998-10-20	Yamagata	
	103	5591136		1997-01-07	Gabriel	
	104	5599314		1997-02-04	Neill	
	105	5304152		1994-04-19	Sams	
	106	5688251		1997-11-18	Chanoch	
Change(s) applied to document,	107	5,674,204 <del>5674204</del>		1997-10-07	Chanoch	

Change(s) applied to document,



**INFORMATION DISCLOSURE  
STATEMENT BY APPLICANT**  
( Not for submission under 37 CFR 1.99)

Application Number		14319388 - GAU: 3763
Filing Date		2014-06-30
First Named Inventor	Robert Frederick Veasey et al.	
Art Unit		
Examiner Name		
Attorney Docket Number		10-015-US-CON9

	86	6562011		2003-05-13	Buch Rasmussen et al.	
	87	6340357		2002-01-22	Poulsen et al.	
	88	6312413		2001-11-06	Jensen et al.	
	89	6302869		2001-10-16	Klitgaard	
	90	6277098		2001-08-21	Klitmose et al.	
	91	6277097		2001-08-21	Mikkelsen et al.	
	92	6248090		2001-06-19	Jensen et al.	
Change(s) applied to document, /K.D./ 11/29/2016	93	<del>6033376</del> 6,033,376		2000-03-07	Rockley	
	94	6033377		2000-03-07	Rasmussen et al.	
Change(s) applied to document, /K.D./ 11/30/2016	95	5928201		07/1999 <del>1997-07-27</del>	Poulsen et al.	
	96	5626566		1997-05-06	Peterson et al.	

**INFORMATION DISCLOSURE  
STATEMENT BY APPLICANT**  
( Not for submission under 37 CFR 1.99)

Application Number		14319388 - GAU: 3763
Filing Date		2014-06-30
First Named Inventor	Robert Frederick Veasey et al.	
Art Unit		
Examiner Name		
Attorney Docket Number		10-015-US-CON9

	64	6010485		2000-01-04	Buch-Rasmussen et al.	
	65	6004297		1999-12-21	Steenfeldt-Jensen et al.	
	66	5984900		1999-11-16	Mikkelsen	
	67	5980491		1999-11-09	Hansen	
	68	5961496		1999-10-05	Nielsen et al.	
	69	5954689		1999-09-21	Poulsen	
	70	5951530		1999-09-14	Steengaard et al.	
Change(s) applied to document, /K.D./ 11/30/2013	71	5947934		09/1999	Hansen, et al.	
				<del>1999-10-07</del>	<del>Hansen et al.</del>	
	72	5898028		1999-04-27	Jensen et al.	
	73	5882718		1999-03-16	Pommer et al.	
	74	5626566		1997-05-06	Peterson et al.	

**INFORMATION DISCLOSURE  
STATEMENT BY APPLICANT**  
( Not for submission under 37 CFR 1.99)

Application Number		14319388 - GAU: 3763
Filing Date		2014-06-30
First Named Inventor	Robert Frederick Veasey et al.	
Art Unit		
Examiner Name		
Attorney Docket Number		10-015-US-CON9

Change(s) applied to document, /K.D./ 11/30/2013	42	5320609		<del>1994-01-17</del> 06/1994	Haber et al.	
	43	5383865		1995-01-24	Michel	
	44	5681285		1997-10-28	Ford et al.	
	45	4568335		1986-02-04	Updike et al.	
	46	5257987		1993-11-02	Athayde et al.	
	47	5318540		1994-06-07	Athayde et al.	
	48	4833379		1989-05-23	Kaibel et al.	
	49	4919596		1990-04-24	Slate et al.	
	50	5207752		1993-05-04	Sorenson et al.	
	51	5246417		1993-09-21	Haak et al.	
52	5445606		1995-08-29	Haak et al.		



APPLICATION NO.	ISSUE DATE	PATENT NO.	ATTORNEY DOCKET NO.	CONFIRMATION NO.
14/319,388	03/28/2017	9604008	10-015-US-CON9	6141

98548 7590 03/08/2017  
McDonnell Boehnen Hulbert & Berghoff LLP  
Sanofi - Aventis  
300 South Wacker Drive  
Chicago, IL 60606

### ISSUE NOTIFICATION

The projected patent number and issue date are specified above.

#### **Determination of Patent Term Adjustment under 35 U.S.C. 154 (b)** (application filed on or after May 29, 2000)

The Patent Term Adjustment is 164 day(s). Any patent to issue from the above-identified application will include an indication of the adjustment on the front page.

If a Continued Prosecution Application (CPA) was filed in the above-identified application, the filing date that determines Patent Term Adjustment is the filing date of the most recent CPA.

Applicant will be able to obtain more detailed information by accessing the Patent Application Information Retrieval (PAIR) WEB site (<http://pair.uspto.gov>).

Any questions regarding the Patent Term Extension or Adjustment determination should be directed to the Office of Patent Legal Administration at (571)-272-7702. Questions relating to issue and publication fee payments should be directed to the Application Assistance Unit (AAU) of the Office of Data Management (ODM) at (571)-272-4200.

APPLICANT(s) (Please see PAIR WEB site <http://pair.uspto.gov> for additional applicants):

Robert Frederick Veasey, Warwickshire, UNITED KINGDOM;  
SANOFI-AVENTIS DEUTSCHLAND GMBH, FRANKFURT AM MAIN, GERMANY;  
Robert Perkins, Warwickshire, UNITED KINGDOM;  
David Aubrey Plumtre, Worcestershire, UNITED KINGDOM;

The United States represents the largest, most dynamic marketplace in the world and is an unparalleled location for business investment, innovation, and commercialization of new technologies. The USA offers tremendous resources and advantages for those who invest and manufacture goods here. Through SelectUSA, our nation works to encourage and facilitate business investment. To learn more about why the USA is the best country in the world to develop technology, manufacture products, and grow your business, visit [SelectUSA.gov](http://SelectUSA.gov).