

*Annou
Alex Slocum
8/27/2019.*

UNITED STATES PATENT AND TRADEMARK OFFICE

BEFORE THE PATENT TRIAL AND APPEAL BOARD

MYLAN PHARMACEUTICALS INC.,
Petitioner,

v.

SANOFI-AVENTIS DEUTSCHLAND GMBH,
Patent Owner

- Case No. IPR2018-01670
- Case No. IPR2018-01675
- Case No. IPR2018-01676
- Case No. IPR2018-01678
- Case No. IPR2018-01679
- Case No. IPR2018-01680
- Case No. IPR2018-01682
- Case No. IPR2018-01684
- Case No. IPR2019-00122
- U.S. Patent No. 8,603,044
- U.S. Patent No. 8,679,069
- U.S. Patent No. 8,992,486
- U.S. Patent No. 9,526,844
- U.S. Patent No. 9,604,008

**DECLARATION OF ALEXANDER SLOCUM, PH.D. IN SUPPORT OF
PATENT OWNER RESPONSES**



WEIL:A97083094\571937.0127

Sanofi Exhibit 2107.001
Mylan v. Sanofi
IPR2018-01680
Mylan Ex.1050

Mylan v. Sanofi - IPR2018-01675

example, a wedge can be driven between two objects to lift one away from the other or driven into an object, as is the case with an axe and a log, to separate it. Most people also know that the distance the wedge moves in is ^{more AS} less than the distance it makes the object move up. This is a result of the conservation of energy: the product of an applied force with the distance over which it is applied (times the efficiency of the system, which is governed by friction) will equal the product of the resulting output force over the distance which it acts. The wedge is a simple transmission that makes life easier for people by helping them amplify the small forces they create with their body in order to do useful work. The same is true with screws and nuts, which are essentially rotary wedges.

32. As mentioned above, in a screw-nut system the application of torque to either a screw or a nut can cause one of the two to move axially, depending on which component is axially fixed and which is rotationally fixed. The application of axial force to one of the components, however, may or may not impart rotation to the other component depending on the circumstances. For example, most people know that if they were to push down on the nut instead of rotating it, the nut will not move. This is because of a small thread angle and high friction. In this case, the threads act as self-locking wedges, and, which is the case where if the wedge angle is small, typically less than 15 degrees, the wedge will not dislodge itself once the user stops applying force to push it in to pry apart objects.

39. Hence a key fundamental goal for injector pens is to keep the axial forces passing through rotating elements as close to the central longitudinal axis of the pen as possible to minimize frictional torques and maximize efficiency.

4. Screw-Nut Systems in Pen Injector Design

40. Back to the principle of conservation of energy: The amount of insulin injected is very small and so the piston that moves in the ampoule must only move a short distance. *See, e.g.*, Ex. 1015, ¶ 0004. However, the needle must slip easily into the skin and with minimal pain so it needs to be a very small diameter. *See, e.g.*, Ex. 1015, ¶ 0005. The resistance to fluid flow through the needle is ^{inversely} proportional to the needle's internal diameter to the fourth power; hence very large forces must be applied to the piston, albeit for a very short distance, to quickly force out the medicament. Because the user can only apply a comparatively modest force, injector pen designers must create a transmission inside the pen to amplify the user's applied force (*i.e.*, a gearing to create a mechanical advantage), which means the user must apply the force over a greater distance than the piston moves as it pushes out the fluid from the ampoule.

41. Due to the nature of their disease process, diabetics have been found to have decreased grip and pinch strength, and are also at risk for development of compression neuropathies that further affect grip strength and hand function (*i.e.*

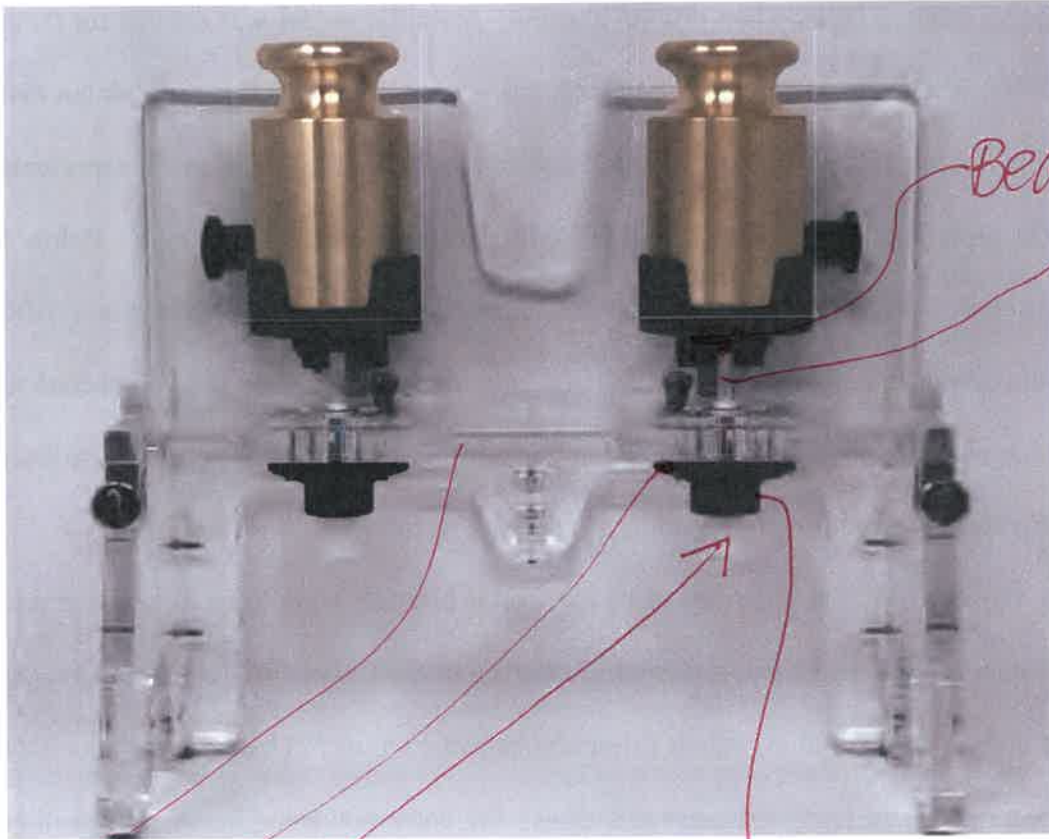

Collar Friction Model Setup

Frame

Grip

Grip housing

housing

[Handwritten signature]
8/27/2019

124. In my opinion, a POSA would have understood that the 486 Patent describes an example of claim 56, including “an interior of a flange,” in its depicted embodiment. Specifically, the 486 Patent describes a clutch means 60 (blue) that includes, at its “second end 64” (or button-end), a “radially inwardly directed flange 62” (yellow). See Ex. 1003, 4:54-55.

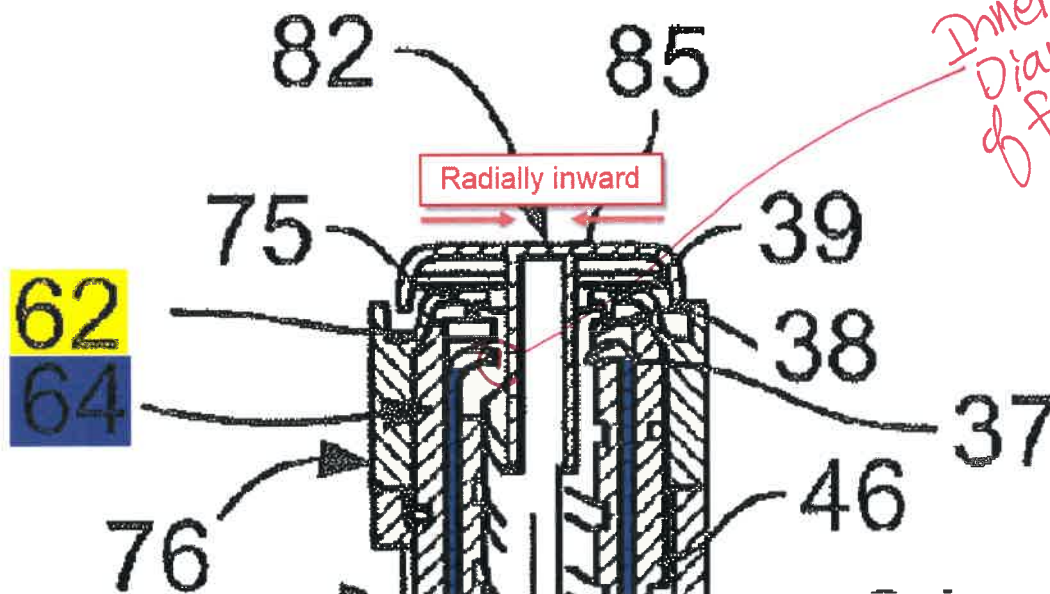

Ex. 1003, Fig. 1 (annotated)

With respect to another figure (Figure 8) illustrating the depicted embodiment, which also shows more detail,⁸ the 486 Patent describes that a series of dog teeth

⁸ We know that both figures 5 and 8 are depicting the same embodiment. See, e.g., Ex. 1003, 2:58-59 (“FIG. 3 shows a sectional view of the pen-type injector of FIG.