

(12) **United States Patent**  
**Klitgaard et al.**

(10) **Patent No.:** **US 6,582,404 B1**  
(45) **Date of Patent:** **\*Jun. 24, 2003**

(54) **DOSE SETTING LIMITER**

(75) Inventors: **Peter Christian Klitgaard**, Smørum (DK); **Steffen Hansen**, Hillerød (DK); **Bo Radmer**, Hillerød (DK); **Claus Schmidt Møller**, Fredensborg (DK)

(73) Assignee: **NNA/S**, Bagsvaerd (DK)

(\* ) Notice: Subject to any disclaimer, the term of this patent is extended or adjusted under 35 U.S.C. 154(b) by 137 days.

This patent is subject to a terminal disclaimer.

(21) Appl. No.: **09/655,922**

(22) Filed: **Sep. 6, 2000**

#### Related U.S. Application Data

(60) Provisional application No. 60/155,612, filed on Sep. 23, 1999.

#### Foreign Application Priority Data

Sep. 16, 1999 (DK) ..... 1999 01309  
(51) **Int. Cl.**<sup>7</sup> ..... **A61M 5/00**; A61M 5/178; A61M 5/135  
(52) **U.S. Cl.** ..... **604/181**; 604/186; 604/207; 604/208; 604/211; 604/224  
(58) **Field of Search** ..... 604/181, 186, 604/207, 208, 211, 224

#### References Cited

##### U.S. PATENT DOCUMENTS

5,947,934 A \* 9/1999 Hansen et al. .... 604/207

##### FOREIGN PATENT DOCUMENTS

DK PCT WO 98/56436 \* 12/1998 ..... A61M/5/24  
EP 0 879 610 A2 11/1998  
WO WO 89/07463 8/1989

WO WO 91/14467 10/1991  
WO WO 93/07922 4/1993  
WO WO 98/10813 3/1998

#### OTHER PUBLICATIONS

Hansen et al., Injection Device, a Preassembled Doses Setting and Injection Mechanism for an Injection Device, and a Method of Assembling an Injection Device, May 1, 2001.\*

\* cited by examiner

*Primary Examiner*—William C. Doerrler

*Assistant Examiner*—Filip Zec

(74) *Attorney, Agent, or Firm*—Marc A. Began, Esq.; Richard W. Book, Esq.; Reza Green, Esq.

#### (57) ABSTRACT

A limiting mechanism which prevents the setting of a dose, which exceeds the amount of liquid left in a cartridge of an injection device, is disclosed. The injection device is the type where a dose is set by rotating a dose setting member relative to a driver and away from a fixed stop in the injection device. The dose setting member interfaces the driver such that the dose setting member can be rotated in one direction without rotating the driver. The dose is injected by rotating back the dose setting member which during the backward rotation carries the driver with it. Rotating the driver causes the piston rod to move forward inside the cartridge and expel some of the liquid contained in the cartridge. The driver is provided with a track having a length which is related to the total amount of liquid in the cartridge and which track is engaged by a track follower coupled to the dose setting member to follow rotation of this dose setting member. Each time a dose is set and injected, the track follower moves further into the track. When the track follower reaches the end of the track the dose setting member can not be rotated further, and a dose larger than the remaining liquid in the cartridge cannot be set.

**4 Claims, 2 Drawing Sheets**

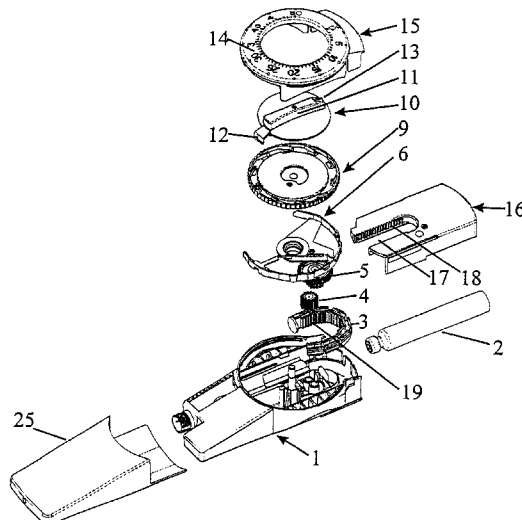

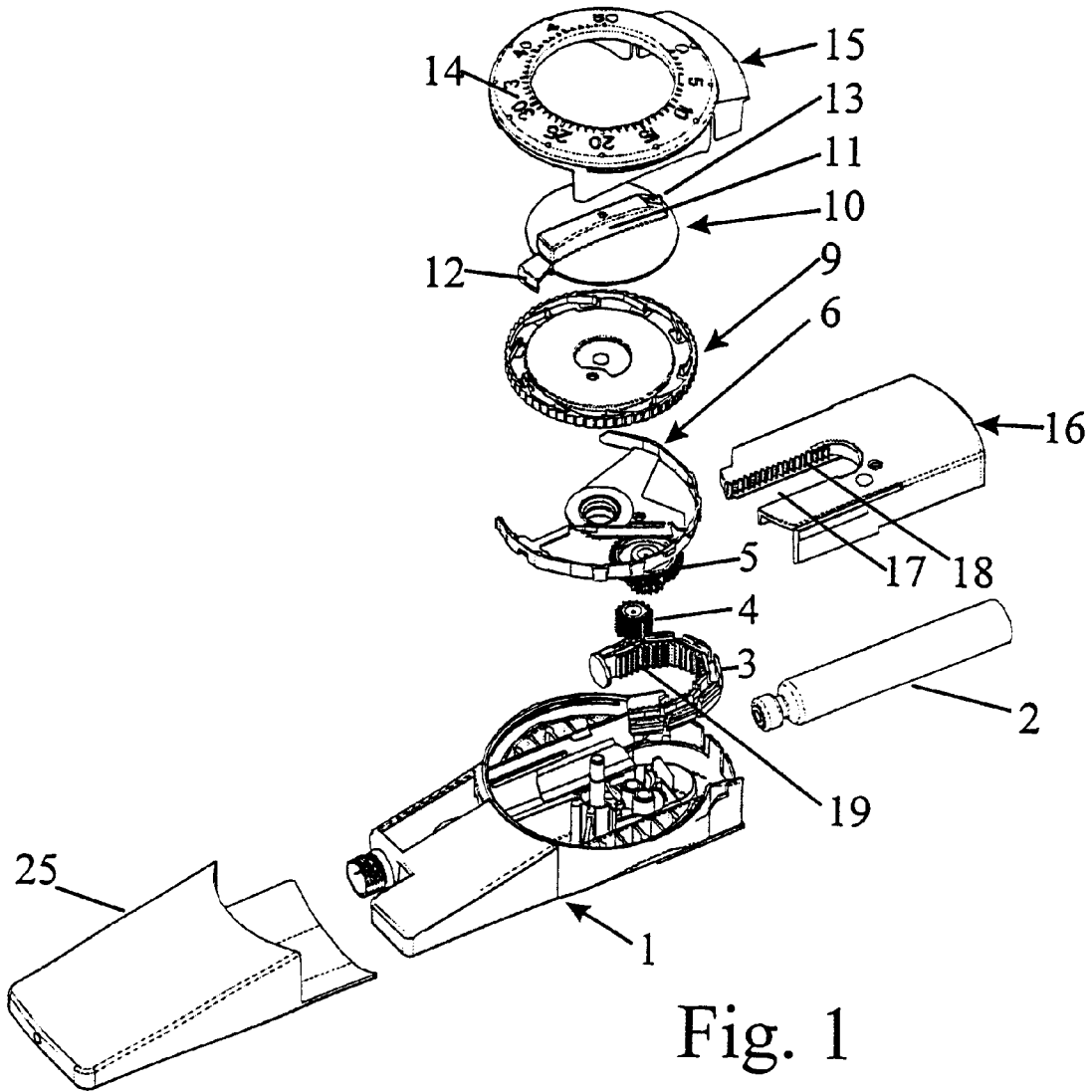

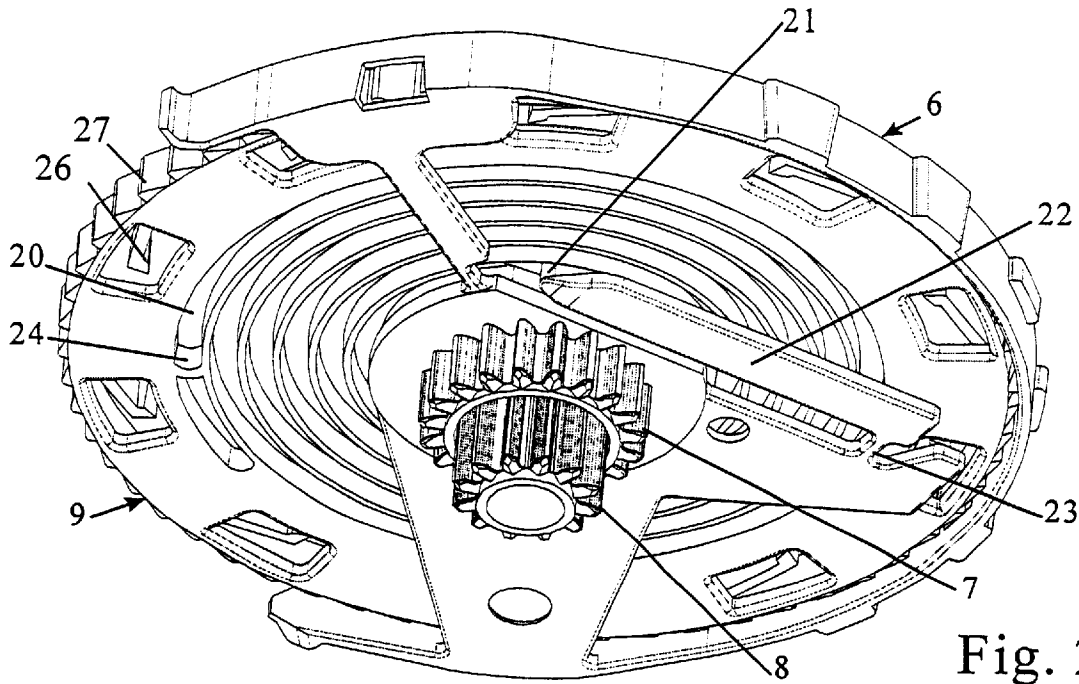

Fig. 2

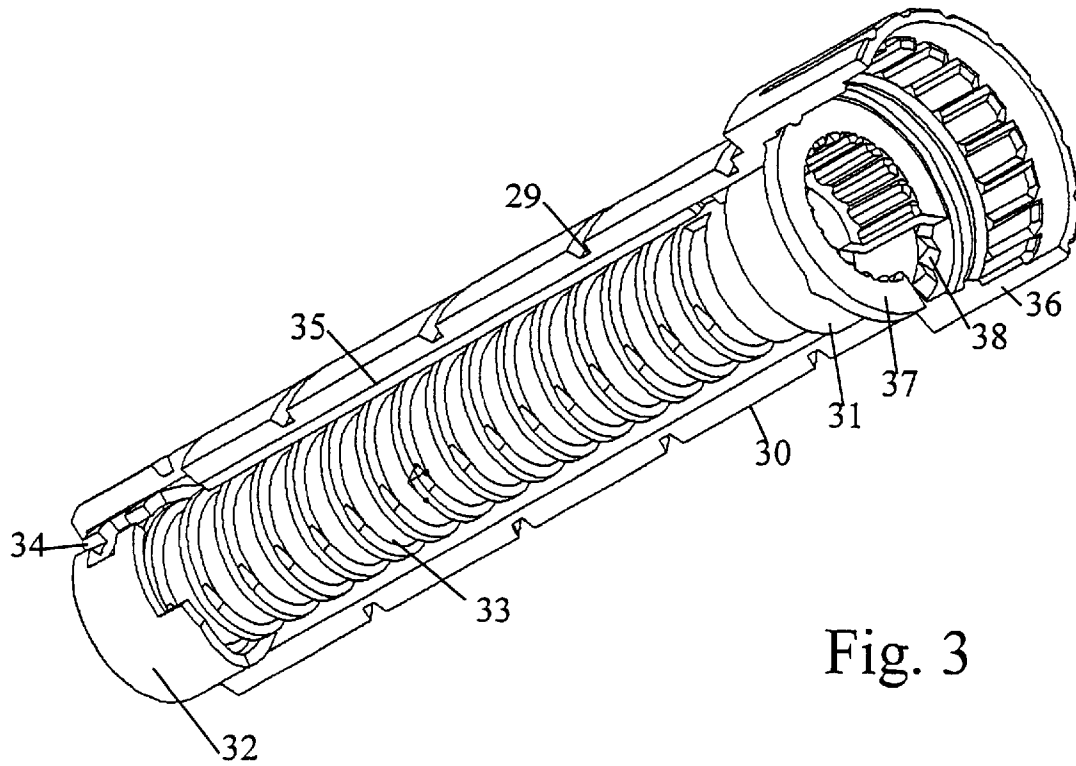

Fig. 3

**DOSE SETTING LIMITER****CROSS-REFERENCE TO RELATED APPLICATIONS**

This application claims priority under 35 U.S.C. 119 of U.S. provisional application No. 60/155,612 filed on Sep. 23, 1999 and Danish application no. PA 1999 01309 filed on Sep. 16, 1999, the contents of which are fully incorporated herein by reference.

**FIELD OF THE INVENTION**

The present invention relates to injection devices wherein the contents of a cartridge are injected as a number of individually set doses.

Such devices have a dose setting mechanism by which the doses are set for subsequent injecting when an injection button is operated. This can be obtained by moving a carrier along a piston rod a distance proportional to the wanted dose and subsequently moving the carrier back to its original position so that the carrier carries the piston rod with it instead of being moved along said piston rod.

**SCOPE OF THE RELATED ART**

From EP 327 910 is known a syringe by which a dose is set by screwing a nut member up along a threaded piston rod away from a stop in a housing. The set dose is injected by pressing the end of the nut member that forms an injection button whereby the nut member is moved back to abutment with the stop again. During the latter movement of the nut member the piston rod is carried along by the nut that does not move relative to this piston rod during the injection.

When a dose is set it is convenient if a limiting device is provided which makes it impossible to set a dose that exceeds the amount of medicament which is left in the cartridge. In EP 327 910 this is obtained by the fact that the thread of the piston rod has such a length that the cartridge is just emptied when the nut is screwed to the end of the thread and then pressed home to its abutment with the stop. By setting a dose the nut can only be screwed to the end of the thread and thereby the size of the last dose is limited to comprise the remaining amount in the cartridge.

The distance the injection button has to be moved corresponds to the distance the piston in the cartridge has to be moved to inject the set dose. Especially by larger cartridges with a large cross section diameter this distance can be very short. To obtain a larger movement of the injection button a sort of gearing may be used so that the distance the injection button has to be moved is proportional with the injected dose but is a number of times the movement of the piston in the cartridge.

EP 608 343 describes an example of such a geared dose setting and injection mechanism. In this device the carrier does not cooperate directly with the threaded piston rod but with a driver element which can move the piston rod when a set dose is injected. In this device the driver element comprises a nut member which is fixed against axial displacement in the injection device. The thread of the nut member engages an outer thread of the piston rod which is secured against rotation in the injection device. By the setting of a dose the carrier is rotated away from a stop to which it is returned when the injection button is operated. During its return the carrier rotates the driver element that moves the piston rod further into the cartridge to press the piston of this cartridge so that a set amount of the medication in the cartridge is pressed out through an injection

needle at the distal end of the cartridge. As the nut member is not moved relative to the piston rod during the setting of a dose, a limiting construction as described above cannot be provided limiting the dose so it does not exceed the amount of liquid left in the injection device.

**OBJECT AND SUMMARY OF THE INVENTION**

An object of the invention is to provide a limiting mechanism which prevents setting of a dose that exceeds the amount of liquid left in a cartridge of an injection device of the geared type wherein a dose is set by rotating a dose setting member relative to a driver and away from a fixed stop in the injection device, and the dose is injected by rotating back the dose setting member which during this rotation carries the driver element with it to rotate this driver element which moves the piston rod forward.

Such a mechanism is according to the invention characterized in that the driver element is provided with a track having a length which is related to the total amount of medicament in the cartridge and which track is engaged by a track follower coupled to the dose setting member to follow rotation of said dose setting member. During the setting of a dose the track follower will be advanced in the track of the driver to a position depending on the set dose as during dose setting the dose setting member and the driver are rotated relative to each other. As during the injection the driver follows the rotation of the dose setting member, the pin of the dose setting member will keep its position in the track of the driver when the set dose is injected. The length of the track is so adapted that the pin reaches the end of the track and makes an increase of the set dose impossible when a dose is set which corresponds to the amount of liquid remaining in the cartridge.

According to the invention the driver may be disk shaped and have a spiral shaped track which is engaged by a cam on a member which is flexibly coupled to the dose setting member so that the pin can be moved radially when it follows the track of the driver.

In another embodiment of the invention the driver may be cylindrical and have a helical track which is engaged by a cam on the dose setting member which is a cylinder concentric with the driver.

The track may be provided as a thread in the driver and the track follower may be a nut shaped member coupled to the dose setting member and provided with a thread engaging the thread of the driver. When a dose is set the dose setting member is screwed with its thread along the thread of the driver. The limitation of the set dose is obtained by giving the threads an appropriate length.

**BRIEF DESCRIPTION OF THE DRAWINGS**

In the following the invention will be explained in further details with references to the drawing, wherein

FIG. 1 shows an exploded view of a syringe with a dose limiter according to the invention;

FIG. 2 shows an enlarged view of the dose setting element and the driver element of the syringe in FIG. 1; and

FIG. 3 shows the dose setting member, the driver, and the track follower of another embodiment of an injection syringe.

**DETAILED DESCRIPTION OF THE INVENTION**

The syringe in FIG. 1 comprises a housing 1 accommodating a cartridge 2 from which the content can be pressed

out by a piston rod **3** which is by injection via gear wheels **4** and **5** advanced a distance corresponding to a dose set by dose setting. A dose setting member **6** is provided with a toothed wheel **7** surrounding a central bore through which a pinion **8** on a driver **9** projects as it is shown in FIG. 2. The dose setting element **6** is operated through an operation element **10** which has a finger grip **11**, a carrier **12** which engages the dose setting member **6**, and an arrow **13** pointing on a scale **14** provided on a lid **15** which forms a part of the housing **1**. FIG. 1 further shows a cap **25** which can be put on to protect a not shown needle which may be mounted on the syringe, and an injection button **16** which is sliding mounted in the housing **1** and which has a recess **17** which is on one of its side surfaces provided with a cogging **18**.

In the assembled syringe the toothed wheel **7** on the dose setting member **6** engages the cogging **18** of the button element **16** whereas the pinion **8** on the driver **9** engages the part with the large diameter of the gear wheel **5** the part of which with the small diameter engages the other gear wheel **4** which further engages a cogging **19** on the piston rod **3**.

The driver member **9** is provided with pawl **26** which with not shown teeth in the housing forms an unidirectional coupling allowing the driver **9** to rotate only in the direction by which the piston rod **3** is advanced into the cartridge **2**. A ratchet is provided by saw tooth shaped protrusions on the dose setting element **6** engaging a saw tooth cogging **27** at the perimeter of the driver **9**, this ratchet being so oriented that only rotation of the dose setting member **6** in the direction in which the driver **9** can move is transmitted from the dose setting member **6** to the driver **9**. By rotation of the dose setting member **6** in the opposite direction the teeth of the ratchet parts will ride over each other.

To set a dose the finger grip **11** of the operation element **10** is gripped and the element **10** is rotated clockwise until the arrow points at the wanted dose on the scale **14**. As mentioned this rotation will make the ratchet parts of the dose setting element and the driver ride over each other. If the dose setting member **6** is rotated in the clockwise direction to reduce the set dose, the ratchet will cause transmission of the rotation from the dose setting member **6** to the driver **9**, but when a torque in this direction is transmitted from the operating element through the carrier **12** to the dose setting member **6**, this dose setting member is deformed so that the protrusion on the dose setting member **6** is drawn out of its engagement with the tothing **27** of the driver **9** and an anticlockwise rotation of the dose setting member **6** is allowed without the rotation being transmitted to the driver **9**.

Due to the engagement between the toothed wheel **7** on the dose setting member **6** and the cogging **18** of the injection button **16** this button will be lifted from the end of the housing **1** when a dose is set and will be lowered when a dose is reduced.

When the injection button **16** is pressed to inject a set dose the engagement between the toothed wheel **7** on the dose setting member **6** and the cogging **18** of the injection button **16** will cause the dose setting member **6** to rotate in an anticlockwise direction. As the torque is not transmitted to the dose setting member **6** by the operating element **10**, the ratchet coupling between the dose setting member **6** and the driver **9** will be active and the driver **9** will be rotated with the dose setting member **6** in the anticlockwise direction and will drive the piston rod **3** into the cartridge.

As it is seen in FIG. 2 the disk shaped driver **9** has in its side facing the dose setting member **6** a spiral shaped track **20** which is engaged by a cam **21** provided at the end of an

arm **22** which is by a flexible beam **23** fastened to the dose setting member **6** so that the arm **22** can swing to let the cam **21** move in the radial direction of the driver **9**. When the dose setting member **6** during the setting of a dose is rotated relative to the driver **9** the cam is moved along the track **20** whereas the cam during the injection due to the concomitant rotation of the dose setting member **6** and the driver **9** remains in its position in the track **20** obtained during the dose setting. This way the position of the cam in the track reflects the total amount of medicine administered. When the cam **21** abuts the end wall **24** of the track **20** the set dose cannot be increased and by adapting the length of the track to the total amount of medicine in the cartridge it is ensured that a dose larger than the amount of medicine remaining in the cartridge cannot be set.

FIG. 3 shows a dose setting member **30** surrounding a driver **31** of another embodiment of a dose setting limiter. The dose setting member **30** is cylindrical and is on its outer wall provided with a helical track **29** which is designed to co-operate with a helical inner ridge in a not shown housing so that the dose setting member **30** is screwed outward in said housing when rotated to set a dose and inward in said housing when rotated to reduce a too large set dose. During the dose setting rotation the dose setting member **30** is rotated freely relative to the driver **31** which it surrounds. Between the dose setting member **30** and the driver **31** a nut member **32** is coupled which can when it is rotated relative to the driver **31** be screwed up along this driver which is at its outer surface provided with a helical track **33**. At its outer wall the nut member **32** is in the axial direction provided with a recess **34** which is engaged by a ridge **35** in the axial direction on the inner side of the dose setting element **30**.

During the setting of a dose the nut member **32** is due to the engagement between the ridge **35** and the recess **34** rotated with the dose setting member **30** relative to the driver **31** so that the position of the nut member **32** on this driver is dependent on the dose set. When the dose is injected by pressing a not shown injection button which is placed in an end part **36** of the dose setting member **30** this button presses a flange **37** at an end of the driver **31** into engagement with coupling teeth **38** at the bottom of the end part **36** of the dose setting member **30**. On its lower not visible side the flange **37** is provided with coupling teeth corresponding to the coupling teeth **38** of the dose setting member **30** and when the dose setting member **30** is due to the engagement between the track **29** in the dose setting member **30** and the ridge in the housing forced to rotate relative to the housing when it is pressed into the housing the rotation will be transmitted to the driver **31** which due to the engaging coupling teeth is forced to rotate with the dose setting member and during this rotation the nut member **32** will maintain its position on the driver **31**. This way the position of the nut member **32** on the driver **31** will always indicate the total sum of set and injected doses. When the length of the helical track **33** in the driver **31** is adapted to the amount of medicine in a cartridge the nut member **32** will reach the end of the track **33** and stop for setting a dose larger than the amount remaining in the cartridge.

What is claimed is:

1. A limiting mechanism that prevents setting of a dose that exceeds the amount of liquid left in a cartridge of an injection device wherein a dose is set by rotating a dose setting member relative to a driver and away from a fixed stop in the injection device, and the dose is injected by rotating back the dose setting member which during this rotation carries the driver with it to rotate this driver which moves the piston rod forward, wherein the driver is provided

# Explore Litigation Insights

Docket Alarm provides insights to develop a more informed litigation strategy and the peace of mind of knowing you're on top of things.

## Real-Time Litigation Alerts



Keep your litigation team up-to-date with **real-time alerts** and advanced team management tools built for the enterprise, all while greatly reducing PACER spend.

Our comprehensive service means we can handle Federal, State, and Administrative courts across the country.

## Advanced Docket Research



With over 230 million records, Docket Alarm's cloud-native docket research platform finds what other services can't. Coverage includes Federal, State, plus PTAB, TTAB, ITC and NLRB decisions, all in one place.

Identify arguments that have been successful in the past with full text, pinpoint searching. Link to case law cited within any court document via Fastcase.

## Analytics At Your Fingertips



Learn what happened the last time a particular judge, opposing counsel or company faced cases similar to yours.

Advanced out-of-the-box PTAB and TTAB analytics are always at your fingertips.

## API

Docket Alarm offers a powerful API (application programming interface) to developers that want to integrate case filings into their apps.

## LAW FIRMS

Build custom dashboards for your attorneys and clients with live data direct from the court.

Automate many repetitive legal tasks like conflict checks, document management, and marketing.

## FINANCIAL INSTITUTIONS

Litigation and bankruptcy checks for companies and debtors.

## E-DISCOVERY AND LEGAL VENDORS

Sync your system to PACER to automate legal marketing.