



US005274832A

United States Patent [19]

[11] Patent Number: 5,274,832

Khan

[45] Date of Patent: Dec. 28, 1993

- [54] SYSTOLIC ARRAY FOR MULTIDIMENSIONAL MATRIX COMPUTATIONS
- [75] Inventor: Emdadur R. Khan, San Jose, Calif.
- [73] Assignee: National Semiconductor Corporation, Santa Clara, Calif.
- [21] Appl. No.: 592,954
- [22] Filed: Oct. 4, 1990
- [51] Int. Cl.⁵ G06F 15/347
- [52] U.S. Cl. 395/800; 364/271.2; 364/258; 364/258.2; 364/276.8; 364/DIG. 1; 364/754
- [58] Field of Search 364/754, 845, 728.05, 364/841; 395/800

Primary Examiner—Eric Coleman
Attorney, Agent, or Firm—Limbach & Limbach

[57] ABSTRACT

A multidimensional systolic array processor uses a multidimensional array of systolically coupled processing elements to perform matrix-vector multiplication of matrix and vector signal sets. A two-dimensional array uses a $P \times Q$ matrix (P rows and Q columns) of processing elements which are coupled to systolically process the signals, e.g. via multiplication and accumulation. The processing elements are coupled both row-to-row and column-to-column for pipeline processing within each row and each column, i.e. multidimensional pipelining, thereby increasing processing parallelism and speed. Interconnectivity of the processing elements is minimized by forming separate column and row signal subsets of the vector signal set which are coupled simultaneously to each processing element in the first row and first column, respectively. Size of the processing elements is minimized by reducing local storage of matrix signal subsets within each processing element. Separate column and row signal subsets of the matrix signal set are formed and coupled into each processing element of the first row and first column, respectively. As the matrix column and row signal subsets are systolically processed and transferred row-to-row and column-to-column, respectively, each signal subset is reduced in size by one signal, thereby requiring the transfer and temporary local storage of successively smaller matrix signal subsets. A three-dimensional processor uses a $P \times Q \times T$ array (T planes of P rows and Q columns) of processing elements which are coupled plane-to-plane-to-plane.

- [56] **References Cited**
- U.S. PATENT DOCUMENTS**
- 4,493,048 1/1985 Kung 364/754
- 4,603,398 7/1986 Bocker 364/845
- 4,701,876 10/1987 McCanny 364/728
- 5,107,452 4/1992 Karmarkar 364/754
- 5,146,543 9/1992 Vassiliadis 395/27

OTHER PUBLICATIONS

- S. Y. Kung & J. N. Hwang, "Parallel Architecture for Artificial Neural Nets," IJCNN, 1989, pp. II-165-II-172.
- N. Ling & M. A. Bayoumi, "Algorithms for High Speed Multi-Dimensional Arithmetic and DSP Systolic Arrays," Proceedings of the 1988 International Conference on Parallel Processing, pp. 367-374.
- S. Y. Kung & J. N. Hwang, "A Unifying Algorithm/Architecture for Artificial Neural Networks," IEEE Magazine, Feb. 1989, pp. 2505-2508.

45 Claims, 18 Drawing Sheets

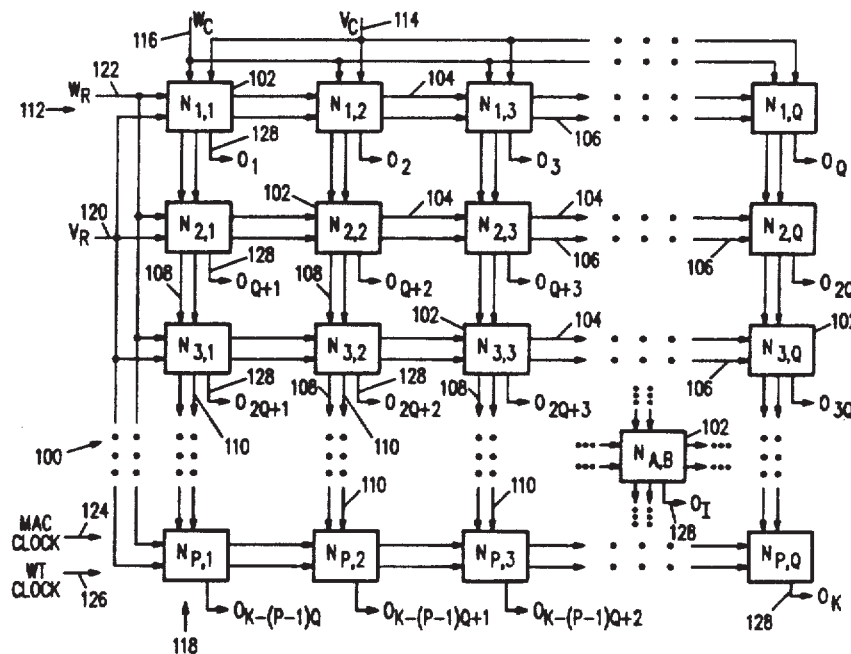

$$\begin{bmatrix} W_{1,1} & W_{1,2} & W_{1,3} & \cdots & W_{1,K} \\ W_{2,1} & W_{2,2} & & & W_{2,K} \\ W_{3,1} & & \ddots & & W_{3,K} \\ \vdots & & & W_{I,J} & \vdots \\ W_{M,1} & W_{M,2} & W_{M,3} & \cdots & W_{M,K} \end{bmatrix} \begin{bmatrix} V_1 \\ V_2 \\ V_3 \\ \vdots \\ V_J \\ \vdots \\ V_K \end{bmatrix} = \begin{bmatrix} O_1 \\ O_2 \\ O_3 \\ \vdots \\ O_I \\ \vdots \\ O_M \end{bmatrix}$$

(PRIOR ART)
FIG. 1

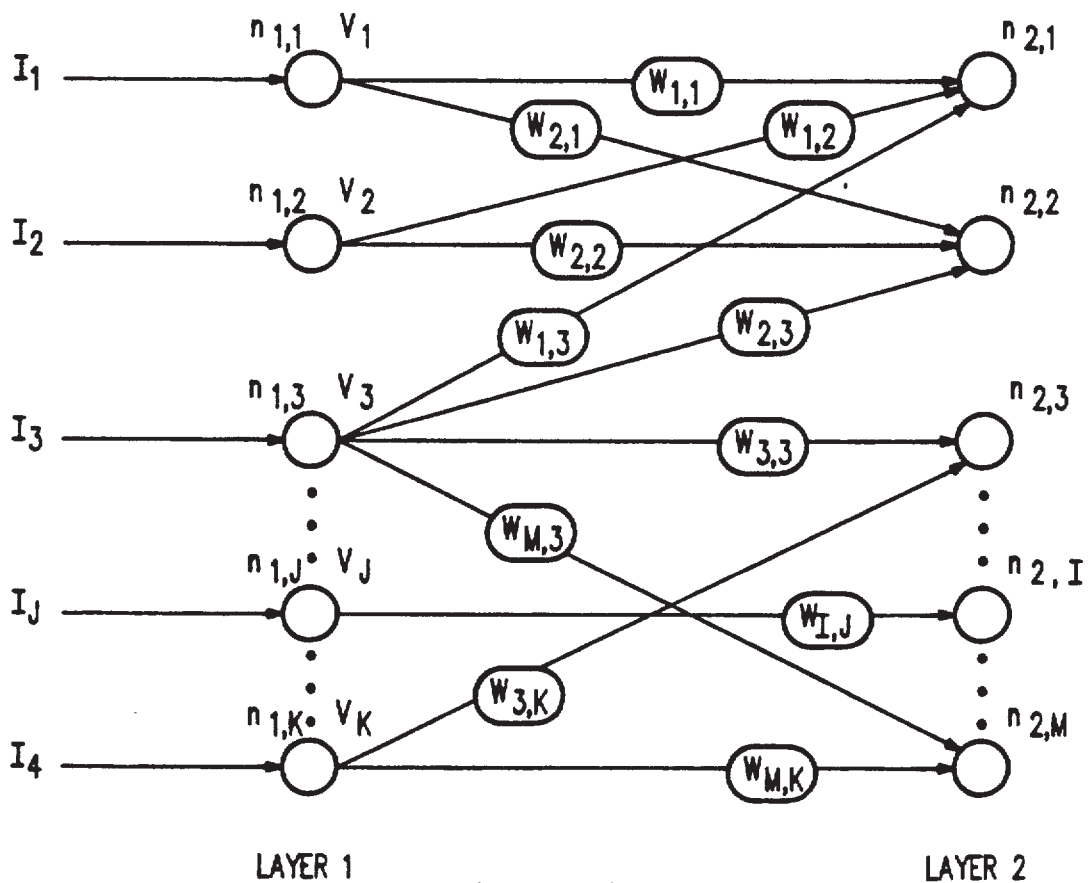

(PRIOR ART)
FIG. 2

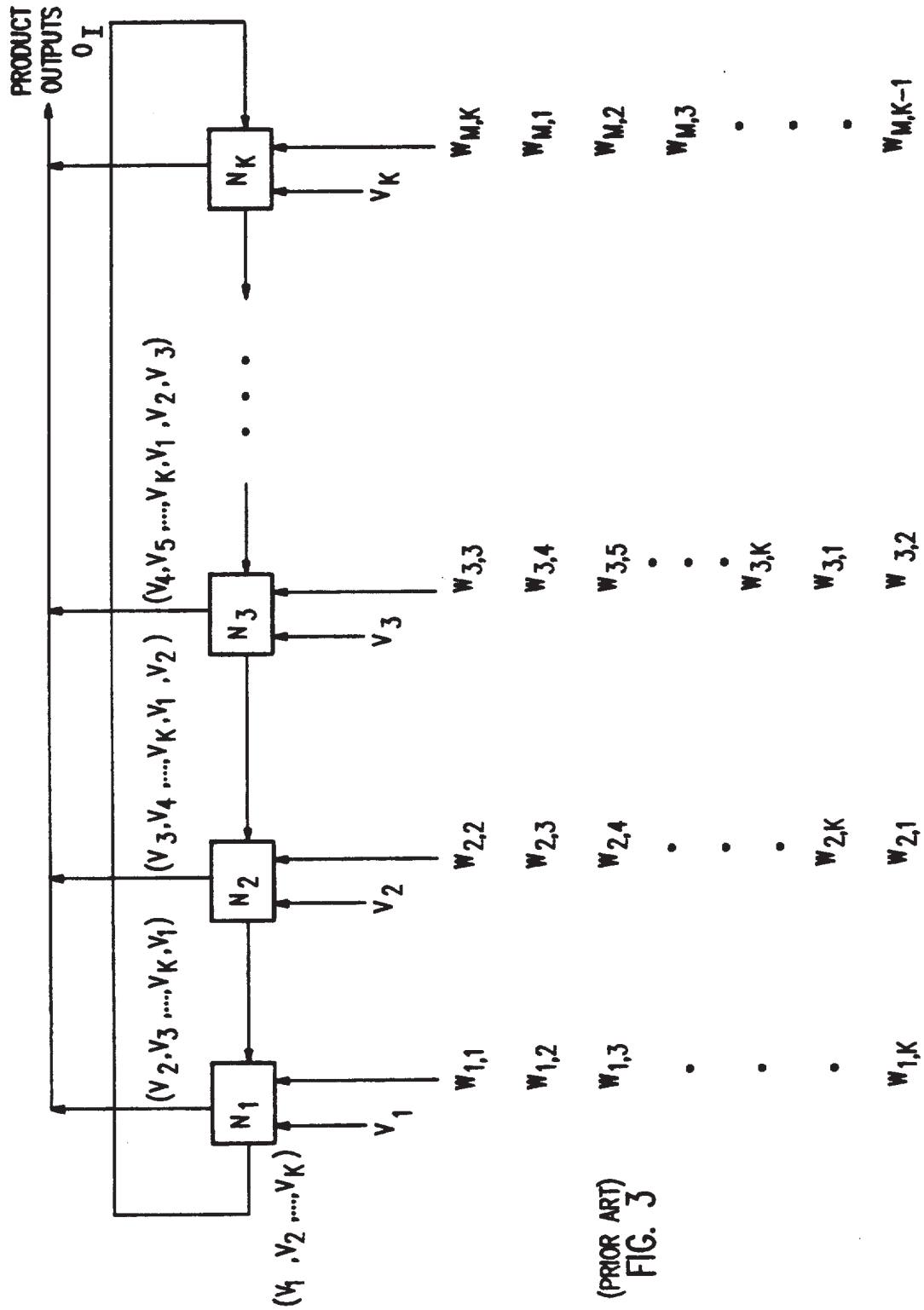

(PRIOR ART)
FIG. 3

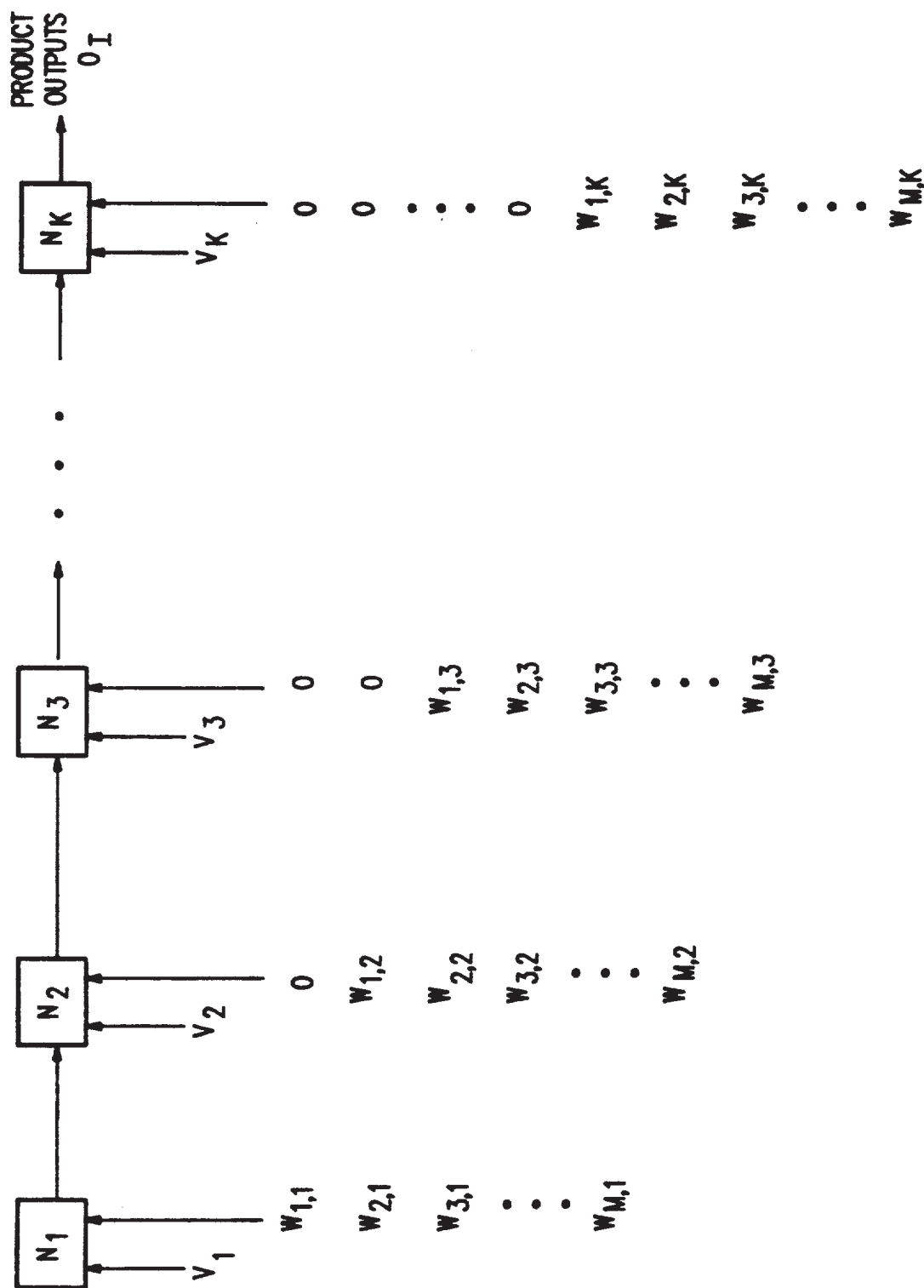

(PRIOR ART)
FIG. 4

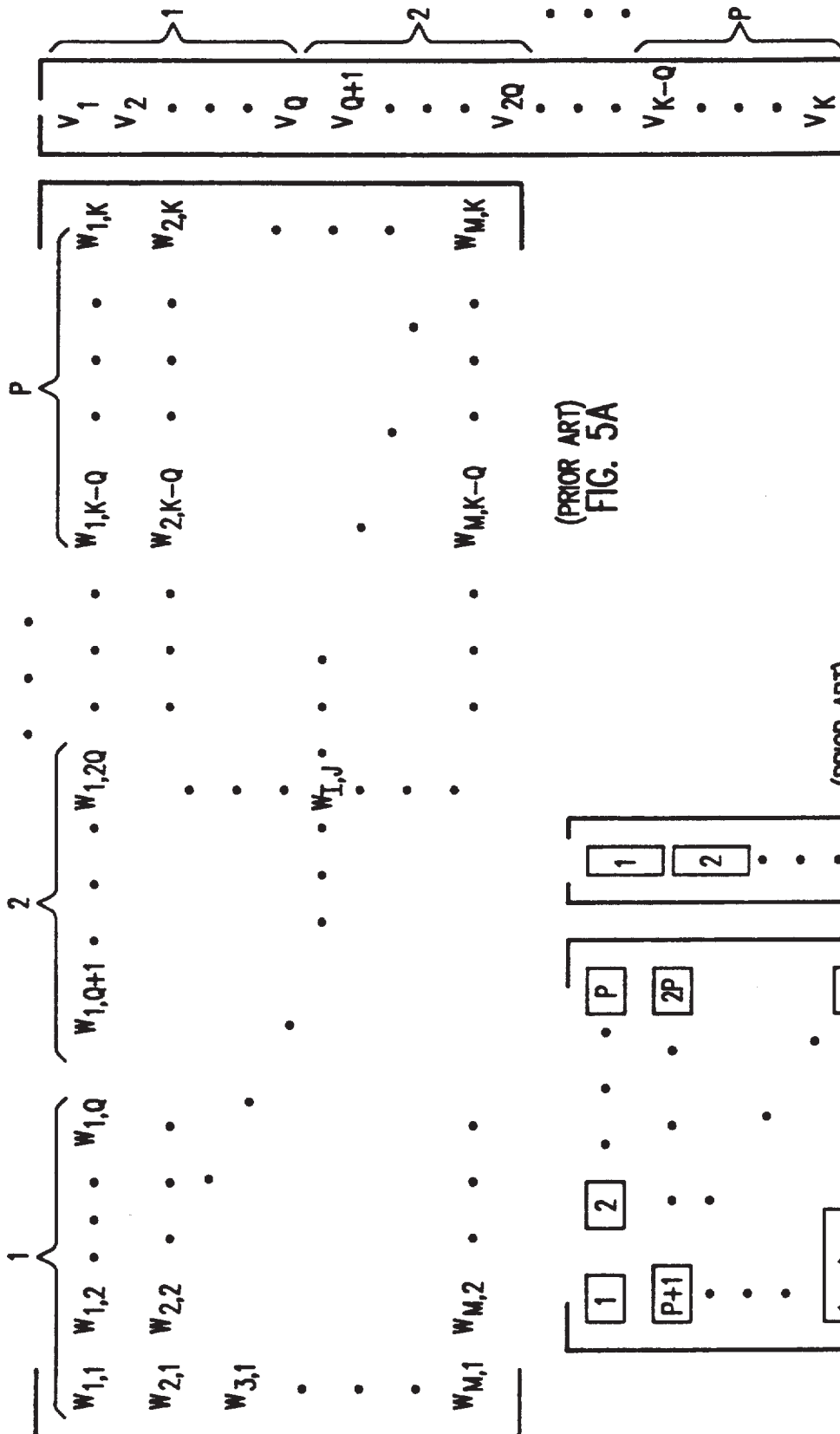

(PRIOR ART)
FIG. 5A

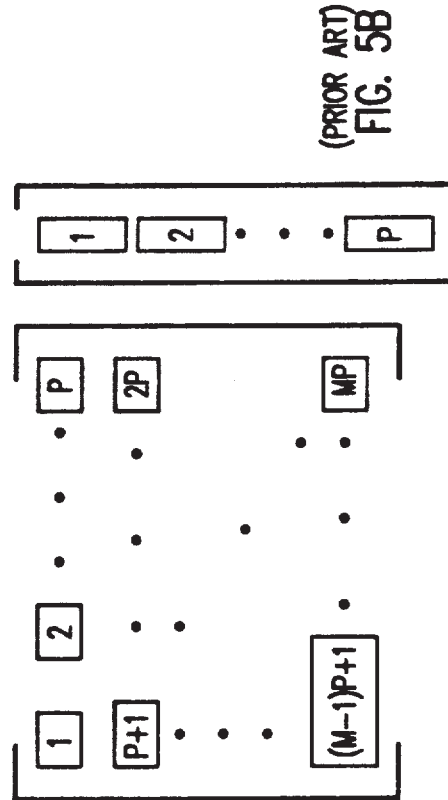

(PRIOR ART)
FIG. 5B

Explore Litigation Insights

Docket Alarm provides insights to develop a more informed litigation strategy and the peace of mind of knowing you're on top of things.

Real-Time Litigation Alerts



Keep your litigation team up-to-date with **real-time alerts** and advanced team management tools built for the enterprise, all while greatly reducing PACER spend.

Our comprehensive service means we can handle Federal, State, and Administrative courts across the country.

Advanced Docket Research



With over 230 million records, Docket Alarm's cloud-native docket research platform finds what other services can't. Coverage includes Federal, State, plus PTAB, TTAB, ITC and NLRB decisions, all in one place.

Identify arguments that have been successful in the past with full text, pinpoint searching. Link to case law cited within any court document via Fastcase.

Analytics At Your Fingertips



Learn what happened the last time a particular judge, opposing counsel or company faced cases similar to yours.

Advanced out-of-the-box PTAB and TTAB analytics are always at your fingertips.

API

Docket Alarm offers a powerful API (application programming interface) to developers that want to integrate case filings into their apps.

LAW FIRMS

Build custom dashboards for your attorneys and clients with live data direct from the court.

Automate many repetitive legal tasks like conflict checks, document management, and marketing.

FINANCIAL INSTITUTIONS

Litigation and bankruptcy checks for companies and debtors.

E-DISCOVERY AND LEGAL VENDORS

Sync your system to PACER to automate legal marketing.