

Exhibit F-11: Chunky SLD

An article entitled, “Automated Target Recognition on SPLASH 2,” by Rencher et al., (“Chunky SLD”), was published in the Proceedings of the Symposium on Field-Programmable Custom Computer Machines, pp. 192-200 in 1997, and is therefore prior art under 35 U.S.C. § 102(b). The ’800 Patent (7,620,800 (“’800 Patent”)) at least under 35 U.S.C. §§ 102(a) and (b).

As described in detail below, Chunky SLD anticipates the asserted claim(s) of the ’800 Patent. To the extent it is argued that Chunky SLD does not expressly disclose certain limitations in the asserted claim, such limitations are inherent. Furthermore, it is found that Chunky SLD does not anticipate the asserted claim, Chunky SLD renders the asserted claim obvious, in combination with other prior art identified in the cover pleading or herein.

This chart is subject to all reservations, objections, and disclaimers in Microsoft’s Invalidation Contentions and any supplement, or modification thereof, which are incorporated herein by reference in their entirety.

Asserted Claim of ’800 Patent	Exemplary Disclosure of Chunky SLD
[1A] A method for data processing in a reconfigurable computing system, the reconfigurable computing system comprising at least one reconfigurable processor, the reconfigurable processor comprising a plurality of functional units, said method comprising:	<p>At least under Plaintiff’s apparent theories of infringement and interpretations alleging that any of Defendant’s accused products satisfy this claim limitation or in combination with one or more references, discloses:</p> <p>Chunky SLD at Abstract: “Automated target recognition is an application area purpose hardware to achieve reasonable performance. FPGA-based platforms provide a high level of performance for ATR systems if the implementation can be adapted to the level of performance and routing resources of these architectures. This paper discusses a mapping of a linear-systolic implementation of an ATR algorithm is mapped to the SPLASH2 architecture. Column-oriented processors were used throughout the design to achieve high performance with limited nearest-neighbor communication. The distributed SPLASH2 memories achieve a high degree of parallelism. The resulting design is scalable and can be implemented on multiple SPLASH2 boards with a linear increase in performance.”</p> <p>Chunky SLD at 196: “The actual SPLASH2 platform consists of a board with 16 chips (plus one for control) arranged in a linear systolic array. Each chip has a limited number of connections to its two nearest neighbors. Each Xilinx 4010 is connected to a 512 kbyte memory. The memory can handle back-to-back reads, or back-to-back writes, but requires a 100 ns (around) cycle when changing from write to read. There is also a crossbar controller.”</p>

Exhibit F-11: Chunky SLD

chips that allows some level of random connection between chips. Up to 16 b chained together to provide a large linear-systolic array of 256 elements.”

Chunky SLD at Figure 6:

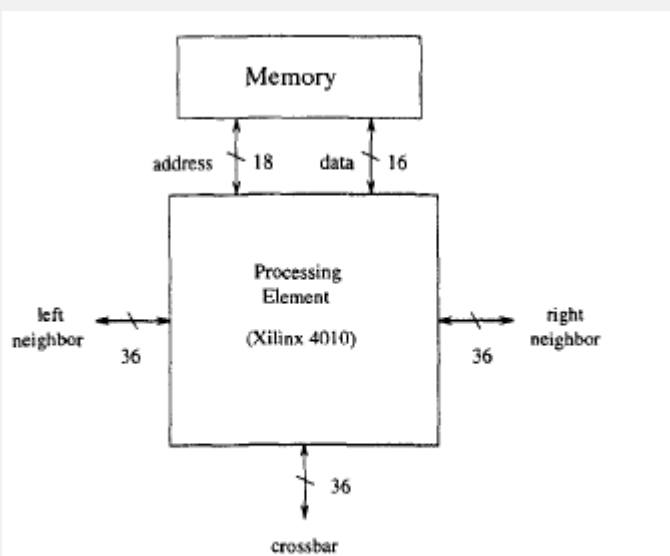

Figure 6: Single Processing Element of SPLASH 2.

Chunky SLD at Figure 7:

Exhibit F-11: Chunky SLD

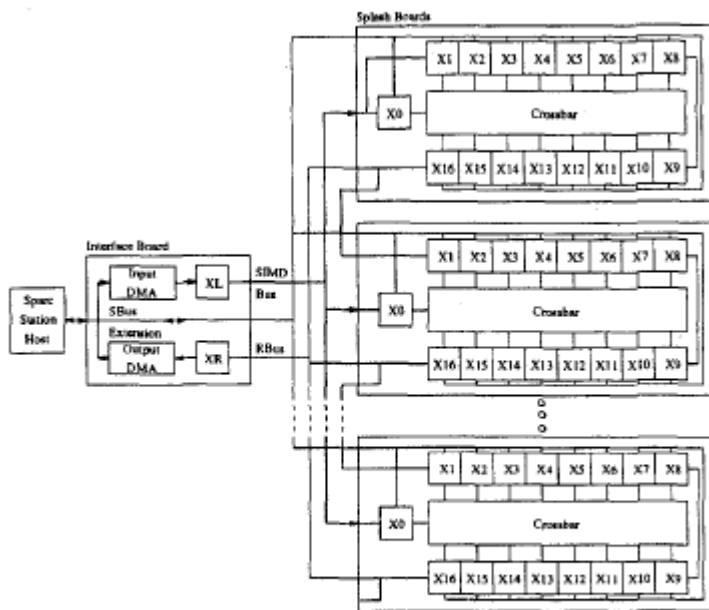

Figure 7: SPLASH 2 platform.

Chunky SLD at Figure 8:

Exhibit F-11: Chunky SLD

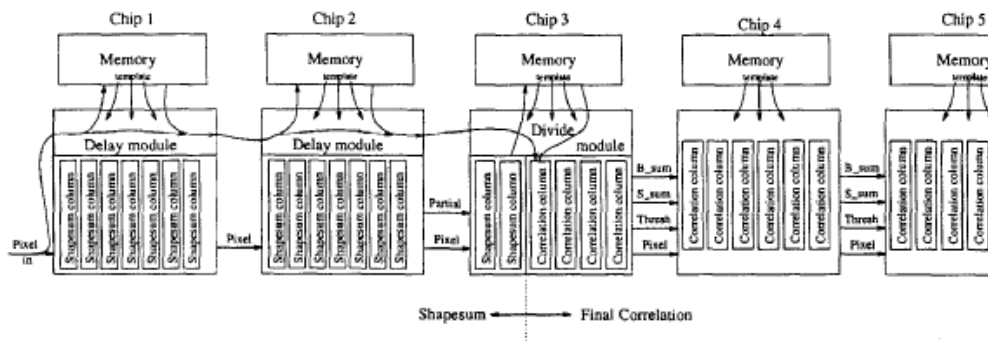

Figure 8: SPLASH 2 Implementation.

To the extent Plaintiff asserts this limitation is not expressly or inherently disclosed by the prior art, or by any other claim construction, or any other claim construction, the claimed subject matter would not have been obvious to a person of ordinary skill in the art considering this reference in light of the knowledge of one of ordinary skill in the art at the time of the alleged invention. The disclosures in one or more of the references identified in Section I.B.2 of the prior art disclose:

[1B] transforming an algorithm into a data driven calculation that is implemented by said reconfigurable computing system at the at least one reconfigurable processor;

At least under Plaintiff’s apparent theories of infringement and interpretations of the claim language, alleging that any of Defendant’s accused products satisfy this claim limitation or in combination with one or more references, discloses:

Chunky SLD at Abstract: “Automated target recognition is an application area where high performance hardware is needed to achieve reasonable performance. FPGA-based platforms provide a high level of performance for ATR systems if the implementation can be adapted to the logic and routing resources of these architectures. This paper discusses a mapping of a linear-systolic implementation of an ATR algorithm is mapped to the SPLASH2 architecture. Column-oriented processors were used throughout the design to achieve high performance with limited nearest-neighbor communication. The distributed SPLASH2 memories are used to achieve a high degree of parallelism. The resulting design is scalable and can be implemented on multiple SPLASH2 boards with a linear increase in performance.”

Exhibit F-11: Chunky SLD

Chunky SLD at 195: “Chunky SLD was implemented on the SPLASH2 board shown itself to be a useful platform and has had numerous applications mapped 10, 111. The implementation was done in VHDL and simulated/synthesized u place and route was done automatically using Xilinx place and route tools.”

Chunky SLD at 196: “The actual SPLASH2 platform consists of a board with (plus one for control) arranged in a linear systolic array. Each chip has a limit its two nearest neighbors. Each Xilinx 4010 is connected to a 512 kbyte mem The memory can handle back-to-back reads, or back-to-back writes, but requi around) cycle when changing from write to read. There is also a crossbar con chips that allows some level of random connection between chips. Up to 16 b chained together to provide a large linear-systolic array of 256 elements.”

Chunky SLD at Figure 6:

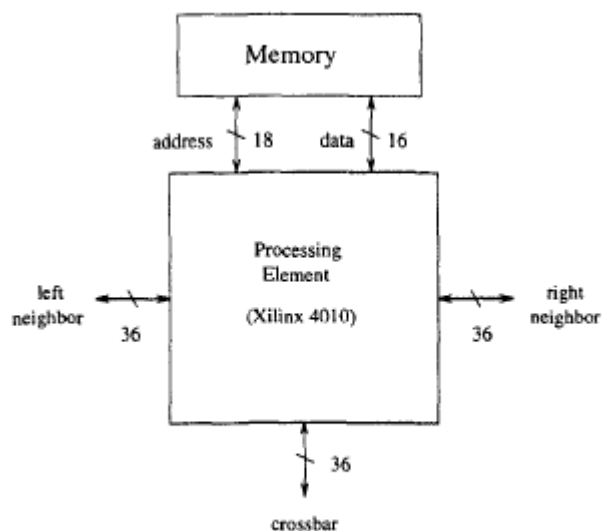

Figure 6: Single Processing Element of SPLASH 2.

Explore Litigation Insights

Docket Alarm provides insights to develop a more informed litigation strategy and the peace of mind of knowing you're on top of things.

Real-Time Litigation Alerts



Keep your litigation team up-to-date with **real-time alerts** and advanced team management tools built for the enterprise, all while greatly reducing PACER spend.

Our comprehensive service means we can handle Federal, State, and Administrative courts across the country.

Advanced Docket Research



With over 230 million records, Docket Alarm's cloud-native docket research platform finds what other services can't. Coverage includes Federal, State, plus PTAB, TTAB, ITC and NLRB decisions, all in one place.

Identify arguments that have been successful in the past with full text, pinpoint searching. Link to case law cited within any court document via Fastcase.

Analytics At Your Fingertips



Learn what happened the last time a particular judge, opposing counsel or company faced cases similar to yours.

Advanced out-of-the-box PTAB and TTAB analytics are always at your fingertips.

API

Docket Alarm offers a powerful API (application programming interface) to developers that want to integrate case filings into their apps.

LAW FIRMS

Build custom dashboards for your attorneys and clients with live data direct from the court.

Automate many repetitive legal tasks like conflict checks, document management, and marketing.

FINANCIAL INSTITUTIONS

Litigation and bankruptcy checks for companies and debtors.

E-DISCOVERY AND LEGAL VENDORS

Sync your system to PACER to automate legal marketing.