



(12) **United States Patent**
Huppenthal et al.

(10) **Patent No.:** **US 7,620,800 B2**
(45) **Date of Patent:** ***Nov. 17, 2009**

(54) **MULTI-ADAPTIVE PROCESSING SYSTEMS AND TECHNIQUES FOR ENHANCING PARALLELISM AND PERFORMANCE OF COMPUTATIONAL FUNCTIONS**

5,020,059 A 5/1991 Gorin et al.
5,072,371 A 12/1991 Benner et al.
5,230,057 A 7/1993 Shido et al.
5,274,832 A 12/1993 Khan
5,471,627 A 11/1995 Means et al.
5,477,221 A 12/1995 Chang et al.

(75) Inventors: **Jon M. Huppenthal**, Colorado Springs, CO (US); **David E. Caliga**, Colorado Springs, CO (US)

(73) Assignee: **SRC Computers, Inc.**, Colorado Springs, CO (US)

(Continued)

FOREIGN PATENT DOCUMENTS

(*) Notice: Subject to any disclaimer, the term of this patent is extended or adjusted under 35 U.S.C. 154(b) by 95 days.

JP 59-206972 11/1984

This patent is subject to a terminal disclaimer.

(Continued)

OTHER PUBLICATIONS

(21) Appl. No.: **11/733,064**

(22) Filed: **Apr. 9, 2007**

Gaudiot, Jean-Luc, Data-Driven Multicomputers in Digital Signal Processing, 1987, IEEE, Proceedings of the IEEE, vol. 75, No. 9, pp. 1220-1234.*

(65) **Prior Publication Data**

US 2007/0204131 A1 Aug. 30, 2007

(Continued)

Related U.S. Application Data

(63) Continuation of application No. 10/285,318, filed on Oct. 31, 2002, now Pat. No. 7,225,324.

Primary Examiner—Eric Coleman
(74) Attorney, Agent, or Firm—Michael C. Martensen; William J. Kubida; Hogan & Hartson LLP

(51) **Int. Cl.**
G06F 15/82 (2006.01)

(52) **U.S. Cl.** **712/226**

(58) **Field of Classification Search** **712/226, 712/15, 19, 215**

See application file for complete search history.

(57) **ABSTRACT**

Multi-adaptive processing systems and techniques for enhancing parallelism and performance of computational functions are disclosed which can be employed in a myriad of applications including multi-dimensional pipeline computations for seismic applications, search algorithms, information security, chemical and biological applications, filtering and the like as well as for systolic wavefront computations for fluid flow and structures analysis, bioinformatics etc. Some applications may also employ both the multi-dimensional pipeline and systolic wavefront methodologies disclosed.

(56) **References Cited**

U.S. PATENT DOCUMENTS

4,727,503 A 2/1988 McWhirter
4,763,294 A 8/1988 Fong
4,872,133 A 10/1989 Leeland
4,962,381 A 10/1990 Helbig, Sr.

52 Claims, 20 Drawing Sheets

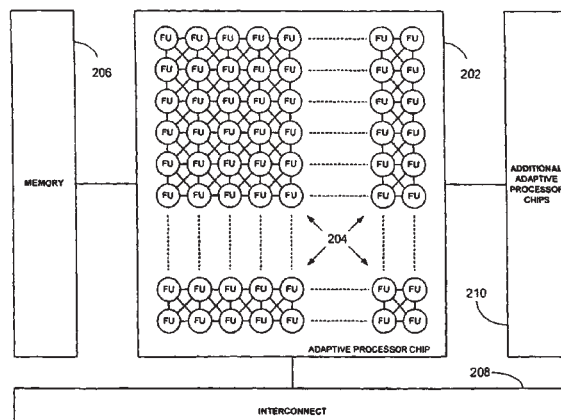

U.S. PATENT DOCUMENTS

5,509,134	A	4/1996	Fandrich et al.
5,570,040	A	10/1996	Lytle et al.
5,640,586	A	6/1997	Pechanek et al.
5,715,453	A	2/1998	Stewart
5,737,766	A	4/1998	Tan
5,784,108	A	7/1998	Skaletzky et al.
5,802,290	A	9/1998	Casselman
5,892,962	A	4/1999	Cloutier
5,903,771	A	5/1999	Sgro et al.
5,915,123	A	6/1999	Mirsky et al.
5,953,502	A	9/1999	Helbig, Sr.
5,956,518	A	9/1999	DeHon et al.
5,966,534	A	10/1999	Cooke et al.
6,023,755	A	2/2000	Casselman
6,052,773	A	4/2000	DeHon et al.
6,061,706	A	5/2000	Gai et al.
6,076,152	A	6/2000	Huppenthal et al.
6,128,663	A	10/2000	Thomas
6,192,439	B1	2/2001	Grunewald et al.
6,215,898	B1	4/2001	Woodfill et al.
6,226,776	B1	5/2001	Panchul et al.
6,289,440	B1	9/2001	Casselman
6,385,757	B1	5/2002	Gupta et al.
6,704,816	B1	3/2004	Burke
6,721,884	B1	4/2004	De Oliveira Kastrup Pereira et al.

FOREIGN PATENT DOCUMENTS

JP 63-086079 4/1988

OTHER PUBLICATIONS

Dennis, J. B., Data Flow Supercomputers, Nov. 1980, IEEE, Computer, pp. 48-56.*

Qunnn M.J., et al., Data-Parallel Programming on Multicomputers, Sep. 1990, IEEE, pp. 69-76.*

Trevleaven, P.C., et al., Data-Driven and Demand-Driven Computer Architecture, 1982, ACM, Computing Surveys vol. 14, No. 1, pp. 93-143.*

Webster, M., Webster's Ninth New Collegiate Dictionary, 1985, Merriam-Webster pub., p. 627.*

Miyamori, Takashi, "REMARc: Reconfigurable Multimedia Array Coprocessor", IEICE Transactions on Information and Systems, Information & Systems Society, Tokyo, JP, vol. E82-D, No. 2, Feb. 1999, pp. 389-397, XP000821922.

Gross Thomas, et al., "Compilation for a High-performance Systolic Array", Sigplan Notices USA, vol. 21, No. 7, Jul. 1986, pp. 27-38, XP002418625.

Rauchwarger, Lawrence, et al., "The LRPD Test: Speculative Run-Time Parallelization of Loops with Privatization and Reduction Parallelization", IEEE Transactions on Parallel and Distributed Systems, IEEE Service Center, Los Alamitos, CA, vol. 10, No. 2, Feb. 1999, pp. 160-180, XP000908318.

Arnold Jeffrey M. et al., "The Splash 2 Processor and Applications", Computer Design: VLSI in Computers and Processors, 1993, ICCD '93 Proceedings, 1993 IEEE International Conference on Cambridge, MA, Oct. 3-6, 1993, Los Alamitos, CA, IEEE Comput. Soc., Oct. 3, 1993, pp. 482-485, XP010134571.

Hwang, Kai, "Computer Architecture and Parallel Processing", Data Flow Computers and VLSI Computations, 1985, McGraw Hill, Chapter 10, pp. 732-807, XP-002418655.

Hartenstein, Reiner W., et al. "A Synthesis System for Bus-based Wavefront Array Architectures", Proceedings, International Conference on Application-Specific Systems, Architectures and Processors, 1996, pp. 274-283, XP002132819.

Alexander, Thomas, et al. "A Reconfigurable Approach To A Systolic Sorting Architecture", ISCAS 89, May 8, 1989, pp. 1178-1182, XP010084477.

Wu, Youfeng, et al. "Better Exploration of Region-Level Value Locality with Integrated Computation Reuse and Value Prediction", Pro-

International Symposium on Computer Architecture, (ISCA), Los Alamitos, CA, IEEE Comp. Soc, US, Jun. 30, 2001, pp. 93-103, XP010552866.

Babb, Jonathan, et al., "Parallelizing applications into silicon", © 1999 IEEE.

Deshpande, Deepali, et al., "Hybrid data/configuration caching for striped FPGAs" © 1999 IEEE.

Purna, Karthikeya, et al., "Temporal partitioning and scheduling data flow graphs for reconfigurable computers", © 1999 IEEE, Publ. No. 0018-9340/99, pp. 579-590.

Gibbs, W. Wayt, "Blitzing bits", © 1999 Scientific American Presents, pp. 57-61.

Gonzalez, Ricardo, "Configurable and extensible processors change system design", Aug. 15-17, 1999, Hot Chips 11 Tutorials, pp. 135-146.

Graham, Paul, et al., "FPGA-based sonar processing", © 1998 ACM 0-89791-978-5/98, pp. 201-208.

Hasebe, A., et al., "Architecture of SIPS, a real time image processing system," © 1988 IEEE, Publ. No. CH2603-9/88/0000/0621, pp. 621-630.

Hammond, Lance, et al., "The Stanford Hydra CMP", Aug. 15-17, 1999 Hot Chips 11 Tutorials, pp. 23-31.

Jean, Jack, et al., "Dynamic reconfiguration to support concurrent applications", © 1999 IEEE, Publ. No. 0018-9340/99, pp. 591-602.

Kastrup, Bernardo, et al., "Concise: a compiler-driven CPLD-based instruction set accelerator", © 1999 IEEE.

Motomura, Masato, et al., "An embedded DRAM-FPGA chip with instantaneous logic reconfiguration", © 1998 IEEE, Publ. No. 0-8186-8900-5/98, pp. 264-266.

McConnell, Ray, "Massively parallel computing on the Fuzion chip", Aug. 15-17, 1999, Hot Chips 11 Tutorials, pp. 83-94.

McShane, Erik, et al., "Functionally integrated systems on a chip: technologies, architectures, CAD tools, and applications", © 1998 IEEE, Publ. No. 8-8186-8424-0/98, pp. 67-75.

Rupp, Charley, et al., "The NAPA adaptive processing architecture", © 1998 The Authors, pp. 1-10.

Saito, Osamu, et al., "A 1M synapse self learning digital neural network chip", © 1998 IEEE, Publ. No. 0-7803-4344/1/98, pp. 94-95.

Schott, Brian, et al., "Architectures for system-level applications of adaptive computing", © 1999 IEEE.

Mencer, Oskar, et al., "PAM-Blox: High Performance FPGA Design for Adaptive Computing", © 1998 IEEE, Conference Paper, INSPEC Abstract Nos. B9611-1265B-044, C9811-5210-009.

Miyamori, Takashi, et al., "A quantitative analysis of reconfigurable coprocessors for multimedia applications", © 1998 IEEE, Conference Paper, INSPEC Abstract Nos. B9811-1265F-011, C9811-5310-010.

Agarwal, A., et al., "The Raw Compiler Project", pp. 1-12, <http://cag-www.lcs.mit.edu/raw>, Proceedings of the Second SUIF Compiler Workshop, Aug. 21-23, 1997.

Albaharna, Osama, et al., "On the viability of FPGA-based integrated coprocessors", © 1996 IEEE, Publ. No. 0-8186-7548-9/96, pp. 206-215.

Amerson, Rick, et al., "Teramac—Configurable Custom Computing", © 1995 IEEE, Publ. No. 0-8186-7086-X/95, pp. 32-38.

Barthel, Dominique Aug. 25-26, 1997, "PVP a Parallel Video coProcessor", Hot Chips IX, pp. 203-210.

Bertin, Patrice, et al., "Programmable active memories: a performance assessment", © 1993 Massachusetts Institute of Technology, pp. 88-102.

Bittner, Ray, et al., "Computing kernels implemented with a worm-hole RTR CCM", © 1997 IEEE, Publ. No. 0-8186-8159-4/97, pp. 98-105.

Buell, D., et al. "Splash 2: FPGAs in a Custom Computing Machine—Chapter 1—Custom Computing Machines: An Introduction", pp. 1-11, <http://www.computer.org/espress/catalog/bp07413/spls-ch1.html> (originally believed published in J. of Supercomputing, vol. IX, 1995, pp. 219-230).

- Chan, Pak, et al., "Architectural tradeoffs in field-programmable-device-based computing systems", © 1993 IEEE, Publ. No. 0-8186-3890-7/93, pp. 152-161.
- Clark, David, et al., "Supporting FPGA microprocessors through retargetable software tools", © 1996 IEEE, Publ. No. 0-8186-7548-9/96, pp. 195-103.
- Cuccaro, Steven, et al., "The CM-2X: a hybrid CM-2/Xilinx prototype", © 1993 IEEE, Publ. No. 0-8186-3890-7/93, pp. 121-130.
- Culbertson, W. Bruce, et al., "Exploring architectures for volume visualization on the Teramac custom computer", © 1996 IEEE, Publ. No. 0-8186-7548-9/96, pp. 80-88.
- Culbertson, W. Bruce, et al., "Defect tolerance on the Teramac custom computer", © 1997 IEEE, Publ. No. 0-8186-8159-4/97, pp. 116-123.
- Dehon, Andre, DPGA-Coupled microprocessors: commodity IC for the early 21st century', © 1994 IEEE, Publ. No. 0-8186-5490-2/94, pp. 31-39.
- Dehon, A., et al., "Matrix a Reconfigurable Computing Device with Configurable Instruction Distribution", Hot Chips IX, Aug. 25-26, 1997, Stanford, California, MIT Artificial Intelligence Laboratory.
- Dhaussy, Philippe, et al., "Global control synthesis for an MIMD/FPGA machine", © 1994 IEEE, Publ. No. 0-8186-5490-2/94, pp. 72-81.
- Elliott, Duncan, et al., "Computational Ram: a memory-SIMD hybrid and its application to DSP", © 1992 IEEE, Publ. No. 0-7803-0246-X/92, pp. 30.6.1-30.6.4.
- Fortes, Jose, et al., "Systolic arrays, a survey of seven projects", © 1987 IEEE, Publ. No. 0018-9162/87/0700-0091, pp. 91-103.
- Gokhale, M., et al., "Processing in Memory: The Terasys Massively Parallel PIM Array" © Apr. 1995, IEEE, pp. 23-31.
- Gunther, Bernard, et al., "Assessing Document Relevance with Run-Time Reconfigurable Machines", © 1996 IEEE, Publ. No. 0-8186-7548-9/96, pp. 10-17.
- Hagiwara, Hiroshi, et al., "A dynamically microprogrammable computer with low-level parallelism", © 1980 IEEE, Publ. No. 0018-9340/80/07000-0577, pp. 577-594.
- Hartenstein, R. W., et al. "A General Approach in System Design Integrating Reconfigurable Accelerators," <http://xputers.informatik.uni-kl.de/papers/paper026-1.html>, IEEE 1996 Conference, Austin, TX, Oct. 9-11, 1996.
- Hartenstein, Reiner, et al., "A reconfigurable data-driven ALU for Xputers", © 1994 IEEE, Publ. No. 0-8186-5490-2/94, pp. 139-146.
- Hauser, John, et al.: "GARP: a MIPS processor with a reconfigurable co-processor", © 1997 IEEE, Publ. No. 0-8186-8159-4/97, pp. 12-21.
- Hayes, John, et al., "A microprocessor-based hypercube, supercomputer", © 1986 IEEE, Publ. No. 0272-1732/86/1000-0006, pp. 6-17.
- Herpel, H. -J., et al., "A Reconfigurable Computer for Embedded Control Applications", © 1993 IEEE, Publ. No. 0-8186-3890-7/93, pp. 111-120.
- Hogl, H., et al., "Enable++: A second generation FPGA processor", © 1995 IEEE, Publ. No. 0-8186-7086-X/95, pp. 45-53.
- King, William, et al., "Using MORRPH in an industrial machine vision system". © 1996 IEEE, Publ. No. 08186-7548-9/96, pp. 18-26.
- Manohar, Swaminathan, et al., "A pragmatic approach to systolic design", © 1988 IEEE, Publ. No. CH2603-9/88/0000/0463, pp. 463-472.
- Mauduit, Nicolas, et al., "Lneuro 1.0: a piece of hardware LEGO for building neural network systems," © 1992 IEEE, Publ. No. 1045-9227/92, pp. 414-422.
- Mirsky, Ethan A., "Coarse-Grain Reconfigurable Computing", Massachusetts Institute of Technology, Jun. 1996.
- Mirsky, Ethan, et al., "Matrix: A Reconfigurable Computing Architecture with Configurable Instruction Distribution and Deployable Resources", © 1996 IEEE, Publ. No. 0-8186-7548-9/96, pp. 157-166.
- Morley, Robert E., Jr., et al., "A Massively Parallel Systolic Array Processor System", © 1988 IEEE, Publ. No. CH2603-9/88/0000/0217, pp. 217-225.
- Peterson, Janes, et al., "Scheduling and partitioning ANSI-C programs onto multi-FPGA CCM architectures", © 1996 IEEE, Publ. No. 0-8186-7548-9/96, pp. 178-187.
- Schmit, Herman, "Incremental reconfiguration for pipelined applications," © 1997 IEEE, Publ. No. 0-8186-8159-4/97, pp. 47-55.
- Sitkoff, Nathan, et al., "Implementing a Genetic Algorithm on a Parallel Custom Computing Machine", Publ. No. 0-8186-7086-X/95, pp. 180-187.
- Stone, Harold, "A logic-in-memory computer", © 1970 IEEE, IEEE Transactions on Computers, pp. 73-78, Jan. 1990.
- Tangen, Uwe, et al., "A parallel hardware evolvable computer POLYP extended abstract", © 1997 IEEE, Publ. No. 0-8186-8159/4/97, pp. 238-239.
- Thornburg, Mike, et al., "Transformable Computers", © 1994 IEEE, Publ. No. 0-8186-5602-6/94, pp. 674-679.
- Tomita, Shinji, et al., "A computer low-level parallelism QA-2", © 1986 IEEE, Publ. No. 0-0384-7495/86/0000/0280, pp. 280-289.
- Trimberger, Steve, et al., "A time-multiplexed FPGA", © 1997 IEEE, Publ. No. 0-8186-8159-4/97, pp. 22-28.
- Ueda, Hirotada, et al., "A multiprocessor system utilizing enhanced DSP's for Image processing", © 1988 IEEE, Publ. No. CH2603-9/88/0000/0611, pp. 611-620.
- Villasenor, John, et al., "Configurable computing", © 1997 Scientific American, Jun. 1997.
- Wang, Quiang, et al., "Automated field-programmable compute accelerator design using partial evaluation", © 1997 IEEE, Publ. No. 0-8186-8159-4/97, pp. 145-154.
- W.H. Manglone-Smith and B.L. Hutchings. Configurable computing: The Road Ahead. In Proceedings of the Reconfigurable Architectures Workshop (RAW'97), pp. 81-96, 1997.
- Wirthlin, Michael, et al., "The Nano processor: a low resource reconfigurable processor", © 1994 IEEE, Publ. No. 0-8186-5490-2/94, pp. 23-30.
- Wirthlin, Michael, et al., "A dynamic instruction set computer", © 1995 IEEE, Publ. No. 0-8186-7086-X/95, pp. 99-107.
- Wittig, Ralph, et al., "One Chip: An FPGA processor with reconfigurable logic", © 1996 IEEE, Publ. No. 0-8186-7548-9/96, pp. 126-135.
- Yamauchi, Tsukasa, et al., "SOP: A reconfigurable massively parallel system and its control-data flow based compiling method", © 1996 IEEE, Publ. No. 0-8186-7548-9/96, pp. 148-156.
- "Information Brief", PCI Bus Technology, © IBM Personal Computer Company, 1997, pp. 1-3.
- Yun, Hyun-Kyu and Silverman, H. F.; "A distributed memory MIMD multi-computer with reconfigurable custom computing capabilities", Brown University, Dec. 10-13, 1997, pp. 7-13.
- Hoover, Chris and Hart, David; "San Diego Supercomputer Center, Timelogic and Sun Validate Ultra-Fast Hidden Markov Model Analysis-One DeCypher-accelerated Sun Fire 6800 beats 2,600 CPUs running Linux-," San Diego Supercomputer Center, http://www.sdsc.edu/Press/02/050802_markovmodel.html, May 8, 2002, pp. 1-3.
- Caliga, David and Barker, David Peter, "Delivering Acceleration: The Potential for Increased HPC Application Performance Using Reconfigurable Logic", SRC Computers, Inc., Nov. 2001, pp. 20.
- Hammes, J.P., Rinker, R. E., McClure, D. M., Böhm, A. P. W., Najjar, W. A., "The SA-C Compiler Dataflow Description", Colorado State University, Jun. 21, 2001, pp. 1-25.
- Callahan, Timothy J. and Wawrzynek, John, "Adapting Software Pipelining for Reconfigurable Computing", University of California at Berkeley, Nov. 17-19, 2000, pp. 8.
- Ratha, Nalini K., Jain, Anil K. and Rover, Diane T., "An FPGA-based Point Pattern Matching Processor with Application to Fingerprint Matching", Michigan State University, Department of Computer Science, pp. 8.
- Dehon, André, "Comparing Computing Machines", University of California at Berkeley, Proceedings of SPIE vol. 3526, Nov. 2-3, 1998, pp. 11.
- Vemuri, Ranga R. and Harr, Randolph E., "Configurable Computing: Technology and Applications", University of Cincinnati and Synopsys Inc., IEEE, Apr. 2000, pp. 39-40.

Haynes, Simon D., Stone, John, Cheung, Peter Y.K. and Luk, Wayne, "Video Image Processing with the Sonic Architecture", Sony Broadcast & Professional Europe, Imperial College, University of London, IEEE, Apr. 2000, pp. 50-57.

Platzner, Marco, "Reconfigurable Accelerators for Combinatorial Problems", Swiss Federal Institute of Technology (ETH) Zurich, IEEE, Apr. 2000, pp. 58-60.

Callahan, Timothy J., Hauser, John R. and Wawrzynek, John, "The Garp Architecture and C Compiler", University of California, Berkeley, IEEE, Apr. 2000, pp. 62-69.

Goldstein, Seth Copen, Schmit, Herman, Budiu, Mihai, Cadambi, Srihari, Moe, Matt and Taylor, R. Reed, "PipeRench: A Reconfigurable Architecture and Compiler", Carnegie Mellon University, IEEE, Apr. 2000, pp. 70-76.

Muchnick, Steven S., "Advanced Compiler Design and Implementation", Morgan Kaufmann Publishers, pp. 217.

Hammes, Jeffrey P., Dissertation "Compiling SA-C to Reconfigurable Computing Systems", Colorado State University, Department of Computer Science, Summer 2000, pp. 179.

Automatic Target Recognition, Colorado State University & USAF, <http://www.cs.colostate.edu/cameron/applications.html>, pp. 1-3.

Chodowiec, Pawel, Khuon, Po, Gaj, Kris, Fast Implementations of Secret-Key Block Ciphers Using Mixed Inner- and Outer-Round Pipelining, George Mason University, Feb. 11-13, 2001, pp. 9.

Hastie, Neil, et al., "The Implementation of Hardware Subroutines on Field Programmable Gate Arrays", XP010005485, Plessey Semiconductors, Tamerton Rd., Plymouth, Devon, England, IEEE, May 13, 1990, Custom Integrated Circuits Conference, pp. 314. 1-4. *the whole document*.

Harbaum, Till, et al., "Design of a Flexible Coprocessor Unit", Institute of Operating Systems and Computer Networks, XP000879556TU Braunschweig, Germany, Proceedings of the Euromicro Conference, Sep. 1999, pp. 335-342. *whole document*.

Mathias P C; Patnaik L M: "Systolic Evaluation of Polynomial Expressions," IEEE Transactions on Computers, vol. 39, No. 5, May 1, 1990, pp. 653-665, XP000116659.

* cited by examiner

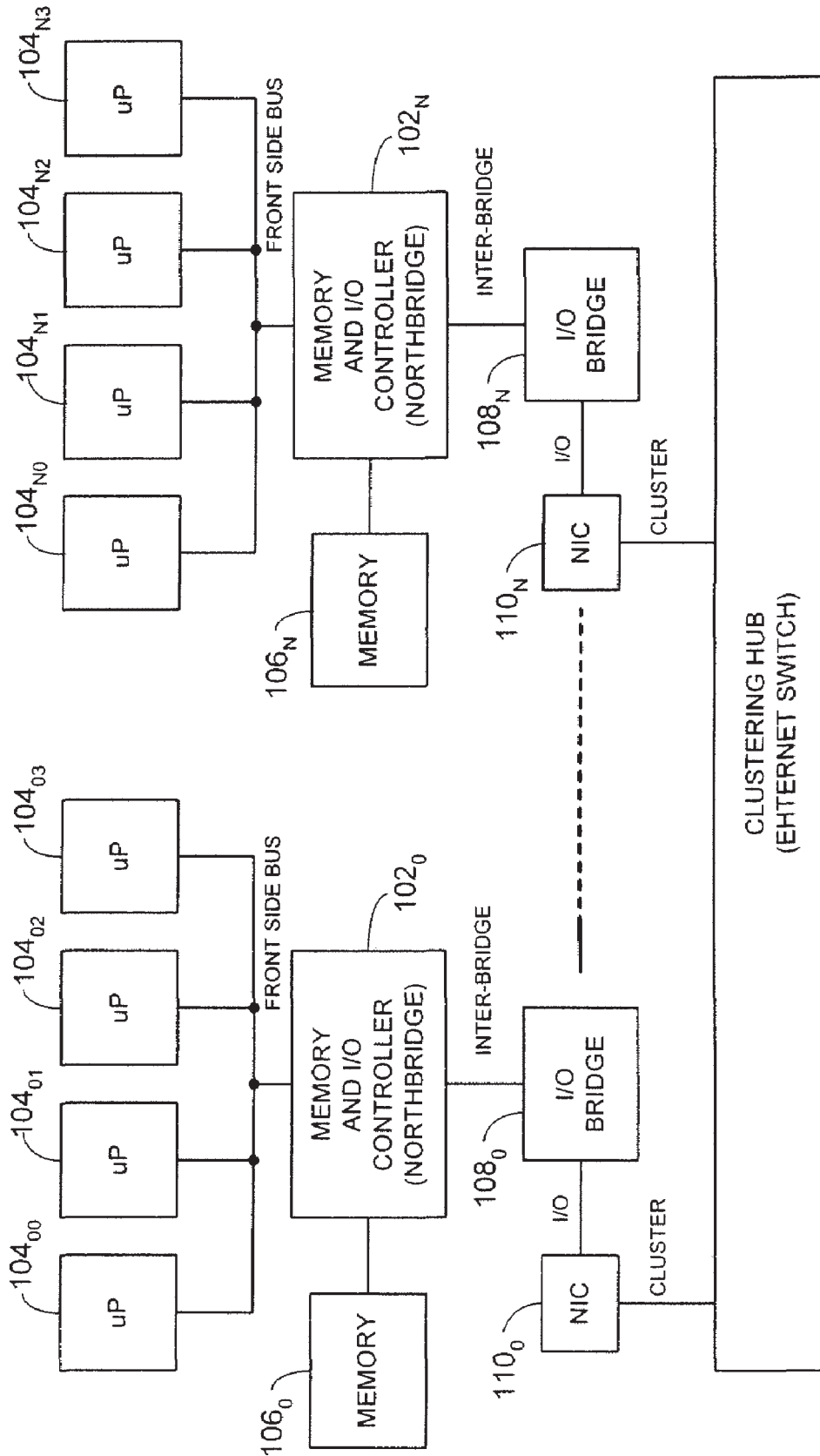

Fig. 1
Prior Art

100

112

Explore Litigation Insights

Docket Alarm provides insights to develop a more informed litigation strategy and the peace of mind of knowing you're on top of things.

Real-Time Litigation Alerts



Keep your litigation team up-to-date with **real-time alerts** and advanced team management tools built for the enterprise, all while greatly reducing PACER spend.

Our comprehensive service means we can handle Federal, State, and Administrative courts across the country.

Advanced Docket Research



With over 230 million records, Docket Alarm's cloud-native docket research platform finds what other services can't. Coverage includes Federal, State, plus PTAB, TTAB, ITC and NLRB decisions, all in one place.

Identify arguments that have been successful in the past with full text, pinpoint searching. Link to case law cited within any court document via Fastcase.

Analytics At Your Fingertips



Learn what happened the last time a particular judge, opposing counsel or company faced cases similar to yours.

Advanced out-of-the-box PTAB and TTAB analytics are always at your fingertips.

API

Docket Alarm offers a powerful API (application programming interface) to developers that want to integrate case filings into their apps.

LAW FIRMS

Build custom dashboards for your attorneys and clients with live data direct from the court.

Automate many repetitive legal tasks like conflict checks, document management, and marketing.

FINANCIAL INSTITUTIONS

Litigation and bankruptcy checks for companies and debtors.

E-DISCOVERY AND LEGAL VENDORS

Sync your system to PACER to automate legal marketing.