



(19) United States

(12) Patent Application Publication (10) Pub. No.: US 2001/0014937 A1

Huppenthal et al.

(43) Pub. Date: Aug. 16, 2001

(54) MULTIPROCESSOR COMPUTER ARCHITECTURE INCORPORATING A PLURALITY OF MEMORY ALGORITHM PROCESSORS IN THE MEMORY SUBSYSTEM

(52) U.S. Cl. 712/15

(57) ABSTRACT

(76) Inventors: Jon M. Huppenthal, Colorado Springs, CO (US); Paul A. Leskar, Colorado Springs, CO (US)

A multiprocessor computer architecture incorporating a plurality of programmable hardware memory algorithm processors ("MAP") in the memory subsystem. The MAP may comprise one or more field programmable gate arrays ("FPGAs") which function to perform identified algorithms in conjunction with, and tightly coupled to, a microprocessor and each MAP is globally accessible by all of the system processors for the purpose of executing user definable algorithms. A circuit within the MAP signals when the last operand has completed its flow thereby allowing a given process to be interrupted and thereafter restarted. Through the use of read only memory ("ROM") located adjacent the FPGA, a user program may use a single command to select one of several possible pre-loaded algorithms thereby decreasing system reconfiguration time. A computer system memory structure MAP disclosed herein may function in normal or direct memory access ("DMA") modes of operation and, in the latter mode, one device may feed results directly to another thereby allowing pipelining or parallelizing execution of a user defined algorithm. The system of the present invention also provides a user programmable performance monitoring capability and utilizes parallelizer software to automatically detect parallel regions of user applications containing algorithms that can be executed in the programmable hardware.

Correspondence Address: HOGAN & HARTSON LLP ONE TABOR CENTER, SUITE 1500 1200 SEVENTEENTH ST DENVER, CO 80202 (US)

(21) Appl. No.: 09/755,744

(22) Filed: Jan. 5, 2001

Related U.S. Application Data

(60) Division of application No. 09/481,902, filed on Jan. 12, 2000, now Pat. No. 6,247,110, which is a continuation of application No. 08/992,763, filed on Dec. 17, 1997, now Pat. No. 6,076,152.

Publication Classification

(51) Int. Cl. G06F 15/80

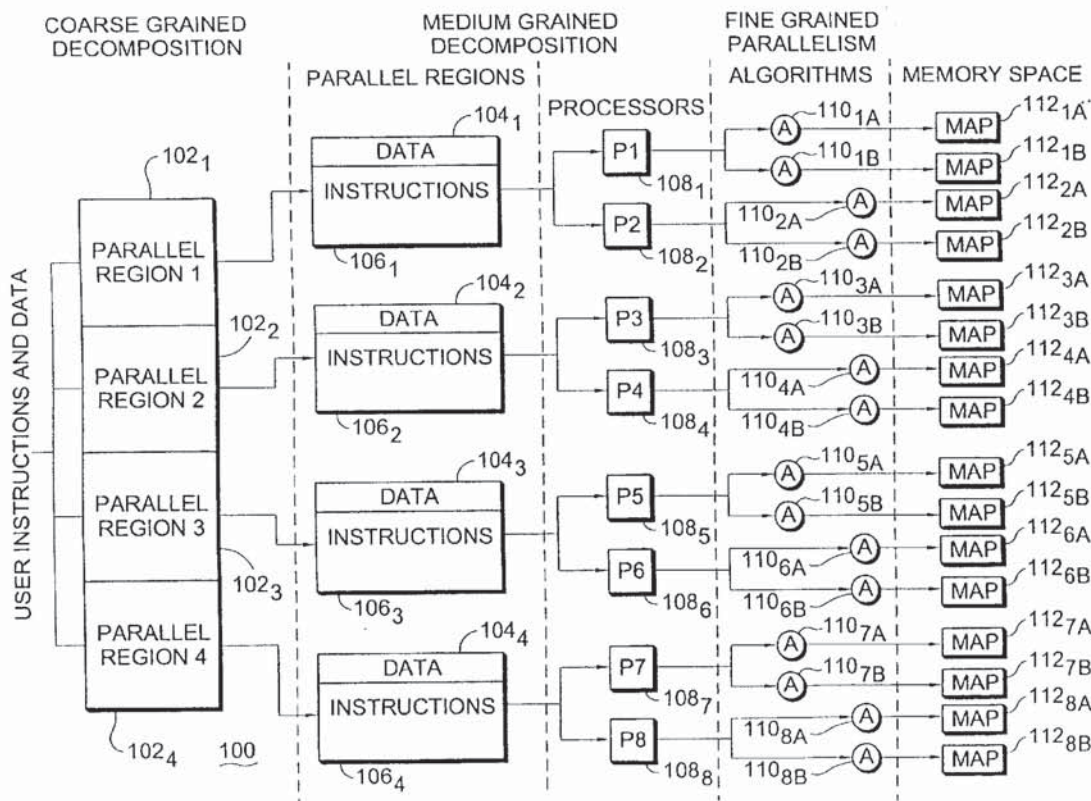

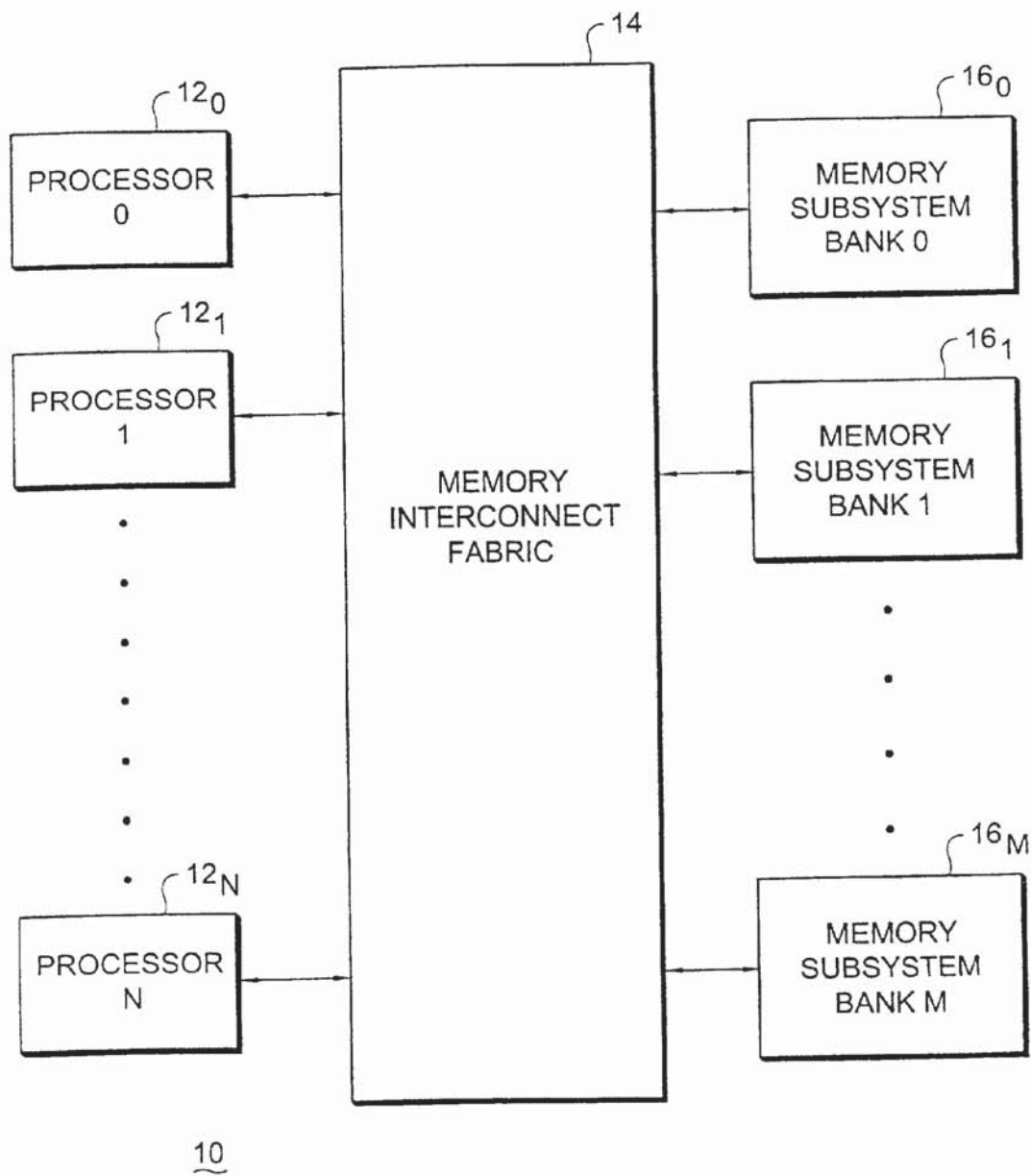

FIG. 1

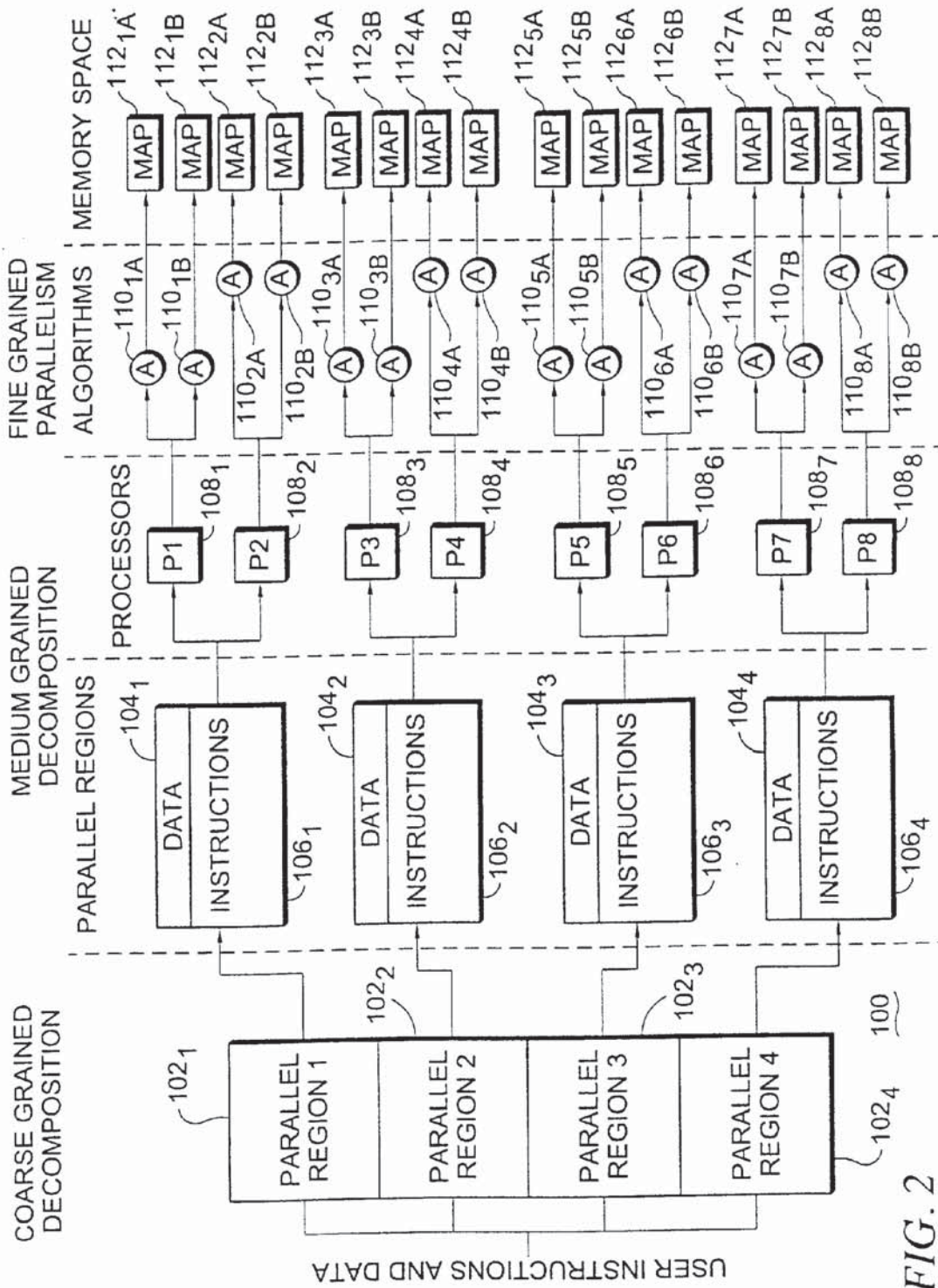
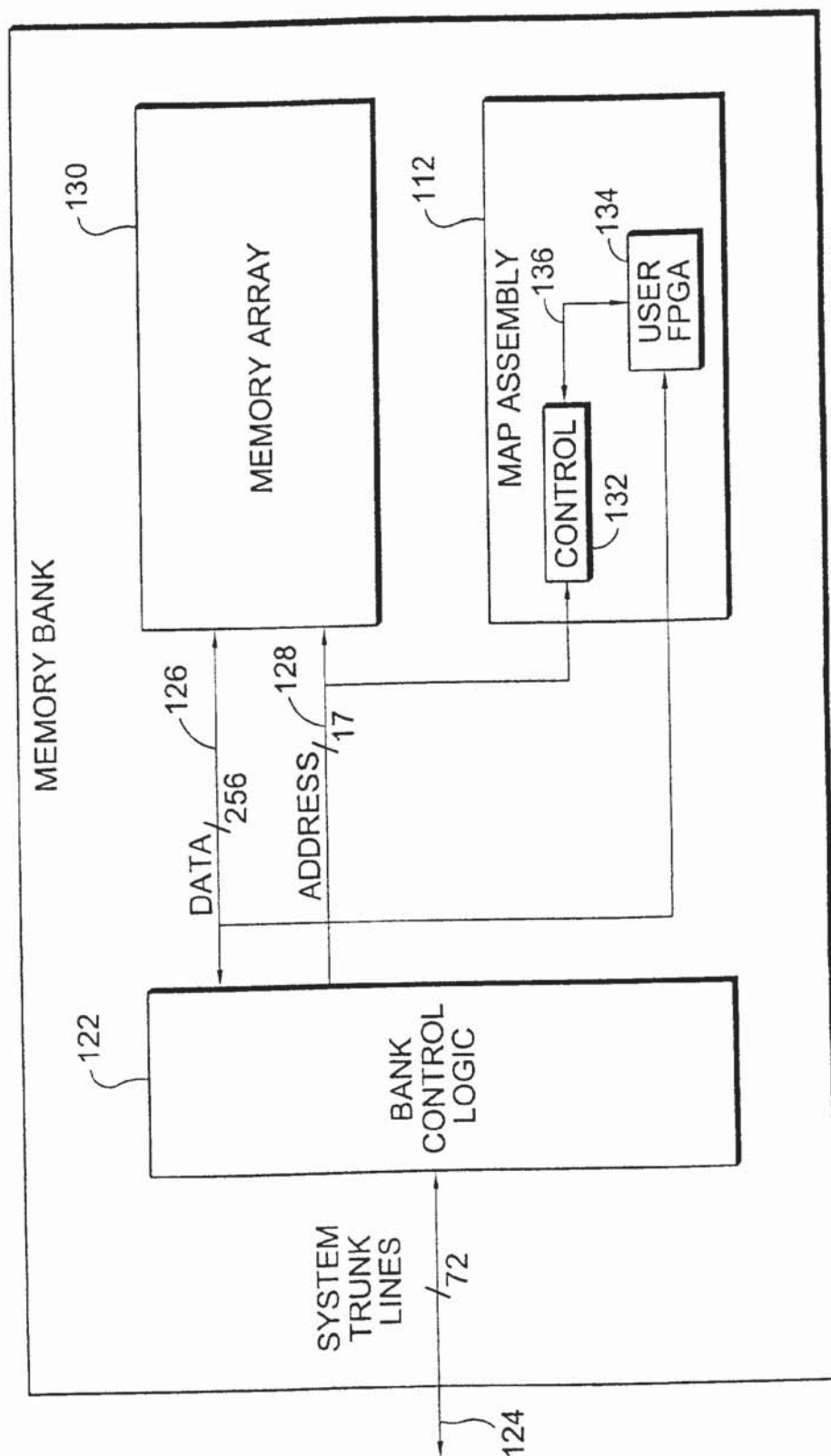

FIG. 2



120

FIG. 3

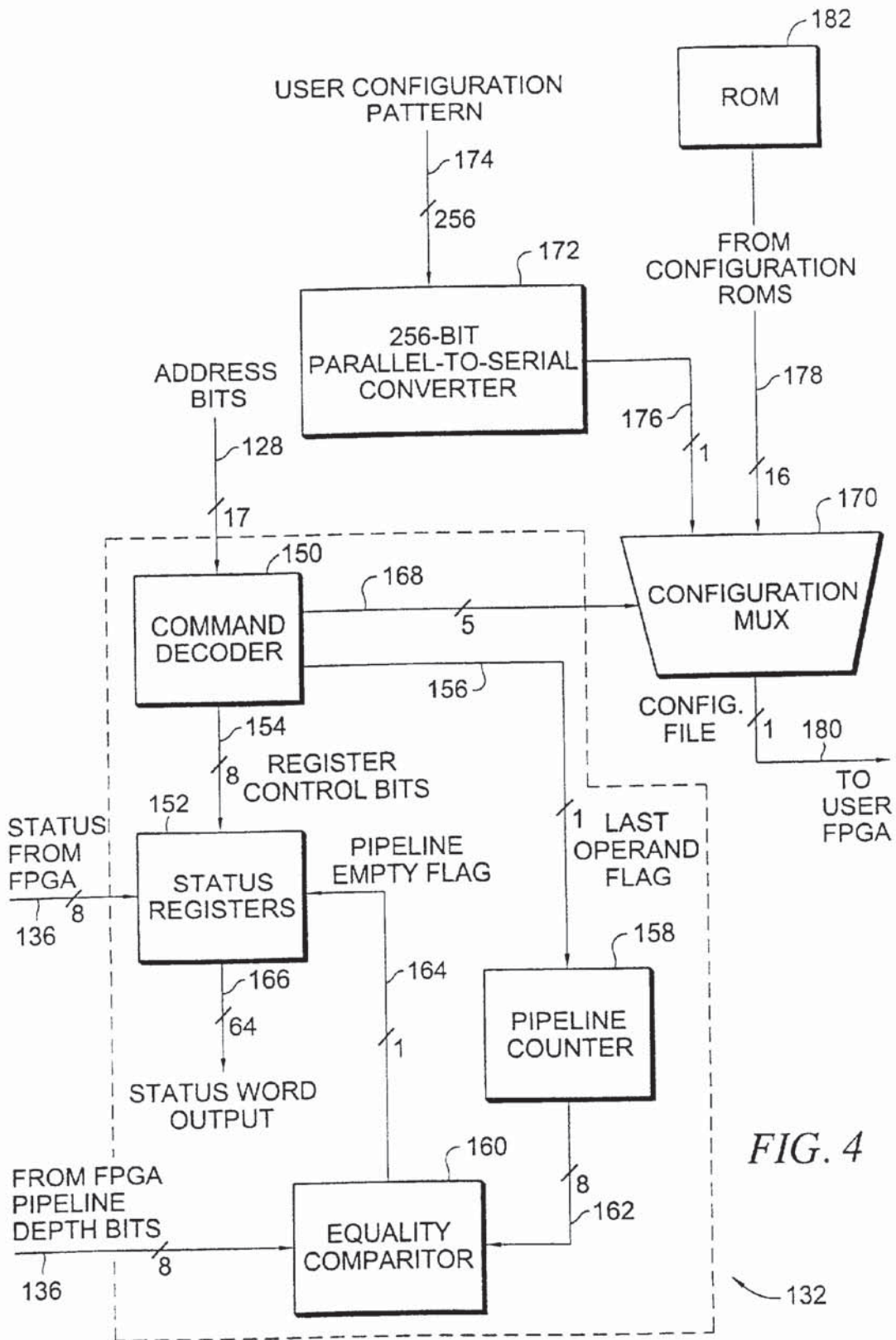

FIG. 4

Explore Litigation Insights

Docket Alarm provides insights to develop a more informed litigation strategy and the peace of mind of knowing you're on top of things.

Real-Time Litigation Alerts



Keep your litigation team up-to-date with **real-time alerts** and advanced team management tools built for the enterprise, all while greatly reducing PACER spend.

Our comprehensive service means we can handle Federal, State, and Administrative courts across the country.

Advanced Docket Research



With over 230 million records, Docket Alarm's cloud-native docket research platform finds what other services can't. Coverage includes Federal, State, plus PTAB, TTAB, ITC and NLRB decisions, all in one place.

Identify arguments that have been successful in the past with full text, pinpoint searching. Link to case law cited within any court document via Fastcase.

Analytics At Your Fingertips



Learn what happened the last time a particular judge, opposing counsel or company faced cases similar to yours.

Advanced out-of-the-box PTAB and TTAB analytics are always at your fingertips.

API

Docket Alarm offers a powerful API (application programming interface) to developers that want to integrate case filings into their apps.

LAW FIRMS

Build custom dashboards for your attorneys and clients with live data direct from the court.

Automate many repetitive legal tasks like conflict checks, document management, and marketing.

FINANCIAL INSTITUTIONS

Litigation and bankruptcy checks for companies and debtors.

E-DISCOVERY AND LEGAL VENDORS

Sync your system to PACER to automate legal marketing.