

Asserted Claim of '800 Patent	Exemplary Disclosure of Splash 2
<p>[1A] A method for data processing in a reconfigurable computing system, the reconfigurable computing system comprising at least one reconfigurable processor, the reconfigurable processor comprising a plurality of functional units, said method comprising:</p>	<p>At least under Plaintiff's apparent theories of infringement and interpretations of the claim, any of Defendant's accused products satisfy this claim limitation, Buell alone or in combination with one or more references, discloses:</p> <p>Buell at 11: "The basic building block from which Splash 2 is made is the Xilinx XC4010 mentioned in Chapter 1, the XC4010 contains a 20 × 20 array of Configurable Logic Blocks."</p> <p>Buell at 11: "Figure 2.2 illustrates the routing structure of the XC4000 series FPGA. Components are three types of signal routing resources including a single-length interconnect between adjacent switch boxes: "S" in Figure 2.2), a double-length interconnect between alternate switch boxes, and routing lines that span the width and height of the chip. The switch boxes contain programmable logic elements that allow each segment to connect to three others. Configuration of the FPGA is done by loading data into on-chip RAM; the hardware to do this in Splash 2 is implicit in our description in this chapter and the general architecture and is discussed in greater length in Chapter 6."</p>

Asserted Claim of '800 Patent

Exemplary Disclosure of Splash 2

Buell at FIG. 2.2:

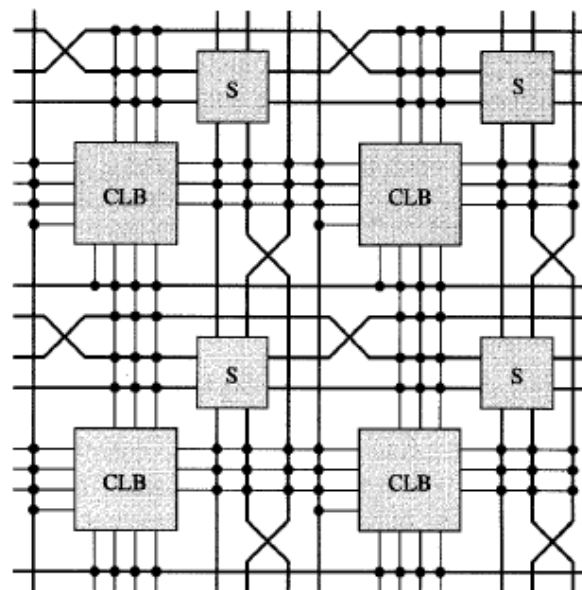
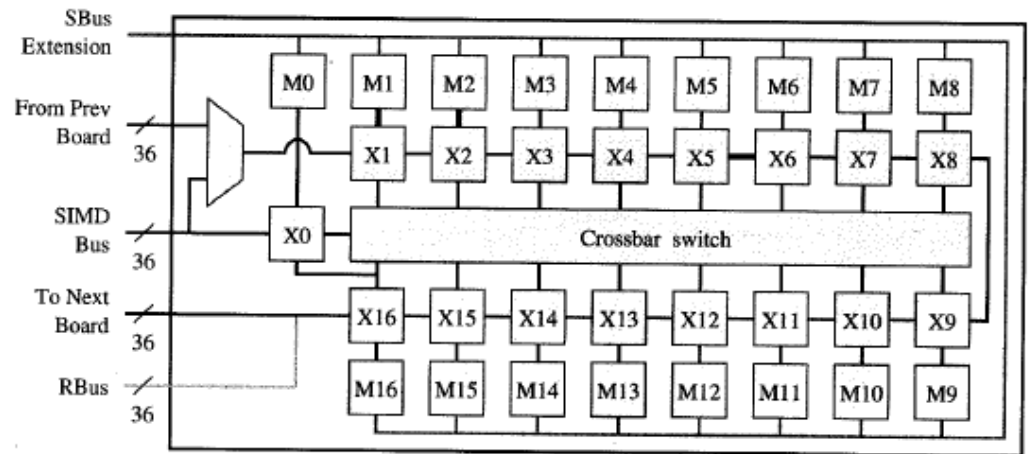

FIGURE 2.2 Xilinx XC4 Structure

**Asserted Claim of '800 Patent**

**Exemplary Disclosure of Splash 2**

Buell at FIG. 2.4



**FIGURE 2.4** Array Board Architecture

Buell at 16: “The Splash 2 Array Board is detailed in Figure 2.4. Each Array Board contains sixteen XC4010 FPGA chips as processing elements. Sixteen of these, X1 through X16, form the processing core and are connected with a 36-bit-wide data path linearly and via a crossbar. To each FPGA is attached 512 Kbytes of memory. Throughout the Splash 2 system, the normal data object has been 32 bits, augmented where possible and sensible with four tag bits. Here, in the connection to memory, we find the one instance in which this design has been compromised. Three 36-bit data paths, 18 bits for a memory address, and 32 bits for memory data would have left far too few pins for controlling each FPGA. The compromise was to reduce the memory data width to 18 bits.”

**Asserted Claim of '800 Patent**

**Exemplary Disclosure of Splash 2**

Buell at 97: "With the onset of the Human Genome Initiative [3] and constant advances in sequencing technology, genetic sequence data are being generated at an ever increasing rate. Biologists are faced with an influx of new sequences that they would like to classify and store, and comparing them to existing databases. The analysis of a newly generated sequence typically involves searching the databases for similar sequences. With the enormous size of the databases, fast algorithms are needed for comparing sequences [11]."

Buell at Figure 8.1:

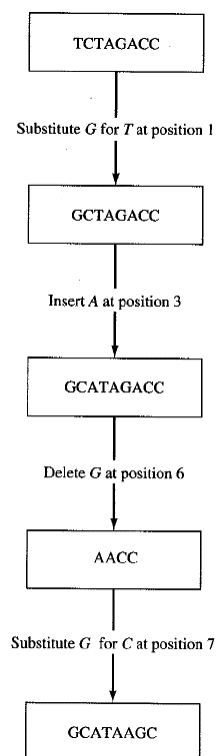

**FIGURE 8.1** Listing of Operations to Transform TCTAGACC into GCATAAGC. Character matches are assumed to have a cost of 0 and are not shown. Assigning a cost of 2 for a substitution, 1 for deletion, and 1 for insertion, the cost of the transformation is 6.

Asserted Claim of '800 Patent	Exemplary Disclosure of Splash 2
	<p>Buell at 97: “In this chapter, we describe two systolic array architectures for sequence comparison and their implementations on the Splash 2 programmable logic array.”</p> <p>Buell at 100: “The locality of reference shown in Figure 8.3 can be exploited to produce systolic array algorithms in which communication is limited to adjacent processors....</p> <p>The systolic architecture and data flow shown in Figure 8.5 were used in the design of P-Matrix and Lopresti [12], a custom VLSI chip for DNA sequence comparison. Each processing element computes the distances along a particular diagonal of the distance matrix.”</p> <p>Buell at 107: “8.3.3 Bidirectional Array  For the DNA version of the bidirectional array, each of the 16 array FPGAs (X1 to X16) contains 24 PE, making a total of 384 PEs in a one-board Splash 2 system. The protein version packs 64 PE per board Splash 2 system. Timing results from XDELAY give a theoretical maximum throughput of 1.5 million characters per second for the DNA version and 3.5 million characters per second for the protein version.”</p>

# Explore Litigation Insights

Docket Alarm provides insights to develop a more informed litigation strategy and the peace of mind of knowing you're on top of things.

## Real-Time Litigation Alerts



Keep your litigation team up-to-date with **real-time alerts** and advanced team management tools built for the enterprise, all while greatly reducing PACER spend.

Our comprehensive service means we can handle Federal, State, and Administrative courts across the country.

## Advanced Docket Research



With over 230 million records, Docket Alarm's cloud-native docket research platform finds what other services can't. Coverage includes Federal, State, plus PTAB, TTAB, ITC and NLRB decisions, all in one place.

Identify arguments that have been successful in the past with full text, pinpoint searching. Link to case law cited within any court document via Fastcase.

## Analytics At Your Fingertips



Learn what happened the last time a particular judge, opposing counsel or company faced cases similar to yours.

Advanced out-of-the-box PTAB and TTAB analytics are always at your fingertips.

## API

Docket Alarm offers a powerful API (application programming interface) to developers that want to integrate case filings into their apps.

## LAW FIRMS

Build custom dashboards for your attorneys and clients with live data direct from the court.

Automate many repetitive legal tasks like conflict checks, document management, and marketing.

## FINANCIAL INSTITUTIONS

Litigation and bankruptcy checks for companies and debtors.

## E-DISCOVERY AND LEGAL VENDORS

Sync your system to PACER to automate legal marketing.