



United States Patent [19]

[11] Patent Number: **5,956,518**

DeHon et al.

[45] Date of Patent: **Sep. 21, 1999**

[54] **INTERMEDIATE-GRAIN RECONFIGURABLE PROCESSING DEVICE**

[75] Inventors: **André DeHon; Ethan Mirsky**, both of Cambridge; **Thomas F. Knight, Jr.**, Belmont, all of Mass.

[73] Assignee: **Massachusetts Institute of Technology**, Cambridge, Mass.

[21] Appl. No.: **08/632,371**

[22] Filed: **Apr. 11, 1996**

[51] Int. Cl.⁶ **G06F 15/80**

[52] U.S. Cl. **395/800.15; 395/653**

[58] Field of Search **395/800.1, 800.15, 395/200.51, 280, 653**

[56] **References Cited**

U.S. PATENT DOCUMENTS

4,597,041	6/1986	Guyer et al.	364/200
4,748,585	5/1988	Chiarulli et al.	364/900
4,754,412	6/1988	Deering	364/736
4,858,113	8/1989	Saccardi	364/200
4,870,302	9/1989	Freeman	307/465
4,873,626	10/1989	Gifford	364/200
5,020,059	5/1991	Gorin et al.	371/11.3
5,233,539	8/1993	Agrawal et al.	364/489
5,239,654	8/1993	Ing-Simmons et al.	395/800
5,241,635	8/1993	Papadopoulos et al.	395/375
5,265,207	11/1993	Zak	395/200.31
5,301,340	4/1994	Cook	395/800
5,305,462	4/1994	Grondalski	395/800.1
5,336,950	8/1994	Popli et al.	307/465
5,426,378	6/1995	Ong	326/39
5,457,644	10/1995	McCollum	364/716
5,684,980	11/1997	Casselmann	395/500

OTHER PUBLICATIONS

Takashi Miyamori et al., "A Quantitative Analysis of Reconfigurable Coprocessors for Multimedia Applications," IEEE Symposium on Field-Programmable Custom Computing Machines Conference (FCCM98), Apr. 15-17, 1998.

Charlé Rupp et al., "The Napa Adaptive Processing Architecture", IEEE Symposium on Field-Programmable Custom Computing Machines Conference (FCCM98), Apr. 15-17, 1998, pp. 1-10.

Stephen M. Scalera et al., The Design and Implementation of a Context Switching FPGA, IEEE Symposium on Field-Programmable Custom Computing .

T. Bridges, "The GPA Machine: A Generally Partitionable MSIMD Architecture," *Third Symposium on the Frontier of Massively Parallel Computation Proceedings IEEE* pp. 196-203 (1990).

P. Clarke, "Pilington Preps Reconfigurable Video DSP," *News* (Aug. 7, 1995).

D.C. Chen, et al., "A Reconfigurable Multiprocess IC for Rapid Prototyping of Algorithmic-Specific High-Speed DSP Data Paths," *IEEE Journal of Solid-State Circuits*, vol. 27 (12): 1895-1904 (Dec 1992).

A.K. Yeung, et al., "TA 6.3: A 2.4GOPS Data-Given Reconfigurable Multiprocessor IC for DSP," *IEEE International Solid-State Circuits Conference*, pp. 108-109, 346 (1995).

(List continued on next page.)

Primary Examiner—Eric Coleman
Attorney, Agent, or Firm—Hamilton, Brook, Smith & Reynolds, P.C.

[57] **ABSTRACT**

A programmable integrated circuit utilizes a large number of intermediate-grain processing elements which are multibit processing units arranged in a configurable mesh. The coarse-grain resources, such as memory and processing, are deployable in a way that takes advantage of the opportunities for optimization present in given problems. To accomplish this, the interconnect supports three different modes of operation: a static value in which a value set by the configuration data is provided to a functional unit, static source in which another functional unit serves as the value source, and a dynamic source mode in which the source is determined by the value from another functional unit.

31 Claims, 20 Drawing Sheets

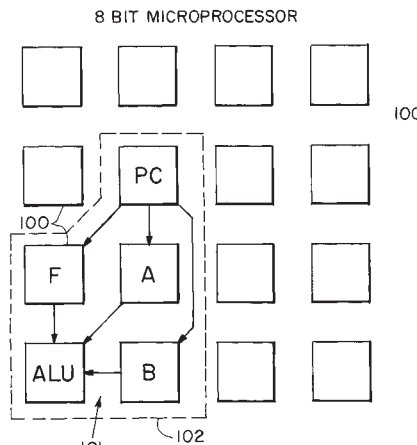

OTHER PUBLICATIONS

- J.E. Brewer, et al., "A Monolithic Processing Subsystem," *IEEE Transactions on Components, Packaging, and Manufacturing Technology—Part B*, vol. 17(3) :310–317 (Aug. 1994).
- I. Gilbert, Chapter 11—Mesh Multiprocessing, *The Lincoln Laboratory Journal*, 1(1) :11.1–11.18 (Spring 1988).
- Ira H. Gilbert, et al., "The Monolithic Synchronous Processor," *Lincoln Laboratory, Massachusetts Institute of Technology, Lexington, MA 02173* (No Date Given).
- G. Masera, et al., "A Microprogrammable Parallel Architecture for DSP," *IEEE*, pp. 824–827, (1991).
- L. Wang, et al., "Distributed Instruction Set Computer," *Proceedings of the 1988 International Conference on Parallel Processing*, vol. 1, pp. 426–429.
- M. Sowa, et al., "Parallel Execution on the Function-Partitioned Processor with Multiple Instruction Streams," *Systems and Computers in Japan*, 22(4) :22–27 (Nov. 1991).
- T. Alexander, et al., "A Reconfigurable Approach to a Systolic Sorting Architecture," *IEEE*, pp. 1178–1182 (1989).
- Z. Blazek, et al., "Design of a Reconfigurable Parallel RISC-Machine," *North-Holland Microprocessing and Microprogramming 21*, pp. 39–46, (1987).
- S. Morton, et al., "The Dynamically Reconfigurable CAP Array Chip I," *IEEE Journal of Solid-State Circuits*, SC21 (5) :820–826 (Oct. 1986).
- L. Snyder, "A Taxonomy of Synchronous Parallel Machines," *Proceedings of the 1988 International Conference on Parallel Processing*, pp. 281–285 (Aug. 1988).
- L. Snyder, "An Inquiry into the Benefits of Multigauge Parallel Computation," *Proceedings of the 1985 International conference on Parallel Processing*, pp. 488–492 (Aug. 1985).
- A. DeHon, "DPGA Utilization and Application," *FPGA '96—ACM/SIGDA Fourth International Symposium on FPGAs, Monterey, CA* (Feb. 11–13, 1996).
- D. Epstein, "Chromatic Raises the Multimedia Bar," *Microprocessor Report*, pp. 23–27 (Oct. 23, 1995).
- J. Labrousse, et al., "Create-Life: A Modular Design Approach for High Performance ASIC's," *IEEE CH2843*, pp. 427–433 (Jan. 1990).
- M. Slater, "MicroUnity Lift Veil on MediaProcessor," *Microprocessor Report*, pp. 11–18 (Oct. 23, 1995).
- E. Tau, et al., "A First Generation DPGA Implementation," *FPD '95—Third Canadian Workshop of Field-Programmable Devices Montreal, Canada* (May 29–Jun. 1, 1995).
- S. Kartashev, et al., "A Multicomputer System with Dynamic Architecture," *IEEE Transactions on Computers*, vol. C–28, No. 10, pp. 704–721 (Oct. 1979).
- D. Bursky, "Programmable Data Paths Speed Computations," *Electronic Design*, pp. 171–174 (May 1, 1995).
- V. Bove, Jr., et al., "Cheops: A Reconfigurable Data-Flow System for Video Processing," *IEEE Transactions on Circuits and Systems for Video Technology*, pp. 140–149 (1995).
- M. Schaffner, "Processing by Data and Program Blocks," *Transactions on Computers*, vol. C–27, No. 11, pp. 1015–1027 (Nov. 1978).
- J. Nickolls, "The Design of the MasPar MP-1: A Cost Effective Massively Parallel Computer," *IEEE CH2843*, pp. 25–28 (Jan. 1990).
- B. Narasimha, "Performance-Oriented, Fully Routable Dynamic Architecture for a Field Programmable Logic Device," *UCB/ERL M93/42, University of California, Berkeley*, pp. 1–21 (Jun. 1993).
- M. Bolotski, et al., "A 1024 Processor 8ns SIMD Array," *Advanced Research in VLSI 1995*, pp. 1–13 (1995).
- D. Cherepacha, et al., "A Datapath Oriented Architecture for FPGAs," *Second International ACM/SIGDA Workshop on Field Programmable Gate Arrays ACM*, pp. 1–11 (Feb. 1994).
- D. Jones, et al., "A Time-Multiplexed FPGA Architecture for Logic Emulation," *Proceedings of the IEEE 1995 Custom Integrated Circuits Conference*, pp. 495–498 (May 1995).
- G. Nutt, "Microprocessor Implementation of a Parallel Processor," *Proceedings of the Fourth Annual Symposium on Computer Architecture*, pp. 147–152, (1977).
- W. Kim, "MasPar MP-2 PE Chip: A Totally Cool Hot Chip," *Proceedings of Hot Chips V*, pp. 1–5 (Mar. 29, 1993).
- E. Mirsky, et al., "Matrix: Coarse-Grain Reconfigurable Computing (Abstract)," *Published at the 5th Annual MIT Student Workshop on Scalable Computing*, pp. 1–2 (Aug. 1995) (Available on the Internet May 1, 1995).
- E. Mirsky, et al., "Matrix: A Reconfigurable Computing Architecture with Configurable Instruction Distribution and Deployable Resources," *Published at FCCM'96—IEEE Symposium on FPGA's for Custom Computing Machines*, pp. 1–10 (Apr. 17–19, 1996).

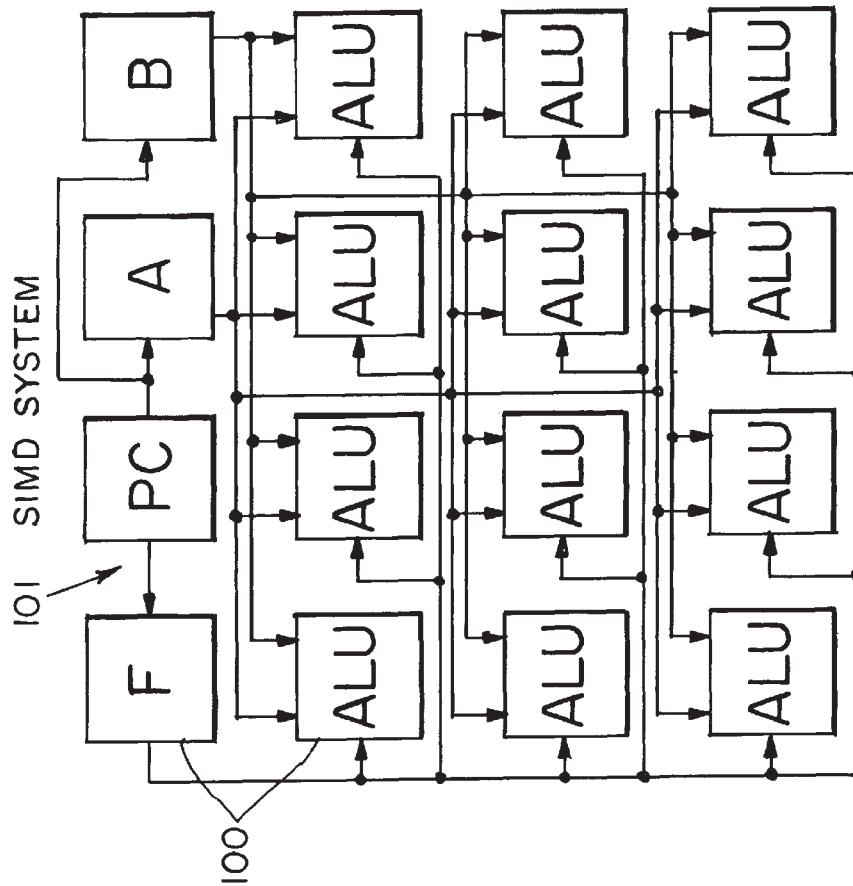

FIG. 2

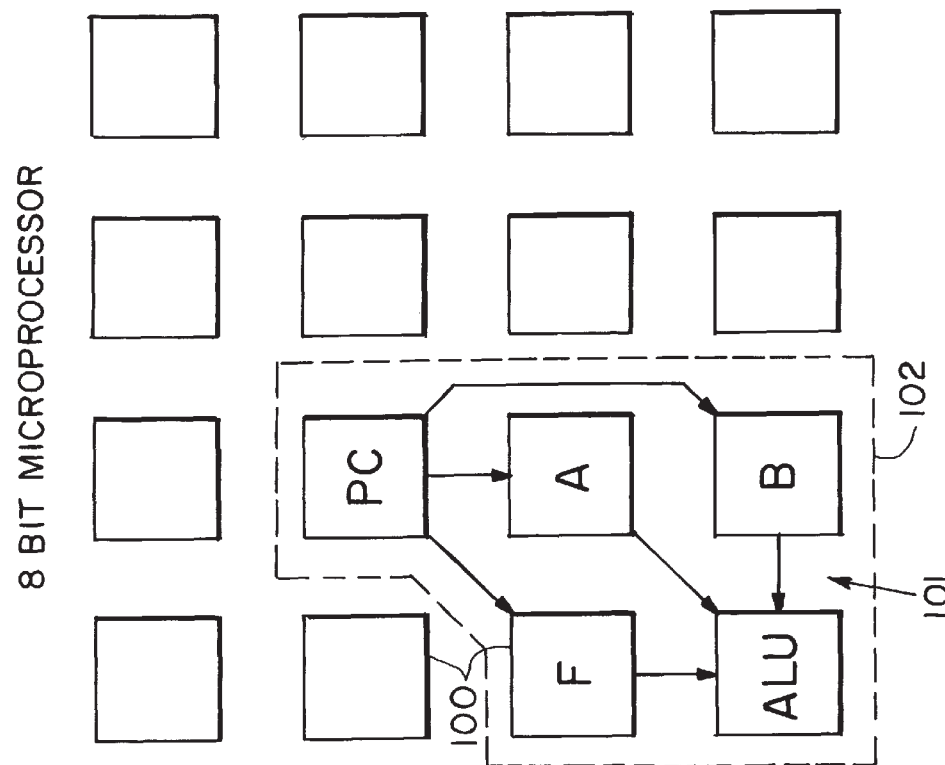

FIG. 1

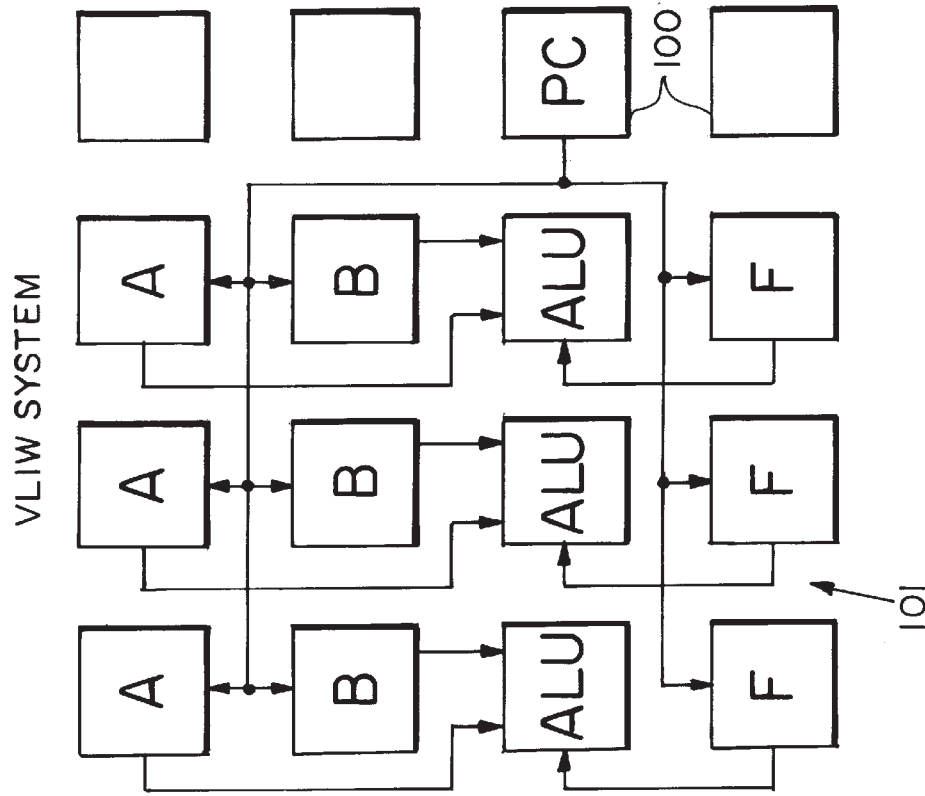

FIG. 4

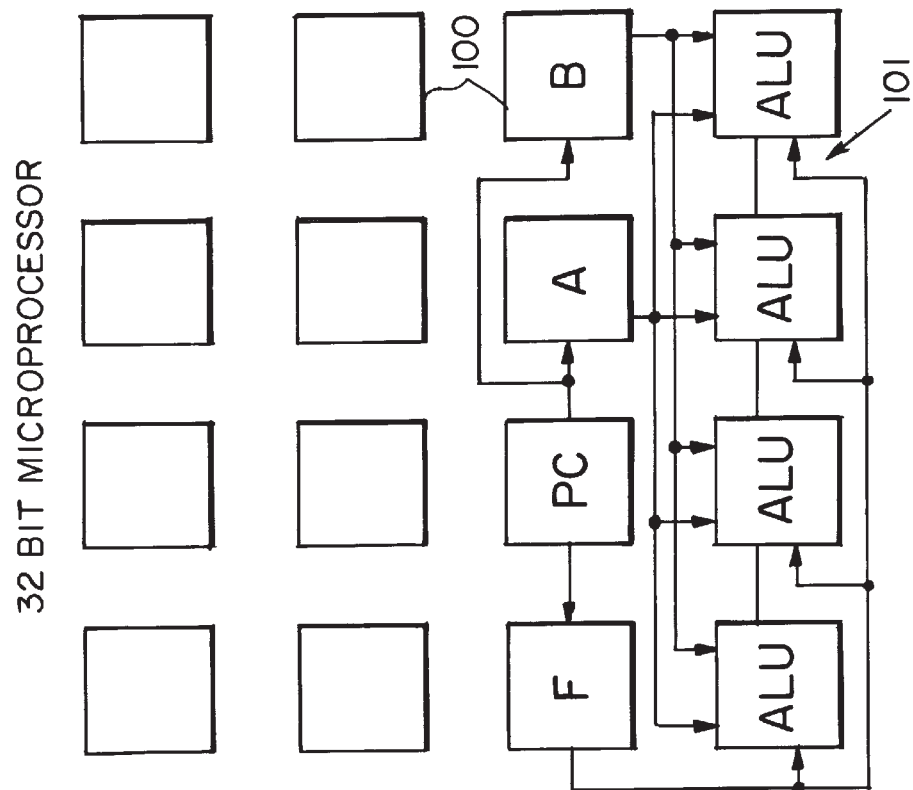

FIG. 3

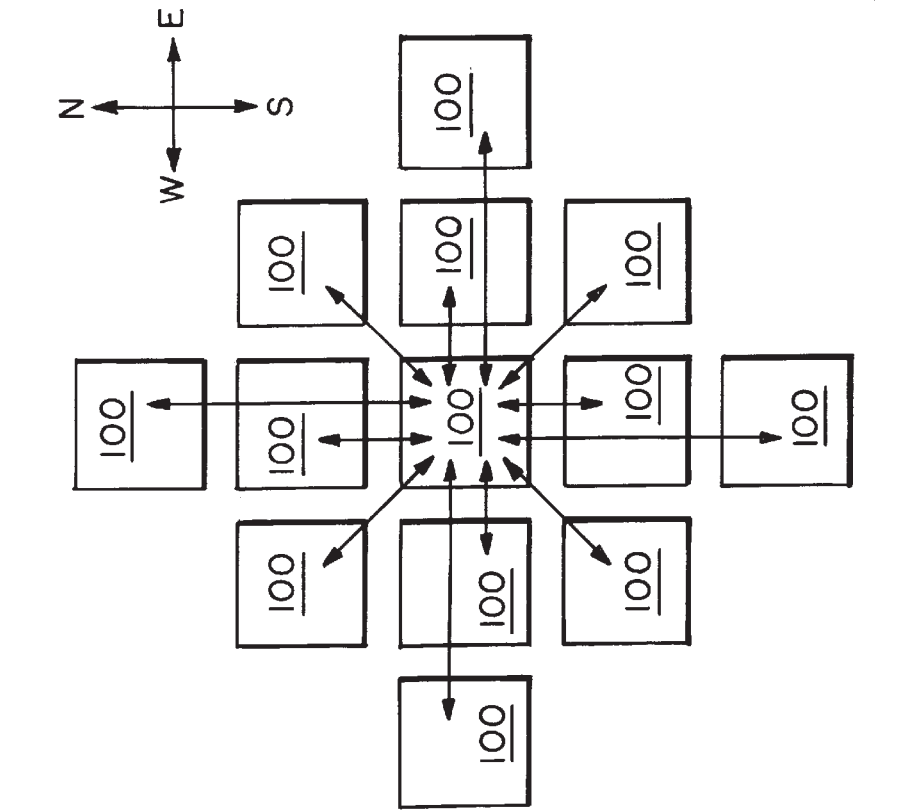

FIG. 7

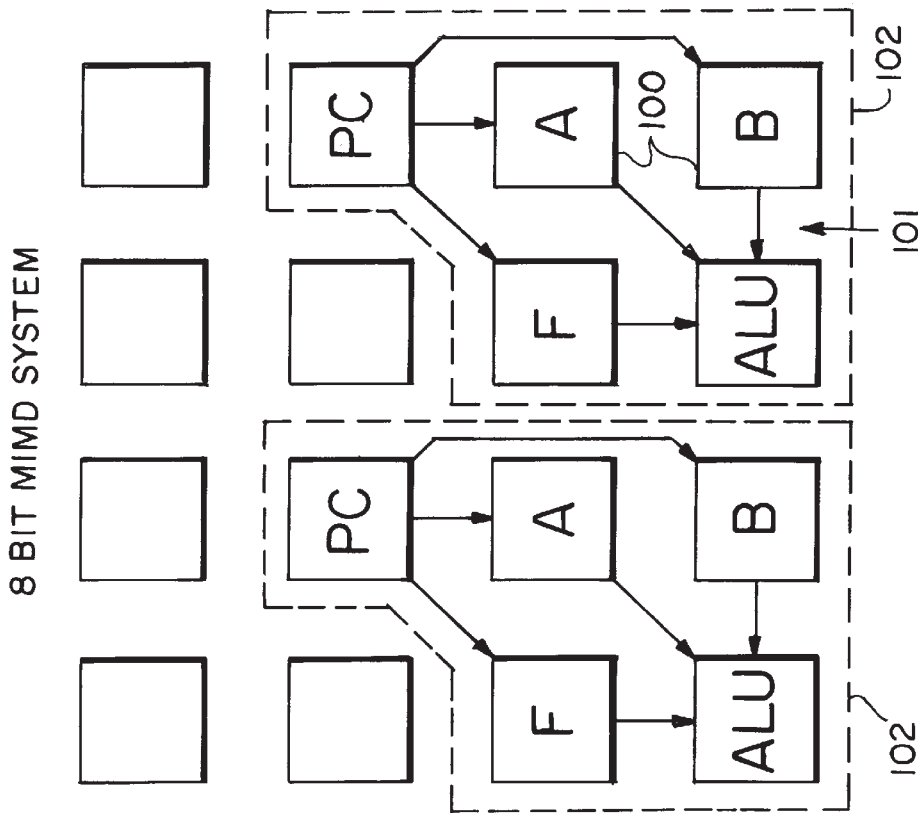

FIG. 5

Explore Litigation Insights

Docket Alarm provides insights to develop a more informed litigation strategy and the peace of mind of knowing you're on top of things.

Real-Time Litigation Alerts



Keep your litigation team up-to-date with **real-time alerts** and advanced team management tools built for the enterprise, all while greatly reducing PACER spend.

Our comprehensive service means we can handle Federal, State, and Administrative courts across the country.

Advanced Docket Research



With over 230 million records, Docket Alarm's cloud-native docket research platform finds what other services can't. Coverage includes Federal, State, plus PTAB, TTAB, ITC and NLRB decisions, all in one place.

Identify arguments that have been successful in the past with full text, pinpoint searching. Link to case law cited within any court document via Fastcase.

Analytics At Your Fingertips



Learn what happened the last time a particular judge, opposing counsel or company faced cases similar to yours.

Advanced out-of-the-box PTAB and TTAB analytics are always at your fingertips.

API

Docket Alarm offers a powerful API (application programming interface) to developers that want to integrate case filings into their apps.

LAW FIRMS

Build custom dashboards for your attorneys and clients with live data direct from the court.

Automate many repetitive legal tasks like conflict checks, document management, and marketing.

FINANCIAL INSTITUTIONS

Litigation and bankruptcy checks for companies and debtors.

E-DISCOVERY AND LEGAL VENDORS

Sync your system to PACER to automate legal marketing.