

(12) **United States Patent**  
**Sinha et al.**

(10) **Patent No.:** **US 6,292,917 B1**  
 (45) **Date of Patent:** **Sep. 18, 2001**

- (54) **UNEQUAL ERROR PROTECTION FOR DIGITAL BROADCASTING USING CHANNEL CLASSIFICATION**
- (75) Inventors: **Deepen Sinha; Carl-Erik Wilhelm Sundberg**, both of Chatham, NJ (US)
- (73) Assignee: **Agere Systems Guardian Corp.**, Orlando, FL (US)
- (\* ) Notice: Subject to any disclaimer, the term of this patent is extended or adjusted under 35 U.S.C. 154(b) by 0 days.
- (21) Appl. No.: **09/163,656**
- (22) Filed: **Sep. 30, 1998**
- (51) Int. Cl.<sup>7</sup> ..... **H03M 13/00**
- (52) U.S. Cl. .... **714/752; 375/299; 714/786; 714/790**
- (58) **Field of Search** ..... **714/752, 790, 714/795, 786; 375/299; 382/232; 455/452, 450; 704/223**

(56) **References Cited**

**U.S. PATENT DOCUMENTS**

5,243,629	*	9/1993	Wei	375/299
5,463,641		10/1995	Dorward et al.	714/755
5,850,482	*	12/1998	Meany et al.	382/232
5,887,263	*	3/1999	Ishii	455/452
5,991,717	*	11/1999	Minde et al.	704/223
6,052,594	*	4/2000	Chuang et al.	455/450
6,108,810	*	8/2000	Kroeger et al.	714/790

**OTHER PUBLICATIONS**

D. Sinha, J.D. Johnston, S. Dorward and S.R. Quackenbush, "The Perceptual Audio Coder," in Digital Audio, Section 42, pp. 42-1 to 42-18, CRC Press, 1998.

N.S. Jayant and E.Y. Chen, "Audio Compression: Technology and Applications," AT&T Technical Journal, pp. 23-34, vol. 74, No. 2, Mar.-Apr. 1995.

J. Hagenauer, "Rate Compatible Punctured Convolutional Codes (RCPC Codes) and their Applications," IEEE Transactions on Communications, vol. 36, No. 4, pp. 389-400, Apr. 1988.

J. Hagenauer et al., "The Performance of Rate-Compatible Punctured Convolutional Codes for Digital Mobile Radio," IEEE Transactions on Communications, vol. 38, No. 7, pp. 966-980, Jul. 1990.

R.V. Cox et al., "Sub-band Speech Coding and Matched Convolutional Channel Coding for Mobile Radio Channels," IEEE Transactions on Acoustics, Speech and Signal Processing, vol. 39, No. 8, pp 1717-1731, Aug. 1991.

A.R. Calderbank and N. Seshadri, "Multilevel Codes for Unequal Error Protection," IEEE Transactions on Information Theory, vol. 39, No. 4, pp. 1234-1248, Jul. 1993.

C.-E.W. Sundberg, "Digital Audio Broadcasting in the FM Band," Proceedings of the IEEE Symposium on Industrial Electronics, Portugal, Jul. 7-11, 1997.

C.-E.W. Sundberg, "Digital Audio Broadcasting: An Overview of Some Recent Activities in the U.S.," Proceedings of Norsig-97, Norwegian Signal Processing Symposium, Tromso, Norway, May 23-24, 1997.

\* cited by examiner

*Primary Examiner*—Albert Decady

*Assistant Examiner*—David Ton

(74) *Attorney, Agent, or Firm*—Ryan, Mason & Lewis, LLP

(57) **ABSTRACT**

The invention provides methods and apparatus for processing information, e.g., audio, video or image information, for transmission in a communication system. In an illustrative embodiment, interference characteristics are determined for a set of n channels to be used to transmit audio information bits, where n is greater than or equal to two. The audio information bits are separated into n classes based on error sensitivity, for example, the impact of errors in particular audio data bits on perceived quality of an audio signal reconstructed from the transmission. The classes of bits are then assigned to the n channels such that the classes of bits having the greatest error sensitivity are transmitted over the channels which are the least susceptible to interference. The interference characteristics associated with the n channels can be determined by, for example, measuring interference levels for one or more of the channels, or obtaining information regarding known interference levels for one or more of the channels. The channels may correspond to different frequency bands, time slots, code division slots or any other type of channels. The invention can provide UEP for different classes of audio information bits even in cases in which the same convolutional code, or the same complementary punctured pair convolutional (CPPC) code pair, is used to encode the classes. The assignment of the classes of bits to the channels, as well as the characteristics of the classes and the channels, may be fixed or dynamic.

**32 Claims, 2 Drawing Sheets**

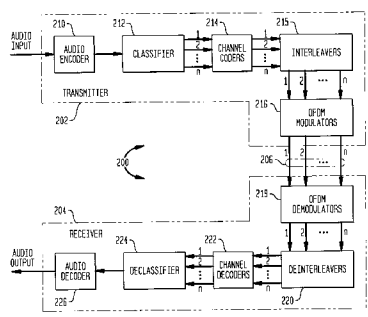

FIG. 1

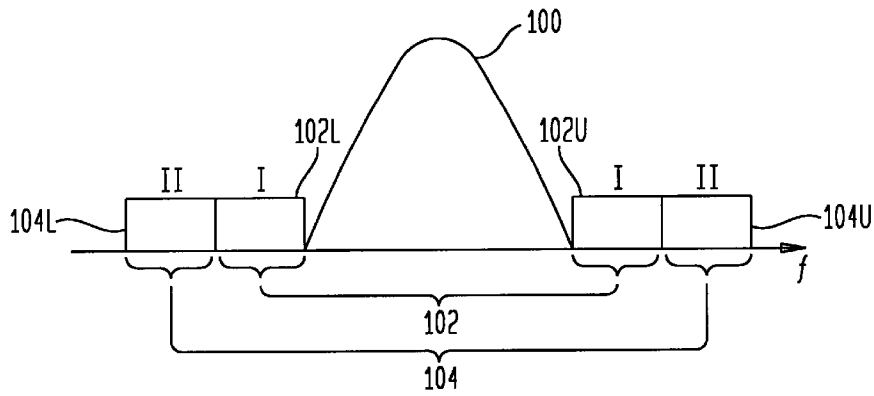

FIG. 2

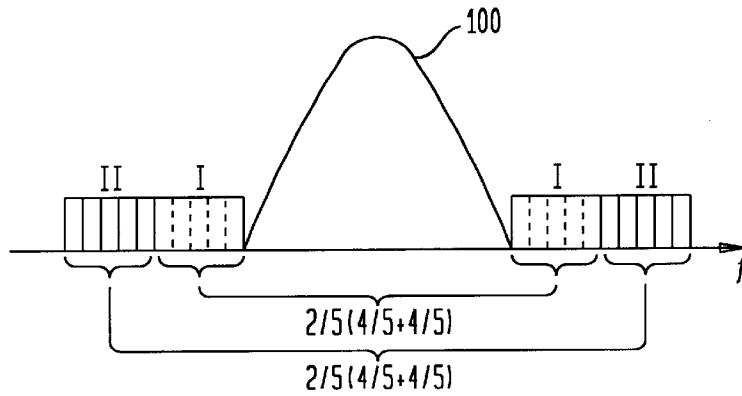

FIG. 3

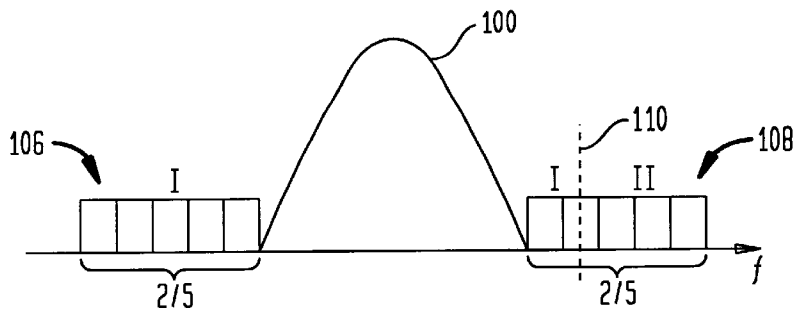

FIG. 4

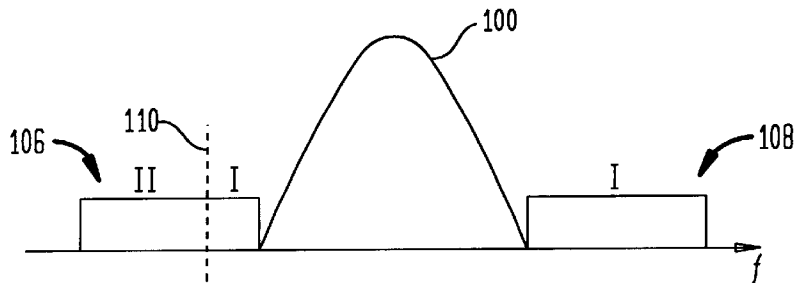
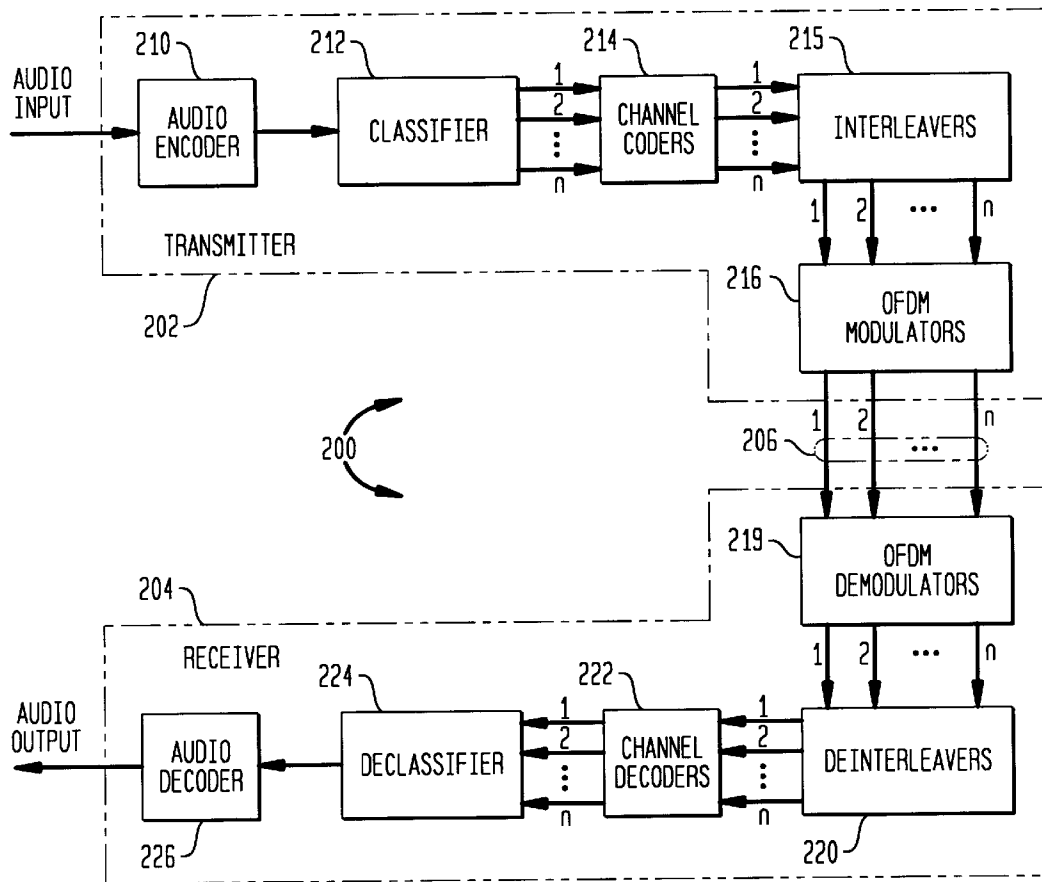

FIG. 5



## UNEQUAL ERROR PROTECTION FOR DIGITAL BROADCASTING USING CHANNEL CLASSIFICATION

### FIELD OF THE INVENTION

The present invention relates generally to digital audio broadcasting (DAB) and other techniques for transmitting information, and more particularly to techniques for providing unequal error protection (UEP) for different classes of audio, video, image or other information bits encoded in a source coding device.

### BACKGROUND OF THE INVENTION

Most source coded bit streams exhibit unequal sensitivity to bit errors. For example, certain source bits can be much more sensitive to transmission errors than others. Moreover, errors in certain bits, such as control bits, may lead to severe error propagation and a corresponding degradation in reconstructed signal quality. Such error propagation can occur, for example, in the output audio bits of an audio coder due to the use of control bits for codebook information, frame size information, synchronization information and so on. The perceptual audio coder (PAC) described in D. Sinha, J.D. Johnston, S. Dorward and S.R. Quackenbush, "The Perceptual Audio Coder," in *Digital Audio*, Section 42, pp. 42-1 to 42-18, CRC Press, 1998, which is incorporated by reference herein, attempts to minimize the bit rate requirements for the storage and/or transmission of digital audio data by the application of sophisticated hearing models and signal processing techniques. In the absence of channel errors, a PAC is able to achieve near stereo compact disk (CD) audio quality at a rate of approximately 128 kbps. At a lower bit rate of 96 kbps, the resulting quality is still fairly close to that of CD audio for many important types of audio material.

The rate of 96 kbps is particularly attractive for FM band transmission applications such as in-band digital audio broadcasting (DAB) systems, which are also known as hybrid in-band on-channel (HIBOC), all-digital IBOC and in-band adjacent channel (IBAC)/in-band reserve channel (IBRC) DAB systems. There is also a similar effort underway to provide digital audio broadcasting at lower audio bit rates in the AM band. For these AM systems, audio bit rates of about 32 to 48 kbps are being considered for daytime transmission and about 16 kbps for nighttime transmission. Higher audio bit rates, greater than about 128 kbps, are being used in multiple channel DAB systems. The transmission channels in the above-noted DAB systems tend to be severely bandlimited and noise limited at the edge of a coverage area. For mobile receivers, fading is also a severe problem. It is therefore particularly important in these and other applications to design an error protection technique that is closely matched to the error sensitivity of the various bits in the compressed audio bit stream.

PACs and other audio coding devices incorporating similar compression techniques are inherently packet-oriented, i.e., audio information for a fixed interval (frame) of time is represented by a variable bit length packet. Each packet includes certain control information followed by a quantized spectral/subband description of the audio frame. For stereo signals, the packet may contain the spectral description of two or more audio channels separately or differentially, as a center channel and side channels (e.g., a left channel and a right channel). Different portions of a given packet can therefore exhibit varying sensitivity to transmission errors. For example, corrupted control information leads to loss of synchronization and possible propagation of errors. On the

other hand, the spectral components contain certain inter-frame and/or interchannel redundancy which can be exploited in an error mitigation algorithm incorporated in a PAC codec. Even in the absence of such redundancy, the transmission errors in different audio components have varying perceptual implications. For example, loss of stereo separation is far less annoying to a listener than spectral distortion in the mid-frequency range in the center channel.

Unequal error protection (UEP) techniques are designed to match error protection capability with sensitivity to transmission errors, such that the most important bits are provided with the highest level of error protection, while less important bits are provided with a lesser level or levels of error protection. A conventional two-level UEP technique for use in DAB applications is described in N.S. Jayant and E.Y. Chen, "Audio Compression: Technology and Applications," *AT&T Technical Journal*, pp. 23-34, Vol. 74, No. 2, March-April 1995. In this technique, which is based on a Reed-Solomon (RS) code, the control information is protected more robustly since it is not possible to use error mitigation on the non-redundant control information. In fact, the proper operation of the error mitigation algorithm used in a PAC codec is itself dependent upon reliable control information. All of the non-control spectral information in this technique is protected using a uniform level of error protection. U.S. patent application Ser. No. 09/022,114, which was filed Feb. 11, 1998 in the name of inventors Deepen Sinha and Carl-Erik W. Sundberg, and which is incorporated by reference herein, discloses techniques for providing UEP of a PAC bitstream by classifying the bits in different categories of error sensitivity. These classes were then matched to a suitable level of error protection to minimize the overall impact of errors, i.e., the most sensitive bits are more protected than the others. Certain of the UEP techniques described in the above-cited application generally provide improvements without regard to the type of channel, and the channel noise is typically assumed to be averaged over time and frequency by interleaving in both time and frequency for each channel code class. Thus, a UEP technique with a more powerful channel code properly matched to the most sensitive source bits always outperforms the corresponding equal error protection (EEP) technique. However, determining the channel codes for such UEP scenarios is often a nontrivial problem, particularly in the case of determining single sideband complementary punctured-pair convolutional codes (CPPC) codes for HIBOC applications. Therefore, although the techniques in the above-cited application provide considerable improvement over prior approaches to UEP for digital audio, further improvements are needed for certain implementations, such as the above-noted HIBOC systems and other similar systems.

### SUMMARY OF THE INVENTION

The present invention provides methods and apparatus for implementing UEP for a source coded bit stream such as that generated by a perceptual audio coder (PAC). In an illustrative embodiment, interference characteristics are determined for a set of  $n$  channels to be used to transmit audio information bits, where  $n$  is greater than or equal to two. The audio information bits are separated into  $n$  classes based on error sensitivity, for example, the impact of errors in particular audio data bits on perceived quality of an audio signal reconstructed from the transmission. The classes of bits are then assigned to the  $n$  channels such that the classes of bits having the greatest error sensitivity are transmitted over the channels which are the least susceptible to interference. The

interference characteristics associated with the  $n$  channels can be determined by, for example, measuring interference levels at different times and locations for one or more of the channels, or obtaining information regarding known interference levels for one or more of the channels. The channels may correspond to different frequency bands, time slots, code division slots or any other type of channels. The channel properties may also change with factors such as time and location within a coverage area.

In accordance with another aspect of the invention, the assignment of the classes of bits to the channels, as well as the characteristics of the classes and the channels, may be fixed or dynamic. For example, in applications in which the interference characteristics associated with one or more of the channels vary as a function of time, position within a coverage area, or other factors, the assignment of the classes of bits to the channels can be varied so as to ensure that the classes of bits having the greatest error sensitivity continue to be transmitted over the channels which are least susceptible to interference. As another example, amounts of channel resources used for particular classes of audio information bits can vary as a function of time.

The invention can provide UEP for different classes of information bits even in cases in which the same convolutional code, or the same CPPC code pair, is used to encode the classes, although different channel codes could also be used to encode the classes. The invention can be applied to other types of digital information, including, for example, video and image information. Moreover, the invention is applicable not only to perceptual coders but also to other types of source encoders using other compression techniques operating over a wide range of bit rates, and can be used with transmission channels other than radio broadcast channels.

#### BRIEF DESCRIPTION OF THE DRAWINGS

FIG. 1 illustrates a two-class frequency division unequal error protection (UEP) technique in accordance with the invention as applied to an exemplary hybrid in-band on-channel (HIBOC) digital audio broadcasting (DAB) system.

FIGS. 2 through 4 illustrate a number of possible alternative implementations of the two-class UEP technique of FIG. 1.

FIG. 5 is a block diagram of a communication system in which an  $n$ -class frequency division UEP technique is implemented in accordance with an illustrative embodiment of the invention.

#### DETAILED DESCRIPTION OF THE INVENTION

The invention will be described below in conjunction with exemplary unequal error protection (UEP) techniques for use in the transmission of audio information bits, e.g., audio bits generated by an audio coder such as the perceptual audio coder (PAC) described in D. Sinha, J.D. Johnston, S. Dorrward and S.R. Quackenbush, "The Perceptual Audio Coder," in *Digital Audio*, Section 42, pp. 42-1 to 42-18, CRC Press, 1998. It should be understood, however, that the UEP techniques of the invention may be applied to many other types of information, e.g., video or image information, and other types of coding devices. In addition, the invention may be utilized with a wide variety of different types of communication applications, including communications over the Internet and other computer networks, and over cellular multimedia, satellite, wireless cable, wireless local

loop, high-speed wireless access and other types of communication systems. Although illustrated at least in part using frequency bands as channels, the invention may also be applied to many other types of channels, such as, for example, time slots, code division multiple access (CDMA) slots, and virtual connections in asynchronous transfer mode (ATM) or other packet-based transmission systems. The term "channel" as used herein should be understood to include any identifiable portion or portions of a communication medium which is used to transmit one or more signals and has an interference characteristic associated therewith, and is thus intended to include, for example, a sub-channel, segment or other portion of a larger channel.

FIG. 1 illustrates channel classification UEP in accordance with an illustrative embodiment of the invention. In this embodiment, which is particularly well-suited for use in HIBOC DAB applications, the channels correspond generally to frequency bands, and the UEP technique is therefore referred to as frequency division UEP. Unlike certain of the approaches described in the above-cited U.S. patent application Ser. No. 09/022,114, which can generally be characterized as time division UEP in which enhanced error protection may be provided for a certain class or classes of audio bits transmitted using a number of different channels, frequency division UEP in accordance with the invention provides enhanced error protection for a given class of bits by assigning that class of bits to a particular channel for transmission.

In the embodiment of FIG. 1, a portion of a frequency spectrum in an exemplary HIBOC DAB system is shown, including an analog host FM signal **100** with associated lower sidebands **102L**, **104L** and corresponding upper sidebands **102U**, **104U**. The sidebands represent portions of the frequency spectrum used to transmit digital audio information, and the sets of sidebands **102L**, **102U** and **104L**, **104U** correspond generally to frequency channels **102**, **104**, respectively, used to transmit the digital audio information. In accordance with the invention, a determination is made as to the interference characteristics associated with each of the frequency channels **102** and **104**. This determination may be based, for example, on actual measurements of average signal-to-interference ratios within the channels, on known or estimated interference levels, or on any other information which provides an indication of relative or absolute interference levels for the channels. For example, it has been estimated based on previous experience with HIBOC systems that the portion of the spectrum of FIG. 1 at the highest and lowest frequencies is typically more susceptible to interference than the portion closest to the analog host FM signal **100**. It will therefore be assumed that one of the channels, i.e., channel **102** in this example, has been determined to be less susceptible to interference than channel **104**.

The illustrative embodiment of the invention, after determining the relative or absolute interference levels associated with  $n$  channels, where  $n \geq 2$ , to be used for transmission of digital audio information, separates the audio information into  $n$  classes of bits based on error sensitivity, and then assigns the  $n$  classes of bits to the  $n$  channels such that the bits most sensitive to errors are transmitted in the channels which are least susceptible to interference. In the FIG. 1 example, the audio information bits are separated into two classes, designated class I and class II, with class I including the bits most sensitive to errors. The determination of error sensitivity may be based on perceptual audio coding considerations such as those described in the above-cited U.S. patent application Ser. No. 09/022,114. For example, class I

# Explore Litigation Insights

Docket Alarm provides insights to develop a more informed litigation strategy and the peace of mind of knowing you're on top of things.

## Real-Time Litigation Alerts



Keep your litigation team up-to-date with **real-time alerts** and advanced team management tools built for the enterprise, all while greatly reducing PACER spend.

Our comprehensive service means we can handle Federal, State, and Administrative courts across the country.

## Advanced Docket Research



With over 230 million records, Docket Alarm's cloud-native docket research platform finds what other services can't. Coverage includes Federal, State, plus PTAB, TTAB, ITC and NLRB decisions, all in one place.

Identify arguments that have been successful in the past with full text, pinpoint searching. Link to case law cited within any court document via Fastcase.

## Analytics At Your Fingertips



Learn what happened the last time a particular judge, opposing counsel or company faced cases similar to yours.

Advanced out-of-the-box PTAB and TTAB analytics are always at your fingertips.

## API

Docket Alarm offers a powerful API (application programming interface) to developers that want to integrate case filings into their apps.

## LAW FIRMS

Build custom dashboards for your attorneys and clients with live data direct from the court.

Automate many repetitive legal tasks like conflict checks, document management, and marketing.

## FINANCIAL INSTITUTIONS

Litigation and bankruptcy checks for companies and debtors.

## E-DISCOVERY AND LEGAL VENDORS

Sync your system to PACER to automate legal marketing.