

# What is the Difference Between Linear and Switching Regulators?

A DC/DC converter that stabilizes the voltage is often referred to as a voltage regulator.

Two types of regulators exist, classified by a conversion method: linear or switching.

## Linear Regulator

As its name suggests, a linear regulator is one where a linear component (such as a resistive load) is used to regulate the output.

It is also sometimes called a series regulator because the control elements are arranged in series between the input and output.

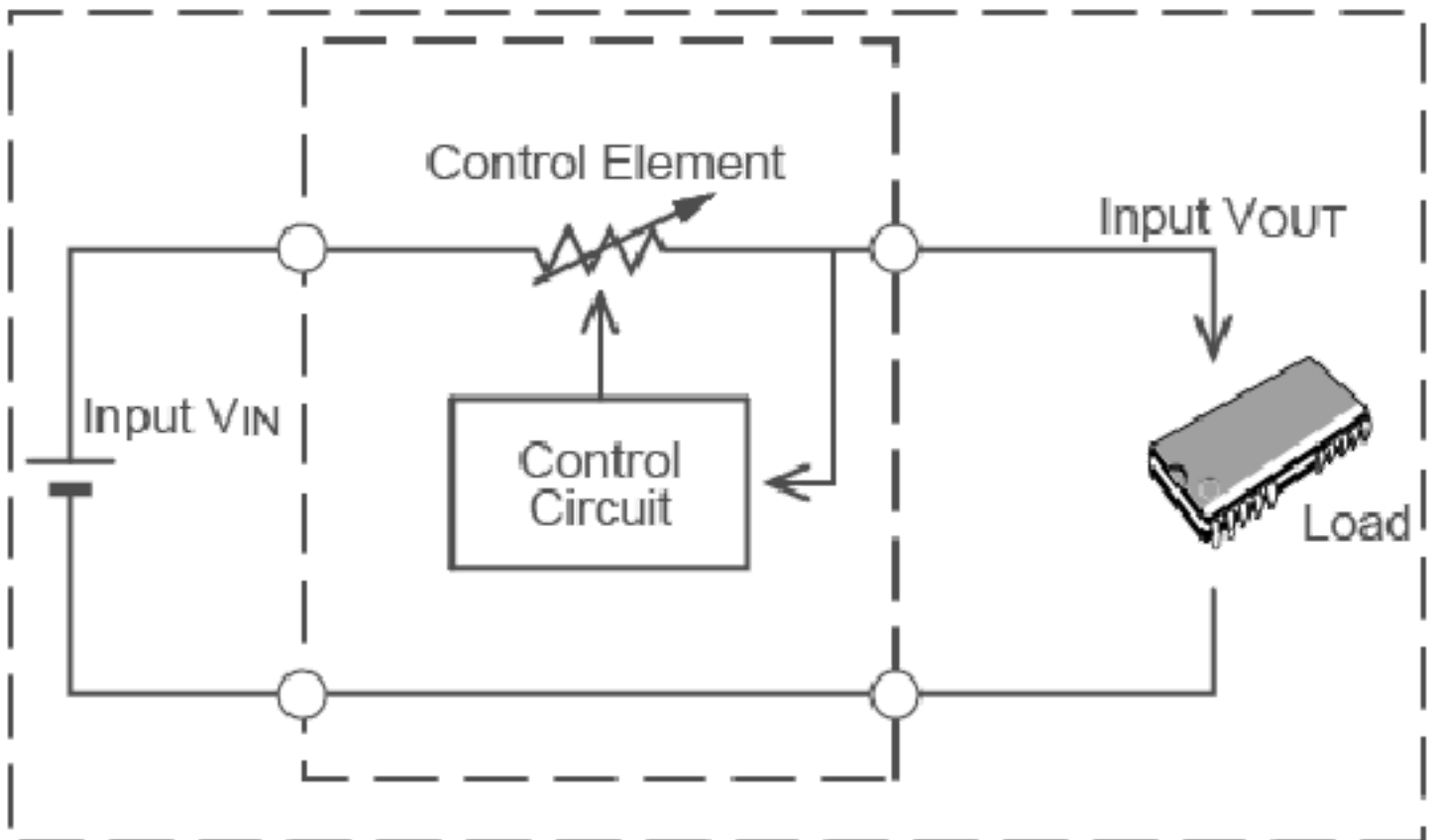

Advantages	Disadvantages
<ul style="list-style-type: none"><li>• Simple circuit configuration</li><li>• Few external parts</li><li>• Low noise</li></ul>	<ul style="list-style-type: none"><li>• Relatively poor efficiency</li><li>• Considerable heat generation</li><li>• Only step-down (buck) operation</li></ul>

## Switching Regulator

A switching regulator is a voltage regulator that uses a switching element to transform the incoming power supply

Power is supplied from the input to the output by turning ON a switch (MOSFET) until the desired voltage is reached.

Once the output voltage reaches the predetermined value the switch element is turned OFF and no input power is consumed.

Repeating this operation at high speeds makes it possible to supply voltage efficiently and with less heat generation.

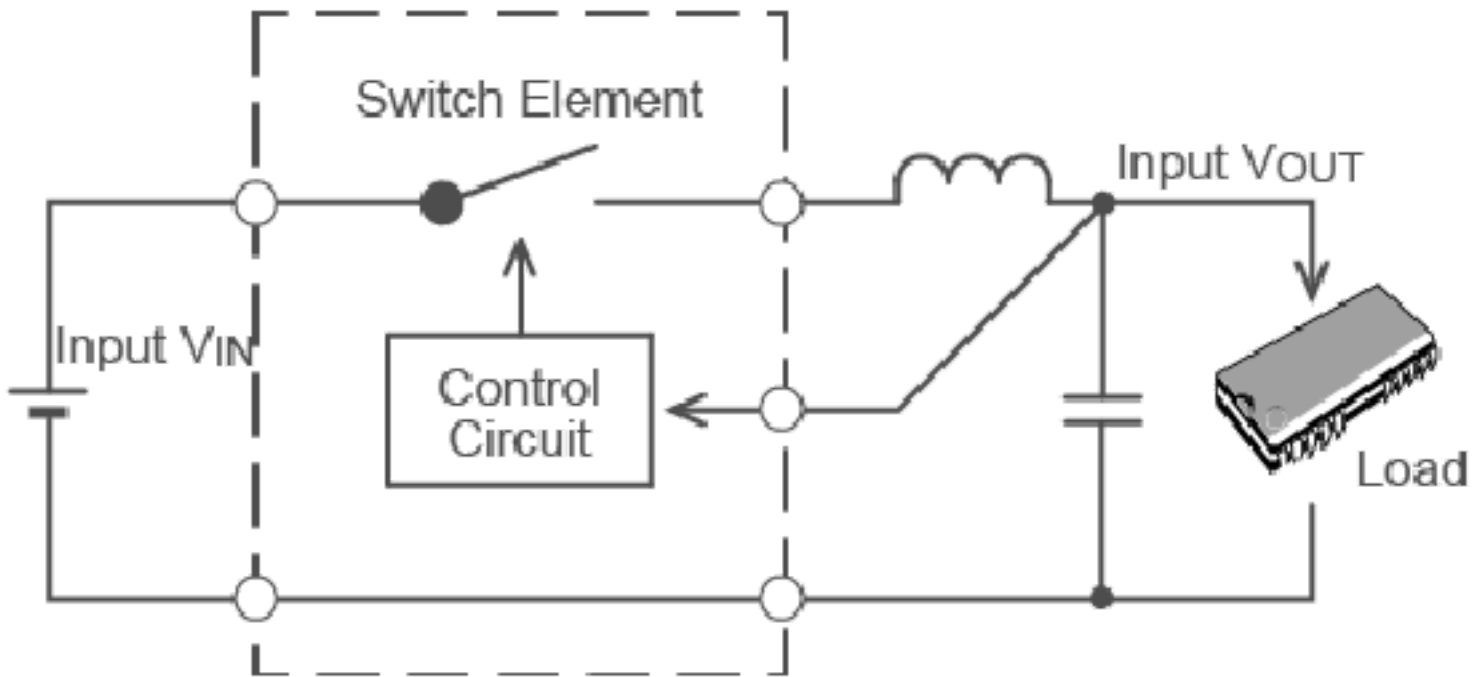

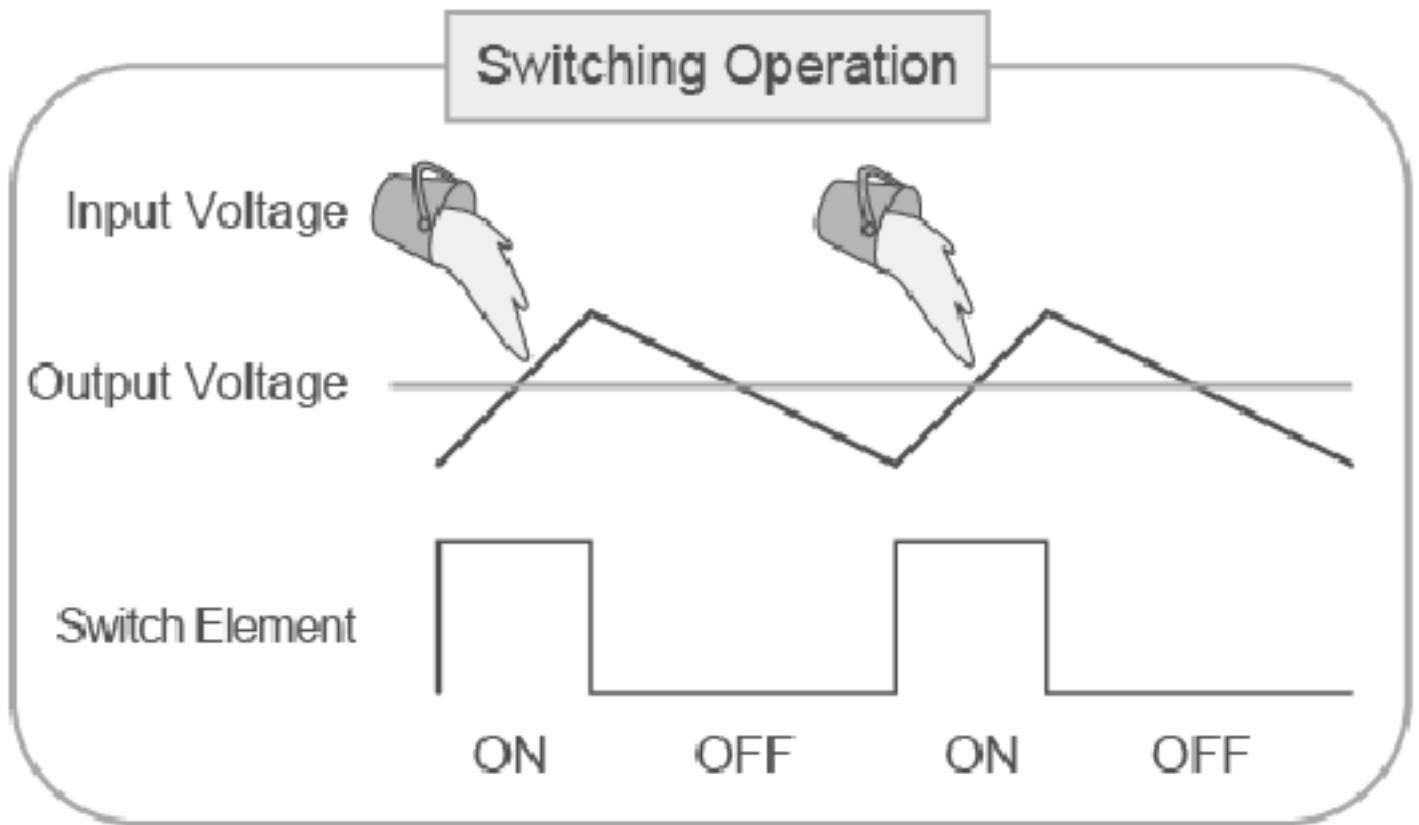

Advantages	Disadvantages
<ul style="list-style-type: none"> <li>• High efficiency</li> <li>• Low heat generation</li> <li>• Boost/buck/negative voltage operation possible</li> </ul>	<ul style="list-style-type: none"> <li>• More external parts required</li> <li>• Complicated design</li> <li>• Increased noise</li> </ul>

Previous

Next

## Electronics Basics

### What is a DC/DC converter?

What is a DC/DC converter?

What is the Difference Between Linear and Switching Regulators?

Operating Principle of Linear Regulators

Linear Regulator Classifications

What is an LDO?

