

Introduction to Space-Time Wireless Communications

Arogyaswami Paulraj, Rohit Nabar and Dhananjay Gore

CAMBRIDGE

Introduction to Space-Time Wireless Communications

Arogyaswami Paulraj

Stanford University

Rohit Nabar

ETH, Zurich

Dhananjay Gore

Stanford University



PUBLISHED BY THE PRESS SYNDICATE OF THE UNIVERSITY OF CAMBRIDGE
The Pitt Building, Trumpington Street, Cambridge, United Kingdom

CAMBRIDGE UNIVERSITY PRESS

The Edinburgh Building, Cambridge CB2 2RU, UK

40 West 20th Street, New York, NY 10011-4211, USA

477 Williamstown Road, Port Melbourne, VIC 3207, Australia

Ruiz de Alarcón 13, 28014 Madrid, Spain

Dock House, The Waterfront, Cape Town 8001, South Africa

<http://www.cambridge.org>

© Cambridge University Press 2003

This book is in copyright. Subject to statutory exception
and to the provisions of relevant collective licensing agreements,
no reproduction of any part may take place without
the written permission of Cambridge University Press.

First published 2003

Printed in the United Kingdom at the University Press, Cambridge

Typefaces Times 10.5/14 pt and Helvetica Neue *System* L^AT_EX 2_ε [TB]

A catalog record for this book is available from the British Library

ISBN 0 521 82615 2 hardback

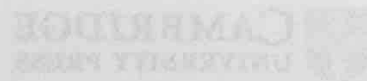

Contents

<i>List of figures</i>	<i>page</i>	xiv
<i>List of tables</i>		xxii
<i>Preface</i>		xxiii
<i>List of abbreviations</i>		xxvi
<i>List of symbols</i>		xxix

1 Introduction

1.1 History of radio, antennas and array signal processing	1
1.2 Exploiting multiple antennas in wireless	6
1.2.1 Array gain	7
1.2.2 Diversity gain	7
1.2.3 Spatial multiplexing (SM)	8
1.2.4 Interference reduction	8
1.3 ST wireless communication systems	9

2 ST propagation

2.1 Introduction	11
2.2 The wireless channel	11
2.2.1 Path loss	12
2.2.2 Fading	12
2.3 Scattering model in macrocells	18
2.4 Channel as a ST random field	20
2.4.1 Wide sense stationarity (WSS)	22
2.4.2 Uncorrelated scattering (US)	22
2.4.3 Homogeneous channels (HO)	23
2.5 Scattering functions	24

2.6 Polarization and field diverse channels	27
2.7 Antenna array topology	28
2.8 Degenerate channels	29
2.9 Reciprocity and its implications	31

3 ST channel and signal models 32

3.1 Introduction	32
3.2 Definitions	32
3.2.1 SISO channel	32
3.2.2 SIMO channel	33
3.2.3 MISO channel	33
3.2.4 MIMO channel	34
3.3 Physical scattering model for ST channels	34
3.3.1 SIMO channel	37
3.3.2 MISO channel	37
3.3.3 MIMO channel	38
3.4 Extended channel models	40
3.4.1 Spatial fading correlation	40
3.4.2 LOS component	41
3.4.3 Cross-polarized antennas	41
3.4.4 Degenerate channels	43
3.5 Statistical properties of \mathbf{H}	43
3.5.1 Singular values of \mathbf{H}	43
3.5.2 Squared Frobenius norm of \mathbf{H}	44
3.6 Channel measurements and test channels	45
3.7 Sampled signal model	48
3.7.1 Normalization	48
3.7.2 SISO sampled signal model	49
3.7.3 SIMO sampled signal model	51
3.7.4 MISO sampled signal model	52
3.7.5 MIMO sampled signal model	53
3.8 ST multiuser and ST interference channels	54
3.8.1 ST multiuser channel	54
3.8.2 ST interference channel	55
3.9 ST channel estimation	56
3.9.1 Estimating the ST channel at the receiver	56
3.9.2 Estimating the ST channel at the transmitter	58

4	Capacity of ST channels	63
4.1	Introduction	63
4.2	Capacity of the frequency flat deterministic MIMO channel	63
4.3	Channel unknown to the transmitter	65
4.4	Channel known to the transmitter	66
4.4.1	Capacities of SIMO and MISO channels	70
4.5	Capacity of random MIMO channels	71
4.5.1	Capacity of \mathbf{H}_w channels for large M	71
4.5.2	Statistical characterization of the information rate	72
4.6	Influence of Ricean fading, fading correlation, XPD and degeneracy on MIMO capacity	77
4.6.1	Influence of the spatial fading correlation	77
4.6.2	Influence of the LOS component	78
4.6.3	Influence of XPD in a non-fading channel	80
4.6.4	Influence of degeneracy	80
4.7	Capacity of frequency selective MIMO channels	81
5	Spatial diversity	86
5.1	Introduction	86
5.2	Diversity gain	86
5.2.1	Coding gain vs diversity gain	89
5.2.2	Spatial diversity vs time/frequency diversity	90
5.3	Receive antenna diversity	90
5.4	Transmit antenna diversity	92
5.4.1	Channel unknown to the transmitter: MISO	93
5.4.2	Channel known to the transmitter: MISO	95
5.4.3	Channel unknown to the transmitter: MIMO	97
5.4.4	Channel known to the transmitter: MIMO	98
5.5	Diversity order and channel variability	100
5.6	Diversity performance in extended channels	102
5.6.1	Influence of signal correlation and gain imbalance	102
5.6.2	Influence of Ricean fading	104
5.6.3	Degenerate MIMO channels	105
5.7	Combined space and path diversity	106

5.8	Indirect transmit diversity	108
5.8.1	Delay diversity	108
5.8.2	Phase-roll diversity	108
5.9	Diversity of a space-time-frequency selective fading channel	109

6	ST coding without channel knowledge at transmitter	112
----------	---	------------

6.1	Introduction	112
6.2	Coding and interleaving architecture	113
6.3	ST coding for frequency flat channels	114
6.3.1	Signal model	114
6.3.2	ST codeword design criteria	115
6.3.3	ST diversity coding ($r_s \leq 1$)	117
6.3.4	Performance issues	123
6.3.5	Spatial multiplexing as a ST code ($r_s = M_T$)	123
6.3.6	ST coding for intermediate rates ($1 < r_s < M_T$)	126
6.4	ST coding for frequency selective channels	129
6.4.1	Signal model	129
6.4.2	ST codeword design criteria	131

7	ST receivers	137
----------	---------------------	------------

7.1	Introduction	137
7.2	Receivers: SISO	137
7.2.1	Frequency flat channel	137
7.2.2	Frequency selective channel	138
7.3	Receivers: SIMO	143
7.3.1	Frequency flat channel	143
7.3.2	Frequency selective channels	144
7.4	Receivers: MIMO	148
7.4.1	ST diversity schemes	148
7.4.2	SM schemes	149
7.4.3	SM with horizontal and diagonal encoding	158
7.4.4	Frequency selective channel	159
7.5	Iterative MIMO receivers	159

8	Exploiting channel knowledge at the transmitter	163
8.1	Introduction	163
8.2	Linear pre-filtering	163
8.3	Optimal pre-filtering for maximum rate	165
8.3.1	Full channel knowledge	165
8.3.2	Partial channel knowledge	166
8.4	Optimal pre-filtering for error rate minimization	168
8.4.1	Full channel knowledge	168
8.4.2	Partial channel knowledge	168
8.5	Selection at the transmitter	171
8.5.1	Selection between SM and diversity coding	171
8.5.2	Antenna selection	172
8.6	Exploiting imperfect channel knowledge	175
9	ST OFDM and spread spectrum modulation	178
9.1	Introduction	178
9.2	SISO-OFDM modulation	178
9.3	MIMO-OFDM modulation	182
9.4	Signaling and receivers for MIMO-OFDM	184
9.4.1	Spatial diversity coding for MIMO-OFDM	184
9.4.2	SM for MIMO-OFDM	186
9.4.3	Space-frequency coded MIMO-OFDM	186
9.5	SISO-SS modulation	188
9.5.1	Frequency flat channel	188
9.5.2	Frequency selective channel	191
9.6	MIMO-SS modulation	193
9.7	Signaling and receivers for MIMO-SS	194
9.7.1	Spatial diversity coding for MIMO-SS	194
9.7.2	SM for MIMO-SS	197
10	MIMO-multiuser	199
10.1	Introduction	199

10.2	MIMO-MAC	201
10.2.1	Signal model	201
10.2.2	Capacity region	202
10.2.3	Signaling and receiver design	207
10.3	MIMO-BC	208
10.3.1	Signal model	208
10.3.2	Forward link capacity	208
10.3.3	Signaling and receiver design	209
10.4	Outage performance of MIMO-MU	213
10.4.1	MU vs SU – single cell	214
10.4.2	MU single cell vs SU multicell	215
10.5	MIMO-MU with OFDM	216
10.6	CDMA and multiple antennas	216

11 ST co-channel interference mitigation 218

11.1	Introduction	218
11.2	CCI characteristics	219
11.3	Signal models	219
11.3.1	SIMO interference model (reverse link)	220
11.3.2	MIMO interference channel (any link)	222
11.3.3	MISO interference channel (forward link)	223
11.4	CCI mitigation on receive for SIMO	224
11.4.1	Frequency flat channel	224
11.4.2	Frequency selective channel	226
11.5	CCI mitigating receivers for MIMO	228
11.5.1	Alamouti coded signal and interference ($M_T = 2$)	229
11.6	CCI mitigation on transmit for MISO	230
11.6.1	Transmit-MRC or matched beamforming	230
11.6.2	Transmit ZF or nulling beamformer	231
11.6.3	Max SINR beamforming with coordination	232
11.7	Joint encoding and decoding	233
11.8	SS modulation	233
11.8.1	ST-RAKE	234
11.8.2	ST pre-RAKE	235
11.9	OFDM modulation	237
11.10	Interference diversity and multiple antennas	237

12	Performance limits and tradeoffs in MIMO channels	240
12.1	Introduction	240
12.2	Error performance in fading channels	240
12.3	Signaling rate vs PER vs SNR	241
12.4	Spectral efficiency of ST coding/receiver techniques	244
12.4.1	D-BLAST	244
12.4.2	OSTBC	245
12.4.3	ST receivers for SM	246
12.4.4	Receiver comparison: Varying M_T/M_R	249
12.5	System design	250
12.6	Comments on capacity	251
	<i>References</i>	254
	<i>Index of common variables</i>	271
	<i>Subject index</i>	272

$r(\mathbf{A})$	rank of the matrix \mathbf{A}
\mathcal{R}	real field
$\Re\{\mathbf{A}\}, \Im\{\mathbf{A}\}$	real and imaginary parts of \mathbf{A} , respectively
$\text{Tr}(\mathbf{A})$	trace of \mathbf{A}
$u(x)$	unit step function, defined as $u(x) = \begin{cases} 1 & \text{if } x \geq 0, x \in \mathcal{R} \\ 0 & \text{if } x < 0, x \in \mathcal{R} \end{cases}$
$\text{vec}(\mathbf{A})$	stacks \mathbf{A} into a vector columnwise ¹
$(x)_+$	defined as $(x)_+ = \begin{cases} x & \text{if } x \geq 0, x \in \mathcal{R} \\ 0 & \text{if } x < 0, x \in \mathcal{R} \end{cases}$
\mathcal{Z}	integer field

¹ If $\mathbf{A} = [\mathbf{a}_1 \ \mathbf{a}_2 \ \dots \ \mathbf{a}_n]$ is $m \times n$, then $\text{vec}(\mathbf{A}) = [\mathbf{a}_1^T \ \mathbf{a}_2^T \ \dots \ \mathbf{a}_n^T]^T$ is $mn \times 1$.

1 Introduction

The radio age began over a 100 years ago with the invention of the radiotelegraph by Guglielmo Marconi and the wireless industry is now set for rapid growth as we enter a new century and a new millennium. The rapid progress in radio technology is creating new and improved services at lower costs, which results in increases in air-time usage and the number of subscribers. Wireless revenues are currently growing between 20% and 30% per year, and these broad trends are likely to continue for several years.

Multiple access wireless communications is being deployed for both fixed and mobile applications. In fixed applications, the wireless networks provide voice or data for fixed subscribers. Mobile networks offering voice and data services can be divided into two classes: high mobility, to serve high speed vehicle-borne users, and low mobility, to serve pedestrian users. Wireless system designers are faced with a number of challenges. These include the limited availability of the radio frequency spectrum and a complex time-varying wireless environment (fading and multipath). In addition, meeting the increasing demand for higher data rates, better quality of service (QoS), fewer dropped calls, higher network capacity and user coverage calls for innovative techniques that improve spectral efficiency and link reliability. The use of multiple antennas at the receiver and/or transmitter in a wireless system, popularly known as space-time (ST) wireless or multiantenna communications or smart antennas is an emerging technology that promises significant improvements in these measures. This book is an introduction to the theory of ST wireless communications.

1.1 History of radio, antennas and array signal processing

The origins of radio date back to 1861 when Maxwell, while at King's College in London, proposed a mathematical theory of electromagnetic (EM) waves. A practical demonstration of the existence of such waves was performed by Hertz in 1887 at the University of Karlsruhe, using stationary (standing) waves. Following this, improvements in the generation and reception of EM waves were pursued by many researchers in Europe. In 1890, Branly in Paris developed a "coherer" that could detect the presence of EM waves using iron filings in a glass bottle. The coherer was further refined by

Righi at the University of Bologna and Lodge in England. Other contributions came from Popov in Russia, who is credited with devising the first radio antenna during his attempts to detect EM radiation from lightning.

In the summer of 1895, Marconi, at the age of 21, was inspired by the lectures on radio waves by Righi at the University of Bologna and he built and demonstrated the first radio telegraph. He used Hertz's spark transmitter, Lodge's coherer and added antennas to assemble his instrument. In 1898, Marconi improved the telegraph by adding a four-circuit tuning device, allowing simultaneous use of two radio circuits. That year, his signal bridged the English Channel, 52 km wide, between Wimereux and Dover. His other technical developments around this time included the magnetic detector, which was an improvement over the less efficient coherer, the rotatory spark and the use of directive antennas to increase the signal level and to reduce interference in duplex receiver circuits. In the next few years, Marconi integrated many new technologies into his increasingly sophisticated radio equipment, including the diode valve developed by Fleming, the crystal detector, continuous wave (CW) transmission developed by Poulsen, Fessenden and Alexanderson, and the triode valve or audio developed by Forrest.

Civilian use of wireless technology began with the installation of the first 2 MHz land mobile radiotelephone system in 1921 by the Detroit Police Department for police car dispatch. The advantages of mobile communications were quickly realized, but its wider use was limited by the lack of channels in the low frequency band. Gradually, higher frequency bands were used, opening up the use of more channels. A key advance was made in 1933, when Armstrong invented frequency modulation (FM), which made possible high quality radio communications. In 1946, a Personal Correspondence System introduced by Bell Systems began service and operated at 150 MHz with speech channels 120 kHz apart. As demand for public wireless services began to grow, the Improved Mobile Telephone Service (IMTS) using FM technology was developed by AT&T. These were the first mobile systems to connect with the public telephone network using a fixed number of radio channels in a single geographic area. Extending such technology to a large number of users with full duplex channels needed excessive bandwidth. A solution was found in the cellular concept (known as cellularization) conceived by Ring at Bell Laboratories in 1947. This concept required dividing the service area into smaller cells, and using a subset of the total available radio channels in each cell. AT&T proposed the first high capacity analog cellular telephone system called the Advanced Mobile Phone Service (AMPS) in 1970. Mobile cellular systems have evolved rapidly since then, incorporating digital communication technology and serve nearly one billion subscribers worldwide today. While the Global System for Mobile (GSM) standard developed in Europe has gathered the largest market share, cellular networks in the USA have used the IS-136 (using time division multiple access or TDMA) and IS-95 (using Code Division Multiple Access or CDMA) standards. With increasing use of wireless internet in the late 1990s, the demand for higher spectral efficiency and data rates has led to the development of the so called Third Generation (3G)

Table 1.1. *Performance goals for antennas in wireless communications*

Antenna design	AOA estimation	Link performance
Gain	Error variance	Coverage
Bandwidth	Bias	Quality
Radiation pattern	Resolution	Interference reduction
Size		Spectral efficiency

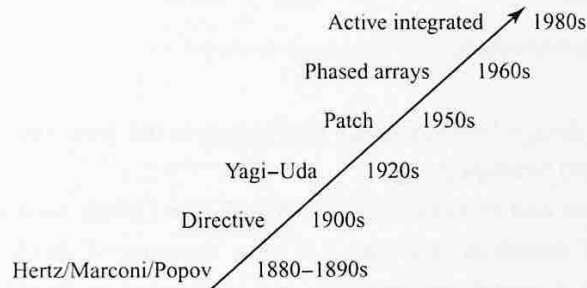
**Figure 1.1:** Developments in antenna (EM) technology.

wireless technologies. 3G standardization failed to achieve a single common world-wide standard and now offers UMTS (wideband CDMA) and 1XRTT as the primary standards. Limitations in the radio frequency (RF) spectrum necessitate the use of innovative techniques to meet the increased demand in data rate and QoS.

The use of multiple antennas at the transmitter and/or receiver in a wireless communication link opens a new dimension – space, which if leveraged correctly can improve performance substantially. Table 1.1 details the three main areas of study in the field of radio antennas and their applications. The first covers the electromagnetic design of the antennas and antenna arrays. The goals here are to meet design requirements for gain, polarization, beamwidth, sidelobe level, efficiency and radiation pattern. The second area is the angle-of-arrival (AOA) estimation and, as the name indicates, focuses on estimating arrival angles of wavefronts impinging on the antenna array with minimum error and high resolution. The third area of technology that this book focuses on is the use of antenna arrays to improve spectral efficiency, coverage and quality of wireless links.

A timeline of the key developments in the field of antenna design is given in Fig. 1.1. The original antenna design work came from Marconi and Popov among others in the early 1900s. Marconi soon developed directional antennas for his cross-Atlantic links. Antenna design improved in frequency of operation and bandwidth in the early part of the twentieth century. An important breakthrough was the Yagi–Uda arrays that offered high bandwidth and gain. Another important development was the patch antenna that offers low profile and cost. The use of antennas in arrays began in World War II, mainly

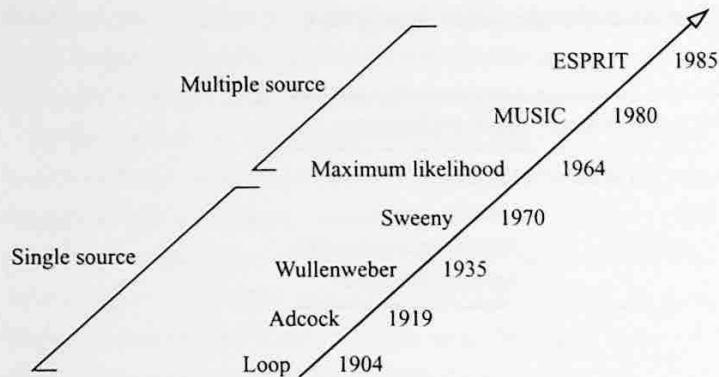

Figure 1.2: Developments in AOA estimation.

for radar applications. Array design brought many new issues to the fore, such as gain, beamwidth, sidelobe level, and beamsteering.

The area of AOA estimation had its beginnings in World War I when loop antennas were used to estimate signal direction (see Fig. 1.2 for a timeline of AOA technology). Adcock antennas were a significant advance and were used in World War II. Wullenweber arrays were developed in 1938 for lower frequencies and where accuracy was important, and are used in aircraft localization to this day. These techniques addressed the single source signal wavefront case. If there are multiple sources in the same frequency channel or multipath arrivals from a single source, new techniques are needed. The problem of AOA estimation in the multisource case was properly addressed in the 1970s and 1980s. Capon's method [Capon *et al.*, 1967], a well-known technique, offered reasonable resolution performance although it suffered from bias even in asymptotically large data cases. The multiple signal classification (MUSIC) technique proposed by Schmidt in 1981 was a major breakthrough. MUSIC is asymptotically unbiased and offers improved resolution performance. Later a method called estimation of signal parameters via rotational invariance techniques (ESPRIT) that has the remarkable advantage of not needing exact characterization of the array manifold and yet achieves optimal performance was proposed [Paulraj *et al.*, 1986; Roy *et al.*, 1986].

The third area of antenna applications in wireless communications is link enhancement (see Fig. 1.3). The use of multiple receive antennas for diversity goes back to Marconi and the early radio pioneers. So does the realization that steerable receive antenna arrays can be used to mitigate co-channel interference in radio systems. The use of antenna arrays was an active research area during and after World War II in radar systems. More sophisticated applications of adaptive signal processing at the wireless receiver for improving diversity and interference reduction had to wait until the 1970s for the arrival of digital signal processors at which point these techniques were vigorously developed for military applications. The early 1990s saw new proposals for using antennas to increase capacity of wireless links. Roy and Ottersten in 1996 proposed the use of base-station antennas to support multiple co-channel users. Paulraj and Kailath in

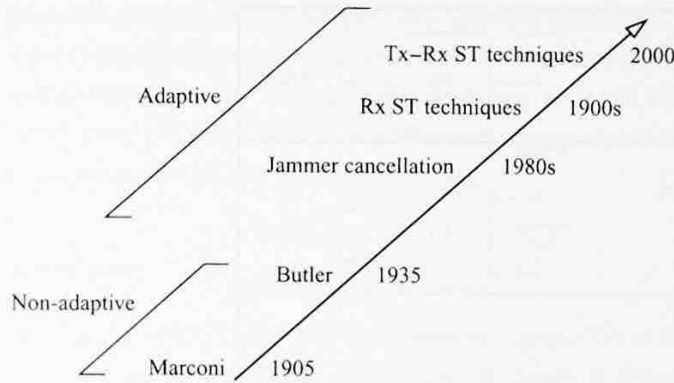

Figure 1.3: Developments in antenna technology for link performance.

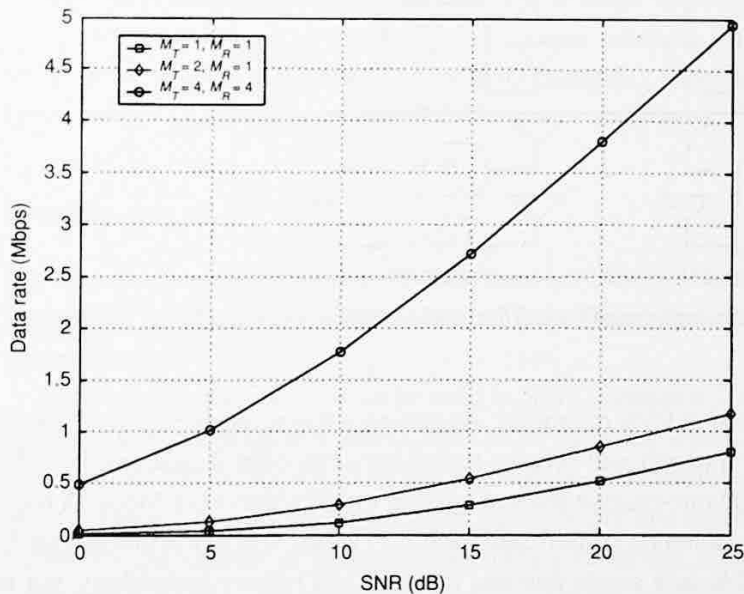

Figure 1.4: Data rate (at 95% reliability) vs SNR for different antenna configurations. Channel bandwidth is 200 KHz.

1994 proposed a technique for increasing the capacity of a wireless link using multiple antennas at both the transmitter and the receiver. These ideas along with the fundamental research done at Bell Labs [Telatar, 1995; Foschini, 1996; Foschini and Gans, 1998; Tarokh *et al.*, 1998] began a new revolution in information and communications theory in the mid 1990s. The goal is to approach performance limits and to explore efficient but pragmatic coding and modulation schemes for wireless links using multiple antennas. Clearly much more work has yet to be done and the field is attracting considerable research talent.

The leverage of ST wireless technology is significant. Figure 1.4 plots the maximum error-free data rate in a 200 KHz fading channel vs the signal to noise ratio (SNR)

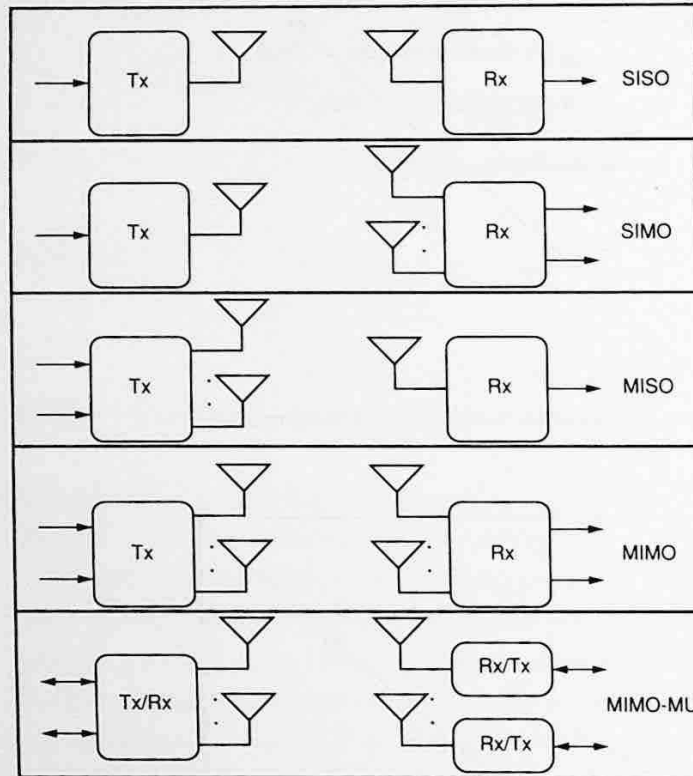

Figure 1.5: Antenna configurations in ST wireless systems (Tx: Transmitter, Rx: Receiver).

that is guaranteed at 95% reliability. Assuming a target receive SNR of 20 dB, current single antenna transmit and receive technology can offer a data rate of 0.5 Mbps. A two-transmit and one-receive antenna system would achieve 0.8 Mbps. A four-transmit and four-receive antenna system can reach 3.75 Mbps. It is worth noting that 3.75 Mbps is also achievable in a single antenna transmit and receive technology, but needs 10^5 times higher SNR or transmit power compared with a four-transmit and four-receive antenna configuration. The technology that can deliver such remarkable gains is the subject of this book.

1.2 Exploiting multiple antennas in wireless

Figure 1.5 illustrates different antenna configurations for ST wireless links. SISO (single input single output) is the familiar wireless configuration, SIMO (single input multiple output) has a single transmit antenna and multiple (M_R) receive antennas, MISO (multiple input single output) has multiple (M_T) transmit antennas and a single receive antenna and MIMO (multiple input multiple output) has multiple (M_T)

transmit antennas and multiple (M_R) receive antennas. The MIMO-MU (MIMO multiuser) configuration refers to the case where a base-station with multiple (M) antennas communicates with P users each with one or more antennas. Both transmit and receive configurations are shown. We sometimes abbreviate SIMO, MISO and MIMO configurations as XIXO.

1.2.1 Array gain

Array gain refers to the average increase in the SNR at the receiver that arises from the coherent combining effect of multiple antennas at the receiver or transmitter or both. Consider, as an example, a SIMO channel. Signals arriving at the receive antennas have different amplitudes and phases. The receiver can combine the signals coherently so that the resultant signal is enhanced. The average increase in signal power at the receiver is proportional to the number of receive antennas. In channels with multiple antennas at the transmitter (MISO or MIMO channels), array gain exploitation requires channel knowledge at the transmitter.

1.2.2 Diversity gain

Signal power in a wireless channel fluctuates (or fades). When the signal power drops significantly, the channel is said to be in a fade. Diversity is used in wireless channels to combat fading.

Receive antenna diversity can be used in SIMO channels [Jakes, 1974]. The receive antennas see independently faded versions of the same signal. The receiver combines these signals so that the resultant signal exhibits considerably reduced amplitude variability (fading) in comparison with the signal at any one antenna. Diversity is characterized by the number of independently fading branches, also known as the diversity order and is equal to the number of receive antennas in SIMO channels.

Transmit diversity is applicable to MISO channels and has become an active area for research [Wittneben, 1991; Seshadri and Winters, 1994; Kuo and Fitz, 1997; Olofsson *et al.*, 1997; Heath and Paulraj, 1999]. Extracting diversity in such channels is possible with or without channel knowledge at the transmitter. Suitable design of the transmitted signal is required to extract diversity. ST diversity coding [Seshadri and Winters, 1994; Guey *et al.*, 1996; Alamouti, 1998; Tarokh *et al.*, 1998, 1999b] is a transmit diversity technique that relies on coding across space (transmit antennas) to extract diversity in the absence of channel knowledge at the transmitter. If the channels of all transmit antennas to the receive antenna have independent fades, the diversity order of this channel is equal to the number of transmit antennas.

Utilization of diversity in MIMO channels requires a combination of the receive and transmit diversity described above. The diversity order is equal to the product of the

number of transmit and receive antennas, if the channel between each transmit–receive antenna pair fades independently.

1.2.3 Spatial multiplexing (SM)

SM offers a linear (in the number of transmit–receive antenna pairs or $\min(M_R, M_T)$) increase in the transmission rate (or capacity) for the same bandwidth and with no additional power expenditure. SM is only possible in MIMO channels [Paulraj and Kailath, 1994; Foschini, 1996; Telatar, 1999a]. In the following we discuss the basic principles of SM for a system with two transmit and two receive antennas. The concept can be extended to more general MIMO channels.

The bit stream to be transmitted is demultiplexed into two half-rate sub-streams, modulated and transmitted simultaneously from each transmit antenna. Under favorable channel conditions, the spatial signatures of these signals induced at the receive antennas are well separated. The receiver, having knowledge of the channel, can differentiate between the two co-channel signals and extract both signals, after which demodulation yields the original sub-streams that can now be combined to yield the original bit stream. Thus SM increases transmission rate proportionally with the number of transmit–receive antenna pairs.

SM can also be applied in a multiuser format (MIMO-MU, also known as space division multiple access or SDMA). Consider two users transmitting their individual signals, which arrive at a base-station equipped with two antennas. The base-station can separate the two signals to support simultaneous use of the channel by both users. Likewise the base-station can transmit two signals with spatial filtering so that each user can decode its own signal adequately. This allows a capacity increase proportional to the number of antennas at the base-station and the number of users.

1.2.4 Interference reduction

Co-channel interference arises due to frequency reuse in wireless channels. When multiple antennas are used, the differentiation between the spatial signatures of the desired signal and co-channel signals can be exploited to reduce the interference. Interference reduction requires knowledge of the channel of the desired signal. However, exact knowledge of the interferer's channel may not be necessary.

Interference reduction (or avoidance) can also be implemented at the transmitter, where the goal is to minimize the interference energy sent towards the co-channel users while delivering the signal to the desired user. Interference reduction allows the use of aggressive reuse factors and improves network capacity.

We note that it may not be possible to exploit all the leverages simultaneously due to conflicting demands on the spatial degrees of freedom (or number of antennas). The degree to which these conflicts are resolved depends upon the signaling scheme and receiver design.

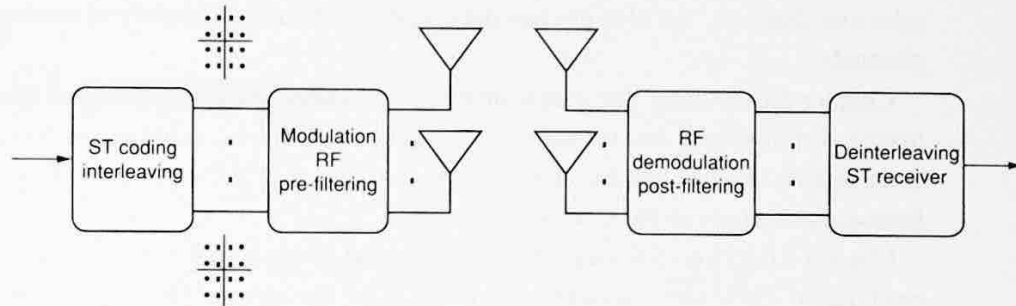

Figure 1.6: Schematic of a ST wireless communication system.

1.3 ST wireless communication systems

Figure 1.6 shows a typical ST wireless system with M_T transmit antennas and M_R receive antennas. The input data bits enter a ST coding block that adds parity bits for protection against noise and also captures diversity from the space and possibly frequency or time dimensions in a fading environment. After coding, the bits (or words) are interleaved across space, time and frequency and mapped to data symbols (such as quadrature amplitude modulation (QAM)) to generate M_T outputs. The M_T symbol streams may then be ST pre-filtered before being modulated with a pulse shaping function, translated to the passband via parallel RF chains and then radiated from M_T antennas. These signals pass through the radio channel where they are attenuated and undergo fading in multiple dimensions before they arrive at the M_R receive antennas. Additive thermal noise in the M_R parallel RF chains at the receiver corrupts the received signal. The mixture of signal plus noise is matched-filtered and sampled to produce M_R output streams. Some form of additional ST post-filtering may also be applied. These streams are then ST deinterleaved and ST decoded to produce the output data bits.

The difference between a ST communication system and a conventional system comes from the use of multiple antennas, ST encoding/interleaving, ST pre-filtering and post-filtering and ST decoding/deinterleaving.

We conclude this chapter with a brief overview of the areas discussed in the remainder of this book. Chapter 2 overviews ST propagation. We develop a channel representation as a vector valued ST random field and derive multiple representations and statistical descriptions of ST channels. We also describe real world channel measurements and models.

Chapter 3 introduces XIXO channels, derives channels from statistical ST channel descriptions, proposes general XIXO channel models and test channel models and ends with a discussion on XIXO channel estimation at the receiver and transmitter.

Chapter 4 studies channel capacity of XIXO channels under a variety of conditions: channel known and unknown to the transmitter, general channel models and frequency

selective channels. We also discuss the ergodic and outage capacity of random XIXO channels.

Chapter 5 overviews the spatial diversity for XIXO channels, bit error rate performance with diversity and the influence of general channel conditions on diversity and ends with techniques that can transform spatial diversity at the transmitter into time or frequency diversity at the receiver.

Chapter 6 develops ST coding for diversity, SM and hybrid schemes for single carrier modulation where the channel is not known at the transmitter. We discuss performance criteria in frequency flat and frequency selective fading environments.

Chapter 7 describes ST receivers for XIXO channels and for single carrier modulation. We discuss maximum likelihood (ML), zero forcing (ZF), minimum mean square error (MMSE) and successive cancellation (SUC) receiver structures. Performance analysis is also provided.

Chapter 8 addresses exploiting channel knowledge by the transmitter through transmit pre-processing, both for the case where the channel is perfectly known and the case where only statistical or partial channel knowledge is available.

Chapter 9 overviews how XIXO techniques can be applied to orthogonal frequency division multiplexing (OFDM) and spread spectrum (SS) modulation scheme. It also discusses how ST coding for single carrier modulation can be extended to the space-frequency or space-code dimensions.

Chapter 10 addresses MIMO-MU where multiple users (each with one or more antennas) communicate with the base (with multiple antennas). A quick summary of capacity, signaling and receivers is provided.

Chapter 11 discusses how multiple antennas can be used to reduce co-channel interference for XIXO signal and interference models. A short review of interference diversity is also provided.

Chapter 12 overviews performance limits of ST channels with optimal and sub-optimal signaling and receivers.

Wireless designers constantly seek to improve the spectrum efficiency/capacity, link reliability, and coverage of wireless networks. Space-time wireless technology that uses multiple antennas along with appropriate signaling and receiver techniques offers a powerful tool for improving wireless performance. Some aspects of this technology have already been incorporated into 3G mobile and fixed wireless standards. More advanced space-time techniques are planned for future mobile networks, wireless LANs and WANs.

The authors present the basics of space-time wireless propagation, the space-time channel, diversity and capacity performance, space-time coding, space-time receivers, interference cancellation for single carrier modulation, and extensions to OFDM and DS-spread spectrum modulation. They also cover space-time multi-user communications and system design tradeoffs.

This book is an introduction to this rapidly growing field for graduate students in wireless communications and for wireless designers in industry. Homework problems and other supporting material are available on a companion website.

Arogyaswami Paulraj is a pioneer of space-time wireless communications technology. He received his Ph.D. from the Indian Institute of Technology and is a Professor of Electrical Engineering at Stanford University, where he supervises the Smart Antennas Research Group. He is the author of nearly 300 research papers and holds 18 patents. He has held several positions in Indian industry, leading programs in military sonars and high-speed computing before moving to Stanford University. He founded Iospan Wireless to develop MIMO space-time technology for fixed wireless access. He is a Fellow of the IEEE and a member of the Indian National Academy of Engineering.

Rohit Nabar was a graduate student in the Smart Antennas Research Group and received his Ph.D. from Stanford University in February 2003. He is currently a post-doctoral researcher at ETH, Zurich.

Dhananjay Gore was a graduate student in the Smart Antennas Research Group and received his Ph.D. from Stanford University in March 2003. He is currently a post-doctoral researcher at Stanford University, California.

Cover design by Sue Watson

CAMBRIDGE
UNIVERSITY PRESS
www.cambridge.org

ISBN 0-521-82615-2



9 780521 826150