

[54] DATA TRANSMISSION SYSTEM EMPLOYING A COMBINATION OF BLOCK ENCODING AND CONVOLUTION ENCODING FOR ERROR PROTECTION

[75] Inventor: Philippe M. O. A. Piret, Lasne, Belgium

[73] Assignee: U.S. Philips Corporation, New York, N.Y.

[21] Appl. No.: 871,013

[22] Filed: Jun. 5, 1986

[30] Foreign Application Priority Data

Jun. 14, 1985 [EP] European Pat. Off. 85200939.8

[51] Int. Cl.⁴ G06F 11/10

[52] U.S. Cl. 371/39; 371/44

[58] Field of Search 371/37, 39, 40, 43, 371/44, 45

[56] References Cited

U.S. PATENT DOCUMENTS

3,891,959 6/1975 Tsuji et al. 371/43
 3,988,677 10/1976 Fletcher et al. 371/37 X
 4,038,636 7/1977 Doland 371/37
 4,178,550 12/1979 Acampora et al. 371/37
 4,240,156 12/1980 Doland 371/43
 4,276,646 6/1981 Haggard et al. 371/37

4,355,392 10/1982 Doi et al. 371/43 X
 4,369,512 1/1983 Brossard et al. 371/43
 4,536,878 8/1985 Rattlingourd et al. 371/43

Primary Examiner—Charles E. Atkinson

Attorney, Agent, or Firm—Thomas A. Briody; Jack Oisher

[57] ABSTRACT

A data transmission system for providing error protection of transmitted data words. The less significant bits of a data word are, by means of matrix multiplication, encoded into a first redundant proto-code word and the more significant bits are, by means of further matrix multiplication and delay by different word recurrence intervals encoded in a set of further redundant proto-code words. A composite of the proto-code word is formed by means of a modulo-2-addition of code words, so that for the less significant data bits a block code is realized, while for the more significant data bits a convolutional encoding is realized. In the decoding, the more significant bits of the composite code word are decoded by means of Viterbi decoding, the Viterbi metric being determined from the deviation between the reconstructed contribution of the less significant bits to such code word and the actually received contribution of such bits to such code word.

7 Claims, 3 Drawing Sheets

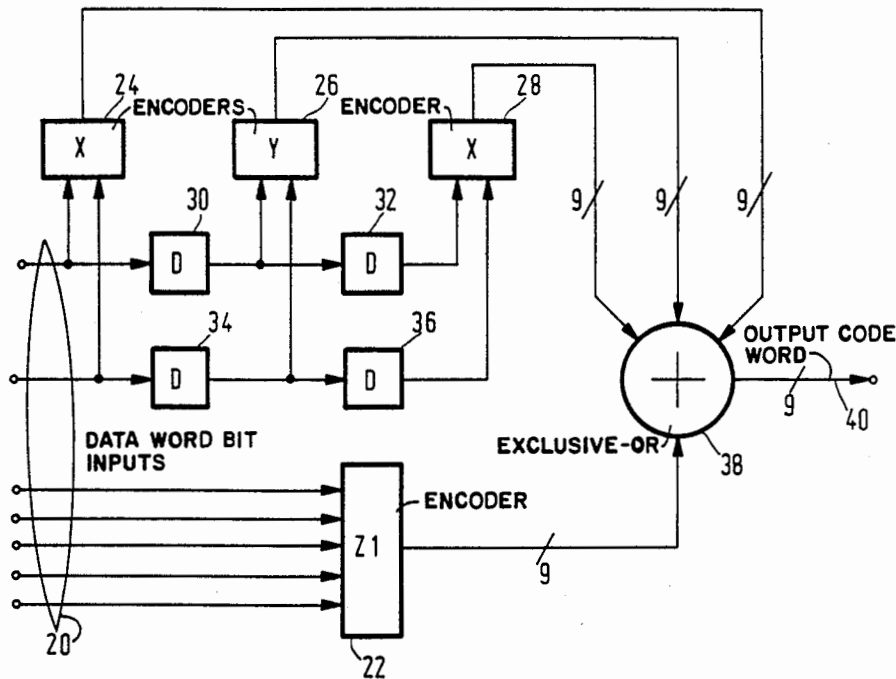

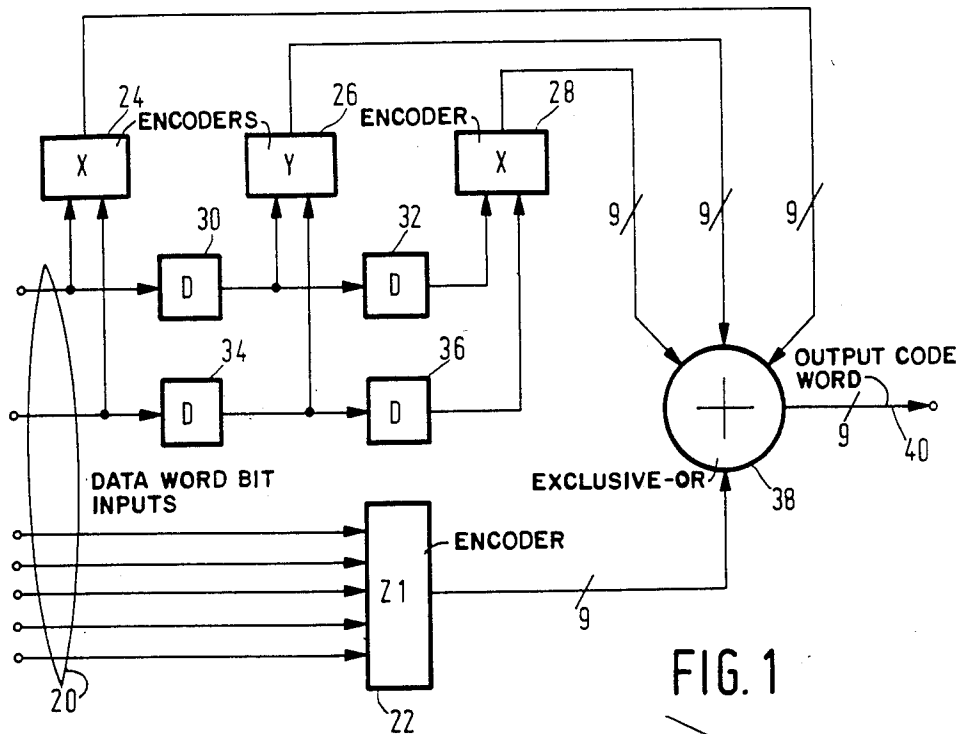

FIG. 1

$$\begin{matrix}
 X' = & \left(\begin{array}{cccccccc}
 1 & 1 & 0 & 1 & 1 & 0 & 1 & 1 \\
 1 & 0 & 0 & 1 & 0 & 0 & 1 & 0
 \end{array} \right) \\
 Y' = & \left(\begin{array}{cccccccc}
 0 & 0 & 1 & 1 & 1 & 0 & 0 & 0 \\
 0 & 0 & 0 & 0 & 0 & 1 & 1 & 1
 \end{array} \right) \\
 Z_4 = & \left(\begin{array}{cccccccc}
 1 & 0 & 0 & 0 & 1 & 1 & 0 & 0 \\
 0 & 1 & 0 & 0 & 1 & 1 & 1 & 1 \\
 0 & 0 & 1 & 0 & 1 & 1 & 0 & 1 \\
 0 & 0 & 0 & 1 & 1 & 0 & 1 & 1
 \end{array} \right)
 \end{matrix}$$

FIG. 3a

$$G_4(D) = \begin{pmatrix} Z'(D) \\ Z_4 \end{pmatrix}$$

FIG. 3b

$$\begin{matrix}
 X = \begin{pmatrix} 0 & 1 & 1 & 0 & 1 & 1 & 0 & 1 & 1 \\ 1 & 0 & 1 & 1 & 0 & 1 & 1 & 0 & 1 \end{pmatrix} \\
 Y = \begin{pmatrix} 1 & 1 & 1 & 0 & 0 & 0 & 1 & 1 & 1 \\ 1 & 1 & 1 & 1 & 1 & 1 & 0 & 0 & 0 \end{pmatrix} \\
 Z1 = \begin{pmatrix} 1 & 0 & 0 & 0 & 0 & 1 & 0 & 1 & 0 \\ 0 & 1 & 0 & 0 & 0 & 1 & 1 & 0 & 0 \\ 0 & 0 & 1 & 0 & 0 & 1 & 1 & 1 & 1 \\ 0 & 0 & 0 & 1 & 0 & 1 & 1 & 0 & 1 \\ 0 & 0 & 0 & 0 & 1 & 1 & 0 & 1 & 1 \end{pmatrix}
 \end{matrix}
 \quad \text{FIG. 2a}$$

$$Z2 = \begin{pmatrix} 1 & 0 & 1 & 0 & 0 & 0 & 1 & 0 & 1 \\ 0 & 1 & 1 & 0 & 0 & 0 & 0 & 1 & 1 \\ 0 & 0 & 0 & 1 & 0 & 1 & 1 & 0 & 1 \\ 0 & 0 & 0 & 0 & 1 & 1 & 0 & 1 & 1 \end{pmatrix}
 \quad \text{FIG. 2b}$$

$$Z3 = \begin{pmatrix} 1 & 0 & 0 & 0 & 0 & 1 & 1 & 0 \\ 0 & 1 & 0 & 0 & 0 & 1 & 0 & 1 \\ 0 & 0 & 1 & 0 & 0 & 1 & 1 & 1 \\ 0 & 0 & 0 & 1 & 0 & 0 & 0 & 1 \\ 0 & 0 & 0 & 0 & 1 & 0 & 1 & 0 \end{pmatrix}
 \quad \text{FIG. 2c}$$

$$G_i = \left(X + \frac{DY}{Z_i} + D^2 X \right)
 \quad \text{FIG. 2d}$$

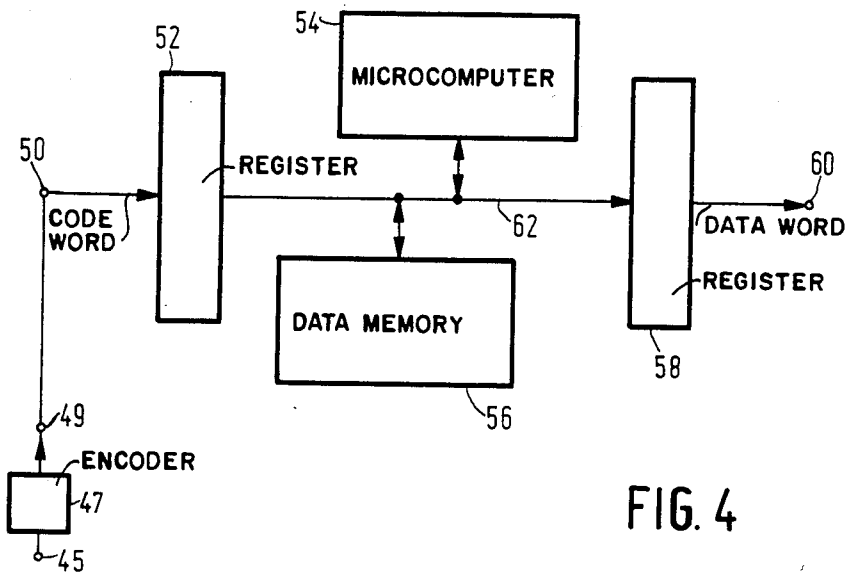

FIG. 4

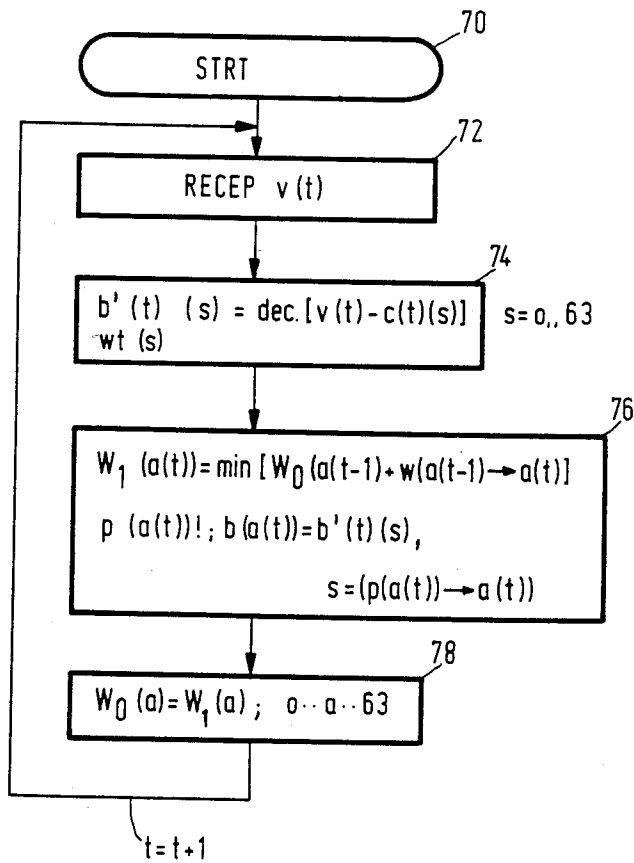

FIG. 5

DATA TRANSMISSION SYSTEM EMPLOYING A COMBINATION OF BLOCK ENCODING AND CONVOLUTION ENCODING FOR ERROR PROTECTION

BACKGROUND OF THE INVENTION

The invention relates to a system for transmitting data words from a transmitting station to a receiving station, wherein redundancy bits are added for protection against bit errors arising in the transmission. With increasing bit rates, and generally noisy transmitting media, various error protection systems have been proposed.

DESCRIPTION OF THE RELATED ART

An example of such a system is described in U.S. Pat. No. 4,312,070 to Coombes et al, which relates to a digital data processing system for use in a mobile trunked dispatch communication system. The system of the present invention is generally applicable to data communication systems wherein communication between stations is subject to burst error phenomena, and each transmitted data word comprises more significant bits and less significant bits. In such situation a higher effective level of reliability can be attained if the more significant bits are better protected than the less significant bits. Such situation typically occurs in audio transmission, notably speech transmission, where errors in the less significant bits make the speech less agreeable or somewhat difficult to understand but an error in a more significant bit can easily make the speech completely incomprehensible. The transmitting medium may be a broadcast medium, or also, for example, a data communication line, or a storage medium, such as magnetic tape.

A burst refers to a series of channel bits wherein the error probability is relatively high. Outside a burst the error probability is relatively low, and the chance for an error to occur is usually independent of any other non-burst errors. Therefore, these errors are called random errors. A burst, which is subject to a high error rate, is caused by only partially understood phenomena which during an interval of time degrade the channel reliability, such as thunderstorms, or movement of the transmitting or receiving station. Especially in mobile radio systems the presence of high-rise buildings also may influence the channel properties. The burst error rate may be for example, 10^{-1} , the random error rate 10^{-3} or less.

SUMMARY OF THE INVENTION

It is an object of the present invention to provide improved encoding which, among other things, provides a high coding efficiency (high rate), allows for easy decoding, gives an increased protection level of more significant bits with respect to less significant bits in a data word, and furthermore allows for matching the error correction capability to the expected burst length.

Such object is realized according to the invention by a system for transmitting data words each comprising a sequence of bits of successive significance levels, such system comprising a transmitting station and a receiver station interconnected by a transmitting medium, the transmitting station comprising an encoder system for encoding data words by means of redundancy bits. Such encoder system comprises a first encoder which by matrix multiplication block encodes a set of less

significant bits of each data word into a first proto-codeword, and also a second encoder which by further matrix multiplication block encodes the remaining, more significant, bits of each data word into a set of n further proto-code words. The second encoder further comprises delay elements for imparting respective different delays to the further proto-code words relative to the recurrence times of successive data words, and also comprises modulo-two adding means for bitwise adding the first proto-code word and n further proto-code words, the latter being derived from as many different data words, thereby convolution encoding the more significant bits. The output of the modulo-two adding means is supplied to the transmitting medium for transmission to the receiver station.

In certain preferred embodiments the number n may be 3, and from each each data word the two most significant bits are encoded by what effectively is a convolutional type encoding. It was found that in this way appreciable error protection could be obtained at only a limited cost of apparatus requirements.

The invention also relates to a transmitter and a receiver for use in such systems. The error protection in a mobile radio system can be provided in both directions, i.e. from a mobile station to a fixed base station, and also in the reverse direction. However, in the latter situation, other factors can also increase the communication reliability, such as increasing the power level transmitted or the antenna configuration. These two measures often are not feasible for applying to a mobile station. The decoding at the received is preferably effected by Viterbi decoding, which is a special kind of maximum likelihood decoding. The Viterbi metric denotes the total incurred amount of deviation from the "true" solution, and which thus must be minimized. It is determined from the deviation between the reconstructed contribution stemming from the less significant bits of the code word, and the actually received contribution from those less significant bits.

BRIEF DESCRIPTION OF THE FIGURES

The invention is further explained by reference to the following Figures, in which:

FIG. 1 is an elementary block diagram of an encoder system;

FIGS. 2a-2d show a first set of code generator matrices;

FIGS. 3a-3b show a second set of code generator matrices;

FIG. 4 is an elementary block diagram of an encoder/decoder system;

FIG. 5 is an elementary flow diagram of the decoding process.

DESCRIPTION OF A PREFERRED EMBODIMENT OF AN ENCODER SYSTEM

In the following, only the encoding and decoding aspects of the system are considered. The remainder, such as modulating and demodulating the code bits to derive channel bits, the physical realization of the channels, the various fields of use of the invention besides mobile telephony, and the construction of the stations and their respective data processing subsystems are ignored, as not relating to the invention proper. FIG. 1 is an elementary block diagram of an encoder system for a (9, 7) convolutional code. Input 20 receives the seven data bits of a data word in parallel. Element 22 is an

Explore Litigation Insights

Docket Alarm provides insights to develop a more informed litigation strategy and the peace of mind of knowing you're on top of things.

Real-Time Litigation Alerts



Keep your litigation team up-to-date with **real-time alerts** and advanced team management tools built for the enterprise, all while greatly reducing PACER spend.

Our comprehensive service means we can handle Federal, State, and Administrative courts across the country.

Advanced Docket Research



With over 230 million records, Docket Alarm's cloud-native docket research platform finds what other services can't. Coverage includes Federal, State, plus PTAB, TTAB, ITC and NLRB decisions, all in one place.

Identify arguments that have been successful in the past with full text, pinpoint searching. Link to case law cited within any court document via Fastcase.

Analytics At Your Fingertips



Learn what happened the last time a particular judge, opposing counsel or company faced cases similar to yours.

Advanced out-of-the-box PTAB and TTAB analytics are always at your fingertips.

API

Docket Alarm offers a powerful API (application programming interface) to developers that want to integrate case filings into their apps.

LAW FIRMS

Build custom dashboards for your attorneys and clients with live data direct from the court.

Automate many repetitive legal tasks like conflict checks, document management, and marketing.

FINANCIAL INSTITUTIONS

Litigation and bankruptcy checks for companies and debtors.

E-DISCOVERY AND LEGAL VENDORS

Sync your system to PACER to automate legal marketing.