

# McGRAW-HILL ENCYCLOPEDIA OF ENGINEERING

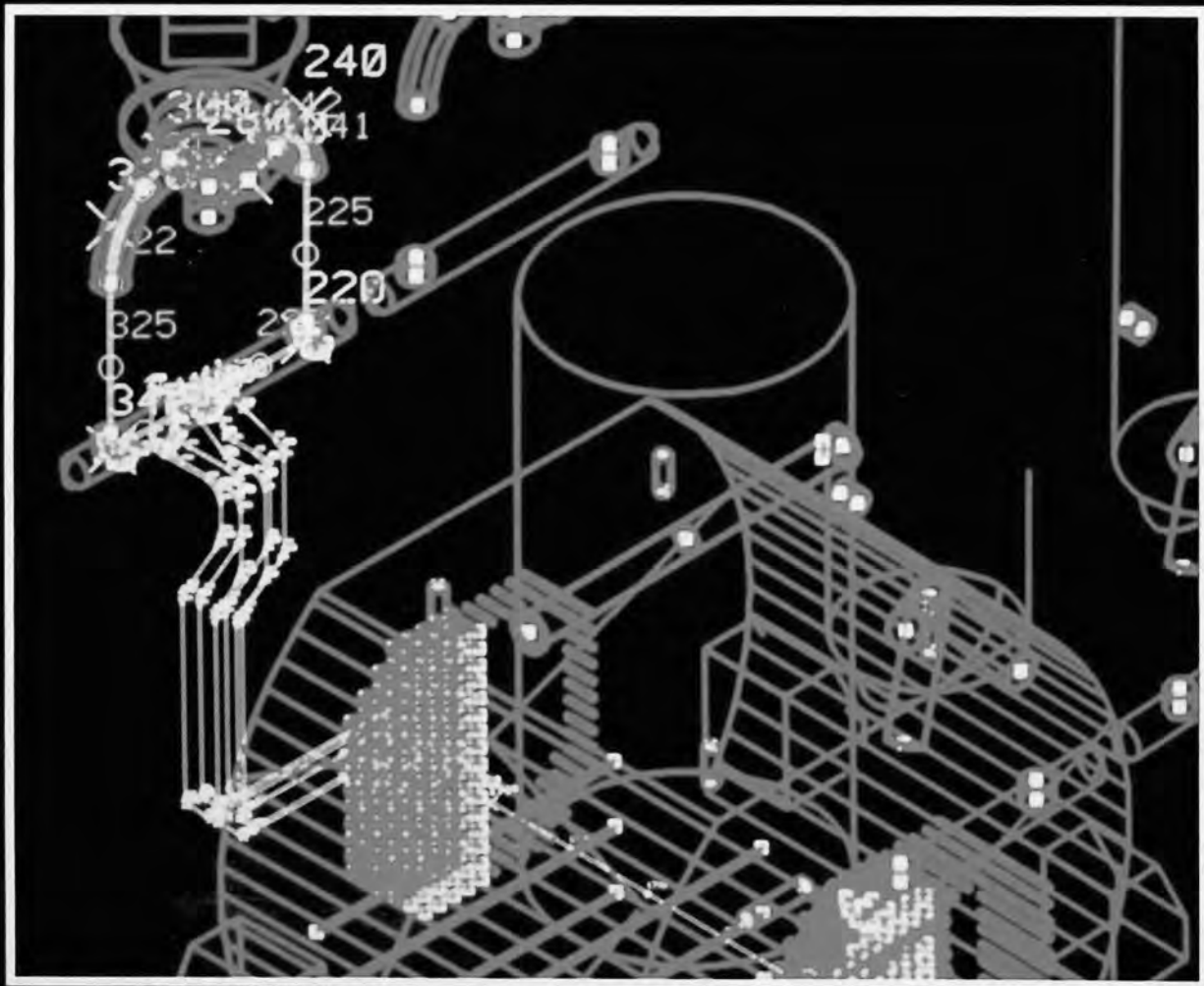

SECOND EDITION

# McGRAW-HILL ENCYCLOPEDIA OF ENGINEERING

SECOND EDITION

**Sybil P. Parker**

Editor in Chief

**McGraw-Hill, Inc.**

New York San Francisco Washington, D.C. Auckland Bogotá  
Caracas Lisbon London Madrid Mexico City Milan Montreal  
New Delhi San Juan Singapore Sydney Tokyo Toronto

Most of the material in this volume has been published previously in the McGRAW-HILL ENCYCLOPEDIA OF SCIENCE & TECHNOLOGY, Seventh Edition, copyright © 1992 by McGraw-Hill, Inc., and in the McGRAW-HILL YEARBOOK OF SCIENCE & TECHNOLOGY, copyright © 1992, 1991, by McGraw-Hill, Inc. All rights reserved.

McGRAW-HILL ENCYCLOPEDIA OF ENGINEERING, Second Edition. Copyright © 1993 by McGraw-Hill, Inc. All rights reserved. Printed in the United States of America. Except as permitted under the United States Copyright Act of 1976, no part of this publication may be reproduced or distributed in any form or by any means, or stored in a database or retrieval system, without the prior written permission of the publisher.

2 3 4 5 6 7 8 9 DOW/DOW 9 8 7 6 5 4

**Library of Congress Cataloging in Publication data**

McGraw-Hill encyclopedia of engineering / Sybil P. Parker, editor in chief. — 2nd ed.

p. cm.

Includes bibliographical references and index.

ISBN 0-07-051392-9

I. Engineering—Encyclopedias. I. Parker, Sybil P. II. McGraw-Hill Inc.

TA9.M36 1993

620'.003—dc20

92-43106

CIP

ISBN 0-07-051392-9

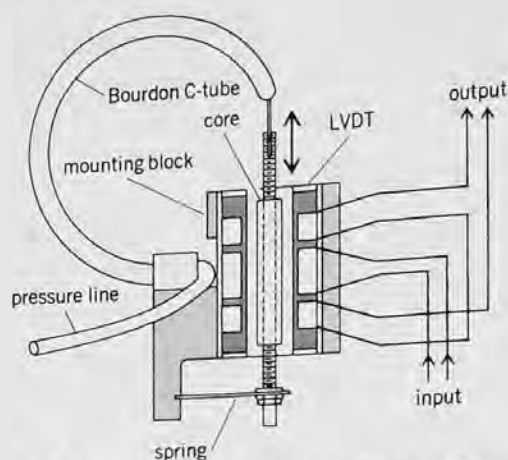

Fig. 2. Bourdon-tube pressure transducer employing a linear variable differential transformer (LVDT). (After E. E. Herceg, *Handbook of Measurement and Control*, Schaevitz Engineering, 1976)

output is zero. This is the balance of null position. When the core is displaced from the null point, the two secondary voltages are no longer alike and the transformer produces an output voltage. With proper design, the output voltage varies linearly with core position over a small range. Motion of the core in the opposite direction produces a similar effect with 180° phase reversal of the alternating output voltage.

The principal advantages of the differential transformer over other displacement transducers, such as the resistance potentiometer, are absence of contacts and infinite resolution. No friction is introduced by the measurement, and movement smaller than a microinch (25 nanometers) can be sensed. The separation between coil and core makes the differential transformer useful in difficult and dangerous environments. Stability of the null makes it ideal as a null sensor in self-balancing devices and servomechanisms. Typical applications are machine tool inspection and gaging, pressure measurement (Fig. 2), liquid level control, load cells, and gyroscopic instruments.

The linear variable differential transformer (LVDT; Fig. 3) is the commercially prevalent form. A rotary version is also manufactured. The E-pickoff (Fig. 4) is an older device. Its linearity is not as good, and its principal use is as a null sensor. Both translational and rotational E-pickoffs are made.

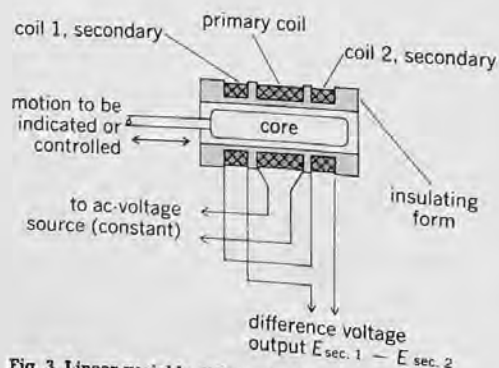

Fig. 3. Linear variable differential transformer (LVDT).

The amplitude of the ac output voltage forms a V-shaped curve when plotted against core position; the phase angle abruptly reverses by 180° at the null point. When the bottom of the V-curve is examined in closer detail, it is seen that the output voltage at balance is not exactly zero. The small residual null voltage consists of higher harmonics of the input frequency, as well as a fundamental frequency component 90 degrees out of phase (called the quadrature component).

Electronic signal conditioning is commonly employed to eliminate the residual and to make the

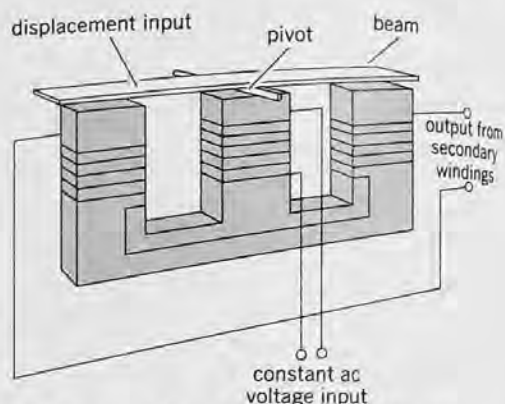

Fig. 4. E-shaped differential transformer. (After P. J. O'Higgins, *Basic Instrumentation*, McGraw-Hill, 1966)

transducer usable with standard dc instrumentation. The electronic circuit consists of an ac oscillator (carrier generator) to drive the input windings, plus a demodulator and an amplifier to convert the output into dc. The microelectronics can be built into the transformer housing, and the resulting package is sold as a dc-LVDT. SEE TRANSFORMER.

Gerald Weiss

**Bibliography.** W. R. Ahrendt and C. J. Savant, Jr., *Servomechanism Practice*, 1960; E. O. Doebelin, *Measurement Systems*, 3d ed., 1982; E. E. Herceg, *Handbook of Measurement and Control*, 1976.

## Digital computer

Any device for performing mathematical calculations on numbers represented digitally; by extension, any device for manipulating symbols according to a detailed procedure or recipe. The class of digital computers includes microcomputers, conventional adding machines and calculators, digital controllers used for industrial processing and manufacturing operations, store-and-forward data communication equipment, and electronic data-processing systems.

In this article emphasis is on electronic stored-program digital computers. These machines store internally many thousands of numbers or other items of information, and control and execute complicated sequences of numerical calculations and other manipulations on this information in accordance with instructions also stored in the machine. The first section of this article discusses digital system fundamentals, reviewing the components and building blocks from which digital systems are constructed. The following section introduces the stored-program general-purpose computer.

final section traces the history of stored-program digital computer systems and shows how the requirements of new applications and the development of new technologies have influenced system design.

**DIGITAL SYSTEM FUNDAMENTALS**

A digital system can be considered from many points of view. At the lowest level it is a network of wires and mechanical parts whose voltages and positions convey coded information. At another level it is a collection of logical elements, each of which embodies certain rules, but which in combination can carry out very complex functions. At a still higher level, a digital system is an arrangement of functional units or building blocks which read (input), write (output), store, and manipulate information.

**Codes.** Numbers are represented within a digital computer by means of circuits that distinguish various discrete electrical signals on wires inside the machine. Theoretically, a signal on a wire could be made to represent any one of several different digits by means of the magnitude of the signal. (For example, a signal from 0 to 1 V could represent the digit zero, a signal between 1 and 2 V could represent the digit one, and so on up to a signal between 9 and 10 V, the digit nine.) In practice, the most reliable and economical circuit elements distinguish between only two signal levels, so that a signal between 0 and 5 V may represent the digit zero and a signal between 5 and 10 V, the digit one. These two-valued signals make it necessary to represent numbers and symbols using a corresponding base-two or binary system. **Table 1** lists the first 20 binary numbers and their decimal equivalents.

Data are stored and manipulated within a digital computer in units called words. The binary digits (called bits), which make up a word, may represent either a binary number or a collection of binary-coded alphanumeric characters. For example, the two-letter word "it" may be stored in a 16-bit computer word as follows, making use of the code shown in **Table 2**:

0100100101010100

The computer word merely contains a binary pattern

**Table 1. Counting from 0 to 19 by decimal and binary numbers**

Decimal number	Binary number
00	0000
01	0001
02	0010
03	0011
04	0100
05	0101
06	0110
07	0111
08	1000
09	1001
10	1010
11	1011
12	1100
13	1101
14	1110
15	1111
16	10000
17	10001
18	10010
19	10011

**Table 2. American standard alphabetic code for binary representation of letters**

1100001	A	11001110	N
11000010	B	01001111	O
01000011	C	11010000	P
11000100	D	01010001	Q
01000101	E	01010010	R
01000110	F	11010011	S
11000111	G	01010100	T
11001000	H	11010101	U
01001001	I	11010110	V
01001010	J	01010111	W
11001011	K	0101000	X
01001100	L	11011001	Y
11001101	M	11011010	Z

of alternating 1's and 0's, and it is up to the computer user to determine whether that word should be interpreted as the English word "it" or as the decimal number 18,772.

**Logical circuit elements.** Two kinds of logical circuits are used in the design and construction of digital computers: decision elements and memory elements. A typical decision element provides a binary output as a function of two or more binary inputs. The AND circuit, for example, has two inputs and an output which is 1 only when both inputs are 1. A memory element stores a single bit of information and is set to the 1 state or reset to the 0 state, depending on the signals on its input lines. And because such a circuit can be caused alternately to store 0's and 1's from time to time, a memory element is commonly called a flip-flop.

These two basic logical elements are all that are required to construct the most elaborate and complex digital arithmetic and control circuits. A simple example of such a circuit is shown in **Fig. 1**. Here the object is to perform a simple binary count, as shown in the table at the bottom of **Fig. 1**. As long as control signal *C* is equal to 1, the counting continues. When the control input is 0, the counter is to remain in whatever state it had last counted to. Two flip-flops are used, labeled *Q1* and *Q2*, and will be made to count through the sequence 0,1,2,3,0,1, . . . . To understand the design, it is necessary to introduce one more concept, the complementary output of a flip-flop. Each flip-flop generally has two output wires, which are always of opposite polarity. When flip-flop *Q1* is storing a 1, output *Q1* is 1 and the complementary output (which is labeled  $\overline{Q1}$  and pronounced *Q1* bar) is 0. When the flip-flop contains a 0, the *Q1* output is 1 and the  $\overline{Q1}$  output is 0.

To analyze the circuit, note first that, when control input *C* is 0, the outputs of all AND gates are 0 and, because the reset and set inputs to both flip-flops are 0, the flip-flops will remain in whatever state they last reached. Now suppose that *Q1* and *Q2* both contain 0 and that the control input becomes 1. While flip-flop *Q2* contains a 0, its *Q2* output is also 0 and AND gate number 1 (labeled AND 1) is effectively turned off so that the reset and set inputs to *Q1* are both 0. Thus flip-flop *Q1* will remain in the 0 state. For the same reason AND gate 4 will also be turned off, and the reset input to flip-flop *Q2* will be 0. However, from flip-flop *Q2* complementary output  $\overline{Q2}$  will be in the 1 state, and (while the control input is 1) AND gate 5 will be turned on and the set input to *Q2* will be 1. Flip-flop *Q2* will thus be turned on by the first clock

# Explore Litigation Insights

Docket Alarm provides insights to develop a more informed litigation strategy and the peace of mind of knowing you're on top of things.

## Real-Time Litigation Alerts



Keep your litigation team up-to-date with **real-time alerts** and advanced team management tools built for the enterprise, all while greatly reducing PACER spend.

Our comprehensive service means we can handle Federal, State, and Administrative courts across the country.

## Advanced Docket Research



With over 230 million records, Docket Alarm's cloud-native docket research platform finds what other services can't. Coverage includes Federal, State, plus PTAB, TTAB, ITC and NLRB decisions, all in one place.

Identify arguments that have been successful in the past with full text, pinpoint searching. Link to case law cited within any court document via Fastcase.

## Analytics At Your Fingertips



Learn what happened the last time a particular judge, opposing counsel or company faced cases similar to yours.

Advanced out-of-the-box PTAB and TTAB analytics are always at your fingertips.

## API

Docket Alarm offers a powerful API (application programming interface) to developers that want to integrate case filings into their apps.

## LAW FIRMS

Build custom dashboards for your attorneys and clients with live data direct from the court.

Automate many repetitive legal tasks like conflict checks, document management, and marketing.

## FINANCIAL INSTITUTIONS

Litigation and bankruptcy checks for companies and debtors.

## E-DISCOVERY AND LEGAL VENDORS

Sync your system to PACER to automate legal marketing.