



UNITED STATES PATENT AND TRADEMARK OFFICE

UNITED STATES DEPARTMENT OF COMMERCE  
United States Patent and Trademark Office  
Address: COMMISSIONER FOR PATENTS  
P.O. Box 1450  
Alexandria, Virginia 22313-1450  
www.uspto.gov

| APPLICATION NUMBER | FILING OR 371(C) DATE | FIRST NAMED APPLICANT | ATTY. DOCKET NO./TITLE |
|--------------------|-----------------------|-----------------------|------------------------|
| 12/137,356         | 06/11/2008            | Charles R. Quirico    | RB113 US               |

**CONFIRMATION NO. 7360**

**POA ACCEPTANCE LETTER**



31834  
BRACCO RESEARCH USA INC.  
Intellectual Property Dept.  
305 COLLEGE ROAD EAST  
PRINCETON, NJ 08540

Date Mailed: 09/05/2013

**NOTICE OF ACCEPTANCE OF POWER OF ATTORNEY**

This is in response to the Power of Attorney filed 08/28/2013.

The Power of Attorney in this application is accepted. Correspondence in this application will be mailed to the above address as provided by 37 CFR 1.33.

/dtvernon/

Office of Data Management, Application Assistance Unit (571) 272-4000, or (571) 272-4200, or 1-888-786-0101



UNITED STATES PATENT AND TRADEMARK OFFICE

UNITED STATES DEPARTMENT OF COMMERCE  
United States Patent and Trademark Office  
Address: COMMISSIONER FOR PATENTS  
P.O. Box 1450  
Alexandria, Virginia 22313-1450  
www.uspto.gov

| APPLICATION NUMBER | FILING OR 371(C) DATE | FIRST NAMED APPLICANT | ATTY. DOCKET NO./TITLE |
|--------------------|-----------------------|-----------------------|------------------------|
| 12/137,356         | 06/11/2008            | Charles R. Quirico    | 56782.1.5              |

**CONFIRMATION NO. 7360**

**POWER OF ATTORNEY NOTICE**

22859  
FREDRIKSON & BYRON, P.A.  
INTELLECTUAL PROPERTY GROUP  
200 SOUTH SIXTH STREET, SUITE 4000  
MINNEAPOLIS, MN 55402



Date Mailed: 09/05/2013

**NOTICE REGARDING CHANGE OF POWER OF ATTORNEY**

This is in response to the Power of Attorney filed 08/28/2013.

- The Power of Attorney to you in this application has been revoked by the assignee who has intervened as provided by 37 CFR 3.71. Future correspondence will be mailed to the new address of record(37 CFR 1.33).

/dtvernon/

Office of Data Management, Application Assistance Unit (571) 272-4000, or (571) 272-4200, or 1-888-786-0101

Under the Paperwork Reduction Act of 1995, no persons are required to respond to a collection of information unless it displays a valid OMB control number.

|  |                        |   |
|--|------------------------|---|
| <b>PATENT - POWER OF ATTORNEY<br/>OR<br/>REVOCATION OF POWER OF ATTORNEY<br/>WITH A NEW POWER OF ATTORNEY<br/>AND<br/>CHANGE OF CORRESPONDENCE ADDRESS</b> | Patent Number          | 8,317,674                                 |
|  | Issue Date             | 11/27/2012                                |
|  | First Named Inventor   | Charles R. QUIRICO                        |
|  | Title                  | Shielding Assemblies For Infusion Systems |
|  | Attorney Docket Number | RB113 US                                  |

I hereby revoke all previous powers of attorney given in the above-identified patent.

 A Power of Attorney is submitted herewith.

OR

 I hereby appoint Practitioner(s) associated with the following Customer Number as my/our attorney(s) or agent(s) with respect to the patent identified above, and to transact all business in the United States Patent and Trademark Office connected therewith:

31,834

OR

 I hereby appoint Practitioner(s) named below as my/our attorney(s) or agent(s) with respect to the patent identified above, and to transact all business in the United States Patent and Trademark Office connected therewith:

| Practitioner(s) Name | Registration Number |
|----------------------|---------------------|
|                      |                     |
|                      |                     |
|                      |                     |
|                      |                     |

Please recognize or change the correspondence address for the above-identified patent to:

 The address associated with the above-mentioned Customer Number.

OR

 The address associated with Customer Number:

OR

 Firm or Individual Name

Address

City

State

Zip

Country

Telephone

Email

I am the:

 Inventor, having ownership of the patent.

OR

 Patent owner.

Statement under 37 CFR 3.73(b) (Form PTO/SB/96) submitted herewith or filed on \_\_\_\_\_

SIGNATURE of Inventor or Patent Owner

Signature

Date

August 26, 2013

Name

Anthony P. Tinari

Telephone

(609) 514-2309

Title and Company

Vice President &amp; General Counsel of Bracco Diagnostics Inc.

NOTE: Signatures of all the inventors or patent owners of the entire interest or their representative(s) are required. Submit multiple forms if more than one signature is required, see below\*.

 \*Total of \_\_\_\_\_ forms are submitted.

This collection of information is required by 37 CFR 1.31, 1.32 and 1.33. The information is required to obtain or retain a benefit by the public which is to file (and by the USPTO to process) an application. Confidentiality is governed by 35 U.S.C. 122 and 37 CFR 1.11 and 1.14. This collection is estimated to take 3 minutes to complete, including gathering, preparing, and submitting the completed application form to the USPTO. Time will vary depending upon the individual case. Any comments on the amount of time you require to complete this form and/or suggestions for reducing this burden, should be sent to the Chief Information Officer, U.S. Patent and Trademark Office, U.S. Department of Commerce, P.O. Box 1450, Alexandria, VA 22313-1450. DO NOT SEND FEES OR COMPLETED FORMS TO THIS ADDRESS. SEND TO: Commissioner for Patents, P.O. Box 1450, Alexandria, VA 22313-1450.

If you need assistance in completing the form, call 1-800-PTO-9199 and select option 2.

## Privacy Act Statement

The Privacy Act of 1974 (P.L. 93-579) requires that you be given certain information in connection with your submission of the attached form related to a patent application or patent. Accordingly, pursuant to the requirements of the Act, please be advised that: (1) the general authority for the collection of this information is 35 U.S.C. 2(b)(2); (2) furnishing of the information solicited is voluntary; and (3) the principal purpose for which the information is used by the U.S. Patent and Trademark Office is to process and/or examine your submission related to a patent application or patent. If you do not furnish the requested information, the U.S. Patent and Trademark Office may not be able to process and/or examine your submission, which may result in termination of proceedings or abandonment of the application or expiration of the patent.

The information provided by you in this form will be subject to the following routine uses:

1. The information on this form will be treated confidentially to the extent allowed under the Freedom of Information Act (5 U.S.C. 552) and the Privacy Act (5 U.S.C. 552a). Records from this system of records may be disclosed to the Department of Justice to determine whether disclosure of these records is required by the Freedom of Information Act.
2. A record from this system of records may be disclosed, as a routine use, in the course of presenting evidence to a court, magistrate, or administrative tribunal, including disclosures to opposing counsel in the course of settlement negotiations.
3. A record in this system of records may be disclosed, as a routine use, to a Member of Congress submitting a request involving an individual, to whom the record pertains, when the individual has requested assistance from the Member with respect to the subject matter of the record.
4. A record in this system of records may be disclosed, as a routine use, to a contractor of the Agency having need for the information in order to perform a contract. Recipients of information shall be required to comply with the requirements of the Privacy Act of 1974, as amended, pursuant to 5 U.S.C. 552a(m).
5. A record related to an International Application filed under the Patent Cooperation Treaty in this system of records may be disclosed, as a routine use, to the International Bureau of the World Intellectual Property Organization, pursuant to the Patent Cooperation Treaty.
6. A record in this system of records may be disclosed, as a routine use, to another federal agency for purposes of National Security review (35 U.S.C. 181) and for review pursuant to the Atomic Energy Act (42 U.S.C. 218(c)).
7. A record from this system of records may be disclosed, as a routine use, to the Administrator, General Services, or his/her designee, during an inspection of records conducted by GSA as part of that agency's responsibility to recommend improvements in records management practices and programs, under authority of 44 U.S.C. 2904 and 2906. Such disclosure shall be made in accordance with the GSA regulations governing inspection of records for this purpose, and any other relevant (*i.e.*, GSA or Commerce) directive. Such disclosure shall not be used to make determinations about individuals.
8. A record from this system of records may be disclosed, as a routine use, to the public after either publication of the application pursuant to 35 U.S.C. 122(b) or issuance of a patent pursuant to 35 U.S.C. 151. Further, a record may be disclosed, subject to the limitations of 37 CFR 1.14, as a routine use, to the public if the record was filed in an application which became abandoned or in which the proceedings were terminated and which application is referenced by either a published application, an application open to public inspection or an issued patent.
9. A record from this system of records may be disclosed, as a routine use, to a Federal, State, or local law enforcement agency, if the USPTO becomes aware of a violation or potential violation of law or regulation.



August 28, 2013

Approved for use through 07/31/2012. OMB 0651-0031  
U.S. Patent and Trademark Office; U.S. DEPARTMENT OF COMMERCE

Under the Paperwork Reduction Act of 1995, no persons are required to respond to a collection of information unless it displays a valid OMB control number.

**STATEMENT UNDER 37 CFR 3.73(b)**

RB113 US

Applicant/Patent Owner: Bracco Diagnostics Inc.

Application No./Patent No.: 8,317,674 Filed/Issue Date: 11/27/2012

Titled: Shielding Assemblies For Infusion Systems

Bracco Diagnostics Inc., a corporation  
(Name of Assignee) (Type of Assignee, e.g., corporation, partnership, university, government agency, etc.)

states that it is:

- 1.  the assignee of the entire right, title, and interest in;
- 2.  an assignee of less than the entire right, title, and interest in  
(The extent (by percentage) of its ownership interest is \_\_\_\_\_ %); or
- 3.  the assignee of an undivided interest in the entirety of (a complete assignment from one of the joint inventors was made)

the patent application/patent identified above, by virtue of either:

A.  An assignment from the inventor(s) of the patent application/patent identified above. The assignment was recorded in the United States Patent and Trademark Office at Reel 021699, Frame 0780, or for which a copy therefore is attached.

OR

B.  A chain of title from the inventor(s), of the patent application/patent identified above, to the current assignee as follows:

1. From: \_\_\_\_\_ To: \_\_\_\_\_

The document was recorded in the United States Patent and Trademark Office at  
Reel \_\_\_\_\_, Frame \_\_\_\_\_, or for which a copy thereof is attached.

2. From: \_\_\_\_\_ To: \_\_\_\_\_

The document was recorded in the United States Patent and Trademark Office at  
Reel \_\_\_\_\_, Frame \_\_\_\_\_, or for which a copy thereof is attached.

3. From: \_\_\_\_\_ To: \_\_\_\_\_

The document was recorded in the United States Patent and Trademark Office at  
Reel \_\_\_\_\_, Frame \_\_\_\_\_, or for which a copy thereof is attached.

Additional documents in the chain of title are listed on a supplemental sheet(s).

As required by 37 CFR 3.73(b)(1)(i), the documentary evidence of the chain of title from the original owner to the assignee was, or concurrently is being, submitted for recordation pursuant to 37 CFR 3.11.

[NOTE: A separate copy (i.e., a true copy of the original assignment document(s)) must be submitted to Assignment Division in accordance with 37 CFR Part 3, to record the assignment in the records of the USPTO. See MPEP 302.08]

The undersigned (whose title is supplied below) is authorized to act on behalf of the assignee.

/M. Caragh Noone, Reg. No. 37,197/

August 28, 2013

Signature

Date

M. Caragh Noone

US Chief Patent Counsel for Bracco Research USA Inc.

Printed or Typed Name

Title

This collection of information is required by 37 CFR 3.73(b). The information is required to obtain or retain a benefit by the public which is to file (and by the USPTO to process) an application. Confidentiality is governed by 35 U.S.C. 122 and 37 CFR 1.11 and 1.14. This collection is estimated to take 12 minutes to complete, including gathering, preparing, and submitting the completed application form to the USPTO. Time will vary depending upon the individual case. Any comments on the amount of time you require to complete this form and/or suggestions for reducing this burden, should be sent to the Chief Information Officer, U.S. Patent and Trademark Office, U.S. Department of Commerce, P.O. Box 1450, Alexandria, VA 22313-1450. DO NOT SEND FEES OR COMPLETED FORMS TO THIS ADDRESS. SEND TO: Commissioner for Patents, P.O. Box 1450, Alexandria, VA 22313-1450.

## Privacy Act Statement

The **Privacy Act of 1974 (P.L. 93-579)** requires that you be given certain information in connection with your submission of the attached form related to a patent application or patent. Accordingly, pursuant to the requirements of the Act, please be advised that: (1) the general authority for the collection of this information is 35 U.S.C. 2(b)(2); (2) furnishing of the information solicited is voluntary; and (3) the principal purpose for which the information is used by the U.S. Patent and Trademark Office is to process and/or examine your submission related to a patent application or patent. If you do not furnish the requested information, the U.S. Patent and Trademark Office may not be able to process and/or examine your submission, which may result in termination of proceedings or abandonment of the application or expiration of the patent.

The information provided by you in this form will be subject to the following routine uses:

1. The information on this form will be treated confidentially to the extent allowed under the Freedom of Information Act (5 U.S.C. 552) and the Privacy Act (5 U.S.C. 552a). Records from this system of records may be disclosed to the Department of Justice to determine whether disclosure of these records is required by the Freedom of Information Act.
2. A record from this system of records may be disclosed, as a routine use, in the course of presenting evidence to a court, magistrate, or administrative tribunal, including disclosures to opposing counsel in the course of settlement negotiations.
3. A record in this system of records may be disclosed, as a routine use, to a Member of Congress submitting a request involving an individual, to whom the record pertains, when the individual has requested assistance from the Member with respect to the subject matter of the record.
4. A record in this system of records may be disclosed, as a routine use, to a contractor of the Agency having need for the information in order to perform a contract. Recipients of information shall be required to comply with the requirements of the Privacy Act of 1974, as amended, pursuant to 5 U.S.C. 552a(m).
5. A record related to an International Application filed under the Patent Cooperation Treaty in this system of records may be disclosed, as a routine use, to the International Bureau of the World Intellectual Property Organization, pursuant to the Patent Cooperation Treaty.
6. A record in this system of records may be disclosed, as a routine use, to another federal agency for purposes of National Security review (35 U.S.C. 181) and for review pursuant to the Atomic Energy Act (42 U.S.C. 218(c)).
7. A record from this system of records may be disclosed, as a routine use, to the Administrator, General Services, or his/her designee, during an inspection of records conducted by GSA as part of that agency's responsibility to recommend improvements in records management practices and programs, under authority of 44 U.S.C. 2904 and 2906. Such disclosure shall be made in accordance with the GSA regulations governing inspection of records for this purpose, and any other relevant (*i.e.*, GSA or Commerce) directive. Such disclosure shall not be used to make determinations about individuals.
8. A record from this system of records may be disclosed, as a routine use, to the public after either publication of the application pursuant to 35 U.S.C. 122(b) or issuance of a patent pursuant to 35 U.S.C. 151. Further, a record may be disclosed, subject to the limitations of 37 CFR 1.14, as a routine use, to the public if the record was filed in an application which became abandoned or in which the proceedings were terminated and which application is referenced by either a published application, an application open to public inspection or an issued patent.
9. A record from this system of records may be disclosed, as a routine use, to a Federal, State, or local law enforcement agency, if the USPTO becomes aware of a violation or potential violation of law or regulation.

Under the Paperwork Reduction Act of 1995, no persons are required to respond to a collection of information unless it displays a valid OMB control number.

**“FEE ADDRESS” INDICATION FORM****Address to:****Mail Stop M Correspondence  
Commissioner for Patents  
P.O. Box 1450  
Alexandria, VA 22313-1450****Fax to:****571-273-6500****- OR -**

**INSTRUCTIONS:** The issue fee must have been paid for application(s) listed on this form. In addition, only an address represented by a Customer Number can be established as the fee address for maintenance fee purposes (hereafter, fee address). A fee address should be established when correspondence related to maintenance fees should be mailed to a different address than the correspondence address for the application.

**When to check the first box below:** If you have a Customer Number to represent the fee address. **When to check the second box below:** If you have no Customer Number representing the desired fee address, in which case a completed Request for Customer Number (PTO/SB/125) must be attached to this form. For more information on Customer Numbers, see the Manual of Patent Examining Procedure (MPEP) § 403.

For the following listed application(s), please recognize as the “Fee Address” under the provisions of 37 CFR 1.363 the address associated with:

 Customer Number: **31,834**
**OR**
 The attached Request for Customer Number (PTO/SB/125) form.

| PATENT NUMBER<br>(if known) | APPLICATION NUMBER |
|-----------------------------|--------------------|
| 8,317,674                   | 12/137,356         |

Completed by (check one):

Applicant/Inventor \_\_\_\_\_ /M. Caragh Noone, Reg. No. 37,197/  
Signature

Attorney or Agent of record \_\_\_\_\_ 37,197 \_\_\_\_\_ M. Caragh Noone  
(Reg. No.) Typed or printed name

Assignee of record of the entire interest. See 37 CFR 3.71. \_\_\_\_\_ (609) 514-2454  
Statement under 37 CFR 3.73(b) is enclosed. Requester's telephone number  
(Form PTO/SB/96)

Assignee recorded at Reel \_\_\_\_\_ Frame \_\_\_\_\_ August 28, 2013  
Date

NOTE: Signatures of all the inventors or assignees of record of the entire interest or their representative(s) are required. Submit multiple forms if more than one signature is required, see below\*.

 \* Total of \_\_\_\_\_ forms are submitted.

This collection of information is required by 37 CFR 1.363. The information is required to obtain or retain a benefit by the public which is to file (and by the USPTO to process) an application. Confidentiality is governed by 35 U.S.C. 122 and 37 CFR 1.11 and 1.14. This collection is estimated to take 5 minutes to complete, including gathering, preparing, and submitting the completed application form to the USPTO. Time will vary depending upon the individual case. Any comments on the amount of time you require to complete this form and/or suggestions for reducing this burden, should be sent to the Chief Information Officer, U.S. Patent and Trademark Office, U.S. Department of Commerce, P.O. Box 1450, Alexandria, VA 22313-1450. DO NOT SEND COMPLETE D FORMS TO THIS ADDRESS. SEND TO: Mail Stop M Correspondence, Commissioner for Patents, P.O. Box 1450, Alexandria, VA 22313-1450.

If you need assistance in completing the form, call 1-800-PTO-9199 and select option 2.

## Privacy Act Statement

The **Privacy Act of 1974 (P.L. 93-579)** requires that you be given certain information in connection with your submission of the attached form related to a patent application or patent. Accordingly, pursuant to the requirements of the Act, please be advised that: (1) the general authority for the collection of this information is 35 U.S.C. 2(b)(2); (2) furnishing of the information solicited is voluntary; and (3) the principal purpose for which the information is used by the U.S. Patent and Trademark Office is to process and/or examine your submission related to a patent application or patent. If you do not furnish the requested information, the U.S. Patent and Trademark Office may not be able to process and/or examine your submission, which may result in termination of proceedings or abandonment of the application or expiration of the patent.

The information provided by you in this form will be subject to the following routine uses:

1. The information on this form will be treated confidentially to the extent allowed under the Freedom of Information Act (5 U.S.C. 552) and the Privacy Act (5 U.S.C. 552a). Records from this system of records may be disclosed to the Department of Justice to determine whether disclosure of these records is required by the Freedom of Information Act.
2. A record from this system of records may be disclosed, as a routine use, in the course of presenting evidence to a court, magistrate, or administrative tribunal, including disclosures to opposing counsel in the course of settlement negotiations.
3. A record in this system of records may be disclosed, as a routine use, to a Member of Congress submitting a request involving an individual, to whom the record pertains, when the individual has requested assistance from the Member with respect to the subject matter of the record.
4. A record in this system of records may be disclosed, as a routine use, to a contractor of the Agency having need for the information in order to perform a contract. Recipients of information shall be required to comply with the requirements of the Privacy Act of 1974, as amended, pursuant to 5 U.S.C. 552a(m).
5. A record related to an International Application filed under the Patent Cooperation Treaty in this system of records may be disclosed, as a routine use, to the International Bureau of the World Intellectual Property Organization, pursuant to the Patent Cooperation Treaty.
6. A record in this system of records may be disclosed, as a routine use, to another federal agency for purposes of National Security review (35 U.S.C. 181) and for review pursuant to the Atomic Energy Act (42 U.S.C. 218(c)).
7. A record from this system of records may be disclosed, as a routine use, to the Administrator, General Services, or his/her designee, during an inspection of records conducted by GSA as part of that agency's responsibility to recommend improvements in records management practices and programs, under authority of 44 U.S.C. 2904 and 2906. Such disclosure shall be made in accordance with the GSA regulations governing inspection of records for this purpose, and any other relevant (*i.e.*, GSA or Commerce) directive. Such disclosure shall not be used to make determinations about individuals.
8. A record from this system of records may be disclosed, as a routine use, to the public after either publication of the application pursuant to 35 U.S.C. 122(b) or issuance of a patent pursuant to 35 U.S.C. 151. Further, a record may be disclosed, subject to the limitations of 37 CFR 1.14, as a routine use, to the public if the record was filed in an application which became abandoned or in which the proceedings were terminated and which application is referenced by either a published application, an application open to public inspection or an issued patent.
9. A record from this system of records may be disclosed, as a routine use, to a Federal, State, or local law enforcement agency, if the USPTO becomes aware of a violation or potential violation of law or regulation.

## Electronic Acknowledgement Receipt

|   |   |
|---|---|
| <b>EFS ID:</b>                              | 16707283                                  |
| <b>Application Number:</b>                  | 12137356                                  |
| <b>International Application Number:</b>    |   |
| <b>Confirmation Number:</b>                 | 7360                                      |
| <b>Title of Invention:</b>                  | SHIELDING ASSEMBLIES FOR INFUSION SYSTEMS |
| <b>First Named Inventor/Applicant Name:</b> | Charles R. Quirico                        |
| <b>Customer Number:</b>                     | 22859                                     |
| <b>Filer:</b>                               | Mary Caragh Noone/Pamela Gewirtz          |
| <b>Filer Authorized By:</b>                 | Mary Caragh Noone                         |
| <b>Attorney Docket Number:</b>              | 56782.1.5                                 |
| <b>Receipt Date:</b>                        | 28-AUG-2013                               |
| <b>Filing Date:</b>                         | 11-JUN-2008                               |
| <b>Time Stamp:</b>                          | 13:04:33                                  |
| <b>Application Type:</b>                    | Utility under 35 USC 111(a)               |

### Payment information:

|                        |    |
|------------------------|----|
| Submitted with Payment | no |
|------------------------|----|

### File Listing:

| Document Number | Document Description          | File Name                                   | File Size(Bytes)/<br>Message Digest                               | Multi Part /.zip | Pages (if appl.) |
|-----------------|-------------------------------|---|---|------------------|------------------|
| 1               | Miscellaneous Incoming Letter | 8-28-13_a_Transmittal_sb21_R<br>B113-US.pdf | 297408<br><small>ff4529c34c7c3509fccc5a0d54f6e44a72782c17</small> | no               | 2                |

### Warnings:

### Information:

|   |  |  |  |    |   |
|---|--|--|--|----|---|
| 2   | Power of Attorney                              | 8-28-13_b_xcutedPOA_RB113-US00P.pdf              | 47863<br>4c4f96e759b204ecbcac165c5bf000dff6470053  | no | 2 |
| <b>Warnings:</b>  |  |  |  |    |   |
| The page size in the PDF is too large. The pages should be 8.5 x 11 or A4. If this PDF is submitted, the pages will be resized upon entry into the Image File Wrapper and may affect subsequent processing  |  |  |  |    |   |
| <b>Information:</b>   |  |  |  |    |   |
| 3   | Assignee showing of ownership per 37 CFR 3.73. | 8-28-13_c_StmntUnder37cfr3-73b_sb96_RB113-US.pdf | 793008<br>6e2be101926c78466f616f1f1f693ff9eb0fc17c | no | 2 |
| <b>Warnings:</b>  |  |  |  |    |   |
| <b>Information:</b>   |  |  |  |    |   |
| 4   | Change of Address                              | 8-28-13_d_FeeAddressIndication_sb47_RB113-US.pdf | 210717<br>7aff3a6a2efb95e859dab8e40df85be1b20a314  | no | 2 |
| <b>Warnings:</b>  |  |  |  |    |   |
| <b>Information:</b>   |  |  |  |    |   |
| <b>Total Files Size (in bytes):</b>   |  |  | 1348996  |    |   |
| <p><b>This Acknowledgement Receipt evidences receipt on the noted date by the USPTO of the indicated documents, characterized by the applicant, and including page counts, where applicable. It serves as evidence of receipt similar to a Post Card, as described in MPEP 503.</b></p> <p><b><u>New Applications Under 35 U.S.C. 111</u></b><br/> <b>If a new application is being filed and the application includes the necessary components for a filing date (see 37 CFR 1.53(b)-(d) and MPEP 506), a Filing Receipt (37 CFR 1.54) will be issued in due course and the date shown on this Acknowledgement Receipt will establish the filing date of the application.</b></p> <p><b><u>National Stage of an International Application under 35 U.S.C. 371</u></b><br/> <b>If a timely submission to enter the national stage of an international application is compliant with the conditions of 35 U.S.C. 371 and other applicable requirements a Form PCT/DO/EO/903 indicating acceptance of the application as a national stage submission under 35 U.S.C. 371 will be issued in addition to the Filing Receipt, in due course.</b></p> <p><b><u>New International Application Filed with the USPTO as a Receiving Office</u></b><br/> <b>If a new international application is being filed and the international application includes the necessary components for an international filing date (see PCT Article 11 and MPEP 1810), a Notification of the International Application Number and of the International Filing Date (Form PCT/RO/105) will be issued in due course, subject to prescriptions concerning national security, and the date shown on this Acknowledgement Receipt will establish the international filing date of the application.</b></p> |  |  |  |    |   |

Under the Paperwork Reduction Act of 1995, no persons are required to respond to a collection of information unless it displays a valid OMB control number.

|  |                      |                                    |
|--|----------------------|------------------------------------|
| <b>TRANSMITTAL FORM</b><br><br><i>(to be used for all correspondence after initial filing)</i> | Application Number   | 12/137,356, now US 8,317,674       |
|  | Filing Date          | 6/11/06, issued 11/27/2012         |
|  | First Named Inventor | Charles R. QUIRICO                 |
|  | Art Unit             | 3735                               |
|  | Examiner Name        | Samuel G. GILBERT                  |
| Total Number of Pages in This Submission   | 7                    | Attorney Docket Number<br>RB113 US |

| <b>ENCLOSURES (Check all that apply)</b>   |   |   |
|--|---|---|
| <input type="checkbox"/> Fee Transmittal Form<br><input type="checkbox"/> Fee Attached<br><input type="checkbox"/> Amendment/Reply<br><input type="checkbox"/> After Final<br><input type="checkbox"/> Affidavits/declaration(s)<br><input type="checkbox"/> Extension of Time Request<br><input type="checkbox"/> Express Abandonment Request<br><input type="checkbox"/> Information Disclosure Statement<br><br><input type="checkbox"/> Certified Copy of Priority Document(s)<br><input type="checkbox"/> Reply to Missing Parts/ Incomplete Application<br><input type="checkbox"/> Reply to Missing Parts under 37 CFR 1.52 or 1.53 | <input type="checkbox"/> Drawing(s)<br><input type="checkbox"/> Licensing-related Papers<br><input type="checkbox"/> Petition<br><input type="checkbox"/> Petition to Convert to a Provisional Application<br><input checked="" type="checkbox"/> Power of Attorney, Revocation Change of Correspondence Address<br><input type="checkbox"/> Terminal Disclaimer<br><input type="checkbox"/> Request for Refund<br><input type="checkbox"/> CD, Number of CD(s) _____<br><input type="checkbox"/> Landscape Table on CD | <input type="checkbox"/> After Allowance Communication to TC<br><input type="checkbox"/> Appeal Communication to Board of Appeals and Interferences<br><input type="checkbox"/> Appeal Communication to TC (Appeal Notice, Brief, Reply Brief)<br><input type="checkbox"/> Proprietary Information<br><input type="checkbox"/> Status Letter<br><input checked="" type="checkbox"/> Other Enclosure(s) (please identify below):<br>Forms PTO/SB/81A; PTO/SB/96; and PTO/SB/47 |
| <input type="checkbox"/> Remarks   |   | No fee is believed due re: Revocation of PoA & Fee Address to request MF statements be mailed to Customer No. 31,834. However, if any fees are deemed necessary, the Director is hereby authorized to charge any required fees and credit any overpayments to Deposit Account No. 50-2168.  |

| <b>SIGNATURE OF APPLICANT, ATTORNEY, OR AGENT</b> |                                    |          |        |
|---|------------------------------------|----------|--------|
| Firm Name   |                                    |          |        |
| Signature   | /M. Caragh Noone, Reg. No. 37,197/ |          |        |
| Printed name                                      | M. Caragh Noone                    |          |        |
| Date  | August 28, 2013                    | Reg. No. | 37,197 |

| <b>CERTIFICATE OF TRANSMISSION/MAILING</b>  |  |      |                 |
|---|--|------|-----------------|
| I hereby certify that this correspondence is being facsimile transmitted to the USPTO or deposited with the United States Postal Service with sufficient postage as first class mail in an envelope addressed to: Commissioner for Patents, P.O. Box 1450, Alexandria, VA 22313-1450 on the date shown below: |  |      |                 |
| Signature   | Electronically Filed Using the EFS-WEB Electronic Filing System of the United States |      |                 |
| Typed or printed name   | Patent and Trademark Office on:  | Date | August 28, 2013 |

This collection of information is required by 37 CFR 1.5. The information is required to obtain or retain a benefit by the public which is to file (and by the USPTO to process) an application. Confidentiality is governed by 35 U.S.C. 122 and 37 CFR 1.11 and 1.14. This collection is estimated to 2 hours to complete, including gathering, preparing, and submitting the completed application form to the USPTO. Time will vary depending upon the individual case. Any comments on the amount of time you require to complete this form and/or suggestions for reducing this burden, should be sent to the Chief Information Officer, U.S. Patent and Trademark Office, U.S. Department of Commerce, P.O. Box 1450, Alexandria, VA 22313-1450. DO NOT SEND FEES OR COMPLETED FORMS TO THIS ADDRESS. SEND TO: **Commissioner for Patents, P.O. Box 1450, Alexandria, VA 22313-1450.**

*If you need assistance in completing the form, call 1-800-PTO-9199 and select option 2.*

## Privacy Act Statement

The **Privacy Act of 1974 (P.L. 93-579)** requires that you be given certain information in connection with your submission of the attached form related to a patent application or patent. Accordingly, pursuant to the requirements of the Act, please be advised that: (1) the general authority for the collection of this information is 35 U.S.C. 2(b)(2); (2) furnishing of the information solicited is voluntary; and (3) the principal purpose for which the information is used by the U.S. Patent and Trademark Office is to process and/or examine your submission related to a patent application or patent. If you do not furnish the requested information, the U.S. Patent and Trademark Office may not be able to process and/or examine your submission, which may result in termination of proceedings or abandonment of the application or expiration of the patent.

The information provided by you in this form will be subject to the following routine uses:

1. The information on this form will be treated confidentially to the extent allowed under the Freedom of Information Act (5 U.S.C. 552) and the Privacy Act (5 U.S.C. 552a). Records from this system of records may be disclosed to the Department of Justice to determine whether disclosure of these records is required by the Freedom of Information Act.
2. A record from this system of records may be disclosed, as a routine use, in the course of presenting evidence to a court, magistrate, or administrative tribunal, including disclosures to opposing counsel in the course of settlement negotiations.
3. A record in this system of records may be disclosed, as a routine use, to a Member of Congress submitting a request involving an individual, to whom the record pertains, when the individual has requested assistance from the Member with respect to the subject matter of the record.
4. A record in this system of records may be disclosed, as a routine use, to a contractor of the Agency having need for the information in order to perform a contract. Recipients of information shall be required to comply with the requirements of the Privacy Act of 1974, as amended, pursuant to 5 U.S.C. 552a(m).
5. A record related to an International Application filed under the Patent Cooperation Treaty in this system of records may be disclosed, as a routine use, to the International Bureau of the World Intellectual Property Organization, pursuant to the Patent Cooperation Treaty.
6. A record in this system of records may be disclosed, as a routine use, to another federal agency for purposes of National Security review (35 U.S.C. 181) and for review pursuant to the Atomic Energy Act (42 U.S.C. 218(c)).
7. A record from this system of records may be disclosed, as a routine use, to the Administrator, General Services, or his/her designee, during an inspection of records conducted by GSA as part of that agency's responsibility to recommend improvements in records management practices and programs, under authority of 44 U.S.C. 2904 and 2906. Such disclosure shall be made in accordance with the GSA regulations governing inspection of records for this purpose, and any other relevant (*i.e.*, GSA or Commerce) directive. Such disclosure shall not be used to make determinations about individuals.
8. A record from this system of records may be disclosed, as a routine use, to the public after either publication of the application pursuant to 35 U.S.C. 122(b) or issuance of a patent pursuant to 35 U.S.C. 151. Further, a record may be disclosed, subject to the limitations of 37 CFR 1.14, as a routine use, to the public if the record was filed in an application which became abandoned or in which the proceedings were terminated and which application is referenced by either a published application, an application open to public inspection or an issued patent.
9. A record from this system of records may be disclosed, as a routine use, to a Federal, State, or local law enforcement agency, if the USPTO becomes aware of a violation or potential violation of law or regulation.





| APPLICATION NO. | ISSUE DATE | PATENT NO. | ATTORNEY DOCKET NO. | CONFIRMATION NO. |
|-----------------|------------|------------|---------------------|------------------|
| 12/137,356      | 11/27/2012 | 8317674    | 56782.1.5           | 7360             |

22859 7590 11/07/2012  
FREDRIKSON & BYRON, P.A.  
INTELLECTUAL PROPERTY GROUP  
200 SOUTH SIXTH STREET, SUITE 4000  
MINNEAPOLIS, MN 55402

### ISSUE NOTIFICATION

The projected patent number and issue date are specified above.

#### **Determination of Patent Term Adjustment under 35 U.S.C. 154 (b)** (application filed on or after May 29, 2000)

The Patent Term Adjustment is 1113 day(s). Any patent to issue from the above-identified application will include an indication of the adjustment on the front page.

If a Continued Prosecution Application (CPA) was filed in the above-identified application, the filing date that determines Patent Term Adjustment is the filing date of the most recent CPA.

Applicant will be able to obtain more detailed information by accessing the Patent Application Information Retrieval (PAIR) WEB site (<http://pair.uspto.gov>).

Any questions regarding the Patent Term Extension or Adjustment determination should be directed to the Office of Patent Legal Administration at (571)-272-7702. Questions relating to issue and publication fee payments should be directed to the Application Assistance Unit (AAU) of the Office of Data Management (ODM) at (571)-272-4200.

APPLICANT(s) (Please see PAIR WEB site <http://pair.uspto.gov> for additional applicants):

Charles R. Quirico, Warren, NJ;  
Ernest Balestracci, Iselin, NJ;  
Daniel Darst, Zimmerman, MN;  
Eric J. Krause, Big Lake, MN;  
Vishal N. Lokhande, Mountain View, CA;  
Jacob S. Childs, Minneapolis, MN;  
Peter B. Madson, Shanghai, CHINA;  
Daniel V. Clements, Minneapolis, MN;

The United States represents the largest, most dynamic marketplace in the world and is an unparalleled location for business investment, innovation, and commercialization of new technologies. The USA offers tremendous resources and advantages for those who invest and manufacture goods here. Through SelectUSA, our nation works to encourage and facilitate business investment. To learn more about why the USA is the best country in the world to develop technology, manufacture products, and grow your business, visit [SelectUSA.gov](http://SelectUSA.gov).

**PART B - FEE(S) TRANSMITTAL**

**Complete and send this form, together with applicable fee(s), to: Mail Mail Stop ISSUE FEE  
 Commissioner for Patents  
 P.O. Box 1450  
 Alexandria, Virginia 22313-1450  
 or Fax (571)-273-2885**

**INSTRUCTIONS:** This form should be used for transmitting the ISSUE FEE and PUBLICATION FEE (if required). Blocks 1 through 5 should be completed where appropriate. All further correspondence including the Patent, advance orders and notification of maintenance fees will be mailed to the current correspondence address as indicated unless corrected below or directed otherwise in Block 1, by (a) specifying a new correspondence address; and/or (b) indicating a separate "FEE ADDRESS" for maintenance fee notifications.

CURRENT CORRESPONDENCE ADDRESS (Note: Use Block 1 for any change of address)

Note: A certificate of mailing can only be used for domestic mailings of the Fee(s) Transmittal. This certificate cannot be used for any other accompanying papers. Each additional paper, such as an assignment or formal drawing, must have its own certificate of mailing or transmission.

22859 7590 10/04/2012  
**FREDRIKSON & BYRON, P.A.**  
**INTELLECTUAL PROPERTY GROUP**  
**200 SOUTH SIXTH STREET, SUITE 4000**  
**MINNEAPOLIS, MN 55402**

**Certificate of Mailing or Transmission**

I hereby certify that this Fee(s) Transmittal is being deposited with the United States Postal Service with sufficient postage for first class mail in an envelope addressed to the Mail Stop ISSUE FEE address above, or being facsimile transmitted to the USPTO (571) 273-2885, on the date indicated below.

|                    |
|--------------------|
| (Depositor's name) |
| (Signature)        |
| (Date)             |

| APPLICATION NO. | FILING DATE | FIRST NAMED INVENTOR | ATTORNEY DOCKET NO. | CONFIRMATION NO. |
|-----------------|-------------|----------------------|---------------------|------------------|
| 12/137,356      | 06/11/2008  | Charles R. Quirico   | 56782.1.5           | 7360             |

TITLE OF INVENTION: SHIELDING ASSEMBLIES FOR INFUSION SYSTEMS

| APPLN. TYPE    | SMALL ENTITY | ISSUE FEE DUE | PUBLICATION FEE DUE | PREV. PAID ISSUE FEE | TOTAL FEE(S) DUE | DATE DUE   |
|----------------|--------------|---------------|---------------------|----------------------|------------------|------------|
| nonprovisional | NO           | \$0           | \$0                 | \$1740               | \$0              | 01/04/2013 |

| EXAMINER          | ART UNIT | CLASS-SUBCLASS |
|-------------------|----------|----------------|
| GILBERT, SAMUEL G | 3735     | 600-005000     |

|   |   |
|---|---|
| <p>1. Change of correspondence address or indication of "Fee Address" (37 CFR 1.363).</p> <p><input type="checkbox"/> Change of correspondence address (or Change of Correspondence Address form PTO/SB/122) attached.</p> <p><input type="checkbox"/> "Fee Address" indication (or "Fee Address" Indication form PTO/SB/47; Rev 03-02 or more recent) attached. <b>Use of a Customer Number is required.</b></p> | <p>2. For printing on the patent front page, list</p> <p>(1) the names of up to 3 registered patent attorneys or agents OR, alternatively, 1 <u>Fredrikson &amp; Byron, PA</u></p> <p>(2) the name of a single firm (having as a member a registered attorney or agent) and the names of up to 2 registered patent attorneys or agents. If no name is listed, no name will be printed. 2 _____</p> <p>3 _____</p> |
|---|---|

3. ASSIGNEE NAME AND RESIDENCE DATA TO BE PRINTED ON THE PATENT (print or type)

PLEASE NOTE: Unless an assignee is identified below, no assignee data will appear on the patent. If an assignee is identified below, the document has been filed for recordation as set forth in 37 CFR 3.11. Completion of this form is NOT a substitute for filing an assignment.

|   |   |
|---|---|
| (A) NAME OF ASSIGNEE<br>BRACCO DIAGNOSTICS INC. | (B) RESIDENCE: (CITY and STATE OR COUNTRY)<br>Princeton, NJ |
|---|---|

Please check the appropriate assignee category or categories (will not be printed on the patent):  Individual  Corporation or other private group entity  Government

|   |   |
|---|---|
| <p>4a. The following fee(s) are submitted:</p> <p><input type="checkbox"/> Issue Fee</p> <p><input type="checkbox"/> Publication Fee (No small entity discount permitted)</p> <p><input type="checkbox"/> Advance Order - # of Copies _____</p> | <p>4b. Payment of Fee(s); (Please first reapply any previously paid issue fee shown above)</p> <p><input type="checkbox"/> A check is enclosed.</p> <p><input type="checkbox"/> Payment by credit card. Form PTO-2038 is attached.</p> <p><input checked="" type="checkbox"/> The Director is hereby authorized to charge the required fee(s), any deficiency, or credit any overpayment, to Deposit Account Number <u>061910</u> (enclose an extra copy of this form).</p> |
|---|---|

5. Change in Entity Status (from status indicated above)

a. Applicant claims SMALL ENTITY status. See 37 CFR 1.27.  b. Applicant is no longer claiming SMALL ENTITY status. See 37 CFR 1.27(g)(2).

NOTE: The Issue Fee and Publication Fee (if required) will not be accepted from anyone other than the applicant; a registered attorney or agent; or the assignee or other party in interest as shown by the records of the United States Patent and Trademark Office.

Authorized Signature /Paul J. LaVanway, Jr./ Date October 15, 2012

Typed or printed name Paul J. LaVanway, Jr. Registration No. 64,610

This collection of information is required by 37 CFR 1.311. The information is required to obtain or retain a benefit by the public which is to file (and by the USPTO to process) an application. Confidentiality is governed by 35 U.S.C. 122 and 37 CFR 1.14. This collection is estimated to take 12 minutes to complete, including gathering, preparing, and submitting the completed application form to the USPTO. Time will vary depending upon the individual case. Any comments on the amount of time you require to complete this form and/or suggestions for reducing this burden, should be sent to the Chief Information Officer, U.S. Patent and Trademark Office, U.S. Department of Commerce, P.O. Box 1450, Alexandria, Virginia 22313-1450. DO NOT SEND FEES OR COMPLETED FORMS TO THIS ADDRESS. SEND TO: Commissioner for Patents, P.O. Box 1450, Alexandria, Virginia 22313-1450.

Under the Paperwork Reduction Act of 1995, no persons are required to respond to a collection of information unless it displays a valid OMB control number.

## Electronic Acknowledgement Receipt

|   |   |
|---|---|
| <b>EFS ID:</b>                              | 13982126                                  |
| <b>Application Number:</b>                  | 12137356                                  |
| <b>International Application Number:</b>    |   |
| <b>Confirmation Number:</b>                 | 7360                                      |
| <b>Title of Invention:</b>                  | SHIELDING ASSEMBLIES FOR INFUSION SYSTEMS |
| <b>First Named Inventor/Applicant Name:</b> | Charles R. Quirico                        |
| <b>Customer Number:</b>                     | 22859                                     |
| <b>Filer:</b>                               | Paul J. LaVanway Jr.                      |
| <b>Filer Authorized By:</b>                 |   |
| <b>Attorney Docket Number:</b>              | 56782.1.5                                 |
| <b>Receipt Date:</b>                        | 15-OCT-2012                               |
| <b>Filing Date:</b>                         | 11-JUN-2008                               |
| <b>Time Stamp:</b>                          | 12:35:46                                  |
| <b>Application Type:</b>                    | Utility under 35 USC 111(a)               |

### Payment information:

|                        |    |
|------------------------|----|
| Submitted with Payment | no |
|------------------------|----|

### File Listing:

| Document Number | Document Description        | File Name             | File Size(Bytes)/<br>Message Digest                                  | Multi Part /.zip | Pages (if appl.) |
|-----------------|-----------------------------|-----------------------|--|------------------|------------------|
| 1               | Issue Fee Payment (PTO-85B) | 56782_1_5ISSUEFEE.pdf | 126984<br><small>3170c686c7f52af5d58ed49131c0f1042e<br/>c7af</small> | no               | 1                |

### Warnings:

### Information:

This Acknowledgement Receipt evidences receipt on the noted date by the USPTO of the indicated documents, characterized by the applicant, and including page counts, where applicable. It serves as evidence of receipt similar to a Post Card, as described in MPEP 503.

**New Applications Under 35 U.S.C. 111**

If a new application is being filed and the application includes the necessary components for a filing date (see 37 CFR 1.53(b)-(d) and MPEP 506), a Filing Receipt (37 CFR 1.54) will be issued in due course and the date shown on this Acknowledgement Receipt will establish the filing date of the application.

**National Stage of an International Application under 35 U.S.C. 371**

If a timely submission to enter the national stage of an international application is compliant with the conditions of 35 U.S.C. 371 and other applicable requirements a Form PCT/DO/EO/903 indicating acceptance of the application as a national stage submission under 35 U.S.C. 371 will be issued in addition to the Filing Receipt, in due course.

**New International Application Filed with the USPTO as a Receiving Office**

If a new international application is being filed and the international application includes the necessary components for an international filing date (see PCT Article 11 and MPEP 1810), a Notification of the International Application Number and of the International Filing Date (Form PCT/RO/105) will be issued in due course, subject to prescriptions concerning national security, and the date shown on this Acknowledgement Receipt will establish the international filing date of the application.



IFW

PART B - FEE(S) TRANSMITTAL

Complete and send this form, together with applicable fee(s), to: Mail Stop ISSUE FEE, Commissioner for Patents, P.O. Box 1450, Alexandria, Virginia 22313-1450 or Fax (571)-273-2885

INSTRUCTIONS: This form should be used for transmitting the ISSUE FEE and PUBLICATION FEE (if required). Blocks 1 through 5 should be completed where appropriate. All further correspondence including the Patent, advance orders and notification of maintenance fees will be mailed to the current correspondence address as indicated unless corrected below or directed otherwise in Block 1, by (a) specifying a new correspondence address; and/or (b) indicating a separate "FEE ADDRESS" for maintenance fee notifications.

CURRENT CORRESPONDENCE ADDRESS (Note: Use Block 1 for any change of address)

Note: A certificate of mailing can only be used for domestic mailings of the Fee(s) Transmittal. This certificate cannot be used for any other accompanying papers. Each additional paper, such as an assignment or formal drawing, must have its own certificate of mailing or transmission.

22859 7590 10/04/2012
FREDRIKSON & BYRON, P.A.
INTELLECTUAL PROPERTY GROUP
200 SOUTH SIXTH STREET, SUITE 4000
MINNEAPOLIS, MN 55402

Certificate of Mailing or Transmission
I hereby certify that this Fee(s) Transmittal is being deposited with the United States Postal Service with sufficient postage for first class mail in an envelope addressed to the Mail Stop ISSUE FEE address above, or being facsimile transmitted to the USPTO (571) 273-2885, on the date indicated below.

10/16/2012 CCHAU2 00000045 061910 12137356
01 FC:1501 30.00 DA 1740.00 OP

Form with fields for Depositor's name, Signature, and Date.

Table with columns: APPLICATION NO., FILING DATE, FIRST NAMED INVENTOR, ATTORNEY DOCKET NO., CONFIRMATION NO.

TITLE OF INVENTION: SHIELDING ASSEMBLIES FOR INFUSION SYSTEMS

Adjustment date: 10/16/2012 CCHAU2
08/20/2012 INTEFSW 00000107 12137356
01 FC:1501 -1740.00 OP

Table with columns: APPLN. TYPE, SMALL ENTITY, ISSUE FEE DUE, PUBLICATION FEE DUE, PREV. PAID ISSUE FEE, TOTAL FEE(S) DUE, DATE DUE

Table with columns: EXAMINER, ART UNIT, CLASS-SUBCLASS

1. Change of correspondence address or indication of "Fee Address" (37 CFR 1.363).
Change of correspondence address (or Change of Correspondence Address form PTO/SB/122) attached.
"Fee Address" indication (or "Fee Address" Indication form PTO/SB/47; Rev. 03-02 or more recent) attached. Use of a Customer Number is required.

2. For printing on the patent front page, list
(1) the names of up to 3 registered patent attorneys or agents OR, alternatively, Fredrikson & Byron, PA
(2) the name of a single firm (having as a member a registered attorney or agent) and the names of up to 2 registered patent attorneys or agents. If no name is listed, no name will be printed.

3. ASSIGNEE NAME AND RESIDENCE DATA TO BE PRINTED ON THE PATENT (print or type)

PLEASE NOTE: Unless an assignee is identified below, no assignee data will appear on the patent. If an assignee is identified below, the document has been filed for recordation as set forth in 37 CFR 3.11. Completion of this form is NOT a substitute for filing an assignment.

(A) NAME OF ASSIGNEE: BRACCO DIAGNOSTICS INC.
(B) RESIDENCE: (CITY and STATE OR COUNTRY): Princeton, NJ

Please check the appropriate assignee category or categories (will not be printed on the patent): Individual [ ] Corporation or other private group entity [X] Government [ ]

4a. The following fee(s) are submitted:

- Issue Fee [ ]
Publication Fee (No small entity discount permitted) [ ]
Advance Order - # of Copies [ ]

4b. Payment of Fee(s): (Please first reapply any previously paid issue fee shown above)

- A check is enclosed. [ ]
Payment by credit card. Form PTO-2038 is attached. [ ]
The Director is hereby authorized to charge the required fee(s), any deficiency, or credit any overpayment, to Deposit Account Number 061910 (enclose an extra copy of this form). [X]

5. Change in Entity Status (from status indicated above)

- a. Applicant claims SMALL ENTITY status. See 37 CFR 1.27. [ ]
b. Applicant is no longer claiming SMALL ENTITY status. See 37 CFR 1.27(g)(2). [ ]

NOTE: The Issue Fee and Publication Fee (if required) will not be accepted from anyone other than the applicant; a registered attorney or agent; or the assignee or other party in interest as shown by the records of the United States Patent and Trademark Office.

Authorized Signature: /Paul J. LaVanway, Jr./

Date: October 15, 2012

Typed or printed name: Paul J. LaVanway, Jr.

Registration No.: 64,610

This collection of information is required by 37 CFR 1.311. The information is required to obtain or retain a benefit by the public which is to file (and by the USPTO to process) an application. Confidentiality is governed by 35 U.S.C. 122 and 37 CFR 1.14. This collection is estimated to take 12 minutes to complete, including gathering, preparing, and submitting the completed application form to the USPTO. Time will vary depending upon the individual case. Any comments on the amount of time you require to complete this form and/or suggestions for reducing this burden, should be sent to the Chief Information Officer, U.S. Patent and Trademark Office, U.S. Department of Commerce, P.O. Box 1450, Alexandria, Virginia 22313-1450. DO NOT SEND FEES OR COMPLETED FORMS TO THIS ADDRESS. SEND TO: Commissioner for Patents, P.O. Box 1450, Alexandria, Virginia 22313-1450.

Under the Paperwork Reduction Act of 1995, no persons are required to respond to a collection of information unless it displays a valid OMB control number.



NOTICE OF ALLOWANCE AND FEE(S) DUE

22859 7590 10/04/2012
FREDRIKSON & BYRON, P.A.
INTELLECTUAL PROPERTY GROUP
200 SOUTH SIXTH STREET, SUITE 4000
MINNEAPOLIS, MN 55402

EXAMINER
GILBERT, SAMUEL G
ART UNIT PAPER NUMBER

3735

DATE MAILED: 10/04/2012

Table with 5 columns: APPLICATION NO., FILING DATE, FIRST NAMED INVENTOR, ATTORNEY DOCKET NO., CONFIRMATION NO.

12/137,356 06/11/2008 Charles R. Quirico 56782.1.5 7360

TITLE OF INVENTION: SHIELDING ASSEMBLIES FOR INFUSION SYSTEMS

Table with 7 columns: APPLN. TYPE, SMALL ENTITY, ISSUE FEE DUE, PUBLICATION FEE DUE, PREV. PAID ISSUE FEE, TOTAL FEE(S) DUE, DATE DUE

nonprovisional NO \$0 \$0 \$1740 \$0 01/04/2013

THE APPLICATION IDENTIFIED ABOVE HAS BEEN EXAMINED AND IS ALLOWED FOR ISSUANCE AS A PATENT. PROSECUTION ON THE MERITS IS CLOSED. THIS NOTICE OF ALLOWANCE IS NOT A GRANT OF PATENT RIGHTS. THIS APPLICATION IS SUBJECT TO WITHDRAWAL FROM ISSUE AT THE INITIATIVE OF THE OFFICE OR UPON PETITION BY THE APPLICANT. SEE 37 CFR 1.313 AND MPEP 1308.

THE ISSUE FEE AND PUBLICATION FEE (IF REQUIRED) MUST BE PAID WITHIN THREE MONTHS FROM THE MAILING DATE OF THIS NOTICE OR THIS APPLICATION SHALL BE REGARDED AS ABANDONED. THIS STATUTORY PERIOD CANNOT BE EXTENDED. SEE 35 U.S.C. 151. THE ISSUE FEE DUE INDICATED ABOVE DOES NOT REFLECT A CREDIT FOR ANY PREVIOUSLY PAID ISSUE FEE IN THIS APPLICATION. IF AN ISSUE FEE HAS PREVIOUSLY BEEN PAID IN THIS APPLICATION (AS SHOWN ABOVE), THE RETURN OF PART B OF THIS FORM WILL BE CONSIDERED A REQUEST TO REAPPLY THE PREVIOUSLY PAID ISSUE FEE TOWARD THE ISSUE FEE NOW DUE.

HOW TO REPLY TO THIS NOTICE:

I. Review the SMALL ENTITY status shown above.

If the SMALL ENTITY is shown as YES, verify your current SMALL ENTITY status:

A. If the status is the same, pay the TOTAL FEE(S) DUE shown above.

B. If the status above is to be removed, check box 5b on Part B - Fee(s) Transmittal and pay the PUBLICATION FEE (if required) and twice the amount of the ISSUE FEE shown above, or

If the SMALL ENTITY is shown as NO:

A. Pay TOTAL FEE(S) DUE shown above, or

B. If applicant claimed SMALL ENTITY status before, or is now claiming SMALL ENTITY status, check box 5a on Part B - Fee(s) Transmittal and pay the PUBLICATION FEE (if required) and 1/2 the ISSUE FEE shown above.

II. PART B - FEE(S) TRANSMITTAL, or its equivalent, must be completed and returned to the United States Patent and Trademark Office (USPTO) with your ISSUE FEE and PUBLICATION FEE (if required). If you are charging the fee(s) to your deposit account, section "4b" of Part B - Fee(s) Transmittal should be completed and an extra copy of the form should be submitted. If an equivalent of Part B is filed, a request to reapply a previously paid issue fee must be clearly made, and delays in processing may occur due to the difficulty in recognizing the paper as an equivalent of Part B.

III. All communications regarding this application must give the application number. Please direct all communications prior to issuance to Mail Stop ISSUE FEE unless advised to the contrary.

IMPORTANT REMINDER: Utility patents issuing on applications filed on or after Dec. 12, 1980 may require payment of maintenance fees. It is patentee's responsibility to ensure timely payment of maintenance fees when due.

**PART B - FEE(S) TRANSMITTAL**

**Complete and send this form, together with applicable fee(s), to: Mail Mail Stop ISSUE FEE  
 Commissioner for Patents  
 P.O. Box 1450  
 Alexandria, Virginia 22313-1450  
 or Fax (571)-273-2885**

**INSTRUCTIONS:** This form should be used for transmitting the ISSUE FEE and PUBLICATION FEE (if required). Blocks 1 through 5 should be completed where appropriate. All further correspondence including the Patent, advance orders and notification of maintenance fees will be mailed to the current correspondence address as indicated unless corrected below or directed otherwise in Block 1, by (a) specifying a new correspondence address; and/or (b) indicating a separate "FEE ADDRESS" for maintenance fee notifications.

CURRENT CORRESPONDENCE ADDRESS (Note: Use Block 1 for any change of address)

Note: A certificate of mailing can only be used for domestic mailings of the Fee(s) Transmittal. This certificate cannot be used for any other accompanying papers. Each additional paper, such as an assignment or formal drawing, must have its own certificate of mailing or transmission.

22859 7590 10/04/2012  
**FREDRIKSON & BYRON, P.A.**  
**INTELLECTUAL PROPERTY GROUP**  
**200 SOUTH SIXTH STREET, SUITE 4000**  
**MINNEAPOLIS, MN 55402**

**Certificate of Mailing or Transmission**

I hereby certify that this Fee(s) Transmittal is being deposited with the United States Postal Service with sufficient postage for first class mail in an envelope addressed to the Mail Stop ISSUE FEE address above, or being facsimile transmitted to the USPTO (571) 273-2885, on the date indicated below.

|                    |
|--------------------|
| (Depositor's name) |
| (Signature)        |
| (Date)             |

| APPLICATION NO. | FILING DATE | FIRST NAMED INVENTOR | ATTORNEY DOCKET NO. | CONFIRMATION NO. |
|-----------------|-------------|----------------------|---------------------|------------------|
| 12/137,356      | 06/11/2008  | Charles R. Quirico   | 56782.1.5           | 7360             |

TITLE OF INVENTION: SHIELDING ASSEMBLIES FOR INFUSION SYSTEMS

| APPLN. TYPE    | SMALL ENTITY | ISSUE FEE DUE | PUBLICATION FEE DUE | PREV. PAID ISSUE FEE | TOTAL FEE(S) DUE | DATE DUE   |
|----------------|--------------|---------------|---------------------|----------------------|------------------|------------|
| nonprovisional | NO           | \$0           | \$0                 | \$1740               | \$0              | 01/04/2013 |

| EXAMINER          | ART UNIT | CLASS-SUBCLASS |
|-------------------|----------|----------------|
| GILBERT, SAMUEL G | 3735     | 600-005000     |

|   |   |
|---|---|
| <p>1. Change of correspondence address or indication of "Fee Address" (37 CFR 1.363).</p> <p><input type="checkbox"/> Change of correspondence address (or Change of Correspondence Address form PTO/SB/122) attached.</p> <p><input type="checkbox"/> "Fee Address" indication (or "Fee Address" Indication form PTO/SB/47; Rev 03-02 or more recent) attached. <b>Use of a Customer Number is required.</b></p> | <p>2. For printing on the patent front page, list</p> <p>(1) the names of up to 3 registered patent attorneys or agents OR, alternatively, 1 _____</p> <p>(2) the name of a single firm (having as a member a registered attorney or agent) and the names of up to 2 registered patent attorneys or agents. If no name is listed, no name will be printed. 2 _____</p> <p>3 _____</p> |
|---|---|

3. ASSIGNEE NAME AND RESIDENCE DATA TO BE PRINTED ON THE PATENT (print or type)

PLEASE NOTE: Unless an assignee is identified below, no assignee data will appear on the patent. If an assignee is identified below, the document has been filed for recordation as set forth in 37 CFR 3.11. Completion of this form is NOT a substitute for filing an assignment.

(A) NAME OF ASSIGNEE \_\_\_\_\_ (B) RESIDENCE: (CITY and STATE OR COUNTRY) \_\_\_\_\_

Please check the appropriate assignee category or categories (will not be printed on the patent) :  Individual  Corporation or other private group entity  Government

|   |  |
|---|--|
| <p>4a. The following fee(s) are submitted:</p> <p><input type="checkbox"/> Issue Fee</p> <p><input type="checkbox"/> Publication Fee (No small entity discount permitted)</p> <p><input type="checkbox"/> Advance Order - # of Copies _____</p> | <p>4b. Payment of Fee(s); (Please first reapply any previously paid issue fee shown above)</p> <p><input type="checkbox"/> A check is enclosed.</p> <p><input type="checkbox"/> Payment by credit card. Form PTO-2038 is attached.</p> <p><input type="checkbox"/> The Director is hereby authorized to charge the required fee(s), any deficiency, or credit any overpayment, to Deposit Account Number _____ (enclose an extra copy of this form).</p> |
|---|--|

5. Change in Entity Status (from status indicated above)

a. Applicant claims SMALL ENTITY status. See 37 CFR 1.27.  b. Applicant is no longer claiming SMALL ENTITY status. See 37 CFR 1.27(g)(2).

NOTE: The Issue Fee and Publication Fee (if required) will not be accepted from anyone other than the applicant; a registered attorney or agent; or the assignee or other party in interest as shown by the records of the United States Patent and Trademark Office.

Authorized Signature \_\_\_\_\_ Date \_\_\_\_\_

Typed or printed name \_\_\_\_\_ Registration No. \_\_\_\_\_

This collection of information is required by 37 CFR 1.311. The information is required to obtain or retain a benefit by the public which is to file (and by the USPTO to process) an application. Confidentiality is governed by 35 U.S.C. 122 and 37 CFR 1.14. This collection is estimated to take 12 minutes to complete, including gathering, preparing, and submitting the completed application form to the USPTO. Time will vary depending upon the individual case. Any comments on the amount of time you require to complete this form and/or suggestions for reducing this burden, should be sent to the Chief Information Officer, U.S. Patent and Trademark Office, U.S. Department of Commerce, P.O. Box 1450, Alexandria, Virginia 22313-1450. DO NOT SEND FEES OR COMPLETED FORMS TO THIS ADDRESS. SEND TO: Commissioner for Patents, P.O. Box 1450, Alexandria, Virginia 22313-1450.

Under the Paperwork Reduction Act of 1995, no persons are required to respond to a collection of information unless it displays a valid OMB control number.



UNITED STATES PATENT AND TRADEMARK OFFICE

UNITED STATES DEPARTMENT OF COMMERCE
United States Patent and Trademark Office
Address: COMMISSIONER FOR PATENTS
P.O. Box 1450
Alexandria, Virginia 22313-1450
www.uspto.gov

Table with 5 columns: APPLICATION NO., FILING DATE, FIRST NAMED INVENTOR, ATTORNEY DOCKET NO., CONFIRMATION NO.
Values: 12/137,356, 06/11/2008, Charles R. Quirico, 56782.1.5, 7360

22859 7590 10/04/2012
FREDRIKSON & BYRON, P.A.
INTELLECTUAL PROPERTY GROUP
200 SOUTH SIXTH STREET, SUITE 4000
MINNEAPOLIS, MN 55402

EXAMINER

GILBERT, SAMUEL G

ART UNIT PAPER NUMBER

3735

DATE MAILED: 10/04/2012

Determination of Patent Term Adjustment under 35 U.S.C. 154 (b)

(application filed on or after May 29, 2000)

The Patent Term Adjustment to date is 945 day(s). If the issue fee is paid on the date that is three months after the mailing date of this notice and the patent issues on the Tuesday before the date that is 28 weeks (six and a half months) after the mailing date of this notice, the Patent Term Adjustment will be 945 day(s).

If a Continued Prosecution Application (CPA) was filed in the above-identified application, the filing date that determines Patent Term Adjustment is the filing date of the most recent CPA.

Applicant will be able to obtain more detailed information by accessing the Patent Application Information Retrieval (PAIR) WEB site (http://pair.uspto.gov).

Any questions regarding the Patent Term Extension or Adjustment determination should be directed to the Office of Patent Legal Administration at (571)-272-7702. Questions relating to issue and publication fee payments should be directed to the Customer Service Center of the Office of Patent Publication at 1-(888)-786-0101 or (571)-272-4200.



## Privacy Act Statement

**The Privacy Act of 1974 (P.L. 93-579)** requires that you be given certain information in connection with your submission of the attached form related to a patent application or patent. Accordingly, pursuant to the requirements of the Act, please be advised that: (1) the general authority for the collection of this information is 35 U.S.C. 2(b)(2); (2) furnishing of the information solicited is voluntary; and (3) the principal purpose for which the information is used by the U.S. Patent and Trademark Office is to process and/or examine your submission related to a patent application or patent. If you do not furnish the requested information, the U.S. Patent and Trademark Office may not be able to process and/or examine your submission, which may result in termination of proceedings or abandonment of the application or expiration of the patent.

The information provided by you in this form will be subject to the following routine uses:

1. The information on this form will be treated confidentially to the extent allowed under the Freedom of Information Act (5 U.S.C. 552) and the Privacy Act (5 U.S.C. 552a). Records from this system of records may be disclosed to the Department of Justice to determine whether disclosure of these records is required by the Freedom of Information Act.
2. A record from this system of records may be disclosed, as a routine use, in the course of presenting evidence to a court, magistrate, or administrative tribunal, including disclosures to opposing counsel in the course of settlement negotiations.
3. A record in this system of records may be disclosed, as a routine use, to a Member of Congress submitting a request involving an individual, to whom the record pertains, when the individual has requested assistance from the Member with respect to the subject matter of the record.
4. A record in this system of records may be disclosed, as a routine use, to a contractor of the Agency having need for the information in order to perform a contract. Recipients of information shall be required to comply with the requirements of the Privacy Act of 1974, as amended, pursuant to 5 U.S.C. 552a(m).
5. A record related to an International Application filed under the Patent Cooperation Treaty in this system of records may be disclosed, as a routine use, to the International Bureau of the World Intellectual Property Organization, pursuant to the Patent Cooperation Treaty.
6. A record in this system of records may be disclosed, as a routine use, to another federal agency for purposes of National Security review (35 U.S.C. 181) and for review pursuant to the Atomic Energy Act (42 U.S.C. 218(c)).
7. A record from this system of records may be disclosed, as a routine use, to the Administrator, General Services, or his/her designee, during an inspection of records conducted by GSA as part of that agency's responsibility to recommend improvements in records management practices and programs, under authority of 44 U.S.C. 2904 and 2906. Such disclosure shall be made in accordance with the GSA regulations governing inspection of records for this purpose, and any other relevant (i.e., GSA or Commerce) directive. Such disclosure shall not be used to make determinations about individuals.
8. A record from this system of records may be disclosed, as a routine use, to the public after either publication of the application pursuant to 35 U.S.C. 122(b) or issuance of a patent pursuant to 35 U.S.C. 151. Further, a record may be disclosed, subject to the limitations of 37 CFR 1.14, as a routine use, to the public if the record was filed in an application which became abandoned or in which the proceedings were terminated and which application is referenced by either a published application, an application open to public inspection or an issued patent.
9. A record from this system of records may be disclosed, as a routine use, to a Federal, State, or local law enforcement agency, if the USPTO becomes aware of a violation or potential violation of law or regulation.

**Notice of Allowability**

|                                      |                                       |  |
|--------------------------------------|---------------------------------------|--|
| <b>Application No.</b><br>12/137,356 | <b>Applicant(s)</b><br>QUIRICO ET AL. |  |
| <b>Examiner</b><br>SAMUEL GILBERT    | <b>Art Unit</b><br>3735               |  |

**-- The MAILING DATE of this communication appears on the cover sheet with the correspondence address--**

All claims being allowable, PROSECUTION ON THE MERITS IS (OR REMAINS) CLOSED in this application. If not included herewith (or previously mailed), a Notice of Allowance (PTOL-85) or other appropriate communication will be mailed in due course. **THIS NOTICE OF ALLOWABILITY IS NOT A GRANT OF PATENT RIGHTS.** This application is subject to withdrawal from issue at the initiative of the Office or upon petition by the applicant. See 37 CFR 1.313 and MPEP 1308.

- 1.  This communication is responsive to papers filed 9/20/2012.
- 2.  An election was made by the applicant in response to a restriction requirement set forth during the interview on \_\_\_\_; the restriction requirement and election have been incorporated into this action.
- 3.  The allowed claim(s) is/are 1-37.
- 4.  Acknowledgment is made of a claim for foreign priority under 35 U.S.C. § 119(a)-(d) or (f).
  - a)  All    b)  Some\*    c)  None    of the:
    - 1.  Certified copies of the priority documents have been received.
    - 2.  Certified copies of the priority documents have been received in Application No. \_\_\_\_ .
    - 3.  Copies of the certified copies of the priority documents have been received in this national stage application from the International Bureau (PCT Rule 17.2(a)).

\* Certified copies not received: \_\_\_\_.

Applicant has THREE MONTHS FROM THE "MAILING DATE" of this communication to file a reply complying with the requirements noted below. Failure to timely comply will result in ABANDONMENT of this application.

**THIS THREE-MONTH PERIOD IS NOT EXTENDABLE.**

- 5.  A SUBSTITUTE OATH OR DECLARATION must be submitted. Note the attached EXAMINER'S AMENDMENT or NOTICE OF INFORMAL PATENT APPLICATION (PTO-152) which gives reason(s) why the oath or declaration is deficient.
  - 6.  CORRECTED DRAWINGS ( as "replacement sheets") must be submitted.
    - (a)  including changes required by the Notice of Draftsperson's Patent Drawing Review ( PTO-948) attached
      - 1)  hereto or 2)  to Paper No./Mail Date \_\_\_\_.
    - (b)  including changes required by the attached Examiner's Amendment / Comment or in the Office action of Paper No./Mail Date \_\_\_\_.
- Identifying indicia such as the application number (see 37 CFR 1.84(c)) should be written on the drawings in the front (not the back) of each sheet. Replacement sheet(s) should be labeled as such in the header according to 37 CFR 1.121(d).**
7.  DEPOSIT OF and/or INFORMATION about the deposit of BIOLOGICAL MATERIAL must be submitted. Note the attached Examiner's comment regarding REQUIREMENT FOR THE DEPOSIT OF BIOLOGICAL MATERIAL.

**Attachment(s)**

- 1.  Notice of References Cited (PTO-892)
- 2.  Notice of Draftsperson's Patent Drawing Review (PTO-948)
- 3.  Information Disclosure Statements (PTO/SB/08), Paper No./Mail Date 9/20/2012
- 4.  Examiner's Comment Regarding Requirement for Deposit of Biological Material
- 5.  Notice of Informal Patent Application
- 6.  Interview Summary (PTO-413), Paper No./Mail Date \_\_\_\_ .
- 7.  Examiner's Amendment/Comment
- 8.  Examiner's Statement of Reasons for Allowance
- 9.  Other \_\_\_\_.

/Samuel G. Gilbert/  
Primary Examiner, Art Unit 3735

## DETAILED ACTION

### ***Continued Examination Under 37 CFR 1.114***

A request for continued examination under 37 CFR 1.114, including the fee set forth in 37 CFR 1.17(e), was filed in this application after allowance or after an Office action under *Ex Parte Quayle*, 25 USPQ 74, 453 O.G. 213 (Comm'r Pat. 1935). Since this application is eligible for continued examination under 37 CFR 1.114, and the fee set forth in 37 CFR 1.17(e) has been timely paid, prosecution in this application has been reopened pursuant to 37 CFR 1.114. Applicant's submission filed on 9/20/2012 has been entered.

### ***Conclusion***

Any inquiry concerning this communication or earlier communications from the examiner should be directed to SAMUEL GILBERT whose telephone number is (571)272-4725. The examiner can normally be reached on Monday-Friday 6:30-3:00.


If attempts to reach the examiner by telephone are unsuccessful, the examiner's supervisor, Charles Marmor II can be reached on 571-272-4730. The fax phone number for the organization where this application or proceeding is assigned is 571-273-8300.

Art Unit: 3735

Information regarding the status of an application may be obtained from the Patent Application Information Retrieval (PAIR) system. Status information for published applications may be obtained from either Private PAIR or Public PAIR. Status information for unpublished applications is available through Private PAIR only. For more information about the PAIR system, see <http://pair-direct.uspto.gov>. Should you have questions on access to the Private PAIR system, contact the Electronic Business Center (EBC) at 866-217-9197 (toll-free). If you would like assistance from a USPTO Customer Service Representative or access to the automated information system, call 800-786-9199 (IN USA OR CANADA) or 571-272-1000.

/Samuel G. Gilbert/  
Primary Examiner, Art Unit 3735



|  |  |  |
|--|--|--|
| <b>Search Notes</b><br><br> | <b>Application/Control No.</b><br><br>12137356 | <b>Applicant(s)/Patent Under Reexamination</b><br><br>QUIRICO ET AL. |
|  | <b>Examiner</b><br><br>SAMUEL GILBERT          | <b>Art Unit</b><br><br>3735  |

| <b>SEARCHED</b> |                            |             |                 |
|-----------------|----------------------------|-------------|-----------------|
| <b>Class</b>    | <b>Subclass</b>            | <b>Date</b> | <b>Examiner</b> |
| 128             | 897,898                    |             |                 |
| 280             | 47.34, 47.35, 79.11, 79.3, |             |                 |
| 208             | 638,651,33.992,79.5,79.6   | 3/26/12     | sgg             |
| update          | above                      | 8/1/2012    | sgg             |
| update          | above                      | 9/26/2012   | sgg             |

| <b>SEARCH NOTES</b> |             |                 |  |
|---------------------|-------------|-----------------|--|
| <b>Search Notes</b> | <b>Date</b> | <b>Examiner</b> |  |
| EAST                | 3/26/12     | sgg             |  |
| EAST                | 8/1/2012    | sgg             |  |
| EAST                | 9/26/2012   | sgg             |  |

| <b>INTERFERENCE SEARCH</b> |                          |             |                 |
|----------------------------|--------------------------|-------------|-----------------|
| <b>Class</b>               | <b>Subclass</b>          | <b>Date</b> | <b>Examiner</b> |
| See                        | EAST search of 8/1/2012  | 8/1/2012    | sgg             |
| See                        | EAST search of 9/26/2012 | 9/26/2012   | sgg             |

|  |  |
|--|--|
|  |  |
|--|--|

Receipt date: 09/20/2012

Doc code: IDS

Doc description: Information Disclosure Statement (IDS) Filed

PTO/SB/08a (01-10)

Approved for use through 07/31/2012. OMB 0651-0031

U.S. Patent and Trademark Office; U.S. DEPARTMENT OF COMMERCE

Under the Paperwork Reduction Act of 1995, no persons are required to respond to a collection of information unless it contains a valid OMB control number.

|   |                        |                    |            |  |
|---|------------------------|--------------------|------------|--|
| <b>INFORMATION DISCLOSURE<br/>STATEMENT BY APPLICANT</b><br>( Not for submission under 37 CFR 1.99) | Application Number     |                    | 12137356   |  |
|   | Filing Date            |                    | 2008-06-11 |  |
|   | First Named Inventor   | Charles R. Quirico |            |  |
|   | Art Unit               |                    | 3735       |  |
|   | Examiner Name          | Samuel G. Gilbert  |            |  |
|   | Attorney Docket Number |                    | 56782.1.5  |  |

| U.S.PATENTS       |         |               |                        |            |   | Remove   |
|-------------------|---------|---------------|------------------------|------------|---|--|
| Examiner Initial* | Cite No | Patent Number | Kind Code <sup>1</sup> | Issue Date | Name of Patentee or Applicant of cited Document | Pages,Columns,Lines where Relevant Passages or Relevant Figures Appear |
|                   | 1       | 5395320       |                        | 1995-03-07 | Padda   |  |

If you wish to add additional U.S. Patent citation information please click the Add button. Add

| U.S.PATENT APPLICATION PUBLICATIONS |         |                    |                        |                  |   | Remove   |
|-------------------------------------|---------|--------------------|------------------------|------------------|---|--|
| Examiner Initial*                   | Cite No | Publication Number | Kind Code <sup>1</sup> | Publication Date | Name of Patentee or Applicant of cited Document | Pages,Columns,Lines where Relevant Passages or Relevant Figures Appear |
|                                     | 1       | 20030139640        |                        | 2003-07-24       | Whittacre                                       |  |
|                                     | 2       | 20050187515        |                        | 2005-08-25       | Varrichio                                       |  |
|                                     | 3       | 20050277833        |                        | 2005-12-15       | Williams  |  |

If you wish to add additional U.S. Published Application citation information please click the Add button. Add

| FOREIGN PATENT DOCUMENTS |         |                                      |                             |                        |                  |   |  | Remove                   |
|--------------------------|---------|--------------------------------------|-----------------------------|------------------------|------------------|---|--|--------------------------|
| Examiner Initial*        | Cite No | Foreign Document Number <sup>3</sup> | Country Code <sup>2</sup> j | Kind Code <sup>4</sup> | Publication Date | Name of Patentee or Applicant of cited Document | Pages,Columns,Lines where Relevant Passages or Relevant Figures Appear | T <sup>5</sup>           |
|                          | 1       |                                      |                             |                        |                  |   |  | <input type="checkbox"/> |

|   |                        |                    |            |
|---|------------------------|--------------------|------------|
| <b>INFORMATION DISCLOSURE<br/>STATEMENT BY APPLICANT</b><br>( Not for submission under 37 CFR 1.99) | Application Number     |                    | 12137356   |
|   | Filing Date            |                    | 2008-06-11 |
|   | First Named Inventor   | Charles R. Quirico |            |
|   | Art Unit               |                    | 3735       |
|   | Examiner Name          | Samuel G. Gilbert  |            |
|   | Attorney Docket Number |                    | 56782.1.5  |

If you wish to add additional Foreign Patent Document citation information please click the Add button **Add**

**NON-PATENT LITERATURE DOCUMENTS** **Remove**

| Examiner Initials* | Cite No | Include name of the author (in CAPITAL LETTERS), title of the article (when appropriate), title of the item (book, magazine, journal, serial, symposium, catalog, etc), date, pages(s), volume-issue number(s), publisher, city and/or country where published. | T <sup>5</sup>           |
|--------------------|---------|---|--------------------------|
|                    | 1       | "POSIJET Integrated FDG dispensing and infusion system" 2008-05   | <input type="checkbox"/> |

If you wish to add additional non-patent literature document citation information please click the Add button **Add**

**EXAMINER SIGNATURE**

|                    |                  |                 |            |
|--------------------|------------------|-----------------|------------|
| Examiner Signature | /Samuel Gilbert/ | Date Considered | 09/26/2012 |
|--------------------|------------------|-----------------|------------|

\*EXAMINER: Initial if reference considered, whether or not citation is in conformance with MPEP 609. Draw line through a citation if not in conformance and not considered. Include copy of this form with next communication to applicant.

<sup>1</sup> See Kind Codes of USPTO Patent Documents at [www.USPTO.GOV](http://www.USPTO.GOV) or MPEP 901.04. <sup>2</sup> Enter office that issued the document, by the two-letter code (WIPO Standard ST.3). <sup>3</sup> For Japanese patent documents, the indication of the year of the reign of the Emperor must precede the serial number of the patent document. <sup>4</sup> Kind of document by the appropriate symbols as indicated on the document under WIPO Standard ST.16 if possible. <sup>5</sup> Applicant is to place a check mark here if English language translation is attached.



## EAST Search History

## EAST Search History (Prior Art)

| Ref # | Hits | Search Query  | DBs                          | Default Operator | Plurals | Time Stamp          |
|-------|------|---|------------------------------|------------------|---------|---------------------|
| L1    | 4    | ((("5395320") or ("20030139640") or ("20050187515") or ("20050277833")).PN.   | US-PGPUB;<br>USPAT;<br>USOCR | OR               | OFF     | 2012/09/26<br>09:14 |
| L2    | 4    | ((("5395320") or ("20030139640") or ("20050187515") or ("20050277833")).PN.   | US-PGPUB;<br>USPAT;<br>USOCR | OR               | OFF     | 2012/09/26<br>09:22 |
| L3    | 72   | ("3997784"   "4625118"   "4679142"   "5885216"   "6767319"   "6908598"   "5827429"   "5485831"   "5739508"   "6157036"   "7504646"   "20090312630"   "7862534"   "3714429"   "4562829"   "4853546"   "5258906"   "20070140958"   "20070213848"   "20080242915"   "20070232980"   "20090312635"   "7163031"   "20090309466"   "4096859"   "4769008"   "4585941"   "5039863"   "7169135"   "20080093564"   "20060151048"   "20100125243"   "20100270226"   "3774036"   "4286169"   "6626862"   "20100312039"   "3483867"   "4336036"   "5765842"   "6870175"   "7204797"   "20070282263"   "5475232"   "6901283"   "7256888"   "20030004463"   "20060015056"   "4994056"   "6347711"   "6558125"   "20080071219"   "4755679"   "7476377"   "20040104160"   "20110071392"   "20050278066"   "3710118"   "4585009"   "20080166292"   "5274239"   "5840026"   "6442418"   "7413123"   "5590648"   "20110172524"   "4466888"   "4623102"   "5702115"   "7612999").PN. | US-PGPUB;<br>USPAT;<br>USOCR | OR               | ON      | 2012/09/26<br>09:22 |
| L4    | 2    | ((("20060151048") or ("5702115")).PN.   | US-PGPUB;<br>USPAT           | OR               | OFF     | 2012/09/26<br>09:22 |
| L5    | 96   | (600/5).CCLS.   | US-PGPUB;<br>USPAT           | OR               | OFF     | 2012/09/26<br>09:22 |
| L6    | 96   | (600/5).CCLS.   | US-PGPUB;<br>USPAT           | OR               | OFF     | 2012/09/26<br>09:22 |
| L7    | 107  | (250/522.1).CCLS.   | US-PGPUB;<br>USPAT           | OR               | OFF     | 2012/09/26<br>09:22 |
| L8    | 327  | (250/507.1).CCLS.   | US-PGPUB;<br>USPAT           | OR               | OFF     | 2012/09/26<br>09:22 |
| L9    | 1    | ("3483867").PN.   | US-PGPUB;<br>USPAT           | OR               | OFF     | 2012/09/26<br>09:22 |
| L10   | 1    | ("20090310523").PN.   | US-PGPUB;<br>USPAT           | OR               | OFF     | 2012/09/26<br>09:22 |
| L11   | 4    | (first adj compartment) with (sidewall adj opening)   | US-PGPUB;                    | OR               | ON      | 2012/09/26<br>09:22 |

|     |      |   |                                  |    |     |                     |
|-----|------|---|----------------------------------|----|-----|---------------------|
|     |      |   | USPAT;<br>USOCR                  |    |     |                     |
| L12 | 0    | L10 and L11   | US-<br>PGPUB;<br>USPAT;<br>USOCR | OR | ON  | 2012/09/26<br>09:22 |
| L13 | 5    | (first adj compartment) same (sidewall adj opening)         | US-<br>PGPUB;<br>USPAT;<br>USOCR | OR | ON  | 2012/09/26<br>09:22 |
| L14 | 0    | L10 and L13   | US-<br>PGPUB;<br>USPAT;<br>USOCR | OR | ON  | 2012/09/26<br>09:22 |
| L15 | 698  | shielding adj assembly                                      | US-<br>PGPUB;<br>USPAT;<br>USOCR | OR | ON  | 2012/09/26<br>09:22 |
| L16 | 0    | L10 and L15   | US-<br>PGPUB;<br>USPAT;<br>USOCR | OR | ON  | 2012/09/26<br>09:22 |
| L17 | 1    | ("20090318745").PN.   | US-<br>PGPUB;<br>USPAT           | OR | OFF | 2012/09/26<br>09:22 |
| L18 | 1    | L11 and L17   | US-<br>PGPUB;<br>USPAT;<br>USOCR | OR | ON  | 2012/09/26<br>09:22 |
| L19 | 1    | L11 and L17   | US-<br>PGPUB;<br>USPAT;<br>USOCR | OR | ON  | 2012/09/26<br>09:22 |
| L20 | 5    | (first adj compartment) same (sidewall adj opening)         | US-<br>PGPUB;<br>USPAT;<br>USOCR | OR | ON  | 2012/09/26<br>09:22 |
| L21 | 1    | L17 and L20   | US-<br>PGPUB;<br>USPAT;<br>USOCR | OR | ON  | 2012/09/26<br>09:22 |
| L22 | 47   | (first adj compartment) and(sidewall adj opening)           | US-<br>PGPUB;<br>USPAT;<br>USOCR | OR | ON  | 2012/09/26<br>09:22 |
| L23 | 47   | (first adj compartment) and (sidewall adj opening)          | US-<br>PGPUB;<br>USPAT;<br>USOCR | OR | ON  | 2012/09/26<br>09:22 |
| L24 | 1    | L17 and L23   | US-<br>PGPUB;<br>USPAT;<br>USOCR | OR | ON  | 2012/09/26<br>09:22 |
| L25 | 697  | (128/897,897).CCLS.   | US-<br>PGPUB;<br>USPAT           | OR | OFF | 2012/09/26<br>09:22 |
| L26 | 4473 | (280/47.34,47.35,79.11,79.3,638,651,33.992,79.5,79.6).CCLS. | US-<br>PGPUB;                    | OR | OFF | 2012/09/26<br>09:22 |

|     |      |   |                              |       |     |                     |  |
|-----|------|---|------------------------------|-------|-----|---------------------|--|
|     |      |   |                              | USPAT |     |                     |  |
| L27 | 22   | ("20040104160"   "20060015056"   "20060151048"   "20090312630"   "20090318745"   "20100125243"   "20100270226"   "20100312039"   "20110071392"   "20110172524"   "3483867"   "4096859"   "4336036"   "4466888"   "4623102"   "4769008"   "4994056"   "5827429"   "6347711"   "6558125"   "7862534").PN.   | US-PGPUB;<br>USPAT;<br>USOCR | OR    | ON  | 2012/09/26<br>09:22 |  |
| L28 | 1    | ("3714429").PN.   | US-PGPUB;<br>USPAT;<br>USOCR | OR    | ON  | 2012/09/26<br>09:22 |  |
| L29 | 5787 | (128/898).CCLS.   | US-PGPUB;<br>USPAT           | OR    | OFF | 2012/09/26<br>09:22 |  |
| L30 | 1776 | (600/3-8).CCLS.   | US-PGPUB;<br>USPAT;<br>USOCR | OR    | OFF | 2012/09/26<br>09:22 |  |
| L31 | 5617 | shield and radiation and door   | US-PGPUB;<br>USPAT;<br>USOCR | OR    | OFF | 2012/09/26<br>09:22 |  |
| L36 | 28   | tinnitus same hz same puls\$3   | US-PGPUB;<br>USPAT;<br>USOCR | OR    | OFF | 2012/09/26<br>09:22 |  |
| L41 | 174  | radiopharmaceutical with shield   | US-PGPUB;<br>USPAT;<br>USOCR | OR    | ON  | 2012/09/26<br>10:11 |  |
| S1  | 72   | ("3997784"   "4625118"   "4679142"   "5885216"   "6767319"   "6908598"   "5827429"   "5485831"   "5739508"   "6157036"   "7504646"   "20090312630"   "7862534"   "3714429"   "4562829"   "4853546"   "5258906"   "20070140958"   "20070213848"   "20080242915"   "20070232980"   "20090312635"   "7163031"   "20090309466"   "4096859"   "4769008"   "4585941"   "5039863"   "7169135"   "20080093564"   "20060151048"   "20100125243"   "20100270226"   "3774036"   "4286169"   "6626862"   "20100312039"   "3483867"   "4336036"   "5765842"   "6870175"   "7204797"   "20070282263"   "5475232"   "6901283"   "7256888"   "20030004463"   "20060015056"   "4994056"   "6347711"   "6558125"   "20080071219"   "4755679"   "7476377"   "20040104160"   "20110071392"   "20050278066"   "3710118"   "4585009"   "20080166292"   "5274239"   "5840026"   "6442418"   "7413123"   "5590648"   "20110172524"   "4466888"   "4623102"   "5702115"   "7612999").PN. | US-PGPUB;<br>USPAT;<br>USOCR | OR    | ON  | 2012/03/19<br>12:09 |  |
| S2  | 2    | ((("20060151048") or ("5702115")).PN.   | US-PGPUB;<br>USPAT           | OR    | OFF | 2012/03/19<br>12:39 |  |
| S3  | 94   | (600/5).CCLS.   | US-PGPUB;<br>USPAT           | OR    | OFF | 2012/03/19<br>15:01 |  |
| S4  | 94   | (600/5).CCLS.   | US-PGPUB;<br>USPAT           | OR    | OFF | 2012/03/19<br>15:01 |  |
| S5  | 101  | (250/522.1).CCLS.   | US-PGPUB;<br>USPAT           | OR    | OFF | 2012/03/19<br>15:09 |  |

|     |     |   |                              |    |     |                     |
|-----|-----|---|------------------------------|----|-----|---------------------|
| S6  | 319 | (250/507.1).CCLS.                                   | US-PGPUB;<br>USPAT           | OR | OFF | 2012/03/19<br>15:16 |
| S7  | 1   | ("3483867").PN.                                     | US-PGPUB;<br>USPAT           | OR | OFF | 2012/03/20<br>08:45 |
| S8  | 1   | ("20090310523").PN.                                 | US-PGPUB;<br>USPAT           | OR | OFF | 2012/03/20<br>09:03 |
| S9  | 3   | (first adj compartment) with (sidewall adj opening) | US-PGPUB;<br>USPAT;<br>USOCR | OR | ON  | 2012/03/20<br>09:04 |
| S10 | 0   | S8 and S9   | US-PGPUB;<br>USPAT;<br>USOCR | OR | ON  | 2012/03/20<br>09:04 |
| S11 | 4   | (first adj compartment) same (sidewall adj opening) | US-PGPUB;<br>USPAT;<br>USOCR | OR | ON  | 2012/03/20<br>09:05 |
| S12 | 0   | S8 and S11  | US-PGPUB;<br>USPAT;<br>USOCR | OR | ON  | 2012/03/20<br>09:06 |
| S13 | 671 | shielding adj assembly                              | US-PGPUB;<br>USPAT;<br>USOCR | OR | ON  | 2012/03/20<br>09:06 |
| S14 | 0   | S8 and S13  | US-PGPUB;<br>USPAT;<br>USOCR | OR | ON  | 2012/03/20<br>09:06 |
| S15 | 1   | ("20090318745").PN.                                 | US-PGPUB;<br>USPAT           | OR | OFF | 2012/03/20<br>09:07 |
| S16 | 1   | S9 and S15  | US-PGPUB;<br>USPAT;<br>USOCR | OR | ON  | 2012/03/20<br>09:08 |
| S17 | 1   | S9 and S15  | US-PGPUB;<br>USPAT;<br>USOCR | OR | ON  | 2012/03/20<br>09:08 |
| S18 | 4   | (first adj compartment) same (sidewall adj opening) | US-PGPUB;<br>USPAT;<br>USOCR | OR | ON  | 2012/03/20<br>09:09 |
| S19 | 1   | S15 and S18   | US-PGPUB;<br>USPAT;<br>USOCR | OR | ON  | 2012/03/20<br>09:09 |
| S20 | 45  | (first adj compartment) and(sidewall adj opening)   | US-PGPUB;<br>USPAT;<br>USOCR | OR | ON  | 2012/03/20<br>09:09 |
| S21 | 45  | (first adj compartment) and (sidewall adj opening)  | US-PGPUB;                    | OR | ON  | 2012/03/20<br>09:09 |

|     |      |  |                                  |    |     |                     |
|-----|------|--|----------------------------------|----|-----|---------------------|
|     |      |  | USPAT;<br>USOCR                  |    |     |                     |
| S22 | 1    | S15 and S21  | US-<br>PGPUB;<br>USPAT;<br>USOCR | OR | ON  | 2012/03/20<br>09:09 |
| S23 | 689  | (128/897,897).CCLS.  | US-<br>PGPUB;<br>USPAT           | OR | OFF | 2012/03/26<br>11:18 |
| S24 | 4393 | (280/47.34,47.35,79.11,79.3,638,651,33.992,79.5,79.6).CCLS.  | US-<br>PGPUB;<br>USPAT           | OR | OFF | 2012/03/26<br>11:29 |
| S25 | 22   | ("20040104160"   "20060015056"   "20060151048"  <br>"20090312630"   "20090318745"   "20100125243"  <br>"20100270226"   "20100312039"   "20110071392"  <br>"20110172524"   "3483867"   "4096859"   "4336036"  <br>"4466888"   "4623102"   "4769008"   "4994056"   "5827429"<br>  "6347711"   "6558125"   "7862534").PN. | US-<br>PGPUB;<br>USPAT;<br>USOCR | OR | ON  | 2012/03/26<br>11:34 |
| S26 | 1    | ("3714429").PN.  | US-<br>PGPUB;<br>USPAT;<br>USOCR | OR | ON  | 2012/03/26<br>11:35 |
| S27 | 5663 | (128/898).CCLS.  | US-<br>PGPUB;<br>USPAT           | OR | OFF | 2012/03/26<br>12:09 |
| S28 | 1763 | (600/3-8).CCLS.  | US-<br>PGPUB;<br>USPAT;<br>USOCR | OR | OFF | 2012/08/02<br>11:13 |
| S29 | 5521 | shield and radiation and door  | US-<br>PGPUB;<br>USPAT;<br>USOCR | OR | OFF | 2012/08/02<br>12:36 |
| S34 | 26   | tinnitus same hz same puls\$3  | US-<br>PGPUB;<br>USPAT;<br>USOCR | OR | OFF | 2012/08/03<br>11:40 |

9/ 26/ 2012 10:15:30 AM  
H:\Workspaces\12137356.wsp


**UNITED STATES PATENT AND TRADEMARK OFFICE**

UNITED STATES DEPARTMENT OF COMMERCE  
**United States Patent and Trademark Office**  
 Address: COMMISSIONER FOR PATENTS  
 P.O. Box 1450  
 Alexandria, Virginia 22313-1450  
 www.uspto.gov

**BIB DATA SHEET**
**CONFIRMATION NO. 7360**

| SERIAL NUMBER   | FILING or 371(c)<br>DATE  | CLASS  | GROUP ART UNIT          | ATTORNEY DOCKET<br>NO.                                       |                     |                           |
|---|---|--|-------------------------|--|---------------------|---------------------------|
| 12/137,356  | 06/11/2008  | 600  | 3735                    | 56782.1.5  |                     |                           |
| <b>APPLICANTS</b>   |   |  |                         |  |                     |                           |
| Charles R. Quirico, Warren, NJ;<br>Ernest Balestracci, Iselin, NJ;<br>Daniel Darst, Zimmerman, MN;<br>Eric J. Krause, Big Lake, MN;<br>Vishal N. Lokhande, Mountain View, CA;<br>Jacob S. Childs, Minneapolis, MN;<br>Peter B. Madson, Shanghai, CHINA;<br>Daniel V. Clements, Minneapolis, MN; |   |  |                         |  |                     |                           |
| ** CONTINUING DATA *****  |   |  |                         |  |                     |                           |
| ** FOREIGN APPLICATIONS *****   |   |  |                         |  |                     |                           |
| ** IF REQUIRED, FOREIGN FILING LICENSE GRANTED **   |   |  |                         |  |                     |                           |
| Foreign Priority claimed  | <input type="checkbox"/> Yes <input checked="" type="checkbox"/> No | <input type="checkbox"/> Met after Allowance | <b>STATE OR COUNTRY</b> | <b>SHEETS DRAWINGS</b>                                       | <b>TOTAL CLAIMS</b> | <b>INDEPENDENT CLAIMS</b> |
| 35 USC 119(a-d) conditions met  | <input type="checkbox"/> Yes <input checked="" type="checkbox"/> No |  | NJ                      | 23   | 37                  | 5                         |
| Verified and  | /SAMUEL G<br>GILBERT/<br>Examiner's Signature                       | Initials                                     |                         |  |                     |                           |
| Acknowledged  |   |  |                         |  |                     |                           |
| <b>ADDRESS</b>  |   |  |                         |  |                     |                           |
| FREDRIKSON & BYRON, P.A.<br>INTELLECTUAL PROPERTY GROUP<br>200 SOUTH SIXTH STREET, SUITE 4000<br>MINNEAPOLIS, MN 55402<br>UNITED STATES   |   |  |                         |  |                     |                           |
| <b>TITLE</b>  |   |  |                         |  |                     |                           |
| SHIELDING ASSEMBLIES FOR INFUSION SYSTEMS   |   |  |                         |  |                     |                           |
| <b>FILING FEE RECEIVED</b>  | FEES: Authority has been given in Paper                             |  |                         | <input type="checkbox"/> All Fees                            |                     |                           |
| 2730  | No. _____ to charge/credit DEPOSIT ACCOUNT                          |  |                         | <input type="checkbox"/> 1.16 Fees (Filing)                  |                     |                           |
|   | No. _____ for following:  |  |                         | <input type="checkbox"/> 1.17 Fees (Processing Ext. of time) |                     |                           |
|   |   |  |                         | <input type="checkbox"/> 1.18 Fees (Issue)                   |                     |                           |
|   |   |  |                         | <input type="checkbox"/> Other _____                         |                     |                           |
|   |   |  |                         | <input type="checkbox"/> Credit                              |                     |                           |

## PATENT WITHDRAWAL NOTICE

DATE WITHDRAWN

9/24/2012

WITHDRAWAL NUMBER

21329

The following application has been **WITHDRAWN** from the

9/25/2012 issue.

SERIAL NO.

12/137,356

PATENT NUMBER

8,273,008

DRAWINGS

1

CLASS

600/005.000

TITLE

SHIELDING ASSEMBLIES FOR INFUSION SYSTEMS

NAME AND ADDRESS

QUIRICO, CHARLES R. Et al  
WARREN NEW JERSEY

REASON FOR WITHDRAWAL

Office of Petitions granted applicant's request to withdraw patent from issue.

APPROVED

/Kimberly Terrell/, Manager

Patent Publication Branch  
Office of Data Management



UNITED STATES PATENT AND TRADEMARK OFFICE

Commissioner for Patents  
United States Patent and Trademark Office  
P.O. Box 1450  
Alexandria, VA 22313-1450  
[www.uspto.gov](http://www.uspto.gov)

Date : September 24, 2012  
TO : Director, Office of Data Management  
FROM : Office of Petitions  
SUBJECT : Withdrawal from Issue of **Application No. 12/137,356**  
  
Applicant(s) : Charles R. Quirco, et al.  
Application No. : 12/137,356  
Filed : June 11, 2008

The above-identified application has been assigned Patent No. 8,273,008 and an issue date of September 25, 2012.

It is hereby directed that this application be withdrawn from issue at the request of the applicant. Do not refund the issue fee.

The following erratum should be published in the Official Gazette if the above-identified application is published in the OG of September 25, 2012:

"All reference to Patent No. 8,273,008 to Charles R. Quirco, et al. of New Jersey for SHIELDING ASSEMBLIES FOR INFUSIONS SYSTEMS appearing in the Official Gazette of September 25, 2012, should be deleted since no patent was granted."

/AMW/  
April M. Wise  
Petitions Examiner  
Office of Petitions

cc: Paul Harrison  
Deneise Boyd  
Mary Louise McAskill  
Niomi Farmer  
Mary E. Johnson (Cookie)  
Bradley Harris  
Kimberly Terrell  
Lamont Fletcher





FREDRIKSON & BYRON, PA  
INTELLECTUAL PROPERTY GROUP  
200 SOUTH SIXTH STREET, SUITE 4000  
MINNEAPOLIS, MN 55402

**MAILED**  
SEP 24 2012  
OFFICE OF PETITIONS

In re Application of :  
Charles R. Quirco, et al. :  
Application No. 12/137,356 : DECISION GRANTING PETITION  
Filed: June 11, 2008 : UNDER 37 CFR 1.313(c)(2)  
Attorney Docket No. 56782.1.5 :

This is a decision on the petition under 37 CFR 1.313(c)(2), filed September 20, 2012, to withdraw the above-identified application from issue after payment of the issue fee.

The petition is **GRANTED**.

The above-identified application is withdrawn from issue for consideration of a submission under 37 CFR 1.114 (request for continued examination). See 37 CFR 1.313(c)(2).

*Petitioner is advised that the issue fee paid on August 17, 2012 cannot be refunded. If, however, this application is again allowed, petitioner may request that it be applied towards the issue fee required by the new Notice of Allowance.<sup>1</sup>*

Telephone inquiries regarding this decision should be directed to undersigned at (571) 272-1642. All other inquiries concerning the examination or status of this application should be directed to the Technology Center.

This application is being referred to Technology Center AU 3735 for processing of the request for continued examination under 37 CFR 1.114 and for consideration of the concurrently filed information disclosure statement.

/AMW/  
April M. Wise  
Petitions Examiner  
Office of Petitions

---

<sup>1</sup> *The request to apply the issue fee to the new Notice may be satisfied by completing and returning the new Part B – Fee(s) Transmittal Form (along with any balance due at the time of submission). Petitioner is advised that the Issue Fee Transmittal Form must be completed and timely submitted to avoid abandonment of the application.*

22859  
Customer Number

Patent Case No.: 56782.1.5

**IN THE UNITED STATES PATENT AND TRADEMARK OFFICE**

First Named Inventor: CHARLES R. QUIRICO  
Application No.: 12/137,356                      Group Art Unit: 3735  
Filed: June 11, 2008                      Examiner: GILBERT, Samuel G.  
Title: SHIELDING ASSEMBLIES FOR INFUSION SYSTEMS

---

**PETITION UNDER 37 CFR 1.313(c)(2) FOR WITHDRAWAL FROM ISSUE**

Mail Stop PETITIONS  
Commissioner for Patents  
PO Box 1450  
Alexandria, VA 22313-1450

Dear Sir:

Applicant hereby petitions for withdrawal of the above-identified patent application from issue. The issue fee for this case was paid August 17, 2012. The Issue Notification mailed September 5, 2012, indicates that the application will issue on September 25, 2012.

Applicant requests that the application be withdrawn from issue in accordance with the provisions of 37 C.F.R. § 1.313(C)(2) to enable the United States Patent and Trademark Office to consider a Request for Continued Examination (being filed on the same date as this petition). The Request for Continued Examination is accompanied by an Information Disclosure Statement listing references not previously considered by the Examiner. The Information Disclosure Statement constitutes a sufficient submission.

This petition is accompanied by the \$130.00 petition fee required under 37 CFR 1.17(h). The Commissioner is further authorized to charge any deficiencies and credit any overpayments to Deposit Account No. 06-1910.

Respectfully submitted,

Dated: September 20, 2012

/Paul J. LaVanway, Jr./

Paul J. LaVanway, Jr.  
Registration No. 64,610

FREDRIKSON & BYRON, P.A.  
200 South Sixth Street, Suite 4000  
Minneapolis, MN 55402-1425 USA  
Telephone: (612) 492-7387  
Facsimile: (612) 492-7077

*Please grant any extension of time necessary for entry; charge any fee due to Deposit Account No. 06-1910.*

5234551

|   |                        |                    |            |  |
|---|------------------------|--------------------|------------|--|
| <b>INFORMATION DISCLOSURE<br/>STATEMENT BY APPLICANT</b><br>( Not for submission under 37 CFR 1.99) | Application Number     |                    | 12137356   |  |
|   | Filing Date            |                    | 2008-06-11 |  |
|   | First Named Inventor   | Charles R. Quirico |            |  |
|   | Art Unit               |                    | 3735       |  |
|   | Examiner Name          | Samuel G. Gilbert  |            |  |
|   | Attorney Docket Number |                    | 56782.1.5  |  |

| U.S.PATENTS       |         |               |                        |            |   | Remove   |
|-------------------|---------|---------------|------------------------|------------|---|--|
| Examiner Initial* | Cite No | Patent Number | Kind Code <sup>1</sup> | Issue Date | Name of Patentee or Applicant of cited Document | Pages,Columns,Lines where Relevant Passages or Relevant Figures Appear |
|                   | 1       | 5395320       |                        | 1995-03-07 | Padda   |  |

If you wish to add additional U.S. Patent citation information please click the Add button.

Add

| U.S.PATENT APPLICATION PUBLICATIONS |         |                    |                        |                  |   | Remove   |
|-------------------------------------|---------|--------------------|------------------------|------------------|---|--|
| Examiner Initial*                   | Cite No | Publication Number | Kind Code <sup>1</sup> | Publication Date | Name of Patentee or Applicant of cited Document | Pages,Columns,Lines where Relevant Passages or Relevant Figures Appear |
|                                     | 1       | 20030139640        |                        | 2003-07-24       | Whittacre                                       |  |
|                                     | 2       | 20050187515        |                        | 2005-08-25       | Varrichio                                       |  |
|                                     | 3       | 20050277833        |                        | 2005-12-15       | Williams  |  |

If you wish to add additional U.S. Published Application citation information please click the Add button.

Add

| FOREIGN PATENT DOCUMENTS |         |                                      |                             |                        |                  |   |  | Remove                   |
|--------------------------|---------|--------------------------------------|-----------------------------|------------------------|------------------|---|--|--------------------------|
| Examiner Initial*        | Cite No | Foreign Document Number <sup>3</sup> | Country Code <sup>2</sup> j | Kind Code <sup>4</sup> | Publication Date | Name of Patentee or Applicant of cited Document | Pages,Columns,Lines where Relevant Passages or Relevant Figures Appear | T <sup>5</sup>           |
|                          | 1       |                                      |                             |                        |                  |   |  | <input type="checkbox"/> |

|   |                        |                    |            |
|---|------------------------|--------------------|------------|
| <b>INFORMATION DISCLOSURE<br/>STATEMENT BY APPLICANT</b><br>( Not for submission under 37 CFR 1.99) | Application Number     |                    | 12137356   |
|   | Filing Date            |                    | 2008-06-11 |
|   | First Named Inventor   | Charles R. Quirico |            |
|   | Art Unit               |                    | 3735       |
|   | Examiner Name          | Samuel G. Gilbert  |            |
|   | Attorney Docket Number |                    | 56782.1.5  |

If you wish to add additional Foreign Patent Document citation information please click the Add button **Add**

**NON-PATENT LITERATURE DOCUMENTS** **Remove**

| Examiner Initials* | Cite No | Include name of the author (in CAPITAL LETTERS), title of the article (when appropriate), title of the item (book, magazine, journal, serial, symposium, catalog, etc), date, pages(s), volume-issue number(s), publisher, city and/or country where published. | T <sup>5</sup>           |
|--------------------|---------|---|--------------------------|
|                    | 1       | "POSIJET Integrated FDG dispensing and infusion system" 2008-05   | <input type="checkbox"/> |

If you wish to add additional non-patent literature document citation information please click the Add button **Add**

**EXAMINER SIGNATURE**

|                    |                 |
|--------------------|-----------------|
| Examiner Signature | Date Considered |
|--------------------|-----------------|

\*EXAMINER: Initial if reference considered, whether or not citation is in conformance with MPEP 609. Draw line through a citation if not in conformance and not considered. Include copy of this form with next communication to applicant.

<sup>1</sup> See Kind Codes of USPTO Patent Documents at [www.USPTO.GOV](http://www.USPTO.GOV) or MPEP 901.04. <sup>2</sup> Enter office that issued the document, by the two-letter code (WIPO Standard ST.3). <sup>3</sup> For Japanese patent documents, the indication of the year of the reign of the Emperor must precede the serial number of the patent document. <sup>4</sup> Kind of document by the appropriate symbols as indicated on the document under WIPO Standard ST.16 if possible. <sup>5</sup> Applicant is to place a check mark here if English language translation is attached.

**INFORMATION DISCLOSURE  
STATEMENT BY APPLICANT**  
( Not for submission under 37 CFR 1.99)

|                        |                    |
|------------------------|--------------------|
| Application Number     | 12137356           |
| Filing Date            | 2008-06-11         |
| First Named Inventor   | Charles R. Quirico |
| Art Unit               | 3735               |
| Examiner Name          | Samuel G. Gilbert  |
| Attorney Docket Number | 56782.15           |

**CERTIFICATION STATEMENT**

Please see 37 CFR 1.97 and 1.98 to make the appropriate selection(s):

That each item of information contained in the information disclosure statement was first cited in any communication from a foreign patent office in a counterpart foreign application not more than three months prior to the filing of the information disclosure statement. See 37 CFR 1.97(e)(1).

**OR**

That no item of information contained in the information disclosure statement was cited in a communication from a foreign patent office in a counterpart foreign application, and, to the knowledge of the person signing the certification after making reasonable inquiry, no item of information contained in the information disclosure statement was known to any individual designated in 37 CFR 1.56(c) more than three months prior to the filing of the information disclosure statement. See 37 CFR 1.97(e)(2).

See attached certification statement.

The fee set forth in 37 CFR 1.17 (p) has been submitted herewith.

A certification statement is not submitted herewith.

**SIGNATURE**

A signature of the applicant or representative is required in accordance with CFR 1.33, 10.18. Please see CFR 1.4(d) for the form of the signature.

|            |                         |                     |            |
|------------|-------------------------|---------------------|------------|
| Signature  | /Paul J. LaVanway, Jr./ | Date (YYYY-MM-DD)   | 2012-09-20 |
| Name/Print | Paul J. LaVanway, Jr.   | Registration Number | 64610      |

This collection of information is required by 37 CFR 1.97 and 1.98. The information is required to obtain or retain a benefit by the public which is to file (and by the USPTO to process) an application. Confidentiality is governed by 35 U.S.C. 122 and 37 CFR 1.14. This collection is estimated to take 1 hour to complete, including gathering, preparing and submitting the completed application form to the USPTO. Time will vary depending upon the individual case. Any comments on the amount of time you require to complete this form and/or suggestions for reducing this burden, should be sent to the Chief Information Officer, U.S. Patent and Trademark Office, U.S. Department of Commerce, P.O. Box 1450, Alexandria, VA 22313-1450. **DO NOT SEND FEES OR COMPLETED FORMS TO THIS ADDRESS. SEND TO: Commissioner for Patents, P.O. Box 1450, Alexandria, VA 22313-1450.**

## Privacy Act Statement

The Privacy Act of 1974 (P.L. 93-579) requires that you be given certain information in connection with your submission of the attached form related to a patent application or patent. Accordingly, pursuant to the requirements of the Act, please be advised that: (1) the general authority for the collection of this information is 35 U.S.C. 2(b)(2); (2) furnishing of the information solicited is voluntary; and (3) the principal purpose for which the information is used by the U.S. Patent and Trademark Office is to process and/or examine your submission related to a patent application or patent. If you do not furnish the requested information, the U.S. Patent and Trademark Office may not be able to process and/or examine your submission, which may result in termination of proceedings or abandonment of the application or expiration of the patent.

The information provided by you in this form will be subject to the following routine uses:

1. The information on this form will be treated confidentially to the extent allowed under the Freedom of Information Act (5 U.S.C. 552) and the Privacy Act (5 U.S.C. 552a). Records from this system of records may be disclosed to the Department of Justice to determine whether the Freedom of Information Act requires disclosure of these records.
2. A record from this system of records may be disclosed, as a routine use, in the course of presenting evidence to a court, magistrate, or administrative tribunal, including disclosures to opposing counsel in the course of settlement negotiations.
3. A record in this system of records may be disclosed, as a routine use, to a Member of Congress submitting a request involving an individual, to whom the record pertains, when the individual has requested assistance from the Member with respect to the subject matter of the record.
4. A record in this system of records may be disclosed, as a routine use, to a contractor of the Agency having need for the information in order to perform a contract. Recipients of information shall be required to comply with the requirements of the Privacy Act of 1974, as amended, pursuant to 5 U.S.C. 552a(m).
5. A record related to an International Application filed under the Patent Cooperation Treaty in this system of records may be disclosed, as a routine use, to the International Bureau of the World Intellectual Property Organization, pursuant to the Patent Cooperation Treaty.
6. A record in this system of records may be disclosed, as a routine use, to another federal agency for purposes of National Security review (35 U.S.C. 181) and for review pursuant to the Atomic Energy Act (42 U.S.C. 218(c)).
7. A record from this system of records may be disclosed, as a routine use, to the Administrator, General Services, or his/her designee, during an inspection of records conducted by GSA as part of that agency's responsibility to recommend improvements in records management practices and programs, under authority of 44 U.S.C. 2904 and 2906. Such disclosure shall be made in accordance with the GSA regulations governing inspection of records for this purpose, and any other relevant (i.e., GSA or Commerce) directive. Such disclosure shall not be used to make determinations about individuals.
8. A record from this system of records may be disclosed, as a routine use, to the public after either publication of the application pursuant to 35 U.S.C. 122(b) or issuance of a patent pursuant to 35 U.S.C. 151. Further, a record may be disclosed, subject to the limitations of 37 CFR 1.14, as a routine use, to the public if the record was filed in an application which became abandoned or in which the proceedings were terminated and which application is referenced by either a published application, an application open to public inspections or an issued patent.
9. A record from this system of records may be disclosed, as a routine use, to a Federal, State, or local law enforcement agency, if the USPTO becomes aware of a violation or potential violation of law or regulation.

## Electronic Patent Application Fee Transmittal

|   |   |
|---|---|
| <b>Application Number:</b>                  | 12137356                                  |
| <b>Filing Date:</b>                         | 11-Jun-2008                               |
| <b>Title of Invention:</b>                  | SHIELDING ASSEMBLIES FOR INFUSION SYSTEMS |
| <b>First Named Inventor/Applicant Name:</b> | Charles R. Quirico                        |
| <b>Filer:</b>                               | Paul J. LaVanway Jr.                      |
| <b>Attorney Docket Number:</b>              | 56782.1.5                                 |

Filed as Large Entity

### Utility under 35 USC 111(a) Filing Fees

| Description                              | Fee Code | Quantity | Amount | Sub-Total in USD(\$) |
|--|----------|----------|--------|----------------------|
| <b>Basic Filing:</b>                     |          |          |        |                      |
| <b>Pages:</b>                            |          |          |        |                      |
| <b>Claims:</b>                           |          |          |        |                      |
| <b>Miscellaneous-Filing:</b>             |          |          |        |                      |
| <b>Petition:</b>                         |          |          |        |                      |
| Petition fee- 37 CFR 1.17(h) (Group III) | 1464     | 1        | 130    | 130                  |

**Patent-Appeals-and-Interference:**

**Post-Allowance-and-Post-Issuance:**

**Extension-of-Time:**



| Description                       | Fee Code | Quantity | Amount | Sub-Total in USD(\$) |
|-----------------------------------|----------|----------|--------|----------------------|
| <b>Miscellaneous:</b>             |          |          |        |                      |
| Request for continued examination | 1801     | 1        | 930    | 930                  |
| <b>Total in USD (\$)</b>          |          |          |        | <b>1060</b>          |

## Electronic Acknowledgement Receipt

|   |   |
|---|---|
| <b>EFS ID:</b>                              | 13798000                                  |
| <b>Application Number:</b>                  | 12137356                                  |
| <b>International Application Number:</b>    |   |
| <b>Confirmation Number:</b>                 | 7360                                      |
| <b>Title of Invention:</b>                  | SHIELDING ASSEMBLIES FOR INFUSION SYSTEMS |
| <b>First Named Inventor/Applicant Name:</b> | Charles R. Quirico                        |
| <b>Customer Number:</b>                     | 22859                                     |
| <b>Filer:</b>                               | Paul J. LaVanway Jr.                      |
| <b>Filer Authorized By:</b>                 |   |
| <b>Attorney Docket Number:</b>              | 56782.1.5                                 |
| <b>Receipt Date:</b>                        | 20-SEP-2012                               |
| <b>Filing Date:</b>                         | 11-JUN-2008                               |
| <b>Time Stamp:</b>                          | 16:40:54                                  |
| <b>Application Type:</b>                    | Utility under 35 USC 111(a)               |

### Payment information:

|  |             |
|--|-------------|
| Submitted with Payment                   | yes         |
| Payment Type                             | Credit Card |
| Payment was successfully received in RAM | \$1060      |
| RAM confirmation Number                  | 3625        |
| Deposit Account                          |             |
| Authorized User                          |             |

### File Listing:

| Document Number | Document Description | File Name | File Size(Bytes)/ Message Digest | Multi Part /.zip | Pages (if appl.) |
|-----------------|----------------------|-----------|----------------------------------|------------------|------------------|
|-----------------|----------------------|-----------|----------------------------------|------------------|------------------|

|   |  |                        |   |         |   |
|---|--|------------------------|---|---------|---|
| 1   | Petition to Withdraw from Issue                    | Petition_56782-1-5.pdf | 88632<br>5fb48593308f656b384867968c2a9a8f6e4b948c   | no      | 2 |
| <b>Warnings:</b>  |  |                        |   |         |   |
| <b>Information:</b>   |  |                        |   |         |   |
| 2   | Request for Continued Examination (RCE)            | RCE-56782-1-5.pdf      | 189349<br>8831117a73a8f1ad69e25d489a0a297dccc75bdb3 | no      | 3 |
| <b>Warnings:</b>  |  |                        |   |         |   |
| This is not a USPTO supplied RCE SB30 form.   |  |                        |   |         |   |
| <b>Information:</b>   |  |                        |   |         |   |
| 3   | Non Patent Literature                              | Posijet.pdf            | 4244122<br>f4131e1134a2c00962cd96c7bfa6d81d41d39b39 | no      | 4 |
| <b>Warnings:</b>  |  |                        |   |         |   |
| <b>Information:</b>   |  |                        |   |         |   |
| 4   | Information Disclosure Statement (IDS) Form (SB08) | 9th-SIDS_56782-1-5.pdf | 612297<br>9278f7381ffa3226b785e42a4b092198f5d02e2f  | no      | 4 |
| <b>Warnings:</b>  |  |                        |   |         |   |
| <b>Information:</b>   |  |                        |   |         |   |
| 5   | Fee Worksheet (SB06)                               | fee-info.pdf           | 32588<br>ac3cd24bd75bc7f46141464a46610e26ee64e767   | no      | 2 |
| <b>Warnings:</b>  |  |                        |   |         |   |
| <b>Information:</b>   |  |                        |   |         |   |
| <b>Total Files Size (in bytes):</b>   |  |                        |   | 5166988 |   |
| <p><b>This Acknowledgement Receipt evidences receipt on the noted date by the USPTO of the indicated documents, characterized by the applicant, and including page counts, where applicable. It serves as evidence of receipt similar to a Post Card, as described in MPEP 503.</b></p> <p><b><u>New Applications Under 35 U.S.C. 111</u></b><br/> <b>If a new application is being filed and the application includes the necessary components for a filing date (see 37 CFR 1.53(b)-(d) and MPEP 506), a Filing Receipt (37 CFR 1.54) will be issued in due course and the date shown on this Acknowledgement Receipt will establish the filing date of the application.</b></p> <p><b><u>National Stage of an International Application under 35 U.S.C. 371</u></b><br/> <b>If a timely submission to enter the national stage of an international application is compliant with the conditions of 35 U.S.C. 371 and other applicable requirements a Form PCT/DO/EO/903 indicating acceptance of the application as a national stage submission under 35 U.S.C. 371 will be issued in addition to the Filing Receipt, in due course.</b></p> <p><b><u>New International Application Filed with the USPTO as a Receiving Office</u></b><br/> <b>If a new international application is being filed and the international application includes the necessary components for an international filing date (see PCT Article 11 and MPEP 1810), a Notification of the International Application Number and of the International Filing Date (Form PCT/RO/105) will be issued in due course, subject to prescriptions concerning national security, and the date shown on this Acknowledgement Receipt will establish the international filing date of the application.</b></p> |  |                        |   |         |   |

Under the Paperwork Reduction Act of 1995, no persons are required to respond to a collection of information unless it contains a valid OMB control number.

## Request for Continued Examination (RCE) Transmittal

Address to:  
Mail Stop RCE  
Commissioner for Patents  
P.O. Box 1450  
Alexandria, VA 22313-1450

|                        |                    |
|------------------------|--------------------|
| Application Number     | 12/137,356         |
| Filing Date            | June 11, 2008      |
| First Named Inventor   | Charles R. Quirico |
| Art Unit               | 3735               |
| Examiner Name          | Samuel G. Gilbert  |
| Attorney Docket Number | 56782.1.5          |

### This is a Request for Continued Examination (RCE) under 37 CFR 1.114 of the above-identified application.

Request for Continued Examination (RCE) practice under 37 CFR 1.114 does not apply to any utility or plant application filed prior to June 8, 1995, or to any design application. See Instruction Sheet for RCEs (not to be submitted to the USPTO) on page 2.

1. **Submission required under 37 CFR 1.114** Note: If the RCE is proper, any previously filed unentered amendments and amendments enclosed with the RCE will be entered in the order in which they were filed unless applicant instructs otherwise. If applicant does not wish to have any previously filed unentered amendment(s) entered, applicant must request non-entry of such amendment(s).
- a.  Previously submitted. If a final Office action is outstanding, any amendments filed after the final Office action may be considered as a submission even if this box is not checked.
- i.  Consider the arguments in the Appeal Brief or Reply Brief previously filed on \_\_\_\_\_
- ii.  Other \_\_\_\_\_
- b.  Enclosed
- i.  Amendment/Reply
- ii.  Affidavit(s)/ Declaration(s)
- iii.  Information Disclosure Statement (IDS)
- iv.  Other Petition
2. **Miscellaneous**
- a.  Suspension of action on the above-identified application is requested under 37 CFR 1.103(c) for a period of \_\_\_\_\_ months. (Period of suspension shall not exceed 3 months; Fee under 37 CFR 1.17(i) required)
- b.  Other \_\_\_\_\_
3. **Fees** The RCE fee under 37 CFR 1.17(e) is required by 37 CFR 1.114 when the RCE is filed. The Director is hereby authorized to charge the following fees, any underpayment of fees, or credit any overpayments, to Deposit Account No. 061910.
- i.  RCE fee required under 37 CFR 1.17(e)
- ii.  Extension of time fee (37 CFR 1.136 and 1.17)
- iii.  Other \_\_\_\_\_
- b.  Check in the amount of \$ \_\_\_\_\_ enclosed
- c.  Payment by credit card (Form PTO-2038 enclosed)

**WARNING: Information on this form may become public. Credit card information should not be included on this form. Provide credit card information and authorization on PTO-2038.**

#### SIGNATURE OF APPLICANT, ATTORNEY, OR AGENT REQUIRED

|                   |                         |                  |                    |
|-------------------|-------------------------|------------------|--------------------|
| Signature         | /Paul J. LaVanway, Jr./ | Date             | September 20, 2012 |
| Name (Print/Type) | Paul J. LaVanway, Jr.   | Registration No. | 64610              |

#### CERTIFICATE OF MAILING OR TRANSMISSION

I hereby certify that this correspondence is being deposited with the United States Postal Service with sufficient postage as first class mail in an envelope addressed to: Mail Stop RCE, Commissioner for Patents, P. O. Box 1450, Alexandria, VA 22313-1450 or facsimile transmitted to the U.S. Patent and Trademark Office on the date shown below.

|                   |  |      |  |
|-------------------|--|------|--|
| Signature         |  | Date |  |
| Name (Print/Type) |  | Date |  |

This collection of information is required by 37 CFR 1.114. The information is required to obtain or retain a benefit by the public which is to file (and by the USPTO to process) an application. Confidentiality is governed by 35 U.S.C. 122 and 37 CFR 1.11 and 1.14. This collection is estimated to take 12 minutes to complete, including gathering, preparing, and submitting the completed application form to the USPTO. Time will vary depending upon the individual case. Any comments on the amount of time you require to complete this form and/or suggestions for reducing this burden, should be sent to the Chief Information Officer, U.S. Patent and Trademark Office, U.S. Department of Commerce, P.O. Box 1450, Alexandria, VA 22313-1450. DO NOT SEND FEES OR COMPLETED FORMS TO THIS ADDRESS. **SEND TO: Mail Stop RCE, Commissioner for Patents, P.O. Box 1450, Alexandria, VA 22313-1450.**

If you need assistance in completing the form, call 1-800-PTO-9199 and select option 2.

Under the Paperwork Reduction Act of 1995, no persons are required to respond to a collection of information unless it contains a valid OMB control number.

## Instruction Sheet for RCEs

(not to be submitted to the USPTO)

### NOTES:

An RCE is not a new application, and filing an RCE will not result in an application being accorded a new filing date.

#### **Filing Qualifications:**

The application must be a utility or plant application filed on or after June 8, 1995. The application cannot be a provisional application, a utility or plant application filed before June 8, 1995, a design application, or a patent under reexamination. See 37 CFR 1.114(e).

#### **Filing Requirements:**

***Prosecution in the application must be closed.*** Prosecution is closed if the application is under appeal, or the last Office action is a final action, a notice of allowance, or an action that otherwise closes prosecution in the application (e.g., an Office action under *Ex parte Quayle*). See 37 CFR 1.114(b).

***A submission and a fee are required at the time the RCE is filed.*** If reply to an Office action under 35 U.S.C. 132 is outstanding (e.g., the application is under final rejection), the submission must meet the reply requirements of 37 CFR 1.111. If there is no outstanding Office action, the submission can be an information disclosure statement, an amendment, new arguments, or new evidence. See 37 CFR 1.114(c). The submission may be a previously filed amendment (e.g., an amendment after final rejection).

### WARNINGS:

#### **Request for Suspension of Action:**

All RCE filing requirements must be met before suspension of action is granted. A request for a suspension of action under 37 CFR 1.103(c) does not satisfy the submission requirement and does not permit the filing of the required submission to be suspended.

#### **Improper RCE will NOT toll Any Time Period:**

***Before Appeal*** - If the RCE is improper (e.g., prosecution in the application is not closed or the submission or fee has not been filed) and the application is not under appeal, the time period set forth in the last Office action will continue to run and the application will be abandoned after the statutory time period has expired if a reply to the Office action is not timely filed. No additional time will be given to correct the improper RCE.

***Under Appeal*** - If the RCE is improper (e.g., the submission or the fee has not been filed) and the application is under appeal, the improper RCE is effective to withdraw the appeal. Withdrawal of the appeal results in the allowance or abandonment of the application depending on the status of the claims. If there are no allowed claims, the application is abandoned. If there is at least one allowed claim, the application will be passed to issue on the allowed claim(s). See MPEP 1215.01.

**See MPEP 706.07(h) for further information on the RCE practice.**

## Privacy Act Statement

The **Privacy Act of 1974 (P.L. 93-579)** requires that you be given certain information in connection with your submission of the attached form related to a patent application or patent. Accordingly, pursuant to the requirements of the Act, please be advised that: (1) the general authority for the collection of this information is 35 U.S.C. 2(b)(2); (2) furnishing of the information solicited is voluntary; and (3) the principal purpose for which the information is used by the U.S. Patent and Trademark Office is to process and/or examine your submission related to a patent application or patent. If you do not furnish the requested information, the U.S. Patent and Trademark Office may not be able to process and/or examine your submission, which may result in termination of proceedings or abandonment of the application or expiration of the patent.

The information provided by you in this form will be subject to the following routine uses:

1. The information on this form will be treated confidentially to the extent allowed under the Freedom of Information Act (5 U.S.C. 552) and the Privacy Act (5 U.S.C. 552a). Records from this system of records may be disclosed to the Department of Justice to determine whether disclosure of these records is required by the Freedom of Information Act.
2. A record from this system of records may be disclosed, as a routine use, in the course of presenting evidence to a court, magistrate, or administrative tribunal, including disclosures to opposing counsel in the course of settlement negotiations.
3. A record in this system of records may be disclosed, as a routine use, to a Member of Congress submitting a request involving an individual, to whom the record pertains, when the individual has requested assistance from the Member with respect to the subject matter of the record.
4. A record in this system of records may be disclosed, as a routine use, to a contractor of the Agency having need for the information in order to perform a contract. Recipients of information shall be required to comply with the requirements of the Privacy Act of 1974, as amended, pursuant to 5 U.S.C. 552a(m).
5. A record related to an International Application filed under the Patent Cooperation Treaty in this system of records may be disclosed, as a routine use, to the International Bureau of the World Intellectual Property Organization, pursuant to the Patent Cooperation Treaty.
6. A record in this system of records may be disclosed, as a routine use, to another federal agency for purposes of National Security review (35 U.S.C. 181) and for review pursuant to the Atomic Energy Act (42 U.S.C. 218(c)).
7. A record from this system of records may be disclosed, as a routine use, to the Administrator, General Services, or his/her designee, during an inspection of records conducted by GSA as part of that agency's responsibility to recommend improvements in records management practices and programs, under authority of 44 U.S.C. 2904 and 2906. Such disclosure shall be made in accordance with the GSA regulations governing inspection of records for this purpose, and any other relevant (*i.e.*, GSA or Commerce) directive. Such disclosure shall not be used to make determinations about individuals.
8. A record from this system of records may be disclosed, as a routine use, to the public after either publication of the application pursuant to 35 U.S.C. 122(b) or issuance of a patent pursuant to 35 U.S.C. 151. Further, a record may be disclosed, subject to the limitations of 37 CFR 1.14, as a routine use, to the public if the record was filed in an application which became abandoned or in which the proceedings were terminated and which application is referenced by either a published application, an application open to public inspection or an issued patent.
9. A record from this system of records may be disclosed, as a routine use, to a Federal, State, or local law enforcement agency, if the USPTO becomes aware of a violation or potential violation of law or regulation.



| APPLICATION NO. | ISSUE DATE | PATENT NO. | ATTORNEY DOCKET NO. | CONFIRMATION NO. |
|-----------------|------------|------------|---------------------|------------------|
| 12/137,356      | 09/25/2012 | 8273008    | 56782.1.5           | 7360             |

22859 7590 09/05/2012  
FREDRIKSON & BYRON, P.A.  
INTELLECTUAL PROPERTY GROUP  
200 SOUTH SIXTH STREET, SUITE 4000  
MINNEAPOLIS, MN 55402

### ISSUE NOTIFICATION

The projected patent number and issue date are specified above.

#### Determination of Patent Term Adjustment under 35 U.S.C. 154 (b) (application filed on or after May 29, 2000)

The Patent Term Adjustment is 1119 day(s). Any patent to issue from the above-identified application will include an indication of the adjustment on the front page.

If a Continued Prosecution Application (CPA) was filed in the above-identified application, the filing date that determines Patent Term Adjustment is the filing date of the most recent CPA.

Applicant will be able to obtain more detailed information by accessing the Patent Application Information Retrieval (PAIR) WEB site (<http://pair.uspto.gov>).

Any questions regarding the Patent Term Extension or Adjustment determination should be directed to the Office of Patent Legal Administration at (571)-272-7702. Questions relating to issue and publication fee payments should be directed to the Application Assistance Unit (AAU) of the Office of Data Management (ODM) at (571)-272-4200.

APPLICANT(s) (Please see PAIR WEB site <http://pair.uspto.gov> for additional applicants):

Charles R. Quirico, Warren, NJ;  
Ernest Balestracci, Iselin, NJ;  
Daniel Darst, Zimmerman, MN;  
Eric J. Krause, Big Lake, MN;  
Vishal N. Lokhande, Mountain View, CA;  
Jacob S. Childs, Minneapolis, MN;  
Peter B. Madson, Shanghai, CHINA;  
Daniel V. Clements, Minneapolis, MN;

The United States represents the largest, most dynamic marketplace in the world and is an unparalleled location for business investment, innovation, and commercialization of new technologies. The USA offers tremendous resources and advantages for those who invest and manufacture goods here. Through SelectUSA, our nation works to encourage and facilitate business investment. To learn more about why the USA is the best country in the world to develop technology, manufacture products, and grow your business, visit [SelectUSA.gov](http://SelectUSA.gov).

|   |                        |                    |            |  |
|---|------------------------|--------------------|------------|--|
| <b>INFORMATION DISCLOSURE<br/>STATEMENT BY APPLICANT</b><br>( Not for submission under 37 CFR 1.99) | Application Number     |                    | 12137356   |  |
|   | Filing Date            |                    | 2008-06-11 |  |
|   | First Named Inventor   | CHARLES R. QUIRICO |            |  |
|   | Art Unit               | 3735               |            |  |
|   | Examiner Name          | GILBERT, SAMUEL G. |            |  |
|   | Attorney Docket Number | 56782.1.5          |            |  |

|   |    |             |  |                                  |               |  |
|---|----|-------------|--|----------------------------------|---------------|--|
|   | 4  | 20090312630 |  | 2009-12-17                       | Hidem         |  |
|   | 5  | 20100125243 |  | 2010-05-20                       | Balestracci   |  |
|   | 6  | 20100270226 |  | 2010-10-28                       | Balestracci   |  |
|   | 7  | 20100312039 |  | 2010-12-09                       | Quirico       |  |
|   | 8  | 20110071392 |  | 2011-03-24                       | Quirico       |  |
|   | 9  | 20110172524 |  | 2011-07-14                       | Hidem         |  |
| Change(s) applied to document, 10/13/11 | 10 | 20060151048 |  | <del>2005-12-27</del><br>07/2006 | Tochon-Danguy |  |

If you wish to add additional U.S. Published Application citation information please click the Add button. [Add](#)

| FOREIGN PATENT DOCUMENTS |         |                                      |                             |                        |                  |   |  | Remove                   |
|--------------------------|---------|--------------------------------------|-----------------------------|------------------------|------------------|---|--|--------------------------|
| Examiner Initial*        | Cite No | Foreign Document Number <sup>3</sup> | Country Code <sup>2</sup> ; | Kind Code <sup>4</sup> | Publication Date | Name of Patentee or Applicant of cited Document | Pages, Columns, Lines where Relevant Passages or Relevant Figures Appear | T <sup>5</sup>           |
|                          | 1       | 0919249                              | EP                          |                        | 1999-06-02       | NISSHO KK                                       |  | <input type="checkbox"/> |
|                          | 2       | 1421960                              | EP                          |                        | 2004-05-26       | GVS S P A                                       |  | <input type="checkbox"/> |



SHIELDING ASSEMBLIES FOR INFUSION SYSTEMS

Change(s) applied  
to document,

/J.M.S./

8/20/2012

RELATED APPLICATIONS

- [01] The present application is related to the following commonly assigned utility patent applications, all of which are filed concurrently herewith and all of which are hereby incorporated by reference in their entireties: ~~Practitioner Docket No. 56782.1.6~~<sup>12/137,363</sup>, entitled: INFUSION SYSTEM CONFIGURATIONS; ~~Practitioner Docket No. 56782.1.7~~<sup>12/137,364</sup>, entitled: INFUSION SYSTEMS INCLUDING COMPUTER-FACILITATED MAINTENANCE AND/OR OPERATION; and ~~Practitioner Docket No. 56782.1.8~~<sup>12/137,377</sup>, entitled: CABINET STRUCTURES SUPPORTING INFUSION SYSTEMS.

TECHNICAL FIELD

- [02] The present invention pertains to systems that generate and infuse radiopharmaceuticals, and, more particularly, to shielding assemblies thereof.

BACKGROUND

- [03] Nuclear medicine employs radioactive material for therapy and diagnostic imaging. Positron emission tomography (PET) is one type of diagnostic imaging, which utilizes doses of radiopharmaceutical, for example, generated by elution within a radioisotope generator that are injected, or infused into a patient. The infused dose of radiopharmaceutical is absorbed by cells of a target organ, of the patient, and emits radiation, which is detected by a PET scanner, in order to generate an image of the organ. An example of a radioactive isotope, which may be used for PET, is Rubidium-82 (produced by the decay of Strontium-82); and an example of a radioisotope generator, which yields a saline solution of Rubidium-82, via elution, is the CardioGen-82® available from Bracco Diagnostics Inc. (Princeton, NJ).
- [04] Whether the half-life of a particular radioactive isotope, employed by a radiopharmaceutical, is relatively short or long, a patient undergoing a nuclear imaging procedure is not typically exposed to a significant amount of radiation.

**PART B - FEE(S) TRANSMITTAL**

**Complete and send this form, together with applicable fee(s), to: Mail Mail Stop ISSUE FEE  
 Commissioner for Patents  
 P.O. Box 1450  
 Alexandria, Virginia 22313-1450  
 or Fax (571)-273-2885**

**INSTRUCTIONS:** This form should be used for transmitting the ISSUE FEE and PUBLICATION FEE (if required). Blocks 1 through 5 should be completed where appropriate. All further correspondence including the Patent, advance orders and notification of maintenance fees will be mailed to the current correspondence address as indicated unless corrected below or directed otherwise in Block 1, by (a) specifying a new correspondence address; and/or (b) indicating a separate "FEE ADDRESS" for maintenance fee notifications.

CURRENT CORRESPONDENCE ADDRESS (Note: Use Block 1 for any change of address)

Note: A certificate of mailing can only be used for domestic mailings of the Fee(s) Transmittal. This certificate cannot be used for any other accompanying papers. Each additional paper, such as an assignment or formal drawing, must have its own certificate of mailing or transmission.

22859 7590 08/08/2012  
**FREDRIKSON & BYRON, P.A.**  
 INTELLECTUAL PROPERTY GROUP  
 200 SOUTH SIXTH STREET, SUITE 4000  
 MINNEAPOLIS, MN 55402

**Certificate of Mailing or Transmission**

I hereby certify that this Fee(s) Transmittal is being deposited with the United States Postal Service with sufficient postage for first class mail in an envelope addressed to the Mail Stop ISSUE FEE address above, or being facsimile transmitted to the USPTO (571) 273-2885, on the date indicated below.

|                    |
|--------------------|
| (Depositor's name) |
| (Signature)        |
| (Date)             |

| APPLICATION NO. | FILING DATE | FIRST NAMED INVENTOR | ATTORNEY DOCKET NO. | CONFIRMATION NO. |
|-----------------|-------------|----------------------|---------------------|------------------|
| 12/137,356      | 06/11/2008  | Charles R. Quirico   | 56782.1.5           | 7360             |

TITLE OF INVENTION: SHIELDING ASSEMBLIES FOR INFUSION SYSTEMS

| APPLN. TYPE    | SMALL ENTITY | ISSUE FEE DUE | PUBLICATION FEE DUE | PREV. PAID ISSUE FEE | TOTAL FEE(S) DUE | DATE DUE   |
|----------------|--------------|---------------|---------------------|----------------------|------------------|------------|
| nonprovisional | NO           | \$1740        | \$300               | \$0                  | \$2040           | 11/08/2012 |

| EXAMINER          | ART UNIT | CLASS-SUBCLASS |
|-------------------|----------|----------------|
| GILBERT, SAMUEL G | 3735     | 600-005000     |

|   |   |
|---|---|
| <p>1. Change of correspondence address or indication of "Fee Address" (37 CFR 1.363).</p> <p><input type="checkbox"/> Change of correspondence address (or Change of Correspondence Address form PTO/SB/122) attached.</p> <p><input type="checkbox"/> "Fee Address" indication (or "Fee Address" Indication form PTO/SB/47; Rev 03-02 or more recent) attached. <b>Use of a Customer Number is required.</b></p> | <p>2. For printing on the patent front page, list</p> <p>(1) the names of up to 3 registered patent attorneys or agents OR, alternatively, 1 <u>Fredrikson &amp; Byron, PA</u></p> <p>(2) the name of a single firm (having as a member a registered attorney or agent) and the names of up to 2 registered patent attorneys or agents. If no name is listed, no name will be printed. 2 _____</p> <p>3 _____</p> |
|---|---|

3. ASSIGNEE NAME AND RESIDENCE DATA TO BE PRINTED ON THE PATENT (print or type)

PLEASE NOTE: Unless an assignee is identified below, no assignee data will appear on the patent. If an assignee is identified below, the document has been filed for recordation as set forth in 37 CFR 3.11. Completion of this form is NOT a substitute for filing an assignment.

|                         |  |
|-------------------------|--|
| (A) NAME OF ASSIGNEE    | (B) RESIDENCE: (CITY and STATE OR COUNTRY) |
| BRACCO DIAGNOSTICS INC. | PRINCETON, NEW JERSEY                      |

Please check the appropriate assignee category or categories (will not be printed on the patent):  Individual  Corporation or other private group entity  Government

|   |  |
|---|--|
| <p>4a. The following fee(s) are submitted:</p> <p><input checked="" type="checkbox"/> Issue Fee</p> <p><input checked="" type="checkbox"/> Publication Fee (No small entity discount permitted)</p> <p><input type="checkbox"/> Advance Order - # of Copies _____</p> | <p>4b. Payment of Fee(s); (Please first reapply any previously paid issue fee shown above)</p> <p><input type="checkbox"/> A check is enclosed.</p> <p><input checked="" type="checkbox"/> Payment by credit card. Form PTO-2038 is attached.</p> <p><input checked="" type="checkbox"/> The Director is hereby authorized to charge the required fee(s), any deficiency, or credit any overpayment, to Deposit Account Number <u>061910</u> (enclose an extra copy of this form).</p> |
|---|--|

5. Change in Entity Status (from status indicated above)

a. Applicant claims SMALL ENTITY status. See 37 CFR 1.27.  b. Applicant is no longer claiming SMALL ENTITY status. See 37 CFR 1.27(g)(2).

NOTE: The Issue Fee and Publication Fee (if required) will not be accepted from anyone other than the applicant; a registered attorney or agent; or the assignee or other party in interest as shown by the records of the United States Patent and Trademark Office.

Authorized Signature /Paul J. LaVanway, Jr./ Date August 16, 2012

Typed or printed name Paul J. LaVanway, Jr. Registration No. 64610

This collection of information is required by 37 CFR 1.311. The information is required to obtain or retain a benefit by the public which is to file (and by the USPTO to process) an application. Confidentiality is governed by 35 U.S.C. 122 and 37 CFR 1.14. This collection is estimated to take 12 minutes to complete, including gathering, preparing, and submitting the completed application form to the USPTO. Time will vary depending upon the individual case. Any comments on the amount of time you require to complete this form and/or suggestions for reducing this burden, should be sent to the Chief Information Officer, U.S. Patent and Trademark Office, U.S. Department of Commerce, P.O. Box 1450, Alexandria, Virginia 22313-1450. DO NOT SEND FEES OR COMPLETED FORMS TO THIS ADDRESS. SEND TO: Commissioner for Patents, P.O. Box 1450, Alexandria, Virginia 22313-1450.

Under the Paperwork Reduction Act of 1995, no persons are required to respond to a collection of information unless it displays a valid OMB control number.

## Electronic Patent Application Fee Transmittal

|   |   |
|---|---|
| <b>Application Number:</b>                  | 12137356                                  |
| <b>Filing Date:</b>                         | 11-Jun-2008                               |
| <b>Title of Invention:</b>                  | SHIELDING ASSEMBLIES FOR INFUSION SYSTEMS |
| <b>First Named Inventor/Applicant Name:</b> | Charles R. Quirico                        |
| <b>Filer:</b>                               | Paul J. LaVanway Jr.                      |
| <b>Attorney Docket Number:</b>              | 56782.1.5                                 |

Filed as Large Entity

### Utility under 35 USC 111(a) Filing Fees

| Description                              | Fee Code | Quantity | Amount | Sub-Total in USD(\$) |
|--|----------|----------|--------|----------------------|
| <b>Basic Filing:</b>                     |          |          |        |                      |
| <b>Pages:</b>                            |          |          |        |                      |
| <b>Claims:</b>                           |          |          |        |                      |
| <b>Miscellaneous-Filing:</b>             |          |          |        |                      |
| <b>Petition:</b>                         |          |          |        |                      |
| <b>Patent-Appeals-and-Interference:</b>  |          |          |        |                      |
| <b>Post-Allowance-and-Post-Issuance:</b> |          |          |        |                      |
| Utility Appl issue fee                   | 1501     | 1        | 1740   | 1740                 |
| Publ. Fee- early, voluntary, or normal   | 1504     | 1        | 300    | 300                  |

| Description               | Fee Code | Quantity | Amount | Sub-Total in USD(\$) |
|---------------------------|----------|----------|--------|----------------------|
| <b>Extension-of-Time:</b> |          |          |        |                      |
| <b>Miscellaneous:</b>     |          |          |        |                      |
| <b>Total in USD (\$)</b>  |          |          |        | <b>2040</b>          |

## Electronic Acknowledgement Receipt

|   |   |
|---|---|
| <b>EFS ID:</b>                              | 13515330                                  |
| <b>Application Number:</b>                  | 12137356                                  |
| <b>International Application Number:</b>    |   |
| <b>Confirmation Number:</b>                 | 7360                                      |
| <b>Title of Invention:</b>                  | SHIELDING ASSEMBLIES FOR INFUSION SYSTEMS |
| <b>First Named Inventor/Applicant Name:</b> | Charles R. Quirico                        |
| <b>Customer Number:</b>                     | 22859                                     |
| <b>Filer:</b>                               | Paul J. LaVanway Jr.                      |
| <b>Filer Authorized By:</b>                 |   |
| <b>Attorney Docket Number:</b>              | 56782.1.5                                 |
| <b>Receipt Date:</b>                        | 17-AUG-2012                               |
| <b>Filing Date:</b>                         | 11-JUN-2008                               |
| <b>Time Stamp:</b>                          | 13:27:22                                  |
| <b>Application Type:</b>                    | Utility under 35 USC 111(a)               |

### Payment information:

|  |             |
|--|-------------|
| Submitted with Payment                   | yes         |
| Payment Type                             | Credit Card |
| Payment was successfully received in RAM | \$2040      |
| RAM confirmation Number                  | 107         |
| Deposit Account                          |             |
| Authorized User                          |             |

### File Listing:

| Document Number | Document Description | File Name | File Size(Bytes)/ Message Digest | Multi Part /.zip | Pages (if appl.) |
|-----------------|----------------------|-----------|----------------------------------|------------------|------------------|
|-----------------|----------------------|-----------|----------------------------------|------------------|------------------|

|                                     |                             |                        |  |    |   |
|-------------------------------------|-----------------------------|------------------------|--|----|---|
| 1                                   | Issue Fee Payment (PTO-85B) | 56782_1_5_ISSUEFEE.pdf | 127242                                   | no | 1 |
|                                     |                             |                        | 7a68c4549b456309b0f155750c03a570de834c20 |    |   |
| <b>Warnings:</b>                    |                             |                        |  |    |   |
| <b>Information:</b>                 |                             |                        |  |    |   |
| 2                                   | Fee Worksheet (SB06)        | fee-info.pdf           | 32238                                    | no | 2 |
|                                     |                             |                        | 59a2c3c562f0f03116bb195dcd78f339b8e30e05 |    |   |
| <b>Warnings:</b>                    |                             |                        |  |    |   |
| <b>Information:</b>                 |                             |                        |  |    |   |
| <b>Total Files Size (in bytes):</b> |                             |                        | 159480                                   |    |   |

**This Acknowledgement Receipt evidences receipt on the noted date by the USPTO of the indicated documents, characterized by the applicant, and including page counts, where applicable. It serves as evidence of receipt similar to a Post Card, as described in MPEP 503.**

**New Applications Under 35 U.S.C. 111**

**If a new application is being filed and the application includes the necessary components for a filing date (see 37 CFR 1.53(b)-(d) and MPEP 506), a Filing Receipt (37 CFR 1.54) will be issued in due course and the date shown on this Acknowledgement Receipt will establish the filing date of the application.**

**National Stage of an International Application under 35 U.S.C. 371**

**If a timely submission to enter the national stage of an international application is compliant with the conditions of 35 U.S.C. 371 and other applicable requirements a Form PCT/DO/EO/903 indicating acceptance of the application as a national stage submission under 35 U.S.C. 371 will be issued in addition to the Filing Receipt, in due course.**

**New International Application Filed with the USPTO as a Receiving Office**

**If a new international application is being filed and the international application includes the necessary components for an international filing date (see PCT Article 11 and MPEP 1810), a Notification of the International Application Number and of the International Filing Date (Form PCT/RO/105) will be issued in due course, subject to prescriptions concerning national security, and the date shown on this Acknowledgement Receipt will establish the international filing date of the application.**



NOTICE OF ALLOWANCE AND FEE(S) DUE

22859 7590 08/08/2012
FREDRIKSON & BYRON, P.A.
INTELLECTUAL PROPERTY GROUP
200 SOUTH SIXTH STREET, SUITE 4000
MINNEAPOLIS, MN 55402

Table with 2 columns: EXAMINER (GILBERT, SAMUEL G), ART UNIT (3735), PAPER NUMBER (7360)

DATE MAILED: 08/08/2012

Table with 5 columns: APPLICATION NO., FILING DATE, FIRST NAMED INVENTOR, ATTORNEY DOCKET NO., CONFIRMATION NO.

TITLE OF INVENTION: SHIELDING ASSEMBLIES FOR INFUSION SYSTEMS

Table with 7 columns: APPLN. TYPE, SMALL ENTITY, ISSUE FEE DUE, PUBLICATION FEE DUE, PREV. PAID ISSUE FEE, TOTAL FEE(S) DUE, DATE DUE

THE APPLICATION IDENTIFIED ABOVE HAS BEEN EXAMINED AND IS ALLOWED FOR ISSUANCE AS A PATENT. PROSECUTION ON THE MERITS IS CLOSED. THIS NOTICE OF ALLOWANCE IS NOT A GRANT OF PATENT RIGHTS. THIS APPLICATION IS SUBJECT TO WITHDRAWAL FROM ISSUE AT THE INITIATIVE OF THE OFFICE OR UPON PETITION BY THE APPLICANT. SEE 37 CFR 1.313 AND MPEP 1308.

THE ISSUE FEE AND PUBLICATION FEE (IF REQUIRED) MUST BE PAID WITHIN THREE MONTHS FROM THE MAILING DATE OF THIS NOTICE OR THIS APPLICATION SHALL BE REGARDED AS ABANDONED. THIS STATUTORY PERIOD CANNOT BE EXTENDED. SEE 35 U.S.C. 151. THE ISSUE FEE DUE INDICATED ABOVE DOES NOT REFLECT A CREDIT FOR ANY PREVIOUSLY PAID ISSUE FEE IN THIS APPLICATION. IF AN ISSUE FEE HAS PREVIOUSLY BEEN PAID IN THIS APPLICATION (AS SHOWN ABOVE), THE RETURN OF PART B OF THIS FORM WILL BE CONSIDERED A REQUEST TO REAPPLY THE PREVIOUSLY PAID ISSUE FEE TOWARD THE ISSUE FEE NOW DUE.

HOW TO REPLY TO THIS NOTICE:

I. Review the SMALL ENTITY status shown above.

If the SMALL ENTITY is shown as YES, verify your current SMALL ENTITY status:

A. If the status is the same, pay the TOTAL FEE(S) DUE shown above.

B. If the status above is to be removed, check box 5b on Part B - Fee(s) Transmittal and pay the PUBLICATION FEE (if required) and twice the amount of the ISSUE FEE shown above, or

If the SMALL ENTITY is shown as NO:

A. Pay TOTAL FEE(S) DUE shown above, or

B. If applicant claimed SMALL ENTITY status before, or is now claiming SMALL ENTITY status, check box 5a on Part B - Fee(s) Transmittal and pay the PUBLICATION FEE (if required) and 1/2 the ISSUE FEE shown above.

II. PART B - FEE(S) TRANSMITTAL, or its equivalent, must be completed and returned to the United States Patent and Trademark Office (USPTO) with your ISSUE FEE and PUBLICATION FEE (if required). If you are charging the fee(s) to your deposit account, section "4b" of Part B - Fee(s) Transmittal should be completed and an extra copy of the form should be submitted. If an equivalent of Part B is filed, a request to reapply a previously paid issue fee must be clearly made, and delays in processing may occur due to the difficulty in recognizing the paper as an equivalent of Part B.

III. All communications regarding this application must give the application number. Please direct all communications prior to issuance to Mail Stop ISSUE FEE unless advised to the contrary.

IMPORTANT REMINDER: Utility patents issuing on applications filed on or after Dec. 12, 1980 may require payment of maintenance fees. It is patentee's responsibility to ensure timely payment of maintenance fees when due.

**PART B - FEE(S) TRANSMITTAL**

**Complete and send this form, together with applicable fee(s), to: Mail Mail Stop ISSUE FEE  
 Commissioner for Patents  
 P.O. Box 1450  
 Alexandria, Virginia 22313-1450  
 or Fax (571)-273-2885**

**INSTRUCTIONS:** This form should be used for transmitting the ISSUE FEE and PUBLICATION FEE (if required). Blocks 1 through 5 should be completed where appropriate. All further correspondence including the Patent, advance orders and notification of maintenance fees will be mailed to the current correspondence address as indicated unless corrected below or directed otherwise in Block 1, by (a) specifying a new correspondence address; and/or (b) indicating a separate "FEE ADDRESS" for maintenance fee notifications.

CURRENT CORRESPONDENCE ADDRESS (Note: Use Block 1 for any change of address)

Note: A certificate of mailing can only be used for domestic mailings of the Fee(s) Transmittal. This certificate cannot be used for any other accompanying papers. Each additional paper, such as an assignment or formal drawing, must have its own certificate of mailing or transmission.

22859 7590 08/08/2012  
**FREDRIKSON & BYRON, P.A.**  
**INTELLECTUAL PROPERTY GROUP**  
**200 SOUTH SIXTH STREET, SUITE 4000**  
**MINNEAPOLIS, MN 55402**

**Certificate of Mailing or Transmission**

I hereby certify that this Fee(s) Transmittal is being deposited with the United States Postal Service with sufficient postage for first class mail in an envelope addressed to the Mail Stop ISSUE FEE address above, or being facsimile transmitted to the USPTO (571) 273-2885, on the date indicated below.

|                    |
|--------------------|
| (Depositor's name) |
| (Signature)        |
| (Date)             |

| APPLICATION NO. | FILING DATE | FIRST NAMED INVENTOR | ATTORNEY DOCKET NO. | CONFIRMATION NO. |
|-----------------|-------------|----------------------|---------------------|------------------|
| 12/137,356      | 06/11/2008  | Charles R. Quirico   | 56782.1.5           | 7360             |

TITLE OF INVENTION: SHIELDING ASSEMBLIES FOR INFUSION SYSTEMS

| APPLN. TYPE    | SMALL ENTITY | ISSUE FEE DUE | PUBLICATION FEE DUE | PREV. PAID ISSUE FEE | TOTAL FEE(S) DUE | DATE DUE   |
|----------------|--------------|---------------|---------------------|----------------------|------------------|------------|
| nonprovisional | NO           | \$1740        | \$300               | \$0                  | \$2040           | 11/08/2012 |

| EXAMINER          | ART UNIT | CLASS-SUBCLASS |
|-------------------|----------|----------------|
| GILBERT, SAMUEL G | 3735     | 600-005000     |

|   |   |
|---|---|
| <p>1. Change of correspondence address or indication of "Fee Address" (37 CFR 1.363).</p> <p><input type="checkbox"/> Change of correspondence address (or Change of Correspondence Address form PTO/SB/122) attached.</p> <p><input type="checkbox"/> "Fee Address" indication (or "Fee Address" Indication form PTO/SB/47; Rev 03-02 or more recent) attached. <b>Use of a Customer Number is required.</b></p> | <p>2. For printing on the patent front page, list</p> <p>(1) the names of up to 3 registered patent attorneys or agents OR, alternatively, 1 _____</p> <p>(2) the name of a single firm (having as a member a registered attorney or agent) and the names of up to 2 registered patent attorneys or agents. If no name is listed, no name will be printed. 2 _____</p> <p>3 _____</p> |
|---|---|

3. ASSIGNEE NAME AND RESIDENCE DATA TO BE PRINTED ON THE PATENT (print or type)

PLEASE NOTE: Unless an assignee is identified below, no assignee data will appear on the patent. If an assignee is identified below, the document has been filed for recordation as set forth in 37 CFR 3.11. Completion of this form is NOT a substitute for filing an assignment.

(A) NAME OF ASSIGNEE \_\_\_\_\_ (B) RESIDENCE: (CITY and STATE OR COUNTRY) \_\_\_\_\_

Please check the appropriate assignee category or categories (will not be printed on the patent) :  Individual  Corporation or other private group entity  Government

|   |  |
|---|--|
| <p>4a. The following fee(s) are submitted:</p> <p><input type="checkbox"/> Issue Fee</p> <p><input type="checkbox"/> Publication Fee (No small entity discount permitted)</p> <p><input type="checkbox"/> Advance Order - # of Copies _____</p> | <p>4b. Payment of Fee(s); (Please first reapply any previously paid issue fee shown above)</p> <p><input type="checkbox"/> A check is enclosed.</p> <p><input type="checkbox"/> Payment by credit card. Form PTO-2038 is attached.</p> <p><input type="checkbox"/> The Director is hereby authorized to charge the required fee(s), any deficiency, or credit any overpayment, to Deposit Account Number _____ (enclose an extra copy of this form).</p> |
|---|--|

5. Change in Entity Status (from status indicated above)

a. Applicant claims SMALL ENTITY status. See 37 CFR 1.27.  b. Applicant is no longer claiming SMALL ENTITY status. See 37 CFR 1.27(g)(2).

NOTE: The Issue Fee and Publication Fee (if required) will not be accepted from anyone other than the applicant; a registered attorney or agent; or the assignee or other party in interest as shown by the records of the United States Patent and Trademark Office.

Authorized Signature \_\_\_\_\_ Date \_\_\_\_\_

Typed or printed name \_\_\_\_\_ Registration No. \_\_\_\_\_

This collection of information is required by 37 CFR 1.311. The information is required to obtain or retain a benefit by the public which is to file (and by the USPTO to process) an application. Confidentiality is governed by 35 U.S.C. 122 and 37 CFR 1.14. This collection is estimated to take 12 minutes to complete, including gathering, preparing, and submitting the completed application form to the USPTO. Time will vary depending upon the individual case. Any comments on the amount of time you require to complete this form and/or suggestions for reducing this burden, should be sent to the Chief Information Officer, U.S. Patent and Trademark Office, U.S. Department of Commerce, P.O. Box 1450, Alexandria, Virginia 22313-1450. DO NOT SEND FEES OR COMPLETED FORMS TO THIS ADDRESS. SEND TO: Commissioner for Patents, P.O. Box 1450, Alexandria, Virginia 22313-1450.

Under the Paperwork Reduction Act of 1995, no persons are required to respond to a collection of information unless it displays a valid OMB control number.





UNITED STATES PATENT AND TRADEMARK OFFICE

UNITED STATES DEPARTMENT OF COMMERCE
United States Patent and Trademark Office
Address: COMMISSIONER FOR PATENTS
P.O. Box 1450
Alexandria, Virginia 22313-1450
www.uspto.gov

Table with 5 columns: APPLICATION NO., FILING DATE, FIRST NAMED INVENTOR, ATTORNEY DOCKET NO., CONFIRMATION NO.
Values: 12/137,356, 06/11/2008, Charles R. Quirico, 56782.1.5, 7360

22859 7590 08/08/2012
FREDRIKSON & BYRON, P.A.
INTELLECTUAL PROPERTY GROUP
200 SOUTH SIXTH STREET, SUITE 4000
MINNEAPOLIS, MN 55402

EXAMINER

GILBERT, SAMUEL G

ART UNIT PAPER NUMBER

3735

DATE MAILED: 08/08/2012

Determination of Patent Term Adjustment under 35 U.S.C. 154 (b)

(application filed on or after May 29, 2000)

The Patent Term Adjustment to date is 945 day(s). If the issue fee is paid on the date that is three months after the mailing date of this notice and the patent issues on the Tuesday before the date that is 28 weeks (six and a half months) after the mailing date of this notice, the Patent Term Adjustment will be 945 day(s).

If a Continued Prosecution Application (CPA) was filed in the above-identified application, the filing date that determines Patent Term Adjustment is the filing date of the most recent CPA.

Applicant will be able to obtain more detailed information by accessing the Patent Application Information Retrieval (PAIR) WEB site (http://pair.uspto.gov).

Any questions regarding the Patent Term Extension or Adjustment determination should be directed to the Office of Patent Legal Administration at (571)-272-7702. Questions relating to issue and publication fee payments should be directed to the Customer Service Center of the Office of Patent Publication at 1-(888)-786-0101 or (571)-272-4200.

## Privacy Act Statement

**The Privacy Act of 1974 (P.L. 93-579)** requires that you be given certain information in connection with your submission of the attached form related to a patent application or patent. Accordingly, pursuant to the requirements of the Act, please be advised that: (1) the general authority for the collection of this information is 35 U.S.C. 2(b)(2); (2) furnishing of the information solicited is voluntary; and (3) the principal purpose for which the information is used by the U.S. Patent and Trademark Office is to process and/or examine your submission related to a patent application or patent. If you do not furnish the requested information, the U.S. Patent and Trademark Office may not be able to process and/or examine your submission, which may result in termination of proceedings or abandonment of the application or expiration of the patent.

The information provided by you in this form will be subject to the following routine uses:

1. The information on this form will be treated confidentially to the extent allowed under the Freedom of Information Act (5 U.S.C. 552) and the Privacy Act (5 U.S.C. 552a). Records from this system of records may be disclosed to the Department of Justice to determine whether disclosure of these records is required by the Freedom of Information Act.
2. A record from this system of records may be disclosed, as a routine use, in the course of presenting evidence to a court, magistrate, or administrative tribunal, including disclosures to opposing counsel in the course of settlement negotiations.
3. A record in this system of records may be disclosed, as a routine use, to a Member of Congress submitting a request involving an individual, to whom the record pertains, when the individual has requested assistance from the Member with respect to the subject matter of the record.
4. A record in this system of records may be disclosed, as a routine use, to a contractor of the Agency having need for the information in order to perform a contract. Recipients of information shall be required to comply with the requirements of the Privacy Act of 1974, as amended, pursuant to 5 U.S.C. 552a(m).
5. A record related to an International Application filed under the Patent Cooperation Treaty in this system of records may be disclosed, as a routine use, to the International Bureau of the World Intellectual Property Organization, pursuant to the Patent Cooperation Treaty.
6. A record in this system of records may be disclosed, as a routine use, to another federal agency for purposes of National Security review (35 U.S.C. 181) and for review pursuant to the Atomic Energy Act (42 U.S.C. 218(c)).
7. A record from this system of records may be disclosed, as a routine use, to the Administrator, General Services, or his/her designee, during an inspection of records conducted by GSA as part of that agency's responsibility to recommend improvements in records management practices and programs, under authority of 44 U.S.C. 2904 and 2906. Such disclosure shall be made in accordance with the GSA regulations governing inspection of records for this purpose, and any other relevant (i.e., GSA or Commerce) directive. Such disclosure shall not be used to make determinations about individuals.
8. A record from this system of records may be disclosed, as a routine use, to the public after either publication of the application pursuant to 35 U.S.C. 122(b) or issuance of a patent pursuant to 35 U.S.C. 151. Further, a record may be disclosed, subject to the limitations of 37 CFR 1.14, as a routine use, to the public if the record was filed in an application which became abandoned or in which the proceedings were terminated and which application is referenced by either a published application, an application open to public inspection or an issued patent.
9. A record from this system of records may be disclosed, as a routine use, to a Federal, State, or local law enforcement agency, if the USPTO becomes aware of a violation or potential violation of law or regulation.

**Notice of Allowability**

**Application No.**

12/137,356

**Examiner**

SAMUEL GILBERT

**Applicant(s)**

QUIRICO ET AL.

**Art Unit**

3735

**-- The MAILING DATE of this communication appears on the cover sheet with the correspondence address--**

All claims being allowable, PROSECUTION ON THE MERITS IS (OR REMAINS) CLOSED in this application. If not included herewith (or previously mailed), a Notice of Allowance (PTOL-85) or other appropriate communication will be mailed in due course. **THIS NOTICE OF ALLOWABILITY IS NOT A GRANT OF PATENT RIGHTS.** This application is subject to withdrawal from issue at the initiative of the Office or upon petition by the applicant. See 37 CFR 1.313 and MPEP 1308.

- 1.  This communication is responsive to papers filed 7/25/2012.
- 2.  An election was made by the applicant in response to a restriction requirement set forth during the interview on \_\_\_\_; the restriction requirement and election have been incorporated into this action.
- 3.  The allowed claim(s) is/are 1-37.
- 4.  Acknowledgment is made of a claim for foreign priority under 35 U.S.C. § 119(a)-(d) or (f).
  - a)  All    b)  Some\*    c)  None    of the:
    - 1.  Certified copies of the priority documents have been received.
    - 2.  Certified copies of the priority documents have been received in Application No. \_\_\_\_ .
    - 3.  Copies of the certified copies of the priority documents have been received in this national stage application from the International Bureau (PCT Rule 17.2(a)).

\* Certified copies not received: \_\_\_\_.

Applicant has **THREE MONTHS FROM THE "MAILING DATE"** of this communication to file a reply complying with the requirements noted below. Failure to timely comply will result in ABANDONMENT of this application.

**THIS THREE-MONTH PERIOD IS NOT EXTENDABLE.**

- 5.  A SUBSTITUTE OATH OR DECLARATION must be submitted. Note the attached EXAMINER'S AMENDMENT or NOTICE OF INFORMAL PATENT APPLICATION (PTO-152) which gives reason(s) why the oath or declaration is deficient.
  - 6.  CORRECTED DRAWINGS ( as "replacement sheets") must be submitted.
    - (a)  including changes required by the Notice of Draftsperson's Patent Drawing Review ( PTO-948) attached
      - 1)  hereto or 2)  to Paper No./Mail Date \_\_\_\_.
    - (b)  including changes required by the attached Examiner's Amendment / Comment or in the Office action of Paper No./Mail Date \_\_\_\_.
- Identifying indicia such as the application number (see 37 CFR 1.84(c)) should be written on the drawings in the front (not the back) of each sheet. Replacement sheet(s) should be labeled as such in the header according to 37 CFR 1.121(d).**
- 7.  DEPOSIT OF and/or INFORMATION about the deposit of BIOLOGICAL MATERIAL must be submitted. Note the attached Examiner's comment regarding REQUIREMENT FOR THE DEPOSIT OF BIOLOGICAL MATERIAL.

**Attachment(s)**

- 1.  Notice of References Cited (PTO-892)
- 2.  Notice of Draftsperson's Patent Drawing Review (PTO-948)
- 3.  Information Disclosure Statements (PTO/SB/08), Paper No./Mail Date 7/3/2012
- 4.  Examiner's Comment Regarding Requirement for Deposit of Biological Material
- 5.  Notice of Informal Patent Application
- 6.  Interview Summary (PTO-413), Paper No./Mail Date \_\_\_\_ .
- 7.  Examiner's Amendment/Comment
- 8.  Examiner's Statement of Reasons for Allowance
- 9.  Other \_\_\_\_.

/Samuel G. Gilbert/  
Primary Examiner, Art Unit 3735

Receipt date: 07/03/2012

Doc code: IDS

Doc description: Information Disclosure Statement (IDS) Filed

PTO/SB/08a (01-10)

Approved for use through 07/31/2012. OMB 0651-0031

U.S. Patent and Trademark Office; U.S. DEPARTMENT OF COMMERCE

Under the Paperwork Reduction Act of 1995, no persons are required to respond to a collection of information unless it contains a valid OMB control number.

|   |                        |                    |
|---|------------------------|--------------------|
| <b>INFORMATION DISCLOSURE STATEMENT BY APPLICANT</b><br>( Not for submission under 37 CFR 1.99) | Application Number     | 12137356           |
|   | Filing Date            | 2008-06-11         |
|   | First Named Inventor   | Charles R. QUIRICO |
|   | Art Unit               | 3735               |
|   | Examiner Name          | Samuel G. GILBERT  |
|   | Attorney Docket Number | 56782.1.5          |

| U.S.PATENTS       |         |               |                        |            |   | Remove   |
|-------------------|---------|---------------|------------------------|------------|---|--|
| Examiner Initial* | Cite No | Patent Number | Kind Code <sup>1</sup> | Issue Date | Name of Patentee or Applicant of cited Document | Pages,Columns,Lines where Relevant Passages or Relevant Figures Appear |
|                   | 1       |               |                        |            |   |  |

If you wish to add additional U.S. Patent citation information please click the Add button. Add

| U.S.PATENT APPLICATION PUBLICATIONS |         |                    |                        |                  |   | Remove   |
|-------------------------------------|---------|--------------------|------------------------|------------------|---|--|
| Examiner Initial*                   | Cite No | Publication Number | Kind Code <sup>1</sup> | Publication Date | Name of Patentee or Applicant of cited Document | Pages,Columns,Lines where Relevant Passages or Relevant Figures Appear |
|                                     | 1       |                    |                        |                  |   |  |

If you wish to add additional U.S. Published Application citation information please click the Add button. Add

| FOREIGN PATENT DOCUMENTS |         |                                      |                             |                        |                  |   |  | Remove                   |
|--------------------------|---------|--------------------------------------|-----------------------------|------------------------|------------------|---|--|--------------------------|
| Examiner Initial*        | Cite No | Foreign Document Number <sup>3</sup> | Country Code <sup>2</sup> j | Kind Code <sup>4</sup> | Publication Date | Name of Patentee or Applicant of cited Document | Pages,Columns,Lines where Relevant Passages or Relevant Figures Appear | T <sup>5</sup>           |
|                          | 1       |                                      |                             |                        |                  |   |  | <input type="checkbox"/> |

If you wish to add additional Foreign Patent Document citation information please click the Add button Add

| NON-PATENT LITERATURE DOCUMENTS |         |   |  | Remove         |
|---------------------------------|---------|---|--|----------------|
| Examiner Initials*              | Cite No | Include name of the author (in CAPITAL LETTERS), title of the article (when appropriate), title of the item (book, magazine, journal, serial, symposium, catalog, etc), date, pages(s), volume-issue number(s), publisher, city and/or country where published. |  | T <sup>5</sup> |
|                                 |         |   |  |                |

|   |                        |                    |            |
|---|------------------------|--------------------|------------|
| <b>INFORMATION DISCLOSURE<br/>STATEMENT BY APPLICANT</b><br>( Not for submission under 37 CFR 1.99) | Application Number     |                    | 12137356   |
|   | Filing Date            |                    | 2008-06-11 |
|   | First Named Inventor   | Charles R. QUIRICO |            |
|   | Art Unit               |                    | 3735       |
|   | Examiner Name          | Samuel G. GILBERT  |            |
|   | Attorney Docket Number |                    | 56782.1.5  |

|  |   |  |                          |
|--|---|--|--------------------------|
|  | 1 | BRACCO, "Cardio-Gen82® Infusion System User's Guide", July 3, 2007, Pages 1-53 | <input type="checkbox"/> |
|--|---|--|--------------------------|

If you wish to add additional non-patent literature document citation information please click the Add button **Add**


**EXAMINER SIGNATURE**

|                    |                  |                 |            |
|--------------------|------------------|-----------------|------------|
| Examiner Signature | /Samuel Gilbert/ | Date Considered | 08/01/2012 |
|--------------------|------------------|-----------------|------------|

\*EXAMINER: Initial if reference considered, whether or not citation is in conformance with MPEP 609. Draw line through a citation if not in conformance and not considered. Include copy of this form with next communication to applicant.

<sup>1</sup> See Kind Codes of USPTO Patent Documents at [www.USPTO.GOV](http://www.USPTO.GOV) or MPEP 901.04. <sup>2</sup> Enter office that issued the document, by the two-letter code (WIPO Standard ST.3). <sup>3</sup> For Japanese patent documents, the indication of the year of the reign of the Emperor must precede the serial number of the patent document. <sup>4</sup> Kind of document by the appropriate symbols as indicated on the document under WIPO Standard ST.16 if possible. <sup>5</sup> Applicant is to place a check mark here if English language translation is attached.



|  |  |  |
|--|--|--|
| <b>Search Notes</b><br><br> | <b>Application/Control No.</b><br><br>12137356 | <b>Applicant(s)/Patent Under Reexamination</b><br><br>QUIRICO ET AL. |
|  | <b>Examiner</b><br><br>SAMUEL GILBERT          | <b>Art Unit</b><br><br>3735  |

| SEARCHED |                            |          |          |
|----------|----------------------------|----------|----------|
| Class    | Subclass                   | Date     | Examiner |
| 128      | 897,898                    |          |          |
| 280      | 47.34, 47.35, 79.11, 79.3, |          |          |
| 208      | 638,651,33.992,79.5,79.6   | 3/26/12  | sgg      |
| update   | above                      | 8/1/2012 | sgg      |

| SEARCH NOTES |          |          |
|--------------|----------|----------|
| Search Notes | Date     | Examiner |
| EAST         | 3/26/12  | sgg      |
| EAST         | 8/1/2012 | sgg      |

| INTERFERENCE SEARCH |                         |          |          |
|---------------------|-------------------------|----------|----------|
| Class               | Subclass                | Date     | Examiner |
| See                 | EAST search of 8/1/2012 | 8/1/2012 | sgg      |

|  |  |
|--|--|
|  |  |
|--|--|

## EAST Search History

## EAST Search History (Prior Art)

| Ref # | Hits | Search Query  | DBs                    | Default Operator | Plurals | Time Stamp       |
|-------|------|---|------------------------|------------------|---------|------------------|
| L4    | 5521 | shield and radiation and door   | US-PGPUB; USPAT; USOCR | OR               | OFF     | 2012/08/02 12:36 |
| S1    | 72   | ("3997784"   "4625118"   "4679142"   "5885216"   "6767319"   "6908598"   "5827429"   "5485831"   "5739508"   "6157036"   "7504646"   "20090312630"   "7862534"   "3714429"   "4562829"   "4853546"   "5258906"   "20070140958"   "20070213848"   "20080242915"   "20070232980"   "20090312635"   "7163031"   "20090309466"   "4096859"   "4769008"   "4585941"   "5039863"   "7169135"   "20080093564"   "20060151048"   "20100125243"   "20100270226"   "3774036"   "4286169"   "6626862"   "20100312039"   "3483867"   "4336036"   "5765842"   "6870175"   "7204797"   "20070282263"   "5475232"   "6901283"   "7256888"   "20030004463"   "20060015056"   "4994056"   "6347711"   "6558125"   "20080071219"   "4755679"   "7476377"   "20040104160"   "20110071392"   "20050278066"   "3710118"   "4585009"   "20080166292"   "5274239"   "5840026"   "6442418"   "7413123"   "5590648"   "20110172524"   "4466888"   "4623102"   "5702115"   "7612999").PN. | US-PGPUB; USPAT; USOCR | OR               | ON      | 2012/03/19 12:09 |
| S2    | 2    | ((("20060151048") or ("5702115")).PN.   | US-PGPUB; USPAT        | OR               | OFF     | 2012/03/19 12:39 |
| S3    | 94   | (600/5).OCLS.   | US-PGPUB; USPAT        | OR               | OFF     | 2012/03/19 15:01 |
| S4    | 94   | (600/5).OCLS.   | US-PGPUB; USPAT        | OR               | OFF     | 2012/03/19 15:01 |
| S5    | 101  | (250/522.1).OCLS.   | US-PGPUB; USPAT        | OR               | OFF     | 2012/03/19 15:09 |
| S6    | 319  | (250/507.1).OCLS.   | US-PGPUB; USPAT        | OR               | OFF     | 2012/03/19 15:16 |
| S7    | 1    | ("3483867").PN.   | US-PGPUB; USPAT        | OR               | OFF     | 2012/03/20 08:45 |
| S8    | 1    | ("20090310523").PN.   | US-PGPUB; USPAT        | OR               | OFF     | 2012/03/20 09:03 |
| S9    | 3    | (first adj compartment) with (sidewall adj opening)   | US-PGPUB; USPAT; USOCR | OR               | ON      | 2012/03/20 09:04 |
| S10   | 0    | S8 and S9   | US-PGPUB;              | OR               | ON      | 2012/03/20 09:04 |



|     |      |  |                                  |    |     |                     |
|-----|------|--|----------------------------------|----|-----|---------------------|
|     |      |  | USPAT;<br>USOCR                  |    |     |                     |
| S11 | 4    | (first adj compartment) same (sidewall adj opening)  | US-<br>PGPUB;<br>USPAT;<br>USOCR | OR | ON  | 2012/03/20<br>09:05 |
| S12 | 0    | S8 and S11   | US-<br>PGPUB;<br>USPAT;<br>USOCR | OR | ON  | 2012/03/20<br>09:06 |
| S13 | 671  | shielding adj assembly   | US-<br>PGPUB;<br>USPAT;<br>USOCR | OR | ON  | 2012/03/20<br>09:06 |
| S14 | 0    | S8 and S13   | US-<br>PGPUB;<br>USPAT;<br>USOCR | OR | ON  | 2012/03/20<br>09:06 |
| S15 | 1    | ("20090318745").PN.  | US-<br>PGPUB;<br>USPAT           | OR | OFF | 2012/03/20<br>09:07 |
| S16 | 1    | S9 and S15   | US-<br>PGPUB;<br>USPAT;<br>USOCR | OR | ON  | 2012/03/20<br>09:08 |
| S17 | 1    | S9 and S15   | US-<br>PGPUB;<br>USPAT;<br>USOCR | OR | ON  | 2012/03/20<br>09:08 |
| S18 | 4    | (first adj compartment) same (sidewall adj opening)  | US-<br>PGPUB;<br>USPAT;<br>USOCR | OR | ON  | 2012/03/20<br>09:09 |
| S19 | 1    | S15 and S18  | US-<br>PGPUB;<br>USPAT;<br>USOCR | OR | ON  | 2012/03/20<br>09:09 |
| S20 | 45   | (first adj compartment) and(sidewall adj opening)  | US-<br>PGPUB;<br>USPAT;<br>USOCR | OR | ON  | 2012/03/20<br>09:09 |
| S21 | 45   | (first adj compartment) and (sidewall adj opening)   | US-<br>PGPUB;<br>USPAT;<br>USOCR | OR | ON  | 2012/03/20<br>09:09 |
| S22 | 1    | S15 and S21  | US-<br>PGPUB;<br>USPAT;<br>USOCR | OR | ON  | 2012/03/20<br>09:09 |
| S23 | 689  | (128/897,897).CCLS.  | US-<br>PGPUB;<br>USPAT           | OR | OFF | 2012/03/26<br>11:18 |
| S24 | 4393 | (280/47.34,47.35,79.11,79.3,638,651,33.992,79.5,79.6).CCLS.  | US-<br>PGPUB;<br>USPAT           | OR | OFF | 2012/03/26<br>11:29 |
| S25 | 22   | ("20040104160"   "20060015056"   "20060151048"  <br>"20090312630"   "20090318745"   "20100125243"  <br>"20100270226"   "20100312039"   "20110071392" | US-<br>PGPUB;<br>USPAT;          | OR | ON  | 2012/03/26<br>11:34 |

|     |      |  |                              |    |     |                     |
|-----|------|--|------------------------------|----|-----|---------------------|
|     |      | "20110172524"   "3483867"   "4096859"   "4336036"   "4466888"   "4623102"   "4769008"   "4994056"   "5827429"   "6347711"   "6558125"   "7862534").PN. | USOCR                        |    |     |                     |
| S26 | 1    | ("3714429").PN.  | US-PGPUB;<br>USPAT;<br>USOCR | OR | ON  | 2012/03/26<br>11:35 |
| S27 | 5663 | (128/898).CCLS.  | US-PGPUB;<br>USPAT           | OR | OFF | 2012/03/26<br>12:09 |
| S28 | 1763 | (600/3-8).CCLS.  | US-PGPUB;<br>USPAT;<br>USOCR | OR | OFF | 2012/08/02<br>11:13 |

8/ 2/ 2012 12:53:56 PM

H:\Workspaces\12137356.wsp


**UNITED STATES PATENT AND TRADEMARK OFFICE**

UNITED STATES DEPARTMENT OF COMMERCE  
**United States Patent and Trademark Office**  
 Address: COMMISSIONER FOR PATENTS  
 P.O. Box 1450  
 Alexandria, Virginia 22313-1450  
 www.uspto.gov

**BIB DATA SHEET**
**CONFIRMATION NO. 7360**

| SERIAL NUMBER   | FILING or 371(c)<br>DATE  | CLASS  | GROUP ART UNIT   | ATTORNEY DOCKET<br>NO. |                     |                           |
|---|---|--|--|------------------------|---------------------|---------------------------|
| 12/137,356  | 06/11/2008  | 600  | 3735   | 56782.1.5              |                     |                           |
| <b>APPLICANTS</b>   |   |  |  |                        |                     |                           |
| Charles R. Quirico, Warren, NJ;<br>Ernest Balestracci, Iselin, NJ;<br>Daniel Darst, Zimmerman, MN;<br>Eric J. Krause, Big Lake, MN;<br>Vishal N. Lokhande, Mountain View, CA;<br>Jacob S. Childs, Minneapolis, MN;<br>Peter B. Madson, Shanghai, CHINA;<br>Daniel V. Clements, Minneapolis, MN; |   |  |  |                        |                     |                           |
| ** CONTINUING DATA *****  |   |  |  |                        |                     |                           |
| ** FOREIGN APPLICATIONS *****   |   |  |  |                        |                     |                           |
| ** IF REQUIRED, FOREIGN FILING LICENSE GRANTED **   |   |  |  |                        |                     |                           |
| Foreign Priority claimed  | <input type="checkbox"/> Yes <input checked="" type="checkbox"/> No | <input type="checkbox"/> Met after Allowance | <b>STATE OR COUNTRY</b>                                      | <b>SHEETS DRAWINGS</b> | <b>TOTAL CLAIMS</b> | <b>INDEPENDENT CLAIMS</b> |
| 35 USC 119(a-d) conditions met  | <input type="checkbox"/> Yes <input checked="" type="checkbox"/> No |  | NJ   | 23                     | 37                  | 5                         |
| Verified and  | /SAMUEL G<br>GILBERT/   | Initials                                     |  |                        |                     |                           |
| Acknowledged  | Examiner's Signature  |  |  |                        |                     |                           |
| <b>ADDRESS</b>  |   |  |  |                        |                     |                           |
| FREDRIKSON & BYRON, P.A.<br>INTELLECTUAL PROPERTY GROUP<br>200 SOUTH SIXTH STREET, SUITE 4000<br>MINNEAPOLIS, MN 55402<br>UNITED STATES   |   |  |  |                        |                     |                           |
| <b>TITLE</b>  |   |  |  |                        |                     |                           |
| SHIELDING ASSEMBLIES FOR INFUSION SYSTEMS   |   |  |  |                        |                     |                           |
| <b>FILING FEE RECEIVED</b>  | FEES: Authority has been given in Paper                             |  | <input type="checkbox"/> All Fees                            |                        |                     |                           |
| 2430  | No. _____ to charge/credit DEPOSIT ACCOUNT                          |  | <input type="checkbox"/> 1.16 Fees (Filing)                  |                        |                     |                           |
|   | No. _____ for following:  |  | <input type="checkbox"/> 1.17 Fees (Processing Ext. of time) |                        |                     |                           |
|   |   |  | <input type="checkbox"/> 1.18 Fees (Issue)                   |                        |                     |                           |
|   |   |  | <input type="checkbox"/> Other _____                         |                        |                     |                           |
|   |   |  | <input type="checkbox"/> Credit                              |                        |                     |                           |

22859  
Customer Number

Patent Case No.: 56782.1.5

**IN THE UNITED STATES PATENT AND TRADEMARK OFFICE**

First Named Inventor: CHARLES R. QUIRICO  
Application No.: 12/137,356                      Group Art Unit: 3735  
Filed: June 11, 2008                      Examiner: GILBERT, Samuel G.  
Title: SHIELDING ASSEMBLIES FOR INFUSION SYSTEMS

---

Mail Stop Amendment  
Commissioner for Patents  
P.O. Box 1450  
Alexandria, VA 22313-1450

**AMENDMENT**

Dear Sir:

In response to the Notice of Non-Compliant Amendment mailed July 10, 2012, the period of response for which runs through August 10, 2012, please amend the application as follows.

**Amendments to the Claims** are reflected in the listing of claims which begins on page 2 of this paper.

**Remarks** begin on page 11 of this paper.

## AMENDMENTS TO THE CLAIMS

This listing of claims will replace all prior versions and listings of claims in the application.

### **Listing of Claims:**

1. (Original) A shielding assembly for an infusion system, the shielding assembly being mounted within a cabinet structure, and the shielding assembly comprising:
  - a plurality of compartments having sidewalls providing barriers to radioactive radiation for the compartments;
  - a corresponding plurality of doors, each door, when open, providing access to the corresponding compartment via an opening in its sidewall, and, when closed, providing further barrier to radioactive radiation for the corresponding compartment;
  - a first compartment of the plurality of compartments enclosed by a first sidewall of the sidewalls and sized to contain a radioisotope generator of the infusion system, the first sidewall including a first sidewall opening oriented upward and aligned with a first upper opening through a shell of the cabinet structure, an upper surface of the shell being located at an elevation with respect to a lowermost portion of the cabinet structure substantially greater than the first sidewall opening and the first upper opening.
  
2. (Original) The shielding assembly of claim 1, wherein the lowermost portion of the cabinet structure is at approximately ground level, the first sidewall opening is at an elevation of between approximately 12 inches and approximately 24 inches with respect to the lowermost portion of the cabinet.
  
3. (Original) The shielding assembly of claim 2, wherein the upper surface of the shell is at an elevation of between approximately 24 inches and 36 inches with respect to the lowermost portion of the cabinet structure.
  
4. (Original) The shielding assembly of claim 1, further comprising a second compartment of the plurality of compartments enclosed by a second sidewall of the sidewalls and sized to

contain a waste bottle of the infusion system, the second sidewall including a second sidewall opening oriented upward and aligned with a second upper opening through the shell of the cabinet structure, the second upper opening being an opening in the upper surface of the shell.

5. (Original) A shielding assembly for an infusion system, the shielding assembly being mounted within a cabinet structure, and the shielding assembly comprising:

a first compartment sized to contain a radioisotope generator of the infusion system, the first compartment being enclosed by a first sidewall that forms a barrier to radioactive radiation, the first sidewall including an opening extending therethrough and a lid, the lid mating with the opening to alternately enclose the first compartment and provide access to the first compartment, via the opening, and the opening being oriented upward and located at a first elevation with respect to a lowermost portion of the cabinet structure;

a second compartment sized to contain a portion of an infusion tubing circuit of the infusion system that is downstream of the generator, the second compartment being enclosed by a second sidewall that forms a barrier to radioactive radiation, the second sidewall including a base portion and a lid portion, the lid portion mating with the base portion to alternately enclose the second compartment and provide access to the second compartment; and

a third compartment sized to contain a waste bottle of the infusion system, the third compartment being enclosed by a third sidewall that forms a barrier to radioactive radiation, the third sidewall including an opening, extending through the third sidewall, and a lid, the lid of the third sidewall mating with the opening of the third sidewall to alternately enclose the third compartment and provide access to the third compartment, via the opening of the third sidewall, the opening of the third sidewall being oriented upward and located at a second elevation with respect to the lowermost portion of the cabinet structure, and the second elevation being greater than the first elevation of the opening of the first sidewall.

6. (Original) The shielding assembly of claim 5, wherein the opening of the first sidewall is aligned with a first upper opening through a shell of the cabinet structure and the opening of the third sidewall is aligned with a second upper opening through the shell of the cabinet structure,

the second upper opening being located at a greater elevation with respect to the lowermost portion of the cabinet structure than the first upper opening.

7. (Original) The shielding assembly of claim 5, wherein an opening through a shell of the cabinet structure provides access to both the lid of the first sidewall and to the lid portion of the second sidewall.

8. (Original) The shielding assembly of claim 5, wherein the lowermost portion of the cabinet structure is at approximately ground level and the first elevation is between approximately 12 inches and approximately 24 inches.

9. (Original) The shielding assembly of claim 5, wherein the lowermost portion of the cabinet structure is at approximately ground level and the second elevation is between approximately 24 inches and approximately 36 inches.

10. (Original) The shielding assembly of claim 5, further comprising:  
a fourth compartment sized to contain another portion of the infusion tubing circuit of the infusion system downstream from the generator, the fourth compartment being enclosed by a portion of the third sidewall and a door that forms a barrier to radioactive radiation, the door mating with the portion of the third sidewall to alternately enclose the fourth compartment and provide access to the fourth compartment; and  
wherein the fourth compartment is immediately adjacent to the second compartment;  
the portion of the infusion tubing circuit contained in the second compartment includes an eluate line, extending from the generator, a patient line, being coupled to the eluate line, and a waste line, being coupled to the eluate line; and  
the other portion of the infusion tubing circuit contained in the fourth compartment includes an extension of the patient line, from the second compartment, and an extension of the waste line, from the second compartment.

11. (Original) The shielding assembly of claim 10, wherein the fourth compartment extends approximately vertically along the portion of the third sidewall, on an opposite side of the third sidewall from the third compartment.
12. (Original) The shielding assembly of claim 11, wherein the fourth compartment includes a retaining member to hold the extension of the patient line and the extension of the waste line in place within the fourth compartment.
13. (Original) The shielding assembly of claim 10, wherein the lid of the third sidewall, when mated with opening of the third sidewall, prevents the door of the fourth compartment from opening to provide access to the fourth compartment.
14. (Original) The shielding assembly of claim 13, wherein the door of the fourth compartment, when mated with the portion of the third sidewall, prevents the lid portion of the second sidewall from opening to provide access to the second compartment.
15. (Original) The shielding assembly of claim 14, wherein the lid portion of the second sidewall, when mated with the base portion of the second sidewall, prevents the lid of the first sidewall from opening to provide access to the first compartment.
16. (Original) The shielding assembly of claim 10, wherein the door of the fourth compartment, when mated with the portion of the third sidewall, prevents the lid portion of the second sidewall from opening to provide access to the second compartment.
17. (Original) The shielding assembly of claim 5, wherein the lid portion of the second sidewall, when mated with the base portion of the second sidewall, prevents the lid of the first sidewall from opening to provide access to the first compartment.
18. (Original) The shielding assembly of claim 5, wherein the lid of the first sidewall is hinged to open in an upward direction; and further comprising a latch component, mounted within the cabinet structure, to hold the lid of the first sidewall in an open position.



19. (Original) The shielding assembly of claim 5, wherein the lid portion of the second sidewall is hinged to open in an upward direction; and further comprising a latch component, mounted within the cabinet structure, to hold the lid portion of the second sidewall in an open position.

20. (Currently Amended) A method for setting up an infusion system, the method comprising:

opening a first door of a shielding assembly of the infusion system to access a first compartment of the assembly and to allow for a second door of the shielding assembly to be opened, wherein the first door defines a first door edge, the second door defines a second door edge, and the first door edge overlaps the second door edge so as to prevent the second door from being opened if the first door is not open; and

opening the second door, after opening the first door, to access a second compartment of the shielding assembly, the second compartment being separate from, and outside of, the first compartment;

placing a radioisotope generator into the second compartment and connecting the generator to an infusion tubing circuit;

placing a portion of the infusion tubing circuit into the first compartment;

closing the second door to enclose the generator within the second compartment; and

closing the first door, after closing the second door, to enclose the portion of the infusion tubing circuit within the first compartment.

21. (Original) The method of claim 20, further comprising unlocking and removing an access panel from a shell of a cabinet structure, which encloses the shielding assembly, to access the first door and the second door of the shielding assembly.

22. (Original) The method of claim 20, further comprising:

opening a third door, prior to opening the first door, to access a third compartment of the shielding assembly and to allow for the first door to be opened;

placing another portion of the infusion tubing circuit into the third compartment; and

closing the third door, after closing the first door, to enclose the other portion of the infusion tubing circuit within the third compartment.

23. (Original) The method of claim 22, further comprising unlocking and removing an access panel from a shell of a cabinet structure, which encloses the shielding assembly, to access the first door, the second door and the third door of the shielding assembly.

24. (Original) The method of claim 22, further comprising:  
opening a fourth door, prior to opening the third door, to access a fourth compartment of the shielding assembly and to allow for the third door to be opened;  
connecting a waste line of the infusion tubing circuit to a waste bottle;  
placing the waste bottle into the fourth compartment; and  
closing the fourth door, after closing the third door, to enclose the waste bottle within the fourth compartment.

25. (Original) The method of claim 20, further comprising securing at least one of the first and second doors in an open position.

26. (Currently Amended) A shielding assembly for an infusion system, the shielding assembly comprising a plurality of compartments and providing a radioactive radiation barrier for the compartments, the assembly further comprising:  
a first door to alternately enclose and provide access to a first compartment of the plurality of compartments, the first compartment sized to contain a radioisotope generator of the infusion system; and  
a second door to alternately enclose and provide access to a second compartment of the plurality of compartments, the second compartment being separate from, and outside of, the first compartment, the second compartment being sized to contain a portion of an infusion tubing circuit of the infusion system that is downstream of the generator, and the second door, when enclosing the second compartment, preventing the first door from opening to provide access to the first compartment,

wherein the first door defines a first door edge, the second door defines a second door edge, and the first door edge overlaps the second door edge so as to prevent the first door from being opened if the second door is not open

27. (Original) The shielding assembly of claim 26, further comprising a third door to alternately enclose and provide access to a third compartment of the plurality of compartments, the third compartment sized to contain another portion of the infusion tubing circuit of the infusion system downstream from the generator, the third door, when enclosing the third compartment, preventing the second door from opening to provide access to the second compartment.
28. (Original) The shielding assembly of claim 27, further comprising a fourth door to alternately enclose and provide access to a fourth compartment of the plurality of compartments, the fourth compartment being sized to contain a waste bottle of the infusion system, the fourth door, when enclosing the fourth compartment, preventing the third door from opening to provide access to the third compartment.
29. (Original) The shielding assembly of claim 28, wherein the third compartment shares a sidewall with the fourth compartment and extends approximately vertically along the shared sidewall.
30. (Original) The shielding assembly of claim 29, wherein the third compartment includes a retaining member attached to the shared sidewall to hold the other portion of the infusion tubing circuit in place along the shared sidewall.
31. (Original) An infusion system comprising:  
a cabinet structure including a shell defining an interior space thereof, the shell including a first opening, a second opening and an access panel, the access panel mating with the second opening and being removable therefrom;  
a lock reversibly engaging the access panel to secure access to the interior space of the cabinet structure;

an eluant source;

a shielding assembly located within the interior space of the cabinet structure, the shielding assembly including a sidewall defining a plurality of compartments and providing a barrier to radioactive radiation for the compartments, the shielding assembly further including a corresponding plurality of doors, each door, when open, providing access to the corresponding compartment via an opening in the sidewall, and, when closed, providing further barrier to radioactive radiation for the corresponding compartment;

a radioisotope generator contained within a first compartment of the plurality of compartments of the shielding assembly and being accessible through the second opening of the shell of the cabinet structure, when the access panel is unlocked, and when a first door of the plurality of doors, which corresponds to the first compartment, is open;

an eluant line coupled to the eluant source and to the generator;

an eluate line coupled to the generator; and

a patient line coupled to the eluate line and extending out from the interior space of the cabinet structure through the first opening of the shell.

32. (Original) The assembly of claim 31, wherein the first door is hinged to open in an upward direction; and further comprising a latch component, mounted within the cabinet structure, to hold the first door in an open position.

33. (Original) The system of claim 31, further comprising:

a waste bottle contained within a second compartment of the plurality of compartments of the shielding assembly; and

a waste line coupled to the eluate line and to the waste bottle;

wherein the shell of the cabinet structure further includes a third opening; and

a second door of the plurality of doors, which corresponds to the second compartment, is aligned with the third opening of the shell, for access thereto, and is located at a higher elevation, with respect to a lowermost surface of the cabinet structure, than that of the second door.

34. (Original) The system of claim 31, further comprising:  
a waste bottle contained within a second compartment of the plurality of compartments of the shielding assembly; and  
a waste line coupled to the eluate line and to the waste bottle;  
wherein a second door of the plurality of doors, which corresponds to the second compartment, when closed, prevents the first door from opening to provide access to the first compartment.
35. (Original) The system of claim 31, wherein:  
the eluate line and at least a portion of the patient line are contained in a second compartment of the plurality of compartments of the shielding assembly; and  
a second door of the plurality of doors, which corresponds to the second compartment, when closed, prevents the first door from opening to provide access to the first compartment.
36. (Original) The system of claim 35, wherein the second door is accessible only through the second opening of the shell of the cabinet structure, when the access panel is unlocked.
37. (Original) The system of claim 35, wherein the first door and the second door are both hinged to open in an upward direction; and further comprising at least one latch component, mounted within the cabinet structure, to hold the first door and the second door in an open position.

### **NEW REMARKS**

This Amendment is responsive to the Notice of Non-Compliant Amendment dated July 10, 2012. Claims 1–37 will be pending upon entry of the Amendment.

Applicant's claim amendments accompanying a response filed on July 3, 2012, were not entered because the claim amendments were deemed non-complaint. The Patent Office indicated that claim 9 recited an incorrect dependency.

Applicant has corrected the claim dependency of claim 9. The claim dependency of claim 9 in the present Amendment is consistent with the claim numbering presented in the original claims filed June 11, 2008, which is the last set of claims entered into the record by the Patent Office. Applicant's remarks accompanying the Amendment submitted on July 3, 2012, are reproduced below. Entry of this corrected Amendment is respectfully requested.

### **REMARKS FROM JULY 3, 2012, FILING**

This Amendment is responsive to the Office Action dated April 4, 2012. Applicant has amended claims 20 and 26. No new matter has been added by way of the amendments, and support for the amendments can be found throughout Applicant's original disclosure including, e.g., at paragraphs [0039] and [0040] and FIGS. 2A and 3A. Claims 1–37 will remain pending upon entry of this Amendment. Reconsideration of the application is respectfully requested.

### **Information Disclosure Statement**

On a 1449 form accompanying the Office Action dated April 4, 2012, the Examiner lined through a reference submitted as part of an information disclosure statement filed on October 24, 2008. In particular, the Examiner lined through a reference identified as "BRACCO, 'Cardio Gen82® Infusion System User's Guide', pages 1–53." The Office Action did not indicate why the cited reference was lined through.

Applicant believes the Examiner lined through the reference because the citation did not include a date identifying the reference. Applicant is submitting a supplemental information disclosure statement along with this response. The supplemental information disclosure statement includes a 1449 form that lists the reference, including the date identified on the reference, as well as another copy of the reference. Applicant respectfully requests that the Examiner consider the listed reference and provide an initialed copy of the 1449 form along with

the next official action. If the Examiner believes that further modification is needed to the form of the citation listed on the 1449 form, Applicant requests that the Examiner contact the undersigned attorney to discuss the 1449 form and appropriate correction.

### **Allowable Subject Matter**

The Office Action indicated that claims 31–37 were allowed and that claims 22–24 were objected to as being dependent upon a rejected claim but would be allowable if rewritten in independent form. Applicant thanks the Examiner for the indication of allowability with respect to claims 22–24 and 31–37 and agrees that the claims present allowable subject matter. However, for the reasons set forth below, Applicant submits that claims 1–21 and 25–30 also present allowable subject matter. Applicant therefore requests that the Examiner reconsider the currently rejected claims and allow all pending claims.

### **Claim Rejections Under 35 U.S.C. § 112, Second Paragraph**

In the Office Action, claims 1–4 were rejected under 35 U.S.C. § 112 second paragraph as purportedly being indefinite for failing to particularly point out and distinctly claim the subject matter which Applicant regards as the invention. Specifically, the Office Action stated that the term “substantially greater” in claim 1 renders the claims indefinite because the term is not defined by the claims and the specification does not provide a standard for ascertaining the requisite degree.<sup>1</sup>

Applicant respectfully traverses the rejection of claims 1–4 under 35 U.S.C. § 112 second paragraph. It is well established that the claim term “substantially” does not render claims indefinite. On a number of occasions, the Court of Appeals for the Federal Circuit has specifically addressed the issue of the term “substantially” in relation to 35 U.S.C. § 112. Most recently, this specific issue was addressed in *Verve v. Crane Cams Inc.*, (CAFC Nov. 14, 2002). The court in *Verve v. Crane Cams, Inc* cited numerous examples of cases holding that the term “substantially” is not an indefinite claim term. In particular, the court in *Verve v. Crane Cams, Inc.* stated:

Expressions such as "substantially" are used in patent documents when warranted by the nature of the invention, in order to accommodate the minor variations that may be appropriate to secure the invention. Such usage may well satisfy the charge to

---

<sup>1</sup> Office Action dated April 4, 2012, at page 2.

"particularly point out and distinctly claim" the invention, 35 U.S.C. §112, and indeed may be necessary in order to provide the inventor with the benefit of his invention. In *Andrew Corp. v. Gabriel Elecs. Inc.*, 847 F.2d 819, 821-22, 6 USPQ2d 2010, 2013 (Fed. Cir. 1988) the court explained that usages such as "substantially equal" and "closely approximate" may serve to describe the invention with precision appropriate to the technology and without intruding on the prior art. The court again explained in *Ecolab Inc. v. Envirochem, Inc.*, 264 F.3d 1358, 1367, 60 USPQ2d 1173, 1179 (Fed. Cir. 2001) that "like the term 'about,' the term 'substantially' is a descriptive term commonly used in patent claims to 'avoid a strict numerical boundary to the specified parameter,'" quoting *Pall Corp. v. Micron Separations, Inc.*, 66 F.3d 1211, 1217, 36 USPQ2d 1225, 1229 (Fed. Cir. 1995).

Moreover, the court in *Verve v. Crane Cams, Inc.* continued by stating:

It is well established that when the term "substantially" serves reasonably to describe the subject matter so that its scope would be understood by persons in the field of the invention, and to distinguish the claimed subject matter from the prior art, it is not indefinite.

The instant case is a classic example of use of a the term "substantially" to describe the subject matter so that its scope would be understood by persons in the field of the invention and use of the term "substantially" is necessary to provide the Applicant with the benefit of his invention. Applicant therefor requests withdrawal of all rejections under 35 U.S.C. § 112, second paragraph.

### **Claim Rejections Under 35 U.S.C. §§ 102(e) and 103(a)**

In the Office Action, claims 1, 4, 20, 21 and 25–27 were rejected under 35 U.S.C. § 102(e) as purportedly being anticipated by Tate, et al. (US 2008/0177126, hereinafter "Tate"). In addition, claims 2, 3, 5 and 7–9 were rejected under 35 U.S.C. § 103(a) as purportedly being unpatentable over Tate. Applicant respectfully traverses the rejections, particularly to the extent the rejections can be considered applicable to the claims as amended. Tate fails to disclose each and every feature of the claims, and there would have been no apparent reason for modification to arrive at the claimed features.

#### ***Independent Claim 1***

Independent claim 1 is directed to a shielding assembly for an infusion system that is mounted within a cabinet structure. The shielding assembly includes a plurality of compartments having sidewalls providing barriers to radioactive radiation and a corresponding plurality of



doors. According to the claim, each door, when open, provides access to a corresponding compartment via an opening in its sidewall, and, when closed, provides further barrier to radioactive radiation for the corresponding compartment. Among other features, claim 1 specifies that an upper surface of a shell of the cabinet structure is located at an elevation with respect to a lowermost portion of the cabinet structure that is substantially greater than a first sidewall opening of the shielding assembly and a first upper opening of the cabinet structure.

In support of the rejection of independent claim 1, the Office Action cited Tate as allegedly each and every feature of the claim.<sup>2</sup> In particular, the Office Action characterized a cap member 684 of a vial access system in Tate as “a plurality of compartments each with doors” according to claim 1 and a lid 20 of Tate as an upper opening in a cabinet structure according to the claim.<sup>3</sup> The Office Action then asserted, without citation, that “the shell opening -20- is at an elevation with respect to the bottom of the device substantially greater than the elevation of the openings with doors - 684-.”<sup>4</sup> Based on the foregoing characterizations, the Office Action asserted that Tate discloses all the features of independent claim 1. Applicant respectfully disagrees.

Tate is directed to a fluid delivery system for delivering doses of pharmaceuticals to a patient.<sup>5</sup> With respect to FIGS. 1A–1E, Tate describes a fluid delivery system 10 that has a retractable lid 20 covering an upper surface 103 that defines a number of recessed portions, such as wells and troughs, into which a vial or container of pharmaceutical may be positioned during an injection procedure.<sup>6</sup> Tate continues to describe this vial of pharmaceutical in connection with FIGS. 4A and 4B. FIG. 4A of Tate is reproduced below for reference:

---

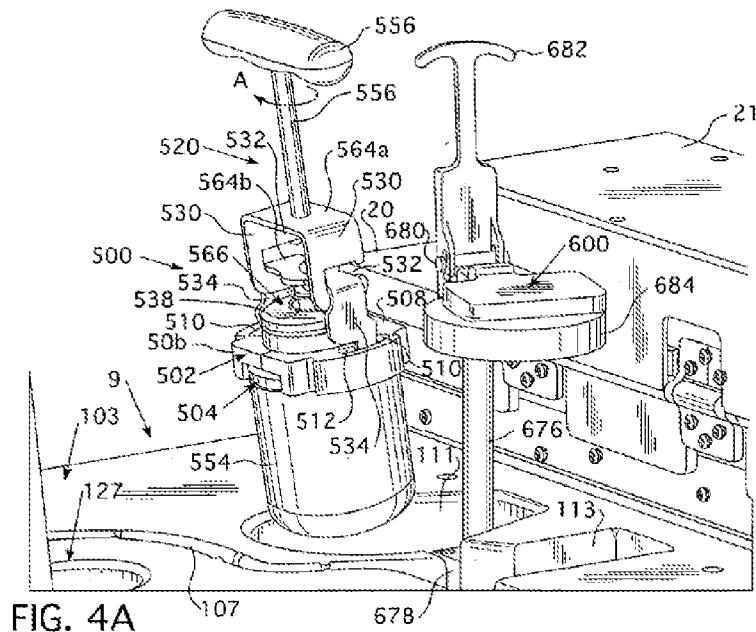
<sup>2</sup> See *id.* at page 3

<sup>3</sup> See *id.*

<sup>4</sup> *Id.*

<sup>5</sup> See, e.g., Tate at paragraph [0012].

<sup>6</sup> See *id.* at paragraph [0072].



With respect to the figure above, Tate describes a vial access system 600 that is removably disposed within a well 111 of fluid delivery system 10 and that operates to hold a vial shield 554 and to access the contents contained in a vial in the vial shield.<sup>7</sup> Tate explains that during operation, an operator uses vial carrying system 500 to transport the vial shield 554 to fluid delivery system 10 and to lower the shield into vial access system 600.<sup>8</sup> Thereafter, Tate describes that the operator disengages the vial carrying system 500 from the vial shield 554 and uses vial access system 600 to access the contents of the vial in the vial shield.<sup>9</sup> In particular, Tate explains that an operator pivots a cap 684 that is rigidly connected to a vertical support arm 676 over vial shield 554 and then lowers the cap to pierce a septum of a vial in the vial container.<sup>10</sup>

The Office Action characterized cap member 684 of Tate as “a plurality of compartments each with doors”.<sup>11</sup> However, Tate does not describe that cap member 684 is even a door for a single compartment of a shielding assembly system much less a plurality of doors corresponding to a plurality of compartments. As outlined above, the cap member 684 of Tate is a component that is lowered over a vial shield 554 positioned within a well 111 of a fluid delivery system.

<sup>7</sup> See *id.* at paragraph [0118].

<sup>8</sup> See *id.* at paragraphs [0127] and [0138].

<sup>9</sup> See *id.*

<sup>10</sup> See *id.* at paragraph [0141] and [0142].

<sup>11</sup> Office Action dated April 4, 2012, at page 3.

Vial shield 554 is not, however, a compartment of a shielding assembly. Instead, vial shield 554 is described by Tate as simply being a “conventional shield or PIG” that is designed to be “transported by personnel.”<sup>12</sup> It is therefore unreasonable to characterize cap member 684 of Tate as a door of a compartment of a shielding assembly, per claim 1.

Moreover, independent claim 1 requires a shielding assembly that has a plurality of compartments and a corresponding plurality of doors, where each door, when open, provides access to a compartment via an opening in its sidewall, and, when closed, provides further barrier to radioactive radiation for the compartment. Tate only illustrates and describes cap member 684 as being a single cap member designed to be positioned over a single vial shield within well 111 of fluid delivery system 10. Accordingly, even assuming *arguendo* that cap member 684 of Tate could be considered a door for a single compartment of a shielding assembly system (which is an assumption Applicant does not concede), the cap member does not expressly or inherently disclose or suggest a shielding assembly that has a plurality of compartments and a corresponding plurality of doors. As the Office Action cited no other portions of Tate as allegedly disclosing these additional features of independent claim 1, the Office Action did not establish by substantial evidence that Tate discloses each and every feature of the claim, as required to support a rejection under 35 U.S.C. § 102.

Furthermore, the Office Action did not establish that Tate discloses a shielding assembly mounted in a cabinet structure where an upper surface of a shell of the cabinet structure is located at an elevation with respect to a lowermost portion of the cabinet structure that is substantially greater than a first sidewall opening of the shielding assembly and a first upper opening of the cabinet structure, as further included in independent claim 1. The Office Action appeared to cite lid 20 of Tate as disclosing a first upper opening of a cabinet structure and cap member 684 of Tate as disclosing a first sidewall opening of a shielding assembly.<sup>13</sup> The Office Action then asserted that “the shell opening -20- is at an elevation with respect to the bottom of the device substantially greater than the elevation of the openings with doors - 684-.”<sup>14</sup>

Yet a shell opening that is at an elevation with respect to the bottom of a device that is substantially greater than the elevation of the openings with doors is not the claim feature recited by independent claim 1. Claim 1 recites an upper surface of a shell of the cabinet structure that

---

<sup>12</sup> See Tate at paragraph [0117].

<sup>13</sup> See Office Action date April 4, 2012, at page 3.

<sup>14</sup> *Id.*

is located at an elevation that is substantially greater than a first sidewall opening of a shielding assembly (apparently identified as cap member 684 in Tate by the Office Action) and a first upper opening of the cabinet structure (apparently identified as lid 20 in Tate by the Office Action). Claim 1 does not recite a relative elevation between a “shell opening” and an “opening with doors” as asserted in the Office Action. Accordingly, because the Office Action failed to put any evidence on record regarding this additional feature of independent claim 1, the Office Action did not establish a *prima facie* case of anticipation of independent claim 1.

For at least the reasons given above, the Office Action did not establish that Tate discloses each and every feature of independent claim 1, as required to support a rejection under 35 U.S.C. § 102. Reconsideration and withdrawal of the rejection are respectfully requested.

If Examiner chooses to maintain any rejection of independent claim 1 based on Tate, Applicant requests a subsequent Non-Final Office Action clearly explaining how the Examiner believes the features of Tate apply to Applicant’s claimed features. Tate is a complex reference spanning over 100 pages with over 50 figures. The Office Action identified only three reference numerals in Tate, without even citing to corresponding portions of the reference where the reference numerals are discussed, as allegedly disclosing all the features of Applicant’s claim. This has given Applicant little guidance to understand how the Examiner is interpreting and applying the Tate reference. In accordance with 37 C.F.R. § 1.104(c)(2), Applicant requests that the Examiner fully explain and clarify the applicability of the Tate reference if any rejection is maintained based on Tate.<sup>15</sup>

### ***Independent Claim 5***

Independent claim 5 is directed to a shielding assembly for an infusion system that is mounted within a cabinet structure. The shielding assembly includes a first compartment sized to contain a radioisotope generator, a second compartment sized to contain a portion of an infusion tubing circuit, and a third compartment sized to contain a waste bottle of the infusion system. Among other features, the claim specifies that the first compartment is enclosed by a first sidewall including a lid, the second compartment is enclosed by a second sidewall including a lid, and the third compartment is enclosed by a third sidewall including a lid. The claim also

---

<sup>15</sup> 37 C.F.R. § 1.104(c)(2) (“When a reference is complex or shows or describes inventions other than that claimed by the applicant, the particular part relied on must be designated as nearly as practicable. The pertinence of each reference, if not apparent, must be clearly explained and each rejected claim specified.”).

states that an opening defined by the first compartment is located at a first elevation, an opening defined by the third compartment is located at a second elevation, and the second elevation is greater than the first elevation.

In support of the rejection of independent claim 5, the Office Action characterized a cap member 684 of a vial access system in Tate as a lid for both a first compartment sized to contain a radioisotope generator and a third compartment sized to contain a waste bottle according to claim 5.<sup>16</sup> The Office Action further characterized a lid 20 of Tate as a lid for a compartment sized to contain a portion of an infusion tubing circuit according to claim 5.<sup>17</sup> While the Office Action acknowledged that Tate does not disclose an opening defined by a third compartment that is located at a second elevation that is greater than an opening defined by a first compartment that is located at a first elevation, the Office Action alleged that such a feature would have been obvious.<sup>18</sup> For a plurality of reasons set for below, Applicant respectfully disagrees that cap member 684 of Tate can be reasonably characterized as a lid for a first compartment and a lid for a third compartment according to claim 5.

First, Tate does not describe that cap member 684 is a lid for even a single compartment of a shielding assembly system much a lid for a first compartment and a lid a third compartment. As discussed in greater detail with respect to the rejection of independent claim 1, the cap member 684 of Tate is a component that is lowered over a vial shield 554 positioned within a well 111 of a fluid delivery system. Vial shield 554 is not a compartment of a shielding assembly. Rather, vial shield 554 is described by Tate as simply being a “conventional shield or PIG” that is designed to be “transported by personnel.”<sup>19</sup> It is therefore unreasonable to characterize cap member 684 of Tate as a lid for even a single compartment of a shielding assembly, per claim 1.

Second, independent claim 5 recites a first compartment that is enclosed by a first sidewall including a lid and a third compartment enclosed by a third sidewall including a lid. Tate only illustrates and describes cap member 684 as being a single cap member designed to be positioned over a single vial shield within well 111 of fluid delivery system 10. Tate in no way describes cap member 684 as being able to alternately enclose and provide access to third well

---

<sup>16</sup> Office Action dated April 4, 2012, at page 6–7.

<sup>17</sup> *Id.* at page 7.

<sup>18</sup> *See id.* at page 7.

<sup>19</sup> *See* Tate at paragraph [0117].

127 in Tate (characterized as a third compartment in the Office Action). Simply put, even if cap member 684 of Tate could be considered a lid for a compartment of a shielding assembly (which is an assertion Applicant does not concede), the cap member does not function as a lid for both first well 111 in Tate (characterized as a first compartment in the Office Action) and also third well 127 (characterized as a third compartment in the Office Action).

Because the Office Action did not establish that Tate discloses a first compartment enclosed by a first sidewall that includes a lid, a second compartment enclosed by a second sidewall that includes a lid, and a third compartment enclosed by a third sidewall that a lid, the Office Action did not establish a *prima facie* case of obviousness with respect to the claim.

Moreover, Applicant respectfully disagrees that it would have been obvious to modify the device of Tate to include so that an opening defined by a first compartment sized to contain a radioisotope generator is located at a first elevation, an opening defined by a third compartment sized to contain a waste bottle is located at a second elevation, and the second elevation is greater than the first elevation, as further included in claim 5. While the Office Action acknowledged that Tate does not disclose this feature, the Office Action asserted the following:

In the absence of showing any criticality in the exact elevation of the opening the selection of any elevation within the range normally expected for expected for a standing human working with a transportable cart. The elevations must not be too high as such would require the user to find means to elevate themselves to open the lids and if the elevations are too low the users arms would not be long enough to reach them inside the cart. The selection of the claimed dimensions are therefore commensurate with normal human anatomy therefore within the ordinary skill of one of ordinary skill in the medical arts.

Applicant respectfully disagrees with the rationale for modifying the Tate reference advanced in the Office Action.

It is well established that when rejecting a claim under 35 U.S.C. § 103, the Patent Office has the initial duty of “identify[ing] a reason that would have prompted a person of ordinary skill in the relevant field to combine the elements in the way the claimed new invention does. This is so because inventions in most, if not all, instances rely upon building blocks long since

uncovered.”<sup>20</sup> In identifying this reason, the Patent Office may not “resort to speculation, unfounded assumptions, or hindsight reconstruction to supply deficiencies in its factual basis.”<sup>21</sup>

In the present case, the Office Action’s rationale for modifying the Tate references relies on speculative and hindsight assumptions that are insufficient to support the legal conclusion of obviousness. In the rejection of independent claim 5, the Office Action asserted that it would have been obvious to modify the Tate device because “the claimed dimensions are . . . commensurate with normal human anatomy [and] therefore within the ordinary skill of one of skill in the medical arts.”<sup>22</sup> Yet the mere fact that a certain modification may be possible – and thus within the skill of one skilled in the technical field – provides no reason why the skilled person would actually so modify the Tate device. Tate describes no benefit to be had or advantage to be gained by providing an opening defined by a third compartment sized to contain a waste bottle that is located at an elevation that is greater than an elevation for an opening defined by a first compartment sized to contain a radioisotope generator. Applicant submits that a person of ordinary skill in the art would not have modified the Tate reference in the manner suggested in the Office Action.

For at least the reasons given above, Tate does not render independent claim 5 unpatentable. Reconsideration and withdrawal of the rejection are respectfully requested.

### ***Independent Claims 20 and 26***

Tate fails to disclose or suggest the features of independent claims 20 and 26. Independent claim 20 is directed to a method for setting up an infusion system that includes opening a first door of a shielding assembly of the infusion system to access a first compartment of the assembly and to allow for a second door of the shielding assembly to be opened. The method also includes, among other features, opening the second door, after opening the first door, to access a second compartment of the shielding assembly, the second compartment being separate from, and outside of, the first compartment. As amended, independent claim 20 specifies that the first door defines a first door edge, the second door defines a second door edge, and that the first door edge overlaps the second door edge so as to prevent the second door from being opened if the first door is not open.

---

<sup>20</sup> *KSR, KSR Int’l Co. v. Teleflex, Inc.* 550 U.S. 398, at 418 (2007).

<sup>21</sup> *In re Warner*, 379 F.2d 1011, 1017 (CCPA 1967).

<sup>22</sup> Office Action dated April 4, 2012, at page 7–8.

In support of the rejection of previously-presented independent claim 20, the Office Action characterized a cap member 684 of a vial access system in Tate as both a first door providing access to a first compartment and a second door providing access to a second compartment.<sup>23</sup> The Office Action then relied on this characterization to assert that Tate anticipates the feature of previously-presented independent claim 20.<sup>24</sup>

Cap member 684 of Tate is not a first door of a shielding assembly and a second door of a shielding assembly per claim 20. Applicant reiterates and incorporates by reference the remarks offered in connection with the rejection of independent claims 1 and 5. Cap member 684 of Tate does not provide access to a compartment of a shielding assembly but rather is used to connect a vial shield positioned within in the device of Tate. For this reason, it is unreasonable to characterize cap member 684 of Tate as a door for even a single compartment of a shielding assembly, per claim 20. Further, claim 20 recites a first door providing access to a first compartment and a second door providing access to a second compartment. Tate only illustrates and describes cap member 684 as being a single cap member designed to be positioned over a single vial shield within well 111 of fluid delivery system 10. Tate in no way describes cap member 684 as being able function as a first door providing access to a first compartment and a second door providing access to a second compartment.

While Applicant does not agree with the propriety of the rejection, Applicant is presently amending independent claim 20 to advance allowance of the application. As amended, independent claim 20 specifies that a first door of the shielding assembly defines a first door edge, a second door of the shielding assembly defines a second door edge, and the first door edge overlaps the second door edge so as to prevent the second door from being opened if the first door is not open. Tate does not include such a feature.

A shielding assembly that includes a first door that defines a first door edge and a second door that defines a second door edge, where the first door edge overlaps the second door edge so as to prevent the second door from being opened if the first door is not open, is not a trivial feature. With such an arrangement, separate compartments of a shielding assembly can be closed by separate doors. Yet by overlapping one door edge with another door edge, a number of distinct actions may be required to access the compartments closed by the doors. For

---

<sup>23</sup> Office Action dated April 4, 2012, at page 3–4.

<sup>24</sup> *Id.*



example, to access the second compartment containing the radioisotope generator, the first door for the first compartment may initially need to be opened before the second door can be opened. This arrangement may reduce the chance that the second compartment is opened accidentally. Avoiding accidental opening of the second compartment may be advantageous given that this compartment may contain the main radioactive source.

Tate does not disclose or suggest a shielding assembly where a first door defines a first door edge, a second door defines a second door edge, and the first door edge overlaps the second door edge so as to prevent the second door from being opened if the first door is not open. Nor does Tate recognize any advantages to be had with such a configuration. Accordingly, for at least the reasons given above, Tate does not render amended independent claim 20 unpatentable.

Independent claim 26 is directed to a shielding assembly for an infusion system that includes a plurality of compartments and that provides a radioactive radiation barrier for the compartments. Among other features, the shielding assembly includes a first door to alternately enclose and provide access to a first compartment of the plurality of compartments and a second door to alternately enclose and provide access to a second compartment of the plurality of compartments. As amended, the claim specifies that the first door defines a first door edge, the second door defines a second door edge, and the first door edge overlaps the second door edge so as to prevent the first door from being opened if the second door is not open. Amended claim 26 is therefore patentable over Tate for at least the reasons given above with respect to claim 20.

### ***Dependent Claims***

Claims 4, 7–9, 21, 25, 27, depend from independent claims 1, 5, 20, or 26 and are therefore patentable for at least the reasons given above with respect to the independent claims, as well as upon additional patentable features and elements claimed in the dependent claims but not explicitly discussed herein.

## **Double Patenting**

In the Office Action, the Examiner provisionally rejected claims 1–19 and 26–30 under the judicially created doctrine of obviousness-type double patenting as being unpatentable over claims 16–28 of US Patent Application No. 12/954,307. In addition, the Examiner also provisionally rejected claims 1–19 and 26–30 under the judicially created doctrine of obviousness-type double patenting as being unpatentable over claims 16–28 of US Patent Application No. 12/865,924.

Applicant notes the provisional status of these rejections. Accordingly, Applicant will address the issue if and when the rejections are formally applied.

## **CONCLUSION**

It is submitted that all claims in this application are in condition for allowance. Applicant respectfully requests reconsideration and prompt allowance of all pending claims.

In view of the fundamental differences identified above, Applicant reserves further comment concerning the additional features set forth in the claims. However, Applicant does not acquiesce in the propriety of the Office Action's application or interpretation of the references with respect to the claims, and reserves the right to present additional arguments in any further prosecution of this application.

The Commissioner is authorized to charge any deficiencies and credit any overpayments to Deposit Account No. 06-1910. The Examiner is invited to telephone the undersigned attorney to discuss this application.

Respectfully submitted,

Dated: July 25, 2012

/Paul J. LaVanway, Jr./

Paul J. LaVanway, Jr.  
Registration No. 64,610

FREDRIKSON & BYRON, P.A.  
200 South Sixth Street, Suite 4000  
Minneapolis, MN 55402-1425 USA  
Telephone: (612) 492-7387  
Facsimile: (612) 492-7077

*Please grant any extension of time necessary for entry; charge any fee due to Deposit Account No. 06-1910.*

5191655\_1.DOC

## Electronic Acknowledgement Receipt

|   |   |
|---|---|
| <b>EFS ID:</b>                              | 13337766                                  |
| <b>Application Number:</b>                  | 12137356                                  |
| <b>International Application Number:</b>    |   |
| <b>Confirmation Number:</b>                 | 7360                                      |
| <b>Title of Invention:</b>                  | SHIELDING ASSEMBLIES FOR INFUSION SYSTEMS |
| <b>First Named Inventor/Applicant Name:</b> | Charles R. Quirico                        |
| <b>Customer Number:</b>                     | 22859                                     |
| <b>Filer:</b>                               | Paul J. LaVanway Jr.                      |
| <b>Filer Authorized By:</b>                 |   |
| <b>Attorney Docket Number:</b>              | 56782.1.5                                 |
| <b>Receipt Date:</b>                        | 25-JUL-2012                               |
| <b>Filing Date:</b>                         | 11-JUN-2008                               |
| <b>Time Stamp:</b>                          | 17:30:48                                  |
| <b>Application Type:</b>                    | Utility under 35 USC 111(a)               |

### Payment information:

|                        |    |
|------------------------|----|
| Submitted with Payment | no |
|------------------------|----|

### File Listing:

| Document Number | Document Description                               | File Name            | File Size(Bytes)/<br>Message Digest                               | Multi Part /.zip | Pages (if appl.) |
|-----------------|--|----------------------|---|------------------|------------------|
| 1               | Amendment Copy Claims/Response to Suggested Claims | 56782_1_5RESPNCA.pdf | 225352<br><small>9de08794d39490027b7e3b1fd092cb35d9dbc94f</small> | no               | 23               |

### Warnings:

### Information:

This Acknowledgement Receipt evidences receipt on the noted date by the USPTO of the indicated documents, characterized by the applicant, and including page counts, where applicable. It serves as evidence of receipt similar to a Post Card, as described in MPEP 503.

**New Applications Under 35 U.S.C. 111**

If a new application is being filed and the application includes the necessary components for a filing date (see 37 CFR 1.53(b)-(d) and MPEP 506), a Filing Receipt (37 CFR 1.54) will be issued in due course and the date shown on this Acknowledgement Receipt will establish the filing date of the application.

**National Stage of an International Application under 35 U.S.C. 371**

If a timely submission to enter the national stage of an international application is compliant with the conditions of 35 U.S.C. 371 and other applicable requirements a Form PCT/DO/EO/903 indicating acceptance of the application as a national stage submission under 35 U.S.C. 371 will be issued in addition to the Filing Receipt, in due course.

**New International Application Filed with the USPTO as a Receiving Office**

If a new international application is being filed and the international application includes the necessary components for an international filing date (see PCT Article 11 and MPEP 1810), a Notification of the International Application Number and of the International Filing Date (Form PCT/RO/105) will be issued in due course, subject to prescriptions concerning national security, and the date shown on this Acknowledgement Receipt will establish the international filing date of the application.

Under the Paperwork Reduction Act of 1995, no persons are required to respond to a collection of information unless it displays a valid OMB control number.

|   |   |                                  |                                       |
|---|---|----------------------------------|---------------------------------------|
| <b>PATENT APPLICATION FEE DETERMINATION RECORD</b><br>Substitute for Form PTO-875 | Application or Docket Number<br><b>12/137,356</b> | Filing Date<br><b>06/11/2008</b> | <input type="checkbox"/> To be Mailed |
|---|---|----------------------------------|---------------------------------------|

| APPLICATION AS FILED – PART I  |   |              | OTHER THAN SMALL ENTITY               |          |    |              |          |
|--|---|--------------|---------------------------------------|----------|----|--------------|----------|
|  | (Column 1)  | (Column 2)   | SMALL ENTITY <input type="checkbox"/> | OR       |    | SMALL ENTITY |          |
| FOR  | NUMBER FILED  | NUMBER EXTRA | RATE (\$)                             | FEE (\$) | OR | RATE (\$)    | FEE (\$) |
| <input type="checkbox"/> BASIC FEE<br><small>(37 CFR 1.16(a), (b), or (c))</small>           | N/A   | N/A          | N/A                                   |          |    | N/A          |          |
| <input type="checkbox"/> SEARCH FEE<br><small>(37 CFR 1.16(k), (j), or (m))</small>          | N/A   | N/A          | N/A                                   |          |    | N/A          |          |
| <input type="checkbox"/> EXAMINATION FEE<br><small>(37 CFR 1.16(o), (p), or (q))</small>     | N/A   | N/A          | N/A                                   |          |    | N/A          |          |
| TOTAL CLAIMS<br><small>(37 CFR 1.16(j))</small>  | minus 20 =  | *            | X \$ =                                |          | OR | X \$ =       |          |
| INDEPENDENT CLAIMS<br><small>(37 CFR 1.16(h))</small>  | minus 3 =   | *            | X \$ =                                |          |    | X \$ =       |          |
| <input type="checkbox"/> APPLICATION SIZE FEE<br><small>(37 CFR 1.16(s))</small>             | If the specification and drawings exceed 100 sheets of paper, the application size fee due is \$250 (\$125 for small entity) for each additional 50 sheets or fraction thereof. See 35 U.S.C. 41(a)(1)(G) and 37 CFR 1.16(s). |              |                                       |          |    |              |          |
| <input type="checkbox"/> MULTIPLE DEPENDENT CLAIM PRESENT<br><small>(37 CFR 1.16(j))</small> |   |              |                                       |          |    |              |          |
|  |   |              | TOTAL                                 |          |    | TOTAL        |          |

\* If the difference in column 1 is less than zero, enter "0" in column 2.

| APPLICATION AS AMENDED – PART II |  |                                  |                                    |               | OTHER THAN SMALL ENTITY |                     |    |                 |                     |
|----------------------------------|--|----------------------------------|------------------------------------|---------------|-------------------------|---------------------|----|-----------------|---------------------|
|                                  | (Column 1)   | (Column 2)                       | (Column 3)                         |               | SMALL ENTITY            | OR                  |    | SMALL ENTITY    |                     |
| AMENDMENT                        | 07/25/2012   | CLAIMS REMAINING AFTER AMENDMENT | HIGHEST NUMBER PREVIOUSLY PAID FOR | PRESENT EXTRA | RATE (\$)               | ADDITIONAL FEE (\$) | OR | RATE (\$)       | ADDITIONAL FEE (\$) |
|                                  | Total (37 CFR 1.16(i))   | * 37                             | Minus ** 37                        | = 0           | X \$ =                  |                     | OR | X \$60=         | 0                   |
|                                  | Independent (37 CFR 1.16(h))   | * 5                              | Minus ***5                         | = 0           | X \$ =                  |                     | OR | X \$250=        | 0                   |
|                                  | <input type="checkbox"/> Application Size Fee (37 CFR 1.16(s))                           |                                  |                                    |               |                         |                     |    |                 |                     |
|                                  | <input type="checkbox"/> FIRST PRESENTATION OF MULTIPLE DEPENDENT CLAIM (37 CFR 1.16(j)) |                                  |                                    |               |                         |                     | OR |                 |                     |
|                                  |  |                                  |                                    |               | TOTAL ADD'L FEE         |                     | OR | TOTAL ADD'L FEE | 0                   |

|           |  |                                  |                                    |               |                 |                     |    |                 |                     |
|-----------|--|----------------------------------|------------------------------------|---------------|-----------------|---------------------|----|-----------------|---------------------|
|           | (Column 1)   | (Column 2)                       | (Column 3)                         |               | SMALL ENTITY    | OR                  |    | SMALL ENTITY    |                     |
| AMENDMENT |  | CLAIMS REMAINING AFTER AMENDMENT | HIGHEST NUMBER PREVIOUSLY PAID FOR | PRESENT EXTRA | RATE (\$)       | ADDITIONAL FEE (\$) | OR | RATE (\$)       | ADDITIONAL FEE (\$) |
|           | Total (37 CFR 1.16(i))   | *                                | Minus **                           | =             | X \$ =          |                     | OR | X \$ =          |                     |
|           | Independent (37 CFR 1.16(h))   | *                                | Minus ***                          | =             | X \$ =          |                     | OR | X \$ =          |                     |
|           | <input type="checkbox"/> Application Size Fee (37 CFR 1.16(s))                           |                                  |                                    |               |                 |                     |    |                 |                     |
|           | <input type="checkbox"/> FIRST PRESENTATION OF MULTIPLE DEPENDENT CLAIM (37 CFR 1.16(j)) |                                  |                                    |               |                 |                     | OR |                 |                     |
|           |  |                                  |                                    |               | TOTAL ADD'L FEE |                     | OR | TOTAL ADD'L FEE |                     |

\* If the entry in column 1 is less than the entry in column 2, write "0" in column 3.  
 \*\* If the "Highest Number Previously Paid For" IN THIS SPACE is less than 20, enter "20".  
 \*\*\* If the "Highest Number Previously Paid For" IN THIS SPACE is less than 3, enter "3".  
 The "Highest Number Previously Paid For" (Total or Independent) is the highest number found in the appropriate box in column 1.

Legal Instrument Examiner:  
 /RUBY JOHNSON/

This collection of information is required by 37 CFR 1.16. The information is required to obtain or retain a benefit by the public which is to file (and by the USPTO to process) an application. Confidentiality is governed by 35 U.S.C. 122 and 37 CFR 1.14. This collection is estimated to take 12 minutes to complete, including gathering, preparing, and submitting the completed application form to the USPTO. Time will vary depending upon the individual case. Any comments on the amount of time you require to complete this form and/or suggestions for reducing this burden, should be sent to the Chief Information Officer, U.S. Patent and Trademark Office, U.S. Department of Commerce, P.O. Box 1450, Alexandria, VA 22313-1450. DO NOT SEND FEES OR COMPLETED FORMS TO THIS ADDRESS. **SEND TO: Commissioner for Patents, P.O. Box 1450, Alexandria, VA 22313-1450.**

If you need assistance in completing the form, call 1-800-PTO-9199 and select option 2.



UNITED STATES PATENT AND TRADEMARK OFFICE


UNITED STATES DEPARTMENT OF COMMERCE  
U.S. Patent and Trademark Office

Address: COMMISSIONER FOR PATENTS  
P.O. Box 1450  
Alexandria, Virginia 22313-1450  
www.uspto.gov

22859 e 2012-07-10

FREDRIKSON & BYRON, P.A.  
INTELLECTUAL PROPERTY GROUP  
200 SOUTH SIXTH STREET, SUITE 4000  
MINNEAPOLIS, MN 55402

**Paper No.**

|   |                                    |
|---|------------------------------------|
| <b>Application No.:</b> 12/137,356<br> | <b>Date Mailed:</b> 2012-07-10     |
| <b>First Named Inventor:</b> Quirico, Charles, R.   | <b>Examiner:</b> GILBERT, SAMUEL G |
| <b>Attorney Docket No.:</b> 56782.1.5   | <b>Art Unit:</b> 3735              |
| <b>Confirmation No.:</b> 7360   | <b>Filing Date:</b> 2008-06-11     |

**Please find attached an Office communication concerning this application or proceeding.**

**Commissioner for Patents**

|   |                                      |                                       |
|---|--------------------------------------|---------------------------------------|
| <b>Notice of Non-Compliant Amendment<br/>(37 CFR 1.121)</b> | <b>Application No.</b><br>12/137,356 | <b>Applicant(s)</b><br>QUIRICO ET AL. |
|   |                                      | <b>Art Unit</b><br>2800               |

**-- The MAILING DATE of this communication appears on the cover sheet with the correspondence address --**

The amendment document filed on 03 July, 2012 is considered non-compliant because it has failed to meet the requirements of 37 CFR 1.121 or 1.4. In order for the amendment document to be compliant, correction of the following item(s) is required.

THE FOLLOWING MARKED (X) ITEM(S) CAUSE THE AMENDMENT DOCUMENT TO BE NON-COMPLIANT:

- 1. Amendments to the specification:
  - A. Amended paragraph(s) do not include markings.
  - B. New paragraph(s) should not be underlined.
  - C. Other \_\_\_\_\_.
- 2. Abstract:
  - A. Not presented on a separate sheet. 37 CFR 1.72.
  - B. Other \_\_\_\_\_.
- 3. Amendments to the drawings:
  - A. The drawings are not properly identified in the top margin as "Replacement Sheet," "New Sheet," or "Annotated Sheet" as required by 37 CFR 1.121(d).
  - B. The practice of submitting proposed drawing correction has been eliminated. Replacement drawings showing amended figures, without markings, in compliance with 37 CFR 1.84 are required.
  - C. Other \_\_\_\_\_.
- 4. Amendments to the claims:
  - A. A complete listing of all of the claims is not present.
  - B. The listing of claims does not include the text of all pending claims (including withdrawn claims)
  - C. Each claim has not been provided with the proper status identifier, and as such, the individual status of each claim cannot be identified. Note: the status of every claim must be indicated after its claim number by using one of the following status identifiers: (Original), (Currently amended), (Canceled), (Previously presented), (New), (Not entered), (Withdrawn) and (Withdrawn-currently amended).
  - D. The claims of this amendment paper have not been presented in ascending numerical order.
  - E. Other: Dependency in claim 9 is incorrect.
- 5. Other (e.g., the amendment is unsigned or not signed in accordance with 37 CFR 1.4): For further explanation of the amendment format required by 37 CFR 1.121, see MPEP § 714.

TIME PERIODS FOR FILING A REPLY TO THIS NOTICE:

1. Applicant is given **no new time period if the non-compliant amendment is an** after-final amendment or an amendment filed after allowance, or a drawing submission (only) If applicant wishes to resubmit the non-compliant after-final amendment with corrections, the **entire corrected amendment** must be resubmitted.
2. Applicant is given **one month**, or thirty (30) days, whichever is longer, from the mail date of this notice to supply the correction, if the non-compliant amendment is one of the following: a preliminary amendment, a non-final amendment (including a submission for a request for continued examination (RCE) under 37 CFR 1.114), a supplemental amendment filed within a suspension period under 37 CFR 1.103(a) or (c), and an amendment filed in response to a Quayle action. If any of above boxes 1 to 4 are checked, the correction required is only the corrected section of the non-compliant amendment in compliance with 37 CFR 1.121.

**Extensions of time** are available under 37 CFR 1.136(a) only if the non-compliant amendment is a non-final amendment or an amendment filed in response to a *Quayle* action.

**Failure to timely respond** to this notice will result in:

**Abandonment** of the application if the non-compliant amendment is a non-final amendment or an amendment filed in response to a *Quayle* action; or

**Non-entry** of the amendment if the non-compliant amendment is a preliminary amendment or supplemental amendment.

Legal Instruments Examiner (LIE), if applicable /PAULA BRITTON/

Telephone No: (571)272-1556

22859

Customer Number

Patent Case No.: 56782.1.5

**IN THE UNITED STATES PATENT AND TRADEMARK OFFICE**

First Named Inventor: CHARLES R. QUIRICO  
Application No.: 12/137,356                      Group Art Unit: 3735  
Filed: June 11, 2008                      Examiner: GILBERT, Samuel G.  
Title: SHIELDING ASSEMBLIES FOR INFUSION SYSTEMS

---

Mail Stop Amendment  
Commissioner for Patents  
P.O. Box 1450  
Alexandria, VA 22313-1450

**AMENDMENT**

Dear Sir:

In response to the Office Action mailed April 4, 2012, the period of response for which runs through July 5, 2012 (July 4<sup>th</sup> falling on a holiday), please amend the application as follows.

**Amendments to the Claims** are reflected in the listing of claims which begins on page 2 of this paper.

**Remarks** begin on page 11 of this paper.



## AMENDMENTS TO THE CLAIMS

This listing of claims will replace all prior versions and listings of claims in the application.

### **Listing of Claims:**

1. (Original) A shielding assembly for an infusion system, the shielding assembly being mounted within a cabinet structure, and the shielding assembly comprising:
  - a plurality of compartments having sidewalls providing barriers to radioactive radiation for the compartments;
  - a corresponding plurality of doors, each door, when open, providing access to the corresponding compartment via an opening in its sidewall, and, when closed, providing further barrier to radioactive radiation for the corresponding compartment;
  - a first compartment of the plurality of compartments enclosed by a first sidewall of the sidewalls and sized to contain a radioisotope generator of the infusion system, the first sidewall including a first sidewall opening oriented upward and aligned with a first upper opening through a shell of the cabinet structure, an upper surface of the shell being located at an elevation with respect to a lowermost portion of the cabinet structure substantially greater than the first sidewall opening and the first upper opening.
  
2. (Original) The shielding assembly of claim 1, wherein the lowermost portion of the cabinet structure is at approximately ground level, the first sidewall opening is at an elevation of between approximately 12 inches and approximately 24 inches with respect to the lowermost portion of the cabinet.
  
3. (Original) The shielding assembly of claim 2, wherein the upper surface of the shell is at an elevation of between approximately 24 inches and 36 inches with respect to the lowermost portion of the cabinet structure.
  
4. (Original) The shielding assembly of claim 1, further comprising a second compartment of the plurality of compartments enclosed by a second sidewall of the sidewalls and sized to

contain a waste bottle of the infusion system, the second sidewall including a second sidewall opening oriented upward and aligned with a second upper opening through the shell of the cabinet structure, the second upper opening being an opening in the upper surface of the shell.

5. (Original) A shielding assembly for an infusion system, the shielding assembly being mounted within a cabinet structure, and the shielding assembly comprising:

a first compartment sized to contain a radioisotope generator of the infusion system, the first compartment being enclosed by a first sidewall that forms a barrier to radioactive radiation, the first sidewall including an opening extending therethrough and a lid, the lid mating with the opening to alternately enclose the first compartment and provide access to the first compartment, via the opening, and the opening being oriented upward and located at a first elevation with respect to a lowermost portion of the cabinet structure;

a second compartment sized to contain a portion of an infusion tubing circuit of the infusion system that is downstream of the generator, the second compartment being enclosed by a second sidewall that forms a barrier to radioactive radiation, the second sidewall including a base portion and a lid portion, the lid portion mating with the base portion to alternately enclose the second compartment and provide access to the second compartment; and

a third compartment sized to contain a waste bottle of the infusion system, the third compartment being enclosed by a third sidewall that forms a barrier to radioactive radiation, the third sidewall including an opening, extending through the third sidewall, and a lid, the lid of the third sidewall mating with the opening of the third sidewall to alternately enclose the third compartment and provide access to the third compartment, via the opening of the third sidewall, the opening of the third sidewall being oriented upward and located at a second elevation with respect to the lowermost portion of the cabinet structure, and the second elevation being greater than the first elevation of the opening of the first sidewall.

6. (Original) The shielding assembly of claim 5, wherein the opening of the first sidewall is aligned with a first upper opening through a shell of the cabinet structure and the opening of the third sidewall is aligned with a second upper opening through the shell of the cabinet structure,

the second upper opening being located at a greater elevation with respect to the lowermost portion of the cabinet structure than the first upper opening.

7. (Original) The shielding assembly of claim 5, wherein an opening through a shell of the cabinet structure provides access to both the lid of the first sidewall and to the lid portion of the second sidewall.

8. (Original) The shielding assembly of claim 5, wherein the lowermost portion of the cabinet structure is at approximately ground level and the first elevation is between approximately 12 inches and approximately 24 inches.

9. (Original) The shielding assembly of claim **Error! Reference source not found.**, wherein the lowermost portion of the cabinet structure is at approximately ground level and the second elevation is between approximately 24 inches and approximately 36 inches.

10. (Original) The shielding assembly of claim 5, further comprising:  
a fourth compartment sized to contain another portion of the infusion tubing circuit of the infusion system downstream from the generator, the fourth compartment being enclosed by a portion of the third sidewall and a door that forms a barrier to radioactive radiation, the door mating with the portion of the third sidewall to alternately enclose the fourth compartment and provide access to the fourth compartment; and  
wherein the fourth compartment is immediately adjacent to the second compartment;  
the portion of the infusion tubing circuit contained in the second compartment includes an eluate line, extending from the generator, a patient line, being coupled to the eluate line, and a waste line, being coupled to the eluate line; and  
the other portion of the infusion tubing circuit contained in the fourth compartment includes an extension of the patient line, from the second compartment, and an extension of the waste line, from the second compartment.

11. (Original) The shielding assembly of claim 10, wherein the fourth compartment extends approximately vertically along the portion of the third sidewall, on an opposite side of the third sidewall from the third compartment.
12. (Original) The shielding assembly of claim 11, wherein the fourth compartment includes a retaining member to hold the extension of the patient line and the extension of the waste line in place within the fourth compartment.
13. (Original) The shielding assembly of claim 10, wherein the lid of the third sidewall, when mated with opening of the third sidewall, prevents the door of the fourth compartment from opening to provide access to the fourth compartment.
14. (Original) The shielding assembly of claim 13, wherein the door of the fourth compartment, when mated with the portion of the third sidewall, prevents the lid portion of the second sidewall from opening to provide access to the second compartment.
15. (Original) The shielding assembly of claim 14, wherein the lid portion of the second sidewall, when mated with the base portion of the second sidewall, prevents the lid of the first sidewall from opening to provide access to the first compartment.
16. (Original) The shielding assembly of claim 10, wherein the door of the fourth compartment, when mated with the portion of the third sidewall, prevents the lid portion of the second sidewall from opening to provide access to the second compartment.
17. (Original) The shielding assembly of claim 5, wherein the lid portion of the second sidewall, when mated with the base portion of the second sidewall, prevents the lid of the first sidewall from opening to provide access to the first compartment.
18. (Original) The shielding assembly of claim 5, wherein the lid of the first sidewall is hinged to open in an upward direction; and further comprising a latch component, mounted within the cabinet structure, to hold the lid of the first sidewall in an open position.

19. (Original) The shielding assembly of claim 5, wherein the lid portion of the second sidewall is hinged to open in an upward direction; and further comprising a latch component, mounted within the cabinet structure, to hold the lid portion of the second sidewall in an open position.

20. (Currently Amended) A method for setting up an infusion system, the method comprising:

opening a first door of a shielding assembly of the infusion system to access a first compartment of the assembly and to allow for a second door of the shielding assembly to be opened, wherein the first door defines a first door edge, the second door defines a second door edge, and the first door edge overlaps the second door edge so as to prevent the second door from being opened if the first door is not open; and

opening the second door, after opening the first door, to access a second compartment of the shielding assembly, the second compartment being separate from, and outside of, the first compartment;

placing a radioisotope generator into the second compartment and connecting the generator to an infusion tubing circuit;

placing a portion of the infusion tubing circuit into the first compartment;

closing the second door to enclose the generator within the second compartment; and

closing the first door, after closing the second door, to enclose the portion of the infusion tubing circuit within the first compartment.

21. (Original) The method of claim 20, further comprising unlocking and removing an access panel from a shell of a cabinet structure, which encloses the shielding assembly, to access the first door and the second door of the shielding assembly.

22. (Original) The method of claim 20, further comprising:

opening a third door, prior to opening the first door, to access a third compartment of the shielding assembly and to allow for the first door to be opened;

placing another portion of the infusion tubing circuit into the third compartment; and

closing the third door, after closing the first door, to enclose the other portion of the infusion tubing circuit within the third compartment.

23. (Original) The method of claim 22, further comprising unlocking and removing an access panel from a shell of a cabinet structure, which encloses the shielding assembly, to access the first door, the second door and the third door of the shielding assembly.

24. (Original) The method of claim 22, further comprising:  
opening a fourth door, prior to opening the third door, to access a fourth compartment of the shielding assembly and to allow for the third door to be opened;  
connecting a waste line of the infusion tubing circuit to a waste bottle;  
placing the waste bottle into the fourth compartment; and  
closing the fourth door, after closing the third door, to enclose the waste bottle within the fourth compartment.

25. (Original) The method of claim 20, further comprising securing at least one of the first and second doors in an open position.

26. (Currently Amended) A shielding assembly for an infusion system, the shielding assembly comprising a plurality of compartments and providing a radioactive radiation barrier for the compartments, the assembly further comprising:  
a first door to alternately enclose and provide access to a first compartment of the plurality of compartments, the first compartment sized to contain a radioisotope generator of the infusion system; and  
a second door to alternately enclose and provide access to a second compartment of the plurality of compartments, the second compartment being separate from, and outside of, the first compartment, the second compartment being sized to contain a portion of an infusion tubing circuit of the infusion system that is downstream of the generator, and the second door, when enclosing the second compartment, preventing the first door from opening to provide access to the first compartment,

wherein the first door defines a first door edge, the second door defines a second door edge, and the first door edge overlaps the second door edge so as to prevent the first door from being opened if the second door is not open

27. (Original) The shielding assembly of claim 26, further comprising a third door to alternately enclose and provide access to a third compartment of the plurality of compartments, the third compartment sized to contain another portion of the infusion tubing circuit of the infusion system downstream from the generator, the third door, when enclosing the third compartment, preventing the second door from opening to provide access to the second compartment.
28. (Original) The shielding assembly of claim 27, further comprising a fourth door to alternately enclose and provide access to a fourth compartment of the plurality of compartments, the fourth compartment being sized to contain a waste bottle of the infusion system, the fourth door, when enclosing the fourth compartment, preventing the third door from opening to provide access to the third compartment.
29. (Original) The shielding assembly of claim 28, wherein the third compartment shares a sidewall with the fourth compartment and extends approximately vertically along the shared sidewall.
30. (Original) The shielding assembly of claim 29, wherein the third compartment includes a retaining member attached to the shared sidewall to hold the other portion of the infusion tubing circuit in place along the shared sidewall.
31. (Original) An infusion system comprising:  
a cabinet structure including a shell defining an interior space thereof, the shell including a first opening, a second opening and an access panel, the access panel mating with the second opening and being removable therefrom;  
a lock reversibly engaging the access panel to secure access to the interior space of the cabinet structure;

an eluant source;

a shielding assembly located within the interior space of the cabinet structure, the shielding assembly including a sidewall defining a plurality of compartments and providing a barrier to radioactive radiation for the compartments, the shielding assembly further including a corresponding plurality of doors, each door, when open, providing access to the corresponding compartment via an opening in the sidewall, and, when closed, providing further barrier to radioactive radiation for the corresponding compartment;

a radioisotope generator contained within a first compartment of the plurality of compartments of the shielding assembly and being accessible through the second opening of the shell of the cabinet structure, when the access panel is unlocked, and when a first door of the plurality of doors, which corresponds to the first compartment, is open;

an eluant line coupled to the eluant source and to the generator;

an eluate line coupled to the generator; and

a patient line coupled to the eluate line and extending out from the interior space of the cabinet structure through the first opening of the shell.

32. (Original) The assembly of claim 31, wherein the first door is hinged to open in an upward direction; and further comprising a latch component, mounted within the cabinet structure, to hold the first door in an open position.

33. (Original) The system of claim 31, further comprising:

a waste bottle contained within a second compartment of the plurality of compartments of the shielding assembly; and

a waste line coupled to the eluate line and to the waste bottle;

wherein the shell of the cabinet structure further includes a third opening; and

a second door of the plurality of doors, which corresponds to the second compartment, is aligned with the third opening of the shell, for access thereto, and is located at a higher elevation, with respect to a lowermost surface of the cabinet structure, than that of the second door.



34. (Original) The system of claim 31, further comprising:  
a waste bottle contained within a second compartment of the plurality of compartments of the shielding assembly; and  
a waste line coupled to the eluate line and to the waste bottle;  
wherein a second door of the plurality of doors, which corresponds to the second compartment, when closed, prevents the first door from opening to provide access to the first compartment.
35. (Original) The system of claim 31, wherein:  
the eluate line and at least a portion of the patient line are contained in a second compartment of the plurality of compartments of the shielding assembly; and  
a second door of the plurality of doors, which corresponds to the second compartment, when closed, prevents the first door from opening to provide access to the first compartment.
36. (Original) The system of claim 35, wherein the second door is accessible only through the second opening of the shell of the cabinet structure, when the access panel is unlocked.
37. (Original) The system of claim 35, wherein the first door and the second door are both hinged to open in an upward direction; and further comprising at least one latch component, mounted within the cabinet structure, to hold the first door and the second door in an open position.

## **REMARKS**

This Amendment is responsive to the Office Action dated April 4, 2012. Applicant has amended claims 20 and 26. No new matter has been added by way of the amendments, and support for the amendments can be found throughout Applicant's original disclosure including, e.g., at paragraphs [0039] and [0040] and FIGS. 2A and 3A. Claims 1–37 will remain pending upon entry of this Amendment. Reconsideration of the application is respectfully requested.

### **Information Disclosure Statement**

On a 1449 form accompanying the Office Action dated April 4, 2012, the Examiner lined through a reference submitted as part of an information disclosure statement filed on October 24, 2008. In particular, the Examiner lined through a reference identified as “BRACCO, ‘Cardio Gen82® Infusion System User’s Guide’, pages 1–53.” The Office Action did not indicate why the cited reference was lined through.

Applicant believes the Examiner lined through the reference because the citation did not include a date identifying the reference. Applicant is submitting a supplemental information disclosure statement along with this response. The supplemental information disclosure statement includes a 1449 form that lists the reference, including the date identified on the reference, as well as another copy of the reference. Applicant respectfully requests that the Examiner consider the listed reference and provide an initialed copy of the 1449 form along with the next official action. If the Examiner believes that further modification is needed to the form of the citation listed on the 1449 form, Applicant requests that the Examiner contact the undersigned attorney to discuss the 1449 form and appropriate correction.

### **Allowable Subject Matter**

The Office Action indicated that claims 31–37 were allowed and that claims 22–24 were objected to as being dependent upon a rejected claim but would be allowable if rewritten in independent form. Applicant thanks the Examiner for the indication of allowability with respect to claims 22–24 and 31–37 and agrees that the claims present allowable subject matter. However, for the reasons set forth below, Applicant submits that claims 1–21 and 25–30 also present allowable subject matter. Applicant therefore requests that the Examiner reconsider the currently rejected claims and allow all pending claims.

### **Claim Rejections Under 35 U.S.C. § 112, Second Paragraph**

In the Office Action, claims 1–4 were rejected under 35 U.S.C. § 112 second paragraph as purportedly being indefinite for failing to particularly point out and distinctly claim the subject matter which Applicant regards as the invention. Specifically, the Office Action stated that the term “substantially greater” in claim 1 renders the claims indefinite because the term is not defined by the claims and the specification does not provide a standard for ascertaining the requisite degree.<sup>1</sup>

Applicant respectfully traverses the rejection of claims 1–4 under 35 U.S.C. § 112 second paragraph. It is well established that the claim term “substantially” does not render claims indefinite. On a number of occasions, the Court of Appeals for the Federal Circuit has specifically addressed the issue of the term “substantially” in relation to 35 U.S.C. § 112. Most recently, this specific issue was addressed in *Verve v. Crane Cams Inc.*, (CAFC Nov. 14, 2002). The court in *Verve v. Crane Cams, Inc* cited numerous examples of cases holding that the term “substantially” is not an indefinite claim term. In particular, the court in *Verve v. Crane Cams, Inc.* stated:

Expressions such as "substantially" are used in patent documents when warranted by the nature of the invention, in order to accommodate the minor variations that may be appropriate to secure the invention. Such usage may well satisfy the charge to "particularly point out and distinctly claim" the invention, 35 U.S.C. §112, and indeed may be necessary in order to provide the inventor with the benefit of his invention. In *Andrew Corp. v. Gabriel Elecs. Inc.*, 847 F.2d 819, 821-22, 6 USPQ2d 2010, 2013 (Fed. Cir. 1988) the court explained that usages such as "substantially equal" and "closely approximate" may serve to describe the invention with precision appropriate to the technology and without intruding on the prior art. The court again explained in *Ecolab Inc. v. Envirochem, Inc.*, 264 F.3d 1358, 1367, 60 USPQ2d 1173, 1179 (Fed. Cir. 2001) that "like the term 'about,' the term 'substantially' is a descriptive term commonly used in patent claims to 'avoid a strict numerical boundary to the specified parameter,'" quoting *Pall Corp. v. Micron Separations, Inc.*, 66 F.3d 1211, 1217, 36 USPQ2d 1225, 1229 (Fed. Cir. 1995).

Moreover, the court in *Verve v. Crane Cams, Inc.* continued by stating:

It is well established that when the term "substantially" serves reasonably to describe the subject matter so that its scope would be understood by persons in the field of the invention, and to distinguish the claimed subject matter from the prior art, it is not indefinite.

---

<sup>1</sup> Office Action dated April 4, 2012, at page 2.

The instant case is a classic example of use of the term “substantially” to describe the subject matter so that its scope would be understood by persons in the field of the invention and use of the term “substantially” is necessary to provide the Applicant with the benefit of his invention. Applicant therefor requests withdrawal of all rejections under 35 U.S.C. § 112, second paragraph.

### **Claim Rejections Under 35 U.S.C. §§ 102(e) and 103(a)**

In the Office Action, claims 1, 4, 20, 21 and 25–27 were rejected under 35 U.S.C. § 102(e) as purportedly being anticipated by Tate, et al. (US 2008/0177126, hereinafter “Tate”). In addition, claims 2, 3, 5 and 7–9 were rejected under 35 U.S.C. § 103(a) as purportedly being unpatentable over Tate. Applicant respectfully traverses the rejections, particularly to the extent the rejections can be considered applicable to the claims as amended. Tate fails to disclose each and every feature of the claims, and there would have been no apparent reason for modification to arrive at the claimed features.

#### ***Independent Claim 1***

Independent claim 1 is directed to a shielding assembly for an infusion system that is mounted within a cabinet structure. The shielding assembly includes a plurality of compartments having sidewalls providing barriers to radioactive radiation and a corresponding plurality of doors. According to the claim, each door, when open, provides access to a corresponding compartment via an opening in its sidewall, and, when closed, provides further barrier to radioactive radiation for the corresponding compartment. Among other features, claim 1 specifies that an upper surface of a shell of the cabinet structure is located at an elevation with respect to a lowermost portion of the cabinet structure that is substantially greater than a first sidewall opening of the shielding assembly and a first upper opening of the cabinet structure.

In support of the rejection of independent claim 1, the Office Action cited Tate as allegedly each and every feature of the claim.<sup>2</sup> In particular, the Office Action characterized a cap member 684 of a vial access system in Tate as “a plurality of compartments each with doors” according to claim 1 and a lid 20 of Tate as an upper opening in a cabinet structure according to

---

<sup>2</sup> See *id.* at page 3



delivery system 10 and to lower the shield into vial access system 600.<sup>8</sup> Thereafter, Tate describes that the operator disengages the vial carrying system 500 from the vial shield 554 and uses vial access system 600 to access the contents of the vial in the vial shield.<sup>9</sup> In particular, Tate explains that an operator pivots a cap 684 that is rigidly connected to a vertical support arm 676 over vial shield 554 and then lowers the cap to pierce a septum of a vial in the vial container.<sup>10</sup>

The Office Action characterized cap member 684 of Tate as “a plurality of compartments each with doors”.<sup>11</sup> However, Tate does not describe that cap member 684 is even a door for a single compartment of a shielding assembly system much less a plurality of doors corresponding to a plurality of compartments. As outlined above, the cap member 684 of Tate is a component that is lowered over a vial shield 554 positioned within a well 111 of a fluid delivery system. Vial shield 554 is not, however, a compartment of a shielding assembly. Instead, vial shield 554 is described by Tate as simply being a “conventional shield or PIG” that is designed to be “transported by personnel.”<sup>12</sup> It is therefore unreasonable to characterize cap member 684 of Tate as a door of a compartment of a shielding assembly, per claim 1.

Moreover, independent claim 1 requires a shielding assembly that has a plurality of compartments and a corresponding plurality of doors, where each door, when open, provides access to a compartment via an opening in its sidewall, and, when closed, provides further barrier to radioactive radiation for the compartment. Tate only illustrates and describes cap member 684 as being a single cap member designed to be positioned over a single vial shield within well 111 of fluid delivery system 10. Accordingly, even assuming *arguendo* that cap member 684 of Tate could be considered a door for a single compartment of a shielding assembly system (which is an assumption Applicant does not concede), the cap member does not expressly or inherently disclose or suggest a shielding assembly that has a plurality of compartments and a corresponding plurality of doors. As the Office Action cited no other portions of Tate as allegedly disclosing these additional features of independent claim 1, the Office Action did not establish by substantial evidence that Tate discloses each and every feature of the claim, as required to support a rejection under 35 U.S.C. § 102.

---

<sup>8</sup> See *id.* at paragraphs [0127] and [0138].

<sup>9</sup> See *id.*

<sup>10</sup> See *id.* at paragraph [0141] and [0142].

<sup>11</sup> Office Action dated April 4, 2012, at page 3.

<sup>12</sup> See Tate at paragraph [0117].

Furthermore, the Office Action did not establish that Tate discloses a shielding assembly mounted in a cabinet structure where an upper surface of a shell of the cabinet structure is located at an elevation with respect to a lowermost portion of the cabinet structure that is substantially greater than a first sidewall opening of the shielding assembly and a first upper opening of the cabinet structure, as further included in independent claim 1. The Office Action appeared to cite lid 20 of Tate as disclosing a first upper opening of a cabinet structure and cap member 684 of Tate as disclosing a first sidewall opening of a shielding assembly.<sup>13</sup> The Office Action then asserted that “the shell opening -20- is at an elevation with respect to the bottom of the device substantially greater than the elevation of the openings with doors - 684-.”<sup>14</sup>

Yet a shell opening that is at an elevation with respect to the bottom of a device that is substantially greater than the elevation of the openings with doors is not the claim feature recited by independent claim 1. Claim 1 recites an upper surface of a shell of the cabinet structure that is located at an elevation that is substantially greater than a first sidewall opening of a shielding assembly (apparently identified as cap member 684 in Tate by the Office Action) and a first upper opening of the cabinet structure (apparently identified as lid 20 in Tate by the Office Action). Claim 1 does not recite a relative elevation between a “shell opening” and an “opening with doors” as asserted in the Office Action. Accordingly, because the Office Action failed to put any evidence on record regarding this additional feature of independent claim 1, the Office Action did not establish a *prima facie* case of anticipation of independent claim 1.

For at least the reasons given above, the Office Action did not establish that Tate discloses each and every feature of independent claim 1, as required to support a rejection under 35 U.S.C. § 102. Reconsideration and withdrawal of the rejection are respectfully requested.

If Examiner chooses to maintain any rejection of independent claim 1 based on Tate, Applicant requests a subsequent Non-Final Office Action clearly explaining how the Examiner believes the features of Tate apply to Applicant’s claimed features. Tate is a complex reference spanning over 100 pages with over 50 figures. The Office Action identified only three reference numerals in Tate, without even citing to corresponding portions of the reference where the reference numerals are discussed, as allegedly disclosing all the features of Applicant’s claim. This has given Applicant little guidance to understand how the Examiner is interpreting and

---

<sup>13</sup> See Office Action date April 4, 2012, at page 3.

<sup>14</sup> *Id.*

applying the Tate reference. In accordance with 37 C.F.R. § 1.104(c)(2), Applicant requests that the Examiner fully explain and clarify the applicability of the Tate reference if any rejection is maintained based on Tate.<sup>15</sup>

### ***Independent Claim 5***

Independent claim 5 is directed to a shielding assembly for an infusion system that is mounted within a cabinet structure. The shielding assembly includes a first compartment sized to contain a radioisotope generator, a second compartment sized to contain a portion of an infusion tubing circuit, and a third compartment sized to contain a waste bottle of the infusion system. Among other features, the claim specifies that the first compartment is enclosed by a first sidewall including a lid, the second compartment is enclosed by a second sidewall including a lid, and the third compartment is enclosed by a third sidewall including a lid. The claim also states that an opening defined by the first compartment is located at a first elevation, an opening defined by the third compartment is located at a second elevation, and the second elevation is greater than the first elevation.

In support of the rejection of independent claim 5, the Office Action characterized a cap member 684 of a vial access system in Tate as a lid for both a first compartment sized to contain a radioisotope generator and a third compartment sized to contain a waste bottle according to claim 5.<sup>16</sup> The Office Action further characterized a lid 20 of Tate as a lid for a compartment sized to contain a portion of an infusion tubing circuit according to claim 5.<sup>17</sup> While the Office Action acknowledged that Tate does not disclose an opening defined by a third compartment that is located at a second elevation that is greater than an opening defined by a first compartment that is located at a first elevation, the Office Action alleged that such a feature would have been obvious.<sup>18</sup> For a plurality of reasons set forth below, Applicant respectfully disagrees that cap member 684 of Tate can be reasonably characterized as a lid for a first compartment and a lid for a third compartment according to claim 5.

---

<sup>15</sup> 37 C.F.R. § 1.104(c)(2) (“When a reference is complex or shows or describes inventions other than that claimed by the applicant, the particular part relied on must be designated as nearly as practicable. The pertinence of each reference, if not apparent, must be clearly explained and each rejected claim specified.”).

<sup>16</sup> Office Action dated April 4, 2012, at page 6–7.

<sup>17</sup> *Id.* at page 7.

<sup>18</sup> *See id.* at page 7.



First, Tate does not describe that cap member 684 is a lid for even a single compartment of a shielding assembly system much a lid for a first compartment and a lid a third compartment. As discussed in greater detail with respect to the rejection of independent claim 1, the cap member 684 of Tate is a component that is lowered over a vial shield 554 positioned within a well 111 of a fluid delivery system. Vial shield 554 is not a compartment of a shielding assembly. Rather, vial shield 554 is described by Tate as simply being a “conventional shield or PIG” that is designed to be “transported by personnel.”<sup>19</sup> It is therefore unreasonable to characterize cap member 684 of Tate as a lid for even a single compartment of a shielding assembly, per claim 1.

Second, independent claim 5 recites a first compartment that is enclosed by a first sidewall including a lid and a third compartment enclosed by a third sidewall including a lid. Tate only illustrates and describes cap member 684 as being a single cap member designed to be positioned over a single vial shield within well 111 of fluid delivery system 10. Tate in no way describes cap member 684 as being able to alternately enclose and provide access to third well 127 in Tate (characterized as a third compartment in the Office Action). Simply put, even if cap member 684 of Tate could be considered a lid for a compartment of a shielding assembly (which is an assertion Applicant does not concede), the cap member does not function as a lid for both first well 111 in Tate (characterized as a first compartment in the Office Action) and also third well 127 (characterized as a third compartment in the Office Action).

Because the Office Action did not establish that Tate discloses a first compartment enclosed by a first sidewall that includes a lid, a second compartment enclosed by a second sidewall that includes a lid, and a third compartment enclosed by a third sidewall that a lid, the Office Action did not establish a *prima facie* case of obviousness with respect to the claim.

Moreover, Applicant respectfully disagrees that it would have been obvious to modify the device of Tate to include so that an opening defined by a first compartment sized to contain a radioisotope generator is located at a first elevation, an opening defined by a third compartment sized to contain a waste bottle is located at a second elevation, and the second elevation is greater than the first elevation, as further included in claim 5. While the Office Action acknowledged that Tate does not disclose this feature, the Office Action asserted the following:

---

<sup>19</sup> See Tate at paragraph [0117].

In the absence of showing any criticality in the exact elevation of the opening the selection of any elevation within the range normally expected for expected for a standing human working with a transportable cart. The elevations must not be too high as such would require the user to find means to elevate themselves to open the lids and if the elevations are too low the users arms would not be long enough to reach them inside the cart. The selection of the claimed dimensions are therefore commensurate with normal human anatomy therefore within the ordinary skill of one of ordinary skill in the medical arts.

Applicant respectfully disagrees with the rationale for modifying the Tate reference advanced in the Office Action.

It is well established that when rejecting a claim under 35 U.S.C. § 103, the Patent Office has the initial duty of “identify[ing] a reason that would have prompted a person of ordinary skill in the relevant field to combine the elements in the way the claimed new invention does. This is so because inventions in most, if not all, instances rely upon building blocks long since uncovered.”<sup>20</sup> In identifying this reason, the Patent Office may not “resort to speculation, unfounded assumptions, or hindsight reconstruction to supply deficiencies in its factual basis.”<sup>21</sup>

In the present case, the Office Action’s rationale for modifying the Tate references relies on speculative and hindsight assumptions that are insufficient to support the legal conclusion of obviousness. In the rejection of independent claim 5, the Office Action asserted that it would have been obvious to modify the Tate device because “the claimed dimensions are . . . commensurate with normal human anatomy [and] therefore within the ordinary skill of one of skill in the medical arts.”<sup>22</sup> Yet the mere fact that a certain modification may be possible – and thus within the skill of one skilled in the technical field – provides no reason why the skilled person would actually so modify the Tate device. Tate describes no benefit to be had or advantage to be gained by providing an opening defined by a third compartment sized to contain a waste bottle that is located at an elevation that is greater than an elevation for an opening defined by a first compartment sized to contain a radioisotope generator. Applicant submits that a person of ordinary skill in the art would not have modified the Tate reference in the manner suggested in the Office Action.

---

<sup>20</sup> *KSR, KSR Int’l Co. v. Teleflex, Inc.* 550 U.S. 398, at 418 (2007).

<sup>21</sup> *In re Warner*, 379 F.2d 1011, 1017 (CCPA 1967).

<sup>22</sup> Office Action dated April 4, 2012, at page 7–8.

For at least the reasons given above, Tate does not render independent claim 5 unpatentable. Reconsideration and withdrawal of the rejection are respectfully requested.

***Independent Claims 20 and 26***

Tate fails to disclose or suggest the features of independent claims 20 and 26. Independent claim 20 is directed to a method for setting up an infusion system that includes opening a first door of a shielding assembly of the infusion system to access a first compartment of the assembly and to allow for a second door of the shielding assembly to be opened. The method also includes, among other features, opening the second door, after opening the first door, to access a second compartment of the shielding assembly, the second compartment being separate from, and outside of, the first compartment. As amended, independent claim 20 specifies that the first door defines a first door edge, the second door defines a second door edge, and that the first door edge overlaps the second door edge so as to prevent the second door from being opened if the first door is not open.

In support of the rejection of previously-presented independent claim 20, the Office Action characterized a cap member 684 of a vial access system in Tate as both a first door providing access to a first compartment and a second door providing access to a second compartment.<sup>23</sup> The Office Action then relied on this characterization to assert that Tate anticipates the feature of previously-presented independent claim 20.<sup>24</sup>

Cap member 684 of Tate is not a first door of a shielding assembly and a second door of a shielding assembly per claim 20. Applicant reiterates and incorporates by reference the remarks offered in connection with the rejection of independent claims 1 and 5. Cap member 684 of Tate does not provide access to a compartment of a shielding assembly but rather is used to connect a vial shield positioned within in the device of Tate. For this reason, it is unreasonable to characterize cap member 684 of Tate as a door for even a single compartment of a shielding assembly, per claim 20. Further, claim 20 recites a first door providing access to a first compartment and a second door providing access to a second compartment. Tate only illustrates and describes cap member 684 as being a single cap member designed to be positioned over a single vial shield within well 111 of fluid delivery system 10. Tate in no way describes

---

<sup>23</sup> Office Action dated April 4, 2012, at page 3–4.

<sup>24</sup> *Id.*

cap member 684 as being able function as a first door providing access to a first compartment and a second door providing access to a second compartment.

While Applicant does not agree with the propriety of the rejection, Applicant is presently amending independent claim 20 to advance allowance of the application. As amended, independent claim 20 specifies that a first door of the shielding assembly defines a first door edge, a second door of the shielding assembly defines a second door edge, and the first door edge overlaps the second door edge so as to prevent the second door from being opened if the first door is not open. Tate does not include such a feature.

A shielding assembly that includes a first door that defines a first door edge and a second door that defines a second door edge, where the first door edge overlaps the second door edge so as to prevent the second door from being opened if the first door is not open, is not a trivial feature. With such an arrangement, separate compartments of a shielding assembly can be closed by separate doors. Yet by overlapping one door edge with another door edge, a number of distinct actions may be required to access the compartments closed by the doors. For example, to access the second compartment containing the radioisotope generator, the first door for the first compartment may initially need to be opened before the second door can be opened. This arrangement may reduce the chance that the second compartment is opened accidentally. Avoiding accidental opening of the second compartment may be advantageous given that this compartment may contain the main radioactive source.

Tate does not disclose or suggest a shielding assembly where a first door defines a first door edge, a second door defines a second door edge, and the first door edge overlaps the second door edge so as to prevent the second door from being opened if the first door is not open. Nor does Tate recognize any advantages to be had with such a configuration. Accordingly, for at least the reasons given above, Tate does not render amended independent claim 20 unpatentable.

Independent claim 26 is directed to a shielding assembly for an infusion system that includes a plurality of compartments and that provides a radioactive radiation barrier for the compartments. Among other features, the shielding assembly includes a first door to alternately enclose and provide access to a first compartment of the plurality of compartments and a second door to alternately enclose and provide access to a second compartment of the plurality of compartments. As amended, the claim specifies that the first door defines a first door edge, the second door defines a second door edge, and the first door edge overlaps the second door edge so

as to prevent the first door from being opened if the second door is not open. Amended claim 26 is therefore patentable over Tate for at least the reasons given above with respect to claim 20.

### ***Dependent Claims***

Claims 4, 7–9, 21, 25, 27, depend from independent claims 1, 5, 20, or 26 and are therefore patentable for at least the reasons given above with respect to the independent claims, as well as upon additional patentable features and elements claimed in the dependent claims but not explicitly discussed herein.

### **Double Patenting**

In the Office Action, the Examiner provisionally rejected claims 1–19 and 26–30 under the judicially created doctrine of obviousness-type double patenting as being unpatentable over claims 16–28 of US Patent Application No. 12/954,307. In addition, the Examiner also provisionally rejected claims 1–19 and 26–30 under the judicially created doctrine of obviousness-type double patenting as being unpatentable over claims 16–28 of US Patent Application No. 12/865,924.

Applicant notes the provisional status of these rejections. Accordingly, Applicant will address the issue if and when the rejections are formally applied.

### **CONCLUSION**

It is submitted that all claims in this application are in condition for allowance. Applicant respectfully requests reconsideration and prompt allowance of all pending claims.

In view of the fundamental differences identified above, Applicant reserves further comment concerning the additional features set forth in the claims. However, Applicant does not acquiesce in the propriety of the Office Action's application or interpretation of the references with respect to the claims, and reserves the right to present additional arguments in any further prosecution of this application.

The Commissioner is authorized to charge any deficiencies and credit any overpayments to Deposit Account No. 06-1910. The Examiner is invited to telephone the undersigned attorney to discuss this application.

Respectfully submitted,

Dated: July 3, 2012

/Paul J. LaVanway, Jr./

Paul J. LaVanway, Jr.  
Registration No. 64,610

FREDRIKSON & BYRON, P.A.  
200 South Sixth Street, Suite 4000  
Minneapolis, MN 55402-1425 USA  
Telephone: (612) 492-7387  
Facsimile: (612) 492-7077

*Please grant any extension of time necessary for entry; charge any fee due to Deposit Account No. 06-1910.*

5107073\_1.DOC

|   |                        |                    |            |  |
|---|------------------------|--------------------|------------|--|
| <b>INFORMATION DISCLOSURE STATEMENT BY APPLICANT</b><br>( Not for submission under 37 CFR 1.99) | Application Number     |                    | 12137356   |  |
|   | Filing Date            |                    | 2008-06-11 |  |
|   | First Named Inventor   | Charles R. QUIRICO |            |  |
|   | Art Unit               | 3735               |            |  |
|   | Examiner Name          | Samuel G. GILBERT  |            |  |
|   | Attorney Docket Number | 56782.1.5          |            |  |

| U.S.PATENTS       |         |               |                        |            |   | Remove   |
|-------------------|---------|---------------|------------------------|------------|---|--|
| Examiner Initial* | Cite No | Patent Number | Kind Code <sup>1</sup> | Issue Date | Name of Patentee or Applicant of cited Document | Pages,Columns,Lines where Relevant Passages or Relevant Figures Appear |
|                   | 1       |               |                        |            |   |  |

If you wish to add additional U.S. Patent citation information please click the Add button. Add

| U.S.PATENT APPLICATION PUBLICATIONS |         |                    |                        |                  |   | Remove   |
|-------------------------------------|---------|--------------------|------------------------|------------------|---|--|
| Examiner Initial*                   | Cite No | Publication Number | Kind Code <sup>1</sup> | Publication Date | Name of Patentee or Applicant of cited Document | Pages,Columns,Lines where Relevant Passages or Relevant Figures Appear |
|                                     | 1       |                    |                        |                  |   |  |

If you wish to add additional U.S. Published Application citation information please click the Add button. Add

| FOREIGN PATENT DOCUMENTS |         |                                      |                             |                        |                  |   |  | Remove                   |
|--------------------------|---------|--------------------------------------|-----------------------------|------------------------|------------------|---|--|--------------------------|
| Examiner Initial*        | Cite No | Foreign Document Number <sup>3</sup> | Country Code <sup>2</sup> j | Kind Code <sup>4</sup> | Publication Date | Name of Patentee or Applicant of cited Document | Pages,Columns,Lines where Relevant Passages or Relevant Figures Appear | T <sup>5</sup>           |
|                          | 1       |                                      |                             |                        |                  |   |  | <input type="checkbox"/> |

If you wish to add additional Foreign Patent Document citation information please click the Add button Add

| NON-PATENT LITERATURE DOCUMENTS |         |   |  | Remove         |
|---------------------------------|---------|---|--|----------------|
| Examiner Initials*              | Cite No | Include name of the author (in CAPITAL LETTERS), title of the article (when appropriate), title of the item (book, magazine, journal, serial, symposium, catalog, etc), date, pages(s), volume-issue number(s), publisher, city and/or country where published. |  | T <sup>5</sup> |
|                                 |         |   |  |                |

|   |                        |                    |
|---|------------------------|--------------------|
| <b>INFORMATION DISCLOSURE<br/>STATEMENT BY APPLICANT</b><br>( Not for submission under 37 CFR 1.99) | Application Number     | 12137356           |
|   | Filing Date            | 2008-06-11         |
|   | First Named Inventor   | Charles R. QUIRICO |
|   | Art Unit               | 3735               |
|   | Examiner Name          | Samuel G. GILBERT  |
|   | Attorney Docket Number | 56782.1.5          |

|   |  |                          |
|---|--|--------------------------|
| 1 | BRACCO, "Cardio-Gen82® Infusion System User's Guide", July 3, 2007, Pages 1-53 | <input type="checkbox"/> |
|---|--|--------------------------|

If you wish to add additional non-patent literature document citation information please click the Add button **Add**

**EXAMINER SIGNATURE**

|                    |  |                 |  |
|--------------------|--|-----------------|--|
| Examiner Signature |  | Date Considered |  |
|--------------------|--|-----------------|--|

\*EXAMINER: Initial if reference considered, whether or not citation is in conformance with MPEP 609. Draw line through a citation if not in conformance and not considered. Include copy of this form with next communication to applicant.

<sup>1</sup> See Kind Codes of USPTO Patent Documents at [www.USPTO.GOV](http://www.USPTO.GOV) or MPEP 901.04. <sup>2</sup> Enter office that issued the document, by the two-letter code (WIPO Standard ST.3). <sup>3</sup> For Japanese patent documents, the indication of the year of the reign of the Emperor must precede the serial number of the patent document. <sup>4</sup> Kind of document by the appropriate symbols as indicated on the document under WIPO Standard ST.16 if possible. <sup>5</sup> Applicant is to place a check mark here if English language translation is attached.



|   |                        |                    |
|---|------------------------|--------------------|
| <b>INFORMATION DISCLOSURE<br/>STATEMENT BY APPLICANT</b><br>( Not for submission under 37 CFR 1.99) | Application Number     | 12137356           |
|   | Filing Date            | 2008-06-11         |
|   | First Named Inventor   | Charles R. QUIRICO |
|   | Art Unit               | 3735               |
|   | Examiner Name          | Samuel G. GILBERT  |
|   | Attorney Docket Number | 56782.15           |

**CERTIFICATION STATEMENT**

Please see 37 CFR 1.97 and 1.98 to make the appropriate selection(s):

That each item of information contained in the information disclosure statement was first cited in any communication from a foreign patent office in a counterpart foreign application not more than three months prior to the filing of the information disclosure statement. See 37 CFR 1.97(e)(1).

**OR**

That no item of information contained in the information disclosure statement was cited in a communication from a foreign patent office in a counterpart foreign application, and, to the knowledge of the person signing the certification after making reasonable inquiry, no item of information contained in the information disclosure statement was known to any individual designated in 37 CFR 1.56(c) more than three months prior to the filing of the information disclosure statement. See 37 CFR 1.97(e)(2).

- See attached certification statement.
- The fee set forth in 37 CFR 1.17 (p) has been submitted herewith.
- A certification statement is not submitted herewith.

**SIGNATURE**

A signature of the applicant or representative is required in accordance with CFR 1.33, 10.18. Please see CFR 1.4(d) for the form of the signature.

|            |                         |                     |            |
|------------|-------------------------|---------------------|------------|
| Signature  | /Paul J. LaVanway, Jr./ | Date (YYYY-MM-DD)   | 2012-07-03 |
| Name/Print | Paul J. LaVanway, Jr.   | Registration Number | 64610      |

This collection of information is required by 37 CFR 1.97 and 1.98. The information is required to obtain or retain a benefit by the public which is to file (and by the USPTO to process) an application. Confidentiality is governed by 35 U.S.C. 122 and 37 CFR 1.14. This collection is estimated to take 1 hour to complete, including gathering, preparing and submitting the completed application form to the USPTO. Time will vary depending upon the individual case. Any comments on the amount of time you require to complete this form and/or suggestions for reducing this burden, should be sent to the Chief Information Officer, U.S. Patent and Trademark Office, U.S. Department of Commerce, P.O. Box 1450, Alexandria, VA 22313-1450. **DO NOT SEND FEES OR COMPLETED FORMS TO THIS ADDRESS. SEND TO: Commissioner for Patents, P.O. Box 1450, Alexandria, VA 22313-1450.**

## Privacy Act Statement

The Privacy Act of 1974 (P.L. 93-579) requires that you be given certain information in connection with your submission of the attached form related to a patent application or patent. Accordingly, pursuant to the requirements of the Act, please be advised that: (1) the general authority for the collection of this information is 35 U.S.C. 2(b)(2); (2) furnishing of the information solicited is voluntary; and (3) the principal purpose for which the information is used by the U.S. Patent and Trademark Office is to process and/or examine your submission related to a patent application or patent. If you do not furnish the requested information, the U.S. Patent and Trademark Office may not be able to process and/or examine your submission, which may result in termination of proceedings or abandonment of the application or expiration of the patent.

The information provided by you in this form will be subject to the following routine uses:

1. The information on this form will be treated confidentially to the extent allowed under the Freedom of Information Act (5 U.S.C. 552) and the Privacy Act (5 U.S.C. 552a). Records from this system of records may be disclosed to the Department of Justice to determine whether the Freedom of Information Act requires disclosure of these records.
2. A record from this system of records may be disclosed, as a routine use, in the course of presenting evidence to a court, magistrate, or administrative tribunal, including disclosures to opposing counsel in the course of settlement negotiations.
3. A record in this system of records may be disclosed, as a routine use, to a Member of Congress submitting a request involving an individual, to whom the record pertains, when the individual has requested assistance from the Member with respect to the subject matter of the record.
4. A record in this system of records may be disclosed, as a routine use, to a contractor of the Agency having need for the information in order to perform a contract. Recipients of information shall be required to comply with the requirements of the Privacy Act of 1974, as amended, pursuant to 5 U.S.C. 552a(m).
5. A record related to an International Application filed under the Patent Cooperation Treaty in this system of records may be disclosed, as a routine use, to the International Bureau of the World Intellectual Property Organization, pursuant to the Patent Cooperation Treaty.
6. A record in this system of records may be disclosed, as a routine use, to another federal agency for purposes of National Security review (35 U.S.C. 181) and for review pursuant to the Atomic Energy Act (42 U.S.C. 218(c)).
7. A record from this system of records may be disclosed, as a routine use, to the Administrator, General Services, or his/her designee, during an inspection of records conducted by GSA as part of that agency's responsibility to recommend improvements in records management practices and programs, under authority of 44 U.S.C. 2904 and 2906. Such disclosure shall be made in accordance with the GSA regulations governing inspection of records for this purpose, and any other relevant (i.e., GSA or Commerce) directive. Such disclosure shall not be used to make determinations about individuals.
8. A record from this system of records may be disclosed, as a routine use, to the public after either publication of the application pursuant to 35 U.S.C. 122(b) or issuance of a patent pursuant to 35 U.S.C. 151. Further, a record may be disclosed, subject to the limitations of 37 CFR 1.14, as a routine use, to the public if the record was filed in an application which became abandoned or in which the proceedings were terminated and which application is referenced by either a published application, an application open to public inspections or an issued patent.
9. A record from this system of records may be disclosed, as a routine use, to a Federal, State, or local law enforcement agency, if the USPTO becomes aware of a violation or potential violation of law or regulation.

## Electronic Patent Application Fee Transmittal

|   |   |
|---|---|
| <b>Application Number:</b>                  | 12137356                                  |
| <b>Filing Date:</b>                         | 11-Jun-2008                               |
| <b>Title of Invention:</b>                  | SHIELDING ASSEMBLIES FOR INFUSION SYSTEMS |
| <b>First Named Inventor/Applicant Name:</b> | Charles R. Quirico                        |
| <b>Filer:</b>                               | Paul J. LaVanway Jr.                      |
| <b>Attorney Docket Number:</b>              | 56782.1.5                                 |

Filed as Large Entity

### Utility under 35 USC 111(a) Filing Fees

| Description                              | Fee Code | Quantity | Amount | Sub-Total in USD(\$) |
|--|----------|----------|--------|----------------------|
| <b>Basic Filing:</b>                     |          |          |        |                      |
| <b>Pages:</b>                            |          |          |        |                      |
| <b>Claims:</b>                           |          |          |        |                      |
| <b>Miscellaneous-Filing:</b>             |          |          |        |                      |
| <b>Petition:</b>                         |          |          |        |                      |
| <b>Patent-Appeals-and-Interference:</b>  |          |          |        |                      |
| <b>Post-Allowance-and-Post-Issuance:</b> |          |          |        |                      |
| <b>Extension-of-Time:</b>                |          |          |        |                      |

| Description                             | Fee Code | Quantity | Amount | Sub-Total in USD(\$) |
|---|----------|----------|--------|----------------------|
| <b>Miscellaneous:</b>                   |          |          |        |                      |
| Submission- Information Disclosure Stmt | 1806     | 1        | 180    | 180                  |
| <b>Total in USD (\$)</b>                |          |          |        | <b>180</b>           |

## Electronic Acknowledgement Receipt

|   |   |
|---|---|
| <b>EFS ID:</b>                              | 13172396                                  |
| <b>Application Number:</b>                  | 12137356                                  |
| <b>International Application Number:</b>    |   |
| <b>Confirmation Number:</b>                 | 7360                                      |
| <b>Title of Invention:</b>                  | SHIELDING ASSEMBLIES FOR INFUSION SYSTEMS |
| <b>First Named Inventor/Applicant Name:</b> | Charles R. Quirico                        |
| <b>Customer Number:</b>                     | 22859                                     |
| <b>Filer:</b>                               | Paul J. LaVanway Jr.                      |
| <b>Filer Authorized By:</b>                 |   |
| <b>Attorney Docket Number:</b>              | 56782.1.5                                 |
| <b>Receipt Date:</b>                        | 03-JUL-2012                               |
| <b>Filing Date:</b>                         | 11-JUN-2008                               |
| <b>Time Stamp:</b>                          | 16:44:27                                  |
| <b>Application Type:</b>                    | Utility under 35 USC 111(a)               |

### Payment information:

|  |             |
|--|-------------|
| Submitted with Payment                   | yes         |
| Payment Type                             | Credit Card |
| Payment was successfully received in RAM | \$180       |
| RAM confirmation Number                  | 5058        |
| Deposit Account                          |             |
| Authorized User                          |             |

### File Listing:

| Document Number | Document Description | File Name | File Size(Bytes)/ Message Digest | Multi Part /.zip | Pages (if appl.) |
|-----------------|----------------------|-----------|----------------------------------|------------------|------------------|
|-----------------|----------------------|-----------|----------------------------------|------------------|------------------|

|   |  |                           |   |         |    |
|---|--|---------------------------|---|---------|----|
| 1   | Amendment Copy Claims/Response to Suggested Claims | 56782_1_5AMEND.pdf        | 384185<br>7aff9d89795a34e091ca3b9e624c12a89310e1bb  | no      | 23 |
| <b>Warnings:</b>  |  |                           |   |         |    |
| <b>Information:</b>   |  |                           |   |         |    |
| 2   | Information Disclosure Statement (IDS) Form (SB08) | 56782_1_5SIDS.pdf         | 612170<br>fa0707971845301beff0ee96c613b4eedad641a6  | no      | 4  |
| <b>Warnings:</b>  |  |                           |   |         |    |
| <b>Information:</b>   |  |                           |   |         |    |
| A U.S. Patent Number Citation or a U.S. Publication Number Citation is required in the Information Disclosure Statement (IDS) form for autoloading of data into USPTO systems. You may remove the form to add the required data in order to correct the Informational Message if you are citing U.S. References. If you chose not to include U.S. References, the image of the form will be processed and be made available within the Image File Wrapper (IFW) system. However, no data will be extracted from this form. Any additional data such as Foreign Patent Documents or Non Patent Literature will be manually reviewed and keyed into USPTO systems.  |  |                           |   |         |    |
| 3   | Non Patent Literature                              | 56782_1_5NPLREFERENCE.pdf | 2885058<br>92ebeee4becb8558892f2a7128cd69fd55ee731e | no      | 53 |
| <b>Warnings:</b>  |  |                           |   |         |    |
| <b>Information:</b>   |  |                           |   |         |    |
| 4   | Fee Worksheet (SB06)                               | fee-info.pdf              | 30525<br>7d551157a9e15e4f21f1d8d412b248f63f5a2085   | no      | 2  |
| <b>Warnings:</b>  |  |                           |   |         |    |
| <b>Information:</b>   |  |                           |   |         |    |
| <b>Total Files Size (in bytes):</b>   |  |                           |   | 3911938 |    |
| <p><b>This Acknowledgement Receipt evidences receipt on the noted date by the USPTO of the indicated documents, characterized by the applicant, and including page counts, where applicable. It serves as evidence of receipt similar to a Post Card, as described in MPEP 503.</b></p> <p><b><u>New Applications Under 35 U.S.C. 111</u></b><br/> <b>If a new application is being filed and the application includes the necessary components for a filing date (see 37 CFR 1.53(b)-(d) and MPEP 506), a Filing Receipt (37 CFR 1.54) will be issued in due course and the date shown on this Acknowledgement Receipt will establish the filing date of the application.</b></p> <p><b><u>National Stage of an International Application under 35 U.S.C. 371</u></b><br/> <b>If a timely submission to enter the national stage of an international application is compliant with the conditions of 35 U.S.C. 371 and other applicable requirements a Form PCT/DO/EO/903 indicating acceptance of the application as a national stage submission under 35 U.S.C. 371 will be issued in addition to the Filing Receipt, in due course.</b></p> <p><b><u>New International Application Filed with the USPTO as a Receiving Office</u></b><br/> <b>If a new international application is being filed and the international application includes the necessary components for an international filing date (see PCT Article 11 and MPEP 1810), a Notification of the International Application Number and of the International Filing Date (Form PCT/RO/105) will be issued in due course, subject to prescriptions concerning national security, and the date shown on this Acknowledgement Receipt will establish the international filing date of the application.</b></p> |  |                           |   |         |    |

Under the Paperwork Reduction Act of 1995, no persons are required to respond to a collection of information unless it displays a valid OMB control number.

|   |   |   |                                  |       |   |               |                                  |                     |                                       |          |                 |                            |  |  |
|---|---|---|----------------------------------|-------|---|---------------|----------------------------------|---------------------|---------------------------------------|----------|-----------------|----------------------------|--|--|
| <b>PATENT APPLICATION FEE DETERMINATION RECORD</b><br>Substitute for Form PTO-875   |   |   |                                  |       | Application or Docket Number<br><b>12/137,356</b> |               | Filing Date<br><b>06/11/2008</b> |                     | <input type="checkbox"/> To be Mailed |          |                 |                            |  |  |
| <b>APPLICATION AS FILED – PART I</b>  |   |   |                                  |       |   |               | <b>OTHER THAN</b>                |                     |                                       |          |                 |                            |  |  |
| (Column 1)  |   |   | (Column 2)                       |       | SMALL ENTITY <input type="checkbox"/>             |               | OR                               |                     | SMALL ENTITY                          |          |                 |                            |  |  |
| FOR   |   | NUMBER FILED  | NUMBER EXTRA                     |       | RATE (\$)   | FEE (\$)      | OR                               |                     | RATE (\$)                             | FEE (\$) |                 |                            |  |  |
| <input type="checkbox"/> BASIC FEE<br><small>(37 CFR 1.16(a), (b), or (c))</small>  |   | N/A   | N/A                              |       | N/A   |               |                                  |                     | N/A                                   |          |                 |                            |  |  |
| <input type="checkbox"/> SEARCH FEE<br><small>(37 CFR 1.16(k), (j), or (m))</small>   |   | N/A   | N/A                              |       | N/A   |               |                                  |                     | N/A                                   |          |                 |                            |  |  |
| <input type="checkbox"/> EXAMINATION FEE<br><small>(37 CFR 1.16(o), (p), or (q))</small>  |   | N/A   | N/A                              |       | N/A   |               |                                  |                     | N/A                                   |          |                 |                            |  |  |
| TOTAL CLAIMS<br><small>(37 CFR 1.16(j))</small>   |   | minus 20 =  | *                                |       | X \$ =  |               |                                  |                     | X \$ =                                |          |                 |                            |  |  |
| INDEPENDENT CLAIMS<br><small>(37 CFR 1.16(h))</small>   |   | minus 3 =   | *                                |       | X \$ =  |               |                                  |                     | X \$ =                                |          |                 |                            |  |  |
| <input type="checkbox"/> APPLICATION SIZE FEE<br><small>(37 CFR 1.16(s))</small>  |   | If the specification and drawings exceed 100 sheets of paper, the application size fee due is \$250 (\$125 for small entity) for each additional 50 sheets or fraction thereof. See 35 U.S.C. 41(a)(1)(G) and 37 CFR 1.16(s). |                                  |       |   |               |                                  |                     |                                       |          |                 |                            |  |  |
| <input type="checkbox"/> MULTIPLE DEPENDENT CLAIM PRESENT <small>(37 CFR 1.16(j))</small>                                       |   |   |                                  |       |   |               |                                  |                     |                                       |          |                 |                            |  |  |
| * If the difference in column 1 is less than zero, enter "0" in column 2.   |   |   |                                  |       |   |               |                                  |                     |                                       |          |                 |                            |  |  |
| <b>APPLICATION AS AMENDED – PART II</b>   |   |   |                                  |       |   |               |                                  |                     |                                       |          |                 |                            |  |  |
| (Column 1)  |   |   | (Column 2)                       |       | (Column 3)  |               |                                  | SMALL ENTITY        |                                       | OR       |                 | OTHER THAN<br>SMALL ENTITY |  |  |
| AMENDMENT   | <b>07/03/2012</b>   |   | CLAIMS REMAINING AFTER AMENDMENT |       | HIGHEST NUMBER PREVIOUSLY PAID FOR                | PRESENT EXTRA | RATE (\$)                        | ADDITIONAL FEE (\$) | OR                                    |          | RATE (\$)       | ADDITIONAL FEE (\$)        |  |  |
|   | <small>Total (37 CFR 1.16(i))</small>   |   | * 37                             | Minus | ** 37   | = 0           | X \$ =                           |                     |                                       |          | X \$60=         | 0                          |  |  |
|   | <small>Independent (37 CFR 1.16(h))</small>   |   | * 5                              | Minus | ***5  | = 0           | X \$ =                           |                     |                                       |          | X \$250=        | 0                          |  |  |
|   | <input type="checkbox"/> Application Size Fee <small>(37 CFR 1.16(s))</small>                           |   |                                  |       |   |               |                                  |                     |                                       |          |                 |                            |  |  |
|   | <input type="checkbox"/> FIRST PRESENTATION OF MULTIPLE DEPENDENT CLAIM <small>(37 CFR 1.16(j))</small> |   |                                  |       |   |               |                                  |                     |                                       |          |                 |                            |  |  |
|   |   |   |                                  |       |   |               | TOTAL ADD'L FEE                  |                     | OR                                    |          | TOTAL ADD'L FEE | <b>0</b>                   |  |  |
| (Column 1)  |   |   | (Column 2)                       |       | (Column 3)  |               |                                  | SMALL ENTITY        |                                       | OR       |                 | OTHER THAN<br>SMALL ENTITY |  |  |
| AMENDMENT   |   |   | CLAIMS REMAINING AFTER AMENDMENT |       | HIGHEST NUMBER PREVIOUSLY PAID FOR                | PRESENT EXTRA | RATE (\$)                        | ADDITIONAL FEE (\$) | OR                                    |          | RATE (\$)       | ADDITIONAL FEE (\$)        |  |  |
|   | <small>Total (37 CFR 1.16(i))</small>   |   | *                                | Minus | **  | =             | X \$ =                           |                     |                                       |          | X \$ =          |                            |  |  |
|   | <small>Independent (37 CFR 1.16(h))</small>   |   | *                                | Minus | ***   | =             | X \$ =                           |                     |                                       |          | X \$ =          |                            |  |  |
|   | <input type="checkbox"/> Application Size Fee <small>(37 CFR 1.16(s))</small>                           |   |                                  |       |   |               |                                  |                     |                                       |          |                 |                            |  |  |
|   | <input type="checkbox"/> FIRST PRESENTATION OF MULTIPLE DEPENDENT CLAIM <small>(37 CFR 1.16(j))</small> |   |                                  |       |   |               |                                  |                     |                                       |          |                 |                            |  |  |
|   |   |   |                                  |       |   |               | TOTAL ADD'L FEE                  |                     | OR                                    |          | TOTAL ADD'L FEE |                            |  |  |
| * If the entry in column 1 is less than the entry in column 2, write "0" in column 3.   |   |   |                                  |       |   |               |                                  |                     |                                       |          |                 |                            |  |  |
| ** If the "Highest Number Previously Paid For" IN THIS SPACE is less than 20, enter "20".                                       |   |   |                                  |       |   |               |                                  |                     |                                       |          |                 |                            |  |  |
| *** If the "Highest Number Previously Paid For" IN THIS SPACE is less than 3, enter "3".  |   |   |                                  |       |   |               |                                  |                     |                                       |          |                 |                            |  |  |
| The "Highest Number Previously Paid For" (Total or Independent) is the highest number found in the appropriate box in column 1. |   |   |                                  |       |   |               |                                  |                     |                                       |          |                 |                            |  |  |
| Legal Instrument Examiner:<br>/PAULA BRITTON/   |   |   |                                  |       |   |               |                                  |                     |                                       |          |                 |                            |  |  |

This collection of information is required by 37 CFR 1.16. The information is required to obtain or retain a benefit by the public which is to file (and by the USPTO to process) an application. Confidentiality is governed by 35 U.S.C. 122 and 37 CFR 1.14. This collection is estimated to take 12 minutes to complete, including gathering, preparing, and submitting the completed application form to the USPTO. Time will vary depending upon the individual case. Any comments on the amount of time you require to complete this form and/or suggestions for reducing this burden, should be sent to the Chief Information Officer, U.S. Patent and Trademark Office, U.S. Department of Commerce, P.O. Box 1450, Alexandria, VA 22313-1450. DO NOT SEND FEES OR COMPLETED FORMS TO THIS ADDRESS. **SEND TO: Commissioner for Patents, P.O. Box 1450, Alexandria, VA 22313-1450.**

If you need assistance in completing the form, call 1-800-PTO-9199 and select option 2.



UNITED STATES PATENT AND TRADEMARK OFFICE

UNITED STATES DEPARTMENT OF COMMERCE  
United States Patent and Trademark Office  
Address: COMMISSIONER FOR PATENTS  
P.O. Box 1450  
Alexandria, Virginia 22313-1450  
www.uspto.gov

| APPLICATION NO.  | FILING DATE | FIRST NAMED INVENTOR | ATTORNEY DOCKET NO. | CONFIRMATION NO. |
|--|-------------|----------------------|---------------------|------------------|
| 12/137,356   | 06/11/2008  | Charles R. Quirico   | 56782.1.5           | 7360             |
| 22859  | 7590        | 04/04/2012           | EXAMINER            |                  |
| FREDRIKSON & BYRON, P.A.<br>INTELLECTUAL PROPERTY GROUP<br>200 SOUTH SIXTH STREET, SUITE 4000<br>MINNEAPOLIS, MN 55402 |             |                      | GILBERT, SAMUEL G   |                  |
|  |             |                      | ART UNIT            | PAPER NUMBER     |
|  |             |                      | 3735                |                  |
|  |             |                      | NOTIFICATION DATE   | DELIVERY MODE    |
|  |             |                      | 04/04/2012          | ELECTRONIC       |

**Please find below and/or attached an Office communication concerning this application or proceeding.**

The time period for reply, if any, is set in the attached communication.

Notice of the Office communication was sent electronically on above-indicated "Notification Date" to the following e-mail address(es):

IP@FREDLAW.COM





## DETAILED ACTION

### ***Claim Rejections - 35 USC § 112***

The following is a quotation of the second paragraph of 35 U.S.C. 112:

The specification shall conclude with one or more claims particularly pointing out and distinctly claiming the subject matter which the applicant regards as his invention.

Claim 1-4 are rejected under 35 U.S.C. 112, second paragraph, as being indefinite for failing to particularly point out and distinctly claim the subject matter which applicant regards as the invention.

Claims 1-4 are rejected under 35 U.S.C. 112, second paragraph, as being indefinite for failing to particularly point out and distinctly claim the subject matter which applicant regards as the invention.

The term "substantially greater" in claim 1 is a relative term which renders the claims indefinite. The term "substantially greater" is not defined by the claim, the specification does not provide a standard for ascertaining the requisite degree, and one of ordinary skill in the art would not be reasonably apprised of the scope of the invention.

### ***Claim Rejections - 35 USC § 102***

The following is a quotation of the appropriate paragraphs of 35 U.S.C. 102 that form the basis for the rejections under this section made in this Office action:

A person shall be entitled to a patent unless –

(b) the invention was patented or described in a printed publication in this or a foreign country or in public use or on sale in this country, more than one year prior to the date of application for patent in the United States.

Art Unit: 3735

(e) the invention was described in (1) an application for patent, published under section 122(b), by another filed in the United States before the invention by the applicant for patent or (2) a patent granted on an application for patent by another filed in the United States before the invention by the applicant for patent, except that an international application filed under the treaty defined in section 351(a) shall have the effects for purposes of this subsection of an application filed in the United States only if the international application designated the United States and was published under Article 21(2) of such treaty in the English language.

Claims 1,4,20, 21 and 25-27 are rejected under 35 U.S.C. 102(e) as being anticipated by Tate et al (2008/0177126 hereinafter Tate).

Claim 1 - Tate teaches a shielding assembly including a plurality of compartments each with doors -684- the doors providing barriers to radiation, the sidewalls of the compartments having an opening facing upward, the generator is within pig -554- and element -20- provides an upper opening of the shell. Wherein the shell opening -20- is at an elevation with respect to the bottom of the device substantially greater than the elevation of the openings with doors -684-

Claim 4 well -127- is a second compartment contains a waste receptacle, paragraph [0081]

Claim 20 - Tate teaches opening a first door -684- of a shielding assembly of the infusion system to access a first compartment of the assembly and to allow for a second door of the shielding assembly to be opened; and opening the second door -684-, after opening the first door, to access a second compartment of the shielding assembly, the second compartment being separate from, and outside of, the first compartment; placing a radioisotope generator -554- into the second compartment and connecting the generator to an infusion tubing circuit;

Art Unit: 3735

placing a portion of the infusion tubing circuit, as shown in figure 2A, into the first compartment; the doors are closed to shield the users of the system.

Claim 21 - unlocking and removing an access panel from a shell of a cabinet structure, which encloses the shielding assembly, to access the first door and the second door of the shielding assembly as set forth in paragraph [0020]

Claim 25 - securing at least one of the first and second doors in an open position is set forth by rotating handle -682-.

Claim 26 - Tate teaches a system, the shielding assembly -9- comprising a plurality of compartments -111- and -127- and providing a radioactive radiation barrier for the compartments, lead, the assembly further comprising:  
a first door-684- to alternately enclose and provide access to a first compartment of the plurality of compartments, the first compartment sized to contain a radioisotope generator of the infusion system; and  
a second door -20- to alternately enclose and provide access to a second compartment of the plurality of compartments, the second compartment being separate from, and outside of, the first compartment, the second compartment being sized to contain a portion of an infusion tubing circuit of the infusion system that is downstream of the generator, and the second door, when enclosing the second compartment, preventing the first door from opening to provide access to the first compartment.

Claim 27 - further comprising a third door -20- to alternately enclose and provide access to a third compartment -107-, -113- and -125- of the plurality of

Art Unit: 3735

compartments, the third compartment sized to contain another portion of the infusion tubing circuit of the infusion system downstream from the generator, the third door, when enclosing the third compartment, preventing the second door from opening to provide access to the second compartment.

### ***Claim Rejections - 35 USC § 103***

The following is a quotation of 35 U.S.C. 103(a) which forms the basis for all obviousness rejections set forth in this Office action:

(a) A patent may not be obtained though the invention is not identically disclosed or described as set forth in section 102 of this title, if the differences between the subject matter sought to be patented and the prior art are such that the subject matter as a whole would have been obvious at the time the invention was made to a person having ordinary skill in the art to which said subject matter pertains. Patentability shall not be negated by the manner in which the invention was made.

Claims 2, 3, are rejected under 35 U.S.C. 103(a) as being unpatentable over Tate et al (2008/0177126).

Claim 2 - Tate teaches a system as claimed but the exact elevations are not set forth. All elevations as claimed are within what is normally expected for a standing human working with a transportable cart. The elevations must not be too high as such would require the user to find means to elevate themselves to open the lids and if the elevations are too low the user's arms would not be long enough to reach them inside the cart. The selection of the claimed dimensions are therefore commensurate with normal human anatomy therefore within the ordinary skill of one of ordinary skill in the medical arts.

Art Unit: 3735

Claim 3 - The shielding assembly of claim 2, wherein the upper surface of the shell is at an elevation of between approximately 24 inches and 36 inches with respect to the lowermost portion of the cabinet structure. All elevations as claimed are within what is normally expected for a standing human working with a transportable cart. The elevations must not be too high as such would require the user to find means to elevate themselves to open the lids and if the elevations are too low the users arms would not be long enough to reach them inside the cart. The selection of the claimed dimensions are therefore commensurate with normal human anatomy therefore within the ordinary skill of one of ordinary skill in the medical arts.

Claim 5 - A shielding assembly for an infusion system, the shielding assembly being mounted within a cabinet structure -9-, and the shielding assembly comprising: a first compartment -111- sized to contain a radioisotope generator of the infusion system, the first compartment being enclosed by a first sidewall that forms a barrier to radioactive radiation, the first sidewall including an opening extending therethrough and a lid -684-, the lid mating with the opening to alternately enclose the first compartment and provide access to the first compartment, via the opening, and the opening being oriented upward and located at a first elevation with respect to a lowermost portion of the cabinet structure;

a second compartment -107-, -113- and -125- sized to contain a portion of an infusion

Art Unit: 3735

tubing circuit of the infusion system that is downstream of the generator, the second compartment being enclosed by a second sidewall that forms a barrier to radioactive radiation, the second sidewall including a base portion and a lid portion -20-, the lid portion mating with the base portion to alternately enclose the second compartment and provide access to the second compartment; and

a third compartment -127- sized to contain a waste bottle -224- of the infusion system, the third compartment being enclosed by a third sidewall that forms a barrier to radioactive radiation, the third sidewall including an opening, extending through the third sidewall, and a lid -684-, the lid of the third sidewall mating with the opening of the third sidewall to alternately enclose the third compartment and provide access to the third compartment, via the opening of the third sidewall, the opening of the third sidewall being oriented upward and located at a second elevation with respect to the lowermost portion of the cabinet structure, and the second elevation being greater than the first elevation of the opening of the first sidewall. However the first and second elevation in Tate are approximately the same.

In the absence of showing any criticality in the exact elevation of the opening the selection of any elevation within the range normally expected for expected for a standing human working with a transportable cart. The elevations must not be too high as such would require the user to find means to elevate themselves to open the lids and if the elevations are too low the users arms would not be long enough to reach them inside the cart. The selection of the claimed dimensions

Art Unit: 3735

are therefore commensurate with normal human anatomy therefore within the ordinary skill of one of ordinary skill in the medical arts.

Claim 7 - wherein an opening through a shell, as shown in figure 1B when lid -20- is opened, provides access to both the lid of the first sidewall and to the lid portion of the second sidewall.

Claim 8 - Tate teaches a system as claimed but the exact elevations are not set forth. All elevations as claimed are within what is normally expected for a standing human working with a transportable cart. The elevations must not be too high as such would require the user to find means to elevate themselves to open the lids and if the elevations are too low the users arms would not be long enough to reach them inside the cart. The selection of the claimed dimensions are therefore commensurate with normal human anatomy therefore within the ordinary skill of one of ordinary skill in the medical arts.

Claim 9 - wherein the upper surface of the shell is at an elevation of between approximately 24 inches and 36 inches with respect to the lowermost portion of the cabinet structure. All elevations as claimed are within what is normally expected for a standing human working with a transportable cart. The elevations must not be too high as such would require the user to find means to elevate themselves to open the lids and if the elevations are too low the users arms would not be long enough to reach them inside the cart. The selection of the



Art Unit: 3735

claimed dimensions are therefore commensurate with normal human anatomy therefore within the ordinary skill of one of ordinary skill in the medical arts.

### ***Double Patenting***

The nonstatutory double patenting rejection is based on a judicially created doctrine grounded in public policy (a policy reflected in the statute) so as to prevent the unjustified or improper timewise extension of the “right to exclude” granted by a patent and to prevent possible harassment by multiple assignees. A nonstatutory obviousness-type double patenting rejection is appropriate where the conflicting claims are not identical, but at least one examined application claim is not patentably distinct from the reference claim(s) because the examined application claim is either anticipated by, or would have been obvious over, the reference claim(s). See, e.g., *In re Berg*, 140 F.3d 1428, 46 USPQ2d 1226 (Fed. Cir. 1998); *In re Goodman*, 11 F.3d 1046, 29 USPQ2d 2010 (Fed. Cir. 1993); *In re Longi*, 759 F.2d 887, 225 USPQ 645 (Fed. Cir. 1985); *In re Van Ornum*, 686 F.2d 937, 214 USPQ 761 (CCPA 1982); *In re Vogel*, 422 F.2d 438, 164 USPQ 619 (CCPA 1970); and *In re Thorington*, 418 F.2d 528, 163 USPQ 644 (CCPA 1969).

A timely filed terminal disclaimer in compliance with 37 CFR 1.321(c) or 1.321(d) may be used to overcome an actual or provisional rejection based on a nonstatutory double patenting ground provided the conflicting application or patent either is shown to

Art Unit: 3735

be commonly owned with this application, or claims an invention made as a result of activities undertaken within the scope of a joint research agreement.

Effective January 1, 1994, a registered attorney or agent of record may sign a terminal disclaimer. A terminal disclaimer signed by the assignee must fully comply with 37 CFR 3.73(b).

Claims 1-19 and 26-30 are provisionally rejected on the ground of nonstatutory obviousness-type double patenting as being unpatentable over claims 16-28 of copending Application No. 12/954,307. Although the conflicting claims are not identical, they are not patentably distinct from each other because the differences are obvious modifications in the scope of the claims and obvious changes to the language of the claims.

This is a provisional obviousness-type double patenting rejection because the conflicting claims have not in fact been patented.

Claims 1-19 and 26-30 are provisionally rejected on the ground of nonstatutory obviousness-type double patenting as being unpatentable over claims 16-28 of copending Application No. 12/865,924. Although the conflicting claims are not identical, they are not patentably distinct from each other because the differences are obvious modifications in the scope of the claims and obvious changes to the language of the claims.

This is a provisional obviousness-type double patenting rejection because the conflicting claims have not in fact been patented.

***Allowable Subject Matter***

Claims 22-24 objected to as being dependent upon a rejected base claim, but would be allowable if rewritten in independent form including all of the limitations of the base claim and any intervening claims.

Claims 31-37 are allowed.

The following is a statement of reasons for the indication of allowable subject matter: the prior art does not teach a system as claimed including a cabinet, shielding assembly including the claimed compartment structure and a lock engaging the access panel.

***Conclusion***

Any inquiry concerning this communication or earlier communications from the examiner should be directed to SAMUEL GILBERT whose telephone number is (571)272-4725. The examiner can normally be reached on Monday-Friday 6:30-3:00.

If attempts to reach the examiner by telephone are unsuccessful, the examiner's supervisor, Charles Marmor II can be reached on 571-272-4730. The fax phone number for the organization where this application or proceeding is assigned is 571-273-8300.

Art Unit: 3735

Information regarding the status of an application may be obtained from the Patent Application Information Retrieval (PAIR) system. Status information for published applications may be obtained from either Private PAIR or Public PAIR. Status information for unpublished applications is available through Private PAIR only. For more information about the PAIR system, see <http://pair-direct.uspto.gov>. Should you have questions on access to the Private PAIR system, contact the Electronic Business Center (EBC) at 866-217-9197 (toll-free). If you would like assistance from a USPTO Customer Service Representative or access to the automated information system, call 800-786-9199 (IN USA OR CANADA) or 571-272-1000.

/Samuel G. Gilbert/  
Primary Examiner, Art Unit 3735

Application/Control Number: 12/137,356  
Art Unit: 3735

Page 13

|                                   |                                       |  |             |
|-----------------------------------|---------------------------------------|--|-------------|
| <b>Notice of References Cited</b> | Application/Control No.<br>12/137,356 | Applicant(s)/Patent Under<br>Reexamination<br>QUIRICO ET AL. |             |
|                                   | Examiner<br>SAMUEL GILBERT            | Art Unit<br>3735   | Page 1 of 1 |

**U.S. PATENT DOCUMENTS**

| * | Document Number<br>Country Code-Number-Kind Code | Date<br>MM-YYYY | Name        | Classification |
|---|--|-----------------|-------------|----------------|
| * | A US-2008/0177126                                | 07-2008         | Tate et al. | 600/5          |
|   | B US-  |                 |             |                |
|   | C US-  |                 |             |                |
|   | D US-  |                 |             |                |
|   | E US-  |                 |             |                |
|   | F US-  |                 |             |                |
|   | G US-  |                 |             |                |
|   | H US-  |                 |             |                |
|   | I US-  |                 |             |                |
|   | J US-  |                 |             |                |
|   | K US-  |                 |             |                |
|   | L US-  |                 |             |                |
|   | M US-  |                 |             |                |


**FOREIGN PATENT DOCUMENTS**

| * | Document Number<br>Country Code-Number-Kind Code | Date<br>MM-YYYY | Country | Name | Classification |
|---|--|-----------------|---------|------|----------------|
|   | N  |                 |         |      |                |
|   | O  |                 |         |      |                |
|   | P  |                 |         |      |                |
|   | Q  |                 |         |      |                |
|   | R  |                 |         |      |                |
|   | S  |                 |         |      |                |
|   | T  |                 |         |      |                |

**NON-PATENT DOCUMENTS**

| * | Document Number<br>Country Code-Number-Kind Code  | Date<br>MM-YYYY | Country | Name | Classification |
|---|---|-----------------|---------|------|----------------|
|   | Include as applicable: Author, Title Date, Publisher, Edition or Volume, Pertinent Pages) |                 |         |      |                |
|   | U   |                 |         |      |                |
|   | V   |                 |         |      |                |
|   | W   |                 |         |      |                |
|   | X   |                 |         |      |                |

\*A copy of this reference is not being furnished with this Office action. (See MPEP § 707.05(a).)  
Dates in MM-YYYY format are publication dates. Classifications may be US or foreign.

|   |  |  |
|---|--|--|
| <b>Index of Claims</b><br><br> | <b>Application/Control No.</b><br>12137356 | <b>Applicant(s)/Patent Under Reexamination</b><br>QUIRICO ET AL. |
|   | <b>Examiner</b><br>SAMUEL GILBERT          | <b>Art Unit</b><br>3735  |

|   |                 |
|---|-----------------|
| ✓ | <b>Rejected</b> |
| = | <b>Allowed</b>  |


|   |                   |
|---|-------------------|
| - | <b>Cancelled</b>  |
| ÷ | <b>Restricted</b> |

|   |                     |
|---|---------------------|
| N | <b>Non-Elected</b>  |
| I | <b>Interference</b> |

|   |                 |
|---|-----------------|
| A | <b>Appeal</b>   |
| O | <b>Objected</b> |

Claims renumbered in the same order as presented by applicant
  CPA
  T.D.
  R.1.47

| CLAIM |          | DATE       |  |  |  |  |  |  |  |
|-------|----------|------------|--|--|--|--|--|--|--|
| Final | Original | 03/26/2012 |  |  |  |  |  |  |  |
|       | 1        | ✓          |  |  |  |  |  |  |  |
|       | 2        | ✓          |  |  |  |  |  |  |  |
|       | 3        | ✓          |  |  |  |  |  |  |  |
|       | 4        | ✓          |  |  |  |  |  |  |  |
|       | 5        | ✓          |  |  |  |  |  |  |  |
|       | 6        | ✓          |  |  |  |  |  |  |  |
|       | 7        | ✓          |  |  |  |  |  |  |  |
|       | 8        | ✓          |  |  |  |  |  |  |  |
|       | 9        | ✓          |  |  |  |  |  |  |  |
|       | 10       | ✓          |  |  |  |  |  |  |  |
|       | 11       | ✓          |  |  |  |  |  |  |  |
|       | 12       | ✓          |  |  |  |  |  |  |  |
|       | 13       | ✓          |  |  |  |  |  |  |  |
|       | 14       | ✓          |  |  |  |  |  |  |  |
|       | 15       | ✓          |  |  |  |  |  |  |  |
|       | 16       | ✓          |  |  |  |  |  |  |  |
|       | 17       | ✓          |  |  |  |  |  |  |  |
|       | 18       | ✓          |  |  |  |  |  |  |  |
|       | 19       | ✓          |  |  |  |  |  |  |  |
|       | 20       | ✓          |  |  |  |  |  |  |  |
|       | 21       | ✓          |  |  |  |  |  |  |  |
|       | 22       | O          |  |  |  |  |  |  |  |
|       | 23       | O          |  |  |  |  |  |  |  |
|       | 24       | O          |  |  |  |  |  |  |  |
|       | 25       | ✓          |  |  |  |  |  |  |  |
|       | 26       | ✓          |  |  |  |  |  |  |  |
|       | 27       | ✓          |  |  |  |  |  |  |  |
|       | 28       | ✓          |  |  |  |  |  |  |  |
|       | 29       | ✓          |  |  |  |  |  |  |  |
|       | 30       | ✓          |  |  |  |  |  |  |  |
|       | 31       | =          |  |  |  |  |  |  |  |
|       | 32       | =          |  |  |  |  |  |  |  |
|       | 33       | =          |  |  |  |  |  |  |  |
|       | 34       | =          |  |  |  |  |  |  |  |
|       | 35       | =          |  |  |  |  |  |  |  |
|       | 36       | =          |  |  |  |  |  |  |  |

|  |  |  |
|--|--|--|
| <b><i>Index of Claims</i></b><br><br> | <b>Application/Control No.</b><br>12137356 | <b>Applicant(s)/Patent Under Reexamination</b><br>QUIRICO ET AL. |
|  | <b>Examiner</b><br>SAMUEL GILBERT          | <b>Art Unit</b><br>3735  |

|   |                 |
|---|-----------------|
| ✓ | <b>Rejected</b> |
| = | <b>Allowed</b>  |

|   |                   |
|---|-------------------|
| - | <b>Cancelled</b>  |
| ÷ | <b>Restricted</b> |

|   |                     |
|---|---------------------|
| N | <b>Non-Elected</b>  |
| I | <b>Interference</b> |

|   |                 |
|---|-----------------|
| A | <b>Appeal</b>   |
| O | <b>Objected</b> |

Claims renumbered in the same order as presented by applicant
  CPA
  T.D.
  R.1.47

| CLAIM |          | DATE       |  |  |  |  |  |  |  |
|-------|----------|------------|--|--|--|--|--|--|--|
| Final | Original | 03/26/2012 |  |  |  |  |  |  |  |
|       | 37       | =          |  |  |  |  |  |  |  |



Receipt date: 01/20/2009

Doc code: IDS

Doc description: Information Disclosure Statement (IDS) Filed

PTO/SB/08a (03-08)

Approved for use through 06/30/2008. OMB 0651-0031

U.S. Patent and Trademark Office; U.S. DEPARTMENT OF COMMERCE

Under the Paperwork Reduction Act of 1995, no persons are required to respond to a collection of information unless it contains a valid OMB control number.

|   |                        |                    |            |  |
|---|------------------------|--------------------|------------|--|
| <b>INFORMATION DISCLOSURE STATEMENT BY APPLICANT</b><br>( Not for submission under 37 CFR 1.99) | Application Number     |                    | 12137356   |  |
|   | Filing Date            |                    | 2008-06-11 |  |
|   | First Named Inventor   | Charles R. Quirico |            |  |
|   | Art Unit               |                    | 3763       |  |
|   | Examiner Name          |                    |            |  |
|   | Attorney Docket Number |                    | 56782.1.5  |  |

**U.S. PATENTS**

| Examiner Initial* | Cite No | Patent Number | Kind Code <sup>1</sup> | Issue Date | Name of Patentee or Applicant of cited Document | Pages, Columns, Lines where Relevant Passages or Relevant Figures Appear |
|-------------------|---------|---------------|------------------------|------------|---|--|
|                   | 1       |               |                        |            |   |  |

If you wish to add additional U.S. Patent citation information please click the Add button.

**U.S. PATENT APPLICATION PUBLICATIONS**

| Examiner Initial* | Cite No | Publication Number | Kind Code <sup>1</sup> | Publication Date | Name of Patentee or Applicant of cited Document | Pages, Columns, Lines where Relevant Passages or Relevant Figures Appear |
|-------------------|---------|--------------------|------------------------|------------------|---|--|
|                   | 1       |                    |                        |                  |   |  |

If you wish to add additional U.S. Published Application citation information please click the Add button.

**FOREIGN PATENT DOCUMENTS**

| Examiner Initial* | Cite No | Foreign Document Number <sup>3</sup> | Country Code <sup>2</sup> j | Kind Code <sup>4</sup> | Publication Date | Name of Patentee or Applicant of cited Document | Pages, Columns, Lines where Relevant Passages or Relevant Figures Appear | T <sup>5</sup>                      |
|-------------------|---------|--------------------------------------|-----------------------------|------------------------|------------------|---|--|-------------------------------------|
|                   | 1       | 2008140351                           | WO                          | A1                     | 2008-11-20       |   |  | <input checked="" type="checkbox"/> |

If you wish to add additional Foreign Patent Document citation information please click the Add button

**NON-PATENT LITERATURE DOCUMENTS**

| Examiner Initials* | Cite No | Include name of the author (in CAPITAL LETTERS), title of the article (when appropriate), title of the item (book, magazine, journal, serial, symposium, catalog, etc), date, pages(s), volume-issue number(s), publisher, city and/or country where published. | T <sup>5</sup> |
|--------------------|---------|---|----------------|
|                    |         |   |                |

|   |                        |                    |            |
|---|------------------------|--------------------|------------|
| <b>INFORMATION DISCLOSURE<br/>STATEMENT BY APPLICANT</b><br>( Not for submission under 37 CFR 1.99) | Application Number     |                    | 12137356   |
|   | Filing Date            |                    | 2008-06-11 |
|   | First Named Inventor   | Charles R. Quirico |            |
|   | Art Unit               |                    | 3763       |
|   | Examiner Name          |                    |            |
|   | Attorney Docket Number |                    | 56782.1.5  |

|   |  |                          |
|---|--|--------------------------|
| 1 |  | <input type="checkbox"/> |
|---|--|--------------------------|


If you wish to add additional non-patent literature document citation information please click the Add button

**EXAMINER SIGNATURE**

|                    |                  |                 |            |
|--------------------|------------------|-----------------|------------|
| Examiner Signature | /Samuel Gilbert/ | Date Considered | 03/20/2012 |
|--------------------|------------------|-----------------|------------|

\*EXAMINER: Initial if reference considered, whether or not citation is in conformance with MPEP 609. Draw line through a citation if not in conformance and not considered. Include copy of this form with next communication to applicant.

<sup>1</sup> See Kind Codes of USPTO Patent Documents at [www.USPTO.GOV](http://www.USPTO.GOV) or MPEP 901.04. <sup>2</sup> Enter office that issued the document, by the two-letter code (WIPO Standard ST.3). <sup>3</sup> For Japanese patent documents, the indication of the year of the reign of the Emperor must precede the serial number of the patent document. <sup>4</sup> Kind of document by the appropriate symbols as indicated on the document under WIPO Standard ST.16 if possible. <sup>5</sup> Applicant is to place a check mark here if English language translation is attached.

|  |  |  |
|--|--|--|
| <b>Search Notes</b><br><br> | <b>Application/Control No.</b><br><br>12137356 | <b>Applicant(s)/Patent Under Reexamination</b><br><br>QUIRICO ET AL. |
|  | <b>Examiner</b><br><br>SAMUEL GILBERT          | <b>Art Unit</b><br><br>3735  |

| SEARCHED |                            |         |          |
|----------|----------------------------|---------|----------|
| Class    | Subclass                   | Date    | Examiner |
| 128      | 897,898                    |         |          |
| 280      | 47.34, 47.35, 79.11, 79.3, |         |          |
| 208      | 638,651,33.992,79.5,79.6   | 3/26/12 | sgg      |

| SEARCH NOTES |         |          |
|--------------|---------|----------|
| Search Notes | Date    | Examiner |
| EAST         | 3/26/12 | sgg      |

| INTERFERENCE SEARCH |          |      |          |
|---------------------|----------|------|----------|
| Class               | Subclass | Date | Examiner |
|                     |          |      |          |

|  |  |
|--|--|
|  |  |
|--|--|

Receipt date: 03/12/2010

Doc code: IDS

Doc description: Information Disclosure Statement (IDS) Filed

PTO/SB/08a (01-10)

Approved for use through 07/31/2012. OMB 0651-0031

U.S. Patent and Trademark Office; U.S. DEPARTMENT OF COMMERCE

Under the Paperwork Reduction Act of 1995, no persons are required to respond to a collection of information unless it contains a valid OMB control number.

|   |                        |                    |            |  |
|---|------------------------|--------------------|------------|--|
| <b>INFORMATION DISCLOSURE STATEMENT BY APPLICANT</b><br>( Not for submission under 37 CFR 1.99) | Application Number     |                    | 12137356   |  |
|   | Filing Date            |                    | 2008-06-11 |  |
|   | First Named Inventor   | Charles R. Quirico |            |  |
|   | Art Unit               |                    | 3735       |  |
|   | Examiner Name          |                    |            |  |
|   | Attorney Docket Number |                    | 56782.1.5  |  |

| U.S.PATENTS       |         |               |                        |            |   |  |
|-------------------|---------|---------------|------------------------|------------|---|--|
| Examiner Initial* | Cite No | Patent Number | Kind Code <sup>1</sup> | Issue Date | Name of Patentee or Applicant of cited Document | Pages,Columns,Lines where Relevant Passages or Relevant Figures Appear |
|                   | 1       | 5590648       |                        | 1997-01-07 | Mitchell et al.                                 |  |

If you wish to add additional U.S. Patent citation information please click the Add button.

| U.S.PATENT APPLICATION PUBLICATIONS |         |                    |                        |                  |   |  |
|-------------------------------------|---------|--------------------|------------------------|------------------|---|--|
| Examiner Initial*                   | Cite No | Publication Number | Kind Code <sup>1</sup> | Publication Date | Name of Patentee or Applicant of cited Document | Pages,Columns,Lines where Relevant Passages or Relevant Figures Appear |
|                                     | 1       | 20070213848        |                        | 2007-09-13       | DeKemp et al.                                   |  |
|                                     | 2       | 20080093564        |                        | 2008-04-24       | Tartaglia et al.                                |  |
|                                     | 3       | 20080242915        |                        | 2008-10-02       | Jackson et al.                                  |  |

If you wish to add additional U.S. Published Application citation information please click the Add button.

| FOREIGN PATENT DOCUMENTS |         |                                      |                           |                        |                  |   |  |                          |
|--------------------------|---------|--------------------------------------|---------------------------|------------------------|------------------|---|--|--------------------------|
| Examiner Initial*        | Cite No | Foreign Document Number <sup>3</sup> | Country Code <sup>2</sup> | Kind Code <sup>4</sup> | Publication Date | Name of Patentee or Applicant of cited Document | Pages,Columns,Lines where Relevant Passages or Relevant Figures Appear | T <sup>5</sup>           |
|                          | 1       | 9615337                              | WO                        |                        | 1996-05-23       | Nilsson   |  | <input type="checkbox"/> |

|  |                        |                    |            |  |
|--|------------------------|--------------------|------------|--|
| <b>Receipt date: 03/12/2010</b><br><br><b>INFORMATION DISCLOSURE STATEMENT BY APPLICANT</b><br>( Not for submission under 37 CFR 1.99) | Application Number     |                    | 12137356   |  |
|  | Filing Date            |                    | 2008-06-11 |  |
|  | First Named Inventor   | Charles R. Quirico |            |  |
|  | Art Unit               |                    | 3735       |  |
|  | Examiner Name          |                    |            |  |
|  | Attorney Docket Number |                    | 56782.1.5  |  |

|  |   |            |    |  |            |                   |                          |
|--|---|------------|----|--|------------|-------------------|--------------------------|
|  | 2 | 02096335   | WO |  | 2002-12-05 | Hill ROM Services | <input type="checkbox"/> |
|  | 3 | 2006074473 | WO |  | 2006-07-13 | Atlas Systems     | <input type="checkbox"/> |
|  | 4 | 2008028165 | WO |  | 2008-03-06 | Catholic Health   | <input type="checkbox"/> |

If you wish to add additional Foreign Patent Document citation information please click the Add button

**NON-PATENT LITERATURE DOCUMENTS**

| Examiner Initials* | Cite No | Include name of the author (in CAPITAL LETTERS), title of the article (when appropriate), title of the item (book, magazine, journal, serial, symposium, catalog, etc), date, pages(s), volume-issue number(s), publisher, city and/or country where published. | T <sup>5</sup>           |
|--------------------|---------|---|--------------------------|
|                    | 1       | NEIL J. EPSTEIN, et al., "A Rb82 infusion system for quantitative perfusion imaging with 3D PET" Applied Radiation and Isotopes, vol. 60, 9 February 2004, pages 921-927, XP002557544 DOI:10, 1016/j. apradiso.2004.02.002                                      | <input type="checkbox"/> |
|                    | 2       | R. KLEIN, et al., "Precision controlled elution of a Sr82/Rb82 generator for cardiac perfusion imaging with positron emission tomography" Physics in Medicine and Biology, vol. 52, 11 January 2007, pages 659-673, XP002557545 DOI:10, 1088/0031-9155/52/3/009 | <input type="checkbox"/> |
|                    | 3       | International Search Report and Written Opinion, dated 02-25-2010 for PCT Application No. PCT/US2009/047027, 22 pages   | <input type="checkbox"/> |
|                    | 4       | International Search Report and Written Opinion, dated 02-17-2010 for PCT Application No. PCT/US2009/047030, 17 pages   | <input type="checkbox"/> |
|                    | 5       | International Search Report and Written Opinion, dated 03-01-2010 for PCT Application No. PCT/US2009/047031, 20 pages   | <input type="checkbox"/> |
|                    | 6       | International Search Report and Written Opinion, dated 02-25-2010 for PCT Application No. PCT/US2009/047034, 15 pages   | <input type="checkbox"/> |

If you wish to add additional non-patent literature document citation information please click the Add button

|  |                        |                    |
|--|------------------------|--------------------|
| <b>Receipt date: 03/12/2010</b><br><br><b>INFORMATION DISCLOSURE<br/>STATEMENT BY APPLICANT</b><br>( Not for submission under 37 CFR 1.99) | Application Number     | 12137356           |
|  | Filing Date            | 2008-06-11         |
|  | First Named Inventor   | Charles R. Quirico |
|  | Art Unit               | 3735               |
|  | Examiner Name          |                    |
|  | Attorney Docket Number | 56782.1.5          |

| <b>EXAMINER SIGNATURE</b> |                  |                 |            |
|---------------------------|------------------|-----------------|------------|
| Examiner Signature        | /Samuel Gilbert/ | Date Considered | 03/20/2012 |

\*EXAMINER: Initial if reference considered, whether or not citation is in conformance with MPEP 609. Draw line through a citation if not in conformance and not considered. Include copy of this form with next communication to applicant.

<sup>1</sup> See Kind Codes of USPTO Patent Documents at [www.USPTO.GOV](http://www.USPTO.GOV) or MPEP 901.04. <sup>2</sup> Enter office that issued the document, by the two-letter code (WIPO Standard ST.3). <sup>3</sup> For Japanese patent documents, the indication of the year of the reign of the Emperor must precede the serial number of the patent document. <sup>4</sup> Kind of document by the appropriate symbols as indicated on the document under WIPO Standard ST.16 if possible. <sup>5</sup> Applicant is to place a check mark here if English language translation is attached.

Receipt date: 07/15/2009

Doc code: IDS

Doc description: Information Disclosure Statement (IDS) Filed

PTO/SB/08a (03-08)

Approved for use through 06/30/2008. OMB 0651-0031

U.S. Patent and Trademark Office; U.S. DEPARTMENT OF COMMERCE

Under the Paperwork Reduction Act of 1995, no persons are required to respond to a collection of information unless it contains a valid OMB control number.

|   |                        |                    |            |
|---|------------------------|--------------------|------------|
| <b>INFORMATION DISCLOSURE<br/>STATEMENT BY APPLICANT</b><br>( Not for submission under 37 CFR 1.99) | Application Number     |                    | 12137356   |
|   | Filing Date            |                    | 2008-06-11 |
|   | First Named Inventor   | Charles R. Quirico |            |
|   | Art Unit               |                    | 3763       |
|   | Examiner Name          |                    |            |
|   | Attorney Docket Number |                    | 56782.1.5  |

| U.S.PATENTS       |         |               |                        |            |   |  | Remove |
|-------------------|---------|---------------|------------------------|------------|---|--|--------|
| Examiner Initial* | Cite No | Patent Number | Kind Code <sup>1</sup> | Issue Date | Name of Patentee or Applicant of cited Document | Pages, Columns, Lines where Relevant Passages or Relevant Figures Appear |        |
|                   | 1       | 3774036       |                        | 1973-11-20 | Gerhart   |  |        |
|                   | 2       | 3997784       |                        | 1976-12-14 | Picunko, et al.                                 |  |        |
|                   | 3       | 4286169       |                        | 1981-08-25 | Rossem  |  |        |
|                   | 4       | 4625118       |                        | 1986-11-25 | Kriwetz et al.                                  |  |        |
|                   | 5       | 4679142       |                        | 1987-07-07 | Lee   |  |        |
|                   | 6       | 4755679       |                        | 1988-07-05 | Wong  |  |        |
|                   | 7       | 4853546       |                        | 1989-08-01 | Abe et al.                                      |  |        |
|                   | 8       | 5039863       |                        | 1991-08-13 | Matsuno et al.                                  |  |        |

Receipt date: 07/15/2009

|                        |                    |
|------------------------|--------------------|
| Application Number     | 12137356           |
| Filing Date            | 2008-06-11         |
| First Named Inventor   | Charles R. Quirico |
| Art Unit               | 3763               |
| Examiner Name          |                    |
| Attorney Docket Number | 56782.1.5          |

**INFORMATION DISCLOSURE  
STATEMENT BY APPLICANT**  
( Not for submission under 37 CFR 1.99)

|    |         |    |            |                   |  |
|----|---------|----|------------|-------------------|--|
| 9  | 5258906 |    | 1993-11-02 | Kroll et al.      |  |
| 10 | 5274239 |    | 1993-12-28 | Lane et al.       |  |
| 11 | 5475232 |    | 1995-12-12 | Powers et al.     |  |
| 12 | 5485831 |    | 1996-01-23 | Holdsworth et al. |  |
| 13 | 5739508 |    | 1998-04-14 | Uber, III         |  |
| 14 | 5840026 |    | 1998-11-24 | Uber, III et al.  |  |
| 15 | 5885216 |    | 1999-03-23 | Evans, III et al. |  |
| 16 | 6157036 |    | 2000-12-05 | Whiting et al.    |  |
| 17 | 6442418 | B1 | 2002-08-27 | Evans, III et al. |  |
| 18 | 6626862 | B1 | 2003-09-30 | Duchon et al.     |  |
| 19 | 6767319 | B2 | 2004-07-27 | Reilly et al.     |  |



|   |                        |                    |            |  |
|---|------------------------|--------------------|------------|--|
| <b>Receipt date: 07/15/2009</b><br><br><b>INFORMATION DISCLOSURE STATEMENT BY APPLICANT</b><br><b>( Not for submission under 37 CFR 1.99)</b> | Application Number     |                    | 12137356   |  |
|   | Filing Date            |                    | 2008-06-11 |  |
|   | First Named Inventor   | Charles R. Quirico |            |  |
|   | Art Unit               |                    | 3763       |  |
|   | Examiner Name          |                    |            |  |
|   | Attorney Docket Number |                    | 56782.1.5  |  |

|  |    |         |    |            |                   |  |
|--|----|---------|----|------------|-------------------|--|
|  | 20 | 6901283 | B2 | 2005-05-31 | Evans, III et al. |  |
|  | 21 | 7169135 | B2 | 2007-01-30 | Duchon et al.     |  |
|  | 22 | 7256888 | B2 | 2007-08-14 | Staehr et al.     |  |
|  | 23 | 7413123 | B2 | 2008-08-19 | Ortenzi           |  |

If you wish to add additional U.S. Patent citation information please click the Add button.

[Add](#)

**U.S.PATENT APPLICATION PUBLICATIONS**

[Remove](#)

| Examiner Initial* | Cite No | Publication Number | Kind Code <sup>1</sup> | Publication Date | Name of Patentee or Applicant of cited Document | Pages,Columns,Lines where Relevant Passages or Relevant Figures Appear |
|-------------------|---------|--------------------|------------------------|------------------|---|--|
|                   | 1       | 20070282263        | A1                     | 2007-12-06       | Kalafut et al.                                  |  |
|                   | 2       | 20080071219        | A1                     | 2008-03-20       | Rhinehart et al.                                |  |
|                   | 3       | 20080166292        | A1                     | 2008-07-10       | Levin et al.                                    |  |

If you wish to add additional U.S. Published Application citation information please click the Add button.

[Add](#)

**FOREIGN PATENT DOCUMENTS**

[Remove](#)

| Examiner Initial* | Cite No | Foreign Document Number <sup>3</sup> | Country Code <sup>2</sup> i | Kind Code <sup>4</sup> | Publication Date | Name of Patentee or Applicant of cited Document | Pages,Columns,Lines where Relevant Passages or Relevant Figures Appear | T <sup>5</sup> |
|-------------------|---------|--------------------------------------|-----------------------------|------------------------|------------------|---|--|----------------|
|                   |         |                                      |                             |                        |                  |   |  |                |

|   |                        |                    |            |  |
|---|------------------------|--------------------|------------|--|
| <b>Receipt date: 07/15/2009</b><br><br><b>INFORMATION DISCLOSURE STATEMENT BY APPLICANT</b><br><b>( Not for submission under 37 CFR 1.99)</b> | Application Number     |                    | 12137356   |  |
|   | Filing Date            |                    | 2008-06-11 |  |
|   | First Named Inventor   | Charles R. Quirico |            |  |
|   | Art Unit               | 3763               |            |  |
|   | Examiner Name          |                    |            |  |
|   | Attorney Docket Number | 56782.15           |            |  |

|  |   |            |    |    |            |                    |                          |
|--|---|------------|----|----|------------|--------------------|--------------------------|
|  | 1 | 2006007750 | WO | A1 | 2006-01-26 | UNIVERSITÄT ZÜRICH | <input type="checkbox"/> |
|--|---|------------|----|----|------------|--------------------|--------------------------|

If you wish to add additional Foreign Patent Document citation information please click the Add button

**NON-PATENT LITERATURE DOCUMENTS**

| Examiner Initials* | Cite No | Include name of the author (in CAPITAL LETTERS), title of the article (when appropriate), title of the item (book, magazine, journal, serial, symposium, catalog, etc), date, pages(s), volume-issue number(s), publisher, city and/or country where published. | T <sup>5</sup>           |
|--------------------|---------|---|--------------------------|
|                    | 1       |   | <input type="checkbox"/> |

If you wish to add additional non-patent literature document citation information please click the Add button

**EXAMINER SIGNATURE**

|                    |                  |                 |            |
|--------------------|------------------|-----------------|------------|
| Examiner Signature | /Samuel Gilbert/ | Date Considered | 03/20/2012 |
|--------------------|------------------|-----------------|------------|

\*EXAMINER: Initial if reference considered, whether or not citation is in conformance with MPEP 609. Draw line through a citation if not in conformance and not considered. Include copy of this form with next communication to applicant.

<sup>1</sup> See Kind Codes of USPTO Patent Documents at [www.USPTO.GOV](http://www.USPTO.GOV) or MPEP 901.04. <sup>2</sup> Enter office that issued the document, by the two-letter code (WIPO Standard ST.3). <sup>3</sup> For Japanese patent documents, the indication of the year of the reign of the Emperor must precede the serial number of the patent document. <sup>4</sup> Kind of document by the appropriate symbols as indicated on the document under WIPO Standard ST.16 if possible. <sup>5</sup> Applicant is to place a check mark here if English language translation is attached.

Receipt date: 05/20/2009

Doc code: IDS

Doc description: Information Disclosure Statement (IDS) Filed

PTO/SB/08a (03-08)

Approved for use through 06/30/2008. OMB 0651-0031

U.S. Patent and Trademark Office; U.S. DEPARTMENT OF COMMERCE

Under the Paperwork Reduction Act of 1995, no persons are required to respond to a collection of information unless it contains a valid OMB control number.

|   |                        |                    |
|---|------------------------|--------------------|
| <b>INFORMATION DISCLOSURE STATEMENT BY APPLICANT</b><br>( Not for submission under 37 CFR 1.99) | Application Number     | 12137356           |
|   | Filing Date            | 2008-06-11         |
|   | First Named Inventor   | Charles R. Quirico |
|   | Art Unit               | 3763               |
|   | Examiner Name          |                    |
|   | Attorney Docket Number | 56782.1.5          |

| U.S. PATENTS      |         |               |                        |            |   |  | Remove |
|-------------------|---------|---------------|------------------------|------------|---|--|--------|
| Examiner Initial* | Cite No | Patent Number | Kind Code <sup>1</sup> | Issue Date | Name of Patentee or Applicant of cited Document | Pages, Columns, Lines where Relevant Passages or Relevant Figures Appear |        |
|                   | 1       |               |                        |            |   |  |        |

If you wish to add additional U.S. Patent citation information please click the Add button. Add

| U.S. PATENT APPLICATION PUBLICATIONS |         |                    |                        |                  |   |  | Remove |
|--------------------------------------|---------|--------------------|------------------------|------------------|---|--|--------|
| Examiner Initial*                    | Cite No | Publication Number | Kind Code <sup>1</sup> | Publication Date | Name of Patentee or Applicant of cited Document | Pages, Columns, Lines where Relevant Passages or Relevant Figures Appear |        |
|                                      | 1       |                    |                        |                  |   |  |        |

If you wish to add additional U.S. Published Application citation information please click the Add button. Add

| FOREIGN PATENT DOCUMENTS |         |                                      |                             |                        |                  |   |  | Remove                   |
|--------------------------|---------|--------------------------------------|-----------------------------|------------------------|------------------|---|--|--------------------------|
| Examiner Initial*        | Cite No | Foreign Document Number <sup>3</sup> | Country Code <sup>2</sup> j | Kind Code <sup>4</sup> | Publication Date | Name of Patentee or Applicant of cited Document | Pages, Columns, Lines where Relevant Passages or Relevant Figures Appear | T <sup>5</sup>           |
|                          | 1       | 2007071022                           | WO                          | A1                     | 2007-06-28       | Robert A. Dekemp                                |  | <input type="checkbox"/> |
|                          | 2       | 2007104133                           | WO                          | A1                     | 2007-09-20       | Robert A. Dekemp                                |  | <input type="checkbox"/> |

If you wish to add additional Foreign Patent Document citation information please click the Add button Add

| NON-PATENT LITERATURE DOCUMENTS |  |  |  |  |  |  |  | Remove |
|---------------------------------|--|--|--|--|--|--|--|--------|
|---------------------------------|--|--|--|--|--|--|--|--------|

|   |                        |                    |            |
|---|------------------------|--------------------|------------|
| <b>INFORMATION DISCLOSURE<br/>STATEMENT BY APPLICANT</b><br>( Not for submission under 37 CFR 1.99) | Application Number     |                    | 12137356   |
|   | Filing Date            |                    | 2008-06-11 |
|   | First Named Inventor   | Charles R. Quirico |            |
|   | Art Unit               |                    | 3763       |
|   | Examiner Name          |                    |            |
|   | Attorney Docket Number |                    | 56782.1.5  |

| Examiner Initials* | Cite No | Include name of the author (in CAPITAL LETTERS), title of the article (when appropriate), title of the item (book, magazine, journal, serial, symposium, catalog, etc), date, pages(s), volume-issue number(s), publisher, city and/or country where published. | T <sup>5</sup>           |
|--------------------|---------|---|--------------------------|
|                    | 1       |   | <input type="checkbox"/> |

If you wish to add additional non-patent literature document citation information please click the Add button

**EXAMINER SIGNATURE**

|                    |                  |                 |            |
|--------------------|------------------|-----------------|------------|
| Examiner Signature | /Samuel Gilbert/ | Date Considered | 03/20/2012 |
|--------------------|------------------|-----------------|------------|

\*EXAMINER: Initial if reference considered, whether or not citation is in conformance with MPEP 609. Draw line through a citation if not in conformance and not considered. Include copy of this form with next communication to applicant.

<sup>1</sup> See Kind Codes of USPTO Patent Documents at [www.USPTO.GOV](http://www.USPTO.GOV) or MPEP 901.04. <sup>2</sup> Enter office that issued the document, by the two-letter code (WIPO Standard ST.3). <sup>3</sup> For Japanese patent documents, the indication of the year of the reign of the Emperor must precede the serial number of the patent document. <sup>4</sup> Kind of document by the appropriate symbols as indicated on the document under WIPO Standard ST.16 if possible. <sup>5</sup> Applicant is to place a check mark here if English language translation is attached.

Receipt date: 10/16/2009

Doc code: IDS

Doc description: Information Disclosure Statement (IDS) Filed

PTO/SB/08a (07-09)

Approved for use through 07/31/2012. OMB 0651-0031

U.S. Patent and Trademark Office; U.S. DEPARTMENT OF COMMERCE

Under the Paperwork Reduction Act of 1995, no persons are required to respond to a collection of information unless it contains a valid OMB control number.

|   |                        |                    |            |  |
|---|------------------------|--------------------|------------|--|
| <b>INFORMATION DISCLOSURE STATEMENT BY APPLICANT</b><br>( Not for submission under 37 CFR 1.99) | Application Number     |                    | 12137356   |  |
|   | Filing Date            |                    | 2008-06-11 |  |
|   | First Named Inventor   | Charles R. Quirico |            |  |
|   | Art Unit               |                    | 3735       |  |
|   | Examiner Name          |                    |            |  |
|   | Attorney Docket Number |                    | 56782.1.5  |  |

| U.S.PATENTS       |         |               |                        |            |   |  | Remove |
|-------------------|---------|---------------|------------------------|------------|---|--|--------|
| Examiner Initial* | Cite No | Patent Number | Kind Code <sup>1</sup> | Issue Date | Name of Patentee or Applicant of cited Document | Pages,Columns,Lines where Relevant Passages or Relevant Figures Appear |        |
|                   | 1       |               |                        |            |   |  |        |

If you wish to add additional U.S. Patent citation information please click the Add button.

Add

| U.S.PATENT APPLICATION PUBLICATIONS |         |                    |                        |                  |   |  | Remove |
|-------------------------------------|---------|--------------------|------------------------|------------------|---|--|--------|
| Examiner Initial*                   | Cite No | Publication Number | Kind Code <sup>1</sup> | Publication Date | Name of Patentee or Applicant of cited Document | Pages,Columns,Lines where Relevant Passages or Relevant Figures Appear |        |
|                                     | 1       | 20030004463        | A1                     | 2003-01-02       | Reilly  |  |        |
|                                     | 2       | 20070140958        | A1                     | 2007-06-21       | DeKemp  |  |        |

If you wish to add additional U.S. Published Application citation information please click the Add button.

Add

| FOREIGN PATENT DOCUMENTS |         |                                      |                             |                        |                  |   |  | Remove                   |
|--------------------------|---------|--------------------------------------|-----------------------------|------------------------|------------------|---|--|--------------------------|
| Examiner Initial*        | Cite No | Foreign Document Number <sup>3</sup> | Country Code <sup>2</sup> i | Kind Code <sup>4</sup> | Publication Date | Name of Patentee or Applicant of cited Document | Pages,Columns,Lines where Relevant Passages or Relevant Figures Appear | T <sup>5</sup>           |
|                          | 1       | 9956117                              | WO                          |                        | 1999-11-04       | General Hospital Corp                           |  | <input type="checkbox"/> |
|                          | 2       | 20050002971                          | WO                          |                        | 2005-01-13       | Iphase Technologies                             |  | <input type="checkbox"/> |

|  |                        |                    |            |  |
|--|------------------------|--------------------|------------|--|
| <b>Receipt date: 10/16/2009</b><br><br><b>INFORMATION DISCLOSURE STATEMENT BY APPLICANT</b><br>( Not for submission under 37 CFR 1.99) | Application Number     |                    | 12137356   |  |
|  | Filing Date            |                    | 2008-06-11 |  |
|  | First Named Inventor   | Charles R. Quirico |            |  |
|  | Art Unit               |                    | 3735       |  |
|  | Examiner Name          |                    |            |  |
|  | Attorney Docket Number |                    | 56782.1.5  |  |

|    |            |    |  |            |                          |                          |
|----|------------|----|--|------------|--------------------------|--------------------------|
| 3  | 2006129301 | WO |  | 2006-12-07 | Spec-Trum Dynamics       | <input type="checkbox"/> |
| 4  | 2008037939 | WO |  | 2008-04-03 | Lerner Protection        | <input type="checkbox"/> |
| 5  | 2008082966 | WO |  | 2008-07-10 | Medrad, Inc.             | <input type="checkbox"/> |
| 6  | 0160303    | EP |  | 1985-11-06 | E.R. Squibb              | <input type="checkbox"/> |
| 7  | 0310148    | EP |  | 1989-04-05 | E.R. Squibb              | <input type="checkbox"/> |
| 8  | 2867084    | FR |  | 2005-09-09 | General Electric Company | <input type="checkbox"/> |
| 9  | 2006325826 | JP |  | 2006-12-07 | S.D. Giken               | <input type="checkbox"/> |
| 10 | 2000350783 | JP |  | 2000-12-19 | Sumitomo Heavy Ind Ltd   | <input type="checkbox"/> |

If you wish to add additional Foreign Patent Document citation information please click the Add button

**NON-PATENT LITERATURE DOCUMENTS**

| Examiner Initials* | Cite No | Include name of the author (in CAPITAL LETTERS), title of the article (when appropriate), title of the item (book, magazine, journal, serial, symposium, catalog, etc), date, pages(s), volume-issue number(s), publisher, city and/or country where published. | T <sup>5</sup>           |
|--------------------|---------|---|--------------------------|
|                    | 1       |   | <input type="checkbox"/> |

If you wish to add additional non-patent literature document citation information please click the Add button

|   |                        |                    |            |
|---|------------------------|--------------------|------------|
| <b>INFORMATION DISCLOSURE<br/>STATEMENT BY APPLICANT</b><br>( Not for submission under 37 CFR 1.99) | Application Number     |                    | 12137356   |
|   | Filing Date            |                    | 2008-06-11 |
|   | First Named Inventor   | Charles R. Quirico |            |
|   | Art Unit               |                    | 3735       |
|   | Examiner Name          |                    |            |
|   | Attorney Docket Number |                    | 56782.1.5  |

| EXAMINER SIGNATURE |                  |                 |            |
|--------------------|------------------|-----------------|------------|
| Examiner Signature | /Samuel Gilbert/ | Date Considered | 03/20/2012 |

\*EXAMINER: Initial if reference considered, whether or not citation is in conformance with MPEP 609. Draw line through a citation if not in conformance and not considered. Include copy of this form with next communication to applicant.

<sup>1</sup> See Kind Codes of USPTO Patent Documents at [www.USPTO.GOV](http://www.USPTO.GOV) or MPEP 901.04. <sup>2</sup> Enter office that issued the document, by the two-letter code (WIPO Standard ST.3). <sup>3</sup> For Japanese patent documents, the indication of the year of the reign of the Emperor must precede the serial number of the patent document. <sup>4</sup> Kind of document by the appropriate symbols as indicated on the document under WIPO Standard ST.16 if possible. <sup>5</sup> Applicant is to place a check mark here if English language translation is attached.

Receipt date: 08/04/2010

Doc code: IDS

Doc description: Information Disclosure Statement (IDS) Filed

PTO/SB/08a (01-10)

Approved for use through 07/31/2012. OMB 0651-0031

U.S. Patent and Trademark Office; U.S. DEPARTMENT OF COMMERCE

Under the Paperwork Reduction Act of 1995, no persons are required to respond to a collection of information unless it contains a valid OMB control number.

|   |                        |                    |            |  |
|---|------------------------|--------------------|------------|--|
| <b>INFORMATION DISCLOSURE STATEMENT BY APPLICANT</b><br>( Not for submission under 37 CFR 1.99) | Application Number     |                    | 12137356   |  |
|   | Filing Date            |                    | 2008-06-11 |  |
|   | First Named Inventor   | CHARLES R. QUIRICO |            |  |
|   | Art Unit               |                    | 3735       |  |
|   | Examiner Name          | Charles Marmor II  |            |  |
|   | Attorney Docket Number |                    | 56782.1.5  |  |

| U.S.PATENTS       |         |               |                        |            |   |  | Remove |
|-------------------|---------|---------------|------------------------|------------|---|--|--------|
| Examiner Initial* | Cite No | Patent Number | Kind Code <sup>1</sup> | Issue Date | Name of Patentee or Applicant of cited Document | Pages,Columns,Lines where Relevant Passages or Relevant Figures Appear |        |
|                   | 1       | 6908598       |                        | 2005-06-21 | Sylvester                                       |  |        |
|                   | 2       | 7163031       |                        | 2007-01-16 | Graves et al.                                   |  |        |
|                   | 3       | 7476377       |                        | 2009-01-13 | Moller  |  |        |
|                   | 4       | 7504646       |                        | 2009-03-17 | Balestracci                                     |  |        |

If you wish to add additional U.S. Patent citation information please click the Add button.

Add

| U.S.PATENT APPLICATION PUBLICATIONS |         |                    |                        |                  |   |  | Remove |
|-------------------------------------|---------|--------------------|------------------------|------------------|---|--|--------|
| Examiner Initial*                   | Cite No | Publication Number | Kind Code <sup>1</sup> | Publication Date | Name of Patentee or Applicant of cited Document | Pages,Columns,Lines where Relevant Passages or Relevant Figures Appear |        |
|                                     | 1       | 20070232980        |                        | 2007-10-04       | Felt  |  |        |
|                                     | 2       | 20090312635        |                        | 2009-12-17       | Shimchuk  |  |        |

If you wish to add additional U.S. Published Application citation information please click the Add button.

Add

| FOREIGN PATENT DOCUMENTS |  |  |  |  |  |  | Remove |
|--------------------------|--|--|--|--|--|--|--------|
|--------------------------|--|--|--|--|--|--|--------|



|  |                        |                    |            |  |
|--|------------------------|--------------------|------------|--|
| <b>Receipt date: 08/04/2010</b><br><br><b>INFORMATION DISCLOSURE STATEMENT BY APPLICANT</b><br>( Not for submission under 37 CFR 1.99) | Application Number     |                    | 12137356   |  |
|  | Filing Date            |                    | 2008-06-11 |  |
|  | First Named Inventor   | CHARLES R. QUIRICO |            |  |
|  | Art Unit               |                    | 3735       |  |
|  | Examiner Name          | Charles Marmor II  |            |  |
|  | Attorney Docket Number |                    | 56782.1.5  |  |

| Examiner Initial* | Cite No | Foreign Document Number <sup>3</sup> | Country Code <sup>2</sup> i | Kind Code <sup>4</sup> | Publication Date | Name of Patentee or Applicant of cited Document | Pages, Columns, Lines where Relevant Passages or Relevant Figures Appear | T <sup>5</sup>           |
|-------------------|---------|--------------------------------------|-----------------------------|------------------------|------------------|---|--|--------------------------|
|                   | 1       | 2004059661                           | WO                          |                        | 2004-07-15       | Lynntech, Inc.                                  |  | <input type="checkbox"/> |
|                   | 2       | 2006026603                           | WO                          |                        | 2006-03-09       | Bracco Diagnostics                              |  | <input type="checkbox"/> |
|                   | 3       | 2006135374                           | WO                          |                        | 2006-12-21       | Lynntech Inc.                                   |  | <input type="checkbox"/> |
|                   | 4       | 2008140351                           | WO                          |                        | 2008-11-20       | Obshchestvo                                     |  | <input type="checkbox"/> |
|                   | 5       | 2010020596                           | WO                          |                        | 2010-02-25       | Stichting Jeroen Bosch                          |  | <input type="checkbox"/> |

If you wish to add additional Foreign Patent Document citation information please click the Add button

**NON-PATENT LITERATURE DOCUMENTS**

| Examiner Initials* | Cite No | Include name of the author (in CAPITAL LETTERS), title of the article (when appropriate), title of the item (book, magazine, journal, serial, symposium, catalog, etc), date, pages(s), volume-issue number(s), publisher, city and/or country where published. | T <sup>5</sup>           |
|--------------------|---------|---|--------------------------|
|                    | 1       |   | <input type="checkbox"/> |

If you wish to add additional non-patent literature document citation information please click the Add button

**EXAMINER SIGNATURE**

|                    |                  |                 |            |
|--------------------|------------------|-----------------|------------|
| Examiner Signature | /Samuel Gilbert/ | Date Considered | 03/20/2012 |
|--------------------|------------------|-----------------|------------|

\*EXAMINER: Initial if reference considered, whether or not citation is in conformance with MPEP 609. Draw line through a citation if not in conformance and not considered. Include copy of this form with next communication to applicant.

## EAST Search History

## EAST Search History (Prior Art)

| Ref # | Hits | Search Query  | DBs                    | Default Operator | Plurals | Time Stamp          |
|-------|------|---|------------------------|------------------|---------|---------------------|
| L1    | 689  | (128/897,897).CCLS.   | US-PGPUB; USPAT        | OR               | OFF     | 2012/03/26<br>11:18 |
| L2    | 4393 | (280/47.34,47.35,79.11,79.3,638,651,33.992,79.5,79.6).CCLS.   | US-PGPUB; USPAT        | OR               | OFF     | 2012/03/26<br>11:29 |
| L3    | 22   | ("20040104160"   "20060015056"   "20060151048"   "20090312630"   "20090318745"   "20100125243"   "20100270226"   "20100312039"   "20110071392"   "20110172524"   "3483867"   "4096859"   "4336036"   "4466888"   "4623102"   "4769008"   "4994056"   "5827429"   "6347711"   "6558125"   "7862534").PN.   | US-PGPUB; USPAT; USOCR | OR               | ON      | 2012/03/26<br>11:34 |
| L4    | 1    | ("3714429").PN.   | US-PGPUB; USPAT; USOCR | OR               | ON      | 2012/03/26<br>11:35 |
| L5    | 5663 | (128/898).CCLS.   | US-PGPUB; USPAT        | OR               | OFF     | 2012/03/26<br>12:09 |
| S1    | 72   | ("3997784"   "4625118"   "4679142"   "5885216"   "6767319"   "6908598"   "5827429"   "5485831"   "5739508"   "6157036"   "7504646"   "20090312630"   "7862534"   "3714429"   "4562829"   "4853546"   "5258906"   "20070140958"   "20070213848"   "20080242915"   "20070232980"   "20090312635"   "7163031"   "20090309466"   "4096859"   "4769008"   "4585941"   "5039863"   "7169135"   "20080093564"   "20060151048"   "20100125243"   "20100270226"   "3774036"   "4286169"   "6626862"   "20100312039"   "3483867"   "4336036"   "5765842"   "6870175"   "7204797"   "20070282263"   "5475232"   "6901283"   "7256888"   "20030004463"   "20060015056"   "4994056"   "6347711"   "6558125"   "20080071219"   "4755679"   "7476377"   "20040104160"   "20110071392"   "20050278066"   "3710118"   "4585009"   "20080166292"   "5274239"   "5840026"   "6442418"   "7413123"   "5590648"   "20110172524"   "4466888"   "4623102"   "5702115"   "7612999").PN. | US-PGPUB; USPAT; USOCR | OR               | ON      | 2012/03/19<br>12:09 |

|     |     |   |                                  |    |     |                     |
|-----|-----|---|----------------------------------|----|-----|---------------------|
| S2  | 2   | ((("20060151048") or ("5702115")).PN.               | US-<br>PGPUB;<br>USPAT           | OR | OFF | 2012/03/19<br>12:39 |
| S3  | 94  | (600/5).CCLS.                                       | US-<br>PGPUB;<br>USPAT           | OR | OFF | 2012/03/19<br>15:01 |
| S4  | 94  | (600/5).CCLS.                                       | US-<br>PGPUB;<br>USPAT           | OR | OFF | 2012/03/19<br>15:01 |
| S5  | 101 | (250/522.1).CCLS.                                   | US-<br>PGPUB;<br>USPAT           | OR | OFF | 2012/03/19<br>15:09 |
| S6  | 319 | (250/507.1).CCLS.                                   | US-<br>PGPUB;<br>USPAT           | OR | OFF | 2012/03/19<br>15:16 |
| S7  | 1   | ("3483867").PN.                                     | US-<br>PGPUB;<br>USPAT           | OR | OFF | 2012/03/20<br>08:45 |
| S8  | 1   | ("20090310523").PN.                                 | US-<br>PGPUB;<br>USPAT           | OR | OFF | 2012/03/20<br>09:03 |
| S9  | 3   | (first adj compartment) with (sidewall adj opening) | US-<br>PGPUB;<br>USPAT;<br>USOCR | OR | ON  | 2012/03/20<br>09:04 |
| S10 | 0   | S8 and S9   | US-<br>PGPUB;<br>USPAT;<br>USOCR | OR | ON  | 2012/03/20<br>09:04 |
| S11 | 4   | (first adj compartment) same (sidewall adj opening) | US-<br>PGPUB;<br>USPAT;<br>USOCR | OR | ON  | 2012/03/20<br>09:05 |
| S12 | 0   | S8 and S11  | US-<br>PGPUB;<br>USPAT;<br>USOCR | OR | ON  | 2012/03/20<br>09:06 |

|     |     |   |                                  |    |     |                     |
|-----|-----|---|----------------------------------|----|-----|---------------------|
| S13 | 671 | shielding adj assembly                              | US-<br>PGPUB;<br>USPAT;<br>USOCR | OR | ON  | 2012/03/20<br>09:06 |
| S14 | 0   | S8 and S13  | US-<br>PGPUB;<br>USPAT;<br>USOCR | OR | ON  | 2012/03/20<br>09:06 |
| S15 | 1   | ("20090318745").PN.                                 | US-<br>PGPUB;<br>USPAT           | OR | OFF | 2012/03/20<br>09:07 |
| S16 | 1   | S9 and S15  | US-<br>PGPUB;<br>USPAT;<br>USOCR | OR | ON  | 2012/03/20<br>09:08 |
| S17 | 1   | S9 and S15  | US-<br>PGPUB;<br>USPAT;<br>USOCR | OR | ON  | 2012/03/20<br>09:08 |
| S18 | 4   | (first adj compartment) same (sidewall adj opening) | US-<br>PGPUB;<br>USPAT;<br>USOCR | OR | ON  | 2012/03/20<br>09:09 |
| S19 | 1   | S15 and S18   | US-<br>PGPUB;<br>USPAT;<br>USOCR | OR | ON  | 2012/03/20<br>09:09 |
| S20 | 45  | (first adj compartment) and (sidewall adj opening)  | US-<br>PGPUB;<br>USPAT;<br>USOCR | OR | ON  | 2012/03/20<br>09:09 |
| S21 | 45  | (first adj compartment) and (sidewall adj opening)  | US-<br>PGPUB;<br>USPAT;<br>USOCR | OR | ON  | 2012/03/20<br>09:09 |
| S22 | 1   | S15 and S21   | US-<br>PGPUB;<br>USPAT;<br>USOCR | OR | ON  | 2012/03/20<br>09:09 |

## **EAST Search History (Interference)**

<This search history is empty>

**3/26/12 12:13:39 PM**

**H:\Workspaces\12137356.wsp**

Receipt date: 12/16/2011

Doc code: IDS

Doc description: Information Disclosure Statement (IDS) Filed

PTO/SB/08a (01-10)

Approved for use through 07/31/2012. OMB 0651-0031

U.S. Patent and Trademark Office; U.S. DEPARTMENT OF COMMERCE

Under the Paperwork Reduction Act of 1995, no persons are required to respond to a collection of information unless it contains a valid OMB control number.

|   |                        |                    |            |
|---|------------------------|--------------------|------------|
| <b>INFORMATION DISCLOSURE<br/>STATEMENT BY APPLICANT</b><br>( Not for submission under 37 CFR 1.99) | Application Number     |                    | 12137356   |
|   | Filing Date            |                    | 2008-06-11 |
|   | First Named Inventor   | CHARLES R. QUIRICO |            |
|   | Art Unit               | 3735               |            |
|   | Examiner Name          | GILBERT, SAMUEL G. |            |
|   | Attorney Docket Number | 56782.1.5          |            |

| U.S.PATENTS       |         |               |                        |            |   | Remove   |
|-------------------|---------|---------------|------------------------|------------|---|--|
| Examiner Initial* | Cite No | Patent Number | Kind Code <sup>1</sup> | Issue Date | Name of Patentee or Applicant of cited Document | Pages,Columns,Lines where Relevant Passages or Relevant Figures Appear |
|                   | 1       | 3483867       |                        | 1969-12-16 | Markovitz                                       |  |
|                   | 2       | 4096859       |                        | 1978-06-27 | Agarwal   |  |
|                   | 3       | 4336036       |                        | 1982-06-22 | Leeke   |  |
|                   | 4       | 4466888       |                        | 1984-08-21 | Verkaart  |  |
|                   | 5       | 4623102       |                        | 1986-11-18 | Hough, Jr.                                      |  |
|                   | 6       | 4769008       |                        | 1988-09-06 | Hessel  |  |
|                   | 7       | 4994056       |                        | 1991-02-19 | Ikeda   |  |
|                   | 8       | 5702115       |                        | 1997-12-30 | Pool  |  |

|   |                        |                    |            |  |
|---|------------------------|--------------------|------------|--|
| <b>INFORMATION DISCLOSURE<br/>STATEMENT BY APPLICANT</b><br>( Not for submission under 37 CFR 1.99) | Application Number     |                    | 12137356   |  |
|   | Filing Date            |                    | 2008-06-11 |  |
|   | First Named Inventor   | CHARLES R. QUIRICO |            |  |
|   | Art Unit               |                    | 3735       |  |
|   | Examiner Name          | GILBERT, SAMUEL G. |            |  |
|   | Attorney Docket Number |                    | 56782.1.5  |  |

|  |    |         |  |            |              |  |
|--|----|---------|--|------------|--------------|--|
|  | 9  | 5765842 |  | 1998-06-16 | Phaneuf      |  |
|  | 10 | 5827429 |  | 1998-10-27 | Ruschke      |  |
|  | 11 | 6347711 |  | 2002-02-19 | Goebel       |  |
|  | 12 | 6558125 |  | 2003-05-06 | Futterknecht |  |
|  | 13 | 7612999 |  | 2009-11-03 | Clark        |  |
|  | 14 | 7862534 |  | 2011-01-04 | Quirico      |  |

If you wish to add additional U.S. Patent citation information please click the Add button.

[Add](#)

**U.S.PATENT APPLICATION PUBLICATIONS**

[Remove](#)

| Examiner Initial* | Cite No | Publication Number | Kind Code <sup>1</sup> | Publication Date | Name of Patentee or Applicant of cited Document | Pages, Columns, Lines where Relevant Passages or Relevant Figures Appear |
|-------------------|---------|--------------------|------------------------|------------------|---|--|
|                   | 1       | 20040104160        |                        | 2004-06-03       | Scagliarini                                     |  |
|                   | 2       | 20060015056        |                        | 2006-01-19       | Ellingboe                                       |  |
|                   | 3       | 20090309466        |                        | 2009-12-17       | Quirico   |  |

|   |                        |                    |            |  |
|---|------------------------|--------------------|------------|--|
| <b>Receipt date: 12/16/2011</b><br><br><b>INFORMATION DISCLOSURE STATEMENT BY APPLICANT</b><br><b>( Not for submission under 37 CFR 1.99)</b> | Application Number     |                    | 12137356   |  |
|   | Filing Date            |                    | 2008-06-11 |  |
|   | First Named Inventor   | CHARLES R. QUIRICO |            |  |
|   | Art Unit               |                    | 3735       |  |
|   | Examiner Name          | GILBERT, SAMUEL G. |            |  |
|   | Attorney Docket Number |                    | 56782.1.5  |  |

|    |             |  |            |               |  |
|----|-------------|--|------------|---------------|--|
| 4  | 20090312630 |  | 2009-12-17 | Hidem         |  |
| 5  | 20100125243 |  | 2010-05-20 | Balestracci   |  |
| 6  | 20100270226 |  | 2010-10-28 | Balestracci   |  |
| 7  | 20100312039 |  | 2010-12-09 | Quirico       |  |
| 8  | 20110071392 |  | 2011-03-24 | Quirico       |  |
| 9  | 20110172524 |  | 2011-07-14 | Hidem         |  |
| 10 | 20060151048 |  | 2005-12-27 | Tochon-Danguy |  |

If you wish to add additional U.S. Published Application citation information please click the Add button. [Add](#)

**FOREIGN PATENT DOCUMENTS**

[Remove](#)

| Examiner Initial* | Cite No | Foreign Document Number <sup>3</sup> | Country Code <sup>2</sup> i | Kind Code <sup>4</sup> | Publication Date | Name of Patentee or Applicant of cited Document | Pages, Columns, Lines where Relevant Passages or Relevant Figures Appear | T <sup>5</sup>           |
|-------------------|---------|--------------------------------------|-----------------------------|------------------------|------------------|---|--|--------------------------|
|                   | 1       | 0919249                              | EP                          |                        | 1999-06-02       | NISSHO KK                                       |  | <input type="checkbox"/> |
|                   | 2       | 1421960                              | EP                          |                        | 2004-05-26       | GVS S P A                                       |  | <input type="checkbox"/> |



|   |                        |                    |            |  |
|---|------------------------|--------------------|------------|--|
| <b>INFORMATION DISCLOSURE<br/>STATEMENT BY APPLICANT</b><br>( Not for submission under 37 CFR 1.99) | Application Number     |                    | 12137356   |  |
|   | Filing Date            |                    | 2008-06-11 |  |
|   | First Named Inventor   | CHARLES R. QUIRICO |            |  |
|   | Art Unit               | 3735               |            |  |
|   | Examiner Name          | GILBERT, SAMUEL G. |            |  |
|   | Attorney Docket Number | 56782.1.5          |            |  |

|  |   |            |    |  |            |                           |  |                          |
|--|---|------------|----|--|------------|---------------------------|--|--------------------------|
|  | 3 | 2009152320 | WO |  | 2009-12-17 | BRACCO DIAGNOSTICS<br>INC |  | <input type="checkbox"/> |
|--|---|------------|----|--|------------|---------------------------|--|--------------------------|

If you wish to add additional Foreign Patent Document citation information please click the Add button **Add**

**NON-PATENT LITERATURE DOCUMENTS**

**Remove**

| Examiner Initials* | Cite No | Include name of the author (in CAPITAL LETTERS), title of the article (when appropriate), title of the item (book, magazine, journal, serial, symposium, catalog, etc), date, pages(s), volume-issue number(s), publisher, city and/or country where published.                                | T <sup>5</sup>           |
|--------------------|---------|--|--------------------------|
|                    | 1       | Brochure, "IV and Liquid Filters: Speedflow Adult 0.2 um Positive", <a href="http://www.gvs.it/flex/FixedPages/UK/LiquidFilters.php/L/UK/ID/Speedflow%20Adjust%....">http://www.gvs.it/flex/FixedPages/UK/LiquidFilters.php/L/UK/ID/Speedflow%20Adjust%....</a> taken off of web on 11/11/2008 | <input type="checkbox"/> |
|                    | 2       | International Search Report and Written Opinion, dated 01-04-2010 for PCT Application No. PCT/US2009/063788, 13 pages  | <input type="checkbox"/> |

If you wish to add additional non-patent literature document citation information please click the Add button **Add**

**EXAMINER SIGNATURE**

|                    |                  |                 |            |
|--------------------|------------------|-----------------|------------|
| Examiner Signature | /Samuel Gilbert/ | Date Considered | 03/20/2012 |
|--------------------|------------------|-----------------|------------|

\*EXAMINER: Initial if reference considered, whether or not citation is in conformance with MPEP 609. Draw line through a citation if not in conformance and not considered. Include copy of this form with next communication to applicant.

<sup>1</sup> See Kind Codes of USPTO Patent Documents at [www.USPTO.GOV](http://www.USPTO.GOV) or MPEP 901.04. <sup>2</sup> Enter office that issued the document, by the two-letter code (WIPO Standard ST.3). <sup>3</sup> For Japanese patent documents, the indication of the year of the reign of the Emperor must precede the serial number of the patent document. <sup>4</sup> Kind of document by the appropriate symbols as indicated on the document under WIPO Standard ST.16 if possible. <sup>5</sup> Applicant is to place a check mark here if English language translation is attached.

Receipt date: 10/24/2008

Doc code: IDS

Doc description: Information Disclosure Statement (IDS) Filed

PTO/SB/08a (03-08)

Approved for use through 06/30/2008. OMB 0651-0031

U.S. Patent and Trademark Office; U.S. DEPARTMENT OF COMMERCE

Under the Paperwork Reduction Act of 1995, no persons are required to respond to a collection of information unless it contains a valid OMB control number.

|   |                        |                    |            |  |
|---|------------------------|--------------------|------------|--|
| <b>INFORMATION DISCLOSURE<br/>STATEMENT BY APPLICANT</b><br>( Not for submission under 37 CFR 1.99) | Application Number     |                    | 12137356   |  |
|   | Filing Date            |                    | 2008-06-11 |  |
|   | First Named Inventor   | Charles R. Quirico |            |  |
|   | Art Unit               |                    |            |  |
|   | Examiner Name          |                    |            |  |
|   | Attorney Docket Number |                    | 56782.1.5  |  |

| U.S.PATENTS       |         |               |                        |            |   |  | Remove |
|-------------------|---------|---------------|------------------------|------------|---|--|--------|
| Examiner Initial* | Cite No | Patent Number | Kind Code <sup>1</sup> | Issue Date | Name of Patentee or Applicant of cited Document | Pages,Columns,Lines where Relevant Passages or Relevant Figures Appear |        |
|                   | 1       | 3710118       |                        | 1973-01-09 | Holgate et al.                                  |  |        |
|                   | 2       | 4562829       |                        | 1986-01-07 | Bergner   |  |        |
|                   | 3       | 4585009       |                        | 1986-04-29 | Barker et al.                                   |  |        |
|                   | 4       | 4585941       |                        | 1986-04-29 | Bergner   |  |        |
|                   | 5       | 6870175       | B2                     | 2005-03-22 | Dell et al.                                     |  |        |
|                   | 6       | 7204797       | B2                     | 2007-04-17 | Reilly et al.                                   |  |        |

If you wish to add additional U.S. Patent citation information please click the Add button.

Add

**U.S.PATENT APPLICATION PUBLICATIONS**

Remove

| Examiner Initial* | Cite No | Publication Number | Kind Code <sup>1</sup> | Publication Date | Name of Patentee or Applicant of cited Document | Pages,Columns,Lines where Relevant Passages or Relevant Figures Appear |
|-------------------|---------|--------------------|------------------------|------------------|---|--|
|-------------------|---------|--------------------|------------------------|------------------|---|--|

|  |                        |                    |            |  |
|--|------------------------|--------------------|------------|--|
| <b>Receipt date: 10/24/2008</b><br><br><b>INFORMATION DISCLOSURE STATEMENT BY APPLICANT</b><br>( Not for submission under 37 CFR 1.99) | Application Number     |                    | 12137356   |  |
|  | Filing Date            |                    | 2008-06-11 |  |
|  | First Named Inventor   | Charles R. Quirico |            |  |
|  | Art Unit               |                    |            |  |
|  | Examiner Name          |                    |            |  |
|  | Attorney Docket Number |                    | 56782.1.5  |  |

|   |             |    |            |               |  |
|---|-------------|----|------------|---------------|--|
| 1 | 20050278066 | A1 | 2005-12-15 | Graves et al. |  |
|---|-------------|----|------------|---------------|--|

If you wish to add additional U.S. Published Application citation information please click the Add button.

**FOREIGN PATENT DOCUMENTS**

| Examiner Initial* | Cite No | Foreign Document Number <sup>3</sup> | Country Code <sup>2</sup> | Kind Code <sup>4</sup> | Publication Date | Name of Patentee or Applicant of cited Document | Pages, Columns, Lines where Relevant Passages or Relevant Figures Appear | T <sup>5</sup>           |
|-------------------|---------|--------------------------------------|---------------------------|------------------------|------------------|---|--|--------------------------|
|                   | 1       | 0102121                              | EP                        | A1                     | 1984-03-07       | DeJong, Rudolf et al                            |  | <input type="checkbox"/> |
|                   | 2       | 2007016170                           | WO                        | A1                     | 2007-02-08       | Fago  |  | <input type="checkbox"/> |
|                   | 3       | 2007030249                           | WO                        | A2                     | 2007-03-15       | Gibson  |  | <input type="checkbox"/> |
|                   | 4       | 2007149108                           | WO                        | A2                     | 2007-12-27       | Pollard   |  | <input type="checkbox"/> |

If you wish to add additional Foreign Patent Document citation information please click the Add button

**NON-PATENT LITERATURE DOCUMENTS**

| Examiner Initials* | Cite No | Include name of the author (in CAPITAL LETTERS), title of the article (when appropriate), title of the item (book, magazine, journal, serial, symposium, catalog, etc), date, pages(s), volume-issue number(s), publisher, city and/or country where published. | T <sup>5</sup>           |
|--------------------|---------|---|--------------------------|
|                    | 1       | BRACCO Brochure, "Rubidium 82 Infusion System, Easy to Operate...Automated...Complete", (C)Bracco Diagnostics, Inc., 0605-002NA, June 2001. (2 pages)   | <input type="checkbox"/> |
|                    | 2       | <del>BRACCO, "Cardio Gen82(R) Infusion System User's Guide", pages 1-42</del>   | <input type="checkbox"/> |

|  |                        |                    |            |
|--|------------------------|--------------------|------------|
| <b>Receipt date: 10/24/2008</b><br><br><b>INFORMATION DISCLOSURE STATEMENT BY APPLICANT</b><br>( Not for submission under 37 CFR 1.99) | Application Number     |                    | 12137356   |
|  | Filing Date            |                    | 2008-06-11 |
|  | First Named Inventor   | Charles R. Quirico |            |
|  | Art Unit               |                    |            |
|  | Examiner Name          |                    |            |
|  | Attorney Docket Number |                    | 56782.1.5  |

|  |   |  |                          |
|--|---|--|--------------------------|
|  | 3 | IMAGING TECHNOLOGY NEWS, web exclusive: "FDG-PET Injector Thrusts New Life into Molecular Imaging", April 2008, 2 pages. | <input type="checkbox"/> |
|--|---|--|--------------------------|

If you wish to add additional non-patent literature document citation information please click the Add button

**EXAMINER SIGNATURE**

|                    |                  |                 |            |
|--------------------|------------------|-----------------|------------|
| Examiner Signature | /Samuel Gilbert/ | Date Considered | 03/20/2012 |
|--------------------|------------------|-----------------|------------|

\*EXAMINER: Initial if reference considered, whether or not citation is in conformance with MPEP 609. Draw line through a citation if not in conformance and not considered. Include copy of this form with next communication to applicant.

<sup>1</sup> See Kind Codes of USPTO Patent Documents at [www.USPTO.GOV](http://www.USPTO.GOV) or MPEP 901.04. <sup>2</sup> Enter office that issued the document, by the two-letter code (WIPO Standard ST.3). <sup>3</sup> For Japanese patent documents, the indication of the year of the reign of the Emperor must precede the serial number of the patent document. <sup>4</sup> Kind of document by the appropriate symbols as indicated on the document under WIPO Standard ST.16 if possible. <sup>5</sup> Applicant is to place a check mark here if English language translation is attached.

Receipt date: 03/02/2012

Doc code: IDS

Doc description: Information Disclosure Statement (IDS) Filed

PTO/SB/08a (01-10)

Approved for use through 07/31/2012. OMB 0651-0031

U.S. Patent and Trademark Office; U.S. DEPARTMENT OF COMMERCE

Under the Paperwork Reduction Act of 1995, no persons are required to respond to a collection of information unless it contains a valid OMB control number.

|   |                        |                    |
|---|------------------------|--------------------|
| <b>INFORMATION DISCLOSURE STATEMENT BY APPLICANT</b><br>( Not for submission under 37 CFR 1.99) | Application Number     | 12137356           |
|   | Filing Date            | 2008-06-11         |
|   | First Named Inventor   | CHARLES R. QUIRICO |
|   | Art Unit               | 3735               |
|   | Examiner Name          | Samuel G. Gilbert  |
|   | Attorney Docket Number | 56782.1.5          |

| U.S.PATENTS       |         |               |                        |            |   | Remove   |
|-------------------|---------|---------------|------------------------|------------|---|--|
| Examiner Initial* | Cite No | Patent Number | Kind Code <sup>1</sup> | Issue Date | Name of Patentee or Applicant of cited Document | Pages,Columns,Lines where Relevant Passages or Relevant Figures Appear |
|                   | 1       | 3714429       |                        | 1973-01-30 | Mozley  |  |

If you wish to add additional U.S. Patent citation information please click the Add button. Add

| U.S.PATENT APPLICATION PUBLICATIONS |         |                    |                        |                  |   | Remove   |
|-------------------------------------|---------|--------------------|------------------------|------------------|---|--|
| Examiner Initial*                   | Cite No | Publication Number | Kind Code <sup>1</sup> | Publication Date | Name of Patentee or Applicant of cited Document | Pages,Columns,Lines where Relevant Passages or Relevant Figures Appear |
|                                     | 1       |                    |                        |                  |   |  |

If you wish to add additional U.S. Published Application citation information please click the Add button. Add

| FOREIGN PATENT DOCUMENTS |         |                                      |                             |                        |                  |   |  | Remove                   |
|--------------------------|---------|--------------------------------------|-----------------------------|------------------------|------------------|---|--|--------------------------|
| Examiner Initial*        | Cite No | Foreign Document Number <sup>3</sup> | Country Code <sup>2</sup> j | Kind Code <sup>4</sup> | Publication Date | Name of Patentee or Applicant of cited Document | Pages,Columns,Lines where Relevant Passages or Relevant Figures Appear | T <sup>5</sup>           |
|                          | 1       |                                      |                             |                        |                  |   |  | <input type="checkbox"/> |

If you wish to add additional Foreign Patent Document citation information please click the Add button Add

| NON-PATENT LITERATURE DOCUMENTS |         |   |                | Remove |
|---------------------------------|---------|---|----------------|--------|
| Examiner Initials*              | Cite No | Include name of the author (in CAPITAL LETTERS), title of the article (when appropriate), title of the item (book, magazine, journal, serial, symposium, catalog, etc), date, pages(s), volume-issue number(s), publisher, city and/or country where published. | T <sup>5</sup> |        |
|                                 |         |   |                |        |

|   |                        |                    |            |
|---|------------------------|--------------------|------------|
| <b>INFORMATION DISCLOSURE<br/>STATEMENT BY APPLICANT</b><br>( Not for submission under 37 CFR 1.99) | Application Number     |                    | 12137356   |
|   | Filing Date            |                    | 2008-06-11 |
|   | First Named Inventor   | CHARLES R. QUIRICO |            |
|   | Art Unit               |                    | 3735       |
|   | Examiner Name          | Samuel G. Gilbert  |            |
|   | Attorney Docket Number |                    | 56782.1.5  |

|  |   |  |                          |
|--|---|--|--------------------------|
|  | 1 |  | <input type="checkbox"/> |
|--|---|--|--------------------------|

If you wish to add additional non-patent literature document citation information please click the Add button **Add**

**EXAMINER SIGNATURE**

|                    |                  |                 |            |
|--------------------|------------------|-----------------|------------|
| Examiner Signature | /Samuel Gilbert/ | Date Considered | 03/26/2012 |
|--------------------|------------------|-----------------|------------|

\*EXAMINER: Initial if reference considered, whether or not citation is in conformance with MPEP 609. Draw line through a citation if not in conformance and not considered. Include copy of this form with next communication to applicant.

<sup>1</sup> See Kind Codes of USPTO Patent Documents at [www.USPTO.GOV](http://www.USPTO.GOV) or MPEP 901.04. <sup>2</sup> Enter office that issued the document, by the two-letter code (WIPO Standard ST.3). <sup>3</sup> For Japanese patent documents, the indication of the year of the reign of the Emperor must precede the serial number of the patent document. <sup>4</sup> Kind of document by the appropriate symbols as indicated on the document under WIPO Standard ST.16 if possible. <sup>5</sup> Applicant is to place a check mark here if English language translation is attached.

## EAST Search History

## EAST Search History (Prior Art)

| Ref # | Hits | Search Query  | DBs                       | Default Operator | Plurals | Time Stamp          |
|-------|------|---|---------------------------|------------------|---------|---------------------|
| L1    | 1    | ("20080177126").PN.   | US-PGPUB;<br>USPAT        | OR               | OFF     | 2012/03/26<br>09:35 |
| L2    | 1    | "684" and 1   | US-PGPUB;<br>USPAT; USOCR | OR               | ON      | 2012/03/26<br>09:35 |
| L3    | 1    | tubing and 1  | US-PGPUB;<br>USPAT; USOCR | OR               | ON      | 2012/03/26<br>09:55 |
| L4    | 1    | lock and 1  | US-PGPUB;<br>USPAT; USOCR | OR               | ON      | 2012/03/26<br>10:54 |
| L5    | 1    | "682" and 1   | US-PGPUB;<br>USPAT; USOCR | OR               | ON      | 2012/03/26<br>10:57 |
| L6    | 1    | access and 1  | US-PGPUB;<br>USPAT; USOCR | OR               | ON      | 2012/03/26<br>11:12 |
| S1    | 650  | (600/38).CCLS.  | US-PGPUB;<br>USPAT        | OR               | OFF     | 2012/03/22<br>23:19 |
| S2    | 162  | (600/39).CCLS.  | US-PGPUB;<br>USPAT        | OR               | OFF     | 2012/03/22<br>23:46 |
| S3    | 289  | (600/40).CCLS.  | US-PGPUB;<br>USPAT        | OR               | OFF     | 2012/03/22<br>23:52 |
| S4    | 136  | (600/41).CCLS.  | US-PGPUB;<br>USPAT        | OR               | OFF     | 2012/03/22<br>23:52 |
| S5    | 2    | ((("3996930") or<br>("5690603")).PN.  | US-PGPUB;<br>USPAT        | OR               | OFF     | 2012/03/23<br>00:09 |
| S6    | 63   | ("0734213"   "2478786"<br>  "3504665"   "3554184"<br>  "3996930"   "4574791"<br>  "5127396"   "5387179"<br>  "D320087").PN. OR<br>("3996930"   "5690603").<br>URPN. | US-PGPUB;<br>USPAT; USOCR | OR               | ON      | 2012/03/23<br>00:09 |
| S7    | 4    | ((("3996930") or<br>("6350230") or<br>("6132366") or<br>("5853362")).PN.  | US-PGPUB;<br>USPAT        | OR               | OFF     | 2012/03/23<br>00:16 |
| S8    | 1    | ("6416460").PN.   | US-PGPUB;<br>USPAT        | OR               | OFF     | 2012/03/23<br>00:29 |
| S9    | 7    | ("4440183"   "5599275"<br>  "5836864").PN. OR<br>("6416460").URPN.  | US-PGPUB;<br>USPAT; USOCR | OR               | ON      | 2012/03/23<br>00:29 |

|     |     |   |                            |    |     |                     |
|-----|-----|---|----------------------------|----|-----|---------------------|
| S10 | 697 | (penis or penile) near3<br>(extend or extending or<br>extended or lengthen or<br>lengthening) | US-PGPUB;<br>USPAT; USOCR  | OR | ON  | 2012/03/23<br>00:31 |
| S11 | 2   | ("5642557").PN. OR<br>("7578785").URPN.   | US-PGPUB;<br>USPAT; USOCR  | OR | ON  | 2012/03/25<br>23:23 |
| S12 | 2   | ("5642557").PN. OR<br>("7578785").URPN.   | US-PGPUB;<br>USPAT; USOCR  | OR | ON  | 2012/03/25<br>23:23 |
| S13 | 70  | penis and enlargement   | FPRS; EPO;<br>JPO; DERWENT | OR | ON  | 2012/03/25<br>23:26 |
| S14 | 15  | penis and tensioning  | FPRS; EPO;<br>JPO; DERWENT | OR | ON  | 2012/03/25<br>23:29 |
| S15 | 12  | penis and adams.in.   | FPRS; EPO;<br>JPO; DERWENT | OR | ON  | 2012/03/25<br>23:30 |
| S16 | 219 | penis and leg   | FPRS; EPO;<br>JPO; DERWENT | OR | ON  | 2012/03/25<br>23:31 |
| S17 | 4   | "2515883"   | FPRS; EPO;<br>JPO; DERWENT | OR | ON  | 2012/03/25<br>23:32 |
| S18 | 1   | ("6416460").PN.   | US-PGPUB;<br>USPAT         | OR | OFF | 2012/03/26<br>01:19 |
| S19 | 7   | ("4440183"   "5599275"<br>  "5836864").PN. OR<br>("6416460").URPN.                            | US-PGPUB;<br>USPAT; USOCR  | OR | ON  | 2012/03/26<br>01:19 |
| S20 | 1   | ("20060151048").PN.   | US-PGPUB;<br>USPAT         | OR | OFF | 2012/03/26<br>07:58 |
| S21 | 3   | ((("5702115") or<br>("5765842") or<br>("7612999")).PN.  | US-PGPUB;<br>USPAT         | OR | OFF | 2012/03/26<br>08:00 |

### EAST Search History (Interference)

< This search history is empty >

**3/26/12 11:17:10 AM**

**H:\Workspaces\12519076.wsp**



|   |                        |                    |            |  |
|---|------------------------|--------------------|------------|--|
| <b>INFORMATION DISCLOSURE STATEMENT BY APPLICANT</b><br>( Not for submission under 37 CFR 1.99) | Application Number     |                    | 12137356   |  |
|   | Filing Date            |                    | 2008-06-11 |  |
|   | First Named Inventor   | CHARLES R. QUIRICO |            |  |
|   | Art Unit               | 3735               |            |  |
|   | Examiner Name          | Samuel G. Gilbert  |            |  |
|   | Attorney Docket Number | 56782.1.5          |            |  |

| U.S.PATENTS       |         |               |                        |            |   | Remove   |
|-------------------|---------|---------------|------------------------|------------|---|--|
| Examiner Initial* | Cite No | Patent Number | Kind Code <sup>1</sup> | Issue Date | Name of Patentee or Applicant of cited Document | Pages,Columns,Lines where Relevant Passages or Relevant Figures Appear |
|                   | 1       | 3714429       |                        | 1973-01-30 | Mozley  |  |

If you wish to add additional U.S. Patent citation information please click the Add button. Add

| U.S.PATENT APPLICATION PUBLICATIONS |         |                    |                        |                  |   | Remove   |
|-------------------------------------|---------|--------------------|------------------------|------------------|---|--|
| Examiner Initial*                   | Cite No | Publication Number | Kind Code <sup>1</sup> | Publication Date | Name of Patentee or Applicant of cited Document | Pages,Columns,Lines where Relevant Passages or Relevant Figures Appear |
|                                     | 1       |                    |                        |                  |   |  |

If you wish to add additional U.S. Published Application citation information please click the Add button. Add

| FOREIGN PATENT DOCUMENTS |         |                                      |                             |                        |                  |   |  | Remove                   |
|--------------------------|---------|--------------------------------------|-----------------------------|------------------------|------------------|---|--|--------------------------|
| Examiner Initial*        | Cite No | Foreign Document Number <sup>3</sup> | Country Code <sup>2</sup> j | Kind Code <sup>4</sup> | Publication Date | Name of Patentee or Applicant of cited Document | Pages,Columns,Lines where Relevant Passages or Relevant Figures Appear | T <sup>5</sup>           |
|                          | 1       |                                      |                             |                        |                  |   |  | <input type="checkbox"/> |

If you wish to add additional Foreign Patent Document citation information please click the Add button Add

| NON-PATENT LITERATURE DOCUMENTS |         |   |  | Remove         |
|---------------------------------|---------|---|--|----------------|
| Examiner Initials*              | Cite No | Include name of the author (in CAPITAL LETTERS), title of the article (when appropriate), title of the item (book, magazine, journal, serial, symposium, catalog, etc), date, pages(s), volume-issue number(s), publisher, city and/or country where published. |  | T <sup>5</sup> |
|                                 |         |   |  |                |

|   |                        |                    |
|---|------------------------|--------------------|
| <b>INFORMATION DISCLOSURE<br/>STATEMENT BY APPLICANT</b><br>( Not for submission under 37 CFR 1.99) | Application Number     | 12137356           |
|   | Filing Date            | 2008-06-11         |
|   | First Named Inventor   | CHARLES R. QUIRICO |
|   | Art Unit               | 3735               |
|   | Examiner Name          | Samuel G. Gilbert  |
|   | Attorney Docket Number | 56782.1.5          |

|   |  |                          |
|---|--|--------------------------|
| 1 |  | <input type="checkbox"/> |
|---|--|--------------------------|

If you wish to add additional non-patent literature document citation information please click the Add button **Add**

**EXAMINER SIGNATURE**

|                    |                 |
|--------------------|-----------------|
| Examiner Signature | Date Considered |
|--------------------|-----------------|

\*EXAMINER: Initial if reference considered, whether or not citation is in conformance with MPEP 609. Draw line through a citation if not in conformance and not considered. Include copy of this form with next communication to applicant.

<sup>1</sup> See Kind Codes of USPTO Patent Documents at [www.USPTO.GOV](http://www.USPTO.GOV) or MPEP 901.04. <sup>2</sup> Enter office that issued the document, by the two-letter code (WIPO Standard ST.3). <sup>3</sup> For Japanese patent documents, the indication of the year of the reign of the Emperor must precede the serial number of the patent document. <sup>4</sup> Kind of document by the appropriate symbols as indicated on the document under WIPO Standard ST.16 if possible. <sup>5</sup> Applicant is to place a check mark here if English language translation is attached.

**INFORMATION DISCLOSURE  
STATEMENT BY APPLICANT**  
( Not for submission under 37 CFR 1.99)

|                        |                    |
|------------------------|--------------------|
| Application Number     | 12137356           |
| Filing Date            | 2008-06-11         |
| First Named Inventor   | CHARLES R. QUIRICO |
| Art Unit               | 3735               |
| Examiner Name          | Samuel G. Gilbert  |
| Attorney Docket Number | 56782.15           |

**CERTIFICATION STATEMENT**

Please see 37 CFR 1.97 and 1.98 to make the appropriate selection(s):

That each item of information contained in the information disclosure statement was first cited in any communication from a foreign patent office in a counterpart foreign application not more than three months prior to the filing of the information disclosure statement. See 37 CFR 1.97(e)(1).

**OR**

That no item of information contained in the information disclosure statement was cited in a communication from a foreign patent office in a counterpart foreign application, and, to the knowledge of the person signing the certification after making reasonable inquiry, no item of information contained in the information disclosure statement was known to any individual designated in 37 CFR 1.56(c) more than three months prior to the filing of the information disclosure statement. See 37 CFR 1.97(e)(2).

- See attached certification statement.
- The fee set forth in 37 CFR 1.17 (p) has been submitted herewith.
- A certification statement is not submitted herewith.

**SIGNATURE**

A signature of the applicant or representative is required in accordance with CFR 1.33, 10.18. Please see CFR 1.4(d) for the form of the signature.

|            |                         |                     |            |
|------------|-------------------------|---------------------|------------|
| Signature  | /Paul J. LaVanway, Jr./ | Date (YYYY-MM-DD)   | 2012-03-02 |
| Name/Print | Paul J. LaVanway, Jr.   | Registration Number | 64,610     |

This collection of information is required by 37 CFR 1.97 and 1.98. The information is required to obtain or retain a benefit by the public which is to file (and by the USPTO to process) an application. Confidentiality is governed by 35 U.S.C. 122 and 37 CFR 1.14. This collection is estimated to take 1 hour to complete, including gathering, preparing and submitting the completed application form to the USPTO. Time will vary depending upon the individual case. Any comments on the amount of time you require to complete this form and/or suggestions for reducing this burden, should be sent to the Chief Information Officer, U.S. Patent and Trademark Office, U.S. Department of Commerce, P.O. Box 1450, Alexandria, VA 22313-1450. **DO NOT SEND FEES OR COMPLETED FORMS TO THIS ADDRESS. SEND TO: Commissioner for Patents, P.O. Box 1450, Alexandria, VA 22313-1450.**

## Privacy Act Statement

The Privacy Act of 1974 (P.L. 93-579) requires that you be given certain information in connection with your submission of the attached form related to a patent application or patent. Accordingly, pursuant to the requirements of the Act, please be advised that: (1) the general authority for the collection of this information is 35 U.S.C. 2(b)(2); (2) furnishing of the information solicited is voluntary; and (3) the principal purpose for which the information is used by the U.S. Patent and Trademark Office is to process and/or examine your submission related to a patent application or patent. If you do not furnish the requested information, the U.S. Patent and Trademark Office may not be able to process and/or examine your submission, which may result in termination of proceedings or abandonment of the application or expiration of the patent.

The information provided by you in this form will be subject to the following routine uses:

1. The information on this form will be treated confidentially to the extent allowed under the Freedom of Information Act (5 U.S.C. 552) and the Privacy Act (5 U.S.C. 552a). Records from this system of records may be disclosed to the Department of Justice to determine whether the Freedom of Information Act requires disclosure of these records.
2. A record from this system of records may be disclosed, as a routine use, in the course of presenting evidence to a court, magistrate, or administrative tribunal, including disclosures to opposing counsel in the course of settlement negotiations.
3. A record in this system of records may be disclosed, as a routine use, to a Member of Congress submitting a request involving an individual, to whom the record pertains, when the individual has requested assistance from the Member with respect to the subject matter of the record.
4. A record in this system of records may be disclosed, as a routine use, to a contractor of the Agency having need for the information in order to perform a contract. Recipients of information shall be required to comply with the requirements of the Privacy Act of 1974, as amended, pursuant to 5 U.S.C. 552a(m).
5. A record related to an International Application filed under the Patent Cooperation Treaty in this system of records may be disclosed, as a routine use, to the International Bureau of the World Intellectual Property Organization, pursuant to the Patent Cooperation Treaty.
6. A record in this system of records may be disclosed, as a routine use, to another federal agency for purposes of National Security review (35 U.S.C. 181) and for review pursuant to the Atomic Energy Act (42 U.S.C. 218(c)).
7. A record from this system of records may be disclosed, as a routine use, to the Administrator, General Services, or his/her designee, during an inspection of records conducted by GSA as part of that agency's responsibility to recommend improvements in records management practices and programs, under authority of 44 U.S.C. 2904 and 2906. Such disclosure shall be made in accordance with the GSA regulations governing inspection of records for this purpose, and any other relevant (i.e., GSA or Commerce) directive. Such disclosure shall not be used to make determinations about individuals.
8. A record from this system of records may be disclosed, as a routine use, to the public after either publication of the application pursuant to 35 U.S.C. 122(b) or issuance of a patent pursuant to 35 U.S.C. 151. Further, a record may be disclosed, subject to the limitations of 37 CFR 1.14, as a routine use, to the public if the record was filed in an application which became abandoned or in which the proceedings were terminated and which application is referenced by either a published application, an application open to public inspections or an issued patent.
9. A record from this system of records may be disclosed, as a routine use, to a Federal, State, or local law enforcement agency, if the USPTO becomes aware of a violation or potential violation of law or regulation.

## Electronic Acknowledgement Receipt

|   |   |
|---|---|
| <b>EFS ID:</b>                              | 12211065                                  |
| <b>Application Number:</b>                  | 12137356                                  |
| <b>International Application Number:</b>    |   |
| <b>Confirmation Number:</b>                 | 7360                                      |
| <b>Title of Invention:</b>                  | SHIELDING ASSEMBLIES FOR INFUSION SYSTEMS |
| <b>First Named Inventor/Applicant Name:</b> | Charles R. Quirico                        |
| <b>Customer Number:</b>                     | 22859                                     |
| <b>Filer:</b>                               | Paul J. LaVanway Jr.                      |
| <b>Filer Authorized By:</b>                 |   |
| <b>Attorney Docket Number:</b>              | 56782.1.5                                 |
| <b>Receipt Date:</b>                        | 02-MAR-2012                               |
| <b>Filing Date:</b>                         | 11-JUN-2008                               |
| <b>Time Stamp:</b>                          | 13:02:53                                  |
| <b>Application Type:</b>                    | Utility under 35 USC 111(a)               |

### Payment information:

|                        |    |
|------------------------|----|
| Submitted with Payment | no |
|------------------------|----|

### File Listing:

| Document Number | Document Description                               | File Name              | File Size(Bytes)/<br>Message Digest                               | Multi Part /.zip | Pages (if appl.) |
|-----------------|--|------------------------|---|------------------|------------------|
| 1               | Information Disclosure Statement (IDS) Form (SB08) | 8th-SIDS_56782-1-5.pdf | 754396<br><small>029d0ca939502faa23a7b771e0742537e3b5799b</small> | no               | 4                |

### Warnings:

### Information:

This Acknowledgement Receipt evidences receipt on the noted date by the USPTO of the indicated documents, characterized by the applicant, and including page counts, where applicable. It serves as evidence of receipt similar to a Post Card, as described in MPEP 503.

**New Applications Under 35 U.S.C. 111**

If a new application is being filed and the application includes the necessary components for a filing date (see 37 CFR 1.53(b)-(d) and MPEP 506), a Filing Receipt (37 CFR 1.54) will be issued in due course and the date shown on this Acknowledgement Receipt will establish the filing date of the application.

**National Stage of an International Application under 35 U.S.C. 371**

If a timely submission to enter the national stage of an international application is compliant with the conditions of 35 U.S.C. 371 and other applicable requirements a Form PCT/DO/EO/903 indicating acceptance of the application as a national stage submission under 35 U.S.C. 371 will be issued in addition to the Filing Receipt, in due course.

**New International Application Filed with the USPTO as a Receiving Office**

If a new international application is being filed and the international application includes the necessary components for an international filing date (see PCT Article 11 and MPEP 1810), a Notification of the International Application Number and of the International Filing Date (Form PCT/RO/105) will be issued in due course, subject to prescriptions concerning national security, and the date shown on this Acknowledgement Receipt will establish the international filing date of the application.

|   |                        |                    |            |
|---|------------------------|--------------------|------------|
| <b>INFORMATION DISCLOSURE<br/>STATEMENT BY APPLICANT</b><br>( Not for submission under 37 CFR 1.99) | Application Number     |                    | 12137356   |
|   | Filing Date            |                    | 2008-06-11 |
|   | First Named Inventor   | CHARLES R. QUIRICO |            |
|   | Art Unit               |                    | 3735       |
|   | Examiner Name          | GILBERT, SAMUEL G. |            |
|   | Attorney Docket Number |                    | 56782.1.5  |

| U.S.PATENTS       |         |               |                        |            |   | Remove   |
|-------------------|---------|---------------|------------------------|------------|---|--|
| Examiner Initial* | Cite No | Patent Number | Kind Code <sup>1</sup> | Issue Date | Name of Patentee or Applicant of cited Document | Pages,Columns,Lines where Relevant Passages or Relevant Figures Appear |
|                   | 1       | 3483867       |                        | 1969-12-16 | Markovitz                                       |  |
|                   | 2       | 4096859       |                        | 1978-06-27 | Agarwal   |  |
|                   | 3       | 4336036       |                        | 1982-06-22 | Leeke   |  |
|                   | 4       | 4466888       |                        | 1984-08-21 | Verkaart  |  |
|                   | 5       | 4623102       |                        | 1986-11-18 | Hough, Jr.                                      |  |
|                   | 6       | 4769008       |                        | 1988-09-06 | Hessel  |  |
|                   | 7       | 4994056       |                        | 1991-02-19 | Ikeda   |  |
|                   | 8       | 5702115       |                        | 1997-12-30 | Pool  |  |

**INFORMATION DISCLOSURE  
STATEMENT BY APPLICANT**  
( Not for submission under 37 CFR 1.99)

|                        |                    |
|------------------------|--------------------|
| Application Number     | 12137356           |
| Filing Date            | 2008-06-11         |
| First Named Inventor   | CHARLES R. QUIRICO |
| Art Unit               | 3735               |
| Examiner Name          | GILBERT, SAMUEL G. |
| Attorney Docket Number | 56782.1.5          |

|    |         |  |            |              |  |
|----|---------|--|------------|--------------|--|
| 9  | 5765842 |  | 1998-06-16 | Phaneuf      |  |
| 10 | 5827429 |  | 1998-10-27 | Ruschke      |  |
| 11 | 6347711 |  | 2002-02-19 | Goebel       |  |
| 12 | 6558125 |  | 2003-05-06 | Futterknecht |  |
| 13 | 7612999 |  | 2009-11-03 | Clark        |  |
| 14 | 7862534 |  | 2011-01-04 | Quirico      |  |

If you wish to add additional U.S. Patent citation information please click the Add button.

[Add](#)

**U.S.PATENT APPLICATION PUBLICATIONS**

[Remove](#)

| Examiner Initial* | Cite No | Publication Number | Kind Code <sup>1</sup> | Publication Date | Name of Patentee or Applicant of cited Document | Pages,Columns,Lines where Relevant Passages or Relevant Figures Appear |
|-------------------|---------|--------------------|------------------------|------------------|---|--|
|                   | 1       | 20040104160        |                        | 2004-06-03       | Scagliarini                                     |  |
|                   | 2       | 20060015056        |                        | 2006-01-19       | Ellingboe                                       |  |
|                   | 3       | 20090309466        |                        | 2009-12-17       | Quirico   |  |



**INFORMATION DISCLOSURE  
STATEMENT BY APPLICANT**  
( Not for submission under 37 CFR 1.99)

|                        |                    |
|------------------------|--------------------|
| Application Number     | 12137356           |
| Filing Date            | 2008-06-11         |
| First Named Inventor   | CHARLES R. QUIRICO |
| Art Unit               | 3735               |
| Examiner Name          | GILBERT, SAMUEL G. |
| Attorney Docket Number | 56782.1.5          |

|    |             |  |            |               |  |
|----|-------------|--|------------|---------------|--|
| 4  | 20090312630 |  | 2009-12-17 | Hidem         |  |
| 5  | 20100125243 |  | 2010-05-20 | Balestracci   |  |
| 6  | 20100270226 |  | 2010-10-28 | Balestracci   |  |
| 7  | 20100312039 |  | 2010-12-09 | Quirico       |  |
| 8  | 20110071392 |  | 2011-03-24 | Quirico       |  |
| 9  | 20110172524 |  | 2011-07-14 | Hidem         |  |
| 10 | 20060151048 |  | 2005-12-27 | Tochon-Danguy |  |

If you wish to add additional U.S. Published Application citation information please click the Add button. [Add](#)

**FOREIGN PATENT DOCUMENTS**

[Remove](#)

| Examiner Initial* | Cite No | Foreign Document Number <sup>3</sup> | Country Code <sup>2</sup> i | Kind Code <sup>4</sup> | Publication Date | Name of Patentee or Applicant of cited Document | Pages, Columns, Lines where Relevant Passages or Relevant Figures Appear | T <sup>5</sup>           |
|-------------------|---------|--------------------------------------|-----------------------------|------------------------|------------------|---|--|--------------------------|
|                   | 1       | 0919249                              | EP                          |                        | 1999-06-02       | NISSHO KK                                       |  | <input type="checkbox"/> |
|                   | 2       | 1421960                              | EP                          |                        | 2004-05-26       | GVS S P A                                       |  | <input type="checkbox"/> |

|   |                        |                    |
|---|------------------------|--------------------|
| <b>INFORMATION DISCLOSURE<br/>STATEMENT BY APPLICANT</b><br>( Not for submission under 37 CFR 1.99) | Application Number     | 12137356           |
|   | Filing Date            | 2008-06-11         |
|   | First Named Inventor   | CHARLES R. QUIRICO |
|   | Art Unit               | 3735               |
|   | Examiner Name          | GILBERT, SAMUEL G. |
|   | Attorney Docket Number | 56782.1.5          |

|   |            |    |  |            |                           |                          |
|---|------------|----|--|------------|---------------------------|--------------------------|
| 3 | 2009152320 | WO |  | 2009-12-17 | BRACCO DIAGNOSTICS<br>INC | <input type="checkbox"/> |
|---|------------|----|--|------------|---------------------------|--------------------------|

If you wish to add additional Foreign Patent Document citation information please click the Add button **Add**

**NON-PATENT LITERATURE DOCUMENTS**

**Remove**

| Examiner Initials* | Cite No | Include name of the author (in CAPITAL LETTERS), title of the article (when appropriate), title of the item (book, magazine, journal, serial, symposium, catalog, etc), date, pages(s), volume-issue number(s), publisher, city and/or country where published.                                | T <sup>5</sup>           |
|--------------------|---------|--|--------------------------|
|                    | 1       | Brochure, "IV and Liquid Filters: Speedflow Adult 0.2 um Positive", <a href="http://www.gvs.it/flex/FixedPages/UK/LiquidFilters.php/L/UK/ID/Speedflow%20Adjust%....">http://www.gvs.it/flex/FixedPages/UK/LiquidFilters.php/L/UK/ID/Speedflow%20Adjust%....</a> taken off of web on 11/11/2008 | <input type="checkbox"/> |
|                    | 2       | International Search Report and Written Opinion, dated 01-04-2010 for PCT Application No. PCT/US2009/063788, 13 pages  | <input type="checkbox"/> |

If you wish to add additional non-patent literature document citation information please click the Add button **Add**

**EXAMINER SIGNATURE**

|                    |                 |
|--------------------|-----------------|
| Examiner Signature | Date Considered |
|--------------------|-----------------|

\*EXAMINER: Initial if reference considered, whether or not citation is in conformance with MPEP 609. Draw line through a citation if not in conformance and not considered. Include copy of this form with next communication to applicant.

<sup>1</sup> See Kind Codes of USPTO Patent Documents at [www.USPTO.GOV](http://www.USPTO.GOV) or MPEP 901.04. <sup>2</sup> Enter office that issued the document, by the two-letter code (WIPO Standard ST.3). <sup>3</sup> For Japanese patent documents, the indication of the year of the reign of the Emperor must precede the serial number of the patent document. <sup>4</sup> Kind of document by the appropriate symbols as indicated on the document under WIPO Standard ST.16 if possible. <sup>5</sup> Applicant is to place a check mark here if English language translation is attached.

**INFORMATION DISCLOSURE  
STATEMENT BY APPLICANT**  
( Not for submission under 37 CFR 1.99)

|                        |                    |
|------------------------|--------------------|
| Application Number     | 12137356           |
| Filing Date            | 2008-06-11         |
| First Named Inventor   | CHARLES R. QUIRICO |
| Art Unit               | 3735               |
| Examiner Name          | GILBERT, SAMUEL G. |
| Attorney Docket Number | 56782.15           |

**CERTIFICATION STATEMENT**

Please see 37 CFR 1.97 and 1.98 to make the appropriate selection(s):

That each item of information contained in the information disclosure statement was first cited in any communication from a foreign patent office in a counterpart foreign application not more than three months prior to the filing of the information disclosure statement. See 37 CFR 1.97(e)(1).

**OR**

That no item of information contained in the information disclosure statement was cited in a communication from a foreign patent office in a counterpart foreign application, and, to the knowledge of the person signing the certification after making reasonable inquiry, no item of information contained in the information disclosure statement was known to any individual designated in 37 CFR 1.56(c) more than three months prior to the filing of the information disclosure statement. See 37 CFR 1.97(e)(2).

- See attached certification statement.
- The fee set forth in 37 CFR 1.17 (p) has been submitted herewith.
- A certification statement is not submitted herewith.

**SIGNATURE**

A signature of the applicant or representative is required in accordance with CFR 1.33, 10.18. Please see CFR 1.4(d) for the form of the signature.

|            |                         |                     |            |
|------------|-------------------------|---------------------|------------|
| Signature  | /Paul J. LaVanway, Jr./ | Date (YYYY-MM-DD)   | 2011-12-16 |
| Name/Print | Paul J. LaVanway, Jr.   | Registration Number | 64,610     |

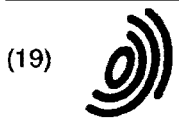
This collection of information is required by 37 CFR 1.97 and 1.98. The information is required to obtain or retain a benefit by the public which is to file (and by the USPTO to process) an application. Confidentiality is governed by 35 U.S.C. 122 and 37 CFR 1.14. This collection is estimated to take 1 hour to complete, including gathering, preparing and submitting the completed application form to the USPTO. Time will vary depending upon the individual case. Any comments on the amount of time you require to complete this form and/or suggestions for reducing this burden, should be sent to the Chief Information Officer, U.S. Patent and Trademark Office, U.S. Department of Commerce, P.O. Box 1450, Alexandria, VA 22313-1450. **DO NOT SEND FEES OR COMPLETED FORMS TO THIS ADDRESS. SEND TO: Commissioner for Patents, P.O. Box 1450, Alexandria, VA 22313-1450.**

## Privacy Act Statement

The Privacy Act of 1974 (P.L. 93-579) requires that you be given certain information in connection with your submission of the attached form related to a patent application or patent. Accordingly, pursuant to the requirements of the Act, please be advised that: (1) the general authority for the collection of this information is 35 U.S.C. 2(b)(2); (2) furnishing of the information solicited is voluntary; and (3) the principal purpose for which the information is used by the U.S. Patent and Trademark Office is to process and/or examine your submission related to a patent application or patent. If you do not furnish the requested information, the U.S. Patent and Trademark Office may not be able to process and/or examine your submission, which may result in termination of proceedings or abandonment of the application or expiration of the patent.

The information provided by you in this form will be subject to the following routine uses:

1. The information on this form will be treated confidentially to the extent allowed under the Freedom of Information Act (5 U.S.C. 552) and the Privacy Act (5 U.S.C. 552a). Records from this system of records may be disclosed to the Department of Justice to determine whether the Freedom of Information Act requires disclosure of these records.
2. A record from this system of records may be disclosed, as a routine use, in the course of presenting evidence to a court, magistrate, or administrative tribunal, including disclosures to opposing counsel in the course of settlement negotiations.
3. A record in this system of records may be disclosed, as a routine use, to a Member of Congress submitting a request involving an individual, to whom the record pertains, when the individual has requested assistance from the Member with respect to the subject matter of the record.
4. A record in this system of records may be disclosed, as a routine use, to a contractor of the Agency having need for the information in order to perform a contract. Recipients of information shall be required to comply with the requirements of the Privacy Act of 1974, as amended, pursuant to 5 U.S.C. 552a(m).
5. A record related to an International Application filed under the Patent Cooperation Treaty in this system of records may be disclosed, as a routine use, to the International Bureau of the World Intellectual Property Organization, pursuant to the Patent Cooperation Treaty.
6. A record in this system of records may be disclosed, as a routine use, to another federal agency for purposes of National Security review (35 U.S.C. 181) and for review pursuant to the Atomic Energy Act (42 U.S.C. 218(c)).
7. A record from this system of records may be disclosed, as a routine use, to the Administrator, General Services, or his/her designee, during an inspection of records conducted by GSA as part of that agency's responsibility to recommend improvements in records management practices and programs, under authority of 44 U.S.C. 2904 and 2906. Such disclosure shall be made in accordance with the GSA regulations governing inspection of records for this purpose, and any other relevant (i.e., GSA or Commerce) directive. Such disclosure shall not be used to make determinations about individuals.
8. A record from this system of records may be disclosed, as a routine use, to the public after either publication of the application pursuant to 35 U.S.C. 122(b) or issuance of a patent pursuant to 35 U.S.C. 151. Further, a record may be disclosed, subject to the limitations of 37 CFR 1.14, as a routine use, to the public if the record was filed in an application which became abandoned or in which the proceedings were terminated and which application is referenced by either a published application, an application open to public inspections or an issued patent.
9. A record from this system of records may be disclosed, as a routine use, to a Federal, State, or local law enforcement agency, if the USPTO becomes aware of a violation or potential violation of law or regulation.



Europäisches Patentamt  
 European Patent Office  
 Office européen des brevets



(11) EP 0 919 249 A1

(12) EUROPEAN PATENT APPLICATION

(43) Date of publication: 02.06.1999 Bulletin 1999/22 (51) Int. Cl.<sup>6</sup>: A61M 1/36

(21) Application number: 98121181.6

(22) Date of filing: 13.11.1998

(84) Designated Contracting States:  
 AT BE CH CY DE DK ES FI FR GB GR IE IT LI LU  
 MC NL PT SE  
 Designated Extension States:  
 AL LT LV MK RO SI

- Kikuchi, Toshihiro  
 Osaka-shi, Osaka-fu 531-8510 (JP)
- Harada, Shinichiro  
 Osaka-shi, Osaka-fu 531-8510 (JP)
- Takagi, Nobuo  
 Osaka-shi, Osaka-fu 531-8510 (JP)
- Wakabayashi, Takahito  
 Osaka-shi, Osaka-fu 531-8510 (JP)

(30) Priority: 20.11.1997 JP 320194/97  
 19.12.1997 JP 350381/97  
 19.06.1998 JP 172805/98

(74) Representative:  
 Weisert, Annekäte, Dipl.-Ing. Dr.-Ing. et al  
 Patentanwälte  
 Kraus Weisert & Partner  
 Thomas-Wimmer-Ring 15  
 80539 München (DE)

(71) Applicant: Nissho Corporation  
 Osaka-shi, Osaka-fu, 531-8510 (JP)

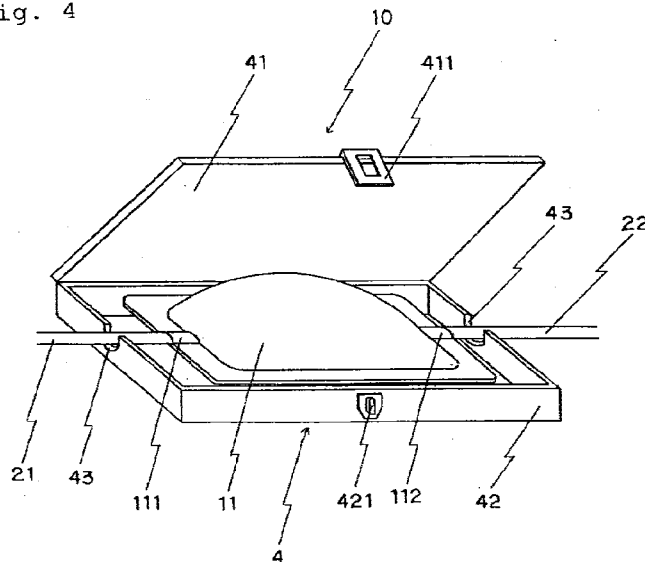
(72) Inventors:  
 • Sasayama, Norihisa  
 Osaka-shi, Osaka-fu 531-8510 (JP)

(54) A blood filter set and a method of recovering blood components by use of the same

(57) This invention relates to a blood filter set comprising a bag body having a blood flow inlet and a blood flow outlet and charged with a filter material, and an accommodation vessel for accommodating said bag

body and a method of recovering blood components by use of the filter set.

Fig. 4



EP 0 919 249 A1

**Description**Field of the Invention

5 [0001] The present invention relates to a filter set for recovering desired blood components from human blood and a method of recovering blood components by use of the filter set.

Background of the Invention

10 [0002] It is known that hematopoietic malady occurs as side effects of chemotherapy for hematopoietic organ tumors such as leukemia etc., and solid tumors, and bone marrow transplant and peripheral blood stem cell transplant are applied as therapies for the hematopoietic malady. These therapies are methods of recovering from hematopoietic malady, in which hematopoietic stem cells and/or hematopoietic precursor cells contained in bone marrow and peripheral blood are transplanted into human body. By establishing these transplant therapies, chemotherapy for tumors such as leukemia and solid tumors was made feasible. Further, it was found in recent years that hematopoietic stem cells and/or hematopoietic precursor cells are also contained in umbilical cord blood, and a therapy by transplanting hematopoietic cells and/or hematopoietic precursor cells from umbilical cord blood is also expected to be a promising method.

15 [0003] Usually, blood used for these transplant therapies is cryopreserved after collecting till transplanting. If cryopreserved blood is contaminated with erythrocytes, the erythrocytes are lysed to cause side effects after thawing, therefore, before thawing the blood to be transplanted erythrocytes should be removed from the blood.

20 [0004] Known methods of removing erythrocytes from blood to be transplanted include a centrifugation method and a filter method. A centrifugation method utilizes the difference in specific gravity between erythrocytes and leukocytes derived from hematopoietic stem cells and/or hematopoietic precursor cells. A filter method of recovering leukocytes utilizes a filter for passing erythrocytes but capturing leukocytes derived from hematopoietic stem cells and/or hematopoietic precursor cells and the leukocytes captured therein is recovered with a washing solution.

25 [0005] However, the centrifugation method requires such skills as not to cause disturbance of the interfaces among separated blood components, while the filter method has the disadvantage of low yield because the density of the filter material is so high as to capture hematopoietic stem cell- and/or hematopoietic precursor cell-derived leukocytes at high concentration, thus making it difficult to remove leukocytes which have adhered to the filter material even if a washing solution is used.

30 [0006] The present invention is to solve these problems, and the object of the present invention is to provide a filter set for efficiently recovering desired blood components from blood and a method of recovering blood components by use of the filter set.

35 [0007] As a result of their eager study for achieving the above object, the present inventors found that desired blood components can be efficiently recovered from blood with a blood filter set which comprises a bag body charged with a filter material and an accommodation vessel for accommodating said bag body. Further, they found that a filter set comprises preferably a bag body consisting of a flexible sheet charged inside with a filter material and a rigid accommodation vessel for accommodating said bag body which is freely expanded in a compressed condition or in a freely expansive and compressive condition. Additionally, they found that mainly leukocytes could be efficiently recovered from blood by a bag body charged inside with a filter material and a flexible tube body accommodating the bag body in a compressed condition in the thickness direction.

Summary of the Invention

45 [0008] That is, the present invention relates to a filter set comprising a bag body having a blood flow inlet and a blood flow outlet and charged with a filter material, and an accommodation vessel for accommodating said bag body.

[0009] One embodiment of this invention is a filter set comprising a bag body having a blood flow inlet and a blood flow outlet and consisting of a flexible sheet charged inside with a filter material, and a rigid accommodation vessel for accommodating said bag body which is freely removed therefrom and for accommodating said bag body in a compressed condition at the time of accommodation.

50 [0010] The rigid accommodation vessel is a rectangular parallelepiped vessel provided with a takeout port from which the bag body can be removed or a vessel provided with a lid which can be opened and closed or the like.

[0011] Another embodiment of this invention is a filter set comprising a bag body having a blood flow inlet and a blood flow outlet and consisting of a flexible sheet charged inside with a filter material, and a rigid accommodation vessel for accommodating said bag body, wherein said bag body is compressed by filling with compressed gas, and after blood is passed through said bag body in a compressed condition, the compressed gas is exhausted to relieve the compression of said bag body through which a washing solution is then passed.

[0012] The rigid accommodation vessel includes a vessel compressing said bag body by filling with compressed gas

and relieving the compression of the bag body by exhausting the compressed gas. Otherwise, the vessel is capable of further expanding the bag body by evacuating the inside of the vessel after relieving the compression condition.

[0013] Another embodiment is a filter set comprising a bag body having a blood flow inlet and a blood flow outlet and being charged inside with a filter material and a flexible tube body accommodating the bag body in a compressed condition in the thickness direction, wherein said bag body can be removed from said tube body.

[0014] The tube body is a heat-shrinkable tube or possesses a similar length to that of the bag body and a smaller volume than that of the bag body. If the tube body is heat-shrinkable, the tube body is preferably provided with a ruptured portion. And if the tube body possesses a similar length to that of the bag body and a smaller volume than that of the bag body, the tube body is preferably provided at least one end with a grasping portion for removing the tube body from the bag body.

[0015] The present invention relates to a method of recovering blood components comprises accommodating a bag body into an accommodation vessel, wherein the bag body has a blood flow inlet and a blood flow outlet and is charged inside with a filter material, passing blood flow through said bag body in a condition compressed by said accommodation vessel to adhere blood components to the filter material, removing the bag body from said accommodation vessel, passing a washing solution through the inside of said bag body in an expanded condition so as to wash off the blood components adhered to said filter material, and recovering the blood components.

[0016] One embodiment of the present invention relates to a method of recovering blood components comprises filling a bag body with compressed gas to compress said bag body, wherein the bag body has a blood flow inlet and a blood flow outlet, consists of a flexible sheet and is charged inside with a filter material and accommodated in a rigid accommodation vessel, passing blood flow through said bag body in a compressed condition to adhere blood component to the filter material, exhausting the compressed gas to relieve the compression condition of said bag body, passing a washing solution through the inside of said bag body so as to wash off the blood components adhered to said filter material and recovering the blood components.

[0017] After the compressed gas is exhausted, the inside of the vessel may be evacuated to further expand said bag body through which the washing solution is then passed to wash and recover blood components having adhered to said filter.

[0018] Another embodiment is a method of recovering blood components comprising passing blood through a bag body in a compressed condition, wherein the bag body has a blood flow inlet and a blood flow outlet, consists of a flexible sheet and is charged with a filter material and accommodated in a flexible tubular body in a compressed condition in the thickness direction, removing the bag body from the flexible tubular body to relieve the compression of the bag body, passing a washing solution through the inside of said bag body so as to wash off the blood components adhered to the filter material, and recovering the blood components.

#### Brief Description of the Drawings

[0019]

Fig. 1 is a drawing showing one example of the filter set of the present invention.

Fig. 2 is a longitudinal section of the filter set shown in Fig. 1.

Fig. 3 is a drawing illustrating the filter set shown in Fig. 1.

Fig. 4 is a drawing showing another example of the filter set of the present invention.

Fig. 5 is a drawing showing the method of recovering blood components according to the present invention.

Fig. 6 is a drawing showing another example of the blood filter set of the present invention.

Fig. 7 is a longitudinal section of the bag body compressed by filling the blood filter set in Fig. 6 with compressed gas.

Fig. 8 is a longitudinal section showing the condition under which the bag body whose compression was relieved by exhausting the compressed gas from the blood filter set shown in Fig. 6.

Fig. 9 shows one example of the filter set of the present invention.

Fig. 10 is a longitudinal section of the filter set shown in Fig. 9.

Fig. 11 shows another example of the filter of the present invention.

#### Description of Preferred Embodiments

[0020] Examples of the present invention are described with reference to the drawings.

[0021] As shown in Figs. 1, 2 and 3, the filter set 1 is composed of bag body 11 charged inside with filter material 12, tube 21 connected to blood flow inlet 111 and tube 22 connected to blood flow outlet 112 for the bag body 11, and an accommodation vessel 3 for accommodating the bag body 11 in a compressed condition. Figs. 1 and 2 show that the bag body 11 has been removed from the accommodation vessel 3 and Fig. 3 shows that the bag body 11 has been

accommodated in the accommodation vessel 3.

[0022] The bag body 11 consists of two flexible sheets welded along the edge thereof. The material of the bag body 11 includes soft polyvinyl chloride, ethylene-vinyl acetate copolymers, styrene-butadiene-styrene copolymers, polyurethane, polyamide, polyester, polyethylene, polypropylene etc. The welding method is preferably thermal welding, high frequency welding, ultrasonic welding, solvent welding or the like.

[0023] The bag body 11 has been charged inside with the filter material 12, and the filter material 12 is sealed along the edge to the weld of the bag body 11. The filter material 12 is to capture desired blood components (mainly leukocytes) from blood, and it is composed preferably of synthetic fibers such as polyester, polypropylene, polyethylene, polymethyl methacrylate, polyamide etc., natural fibers such as cotton etc.

[0024] The diameter of the fiber is preferably in the range of 0.1 to 40  $\mu\text{m}$ , preferably 0.5 to 25  $\mu\text{m}$ , more preferably 0.5 to 10  $\mu\text{m}$ , and most preferably 0.5 to 3  $\mu\text{m}$ , and in the case of a diameter of less than 0.1  $\mu\text{m}$ , spaces between the fibers per unit area tend to become small thus increasing filtration resistance, while in the case of a diameter of more than 40  $\mu\text{m}$ , the volume of the fibers tends to become large thus increasing absorption of undesired blood components.

[0025] The bulk density of fiber agglomerate in compressed bag body 11 is 0.05 to 0.50  $\text{g}/\text{cm}^3$ , preferably 0.08 to 0.30  $\text{g}/\text{cm}^3$ , and more preferably 0.10 to 0.20  $\text{g}/\text{cm}^3$ . If the bulk density is less than 0.05  $\text{g}/\text{cm}^3$ , the yield of leukocytes recovered in the filter tends to decrease, and if the bulk density exceeds 0.50  $\text{g}/\text{cm}^3$ , the flow rate of blood passing through the filter tends to decrease.

[0026] The amount of the filter material 12 charged may be any amount enough to achieve degrees of capture possessed by a conventional leukocyte-removing filter in a compressed condition.

[0027] This filter material 12 may be formed of two or more materials or may comprise layers of different substances or different mesh sizes laminated therein. If the filter material 12 is composed of a multi-layer fiber agglomerate, at least one layer has a fiber diameter of 25  $\mu\text{m}$  or less and a bulk density of 0.05 to 0.50  $\text{g}/\text{cm}^3$  in a compressed condition. The multi-layer structure is composed of 2 to 6 layers, where a layer near the blood flow inlet consisting of fiber agglomerate having a large fiber diameter and a high bulk density and a layer near the blood flow outlet consisting of a fiber agglomerate having a small fiber diameter and a low bulk density are preferably arranged so that leukocytes can be captured in the order of a decreasing diameter through the layers.

[0028] For example, if the filter material 12 in compressed bag body 11 is a multi-layer fiber agglomerate consisting of a fiber agglomerate with a fiber diameter of 10  $\mu\text{m}$  and a bulk density of 0.23  $\text{g}/\text{cm}^3$  as a first layer, a fiber agglomerate with a fiber diameter of 3.5  $\mu\text{m}$  and a bulk density of 0.11  $\text{g}/\text{cm}^3$  as a second layer and a fiber agglomerate with a fiber diameter of 1.8  $\mu\text{m}$  and a bulk density of 0.12  $\text{g}/\text{cm}^3$  as a third layer, then blood components with large diameters will be captured by the first layer, monocytes and granulocytes by the second layer and lymphocytes by the third layer.

[0029] This filter material 12 may be formed of two or more materials or may comprise layers of different substances or different mesh sizes laminated therein. Further, the filter material 12 is not limited to the structure in which it is sealed along the edge to the weld of the bag body 11, and as shown in e.g. Japanese Laid-Open Patent Publication No. 67952/1995, the filter material may be formed into a hanging-bell form, and its edge is sealed by welding from a lower part to the side while an upper part is open and the end of the upper part is welded with a bag body.

[0030] In the bag body 11, the blood flow inlet 111 and the blood flow outlet 112 are arranged in the opposite side to each other relative to the filter material 12, and blood introduced from the blood flow inlet 111 is passed through the filter material 12 and discharged from the blood flow outlet 112. Similarly, a washing solution introduced from the blood flow inlet 111 or the blood flow outlet 112 is passed through the filter material 12 and discharged from the blood flow outlet 112 or the blood flow inlet 111. The bag body 11 made of a flexible sheet charged with the filter material 12 is freely expansive and compressive, and spaces between the fibers in the filter material 12 are variable, therefore, spaces between the fibers are made small when blood is passed, while spaces between the fibers is made large when a washing solution is passed. Here, the washing solution is to wash away the blood components having adhered to filter material 12 and recover them, and it is preferably physiological saline, Hank's solution, Dulbecco phosphate buffer, dextran etc. which may optionally contain human serum albumin or an anti-coagulation agent.

[0031] Tube 21 is connected to the blood flow inlet 111, and tube 22 is connected to the blood flow outlet 112. The connection method includes welding, adhesion, connection by a connector, etc. In the case of connection by a connector, usually the tube 21 has been connected to the bag body 11, but the tube 21 may be aseptically connected to the bag body 11 just before use. When the filter set of the present invention is used, one end of tubes 21 and 22 is attached to the bag body 11, and a blood bag (not shown) is attached to the other end of tubes 21 and 22, but in place of tubes 21 and 22, syringes etc. may be connected to the blood flow inlet 111 and the blood flow outlet 112.

[0032] The accommodation vessel 3 is a rectangular parallelepiped vessel which is formed of a rigid material so as to accommodate the bag body 11 in a compressed condition and which is provided with the bag body-removing port 31 from which the bag body 11 can be removed. The vessel is attached so as to slide freely in the longitudinal direction on tube 21 attached to the side of the blood flow inlet 111. The material includes synthetic resin such as polycarbonate, polystyrene, rigid polyvinyl chloride, polypropylene etc. or metals. The accommodation vessel 3 preferably has a size enough to compress the bag body 11 to achieve degrees of capture possessed by a conventional leukocyte-removing



filter. However, the accommodation vessel 3 in the present invention is not limited to the shape shown in Figs. 1, 2 and 3, and the accommodation vessel 3 may have any shape by which the bag body 11 is accommodated in a compressed condition so as to capture desired blood components and from which the bag body 11 can be removed so as to efficiently recover blood components captured in the filter material 12.

5 [0033] The filter set of the present invention may be constituted as shown in Fig. 4. The accommodation vessel 4 has a lid 41, which can be opened and closed freely, the bag body accommodated therein is compressed by closing the lid 41 in Fig.4. A groove 43 in which a tube connected with a bag body 11 is inserted and a connecting means to close a lid 41 are provided with the accommodation vessel 4. The connecting means may be such that can not put out the connection by the resiliency of the compressed bag body when the lid is closed. For instance, they are constituted with an arm 411 provided with the lid 41 and a protuberance 421 connected with said arm 411 and provided with the vessel body 42. In this example this filter set has advantages that there is no risk for damaging the bag body 11 and it may be possible to relieve a compression of the bag body 11 more rapidly because the bag body is not necessarily operated directly and the lid of the accommodation vessel is to be opened simply.

10 [0034] The method of recovering hematopoietic stem cell- and/or hematopoietic precursor cell-derived leukocytes from umbilical cord blood by use of the filter set 1 shown in Figs. 1, 2 and 3 is described.

[0035] First, the bag body 11 is accommodated in the accommodation vessel 3, and umbilical cord blood is passed from the blood flow inlet 111, through the bag body 11 in a compressed condition, to the blood flow outlet 112. In this step, the filter material 12 is compressed and spaces between the fibers are made small, so leukocytes derived from hematopoietic stem cells and/or hematopoietic precursor cells can be accurately captured.

20 [0036] Then, the bag body 11 is removed from the accommodation vessel 3, and a washing solution is passed from the blood flow outlet 112 to the blood flow inlet 111. In this step, the compression of the filter material 12 is relieved and spaces between the fibers are made large, so hematopoietic stem cell-and/or hematopoietic precursor cell-derived leukocytes having adhered to the filter material 12 can be easily removed and easily washed away with the washing solution for recovery. Because spaces between the fibers are made large, the washing solution can be easily passed therethrough to reduce the time necessary for passing the solution. Here, the washing solution may be introduced from the blood flow inlet 111 or blood flow outlet 112.

[0037] The washing solution containing leukocytes derived from hematopoietic stem cells and/or hematopoietic precursor cells is once recovered in a vessel and then separated by centrifugation or passage through a filter, whereby hematopoietic stem cells and/or hematopoietic precursor cells are recovered. At this step, a filter capturing granulocytes and monocytes but passing hematopoietic stem cells and/or hematopoietic precursor cells is preferably used.

30 [0038] The blood filter set of the present invention is described with reference to Figs. 6, 7 and 8. The blood filter set 1 is composed of the bag body 11 charged inside with the filter material 12, tube 21 connected to blood flow inlet 111 and tube 22 connected to blood flow outlet 112 for the bag body 11, and the rigid accommodation vessel 3 for accommodating the bag body 11. The accommodation vessel 3 includes ports 31, 32 provided on regions where tubes 21, 22 connected to the bag body 11 penetrate the accommodation vessel 3, in order to maintain the airtightness of the vessel. Introduction and discharge of gas is conducted through the 2-directional stopcock 33.

[0039] The accommodation vessel 3 is a rectangular parallelepiped vessel which is formed of a rigid material so as to accommodate the bag body 11 in a compressed condition by filling the vessel with compressed gas and which is provided with ports 31, 32 for maintaining the airtightness of the tube-connecting portions and with the 2-directional stopcock 33 for introducing and discharging gas. O-rings (not shown) are inserted into between ports 31, 32 and tubes 21, 22 to maintain the airtightness of the accommodation vessel 3. If the accommodation vessel 3 is formed of synthetic resin, the port and the tube may be welded by ultrasonic wave. The compressed gas used includes inert gases such as air, nitrogen, argon etc.

45 [0040] Because the bag body 11 is compressed to achieve degrees of capture possessed by a conventional leukocyte-removing filter; the accommodation vessel 3 should be formed of a material capable of enduring the compression. The material includes synthetic resin such as polycarbonate, polystyrene, rigid polyvinyl chloride etc. and metals such as stainless steel, aluminum etc. The accommodation vessel 3 is preferably in such a size that it can accommodate the bag body 11 expanded to increase spaces between the fibers in the filter material 12.

50 [0041] However, the accommodation vessel 3 in the present invention is not limited to the shape shown in the drawings and may have any shape by which the bag body 11 can be accommodated in a compressed condition so as to capture desired blood components and the bag body 11 can be expanded so as to efficiently recover blood components captured in the filter material 12.

[0042] Fig. 5 is a drawing showing the method of collecting blood components by use of the blood filter set in Fig. 6. Blood components collecting apparatus 50 in Fig. 5 includes a filter set of this invention.

55 [0043] From the blood bag 51 in which whole blood was accommodated, the whole blood is passed through the 3-directional stopcock 55, then tube 21, and introduced from the blood flow inlet 111 into the inside of the bag body 11 in a compressed condition. Leukocytes in the filter material 12 have been captured for example in spaces between the fibers therein, while erythrocytes are passed through the filter material 12, then through the blood flow outlet 112, tube 22

and 3-directional stopcock 56 and are recovered in the erythrocyte-recovering bag 53. The erythrocyte-recovering bag 53 can also accommodate platelets in addition to erythrocytes, depending on the type of the filter material 12. Thereafter, a washing solution in the wash bag 52 is passed through the 3-directional stopcock 55, tube 21, and blood flow inlet 111, thus washing away leukocytes from the filter material 12 having spaces increased between the fibers, whereby the leukocytes are passed through the blood flow outlet 112, tube 22, and 3-directional stopcock 56 and recovered in the leukocyte-recovering bag 54.

**[0044]** The method of recovering hematopoietic stem cell- and/or hematopoietic precursor cell-derived leukocytes from umbilical cord blood by use of the filter set 1 in Fig.6 is described.

**[0045]** First, umbilical cord blood is passed from the blood flow inlet 111, through the bag body 11 compressed in the accommodation vessel 3 by filling the vessel with compressed gas, to the blood flow outlet 112. In this step, the filter material 12 is also compressed, and leukocytes derived from hematopoietic stem cells and/or hematopoietic precursor cells are captured in spaces between the fibers. The compressed gas may be filled by a pump or may be injected by a syringe that was directly connected to the 2-directional stopcock 33.

**[0046]** Then, the 2-directional stopcock 33 is opened, and the compressed gas is exhausted from the accommodation vessel 3 to relieve the compressed condition of the bag body 11, thus expanding the bag body 11 through which the washing solution is then passed from the blood flow inlet 111 to blood flow outlet 112. During this step, the compression of the filter material 12 is also relieved and spaces between the fibers are made large, so leukocytes derived from hematopoietic stem cells and/or hematopoietic precursor cells having adhered to the filter material 12 are easily removed, easily washed away with the washing solution, and recovered in the leukocyte-recovering bag 54 in Fig. 6. Here, the washing solution may be introduced from the blood flow inlet 111 or blood flow outlet 112.

**[0047]** The washing solution containing leukocytes derived from hematopoietic stem cells and/or hematopoietic precursor cells is once recovered in a blood-recovery vessel and then separated by centrifugation or passage through a filter, whereby hematopoietic stem cells and/or hematopoietic precursor cells are recovered. As the filter used, a filter capturing granulocytes and monocytes but passing hematopoietic stem cells and/or hematopoietic precursor cells is preferably used.

**[0048]** In this case, the inside of the vessel is further evacuated by exhausting the compressed gas followed by evacuation by a vacuum pump, or by reducing the pressure in the vessel by use of the syringe connected to the 2-directional stopcock 33, whereby the bag body 11 is further expanded and spaces between the fibers in the filter are further enlarged thus facilitating recovery and reducing the time required for recovery.

**[0049]** As described above, because the filter set of the present invention can relieve the compressed condition by merely opening the 2-directional stopcock 33, its operation is easier than in the prior art. Further, the washing solution can be easily passed by increasing spaces between the fibers to reduce the time necessary for passing the solution.

**[0050]** As shown in Figs. 9,10 and 11, the filter set is composed of bag body 11 charged inside with filter material 12, tube 21 connected to blood flow inlet 111 and tube 22 connected to blood flow outlet 112 for the bag body 11, and flexible tube body 6 or 7 for accommodating the bag body 11 in a compressed state in the thickness direction.

**[0051]** The bag body 11 consists of two flexible sheets which were welded along the edge thereof by thermal welding, high-frequency welding, ultrasonic welding, solvent welding or the like. The material of the bag body 11 is preferably synthetic resin such as soft polyvinyl chloride, ethylene-vinyl acetate copolymers, styrene-butadiene-styrene copolymers, polyurethane, polyamide, polyester, polyethylene, polypropylene etc.

**[0052]** As shown in Fig. 10, the bag body 1 has been charged inside with the filter material 12. The filter material 12 is to capture mainly leukocytes from blood, and it is composed preferably of synthetic fibers such as polyester, polypropylene, polyethylene, polymethyl methacrylate, polyamide etc., natural fibers such as cotton, etc. The diameter of the fiber is preferably in the range of 0.1 to 40  $\mu\text{m}$ , and in the case of a diameter of less than 0.1  $\mu\text{m}$ , spaces between the fibers per unit area tend to become small thus increasing filtration resistance, while in the case of a diameter of more than 40  $\mu\text{m}$ , the volume of the fibers tends to become large thus increasing absorption of excess blood components. The amount of the filter material 12 charged may be any amount enough to achieve degrees of capture possessed by a conventional leukocyte-removing filter in a compressed condition.

**[0053]** The tube body 6 shown in Fig. 9 consists of a heat-shrinkable tube formed of one or more layers of synthetic resin such as polyvinyl chloride, polyester, polypropylene, polyethylene, polystyrene etc., and after the bag body 11 is accommodated therein, the tube body 3 is heat-shrunk to compress the bag body 11 in a desired shrinkage condition. The tube body 6 may be provided at one end (in the side of tube 22) with a ruptured portion such as V-shaped cutting 61, and a perforation may be provided along the longitudinal direction from the cutting 61 so that after blood is passed through the bag body 11, the tube body 6 can be easily ruptured along the perforation 62. The tube body 6 is not particularly limited, but usually formed to have a thickness of about 10 to 100  $\mu\text{m}$ .

**[0054]** As shown in Fig. 11, the tube body possessing a similar length to that of the bag body 1 and a smaller volume than that of the bag body 11 can be used to accommodate the bag body 11 in a desired compressed condition. The tube body 7 may be provided at one end (in the side of tube 22) with a grasping portion 63 for removing the tube body 7 from the bag body 11. After blood is passed through the bag body 11, the tube body 7 easily slides so that it can be

removed from the bag body 11. That is, it can easily slide for removal from the bag body 11 by supporting the bag body 11 with one hand and pulling the grasping portion 63 with the other hand. The material of the tube body 7 is preferably synthetic resin such as polyvinyl chloride, polyethylene, polypropylene etc. The grasping portion 63 may be formed of synthetic resin such as polypropylene, polyethylene etc., but the grasping portion 63, if provided in a rib form along the edge of the tube body 7 as shown in this example, is formed preferably into one body using the same material as the tube body 7.

**[0055]** The tube body may be in any shape enough to compress the bag body 11 to achieve degrees of capture possessed by a conventional leukocyte-removing filter, and the shape is not limited to the shapes shown in Figs. 9 and 11.

**[0056]** The method of recovering hematopoietic stem cell- and/or hematopoietic precursor cell-derived leukocytes from umbilical cord blood is described with reference to Fig. 9.

**[0057]** First, umbilical cord blood is passed from the blood flow inlet 111, through the bag body 11 accommodated in the tube body 6, to the blood flow outlet 112. In this step, the filter material 12 is compressed to attain suitable spaces between the fibers, therefore, leukocytes derived from hematopoietic stem cells and/or hematopoietic precursor cells can be accurately captured.

**[0058]** Then, the tube body 6 is ruptured along the perforation 62 from the ruptured portion 61 to remove the bag body 11 from the tube body 6, and a washing solution is passed from the blood flow outlet 112 to the blood flow inlet 111. During this step, the compression of the filter material 12 is relieved and spaces between the fibers are made large, therefore, leukocytes derived from hematopoietic stem cells and/or hematopoietic precursor cells having adhered to the filter material 11 are easily removed and easily washed away with the washing solution for recovery. Because spaces between the fibers are made large, the washing solution can be easily passed therethrough to reduce the time necessary for passing the solution. Here, the washing solution may be introduced from the blood flow inlet 111 or blood flow outlet 112.

#### Example 1

**[0059]** The filter set 1 shown in Fig. 1 is used. The filter material 12 charged in the bag body 11 consists of a 3-layer nonwoven fabric (filtration area 12.6 cm<sup>2</sup>) using polyethylene terephthalate fibers. The structure of the three layers in the bag body 11 compressed in the accommodation vessel 3 consists of a nonwoven fabric with a fiber diameter of 10 μm and a bulk density of 0.23 g/cm<sup>3</sup> in an upper layer as a first layer, a nonwoven fabric with a fiber diameter of 3.5 μm and a bulk density of 0.09 g/cm<sup>3</sup> in an interlayer as a second layer and a nonwoven fabric with a fiber diameter of 1.8 μm and a bulk density of 0.12 g/cm<sup>3</sup> in a sublayer as a third layer. The weight ratio thereof was 52: 21: 27, and the total thickness was 7.4 mm.

**[0060]** As shown in Fig. 3, the bag body 11 was accommodated in the accommodation vessel and 100 ml bovine blood containing ACD solution as an anti-coagulation agent was passed therethrough under a compressed condition at a flow rate of 5 ml/min. whereby leukocytes were captured in the inside of the bag body 11 while erythrocytes were passed through the bag body 11 and recovered in the erythrocyte-recovering bag 53 shown in Fig. 5.

**[0061]** The yield of erythrocytes recovered in the erythrocyte-recovering bag 53 was 92 %, and the yield of platelets therein was 15 %.

**[0062]** Then, the 3-directional stopcock 56 was closed and then the accommodation vessel was removed as shown in Fig. 1 and the compressed condition of the bag body 11 was relieved. And after the bag body 11 was filled with dextran to widen spaces between the fibers, 150 ml dextran solution was poured out at a flow rate of 15 ml/min. and accommodated into the leukocyte accommodation bag 54. The ratio of enlargement of the filter material 12 due to removing of the bag body 11 from the accommodation vessel 3 and the recovery of leukocytes recovered in the leukocyte-recovering bag 54 are shown in Table 1.

**[0063]** The volume expansion ratio is the ratio of the inner volume of the bag body 11 in which the compression of the filter material 12 was relieved by removing the accommodation vessel versus the inner volume of the bag body 11 in which the filter material 12 was compressed by accommodating the bag body in the accommodation vessel. The leukocyte recovery ratio is the ratio of the number of leukocytes in the dextran solution recovered in the leukocyte-recovering bag 54 versus the number of leukocytes in blood accommodated in the blood bag 51.

#### Example 2

**[0064]** The filter set 1 shown in Fig. 1 is used. A nonwoven fabric with a fiber diameter of 10 μm and a nonwoven fabric with a fiber diameter of 1.83 μm were immersed in 0.25 % 2-hydroxyethyl methacrylate/diethylaminoethyl methacrylate copolymer in ethanol to make a 2-layer laminate. A filter material 12 having a 2-layer structure consisting of said nonwoven fabric having a fiber diameter of 10 μm and a bulk density of 0.32 g/cm<sup>3</sup> as an upper layer (first layer) and said nonwoven fabric with a fiber diameter of 1.83 μm and a bulk density of 0.12 g/cm<sup>3</sup> as a sublayer (second layer) in a compressed condition (volume ratio 72.7 : 27.3) was accommodated in a bag body 11 (filtration area 12.6 cm<sup>2</sup>).

[0065] The bag body 11 was accommodated in the accommodation vessel 3, and 50 ml umbilical cord blood using a heparin solution as an anti-coagulation agent was passed therethrough at a flow rate of 5 ml/min. whereby leukocytes derived from hematopoietic stem cells and/or hematopoietic precursor cells were captured in the filter material 12 in the inside of the bag body 11. Erythrocytes and platelets were passed through the bag body 11 and recovered in the erythrocyte-recovering bag 53. The yield of erythrocytes recovered in the erythrocyte-recovering bag 53 was 85 % and the yield of platelets therein was 81 %. Then, after closing the 3-directional stopcock 56, removing the accommodation vessel and relieving the compression of the bag body, dextran solution was passed into the bag body 11 so that leukocytes derived from hematopoietic stem cells and/or hematopoietic precursor cells were recovered in the leukocyte-recovering bag 54.

[0066] The volume expansion ratio of the bag body 11 and the yield of leukocytes recovered in the leukocyte-recovering bag 54, as determined in the same manner as in Example 1, are shown in Table 1.

Example 3

[0067] The similar experiment to Example 1 was done by using the filter set 10 shown in Fig. 4. The bag body 11 and the filter material 12 are same as in Example 1.

[0068] The ratio of enlargement of the bag body 11 due to opening the lid and the recovery of leukocytes recovered in the leukocyte-recovering bag 54 are shown in Table 1.

[0069] The volume expansion ratio is the ratio of the inner volume of the bag body 11 in which the compression of the filter material 12 was relieved by opening the lid versus the inner volume of the bag body 11 in which the filter material 12 was compressed by closing the lid. The leukocyte recovery ratio is the ratio of the number of leukocytes in the dextran solution recovered in the leukocyte-recovering bag 54 versus the number of leukocytes in blood accommodated in the blood bag 51.

Example 4

[0070] The similar experiment to Example 2 was done by using the filter set 10 shown in Fig. 4. The bag body 11 and the filter material 12 are same as in Example 2.

[0071] The ratio of enlargement of the bag body 11 due to opening the lid and the recovery of leukocytes recovered in the leukocyte-recovering bag 54 are shown in Table 1.

Table 1

|           | Volume expansion ratio (fold) | Leukocyte recovery ratio (%) |
|-----------|-------------------------------|------------------------------|
| Example 1 | 1.00                          | 42.6                         |
|           | 1.51                          | 78.2                         |
| Example 2 | 1.01                          | 41.5                         |
|           | 1.46                          | 76.5                         |
| Example 3 | 1.00                          | 49.6                         |
|           | 1.48                          | 83.2                         |
| Example 4 | 1.00                          | 41.5                         |
|           | 1.51                          | 80.6                         |

Example 5

[0072] The filter set 1 shown in Fig. 6 is used. The filter material 12 charged in the bag body 11 consists of a 3-layer nonwoven fabric (filtration area 12.6 cm<sup>2</sup>) using polyethylene terephthalate fibers. The structure of the three layers in the bag body 11 compressed in the accommodation vessel 3 consists of a nonwoven fabric with a fiber diameter of 10 μm and a bulk density of 0.19 g/cm<sup>3</sup> in an upper layer as a first layer, a nonwoven fabric with a fiber diameter of 3.5 μm and a bulk density of 0.05 g/cm<sup>3</sup> in an interlayer as a second layer and a nonwoven fabric with a fiber diameter of 1.8 μm and a bulk density of 0.14 g/cm<sup>3</sup> in a sublayer as a third layer. The weight ratio thereof was 52: 21: 27, and the total thickness was 6.0 mm.

[0073] As shown in Fig. 7, the bag body 11 was compressed by injecting compressed air into the accommodation vessel 3 by use of a syringe, and 100 ml bovine blood containing ACD solution as an anti-coagulation agent was passed therethrough under a compressed condition at a flow rate of 5 ml/min. whereby leukocytes were captured in the inside of the bag body 11 while erythrocytes were passed through the bag body 11 and recovered in the erythrocyte-recovering bag 53 shown in Fig. 5.

[0074] The yield of erythrocytes recovered in the erythrocyte-recovering bag 53 was 90 %, and the yield of platelets therein was 13 %.

[0075] Then, the 3-directional stopcock 56 was closed and then the 2-directional stopcock 33 was opened to exhaust the compressed air from the accommodation vessel 3 so that as shown in Fig. 8, the bag body 11 was expanded due to relieved compression. Thereafter, the bag body 11 was filled with dextran solution to widen spaces between the fibers. After shifting the direction of the 3-directional stopcock 56 to the leukocyte-recovering bag 54, 150 ml dextran solution was passed at a flow rate of 15 ml/min. and recovered in the leukocyte-recovering bag 54. The compressed air was exhausted from the accommodation vessel 3. The ratio of enlargement of the filter material 12 due to the relieved compression of the bag body 11 and the recovery of leukocytes recovered in the leukocyte-recovering bag 54 are shown in Table 2.

[0076] The volume expansion ratio is the ratio of the inner volume of the bag body 11 in which the compression of the filter material 12 was relieved by exhausting the compressed air versus the inner volume of the bag body 11 in which the filter material 12 was compressed by filling the accommodation vessel 3 with the compressed air. The leukocyte recovery ratio is the ratio of the number of leukocytes in the dextran recovered in the leukocyte-recovering bag 54 versus the number of leukocytes in blood recovered in the blood bag 51.

Table 2

|                               |      |      |      |      |      |      |      |
|-------------------------------|------|------|------|------|------|------|------|
| Volume expansion ratio (fold) | 1.00 | 1.05 | 1.20 | 1.40 | 1.60 | 1.80 | 2.00 |
| Leukocyte recovery ratio (%)  | 32.0 | 52.0 | 75.0 | 84.0 | 85.0 | 84.0 | 83.0 |

[0077] As is evident from Table 2, the yield of leukocyte increases with an increasing volume expansion ratio, but when the volume expansion ratio is 1.4 or more, the yield becomes nearly constant.

Example 6

[0078] The filter set 1 shown in Fig. 6 is used. A nonwoven fabric with a fiber diameter of 10 μm and a nonwoven fabric with a fiber diameter of 1.8 μm were immersed in 0.25 % 2-hydroxyethyl methacrylate/diethylaminoethyl methacrylate copolymer in ethanol to make a 2-layer laminate. A filter material 12 having a 2-layer structure consisting of said nonwoven fabric having a fiber diameter of 10 μm and a bulk density of 0.3 g/cm<sup>3</sup> as an upper layer (first layer) and said nonwoven fabric with a fiber diameter of 1.8 μm and a bulk density of 0.14 g/cm<sup>3</sup> as a sublayer (second layer) in a compressed condition (volume ratio 72.7 : 27.3) was accommodated in a bag body 11 (filtration area 12.6 cm<sup>2</sup>).

[0079] The bag body 11 was compressed by injecting compressed air into the accommodation vessel 3 by use of a syringe, and 50 ml umbilical cord blood using a heparin solution as an anti-coagulation agent was passed therethrough at a flow rate of 5 ml/min. whereby leukocytes derived from hematopoietic stem cells and/or hematopoietic precursor cells were captured in the filter material 12 in the inside of the bag body 11.

[0080] Erythrocytes and platelets were passed through the bag body 11 and recovered in the erythrocyte-recovering bag 53. The yield of erythrocytes recovered in the erythrocyte-recovering bag 53 was 87 % and the yield of platelets therein was 91 %. Then, the 3-directional stopcock 56 was closed and then the 2-directional stopcock 33 was opened to exhaust the compressed air thus relieving the compressed condition of the bag body 11, and dextran solution was passed into the bag body 11 so that leukocytes derived from hematopoietic stem cells and/or hematopoietic precursor cells were recovered in the leukocyte-recovering bag 54.

[0081] The volume expansion ratio of the bag body 11 and the yield of leukocytes recovered in the leukocyte-recovering bag 54, as determined in the same manner as in Example 1, are shown in Table 3.

Table 3

|                               |      |      |      |      |      |      |      |
|-------------------------------|------|------|------|------|------|------|------|
| Volume expansion ratio (fold) | 1.00 | 1.05 | 1.20 | 1.40 | 1.60 | 1.80 | 2.00 |
| Leukocyte recovery ratio (%)  | 41.0 | 48.0 | 78.0 | 85.0 | 87.0 | 87.0 | 85.0 |

[0082] As is evident from Table 3, the yield of leukocyte increases with an increasing volume expansion ratio, but when

the volume expansion ratio is 1.4 or more, the yield becomes nearly constant.

Effects of the Invention

5 [0083] As is evident from the foregoing description, blood components having adhered to the filter material can be efficiently recovered by the blood filter set of the present invention. Further, the time required for passing the washing solution can be reduced. The filter set of the present invention can relieve the compression of the filter material in simple operation.

10 Explanation of the Reference signs

[0084]

- 1,10 filter set,
- 15 11 bag body,
- 12 filter material,
- 111 blood flow inlet,
- 112 blood flow outlet,
- 21,22 tube,
- 20 3,4 accommodation vessel
- 31,32 bag body-removing port
- 33 2-directional stopcock
- 41 lid
- 411 arm
- 25 42 vessel body
- 421 protuberance
- 43 groove
- 50 blood components collecting apparatus
- 51 blood bag
- 30 52 washing solution bag
- 53 erythrocyte-recovering bag
- 54 leukocyte-recovering bag
- 55,56 3-directional stopcock
- 61 ruptured portion
- 35 62 perforation
- 63 grasping portion

**Claims**

- 40 1. A blood filter set comprising a bag body having a blood flow inlet and a blood flow outlet and charged with a filter material, and an accommodation vessel for accommodating said bag body.
- 2. The blood filter set of claim 1 wherein the accommodation vessel is for accommodating said bag body which is freely removed therefrom and for accommodating said bag body in a compressed condition at the time of accom-  
45 modation.
- 3. The blood filter set of claim 1 wherein the accommodation vessel has a lid, which can be opened and closed easily.
- 4. The blood filter set of claim 1 wherein said bag body is compressed by filling with compressed gas, and after blood  
50 is passed through said bag body in a compressed condition, the compressed gas is exhausted to relieve the compression of said bag body and then a washing solution is passed through the bag body.
- 5. The blood filter set of claim 4 wherein the accommodation vessel further expands said bag body by evacuating the inside of the accommodation vessel.
- 55 6. The blood filter set of claim 1 wherein the bag body consists of a flexible sheet.
- 7. The blood filter set of claim 1 wherein the accommodation vessel is rigid.

8. The blood filter set of claim 1 wherein the accommodation vessel is a flexible tubular body.
9. The blood filter set of claim 1 wherein the filter material is a fiber.
- 5 10. The blood filter set of claim 9 wherein the diameter of the fiber is in the range of 0.1 to 40  $\mu\text{m}$ .
11. The blood filter set of claim 9 wherein the bulk density of fiber agglomerates in compressed bag body is 0.05 to 0.50  $\text{g/cm}^3$ .
- 10 12. A blood filter set comprising a bag body having a blood flow inlet and a blood flow outlet and consisting of a flexible sheet charged inside with a filter material, and a rigid accommodation vessels for accommodating said bag body which is freely removed therefrom and for accommodating said bag body in a compressed condition at the time of accommodation.
- 15 13. A blood filter set comprising a bag body having a blood flow inlet and a blood flow outlet and consisting of a flexible sheet charged inside with a filter material, and a rigid accommodation vessel for accommodating said bag body, wherein said bag body is compressed by filling with compressed gas, and after blood is passed through said bag body in a compressed condition, the compressed gas is exhausted to relieve the compression of said bag body through which a washing solution is then passed.
- 20 14. The blood filter set of claim 12 or 13 wherein said accommodation vessel further expands said bag body by evacuating the inside of the vessel.
- 25 15. A blood filter set comprising a bag body having a blood flow inlet and a blood flow outlet and being charged with a filter material, and a flexible tube body accommodating the bag body in a compressed condition in the thickness direction, wherein said body can be removed from said tube body.
16. The blood filter set of claim 15 wherein the tube body is heat-shrinkable.
- 30 17. The blood filter set of claim 15 wherein the tube is provided with a ruptured portion.
18. The blood filter set of claim 15 wherein the tube body possesses a similar length to that of the bag body and a smaller volume than that of the bag body.
- 35 19. The blood filter set of claim 15 wherein the tube body is provided at least one end thereof, with a grasping portion for removing the tube body from the bag body.
20. A method of recovering blood components comprises
  - 40 accommodating a bag body into an accommodation vessel, wherein the bag body has a blood flow inlet and a blood flow outlet and is charged inside with a filter material, passing blood flow through said bag body in the condition compressed by said accommodation vessel to adhere blood components to the filter material,
  - 45 removing the bag body from said accommodation vessel,
  - passing a washing solution through the inside of said bag body in an expanded condition so as to wash off the blood components adhered to said filter material, and recovering the blood components.
- 50 21. The method of claim 20 wherein the bag body consists of a flexible sheet.
22. The method of claim 20 wherein the accommodation vessel is rigid.
23. The method of claim 20 wherein the filter material is a fiber.
- 55 24. The method of claim 20 wherein the blood component is leukocyte.
25. A method of recovering blood components comprises

filling a bag body with compressed gas to compress said bag body, wherein the bag body has a blood flow inlet and a blood flow outlet, consists of a flexible sheet and is charged inside with a filter material and accommodated in a rigid accommodation vessel,

5 passing blood flow through said bag body in a compressed condition to adhere blood components to the filter material, exhausting the compressed gas to relieve the compression condition of said bag body, passing a washing solution through the inside of said bag body so as to wash off the blood components adhered to said filter material, and recovering blood components.

10 **26.** The methods of recovering blood components of claim 25 wherein further evacuating the inside of vessel to expand said bag body after the compressed gas is exhausted.

**27.** A method of recovering blood components comprising

15 passing blood through a bag body in a compressed condition, wherein the bag body has a blood flow inlet and a blood flow outlet, consists of a flexible sheet and is charged with a filter material and accommodated in a flexible tubular body in a compressed condition in the thickness direction, removing the bag body from the flexible tubular body to relieve the compression of the bag body, passing a washing solution through the inside of said bag body so as to wash off the blood components  
20 adhered to the filter material, and recovering the blood components.

25

30

35

40

45

50

55



Fig. 1

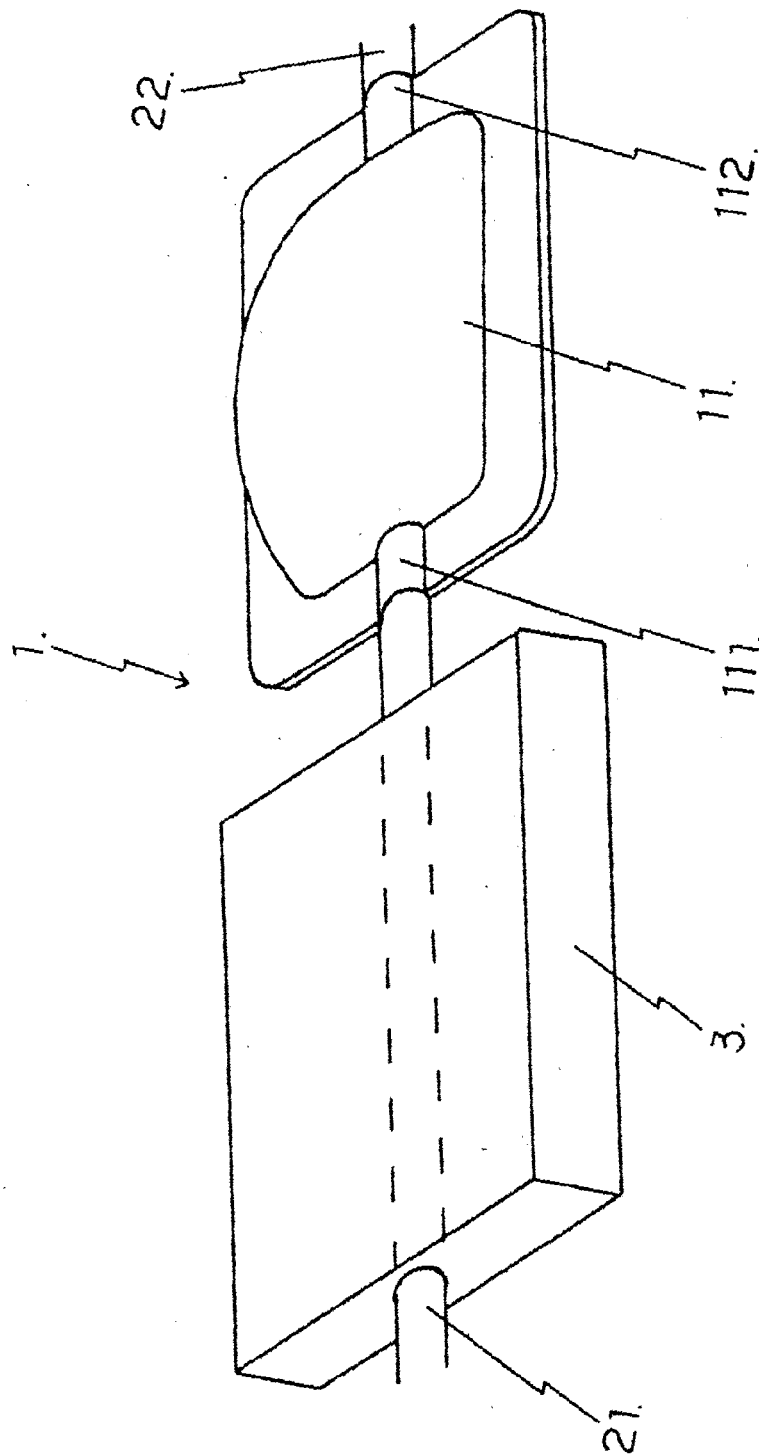
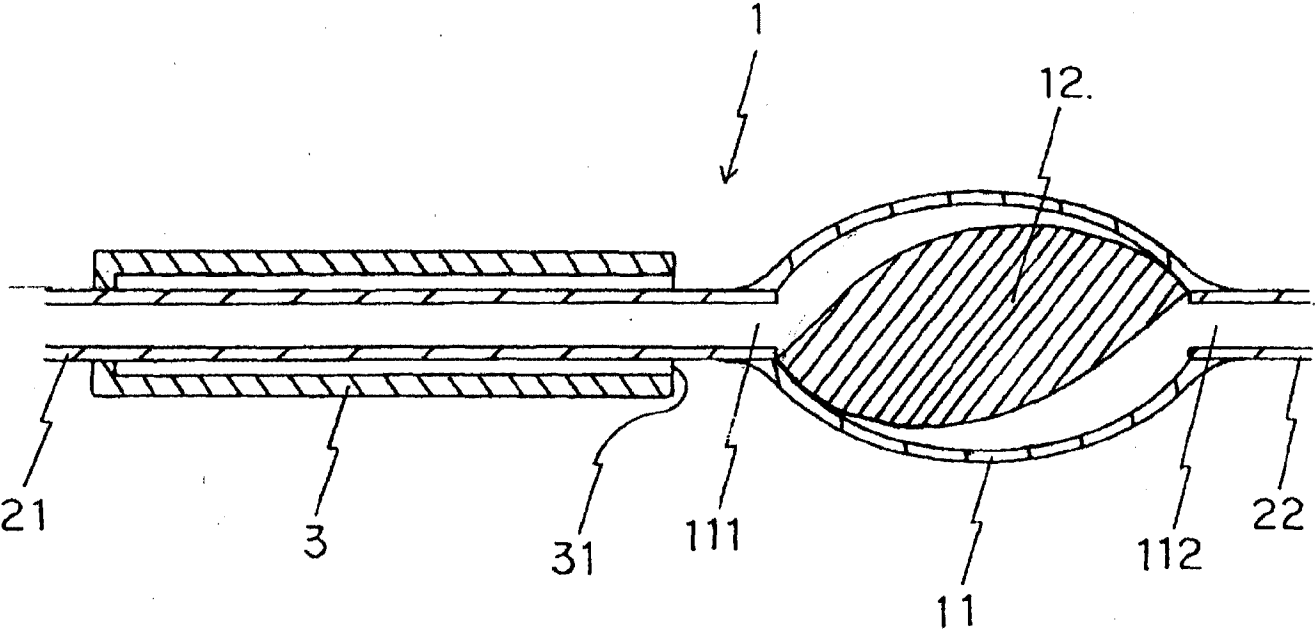


Fig. 2



14

EP 0 919 249 A1

Fig. 3

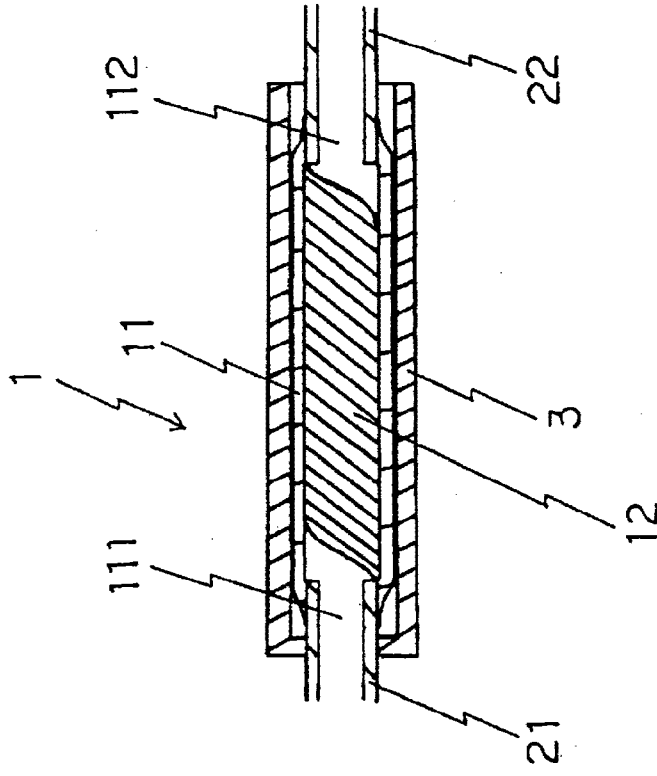


Fig. 4

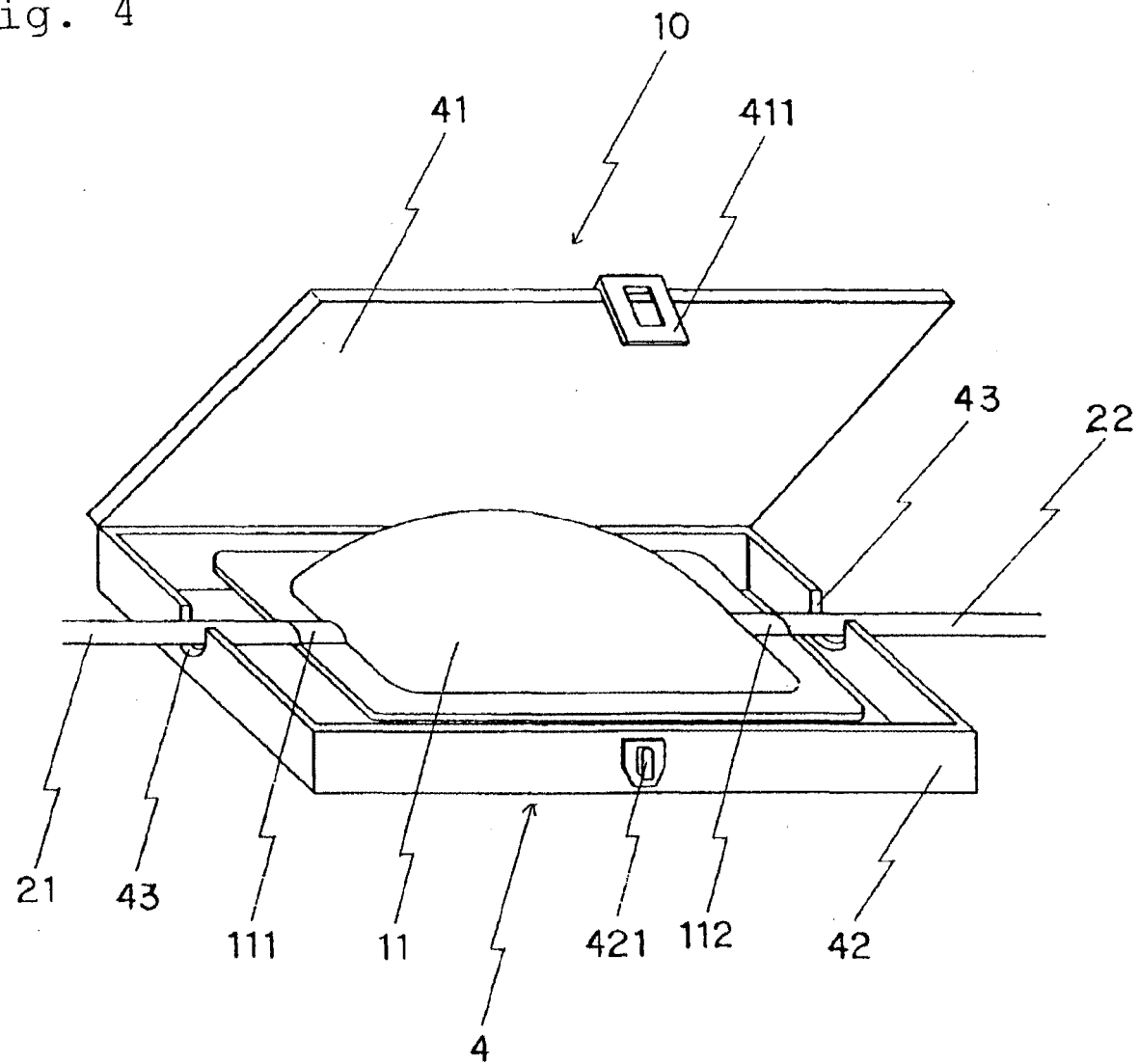


Fig. 5

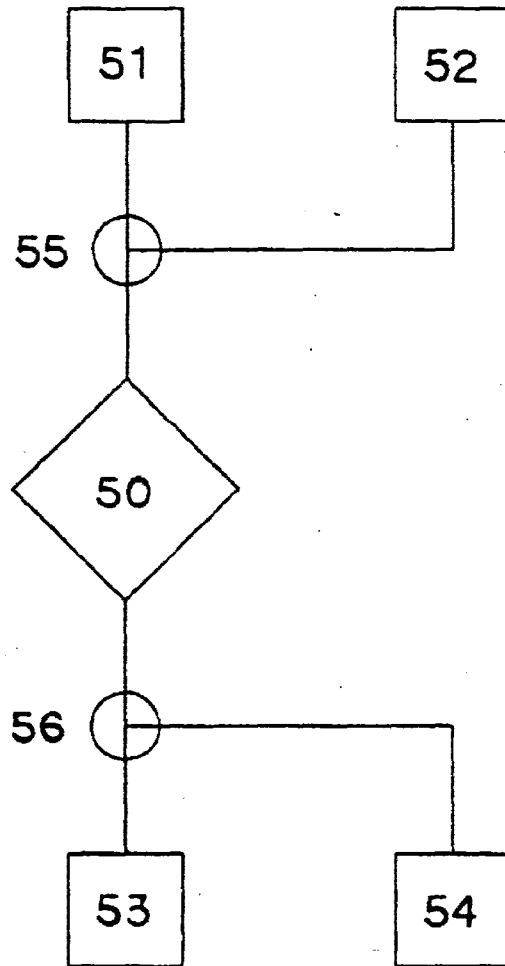


Fig. 6

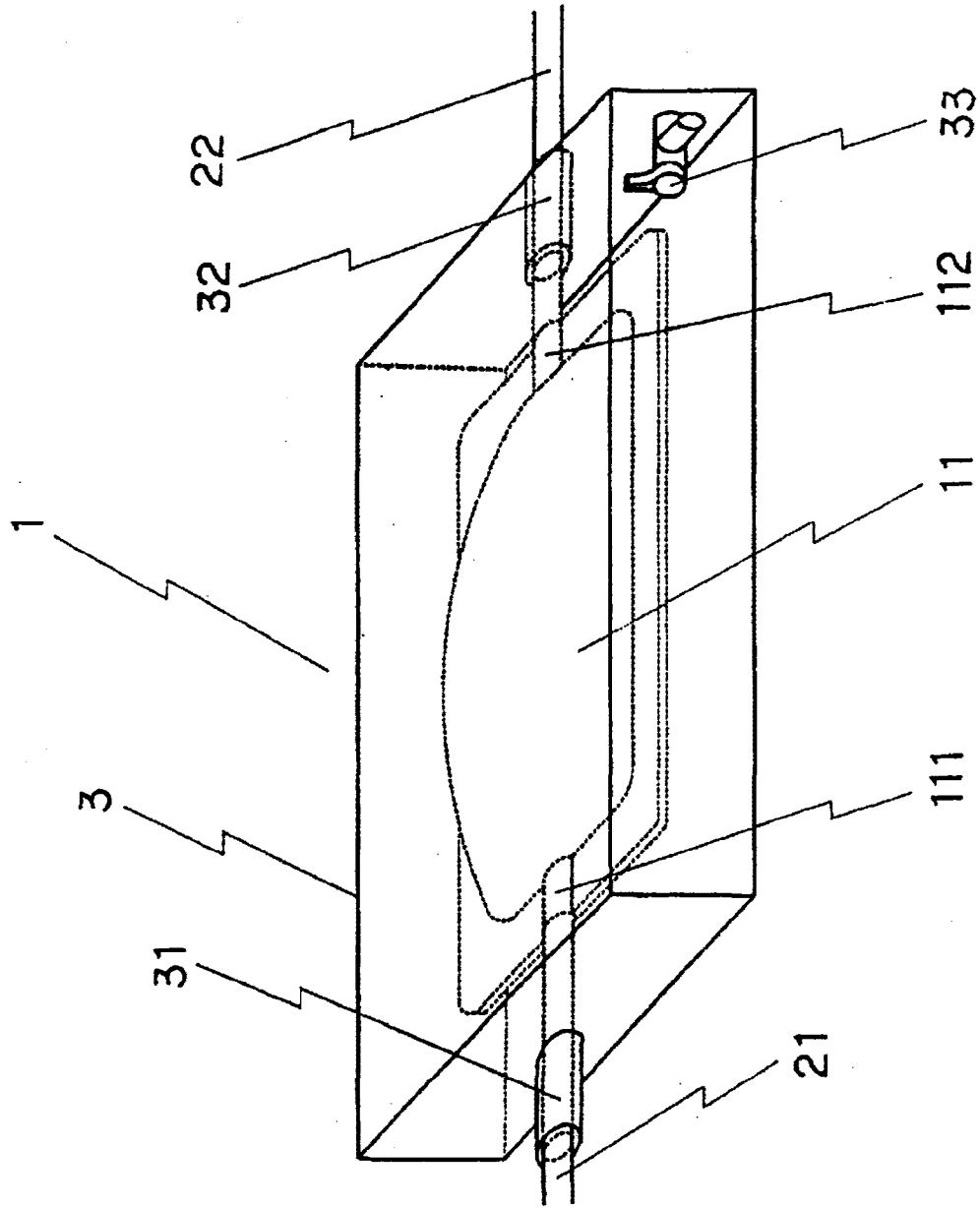


Fig. 7

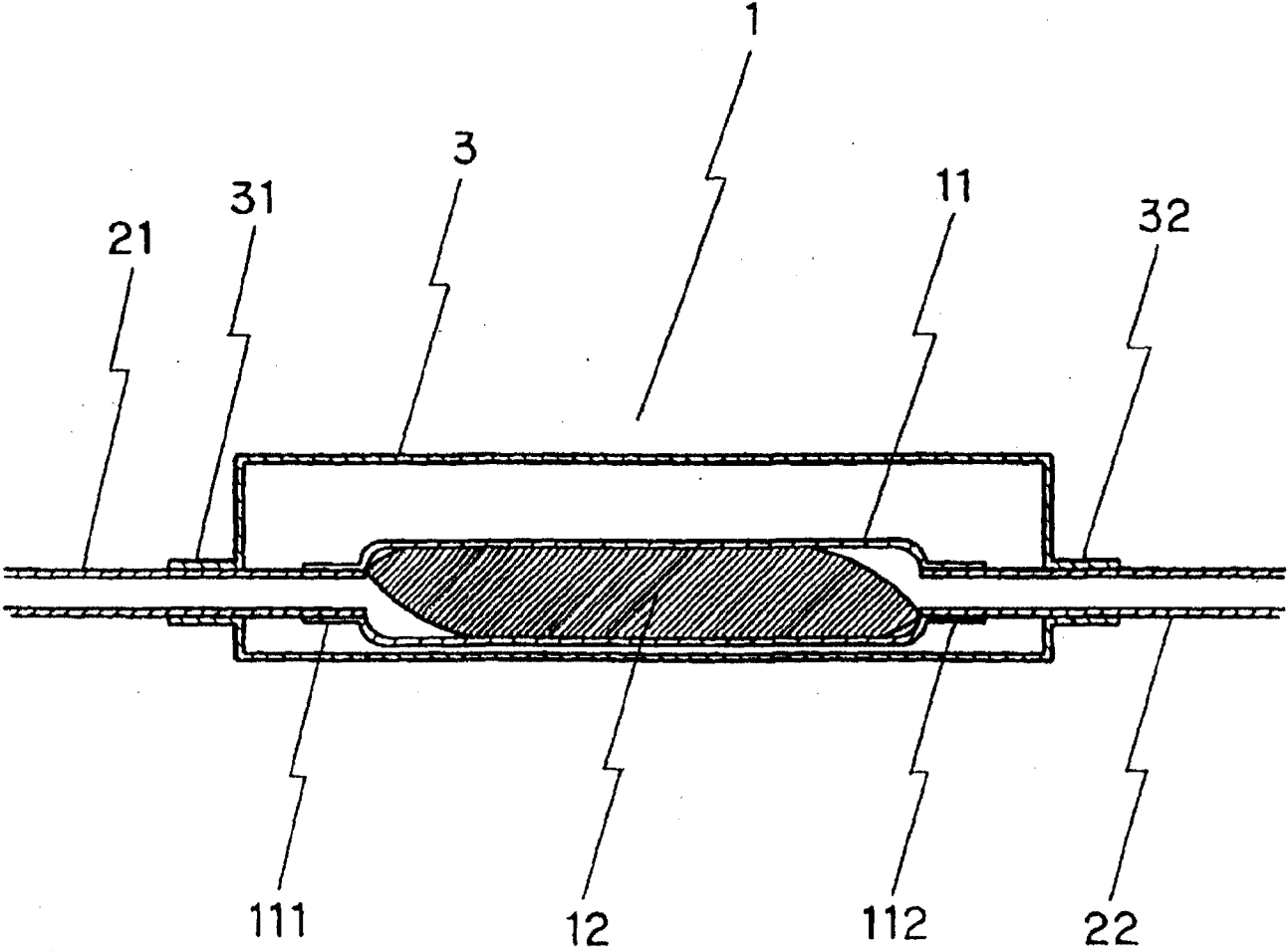
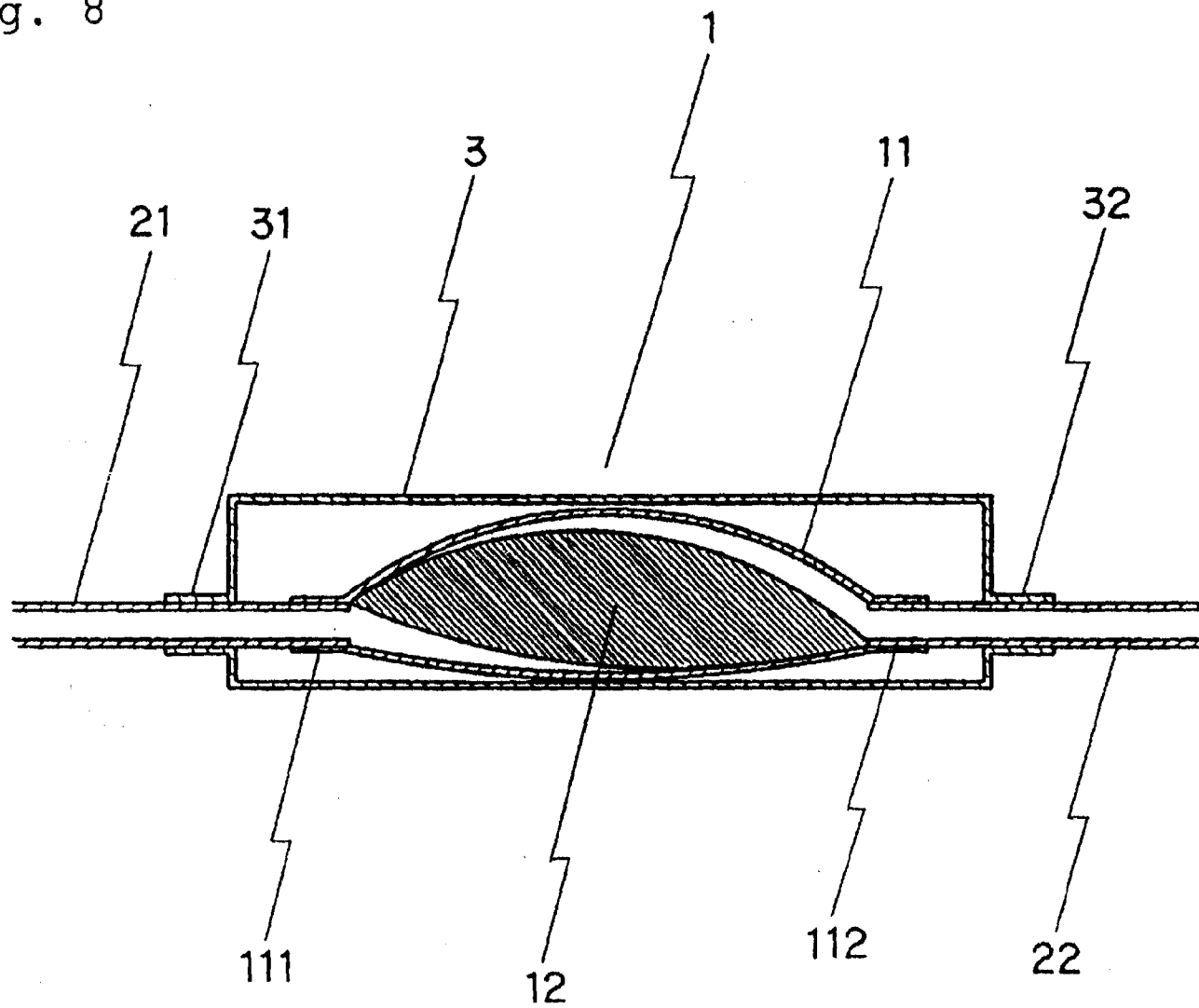


Fig. 8



20

EP 0 919 249 A1



Fig. 9

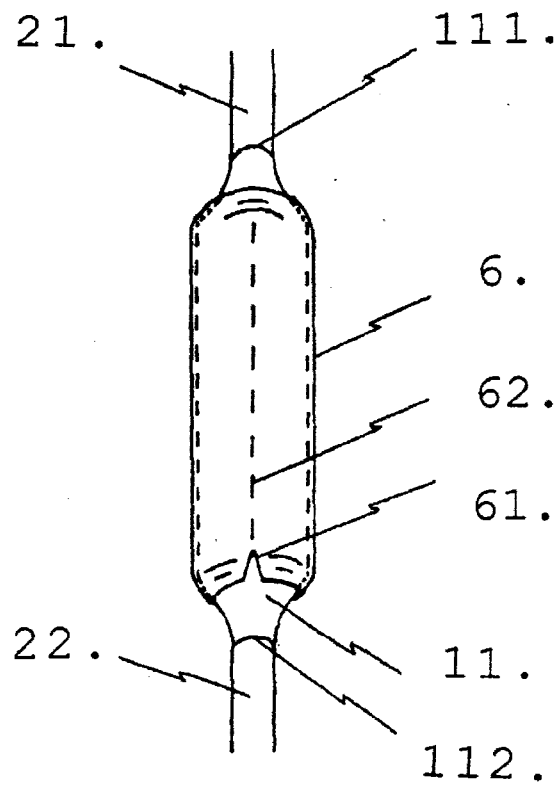


Fig. 10

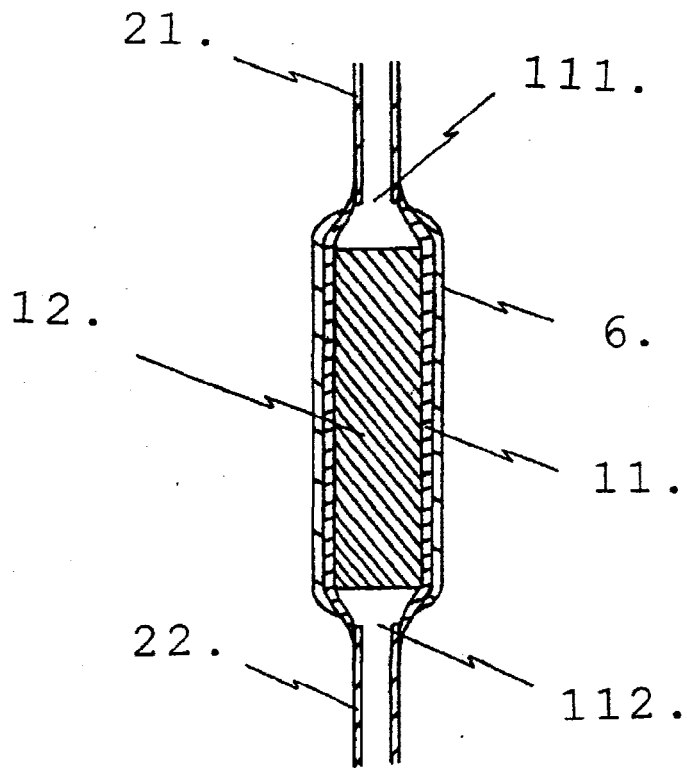
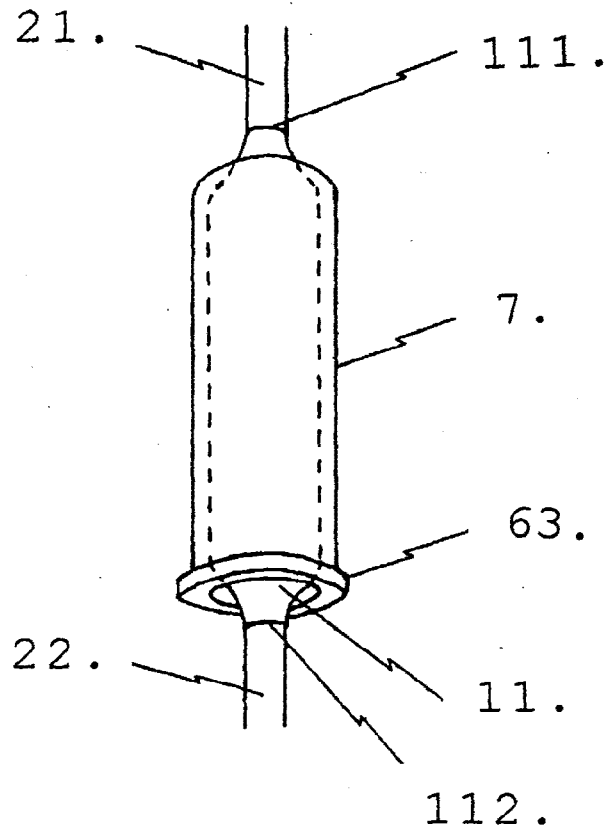


Fig. 11





European Patent Office

EUROPEAN SEARCH REPORT

Application Number  
EP 98 12 1181

| DOCUMENTS CONSIDERED TO BE RELEVANT   |  |  |  |
|---|--|--|--|
| Category  | Citation of document with indication, where appropriate, of relevant passages  | Relevant to claim  | CLASSIFICATION OF THE APPLICATION (Int.Cl.6) |
| A   | EP 0 280 052 A (DONGBEI POWER COLLEGE)<br>31 August 1988<br><br>* column 5, line 17 - line 36 *<br>* column 6, line 9 - line 47 *<br>* figures * | 1,4,6,7,<br>9,12,13,<br>15,20,<br>25,27  | A61M1/36                                     |
| A   | US 4 416 777 A (KURODA TORU ET AL)<br>22 November 1983<br>* column 10, line 6 - line 18 *<br>* column 11, line 3 - line 17 *                     |  |  |
|   |  |  | TECHNICAL FIELDS SEARCHED (Int.Cl.6)         |
|   |  |  | B01D<br>A61M                                 |
| The present search report has been drawn up for all claims  |  |  |  |
| Place of search<br><b>THE HAGUE</b>   |  | Date of completion of the search<br><b>17 February 1999</b>  | Examiner<br><b>Vereecke, A</b>               |
| CATEGORY OF CITED DOCUMENTS   |  | T : theory or principle underlying the invention<br>E : earlier patent document, but published on, or after the filing date<br>D : document cited in the application<br>L : document cited for other reasons<br>& : member of the same patent family, corresponding document |  |
| X : particularly relevant if taken alone<br>Y : particularly relevant if combined with another document of the same category<br>A : technological background<br>O : non-written disclosure<br>P : intermediate document |  |  |  |

EPO FORM 1503 03/82 (P/4C01)

**ANNEX TO THE EUROPEAN SEARCH REPORT  
ON EUROPEAN PATENT APPLICATION NO.**

EP 98 12 1181

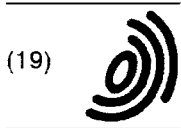
This annex lists the patent family members relating to the patent documents cited in the above-mentioned European search report. The members are as contained in the European Patent Office EDP file on  
The European Patent Office is in no way liable for these particulars which are merely given for the purpose of information.

17-02-1999

| Patent document<br>cited in search report | Publication<br>date | Patent family<br>member(s) | Publication<br>date |
|---|---------------------|----------------------------|---------------------|
| EP 0280052    A                           | 31-08-1988          | CN 1004400 B               | 07-06-1989          |
|   |                     | DE 3850792 D               | 01-09-1994          |
|   |                     | DE 3850792 T               | 24-11-1994          |
|   |                     | DE 8804741 U               | 01-06-1988          |
|   |                     | FI 880346 A,B              | 28-07-1988          |
|   |                     | JP 2514997 B               | 10-07-1996          |
|   |                     | JP 63229104 A              | 26-09-1988          |
|   |                     | US 4851136 A               | 25-07-1989          |
| US 4416777    A                           | 22-11-1983          | JP 1279473 C               | 29-08-1985          |
|   |                     | JP 56053616 A              | 13-05-1981          |
|   |                     | JP 60003367 B              | 28-01-1985          |
|   |                     | DE 3038196 A               | 23-04-1981          |
|   |                     | FR 2467403 A               | 17-04-1981          |
|   |                     | GB 2062498 A,B             | 28-05-1981          |

EPO FORM P1069

For more details about this annex : see Official Journal of the European Patent Office, No. 12/82



(12) **EUROPEAN PATENT APPLICATION**

(43) Date of publication:  
**26.05.2004 Bulletin 2004/22**

(51) Int Cl.7: **A61M 5/165**

(21) Application number: **03025258.9**

(22) Date of filing: **06.11.2003**

(84) Designated Contracting States:  
**AT BE BG CH CY CZ DE DK EE ES FI FR GB GR  
 HU IE IT LI LU MC NL PT RO SE SI SK TR**  
 Designated Extension States:  
**AL LT LV MK**

(72) Inventors:  
 • **Scagliarini, Massimo**  
 40136 Bologna (IT)  
 • **Bettini, Emanuele**  
 40050 Monte San Pietro (Bologna) (IT)

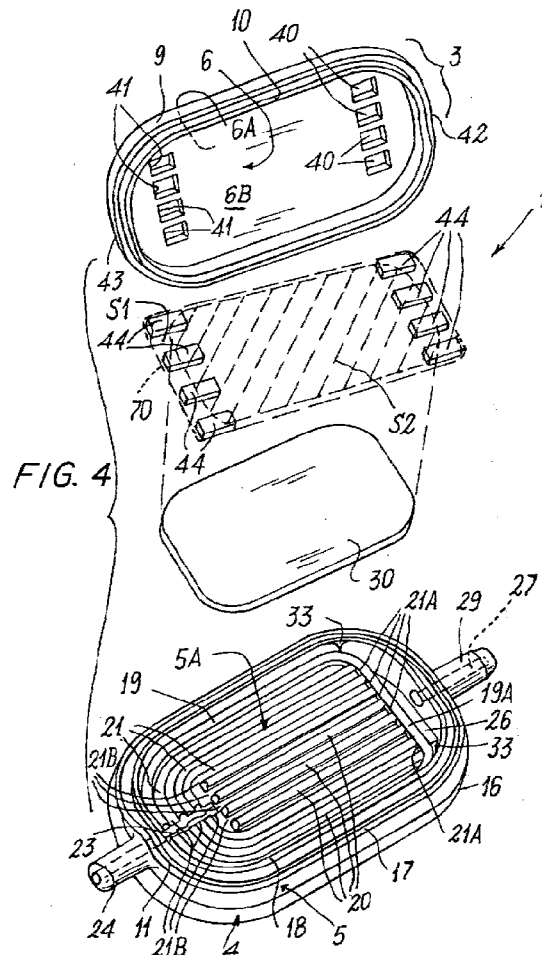
(30) Priority: **21.11.2002 IT MI20022473**

(74) Representative: **Ripamonti, Enrico, Dr. Ing. et al**  
**Ing. A. Giambrocono & C. s.r.l.,**  
 19/B, Via Rosolino Pilo  
 20129 Milano (IT)

(71) Applicant: **GVS S.p.A.**  
 40069 Zola Predosa (Bologna) (IT)

(54) **Infusion filter operating in various tridimensional positions**

(57) A filter (1) comprises a box casing (2) in which at least one cavity (37) is present between an outer element (3, 4) of said casing (2) and an inner surface (5A, 5B) presenting a plurality of channels (21) on which a corresponding hydrophilic filtering membrane (30) lies, said cavity (37) communicating with a conduit (27) for entry of the fluid into the filter (1) and said channels (21) being connected to a conduit (23) for exit of said fluid, in said outer element (3, 4) there being provided through apertures (40, 41) with which hydrophobic membranes (44) are associated. A surface (S1) bounded by the shortest possible ideal closed line (70), which totally comprises all the hydrophobic membranes (44), contains substantially within its interior the projection thereon of the useful hydrophilic surface (S2) of the hydrophilic filtering membrane (30), this enabling the filter (1) to be employed in a plurality of spatial positions during its use.



## Description

**[0001]** The present invention relates to an infusion filter in accordance with the introduction to the main claim.

**[0002]** Filters of the same type as the present invention have been known for some time. They present small dimensions, but must be used in well defined spatial orientations to prevent the formation of air bubbles within the filter which, if they should reach the patient by being conveyed by the fluid, would result in serious well-known problems.

**[0003]** An object of the present invention is to provide an infusion filter which is improved with respect to similar known filters.

**[0004]** A particular object of the invention is to provide a filter of the stated type which during use can be disposed in a multiplicity of spatial positions without this involving risks to the correct fluid flow to a patient.

**[0005]** Another object is to provide a filter of the stated type which can be used reliably and safely.

**[0006]** These and other objects which will be apparent to the expert of the art are attained by a filter in accordance with the accompanying claims.

**[0007]** The present invention will be more apparent from the accompanying drawing, which is provided by way of non-limiting example and in which:

Figure 1 is a front view of a filter according to the invention;

Figure 2 is a side view of the filter of Figure 1;

Figure 3 is a section on the line 3-3 of Figure 1;

Figure 4 is an exploded view of the filter of Figure 1;

Figure 5 is a schematic view of a characteristic of Figure 1;

Figure 6 is a perspective view of a variant of the filter of Figure 1;

Figure 7 is a partial perspective view of another variant of the filter of Figure 1;

Figure 8 is a section on the line 8-8 of Figure 7;

Figure 9 is a partial perspective view of a further variant of the filter of Figure 1;

Figure 10 is a section on the line 10-10 of Figure 9;

Figure 11 is a partial perspective view of another variant of the filter of Figure 1;

Figure 12 is a section on the line 12-12 of Figure 11;

Figure 13 is a partial perspective view of another variant of the filter of Figure 1;

Figure 14 is a section on the line 14-14 of Figure 13;

Figure 15 is a perspective view from above of a further variant of the filter of Figure 1; and

Figure 16 is a section on the line 16-16 of Figure 15.

**[0008]** With reference to said Figures from 1 to 14, a filter according to the invention is indicated overall by 1 and comprises a box casing 2 defined, in the example under examination, by a first and a second outer element 3, 4 closing an intermediate element 5. These box

casing elements 3, 4 and 5 are constructed preferably of plastic material in any known manner.

**[0009]** The outer elements 3 and 4 comprise a flat portion 6 and 7 having opposing faces 6A, 6B and 7A, 7B respectively. In proximity to the edge 9 of said portions 6, 7, there projects from their face 6B, 7B, which is internal with respect to the casing 2 (the face 6A and 7A being an external face of this latter), a shoulder 10 arranged to cooperate with a recess 11 provided in the facing surface of the element 5, in order to secure the elements 3 and 4 to the intermediate element 5. This fixing is obtained in any known manner, for example by ultrasonic bonding, gluing or other means.

**[0010]** The surface facing the face 6B is indicated in the figures by 5A, while the surface facing the face 7B is indicated by 5B.

**[0011]** Only one of the surfaces 5A and 5B is described hereinafter as these are identical. Likewise only one of the elements 3 and 4 is described hereinafter, it being understood that everything stated for the surface 5A and for the element 3 is also valid for the surface 5B and for the element 4.

**[0012]** The intermediate element 5 presents a rounded edge 16 and comprises on the face 5A, starting from its periphery and progressing towards its interior, a pair of spaced-apart parallel annular shoulders 17 and 18 defining the aforesaid recess 11, an annular step 19 and a plurality of parallel ribs 20, circumscribed by the step 19 and defining channels 21 closed at one end 21A by the step 19 and open at their other end 21B where they communicate with a conduit 23 leaving the element 5 via a stem 24 projecting from the edge 16 of said element.

**[0013]** The step 19 and the parallel ribs 20 have a height less than the shoulders 17 and 18. Between the step 19 and the shoulder 18 a cavity 26 is present communicating with an entry conduit 27 which penetrates into the element 5 (via the shoulders 17 and 18) by passing through a stem 29 projecting from the edge 16. Preferably the stem 29 is coaxial with the stem 24, they both lying along a central axis A of the element 5.

**[0014]** The step 19 and the ribs 20 can be formed directly in one piece with the element 5 or can be formed on a separate piece inserted within the shoulders 17 and 18 of the element 5 in such a manner as to rest along the shoulder 18 in correspondence with two of its side portions, but spaced from said shoulder 18 so as to define the cavity 26.

**[0015]** As stated, the free ends of the step 19 and of the ribs 20 lie at least in a plane distant from that in which the ends of the shoulders 17 and 18 lie. Within this space a hydrophilic filter membrane 30 is positioned to rest against the shoulder 18 but not to cover the cavity 26. In this respect, in correspondence with this latter, during filter assembly the hydrophilic membrane 30 is maintained distant from the shoulder 18 by cusp-shaped projections 33 jutting from this shoulder in correspondence with a transverse part 19A of the step 19 perpendicular

to said axis A. The membrane is finally rested on the ends of the ribs 20 and is finally fixed to the transverse part 19A and to the step 10 in known manner, for example by hot bonding.

**[0016]** When the intermediate element 5 is completed (i.e. also provided with the membranes 30), cavities 37 communicating with the aforesaid cavities 26 are present between its faces 5A and 5B and the adjacent faces 6B and 7B of the outer elements 3 and 4.

**[0017]** Each outer element 3, 4 (also having a rounded edge 9 such as that of the element 5) comprises at least two through apertures 40 and 41 each provided in proximity to sides 42 and 43 of said element which are perpendicular to the axis A. A hydrophobic membrane 44 of known type is positioned in correspondence with each of these apertures.

**[0018]** In particular, in Figures 1-4 each outer element 3, 4 comprises four apertures 40 and four adjacent apertures 41. However the number of these apertures can also be different: for example, in Figure 6, in correspondence with the sides 42 and 43 of the elements 3 and 4 a single aperture 40 and 41 is present having an evidently large transverse length. A single aperture 40 and 41 is also present in Figure 7, in proximity to said sides; however each of these apertures is connected to a large underlying recess 45 (rectangular in this example) provided within the interior face 6B of the portion 6 of the element 3 in correspondence with which a hydrophobic membrane 44 is present. In contrast, in Figure 9 in correspondence with each side 42 and 43 (only the side 42 is shown) a pair of apertures 40 and 41 are present, connected to an underlying recess 47 of larger dimensions provided within the face 6B of the portion 6; a step 48 is present between the aperture 40 (or 41) and the underlying recess 47, the hydrophobic membrane 44 being positioned in correspondence with this recess. In Figure 11, within the face 6B of the portion 6 of the element 3, in correspondence with each side 42 and 43, a substantially rectangular recess 50 is present, connected to two conduits 51 opening into the face 6A via corresponding apertures 40 (and 41). Finally in Figure 13, in the face 6B of the portion 6 (in proximity to the sides 42 and 43) a circular recess 53 is provided connected to the apertures 40 (or 41) via channels 54 with their axis inclined to the plane of the face 6A in which the apertures 40 (or 41) are located.

**[0019]** It should be noted that each membrane is preferably and advantageously associated with the relative aperture 40 or 41 or with the recess 45, 47, 50, 53 by being fixed to the face 6B of the part 3, rather than by being inserted into the respective hole or recess. This enables a filtering surface to be obtained which is larger than that obtained if the membrane were inserted into the corresponding hole or recess in that, in this latter case, a part of the useful volume of the membrane would be occupied by the bond between the membrane and the wall of the corresponding hole or recess.

**[0020]** The hydrophobic surfaces defined by the

membrane 44 can be all connected together by a closed line 70, shown dashed in Figure 4 and full in Figure 5. Preferably, this line is the shortest which ideally connects together all the said surfaces of the membranes 44, i.e. it is defined by rectilinear portions in the example of the figures. According to the invention, this closed line defines a surface S1 within which the projection of the useful hydrophilic surface S2 of the underlying membrane 30 substantially falls, the "useful" surface meaning the effectively filtering surface of the membrane 30. The surface S1 is that enclosed by the line 70, the surface S2 being the hatched surface in Figures 4 and 5.

**[0021]** By virtue of this characteristic, after a usual line priming phase, proper filter effectiveness is achieved whatever its position in space during its use (vertical to, inclined to or parallel to an underlying plane). This is because the fluid entering the filter 1 is able to completely occupy the cavity 37 by expelling the air present therein and filtering through substantially the entire useful surface of the membrane (in the aforesaid sense). In this manner, the filter is completely operative, and effective in filtering the entering fluid, in that substantially the entire useful surface of the hydrophilic membrane 30 (at most except for a peripheral portion) participates in the filtering. In addition, the channels 21 are completely filled by the fluid which filters through the membrane 30 such that from one end 21A (that facing the entry conduit 27) to their other end 21B (that communicating with the exit conduit 23) they contain no residual air bubbles, with obvious positive implications for the fluid feed to the user.

**[0022]** It should be noted that at most, under utilization conditions, a possible minimum part of the useful surface S2 of the projection of the hydrophilic membrane 30 can lie outside the surface S1, provided that the geometry of the seat in which the membrane 30 is positioned enables the surface tension effect of the filtered fluid to be utilized, this effect occurring if the distance between the membrane 30 and the face 6B of the portion 6 (i.e. the depth of the cavity 37 measured perpendicular to the axis A) lies between 0.1 mm and 3 mm, preferably between 0.5 and 2 mm and advantageously between 0.5 mm and 1.5 mm. Under these conditions, the possible minimum (peripheral) surface part of the membrane 30, the projection of which does not fall within the surface S1, becomes in any event a fluid passage by capillary effect, with consequent complete use of the capacity of said membrane (i.e. the hydrophilic filtering surface of the membrane 30 is always 100% of its area).

**[0023]** By virtue of the invention, the described and claimed filter presents high functional capacity, exceeding that of known filters. This is because of the arrangement of the apertures 40 and 41 provided with the hydrophobic membranes 44, by virtue of which a high functional capacity of the filtering surface is obtained; this is also due to the fact that these apertures cooperate directly (as in Figures 1-6) or indirectly (as in Figures 7-14) with membranes 44 of considerable area (even greater



than that of said apertures, as in Figures 7-14), which ensure a high air flow from the casing 2 of the filter 1.

**[0024]** Other embodiments are evidently possible within the light of the present description, provided they remain within the scope of the accompanying claims. For example, each membrane 30 can be of any form, including complex (as can the arrangement of the underlying channels 21), the filter operating effectively provided the apertures present within the outer element 3 or 4 which face said membrane are such as to define, by means of the closed line which joins them together, the surface S1 with the aforescribed characteristics. In the limit, a single aperture of large dimensions can be present in said element.

**[0025]** Another embodiment of the invention is shown in Figures 15 and 16 in which parts corresponding to those of the already described figures are indicated by the same reference numerals. In the figures under examination, the filter presents the apertures 40 and 41 connected to differently shaped recesses: the apertures 40 are associated with a recess 50 in accordance with the embodiment of Figure 11, while the aperture 41 is associated with a recess 45 in accordance with the embodiment of Figure 7.

**[0026]** The embodiment under examination also presents other differences with those already described; for example, in correspondence with the shoulder 17 and around the stems 24 and 29, the element 5 presents circular rims 93 spaced from the corresponding stems and defining therewith recesses 94 for accepting the end of a corresponding contact or tube connected to a vessel of liquid (for example physiological liquid), in the case of the stem 29, or connected to the patient in the case of the stem 24. The rim 93 is essentially a prolongation of the shoulder 17.

**[0027]** The shoulder 18 is originally formed of tapered shape (triangular in cross-section) such that when inserted into a recess 10A adjacent to the shoulder 10 and provided in each face 6B, 7B of the elements 3 and 4 towards the interior of the filter, it can be fused into this recess during for example the hot bonding, so securely joining the element 5 to the adjacent elements 3 and 4.

**[0028]** Finally, the apertures 40 and 41 are connected to recesses 97 formed in the external face 6A, 7A of the flat portions 6 and 7 to facilitate the escape of air from these apertures. These recesses lie parallel to the (longitudinal) axis A of the filter.

**[0029]** Said apertures, and those of the filter represented in the previously described figures, can be closed by suitable plugs (not shown) which can be maintained connected to the filter casing 2 (for example by a filiform connection element, for example of plastic material) or can be of the type completely separable from the filter. The purpose of these plugs is to prevent air being drawn from the outside into the filter interior when one of the tubes connected to the filter (in particular, that connected to a vessel of liquid) is subjected to vacuum caused for example by a syringe.

**[0030]** Embodiments in which the membrane element 5 presents two opposing surfaces 5A and 5B provided with channels 21 have been described and shown in the figures. However the scope of the present invention also comprises a filter in which this element 5 presents a single face (for example, 5A) provided with channels, whereas the other (the face 5B) is completely flat. In this case, the outer element 4 is not present and the face 5B of the element 5 closes the filter on the side opposite that on which the element 3 is present.

## Claims

1. A filter (1) for filtering a fluid directed towards a patient, comprising a box casing (2) in which at least one cavity (37) is present defined by an outer element (3, 4) of said casing (2) and an inner surface (5A, 5B) presenting a plurality of channels (21) on which a corresponding hydrophilic filtering membrane (30) lies, said cavity (37) communicating with a conduit (27) for entry of the fluid into the filter (1) and said channels (21) being connected to a conduit (23) for exit of said fluid from the filter (1), in said element (3, 4) of the box casing (2) there being provided spaced-apart through apertures (40, 41) close to its opposing ends (42, 43) and with which hydrophobic membranes (44) are associated, **characterised in that** a surface (S1) bounded by an ideal closed line (70), which totally comprises all the hydrophobic membranes (44), contains substantially within its interior the projection thereon of the useful hydrophilic surface (S2) of the hydrophilic filtering membrane (30), this enabling the filter (1) to be employed in a plurality of spatial positions during its use.
2. A filter as claimed in claim 1, **characterised in that** the closed line bounding the surface (S1) comprising the hydrophobic membranes (44) is the shortest line which joins these latter together.
3. A filter as claimed in claim 1, **characterised in that** the distance between said element (3, 4) of the box casing (2) and the hydrophilic filtering membrane (30) lies between 0.1 mm and 3 mm, preferably between 0.5 mm and 2 mm.
4. A filter as claimed in claim 3, **characterised in that** the distance between said element (3, 4) of the box casing (2) and the hydrophilic filtering membrane (30) lies between 0.5 mm and 1.5 mm.
5. A filter as claimed in claim 1, **characterised in that** the through apertures (40, 41) have a size identical to that of the membranes (44) associated with them.
6. A filter as claimed in claim 1, **characterised in that**

the through apertures (40, 41) have a size less than that of the membranes (44) associated with them.

7. A filter as claimed in claim 6, **characterised in that** each membrane (44) is associated with a recess (45, 47, 50, 53) provided within a face (6B, 7B) of the element (3, 4) of the box casing (2) facing the hydrophilic membrane (30), with said recess (45, 47, 50, 53) there being associated at least one aperture (40, 41) opening into the opposing face (6A, 7A) of said element (3, 4), between said aperture and said recess there being present at least one step (48) so that the aperture has a size less than that of the recess.
8. A filter as claimed in claim 7, **characterised in that** the recess is of polygonal shape.
9. A filter as claimed in claim 7, **characterised in that** the recess is of circular shape.
10. A filter as claimed in claim 1, **characterised in that** each hydrophobic membrane (44) has a surface greater than that of the aperture (40, 41) with which it is associated.
11. A filter as claimed in claim 10, **characterised in that** the hydrophobic membrane is fixed to that face (6B, 7B) of the element (3, 4) of the box casing (2) facing the hydrophilic membrane (30), in correspondence with the relative aperture (40, 41).
12. A filter as claimed in claim 1, **characterised in that** the channels (21) of the inner surface (5A, 5B) present a closed end (21A) facing and close to the entry conduit (27), and the other end (21B) connected to the exit conduit (23).
13. A filter as claimed in claim 12, **characterised in that** the closed end (21 A) of said channels (21) is closed by an annular element (19) which surrounds said channels (21).
14. A filter as claimed in claim 1, **characterised in that** the entry conduit (27) and exit conduit (23) are provided within an element (5) of the box casing (2) presenting the surface (5A, 5B) with the channels (21) and connected to the outer element (3, 4) of said casing (2).
15. A filter as claimed in claim 14, **characterised in that** the entry conduit (27) and exit conduit (23) are provided within stems (29, 24) projecting from the box casing element (5) provided with channels (21).
16. A filter as claimed in claim 15, **characterised in that** around each stem (24, 29) an annular rim (93) is present defining with the corresponding stem (24,

29) a recess (94) for receiving the end of a corresponding conduit connected to the filter.

17. A filter as claimed in claim 14, **characterised in that** the element (5) with the surface (5A) provided with channels (21) presents a second surface (5B), opposing the surface (5A) with channels, but not provided with these latter.
18. A filter as claimed in claim 14, **characterised in that** the element (5) with the surface (5A) provided with channels (21) presents a second surface (5B), opposing the surface (5A) with channels (21) and shaped as this latter, to the front of said second surface (5B), also provided with channels (21) on which a hydrophilic membrane (30) is superposed, there being positioned a second outer element (4) of the box casing (2) provided with apertures (40, 41) with which hydrophobic membranes (44) are associated, between said second outer element (4) and the element (5) with the surfaces (5A, 5B) provided with channels (21) there being present a cavity (37) connected to the entry conduit (27), said element (5) with the surfaces (5A, 5B) provided with channels (21) being intermediate between the outer elements (3, 4) of the box casing (2).
19. A filter as claimed in claim 1, **characterised in that** the apertures (40, 41) are connected to recesses (97) provided in a free face (6A, 6B) of the corresponding outer element (3, 4).
20. A filter as claimed in claim 19, **characterised in that** the recesses (97) lie parallel to the longitudinal axis (A) of the filter.
21. A filter as claimed in claim 1, **characterised in that** the apertures (40, 41) cooperate with removable shut-off members.
22. A filter as claimed in claim 21, **characterised in that** the shut-off members are connected to the filter casing (2).
23. A filter as claimed in claim 22, **characterised in that** the shut-off members are completely separable from the filter casing (2).

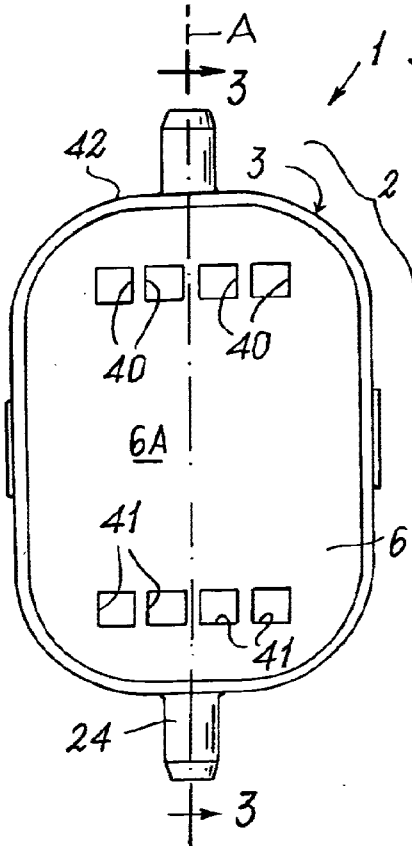


FIG. 1

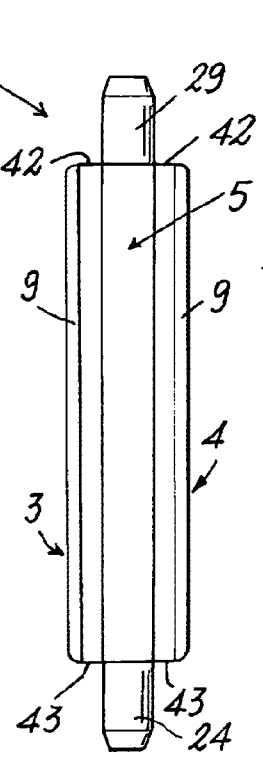


FIG. 2

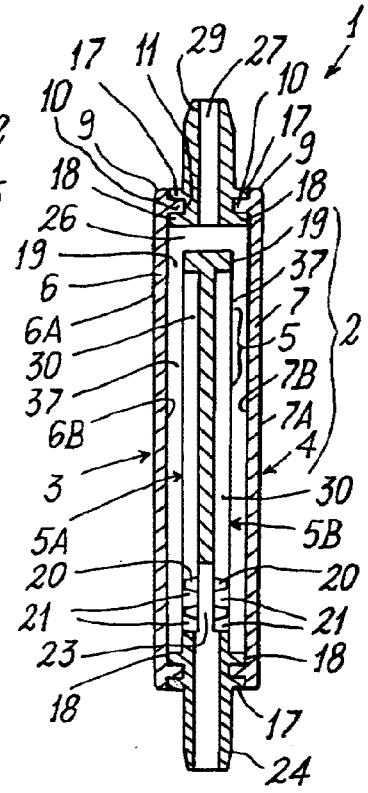


FIG. 3

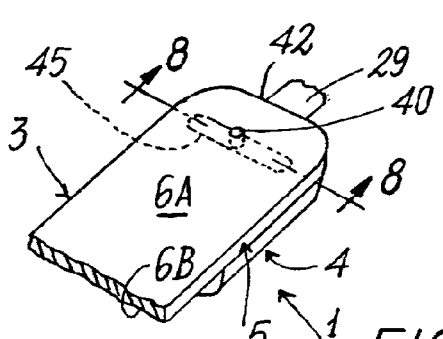


FIG. 7

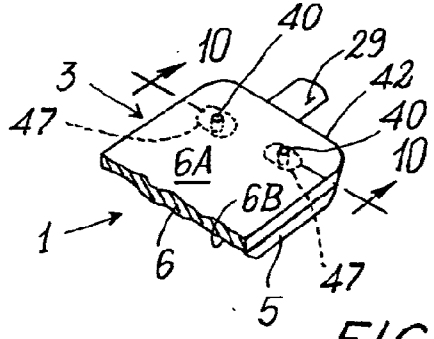


FIG. 9

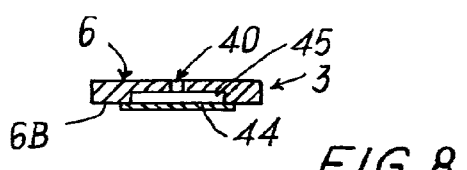


FIG. 8

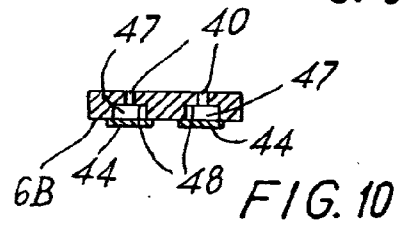
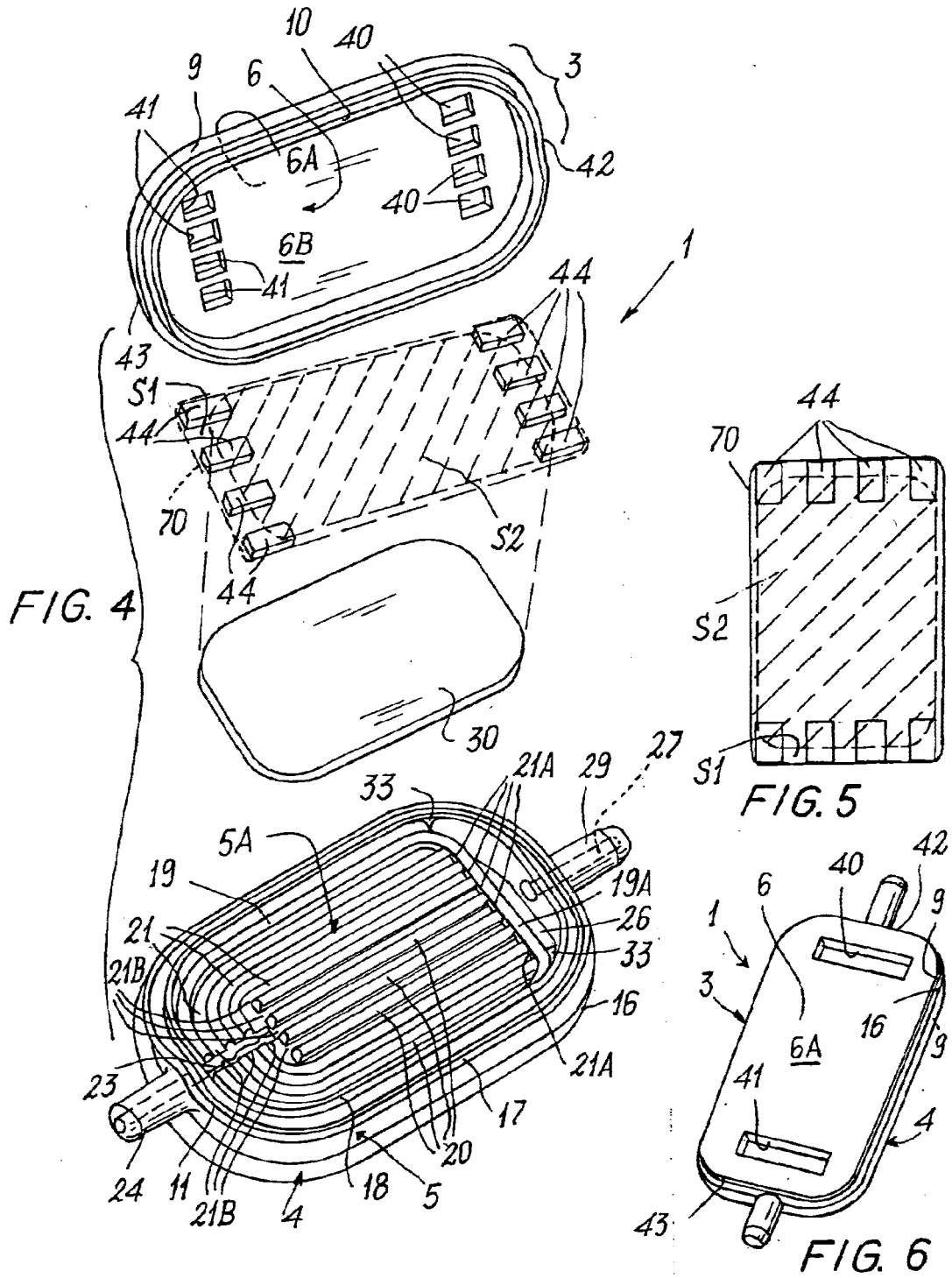
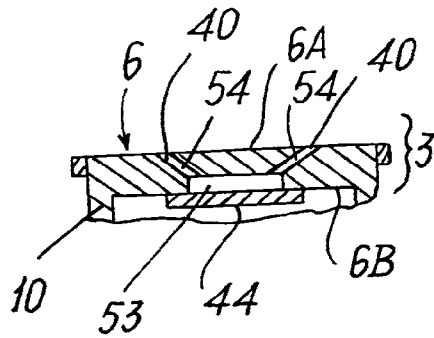
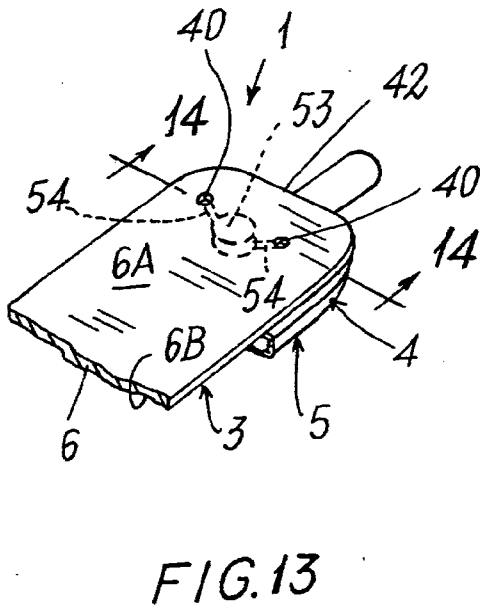
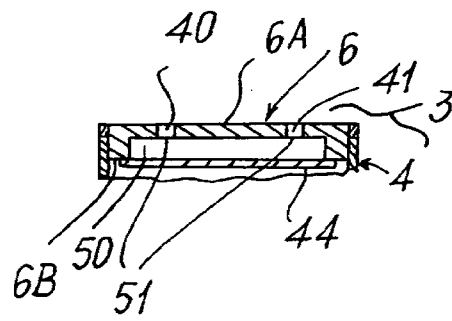
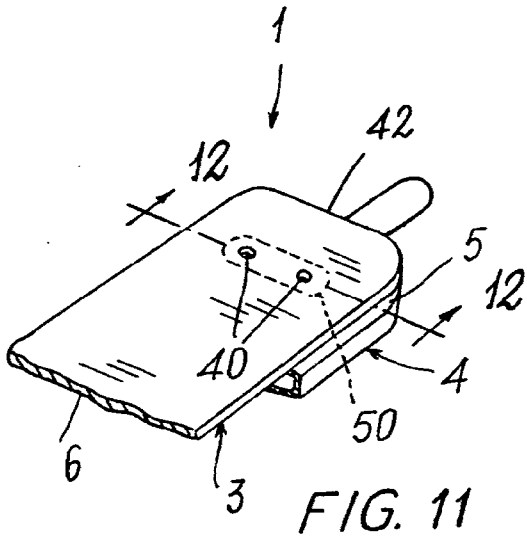


FIG. 10





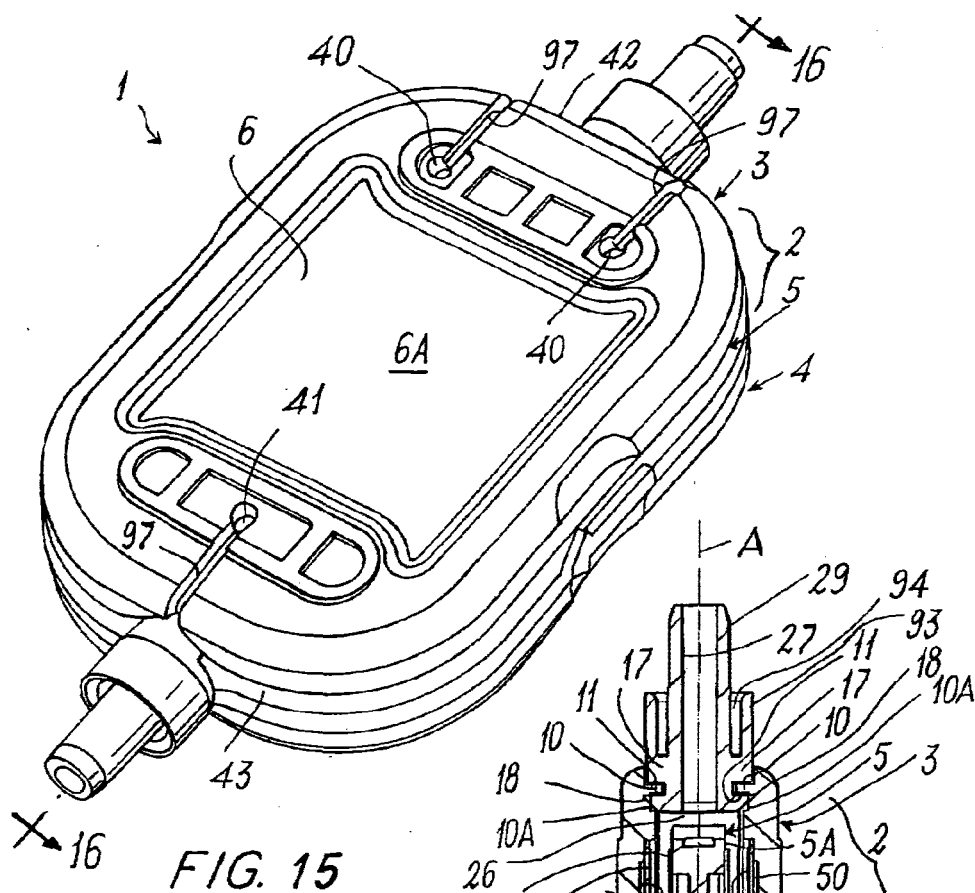


FIG. 15

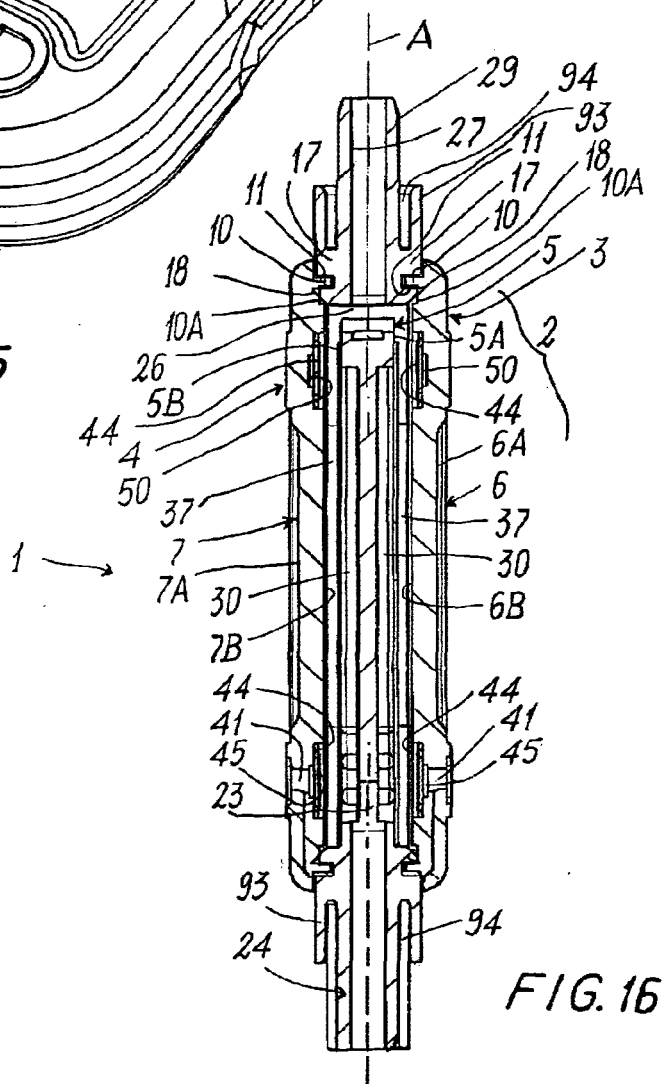


FIG. 16



European Patent Office

EUROPEAN SEARCH REPORT

Application Number  
EP 03 02 5258

| DOCUMENTS CONSIDERED TO BE RELEVANT   |   |   |  |
|---|---|---|--|
| Category  | Citation of document with indication, where appropriate, of relevant passages   | Relevant to claim                                   | CLASSIFICATION OF THE APPLICATION (Int.Cl.7) |
| X   | EP 1 208 857 A (GVS S. R. L.)<br>29 May 2002 (2002-05-29)   | 1,2,5-23  | A61M5/165                                    |
| Y   | * paragraph [0007] - paragraph [0018] *<br>* column 3, line 36 - line 47; figures 1-5 *   | 3,4   |  |
| Y   | ---<br>US 4 525 182 A (RISING DONALD B ET AL)<br>25 June 1985 (1985-06-25)<br>* abstract *<br>* column 1, line 17 - line 28 *<br>* column 2, line 36 - line 56; figures 1-4,6 * | 3,4   |  |
| A   | ---<br>WO 01 41844 A (KRAUS MENAHEM ; TEVA MEDICAL IND LTD (IL)) 14 June 2001 (2001-06-14)  |   |  |
| A   | ---<br>EP 0 784 988 A (FILTERTEK INC)<br>23 July 1997 (1997-07-23)  |   |  |
| A   | ---<br>EP 0 489 403 A (PALL CORP)<br>10 June 1992 (1992-06-10)  |   |  |
| A   | ---<br>US 5 622 626 A (MATKOVICH VLADO I ET AL)<br>22 April 1997 (1997-04-22)<br>-----  |   | TECHNICAL FIELDS SEARCHED (Int.Cl.7)<br>A61M |
| The present search report has been drawn up for all claims  |   |   |  |
| Place of search<br>THE HAGUE  |   | Date of completion of the search<br>29 January 2004 | Examiner<br>Michels, N                       |
| <p>CATEGORY OF CITED DOCUMENTS</p> <p>X : particularly relevant if taken alone<br/>                     Y : particularly relevant if combined with another document of the same category<br/>                     A : technological background<br/>                     O : non-written disclosure<br/>                     P : intermediate document</p> <p>T : theory or principle underlying the invention<br/>                     E : earlier patent document, but published on, or after the filing date<br/>                     D : document cited in the application<br/>                     L : document cited for other reasons</p> <p>* : member of the same patent family, corresponding document</p> |   |   |  |

EPC FORM 1503 03 02 (P04/G01)

ANNEX TO THE EUROPEAN SEARCH REPORT  
ON EUROPEAN PATENT APPLICATION NO.

EP 03 02 5258

This annex lists the patent family members relating to the patent documents cited in the above-mentioned European search report.  
The members are as contained in the European Patent Office EDP file on  
The European Patent Office is in no way liable for these particulars which are merely given for the purpose of information.

29-01-2004

| Patent document<br>cited in search report |   | Publication<br>date | Patent family<br>member(s) | Publication<br>date |
|---|---|---------------------|----------------------------|---------------------|
| EP 1208857                                | A | 29-05-2002          | EP 1208857 A1              | 29-05-2002          |
|   |   |                     | US 2002058913 A1           | 16-05-2002          |
| US 4525182                                | A | 25-06-1985          | DE 3467718 D1              | 07-01-1988          |
|   |   |                     | EP 0154645 A1              | 18-09-1985          |
|   |   |                     | JP 60502091 T              | 05-12-1985          |
|   |   |                     | WO 8500987 A1              | 14-03-1985          |
| WO 0141844                                | A | 14-06-2001          | AU 7309200 A               | 18-06-2001          |
|   |   |                     | EP 1237602 A1              | 11-09-2002          |
|   |   |                     | WO 0141844 A1              | 14-06-2001          |
| EP 0784988                                | A | 23-07-1997          | US 5827429 A               | 27-10-1998          |
|   |   |                     | CA 2195360 A1              | 19-07-1997          |
|   |   |                     | DE 69725629 D1             | 27-11-2003          |
|   |   |                     | EP 0784988 A1              | 23-07-1997          |
| EP 0489403                                | A | 10-06-1992          | US 5252222 A               | 12-10-1993          |
|   |   |                     | CA 2054933 A1              | 04-06-1992          |
|   |   |                     | DE 69131288 D1             | 08-07-1999          |
|   |   |                     | DE 69131288 T2             | 23-09-1999          |
|   |   |                     | EP 0489403 A2              | 10-06-1992          |
|   |   |                     | JP 5184670 A               | 27-07-1993          |
|   |   |                     | US 5536413 A               | 16-07-1996          |
| US 5622626                                | A | 22-04-1997          | AU 3513595 A               | 10-11-1995          |
|   |   |                     | DE 19580356 T0             | 24-04-1997          |
|   |   |                     | EP 0792182 A1              | 03-09-1997          |
|   |   |                     | JP 9511932 T               | 02-12-1997          |
|   |   |                     | WO 9528215 A1              | 26-10-1995          |

EPO FORM P/035

For more details about this annex : see Official Journal of the European Patent Office, No. 12/82



(19) World Intellectual Property Organization  
International Bureau



(43) International Publication Date  
17 December 2009 (17.12.2009)

(10) International Publication Number  
**WO 2009/152320 A2**

(51) International Patent Classification:

A61M 5/14 (2006.01) A61M 36/00 (2006.01)  
G21F 5/015 (2006.01)

Apartment 601, Changning District, Shanghai, 200051 (CN). CLEMENTS, Daniel, V. [US/US]; 4707 Emerson Avenue North, Minneapolis, MN 55430 (US).

(21) International Application Number:

PCT/US2009/047027

(74) Agents: BELDEN, Elisabeth, L. et al.; Fredrikson & Byron, P.A., 200 South Sixth Street, Suite 4000, Minneapolis, MN 55402-1425 (US).

(22) International Filing Date:

11 June 2009 (11.06.2009)

(81) Designated States (unless otherwise indicated, for every kind of regional protection available): AE, AG, AL, AM, AO, AT, AU, AZ, BA, BB, BG, BH, BR, BW, BY, BZ, CA, CH, CL, CN, CO, CR, CU, CZ, DE, DK, DM, DO, DZ, EC, EE, EG, ES, FI, GB, GD, GE, GH, GM, GT, HN, HR, HU, ID, IL, IN, IS, JP, KE, KG, KM, KN, KP, KR, KZ, LA, LC, LK, LR, LS, LT, LU, LY, MA, MD, ME, MG, MK, MN, MW, MX, MY, MZ, NA, NG, NI, NO, NZ, OM, PE, PG, PH, PL, PT, RO, RS, RU, SC, SD, SE, SG, SK, SL, SM, ST, SV, SY, TJ, TM, TN, TR, TT, TZ, UA, UG, US, UZ, VC, VN, ZA, ZM, ZW.

(25) Filing Language:

English

(26) Publication Language:

English

(30) Priority Data:

12/137,364 11 June 2008 (11.06.2008) US  
12/137,363 11 June 2008 (11.06.2008) US  
12/137,377 11 June 2008 (11.06.2008) US  
12/137,356 11 June 2008 (11.06.2008) US

(71) Applicant (for all designated States except US): BRACCO DIAGNOSTICS INC. [US/US]; 107 College Road East, Princeton, NJ 08540 (US).

(84) Designated States (unless otherwise indicated, for every kind of regional protection available): ARIPO (BW, GH, GM, KE, LS, MW, MZ, NA, SD, SL, SZ, TZ, UG, ZM, ZW), Eurasian (AM, AZ, BY, KG, KZ, MD, RU, TJ, TM), European (AT, BE, BG, CH, CY, CZ, DE, DK, EE, ES, FI, FR, GB, GR, HR, HU, IE, IS, IT, LT, LU, LV, MC, MK, MT, NL, NO, PL, PT, RO, SI, SK, TR), OAPI (BF, BJ, CF, CG, CI, CM, GA, GN, GQ, GW, ML, MR, NE, SN, TD, TG).

(72) Inventors; and

(75) Inventors/Applicants (for US only): QUIRICO, Charles, R. [US/US]; 19 Robin Road, Warren, NJ 07059 (US). BALESTRACCI, Ernest [US/US]; 404 Hampton Lane, Iselin, NJ 08830 (US). DARST, Daniel, D. [US/US]; 25540 96th Street NW, Zimmerman, MN 55398 (US). KRAUSE, Eric, J. [US/US]; 3360 Lake Ridge Drive, Big Lake, MN 55309 (US). LOKHANDE, Vishal, N. [IN/US]; 100 North Whisman Road, Apartment #1412, Mountain View, CA 94043 (US). CHILDS, Jacob, S. [US/US]; 30 W. 22nd Street, Apartment #202, Minneapolis, MN 55404 (US). MADSON, Peter, B. [US/CN]; 388 Furongjiang Lu, Building 3,

Published:

— without international search report and to be republished upon receipt of that report (Rule 48.2(g))



WO 2009/152320 A2

(54) Title: SHIELDING ASSEMBLIES FOR INFUSION SYSTEMS

(57) Abstract: A shielding assembly for an infusion system includes a plurality of compartments and a door for each compartment, and provides a radioactive radiation barrier for the compartments. One of the compartments contains one or more radioisotope generators of the infusion system and another of the compartments may contain a waste bottle of the infusion system. An opening into each of the generator and waste bottle compartments may be oriented upward, and the opening into the latter may be at a higher elevation than the opening into the former, for example, to facilitate independent removal and replacement of each. A door of at least one of the compartments, other than the generator compartment, when closed, may prevent the door of the generator compartment from being opened. A cabinet structure for the infusion system may enclose the shielding assembly and secure the generator.

## SHIELDING ASSEMBLIES FOR INFUSION SYSTEMS

## RELATED APPLICATIONS

5 The present application claims priority to the following U.S. patent applications: U.S. Patent Application No. 12/137,356, filed June 11, 2008; U.S. Patent Application No. 12/137,363, filed June 11, 2008; U.S. Patent Application No. 12/137,364, filed June 11, 2008; and U.S. Patent Application No. 12/137,377, filed June 11, 2008.

## 10 TECHNICAL FIELD

The present invention pertains to systems that generate and infuse radiopharmaceuticals, and, more particularly, to shielding assemblies thereof.

## BACKGROUND

15 Nuclear medicine employs radioactive material for therapy and diagnostic imaging. Positron emission tomography (PET) is one type of diagnostic imaging, which utilizes doses of radiopharmaceutical, for example, generated by elution within a radioisotope generator that are injected, or infused into a patient. The infused dose of radiopharmaceutical is absorbed by cells of a target organ, of the patient, and emits  
20 radiation, which is detected by a PET scanner, in order to generate an image of the organ. An example of a radioactive isotope, which may be used for PET, is Rubidium-82 (produced by the decay of Strontium-82); and an example of a radioisotope generator, which yields a saline solution of Rubidium-82, via elution, is the CardioGen-82® available from Bracco Diagnostics Inc. (Princeton, NJ).

25 Whether the half-life of a particular radioactive isotope, employed by a radiopharmaceutical, is relatively short or long, a patient undergoing a nuclear imaging procedure is not typically exposed to a significant amount of radiation. However those personnel, whose job it is to set up and maintain radiopharmaceutical infusion systems, and to administer doses therefrom, are subject to more frequent exposures to radiation.  
30 Therefore, shielding assemblies, which provide a radiation barrier to protect these personnel from excessive exposure to radiation sources, are an important component of radiopharmaceutical generators and infusion systems. These shielding assemblies are typically formed with lead sidewalls, the bulk and weight of which can pose

difficulties for the personnel who regularly set up, maintain and use the systems. Thus, there is a need for improved shielding assemblies employed by systems that generate and infuse radiopharmaceuticals.

5 BRIEF DESCRIPTION OF THE DRAWINGS

The following drawings are illustrative of particular embodiments of the present invention and therefore do not limit the scope of the invention. The drawings are not to scale (unless so stated) and are intended for use in conjunction with the explanations in the following detailed description. Embodiments of the present  
10 invention will hereinafter be described in conjunction with the appended drawings, wherein like numerals denote like elements.

Figure 1A is a first perspective view of an infusion system, according to some embodiments of the present invention.

Figure 1B is another perspective view of a portion of a cabinet structure of the  
15 system shown in Figure 1A, according to some embodiments.

Figure 1C is a second perspective view of the system shown in Figure 1A, according to some embodiments.

Figure 1D is a schematic of an infusion circuit, according to some  
embodiments of the present invention.

Figure 1E is a perspective view of exemplary sample vial shielding that may be  
20 employed in conjunction with the infusion system of Figure 1A.

Figure 2A is a perspective view of a shielding assembly for an infusion system, such as that shown in Figures 1A-C, according to some embodiments of the present  
invention.

Figure 2B is a perspective view of a framework of the system, according to  
25 some embodiments, with an enlarged detailed view of a component of the system, according to some embodiments.

Figure 3A is another perspective view of the shielding assembly shown in  
Figure 2A.

Figure 3B is a perspective view of the infusion circuit, shown in Figure 1C,  
30 configured and routed, according to some embodiments.

Figure 3C is a perspective view of a disposable infusion circuit subassembly, according to some embodiments.

Figure 3D is a frame for the subassembly shown in Figure 3C, according to some embodiments.

Figure 4 is a main menu screen shot from an interface of a computer, which may be included in systems of the present invention, according to some embodiments.

5 Figure 5A is a schematic showing a first group of successive screen shots from the computer interface, according to some embodiments.

Figure 5B is a pair of screen shots from the computer interface, which provide indications related to eluant volume levels in a reservoir of the system, according to some embodiments.

10 Figure 5C is a schematic showing a second group of successive screen shots from the computer interface, according to some embodiments.

Figure 6 is a schematic showing a third group of successive screen shots from the computer interface, according to some embodiments.

15 Figures 7A-C are schematics showing a fourth group of successive screen shots from the computer interface, according to some embodiments.

Figures 8A-B are schematics showing a fifth group of successive screen shots from the computer interface, according to some embodiments.

Figures 9A-C are schematics showing a sixth group of successive screen shots from the computer interface, according to some embodiments.

20 Figure 10 is a schematic showing a seventh group of successive screen shots from the computer interface, according to some embodiments.

Figure 11 is an exemplary report which may be generated by the computer included in infusion systems, according to some embodiments.

25 Figures 12A-B are schematics of alternative infusion circuits that may be employed by embodiments of the present invention.

Figure 12C is a schematic illustrating exemplary activity profiles of injected doses of a radiopharmaceutical.

#### DETAILED DESCRIPTION

30 The following detailed description is exemplary in nature and is not intended to limit the scope, applicability, or configuration of the invention in any way. Rather, the following description provides practical illustrations for implementing exemplary

embodiments. Utilizing the teaching provided herein, those skilled in the art will recognize that many of the examples have suitable alternatives that can be utilized.

Figure 1A is a first perspective view of an infusion system 10, according to some embodiments of the present invention, wherein system 10 is shown supported by  
5 a cabinet structure, which includes a platform 113 (seen better in Figure 2B) and a shell 13; shell 13 extends upward from a skirt 11, that surrounds platform 113, to surrounds an interior space in which a portion of infusion system 10 is contained (-  
seen in Figure 1C). Shell may be formed from panels of injection-molded polyurethane fitted together according to methods known to those skilled in the art. Figure 1A  
10 illustrates the cabinet structure of system 10 including a grip or handle 14, which extends laterally from shell 13, in proximity to an upper surface 131 thereof, and a post 142, which extends upward from shell 13, and to which a work surface, or tray 16 and a computer 17 are, preferably, attached, via an ergonomic, positionable mount.  
According to some embodiments, computer 17 is coupled to a controller of system 10,  
15 which is mounted within the interior space surrounded by shell 13; and, a monitor 172 of computer 17 not only displays indications of system operation for a user of system 10, but also serves as a device for user input (e.g. touch screen input). However, according to alternate embodiments, another type of user input device, known to those skilled in the art, may be employed by computer 17. Other types of user input devices  
20 may be included, for example, a keyboard, a series of control buttons or levers, a bar code reader (or other reader of encoded information), a scanner, a computer readable medium containing pertinent data, etc. The user input device may be mounted on the cabinet structure of system 10, as shown, or may be tethered thereto; alternatively the user input device may be remote from system 10, for example, located in a separate  
25 control room. According to some additional embodiments, another user input device, for example, in addition to a touch screen of computer 17, may be remote from system 10 and used to start and stop infusions, as well as to monitor system operation both during quality control infusions and during patient infusions. Operation of system 10, which is facilitated by computer 17, will be described below, in conjunction with  
30 Figures 4-9C.

Figure 1A further illustrates two pairs of wheels 121, 122, mounted to an underside of platform 113, to make system 10 mobile; handle 14 is shown located at an elevation suitable for a person to grasp in order to maneuver system 10, from one

location for another, upon pairs of wheels 121, 122. According to some preferred embodiments, one or both pairs of wheels 121, 122, are casters, allowing for rotation in a horizontal plane (swivel), in order to provide additional flexibility for maneuvering system 10 in relatively tight spaces.

5           Figure 1B is a perspective view of a portion of system 10, on a side 111 of the cabinet structure, which is in proximity to wheels 121. Figure 1B illustrates a lever or pedal 125, which is located for activation by a foot of the person, who grasps handle 14 to maneuver system 10. In a neutral position, pedal 125 allows wheels 121, 122 to rotate, and, if embodied as casters, to swivel freely. Pedal 125 may be depressed to a  
10           first position which prevents a swiveling of wheels 122, according to those embodiments in which wheels 122 are casters, and may be further depressed to brake wheels 121, 122 from rolling and swiveling, upon reaching a desired location. According to some embodiments, braking may be designed to slow system 10, for example, when rolling down an incline, and, according to yet further embodiments,  
15           system 10 may include a motor to power movement thereof.

          Figure 1B further illustrates: a rear access panel 174 of shell 13, for example, providing access to circuit boards of the aforementioned controller contained within the interior space that is surrounded by shell 13; an optional lock 184, to secure panel 174; a power jack 118, for connecting system 10 to a power source; and a printer 117  
20           for providing documentation of each patient infusion carried out by system 10, and of system quality control test results. In some embodiments, system 10 may further include a power strip by which auxiliary equipment may be powered, and one or more additional electrical connectors, or ports (not shown), which are supported by platform 113 and may be integrated into shell 13, for example, in proximity to jack  
25           118 or printer 117; these electrical connectors/ports allow system 10 to communicate with, other devices used for nuclear imaging procedures, for example, a PET scanner/camera, and/or for coupling to an intranet network, and/or to the internet, for example, to link up with software programs for various types of data analysis, and/or to link to computers of consulting clinicians/physicians, and/or to link into service  
30           providers and/or component suppliers data bases for enhanced maintenance and inventory management.

          Figure 1A further illustrates upper surface 131 of shell 13 including several openings 133, 135, 139 formed therein. Figure 1C is a partially exploded perspective

view of system 10, wherein a removable access panel 132 is shown as a contoured portion of upper surface 131, which, when exposed, by lifting away a bin 18, that mates therewith, may be removed from another opening 137 formed in upper surface 131. Figure 1C also provides a better view of another panel 134 which may be lifted  
5 away from opening 139. According to the illustrated embodiment, openings 139 and 137 provide a user of system 10 with independent access to separate portions of infusion system 10, which are contained within shell 13, for example, to set up and maintain system 10; and openings 133 and 135 provide passageways for tubing lines to pass through shell 13. Figure 1C further illustrates an optional switch 102, which in  
10 case of an emergency, may be activated to abort function of system 10. With reference to Figures 1A and 1C, it may be appreciated that an arrangement of features formed in upper surface 131 of shell 13, in conjunction with bin 18, tray 16 and computer 17, provide a relatively ergonomic and organized work area for technical personnel who operate system 10.

15 Turning now to Figure 1D, a schematic of an infusion circuit 300, which may be incorporated by system 10, is shown. Figure 1D illustrates circuit 300 generally divided into a first part 300A, which includes components mounted outside shell 13, and a second part 300B, which includes components mounted within the interior space surrounded by shell 13. (Parts 300A and 300B are delineated by dotted lines in Figure  
20 1D.) Figure 1D further illustrates second part 300B of circuit 300 including a portion contained within a shielding assembly 200, which is designated schematically as a dashed line. Some embodiments of shielding assembly 200 will be described in greater detail, in conjunction with Figures 2A-B and 3A-B, below.

According to the illustrated embodiment, circuit 300 includes: an eluant  
25 reservoir 15, for example, a bag, bottle or other container, containing saline as the eluant, which is shown hanging from a post, or hanger 141 above upper surface 131 of shell 13 in Figure 1A; a syringe pump 33, for pumping the eluant from reservoir 15, and a pressure syringe 34 (or other device or sensor), for monitoring pumping pressure; a filter 37, which may also serve as a bubble trap, for the pumped eluant; a  
30 radioisotope generator 21, through which the filtered eluant is pumped to create a radioactive eluate, for example an eluate carrying Rubidium-82 that is generated by the decay of Strontium-82, via elution, within a column of generator 21; and an activity detector 25, for measuring the activity of the eluate discharged from generator 21, in

order to provide feedback for directing the flow of the eluate, via a divergence valve 35WP, either to a waste bottle 23 or through a patient line 305p, for example, to inject a dose of the radiopharmaceutical eluate into a patient. With reference back to Figure 1A, patient line 305p is shown extending out from shell 13, through opening 135, to a distal end thereof, which, according to some embodiments, includes a filter. Patient line 305p may be coupled to another line that includes a patient injection needle (not shown). Alternatively, patient line 305p may be coupled to another line (not shown), which extends from a source of another active substance, for example, a stress agent; the other line is coupled to the line that includes the patient injection needle, in order to permit injection of the additional active substance.

Figure 1D illustrates an eluant tubing line 301 coupled to reservoir 15 and to pump 33, and, with reference to Figures 1A-B, it may be appreciated that opening 133 provides the passageway for tubing line 301 to enter the interior space surrounded by shell 13. According to some preferred embodiments, opening 133 includes a grommet-type seal that prevents leakage of eluant, which may spill from reservoir 15, into the interior space through opening 133, while allowing a user to assemble tubing line 301 through opening 133. Likewise opening 135, which provides a passageway for patient line 305p, may include a grommet-type seal. According to some embodiments, shell 13 further supports holders to safely hold, for example, during transport of system 10, portions of tubing lines that extend outward therefrom, for example, line 301 and/or line 305p.

Figure 1D further illustrates another eluant tubing line 302 coupled to pump 33 and a divergence valve 35BG, which may either direct pumped eluant through a tubing line 304, to generator 21, or direct the pumped eluant through a by-pass tubing line 303, directly to patient line 305p. Divergence valve 35BG, as well as divergence valve 35WP, which directs eluate from an eluate tubing line 305 either to a waste line 305w or to patient line 305p, may each be automatically operated by a corresponding servomotor (not shown), coupled to the controller (not shown) of system 10, which controller receives feedback from activity detector 25. When system 10 is operating for automatic infusion, to deliver a dose of radiopharmaceutical to a patient, for example, Rubidium-82 for diagnostic imaging, divergence valve 35BG is initially set to direct eluant to generator 21 and divergence valve 35WP is set to direct eluate from generator into waste bottle 23, until activity detector 25 detects the desired activity of



the eluate, at which time the feedback from activity detector 25 causes the controller to direct the corresponding servo-motor to re-set valve 35WP for diverting the flow of eluate into patient line 305p. According to some embodiments, once a prescribed volume of the eluate has passed through patient line 305p, the controller directs the  
5 corresponding servomotor to re-set divergence valve 35BG for diverting the flow of eluant through by-pass line 303 and into patient line 305p in order to flush, or push any eluate remaining in patient line 305p into the patient. According to some  
embodiments, the controller may also direct the corresponding servomotor to re-set divergence valve 35WP back toward waste bottle 23, prior to the flush through by-pass  
10 line 303, in order to prevent back flow of eluant, through line 305, toward generator 21. According to some preferred methods of operation, in certain situations, which will be described in greater detail below, eluant is pumped through by-pass line 303 immediately following the flow of the prescribed volume of eluate into patient line  
305p, at a higher speed, in order to push the eluate in patient line 305, thereby  
15 increasing a flow rate of the injection of eluate out from patient line 305p and into patient. For example, once the prescribed volume of eluate has flowed into patient line 305p, and once divergence valve 35BG is set to divert flow through by-pass line 303, the speed of pump 33 may be adjusted to increase the flow rate of eluant to between  
approximately 70mL/min and approximately 100mL/min. This method for increasing  
20 the injection flow rate, is desirable, if a relatively high flow rate is desired for patient injection and a flow rate through generator 21 is limited, for example, to below approximately 70mL/min, maximum (typical flow rate may be approximately  
50mL/min), in order to avoid an excessive back pressure created by the column of generator 21 in upstream portions of tubing circuit 300; the excessive back pressure  
25 could damage filter 37 or otherwise impede flow through eluant tubing line 302.

Although not shown in Figure 1D, a number of sensors, for example, to measure pressure and/or flow velocity, may be incorporated into circuit 300, according to some alternate embodiments, in order to monitor for flow anomalies, for example, related to occlusions/plugs in circuit 300 and/or leaks, and/or to provide feedback for  
30 control of an activity level of infused doses of radiopharmaceutical. Suitable sensors for any of the above purposes are known to those skilled in the art. Examples of flow meters that may be incorporated into circuit 300, include the Innova-Sonic® Model  
205 Transit-Time Ultrasonic Liquid Flow Meter that employs digital signal processing

(available from Sierra Instruments, Inc.) and the Flocat LA10-C differential pressure flow meter. One example of a pressure sensor that may be employed to detect infusion circuit occlusions is the PRO / Pressure-Occlusion Detector (available from INTROTEK® of Edgewood, NY, a subsidiary of Magnetrol of Downers Grove, IL), which employs pulse-type ultrasound; this sensor detects subtle changes in positive and negative air pressure and produces a corresponding passive resistive output signal, which may be routed to the system controller and/or computer 17. On or more of this type of sensor may be incorporated into infusion circuit 300 by simply fitting the sensor around any of the tubing lines of infusion circuit 300; in fact, the PRO / Pressure-Occlusion Detector may be a suitable alternative to pressure syringe 34 of circuit 300. Other types of pressure sensors, for example, similar to those known in the art for blood pressure monitoring, may be employed in infusion circuit 300.

System 10 may further include sensors to detect fluid levels in eluant reservoir 15 and waste bottle 23. Some examples of such sensors, which also employ the aforementioned pulse-type ultrasound, are the Drip Chamber Liquid Level Sensor and the CLD / Continuous Level Detector (both available from INTROTEK®); alternatively, for example, an HPQ-T pipe mounted, self-contained liquid sensor (available from Yamatake Sensing Control, Ltd.), or an SL-630 Non-Invasive Disposable/Reusable Level Switch (available from Cosense, Inc. of Hauppauge, NY) may be employed to detect the fluid levels. Alternately or in addition, system 10 can include additional radiation and/or moisture detection sensors, which can detect leaks. With reference to Figure 1D, such sensors are preferably located in proximity to fittings 311, 312, 313, 314 and 315 that join portions of circuit 300 to one another. Some examples of leak detection sensors include, without limitation, those in the HPQ-D leak detection sensor family, and the HPF-D040 fiberoptic leak detector (all available from Yamatake Sensing Control, Ltd.). System 10 may further include additional sensors to detect contaminants and/or air bubbles within the tubing lines of circuit; examples of such sensors include the Point-air Detection (PAD) Sensor, that employs pulse-type ultrasound for air bubble detection, and the Blood Component Detector that employs optical sensing technology to perform Colorimetry-based fluid detection of unwanted elements in the tubing lines (both available from INTROTEK®).

According to those embodiments that include any of the above sensors, the sensors are linked into the controller of system 10 and/or computer 17, either of which may provide a signal to a user of system 10, when a flow anomaly is detected, and/or information to the user, via monitor 172, concerning fluid levels, pressure and/or flow through circuit 300. Computer 17 may be pre-programmed to display, for example, on monitor 172, a graphic of infusion circuit 300 wherein each zone of the circuit, where an anomaly has been detected, is highlighted, and/or to provide guidance, to the system user, for correcting the anomaly. It should be noted that the alternative infusion circuits illustrated in Figures 12A-B, which will be described below, may also include any or all of these types of sensors.

With further reference to Figure 1D, it may be appreciated that shielding assembly 200 encloses those portions of circuit 300 from which radioactive radiation may emanate, with the exception of that portion of patient line 305p, which must extend out from shielding assembly 200 in order to be coupled to the patient for injection, or in order to be coupled to shielded sample vials, as will be described below. Thus, technical personnel, who operate system 10, are protected from radiation by shielding assembly 200, except at those times when an infusion is taking place, or when quality control tests require collection of eluate into sample vials. During infusions and quality control test sample collection, all technical personnel are typically in another room, or otherwise distanced from system 10, in order to avoid exposure to radiation during the infusion, and, according to some preferred embodiments of the present invention, system 10 includes at least one means for informing technical personnel that an infusion is about to take place or is taking place. With reference back to Figures 1A and 1C, system 10 is shown including a light projector 100, mounted on post 142. According to the illustrated embodiment, projector 100, projects a light signal upward, for maximum visibility, when pump 33 is pumping eluant and elution is taking place within generator 21, or at all times when pump 33 is pumping eluant. According to some embodiments, the light signal flashes on and off when the eluate is being diverted from generator 21 into waste bottle 23, and the light signal shines steadily when the eluate is being diverted through patient line 305p, or visa versa. According to other embodiments, a projector 100 shines a light having a first color, to indicate that eluate is being diverted to waste bottle 23, and then shines a light having a second, different color, to indicate that eluate is being

directed to patient line 305p for infusion. Light projector 100 may further project a more rapidly flashing light, for example, for approximately five seconds, once a peak bolus of radioactivity is detected in the eluate, to provide further information to technical personnel. Alternative means of informing technical personnel that an  
5 infusion is taking place may also be incorporated by system 10, for example, including audible alarms or other types of visible or readable signals that are apparent at a distance from system, including in the control room.

It should be noted that, according to alternate embodiments, system 10 includes an 'on board' dose calibrator for quality control tests, and circuit 300 is expanded to  
10 include elements for an automated collection of eluate samples for activity measurements, via the on board dose calibrator. According to a first set of these alternate embodiments, a sample collection reservoir is integrated into circuit 300, downstream of divergence valve 35WP and in communication with tubing line 305P, in order to receive quality control test samples of eluate, via tubing line 305P, and both  
15 the reservoir and the dose calibrator are located in a separate shielded well. According to a second set of these alternate embodiments, waste bottle 23 is configured to receive the quality control test samples of eluate, via tubing line 305W, and a dose calibrator is integrated into shielding assembly 200. Quality control procedures will be described in greater detail below, in conjunction with Figures 6-8B.

When maintenance of system 10 requires the emptying waste bottle 23,  
20 relatively easy access to waste bottle 23 is provided through opening 139 in top surface 131 of shell 13. It should be noted that technical personnel are preferably trained to empty waste bottle 23 at times when the eluate, contained in waste bottle 23, has decayed sufficiently to ensure that the radioactivity thereof has fallen below a  
25 threshold to be safe. Opening 139 is preferably located at an elevation of between approximately 2 feet and approximately 3 feet; for example, opening 139 may be at an elevation of approximately 24 inches, with respect to a lower surface of platform 113, or at an elevation of approximately 32 inches, with respect to a ground surface upon which wheels 121, 122 rest. According to the illustrated embodiment, opening 139 is  
30 accessed by lifting panel 134; just within opening 139, a shielded lid or door 223 (Figure 2A) may be lifted away from a compartment of shielding assembly 200 that contains waste bottle 23. With further reference to Figure 1C, it may be appreciated that opening 137 provides access to other portions of circuit 300 for additional

maintenance procedures, such as changing out generator 21 and/or other components of circuit 300, as will be described below.

For those embodiments of system 10 in which automated quality control tests are performed and/or when system 10 is employed for relatively high volume  
5 operation, management of waste may become burdensome, even though access to waste bottle 23 is greatly facilitated, as described above. Thus, in order to facilitate waste management, some embodiments of system 10 may employ a separation system to separate salts, including radioactive elements, from water, for example, via  
10 evaporation or reverse osmosis. In an evaporation type system, the water component of the waste is evaporated, while in a reverse osmosis type system the water is separated from the salts, and, then, once confirmed to be non-radioactive, via a radiation detector, is piped to a drain. According to some other embodiments, circuit 300 may be configured so that the waste may be used to purge air from the tubing lines thereof and/or to perform the bypass flush that was described above, preferably after  
15 the radioactivity of the waste drops below a critical threshold.

Figures 1A and 1C further illustrate a pair of relatively shallow external recesses 190, which are formed in upper surface 131 of shell 13, for example, in order to catch any spills from infusion system; one of recesses 190 is shown located in proximity to post, or hanger 141, which holds reservoir 15, and in proximity to  
20 opening 133, through which tubing line 301 passes. Another recess 192 is shown formed in upper surface 131; a width and depth of recess 192 may accommodate storage of technical documentation associated with infusion system 10, for example, a technical manual and/or maintenance records, or printouts from printer 117 (Figure 1B). With reference to Figure 1C, upper surface 131 of shell 13 is shown to also  
25 include additional recesses 101, which are each sized to hold a shielded test vial, which contains samples from infusion system 10, for example, for breakthrough testing and/or calibration, which will be described in greater detail, below. An exemplary test vial shield is shown in Figure 1E. The test vial shield of Figure 1E is preferably formed from Tungsten rather than lead, for example, to reduce exposure to lead, for improved shielding, and to reduce the weight of the shield. Figure 1E  
30 illustrates the test vial shield including a handle to simplify manipulation thereof, but alternative configurations of test vial shields have no handle – for these a sling, or strap, may be employed for handling.

Additional receptacles 180 are shown formed in bin 18, on either side of a handle 182, which facilitates removal of bin 18 away from shell 13. Technical personnel may, thus, conveniently transport bin 18 to a storage area for a collection of supplies, for example, sharps, gloves, tubing lines, etc. . . . , into one or more receptacles 180 thereof, and/or to a waste container where separate receptacles 180 of bin 18 may be emptied of waste, such as packaging for the aforementioned supplies, for example, deposited therein during infusion procedures. According to some embodiments, one or more additional receptacles are formed in one or more disposal containers, for example, to contain sharps and/or radioactive waste (other than that contained in waste bottle 23), which may be integrated into bin 18, or otherwise fitted into, or attached to shell 13, separate from bin 18.

Figure 2A is a perspective view of shielding assembly 200, according to some embodiments of the present invention. With reference to Figures 1C and 2A, together, it may be appreciated that opening 137, in upper surface 131 of shell 13, provides access to a lid or door 221 of a sidewall 201 of shielding assembly 200, which sidewall 201 encloses a compartment sized to contain a radioisotope generator of system 10, for example, generator 21, previously introduced. It should be noted that, according to alternate embodiments, the compartment enclosed by sidewall 201 is large enough to hold more than one generator, for example, to increase system operating efficiency for relatively high volume operation. In some of these alternate embodiments, tubing lines 304 and 305 are each branched for parallel flow through the multiple generators, in which case divergence valves may be employed to alternate the flow through the generators, one at a time. In others of these alternate embodiments, the multiple generators are connected in series between tubing line 304 and tubing line 305. In addition, a reservoir for accumulating eluate may be included in circuit 300, downstream of the generators and upstream of divergence valve 35 WP, in conjunction with a second pump, in some cases. Embodiments including multiple generators and/or an eluate reservoir and second pump can be employed to better manage an activity level of each dose, or patient injection, for example, as described below, in conjunction with Figures 12A-B.

According to the embodiment illustrated in Figure 2A, opening 137 and door 221 are located at a lower elevation, for example, with respect to platform 113, than are opening 139 and lid 223, which provide access to the compartment being formed

by a sidewall 203 of shielding assembly 200 to contain waste bottle 23, as previously described. When panel 132 is separated from shell 13, and door 221 opened, generator 21 may be lifted out from an opening 231 (Figure 3A) which mates with door 221 of sidewall 201. A weight of generator 21, which includes its own shielding, may be  
5 between approximately 23 and approximately 25 pounds, thus, according to some preferred embodiments of the present invention, the elevation of each of openings 137 and 231, with respect to the lowermost portion of the cabinet structure, is between approximately 1 foot and approximately 2 feet, in order to facilitate an ergonomic stance for technical personnel to lift generator 21 out from the compartment.  
10 According to an exemplary embodiment, when shielding assembly 200 is contained in the cabinet structure of Figure 1A, openings 137 and 231 are located at an elevation of approximately 12 inches, with respect to the lower surface of platform 113, or at an elevation of approximately 19 inches, with respect to the ground surface upon which wheels 121, 122 rest. Figure 1C further illustrates access panel 132 including a  
15 security lock 138, which mates with a framework 19 of system 10, shown in Figure 2B, in order to limit access to generator 21.

Figures 1C and 2A further illustrate a lid or a door 225 of another sidewall 205 (Figure 3A) of shielding assembly 200, which encloses another compartment that is accessible through opening 137 of shell 13, and which is located adjacent the  
20 compartment enclosed by sidewall 201. Each of doors 221, 225 are shown being attached by a corresponding hinge H, and another door 227 is shown attached to sidewall 203 by another hinge H. Figure 2A illustrates each of lid 223 and doors 221, 225, 227 including a handle 232, 212, 252 and 272, respectively, for moving lid 223 and doors 221, 225, 227, in order to provide access to the corresponding  
25 compartments, which can be seen in Figures 3A-B. Figure 2A further illustrates optional thumb screws 290, one securing lid 223 to sidewall 203 and another securing door 221 to sidewall 201, or other means for securing the doors, which are known to those skilled in the art, may be incorporated. Each sidewall 201, 203, 205 and the corresponding lid/door 223, 221, 225, 227 thereof may be individually cast from 3%  
30 antimony lead, or from other known shielding materials, and then assembled together according to methods known to those skilled in the art.

According to the illustrated embodiment, doors 221, 225 are hinged to open in an upward direction, per arrows D and C, and, with reference back to Figure 1C, a

latch component 191 is provided to hold each of doors 221, 225 in an opened position, thereby, preventing doors 221, 225 from falling closed, which could pinch/crush fingers of technical personnel and/or tubing lines of circuit 300, when in the midst of a maintenance procedure. Figure 2B is a perspective view of framework 19 of the cabinet structure of system 10, according to some embodiments, to which latch component 191 is mounted; Figure 2B includes an enlarged detailed view of latch component 191, according to some embodiments. Figure 2B illustrates latch component 191 including a first pin 193, corresponding to door 225, and a second pin 195, corresponding to door 221; each pin 193, 195 includes a lever end 193A, 193B, respectively, and a holding end 193B, 195B, respectively. An edge of each door 221, 225, upon opening of doors 221, 225, may push past the holding end 195B, 193B of the corresponding pin 195, 193, in a first direction, per arrow F, and then may rest against a respective side S95 and S93 of each end 195B, 193B, until the corresponding lever end 195A, 193A is rotated in a counter-clockwise direction, per arrow cc, thereby moving the corresponding holding end 193B, 195B to make way for the closing of doors 221, 225. Doors 221, 225 being held by latch component 191 in an open position may be seen in Figure 3A.

With further reference to Figure 2A, according to some preferred embodiments of the present invention, an edge of door 225 overlaps door 221 to prevent door 221 from being opened, per arrow D, if door 225 is not opened, per arrow C; and an edge of door 227 overlaps an edge of door 225 to prevent door 225 from being opened if door 227 is not opened, per arrow B; and an edge of lid 223 overlaps door 227 to prevent door 227 from being opened if lid 223 is not opened, per arrow A. Thus, access to the compartment enclosed by sidewall 201 and containing generator 21 is only systematically allowed through a sequential opening of lid 223 and doors 227, 225, 221, since, when generator 21 is replaced it is typically desirable to also replace those portions of circuit 300 which are shielded behind lid 223 and doors 227, 225. The routing of these portions of circuit 300 will be described in conjunction with Figures 3A-C.

Figure 3A is another perspective view of shielding assembly 200, according to some embodiments of the present invention. In Figure 3A, lid 223 and doors 221, 225, and 227 are opened to provide a view into openings 233, 235 and 231 of sidewalls 203, 205 and 201, respectively, and into a passageway 207, which is formed in



sidewall 203, opposite the compartment, which contains waste bottle 23. Passageway 207 is shown extending vertically along sidewall 203 and having a grooved extension 213 formed in a perimeter surface of opening 233. An optional retaining member 237, for example, formed from an elongate strip of resilient plastic having a generally c-  
5 shape cross-section, is shown being mounted along a length of passageway 207 to hold lines 305w and 305p in place within passageway 207. Figure 3A further illustrates a pair of passageways 251b and 251g, which are formed as grooves in a portion of sidewall 205, and another pair of passageways 215i and 215o, which are formed as grooves in a portion of sidewall 201. A routing of portions of tubing circuit 300  
10 (Figure 1D) through passageways 207, 251b, 251c, 215i and 215o is shown in Figure 3B.

Figure 3B illustrates tubing line 304 being routed through passageways 251g and 215i, eluate tubing line 305 being routed through passageway 215o, and both waste line 305w and patient line 305p being routed along passageway 207. Waste line  
15 305w further extends through grooved extension 213 to waste bottle 23, and patient line 305p further extends outward from shielding assembly 200, for example, to extend out through opening 135 in upper surface 131 of shell 13 (Figure 1A). According to the illustrated embodiment, each passageway formed in shielding assembly 200, by being accessible along a length thereof, can facilitate a relatively easy routing of the  
20 corresponding tubing line therethrough, when the corresponding lid/door is open, and a depth of each passageway prevents pinching and/or crushing of the corresponding tubing line routed therethrough, when the corresponding lid/door is closed down thereover. With further reference to Figures 3A-B, it may be appreciated that the compartment formed by sidewall 201 may have a shape matching an exterior contour  
25 of generator 21, such that generator 21 is 'keyed' to the compartment, for example, to prevent installation of an improper generator into system 10, and/or to facilitate the proper orientation of generator 21 within the compartment for the proper routing of tubing lines. Alternately, or in addition, according to alternate embodiments, if system  
30 10 includes a reader of encoded information in communication with computer 17, a unique identification and/or data associated with each generator may be provided, for example, in a bar code label or a radiofrequency identification (RFID) tag that is attached to each generator, so that the reader may transfer the information to computer 17, when a generator is installed, in order to either enable system operation or to

provide an indication to the user that an incorrect generator has been installed. Of course a user of system 10 may, alternately, manually enter information, that is provided on a generator label or marking, into computer 17, in order to either enable system 10, or to receive feedback from computer 17 that the incorrect generator is installed.

5

Figure 3A further illustrates sidewall 205 including a valve actuator receptacle 253, into which divergence valve 35WP is mounted, to be controlled by one of the servomotors (not shown) of system 10, and an opening 325 for activity detector 25. Activity detector 25 is mounted in a shielded well 255 that extends downward from opening 325 (shown in Figure 3B), and, with reference to Figure 3B, tubing line 305 passes over opening 325 so that detector 25 can detect an activity of the eluate, which passes therethrough. According to some embodiments, the positioning, within the compartment enclosed by sidewall 205, of the components of the portion of infusion circuit 300 which are shown routed therein, is facilitated by providing the components mounted in a frame 39 as a disposable subassembly 390, an embodiment of which is illustrated by Figures 3C-D.

10

15

Figure 3C is a perspective view of subassembly 390, and Figure 3D is a perspective view of frame 39. According to the embodiment illustrated by Figure 3D, frame 39 is formed from mating trays 39A, 39B, for example, formed from a thermoformed plastic, which fit together to capture, therebetween, and hold, in fixed relation to a perimeter edge of frame 39, divergence valve 35WP and portions of eluant tubing line 304, by-pass tubing line 303, eluate tubing line 305, waste line 305w and patient line 305p. Figure 3C illustrates the perimeter edge divided into a first side 391, a second side 392, opposite first side 391, a third side 393, extending between first and second sides 391, 392, and a fourth side 394, opposite third side 393. Although Figure 3D shows trays 39A, 39B individually formed for fitting together, according to alternate embodiments, mating trays of frame 39 may be parts of a continuous sheet of plastic folded over on itself.

20

25

According to the illustrated embodiment, an end 404A, of eluant line 304, and an end 403, of by-pass line 303 extend from third side 393 of frame 39 to couple with divergence valve 35BG and an upstream section of eluant tubing line 302. Figure 3C further illustrates an opposite end 404B of eluant line extending from first side 391 of frame 39, alongside a similarly extending end 405 of eluate line 305, and ends 406 and

30

407 of patient line 305p and waste line 305w, respectively, extending from second side 392 of frame 39. Although ends 406, 407 are shown extending upward from tray 39a, as they would within shielding assembly 200, it should be appreciated that the tubing lines of circuit 300 are preferably flexible and would drop down under their own weight rather than extending upward, as shown, if not supported. Referring back to Figure 1D, in conjunction with Figure 3C, it can be seen that the aforementioned fittings are provided for coupling subassembly 390 into circuit 300: first fitting 311 couples the section of eluant line 302 to filter 37; second fitting 312 couples eluant line 304 to an inlet port of generator 21; third fitting 313, which may incorporate a check valve, couples eluate line 305 to an outlet port of generator 21; fourth fitting 314 couples waste line 305w to waste bottle 23; and fifth fitting 315 couples patient line 305p to an extension thereof, which extends outside shell 13 (designated by the dotted line). Each of the fittings 311, 312, 313, 314, 315 may be of the Luer type, may be a type suitable for relatively high pressure applications, or may be any other suitable type that is known to those skilled in the art.

As previously mentioned, when generator 21 is replaced, it is typically desirable to also replace those portions of circuit 300 which are shielded behind lid 223 and doors 227, 225, and, in those instances wherein system 10 is moved to a new site each day, these portions may be replaced daily. Thus, according to the illustrated embodiment, these portions are conveniently held together by frame 39, as subassembly 390, in order to facilitate relatively speedy removal and replacement, while assuring a proper assembly orientation, via registration with features formed in sidewall 205 (Figure 3A), for example: registration of divergence valve 35WP with valve actuator receptacle 253, registration of tubing line ends 403 and 404A with passageways 251b and 251g, respectively, registration of tubing line ends 404B and 405 with passageways 215i and 215o, respectively, and registration of tubing line ends 406 and 407 with passageway 207.

With further reference to Figure 3B, other portions of tubing circuit 300 are shown. Figure 3B illustrates eluant tubing line 301 extending from reservoir 15, outside of shell 13 (Figure 1A), to syringe pump 33, which is mounted to an actuating platform 433. According to the illustrated embodiment, platform 433 is actuated by another servomotor (not shown) of system 10, which is controlled by the controller and computer 17 of system 10, to cause a plunger of pump 33 to move, per arrow I, so

as to draw in eluant, from reservoir 15, through tubing line 301, and then to cause the plunger to move in the opposite direction so as to pump the eluant, through tubing line 302, to either generator 21 or to by-pass line 303. Although the illustrated embodiment includes syringe pump 33, other suitable pumps, known to those skilled  
5 in the art, may be substituted for pump 33, in order to draw eluant from reservoir 15 and to pump the eluant throughout circuit 300. Although not shown, it should be appreciated that divergence valve 35BG is fitted into another valve actuating receptacle mounted within shell 13 and coupled to yet another servomotor (not shown) of system 10.

10 Figure 3B further illustrates a filter holder 317 that is mounted alongside an interior surface of shell 13 to hold filter 37 (Figure 1D) of tubing line 302. Filter holder 317, like frame 39 for subassembly 390, may be formed from a thermoformed plastic sheet; holder 317 may have a clam-shell structure to enclose filter 37 in an interior space, yet allow tubing line 302, on either side of filter 37, to extend out from  
15 the interior space, in between opposing sides of the clam-shell structure. Holder 317 is shown including an appendage 307 for hanging holder 317 from a structure (not shown) inside shell 13.

Turning now to Figures 4-9C details concerning computer-facilitated operation of system 10 will be described, according to some embodiments of the present  
20 invention. As previously mentioned, and with reference back to Figure 1A, computer 17 of system 10 includes monitor 172, which, preferably, not only displays indications of system operation to inform a user of system 10, but is also configured as a touch screen to receive input from the user. It should be understood that computer 17 is coupled to the controller of system 10, which may be mounted within the interior  
25 space surrounded by shell 13. Although Figure 1A shows computer 17 mounted to post 142 of system 10, for direct hardwiring to the controller of system 10, according to some alternate embodiments, computer 17 is coupled to the controller via a flexible lead that allows computer 17 to be positioned somewhat remotely from those portions of system 10, from which radioactive radiation may emanate; or, according to some  
30 other embodiments, computer 17 is wirelessly coupled, for example, via two-way telemetry, to the controller of system 10, for even greater flexibility in positioning computer 17, so that the operation of system 10 may be monitored and controlled remotely, away from radioactive radiation.

According to some preferred embodiments, computer 17 is pre-programmed to guide the user, via monitor 172, through procedures necessary to maintain system 10, to perform quality control tests on system 10, and to operate system 10 for patient infusions, as well as to interact with the user, via the touch-screen capability of  
5 monitor 172, according to preferred embodiments, in order to track volumes of eluant and eluate contained within system 10, to track a time from completion of each elution performed by system 10, to calculate one or more system parameters for the quality control tests, and to perform various data operations. Computer 17 may also be pre-programmed to interact with the controller of system 10 in order to keep a running  
10 tally or count of elutions per unit time, for a given generator employed by the system, and may further categorize each of the counted elutions, for example, as being generated either as a sample, for quality control testing, or as a dose, for patient injection. The elution count and categorization, along with measurements made on each sample or dose, for example, activity level, volume, flow rate, etc..., may be  
15 maintained in a stored record on computer 17. All or a portion of this stored information can be compiled in a report, to be printed locally, and/or to be electronically transferred to a remote location, for example, via an internet connection to technical support personnel, suppliers, service providers, etc..., as previously described. Computer 17 may further interact with the user and/or a reader of encoded  
20 information, for example, a bar code reader or a radiofrequency identification (RFID) tag reader, to store and organize product information collected from a product labels/tags, thereby facilitating inventory control, and/or confirming that the proper components, for example, of the tubing circuit, and/or accessories, and/or solutions are being used in the system.

25 It should be understood that screen shots shown in Figures 4-9C are exemplary in nature and are presented to provide an outline of some methods of the present invention in which computer 17 facilitates the aforementioned procedures, without limiting the scope of the invention to any particular computer interface format. Computer 17 may also include a pre-programmed user manual, which may be viewed  
30 on monitor 172, either independent of system operation or in conjunction with system operation, for example, via pop-up help screens. Although the English language is employed in the screen shots of Figures 4-9C, it should be understood that, according

to some embodiments, computer 17 is pre-programmed to provide guidance in multiple languages.

Figure 4 is a screen shot of a main menu 470, which is presented by computer 17 on monitor 172, according to some embodiments. Main menu 470 includes a listing of each computer-facilitated operation that may be selected by the user, once the user has logged on. According to some multi-lingual embodiments, computer 17 presents a list of languages from which the user may select, prior to presenting main menu 470.

Figure 5A is a schematic showing a series of screen shots which includes a log in screen 570. According to some embodiments, when the user touch-selects the data entry fields of screen 570 or 571, or of any of the other screens presented herein, below, a virtual keyboard is displayed for touch-select data entry into the selected data entry field; alternately, computer 17 may be augmented with another type of device for user data entry, examples of which include, without limitation, a peripheral keyboard device, a storage medium (i.e. disk) reader, a scanner, a bar code reader (or other reader of encoded information), a hand control (i.e. mouse, joy stick, etc...). Although not shown, according to some embodiments, screen 570 may further include another data entry field in which the user is required to enter a license key related to the generator employed by system 10 in order to enable operation of system 10; the key may be time sensitive, related to generator contract terms. Of course any number of log in requirements may be employed, according to various embodiments, and may be presented on multiple sequentially appearing screens rather than on a single log in screen.

After the user enters the appropriate information into data entry fields of log in screen 570, computer 17 presents a request for the user to confirm the volume of eluant that is within reservoir 15 (e.g. saline in saline bag), via a screen 571, and then brings up main menu 470. If the user determines that the volume of eluant/saline is insufficient, the user selects a menu item 573, to replace the saline bag. If system 10 includes an encoded information reader, such as a bar code or RFID tag reader, confirmation that the selected reservoir is proper, i.e. contains the proper saline solution, may be carried out by computer 17, prior to connecting the reservoir into circuit 300, by processing information read from a label/tag attached to the reservoir. Alternatively, or in addition, tubing line 301 of circuit 300 may be provided with a

connector which only mates with the proper type of reservoir 15. According to some embodiments, system 10 may further include an osmolarity or charge detector, which is located just downstream of reservoir 15 and is linked to computer 17, so that an error message may be presented on monitor 172 stating that the wrong osmolarity or charge is detected in the eluant supplied by reservoir, indicating an improper solution. One example of a charge detector that may be employed by system 10 is the SciCon™ Conductivity Sensor (available from SciLog, Inc. of Middleton, WI).

Once the reservoir/saline bag is successfully replaced, computer 17 prompts the user to enter a quantity of saline contained by the new saline bag, via a screen 574. Alternately, if system 10 includes the aforementioned reader, and the saline bag includes a tag by which volume information is provided, the reader may automatically transfer the quantity information to computer 17. Thus, computer 17 uses either the confirmed eluant/saline volume, via screen 571, or the newly entered eluant/saline volume as a baseline from which to track depletion of reservoir volume, via activations of pump 33, in the operation of system 10. With reference to Figure 5B, during the operation of system 10, when computer 17 detects that the eluant reservoir/saline bag has been depleted to a predetermined volume threshold, computer 17 warns the user, via a screen 577. If the user has disregarded screen 577 and continues to deplete the saline bag, computer 17 detects when the saline bag is empty and provides indication of the same to the user, via a screen 578. To replenish the reservoir/saline bag, the user may either refill the reservoir/bag or replace the empty reservoir/bag with a full reservoir/bag. According to some embodiments, system 10 automatically precludes any further operation of the system until the reservoir is replenished. It should be noted that, as previously mentioned, system 10 can include a fluid level sensor coupled to the eluant reservoir in order to detect when the level of saline drops below a certain level.

In addition to tracking the volume of eluant in reservoir 15, computer 17 also tracks a volume of the eluate which is discharged from generator 21 into waste bottle 23. With reference to Figure 5C, an item 583 is provided in main menu 470, to be selected by the user when the user empties waste bottle 23. When the user selects item 583, computer 17 presents a screen 584, by which the user may effectively command computer 17 to set a waste bottle level indicator to zero, once the user has emptied waste bottle 23. Typically, the user, when powering up system 10 for operation, each

day, will either empty waste bottle 23, or confirm that waste bottle 23 was emptied at the end of operation the previous day, and utilize screen 584 to set the waste bottle level indicator to zero. Thus, computer 17, can track the filling of waste bottle 23 via monitoring of the operation of pump 33 and divergence valve 35WP, and provide an indication to the user when waste bottle 23 needs to be emptied, for example, via presentation of screen 584, in order to warn the user that, unless emptied, the waste bottle will overflow. According to some embodiments, system 10 automatically precludes any further operation of the system until the waste bottle is emptied. According to some alternative embodiments, a fluid level sensor may be coupled to waste bottle, for example, as mentioned above in conjunction with Figure 1D, in order to automatically detect when waste bottle is filled to a predetermined level and to provide, via computer 17, an indication to the user that waste bottle 23 needs to be emptied and/or to automatically preclude operation of system 10 until the waste bottle is emptied.

In addition to the above maintenance steps related to eluant and eluate volumes of system 10, the user of system 10 will typically perform quality control tests each day, prior to any patient infusions. With reference to Figure 6, according to preferred methods, prior to performing the quality control tests (outlined in conjunction with Figures 7A-C and 8A-B), the user may select an item 675 from main menu 470, in order to direct system 10 to wash the column of generator 21. During the generator column wash, which is performed by pumping a predetermined volume of eluant, for example, approximately 50 milliliters, through generator 21 and into waste bottle 23, computer 17 provides an indication, via a screen 676, that the wash is in progress. Also, during the generator column wash, the system may provide a signal to indicate that eluate it being diverted to waste bottle 23, for example, light projector 100 (Figure 1C) may project a flashing light signal, as previously described.

Figure 6 further illustrates a screen 677, which is presented by computer 17 upon completion of the column wash, and which provides an indication of a time lapse since the completion of the wash, in terms of a time countdown, until a subsequent elution process may be effectively carried out. While screen 677 is displayed, system 10 may be refilling, from reservoir 15, pump 33, which has a capacity of approximately 55 milliliters, according to some embodiments. According to some preferred embodiments of the present invention, computer 17 starts a timer once any



elution process is completed and informs the user of the time lapse, either in terms of the time countdown (screen 677), or in terms of a time from completion of the elution, for example, as will be described in conjunction with Figure 7B. According to an exemplary embodiment, wherein generator 21 is the CardioGen-82® that yields a saline solution of Rubidium-82, produced by the decay of Strontium-82, via the elution, a time required between two effective elution processes is approximately 10 minutes.

Once the appropriate amount of time has lapsed, after the elution process of generator column wash, a first quality control test may be performed. With reference to Figure 7A, the user may select, from main menu 470, an item 773A, which directs computer 17 to begin a sequence for breakthrough testing. According to some embodiments, in conjunction with the selection of item 773A, the user attaches a needle to an end of patient line 305p and inserts the needle into to a test vial, for the collection of an eluate sample therefrom, and, according to Figure 7A, computer 17 presents a screen 774, which instructs the user to insert the test vial into a vial shield, which may be held in recess 101 of shell 13 (Figure 1C).

Figure 7A further illustrates a subsequent screen 775, by which computer 17 receives input, from the user, for system 10 to start the breakthrough elution, followed by a screen 776, which provides both an indication that the elution is in progress and an option for the user to abort the elution. As previously described, the system may provide a signal to indicate that elution is in progress, for example, light projector 100 (Figure 1C) may project a flashing light signal during that portion of the elution process when eluate is diverted from generator 21 through waste line 305w and into waste bottle 23, and then a steady light signal during that portion of the elution process when the eluate is diverted from generator 21 through patient line 305p and into the test vial, for example, once activity detector 25 detects a dose rate of approximately 1.0 mCi/sec in the eluate discharged from generator 21. Another type of light signal, for example, the more rapidly flashing light, as previously described, may be projected when a peak bolus of radioactivity is detected in the eluate.

Upon completion of the elution process for breakthrough testing, computer 17 presents a screen 777, shown in Figure 7B, which, like screen 677, provides an indication of a time lapse since the completion of the elution, but now in terms of a time since completion of the breakthrough elution process. When the user transfers

the vial containing the sample of eluate into a dose calibrator, to measure the activity of the sample, the user may make a note of the time lapse indicated on screen 777. With further reference to Figure 7B, once the user has received the activity measure from the dose calibrator, the user proceeds to a screen 778, which includes data entry fields for the activity measure and the time between that at which the dose calibrator measured the activity of the sample and that at which the elution was completed. The user may enter the data via the touch-screen interface of monitor 172, or via any of the other aforementioned devices for user data entry. According to some alternate embodiments, computer 17 may receive the data, electronically, from the dose calibrator, either via wireless communication or a cable connection.

After the data is entered by the user, computer 17 presents screen 779, from which the user moves back to main menu 470 to perform a system calibration, for example, as will be described in conjunction with Figures 8A-B, although the breakthrough testing is not completed. With reference back to Figure 7A, an item 773B is shown, somewhat faded, in main menu 470; item 773B may only be effectively selected following the completion of steps for item 773A, so as to perform a second stage of breakthrough testing. In the second stage, the breakthrough of the sample of eluate collected in the test vial for the breakthrough testing is measured, at a time of approximately 60 minutes from the completion of the elution that produced the sample. With reference to Figure 7C, after the user has selected item 773B from main menu 470, in order to direct computer 17 to provide breakthrough test results, a screen 781 is displayed. Screen 781 includes, for reference, the values previously entered by the user in screen 778, along with another pair of data entry fields into which the user is instructed to enter the breakthrough reading of the sample at 60 minutes and the background radiation reading, respectively. After the user enters this remaining information, as described above, computer 17 may calculate and then display, on a screen 782, the breakthrough test results. According to the illustrated embodiment, computer 17 also displays on screen 782 pre-programmed allowable limits for the results, so that the user may verify that the breakthrough test results are in compliance with acceptable limits, before moving on to a patient infusion. According to some embodiments, system 10 will not allow an infusion if the results exceed the acceptable limits, and may present a screen explaining that the results are outside the acceptable

limits; the screen may further direct the user to contact the generator supplier, for example, to order a replacement generator.

With reference to Figure 8A, during the aforementioned 60 minute time period, while waiting to complete the breakthrough testing, the user may perform calibration  
5 by selecting item 873 from main menu 470. Upon selection of item 873, computer 17 presents a screen 874, which instructs the user to insert a new test vial into an elution vial shield. In addition to placing the vial in the shield, the user, preferably, replaces patient line 305p with a new patient line, and then attaches a needle to the end of the new patient line for insertion into the test vial, in order to collect an eluate sample  
10 therefrom. After performing these steps, the user may move to screen 875, wherein a plurality of data entry fields are presented; all or some of the fields may be filled in with pre-programmed default parameters, which the user has an option to change, if necessary. Once the user confirms entry of desired parameters for the calibration, the user may enter a command, via interaction with a subsequent screen 876, to start the calibration elution.  
15

With reference to Figure 8B, after computer 17 starts the elution process, a screen 87 informs the user that the calibration elution is in progress and provides an option to abort the elution. As previously described, the system may provide an indication that elution is in progress, for example, light projector 100 (Figure 1C) may  
20 project a flashing light signal during that portion of the elution process when eluate is diverted from generator 21 through waste line 305w and into waste bottle 23, and then a steady light signal during that portion of the elution process when activity detector 25 has detected that a prescribed dose rate threshold is reached, for example, 1.0 mCi/sec, and the eluate is being diverted from generator 21, through the new patient  
25 line, and into the test vial. Another type of light signal, for example, the more rapidly flashing light, as previously described, may be projected when a peak bolus of radioactivity is detected in the eluate. Upon completion of the elution process for calibration, computer 17 presents a screen 878, which provides an indication of a time lapse since the completion of the elution, in terms of a time since completion of the  
30 calibration elution process. When the user transfers the vial containing the sample of eluate into the dose calibrator, to measure the activity of the sample, the user may make a note of the time lapse indicated on screen 878. With further reference to Figure 8B, once the user has received the activity measure from the dose calibrator, the

user proceeds to a screen 879, which includes data entry fields for the activity measure and the time, with respect to the completion of elution, at which the dose calibrator measured the activity of the sample. Once the data is input by the user, as described above, computer calculates a calibration coefficient, or ratio, and presents the ratio on  
5 a screen 880. According to Figure 8B, screen 880 further provides an indication of a desirable range for the calibration ratio and presents an option for the user to reject the calculated ratio, in which case, the user may instruct computer 17 to recalculate the ratio.

As previously mentioned, some alternate embodiments of the present invention  
10 include an on board dose calibrator so that the entire sequence of sample collection and calculation steps, which are described above, in conjunction with Figures 6-8B, for the quality control procedures, may be automated. This automated alternative preferably includes screen shots, similar to some of those described above, which provide a user of the system with information at various stages over the course of the automated procedure and that provide the user with opportunities to modify, override  
15 and/or abort one or more steps in the procedure. Regardless of the embodiment (i.e. whether system 10 employs an on board dose calibrator or not), computer 17 may further collect all quality control test parameters and results into a stored record and/or compile a report including all or some of the parameters and results for local print out and/or electronic transfer to a remote location.  
20

With reference to Figure 9A, upon completion of the above-described quality control tests, the user may select an item 971, from main menu 470, in order to direct system 10 to begin a procedure for the generation and automatic infusion of a radiopharmaceutical into a patient. As previously described, system 10 infuses the  
25 patient with the radiopharmaceutical so that nuclear diagnostic imaging equipment, for example, a PET scanner, can create images of an organ of the patient, which absorbs the radiopharmaceutical, via detection of radioactive radiation therefrom. According to Figure 9A, upon selection of item 971, computer 17 presents a screen 972 which includes a data entry field for a patient identification number. This identification  
30 number that is entered by the user is retained by computer 17, in conjunction with the pertinent system parameters associated with the patient's infusion. After the user enters the patient identification number, computer 17 directs, per a screen 973, the user to attach a new patient line and to purge the patient line of air. A subsequent screen

974 presented by computer 17 includes data entry fields by which the user may establish parameters for the automatic infusion; all or some of the fields may be filled in with pre-programmed default parameters, which the user has an option to change, if necessary.

5           With reference to Figure 9B, if pump 33 does not contain enough eluant/saline for the patient infusion, computer 17 will present a warning, via a screen 901, which includes an option for the user to direct the refilling of pump 33, via a subsequent screen 902. Once pump 33 has been filled, computer 17 presents an indication to the user, via a screen 903. According to some embodiments, if the user does not re-fill  
10           pump 33, yet attempts to proceed with an infusion, system 10 will preclude the infusion and present another screen, that communicates to the user that no infusion is possible, if the pump is not refilled, and asking the user to refill the pump, as in screen 901. When pump 33 contains a sufficient volume of eluant for the patient infusion, computer 17 presents a screen 975, which is shown in Figure 9C, and allows the user  
15           to enter a command for system 10 to start the patient infusion. During the infusion, computer 17 provides the user with an indication that the infusion is in process and with a option for the user to abort the infusion, via a screen 976. As previously described, the system may provide an indication that an elution is in progress, for example, light projector 100 (Figure 1C) may project a flashing light signal during that  
20           portion of the elution process when eluate is diverted from generator 21 through waste line 305w and into waste bottle 23, and then a steady light signal during that portion of the elution process when activity detector 25 has detected that a prescribed dose rate threshold is reached, for example, 1.0 mCi/sec, and the eluate is being diverted from generator 21, through the new patient line for infusion into the patient. Another type  
25           of light signal, for example, the more rapidly flashing light, previously described, may be projected when a peak bolus of radioactivity is detected in the eluate. At the completion of the infusion, a screen 977 is displayed by computer 17 to inform the user of the completion of the infusion and a time since the completion. Computer 17 also displays a summary of the infusion, per screen 978.

30           With further reference to Figure 9C, screen 976 shows an exemplary activity profile (activity - mCi/sec, on y-axis, versus time - sec, on x-axis) for the infusion/injected dose (designated between the two vertical lines). Those skilled in the art will appreciate that the shape of this profile depends upon the infusion flow rate,

for a given volume of the dose, which flow rate is controlled, for example, by the speed at which pump 33 drives flow through the patient line, and upon the amount of Strontium-82 remaining in the generator. In the absence of flow rate control, activity profiles may change over the life of the generator. Furthermore, the peak bolus of radioactivity, particularly for injected doses from a relatively new generator, may exceed a saturation level of the imaging equipment, i.e. PET scanner. According to some preferred methods of the present invention, in order to maintain relatively consistent, and desirable/effective, activity profiles for patient injections, over the life of the generator, the operating speed of pump 33 may be varied (both over the course of a single injection and from injection to injection), according to feedback from activity detector 25. Such a method may be implemented via incorporation of another quality control test in which pump 33 is operated to drive flow through the generator at a constant rate, in order to collect, into computer, a plurality of activity measurements from activity detector 25; the plurality of measurements comprise a characteristic, or baseline activity profile from which the computer 17 may calculate an appropriate flow rate profile to control a speed of pump 33, in order to achieve the desirable/effective activity profile. In general, at the start of generator life, when Strontium-82 is plentiful, the pump is controlled to drive infusion flow at relatively lower rates, and, then, toward the end of generator life, when much of the Strontium-82 has been depleted, the pump is controlled to drive infusion flow at relatively higher rates. As was described above, in conjunction with Figure 1D, if a desired infusion/injection flow rate is relatively high, that is, high enough to create too much back pressure, via flow through the column of generator 21, by-pass line 303 may be employed by adjusting divergence valve 35BG to divert a flow of eluant therethrough after a sufficient volume has been pumped through generator at a lower flow rate. According to this method, once a dose of eluate, from generator 21, has flowed into patient line 305p, divergence valve 35BG is set to divert the flow of eluant through by-pass line 303, and then pump speed is increased to pump eluant at a higher flow rate in order to push the dose out from patient line 305p, for injection at the higher flow rate.

Consistency of activity profiles among injected doses can greatly facilitate the use of PET scanning for the quantification of flow, for example, in coronary perfusion studies. Alternative infusion circuit configurations, operable according to alternative methods, to achieve consistency of activity profiles among injected doses, as well as a

more uniform level of radioactivity across each individual dose, will be described below, in conjunction with Figures 12A-C.

Printer 117 (Figure 1B) may be activated to print out a hard copy of the infusion summary, on which the patient identification number and pertinent infusion  
5 and system parameters are also printed, for reference. Alternatively, or in addition, according to some embodiments, the summary may be downloaded onto a computer readable storage device to be electronically transferred to one or more remote computers and/or the summary may be automatically transferred to the one or more  
10 remote computers, via wireless communication or a cable connection, for example, over an intranet network and/or the internet. In order to protect private patient information, the files may be encrypted for transmission over the internet. The one or more remote computers may be included, for example, in a hospital information system, and/or a billing system, and/or in a medical imaging system. Infusion parameters, for example, corresponding to the activity profile, may also be collected  
15 and electronically transferred for analysis in conjunction with captured images, for example, in order to quantify coronary flow, via a software package that is loaded into a system that includes the PET scanner.

With reference back to Figure 9A the user may select an item 995, from main menu 470, in order have system 10 perform data operations, such as, archiving a data  
20 base of patient infusion information and quality control test results, transmitting patient infusion summary records to USB mass storage devices, and various types of data filtering, for example, according to date ranges and/or patient identification numbers, for example, to search for a particular set of data and/or to compile a summary report of related sets of data. Additionally, certain information, which is  
25 collected by computer 17 over the course of system operation, and which defines system operation, may be transmitted to a local or remote computerized inventory system and/or to computers of technical support personnel, maintenance/service providers and/or suppliers of infusion circuit elements/components, thereby facilitating more efficient system operation and maintenance.

30 Turning now to Figure 10, an item 981 for computer-facilitated purging of the tubing lines of system 10 is shown included in main menu 470. When a user selects item 981, computer 17 guides the user to select either an air purge or a saline purge. The direction provided by computer 17 is not explicitly laid out herein, for a saline

purge, as procedures for saline purging should be readily apparent to those skilled in the art, with reference to the schematic of infusion circuit 300 shown in Figure 1D. A saline purge of circuit 300 is desired to assure that all the air is removed from circuit 300 when a new generator and/or a new complete or partial tubing set is installed. An air purge of the tubing lines of circuit 300 may be performed after removing reservoir 15, by-passing generator 21, by connecting tubing line 304 to tubing line 305, and coupling patient line 305p to a vial, for example, as is directed by the computer interface, in screens 983 and 984 shown in Figure 10. The air purge is desirable for blowing out the tubing lines, thereby removing all remaining eluant and eluate, prior to installing a new generator and/or prior to transporting system 10 from one site to another. If generator 21 is not depleted and will be used in system 10 at the new site, it is important to by-pass the generator prior to purging the tubing lines of circuit 300 with air, so that air is not blown across the generator, since air through generator 21 may compromise both the function and the aseptic nature of generator 21.

According to preferred embodiments, once the user has followed the instructions presented in screens 983 and 984 and selects to start the air purge, for example, via screen 985, computer 17 directs the controller of system 10 to carry out a complete air purge, in which pump 33 and divergence valves 35BG and 35WP are automatically controlled. The automated air purge preferably includes the following steps, which may be best understood with reference to tubing circuit 300 in Figure 1D: pumping any remaining volume of eluant left in pump 33, through lines 302, 304, 305 and 305w, to waste bottle 23; refilling pump 33 with air and pumping the air through lines 302, 304, 305 and 305w, into waste bottle 23 (lines 304 and 305 have been previously connected directly to one another, in order to by-pass generator 21; if generator 21 is depleted and will be replaced with a new generator, pumping air through generator 21 may be acceptable); refilling pump 33 with air and then pumping a portion of the air through lines 302, 304, 305 and 305p, into the vial, and then a remaining portion of the air through lines 302, 304, 303 and 305p, into the vial. With reference to Figure 1D and the previous description of divergence valves 35BG, 35WP, it should be understood how divergence valves 35BG, 35WP are automatically controlled to carry out the above steps.

The purge operations, which are facilitated by selecting item 981 from main menu 470, may also be accessed via the selection of an item 991 for generator setup.



When the user selects item 991, computer 17 may present an option for guidance in removing an old, depleted, generator and a set of tubing lines, prior to installing the new generator, or an option to just be guided in the installation of the new generator. According to some embodiments, computer 17 is pre-programmed to calculate an amount of activity left in a depleted generator, for example, by tracking activity of eluate over a life of the generator. At an end of the life of the generator, computer 17 may further compile this information, along with other pertinent generator information, into a report that may accompany a declaration of dangerous goods for shipping the depleted generator out for disposal or, in some cases, back to the manufacturer for investigation. An example of such a report is shown in Figure 11. According to those embodiments of system 10 that include an encoded information reader, computer 17 may confirm that the new generator is proper by processing information that is read from an encoded label/tag attached thereto.

Figures 12A-B are schematics of alternative infusion circuits 1300A, 1300B that may be employed by system 10, in place of circuit 300 (Figure 1D), according to some additional embodiments of the present invention. Circuits 1300A, 1300B are configured to allow for alternative methods of operation, to that previously described for circuit 300, when a relatively even, or uniform level of activity over each injected dose, along with the relatively consistent level of activity from injection to injection is desired, for example, in order to facilitate a quantification of coronary artery blood flow via PET scanning. Figure 12C is a schematic illustrating activity profiles 1200A, 1200B for two injected doses, wherein profile 1200B has a more uniform level of activity than profile 1200A; profile 1200B may be achieved via the operation of circuits 1300A, 1300B as described below.

Similar to circuit 300 (Figure 1D), dashed lines are shown in each of Figures 12A-B to indicate a general boundary of a shielding assembly for portions of each circuit 1300A, 1300B. The shielding assembly for each of circuits 1300A, 1300B may be very similar, in most respects, to shielding assembly 200, which is described above for system 10, and the elements of each of circuits 1300A, 1300B may be arranged with respect to their respective shielding and with respect to shell 13 of system 10 in a similar manner to that described above for circuit 300.

Figure 12A illustrates circuit 1300A including, like the previously described circuit 300, eluant reservoir 15, pump 33, radioisotope generator 21, through which the

filtered eluant is pumped to create the radioactive eluate, activity detector 25, and waste bottle 23. Figure 12A further illustrates two filters 37 and two pressure transducers 1334 included in circuit 1300A. Circuit 1300A further includes by-pass tubing line 303, which is located downstream of divergence valve 35BG, like in circuit 5 300, and which accommodates the previously described eluant/saline flush. However, in contrast to circuit 300, circuit 1300A further includes a linear/proportional valve 1335 integrated into by-pass/flush line 303 so that circuit 1300A may be operated, for example, according to pre-programmed parameters of computer 17, in conjunction with feedback of information from activity detector 25, for a controlled by-pass of 10 generator 21 in order to mix eluant with eluate and, thereby, achieve a relatively uniform level of activity over each patient injection, for example, according to profile 1200B of Figure 12C. It should be noted that, in addition to the controlled mixing, a flow rate of each injection may be varied, if necessary, in order to maintain a consistent activity level.

15 Figure 12B illustrates circuit 1300B including, like the previously described circuit 300, eluant reservoir 15, pump 33, radioisotope generator 21, activity detector 25, and waste bottle 23, as well as the two filters 37 and two pressure transducers 1334, as in circuit 1300A. In contrast to circuits 300 and 1300A, circuit 1300B further includes an eluate reservoir 1350, which is shown located downstream of generator 20 21, in between first and second segments 305A, 305B of the eluate tubing line. It should be noted that a pump is combined with reservoir 1350, for example, similar to syringe pump 33, such that, when a divergence valve 1335IO is set to allow fluid communication between reservoir 1350 and tubing line segment 305A, the associated pump may be operated to draw in a volume of eluate, and, then, when divergence 25 valve 1335IO is set to allow fluid communication between reservoir 1350 and tubing line segment 305B, the pump may be operated to push the volume of eluate out through tubing line segment 305B for a patient injection, when divergence valve 35WP is set to direct flow into patient line 305p. With reference back to Figures 3A-B, sidewall 205 of shielding assembly 200 may be enlarged to further enclose eluate 30 reservoir 1350. For example, another shielded well, to house the eluate reservoir, may extend alongside well 255, in which activity detector 25 is described as being mounted. Furthermore, sidewall 205 may include another valve actuator receptacle for

divergence valve 1335IO, similar to receptacle 253, shown in Figure 3A for divergence valve 35WP.

Collection of discrete volumes of eluate, in reservoir 1350, may help to achieve a more uniform activity level over each injection, for example, like that of profile  
5 1200B in Figure 12C, and, according to preferred methods, feedback from activity detector 25 may be used to control the pump associated with reservoir 1350, in order to vary injection flow rate and, thereby, maintain a relatively consistent activity level across multiple injections, and, when necessary, to vary injection flow rate over an individual injection to maintain the uniform activity level. Feedback from the  
10 pressure transducer 1334, that is downstream from detector 25, and/or from a flow meter (not shown) of circuit 1300B may also be used to control the varying of injection flow rate.

With further reference to Figures 12A-B, it should be noted that alternative circuits may be configured to employ a combination of the methods described for  
15 circuits 1300A and 1300B. Furthermore, some infusion circuits of the present invention may employ multiple generators 21, as mentioned above, in conjunction with Figure 2A, to help maintain the relatively uniform level of activity over each injection and the relatively consistent level of activity from injection to injection.

In the foregoing detailed description, the invention has been described with  
20 reference to specific embodiments. However, it may be appreciated that various modifications and changes can be made without departing from the scope of the invention as set forth in the appended claims.

25

We claim:

1. A shielding assembly for an infusion system, the shielding assembly being mounted within a cabinet structure, and the shielding assembly comprising:  
a first compartment sized to contain one or more radioisotope generators of the  
5 infusion system, the first compartment being enclosed by a first sidewall that forms a barrier to radioactive radiation, the first sidewall including an opening extending therethrough and a lid, the lid mating with the opening to alternately enclose the first compartment and provide access to the first compartment, via the opening, and the opening being oriented upward and located at a first elevation<sub>1</sub> with respect to a  
10 lowermost portion of the cabinet structure;  
a second compartment sized to contain a portion of an infusion tubing circuit of the infusion system that is downstream of the one or more generators, the second compartment being enclosed by a second sidewall that forms a barrier to radioactive radiation, the second sidewall including a base portion and a lid portion, the lid portion  
15 mating with the base portion to alternately enclose the second compartment and provide access to the second compartment; and  
a third compartment sized to contain a waste bottle of the infusion system, the third compartment being enclosed by a third sidewall that forms a barrier to radioactive radiation, the third sidewall including an opening, extending through the third  
20 sidewall, and a lid, the lid of the third sidewall mating with the opening of the third sidewall to alternately enclose the third compartment and provide access to the third compartment, via the opening of the third sidewall, the opening of the third sidewall being oriented upward and located at a second elevation, with respect to the lowermost portion of the cabinet structure, and the second elevation being greater than the first  
25 elevation of the opening of the first sidewall.
2. The shielding assembly of claim 1, wherein the opening of the first sidewall is aligned with a first upper opening through a shell of the cabinet structure and the opening of the third sidewall is aligned with a second upper opening through the shell  
30 of the cabinet structure, the second upper opening being located at a greater elevation<sub>2</sub> with respect to the lowermost portion of the cabinet structure<sub>2</sub> than the first upper opening.

3. The shielding assembly of claim 1, wherein an opening through a shell of the cabinet structure provides access to both the lid of the first sidewall and to the lid portion of the second sidewall.
- 5 4. The shielding assembly of claim 1, wherein the lowermost portion of the cabinet structure is at approximately ground level and the first elevation is between approximately 12 inches and approximately 24 inches.
- 10 5. The shielding assembly of claim 1, wherein the lowermost portion of the cabinet structure is at approximately ground level and the second elevation is between approximately 24 inches and approximately 36 inches.
- 15 6. The shielding assembly of claim 1, further comprising:  
a fourth compartment sized to contain another portion of the infusion tubing circuit of the infusion system downstream from the one or more generators, the fourth compartment being enclosed by a portion of the third sidewall and a door that forms a barrier to radioactive radiation, the door mating with the portion of the third sidewall to alternately enclose the fourth compartment and provide access to the fourth compartment; and  
20 wherein the fourth compartment is immediately adjacent to the second compartment; the portion of the infusion tubing circuit contained in the second compartment includes an eluate line, extending from the one or more generators, a patient line, being coupled to the eluate line, and a waste line, being coupled to the eluate line; and  
the other portion of the infusion tubing circuit contained in the fourth compartment  
25 includes an extension of the patient line, from the second compartment, and an extension of the waste line, from the second compartment.
- 30 7. The shielding assembly of claim 6, wherein the fourth compartment extends approximately vertically along the portion of the third sidewall, on an opposite side of the third sidewall from the third compartment.

8. The shielding assembly of claim 7, wherein the fourth compartment includes a retaining member to hold the extension of the patient line and the extension of the waste line in place within the fourth compartment.
- 5 9. The shielding assembly of claim 6, wherein the lid of the third sidewall, when mated with opening of the third sidewall, prevents the door of the fourth compartment from opening to provide access to the fourth compartment.
- 10 10. The shielding assembly of claim 9, wherein the door of the fourth compartment, when mated with the portion of the third sidewall, prevents the lid portion of the second sidewall from opening to provide access to the second compartment.
- 15 11. The shielding assembly of claim 10, wherein the lid portion of the second sidewall, when mated with the base portion of the second sidewall, prevents the lid of the first sidewall from opening to provide access to the first compartment.
- 20 12. The shielding assembly of claim 6, wherein the door of the fourth compartment, when mated with the portion of the third sidewall, prevents the lid portion of the second sidewall from opening to provide access to the second compartment.
- 25 13. The shielding assembly of any of claims 1-5, wherein the lid portion of the second sidewall, when mated with the base portion of the second sidewall, prevents the lid of the first sidewall from opening to provide access to the first compartment.
- 30 14. The shielding assembly of any of claims 1-5, wherein the lid of the first sidewall is hinged to open in an upward direction; and further comprising a latch component, mounted within the cabinet structure, to hold the lid of the first sidewall in an open position.
15. The shielding assembly of any of claims 1-5, wherein the lid portion of the second sidewall is hinged to open in an upward direction; and further comprising a latch component, mounted within the cabinet structure, to hold the lid portion of the second sidewall in an open position.

16. A method for setting up an infusion system, the method comprising:  
opening a first door of a shielding assembly of the infusion system to access a first compartment of the assembly and to allow for a second door of the shielding assembly to be opened; and  
5 opening the second door, after opening the first door, to access a second compartment of the shielding assembly, the second compartment being separate from, and outside of, the first compartment;  
placing a radioisotope generator into the second compartment and connecting the generator to an infusion tubing circuit;  
10 placing a portion of the infusion tubing circuit into the first compartment;  
closing the second door to enclose the generator within the second compartment; and  
closing the first door, after closing the second door, to enclose the portion of the infusion tubing circuit within the first compartment.
- 15 17. The method of claim 16, further comprising unlocking and removing an access panel from a shell of a cabinet structure, which encloses the shielding assembly, to access the first door and the second door of the shielding assembly.
18. The method of claim 16, further comprising:  
20 opening a third door, prior to opening the first door, to access a third compartment of the shielding assembly and to allow for the first door to be opened;  
placing another portion of the infusion tubing circuit into the third compartment; and  
closing the third door, after closing the first door, to enclose the other portion of the infusion tubing circuit within the third compartment.
- 25 19. The method of claim 18, further comprising unlocking and removing an access panel from a shell of a cabinet structure, which encloses the shielding assembly, to access the first door, the second door and the third door of the shielding assembly.

20. The method of claim 18, further comprising:  
opening a fourth door, prior to opening the third door, to access a fourth compartment  
of the shielding assembly and to allow for the third door to be opened;  
connecting a waste line of the infusion tubing circuit to a waste bottle;  
5 placing the waste bottle into the fourth compartment; and  
closing the fourth door, after closing the third door, to enclose the waste bottle within  
the fourth compartment.
21. The method of any of claims 16-20, further comprising securing at least one of the  
10 first and second doors in an open position.
22. A shielding assembly for an infusion system, the shielding assembly comprising a  
plurality of compartments and providing a radioactive radiation barrier for the  
compartments, the assembly further comprising:  
15 a first door to alternately enclose and provide access to a first compartment of the  
plurality of compartments, the first compartment sized to contain one or more  
radioisotope generators of the infusion system; and  
a second door to alternately enclose and provide access to a second compartment of  
the plurality of compartments, the second compartment being separate from, and  
20 outside of, the first compartment, the second compartment being sized to contain a  
portion of an infusion tubing circuit of the infusion system that is downstream of the  
one or more generators, and the second door, when enclosing the second compartment,  
preventing the first door from opening to provide access to the first compartment.
- 25 23. The shielding assembly of claim 22, further comprising a third door to alternately  
enclose and provide access to a third compartment of the plurality of compartments,  
the third compartment sized to contain another portion of the infusion tubing circuit of  
the infusion system downstream from the one or more generators, the third door, when  
enclosing the third compartment, preventing the second door from opening to provide  
30 access to the second compartment.
24. The shielding assembly of claim 23, further comprising a fourth door to alternately  
enclose and provide access to a fourth compartment of the plurality of compartments,



the fourth compartment being sized to contain a waste bottle of the infusion system, the fourth door, when enclosing the fourth compartment, preventing the third door from opening to provide access to the third compartment.

- 5 25. The shielding assembly of claim 24, wherein the third compartment shares a sidewall with the fourth compartment and extends approximately vertically along the shared sidewall.
- 10 26. The shielding assembly of claim 25, wherein the third compartment includes a retaining member attached to the shared sidewall to hold the other portion of the infusion tubing circuit in place along the shared sidewall.
- 15 27. An infusion system comprising:  
a cabinet structure including a shell defining an interior space thereof, the shell including a first opening, a second opening and an access panel, the access panel mating with the second opening and being removable therefrom;  
a lock reversibly engaging the access panel to secure access to the interior space of the cabinet structure;  
an eluant source;
- 20 a shielding assembly located within the interior space of the cabinet structure, the shielding assembly including a sidewall defining a plurality of compartments and providing a barrier to radioactive radiation for the compartments, the shielding assembly further including a corresponding plurality of doors, each door, when open, providing access to the corresponding compartment via an opening in the sidewall,
- 25 and, when closed, providing further barrier to radioactive radiation for the corresponding compartment;
- one or more radioisotope generators contained within a first compartment of the plurality of compartments of the shielding assembly and being accessible through the second opening of the shell of the cabinet structure, when the access panel is unlocked,
- 30 and when a first door of the plurality of doors, which corresponds to the first compartment, is open;
- an eluant line coupled to the eluant source and to the one or more generators;
- an eluate line coupled to the one or more generators; and

a patient line coupled to the eluate line and extending out from the interior space of the cabinet structure through the first opening of the shell.

28. The assembly of claim 27, wherein the first door is hinged to open in an upward  
5 direction; and further comprising a latch component, mounted within the cabinet structure, to hold the first door in an open position.

29. The system of claim 27, further comprising:  
a waste bottle contained within a second compartment of the plurality of compartments  
10 of the shielding assembly; and  
a waste line coupled to the eluate line and to the waste bottle;  
wherein the shell of the cabinet structure further includes a third opening; and  
a second door of the plurality of doors, which corresponds to the second compartment,  
is aligned with the third opening of the shell, for access thereto, and is located at a  
15 higher elevation, with respect to a lowermost surface of the cabinet structure, than that of the second door.

30. The system of claim 27, further comprising:  
a waste bottle contained within a second compartment of the plurality of compartments  
20 of the shielding assembly; and  
a waste line coupled to the eluate line and to the waste bottle;  
wherein a second door of the plurality of doors, which corresponds to the second compartment, when closed, prevents the first door from opening to provide access to the first compartment.

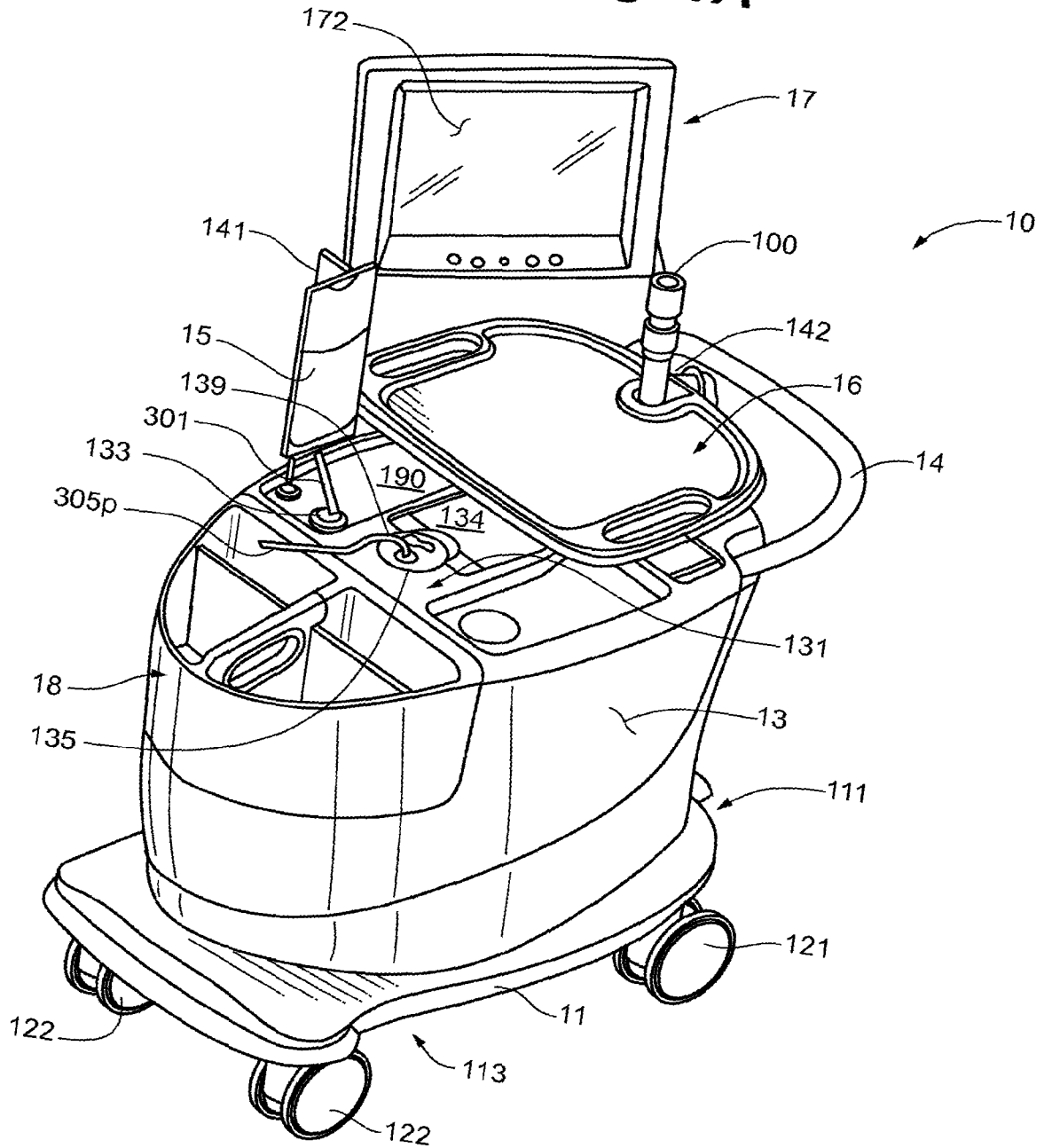
25

31. The system of claim 27, wherein:  
the eluate line and at least a portion of the patient line are contained in a second  
compartment of the plurality of compartments of the shielding assembly; and  
a second door of the plurality of doors, which corresponds to the second compartment,  
30 when closed, prevents the first door from opening to provide access to the first compartment.

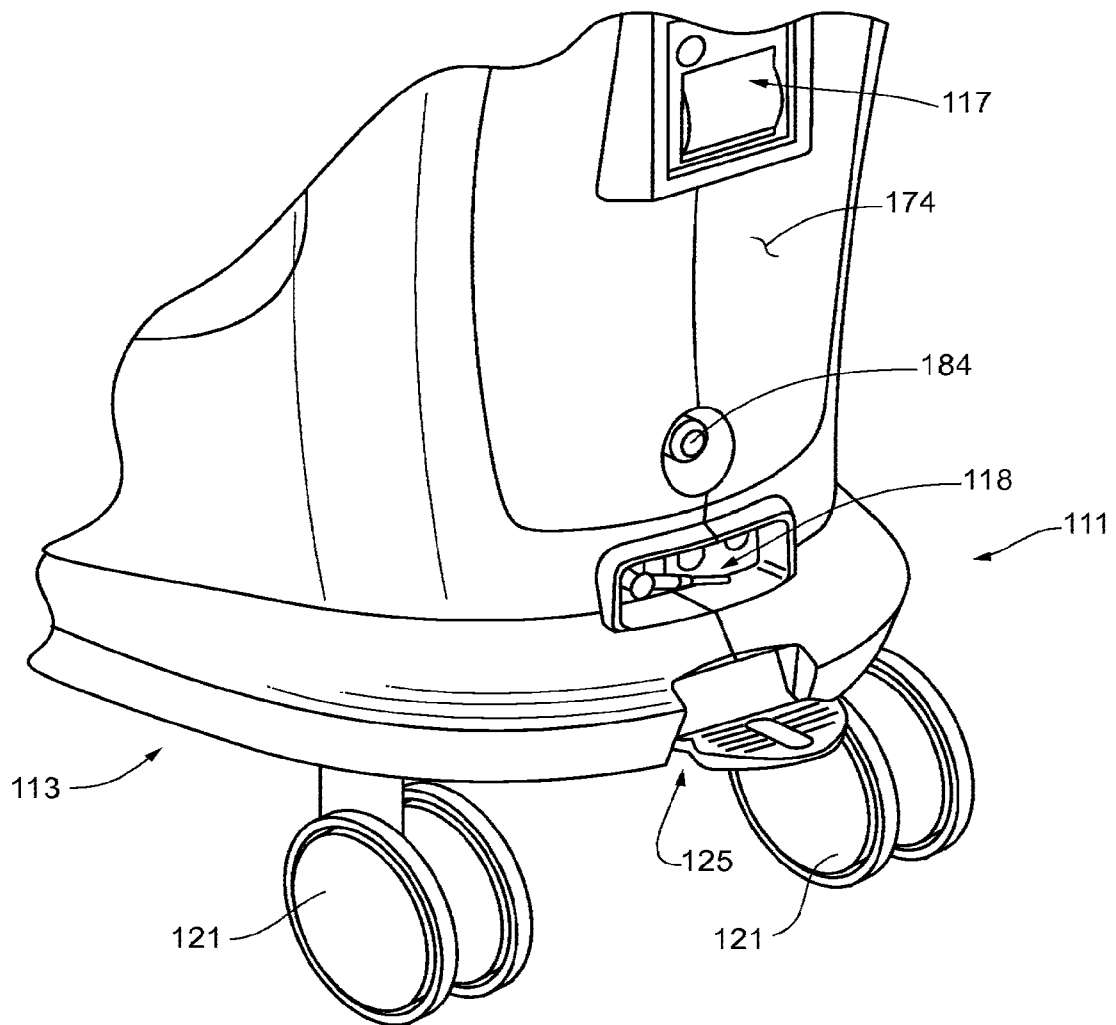
32. The system of claim 31, wherein the second door is accessible only through the second opening of the shell of the cabinet structure, when the access panel is unlocked.
33. The system of claim 31, wherein the first door and the second door are both hinged to open in an upward direction; and further comprising at least one latch component, mounted within the cabinet structure, to hold the first door and the second door in an open position.
34. A shielding assembly for an infusion system, the shielding assembly being mounted within a cabinet structure, and the shielding assembly comprising:  
a plurality of compartments having sidewalls providing barriers to radioactive radiation for the compartments;  
a corresponding plurality of doors, each door, when open, providing access to the corresponding compartment via an opening in its sidewall, and, when closed, providing further barrier to radioactive radiation for the corresponding compartment;  
a first compartment of the plurality of compartments enclosed by a first sidewall of the sidewalls and sized to contain one or more radioisotope generators of the infusion system, the first sidewall including a first sidewall opening oriented upward and aligned with a first upper opening through a shell of the cabinet structure;  
wherein an upper surface of the shell is located at an elevation, with respect to a lowermost portion of the cabinet structure, such that the elevation of the upper surface is substantially greater than that of the first sidewall opening and the first upper opening.
35. The shielding assembly of claim 34, wherein the lowermost portion of the cabinet structure is at approximately ground level, the first sidewall opening is at an elevation of between approximately 12 inches and approximately 24 inches with respect to the lowermost portion of the cabinet.
36. The shielding assembly of claim 35, wherein the elevation of the upper surface of the shell is between approximately 24 inches and 36 inches, with respect to the lowermost portion of the cabinet structure.

37. The shielding assembly of claim 1, further comprising a second compartment of the plurality of compartments enclosed by a second sidewall of the sidewalls and sized to contain a waste bottle of the infusion system, the second sidewall including a second sidewall opening oriented upward and aligned with a second upper opening through the shell of the cabinet structure, the second upper opening being an opening in the upper surface of the shell.

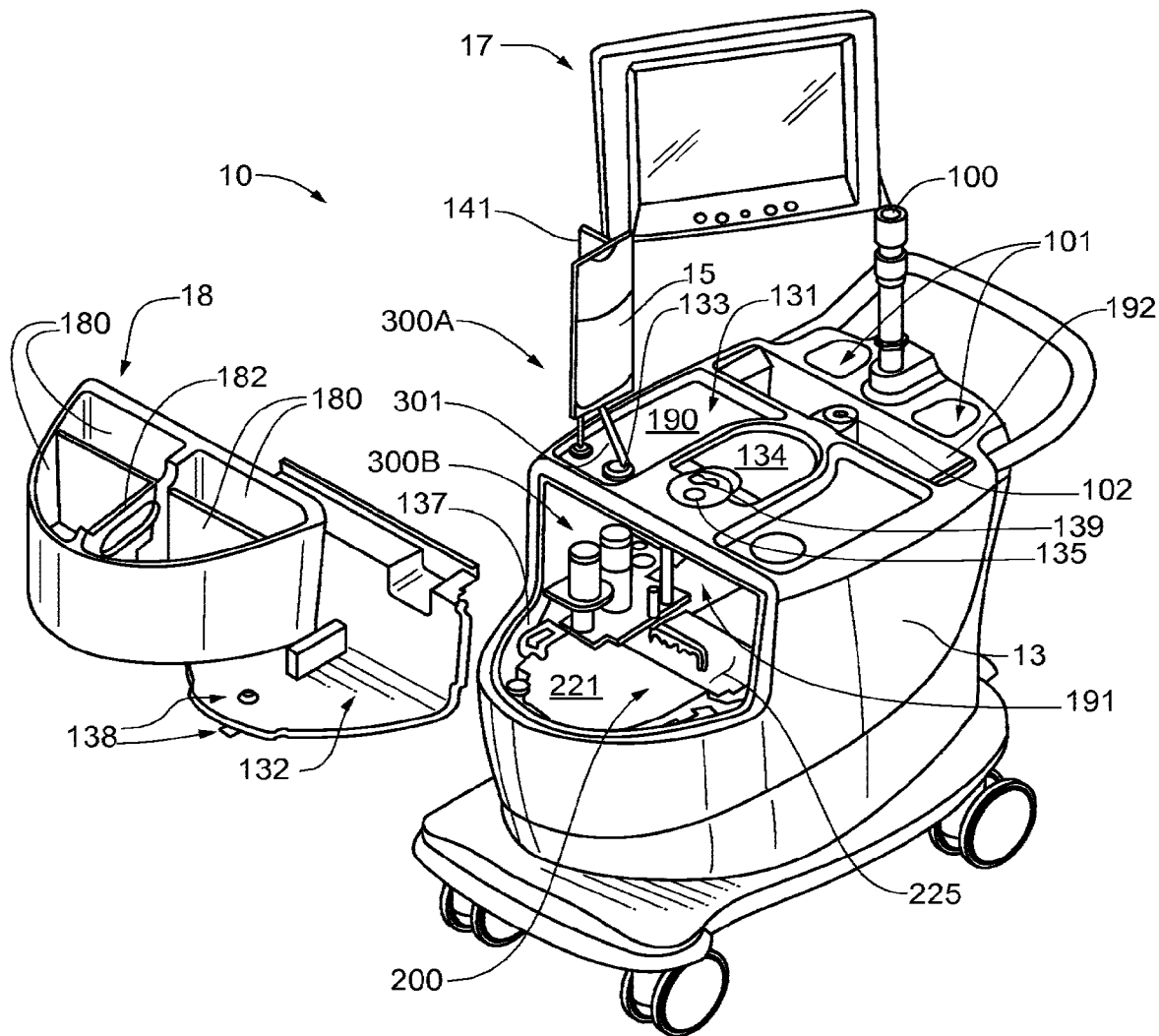
Fig. 1A



**Fig. 1B**



**Fig. 1C**

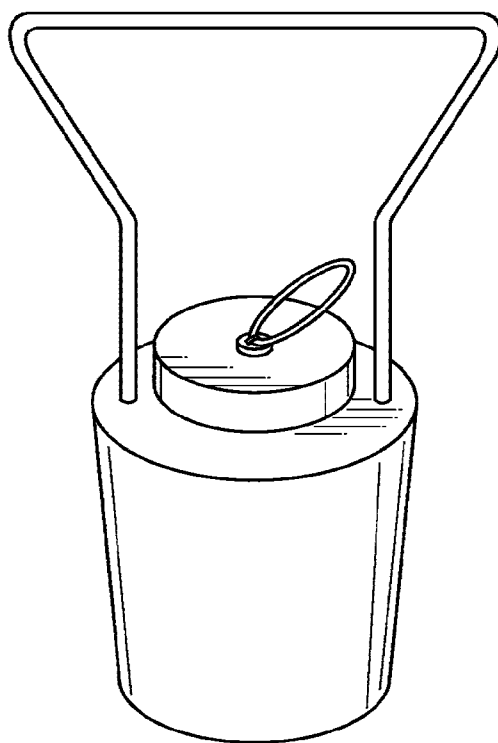






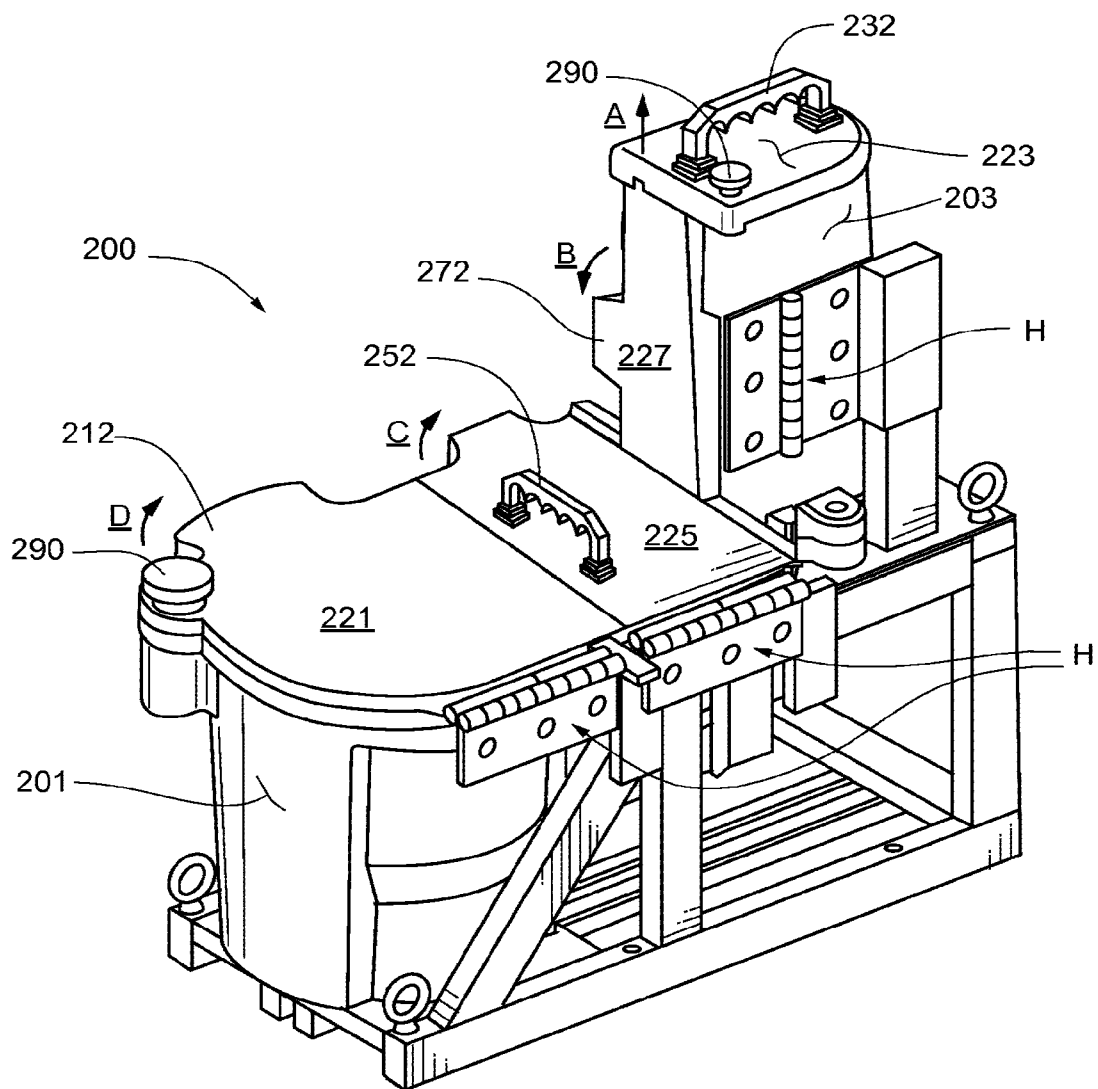
5/27

**Fig. 1E**



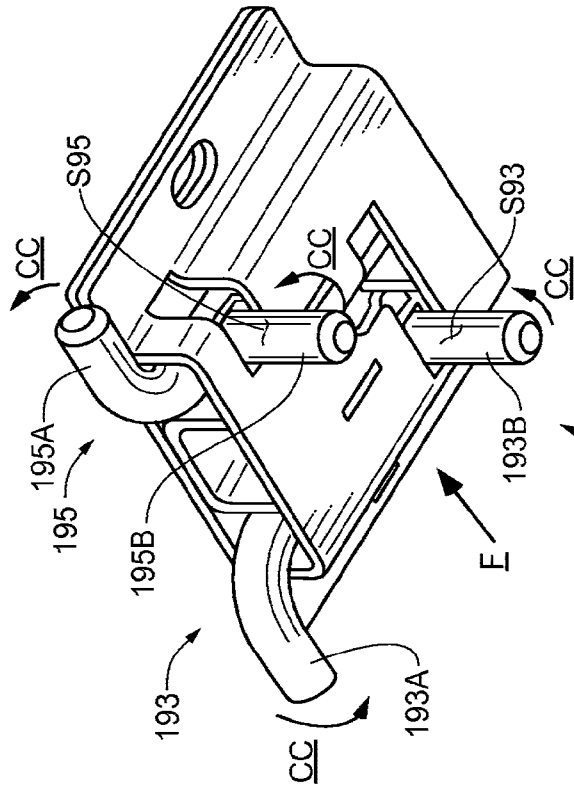
6/27

**Fig. 2A**

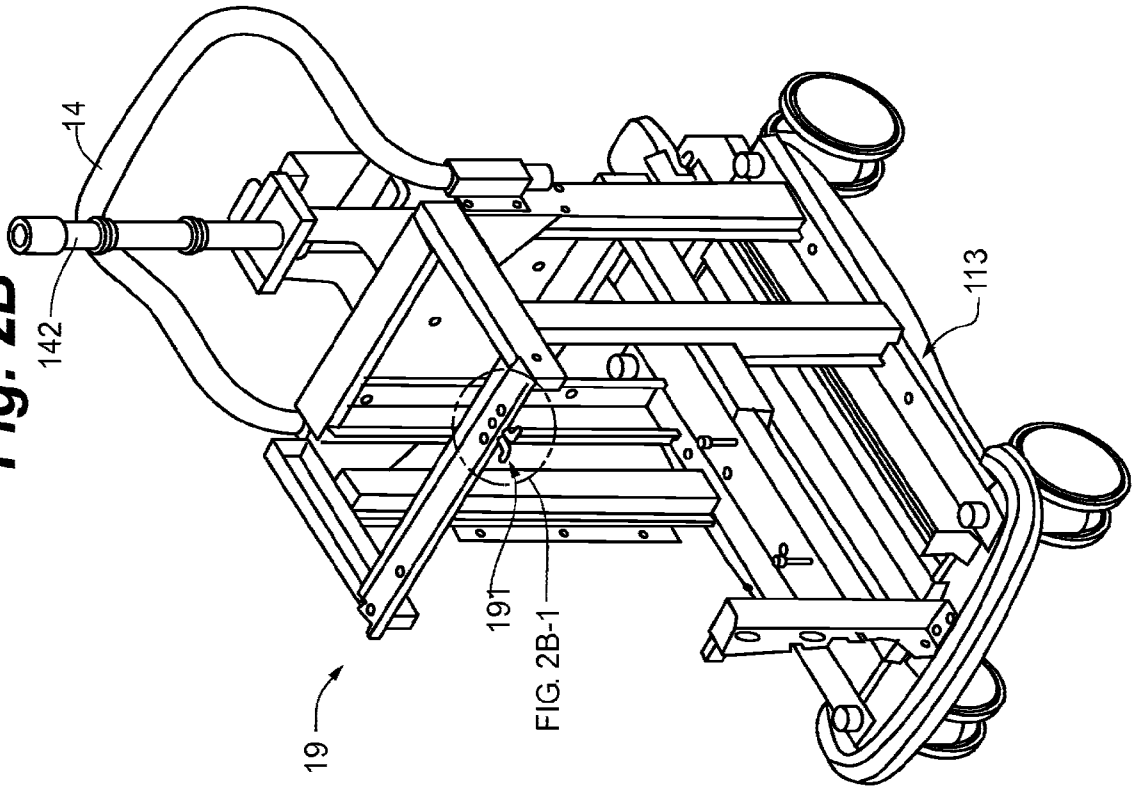


7/27

**Fig. 2B-1**

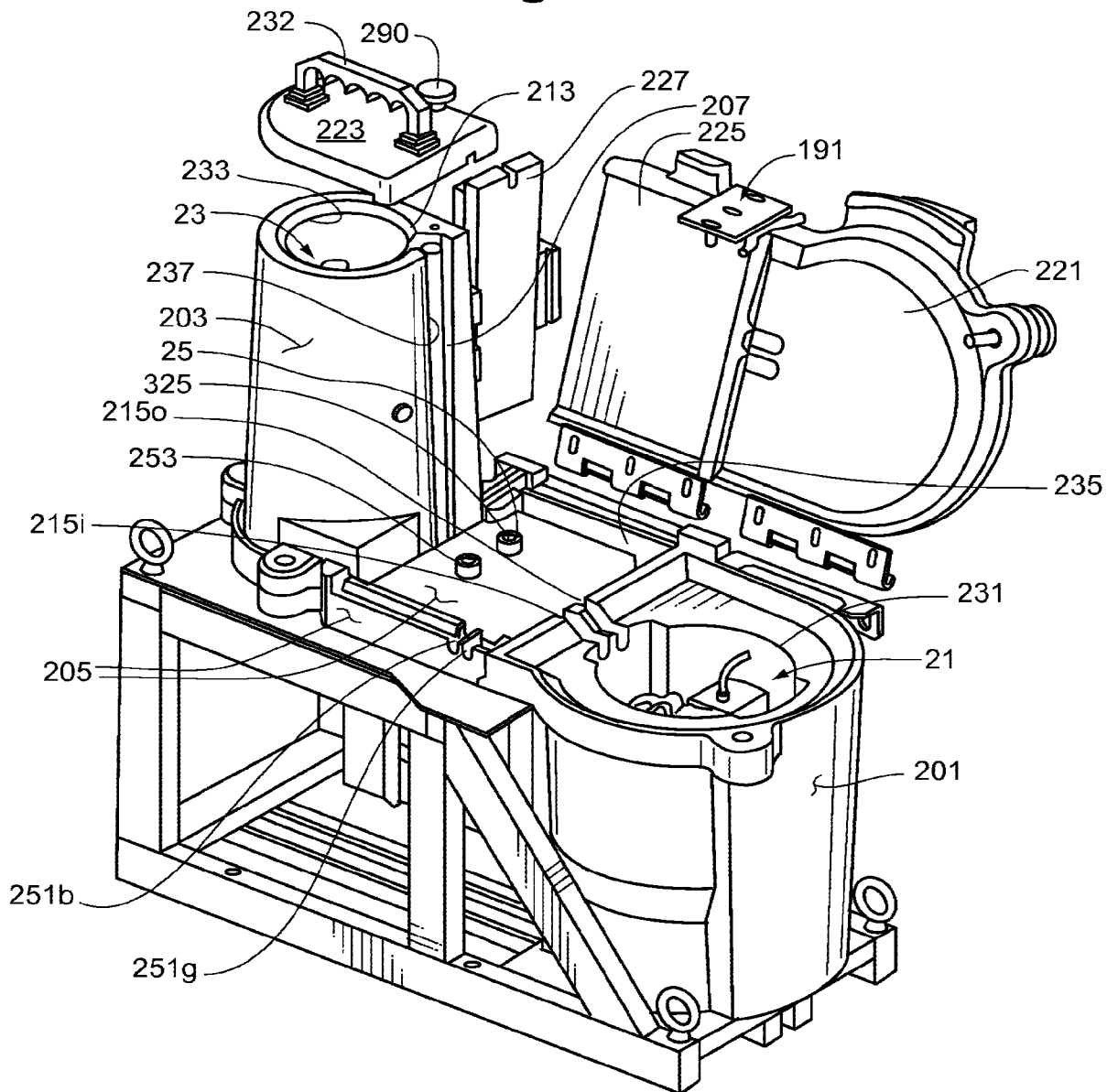


**Fig. 2B**



8/27

**Fig. 3A**



9/27

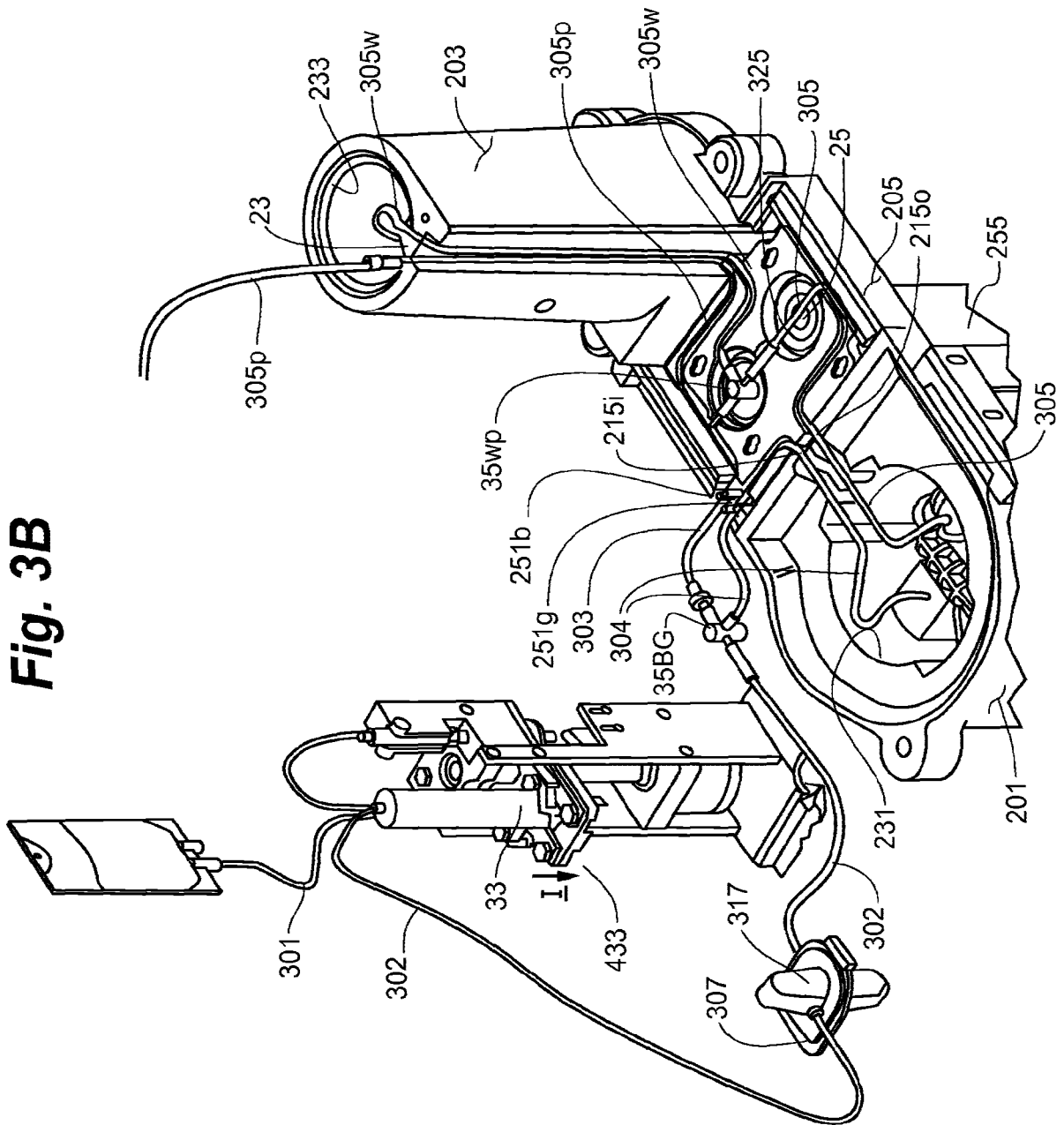


Fig. 3B



11/27

**Fig. 4**

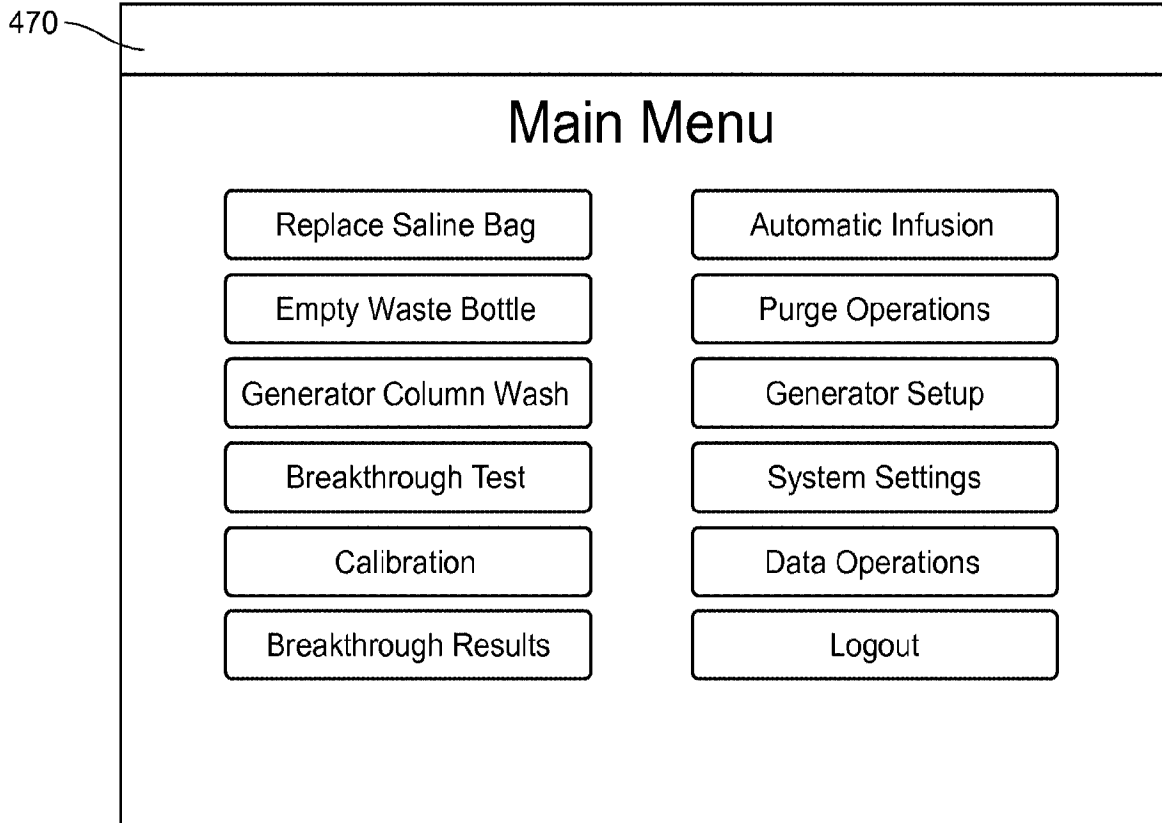
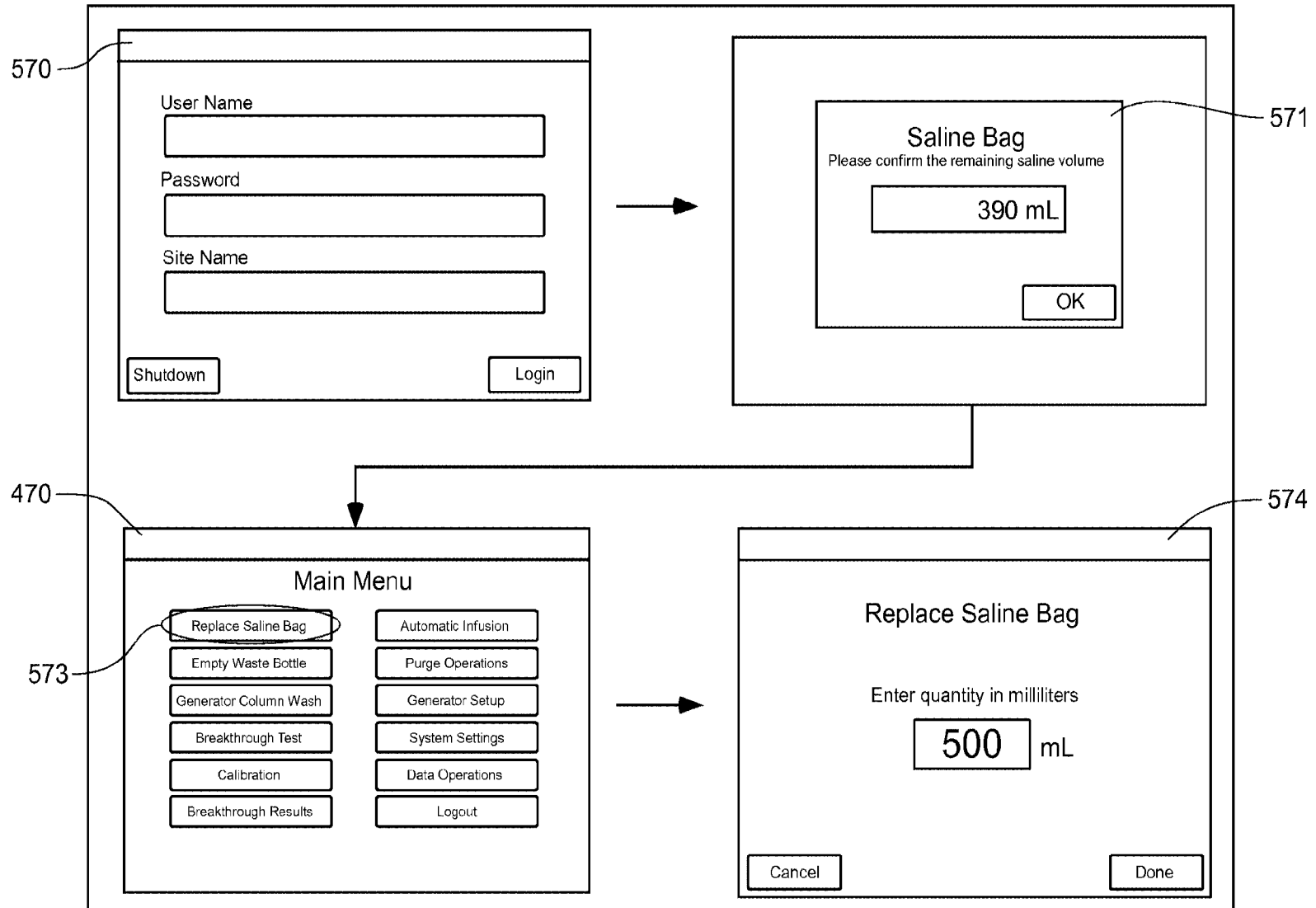


Fig. 5A





**Fig. 5B**

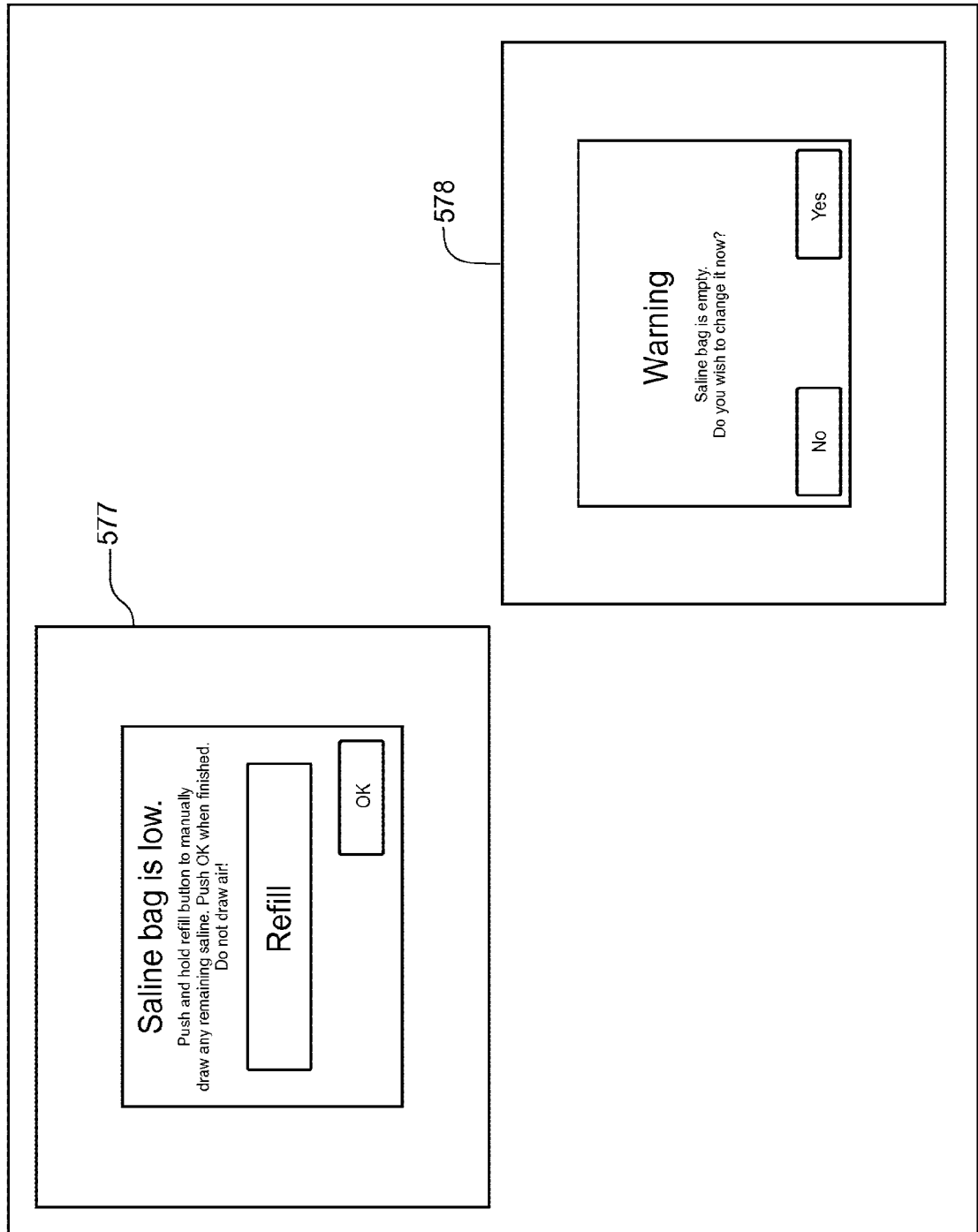
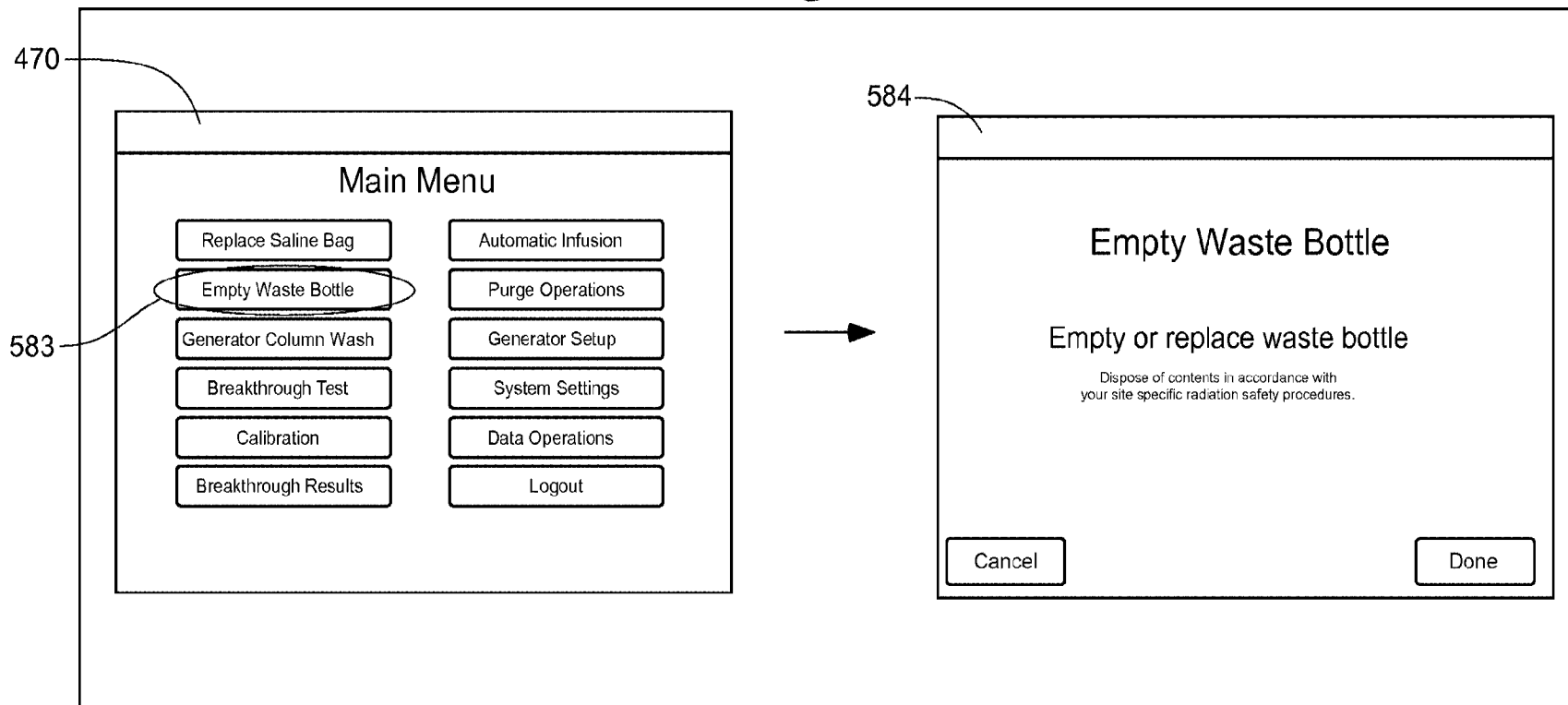


Fig. 5C



14/27

**Fig. 6**

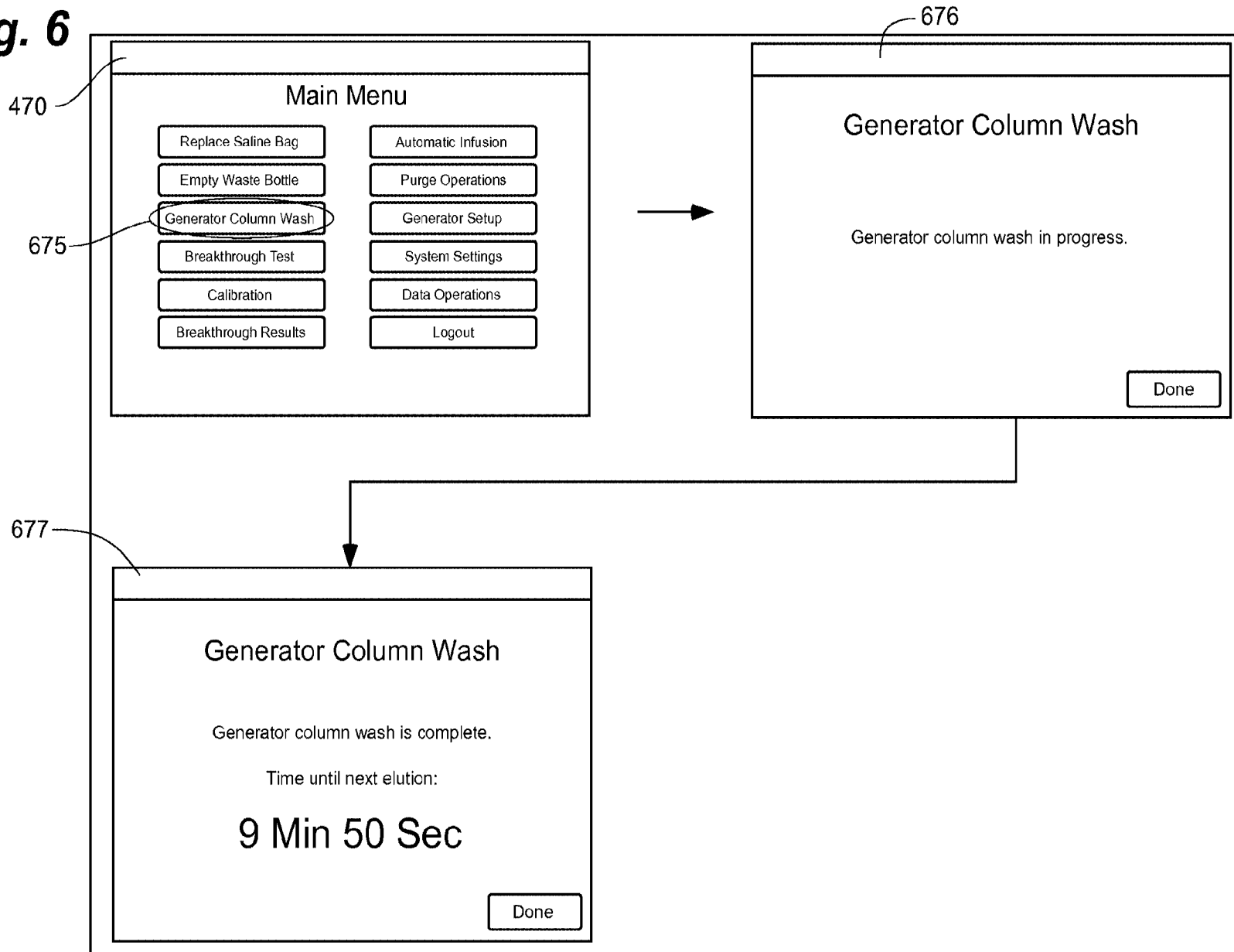


Fig. 7A

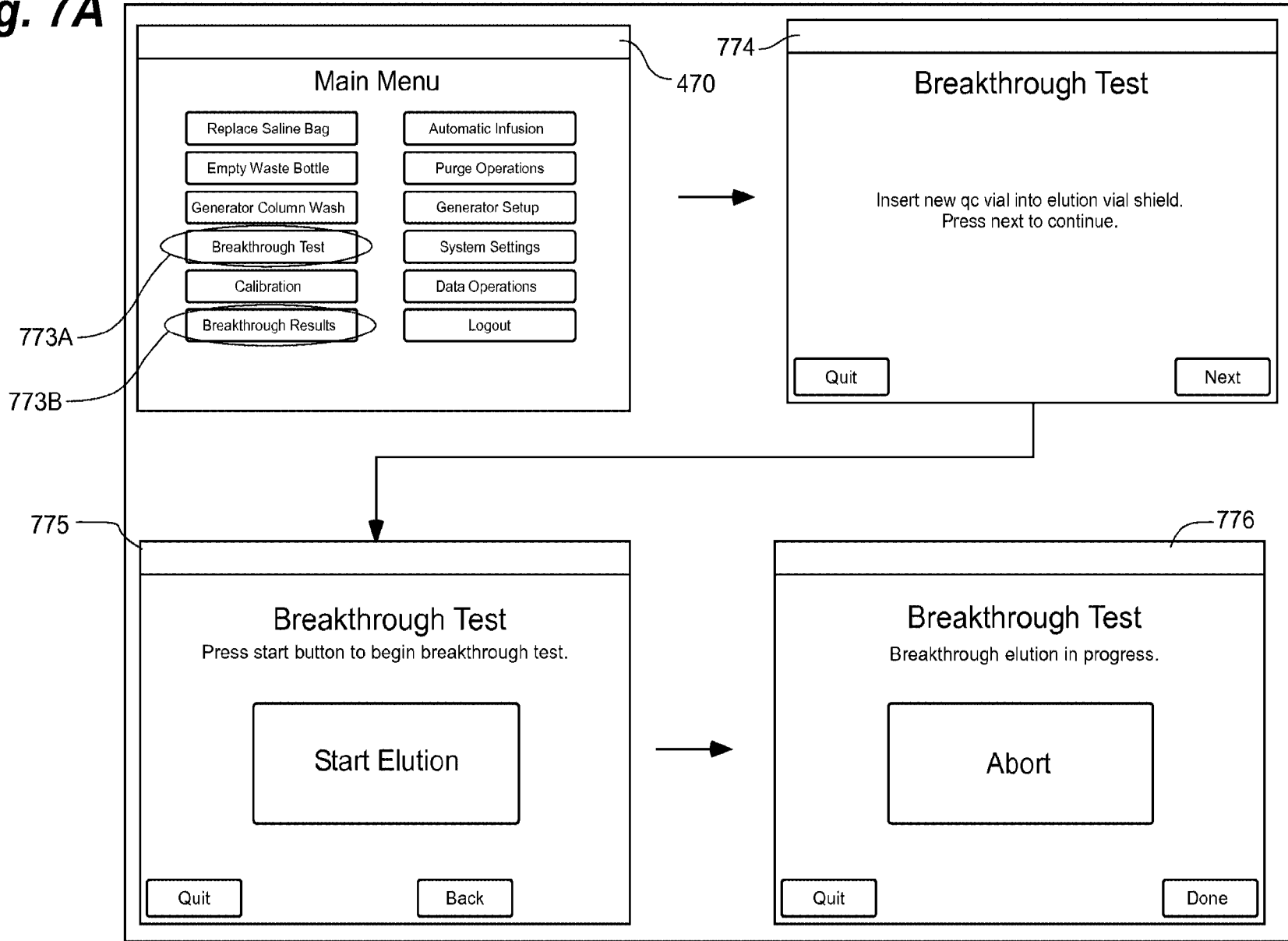


Fig. 7B

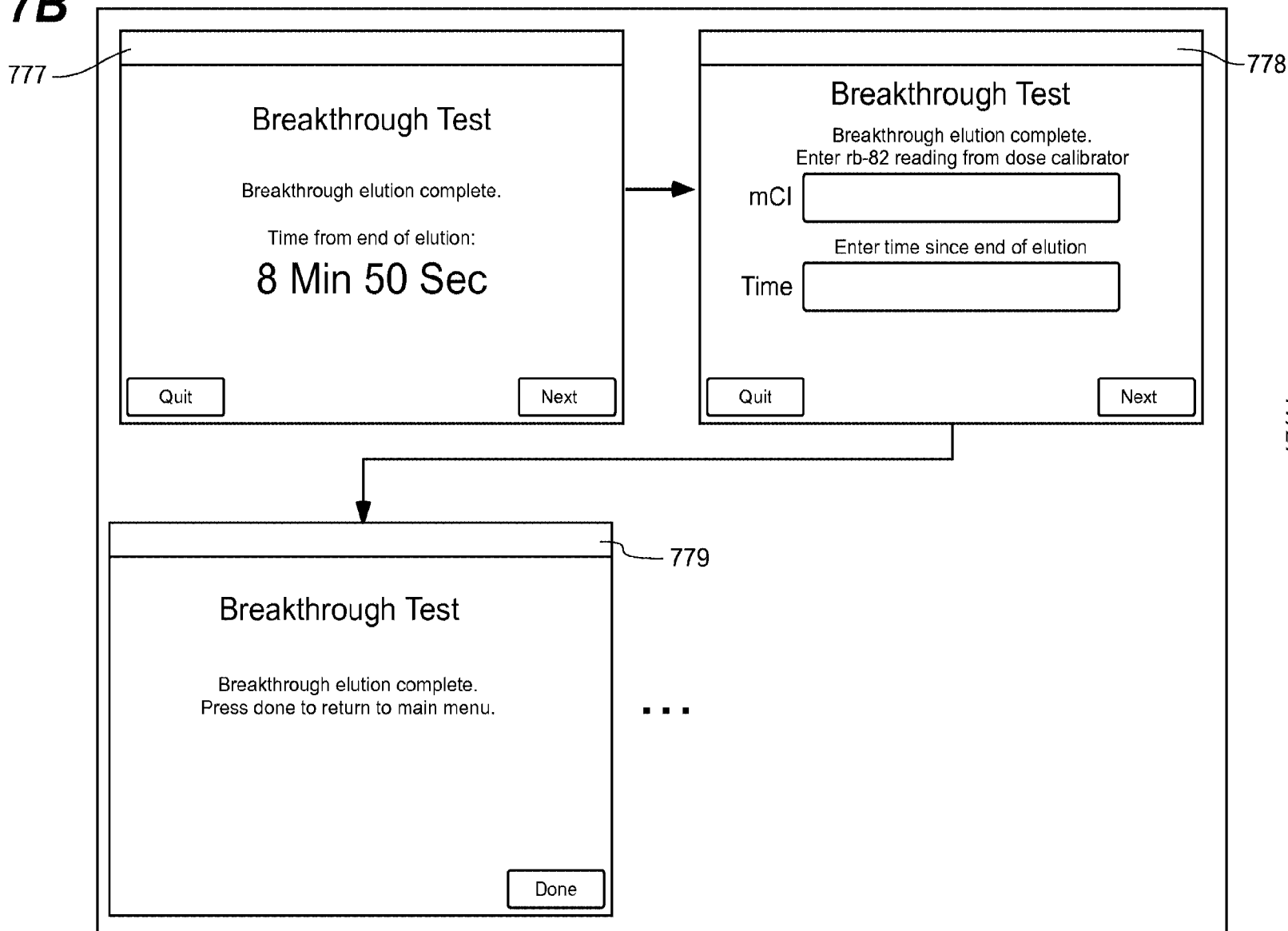
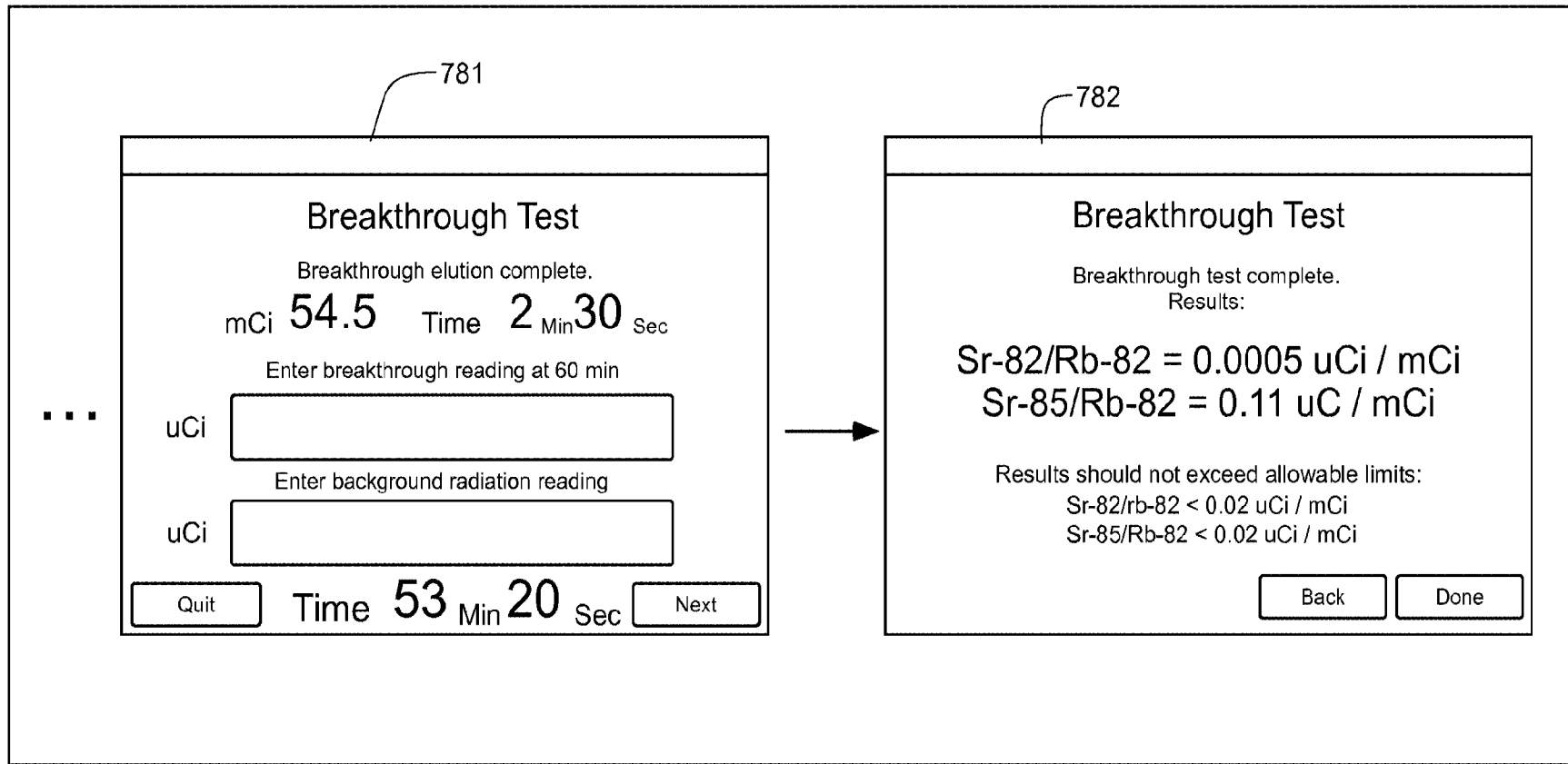


Fig. 7C



18/27

Fig. 8A

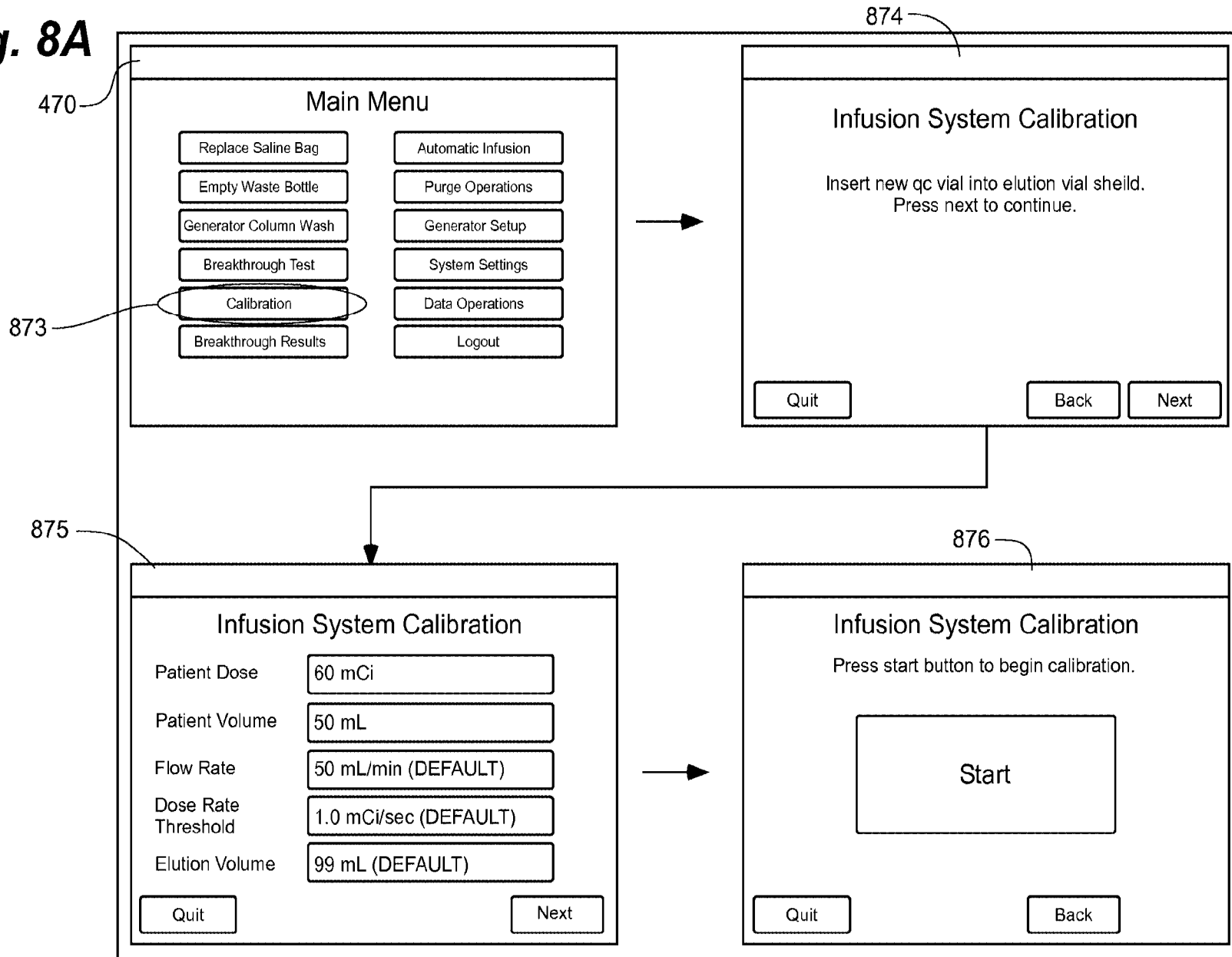
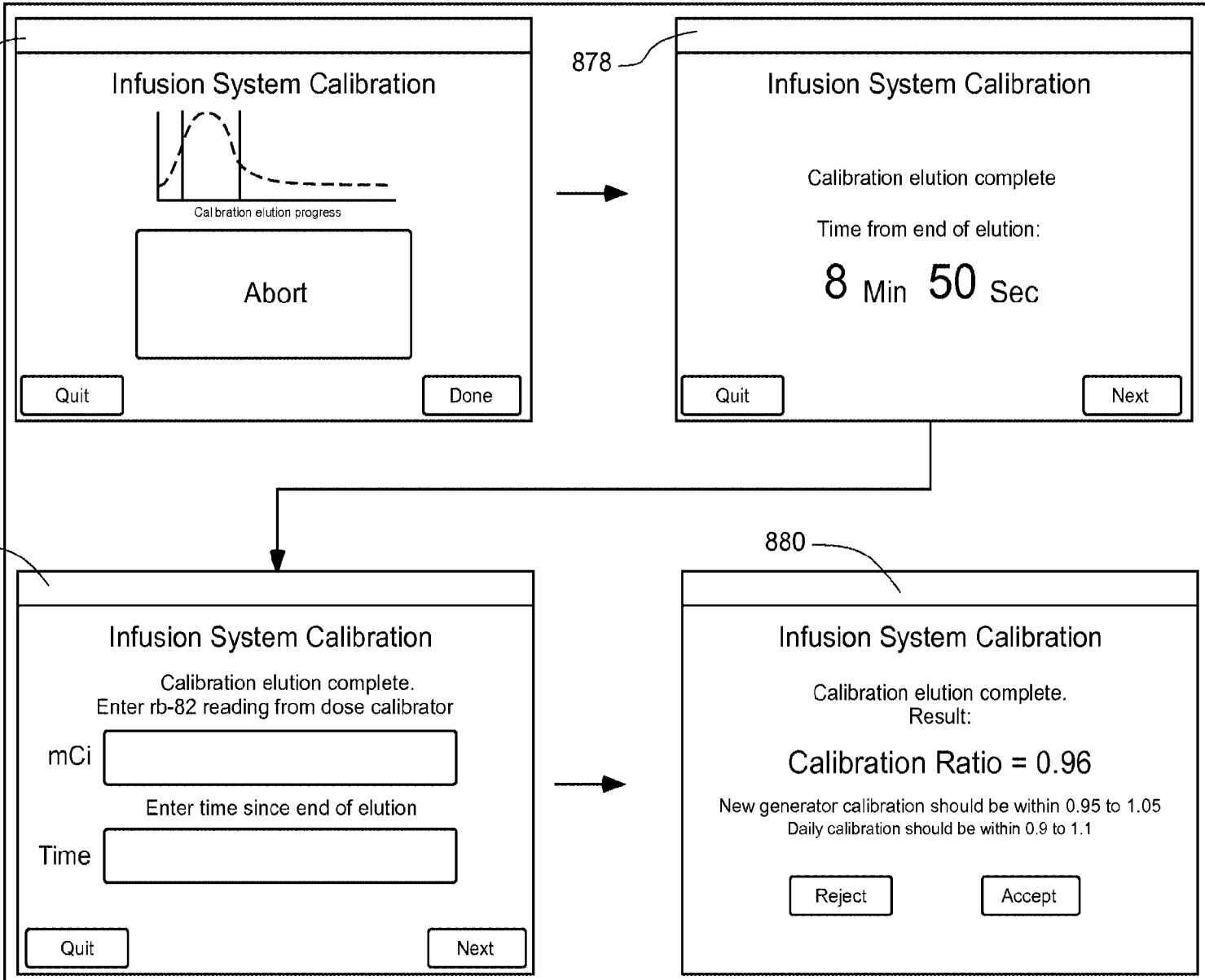


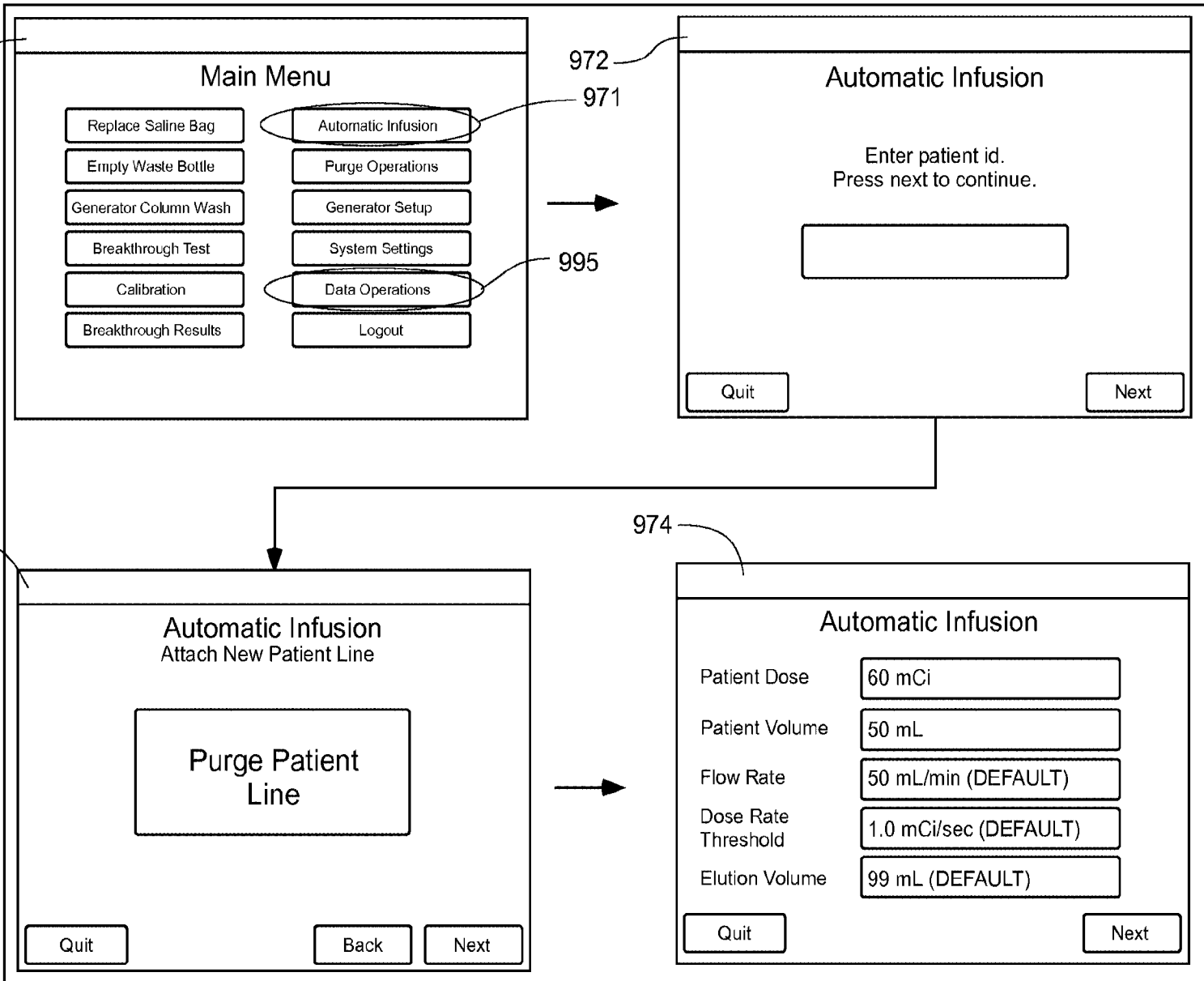
Fig. 8B





**Fig. 9A**

470



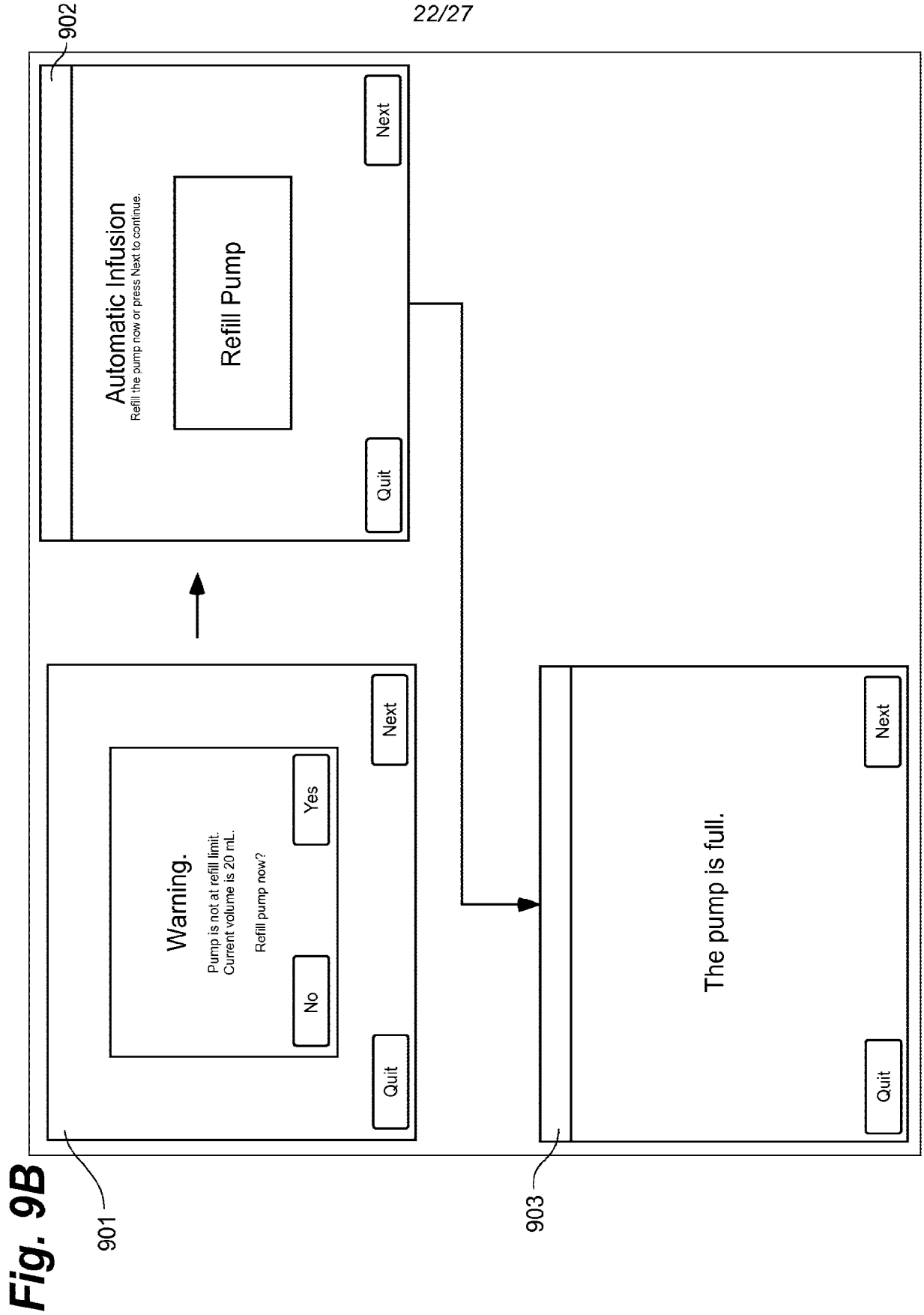
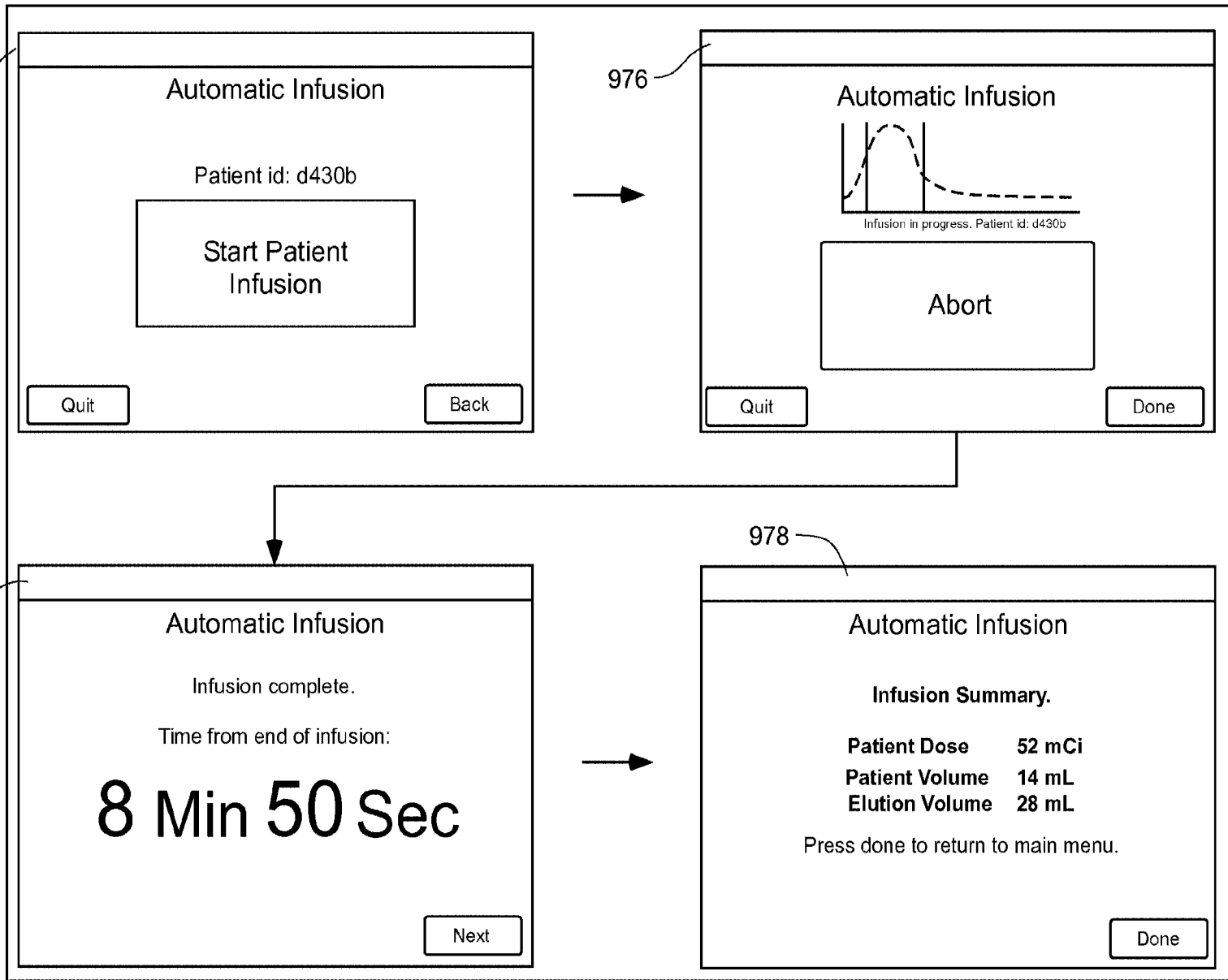
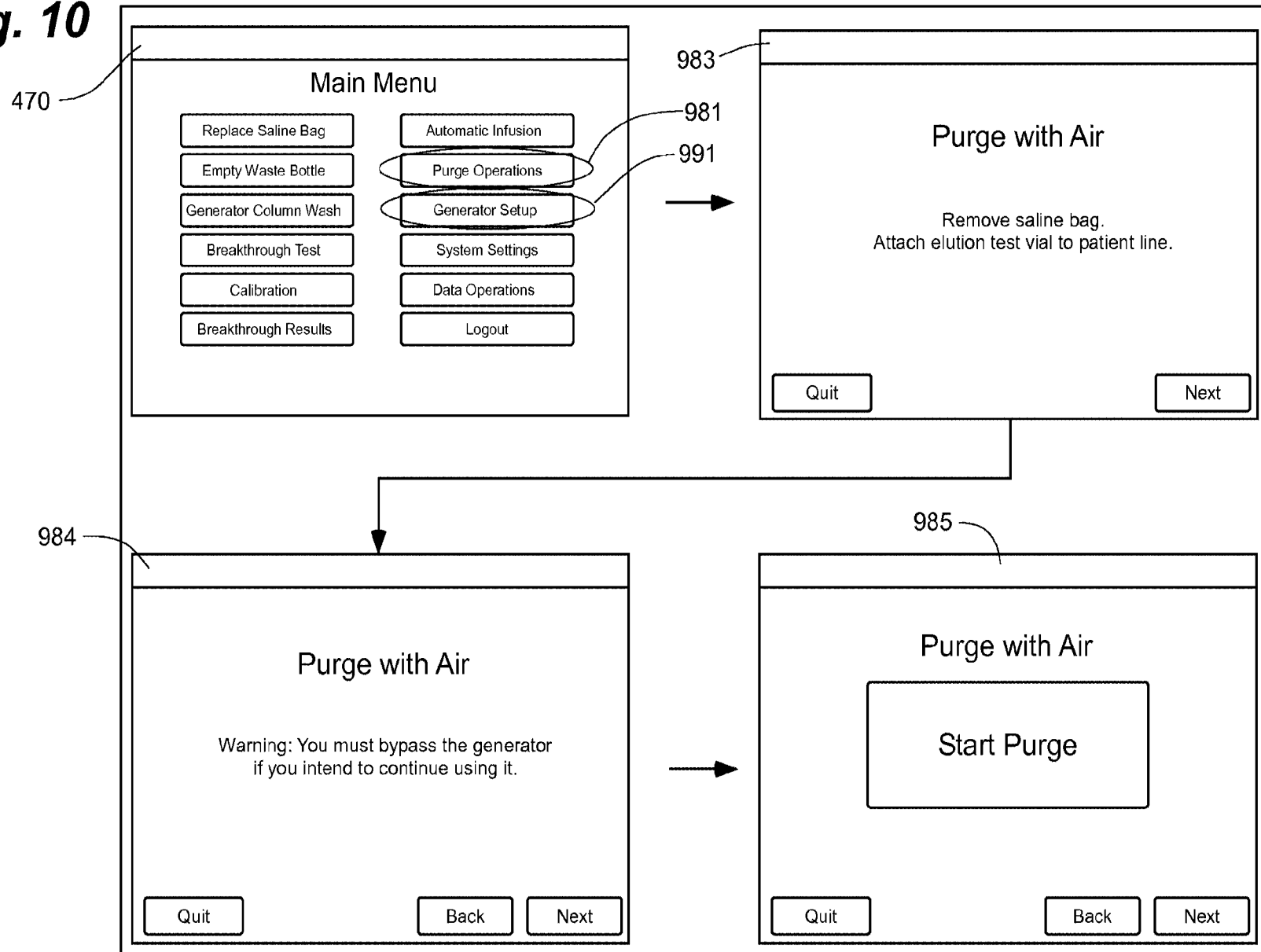


Fig. 9B

Fig. 9C



**Fig. 10**



**Fig. 11**

CARDIOGEN-82 GENERATOR MONTHLY RECEIPT/RETURN WORKSHEET

| GENERATOR RECEIPT    |            |     |
|----------------------|------------|-----|
| DATE OF DELIVERY:    | 11/9/2008  |     |
| DATE OF CALIBRATION: | 11/10/2008 |     |
| LOT NUMBER:          |            |     |
| Sr-82 ACTIVITY:      | 100        | mCi |
| TOTAL ACTIVITY:      | 256        | mCi |
| Sr-85 ACTIVITY:      | 156        | mCi |

| RECEIPT SURVEY |      |   |
|----------------|------|---|
| SURFACE:       | 10.0 | mrem/hr (MUST BE < 50 mrem/hr)                |
| 1 METER:       | 0.6  | mrem/hr (MUST BE < 1 mrem/hr)                 |
| SURFACE WIPE:  | 1599 | dpm (MUST BE < 2200 dpm/100 cm <sup>2</sup> ) |

| GENERATOR RETURN             |            |  |
|------------------------------|------------|--|
| DATE OF RETURN:              | 12/27/2008 |  |
| DAYS SINCE CALIBRATION DATE: | 47         |  |

| RETURN SURVEY |      |   |
|---------------|------|---|
| SURFACE:      | 5.6  | mrem/hr (MUST BE < 50 mrem/hr)                |
| 1 METER:      | 0.2  | mrem/hr (MUST BE < 1 mrem/hr)                 |
| SURFACE WIPE: | 1278 | dpm (MUST BE < 2200 dpm/100 cm <sup>2</sup> ) |

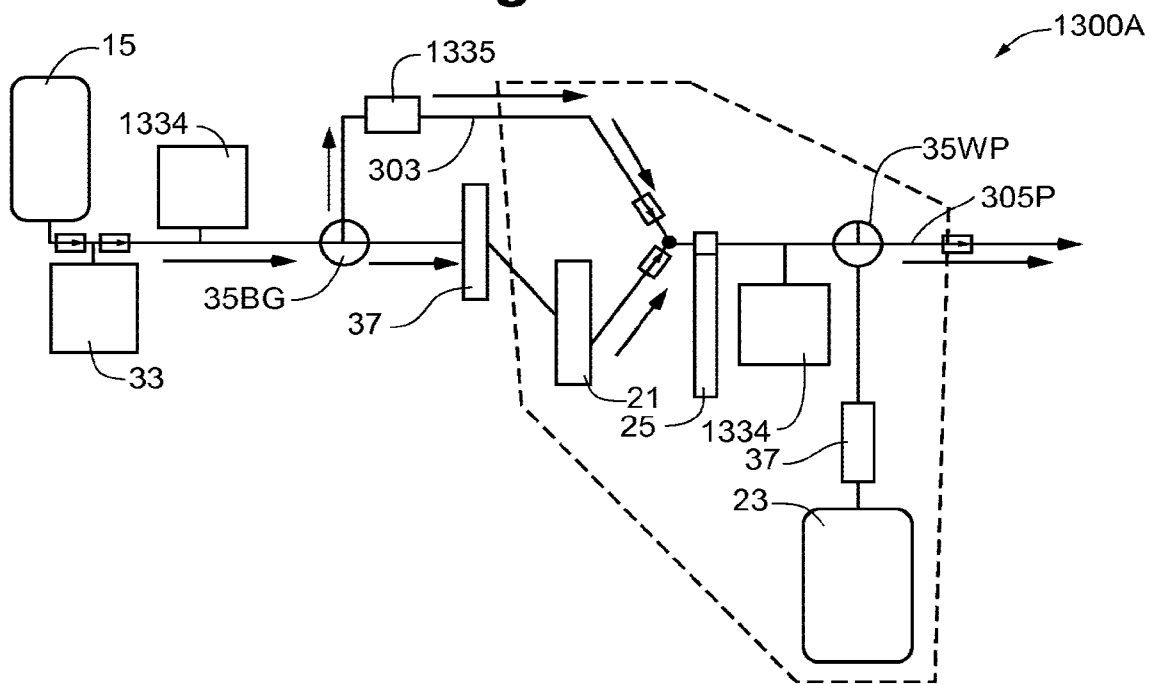
| Sr-82 RETURN CALCULATIONS |        |     |
|---------------------------|--------|-----|
| INITIAL Sr-82 ACTIVITY:   | 100    | mCi |
| DECAY FACTOR:             | 0.2718 |     |
| REMAINING Sr-82 IN mCi:   | 27.18  | mCi |
| REMAINING Sr-82 IN GBq    | 1.01   | GBq |

| SUMMARY                     |        |     |
|-----------------------------|--------|-----|
| TOTAL Sr-82/Sr-85 ACTIVITY: | 120.95 | mCi |
| TOTAL Sr-82/Sr-85 ACTIVITY: | 4.48   | GBq |
| TRANSPORT INDEX:            | 0.2    |     |

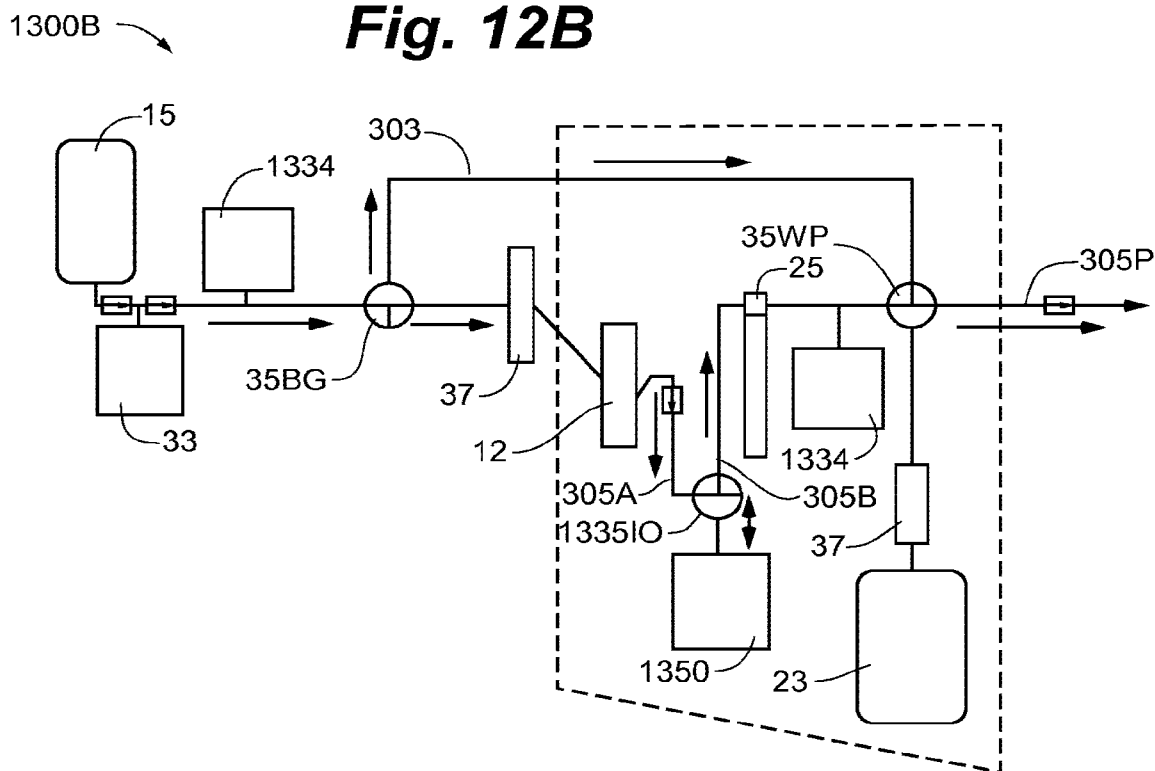
| Sr-85 RETURN CALCULATIONS |        |     |
|---------------------------|--------|-----|
| INITIAL Sr-85 ACTIVITY:   | 156    | mCi |
| DECAY FACTOR:             | 0.6011 |     |
| REMAINING Sr-85 IN mCi:   | 93.77  | mCi |
| REMAINING Sr-85 IN GBq    | 3.47   | GBq |

25/27

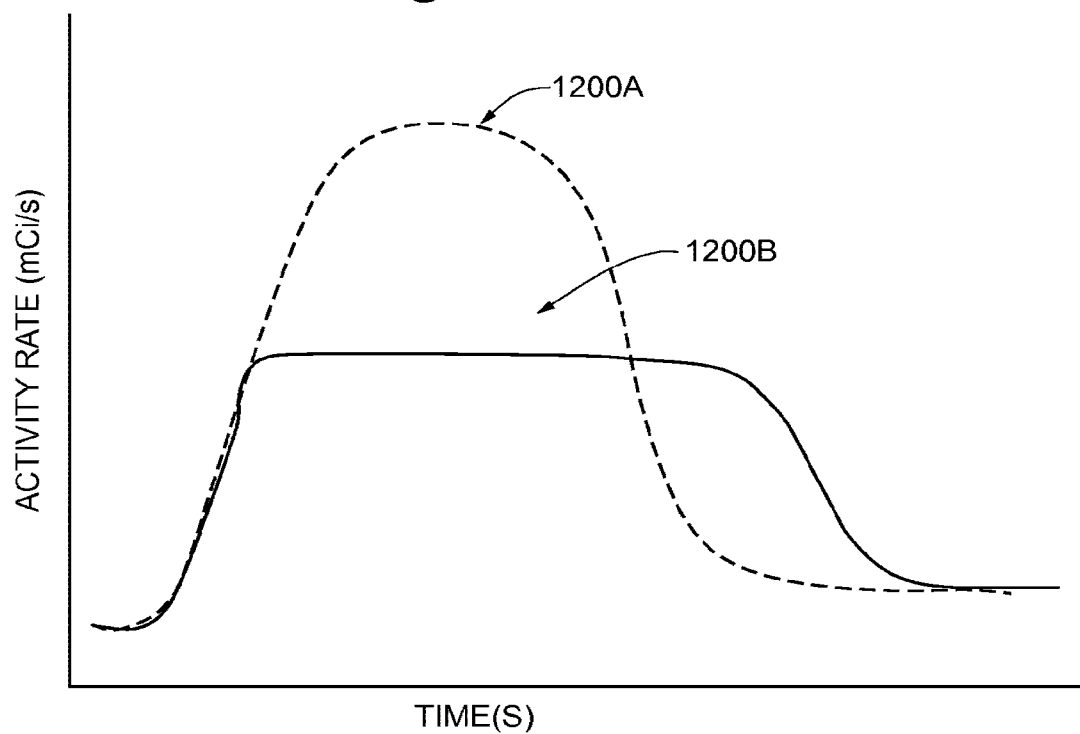
**Fig. 12A**



**Fig. 12B**



**Fig. 12C**



PATENT COOPERATION TREATY

PCT

INTERNATIONAL SEARCH REPORT

(PCT Article 18 and Rules 43 and 44)

|  |  |   |   |
|--|--|---|---|
| Applicant's or agent's file reference<br>56782.1.9.1 | <b>FOR FURTHER ACTION</b>                                |   | see Form PCT/ISA/220<br>as well as, where applicable, item 5 below. |
| International application No.<br>PCT/US2009/063788   | International filing date (day/month/year)<br>10/11/2009 | (Earliest) Priority Date (day/month/year)<br>19/11/2008 |   |
| Applicant<br><br>BRACCO DIAGNOSTICS INC.             |  |   |   |

This international search report has been prepared by this International Searching Authority and is transmitted to the applicant according to Article 18. A copy is being transmitted to the International Bureau.

This international search report consists of a total of 6 sheets.

It is also accompanied by a copy of each prior art document cited in this report.

1. **Basis of the report**

a. With regard to the **language**, the international search was carried out on the basis of:

the international application in the language in which it was filed

a translation of the international application into \_\_\_\_\_, which is the language of a translation furnished for the purposes of international search (Rules 12.3(a) and 23.1(b))

b.  This international search report has been established taking into account the **rectification of an obvious mistake** authorized by or notified to this Authority under Rule 91 (Rule 43.6bis(a)).

c.  With regard to any **nucleotide and/or amino acid sequence** disclosed in the international application, see Box No. I.

2.  **Certain claims were found unsearchable** (See Box No. II)

3.  **Unity of invention is lacking** (see Box No III)

4. With regard to the **title**,

the text is approved as submitted by the applicant

the text has been established by this Authority to read as follows:

5. With regard to the **abstract**,

the text is approved as submitted by the applicant

the text has been established, according to Rule 38.2(b), by this Authority as it appears in Box No. IV. The applicant may, within one month from the date of mailing of this international search report, submit comments to this Authority

6. With regard to the **drawings**,

a. the figure of the **drawings** to be published with the abstract is Figure No. 1

as suggested by the applicant

as selected by this Authority, because the applicant failed to suggest a figure

as selected by this Authority, because this figure better characterizes the invention

b.  none of the figures is to be published with the abstract



**A. CLASSIFICATION OF SUBJECT MATTER**  
 INV. A61M5/165 A61M5/14 A61M5/38  
 ADD. A61M5/00 A61M39/28

According to International Patent Classification (IPC) or to both national classification and IPC

**B. FIELDS SEARCHED**

Minimum documentation searched (classification system followed by classification symbols)  
 A61M

Documentation searched other than minimum documentation to the extent that such documents are included in the fields searched

Electronic data base consulted during the international search (name of data base and, where practical, search terms used)

EPO-Internal, WPI Data

**C. DOCUMENTS CONSIDERED TO BE RELEVANT**

| Category* | Citation of document, with indication, where appropriate, of the relevant passages  | Relevant to claim No. |
|-----------|---|-----------------------|
| X         | US 3 483 867 A (MARKOVITZ MEYER)<br>16 December 1969 (1969-12-16)<br>figures 1-4<br>column 2, line 60 - column 7, line 9        | 1-10,<br>15-20        |
| X         | US 4 994 056 A (IKEDA DANIEL P [US])<br>19 February 1991 (1991-02-19)<br>figures 1-8<br>column 3, line 51 - column 5, line 68   | 1-10                  |
| X         | US 4 466 888 A (VERKAART WESLEY H [US])<br>21 August 1984 (1984-08-21)<br>figures 1-16<br>column 3, line 48 - column 8, line 57 | 1-10                  |
|           | -----<br>-/--   |                       |

Further documents are listed in the continuation of Box C.

See patent family annex.

\* Special categories of cited documents :

- "A" document defining the general state of the art which is not considered to be of particular relevance
- "E" earlier document but published on or after the international filing date
- "L" document which may throw doubts on priority claim(s) or which is cited to establish the publication date of another citation or other special reason (as specified)
- "O" document referring to an oral disclosure, use, exhibition or other means
- "P" document published prior to the international filing date but later than the priority date claimed

- "T" later document published after the international filing date or priority date and not in conflict with the application but cited to understand the principle or theory underlying the invention
- "X" document of particular relevance; the claimed invention cannot be considered novel or cannot be considered to involve an inventive step when the document is taken alone
- "Y" document of particular relevance; the claimed invention cannot be considered to involve an inventive step when the document is combined with one or more other such documents, such combination being obvious to a person skilled in the art.
- "&" document member of the same patent family

Date of the actual completion of the international search

24 March 2010

Date of mailing of the international search report

01/04/2010

Name and mailing address of the ISA/

European Patent Office, P.B. 5818 Patentlaan 2  
 NL - 2280 HV Rijswijk  
 Tel. (+31-70) 340-2040,  
 Fax: (+31-70) 340-3016

Authorized officer

Reinbold, Sylvie

C(Continuation). DOCUMENTS CONSIDERED TO BE RELEVANT

| Category* | Citation of document, with indication, where appropriate, of the relevant passages  | Relevant to claim No. |
|-----------|---|-----------------------|
| X         | EP 0 919 249 A1 (NISSHO KK [JP] NIPRO CORP [JP]) 2 June 1999 (1999-06-02)<br>figures 1-11<br>paragraph [0021] - paragraph [0058]<br>paragraph [0033]                | 1-10                  |
| A         | EP 1 421 960 A1 (GVS S P A [IT])<br>26 May 2004 (2004-05-26)<br>figures 1-16<br>paragraph [0009] - paragraph [0030]   | 1-10,<br>15-20        |
| E         | WO 2009/152320 A2 (BRACCO DIAGNOSTICS INC [US]; QUIRICO CHARLES R [US]; BALESTRACCI ERNES) 17 December 2009 (2009-12-17)<br>figure 3b<br>page 19, line 10 - line 15 | 1-10,<br>15-20        |

**FURTHER INFORMATION CONTINUED FROM PCT/ISA/ 210**

Continuation of Box II.1

Claims Nos.: 11-14

Claims 11 to 14 relate to a method for assembling a membrane filter. Said method is carried out within the human body because connecting a line to the fluid outlet filter is a connection with a catheter which is introduced to the patient. Consequently, the method defined in claims 11 to 14 is considered as a method for the treatment of the human body by surgery and therapy. The application does not meet the requirement of Rule 39.1)iv), because these claims are methods of treatment of the human body.

# INTERNATIONAL SEARCH REPORT

International application No.  
PCT/US2009/063788

## Box No. II Observations where certain claims were found unsearchable (Continuation of item 2 of first sheet)

This international search report has not been established in respect of certain claims under Article 17(2)(a) for the following reasons:

1.  Claims Nos.: 11-14  
because they relate to subject matter not required to be searched by this Authority, namely:  
see FURTHER INFORMATION sheet PCT/ISA/210
2.  Claims Nos.:  
because they relate to parts of the international application that do not comply with the prescribed requirements to such an extent that no meaningful international search can be carried out, specifically:
3.  Claims Nos.:  
because they are dependent claims and are not drafted in accordance with the second and third sentences of Rule 6.4(a).

## Box No. III Observations where unity of invention is lacking (Continuation of item 3 of first sheet)

This International Searching Authority found multiple inventions in this international application, as follows:

1.  As all required additional search fees were timely paid by the applicant, this international search report covers all searchable claims.
2.  As all searchable claims could be searched without effort justifying an additional fees, this Authority did not invite payment of additional fees.
3.  As only some of the required additional search fees were timely paid by the applicant, this international search report covers only those claims for which fees were paid, specifically claims Nos.:
4.  No required additional search fees were timely paid by the applicant. Consequently, this international search report is restricted to the invention first mentioned in the claims; it is covered by claims Nos.:

### Remark on Protest

- The additional search fees were accompanied by the applicant's protest and, where applicable, the payment of a protest fee.
- The additional search fees were accompanied by the applicant's protest but the applicable protest fee was not paid within the time limit specified in the invitation.
- No protest accompanied the payment of additional search fees.

| Patent document cited in search report |    | Publication date | Patent family member(s) | Publication date |
|--|----|------------------|-------------------------|------------------|
| US 3483867                             | A  | 16-12-1969       | NONE                    |                  |
| US 4994056                             | A  | 19-02-1991       | WO 9107205 A1           | 30-05-1991       |
| US 4466888                             | A  | 21-08-1984       | AT 16350 T              | 15-11-1985       |
|  |    |                  | AU 7087681 A            | 26-11-1981       |
|  |    |                  | DE 3172813 D1           | 12-12-1985       |
|  |    |                  | DK 219881 A             | 21-11-1981       |
|  |    |                  | EP 0040427 A1           | 25-11-1981       |
|  |    |                  | ES 8300479 A1           | 01-02-1983       |
|  |    |                  | JP 57049457 A           | 23-03-1982       |
| EP 0919249                             | A1 | 02-06-1999       | DE 69828571 D1          | 17-02-2005       |
|  |    |                  | DE 69828571 T2          | 02-06-2005       |
|  |    |                  | US 6129853 A            | 10-10-2000       |
| EP 1421960                             | A1 | 26-05-2004       | US 2004104160 A1        | 03-06-2004       |
| WO 2009152320                          | A2 | 17-12-2009       | WO 2009152322 A2        | 17-12-2009       |
|  |    |                  | WO 2009152323 A2        | 17-12-2009       |
|  |    |                  | WO 2009152326 A2        | 17-12-2009       |

# PATENT COOPERATION TREATY

From the  
INTERNATIONAL SEARCHING AUTHORITY

# PCT

**WRITTEN OPINION OF THE  
INTERNATIONAL SEARCHING AUTHORITY  
(PCT Rule 43bis.1)**

To:

see form PCT/ISA/220

Date of mailing  
(day/month/year) see form PCT/ISA/210 (second sheet)

Applicant's or agent's file reference  
see form PCT/ISA/220

**FOR FURTHER ACTION**  
See paragraph 2 below

International application No.  
PCT/US2009/063788

International filing date (day/month/year)  
10.11.2009

Priority date (day/month/year)  
19.11.2008

International Patent Classification (IPC) or both national classification and IPC  
INV. A61M5/165 A61M5/14 A61M5/38  
ADD. A61M5/00 A61M39/28

Applicant  
BRACCO DIAGNOSTICS INC.

**1. This opinion contains indications relating to the following items:**

- Box No. I Basis of the opinion
- Box No. II Priority
- Box No. III Non-establishment of opinion with regard to novelty, inventive step and industrial applicability
- Box No. IV Lack of unity of invention
- Box No. V Reasoned statement under Rule 43bis.1(a)(i) with regard to novelty, inventive step or industrial applicability; citations and explanations supporting such statement
- Box No. VI Certain documents cited
- Box No. VII Certain defects in the international application
- Box No. VIII Certain observations on the international application

**2. FURTHER ACTION**

If a demand for international preliminary examination is made, this opinion will usually be considered to be a written opinion of the International Preliminary Examining Authority ("IPEA") except that this does not apply where the applicant chooses an Authority other than this one to be the IPEA and the chosen IPEA has notified the International Bureau under Rule 66.1bis(b) that written opinions of this International Searching Authority will not be so considered.

If this opinion is, as provided above, considered to be a written opinion of the IPEA, the applicant is invited to submit to the IPEA a written reply together, where appropriate, with amendments, before the expiration of 3 months from the date of mailing of Form PCT/ISA/220 or before the expiration of 22 months from the priority date, whichever expires later.

For further options, see Form PCT/ISA/220.

**3. For further details, see notes to Form PCT/ISA/220.**

Name and mailing address of the ISA:



European Patent Office  
D-80298 Munich  
Tel. +49 89 2399 - 0  
Fax: +49 89 2399 - 4465

Date of completion of  
this opinion

see form  
PCT/ISA/210

Authorized Officer

Reinbold, Sylvie

Telephone No. +49 89 2399-7918



---

**Box No. I Basis of the opinion**

---

1. With regard to the **language**, this opinion has been established on the basis of:
  - the international application in the language in which it was filed
  - a translation of the international application into , which is the language of a translation furnished for the purposes of international search (Rules 12.3(a) and 23.1 (b)).
2.  This opinion has been established taking into account the **rectification of an obvious mistake** authorized by or notified to this Authority under Rule 91 (Rule 43bis.1(a))
3. With regard to any **nucleotide and/or amino acid sequence** disclosed in the international application and necessary to the claimed invention, this opinion has been established on the basis of:
  - a. type of material:
    - a sequence listing
    - table(s) related to the sequence listing
  - b. format of material:
    - on paper
    - in electronic form
  - c. time of filing/furnishing:
    - contained in the international application as filed.
    - filed together with the international application in electronic form.
    - furnished subsequently to this Authority for the purposes of search.
4.  In addition, in the case that more than one version or copy of a sequence listing and/or table relating thereto has been filed or furnished, the required statements that the information in the subsequent or additional copies is identical to that in the application as filed or does not go beyond the application as filed, as appropriate, were furnished.
5. Additional comments:

**Box No. III Non-establishment of opinion with regard to novelty, inventive step and industrial applicability**

The questions whether the claimed invention appears to be novel, to involve an inventive step (to be non obvious), or to be industrially applicable have not been examined in respect of

- the entire international application
- claims Nos. 11-14

because:

- the said international application, or the said claims Nos. relate to the following subject matter which does not require an international search (*specify*):
- the description, claims or drawings (*indicate particular elements below*) or said claims Nos. are so unclear that no meaningful opinion could be formed (*specify*):
- the claims, or said claims Nos. are so inadequately supported by the description that no meaningful opinion could be formed (*specify*):
- no international search report has been established for the whole application or for said claims Nos. 11-14
- a meaningful opinion could not be formed without the sequence listing; the applicant did not, within the prescribed time limit:
  - furnish a sequence listing on paper complying with the standard provided for in Annex C of the Administrative Instructions, and such listing was not available to the International Searching Authority in a form and manner acceptable to it.
  - furnish a sequence listing in electronic form complying with the standard provided for in Annex C of the Administrative Instructions, and such listing was not available to the International Searching Authority in a form and manner acceptable to it.
  - pay the required late furnishing fee for the furnishing of a sequence listing in response to an invitation under Rules 13<sup>ter</sup>.1(a) or (b).
- a meaningful opinion could not be formed without the tables related to the sequence listings; the applicant did not, within the prescribed time limit, furnish such tables in electronic form complying with the technical requirements provided for in Annex C-*bis* of the Administrative Instructions, and such tables were not available to the International Searching Authority in a form and manner acceptable to it.
- the tables related to the nucleotide and/or amino acid sequence listing, if in electronic form only, do not comply with the technical requirements provided for in Annex C-*bis* of the Administrative Instructions.
- See Supplemental Box for further details



---

**Box No. V Reasoned statement under Rule 43bis.1(a)(i) with regard to novelty, inventive step or industrial applicability; citations and explanations supporting such statement**

---

1. Statement

|                               |             |                        |
|-------------------------------|-------------|------------------------|
| Novelty (N)                   | Yes: Claims | <u>16-17, 20</u>       |
|                               | No: Claims  | <u>1-10, 15, 18-19</u> |
| Inventive step (IS)           | Yes: Claims |                        |
|                               | No: Claims  | <u>1-10, 15-20</u>     |
| Industrial applicability (IA) | Yes: Claims | <u>1-10, 15-20</u>     |
|                               | No: Claims  |                        |

2. Citations and explanations

see separate sheet

---

**Box No. VIII Certain observations on the international application**

---

The following observations on the clarity of the claims, description, and drawings or on the question whether the claims are fully supported by the description, are made:

see separate sheet

**Re Item III**

**Non-establishment of opinion with regard to novelty, inventive step and industrial applicability**

Claims 11 to 14 relate to a method for assembling a membrane filter. Said method is carried out within the human body because connecting a line to the fluid outlet filter is a connection with a catheter which is introduced to the patient.

Consequently, the method defined in claims 11 to 14 is considered as a method for the treatment of the human body by surgery and therapy. The application does not meet the requirement of Rule 39.1(iv), because these claims are methods of treatment of the human body.

Thus, the subject-matter of these claims has not been searched and consequently no examination was carried out for those claims (Rule 66.1 (e) PCT).

**Re Item V**

**Reasoned statement under Rule 66.2(a)(ii) with regard to novelty, inventive step or industrial applicability; citations and explanations supporting such statement**

1 Reference is made to the following documents:

|    |                   |
|----|-------------------|
| D1 | US 3 483 867 A    |
| D2 | US 4 994 056 A    |
| D3 | US 4 466 888 A    |
| D4 | EP 0 919 249 A1   |
| D5 | EP 1 421 960 A1   |
| D6 | WO 2009/152320 A2 |

**Novelty Article 33(2) PCT**

2 The present application does not meet the criteria of Article 33 (1) PCT, because the subject-matter of **claims 1-10 and 15,18 and 19** does not seem to be new in the sense of Article 33(2) PCT.

2.1 The document D1 is regarded as being the closest prior art and discloses (the references in parentheses applying to this document) a removable clamp (10) for supporting a housing (52) of a membrane filter, the housing including a first major surface, a second major surface, opposite the first major surface, and a thickness, the thickness being defined from the first major surface to the second major surface, at a location around a common perimeter of the surfaces, and being less than a length and a width of each surface, the length

of each surface extending between a fluid inlet (60) and a fluid outlet (62) of the filter, the width of each surface extending approximately orthogonal to the length, and the clamp comprising:

a first support wall (14) including a first end and a second end, opposite the first end;

a second support wall (12), opposite the first support wall, including a first, terminal end and a second end, opposite the first, terminal end, the second end of the second support wall being fixedly and flexibly connected to the first end of the first support wall to allow the first, terminal end of the second support wall to move toward and away from the first support wall; and

a locking feature (18) connected to the second end of the first support wall and being configured to engage and disengage the first, terminal end of the second support wall (12);

wherein the first support wall has a width (see figure 4), defined from the first end thereof to the second end thereof, and the width of the first support wall spans the width of the housing of the filter, when the clamp is assembled about the housing;

the first support wall, in proximity to the first end thereof, is spaced apart from the second support wall, in proximity to the second end thereof, over a distance that spans the thickness of the housing when the clamp is assembled around the housing;

the clamp (10) supports the housing when the clamp is assembled around the housing and the locking feature engages the first, terminal end of the second support wall (figure 4);

and the clamp (10) is removable from around the housing when the locking feature disengages the first, terminal end of the second support wall.

Therefore the subject matter of claim 1 is not novel over document D1.

2.2 Moreover the technical features of claims 2,6,7,15,18 and 19 are disclosed by the document D1. (infusion system (112))

2.3 Furthermore the technical features of claims 1 to 10 are shown by documents D2 to D4.

Document D2: figure 1 to 8, clamp (20), locking feature (46,48)

Document D3 : figure 1 to 16, clamp (20+22) having a first wall (20) and second wall (22), locking feature (39)

Document D4: figure 1 to 11, clamp (10) having a first wall (4) and second wall, locking feature (411)

**Inventive Step Article 33(3) PCT**

3 The present application does not meet the criteria of Article 33 (1) PCT, because the subject-matter of **claims 16,17 and 20** does not seem to involve an inventive step in the sense of Article 33(3) PCT. Document D1 is the closest prior art.

The feature of claims 16,17 and 20 (cabinet) is merely one of several straightforward possibilities from which the skilled person would select, in accordance with circumstances, without the exercise of inventive skill, in order to solve the problem posed. Consequently, the subject-matter of these claims also lacks an inventive step.

**Further Comments**

4 Contrary to the requirements of Rule 5.1(a)(ii) PCT, the **relevant background** art disclosed in the documents D1-D5 are not mentioned in the description, nor are these documents identified therein.

5 Independent claim 1 is not in the **two-part form** in accordance with Rule 6.3 (b) PCT, which in the present case would be appropriate, with those features known in combination from the prior art (document D1) being placed in the preamble (Rule 6.3(b)(i) PCT) and with the remaining features being included in the characterising part (Rule 6.3(b)(ii) PCT).

6 The features of the claims are not provided with **reference signs** placed in parentheses (Rule 6.2(b) PCT).

**Re Item VIII**

**Certain observations on the international application**

**Clarity Article 6 PCT**

7 Claim 1 does not meet the requirements of Article 6 PCT in that the matter for which protection is sought is not clearly defined. Claim 1 defines a removable clamp in combination with a housing of a membrane filter. However this housing of a membrane filter is not part of the subject matter of said claim 1. Therefore the definition of the subject - matter of said claim 1 is unclear, Article 6 PCT.

8 Furthermore, the removable clamp as defined in claim 1 is a definition of a normal clamp, which is already known from the skilled person in the art.

9 Claim 15 comprises all the features of claim 1 and is therefore not appropriately formulated as a claim dependent on the latter (Rule 6.4 PCT).

## Electronic Acknowledgement Receipt

|   |   |
|---|---|
| <b>EFS ID:</b>                              | 11635340                                  |
| <b>Application Number:</b>                  | 12137356                                  |
| <b>International Application Number:</b>    |   |
| <b>Confirmation Number:</b>                 | 7360                                      |
| <b>Title of Invention:</b>                  | SHIELDING ASSEMBLIES FOR INFUSION SYSTEMS |
| <b>First Named Inventor/Applicant Name:</b> | Charles R. Quirico                        |
| <b>Customer Number:</b>                     | 22859                                     |
| <b>Filer:</b>                               | Paul J. LaVanway Jr.                      |
| <b>Filer Authorized By:</b>                 |   |
| <b>Attorney Docket Number:</b>              | 56782.1.5                                 |
| <b>Receipt Date:</b>                        | 16-DEC-2011                               |
| <b>Filing Date:</b>                         | 11-JUN-2008                               |
| <b>Time Stamp:</b>                          | 14:49:13                                  |
| <b>Application Type:</b>                    | Utility under 35 USC 111(a)               |

### Payment information:

|                        |    |
|------------------------|----|
| Submitted with Payment | no |
|------------------------|----|

### File Listing:

| Document Number | Document Description                               | File Name              | File Size(Bytes)/<br>Message Digest                                    | Multi Part /.zip | Pages (if appl.) |
|-----------------|--|------------------------|--|------------------|------------------|
| 1               | Information Disclosure Statement (IDS) Form (SB08) | 7th-SIDS_56782-1-5.pdf | 979774<br><small>ed28ac39b47506f8da3e745fb4f1c316f7ea<br/>e13f</small> | no               | 6                |

### Warnings:

### Information:

|   |                       |                                |  |    |    |
|---|-----------------------|--------------------------------|--|----|----|
| 2   | Foreign Reference     | EP0919249A1.pdf                | 1041653<br>120cd7eac47e368daa3cf979f03c445e82efaf6     | no | 25 |
| <b>Warnings:</b>  |                       |                                |  |    |    |
| <b>Information:</b>   |                       |                                |  |    |    |
| 3   | Foreign Reference     | EP1421960A1.pdf                | 602979<br>df441eea183dc8af25823419d1535d4e3da6f32c     | no | 11 |
| <b>Warnings:</b>  |                       |                                |  |    |    |
| <b>Information:</b>   |                       |                                |  |    |    |
| 4   | Foreign Reference     | WO2009152320A2.pdf             | 3029042<br>50db57966273fb4a35de35c1a630c2a1c081c822    | no | 71 |
| <b>Warnings:</b>  |                       |                                |  |    |    |
| <b>Information:</b>   |                       |                                |  |    |    |
| 5   | Non Patent Literature | Brochure-IV-Liquid-Filters.pdf | 88247<br>79b0e5e0fee23e68fcae6694762ca1c596bd35a       | no | 2  |
| <b>Warnings:</b>  |                       |                                |  |    |    |
| <b>Information:</b>   |                       |                                |  |    |    |
| 6   | Non Patent Literature | ISR-56782-1-9-1.pdf            | 1532421<br>b210207372ffa5795795892305aa08527a8279c5d05 | no | 13 |
| <b>Warnings:</b>  |                       |                                |  |    |    |
| <b>Information:</b>   |                       |                                |  |    |    |
| <b>Total Files Size (in bytes):</b>   |                       |                                | 7274116  |    |    |
| <p><b>This Acknowledgement Receipt evidences receipt on the noted date by the USPTO of the indicated documents, characterized by the applicant, and including page counts, where applicable. It serves as evidence of receipt similar to a Post Card, as described in MPEP 503.</b></p> <p><b><u>New Applications Under 35 U.S.C. 111</u></b><br/> <b>If a new application is being filed and the application includes the necessary components for a filing date (see 37 CFR 1.53(b)-(d) and MPEP 506), a Filing Receipt (37 CFR 1.54) will be issued in due course and the date shown on this Acknowledgement Receipt will establish the filing date of the application.</b></p> <p><b><u>National Stage of an International Application under 35 U.S.C. 371</u></b><br/> <b>If a timely submission to enter the national stage of an international application is compliant with the conditions of 35 U.S.C. 371 and other applicable requirements a Form PCT/DO/EO/903 indicating acceptance of the application as a national stage submission under 35 U.S.C. 371 will be issued in addition to the Filing Receipt, in due course.</b></p> <p><b><u>New International Application Filed with the USPTO as a Receiving Office</u></b><br/> <b>If a new international application is being filed and the international application includes the necessary components for an international filing date (see PCT Article 11 and MPEP 1810), a Notification of the International Application Number and of the International Filing Date (Form PCT/RO/105) will be issued in due course, subject to prescriptions concerning national security, and the date shown on this Acknowledgement Receipt will establish the international filing date of the application.</b></p> |                       |                                |  |    |    |

|   |                        |                    |
|---|------------------------|--------------------|
| <b>INFORMATION DISCLOSURE<br/>STATEMENT BY APPLICANT</b><br>( Not for submission under 37 CFR 1.99) | Application Number     | 12137356           |
|   | Filing Date            | 2008-06-11         |
|   | First Named Inventor   | CHARLES R. QUIRICO |
|   | Art Unit               | 3735               |
|   | Examiner Name          | Charles Marmor II  |
|   | Attorney Docket Number | 56782.1.5          |

| U.S.PATENTS   |         |               |                        |            |   |  | Remove |
|---|---------|---------------|------------------------|------------|---|--|--------|
| Examiner Initial*   | Cite No | Patent Number | Kind Code <sup>1</sup> | Issue Date | Name of Patentee or Applicant of cited Document | Pages,Columns,Lines where Relevant Passages or Relevant Figures Appear |        |
|   | 1       | 6908598       |                        | 2005-06-21 | Sylvester                                       |  |        |
|   | 2       | 7163031       |                        | 2007-01-16 | Graves et al.                                   |  |        |
|   | 3       | 7476377       |                        | 2009-01-13 | Moller  |  |        |
|   | 4       | 7504646       |                        | 2009-03-17 | Balestracci                                     |  |        |
| If you wish to add additional U.S. Patent citation information please click the Add button. |         |               |                        |            |   |  | Add    |

| U.S.PATENT APPLICATION PUBLICATIONS  |         |                    |                        |                  |   |  | Remove |
|--|---------|--------------------|------------------------|------------------|---|--|--------|
| Examiner Initial*  | Cite No | Publication Number | Kind Code <sup>1</sup> | Publication Date | Name of Patentee or Applicant of cited Document | Pages,Columns,Lines where Relevant Passages or Relevant Figures Appear |        |
|  | 1       | 20070232980        |                        | 2007-10-04       | Felt  |  |        |
|  | 2       | 20090312635        |                        | 2009-12-17       | Shimchuk  |  |        |
| If you wish to add additional U.S. Published Application citation information please click the Add button. |         |                    |                        |                  |   |  | Add    |
| FOREIGN PATENT DOCUMENTS   |         |                    |                        |                  |   |  | Remove |

**INFORMATION DISCLOSURE  
STATEMENT BY APPLICANT**  
( Not for submission under 37 CFR 1.99)

|                        |                    |
|------------------------|--------------------|
| Application Number     | 12137356           |
| Filing Date            | 2008-06-11         |
| First Named Inventor   | CHARLES R. QUIRICO |
| Art Unit               | 3735               |
| Examiner Name          | Charles Marmor II  |
| Attorney Docket Number | 56782.1.5          |

| Examiner Initial* | Cite No | Foreign Document Number <sup>3</sup> | Country Code <sup>2</sup> i | Kind Code <sup>4</sup> | Publication Date | Name of Patentee or Applicant of cited Document | Pages, Columns, Lines where Relevant Passages or Relevant Figures Appear | T <sup>5</sup>           |
|-------------------|---------|--------------------------------------|-----------------------------|------------------------|------------------|---|--|--------------------------|
|                   | 1       | 2004059661                           | WO                          |                        | 2004-07-15       | Lynntech, Inc.                                  |  | <input type="checkbox"/> |
|                   | 2       | 2006026603                           | WO                          |                        | 2006-03-09       | Bracco Diagnostics                              |  | <input type="checkbox"/> |
|                   | 3       | 2006135374                           | WO                          |                        | 2006-12-21       | Lynntech Inc.                                   |  | <input type="checkbox"/> |
|                   | 4       | 2008140351                           | WO                          |                        | 2008-11-20       | Obshchestvo                                     |  | <input type="checkbox"/> |
|                   | 5       | 2010020596                           | WO                          |                        | 2010-02-25       | Stichting Jeroen Bosch                          |  | <input type="checkbox"/> |

If you wish to add additional Foreign Patent Document citation information please click the Add button

**NON-PATENT LITERATURE DOCUMENTS**

| Examiner Initials* | Cite No | Include name of the author (in CAPITAL LETTERS), title of the article (when appropriate), title of the item (book, magazine, journal, serial, symposium, catalog, etc), date, pages(s), volume-issue number(s), publisher, city and/or country where published. | T <sup>5</sup>           |
|--------------------|---------|---|--------------------------|
|                    | 1       |   | <input type="checkbox"/> |

If you wish to add additional non-patent literature document citation information please click the Add button

**EXAMINER SIGNATURE**

|                    |  |                 |  |
|--------------------|--|-----------------|--|
| Examiner Signature |  | Date Considered |  |
|--------------------|--|-----------------|--|

\*EXAMINER: Initial if reference considered, whether or not citation is in conformance with MPEP 609. Draw line through a citation if not in conformance and not considered. Include copy of this form with next communication to applicant.



**INFORMATION DISCLOSURE  
STATEMENT BY APPLICANT**  
( Not for submission under 37 CFR 1.99)

|                        |                    |
|------------------------|--------------------|
| Application Number     | 12137356           |
| Filing Date            | 2008-06-11         |
| First Named Inventor   | CHARLES R. QUIRICO |
| Art Unit               | 3735               |
| Examiner Name          | Charles Marmor II  |
| Attorney Docket Number | 56782.1.5          |

<sup>1</sup> See Kind Codes of USPTO Patent Documents at [www.USPTO.GOV](http://www.USPTO.GOV) or MPEP 901.04. <sup>2</sup> Enter office that issued the document, by the two-letter code (WIPO Standard ST.3). <sup>3</sup> For Japanese patent documents, the indication of the year of the reign of the Emperor must precede the serial number of the patent document. <sup>4</sup> Kind of document by the appropriate symbols as indicated on the document under WIPO Standard ST.16 if possible. <sup>5</sup> Applicant is to place a check mark here if English language translation is attached.

|   |                        |                    |
|---|------------------------|--------------------|
| <b>INFORMATION DISCLOSURE<br/>STATEMENT BY APPLICANT</b><br>( Not for submission under 37 CFR 1.99) | Application Number     | 12137356           |
|   | Filing Date            | 2008-06-11         |
|   | First Named Inventor   | CHARLES R. QUIRICO |
|   | Art Unit               | 3735               |
|   | Examiner Name          | Charles Marmor II  |
|   | Attorney Docket Number | 56782.1.5          |

**CERTIFICATION STATEMENT**

Please see 37 CFR 1.97 and 1.98 to make the appropriate selection(s):

That each item of information contained in the information disclosure statement was first cited in any communication from a foreign patent office in a counterpart foreign application not more than three months prior to the filing of the information disclosure statement. See 37 CFR 1.97(e)(1).

**OR**

That no item of information contained in the information disclosure statement was cited in a communication from a foreign patent office in a counterpart foreign application, and, to the knowledge of the person signing the certification after making reasonable inquiry, no item of information contained in the information disclosure statement was known to any individual designated in 37 CFR 1.56(c) more than three months prior to the filing of the information disclosure statement. See 37 CFR 1.97(e)(2).

See attached certification statement.

Fee set forth in 37 CFR 1.17 (p) has been submitted herewith.

None

**SIGNATURE**

A signature of the applicant or representative is required in accordance with CFR 1.33, 10.18. Please see CFR 1.4(d) for the form of the signature.

|            |                         |                     |            |
|------------|-------------------------|---------------------|------------|
| Signature  | /Elisabeth Lacy Belden/ | Date (YYYY-MM-DD)   | 2010-08-04 |
| Name/Print | Elisabeth Lacy Belden   | Registration Number | 50,751     |

This collection of information is required by 37 CFR 1.97 and 1.98. The information is required to obtain or retain a benefit by the public which is to file (and by the USPTO to process) an application. Confidentiality is governed by 35 U.S.C. 122 and 37 CFR 1.14. This collection is estimated to take 1 hour to complete, including gathering, preparing and submitting the completed application form to the USPTO. Time will vary depending upon the individual case. Any comments on the amount of time you require to complete this form and/or suggestions for reducing this burden, should be sent to the Chief Information Officer, U.S. Patent and Trademark Office, U.S. Department of Commerce, P.O. Box 1450, Alexandria, VA 22313-1450. **DO NOT SEND FEES OR COMPLETED FORMS TO THIS ADDRESS. SEND TO: Commissioner for Patents, P.O. Box 1450, Alexandria, VA 22313-1450.**

## Privacy Act Statement

The Privacy Act of 1974 (P.L. 93-579) requires that you be given certain information in connection with your submission of the attached form related to a patent application or patent. Accordingly, pursuant to the requirements of the Act, please be advised that: (1) the general authority for the collection of this information is 35 U.S.C. 2(b)(2); (2) furnishing of the information solicited is voluntary; and (3) the principal purpose for which the information is used by the U.S. Patent and Trademark Office is to process and/or examine your submission related to a patent application or patent. If you do not furnish the requested information, the U.S. Patent and Trademark Office may not be able to process and/or examine your submission, which may result in termination of proceedings or abandonment of the application or expiration of the patent.

The information provided by you in this form will be subject to the following routine uses:

1. The information on this form will be treated confidentially to the extent allowed under the Freedom of Information Act (5 U.S.C. 552) and the Privacy Act (5 U.S.C. 552a). Records from this system of records may be disclosed to the Department of Justice to determine whether the Freedom of Information Act requires disclosure of these records.
2. A record from this system of records may be disclosed, as a routine use, in the course of presenting evidence to a court, magistrate, or administrative tribunal, including disclosures to opposing counsel in the course of settlement negotiations.
3. A record in this system of records may be disclosed, as a routine use, to a Member of Congress submitting a request involving an individual, to whom the record pertains, when the individual has requested assistance from the Member with respect to the subject matter of the record.
4. A record in this system of records may be disclosed, as a routine use, to a contractor of the Agency having need for the information in order to perform a contract. Recipients of information shall be required to comply with the requirements of the Privacy Act of 1974, as amended, pursuant to 5 U.S.C. 552a(m).
5. A record related to an International Application filed under the Patent Cooperation Treaty in this system of records may be disclosed, as a routine use, to the International Bureau of the World Intellectual Property Organization, pursuant to the Patent Cooperation Treaty.
6. A record in this system of records may be disclosed, as a routine use, to another federal agency for purposes of National Security review (35 U.S.C. 181) and for review pursuant to the Atomic Energy Act (42 U.S.C. 218(c)).
7. A record from this system of records may be disclosed, as a routine use, to the Administrator, General Services, or his/her designee, during an inspection of records conducted by GSA as part of that agency's responsibility to recommend improvements in records management practices and programs, under authority of 44 U.S.C. 2904 and 2906. Such disclosure shall be made in accordance with the GSA regulations governing inspection of records for this purpose, and any other relevant (i.e., GSA or Commerce) directive. Such disclosure shall not be used to make determinations about individuals.
8. A record from this system of records may be disclosed, as a routine use, to the public after either publication of the application pursuant to 35 U.S.C. 122(b) or issuance of a patent pursuant to 35 U.S.C. 151. Further, a record may be disclosed, subject to the limitations of 37 CFR 1.14, as a routine use, to the public if the record was filed in an application which became abandoned or in which the proceedings were terminated and which application is referenced by either a published application, an application open to public inspections or an issued patent.
9. A record from this system of records may be disclosed, as a routine use, to a Federal, State, or local law enforcement agency, if the USPTO becomes aware of a violation or potential violation of law or regulation.

(12) INTERNATIONAL APPLICATION PUBLISHED UNDER THE PATENT COOPERATION TREATY (PCT)

(19) World Intellectual Property  
Organization  
International Bureau



(43) International Publication Date  
15 July 2004 (15.07.2004)

PCT

(10) International Publication Number  
WO 2004/059661 A1

- (51) International Patent Classification<sup>7</sup>: G21G 4/08
- (21) International Application Number: PCT/US2002/041676
- (22) International Filing Date: 30 December 2002 (30.12.2002)
- (25) Filing Language: English
- (26) Publication Language: English
- (71) Applicant: LYNNTECH, INC. [US/US]; 7610 Eastmark Drive, College Station, TX 77845 (US).
- (72) Inventor: SYLVESTER, Paul; 80 N. Warren, Apt.16, Woburn, MA 01801 (US).
- (74) Agent: STREETS, Jeffrey, L.; Streets & Steele, 13831 Northwest Freeway, Suite 355, Houston, TX 77040 (US).
- (81) Designated States (*national*): AE, AG, AL, AM, AT, AU, AZ, BA, BB, BG, BR, BY, BZ, CA, CH, CN, CO, CR, CU, CZ, DE, DK, DM, DZ, EC, EE, ES, FI, GB, GD, GE, GH, GM, HR, HU, ID, IL, IN, IS, JP, KE, KG, KP, KR, KZ, LC, LK, LR, LS, LI, LU, LV, MA, MD, MG, MK, MN, MW, MX, MZ, NO, NZ, OM, PH, PL, PT, RO, RU, SD, SE, SG, SK, SL, TJ, TM, TN, TR, TT, TZ, UA, UG, UZ, VN, YU, ZA, ZM, ZW.
- (84) Designated States (*regional*): ARIPO patent (GH, GM, KE, LS, MW, MZ, SD, SL, SZ, TZ, UG, ZM, ZW), Eurasian patent (AM, AZ, BY, KG, KZ, MD, RU, TJ, TM), European patent (AT, BE, BG, CH, CY, CZ, DE, DK, EE, ES, FI, FR, GB, GR, IE, IT, LU, MC, NL, PT, SE, SI, SK, TR), OAPI patent (BF, BJ, CF, CG, CI, CM, GA, GN, GQ, GW, ML, MR, NE, SN, TD, TG).
- Published:**  
— with international search report
- For two-letter codes and other abbreviations, refer to the "Guidance Notes on Codes and Abbreviations" appearing at the beginning of each regular issue of the PCT Gazette.*



WO 2004/059661 A1

(54) Title: RUBIDIUM-82 GENERATOR BASED ON SODIUM NONATITANATE SUPPORT, AND SEPARATION METHODS FOR THE RECOVERY OF THE RECOVERY OF STRONTIUM-82 FROM IRRADIATED TARGETS

(57) Abstract: Sodium nonatitanate compositions, a method using the composition for recovery of <sup>82</sup>Sr from irradiated targets, and a method using the composition for generating <sup>82</sup>Rb. The sodium nonatitanate materials of the invention are highly selective at separating strontium from solutions derived from the dissolution of irradiated target materials, thus reducing target processing times. The compositions also have a very low affinity for rubidium, making it an ideal material for use as a <sup>82</sup>Rb generator. Sodium nonatitanate materials of this type both improve the recovery of <sup>82</sup>Sr and provide a safer, more effective <sup>82</sup>Rb generator system.

## RUBIDIUM-82 GENERATOR BASED ON SODIUM NONATITANATE SUPPORT, AND SEPARATION METHODS FOR THE RECOVERY OF STRONTIUM-82 FROM IRRADIATED TARGETS

**BACKGROUND OF THE INVENTION****Field of the Invention**

This invention relates to the selective separation of strontium-82 from other radioisotopes, such as those resulting from an irradiated molybdenum target, and in the manufacture of a rubidium-82 generator.

**Background of the Related Art**

The use of radioisotopes as diagnostic and imaging agents in medicine has expanded rapidly in recent years. Positron ( $\beta^+$ ) emitters are particularly useful in the study of metabolic processes because the positron-electron annihilation reaction produces a pair of gamma rays with an energy level of 511 keV travelling in opposite directions. By placing a series of detectors around a patient who has been administered a positron emitter, both the location and amount of radioactivity can be accurately determined. This property is utilized in Positron Emission Tomography (PET) to image metabolic processes *in vivo*. Rubidium-82 ( $^{82}\text{Rb}$ ) is a short-lived positron-emitting isotope ( $T_{1/2} = 75$  seconds) that is increasingly being used to study blood flow through the heart and brain. Physiologically, rubidium is an analogue of potassium, and consequently enters the body's large potassium pool, which has a comparatively slow turnover. Thus, after  $^{82}\text{Rb}$  is injected intravenously, the tracer's uptake in tissue reflects the rate of delivery, i.e. blood flow, and thus  $^{82}\text{Rb}$  rapidly builds up in the heart. This can be used, for example, to study blood-brain barrier leakage and heart muscle perfusion.

The short half-life of  $^{82}\text{Rb}$  means that it must be supplied to physicians in the form of a generator, where the parent  $^{82}\text{Sr}$  ( $T_{1/2} = 25$  days) is immobilized on a solid substrate or support and  $^{82}\text{Rb}$  eluted as required. The generators that are currently available use hydrous tin oxide to immobilize the  $^{82}\text{Sr}$  and allow the elution of  $^{82}\text{Rb}$  by saline or other appropriate eluant. The  $^{82}\text{Sr}$  ( $T_{1/2} = 25$  days) is accompanied by unwanted  $^{85}\text{Sr}$  ( $T_{1/2} = 64$  days), generated as a by-product during the manufacture of  $^{82}\text{Sr}$ , wherein both isotopes have a relatively long half-life and a high radiotoxicity due to their tendency to accumulate in bone. Thus, it is essential to minimize or eliminate the introduction of  $^{82}\text{Sr}$  and  $^{85}\text{Sr}$  into a patient during the administration of  $^{82}\text{Rb}$ . Although hydrous tin oxide has proved acceptable to date

for use in generators, new materials exhibiting far higher strontium affinities, improved strontium/rubidium separation factors and greater radiolytic stability are needed in order to lower the amount of  $^{82}\text{Sr}$  and  $^{85}\text{Sr}$  released during elution of the  $^{82}\text{Rb}$ .

The parent  $^{82}\text{Sr}$  is generated by the proton irradiation of rubidium, rubidium chloride or molybdenum targets followed by dissolution and processing to isolate the  $^{82}\text{Sr}$ . The demand for  $^{82}\text{Rb}$  generators has grown so great that there is a need to reduce processing times and to increase the yield of  $^{82}\text{Sr}$  from processed targets. One method of improving the supply of  $^{82}\text{Sr}$  is to improve the processes used to extract  $^{82}\text{Sr}$  from irradiated targets. Current methods utilize organic ion exchange or chelating resins to extract very low levels of strontium from dissolved targets containing molar concentrations of inert ions. However, a satisfactory separation of  $^{82}\text{Sr}$  from the target materials and other radioisotopes generated during the irradiation procedure requires multiple treatment steps due to the relatively low affinity and low selectivity of the organic ion exchange resins for  $^{82}\text{Sr}$ .

$^{82}\text{Sr}$  is produced by the proton irradiation of molybdenum metal, rubidium metal and rubidium chloride targets. The irradiation process also produces a range of other radioactive isotopes (e.g.  $^{88}\text{Y}$ ,  $^{88}\text{Zr}$ ,  $^{85}\text{Sr}$ ) and as a consequence, a series of carefully designed separation procedures have been designed to separate the desired  $^{82}\text{Sr}$  from other radioisotopes and inactive species present. The primary method used to separate  $^{82}\text{Sr}$  is by a series of ion exchange and selective elution steps. Typically, AG 50 W-X8 ion exchange resin is used to separate  $^{82}\text{Sr}$  from dissolved targets. However, this resin is relatively non-selective and will absorb numerous polyvalent cations (e.g.,  $^{88}\text{Y}$ ) in addition to the desired  $^{82}\text{Sr}$ . Consequently, multiple separation steps are required to isolate  $^{82}\text{Sr}$  from the other isotopes present.

$^{82}\text{Rb}$  can be conveniently supplied to physicians in the form of a generator in which the parent  $^{82}\text{Sr}$  is immobilized on an ion exchange material and the  $^{82}\text{Rb}$  eluted when required. This means that  $^{82}\text{Rb}$  PET can be performed at clinical facilities where a typical generator may last several months before the yield of  $^{82}\text{Rb}$  diminishes below a usable level.

To be suitable for use in a  $^{82}\text{Rb}$  generator, an ion exchange material must exhibit a high affinity for strontium but a low affinity for rubidium, allowing the  $^{82}\text{Rb}$  daughter to be eluted from a column containing immobilized  $^{82}\text{Sr}$ . Generators have been proposed that were based on a number of separation media including Chelex 100,  $\text{Al}_2\text{O}_3$ ,  $\text{Sb(V)}$  hexacyanoferrate, polyantimonic acid, titanium vanadate and hydrated tin(IV) oxide, with the hydrated tin(IV) oxide being the most widely used.

However, the crucial component of any system is the actual ion exchange material containing the immobilized  $^{82}\text{Sr}$  parent. Current systems using hydrous tin

oxide have a limited life due to the breakdown of the hydrous tin dioxide, necessitating frequent replacement.

Therefore, there is a need for a highly strontium selective ion exchange material in place of ion exchange resins and hydrated tin(IV) oxide, so that the separation and recovery of  $^{82}\text{Sr}$  from Rb, RbCl and Mo targets is greatly facilitated. This will lead to a reduction in processing steps, a decrease in target processing times and thus a decrease in the cost of the  $^{82}\text{Sr}$  product. There is also a need for an ion exchange material suitable for use as a  $^{82}\text{Rb}$  generator having a very high selectivity for  $^{82}\text{Sr}$  and a very low selectivity for  $^{82}\text{Rb}$  to allow elution of the  $^{82}\text{Rb}$  by isotonic saline or other solutions.

### SUMMARY OF THE INVENTION

The present invention provides a method of chemically isolating strontium-82 from proton-irradiated molybdenum targets. This comprises dissolving the molybdenum metal target containing the strontium-82, adjusting the pH of the dissolved molybdenum target solution to an alkaline pH, removing precipitates from the solution, and then absorbing the strontium-82 from the solution onto a support comprising sodium nonatitanate. Sodium nonatitanate can also be applied to the efficient recovery of strontium-82 from alkaline RbCl solutions produced during the processing of proton-irradiated rubidium metal and rubidium chloride targets.

The present invention also provides a rubidium-82 generator, comprising a strontium-82 support medium comprising sodium nonatitanate. Preferably, the sodium nonatitanate is characterized by a strontium selectivity greater than 250,000 mL/g at an alkaline pH, and/or the sodium nonatitanate is characterized by a rubidium selectivity less than 100 mL/g at an alkaline pH. More preferably, the sodium nonatitanate is characterized by a strontium/rubidium separation factor greater than 1,000, and even more preferably greater than 100,000.

The rubidium-82 generator is prepared by a process comprising: preparing sodium nonatitanate from titanium isopropoxide and aqueous sodium hydroxide; heating the sodium nonatitanate at a temperature between 100°C and 250°C for a period between 12 hours and 2 weeks; and absorbing strontium-82 on the sodium nonatitanate from an aqueous solution comprising strontium-82 and a soluble sodium salt, wherein the sodium salt concentration is between 0.1 and 1 molar. It is also preferred that the titanium isopropoxide and the aqueous sodium hydroxide solution are provided at a sodium hydroxide to titanium isopropoxide molar ratio of greater than 0.44, but preferably providing a large molar excess of sodium

hydroxide. The sodium hydroxide to titanium isopropoxide molar ratio is preferably between 1 and 10, more preferably between 2 and 6, and most preferably about 4.

Furthermore, the invention provides a process for preparing a solution containing rubidium-82. The process comprises providing a solution containing strontium-82 at a pH between 10 and 14, absorbing the strontium-82 from the solution onto a sodium nonatitanate support medium, and eluting rubidium-82 from the sodium nonatitanate support medium with a solvent. The solvent is preferably selected from the group consisting of water and saline solutions. More particularly, the solvent may be an aqueous solution having a sodium chloride concentration between 0.001 molar and 1 molar, preferably between 0.2 molar and 1 molar. The solvent may also be a pharmaceutical grade isotonic saline and buffer solution.

#### **DETAILED DESCRIPTION OF THE INVENTION**

The present invention provides improved sodium nonatitanate compositions, a method using the composition for recovery of  $^{82}\text{Sr}$  from irradiated targets, and a method using the composition for generating  $^{82}\text{Rb}$ . The sodium nonatitanate materials of the invention are far more selective at separating strontium from solutions derived from the dissolution of irradiated target materials than current ion exchange resins used in the production of  $^{82}\text{Sr}$ . The present invention reduces the number of processing steps required, and thus leads to a decrease in target processing times and a reduction in the cost of the  $^{82}\text{Sr}$  product. Waste generation and disposal are also decreased.

According to the present invention, synthetic conditions are adjusted to produce a material with improved properties more applicable to  $^{82}\text{Sr}$  processing. The sodium nonatitanate of the present invention has been found to have a very low affinity for rubidium in addition to an exceptionally high affinity for strontium, making it ideal for use as a replacement for the hydrous tin dioxide used in current  $^{82}\text{Rb}$  generators. Sodium nonatitanate materials of this type will both improve the recovery of  $^{82}\text{Sr}$  and lead to a safer, more effective  $^{82}\text{Rb}$  generator system for clinical applications.

Sodium nonatitanate,  $\text{Na}_4\text{Ti}_9\text{O}_{20}\cdot x\text{H}_2\text{O}$ , is an inorganic ion exchange material that has been used for the removal of  $^{90}\text{Sr}$  from neutral and alkaline nuclear wastes. The sodium nonatitanate of the present invention has a number of advantages over conventional organic ion exchange resins (e.g., Chelex 100) that include: very high selectivity for trace levels of strontium in the presence of molar concentrations of other ions at alkaline pH; very low affinity for rubidium; excellent radiation, chemical and thermal stability so that there is no release of contaminants (e.g. Ti) into the  $^{82}\text{Rb}$  product; rapid reaction kinetics; high cation exchange capacity; absorbed ions readily stripped by treatment with dilute mineral acid allowing the sodium nonatitanate to be recycled, if desired; scale up of similar synthesis has



already been demonstrated; and the sodium nonatitanate powder can be manufactured into pellets appropriate for column operations. Other chemically related sodium titanate materials suitable for use in the same manner as the aforementioned sodium nonatitanate ( $\text{Na}_4\text{Ti}_9\text{O}_{20}\cdot x\text{H}_2\text{O}$ ) include other titanate materials exhibiting high Sr affinity and low Rb affinity, including Sr-Treat (available from Selion Oy) and monosodium titanate (available from Boulder Scientific). It is also anticipated that analogous zirconates may exhibit similar properties.

The invention also provides important improvements in the processing of irradiated targets to recover  $^{82}\text{Sr}$ . Sodium nonatitanate has a much greater affinity for  $^{82}\text{Sr}$  than currently used ion exchange resins, and a low affinity for other radioactive isotopes. Consequently, the use of sodium nonatitanate greatly simplifies the extraction process by reducing the number of separation steps that are required to produce chemically pure  $^{82}\text{Sr}$ . Thus, targets can be processed more rapidly and the recovery of  $^{82}\text{Sr}$  improved. Improved isotope selectivity may also facilitate the isolation of other useful isotopes from the targets, leading to greater payback from target processing operations.

Furthermore, less than 1g of sodium nonatitanate material is needed in a  $^{82}\text{Rb}$  generator and 1 kg of this material is expected to be sufficient to process a large number of targets, even if the sodium nonatitanate material is not recycled and is disposed of after one use. Consequently, the additional cost incurred by the use of sodium nonatitanate will be negligible in comparison with the cost savings achieved in the  $^{82}\text{Sr}$  production.

It has been determined that replacing hydrous tin dioxide with sodium nonatitanate reduces the amount of  $^{82}\text{Sr}$  released during the operation of the  $^{82}\text{Rb}$  generator, thereby reducing the exposure of the patient to  $^{82}\text{Sr}$ . Sodium nonatitanate is also more chemically stable and less likely to leach non-radioactive contaminants into solution during operation of the generator. The sodium nonatitanate is also more amenable to recycling since the  $^{82}\text{Sr}$  can readily be stripped with mineral acid without producing additional impurities. Recycling of  $^{82}\text{Sr}$  generators is already being used as a source of additional  $^{82}\text{Sr}$ , and improvements to the recycling procedure (obtained by using a superior ion exchange material) will facilitate the recovery of  $^{82}\text{Sr}$  from this source.

Although the sodium nonatitanate may be used as a direct replacement for hydrous tin dioxide in the  $^{82}\text{Rb}$  generator, it is also possible to use sodium nonatitanate in the form of a disposable add-on filter that could be used to trap any  $^{82}\text{Sr}$  that is leached from the generator during the production of  $^{82}\text{Rb}$ .

The first step in preparing a  $^{82}\text{Rb}$  generator is to load the parent  $^{82}\text{Sr}$  onto the sodium nonatitanate material and place the ion exchange material into a suitable column. It is essential that sufficient time be allowed for the  $^{82}\text{Sr}$  to be absorbed by the sodium

nonatitanate material in order to maximize the loading of the parent radioisotope per gram of ion exchange material.

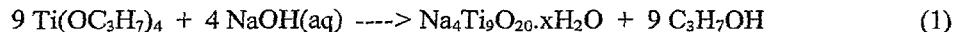
Sodium nonatitanate should be loaded with  $^{82}\text{Sr}$  before being placed in an ion exchange column, to avoid preferential loading of the  $^{82}\text{Sr}$  on the top of the ion exchange column rather than uniformly throughout the material. This high concentration of radioactivity on a very small volume may result in undesirable radiolytic problems. Although sodium nonatitanate has been shown to be highly resistant to radiation damage, it is considered prudent to avoid any potential problems.

### EXAMPLES

These Examples investigated the suitability of sodium nonatitanate for the use in separating  $^{82}\text{Sr}$  from irradiated targets and in the construction of a  $^{82}\text{Sr}/^{82}\text{Rb}$  generator. Initial batch experiments compared the rubidium and strontium selectivities of a number of different sodium nonatitanate samples with commercially available ion exchange materials (e.g. AW 500, Chelex 100) and some experimental materials that had also exhibited high strontium selectivities (e.g. sodium titanosilicate). Column experiments were then performed using target simulants and generator simulants on materials that exhibited favorable selectivity characteristics. Some work was also performed to investigate the likely interference from other isotopes present in irradiated targets on the production of  $^{82}\text{Sr}$ .

#### Example 1 - Preparation of Sodium Nonatitanate

Sodium nonatitanate ( $\text{NaTi}$ ) was synthesized hydrothermally as follows. 77.5 g of titanium isopropoxide was added to 84.35 g of a 50 wt.% solution of  $\text{NaOH}$  with vigorous stirring and 60 mL of deionized water was added. The resultant gel was heated at approximately  $108^\circ\text{C}$  for 3 hours, transferred to a hydrothermal pressure vessel with an additional 90 mL of deionized water, and heated at either  $170^\circ\text{C}$  or  $200^\circ\text{C}$  for times ranging from 21 hours to 1 week. After the allotted time, the materials were filtered, washed with ethanol to remove residual base and dried at  $60^\circ\text{C}$ . The mass of sodium nonatitanate produced was approximately 31 g. Each sample was characterized using x-ray powder diffraction (XRD). The reaction is outlined in Equation 1.



The crystallinity of the material was shown to be dependent upon the reaction time and temperature, with the most crystalline materials being produced after 1 week of hydrothermal treatment ( $200^\circ\text{C}$  for 7 days). Samples that received no hydrothermal treatment,

or only a few days, were virtually amorphous with only a few very broad reflections visible on the XRD pattern.

The theoretical cation exchange capacity (CEC) of sodium nonatitanate is quite high and has a value of 4.74 meq/g, which compares favorably with organic ion exchange resins.

Alternative titanium salts that could be used to manufacture sodium nonatitanate include titanium tetrachloride,  $TiCl_4$ , and titanium sulfate,  $TiOSO_4 \cdot xH_2SO_4 \cdot yH_2O$ . However, hydrolysis of these salts leads to the generation of hydrochloric acid and sulfuric acid, respectively, and thus additional base is required during the hydrothermal process. The final product also needed to be exhaustively washed to remove residual sodium chloride or sodium sulfate. Consequently, titanium isopropoxide (which hydrolyzes to form propanol) is the preferred starting material because the final product is free from additional sodium salts.

### Example 2 - Determination of Strontium Selectivity

Sodium nonatitanate and a variety of other ion exchange materials were obtained and evaluated for use in the separation of  $^{82}Sr$  from targets and in a  $^{82}Rb$  generator. These materials are described below in Table 1.

**Table 1. Characteristics of ion exchange materials evaluated in this study.**

| Material  | Source   | Sample Preparation   |
|---|--|--|
| Na-Clinoptilolite   | GSA Resources, AZ  | Ground to powder.  |
| AW500   | Aldrich (1.6 mm Pellets)                                       | Ground to powder.  |
| Hydrous $SnO_2$   | Synthesized in house   | NaOH + $SnCl_4$ . Washed with acetic acid/sodium acetate buffer.       |
| K+ Pharmacosiderite<br>( $K_3H(TiO)_4(SiO_4)_3 \cdot 4H_2O$ ) | Synthesized according to literature method.                    | None. Used as synthesized.   |
| Sodium Titanosilicate<br>( $Na_2Ti_2O_3SiO_4 \cdot 2H_2O$ )   | Synthesized according to literature method.                    | None. Used as synthesized.   |
| AG 50W-X8 (Na+)<br>(25 - 50 Mesh)                             | BioRad. Strong acid ion exchange resin.                        | Converted to Na+ form (for alkaline solutions only)                    |
| Chelex 100 (Na+)<br>(50 - 100 Mesh)                           | BioRad. Chelating resin with iminodiacetic acid functionality. | None. Used as received.  |
| Sodium Nonatitanate   | Honeywell, IL  | None. Used as received.  |
| Hydrous $SiO_2$   | Synthesized in house   | Acetic acid hydrolysis of tetraethyl orthosilicate. Washed with $H_2O$ |

|                          |                      |   |
|--------------------------|----------------------|---|
| Hydrous TiO <sub>2</sub> | Synthesized in house | Hydrolysis of titanium isopropoxide. Washed with H <sub>2</sub> O |
| Hydrous ZrO <sub>2</sub> | Synthesized in house | ZrOCl <sub>2</sub> + NaOH. Washed with deionized water.           |

The strontium selectivity of the ion exchange materials of Table 1 was evaluated in sodium chloride and rubidium chloride solutions using radiotracer techniques. Samples were evaluated using a simple batch technique to allow the rapid screening of a large number of materials over a range of ionic strengths. Blanks were run for each matrix to check for any loss of strontium during filtration or absorption of strontium onto the scintillation vials. In all solutions evaluated, strontium absorption was negligible.

0.05g of each of the ion exchange materials was contacted with 10 mL of a solution, spiked with <sup>89</sup>Sr, in a capped scintillation vial. (The total strontium content was approximately 1.6 ppm, thus preventing any loss of strontium in solution due to precipitation of sparingly soluble Sr(OH)<sub>2</sub> at alkaline pH values.) The mixtures were shaken for 6 hours, filtered through a 0.2 μm syringe filter and the residual activity determined using liquid scintillation counting (LSC). Distribution Coefficients (K<sub>d</sub> values) were then determined according to Equation 2:

$$K_d = (A_i - A_f) / A_f * v/m \quad (2)$$

where: A<sub>i</sub> = initial activity in solution (counts per minute (cpm)/mL)

A<sub>f</sub> = final activity in solution (cpm/mL)

v = volume of solution (mL)

m = mass of exchanger (g)

The final pH of the solution was also noted. The period of 6 hours was chosen to allow equilibrium to be reached for each of the ion exchange materials. However, previous work on the titanosilicates and titanates had shown the reaction rates to be rapid with the majority of the uptake occurring in only a few minutes. The concentration of the chloride solutions was varied from 1M to 0.001M to evaluate the effect of increasing Rb<sup>+</sup> and Na<sup>+</sup> concentrations on the uptake of Sr<sup>2+</sup>. All experiments were performed in duplicate, and if significant variations between duplicate samples occurred, the experiments were repeated until good agreements on the K<sub>d</sub> values were obtained. The results are shown in Tables 2 and 3 and represented the average K<sub>d</sub> obtained, quoted to 3 significant figures.

**Table 2. Strontium selectivity data from unbuffered sodium chloride solutions.**

| Ion Exchange Material    | $K_d$ mL/g |           |            |           |
|--------------------------|------------|-----------|------------|-----------|
|                          | 1M NaCl    | 0.1M NaCl | 0.01M NaCl | 0.001M    |
| <b>NaCl</b>              |            |           |            |           |
| Na-Clinoptilolite        | 8          | 124       | 3,260      | 36,900    |
| AW500                    | 1,860      | 88,300    | 1,270,000  | 1,210,000 |
| Hydrous SnO <sub>2</sub> | 767        | 43,000    | 124,000    | 51,800    |
| K+ Pharmacosiderite      | 18,300     | 251,000   | 594,000    | 281,000   |
| Sodium Titanosilicate    | 556,000    | 273,000   | 119,000    | 42,900    |
| AG 50W (Na+)             | 32         | 3,380     | 365,000    | 2,510,000 |
| Chelex 100 (Na+)         | 610        | 26,400    | 726,000    | 1,300,000 |
| NaTi (Honeywell)         | 80,600     | 1,030,000 | 258,000    | 166,000   |
| NaTi (No hydrothermal)   | 1,530,000  | 2,570,000 | 739,000    | 372,000   |
| NaTi (170°C, 21hr)       | 1,030,000  | 1,240,000 | 272,000    | 172,000   |
| NaTi (170°C, 3d)         | 959,000    | 633,000   | 218,000    | 93,100    |
| NaTi (170°C, 7d)         | 167,000    | 834,000   | 264,000    | 90,400    |
| NaTi (200°C, 21hr)       | 439,000    | 1,390,000 | 197,000    | 120,000   |
| NaTi (200°C, 3 d)        | 261,000    | 898,000   | 251,000    | 158,000   |
| NaTi (200°C, 7d)         | 195,000    | 955,000   | 265,000    | 214,000   |
| ZrO <sub>2</sub>         | 3,360      | 52,200    | 213,000    | 232,000   |

Table 3. Strontium selectivity data from unbuffered rubidium chloride solutions

| Material                 | $K_d$ mL/g |           |            |           |
|--------------------------|------------|-----------|------------|-----------|
|                          | 1M RbCl    | 0.1M RbCl | 0.01M RbCl | 0.001M    |
| <b>RbCl</b>              |            |           |            |           |
| Na-Clinoptilolite        | 19         | 3         | 88         | 11,000    |
| AW500                    | 9,750      | 107,000   | 1,020,000  | 1,280,000 |
| Hydrous SnO <sub>2</sub> | 766        | 66,100    | 104,000    | 51,800    |
| K+ Pharmacosiderite      | 1,950      | 40,800    | 419,000    | 427,000   |
| Sodium Titanosilicate    | 12,600     | 94,700    | 164,000    | 179,000   |
| AG-50W (Na+)             | 44         | 3,870     | 237,000    | 800,000   |
| Chelex 100 (Na+)         | 1,580      | 38,400    | 555,000    | 977,000   |
| NaTi (Honeywell)         | 13,900     | 108,000   | 279,000    | 324,000   |
| NaTi (No hydrothermal)   | 14,220     | 116,000   | 345,000    | 429,000   |
| NaTi (170°C, 21hr)       | 10,500     | 71,700    | 193,000    | 205,000   |
| NaTi (170°C, 3d)         | 15,100     | 39,500    | 68,000     | 95,200    |
| NaTi (170°C, 7d)         | 23,000     | 55,800    | 31,200     | 110,000   |
| NaTi (200°C, 21hr)       | 11,000     | 66,400    | 110,000    | 103,000   |
| NaTi (200°C, 3 d)        | 10,600     | 56,800    | 146,000    | 158,000   |
| NaTi (200°C, 7d)         | 10,500     | 57,400    | 146,000    | 158,000   |
| ZrO <sub>2</sub>         | 3,000      | 42,400    | 184,000    | 221,000   |

Comparing the selectivity data from sodium and rubidium solutions, it is evident that rubidium ions cause a reduction in affinity for the strontium ion for all of the exchangers indicating that the affinity of these materials for rubidium is significantly higher than the affinity for sodium ions. The pH of the final solutions was generally alkaline for the nonatitanates (NaTi) and titanosilicates, with pH values as high as 12 being measured. This was due to hydrolysis of the exchangers resulting in the absorption of protons and the release

of sodium ions, thus increasing the pH of the aqueous phase. This effect can be overcome, if desired, by buffering the solution.

The most distinct trend was observed in 1M NaCl solutions for the sodium nonatitanate samples. The highest  $K_d$  was observed for the non-hydrothermal material and the  $K_d$  values decreased with increasing reaction time for both the 200°C and 170°C materials. Clearly, strontium uptake is facilitated by having a low-crystallinity material. This suggests that as the crystallinity increases and the size of the nonatitanate crystallites also increases, it becomes thermodynamically less favorable for exchange of the sodium ions by strontium. It is also interesting to note that the majority of the sodium nonatitanates exhibit a higher selectivity for strontium in 1M NaCl than in 0.001M NaCl. This indicates that the higher ionic strength facilitates the  $\text{Na}^+/\text{Sr}^{2+}$  exchange reaction and more than compensates for the increased competition for the ion exchange sites from the additional  $\text{Na}^+$  ions.

This data shows that sodium nonatitanate is an ideal material for the recovery of  $^{82}\text{Sr}$  from irradiated rubidium and rubidium chloride targets and in the manufacture of a  $^{82}\text{Rb}$  generator.

### Example 3 - Rubidium Selectivity from NaCl Solutions

For an ion exchange material to be suitable for use in a  $^{82}\text{Rb}$  generator, it must have a very high selectivity for strontium to prevent any loss of  $^{82}\text{Sr}$  from the ion exchange column and release to the patient undergoing a PET scan. This property was clearly demonstrated in Example 2. It must also have a very low selectivity towards rubidium, thus allowing  $^{82}\text{Rb}$  to be released into solution as saline is passed through the  $^{82}\text{Rb}$  generator. Consequently, the rubidium selectivity of the ion exchange materials was evaluated in sodium chloride media following the procedure described in Example 2. The same procedure was followed using  $^{86}\text{Rb}$  to spike the solutions to give an activity of approximately 200,000 cpm/mL. Total rubidium in solution was < 0.05 ppm. The selectivities of the materials are shown below in Table 4.

**Table 4. Rubidium selectivity data from unbuffered sodium chloride solutions.**

| Material                     | 86Rb $K_d$ mL/g |           |            |        |
|------------------------------|-----------------|-----------|------------|--------|
|                              | 1M NaCl         | 0.1M NaCl | 0.01M NaCl | 0.001M |
| <b>NaCl</b>                  |                 |           |            |        |
| AW500                        | 116             | 620       | 4,920      | 21,900 |
| Hydrous $\text{SnO}_2$       | 1               | 6         | 36         | 290    |
| K+ Pharmacosiderite          | 148             | 475       | 2,030      | 4,020  |
| Sodium Titanosilicate        | 8,010           | 194,000   | 114,000    | 75,800 |
| AG 50W ( $\text{Na}^+$ )     | 7               | 75        | 688        | 6,680  |
| Chelex 100 ( $\text{Na}^+$ ) | 3               | 8         | 43         | 256    |
| NaTi (Honeywell)             | 9               | 102       | 488        | 817    |

|                        |   |    |     |     |
|------------------------|---|----|-----|-----|
| NaTi (No hydrothermal) | 4 | 59 | 280 | 446 |
| NaTi (170°C, 21hr)     | 9 | 56 | 209 | 297 |
| NaTi (170°C, 3d)       | 7 | 46 | 198 | 311 |
| NaTi (170°C, 7d)       | 3 | 15 | 47  | 71  |
| NaTi (200°C, 21hr)     | 8 | 79 | 334 | 502 |
| NaTi (200°C, 3d)       | 8 | 52 | 207 | 307 |
| NaTi (200°C, 7d)       | 4 | 25 | 111 | 178 |
| ZrO <sub>2</sub>       | 1 | 12 | 60  | 154 |

From the data in Table 4, it is clear that all of the sodium nonatitanate materials have a very low affinity for rubidium, particularly in the presence of relatively high amounts of sodium ions. In general, the rubidium selectivity decreased with increasing reaction time for both series of nonatitanates (170°C and 200°C) with the lowest affinity being demonstrated by the sample that was heated hydrothermally at 170°C for 1 week. Uptake was negligible in 1M NaCl and the very low reduction in activity that was noted could be accounted for by absorption of rubidium during filtration and by pipetting errors during the counting procedure. Consequently, samples with  $K_d$  values that were below 10 mL/g can be considered to have no affinity at all for <sup>86</sup>Rb. Some rubidium uptake was evident in very dilute sodium solutions, but the  $K_d$  values were low for all of the titanate samples. This suggests that the uptake of rubidium was more likely due to the materials having an exceptionally low affinity for sodium rather than any real affinity for rubidium. All of the sodium nonatitanate materials performed better than the commercially available sample obtained from Honeywell Inc. The materials are clearly ideal for use in a <sup>82</sup>Rb generator.

Hydrous tin dioxide exhibited some of the lowest rubidium affinities and was comparable with Chelex 100, the best of the nonatitanates and the hydrous zirconium dioxide. However, hydrous tin dioxide exhibited much lower strontium  $K_d$  values than the nonatitanates. Therefore, nonatitanate materials are preferred because they have higher strontium/rubidium separation factors. Hydrous tin dioxide also has a limited pH stability range and significant dissolution and release of absorbed strontium is likely to occur should any significant pH perturbations occur outside the range of pH 4 to pH 9. Radiation stability of hydrous tin dioxide is also limited, with particle breakdown causing current <sup>82</sup>Rb generators to be replaced before decay has reduced the <sup>82</sup>Rb below useable levels.

The rubidium selectivity data also indicates that AW500, potassium Pharmacosiderite and the sodium titanate have a strong affinity for rubidium in a range of saline solutions. Consequently, these materials will be unsuitable for use in a <sup>82</sup>Rb generator and have only limited applications in the processing of irradiated target materials.

#### Example 4 - Sr and Rb Selectivity in 0.1M Sodium Acetate/Acetic Acid Buffer

In order to prevent hydrolysis reactions from raising the pH as described above, some strontium and rubidium selectivity experiments were performed in a 0.1M sodium acetate / acetic acid buffer solution. In these tests, the final pH remained between 5.2 and 6.3, which is a more clinically acceptable pH for an  $^{82}\text{Rb}$  infusion. Rubidium  $K_d$  values remained low, as expected, following the trend observed in Table 5. Strontium  $K_d$  values were considerably lower, with a maximum  $K_d$  value of 80,000 mL/g being obtained for the sodium nonatitanate sample that was heated hydrothermally at 170°C for 21 hours. This is considerably lower than the  $K_d$  value of over 1,200,00 mL/g that was obtained in unbuffered 0.1M NaCl. The  $K_d$  values obtained for the other ion exchange materials were also considerably lower. However, the Sr/Rb separation factors remained high and the sodium nonatitanates still outperformed hydrous tin dioxide and the organic ion exchange resins. The affinity of sodium nonatitanate for strontium is greatest at higher pH values.

#### **Example 5 - Molybdenum Targets**

The basic steps of a proposed process to obtain  $^{82}\text{Sr}$  from irradiated molybdenum targets are as follows:

1. Dissolve the irradiated molybdenum target in 30% hydrogen peroxide, ensuring excess hydrogen peroxide is destroyed.
2. Add sodium hydroxide to bring the pH to approximately 12.
3. Filter the solution to remove any precipitate. It is predicted that the majority of  $^{88}\text{Zr}$  and  $^{59}\text{Fe}$  will be found in the precipitate, and experiments already performed have confirmed that 99% or more of the  $^{88}\text{Y}$  precipitated out of solution on the addition of NaOH.
4. Pass the solution through a column of sodium nonatitanate and wash the column with two bed volumes of 0.1M NaCl, adjusted to pH 12 with NaOH.  $^{82}\text{Sr}$  and  $^{85}\text{Sr}$  will be absorbed.  $^{82}\text{Rb}$  and other Rb isotopes will remain in the aqueous phase. Molybdate anions will also pass through the column.
5. The column can then be stripped using dilute mineral acid to recover the  $^{82}\text{Sr}$  and the sodium nonatitanate reused or discarded.

There is a range of other isotopes present in addition to  $^{82}\text{Sr}$ , including  $^{75}\text{Se}$ ,  $^{73}\text{As}$ ,  $^{74}\text{As}$ ,  $^{7}\text{Be}$ ,  $^{68}\text{Ge}$ ,  $^{48}\text{V}$ ,  $^{60}\text{Co}$  (and other Co isotopes),  $^{54}\text{Mn}$ ,  $^{51}\text{Cr}$  and  $^{95}\text{mTc}$ . In the alkaline target solution, Se, As, V, Ge, Cr, Mn and Tc are expected to be present as anions and thus will not be absorbed onto the sodium nonatitanate. Significant amounts of Co would be expected to precipitate when the target solution is neutralized, and thus little is expected to be available under alkaline conditions to absorb onto the sodium nonatitanate. The most



likely isotope to be absorbed is beryllium, because it is a Group II metal with a similar aqueous chemistry to strontium. However, the affinity of sodium nonatitanate for Group II metals decreases in the order  $Sr > Ca > Mg$ . No data is available for beryllium, but if the trend continues, the affinity would be expected to be low. Thus, any absorbed  $^7Be$  would be readily removed by an alkaline sodium chloride (or similar) wash.

The current process for recovering  $^{82}Sr$  from irradiated rubidium metal and rubidium chloride targets requires minimal modification to facilitate the use of sodium nonatitanate. Both targets are processed following standard processing procedures to generate rubidium chloride solutions in an ammonia/ammonium chloride buffer solution. These solutions are then passed through a sodium nonatitanate column and washed with additional buffer to remove any weakly held rubidium cations. Strontium and possibly some other cationic species present will be absorbed onto the nonatitanate column, whereas rubidium cations, ammonium cations and anions will rapidly pass through the column. If additional cations are absorbed onto the sodium nonatitanate, they can be selectively removed by washing with an appropriate eluant (e.g. citrate, nitrilotriacetate.) The strontium selectivity of sodium nonatitanate has been shown to be unaffected by a number of common complexants and as a consequence, it should be a relatively simple manner to elute any undesirable cations from the column, leaving pure  $^{82/85}Sr$ .

Figure 1 clearly shows the exceptionally high affinity of the sodium nonatitanate materials in comparison with the currently utilized organic resin Chelex 100. All of the sodium nonatitanates performed equally well in the buffered rubidium target solutions indicating that the synthetic conditions are not too important when the material is being used in solutions containing high concentrations of rubidium ions. Thus, by replacing the Chelex 100 with sodium nonatitanate, a more efficient  $^{82}Sr$  isolation can be achieved.

It has also been shown that it is possible to tailor the selectivity of the sodium nonatitanate to achieve the optimum  $Sr/Rb$  separation by manipulating the reaction conditions. The differing selectivities were most obvious in sodium solutions, with the less crystalline materials exhibiting the highest strontium distribution coefficients. However, the series of nonatitanates showed little difference in behavior when the predominant cation in solution was  $Rb^+$ . The materials synthesized clearly demonstrated superior characteristics to the commercially available sample in almost all matrices evaluated. The majority of the sodium nonatitanate samples also exhibited greater strontium selectivities than hydrous tin dioxide in a range of sodium chloride solutions, from 1M to 0.001M. Rubidium selectivities were low, making the sodium nonatitanate ideal as a replacement for hydrous tin dioxide in a  $^{82}Rb$  generator.

Commercially, one method of  $^{82}\text{Sr}$  production is via the proton spallation reaction with natural molybdenum metal targets. A simulated molybdate target solution was prepared as follows. 12.5 g of molybdenum powder was carefully dissolved in 30%  $\text{H}_2\text{O}_2$  solution and made up to a total volume of 500 mL to produce a clear yellow solution of molybdic acid,  $\text{H}_2\text{MoO}_4$ . Solid sodium hydroxide granules totaling 10.9 g were then carefully added to neutralize the solution and bring the pH to approximately 12.3. The colorless solution was then filtered to remove any precipitate. This alkaline molybdate solution was spiked with either  $^{86}\text{Rb}$  or  $^{89}\text{Sr}$  and  $K_d$  values determined as described previously. Separation factors for the strontium/rubidium selectivity were also calculated by dividing the strontium  $K_d$  by the rubidium  $K_d$ , thus allowing the relative affinities of the ion exchange materials to be directly compared. The results are illustrated below in Table 5.

**Table 5. Strontium and rubidium absorption from simulated molybdate target solutions**

| Material                      | Sr $K_d$ mL/g | Rb $K_d$ mL/g | Separation Factor |
|-------------------------------|---------------|---------------|-------------------|
| AW500                         | 7,070         | 194           | 36.4              |
| K+ Pharmacosiderite           | 187,000       | 142           | 1320              |
| Sodium Titanosilicate         | 547,000       | 6500          | 84.2              |
| Chelex 100 (Na <sup>+</sup> ) | 3,120         | 5             | 624               |
| AG 50W-X8 (Na <sup>+</sup> )  | 69            | 18            | 3.83              |
| NaTi (Honeywell)              | 337,000       | 27            | 12,500            |
| NaTi (No hydrothermal)        | 1,690,000     | 12            | 141,000           |
| NaTi (170°C, 21hr)            | 1,000,000     | 12            | 83,300            |
| NaTi (170°C, 3d)              | 829,000       | 14            | 59,200            |
| NaTi (170°C, 7d)              | 324,000       | 3             | 108,000           |
| NaTi (200°C, 21hr)            | 954,000       | 12            | 79,500            |
| NaTi (200°C, 3 d)             | 687,000       | 11            | 62,500            |
| NaTi (200°C, 7d)              | 772,000       | 9             | 85,800            |
| ZrO <sub>2</sub>              | 168,000       | 8             | 21,000            |

From this data, it is clear that the sodium nonatitanate materials are far superior to Chelex 100 and AG 50W-X8 ion exchange resins for the recovery of  $^{82}\text{Sr}$  from irradiated molybdenum targets. High  $K_d$  values in excess of 500,000 mL/g indicate that almost 100% strontium removal was achieved by some of the nonatitanate samples, with the residual strontium in solution approaching background levels. In the alkaline conditions used in this test, the Chelex 100 resin had the lowest affinity for strontium of all of the materials evaluated. The selectivity of the sodium nonatitanate for rubidium was lowest for the sodium nonatitanate material that was prepared by heating for 1 week at 170°C to obtain a relatively crystalline product. However, strontium selectivity also decreased with increasing reaction time.

The best overall strontium/rubidium separation factor was obtained for the material that had not undergone any hydrothermal treatment. All of the materials performed better than the commercially available nonatitanate materials. Thus, it is possible to alter the selectivity of the material by controlling the reaction conditions to produce an improved sodium nonatitanate material for use in  $^{82}\text{Sr}$  separations. Rubidium selectivities were very low for all of the nonatitanates, indicating minimal rubidium absorption would occur in a column process and that any rubidium absorbed would be readily removed by a dilute saline wash.

The sodium titanate, potassium Pharmacosiderite and AW500 exhibit selectivities for rubidium that are too high to allow their use in the selective removal of  $^{82}\text{Sr}$  from irradiated molybdenum targets. This high selectivity would result in some rubidium being retained on the column that would not be readily removed by a simple saline wash, thus leading to contamination of the  $^{82}\text{Sr}$  product with both radioactive and stable rubidium isotopes. Hydrous tin oxide was not evaluated because, due to the amphoteric nature of tin, significant dissolution would be expected at a pH in excess of 12.

#### Example 6 - Acid Molybdate Target Solutions

Sodium nonatitanate has a relatively low affinity for strontium at pH values less than 6, and was not expected to exhibit any affinity for strontium from the acidic molybdate target solutions prior to the addition of sodium hydroxide.  $K_d$  values were determined to confirm this and to compare it with the  $K_d$  values for both Chelex 100 and AG 50W-X8 under identical conditions. The data obtained is shown below in Table 6.

**Table 6. The affinity of selected ion exchange materials for strontium in acidic molybdate target solutions**

| Ion Exchange Material Solution  | Sr $K_d$ mL/g | Final pH of |
|---------------------------------|---------------|-------------|
| Chelex 100                      | 25            | 1.43        |
| AG 50W-X8                       | 18,300        | 1.42        |
| Sodium Nonatitanate (Honeywell) | 1,260         | 1.53        |

These data clearly indicate that for the processing of acid molybdate solutions, the strong acid ion exchange resin AG 50W-X8 is the preferred medium. However, the Sr  $K_d$  value of 18,300 mL/g in the acidic media is nearly two orders of magnitude lower than the  $K_d$  value of 1,690,000 mL/g that was obtained for the best of the sodium nonatitanate materials in alkaline molybdate solutions. Consequently, it is evident that  $^{82}\text{Sr}$  can be recovered more effectively from alkaline solution using sodium nonatitanate than is currently achieved using AG 50W-X8 from acidic media.

### Example 7 - Rubidium and Rubidium Chloride Target Solutions

The processing of either rubidium chloride or rubidium metal targets follows a similar procedure once the target has been successfully dissolved. In essence,  $^{82}\text{Sr}$  needs to be selectively extracted from a solution of  $\text{RbCl}$  in a  $0.1 \text{ M NH}_3 / 0.1\text{M NH}_4\text{Cl}$  buffer adjusted to a pH of between 9 and 10. Batch experiments were performed in simulated buffer solutions to determine the strontium selectivity in the presence of high concentrations of rubidium ions. Only the ion exchange materials that exhibited high strontium selectivities in the initial scoping studies with  $\text{NaCl}$  solutions were evaluated.  $K_d$  values were obtained as described previously. Two rubidium chloride solutions were selected which represent typical rubidium concentrations obtained during the processing of rubidium metal ( $1.95 \text{ M Rb}^+$ ) and rubidium chloride targets ( $0.68 \text{ M Rb}^+$ ). In both cases, Chelex 100 is used in the preliminary step to remove the  $^{82}\text{Sr}$  from the buffered rubidium solutions. The  $K_d$  values for the ion exchange materials are shown in Figure 1.

In the buffered rubidium solutions, there is little difference between the different nonatitanates evaluated. This is in stark contrast to the sodium molybdate solutions where a large variation in the performance of the titanates was observed. The nonatitanates were clearly the most effective materials at removing strontium from the buffered solutions with strontium  $K_d$  values of around  $15,000 \text{ mL/g}$  in  $0.68 \text{ M Rb}^+$  solutions and approximately  $5,000 \text{ mL/g}$  in  $1.96 \text{ M Rb}^+$  solutions. By contrast, Chelex 100 ion exchange resin gave  $K_d$  values of less than  $1,000 \text{ mL/g}$  in both solutions. Hydrous titanium oxide and hydrous tin oxide also exhibited appreciable  $K_d$  values, but they performed less efficiently than the nonatitanates in both solutions. Consequently, this data demonstrates that using sodium nonatitanate in place of Chelex 100 ion exchange resin will greatly increase the amount of strontium extracted from the target solutions.

The ion exchange materials were also evaluated for their rubidium selectivity from  $0.1 \text{ M NH}_3 / 0.1\text{M NH}_4\text{Cl}$  buffer solution. The buffer was prepared, spiked with  $^{86}\text{Rb}$  and the pH adjusted to approximately 9.25 with concentrated ammonia.  $^{86}\text{Rb}$   $K_d$  values were then determined following the method described earlier. All of the sodium nonatitanates had a  $K_d < 20 \text{ mL/g}$ . The very low rubidium selectivity in the pure buffer is almost certainly due to competition from  $\text{NH}_4^+$  ions for the available ion exchange sites. Consequently, absorption of rubidium during the processing of rubidium and rubidium chloride targets will be minimal, and any rubidium absorbed will be readily removed by washing with additional  $0.1 \text{ M NH}_3 / 0.1\text{M NH}_4\text{Cl}$  buffer solution. Thus, a clean separation of  $^{82}\text{Sr}$  from these targets can be obtained using sodium nonatitanate.

The performance could also be improved by removing the buffer and increasing the pH to improve the amounts of strontium absorbed. (Buffers were initially utilized to maximize the performance of the organic ion exchange resins currently used and are not essential to the  $^{82}\text{Sr}$  recovery process.)

#### **Example 9 - Kinetic Experiments**

In order for the sodium nonatitanate materials to find applications in the processing of irradiated target solutions, they must exhibit fast ion exchange kinetics allowing solutions to be passed through an ion exchange column at an acceptable rate. The kinetics of strontium absorption from alkaline molybdate target solutions was evaluated using a simple batch procedure. Ion exchange material, in the amount of 0.05 g, was shaken with 10 mL of molybdate solution spiked with  $^{89}\text{Sr}$  to give a total activity of approximately 155,000 cpm/mL. After an allotted time, the material was filtered through a 0.2 m syringe filter and the activity in the aqueous phase determined by LSC. The results are shown below in Figure 2.

From the data in Figure 2, it is clear that the reaction kinetics for the sodium nonatitanate powder is extremely rapid, with over 99 % of the  $^{89}\text{Sr}$  removed in only 1 minute. By contrast, the reaction kinetics of the organic ion exchanged resins was much slower and the total amount of  $^{89}\text{Sr}$  removed after 1 hour was much less.

The exceedingly rapid kinetics can partly be explained by the fact that the nonatitanate was in the form of a fine powder, whereas the two resins were in the form of beads (see Table 1). As a consequence, a relatively slow reaction rate would be expected for the beads because the uptake of  $^{82}\text{Sr}$  will be dependent upon the rate of diffusion of the  $^{82}\text{Sr}$  to the internal functional groups. The rate of uptake of a sample of sodium nonatitanate pellets (using hydrous titanium dioxide as a binder) was significantly slower than the powdered form, but the kinetics and amount of  $^{82}\text{Sr}$  absorbed was still significantly better than for either of the two organic resins. As the pelletization process is improved, it is expected that the kinetics and selectivity of the pelletized sodium nonatitanate will improve substantially. Other sodium nonatitanate powders of varying crystallinities also showed rapid kinetics. Other potentially suitable binders for forming suitable pellets include titanium isopropoxide or tetraethyl orthosilicate (TEOS) as a binder precursor.

#### **Example 10 - $^{82}\text{Sr}$ Removal from Irradiated Targets Using Pelletized Sodium Nonatitanate**

A sample of sodium nonatitanate was mixed with titanium isopropoxide as a binder and the resulting paste dried at 105°C for 12 hours. The material was gently broken up using a mortar and pestle and then sieved to produce particles in the range 40 to 60 mesh. The binder content was approximately 20%. These particles were then used to assess the extraction of  $^{89}\text{Sr}$  from simulated target solutions.

1 mL of pelletized sodium nonatitanate was slurried into a column and the target simulant that had been spiked with  $^{89}\text{Sr}$  to give an activity of approximately 200,000 cpm/mL was passed through the column at a flow rate of 15 mL per hour. The amount of activity removed from solution was then determined. The results are given below in Table 1.

**Table 1. Removal of  $^{82}\text{Sr}$  From Irradiated Target Solutions**

| Target (%)        | Solution Composition  | Volume (mL) | $^{82}\text{Sr}$ Removed |
|-------------------|---|-------------|--------------------------|
| Rubidium Metal    | 1.95M RbCl in<br>0.1M $\text{NH}_3/\text{NH}_4\text{Cl}$<br>Buffer, pH10  | 20          | 97.3                     |
| Rubidium Chloride | 0.68M RbCl in<br>0.1M $\text{NH}_3/\text{NH}_4\text{Cl}$<br>Buffer, pH 10 | 20          | 98.8                     |
| Molybdenum Metal  | 0.26M $\text{Na}_2\text{MoO}_4$ , pH 12                                   | 20          | 99.9                     |

This data clearly shows the effectiveness of sodium nonatitanate at removing strontium isotopes from  $^{82}\text{Sr}$  target materials. Rubidium absorption under these conditions is minimal.

#### **Example 11 - Elution of Strontium**

Strontium was quantitatively eluted from the sodium nonatitanate column of Example 10 using 6M nitric acid. Hydrochloric acid was found to be much less effective and also resulted in breakdown of the sodium nonatitanate particles and blocked the ion exchange column.

While the foregoing is directed to the preferred embodiment of the present invention, other and further embodiments of the invention may be devised without

departing from the basic scope thereof, and the scope thereof is determined by the claims that follow.

What is claimed is:

1. A rubidium-82 generator, comprising:
  - (a) a strontium-82 support medium comprising sodium nonatitanate.
2. The rubidium-82 generator of claim 1, wherein the sodium nonatitanate is characterized by a strontium selectivity greater than 250,000 mL/g at an alkaline pH.
3. The rubidium-82 generator of claim 1, wherein the sodium nonatitanate is characterized by a rubidium selectivity less than 100 mL/g at an alkaline pH.
4. The rubidium-82 generator of claim 1, wherein the sodium nonatitanate is characterized by a strontium/rubidium separation factor greater than 1,000.
5. The rubidium-82 generator of claim 1, wherein the sodium nonatitanate is characterized by a strontium/rubidium separation factor greater than 100,000.
6. A process for preparing a rubidium-82 generator, comprising:
  - (a) preparing sodium nonatitanate from titanium isopropoxide and aqueous sodium hydroxide;
  - (b) heating the sodium nonatitanate at a temperature between 100°C and 250°C for a period between 12 hours and 2 weeks; and
  - (c) absorbing strontium-82 on the sodium nonatitanate from an aqueous solution comprising strontium-82 and sodium chloride, wherein the sodium chloride concentration is between 0.1 and 1 molar.
7. The process of claim 6, wherein the molar ratio of aqueous sodium hydroxide to titanium isopropoxide is in excess of 0.44.
8. The process of claim 6, wherein the molar ratio of aqueous sodium hydroxide to titanium isopropoxide is between 2 and 6.
9. A method of chemically isolating strontium-82 from a proton-irradiated molybdenum target, comprising:
  - (a) dissolving the molybdenum metal target containing the strontium-82;
  - (b) adjusting the pH of the dissolved molybdenum target solution to an alkaline pH;



- (c) removing precipitates from the solution; and then
  - (d) absorbing the strontium-82 from the solution onto a support comprising sodium nonatitanate.
10. A process for preparing a solution containing rubidium-82, comprising:
- (a) providing a solution containing strontium-82 at a pH between 10 and 14;
  - (b) absorbing strontium-82 onto a sodium nonatitanate support medium; and
  - (c) eluting rubidium-82 from the sodium nonatitanate support medium with a solvent.
11. The process of claim 10, wherein the solvent is selected from the group consisting of water and saline solutions.
12. The process of claim 10, wherein the solvent is an aqueous solution having a sodium chloride concentration between 0.001 molar and 1 molar.
13. The process of claim 10, wherein the solvent is an aqueous solution having a sodium chloride concentration between 0.2 molar and 1 molar.
14. The process of claim 10, wherein the solvent is a pharmaceutical-grade saline and buffer solution.
15. A method of chemically isolating strontium-82 from a proton-irradiated rubidium or rubidium chloride target, comprising:
- (a) dissolving the target containing the strontium-82;
  - (b) adjusting the pH of the dissolved target solution to an alkaline pH;
  - (c) removing precipitates from the solution; and then
  - (d) absorbing the strontium-82 from the solution onto a support comprising sodium nonatitanate without absorbing rubidium.

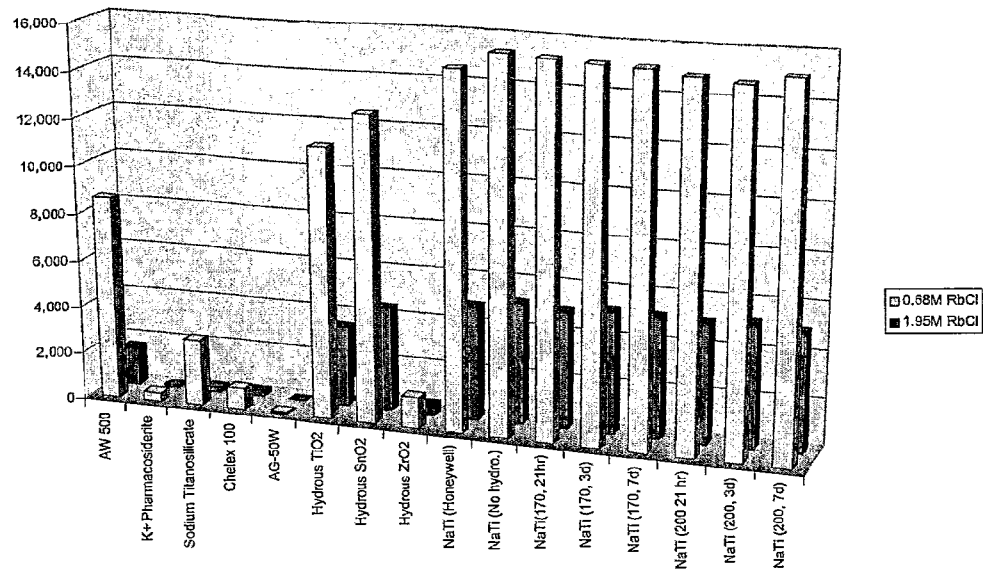


Figure 1. <sup>82</sup>Sr K<sub>d</sub> Values for the ion exchange materials from simulated rubidium and rubidium chloride target solutions

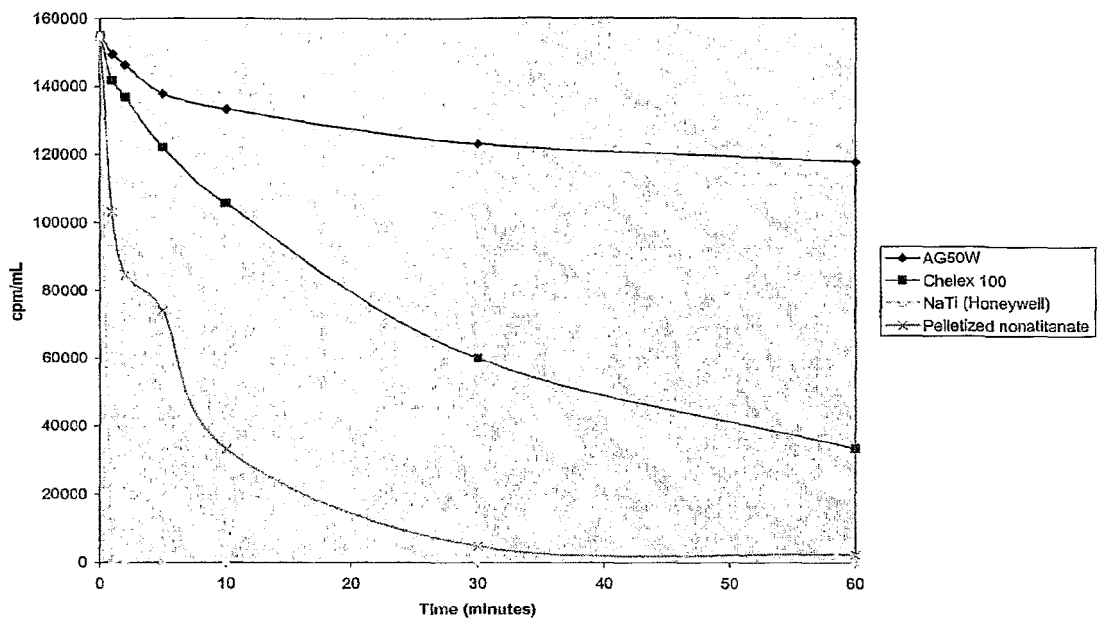


Figure 2. The reduction of <sup>82</sup>Sr activity with increasing time.

**INTERNATIONAL SEARCH REPORT**

International Application No

PCT/US 02/41676

**A. CLASSIFICATION OF SUBJECT MATTER**  
IPC 7 G21G4/08

According to International Patent Classification (IPC) or to both national classification and IPC

**B. FIELDS SEARCHED**

Minimum documentation searched (classification system followed by classification symbols)

IPC 7 G21G

Documentation searched other than minimum documentation to the extent that such documents are included in the fields searched

Electronic data base consulted during the international search (name of data base and, where practical, search terms used)

EPO-Internal, WPI Data, INSPEC, COMPENDEX

**C. DOCUMENTS CONSIDERED TO BE RELEVANT**

| Category * | Citation of document, with indication, where appropriate, of the relevant passages                     | Relevant to claim No. |
|------------|--|-----------------------|
| A          | EP 0 043 650 A (SQUIBB & SONS INC)<br>13 January 1982 (1982-01-13)<br>the whole document<br>---        | 1-15                  |
| A          | US 3 953 567 A (GRANT PATRICK M ET AL)<br>27 April 1976 (1976-04-27)<br>the whole document<br>---      | 1-15                  |
| A          | US 4 406 877 A (NEIRINCKX RUDI D ET AL)<br>27 September 1983 (1983-09-27)<br>the whole document<br>--- | 1-15                  |
| A          | US 3 957 945 A (GRANT PATRICK M ET AL)<br>18 May 1976 (1976-05-18)<br>the whole document<br>---        | 9                     |
|            | -/--   |                       |

Further documents are listed in the continuation of box C.

Patent family members are listed in annex.

\* Special categories of cited documents:

- \*A\* document defining the general state of the art which is not considered to be of particular relevance
- \*E\* earlier document but published on or after the international filing date
- \*L\* document which may throw doubts on priority claim(s) or which is cited to establish the publication date of another citation or other special reason (as specified)
- \*O\* document referring to an oral disclosure, use, exhibition or other means
- \*P\* document published prior to the international filing date but later than the priority date claimed

- \*T\* later document published after the international filing date or priority date and not in conflict with the application but cited to understand the principle or theory underlying the invention
- \*X\* document of particular relevance; the claimed invention cannot be considered novel or cannot be considered to involve an inventive step when the document is taken alone
- \*Y\* document of particular relevance; the claimed invention cannot be considered to involve an inventive step when the document is combined with one or more other such documents, such combination being obvious to a person skilled in the art.
- \*G\* document member of the same patent family

Date of the actual completion of the international search

15 September 2003

Date of mailing of the international search report

25/09/2003

Name and mailing address of the ISA

European Patent Office, P.B. 5818 Patentlaan 2  
NL - 2280 HV Rijswijk  
Tel. (+31-70) 340-2040, Tx. 31 651 epo nl,  
Fax: (+31-70) 340-3016

Authorized officer

Ludi, M

## INTERNATIONAL SEARCH REPORT

International Application No

PCT/US 02/41676

| C.(Continuation) DOCUMENTS CONSIDERED TO BE RELEVANT |   |                       |
|--|---|-----------------------|
| Category *   | Citation of document, with indication, where appropriate, of the relevant passages  | Relevant to claim No. |
| A  | <p>SYLVESTER P ET AL: "AN ASSESSMENT OF INORGANIC ION-EXCHANGE MATERIALS FOR THE REMOVAL OF STRONTIUM FROM SIMULATED HANFORD TANK WASTES" SEPARATION SCIENCE AND TECHNOLOGY, DEKKER,, NEW YORK, NY,, US, vol. 34, no. 10, 1999, pages 1981-1992, XP009013438<br/>ISSN: 0149-6395<br/>the whole document</p> <p style="text-align: center;">---</p>                            | 1-15                  |
| A  | <p>SAHA G B ET AL: "USE OF THE 82SR/82RB GENERATOR IN CLINICAL PET STUDIES" INTERNATIONAL JOURNAL OF RADIATION APPLICATIONS AND INSTRUMENTATION PART B: NUCLEAR MEDICINE AND BIOLOGY, ELSEVIER SCIENCE PUBLISHERS, NEW YORK, NY, US, vol. 17, no. 8, 1990, pages 763-768, XP000166064<br/>ISSN: 0883-2897<br/>the whole document</p> <p style="text-align: center;">-----</p> | 1                     |

Form PCT/ISA/210 (continuation of second sheet) (July 1992)

## INTERNATIONAL SEARCH REPORT

Information on patent family members

International Application No

PCT/US 02/41676

| Patent document cited in search report |            | Publication date | Patent family member(s) | Publication date |
|--|------------|------------------|-------------------------|------------------|
| EP 0043650                             | A          | 13-01-1982       | US 4400358 A            | 23-08-1983       |
|  |            |                  | AT 22188 T              | 15-09-1986       |
|  |            |                  | AU 548918 B2            | 09-01-1986       |
|  |            |                  | AU 7135281 A            | 07-01-1982       |
|  |            |                  | CA 1176618 A1           | 23-10-1984       |
|  |            |                  | DE 3175292 D1           | 16-10-1986       |
|  |            |                  | EP 0043650 A2           | 13-01-1982       |
|  |            |                  | IE 51449 B1             | 24-12-1986       |
|  |            |                  | JP 1662587 C            | 19-05-1992       |
|  |            |                  | JP 3025760 B            | 08-04-1991       |
|  |            |                  | JP 57030545 A           | 18-02-1982       |
| ZA 8103677 A                           | 30-06-1982 |                  |                         |                  |
| US 3953567                             | A          | 27-04-1976       | CA 1057946 A1           | 10-07-1979       |
|  |            |                  | CH 591750 A5            | 30-09-1977       |
|  |            |                  | DE 2542415 A1           | 15-04-1976       |
|  |            |                  | FR 2286480 A1           | 23-04-1976       |
|  |            |                  | JP 51060900 A           | 27-05-1976       |
| US 4406877                             | A          | 27-09-1983       | AU 7068681 A            | 10-12-1981       |
|  |            |                  | CA 1171354 A1           | 24-07-1984       |
|  |            |                  | EP 0041356 A1           | 09-12-1981       |
|  |            |                  | JP 57031624 A           | 20-02-1982       |
|  |            |                  | ZA 8103320 A            | 26-05-1982       |
| US 3957945                             | A          | 18-05-1976       | NONE                    |                  |

(19) World Intellectual Property Organization  
International Bureau



(43) International Publication Date  
9 March 2006 (09.03.2006)

PCT

(10) International Publication Number  
**WO 2006/026603 A2**

(51) International Patent Classification:  
A61K 51/00 (2006.01)

(74) Agents: SUTTON, Paul, J. et al.; Greenberg Traurig, LLP, Met Life Building, 200 Park Avenue, New York, NY 10166 (US).

(21) International Application Number:  
PCT/US2005/030796

(81) Designated States (unless otherwise indicated, for every kind of national protection available): AE, AG, AL, AM, AT, AU, AZ, BA, BB, BG, BR, BW, BY, BZ, CA, CH, CN, CO, CR, CU, CZ, DE, DK, DM, DZ, EC, EE, EG, ES, FI, GB, GD, GE, GH, GM, HR, HU, ID, IL, IN, IS, JP, KE, KG, KM, KP, KR, KZ, LC, LK, LR, LS, LT, LU, LV, MA, MD, MG, MK, MN, MW, MX, MZ, NA, NG, NI, NO, NZ, OM, PG, PH, PL, PT, RO, RU, SC, SD, SE, SG, SK, SL, SM, SY, TJ, TM, TN, TR, TT, TZ, UA, UG, US, UZ, VC, VN, YU, ZA, ZM, ZW.

(22) International Filing Date: 30 August 2005 (30.08.2005)

(25) Filing Language: English

(26) Publication Language: English

(30) Priority Data:  
60/605,481 30 August 2004 (30.08.2004) US

(71) Applicant (for all designated States except US):  
**BRACCO DIAGNOSTICS INC.** [US/US]; 107 College Road East, Princeton, NJ 08540 (US).

(84) Designated States (unless otherwise indicated, for every kind of regional protection available): ARIPO (BW, GH, GM, KE, LS, MW, MZ, NA, SD, SL, SZ, TZ, UG, ZM, ZW), Eurasian (AM, AZ, BY, KG, KZ, MD, RU, TJ, TM), European (AT, BE, BG, CH, CY, CZ, DE, DK, EE, ES, FI, FR, GB, GR, HU, IE, IS, IT, I, LU, LV, MC, NL, PL, PT, RO, SE, SI, SK, TR), OAPI (BF, BJ, CF, CG, CI, CM, GA, GN, GQ, GW, ML, MR, NE, SN, TD, TG).

(72) Inventors; and

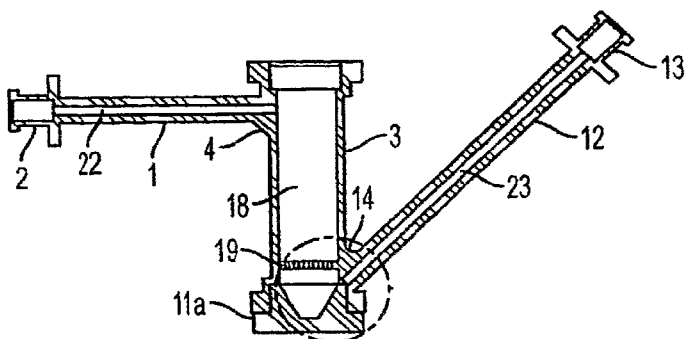
(75) Inventors/Applicants (for US only): **BALESTRACCI, Ernest** [US/US]; Woodbridge Hills, 404 Hampton Lane, Iselin, NJ 08830 (US). **MELCHORE, James, A., Jr.** [US/US]; 12 Staats Road, Bloomsbury, NJ 08804 (US). **MONTEFERRANTE, Jo, Anna** [US/US]; 18 Johnston Drive, Flemington, NJ 08822 (US). **KUCHAREWICZ ROPIAK, Irene** [US/US]; 15122 East Run Drive, Lawrenceville, NJ 08648 (US). **SCHRAMM, Ernest** [DE/US]; 815 Prospect Avenue, Milltown, NJ 08850 (US). **ZODDA, Julius, P.** [US/US]; 3 Tigers Court, Mercerville, NJ 08619 (US).

**Published:**

— without international search report and to be republished upon receipt of that report

For two-letter codes and other abbreviations, refer to the "Guidance Notes on Codes and Abbreviations" appearing at the beginning of each regular issue of the PCT Gazette.

(54) Title: IMPROVED CONTAINERS FOR PHARMACEUTICALS, PARTICULARLY FOR USE IN RADIOISOTOPE GENERATORS



(57) Abstract: The invention is directed to improved containers for pharmaceuticals and any tubing and tubing connectors associated therewith, particularly containers for pharmaceuticals which are irradiated, heated or otherwise subjected to increased pressure. In a preferred embodiment, the invention is directed to an improved container for use in a radioisotope generator, such as a rubidium-82 generator.

WO 2006/026603 A2

**IMPROVED CONTAINERS FOR PHARMACEUTICALS,  
PARTICULARLY FOR USE IN RADIOISOTOPE GENERATORS**

**TECHNICAL FIELD OF THE INVENTION**

The invention is directed to improved containers for pharmaceuticals and the tubing and tubing connectors associated therewith, particularly containers for pharmaceuticals which are heated, irradiated or otherwise subjected to increased pressure. In a preferred embodiment, the invention is directed to an improved container for use in a radioisotope generator. Specifically, the designs and materials of the column container and its closure and associated tubing and tubing connectors have been improved.



## SUMMARY OF THE INVENTION

The invention includes improved pharmaceutical containers, particularly improved containers for pharmaceuticals that are subjected to increased pressure (such as by heating or other means) and/or are subjected to radioactivity. In a preferred embodiment, the invention is directed to an improved container, also called a column, for use in a radioisotope generator. In an especially preferred embodiment, the improved column is for use with rubidium-82 generator such as those disclosed in U.S. Patent Nos. 3,953,567; 4,400,358; 4,406,877; 4,562,829; 4,585,009; 4,585,941; and 5,497,951, incorporated herein by reference in their entirety. In a particularly preferred embodiment, the improved column is used in a rubidium-82 generator such as that sold under the trade name CardioGen®.

The improved pharmaceutical container of the invention includes an improved seal and crimping process, as well as changes to the design of the stopper and the container to prevent blockages and improve consistency in packing and closing the container, which improves flow rate and elution from the column.

Further improvements include constructing the container and stopper out of radiation resistant or tolerant materials. In addition, flexible tubing used with the container is made of a radiation resistant or tolerant material, and the Luer locks used to fasten the flexible tubing to the container is made of a radiation resistant or tolerant material and is further improved to insure a tight, secure lock which will not inadvertently loosen or disconnect.

Specifically, the improved container has a new, stronger seal which is used to crimp the stopper in a pharmaceutical container and particularly, which is used to seal a radioisotope generator column/stopper assembly system, such as the CardioGen® system. This improved seal prevents leakage, even at increased pressure, and reduces ballooning of the rubber stopper material. The seal has a configuration similar to one of those shown in Fig. 5B through Fig. 5F and Fig. 6 and is made of any suitably strong material including

metal or plastic. A pneumatically operated automatic or semi-automatic crimper, set at optimized pressure, is preferably used to crimp the seal during assembly of a pharmaceutical container such as a radioisotope generator column/stopper assembly system. The invention includes identification of optimized crimping pressure(s) for crimping the seal (regardless of material) to a pharmaceutical container such as a glass or plastic vial or column and thus securing in place a rubber closure(s) when using an automatic crimping system and/or manual crimping.

The stopper which is crimped into place is also improved. Specifically, it is made of a material which is radiation resistant or tolerant, is resistant to ballooning and can withstand at least the pressures at which the container operates. Additionally, the configuration and placement of the stopper are improved. For example, the improved stoppers form tight seals with the column and reduce the "dead volume" at the bottom of the column— space where non-radioactive, decayed eluate could mix with (and dilute) fresh, radioactive eluate, reducing the efficacy of the eluent.

The improved pharmaceutical container also includes improvements to the design which improve its packing/assembly and thus ensure specified flow of eluent through the container.

These improvements are illustrated in the context of a radioisotope generator column container. Flow rate of the eluent through the column could be partially or completely blocked if the stopper blocks the outlet arm of the column. As shown in Figure 1, the outlet arm of the container of the invention has been repositioned slightly and a small piece of plastic removed from the inside edge of the column to create a recess or notch where the outlet arm enters the column lumen to prevent a stopper from blocking flow. See Figure 4. A small reinforcement piece of resin is added to the outside of the column between the outlet arm and column body to provide additional strength.

Another improvement in the containers of the invention addresses consistency of assembly and packing of the containers. In prior columns for a radioisotope generator, a plastic basket or spacer was supplied separately and was placed on the top of the column packing before the seal was inserted and the seal crimped into place. In these prior columns, placement of the baskets or spacers, which hold the column packing in place, could vary significantly, potentially creating some problems with consistency in packing. In the improved columns, two small orientation knobs have been added to the outside of the top basket/spacer and the orientation knobs are positioned 180° apart. These knobs fit into two small slots cut into the wall of the column. This combination eliminates the potential variability of manual alignment and depth placement of the basket/spacer into the column and ensures a consistent fit every time. Critical to the function of the column is the alignment of the basket/spacer openings with the column inlet in the top arm. This prevents potential misalignment and consequent restricted flow and possible back pressure and also ensures consistent and timely output of eluent to the patient.

Another improvement is to make the column assembly out of a radiation resistant or tolerant material, such as radiation resistant polypropylene. Likewise, the flexible tubing and Luer connector are made of radiation resistant or tolerant materials, such as radiation resistant polyvinylchloride. Furthermore, the Luer connector on the flexible tube and its counterpart Luer connector on the column assembly are configured to provide for a tight lock which will not leak and which will not loosen or inadvertently disconnect during use.

## THE TECHNICAL PROBLEM AND ITS SOLUTION

The invention was designed to solve a number of technical problems experienced with prior art pharmaceutical containers.

### 1. Leakage From the Stopper/Column Interface

Leakage from the flange (or other area) of the seal of prior pharmaceutical containers such as column/stopper assembly systems was found to occur when the system was exposed to increasing pressure.

The new seal, consisting of a stronger material crimped at optimized crimping pressure, prevents leakage at the flange seal area even at increasing pressure.

### 2. Ballooning

Ballooning and/or burst of rubber materials (both before and after irradiation) through the center hole of current aluminum seals has been observed when they are subject to repeated pulsations of pressure cycling. The seals of the invention, which are stronger and are crimped at optimized pressure, reduce the likelihood of this problem. However, in a preferred embodiment the seal used in the improved container of the invention has a center hole of reduced size. For example, a seal with the configuration of those in Fig. 5B, Fig. 5C, Fig. 5E or Fig. 6 may preferably be used. Due to the small center hole and strength of these seals, and crimping at optimized pressure, ballooning and/or burst of rubber materials is prevented. Consequently, pharmaceutical containers of the invention, and particularly column/stopper systems of the invention, can be exposed to much higher pressures during use of the system in the field.

In addition, the larger surface area of the crimp resulting from the reduction of the diameter of the center hole serves as additional support for the rubber closure and inhibits possible rupture as it is weakened over time due to the cumulative effect of exposure to radiation from the column or container content.

Also, the stopper is made of a radiation resistant or tolerant material. This also helps prevent ballooning and bursting.

### **3. Leakage Through Puncture Points**

Leakage through puncture points has been observed in prior art pharmaceutical containers. Such leakage may be eliminated in containers of the invention through a combination of the stronger seal material, preferably a smaller center hole, and crimping at optimized pressure.

### **4. Splitting of the Seal**

Splitting or tearing of current aluminum seals has been observed at pressures intended for use with a pharmaceutical container system (or pressures to which the system can potentially be exposed during intended usage in the field).

Due to the strength of the new seal material, no splitting or rupture of seal material is observed at pressures intended for use. For example, the seals on the columns of the invention do not split or rupture when used in, for example, a rubidium generator at intended pressures.

### **5. Inconsistent Manual Crimping Procedure**

The manual crimping procedure commonly used with many prior container systems, including radioisotope column systems, is not always consistent and thus may not result in reproducible crimping pressures. Over-pressuring can result in buckling and collapse of the skirt of the seal material, the closure and/or the container. Under-pressuring can result in a loose overseal. Use of the automatic or semi-automatic crimping procedure of the invention with compressed or pressurized air results in consistent/reproducible crimping pressures, and enables selection of optimized crimping pressures when crimping various seal materials.

### **6. Maintenance of Consistent Flow/Reduction of Back Pressure**

In some prior pharmaceutical columns, flow rate of the eluent through the column could be partially or completely blocked because the stopper blocked the outlet arm of the column. The outlet arm of the container of the invention has been repositioned slightly and a small piece of plastic removed from the inside edge of the column to create a recess or notch where the outlet arm enters the column lumen to prevent a stopper from blocking flow. A small reinforcement piece of resin is added to the outside of the column between the outlet arm and column body to provide additional strength. The recessed outlet arm and notch near the bottom of the column body greatly reduces the chance of back pressure due to a stopper blocking the outlet arm.

#### **7. Inconsistent Positioning Within Column**

In a column for a radioisotope generator, a plastic basket or spacer is supplied separately and is placed on the top of the packed column before the seal or closure is inserted and the seal crimped into place. In prior columns, the baskets/spacers, which hold the column packing in place, were not easily positioned consistently both in terms of depth and orientation. In the improved columns of the invention, two small orientation knobs have been added to the outside of the top basket/spacer and these orientation knobs are positioned 180° apart. These knobs fit into two small slots cut into the wall of the column. This combination eliminates the potential variability of manual placement of the basket into the column, ensuring a consistent fit from generator to generator and reducing the variability in packing density associated with this manual process.

#### **8. Degradation Due To Radiation**

Many materials degrade when exposed to radiation. Degradation includes possible changes in color, loss of flexibility, increased brittleness and the leaching out of various substances from the materials. To avoid these potential problems, the column assembly,

stopper, flexible tubing and Luer connectors are made out of radiation resistant or tolerant materials.

Frequently, when a material is said to be radiation resistant or tolerant, that means the material can withstand the amount of radiation used for sterilization, which is typically about 25 kGy. For the purposes of the present invention, however, a material is radiation resistant or tolerant when it can be exposed to about 145 kGy radiation and not degrade to the point where the functioning of the column assembly will be adversely affected.

#### **9. Properly Closed Luer Locks**

Luer locks are known in the art. However, it can be difficult to determine when a Luer lock has been sufficiently tightened to form a tight, non-leaking lock. Thus, one improvement is to provide for one or more tabs on each Luer connector. When the tabs achieve a certain orientation with respect to each other, for example when the tabs line up, such orientation means that the Luer lock has been sufficiently tightened.

Another potential difficulty with Luer locks is that they can come loose, i.e. disconnect, during use, which has the potential of causing a leak. To overcome this potential difficulty, the Luer connectors screw together and are each provided with one or more tabs. As the Luer connectors approach their fully tightened position, the tabs overlap. Further tightening causes the overlapping tabs to pass by each other, which can cause a clicking sound or sensation. When this occurs, the Luer lock is sufficiently tightened. Also, the Luer locks cannot become loose, e.g. unscrew, because the overlapping tabs will inhibit this action.

**BRIEF DESCRIPTION OF THE FIGURES**

Figs. **1A** through **1G** illustrate the inventive column assembly from different angles and cross sections.

Figs. **2A** through **2D** illustrate an alternative embodiment of the inventive assembly from different angles and cross sections.

Figs. **3A** through **3D** illustrate a spacer or basket used in the inventive column assembly.

Fig. **4** illustrates a detailed view of the bottom of the inventive column assembly.

Fig. **5A** is a prior art crimp seal.

Figs. **5B** through **5F** illustrate various crimp seals that may be used with the inventive column assembly.

Figs. **6A** and **6B** illustrate a preferred crimp seal.

Figs. **7A** through **7D** illustrate a stopper for use with the inventive column assembly.

Figs. **8A** through **8D** illustrate an improved Luer lock.



**DETAILED DESCRIPTION OF THE INVENTION**

Referring now to Fig. 1, Fig. 1A shows a side view and Fig. 1B shows a bottom view of the inventive container (e.g., column assembly) of one embodiment of the invention. Fig. 1C is another side view of the inventive column assembly, cut along line A-A of Fig. 1B. Fig. 1D is detail B from Fig. 1C, at a scale of 3:1 compared to Fig. 1C. Fig. 1E is a top view of the inventive column assembly, cut along line E-E of Fig. 1A. Fig. 1F is another side view of the inventive column assembly, cut along line C-C of Fig. 1B. Fig. 1G is detail D of Fig. 1F, at a scale of 2:1 compared to Fig. 1F.

Fig. 1A has an inlet arm 1 which has an inlet arm female Luer cap 2 at its distal end. The proximal end of the inlet arm 1 attaches to the upper portion of a column 3. There is also an inlet arm support means 4 to support the inlet arm 1. The support means is preferably material which is added to support the inlet arm 1. Preferably, this material is the same material used to construct the column assembly. As shown, the inlet arm support means 4 is a triangular shaped member attached to the inlet arm 1 and the column 3, although the shape of the support is not limited to a triangle. It can be square, a bar passing from the inlet arm 1 to the column 3, or any other suitable shape.

The column 3 has a top portion 5 and a bottom portion 6. The top portion 5 comprises a first top portion 7 and a second top portion 8. The first top portion 7 is on top of and has a diameter greater than the second top portion 8, which is on top of and has a greater diameter than the column 3.

The bottom portion 6 of the column 3 has a similar configuration. It has a first bottom portion 9 and a second bottom portion 10. The first bottom portion 9 sits below and has a greater diameter than the second bottom portion 10, which sits below and has a greater diameter than the column 3. Also shown is a bottom stopper 11.

An outlet arm **12** is attached to the bottom portion of the column **3**. The distal end of the outlet arm **12** terminates in an outlet arm female Luer cap **13**. There is also an outlet arm support means **14** to support the outlet arm **12**. The support means is preferably material which is added to support the outlet arm **12**. Preferably, this material is the same material used to construct the column assembly. As shown, the outlet arm support means **14** is a triangular shaped member which attaches to the column and the outlet arm **12**, although the shape of the support is not limited to a triangle. It can be a square, a bar passing from the outlet arm **12** to the column **3**, or any other suitable shape.

Fig. **1C** shows a cross section of the inventive column assembly, cut through line A-A of Fig. **1B**. As shown, the inlet arm **1**, column **3** and outlet arm **12** are hollow.

Turning to the hollow interior or lumen of the column **3**, it first defines a top stopper receptacle area **15**. Below that and in communication with it is a top basket receptacle area **16**. As shown in Fig. **1C**, the top basket receptacle area **16** contains a top basket or spacer **17**. Following that is a packing material containing area **18**. Underneath the packing material containing area **18** is a bottom screen **19**, followed by a bottom open area **20**. Underneath the bottom open area **20** is a bottom stopper receptacle area **21**.

Fig. **1C** shows the bottom stopper **11** inserted into the bottom stopper receptacle area **21** of the column **3**. Note that the bottom stopper **11** consumes most of the bottom stopper receptacle area **21**. This minimizes the dead volume in the bottom stopper receptacle area **21**. Minimization of the dead volume minimizes mixing of fresh, radioactive eluent with non-radioactive or decayed eluent, which could dilute the fresh eluent, thereby maintaining a narrow rubidium-82 bolus profile.

The inlet arm **1** and outlet arm **12** are each hollow, the hollow portions being **22** and **23** respectively, and are in communication with the hollow portion of the column **3**. As

shown in Fig. 1C, the hollow portion 22 of the inlet arm 1 is in communication with the top basket receptacle area 16.

The intersection of the column 3 and the outflow arm 12 is shown in more detail in Fig. 1D. As shown therein, no portion of the outflow arm 12 extends into the hollow portion of the column 3, as was the case with certain prior art column assemblies. Also, the hollow portion 23 of the outflow arm 12 intersects the hollow portion of column 3 at the top of the bottom stopper receptacle area 21 or at about the place the bottom stopper receptacle area 21 and the bottom open area 20 intersect. This configuration, not found in prior art column assemblies, prevents the bottom stopper 11 from blocking the outflow arm 12.

In a preferred embodiment, an outflow notch 25 is formed where the hollow portion 23 of the outflow arm 12 intersects the hollow interior of the column 3, thus further preventing any blockage of the outflow arm 12 by the bottom stopper 11. This embodiment is shown in more detail in Fig. 4.

Fig. 1E is a top view of the inventive column assembly. Visible from this perspective are, for example, the top basket or spacer 17 and the top basket receptacle area 16. Also shown are notches 24a and 24b.

The notches 24a and 24b are made in the wall of the top basket receptacle area 16. As shown in Fig. 1E, they are 180 degrees opposed to each other. They are configured to cooperate with a pair of protrusions which appear on a top basket (discussed below with respect to Fig. 3) such that the protrusions fit into notches 24a and 24b. This configuration insures proper placement of the top basket into the top basket receptacle area 16 so that the top basket is straight and at the correct depth. In prior art column assemblies, which lacked these notches and protrusions, it was possible to insert the top basket in such a manner that it was not straight and/or at the wrong depth, which adversely affected the function of the column assembly.

Fig. **1E** shows two notches **24a** and **24b** 180° opposed to each other. It is understood that the present invention is not limited to this configuration. Rather, there can be 1, 3, 4, 5, 6 or more notches or even a ledge present in the wall of the top basket receptacle area **16** in any configuration, so long as these notches (or ledge) cooperate with protrusions on the top basket to insure its proper fit.

Fig. **1F** shows a side view of the inventive column assembly, cut along line C-C of Fig. **1B**. Fig. **1G** is detail D of Fig. **1E**, showing an alternative embodiment for the first top portion **7a**. As shown in Fig. **1G**, this first top portion **7a** slopes downwardly from its top, whereas the first top portion **7** of Fig. **1F** is squared off, i.e., non-sloping.

Fig. **2** shows an alternative embodiment of the inventive column assembly. As shown in Fig. **2D**, which is detail B from Fig. **2C** at a scale of 3:1, the bottom stopper **11a** is configured to fit into substantially all of the space of the bottom stopper receptacle area **21**. This insures a better fit between the outer wall of the bottom stopper **11a** and the inner wall of the bottom stopper receptacle area **21**, thus further insuring against any leaks. In addition, the stopper **11a** reduces the dead volume in the bottom stopper receptacle area **21**. Minimization of the dead volume minimizes mixing with non-radioactive or decayed eluent, which could dilute the fresh eluent, thereby maintaining a narrow rubidium-82 bolus profile. The bottom stopper **11a** further comprises a bottom stopper hollow space **11b**. This bottom stopper hollow space **11b** helps prevent the bottom stopper **11a** from blocking the outflow arm **12**.

The column assembly is preferably made of polypropylene. Prior art column assemblies were made with H5820 polypropylene. While that product can still be used, in a preferred embodiment the polypropylene random copolymers PP P5M4R-034 or PP 13R9A (Huntsman Polymers (The Woodlands, TX)) can be used because they are more resistant to radiation than the prior art H5820 polypropylene. See the Prospector X5 data sheets with

ATSM and ISO properties for PP P5M4R-034 and PP 13R9A, which are incorporated herein by reference in their entirety. Of the two Huntsman polypropylenes, PP 13R9A is the more preferred, based upon UV profile, Instron stress testing and appearance after gamma-irradiation.

The manufacturing process for the inventive column assembly has also been improved. A new automatic mold has been designed which improves the quality and appearance of the column assembly, and which increases the efficiency of the manufacturing process. Manufacturing is presently done by Duerr Molding (Union, N.J.).

For example, pins are used to form the hollow portions of the inlet arm **22** and outflow arm **23**. In the prior art molding process, these pins were not fixed, so they floated. As a result, the side wall thickness of the inlet arm **1** and outlet arm **12** varied. In the present process, the pins are fixed. Therefore, the thickness of the side walls is more uniform.

Also, as described above, the position of the outflow arm **12** has been moved, the outflow arm no longer protrudes into the hollow interior or lumen of the column **3**, and the outflow arm resides in a recess or notch. This prevents the outflow arm from being blocked. Furthermore, support means **4**, **14** are provided to strengthen the inlet arm **1** and the outflow arm **12**. In addition, notches **24a** and **24b** are provided for the proper placement of the top basket.

Further improvement to the manufacturing process and column assembly are described throughout the instant specification.

The packing material area **18** of the column **3** is designed to receive packing material. The type of packing material used depends upon the intended use of the column arrangement.

When used as, for example, a rubidium-82 generator, such as CardioGen®, the packing material is one which will adhere strontium-82 but will allow for the elution of rubidium-82. Strontium(II)-82 decays into rubidium(I)-82. Elution of strontium-82 is not

desired because it binds to bone and exposes the patient to unnecessary radiation exposure. Presently, stannic oxide is the preferred packing material.

The packing material is loaded into the column **3** in a conventional manner. The column **3** is then loaded with strontium-82 in a conventional manner. For example, the closure is punctured by a needle (or similar device) containing the strontium-82 solution. The strontium-82 solution is slowly added to the top of the packed column and allowed to flow through it by the force of gravity. If necessary, a small vacuum can be used. Also, the packing material is preferably wetted before the strontium-82 is added. Slow addition of the strontium-82 is preferred because it will result in the strontium-82 being absorbed as close to the top of the column as possible.

Filters, preferably fiberglass filters, can also be used in this conventional loading procedure. For example, two fiberglass filters are first placed in the column **3**, then a portion of the packing material is added, followed by a single fiberglass filter, then the remainder of the packing material, then two more fiberglass filters. Once filled, the top basket or spacer **17** is inserted into the top basket receptacle area **16**. The top basket **17** acts as a retainer to hold the packing material in place.

Fig. **3** shows schematics of the spacer or top basket **26** of the inventive column assembly. The spacer or top basket **26** is cylindrical in shape with an open top portion **27** and a screen **28** at the bottom portion **29**. Another top basket or spacer **17** of similar configuration is shown in Fig. **1**, placed in the top basket receptacle area **16**.

As shown in the embodiment of Figs. **3B** and **3D**, the top basket **26** actually has three cylindrical areas, a top cylindrical area **30**, a middle cylindrical area **31** and a lower cylindrical area **32**. The top **30** and bottom **32** cylindrical areas have diameters about equal to each other, and their diameters are greater than the diameter of the middle cylindrical area **31**.

The top basket **26** also contains protrusions **33a**, **33b** which are designed to cooperate with notches **24a**, **24b** in the top basket receptacle area **16**. In operation, the protrusions **33a**, **33b** fit into the notches **24a**, **24b** to insure proper alignment of the top basket **26** in the top basket receptacle area **16**. When so positioned, the top basket **26** acts as a retainer to hold the packing material in place.

As shown in Figs. **3A** and **3C**, the two protrusions **33a**, **33b** are 180° opposed to each other. They are located at the top cylindrical area **30**. As was the case with the notches **24a**, **24b**, the present invention is not limited to this configuration. Rather, there can be 1, 3, 4, 5, 6 or more protrusions, in any orientation, so long as they cooperate with the notches to help insure a proper fit for the top basket **26**.

The top basket **26** also contains a side opening **34**. As shown in Figs. **3B** and **3D**, the side opening is in the middle cylindrical area **31** of the top basket **26**. The purpose of the side opening is to line up with the inlet arm **1** when the top basket **26** is placed in the top basket receptacle area **16**. In this arrangement, when a liquid is introduced into the inlet arm **1**, it will pass through the side opening **34** into the top basket **26**.

The top basket **26** can be made of any suitable material, such as polypropylene. Preferably, the material will be radiation resistant, i.e. resistant to degradation in the presence of a radioactive material. More preferably, the top basket **26** is made of the same material used to construct the column assembly. In a preferred embodiment, that material is PP P5M4-R-034 or PP 13R9A polypropylene (Huntsman Polymers (The Woodlands, TX)). Even more preferably, the material is the PP 13R9A polypropylene. In a yet further preferred embodiment, the top basket **26** is molded at the same time the rest of the column assembly is molded.

As discussed above, Fig. **4** shows a detailed view of the bottom **6** portion of the column **3**. Fig. **4** shows the outflow notch **25** where the hollow portion **23** of the outflow arm

**12** intersects the hollow interior of the column **3**. The outlet notch **25** prevents blockage of the hollow portion **23** of the outflow arm **12** by the bottom stopper **11** (not shown in Fig. 4).

Fig. 5 shows various types of crimp seals to use with the present invention. Fig. 5A shows the current, prior art crimp seal. Figs 5B-5F show various alternate embodiments of the crimp seal.

The function of the crimp seal is to form a tight, crimped seal between the stoppers (described below) and the pharmaceutical container to prevent leakage. Also, a central hole is provided in the crimp seal to allow for the insertion of a needle or similar device. In one preferred embodiment the pharmaceutical container is a column, or column assembly, such as one used in a rubidium generator.

The crimp seal can be made of any material, such as plastic or metal. The material should preferably be radiation resistant, and of sufficient strength to withstand pressures of at least 90 psi and preferably up to 160 psi. More preferably, the material should be metal. Preferred metals comprise aluminum, steel and tin, or suitable alloys or mixtures thereof. The metal can be optionally coated. For example, tin coated steel can be used.

The diameter of the crimp seal will vary according to use, for example, vary according to the diameter of the pharmaceutical container which is to be crimped. With respect to a column assembly to be used as a rubidium-82 generator, such as CardioGen®, the diameter of the crimp seal is preferably about 20 mm across its top.

Fig. 5A shows a conventional prior art crimp seal **35**. It is made out of aluminum which is about 0.2 mm thick, has a flat top portion **36** with a diameter of about 20 mm with central hole **37** of about 9.5mm in diameter and a skirt **38** about 7.5mm high.

There are several potential problems with this prior art crimp seal. First, because aluminum with a thickness of only about 0.2 mm is used, the crimp seal might not be strong enough to insure a strong, leakproof seal. Second, the central hole **37** is large, and therefore



the stopper might not be properly supported. Also, the larger central hole **37** may allow for ballooning of the stopper. Third, this crimp seal is manually crimped to the column **3**. Manual crimping can result in undesirable variability of crimping pressure and, accordingly, can affect how well the crimp seal **35** seals the column **3** to prevent leakage.

Fig. **5B** shows one type of useful crimp seal **39**. This crimp seal **39** comprises two parts, a top crimp member **40** and a bottom washer **41**. Both the top crimp member **40** and the bottom washer **41** are made of aluminum (vendor – West). The thickness of the aluminum for each part can vary depending upon the intended use, but the aluminum used for each member is generally about 0.2 mm thick.

The top crimp member **40** has a central hole **42** and a skirt **43**. The size of each, and the diameter of the crimp seal, can vary depending upon use. As shown in Fig. **5B**, the central hole **42** has a diameter of about 6.4mm and the skirt **43** is about 7.6mm high. The diameter of the top crimp member **40** is about 20 mm. The top crimp member **40** also has a cover **44**, which covers the central hole **42** when not in use but can be pulled or peeled back when in use. Also, while none of Figs. **5C** through **5F** or Fig. **6** show a cover, it is understood that each of these embodiments can employ a cover if desired.

Fig. **5B** also employs a bottom washer **41**. The bottom washer **41** contains a central hole **45**. The bottom washer central hole **45** can have a diameter greater than, the same as or smaller than the diameter of the central hole **42** in the top crimp member **40**. As shown in Fig. **5B**, both central holes **45**, **42** have about the same diameter, i.e. about 6.4mm. The bottom washer **41** does not have a skirt. The diameter of the bottom washer **41** is about 20 mm.

When used, the bottom washer **41** is placed below the top crimp member **40** and both are crimped into place. Crimping is preferably performed via an automatic or semi-automatic

crimper, which is discussed in more detail below. In the alternative, other processes which control the crimping pressure applied can be used.

Fig. **5C** shows another embodiment of the inventive crimp seals. This crimp seal **46** comprises a single member. It is made out of steel (vendor – Microliter). The thickness of the steel can vary according to the intended use, but is generally about 0.2 mm thick. This crimp seal **46** is about 20 mm in diameter, contains a central hole **47** of about 5.0mm in diameter and has a skirt **48** about 7.2mm high. The crimp seal **46** is preferably crimped into place using an automatic or semi-automatic crimper, although other processes which control the pressure applied can be used.

Fig **5D** shows yet another embodiment of the inventive crimp seals. This crimp seal **49** comprises a single member. It is made out of steel (vendor – Microliter). The thickness of the steel can vary according to the intended use, but is generally about 0.2 mm thick. This crimp seal **49** has a diameter of about 20mm, contains a central hole **50** of about 8.0mm in diameter and a skirt **51** about 7.2mm high. The crimp seal **49** is preferably crimped into place using an automatic crimper, although other processes which control the pressure applied can be used.

Fig. **5E** is yet still another embodiment of the inventive crimp seals. This embodiment comprises two parts, a top crimp member **52** and a bottom washer **53**. Both the top crimp member **52** and the bottom washer **53** are made of aluminum (vendor – Microliter). The thickness of the aluminum can vary depending upon the intended use, but the aluminum used for each member is generally about 0.2 mm thick.

The top crimp member **52** has a central hole **54** and a skirt **55**. The central hole **54** has a diameter of about 9.6 mm and the skirt **55** is about 7.6 mm high. The top crimp member **52** has a diameter of about 20mm.

The top crimp member **52** also contains an insert **56**, which is seated in or under the central hole **54**. The insert **56** can be made of any suitable substance, but is preferable made of metal, such as steel, aluminum or tin, or plastic. The insert **56** also contains an insert central hole **57**, which has a diameter of about 5 mm.

The bottom washer **53** also has a central hole **58**, which has a diameter of about 5 mm. The bottom washer **53** is about 20 mm in diameter and it does not have a skirt.

When used, the bottom washer **53** is placed below the top crimp member **52** and the insert **56** and then all are crimped into place. Crimping is preferably performed using an automatic or semi-automatic crimper, although other processes which control the pressure applied can be used.

Fig. **5F** shows yet another embodiment of the inventive crimp seals. Like Fig. **5E**, Fig. **5F** employs two members, a top crimp member **59** and a bottom washer **60**. Both members are made of aluminum (vendor-Microliter). While the thickness of the aluminum can vary with the intended use, generally each member is about 0.2 mm thick.

The top crimp member **59** contains a central hole **61** and a skirt **62**. The central hole **61** has a diameter of about 9.6 mm and the skirt **62** is about 7.6 mm high. The top crimp member **59** has a diameter of about 20mm.

The bottom washer **60** also has a central hole **63**. The bottom washer central hole **63** has a diameter of about 11.4 mm. The diameter of the entire bottom washer **60** is about 20mm. The bottom washer **60** does not have a skirt.

When used, the bottom washer **60** is placed below the top crimp member **59**. Both are then crimped into place. Preferably, an automatic crimper is employed, although other processes which control the pressure applied can be used.

Fig. **6** is an alternate and preferred embodiment of the inventive crimp seals. This crimp seal **64** comprises a single member. It is made out of steel (vendor – Microliter), code

#20-000 M. See the Microliter Product Catalog, which is incorporated herein by reference in its entirety. The thickness of the steel is about 0.20 mm.

The crimp seal **64** contains a central hole **65** and a skirt **66**. The central hole **65** is about 5.00 mm  $\pm$  0.25 mm in diameter and the skirt **66** is about 7.00 mm  $\pm$  0.25 mm high. The entire crimp seal **64** has a diameter of about 20.75 mm  $\pm$  0.25 mm. The crimp seal **64** is preferably crimped into place using an automatic or semi-automatic crimper.

Fig. 7 shows an improved stopper **67** to be used with the inventive column assembly. The stopper **67** is preferably made from a material which will form a tight seal with the column assembly. In a preferred embodiment the stopper **67** is made of a material which is also resistant to radiation.

Prior art stoppers were made of materials such as Itran-Tompkins PT-29 green neoprene rubber. This material had two potential disadvantages. First, it could degrade when exposed to radiation. Second, it contained latex, which could cause allergic reactions.

Various materials were compared to the PT-29 green neoprene used in the prior art. These materials included neoprene, isoprene, bromobutyl, chlorobutyl, nitrile, isoprene/chlorobutyl, EPDM (ethylene propylene diene monomer) and Viton®. These materials were coated, uncoated, siliconized and non-siliconized.

These materials were made into column assembly stoppers and were irradiated simulating the exposure from a 100mCi generator over a time period of 45 days (about 145 kGy). Irradiated stoppers were compared to non-irradiated controls by integrity (pressure) testing of the column/stopper assemblies. Assemblies were pressurized to determine load pressure required to cause ballooning of rubber materials or leaks/burst at the seal closure (up to about 200 psi). In addition, for the purpose of determining potential rubber extractables and/or leachables, additional column/stopper assemblies were irradiated in the presence of

0.9% saline solution. The saline solution was then scanned at 250nm for UV absorbing extractables.

Three elastomeric compositions were identified as suitable to use in the stoppers of the invention: West Pharmaceutical Services (Lionville, PA) 4588/40 isoprene/chlorobutyl; American Stelmi (Princeton, NJ) 6720 bromobutyl; and Helvoet-Pharma (Pennsauken, NJ) Helvoet FM 140/0 chlorobutyl. Of these materials, the most preferred product to use is the West 4588/40 isoprene/chlorobutyl. Other materials may be used as long as they provide the stopper characteristics specified herein.

The stopper **67** should be configured so that it forms a tight seal with the column assembly and minimizes the dead volume (mixing), thus maintaining a narrow rubidium-82 bolus profile and maximizing efficiency. One preferred structure for the stopper is shown in Fig 7.

Referring to Fig **7B**, the stopper **67** comprises a generally cylindrical top section **68** and a generally cylindrical bottom section **69**. The diameter of the stopper bottom section **69** is about the same as or slightly larger than the inside diameter of the first top portion **7** and first bottom portion **9** of the cylinder **3**, assuming both of these portions **7**, **9** have the same diameter. If these portions have different diameters, then the cylindrical bottom section **69** of the stopper **67** will have about the same or slightly larger inside diameter as the portion **7**, **9** it is intended to be inserted into. The reason for this configuration is to insure a tight fit between the stopper **67** and the first top **7** and first bottom **9** portions of the cylinder **3**. A tight cylinder **3**/ stopper **67** interface helps prevent leakage.

The stopper top section **68** has a greater diameter than the stopper bottom section **69** to prevent the stopper **67** from being inserted too far into the cylinder **3**. In addition, optionally the stopper top section **68** can have a curved upper edge **70**.

The stopper bottom section **69**, in one preferred embodiment, contains a U-shaped groove **71** in its base. See Fig 7A. The U-shaped groove **71** traverses greater than half the length of the stopper bottom section **69**, and it terminates in a semi-circular section **72**. Preferably, the center point **73** of the semicircular section **72** should be about at the center point of the stopper bottom section **69**.

The stopper top section **68** contains a central circular indentation **74** in its top surface. See Fig 7C. Preferably, the diameter of the central circular indentation **74** has a diameter about equal to the width of the U-shape groove **71**. As shown in Figs **7B** and **7D**, the central circular indentation **74** and the U-shaped groove **71** should preferably line up with each other when the stopper is viewed through its cross-section. The central circular indentation **74** and U-shaped groove **71** allow for easy insertion of a needle or similar device into the stopper **67**.

The surface of the stopper top section **68** also contains three spherical dots **75a**, **75b**, **75c** and an indicia, such as a spherical lug **76**. They are spaced equidistant from each other around the central circular indentation **74**. Also, the spherical lug **76** is placed so that it is above the U-shaped groove **71**. In this configuration, when the stopper **67** is inserted into the first top portion **7** of the column **3**, the spherical lug **76** can be lined up with the inlet arm **1**. Thus, the open end of the U-shaped groove **71** will face the inlet arm **1**, thus preventing its blockage.

The same holds true for the first bottom portion **9** of the column **3**. When the stopper **67** (stopper **11** shown in Fig. 1 and stopper **11b** in Fig. 2 can have the same or different configurations from stopper **67**) is inserted therein, the spherical lug **76** is lined up with the outlet arm **12**. The open end of the U-shaped groove **71** will then face the outlet arm **12** and prevent its blockage.

It is understood that the present invention is not limited to a U-shaped groove **71**. Any other configuration, such as a notch, can be used so long as any potential blockage is

avoided. In fact, if there is no potential for blockage, the U-shaped groove 71 or alternative structure can be eliminated.

The stopper 67 is affixed to the column 3 via crimping, using the crimping seals described above in Figs. 5 and 6. In the prior art, crimping was performed manually. The disadvantage of manual crimping is that it is not always uniform. One problem this can cause is leakage. To overcome this potential problem, the present invention preferably uses automatic or semi-automatic crimping.

Any automatic or semi-automatic crimper can be used for the present invention, so long as it can consistently crimp seals at a specified, controlled pressure. One preferred type of automatic crimper is a pneumatic crimper, which is powered by gas. One example of a pneumatic crimper suitable for the present invention is an AP/CP2000 Lightweight Air Crimper/Decapper (Laboratory Precision Limited, UK). See Laboratory Precision Limited brochure copyrighted April 4, 2001, which is incorporated herein by reference in its entirety.

In the crimping process, a stopper 67 is inserted into the top portion 5 or bottom portion 6 of the column 3, so that it is seated in the first top portion 7 or first bottom portion 9, respectively. A crimp seal or a crimp seal and washer (see Figs. 5 and 6) is/are placed over the stopper 67. The crimp seal or crimp seal and washer are then crimped into place, either manually or, preferably, automatically or semi-automatically. While the crimping pressure used is optimized based upon the configuration and material of the crimp seal and stopper, generally about  $117 \pm 3$  psi pressure is used.

The resulting crimped crimp seal/stopper configuration can withstand the operative pressures of the system and can further withstand pressures of at least 90 psi and preferably up to 200 psi.

When in operation, connector tubes (not shown) are connected to the column assembly. Referring to Fig 1A, both the inlet arm 1 and the outlet arm 12 have a female Luer

cap **2**, **13** at their distal ends. These female Luer caps **2**, **13** engage male Luer caps at the proximal ends of the connector tubes.

Prior art connector tubes can discolor from clear to brown and harden upon prolonged exposure to radiation. Also, the Luer connector can discolor and become brittle. In addition, the Luer connectors can loosen or become unintentionally disconnected during shipping or use.

Accordingly, the present invention includes constructing connector tubing out of radiation resistant materials. Preferably, the tubing is made from a flexible radiation resistant polyvinyl chloride (PVC) and the Luer connector is made from a rigid radiation resistant PVC. For example, a preferred material for constructing the tubing is AlphaGary PVC 2232 A/R-78S Clear 030X. See AlphaGary Test Result Certificate, Report Date 8/20/99; Technical Data, Date of Origin 8/99; and Material Safety Data Sheet printed 04/05/00; which are incorporated herein by reference in their entirety. A preferred material for constructing the Luer connector is AlphaGary PVC 2212 RHT/1-118 Clear 080X. See AlphaGary Data Sheet, Revision Date 4/02, which is incorporated herein by reference in its entirety. Also, using this AlphaGary rigid PVC for the Luer connector allows the heat bonding of tubing to the Luer connector.

The present invention further includes an improved Luer lock. The improvements are described below. An embodiment of this improved Luer lock is set forth in Fig. **8**. These improved Luer locks can be used with the pharmaceutical containers of the present invention, or in any other indication where it is desirable to have a connection that will not inadvertently loosen or disconnect.

In the embodiment of Fig. **8**, Fig **8A** show a side view of the inventive column assembly with the inlet arm **1** projecting forward. Also shown is the female Luer cap **2** at the distal end of the inlet arm **1**.



As shown in Fig. **8C**, the female Luer cap **2** terminates in a flange **77**. The flange **77** can be flat or, as shown, contain a groove **78**. Other configurations, known in the art, can also be used.

The flange **77** is configured to engage and mate with threads **78** in a male Luer cap **79**. When the two caps **2**, **79** are screwed together, they form a tight Luer lock which will be leak resistant. This configuration is shown in Fig. **8D**.

One difficulty with a Luer lock is to know when the male and female caps **79**, **2** have been connected sufficiently to form a tight lock. To overcome this problem, one or more tabs are provided on each of the male **79** and female Luer caps **2**. As shown for example in Figs. **8C** and **8D**, two tabs are provided on each cap **80a**, **80b**, **81a** and **81b**, although it is understood that the invention is not limited to this configuration only. For example, each of the Luer caps can also contain 1, 3, 4, 5, 6 or more tabs.

In one embodiment, the female Luer cap tabs **80a**, **80b** and the male Luer cap tabs **81a**, **81b** are so positioned that when the Luer locks is sufficiently tight, the tabs line up with each other. This way, a user knows when tightening is completed. The present invention, however, is not limited to this one configuration, so long as the tab or tabs on each of the Luer connectors **79**, **2** are arranged in a desired configuration to demonstrate that the Luer connectors **79**, **2** are sufficiently tightened. In another preferred embodiment, as shown in Fig **8D**, the male Luer cap tabs **81a**, **81b** overlap with the female Luer cap tabs **80a**, **80b**. The tabs are so positioned that this overlap occurs when the tightening is complete. At the point of desired tightening, the tabs **80a**, **80b**, **81a**, **81b** pass by or click past each other. That way, the Luer locks cannot be over- or under-tightened. Also, inadvertent loosening or disconnection of the Luer lock during use or shipping is prevented by the overlapping of the tabs, preventing the Luer connectors **79**, **2** from turning in a loosening direction.

When the inventive column assembly is used as, for example, a rubidium-82 generator, it is pre-packaged with strontium-82 in the factory. That is, the product shipped to the customer is radioactive. Therefore, the radioactive column assembly is shipped in a shielded (e.g. lead) container.

Nevertheless, leakage is still a concern upon shipping. Thus, to improve safety when the radioactive column assembly is shipped, an inventive improvement is to ship the product with a liquid absorbent pad. Preferably, the shipping pad is a GP100 absorbent pad (Shell Packaging Corporation, Springfield, NJ). GP100 is a 100% polypropylene non-woven mat of randomly oriented micro-fibers (2-10 micron diameters). See SPC General Product Specifications for GP100 dated May 26, 2003, which is incorporated herein by reference in its entirety. This type of shipping pad, which may have various configurations, thicknesses or absorbent capacities, is useful in absorbing any leaks which may occur.

## SUMMARY OF THE PREFERRED EMBODIMENTS

### Improved Seal

The new seal, which is used to crimp the rubber stopper in place in a pharmaceutical container and particularly, which is used to seal a radioisotope generator column/stopper assembly system, such as CardioGen®, is preferably made of a sufficiently strong material to eliminate the problems discussed above. Figs. **5B** through **5F** and Fig. **6** illustrate various method of reinforcing the top portion of the seal by use of a second layer (washer) or use of a stronger material such as steel/tin in addition to reducing the size of the center hole. The material may include metal or plastic, but is preferably metal. The metal may include heavy gauge aluminum, steel or tin, but is preferably steel or tin. The seal generally has the configuration shown in Fig. **5B** through **5F** and Fig. **6** and may have a small or large central hole, a shorter or longer skirt and optionally, a cover (e.g., plastic or aluminum over the central hole). The dimensions of the seal will vary, and one skilled in the art will understand that they should be appropriate to the container which is being sealed. Approximate dimensions for seals for a radioisotope generator column are shown in the various examples in Figure **5** and in Fig. **6**. These dimensions are approximate and are not intended to be limiting.

The central hole of the seals of the invention may vary in size. In a preferred embodiment the seal has a smaller central hole such as, for example, those proportional to the central holes shown in Fig. **5B**, Fig. **5C**, Fig. **5E** and Fig **6**.

In one embodiment, seals of Fig. **5B** through Fig **5F** and Fig. **6** are used to seal a radioisotope generator column. These seals are available from the vendors West Pharmaceutical Services (Lionville, PA) and Microliter Analytical Supplies Inc. (Suwanee, GA). In a particularly preferred embodiment, the central hole of the seal is reduced in size such as in the seals in Fig. **5B**, Fig. **5C**, Fig. **5E** and Fig. **6**. The preferred configuration for

this application is a 1-piece steel/tin crimp with a center hole of approximately 4-5 mm diameter and a skirt length of approximately 7.2 to 7.5mm as shown in Fig. 6.

The combination of using a stronger material such as steel/tin or heavier gauge aluminum and reduction of the center hole results in optimum performance in maintaining a secure leakage free seal under high pressure and particularly repeated exposure (pulsing or cycling) to high pressure as occurs with the use of the rubidium-82 generator as the enlarged surface area of the crimp limits excessive expansion of the rubber closure under pressure.

The use of a stronger material such as steel/tin or heavy gauge aluminum further improves the performance of the crimp by reducing the likelihood of failure due to relaxation or fatigue of the seal flange which is formed at the point where the crimp skirt is folded under the column or container flange when exposed to high or pulsating pressures. It is understood that the skirt length can be varied to provide a proper fit with the container/rubber seal combination to which it is applied.

### **Improved Seal**

In a preferred embodiment improved stoppers are used. Such stoppers are made of a radiation resistant material, preferably isoprene/chlorobutyl and most preferably West 4588/40 isoprene/chlorobutyl. Additionally, the configuration and placement of the stoppers are improved so that they form tight seals with the column, do not block the inlet or outlet arms and reduce the "dead volume" at the bottom of the column. In a preferred embodiment the stoppers are designed to facilitate insertion of a needle or similar device and contain indicia indicating proper insertion orientation. In the most preferred embodiment, the stoppers have the configuration shown in Fig 7A, Fig 7B and Fig. 7C.

### **Automatic Crimper and Improved Crimping Process**

In a preferred embodiment, an automatic or semi-automatic crimper is used to crimp the seals of the invention. The automatic or semi-automatic crimper is set at an optimized

pressure and is able to crimp seals of any material during assembly of a pharmaceutical container such as a radioisotope generator column/stopper assembly system. Suitable automatic crimpers include pressurized and/or compressed air crimpers such as those available from Laboratory Precision Limited under the trade name/model number AP/CP2000. Use of the automatic or semi-automatic crimping procedure of the invention with compressed or pressurized air results in consistent/reproducible crimping pressures, and enables selection of optimized crimping pressures when crimping various seal materials.

Use of optimized pressures improves the performance of the seals of the invention and also improves performance of seals of only moderate strength, such as lighter gauge aluminum and some plastics.

The automatic or semi-automatic, pneumatically powered crimper used to apply the seal is preferably operated at an optimized pressure of between 60 – 140 psi. However, although automatic or semi-automatic crimpers are preferred, it should be noted that application of the seal is not limited to automated equipment, and systems ranging from manual to fully automatic may be used, provided their operation can be optimized to produce repeatable and consistent predetermined pressures in applying the seals.

#### **Column Design Improvements**

**Manufacturing Process:** To create the new column design, a new automatic mold has been designed. The mold and the new columns produced therein exhibit improved column quality and appearance. The new mold also increases the efficiency of the manufacturing process. The increased speed of the new automated mold enables one operator to run the process efficiently.

**Column Design:** The improved pharmaceutical container also includes improvements to the design which ensure specified flow of eluent through the container and improve its packing and consistency. In one embodiment the improved container comprises a column

used in a radioisotope generator. The improved column includes a repositioned outlet arm, and the column outlet resides in a recess or notch in the inside ledge of the column where the outlet arm enters the column lumen, to prevent a stopper from blocking the flow. These improvements further include introducing small reinforcement pieces of resin to the outside of the column between the outlet arm and column body and between the inlet arm and column body to provide additional strength. Additionally, the seam of the inlet and outlet arms has been eliminated by changing the mold runners. This change has improved the consistency of the inlet and outlet arm diameters and made the arms stronger.

Furthermore, to address consistency of packing of the containers, two small alignment slots have been cut into the wall of the column to receive the orientation knobs on the baskets that properly align and seat the basket in the column and limit the insertion depth into the column. This improves the consistency of packing density and eliminates potential blockage of the inlet arm. Additionally, in one embodiment, the improved column has stopper flanges and Luer flanges with much smoother surfaces with sharper edges to improve the sealing ability of the crimp. These attributes improve stopper and Luer contact to the column and greatly reduce the chance of leakage. Also, the flashing on the column is reduced greatly to enhance the appearance of the part.

Finally, the column assembly is made from a radiation resistant or tolerant material. The most preferred material is Huntsman PP 13R9A polypropylene.

#### **Luer Lock and Connector Tube Improvements**

The Luer locks and connector tubes used with the column have also been improved. First, the connector tubes are made from a radiation resistant or tolerant material. Preferably, this material is AlphaGary PVC 2232 A/R-78S clear 030X.

Second, the terminal end of the connector tube which attaches to the column contains a male Luer cap. This male Luer cap is made of a radiation resistant material, preferably AlphaGary PVC 2212RHT/1-118 clear 080X.

Third, the male and female Luer caps screw together and each contains tabs, preferably two tabs each. When the tabs line up with each other in one embodiment or overlap with each other in another embodiment, that indicates that the two Luer caps are sufficiently tightened or screwed together to form a tight seal or lock. Also, in a preferred embodiment the overlapping tabs prevent the Luer caps from becoming loose, ie unscrewing inadvertently.

#### **Shipping Improvements**

The columns can be shipped pre-loaded with, for example, strontium-82. Therefore, the columns are shipped in sealed containers containing GP-100 absorbent material to absorb any leakage.

The above description is to be taken as illustrative and not in the limiting sense. Many modifications can be made to the design without deviating from the scope thereof.

**What Is Claimed Is:**

1. An improved pharmaceutical container for containing a pharmaceutical agent which is heated, subjected to increased pressure or radioactive, comprising:

- a. an inlet arm,
- b. a hollow column, and
- c. an outlet arm,

wherein the improvement comprises configuring the outlet arm so that it does not protrude into the hollow portion of the column, and support means to support the inlet arm and the outlet arm.

2. The improved pharmaceutical container of claim 1, wherein the container is constructed of a material which is resistant to radiation.

3. The improved pharmaceutical container of claim 1 or 2, wherein the container is constructed of a radiation resistant polypropylene.

4. The improved pharmaceutical container of any of claims 1 through 3, wherein the container is constructed of PP 13R9A polypropylene.

5. An improved pharmaceutical container of any one of claims 1 through 4, wherein a notch is provided in the hollow column at the point where the outflow arm intersects the hollow column.

6. The improved pharmaceutical container of any one of claims 1 through 5, further comprising a basket receptacle area inside the column for receiving a basket where the inlet arm intersects the column, said basket receptacle area further comprising one or more notches, said notches configured to cooperate with one or more protrusions on a basket to be inserted into the basket receptacle area in such a way so as to insure that the basket is properly seated in the basket receptacle area.



7. The improved pharmaceutical container of any one of claims 1 through 6, further comprising two stoppers which form tight seals with and prevent leakage from an open top end and an open bottom end of the column, wherein said stoppers are made of a material which is resistant to radiation, optionally further comprising a packing material and/or a pharmaceutical agent.

8. The improved pharmaceutical container of claim 7, wherein the bottom stopper takes up substantially all of the space at the open bottom end of the column, without blocking the outlet arm, so as to reduce the amount of the dead volume at the bottom of the column.

9. The improved pharmaceutical container of claim 7 or 8, wherein said stoppers are made of a material selected from the group consisting of isoprene/chlorobutyl, bromobutyl and FM 140/0 chlorobutyl.

10. The improved pharmaceutical container of claim any one of claims 7 through 9, wherein said stoppers are made of isoprene/chlorobutyl.

11. The improved pharmaceutical container of any one of claims 7 through 10, wherein each of said stoppers comprises a top cylindrical portion and a bottom cylindrical portion, said bottom cylindrical portion having a diameter sufficient to insure a tight seal between the stopper and the cylinder interface, and said top cylindrical portion having a diameter greater than the bottom cylindrical portion.

12. The improved pharmaceutical container of claim 11, wherein the bottom cylindrical portion contains a U-shaped channel at its base.

13. The improved pharmaceutical container of claim 12, wherein the top cylindrical portion has indicia disposed on its surface, said indicia disposed so that it indicates the direction of the open end of the U-shaped channel.

14. The improved pharmaceutical container of any one of claims 8 through 13, further comprising a centrally located indentation at a top end of the stopper.

15. The improved pharmaceutical container of any one of claims 8 through 14, wherein the stoppers are held in place by crimping a crimp seal around the stoppers to affix them to the container.

16. The improved pharmaceutical container of claim 15, wherein the crimping is performed with an automatic or semi-automatic crimper.

17. The improved pharmaceutical container of claim 15 or 16, wherein the automatic crimper is a pneumatic crimper.

18. The improved pharmaceutical container of any one of claims 15 through 17, wherein the crimp seal is crimped at a pressure of about 60-140 psi.

19. The improved pharmaceutical container of any one of claims 15 through 18, wherein the crimp seal is constructed of a material which is resistant to radiation.

20. The improved pharmaceutical container of any one of any one of claims 15 through 19, wherein the crimp seal is constructed of a material selected from the group consisting of aluminum, steel and tin.

21. The improved pharmaceutical container of any one of claims 15 through 20, wherein the crimped stopper is able to withstand a pressure of between 90 psi and 200 psi inside the sealed container.

22. The improved pharmaceutical container of any one of claims 15 through 21, wherein the crimp seal is made of aluminum and comprises a top crimp member and a bottom washer.

23. The improved pharmaceutical container of claims 15 through 21, wherein the crimp seal is made of steel and comprises a single crimp seal member.

24. The improved pharmaceutical container of claim 22, wherein the top crimp member comprises a generally circular surface with a central hole and a skirt, and the bottom washer comprises a generally circular surface with a central hole.

25. The improved pharmaceutical container of claim 23, wherein the crimp seal member comprises a generally circular surface with a central hole and a skirt.

26. The improved pharmaceutical container of claim 22 or 24, wherein the top crimp member further comprises an insert, said insert being seated in or under the central hole, and further wherein said insert contains a central hole whose diameter is less than the diameter of the central hole in the top crimp member.

27. The improved pharmaceutical container of any one of claims 15 through 21, 23 and 25, wherein said crimp seal comprises a single crimp seal member made of steel with a generally circular surface having a diameter of about  $20.75 \text{ mm} \pm 0.25 \text{ mm}$  and a skirt with a height of about  $7.00 \text{ mm} \pm 0.25 \text{ mm}$ , and wherein said generally circular surface has a central hole with a diameter of about  $5.00 \text{ mm} \pm 0.25 \text{ mm}$ .

28. The improved pharmaceutical container of any one of claims 15 through 27, further comprising a removable cover which covers the central hole in the top crimp member.

29. The improved pharmaceutical container of any one of claims 1 through 28, for generating rubidium-82.

30. The improved pharmaceutical container of any one of claims 1 through 29, further comprising a first connector tube which attaches to the inlet arm via a Luer lock, and a second connector tube which attaches to the outlet arm via a Luer lock, wherein a portion of each Luer lock is affixed to each of the connector tubes and another portion of the Luer locks is affixed to each of the inlet arm and outlet arm.

31. The improved pharmaceutical container of claim 30, wherein the connector tubes and the Luer lock portions attached to the connector tubes are made of materials which are resistant to radiation.

32. The improved pharmaceutical container of claim 30 or 31, wherein the connector tubes are made of a flexible, radiation resistant polyvinyl chloride and the Luer lock portions attached to the connector tubes are made of a rigid, radiation resistant polyvinyl chloride.

33. The improved pharmaceutical container of any one of claims 30 through 32, wherein the connector tubes are made of PVC 2232 A/R-78S clear 030X and the Luer lock portions attached to the connector tubes are made of PVC 2212 RHT/1-118 clear 080X.

34. An improved Luer lock comprising a female Luer cap and a male Luer cap, wherein one of said Luer caps contains a flange and the other of said Luer caps contains threads, configured so that the flange and threads cooperate with each other in such a way that the female Luer cap and male Luer cap can be screwed together, wherein the improvement comprises providing for one or a plurality of tabs on each of the male and female Luer caps, wherein the tabs on the male Luer cap and the tabs on the female Luer cap achieve a desired configuration with respect to each other when the tightening of the two Luer caps together is complete.

35. The improved Luer lock of claim 34, wherein the male and female Luer caps each contain two tabs.

36. The improved Luer lock of claim 34 or 35, wherein the desired configuration is where the respective tabs on the male Luer cap and the female Luer cap line up with each other.

37. The improved Luer lock of claim 34 or 35, wherein the desired configuration is where the respective tabs on the male Luer cap and the female Luer cap overlap with each other, thus preventing overtightening or inadvertent loosening of the Luer lock.

38. The improved pharmaceutical container of any one of claims 1 through 33, which is shipped or packed in with an absorbent material.

39. The improved pharmaceutical container of claim 38, wherein the absorbent material is GP-100.

40. An improved rubidium -82 generator comprising:

- a. a hollow column with a top portion, a middle portion and a bottom portion, said top portion including one or more notches, and a screen separating the middle portion and the bottom portion;
- b. a top basket with one or more protrusions, said one or more protrusions configured to cooperate with the one or more notches in the top portion of the hollow column so as to cause the proper seating of the top basket in the top portion of the hollow column, said top basket further comprising a screen at its base and a side opening;
- c. an inlet arm which intersects the hollow column at its top portion at a point where the inlet arm is aligned with the side opening in the top basket, and further wherein the inlet arm has a female Luer cap at its distal end, said female Luer cap containing one or more tabs on its outer surface;
- d. an outlet arm which intersects but does not protrude into the hollow column at its bottom portion, wherein a notch is provided at the point of intersection on the bottom portion's inner surface, and further

wherein the outlet arm has a female Luer cap at its distal end, said female Luer cap containing one or more tabs on its outer surface;

- e. support means to support the inlet arm and the outlet arm to the hollow column

wherein said hollow column, top basket, inlet arm, outlet arm and support means are constructed of a radiation resistant polypropylene;

- f. a packing material comprising stannic oxide with strontium-82 adhered to it, said packing material placed in the middle portion of the hollow column above the bottom screen and below the screen of the top basket;
- g. a top stopper comprising a radiation resistant material, said top stopper configured to form a tight seal with the top portion of the hollow column but which does not block the inlet arm;
- h. a bottom stopper comprising a radiation resistant material, said bottom stopper configured to form a tight seal with the bottom portion of the hollow column and minimizing the dead space in the bottom portion of the hollow column, without blocking the outlet arm;
- i. first a crimp seal to crimp the top stopper to the top portion of the hollow column and a second crimp seal to crimp the bottom stopper to the bottom portion of the hollow column, wherein each crimp seal comprises steel with a thickness of about 0.2mm and a central hole about 5.0mm in diameter, wherein each crimp seal is crimped to a pressure of about 117 psi;
- j. a first flexible tube comprising a flexible, radiation resistant polyvinyl chloride with a first male Luer cap comprising a rigid, radiation

resistant polyvinyl chloride at one end of said first flexible tube, said first male Luer cap being configured to cooperate with the female Luer cap at the distal end of the inlet arm so that the two Luer caps can be screwed together to form a tight Luer lock, and wherein said first male Luer cap contains one or more tabs on its outer surface which will align with the one or more tabs on the outer surface of the female Luer cap at the distal end of the inlet arm, such that when the two Luer caps are screwed together these tabs achieve a desired configuration with respect to each other when the tightening of the Luer caps is complete; and

- k. a second flexible tube comprising a flexible, radiation resistant polyvinyl chloride with a second male Luer cap comprising a rigid, radiation resistant polyvinyl chloride at one end of said second flexible tube, said second male Luer cap being configured to cooperate with the female Luer cap at the distal end of the outlet arm so that the two of them can be screwed together to form a tight Luer lock, and wherein said second male Luer cap contains one or more tabs which will align with the one or more tabs on the female Luer cap at the distal end of the outlet arm, such that when the two Luer caps are screwed together these tabs achieve a desired configuration with respect to each other when the tightening of the Luer caps is complete.

41. An improved rubidium-82 generator comprising:
  - a. a hollow column with a top portion, a middle portion and a bottom portion, said top portion including one or more notches, and a screen separating the middle portion and the bottom portion;

- b. a top basket with one or more protrusions, said one or more protrusions configured to cooperate with the one or more notches in the top portion of the hollow column so as to cause the proper seating of the top basket in the top portion of the hollow column, said top basket further comprising a screen at its base and a side opening;
- c. an inlet arm which intersects the hollow column at its top portion at a point where the inlet arm is aligned with the side opening in the top basket, and further wherein the inlet arm has a female Luer cap at its distal end, said female Luer cap containing one or more tabs on its outer surface;
- d. an outlet arm which intersects but does not protrude into the hollow column at its bottom portion, wherein a notch is provided at the point of intersection on the bottom portion's inner surface, and further wherein the outlet arm has a female Luer cap at its distal end, said female Luer cap containing one or more tabs on its outer surface;
- e. support means to support the inlet arm and the outlet arm to the hollow column

wherein said hollow column, top basket, inlet arm, outlet arm and support means are constructed of a radiation resistant polypropylene;

- f. a packing material comprising stannic oxide with strontium-82 adhered to it, said packing material placed in the middle portion of the hollow column above the bottom screen and below the screen of the top basket;



- g. a top stopper comprising a radiation resistant material, said top stopper configured to form a tight seal with the top portion of the hollow column but which does not block the inlet arm;
- h. a bottom stopper comprising a radiation resistant material, said bottom stopper configured to form a tight seal with the bottom portion of the hollow column and minimizing the dead space in the bottom portion of the hollow column, without blocking the outlet arm;
- i. first a crimp seal to crimp the top stopper to the top portion of the hollow column and a second crimp seal to crimp the bottom stopper to the bottom portion of the hollow column, wherein each crimp seal comprises steel with a thickness of about 0.2mm and a central hole about 5.0mm in diameter, wherein each crimp seal is crimped to a pressure of about 117 psi;
- j. a first flexible tube comprising a flexible, radiation resistant polyvinyl chloride with a first male Luer cap comprising a rigid, radiation resistant polyvinyl chloride at one end of said first flexible tube, said first male Luer cap being configured to cooperate with the female Luer cap at the distal end of the inlet arm so that the two Luer caps can be screwed together to form a tight Luer lock and where said first male Luer cap contains one or more tabs on its outer surface which will overlap with the one or more tabs on the outer surface of the female Luer cap at the distal end of the inlet arm, such that when the two Luer caps are screwed together these tabs overlap and are pushed past each other, and a tight Luer lock which is resistant to inadvertent loosening is formed; and

- k. a second flexible tube comprising a flexible, radiation resistant polyvinyl chloride with a second male Luer cap comprising a rigid, radiation resistant polyvinyl chloride at one end of said second flexible tube, said second male Luer cap being configured to cooperate with the female Luer cap at the distal end of the outlet arm so that the two of them can be screwed together to form a tight Luer lock, and wherein said second male Luer cap contains one or more tabs which will overlap with the one or more tabs on the female Luer cap at the distal end of the outlet arm, such that when the two Luer caps are screwed together these tabs overlap and are pushed past each other, and a tight Luer lock which is resistant to inadvertent loosening is formed.

42. The improved pharmaceutical container of any one of claims 30 through 33 wherein the Luer locks comprise a female Luer cap and a male Luer cap, wherein one of said Luer caps contains a flange and the other of said Luer caps contains threads, configured so that the flange and threads cooperate with each other in such a way that the female Luer cap and male Luer cap can be screwed together, wherein the improvement comprises providing for one or a plurality of tabs on each of the male and female Luer caps, wherein the tabs on the male Luer cap and the tabs on the female Luer cap achieve a desired configuration with respect to each other when the tightening of the two Luer caps together is complete.

1/14

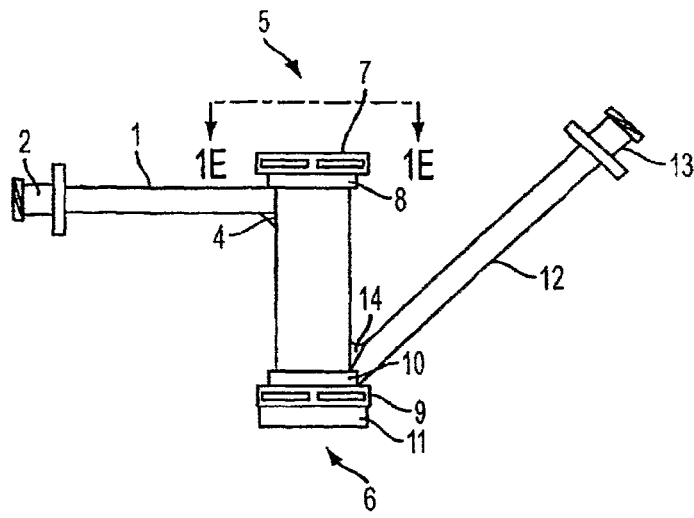


FIG. 1A

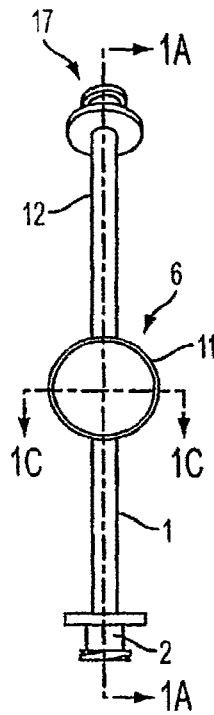


FIG. 1B

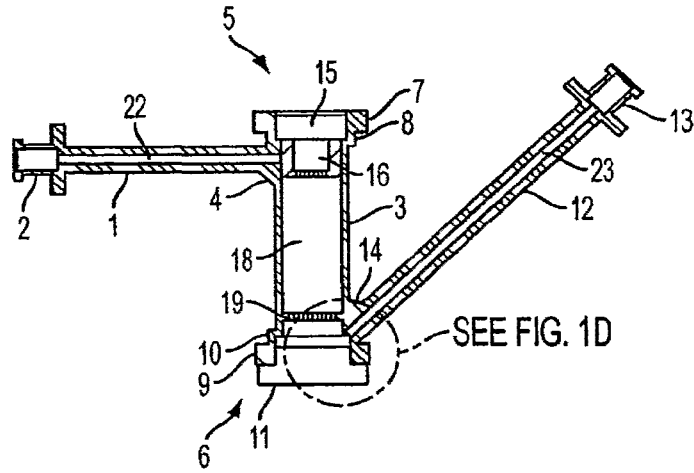


FIG. 1C

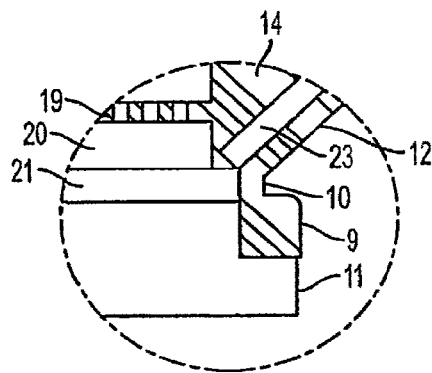


FIG. 1D

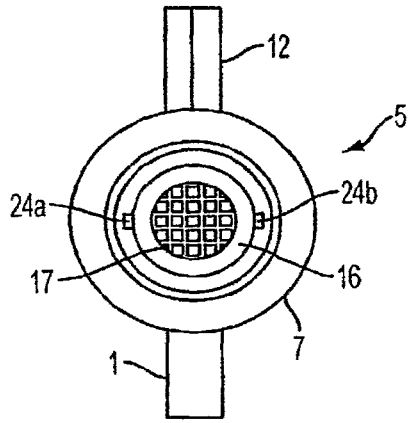


FIG. 1E

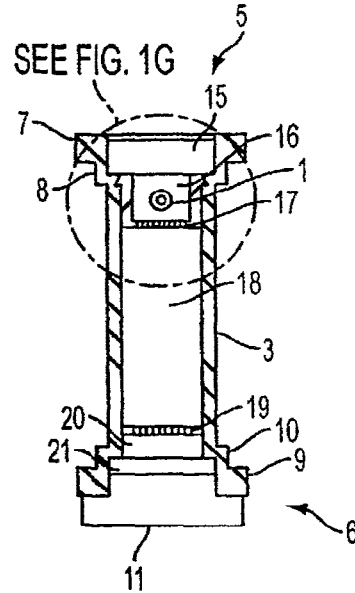


FIG. 1F

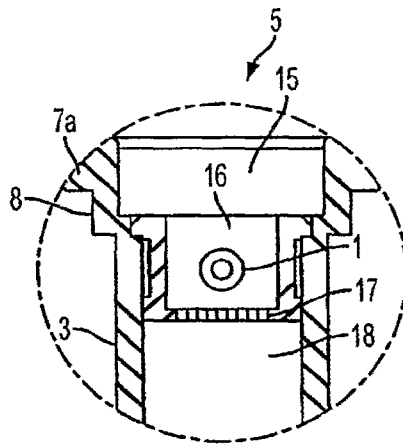


FIG. 1G

4/14

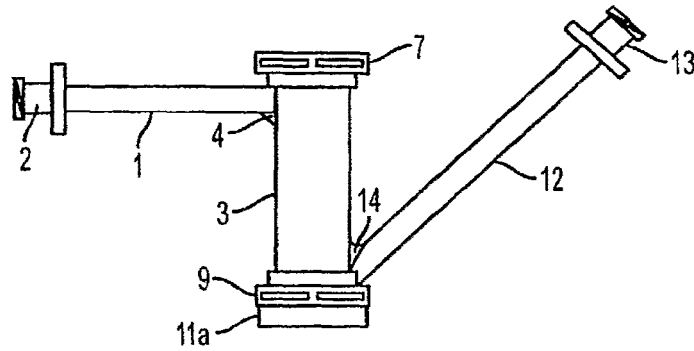


FIG. 2A

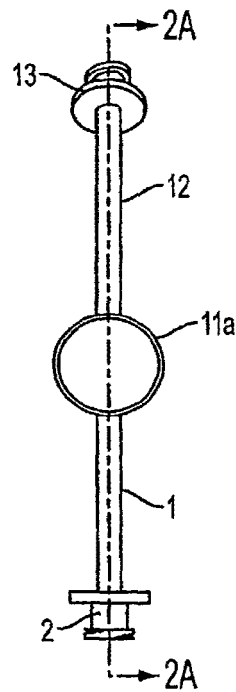


FIG. 2B

5/14

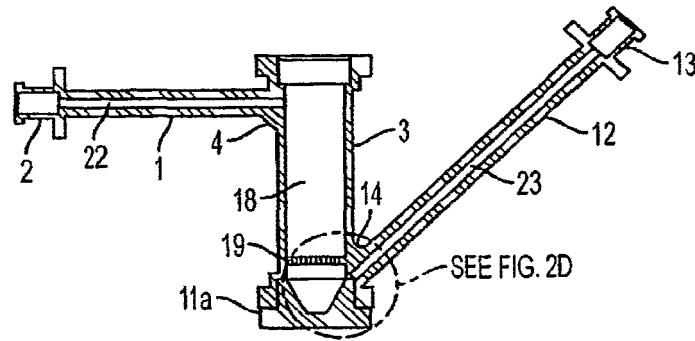


FIG. 2C

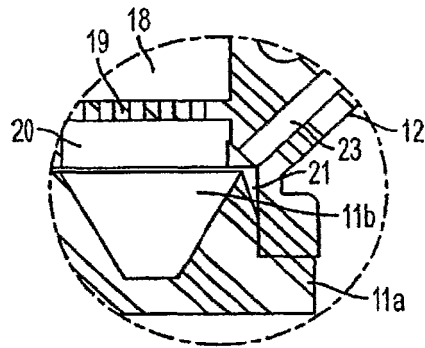


FIG. 2D

6/14

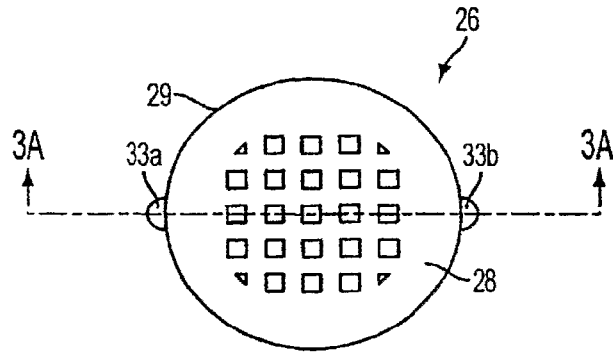


FIG. 3A

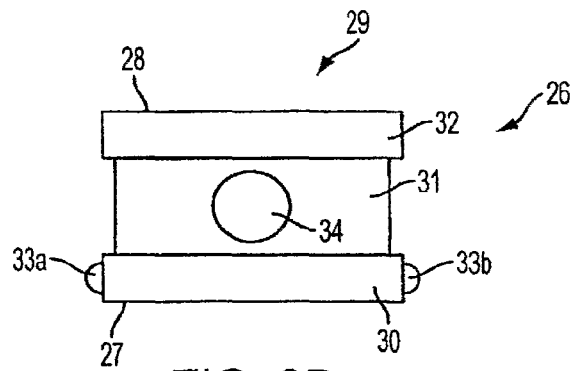


FIG. 3B



7/14

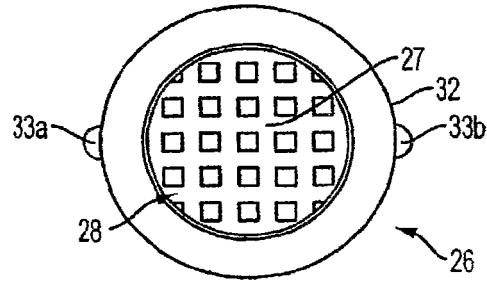


FIG. 3C

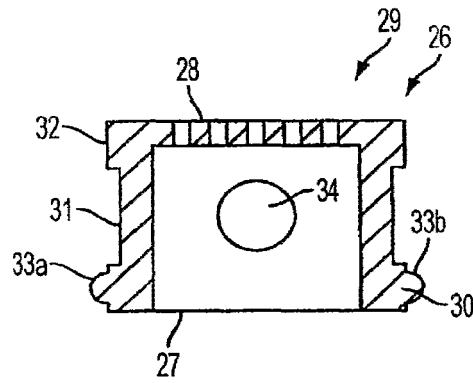


FIG. 3D

8/14

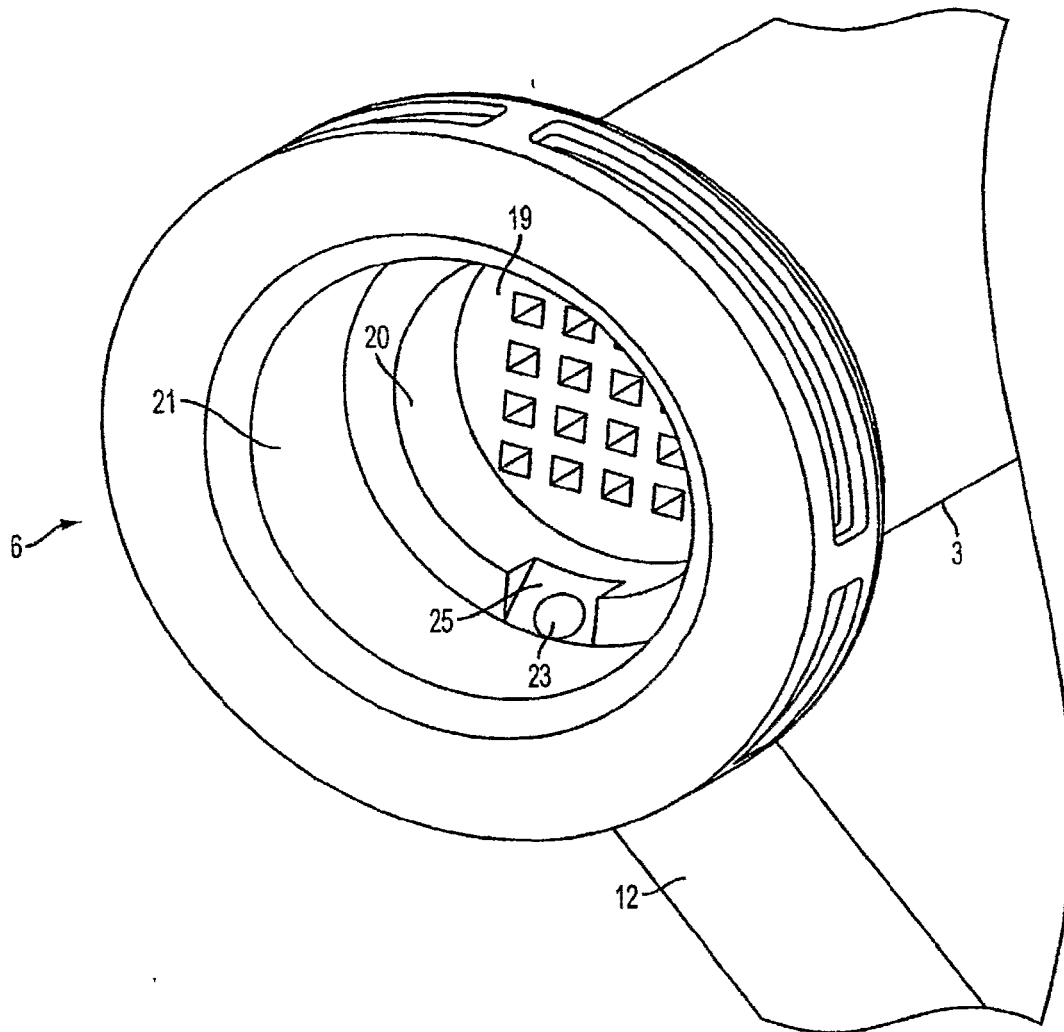


FIG. 4

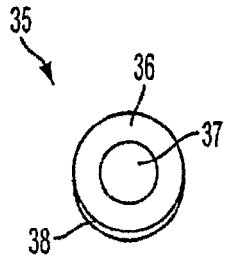


FIG. 5A  
PRIOR ART

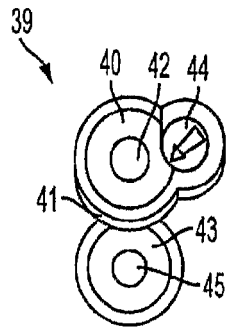


FIG. 5B

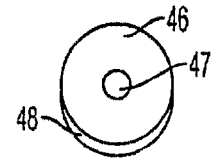


FIG. 5C

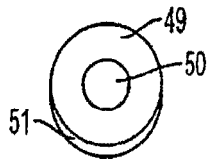


FIG. 5D

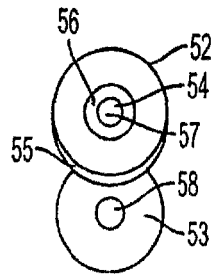


FIG. 5E

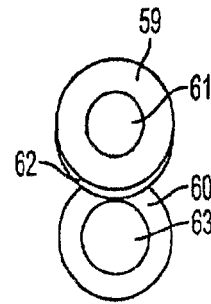


FIG. 5F

10/14

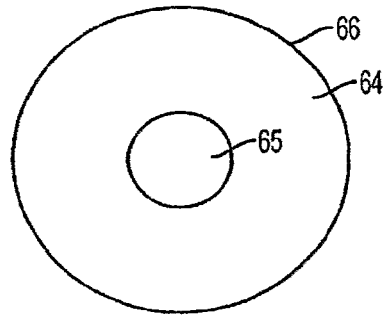


FIG. 6A



FIG. 6B

11/14

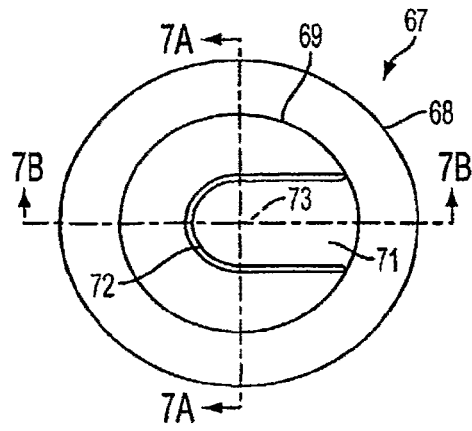


FIG. 7A

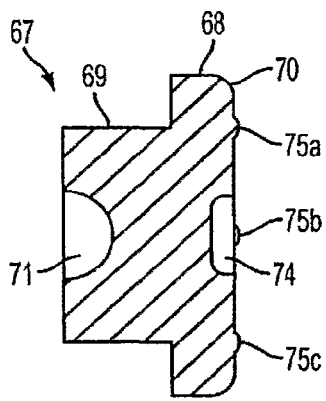


FIG. 7B

1214

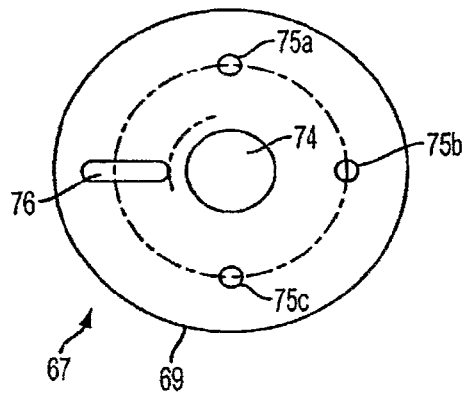


FIG. 7C

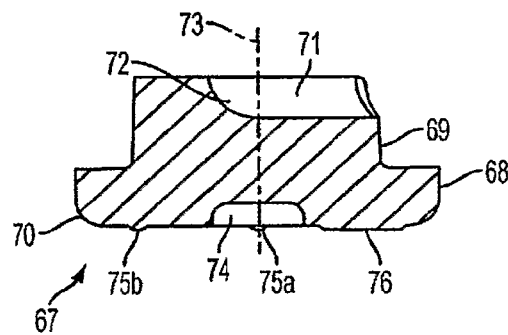


FIG. 7D

13/14

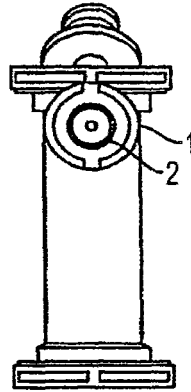


FIG. 8A

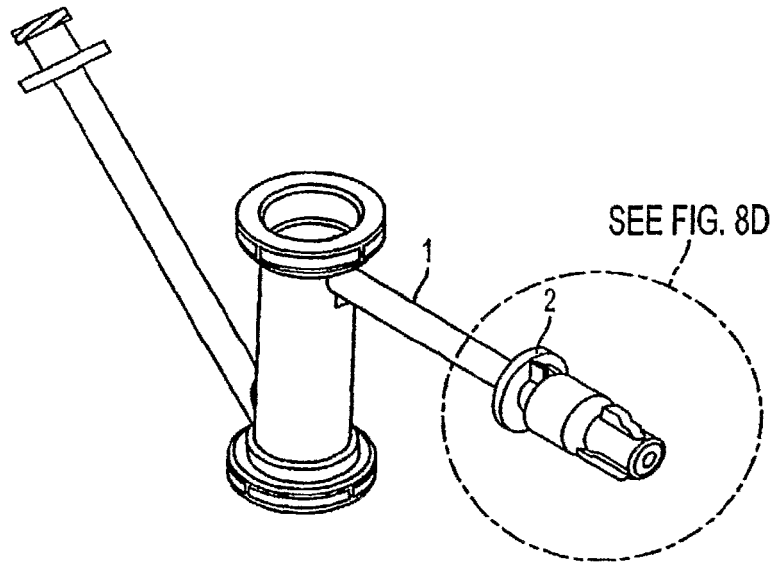


FIG. 8B

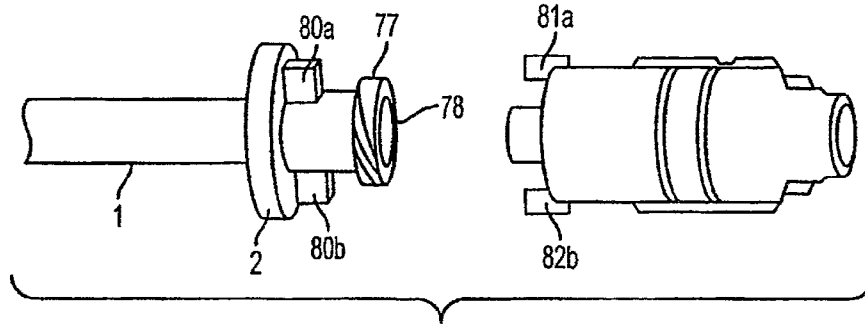


FIG. 8C

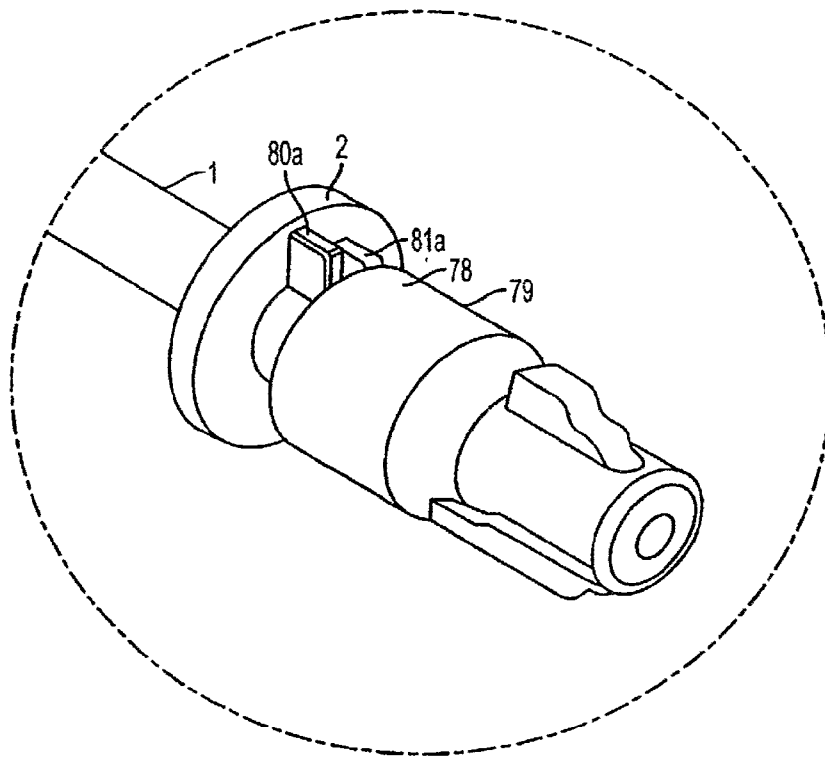


FIG. 8D



(19) World Intellectual Property Organization  
International Bureau



(43) International Publication Date  
21 December 2006 (21.12.2006)

PCT

(10) International Publication Number  
**WO 2006/135374 A2**

- (51) **International Patent Classification:**  
*G21G 4/08* (2006.01)      *A61K 51/00* (2006.01)  
*A61K 51/12* (2006.01)      *B01D 15/00* (2006.01)
- (21) **International Application Number:**  
PCT/US2005/025605
- (22) **International Filing Date:** 19 July 2005 (19.07.2005)
- (25) **Filing Language:** English
- (26) **Publication Language:** English
- (30) **Priority Data:**  
10/894,870      19 July 2004 (19.07.2004)      US
- (71) **Applicant (for all designated States except US):** LYN-NTECH, INC. [US/US]; 7607 Eastmark Drive, College Station, TX 77840 (US).
- (72) **Inventors; and**
- (75) **Inventors/Applicants (for US only):** MOLLER, Teresia [FI/US]; 702 San Saba, College Station, TX 77845 (US). ADAMS, Todd [US/US]; 9388 Hancy Road, Franklin, TX 77856 (US). CISAR, Alan [US/US]; 15603 Juniper Hollow Way, Cypress, TX 77433 (US). GALI, Hariprasad [IN/US]; 7600 Central Park Lane #1603, College Station, TX 77840 (US). SYLVESTER, Paul [GB/US]; 14 Florence Road, Waltham MA 02453 (GB).
- (74) **Agent:** CAMPIGOTTO, Frank, J.; STREETS & STEELE, 13831 Northwest Freeway, Suite 355, Houston, TX 77040 (US).
- (81) **Designated States (unless otherwise indicated, for every kind of national protection available):** AE, AG, AL, AM, AT, AU, AZ, BA, BB, BG, BR, BW, BY, BZ, CA, CH, CN, CO, CR, CU, CZ, DE, DK, DM, DZ, EC, EE, EG, ES, FI, GB, GD, GE, GH, GM, HR, HU, ID, IL, IN, IS, JP, KE, KG, KM, KP, KR, KZ, LC, LK, LR, LS, LT, LU, LV, MA, MD, MG, MK, MN, MW, MX, MZ, NA, NG, NI, NO, NZ, OM, PG, PH, PL, PT, RO, RU, SC, SD, SE, SG, SK, SL, SM, SY, TJ, TM, TN, TR, TT, TZ, UA, UG, US, UZ, VC, VN, YU, ZA, ZM, ZW.
- (84) **Designated States (unless otherwise indicated, for every kind of regional protection available):** ARIPO (BW, GH, GM, KE, LS, MW, MZ, NA, SD, SL, SZ, TZ, UG, ZM, ZW), Eurasian (AM, AZ, BY, KG, KZ, MD, RU, TJ, TM), European (AT, BE, BG, CH, CY, CZ, DE, DK, EE, ES, FI, FR, GB, GR, HU, IE, IS, IT, LT, LU, LV, MC, NL, PL, PT, RO, SE, SI, SK, TR), OAPI (BF, BJ, CF, CG, CI, CM, GA, GN, GQ, GW, ML, MR, NE, SN, TD, TG).

**Published:**  
— without international search report and to be republished upon receipt of that report

For two-letter codes and other abbreviations, refer to the "Guidance Notes on Codes and Abbreviations" appearing at the beginning of each regular issue of the PCT Gazette.



WO 2006/135374 A2

(54) **Title:** RUBIDIUM-82 GENERATOR BASED ON SODIUM NONATITANATE SUPPORT, AND IMPROVED SEPARATION METHODS FOR THE RECOVERY OF STRONTIUM-82 FROM IRRADIATED TARGETS

(57) **Abstract:** Sodium nonatitanate compositions, a method using the composition for recovery of <sup>82</sup>Sr from irradiated targets, and a method using the composition for generating <sup>82</sup>Rb. The sodium nonatitanate materials of the invention are highly selective at separating strontium from solutions derived from the dissolution of irradiated target materials, thus reducing target processing times. The compositions also have a very low affinity for rubidium, making it an ideal material for use as a <sup>82</sup>Rb generator. Sodium nonatitanate materials of this type both improve the recovery of <sup>82</sup>Sr and provide a safer, more effective <sup>82</sup>Rb generator system.

RUBIDIUM-82 GENERATOR BASED ON SODIUM NONATITANATE SUPPORT, AND  
IMPROVED SEPARATION METHODS FOR THE RECOVERY OF STRONTIUM-82 FROM  
IRRADIATED TARGETS

BACKGROUND OF THE INVENTION

Field of the Invention

[001] This invention relates to the selective separation of strontium-82 from other radioisotopes, such as those resulting from irradiated molybdenum or rubidium targets, and in the manufacture of a rubidium-82 generator.

Background of the Related Art

[002] The use of radioisotopes as diagnostic and imaging agents in medicine has expanded rapidly in recent years. Positron ( $\beta^+$ ) emitters are particularly useful in the study of metabolic processes because the positron-electron annihilation reaction produces a pair of gamma rays with an energy level of 511 keV travelling in opposite directions. By placing a series of detectors around a patient who has been administered a positron emitter, both the location and amount of radioactivity can be accurately determined. This property is utilized in Positron Emission Tomography (PET) to image metabolic processes *in vivo*. Rubidium-82 ( $^{82}\text{Rb}$ ) is a short-lived positron-emitting isotope ( $T_{1/2} = 76$  seconds) that is increasingly being used to study blood flow through the heart and brain. Physiologically, rubidium is an analogue of potassium, and consequently enters the body's large potassium pool, which has a comparatively slow turnover. Thus, after  $^{82}\text{Rb}$  is injected intravenously, the tracer's uptake in tissue reflects the rate of delivery, *i.e.*, blood flow, and thus  $^{82}\text{Rb}$  rapidly builds up in the heart. This can be used, for example, to study blood-brain barrier leakage and heart muscle perfusion.

[003] The short half-life of  $^{82}\text{Rb}$  means that it must be supplied to physicians in the form of a generator, where the parent  $^{82}\text{Sr}$  ( $T_{1/2} = 25$  days) is immobilized on a solid substrate or support and  $^{82}\text{Rb}$  eluted as required. The generators that are currently available use hydrous tin oxide to immobilize the  $^{82}\text{Sr}$  and allow the elution of  $^{82}\text{Rb}$  by saline or other appropriate eluant. The  $^{82}\text{Sr}$  ( $T_{1/2} = 25$  days) is accompanied by unwanted  $^{85}\text{Sr}$  ( $T_{1/2} = 64$  days), generated as a by-product during the manufacture of  $^{82}\text{Sr}$ , wherein both isotopes have a relatively long half-life and

a high radiotoxicity due to their tendency to accumulate in bone. Thus, it is essential to minimize or eliminate the introduction of  $^{82}\text{Sr}$  and  $^{85}\text{Sr}$  into a patient during the administration of  $^{82}\text{Rb}$ . Although hydrous tin oxide has proved acceptable to date for use in generators, new materials exhibiting far higher strontium affinities, improved strontium/rubidium separation factors and greater radiolytic stability are needed in order to lower the amount of  $^{82}\text{Sr}$  and  $^{85}\text{Sr}$  released during elution of the  $^{82}\text{Rb}$ .

[004] The parent  $^{82}\text{Sr}$  is generated by the proton irradiation of rubidium, rubidium chloride or molybdenum targets followed by dissolution and processing to isolate the  $^{82}\text{Sr}$ . The demand for  $^{82}\text{Rb}$  generators has grown so great that there is a need to reduce processing times and to increase the yield of  $^{82}\text{Sr}$  from processed targets. One method of improving the supply of  $^{82}\text{Sr}$  is to improve the processes used to extract  $^{82}\text{Sr}$  from irradiated targets. Current methods utilize organic ion exchange or chelating resins to extract very low levels of strontium from dissolved targets containing molar concentrations of inert ions. However, a satisfactory separation of  $^{82}\text{Sr}$  from the target materials and other radioisotopes generated during the irradiation procedure requires multiple treatment steps due to the relatively low affinity and low selectivity of the organic ion exchange resins for  $^{82}\text{Sr}$ .

[005]  $^{82}\text{Sr}$  is produced by the proton irradiation of molybdenum metal, rubidium metal and rubidium chloride targets. The irradiation process also produces a range of other radioactive isotopes (*e.g.*,  $^{88}\text{Y}$ ,  $^{88}\text{Zr}$ ,  $^{85}\text{Sr}$ ) and as a consequence, a series of carefully designed separation procedures have been designed to separate the desired  $^{82}\text{Sr}$  from other radioisotopes and inactive species present. The primary method used to separate  $^{82}\text{Sr}$  is by a series of ion exchange and selective elution steps. Typically, AG 50 W-X8 ion exchange resin is used to separate  $^{82}\text{Sr}$  from dissolved targets. However, this resin is relatively non-selective and will absorb numerous polyvalent cations (*e.g.*,  $^{88}\text{Y}$ ) in addition to the desired  $^{82}\text{Sr}$ . Consequently, multiple separation steps are required to isolate  $^{82}\text{Sr}$  from the other isotopes present.

[006]  $^{82}\text{Rb}$  can be conveniently supplied to physicians in the form of a generator in which the parent  $^{82}\text{Sr}$  is immobilized on an ion exchange material and the  $^{82}\text{Rb}$  eluted when required. This means that  $^{82}\text{Rb}$  PET can be performed at clinical facilities where a typical generator lasts about a month before the yield of  $^{82}\text{Rb}$  diminishes below a usable level.

[007] To be suitable for use in a  $^{82}\text{Rb}$  generator, an ion exchange material must exhibit a high affinity for strontium but a low affinity for rubidium, allowing the  $^{82}\text{Rb}$  daughter to be eluted from a column containing immobilized  $^{82}\text{Sr}$ . Generators have been proposed that were

based on a number of separation media including Chelex 100,  $\text{Al}_2\text{O}_3$ ,  $\text{Sb(V)}$  hexacyanoferrate, polyantimonic acid, titanium vanadate and hydrated tin(IV) oxide, with the hydrated tin(IV) oxide being the most widely used.

[008] However, the crucial component of any system is the actual ion exchange material containing the immobilized  $^{82}\text{Sr}$  parent. Current systems using hydrous tin oxide have a limited life due to the breakdown of the hydrous tin dioxide, necessitating frequent replacement.

[009] Therefore, there is a need for a highly strontium selective ion exchange material for use in place of ion exchange resins and hydrated tin(IV) oxide, so that the separation and recovery of  $^{82}\text{Sr}$  from Rb,  $\text{RbCl}$  and Mo targets is greatly facilitated. A replacement for the ion exchange resin will lead to a reduction in processing steps, a decrease in target processing times and thus a decrease in the cost of the  $^{82}\text{Sr}$  product. An ion exchange material suitable for use as a  $^{82}\text{Rb}$  generator will have a very high selectivity for  $^{82}\text{Sr}$  and a very low selectivity for  $^{82}\text{Rb}$  to allow elution of the  $^{82}\text{Rb}$  by isotonic saline or other solutions and will offer a longer operating life or improved operating conditions compared to hydrated tin(IV) oxide.

#### SUMMARY OF THE INVENTION

[010] The present invention provides a method of chemically isolating strontium-82 from proton-irradiated molybdenum targets. This comprises dissolving the molybdenum metal target containing the strontium-82, adjusting the pH of the dissolved molybdenum target solution to an alkaline pH, removing precipitates from the solution, and then absorbing the strontium-82 from the solution onto a support comprising sodium nonatitanate. Sodium nonatitanate can also be applied to the efficient recovery of strontium-82 from alkaline  $\text{RbCl}$  solutions produced during the processing of proton-irradiated rubidium metal and rubidium chloride targets.

[011] The present invention also provides a rubidium-82 generator, comprising a strontium-82 support medium comprising sodium nonatitanate. Preferably, the sodium nonatitanate is characterized by a strontium selectivity greater than 250,000 mL/g at an alkaline pH, and/or the sodium nonatitanate is characterized by a rubidium selectivity less than 100 mL/g at an alkaline pH. More preferably, the sodium nonatitanate is characterized by a strontium/rubidium separation factor greater than 1,000, and even more preferably greater than 100,000.

[012] The rubidium-82 generator is prepared by a process comprising: preparing sodium nonatitanate from titanium isopropoxide and aqueous sodium hydroxide; heating the sodium

nonatitanate at a temperature between 100°C and 250°C for a period between 12 hours and 2 weeks; and absorbing strontium-82 on the sodium nonatitanate from an aqueous solution comprising strontium-82 and a soluble sodium salt, wherein the sodium salt concentration is between 0.1 and 1 molar. It is also preferred that the titanium isopropoxide and the aqueous sodium hydroxide solution are provided at a sodium hydroxide to titanium isopropoxide molar ratio of greater than 0.44, but preferably providing a large molar excess of sodium hydroxide. The sodium hydroxide to titanium isopropoxide molar ratio is preferably between 1 and 10, more preferably between 2 and 6, and most preferably about 4.

[013] Furthermore, the invention provides a process for preparing a solution containing rubidium-82. The process comprises providing a solution containing strontium-82 at a pH between 10 and 14, absorbing the strontium-82 from the solution onto a sodium nonatitanate support medium, and eluting rubidium-82 from the sodium nonatitanate support medium with a solvent. The solvent is preferably selected from the group consisting of water and saline solutions. More particularly, the solvent may be an aqueous solution having a sodium chloride concentration between 0.001 molar and 1 molar, preferably between 0.1 molar and 1 molar. The solvent may also be a pharmaceutical grade isotonic saline and buffer solution.

#### BRIEF DESCRIPTION OF THE DRAWINGS

[014] FIG. 1 is a graph showing  $^{82}\text{Sr}$   $K_d$  values for the ion exchange materials from simulated rubidium and rubidium chloride target solutions.

[015] FIG. 2 is a graph showing the reduction of  $^{82}\text{Sr}$  activity with increasing time.

[016] FIG. 3 is a graph showing the effect of pH on the uptake of  $^{85}\text{Sr}$  using normal saline as an eluant.

[017] FIG. 4 is a graph showing  $^{85}\text{Sr}$   $K_d$  values in normal saline for NaTi samples of various pellet size.

[018] FIG. 5 is a schematic drawing of a system having a sodium nonatitanate column in accordance with the present invention.

[019] FIGS. 6A-6B are graphs showing the pH of saline solutions at the inlet and outlet of a  $^{82}\text{Sr}/^{82}\text{Rb}$  column.

DETAILED DESCRIPTION OF THE INVENTION

[020] The present invention provides improved sodium nonatitanate compositions, a method using the composition for recovery of  $^{82}\text{Sr}$  from irradiated targets, and a method using the composition for generating  $^{82}\text{Rb}$ . The sodium nonatitanate materials of the invention are far more selective at separating strontium from solutions derived from the dissolution of irradiated target materials than current ion exchange resins used in the production of  $^{82}\text{Sr}$ . The present invention reduces the number of processing steps required, and thus leads to a decrease in target processing times and a reduction in the cost of the  $^{82}\text{Sr}$  product. Waste generation and disposal are also decreased.

[021] According to the present invention, synthetic conditions are adjusted to produce a material with improved properties more applicable to  $^{82}\text{Sr}$  processing. The sodium nonatitanate of the present invention has been found to have a very low affinity for rubidium in addition to an exceptionally high affinity for strontium, making it ideal for use as a replacement for the hydrous tin dioxide used in current  $^{82}\text{Rb}$  generators. Sodium nonatitanate materials of this type will both improve the retention of  $^{82}\text{Sr}$  and lead to a safer, more effective  $^{82}\text{Rb}$  generator system for clinical applications.

[022] Sodium nonatitanate,  $\text{Na}_4\text{Ti}_9\text{O}_{20}\cdot x\text{H}_2\text{O}$ , is an inorganic ion exchange material that has been used for the removal of  $^{90}\text{Sr}$  from neutral and alkaline nuclear wastes. The sodium nonatitanate of the present invention has a number of advantages over conventional organic ion exchange resins (*e.g.*, Chelex 100) that include: very high selectivity for trace levels of strontium in the presence of molar concentrations of other ions at alkaline pH; very low affinity for rubidium; excellent radiation, chemical and thermal stability so that there is no release of contaminants (*e.g.*, Ti) into the  $^{82}\text{Rb}$  product; rapid reaction kinetics; high cation exchange capacity; absorbed ions are readily stripped by treatment with dilute mineral acid allowing the sodium nonatitanate to be recycled, if desired; scale up of similar synthesis has already been demonstrated; and the sodium nonatitanate powder can be manufactured into pellets appropriate for column operations. Other chemically related sodium titanate materials suitable for use in the same manner as the aforementioned sodium nonatitanate ( $\text{Na}_4\text{Ti}_9\text{O}_{20}\cdot x\text{H}_2\text{O}$ ) include other titanate materials exhibiting high Sr affinity and low Rb affinity, including Sr-Treat (available from Selion Oy) and monosodium titanate (available from Boulder Scientific) It is also anticipated that analogous zirconates may exhibit similar properties.

[023] The invention also provides important improvements in the processing of irradiated targets to recover  $^{82}\text{Sr}$ . Sodium nonatitanate has a much greater affinity for  $^{82}\text{Sr}$  than currently used ion exchange resins, and a low affinity for other radioactive isotopes. Consequently, the use of sodium nonatitanate greatly simplifies the extraction process by reducing the number of separation steps that are required to produce chemically pure  $^{82}\text{Sr}$ . Thus, targets can be processed more rapidly and the recovery of  $^{82}\text{Sr}$  improved. Improved isotope selectivity may also facilitate the isolation of other useful isotopes from the targets, leading to greater payback from target processing operations.

[024] Furthermore, less than 1 g of sodium nonatitanate material is needed in a  $^{82}\text{Rb}$  generator and 1 kg of this material is expected to be sufficient to process a large number of targets, even if the sodium nonatitanate material is not recycled and is disposed of after one use. Consequently, the additional cost incurred by the use of sodium nonatitanate will be negligible in comparison with the cost savings achieved in the  $^{82}\text{Sr}$  production.

[025] It has been determined that replacing hydrous tin dioxide with sodium nonatitanate reduces the amount of  $^{82}\text{Sr}$  released during the operation of the  $^{82}\text{Rb}$  generator, thereby reducing the exposure of the patient to  $^{82}\text{Sr}$ . Sodium nonatitanate is also more chemically stable and less likely to leach non-radioactive contaminants into solution during operation of the generator. The sodium nonatitanate is also more amenable to recycling since the  $^{82}\text{Sr}$  can readily be stripped with mineral acid without producing additional impurities. Recycling of  $^{82}\text{Sr}$  generators is already being used as a source of additional  $^{82}\text{Sr}$ , and improvements to the recycling procedure (obtained by using a superior ion exchange material) will facilitate the recovery of  $^{82}\text{Sr}$  from this source.

[026] Although the sodium nonatitanate may be used as a direct replacement for hydrous tin dioxide in the  $^{82}\text{Rb}$  generator, it is also possible to use sodium nonatitanate in the form of a disposable add-on filter that could be used to trap any  $^{82}\text{Sr}$  that is leached from the generator during the production of  $^{82}\text{Rb}$ .

[027] The first step in preparing a  $^{82}\text{Rb}$  generator is to load the parent  $^{82}\text{Sr}$  onto the sodium nonatitanate material and place the ion exchange material into a suitable column. It is essential that sufficient time be allowed for the  $^{82}\text{Sr}$  to be absorbed by the sodium nonatitanate material in order to maximize the loading of the parent radioisotope per gram of ion exchange material.

[028] For an  $^{82}\text{Rb}$  generator, the sodium nonatitanate may be loaded into the column and then loaded with  $^{82}\text{Sr}$  although this method results in depositing a disproportionate amount of the  $^{82}\text{Sr}$  at the top of the column with the remainder of the column remaining as a guard bed to collect any  $^{82}\text{Sr}$  that migrates down the column. Alternatively, the sodium nonatitanate may be loaded with  $^{82}\text{Sr}$  before being placed in an ion exchange column to avoid preferentially loading the  $^{82}\text{Sr}$  on the top of the ion exchange. A high concentration of radioactivity on a very small volume of sodium nonatitanate may result in undesirable radiolytic problems. Although sodium nonatitanate has been shown to be highly resistant to radiation damage, it is always considered prudent to avoid any unnecessary radiation exposure.

[029] In the medical field, use of the  $^{82}\text{Rb}$  generator preferably provides a saline solution that can be intravenously injected into a patient as an imaging agent at a pH of between about 4.5 and about 7. To achieve the desired pH range of the eluted  $^{82}\text{Rb}$  solution, a neutralization step may be performed on the sodium nonatitanate to lower the pH of the sodium nonatitanate. An  $^{82}\text{Rb}$  generator having sodium nonatitanate that has not been neutralized to a lower pH produces an  $^{82}\text{Rb}$  eluate solution having a higher pH than is desired for an injectable pharmaceutical in the medical field. For example, using a normal saline eluant having an initial pH of about 7.6 to elute  $^{82}\text{Rb}$  from an  $^{82}\text{Rb}$  generator having sodium nonatitanate that has not been neutralized to a lower pH can produce an eluate with a pH as high as 9.5. Even though over time the pH of the eluate slowly declines as more eluant is run through the generator, it is preferable and more efficient that the  $^{82}\text{Rb}$  eluate produced from the generator is immediately suitable for medical use. In one experiment, it was determined that a 2.92 g alkaline nonatitanate column required about 44 L of pH 6.2 saline eluant throughput to lower the pH level of the eluate to within the desired pH range. However, the use of such a high volume of eluant before the  $^{82}\text{Rb}$  solution is produced at a desired pH level is unacceptable.

[030] The neutralization step added to the nonatitanate synthesis effectively lowers the pH of the ion exchanger and provides an  $^{82}\text{Rb}$  solution having the desired pH range from the first use of the generator. The neutralization step includes adding an acid to the final stage of the nonatitanate synthesis. This neutralization step has no significant effect on the high separation factor that the nonatitanate possesses for strontium and rubidium as required for use in an  $^{82}\text{Rb}$  generator. However, using the sodium nonatitanate that has been neutralized to a lower pH results in an  $^{82}\text{Rb}$  product having an acceptable pH difference of less than one pH unit between the eluant and the eluate.



[031] The neutralization step includes resuspending the sodium nonatitanate product in a liquid and then adding an acid to lower the pH to between about 7 and about 9, preferably between about 7.2 and about 8.5. The pH is more preferably lowered to between about 7.5 and about 8.3 and most preferably to between about 7.8 and about 8.2. Sodium nonatitanate is partially neutralized by contacting the sodium nonatitanate product with the acidic liquid. The product may be centrifuged, the supernatant poured off, and, if desired, the process repeated to neutralize the sodium nonatitanate product again to obtain the target pH. The liquid may be any suitable liquid such as normal saline, dilute sodium chloride, water or preferably, deionized water. Any strong acid may be added to lower the pH such as, for example, nitric acid, sulfuric acid, or preferably hydrochloric acid.

[032] It is important to maintain the pH of the sodium nonatitanate above a minimum pH during the neutralization step because lowering the pH below neutral also lowers the separation efficiency of Sr/Rb. There is a correlation shown in between pH and the uptake of both  $^{85}\text{Sr}$  and  $^{82}\text{Rb}$ . At high pH, the uptake of  $^{85}\text{Sr}$  is high while the uptake of  $^{82}\text{Rb}$  is low. At pH between about 6 and about 7, the uptake of  $^{85}\text{Sr}$  starts to decrease while the uptake of  $^{82}\text{Rb}$  remains the same or slightly increases. At pH values lower than about 4, the affinity for  $^{85}\text{Sr}$  decreases dramatically.

[033] As the pH of the equilibrium saline solution passing through the column increases, the nonatitanate affinity for the strontium increases while the affinity for the rubidium decreases. Therefore, lowering the pH of the produced nonatitanate by performing a neutralizing step at the end of the method of producing the nonatitanate results in generator having a shorter life. To optimize the life time and separation efficiency, either the neutralization step may be omitted or a less complete neutralization step may be performed to achieve a lesser degree of neutralization.

[034] Optionally, an adjustment may be made to the pH of the eluate product obtained from the nonatitanate column that was produced without a neutralization step or was only slightly neutralized during the neutralization step. If the eluate product from the generator has a pH above the desired range, the pH of the eluate product may be decreased to the desired pH range by adding an acid. Acceptable acids include any acid suitable for neutralizing the eluant without rendering the neutralized eluant unsuitable for injection into a patient during a medical procedure as known by those having ordinary skill in the art. Suitable acids would include, for

example, hydrochloric acid (HCl) and acetic acid (CH<sub>3</sub>COOH). HCl is preferred because the salt produced by the neutralizing reaction is NaCl, which is already present in the solution.

[035] The acid may be added automatically to adjust the pH or the acid may be added manually. A pH meter preferably measures the pH of the eluate product. Alternatively, other means, such as pH indicating strips, may be used to measure the pH of the eluate. Preferably a pH meter monitors the pH of the eluate as the acid is added to obtain the eluate target pH of between about 4.5 and about 7. The acid may be added using a gravity system to drip or pour the acid into the eluate. Alternatively, a pressure system, such as a syringe, a pump or a gas pressurized system may be used to add the acid to the eluate. When the acid is added automatically, a controller monitors the output signal from a pH meter and adjusts a valve or a pump rate to add the amount of acid necessary to obtain the eluate target pH. If adjusted manually, acid may be added to the eluate by an operator, preferably in pre-packaged amounts, until a pH meter or indicator strip indicates that the target pH has been achieved. Preferably, the acid is added automatically to the eluate as the eluate flows from the column.

[036] The size of the sodium nonatitanate particles used in the generator is an important factor. The use of large particles of sodium nonatitanate in a column provides low flow resistance of the eluant through the column but large particles cannot be packed into a column or elutable container as densely as smaller particles may be packed. Furthermore, large particles create long diffusion paths over which the <sup>82</sup>Rb generated by the decay of <sup>82</sup>Sr atoms located deep in the particle must travel while diffusing from the centers of the large particles. In contrast, fine particles of sodium nonatitanate permit more material to be packed into a column of a given volume and provide shorter diffusion paths out of the particles, but the fine particles produce greater flow resistance to the eluant during the elution of the <sup>82</sup>Rb from the generator.

[037] Therefore, the <sup>82</sup>Rb generator preferably includes smaller particles of sodium nonatitanate because the shorter diffusion path allows the particles to equilibrate with the eluant more quickly and because the smaller particles pack more densely into a column of a given size. Both of these factors together promote the elution of <sup>82</sup>Rb using a small volume of saline solution as the eluant and obtaining a high concentration of <sup>82</sup>Rb in the eluate. Preferably, the particles of sodium nonatitanate are made as small as possible without causing excessive back pressure from the flow of the eluant through the column. Preferably, the size of the particles used in the <sup>82</sup>Rb generator range between about 50 μm and about 200 μm. More preferably, the particle size of

the sodium nonatitanate is between about 75 and about 150  $\mu\text{m}$  and most preferably between about 75 and about 100  $\mu\text{m}$ .

[038] Low porosity is a preferred characteristic of the sodium nonatitanate particles for use in the  $^{82}\text{Rb}$  generator of the present invention. If the particles are highly porous, much of the parent  $^{82}\text{Sr}$  deposits within the pores, which creates a longer diffusion path for the  $^{82}\text{Rb}$  to diffuse from the pores into the saline eluant. The  $^{82}\text{Rb}$  generated from the  $^{82}\text{Sr}$  deposited deep within a pore continues to decay while diffusing from the pore into the eluant stream, which results in a loss of the generated  $^{82}\text{Rb}$  and thereby, a lower  $^{82}\text{Rb}$  yield.

[039] The column aspect ratio is a factor that contributes to the optimum operation of the  $^{82}\text{Rb}$  generator of the present invention. The aspect ratio of a column is the column length over the column diameter. Increasing column length at constant diameter provides for greater retention of  $^{82}\text{Sr}$  and thereby minimizes the amount of leached  $^{82}\text{Sr}$  in the final eluate product. However, as the column length increases, total pressure drop through the column increases, causing higher back pressure at the inlet to the column. The column aspect ratio affects the properties of the  $^{82}\text{Rb}$  generator even at constant column volume and sodium nonatitanate mass.

[040] A long, narrow column having a high aspect ratio offers greater resistance to the flow of the eluant and generates a higher backpressure at the inlet to the column. Because the velocity of a given volume of eluant is higher in a column having a high aspect ratio, the flow through the column having a high aspect ratio is more turbulent, which increases mixing within the eluant stream. Comparatively, a short, wide column having a low aspect ratio operates with a lower velocity of a given volume of eluant through the column and operates at lower pressure drop with less mixing. However, channeling through the bed can occur at low velocities resulting in the eluant bypassing some of the ion exchange material and providing a lower yield. While a wide range of column aspect ratios are acceptable, preferably, without limitation, the aspect ratio may be between about 4 and 50, more preferably between about 6 and about 20.

[041] Preferably, the column or other elutable container is not loaded with uniform material over its entire length. The portion of the column closest to the generator outlet preferably holds sodium nonatitanate containing no  $^{82}\text{Sr}$ , serving as a guard bed to intercept any  $^{82}\text{Sr}$  or  $^{85}\text{Sr}$  released from the generator. By intercepting and capturing any released  $^{82}\text{Sr}$  and  $^{85}\text{Sr}$ , the product eluant is safe for use as an  $^{82}\text{Rb}$  tracer. The guard bed may be formed with sodium nonatitanate that was produced without the neutralization step so that the affinity to capture strontium is at its highest level and the affinity to capture rubidium is at its lowest level.

Optionally, the guard bed may be placed in a second separate container, receiving the eluate from the outlet of the generator, to filter any strontium from the eluant eluted from the  $^{82}\text{Rb}$  generator. Alternatively, a guard bed may be installed in the generator as described above coupled with a separate filter containing sodium nonatitanate as an added precaution.

[042] Optionally, the sodium nonatitanate may be supported on the surface of a non-porous support. Placing the sodium nonatitanate in a thin layer on a non-porous support provides the advantage of placing all of the sodium nonatitanate in close contact with the eluant, thereby minimizing the length of the diffusion path of the  $^{82}\text{Rb}$  from the nonatitanate to the eluant. Suitable non-porous support materials include inorganic materials that are not damaged in a high radiation field, such as fiberglass, fine glass beads, ceramics, and other similar materials known to those skilled in the art. It is critical that any material chosen for this function does not release anything into the eluate that could contaminate the product.

[043] The examples that follow disclose the methods and materials for the  $^{82}\text{Rb}$  generator. Examples 12-18 further disclose the nonatitanate neutralized to a lower pH for providing an eluate having a pH within the desired range.

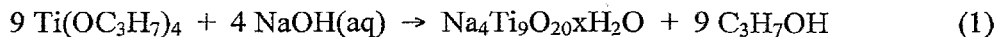
## EXAMPLES

[044] These Examples investigated the suitability of sodium nonatitanate for the use in separating  $^{82}\text{Sr}$  from irradiated targets and in the construction of an  $^{82}\text{Sr}/^{82}\text{Rb}$  generator. Initial batch experiments compared the rubidium and strontium selectivities of a number of different sodium nonatitanate samples with commercially available ion exchange materials (*e.g.*, AW 500, Chelex 100) and some experimental materials that had also exhibited high strontium selectivities (*e.g.*, sodium titanate). Column experiments were then performed using target simulants and generator simulants on materials that exhibited favorable selectivity characteristics. Some work was also performed to investigate the likely interference from other isotopes present in irradiated targets on the production of  $^{82}\text{Sr}$ .

### Example 1 - Preparation of Sodium Nonatitanate

[045] Sodium nonatitanate (NaTi) was synthesized hydrothermally as follows. 77.5 g of titanium isopropoxide was added to 84.35 g of a 50 wt% solution of NaOH with vigorous stirring and 60 mL of deionized water was added. The resultant gel was heated at approximately 108 °C

for 3 hours, transferred to a hydrothermal pressure vessel with an additional 90 mL of deionized water, and heated at either 170 °C or 200 °C for times ranging from 21 hours to 1 week. After the allotted time, the materials were filtered, washed with ethanol to remove residual base and dried at 60 °C. The mass of sodium nonatitanate produced was approximately 31 g. Each sample was characterized using x-ray powder diffraction (XRD). The reaction is outlined in Equation 1.



[046] The crystallinity of the material was shown to be dependent upon the reaction time and temperature, with the most crystalline materials being produced after 1 week of hydrothermal treatment (200 °C for 7 days). Samples that received no hydrothermal treatment, or only a few days, were virtually amorphous with only a few very broad reflections visible on the XRD pattern.

[047] The theoretical cation exchange capacity (CEC) of sodium nonatitanate is quite high and has a value of 4.74 meq/g, which compares favorably with organic ion exchange resins.

[048] Alternative titanium salts that could be used to manufacture sodium nonatitanate include titanium tetrachloride,  $\text{TiCl}_4$ , and titanium sulfate,  $\text{TiOSO}_4 \cdot \text{xH}_2\text{SO}_4 \cdot \text{yH}_2\text{O}$ . However, hydrolysis of these salts leads to the generation of hydrochloric acid and sulfuric acid, respectively, and thus additional base is required to neutralize the acids during the hydrothermal process. The final product also needed to be exhaustively washed to remove residual sodium chloride or sodium sulfate. Consequently, titanium isopropoxide (which hydrolyzes to form propanol) or titanium dioxide  $\text{TiO}_2$  is the preferred starting material because the final product is free from additional sodium salts.

#### Example 2 - Determination of Strontium Selectivity

[049] Sodium nonatitanate and a variety of other ion exchange materials were obtained and evaluated for use in the separation of  $^{82}\text{Sr}$  from targets and in a  $^{82}\text{Rb}$  generator. These materials are described below in Table 1.

Table 1 - Characteristics of Ion Exchange Materials Evaluated in this Study

| Material  | Source  | Sample Preparation   |
|---|---|--|
| Na-Clinoptilolite   | GSA Resources, AZ   | Ground to powder.  |
| AW500   | Aldrich (1.6 mm Pellets)                                      | Ground to powder   |
| Hydrous SnO <sub>2</sub>  | Synthesized in house  | NaOH + SnCl <sub>4</sub> . Washed with acetic acid/sodium acetate buffer         |
| K <sup>+</sup> Pharmacosiderite<br>(K <sub>3</sub> H(TiO) <sub>4</sub> (SiO <sub>4</sub> ) <sub>3</sub> ·4H <sub>2</sub> O) | Synthesized according to literature method                    | None. Used as synthesized  |
| Sodium Titanosilicate<br>(Na <sub>2</sub> Ti <sub>2</sub> O <sub>3</sub> SiO <sub>4</sub> ·2H <sub>2</sub> O)               | Synthesized according to literature method                    | None. Used as synthesized  |
| AG 50W-X8 (Na <sup>+</sup> )<br>(25 - 50 Mesh)  | BioRad. Strong acid ion exchange resin.                       | Converted to Na <sup>+</sup> form (for alkaline solutions only)                  |
| Chelex 100 (Na <sup>+</sup> )<br>(50 - 100 Mesh)  | BioRad. Chelating resin with iminodiacetic acid functionality | None. Used as received   |
| Sodium Nonatitanate   | Honeywell, IL   | None. Used as received   |
| Hydrous SiO <sub>2</sub>  | Synthesized in house  | Acetic acid hydrolysis of tetraethyl orthosilicate. Washed with H <sub>2</sub> O |
| Hydrous TiO <sub>2</sub>  | Synthesized in house  | Hydrolysis of titanium isopropoxide. Washed with H <sub>2</sub> O                |
| Hydrous ZrO <sub>2</sub>  | Synthesized in house  | ZrOCl <sub>2</sub> + NaOH. Washed with deionized water                           |

[050] The strontium selectivity of the ion exchange materials of Table 1 was evaluated in sodium chloride and rubidium chloride solutions using radiotracer techniques. Samples were evaluated using a simple batch technique to allow the rapid screening of a large number of materials over a range of ionic strengths. Blanks were run for each matrix to check for any loss of strontium during filtration or absorption of strontium onto the scintillation vials. In all solutions evaluated, strontium absorption was negligible.

[051] 0.05 g of each of the ion exchange materials was contacted with 10 mL of a solution, spiked with <sup>89</sup>Sr, in a capped scintillation vial. (The total strontium content was approximately 1.6 ppm, thus preventing any loss of strontium in solution due to precipitation of sparingly soluble Sr(OH)<sub>2</sub> at alkaline pH values.) The mixtures were shaken for 6 hours, filtered through a 0.2 μm syringe filter and the residual activity determined using liquid scintillation counting (LSC). Distribution Coefficients (K<sub>d</sub> values) were then determined according to Equation 2:

$$K_d = (A_i - A_f) / A_f * V/m \quad (2)$$

where: A<sub>i</sub> = initial activity in solution (counts per minute (cpm)/mL)

A<sub>f</sub> = final activity in solution (cpm/mL)

V = volume of solution (mL)

m = mass of exchanger (g)

[052] The final pH of the solution was also noted. The period of 6 hours was chosen to allow equilibrium to be reached for each of the ion exchange materials. However, previous work on the titanosilicates and titanates had shown the reaction rates to be rapid with the majority of the uptake occurring in only a few minutes. The concentration of the chloride solutions was varied from 1M to 0.001M to evaluate the effect of increasing Rb<sup>+</sup> and Na<sup>+</sup> concentrations on the uptake of Sr<sup>2+</sup>. All experiments were performed in duplicate, and if significant variations between duplicate samples occurred, the experiments were repeated until good agreements on the K<sub>d</sub> values were obtained. The results are shown in Tables 2 and 3 and represented the average K<sub>d</sub> obtained, quoted to 3 significant figures.

Table 2 - Strontium Selectivity Data from Unbuffered Sodium Chloride Solutions

| Ion Exchange Material           | K <sub>d</sub> mL/g |           |            |             |
|---------------------------------|---------------------|-----------|------------|-------------|
|                                 | 1M NaCl             | 0.1M NaCl | 0.01M NaCl | 0.001M NaCl |
| Na-Clinoptilolite               | 8                   | 124       | 3,260      | 36,900      |
| AW500                           | 1,860               | 88,300    | 1,270,000  | 1,210,000   |
| Hydrous SnO <sub>2</sub>        | 767                 | 43,000    | 124,000    | 51,800      |
| K <sup>+</sup> Pharmacosiderite | 18,300              | 251,000   | 594,000    | 281,000     |
| Sodium Titanosilicate           | 556,000             | 273,000   | 119,000    | 42,900      |
| AG 50W (Na <sup>+</sup> )       | 32                  | 3,380     | 365,000    | 2,510,000   |
| Chelex 100 (Na <sup>+</sup> )   | 610                 | 26,400    | 726,000    | 1,300,000   |
| NaTi (Honeywell)                | 80,600              | 1,030,000 | 258,000    | 166,000     |
| NaTi (No hydrothermal)          | 1,530,000           | 2,570,000 | 739,000    | 372,000     |
| NaTi (170°C, 21hr)              | 1,030,000           | 1,240,000 | 272,000    | 172,000     |
| NaTi (170°C, 3d)                | 959,000             | 633,000   | 218,000    | 93,100      |
| NaTi (170°C, 7d)                | 167,000             | 834,000   | 264,000    | 90,400      |
| NaTi (200°C, 21hr)              | 439,000             | 1,390,000 | 197,000    | 120,000     |
| NaTi (200°C, 3 d)               | 261,000             | 898,000   | 251,000    | 158,000     |
| NaTi (200°C, 7d)                | 195,000             | 955,000   | 265,000    | 214,000     |
| ZrO <sub>2</sub>                | 3,360               | 52,200    | 213,000    | 232,000     |

Table 3 - Strontium Selectivity Data from Unbuffered Rubidium Chloride Solutions

| Material                 | $K_d$ mL/g |           |            |             |
|--------------------------|------------|-----------|------------|-------------|
|                          | 1M RbCl    | 0.1M RbCl | 0.01M RbCl | 0.001M RbCl |
| Na-Clinoptilolite        | 19         | 3         | 88         | 11,000      |
| AW500                    | 9,750      | 107,000   | 1,020,000  | 1,280,000   |
| Hydrous SnO <sub>2</sub> | 766        | 66,100    | 104,000    | 51,800      |
| K+ Pharmacosiderite      | 1,950      | 40,800    | 419,000    | 427,000     |
| Sodium Titanosilicate    | 12,600     | 94,700    | 164,000    | 179,000     |
| AG-50W (Na+)             | 44         | 3,870     | 237,000    | 800,000     |
| Chelex 100 (Na+)         | 1,580      | 38,400    | 555,000    | 977,000     |
| NaTi (Honeywell)         | 13,900     | 108,000   | 279,000    | 324,000     |
| NaTi (No hydrothermal)   | 14,220     | 116,000   | 345,000    | 429,000     |
| NaTi (170°C, 21hr)       | 10,500     | 71,700    | 193,000    | 205,000     |
| NaTi (170°C, 3d)         | 15,100     | 39,500    | 68,000     | 95,200      |
| NaTi (170°C, 7d)         | 23,000     | 55,800    | 31,200     | 110,000     |
| NaTi (200°C, 21hr)       | 11,000     | 66,400    | 110,000    | 103,000     |
| NaTi (200°C, 3 d)        | 10,600     | 56,800    | 146,000    | 158,000     |
| NaTi (200°C, 7d)         | 10,500     | 57,400    | 146,000    | 158,000     |
| ZrO <sub>2</sub>         | 3,000      | 42,400    | 184,000    | 221,000     |

[053] Comparing the selectivity data from sodium and rubidium solutions, it is evident that rubidium ions cause a reduction in affinity for the strontium ion for all of the exchangers indicating that the affinity of these materials for rubidium is significantly higher than the affinity for sodium ions. The pH of the final solutions was generally alkaline for the nonatitanates (NaTi) and titanosilicates, with pH values as high as 12 being measured. This was due to hydrolysis of the exchangers resulting in the absorption of protons and the release of sodium ions, thus increasing the pH of the aqueous phase. This effect can be overcome, if desired, by buffering the solution.

[054] The most distinct trend was observed in 1M NaCl solutions for the sodium nonatitanate samples. The highest  $K_d$  was observed for the non-hydrothermal material and the  $K_d$  values decreased with increasing reaction time for both the 200 °C and 170 °C materials. Clearly, strontium uptake is facilitated by having a low-crystallinity material. This suggests that as the crystallinity increases and the size of the nonatitanate crystallites also increases, it becomes thermodynamically less favorable for exchange of the sodium ions by strontium. It is also interesting to note that the majority of the sodium nonatitanates exhibit a higher selectivity for strontium in 1M NaCl than in 0.001M NaCl. This indicates that the higher ionic strength facilitates the  $\text{Na}^+/\text{Sr}^{2+}$  exchange reaction and more than compensates for the increased competition for the ion exchange sites from the additional  $\text{Na}^+$  ions.



[055] This data shows that sodium nonatitanate is an ideal material for the recovery of  $^{82}\text{Sr}$  from irradiated rubidium and rubidium chloride targets and in the manufacture of a  $^{82}\text{Rb}$  generator.

### Example 3 - Rubidium Selectivity from NaCl Solutions

[056] For an ion exchange material to be suitable for use in a  $^{82}\text{Rb}$  generator, it must have a very high selectivity for strontium to prevent any loss of  $^{82}\text{Sr}$  from the ion exchange column and release to the patient undergoing a PET scan. This property was clearly demonstrated in Example 2. It must also have a very low selectivity towards rubidium, thus allowing  $^{82}\text{Rb}$  to be released into solution as saline is passed through the  $^{82}\text{Rb}$  generator. Consequently, the rubidium selectivity of the ion exchange materials was evaluated in sodium chloride media following the procedure described in Example 2. The same procedure was followed using  $^{86}\text{Rb}$  to spike the solutions to give an activity of approximately 200,000 cpm/mL. Total rubidium in solution was < 0.05 ppm. The distribution coefficients of the materials are shown below in Table 4.

Table 4 - Rubidium Selectivity Data from Unbuffered Sodium Chloride Solutions

| Ion Exchange Material    | 1M NaCl | 0.1M NaCl | 0.01M NaCl | 0.001M NaCl |
|--------------------------|---------|-----------|------------|-------------|
| AW500                    | 116     | 620       | 4920       | 21900       |
| Hydrous SnO <sub>2</sub> | 1       | 6         | 36         | 290         |
| K+ Pharmacosiderite      | 148     | 475       | 2030       | 4020        |
| Sodium Titanosilicate    | 8,010   | 194,000   | 114000     | 75800       |
| AG 50W (Na+)             | 7       | 75        | 688        | 6680        |
| Chelex 100 (Na+)         | 3       | 8         | 43         | 256         |
| NaTi (Honeywell)         | 9       | 102       | 488        | 817         |
| NaTi (No hydrothermal)   | 4       | 59        | 280        | 446         |
| NaTi (170°C, 21hr)       | 9       | 56        | 209        | 297         |
| NaTi (170°C, 3d)         | 7       | 46        | 198        | 311         |
| NaTi (170°C, 7d)         | 3       | 15        | 47         | 71          |
| NaTi (200°C, 21hr)       | 8       | 79        | 334        | 502         |
| NaTi (200°C, 3d)         | 8       | 52        | 207        | 307         |
| NaTi (200°C, 7d)         | 4       | 25        | 111        | 178         |
| ZrO <sub>2</sub>         | 1       | 12        | 60         | 154         |

Table 4A - Strontium-Rubidium Separation Factor

| Ion Exchange Material           | 1M NaCl | 0.1M NaCl | 0.01M NaCl | 0.001M NaCl |
|---------------------------------|---------|-----------|------------|-------------|
| AW500                           | 16.0    | 142       | 258        | 55.3        |
| Hydrous SnO <sub>2</sub>        | 767     | 7,167     | 3,444      | 179         |
| K <sup>+</sup> Pharmacosiderite | 124     | 528       | 293        | 69.9        |
| Sodium Titanosilicate           | 69.4    | 1.41      | 1.04       | 0.57        |
| AG 50W (Na <sup>+</sup> )       | 4.57    | 45.1      | 531        | 376         |
| Chelex 100 (Na <sup>+</sup> )   | 203     | 3,300     | 16,884     | 5,078       |
| NaTi (Honeywell)                | 8,956   | 10,098    | 529        | 203         |
| NaTi (No hydrothermal)          | 382,500 | 43,559    | 2,639      | 834         |
| NaTi (170 C, 21hr)              | 114,444 | 22,143    | 1,301      | 579         |
| NaTi (170 C, 3d)                | 137,000 | 1,370     | 1,101      | 299         |
| NaTi (170 C, 7d)                | 55,667  | 55,600    | 5,617      | 1,273       |
| NaTi (200 C, 21hr)              | 54,875  | 17,595    | 590        | 239         |
| NaTi (200 C, 3d)                | 32,625  | 17,269    | 1,213      | 515         |
| NaTi (200 C, 7d)                | 48,750  | 38,200    | 2,387      | 1,202       |
| ZrO <sub>2</sub>                | 3,360   | 4,350     | 3,550      | 1,506       |

Table 4B - Percent Rubidium Retention Generated on 0.1 g of Exchanger in NaCl Solution

| Ion Exchange Material           | 1M NaCl | 0.1M NaCl | 0.01M NaCl | 0.001M NaCl |
|---------------------------------|---------|-----------|------------|-------------|
| AW500                           | 18.8    | 55.4      | 90.8       | 97.8        |
| Hydrous SnO <sub>2</sub>        | 0.2     | 1.2       | 6.7        | 36.7        |
| K <sup>+</sup> Pharmacosiderite | 22.8    | 48.7      | 80.2       | 88.9        |
| Sodium Titanosilicate           | 94.1    | 99.7      | 99.6       | 99.3        |
| AG 50W (Na <sup>+</sup> )       | 1.4     | 13.0      | 57.9       | 93.0        |
| Chelex 100 (Na <sup>+</sup> )   | 0.6     | 1.6       | 7.9        | 33.9        |
| NaTi (Honeywell)                | 1.8     | 16.9      | 49.4       | 62.0        |
| NaTi (No hydrothermal)          | 0.8     | 10.6      | 35.9       | 47.1        |
| NaTi (170 C, 21hr)              | 1.8     | 10.1      | 29.5       | 37.3        |
| NaTi (170 C, 3d)                | 1.4     | 8.4       | 28.4       | 38.3        |
| NaTi (170 C, 7d)                | 0.6     | 2.9       | 8.6        | 12.4        |
| NaTi (200 C, 21hr)              | 1.6     | 13.6      | 40.0       | 50.1        |
| NaTi (200 C, 3d)                | 1.6     | 9.4       | 29.3       | 38.0        |
| NaTi (200 C, 7d)                | 0.8     | 4.8       | 18.2       | 26.3        |
| ZrO <sub>2</sub>                | 0.2     | 2.3       | 10.7       | 23.5        |

[057] From the data in Table 4, it is clear that all of the sodium nonatitanate materials have a very low affinity for rubidium, particularly in the presence of relatively high amounts of sodium ions. In general, the rubidium selectivity decreased with increasing reaction time for both series of nonatitanates (170 °C and 200 °C) with the lowest affinity being demonstrated by the sample that was heated hydrothermally at 170 °C for 1 week. Uptake was negligible in 1M NaCl and the very low reduction in activity that was noted could be accounted for by absorption of rubidium during filtration and by pipetting errors during the counting procedure. Consequently, samples with  $K_d$  values that were below 10 mL/g can be considered to

have no affinity at all for  $^{86}\text{Rb}$ . Some rubidium uptake was evident in very dilute sodium solutions, but the  $K_d$  values were low for all of the titanate samples. This suggests that the uptake of rubidium was more likely due to the materials having an exceptionally low affinity for sodium rather than any real affinity for rubidium. All of the sodium nonatitanate materials performed better than the commercially available sample obtained from Honeywell, Inc. The materials are clearly ideal for use in a  $^{82}\text{Rb}$  generator.

[058] Hydrous tin dioxide exhibited some of the lowest rubidium affinities and was comparable with Chelex 100, the best of the nonatitanates and the hydrous zirconium dioxide. However, hydrous tin dioxide exhibited much lower strontium  $K_d$  values than the nonatitanates. Therefore, nonatitanate materials are preferred because they have higher strontium/rubidium separation factors. Hydrous tin dioxide also has a limited pH stability range and significant dissolution and release of absorbed strontium is likely to occur should any significant pH perturbations occur outside the range of pH 4 to pH 9. Radiation stability of hydrous tin dioxide is also limited, with particle breakdown causing current  $^{82}\text{Rb}$  generators to be replaced before decay has reduced the  $^{82}\text{Rb}$  below useable levels.

[059] The rubidium selectivity data also indicates that AW500, potassium Pharmacosiderite and the sodium titanosilicate have a strong affinity for rubidium in a range of saline solutions. Consequently, these materials will be unsuitable for use in a  $^{82}\text{Rb}$  generator and have only limited applications in the processing of irradiated target materials.

#### Example 4 - Strontium and Rubidium Selectivity in 0.1M Sodium Acetate/Acetic Acid Buffer

[060] In order to prevent hydrolysis reactions from raising the pH as described above, some strontium and rubidium selectivity experiments were performed in a 0.1M sodium acetate / acetic acid buffer solution. In these tests, the final pH remained between 5.2 and 6.3, which is a more clinically acceptable pH for an  $^{82}\text{Rb}$  infusion. Rubidium  $K_d$  values remained low, as expected, following the trend observed in Table 5. Strontium  $K_d$  values were considerably lower, with a maximum  $K_d$  value of 80,000 mL/g being obtained for the sodium nonatitanate sample that was heated hydrothermally at 170 °C for 21 hours. This is considerably lower than the  $K_d$  value of over 1,200,000 mL/g that was obtained in unbuffered 0.1M NaCl (pH ~ 12). The  $K_d$  values obtained for the other ion exchange materials were also considerably lower. However, the Sr/Rb separation factors remained high and the sodium nonatitanates still outperformed hydrous

tin dioxide and the organic ion exchange resins. The affinity of sodium nonatitanate for strontium is greatest at higher pH values.

#### Example 5 - Molybdenum Targets

[061] The basic steps of a proposed process to obtain  $^{82}\text{Sr}$  from irradiated molybdenum targets are as follows:

1. Dissolve the irradiated molybdenum target in 30% hydrogen peroxide, ensuring excess hydrogen peroxide is destroyed.
2. Add sodium hydroxide to bring the pH to approximately 12.
3. Filter the solution to remove any precipitate. It is predicted that the majority of  $^{88}\text{Zr}$  and  $^{59}\text{Fe}$  will be found in the precipitate, and experiments have confirmed that 99% or more of the  $^{88}\text{Y}$  precipitated out of solution on the addition of NaOH.
4. Pass the solution through a column of sodium nonatitanate and wash the column with two bed volumes of 0.1M NaCl, adjusted to pH 12 with NaOH.  $^{82}\text{Sr}$  and  $^{85}\text{Sr}$  will be absorbed.  $^{82}\text{Rb}$  and other Rb isotopes will remain in the aqueous phase. Molybdate anions will also pass through the column.
5. The column can then be stripped using dilute mineral acid to recover the  $^{82}\text{Sr}$  and the sodium nonatitanate reused or discarded.

[062] There is a range of other isotopes present in addition to  $^{82}\text{Sr}$ , including  $^{75}\text{Se}$ ,  $^{73}\text{As}$ ,  $^{74}\text{As}$ ,  $^7\text{Be}$ ,  $^{68}\text{Ge}$ ,  $^{48}\text{V}$ ,  $^{60}\text{Co}$  (and other Co isotopes),  $^{54}\text{Mn}$ ,  $^{51}\text{Cr}$  and  $^{95\text{m}}\text{Tc}$ . In the alkaline target solution, Se, As, V, Ge, Cr, Mn and Tc are expected to be present as anions and thus will not be absorbed onto the sodium nonatitanate. Significant amounts of Co would be expected to precipitate when the target solution is neutralized, and thus little is expected to be available under alkaline conditions to absorb onto the sodium nonatitanate. The most likely isotope to be absorbed is beryllium, because it is a Group II metal with a similar aqueous chemistry to strontium. However, the affinity of sodium nonatitanate for Group II metals decreases in the order  $\text{Sr} > \text{Ca} > \text{Mg}$ . No data is available for beryllium, but if the trend continues, the affinity would be expected to be low. Thus, any absorbed  $^7\text{Be}$  would be readily removed by an alkaline sodium chloride (or similar) wash.

[063] The current process for recovering  $^{82}\text{Sr}$  from irradiated rubidium metal and rubidium chloride targets requires minimal modification to facilitate the use of sodium nonatitanate. Both targets are processed following standard processing procedures to generate

rubidium chloride solutions in an ammonia/ammonium chloride buffer solution. These solutions are then passed through a sodium nonatitanate column and washed with additional buffer to remove any weakly held rubidium cations. Strontium and possibly some other cationic species present will be absorbed onto the nonatitanate column, whereas rubidium cations, ammonium cations and anions will rapidly pass through the column. If additional cations are absorbed onto the sodium nonatitanate, they can be selectively removed by washing with an appropriate eluant (e.g., citrate, nitrilotriacetate.) The strontium selectivity of sodium nonatitanate has been shown to be unaffected by a number of common complexants and as a consequence, it should be a relatively simple manner to elute any undesirable cations from the column, leaving pure  $^{82/85}\text{Sr}$ .

[064] FIG. 1 clearly shows the exceptionally high affinity of the sodium nonatitanate materials in comparison with the currently utilized organic resin Chelex 100. All of the sodium nonatitanates performed equally well in the buffered rubidium target solutions indicating that the synthetic conditions are not too important when the material is being used in solutions containing high concentrations of rubidium ions. Thus, by replacing the Chelex 100 with sodium nonatitanate, a more efficient  $^{82}\text{Sr}$  isolation can be achieved.

[065] It has also been shown that it is possible to tailor the selectivity of the sodium nonatitanate to achieve the optimum Sr/Rb separation by manipulating the reaction conditions. The differing selectivities were most obvious in sodium solutions, with the less crystalline materials exhibiting the highest strontium distribution coefficients. However, the series of nonatitanates showed little difference in behavior when the predominant cation in solution was  $\text{Rb}^+$ . The materials synthesized clearly demonstrated superior characteristics to the commercially available sample in almost all matrices evaluated. The majority of the sodium nonatitanate samples also exhibited greater strontium selectivities than hydrous tin dioxide in a range of sodium chloride solutions, from 1M to 0.001M. Rubidium selectivities were low, making the sodium nonatitanate ideal as a replacement for hydrous tin dioxide in a  $^{82}\text{Rb}$  generator.

[066] Commercially, one method of  $^{82}\text{Sr}$  production is *via* the proton spallation reaction with natural molybdenum metal targets. A simulated molybdate target solution was prepared as follows: 12.5 g of molybdenum powder was carefully dissolved in 30%  $\text{H}_2\text{O}_2$  solution and made up to a total volume of 500 mL to produce a clear yellow solution of molybdic acid,  $\text{H}_2\text{MoO}_4$ . Solid sodium hydroxide granules totaling 10.9 g were then carefully added to neutralize the solution and bring the pH to approximately 12.3. The colorless solution was then filtered to remove any precipitate. This alkaline molybdate solution was spiked with either  $^{86}\text{Rb}$  or  $^{89}\text{Sr}$  and

$K_d$  values determined as described previously. Separation factors for the strontium/rubidium selectivity were also calculated by dividing the strontium  $K_d$  by the rubidium  $K_d$ , thus allowing the relative affinities of the ion exchange materials to be directly compared. The results are illustrated below in Table 5.

Table 5 - Strontium and Rubidium Absorption from Simulated Molybdate Target Solutions

| Material               | Sr $K_d$ , mL/g | Rb $K_d$ , mL/g | Separation Factor |
|------------------------|-----------------|-----------------|-------------------|
| AW500                  | 7,070           | 194             | 36.4              |
| K+ Pharmacosiderite    | 187,000         | 142             | 1320              |
| Sodium Titanosilicate  | 547,000         | 6500            | 84.2              |
| Chelex 100 (Na+)       | 3,120           | 5               | 624               |
| AG 50W-X8 (Na+)        | 69              | 18              | 3.83              |
| NaTi (Honeywell)       | 337,000         | 27              | 12,500            |
| NaTi (No hydrothermal) | 1,690,000       | 12              | 141,000           |
| NaTi (170°C, 21hr)     | 1,000,000       | 12              | 83,300            |
| NaTi (170°C, 3d)       | 829,000         | 14              | 59,200            |
| NaTi (170°C, 7d)       | 324,000         | 3               | 108,000           |
| NaTi (200°C, 21hr)     | 954,000         | 12              | 79,500            |
| NaTi (200°C, 3 d)      | 687,000         | 11              | 62,500            |
| NaTi (200°C, 7d)       | 772,000         | 9               | 85,800            |
| ZrO <sub>2</sub>       | 168,000         | 8               | 21,000            |

[067] From this data, it is clear that the sodium nonatitanate materials are far superior to Chelex 100 and AG 50W-X8 ion exchange resins for the recovery of <sup>82</sup>Sr from irradiated molybdenum targets. High  $K_d$  values in excess of 500,000 mL/g indicate that almost 100% strontium removal was achieved by some of the nonatitanate samples, with the residual strontium in solution approaching background levels. In the alkaline conditions used in this test, the Chelex 100 resin had the lowest affinity for strontium of all of the materials evaluated. The selectivity of the sodium nonatitanate for rubidium was lowest for the sodium nonatitanate material that was prepared by heating for 1 week at 170 °C to obtain a relatively crystalline product. However, strontium selectivity also decreased with increasing reaction time.

[068] The best overall strontium/rubidium separation factor was obtained for the material that had not undergone any hydrothermal treatment. All of the materials performed better than the commercially available nonatitanate materials. Thus, it is possible to alter the selectivity of the material by controlling the reaction conditions to produce an improved sodium nonatitanate material for use in <sup>82</sup>Sr separations. Rubidium selectivities were very low for all of

the nonatitanates, indicating minimal rubidium absorption would occur in a column process and that any rubidium absorbed would be readily removed by a dilute saline wash.

[069] The sodium titanate, potassium Pharmacosiderite and AW500 exhibit selectivities for rubidium that are too high to allow their use in the selective removal of  $^{82}\text{Sr}$  from irradiated molybdenum targets. This high selectivity would result in some rubidium being retained on the column that would not be readily removed by a simple saline wash, thus leading to contamination of the  $^{82}\text{Sr}$  product with both radioactive and stable rubidium isotopes. Hydrous tin oxide was not evaluated because, due to the amphoteric nature of tin, significant dissolution would be expected at a pH in excess of 12.

#### Example 6 - Acid Molybdate Target Solutions

[070] Sodium nonatitanate has a relatively low affinity for strontium at pH values less than 6, and was not expected to exhibit any affinity for strontium from the acidic molybdate target solutions prior to the addition of sodium hydroxide.  $K_d$  values were determined to confirm this and to compare it with the  $K_d$  values for both Chelex 100 and AG 50W-X8 under identical conditions. The data obtained is shown below in Table 6.

Table 6 - Affinity of Selected Ion Exchange Materials for Strontium in Acidic Molybdate Target Solutions

| Ion Exchange Material           | Sr $K_d$ mL/g | Final pH of Solution |
|---------------------------------|---------------|----------------------|
| Chelex 100                      | 25            | 1.43                 |
| AG 50W-X8                       | 18,300        | 1.42                 |
| Sodium Nonatitanate (Honeywell) | 1,260         | 1.53                 |

[071] These data clearly indicate that for the processing of acid molybdate solutions, the strong acid ion exchange resin AG 50W-X8 is the preferred medium. However, the Sr  $K_d$  value of 18,300 mL/g in the acidic media is nearly two orders of magnitude lower than the  $K_d$  value of 1,690,000 mL/g that was obtained for the best of the sodium nonatitanate materials in alkaline molybdate solutions. Consequently, it is evident that  $^{82}\text{Sr}$  can be recovered more effectively from alkaline solution using sodium nonatitanate than is currently achieved using AG 50W-X8 from acidic media.

### Example 7 - Rubidium and Rubidium Chloride Target Solutions

[072] The processing of either rubidium chloride or rubidium metal targets follows a similar procedure once the target has been successfully dissolved. In essence,  $^{82}\text{Sr}$  needs to be selectively extracted from a solution of  $\text{RbCl}$  in a  $0.1\text{ M NH}_3 / 0.1\text{M NH}_4\text{Cl}$  buffer adjusted to a pH of between 9 and 10. Batch experiments were performed in simulated buffer solutions to determine the strontium selectivity in the presence of high concentrations of rubidium ions. Only the ion exchange materials that exhibited high strontium selectivities in the initial scoping studies with  $\text{NaCl}$  solutions were evaluated.  $K_d$  values were obtained as described previously. Two rubidium chloride solutions were selected which represent typical rubidium concentrations obtained during the processing of rubidium metal ( $1.95\text{ M Rb}^+$ ) and rubidium chloride targets ( $0.68\text{ M Rb}^+$ ). In both cases, Chelex 100 is used in the preliminary step to remove the  $^{82}\text{Sr}$  from the buffered rubidium solutions. The  $K_d$  values for the ion exchange materials are shown in FIG. 1.

[073] In the buffered rubidium solutions, there is little difference between the different nonatitanates evaluated. This is in stark contrast to the sodium molybdate solutions where a large variation in the performance of the titanates was observed. The nonatitanates were clearly the most effective materials at removing strontium from the buffered solutions with strontium  $K_d$  values of around  $15,000\text{ mL/g}$  in  $0.68\text{ M Rb}^+$  solutions and approximately  $5,000\text{ mL/g}$  in  $1.96\text{ M Rb}^+$  solutions. By contrast, Chelex 100 ion exchange resin gave  $K_d$  values of less than  $1,000\text{ mL/g}$  in both solutions. Hydrous titanium oxide and hydrous tin oxide also exhibited appreciable  $K_d$  values, but they performed less efficiently than the nonatitanates in both solutions. Consequently, this data demonstrates that using sodium nonatitanate in place of Chelex 100 ion exchange resin will greatly increase the amount of strontium extracted from the target solutions.

[074] The ion exchange materials were also evaluated for their rubidium selectivity from  $0.1\text{ M NH}_3 / 0.1\text{M NH}_4\text{Cl}$  buffer solution. The buffer was prepared, spiked with  $^{86}\text{Rb}$  and the pH adjusted to approximately 9.25 with concentrated ammonia.  $^{86}\text{Rb}$   $K_d$  values were then determined following the method described earlier. All of the sodium nonatitanates had a  $K_d < 20\text{ mL/g}$ . The very low rubidium selectivity in the pure buffer is almost certainly due to competition from  $\text{NH}_4^+$  ions for the available ion exchange sites. Consequently, absorption of rubidium during the processing of rubidium and rubidium chloride targets will be minimal, and any rubidium absorbed will be readily removed by washing with additional  $0.1\text{ M NH}_3 / 0.1\text{M}$



NH<sub>4</sub>Cl buffer solution. Thus, a clean separation of <sup>82</sup>Sr from these targets can be obtained using sodium nonatitanate.

[075] The performance could also be improved by removing the buffer and increasing the pH to improve the amounts of strontium absorbed. (Buffers were initially utilized to maximize the performance of the organic ion exchange resins currently used and are not essential to the <sup>82</sup>Sr recovery process.)

#### Example 8 - Kinetic Experiments

[076] In order for the sodium nonatitanate materials to find applications in the processing of irradiated target solutions, they must exhibit fast ion exchange kinetics allowing solutions to be passed through an ion exchange column at an acceptable rate. The kinetics of strontium absorption from alkaline molybdate target solutions was evaluated using a simple batch procedure. Ion exchange material, in the amount of 0.05 g, was shaken with 10 mL of molybdate solution spiked with <sup>89</sup>Sr to give a total activity of approximately 155,000 cpm/mL. After an allotted time, the material was filtered through a 0.2 m syringe filter and the activity in the aqueous phase determined by LSC. The results are shown below in FIG. 2.

[077] From the data in FIG. 2, it is clear that the reaction kinetics for the sodium nonatitanate powder is extremely rapid, with over 99 % of the <sup>89</sup>Sr removed in only 1 minute. By contrast, the reaction kinetics of the organic ion exchange resins was much slower and the total amount of <sup>89</sup>Sr removed after 1 hour was much less.

[078] The exceedingly rapid kinetics can partly be explained by the fact that the nonatitanate was in the form of a fine powder, whereas the two resins were in the form of beads (see Table 1). As a consequence, a relatively slow reaction rate would be expected for the beads because the uptake of <sup>82</sup>Sr will be dependent upon the rate of diffusion of the <sup>82</sup>Sr to the internal exchange sites. The rate of uptake of a sample of sodium nonatitanate pellets (using hydrous titanium dioxide as a binder) was significantly slower than the powdered form, but the kinetics and amount of <sup>82</sup>Sr absorbed was still significantly better than for either of the two organic resins. As the pelletization process is improved, it is expected that the kinetics and selectivity of the pelletized sodium nonatitanate will improve substantially. Other sodium nonatitanate powders of varying crystallinities also showed rapid kinetics. Other potentially suitable binders for forming suitable pellets include titanium isopropoxide or tetraethyl orthosilicate (TEOS) as a binder precursor.

### Example 9 - $^{82}\text{Sr}$ Removal from Irradiated Targets Using Pelletized Sodium Nonatitanate

[079] A sample of sodium nonatitanate was mixed with titanium isopropoxide as a binder and the resulting paste dried at 105 °C for 12 hours. The material was gently broken up using a mortar and pestle and then sieved to produce particles in the range 40 to 60 mesh. The binder content was approximately 20%. These particles were then used to assess the extraction of  $^{89}\text{Sr}$  from simulated target solutions.

[080] 1 mL of pelletized sodium nonatitanate was slurried into a column and the target simulant that had been spiked with  $^{89}\text{Sr}$  to give an activity of approximately 200,000 cpm/mL was passed through the column at a flow rate of 15 mL per hour. The amount of activity removed from solution was then determined. The results are given below in Table 7.

Table 7 - Removal of  $^{89}\text{Sr}$  from Irradiated Target Solutions

| Target            | Solution Composition  | Volume (mL) | $^{89}\text{Sr}$ Removed (%) |
|-------------------|---|-------------|------------------------------|
| Rubidium Metal    | 1.95M RbCl in 0.1M $\text{NH}_3/\text{NH}_4\text{Cl}$ Buffer, pH10  | 20          | 97.3                         |
| Rubidium Chloride | 0.68M RbCl in 0.1M $\text{NH}_3/\text{NH}_4\text{Cl}$ Buffer, pH 10 | 28          | 98.8                         |
| Molybdenum Metal  | 0.26M $\text{Na}_2\text{MoO}_4$ , pH 12                             | 20          | 99.9                         |

[081] This data clearly shows the effectiveness of sodium nonatitanate for removing strontium isotopes from  $^{82}\text{Sr}$  target materials. Rubidium absorption under these conditions is minimal.

### Example 10 - Elution of Strontium

[082] Strontium was quantitatively eluted from the sodium nonatitanate column of Example 9 using 6M nitric acid. Hydrochloric acid was found to be much less effective and also resulted in breakdown of the sodium nonatitanate particles and blocked the ion exchange column.

### Example 11 – Formation of Acid Washed Sodium Nonatitanate Pellets

[083] As described in Example 1, sodium nonatitanate (NaTi) was synthesized hydrothermally as follows. 77.5 g of titanium isopropoxide was added to 84.35 g of a 50 wt. % solution of NaOH with vigorous stirring and 60 mL of deionized water was added. The resultant gel was heated at approximately 108 °C for 3 hours, transferred to a hydrothermal pressure vessel

with an additional 90 mL of deionized water, and heated at either 170 °C or 200 °C for times ranging from 21 hours to 1 week.

[084] After the hydrothermal treatment disclosed in Example 1, the vessel was cooled down and the sodium nonatitanate was transferred into a centrifuge tube and separated from solution by centrifugation (3,300 rpm for 14 minutes). The recovered nonatitanate was washed by resuspending it in 500 mL of deionized water (DIW) by mixing it thoroughly and then again separated by centrifugation. These washing steps were repeated twice.

[085] The pH of deionized water was adjusted to 3 by the addition of HCl. The washed nonatitanate was added to the low pH DIW and mixed thoroughly. The nonatitanate was recovered through centrifugation and dried in a 60 °C oven for two nights. The hard acid washed nonatitanate was then ground, sized and sieved to 50x100 mesh and 100x200 mesh using nylon screens. Fines were washed off and the pellets were dried at 60 °C.

#### Example 12 – Formation of Neutralized Nonatitanate Pellets

[086] Sodium nonatitanate was prepared by treating it hydrothermally for 21 hours at 200 °C. The white product was washed by suspending it in DIW with stirring. 3 M nitric acid was added dropwise to maintain a pH of 8.0 for one hour. After a final DIW wash, the material was dried overnight at 60 °C. The dried material was sized into particles using a series of nylon sieves, and collecting the 100x200 mesh particles for column use. The sized material was rinsed of fines.

[087] Pellet size is a factor that affects the performance of the  $^{82}\text{Sr}/^{82}\text{Rb}$  generator column because higher Sr uptake is obtained with finer particles due to the faster sorption with the material having the smaller particle size and resulting greater surface area. FIG. 4 is a graph showing the  $^{85}\text{Sr}$   $K_d$  values in normal saline for NaTi samples of various pellet size, without a binder.

#### Example 13 – Packing Column with Sodium Nonatitanate and Loading with Parent $^{82}\text{Sr}$

[088] To prepare the generator column, the sodium nonatitanate particles were suspended in saline and slurried into the column. First, 1.125 g of exchanger was introduced into the column and sandwiched between two filters (GB003, Schleicher & Schuell blotting paper). This bed provided a guard bed to trap any strontium that was released from the bed above. Next, about 0.375 g of exchanger was equilibrated with inactive strontium ( $\text{SrCl}_2$ ) in saline, to simulate

a full loading of  $^{82}\text{Sr}$ . This material was placed on top of the guard bed and topped with a third filter.

#### Example 14 – Balancing pH by the Addition of Acid

[089] Nonatitanate is prepared as described in Example 12 except that the pH is adjusted to 11 instead of 8.0. The material is equilibrated with  $^{82}\text{Sr}$  and loaded into a column having a guard bed as described in Example 13. The column is eluted with normal (0.9 %) saline with 50 mL/min flow. The resulting solution contains a high yield of  $^{82}\text{Rb}$  in 49mL of solution at pH 10. This solution is dosed with 1 mL of 0.05 M HCl, neutralizing the basicity of the saline to yield 50 mL of solution at pH 7, suitable for use as a medical pharmaceutical as previously described.

#### Example 15 – Supported Sodium Nonatitanate

[090] Fine glass helices of the type commonly used to pack a high efficiency distillation column are dipped in a dilute (5 wt. %) solution of sodium metasilicate. The helices are allowed to drain so only a thin film of solution remains on their surfaces. The helices are then gently rolled in finely powdered (<400 mesh, < 38  $\mu\text{m}$ ) sodium nonatitanate to coat the surfaces with the powder. The coated helices are dried and the metasilicate solution is rendered insoluble by heating to 175 °C in air for 16 hours. The helices are now ready for use in a generator.

#### Example 16 – Pelletization of the Ion Exchanger

[091] After hydrothermal treatment and washing the material was then resuspended in DIW that has had the pH adjusted to 3 with HCl, mixed thoroughly after which the solid and liquid phases were separated as before. The wet exchanger was dried in a 60 °C oven for two nights, the hard product ground, sized and sieved to 50x100 mesh and 100x200 mesh using nylon screens. Fines were washed off and the pellets dried at 60 °C. These pellets were ready for further testing.

#### Example 17 – Elution at Lower pH

[092] The column packed with NaTi (neutralized to pH 8.0 as described in Example 12) was eluted using the syringe pump system as shown in FIG. 5. USP saline (purchased in 1 L bottles from Fisher Scientific), was methodically drawn into a 60 mL syringe and pushed through

the column in 50 mL increments at a flow rate of 50 mL/min. The eluates were collected in 50 mL falcon tubes. A 5 mL sample of each eluate was analyzed for <sup>85</sup>Sr activity by gamma spectroscopy (Wallac 1480 Wizard 3) and the pHs recorded. Over 20 L of USP saline were pumped through the column during the experiment with no <sup>85</sup>Sr breakthrough observed.

[093] The results are shown in FIGS. 6A-6B, which show that all of the saline was eluted at pH values acceptable for injection into a human. The neutralized material retains its strong strontium binding ability and no breakthrough of <sup>82,85</sup>Sr was observed in over 20 L of eluted USP saline (after the initial washout in 200 mL).

[094] Table 8 provides reproducibility and quality control data of final batches of sodium nonatitanate described by the synthesis procedure, sizing of pellets and <sup>85</sup>Sr and <sup>86</sup>Rb K<sub>d</sub> values.

| ID           | Treatment          | Synthesis Yield (Dry weight, g) | Sizing of pellets        |                           |                        |                        | Loss to sizing (% of total) | <sup>85</sup> Sr K <sub>d</sub> in saline/ equilibration pH | <sup>86</sup> Rb K <sub>d</sub> in saline/ equilibration pH |
|--------------|--------------------|---------------------------------|--------------------------|---------------------------|------------------------|------------------------|-----------------------------|---|---|
|              |                    |                                 | 50-100 mesh (% of total) | 100-200 mesh (% of total) | >100 mesh (% of total) | >200 mesh (% of total) |                             |   |   |
| TA-A-78      | 'Acid wash'        | 28.3                            | 65.6                     | 23.0                      | x                      | 9.5                    | 1.98                        | 1,970,632.5 / 9.89  | 56.6 / 9.89   |
| TA-A-80      | 'Acid wash'        | 19.3                            | 47.2                     | 27.5                      | x                      | 21.6                   | 3.77                        | 10,603,837.65 / 9.44  | 84.65 / 9.39  |
| TA-A-83      | 'Acid wash'        | 21.4                            | 48.9                     | 21.0                      | x                      | 25.7                   | 4.48                        | 5,866,141.8 / 9.43  | x   |
| TA-A-84 1-12 | Neutralized (pH 8) | 12.3                            | x                        | 46.9                      | x                      | 53.1                   | 0.00                        | 520,951.3 / 6.82  | 188.6 / 6.87  |
| TA-A-84 3-19 | Neutralized (pH 8) | 13.0                            | 38.4                     | x                         | 59.7                   | x                      | 1.85                        | 1,518,239.55 / 6.72   | 232.75 / 6.79   |
| TA-A-87 3-30 | Neutralized (pH 8) | 13.2                            | 60.8                     | x                         | 34.0                   | x                      | 5.16                        | 1,120,327.3 / 6.72  | 232.65 / 6.70   |
| TA-A-87 4-1  | Neutralized (pH 8) | 12.1                            | 52.9                     | x                         | 42.2                   | x                      | 4.88                        | 1,007,944.3 / 6.78  | 245.3 / 6.78  |
| TA-A-88      | 'Acid wash'        | 25.0                            | 49.4                     | x                         | 43.0                   | x                      | 7.64                        | 4,656,739.8 / 9.67  | 71.5 / 9.62   |

designates materials used for K<sub>d</sub> determination  
 equilibration time of several days for K<sub>d</sub> determination

[095] While the foregoing is directed to the preferred embodiment of the present invention, other and further embodiments of the invention may be devised without departing from the basic scope thereof, and the scope thereof is determined by the claims that follow.

CLAIMS

What is claimed is:

1. A rubidium-82 generator, comprising:  
a strontium-82 support medium comprising partially neutralized sodium nonatitanate characterized by a strontium/rubidium separation factor greater than 12,500.
2. The rubidium-82 generator of claim 1, wherein the separation factor is determined in an aqueous sodium chloride solution.
3. The rubidium-82 generator of claim 2, wherein the aqueous sodium chloride solution has a sodium chloride concentration from 0.001 molar to 1 molar.
4. The rubidium-82 generator of claim 2, wherein the aqueous sodium chloride solution is buffered to control acidity.
5. The rubidium-82 generator of claim 2, wherein the aqueous sodium chloride solution is unbuffered.
6. The rubidium-82 generator of claim 1, wherein the sodium nonatitanate is characterized by a strontium selectivity greater than about 85,000 mL/g in a 0.1 molar or 1 molar aqueous sodium chloride solution.
7. The rubidium-82 generator of claim 1, wherein the sodium nonatitanate is characterized by a rubidium selectivity less than 100 mL/g in a 0.1 molar aqueous sodium chloride solution.
8. The rubidium-82 generator of claim 1, wherein the sodium nonatitanate is characterized by a strontium/rubidium separation factor greater than 10,000 in a 1 molar aqueous sodium chloride solution.

9. The rubidium-82 generator of claim 1, wherein the sodium nonatitanate is characterized by a rubidium retention of less than 1.8 % in a 1 molar aqueous sodium chloride solution.
10. The rubidium-82 generator of claim 1, wherein the sodium nonatitanate is characterized by a rubidium retention of less than about 13.6 % in a 0.1 molar aqueous sodium chloride solution.
11. The rubidium-82 generator of claim 1, wherein the sodium nonatitanate is characterized by a rubidium retention of less than about 40 % in a 0.01 molar aqueous sodium chloride solution.
12. The rubidium-82 generator of claim 1, wherein the sodium nonatitanate is characterized by a rubidium retention of less than about 50 % in a 0.001 molar aqueous sodium chloride solution.
13. The rubidium-82 generator of claim 1, wherein the sodium nonatitanate is characterized by a strontium selectivity greater than 250,000 mL/g at an alkaline pH.
14. The rubidium-82 generator of claim 1, wherein the sodium nonatitanate is characterized by a rubidium selectivity less than 100 mL/g at an alkaline pH.
15. The rubidium-82 generator of claim 1, wherein the sodium nonatitanate is characterized by a strontium/rubidium separation factor greater than 100,000.
16. The rubidium-82 generator of claim 1, further comprising strontium-82 absorbed on the sodium nonatitanate.
17. The rubidium-82 generator of claim 1, further comprising a sodium nonatitanate filter medium disposed to receive effluent from the strontium-82 support medium to trap strontium-82 leached from the generator.

18. The rubidium-82 generator of claim 1, further comprising a column, wherein the sodium nonatitanate is disposed in the column.
19. The rubidium-82 generator of claim 1, wherein the sodium nonatitanate is characterized by a strontium/rubidium separation factor greater than 59,200.
20. The rubidium-82 generator of claim 1, wherein the sodium nonatitanate is characterized by a strontium/rubidium separation factor greater than or equal to 79,500.
21. The rubidium-82 generator of claim 1, wherein the partially neutralized sodium nonatitanate is characterized by raising a pH of a normal saline eluant from about 7 to less than about 8 when eluted from the generator, wherein the generator has eluted less than about 1 L of eluate.
22. The rubidium-82 generator of claim 1, wherein the partially neutralized sodium nonatitanate is characterized by raising a pH of a normal saline eluant from about 6.5 to less than about 7.5 when eluted from the generator, wherein the generator has eluted less than about 1 L of eluate.
23. The rubidium-82 generator of claim 1, further comprising:  
means for neutralizing an eluate eluted from the partially neutralized sodium nonatitanate.
24. The rubidium-82 generator of claim 1, wherein the sodium nonatitanate is supported on a surface of a substrate.
25. The rubidium-82 generator of claim 13, wherein the substrate is non-porous.
26. The rubidium-82 generator of claim 14, wherein the substrate is selected from glass, fiberglass, ceramics, fine glass beads or combinations thereof.



27. A rubidium-82 generator, comprising:
  - a strontium-82 support medium comprising sodium nonatitanate characterized by a strontium/rubidium separation factor greater than 12,500 at an alkaline pH; and
  - means for neutralizing an eluate eluted from the generator.
28. The rubidium-82 generator of claim 27, wherein the eluate is neutralized to a pH of between about 4.5 and about 7.
29. The rubidium-82 generator of claim 27, wherein the eluate is neutralized to a pH suitable for injection into a patient during a medical procedure.
30. The rubidium-82 generator of claim 27, wherein the means for neutralizing an eluate comprise automatic means.
31. The rubidium-82 generator of claim 27, wherein the separation factor is determined in an aqueous sodium chloride solution.
32. The rubidium-82 generator of claim 31, wherein the aqueous sodium chloride solution has a sodium chloride concentration from 0.001 molar to 1 molar.
33. The rubidium-82 generator of claim 31, wherein the aqueous sodium chloride solution is buffered to control acidity.
34. The rubidium-82 generator of claim 31, wherein the aqueous sodium chloride solution is unbuffered.
35. The rubidium-82 generator of claim 27, wherein the sodium nonatitanate is characterized by a strontium selectivity greater than about 85,000 mL/g in a 0.1 molar or 1 molar aqueous sodium chloride solution.

36. The rubidium-82 generator of claim 27, wherein the sodium nonatitanate is characterized by a rubidium selectivity less than 100 mL/g in a 0.1 molar aqueous sodium chloride solution.
37. rubidium-82 generator of claim 27, wherein the sodium nonatitanate is characterized by a strontium/rubidium separation factor greater than 10,000 in a 1 molar aqueous sodium chloride solution.
38. The rubidium-82 generator of claim 27, wherein the sodium nonatitanate is characterized by a rubidium retention of less than 1.8 % in a 1 molar aqueous sodium chloride solution.
39. The rubidium-82 generator of claim 27, wherein the sodium nonatitanate is characterized by a rubidium retention of less than about 13.6 % in a 0.1 molar aqueous sodium chloride solution.
40. The rubidium-82 generator of claim 27, wherein the sodium nonatitanate is characterized by a rubidium retention of less than about 40 % in a 0.01 molar aqueous sodium chloride solution.
41. The rubidium-82 generator of claim 27, wherein the sodium nonatitanate is characterized by a rubidium retention of less than about 50 % in a 0.001 molar aqueous sodium chloride solution.
42. The rubidium-82 generator of claim 27, wherein the sodium nonatitanate is supported on a surface of a substrate.
43. The rubidium-82 generator of claim 42, wherein the substrate is non-porous.
44. The rubidium-82 generator of claim 43, wherein the substrate is selected from glass, fiberglass, ceramics, fine glass beads or combinations thereof.

45. A process for preparing a rubidium-82 generator, comprising:  
preparing sodium nonatitanate from titanium isopropoxide and aqueous sodium hydroxide;  
heating the sodium nonatitanate at a temperature between 100°C and 250°C for a period between 12 hours and 2 weeks;  
lowering the pH of the sodium nonatitanate; and  
absorbing strontium-82 on the neutralized sodium nonatitanate from an aqueous solution comprising strontium-82 and a soluble sodium salt.
46. The method of claim 45, wherein the soluble sodium salt concentration is between about 0.1 and about 1 molar.
47. The process of claim 45, wherein the soluble sodium salt is sodium chloride.
48. The process of claim 45, wherein the molar ratio of aqueous sodium hydroxide to titanium isopropoxide is in excess of 0.44.
49. The process of claim 45, wherein the molar ratio of aqueous sodium hydroxide to titanium isopropoxide is between 2 and 6.
50. The process of claim 45, wherein the aqueous sodium hydroxide is about 50 wt% sodium hydroxide.
51. The process of claim 45, further comprising:  
filtering the sodium nonatitanate from the solution.
52. The process of claim 51, further comprising:  
washing the sodium nonatitanate with ethanol.

53. The process of claim 52, further comprising:  
drying the sodium nonatitanate.
54. The process of claim 45, wherein the molar ratio of aqueous sodium hydroxide to titanium isopropoxide is between about 1 and 10.
55. The process of claim 45, wherein the sodium nonatitanate is heated in a pressure vessel.
56. The process of claim 45, wherein the sodium nonatitanate is prepared in the absence of titanium chlorides and sulfates.
57. The process of claim 45, wherein the step of neutralizing the sodium nonatitanate further comprises:  
suspending the sodium nonatitanate in a liquid; and  
adding an acid to the liquid to lower the pH.
58. The process of claim 57, wherein the step of adding an acid lowers the pH to between about 7 and about 9.
59. The process of claim 57, wherein the step of adding an acid lowers the pH to between about 7 and about 8.3.
60. The process of claim 57, wherein the liquid comprises water.
61. The process of claim 57, wherein the acid is a strong mineral acid.
62. The process of claim 45, further comprising:  
loading the sodium nonatitanate into a column.
63. The process of claim 45, further comprising:

supporting the sodium nonatitanate on a non-porous substrate.

64. The process of claim 45, wherein the solution containing strontium-82 is an acidic aqueous solution.
65. A method of chemically isolating strontium-82 from a proton-irradiated molybdenum target, comprising:
- (a) dissolving the molybdenum target containing the strontium-82;
  - (b) adjusting the pH of the dissolved molybdenum target solution to an alkaline pH;
  - (c) removing precipitates from the solution; and then
  - (d) absorbing the strontium-82 from the solution onto a support comprising sodium nonatitanate.
66. The method of claim 65, wherein the molybdenum target is dissolved in hydrogen peroxide.
67. The method of claim 65, wherein the pH is adjusted with sodium hydroxide.
68. The method of claim 65, wherein the pH is adjusted to about 12.
69. The method of claim 65, further comprising:
- stripping the strontium-82 from the sodium nonatitanate.
70. The method of claim 65, wherein the strontium-82 is stripped from the sodium nonatitanate with mineral acid.
71. The method of claim 65, further comprising:
- washing the sodium nonatitanate with a buffer solution
72. The method of claim 65, wherein the sodium nonatitanate is characterized by a strontium/rubidium separation factor greater than 12,500.

73. The method of claim 65, wherein the sodium nonatitanate is characterized by a strontium/rubidium separation factor greater than or equal to 59,200.
74. The method of claim 65, wherein the sodium nonatitanate is characterized by a strontium/rubidium separation factor greater than or equal to 100,000.
75. A process for preparing a solution containing rubidium-82, comprising:  
providing a solution containing strontium-82;  
absorbing strontium-82 onto a sodium nonatitanate support medium; and  
eluting rubidium-82 from the sodium nonatitanate support medium with an eluant:  
receiving a rubidium-82 eluate formed from the eluting step; and  
adjusting a pH of the eluate.
76. The process of claim 75, wherein the eluant is selected from the group consisting of water and saline solutions.
77. The process of claim 75, wherein the eluant is an aqueous solution having a sodium chloride concentration between 0.001 molar and 1 molar.
78. The process of claim 75, wherein the eluant is an aqueous solution having a sodium chloride concentration between 0.2 molar and 1 molar.
79. The process of claim 75, wherein the eluant is a pharmaceutical-grade saline and buffer solution.
80. The process of claim 75, wherein the sodium nonatitanate is characterized by a strontium/rubidium separation factor greater than 12,500.

81. The process of claim 75, wherein the sodium nonatitanate is characterized by a strontium/rubidium separation factor greater than or equal to 59,200.
82. The process of claim 75, wherein the sodium nonatitanate is characterized by a strontium/rubidium separation factor greater than or equal to 100,000.
83. The process of claim 75, further comprising:  
disposing the sodium nonatitanate support medium into a column.
84. The process of claim 75, wherein the eluate is alkaline.
85. The process of claim 75, further comprising:  
buffering the solvent.
86. The process of claim 75, wherein the pH of the eluate is adjusted to between about 4.5 and about 7.
87. The process of claim 75, wherein the pH of the eluate is adjusted to a pH suitable for injecting into a patient during a medical procedure.
88. The process of claim 75, wherein the step of adjusting a pH of the eluate comprises;  
adding an acid to the eluate.
89. The process of claim 88, wherein the acid is HCl.
90. The process of claim 75, further comprising:  
partially neutralizing the sodium nonatitanate before the step of absorbing strontium-82 onto a sodium nonatitanate support medium.

91. A method of chemically isolating strontium-82 from a proton-irradiated rubidium or rubidium chloride target, comprising:
- (a) dissolving the target containing the strontium-82;
  - (b) adjusting the pH of the dissolved target solution to an alkaline pH;
  - (c) removing precipitates from the solution; and then
  - (d) absorbing the strontium-82 from the solution onto a support comprising sodium nonatitanate without absorbing rubidium.
92. The method of claim 91, wherein the dissolved target solution includes a buffer.
93. The method of claim 92, wherein the buffer is an ammonia/ammonium chloride buffer.
94. The method of claim 92, wherein the pH is between 9 and 10.
95. The method of claim 91, wherein the pH is greater than 10.
96. The method of claim 91, further comprising:  
stripping the strontium-82 from the sodium nonatitanate.
97. The method of claim 96, wherein the strontium-82 is stripped from the sodium nonatitanate with mineral acid.
98. The method of claim 91, further comprising:  
washing the sodium nonatitanate with a buffer solution.
99. The method of claim 91, wherein the sodium nonatitanate is characterized by a strontium/rubidium separation factor greater than 12,500.
100. The method of claim 91, wherein the sodium nonatitanate is characterized by a strontium/rubidium separation factor greater than or equal to 59,200.



101. The method of claim 91, wherein the sodium nonatitanate is characterized by a strontium/rubidium separation factor greater than or equal to 100,000.

102. A process for preparing a rubidium-82 generator, comprising:

preparing sodium nonatitanate from titanium tetrachloride or titanium sulfate and aqueous sodium hydroxide;

heating the sodium nonatitanate at a temperature between 100°C and 250°C for a period between 12 hours and 2 weeks;

lowering the pH of the sodium nonatitanate; and

absorbing strontium-82 on the neutralized sodium nonatitanate from an aqueous solution comprising strontium-82 and a soluble sodium salt.

103. The process of claim 102, wherein the soluble sodium salt concentration is between about 0.1 and about 1 molar.

104. The process of claim 102, wherein the soluble sodium salt is sodium chloride.

105. The process of claim 102, wherein the aqueous sodium hydroxide is about 50 wt% sodium hydroxide.

106. The process of claim 102, wherein the molar ratio of aqueous sodium hydroxide to titanium tetrachloride or titanium sulfate is between about 1 and 12.

107. The process of claim 102, further comprising:

filtering to collect the sodium nonatitanate; and

washing the sodium nonatitanate to remove sodium chloride or sodium sulfate.

108. The process of claim 102, wherein the step of neutralizing the sodium nonatitanate further comprises:

suspending the sodium nonatitanate in a liquid; and  
adding an acid to the liquid to lower the pH.

109. The process of claim 108, wherein the step of adding an acid lowers the pH to between about 7 and about 9.

110. The process of claim 108, wherein the step of adding and acid lowers the pH to between about 7.2 and about 8.

111. The process of claim 108, wherein the liquid comprises water.

112. The process of claim 108, wherein the acid is a strong mineral acid.

113. The process of claim 102, further comprising:  
loading the sodium nonatitanate into a column.

114. The process of claim 102, further comprising:  
supporting the sodium nonatitanate on a substrate.

115. The process of claim 102, wherein the solution containing strontium-82 is an acidic aqueous solution.

116. A process, comprising:  
eluting a solution of rubidium-82 from a strontium-82 support medium comprising sodium nonatitanate with an aqueous eluant; and  
adjusting a pH of the solution.

117. The process of claim 116, wherein the aqueous eluant is selected from the group consisting of water and saline solutions.

118. The process of claim 116, wherein the aqueous eluant has a sodium chloride concentration between 0.001 molar and 1 molar.

119. The process of claim 116, wherein the aqueous eluant has a sodium chloride concentration between 0.2 molar and 1 molar.

120. The process of claim 116, wherein the aqueous eluant is a saline and buffer solution suitable for human injection.

121. The process of claim 116, wherein the sodium nonatitanate is a reaction product of titanium isopropoxide and aqueous sodium hydroxide.

122. The process of claim 116, further comprising passing the rubidium-82 solution through a sodium nonatitanate filter to selectively remove any strontium-82 or strontium-85 from the solution.

123. The process of claim 116, further comprising disposing of the sodium nonatitanate filter.

124. The process of claim 116, further comprising using the rubidium-82 solution as a medical diagnostic agent or medical imaging agent.

125. The process of claim 124, further comprising injecting the rubidium-82 solution intravenously.

126. The process of claim 116, further comprising stripping strontium-82 from the sodium nonatitanate.

127. The process of claim 126, further comprising recovering the stripped strontium-82.

128. The process of claim 127, further comprising recycling the sodium nonatitanate.

129. The process of claim 116, wherein the sodium nonatitanate has not undergone hydrothermal treatment.

130. The process of claim 116 wherein the step of adjusting the pH further comprises:  
adding an acid to the solution.

131. The process of claim 116, wherein the pH is adjusted to between about 4 and about 7.5.

1/5

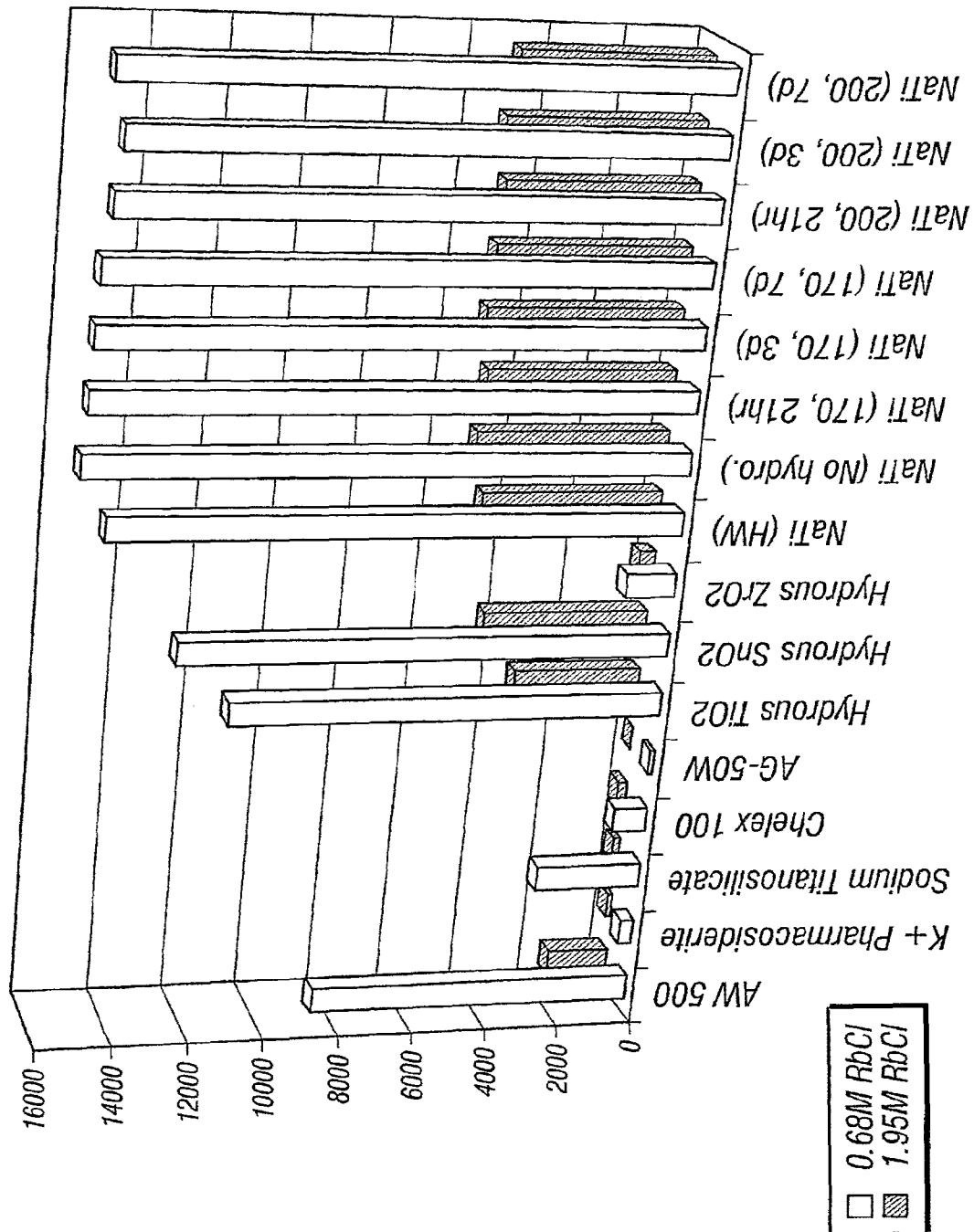


FIG. 1

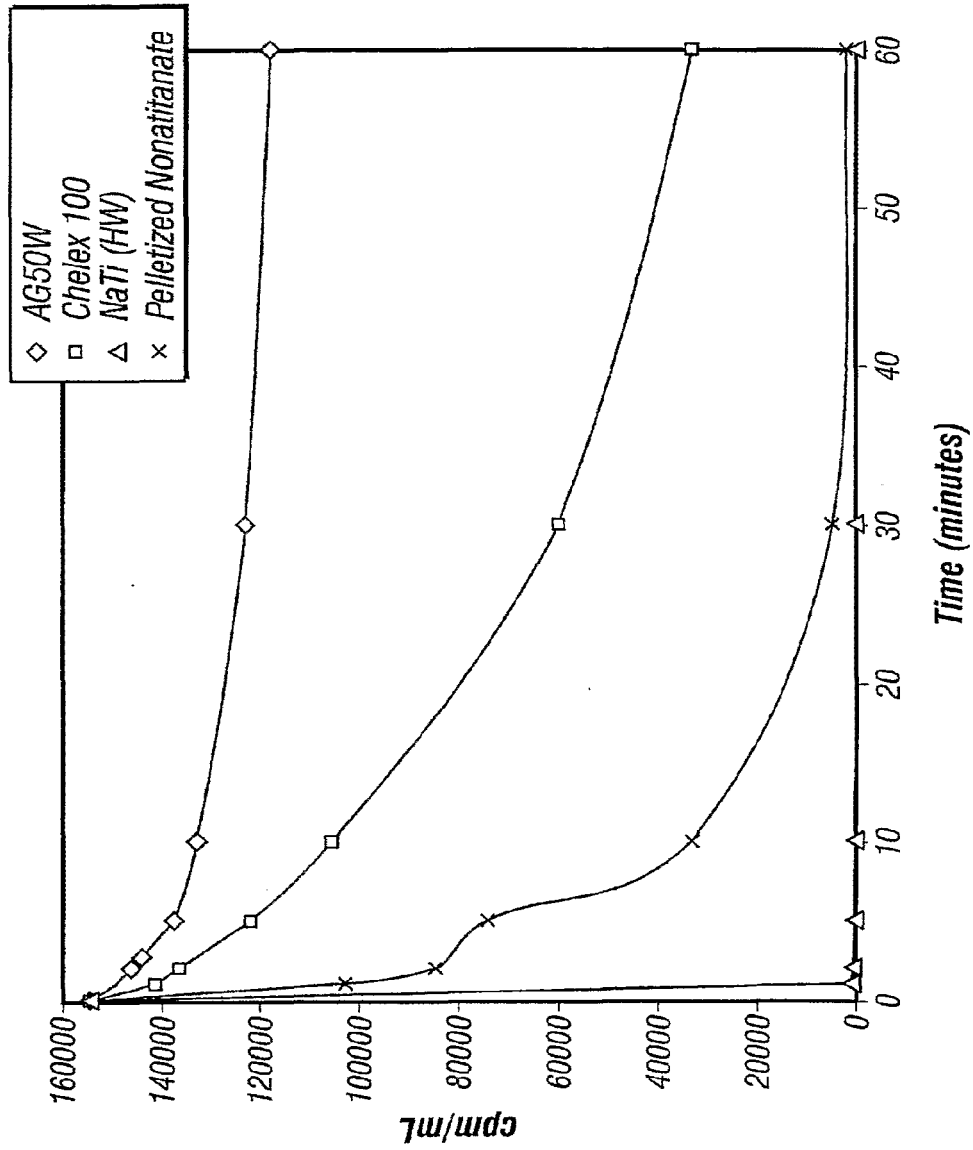


FIG. 2

3/5

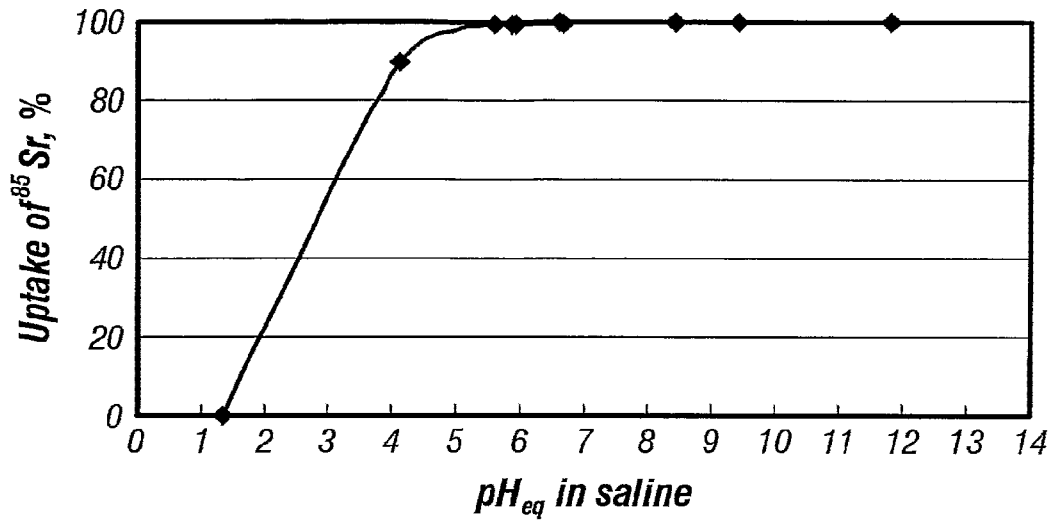


FIG. 3

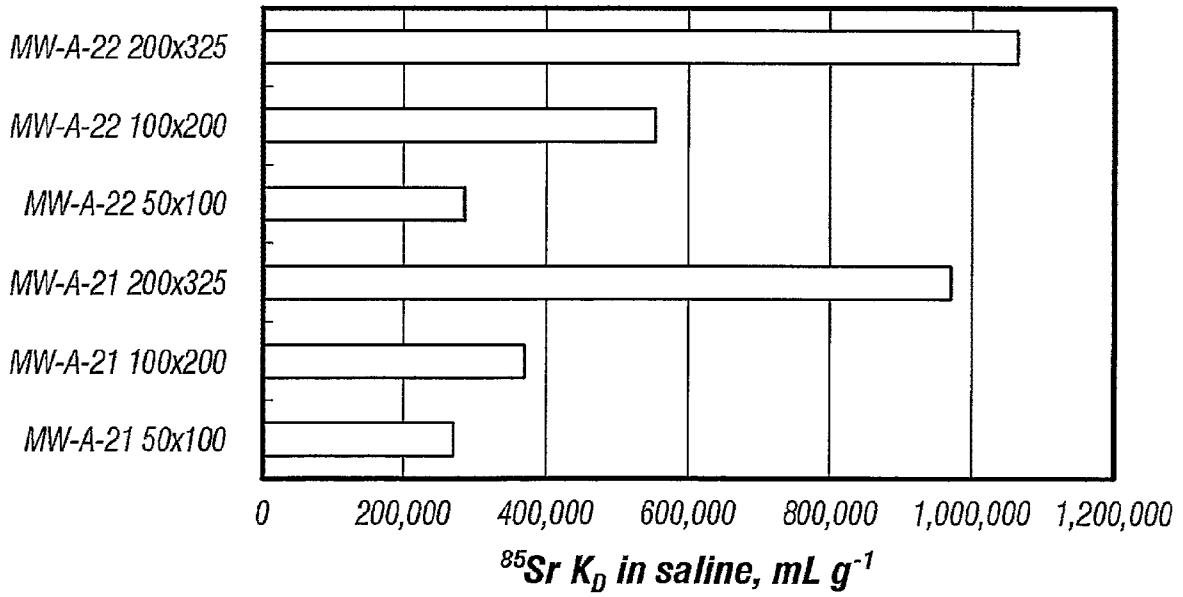
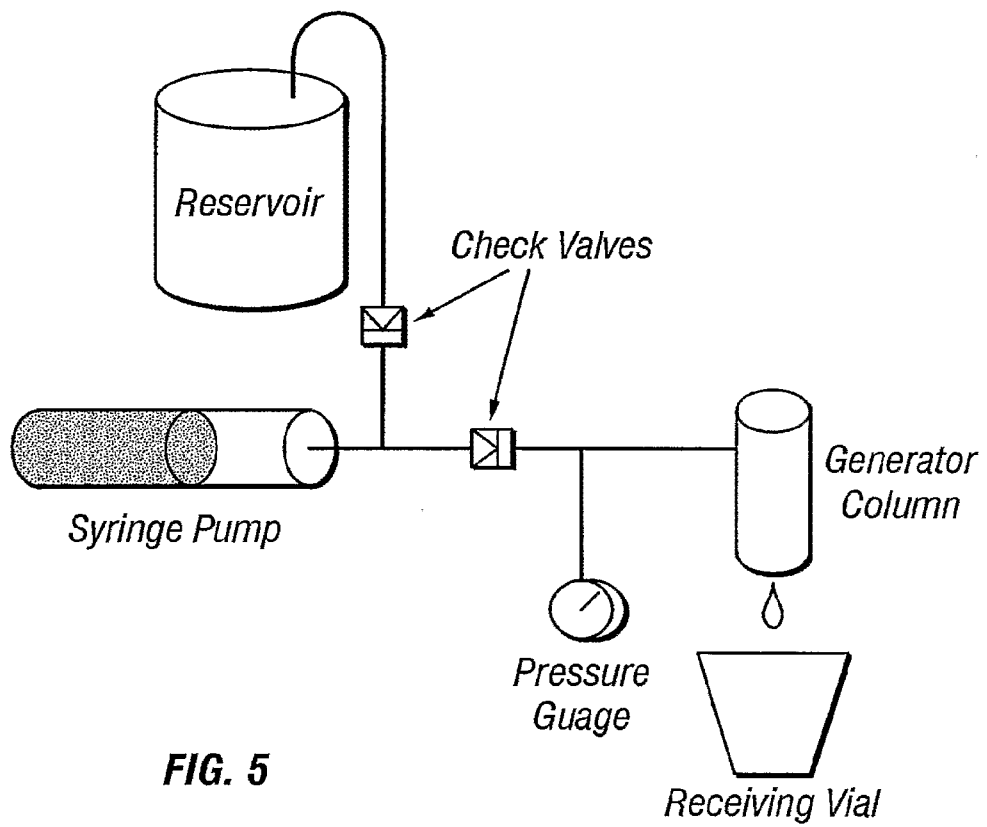


FIG. 4

4/5



**FIG. 5**



5/5

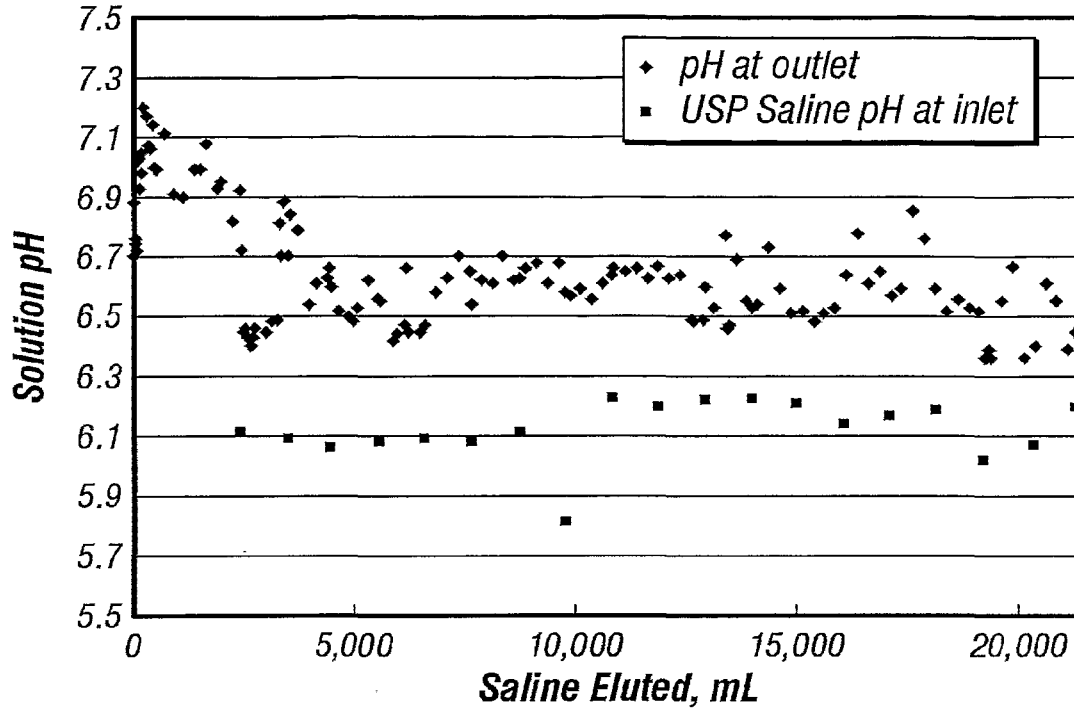


FIG. 6A

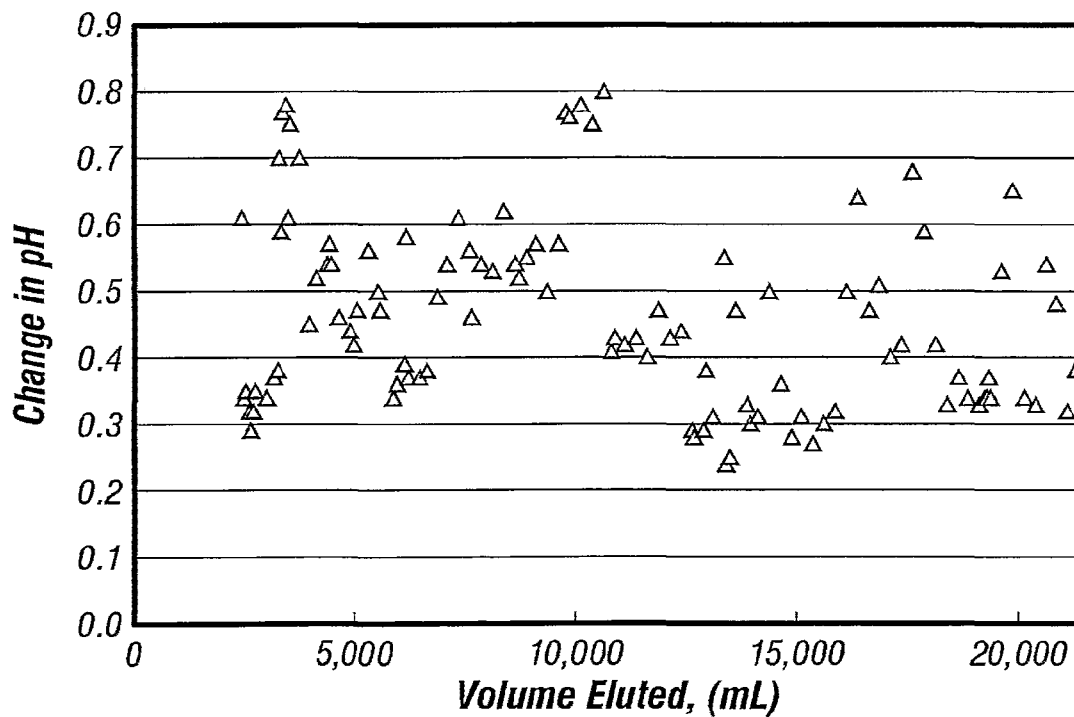


FIG. 6B

## AUTOMATED STRONTIUM-RUBIDIUM INFUSION SYSTEM

The invention relates to medical engineering, and particularly to means for automation of a process for producing a diagnostic solution from a radionuclide strontium-rubidium generator and remote carrying out a checked infusion with automatic checking main process characteristics, such as an introduced activity value, presence of air bubbles as well as a solution weight and activity in a waste container.

One of the most perspective directions in the nuclear diagnostics is the positron emission tomography (PET). Such short and ultra-short living isotopes as C-11, O-15, N-13, and F-18 are used in the PET centers. This obliges to have cyclotrons at the place of diagnostic for making such isotopes. It is possible to widen the functionality of the PET diagnostics in use of generator systems having a parent radionuclide lifetime significantly longer than a lifetime of radionuclides made in cyclotrons of the PET centers. Generator systems  $^{82}\text{Sr}$  ( $t_{1/2} = 25.6$  days)  $\rightarrow$   $^{82}\text{Rb}$  ( $t_{1/2} = 75$  seconds) and  $^{68}\text{Ge}$  ( $t_{1/2} = 271$  days)  $\rightarrow$   $^{68}\text{Ga}$  ( $t_{1/2} = 78.3$  minutes) are the most promising systems among the PET isotope generators.

Therefore, it is possible to say with respect to generator isotopes that any clinics having PET scanners within a region, a country or a group of countries are to be provided with said isotopes.

Generator systems can find the widest use in so called mobile PET scanners mounted in auto-trailers and called for servicing clinics that have no both own cyclotrons and own PET scanners. Absence of "affixment" of such a mobile PET scanner to an isotope base substantially widens a radius of the territory serviced thereby.

A strontium-rubidium infusion system for producing a diagnostic solution from a radionuclide strontium-rubidium generator and carrying out a checked infusion is known (US 4,562,829, 1986), said system comprising: an eluent tank connected by respective pipes of a transporting system via a first three-way valve to a syringe pump; a strontium-rubidium generator with a first filter and a first pressure sensor at an input; a second three-way valve whose first opening is coupled via a second filter to means for infusing an eluent into a patient and whose second opening is coupled to an eluate surplus storing and collecting means; radioactivity measurement means; and a check and control system. The prior art system is not optimal in a degree of radioactive radiation protection and in a service life of a generator column.

The disclosed invention is directed to elimination of the listed disadvantages. The technical result to be accomplished by using the inventive system consists in enhancement of

effectiveness in carrying out of a diagnostic procedure due to automation of the infusion procedure, reducing undesirable irradiation doses for a patient and maintenance personnel, increasing exploitation lifetimes of a generator column.

The essence of the disclosed invention consists in that an automated strontium-  
5 rubidium infusion system comprises: an eluent tank, a strontium-rubidium generator with a filter and a pressure sensor at an input; means for infusing an eluent into a patient, said tank, generator and means being connected by a transporting system to pipes and two three-way valves; radioactivity measuring means; and a check and control unit. At the same time, the eluent tank is connected via first and second openings of the first three-way valve to a syringe  
10 pump, a first opening of the second three-way valve is coupled by pipes via a second filter to the means for infusing the eluent into the patient and is coupled by a second opening thereof to a waste receptacle. The system further comprises: third and fourth three-way valves; first and second air bubble detectors coupled to the check and control unit being in communication with a computer, said third three-way valve being connected by first and second openings via  
15 pipes to a third opening of the first three-way valve and to an input of the strontium-rubidium generator, respectively, an output of the generator being coupled to a first opening of the fourth three-way valve, wherein the third opening of the third valve and a second opening of the fourth valve are in communication by a pipe, the first air bubble detector is mounted on a pipe between the eluent tank and the first opening of the first valve while the second detector  
20 is mounted on a pipe between the third openings of the fourth and second valves.

Further, the radioactivity measurement means include first and second activity sensors. At the same time, the first activity sensor is placed on a pipe between the third openings of the fourth and second valves and is embodied as a beta detector.

A radiation protection of the eluate surplus collecting and storing means may be  
25 implemented as a protection box including waste weight check means in the form of a force sensor, while the second activity sensor in the form of a gamma detector may be mounted within an opening of the protective box in order to determine a radioactivity level.

A column of the strontium-rubidium generator has a radiation protection including external main and transportation protective containers, said main protection container being  
30 mounted stationary on a shelf of a bogie.

The system is mounted in a closed movable housing. Further, the housing is provided with a shifting tabletop.

The essence of the invention is explained by drawings as follows:

Fig. 1 is a diagram of an infusion system;

Fig. 2 is a general side view of a generator plant;

Fig. 3 is a general top view of the generator plant.

Conditional notation used in drawings is listed below:

- 1 – Eluent tank
- 5 2, 3, 4, 5 – three-way valves
- 6, 7 – activity sensors
- 8, 9 – pressure sensors
- 10 – Syringe pump
- 11 – strontium-rubidium generator
- 10 12 – Check and control unit
- 13 – Weight sensor
- 14 – Remote computer
- 15, 16 – filters
- 17, 18 – air bubble detectors
- 15 19 – Means (needle) for infusing an eluent into a patient
- 20 – Eluent and eluate waste receptacle
- 21 – Movable housing
- 22 – Stand
- 23 – Protective container of strontium-rubidium generator
- 20 24 – Protective container for beta detector
- 25 – Power supply source
- 26 – Protective box of waste reservoir
- 27 – Shifting tabletop

An automated strontium-rubidium infusion system includes means for generating  
25 rubidium-82 in a solution which can be infused into a patient, exactly, a rubidium-strontium  
generator 11 (Fig. 1) of a traditional type in a transporting container. This container is placed  
in a protective external main container 23 and fulfils a main radiation protection function  
together with the latter. The assembled system may be mounted in a movable housing 21 (Fig.  
2) covered by decorative panels (not shown). There is a stand 22 mounted on a tabletop and  
30 having an eluent tank fastened thereon. There are a syringe pump 10 and a computer 14  
further mounted here. Components mounted on an upper shelf of the movable housing 21 are  
as follows:

- the main protective container 23 into which a standard transporting container with  
the strontium-rubidium generator 11 is placed;

- a protective box 24 with a beta activity detector placed therein and measuring the activity of a solution passed through the strontium-rubidium generator 11;

- a power supply source 25.

A protective box 26 is placed at a lower shelf, said box having an eluent and eluate waste receptacle arranged therein.

A top lid of the container 23 is turned back in Fig. 3, which makes it possible to see a cavity into which the transporting container with the strontium-rubidium generator 11 is placed. In order to make easier the access to the main protective container 23 during recharging a generator system (there are removal of the transporting container with the used column of the strontium-rubidium generator 11 and installation of a transporting container with a fresh column), a tabletop part is made as a shifting tabletop 27 which provides convenience in operation.

Further, the system includes means for infusion, exactly (Fig. 1): a remote-controlled syringe pump 10 whose rod is actuated, for example, by a step motor; means for automated filling the syringe pump with an eluent (a 0.9% NaCl solution); a system for transporting an eluent and an eluate to a patient or an eluent and eluate waste receptacle, said transporting system being provided with multi-way (three-way) valves 2 to 5 (Fig. 1) that ramify the transporting system in accordance with a job making program; antibacterial protection means, exactly, antibacterial filters 15 and 16 at an input and at an output of the transporting system; eluate activity measurement means 6 and 7 for monitoring and dosing in infusion into a patient; pressure measurement means 8 and 9 for measurement a pressure in the transporting system, said means being designed for measuring occlusion as well; an eluent and eluate waste receptacle 20 also capable of measuring a solution activity value and a solution weight in a waste reservoir 13; means 12 for automated check throughout the eluation process and components thereof, implemented by on-board or remote computers 14.

The tank 1 with an eluent (for example, brine) is connected by a plastic fitting to a pipe (for example, an infusion tube that has an outer diameter of 2.5 mm with an inner diameter of 1.5 mm). Lengths of such tubes (pipes) are used further to build the transporting system as a whole for infusion. Other end of the pipe is attached via an air bubble detector 17 that generates a signal to a check and control unit 12 in case of passing an air bubble, and said unit generates a control signal to valves 2, 3, 4, and 5 as a result of which the eluent solution comprising the air bubble is removed into the eluent and eluate waste receptacle 20 and does not passes through the column of the strontium-rubidium generator 11.

The valve 2 switches the infusion system into one of two possible operating modes for: (1) filling the syringe when the syringe pump 10 operates for suction the brine from the eluent tank 1 (via the first and second openings of the valve); or (2) infusing, that is, supplying the brine from the filled syringe of the syringe pump 10 into the infusion system  
5 (via the first and third openings of the valve).

Further, the three-way valve 2 is connected by a length of a connecting tube to the first opening of the third three-way valve 4 whose second opening is connected via the first filter 15 to an input of the column of the strontium-rubidium generator 11. The first pressure sensor 8 checks a pressure at the input of the column of the strontium-rubidium generator 11.

10 The third opening of the valve 4 via a length of a connecting tube is connected to the second opening of the fourth three-way valve 5. This valve (the first opening) also has connections to an output tube of the column of the strontium-rubidium generator 11 and an extension of the infusion system in the third opening.

When the syringe pump operates in the operating “infusion” mode, the pair of three-  
15 way valves 4, 5, while operating in synchronism, allows either pumping the brine from the syringe 10 via the column of the strontium-rubidium generator 11 further to the infusion system already in the form of an eluate, that is, a Rb-82-enriched solution, or pumping the brine into the infusion system while by-passing the strontium-rubidium generator 11. Thus operating mode is used when a necessary Rb-82 activity amount has been made and should be  
20 delivered to a patient 19 while the infusion system should be filled with the inactive brine at the end of infusion into the patient. When the brine pumping mode is used, practically the entire transporting system, exceptive for a connecting pipe from the strontium-rubidium generator output to the fourth three-way valve, will be filled with the non-radioactive brine and will not be a source of additional undesirable radioactivity for the patient and the  
25 maintenance personnel; additionally, a brine volume necessary to after-press the made eluate into the patient will not pass through and deplete the column of the strontium-rubidium generator, because it is known that a potency of the generator depends not only upon a time of using thereof but also upon a volume of the brine passed through the generator.

There are a first radioactivity detector 6 (a beta detector) and a second air bubble  
30 detector 18 mounted on a pipe from the third opening of the fourth three-way valve 5 to the third opening of the second three-wave valve 3, said air bubble detector being similar to the first air bubble detector 17.. When an air bubble is detected, the detector 18 generates a signal to the check and control unit that generates a control signal to the second three-way valve 3. As a result, an eluate comprising the air bubble is removed into the eluent and eluate waste

receptacle 20. If an air bubble is not detected, the eluate is directed via the first of said three-way valve 3 and the second filter 16 into the patient, that is, onto a needle 19.

The radioactivity detector 6 operates in real time and measures the Rb-82 activity at a location of the detector 18.

5           The check for filling said waste receptacle with a liquid is carried out by a force sensor (not shown). To measure a radioactivity present in the eluent and eluate waste receptacle, the second radioactivity sensor 7 (a gamma detector) is used. The radiation protection of the eluate surplus collecting and storing means is implemented as a protection box including a force sensor, while the second activity sensor is mounted within an opening  
10 of the protective box.

During infusion into the patient, the second three-way valve 3 is switched for passing the eluent to a pipe connected to the needle 19 via a Millipore filter 16. There is a second pressure sensor 9 mounted in this section which allows measurement of an occlusion pressure when an Rb-82-containing solution is administered into the patient.

15           The process of operating the strontium-rubidium infusion system takes place under control of a control computer program that registers a status of each of devices included in the infusion system at moments of starting and finishing a step, and also registers actions of said devices under condition of their normal functioning and in case if an emergency situation occurs.

20           To exclude overfilling the eluent and eluate waste receptacle 20 with a radioactive liquid, a level of said liquid is remotely checked using the force sensor; in doing so, there is monitoring of a total container and liquid weight (volume) and a limit value thereof. Additionally, by fixing a weight of the empty waste collection receptacle, a system for scheduled interrogating the check and control unit receives information that the receptacle is  
25 mounted in a container. A maximum waste volume in the receptacle is 250 ml.

The check and control unit 12 is coupled to a remote computer whose display displays a graphical mnemonic diagram of the generator device, said diagram providing observation of parameters to be checked in an automatic mode and parameters for operating control of individual members (the electromagnetic three-way valves 2 to 5 and the pump 10) in a  
30 manual mode. The diagram makes it possible to observe a current state of all members (the valves 2 to 5, the air bubble detectors 17, 18) of the disclosed infusion system, and operation of the syringe pump 10. The system also allows reception of information about parameters of a pressure in a line from the pressure sensors 8, 9, and reception of information about an

eluate activity at an output of the generator column 11 and a total activity, a weight of the eluate and eluent waste receptacle 20, an activity in said receptacle from the detectors 6, 7.

The check and control unit 12 of the system is connected to control members of the generator plant, that is, the electromagnetic three-way valves 2, 3, 4, 5 and the pump 10, and also includes members for gathering and processing signals from the sensors 6, 7 (the radioactivity sensors), 8, 9 (the pressure sensors), and 17, 18 (the bubble detectors). The control unit 12 is in communication with a panel personal computer (PPC) or any other remote computer (14) through an Ethernet channel. The control unit receives commands from the PPC or remote computer to execute individual steps of the generator plant operating program and informs said computers about a current state of members controlled thereby and a state of system sensors.

The disclosed system improves the safety of use due to the fact that automation of the infusion process has allowed significant reduction in the radioactive irradiation because the system includes additional members that provide ramification of pipes. As a result, it is possible to after-press the made eluate into the patient by the eluent while by-passing the strontium-rubidium generator. At the same time, the pipe is pumped through by the non-radioactive eluent and there is no additional depletion of the strontium-rubidium generator, which makes the life thereof longer. Further, the risk of presence of air bubbles in the eluent delivered into the patient is excluded because of introducing air bubbles into the system of detectors, while detection of said air bubbles immediately results in direction of the eluent and eluate wastes to the eluent and eluate waste receptacle via branches of the pipe without depletion of the strontium-rubidium generator.



**CLAIMS**

1. An automated strontium-rubidium infusion system comprising:  
5 an eluent tank;  
a strontium-rubidium generator with a filter and a pressure sensor at an input;  
means for infusing an eluent into a patient, said tank, generator and means being  
connected by a transporting system to pipes and two three-way valves;  
radioactivity measuring means; and  
10 a check and control unit,  
wherein the eluent tank is connected via first and second openings of the first three-  
way valve to a syringe pump, a first opening of the second three-way valve is coupled by  
pipes via a second filter to the means for infusing the eluent into the patient and is coupled by  
a second opening thereof to a waste receptacle,

15 said system being characterized in that it further comprises:  
third and fourth three-way valves;  
first and second air bubble detectors coupled to the check and control unit being in  
communication with a computer,  
said third three-way valve being connected by first and second openings via pipes to a  
20 third opening of the first three-way valve and to an input of the strontium-rubidium generator,  
respectively, an output of the generator being coupled to a first opening of the fourth three-  
way valve,

25 wherein the third opening of the third valve and a second opening of the fourth valve  
are in communication by a pipe, the first air bubble detector is mounted on a pipe between the  
eluent tank and the first opening of the first valve while the second detector is mounted on a  
pipe between the third openings of the fourth and second valves.

2. The system according to claim 2, characterized in that the radioactivity  
measurement means include first and second activity sensors.

3. The system according to claim 3, characterized in that the first activity sensor is  
30 placed on a pipe between the third openings of the fourth and second valves and is embodied  
as a beta detector.

4. The system according to claim 2, characterized in that the waste receptacle is  
implemented as a protection box including waste weight check means in the form of a force

sensor, while the second activity sensor in the form of a gamma detector is mounted within an opening of the protective box.

5 5. The system according to claim 1, characterized in that the strontium-rubidium generator has a radiation protection including external main and transportation protective containers, said main protection container being mounted stationary on a shelf of a bogie.

6. The system according to claim 1, characterized in that it is mounted in a closed movable housing.

7. The system according to claim 6, characterized in that the housing is provided with a shifting tabletop.

(12) МЕЖДУНАРОДНАЯ ЗАЯВКА, ОПУБЛИКОВАННАЯ В СООТВЕТСТВИИ С  
ДОГОВОР О ПАТЕНТНОЙ КООПЕРАЦИИ (РСТ)

(19) Всемирная Организация  
Интеллектуальной Собственности  
Международное бюро



(43) Дата международной публикации  
20 ноября 2008 (20.11.2008)

РСТ

(10) Номер международной публикации  
WO 2008/140351 A1

(51) Международная патентная классификация:  
A61M 5/168 (2006.01) A61B 6/00 (2006.01)  
A61M 36/06 (2006.01)

(21) Номер международной заявки: РСТ/RU2008/000211

(22) Дата международной подачи:  
4 апреля 2008 (04.04.2008)

(25) Язык подачи: Русский

(26) Язык публикации: Русский

(30) Данные о приоритете:  
2007113009 9 апреля 2007 (09.04.2007) RU

(71) Заявитель (для всех указанных государств,  
кроме US): ОБЩЕСТВО С ОГРАНИЧЕННОЙ  
ОТВЕТСТВЕННОСТЬЮ "ПОЗИТОМ-ПРО"  
(OBSHCHESTVO S OGRANICHENNOY OTVET-  
STVENNOSTIU "NAUCHNO-PROIZVODSTVEN-  
NAYA FIRMA "POZITOM-PRO") [RU/RU]; ул.  
Большая Черемушкинская, д. 25, кв. 180, Москва,  
117218, Moscow (RU).

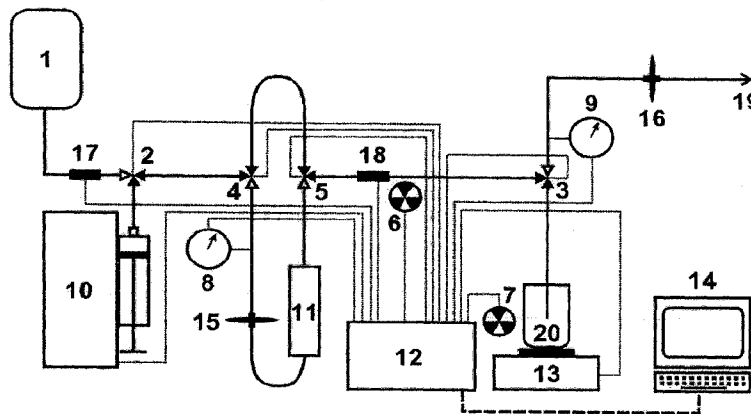
(72) Изобретатели; и

(75) Изобретатели/Заявители (только для US):  
ШИМЧУК Геннадий Григорьевич (SHIMCHUK,  
Gennady Grigorievich) [RU/RU]; ул. Болотниковская,  
д. 49, кв. 88, Москва, 117209, Moscow (RU).  
ПАХОМОВ Геннадий Аркадьевич (PAKHOMOV,  
Gennady Arkadyevich) [RU/RU]; Ореховый  
бульвар, д. 12, корп. 2, кв.405, Москва, 115582,  
Moscow (RU). ШИМЧУК Григорий Геннадьевич  
(SHIMCHUK, Grigory Gennadyevich) [RU/RU]; ул.  
Болотниковская, д. 49, кв. 88, Москва, 117209, Moscow  
(RU). УТЕНКОВ Алексей Борисович (UTENKOV,  
Alekssei Borisovich) [RU/RU]; ул. Профсоюзная, д.  
17, корп. 1, кв. 33, Москва, 117218, Moscow (RU).  
ГАЛОЧКИН Валерий Тимофеевич (GALOSHKIN,  
Valery Timofeevich) [RU/RU]; ул. Центральная,  
д. 18, кв. 16, Троицк, Московская обл., 142092,  
Troitsk (RU). ОГУРЦОВ Александр Владиславович  
(OGURTSOV, Aleksandr Vladislavovich) [RU/RU]; ул.  
Островитянова, д. 45, корп. 2, кв. 81, Москва, 109651,

[продолжение на следующей странице]

(54) Title: AUTOMATED STRONTIUM-RUBIDIUM INFUSION SYSTEM

(54) Название изобретения: АВТОМАТИЗИРОВАННАЯ СТРОНЦИЙ - РУБИДИЕВАЯ ИНФУЗИОННАЯ СИСТЕМА



Фиг. 1

(57) Abstract: The invention relates to medical engineering. The inventive automated strontium-rubidium infusion system comprises a container with eluent, a strontium-rubidium generator with a filter and a pressure sensor and an eluate infusion unit, which are connected by means of a transporting system provided with pipes and two three-way valves, radioactivity measuring means and a control and operating unit. An eluent container is connected to a syringe pump via the first valve, the second three-way valve is connected to the eluate infusion unit and a waste receptacle via the second filter. First and second air bubbles detectors are connected to the control and operating unit. The second three-way valve is connected to the first three-way valve and to the input of the strontium-rubidium generator. The generator output is connected to the fourth valve which is connected to the third valve. The first air bubbles detector is placed between the eluent container and the first valve and the second air bubbles detector is placed between the fourth and second valves.

[продолжение на следующей странице]



WO 2008/140351 A1



Moscow (RU). КОСТИУЧЕНКО Валерий Иванович (KOSTUCHENKO, Valery Ivanovich) [RU/RU]; ул. Маршала Рыбалко, д. 12, корп. 2, кв. 9, Москва, 123098, Moscow (RU).

OM, PG, PH, PL, PT, RO, RS, SC, SD, SE, SG, SK, SL, SM, SV, SY, TJ, TM, TN, TR, TT, TZ, UA, UG, US, UZ, VC, VN, ZA, ZM, ZW.

(74) Агент: ОБЩЕСТВО С ОГРАНИЧЕННОЙ ОТВЕТСТВЕННОСТЬЮ "ПАТЕНТ-ГАРАНТ" (OBSHESTVO S OGRANICHENNOY OTVETSTVENNOSTIU "PATENT-GARANT"); Шлюзовая набережная, д. 6, стр. 4-5, Москва, 115114, Moscow (RU).

(84) Указанные государства (если не указано иначе, для каждого вида региональной охраны): ARIPO (BW, GH, GM, KE, LS, MW, MZ, NA, SD, SL, SZ, TZ, UG, ZM, ZW), евразийский (AM, AZ, BY, KG, KZ, MD, RU, TJ, TM), европейский патент (AT, BE, BG, CH, CY, CZ, DE, DK, EE, ES, FI, FR, GB, GR, HR, HU, IE, IS, IT, LI, LU, LV, MC, MT, NL, NO, PL, PT, RO, SE, SI, SK, TR), OAPI (BF, BJ, CF, CG, CI, CM, GA, GN, GQ, GW, ML, MR, NE, SN, TD, TG).

(81) Указанные государства (если не указано иначе, для каждого вида национальной охраны): AE, AG, AL, AM, AO, AT, AU, AZ, BA, BB, BG, BH, BR, BW, BY, BZ, CA, CH, CN, CO, CR, CU, CZ, DE, DK, DM, DO, DZ, EC, EE, EG, ES, FI, GB, GD, GE, GH, GM, GT, HN, HR, HU, ID, IL, IN, IS, JP, KE, KG, KM, KN, KP, KR, KZ, LA, LC, LK, LR, LS, LT, LU, LY, MA, MD, ME, MG, MK, MN, MW, MX, MY, MZ, NA, NG, NI, NO, NZ,

Декларация в соответствии с правилом 4.17:

— об авторстве изобретения (правило 4.17 (iv))

Опубликована:

— с отчётом о международном поиске

(57) Реферат: Изобретение относится к медицинской технике. Автоматизированная стронций - рубидиевая инфузионная система содержит емкость с элюэтом, стронций-рубидиевый генератор с фильтром и датчиком давления, средство для инфузии элюата, соединенные системой транспортировки с трубопроводами и двумя трехходовыми клапанами, средства для измерения радиоактивности и блок контроля и управления. Емкость с элюэтом через первый клапан соединена со шприцевым насосом, второй трехходовой клапан соединен через второй фильтр со средством для инфузии элюата и со сборником отходов. Первый и второй детекторы воздушных пузырьков подключены к блоку контроля и управления. Второй трехходовой клапан связан с первым трехходовым клапаном и входом стронций-рубидиевого генератора. Выход генератора подключен к четвертому клапану, соединенному с третьим клапаном. Первый детектор воздушных пузырьков установлен между емкостью с элюэтом и первым клапаном, а второй детектор - между четвертым и вторым клапанами.

### Автоматизированная стронций – рубидиевая инфузионная система

Изобретение относится к медицинской технике, в частности к  
5 средствам автоматизации процесса производства диагностического раствора  
от радионуклидного стронций-рубидиевого генератора и дистанционного  
проведения контролируемой инфузии, с автоматическим контролем  
основных характеристик процесса, таких как величина вводимой  
активности, величина окклюзии, наличие воздушных пузырей, а также вес и  
10 активность раствора в контейнере с отходами.

Одним из наиболее перспективных направлений в ядерной  
диагностике является позитронно-эмиссионная томография (ПЭТ).  
Для работы в ПЭТ-центрах используют такие коротко и ультра-  
короткоживущие изотопы как – C-11, O-15, N-13, F-18. Это  
15 обязывает иметь на месте проведения диагностики циклотроны для  
наработки таких изотопов. Возможности ПЭТ-диагностики могут  
быть существенно расширены при использовании генераторных  
систем, время жизни материнского радионуклида которых  
значительно превышает время жизни нарабатываемых на  
20 циклотронах ПЭТ-центров радионуклидов. Наиболее перспективными  
среди изотопных генераторов для ПЭТ стоят генераторные системы  
 $^{82}\text{Sr}$  ( $t_{1/2}=25,6$  дней)  $\rightarrow$   $^{82}\text{Rb}$  ( $t_{1/2}=75$  сек) и  $^{68}\text{Ge}$  ( $t_{1/2}=271$  дней)  $\rightarrow$   $^{68}\text{Ga}$   
( $t_{1/2}=68,3$  мин).

Поэтому в применении к генераторным изотопам можно говорить о  
25 снабжении ими любых клиник, обладающих ПЭТ-сканнерами, в рамках  
региона, государства или группы государств.

Наибольшее применение генераторные системы могут найти в  
смонтированных в автотрейлерах так называемых мобильных ПЭТ,  
вызываемых для обслуживания клиник, не имеющих не только собственных  
30 циклотронов, но и собственных ПЭТ-сканнеров. При отсутствии «привязки»  
такого мобильного ПЭТ-сканнера к изотопной базе существенно  
расширяется радиус обслуживаемой им территории.

Известна стронций-рубидиевая инфузионная система производства диагностического раствора от радионуклидного стронций-рубидиевого генератора и проведения контролируемой инфузии (US 4562829, 1986), включающая емкость с элюентом, соединенную соответствующими трубопроводами системы транспортировки через первый трехходовой клапан с шприцевым насосом, стронций-рубидиевый генератор с первыми фильтром и датчиком давления на входе, второй трехходовой клапан, первое отверстие которого подключено через второй фильтр к средству для инфузии элюата пациенту, а второе – к средству для сбора и хранения излишков элюата, средства для измерения радиоактивности и система контроля и управления. Известная система не является оптимальной по степени защиты от радиоактивного излучения и по сроку службы генераторной колонки.

Предлагаемое изобретение направлено на устранение перечисленных недостатков. Достижимый при ее использовании технический результат заключается в повышении эффективности проведения диагностической процедуры за счет автоматизации процедуры инфузии, снижении доз нежелательного радиоактивного облучения пациента и обслуживающего персонала, увеличении сроков эксплуатации генераторной колонки.

Сущность предлагаемого изобретения заключается в том, что автоматизированная стронций – рубидиевая инфузионная система, содержит емкость с элюентом, стронций-рубидиевый генератор с фильтром и датчиком давления на входе, средство для инфузии элюата пациенту, соединенные системой транспортировки с трубопроводами и двумя трехходовыми клапанами, средства для измерения радиоактивности и блок контроля и управления. Причем емкость с элюентом через первое и второе отверстия первого трехходового клапана соединена с шприцевым насосом, первое отверстие второго трехходового клапана подключено трубопроводами через второй фильтр к средству для инфузии элюата пациенту, а второе отверстие – к сборнику отходов. В систему

дополнительно введены третий и четвертый трехходовые клапаны, первый и второй детекторы воздушных пузырьков, подключенные к блоку контроля и управления, связанного с компьютером, при этом третий трехходовой клапан связан первым и вторым отверстиями через трубопроводы с третьим  
5 отверстием первого трехходового клапана и входом стронций – рубидиевого генератора, соответственно. Выход генератора подключен к первому отверстию четвертого трехходового клапана, причем третье отверстие третьего клапана и второе отверстие четвертого клапана связаны трубопроводом, первый детектор воздушных пузырьков установлен на  
10 трубопроводе между емкостью с элюэтом и первым отверстием первого клапана, а второй детектор установлен на трубопроводе между третьими отверстиями четвертого и второго клапанов.

Кроме того, средства для измерения радиоактивности включают первый и второй датчики активности. При этом первый датчик активности  
15 размещен на трубопроводе между третьими отверстиями четвертого и второго клапанов и выполнен в виде бета-детектора.

Радиационная защита средства для сбора и хранения излишков элюата может быть выполнена в виде защитного бокса, включающего средство контроля веса отходов в виде датчика усилия, а в отверстии  
20 защитного бокса установлен второй датчик активности для определения уровня радиоактивности отходов в виде гамма-детектор.

Колонка стронций – рубидиевого генератора имеет радиационную защиту, включающую, предпочтительно, внешний основной и транспортный защитные контейнеры, при этом основной защитный  
25 контейнер стационарно установлен на полке тележки.

Система устанавливается в закрытом перемещаемом корпусе. Кроме того, корпус снабжен сдвигающейся столешницей.

Сущность изобретения поясняется следующими чертежами:

Фиг. 1 – схема инфузионной системы;

30 фиг. 2 – представлен общий вид генераторной установки сбоку;

фиг. 3 – общий вид генераторной установки сверху.

Ниже перечислены условные обозначения, используемые на чертже:

- 1 – емкость с элюентом
- 5 2, 3, 4, 5 – трехходовые клапаны
- 6, 7 – датчики активности
- 8, 9 – датчики давления
- 10 – шприцевой насос
- 11 – стронций-рубидиевый генератор
- 10 12 – блок контроля и управления
- 13 – датчик веса
- 14 – удаленный компьютер
- 15, 16 – фильтры
- 17, 18 – детекторы воздушных пузырьков
- 15 19 – средство для инфузии элюата пациенту (игла)
- 20 – сборник отходов элюента и элюата
- 21 – перемещаемый корпус
- 22 – штатив
- 23 – защитный контейнер стронций – рубидиевого генератора
- 20 24 – защитный контейнер для бета – детектора
- 25 – источник питания
- 26 – защитный бокс емкости для отходов
- 27 – сдвигающаяся столешница.

Автоматизированная стронций – рубидиевая инфузионная система  
25 включает в себя средства для генерации рубидия-82 в растворе, который может быть введен пациенту, а именно стронций-рубидиевый генератор 11 (фиг.1), обычного типа в транспортном контейнере. Этот контейнер помещается в защитный внешний основной контейнер 23 и совместно с последним осуществляет функцию основной радиационной защиты.  
30 Система в сборе может устанавливаться в перемещаемом корпусе 21 (фиг.



2), закрытым декоративными панелями (не показано). На столешнице установлен штатив 22 с укрепленном на нем емкостью с элюентом 1. Кроме того, здесь установлен шприцевой насос 10 и компьютер 14. На верхней полке перемещаемого корпуса 21 установлены:

- 5           - основной защитный контейнер 23, внутрь которого помещен стандартный транспортный контейнер со стронций-рубидиевым генератором 11;
- защитный бокс 24 с размещенным внутри него детектором бета-активности, измеряющим активность раствора, прошедшего через
- 10          стронций-рубидиевый генератор;
- источник питания 25.

На нижней полке размещен защитный бокс 26, внутри которого располагается сборник отходов элюента и элюата.

На фиг. 3 верхняя крышка контейнера 23 откинута, что позволяет

15          увидеть полость, внутрь которой помещается транспортный контейнер со стронций-рубидиевым генератором 11. Для того, чтобы облегчить доступ к основному защитному контейнеру 23 во время перезарядки генераторной системы (извлекается транспортный контейнер с отработавшей колонкой стронций-рубидиевого генератора 11 и устанавливается транспортный

20          контейнер со свежей генераторной колонкой) – часть столешницы выполнена в виде сдвигающейся столешницы 27, обеспечивающей удобство при работе.

Кроме того, система включает в себя средства для проведения инфузии, а именно (фиг. 1): шприцевой дистанционно управляемый

25          инфузионный насос 10, шток которого приводится в действие, например, шаговым двигателем; средства для автоматизированного заполнения шприцевого насоса элюентом 1 (0.9 % раствором NaCl); систему транспортировки элюента и элюата до пациента или сборника отходов элюента и элюата; снабженную многоходовыми (трехходовыми) клапанами

30          2 – 5 (фиг.1), осуществляющими ветвление системы транспортировки в

соответствии с программой проведения работ; антибактериальные средства защиты, а именно антибактериальные фильтры 15 и 16 на входе и выходе системы транспортировки; средства измерения активности элюата для текущего контроля и дозирования при инфузии в пациента 6 и 7; средства измерения давления 8 и 9 в транспортной системе, в том числе и для измерения окклюзии; сборник отходов элюента и элюата 20, в том числе с измерением величины активности и веса раствора в емкости для отходов 13 и осуществления защиты от радиоактивности; средства автоматизированного контроля всего процесса элюации и его составных частей 12, осуществляемого с помощью бортового или удаленного компьютеров 14.

В описываемой системе емкость с элюентом 1 (соляным раствором) соединена пластиковым фитингом с трубопроводом (например, трубкой для инфузий, которая имеет внешний диаметр 2.5 мм при внутреннем диаметре 1.5 мм). Отрезки таких трубочек (трубопроводы) далее используются для построения всей транспортной системы для инфузии. Другой конец трубопровода подсоединен через детектор воздушных пузырьков 17, который, в случае прохождения воздушного пузырька, вырабатывает сигнал на блок контроля и управления 12, который вырабатывает управляющий сигнал на клапаны 2, 3, 4 и 5, в результате чего, раствор элюента, содержащий воздушный пузырек, удаляется в сборник отходов элюента и элюата 20, не проходя колонку стронций-рубидиевого генератора 11.

Клапан 2 осуществляет перевод инфузионной системы в один из двух возможных режимов работы: (1) заполнение шприца при работе шприцевого насоса 10 на всасывание соляного раствора из емкости с элюентом 1 (через первое и второе отверстия клапана) или (2) инфузию, т.е. подачу соляного раствора из заполненного шприца шприцевого насоса 10 в инфузионную систему (через первое и третье отверстия клапана).

Трехходовой клапан 2 далее соединен отрезком соединительной трубки с первым отверстием третьего трехходового клапана 4, второе отверстие которого соединено через первый фильтр 15 с входом колонки стронций-рубидиевого генератора 11. Контроль давления на входе в колонку стронций-рубидиевого генератора 11 осуществляется первым датчиком давления 8.

Третьим отверстием клапан 4, через отрезок соединительной трубки, подсоединен ко второму отверстию четвертого трехходового клапана 5. Этот клапан также имеет соединения с выходной трубкой колонки стронций-рубидиевого генератора 11 (первое отверстие) и продолжением инфузионной системы на третьем отверстии.

В режиме работы шприцевого насоса «инфузия» пара трехходовых клапанов 4, 5, работая синхронно, позволяет либо прокачивать соляной раствор из шприца 10 через колонку стронций-рубидиевого генератора дальше в инфузионную систему уже в виде элюата, т.е. раствора, обогащенного Rb-82, либо прокачивать соляной раствор в инфузионную систему, минуя стронций-рубидиевый генератор 11. Этот режим работы используется тогда, когда необходимое количество активности Rb-82 наработано и оно должно быть доставлено пациенту 19, а инфузионная система должна быть заполнена неактивным соляным раствором на конец инфузии в пациента. При использовании режима прокачки соляного раствора практически вся инфузионная система, за исключением соединительного трубопровода от выхода из стронций-рубидиевого генератора до четвертого трехходового клапана, будет заполнена нерадиоактивным соляным раствором и не будет являться источником дополнительной нежелательной радиоактивности на пациента и обслуживающий персонал; кроме того, объем соляного раствора, необходимый для додавливания наработанного элюата в пациента не будет проходить через колонку стронций-рубидиевого генератора и истощать ее, т.к. известно, что потенция генератора зависит не только от времени его

эксплуатации, но также и от объема пропущенного через него соляного раствора.

На трубопроводе от третьего отверстия четвертого трехходового клапана 5 до третьего отверстия второго трехходового клапана 3  
5 установлены первый детектор радиоактивности 6 (бета-детектор) и второй детектор воздушных пузырьков 18, аналогичный первому детектору пузырьков 17. При обнаружении воздушного пузырька, детектор 18 вырабатывает сигнал на блок контроля и управления, который вырабатывает управляющий сигнал на клапан второго трехходового клапана 3. В  
10 результате, элюат содержащий воздушный пузырек, удаляется в сборник отходов элюента и элюата 20. Если воздушный пузырек не обнаружен, элюат направляется через первое отверстие трехходового клапана 3 и второй фильтр 16 в пациента, т.е. на иглу 19

Детектор радиоактивности 6 работает в режиме реального времени  
15 и измеряет активность Rb-82 в месте расположения детектора 18.

Контроль за наполнением сборника для отходов жидкостью осуществляется с помощью датчика усилий (не показан). Для измерения радиоактивности, содержащейся в сборнике для отходов элюента и элюата используется второй датчик радиоактивности 7 (гамма-детектор).  
20 Радиационная защита средства для сбора и хранения излишков элюата выполнена в виде защитного бокса, в состав которого включен датчик усилия, а в отверстии защитного бокса установлен второй датчик активности.

При осуществлении инфузии в пациента второй трехходовой  
25 клапан 3 переключен на пропускание элюата на трубопровод соединенный с иглой 19 через миллипоровский фильтр 16. На этом отрезке установлен второй датчик давления 9, позволяющий измерять давление окклюзии при введении раствора, содержащего Rb-82, в пациента.

Процесс работы стронций-рубидиевой инфузионной системы происходит под управлением управляющей компьютерной программы, в которой прописывается состояние каждого из устройств, входящих в инфузионную систему, на момент начала и окончания выполнения шага, также прописываются действия этих устройств и условия их функционирования в нормальных условиях и в случае возникновения аварийной ситуации.

Для исключения переполнения в сборнике отходов элюента и элюата 20 радиоактивной жидкости, осуществляется дистанционный контроль за предельным значением ее уровня с помощью датчика усилия, при этом контролируется общий вес тары и жидкости, осуществляется текущий контроль за значением веса (объема) жидкости и за предельным его значением. Кроме того, фиксируя вес пустой тары для сбора отходов, система регламентного опроса блока контроля и управления установки получает информацию о том, что тара установлена в контейнере. Максимальный объем отходов в таре составляет 250 мл.

Блок контроля и управления подключен к удаленному компьютеру, на дисплее которого отображается графическая мнемосхема генераторного устройства, обеспечивающая наблюдение контролируемых параметров в автоматическом режиме и оперативного управления отдельными элементами (электромагнитными трехходовыми клапанами 2 - 5, насосом 10) в ручном режиме. Схема позволяет наблюдать за текущим состоянием всех элементов описываемой системы инфузии (клапанов 2-5, детекторов воздушных пузырьков 17, 18) и за работой шприцевого насоса 10. Также она позволяет получать информацию о параметрах давления в магистральных от датчиков давления 8, 9, активности элюата на выходе из генераторной колонки 11 и суммарной активности, веса емкости сборника отходов элюента и элюата 20, активности в емкости с отходами от детекторов 6,7.

Блок контроля и управления 12 системы связан с управляющими элементами генераторной установки – электромагнитными трехходовыми

клапанами 2, 3, 4, 5 и насосом 10, а также включает элементы для сбора и обработки сигналов с датчиков 6, 7 (датчики радиоактивности), 8, 9 (датчики давления), 17, 18 (детекторы воздушных пузырьков). Блок управления 12 связан с панельным персональным компьютером (PPC) или любым другим удаленным компьютером (14) по каналу Ethernet. Он получает команды от PPC или удаленного компьютера на выполнение отдельных шагов программы работы генераторной установки и информирует их о текущем состоянии управляемых им элементов и состоянии датчиков системы.

Описываемая система повышает безопасность эксплуатации, так как автоматизация процесса инфузии позволила значительно сократить радиоактивное облучение за счет введения в систему дополнительных клапанов, обеспечивающих ветвление трубопроводов. В результате, появилась возможность додавливания наработанного элюата в пациента элюентом, минуя стронций – рубидиевый генератор. При этом трубопровод прокачивается нерадиоактивным элюентом и не происходит дополнительного истощения стронций – рубидиевого генератора, что увеличивает срок его эксплуатации. Кроме того, исключается риск содержания воздушных пузырьков в элюанте, доставляемого пациенту, за счет введения в систему детекторов воздушных пузырьков, при обнаружении которых, элюент сразу направляется к сборнику отходов элюента и элюата через ответвления трубопровода, не истощая стронций – рубидиевый генератор.

**Формула изобретения**

1. Автоматизированная стронций – рубидиевая инфузионная  
5 система, содержащая емкость с элюентом, стронций-рубидиевый генератор  
с фильтром и датчиком давления на входе, средство для инфузии элюата  
пациенту, соединенные системой транспортировки с трубопроводами и  
двумя трехходовыми клапанами, средства для измерения радиоактивности и  
10 блок контроля и управления, причем емкость с элюентом через первое и  
второе отверстия первого трехходового клапана соединена с шприцевым  
насосом, первое отверстие второго трехходового клапана подключено  
трубопроводами через второй фильтр к средству для инфузии элюата  
пациенту, а второе отверстие – к сборнику отходов, отличающаяся тем, что  
15 дополнительно введены третий и четвертый трехходовые клапаны, первый и  
второй детекторы воздушных пузырьков, подключенные к блоку контроля и  
управления, связанного с компьютером, при этом третий трехходовой  
клапан связан первым и вторым отверстиями через трубопроводы с третьим  
отверстием первого трехходового клапана и входом стронций – рубидиевого  
20 генератора, соответственно, выход генератора подключен к первому  
отверстию четвертого трехходового клапана, причем третье отверстие  
третьего клапана и второе отверстие четвертого клапана связаны  
трубопроводом, первый детектор воздушных пузырьков установлен на  
трубопроводе между емкостью с элюентом и первым отверстием первого  
25 клапана, а второй детектор установлен на трубопроводе между третьими  
отверстиями четвертого и второго клапанов.

2. Система по п.1, отличающаяся тем, что средства для измерения  
радиоактивности включают первый и второй датчики активности.

3. Система по п.2, отличающаяся тем, что первый датчик  
активности размещен на трубопроводе между третьими отверстиями  
30 четвертого и второго клапанов и выполнен в виде бета-детектора.

4. Система по п.1, отличающаяся тем, что радиационная защита  
сборника отходов выполнена в виде защитного бокса, включающего

средство контроля веса отходов, выполненного в виде датчика усилия, а в отверстии

защитного бокса установлен второй датчик активности для определения радиоактивности отходов, в виде гамма-детектора.

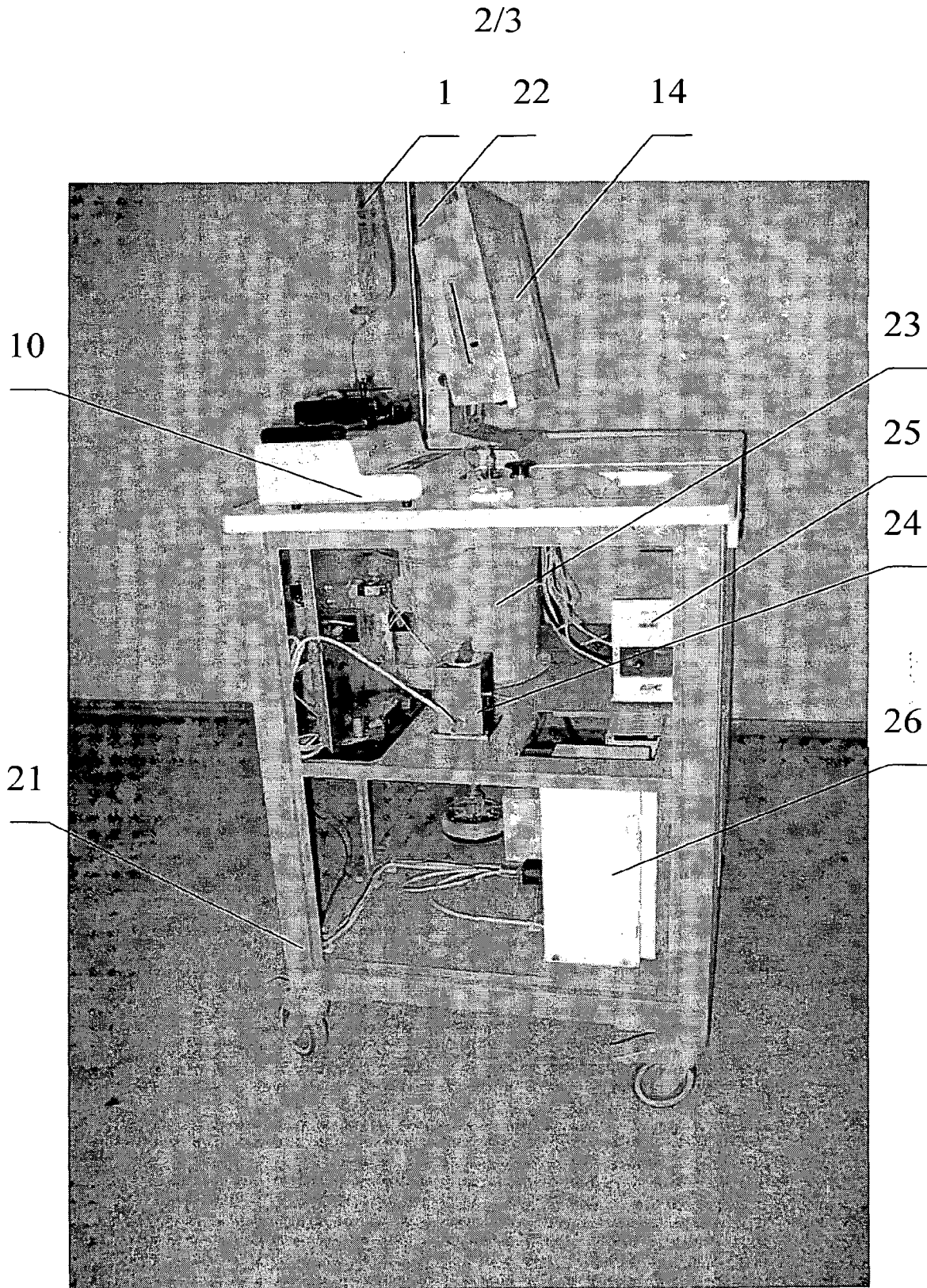
5            5. Система по п.1, отличающаяся тем, что стронций – рубидиевый генератор имеет радиационную защиту, включающую внешний основной и транспортный защитные контейнеры, при этом основной защитный контейнер стационарно установлен на полке тележки.

10           6. Система по п.1, отличающаяся тем, что она установлена в закрытом перемещаемом корпусе.

7. Система по п.6, отличающаяся тем, что корпус снабжен сдвигающейся столешницей.

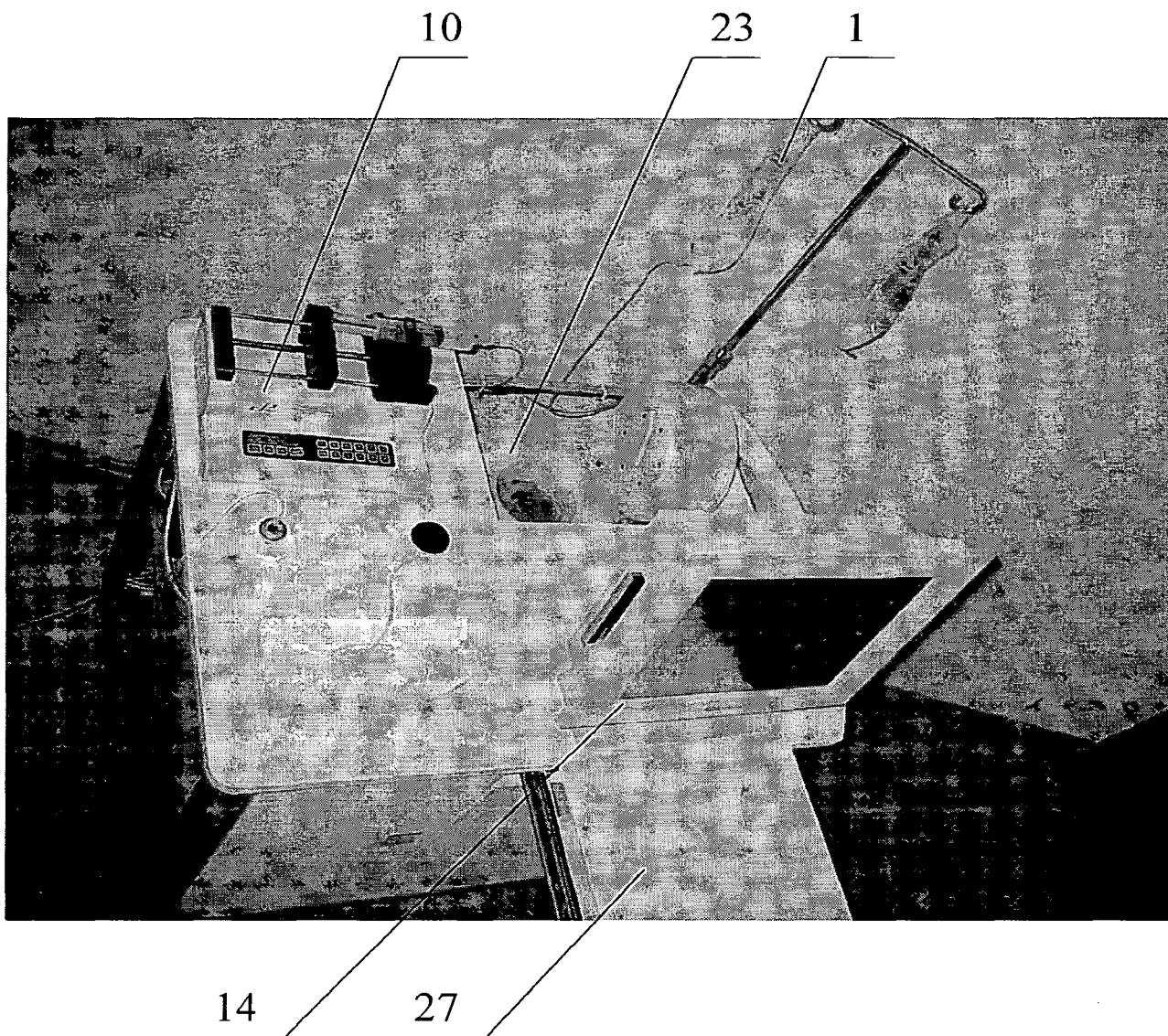






Фиг. 2

3/3



Фиг. 3

## INTERNATIONAL SEARCH REPORT

International application No.

PCT/RU2008/000211

| A. CLASSIFICATION OF SUBJECT MATTER   |  | <i>A61M 5/168 (2006.01)</i><br><i>A61M 36/06 (2006.01)</i><br><i>A61B 6/00 (2006.01)</i>   |
|---|--|--|
| According to International Patent Classification (IPC) or to both national classification and IPC   |  |  |
| B. FIELDS SEARCHED  |  |  |
| Minimum documentation searched (classification system followed by classification symbols)<br>A61M 36/00-36/06, 5/00-5/155, AGIB 6/00-6/10, A61M 5/168   |  |  |
| Documentation searched other than minimum documentation to the extent that such documents are included in the fields searched   |  |  |
| Electronic data base consulted during the international search (name of data base and, where practicable, search terms used)<br>http://www.uspto.gov; http://depatisnet.dpma.de; http://ep.espacenet.com; http://www.fips.ru;<br>http://www.eapatis.com |  |  |
| C. DOCUMENTS CONSIDERED TO BE RELEVANT  |  |  |
| Category*   | Citation of document, with indication, where appropriate, of the relevant passages   | Relevant to claim No.  |
| A   | US 4562829 A (E.R. SQUIBB & SONS, INC.), 07.01.1986, the abstract, figure 1  | 1-7  |
| A   | EP 0310148 A (E.R. SQUIBB & SONS, INC), 05.04.1988, the claims, figure   | 1-7  |
| A   | RU 2219959 C2 (FEDERALNOE GOSUDARSTVENNOE UNITARNOE PREDPRIYATIE NAUCHNO-ISSLEDOVATELSKY INSTITUT ELEKTROMEKHANIKI) 27.12.2003, the claims, figure 1 | 1-7  |
| <input type="checkbox"/> Further documents are listed in the continuation of Box C. <input type="checkbox"/> See patent family annex.   |  |  |
| * Special categories of cited documents:  | “T”  | later document published after the international filing date or priority date and not in conflict with the application but cited to understand the principle or theory underlying the invention  |
| “A” document defining the general state of the art which is not considered to be of particular relevance  | “X”  | document of particular relevance; the claimed invention cannot be considered novel or cannot be considered to involve an inventive step when the document is taken alone   |
| “E” earlier application or patent but published on or after the international filing date   | “Y”  | document of particular relevance; the claimed invention cannot be considered to involve an inventive step when the document is combined with one or more other such documents, such combination being obvious to a person skilled in the art |
| “L” document which may throw doubts on priority claim(s) or which is cited to establish the publication date of another citation or other special reason (as specified)   | “&”  | document member of the same patent family  |
| “O” document referring to an oral disclosure, use, exhibition or other means  |  |  |
| “P” document published prior to the international filing date but later than the priority date claimed  |  |  |
| Date of the actual completion of the international search<br>24 July 2008   | Date of mailing of the international search report<br>04 September 2008  |  |
| Name and mailing address of the ISA/<br>RU  | Authorized officer   |  |
| Facsimile No.   | Telephone No.  |  |

# ОТЧЕТ О МЕЖДУНАРОДНОМ ПОИСКЕ

Международная заявка №  
PCT/RU 2008/000211

| <b>А. КЛАССИФИКАЦИЯ ПРЕДМЕТА ИЗОБРЕТЕНИЯ:</b> <i>A61M 5/168 (2006.01)</i><br><i>A61M 36/06 (2006.01)</i><br>Согласно Международной патентной классификации МПК <i>A61B 6/00 (2006.01)</i>  |   |   |   |   |   |     |   |  |     |   |   |     |  |
|--|---|---|---|---|---|-----|---|--|-----|---|---|-----|--|
| <b>В. ОБЛАСТИ ПОИСКА:</b><br>Проверенный минимум документации (система классификации с индексами классификации):<br>Другая проверенная документация в той мере, в какой она включена в поисковые подборки:<br><br><p style="text-align: center;">A61M 36/00-36/06, 5/00-5/155, A61B 6/00-6/10, A61M 5/168</p>  |   |   |   |   |   |     |   |  |     |   |   |     |  |
| Электронная база данных, использовавшаяся при поиске (название базы и, если, возможно, используемые поисковые термины): <a href="http://www.uspto.gov">http://www.uspto.gov</a> ; <a href="http://depatisnet.dpma.de">http://depatisnet.dpma.de</a> ; <a href="http://ep.espacenet.com">http://ep.espacenet.com</a> ; <a href="http://www.fips.ru">http://www.fips.ru</a> ; <a href="http://www.eapatis.com">http://www.eapatis.com</a>  |   |   |   |   |   |     |   |  |     |   |   |     |  |
| <b>С. ДОКУМЕНТЫ, СЧИТАЮЩИЕСЯ РЕЛЕВАНТНЫМИ:</b>   |   |   |   |   |   |     |   |  |     |   |   |     |  |
| <table border="1"> <thead> <tr> <th>Категория*</th> <th>Цитируемые документы с указанием, где это возможно, релевантных частей</th> <th>Относится к пункту №</th> </tr> </thead> <tbody> <tr> <td>A</td> <td>US 4562829 A (E.R. SQUIBB &amp; SONS, INC.) 07.01.1986, реферат, фиг. 1</td> <td>1-7</td> </tr> <tr> <td>A</td> <td>EP 0310148 A (E.R. SQUIBB &amp; SONS, INC) 05.04.1989, формула, фиг.</td> <td>1-7</td> </tr> <tr> <td>A</td> <td>RU 2219959 C2 (ФЕДЕРАЛЬНОЕ ГОСУДАРСТВЕННОЕ УНИТАРНОЕ ПРЕДПРИЯТИЕ НАУЧНО-ИССЛЕДОВАТЕЛЬСКИЙ ИНСТИТУТ ЭЛЕКТРОМЕХАНИКИ) 27.12.2003, формула, фиг. 1</td> <td>1-7</td> </tr> </tbody> </table>  | Категория*  | Цитируемые документы с указанием, где это возможно, релевантных частей  | Относится к пункту №  | A | US 4562829 A (E.R. SQUIBB & SONS, INC.) 07.01.1986, реферат, фиг. 1 | 1-7 | A | EP 0310148 A (E.R. SQUIBB & SONS, INC) 05.04.1989, формула, фиг. | 1-7 | A | RU 2219959 C2 (ФЕДЕРАЛЬНОЕ ГОСУДАРСТВЕННОЕ УНИТАРНОЕ ПРЕДПРИЯТИЕ НАУЧНО-ИССЛЕДОВАТЕЛЬСКИЙ ИНСТИТУТ ЭЛЕКТРОМЕХАНИКИ) 27.12.2003, формула, фиг. 1 | 1-7 |  |
| Категория*   | Цитируемые документы с указанием, где это возможно, релевантных частей  | Относится к пункту №  |   |   |   |     |   |  |     |   |   |     |  |
| A  | US 4562829 A (E.R. SQUIBB & SONS, INC.) 07.01.1986, реферат, фиг. 1   | 1-7   |   |   |   |     |   |  |     |   |   |     |  |
| A  | EP 0310148 A (E.R. SQUIBB & SONS, INC) 05.04.1989, формула, фиг.  | 1-7   |   |   |   |     |   |  |     |   |   |     |  |
| A  | RU 2219959 C2 (ФЕДЕРАЛЬНОЕ ГОСУДАРСТВЕННОЕ УНИТАРНОЕ ПРЕДПРИЯТИЕ НАУЧНО-ИССЛЕДОВАТЕЛЬСКИЙ ИНСТИТУТ ЭЛЕКТРОМЕХАНИКИ) 27.12.2003, формула, фиг. 1   | 1-7   |   |   |   |     |   |  |     |   |   |     |  |
| <input type="checkbox"/> последующие документы указаны в продолжении графы С. <input type="checkbox"/> данные о патентах-аналогах указаны в приложении   |   |   |   |   |   |     |   |  |     |   |   |     |  |
| <table border="0"> <tr> <td style="vertical-align: top;">                     * Особые категории ссылочных документов:<br/>                     А документ, определяющий общий уровень техники и не считающийся особо релевантным<br/>                     Е более ранняя заявка или патент, но опубликованная на дату международной подачи или после нее<br/>                     L документ, подвергающий сомнению притязание (я) на приоритет, или который приводится с целью установления даты публикации другого ссылочного документа, а также в других целях (как указано)<br/>                     О документ, относящийся к устному раскрытию, использованию, экспонированию и т.д.<br/>                     Р документ, опубликованный до даты международной подачи, но после даты испрашиваемого приоритета                 </td> <td style="vertical-align: top;">                     Т более поздний документ, опубликованный после даты международной подачи или приоритета, но приведенный для понимания принципа или теории, на которых основывается изобретение<br/>                     X документ, имеющий наиболее близкое отношение к предмету поиска; заявленное изобретение не обладает новизной или изобретательским уровнем, в сравнении с документом, взятым в отдельности<br/>                     Y документ, имеющий наиболее близкое отношение к предмету поиска; заявленное изобретение не обладает изобретательским уровнем, когда документ взят в сочетании с одним или несколькими документами той же категории, такая комбинация документов очевидна для специалиста<br/>                     &amp; документ, являющийся патентом-аналогом                 </td> </tr> </table> |   | * Особые категории ссылочных документов:<br>А документ, определяющий общий уровень техники и не считающийся особо релевантным<br>Е более ранняя заявка или патент, но опубликованная на дату международной подачи или после нее<br>L документ, подвергающий сомнению притязание (я) на приоритет, или который приводится с целью установления даты публикации другого ссылочного документа, а также в других целях (как указано)<br>О документ, относящийся к устному раскрытию, использованию, экспонированию и т.д.<br>Р документ, опубликованный до даты международной подачи, но после даты испрашиваемого приоритета | Т более поздний документ, опубликованный после даты международной подачи или приоритета, но приведенный для понимания принципа или теории, на которых основывается изобретение<br>X документ, имеющий наиболее близкое отношение к предмету поиска; заявленное изобретение не обладает новизной или изобретательским уровнем, в сравнении с документом, взятым в отдельности<br>Y документ, имеющий наиболее близкое отношение к предмету поиска; заявленное изобретение не обладает изобретательским уровнем, когда документ взят в сочетании с одним или несколькими документами той же категории, такая комбинация документов очевидна для специалиста<br>& документ, являющийся патентом-аналогом |   |   |     |   |  |     |   |   |     |  |
| * Особые категории ссылочных документов:<br>А документ, определяющий общий уровень техники и не считающийся особо релевантным<br>Е более ранняя заявка или патент, но опубликованная на дату международной подачи или после нее<br>L документ, подвергающий сомнению притязание (я) на приоритет, или который приводится с целью установления даты публикации другого ссылочного документа, а также в других целях (как указано)<br>О документ, относящийся к устному раскрытию, использованию, экспонированию и т.д.<br>Р документ, опубликованный до даты международной подачи, но после даты испрашиваемого приоритета  | Т более поздний документ, опубликованный после даты международной подачи или приоритета, но приведенный для понимания принципа или теории, на которых основывается изобретение<br>X документ, имеющий наиболее близкое отношение к предмету поиска; заявленное изобретение не обладает новизной или изобретательским уровнем, в сравнении с документом, взятым в отдельности<br>Y документ, имеющий наиболее близкое отношение к предмету поиска; заявленное изобретение не обладает изобретательским уровнем, когда документ взят в сочетании с одним или несколькими документами той же категории, такая комбинация документов очевидна для специалиста<br>& документ, являющийся патентом-аналогом |   |   |   |   |     |   |  |     |   |   |     |  |
| Дата действительного завершения международного поиска: 24 июля 2008 (24.07.2008)   | Дата отправки настоящего отчета о международном поиске: 04 сентября 2008 (04.09.2008)   |   |   |   |   |     |   |  |     |   |   |     |  |
| Наименование и адрес ISA/RU<br>ФГУ ФИПС, РФ, 123995, Москва, Г-59, ГСП-5,<br>Бережковская наб., 30, 1<br>Факс: (499) 243-3337  | Уполномоченное лицо:<br><p style="text-align: right;">Л. Черепанова</p> Телефон № (499) 240-25-91   |   |   |   |   |     |   |  |     |   |   |     |  |

Форма PCT/ISA/210 (второй лист)(июль 2008)

(19) World Intellectual Property Organization  
International Bureau



(43) International Publication Date  
25 February 2010 (25.02.2010)

(10) International Publication Number  
**WO 2010/020596 A1**

- (51) **International Patent Classification:**  
G21G 4/08 (2006.01)
- (21) **International Application Number:**  
PCT/EP2009/060584
- (22) **International Filing Date:**  
14 August 2009 (14.08.2009)
- (25) **Filing Language:** English
- (26) **Publication Language:** English
- (30) **Priority Data:**  
08075710.7 18 August 2008 (18.08.2008) EP
- (71) **Applicant (for all designated States except US):** Stichting Jeroen Bosch Ziekenhuis [NL/NL]; Tolbrugstraat 11, NL-5211 RW 's HERTOGENBOSCH (NL).
- (72) **Inventor: and**
- (75) **Inventor/Applicant (for US only):** Claessens, Roland Antonius Maria Johannes [NL/NL]; Langstraat 117, NL-6596 BN Milsbeek (NL).
- (74) **Agent:** VAN KOOLJ, Adriaan; Sweelinckplein 1, NL-2517 GK Den Haag (NL).
- (81) **Designated States (unless otherwise indicated, for every kind of national protection available):** AE, AG, AL, AM, AO, AT, AU, AZ, BA, BB, BG, BH, BR, BW, BY, BZ, CA, CH, CL, CN, CO, CR, CU, CZ, DE, DK, DM, DO, DZ, EC, EE, EG, ES, FI, GB, GD, GE, GH, GM, GT, HN, HR, HU, ID, IL, IN, IS, JP, KE, KG, KM, KN, KP, KR, KZ, LA, LC, LK, LR, LS, LT, LU, LY, MA, MD, ME, MG, MK, MN, MW, MX, MY, MZ, NA, NG, NI, NO, NZ, OM, PE, PG, PH, PL, PT, RO, RS, RU, SC, SD, SE, SG, SK, SL, SM, ST, SV, SY, TJ, TM, TN, TR, TT, TZ, UA, UG, US, UZ, VC, VN, ZA, ZM, ZW.
- (84) **Designated States (unless otherwise indicated, for every kind of regional protection available):** ARIPO (BW, GH, GM, KE, LS, MW, MZ, NA, SD, SL, SZ, TZ, UG, ZM, ZW), Eurasian (AM, AZ, BY, KG, KZ, MD, RU, TJ, TM), European (AT, BE, BG, CH, CY, CZ, DE, DK, EE, ES, FI, FR, GB, GR, HR, HU, IE, IS, IT, LT, LU, LV, MC, MK, MT, NL, NO, PL, PT, RO, SE, SI, SK, SM, TR), OAPI (BF, BJ, CF, CG, CI, CM, GA, GN, GQ, GW, ML, MR, NE, SN, TD, TG).
- Published:**  
— with international search report (Art. 21(3))

(54) **Title:** STRONTIUM-82/RUBIDIUM-82 GENERATOR, METHOD FOR PRODUCING A RUBIDIUM-82 COMPRISING DIAGNOSTIC AGENT, SAID DIAGNOSTIC AGENT AND ITS USE IN MEDICINE

(57) **Abstract:** The invention relates to a strontium-82/rubidium-82 generator, comprising a column filled with a cationic exchanger loaded with strontium-82, and having an inlet and an outlet, and a liquid medium, wherein parts of the column, inlet and outlet coming into contact with the liquid medium are iron-free, preferably metal-free, to a method for producing rubidium-82, and to the obtained diagnostic agent.



WO 2010/020596 A1

**STRONTIUM-82/RUBIDIUM-82 GENERATOR, METHOD FOR  
PRODUCING A RUBIDIUM-82 COMPRISING DIAGNOSTIC AGENT, SAID  
DIAGNOSTIC AGENT AND ITS USE IN MEDICINE**

The present invention relates to a strontium-82/rubidium-82 generator, to a method for producing a rubidium-82 comprising diagnostic agent using such strontium-82/rubidium-82 generator, to the diagnostic agent obtainable therewith, and to the use of this diagnostic agent in medicine.

In nuclear medicine conventional diagnostic techniques are applied for coronary artery disease imaging and for the determination of the severity of the disease. Diagnostic agents used for the determination of myocardial perfusion comprise thallium-201 or technetium-99m. However, these diagnostic agents are limited in use by the occurrence of attenuation artefacts and do not permit an accurate estimation of extension and severity of coronary artery disease.

These drawbacks make rubidium a better choice as a potassium-analog. Rubidium-82 is suitable for positron emission tomography, because Rubidium-82 is a positron emitter rendering higher quality images than conventional gamma camera imaging. Moreover Rubidium-82 is a radionuclide with an ultra-short half-life ( $t_{1/2}=75s$ ). This ultra-short half life allows high doses at short imaging times but urges production of rubidium-82 near the patient.

Presently, a strontium-82/rubidium-82 generator comprises a generator column assembly comprising adaptors with nuts and ferrules, a column and two micro filters. The generator column is about 2.6cm in length, 6mm internal diameter and has a 0.5mm wall thickness. All

components are made of stainless steel type 316. The cationic exchanger may be  $\alpha$ -hydrous tin oxide loaded with about 50mCi strontium-82. The liquid medium in the strontium-82 loaded cationic exchanger is physiological  
5 0.9% sodium chloride. Sterile and pyrogen free 0.9% sodium chloride is also used as elution medium.

This known strontium-82/rubidium-82 generator may be used for several days to several weeks. However, the known generator is not sufficiently stable for use during  
10 an extended period of time. Such stability is determined by a so-called breakthrough of strontium-82 during elution. An early breakthrough of strontium-82 blocks the possibility of reloading the cationic exchanger with strontium-82 for a continued production of the rubidium-  
15 82 diagnostic agent. Furthermore, using a generator for an extended period of time requires a method of sterilization of it.

Further research revealed that by using a physiological buffer having a pH of 6-8.5 as an elution  
20 medium for rubidium-82, the stability of the strontium-82/rubidium-82 generator can be substantially improved. A substitution of the physiological 0.9% sodium chloride elution medium by a physiological buffer having a pH of 6-8.5 as such is not recommendable in relation to the  
25 daily use of the generator. In particular, after use of a sterilization medium in the form of hypochlorite solution it turned out that a gelatinous material is formed jeopardizing the functionality of the strontium-82/rubidium-82 generator, in particular because the  
30 column filters become clogged and ultimately blocked.

The present invention is based on the insight that a strontium-82/rubidium-82 generator having parts coming into contact with the liquid medium, which part has been made of iron-free and preferably of metal-free



material, that such clogging gelatinatious material is not formed and the generator has the desired improved stability and may be reloaded with strontium-82 several times without any significant breakthrough of strontium-  
5 82. At the same time, optimal performance and sterility are maintained. The continued use of the strontium-82/rubidium-82 generator and the option of reloading without significant strontium-82 breakthrough results in an extended operation time period before the generator is  
10 to be recycled and the cationic exchanger renewed and subsequently loaded again with strontium-82. This results in an extensive reduction in costs.

For instance, a generator according to the invention may be used over an extended period of time  
15 such as 2-6 months at substantially constant stability.

Accordingly, the present invention provides a strontium-82/rubidium-82 generator, comprising a column filled with a cationic exchanger loaded with strontium-82, and having an inlet and an outlet, and a liquid  
20 medium, wherein parts of the column, inlet and outlet coming into contact with the liquid medium are iron-free, preferably metal-free.

This strontium-82/rubidium-82 generator according to the invention is suitable for elution with a  
25 physiological buffer having a pH of 6-8.5 and for sterilization using a hypochlorite solution, without the occurrence of deteriorating clogging and ultimately blocking of the generator due to the formation of gelatinatious material. Without being bound to any  
30 theory, it might be that the gelatinatious material formed comprises a water insoluble iron salt. Iron likely originates from the metallic parts of the generator and the counter ions such as phosphate, originate from the elution medium being a physiological buffer, for instance

a phosphate buffer saline solution having a pH of 7.2-7.4.

It is possible that the strontium-82/rubidium-82 generator during storage, transport or out of use for other reasons, may comprise a liquid medium other than the elution medium according to the invention. But, for elution and for maintaining the extended stability, it is required according to the invention that the elution medium for rubidium-82 is a physiological buffer having a pH of 6-8.5. The lower limit for the pH is selected such as to allow to an acceptable extent such as per volume, the elution of rubidium-82 from the cationic exchanger. Accordingly, the lower is the pH, the better is the rubidium-82 elution. However, due to the very short half time of rubidium-82, it is required that the elution medium is almost directly to be administered by for instance intravenous injection into the patient. Preferred is therefore a physiological buffer having a pH in the range of 7-8 and more preferably in the range of 7.2-7.4. A physiological buffer involves that the osmolarity of the buffer is selected such that the injection into a patient will not result in any adverse effects, taking into account a volume to be injected of about 2-30ml at a rate of about 10-80ml/minute.

Suitable physiological buffers comprise citrate/sodium hydroxide buffer, citrate/phosphate buffer, borate/hydrogen chloride buffer, boric acid/sodium hydroxide buffer, Tris buffer, veronal/HCl buffer and piperazine/sodium hydroxide buffer. Preferred physiological buffers are carbonate buffers, phosphate buffers and Tris buffers.

In order to avoid any leaching of metal from the generator, the part of column, inlet and outlet inclusive ferrules, tubings and the like are to be made of iron-

free and preferably metal-free material or coated with metal-free material.

Metal-free means in particular iron-free. Accordingly, it is possible that the column, inlet and outlet or any generator elements may be made of an iron-free metal, such as titanium. However, in the alternative it is preferred that the relevant parts of the column inlet and outlet coming into contact with the liquid medium are made of less expensive metal-free material. A suitable metal-free material is a plastic such as PEEK or Teflon. PEEK material is preferred because PEEK material is already used for columns, inlet and outlet within the HPLC chromatography technique. Such plastic material is of lower costs than iron-free metal material suitable for use in the generator.

In order to guarantee that the rubidium-82 produced as a diagnostic agent with the strontium-82/rubidium-82 generator is suitable for human use intravenously it is mandatory that the generator is frequently, and when needed, sterilized using a sterilization medium. Such sterilization medium is preferably hypochlorite solution of suitable concentration. Hypochlorite has the advantages of a broad anti-bacterial and anti-viral spectrum, relatively easy removal by washing from the generator, and a low detection level. Prior to use this sterilization medium has to be exchanged for either a storage and transportation medium, or directly with the physiologically buffer intended as the elution medium.

A full operation generator assembly for generating and producing the rubidium-82 diagnostic agent in the direct presence of a patient is feasible when the generator comprises

- i) a source for the physiological elution buffer;

- ii) a source for the sterilisation buffer;
- iii) a pump for connecting and transporting the sources to the inlet of the column;
- iv) a dose calibrator connected to the outlet of the  
5 column; and
- v) a patient administration line connected to the dose calibrator.

Such generator is a full service generator for elution, sterilization, and application to the patient  
10 and for measuring the radioactive dose generated and a continuous survey of a possible breakthrough of strontium-82. With such full service generator it is preferred that the generator is arranged on a mobile vehicle, such as it is easily transportable between the  
15 storage, the radiopharmacy laboratory and the diagnostic room.

It is noted that any cationic exchanger may be used as long as rubidium-82 is selectively eluted. A suitable material is tin oxide, such as  $\alpha$ -hydrous tin  
20 oxide ( $\text{Sn}_2\text{O} \cdot x\text{H}_2\text{O}$ ;  $x=1-2$ ) or  $\alpha$  stannic acid.

Another aspect of the present invention relates to the production of rubidium-82. This method comprises the use of the afore mentioned strontium-82/rubidium-82 generator according to the invention and to elute the  
25 generator with the elution buffer being a physiological buffer having in general a pH of 6-8.5, preferably a pH of 7-8 and more preferably of 7.2-7.4. Accordingly, this rubidium-82 diagnostic agent is essentially characterized by the presence of this well defined elution buffer.

30 As discussed here and above, the methods of the present invention allow the sterilization of the strontium-82/rubidium-82 generator using a sterilization buffer, preferably in the form of a hypochlorite solution. Accordingly, the sterilization of the generator

is guaranteed as well as the sterile and pyrogen free character of the rubidium-82 produced therewith.

A last aspect of the present invention relates in particular to the diagnostic agent being in the form of a solution with the elution buffer being the afore  
5 mentioned physiological buffer having a pH of 6-8.5. Such diagnostic agent is suitable for use in medicine such as for myocardial perfusion imaging.

Mentioned and other features and advantages of the generator, its production process and its use as a  
10 diagnostic agent will be further illustrated in the description of the drawings and the example which follow and which are given for illustrative purposes without the intention to limit the present invention to any extent.

Figure 1 is a schematic illustration of the rubidium-82 generator in the form of a full surface  
15 generator suitable for direct application to a patient;

Figure 2 shows the activity of strontium-82 (Bq) in the eluate per 37MBq rubidium-82, the maximum  
20 allowable ratio of Sr-82/Rb-82 is about 750 (ppm); and

Figure 3 shows the activity of strontium-85 (Bq) in the eluate of the generator per 37MBq rubidium-82. The maximum ratio Sr-85/rubidium-82 is about 7500 ppm.

Figure 4 shows the contamination of Sr-82 in the generator's eluate.  
25

Figure 5 shows the contamination of Sr-82 in the eluates expressed as Bq Sr-82 per MBq Rb-82.

Figure 6 shows the contamination of Sr-85 in the eluates expressed as Bq Sr-85 per MBq Rb-82.

Figure 1 shows a strontium-82/rubidium-82 generator 1 according to the invention. The generator 1  
30 comprises a column 2 made of PEEK. The column has the following dimensions (length 5.0 cm, internal diameter 0.75 cm, wall thickness 3.25 mm). The column 2 is loaded

with 4 grams  $\alpha$  stannic acid (particle size 75-150 $\mu$ m) in 0.1N ammonium chloride buffer. The column 2 is washed with 0.1N ammonium chloride (pH 10). Subsequently, the column is washed with 2M sodium chloride and with 0.05% hypochlorite solution. The inlet 3 and the outlet 4 are provided with a valve 5 and 6. The inlet 3 is connected to a multi-valve 7 and the outlet 4 to a multi-valve 8. A bypass 9 extends between the multi-valves 7 and 8 which allows transporting liquid medium through the generator 1 while bypassing the column 2.

Strontium-82 (>25mCi Sr-82/mg Sr, Sr-85/Sr-82<5, Rb-83/Sr-82<0.15; Rb-84/Sr-82< 0.15; Sr-83/Sr-82<0.0015; other nuclides/Sr-82<0.01) was neutralized with 0.5ml 0.5M Tris buffer (pH 7.5). After the addition of 3.5ml physiological buffered saline, the mixture was applied via a milipore filter (22 $\mu$ m) on the column 2.

Subsequently, the column 2 is washed with phosphate buffered saline pH 7.4 (8.2g sodium chloride, 3.1g Na<sub>2</sub>HPO<sub>4</sub>.12H<sub>2</sub>O and 0.3g NaH<sub>2</sub>PO<sub>4</sub>.2H<sub>2</sub>O from the container 15.

The 0.05% hypochlorite solution was applied from a container 11 via a multi-valve 12, an air bubble trap 13, the peristaltic pump 14, the filter 10 and then via the valve 7 and 5 to the column 2. It is noted that the tubings are made of PEEK tubings. The column filters (not shown) are 10  $\mu$ m titanium filters or metal filter holders coated with PEEK or Teflon coating. The sterile filters are Millex Millipore 0.22  $\mu$ m membrane filters, diameter 25 mm.

Prior to use for patients, the generator 1 is flushed with physiological buffered saline originating from the container 15 until the eluate does not color a 10% potassium iodide solution. Subsequently, the phosphate elution buffer (pH 7.4) is applied from the source 16 through the column 2. The eluate comprising

rubidium-82 is passed through a dose calibrator 17 calibrated for rubidium-82 measurement.

Figure 2 shows the activity of strontium-82 in the eluate of the column 2 dependent on the elution volume. Clearly, the maximum allowable ratio of SR-82/RB-82 (about 750ppm) was never surpassed except for one occasion which occurred after the third reload of the column 2 with strontium-82. During testing a large amount of air was introduced on the column 2. In an attempt to remove this air the increased leakage of strontium-82 occurred. After normalization the ratio SR-82/RB-82 remained far below the maximum allowable value over several reloads of the same column 2.

The dose calibrator 17 is connected via a multi valve 18 with either a waste container 19 or to a valve 20 for subsequent administration to the patient. However, the tubing 21 could be disconnected at the connection 22 and directly used for administration to the patient.

Filters 23, 24 and 25 guarantee sterile manipulation of the generator 1.

The measuring mode of the dose calibrator 17 is the integral mode. Accordingly, after the desired dose of strontium-82 is eluted from the column 2 the valves towards the column 2 are closed and elution medium is transported via the bypass tube 9 for flushing the system.

After a waiting time of about 5 minutes a subsequent elution and generation of a new strontium-82 diagnostic agent dose is possible.

After use the system is sterilized by flushing from the container 11 the 0.05% hypochlorite solution. The generator 1 may be stored in the hypochlorite solution or in physiological buffered saline or in the elution buffer.

The diagnostic agent comprising rubidium-82 in the physiological buffer having a pH of 6-8.5 showed during myocardial perfusion imaging with positron emission tomography with better imaging quality at lower radiation exposure to patient. The function of the heart could be determined under rest and stress with an interval between waiting time of about 6 minutes for applying the adenosine or dobutamine infusion as a stress generating agent.

Figure 3 shows the activity of strontium-85 (Bq) in the eluate of the generator per 37MBq rubidium-82. The maximum ratio SR-85/rubidium-82 is about 7500 ppm. The activity of strontium-85 is well below the maximum of the ratio of Sr-82/Rb-82.

The increased stability of the strontium binding to the carrier material (hydrous stannic oxide) is obtained by increasing the pH to a value of 7.4 by means of a phosphate buffered saline, used as elution fluid. This increased stability allows an extended period of use of the generator of at least 3 supplementary months as compared to commercially available generators which have to be replaced each month. The generator can be refilled every 4 weeks reducing the costs for strontium-82 significantly.

#### **EXAMPLE**

In order to illustrate the contamination of generator eluates with Sr-82 and Sr-85 the following experiment was performed.

On day 1 a typical generator column was loaded with 2.3 GBq Sr-82. The generator was eluted repeatedly with phosphate buffered saline (PBS) at pH=7.4. On day 26 and at an elution volume of 3.2 liter the generator was reloaded with 2.2 GBq Sr-82. Again, the generator was



eluted repeatedly with PBS. On day 66 and at a total elution volume of 6.3 liter the generator was reloaded for a second time with 1.2 GBq Sr-82. Again, the generator was eluted repeatedly with PBS (pH=7.4). The  
5 total elution volume was 7.9 liter.

Figure 4 represents the contamination of Sr-82 in the generator's eluate. The curve spikes represent the moments of reloading. Figure 5 shows the contamination of Sr-82 in the eluates (lower curve) expressed as Bq Sr-82  
10 per 37 MBq Rb-82 and the maximal contamination of Sr-82 (higher curve) acceptable in the currently commercially available Rb-82 generators (Bracco). The level of contamination of Sr-82 is well below the acceptable contamination in the known generators. Figure 6 shows the  
15 contamination of Sr-85 in the eluates (lower curve) expressed as Bq Sr-85 per 37 MBq Rb-82 and the maximal contamination of Sr-85 (higher curve) acceptable in currently commercially available Rb-82 generators (Bracco). The level of contamination of Sr-82 is well  
20 below the acceptable contamination in the known generators. After three loadings and an elution volume of approximately 8 liters the contaminations of Sr-82 and Sr-85 are still far below the limit. Reloading a Sr-85/Rb-82 generator is of advantage because it reduces  
25 costs for Sr-82 by 30% and makes the transport of the generator back to the factory unnecessary.

**CLAIMS**

1. Strontium-82/rubidium-82 generator, comprising a column filled with a cationic exchanger loaded with strontium-82, and having an inlet and an outlet, and a liquid medium, wherein parts of the column, inlet and outlet coming into contact with the liquid medium are iron-free, preferably metal-free.

2. Generator according to claim 1, wherein the liquid medium is an elution medium for rubidium-82, and is a physiological buffer having a pH of 6 to 8.5, preferably a pH of 7 to 8, more preferably a pH of 7.2 to 7.4.

3. Generator according to claim 1 or 2, wherein the physiological buffer is a carbonate buffer, phosphate buffer or Tris buffer.

4. Generator according to any one of claims 1 to 3, wherein the parts of the column, the inlet and the outlet are coated with a iron-free material and/or are made from a iron-free material, preferably metal free material.

5. Generator according to claim 4, wherein the metal-free material is a plastic, such as PEEK or Teflon.

6. Generator according to any one of claims 1 to 5, wherein the liquid medium is a sterilization medium, preferably a hypochlorite solution.

7. Generator according to any one of claims 1 to 6, comprising:

- i) a source for the physiological elution buffer;
- ii) a source for the sterilisation buffer;
- iii) a pump for connecting and transporting the sources to the inlet of the column;
- iv) a dose calibrator connected to the outlet of the column; and

v) a patient administration line connected to the dose calibrator.

8. Generator according to claim 7, arranged on a mobile vehicle.

5 9. Generator according to any one of claims 1 to 8, wherein the cationic exchanger is reloaded at least one time with strontium-82.

10 10. Method for producing a rubidium-82 comprising a diagnostic agent, comprising the steps of eluting a strontium-82/rubidium-82 generator according to any one of claims 1 to 9 with the elution buffer defined in any one of claims 2 to 9.

15 11. Method according to claim 10, comprising the step of sterilizing the strontium-82/rubidium-82 generator using a sterilization buffer, preferably a hypochlorite solution.

12. Method according to claim 10 or 11, comprising the step of storing/transporting the strontium-82/rubidium-82 generator.

20 13. Diagnostic agent obtainable with the method according to any one of claims 10 to 12.

14. Diagnostic agent according to claim 13, for use in medicine, such as for myocardial perfusion imaging.

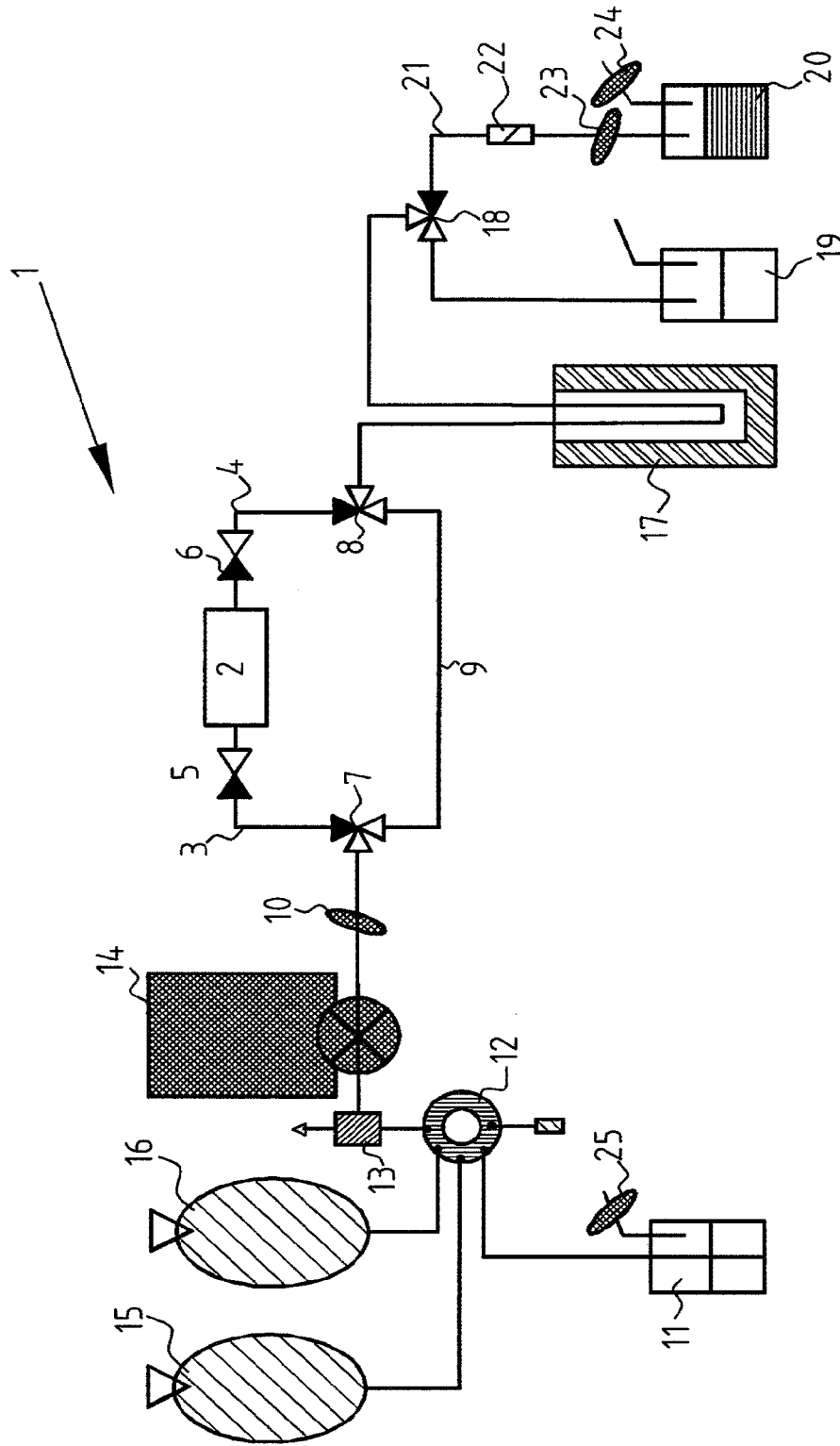


FIG. 1

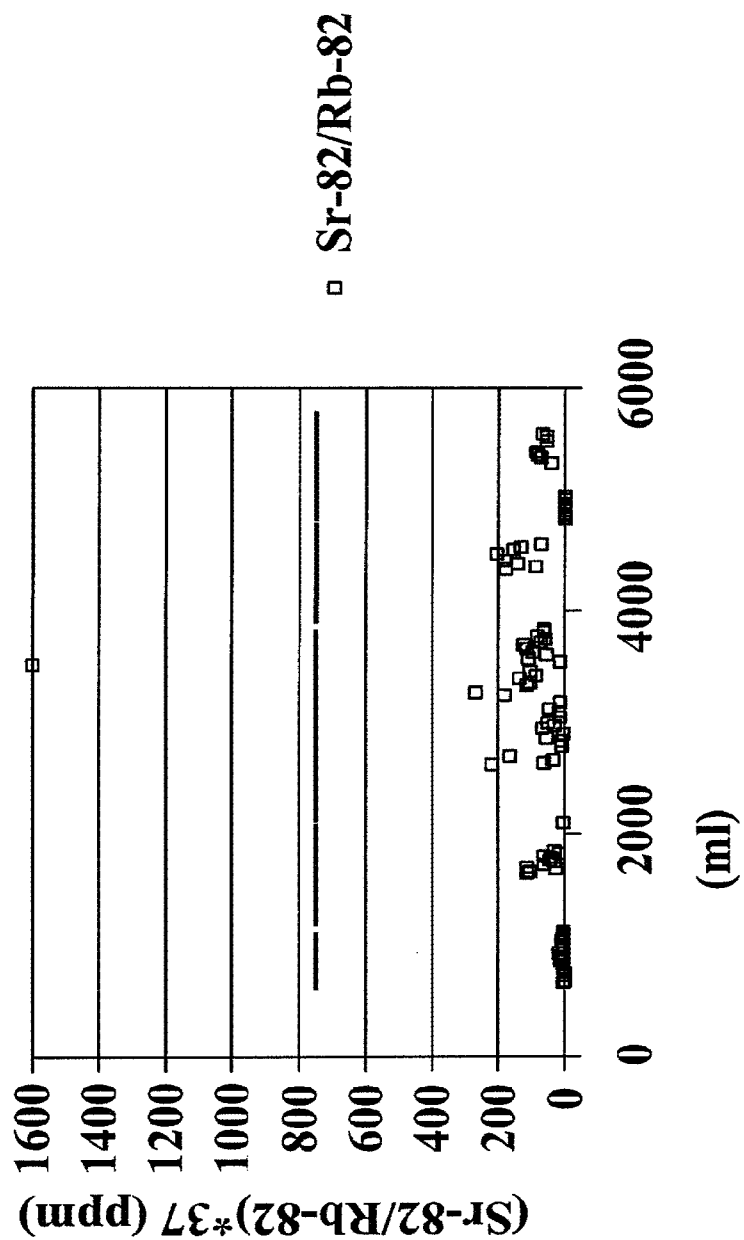


FIG. 2

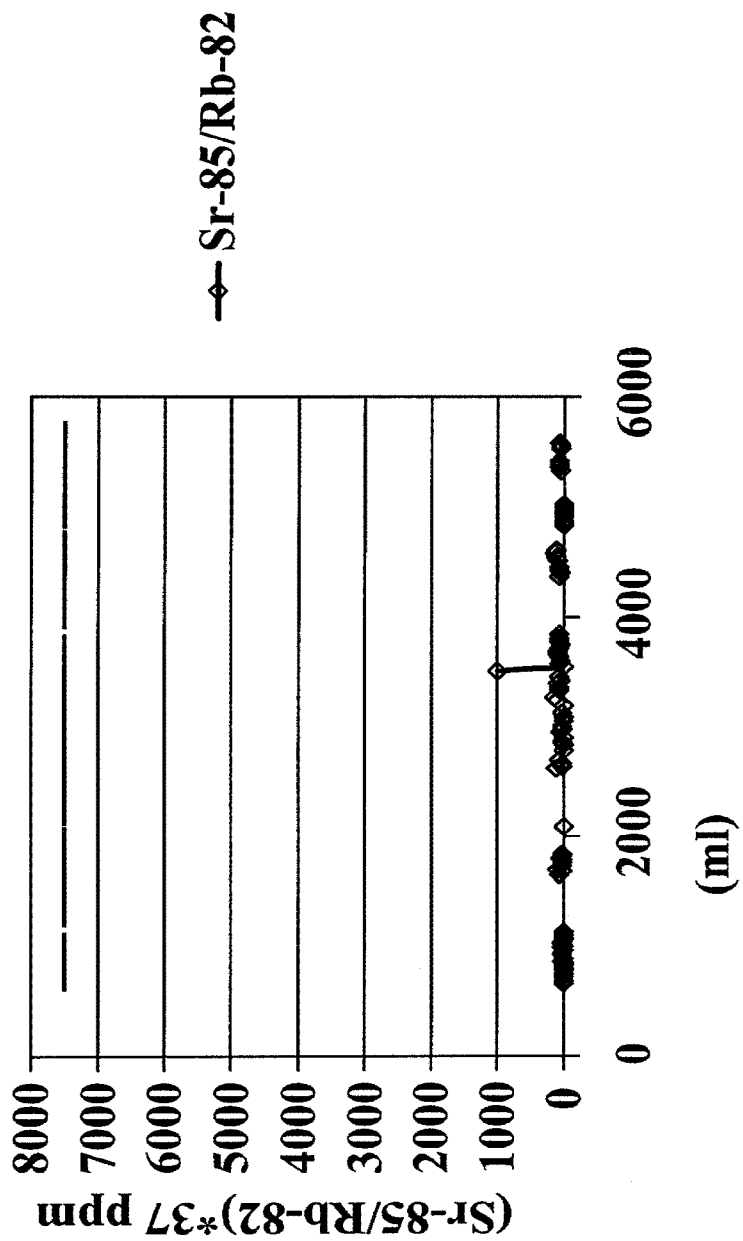
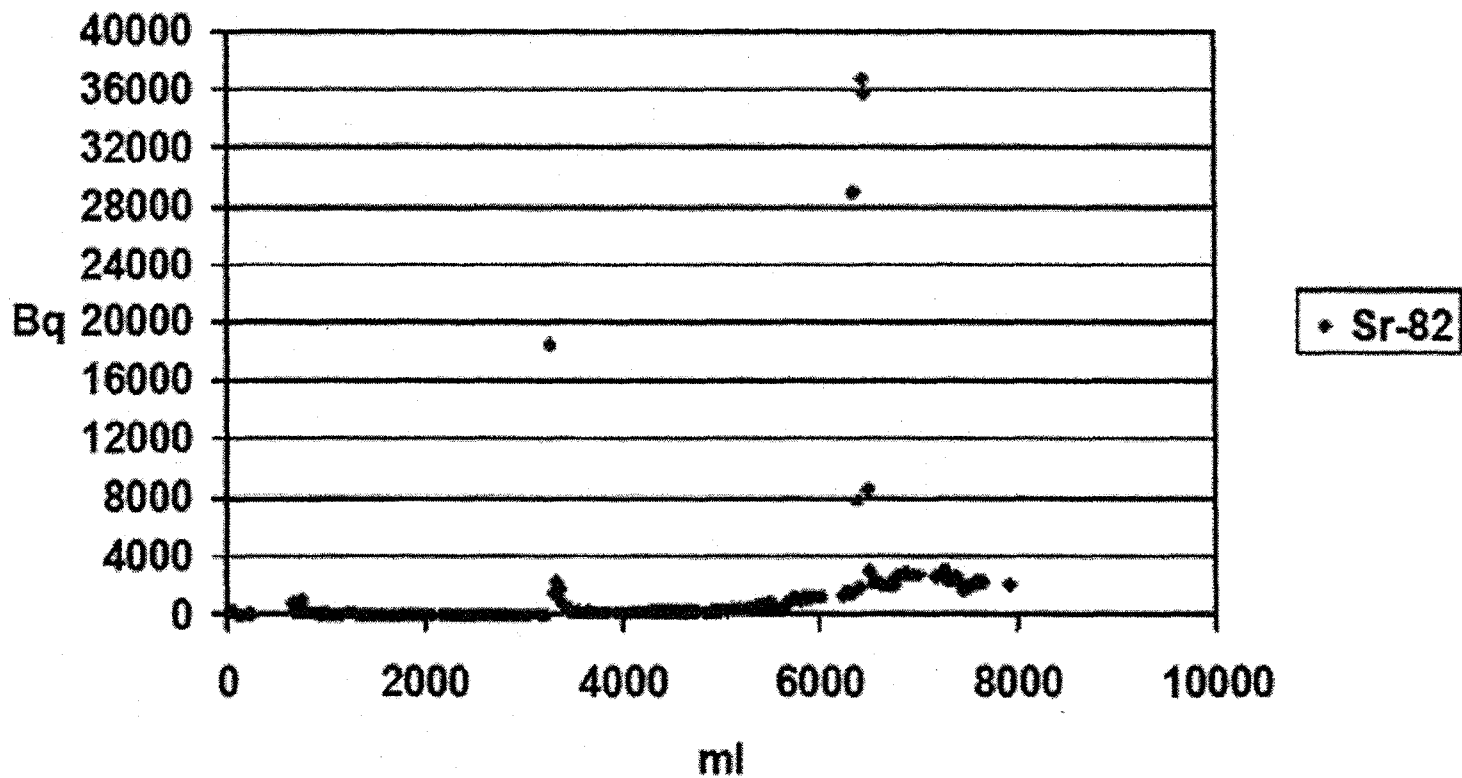
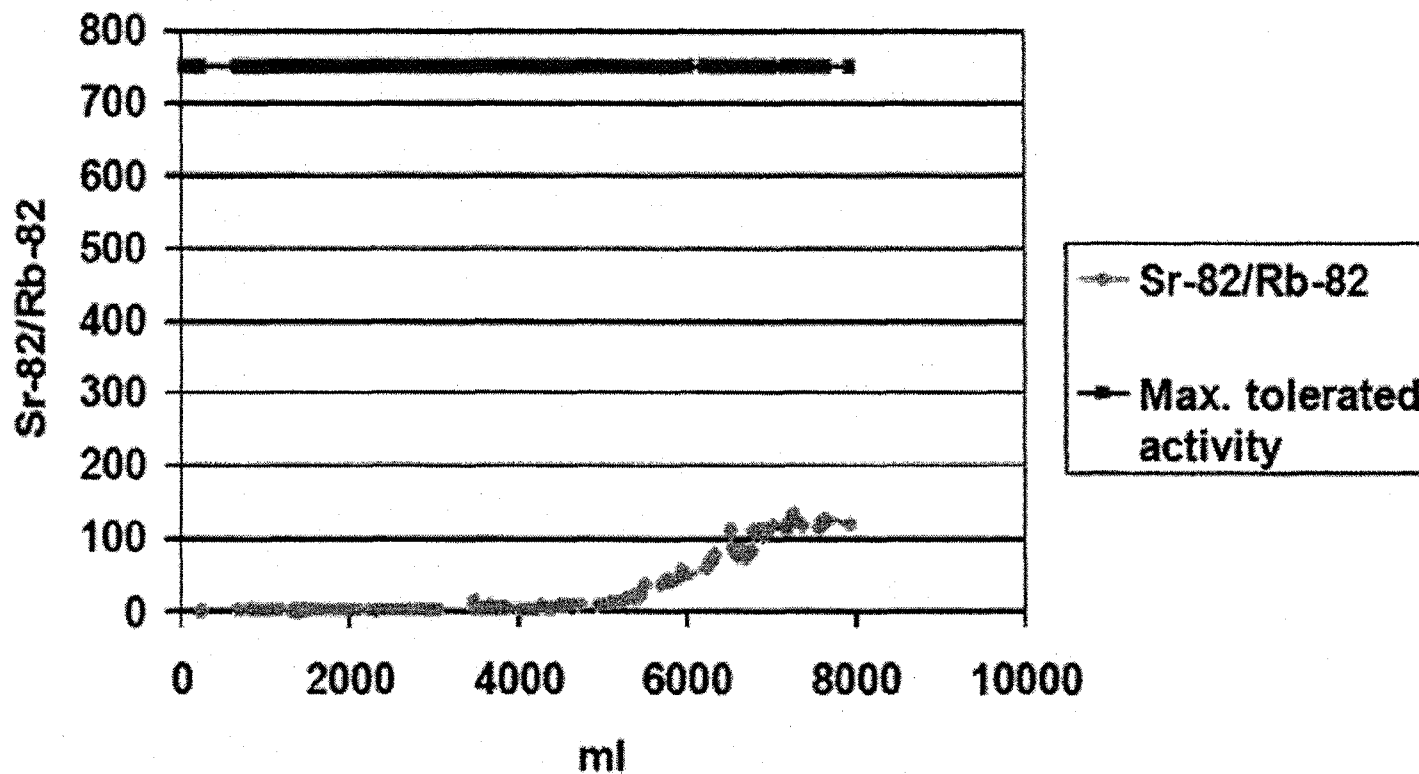


FIG. 3

# Leakage of Sr-82 from a 60 mCi Rb-generator loaded three times, in use for approx. 3 months

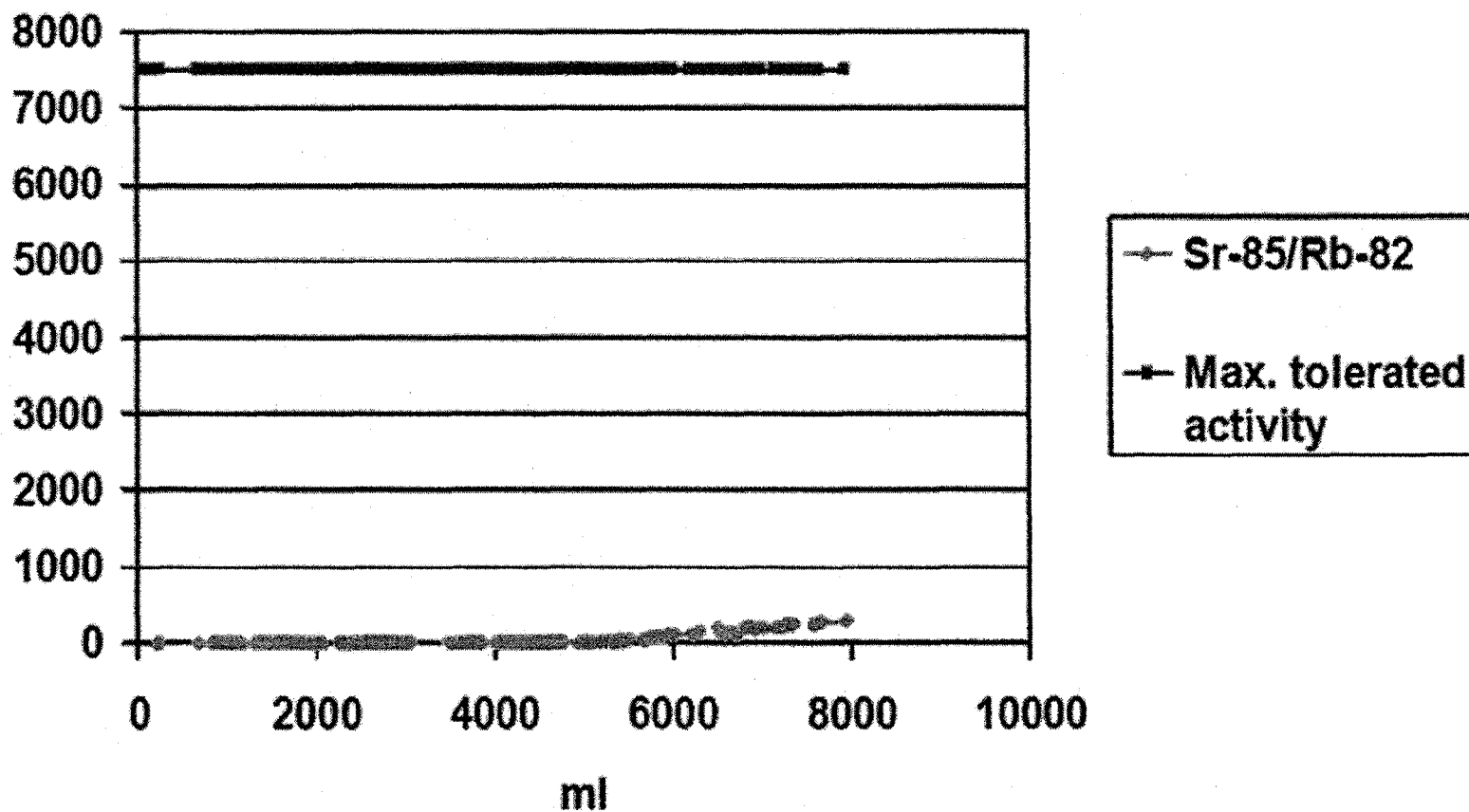


### Sr-82 leakage (Bq) per 37 MBq Rb-82





### Sr-85 leakage (Bq) per 37 MBq Rb-82



# INTERNATIONAL SEARCH REPORT

International application No  
PCT/EP2009/060584

| <b>A. CLASSIFICATION OF SUBJECT MATTER</b><br>INV. G21G4/08   |   |                       |
|---|---|-----------------------|
| According to International Patent Classification (IPC) or to both national classification and IPC   |   |                       |
| <b>B. FIELDS SEARCHED</b>   |   |                       |
| Minimum documentation searched (classification system followed by classification symbols)<br>G21G A61K B01D   |   |                       |
| Documentation searched other than minimum documentation to the extent that such documents are included in the fields searched   |   |                       |
| Electronic data base consulted during the international search (name of data base and, where practical, search terms used)  |   |                       |
| <b>C. DOCUMENTS CONSIDERED TO BE RELEVANT</b>   |   |                       |
| Category*   | Citation of document, with indication, where appropriate, of the relevant passages  | Relevant to claim No. |
| X   | WO 2006/135374 A (LYNNTECH INC [US];<br>MOLLER TERESIA [US]; ADAMS TODD [US];<br>CISAR ALAN [U]<br>21 December 2006 (2006-12-21)<br>paragraphs [0008], [0009], [0029] -<br>[0040], [0042], [0092] - [0095]; figure<br>5   | 1-4, 6,<br>9-14       |
| X   | WO 2004/105049 A (UNIV ALBERTA SIMON<br>FRASER UNIV [CA]; ZYUZIN ALEXANDER [CA])<br>2 December 2004 (2004-12-02)<br>page 2, lines 1-18  | 1, 4, 9,<br>10, 12-14 |
| A   | US 2007/140958 A1 (DEKEMP ROBERT A [CA])<br>21 June 2007 (2007-06-21)<br>paragraph [0019]   | 1-14                  |
| <input type="checkbox"/> Further documents are listed in the continuation of Box C. <span style="margin-left: 100px;"><input checked="" type="checkbox"/> See patent family annex.</span>   |   |                       |
| * Special categories of cited documents :   |   |                       |
| *A* document defining the general state of the art which is not considered to be of particular relevance<br>*E* earlier document but published on or after the international filing date<br>*L* document which may throw doubts on priority claim(s) or which is cited to establish the publication date of another citation or other special reason (as specified)<br>*O* document referring to an oral disclosure, use, exhibition or other means<br>*P* document published prior to the international filing date but later than the priority date claimed | *T* later document published after the international filing date or priority date and not in conflict with the application but cited to understand the principle or theory underlying the invention<br>*X* document of particular relevance: the claimed invention cannot be considered novel or cannot be considered to involve an inventive step when the document is taken alone<br>*Y* document of particular relevance: the claimed invention cannot be considered to involve an inventive step when the document is combined with one or more other such documents, such combination being obvious to a person skilled in the art.<br>*B* document member of the same patent family |                       |
| Date of the actual completion of the international search<br><br><p style="text-align: center;">26 November 2009</p>  | Date of mailing of the international search report<br><br><p style="text-align: center;">07/12/2009</p>   |                       |
| Name and mailing address of the ISA/<br>European Patent Office, P.B. 5616 Patentlaan 2<br>NL - 2280 HV Rijswijk<br>Tel. (+31-70) 340-2040.<br>Fax: (+31-70) 340-3016  | Authorized officer<br><br><p style="text-align: center;">Lohberger, Severin</p>   |                       |

# INTERNATIONAL SEARCH REPORT

Information on patent family members

International application No

PCT/EP2009/060584

| Patent document cited in search report |    | Publication date | Patent family member(s) |               | Publication date |
|--|----|------------------|-------------------------|---------------|------------------|
| WO 2006135374                          | A  | 21-12-2006       | NONE                    |               |                  |
| WO 2004105049                          | A  | 02-12-2004       | US                      | 2006022127 A1 | 02-02-2006       |
| US 2007140958                          | A1 | 21-06-2007       | AU                      | 2006326814 A1 | 28-06-2007       |
|  |    |                  | CA                      | 2562340 A1    | 21-06-2007       |
|  |    |                  | WO                      | 2007071022 A1 | 28-06-2007       |
|  |    |                  | EP                      | 1973624 A1    | 01-10-2008       |
|  |    |                  | JP                      | 2009520953 T  | 28-05-2009       |

## Electronic Acknowledgement Receipt

|   |   |
|---|---|
| <b>EFS ID:</b>                              | 8149823                                   |
| <b>Application Number:</b>                  | 12137356                                  |
| <b>International Application Number:</b>    |   |
| <b>Confirmation Number:</b>                 | 7360                                      |
| <b>Title of Invention:</b>                  | SHIELDING ASSEMBLIES FOR INFUSION SYSTEMS |
| <b>First Named Inventor/Applicant Name:</b> | Charles R. Quirico                        |
| <b>Customer Number:</b>                     | 22859                                     |
| <b>Filer:</b>                               | Elisabeth Lacy Belden                     |
| <b>Filer Authorized By:</b>                 |   |
| <b>Attorney Docket Number:</b>              | 56782.1.5                                 |
| <b>Receipt Date:</b>                        | 04-AUG-2010                               |
| <b>Filing Date:</b>                         | 11-JUN-2008                               |
| <b>Time Stamp:</b>                          | 10:40:02                                  |
| <b>Application Type:</b>                    | Utility under 35 USC 111(a)               |

### Payment information:

|                        |    |
|------------------------|----|
| Submitted with Payment | no |
|------------------------|----|

### File Listing:

| Document Number | Document Description                                    | File Name              | File Size(Bytes)/<br>Message Digest                                    | Multi Part /.zip | Pages (if appl.) |
|-----------------|---|------------------------|--|------------------|------------------|
| 1               | Information Disclosure Statement (IDS)<br>Filed (SB/08) | 6th-SIDS_56782-1-5.pdf | 854006<br><small>8b3ddca04c2b3d1b39097e35a70772742cc<br/>4bd81</small> | no               | 5                |

### Warnings:

### Information:

|                                     |                   |                    |  |    |    |
|-------------------------------------|-------------------|--------------------|--|----|----|
| 2                                   | Foreign Reference | WO2004059661A1.pdf | 1378510                                  | no | 27 |
|                                     |                   |                    | 90312f92d7372cc3550f43aebce82c4c3bd9cd9d |    |    |
| <b>Warnings:</b>                    |                   |                    |  |    |    |
| <b>Information:</b>                 |                   |                    |  |    |    |
| 3                                   | Foreign Reference | WO2006026603A2.pdf | 2131441                                  | no | 58 |
|                                     |                   |                    | 5c57ca5831eba5bdeb48e1135fbd24aeca2aabe1 |    |    |
| <b>Warnings:</b>                    |                   |                    |  |    |    |
| <b>Information:</b>                 |                   |                    |  |    |    |
| 4                                   | Foreign Reference | WO2006135374A2.pdf | 2328171                                  | no | 49 |
|                                     |                   |                    | b564acc91f94f50b33ee35c287905b5ebdeffa25 |    |    |
| <b>Warnings:</b>                    |                   |                    |  |    |    |
| <b>Information:</b>                 |                   |                    |  |    |    |
| 5                                   | Foreign Reference | WO2008140351.pdf   | 7418231                                  | no | 28 |
|                                     |                   |                    | d0ce814cc2983495bdb5706c807d21fd88031eaa |    |    |
| <b>Warnings:</b>                    |                   |                    |  |    |    |
| <b>Information:</b>                 |                   |                    |  |    |    |
| 6                                   | Foreign Reference | WO2010020596A1.pdf | 855471                                   | no | 22 |
|                                     |                   |                    | cce61168205cab3246c9da57caa8a9e4ef9f0749 |    |    |
| <b>Warnings:</b>                    |                   |                    |  |    |    |
| <b>Information:</b>                 |                   |                    |  |    |    |
| <b>Total Files Size (in bytes):</b> |                   |                    | 14965830                                 |    |    |

**This Acknowledgement Receipt evidences receipt on the noted date by the USPTO of the indicated documents, characterized by the applicant, and including page counts, where applicable. It serves as evidence of receipt similar to a Post Card, as described in MPEP 503.**

**New Applications Under 35 U.S.C. 111**

**If a new application is being filed and the application includes the necessary components for a filing date (see 37 CFR 1.53(b)-(d) and MPEP 506), a Filing Receipt (37 CFR 1.54) will be issued in due course and the date shown on this Acknowledgement Receipt will establish the filing date of the application.**

**National Stage of an International Application under 35 U.S.C. 371**

**If a timely submission to enter the national stage of an international application is compliant with the conditions of 35 U.S.C. 371 and other applicable requirements a Form PCT/DO/EO/903 indicating acceptance of the application as a national stage submission under 35 U.S.C. 371 will be issued in addition to the Filing Receipt, in due course.**

**New International Application Filed with the USPTO as a Receiving Office**

**If a new international application is being filed and the international application includes the necessary components for an international filing date (see PCT Article 11 and MPEP 1810), a Notification of the International Application Number and of the International Filing Date (Form PCT/RO/105) will be issued in due course, subject to prescriptions concerning national security, and the date shown on this Acknowledgement Receipt will establish the international filing date of the application.**

|   |                        |                    |            |  |
|---|------------------------|--------------------|------------|--|
| <b>INFORMATION DISCLOSURE STATEMENT BY APPLICANT</b><br>( Not for submission under 37 CFR 1.99) | Application Number     |                    | 12137356   |  |
|   | Filing Date            |                    | 2008-06-11 |  |
|   | First Named Inventor   | Charles R. Quirico |            |  |
|   | Art Unit               |                    | 3735       |  |
|   | Examiner Name          |                    |            |  |
|   | Attorney Docket Number |                    | 56782.1.5  |  |

| U.S.PATENTS       |         |               |                        |            |   |  |
|-------------------|---------|---------------|------------------------|------------|---|--|
| Examiner Initial* | Cite No | Patent Number | Kind Code <sup>1</sup> | Issue Date | Name of Patentee or Applicant of cited Document | Pages,Columns,Lines where Relevant Passages or Relevant Figures Appear |
|                   | 1       | 5590648       |                        | 1997-01-07 | Mitchell et al.                                 |  |

If you wish to add additional U.S. Patent citation information please click the Add button.

| U.S.PATENT APPLICATION PUBLICATIONS |         |                    |                        |                  |   |  |
|-------------------------------------|---------|--------------------|------------------------|------------------|---|--|
| Examiner Initial*                   | Cite No | Publication Number | Kind Code <sup>1</sup> | Publication Date | Name of Patentee or Applicant of cited Document | Pages,Columns,Lines where Relevant Passages or Relevant Figures Appear |
|                                     | 1       | 20070213848        |                        | 2007-09-13       | DeKemp et al.                                   |  |
|                                     | 2       | 20080093564        |                        | 2008-04-24       | Tartaglia et al.                                |  |
|                                     | 3       | 20080242915        |                        | 2008-10-02       | Jackson et al.                                  |  |

If you wish to add additional U.S. Published Application citation information please click the Add button.

| FOREIGN PATENT DOCUMENTS |         |                                      |                           |                        |                  |   |  |                          |
|--------------------------|---------|--------------------------------------|---------------------------|------------------------|------------------|---|--|--------------------------|
| Examiner Initial*        | Cite No | Foreign Document Number <sup>3</sup> | Country Code <sup>2</sup> | Kind Code <sup>4</sup> | Publication Date | Name of Patentee or Applicant of cited Document | Pages,Columns,Lines where Relevant Passages or Relevant Figures Appear | T <sup>5</sup>           |
|                          | 1       | 9615337                              | WO                        |                        | 1996-05-23       | Nilsson   |  | <input type="checkbox"/> |

|   |                        |                    |
|---|------------------------|--------------------|
| <b>INFORMATION DISCLOSURE<br/>STATEMENT BY APPLICANT</b><br>( Not for submission under 37 CFR 1.99) | Application Number     | 12137356           |
|   | Filing Date            | 2008-06-11         |
|   | First Named Inventor   | Charles R. Quirico |
|   | Art Unit               | 3735               |
|   | Examiner Name          |                    |
|   | Attorney Docket Number | 56782.1.5          |

|  |   |            |    |  |            |                   |  |                          |
|--|---|------------|----|--|------------|-------------------|--|--------------------------|
|  | 2 | 02096335   | WO |  | 2002-12-05 | Hill ROM Services |  | <input type="checkbox"/> |
|  | 3 | 2006074473 | WO |  | 2006-07-13 | Atlas Systems     |  | <input type="checkbox"/> |
|  | 4 | 2008028165 | WO |  | 2008-03-06 | Catholic Health   |  | <input type="checkbox"/> |

If you wish to add additional Foreign Patent Document citation information please click the Add button

**NON-PATENT LITERATURE DOCUMENTS**

| Examiner Initials* | Cite No | Include name of the author (in CAPITAL LETTERS), title of the article (when appropriate), title of the item (book, magazine, journal, serial, symposium, catalog, etc), date, pages(s), volume-issue number(s), publisher, city and/or country where published. | T <sup>5</sup>           |
|--------------------|---------|---|--------------------------|
|                    | 1       | NEIL J. EPSTEIN, et al., "A Rb82 infusion system for quantitative perfusion imaging with 3D PET" Applied Radiation and Isotopes, vol. 60, 9 February 2004, pages 921-927, XP002557544 DOI:10, 1016/j. apradiso.2004.02.002                                      | <input type="checkbox"/> |
|                    | 2       | R. KLEIN, et al., "Precision controlled elution of a Sr82/Rb82 generator for cardiac perfusion imaging with positron emission tomography" Physics in Medicine and Biology, vol. 52, 11 January 2007, pages 659-673, XP002557545 DOI:10, 1088/0031-9155/52/3/009 | <input type="checkbox"/> |
|                    | 3       | International Search Report and Written Opinion, dated 02-25-2010 for PCT Application No. PCT/US2009/047027, 22 pages   | <input type="checkbox"/> |
|                    | 4       | International Search Report and Written Opinion, dated 02-17-2010 for PCT Application No. PCT/US2009/047030, 17 pages   | <input type="checkbox"/> |
|                    | 5       | International Search Report and Written Opinion, dated 03-01-2010 for PCT Application No. PCT/US2009/047031, 20 pages   | <input type="checkbox"/> |
|                    | 6       | International Search Report and Written Opinion, dated 02-25-2010 for PCT Application No. PCT/US2009/047034, 15 pages   | <input type="checkbox"/> |

If you wish to add additional non-patent literature document citation information please click the Add button

|   |                        |                    |
|---|------------------------|--------------------|
| <b>INFORMATION DISCLOSURE<br/>STATEMENT BY APPLICANT</b><br>( Not for submission under 37 CFR 1.99) | Application Number     | 12137356           |
|   | Filing Date            | 2008-06-11         |
|   | First Named Inventor   | Charles R. Quirico |
|   | Art Unit               | 3735               |
|   | Examiner Name          |                    |
|   | Attorney Docket Number | 56782.1.5          |

**EXAMINER SIGNATURE**

|                    |  |                 |  |
|--------------------|--|-----------------|--|
| Examiner Signature |  | Date Considered |  |
|--------------------|--|-----------------|--|

\*EXAMINER: Initial if reference considered, whether or not citation is in conformance with MPEP 609. Draw line through a citation if not in conformance and not considered. Include copy of this form with next communication to applicant.

<sup>1</sup> See Kind Codes of USPTO Patent Documents at [www.USPTO.GOV](http://www.USPTO.GOV) or MPEP 901.04. <sup>2</sup> Enter office that issued the document, by the two-letter code (WIPO Standard ST.3). <sup>3</sup> For Japanese patent documents, the indication of the year of the reign of the Emperor must precede the serial number of the patent document. <sup>4</sup> Kind of document by the appropriate symbols as indicated on the document under WIPO Standard ST.16 if possible. <sup>5</sup> Applicant is to place a check mark here if English language translation is attached.



|   |                        |                    |
|---|------------------------|--------------------|
| <b>INFORMATION DISCLOSURE<br/>STATEMENT BY APPLICANT</b><br>( Not for submission under 37 CFR 1.99) | Application Number     | 12137356           |
|   | Filing Date            | 2008-06-11         |
|   | First Named Inventor   | Charles R. Quirico |
|   | Art Unit               | 3735               |
|   | Examiner Name          |                    |
|   | Attorney Docket Number | 56782.1.5          |

**CERTIFICATION STATEMENT**

Please see 37 CFR 1.97 and 1.98 to make the appropriate selection(s):

That each item of information contained in the information disclosure statement was first cited in any communication from a foreign patent office in a counterpart foreign application not more than three months prior to the filing of the information disclosure statement. See 37 CFR 1.97(e)(1).

**OR**

That no item of information contained in the information disclosure statement was cited in a communication from a foreign patent office in a counterpart foreign application, and, to the knowledge of the person signing the certification after making reasonable inquiry, no item of information contained in the information disclosure statement was known to any individual designated in 37 CFR 1.56(c) more than three months prior to the filing of the information disclosure statement. See 37 CFR 1.97(e)(2).

- See attached certification statement.
- Fee set forth in 37 CFR 1.17 (p) has been submitted herewith.
- None

**SIGNATURE**

A signature of the applicant or representative is required in accordance with CFR 1.33, 10.18. Please see CFR 1.4(d) for the form of the signature.

|            |                       |                     |            |
|------------|-----------------------|---------------------|------------|
| Signature  | /Elisabeth L. Belden/ | Date (YYYY-MM-DD)   | 2010-03-12 |
| Name/Print | Elisabeth L. BELDEN   | Registration Number | 50,751     |

This collection of information is required by 37 CFR 1.97 and 1.98. The information is required to obtain or retain a benefit by the public which is to file (and by the USPTO to process) an application. Confidentiality is governed by 35 U.S.C. 122 and 37 CFR 1.14. This collection is estimated to take 1 hour to complete, including gathering, preparing and submitting the completed application form to the USPTO. Time will vary depending upon the individual case. Any comments on the amount of time you require to complete this form and/or suggestions for reducing this burden, should be sent to the Chief Information Officer, U.S. Patent and Trademark Office, U.S. Department of Commerce, P.O. Box 1450, Alexandria, VA 22313-1450. **DO NOT SEND FEES OR COMPLETED FORMS TO THIS ADDRESS. SEND TO: Commissioner for Patents, P.O. Box 1450, Alexandria, VA 22313-1450.**

## Privacy Act Statement

The Privacy Act of 1974 (P.L. 93-579) requires that you be given certain information in connection with your submission of the attached form related to a patent application or patent. Accordingly, pursuant to the requirements of the Act, please be advised that: (1) the general authority for the collection of this information is 35 U.S.C. 2(b)(2); (2) furnishing of the information solicited is voluntary; and (3) the principal purpose for which the information is used by the U.S. Patent and Trademark Office is to process and/or examine your submission related to a patent application or patent. If you do not furnish the requested information, the U.S. Patent and Trademark Office may not be able to process and/or examine your submission, which may result in termination of proceedings or abandonment of the application or expiration of the patent.

The information provided by you in this form will be subject to the following routine uses:

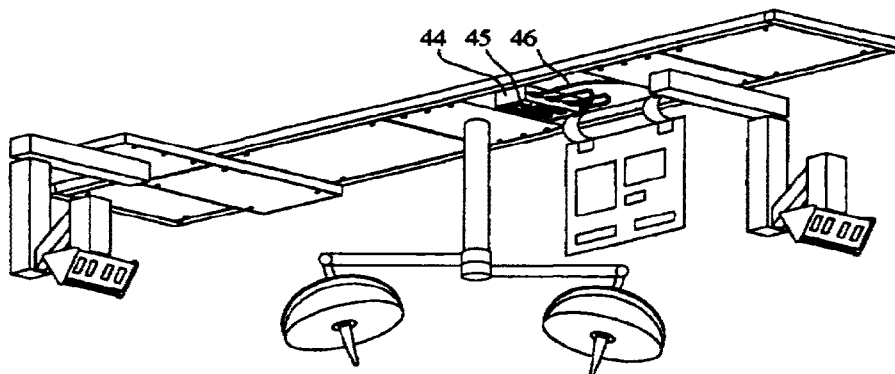
1. The information on this form will be treated confidentially to the extent allowed under the Freedom of Information Act (5 U.S.C. 552) and the Privacy Act (5 U.S.C. 552a). Records from this system of records may be disclosed to the Department of Justice to determine whether the Freedom of Information Act requires disclosure of these records.
2. A record from this system of records may be disclosed, as a routine use, in the course of presenting evidence to a court, magistrate, or administrative tribunal, including disclosures to opposing counsel in the course of settlement negotiations.
3. A record in this system of records may be disclosed, as a routine use, to a Member of Congress submitting a request involving an individual, to whom the record pertains, when the individual has requested assistance from the Member with respect to the subject matter of the record.
4. A record in this system of records may be disclosed, as a routine use, to a contractor of the Agency having need for the information in order to perform a contract. Recipients of information shall be required to comply with the requirements of the Privacy Act of 1974, as amended, pursuant to 5 U.S.C. 552a(m).
5. A record related to an International Application filed under the Patent Cooperation Treaty in this system of records may be disclosed, as a routine use, to the International Bureau of the World Intellectual Property Organization, pursuant to the Patent Cooperation Treaty.
6. A record in this system of records may be disclosed, as a routine use, to another federal agency for purposes of National Security review (35 U.S.C. 181) and for review pursuant to the Atomic Energy Act (42 U.S.C. 218(c)).
7. A record from this system of records may be disclosed, as a routine use, to the Administrator, General Services, or his/her designee, during an inspection of records conducted by GSA as part of that agency's responsibility to recommend improvements in records management practices and programs, under authority of 44 U.S.C. 2904 and 2906. Such disclosure shall be made in accordance with the GSA regulations governing inspection of records for this purpose, and any other relevant (i.e., GSA or Commerce) directive. Such disclosure shall not be used to make determinations about individuals.
8. A record from this system of records may be disclosed, as a routine use, to the public after either publication of the application pursuant to 35 U.S.C. 122(b) or issuance of a patent pursuant to 35 U.S.C. 151. Further, a record may be disclosed, subject to the limitations of 37 CFR 1.14, as a routine use, to the public if the record was filed in an application which became abandoned or in which the proceedings were terminated and which application is referenced by either a published application, an application open to public inspections or an issued patent.
9. A record from this system of records may be disclosed, as a routine use, to a Federal, State, or local law enforcement agency, if the USPTO becomes aware of a violation or potential violation of law or regulation.



## INTERNATIONAL APPLICATION PUBLISHED UNDER THE PATENT COOPERATION TREATY (PCT)

|   |   |  |
|---|---|--|
| <b>(51) International Patent Classification <sup>6</sup> :</b><br><b>E04B 9/06, A61G 12/00, A61B 19/02</b>  | <b>A1</b>   | <b>(11) International Publication Number:</b> <b>WO 96/15337</b><br><b>(43) International Publication Date:</b> 23 May 1996 (23.05.96) |
| <b>(21) International Application Number:</b> PCT/SE95/01346<br><b>(22) International Filing Date:</b> 14 November 1995 (14.11.95)<br><b>(30) Priority Data:</b><br>9403972-4            15 November 1994 (15.11.94)    SE<br>9404354-4            14 December 1994 (14.12.94)    SE<br>9501522-8            24 April 1995 (24.04.95)        SE<br><br><b>(71)(72) Applicant and Inventor:</b> NILSSON, Agne [SE/CY];<br>Aloni House, Phinikaria Village, Limasol (CY).<br><br><b>(74) Agent:</b> ASKETORP, Göran, P.; Asketorp Patent & Juridik AB,<br>P.O. Box 1, S-239 21 Skanör (SE). | <b>(81) Designated States:</b> AM, AT, AU, BB, BG, BR, BY, CA, CH, CN, CZ, DE, DK, EE, ES, FI, GB, GE, HU, IS, JP, KE, KG, KP, KR, KZ, LK, LR, LT, LU, LV, MD, MG, MN, MW, MX, NO, NZ, PL, PT, RO, RU, SD, SE, SG, SI, SK, TJ, TM, TT, UA, UG, US, UZ, VN, European patent (AT, BE, CH, DE, DK, ES, FR, GB, GR, IE, IT, LU, MC, NL, PT, SE), OAPI patent (BF, BJ, CF, CG, CI, CM, GA, GN, ML, MR, NE, SN, TD, TG), ARIPO patent (KE, LS, MW, SD, SZ, UG).<br><br><b>Published</b><br><i>With international search report.</i> |  |

**(54) Title:** MOUNTING DEVICE FOR HOSPITAL EQUIPMENT, MEDICAL SUPPORT SERVICE UNIT THEREFOR AND SERVICE MOBIL

**(57) Abstract**

Supportive structure to be attached to a ceiling of a hospital room for supporting hospital equipment. The supporting structure comprises beams attached to the ceiling and forming a rectangular space. Inside the space, there are non-interchangeable gas connectors attached to a gas supply of the hospital and a gas-tight electric box comprising terminals connected to the electric supply of the hospital. The equipment is mounted on support plates, which in turn are supported by support profiles attached to beams. The equipment is connected to the non-interchangeable gas connectors inside the space. Gas-tight hoses are provided between the electric box and the equipment for enclosing the electric wires between the terminals of the electric box and the equipment. In this way separate gas-tight passages are provided for the electric wires, avoiding hazard risks. The support plates support medical support service units for intensive care rooms forming a support structure for equipment necessary close to the bed in an intensive care room, such as a monitor (90), suction units (97), blood pressure monitors. The service unit is a rectangular frame (85, 86, 87, 88) supported by a pivotable arm (82, 83, 80) and a bearing (84), in order to extend essentially vertically from the arm and downwards to adjacent the floor. The rectangular space is sufficiently open for allowing sight through the frame for supervision of the patient. The space outside the vertical beams is free for service staff to work. The service unit can also be supported by a stand including wheels:

*FOR THE PURPOSES OF INFORMATION ONLY*

Codes used to identify States party to the PCT on the front pages of pamphlets publishing international applications under the PCT.

|    |                          |    |                                       |    |                          |
|----|--------------------------|----|---------------------------------------|----|--------------------------|
| AT | Austria                  | GB | United Kingdom                        | MR | Mauritania               |
| AU | Australia                | GE | Georgia                               | MW | Malawi                   |
| BB | Barbados                 | GN | Guinea                                | NE | Niger                    |
| BE | Belgium                  | GR | Greece                                | NL | Netherlands              |
| BF | Burkina Faso             | HU | Hungary                               | NO | Norway                   |
| BG | Bulgaria                 | IE | Ireland                               | NZ | New Zealand              |
| BJ | Benin                    | IT | Italy                                 | PL | Poland                   |
| BR | Brazil                   | JP | Japan                                 | PT | Portugal                 |
| BY | Belarus                  | KE | Kenya                                 | RO | Romania                  |
| CA | Canada                   | KG | Kyrgystan                             | RU | Russian Federation       |
| CF | Central African Republic | KP | Democratic People's Republic of Korea | SD | Sudan                    |
| CG | Congo                    | KR | Republic of Korea                     | SE | Sweden                   |
| CH | Switzerland              | KZ | Kazakhstan                            | SI | Slovenia                 |
| CI | Côte d'Ivoire            | LI | Liechtenstein                         | SK | Slovakia                 |
| CM | Cameroon                 | LK | Sri Lanka                             | SN | Senegal                  |
| CN | China                    | LU | Luxembourg                            | TD | Chad                     |
| CS | Czechoslovakia           | LV | Latvia                                | TG | Togo                     |
| CZ | Czech Republic           | MC | Monaco                                | TJ | Tajikistan               |
| DE | Germany                  | MD | Republic of Moldova                   | TT | Trinidad and Tobago      |
| DK | Denmark                  | MG | Madagascar                            | UA | Ukraine                  |
| ES | Spain                    | ML | Mali                                  | US | United States of America |
| FI | Finland                  | MN | Mongolia                              | UZ | Uzbekistan               |
| FR | France                   |    |                                       | VN | Viet Nam                 |
| GA | Gabon                    |    |                                       |    |                          |

TITLE: Mounting device for hospital equipment, medical support service unit  
therefor and service mobil

5

#### AREA OF INVENTION

The present invention relates to a mounting device for mounting hospital equipment in  
the ceiling of a operation room and medical support service unit mounted in said mounting  
10 device as well as a service mobil to be used in hospital rooms.

#### PRIOR ART

A mounting device for mounting equipment in the ceiling of a hospital room is  
previously known from e.g. EP-A2-0 215 212. Said mounting device comprises electric wires  
and/or fluid ducts. Moreover, it includes a support device for medical equipment.

15 EP-A2-0 257 299 discloses a support arm suspended in the ceiling and for supporting  
equipment close to a bed at a hospital.

Another support arm system and mounting equipment for a hospital is disclosed in  
CH-A5-568 459 (correspondig to US -A-3,931,452).

20 US-A-5,108,064 discloses a applicance support for use in particular in intensive care  
stations and comprising a support arm for receiving support members for the appliances and  
supply connections for operating the same.

EP-A1-0 219 274 discloses a support frame for medical appartuses to be used close to  
the bed at a hospital and supported by wheels.

25 An intravenous infusion device mobile is disclosed in EP-B1-477 551. The mobile  
carries a number of infusion devices necessary for the patient. DE-C1-41 04 814 discloses an  
intravenous infusion device in more details.

The mounting devices for support close to the ceiling of a hospital room and as  
disclosed in the prior art have the drawbacks that they do not solve the problem of separating  
the supply means for gas and electricity, which results in a potential risk.

30 Moreover, in a hospital room, the equipment to be used at the bed side need to be  
supported in a convenient and practical way. The prior art support devices have drawbacks as  
to the practicallity and availability of the electric connectors as well as gas connectors.

Within intensive care there is required many service functions such as: several types of  
drip and infusion systems for nutrition, liquid balance and drug supply; monitoring systems for  
35 various vital systems; respiratory support systems and also complete take-over of respiration.

All the above service must be present since the actual need cannot be pre-planned. It is  
also required that the personnel can conveniently reach the patient for exchanging drip  
cannulas, making free the respiratory tracts and even be able to do heart massage.

The necessary equipment has to be supported, either by a ceiling attached support

system or by a mobile provided with wheels.

#### DISCLOSURE OF THE INVENTION

According to the present invention, there is provided a supportive structure intended to be attached to the ceiling of the hospital room for supporting hospital equipment and comprising support beams and profiles enclosing internal gas connections and electric connections. The connections for electricity are separated in a gas tight enclosure preventing any contact with gases, which may leak from the gas supplies. Thus, a completely safe installation is obtained.

According to the present invention, there is also provided a new medical support service unit for intensive care which is more convenient and less cumbersome than previous systems, and is moveable in relation to the bed and still is sufficiently rigid to support also heavy equipment. Thus, there is provided a medical support service unit for intensive care rooms comprising connectors for gas supply and suction, electric power supply and other electric connectors as required and forming a support structure for equipment necessary close to the bed in an intensive care room, such as a monitor, suction units, gas supply units, blood pressure monitors. According to the invention, the unit comprises a rectangular frame of beams, encircling a rectangular space, said frame being supported by a pivotable arm and a bearing mounted in the ceiling of the room, in order to extend essentially vertical from the arm and downwards to adjacent the floor of said room. The rectangular space encloses equipment which are well protected inside the frame, and said rectangular space is sufficiently open for allowing sight through the frame for supervision of the patient and contact with other staff and the area around the vertical beams being free for service. The vertical beams comprises electric connections and outlets mounted in or at the vertical beams. A gas panel is mounted across the vertical beams.

A further object of the present invention is to provide a mobile where all equipment needed for the intravenous supply services can be included, such as intravenous pumps of the peristaltic or syringe type, nipples, catheters, needles, valves and other small parts, monitors which analyses and monitors the operation of the equipment and the vital functions of the patient. In this way all equipment required for this function can be gathered to one unit. A complete medical support system is obtained for intensive or critical care, which means that the nurses and doctors are given ample place to do their contributions to the care of the patient. The ergonomic and working environmental situation is enhanced, which means that the staff feel more safe and will not be stressed.

Further details appear from the attached patent claims.

#### SHORT DESCRIPTION OF THE DRAWINGS

Further objects, features and advantages of the present invention will appear from the following detailed description of preferred embodiments shown on the attached drawings.

Fig. 1 is a perspective view of a supportive structure according to the invention.

Fig. 2 is an enlarged cross-sectional view of a part of the supportive structure

according to the invention.

Fig. 3 is an enlarged cross-sectional view of another part of the supportive structure according to the invention.

Fig. 4 is a perspective view similar to Fig. 1 and shows the gas conduits.

5 Fig. 5 is a perspective view of the lower side of the supportive structure and shows the electric box.

Fig. 6 is a perspective view in an enlarged scale of the electric box according to the invention.

10 Fig. 7 is a perspective view of an equipment mounted beside the supportive structure in a side bracket.

Fig. 8 is an exploded view of the side bracket mounting according to Fig. 7.

Fig. 9 is a perspective view of a service unit according to prior art.

Fig. 10 is a perspective view similar to Fig. 1 of a preferred embodiment of a service unit according to the invention.

15 Fig. 11 is a perspective view of the service unit according to Fig. 10 from the other side.

Fig. 12 is a side view of the unit seen from the bedside without any equipment.

Fig. 13 is an end view of the unit according to Fig. 12.

Fig. 14 is a side view of the unit according to Fig. 12 seen from the nurse side.

20 Figs. 15 and 16 are elevation views of the side of the vertical beams.

Fig. 17 is a cross-sectional view of a vertical beam with a bracket mounted thereon.

Fig. 18 is a perspective view of a ventilation mobile, seen from the nurse side.

25 Fig. 19 is a perspective view of the ventilation mobile according to Fig. 18, seen from the patient side.

Fig. 20 is a perspective view of a critical care mobile according to the invention, seen from the patient side.

Fig. 21 is a perspective view of the critical care mobile according to Fig. 20, seen from the opposite side compared to Fig. 3.

30 Fig. 22 is a perspective view of a pump module intended to be attached to the mobile according to Figs. 20 and 21.

Fig. 23 is a perspective view of a standard mobile according to the invention, seen from the nurse side.

35 Fig. 24 is a perspective view of the standard mobile according to Fig. 23, seen from the opposite side compared to Fig. 23.

Fig. 25 is a perspective view of the standard mobile according to Figs. 23 and 24, seen from the patient side and used for another purpose.

Fig. 26 is a perspective view of the standard mobile according to Fig. 25, seen from the opposite side compared to Fig. 25.

## DETAILED DESCRIPTION OF THE INVENTION

Fig. 1 is a perspective view of the supportive structure comprising steel girders making up the installation.

5 The supportive structure comprises a rectangular framework of rigid square steel girders. In the drawings there are shown two longitudinal girders 1, 2, each for example 3600 mm long, interconnected by two transversal girders 3, 4, each for example 600 mm long. Several vertical L-beams 5 - 12 are welded to the square girders at suitable locations as shown on the drawings. Further horizontal L-beams 13 - 17 interconnect the vertical L-beams to form a supportive structure as shown on the drawing.

10 Each vertical L-beam is intended to be connected to mounting members 18, one of which is shown on the drawing above L-beam 6. It is to be understood that such mounting members are positioned above each of the vertical L-beams.

The mounting member comprises a vertical, hollow, square beam 19 attached to a support plate 20. The support plate 20 is attached to the ceiling of the operating room by several  
15 screws 21, schematically shown on the drawing.

The square beam 19 of the mounting member 18 has an inner dimension suitable for entering the vertical L-beam inside it. As an example, the square beam can have an external size of 50 x 50 mm, and a wall thickness of about 2 mm, and thus the inside dimension is about 46 x 46 mm. The L-beam can have a corresponding dimension so that it fits inside the square  
20 beam, such as a width of 45 mm.

When mounting the supporting structure in an operating room, the mounting members are attached to the ceiling in appropriate locations. The vertical L-beams 5 - 12 are introduced into the square beams until the supportive structure is horizontal, and then the L-beams 5 - 12 are welded to the square beams. In this way it is possible to obtain a horizontal supportive  
25 structure also when the ceiling is not completely horizontal or is uneven.

As mentioned above, the supportive structure comprises four girders, such as square girders of steel and having a dimension of 50 x 50 mm. The girders have to be strong enough for supporting heavy equipment and can be made with a wall thickness of 2,4 mm.

In order to adapt this supportive structure to support different operating equipment, such as operation lamps, connector centrals for gas supply and electric supplies etc., there is provided according to the invention a support profile made from extruded aluminum having a shape shown in Fig. 2 to the left, and being generally L-shaped. The support profile is intended to be placed along the longitudinal girders. If the support profile is as long as the girder, such as 3600 mm, then the support profile has recesses for passing the vertical L-beams 5 - 12.

35 The support profile 22 is shown in more details in Fig. 2 and comprises a first horizontal leg 23 intended to be placed on the horizontal upper surface 24 of the girder, and a vertical leg 25 intended to be placed along the vertical side surface 26 of the girder facing the inside of the rectangular space formed by the supportive structure. The horizontal leg 23 has a hook flange 27 passing a short distance along the opposite vertical side surface of the girder



facing outwards. Thus, the support profile is hanged upon the girder by placing the hook flange 27 over the girder and the profile will hang as shown in Fig. 2. The support profile has several other flanges, the operation of which will be described below.

5 Somewhere along the upper horizontal surface of the support profile, there is a flange 28 inclined about 45° upwards as shown to the left in Fig. 2. This flange is for supporting a ceiling or lid plate 39 extending from one girder to the other and covering the whole supporting structure at the top. Preferably, the ceiling plate 39 is extending inclined upwards about 50 mm and then extends in a horizontal direction. The ceiling plate 39 is attached to the flange 28 by rivets or screws.

10 The support profile is further provided with a depending flange 29 close to the intersection between the horizontal and vertical legs 23, 25 forming a pocket 30 facing downwards and extending along the entire length of the support profile. Furthermore, the vertical leg 25, at the bottom is provided with a horizontal flange or support surface 31 extending inside the rectangular area of the supportive structure. The object of the pocket 30 and the surface or flange 31 is to support an L-beam, as shown in broken lines in Fig. 2. The pocket 30 is provided with an enlargement 32 enabling the introduction of a L-beam 33 as shown in Fig. 2 by broken lines.

15 As shown at the right side of Fig. 3, each girder is provided with a cover profile 34 extending along the entire length of the girder. The cover profile is locked in place by a lock profile 35, which can be placed on intermediate positions or can be a longitudinal profile. The lock profile 35 is screwed to the hook flange 27 of the support profile 22, thus completing the grip around the girder. In this way, a very reliable support profile construction is attached to the girders.

20 As shown to the left in Fig. 2, a longitudinal L-beam 33 can be inserted with its vertical leg into said pocket 30 and resting upon the support surface 31. The L-beam 33 has three holes along its horizontal leg, into which holes are inserted screws for supporting any equipment to be attached to the supportive structure. Such equipment is mounted on a strong support plate 36 having a standardized size, such as 600 x 300 mm. The girders are mounted so that the distance between a depending inverted T-flange 37 of one girder to the corresponding T-flange 37' of the other girder is 600 mm. The above-mentioned L-beam 33 has a length of 300 mm. Thus, the support plate 36 for the equipment can be inserted between the T-flanges and attached to the L-beams arranged as described above. By drawing the screws, the L-beam 33 and the support plate 36 will squeeze the support surface 31 therebetween forming a tight attachment between the support plate 36, the L-beam 33 and the support profile 22. Preferably, the L-beam has a cushion 38 outside the holes as shown in Fig. 2, to the right.

35 By loosening the screws, the support plate will be moveable along the length of the support profiles and thus along the girders, in order to place the equipment where needed. When the right position has been obtained, the screws are tightened. The equipment can be

remounted by loosening the screws and removing them completely, whereupon the support plate is free from the L-beams. Mounting and dismounting of the equipment can take place without making or leaving screw holes in the supportive structure.

5 When the equipment has been mounted as mentioned above, the spaces between the support plates of respective equipment is downwardly covered by lid plates 40, which preferably are of standard size, or can be cut to the desired size. It is preferred to use a modular size, so that the support plates are placed within modules of a width of 300 mm.

10 The lid plates 40 are shown in more details in Fig. 3 and are provided with hooks 41, hooking around one of the edges of the inverted T-flange 37. The other side interact with the corresponding edge by a locking arrangement such as an excentric lock (not shown). When the lock is disengaged, the lid plate 40 can be swung down hanging in the hooks 41 when access to the interior of the supportive structure is required as shown in broken lines in Fig. 3.

15 As shown in Fig. 4, gas conduits 42 are entering the supportive structure from above. Such gas conduits come from the hospital central supply of gas into each room at convenient locations and are connected to non-interchangeable connectors inside the supportive structure. From such connectors, the gas is further supplied to the equipment needing gas supply.

20 Moreover, electric wires 43 enter the supportive structure from above, as also shown in Fig. 4. These wires enter an electric box 44 (see Fig. 5), provided with suitable terminals. The box is completely gas tight and the holes, through which the wires enter the box are sealed. Thus, there is provided separate and sealed compartments for the electric supply as is required for avoiding risks in connection with gases, such as oxygen gas.

25 The electric box has a removeable and sealed cover, which is removed in Fig. 5 exposing the terminals 45 inside the box 44. The electric box is also provided with further holes, which originally are sealed or unbroken. When an equipment needs electric supply, a hose 46 is provided from the electric box to the equipment as shown more clearly in Fig. 6. The hose 46 is gas tightly attached to the electric box by a coupling 47 connected to the box 44 with screws and having a sealing thereto. The other end of the hose is connected to the equipment in a similar way. The electric wires are placed inside said hose and connected to the terminals 45 in the electric box and to the contactors (not shown) of the equipment. Thus, the electric wires are placed inside said hose and are sealed from any space that might include gas. Thus, there is obtained a completely safe mounting of electric wires in combination with gas conduits.

35 As further shown in Figs. 5 and 6, the lid plate 40 is shown swung down and hanging in the hooks 41. The inside surface of said lid plate 40 can be provided with circuit diagrams and instruction notes 48 as shown. Moreover, the lid plate is provided with several holes 49. These holes operate as vent holes for venting any gas leaking from the gas non-interchangeable couplings to the surroundings. Further such holes 49 are provided in the bottom closures of the supportive structure where necessary.

As shown in Fig. 3, the cover profile 34 is provided with a horizontal flange 47

extending outwards from the space occupied by the supportive structure. This flange 47 is intended to support an extra ceiling 48 of the room, such as a slab, which is often used for obtaining a more clean ceiling surface in the operation room.

5 It is obvious that the lock profile 35 can be constructed as an integral portion of the cover profile 34 if this is more convenient.

Sometimes it is desired to place the equipment displaced in the side direction in relation to the supportive structure. Such a bracket mounting is shown in more details in Figs. 7 and 8. The side bracket is made up of four U-beams forming a rectangular frame 50. The frame is provided with a transversal beam 51. Said beam 51 and one transversal side 52 of said frame  
10 are connected to the L-beams 33 as shown in Fig. 2 so that the entire frame 50 is moveable along the supportive structure shown at 53. The frame 50 is locked in position by several screws 54 engaging said L-beams 33 as described above. The frame 50 is provided with screw bolts 55 adapted for engagement with a support plate 56 of the equipment as shown in Fig. 16. The final mounting is shown in Fig. 7.

15 Fig. 9 is a perspective view of a service unit according to the prior art, the POWER COLUMN from Hill-Rom. It comprises a rectangular column 61 extending from the ceiling 62 to the floor 63 and fixed thereto. The column is about 2400 mm x 600 mm x 200 mm. The column is mounted about 45° in relation to the adjacent wall. A bed is placed so that the head portion thereof is close to the column. Usually, the bed extends perpendicular to the wall.

20 The column is provided with several electric outlets 64 and connectors along the vertical short sides 65. Along the long side 66 facing the bed, there is mounted equipment of different types, such as suction devices 69, gas outlets 68. Moreover, a monitor 70 is mounted at a support 71. On the backside there is mounted a shelf 72, where the nurse can write on the patient card, and several boxes 73 for different purposes such as including small details used at  
25 the place and a waste basket.

There are several drawbacks with such a service column. It is fixed at the floor which makes it necessary to move the bed, if access to the bed should be required from all four sides in an emergency situation. It happens sometimes that the weight of the patient is monitored by weighting units between the bed and the floor, and a movement of the bed disturbs such a set-up and requires re-calibration of the weighting units.  
30

Since the column is fixed to the floor, it is difficult to clean around the column.

The equipment, and specifically the monitor extends rather long out from the column, which takes up a lot of place. When the nurse makes her patient records, she is positioned behind the column and cannot see the patient, if an emergency situation should arise.

35 If new equipment is to be mounted, such as a further suction outlet, it is necessary to make new holes in the column construction which is difficult and disturbs other intensive care patients and functions.

A service unit for an intensive care room obviating all the above-mentioned drawbacks with the fixedly mounted column, is shown in Figs. 10 and 11.

The service unit according to the invention hangs in a support arm supported from the ceiling of the room. Such support arms are frequently used in hospitals, especially in operating rooms.

5 A support plate 80 is attached to the ceiling fixture by several bolts 81. To the support plate 80 is attached a support arm 82 extending horizontally below the ceiling and being  
10 pivotable by bearings 83. At the end of the arm, there are further bearings 84 attached to the middle of a horizontally extending beam 85. At the end of beam 85, two vertical beams 86, 87 are attached interconnected at the lower end by a bottom beam 88. Thus, beams 85, 86, 87 and 88 form a rectangular frame as shown in Figs. 10 and 11. The rectangular frame is supported at  
15 its vertical symmetry axis by said bearing 84. The bottom beam 88 is placed a short distance above the floor, such as 30 cm above the floor for the necessary convenient cleaning of the floor.

The support plate is attached in the room so, that the rectangular frame can be positioned close to the wall in a first position when not used and swung out close to the head  
15 end of an adjacent bed when used. The rectangular frame is pivotable around its vertical symmetry axis as shown by arrow 89.

The equipment which must be present close to the bed, is mounted in the free space between the vertical beams 86 and 87, as shown by monitor 90 mounted on a shelf 91. The equipment is inserted between the vertical beams and facing the bed side.

20 On the backside shown in Fig. 10, there is inserted between the vertical beams other types of equipment necessary for the nurse, such as a writing table 92 or commode for the nurse where she can have the patient record and further things for writing purposes. The commode may comprise small boxes containing needles, connector and other accessories for drip, drainage etc.

25 Alternatively, the commode can be replaced by a PC-station connected to a centralised patient monitoring and recording system, including a video display and keyboard.

At the bottom there is a file box 93. Above the table 92 there is a further shelf 94 for placing stationery, scalpels and other small things handy when arranging for drips etc. A lamp 95 provides a good working light.

30 It is clear from Figs. 10 and 11 that a nurse doing her patient records can still observe the patient, through the free space in the interior of the rectangular frame. Only the vertical beams occlude the sight.

At the side usually facing the bed and shown in Fig. 11 there is provided all equipment needed for the patient, such as the monitor 90 mentioned above, a gas panel 96 having gas  
35 inlets and a connector for suction connected to a suction collector bottle 97. Several horizontal support rails 98 extend between the vertical beams for supporting further equipment, such as an oxygen therapy unit, timers in case of heart arrest, etc. A lamp 99 provides convenient lighting to the support service system equipment arranged on the unit. The lamp has an oval light up area only to light up the equipment.

A support stand 100 for infusion bags can be attached to the vertical beams as explained in more details below.

The service unit according to Figs. 10 and 11 is shown without equipment and in side and end views in Figs. 12, 13 and 14. The same details as in Figs. 10 and 11 have the same  
5 reference numerals.

In Fig. 13 there is shown a different type of lamp 101 included below the shelf 94.

As appears clearly from Fig. 12, the gas panel 96 is provided with several modules 102, 103, 104, 105 and 106. Modules 103 and 105 are blank modules without anything mounted. Module 104 comprises three medical gas pressure indicators showing bright red  
10 warning colour when pressure is too low from the central supply, such as oxygen, nitrous oxide and compressed air. To the left, 102 and to the right 106 are two modules having suction units. Other modules can be mounted at positions 103 and 105 without any mechanical work.

The gas panel is connected to the hospital's central gas supply via flexible hoses inside beam 86, beam 85, through bearing 84, arm 82, bearing 83 and support plate 80.

At the sides of the vertical beams 86 and 87 there are several connectors for electric power supply and for signal lines. Thus, the left beam 86, seen according to Fig. 12 is provided with the connectors shown in Fig. 15. Such connectors are power supply outlet 107 and small signal connector 108 intended for the monitor 90. Thus, the wires to the monitor are short. At the bottom there are shown five outlets 109 for power supply (220 V). In between  
15 20 there are two blank modules 110, 111, but these modules can be provided with electric outlets and connectors if required. Other module configurations can easily be arranged.

The corresponding right beam 87 is provided with other connectors as required and shown in Fig. 16. The electric power supply wires and signal wires are enclosed inside the vertical beams 86 and 87 and pass to the hospital's central supply and network the same way as  
25 the gas lines.

Thus, it is clear that the rectangular frame can include all functions and equipment necessary for the service function intended. It is easy to adapt the rectangular frame to whatever need should there be.

Since the interior of the rectangular frame is available, compared to the column shown in Fig. 9, the large equipment such as the monitor etc. can be housed between the vertical beams 86, 87 so that they do not occupy large area and do not extend far away from the frame. Such equipment will be positioned below the support bearing 84, and thus, the rectangular frame will be steadily supported by the bearing 84. The equipment will not tend to twist the frame. Thus, a stable service unit is obtained in spite of the fact that it is moveable, which  
30 35 makes it easy to clean the floor. Such equipment is inserted inside the space limited by the vertical beams interleaved from one side or the other. The area outside the vertical beams is free for the support service and comprises the outlets necessary for the service, such as gas outlets and electric outlets.

It is noted that the bearings 83, 84 are of a type allowing very limited movement but

rotation around the vertical axis of the bearing. Thus, the rectangular frame is rather rigid and do not move easily, unless movement is wanted. Since all equipment is rather central in the frame, it will be still further stable.

5 The stability can be further improved by adding a lock in the bearing so that they are locked in position as soon as the frame has been moved into place. Such lock can be a friction clutch or key locking. The lock can be operated by hand, via a wire that can be pulled by hand, or be electrically and/or magnetically operated. Such lock can be included in one or both of the bearings 83, 84.

10 Moreover, the space between the vertical beams is free so that the patient can be observed even if the personnel is behind the service unit.

In Fig. 17 there is shown a cross-section through a corner of the vertical beams 86, 87. The beam is provided with vertical grooves 115, 116 in which a bracket 112 can engage. To the bracket 112 can be attached further equipment such as a holder 100 for infusion bags etc. The bracket 112 is locked to the beam by a latch 118 and a screw connection 117 as  
15 shown. Other types of equipment can also be attached in this manner.

In Fig. 11 there is shown a treatment lamp 113 attached to the end of the pivotable arm 82. This lamp will be relatively fixed even when the rectangular frame is pivoted around the axis of bearing 84. Thus, said lamp 113 can conveniently be used for illuminating the patient being treated with a constant light. moreover, in Fig. 10 there is shown a telephone 114 in a  
20 convenient place. It is easy to install telephone lines in the rectangular frame or the beams.

Critical care of today manage to handle more and more severely ill patients, due to the high capacity of the technique of today in combination with specially educated doctors and nurses. However, this make it necessary to use a great number of different equipment around the patient. In addition to equipment analysing and monitoring the patient, he also requires  
25 supply of a lot of nutrients, blood plasma, different anaesthesia etc. Such supply must be controlled which means that old-fashion drop controlled infusion cannot be used any longer and are replaced with electronically controlled infusion pumps and syringes. Up to sixteen such pumps can be used at the same time for a single patient. One common way of using such automatic pumps today is to attach such a pump to the infusion stand with a coupling. The  
30 pump is provided with electric power via a wire and is connected to supervisory equipment via a signal cable. It is realised that such a system will be a mess of wires and hoses if used for sixteen pumps. The environment in such critical care rooms can be stressing for the nurses leading to errors and mistakes. It is necessary to further structure and integrate the different functions at such a critical care room.

35 Fig. 17 shows a ventilation mobile including equipment necessary for respiratory support and for keeping the respiratory ways free, such as oxygen supply units and suction units, as well as further equipment necessary for the critical care, such as supplies for anaesthesia gases. The ventilation mobile is supported by several swivel wheels.

The ventilation mobile 121 comprises a bottom frame 122 supported by several wheels

123 to form a transportable unit. Two vertical pillars 124, 125 extend from the bottom frame to define a vertical rectangular space. Each vertical pillar comprises several outlets for electric power supply 127 and medical gas outlets 126. All power outlets are supplied with 220 V mains power by a power wire 128 connected to a power outlet 129 at the wall of the room and the signal outlets are connected to a corresponding wall mounted signal connector 130, if used (no wire shown in Fig. 17). Moreover, the mobile is provided with a suction unit panel 131 connected to the hospital's central supply of gas via lines or hoses 132, 133, 134. As shown, power wire 128 and hoses 132, 133, 134 are supported by a pivotable arm 135 having hooks 136 supporting said wire and hoses. In this way the pivotable arm 135 can be made smaller and cheaper, compared to if the arm should enclose the hoses.

The vertical pillars 124, 125 and the bottom frame 122 form a vertical rectangular space inside which equipment can be mounted without extending into the space needed for the treatment of the patient. Thus, a large monitor is shown at the top on a shelf, which can be inclined. Moreover, the pillars encloses a writing table facing away from the bed, where the nurse can make the necessary recording and still observe the patient through the open space between the pillars.

As shown in broken lines in Fig. 19, the mobile can be provided with the equipment desired for a specific patient, such as a ventilator supported by said mobile bottom frame 122.

As further shown in Figs. 20 and 21, the same mobile can instead be constructed as an intravenous mobile or critical care mobile 140. In this case it is not necessary to have gas supplies from the hospital's central supply, but the mobile is only connected to 220 V by a power wire (not shown). The mobile can also be connected to the hospital's central computer system, in order to take advantage of the computerised patient recording system used at many hospitals today. Such wires are connected to wall mounted outlet sockets.

As appears from Figs. 20 and 21, the critical care mobile has the same bottom frame 122, wheels 123 and vertical pillars 124, 125. The side of the mobile facing the bed is provided with several mounting rails, for example four rails 141 as shown in Fig. 21. On said rails 141 are mounted several infusion pumps represented by rectangular boxes 142 if Fig. 20. Said infusion pumps can be of the peristaltic type providing infusion solutions from infusion bags hanging on hooks 143 of a stand 144. There are two such stands 144, one at each pillar, each stand being provided with five hooks. The infusion pumps can also be of the syringe type providing a beneficial agent to the patient, such as antibiotics, insulin etc.

The CC (critical care) mobile 140 is furthermore provided with a shelf 145 bridging the two pillars 124, 125 at the upper end thereof. The shelf 145 can support a monitor (not shown) or whatever is needed in the specific circumstance, such as fluid balance monitors and other analysis and monitoring equipment. Two of the rails support infusion pumps 142. The two bottom rails 141 support one shelf 146, which can be used for syringe pumps and a second shelf 147 which can be used for accessories, such as needles, catheters, etc. If more infusion or syringe pumps are needed, such pumps can replace one or both of said shelves 146.

147.

At the side opposite the patient, the CC mobile 140 is provided with a writing table 148 and a few drawers 149 for enclosing accessories at a convenient position for the nurse.

The pillars 124, 125 of the CC mobile 140 are provided with outlet sockets for providing electric power and signal wires to the pumps etc. of the mobile.

Fig. 22 shows the infusion pump sets in more details regarding the attachment to the rails 141. The infusion pumps are mounted in modules, for example a module 150 of two infusion pumps or a module 151 of three infusion pumps as shown in Fig. 22. Each module 150, 151 is interconnected so that only one power wire and one signal wire are needed for each module. The module comprises a holder 152, which in principle is a spring loaded hook, grasping around the support rail 141 when brought into engagement therewith.

Each module is provided with handles 153 for easy mounting and dismounting. The modules are stored in the hospital equipment store and when needed taken out and hooked on the support rail. As many pumps as required are mounted and used. By such a module system, it is possible to adapt each mobile to the requirements of each patient. Each module is provided with some co-operating means for engagement with the respective infusion pump. In this way, pumps of different manufacturers can be mounted together if that is desired.

Figs. 23 and 24 shows a standard mobile according to the invention. The standard mobile 160 is provided with a bottom frame 162 of a more simple structure having four wheels 163 and a single vertical pillar 164. The single pillar is provided with four support rails 161, two infusion bag stands 165, a couple of shelves 166, 167, 168, and a writing table 169. Moreover, an electric panel 170 is provided instead of providing the pillar with electric outlets. This standard mobile 160 can in principle have the same equipment as the CC module 140 described above, but it is smaller and designed for more normal IC cases.

As shown in Figs. 25 and 26, the standard mobile 160 can alternatively be provided as a surgical mobile having one or two individual operation suction units 171, 171' connected to a gas panel 172. Moreover, there is provided a top shelf 173 for any equipment, such as a monitor or a fiber optical light source etc., and a table 174 with a drawer for other equipment, e.g. electrosurgical units. As shown in Fig. 26, there is provided an electric panel 175 with automatic circuit breakers. The gas panel 172 and electric panel 175 are connected to the hospital's central supply via flexible cables 176 and hoses 177 supported by a stand 178 as shown in Fig. 26. The pillar 179 is provided with compressed air outlets 180 for connection to any surgical tools. The upper shelf 173 is pivotable for convenient access from all sides.

Such a standard mobile can be used for many purposes within a hospital.

Although several embodiments have been described above with reference to the appended drawings, it is obvious to a skilled person that different modifications can be made to the embodiments shown on the drawings and different combinations can be made without departing from the inventive idea of the invention. Such modifications obvious to a skilled person reading this specification is intended to be within the scope of the invention.



## PATENT CLAIMS

1. Supportive structure intended to be attached at a ceiling of a hospital room for supporting hospital equipment, comprising supporting beams (1, 2, 3, 4) and support profiles (22) for supporting the equipment and for forming a space enclosing gas connections and electric connections for said equipment, characterized in that gas ducts (42) are adapted to enter said space and connected to outlets for connection to said equipment, and that electrical wires (43) are adapted to enter inside an electric box (44), comprising contacts (45) and being gas tight, and in that hoses (46) are adapted between said equipment and said electric box and including gastight connections (47) for comprising said electrical wires (43) between the contacts in said electric box and said equipment.

2. Structure according to claim 1, characterized by a framework of beams (1, 2, 3, 4), being attached, by several vertical beams (5 - 12), to mounting members (18) attached to the ceiling, so that said framework is adapted essentially horizontally close to the ceiling, whereby said support profiles (22) each comprises a horizontal leg (23) intended to cooperate with an upper surface of the corresponding beam and a vertical leg (25) intended to cooperate with the inner surface of the corresponding beam; and in that said support profile (22) each comprises a connection means (33, 30, 31) for connection to said equipment and for supporting it.

3. Structure according to claim 2, characterized in that said connection means comprises a longitudinal L-beam (33), the vertical leg of which being adapted to be inserted in a pocket (30) adapted in the support profile (22) and the horizontal leg of which being adapted to cooperate with a flange surface (31) so that said L-beam is supported by said support profile (22) and in that said L-beam is provided with a connection means for connection to said equipment.

4. Structure according to claim 3, characterized in that said equipment is mounted at a support plate (36) extending over said rectangular framework and in that the support plate is provided with several holes corresponding to holes in said L-beam so that said support plate can be attached to said L-beam and at the tightening of the screws, jamming said flange surface between said support plate and said L-beam.

5. Structure according to claim 2, 3 or 4, characterized in that said support profile (22) further comprises a hook flange (27) adapted to hook around said beam at the opposite side of said vertical leg.

6. Structure according to claim 5, characterized in that said support profile (22) comprises a lock profile (35) adapted to be attached to said hook flange (27) and a cover profile (34) adapted below said beam so that said beam is completely surrounded by said support profile, at least along a portion of the length thereof.

7. Structure according any one of the previous claims, characterized in that said space is covered by plates (36, 40) at least one of which being provided with ventilation holes (49).

8. Structure according any one of the previous claims, characterized in that said gas connections are non-interchangeable gas connections.

9. Medical support service unit for intensive care rooms comprising connectors, such as for gas supply and suction, electric power supply and other electric connectors as required and forming a support structure for equipment necessary close to the bed in an intensive care room, such as a monitor (90), suction units (97), blood pressure monitors, characterized by

a rectangular frame, preferably of four beams (85, 86, 87, 88), encircling an essentially rectangular space, said frame being supported by a pivotable arm (82, 83, 80) and a bearing (84), in order to extend essentially vertical from the arm and downwards to adjacent the floor of said room;

said rectangular space enclosing equipment (90, 92) interleaved from one side or the other which are well protected by the frame, and said rectangular space being sufficiently open for allowing sight through the frame for supervision of the patient and the area around the vertical beams being free for service.

10. Service unit according to claim 9, characterized in that said rectangular frame comprises two vertical beams (86, 87) interconnected at the top and bottom by horizontal beams (85, 88), the upper horizontal beam being connected to said bearing (84) at the pivotable arm (82, 83) at or adjacent the middle of the horizontal beam (85).

20 11. Service unit according to claim 9 or 10, characterized in that said rectangular frame comprises electric connections (108) and outlets (107, 109) mounted in or at the vertical beams (86, 87).

12. Service unit according to claim 9, 10 or 11, characterized in that a gas panel (96) is mounted across the vertical beams.

25 13. Service unit according to anyone of claims 9 - 12, characterized in that said vertical beams (86, 87) comprises grooves extending along the beams for attachment of brackets (112) for supporting holders (100) or other equipment.

14. Service unit according to anyone of claims 9 - 13, characterized by a locking device in one or both of the bearings (83, 84) for further improving the stability of the rectangular frame.

30 15. Service mobile for carrying medical equipment, comprising a bottom frame (122) supported by wheels (123), characterized by at least one vertical pillar (124, 125) including electric outlets of power type and signal type, said pillar supporting equipment required for monitoring vital functions and for the medical service, such as infusion pumps of the peristaltic or syringe type, oxygen therapy units, surgical suction units, gas supplies etc.

1 / 16

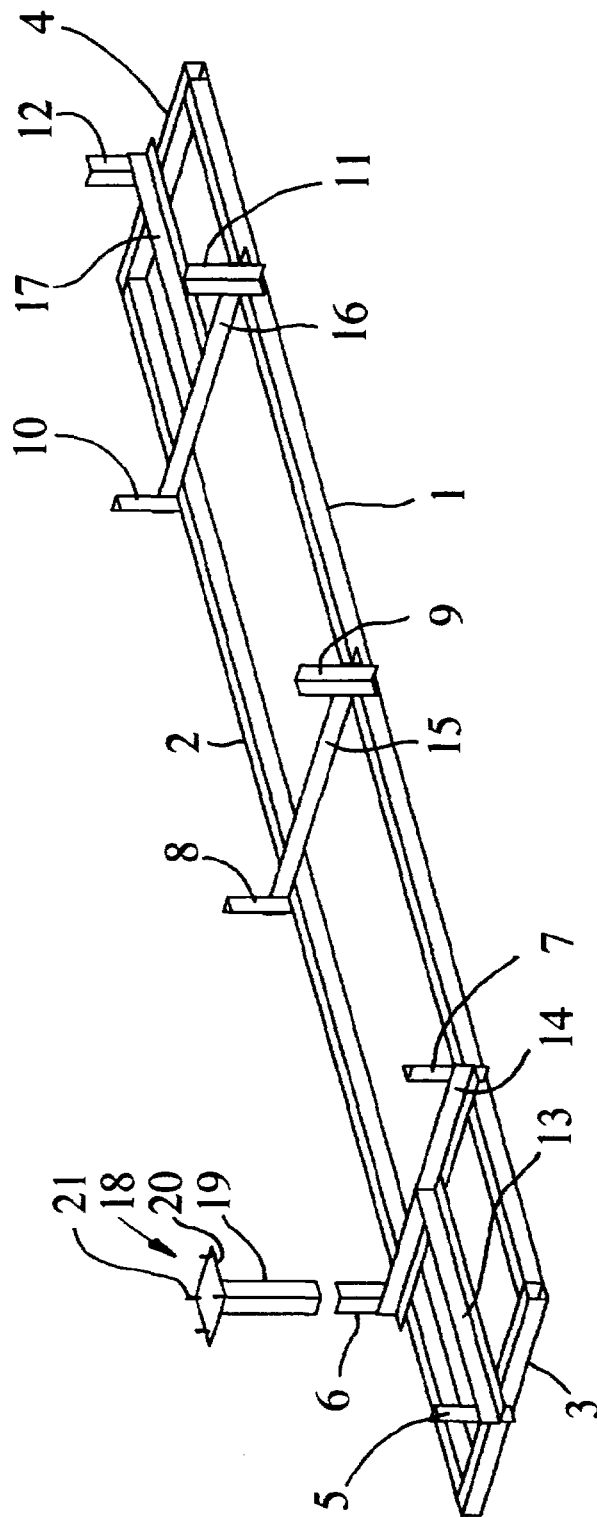


Fig. 1

**SUBSTITUTE SHEET**

2 / 16

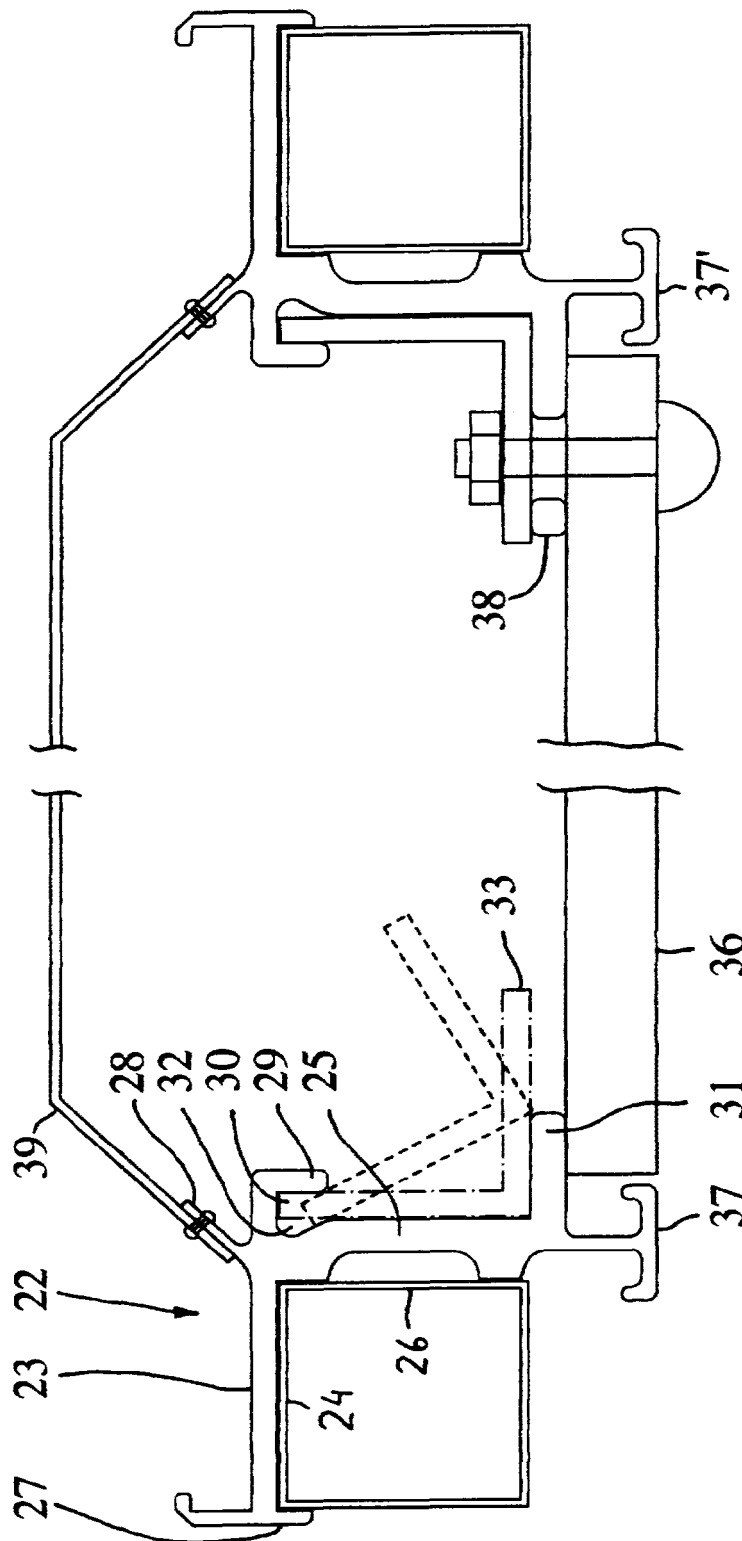


Fig. 2

**SUBSTITUTE SHEET**

3 / 16

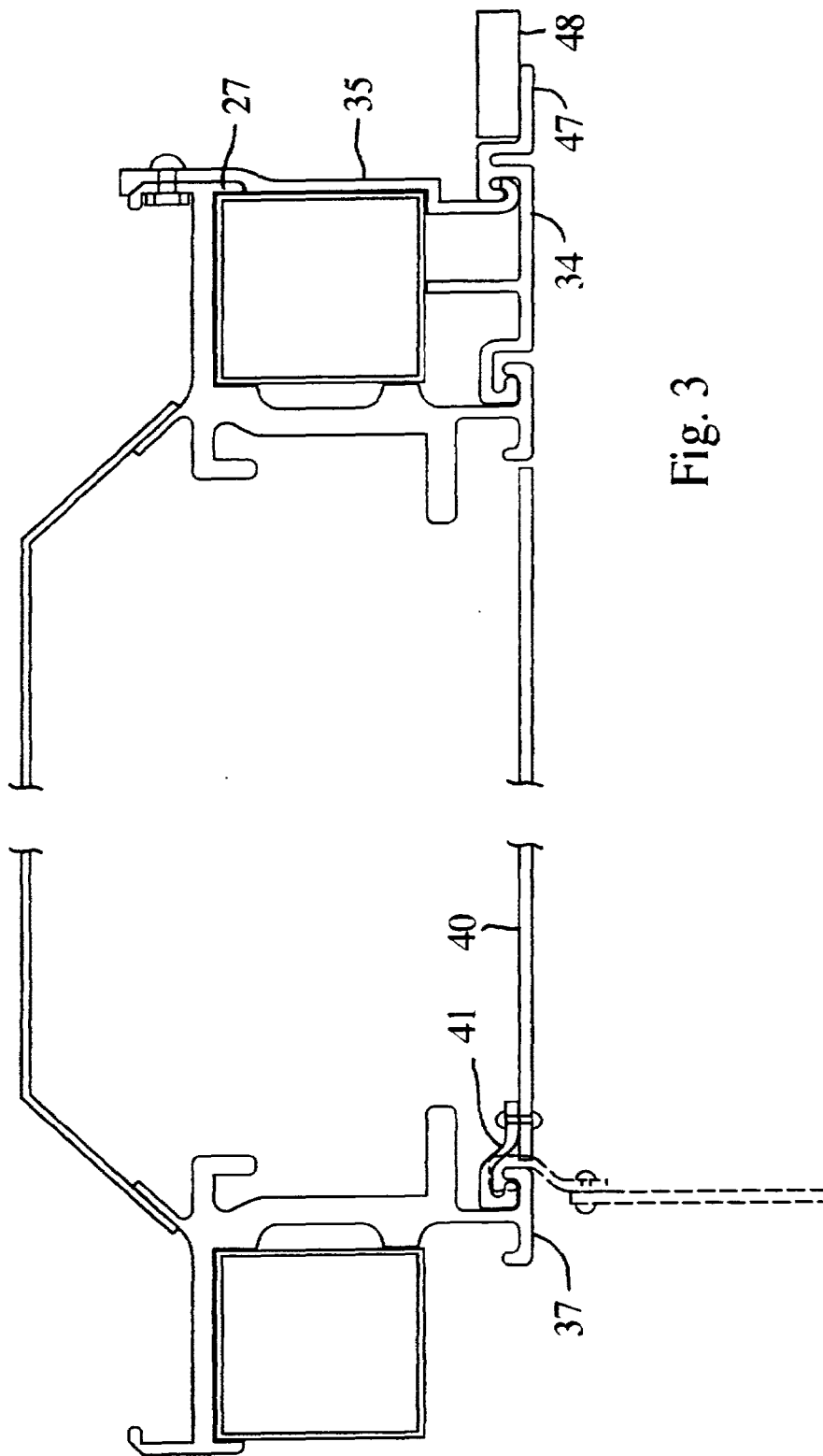


Fig. 3

**SUBSTITUTE SHEET**

4 / 16

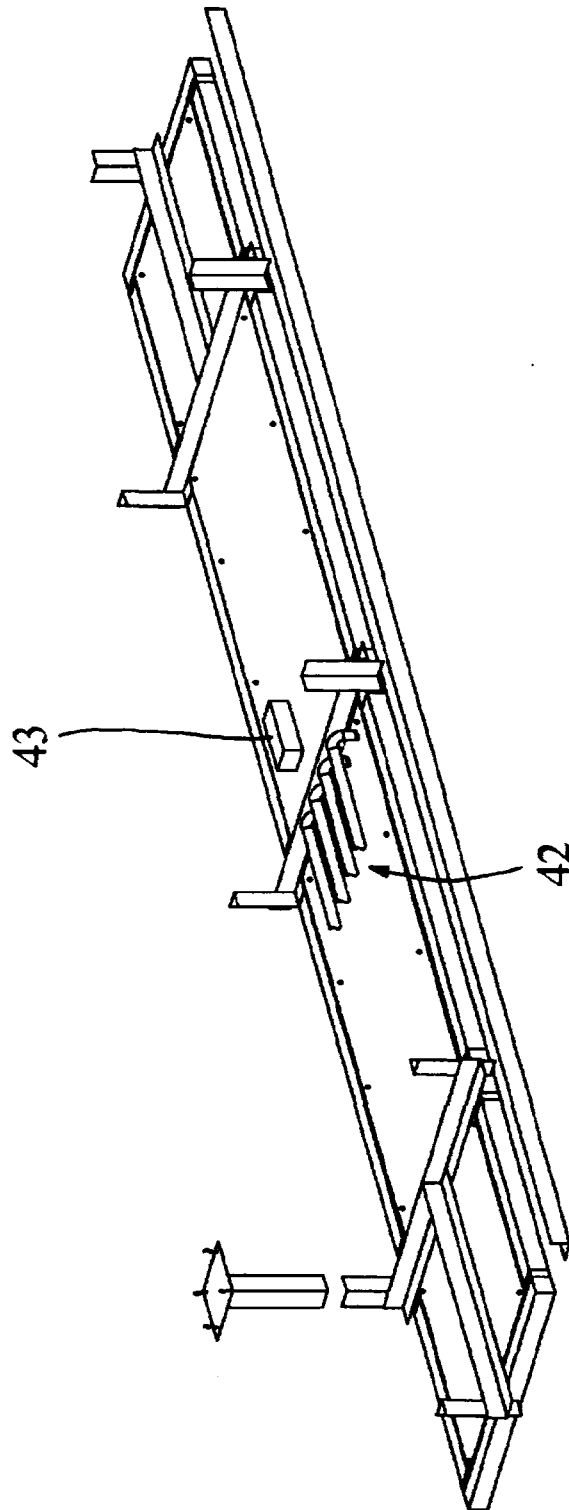
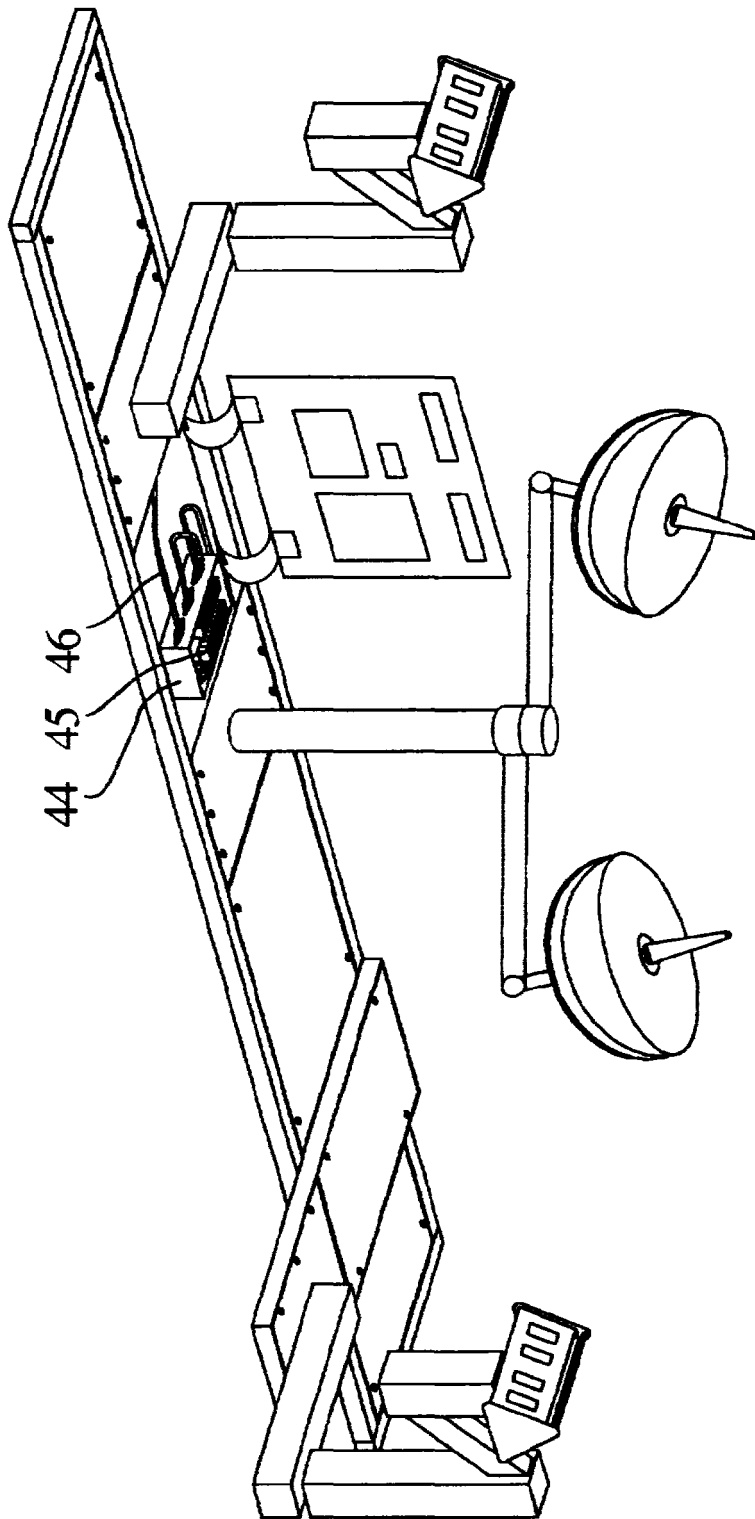


Fig. 4

**SUBSTITUTE SHEET**

Fig. 5



**SUBSTITUTE SHEET**

6 / 16

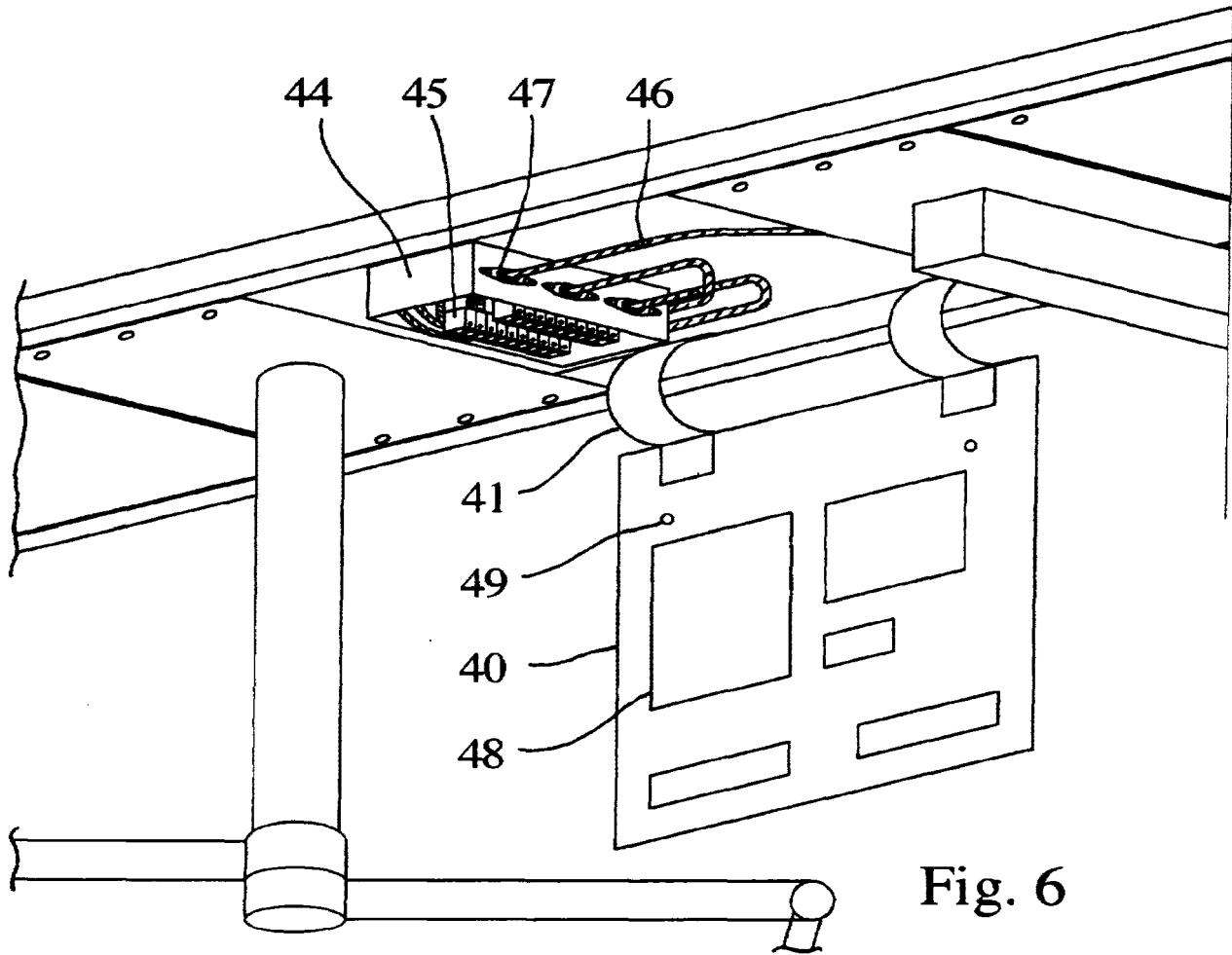


Fig. 6



7 / 16

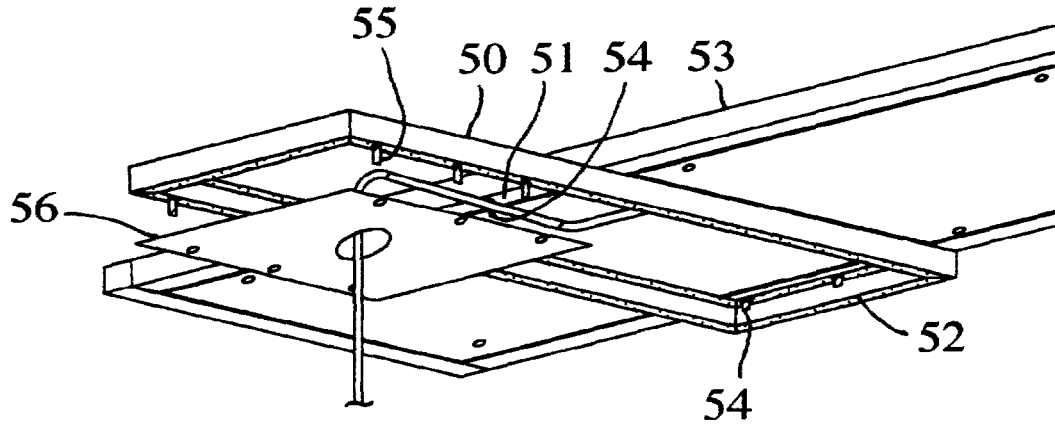


Fig. 8

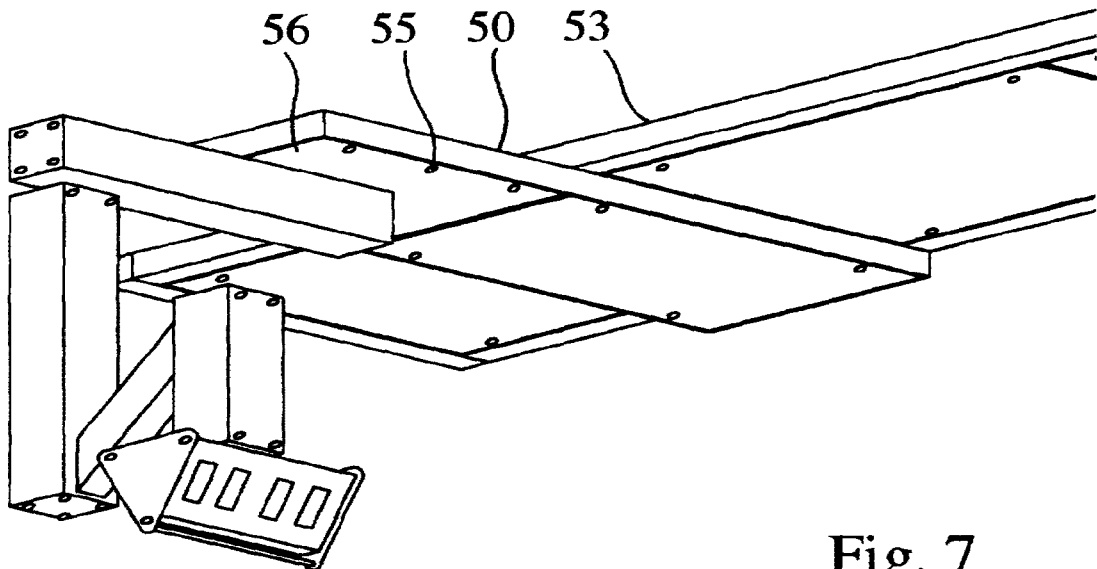


Fig. 7

**SUBSTITUTE SHEET**

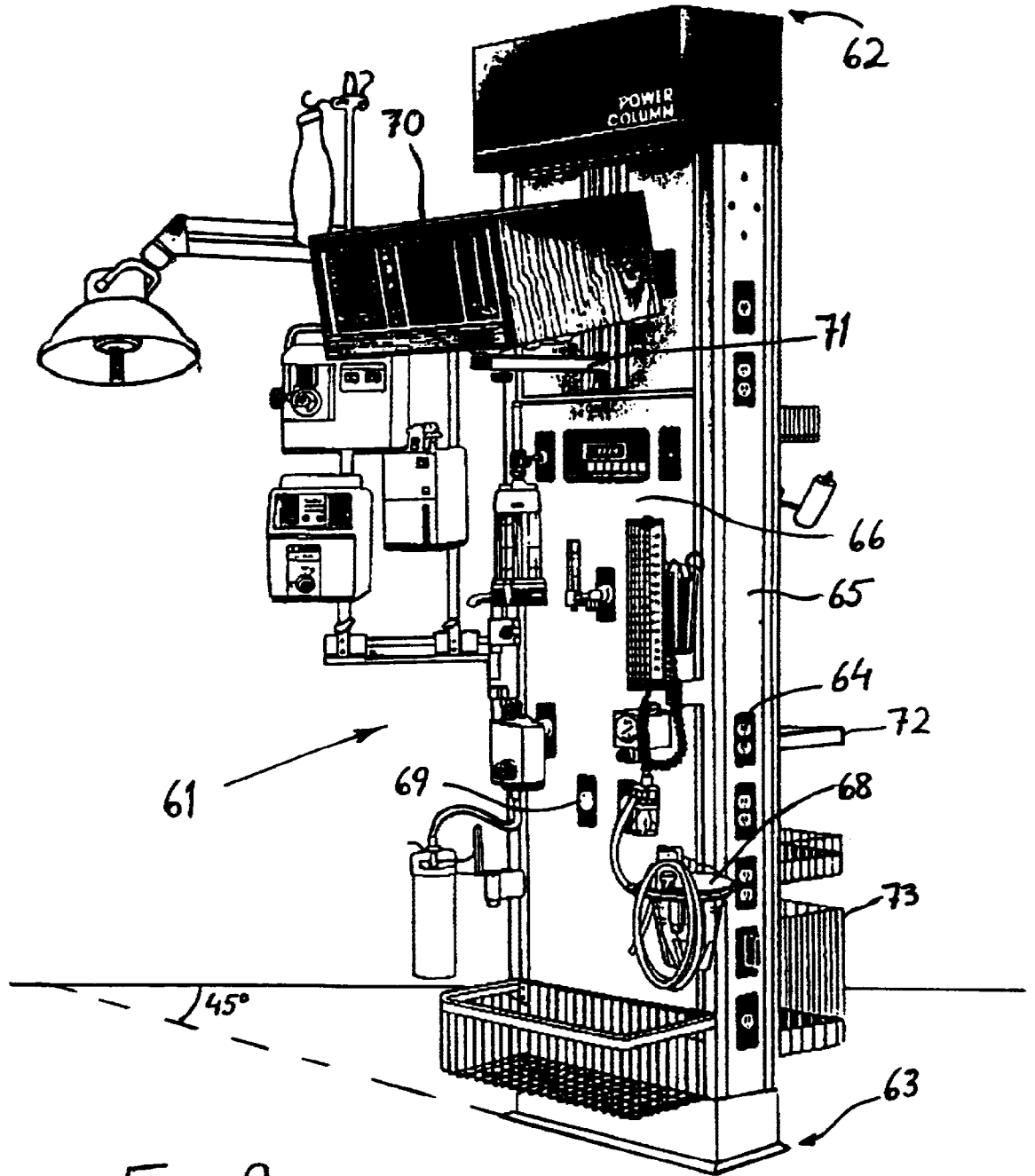
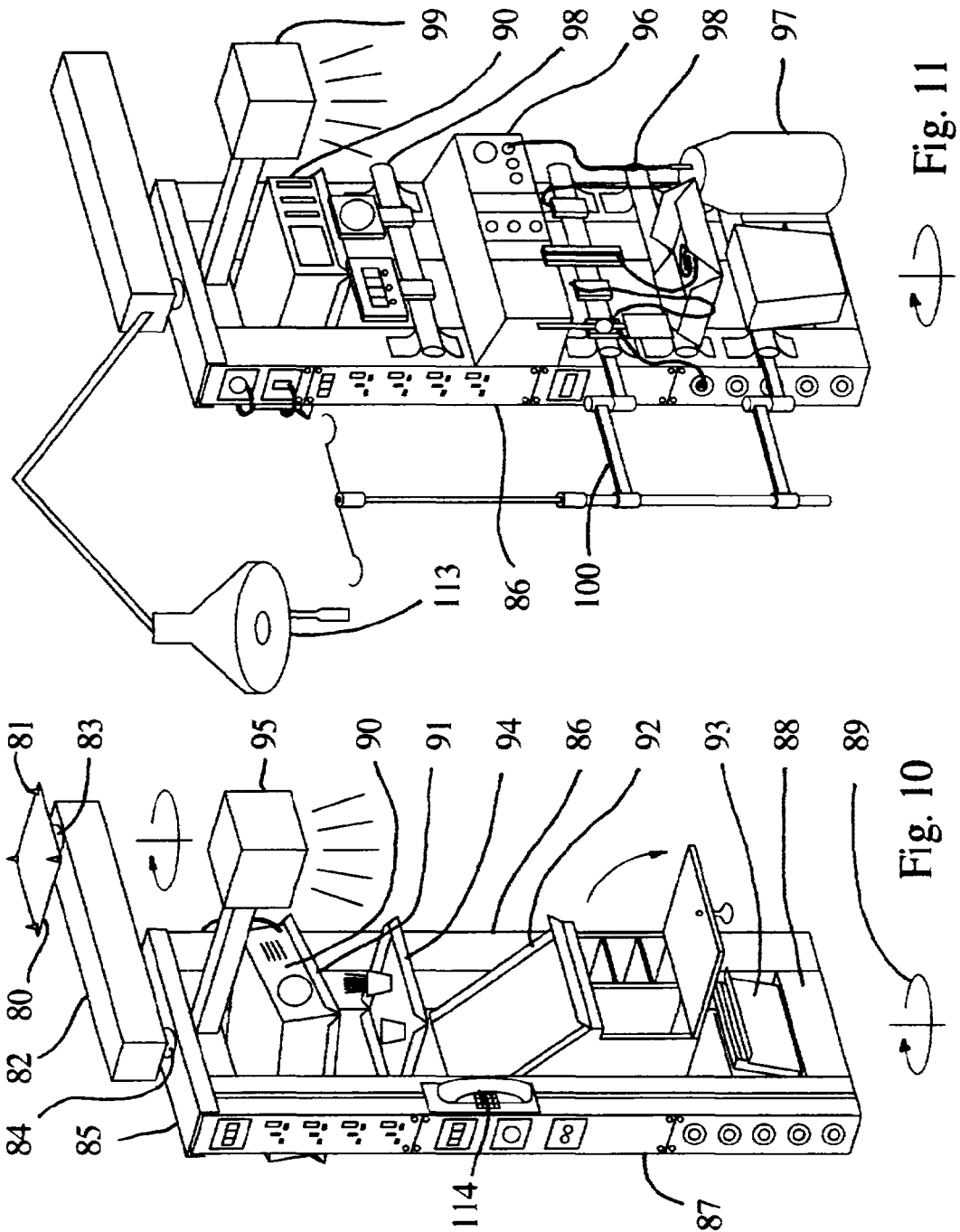


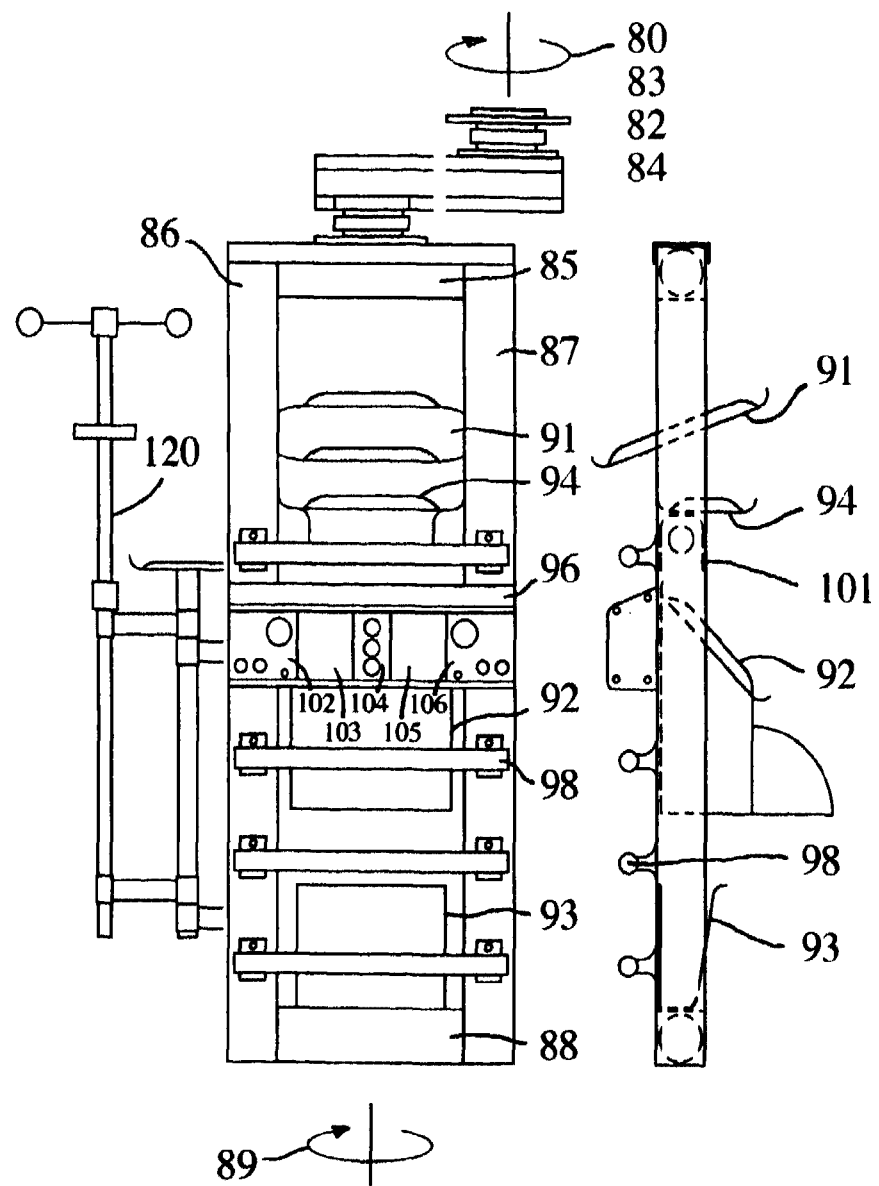
Fig. 9

**SUBSTITUTE SHEET**



**SUBSTITUTE SHEET**

**SUBSTITUTE SHEET**




89   
Fig. 12

Fig. 13

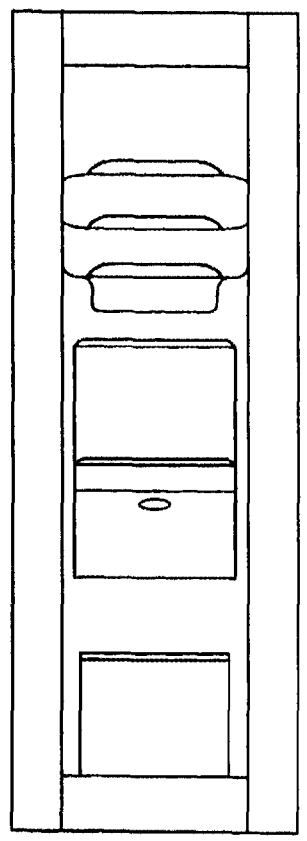


Fig. 14

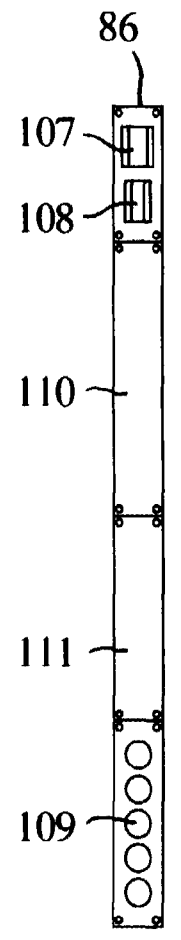
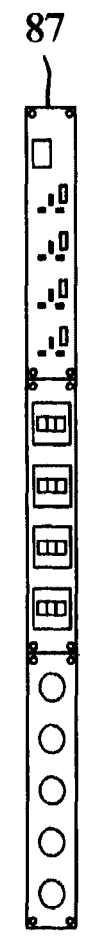


Fig. 15 Fig. 16



10 / 16

11 / 16

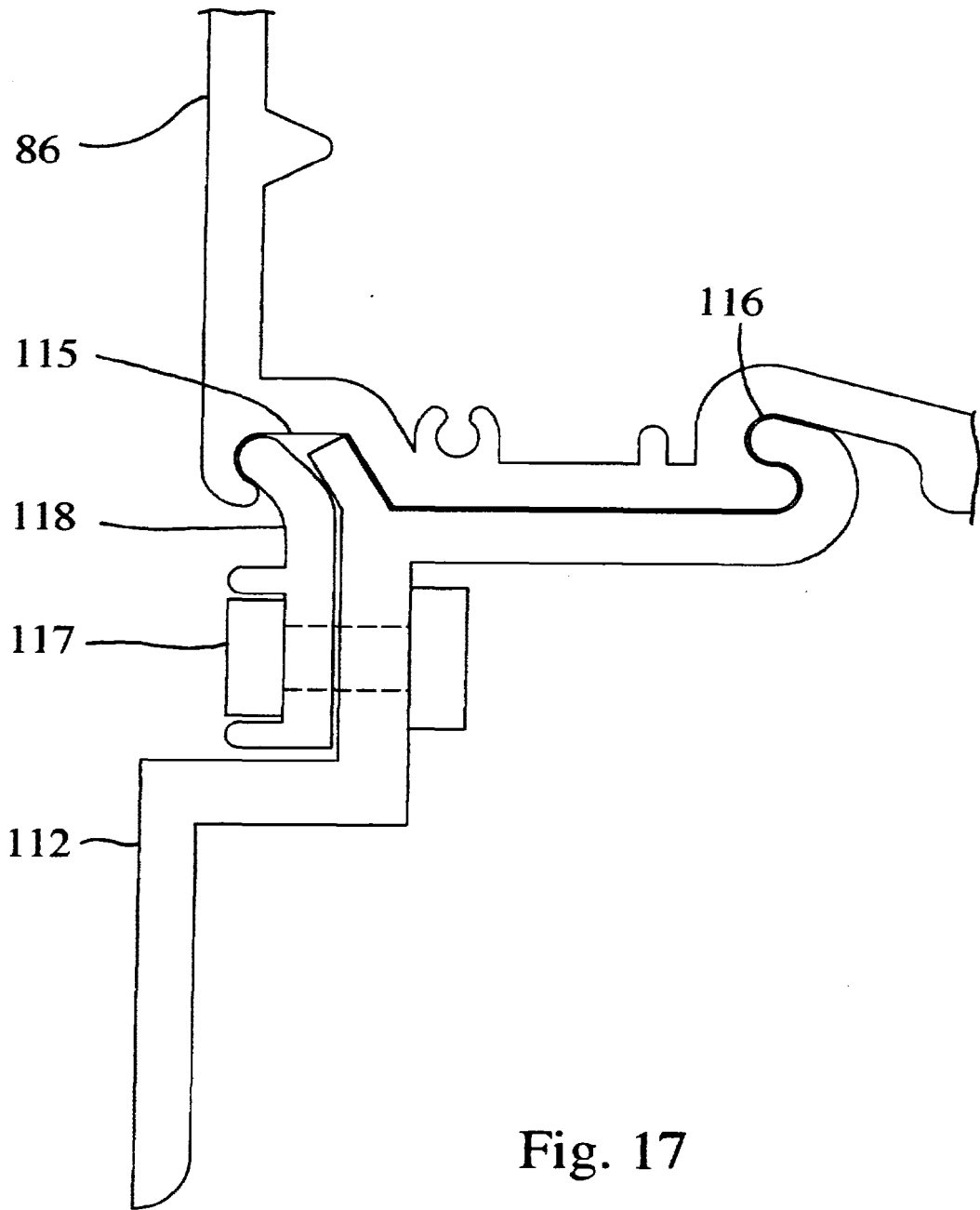


Fig. 17

**SUBSTITUTE SHEET**

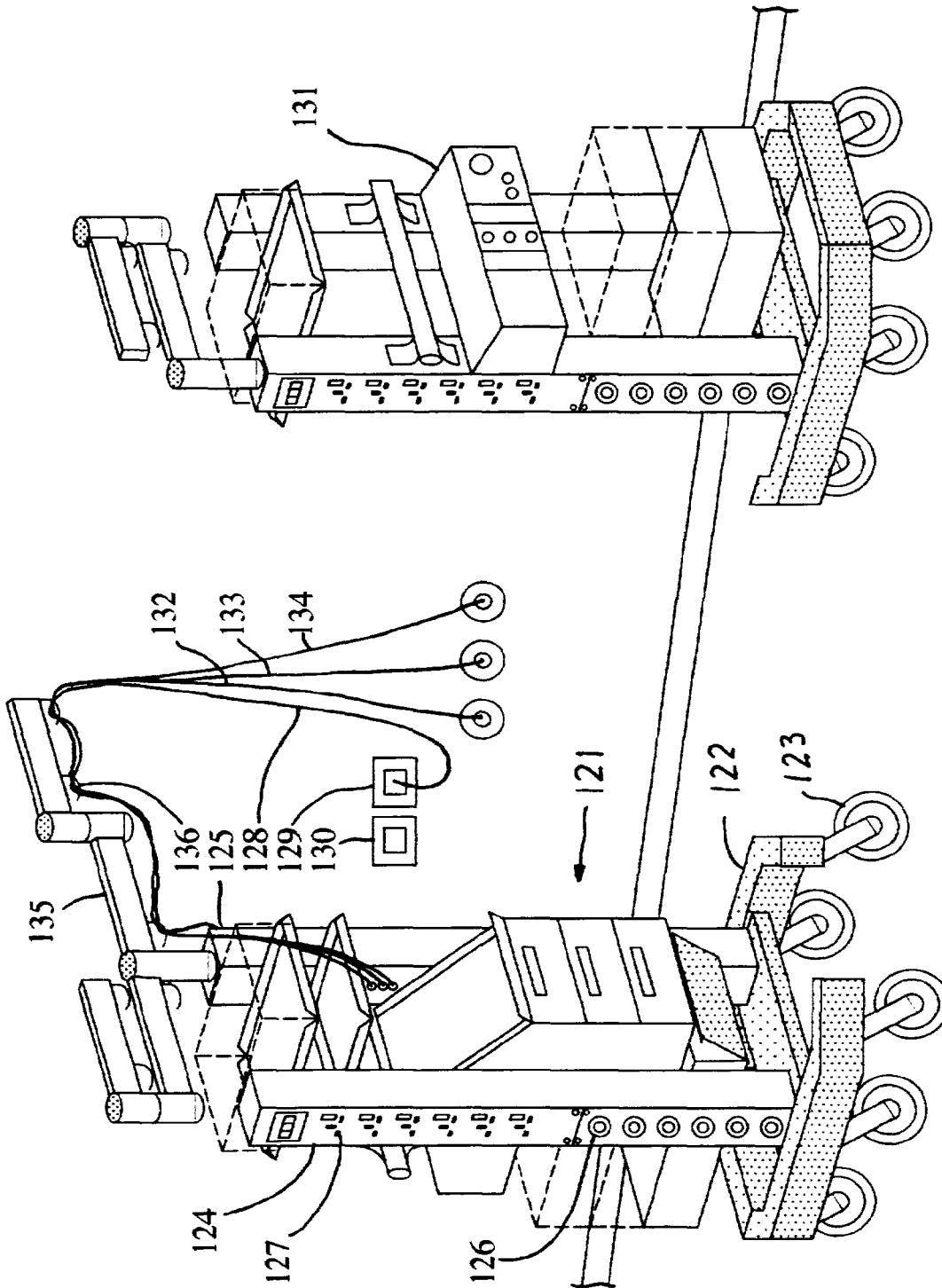


Fig. 19

Fig. 18

**SUBSTITUTE SHEET**

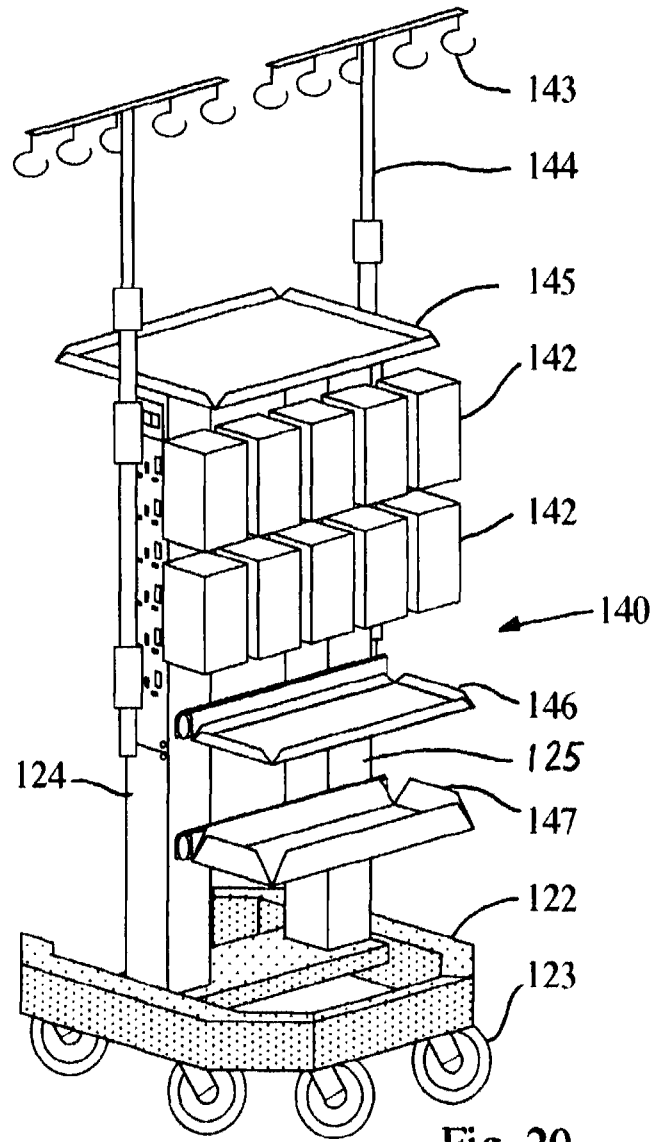


Fig. 20

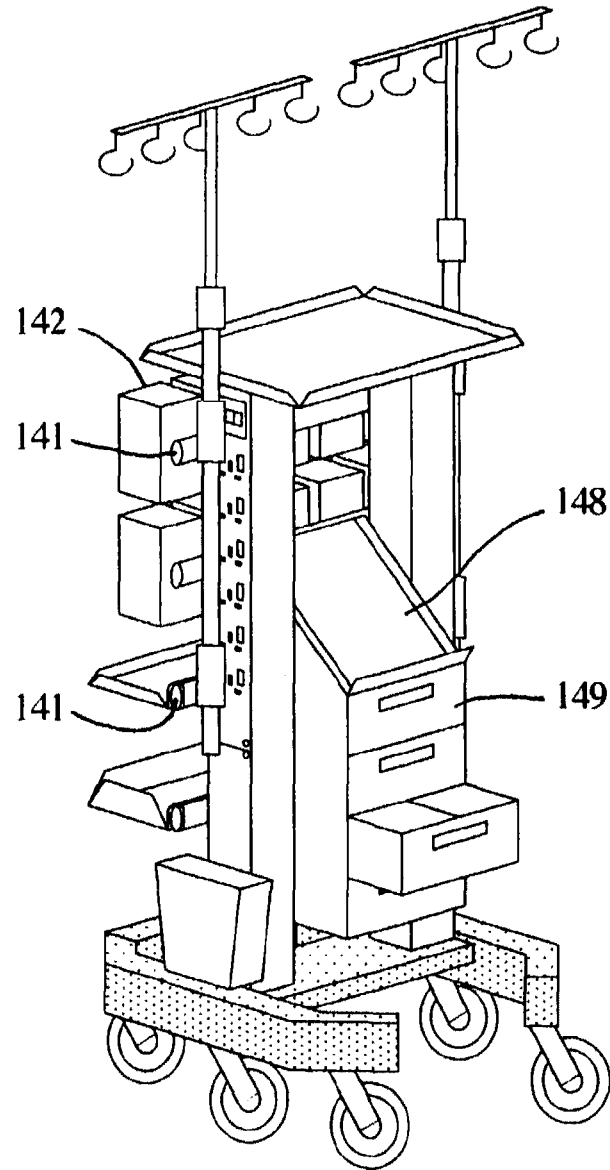


Fig. 21

14 / 16

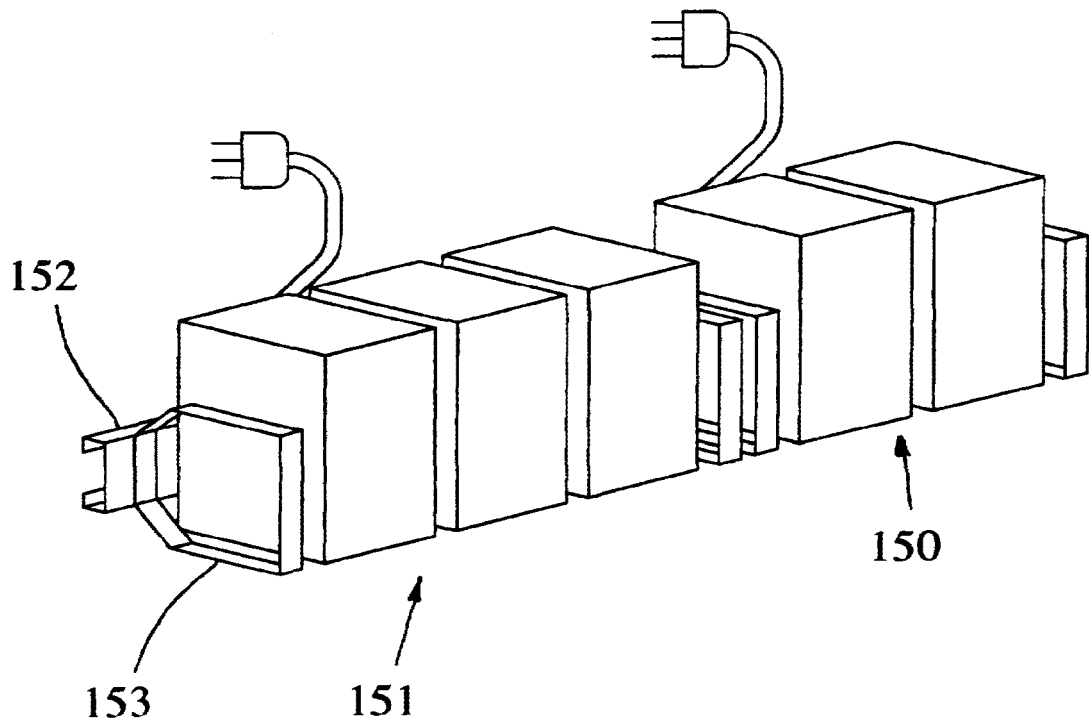


Fig. 22

**SUBSTITUTE SHEET**



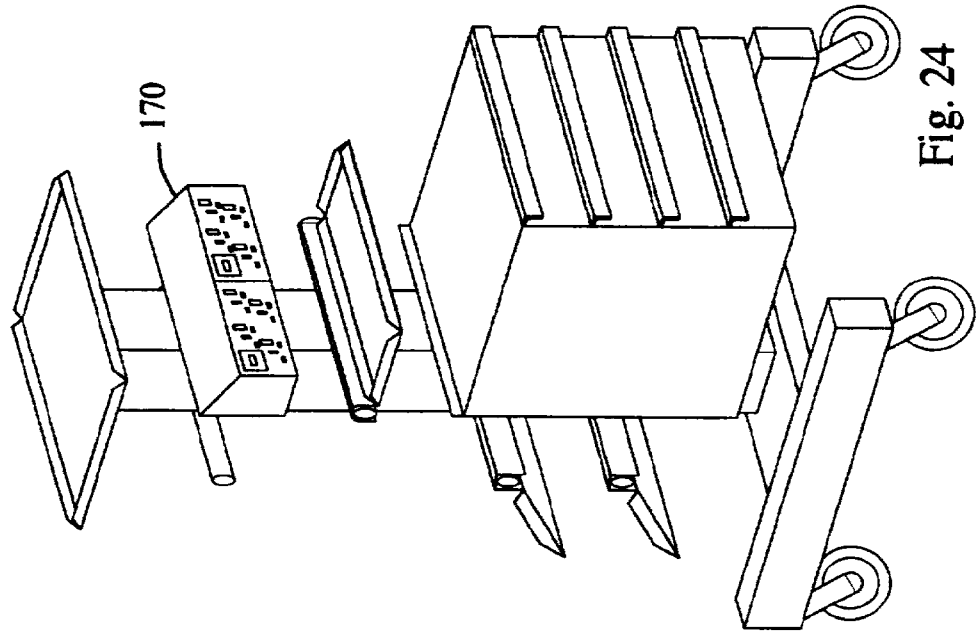


Fig. 24

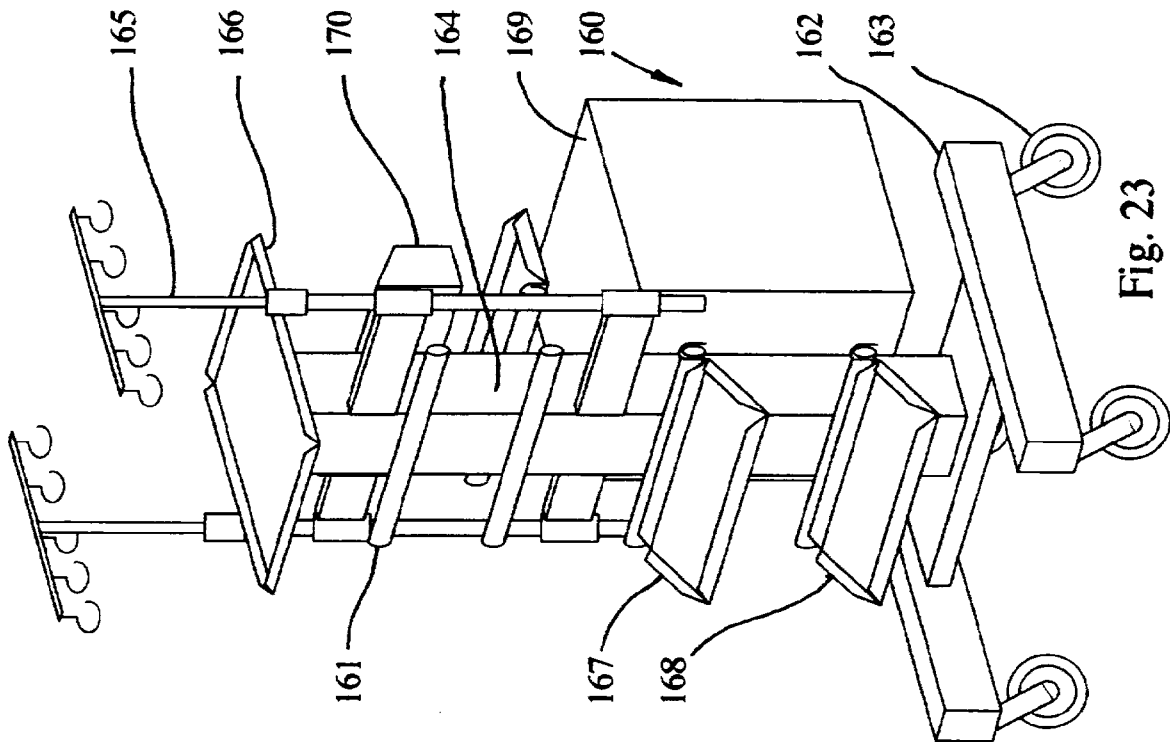


Fig. 23

**SUBSTITUTE SHEET**

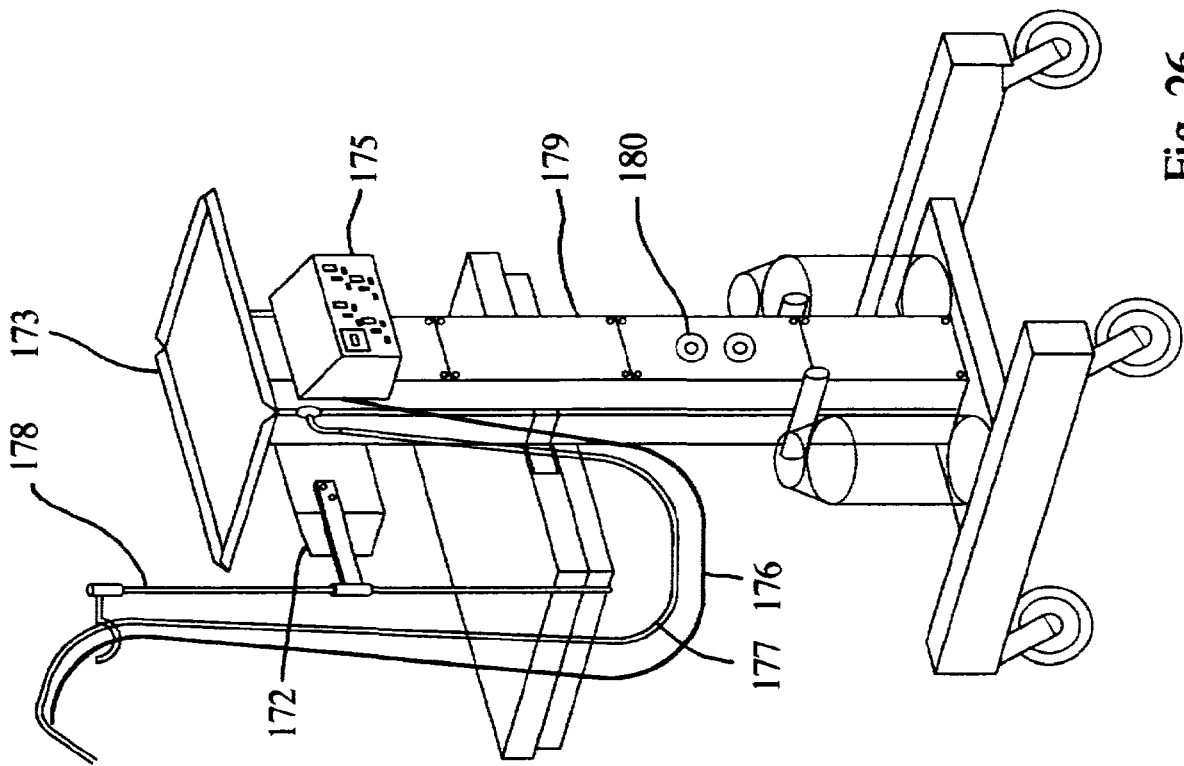


Fig. 26

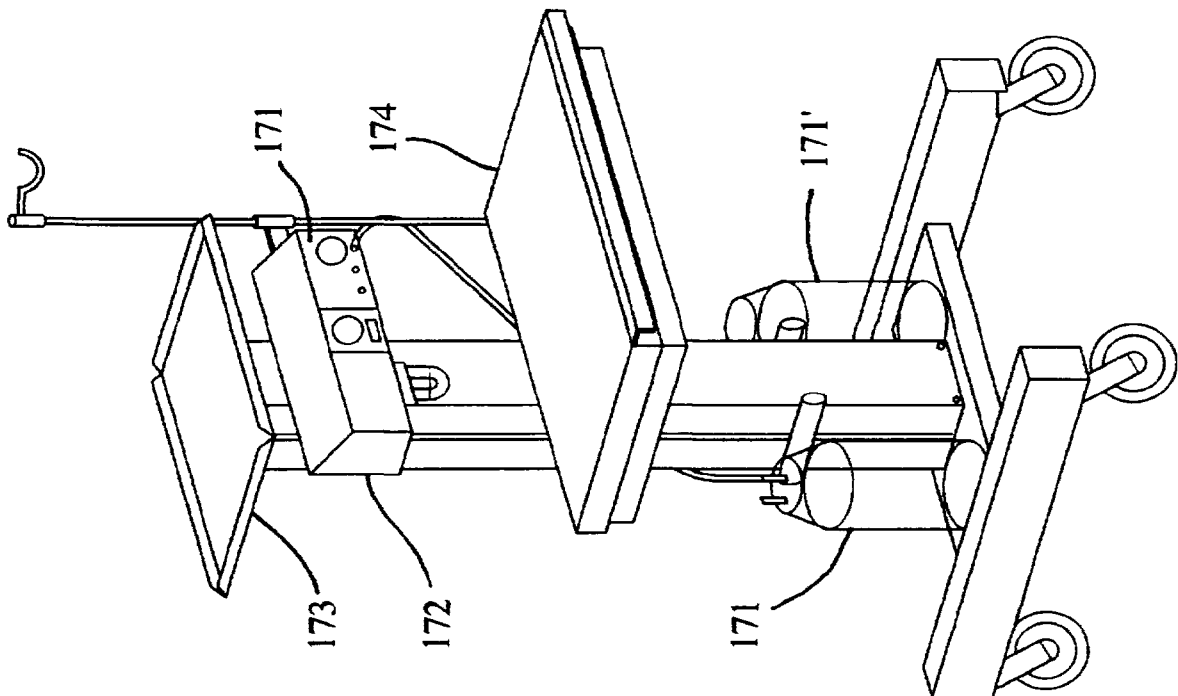


Fig. 25

**SUBSTITUTE SHEET**

## INTERNATIONAL SEARCH REPORT

International application No.

PCT/SE 95/01346

## A. CLASSIFICATION OF SUBJECT MATTER

IPC6: E04B 9/06, A61G 12/00, A61B 19/02

According to International Patent Classification (IPC) or to both national classification and IPC

## B. FIELDS SEARCHED

Minimum documentation searched (classification system followed by classification symbols)

IPC6: A61B, A61G, E04B, E04F, E04H

Documentation searched other than minimum documentation to the extent that such documents are included in the fields searched

SE,DK,FI,NO classes as above

Electronic data base consulted during the international search (name of data base and, where practicable, search terms used)

## C. DOCUMENTS CONSIDERED TO BE RELEVANT

| Category* | Citation of document, with indication, where appropriate, of the relevant passages  | Relevant to claim No. |
|-----------|---|-----------------------|
| X         | EP 0215212 A2 (TRILUX-LENZE GMBH & CO. KG),<br>25 March 1987 (25.03.87), column 4,<br>line 37 - column 6, line 8, figures 1-4<br>-- | 1,2,7,8               |
| X         | CH 568459 A5 (A.L.H., NILSSON), 31 October 1975<br>(31.10.75), column 3, line 42 - column 4, line 45,<br>figures 1-5<br>--          | 1,7,8                 |
| A         | --  | 15                    |
| A         | EP 0257299 A2 (KREUZER, F.), 2 March 1988<br>(02.03.88), column 2, line 13 - line 43, figures 1,<br>2<br>--                         | 1,7,8                 |

 Further documents are listed in the continuation of Box C. See patent family annex.

\* Special categories of cited documents:

"A" document defining the general state of the art which is not considered to be of particular relevance

"E" earlier document but published on or after the international filing date

"L" document which may throw doubts on priority claim(s) or which is cited to establish the publication date of another citation or other special reason (as specified)

"O" document referring to an oral disclosure, use, exhibition or other means

"P" document published prior to the international filing date but later than the priority date claimed

"T" later document published after the international filing date or priority date and not in conflict with the application but cited to understand the principle or theory underlying the invention

"X" document of particular relevance: the claimed invention cannot be considered novel or cannot be considered to involve an inventive step when the document is taken alone

"Y" document of particular relevance: the claimed invention cannot be considered to involve an inventive step when the document is combined with one or more other such documents, such combination being obvious to a person skilled in the art

"&amp;" document member of the same patent family

Date of the actual completion of the international search

12 February 1996

Date of mailing of the international search report

15 -02- 1996

Name and mailing address of the ISA/  
Swedish Patent Office  
Box 5055, S-102 42 STOCKHOLM  
Facsimile No. +46 8 666 02 86

Authorized officer

Ingemar Hedlund  
Telephone No. +46 8 782 25 00

## INTERNATIONAL SEARCH REPORT

International application No.

PCT/SE 95/01346

## C (Continuation). DOCUMENTS CONSIDERED TO BE RELEVANT

| Category* | Citation of document, with indication, where appropriate, of the relevant passages                               | Relevant to claim No. |
|-----------|--|-----------------------|
| X         | US 4993683 A (F. KREUZER), 19 February 1991<br>(19.02.91), column 2, line 21 - line 58, figures<br>1-3           | 9                     |
| A         | --   | 15                    |
| X         | EP 0603093 A1 (CHICOINE MEDICAL), 22 June 1994<br>(22.06.94), figure 1, claim 1                                  | 9                     |
| A         | EP 0219274 A2 (THE BOC GROUP, INC.), 22 April 1987<br>(22.04.87), figure 1, claim 1                              | 9,15                  |
| A         | US 5108064 A (F. KREUZER), 28 April 1992<br>(28.04.92), figure 1, claim 1  | 9                     |
| X         | EP 0477551 A1 (B. BRAUN MELSUNGEN AG),<br>1 April 1992 (01.04.92), column 4,<br>line 12 - line 46, figures 1,2   | 15                    |
| X         | FR 2702140 A1 (TECHNOBLOC SOCIETE A RESPONSABILITE<br>LIMITEE), 9 Sept 1994 (09.09.94), figures 1,2,<br>abstract | 15                    |
|           | -----  |                       |

INTERNATIONAL SEARCH REPORT

International application No.

PCT/SE 95/01346

Box I Observations where certain claims were found unsearchable (Continuation of item 1 of first sheet)

This international search report has not been established in respect of certain claims under Article 17(2)(a) for the following reasons:

- 1.  Claims Nos.:  
because they relate to subject matter not required to be searched by this Authority, namely:
  
- 2.  Claims Nos.:  
because they relate to parts of the international application that do not comply with the prescribed requirements to such an extent that no meaningful international search can be carried out, specifically:
  
- 3.  Claims Nos.:  
because they are dependent claims and are not drafted in accordance with the second and third sentences of Rule 6.4(a).

Box II Observations where unity of invention is lacking (Continuation of item 2 of first sheet)

This International Searching Authority found multiple inventions in this international application, as follows:

Supportive structure intended to be attached at a ceiling of a hospital room according to claims 1-8.

Medical support service unit for intensive care rooms according to claims 9-14.

Service mobile for carrying medical equipment according to claim 15.

- 1.  As all required additional search fees were timely paid by the applicant, this international search report covers all searchable claims.
- 2.  As all searchable claims could be searched without effort justifying an additional fee, this Authority did not invite payment of any additional fee.
- 3.  As only some of the required additional search fees were timely paid by the applicant, this international search report covers only those claims for which fees were paid, specifically claims Nos.:
  
- 4.  No required additional search fees were timely paid by the applicant. Consequently, this international search report is restricted to the invention first mentioned in the claims; it is covered by claims Nos.:

Remark on Protest

- The additional search fees were accompanied by the applicant's protest.
- No protest accompanied the payment of additional search fees.

## INTERNATIONAL SEARCH REPORT

Information on patent family members

05/01/96

International application No.

PCT/SE 95/01346

| Patent document cited in search report | Publication date | Patent family member(s) | Publication date |
|--|------------------|-------------------------|------------------|
| EP-A2- 0215212                         | 25/03/87         | DE-A- 3533229           | 26/03/87         |
| CH-A5- 568459                          | 31/10/75         | AT-B- 342254            | 28/03/78         |
|  |                  | CA-A- 1013278           | 05/07/77         |
|  |                  | DE-A, B, B 2347854      | 18/04/74         |
|  |                  | FR-A, B- 2200418        | 19/04/74         |
|  |                  | GB-A- 1451365           | 29/09/76         |
|  |                  | NL-A- 7313210           | 28/03/74         |
|  |                  | SE-B- 365841            | 01/04/74         |
|  |                  | US-A- 3931452           | 06/01/76         |
| EP-A2- 0257299                         | 02/03/88         | DE-A- 3627517           | 21/04/88         |
|  |                  | DE-A- 3778789           | 11/06/92         |
|  |                  | JP-A- 63049153          | 01/03/88         |
| US-A- 4993683                          | 19/02/91         | DE-D- 3884926           | 00/00/00         |
|  |                  | DE-U- 8716928           | 27/04/89         |
|  |                  | EP-A, A, A 0321822      | 28/06/89         |
|  |                  | JP-A- 1204665           | 17/08/89         |
| EP-A1- 0603093                         | 22/06/94         | NONE                    |                  |
| EP-A2- 0219274                         | 22/04/87         | AU-B, B- 572032         | 28/04/88         |
|  |                  | AU-A- 6272386           | 30/04/87         |
|  |                  | JP-A- 62087155          | 21/04/87         |
| US-A- 5108064                          | 28/04/92         | CA-A- 2029492           | 11/05/91         |
|  |                  | DE-A, C- 3937518        | 16/05/91         |
|  |                  | DE-U- 8916163           | 09/06/94         |
|  |                  | EP-A, A, A 0427130      | 15/05/91         |
|  |                  | JP-A- 3272395           | 04/12/91         |
| EP-A1- 0477551                         | 01/04/92         | AT-T- 117535            | 15/02/95         |
|  |                  | DE-C- 4030368           | 14/11/91         |
|  |                  | DE-D- 59104385          | 00/00/00         |
| FR-A1- 2702140                         | 09/09/94         | NONE                    |                  |

(19) World Intellectual Property Organization  
International Bureau



(43) International Publication Date  
5 December 2002 (05.12.2002)

PCT

(10) International Publication Number  
WO 02/096335 A2

- (51) International Patent Classification<sup>7</sup>: A61G
- (21) International Application Number: PCT/US02/16404
- (22) International Filing Date: 23 May 2002 (23.05.2002)
- (25) Filing Language: English
- (26) Publication Language: English
- (30) Priority Data: 60/293,949 25 May 2001 (25.05.2001) US
- (71) Applicant (for all designated States except US): HILL-ROM SERVICES, INC. [US/US]; 1069 State Route 46 East, Batesville, IN 47006-9167 (US).
- (72) Inventors; and
- (75) Inventors/Applicants (for US only): GALLANT, Dennis, J. [US/US]; 10208 Cartha Lane, Harrison, OH 45030

(US). LANCI, Dennis, M. [US/US]; 7999 Paseo Esmerado, Carlsbad, CA 92009 (US).

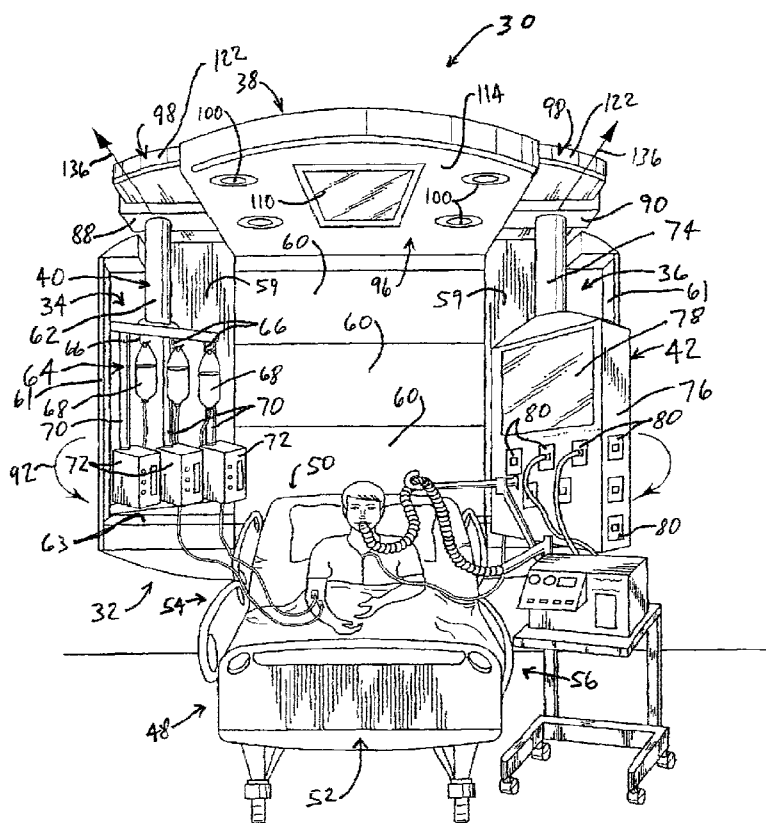
(74) Agent: CONARD, Richard, D.; Barnes & Thornburg, 11 South Meridian Street, Indianapolis, IN 46204 (US).

(81) Designated States (national): AE, AG, AL, AM, AT, AU, AZ, BA, BB, BG, BR, BY, BZ, CA, CH, CN, CO, CR, CU, CZ, DE, DK, DM, DZ, EC, EE, ES, FI, GB, GD, GE, GH, GM, HR, HU, ID, IL, IN, IS, JP, KE, KG, KP, KR, KZ, LC, LK, LR, LS, LT, LU, LV, MA, MD, MG, MK, MN, MW, MX, MZ, NO, NZ, OM, PH, PL, PT, RO, RU, SD, SE, SG, SI, SK, SL, TJ, TM, TN, TR, TT, TZ, UA, UG, US, UZ, VN, YU, ZA, ZM, ZW.

(84) Designated States (regional): ARIPO patent (GH, GM, KE, LS, MW, MZ, SD, SL, SZ, TZ, UG, ZM, ZW), Eurasian patent (AM, AZ, BY, KG, KZ, MD, RU, TJ, TM), European patent (AT, BE, CH, CY, DE, DK, ES, FI, FR, GB, GR, IE, IT, LU, MC, NL, PT, SE, TR), OAPI patent

[Continued on next page]

(54) Title: ARCHITECTURAL SYSTEM ADAPTABLE TO PATIENT ACUITY LEVEL



(57) Abstract: An architectural system (30, 230, 330) adaptable to patient acuity level has headwall unit (32, 232) with a cavity (34, 36, 234, 236), a ceiling unit (38, 238, 338), and a column (40,42) coupled to the ceiling unit (38, 238, 338). The column (40, 42) is movable between a first position in which at least a majority of the column (40, 42) is situated in the cavity (34, 36, 234, 236) and a second position in which the column (40, 42) is situated outside the cavity (34, 36, 234, 236). Various types of patient-care equipment are also disclosed. The patient-care equipment is included in, or is coupleable to, one or more of the ceiling unit (38, 238, 338), the headwall unit (32, 232), or the column (40, 42).



WO 02/096335 A2



(BF, BJ, CF, CG, CI, CM, GA, GN, GQ, GW, ML, MR, NE, SN, TD, TG).

*For two-letter codes and other abbreviations, refer to the "Guidance Notes on Codes and Abbreviations" appearing at the beginning of each regular issue of the PCT Gazette.*

**Published:**

— *without international search report and to be republished upon receipt of that report*



## ARCHITECTURAL SYSTEM ADAPTABLE TO PATIENT ACUITY LEVEL

## CROSS-REFERENCE TO RELATED APPLICATION

This application claims priority under 35 U.S.C. § 119(e) to U.S. Provisional Patent Application Serial No. 60/293,949, filed on May 25, 2001, the disclosure of which is hereby incorporated by reference herein.

## BACKGROUND AND SUMMARY

The present disclosure relates to architectural systems, such as headwalls, columns, and ceiling-suspended arm assemblies used in hospitals, and particularly to an architectural system adaptable to patient acuity level. More particularly, the present disclosure relates to an architectural system that is configured to deliver services, such as medical gases, to a patient and/or that is configured to support patient-care devices for delivering intensive care services to a patient.

Architectural systems, such as headwalls, columns, and ceiling-suspended arm assemblies, through which medical gases are accessible via medical service outlets are known. Headwalls, columns, and arm assemblies having rails, tracks, or brackets for attachment of patient-care devices and having electrical outlets for delivering power to the patient-care devices are also known. Patients in critical condition are oftentimes located in an intensive care unit of a hospital, whereas patients in stable condition are oftentimes located in a standard patient room. Architectural systems in intensive care units are generally configured to hold more patient-care devices and provide more types of medical services than architectural systems found in a standard patient room.

The numbers of patients in critical condition and the numbers of patients in stable condition fluctuate in a hospital over time. Thus, at any given time there may be either a shortage or excess of spaces for patients in an intensive care unit. In addition, at any given time there may be either a shortage or surplus of standard hospital rooms. Thus, there is a need for an architectural system that is adaptable to patients having high, medium, and low acuity levels so that hospitals have the flexibility to meet the needs of the patient population at any give time.

According to this disclosure, an architectural system adaptable to an acuity level of a patient supported by a hospital bed in a patient room having a wall

-2-

and a ceiling is provided. The architectural system comprises a wall unit coupled to the wall and having a cavity, a ceiling unit coupled to the ceiling, and a column coupled to the ceiling unit for movement between a first position in which at least a majority of the column is situated in the cavity and a second position in which the column is situated outside the cavity.

5  
10  
15  
20  
25  
30  
Various patient-care devices and equipment are attachable to the column. Such patient care devices include, for example, IV racks, infusion pumps, ventilation equipment, heart rate monitoring equipment, and patient data acquisition equipment. In an illustrative embodiment, a number of medical service outlets, such as gas outlets and electrical outlets, are coupled to the column. Also in the illustrative embodiment, a number of doors are coupled to the wall unit for opening and closing the cavity. Thus, when the column is in the cavity, the doors may be moved to closed positions shielding the column and the equipment carried by the column from view and blocking access to the medical service outlets on the column. Opening the doors, but leaving the column in the cavity of the headwall unit, permits access to some of the medical service outlets and to some portions of the equipment carried by the column. When the column is moved out of the cavity, all of the medical service outlets and all pertinent portions of the equipment carried by the column are accessible.

Also according to this disclosure, a ceiling unit having one or more pieces of equipment coupled thereto is provided. Such equipment includes, for example, a reading light, an examination light, a display screen, air curtain generation equipment, a privacy curtain, a temperature sensor, an air quality sensor, an air purifier, aroma therapy equipment, a motion sensor, and a proximity sensor. In one illustrative embodiment, an arm assembly is coupled to the ceiling unit and supports an overbed table. The arm assembly permits the overbed table to be moved from one side of a hospital bed to an opposite side of the hospital bed.

A mobile cart is also disclosed herein. In an illustrative embodiment, the mobile cart comprises an upstanding pedestal, a plurality of legs coupled to a bottom of the upstanding pedestal, and a plurality of wheels. Each wheel is coupled to a respective leg of the plurality of legs. The legs, along with the wheels coupled thereto, are each movable between a first position extending outwardly from beneath the upstanding pedestal and a second position tucked beneath the upstanding pedestal.

-3-

The mobile cart is attachable to a ceiling-mounted column or an arm assembly. The mobile cart is also attachable to a hospital bed to be transported with the bed. When the mobile cart is attached to either the column, the arm assembly, or the bed, the wheels of the mobile cart are spaced apart for the floor. A headwall unit having a cavity configured to receive the mobile cart is also disclosed. The mobile cart carries one or more pieces of patient-care equipment such as, for example, an IV pole, an infusion pump, a ventilator control unit, a gas tank, a gas control unit, a vital signs monitor, an on-board computer, a receiver, a transmitter, and a battery.

Further according to this disclosure, a set of hospital equipment comprises a headwall, a blanket, a unit housed in the headwall, and a hose coupled to the blanket and coupled to the unit, a thermoregulation medium being moved between the blanket and the unit through the hose. The thermoregulation medium includes, for example, heated air, cooled air, a heated liquid, or a cooled liquid. In some embodiments, in which the thermoregulation medium is heated or cooled air, the blanket has a plurality of perforations through which the heated or cooled air is expelled.

Additional features will become apparent to those skilled in the art upon consideration of the following detailed description of illustrative embodiments exemplifying the best mode of carrying out the various inventions disclosed herein as presently perceived.

#### BRIEF DESCRIPTION OF THE DRAWINGS

The detailed description particularly refers to the accompanying figures, in which:

Fig. 1 is a perspective view of an architectural system adaptable to patient acuity level according to this disclosure showing a headwall unit behind a hospital bed on which a patient is resting, a ceiling unit extending from the headwall unit, the ceiling unit overlying the hospital bed, an IV rack situated in a first cavity of the headwall unit, and a housing having a display screen and a number of medical service outlets situated in a second cavity of the headwall unit;

Fig. 2 is a perspective view, similar to Fig. 1, showing a first column moved out of first cavity so that the IV rack carried by the first column is situated alongside a first side of the hospital bed and a second column moved out of the

-4-

second cavity so that the housing included as part of the second column is situated alongside a second side of the hospital bed;

Fig. 3 is a top plan view of a portion of the architectural system of Fig. 1 showing the first and second columns received in the first and second cavities, respectively, of the headwall unit and showing a head end of the hospital bed situated in close proximity to the headwall unit;

Fig. 4 is a top view, similar to Fig. 3, showing the first and second columns moved out of the first and second cavities, respectively, of the headwall unit and showing the hospital bed moved away from the headwall unit by a sufficient amount to permit a caregiver to stand between the head end of the hospital bed and the headwall unit;

Fig. 5 is a transverse sectional view of a portion of the architectural system of Fig. 1 showing rollers of the second column engaging a track of the ceiling unit and showing medical service lines (in phantom) extending from each of the medical service outlets, through the second column, and through the ceiling unit;

Fig. 6 is a longitudinal sectional view of a portion of the architectural system of Fig. 1 showing the second column being movable between a first position (in solid) in close proximity to the headwall unit and a second position (in phantom) spaced from the headwall unit and showing the medical lines being routed into a central region of the ceiling unit to accommodate the movement of the second column between the first and second positions;

Fig. 7 is a top plan view of a portion of the architectural system of Fig. 1 showing the first and second columns in a number of positions and showing the routing of the medical lines from the central region of the ceiling unit to the first and second columns;

Fig. 8 is a perspective view of the architectural system of Fig. 1 showing the first column carrying an IV rack having a bottom plate arranged for coupling to a pair of upright posts that are mounted to a distal end of a support arm extending from a bed frame of the hospital bed;

Fig. 9 is a side elevation view of the architectural system of Fig. 8 showing the first column (in solid) supporting the IV rack above the upright posts and showing the first column (in phantom) supporting the IV rack in the first cavity of the headwall unit;

Fig. 10 is a side elevation view, similar to Fig. 9, showing the IV rack decoupled from the first column and coupled to the hospital bed to be transported with the hospital bed;

5 Fig. 11 is a perspective view of a first alternative embodiment of an architectural system according to this disclosure showing the ceiling unit having lateral extensions for supporting auxiliary equipment laterally outward of the first and second columns, a first set of door panels covering the first column, and a second set of door panels being opened by varying amounts to partially uncover various portions of the second column;

10 Fig. 12 is a perspective view of a portion of the architectural system of Fig. 11 showing a privacy curtain moved out of an auxiliary cavity of the headwall unit and hanging from one of the lateral extensions of the ceiling unit;

15 Fig. 13 is a perspective view, similar to Fig. 12, showing an alternative embodiment of a privacy curtain extending downwardly from one of the lateral extensions of the ceiling unit;

Fig. 14 is a perspective view, similar to Figs. 12 and 13, but of another portion of the architectural system of Fig. 11 showing an auxiliary IV pole moved out of an auxiliary compartment of the headwall unit and hanging from one of the lateral extensions of the ceiling unit;

20 Fig. 15 is a perspective view of a second alternative embodiment of an architectural system according to this disclosure showing a plurality of openings formed in a perimetral region of the ceiling unit and showing air curtain generation equipment (in phantom) operating to move air out of the plurality of openings to form vertical air curtains along the foot end and opposite sides of the hospital bed;

25 Fig. 16 is a bottom plan view of the ceiling unit of Fig. 15 showing, in phantom, a fan and a set of channels through which air moves to reach the plurality of openings;

30 Fig. 17 is a perspective view of an environmentally-controlled hospital room showing a patient supported by a hospital bed in the room, a disposable thermoregulation blanket covering a portion of the patient, the disposable thermoregulation blanket being coupled via a hose to a thermoregulation unit housed in a headwall of the hospital room, and an environmental control canopy coupled to a ceiling of the hospital room above the hospital bed;

-6-

Fig. 18 is a perspective view of a mobile cart according to this disclosure showing the mobile cart having a somewhat rectangular upstanding pedestal, the pedestal having a fairly small depth dimension between a front face and a rear face of the pedestal, the mobile cart having four horizontally extending support legs coupled to the bottom of the pedestal, a set of casters coupled to distal ends of the support legs, and each support leg being pivotable relative to the pedestal about a respective vertical axis between a first position (in solid) extending outwardly from beneath the pedestal and a second position (in phantom) tucked beneath the pedestal;

Fig. 19 is a side plan view of a first hospital room showing the mobile cart of Fig. 18 being mounted to a head end of a hospital bed, a second mobile cart, like the mobile cart of Fig. 18, being suspended from a ceiling of the room by an arm assembly, the support legs of the two mobile carts all being in their respective second positions, and the casters of the two mobile carts all being spaced apart from a floor of the room;

Fig. 20 is side plan view of a second hospital room showing the mobile cart (in phantom) being situated in a cavity (in phantom) formed in a headwall of the hospital room;

Fig. 21 is a perspective view of a hospital bed supported on a floor of a hospital room and an overbed table assembly that is suspended from a ceiling of a hospital room showing the overbed table assembly including a hub unit coupled to the ceiling above the hospital bed, an arm assembly coupled to the hub unit and extending downwardly therefrom, an entertainment-and-control panel coupled to a vertical arm of the arm assembly, an overbed table coupled to the vertical arm beneath the entertainment-and-control panel, and a telephone coupled to the overbed table;

Fig. 22 is a perspective view of a portion of the overbed table assembly of Fig. 40 showing the overbed table assembly including a service-delivery housing coupled to an underside of the overbed table and a plurality of medical service outlets on an end face of the service-delivery housing; and

Fig. 23 is a top plan view of the hospital bed and the overbed table assembly of Fig. 22 showing the arm assembly moving between a first position (in solid) having the overbed table extending over a lap of the patient from a first side of the hospital bed and a second position (in phantom) having the overbed table extending over the lap of the patient from a second side of the bed and showing that

the service-delivery housing moves around a foot end of the bed as the arm assembly moves between the first and second positions.

#### DETAILED DESCRIPTION OF THE DRAWINGS

5                   An first embodiment of an architectural system 30 according to this disclosure comprises a headwall unit 32 having a first cavity 34 and a second cavity 36, a ceiling unit 38, a first column 40, and a second column 42 as shown in Figs. 1 and 2. Columns 40, 42 hang downwardly from ceiling unit 36 and are each independently movable between respective storage positions situated within a  
10                   respective cavity 34, 36 and a plurality of use positions situated outside of cavities 34, 36. Headwall unit 32 is configured for attachment to a wall 44 of a hospital room and ceiling unit 38 is configured for attachment to a ceiling 46 of the hospital room.

                  A hospital bed 48 is situated in the hospital room such that a head end 50 of the bed 48 is near headwall unit 32 and a foot end of the bed is spaced from  
15                   head wall unit 32 as shown in Figs. 1-4. Columns 40, 42 are spaced apart by a sufficient distance to permit hospital bed 48 to occupy the space defined between columns 40, 42 when columns 40, 42 are situated outside of cavities 34, 36 as shown, for example, in Figs. 2 and 4. Thus, column 40 is positioned alongside a first side 54 of hospital bed 48 when outside of cavity 34 and column 42 is positioned alongside a  
20                   second side 56 of hospital bed 48 when outside of cavity 36.

                  Columns 40, 42 each carry patient-care equipment, some of which is configured to provide medical services to high acuity patients, such as critical patients requiring intensive care. Patient-care equipment needed for medium acuity patients, such as patients requiring medical gas to aid respiration and intravenous (IV) fluids  
25                   are also carried on one or both of columns 40, 42. For medium acuity patients, columns 40, 42 are usually placed in cavities 34, 36 in the respective storage positions and the needed medical services are provided to the patient from columns 40, 42 as shown in Figs. 1 and 3. Optionally, columns 40, 42 may be moved out of cavities 34, 36 for medium acuity patients. For high acuity patients, columns 40, 42 are usually  
30                   moved out of cavities 34, 36 to positions alongside bed 48 so that multiple medical services are accessible to the patient and to other pieces of medical equipment as shown, for example, in Figs. 2 and 4. For low acuity patients that do not require

medical services from columns 40, 42, columns 40, 42 are usually placed in the storage positions so as to be out of the way.

Headwall unit 32 has a plurality of doors 58 that are movable between closed positions covering associated portions of columns 40, 42 and opened positions  
5 allowing access to the associated portions of columns 40, 42. For low acuity patients, doors 58 are typically closed to conceal columns 40, 42 from view. In the illustrative embodiment, each of doors 58 slides horizontally behind an associated central panel 60 of headwall unit 32. In some alternative embodiments, doors 58 slide horizontally in front of the associated central panels 60. In other alternative embodiments, doors  
10 58 either raise or lower or pivot when moving between opened and closed positions. In the illustrative embodiment in which doors 58 slide horizontally behind panels 60, each of panels 60 is large enough to accommodate both of the associated doors 58 therebehind. It is within the scope of this disclosure for headwall unit 32 to have tracks or other surfaces (not shown) on which doors 58 slide. It is also within the  
15 scope of this disclosure for rollers (not shown) to be coupled to doors 58 and for the rollers to roll on tracks or surfaces as doors 58 move between the opened and closed positions.

In the illustrative embodiment, three doors 58 are associated with cavity 34 to cover top, middle, and lower portions of cavity 34 and three doors 58 are  
20 associated with cavity 36 to cover top, middle, and lower portions of cavity 36. In alternative embodiments, more or less than three doors are provided for covering respective cavities 34, 36. Optionally, locking mechanisms (not shown) are mounted to each door 58 for locking the respective door in the closed position to prevent a patient or any other unauthorized person from opening doors 58 to gain access to the  
25 equipment mounted on columns 40, 42.

Headwall unit 32 has a frame (not shown) to which central panels 60 couple. Headwall unit 32 has other panels or walls, such as a vertical back wall 59 and a pair of outer side walls 61 that extend from back wall in perpendicular relation therewith. In addition, headwall unit 32 has horizontal walls 63 that underlie cavities  
30 34, 36 and inner side walls 65 that are spaced from, but parallel with, walls 61 as shown in Fig. 8. Cavities 34, 36 are defined, in part, by walls 59, 61, 63, 65. One or more of walls 59, 61, 63, 65 are coupled to the frame of headwall unit 32. In the illustrative embodiment, headwall unit 32 includes a lower portion 67 that is situated



between a floor 69 of the hospital room and the portion of headwall unit 32 having central panels 60 associated therewith as shown in Fig. 8. A set of auxiliary medical service outlets 71 are coupled to lower portion 67. In addition, the portions of headwall unit 32 in which cavities 34, 36 are defined overhang underlying portions of floor 69 that are laterally outward of lower portion 67.

As previously mentioned, columns 40, 42 carry patient-care equipment. Column 40 is configured to have patient-care equipment attached thereto and detached therefrom, whereas column 42 has patient-care equipment integrated therewith as shown in Figs. 1 and 2. In the illustrative example, column 40 has a vertical arm 62 and an IV rack 64 coupled to vertical arm 62 by suitable couplers such as, for example, clamps, brackets, latches, grippers, or hooks. IV rack 64 has one or more hooks 66 to which IV bags 68 couple and one or more poles 70 to which infusion pumps 72 couple. It is within the scope of this disclosure for any type of medical equipment capable of coupling to an IV pole to be coupled to IV rack. As shown in Figs. 9 and 10, one or more medical service outlets 73 are mounted to arm 62 of column 40. Services accessible via outlets 73 include electrical services, such as electrical power and data transfer, and pneumatic services, such as medical gases or suction. Illustratively, electrical power is provided to infusion pump 72 from one of outlets 73 as shown in Fig. 9.

In the illustrative example, column 42 has a vertical arm 74 and a housing 76 coupled to arm 74. A display screen 78 is coupled to an upper portion of housing 76 and a plurality of medical service outlets 80 are coupled to a lower portion of housing 76. Services available via outlets 80 include similar electrical and/or pneumatic services as are available from outlets 73. Service-delivery lines 82 are routed from each of outlets 80 through housing 76 and arm 74 of column 42 and through ceiling unit 38 as shown in Figs. 5-7. In addition, service-delivery lines 84 are routed from each of outlets 73 through arm 62 of column 40 and through ceiling unit 38 as shown in Fig. 7. In addition, lines 82, 84 are routed into ceiling 46 through an opening 86 that is formed in ceiling above a central region of ceiling unit 38.

Column 40 has a carriage 88 to which arm 62 is coupled and column 42 has a carriage 90 to which arm 74 is coupled as shown in Fig. 2. In some embodiments, arm 62 and IV rack 64 (or any other patient-care equipment coupled to arm 62) are pivotable about a vertical axis relative to carriage 88 in a first direction as

indicated by arrow 92, shown in Fig. 2, and in an opposite, second direction as indicated by arrow 94, shown in Fig. 4. In other embodiments, arm 62 is fixed relative to carriage 88 but the coupler to which IV rack 64 (or other patient-care equipment) couples is pivotable relative to arm 64 in directions 92, 94. Similarly, in  
5 some embodiments, arm 74 and housing 76 are pivotable about a vertical axis relative to carriage 90 in first and second directions and, in other embodiments, arm 74 is fixed relative to carriage 90 and housing 76 is pivotable relative to arm 74 about a vertical axis in first and second directions. Various angular orientations of columns 40, 42 about their respective vertical axes are shown in Fig. 7. In illustrative  
10 embodiments, the vertical axes about which IV rack 64 and housing 76 pivot extend through associated vertical arms 62, 74.

Ceiling unit 38 of system 30 has a central portion or canopy 96 and a pair of side portions or tracks 98 as shown, for example, in Figs. 1 and 2. Canopy 96 generally overlies bed 48, whereas tracks 98 are situated laterally outward of canopy  
15 96. Canopy 96 has a set of lights 100 integrated therein. Lights 100 include reading lights and/or examination lights. In some embodiments, reading lights comprise standard incandescent or fluorescent bulbs, whereas examination lights comprise, for example, halogen bulbs and color-correction filters. All types of reading lights and examination lights are contemplated by this disclosure as being included in ceiling  
20 unit 38. Illustrative canopy 96 also has a display screen 110 integrated therein. In other embodiments, display screen 110 is omitted. Various images, such as family photos and nature scenes may be displayed on screen 110.

Ceiling unit 38 has a first or proximal end coupled to or overlying portions of headwall unit 32 and an opposite, distal end that is spaced apart from  
25 headwall unit 32. Thus, ceiling unit 38 extends from headwall unit 32 along ceiling 46 of the hospital room. Canopy 96 comprises a housing or frame 112 and a cosmetic cover or panel 114 that couples to frame 112 as shown in Figs. 5 and 6. Frame 112 includes portions (not shown) that couple to ceiling 46 and/or to headwall unit 32 with suitable couplers such as, for example, bolts, rivets, welds, clamps, tabs, and the  
30 like. The various pieces of equipment carried by ceiling unit 38, including lights 100 and screen 110, are mounted to frame 112 and extend through appropriately sized openings formed in panel 114. In addition, portions of lines 82, 84 loosely drape over frame 112 and cover 114 as shown in Figs. 5 and 6. Lines 82, 84 are routed through

suitably sized slots or spaces 116 that are provided between frame 112 and ceiling 46, or alternatively, between other portions of ceiling unit 38 through which lines 82, 84 are routed.

As columns 40, 42 move between the storage and various use positions, lines 82, 84 move relative to ceiling unit 38 in a somewhat random manner. However, frame 112 and cover 114 are situated beneath portions of lines 82, 84 to shield these portions of lines 82, 84 from view. Other portions of lines 82, 84 are shielded from view by columns 40, 42, respectively. In the illustrative embodiment, panel 114 has lateral side portions 118 that underlie portions of carriages 88, 90 as shown in Fig. 5 with respect to carriage 90. Side portions 118 further shield lines 82, 84 from view. Lines 82, 84 have sufficient slack in the interior region of canopy 96 to permit columns 40, 42 to move from the respective storage positions to the respective farthest use positions adjacent the distal end of associated tracks 98. It is within the scope of this disclosure for one or more line management mechanisms, such as strain reliefs, hoses, conduits, cables, cable ties, articulating segmented channels, and the like, to be coupled to lines 82, 84 either to guide or control the movement of lines 82, 84 or to restrain the movement of lines 82, 84 in a desired manner as columns 40, 42 move between the storage positions in cavities 34, 36, respectively, and the various positions outside of cavities 34, 36.

Each illustrative track 98 comprises a track member 120 and a cosmetic cover or panel 122 coupled to the respective member 120 as shown in Fig. 5. Suitable couplers, such as illustrative bolts 123, couple track member 120 to ceiling 46 or, in alternative embodiments, to portions of frame 112 that overlie tracks 98. The proximal ends of track members 120 overlie respective cavities 34, 36 to permit carriages 88, 90 to move along track members 120 into cavities 34, 36, respectively. Columns 40, 42 each comprise a plurality of rollers 124 some of which engage a first roller-engaging surface 126 of the associated member 120 and others of which engage a second roller-engaging surface 128 of the associated member 120 as also shown in Fig. 5. Surfaces 126, 128 are each elongated and extend generally perpendicularly relative to wall 44 of the hospital room. Thus, surfaces 126 are parallel with surfaces 128. In addition, surfaces 126, 128 lie in a common horizontal plane. In some alternative embodiments, track members 120 are curved and in other alternative embodiments, track members 120 are not parallel to each other.

Carriages 88, 90 are each somewhat U-shaped having central portions 130 that underlie track members 120 and having a pair of side portions 132 that extend upwardly from respective central portions 130 such that track members 120 are situated between respective side portions 132. Rollers 124 each have shafts 134 that are coupled to side portions 132 and that extend horizontally therefrom in a cantilevered manner toward associated track members 120. As columns 40, 42 move along tracks 98, such as, for example, in directions 136 away from respective cavities 34, 36 as shown in Figs. 2, 4, and 6-8, rollers 124 roll along corresponding surfaces 126, 128. Of course, rollers 124 also roll along surfaces 126, 128 when columns 40, 42 move along tracks 98 in directions opposite to directions 136.

According to this disclosure, housing 76 carries electrical circuitry to control the operation of display screen 78. In some embodiments, housing also carries electrical circuitry to control the operation of display screen 110 and lights 100. In other embodiments, some or all of the circuitry that controls the operation of screens 78, 110 and lights 100 are housed in portions of head wall unit 32. Such circuitry includes for example, one or more of a microprocessor or microcontroller, input/output circuitry, signal conditioning circuitry, signal conversion (analog-to-digital and/or digital-to-analog) circuitry, power conditioning circuitry, memory circuitry, and the like. In addition, a user interface is provided on column 42 to permit a user to enter commands and retrieve data for display on screen 78. In the illustrative embodiment, screen 78 is a touch screen and the user input on column 42 comprises user input buttons 138 displayed on screen 78 as shown, for example, in Fig. 8.

In some embodiments, the electrical circuitry that controls the operation of display screen 78 is coupled to the hospital's computer network or ethernet. In such embodiments, any of the information available on the network is viewable on display screen 78. For example, a caregiver is able to retrieve a patient's medical records (e.g., laboratory test results, medical diagnosis, patient charts, x-rays, and so on) from the network for viewing on screen 78. In addition, patient point-of-care data, such as vital signs data (e.g., heart rate, blood pressure, neurological activity, respiration rate, patient temperature, pulse oximetry) and data associated with the operation of patient-care equipment (e.g., data from one or more ventilators, infusion pumps, electrocardiographs, electroencephalographs), may be displayed on

screen 78. Thus, the circuitry associated with screen 78 is programmed and/or configured to receive and process various types of data signals indicative of the information to be displayed on screen 78. It is within the scope of this disclosure for all types of data associated with the care of a patient to be displayed on screen 78. In addition, it is within the scope of this disclosure for screen 78 to display multiple types of data simultaneously, such as in a split screen format. Furthermore, in those embodiments in which the hospital computer network is coupled to the Internet, then information accessible via the Internet is also able to be displayed on screen 78.

An alternative IV rack 164 that is attachable to and detachable from vertical arm 62 is shown in Figs. 8-10. IV rack 164 is similar to IV rack 64 and therefore, where appropriate, like reference numerals are used to denote components of IV rack 164 that are substantially similar to like components of IV rack 64. As was the case with IV rack 64, IV rack 164 couples to arm 62 with suitable couplers such as, for example, clamps, brackets, latches, grippers, hooks, or the like. The main difference between IV rack 164 and IV rack 64 is that IV rack 164 has a horizontal plate 140 coupled to the lower ends of poles 70. Plate 140 has one or more openings or sockets 142 as shown in Fig. 8.

An arm assembly 144 for carrying IV rack 164 includes an arm 146 coupled to bed 48 for pivoting movement about a vertical axis, a horizontal plate 148 coupled to arm 144, and a pair of posts 150 extending vertically upwardly from plate 146. Arm 146 is movable to a first position extending laterally outwardly from bed 48 to support plate 148 and posts 150 at a location which permits coupling of IV rack 164 to arm assembly 144 as shown in Figs. 8 and 9. Vertical arm 62 and carriage 88 are movable along track 98 to position IV rack over plate 148 and posts 150. In addition, IV rack 164, or the combination of arm 62 and IV rack 164, is rotatable about the vertical axis extending through arm 62 to orient IV rack 164 such that sockets 142 are aligned with posts 150. After IV rack 164 is properly oriented over arm assembly 144, as shown in Figs. 8 and 9, IV rack 164 is lowered in the direction of arrow 152, shown in Fig. 8, so that posts 150 are received in sockets 142 and so that plate 140 rests upon plate 148, thereby to couple IV rack 164 to arm assembly 144.

In some embodiments, the coupler that couples IV rack 164 to arm 62 is movable vertically relative to arm 62 to permit raising and lowering of IV rack 164

-14-

and, in other embodiments, arm 62 comprises telescoping segments that permit raising and lowering of IV rack 164. Alternatively, IV rack 164 is decoupled from arm 62 and is lowered manually onto arm assembly 144. It is also within the scope of this disclosure for an upper frame 154 of bed 48 to be lifted relative to a base 156 of bed 48 so that posts 150 enter into openings 142 and so that plate 148 moves into engagement with plate 140. In some embodiments, additional mechanisms (not shown), such as latches on plate 142 or plate 150, pins that extend through posts 150, caps that snap or thread onto posts, clamps that grip plates 140, 148, and the like, are provided to lock IV rack 164 to arm assembly 144. After IV rack 164 is coupled to arm assembly 144 and decoupled from arm 62, arm 146 is pivotable relative to bed 48 to a second position having IV rack 164 supported alongside bed 48 as shown in Fig. 10. Thus, bed 48 and IV rack 164 coupled to bed 48 are transportable through the hospital without needing to disconnect IV lines from the patient carried by bed 48.

Referring now to Figs. 11-14, an alternative architectural system has a headwall unit 232 and a ceiling unit 238 that are substantially similar to headwall unit 32 and ceiling unit 38, respectively, of system 30. Therefore, where applicable, like reference numerals are used to denote components of system 230 that are substantially similar to like components of system 30. One of the differences between system 230 and system 30 is that headwall unit 232 of system 230 has a pair of auxiliary cavities 234, 236 (see Figs. 12 and 14) that are laterally outboard of cavities 34, 36, respectively. A pair of doors 235, 237 are each independently movable between a closed position, shown in Fig. 11, in which the respective cavity 234, 236 and any items or equipment stored therein are inaccessible and an opened position in which the respective cavity 234, 236 and any items or equipment stored therein are accessible. In the illustrative embodiment, doors 235, 237 pivot about respective vertical axes when moving between the opened and closed positions. Suitable locking mechanisms are provided in some embodiments for locking doors 235, 237 in the closed positions. As was the case with system 30, doors 58 of system 230 are movable to open and close cavities 34, 36.

Headwall unit 232 has additional medical service outlets 216 mounted on a pair of lower vertical panels 218 which are situated beneath the lowermost pair of doors 58 as shown in Figs. 11, 14, and 14. Headwall unit 232 also has a pair of lower doors 220 that are movable between respective first positions in which doors

220 cover the associated outlets 216 and respective opened positions in which outlets 216 are uncovered for use. It is within the scope of this disclosure for system 30 to also have outlets 216, panels 218, and doors 220. In some embodiments, auxiliary outlets 71 and outlets 216 are included in the headwall unit and, in other  
5 embodiments, only one or the other set of outlets 71, 216 are included in the headwall unit.

Another of the differences between system 230 and system 30 is that ceiling unit 238 of system 230 has tracks 198 which are wider than tracks 98 of system 30. Thus, tracks 198 extend laterally outward from canopy 96 of ceiling unit  
10 238 by a greater amount than tracks 98 extend laterally outward from canopy 96 of ceiling unit 38. Each of tracks 198 has a cosmetic cover or panel 210. Each panel 210 has a first elongated slot 212 and a second elongated slot 214. In the illustrative embodiment, slots 212 are parallel with slots 214. Each slot 212 receives a respective side portion 132 of the associated carriage 88, 90 of the respective column 40, 42.  
15 Thus, provision of slots 212 in covers 210 allows columns 40, 42 of system 230 to move without interference from panels 210 between the respective storage positions within cavities 34, 36 and the various positions outside of cavities 34, 36.

In some embodiments, slots 214 are situated beneath respective track members (not shown) that are configured to support auxiliary equipment which is  
20 moved out of auxiliary cavities 234, 236 and, in other embodiments, auxiliary equipment is situated above slots 214. In the example shown in Fig. 12, a privacy curtain 240 is movable from a storage position in which curtain 240 is situated within cavity 236 to a use position in which a majority of curtain 240 is drawn out of cavity 236. In the use position, curtain 240 hangs downwardly from substantially the entire  
25 length of the track member situated above the respective slot 214. Illustrative curtain 240 has a flexible curtain panel 242, a plurality of sliders 244, and a plurality of strands 246. Each strand 246 extends between panel 242 and a respective slider 244. Sliders 244 are movable along the track member situated above slot 214. Thus, when curtain 240 is in the storage position, all of sliders 244 are grouped together within  
30 cavity 236 and when curtain 240 is in the use position, sliders 244 are spaced apart along the length of slot 214.

In the example shown in Fig. 13, a privacy curtain 250 is extendable downwardly out of the associated slot 214 to a use position and is retractable

upwardly through slot 214 to a storage position. Curtain 250 has a flexible curtain panel 252 and a bottom member 254 coupled to a bottom portion of panel 252. Member 254 adds weight to curtain 250 to prevent excessive movement of curtain 250 away from a vertical hanging configuration as shown in Fig. 13. A rotatable shaft (not shown) on which panel 252 winds when retracting and unwinds when extending is situated above slot 214. In some embodiments, a motor (not shown) is coupled to shaft and is operated to rotate the shaft in the appropriate directions to wind and unwind panel 252. In such embodiments, a user input, such as one or more switches, buttons, levers, or the like, is accessible on headwall unit 232 to control the motor. In alternative embodiments, curtain 250 is extended and retracted manually, similar to the manner in which conventional window shades are pulled down to cover a window and are manipulated so that a spring causes an associated shaft to wind up the window shade.

In the example shown in Fig. 14, an auxiliary IV pole 160 hangs downwardly from a carriage 162 that is slideable along a track member (not shown) which is situated above the respective slot 214. Pole 160 and carriage 162 are movable between a storage position in cavity 234 and a number of use positions outside of cavity 234. One or more hooks 166 are coupled to pole 160 for holding IV bags 68. In the illustrative embodiment, a dedicated infusion pump 172 is mounted to a bottom end of pole 160. In alternative embodiments, infusion pumps 72 are attachable to and detachable from other portions of pole 160. It is within the scope of this disclosure for any type of patient-care equipment that is capable of coupling to an IV pole to be coupled to pole 160.

Although curtain 240 is shown in Fig. 12 as being associated with cavity 236 and although pole 160 is shown in Fig. 14 as being associated with cavity 234, it is within the scope of this disclosure for curtains, IV poles, and any other type of track-mounted auxiliary equipment, such as exam lights, water hoses, suction hoses, traction devices, and the like, to be associated with either of cavities 234, 236. In addition, it is within the scope of this disclosure for the various walls of headwall unit 232 that bound cavities 234, 236, such as back wall 259, side wall 261, and bottom wall 263 (see Fig. 14), to be appropriately sized and configured so that cavities 234, 236 are large enough to receive the track mounted equipment to be stored therein. In addition, in those embodiments having auxiliary equipment, such as



curtain 250 that extends and retracts out of slots 214, then cavities 234, 236 may have storage shelves therein.

Referring now to Figs. 15 and 16, an alternative architectural system 330 includes a headwall unit 232, that is substantially similar to headwall unit 232 of system 230, and a ceiling unit 338 from which a set of air curtains 270 are directed downwardly around three sides of hospital bed 48. In the illustrative embodiment, the set of air curtains are adjacent foot end 52 and sides 54, 56 of bed 48. A suitable amount of space is provided between air curtains 270 and bed 48 to permit a caregiver to stand therebetween. Air curtains 270 provide a modicum of environmental isolation for the patient on bed 48. Thus, air borne contaminants outside the patient space bounded by air curtains 270 are prevented from entering the patient space. In some embodiments, air curtains 270 are heated and/or humidified to control the temperature and humidity of the patient space. In such embodiments, heating equipment (not shown) and/or humidifying equipment (not shown) is housed in either ceiling unit 338 or headwall unit 232 or both.

An air curtain generator 272, such as a fan, blower, pump, or the like, is housed in canopy 96 of ceiling unit 338 as shown in Figs. 15 and 16. An air-intake opening 274 is formed in cover 114 of canopy 96 and an air filter 276 covers opening 274 to filter contaminants from the ambient environment. Air curtain generator 272 is situated in a central chamber 278 of canopy 96 and an air-inlet duct 280 extends from opening 274 to chamber 278. A network of air-outlet ducts 282 extend from chamber 278 throughout ceiling unit 338, including along the outer regions of lateral side portions 198 and including along the front distal regions of canopy 96 and portions 198. Duct 280 overlies some of ducts 282 as shown in Fig. 16. In the illustrative embodiment of system 330, a plurality of air-exit openings or slots 284 are formed along the side and front peripheral regions of the underside of ceiling unit 338. Operation of air curtain generator 272 moves air from the ambient environment through each of filter 276, duct 280, chamber 278, ducts 282, and openings 284 to form air curtains 270.

A controller (not shown) housed in ceiling unit 338 or headwall unit 232 or both operates to control air curtain generator 272, the heating equipment (if any), and the humidification equipment (if any). A user interface is provided on one or both of columns 40, 42 or on headwall unit 232. A user inputs operational

parameters, such as, for example, fan speed (high, medium, low), air temperature, and air humidity, to the controller via the user interface. In addition, system 330 has various sensors, such as, for example, a fan speed sensor, a temperature sensor, and a humidity sensor that provides feedback to the controller so that appropriate  
5 commands from the controller can be provided to air curtain generator 272, the heating system, and the humidification system to adjust the operation of these devices, if appropriate.

According to one aspect of the present disclosure, a patient rests on a hospital bed 534 in an environmentally-controlled hospital room 532 as shown in Fig.  
10 17. Covering the patient is a disposable heating/cooling blanket 536. Blanket 536 is coupled via a pair of heating/cooling hoses 540 to a heating/cooling unit 538 housed in a headwall 542 of room 532. When the patient is to be cooled, unit 538 operates to provide a cooling medium, such as cool air or cool liquid, through one of hoses 540 to blanket 536 and the other of hoses 540 provides the cooling medium back to unit 538  
15 after circulation of the cooling medium through blanket 536. When the patient is to be heated, unit 538 operates to provide a heating medium, such as heated air or heated liquid, through one of hoses 540 to blanket 536 and the other of hoses 540 provides the cooling medium back to unit 538 after circulation of the heating medium through blanket 536. In those embodiments having heated air or cooled air circulated through  
20 blanket 536, perforations are formed in the surface of blanket 536 facing the patient so that a portion of the heated or cooled air being circulated through blanket 536 is able to escape from blanket 536 through the perforations and convectively heat or cool, as the case may be, the patient.

Bed 534 includes a pendant controller 544 that a patient uses to control  
25 heating/cooling unit 538 in a desired manner when pendant controller 544 is not locked out. In some embodiments, pendant controller 544 also is used to control other bed functions, such as articulation, raising, and lowering of the bed deck, and to control room entertainment and communication functions, such as television, radio, and nurse call. Bed 534 includes a footboard 546 having a control panel 548 that is  
30 used by a caregiver to control operation of unit 538, to control operation of various bed functions, and to control various entertainment and communication functions. Control panel 548 is also used by the caregiver to lock out one or more functions of

pendant controller 544. For example, the caregiver can lock out the ability of pendant controller 544 to operate unit 538.

An ceiling unit or overhead canopy 550 is coupled to a ceiling 552 of hospital room 532 above bed 534 as shown in Fig. 17. Canopy 550 includes various systems that control the environment of room 532. For example, canopy 532 includes an overhead temperature sensor (not shown), an overhead air quality sensor (not shown), an overhead air purifier (not shown), aroma therapy equipment (not shown), motion or proximity sensors 554 for detecting the presence of other people in the hospital room, examination lights 556, reading lights (not shown), and a video screen 558 for displaying one or more preselected images. Such images may include a scene from nature or other restful scenes. Such images may also include images that transition at the appropriate times during a 24-hour period from day images, such as clouds and sun, to night images, such as moon and stars. Images of the patients family may also be displayed on screen 558.

In some embodiments of room 532, the room lights are controlled to dim slowly as the daytime turns to evening. In addition, a recording of evening sounds, such as owls, night birds, crickets, and wind in the trees is played by audio equipment housed in overhead canopy 550. Eventually, the room lights are turned completely off and the night sounds fade away. In other embodiments of room 532, a video screen similar to or larger than video screen 558 is mounted to a room wall, preferably a wall that confronts the foot end of bed 534. In such alternative hospital rooms, television images, internet images, educational information, patient schedule, imagery to promote relaxation, and video conferencing images are selectively displayed on the video screen.

Bed 534, unit 538, and ceiling unit 550 each have their own controllers for monitoring and controlling the various functions associated with these devices. Each of such controllers include, for example, one or more microprocessors, microcontrollers, memory circuitry, input/output circuitry, signal conditioning circuitry, signal conversion circuitry, power conditioning circuitry, and the like. It is within the scope of this disclosure for each of the controllers of bed 534, unit 538, and canopy 550 to be coupled to the hospital computer network to exchange data with the network. In some embodiments, parameters for controlling bed 534, unit 538, and canopy 550 are entered by computers that are located remotely from room 532. Thus,

for example, if a patient places a nurse call requesting the heating/cooling function of unit 538 and blanket 536 be adjusted or discontinued, the nurse receiving the call is able to adjust the amount of heating/cooling provided to the patient via blanket 536.

Referring now to Figs. 18-20, a mobile cart 560 includes a somewhat rectangular upstanding pedestal 562, four horizontally extending support legs 564  
5 coupled to the bottom of pedestal 562, and a set of wheels or casters 566 coupled to distal ends of corresponding support legs 564. Pedestal 562 has a fairly small depth dimension between a front face 568 thereof, shown best in Fig. 18, and a rear face 570 thereof, shown in Figs. 19 and 20. Each support leg 564 is pivotable relative to  
10 pedestal 562 about a respective vertical axis between a first position extending outwardly from beneath pedestal 562 as shown in Fig. 18 and a second position tucked beneath pedestal 562 as shown in Figs. 18-20.

When legs 564 are in the second positions, legs 564 and casters 566 are positioned to lie completely under and within the foot print of pedestal 562. In  
15 addition, when legs 564 are in the second positions, legs 564 extend in substantially parallel relation with front and rear faces 568, 570 of pedestal 562. When legs 564 are in the first positions, a majority of legs 564 are positioned to lie outside the foot print of pedestal 562 and legs 564 extend in substantially perpendicular relation to front and rear faces 568, 570 of pedestal 562. Suitable locking or retention  
20 mechanisms are provided either on legs 564 or pedestal 562 to lock or retain legs 564 in the respective first and second positions. The stability of cart 560 on a floor is greater when legs 564 are in the first positions than when legs 564 are in their second positions.

Mobile cart 560 is couplable to and transportable with a wheeled  
25 hospital bed or stretcher 572 from an operating room 574, shown in Fig. 19, to an intensive care unit room (not shown), and then to a regular hospital room 578, shown in Fig. 20. Of course, rooms 574, 578 are shown merely as examples of hospital rooms and therefore, cart 560 may be transported with stretcher 572 to any location in a hospital that stretcher 572 is capable of going. Cart 560 may also be transported by  
30 itself throughout a hospital when legs 564 are in their first positions having casters 566 rolling along the floor of the hospital.

An asset tracking system (not shown) included in a hospital includes a plurality of transmitters, receivers, and/or transmitter/receiver units 576 (collectively

referred to as “transmitter/receiver units 576”) located throughout the hospital. One such transmitter/receiver unit 576 is shown in Fig. 36. Transmitter/receiver units 576 cooperate with remote equipment, such as computers, included in the asset tracking system to track the whereabouts of mobile carts 560 throughout the hospital. Thus, each cart 560 to be tracked includes a transmitter/receiver unit (not shown) that, when prompted by a signal from transmitter/receiver units 576, emits a signal that is sensed by one or more transmitter/receiver units 576 in the vicinity thereof.

Cart 560 is couplable to hospital bed 572 as previously mentioned. Cart 560 is also couplable to arm assemblies 598 included, for example, in operating room 574 and in intensive care unit rooms (not shown). Arm assemblies 598 extend from the ceilings of the respective rooms, such as room 574 as shown in Figs. 19. When cart 560 is coupled to arm assemblies 578, cart 560 is suspended from the ceiling of the respective room so that casters 566 of cart 560 are spaced apart from the floor of the respective rooms. Casters 566 are also spaced apart from the floor of the respective rooms when cart 560 is coupled to bed 572. It is within the scope of this disclosure for cart 560 to be coupled to or included in columns 40, 42 of any of architectural systems 30, 230, 330, as well as any alternatives of these, described above with regard to Figs. 1-16.

Cart 560 includes suitable couplers (not shown) that interface with couplers (not shown) included in bed 572, with couplers (not shown) included in arm assemblies 578, and with couplers (not shown) included in columns 40, 42. Suitable couplers may include, for example, hooks, clips, posts, latches, sockets, rails, channels, slots, bands, straps, fingers, flanges, lugs, bails, wires, magnets, plates, and the like, as well as combinations of these. Cart 560 includes a handle 580 appended to the top of pedestal 562 as shown in Figs. 18 and 19. A caregiver grips handle 580 to maneuver cart 560 along a floor of the hospital and to carry cart 560, such as during attachment to or detachment from bed 572, arm assemblies 578, or columns 40, 42.

A headwall 582 of room 578 is formed to include a cavity 584 that is configured to receive cart 560 as shown in Fig. 20. In addition, cart 560 is received in cavities 34, 36 (or cavities 23, 236) when cart 560 is coupled to or included in columns 40, 42 and columns 40, 42 are moved to the storage positions. When cart 560 is situated in cavity 584, legs 564 are in the respective second positions and

casters 566 rest upon a ledge surface 586 that underlies cavity 584. Pedestal 562 of cart 560 is configured to carry one or more IV poles 588 as shown in Figs. 18-20. Cavity 584 has sufficient height to accommodate cart 560 and any IV poles 588 coupled thereto as shown in Fig. 20. Hooks 587 are provided at the top of IV poles 588 for attachment of IV bags 68.

Pedestal 562 includes recesses or compartments 589 that are adapted to carry various patient-monitoring and patient-care modules or equipment 590, shown best in Fig. 18. Such patient-care equipment includes, for example, infusion pumps, ventilator control units, gas control units, vital signs monitors, and the like. Some modules 590 are coupled to the patient, via sensor lines, to monitor various physiological conditions and vital signs of the patient. In some embodiments, cart 560 includes an on-board computer system that interfaces with modules 590 and with a receiver/transmitter unit on cart 560. In such embodiments, patient-data from modules 590 is either transmitted to the hospital network via the receiver/transmitter unit or the patient-data is stored in the computer system until a hard-wire or optical connection is made to the network. When the computer system is communicatively coupled to the network, a caregiver located in the hospital remote from cart 560 is able to access the network with a remote computer terminal, for example, to obtain the status of the patient being monitored by modules 590 carried by cart 560. Cart 560 includes a battery (not shown) to provide power to any electrical components, such as modules 590 and the computer system, carried by cart 560.

Pedestal 562 is formed to include service delivery ports 592. Tanks (not shown) containing oxygen or other types of medical gases are situated in an interior region of pedestal 562. In some embodiments, such tanks are included in a ventilator system carried by cart 560. In such embodiments, hoses 594, one of which is shown in Fig. 20, are coupled to respective ports 592 and extend from ports 592 either to the patient or to associated medical equipment. Cart 560 is configured to carry other types of medical devices, including drug infusion devices, that are associated with providing intensive care to a patient. Such devices are sometimes referred to as LSTAT (Life Support for Trauma and Transport) devices. Because cart 560 carries most, if not all, of the medical equipment necessary to provide intensive care to the patient and because cart 560 is transported with the patient throughout the hospital, the need to disconnect and reconnect IV lines, ventilator hoses, sensor lines,

and the like from the patient before and after transport is avoided, as is the need to manage multiple wheeled stands or carts during transport of the patient throughout a hospital.

Referring now to Figs. 21-23, a ceiling-mounted overbed table  
5 assembly 656 includes a ceiling unit or hub unit 658 coupled to ceiling 46 of a  
hospital room, an arm assembly 660 coupled to hub unit 658, an overbed table 662  
coupled to arm assembly 660, and a patient-care housing 664 coupled to and  
extending downwardly from an undersurface of table 662. In alternative  
embodiments, housing 664 is coupled to arm assembly 660 and is situated, at least in  
10 part, beneath table 662. Hub unit 658 includes an annular upper portion 666 having a  
frustoconical shape, an annular lower portion 668 shaped like a disc, and an annular  
slot 670 defined between portions 666, 668 as shown in Fig. 40. Hub unit 658 further  
includes a plurality of exam and reading lights 672 coupled to lower portion 668 and  
arranged to direct light downwardly therefrom. In alternative embodiments, hub 568  
15 has shapes other than annular, such as elliptical, polygonal (i.e., square, rectangular,  
triangular, and so on), and the like.

Arm assembly 660 includes a first arm 674 extending horizontally  
from slot 670 and a second arm 676 extending vertically downwardly from a distal  
end 678 of first arm 674 as shown in Fig. 21. Hub unit 658 includes a shaft assembly  
20 (not shown) that interconnects portions 666, 668 of hub unit 658. A proximal end  
(not shown) of first arm 674 is coupled to the shaft assembly for pivoting movement  
about a vertical axis 680. Table 662 and housing 664 are coupled to a lower end of  
arm 676 for pivoting movement about a vertical axis 682, shown in Figs. 21 and 22.  
Alternatively, table 662 and housing 664 are fixed with respect to arm 676 and arm  
25 676 is coupled to arm 674 for rotation about axis 682.

Second arm 676, table 662, and housing 664 are movable between a  
first position situated on a first side of a hospital bed 684 and a second position  
situated on a second side of hospital bed 684 as shown in Fig. 23. During movement  
between the first and second positions, arm 676, table 662, and housing 664 move  
30 along an arcuate path, indicated by a curved double-headed arrow 688 shown in Fig.  
23, around a foot end 686 of bed 684. First arm 674 has sufficient length to allow  
housing 664 to clear foot end of bed 684 during movement between the first and  
second positions. Assembly 656 includes suitable locking mechanisms to lock arm

assembly 660 and table 662 in the first and second positions. When in either the first position or the second position, table 662 extends horizontally from arm 676 in a cantilevered manner and is positioned, in part, over the lap of a patient supported by bed 684. In some embodiments, assembly 656 includes drive mechanisms that  
5 operate to adjust the vertical position of table 662 and housing 664 relative to arm 676.

Assembly 656 includes a telephone 690 having a handset that resides in a recess formed in the upper surface of table 662. Assembly 656 also includes an entertainment-and-control panel 692 that is coupled to arm 676 of arm assembly 660  
10 via a post 694 that extends horizontally away from arm 676 above table 662 as shown in Figs. 40 and 41. Illustrative panel 692 is a touch screen that permits the patient to control, for example, room lighting, room temperature, television functions, nurse call functions, and the like. Panel 692 is also operable to display various images such as, for example, television images, internet images, educational information, patient  
15 schedule, patient billing information, and video conferencing images. Controls panels having any combination of the above-mentioned control functions and entertainment functions are within the scope of this disclosure. Telephone 690 is used in a conventional manner for placement of phone calls.

A plurality of medical service outlets 696 and a plurality of patient-monitor modules 698 are coupled to an end face 700 of housing 664 as shown in Fig.  
20 22. Modules 698 are arranged in side-by-side relation along an upper portion of end face 700 and medical service outlets 696 are arranged in side-by-side relation beneath modules 698. Each of modules 698 receive patient-data signals via patient-data lines (not shown) that are coupled to modules 698 and to the patient to monitor various  
25 physiological conditions of the patient. Patient conditions to be monitored may include temperature, heart rate, blood oxygenation, respiration, brain activity, and the like. Services provided by outlets 696 may include, for example, medical gases, vacuum, and power. Outlets 696 receive the associated services via lines (not shown) that are routed to outlets 696 from the ceiling of the hospital room, through hub unit  
30 658, though interior regions of arms 674, 676, through an opening in table 662, and into an interior region of housing 664. Outlets 696 and modules 698 are positioned on housing 664 so as to be generally inaccessible to a patient lying on bed 684 when assembly 656 is in either the first position or the second position.



It is contemplated by this disclosure that table 662 and/or housing 664, along with outlets 696 and modules 698 associated with housing 664 may be suspended from a ceiling of a hospital room by other types of arm assemblies or columns. For example, it is within the scope of this disclosure for table 662 and/or housing 664 to be coupled to or included in columns 40, 42 of any of architectural systems 30, 230, 330 described above. In such embodiments, table 662 or a part thereof flips up, such as by pivoting about a horizontal axis, thereby placing table 662 is in a substantially vertical orientation for storage in the associated cavity 34, 36, 234, 236 of the associated headwall unit 32, 232. When the column 40, 42 associated with table 662 is moved out of the associated cavity 34, 36, 234, 236, table 662 is flipped down to a substantially horizontal orientation for use.

Although various apparatus and systems have been described in detail with reference to certain preferred embodiments, variations and modifications of each of these apparatus and systems exist within the scope and spirit of the invention as described and defined in the following claims.

## CLAIMS

1. An architectural system adaptable to an acuity level of a patient supported by a hospital bed in a patient room having a wall and a ceiling, the  
5 architectural system comprising  
a wall unit coupled to the wall and having a cavity,  
a ceiling unit coupled to the ceiling, and  
a column coupled to the ceiling unit for movement between a first  
position in which at least a majority of the column is situated in the cavity and a  
10 second position in which the column is situated outside the cavity.
2. The architectural system of claim 1, wherein the column includes a vertical member and a patient care device coupled to the vertical member.
3. The architectural system of claim 2, wherein the patient care device comprises an IV rack that is situated in the cavity when the column is in the  
15 first position.
4. The architectural system of claim 2, wherein the patient care device comprises a housing having a plurality of medical service outlets and the housing is situated in the cavity when the column is in the first position.
5. The architectural system of claim 4, wherein at least one of the  
20 medical service outlets is a medical gas outlet.
6. The architectural system of claim 4, wherein at least one of the medical service outlets is an electrical outlet.
7. The architectural system of claim 4, wherein the wall unit has a door that is movable between a closed position blocking access to the plurality of  
25 medical service outlets when the column is in the first position and an opened position allowing access to the medical service outlets when the column is in the first position.
8. The architectural system of claim 2, wherein the patient care device comprises a display screen that is situated in the cavity when the column is in the first position.
9. The architectural system of claim 8, wherein the wall unit has a door that is movable between a closed position covering the display screen to shield  
30 the display screen from view when the column is in the first position and an opened

-27-

position uncovering the display screen to permit the display screen to be viewed when the column is in the first position.

10. The architectural system of claim 2, wherein the patient care device is pivotable about an axis relative to the vertical member when the column is  
5 in the second position.

11. The architectural system of claim 10, wherein the axis is vertical and extends through the vertical member.

12. The architectural system of claim 1, wherein the ceiling unit comprises a track member and the column comprises a carriage that moves along the  
10 track member as the column moves between the first and second positions.

13. The architectural system of claim 12, wherein a portion of the track member overlies the cavity.

14. The architectural system of claim 12, wherein the track member comprises elongated first and second roller-engaging surfaces, the first roller-  
15 engaging surface is parallel to the second roller-engaging surface, the carriage comprises a housing and a plurality of roller coupled to the housing, at least one of the plurality of rollers engages the first roller-engaging surface, and at least another of the plurality of roller engages the second roller-engaging surface.

15. The architectural system of claim 1, wherein the ceiling unit  
20 comprises a housing and a light coupled to the housing.

16. The architectural system of claim 1, wherein the ceiling unit comprises a housing and a display screen coupled to the housing.

17. The architectural system of claim 1, wherein the ceiling unit comprises a housing having a plurality of openings and the ceiling unit comprises an  
25 air curtain generator that operates to expel air downwardly from the plurality of openings to create at least one air curtain.

18. The architectural system of claim 17, wherein the housing has an air-intake opening, the ceiling unit comprises an air-permeable filter covering the air-intake opening, and operation of the air curtain generator draws air from the  
30 patient room through the filter.

19. The architectural system of claim 1, wherein the column comprises a medical service outlet and further comprising a medical service delivery

line that is routed from the medical service outlet, through the column, and through the ceiling unit.

20. The architectural system of claim 1, further comprising a privacy curtain hanging downwardly from the ceiling unit, the wall unit having a  
5 compartment, and the privacy curtain being movable between a storage position in which a majority of the privacy curtain is situated in the compartment and a use position in which a majority of the privacy curtain is situated outside the compartment.

21. The architectural system of claim 1, further comprising a  
10 privacy curtain coupled to the ceiling unit and movable between a use position hanging downwardly from the ceiling unit and a storage position retracted into the ceiling unit.

22. An architectural system adaptable to an acuity level of a patient supported by a hospital bed in a patient room having a wall and a ceiling, the  
15 architectural system comprising

a wall unit coupled to the wall, the wall unit having a first cavity and a second cavity,

a first track member coupled to the ceiling,

a second track member coupled to the ceiling,

20 a first column coupled to the first track member for movement between a first position in which at least a majority of the first column is situated in the first cavity and a second position in which the first column is situated outside the cavity alongside a first side of the hospital bed, and

a second column coupled to the second track member for movement  
25 between a first position in which at least a majority of the second column is situated in the second cavity and a second position in which the second column is situated outside the cavity alongside a second side of the hospital bed.

23. The architectural system of claim 22, wherein the wall unit has a first door that is movable between a closed position blocking access to at least a  
30 portion of the first column when the first column is in the first position and an opened position permitting access to the portion of the first column.

24. The architectural system of claim 22, wherein the first track member is elongated, the second track member is elongated, and the first track member is parallel with the second track member.

25. The architectural system of claim 22, wherein the first track member comprises elongated first and second roller-engaging surfaces, the first roller-engaging surface is parallel to the second roller-engaging surface, the column comprises a carriage having a housing and a plurality of rollers coupled to the housing, at least one of the plurality of rollers engages the first roller-engaging surface, and at least another of the plurality of rollers engages the second roller-engaging surface.

26. The architectural system of claim 22, further comprising a canopy situated at least in part between the first and second track members and a light coupled to the canopy.

27. The architectural system of claim 22, further comprising a canopy situated at least in part between the first and second track members and a display screen coupled to the canopy.

28. The architectural system of claim 22, further comprising a canopy situated at least in part between the first and second track members and air curtain generation equipment coupled to the canopy.

29. An apparatus for use in a hospital room having a ceiling, the apparatus comprising

a canopy adapted to be coupled to the ceiling of the hospital room, and environmental control equipment coupled to the canopy.

30. The apparatus of claim 29, wherein the environmental control equipment comprises a temperature sensor.

31. The apparatus of claim 29, wherein the environmental control equipment comprises an air quality sensor.

32. The apparatus of claim 29, wherein the environmental control equipment comprises an air purifier.

33. The apparatus of claim 29, wherein the environmental control equipment comprises aroma therapy equipment.

34. The apparatus of claim 29, further comprising a motion sensor coupled to the canopy.

35. The apparatus of claim 29, further comprising a proximity sensor coupled to the canopy.
36. The apparatus of claim 29, wherein the environmental control equipment comprises at least one examination light.
- 5 37. The apparatus of claim 29, wherein the environmental control equipment comprises at least one reading light.
38. The apparatus of claim 29, further comprising a video screen coupled to the canopy.
39. A mobile cart for use in a hospital to provide care to a patient,  
10 the mobile cart comprising  
an upstanding pedestal,  
a plurality of legs coupled to a bottom of the upstanding pedestal,  
a plurality of wheels, each wheel being coupled to a respective leg of  
the plurality of legs, the legs along with the wheels coupled thereto each being  
15 movable between a first position extending outwardly from beneath the upstanding  
pedestal and second position tucked beneath the upstanding pedestal, and  
a plurality of patient-care modules coupled to the upstanding pedestal.
40. The mobile cart of claim 39, further comprising at least one IV  
pole coupled to the upstanding pedestal.
- 20 41. The mobile cart of claim 39, wherein the upstanding pedestal  
has a top wall and further comprising a handle coupled to the top wall, the handle  
being grippable to maneuver the mobile cart.
42. The mobile cart of claim 39, wherein each wheel of the  
plurality of wheels is able to swivel about a respective vertical axis.
- 25 43. The mobile cart of claim 39, wherein each leg of the plurality  
of legs is able to swivel about a respective vertical axis.
44. The mobile cart of claim 39, wherein the upstanding pedestal  
has a compartment adapted to carry at least one of the plurality of patient-care  
modules.
- 30 45. The mobile cart of claim 39, wherein at least one of the  
plurality of patient-care modules is an infusion pump.
46. The mobile cart of claim 39, wherein at least one of the  
plurality of patient-care modules is a ventilator control unit.

47. The mobile cart of claim 39, wherein at least one of the plurality of patient-care modules is a gas control units.

48. The mobile cart of claim 39, wherein at least one of the plurality of patient-care modules is a vital signs monitor.

5 49. The mobile cart of claim 39, wherein at least one of the plurality of patient-care modules is configured to monitor a physiological condition of the patient.

50. The mobile cart of claim 39, further comprising an on-board computer system that interfaces with at least one of the plurality of patient-care  
10 modules.

51. The mobile cart of claim 50, further comprising a receiver and a transmitter and the on-board computer system interfaces with the receiver and the transmitter.

52. The mobile cart of claim 50, wherein the on-board computer  
15 system is configured to transmit wirelessly patient data from at least one of the plurality of patient-care modules.

53. The mobile cart of claim 50, wherein the on-board computer system is configured to store patient data from at least one of the plurality of patient-care modules until a hard-wire connection is made between the on-board computer  
20 system and an external computer network.

54. The mobile cart of claim 50, wherein the on-board computer system is configured to store patient data from at least one of the plurality of patient-care modules until an optical connection is made between the on-board computer system and an external computer network.

25 55. The mobile cart of claim 50, further comprising a battery configured to provide power to the on-board computer system and to at least one of the plurality of patient-care modules.

56. The mobile cart of claim 39, wherein at least one of the plurality of patient-care modules comprises a medical gas tank housed in the  
30 upstanding pedestal and further comprising a service delivery port that is coupled to the upstanding pedestal and through which medical gas from the medical gas tank is accessible.

57. A set of equipment for use in a hospital room having a floor, the set of equipment comprising
- a hospital bed supported by the floor,
  - an arm assembly hanging in the hospital room, and
  - 5 a mobile cart that is selectively couplable to the hospital bed and to the arm assembly and that is selectively decouplable from the hospital bed and from the arm assembly, the mobile cart having wheels that are spaced apart from the floor when the mobile cart is coupled to the hospital bed and when the mobile cart is coupled to the arm assembly, the wheels engaging the floor when the mobile cart is
  - 10 decoupled from the hospital bed and decoupled from the arm assembly.
58. The set of equipment of claim 57, wherein the mobile cart comprises a pedestal and at least one IV pole coupled to the pedestal.
59. The set of equipment of claim 57, wherein the mobile cart comprises a pedestal having a top wall, the mobile cart has a handle coupled to the top
- 15 wall, and the handle is grippable to maneuver the mobile cart.
60. The set of equipment of claim 57, wherein the mobile cart comprises a pedestal and a patient-care module coupled to the pedestal.
61. The set of equipment of claim 60, wherein the pedestal has a compartment adapted to carry the patient-care module.
- 20 62. The set of equipment of claim 60, wherein the patient-care module is an infusion pump.
63. The set of equipment of claim 60, wherein the patient-care module is a ventilator control unit.
64. The set of equipment of claim 60, wherein the patient-care
- 25 module is a gas control unit.
65. The set of equipment of claim 60, wherein the patient-care module is a vital signs monitor.
66. The set of equipment of claim 60, wherein the patient-care module is configured to monitor a physiological condition of the patient.
- 30 67. The set of equipment of claim 60, wherein the mobile cart has an on-board computer system that interfaces with the patient-care module.



68. The set of equipment of claim 60, wherein the mobile cart has a receiver, the mobile cart has a transmitter, and the on-board computer system interfaces with the receiver and the transmitter.

69. The set of equipment of claim 60, wherein the on-board  
5 computer system is configured to transmit wirelessly patient data from the patient-care module.

70. The set of equipment of claim 60, wherein the on-board  
computer system is configured to store patient data from the patient-care module until  
a hard-wire connection is made between the on-board computer system and an  
10 external computer network.

71. The set of equipment of claim 60, wherein the on-board  
computer system is configured to store patient data from at least one of the plurality  
of patient-care modules until an optical connection is made to an external computer  
network.

72. The set of equipment of claim 60, wherein the mobile cart has a  
15 battery configured to provide power to the on-board computer system and to the  
patient-care module.

73. The set of equipment of claim 60, wherein the patient-care  
module comprises a medical gas tank housed in the pedestal, the mobile cart has a  
20 service delivery port coupled to the pedestal, and medical gas from the medical gas  
tank is accessible via the service delivery port.

74. The set of equipment of claim 57, wherein the arm assembly  
has a plurality of articulated arm segments.

75. The set of equipment of claim 57, wherein the arm assembly  
25 comprises a vertical column.

76. The set of equipment of claim 75, further comprising a track  
member along which the vertical column is movable.

77. A set of hospital equipment comprising  
a mobile cart carrying patient-care equipment and having a plurality of  
30 wheels, and

a headwall formed to include a cavity that receives the mobile cart, the  
headwall having a ledge surface, the plurality of wheels of the mobile cart engaging  
the ledge surface when the mobile cart is received in the cavity.

78. The set of hospital equipment of claim 77, wherein a portion of the headwall overlies the cavity.

79. The set of hospital equipment of claim 77, wherein the mobile cart has a pedestal and an IV pole coupled to the pedestal and wherein the cavity is  
5 sized to receive the pedestal and the IV pole.

80. The set of hospital equipment of claim 77, wherein the mobile cart has a pedestal and a plurality of legs coupled to the pedestal and wherein each wheel of the plurality of wheels is coupled to a respective leg of the plurality of legs.

81. The set of hospital equipment of claim 80, wherein the plurality  
10 of legs, along with the wheels coupled thereto, are each movable between a first position extending outwardly from beneath the pedestal and second position tucked beneath the pedestal.

82. The set of hospital equipment of claim 77, wherein the headwall has a panel and at least one medical service outlet that is coupled to the  
15 panel and through which a medical service is accessible.

83. An apparatus comprising  
an arm assembly adapted to be suspended from a ceiling of a hospital room, and  
an overbed table coupled to the arm assembly to be supported by the  
20 arm assembly above a floor of the hospital room.

84. The apparatus of claim 83, wherein the overbed table has a table surface that is substantially horizontal, the arm assembly is configured to permit repositioning of the overbed table in the hospital room, and the table surface remains at a substantially constant elevation above the floor as the overbed table is  
25 repositioned.

85. The apparatus of claim 83, further comprising a control panel coupled to the arm assembly and the control panel having a user input.

86. The apparatus of claim 85, wherein the user input is engageable to control a light in the hospital room.

87. The apparatus of claim 85, wherein the user input is engageable to control a temperature of the hospital room.  
30

88. The apparatus of claim 85, wherein the user input is engageable to control at least one function of a television situated in the hospital room.

89. The apparatus of claim 85, wherein the user input is engageable to place a nurse call signal.

90. The apparatus of claim 85, wherein the control panel has a screen on which video images are displayed.

5 91. The apparatus of claim 85, wherein the control panel has a screen on which images accessed via the internet are displayed.

92. The apparatus of claim 85, wherein the control panel has a screen on which a patient schedule is displayed.

10 93. The apparatus of claim 85, wherein the control panel has a screen on which education information is displayed.

94. The apparatus of claim 85, wherein the control panel has a screen on which patient billing information is displayed.

95. The apparatus of claim 85, wherein the control panel has a screen on which video conferencing images are displayed.

15 96. The apparatus of claim 85, wherein the control panel is situated above the overbed table.

97. The apparatus of claim 85, wherein the control panel comprises a touch screen and the user input comprises an area on the touch screen.

20 98. The apparatus of claim 83, further comprising a telephone, the overbed table having a recess, and the telephone having a handset that resides in the recess.

25 99. The apparatus of claim 83, further comprising a housing coupled to the overbed table, a medical service outlet coupled to the table, and a service-delivery line routed from the medical service outlet, through the housing, and through the arm assembly.

100. The apparatus of claim 99, wherein the housing extends downwardly from the overbed table and terminates at a bottom end that is spaced apart from the floor.

30 101. The apparatus of claim 83, further comprising a housing coupled to the overbed table and a patient-monitor module coupled to the housing, the patient-monitor module being configured to receive a patient-data signal indicative of a physiological condition of a patient.

102. An apparatus comprising

-36-

a hub unit adapted to mount to a ceiling of a hospital room,  
an arm assembly coupled to the hub unit,  
an overbed table coupled to the arm assembly, and  
a housing coupled to one of the arm assembly and the overbed table,  
5 the housing carrying one of a medical service outlet and a patient-monitor module.

103. The apparatus of claim 102, wherein the hub unit comprises an upper portion, a lower portion, and an annular slot defined between the upper and lower portions and wherein the arm assembly comprises a first arm segment that is rotatable relative to the first and second portions within the slot.

104. The apparatus of claim 103, wherein the first arm segment extends from the slot and terminates at a distal end and the arm assembly comprises a second arm segment extending downwardly from the distal end of the first arm segment.

105. The apparatus of claim 104, wherein the overbed table is coupled to a lower end portion of the second arm segment.

106. The apparatus of claim 104, wherein the second arm, the overbed table, and the housing rotate as a unit relative to the first arm segment.

107. The apparatus of claim 104, wherein the overbed table and the housing rotate as a unit relative to the second arm segment.

108. The apparatus of claim 103, wherein the hub unit further includes a plurality lights coupled to the lower portion and arranged to direct light downwardly from the lower portion.

109. A set of hospital equipment comprising  
a headwall,  
25 a blanket,  
a unit housed in the headwall, and  
a hose coupled to the blanket and coupled to the unit, a thermoregulation medium being moved between the blanket and the unit through the hose.

110. The set of hospital equipment of claim 107, wherein the thermoregulation medium comprises a cooled liquid.

111. The set of hospital equipment of claim 109, wherein the thermoregulation medium comprises cooled air.

-37-

112. The set of hospital equipment of claim 109, wherein the thermoregulation medium comprises a heated liquid.

113. The set of hospital equipment of claim 109, wherein the thermoregulation medium comprises heated air.

5 114. The set of hospital equipment of claim 109, wherein the blanket has internal passages through which the thermoregulation medium travels.

115. The set of hospital equipment of claim 114, wherein the blanket has a plurality of perforations through which a portion of the thermoregulation medium escapes from the internal passages of the blanket.

10 116. The set of hospital equipment of claim 109, wherein the thermoregulation medium is a heated medium when the patient is to be heated and the thermoregulation medium is a cooled medium when the patient is to be cooled.

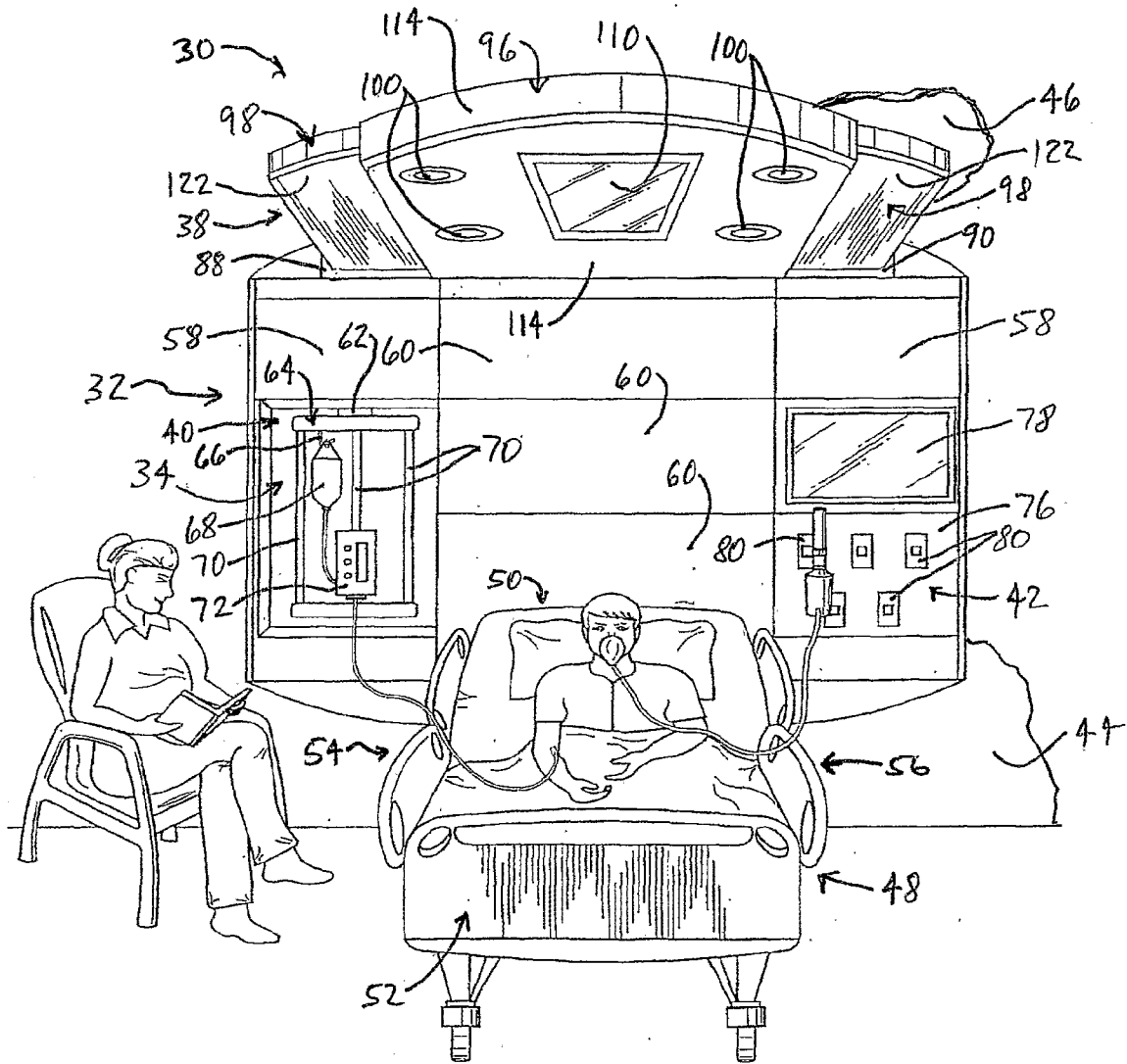


Fig. 1

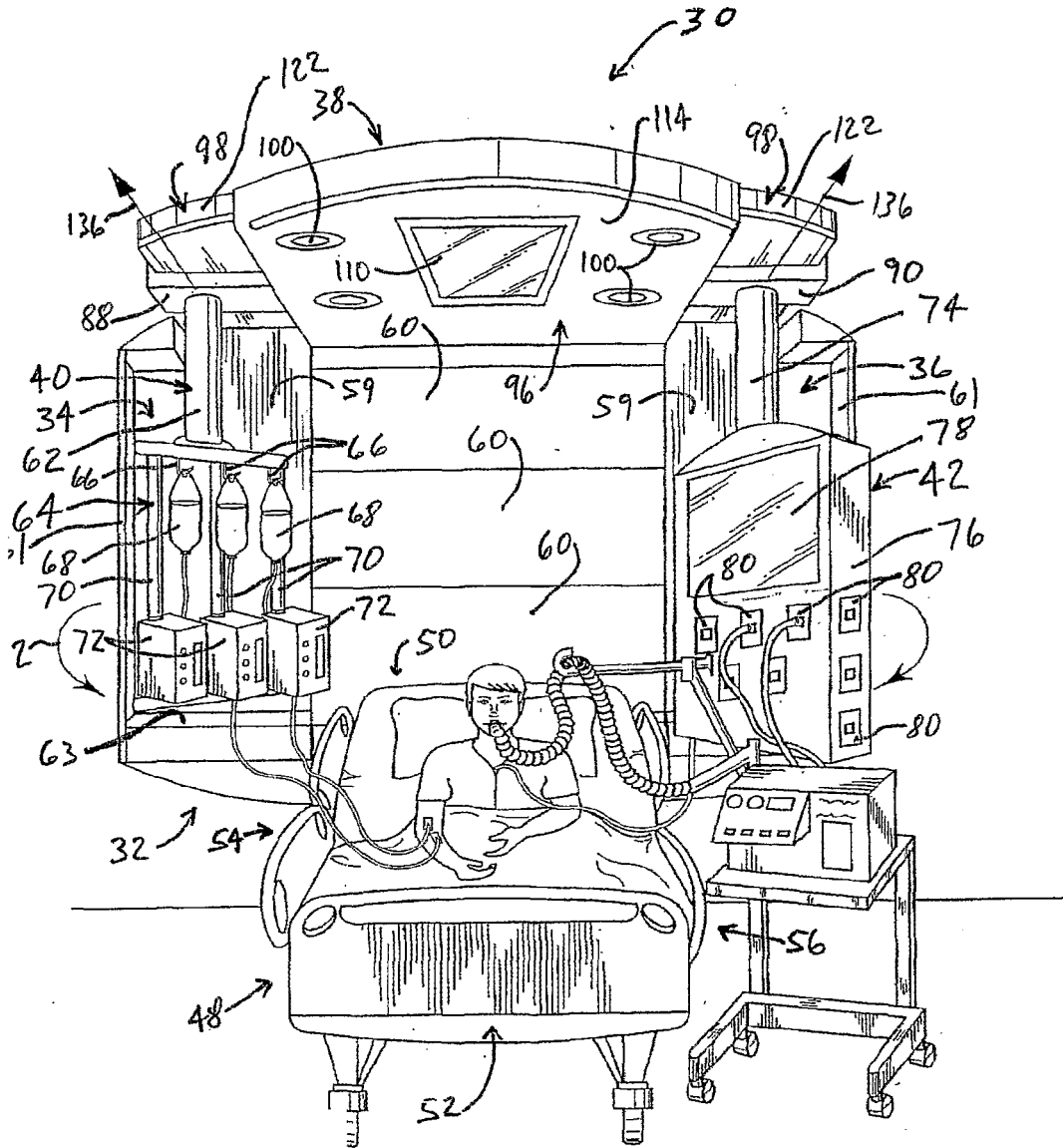
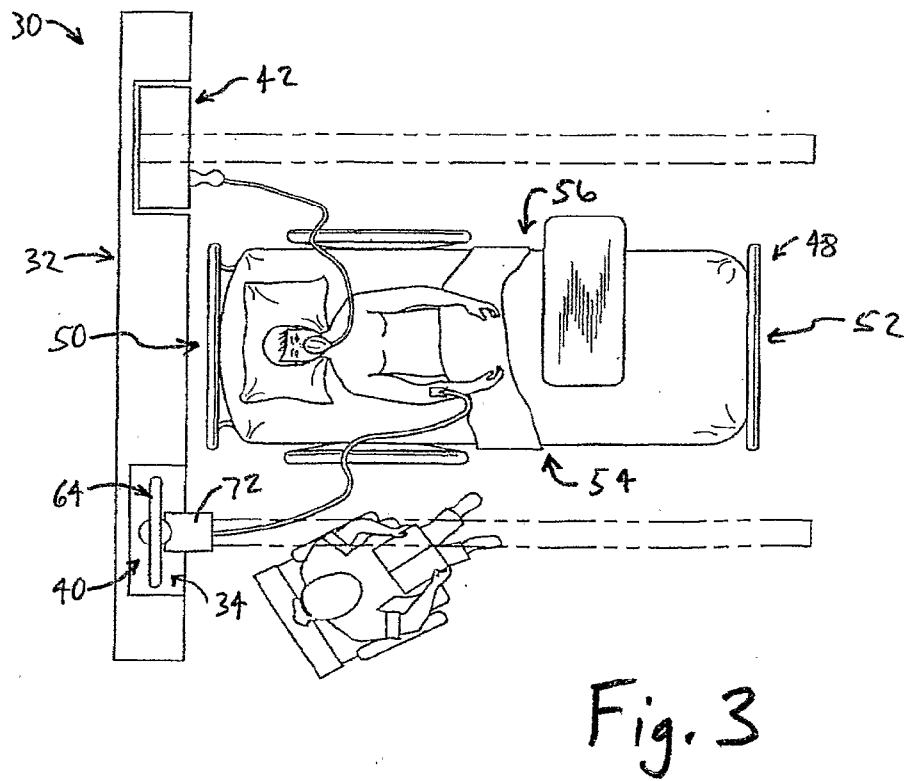
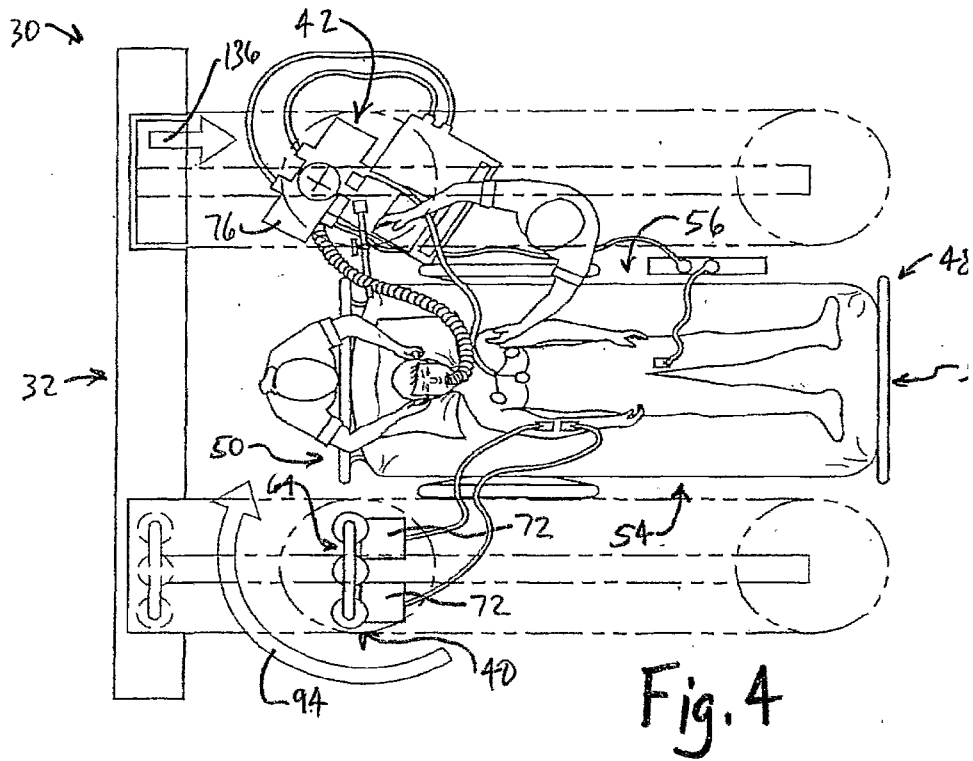


Fig. 2





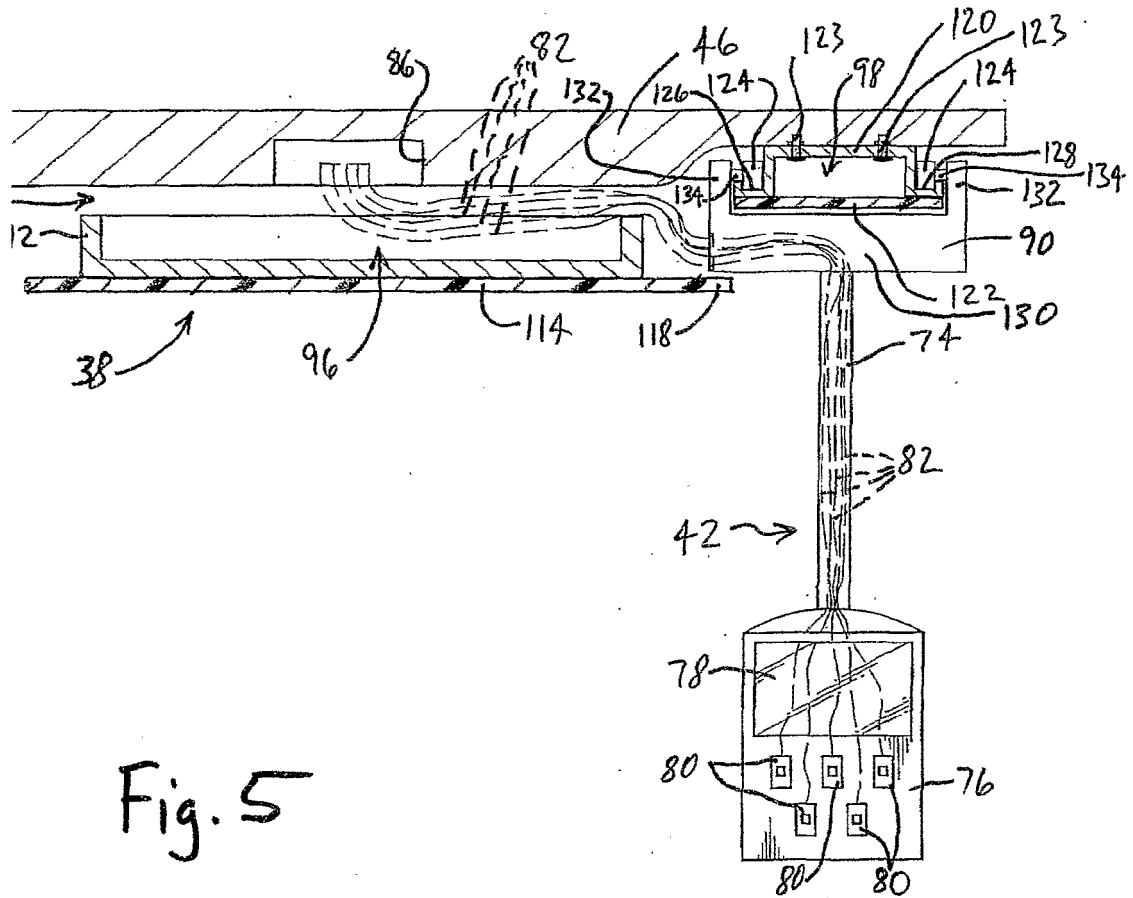


Fig. 5

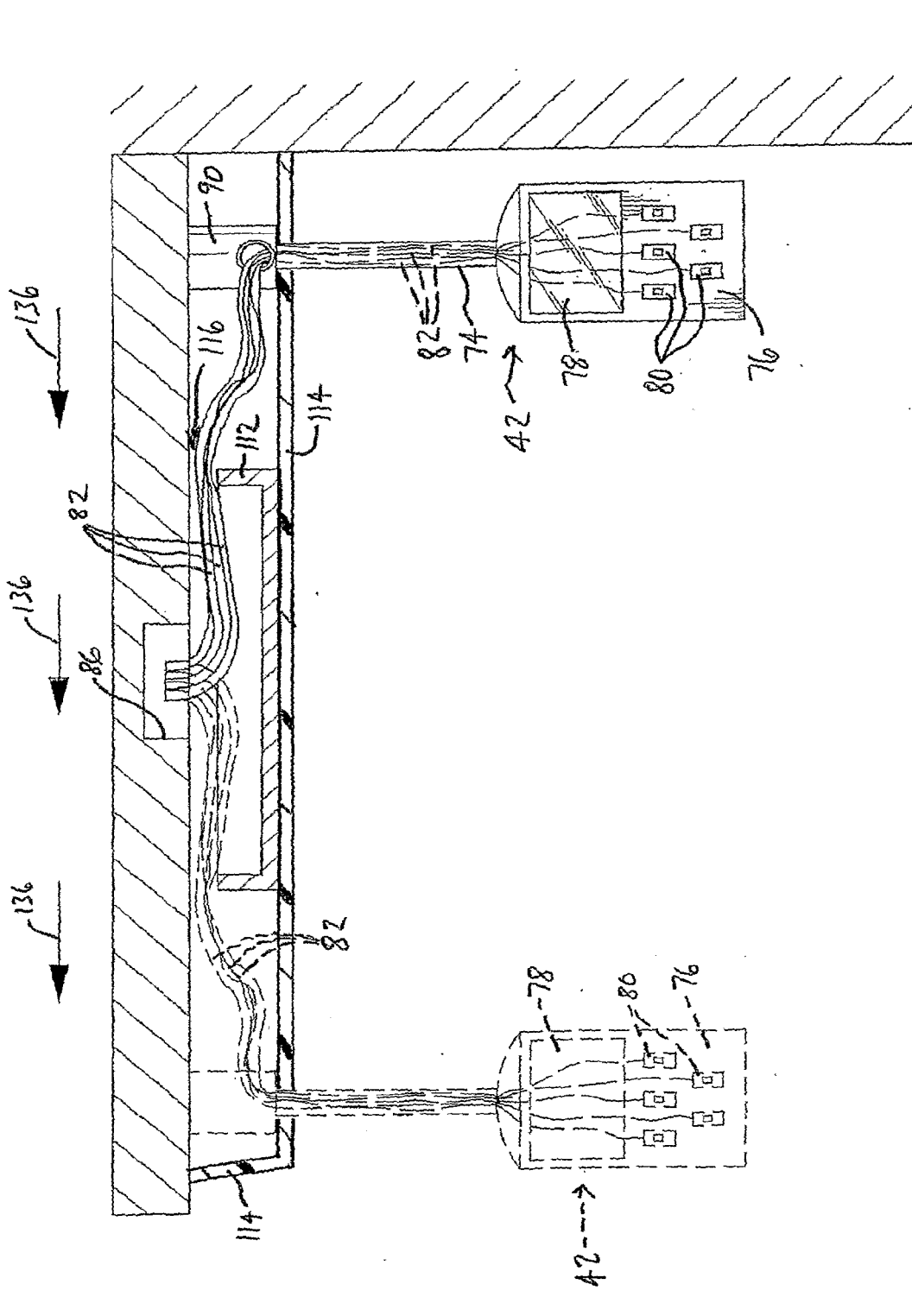


Fig. 6

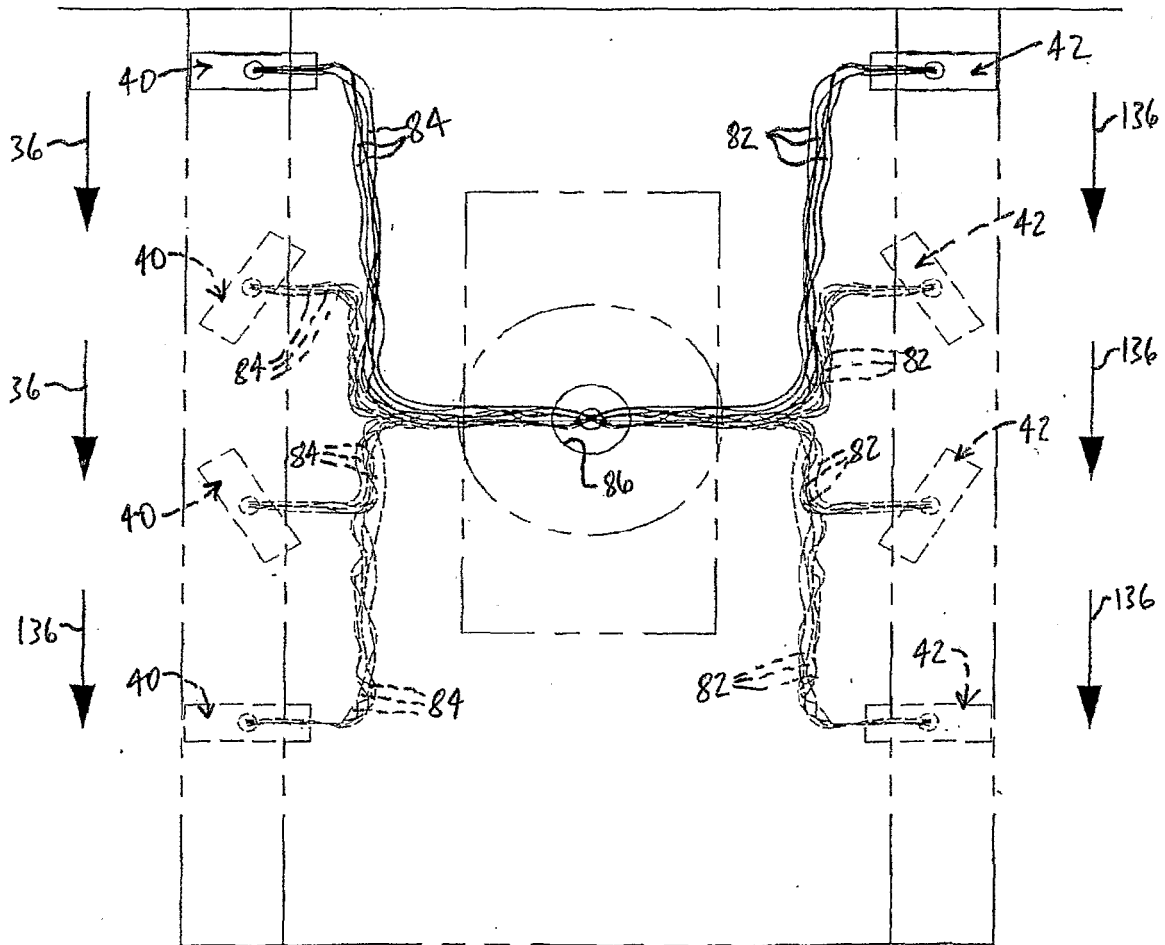


Fig. 7

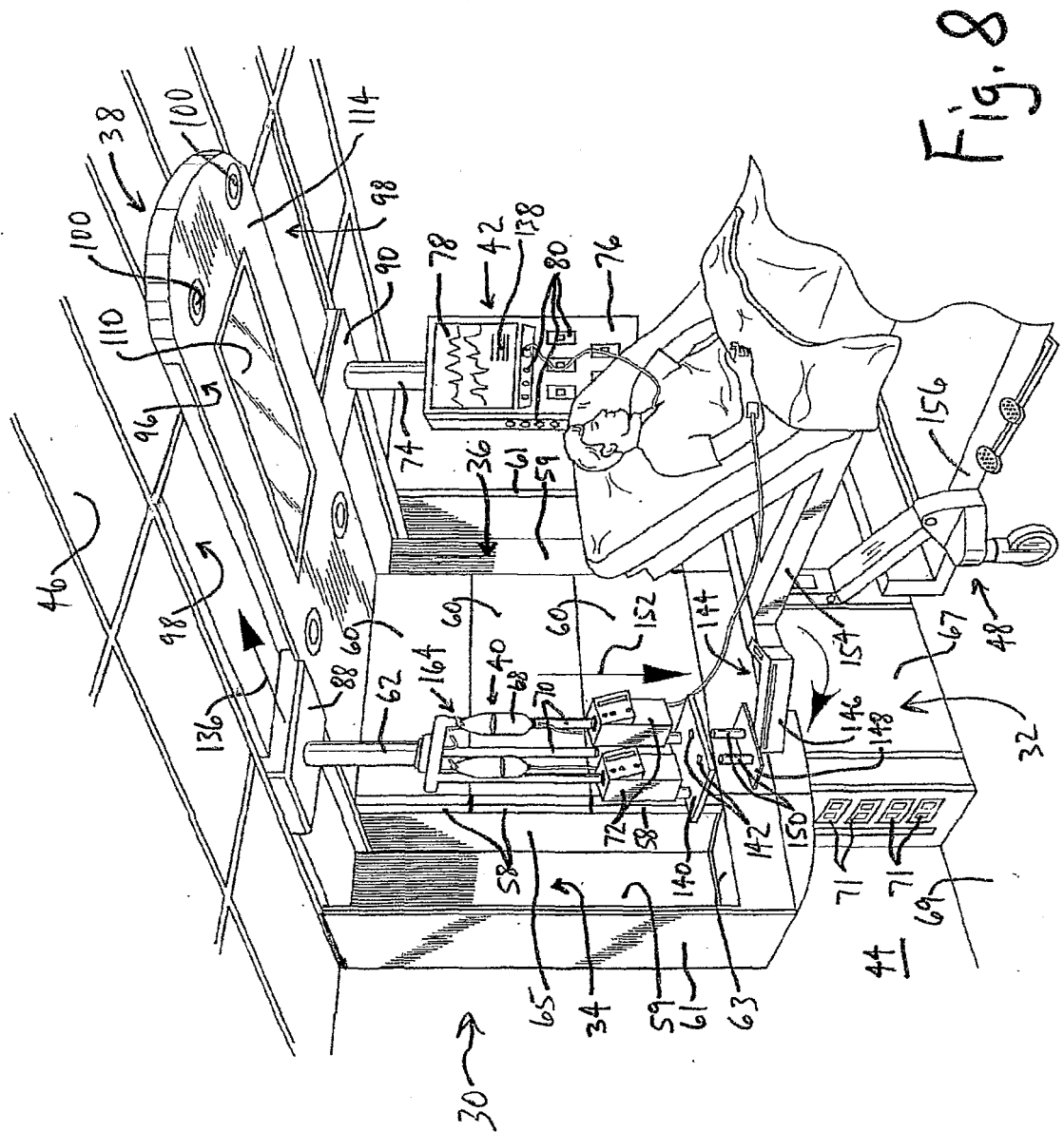


Fig. 8

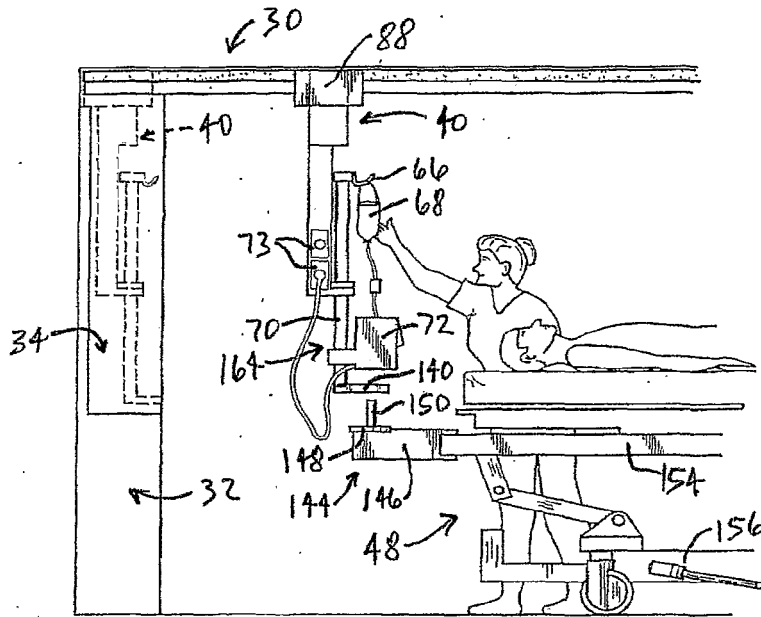


Fig. 9

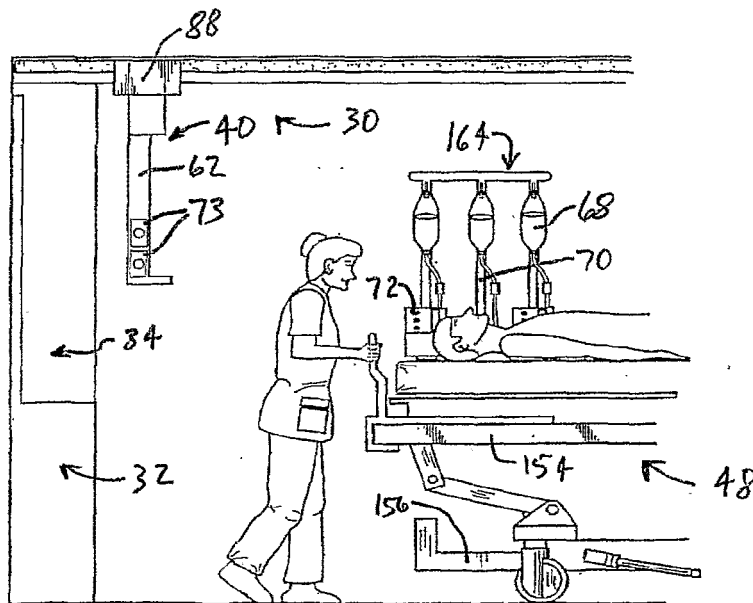


Fig. 10

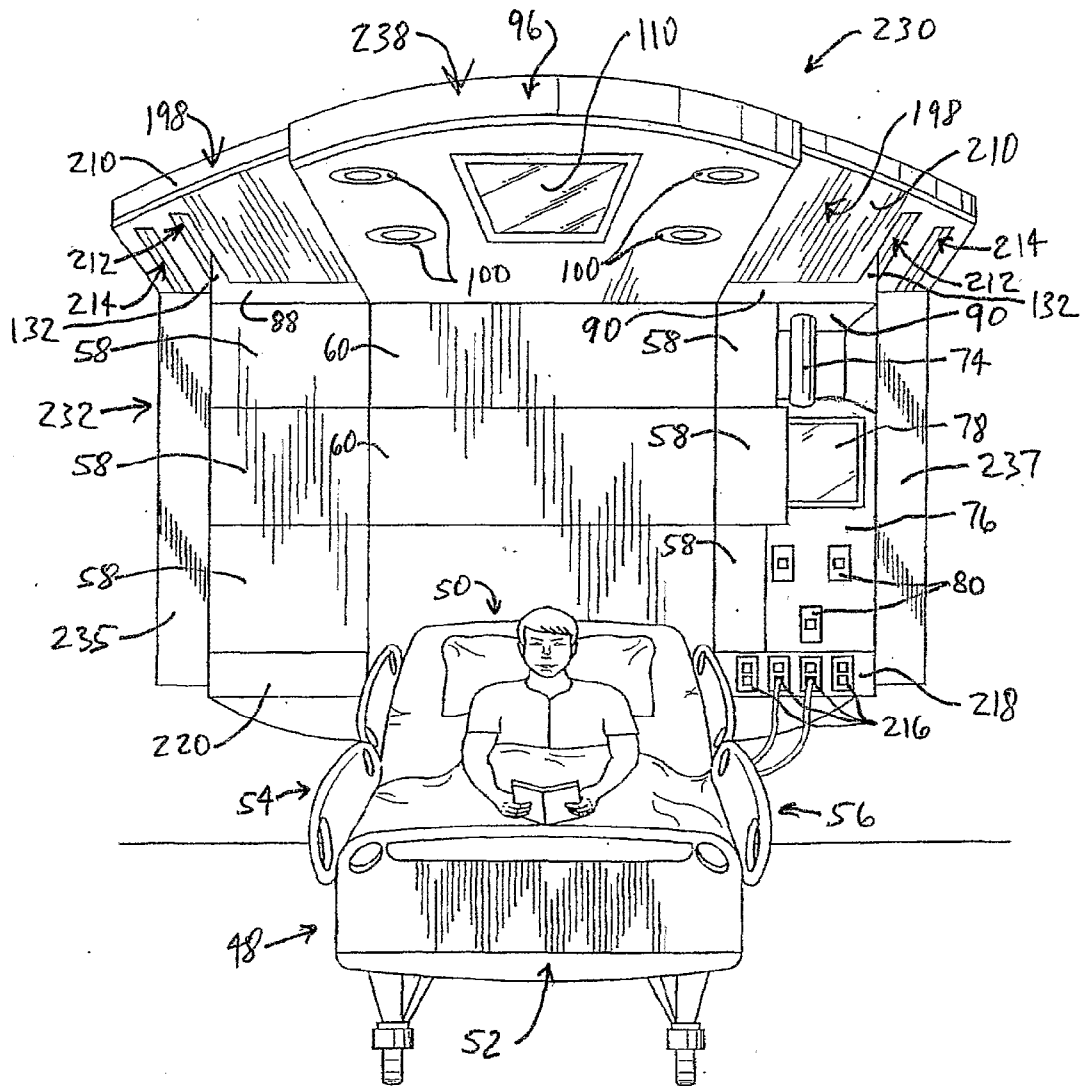


Fig. 11