

-3-

should be minimized. In the case of the above-mentioned gold-195m isotope having a half-life of approximately 30 seconds, it is very much desired, if not necessary, to administer said isotope directly from the generator to the patient. In a clinic in which radioactive isotopes for diagnostic purposes are used, the apparatus necessary for detection, for example, a gamma camera with special collimator and a computer, is usually fixedly arranged. For a radiodiagnostic examination the patient is then brought (wheeled) to the detection apparatus.

It is therefore obvious to give the very short-living material to be used for the examination, in particular a generator for producing a very short-living isotope, a fixed place close to the detection apparatus. It is feasible that high requirements as regards the shielding from radioactive radiation have to be imposed upon such a device beside the patient to be examined ("bed-side arrangement"). In fact, not only the hospital personnel familiar with handling radioactive material will have to be present near the radiation source for a longer period of time, but also other personnel accompanying the patient will have to be shielded from unnecessary radioactive radiation. Moreover it is of utmost importance for the examination that the source of radiation should be shielded carefully from the gamma camera which is very disturbance-sensitive to background radiation.

A fixed arrangement as suggested above which would satisfy these requirements, however, has important practical disadvantages, namely:

(1) it is not possible to move the device around the patient's bed. This is a disadvantage because in examinations with very short-living radioactive isotopes, the organ, for example, the heart, has to be inspected usually in various directions by means of the gamma camera, so as to gain optimum insight in the function of the organ. A fixed bed-side arrangement of the radioactive material to be administered considerably

restricts the possibilities of moving the bed with the patient with respect to the gamma camera. This disadvantage is the larger since, for reasons which will be stated hereinafter, the connection between the source of the radioactive material and the patient should be as short as possible.

- (2) Assembling of the device must take place for the greater part under aseptic conditions because the radioactive material must be introduced into the patient's body directly and cannot be previously subjected to a separate sterilization.

Because the device with radioactive material, in particular the radio isotope generator, will be used for a longer period of time, such an assembling should be carried out under so-called laminar flow conditions, and therefore requires provisions which are particularly difficult to realize in an examination room.

- (3) Another important disadvantage relates to the working with radioactive material upon assembling the device. As a matter of fact, the shielding from radioactive radiation is not yet optimum during the assembly, so that such an assembly, in which large quantities of not yet optimally shielded activity are handled, should therefore take place in a so-called hot-lab of a nuclear medical department of a clinic and not in an examination room for patients where in addition disturbance-sensitive detection apparatus is arranged.

It is the object of the present invention to provide a shielding device for a reservoir comprising radioactive material, in particular a column for a radioisotope generator, which does not exhibit the above-mentioned disadvantages.

For that purpose, the shielding device according to the invention is provided with means with which the device can be moved forward. The complete device comprising radioactive material can now be assembled in suitable rooms intended for this purpose and can then be wheeled to

-5-

the examination room beside the patient's bed. Because the shielding device can be freely shifted, the device can be moved at will around the patient during the examination. Such a movable shielding device for a column for a radio-

5 isotope generator is moreover more flexible because the device can be used, if desired, for any generator, for example, a rubidium-krypton-81m, a strontium-rubidium 82 or a mercury-gold 195m generator.

10 It is of course necessary that the shielding device should also satisfy all conventional safety requirements in addition to the above-mentioned radiological safety requirements. This involves, for example, that the device should be sufficiently stable and be protected as well as possible from calamities, for example, a fire; in

15 the latter case, of course, it should be prevented that the radioactive radiation can pass the shielding device and enter the examination room.

20 Preferably the device in addition comprises provisions for the safe handling of radioactive material, such as a receptacle for waste fluid, a work-top, etc. These provisions enable the user to carry out various manipulations with radioactive materials at different places without risky manually displacing these materials, be-

25 cause, as a matter of fact, the device can be moved forward.

On its lower side the shielding device preferably comprises at least three, preferably five, casters to be able to easily turn and manoeuvre the heavy device in the

30 restricted space around a patient. As a result of the lead cover, a shielding device according to the invention approaches a weight of approximately 360 kg.

Furthermore it is desired to provide the device with a grip at a height which is suitable for hand-movement. For this purpose, a grip consisting of a circumferential tubular or rod-shaped member connected to the out-

35 side of the lead cover has proved particularly suitable. When such a grip having no projections is used, it is

-6-

avoided that components of the device or connections can be drawn along or loose during movement of the shielding device.

5 When using the device it is often necessary to temporarily store radioactive waste material. For example, when a gold-195_m generator is used, the generator column must first be rinsed several times with eluent before an eluate is obtained having a composition which is sufficiently constant for administration to a patient. It is
10 therefore advantageous that the device moreover comprises a separate lead-shielded space for a receptacle for radioactive waste material.

15 Because the radioactive liquid has to be introduced directly into the patient's body, the means for doing this are preferably connected on or to the shielding device.

20 In a suitable embodiment the shielding device according to the invention comprises a base in which the means to move the device are present, a central part of reduced outside diameter in which the lead cover for the reservoir containing radioactive material is present, and
25 a top part which comprises: the lead closure for the access in the cover, the grip, the access to the shielded space for the waste reservoir and the means to introduce a radioactive liquid into a patient's body.

30 As a result of the large diameter of grip and base as compared with that of the reservoir shielded by means of a lead cover, the distance between the radiation source and the operating personnel is increased, for
35 example, by a factor of approximately 2. As a result of this the radiation received is still further reduced, for example, by a factor of approximately 4 as compared with the radiation at the outer surface of the shielded reservoir.

 Lead is vulnerable because it is a soft metal. Moreover, it has a low melting-point, 327°C, so that in the case of a fire, it will melt and drip away, thus allo-

-7-

wing radioactive radiation to be released from the cover. Therefore, the lead cover for the reservoir consists preferably and in agreement with the requirements which are imposed upon the storage of radioactive material in various countries, of a lead vessel which is open at its top and which is enclosed between sheet material of iron or steel, protected on the outside against corrosion, or of stainless steel, while the open top end accessible for the reservoir can be closed by a lead lid provided with the same sheet material on the outside, an aperture for a connection between the reservoir and the means for introducing a radioactive liquid into a patient's body being present in the lid or between the vessel and the lid. The sheet material which can withstand high temperatures ensures sufficient safety for the ambience in the case of a calamity, for example, a fire, so that the lead shielding remains contained and no undesired radioactive radiation can get out of the shielding system.

It cannot always be avoided that a little radioactive liquid is spilled when installing or using the source of the radioactive material. Then it is difficult to thoroughly clean the vessel which forms part of the heavy shielding device. Therefore, a stainless steel vessel is preferably present between the substantially lead vessel and the reservoir, which stainless steel vessel comprises on its open top a radially outwardly projecting flange to which the lid can be sealingly connected.

The shielding device in accordance with the invention serves in particular for shielding a radio isotope generator. The provisions necessary upon eluting a generator column are preferably connected on or to the above-mentioned top part of the device, namely a reservoir for the eluent for the generator column which communicates with the column; means for pumping or injecting the eluent out of the eluent reservoir into the column; means for bringing the resulting eluate out of the column into a patient's body; means for adding a rinsing of formulating

-8-

liquid to the eluate; and a tube which is connected on one side to the means for adding the rinsing or formulating liquid and which on its other side has a member which can be connected to an auxiliary means to admit liquids to the blood vessels or body cavities of a patient.

In order to be able to handle all operating members easily, rapidly and safely, a connection and operating block or tray is connected to the top part, in which block are accommodated injection means for the eluent and the eluate, valves to prevent undesired directions of flow of liquids, cocks to enable or block the passage of liquids, and connection provisions for the means provided in the block both mutually and to the tubes which are connected to the reservoirs, the column and the auxiliary means to be used for the administration to a patient. Preferably the operating block or tray is attached on top of the lid of the lead vessel and the lid is provided with a bore to let pass connecting tubes from the generator to the auxiliary means for injection and from the auxiliary means to the waste fluid receptacle thereby shielding the environment as far as possible from radiation emanating from these tubes when radioactive liquid passes through them. The above embodiment has the advantage that an optimum safety can be reached inspite of the excess pressure at which generally the radioactive liquid is administered to a patient. Moreover, the path which the eluate has to cover, hence the distance between the generator and the patient, can be kept as short as possible. This latter is of importance in particular because, when very short-living radio-isotopes are used, high requirements are generally imposed upon the volume to be administered to the patient and in which the radioactive material is present. As described in the above-mentioned Netherlands Patent Application 8201591, repeated administrations within a short period of time are necessary for various applications. In order to enable such examinations, the volume in which the reactivity is

present must be as small as possible.

The invention will now be described in greater detail with reference to an embodiment which is shown in the accompanying drawings.

5 Figure 1 is a side-view of a shielding device according to the invention; figure 2 shows the same shielding device from top. Figure 1 is for the greater part a longitudinal sectional view of the shielding device taken on the line I-I of fig. 2, viewed in the direction of the arrows. Figure 3 is a longitudinal sectional view of a part of the device taken on the line III-III of fig. 2. The operation of the device will be described in detail with reference to figure 4. Figure 4 shows an exploded view of a part of the device.

15 The base 21 of the screening device shown in Figure 1 comprises a base plate 23 which is hooded with a stove-enamelled sheet iron cap 22 below which five casters 24 are connected so as to be rotatable.

20 The central part 25 is mounted on said base plate and comprises a lead vessel 26 which is enclosed between stove-enamelled sheet iron 27. A second vessel 29 which is manufactured from stainless steel and comprises a radially outwardly projecting flange 28 is provided in the vessel. The generator 31 is placed in vessel 29. Between the bottoms of the vessels 27 and 29 a space 30 remains in which heating elements, for example a heating plate, can be accommodated. As described in the above-mentioned Netherlands Patent Application 8202407 it may be useful when certain radio isotope generators are used, for example, a gold-195m generator, to heat the generator column during the elution. If desired, a bore may be recessed in vessel 26 for leading through a supply for the heating means.

35 As shown in figures 1 and 2 a grip 33 in the form of a circumferential tube which is connected to the vessel by means of three spoke-shaped elements 34 is provided around the top part of the device. The vessel 26 can be closed on its top side by means of a lead lid 36 mounted

-10-

in stove-enamelled sheet iron 35 and connected to the vessel so as to be pivotable at 37. For compensation of the weight of the lid, a spring mechanism 38 is provided. The lid can be clamped sealingly on the vessel (flange 28) by means of a clamping lock 39 provided with a handle. A bore 32 is present in lid 36 for leading through two connection tubes, the outlets of which are framed in a suitable mount 45, comprising a steel tube encased in lead, erected on the lid of the lead vessel and forming a base for an operating block or tray. Between the circumferential grip and the upper edge of the lead vessel, a circumferential stainless steel top 40 having upright edges is present on which auxiliary means necessary for using the device can be placed.

A small lead vessel 41, also mounted in stove-enamelled sheet iron, for a receptacle 12a for waste material is present in an aperture of the top 40, which vessel is connected to the large vessel 27 and can be closed by means of a lead lid 43 provided with a grip 44.

On top of mount 45 is connected an operating block or tray 46 in or on which two syringes can be accommodated, as well as other auxiliary means needed during operation of the device.

Figure 3 shows a waste overflow bottle 12b placed on top 40. The inlet of the overflow bottle is connected to the outlet tube 11b of receptacle 12a.

As shown in Figure 1, two reservoirs 1 and 2 for eluent and rinsing or formulating liquid, respectively, are clamped in a stand 16 mounted on the edge of vessel 27.

As shown in Figure 4, two syringes 5 and 9 provided on their front sides with connection means in the form of Luer cones are connected to three-way cocks, the former directly to a three-way cock 4a and the latter to a three-way cock 4b via two valves 8a and 8b.

The use of the device shown will be explained with reference to figure 4. All connections between the various components, for the greater part tube connections

-11-

and Luer connections, are produced under laminar flow conditions.

5 During operation of the device the tube connections are provided between eluent reservoir 1 and an outlet of three-way cock 4a, the inlet aperture of the generator column 13 and the other outlet of three-way cock 4a, the reservoir with rinsing or formulating liquid 2 and valve 8a, the drain aperture of the generator column 15 and valve 8b, the receptacle for waste fluid 12a and an
10 outlet of three-way cock 4b and the auxiliary means to be used for administration to a patient and the other outlet of three-way cock 4b.

When the device is used, first three-way cock 4b
15 is opened to communicate the eluate duct 7 through cock 10b and valve 8b with the waste fluid receptacle 12a. Overflow bottle 12b is connected to receptacle 12a through a tube 11b and serves as an extra safety. By means of three-way cock 4a, syringe 5 is communicated with eluent
20 reservoir 1, after which the syringe is filled with 2 ml of eluent. Eluent reservoir 1 and rinsing agent reservoir 2, clamped in stand 16, are provided with dropping chambers 3a and 3b. After opening the cock 10a, syringe 9 is filled with a saline solution from reservoir 2 (through
25 valve 8a); the tube is then closed by clamping by means of clamb 17. After having turned three-way cock 4a, the contents of syringe 5 are injected through tube 6 into the generator column 14 at 13; after-rinsing is carried out with 2 ml of saline solution from syringe 9. All the wash
30 liquid (eluate) rinsed through the column and leaving the generator column at 15, as well as the rinsing liquid is collected through tubes 7 and 11a in the waste receptacle 12a.

After having repeated this operation several
35 times, the generator is ready for connection to a patient. For that purpose, a sterile tube, connected to three-way cock 4b, is filled with a saline solution from syringe 9 after opening said valve, and is then connected to an

-12-

auxiliary means to administer the radioactive liquid to a patient, for example, a needle or a catheter. After having placed the patient in a suitable position below a gamma camera, the generator is eluted with 2 ml of eluent by means of syringe 5, the eluate being injected directly into the patient. All remaining radioactivity is then removed from the device by rinsing with 10 ml of saline solution from reservoir 2 by means of syringe 9.

The examination may be repeated any desirable number of times.

CLAIMS:

5 1. A shielding device for a reservoir comprising a radioactive material and having an inlet and an outlet aperture, in particular a column for a radio-isotope generator, comprising a lead cover for the reservoir in which a closable access for the reservoir is recessed, characterized in that the shielding device is provided with means with which the device can be moved forward.

10 2. A device as claimed in Claim 1, characterized in that the device comprises in addition provisions for the safe handling of radioactive material.

15 3. A device as claimed in Claim 1 or 2, characterized in that the device comprises on its lower side at least three, preferably five, casters.

4. A device as claimed in any of the preceding Claims, characterized in that the device comprises a grip, preferably consisting of a circumferential tubular or rod-shaped member connected to the outside of the lead cover.

20 5. A device as claimed in any of the preceding Claims, characterized in that the device comprises in addition a separate lead-shielded space for a reservoir for radioactive waste material.

25 6. A device as claimed in any of the preceding Claims, characterized in that the device is provided with means for introducing a radioactive liquid into a patient's body, while the environment is shielded as far as possible from radiation emanating from these means when radioactive liquid passes through them.

30 7. A device as claimed in Claim 6, characterized in that the device comprises a base in which the means to move the device are present, a central part of reduced outside diameter in which the lead cover for the reservoir containing the radioactive material is present, and a top part which comprises: the lead closure for the access in
35 the cover, the grip, the access to the shielded space for the waste reservoir and the means to introduce a radioactive liquid into a patient's body.

-14-

8. A device as claimed in Claim 7, characterized in that the lead cover for the reservoir consists of a lead vessel which is open at its top and which is enclosed between sheet material of iron or steel treated externally against corrosion, or of stainless steel, while the open top end accessible for the reservoir can be closed by means of a lead lid provided on its outside with the same sheet material, an aperture for a connection between the reservoir and the means for introducing a radioactive liquid into a patient's body being present in the lid or between the vessel and the lid.

9. A device as claimed in Claim 8, characterized in that a vessel of stainless steel which at its open top side comprises a radially outwardly projecting flange to which the lid can be sealingly connected, is present between the substantially lead vessel and the reservoir.

10. A shielding device as claimed in any of the Claims 7-9 for a radio-isotope generator, characterized in that there are additionally connected on or to the top part: a reservoir for an eluent for the generator column which communicates with the column; means for pumping or injecting the eluent out of the eluent reservoir into the column; means to bring the resulting eluate out of the column into a patient's body; means to add a rinsing or formulating liquid to the eluate; and a tube which is connected on one side to the means for adding the rinsing or formulating liquid and which comprises on the other side a member which can be connected to an auxiliary means to admit liquid to blood vessels or body cavities of a patient.

11. A device as claimed in Claim 10, characterized in that a connection and operating block or tray is connected to the top part, in which block are accommodated injection means for the eluent and the eluate, valves to prevent undesired directions of flow of liquids, cocks to enable or block the passage of liquids, and connection means for the means accommodated in the block both mutually

-15-

and to the tubes which are connected to the reservoirs,
the column and the auxiliary means to be used for adminis-
tering to a patient.

5

10

15

20

25

30

35

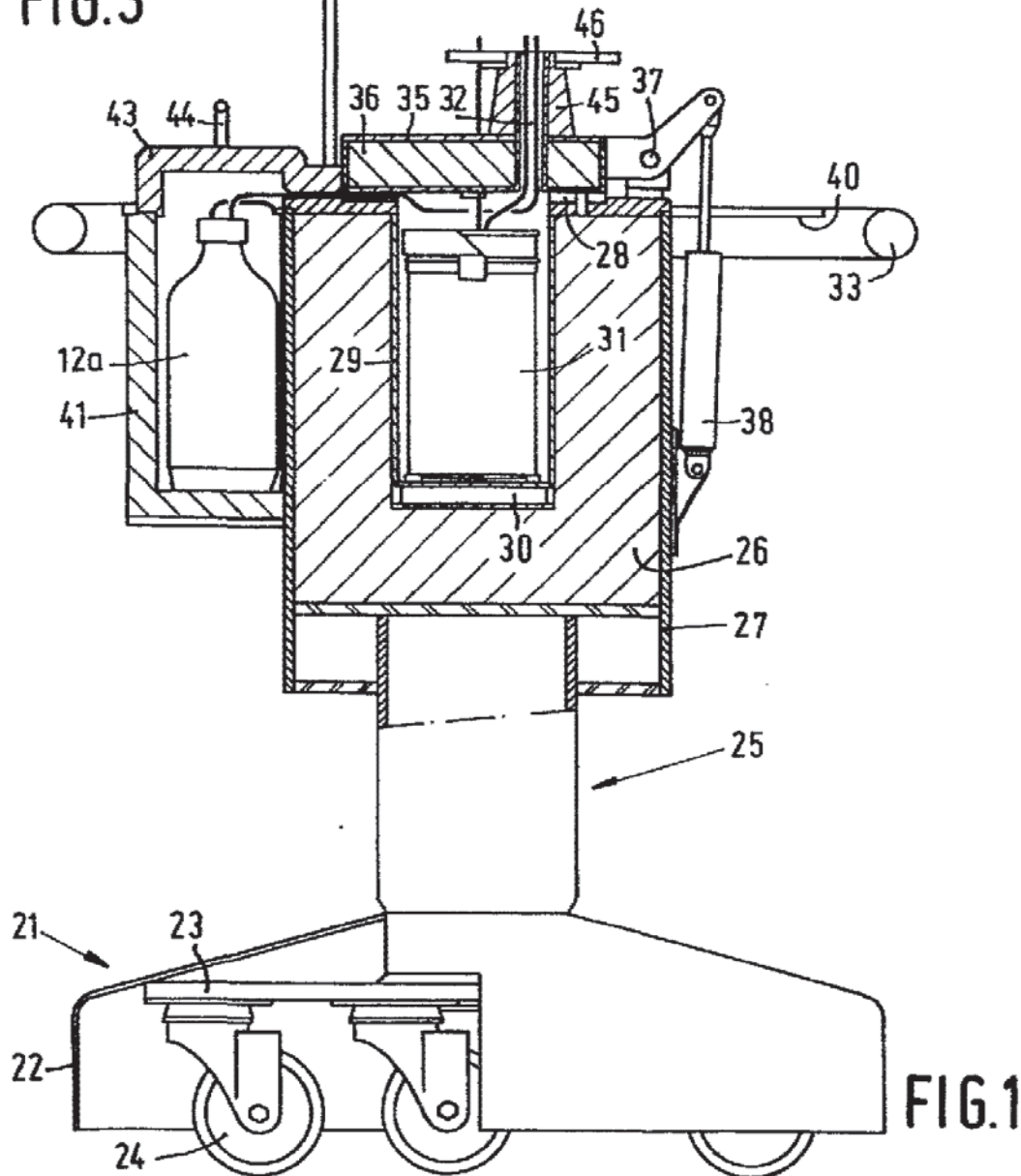
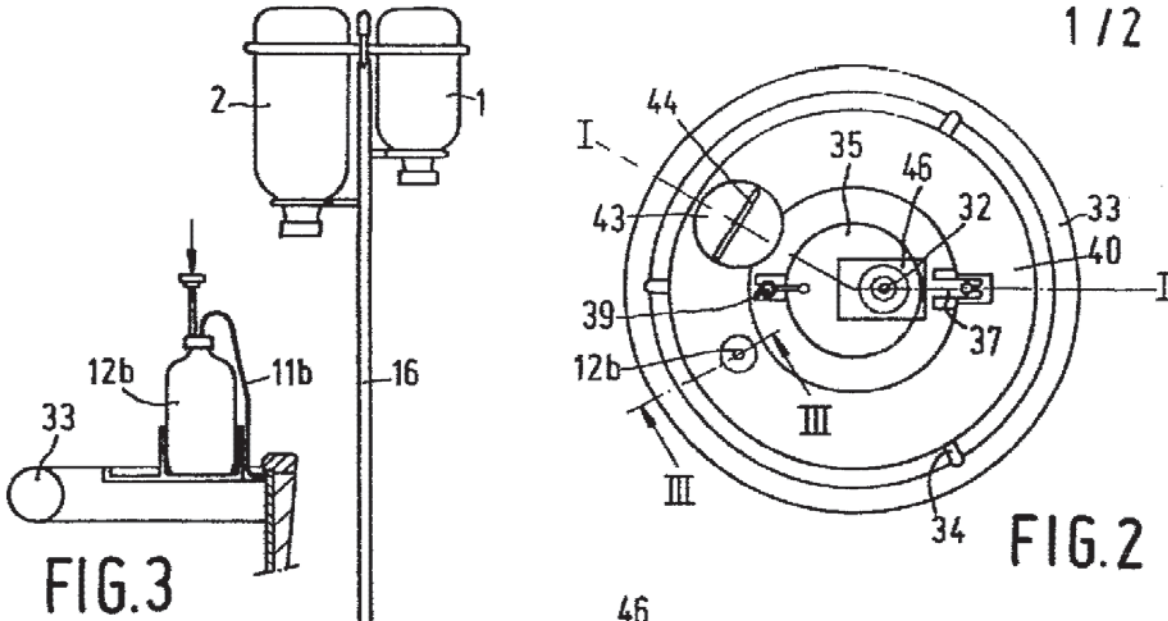

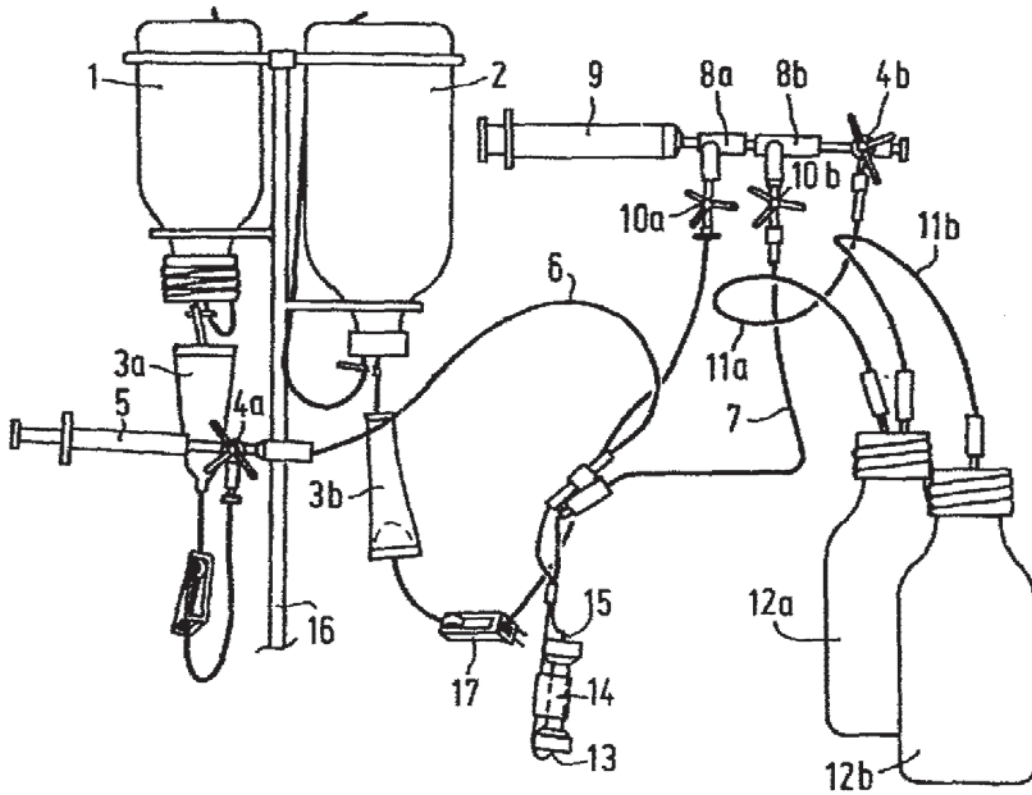

FIG. 4



DOCUMENTS CONSIDERED TO BE RELEVANT			
Category	Citation of document with indication, where appropriate, of relevant passages	Relevant to claim	CLASSIFICATION OF THE APPLICATION (Int. Cl. ²)
A	GB-A-1 234 020 (C.E.A.) * Claim 1; figure 1; page 2, lines 83-90; page 3, lines 68-76 *	1,2,7	G 21 G 1/04
A	GB-A-2 033 288 (BYK MALLINCKRODT) * Claim 1; figure 1; page 3, lines 29-40 *	1,2	
A	US-A-3 710 118 (R.L. HOLGATE) * Claims 1,2 *	1,10	
			TECHNICAL FIELDS SEARCHED (Int. Cl. ²)
			G 21 G G 21 F
The present search report has been drawn up for all claims			
Place of search THE HAGUE		Date of completion of the search 17-11-1983	Examiner NICOLAS H.J.F.
CATEGORY OF CITED DOCUMENTS			
X : particularly relevant if taken alone Y : particularly relevant if combined with another document of the same category A : technological background O : non-written disclosure P : intermediate document		T : theory or principle underlying the invention E : earlier patent document, but published on, or after the filing date D : document cited in the application L : document cited for other reasons & : member of the same patent family, corresponding document	

EPO Form 1503, 03.82

(19) World Intellectual Property Organization
International Bureau



(43) International Publication Date
8 February 2007 (08.02.2007)

PCT

(10) International Publication Number
WO 2007/016170 A1

(51) International Patent Classification:
A61N 5/00 (2006.01) G21G 4/08 (2006.01)
G21F 5/015 (2006.01)

(72) Inventor; and
(75) Inventor/Applicant (for US only): FAGO, Frank
[US/US]; 4508 Estate Court, Mason, Ohio 45040 (US).

(21) International Application Number:
PCT/US2006/029055

(74) Agents: SEURER, Jerad, G. et al.; Mallinckrodt Inc., 675
McDonnell Boulevard, P.O. Box 5840, St. Louis, Missouri
63134 (US).

(22) International Filing Date: 26 July 2006 (26.07.2006)

(81) Designated States (unless otherwise indicated, for every
kind of national protection available): AE, AG, AL, AM,
AT, AU, AZ, BA, BB, BG, BR, BW, BY, BZ, CA, CH, CN,
CO, CR, CU, CZ, DE, DK, DM, DZ, EC, EE, EG, ES, FI,
GB, GD, GE, GH, GM, HN, HR, HU, ID, IL, IN, IS, JP,
KE, KG, KM, KN, KP, KR, KZ, LA, LC, LK, LR, LS, LT,
LU, LV, LY, MA, MD, MG, MK, MN, MW, MX, MZ, NA,
NG, NI, NO, NZ, OM, PG, PH, PL, PT, RO, RS, RU, SC,
SD, SE, SG, SK, SL, SM, SY, TJ, TM, TN, TR, TT, TZ,
UA, UG, US, UZ, VC, VN, ZA, ZM, ZW.

(25) Filing Language: English

(26) Publication Language: English

(30) Priority Data:
60/702,927 27 July 2005 (27.07.2005) US

(71) Applicant (for all designated States except US):
MALLINCKRODT INC. [US/US]; 675 McDonnell
Boulevard, P.O. Box 5840, St. Louis, Missouri 63134
(US).

(84) Designated States (unless otherwise indicated, for every
kind of regional protection available): ARIPO (BW, GH,
GM, KE, LS, MW, MZ, NA, SD, SL, SZ, TZ, UG, ZM,
ZW), Eurasian (AM, AZ, BY, KG, KZ, MD, RU, TJ, TM),

[Continued on next page]

(54) Title: SYSTEM AND METHOD OF IDENTIFYING ELUANT AMOUNTS SUPPLIED TO A RADIOISOTOPE GENERATOR

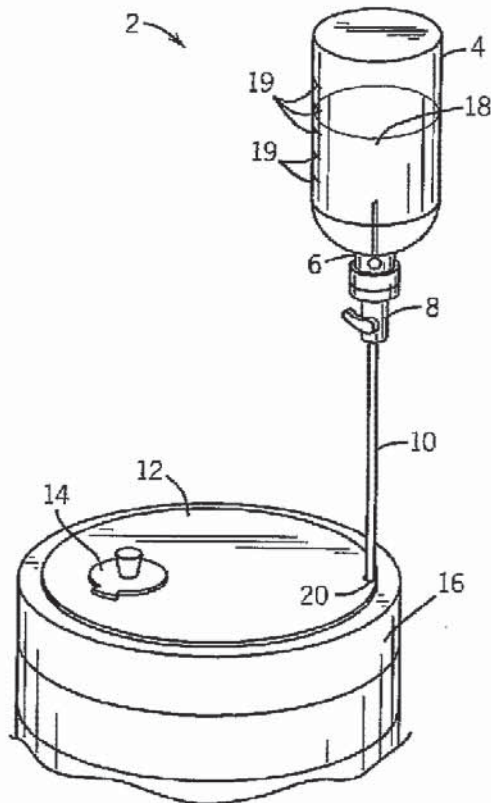

(57) Abstract: The invention, is directed to a system including a shielded container (16), a radioisotope generator disposed within the shielded container, and an elution supply mechanism. The elution supply mechanism may include an eluant supply container (4) at least partially external to the shielded container (16), a conduit (10) extending between an inlet (20) of the radioisotope generator and an outlet (6, 8) of the eluant supply container, and an eluant visualization portal.

WO 2007/016170 A1



European (AT, BE, BG, CH, CY, CZ, DE, DK, EE, ES, FI, FR, GB, GR, HU, IE, IS, IT, LT, LU, LV, MC, NL, PL, PT, RO, SE, SI, SK, TR), OAPI (BF, BJ, CF, CG, CI, CM, GA, GN, GQ, GW, ML, MR, NE, SN, TD, TG).

Published:

— with international search report

— before the expiration of the time limit for amending the claims and to be republished in the event of receipt of amendments

For two-letter codes and other abbreviations, refer to the "Guidance Notes on Codes and Abbreviations" appearing at the beginning of each regular issue of the PCT Gazette.

SYSTEM AND METHOD OF IDENTIFYING ELUANT AMOUNTS SUPPLIED TO A RADIOISOTOPE GENERATOR

FIELD OF THE INVENTION

[0001] The invention relates generally to the field of nuclear medicine. Specifically, the invention relates to a system and method of identifying an amount or flow of eluant in an elution system configured to enable extraction of a radioactive material from a radioisotope generator for use in the practice of nuclear medicine.

BACKGROUND

[0002] This section is intended to introduce the reader to various aspects of art that may be related to various aspects of the present invention, which are described and/or claimed below. This discussion is believed to be helpful in providing the reader with background information to facilitate a better understanding of the various aspects of the present invention. Accordingly, it should be understood that these statements are to be read in this light, and not as admissions of prior art.

[0003] Nuclear medicine is a branch of health science that utilizes radioactive material for diagnostic and therapeutic purposes by injecting a patient with a small dose of the radioactive material, which concentrates in certain organs or biological regions of the patient. Radioactive materials typically used for nuclear medicine include Technetium-99m, Indium-113m, and Strontium-87m among others. Some radioactive materials naturally concentrate toward a particular tissue; for example, iodine concentrates toward the thyroid. However, radioactive materials are often combined with a tagging or organ-seeking agent, which targets the radioactive material for the desired organ or biologic region of the patient. These radioactive materials alone or in combination with a tagging agent are typically defined as radiopharmaceuticals in the field of nuclear medicine. At relatively lower doses of the radiopharmaceutical, a radiation imaging system (e.g., a gamma camera) can provide an image of the organ or biological region that collects the radiopharmaceutical. Irregularities in the image are often indicative of a pathologic condition, such as cancer. Higher doses of the radiopharmaceutical may be used to deliver a therapeutic dose of radiation directly to the pathologic tissue, such as cancer cells.

[0004] A variety of elution systems are used to generate radiopharmaceuticals. Unfortunately, radioactive shielding containers of these systems tend to block visualization of the state and progress of the elution process. For example, the amount of available eluant

and/or the amount of extracted eluate are generally unknown without opening one or more of the radioactive shielding containers. Rather, the pharmacist typically has to wait an estimated amount of time to ensure the process is complete, which results in wasted time or premature termination of the process. If a specific amount of eluate is desired, then the time estimation may tend to result in too much or too little of the eluate.

SUMMARY

[0005] The present invention, in certain embodiments, is directed to identifying or monitoring a volume, mass, weight, displacement or flow of a supply element (e.g., eluant) and/or an output eluate associated with eluting a radioisotope from a generator product in the field of nuclear medicine. Specifically, in some embodiments, visual access may be provided into an eluant supply container to facilitate performance of elution procedures. For example, a visual portal into an eluant supply container during an elution can provide data for measuring and calculating metrics relating to completion of full or partial elutions and data relating to when a generator is available for milking. Other embodiments may measure an amount or flow of eluant and/or eluate, such that a user can directly view the measurement (e.g., scale or flow meter) or indirectly view the measurement on a remote display screen or computer.

[0006] Certain aspects commensurate in scope with the originally claimed invention are set forth below. It should be understood that these aspects are presented merely to provide the reader with a brief summary of certain forms the invention might take and that these aspects are not intended to limit the scope of the invention. Indeed, the invention may encompass a variety of aspects that may not be set forth below.

[0007] In accordance with a first aspect of the present invention, there is provided a system having a shielded container, a radioisotope generator disposed within the shielded container, and an elution supply mechanism. The elution supply mechanism has an eluant supply container at least partially (and in some cases, completely) external to the shielded container, a conduit extending between an inlet of the radioisotope generator and an outlet of the eluant supply container, and an eluant visualization portal.

[0008] In accordance with a second aspect of the present invention, there is provided a system that includes a radiation shielded container having a receptacle and a cover disposed over an opening in the receptacle, a radioisotope generator disposed within the receptacle below the cover, and an eluant supply mechanism. The eluant supply mechanism includes an eluant supply container and a conduit coupled with the eluant supply container and the

radioisotope generator. The conduit is disposed at least partially within the shielded container, and an eluant measurement device is coupled to the eluant supply mechanism.

[0009] A third aspect of the present invention is directed to a method of using a radioisotope elution system. With regard to this third aspect, a radioisotope generator that is disposed inside a radiation shielded container receives an amount of eluant. The amount of eluant received by the radioisotope generator is visually indicated outside the radiation shielded container. In addition, radioactive material is eluted from the radioisotope generator.

[0010] In accordance with a fourth aspect of the present invention, there is provided a system including an eluant supply mechanism and a radiation shielded lid having an aperture defined therein. The eluant supply mechanism includes an eluant supply container, a conduit coupled to the eluant supply container and at least partially disposed in the aperture, and an eluant measurement feature.

[0011] Various refinements exist of the features noted above in relation to the various aspects of the present invention. Further features may also be incorporated in these various aspects as well. These refinements and additional features may exist individually or in any combination. Again, the brief summary presented above is intended only to familiarize the reader with certain aspects and contexts of the present invention without limitation to the claimed subject matter.

BRIEF DESCRIPTION OF THE DRAWINGS

[0012] These and other features, aspects, and advantages of the present invention will become better understood when the following detailed description is read with reference to the accompanying drawings in which like characters represent like parts throughout the drawings, wherein:

[0013] FIG. 1 is a perspective view of an exemplary embodiment of a generator product including a visually accessible eluant supply bottle, a vented spike, a stop cock, tubing, a shielded lid, a shielded lid plug, and a shielded container;

[0014] FIG. 2 is a partial cross-sectional side view of an exemplary embodiment of the generator product, wherein the tubing may pass through an aperture defined along an edge of the lid and into the shielded container;

[0015] FIG. 3 is a top view of an exemplary embodiment of a portion of the generator product, wherein the lid may be mounted over an opening in the shielded container;

[0016] FIG. 4 is a cross-sectional side view of an exemplary embodiment of the generator product, wherein the tubing may be coupled to the generator via an inlet needle and the lid plug may be replaced by an elution assembly;

[0017] FIG. 5 is a partial perspective view of an exemplary embodiment of the generator product, wherein a syringe pump may be incorporated in the place of the eluant supply bottle;

[0018] FIG. 6 is a partial perspective view of an exemplary embodiment of the generator product, wherein a drip chamber may be incorporated in the tubing;

[0019] FIG. 7 is a partial perspective view of an exemplary embodiment of the generator product that may include the drip chamber, an electronic drop counter, a display, and a computer, wherein the electronic drop counter may be utilized to count the drops passing through the drip chamber;

[0020] FIG. 8 is a partial perspective view of an exemplary embodiment of the generator product, wherein the eluant supply may be utilized with a splitter or manifold to supply a plurality of generators, each disposed within a shielded container;

[0021] FIG. 9 is a partial perspective view of an exemplary embodiment of the generator product, wherein the eluant supply bottle may be at least partially shielded and may include a visualization window that facilitates viewing and measurement of eluant levels in the bottle, and wherein the drip chamber and drop counter may be disposed within the shielded container; and

[0022] FIG. 10 is a partial perspective view of an exemplary embodiment of the generator product, wherein the eluant supply bottle, the drip chamber, and the drop counter may be disposed within the shielded container, and wherein the display may be positioned external to the shielded container along with a portion of a level gauge coupled to the eluant supply bottle.

DETAILED DESCRIPTION OF SPECIFIC EMBODIMENTS

[0023] One or more exemplary embodiments of the present invention are described below. In an effort to provide a concise description of these embodiments, some features of an actual implementation may not be described in the specification. It should be appreciated that in the development of any such actual implementation, as in any engineering or design project, numerous implementation-specific decisions may be made to achieve the developers' specific goals, such as compliance with system-related and business-related constraints, which may vary from one implementation to another. Such a development effort would be a routine

undertaking of design, fabrication, and manufacture for those of ordinary skill having the benefit of this disclosure.

[0024] The embodiments discussed in detail below relate to a system and method for facilitating efficient extraction of radioactive material (e.g., a radioisotope) from a radioisotope generator during a radioisotope elution process. Indeed, embodiments of the present invention facilitate efficient use of time and resources by providing direct or indirect visual access to an eluant supply and/or an eluate output during a radioisotope elution process. In other words, techniques are disclosed for identifying or tracking a volume, mass, weight, displacement, and/or flow of a supply eluant and/or an output eluate associated with eluting a radioisotope from a radioisotope generator via direct visualization or non-visual measurements that can be visualized remotely. As discussed below, these techniques may include a scale to monitor changes in weight of a supply eluant and/or an output eluate. Additionally or alternatively, these techniques may include a flow meter or displacement gauge, graduated volume marks on the supply and/or output container, and so forth.

[0025] FIG. 1 shows an exemplary embodiment of a generator product 2 that includes a visually accessible eluant supply container (here, a bottle) 4, a vented spike 6, a stop cock 8, tubing 10, a radioactivity shielded lid 12, a radioactivity shielded lid plug 14, and a radioactivity shielded container 16 (e.g., an auxiliary shield). In some embodiments, the lid plug 14 may be replaced by an elution assembly. It should be noted that the term "generator product" herein interchangeably refers to both a radioisotope elution system and/or a radioisotope generator assembly. A radioisotope generator assembly may include a radioisotope generator, a radioactivity shielded container, an eluant supply container, a radioactivity shielded lid, and a lid plug. A radioisotope elution system may include the radioisotope generator assembly, wherein the lid plug is replaced with an elution assembly that includes an eluate output container and an elution shield surrounding the eluate output container.

[0026] As illustrated in FIG. 1, the eluant supply container 4 may be entirely or at least partially transparent (or translucent) and external to the shielded container 16, thereby providing a visualization portal into the bottle 4. In some embodiments, the supply bottle 4 may be partially external and/or partially internal to the shielded container 16. The supply bottle 4 can be fully or partially composed of glass, hard plastic, soft plastic, and other appropriate material(s) that allow visual access. As such, a user can visualize eluant 18 disposed within the bottle 4. Because the eluant 18 is visible, a user can observe how much of it has been used during an elution process and/or how much of it remains after an elution process. For example, in the illustrated embodiment, a user can visually monitor the level of eluant in the bottle 4 with respect to index marks 19, which correspond to predefined metrics

(e.g., volume). This facilitates determination of when an elution process is complete. Further, if a partial elution (e.g., an elution to partially fill a standard sized eluate output container) is desired, visual access to the eluant supply may facilitate accurate performance of the partial elution. The eluant supply container 4 may be coupled to a generator disposed within the shielded container 16 via the tubing 10. Incidentally, "coupled" or the like herein generally refers to two or more components that are either directly or indirectly connected to one another. In this particular example, the coupling of the eluant supply container 4 and the generator may be characterized as a fluid coupling of those components. Incidentally, "fluidly coupling" or the like refers to a coupling of first and second components so that molecules of a substance(s) (such as a liquid or gas) may be substantially confined within and capable of flowing between the first and second components.

[0027] The tubing 10 can be a rigid or flexible conduit (e.g., flexible tubing or a needle) capable of enabling flow of the eluant 18 from the eluant supply container 4 to the generator. In some embodiments, the tubing 10 is transparent and/or translucent, which further facilitates observation of the eluant flow from the eluant supply 18 to the generator. The tubing 10 may be coupled to the eluant supply container 4 in any appropriate manner, such as via a stopcock 8 and a vented spike 6. In the illustrated embodiment, the eluant supply container 4 may be made of a generally rigid material that does not collapse as the eluant 18 is evacuated. Accordingly, the vented spike 6 may allow filtered air to enter into the bottle 4 to reduce the likelihood of a vacuum (e.g., a state of negative pressure) inside the bottle 4 when the eluant 18 flows out. In other embodiments, the eluant supply container 4 may be made of flexible material that collapses as it is evacuated with or without aid by the vented spike 6. The stopcock 8 may enable a user to regulate flow of the eluant 18 from the bottle 4 through the tubing 10 and into the generator. For example, the stopcock 8 may include a valve that opens and closes by means of a tapered plug, enabling a user to control flow of eluant 18 between the bottle 4 and the generator.

[0028] The tubing 10 may pass into the shielded container 16 through the lid 12 via an aperture 20 in the lid 12. In some embodiments, the aperture 20 may be formed in a central portion of the lid 12 and may include a nipple or other connection mechanism. However, in the illustrated embodiment, the aperture 20 is disposed along the circumference of the lid 12 such that a gap is formed between the edge of the lid 12 and the shielded container 16. The aperture 20 is illustrated in FIG. 2, which is a partial cross-sectional view of the generator product 2, wherein the tubing 10 passes through the aperture 20 disposed along the edge of the lid 10 and into the shielded container 16. Specifically, FIG. 2 illustrates the tubing 10 passing between the lid 10 and a top section of the shielded container 16 through the aperture 20 and coupling with a generator 22 via a coupling mechanism 24 (e.g., a needle, a nipple,

threaded fastener, flange, and/or the like). In some embodiments, the coupling mechanism 24 may include a check valve that reduces the likelihood of backflow of eluant and/or eluate from the generator 22 to the tubing 10 (and possible even the eluant supply container 4). In some embodiments, the tubing 10 may include a check valve disposed therein to reduce the likelihood of backflow from downstream tubing to upstream tubing and/or to the eluant supply container 4. It should be noted that in some embodiments, the tubing 10 may pass through an opening in the side of the shielded container 16. For example, in some embodiments, the tubing 10 may pass through an opening formed between sectional rings 26 that are stacked to form the shielded container 16.

[0029] FIG. 3 is a top view of a portion of the generator product 2, wherein the lid 12 is mounted over an opening in the shielded container 16. Specifically, FIG. 3 illustrates the aperture 20 disposed along an edge of the lid 12 and forming a gap between the lid 12 and the shielded container 16. As noted above, in some embodiments, the aperture 20 may be located in a generally central location on the lid 12 or in a side portion of the shielded container 16. In some embodiments, the aperture 20 and the tubing 10 may correspond in size so that the tubing 10 is tightly secured when engaged with the aperture 20. In other embodiments, the aperture 20 may be larger than the tubing 10, allowing maneuverability of the tubing 10 while it is engaged in the aperture 20. In still other embodiments, the tubing 10 includes one or more seals or the like that operate to secure the tubing 10 in the aperture 20 and prevent flow (e.g., air flow) in and out of the shielded container 16 through the aperture 20.

[0030] FIG. 4 is a cross-sectional side view of the generator product 2, wherein the tubing 10 is shown coupled to the generator 22 via a hollow inlet needle 28 and the lid plug 14 has been replaced by an elution assembly 28. The illustrated elution assembly 28 includes an elution shield 32 at least generally disposed about an eluate collection bottle 34. The elution shield 32 is designed to shield users from radioactive elements that are received by elution into the bottle 34. The eluate collection bottle 34 may be coupled to the generator 22 via a hollow outlet needle 36. During a wet elution process (e.g., an elution process wherein the generator generally remains charged), the eluate collection bottle 34 may be coupled to the generator 22 to enable eluate residing in the generator 22 to circulate through the generator 22 and into the evacuated collection bottle 34. The generator 22 is a shielded container that holds a parent radioisotope, such as Molybdenum-99 absorbed to alumina beads or another suitable exchange medium. The daughter radioisotope (e.g., Technetium-99M) is held chemically less tightly than the parent, thereby enabling flowing eluant to flush the desired radioisotope from the radioisotope generator 22 into the collection bottle 34 as eluate.

[0031] The eluate collection bottle 34 may have a standard or predefined volume, which may begin in an evacuated condition. A pressure drop into the evacuated eluate collection bottle 34 may facilitate eluate residing in the generator 22 to begin filling the bottle 34. Correspondingly, eluant 18 from the eluant supply container 4 may begin flowing into the generator 22 to replace the eluate passing to the collection bottle 34. Indeed, once the eluate collection bottle 34 is connected to the generator 22, a user can observe that eluant levels in the eluant supply container 4 go down in an amount generally corresponding to the amount of eluate received in the eluate collection bottle 34. For example, a user can observe the volume of eluant 18 leaving the eluant supply container 4 by comparing the eluant level in the supply bottle 4 over time with the index marks 19. This visualization may tend to facilitate determining when the elution process is complete (e.g., the eluate collection bottle 34 is full), and/or may facilitate performance of partial elutions, in which the eluate collection bottle 34 is partially filled with eluate. It should be noted that in some embodiments, the eluate collection bottle 34 may not begin in an evacuated condition. For example, in some embodiments, other system conditions (e.g., generated pressure and/or gravity) may cause flow into the eluate collection bottle 34.

[0032] FIG. 5 illustrates an alternative embodiment of the generator product 2, wherein a graduated syringe pump 40 may be incorporated in the place of the eluant supply container 4. The syringe pump 40 is adapted to inject the eluant 18 into the generator 22 via the tubing 10. Because the syringe pump 40 generates pressure, an evacuated eluate collection bottle 34 may or may not be used in this embodiment. For example, a collection bottle 34 with a vent for expelling air may be used to collect the eluate. While the syringe pump 40 may drive the elution, the graduations or volumetric marks 19 may enable a user to measure and/or observe the amount of eluant injected into the generator 22. In other embodiments, other electrical and/or mechanical pumps and measurement systems may be used to supply and measure amounts of eluant supplied to the generator 22. For example, the system may include an electrical/mechanical scale, flow meter, and so forth. Moreover, the measurements may be visualized by a user directly or indirectly via a remote monitoring system, e.g., a computer. It should be noted that FIG. 5 also illustrates that the aperture 20 may be disposed in a generally central portion of the lid 12. Additionally, as shown in FIG. 5, the tubing 10 may be coupled to a nipple 42 that passes through the lid 12 and couples to the generator 22 within the shielded container 16.

[0033] FIG. 6 shows an exemplary embodiment of the generator product 2, wherein a drip chamber 44 is incorporated in the tubing 10 to facilitate tracking or identification of an amount of eluant flowing into the generator 22. The drip chamber 44 may facilitate measurement of the eluant passing between the eluant supply container 4 and the generator 22 in a variety of

ways. For example, an observer can manually calculate the amount of transferred eluant by counting the drops that pass through the drip chamber 44. For instance, thirty drops of the eluant may correspond to one milliliter of eluant. As another example, in the embodiment illustrated in FIG. 7, an electronic drop counter 46 may be utilized to count the drops passing through the drip chamber 44 by, for example, detecting motion in the drip chamber 44. In one embodiment, the drop counter 46 may include an infra-red light emitting diode (LED) 48 and a photo detector 50. The LED 48 and photo detector 50 are aligned such that the photo detector 50 receives a light beam from the LED 48. When a drop passes through the drop counter 46, it breaks the light beam and the drop counter 46 outputs and/or stores data corresponding to the break. This facilitates measurement of the number of drops and the provision of metrics relating to the amount of eluant being passed from the eluant supply container 4 through the drip chamber 44 and into the generator 22. Metrics can be calculated from the data retrieved by the drop counter 46 manually, in the drop counter 46 itself, or in other devices capable of receiving data and performing calculations.

[0034] As illustrated in FIG. 7, the drop counter 46 may be communicatively coupled to a display 52 for display of metrics relating to the elution process. The drop counter 46 may be coupled to an electronic device and/or computer 54 (e.g., a laptop computer) to store data, facilitate communication with other devices, and/or perform calculations relating to the elution process. It should be noted that in some embodiment, the display 52 may be incorporated into the computer 54. In other words, rather than having a separate display 52, a computer screen 56 of the computer 54 may be utilized for displaying data associated with the elution process. For example, a volume associated with the number of counted drops (e.g., thirty drops corresponds to one milliliter) can be calculated and displayed on the computer screen 56. A time associated with each counted drop can be displayed on the computer screen 56. The volume and/or time associated with each elution process may be tracked and displayed to enable a user (or the computer 54) to estimate when the generator will be ready for another elution process. For example, a value corresponding to an expected radioactivity level of an elution at a certain time can be calculated and displayed on the computer screen 56. By further example, a user (or the computer) can determine an actual radioactivity level of an eluate at a given time. The radioactivity level information can be programmed into the computer 54 if that information is not already in the computer, for example, which can incorporate other data (e.g., time data from the drop counter 46) to determine an expected radioactivity level at a specified future time. In some embodiments, a certain time when an elution should be performed, based on data from the drop counter 46 and/or predefined data (e.g., a calculated expected radioactivity level), can be calculated and displayed on the computer screen 56.

[0035] FIG. 8 shows another exemplary embodiment of the generator product 2, wherein the eluant supply container (here, a bag) 4 may be utilized with a manifold or splitter 60 to supply a plurality of generators 22, each disposed within a shielded container 16. As illustrated, this generator product 2 may have a variety of different measurement and visualization features that may complement or supplement one another. The single bulk supply of eluant (e.g., eluant supply container 4) may increase the likelihood that the individual generators 22 have sufficient eluant during individual or simultaneous operation. In addition, the total eluate output from all of the generators may be tracked or visualized by comparing the eluant level inside the bag 4 against the index marks 19.

[0036] Still referring to FIG. 8, the computer 54 may be coupled to each of a plurality of drop counters 46 and/or displays 52 that provide data relating to elution processes in each of the generators 22, thus enabling collection and provision of data relating to generator usage individually and/or collectively. For example, based on time stamped usage data and related calculations, the computer 54 may indicate that a particular generator 22 in a set of generators should be milked before the others based on a greater likelihood that it may produce an eluate with an appropriate and/or desired radioactivity level. Further, having a single source of eluant may facilitate rapid replacement of the eluant source (e.g., eluant supply container or bag 4) for multiple generators 22. It should be noted that in the embodiment illustrated in FIG. 8, the eluant supply container or bag 4 may be a transparent or translucent rigid container or a collapsible plastic bag with or without a vent to facilitate flow. Thus, the level of eluant may be directly visualized in the container or bag 4. In some embodiments, the container or bag 4 may be mounted on or hung from a scale 57 to measure weight changes in the container or bag 4 and, thus, track the amount of eluant flowing into the generators. For example, an initial weight of the container or bag 4 may be weighed as a reference, followed by a manual or electronic tracking of reduced weight of the container or bag 4. Alternatively, a separate scale 57 may be attached independently to each of a plurality of eluate supply containers for the generators 22.

[0037] FIG. 9 shows an exemplary embodiment of the generator product 2, wherein the eluant supply container 4 may be at least partially shielded and may include a visualization window 66 that facilitates viewing and measurement of eluant levels in the bottle 4. The window 66 may operate as a visualization portal, which may include index marks 19 that can operate as a measurement feature corresponding to volume or another metric. Further, the illustrated embodiment may include the drip chamber 44 and drop counter 46 disposed within the shielded container 16. Again, the drop counter 46 may be communicatively coupled to the display 52, which may be disposed on the outside of the shielded container 16 to facilitate visual access or identification of the eluant level. Indeed, because the display 52 provides

virtual visual access to the eluant supply, the eluant supply container 4 can be disposed within the shielded container, as illustrated by FIG. 10. It should be noted that in FIG. 10 additional access to the eluant level in the eluant supply container 4 may be provided by a level gauge 68 at least partially external to the shielded container. The level gauge 68 can be electronic (e.g., sensor, switches, and electronic display) or manual (e.g., sight glass, circular sight port, or float).

[0038] While the invention may be susceptible to various modifications and alternative forms, specific embodiments have been shown by way of example in the drawings and have been described in detail herein. However, it should be understood that the invention is not intended to be limited to the particular forms disclosed. Rather, the invention is to cover all modifications, equivalents, and alternatives falling within the spirit and scope of the invention as defined by the following appended claims.

CLAIMS:

1. A system, comprising:
a radioactivity shielded container;
a radioisotope generator disposed within the radioactivity shielded container; and
an elution supply mechanism comprising:
 an eluant supply container at least partially external to the radioactivity shielded container;
 a conduit extending between an inlet of the radioisotope generator and an outlet of the eluant supply container; and
 an eluant visualization portal.
2. The system of claim 1, wherein the elution supply mechanism comprises a drip chamber.
3. The system of claim 2, wherein the eluant visualization portal comprises a transparent or translucent portion of the drip chamber.
4. The system of claim 2, comprising a drop counter coupled to the drip chamber.
5. The system of claim 4, comprising an electronic measurement device communicatively coupled to the drop counter.
6. The system of claim 4, wherein the electronic measurement device comprises a computer.
7. The system of claim 1, wherein the radioactivity shielded container comprises a radioactivity shielded lid including an aperture having the conduit extending therethrough.
8. The system of claim 7, wherein the aperture is disposed along an edge of the radioactivity shielded lid.
9. The system of claim 1, wherein the radioactivity shielded container comprises a radioactivity shielded lid having a hollow nipple coupled to the conduit.

10. The system of claim 1, wherein the eluant visualization portal comprises a transparent or translucent portion of the eluant supply container having demarcations corresponding to levels of eluant in the eluant supply container.

11. The system of claim 1, wherein the outlet of the elution supply container comprises a conduit splitter coupled to the conduit and at least one other conduit that leads to a different radioisotope generator.

12. The system of claim 1, wherein the elution supply mechanism comprises a pump.

13. The system of claim 12, wherein the pump comprises an eluant measurement system.

14. A system, comprising:
a radiation shielded container comprising a receptacle and a cover disposed over an opening in the receptacle;
a radioisotope generator disposed within the receptacle; and
an eluant supply mechanism comprising:
an eluant supply container;
a conduit coupled with the eluant supply container and the radioisotope generator, the conduit disposed at least partially within the shielded container; and
an eluant measurement device coupled to the eluant supply mechanism.

15. The system of claim 14, wherein the cover includes an aperture having the conduit extending therethrough.

16. The system of claim 14, wherein the conduit comprises a length of flexible tubing.

17. The system of claim 14, wherein the conduit comprises a hollow needle.

18. The system of claim 14, wherein the eluant measurement device comprises an eluant level gauge coupled with the eluant supply container.

19. The system of claim 14, wherein the eluant measurement device comprises a drip chamber.

20. The system of claim 19, wherein the eluant measurement device comprises a drop counter coupled to the drip chamber.

21. The system of claim 14, wherein the eluant measurement device is at least partially disposed inside the radiation shielded container.

22. The system of claim 21, wherein the eluant measurement device comprises a drop counter disposed within the radiation shielded container.

23. The system of claim 14, comprising an electronic display disposed at least partially external to the radiation shielded container and coupled to the eluant measurement device.

24. The system of claim 14, wherein the eluant measurement device comprises a scale.

25. A method of operating a radioisotope elution system, comprising:
receiving an amount of eluant into a radioisotope generator disposed inside a radiation shielded container;
visually indicating an amount of the eluant received by the radioisotope generator, wherein the visually indicating occurs at a location outside the radiation shielded container;
and
eluting radioactive material from the radioisotope generator.

26. The method of claim 25, comprising calculating a metric based on the amount of eluant received into the radioisotope generator.

27. The method of claim 26, comprising calculating a suggested time for performing a future elution based on the metric.

28. The method of claim 25, comprising creating a time stamp when the amount of eluant is received.

29. The method of claim 25, comprising measuring the amount of eluant received from within the radiation shielded container.

30. The method of claim 29, wherein measuring comprises counting drops of the eluant.

31. The method of claim 25, wherein visually indicating comprises electronically displaying a metric of the amount of eluant received.

32. The method of claim 25, wherein visually indicating comprises providing a visual line of sight to the eluant.

33. The method of claim 25, wherein measuring comprises weighing the eluant with a scale.

34. A system, comprising:
a radiation shielded lid comprising an aperture; and
an eluant supply mechanism comprising:
 an eluant supply container;
 a conduit coupled to the eluant supply container and at least partially disposed in the aperture; and
 an eluant measurement feature.

35. The system of claim 34, wherein the eluant measurement feature comprises a drip chamber and an electronic drop counter coupled to the drip chamber.

36. The system of claim 34, wherein the eluant measurement feature comprises an eluant visualization portal.

37. The system of claim 34, wherein the eluant measurement feature comprise a scale.

1 / 8

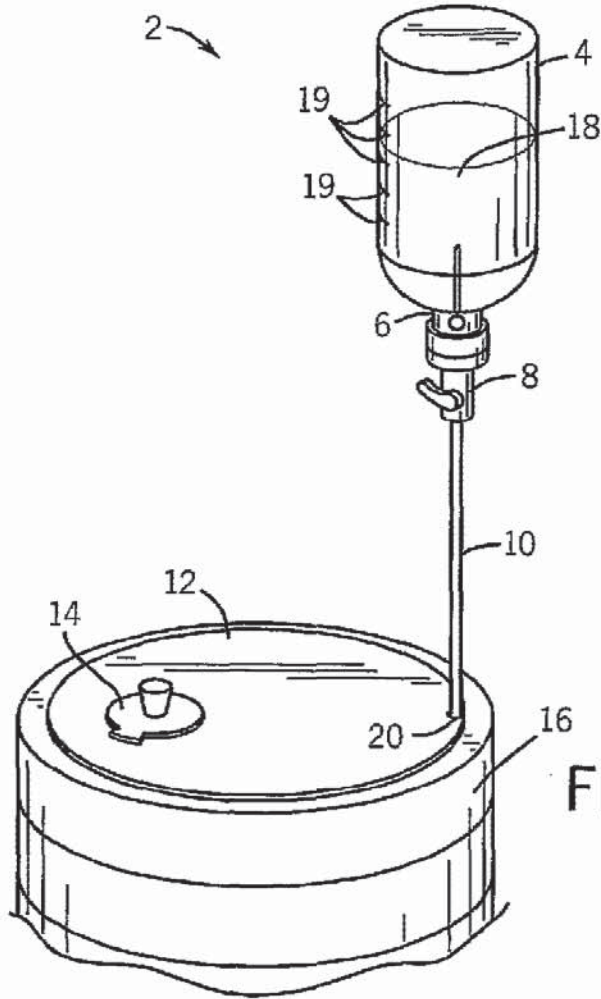

FIG. 1

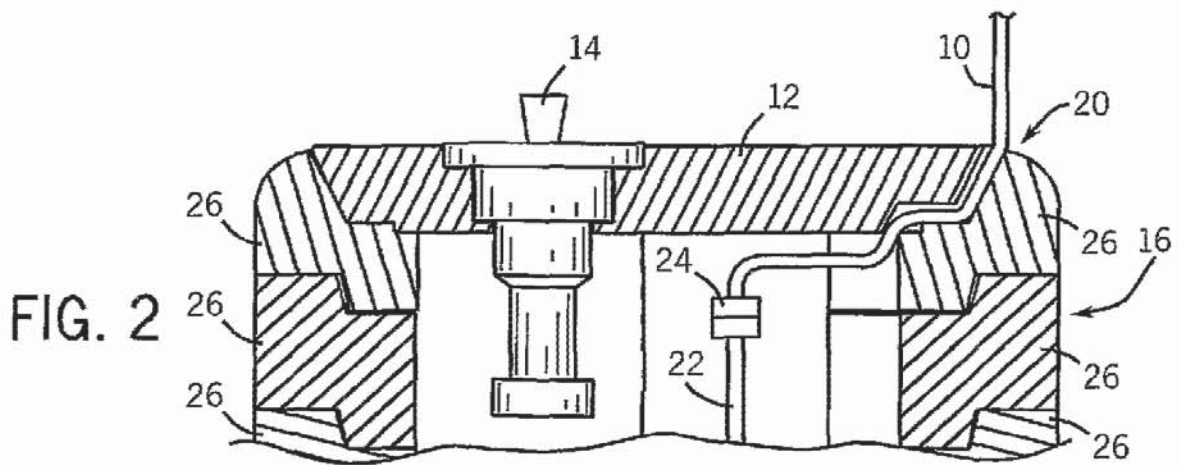

FIG. 2

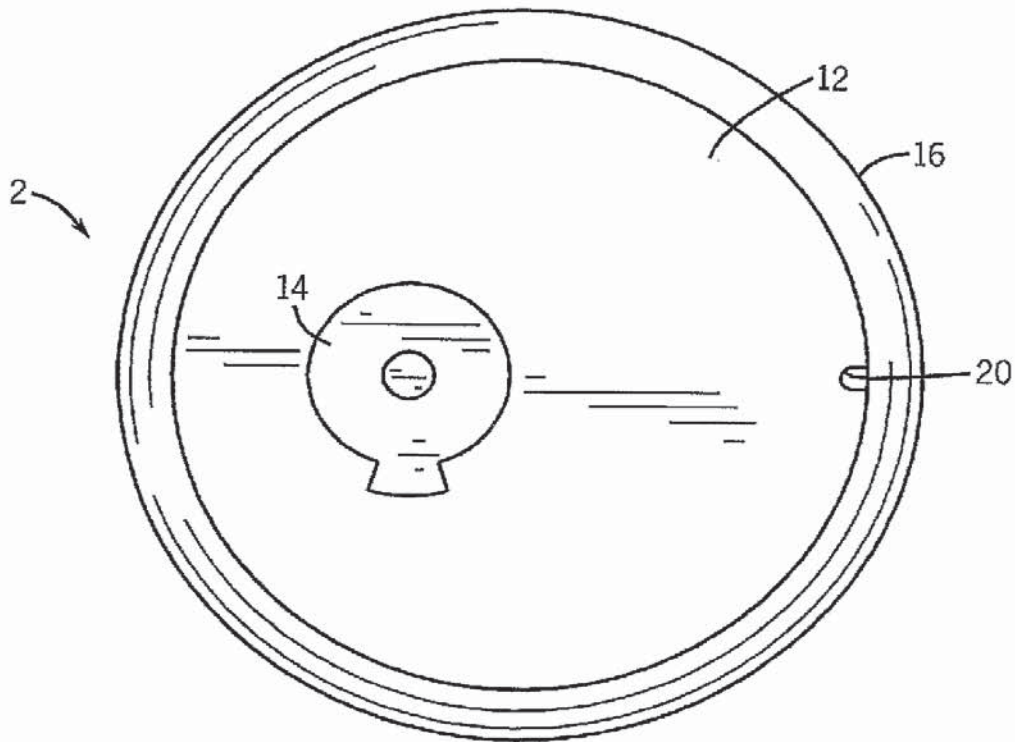
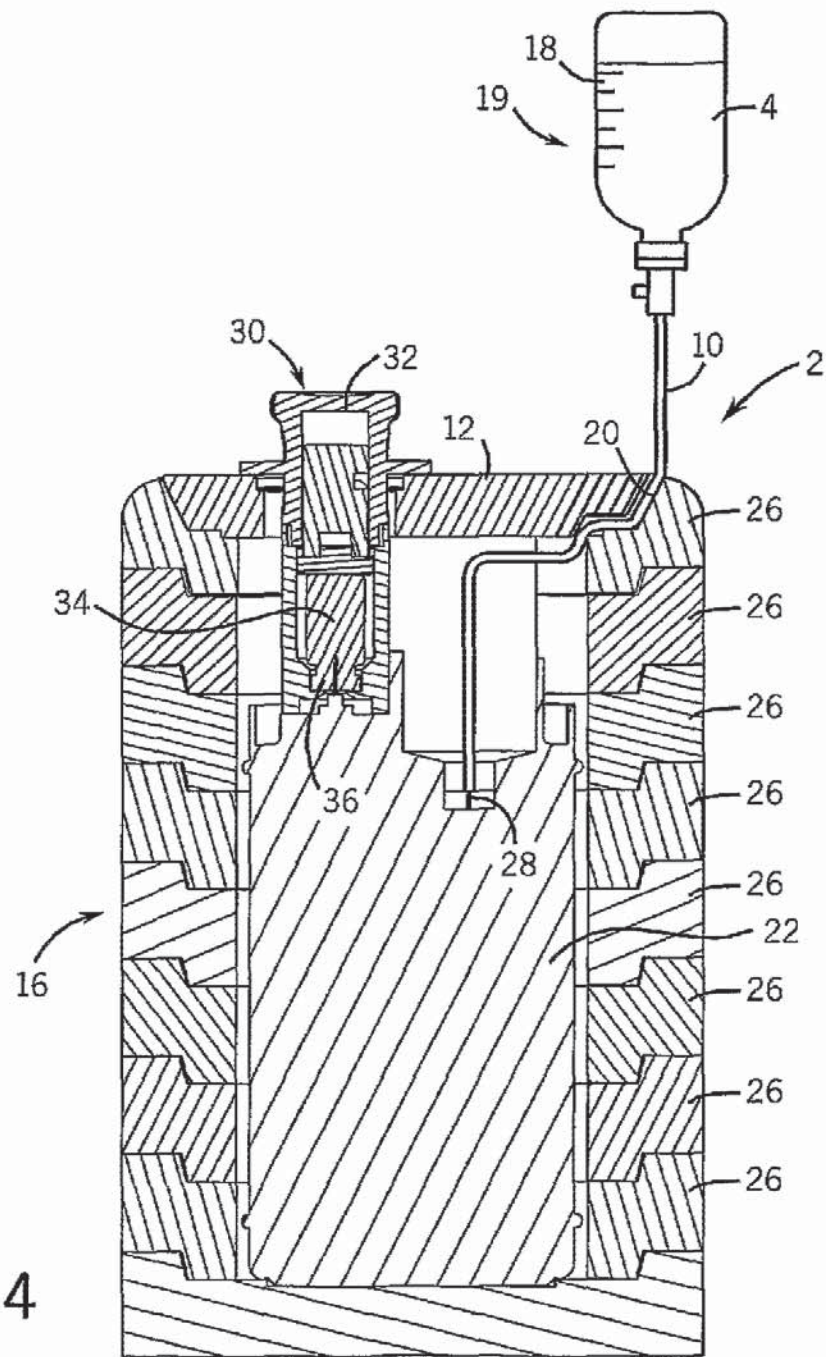

FIG. 3



4 / 8

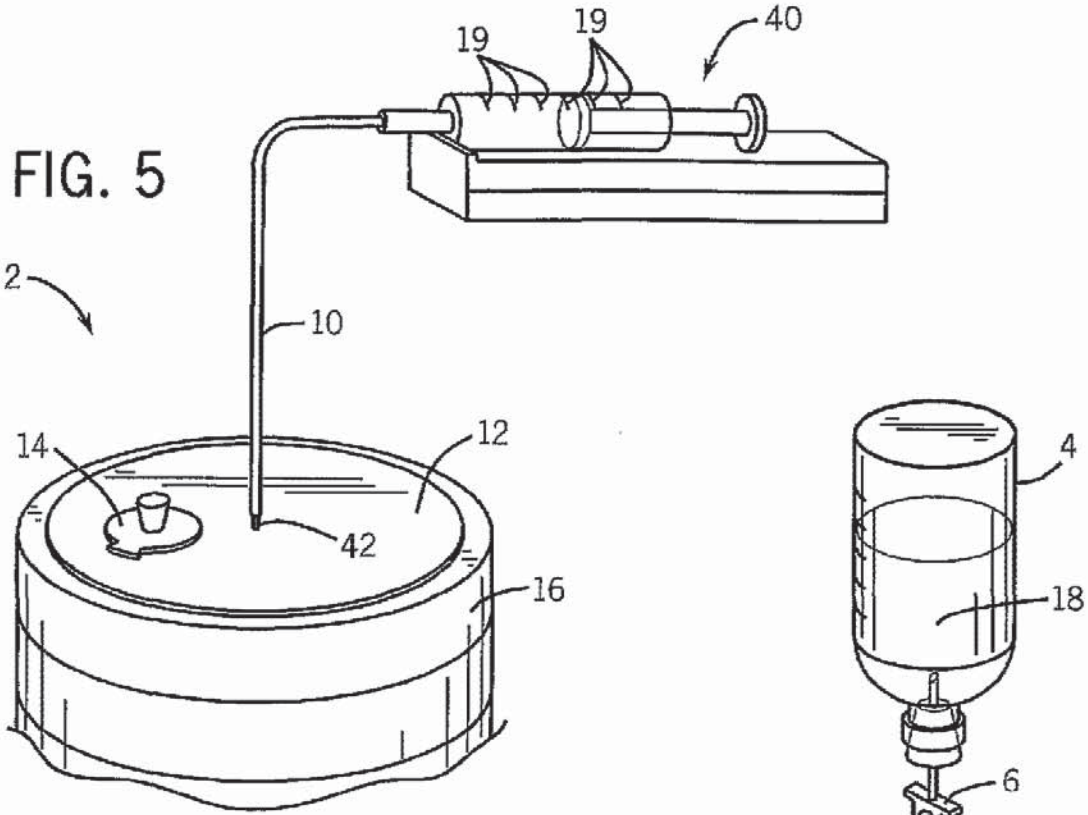

FIG. 5

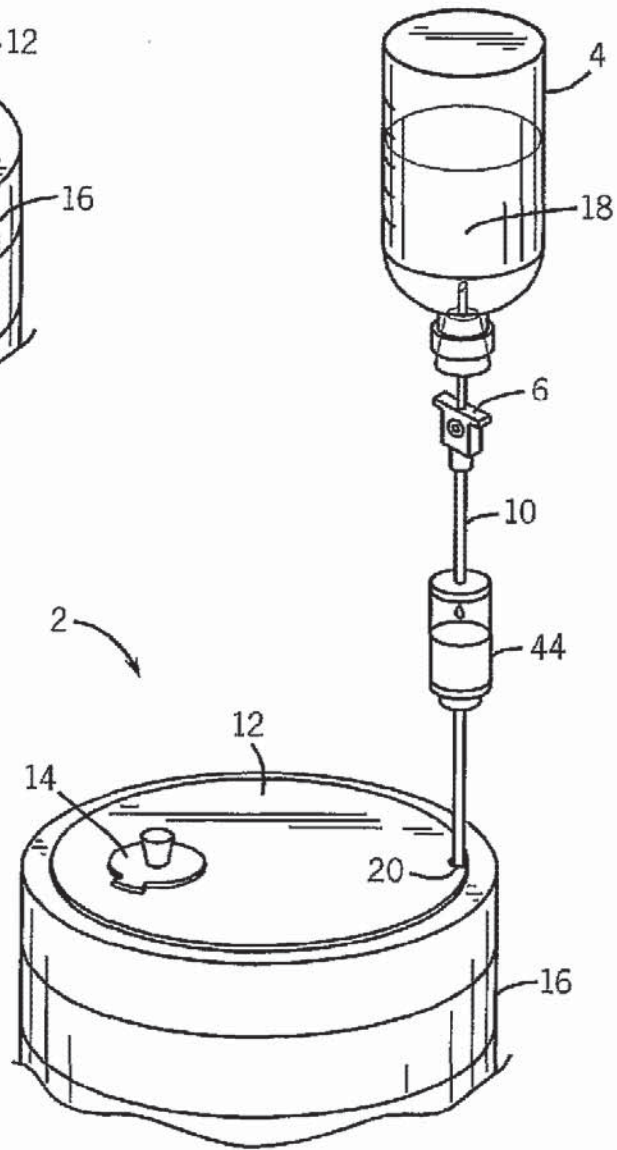
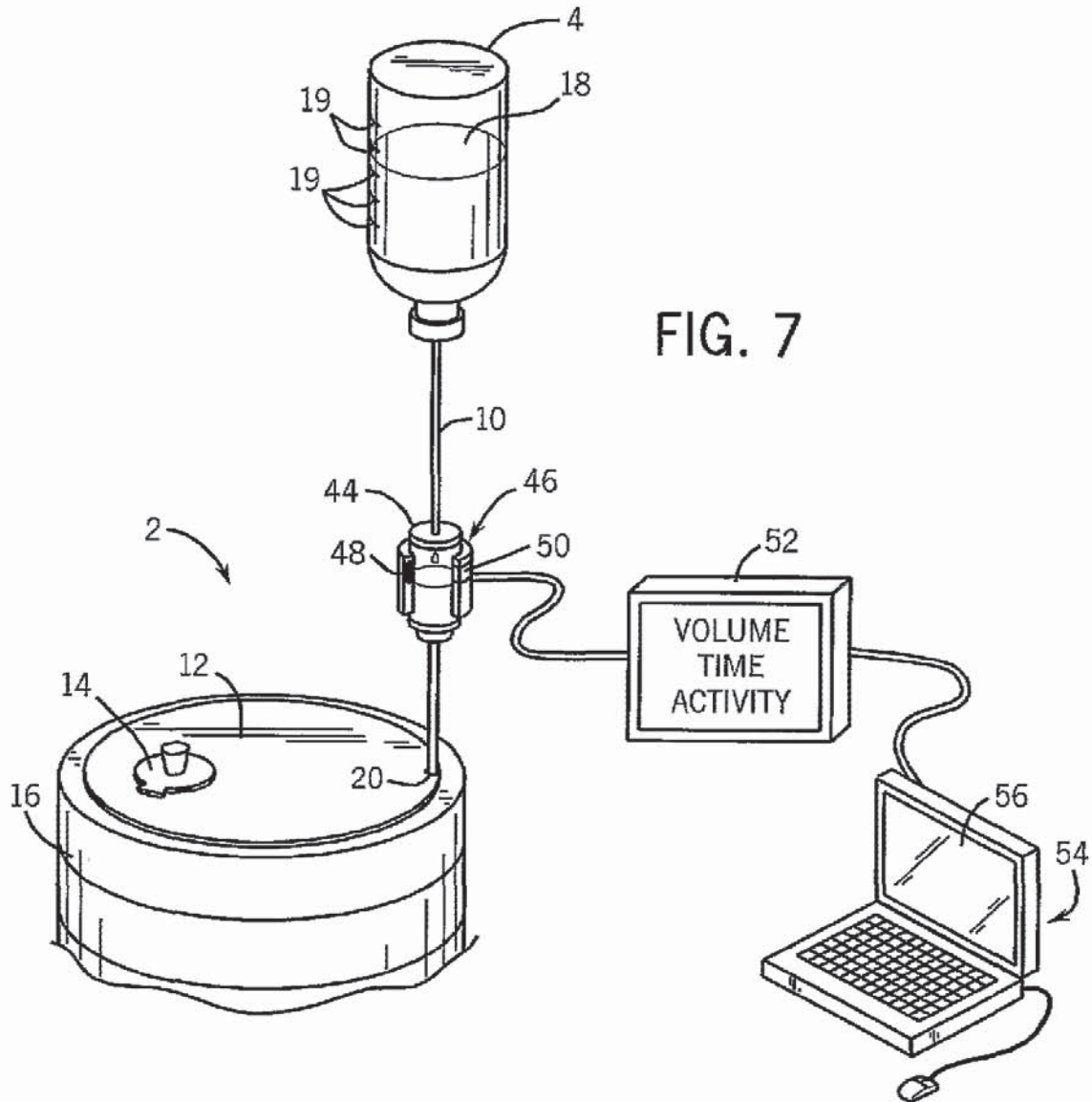

FIG. 6



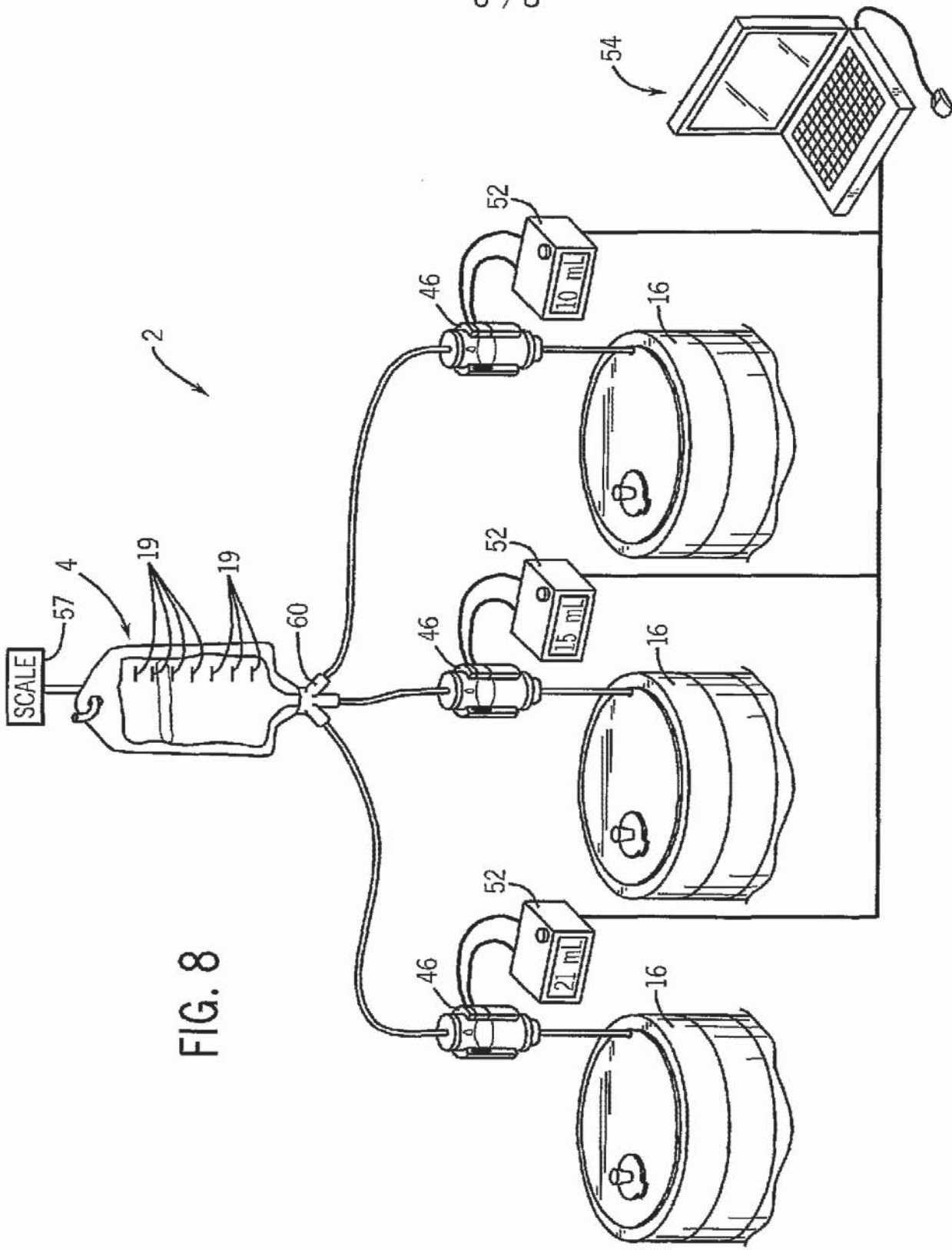
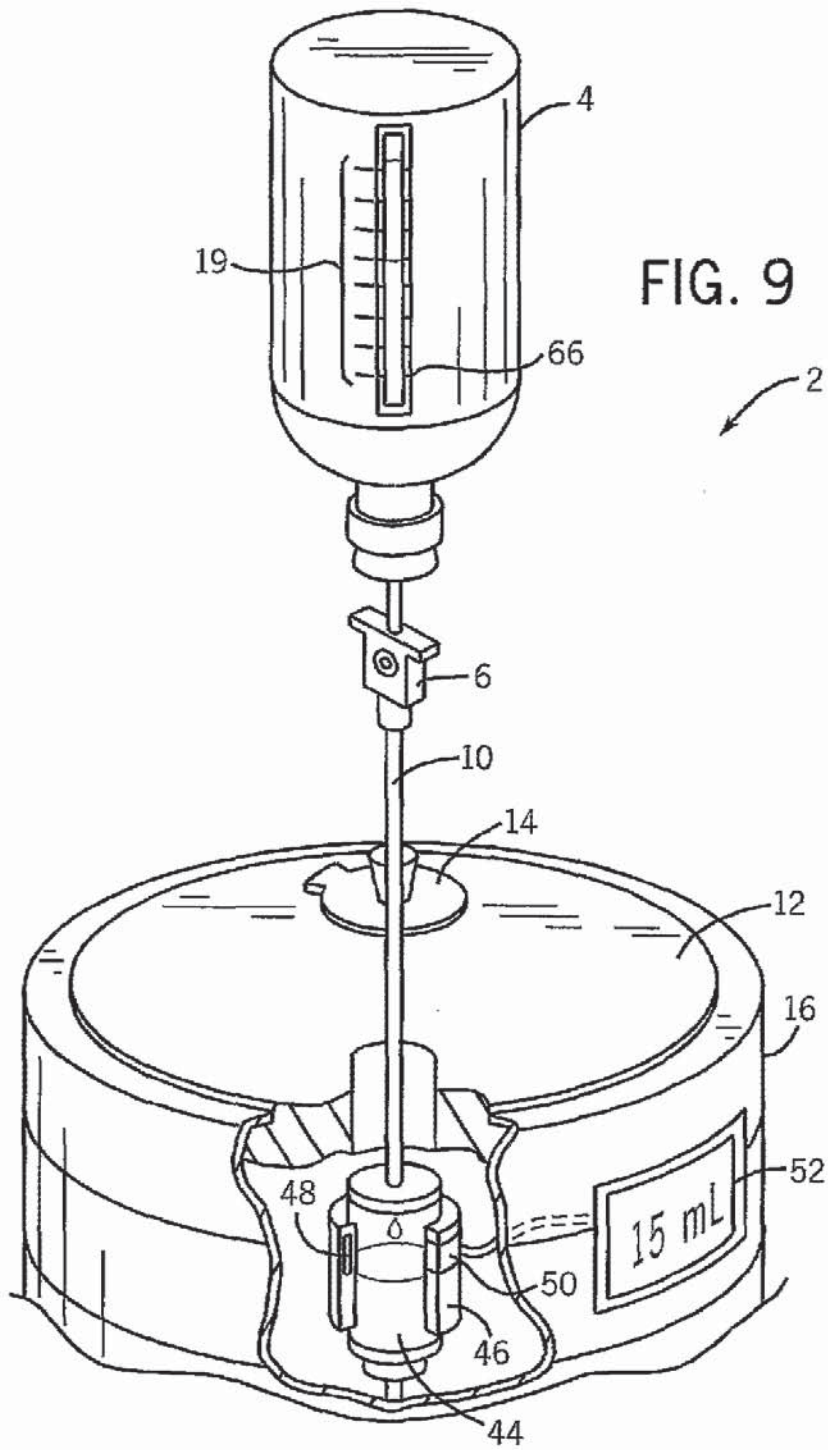

FIG. 8



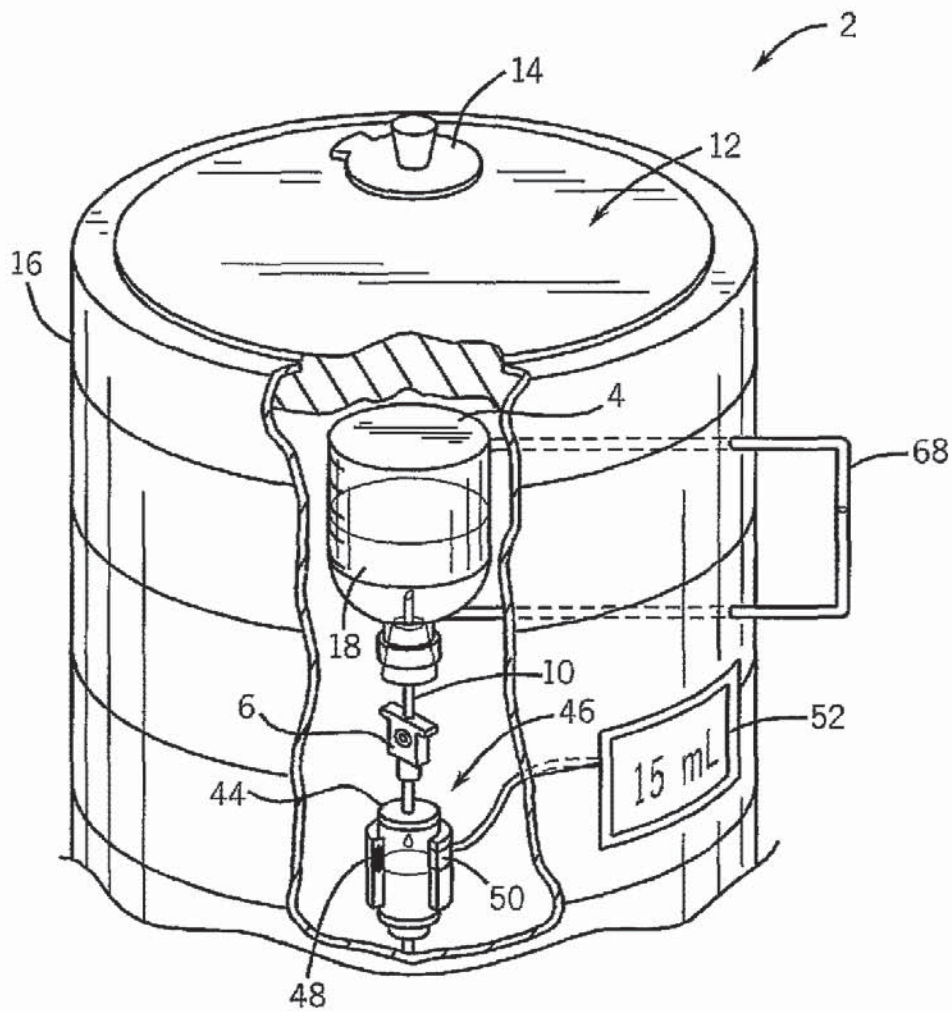

FIG. 10

INTERNATIONAL SEARCH REPORT

International application No
PCT/US2006/029055

A. CLASSIFICATION OF SUBJECT MATTER
INV. A61N5/00 G21F5/015 G21G4/08

According to International Patent Classification (IPC) or to both national classification and IPC

B. FIELDS SEARCHED
 Minimum documentation searched (classification system followed by classification symbols)
A61N G21F G21G

Documentation searched other than minimum documentation to the extent that such documents are included in the fields searched

Electronic data base consulted during the international search (name of data base and, where practical, search terms used)
EPO-Internal

C. DOCUMENTS CONSIDERED TO BE RELEVANT

Category*	Citation of document, with indication, where appropriate, of the relevant passages	Relevant to claim No.
X	EP 0 102 121 A (BYK MALLINCKRODT CIL BV [NL]) 7 March 1984 (1984-03-07)	1-3, 7-10, 14-19, 24,25, 32,34, 36,37
Y	page 11, line 13 ~ line 32; figures 1,4	20,23, 31,35
Y	US 4 321 461 A (WALTER JR DAVID E ET AL) 23 March 1982 (1982-03-23) abstract; claims 1-14; figures 1,3	20,23, 31,35
X	US 3 774 036 A (GERHART J) 20 November 1973 (1973-11-20)	1,12,13, 25,32
Y	abstract; column 4, line 47 - line 49; claims 1,12; figures 1,4	1-3,7, 10,14-19

Further documents are listed in the continuation of Box C. See patent family annex.

* Special categories of cited documents :

"A" document defining the general state of the art which is not considered to be of particular relevance

"E" earlier document but published on or after the international filing date

"L" document which may throw doubts on priority claim(s) or which is cited to establish the publication date of another citation or other special reason (as specified)

"O" document referring to an oral disclosure, use, exhibition or other means

"P" document published prior to the international filing date but later than the priority date claimed

"T" later document published after the international filing date or priority date and not in conflict with the application but cited to understand the principle or theory underlying the invention

"X" document of particular relevance; the claimed invention cannot be considered novel or cannot be considered to involve an inventive step when the document is taken alone

"Y" document of particular relevance; the claimed invention cannot be considered to involve an inventive step when the document is combined with one or more other such documents, such combination being obvious to a person skilled in the art.

"&" document member of the same patent family

Date of the actual completion of the international search 24 November 2006	Date of mailing of the international search report 05/12/2006
--	---

Name and mailing address of the ISA/ European Patent Office, P.B. 5818 Patentlaan 2 NL - 2280 HV Rijswijk Tel. (+31-70) 340-2040, Tx. 31 651 epo nl, Fax: (+31-70) 340-3016	Authorized officer Smith, Christopher
---	---

INTERNATIONAL SEARCH REPORT

International application No
PCT/US2006/029055

C(Continuation). DOCUMENTS CONSIDERED TO BE RELEVANT		
Category*	Citation of document, with indication, where appropriate, of the relevant passages	Relevant to claim No.
Y	WO 03/069632 A2 (SIGMA TAU IND FARMACEUTI [IT]; PAGANELLI GIOVANNI [IT]; CHINOL MARCO []) 21 August 2003 (2003-08-21) page 3, line 13 - line 33; claims 1,7; figures 1-5	1-3,7, 10,14-19
A	EP 0 005 606 A (SHUKLA VISHNU SHANKER) 28 November 1979 (1979-11-28)	

INTERNATIONAL SEARCH REPORT

International application No.
PCT/US2006/029055

Box II Observations where certain claims were found unsearchable (Continuation of item 2 of first sheet)

This International Search Report has not been established in respect of certain claims under Article 17(2)(a) for the following reasons:

1. Claims Nos.:
because they relate to subject matter not required to be searched by this Authority, namely:

2. Claims Nos.:
because they relate to parts of the International Application that do not comply with the prescribed requirements to such an extent that no meaningful International Search can be carried out, specifically:

3. Claims Nos.:
because they are dependent claims and are not drafted in accordance with the second and third sentences of Rule 6.4(a).

Box III Observations where unity of invention is lacking (Continuation of item 3 of first sheet)

This International Searching Authority found multiple inventions in this international application, as follows:

see additional sheet

1. As all required additional search fees were timely paid by the applicant, this International Search Report covers all searchable claims.
2. As all searchable claims could be searched without effort justifying an additional fee, this Authority did not invite payment of any additional fee.
3. As only some of the required additional search fees were timely paid by the applicant, this International Search Report covers only those claims for which fees were paid, specifically claims Nos.:

4. No required additional search fees were timely paid by the applicant. Consequently, this International Search Report is restricted to the invention first mentioned in the claims; it is covered by claims Nos.:

Remark on Protest

- The additional search fees were accompanied by the applicant's protest.
- No protest accompanied the payment of additional search fees.

FURTHER INFORMATION CONTINUED FROM PCT/ISA/ 210.

This International Searching Authority found multiple (groups of) inventions in this international application, as follows:

1. claims: 1-20, 23-26, 28, 31-32, 34-37

A splitter in the conduit coupled to at least one other radioisotope generator.

2. claims: 1-10, 12-26, 28-32, 34-37

A measurement device within the shielded container.

3. claims: 1-10, 12-20, 23-28, 31-32, 34-37

Calculation of a future elution time based on a metric.

4. claims: 1-10, 12-20, 23-26, 28, 31-37

Weiging the eluant with a scale.

INTERNATIONAL SEARCH REPORT

Information on patent family members

International application No PCT/US2006/029055

Patent document cited in search report	A	Publication date	Patent family member(s)	Publication date
EP 0102121	A	07-03-1984	NONE	
US 4321461	A	23-03-1982	NONE	
US 3774036	A	20-11-1973	NONE	
WO 03069632	A2	21-08-2003	AU 2003209692 A1	04-09-2003
			BR 0307561 A	11-01-2005
			CA 2472777 A1	21-08-2003
			CN 1630914 A	22-06-2005
			EP 1474809 A2	10-11-2004
			IT RM20020071 A1	11-08-2003
			JP 2005517936 T	16-06-2005
			MX PA04007693 A	10-11-2004
			US 2005154275 A1	14-07-2005
EP 0005606	A	28-11-1979	AU 4690379 A	15-11-1979
			US 4233973 A	18-11-1980

(19) World Intellectual Property Organization
International Bureau



(43) International Publication Date
15 March 2007 (15.03.2007)

PCT

(10) International Publication Number
WO 2007/030249 A2

- (51) **International Patent Classification:**
G21G 4/08 (2006.01) B65B 3/00 (2006.01)
- (21) **International Application Number:**
PCT/US2006/030766
- (22) **International Filing Date:** 8 August 2006 (08.08.2006)
- (25) **Filing Language:** English
- (26) **Publication Language:** English
- (30) **Priority Data:**
60/706,793 9 August 2005 (09.08.2005) US
- (71) **Applicant (for all designated States except US):**
MALLINCKRODT INC. [US/US]; 675 McDonnell
Boulevard, P.O. Box 5840, St. Louis, Missouri 63134
(US).
- (72) **Inventor; and**
- (75) **Inventor/Applicant (for US only):** GIBSON, Chad, M.
[US/US]; 1533 Northview Avenue, Cincinnati, Ohio 45223
(US).
- (74) **Agents:** SEURER, Jerad, G. et al.; Mallinckrodt Inc., 675
McDonnell Boulevard, P.O. Box 5840, St. Louis, Missouri
63134 (US).
- (81) **Designated States (unless otherwise indicated, for every
kind of national protection available):** AE, AG, AL, AM,
AT, AU, AZ, BA, BB, BG, BR, BW, BY, BZ, CA, CH, CN,
CO, CR, CU, CZ, DE, DK, DM, DZ, EC, EE, EG, ES, FI,
GB, GD, GE, GH, GM, HN, HR, HU, ID, IL, IN, IS, JP,
KE, KG, KM, KN, KP, KR, KZ, LA, LC, LK, LR, LS, LT,
LU, LV, LY, MA, MD, MG, MK, MN, MW, MX, MZ, NA,
NG, NI, NO, NZ, OM, PG, PH, PL, PT, RO, RS, RU, SC,
SD, SE, SG, SK, SL, SM, SY, TJ, TM, TN, TR, TT, TZ,
UA, UG, US, UZ, VC, VN, ZA, ZM, ZW.
- (84) **Designated States (unless otherwise indicated, for every
kind of regional protection available):** ARIPO (BW, GH,
GM, KE, LS, MW, MZ, NA, SD, SI, SZ, TZ, UG, ZM,
ZW), Eurasian (AM, AZ, BY, KG, KZ, MD, RU, TJ, TM),
European (AT, BE, BG, CH, CY, CZ, DE, DK, EE, ES, FI,
FR, GB, GR, HU, IE, IS, IT, LT, LU, LV, MC, NL, PL, PT,
RO, SE, SI, SK, TR), OAPI (BF, BJ, CF, CG, CI, CM, GA,
GN, GQ, GW, ML, MR, NE, SN, TD, TG).
- Published:**
— without international search report and to be republished
upon receipt of that report
- For two-letter codes and other abbreviations, refer to the "Guidance Notes on Codes and Abbreviations" appearing at the beginning of each regular issue of the PCT Gazette.*



WO 2007/030249 A2

(54) **Title:** RADIOISOTOPE GENERATION SYSTEM HAVING PARTIAL ELUTION CAPABILITY

(57) **Abstract:** In a radioisotope generation system and method for dispensing a radioactive eluate, a radioisotope generator is operable to dispense the eluate. During dispensing, a monitoring system may monitor the dispensed amount of eluate and may generate a signal indicative of the amount of eluate dispensed. In particular embodiments, the monitoring system may generate a signal corresponding to the dispensing of a desired amount of eluate. The monitoring system may particularly monitor the level of fluid in a cavity or container into which the eluate is dispensed, the weight of the eluate dispensed, an elapsed time during which the eluate is dispensed, and/or other characteristic of the dispensed eluate, each of which may be corresponded to the amount of dispensed eluate. The system may be equipped with an interruption system that interrupts the dispensing of the eluate in response to the signal generated by the monitoring system.

RADIOISOTOPE GENERATION SYSTEM HAVING PARTIAL ELUTION CAPABILITY

FIELD OF THE INVENTION

The present invention relates generally to radioisotope generation systems, and more particularly to radioisotope generation systems that facilitate dispensing of a desired amount of eluate from a radioisotope generator.

BACKGROUND

Radioisotope generators are used to obtain a solution comprising a daughter radioisotope (e.g., technetium-99) from a parent radioisotope (e.g., molybdenum-99) which produces the daughter radioisotope by radioactive decay. One common radioisotope generator includes a column containing the parent radioisotope adsorbed on a carrier medium (e.g., alumina). The carrier medium has a relatively higher adsorptive capacity for the parent radioisotope and a relatively lower adsorptive capacity for the daughter radioisotope. As the parent radioisotope decays, a quantity of the desired daughter radioisotope is produced in the column. The column can be washed by passing a suitable eluant (e.g., a sterile saline solution) through the column such that the resulting eluate contains the daughter radioisotope (e.g., in the form of a dissolved salt), which makes the eluate useful in nuclear medicine. For example, the eluate may be adapted for intravenous administration for any of a variety of diagnostic and/or therapeutic procedures.

To obtain a quantity of the eluate from the generator, a container (e.g., a vial) may be connected to an outlet of the column at a tapping point of the generator to receive the eluate containing the daughter radioisotope. The container may be an evacuated container, in which case the partial vacuum in the container is used to draw eluant through the column from an eluant reservoir in fluid communication with an inlet to the column, thereby eluting the daughter radioisotope from the column. Using vacuum pressure in the container to draw eluate out of the generator avoids the need to pressurize the radioactive materials, as would be the result if the fluids were pumped through the column, thereby reducing the risk of accidental release of radioactive materials.

Another advantage of using vacuum pressure in the container to draw eluate out of the generator column is the elimination of the need for moving parts to cause the fluid flow. This may make the system more resistant to mechanical failure and may also render operation of the system relatively simple and clean. Because the eluate may be dispensed directly from the outlet of the generator column to the container, there is no need to clean an intermediate chamber/reservoir of the type used in some prior art systems (e.g., U.S. Patent No. 4,625,118). Unnecessary cleaning is not only undesirable from the standpoint of the cost (in materials and time) of the cleaning itself, but in some circumstances trace residues of cleaning chemicals can also have a negative impact of the yield from the system, as noted in

U.S. Patent No. 5,580,541. Thus, the simplicity of using vacuum pressure in an evacuated container to draw eluate from the generator directly into the container is desirable for a variety of reasons.

The same generator column may be used to fill a number of containers with eluate before the radioisotopes in the column are spent. The amount of eluate needed at any time may vary depending on the number of prescriptions that need to be filled by the radiopharmacy and/or the remaining concentration of radioisotopes in the generator column. One way to vary the amount of eluate drawn from the column is to vary the volume of the containers. For example, different sized containers having volumes ranging from about 5 mL to about 30 mL are common. In particular, standard elution vials having volumes of 5 mL, 10 mL, or 20 mL are currently available in the industry and may be used to facilitate dispensing of the corresponding amount of eluate from the generator column.

Unfortunately, the use of multiple different types of containers has significant disadvantages. For example, a radiopharmacy may use different labels, rubber stoppers, flanged metal caps, lead shields, and/or spacers to handle different sized containers, requiring the radiopharmacy to keep supplies of these items in stock for each type of container. Likewise, packaging for transport of the filled containers to healthcare facilities must also account for the different dimensions of the containers.

Another way to vary the amount of eluate dispensed to a container is to interrupt the elution process before the container is completely filled. For example, U.S. Pat. No. 4,387,303 discloses a system that permits an elution process to be interrupted before the container is completely filled. In particular, the radiopharmacist estimates when to interrupt the dispensing process based on a desire to only partially fill the container to a certain amount. The process is interrupted simply by manually removing the container from the generator tap. By interrupting the elution process at the right time, the container could be partially filled to obtain any desired amount of eluate equal to or less than the capacity of the vial. Another advantage of interrupting the elution process before a container is filled to capacity is that it is easier to draw the eluate from the container when it is not completely filled.

Unfortunately, it is not easy to identify the level of the eluate in a partially filled container. For instance, the container may be housed in a radiation shield that prevents visual inspection of the level of eluate in the container. Educated guesswork and/or trial and error are generally used to interrupt the elution based on an estimate of how much eluate is in the container. However, use of this method can easily lead to overfilling or underfilling of a container, both of which may result in undesirable inefficiencies. Even if it is possible for a person to visually monitor the level of eluate in the container (e.g., through a leaded glass window in the radiation shield), a person would have to dedicate some of his or her attention to monitoring the elution process to stop it at the right time. This would detract from the person's ability to do other things. Further, if the person were distracted, it would be easy to fill the container more than intended.

Thus, some may say there is a need for a radioisotope generation system that facilitates dispensing of a desired amount of eluate from a radioisotope generator.

SUMMARY

One aspect of the invention is directed to a radioisotope generation system for dispensing a radioactive eluate (i.e., an eluate including a radioisotope) into a container for holding such an eluate. A radioisotope generator of the system is operable to dispense the eluate into the container. While the eluate is being dispensed by the generator into the container, a monitoring system monitors the amount of eluate dispensed into the container and generates a signal indicative of the amount of eluate dispensed into the container.

Another aspect of the invention is directed to a radioisotope generation system having a radioisotope generator that is operable to dispense radioactive eluate. An elution shield of the system has an internal cavity for receiving the eluate dispensed from the generator and is constructed at least in part of a radiation-absorbing material. A monitoring system monitors the dispensing of eluate by the generator to the cavity of the shield and is operable to generate a signal in response to the dispensing of a desired amount of eluate into the cavity and/or the elapsing of a predetermined elapsed time during which eluate is dispensed into the cavity.

Still another aspect of the invention is directed to a radioisotope generation system that includes a radioisotope generator for dispensing radioactive eluate. This system also includes a dispensed eluate sensor that may be used to sense an amount of eluate that has been dispensed from the generator, and a signaling device that is communicatively connected with the sensor. Incidentally, "communicatively connected" or the like herein refers to a relationship of first and second components characterized in that at least an electrical signal can be conveyed at least from one of the components to the other.

Yet another aspect of the invention is directed to a method for dispensing a radioactive eluate. In this method, eluate is dispensed from a radioisotope generator into a container while the container and the generator are in fluid communication. Incidentally, "fluid communication" or the like herein refers to a relationship between at least first and second components of a system; this relationship being such that a substance(s) (e.g., a liquid and/or gas) may flow through the system at least from one of the components to the other. In any event, in this method, the dispensing of the eluate into the container is monitored (e.g., using one or more appropriate sensors). Further, a signal (e.g., visible and/or audible) indicative of an amount of eluate dispensed is provided.

Still yet another aspect of the invention is directed to a method of providing a radioactive eluate. In this method, eluate is dispensed from a radioisotope generator into a cavity of an elution shield. An amount of eluate in the cavity is monitored during at least a portion of the eluate being dispensed. A signal (e.g., visible and/or audible) is automatically generated in response to detecting a desired amount of eluate in the cavity and/or a passing of a predetermined elapsed time during which the eluate is dispensed.

In yet another aspect, the present invention is directed to a method of providing a radioactive eluate. In this method, eluate is dispensed from a radioisotope generator into a container while the container and the generator are in fluid communication. An amount of the eluate that is dispensed into

the container is determined, and a signal (e.g., visible and/or audible) is electronically triggered as a result of the amount of eluate that is determined (e.g., a threshold amount).

In still yet another aspect of the invention, an amount of radioactive eluate eluted from a radioisotope generation system in an elution procedure is determined. In addition, an electrical condition of the system is changed based on the amount of eluate that is determined to be eluted. By way of example, a change in electrical condition may refer to a closing and/or opening of an electrical circuit of the system. As another example, a change in electrical condition may refer to an alteration of an electrical signal between first and second components of the system. As still another example, a change in electrical condition may refer to a change in capacitance between first and second electrical conductors of the system.

Various refinements exist of the features noted in relation to the above-mentioned aspects of the present invention. Further features may also be incorporated in the above-mentioned aspects of the present invention as well. These refinements and additional features may exist individually or in any combination. For instance, various features discussed below in relation to any of the illustrated embodiments of the present invention may be incorporated into any of the aspects of the present invention.

BRIEF DESCRIPTION OF THE DRAWINGS

Fig. 1 is a schematic diagram of a radioisotope generation system according to one embodiment of the present invention;

Fig. 2 is an enlarged view of a portion of the system of Fig. 1 illustrating a monitoring system thereof;

Fig. 3 is a schematic diagram of a radioisotope generation system similar to the system of Fig. 1 but further having an automatic interruption system.

Fig. 4 is an enlarged schematic diagram of an alternative embodiment of the monitoring system of Figs. 1 and 3;

Fig. 5 is an enlarged schematic diagram of a monitoring system according to another alternative embodiment;

Fig. 6 is an enlarged schematic diagram of a monitoring system of still another alternative embodiment;

Fig. 7 is a schematic diagram of an alternative embodiment of a radiation generation system of the present invention; and

Fig. 8 is a schematic diagram of one embodiment of a selector useful with the radiation generation system of Figs. 1, 3 and 7.

Corresponding reference characters indicate corresponding parts throughout the drawings.

DETAILED DESCRIPTION OF ILLUSTRATED EMBODIMENTS

Referring now to the drawings, in particular to Fig. 1, a radioisotope generation system of the present invention is generally designated 101. The system comprises a radioisotope generator having a column 103 containing a carrier, having a parent radioisotope (e.g., Molybdenum - 99) that decays into a daughter radioisotope (e.g., Technetium - 99m), adsorbed thereon. The generator column 103 may be enclosed in a conventional radiation-shield 105 as shown in the embodiment of Fig. 1. The generator column 103 has an inlet 107, which may be connected to an eluant reservoir 111 by a suitable inlet conduit 113. The column 103 also has an outlet 117 that may be connected to a tapping point 119 by a suitable outlet conduit 121.

The eluant reservoir 111 contains eluant (e.g., saline solution or other fluid capable of eluting the daughter radioisotope from the generator column), with the reservoir sized to contain enough eluant for multiple elutions. However, the eluant reservoir may alternatively be sized to contain no more eluant than is sufficient for a single elution without departing from the scope of the invention. The eluant reservoir may be a flexible (e.g., collapsible) bag or a substantially rigid container without departing from the scope of the invention. Where the container is rigid, a pressure relief system (e.g., a filtered vent to atmosphere) may be used so that withdrawal of eluant from the eluant reservoir does not create a vacuum in the eluant reservoir. The eluant reservoir 111 may be suitably mounted on the system 101 above the level of the generator column 103 as shown in Fig. 1.

The tapping point 119 may be constructed to allow a container 125 to be mounted thereon for fluid communication between the container and the generator column 103 via the outlet conduit 121. For example, in one embodiment (illustrated in Fig. 1) a hollow needle 127 capable of piercing a septum on the container 125 may be attached to the end of the outlet conduit 121 to serve as the tapping point. The system 101 may be configured so the tapping point 119 is above the level of the generator column 103 as in the illustrated embodiment. The system 101 may be configured so that the tapping point 119 is also at about the same level as the eluant reservoir 111.

The radioisotope generation system 101 may further comprise an elution shield 131 constructed to have an internal cavity 133 for receiving the eluate from the generator column 103 via the output conduit 121 and tapping point 119. In particular embodiments, the elution shield 131 may be constructed to house the container 125 within the internal cavity 133 thereof with the container connected to the generator at the tapping point as illustrated in Fig. 1. For example, the elution shield 131 shown in the drawings is constructed to have a cavity 133 sized and shaped to hold the container 125 and an opening 139 through which the needle 127 may be inserted to provide fluid communication between the container and the generator column 103 while the container is in the cavity. Other configurations of the radioisotope generation system are also contemplated to be within the scope of the invention, as long as the system is operable to dispense eluate to the cavity of the elution shield, and in particular embodiments to a container disposed in the cavity.

Fluid flow through the system 101 may be suitably controlled by one or more valves. For example, the system 101 may include at least one pinch valve 141, which is operable to selectively block the flow of eluate through the outlet conduit 121 to the container 125 (broadly, the internal cavity 133 of the elution shield 131). The pinch valve 141 may in part define an interruption system of the type described in U.S. Patent No. 4,387,303, which is hereby incorporated by reference to the extent it is consistent, for allowing the flow of eluate to from the generator column 103 to the container 125 to be interrupted before the container is filled to its maximum volume. The term "maximum volume" as used in reference to the container 125 refers to that volume to which an evacuated container would be filled if the elution process were allowed to proceed until the pressure in the container increased enough to stop the inflow of fluids.

The elution shield 131 may comprise one or more radiation-absorbing materials (e.g., lead, tungsten, depleted uranium, etc.) to protect workers from radiation emitted by the eluate after it is received in the container 125. Those skilled in the art will know how to construct an elution shield having a sufficient amount of radiation-absorbing material in view of the type and amount of radiation expected to provide a desired level of protection against radiation exposure. The elution shield 131 may be substantially opaque, as indicated in the drawings, which inhibits manual monitoring of the amount of eluate in the container 125. However, the present invention is not limited to generation systems having opaque elution shields. Accordingly, an elution shield having a viewing window (e.g., leaded glass window) that allows viewing of the contents of the elution shield is contemplated to be within the scope of the invention.

The generation system 101 also comprises a monitoring system 151 capable of automatically monitoring the dispensing of eluate from the generator column 103 to the container 125, e.g., to monitor the amount of eluate dispensed into the container (broadly, into the cavity 133). The monitoring system 151 may generally be any system operable to automatically determine (e.g., sense, measure, meter, calculate, or otherwise gauge) the amount of eluate in the container 125 as eluate is dispensed from the generator column 103 into the container. For example, a radioisotope generation system may include a dispensed eluate sensor capable of determining the amount of eluate eluted from a generator communicatively connected to a signaling device. The dispensed eluate sensor may be a component of the elution shield 131, associated with other components of a radioisotope generation system or even be characterized as a component of the system in and of itself. It is contemplated that the monitoring system 151 may be operable to monitor the dispensing of eluate on a substantially continuous basis or on an intermittent basis.

Referring to Fig. 2, one embodiment of a suitable monitoring system comprises a liquid level sensor 161 capable of detecting the level of the eluate in the container 125. For example, an infrared LED 163 and corresponding infrared detector 165 (e.g., photo diode) may be mounted inside the cavity 133 of the elution shield 131 in spaced relation to one another. The LED 163 (upon operation of the monitoring system) emits light (e.g., infrared light) which reflects off the upper surface 167 of the

liquid back to the detector 165. Data from the detector 165 is transmitted (e.g., by hardwiring or wireless transmission) to a suitable processor 171 having circuitry and/or software enabling it to determine the path length of the reflected light based on the data, and thereby to determine the fluid level of the eluate in the container 125 as a function of the path length of the reflected light. The teachings disclosed in U.S. Patent No. 5,291,031, which is hereby incorporated by reference to the extent it is consistent, may be used to construct a suitable processor capable of measuring the path length of the reflected light. It is contemplated that the container may be configured (e.g., contoured) to alter the path of light from the LED 163 to the upper surface 167 of the liquid and/or from the upper surface of the liquid to the infrared detector 165 to facilitate operation of level sensor 161. For example, the container may focus the light in a manner analogous to a lens. It is also contemplated that one or more lenses that are distinct from the container may be used to focus the light. Further, the use of the level sensor 161 without any lenses and/or with a container that is not configured to modify the path of light in any particular way is within the scope of the invention.

The fluid level in the container 125 corresponds to the amount of eluate in the container. Accordingly, the processor 171 (Fig. 1) is also capable of determining the corresponding amount of eluate in the container 125 based at least in part on the determined fluid level in the container. In particular embodiments, the processor 171 may further compare the determined amount of eluate in the container 125 to a desired amount of eluate to be dispensed into the container.

The monitoring system 151 is further operable to generate a signal once it determines that a desired amount of eluate has been received by (e.g., dispensed into) the container 125 (broadly, the internal cavity 133 of the elution shield 131). In one embodiment, the signal may be perceptible exterior of the elution shield 131, and in particular it may be perceptible to humans (such as radiopharmacists or other operators of the generation system). For example, the signal may be a light (broadly, a visual signal) or noise (broadly, an audible signal) perceptible to workers to alert them that it is time to interrupt the elution process. The monitoring system 151 illustrated in Figs. 1 and 2, for instance, comprises a piezoelectric speaker 175 (broadly, a signaling device) activated by the processor 171 once the processor determines that the desired amount of eluate has been dispensed into the container 125 to make an audible noise perceptible to a worker in the vicinity. The signaling device may be a component of the elution shield 131, as indicated for example by connection of the piezoelectric speaker 175 to the elution shield in Fig. 2. In some embodiments, the processor 117 may function as a signaling device and may be operable to change an electrical condition of the system (e.g., open and/or close a circuit of the system, change a voltage applied to one or more components of the system, etc.) in a manner that is in and of itself imperceptible to unaided humans, although such a change in an electrical condition of the system by the processor may ultimately produce a tangible result (e.g., activation of an interruption system as described below) that may be perceptible to humans, if any are in a position to observe the result.

The generation system 101 may also comprise a selector in communication with the processor 171 and operable to allow a user to pre-select (e.g. prior to operation of the radioisotope generator to dispense eluate into the container) the desired amount of eluate to be dispensed into the container 125. Virtually any device capable of providing user input to the processor 171 can be used as the selector. For example, the selector may comprise a hall effect sensor dial 181 as illustrated in Fig. 8, a set of buttons, a potentiometer, a touch screen display, a computer terminal, or the like. The selector may be operable to allow the user to pre-select the desired amount of eluate from a set of predetermined desired amounts. For example, in the illustrated embodiment of Fig. 8, the hall effect sensor dial has indicia 183 that indicates the desired amount of eluate to be dispensed and a set of magnetic elements 185 and hall effect sensors 187 positioned to determine which of the indicia is aligned with a fixed marking 189 (e.g., a selection arrow). In other embodiments, the selector may instead be operable to allow the user to select any desired amount of eluate within a range of permissible amounts. For example, the selector may allow the user to select a set amount of eluate, or the selector may allow the user to select a certain fill percentage (e.g., 25%, 50%, etc.) of the container.

It is understood that the system 101 may also permit the user to opt to fill the container 125 to its maximum volume, such as by including on the selector a setting for disabling the monitoring system 151 or selecting a desired amount of eluate about equal to the maximum volume of the container. It may be more desirable to stop the dispensing just before the container 125 is filled to its maximum volume (e.g., to facilitate piercing the septum of the container to draw eluate into a syringe) rather than disable the monitoring system 151.

According to one embodiment of a method of the present invention for dispensing a desired amount of eluate to the container 125 (broadly, the cavity 133 of the elution shield 131), a user uses the selector to pre-select a desired amount of eluate to be dispensed from the generator column 103 into the container. An evacuated container 125 may be loaded into the elution shield 131 and connected to the generator column 103 by insertion of the needle 127 through a septum of the container. The pinch valve 141 may be opened (if it was initially closed) such that the vacuum pressure in the container 125 induces the eluant to flow from the eluant reservoir 111, through the inlet conduit 113 and into generator column 103 while eluate comprising the desired daughter radioisotope flows out of the generator column, through the outlet conduit 121, and into the cavity 133, and in the illustrated embodiment into the container. The vacuum pressure in the evacuated container 125 may induce the flow without pressurizing either the eluant or eluate above atmospheric pressure.

The monitoring system 151 monitors the dispensing of eluate into the container 125. For example, for the embodiment illustrated in Figs. 1 and 2, the infrared LED 163 may emit light that is detected by the detector 165 after reflecting off of the upper surface 167 of the eluate in the container 125. The processor 171 determines the amount of eluate in the container 125 based on the fluid level data it receives from the detector 165. When the processor 171 determines that the amount of eluate in the container 125 is in a range from about equal to through greater than the pre-selected desired amount

of eluate, the processor activates the piezoelectric speaker 175 (e.g., by changing a voltage applied to one or more electrodes of the piezoelectric speaker) to produce an audible signal. The processor 117 may activate the piezoelectric speaker when it determines a threshold amount of eluate has been eluted from the generator 103. In one embodiment, the processor 117 activates the piezoelectric speaker just before the amount of eluate in the container reaches the desired amount of eluate to account for the expected delay between activation of the speaker 175 and manual interruption of the elution process.

A person in the vicinity of the radioisotope generation system 101 (e.g., a radiopharmacist or other worker) may perceive the signal (e.g., see in the case of a visual signal and/or hear in the case of an audible signal) from the monitoring system 151 and thereby be alerted to the fact that the desired quantity of eluate has been dispensed into the container 125. The person may then interrupt the flow of eluate into the container 125 (e.g., by manually closing the pinch valve 141 and/or by disconnecting the container 125 from the outlet conduit 121). After the radioisotope generation process is complete, the user may use the selector to change the desired amount of eluate to a different amount and repeat the process to obtain a different amount of eluate in another container.

With reference now to Fig. 3, in another embodiment of a radioisotope generation system 201 of the present invention the system may further comprise an interruption system operable to automatically (as opposed to manually) interrupt the dispensing of eluate into the container 125 in response to an electronic signal generated by the monitoring system 151 once the determined amount of eluate in the container is approximately equal to the desired amount of eluate. For example, the processor 117 may alter an electrical condition of the system (e.g., open and/or close a circuit of the system, change a voltage applied to a component of the system, etc.) to activate the interruption system. It is understood that the electronic signal generated by the monitoring system 151 to activate the interruption system may be instead of, or in addition to, a signal that is perceptible exterior of the elution shield 131 (e.g., an audible or visible signal).

The interruption system may comprise a valve actuator 209 operable to close the pinch valve 141 in response to the signal from the monitoring system 151. Other suitable interruption systems may comprise an actuator (not shown) operable to disconnect the container 125 from the generator column 103 by withdrawing the needle 127 from the container in response to the signal from the monitoring system 151, such as by movement of the container, movement of the needle, or both. Construction and operation of the generation system 201 of Fig. 3 is otherwise substantially the same as the construction and operation of the system 101 of Fig. 1.

It is understood that suitable monitoring systems other than that illustrated in Figs. 1-3 and described previously may be used without departing from the scope of this invention. For example, Fig. 4 illustrates a portion 351 of one alternative embodiment of a suitable monitoring system comprising an ultrasonic liquid level sensor 361 having an ultrasonic transmitter and receiver (e.g., a resonator 363 that transmits ultrasound in an active mode and receives ultrasound in a passive mode) mounted in the cavity 133 of the elution shield 131. Operation of the liquid level sensor 361 shown in

Fig. 4 involves emitting ultrasonic energy (e.g., a burst or chirp) from the transmitter 363 and detecting the echo of the ultrasonic energy reflecting off the fluid level surface 167 of the eluate. Data from the ultrasonic detector 363 may be transmitted (by wire or wirelessly) to the processor 171 whereby the processor determines the level of the eluate based on the data relating to the echo. The processor 171 may determine the amount of eluate in the container 125 (broadly, the cavity 133 of the elution shield 131) based at least in part on the determined fluid level of the eluate.

Another embodiment of a suitable monitoring system 451 is illustrated in part in Fig. 5. Such a monitoring system 451 comprises an inductive liquid level sensor 461. The inductive sensor comprises a conductive coil 463 turning about at least a part of the cavity 133 of the elution shield 131, and in the illustrated embodiment about the outer surface of the container 125 within the cavity. The inductance of the coil 463 may vary depending on the fluid level of eluate in the container 125. Operation of the monitoring system 451 of Fig. 5 may include measuring the inductance of the coil 463 and using the processor 171 to determine the level of eluate in the container 125 based on the inductance of the coil. Similarly, a capacitive sensor (not shown) comprising a pair of parallel conductors in opposing relation to one another may be positioned in the cavity so that the capacitance of the conductors varies depending of the level of eluate in the container 125, in which case the monitoring may include measuring the capacitance of the conductors and using the processor 171 to determine the level of eluate as a function thereof. As in previous embodiments, the fluid level of eluate corresponds to the amount of eluate in the container 125 (broadly, the cavity 133).

Fig. 6 illustrates part of yet another embodiment of a suitable monitoring system 551 in which the monitoring system comprises one or more pressure sensors 563 operable to determine the weight of the eluate in the container 125 (broadly, the cavity 133). For example, a pressure sensor 563 may be positioned in the cavity 133 of the elution shield 131 with the weight of the container 125 bearing down against the sensor. Data from the pressure sensor 563 may be sent to the processor 171, which correlates the pressure exerted on the pressure sensor to the weight of eluate in the container 125. The weight of the eluate corresponds to the amount of eluate in the container 125. A system incorporating the monitoring system 551 of Fig. 6 may otherwise operate substantially the same as the systems 101, 201 shown in Figs. 1-3.

Fig. 7 illustrates another embodiment of a radioisotope generation system 601 of the present invention similar to the systems of Figs. 1 and 3. The monitoring system of this embodiment, however, comprises a timer 691 operable to monitor an elapsed time during which eluate is dispensed from the generator column 103 into the container 125 (broadly, the cavity 133 of the elution shield 131). In particular, the elapsed time may be monitored relative to the time at which dispensing of eluate into the container 125 is initiated. The timer 691 can be used to gauge the amount of eluate dispensed into the container 125 based on previously calibrated data regarding the amount of time required for eluate to accumulate in the container under similar operating conditions. In this case, the monitoring system 651 may be operable to generate a signal in response to a predetermined elapsed time corresponding to a

desired amount of eluate to be dispensed into the container 125. The selector may be operable to pre-select the predetermined elapsed time during which eluate is to be dispensed into the container 125.

In one embodiment the timer 691 may comprise a timer initiation system 693 adapted to start the timer automatically upon connection of the container 125 (and/or the elution shield 131) to the outlet conduit 121. For example, one or more sensors 695 (e.g., a hall effect sensor, optical sensor, RFID sensor, proximity sensor, or the like) may generate a signal upon connection of the container 125 to the outlet conduit 121. The timer 691 may be operable to begin monitoring the elapsed time in response to the signal indicating that the container 125 has been connected to the outlet conduit 121. Alternatively, the timer 691 may be started manually by a person when he or she connects the container 125 to the outlet conduit 121 without departing from the scope of the invention.

It is understood that the configuration of the radioisotope generation system can be different from the configurations discussed above and shown in the drawings without departing from the scope of the invention. Although the systems described and shown above involve dispensing of eluate into a container housed within an elution shield, it is understood that the elution system can dispense eluate directly into the cavity of the shield, or that the container may be unshielded, without departing from the scope of the invention.

Although a pinch valve is used to facilitate interruption of the elution in the illustrated embodiments, other types of valves could be used instead without departing from the scope of the invention. Likewise, the invention is operable without any valving as disconnection of the vacuum pressure source (e.g., the partially filled container) may be sufficient to interrupt the elution process in and of itself.

While in each of the illustrated embodiments the monitoring system generates a signal upon determining that the amount of eluate dispensed into the container is approximately equal to a desired amount of eluate, it is contemplated that the monitoring system may instead, or may additionally, generate a continuous or intermittent signal prior to the desired amount of eluate being dispensed into the container, e.g., indicative of the determined amount of eluate in the container (broadly, the cavity). For example, in one embodiment the signal may comprise visual or audible signals that indicate various incremental amounts of eluate dispensed into the container. Examples of such signals include, without limitation, lights, digital displays, alphanumeric displays or other suitable visual indicators of the amount of eluate dispensed into the container. Other examples include audible signals that may or may not increase in intensity as the amount of eluate in the container increases.

When introducing elements of the present invention or the preferred embodiments thereof, the articles "a", "an", "the", and "said" are intended to mean that there are one or more of the elements. The terms "comprising", "including", and "having" are intended to be inclusive and mean that there may be additional elements other than the listed elements. Moreover, the use of "top" and "bottom" and variations of these terms is made for convenience, but does not require any particular orientation of the components.

As various changes could be made in the above products and methods without departing from the scope of the invention, it is intended that all matter contained in the above description and shown in the accompanying drawings shall be interpreted as illustrative and not in a limiting sense.

CLAIMS:

What is claimed is

1. A radioisotope generation system comprising:
a radioisotope generator operable to dispense radioactive eluate into a container; and
a monitoring system operable while the radiation generator system dispenses eluate into the container to monitor the amount of eluate dispensed into the container and to generate a signal indicative of the amount of eluate dispensed into the container.
2. A radioisotope generation system as in claim 1 wherein the monitoring system is operable to generate a signal when a desired amount of eluate has been dispensed into the container.
3. A radioisotope generation system as in claim 2 further comprising a selector for selectively setting the desired amount of eluate to be dispensed into the container.
4. A radioisotope generation system as in claim 2 wherein the generation system is operable to automatically interrupt dispensing of the eluate into the container in response to the signal.
5. A radioisotope generation system as in claim 1 wherein the signal is perceptible exterior of the container.
6. A radioisotope generation system as in claim 5 wherein the signal is at least one of visually and audibly perceptible exterior of the container.
7. A radioisotope generation system as in claim 1 wherein the signal is perceptible by a human.
8. A radioisotope generation system as in claim 1 wherein the monitoring system comprises a level sensor operable to sense a level of eluate in the container, the level corresponding to the amount of eluate in the container.
9. A radioisotope generation system as in claim 8 wherein the level sensor is selected from the group consisting of optical sensors, infrared sensors, ultrasonic sensors, inductive sensors, and capacitive sensors.
10. A radioisotope generation system as in claim 1 wherein the monitoring system comprises a timer operable to monitor an elapsed time during which eluate is dispensed into the container, the elapsed time being relative to a time at which the dispensing of eluate into the container is initiated, the elapsed time corresponding to the amount of eluate in the container.

11. A radioisotope generation system as in claim 10 wherein the monitoring system is operable to generate a signal following dispensing of eluate into the container for a predetermined elapsed time wherein the predetermined elapsed time corresponds to a desired amount of eluate to be dispensed into the container.

12. A radioisotope generation system as in claim 11 wherein the predetermined elapsed time is selectively adjustable at least prior to the dispensing of eluate into the container being initiated.

13. A radioisotope generation system as in claim 10 further comprising a timer initiation system operable to automatically start the timer when dispensing of eluate into the container is initiated.

14. A radioisotope generation system as in claim 13 wherein the timer initiation system comprises a sensor selected from the group consisting of hall effect sensors, optical sensors, and RFID tags.

15. A radioisotope generation system as in claim 1 wherein the monitoring system comprises a sensor operable to determine the weight of eluate in the container, the weight corresponding to the amount of eluate in the container.

16. A method for dispensing radioactive eluate, the method comprising:
dispensing eluate from a radioisotope generator into a container while the container and the generator are in fluid communication;
monitoring the dispensing; and
providing a signal indicative of an amount of the eluate dispensed into the container.

17. A method as in claim 16 wherein the providing comprises providing a signal when the amount of eluate in the container is approximately equal to a desired amount of eluate, the method further comprising interrupting the dispensing of eluate into the container in response to the signal.

18. A method as in claim 17 wherein the interrupting comprises automatically interrupting the dispensing of eluate into the container in response to the signal.

19. A method as in claim 17 wherein the interrupting comprises manually interrupting the dispensing of eluate into the container in response to the signal.

20. A method as in claim 17 further comprising selectively adjusting the desired amount of eluate to be dispensed into the container, the selectively adjusting being conducted prior to the operating of the radioisotope generator.

21. A method as in claim 16 wherein the monitoring comprises monitoring an elapsed time, starting from initiation of the dispensing, during which eluate is dispensed into the container, the elapsed time corresponding to the amount of eluate dispensed into the container.

22. A method as in claim 16 wherein the monitoring comprises sensing a level of eluate in the container, the level corresponding to an amount of eluate dispensed into the container.

23. A method as in claim 16 wherein the monitoring comprises sensing a weight of the eluate in the container, the weight corresponding to an amount of eluate dispensed into the container.

24. A method as in claim 16 further comprising generating an electrical signal based on the monitoring.

25. A method as in claim 24 wherein the providing results from the electrical signal generated.

26. A radioisotope generation system comprising:
a radioisotope generator operable to dispense eluate;
an elution shield having an internal cavity for receiving eluate dispensed from the generator, the elution shield being constructed at least in part of a radiation-absorbing material; and
a monitoring system for monitoring the dispensing of eluate by the generator to the cavity of the shield, the monitoring system being operable to generate a signal in response to at least one of receipt of a desired amount of eluate in the cavity and elapse of a predetermined time period during which eluate is dispensed into the cavity.

27. A radioisotope generation system as in claim 26 further comprising a container disposed in the cavity for receiving the eluate therein, the container being adapted to hold a maximum volume of eluate, the monitoring system being capable of generating the signal in response to receipt of a desired amount of eluate in the container, the desired amount of eluate being less than the maximum volume of the container.

28. A radioisotope generation system as in claim 26 further comprising a container disposed in the cavity for receiving the eluate therein, the container being adapted to hold a maximum volume of eluate, the monitoring system being capable of generating the signal in response to a predetermined

elapsed time during which eluate is dispensed into the container, the predetermined elapsed time corresponding to a desired amount of eluate to be dispensed into the container.

29. A radioisotope generation system as in claim 26 wherein the generation system is operable to automatically interrupt dispensing of the eluate into the cavity in response to the signal.

30. A radioisotope generation system as in claim 26 wherein the signal is perceptible exterior of the elution shield.

31. A radioisotope generation system as in claim 30 wherein the signal is at least one of visually and audibly perceptible exterior of the elution shield.

32. A radioisotope generation system as in claim 26 wherein the signal is perceptible by a human.

33. A radioisotope generation system as in claim 26 wherein the monitoring system comprises a level sensor operable to sense the level of eluate in the cavity, the level corresponding to the amount of eluate in the cavity.

34. A radioisotope generation system as in claim 26 wherein the monitoring system comprises a timer operable to monitor an elapsed time during which eluate is dispensed into the cavity, the elapsed time being relative to a time at which the dispensing of eluate into the cavity is initiated, the elapsed time corresponding to the amount of eluate in the cavity, the monitoring system being operable to generate a signal following dispensing of eluate into the cavity for a predetermined elapsed time wherein the predetermined elapsed time corresponds to the desired amount of eluate in the cavity.

35. A radioisotope generation system as in claim 34 further comprising a timer initiation system operable to automatically start the timer when dispensing of eluate into the cavity is initiated.

36. A radioisotope generation system as in claim 34 wherein the predetermined elapsed time is selectively adjustable at least prior to the dispensing of eluate into the cavity being initiated.

37. A radioisotope generation system as in claim 26 wherein the monitoring system comprises a sensor operable to determine the weight of eluate in the cavity, the weight corresponding to the amount of eluate in the cavity.

38. A method of producing radioactive eluate, the method comprising:

dispensing eluate from a radioisotope generator into a cavity of an elution shield;
monitoring an amount of eluate in the cavity during at least a portion of the dispensing; and
automatically generating a signal in response to detecting at least one of a desired amount of
eluate in the cavity and a passing of a predetermined elapsed time during the dispensing.

39. A method as in claim 38 wherein the dispensing comprises dispensing eluate into a
container disposed in the cavity of the elution shield, the container being adapted to hold a maximum
volume of eluate, wherein the automatically generating occurs in response to receipt of a desired
amount of eluate in the container, the desired amount being less than the maximum volume.

40. A method as in claim 38 wherein the dispensing comprises dispensing eluate into a
container disposed in the cavity of the elution shield, the container being adapted to hold a maximum
volume of eluate, wherein the automatically generating occurs in response to the passing of a
predetermined elapsed time during which eluate is dispensed into the container, the predetermined
elapsed time corresponding to an amount of eluate in the container less than the maximum volume.

41. A method as in claim 38 further comprising manually interrupting the dispensing in
response to the signal.

42. A method as in claim 38 further comprising automatically interrupting the dispensing in
response to the signal.

43. A method as in claim 38, wherein the monitoring comprises sensing a level of dispensed
eluate in the cavity, the level corresponding to the amount of eluate in the cavity.

44. A method as in claim 38, wherein the monitoring comprises sensing a weight of the eluate
in the cavity, the weight corresponding to the amount of eluate in the cavity.

45. A method as in claim 38 further comprising selectively varying at least one of the desired
amount of eluate in the cavity and the predetermined elapsed time during which eluate is dispensed into
the cavity, wherein the selectively varying occurs prior to the dispensing.

46. A radioisotope generation system comprising:
a radioisotope generator for dispensing radioactive eluate; and
a dispensed eluate sensor capable of determining an amount of eluate eluted from the generator;
and
a signaling device communicatively connected with the sensor.

47. A system as in claim 46 wherein the sensor comprises at least one of an optical sensor, an infrared sensor, an ultrasonic sensor, an inductive sensor, and a capacitive sensor.

48. A system as in claim 46 wherein the signaling device is capable of providing at least one of an audio signal and a visual signal.

49. A system as in claim 46 further comprising an elution shield having an internal cavity for receiving eluate dispensed from the generator, wherein the elution shield is constructed at least in part of a radiation-shielding material, and wherein at least one of the dispensed eluate sensor and the signaling device is a component of the elution shield.

50. A system as in claim 49 wherein the dispensed eluate sensor and the signaling device are components of the elution shield.

51. A method of dispensing a radioactive eluate comprising:
determining an amount of radioactive eluate eluted from a radioisotope generator of a radioisotope generation system in an elution procedure; and
changing an electrical condition of the system based on the determining.

52. A method as in claim 51, wherein the changing comprises closing an electrical circuit of the system.

53. A method as in claim 51, wherein the changing comprises opening an electrical circuit of the system.

54. A method as in claim 51, wherein the changing occurs as a result of determining a threshold amount of the eluate.

55. A method as in claim 51, further comprising providing at least one of an audible signal and a visual signal as a result of the changing.

56. A method as in claim 51, wherein the changing comprises altering an electrical signal between first and second components of the system.

57. A method as in claim 51, wherein the changing comprises changing a voltage applied to a component of the system.

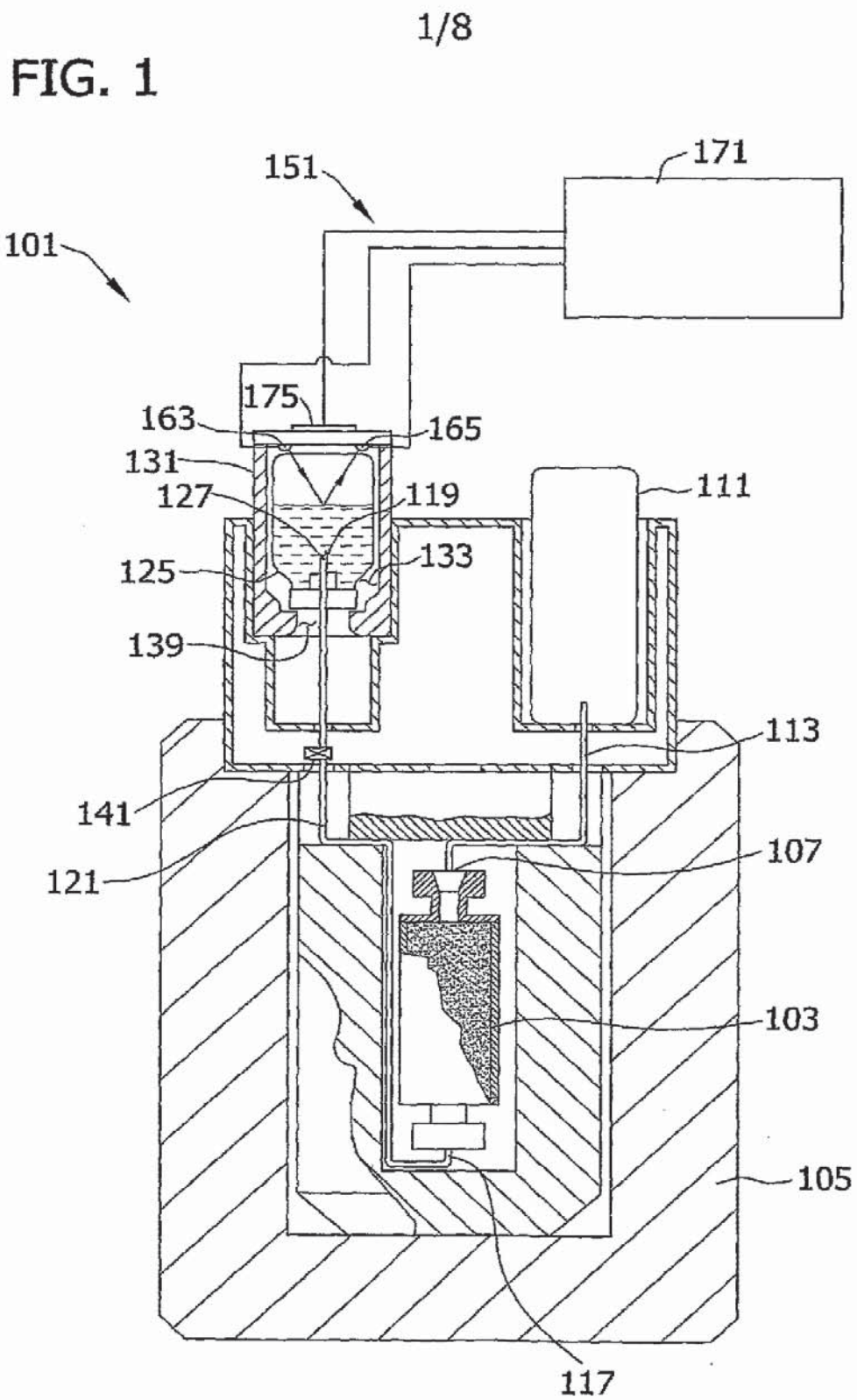

3/8

FIG. 3

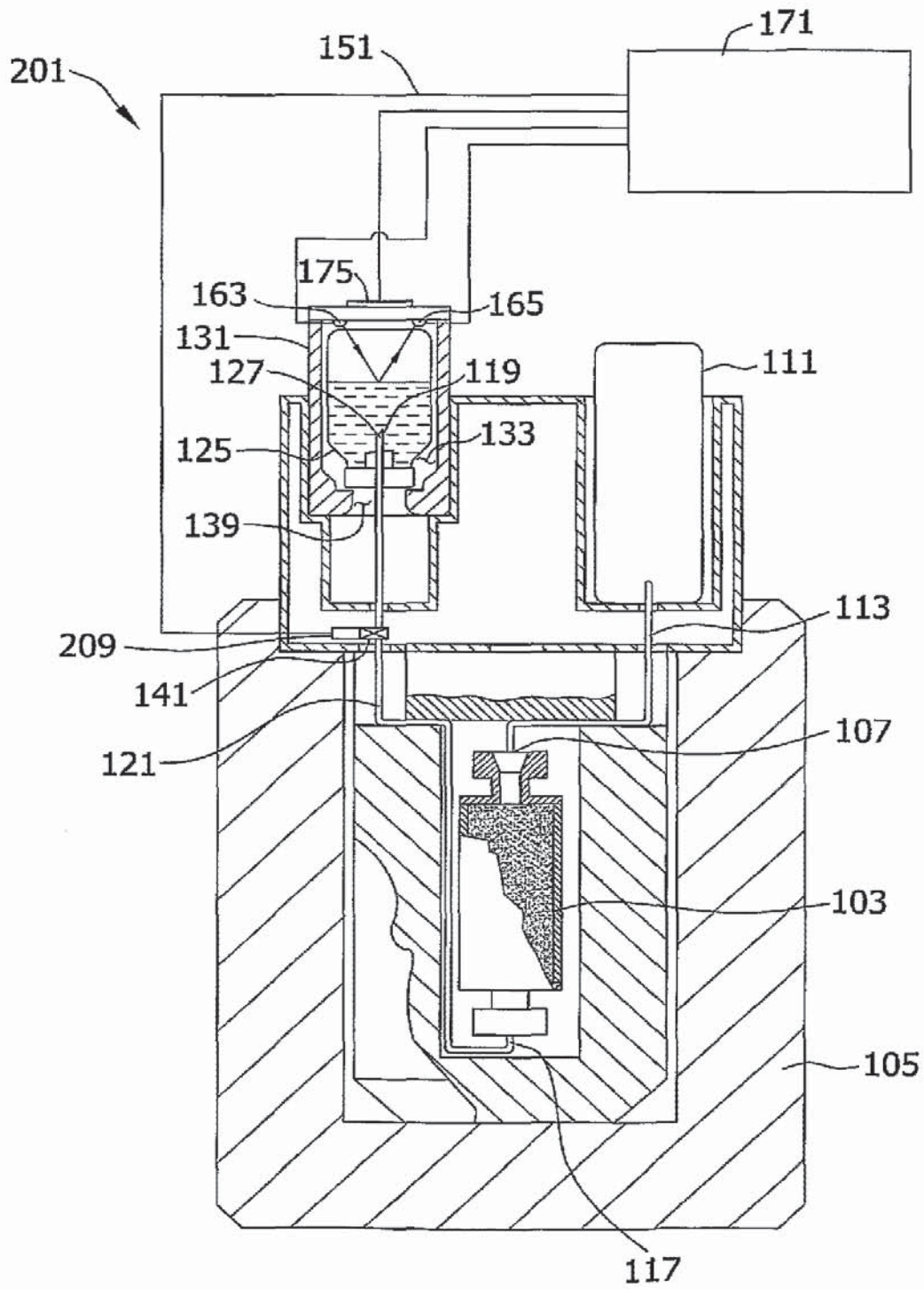

4/8

FIG. 4

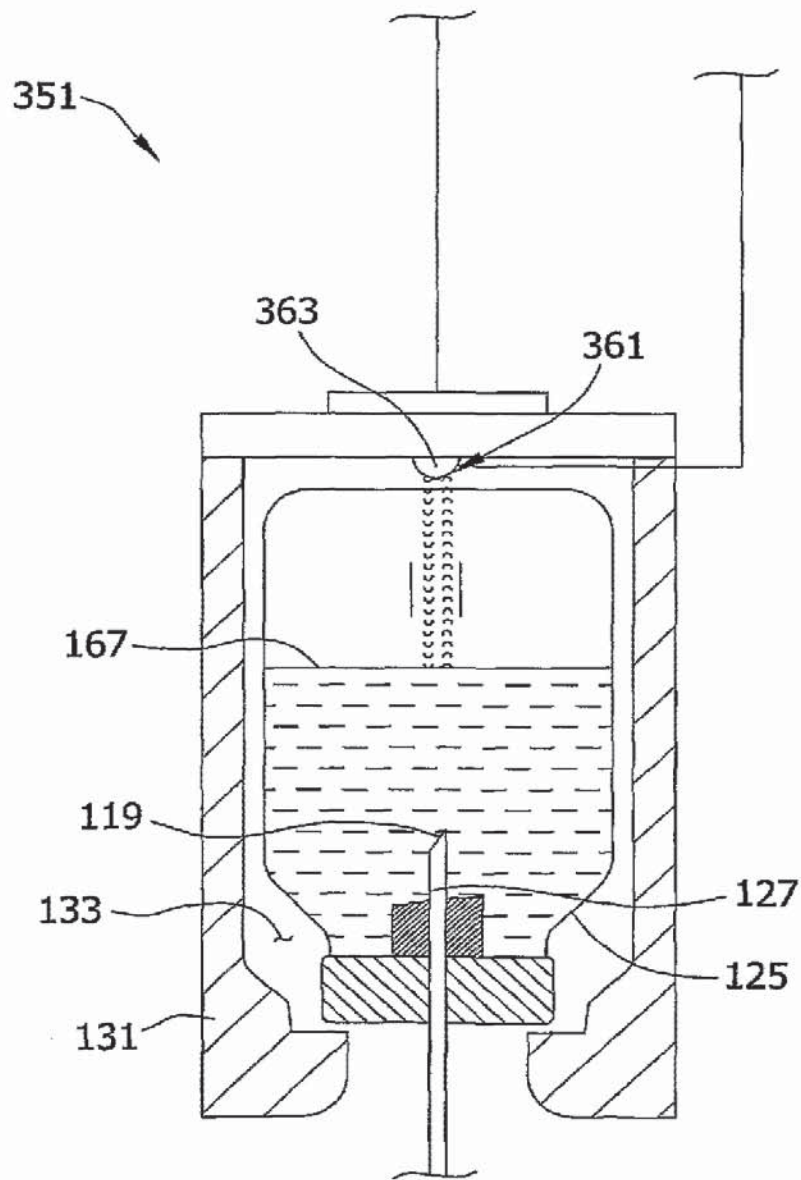

5/8

FIG. 5

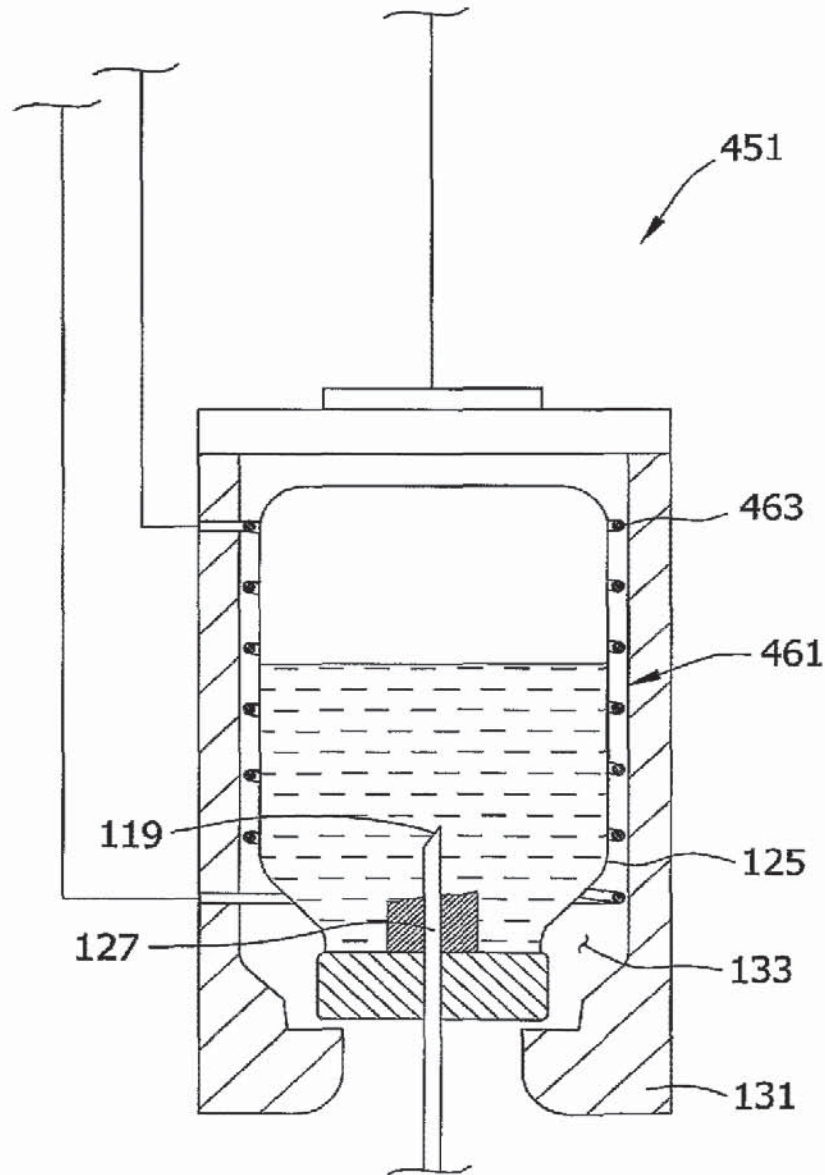

6/8

FIG. 6

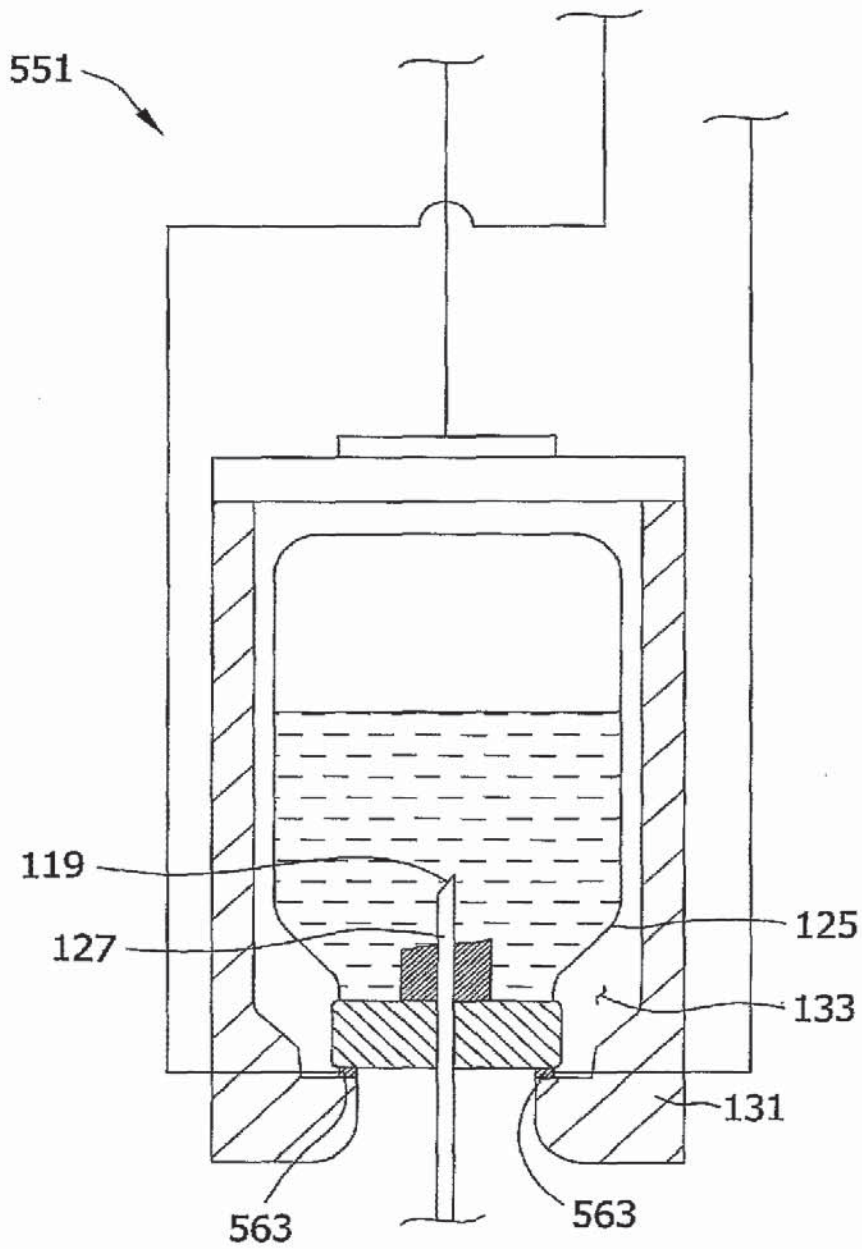

7/8

FIG. 7

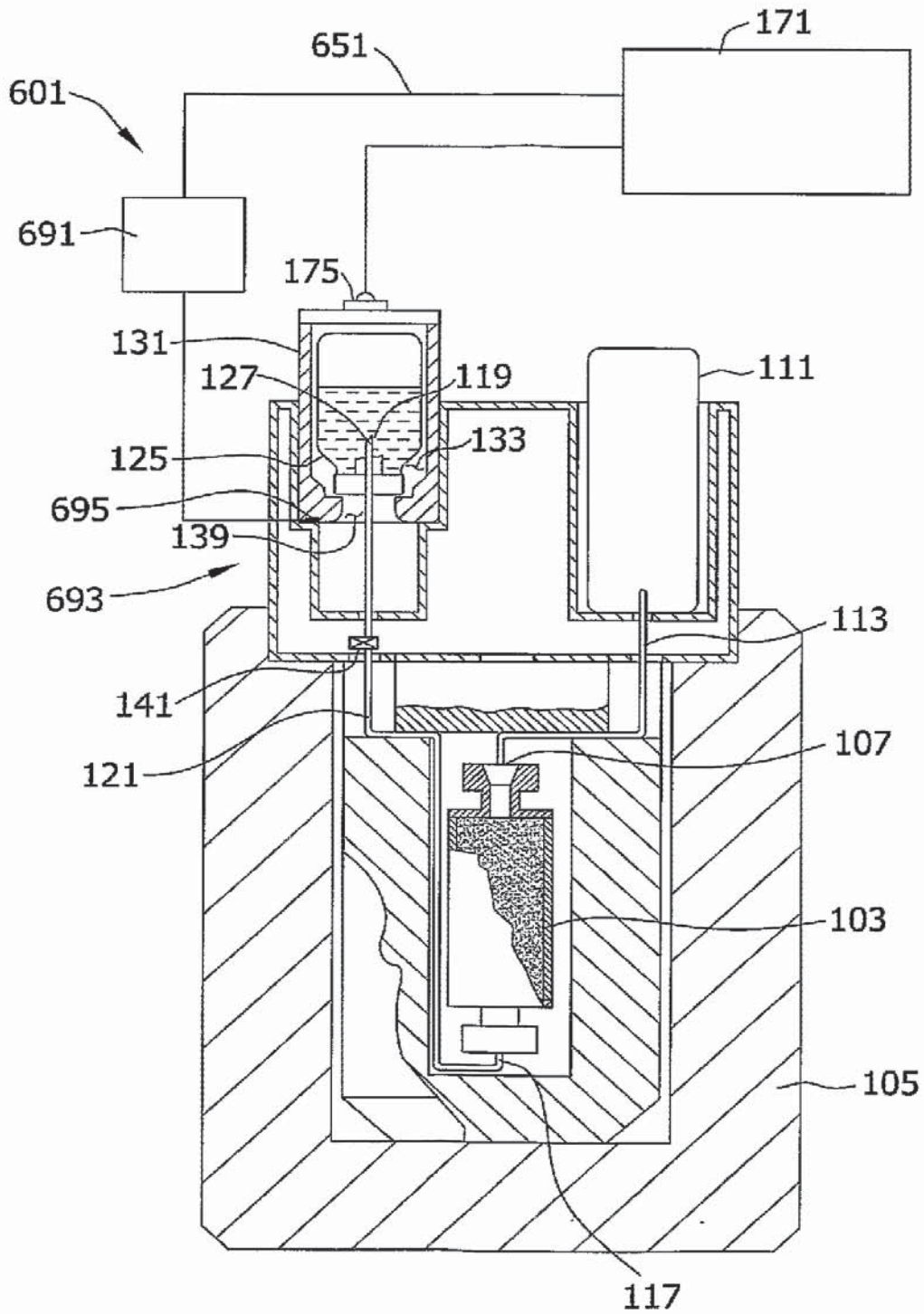

8/8

FIG. 8

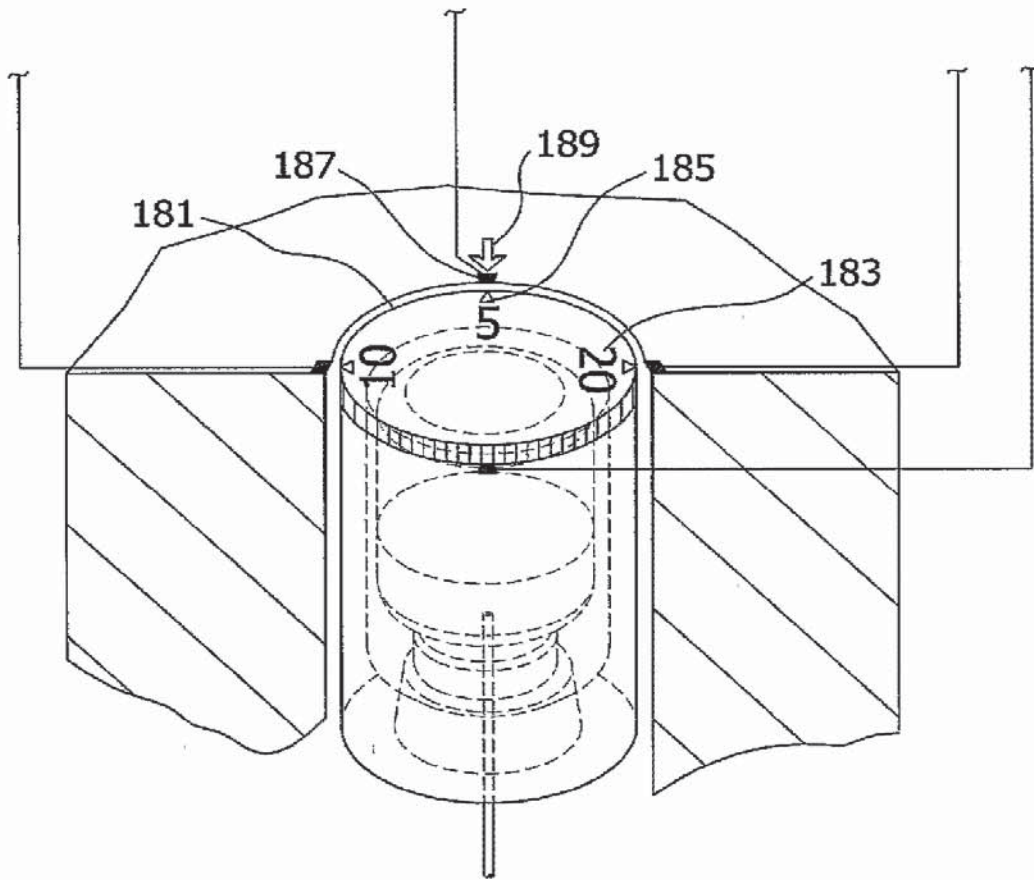

(19) World Intellectual Property Organization
International Bureau



(43) International Publication Date
27 December 2007 (27.12.2007)

PCT

(10) International Publication Number
WO 2007/149108 A2

- (51) International Patent Classification: **Not classified**
- (21) International Application Number:
PCT/US2006/033442
- (22) International Filing Date: 28 August 2006 (28.08.2006)
- (25) Filing Language: English
- (26) Publication Language: English
- (30) Priority Data:
60/712,106 29 August 2005 (29.08.2005) US
- (71) Applicant (for all designated States except US):
MALLINCKRODT INC. [US/US]; 675 McDonnell
Boulevard, P.O. Box 5840, St. Louis, Missouri 63134
(US).
- (72) Inventor; and
- (75) Inventor/Applicant (for US only): **POLLARD, Ralph,
E., Jr.** [US/US]; 6554 East River Road, Fairfield, Ohio
45014 (US).
- (74) Agents: **SEURER, Jerad, G.** et al.; Mallinckrodt Inc., 675
McDonnell Boulevard, P.O. Box 5840, St. Louis, Missouri
63134 (US).
- (81) Designated States (unless otherwise indicated, for every
kind of national protection available): AE, AG, AL, AM,
AT, AU, AZ, BA, BB, BG, BR, BW, BY, BZ, CA, CH, CN,
CO, CR, CU, CZ, DE, DK, DM, DZ, EC, EE, EG, ES, FI,
GB, GD, GE, GH, GM, HN, HR, HU, ID, IL, IN, IS, JP,
KE, KG, KM, KN, KP, KR, KZ, LA, LC, LK, LR, LS, LT,
LU, LV, LY, MA, MD, ME, MG, MK, MN, MW, MX, MY,
MZ, NA, NG, NI, NO, NZ, OM, PG, PH, PL, PT, RO, RS,
RU, SC, SD, SE, SG, SK, SL, SM, SV, SY, TJ, TM, TN,
TR, TT, TZ, UA, UG, US, UZ, VC, VN, ZA, ZM, ZW.
- (84) Designated States (unless otherwise indicated, for every
kind of regional protection available): ARIPO (BW, GH,
GM, KE, LS, MW, MZ, NA, SD, SI, SZ, TZ, UG, ZM,
ZW), Eurasian (AM, AZ, BY, KG, KZ, MD, RU, TJ, TM),
European (AT, BE, BG, CH, CY, CZ, DE, DK, EE, ES, FI,
FR, GB, GR, HU, IE, IS, IT, LT, LU, LV, MC, NL, PL, PT,
RO, SE, SI, SK, TR), OAPI (BF, BJ, CF, CG, CI, CM, GA,
GN, GQ, GW, ML, MR, NE, SN, TD, TG).
- Published:**
— without international search report and to be republished
upon receipt of that report
- For two-letter codes and other abbreviations, refer to the "Guidance Notes on Codes and Abbreviations" appearing at the beginning of each regular issue of the PCT Gazette.



WO 2007/149108 A2

(54) Title: SYSTEM AND METHOD FOR ELUTING RADIOISOTOPE TO A CONTAINER DISPOSED OUTSIDE OF A RADIOISOTOPE GENERATOR ASSEMBLY

(57) Abstract: The invention, in one characterization, may be said to be directed to a radiopharmaceutical system that may be utilized in radioisotope elution procedures. In some embodiments, the system may include a radioisotope generator assembly having a radiation shield with a receptacle and a cover disposed over the receptacle. The system may also include a radioisotope generator disposed in the receptacle below the cover. Some embodiments of the system may include an eluate extraction mechanism having an eluate conduit fluidly coupled to a hollow output needle of the radioisotope generator, and a radiation shielded housing disposed outside the radiation shield. The eluate extraction mechanism also may include a hollow needle fluidly coupled to the eluate conduit opposite the radioisotope generator, wherein the hollow needle is disposed inside the radiation shielded housing.

SYSTEM AND METHOD FOR ELUTING RADIOISOTOPE TO A CONTAINER DISPOSED OUTSIDE OF A RADIOISOTOPE GENERATOR ASSEMBLY

FIELD OF THE INVENTION

[0001] The invention relates generally to the field of nuclear medicine. Specifically, the invention relates to a system and method for eluting a radioisotope from a radioisotope generator to an eluate container disposed outside of an auxiliary shield containing the radioisotope generator.

BACKGROUND

[0002] This section is intended to introduce the reader to various aspects of art that may be related to various aspects of the present invention, which are described and/or claimed below. This discussion is believed to be helpful in providing the reader with background information to facilitate a better understanding of the various aspects of the present invention. Accordingly, it should be understood that these statements are to be read in this light, and not as admissions of prior art.

[0003] Nuclear medicine utilizes radioactive material for diagnostic and therapeutic purposes by injecting a patient with a small dose of the radioactive material, which concentrates in certain organs or biological regions of the patient. Radioactive materials typically used for nuclear medicine include Technetium-99m, Indium-113m, and Strontium-87m among others. Some radioactive materials naturally concentrate toward a particular tissue, for example, iodine concentrates toward the thyroid. However, radioactive materials are often combined with a tagging or organ-seeking agent, which targets the radioactive material for the desired organ or biologic region of the patient. These radioactive materials alone or in combination with a tagging agent may be to as radiopharmaceuticals in the field of nuclear medicine. At relatively lower doses of the radiopharmaceutical, a radiation imaging system (e.g., a gamma camera) provides an image of the organ or biological region that collects the radiopharmaceutical. Irregularities in the image are often indicative of a pathologic condition, such as cancer. Higher doses of the radiopharmaceutical may be used to deliver a therapeutic dose of radiation directly to the pathologic tissue, such as cancer cells.

[0004] A variety of systems are used to generate, enclose, transport, dispense, and administer radiopharmaceuticals. Unfortunately, these systems often use different containers and shielding structures and, thus, the radiopharmaceuticals tend to be repeatedly exchanged from one container to another during the various steps from elution to eventual administration to a patient. In addition, these systems often involve repeated connection and disconnection of components, such as male and female connectors of containers. Unfortunately, the male connectors can be damaged due to misalignment with the corresponding female connectors. For example, hollow needles can be bent, crushed, or

broken due to misalignment with female connectors. As a result, the systems may operate less effectively or become completely useless. If the systems contain radiopharmaceuticals, then the damaged connectors can result in monetary losses, delays with respect to nuclear medicine procedures, and/or undesired exposure of technicians (or other personnel) to radiation.

SUMMARY

[0005] The present invention, in certain embodiments, is directed to removability and replaceability of a hollow needle that pierces an eluate container (e.g., a septum thereof) in a radioisotope elution system. Specifically, in some embodiments, a removable hollow needle may be coupled to a radioisotope generator via an eluate conduit, which in turn may be coupled to an output needle of the radioisotope generator. Instead of directly coupling the eluate container with the output needle of the generator, the removable hollow needle may be used for connections and disconnections with the eluate container. In this manner, the removable hollow needle may reduce the likelihood of damage to the generator output needle, while possibly reducing the cost and downtime associated with any potential damage to the removable hollow needle. In some embodiments, the removable hollow needle may be disposed outside of a radiation shield that is disposed about the radioisotope generator. As such, a user may access and replace the removable hollow needle without opening the radiation shield. Some embodiments of the present invention may enable a user to access and view the eluate container without opening the radiation shield.

[0006] Certain aspects commensurate in scope with the originally claimed invention are set forth below. It should be understood that these aspects are presented merely to provide the reader with a brief summary of certain forms the invention might take and that these aspects are not intended to limit the scope of the invention. Indeed, the invention may encompass a variety of features and aspects that may not be set forth below.

[0007] A first aspect of the invention is directed to a radiopharmaceutical system that includes a radioisotope generator assembly and an eluate extraction mechanism. The radioisotope generator assembly includes a radiation shield having a receptacle, a cover disposed over the receptacle, and a radioisotope generator disposed in the receptacle below the cover. The eluate extraction mechanism includes an eluate conduit fluidly coupled to a hollow output needle of the radioisotope generator, a radiation shielded housing disposed outside the radiation shield, and a hollow needle fluidly coupled to the eluate conduit opposite the radioisotope generator. The hollow needle of the generator is disposed inside the radiation shielded housing of the eluate extraction mechanism. Incidentally, "fluidly coupled" or the like herein refers to a joining of a first component to a second component or to one or more components which may be connected with the second component, or to joining the first component to part of a system that includes the second component so that the molecules of

a substance(s) (such as a liquid or gas) are capable of flowing through the system, including through both the first and second components.

[0008] A second aspect of the invention is directed to an eluate extraction mechanism that includes a radiation shielded housing and an eluate conduit. The eluate conduit has a radioisotope generator end disposed outside the radiation shielded housing and an opposite end disposed inside the radiation shielded housing. The eluate extraction mechanism also includes a hollow injection needle fluidly coupled to the opposite end of the eluate conduit. In addition, the eluate extraction mechanism includes a plunger coupled to the radiation shielded housing movably through a guide structure. The plunger is typically coupled to the hollow injection needle inside the radiation shielded housing.

[0009] Yet a third aspect of the invention is directed to an eluate extraction mechanism that includes a radiation shielded housing and a shielded eluate collection assembly. This shielded eluate collection assembly may be disposed removably inside the radiation shielded housing adjacent a door of the housing. The eluate extraction mechanism includes an eluate conduit having a radioisotope generator end disposed outside the radiation shielded housing and an opposite end disposed inside the radiation shielded housing. In addition, the eluate extraction mechanism includes a hollow needle fluidly coupled to the opposite end of the eluate conduit. The hollow needle may be moved between a connected position and a disconnected position relative to the shielded eluate collection assembly.

[0010] Still a fourth aspect of the invention is directed to a method of using a radiopharmaceutical system. In this method, an eluant is supplied into a radioisotope generator, and a radioisotope is eluted in the radioisotope generator. An eluate (including the radioisotope) is received at an output of the radioisotope generator. This eluate flows from the output through an eluate conduit and a hollow needle that is removably inserted, via movement of a plunger, into an eluate container.

[0011] Various refinements exist of the features noted above in relation to the various aspects of the present invention. Further features may also be incorporated in these various aspects as well. These refinements and additional features may exist individually or in any combination. For instance, various features discussed below in relation to one or more of the specific embodiments may be incorporated into any of the above-described aspects of the present invention alone or in any combination. Again, the brief summary presented above is intended only to familiarize the reader with certain aspects and contexts of the present invention without limitation to the claimed subject matter.

BRIEF DESCRIPTION OF THE FIGURES

[0012] These and other aspects, features, and advantages of the present invention will become better understood when the following detailed description is read with reference to the accompanying figures in which like characters represent like parts throughout the figures, wherein:

[0013] FIG. 1 is a front perspective view of an exemplary embodiment of a radioisotope elution system including an eluate extraction mechanism disposed outside a radioisotope generator assembly, wherein the eluate extraction mechanism is disposed above a cover of an auxiliary shield containing a radioisotope generator, and the eluate extraction mechanism includes a plunger;

[0014] FIG. 2 is a rear perspective view of the radioisotope elution system as illustrated in FIG. 1, further illustrating a door coupled to the eluate extraction mechanism via a hinge;

[0015] FIG. 3 is a cross-sectional side view of the radioisotope elution system as illustrated in FIGS. 1 and 2, further illustrating the eluate extraction mechanism in an open, non-circulating configuration, wherein the door is rotated open and the plunger includes a hollow injection needle uncoupled from an eluate container;

[0016] FIG. 4 is a cross-sectional side view of the radioisotope elution system as illustrated in FIG. 3, further illustrating the eluate extraction mechanism in a closed, circulating configuration, wherein the door is rotated closed and the hollow injection needle is coupled to the eluate container;

[0017] FIG. 5 is a rear perspective view of the radioisotope elution system as illustrated in FIG. 4, further illustrating an open viewing slot in a shielded eluate assembly having the eluate container disposed inside;

[0018] FIG. 6 is a cross-sectional side view of the radioisotope elution system as illustrated in FIG. 5, further illustrating the shielded eluate assembly removed from the eluate extraction mechanism when the hollow injection needle is uncoupled from the eluate container and the door is disposed in an open position;

[0019] FIG. 7 is an exploded cross-sectional side view of the radioisotope elution system as illustrated in FIG. 6, illustrating the hollow injection needle removed from the plunger of the eluate extraction mechanism;

[0020] FIG. 8 is an exploded cross-sectional view of the eluate extraction mechanism as illustrated in FIG. 7, further illustrating details of the hollow injection needle removed from the plunger of the eluate extraction mechanism;

[0021] FIG. 9 is a top perspective view of an exemplary embodiment of the plunger as illustrated in FIG. 8, further illustrating a removable fluid coupling disposed at a bottom side of the plunger;

[0022] FIG. 10 is a bottom perspective view of the plunger as illustrated in FIG. 9;

[0023] FIG. 11 is an exploded perspective view of the plunger as illustrated in FIGS. 9 and 10, further illustrating the removable fluid coupling having a bossed portion or rail exploded laterally from a slot in the bottom side of the plunger;

[0024] FIG. 12 is a side view of an embodiment of the removable fluid coupling as illustrated in FIGS. 9-11;

[0025] FIG. 13 is a bottom view of an embodiment of the plunger as illustrated in FIGS. 9-11, further illustrating the plunger without the removable fluid coupling;

[0026] FIGS. 14 and 15 are rear perspective views of the eluate extraction mechanism as illustrated in FIGS. 1-8, further illustrating an alignment adapter disposed about an eluate conduit of the eluate extraction mechanism;

[0027] FIG. 16 is a flowchart illustrating an exemplary embodiment of a nuclear medicine process using a radiopharmaceutical acquired by the radioisotope elution system as illustrated in FIGS. 1-15;

[0028] FIG. 17 is a block diagram illustrating an exemplary embodiment of a radiopharmacy or system utilizing the radioisotope elution system as illustrated in FIGS. 1-15; and

[0029] FIG. 18 is a block diagram illustrating an exemplary embodiment of a nuclear imaging system utilizing a radiopharmaceutical acquired by the radioisotope elution system as illustrated in FIGS. 1-15.

DETAILED DESCRIPTION OF SPECIFIC EMBODIMENTS

[0030] One or more specific embodiments of the present invention will be described below. In an effort to provide a concise description of these embodiments, all features of an actual implementation may not be described in the specification. It should be appreciated that in the development of any such actual implementation, as in any engineering or design project, numerous implementation-specific decisions must be made to achieve the developers' specific goals, such as compliance with system-related and business-related constraints, which may vary from one implementation to another. Moreover, it should be appreciated that such a development effort might be complex and time consuming, but would nevertheless be a routine undertaking of design, fabrication, and manufacture for those of ordinary skill having the benefit of this disclosure.

[0031] FIGS. 1 and 2 are perspective views of an exemplary embodiment of a radioisotope elution system 10 having an eluate extraction mechanism 12 mounted outside, and specifically on top of, a radioisotope generator assembly 14. The radioisotope generator assembly 14 may include a radiation shielded container or auxiliary shield 16, which may receive and at least substantially enclose a

radioisotope generator 18 and an eluant supply container 20 as discussed below with reference to FIG. 3. The eluate extraction mechanism 12 and the auxiliary shield 16 may include a variety of radiation-shielding materials, such as lead, tungsten, tungsten impregnated plastic and/or another suitable radiation shielding material. The eluate extraction mechanism 12 may be mounted at least partially or entirely outside of the auxiliary shield 16 in a variety of configurations, orientations, and positions, such that an elution process may be performed to output an eluate to a position outside of the auxiliary shield 16. For example, the eluate extraction mechanism 12 may be mounted along a generally horizontal surface on top of a cover 22 that generally closes a receptacle 24 of the auxiliary shield 16. Alternatively, the eluate extraction mechanism 12 may be mounted to the auxiliary shield 16 along a generally vertical surface or a side of the auxiliary shield 16. Alternatively, the eluate extraction mechanism 12 may be mounted separate from the radioisotope generator assembly 14. For example, the eluate extraction mechanism 12 may be disposed next to, above, below, or in a variety of remote locations relative to the radioisotope generator assembly 14, wherein an eluate conduit 52 may couple the eluate extraction mechanism 12 to the radioisotope generator assembly 14 as discussed in further detail below with reference to FIG. 3.

[0032] In the illustrated embodiment of FIGS. 1 and 2, the eluate extraction mechanism 12 may be removably coupled to the cover 22, such that the eluate extraction mechanism 12 can be installed and removed without removing the cover 22 from the receptacle 24. In this manner, the eluate extraction mechanism 12 may improve the containment of radioactivity from the radioisotope generator 18 disposed within the auxiliary shield 16. If the radioisotope generator assembly 14 is not being used for an elution process, then the eluate extraction mechanism 12 may be removed and replaced with a radiation shielded plug that may extend into and/or cover the passage 48 in the cover 22. If an elution process is desired now or in the near future, then the radiation shielded plug may be removed and replaced with the eluate extraction mechanism 12 on or over the cover 22. The eluate extraction mechanism 12 may be removably coupled to the cover 22 by a variety of fasteners and alignment structures. For example, the fasteners may include screws, bolts, or other threaded fasteners. The fasteners also may include latches or tool free connectors, such as snap-fit mechanisms, boss members that mate with keyhole slots, and so forth. The fasteners may also include hinges, adhesives, and compressive or interference fits. Alternatively, the eluate extraction mechanism 12 and the cover 22 may be integrally formed as one structure, which may be mounted on top of the auxiliary shield 16.

[0033] FIG. 3 is a cross-sectional side view of an embodiment of the radioisotope elution system 10 as illustrated in FIGS. 1 and 2, further illustrating the eluate extraction mechanism 12 in an open, non-circulating configuration on top of the radioisotope generator assembly 14. As illustrated, the radioisotope generator assembly 14 may include the auxiliary shield 16 and the radioisotope generator 18 disposed in the receptacle 24 below the cover 22 of the auxiliary shield 16. The radioisotope generator assembly 14 also may include the eluant supply container 20 coupled to one or more hollow

input needles 26 of the radioisotope generator 18. For example, the one or more hollow input needles 26 may pierce a flexible insert 28, such as a rubber material, disposed within a head 30 of the eluant supply container 20. In this manner, the one or more hollow input needles 26 fluidly couple the eluant supply container 20 with an internal radioisotope element, such as molybdenum-99, disposed inside the radioisotope generator 18. The eluant supply container 20 may be disposed entirely or at least substantially inside the auxiliary shield 16 in the receptacle 24 below the cover 22, as illustrated in FIG. 3. Alternatively, the eluant supply container 20 may be disposed at least partially or entirely outside the auxiliary shield 16 in other embodiments of the radioisotope elution system 10. As discussed in further detail below, the eluant supply container 20 may hold a variety of eluants, such as a saline solution, suitable for eluting a radioisotope (e.g., technetium-99m) from the radioisotope generator 18 into the eluate extraction mechanism 12.

[0034] As illustrated in FIG. 3, the eluate extraction mechanism 12 may have a shielded eluate assembly 34 disposed removably inside a radiation shielded housing 36 on top of the cover 22. The illustrated radiation shielded housing 36 may have a variety of shapes and configurations. For example, the radiation shielded housing 36 may have a generally L-shaped or angled structure having a top or elongated housing portion 38 and a bottom housing portion 40.

[0035] The radiation shielded housing 36 also may have a cover alignment member 42 disposed about an opening 44 in a base 46. In certain embodiments, the cover alignment member 42 may improve the alignment of the eluate extraction mechanism 12 with a passage 48 through the cover 22 of the auxiliary shield 16. For example, the base 46 may have a generally flat bottom surface 50, and the cover alignment member 42 may protrude outwardly from the flat surface 50. In view of this protruding characteristic, the cover alignment member 42 may fit or extend at least partially inside or through the passage 48 when the eluate extract mechanism 12 is mounted on the cover 22. In this manner, the cover alignment member 42 may increase the likelihood of proper alignment with the radioisotope generator 18 disposed inside the auxiliary shield 16. For example, the cover alignment member 42 may improve alignment between conduits, hollow needles, and various connections between the eluate extraction mechanism 12 and the radioisotope generator 18.

[0036] Regarding the various fluid connections, the eluate extraction mechanism 12 of FIG. 3, for example, may include an eluate conduit 52 that may pass through the radiation shielded housing 36 and the passage 48 in the cover 22. At one end, the eluate conduit 52 may be coupled with a hollow output needle 54 on the radioisotope generator 18. At an opposite end from the hollow output needle 54, the eluate conduit 52 may be coupled to a plunger 56 movably coupled to the eluate extraction mechanism 12 along a path of travel, e.g., a linear path of vertical motion. For example, the plunger 56 may be moveably disposed in a guide structure or passage 58 within the top or elongated housing portion 38 of the eluate extraction mechanism 12. The plunger 56 also may include a hollow injection needle 60 or

another suitable fluid connector. Thus, the plunger 56 and the hollow injection needle 60 may be jointly moved along a path of travel between a connected position and a disconnection position between the hollow injection needle 60 and an eluate container 74 as discussed in further detail below. The hollow injection needle 60, or other suitable fluid connector, may be removably coupled to the eluate conduit 52 via a releasable fastener 62. For example, the fastener 62 may include a luer connection, a compression fit mechanism, a threaded joint, snap-fit members, latches, or another release mechanism.

[0037] As discussed in detail below, the hollow injection needle 60 may be accessed, removed, serviced, or replaced independent and remote from the hollow output needle 54 on the radioisotope generator 18. Moreover, the coupling of the eluate conduit 52 and the hollow output needle 54 may be maintained during the life or use of a radioisotope generator 18, thereby reducing the likelihood of bending or damaging the hollow output needle 54. Instead, over the course of repeated use of the radioisotope elution system 10, the hollow injection needle 60 may be repeatedly connected and disconnected with the shielded eluate assembly 34. In view of the removability of the hollow injection needle 60, any bending or damage may be easily and cheaply serviced by replacing the needle 60 rather than the entire radioisotope generator 18. Moreover, the hollow injection needle 60 is disposed outside the auxiliary shield 16, such that servicing may be performed without removing the cover 22 and being exposed to radiation from the radioisotope generator 18.

[0038] As further illustrated in FIG. 3, the shielded eluate assembly 34 may be inserted and removed from a region 64 generally below the plunger 56 via a door opening 66 along a side of the top or elongated housing portion 38. The radiation shielded housing 36 also includes a selective access door 68 having a hinge 70 coupled to the elongated housing portion 38 adjacent the door opening 66. Accordingly, radiation shielded housing 36 including the door 68 may provide substantially continuous radioactive shielding about the shielded eluate assembly 34 outside of the auxiliary shield 16, while the door 68 and opening 66 may enable a user to view and selectively access the shielded eluate assembly 34 quickly and easily without opening the auxiliary shield 16. In addition, as discussed below, the shielded eluate assembly 34 may have a variety of features, such as a slot 93 and a door 94, to enable viewing of the extracted eluate. As illustrated in FIG. 3, the door 68 can open and close the door opening 66 for selective access, insertion, and removal of the shielded eluate assembly 34. In other embodiments, the door 68 may be coupled to the radiation shielded housing 36 via a sliding mechanism, a spring-loaded mechanism, a swinging mechanism, or another suitable opening and closing mechanism configured to enable selective access, viewing, insertion, and removal of the shielded eluate assembly 34.

[0039] The shielded eluate assembly 34 as illustrated in FIG. 3 may include an eluate container shield 72 disposed about an eluate container 74, such as an evacuated vial, bottle, or other container in a vacuum condition. The eluate container shield 72 may include a variety of radiation-shielding

materials, such as lead, tungsten, tungsten impregnated plastic and/or another suitable radiation shielding material. The eluate container 74 may include a variety of transparent or translucent materials, such as glass. The eluate container shield 72 may include a cap 76 coupled to a shielded cup structure 78, such that the eluate container 74 may be generally aligned with an opening 80 through the cap 76. The cap 76 may be coupled to the shielded cup structure 78 via threads, an interference fit, a snap-fit mechanism, or another suitable attachment mechanism. The eluate container 74 may be aligned with the opening 80 via a variety of alignment mechanisms, such as an alignment adapter or ring 82 disposed about the eluate container 74 inside the shielded cup structure 78. Alternatively, the opening 80 may have a protruding portion facing downwardly toward a head 84 of the eluate container 74, such that the head 84 may be aligned with the opening 80.

[0040] The eluate extraction mechanism 12 as illustrated in FIG. 3 may also include a variety of alignment mechanisms to improve alignment of the shielded eluate assembly 34 relative to the hollow injection needle 60 coupled to the plunger 56. For example, the eluate extraction mechanism 12 may include one or more alignment members or tabs 86 along the base 46 of the radiation shielded housing 84. The alignment members or tabs 86 may increase the likelihood that the shielded eluate assembly 34 fits snugly between the tab 86 and the door 68 when the door 68 is closed over the door opening 66. In addition to the snug fit, the alignment members or tabs 86 may position a center of the head 84 (and longitudinal axis) of the eluate container 74 with a longitudinal axis of the hollow injection needle 60 and the direction of motion of the plunger 56. In this manner, the hollow injection needle 60 may be connected and disconnected in a generally centered and straight direction into and out of the eluate container 74, thereby reducing the likelihood of bending or damaging the hollow injection needle 60. Again, a variety of fasteners, alignment mechanisms, containers, and configurations of the eluate extraction mechanism 12 may be employed to elute a radioisotope to the shielded eluate assembly 34 generally outside the confines of the radioisotope generator assembly 14.

[0041] FIG. 4 is a cross-sectional side view of and embodiment of the radioisotope elution system 10 as illustrated in FIG. 3, further illustrating the eluate extraction mechanism 12 disposed in a closed, fluidly coupled configuration with the radioisotope generator assembly 14. As illustrated by arrow 88, the door 68 has been rotated about the hinge 70 to close the door opening 66, such that the shielded eluate assembly 34 may be snugly fit between the alignment tab 86 and the door 68. In this manner, the alignment tab 86 and the door 68 can secure and align the opening 80 in the eluate container shield 72 in a generally centered position with the hollow injection needle 60 of the plunger 56. In addition, the head 84 of the eluate container 74 may be generally aligned or centered with the opening 80 and the hollow injection needle 60 via the alignment adapter or ring 82 disposed about the eluate container 74 inside the shielded cup structure 78. With the eluate container 74 generally aligned or centered with the hollow injection needle 60, the plunger 56 may be depressed downwardly as indicated by arrow 90 to

pierce the hollow injection needle 60 into the eluate container 74 through a flexible insert 92, such as a rubber material, in the head 84 of the eluate container 74.

[0042] In certain embodiments, the eluate container 74 may be in vacuum, such that the pressure differential between the eluant supply container 20 and the eluate container 74 facilitates circulation of the eluant 32 through the radioisotope generator 18 and out through the eluate conduit 52 into the eluate container 74. As the eluant 32, e.g., a saline solution, circulates through the radioisotope generator 18, the circulating eluant 32 generally washes out or elutes a radioisotope, e.g., Technetium-99m. For example, one embodiment of the radioisotope generator 18 includes a radiation shielded outer casing (e.g., lead shell) that encloses a radioactive parent, such as molybdenum-99, adsorbed to the surfaces of beads of alumina or a resin exchange column. Inside the radioisotope generator 18, the parent molybdenum-99 transforms, with a half-life of about 67 hours, into metastable technetium-99m. The daughter radioisotope, e.g., technetium-99m, is generally held less tightly than the parent radioisotope, e.g., molybdenum-99, within the radioisotope generator 18. Accordingly, the daughter radioisotope, e.g., technetium-99m, can be extracted or washed out with a suitable eluant, such as an oxidant-free physiologic saline solution. The eluate output from the radioisotope generator 18 into the eluate container 74 generally includes the eluant 32 and the washed out or eluted radioisotope from within the radioisotope generator 18. Upon receiving the desired amount of eluate within the eluate container 74, the plunger 56 may be withdrawn outwardly from the shielded eluate assembly 34, such that the circulation and output of eluate is terminated. As discussed in further detail below, the extracted daughter radioisotope can then, if desired, be combined with a tagging agent to facilitate diagnosis or treatment of a patient (e.g., in a nuclear medicine facility).

[0043] After or during the elution process, the door 68 may be rotated open to view the level or amount of eluate collected within the eluate container 74. For example, the eluate container shield 72 may include one or more viewing windows or openings to enable a user to view the quantity of eluate within the container 74. FIG. 5 is a rear perspective view of an embodiment of the radioisotope elution system 10 of FIG. 4, further illustrating the eluate extraction mechanism 12 with the plunger 56 depressed and the door 68 opened to enable viewing of the eluate through a viewing window or slot 93 in the shielded cup structure 78 of the shielded eluate assembly 34. The slot 93, if included, also may be removably covered by a door 94 disposed along the outer walls of the shielded cup structure 78. In certain embodiments, the door 94 may include a sliding door, a rotating door, a sleeve disposed about the shielded eluate assembly 34, or another suitable mechanism for opening and closing the viewing window or slot 93.

[0044] FIG. 6 is a cross-sectional side view of an embodiment of the elution system 10 of FIGS. 3 and 4, further illustrating the plunger 56 withdrawn in an upward direction as indicated by arrow 96, the door 68 opened in a counterclockwise direction as indicated by arrow 98, and the shielded eluate

assembly 34 withdrawn from the eluate extraction mechanism 12 in an outward direction as indicated by arrow 100. In certain embodiments, the shielded eluate assembly 34 may be a radiopharmaceutical dosing assembly, such that one or more doses of the radioisotope may be extracted directly into a syringe or other container for delivery to a hospital or other medical facility. In other words, the eluate extraction mechanism 12 may reduce the number of shielded containers involved in the radiopharmaceutical preparation process within a radiopharmacy. For example, the eluate extraction mechanism 12 may eliminate the use of a shielded eluate container configured to fit within the passage 48 in the cover 22 and/or with the top side of the radioisotope generator 18 inside the auxiliary shield 16. Thus, the eluate extraction mechanism 12 enables output of the eluate directly into the shielded eluate assembly 34, which may then be used to prepare one or more radiopharmaceutical doses without first transferring the eluate to another shielded container assembly.

[0045] FIG. 7 is an exploded cross-sectional side view of an embodiment of the radioisotope elution system 10 of FIG. 6, further illustrating the removability and replaceability of various components including the hollow injection needle 60 of the eluate extraction mechanism 12. In addition, FIG. 8 is an exploded cross-sectional side view of an embodiment of the eluate extraction mechanism 12, further illustrating the removability and replaceability of the hollow injection needle 60. As illustrated, if the hollow injection needle 60 becomes damaged, bent, clogged, or inoperable during an elution process, then the hollow injection needle 60 may be removed and replaced with another needle 60 to ensure proper circulation of fluids through the elution system 10 into the shielded eluate assembly 34. The eluate extraction mechanism 12 and the removable hollow injection needle 60 may increase the life and operational efficiency of the radioisotope generator assembly 14, for example, by substantially reducing the likelihood of an inoperable generator assembly 14 that may be caused by damage to the hollow output needle 54 coupled to the radioisotope generator 18, among other reasons.

[0046] In other words, after making the initial connection between the hollow output needle 54 of the radioisotope generator 18 and the eluate conduit 52 of the eluate extraction mechanism 12, the connections and disconnections with the eluate container 74 may be made with the plunger 56 and the hollow injection needle 60 rather than the hollow output needle 54. For example, each time an amount of eluate is desired from the radioisotope generator 18, the hollow injection needle 60 may be inserted into the eluate container 74 and then removed after the amount of eluate is collected in the container 74. However, the eluate conduit 52 may remain continuously coupled to the hollow output needle 54 of the radioisotope generator 18 during each elution process. Therefore, any likelihood of potential damage to the eluate output connectors (e.g., hollow needles) may be moved away from the radioisotope generator 18 to the eluate extraction mechanism 12. Any potential damage to hollow injection needle 60 can be easily and cheaply addressed by replacing the hollow injection needle 60, whereas the relatively lower potential for damage to the hollow output needle 54 may be addressed by replacing the entire radioisotope generator 18. For these reasons, the removability and replaceability of the hollow

injection needle 60 may reduce downtime, costs, and difficulty in repairing the system 10 in the event of damage to the eluate output connectors.

[0047] FIGS. 9-13 are various views of an embodiment of the plunger 56, further illustrating connection mechanisms for the eluate conduit 52 and the hollow injection needle 60. FIGS. 9 and 10 are top and bottom perspective views of the plunger 56 illustrating a removable fluid coupling 57 that may be removably coupled to a bottom side 59 of the plunger 56. As illustrated in FIGS. 9 and 10, the removable fluid coupling 57 may include an eluate conduit connector 61 extending laterally from the coupling 57, such that the eluate conduit 52 can fit securely and removably about the connector 61. The illustrated eluate conduit connector 61 also may include a variety of raised and lowered portions, such as a series of rings 63, to resist separation between the eluate conduit 52 (e.g., a flexible tube) and the connector 61. In the illustrated embodiment, the connector 61 is oriented at about 90 degrees relative to the hollow injection needle 60. However, the connector 61 may be oriented at a variety of angles in other embodiments of the plunger 56. The hollow injection needle 60 may be generally aligned with a centerline 65 of the plunger 56, such that the needle 60 can be inserted and removed in a straight direction relative to the centerline of the eluate container 74. In certain embodiments, the hollow injection needle 60 may be removably coupled to the removable fluid coupling 57. Alternatively, the hollow injection needle 60 may be an integral portion of the removable fluid coupling 57. In either embodiment, the hollow injection needle 60 may be quickly removed and inexpensively replaced if the needle 60 becomes damaged during use.

[0048] For example, turning to FIG. 11, the plunger 56 may include a slot 67 (e.g., a T-shaped slot) to receive a bossed portion or rail 69 (e.g., a T-shaped head) of the removable fluid coupling 57. As illustrated in FIG. 11, the slot 67 may include a narrow outer opening 71 leading into an enlarged inner channel 73. Similarly, the bossed portion 69 may include a narrow inner portion 75 leading to an enlarged outer portion 77. FIG. 12 is a side view of the removable fluid coupling 57, further illustrating the geometry of the portions 75 and 77. As indicated by arrow 79 in FIG. 11, the fluid coupling 57 may removably couple with the plunger 56 by laterally or horizontally moving the bossed portion or rail 69 into the slot 67. In this manner, the fluid coupling 57 may be vertically interlocked with the plunger 56. In addition, the top of the bossed portion or rail 69 may include a detent 81 to interlock removably with a protrusion 83 inside the slot 67, as illustrated in FIGS. 11 and 13. In certain embodiments, the detent 81 illustrated in FIG. 11 may be a concave recess, and the protrusion 83 illustrated in FIG. 13 may be a convex protrusion or ball-shaped portion. FIG. 13 is a bottom view of the plunger 56 illustrating an embodiment of the protrusion 83 positioned toward the interior or center of the plunger 56. At this interior position, the protrusion 83 may engage the detent 81 as the bossed portion or rail 69 of the removable fluid coupling 57 slides into the slot 67 of the plunger 56. In certain embodiments, the protrusion 83 and the detent 81 may snap-fit together, thereby removably securing the bossed portion or rail 69 in a lateral or horizontal direction relative to the slot 67. In this manner, a user may quickly

install, remove, and replace the removable fluid coupling 67 relative to the slot 67 and rail 69 via the vertical interlocking between the slot 67 and rail 69 and the horizontal interlocking between the detent 81 and protrusion 83. In other embodiments, the removable fluid coupling 67 may be coupled to the plunger 56 via threads, latches, pin and grooves, and so forth.

[0049] Referring again to FIG. 11, the plunger 56 may include one or more guiding rails 85, which may extend vertically lengthwise along the exterior of the plunger 56. These guiding rails 85 may have a generally rectangular geometry or another suitable geometry, which slides lengthwise along a mating portion of the guide structure or passage 58 within the radiation shielded housing 36. In this manner, the guiding rails 85 may ensure proper alignment of the hollow injection needle 60 relative to the eluate container 74 and, also, ensure proper positioning of the eluate conduit connector 61 relative to the eluate conduit 52. However, other embodiments of the plunger 56 may employ a variety of alternative alignment mechanisms.

[0050] FIGS. 14 and 15 are perspective views of an embodiment of the eluate extraction mechanism 12, further illustrating alignment features that may facilitate alignment with the radioisotope generator assembly 14. As illustrated, the radiation shielding housing 84 has a generally L-shaped or 90 degree elbow-shaped geometry. However, any other suitable shapes, structures, or geometries are within the scope of the disclosed system. Moreover, the cover alignment member 42 may have a variety of shapes and configurations to facilitate alignment of the eluate extraction mechanism 12 and the eluate conduit 52 with the radioisotope generator assembly 14. For example, the cover alignment member 42 may have an elongated portion 102, such as an alignment adapter, that may be configured to fit and align with the passage 48 in the cover 22 and a top portion of the radioisotope generator 18. The elongated portion 102 may be an integral part of the eluate extraction mechanism 12 or the elongated portion 102 may be a removable structure having a suitable fastener, such as threads, latches, or snap-fit members, among other fasteners. In addition, the conduit 52 may be at least partially rigid (or rigidly supported) to facilitate the connection and alignment with the hollow output needle 54 of the radioisotope generator 18. For example, the eluate conduit 52 may be supported along most of its length by the alignment portion 102, such that the eluate conduit 52 may be generally centered with the hollow output needle 54 of the radioisotope generator 18 during insertion and removal of the eluate extraction mechanism 12 relative to the cover 22. However, a variety of mounting mechanisms and alignment devices may be utilized with the eluate extraction mechanism 12.

[0051] FIG. 16 is a flowchart illustrating an exemplary nuclear medicine process utilizing the radioactive isotope produced by the elution system 10 illustrated with reference to FIGS. 1-15. As illustrated, the process 104 begins by providing a radioactive isotope for nuclear medicine at block 106. For example, block 106 may include eluting technetium-99m from the radioisotope generator 18 illustrated and described in detail above. At block 108, the process 104 proceeds by providing a

tagging agent (e.g., an epitope or other appropriate biological directing moiety) adapted to target the radioisotope for a specific portion, e.g., an organ, of a patient. At block 110, the process 104 then proceeds by combining the radioactive isotope with the tagging agent to provide a radiopharmaceutical for nuclear medicine. In certain embodiments, the radioactive isotope may have natural tendencies to concentrate toward a particular organ or tissue and, thus, the radioactive isotope may be characterized as a radiopharmaceutical without adding any supplemental tagging agent. At block 112, the process 104 then may proceed by extracting one or more doses of the radiopharmaceutical into a syringe or another container, such as a container suitable for administering the radiopharmaceutical to a patient in a nuclear medicine facility or hospital. At block 114, the process 104 proceeds by injecting or generally administering a dose of the radiopharmaceutical into a patient. After a pre-selected time, the process 104 proceeds by detecting/imaging the radiopharmaceutical tagged to the patient's organ or tissue (block 116). For example, block 116 may include using a gamma camera or other radiographic imaging device to detect the radiopharmaceutical disposed on or in or bound to tissue of a brain, a heart, a liver, a tumor, a cancerous tissue, or various other organs or diseased tissue.

[0052] FIG. 17 is a block diagram of an exemplary system 118 for providing a syringe having a radiopharmaceutical disposed therein for use in a nuclear medicine application. As illustrated, the system 118 includes the radioisotope elution system 10 previously described with regard to FIGS. 1-15. The system 118 also includes a radiopharmaceutical production system 120, which functions to combine a radioisotope 122 (e.g., technetium-99m solution acquired through use of the radioisotope elution system 10) with a tagging agent 124. In some embodiment, this radiopharmaceutical production system 120 may refer to or include what are known in the art as "kits" (e.g., Technescan® kit for preparation of a diagnostic radiopharmaceutical). Again, the tagging agent may include a variety of substances that are attracted to or targeted for a particular portion (e.g., organ, tissue, tumor, cancer, etc.) of the patient. As a result, the radiopharmaceutical production system 120 produces or may be utilized to produce a radiopharmaceutical including the radioisotope 122 and the tagging agent 124, as indicated by block 126. The illustrated system 118 may also include a radiopharmaceutical dispensing system 128, which facilitates extraction of the radiopharmaceutical into a vial or syringe 130. In certain embodiments, the various components and functions of the system 118 are disposed within a radiopharmacy, which prepares the syringe 130 of the radiopharmaceutical for use in a nuclear medicine application. For example, the syringe 130 may be prepared and delivered to a medical facility for use in diagnosis or treatment of a patient.

[0053] FIG. 18 is a block diagram of an exemplary nuclear medicine imaging system 132 utilizing the syringe 130 of radiopharmaceutical provided using the system 118 of FIG. 12. As illustrated, the nuclear medicine imaging system 132 includes a radiation detector 134 having a scintillator 136 and a photo detector 138. In response to radiation 140 emitted from a tagged organ within a patient 142, the scintillator 136 emits light that is sensed and converted to electronic signals by the photo detector 138.

Although not illustrated, the imaging system 132 also can include a collimator to collimate the radiation 140 directed toward the radiation detector 134. The illustrated imaging system 132 also includes detector acquisition circuitry 144 and image processing circuitry 146. The detector acquisition circuitry 144 generally controls the acquisition of electronic signals from the radiation detector 134. The image processing circuitry 146 may be employed to process the electronic signals, execute examination protocols, and so forth. The illustrated imaging system 132 also includes a user interface 148 to facilitate user interaction with the image processing circuitry 146 and other components of the imaging system 132. As a result, the imaging system 132 produces an image 150 of the tagged organ within the patient 142. Again, the foregoing procedures and resulting image 150 directly benefit from the radiopharmaceutical produced by the elution system 10 as illustrated and described with reference to FIGS. 1-15.

[0054] When introducing elements of the present invention or various embodiments thereof, the articles “a”, “an”, “the”, and “said” are intended to mean that there are one or more of the elements. The terms “comprising”, “including”, and “having” are intended to be inclusive and mean that there may be additional elements other than the listed elements. Moreover, the use of “top”, “bottom”, “above”, “below” and variations of these terms is made for convenience, but does not require any particular orientation of the components.

[0055] While the invention may be susceptible to various modifications and alternative forms, specific embodiments have been shown by way of example in the figures and have been described in detail herein. However, it should be understood that the invention is not intended to be limited to the particular forms disclosed. Rather, the invention is to cover all modifications, equivalents, and alternatives falling within the spirit and scope of the invention as defined by the following appended claims.

CLAIMS:

1. A radiopharmaceutical system, comprising:
a radioisotope generator assembly, comprising:
a radiation shield having a receptacle and a cover disposed over the receptacle; and
a radioisotope generator disposed in the receptacle below the cover; and
an eluate extraction mechanism, comprising:
an eluate conduit fluidly coupled to a hollow output needle of the radioisotope generator;
a radiation shielded housing disposed outside the radiation shield; and
a hollow needle fluidly coupled to the eluate conduit opposite the radioisotope generator wherein the hollow needle is disposed inside the radiation shielded housing.
2. The radiopharmaceutical system of claim 1, wherein the eluate conduit is disposed at least mostly within the radiation shield and the radiation shielded housing.
3. The radiopharmaceutical system of claim 1, wherein the hollow needle is mounted along a path of movement within the radiation shielded housing.
4. The radiopharmaceutical system of claim 1, further comprising an eluate container, wherein the eluate container is disposed removably inside the radiation shielded housing adjacent a door.
5. The radiopharmaceutical system of claim 4, wherein the radiation shielded housing comprises an alignment member disposed adjacent the eluate container opposite the door.
6. The radiopharmaceutical system of claim 1, further comprising an eluate container, wherein the eluate container is disposed inside an eluate container shield comprising a radiation shielding material, wherein the eluate container shield comprises an eluate container viewing window.
7. The radiopharmaceutical system of claim 1, further comprising an eluate container, wherein the eluate container is disposed inside an eluate container shield comprising a radiation shielding material, wherein an alignment adapter is disposed between the eluate container and the eluate container shield.
8. The radiopharmaceutical system of claim 1, wherein the radiation shielded housing is mounted on top of the cover.

9. The radiopharmaceutical system of claim 8, wherein the radiation shielded housing comprises an alignment portion disposed at least partially into a passage in the cover.

10. The radiopharmaceutical system of claim 9, wherein the eluate conduit extends through the alignment portion and the passage.

11. The radiopharmaceutical system of claim 1, wherein the hollow needle is coupled to a plunger via a releasable fastener.

12. The radiopharmaceutical system of claim 11, wherein the releasable fastener comprises a luer connector.

13. The radiopharmaceutical system of claim 1, comprising an eluant supply container fluidly coupled to the radioisotope generator.

14. The radiopharmaceutical system of claim 13, wherein the eluant supply container is disposed inside the radiation shield.

15. An eluate extraction mechanism, comprising:
a radiation shielded housing;
an eluate conduit having a radioisotope generator end disposed outside the radiation shielded housing and an opposite end disposed inside the radiation shielded housing;
a hollow injection needle fluidly coupled to the opposite end of the eluate conduit; and
a plunger coupled to the radiation shielded housing movably through a guide structure, wherein the plunger is coupled to the hollow injection needle inside the radiation shielded housing.

16. The eluate extraction mechanism of claim 15, wherein the hollow injection needle comprises a release mechanism.

17. The eluate extraction mechanism of claim 15, wherein the plunger has a path of travel including a connected position and a disconnected position between the hollow injection needle and an eluate container disposed inside the radiation shielded housing.

18. The eluate extraction mechanism of claim 17, wherein the eluate container is disposed removably inside the radiation shielded housing adjacent a door.

19. The eluate extraction mechanism of claim 17, wherein the eluate container is disposed inside an eluate container shield comprising a radiation shielding material, wherein the eluate container shield comprises a viewing window and the eluate container comprises a transparent or translucent material.

20. The eluate extraction mechanism of claim 15, wherein the eluate extraction mechanism comprises a generator alignment portion protruding from a base of the radiation shielded housing.

21. An eluate extraction mechanism, comprising:
a radiation shielded housing comprising a door;
a shielded eluate collection assembly disposed removably inside the radiation shielded housing adjacent the door;
an eluate conduit having a radioisotope generator end disposed outside the radiation shielded housing and an opposite end disposed inside the radiation shielded housing; and
a hollow needle fluidly coupled to the opposite end of the eluate conduit, wherein the hollow needle includes a connected position and a disconnected position relative to the shielded eluate collection assembly.

22. The eluate extraction mechanism of claim 21, comprising an actuator disposed through the radiation shielded housing and coupled to the hollow needle.

23. The eluate extraction mechanism of claim 21, wherein the shielded eluate collection assembly comprises an eluate container disposed inside an eluate container shield comprising a radiation shielding material, wherein the eluate container shield comprises a viewing window and the eluate container comprises a transparent or translucent material.

24. The eluate extraction mechanism of claim 21, wherein the eluate extraction mechanism comprises a generator alignment portion protruding from a base of the radiation shielded housing.

25. A method of using a radiopharmaceutical system, the method comprising:
supplying an eluant into a radioisotope generator;
eluting a radioisotope in the radioisotope generator;
receiving an eluate at an output of the radioisotope generator; and
flowing the eluate from the output along an eluate conduit to a hollow needle that is removably inserted into an eluate container via a plunger.

26. The method of claim 25, wherein flowing comprises transferring the eluate through a radiation shield disposed about the radioisotope generator and directly into a radiation shielded housing disposed outside the radiation shield, wherein the radiation shielded housing is disposed about the eluate container, the hollow needle, and at least a portion of the plunger.

27. The method of claim 25, comprising maintaining a continuous connection between the output and the eluate conduit during connections and disconnections between the hollow needle and the eluate container.

28. The method of claim 25, comprising enabling selective viewing of the eluate within the eluate container via a window.

29. The method of claim 25, comprising enabling selective access to the eluate container via a door.

30. The method of claim 25, comprising guiding the plunger along a path of movement between an engaged position and a disengaged position with the eluate container.

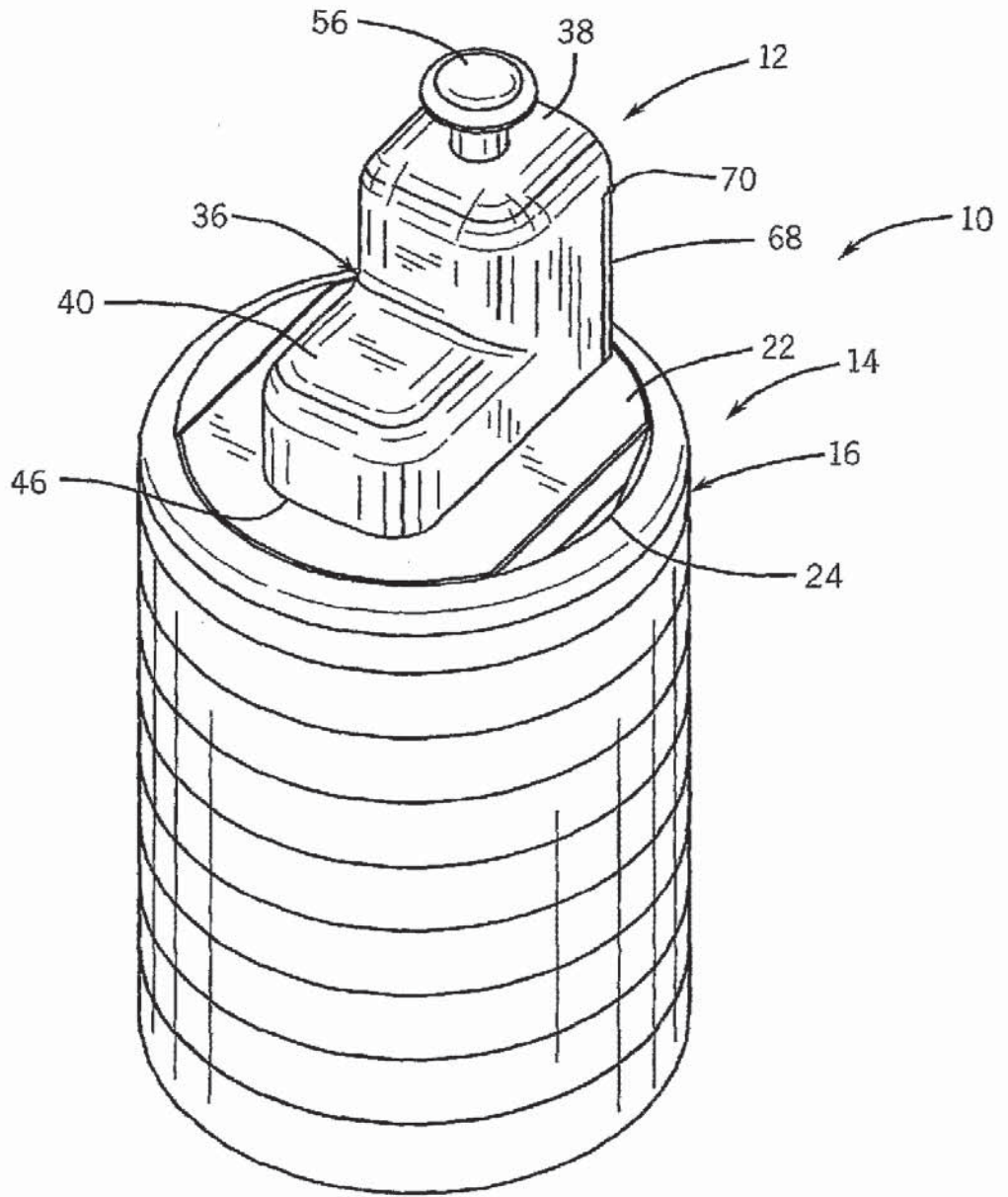

FIG. 1

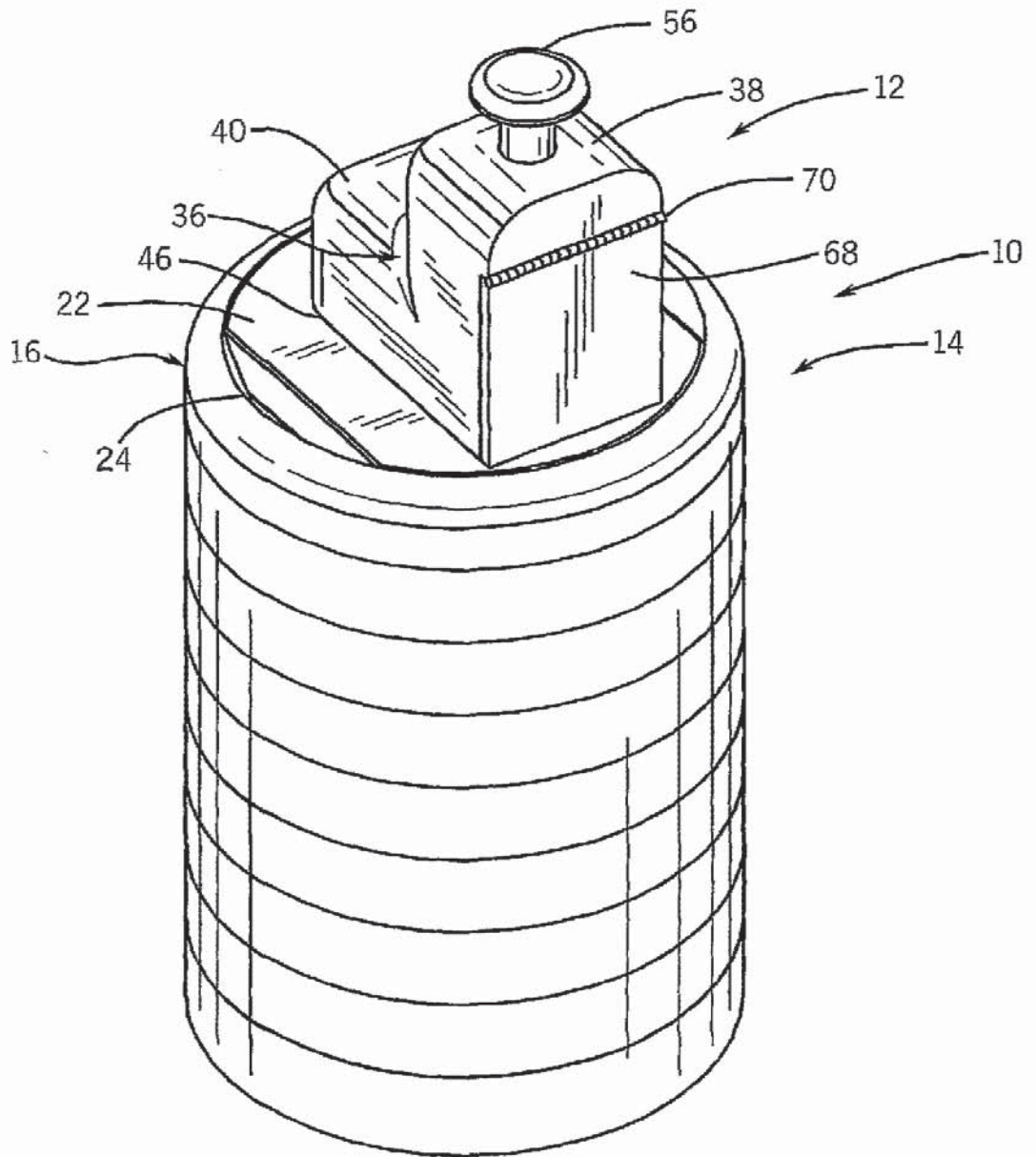

FIG. 2

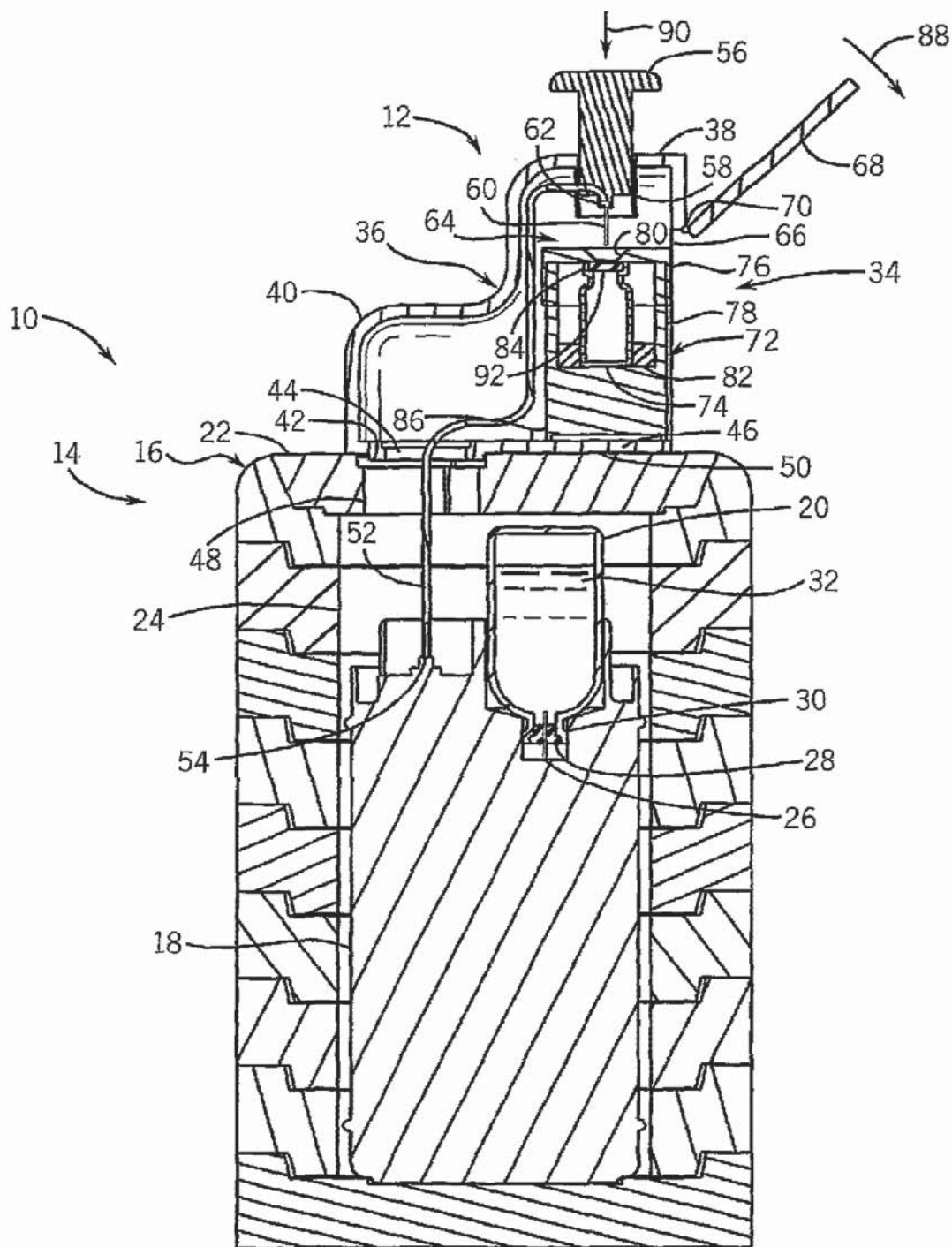

FIG. 3

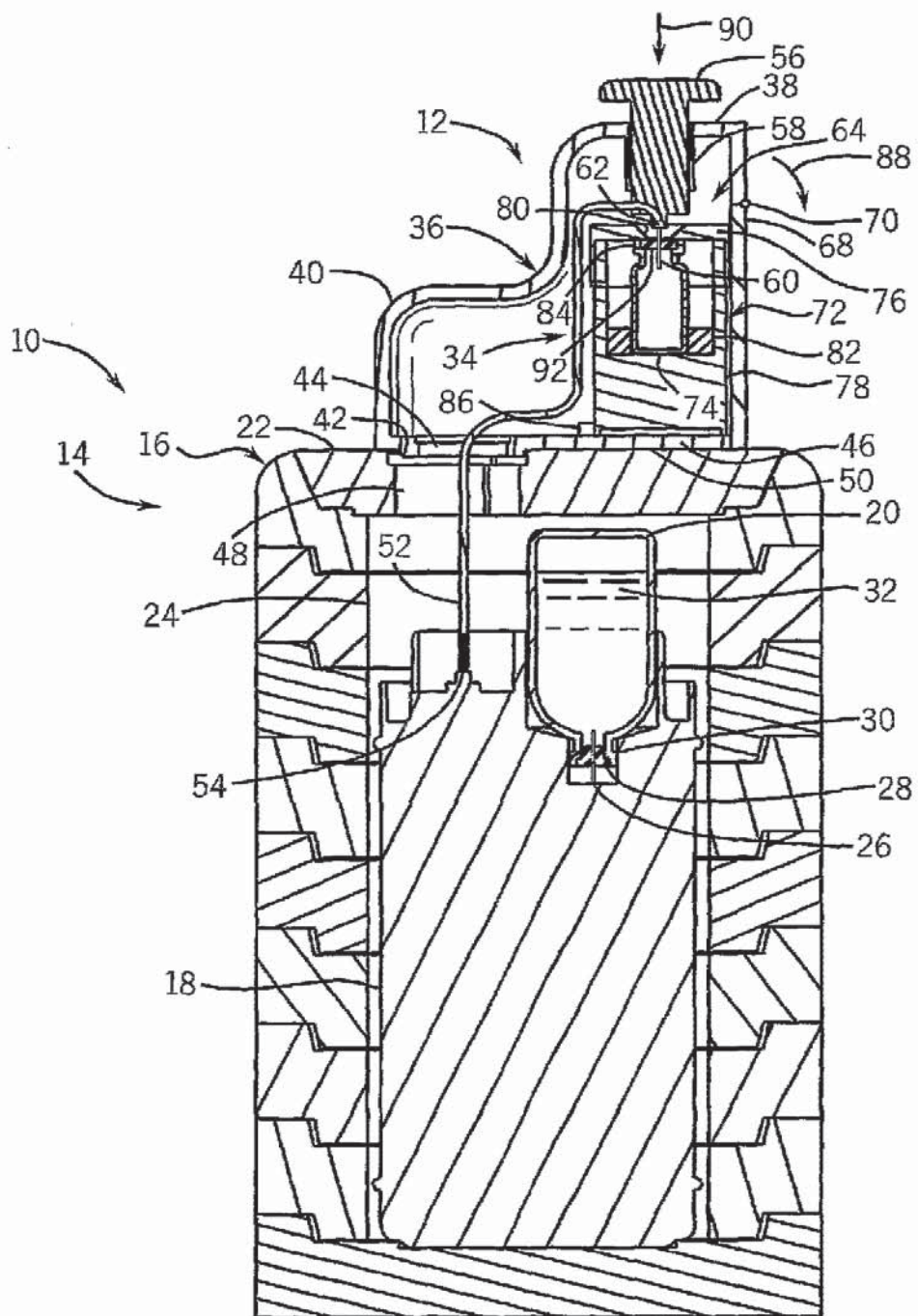

FIG. 4

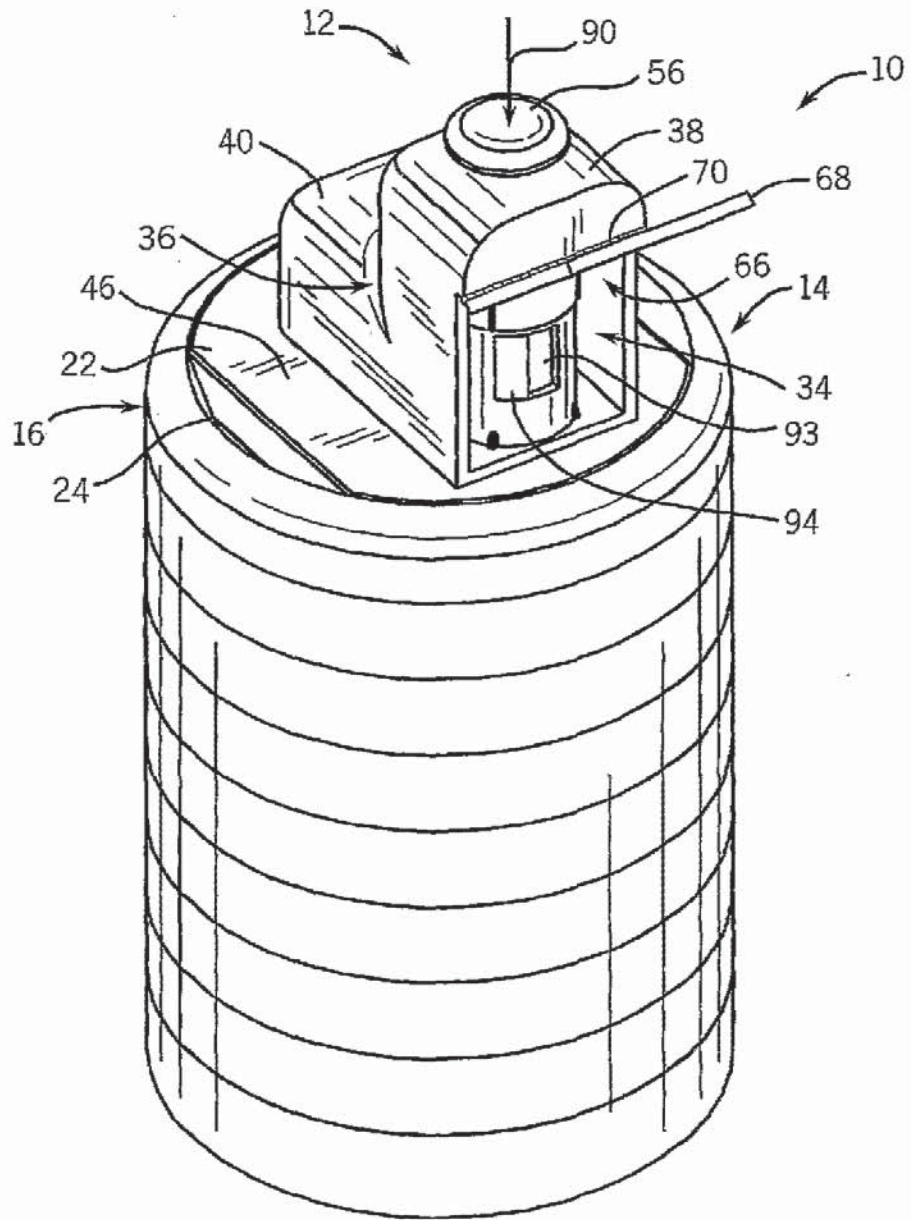

FIG. 5

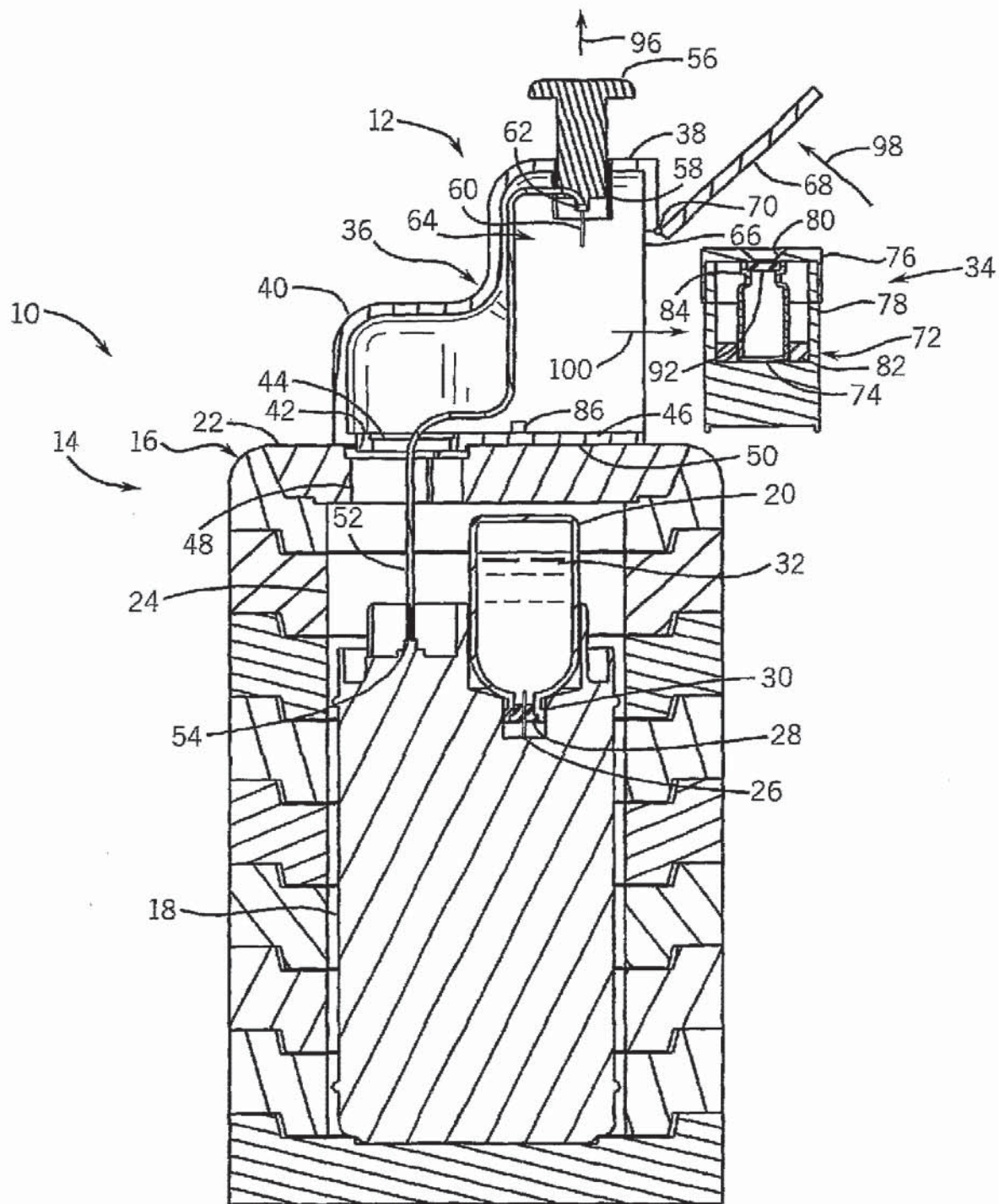
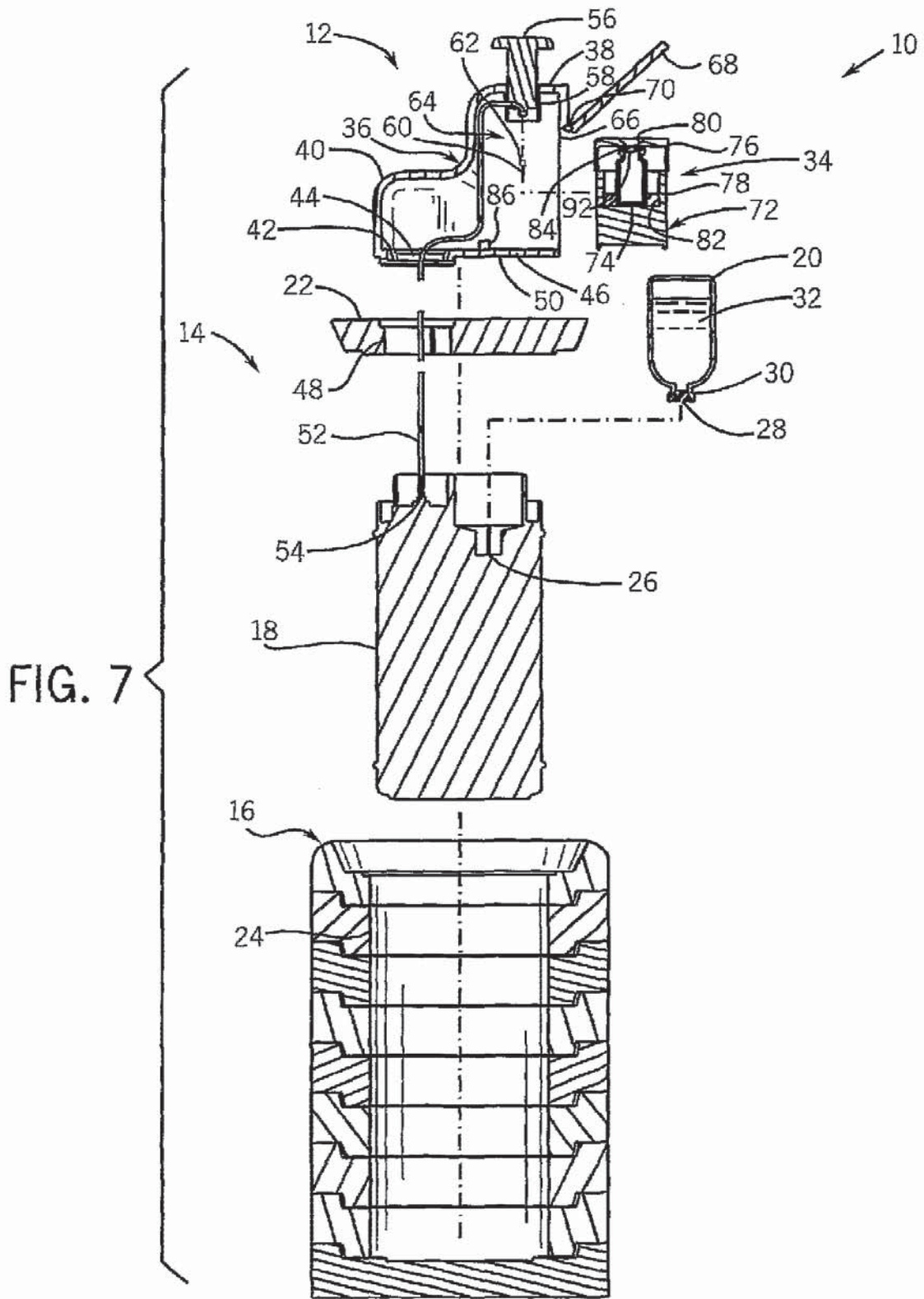

FIG. 6



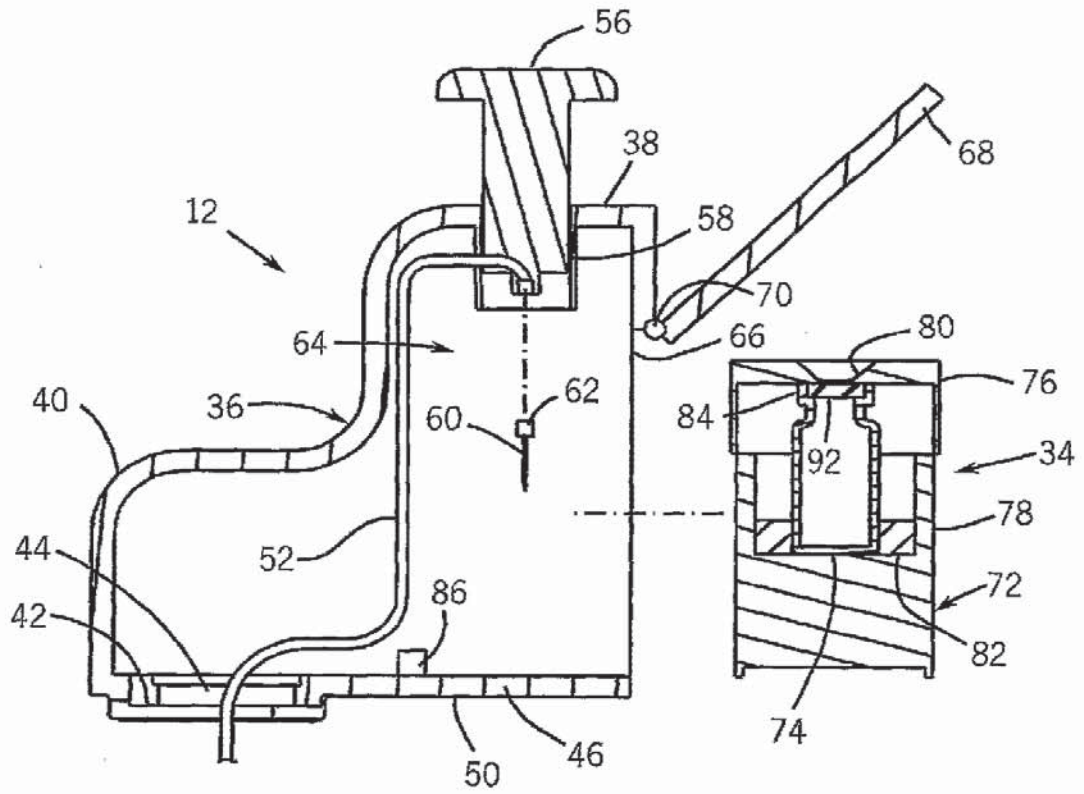

FIG. 8

FIG. 9

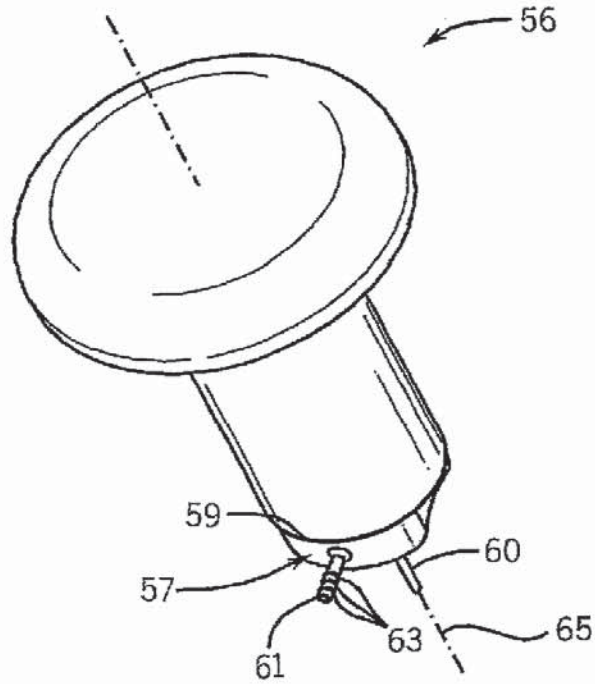
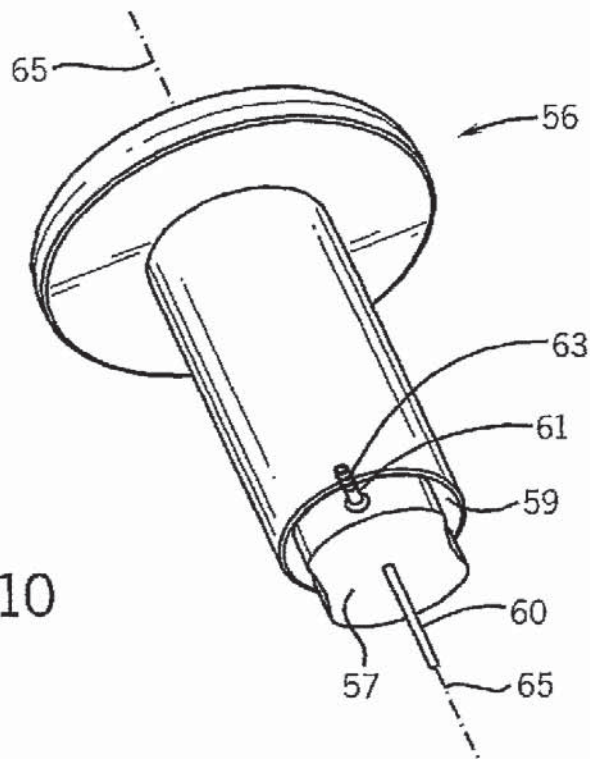

FIG. 10



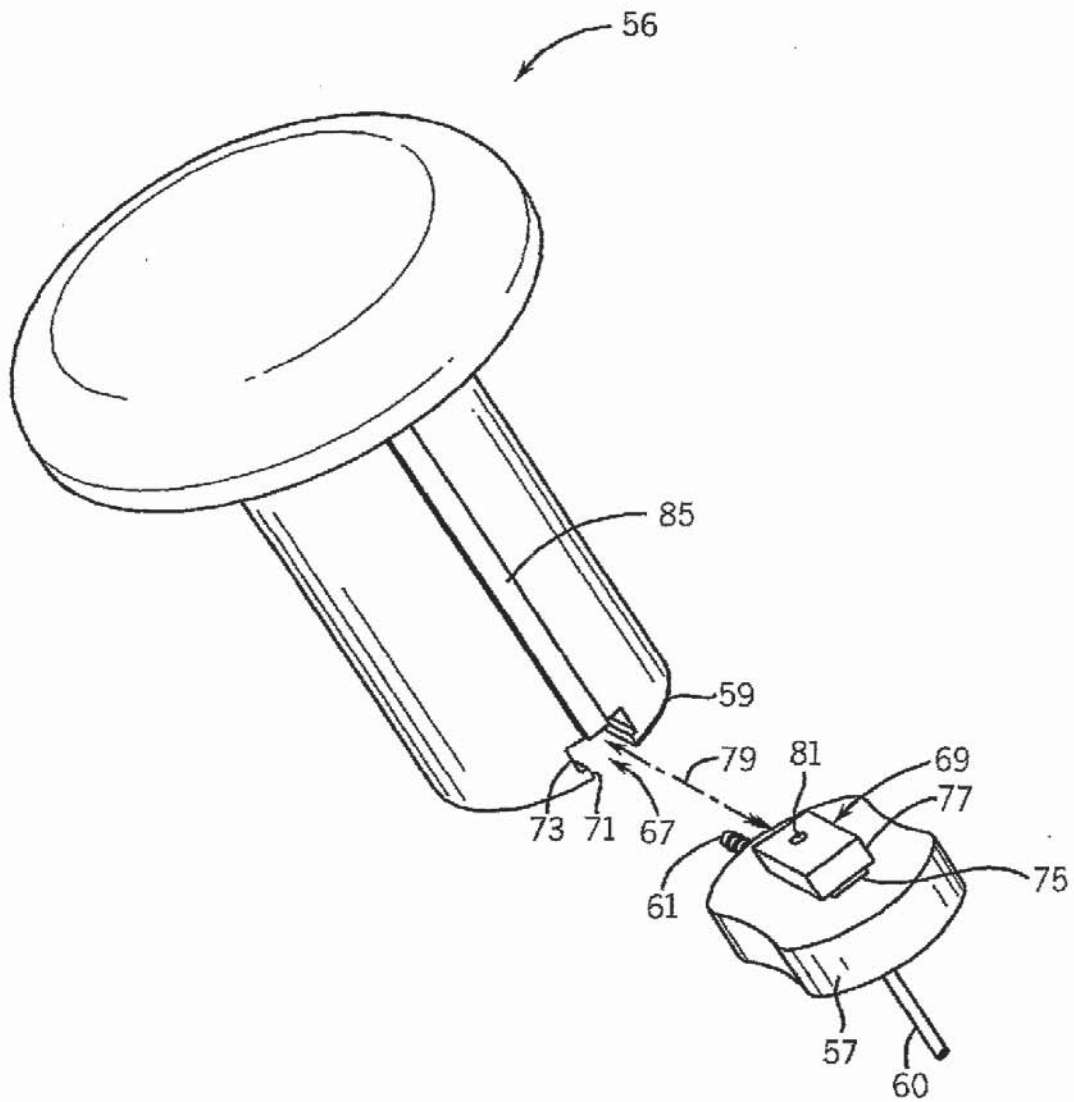

FIG. 11

FIG. 12

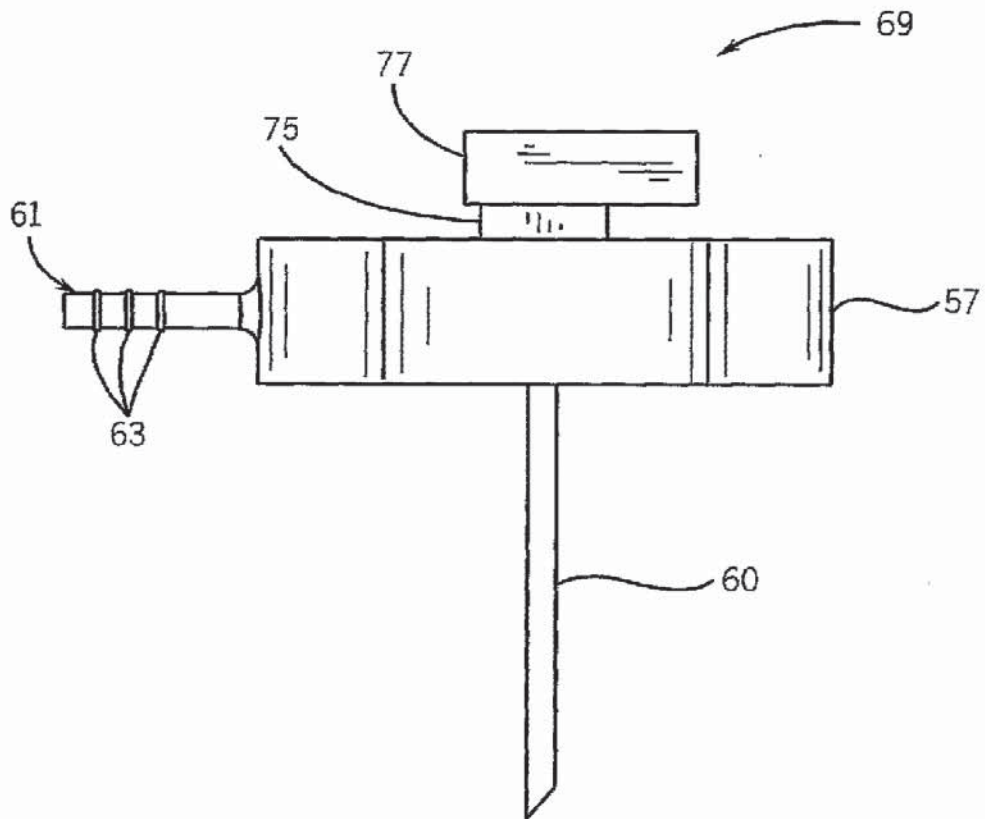

FIG. 13

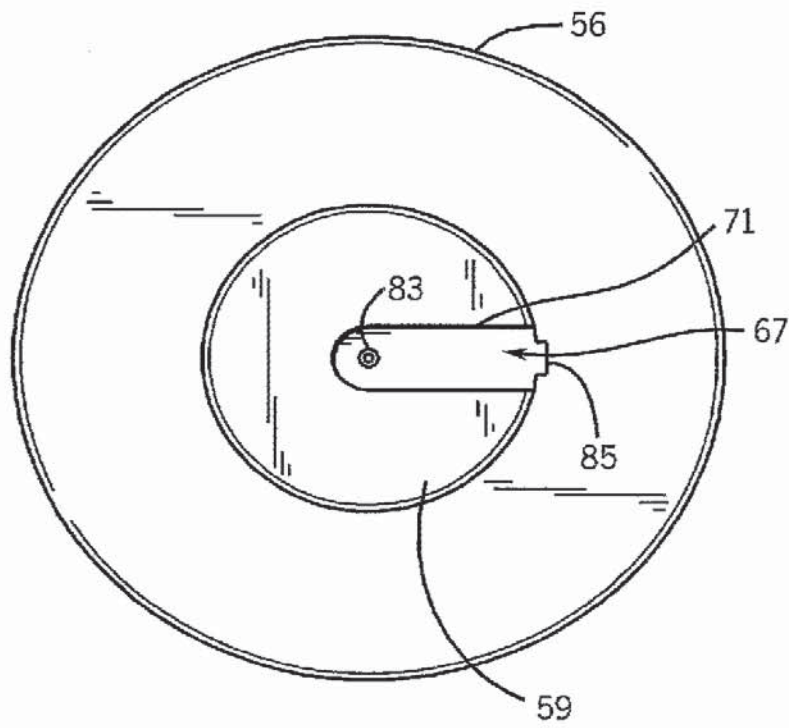

FIG. 14

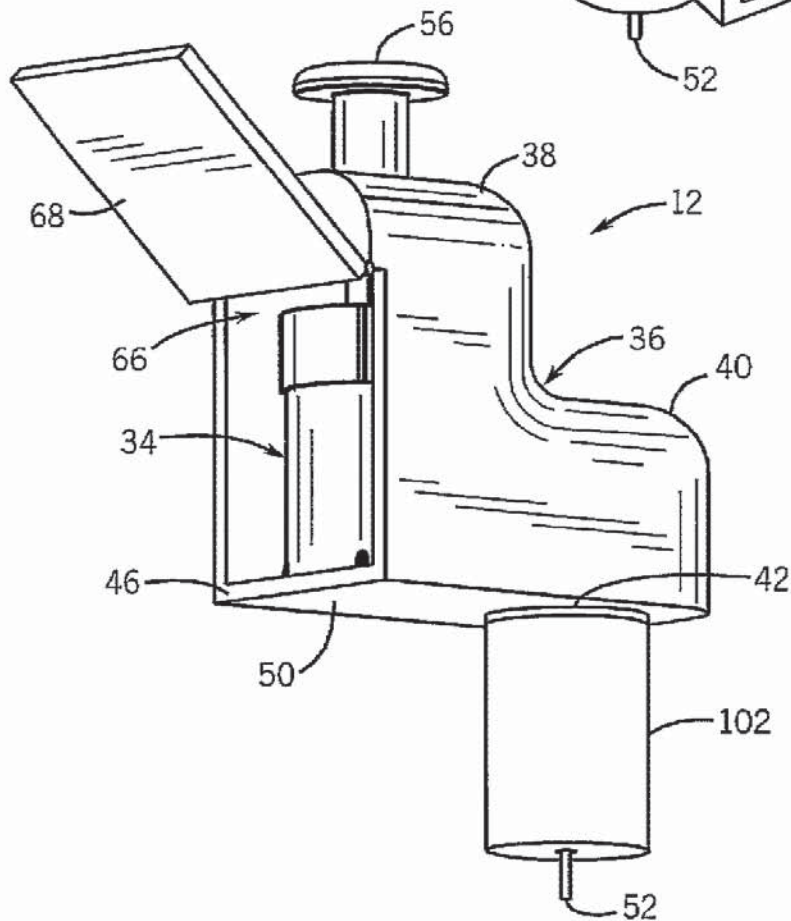
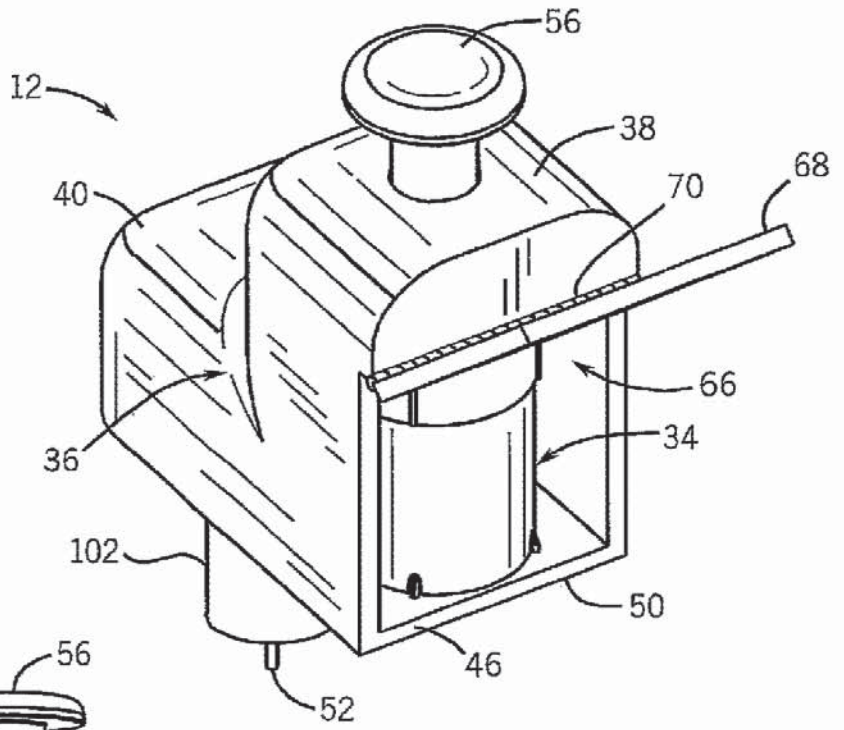

FIG. 15

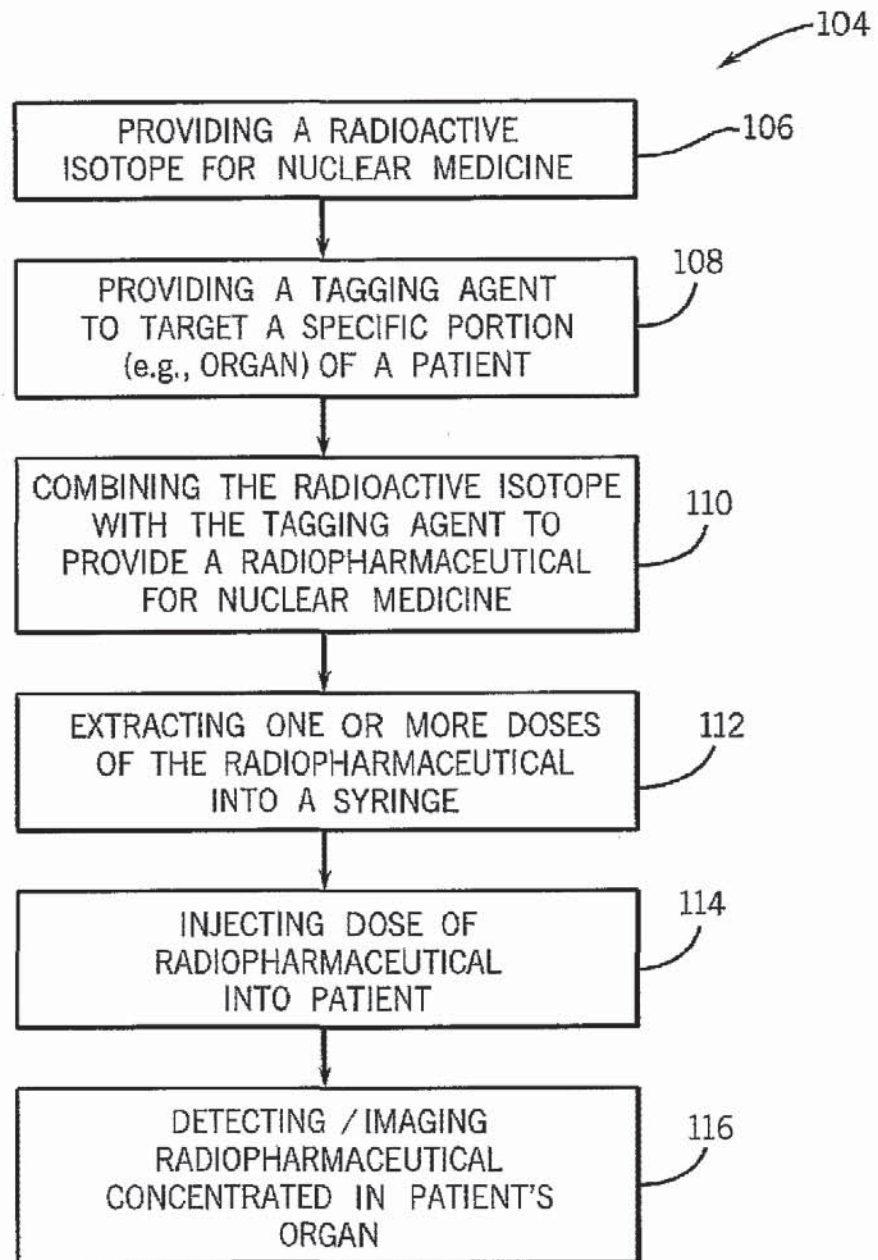

FIG. 16

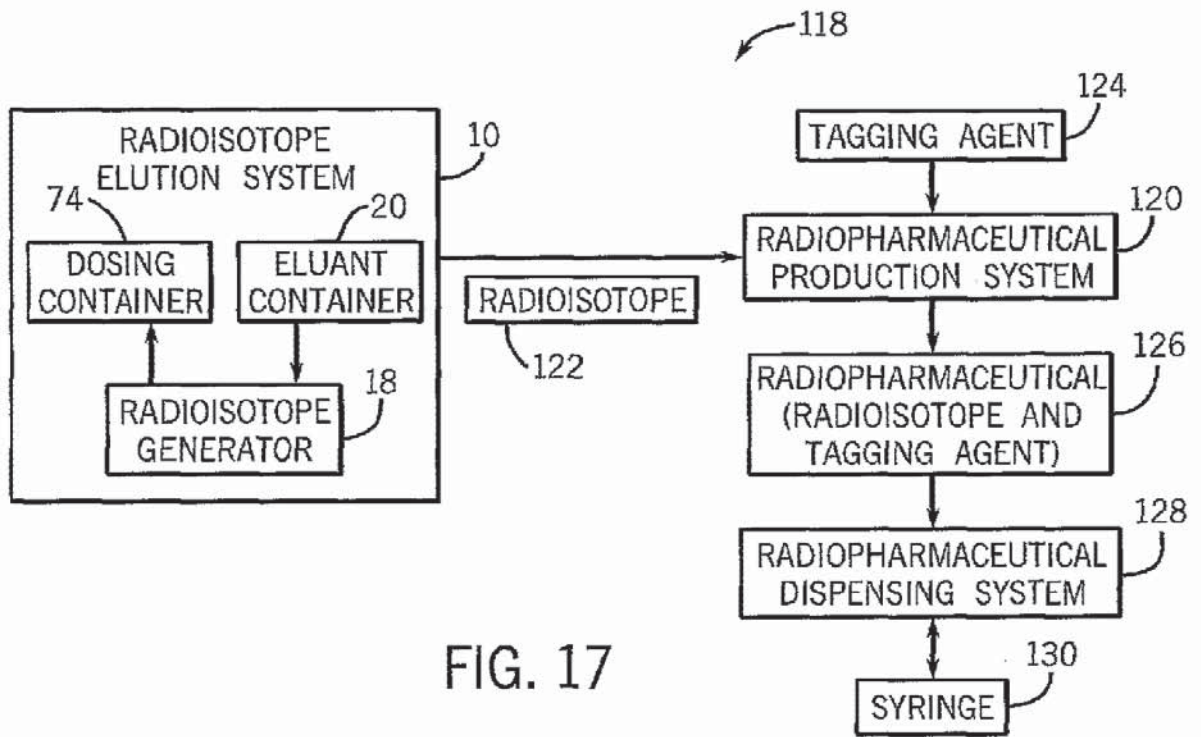

FIG. 17

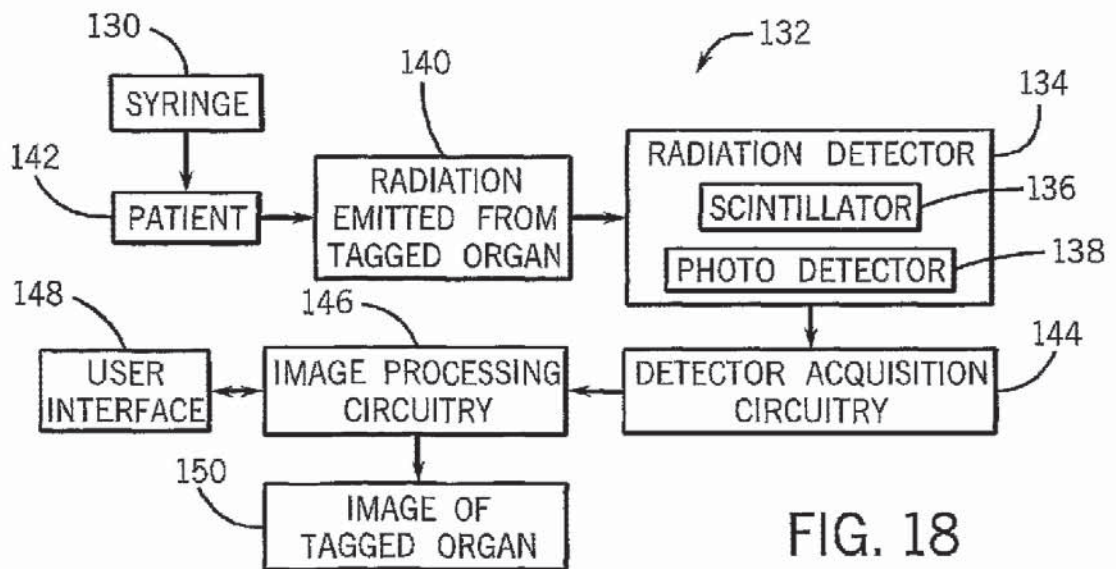

FIG. 18

Electronic Patent Application Fee Transmittal

Application Number:	12137356
Filing Date:	11-Jun-2008
Title of Invention:	SHIELDING ASSEMBLIES FOR INFUSION SYSTEMS
First Named Inventor/Applicant Name:	Charles Quirico
Filer:	Elisabeth Lacy Belden
Attorney Docket Number:	56782.1.5

Filed as Large Entity

Utility under 35 USC 111(a) Filing Fees

Description	Fee Code	Quantity	Amount	Sub-Total in USD(\$)
Basic Filing:				
Pages:				
Claims:				
Miscellaneous-Filing:				
Late filing fee for oath or declaration	1051	1	130	130

Petition:

Patent-Appeals-and-Interference:

Post-Allowance-and-Post-Issuance:

Extension-of-Time:

Description	Fee Code	Quantity	Amount	Sub-Total in USD(\$)
Extension - 2 months with \$0 paid	1252	1	490	490
Miscellaneous:				
Total in USD (\$)				620

Electronic Acknowledgement Receipt

EFS ID:	4172000
Application Number:	12137356
International Application Number:	
Confirmation Number:	7360
Title of Invention:	SHIELDING ASSEMBLIES FOR INFUSION SYSTEMS
First Named Inventor/Applicant Name:	Charles Quirico
Customer Number:	22859
Filer:	Elisabeth Lacy Belden
Filer Authorized By:	
Attorney Docket Number:	56782.1.5
Receipt Date:	24-OCT-2008
Filing Date:	11-JUN-2008
Time Stamp:	14:49:21
Application Type:	Utility under 35 USC 111(a)

Payment information:

Submitted with Payment	yes
Payment Type	Credit Card
Payment was successfully received in RAM	\$620
RAM confirmation Number	93
Deposit Account	
Authorized User	

File Listing:

Document Number	Document Description	File Name	File Size(Bytes)/ Message Digest	Multi Part /.zip	Pages (if appl.)
1669 or 1734					

1	Applicant Response to Pre-Exam Formalities Notice	56782_1_5_ResponseToMP.pdf	70176 a5d8d71bdb45f169a0287fc223b79ba84191b54b	no	1
Warnings:					
Information:					
2	Oath or Declaration filed	56782_1_5_Declaration_signed.pdf	1887042 5b96dc66972871e6a12a83202c7f44695222243f	no	28
Warnings:					
Information:					
3	Drawings-only black and white line drawings	56782_1_5_6_7_8_ReplacementDrawings.pdf	3359510 ae834f3ef728a795bd8e3c6fc52bbf8aba052235	no	23
Warnings:					
Information:					
4	Extension of Time	56782_1_5_Extension_2Mo.pdf	218319 796b1eacf6db303659014d9f940736fa92a4d0ce	no	2
Warnings:					
Information:					
5	Information Disclosure Statement (IDS) Filed (SB/08)	56782_1_5_IDS.pdf	849510 049e2a8f2d00125668e684025bc18077e5e4cce5	no	5
Warnings:					
Information:					
6	Foreign Reference	56782_1_EP0102121A1.pdf	513030 2ed3206792c3e4b85d5ea5ac7e216731e1a30015	no	19
Warnings:					
Information:					
7	Foreign Reference	56782_1_WO2007016170A1.pdf	632231 79a7df3d71191d8a1e9ae052dfa29d9ecd8e8c	no	30
Warnings:					
Information:					
8	Foreign Reference	56782_1_WO2007030249A2.pdf	730545 4b1bc48163a305542f3f34c114cd3a192aab0c8f	no	27
Warnings:					
Information:					
9	Foreign Reference	56782_1_WO2007149108A2.pdf	966637 9f863086ccd268122413dd0bc063a2050e8d1937	no	35
Warnings:					
Information:					

10	NPL Documents	56782_1_9300003_Rev11_User_Guide_highlited.pdf	1610985 73c8467a0013420f88c2810b68bce640a8e5e1d4	no	53
Warnings:					
Information:					
11	NPL Documents	56782_1_CardioGenInfusionSystemSalesPiece.pdf	4907055 7b8216505438b99f98271b5264c01aa175ae0c	no	2
Warnings:					
Information:					
12	NPL Documents	56782_1_IntegoArticle.pdf	114715 c00696d16ac6f03d84c29c8250c4614949ae295f	no	2
Warnings:					
Information:					
13	Fee Worksheet (PTO-06)	fee-info.pdf	32609 9a966539e9ef99804882e48f51e0c917612b561b	no	2
Warnings:					
Information:					
Total Files Size (in bytes):			15892364		

This Acknowledgement Receipt evidences receipt on the noted date by the USPTO of the indicated documents, characterized by the applicant, and including page counts, where applicable. It serves as evidence of receipt similar to a Post Card, as described in MPEP 503.

New Applications Under 35 U.S.C. 111

If a new application is being filed and the application includes the necessary components for a filing date (see 37 CFR 1.53(b)-(d) and MPEP 506), a Filing Receipt (37 CFR 1.54) will be issued in due course and the date shown on this Acknowledgement Receipt will establish the filing date of the application.

National Stage of an International Application under 35 U.S.C. 371

If a timely submission to enter the national stage of an international application is compliant with the conditions of 35 U.S.C. 371 and other applicable requirements a Form PCT/DO/EO/903 indicating acceptance of the application as a national stage submission under 35 U.S.C. 371 will be issued in addition to the Filing Receipt, in due course.

New International Application Filed with the USPTO as a Receiving Office

If a new international application is being filed and the international application includes the necessary components for an international filing date (see PCT Article 11 and MPEP 1810), a Notification of the International Application Number and of the International Filing Date (Form PCT/RO/105) will be issued in due course, subject to prescriptions concerning national security, and the date shown on this Acknowledgement Receipt will establish the international filing date of the application.

POWER OF ATTORNEY TO PROSECUTE APPLICATIONS BEFORE THE USPTO

I hereby revoke all previous powers of attorney given in the application identified in the attached statement under 37 CFR 3.73(b).

I hereby appoint:

Practitioners associated with the Customer Number: 22859

as attorney(s) or agent(s) to represent the undersigned before the United States Patent and Trademark Office (USPTO) in connection with any and all patent applications assigned only to the undersigned according to the USPTO assignment records or assignment documents attached to this form in accordance with 37 CFR 3.73(b).

The practitioners associated with customer number 022859 (Fredrikson & Byron, P.A.) are hereby granted authorization to sign the attached statement under 37 CFR §3.73(b) that evidences ownership by **Bracco Diagnostics, Inc.**

Please change the correspondence address for the application identified in the attached statement under 37 CFR 3.73(b) to:

The address associated with the Customer Number: 22859

OR

<input type="checkbox"/>	Firm or Individual Name			
Address				
City		State		Zip
Country				
Telephone		Email		

Assignee Name and Address:

Bracco Diagnostics, Inc.
107 College Road East
Princeton, NJ 08540

A copy of this form, together with a statement under 37 CFR 3.73(b) (Form PTO/SB/96 or equivalent) is required to be filed in each application in which this form is used. The statement under 37 CFR 3.73(b) may be completed by one of the practitioners appointed in this form if the appointed practitioner is authorized to act on behalf of the assignee, and must identify the application in which this Power of Attorney is to be filed.

SIGNATURE of Assignee of Record

The individual whose signature and title is supplied below is authorized to act on behalf of the assignee

Signature			
Name	Michael R. von Ohlen	Date	5/9/08
Title	Corporate Counsel	Telephone	609-814-2303

Under the Paperwork Reduction Act of 1995, no persons are required to respond to a collection of information unless it displays a valid OMB control number.

STATEMENT UNDER 37 CFR 3.73(b)

Applicant/Patent Owner: Charles R. Quirico et al.

Application No./Patent No.: 12/137,356 Filed/Issue Date: June 11, 2008

Entitled: SHIELDING ASSEMBLIES FOR INFUSION SYSTEMS

Bracco Diagnostics Inc., a Corporation
(Name of Assignee) (Type of Assignee, e.g., corporation, partnership, university, government agency, etc.)

states that it is:

- 1. the assignee of the entire right, title, and interest; or
- 2. an assignee of less than the entire right, title and interest
(The extent (by percentage) of its ownership interest is _____ %)

in the patent application/patent identified above by virtue of either:

A. An assignment from the inventor(s) of the patent application/patent identified above. The assignment was recorded in the United States Patent and Trademark Office at Reel 021699, Frame 0780, or for which a copy therefore is attached.

OR

B. A chain of title from the inventor(s), of the patent application/patent identified above, to the current assignee as follows:

1. From: _____ To: _____

The document was recorded in the United States Patent and Trademark Office at
Reel _____, Frame _____, or for which a copy thereof is attached.

2. From: _____ To: _____

The document was recorded in the United States Patent and Trademark Office at
Reel _____, Frame _____, or for which a copy thereof is attached.

3. From: _____ To: _____

The document was recorded in the United States Patent and Trademark Office at
Reel _____, Frame _____, or for which a copy thereof is attached.

Additional documents in the chain of title are listed on a supplemental sheet.

As required by 37 CFR 3.73(b)(1)(i), the documentary evidence of the chain of title from the original owner to the assignee was, or concurrently is being, submitted for recordation pursuant to 37 CFR 3.11.

[NOTE: A separate copy (i.e., a true copy of the original assignment document(s)) must be submitted to Assignment Division in accordance with 37 CFR Part 3, to record the assignment in the records of the USPTO. See MPEP 302.08]

The undersigned (whose title is supplied below) is authorized to act on behalf of the assignee.

/Elisabeth Lacy Belden/
Signature

October 24, 2008
Date

Elisabeth Lacy Belden
Printed or Typed Name

612-492-7000
Telephone Number

Patent Agent
Title

Privacy Act Statement

The **Privacy Act of 1974 (P.L. 93-579)** requires that you be given certain information in connection with your submission of the attached form related to a patent application or patent. Accordingly, pursuant to the requirements of the Act, please be advised that: (1) the general authority for the collection of this information is 35 U.S.C. 2(b)(2); (2) furnishing of the information solicited is voluntary; and (3) the principal purpose for which the information is used by the U.S. Patent and Trademark Office is to process and/or examine your submission related to a patent application or patent. If you do not furnish the requested information, the U.S. Patent and Trademark Office may not be able to process and/or examine your submission, which may result in termination of proceedings or abandonment of the application or expiration of the patent.

The information provided by you in this form will be subject to the following routine uses:

1. The information on this form will be treated confidentially to the extent allowed under the Freedom of Information Act (5 U.S.C. 552) and the Privacy Act (5 U.S.C. 552a). Records from this system of records may be disclosed to the Department of Justice to determine whether disclosure of these records is required by the Freedom of Information Act.
2. A record from this system of records may be disclosed, as a routine use, in the course of presenting evidence to a court, magistrate, or administrative tribunal, including disclosures to opposing counsel in the course of settlement negotiations.
3. A record in this system of records may be disclosed, as a routine use, to a Member of Congress submitting a request involving an individual, to whom the record pertains, when the individual has requested assistance from the Member with respect to the subject matter of the record.
4. A record in this system of records may be disclosed, as a routine use, to a contractor of the Agency having need for the information in order to perform a contract. Recipients of information shall be required to comply with the requirements of the Privacy Act of 1974, as amended, pursuant to 5 U.S.C. 552a(m).
5. A record related to an International Application filed under the Patent Cooperation Treaty in this system of records may be disclosed, as a routine use, to the International Bureau of the World Intellectual Property Organization, pursuant to the Patent Cooperation Treaty.
6. A record in this system of records may be disclosed, as a routine use, to another federal agency for purposes of National Security review (35 U.S.C. 181) and for review pursuant to the Atomic Energy Act (42 U.S.C. 218(c)).
7. A record from this system of records may be disclosed, as a routine use, to the Administrator, General Services, or his/her designee, during an inspection of records conducted by GSA as part of that agency's responsibility to recommend improvements in records management practices and programs, under authority of 44 U.S.C. 2904 and 2906. Such disclosure shall be made in accordance with the GSA regulations governing inspection of records for this purpose, and any other relevant (*i.e.*, GSA or Commerce) directive. Such disclosure shall not be used to make determinations about individuals.
8. A record from this system of records may be disclosed, as a routine use, to the public after either publication of the application pursuant to 35 U.S.C. 122(b) or issuance of a patent pursuant to 35 U.S.C. 151. Further, a record may be disclosed, subject to the limitations of 37 CFR 1.14, as a routine use, to the public if the record was filed in an application which became abandoned or in which the proceedings were terminated and which application is referenced by either a published application, an application open to public inspection or an issued patent.
9. A record from this system of records may be disclosed, as a routine use, to a Federal, State, or local law enforcement agency, if the USPTO becomes aware of a violation or potential violation of law or regulation.

Electronic Acknowledgement Receipt

EFS ID:	4173258
Application Number:	12137356
International Application Number:	
Confirmation Number:	7360
Title of Invention:	SHIELDING ASSEMBLIES FOR INFUSION SYSTEMS
First Named Inventor/Applicant Name:	Charles Quirico
Customer Number:	22859
Filer:	Elisabeth Lacy Belden
Filer Authorized By:	
Attorney Docket Number:	56782.1.5
Receipt Date:	24-OCT-2008
Filing Date:	11-JUN-2008
Time Stamp:	16:02:23
Application Type:	Utility under 35 USC 111(a)

Payment information:

Submitted with Payment	no
------------------------	----

File Listing:

Document Number	Document Description	File Name	File Size(Bytes)/ Message Digest	Multi Part /.zip	Pages (if appl.)
1	Power of Attorney	56782_PowerofAttorney.pdf	58043 <small>283a0d970401b4122cc59ee7ac526c528e684bf5</small>	no	1

Warnings:

Information:

2	Assignee showing of ownership per 37 CFR 3.73(b).	56782_1_5_Statement.pdf	178641 5947f3b1a496533962f5fb47623d891fe71120f7	no	2
---	---	-------------------------	--	----	---

Warnings:

Information:

Total Files Size (in bytes):	236684
-------------------------------------	--------

This Acknowledgement Receipt evidences receipt on the noted date by the USPTO of the indicated documents, characterized by the applicant, and including page counts, where applicable. It serves as evidence of receipt similar to a Post Card, as described in MPEP 503.

New Applications Under 35 U.S.C. 111

If a new application is being filed and the application includes the necessary components for a filing date (see 37 CFR 1.53(b)-(d) and MPEP 506), a Filing Receipt (37 CFR 1.54) will be issued in due course and the date shown on this Acknowledgement Receipt will establish the filing date of the application.

National Stage of an International Application under 35 U.S.C. 371

If a timely submission to enter the national stage of an international application is compliant with the conditions of 35 U.S.C. 371 and other applicable requirements a Form PCT/DO/EO/903 indicating acceptance of the application as a national stage submission under 35 U.S.C. 371 will be issued in addition to the Filing Receipt, in due course.

New International Application Filed with the USPTO as a Receiving Office

If a new international application is being filed and the international application includes the necessary components for an international filing date (see PCT Article 11 and MPEP 1810), a Notification of the International Application Number and of the International Filing Date (Form PCT/RO/105) will be issued in due course, subject to prescriptions concerning national security, and the date shown on this Acknowledgement Receipt will establish the international filing date of the application.



UNITED STATES PATENT AND TRADEMARK OFFICE

UNITED STATES DEPARTMENT OF COMMERCE
United States Patent and Trademark Office
Address: COMMISSIONER FOR PATENTS
P.O. Box 1450
Alexandria, Virginia 22313-1450
www.uspto.gov

Table with 7 columns: APPLICATION NUMBER, FILING or 371(c) DATE, GRP ART UNIT, FIL FEE REC'D, ATTY,DOCKET,NO, TOT CLAIMS, IND CLAIMS. Row 1: 12/137,356, 06/11/2008, 3763, 2300, 56782.1.5, 37, 5

CONFIRMATION NO. 7360

22859
INTELLECTUAL PROPERTY GROUP
FREDRIKSON & BYRON, P.A.
200 SOUTH SIXTH STREET
SUITE 4000
MINNEAPOLIS, MN 55402

FILING RECEIPT



Date Mailed: 07/01/2008

Receipt is acknowledged of this non-provisional patent application. The application will be taken up for examination in due course. Applicant will be notified as to the results of the examination. Any correspondence concerning the application must include the following identification information: the U.S. APPLICATION NUMBER, FILING DATE, NAME OF APPLICANT, and TITLE OF INVENTION. Fees transmitted by check or draft are subject to collection. Please verify the accuracy of the data presented on this receipt. If an error is noted on this Filing Receipt, please submit a written request for a Filing Receipt Correction. Please provide a copy of this Filing Receipt with the changes noted thereon. If you received a "Notice to File Missing Parts" for this application, please submit any corrections to this Filing Receipt with your reply to the Notice. When the USPTO processes the reply to the Notice, the USPTO will generate another Filing Receipt incorporating the requested corrections

Applicant(s)

- Charles Quirico, Residence Not Provided;
Ernest Balestracci, Residence Not Provided;
Dan D. Darst, Residence Not Provided;
Eric J. Krause, Residence Not Provided;
Vishal N. Lokhande, Residence Not Provided;
Jake Childs, Residence Not Provided;
Pete Madson, Residence Not Provided;
Dan Clements, Residence Not Provided;

Assignment For Published Patent Application

BRACCO DIAGNOSTICS, INC., Princeton, NJ

Power of Attorney: None

Domestic Priority data as claimed by applicant

Foreign Applications

Projected Publication Date: To Be Determined - pending completion of Missing Parts

Non-Publication Request: No

Early Publication Request: No

Title

SHIELDING ASSEMBLIES FOR INFUSION SYSTEMS

Preliminary Class

604

PROTECTING YOUR INVENTION OUTSIDE THE UNITED STATES

Since the rights granted by a U.S. patent extend only throughout the territory of the United States and have no effect in a foreign country, an inventor who wishes patent protection in another country must apply for a patent in a specific country or in regional patent offices. Applicants may wish to consider the filing of an international application under the Patent Cooperation Treaty (PCT). An international (PCT) application generally has the same effect as a regular national patent application in each PCT-member country. The PCT process **simplifies** the filing of patent applications on the same invention in member countries, but **does not result** in a grant of "an international patent" and does not eliminate the need of applicants to file additional documents and fees in countries where patent protection is desired.

Almost every country has its own patent law, and a person desiring a patent in a particular country must make an application for patent in that country in accordance with its particular laws. Since the laws of many countries differ in various respects from the patent law of the United States, applicants are advised to seek guidance from specific foreign countries to ensure that patent rights are not lost prematurely.

Applicants also are advised that in the case of inventions made in the United States, the Director of the USPTO must issue a license before applicants can apply for a patent in a foreign country. The filing of a U.S. patent application serves as a request for a foreign filing license. The application's filing receipt contains further information and guidance as to the status of applicant's license for foreign filing.

Applicants may wish to consult the USPTO booklet, "General Information Concerning Patents" (specifically, the section entitled "Treaties and Foreign Patents") for more information on timeframes and deadlines for filing foreign patent applications. The guide is available either by contacting the USPTO Contact Center at 800-786-9199, or it can be viewed on the USPTO website at <http://www.uspto.gov/web/offices/pac/doc/general/index.html>.

For information on preventing theft of your intellectual property (patents, trademarks and copyrights), you may wish to consult the U.S. Government website, <http://www.stopfakes.gov>. Part of a Department of Commerce initiative, this website includes self-help "toolkits" giving innovators guidance on how to protect intellectual property in specific countries such as China, Korea and Mexico. For questions regarding patent enforcement issues, applicants may call the U.S. Government hotline at 1-866-999-HALT (1-866-999-4158).

LICENSE FOR FOREIGN FILING UNDER

Title 35, United States Code, Section 184

Title 37, Code of Federal Regulations, 5.11 & 5.15

GRANTED

The applicant has been granted a license under 35 U.S.C. 184, if the phrase "IF REQUIRED, FOREIGN FILING LICENSE GRANTED" followed by a date appears on this form. Such licenses are issued in all applications where the conditions for issuance of a license have been met, regardless of whether or not a license may be required as

set forth in 37 CFR 5.15. The scope and limitations of this license are set forth in 37 CFR 5.15(a) unless an earlier license has been issued under 37 CFR 5.15(b). The license is subject to revocation upon written notification. The date indicated is the effective date of the license, unless an earlier license of similar scope has been granted under 37 CFR 5.13 or 5.14.

This license is to be retained by the licensee and may be used at any time on or after the effective date thereof unless it is revoked. This license is automatically transferred to any related applications(s) filed under 37 CFR 1.53(d). This license is not retroactive.

The grant of a license does not in any way lessen the responsibility of a licensee for the security of the subject matter as imposed by any Government contract or the provisions of existing laws relating to espionage and the national security or the export of technical data. Licensees should apprise themselves of current regulations especially with respect to certain countries, of other agencies, particularly the Office of Defense Trade Controls, Department of State (with respect to Arms, Munitions and Implements of War (22 CFR 121-128)); the Bureau of Industry and Security, Department of Commerce (15 CFR parts 730-774); the Office of Foreign Assets Control, Department of Treasury (31 CFR Parts 500+) and the Department of Energy.

NOT GRANTED

No license under 35 U.S.C. 184 has been granted at this time, if the phrase "IF REQUIRED, FOREIGN FILING LICENSE GRANTED" DOES NOT appear on this form. Applicant may still petition for a license under 37 CFR 5.12, if a license is desired before the expiration of 6 months from the filing date of the application. If 6 months has lapsed from the filing date of this application and the licensee has not received any indication of a secrecy order under 35 U.S.C. 181, the licensee may foreign file the application pursuant to 37 CFR 5.15(b).



UNITED STATES PATENT AND TRADEMARK OFFICE

UNITED STATES DEPARTMENT OF COMMERCE
United States Patent and Trademark Office
Address: COMMISSIONER FOR PATENTS
P.O. Box 1450
Alexandria, Virginia 22313-1450
www.uspto.gov

Table with 4 columns: APPLICATION NUMBER (12/137,356), FILING OR 371(C) DATE (06/11/2008), FIRST NAMED APPLICANT (Charles Quirico), ATTY. DOCKET NO./TITLE (56782.1.5)

CONFIRMATION NO. 7360

FORMALITIES LETTER



22859
INTELLECTUAL PROPERTY GROUP
FREDRIKSON & BYRON, P.A.
200 SOUTH SIXTH STREET
SUITE 4000
MINNEAPOLIS, MN 55402

Date Mailed: 07/01/2008

NOTICE TO FILE MISSING PARTS OF NONPROVISIONAL APPLICATION

FILED UNDER 37 CFR 1.53(b)

Filing Date Granted

Items Required To Avoid Abandonment:

An application number and filing date have been accorded to this application. The item(s) indicated below, however, are missing. Applicant is given TWO MONTHS from the date of this Notice within which to file all required items and pay any fees required below to avoid abandonment.

- The oath or declaration is missing. A properly signed oath or declaration in compliance with 37 CFR 1.63, identifying the application by the above Application Number and Filing Date, is required. Note: If a petition under 37 CFR 1.47 is being filed, an oath or declaration in compliance with 37 CFR 1.63 signed by all available joint inventors, or if no inventor is available by a party with sufficient proprietary interest, is required.

The application is informal since it does not comply with the regulations for the reason(s) indicated below.

The required item(s) identified below must be timely submitted to avoid abandonment:

- Replacement drawings in compliance with 37 CFR 1.84 and 37 CFR 1.121(d) are required. The drawings submitted are not acceptable because: Numbers, letters, and reference characters on the drawings must measure at least 0.32 cm (1/8 inch) in height. See Figure(s) 5A-7A,8A-10. The drawings submitted to the Office are not electronically reproducible because portions of figures 4-10 are missing and/or blurry.

Applicant is cautioned that correction of the above items may cause the specification and drawings page count to exceed 100 pages. If the specification and drawings exceed 100 pages, applicant will need to submit the required application size fee.

The applicant needs to satisfy supplemental fees problems indicated below.

The required item(s) identified below must be timely submitted to avoid abandonment:

- To avoid abandonment, a surcharge (for late submission of filing fee, search fee, examination fee or oath or declaration) as set forth in 37 CFR 1.16(f) of **\$130** for a non-small entity, must be submitted with the missing items identified in this notice.

SUMMARY OF FEES DUE:

Total additional fee(s) required for this application is **\$130** for a non-small entity

- **\$130** Surcharge.

Replies should be mailed to:

Mail Stop Missing Parts
Commissioner for Patents
P.O. Box 1450
Alexandria VA 22313-1450

Registered users of EFS-Web may alternatively submit their reply to this notice via EFS-Web.

<https://sportal.uspto.gov/authenticate/AuthenticateUserLocalEPF.html>

For more information about EFS-Web please call the USPTO Electronic Business Center at **1-866-217-9197** or visit our website at <http://www.uspto.gov/ebc>.

If you are not using EFS-Web to submit your reply, you must include a copy of this notice.

/megga/

Office of Data Management, Application Assistance Unit (571) 272-4000, or (571) 272-4200, or 1-888-786-0101

Under the Paperwork Reduction Act of 1995, no persons are required to respond to a collection of information unless it contains a valid OMB control number.

Application Data Sheet 37 CFR 1.76		Attorney Docket Number	56782.1.5
		Application Number	
Title of Invention	SHIELDING ASSEMBLIES FOR INFUSION SYSTEMS		
<p>The application data sheet is part of the provisional or nonprovisional application for which it is being submitted. The following form contains the bibliographic data arranged in a format specified by the United States Patent and Trademark Office as outlined in 37 CFR 1.76. This document may be completed electronically and submitted to the Office in electronic format using the Electronic Filing System (EFS) or the document may be printed and included in a paper filed application.</p>			

Secrecy Order 37 CFR 5.2

Portions or all of the application associated with this Application Data Sheet may fall under a Secrecy Order pursuant to 37 CFR 5.2 (Paper filers only. Applications that fall under Secrecy Order may not be filed electronically.)

Applicant Information:

Applicant 1					Remove
Applicant Authority <input checked="" type="radio"/> Inventor		<input type="radio"/> Legal Representative under 35 U.S.C. 117		<input type="radio"/> Party of Interest under 35 U.S.C. 118	
Prefix	Given Name	Middle Name	Family Name	Suffix	
	Charles		Quirico		
Residence Information (Select One) <input checked="" type="radio"/> US Residency <input type="radio"/> Non US Residency <input type="radio"/> Active US Military Service					
City		State/Province		Country of Residence i	
Citizenship under 37 CFR 1.41(b) i					
Mailing Address of Applicant:					
Address 1					
Address 2					
City		State/Province			
Postal Code		Countryⁱ			
Applicant 2					Remove
Applicant Authority <input checked="" type="radio"/> Inventor		<input type="radio"/> Legal Representative under 35 U.S.C. 117		<input type="radio"/> Party of Interest under 35 U.S.C. 118	
Prefix	Given Name	Middle Name	Family Name	Suffix	
	Ernest		Balestracci		
Residence Information (Select One) <input checked="" type="radio"/> US Residency <input type="radio"/> Non US Residency <input type="radio"/> Active US Military Service					
City		State/Province		Country of Residence i	
Citizenship under 37 CFR 1.41(b) i					
Mailing Address of Applicant:					
Address 1					
Address 2					
City		State/Province			
Postal Code		Countryⁱ			
Applicant 3					Remove
Applicant Authority <input checked="" type="radio"/> Inventor		<input type="radio"/> Legal Representative under 35 U.S.C. 117		<input type="radio"/> Party of Interest under 35 U.S.C. 118	
Prefix	Given Name	Middle Name	Family Name	Suffix	
	Dan	D.	Darst		
Residence Information (Select One) <input checked="" type="radio"/> US Residency <input type="radio"/> Non US Residency <input type="radio"/> Active US Military Service					
City		State/Province		Country of Residence i	

Under the Paperwork Reduction Act of 1995, no persons are required to respond to a collection of information unless it contains a valid OMB control number.

Application Data Sheet 37 CFR 1.76		Attorney Docket Number	56782.15
		Application Number	
Title of Invention	SHIELDING ASSEMBLIES FOR INFUSION SYSTEMS		

Citizenship under 37 CFR 1.41(b) i			
Mailing Address of Applicant:			
Address 1			
Address 2			
City		State/Province	
Postal Code		Country ⁱ	

Applicant 4			Remove
Applicant Authority <input checked="" type="radio"/> Inventor		<input type="radio"/> Legal Representative under 35 U.S.C. 117	<input type="radio"/> Party of Interest under 35 U.S.C. 118
Prefix	Given Name	Middle Name	Family Name
	Eric	J.	Krause
Residence Information (Select One) <input checked="" type="radio"/> US Residency <input type="radio"/> Non US Residency <input type="radio"/> Active US Military Service			
City		State/Province	Country of Residence ⁱ

Citizenship under 37 CFR 1.41(b) i			
Mailing Address of Applicant:			
Address 1			
Address 2			
City		State/Province	
Postal Code		Country ⁱ	

Applicant 5			Remove
Applicant Authority <input checked="" type="radio"/> Inventor		<input type="radio"/> Legal Representative under 35 U.S.C. 117	<input type="radio"/> Party of Interest under 35 U.S.C. 118
Prefix	Given Name	Middle Name	Family Name
	Vishal	N.	Lokhande
Residence Information (Select One) <input checked="" type="radio"/> US Residency <input type="radio"/> Non US Residency <input type="radio"/> Active US Military Service			
City		State/Province	Country of Residence ⁱ

Citizenship under 37 CFR 1.41(b) i			
Mailing Address of Applicant:			
Address 1			
Address 2			
City		State/Province	
Postal Code		Country ⁱ	

Applicant 6			Remove
Applicant Authority <input checked="" type="radio"/> Inventor		<input type="radio"/> Legal Representative under 35 U.S.C. 117	<input type="radio"/> Party of Interest under 35 U.S.C. 118
Prefix	Given Name	Middle Name	Family Name
	Jake		Childs
Residence Information (Select One) <input checked="" type="radio"/> US Residency <input type="radio"/> Non US Residency <input type="radio"/> Active US Military Service			
City		State/Province	Country of Residence ⁱ

Citizenship under 37 CFR 1.41(b) i			
---	--	--	--

Under the Paperwork Reduction Act of 1995, no persons are required to respond to a collection of information unless it contains a valid OMB control number.

Application Data Sheet 37 CFR 1.76		Attorney Docket Number	56782.1.5
		Application Number	
Title of Invention	SHIELDING ASSEMBLIES FOR INFUSION SYSTEMS		

Mailing Address of Applicant:				
Address 1				
Address 2				
City		State/Province		
Postal Code		Country ⁱ		
Applicant 7				<input type="button" value="Remove"/>
Applicant Authority <input checked="" type="radio"/> Inventor		<input type="radio"/> Legal Representative under 35 U.S.C. 117		<input type="radio"/> Party of Interest under 35 U.S.C. 118
Prefix	Given Name	Middle Name	Family Name	Suffix
	Pete		Madson	
Residence Information (Select One) <input checked="" type="radio"/> US Residency <input type="radio"/> Non US Residency <input type="radio"/> Active US Military Service				
City		State/Province	Country of Residence ⁱ	
Citizenship under 37 CFR 1.41(b) ⁱ				
Mailing Address of Applicant:				
Address 1				
Address 2				
City		State/Province		
Postal Code		Country ⁱ		
Applicant 8				<input type="button" value="Remove"/>
Applicant Authority <input checked="" type="radio"/> Inventor		<input type="radio"/> Legal Representative under 35 U.S.C. 117		<input type="radio"/> Party of Interest under 35 U.S.C. 118
Prefix	Given Name	Middle Name	Family Name	Suffix
	Dan		Clements	
Residence Information (Select One) <input checked="" type="radio"/> US Residency <input type="radio"/> Non US Residency <input type="radio"/> Active US Military Service				
City		State/Province	Country of Residence ⁱ	
Citizenship under 37 CFR 1.41(b) ⁱ				
Mailing Address of Applicant:				
Address 1				
Address 2				
City		State/Province		
Postal Code		Country ⁱ		
All Inventors Must Be Listed - Additional Inventor Information blocks may be generated within this form by selecting the Add button.				
				<input type="button" value="Add"/>

Correspondence Information:

Enter either Customer Number or complete the Correspondence Information section below. For further information see 37 CFR 1.33(a).				
<input type="checkbox"/> An Address is being provided for the correspondence Information of this application.				
Customer Number	22859			
Email Address		<input type="button" value="Add Email"/>	<input type="button" value="Remove Email"/>	

Under the Paperwork Reduction Act of 1995, no persons are required to respond to a collection of information unless it contains a valid OMB control number.

Application Data Sheet 37 CFR 1.76		Attorney Docket Number	56782.1.5
		Application Number	
Title of Invention	SHIELDING ASSEMBLIES FOR INFUSION SYSTEMS		

Application Information:

Title of the Invention	SHIELDING ASSEMBLIES FOR INFUSION SYSTEMS		
Attorney Docket Number	56782.1.5	Small Entity Status Claimed	<input type="checkbox"/>
Application Type	Nonprovisional		
Subject Matter	Utility		
Suggested Class (if any)		Sub Class (if any)	
Suggested Technology Center (if any)			
Total Number of Drawing Sheets (if any)	23	Suggested Figure for Publication (if any)	

Publication Information:

<input type="checkbox"/>	Request Early Publication (Fee required at time of Request 37 CFR 1.219)
<input type="checkbox"/>	Request Not to Publish. I hereby request that the attached application not be published under 35 U.S.C. 122(b) and certify that the invention disclosed in the attached application has not and will not be the subject of an application filed in another country, or under a multilateral international agreement, that requires publication at eighteen months after filing.

Representative Information:

Representative information should be provided for all practitioners having a power of attorney in the application. Providing this information in the Application Data Sheet does not constitute a power of attorney in the application (see 37 CFR 1.32). Enter either Customer Number or complete the Representative Name section below. If both sections are completed the Customer Number will be used for the Representative Information during processing.			
Please Select One:	<input checked="" type="radio"/> Customer Number	<input type="radio"/> US Patent Practitioner	<input type="radio"/> Limited Recognition (37 CFR 11.9)
Customer Number	22859		

Domestic Benefit/National Stage Information:

This section allows for the applicant to either claim benefit under 35 U.S.C. 119(e), 120, 121, or 365(c) or indicate National Stage entry from a PCT application. Providing this information in the application data sheet constitutes the specific reference required by 35 U.S.C. 119(e) or 120, and 37 CFR 1.78(a)(2) or CFR 1.78(a)(4), and need not otherwise be made part of the specification.			
Prior Application Status			<input type="button" value="Remove"/>
Application Number	Continuity Type	Prior Application Number	Filing Date (YYYY-MM-DD)
Additional Domestic Benefit/National Stage Data may be generated within this form by selecting the Add button.			<input type="button" value="Add"/>

Foreign Priority Information:

This section allows for the applicant to claim benefit of foreign priority and to identify any prior foreign application for which priority is not claimed. Providing this information in the application data sheet constitutes the claim for priority as required by 35 U.S.C. 119(b) and 37 CFR 1.55(a).

Under the Paperwork Reduction Act of 1995, no persons are required to respond to a collection of information unless it contains a valid OMB control number.

Application Data Sheet 37 CFR 1.76		Attorney Docket Number	56782.1.5
		Application Number	
Title of Invention	SHIELDING ASSEMBLIES FOR INFUSION SYSTEMS		

				<input type="button" value="Remove"/>
Application Number	Country ⁱ	Parent Filing Date (YYYY-MM-DD)	Priority Claimed	
			<input type="radio"/> Yes <input checked="" type="radio"/> No	
Additional Foreign Priority Data may be generated within this form by selecting the Add button.				<input type="button" value="Add"/>

Assignee Information:

Providing this information in the application data sheet does not substitute for compliance with any requirement of part 3 of Title 37 of the CFR to have an assignment recorded in the Office.				
Assignee 1			<input type="button" value="Remove"/>	
If the Assignee is an Organization check here. <input checked="" type="checkbox"/>				
Organization Name	Bracco Diagnostics, Inc.			
Mailing Address Information:				
Address 1	107 College Road East			
Address 2				
City	Princeton	State/Province	NJ	
Country ⁱ	US	Postal Code	08540	
Phone Number		Fax Number		
Email Address				
Additional Assignee Data may be generated within this form by selecting the Add button.				<input type="button" value="Add"/>

Signature:

A signature of the applicant or representative is required in accordance with 37 CFR 1.33 and 10.18. Please see 37 CFR 1.4(d) for the form of the signature.					
Signature	/Charles D. Segelbaum/		Date (YYYY-MM-DD)	2008-06-11	
First Name	Charles D.	Last Name	Segelbaum	Registration Number	42138

This collection of information is required by 37 CFR 1.76. The information is required to obtain or retain a benefit by the public which is to file (and by the USPTO to process) an application. Confidentiality is governed by 35 U.S.C. 122 and 37 CFR 1.14. This collection is estimated to take 23 minutes to complete, including gathering, preparing, and submitting the completed application data sheet form to the USPTO. Time will vary depending upon the individual case. Any comments on the amount of time you require to complete this form and/or suggestions for reducing this burden, should be sent to the Chief Information Officer, U.S. Patent and Trademark Office, U.S. Department of Commerce, P.O. Box 1450, Alexandria, VA 22313-1450. DO NOT SEND FEES OR COMPLETED FORMS TO THIS ADDRESS. **SEND TO: Commissioner for Patents, P.O. Box 1450, Alexandria, VA 22313-1450.**

Privacy Act Statement

The Privacy Act of 1974 (P.L. 93-579) requires that you be given certain information in connection with your submission of the attached form related to a patent application or patent. Accordingly, pursuant to the requirements of the Act, please be advised that: (1) the general authority for the collection of this information is 35 U.S.C. 2(b)(2); (2) furnishing of the information solicited is voluntary; and (3) the principal purpose for which the information is used by the U.S. Patent and Trademark Office is to process and/or examine your submission related to a patent application or patent. If you do not furnish the requested information, the U.S. Patent and Trademark Office may not be able to process and/or examine your submission, which may result in termination of proceedings or abandonment of the application or expiration of the patent.

The information provided by you in this form will be subject to the following routine uses:

1. The information on this form will be treated confidentially to the extent allowed under the Freedom of Information Act (5 U.S.C. 552) and the Privacy Act (5 U.S.C. 552a). Records from this system of records may be disclosed to the Department of Justice to determine whether the Freedom of Information Act requires disclosure of these records.
2. A record from this system of records may be disclosed, as a routine use, in the course of presenting evidence to a court, magistrate, or administrative tribunal, including disclosures to opposing counsel in the course of settlement negotiations.
3. A record in this system of records may be disclosed, as a routine use, to a Member of Congress submitting a request involving an individual, to whom the record pertains, when the individual has requested assistance from the Member with respect to the subject matter of the record.
4. A record in this system of records may be disclosed, as a routine use, to a contractor of the Agency having need for the information in order to perform a contract. Recipients of information shall be required to comply with the requirements of the Privacy Act of 1974, as amended, pursuant to 5 U.S.C. 552a(m).
5. A record related to an International Application filed under the Patent Cooperation Treaty in this system of records may be disclosed, as a routine use, to the International Bureau of the World Intellectual Property Organization, pursuant to the Patent Cooperation Treaty.
6. A record in this system of records may be disclosed, as a routine use, to another federal agency for purposes of National Security review (35 U.S.C. 181) and for review pursuant to the Atomic Energy Act (42 U.S.C. 218(c)).
7. A record from this system of records may be disclosed, as a routine use, to the Administrator, General Services, or his/her designee, during an inspection of records conducted by GSA as part of that agency's responsibility to recommend improvements in records management practices and programs, under authority of 44 U.S.C. 2904 and 2906. Such disclosure shall be made in accordance with the GSA regulations governing inspection of records for this purpose, and any other relevant (i.e., GSA or Commerce) directive. Such disclosure shall not be used to make determinations about individuals.
8. A record from this system of records may be disclosed, as a routine use, to the public after either publication of the application pursuant to 35 U.S.C. 122(b) or issuance of a patent pursuant to 35 U.S.C. 151. Further, a record may be disclosed, subject to the limitations of 37 CFR 1.14, as a routine use, to the public if the record was filed in an application which became abandoned or in which the proceedings were terminated and which application is referenced by either a published application, an application open to public inspections or an issued patent.
9. A record from this system of records may be disclosed, as a routine use, to a Federal, State, or local law enforcement agency, if the USPTO becomes aware of a violation or potential violation of law or regulation.

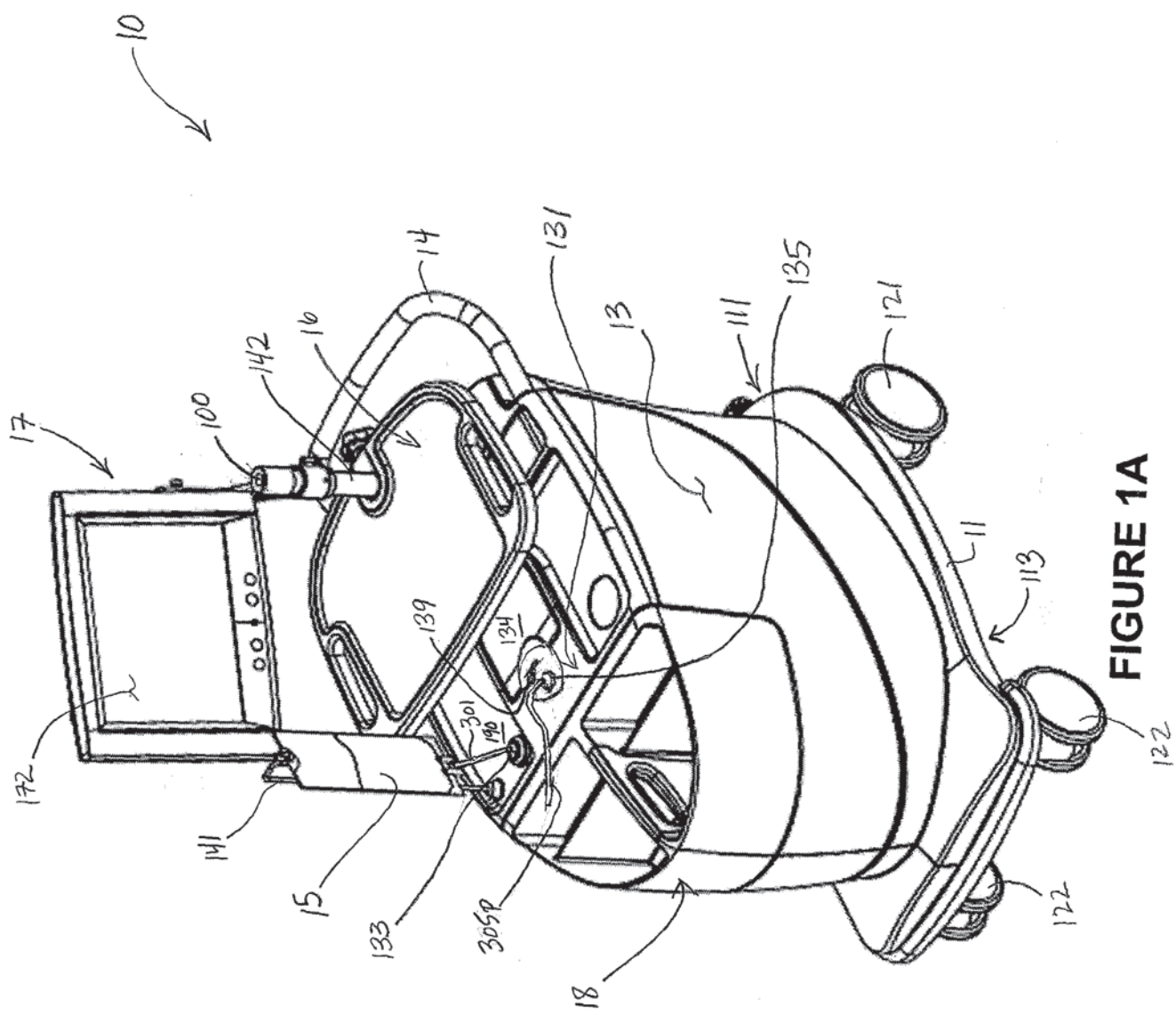

FIGURE 1A

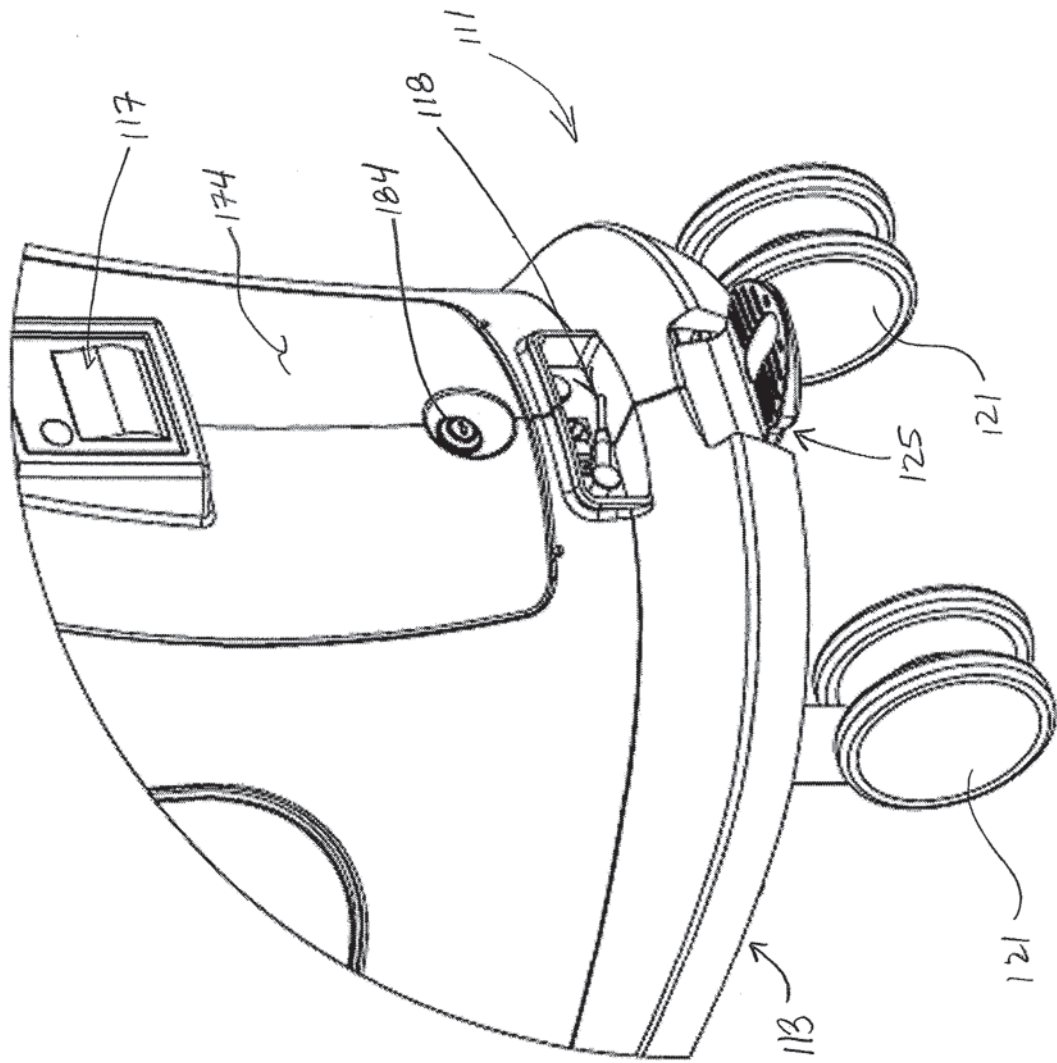

FIGURE 1B

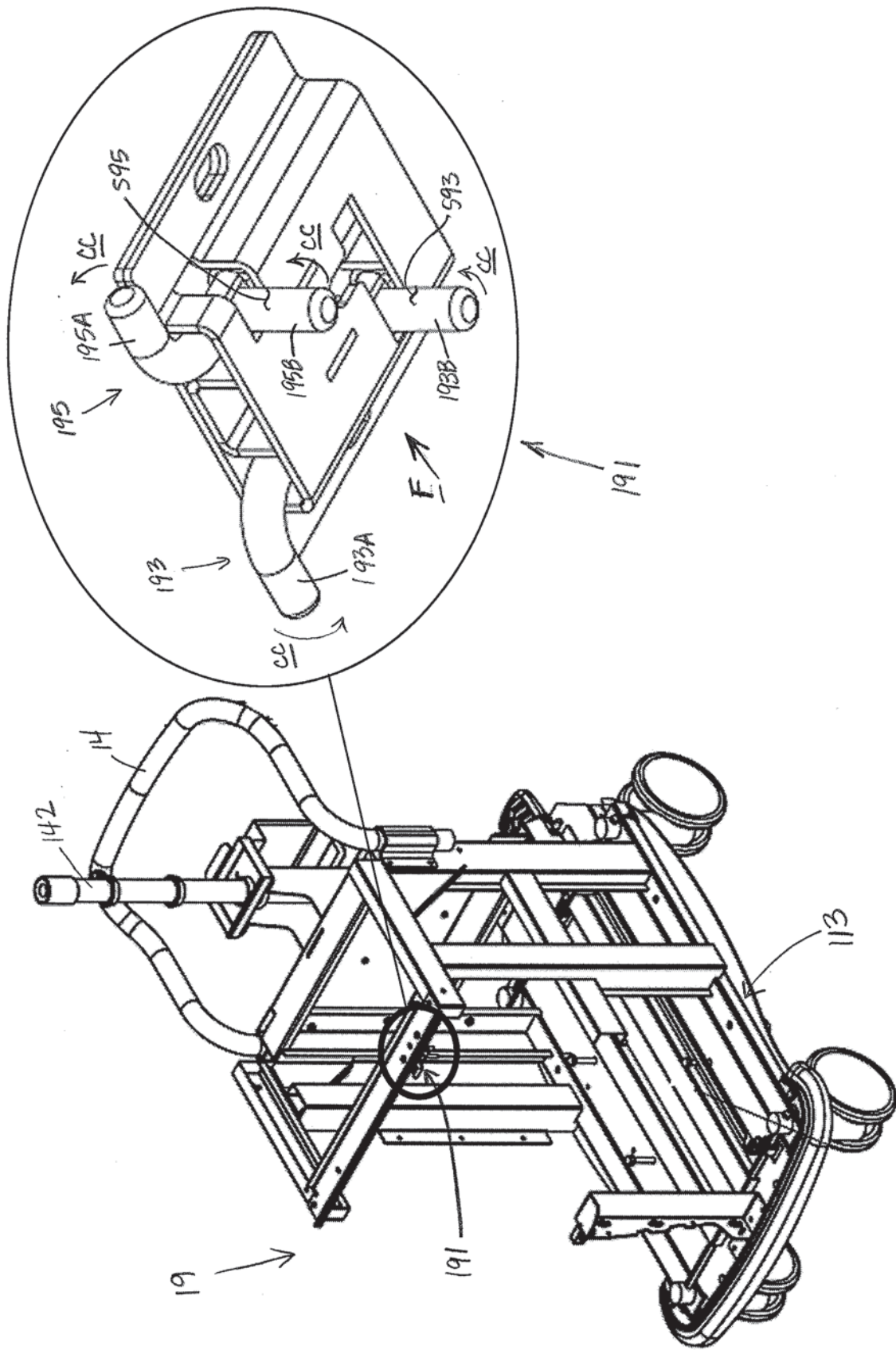

FIGURE 2B

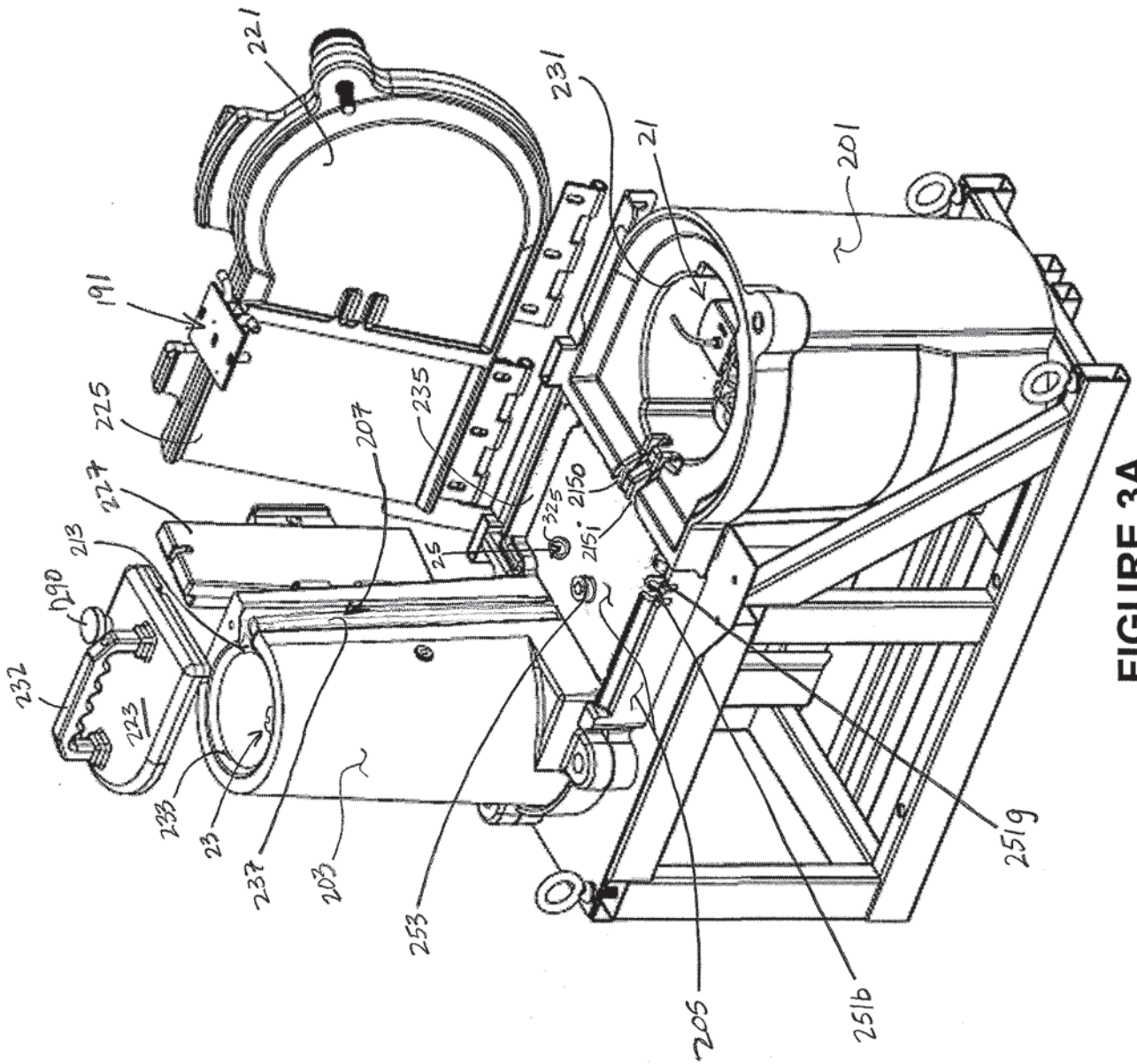

FIGURE 3A

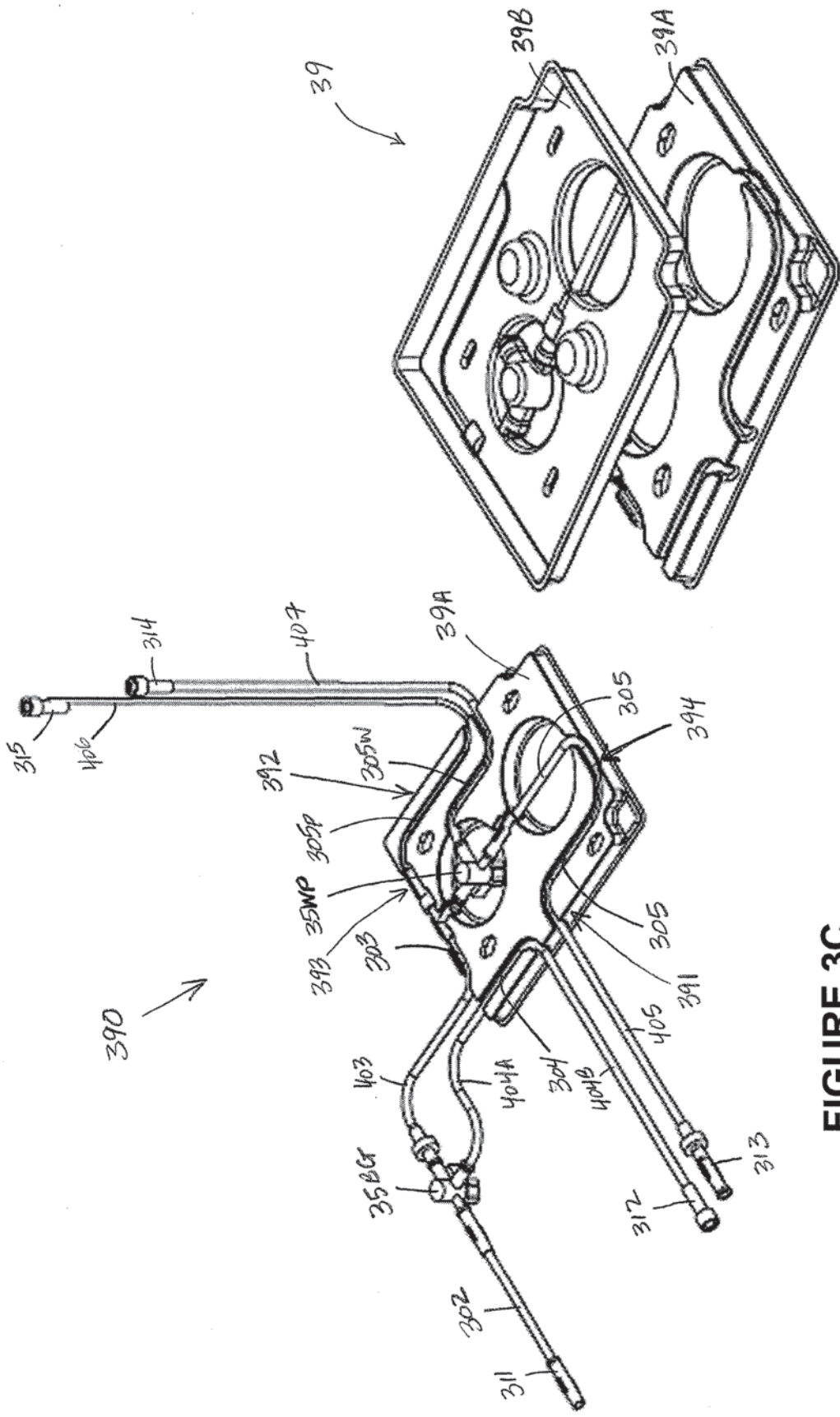

FIGURE 3C

FIGURE 3D

470

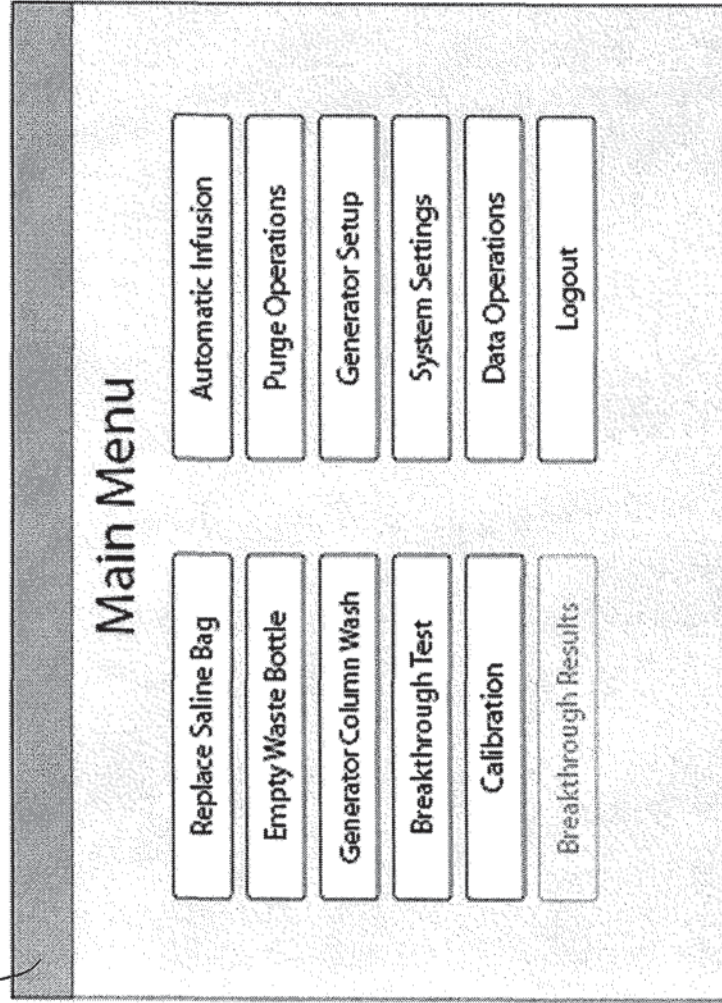

FIGURE 4

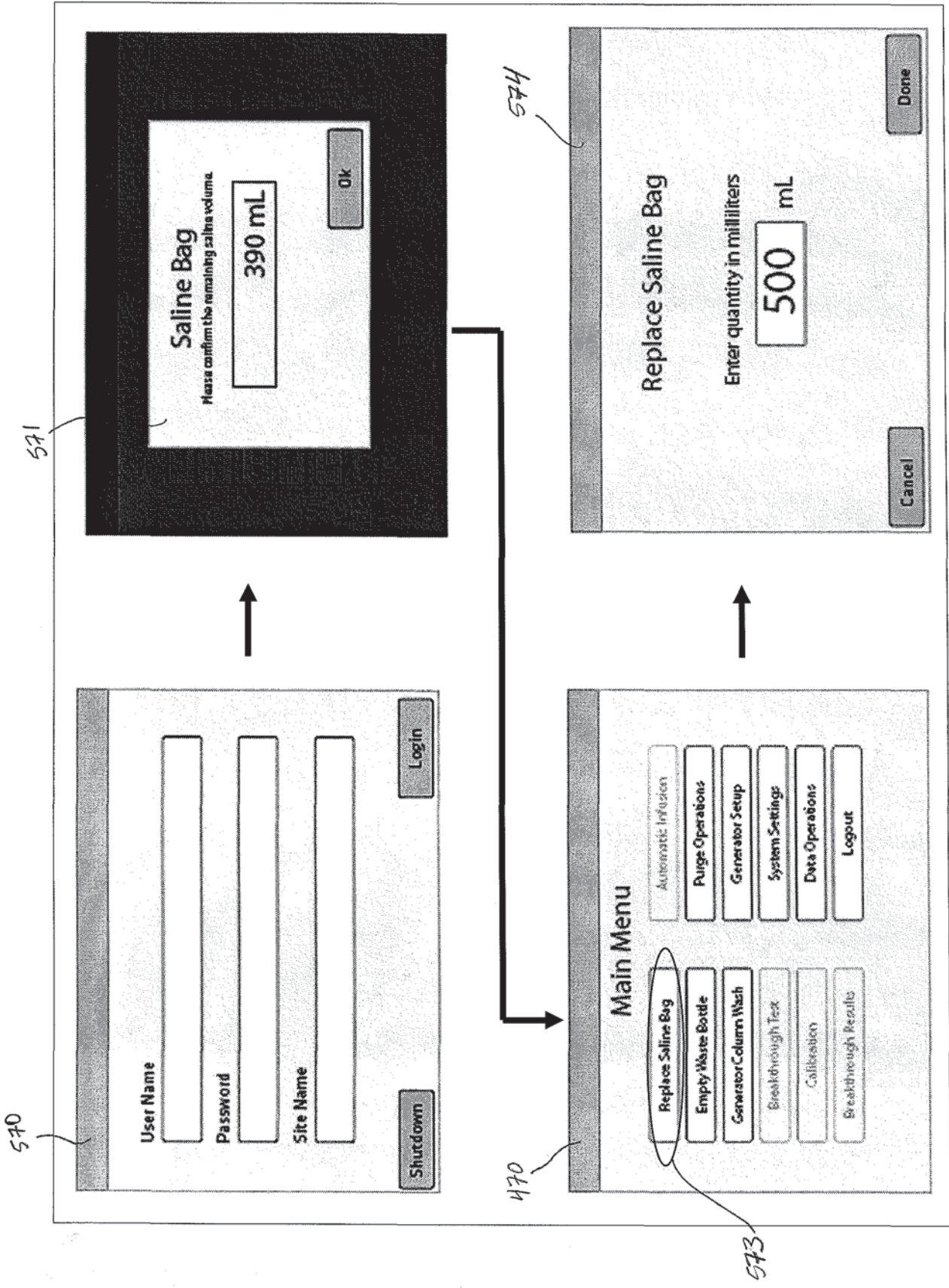
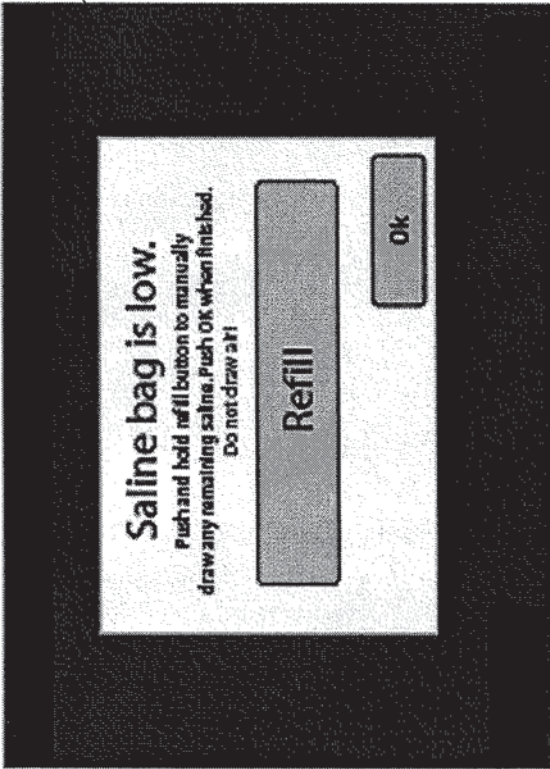

FIGURE 5A



578

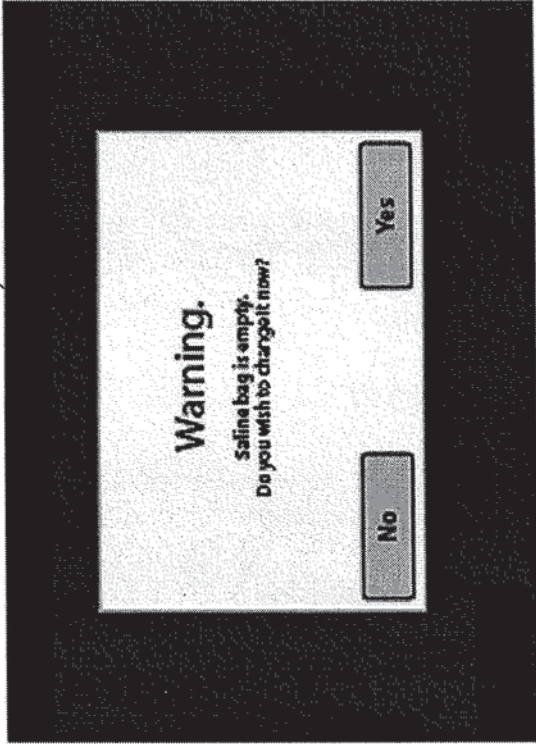

FIGURE 5B

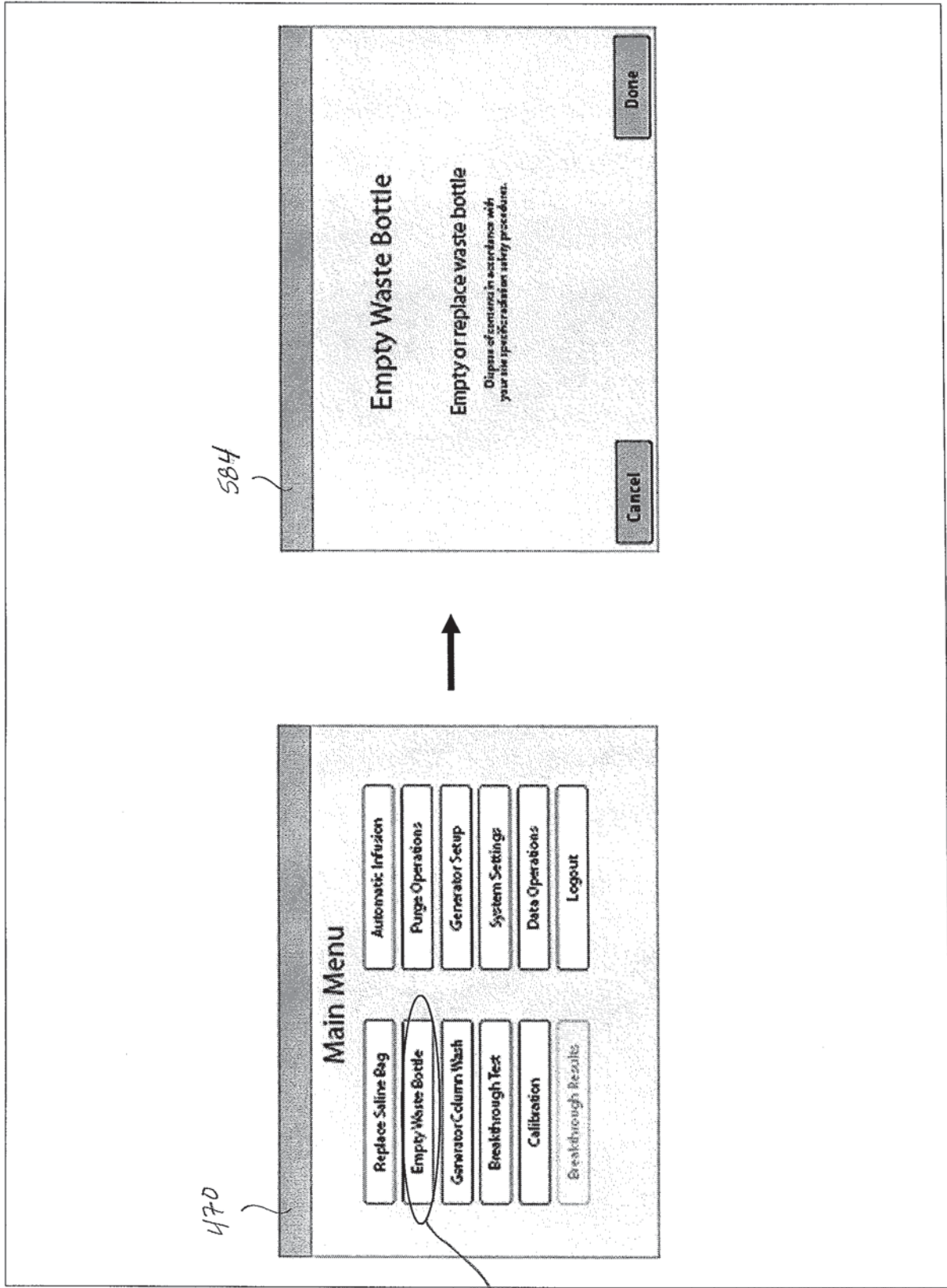

FIGURE 5C