

Fig. 13

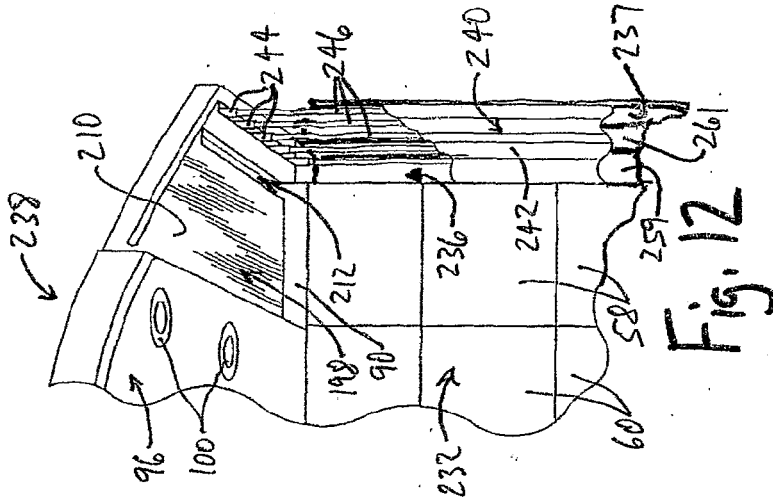


Fig. 12

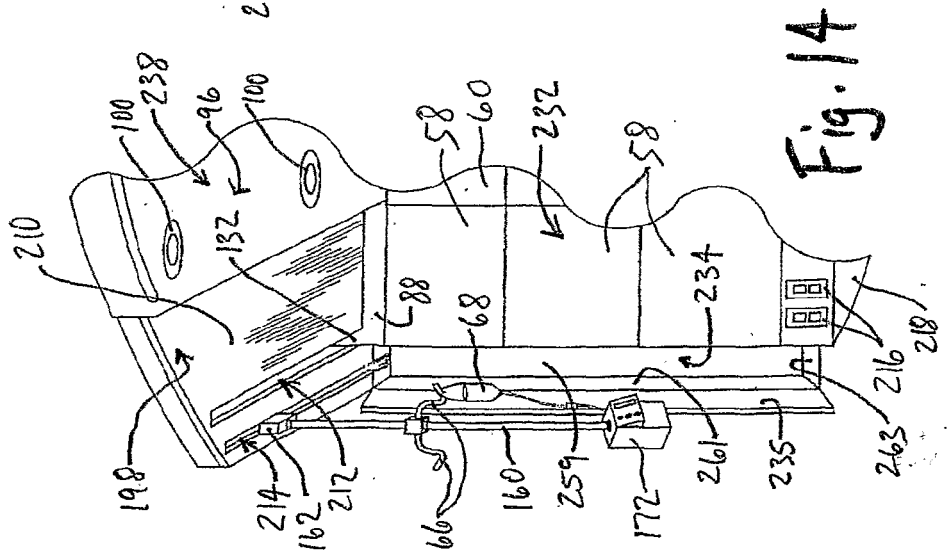


Fig. 14

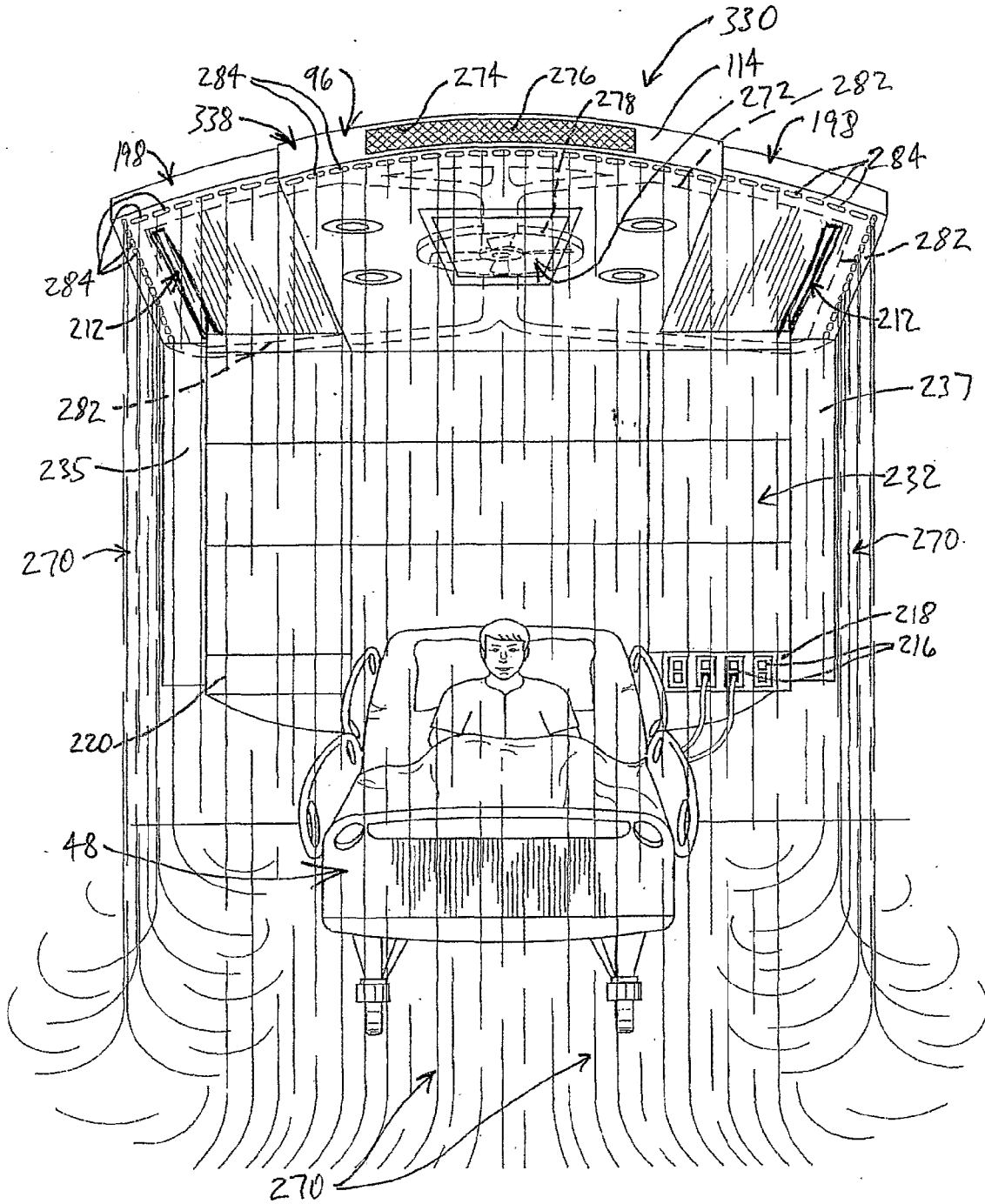


Fig. 15

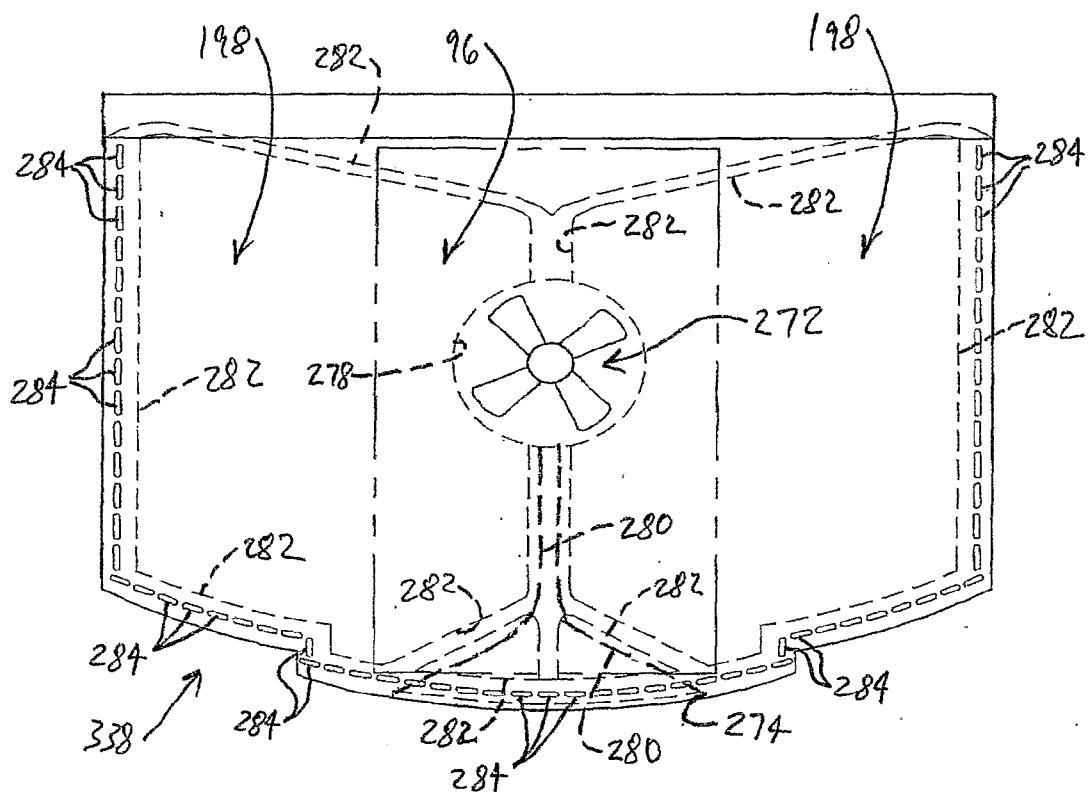


Fig. 16

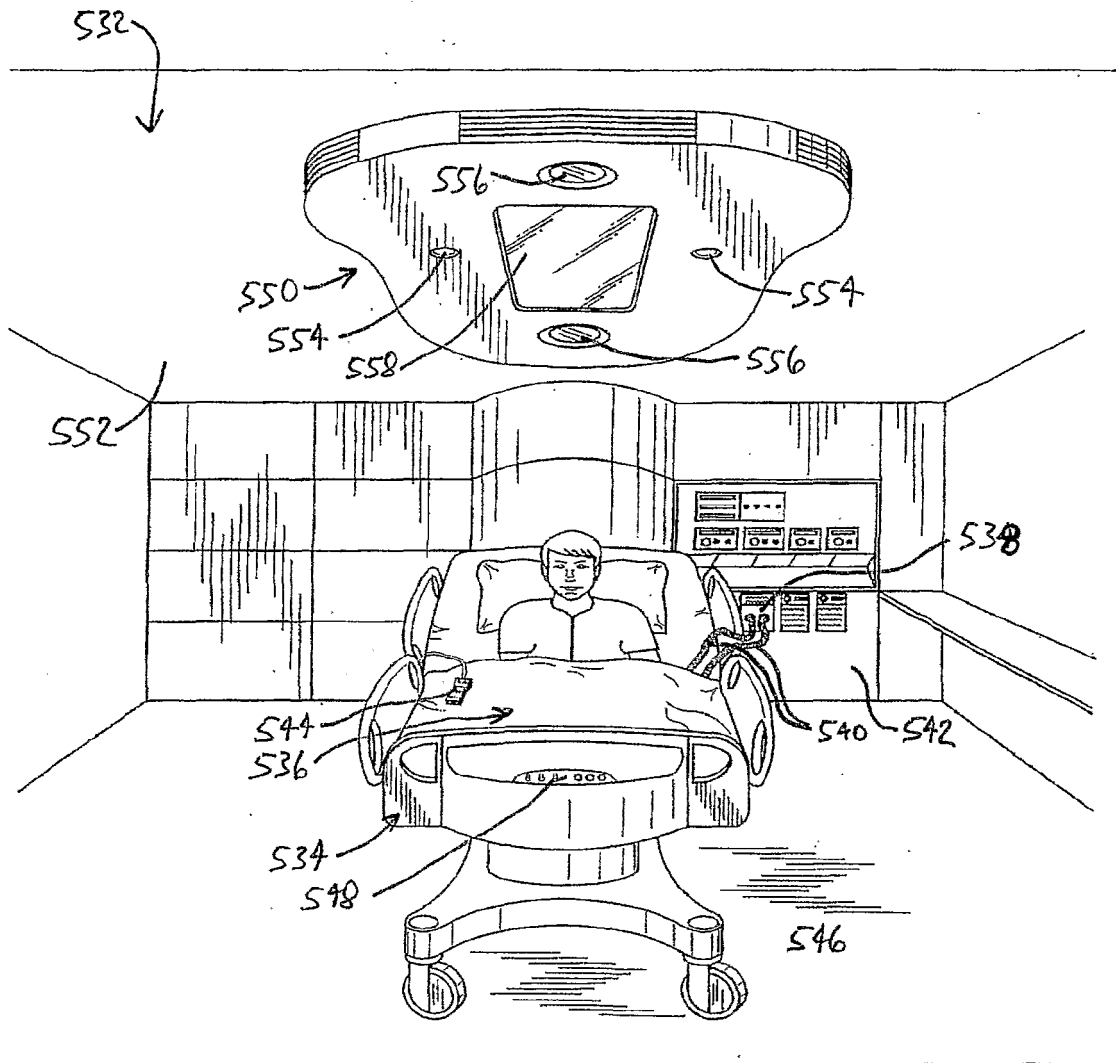


Fig. 17



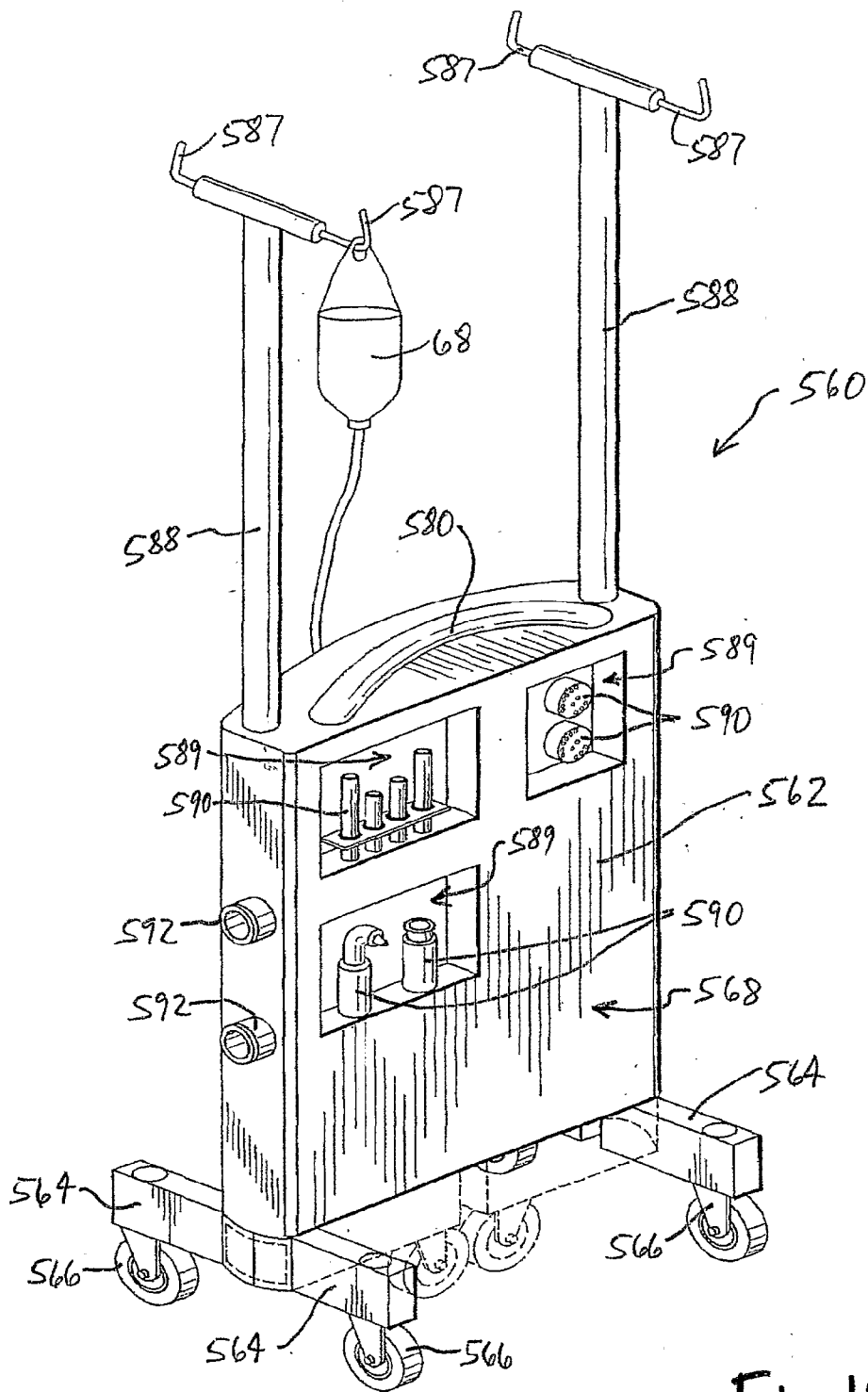


Fig. 18

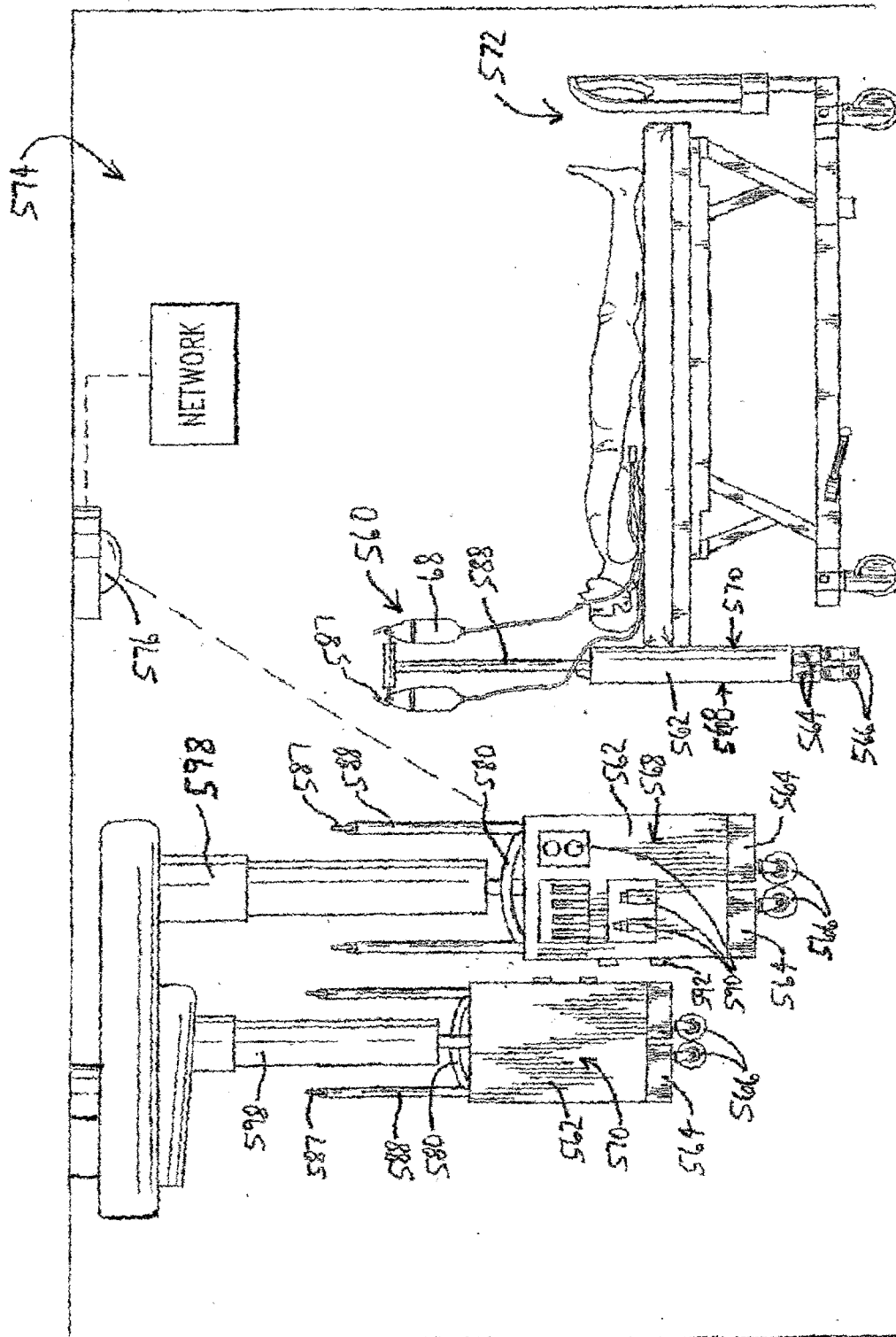


Fig. 19

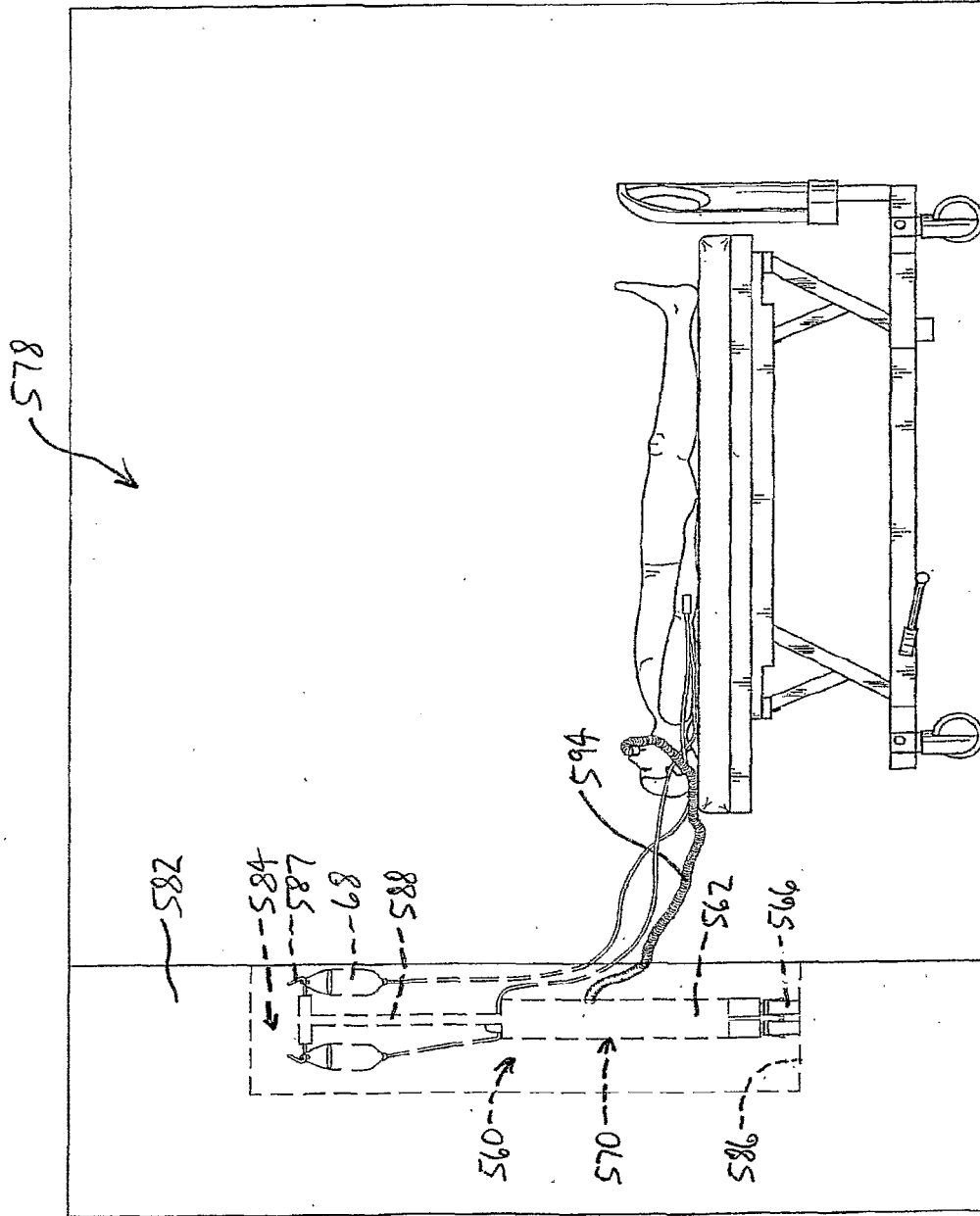


Fig. 20

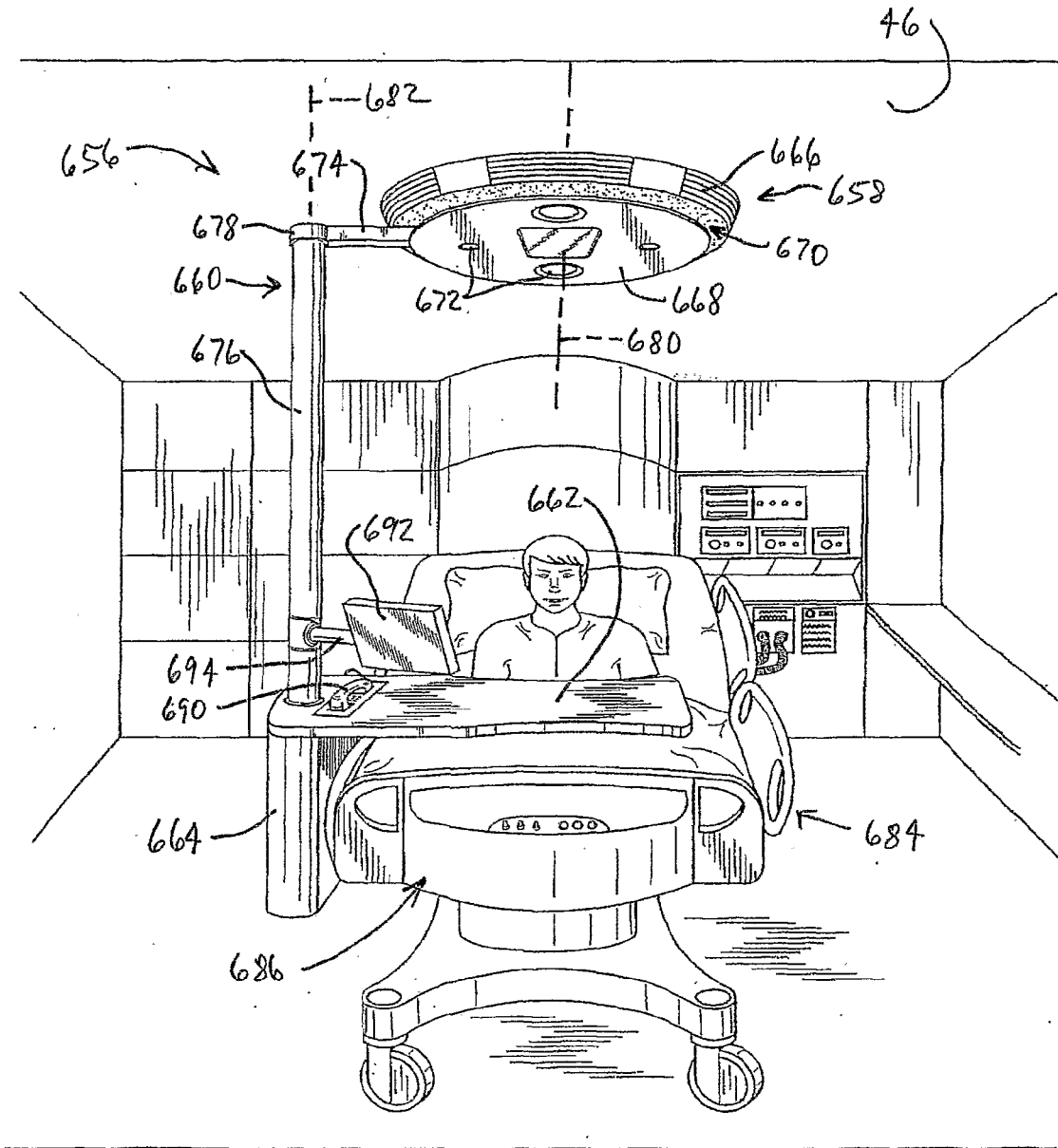


Fig. 21

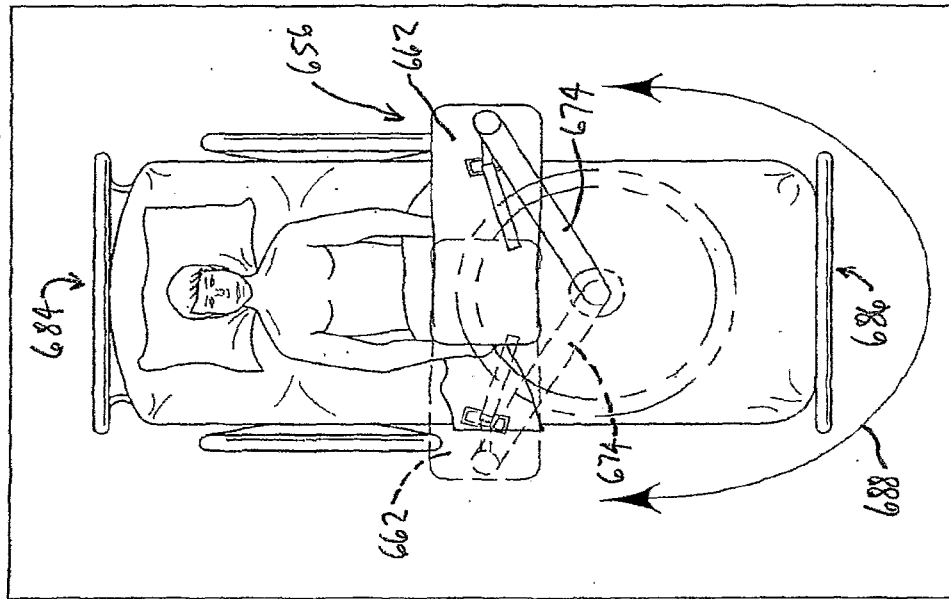


Fig. 23

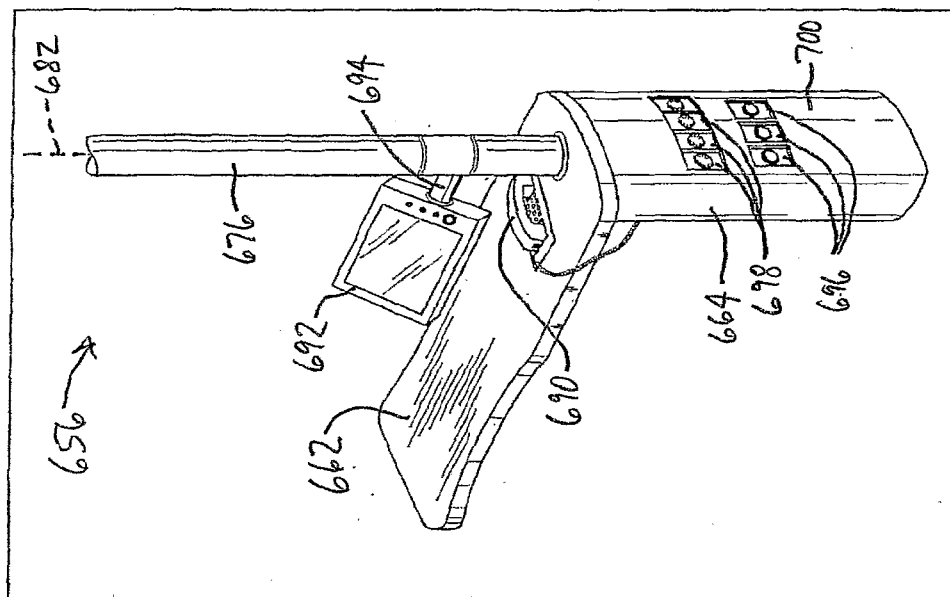


Fig. 22

(19) World Intellectual Property Organization  
International Bureau



(43) International Publication Date  
13 July 2006 (13.07.2006)

PCT

(10) International Publication Number  
**WO 2006/074473 A2**

- (51) International Patent Classification:  
*B62M 1/00* (2006.01)     *A61H 3/00* (2006.01)
- (21) International Application Number:  
PCT/US2006/000893
- (22) International Filing Date: 10 January 2006 (10.01.2006)
- (25) Filing Language: English
- (26) Publication Language: English
- (30) Priority Data:  
60/642,836     10 January 2005 (10.01.2005)     US
- (71) Applicant (for all designated States except US): **ATLAS SYSTEMS, INC.** [US/US]; 2962 Golden Harvest Lane, Fort Collins, CO 80528 (US).
- (72) Inventors; and
- (75) Inventors/Applicants (for US only): **LIVENGOOD, Amy. L.** [US/US]; 2962 Golden Harvest Lane, Fort Collins, CO 80528 (US). **LIVENGOOD, Joseph, C.** [US/US]; 2962 Golden Harvest Lane, Fort Collins, CO 80528 (US). **PHILLIPS, Barry, T.** [US/US];

1315 Miramont Drive, Fort Collins, CO 80524 (US). **ZIEMKOWSKI, Theodore, B.** [US/US]; 1041 Sablewood Drive, Loveland, CO 80538 (US).

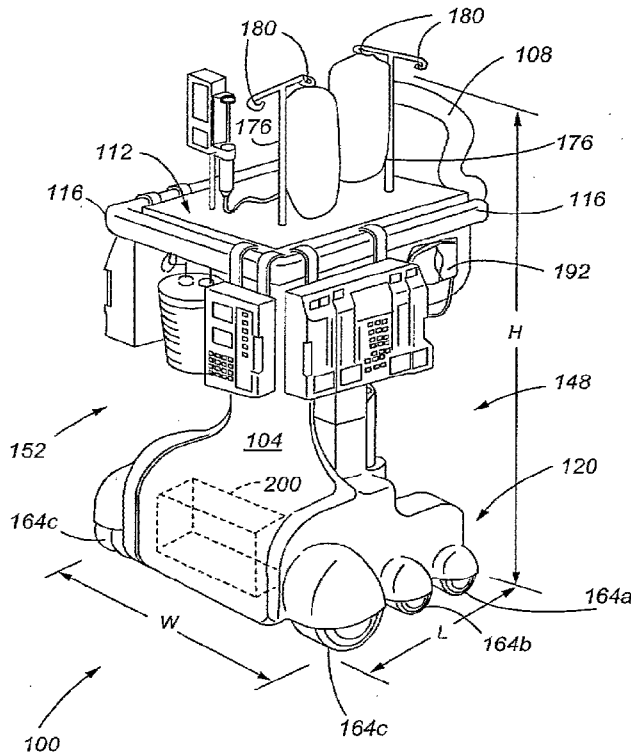
(74) Agents: **YASKANIN, Mark, L.** et al.; Sheridan Ross P.C., 1560 Broadway, Suite 1200, Denver, Colorado 80202-5141 (US).

(81) Designated States (unless otherwise indicated, for every kind of national protection available): AE, AG, AL, AM, AT, AU, AZ, BA, BB, BG, BR, BW, BY, BZ, CA, CH, CN, CO, CR, CU, CZ, DE, DK, DM, DZ, EC, EE, EG, ES, FI, GB, GD, GE, GH, GM, HR, HU, ID, IL, IN, IS, JP, KE, KG, KM, KN, KP, KR, KZ, LC, LK, LR, LS, LT, LU, LV, LY, MA, MD, MG, MK, MN, MW, MX, MZ, NA, NG, NI, NO, NZ, OM, PG, PH, PL, PT, RO, RU, SC, SD, SE, SG, SK, SL, SM, SY, TJ, TM, TN, TR, TT, TZ, UA, UG, US, UZ, VC, VN, YU, ZA, ZM, ZW.

(84) Designated States (unless otherwise indicated, for every kind of regional protection available): ARIPO (BW, GH, GM, KE, LS, MW, MZ, NA, SD, SL, SZ, TZ, UG, ZM, ZW), Eurasian (AM, AZ, BY, KG, KZ, MD, RU, TJ, TM),

[Continued on next page]

(54) Title: MODULAR PATIENT SUPPORT SYSTEM



(57) Abstract: A patient support platform provides a solution for healthcare facilities and nursing staff to address patient and staff safety, patient mobility, patient comfort, the availability of patient information, monitoring drugs and therapy provided, and controlling health care expenses. The patient support platform preferably includes a transmission system that allows the patient and/or medical staff member to choose a stop, walk or roll mode. The transmission system preferably includes a drag wheel for applying a braking force in response to a voltage generated by a braking motor. The platform supports a plurality of devices that may be attached or associated with a patient throughout their stay at a healthcare facility. The support platform also preferably includes a mechanism for releasably attaching the support platform to another structure, such as a bed. Embodiments of the present invention include multiple non-medical uses of the platform.

WO 2006/074473 A2



European (AT, BE, BG, CH, CY, CZ, DE, DK, EE, ES, FI, FR, GB, GR, HU, IE, IS, IT, LT, LU, LV, MC, NL, PL, PT, RO, SE, SI, SK, TR), OAPI (BF, BJ, CF, CG, CI, CM, GA, GN, GQ, GW, ML, MR, NE, SN, TD, TG).

*For two-letter codes and other abbreviations, refer to the "Guidance Notes on Codes and Abbreviations" appearing at the beginning of each regular issue of the PCT Gazette.*

**Published:**

- *without international search report and to be republished upon receipt of that report*

## MODULAR PATIENT SUPPORT SYSTEM

## FIELD OF THE INVENTION

The present invention is directed to an apparatus used in the field of medicine, and more particularly, to a moveable and modular patient support system with a relatively small  
5 form factor.

## BACKGROUND OF THE INVENTION

Current practice for patients in a healthcare facility involves having multiple unrelated treatment, maintenance and/or monitoring devices that are attached to the patient. These include intravenous fluids and drugs, drainage catheters, suction catheters, leg  
10 compression stockings and vital sign monitoring devices. Such devices often create a hazard for the patient both directly and indirectly. The myriad of devices may become entangled and inadvertently removed if not adequately accounted for by the patient or caregiver. This may require an invasive intervention, including surgery, in order to replace the removed device.

The number of devices generally associated with the patient require the patient to  
15 have the physical and mental ability to manage organizing or carrying the devices to ambulate even as far as the bathroom. Since patients are debilitated by the nature of their illness and medications, two staff persons are frequently required to help the patient move even short distances. One staff member must assist the patient, providing physical support, while the other manages the attached devices. The patients thus do not get out of bed and ambulate as  
20 often since the staff of the typical health facility is not able to provide this kind of support readily to all of the patients at all times.

The resulting immobility increases the patient's risk for deep venous thrombosis, pulmonary embolus and pneumonia. Additionally, mobility improves gut motility and decreases the time a patient must wait before obtaining enteral nutrition and ultimately  
25 discharge from the healthcare facility. Patients that require prolonged hospital stays or admission to skilled-nursing facilities for non-medical indications related to mobility and personnel support may be able to be discharged home sooner with a device that provides the



same type of care. The cost to the healthcare system may be reduced by decreasing the stays in expensive healthcare facilities and decreasing complications that are costly both in patient morbidity and monetary value.

The patient-care staff is also at risk for injury, as they must provide physical support to the debilitated patient. Back injuries are frequent in healthcare staff as a result of the physical nature of assistance provided. Allowing the patient to rely on an ambulatory assist device will help the patient-care staff as well by keeping them out of harm's way.

Current poles that provide an intravenous ("IV") fluid and/or liquid medication delivery source are often times taken with patients when the patient moves around, such as when a patient walks in a hospital hallway. The patient typically places at least one hand on the IV pole to move the IV pole while walking. However, typical IV poles are approximately 6 to 7 feet tall, and are often unstable for providing weight support to a patient, particularly when one or more substantially full IV bags are positioned near the top of the pole. As a result, a patient is at risk of further injury by falling if the IV pole tips and/or falls over. In addition, in order to prevent tipping, conventional IV poles have widely spread wheels, which require a large amount of floor space. IV poles are completely unable to manage uneven terrain as is found outside the confines of the patient care facility, and as may be found at home or in the field for disasters or military operations.

In addition to being relatively unstable, current IV poles do not provide for the additional needs of a patient that is moving about. For example, IV poles do not include an oxygen source for assisting the patient with breathing. Current IV poles also do not include various pumps or suction devices that may be necessary for continuous operation to provide proper medical treatment to the patient. In addition, vitals monitoring equipment and communication devices are typically not present on a standard IV pole. Furthermore, even if an IV pole is adapted to include a monitoring device or pump, the IV pole tends to become even more unstable because the resulting added weight of the device typically is positioned

relatively high along the pole.

In connection with patients that require assistance walking, various “walker” devices are available. A typical walker includes handrails interconnected to a stable base. However, because use of a walker usually requires both hands of the patient, a patient is typically unable  
5 to take an IV pole with them when using a walker.

A further difficulty exists when a patient needs to be moved from one room to another while in their bed. If the patient requires oxygen, an oxygen bottle must be provided, and is typically placed on the bed while moving the bed. This can create difficulties depending upon the size of the bed and the patient. Additionally, portable suction and vitals  
10 monitoring are not readily available for every patient. Accordingly, it would be advantageous to provide an apparatus that includes oxygen and other physiological support adjacent to the bed, wherein the apparatus can be attached to the bed while moving the bed. Such an apparatus would therefore also be advantageous to overcome the difficulty of maintaining monitoring equipment and/or IV fluids adjacent to the patient while moving the patient’s bed.  
15 The efficiency of the staff will benefit since only a single staff member will be required to move a patient since a second staff member is not required to push the IV pole and attachments. This also prevents the need for the staff member to move the patient to a wheelchair for transfer as is currently often done in order for a single staff member to manage the transfer. Eliminating this move prevents an opportunity for a patient fall resulting in  
20 injury with only a single staff member assisting.

Patient care devices and services such as suction and oxygen are not built in to the facilities of several countries and regions. This is also true in field situations of military conflict or civilian disaster. Patients may be far from a medical facility or in the hallway of a medical facility not equipped with patient support equipment/services.

25 Yet a further difficulty exists in maintaining electrical power to electronic devices such as monitoring equipment, suction pumps and/or injection pumps while the patient is

walking with an IV pole or walker, or while the patient is being moved in their bed or while the patient is not located next to an electrical outlet. This may occur in: 1) the operating room while needing to adjust the bed height or keep the pumps charged during a long procedure, 2) during a disaster when patients may be stationed in hallways or temporary areas, 3) during military conflict or civilian situations that require creation of field hospitals with limited generator availability, and 4) in countries or regions that do not have consistent access to power. Accordingly, an apparatus that maintains electrical power to these devices would be advantageous, as would an apparatus that provides power in case of an electrical outage or blackout.

10

#### SUMMARY OF THE INVENTION

The present invention solves the above-mentioned deficiencies by providing a mobile cart or platform that is structurally stable, and can thereby provide weight-bearing assistance to a patient without being predisposed to tipping over. In addition, the platform preferably includes one or more additional features, such as an oxygen source, power supply, injection pump, suction pump, body fluid collection devices, vital monitoring equipment, integrated IV pole and communication equipment.

In accordance with embodiments of the present invention, a modular patient support system is provided, wherein the support system typically resembles a platform, and includes a handrail interconnected to a base having three or more wheels. The support system or platform additionally may include a battery or uninterruptible power supply for serving as an emergency power supply, and/or for powering associated equipment, including the bed, while the patient is walking or being moved in a bed with the support system positioned adjacent the bed. The support platform also may include modular receptacles for receiving a variety of devices, including suction pumps, injection pumps, collection devices, monitoring equipment, and communication devices. An electrical wiring network may be provided such that the

modular devices interconnected to the support platform receive electrical power directly at the modular receptacles, thereby minimizing the presence of numerous power cords. Such additional equipment is powered by the uninterruptible power supply when the support platform is disengaged from a stationary power supply, such as an electrical wall outlet.

5           In accordance with other embodiments of the present invention, the support platform may include an on-board communication system to send monitoring information or other data to a nurses' PDA, central station or alarm system. The communication system may include wireless communication to transmit a patient's vitals, equipment status, fluid volumes, therapy status and location for providing information while a patient is using the support  
10 platform as a walking aid. An interface may be provided for the healthcare providers to be able to access and interact with the facility's electronic medical record system.

          In accordance with other embodiments of the present invention, the support platform may include a checkpoint validation system to ensure the correct therapy is administered to the correct patient. This may involve identification of the patient, platform and therapy (such  
15 as intravenous fluids, medications or equipment) with devices such as barcodes, radiofrequency identifiers or other similar technology to match and track all therapy provided.

          In accordance with other embodiments of the present invention, the support system also may also include an on-board oxygen supply and associated tubing. Additionally, the support platform may include an IV fluids/medication support assembly, such as an IV pole  
20 with an attachment hook.

          The support platform may be configured in a variety of ways, to include a cabinet or other enclosure for holding items such as a urine collection bag, body fluid collection bag and suction canister. The configuration of the support platform also may include specially sized compartments for bottles or cups, and may include other built-in features such as a tray, radio,  
25 television, phone, computer or other communication device, wherein some of these devices may also be interconnected to the support platform's power supply.

In a separate aspect of the invention, an attachment device is provided for detachably attaching the support platform to another structure, such as the patient's bed. The attachment device may include an attachment adapter capable of being interconnected to a variety of bed frame structures, regardless of whether the framing includes square or round rails or posts.

5 The attachment device not only secures the support platform to the bed so that it is not moved when accidentally bumped, but it also enables the support platform to be moved with the bed without the need for a separate attendant to move the support platform. In at least one embodiment, a plurality of bed hooks are used to enable the platform to grasp another object, such as a bed, when the bed is raised to impinge upon the underside of the bed hooks.

10 In a separate aspect of the invention, the support platform includes an umbilical cord having a common plug for interconnecting a plurality of systems to a single outlet, such as a wall outlet. The umbilical cord may support a variety of systems, including electrical power, oxygen, suction, and/or a communication connection.

In accordance with embodiments of the present invention, a locking brake may  
15 optionally be provided to limit movement of the platform if the brake is engaged. The brake may have mechanisms that engage it actively and/or passively. This may include a 'kill-switch' device that detects separation of the patient from the platform in situations that may result in patient injury if such event occurs.

In accordance with embodiments of the present invention, a transmission system may  
20 be provided to allow a user or other person to place the platform in one of a plurality of possible translation modes. In at least one embodiment, the transmission system includes stop, walk and roll modes. The stop mode engages a brake to contact the underlying surface, thereby substantially preventing the platform from rolling. In addition, in at least one embodiment, both a drag wheel and a brake are in contact with the floor when the platform is  
25 set in the stop mode. The walk mode includes raising the brake, if present, and engaging a drag wheel to contact the floor. Although not prevented from moving, the walk mode helps

prevent undesirable fast movement of the platform. In one embodiment, the drag wheel may comprise a wheel that is preset to turn at a very slow rate. Alternatively, in at least one embodiment the drag wheel may be interconnected to a braking motor, operated as a generator powered by the drag wheel, that applies a resistive force or an increased resistive force to the drag wheel when velocities increase above an undesirable level. For example, if a patient is standing adjacent the support platform and starts to slip while holding the handle of the platform, the braking motor will apply a resistive force to the drag wheel, thereby preventing the support platform from moving away from the patient and/or moving away from the patient at a high rate of speed. A variety of motor braking circuit configurations and braking functions are available for controlling the resistive force applied to the drag wheel using the braking motor. For example, a motor braking circuit may provide different resistive loads to the braking motor based on the velocity of the braking motor. In addition, the motor braking circuit does not require any source of power other than the power generated as a result of the rotation of the braking motor by the drag wheel. In the roll mode the transmission disengages both the brake and the drag wheel, such that the platform may be easily rolled. This setting is anticipated for use, for example, when an attendant is moving the platform.

Thus, in accordance with at least one embodiment of the present invention, a personal support platform for traversing an underlying surface is provided, the platform comprising a frame and a plurality of wheels interconnected to the frame. In addition, the platform comprises a transmission system interconnected to the frame, the transmission system providing a number of user selectable modes, the user selectable modes comprising at least a stop mode, a walk mode and a roll mode. Finally, in at least one embodiment, the platform further comprises a means for selectively choosing one of the stop, walk and roll modes by a user from a standing position adjacent the frame.

In a separate aspect of the invention, a transmission system of the platform comprises

a drag wheel that is selectively moveable from a first raised position in the roll mode to a second lowered position in the walk mode, and wherein the drag wheel is for contacting the underlying surface when in the second lowered position. In addition, in accordance with at least one embodiment, the transmission system comprises a cam interconnected to the frame and the drag wheel, wherein the cam is rotatably movable to raise and lower the drag wheel from the first raised position in the roll mode to the second lowered position in the walk mode. The transmission system may also further comprise an automatic brake interconnected to the drag wheel, wherein the automatic brake comprises a braking motor driven by the drag wheel and circuitry, wherein the circuitry provides a resistive load to the braking motor to apply a braking force on the drag wheel. In addition, in at least one embodiment, the resistive load comprises a number of load ranges, wherein a first load range provides a first resistive load within a first velocity range for the braking motor, and wherein a second load range provides a second resistive load within a second velocity range for the braking motor. Also, the second velocity range may be automatically selected once a threshold velocity of the braking motor is reached.

In a separate aspect of the invention, a transmission system of the platform may comprise a brake interconnected to the frame, wherein the brake is selectively moveable from a first raised position in the walk and roll modes to a second lowered position in the stop mode, and wherein the brake is for contacting the underlying surface when in the second position. In at least one embodiment, the brake comprises a stopper frictionally engaging the underlying surface. In yet a separate aspect of the invention, the platform may comprise a cam having a first channel interconnected to the brake. In at least one embodiment of the invention, the cam comprises a second channel interconnected to a drag wheel. In accordance with at least one embodiment of the invention, the first channel comprises a first ramp for raising and lowering a first post interconnecting the drag wheel to the cam, and wherein the second channel comprises a second ramp for raising and lowering a second post

interconnecting the stopper to the cam.

In a separate aspect of the invention, a means for selectively choosing the mode of the transmission system comprises a first handle at a rear portion of the frame, wherein the handle is selectively adjusting a setting of the transmission system. In at least one embodiment, the  
5 transmission system may further comprise a second handle at a front portion of the frame, wherein the second handle can also be used for selectively adjusting a setting of the transmission system.

In a separate aspect of the invention, the platform comprises at least one grasping mechanism for interconnecting the frame to another structure. In at least one embodiment of  
10 the invention, the grasping mechanism comprises a rotatable gripper arm that engages the other structure. In addition, in at least one embodiment, the rotatable gripper arm rotates about a first axis in a direction away from the frame, and rotates about a second axis to grasp the other structure, wherein the second axis is transverse to the first axis.

It is a further aspect of the present invention to utilize a variety of devices to provide  
15 functionality to a personal support platform. Accordingly, in at least one embodiment of the present invention, a personal support platform for traversing an underlying surface is provided, comprising a frame and means for rotating interconnected to said frame and contacting the underlying surface. The platform further comprises means for frictionally engaging the underlying surface and interconnected to said frame; and means for variably  
20 controlling a resistance provided by said means for frictionally engaging. In at least one embodiment of the invention, the means for rotating comprises a plurality of wheels. In addition, in at least one embodiment of the invention the means for frictionally engaging comprises a drag wheel. In accordance with at least one embodiment of the invention, the means for frictionally engaging is interconnected to a means for adjusting a position of said  
25 means for frictionally engaging, wherein said means for adjusting may alter a position of said means for frictionally engaging from a first position in contact with the underlying surface to



second position wherein said means for frictionally engaging does not contact the underlying surface. In at least one embodiment of the invention, the means for adjusting comprises a selectably positionable cam for raising and lowering said means for frictionally engaging. In addition, in at least one embodiment of the invention the means for variably controlling a  
5 resistance comprises a passive braking motor. In a separate aspect of the invention, the passive braking motor comprises a motor braking circuit interconnected to the passive braking motor. In at least one embodiment, the braking circuit includes a first circuit stage, including a switching mechanism, wherein an activation voltage for the first circuit stage is defined. The circuit also includes, a load resistor, wherein when the passive braking motor produces an  
10 amount of power sufficient to produce a voltage at the switching mechanism that is equal to or greater than the activation voltage and above a current is allowed to pass through the load resistor.

As noted above, embodiments of the present invention may comprise a braking system. Thus, in accordance with at least one embodiment of the invention, a passive variable  
15 braking system is provided, comprising:

- a motor;
- a motor braking circuit interconnected to the motor, including:
  - a first circuit stage, including:
    - a switching mechanism, wherein an activation voltage for the first  
20 circuit stage is defined; and
    - a load resistor, wherein when the motor produces an amount of power sufficient to produce a voltage at the switching mechanism that is equal to or greater than the activation voltage and above a current is allowed to pass through the load resistor.

25 In a separate aspect of the invention, the motor braking circuit of the passive variable braking system further comprises:

a second circuit stage in parallel with the first circuit stage, the second circuit stage including:

a switching mechanism, wherein an activation voltage for the second stage is defined;

5 a load resistor, wherein when the motor produces an amount of power sufficient to produce a voltage at the switching mechanism that is equal to or greater than the activation voltage and above a current is allowed to pass through the load resistor, wherein the activation voltage for the second stage is greater than the activation voltage for the first stage, and wherein when the activation voltage for the  
10 second stage is met or exceeded a current continues to be allowed to pass through the load resistor of the first circuit stage.

In yet a separate aspect of the invention, the passive variable braking system further comprises:

a switch, wherein the first and second circuit stages comprise a number of load  
15 resistors, wherein the switch is operable to select one of each of the load resistors included in the first and second circuit stages to provide a selected resistance at the motor.

In a separate aspect of the invention, the motor braking circuit of the passive variable braking system further comprises:

a second circuit stage in parallel with the first circuit stage, the second circuit stage,  
20 including:

a switching mechanism, wherein an activation voltage for the second stage is defined; and

a load resistor, wherein when the motor produces an amount of power sufficient to produce a voltage at the switching mechanism that is equal to or greater  
25 than the activation voltage and above a current is allowed to pass through the load

resistor, and wherein the activation voltage for the second stage has a polarity that is opposite the activation voltage for the first stage.

In a separate aspect of the invention, the switching mechanism of the passive variable braking system comprises a zener diode.

5 In a separate aspect of the invention, the switching mechanism of the passive variable braking system comprises a pair of voltage dividing resistors and a transistor, wherein a voltage divided by the pair of resistors is provided to a gate of the transistor.

In yet a separate aspect of the invention, the switching mechanism of the passive variable braking system comprises a resistor interconnected to a Silicon Controlled Rectifier.

10 In yet a separate aspect of the invention, the passive variable braking system further comprises a drag wheel interconnected to the motor, wherein the motor is driven by the drive wheel. In yet a separate aspect of the invention, the drive wheel is interconnected to the motor by a gearbox.

In still yet a separate aspect of the invention, the switching mechanisms of the passive variable braking system of the first and second circuit stages each comprise a zener diode, and  
15 wherein the first and second stages each additionally include a blocking diode.

It is a separate aspect of the present invention to provide a method of using a support platform that comprises one or more features of the device described herein. Accordingly, a method of using a personal support platform is provided, the method comprising selecting a  
20 transmission mode for a transmission system operably associated with the personal support platform, wherein the transmission system provides a number of user selectable transmission modes, and wherein the user selectable transmission modes comprise at least a stop mode, a walk mode and a roll mode. In accordance with at least one embodiment of the present invention, the personal support platform for use includes a frame, a plurality of wheels  
25 interconnected to the frame, and a transmission control device operably interconnected to the transmission system, the transmission control device adapted for allowing a user to selectively

choose one of the stop, walk and roll modes. In the method of use, the selecting step comprises manipulating the transmission control device to one of the stop, walk and roll modes. In addition, in at least one embodiment, the manipulating step comprises moving a control bar operably interconnected to the frame and a cam, wherein the control bar controls  
5 positions of a drag wheel and a brake that are operably interconnected with the cam. In a separate aspect of the invention, in at least one embodiment the method of use also comprises inducing a braking force on the drag wheel by at least temporarily increasing a velocity of the frame, wherein the resistive force is imposed by an automatic brake interconnected to the drag wheel, wherein the automatic brake comprises a braking motor driven by the drag wheel and  
10 circuitry, and wherein the circuitry provides a resistive load to the braking motor to apply a braking force on the drag wheel. In addition, in at least one embodiment, the method also comprises releasably connecting the platform to another structure using at least one grasping mechanism interconnected to the frame, and may further comprise impinging at least a portion of the other structure against the rotatable gripper arm.

15 In accordance with embodiments of the present invention, a method of using a personal support platform is provided comprising: providing a drag wheel interconnected to the platform, the drag wheel for contacting a surface under the platform; positioning the drag wheel to contact the surface under the platform; and applying a braking to the platform through the drag wheel by applying at least a first braking resistance to the drag wheel for at  
20 least a first velocity range of the drag wheel. In at least one aspect of the invention, the method may further comprise providing at least a second braking resistance to the drag wheel for at least a second velocity range of the drag wheel. In another aspect of the invention, the second velocity range is automatically selected once a threshold velocity of a braking motor is reached. In accordance with at least one embodiment of the invention, the positioning step of  
25 the drag wheel further comprises manipulating a transmission control device to lower the drag wheel in contact with the surface under the platform. The method may further comprise

engaging a stopper to contact the surface underlying the platform. In addition, the method may comprise releasably connecting the platform to another structure using at least one grasping mechanism interconnected to the platform. In accordance with at least one embodiment of the invention, the step of releasably connecting the platform to another  
5 structure may also comprise impinging at least a portion of the other structure against a portion of the grasping mechanism.

Various embodiments of the present invention are set forth in the attached figures and in the detailed description of the invention as provided herein and as embodied by the claims. It should be understood, however, that this Summary of the Invention may not contain all of  
10 the aspects and embodiments of the present invention, is not meant to be limiting or restrictive in any manner, and that the invention as disclosed herein is and will be understood by those of ordinary skill in the art to encompass obvious improvements and modifications thereto.

Additional advantages of the present invention will become readily apparent from the  
15 following discussion, particularly when taken together with the accompanying drawings.

#### BRIEF DESCRIPTION OF THE DRAWINGS

- Fig. 1 is a perspective view of an apparatus in accordance with embodiments of the present invention;
- 20 Fig. 2 is a perspective view of another apparatus in accordance with embodiments of the present invention;
- Fig. 3 is a front elevation view of yet another apparatus in accordance with embodiments of the present invention;
- Fig. 4 is a front perspective view of the platform shown in Fig. 3;
- 25 Fig. 5 is a rear perspective view of the platform shown in Fig. 3;
- Fig. 6 is a rear perspective view of the platform shown in Fig. 3, wherein the platform

is shown without a surface layer;

Fig. 7 is a bottom view of the wheels of the platform shown in Fig. 3;

Figs. 8 and 9 are bottom views of alternate wheel orientations and platform base shapes;

5 Fig. 10 is a partial enlarged rear perspective view of an upper portion of the platform shown in Fig. 3;

Figs. 11A and 11B are side elevation views of an embodiment of a bed hook;

Figs. 12-14 are side elevation views of the bed hook of Figs. 11A and 11B in various operable positions with a bed;

10 Fig. 15 is a transparent rear perspective view of the platform shown in Fig. 3, wherein the platform structure is superimposed over an embodiment of a transmission system;

Fig. 16 is a partial enlarged rear perspective view of the platform shown in Fig. 15, wherein the handle of the transmission control mechanism is shown in its alternate positions;

15 Fig. 17 is a perspective view of alternate positions of the transmission control mechanism shown in Fig. 15;

Fig. 18 is an enlarged perspective view of a portion of the device shown in Fig. 17;

Fig. 19 is a perspective view of a portion of the transmission system shown in Fig. 15;

20 Fig. 20 is an enlarged side elevation view of the device shown in Fig. 19;

Fig. 21 is perspective view of an alternate embodiment of the device shown in Fig. 19;

Figs. 22-25 are various embodiments of motor braking circuits associated with the automatic braking system feature;

25 Fig. 26 is a braking force to velocity diagram associated with the automatic braking system feature; and

Fig. 27 is a schematic depiction of components that may be included in embodiments

of the present invention.

#### DETAILED DESCRIPTION OF THE INVENTION

In accordance with embodiments of the present invention, a platform is provided that  
5 has application for use in a variety of fields, one of which is in the field of health care.

Various embodiments of the platform may include an ergonomic structure suited for a patient to use the platform as a walking aid. In addition, embodiments of the invention may also comprise structure for accommodating on-board health monitoring and/or treatment equipment. These and other features are described in detail below.

10 Referring now to Fig. 1, an apparatus constructed in accordance with an embodiment of the present invention is generally identified by reference numeral 100. Support platform 100 includes a chassis, support frame or body 104 having a platform handle 108 located at or near a top 112 of the platform 100. The platform 100 also includes a perimeter rail 116 at its top 112, wherein the perimeter rail 116 is adapted for receiving a variety of health monitoring,  
15 treatment, or maintenance devices, such as equipment currently available for these purposes. The platform 100 further includes a base 120 described in further detail below.

Referring now to Fig. 2, an embodiment in accordance with the present invention is depicted wherein support platform 100' internalizes at least one of a number of ancillary devices that may be associated with the platform, and more preferably, the platform 100'  
20 internalizes a plurality of such ancillary devices. Accordingly, the support platform 100' preferably includes one or more modular receptacles 124 for items such as suction pumps, IV pumps, infusion pumps, and/or monitoring equipment. In addition, the support platform 100' may further included a receptacle or port for a personal computer 128. The receptacles  
25 replace the current pump technology and incorporate the devices into the platform to reduce its profile, overall weight and simplify the total set of devices attached to the patient.

Referring now to Figs. 3-5, an embodiment in accordance with the present invention

is depicted as support platform 100". Support platform 100" features a substantially open top 112 with a pair of elevated rails 132. In accordance with embodiments of the present invention, the perimeter of the top 112 includes a skirt 136 with one or more openings 138 for receiving hooks or other connecting hardware to attach a variety of health monitoring, maintenance and/or treatment devices.

Thus, embodiments of the present invention may comprise a substantially open configuration, as shown in Fig. 1 as support platform 100, or a modular and substantially internalized configuration, as shown in Fig. 2 as support platform 100', or an alternate configuration having interior cabinet space with a substantially open top 112, as shown in Figs. 3-5 as support platform 100", or other configurations, all of which are encompassed by the present invention and this description. Although support platforms 100, 100', 100" may have a variety of different features, they may also share similar structure and have various combinations of features. The following text and associated referenced drawings describe features that may be used individually or in combination for various embodiments of the present invention.

Referring to Figs. 1-3, support platform 100, 100', 100" include a body 104 having a height H. Height H is preferably a sufficient height for allowing a patient to stand and grasp platform handle 108 at the top 112 of the support platform 100, 100', 100" to aid the patient in support and/or balance while walking or standing. Height H is preferably adjustable, thereby allowing the support platform 100, 100', 100" to be modified to accommodate the height of the patient. Since patients vary from small children to large adults, the height H of the support platform 100, 100', 100" pertains to a functional aspect of the invention. Accordingly, the body 104 may include an adjustable or telescoping means for selectively varying the height H of body 104. The telescoping means may include one or more adjustable columns, and/or otherwise include interchangeable columns 140, such as those shown in Fig. 6, wherein Fig. 6 depicts a skeletonized view support platform 100". In



accordance with embodiments of the present invention, the columns 140 allow for adjustment of the height of the platform. Further, and in accordance with other embodiments of the present invention, one or more spacers 144 may also be incorporated into the body 104 of the support platform 100, 100', 100", wherein each spacer 144 serves to add additional height. In  
5 at least one embodiment, the spacer 144 comprises a supplemental height member having a thickness of between about 1-6 inches, and more preferably between about 2 to 4 inches. For the various embodiments of the present invention, the height H of the support platform 100, 100', 100" is between about 24 and 48 inches tall, and more preferably, between about 30 and 40 inches tall. However, other heights for short, tall and physically challenged individuals,  
10 and/or for platforms having other uses other than in the health care field are all within the scope of the present invention.

As noted above, the frame 104 of support platform 100, 100', 100" preferably includes a base 120, wherein the base has a stable configuration for supporting both the items on the support platform 100, 100', 100", as well as being able to support the added weight of a  
15 patient leaning on the platform handle 108. Accordingly, the base 120 is relatively large, but not too large so as to be clumsy to manipulate. For the embodiments shown in Figs. 1-5, the base 120 is substantially rectangular in shape, with a width W and a length L. For a rectangular base 120, the width W is preferably between about 16 to 28 inches wide, and more preferably between about 18 to 24 inches wide. The length L is preferably between  
20 about 16 to 28 inches long, and more preferably between about 18 to 24 inches long. However, it is to be understood that the base 120 may be a variety of shapes and configurations. For example, the base 120 may have a footprint that is substantially circular or hexagonal in shape.

As best seen in Fig. 6, the base 120 has a rear portion 148 and a front portion 152.  
25 Rear portion 148 preferably includes spaced apart base beams 156. The base beams 156 are preferably spaced apart to provide a preferential unobstructed area or opening 160 for the

patient to place their feet while holding the platform handle 108 and walking. Accordingly, the base beams 156 are preferably spaced apart a distance D, where distance D preferably varies between about 10 inches and 24 inches, and more preferably between about 14 inches and 20 inches. Providing a properly sized spaced apart distanced D provides for increased  
5 safety for the patient so that the patient does not trip when walking with the support platform 100, 100', 100".

In accordance with other embodiments of the invention, the base 120 may not be directional, or alternatively, the direction may be determined by the user to maximize the benefit of the wheel design to their health and expected use. For example, the wheel  
10 configuration may benefit weaker patients to overcome small obstacles when the base is oriented in a first direction. Conversely, healthier patients that expect to travel farther and faster may find that they have better control of the invention by changing the direction of the platform by 180°.

The base 120 preferably includes a plurality of casters or wheels 164. More  
15 preferably, the base 120 includes at least three wheels set in a triangular orientation, and more preferably yet, at least four, five or six wheels spaced apart in various configurations along the bottom of the footprint of base 120. As seen in Fig. 6, and in accordance with embodiments of the present invention, at least some of the wheels 164 preferably include a swivel connector 172 between the wheel 164 and the base 120 of support platform 100, 100',  
20 100". For example, the middle pair of wheels 164b and the rear pair of wheels 164a (interconnected by the base beams 156) may include swivel connectors 172, while the orientation of the front wheels 164c may be fixed. Alternatively, all wheels 164 may have a swivel connector 172 between the wheel 164 and the base 120.

Referring now to Fig. 7, the underside of base 120 of a first preferred embodiment is  
25 illustrated. Base 120 is shown having a substantially C-shaped overall footprint when viewed from a side of the support platform 100, 100', 100". In accordance with at least one

embodiment of the present invention, the base 120 comprises six wheels 164 that provide a means for rotating that is interconnected to the frame and contacting the underlying surface, such as a floor surface. A first pair of wheels 164a is preferably positioned under beams 156 at the rear portion 148 of the base 120, such that one wheel 164a is under a left base beam 156 and another 164a is under the right base beam 156. In addition, a second pair of wheels 164b is preferably positioned at an intermediate position along the length of the support platform 100, 100', 100'', such as along a mid-axis MA-MA of base 120. Again, one wheel 164b is preferably located under the left side of the platform, and another wheel 164b is located under the right side of the support platform 100, 100', 100''. Finally, a third set of wheels 164c is preferably located toward a front portion 152 of the support platform 100, 100', 100''. In at least one embodiment of the invention, the front wheels 164c are set closer to a center longitudinal axis C-C of the platform as compared to the first and second pairs of wheels 164a, 164b at the rear and intermediate positions along the support platform 100, 100', 100''. In accordance with at least one embodiment of the invention, the third set of wheels 164c preferably comprise a larger diameter than at least one of the first pair of wheels 164a and the second pair or wheels 164b. In addition, for the wheel configuration shown in Fig. 7, the first wheels 164a on the right and left sides are substantially equidistant from the center longitudinal axis C-C as the second wheels 164b on both the right and left sides of the support platform 100, 100', 100''.

Referring now to Figs. 8 and 9, and in accordance with embodiments of the present invention, alternative arrangements of the wheels 164 are within the scope of the present invention. Fig. 8 depicts a configuration wherein the wheels 164a, 164b, and 164c are all equidistant from the center longitudinal axis C-C of the support platform 100, 100', 100''. With regard to Fig. 9, a modified shape of the base is shown as base 120'. Base 120' is shown with five wheels 164, wherein the base 120' has a substantially circular footprint but with an arcuate shaped opening 160 bounded by an arcuate shaped front base portion 168 for the

patient's feet as they walk with the support platform 100, 100', 100". Other configurations of the base are considered within the scope of the present invention.

In accordance with various embodiments of the present invention, the wheel positions includes alternate configurations designed to best address the issues of overcoming a raised  
5 obstacle such as a carpet/tile transition or door threshold, spanning a gap such as an elevator threshold, maintaining extreme maneuverability in areas with limited space, and maintaining directional tracking to aid with control as a patient ambulates. Accordingly, the alternative wheel configurations of the present invention provide for advantageous maneuverability and stability, and thus increased safety for the patient using the support platform 100, 100', 100".

10 The wheels 164 are preferably sized to provide added stability to the support platform 100, 100', 100". Accordingly, wheels 164 are preferably between about 2 to 10 inches in diameter, and more preferably between about 3 to 9 inches in diameter, and more preferably yet, a combination of wheels with the smaller wheels 164a, 164b measuring about 3 to 5 inches in diameter and the larger wheels 164c measuring about 7 to 8 inches in diameter.

15 Referring again to Figs. 1-3, the platform handle 108 is an integral part of the support platform 100, 100', 100". In at least one embodiment of the invention, the handle 108 comprises a particular ergonomic design that allows the user to push and use the platform while their hands are kept in a comfortable position. The design also minimizes the ability of the user to tip the platform when applying a force to the platform handle 108.

20 In accordance with another aspect of the invention, the support platform 100, 100', 100" includes a platform top 112 for holding a number of optional components (also referred to as "ancillary devices") as discussed hereafter. The platform top 112 is preferably operatively interconnected to a means for holding an IV bag. The means for holding an IV bag preferably includes at least a section of a pole 176, and/or a hook 180, and/or a rail 132,  
25 and/or the skirt 136 with a carabiner clip, and/or other hook attachment located either above or below the platform top 112. Additionally, existing IV, enteral and syringe pumps used by

health-care facilities will be accommodated on either a pole 176 or rail system 132 located on top of the platform top 112. The support platform 100, 100', 100" will be able to accommodate from zero to six pumps, and more preferably zero to four pumps. For the embodiments depicted in Figs. 1-5, various maintenance and treatment devices are hung or  
5 otherwise interconnected to the support platform 100, 100', 100", on the rails 132, resting on the top 112, or hanging from the skirt 136.

In accordance with embodiments of the present invention, an attachment device comprising a custom carabiner may be provided and used to releasably attach IV bags or other medical equipment, such as an infusion pump, to the platform's support structure. For  
10 example, such attachment devices may be used both on the rail 132 or the skirt 136 the support platform 100, 100', 100". In accordance with at least one embodiment of the present invention, the carabiners provide adequate gate clearance to accommodate both the rail 132 or skirt 136, and provide easy interconnectivity and removability of the previously listed devices or IV bags from the support platform 100, 100', 100". In another aspect of the invention, the  
15 carabiners preferably comprise of different colors in order to categorize IV fluids for rapid easy identification by healthcare providers. For example, IV fluids without added medication may hang from blue carabiners, IV fluids with antibiotic additives may hang from green carabiners, and IV fluids containing vasopressor additives may hang from red carabiners.

The platform top 112 or other portions of the frame 104 can include one or more  
20 other devices or apparatus, including such items as fluid reservoirs, metering pumps, cup/bottle holders, trays, a sitting stool, monitoring devices, computers, and communication devices, as well as a television, camera, phone or radio. Power receptacles 184 may also be provided either associated with the platform top 112 or frame 104 that will allow for multiple electronic devices to be plugged into either side of the platform. The consumer may or may  
25 not decide the number of receptacles. In addition, a retractable power cord 188 may also be provided on the support platform 100, 100', 100".

In a separate aspect of the invention, the support platform 100, 100', 100'' preferably includes communication equipment to receive vital sign information from the patient by wired or wireless means. The information may then be transmitted wirelessly to the appropriate medical staff or alarm systems while the patient is using the support platform 100, 100', 100''.

5 The support platform 100, 100', 100'' preferably is interconnected to a stationary outlet while at the patient's bed, and then when disconnected to allow movement, the on-board communication system preferably provides wireless signals.

The vital sign collection equipment is considered an integral part of the invention as these interact explicitly with the support platform 100, 100', 100''. The devices gather  
10 information regarding a patient's heart rate, non-invasive blood pressure, arterial blood pressure, central venous pressure, urine output, abdominal compartment pressure, respiratory rate, oxygen saturation and any other information that may be relevant to a patient's care. Other data from devices such as the bed and ventilator to include patient weight, bed alarms and ventilator parameters may be received and transmitted through the support platform as  
15 well.

In a separate aspect of the invention, the support platform 100, 100', 100'' preferably includes an on-board oxygen supply 192. In use, for those patients needing an oxygen supply, the tubing is preferably directly interconnected to the patient. The oxygen supply may be an existing oxygen bottle system or preferably includes tubing connections to allow the  
20 support platform 100, 100', 100'' to be interconnected to a stationary oxygen source, such as a wall outlet that carries and delivers oxygen to a patient's hospital room. Accordingly, the support platform 100, 100', 100'' can be positioned at the side of the patient's bed, and when the patient leaves his or her bed, the tubing from the support platform 100, 100', 100'' is disconnected from the stationary oxygen source, without substantial interruption in the flow  
25 of oxygen to the patient. Accordingly, the support platform 100, 100', 100'' preferably includes a bypass connection for utilizing a stationary oxygen source when the support

platform 100, 100', 100" has tubing interconnected to the stationary oxygen source.

In yet a separate aspect of the invention, the support platforms 100, 100', 100" preferably includes a chargeable battery and/or chargeable uninterruptible power supply, (where a chargeable battery and/or chargeable uninterruptible power supply is herein referred to collectively or singularly simply as "UPS") 200. The UPS 200 is preferably located near the base 120 to provide a relatively low center of gravity for the support platform 100, 100', 100". The UPS 200 allows the support platform 100, 100', 100" to be unplugged from a stationary power source, such as a wall outlet, with the platform's UPS 200 maintaining power to all of the on-board systems, such as the injection pumps, suction pumps, and vital sign monitoring equipment. In addition, the UPS 200 provides a back-up power supply to the electronic devices interconnected to it. Therefore, in the event of a power outage, the UPS 200 provides emergency power to the electrical devices interconnected to the platform's UPS 200. This is particularly advantageous for site locations that do not have an emergency back-up generator connected to the building's power supply. Preferably, the UPS 200 charges when it is plugged into a wall outlet while the devices remain operational.

For platforms utilizing electrical devices, the support platform 100, 100', 100" is preferably pre-wired and includes an electrical system. Therefore, the support platform's built-in modularity and electrical system limits the number of cords to power the modular electrical devices, such as pumps or monitoring devices. Accordingly, in one preferred embodiment, injection pumps, suction pumps, monitoring devices, and/or communication equipment can be quickly snapped into place into the frame 104 of support platform 100, 100', 100", such as in the platform top 112 of the support platform, with the power supply to the subject device provided by the hook-up port 184 or receiving connector on the support platform 100, 100', 100".

In a separate aspect of the invention, the support platform 100, 100', 100" preferably includes an umbilical cord (not shown) having common plug for interconnecting a plurality of

systems to a single outlet, such as a wall outlet. The umbilical cord may include a variety of systems, including electrical power, oxygen, suction, and/or a communication connection. When the patient uses the support platform 100, 100', 100" as a walking aid, or when the patient is moved in their bed with the support platform 100, 100', 100" interconnected to the bed or the support platform 100, 100', 100" is otherwise made mobile, the common plug is removed from the wall outlet, thereby not only freeing the support platform from being tethered to the wall, but also engaging the on-board UPS 200 to power any interconnected devices, as well as engaging the on-board oxygen supply and suction pump to the patient, if in use. Therefore, the umbilical cord and associated common plug allows for a quick and easy disengagement from a stationary hook-up. In addition, in order to engage the support platform 100, 100', 100" to the systems available from a stationary source, such as a wall outlet, the common plug attached to the umbilical cord is simply engaged with the wall outlet, thus bypassing and/or recharging the support platform's on-board systems.

In yet a separate aspect of the invention, the support platform 100, 100', 100" preferably includes tube and wiring bundling channels or clips to organize the various tubes or wires that lead from the platform to the patient. The tube and wiring bundles are preferably situated to minimize the potential for the tubes or wires to interfere with objects as the support platform 100, 100', 100" is pushed by the patient or the patient is transferred by other personnel.

In yet a separate aspect of the invention, a hip or other body attachment (not shown) or aid can be provided to assist a patient in moving the support platform when the patient has a physical impediment to grasping the platform handle 108, such as may be the case if the patient has a broken arm, leg, pelvis, shoulder, scapula or ribs. Other physical impairments such as arm and leg amputations can be addressed with other attachments either to the platform or patient. A hip attachment would be one such attachment that would interconnect the support platform 100, 100', 100" to the patient, such as by a cushioned bar positioned at or



near the patient's hip.

In a separate aspect of the invention, the support platform may include an interior space and/or compartments for holding reservoirs or bags. For example, as shown in Figs. 2-5, the support platform 100', 100" may include a cabinet area 204 or other enclosure, the cabinet area 204 preferably including one or more drawers 208, doors 212 and/or access panels 216. Hooks or modular receptacles can be provided within the cabinet space. The interior space or cabinet area 204 can be configured to receive one or more urine or drainage bags. More preferably, in accordance with embodiments of the invention, the collection chambers can accommodate canister assemblies (not shown) designed to provide a mechanism of measuring the volume of the canisters automatically. This system may include a float, conduction or transmission mechanism. This information could then be converted to electronic data that could be transmitted along with other patient vital statistics as described elsewhere in this document.

Referring now to Figs. 10-14, and in accordance with another aspect of the invention, the support platform 100, 100', 100" comprises a mechanism for being releasably attached to another object, such as a bed, hand rail, vehicle, etc. In accordance with at least one embodiment of the invention, support platform 100, 100', 100" includes at least one bed hook 1000, and more preferably, a plurality of bed hooks 1000. The bed hooks 1000 provide a means for temporarily docking the support platform 100, 100', 100" to a bed when the platform is not being used as walker by a patient. The bed hooks 1000 allow the support platform 100, 100', 100" to remain stationary and attached to the patient's bed if it is inadvertently bumped by a hospital staff member, patient, or visitor. In addition, the bed hooks 1000 can be used to secure the support platform to the patient's bed if the patient is moved while remaining within the bed and the support platform is required to move with the bed. For this type of use, an additional staff member is not needed to roll the support platform 100, 100', 100" adjacent to the moving bed. The bed hooks 1000 allow the support

platform 100, 100', 100'' to be lifted by another object, such as the patient's bed, such that the wheels 164 the platform are suspended, thereby making transportation easier because only the wheels on the bed need be controlled.

Referring now to Figs. 5 and 10, an upper portion 220 of a support platform 100, 100', 100'' is shown that includes a pair of bed hooks 1000, wherein a first bed hook 1000 is located adjacent to or at a right side of the support platform 100, 100', 100'' and a second bed hook 1000 is located adjacent to or at a left side of the support platform 100, 100', 100''. For the embodiment of the support platform 100'' shown in Figs. 3-5, the bed hooks 1000 are located at the rear portion 148 of the support platform 100''. However, it is to be understood that the bed hooks 1000 may be used on any version of the support platform, including support platform 100, 100', 100'', and furthermore, the bed hooks 1000 may be located not only at the rear 148 of the support platform, but also at the front 152 or along a side of the support platform.

Each bed hook 1000 preferably includes an arm member 1004 that is rotatable in at least one direction, or outward from the support platform, such as per arrow A<sub>1</sub>. In addition, at least a portion of the arm member 1004 is also rotatable in a second direction when engaging a bed or other object to which it is being attached, such as per arrow A<sub>2</sub>. More particularly, and as described in additional detail below, the arm member 1004 is first rotated to extend away from the platform, as per arrow A<sub>1</sub>, and then the arm member 1004 may be rotated again as per arrow A<sub>2</sub> to engage the bed or other object. As shown in Fig. 10, arm member 1004 is preferably located in a retracted or first position 1008, wherein the arm member 1004 is closed or positioned substantially adjacent the upper portion 220 of the support platform 100, 100', 100''. More particularly, when closed, a side surface 1012 of the arm member 1004 is situated adjacent a rear side 1016 of the support platform 100, 100', 100''. The arm member 1004 is then rotated on a hinge 1020 to an open or second position

1024 for engagement with an object, such as a bed. Thus, the bed hooks 1000 preferably feature a plurality of positions so that they remain unobtrusive when not in use. In addition, the bed hooks 1000 preferably include a material suitable for gripping, such as a plastic or rubber pad (not shown).

5 Referring now to Figs. 11A and 11B, the arm member 1004 is shown in an extended or open position 1024. In accordance with embodiments of the present invention, the arm member 1004 includes a lateral branch 1100 and a rotatable gripper portion 1104. The gripper portion 1104 is rotatably interconnected to the lateral branch 1100 by a pin 1108. In accordance with embodiments of the present invention, the gripper portion 1104 includes a  
10 pinching finger 1112 that has an inside surface 1116 for contacting the bed or object to which the support platform 100, 100', 100'' is to be attached. In addition, the gripper portion 1104 further includes an upper finger 1120 with an underside 1124 for also contacting the bed or object to which the support platform is to be attached. As shown in Fig. 11A, the gripper portion 1104 is in an unhooked position 1128. Upon rotation of the gripper portion 1104  
15 about pin 1108, the pinching finger 1112 moves toward the support platform to clamp or engage the bed.

Referring now to Figs. 12-14, a support platform 100, 100', 100'' with bed hooks 1000 is shown in use. As shown in Fig. 12, the bed hooks 1000 are depicted in the open position 1024 prior to engaging a portion of the bed B, such as a head board, foot board or  
20 rail. The portion of the bed B to engage the support platform 100, 100', 100'' is then raised. As seen in Fig. 13, an upper surface BS of the bed B contacts the underside 1124 of the upper finger 1120 of the gripper portion 1104. Referring now to Fig. 14, as the bed B is raised further, the gripper portion 1104 rotates about pin 1108 relative to the lateral branch 1100. In so doing, the pinching finger 1112 rotates toward the rear side 1016 of the support platform  
25 100, 100', 100'', thereby pinching the bed B between the inside surface 1112 of the pinching finger and the rear surface 1016 of the support platform 100, 100', 100''. With continued

raising the bed B, the bed B will lift the support platform 100, 100', 100" from the floor. The bed B can then be moved with the support platform 100, 100', 100" releasably attached to the bed B. The bed hooks 1000 thus provide a means for moving the platform and the bed as a unit, without the need for a separate attendant or nurse to guide the support platform as  
5 another person moves the bed.

In accordance with embodiments of the present invention, an alternative attachment device (not shown) may be used to releasably attach the support platform 100, 100', 100" to a bed or other object. For example, the platform handle 108 may be modified for engaging a portion the bed or another object. Such alternative attachment device may include an  
10 adjustable setting that allows the alternative attachment device to be configured for use with a variety of bed frames or wheelchair configurations or other vehicles, such as automobiles or motorized platforms.

Referring now to Fig. 15, and in accordance with at least one embodiment of the invention, the support platform 100, 100', 100" may include a selectable transmission system  
15 1500. Fig. 15 illustrates a number of components of the transmission system 1500 in solid lines, with other aspects of the support platform 100, 100', 100" superimposed over the transmission system. It is to be understood that the transmission system 1500 is also applicable to support platform 100, 100', 100", as well as other platforms that embody the present invention.

In general, the transmission system 1500 comprises a selectable control bar 1504 that  
20 is connected to a control shaft 1508 that controls a transmission applicator mechanism 1512. In accordance with embodiments of the present invention, transmission system 1500 preferably has a plurality of settings or modes that can be selected using the control bar 1504. For the embodiments illustrated in Figs. 15-21, three different settings are provided; however,  
25 it is to be understood that a transmission system with an alternate number settings is possible, such as two settings.

Referring now to Figs. 16 and 17 that each show a portion of the transmission system 1500, the control bar 1504 is preferably interconnected to a handle 1600, wherein the handle 1600 is movable along slot 1604, thereby allowing a user or healthcare staff member to select the setting for the transmission system 1500. More particularly, as shown in Fig. 16, a first setting corresponds to a stop mode, a second setting corresponds to a walk mode, and a third setting corresponds to a roll mode. In accordance with the embodiment and view shown in Fig. 16, the stop mode is the left-most position 1608a shown for the handle 1600, the walk mode is an intermediate position 1608b shown for handle 1600, and the roll mode is the right-most position 1608c shown for handle 1600. In general, the stop mode corresponds to having the support platform 100, 100', 100" stationary, the walk mode corresponds to placing the support platform 100, 100', 100" in a controlled state for a patient to ambulate using the support platform 100, 100', 100" as a walking aid, and the roll mode corresponds to a free-rolling state wherein the support platform 100, 100', 100" can be quickly and easily rolled, such as by a healthcare staff member moving the support platform 100, 100', 100" to a patient's room from a storage area.

In accordance with embodiments of the present invention, and as best seen in Figs. 17 and 18, although not required, a second handle 1600 may be positioned at the front of the support platform 100, 100', 100" to allow control of the transmission system 1500 from the front of the support platform 100, 100', 100". This configuration offers several advantages, including that a healthcare staff member can set the transmission system 1500 when a patient is at the rear of the support platform 100, 100', 100" and substantially blocking the handle 1600 at the rear of the support platform 100, 100', 100". Whether at the front or back of the support platform 100, 100', 100", the handle 1600 is generally moved transversely to a vertical axis V-V of the support platform 100, 100', 100" within the slot 1604. The handle 1600 is preferably interconnected to the control bar 1504 using an interconnection mechanism

1800 comprising connecting hardware 1804 that allows an end 1700 of the control bar 1504 to rotate relative to the handle 1600, such that a longitudinal axis H-H of the handle 1600 remains substantially parallel to a front to rear axis A-A of the support platform 100, 100', 100" as the handle 1600 is moved along slot 1604. The control bar 1504 rotates at pivot point 5 1704 about a rotational axis that corresponds to the longitudinal axis S-S of the control shaft 1508. Although only one control shaft 1508 is shown, the control bar 1504 may be interconnected to a plurality of shafts that lead to one or more transmission applicator mechanisms.

Referring now to Figs. 19 and 20, and in accordance with at least one embodiment of 10 the present invention, a transmission applicator mechanism 1512 is shown that includes functionality corresponding to the three transmission settings of stop mode 1608a, walk mode 1608b and roll mode 1608c. The transmission applicator mechanism 1512 generally includes a cam 1900 that is connected to the control shaft 1508. In at least one embodiment, the cam 1900 provides at least a means for adjusting the position of the drag wheel. When the handle 15 1600 is moved along slot 1604, the control bar 1504 rotates the control shaft 1508, and the cam 1900 also rotates. As the cam 1900 rotates, the transmission applicator mechanism 1512 either (1) applies both a brake assembly 1904 and a drag wheel assembly 1908 to the floor (or other surface under the platform) when the transmission system 1500 is set to the stop mode 1608a, (2) maintains the brake assembly 1904 in a raised position while the drag wheel 20 assembly 1908 contacts the floor when the transmission system 1500 is in the walk mode 1608b, or (3) maintains both the brake assembly 1904 and the drag wheel assembly 1908 in raised positions while the transmission system 1500 is in the roll mode 1608c.

The brake assembly 1904 may comprise a variety of configurations, and in one embodiment comprises a post 2000 that is connected to a stopper 2004 at the distal end 2008 25 of the post 2000. The stopper 2004 may comprise a variety of materials and configurations, but generally includes characteristics that will generate a relatively large frictional force with

the underlying floor. For example, the stopper 2004 may comprise a rubber or plastic structure that tends to generate a large amount friction with the floor. Although the example stopper 2004 shown in Fig. 20 is cylindrical in shape with a circular distal end 2012 for contacting the floor, the stopper 2004 may be elongated in a direction transverse to the post 5 2000 such that a relatively wide contact area is formed with the floor. The post 2000 extends from the stopper 2004 to the cam 1900, and includes an upper flange 2016 at its proximal end 2020 at the cam 1900, and a lower flange 2024 that resides adjacent and below a base panel 2028. As will be discussed in more detail below, the brake assembly 1904 also preferably includes a biasing member 2032 that resides between the lower flange 2024 and the stopper 10 2004. As shown in Fig. 20, and in accordance with at least one embodiment, the biasing member 2032 comprises a compression spring, but may also comprise other structure, such as an air cylinder.

The drag wheel assembly 1908 provides a means for frictionally engaging the underlying surface, and in at least one embodiment comprises a wheel 2036 interconnected to 15 the base panel 2028 by a movable linkage arm 2040, wherein the linkage arm 2040 can be lowered and raised to either apply the wheel 2036 to the floor, or to raise the wheel 2036 from contacting the floor. As discussed in more detail below, the drag wheel assembly 1908 preferably incorporates a rotation resistance mechanism that is interconnected to the wheel 2036 such that the wheel 2036 acts as a governor to control the speed of the support platform 20 100, 100', 100". The linkage arm 2040 is preferably interconnected to the cam 1900 by a post 2044 that extends from a pivot point 2048 at the linkage arm 2040 to the cam 1900. The post 2044 includes an upper flange 2016 at its proximal end 2020 at the cam 1900, and a lower flange 2024 that resides adjacent and below the base panel 2028. The assembly for the drag wheel assembly 1908 also preferably includes a biasing member 2032 that resides between 25 the lower flange 2024 and the pivot point 2048 at the linkage arm 2040.

Referring still to Figs. 19 and 20, and in accordance with at least one embodiment of

the present invention, the cam 1900 includes a first curved or arc-shaped channel 1912 to control the brake assembly 1904, and a second curved or arc-shaped channel 1916 to control the drag wheel assembly 1908. When handle 1600 is moved to the stop mode 1608a, the control bar 1504 rotates the control shaft 1508 such that the post 2000 of the brake assembly 1904 and the post 2044 of the drag wheel assembly 1908 are located at first positions 1920 and 1924 of the channels 1912 and 1916, respectively. At these first positions 1920 and 1924, both the brake assembly 1904 and the drag wheel assembly 1908 are engaged such that the stopper 2004 and wheel 2036 are in contact with the floor. When at the first position 1920, the post 2000 is in a lowered position because the cam thickness at the first position 1920 is such that the upper flange 2016 of post 2000 is lower relative to the base panel 2028. When in the first position 1920, the biasing member 2032 of post 2000 forces the stopper 2004 downward and in contact with the floor. Similarly, when post 2044 is in the first position 1924, the upper flange 2016 of post 2044 is also lower relative to the base panel 2028 and the biasing member 2032 of post 2044 forces the linkage arm 2040 downward and places the wheel 2036 in contact with the floor.

Upon sliding handle 1600 to the walk mode 1608b position, the control bar 1504 rotates and turns the control shaft 1508, thereby turning the cam 1900. As the cam 1900 is turned, posts 2000 and 2044 remain laterally stationary and traverse the cam 1900 along channels 1912 and 1916, respectively. The posts 2000 and 2044 are then located at the second positions 1928 and 1932 along the first and second channels 1912 and 1916, respectively. In addition, as the proximal end 2020 of post 2000 for the brake assembly 1904 moves along first curved channel 1912 from the first position 1920 toward the second position 1928, the post 2000 rises because the upper flange 2016 of post 2000 encounters cam transition ramp 1936. The rise in cam transition ramp 1936 pulls the stopper 2004 off the floor and compresses the biasing member 2032 between the stopper 2004 and the lower flange 2024. In addition, as the cam 1900 is turned, the post 2044 remains in its lowered



position because the elevation of the upper flange 2016 of the post 2044 at the second position 1932 is substantially equal in elevation to the elevation of the upper flange 2016 when the post 2044 is in the first position 1924.

Upon sliding handle 1600 from the walk mode 1608b position to the roll mode 1608c position, the control bar 1504 again rotates and turns the control shaft 1508, thereby once again turning the cam 1900. Once again, the posts 2000 and 2044 remain laterally stationary and traverse the cam 1900 further along channels 1912 and 1916, respectively. The posts 2000 and 2044 are then located at the third positions 1940 and 1944 along the first and second channels 1912 and 1916, respectively. In addition, as the proximal end 2020 of post 2044 for the drag wheel assembly 1908 moves along second curved channel 1916 from the second position 1932 toward the third position 1944, the post 2044 rises because the upper flange 2016 of post 2044 encounters a second cam transition ramp 1936. The rise in cam transition ramp 1936 pulls the linkage arm 2040 upward and the wheel 2036 off the floor and also compresses the biasing member 2032 between the pivot point 2048 of the linkage arm 2040 and the lower flange 2024 of post 2044. In addition, as the cam 1900 is turned from the walk mode 1608b to the roll mode 1608c, the post 2000 remains in its upper position because the elevation of the upper flange 2016 of the post 2000 between the second position 1928 and third position 1940 is substantially equal in elevation.

The biasing members 2032 for both posts 2000 and 2044 place the brake assembly 1904 and the friction wheel assembly 1908 in a preferred state of engagement because the biasing members 2032 tend to force the down the stopper 2004 and the wheel 2036. That is, work has to be done against the biasing member 2032 for post 2000 to move the handle 1600 from the stop mode 1608a to the walk mode 1608b, and work also has to be done against the biasing member 2032 for post 2044 to move the handle 1600 from the walk mode 1608b to the roll mode 1608c. Thus, if a person is operating the support platform 100, 100', 100" in walk mode 1608b, it is relatively easy to place the handle 1600 in stop mode 1608a and apply

the stopper 2004 to the floor because the biasing member 2032 of post 2000 tends to want to force the post 2000 and stopper 2004 downward. This is a safety feature of the transmission system 1500.

Referring now to Fig. 21, an alternate embodiment of a transmission applicator mechanism 1512' is shown. For clarity, the base panel 2028 has been omitted from Fig. 21. Similar to that described above for the assembly 1512 shown in Figs. 19 and 20, the cam 1900' shown in Fig. 21 includes a first channel 1912 for controlling post 2000 of the brake assembly 1904. The transmission applicator mechanism 1512' further includes a drag wheel assembly 1908' that utilizes two posts 2004a' and 2004b' to control the vertical position of the wheel 2036 through two channels 1916a' and 1916b' in cam 1900'. Although a linkage arm 2040 is not used with transmission applicator mechanism 1512', the operation of the transmission applicator mechanism 1512' is similar to that described above for transmission applicator mechanism 1512. Thus, upon rotation of the cam 1900' in stop mode, the stopper 2004 and wheel 2036 are lowered to contact the floor, and in walk mode the stopper 2004 is raised, while in roll mode both the stopper 2004 and the wheel 2036 are raised from contacting the floor. Thus, the transmission system 1500 may take on a variety of configurations, including alternate transmission applicator mechanisms, and such alternate embodiments and modifications are encompassed by the present invention.

Referring now to Figs. 20 and 21, and as mentioned above, the drag wheel assembly 1908 preferably includes a rotation resistance mechanism 2052 that is interconnected to the drive wheel 2036, thereby enabling the wheel 2036 to restrict the speed of the support platform 100, 100', 100". In accordance with embodiments of the present invention, the rotation resistance mechanism 2052 may take the form of a friction pad (not shown) that engages at least a portion of the wheel 2036 and/or structure operably interconnected to the wheel 2036. More preferably, however, the rotation resistance mechanism 2052 comprises a braking motor 2056 interconnected to the wheel 2036, such as by way of the wheel's axle. In

accordance with embodiments of the present invention, the braking motor 2056 is interconnected to the wheel 2036 through a gearbox. The braking motor 2056 applies a force to the wheel 2036 to slow the wheel 2036 under the principle that little or no wheel speed requires the application of no braking, but high wheel speed requires the application of  
5 braking work on the wheel 2036 by the braking motor 2056. More particularly, as wheel speed increases, the output of the braking motor 2056 increases. The increased output results in an increased load on the braking motor 2056, increasing the braking force applied to the wheel 2036. The braking motor 2056 may comprise a permanent magnet DC motor. Furthermore, as can be appreciated by one of skill in the art after consideration of the present  
10 invention, the braking motor 2056 is not connected to a source of electrical power, but is instead driven as a generator (i.e., a source of electrical power) by the wheel 2036.

Referring now to Fig. 22, a schematic of a motor braking circuit 2200 for applying a braking force to the wheel 2036 in response to a voltage generated by the braking motor 2056 in accordance with embodiments of the present invention is illustrated. The circuit shown in Fig.  
15 22 is a multi-stage Zener diode auto-transmission system or braking circuit 2200 for automatically applying a braking force to the wheel 2036. In general, use of a number of different Zener diodes allows different stages of resistance to be applied progressively, as the voltage produced by the motor increases. As can be appreciated by one of skill in the art, the voltage produced by the braking motor 2056 will tend to increase as the rotational velocity of  
20 the wheel 2036 driving the braking motor 2056 increases. Furthermore, by switching in additional resistive loads as the voltage produced by the braking motor 2056 increases, and therefore drawing more current, the braking effect of the braking motor 2056 can be increased in steps.

In accordance with embodiments of the present invention, each stage 2204 of the  
25 circuit 2200 comprises at least one zener diode 2208 and at least one load resistor 2212. The zener diode ZD1 2208 of the first stage 2204a is selected to have a turn on or a breakdown

voltage (*i.e.* a zener voltage) that is relatively low. When the zener voltage is exceeded, the zener diode ZD1 2208 conducts, allowing current to pass through the load resistor R1 2212. Accordingly, the zener diode ZD1 2208 acts as a switching mechanism. The current draw from the introduction of this load will load the braking motor 2056 such that the resistance to rotation of the wheel 2036 (not shown in Fig. 22) will increase essentially linearly with  
5 increased speed. The second stage 2204b is in parallel with the first stage 2204a and has a zener diode ZD2 2208 that is selected to have a zener voltage that is higher than the first zener diode ZD1 2208. If the voltage produced by the braking motor 2056 meets or exceeds the zener voltage of the second zener diode ZD2 2208, the second zener diode ZD2 2208  
10 conducts, allowing current to pass through the load resistor R2 2212 associated with the second stage 2204b of the circuit 2200. Accordingly, this zener diode ZD2 2258 also acts as a switching mechanism. Since the first zener voltage is lower than the second zener voltage, the first zener diode ZD1 2208 will continue to conduct while the second zener diode ZD2 2208 is conducting. Accordingly, two current paths through two of the stages 2204 will be  
15 active, increasing the rate at which the load increases with increased braking motor 2056 speed as compared to when only the first zener diode ZD1 2208 is conducting. As shown in Fig. 22, additional parallel circuit branches or stages 2204 comprising additional zener diode 2208 and load resistor 2212 pairs can be included, to provide any number of steps in the resistance produced at the wheel 2036 as the rotational speed of the wheel 2036 increases.  
20 For example, in Fig. 22 three stages 2204 (stages 2204a, 2204b and 2204c) are included. However, fewer or additional stages 2204 may be included depending on the desired number of steps in the rate of resistance provided by the circuit 2200.

As can be appreciated by one of skill in the art, the zener voltage is generally higher than the voltage at which a zener diode will conduct a forward current. Therefore, if the  
25 braking motor 2056 is operated in the opposite direction, such that if a negative voltage is produced at the first terminal of the braking motor 2056, a circuit with branches or stages

configured like the first three branches 2204a-c of Fig. 22 will allow the load introduced by the associated resistors to be applied at a much lower voltage than when the motor is operated in the other direction. This may be desirable, for example where it is desirable to have the platform move only in a forward direction while in the walk mode. In order to allow for

5 resistance to be applied in a similar fashion in either a forward or reverse direction, blocking diodes 2216 can be introduced in the circuit branches. By introducing blocking diodes 2216, current is only conducted by a stage 2204 when a voltage is applied to that stage's 2204 zener diode 2208 as a reverse voltage, because the blocking diode 2216 will prevent a forward voltage from being applied to this zener diode 2208. Additional circuit branches 2204 can

10 then be provided for progressively introducing a load when the braking motor 2056 is operated in the reverse direction. These additional circuit branches 2204 (see branches 2204d, 2204e and 2204f in Fig. 22) are oriented such that the associated zener diode 2208 and blocking diode 2216 are opposite the orientation of those included in the circuit branches for providing progressively increasing braking force in the forward (opposite) direction (branches

15 2204a, 2204b and 2204c in Fig. 22). Although only three stages or branches 2204 for applying a braking force in a reverse direction are shown, it should be appreciated that fewer or additional of such stages may be provided.

Referring now to Fig. 23, an alternate embodiment for motor braking circuitry is shown. The motor braking circuit 2300 shown in Fig. 23 is a multi-stage metal-oxide

20 semiconductor field-effect transistor (MOSFET) auto-transmission system for automatically applying a braking force to the drive wheel 2036. In general, in the first stage 2302a, when the voltage divided down by resistors R2 2304 and R7 2304 is greater than  $V_{th}$  of transistor Q1 2308, transistor Q1 2308 will turn on and apply the load resistor R8 2312 to the braking motor 2056. Accordingly, the voltage dividing resistors 2304 and the transistor 2308

25 comprise a switching mechanism. Subsequent stages in parallel with the first stage set to different points will add more load in a similar fashion once the set voltage for such stages is

met or exceeded. For example, a second stage 2302b is illustrated in Fig. 23, which may be configured to turn on at a higher voltage than the first stage 2303a. The transistors Q3 and Q4 2308 in the third 2302c and fourth 2302d stages are set in the opposite direction and will work in the reverse direction. Accordingly, the third and fourth stages 2303 and may be included in  
5 order to apply stages of resistance when the braking motor 2056 is turned in a direction opposite the direction the braking motor 2056 is turned to activate the first and second stages 2302a-b. Also, the body diodes of the transistors 2308 may be blocked or protected by a blocking diode 2316. Although four stages 2302 are shown in Fig. 23 (two for activation in a forward direction and two for activation in a reverse direction), it should be appreciated that  
10 any number of stages 2302 can be provided.

Referring now to Fig. 24, an additional alternate embodiment for motor braking circuitry is shown. The motor braking circuit 2400 shown in Fig. 24 is a multi-stage Silicon Controlled Rectifier (SCR) braking system for automatically applying a braking force to the wheel 2036 (not shown in Fig. 24). In general, in the first stage 2404a, when the voltage  
15 across resistor R15 2408 gets high enough to send a trigger current through SCR D1 2412 allowing current to pass through load resistor R16 2416, SCR D1 2412 latches on and applies the load resistor R16 2415 to the motor 2056 until the motor voltage drops to the point where there is almost no more current through R16. The SCR 2412 and the resistor 2408 therefore comprise a switching mechanism. The second stage 2404b, in parallel with the first stage  
20 2404a, has a resistor R17 2408 selected such that a trigger current is not sent through the associated SCR D5 2412 until after the first stage 2404a has turned on. Accordingly, the resistance to movement of the braking motor 2056 can be stepped up once the output of the braking motor 2056 exceeds a predetermined amount. Third 2404c and fourth 2404d stages, each having an SCR 2412 having an orientation that is opposite the orientation of the SCRs  
25 2412 of the first 2404a and second 2404b stages can be provided to apply stages of braking force in a reverse direction. The third 2404c and fourth 2404d stages also include trigger

resistors R19 and R20 that are connected to an opposite node of the braking motor 2056 as compared to the trigger resistors R15 2408 and R17 2408 of the first 2404a and second 2404b stages. Although only two stages are shown for providing braking resistance in each direction, it can be appreciated that any number of stages maybe provided. Unlike  
5       embodiments described in connection with Figs. 22 and 23, the embodiment illustrated by Fig. 24 does not switch out the load resistor of a stage at the trigger voltage for that stage, but instead retains the current path through the load resistor until a much lower voltage is reached (*e.g.* almost zero).

Referring now to Fig. 25, an alternate embodiment for motor braking circuitry is  
10       shown. The motor braking circuit 2500 shown in Fig. 25 is a hybrid circuit for automatically applying a braking force to the drive wheel 2036. In general, both an auto-transmission and an auto-braking feature are applied when different set resistances are achieved as a result of the voltage generated by the braking motor 2056. More particularly, the first stage 2502a is a stage incorporating a first switching mechanism for introducing a load resistor at a first  
15       voltage, while the second stage 2502b, which is in parallel with the first stage 2502a, incorporates a second switching mechanism for introducing a second load resistor at a second voltage. In the particular example of Fig. 25, the first stage 2502a uses a field effect transistor 2510 that allows current to pass through a first load resistor R23 2504 when the voltage divided down by set resistors R21 and R22 2508 is at a selected value. The second stage  
20       2502b incorporates a silicone controlled rectifier 2512 that is switched on by a trigger current through resistor R24 2516 when the voltage across that resistor reaches a predetermined value, allowing current to pass through the load resistor R25 2520. The particular arrangement illustrated in Fig. 25 may be useful in selected applications, for example where it is desirable to have a mobile platform brought back to a standstill (or near standstill) after it  
25       has reached a velocity that exceeds a pre-determined bound. Specifically, the first stage load resistor R23 2504 can be switched in at a relatively low voltage, while the second load

resistor R25 2520 can be switched in at a higher voltage, and the second load resistor will remain switched in until the voltage is almost zero. As can be appreciated by one of skill in the art, additional stages, hybrid or otherwise, can be combined with the illustrated stages 2502a-b, for applying a load resistance in the same or in opposite direction from the  
5 illustrated stages 2502.

Fig. 26 is a graph depicting how the braking force produced by a braking motor 2056 can be progressively increased with increased braking motor 2055 velocity by using an auto transmission or braking system circuit in accordance with embodiments of the present invention. With specific reference to plot 2600, in a first speed range 2604, the force may  
10 remain essentially constant, for example due to the friction of the various platform wheels and of the unloaded braking motor 2056. The first speed range 2604 corresponds to a platform velocity (and therefore a drive wheel 2036 and braking motor 2056 velocity) at which the output produced by the rotation of the braking motor 2056 produces a voltage that is not high enough to cause a stage of a motor braking circuit to establish a current path across a load  
15 resistor. Once the maximum speed in the first speed range is exceeded, a second speed range 2608 may be entered in which the braking motor 2056 is operated to apply a braking force, by applying a load through a braking circuit. More particularly, the minimum speed of the second speed range 2608 occurs at a rotationally velocity of the braking motor 2056 at which the braking motor 2056 produces a voltage sufficient to trigger application of a load stage or  
20 branch of the motor braking circuit. The force applied by the braking motor 2056, and therefore the force required to continue moving the platform initially experiences a step increase, and then increases at an essentially linear rate due to the introduction of the resistive load. In a third speed range 2612, the braking motor 2056 is producing a voltage that is high enough to trigger application of a second load branch, as well as the first load branch. Upon  
25 application of the second load branch, the resistance takes a step increase, and then increases with the voltage output by the braking motor at a rate that is greater than the rate of increase



when only the first load was active. Where the first and second load branch or branches each add equal resistive loads, the slope of the increase in the force required to continue rotating the braking motor 2056 increases with velocity at approximately twice the previous rate. If a third stage is included in the circuit, a fourth speed range 2616 can be defined. When the fourth range 2616 is entered, another step increase in the force occurs when the third stage load resistor is added, and the resistance then increases at a linear rate that is greater than the rate of increase in the previous range.

When the velocity of the braking motor 2056 is decreasing, the force applied to the drive wheel 2036 by the braking motor 2056 will follow the same curve as when the velocity was increasing if a zener diode or a pair of dividing resistors and a transistor are used as the switching mechanisms. However, where a resistor and an SCR are used as a switching mechanism, the load resistor associated with such a switching mechanism will continue to be applied until the velocity of the braking motor 2056 (and hence its output) is almost zero. For instance, in a three stage braking circuit in which every stage comprises a resistor and an SCR switching mechanism, once the third speed range 2616 is entered, as the velocity of the motor decreases path 2618 will be followed.

In accordance with other embodiments of the present invention, the values of load resistors included in stages of a braking circuit can be selected from a number of different values to provide a selected resistance at the drive wheel 2036. For example, a ganged switch may be used to select from two or more load resistors that are applied at one or more of the speed ranges. In accordance with still other embodiments of the present invention, a switch for selecting a load resistor can be separately provided for selecting the load resistor or resistors that are applied in forward and reverse directions with respect to the platform. User selectable resistance can also be achieved through use of a potentiometer in place of one or more of the provided load resistors, provided the potentiometer has a suitable load rating. An example of the effect of selecting different, higher resistance load resistors applied at different

stages of the braking motor circuit is shown in Fig. 26 as plot 2620. As alternative to being user selectable, the load resistors may be selected or (in the case of a potentiometer) tuned by operation of a switch that is not normally user accessible. In addition, it should be appreciated that a braking motor circuit in accordance with embodiments of the present invention may be tuned such that a load resistor is immediately or almost immediately provided with current by the braking motor 2056, which would eliminate or shorten the first range 2604 during which there is no or almost no increase in the resistive force produced by the braking motor 2056 with increased velocity of the platform. Such tuning may be user adjustable. It can be appreciated by one of skill in the art that the motor braking circuitry provides a means for variably controlling a resistance to the braking motor 2056.

In accordance with embodiments of the present invention, the weight of platform may be adjustable to provide a larger normal force for allowing more braking and/or stopping force to be effectively applied when the brake assembly 1904 and/or drag wheel assembly 1908 are engaged. For example, additional ballast (sand filled articles, weights, etc.) may be located on the support platform 100, 100', 100" to increase the weight of the support platform 100, 100', 100".

It is noted that the transmission system 1500 and/or the rotation resistance mechanism 2052 have application to a variety of platforms and/or mobile devices. For example, a walker may be adapted to incorporate one or more of the transmission system 1500 and the rotation resistance mechanism 2052. As other possible examples of alternative uses, a wheel chair, a baby stroller, a beverage platform for airlines, and/or a serving platform for cruise ships may incorporate these systems, and such applications and others are within the scope of the present invention.

Referring now to Fig. 27, a block diagram or schematic depiction of some of the possible components of the support platform 100, 100', 100" are illustrated. Additional components other than those shown in Fig. 27 are also within the scope of the present

invention, including other components described herein, as well as additional items such as a built-in folding seat or a shade canopy/umbrella.

In use, the support platform 100, 100', 100" is initially positioned near the patient's bed. The support platform 100, 100', 100" can be then be modified to meet the patient's  
5 needs, such as by adding an IV bag, suction pump, injection pump, and/or oxygen supply, and by adding one or more devices to monitor the vital signs of the patient. By plugging the UPS 200 into an electrical outlet, such as a wall outlet, power can be supplied directly to the support platform, and therefore, power is supplied to items interconnected to the electrical system of the platform. In addition, if available and prescribed, oxygen can be directly  
10 supplied to the patient by connecting a stationary oxygen supply to the platform. The platform may also be secured to the patient's bed by utilizing bed hooks 1000 mounted on the support platform 100, 100', 100" to clamp the platform to the framing of the patient's bed.

When the patient is required to be moved from the room while in bed, the support platform can be disengaged from the provided stationary connections by unplugging or  
15 otherwise disengaging the connections to the platform, and then subsequently moving the support platform 100, 100', 100" while moving the patient's bed. If the support platform is interconnected to the bed, such as by bed hooks 1000, a separate attendant or nurse may not be needed to move the support platform 100, 100', 100" while moving the bed.

As the patient becomes mobile, the support platform can be used as a walking aid by  
20 disengaging the support platform systems from the stationary supply sources, such as electrical power or oxygen. By grasping the handle with one or two hands and pushing the platform, the patient can move away from the bed while IV fluids, pumps, and monitoring equipment on the support platform maintain treatment to the patient.

As can be appreciated by one of skill in the art after consideration of the present  
25 disclosure, embodiments of the present invention may provide physiological support to a patient that might not otherwise be conveniently available. For example, in connection with

hospitals or clinics in underdeveloped areas, a support platform 100, 100', 100" in accordance with the present invention may provide an integrated package for supplying a patient with oxygen, fluids, suction, waste receptacles, monitoring devices, and electrical power.

Furthermore, a support platform 100, 100', 100" in accordance with embodiments of the present invention provides an integrated structure from which such physiological support can be supplied. As can also be appreciated from the description provided herein, the particular features or modules included as part of a support platform 100, 100', 100" in accordance with embodiments of the present invention can be selected according to the particular needs of a patient and can be changed as the needs of the patient change.

10 In summary, the present invention provides a stable apparatus for assisting a patient walking. Nurses will be able to make better use of their time in the direct care of patients. Patients may have decreased hospital stays, complication rates and less time in skilled-nursing facilities. Fewer therapeutic errors will result and nurses will be at decreased risk for back injuries. The apparatus may include an IV fluids assembly, while also optionally providing modular receptacles for receiving a pump, and further providing an optional uninterruptible power supply for powering one or more electronic devices, such as a pump or one or more pieces of monitoring equipment. The support platform preferably includes adjustable components, including an adjustable handle. The support platform also preferably includes an expandable configuration, such that while the platform may initially be used for simply holding an IV bag, it can be quickly modified to incorporate other prescribed treatments, such as an oxygen supply or injection pump. As the patient progresses through treatment, the support platform transitions from a bedside equipment station and emergency power supply, to a walking aid and wireless communications apparatus.

25 In accordance with the embodiments of the invention, the platform comprises a ruggedized version that enables the platform to be used in conditions outside of the confines of a healthcare facility. This may include conditions such as military field operations, on-site

disasters and underdeveloped regions. The basic premise of the platform is described above, with one or more of the following modifications:

- 1) larger wheels between the diameters of 6 to 12 inches to traverse rough terrain;
- 2) a raised base in order to provide greater ground clearance;
- 5 3) a broadened base width in order to provide greater stability on unlevel terrain; and
- 4) the materials may be altered in order to have greater impact tolerance and protection in extreme environments such as high dust, extreme temperatures, air drops, high humidity and inclement weather.

In accordance with still other embodiments of the invention, the platform can be adapted for use in the operating suite environment. Devices such as a headlamp, cautery device, sequential compression device, suction, laparoscopy equipment and gasses may be incorporated onto the platform. This places all of these devices on a single platform both in their current form and in future forms that are designed to fit in as modules that would reduce the overall size and weight of the device. A UPS would again be provided to power the devices and allow the batteries to be removed from each of the individual devices. This would be of benefit both in current OR's and in conditions such as military field conditions or less-developed regions where a self-contained platform would simplify the equipment and reduce the overall bulk. Each platform would be able to be individually configured to meet the specific needs to the user. The user would be able to easily swap modules at the site of use to change the configuration as well.

In accordance with yet another embodiment of the invention, a platform is provided for use in veterinary medicine. One variation comprises a platform for use in small-animal veterinary medicine that is designed for indoor use with modules specific for the care of smaller animals. A second variation comprises a platform for use with larger animals that is more akin to the ruggedized version described above to address the specific concerns of large-animal veterinary medicine.

In accordance with still other embodiments of the present invention, non-medical applications of the device are within the scope of this invention. Brief descriptions of some of the variations are provided. This is not limiting in nature and other variations which utilize the common core of the platform with modifications of the functions and modules provided

5 are intended to be included in the scope of this invention. Several features may be considered common in the platform design or may be found in several variations. The cosmetic appearance of the platform is flexible and appealing including the ability for the user to select color. The small form factor of the invention is maintained and it is to be portable and remain unobtrusive in the environment of use. The device may be modified in order to be moved up

10 and down stairs by a single user without damage to the platform or stairs. A motorized wheel or wheels may be added to aid in the motion of the invention for certain applications. The invention may be modified to include a stepping stool or mini-ladder that provides a stable system for the user with the brake enabled. Additionally, the invention may be modified to help stabilize a ladder by applying the brake and attaching directly to a taller ladder than

15 provided on the platform. A universal power supply may be provided to power internal and external electrical devices.

A non-medical embodiment of this invention may be for use in a beauty salon. The invention may include a sink with drain, water supply and storage compartments in order to provide a beautician or stylist with all of the elements required to cut, style and wash a

20 client's hair.

A non-medical embodiment of this invention may be for use in pet and animal grooming. The invention may include a sink, drain, grooming surface, hooks and compartments for grooming supplies, food and toys. The device may be expected to be used at professional grooming salons, in showmanship venues and at home.

25 A non-medical embodiment of this invention may be for use in a garage for auto mechanics. The invention may contain an air compressor, hangar for a light source, tool

compartments, hangar for a sleeper platform and compatibility with diagnostic hardware and software. This may include wireless transmission of data to a central diagnostic unit. This would allow a single mechanic or multiple mechanics with similar devices to work autonomously in a garage with their vital equipment readily available at their side.

5 A non-medical embodiment of this invention may be for use at home or in a handyman shop as a tool caddy. The invention may contain an air compressor, light source, tool compartments, compartments for accessories such as screws and nails, and an attachment to help stabilize a footstool or ladder.

A non-medical embodiment of this invention may be for use in indoor or outdoor  
10 landscaping. The wheel base will be modified to indoor or outdoor as similarly described previously for the medical aspect of this invention. The invention may also include a pressurized liquid tank or tanks for water, pesticides or fertilizers. Additional features may include a debris bin and storage bins for tools.

A non-medical embodiment of this invention may be for use in building maintenance.  
15 The invention may include a power supply, air compressor, compressed fluid storage, diagnostic equipment, wireless transmission capability, computer integration, tool compartments, attachments for spools of wire or tubing, a work stool and the ability to stabilize a ladder by enabling the brake and attaching to a ladder. It may also have a built in stepping stool or mini-ladder.

20 A non-medical embodiment of this invention may be for use by the elderly or handicapped in order to become more independent in or outside of the home. The stability of the structure will provide the user an aide in ambulation. Additionally, the invention will provide support, unlike current ambulatory aide devices, such as oxygen, compartments to hold drainage bags, cellular/wireless support to provide emergency aide, compartments to  
25 hold supplies, personals and groceries or other personal goods, a resting stool and an umbrella. Aide devices as in the medical version of the platform will be used for persons with

disabilities such as amputations, paralysis or other chronic conditions to allow them to use the platform effectively. A connector or system, such as the one previously developed to connect the invention to a hospital bed, may be developed to connect to a trailer hitch for easy transport with a vehicle. A portion or portions of the invention may easily detach for transfer  
5 of the module to a vehicle or residence without requiring transfer of the entire platform. The hope with this embodiment is to mobilize and reintroduce persons into society that were previously confined or restricted secondary to their disabilities.

While various embodiments of the present invention have been described in detail, it is apparent that modifications and adaptations of those embodiments will occur to those  
10 skilled in the art. However, it is to be expressly understood that such modifications and adaptations are within the spirit and scope of the present invention.



What is claimed is:

1. A personal support platform for traversing an underlying surface, comprising:  
a frame;  
a plurality of wheels interconnected to said frame;  
5 a transmission system interconnected to said frame, said transmission system providing a number of user selectable modes, said user selectable modes comprising at least a stop mode, a walk mode and a roll mode; and  
means for selectively choosing one of said stop, walk and roll modes by a user from a standing position adjacent said frame.  
10
2. The platform as claimed in Claim 1, wherein said transmission system comprises a drag wheel that is selectively moveable from a first raised position in said roll mode to a second lowered position in said walk mode, and wherein said drag wheel is for contacting the underlying surface when in said second lowered  
15 position.
3. The platform as claimed in Claim 2, wherein said transmission system comprises a cam interconnected to said frame and the drag wheel, wherein said cam is rotatably movable to raise and lower said drag wheel from said first raised  
20 position in said roll mode to said second lowered position in said walk mode.
4. The platform as claimed in Claim 3, further comprising an automatic brake interconnected to said drag wheel, said automatic brake comprising a braking motor driven by said drag wheel and circuitry, wherein said circuitry provides a  
25 resistive load to the braking motor to apply a braking force on the drag wheel.

5. The platform as claimed in Claim 4, wherein said resistive load comprises a number of load ranges, wherein a first load range provides a first resistive load within a first velocity range for said braking motor, and wherein a second load range provides a second resistive load within a second velocity range for said  
5 braking motor.
6. The platform as claimed in Claim 5, wherein said second velocity range is automatically selected once a threshold velocity of said braking motor is reached.
- 10 7. The platform as claimed in Claim 1, wherein said transmission system comprises a brake interconnected to said frame, wherein said brake is selectively moveable from a first raised position in said walk and roll modes to a second lowered position in said stop mode, wherein said brake is for contacting the underlying surface when in said second position.
- 15 8. The platform as claimed in Claim 7, wherein said brake comprises a stopper frictionally engaging the underlying surface.
9. The platform as claimed in Claim 7, further comprising a cam having a first  
20 channel interconnected to said brake.
10. The platform as claimed in Claim 9, wherein said cam comprises a second channel interconnected to a drag wheel.
- 25 11. The platform as claimed in Claim 10, wherein first channel comprises a first ramp for raising and lowering a first post interconnecting said drag wheel to said cam,

and wherein said second channel comprises a second ramp for raising and lowering a second post interconnecting said stopper to said cam.

- 5
12. The platform as claimed in Claim 1, wherein said means for selectively choosing comprises a first handle at a rear portion of said frame, said handle selectively adjusting a setting of said transmission system.
- 10
13. The platform as claimed in Claim 12, further comprising a second handle at a front portion of said frame, said second handle selectively adjusting a setting of said transmission system.
14. The platform as claimed in Claim 1, wherein the user can select stop mode to engage a friction mechanism with the underlying surface.
- 15
15. The platform as claimed in Claim 1, further comprising at least one grasping mechanism for interconnecting said frame to another structure.
16. The platform as claimed in Claim 15, wherein said grasping mechanism comprises a rotatable gripper arm that engages the other structure.
- 20
17. The platform as claimed in Claim 16, wherein said rotatable gripper arm rotates about a first axis in a direction away from said frame, and rotates about a second axis to grasp the other structure, wherein said second axis is transverse to said first axis.
- 25

18. A personal support platform for traversing an underlying surface, comprising:  
a frame;  
means for rotating interconnected to said frame and contacting the underlying  
surface;  
5 means for frictionally engaging the underlying surface and interconnected to said  
frame; and  
means for variably controlling a resistance provided by said means for frictionally  
engaging.
- 10 19. The platform as claimed in Claim 18, wherein said means for rotating comprises  
a plurality of wheels.
20. The platform as claimed in Claim 18, wherein said means for frictionally  
engaging comprises a drag wheel.
- 15 21. The platform as claimed in Claim 18, wherein said means for frictionally  
engaging is interconnected to a means for adjusting a position of said means for  
frictionally engaging, wherein said means for adjusting may alter a position of  
said means for frictionally engaging from a first position in contact with the  
20 underlying surface to second position wherein said means for frictionally  
engaging does not contact the underlying surface.
22. The platform as claimed in Claim 21, wherein said means for adjusting comprises  
a selectably positionable cam for raising and lowering said means for frictionally  
25 engaging.

23. The platform as claimed in Claim 18, wherein said means for variably controlling a resistance comprises a passive braking motor.
24. The platform as claimed in Claim 23, wherein said passive braking motor  
5 comprises:  
a motor braking circuit interconnected to the passive braking motor, including:  
a first circuit stage, including:  
a switching mechanism, wherein an activation voltage for the first  
circuit stage is defined;  
10 a load resistor, wherein when the passive braking motor produces an  
amount of power sufficient to produce a voltage at the switching mechanism that is equal to  
or greater than the activation voltage and above a current is allowed to pass through the load  
resistor.
- 15 25. A method of using a personal support platform, the method comprising:  
providing a drag wheel interconnected to the platform, the drag wheel for  
contacting a surface under the platform;  
positioning the drag wheel to contact the surface under the platform; and  
applying a braking to the platform through the drag wheel by applying at least a  
20 first braking resistance to the drag wheel for at least a first velocity range of the drag  
wheel.
26. The method as claimed in Claim 25, further comprising providing at least a  
second braking resistance to the drag wheel for at least a second velocity range of  
25 the drag wheel.

27. The method as claimed in Claim 26, wherein said second velocity range is automatically selected once a threshold velocity of a braking motor is reached.
28. The method as claimed in Claim 25, wherein said positioning step further  
5 comprises manipulating a transmission control device to lower the drag wheel in contact with the surface under the platform.
29. The method as claimed in Claim 25, further comprising engaging a stopper to contact the surface underlying the platform.  
10
30. The method as claimed in Claim 25, further comprising releasably connecting the platform to another structure using at least one grasping mechanism interconnected to the platform.
31. The method as claimed in Claim 30, further comprising impinging at least a  
15 portion of the other structure against a portion of said grasping mechanism.
32. A passive variable braking system, comprising:  
a motor;  
20 a motor braking circuit interconnected to the motor, including:  
a first circuit stage, including:  
a switching mechanism, wherein an activation voltage for the first  
circuit stage is defined;  
a load resistor, wherein when the motor produces an amount of  
25 power sufficient to produce a voltage at the switching mechanism that is equal to or

greater than the activation voltage and above a current is allowed to pass through the load resistor.

33. The system of Claim 32, wherein the motor braking circuit further comprises:

5 a second circuit stage in parallel with the first circuit stage, the second circuit stage including:

a switching mechanism, wherein an activation voltage for the second stage is defined;

a load resistor,

10 wherein when the motor produces an amount of power sufficient to produce a voltage at the switching mechanism that is equal to or greater than the activation voltage and above a current is allowed to pass through the load resistor,

15 wherein the activation voltage for the second stage is greater than the activation voltage for the first stage, and

wherein when the activation voltage for the second stage is met or exceeded a current continues to be allowed to pass through the load resistor of the first circuit stage.

20 34. The system of Claim 33, further comprising:

a switch,

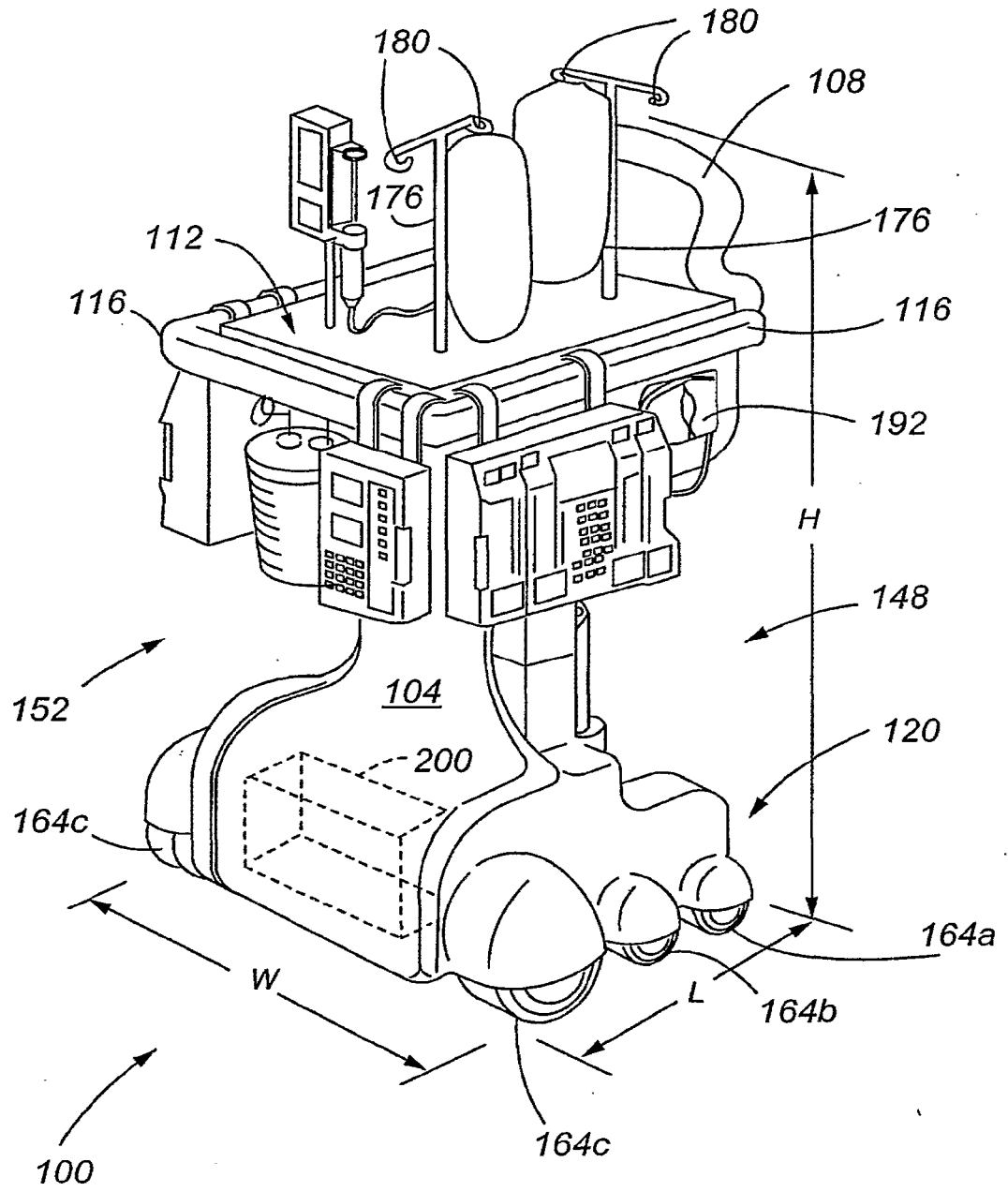
wherein the first and second circuit stages comprise a number of load resistors,

25 wherein the switch is operable to select one of each of the load resistors included in the first and second circuit stages to provide a selected resistance at the motor.

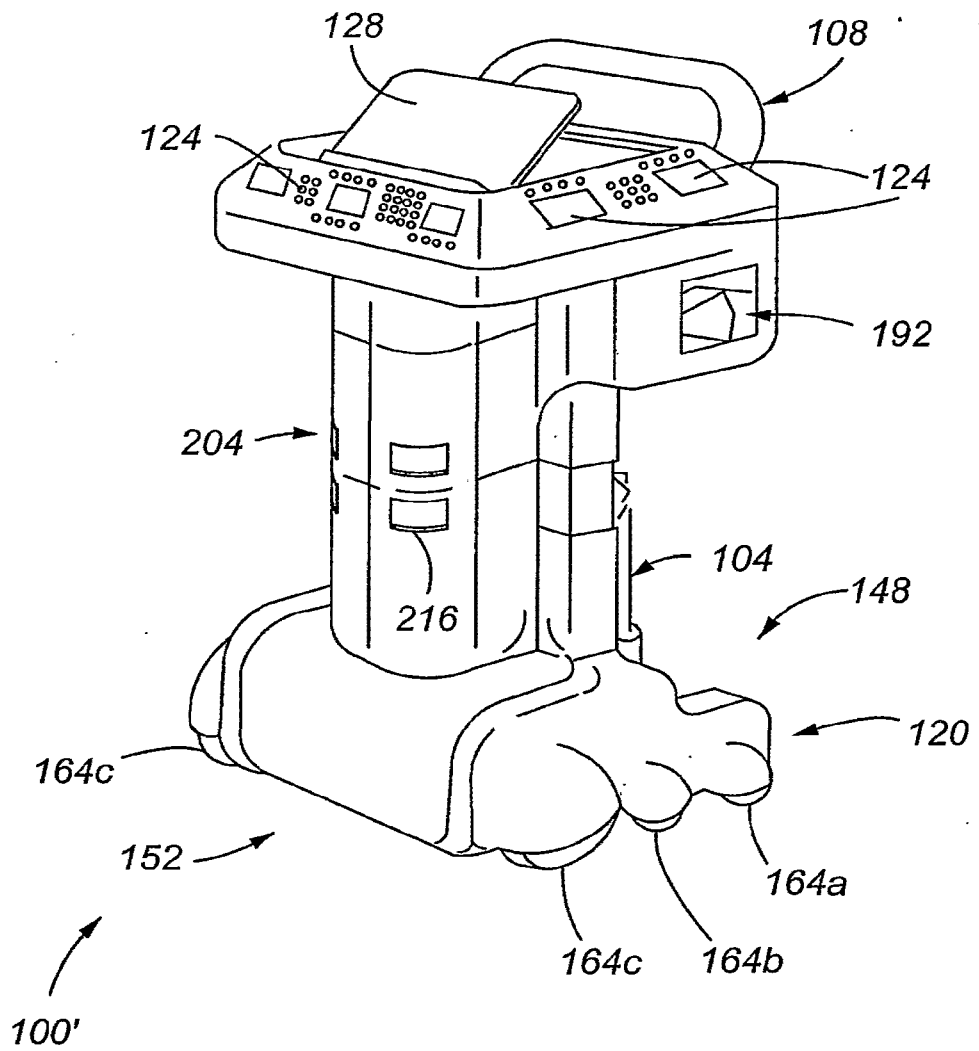
35. The system of Claim 32, where the motor braking circuit further comprises:  
a second circuit stage in parallel with the first circuit stage, the second circuit stage,  
including:  
a switching mechanism, wherein an activation voltage for the second stage  
5 is defined;  
a load resistor,  
wherein when the motor produces an amount of power  
sufficient to produce a voltage at the switching mechanism that is equal to  
or greater than the activation voltage and above a current is allowed  
10 to pass through the load resistor, and  
wherein the activation voltage for the second stage has a polarity  
that is opposite the activation voltage for the first stage.
36. The system of Claim 32, wherein the switching mechanism comprises a zener  
15 diode.
37. The system of Claim 32, wherein the switching mechanism comprises a pair of  
voltage dividing resistors and a transistor, wherein a voltage divided by the pair  
of resistors is provided to a gate of the transistor.  
20
38. The system of Claim 32, wherein the switching mechanism comprises a resistor  
interconnected to a Silicon Controlled Rectifier.
39. The system of Claim 32, further comprising:  
25 a drag wheel interconnected to the motor, wherein the motor is driven by the drive  
wheel.



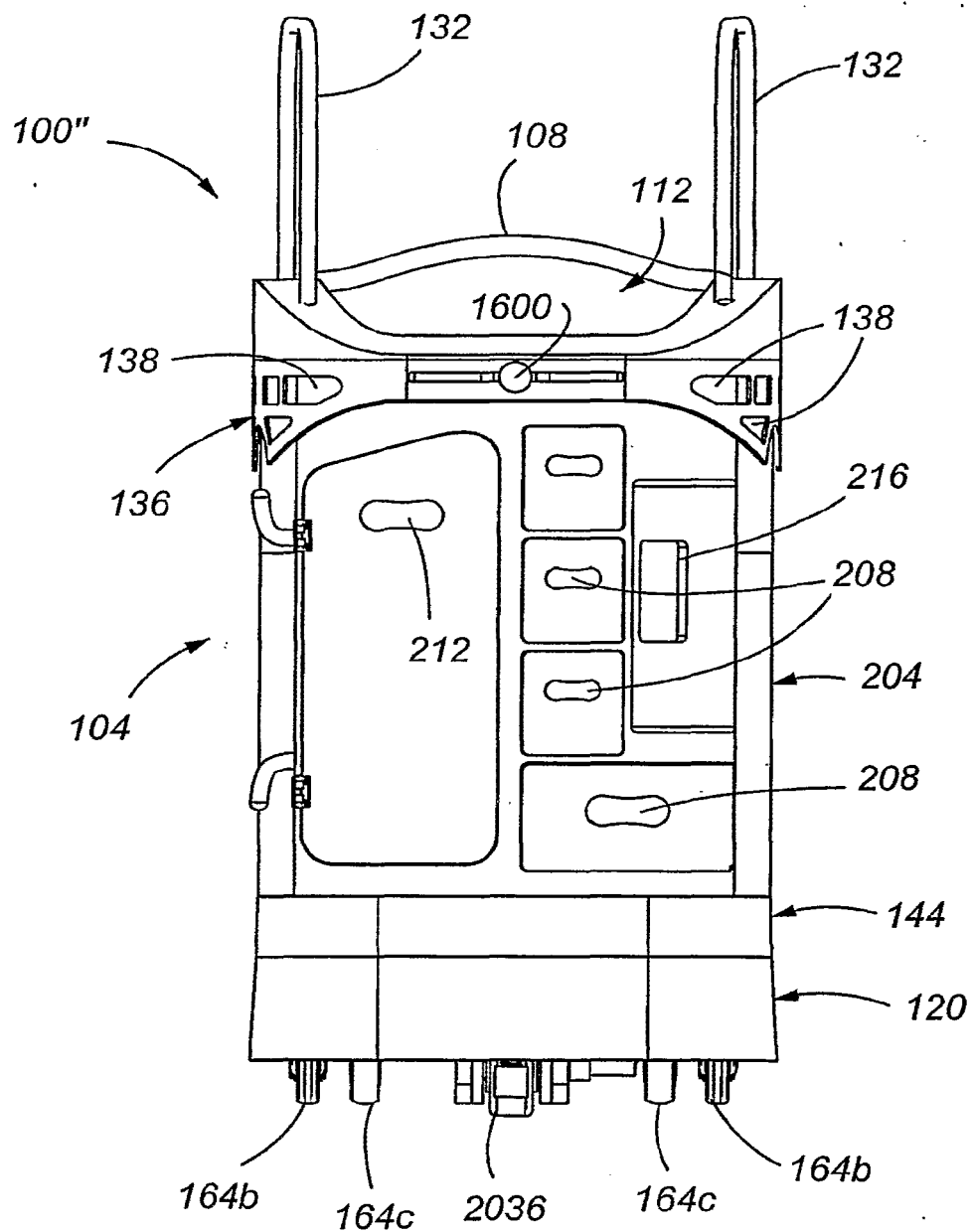
40. The system of Claim 39, wherein the drive wheel is interconnected to the motor by a gearbox.
- 5 41. The system of Claim 33, wherein the switching mechanisms of the first and second circuit stages each comprise a zener diode, and wherein the first and second stages each additionally include a blocking diode.



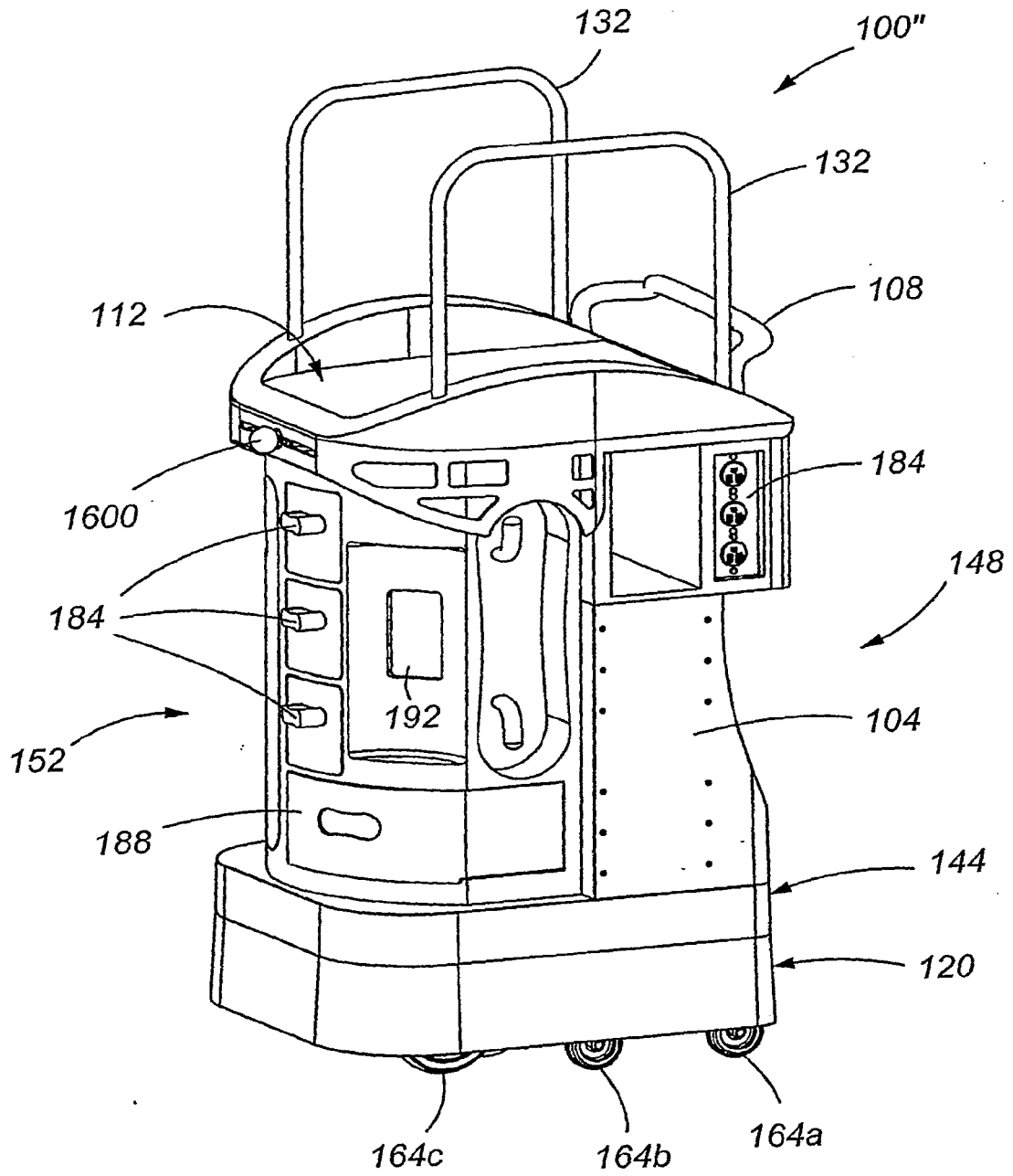
**Fig. 1**



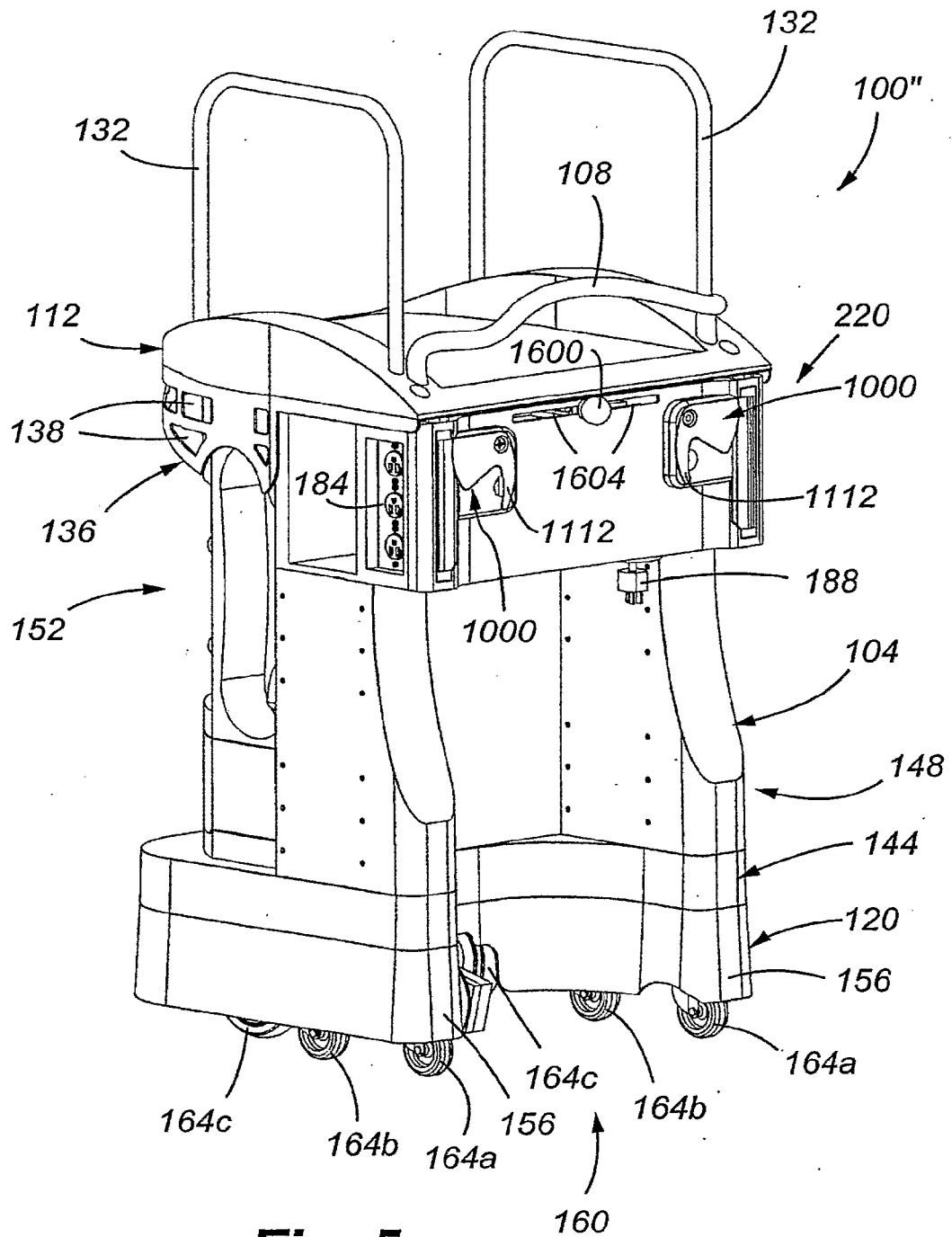
**Fig. 2**



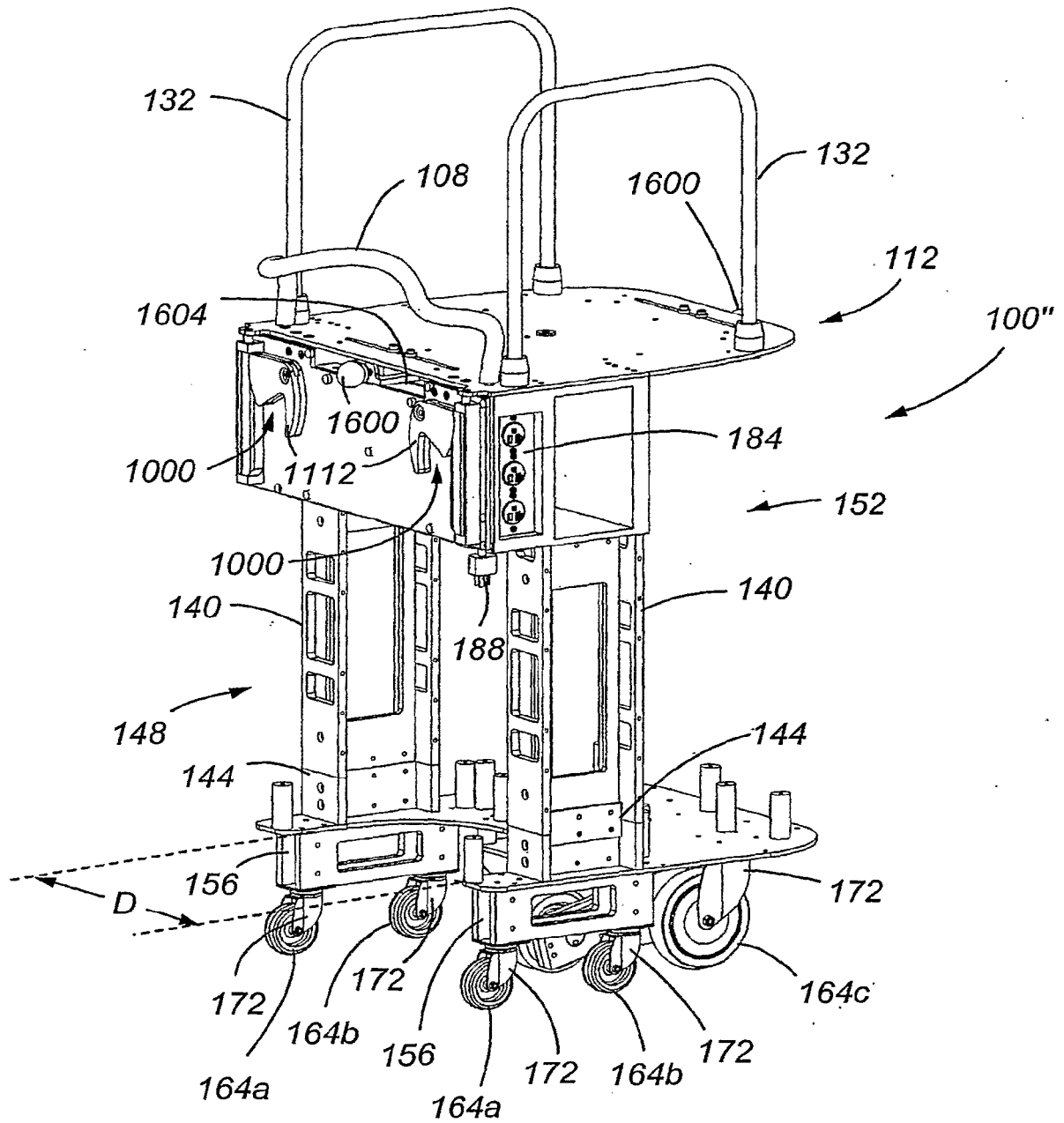
**Fig. 3**



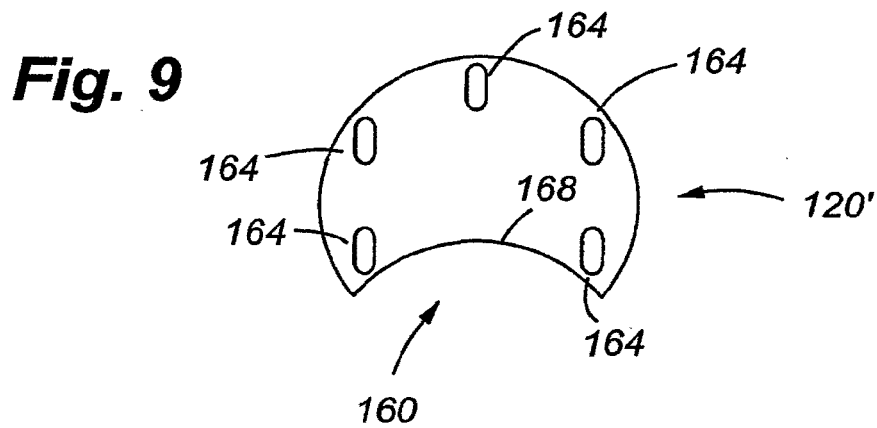
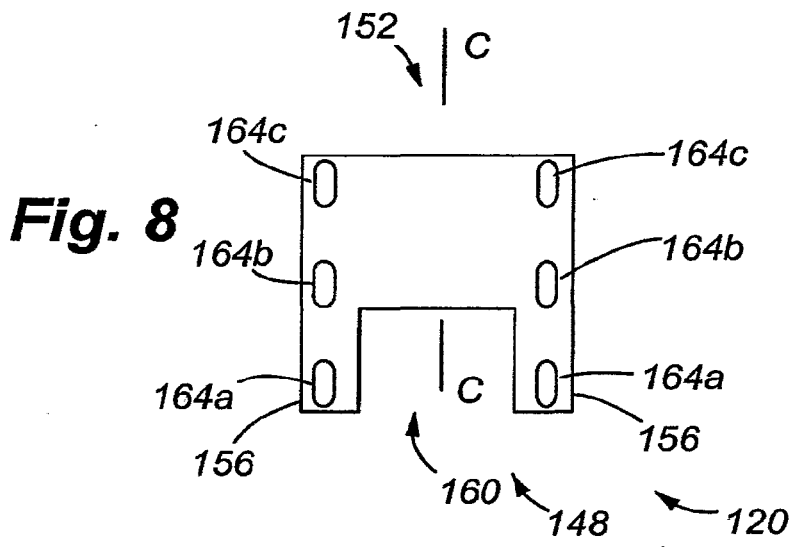
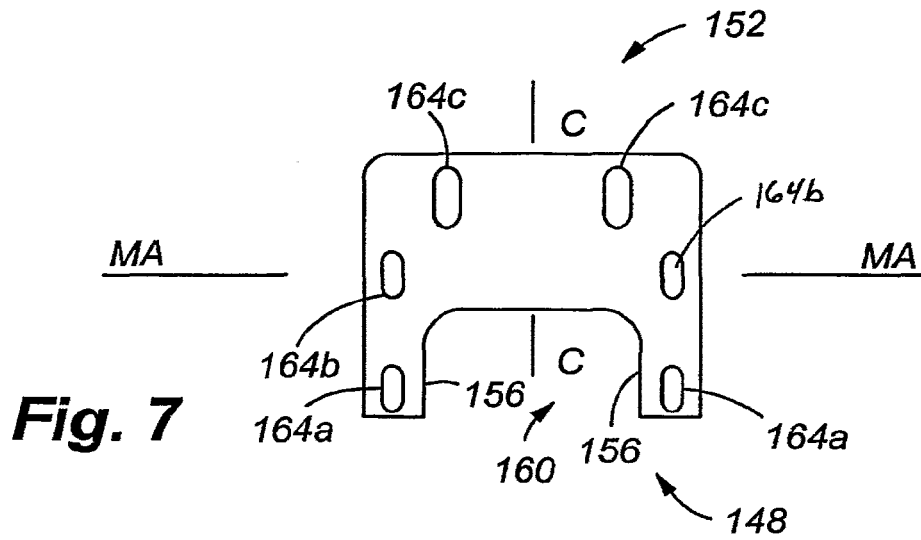
**Fig. 4**



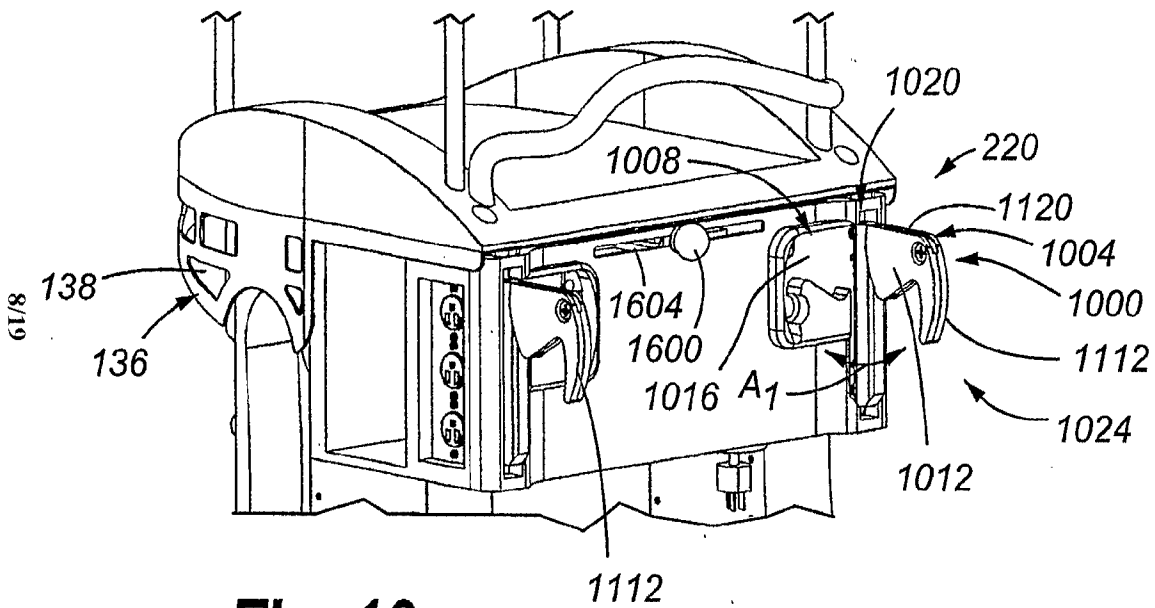
**Fig. 5**



**Fig. 6**

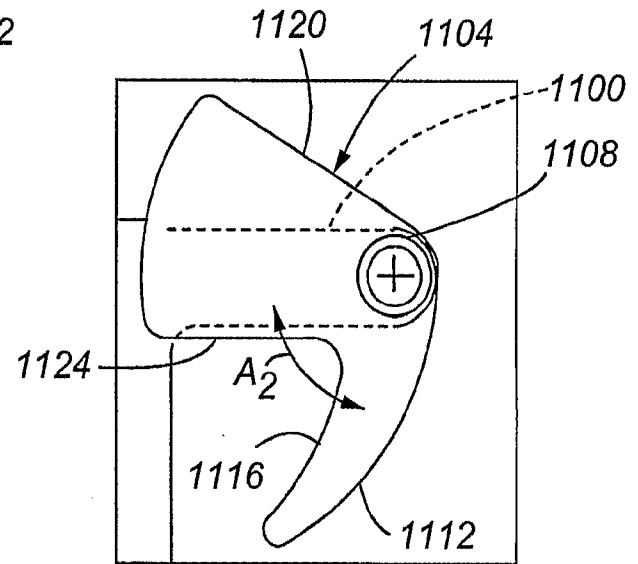
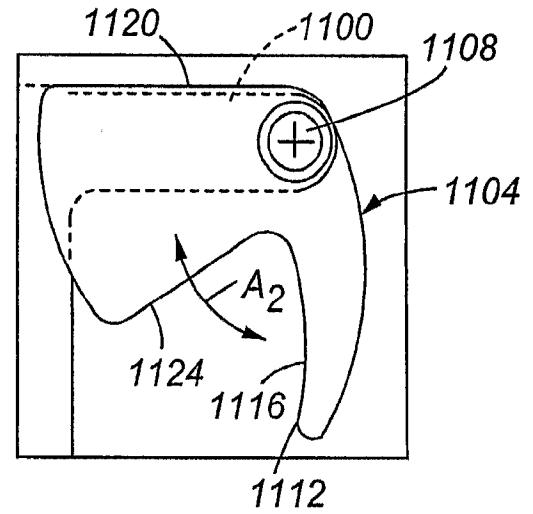




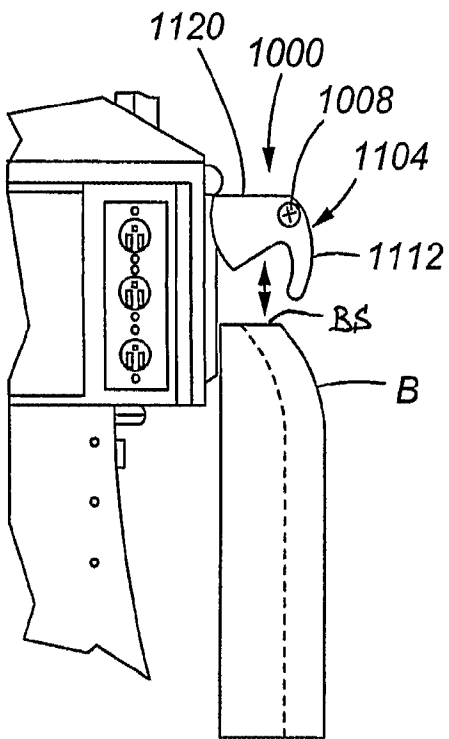


**Fig. 10**

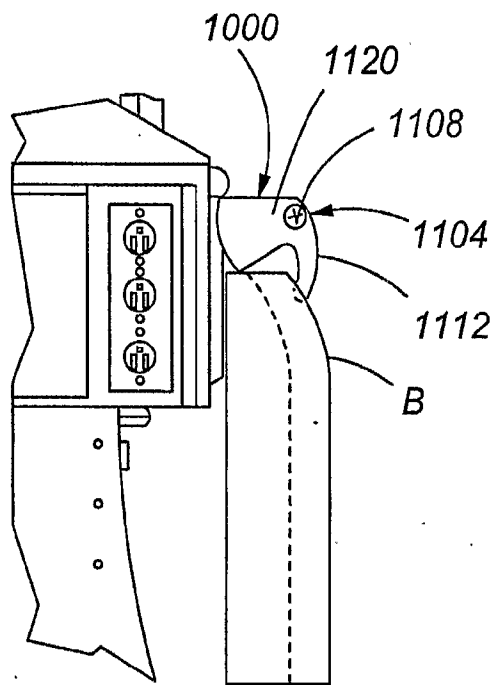
**Fig. 11A**



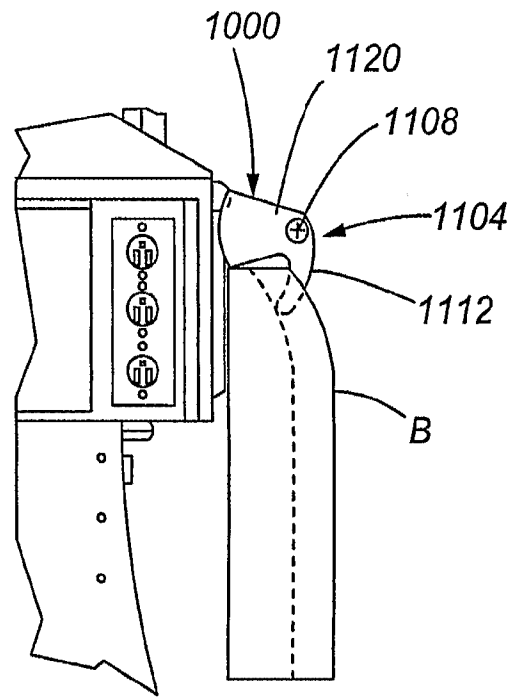
**Fig. 11B**



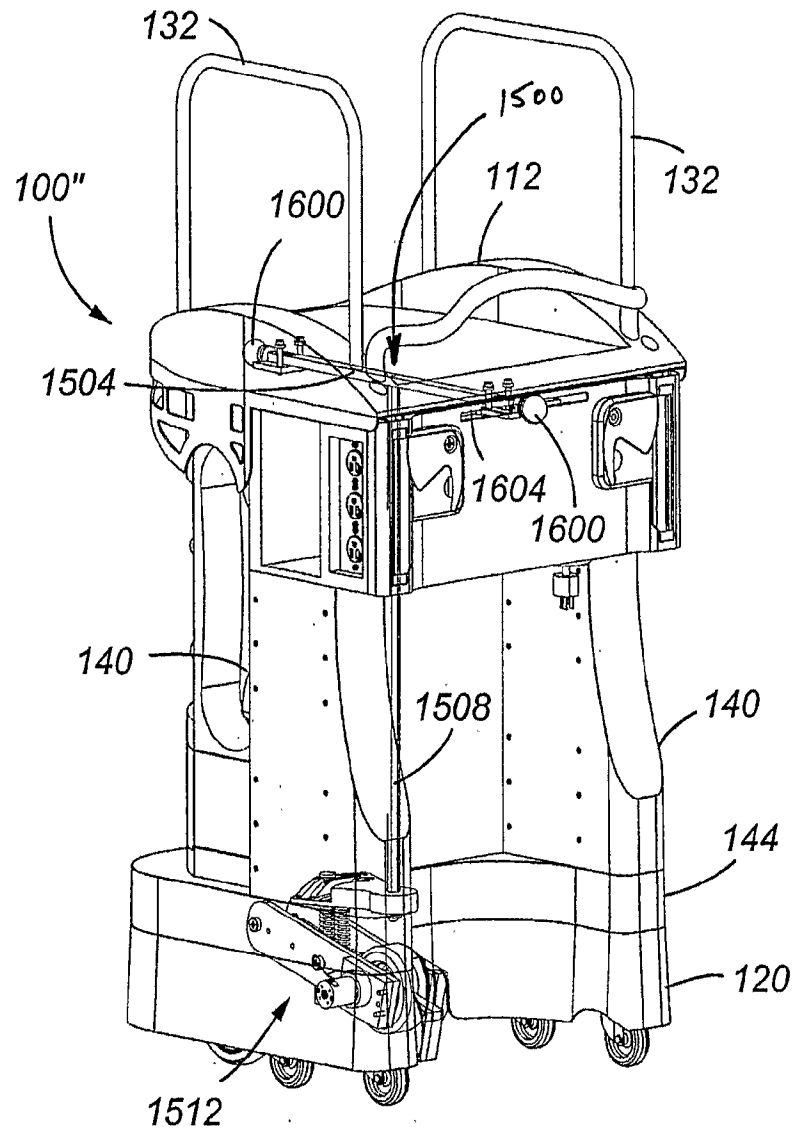
**Fig. 12**



**Fig. 13**

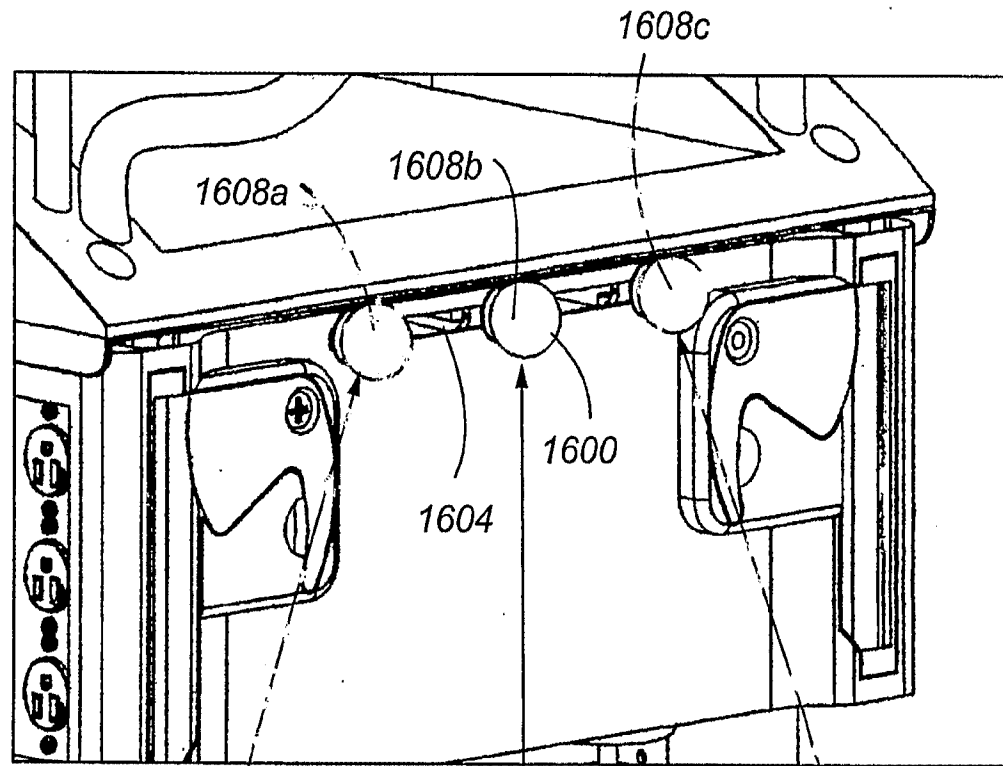


**Fig. 14**



**Fig. 15**

**Fig. 16**



Stop Mode:  
Brake Down  
Drive Wheel Down

Walk Mode:  
Brake Up  
Drive Wheel Down

Roll Mode:  
Brake Up  
Drive Wheel Up

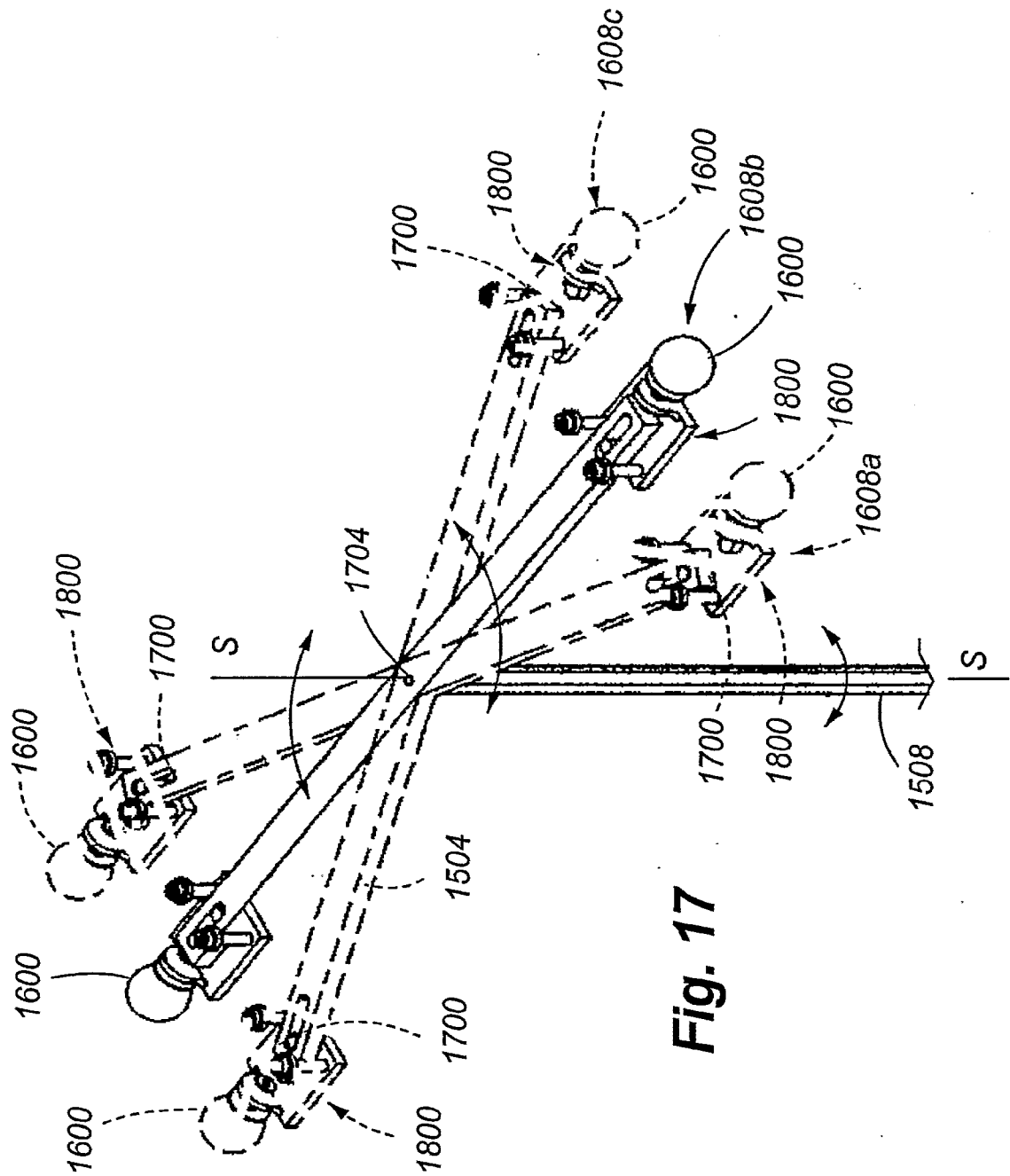
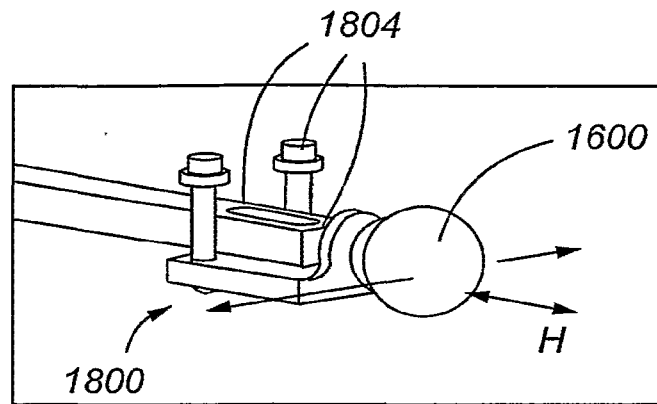
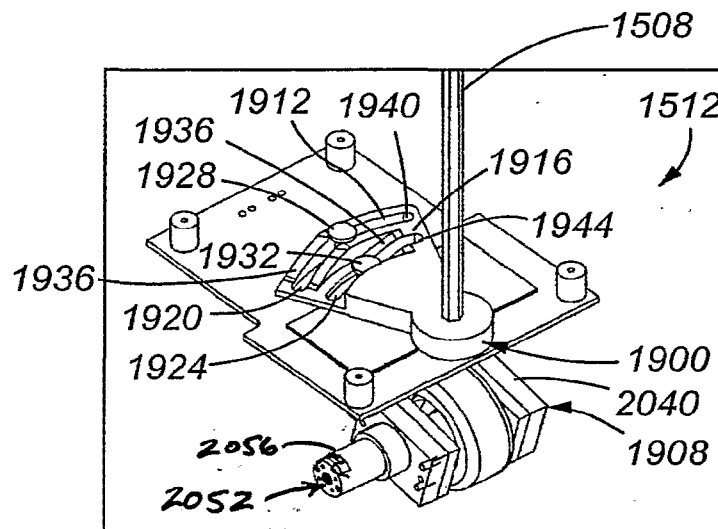


Fig. 17



**Fig. 18**



**Fig. 19**

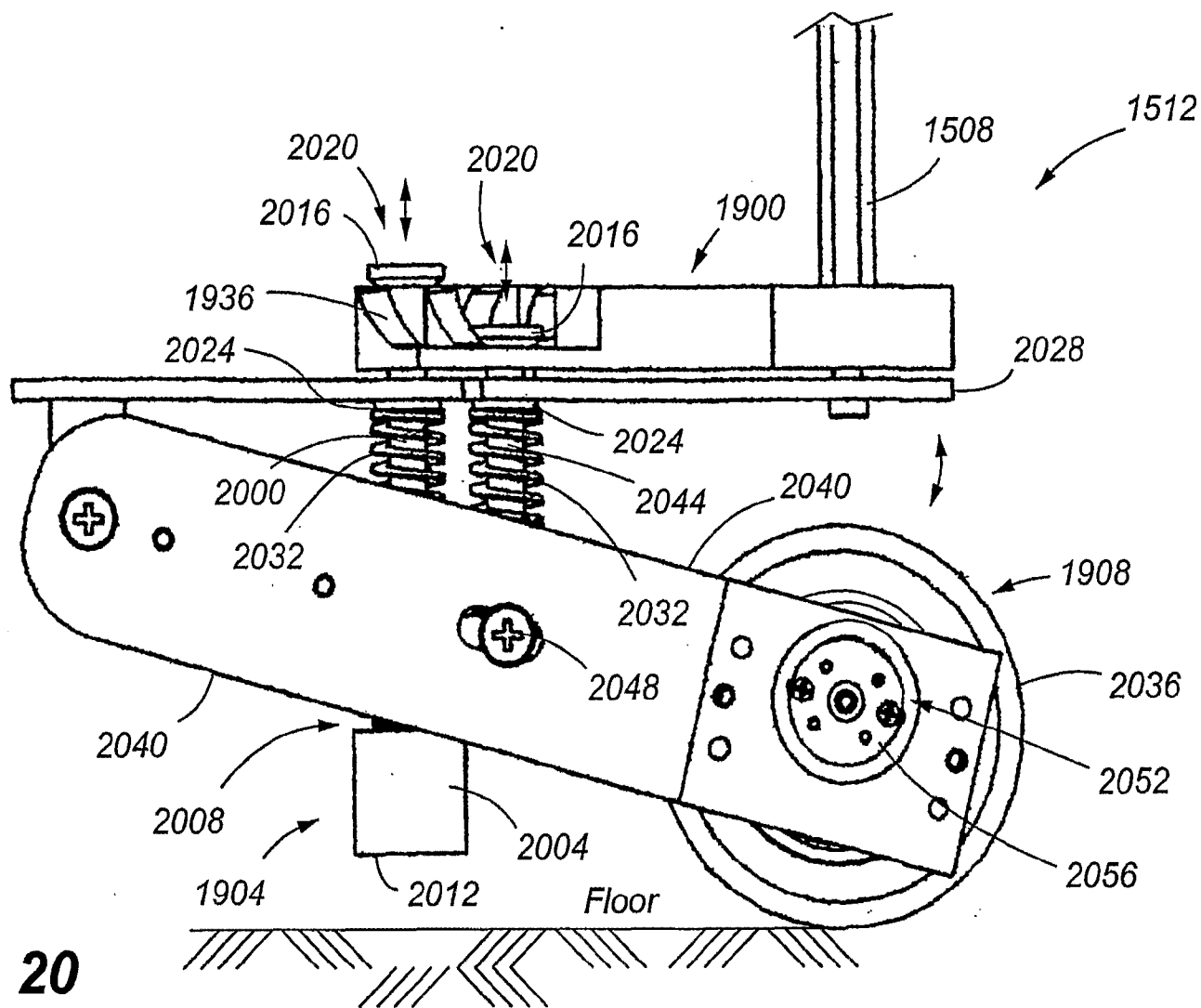
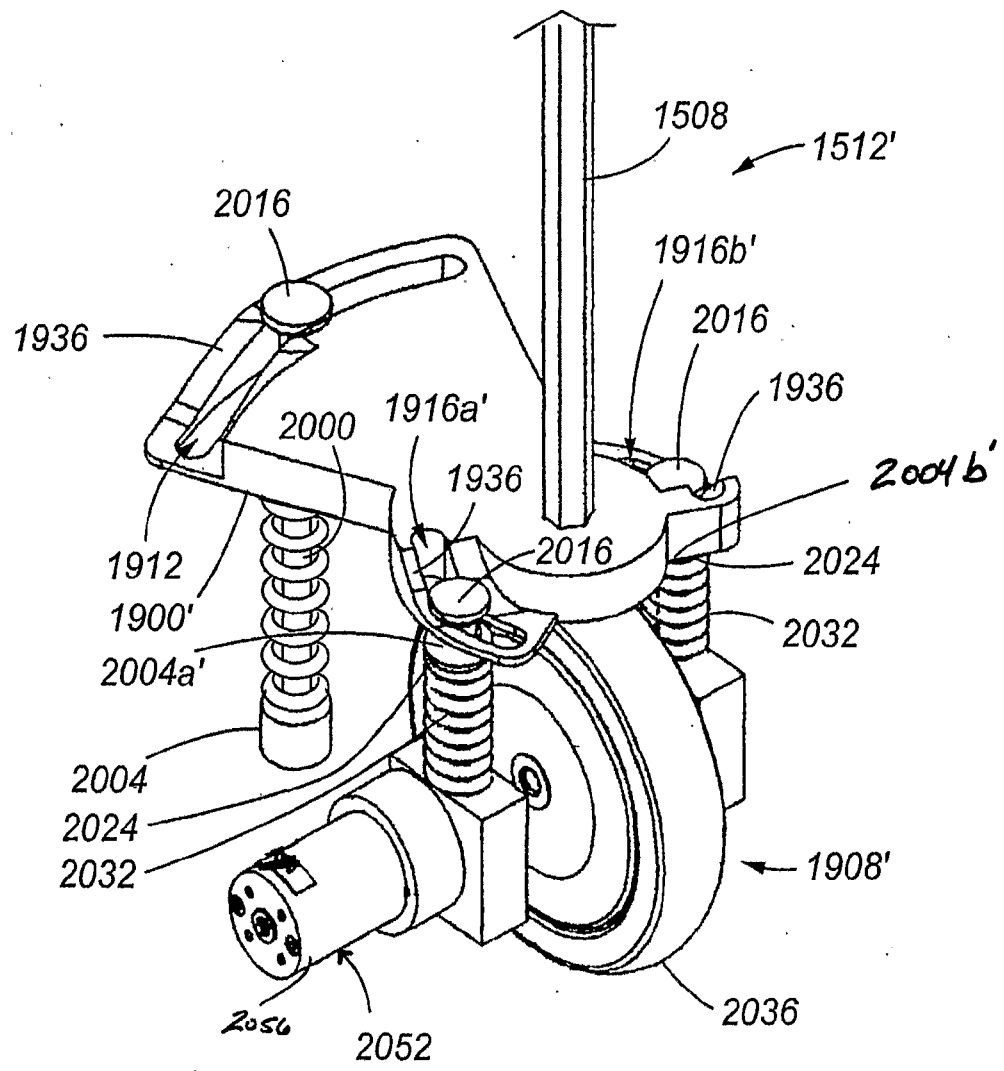


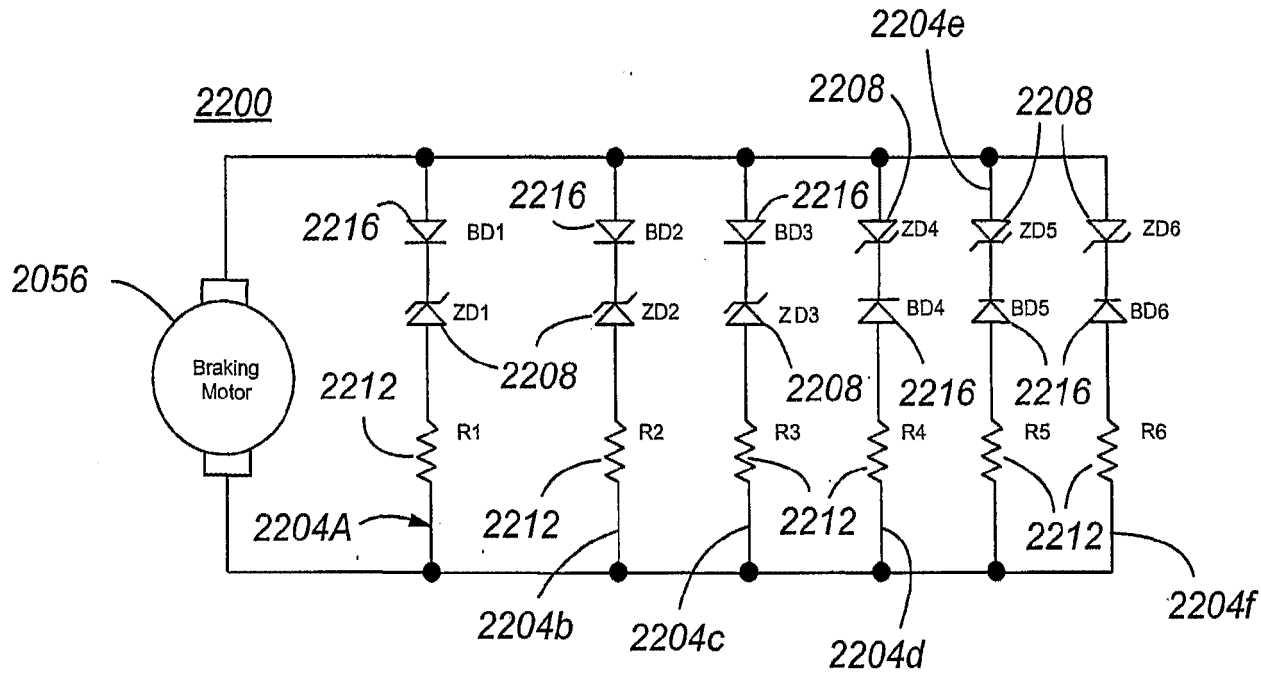
Fig. 20



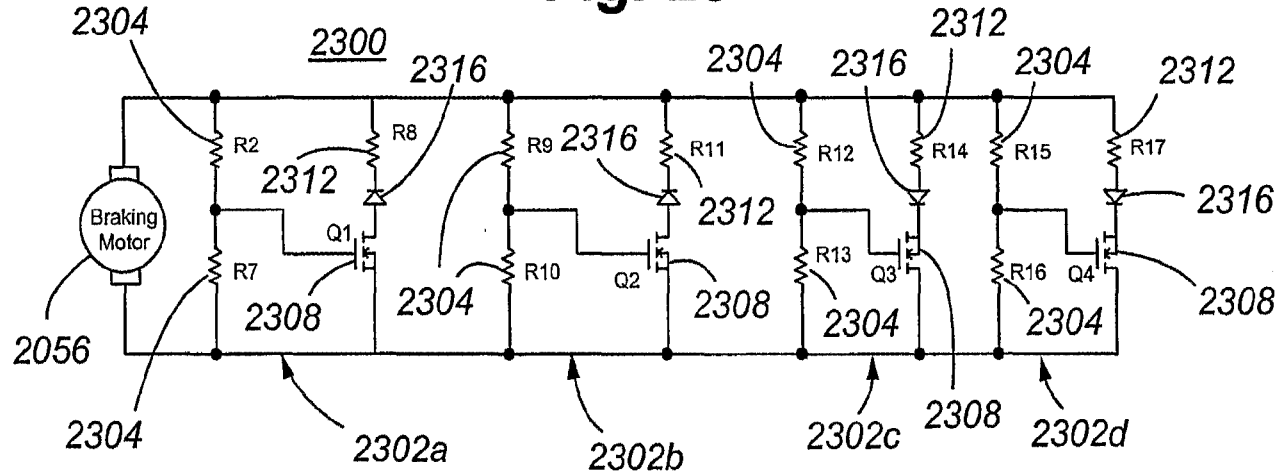
**Fig. 21**



**Fig. 22**

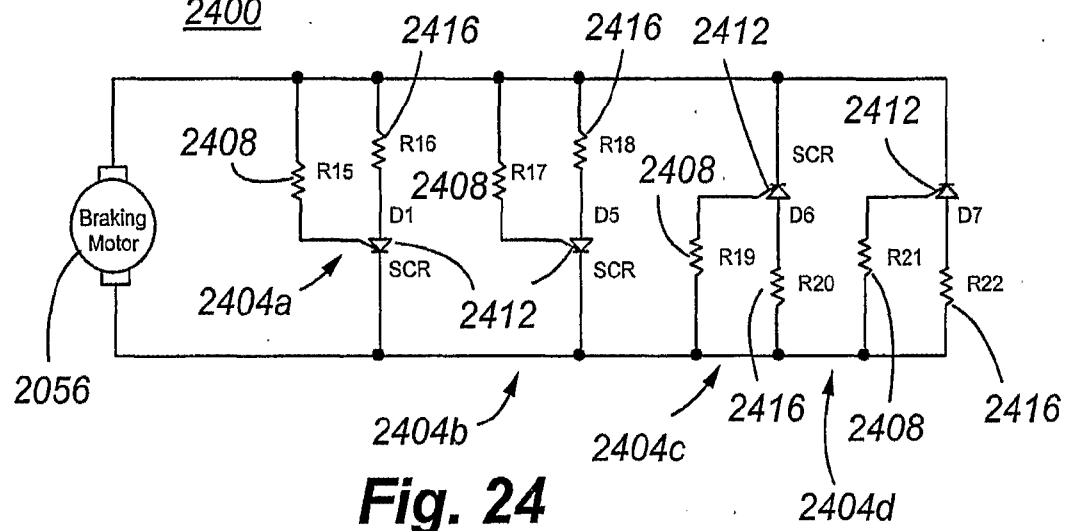


**Fig. 23**



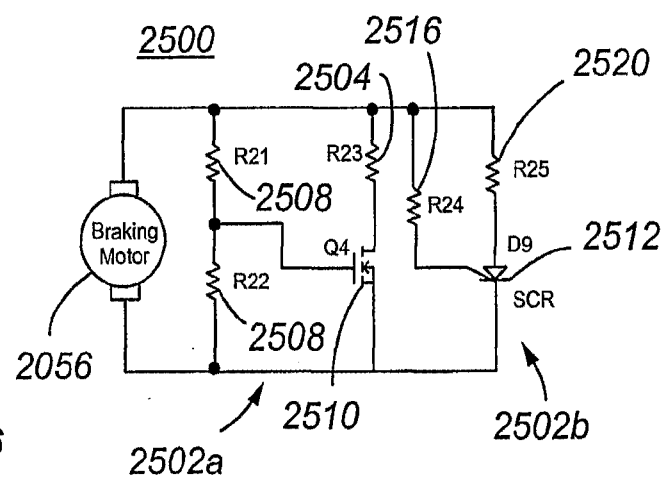
17/19

**2400**

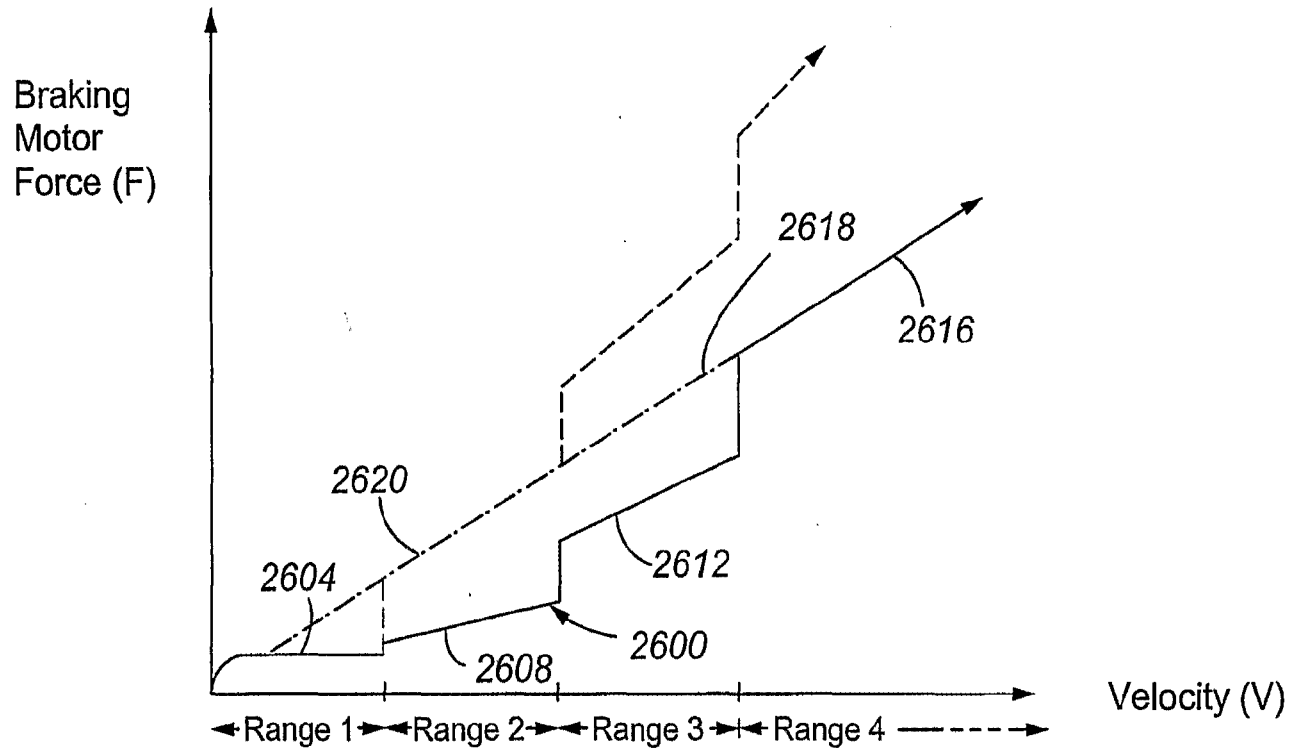


**Fig. 24**

**2500**



**Fig. 25**



**Fig. 26**

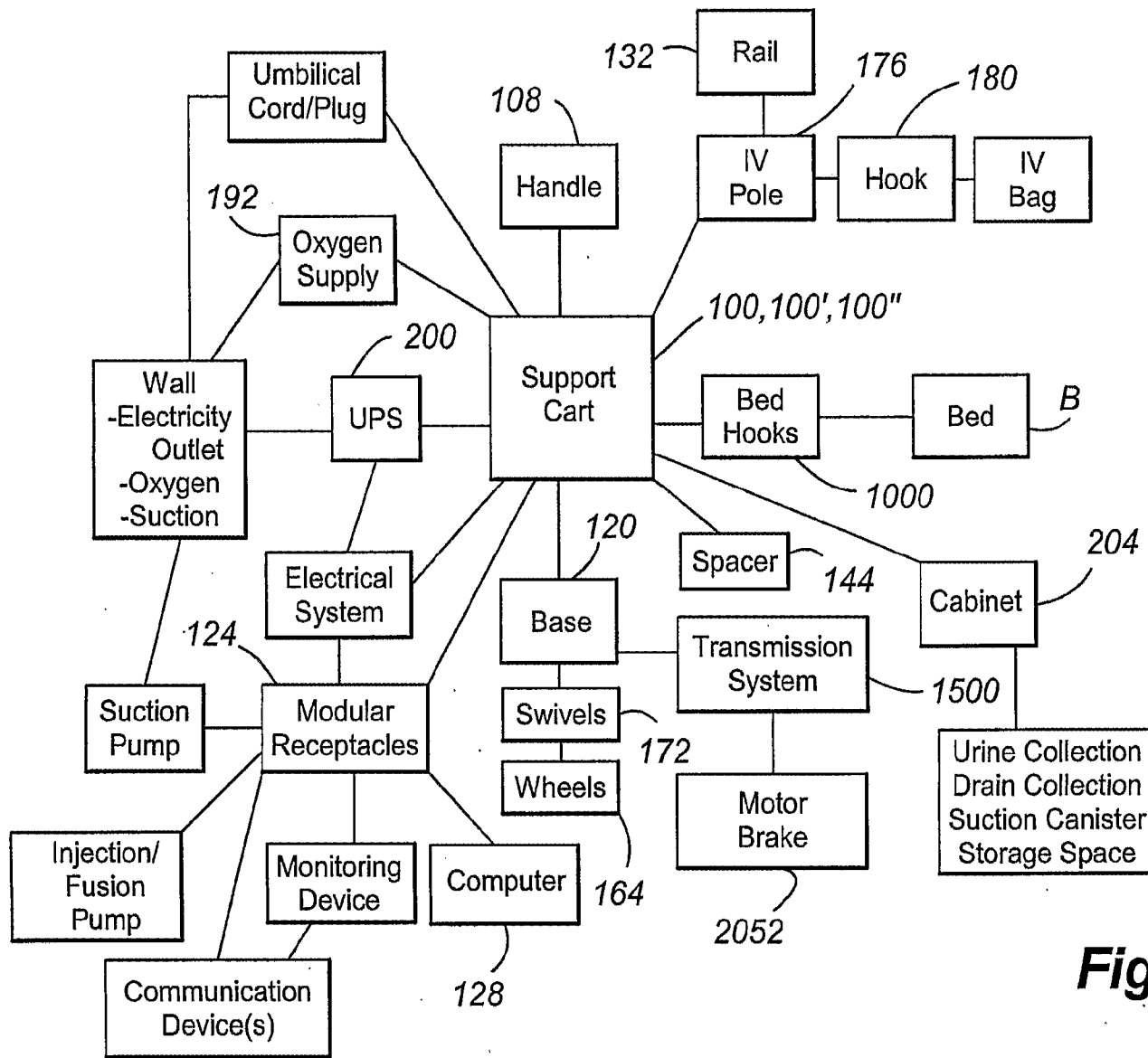


Fig. 27

(19) World Intellectual Property Organization  
International Bureau



(43) International Publication Date  
6 March 2008 (06.03.2008)

PCT

(10) International Publication Number  
WO 2008/028165 A2

(51) International Patent Classification:  
A61M 5/20 (2006.01)

(74) Agents: BENSON, Stephen, P. et al.; Welsh & Katz, Ltd.,  
120 South Riverside Plaza, Floor 22, Chicago, IL 60606-  
3912 (US).

(21) International Application Number:  
PCT/US2007/077460

(81) Designated States (unless otherwise indicated, for every  
kind of national protection available): AE, AG, AL, AM,  
AT, AU, AZ, BA, BB, BG, BH, BR, BW, BY, BZ, CA, CH,  
CN, CO, CR, CU, CZ, DE, DK, DM, DO, DZ, EC, EE, EG,  
ES, FI, GB, GD, GE, GH, GM, GT, HN, HR, HU, ID, IL,  
IN, IS, JP, KE, KG, KM, KN, KP, KR, KZ, LA, LC, LK,  
LR, LS, LT, LU, LY, MA, MD, ME, MG, MK, MN, MW,  
MX, MY, MZ, NA, NG, NI, NO, NZ, OM, PG, PH, PL,  
PT, RO, RS, RU, SC, SD, SE, SG, SK, SL, SM, SV, SY,  
TJ, TM, TN, TR, TT, TZ, UA, UG, US, UZ, VC, VN, ZA,  
ZM, ZW.

(22) International Filing Date: 31 August 2007 (31.08.2007)

(25) Filing Language: English

(26) Publication Language: English

(30) Priority Data:  
60/824,222 31 August 2006 (31.08.2006) US

(71) Applicant (for all designated States except US):  
CATHOLIC HEALTHCARE WEST(D/B/A ST.  
JOSEPH'S HOSPITAL AND MEDICAL CENTER)  
[US/US]; 3200 North Central Avenue, 10th, Phoenix, AZ  
85012 (US).

(84) Designated States (unless otherwise indicated, for every  
kind of regional protection available): ARIPO (BW, GH,  
GM, KE, LS, MW, MZ, NA, SD, SL, SZ, TZ, UG, ZM,  
ZW), Eurasian (AM, AZ, BY, KG, KZ, MD, RU, TJ, TM),  
European (AT, BE, BG, CH, CY, CZ, DE, DK, EE, ES, FI,  
FR, GB, GR, HU, IE, IS, IT, LT, LU, LV, MC, MT, NL, PL,  
PT, RO, SE, SI, SK, TR), OAPI (BF, BJ, CF, CG, CI, CM,  
GA, GN, GQ, GW, ML, MR, NE, SN, TD, TG).

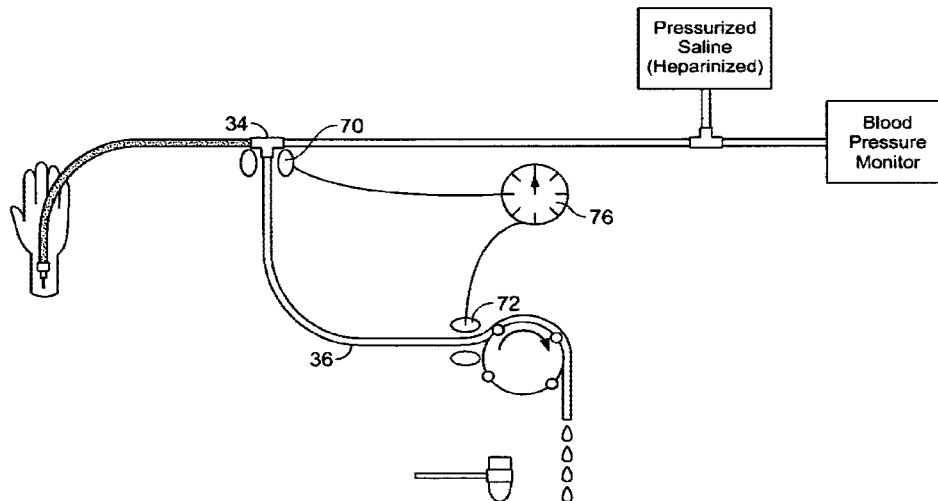
(72) Inventors; and

(75) Inventors/Applicants (for US only): DESHMUKH,  
Vivek, R. [US/US]; 2150 Pennsylvania Avenue, N.W.,  
Washington, DC 20037 (US). CRAWFORD, Neil  
[US/US]; 350 West Thomas Road, Phoenix, AZ 85013  
(US).

Published:

— without international search report and to be republished  
upon receipt of that report

(54) Title: AUTOMATED BLOOD DRAW SYSTEM



(57) Abstract: An automated blood draw system operates in conjunction with an arterial or venous line. The aspiration mechanism allows the rate of aspiration, volume of aspirate, and the time interval of aspiration to be predetermined. Blood can be collected in sequential collection vials for subsequent analysis of a given laboratory parameter, or delivered directly to integrated analysis devices. While a predetermined volume of aspirate can be wasted, excessive aspiration is prevented by monitoring waste obtained in a collection receptacle. A flush system maintains the patency of the line without contamination of the specimen.

WO 2008/028165 A2

## TITLE OF THE INVENTION

## AUTOMATED BLOOD DRAW SYSTEM

## FIELD OF THE INVENTION

- (0001) The invention relates to devices used to secure blood samples from humans and animals for purposes of medical studies and patient care. More specifically the invention relates to automated blood drawing devices.

## BACKGROUND OF THE INVENTION

- (0002) Periodic sampling of blood is important in a number of applications including applications related to medical studies and in monitoring patient progress and/or overall health. For example, it is often desirable to determine blood glucose levels over time after a meal in order to determine the efficacy of the body in metabolizing glucose, especially as it relates to diabetic care. Traditionally, blood drawn for the purposes of monitoring blood parameters has been done manually. In a hospital or other research or medical environment, a phlebotomist will manually draw blood by accessing a port on an existing venous or arterial line by inserting a needle in a shunt and drawing blood out using a syringe. In order to best assess the patient's health and/or to make the best study of blood and the body systems being analyzed, blood is often drawn at particular intervals known as time-points. When the blood sampling time-points are spread out, it is possible to manually draw blood,

with a needle and syringe, without the need to pre-establish a blood line with an access port.

(0003) In many applications, the time-points needed for periodic blood sampling is large and blood is sampled frequently. In these cases, manual sampling of blood has numerous disadvantages. Often, manual sampling relies on a healthcare professional that has additional responsibilities besides sampling blood from the patient. In these cases the risk that a time-point sampling could be delayed or missed entirely is high. However, to avoid missing a time-point sample one or more full time attendants are required. This is an expensive and labor intensive requirement.

(0004) Even where the blood drawing technician timely arrives to sample blood, the temporal resolution of the time-point sampling is low. It is difficult for the technician to accurately determine the exact time that the blood was drawn, and in some cases the difference between the actual time-point sampling versus the desired time-point sampling may vary, for example, by tens of seconds to several minutes. With frequent sampling, such variance is counterproductive to the tests being performed.

(0005) It is therefore an object of the present invention to provide an improved system for obtaining periodic time-point sampling of blood so as to, for example, ease the labor requirements of time-point blood sampling and to significantly reduce or eliminate inherent error in manual blood sampling performed according to the current methodology.

## SUMMARY OF THE INVENTION

- (0006) It is an object of the present invention to provide for an improved automated blood drawing apparatus. The improved automated blood drawing system allows for accurate and efficient sequential sampling of blood with reduced risk of contamination and ease of use.
- (0007) For the purposes of obtaining periodic blood sampling from a patient or research participant, in a first embodiment of the device of the present invention, a 3-way valve assembly is incorporated into a venous or arterial line in close proximity to a patient. The valve assembly is comprised of a first, second and third port. The venous or arterial line is connected to a first port of the valve assembly and an isotonic saline source is connected via a fluid line to the second port of the valve assembly. The first and second ports are thereby configured as fluid entry points into the valve assembly. The third port is attached to aspiration tubing for the purpose of draining the valve assembly into, either a sample collecting receptacle or into a waste receptacle, as will be described below. Arterial or venous blood or saline solution may pass through the valve assembly and enter a fluid line connected to the third port of the valve assembly. The valve assembly is configured to alternatively inhibit the flow of blood or the saline solution depending on the valve assembly setting.
- (0008) In one embodiment of the invention, the valve assembly is a commercially available 3-way stopcock assembly. The 3-way stopcock assembly may be



manually controlled; however, automated control is preferred and provided for in embodiments of the present invention. Automated control may be accomplished, in one embodiment, by a rotary servo motor clamped to a stopcock assembly comprised of the 3-way stopcock and a durable holding device or base. The 3-way stopcock is used to control the flow of fluids from a set of tubes attached, respectively, to the source of blood and to a source of flushing solution.

(0009) As will be understood by those having ordinary skill in the art, the automated or manual control of the valve assembly as configured in one embodiment will allow for the valve be used to open and/or close, alternatively, two separate positions (blood and flushing solution) in the system. Therefore, when the valve assembly is connected to tubing as described above and the stopcock is turned to a first position, either manually or through automation, saline solution will be drawn from its source, through the stopcock from the fluid line attached at the second port and into aspiration tubing attached at the third port of the valve assembly. Alternatively, when the stopcock is in a second position, saline solution is prohibited from flowing through the valve body and into the aspiration tubing. Instead, blood will flow from the arterial or venous line, through the valve body and into the aspiration tubing. It will be understood by persons having ordinary skill in the art that a stop position can be included in the valve assembly or that a separate valve can be installed

upstream of the main valve assembly in the saline solution line such that the flow of fluid can be stopped completely as needed.

- (00010) Fluid flow through the plurality of fluid lines is controlled by an infusion pump. Activation of the infusion pump results in fluid flow from the venous or arterial line or from the saline source depending on the setting of the valve assembly. In a preferred embodiment of the invention, the infusion pump is pre-programmed for a specific fluid flow rate, to allow for a specific volume of fluid and/or to operate for a specific period of time. In this way, the healthcare professional can predetermine the volume of blood to be drawn from a patient at a specific blood sampling time-point.
- (00011) The infusion pump used in such embodiments acts in coordination with an automated control system for the valve assembly. Coordination of the infusion pump and automated valve assembly may be accomplished via serial port programming of the infusion pump and valve assembly control. For example, PC based systems used to control anesthetic drug infusions have been adapted for use with a variety of commercially available medical infusion pumps. Alternatively, the infusion pump may be independently operated by a relay switch controlling power to the infusion pump while the valve assembly is manually or independently automatically operated.
- (00012) For example, when a sampling of blood is desired, the valve assembly is automatically set to allow blood from the venous or arterial line to flow through the valve assembly and into the aspiration tubing. When the desired

amount of blood has been obtained, the valve assembly may be automatically programmed to inhibit flow from the arterial or venous line and to allow fluid flow from the saline source into the aspiration tubing. Flushing of the aspiration tubing following blood sampling is desired. Once flushing of the aspiration tubing has been obtained, the infusion pump is programmed to shut off until the next scheduled blood sampling time-point.

(00013) Blood flowing into the aspiration tubing is collected for simultaneous or subsequent analysis of a given blood parameter or for blood drug concentration. Blood may be collected upon exit from the aspiration tubing in a blood collecting vial. Placement of the blood vial in the stream of the blood exiting the aspiration tubing is accomplished automatically via a commercially available fraction collector suitable for the purpose. Alternatively, blood may be collected in a bolus in heat sealable tubing. Date and time stamping of the bolus identifies the samples for subsequent analysis.

(00014) Appropriate safety features are preferably incorporated into the blood drawing apparatus. In those applications where blood exiting the aspiration tubing flows into an open vial, introduction of air into the arterial or venous line is of particular concern. To avoid the unwanted introduction of air, prior flushing of the aspiration tubing prior to a given sampling may be accomplished. Alternatively, an infusion pump may be incorporated with an internal sensor able to detect air entering the fluid lines. Other safety features, such as

pressurized expulsion of blood from the aspiration tubing may be used independently or in coordination with other safety features of the system.

(00015) Malfunction and erroneous programming of the automated blood drawing apparatus is of particular concern as it may result in excessive pumping of venous or arterial blood from the a patient, or infusion of excessive saline into the venous or arterial line attached to the patient. A float sensor may be incorporated into an overflow tank so as to monitor excessive wasting of blood or saline flowing from the aspiration tubing. An alarm may be activated when the waste tank contents reach a predetermined level and power from the infusion pump may be automatically cut. Alternatively, an optical sensor may be incorporated at a desired location in at least one of the plurality of fluid lines so as to detect and calculate the volume of blood flowing through the tubing at a given sampling time. Once the volume exceeds a predetermined limit the user is notified or the system may be programmed to automatically shut off. Other sensing devices may be used independently or in addition to the safety features already described, such as mechanical, ultrasonic, or other acceptable flow sensing technologies.

(00016) An automated blood drawing apparatus consistent with the present invention may be adapted for use in systems currently established for manual blood drawing and monitoring. For example, manual systems have been developed for simultaneous monitoring of blood pressure in between blood sampling.

These systems may be successfully adapted utilizing the automated features described herein.

- (00017) Other modifications and improvements of currently available and described devices will become apparent to those skilled in the art from the detailed description of the invention below. The current invention is not limited by the specific and preferred embodiments described herein.

#### BRIEF DESCRIPTION OF THE DRAWINGS

- (00018) Further objects of the invention, together with additional features contributing thereto and advantages occurring therefrom, will be apparent from the following description of the invention when read in conjunction with the accompanying drawings; wherein:
- (00019) FIG. 1 depicts a schematic representation of a single time-point sampling of blood by an automated blood drawing apparatus according to a specific embodiment of the present invention;
- (00020) FIG. 2 depicts a schematic representation of the blood collection vials on a carousel-type device and a waste collector all used in association with a specific embodiment of the present invention;
- (00021) FIG. 3 depicts a specific embodiment of the automated blood draw device incorporated into an arterial line pre-established to monitor blood pressure;
- (00022) FIG. 4 depicts a specific embodiment of the automated blood draw device utilizing optical sensors and a timing element to improve efficiency of the device;

- (00023) FIG. 5 depicts a specific embodiment of the automated blood draw device wherein coordination of apparatus components is accomplished via a single computer;
- (00024) FIG. 6 depicts a specific embodiment of the automated blood draw device wherein sampled blood is collected in a bolus of pliable material;
- (00025) FIG. 7 depicts another specific embodiment of the automated blood draw device wherein sampled blood is collected in a bolus of pliable material.

#### DETAILED DESCRIPTION OF THE INVENTION

- (00026) While the present invention is susceptible of embodiment in various forms, there is shown in the drawings and will hereinafter be described a presently preferred embodiment with the understanding that the present disclosure is to be considered an exemplification of the invention and is not intended to limit the invention to the specific embodiments illustrated. It should be further understood that the title of this section of the specification, namely "Detailed Description of the Invention", relates to a requirement of the United States Patent Office, and does not imply, nor should be inferred to limit the subject matter disclosed herein.
- (00027) Referring to **FIG. 1**, In a particular embodiment of the present invention a valve assembly is comprised of a 3-way stopcock **8**, a solid base and a rotary servo motor, all of which are known to persons having ordinary skill in the art. Disposable 3-way stopcocks appropriate for the patient environment are commercially available and preferred for their ease of use. The 3-way

stopcock is provided with means for selectively determining the position of an internal valve within the stopcock body to allow fluid flow through the stopcock body from one of two input ports and out of a third port.

(00028) A solid base, such as of metal or hard plastic, is provided to receive and securely clamp the stopcock body. Ideally, placement of the stopcock valve assembly at the base is accomplished without tools. For example, the stopcock assembly may be placed by press fitting the assembly to the base. The solid base may also be associated with means providing easy access by a health care professional to the 3-way stopcock. Additionally, a rotary servo motor may be clamped to the stopcock body and base to allow automated operation of the internal valve so as to determine at least two positions of the valve. The rotary servo motor in conjunction with the 3-way stopcock and solid base comprises the valve assembly.

(00029) It will be apparent to one skilled in the art that the invention is not limited to the specific valve assembly described. For example, the 3-way stopcock may be replaced in appropriate applications with a 1-way or 4-way stopcock incorporated into the previously described valve assembly. Alternatively, T-branches as commonly known in the art may be used to interconnect tubing. A T-branch is comprised of a first, second and third port that can accept the blood line 2, flushing line 4 and aspiration line 6 of FIG. 1 respectively. In lieu of the valve apparatus of the stopcock, multiple blunt pinchers may be used to facilitate or inhibit fluid flow in the plurality of fluid lines. Before

use, the interconnected tubing would be pressed into the jaws of the pinchers. In one embodiment of the invention, servo motors may be used to control the pinchers, enabling one or more sections of tubing to be pinched closed while simultaneously releasing one or more sections of tubing, thereby facilitating fluid flow. Other modifications of the valve assembly consistent with the spirit and scope of the present invention will be obvious to those skilled in the art. The preceding is included for completeness of the description and while numerous elements described are not shown in the illustration, persons having ordinary skill in the art will understand the use and placement of such elements.

(00030) Referring now to **FIG. 1**, in one particular embodiment of the invention utilizing a valve assembly with a 3-way stopcock, the 3-way stopcock **8** valve assembly is associated with a patient blood line **2**. The blood line **2** is connected at an origin position to a patient, in a manner well known to medical and research professionals, and at a terminal position to a first port **10** of the 3-way stopcock **8**. Preferably, the length of the blood line **2** is kept small so the total volume of blood required to fill the blood line is minimized and excessive blood waste from the patient is avoided. In an alternative embodiment of the invention, the blood line is a previously established venous or arterial line wherein the valve assembly is incorporated into the venous or arterial line at a position in close proximity to the patient.



(00031) A fluid line **4** is connected at an origin position to a flushing solution source **16** and at a terminal position to a second port **12** of the 3-way stopcock **8** valve assembly. It will be understood by persons having ordinary skill in the art that the flushing solution will be utilized to cleanse the valve and aspiration tubing preceding each blood sampling as will be described in detail below. In a specific embodiment of the invention, the flushing solution source **16** attached to the origin of the fluid line **4** is comprised of an isotonic saline solution. In some applications it may be desirable to utilize an isotonic flushing solution with additives, such as heparin, to better effectuate clearing of the automated blood apparatus of blood in between sampling. The flushing solution is utilized in applications according to the invention so as to flush the stopcock valve and the aspiration tubing after a given sampling of blood and to further ensure fluid flow through the stopcock valve and the plurality of fluid lines does not become obstructed.

(00032) Finally, aspiration tubing **6** is connected at an origin position to a third and final port **14** of the 3-way stopcock **8** valve assembly. The terminus of the aspiration tubing allows for elimination of fluid originating from either the blood line **2** or the fluid line **4** into appropriate collecting means or into a waste collection tub **26** (see **FIG. 2**). Where it is desired to incorporate the valve assembly into a pre-existing venous or arterial line, the pre-existing line is cut and the cut termini of the venous or arterial line are attached at the first and third ports of a 3-way stopcock as previously described, forming the

blood line and the aspiration tubing respectively. The flushing line 4 is then established as previously described.

(00033) Referring now to **FIG. 1A**, when the 3-way stopcock is manually or automatically set to a first position the flushing solution 16 is drawn into the flushing line 4, through the stopcock 8 and into the aspiration tubing 6 attached at the third port of the stopcock. Flushing solution is prohibited from entering the blood line 2 attached to the first port of the stopcock. Alternatively, as shown in **FIG. 1B**, when the 3-way stopcock is set to a second position blood is drawn into the blood line 2, through the stopcock 8 and into the aspiration tubing 6. Blood is prohibited from flowing into the fluid line 4 attached to the second port of the stopcock when the stopcock is in either the first or second position. Flushing solution and blood passing through the stopcock body and into the aspiration tubing is collected, wasted and/or analyzed as described in detail herein.

(00034) Referring generally to **FIG. 1**, fluid flow from the flushing solution source 16 or from the blood line 2 is controlled by an infusion pump 18. When the infusion pump is inactive, fluid flow through the stopcock body 8 is inhibited. Upon activation of the infusion pump, fluid flows through the stopcock body 8 and into the aspiration tubing 6. Activation of the infusion pump may be manually effectuated. Alternatively, in a preferred embodiment of the invention, activation of the infusion pump 18, the rate of fluid flow into the aspiration tubing 6, the volume of aspirate, and/or the time interval of

aspiration are pre-programmed and automated. In one embodiment of the invention, an analog infusion pump operable by a relay switch controls power to the infusion pump. Alternatively, serial port programming of the infusion pump **18** can be used to control fluid flow through the stopcock body **8** and into the aspiration tubing **6**. For example, PC based systems used to control anesthetic drug infusions have been adapted for use with a variety of commercially available medical infusion pumps and may be successfully adapted for use with the present invention.

(00035) According to one embodiment of the invention, blood is collected upon exit from the aspiration tubing **6** in a vial **20** of an appropriate size for the application. Preferably, vial placement in the blood stream is accomplished automatically. For example, **FIG. 1** depicts a linear actuator **28** that may be used to place a vial **20** in one of two positions. A first position, shown in **FIG. 1A**, places the vial **20** out of the stream of fluid flowing from the aspiration tubing **6**. When the linear actuator **28** is in this position, fluid flowing from the aspiration tubing **6** is collected in a waste receptacle. A second position of the linear actuator **28**, shown for example in **FIG. 1D**, places a collection vial **20** in the path of blood flow and allows for the collection of blood exiting from the aspiration tubing **6**.

(00036) Alternatively, it may be desirable to sequentially obtain blood from the aspiration tubing **6** in multiple collection vials. An apparatus, such as a fraction collector able to hold multiple vials and sequentially place them in a

stream of blood flowing from the aspiration tubing may be used. In one embodiment of the invention demonstrated at **FIG. 2**, a rotating tray **22** capable of holding a plurality of vials **24** is used for the purposes of obtaining sequential blood samples automatically and without manual intervention. Flushing solution and stagnant blood exiting the aspiration tubing **6** is collected in a waste tub **26** located beneath the rotating tray **22**. When the waste fluid has been fully cleared from the aspiration line **6**, the rotating tray automatically places the next available collection vial **24** into the blood stream thereby collecting the desired time-point blood sample. In one specific embodiment of the invention, the rotating tray may be coupled with a point-of-care analyzer such as an ACT monitor to analyze blood parameters in the collected sample. While the sample is being analyzed, the adjacent vial is positioned to gather the next sample. This system allows for automation of several samples sequentially. The ACT analysis cartridge may be changed by the health care provider at change of shift or at set intervals.

(00037) Referring again to **FIG. 1**, a time-point sampling of blood from a patient according to one embodiment of the invention is shown. The 3-way stopcock **8** valve is manually or automatically set to a first position to allow flushing solution **16** to flow into the aspiration tubing **6**. The infusion pump **18** is activated manually or automatically to completely flush the stopcock body **8** and the aspiration line **6**, as shown at **FIG. 1A**. Flushing solution exits from the aspiration tubing **6** into a waste receptacle. Adequate flushing of the

aspiration tubing allows for accurate blood sampling and prevents contamination of the aspiration line.

(00038) Referring now to **FIG. 1B** and **1C**, once the aspiration line **6** has been adequately flushed, the stopcock valve is manually or automatically set to a second position, thereby allowing blood to flow through the stopcock body **8** and into the aspiration tubing **6**. The infusion pump **18** is activated manually or automatically to allow blood from the blood line **2** to enter the aspiration tubing **6**. The blood line **2** will be filled with stagnant blood left over from the previous time-point blood sampling and must be eliminated from the system before the time-point blood sample is collected, as shown in **FIG. 1C**. Likewise, flushing solution filling the stopcock body and the aspiration tubing must be eliminated from the system, as shown in **FIG. 1B**. Stagnant blood and flushing solution are eliminated from the system and collected in a waste container. The linear actuator **28** may be manually operated or automated in conjunction with the infusion pump **18** to ensure the vial **20** remains in a first position out of the stream of fluid exiting the aspiration tubing **6** until such time that the flushing solution and stagnant blood have cleared the system.

(00039) In one embodiment of the invention, a second infusion pump may be placed along the blood line **2** between the stopcock **8** and the patient to allow for flushing of the blood line **2** in between blood sampling. The infusion pump is activated at the end of a time-point blood sampling either before or after the aspiration tubing **6** has been flushed. Appropriate flushing solution **16** flows

through the valve body and into the blood line 2, and toward the patient. The infusion pump may be manually or automatically operated to ensure excessive flushing solution does not enter the blood line 2 and thereby the patient. An appropriate valve assembly is selected in systems calling for flushing of the blood line between time-point blood sampling and other modifications apparent to one skilled in the art are within the scope of the invention.

(00040) Referring now to **FIG. 1D**, the linear actuator 28 is manually or automatically activated to move the collection vial 20 into the stream of blood exiting the aspiration tubing 6. A time-point sampling of blood is collected manually or automatically. In a preferred embodiment of the invention, the blood sample is collected automatically. The system is pre-programmed to calculate the amount of blood flowing into the aspiration tubing from the patient. System dependent parameters that may be entered by a technician include the length of the blood line 2, the length of the aspiration tubing 6, the infusion pump 18 speed or the volume rate of fluid flowing through the aspiration tubing 6 and/or the volume of blood to be sampled at each time-point. In certain applications, it may be desirable to deliver a quantity of flushing solution to the collection vial, for example, to deliver an additive such as heparin present in the flushing solution. In this manner, vials pre-packaged containing heparin or any other desired additive may be obviated.

(00041) Once the desired volume of blood for a time-point sample has entered the aspiration tubing 6, the stopcock 8 valve is set to a first position to allow

flushing solution **16** to enter the stopcock body and flow into the aspiration tubing **6**. In this manner, the total volume of blood drawn from the patient at each time-point sampling is carefully calculated and the system may be programmed to minimize wasting. Minimization of wasting is particularly important where a number of time-point blood samples are required over a relatively short period of time.

(00042) After the desired volume of blood has been collected in the collection vial **20**, the linear actuator **28** moves the collection vial out of the stream of blood exiting the aspiration tubing **6**, as shown in **FIG. 1E** and **1F**. To provide for accurate blood sampling and to prevent contamination the aspiration tubing must be flushed between sequential blood draws. The stopcock **8** and aspiration tubing **6** are completely flushed with flushing solution **16**. In one embodiment of the invention, the automated blood draw system is programmed to allow the residual blood and a predetermined amount of flushing solution to pass through the aspiration tubing **6** and into the waste collection container. Flushing is coordinated to avoid collection of flushing solution in the blood collection vials and to minimize blood waste.

(00043) Once the aspiration tubing **6** has been completely flushed, the infusion pump **18** is manually or automatically shut off to inhibit the flow of fluid through the system. The automated blood draw system is inactive until the next scheduled time-point blood sampling is desired. Blood collected in the collection vial **20**

is manually or automatically stored or processed and a new collection vial prepared for the next sampling.

(00044) A specific embodiment of the invention has been described whereby time-point blood samples are collected in collection vials **20**. Alternatively, a time-point blood sample may be collected as a bolus within a heat-sealable sheath of pliable tubing as shown in **FIGS. 6** and **7**. Referring to **FIG. 7**, blood exiting the aspiration tubing is introduced into the pliable collection tubing material **164**. Once the desired volume of blood has entered the collection tubing, heating and pressure means, for example heated wires and pressure rollers, are provided for heat-sealing at a first **182** and second **184** position along the tubing length, thereby creating a bolus **176** of blood of the desired volume. A time-point sample identifying stamp may be pressed into a crimped portion **178** of the pliable material. Air may be evacuated from the bolus prior to heat sealing to ensure the integrity of the sample prior to processing. The heat sealed bolus is then cut from the remaining tubing utilizing, for example, a plurality of cutting elements **170** and **172** adjacent the heating elements **160**, **162**. Flushing of the aspiration tubing may then proceed as previously described and the tubing material advanced for a subsequent sampling.

(00045) In one embodiment of the invention, referring to **FIG. 6**, an automated device for pinching, cutting, and advancement of the pliable collection tubing containing a bolus of blood may utilize first **202** and second **200** rolling



elements positioned adjacent heated wires **204, 206**. The heated wires may be pre-spaced to an appropriate separation to achieve the desired bolus volume. The heated wires **204, 206** are capable of pressing in on the pliable tubing **212** while heating the material so as to seal the tubing material upon cooling. A guillotine **208** for cutting the heat sealed bolus is provided adjacent the second roller means. Preferably, when the collected bolus has been sealed from the unused collection tubing, means are provided **210** for time marking either directly to the tubing or to a label attached to the tubing the time at which the blood sample was sealed and any other identifying information that may be helpful when later handling the bolus. Collection tubing used in accordance with the invention should be supplied with sufficient excess material to allow for collection of the desired number of blood samples without the risk of running out of the pliable collection tubing.

(00046) In some applications, it may be desirable to further automate the device to allow for immediate analysis of one or more blood parameters. For example, it is often necessary to perform real-time evaluation of the Activated Clotting Time (ACT) of a given blood sample. In current practice, a health care provider is often required to manually recover a collected sample of blood so as to perform real-time ACT analysis. The present invention may be successfully practiced to automate the ACT analysis so as to provide faster and more efficient blood parameter readings.

- (00047) An automated blood sampling device according to a specific embodiment of the present invention may be pre-programmed to periodically determine the Activated Clotting Time of an aspirated volume of blood. Automated means known in the art are adapted to perform ACT analysis of a blood volume collected in a collection vial as previously described and to provide real-time display of ACT. Alternatively, blood may be delivered automatically to a testing apparatus that is moved into the stream of blood exiting the aspiration tubing after a blood sample has been obtained in a collection vial. The testing apparatus is adapted to perform ACT analysis on the sample in the usual way. It will be obvious to one skilled in the art that further automation of the invention to allow for blood parameter analysis is not limited to the specific embodiments described.
- (00048) The invention may also be successfully adapted for practice with an arterial line that has been established to monitor blood pressure and to allow the delivery of pressurized saline. In these applications it is possible to allow for the periodic sampling of blood while maintaining the functionality of the blood pressure monitoring system.
- (00049) Referring to **FIG. 3**, a normal arterial line **30** is provided with access means in the form of a port **32** adjacent the insertion of the arterial line **30** into a patient. The port **32** provides access to the patient's bloodstream for delivery of medication. Upstream of the port **32**, a 3-way stopcock **34** is inserted by cutting the pre-existing arterial line and attaching the cut termini to a first **50**

and third 52 port of the stopcock body. Aspiration tubing 36 is attached to a second 54 port of the stopcock body. The stopcock 34 is inserted such that the pressurized saline source 38 and blood pressure monitoring means 40 are located upstream.

(00050) Fluid lines incorporating the pressurized saline source 38 and blood pressure monitoring means 40 into the automated blood drawing device are set up in the usual manner. For example, a second 3-way stopcock 46 receives fluid lines from the saline source 38 and blood pressure monitoring means 40 at a second 56 and third 58 port of the stopcock 46 body respectively. The transmission line 60 is attached at an origin to the third port 52 of the stopcock 34 and at a terminus to the third port 62 of the stopcock 46 receiving fluid lines from the saline source 38 and blood pressure monitoring device 40. The first 34 and second 46 stopcocks may be manually or automatically controlled, for example, utilizing rotary servo motors.

(00051) The saline source 38 connected via the upstream stopcock 46 may be used to flush the aspiration tubing 36 and optionally the arterial line 30 in between time-point blood sampling. The stopcock valves, infusion pump, and linear actuator 44 used to collect sample blood may be manually or automatically controlled. System flushing, blood collection, and wasting of flushing fluid and stagnant blood is accomplished in the manner previously described. The pressurized saline source 38 acts similarly to the flushing solution 16 of FIG.

1 when the stopcock 46 valve is set in a first position allowing pressurized saline to flow through the stopcock body and into the transmission line 60.

(00052) It will be readily apparent to one skilled in the art that pre-programming of the automated blood draw system is preferred. In one embodiment of the invention, multiple programming interfaces may be used to independently control an infusion pump, a stopcock valve assembly comprised of a servo motor and a blood fraction collecting device. User interfaces are commonly associated with commercially available servo motors, infusion pumps and fraction collectors.

(00053) Alternatively, referring to **FIG. 5**, in a preferred embodiment of the invention, a single user interface 104 is provided for programming a computer 106. For example, a single computer interface 104 may be used to accept programming input to control a servo motor 100, an infusion pump 18 and vial carousel 102 according to the present invention. Appropriate system parameters are entered into the computer and a microprocessor coordinates the operation of the component parts to achieve the desired result by generating output signals 108, 110, 112. While systems with a single user interface are preferred, the present invention is not limited to single user interface systems or to systems designed for automated operation.

(00054) The computer 106 may also be adapted to receive output signals 114, 116, 118 generated by monitoring devices. Monitoring devices may include, for example, a fluid waste container 120 or fluid sensors 122, 124. The present

invention is not limited to the specific monitoring devices described herein, and one skilled in the art will recognize obvious modifications that are within the scope of the present invention.

(00055) The automated blood drawing system according to the present invention may be further automated to provide for more precise measuring of blood flow through the stopcock body and into the aspiration tubing. In one embodiment of the present inventions, referring to **FIG. 4**, optical sensor switches are provided in cooperation with timing means and together are adapted to measure the quantity of blood passing through the aspiration tubing at a given sampling. A first optical sensor **70** is placed along the aspiration tubing **36** adjacent the valve body **34**. A second optical sensor **72** is placed along the aspiration tubing **36** at a position downstream of the valve body **34** and before the open end of the aspiration tubing **36**. The optical sensors are able to detect whether blood or flushing solution is flowing through the aspiration tubing **36** adjacent the respective sensor based on the absorption properties of the liquid.

(00056) The first **70** and second **72** optical sensors are provided with means for communicating with a timer **76**. The timer **76** may be, for example, a mechanical timer, a digital recorder, or a computer. In a preferred embodiment of the invention, when blood enters the aspiration tubing **36** from the valve body **34** the first optical sensor **70** sends a signal to a timing computer **76**, resulting in the initiation of the timing clock. When the blood reaches the second sensor **72**, a signal is sent to the timing computer **76**. The

computer then calculates the rate of blood flow through the aspiration tubing 36 based on pre-programmed system parameters and the timing between activation of the first and second optical sensors. This information may be used by the computer to coordinate other system components resulting in efficient blood sampling. Likewise, the optical sensors are able to calculate the rate of flushing solution passing through the aspiration tubing so as to ensure adequate flushing of the line.

(00057) The information obtained from the optical sensors and delivered to the computer may also be used to generate a time stamp for a given time-point blood sampling. The exact timing of the blood draw, the volume of blood obtained, and other pertinent system parameters may be recorded to a database for future reference. Other modifications of the system utilizing optical sensors to coordinate functionality of various components within the scope of the present invention will be apparent to those skilled in the art.

(00058) Consistent with the scope of the invention, appropriate safety features may be incorporated into particular embodiments of the invention. For example, in those applications where collection blood is delivered directly into an open vial, accidental introduction of air into the arterial or venous line is a particular safety concern. Referring to **FIG. 1A**, to prevent unwanted introduction of air into the plurality of fluid lines, isotonic saline solution may be run through the aspiration tubing 6 before the stopcock 8 valve is set to a second position, thereby allowing blood to enter the aspiration tubing 6. In

addition, the infusion pump 18 may be adapted with an internal alarm programmed to sound when air enters the aspiration tubing 6.

(00059) In another embodiment of the invention adapted to prevent air from entering the system, blood and saline may be pressure forced through the stopcock body and aspiration tubing rather than allowing sample or waste fluid to drip freely from the terminus of the aspiration tubing and into the desired collection receptacle or waste collector. A valve that opens only after exceeding a minimum pressure may be used since the infusion pump creates pressure downstream of the valve.

(00060) An additional safety consideration is a potential malfunction or erroneous programming of the automated blood draw system that may result in excessive pumping of arterial or venous blood through the aspiration tubing and into the collection container. A fluid float, such as those commonly used to indicate gas level in a closed tank may be used to monitor the level of waste collected in a waste container. An alarm may be programmed to activate when excessive fluid is collected. In an alternative embodiment of the invention, power to the infusion pumps may be cut when the fluid level in the waste container has passed a pre-determined level indicating excessive fluid waste by the system.

(00061) In another embodiment of the invention, an optical system sensitive to the difference in light absorption between clear flushing solution and opaque blood may be used to monitor when blood is being aspirated. Such a device

may be placed at a point along the aspiration tubing before or after the infusion pump. The volume of aspirated blood may be calculated, based for example on the length of time the infusion pump has been operational, volume of through-flow per second for the tubing and infusion pump used, and/or on whether blood or saline was being pumped through the system during the infusion pumps operation. If this blood volume exceeds a pre-set limit of aspiration, the user would be notified and/or power to the infusion pump would be cut.

(00062) In yet another embodiment of the invention, a flow sensor may be placed around or in series with the section of tubing coming from the patient's blood line, before the intersection of the blood line with the saline line, to monitor the amount of blood flowing out of the patient. This flow sensor could be mechanical (e.g., paddle wheel), ultrasonic (e.g., Doppler), or be comprised of other accepted flow sensing technology. When total volume of blood outflow exceeds a pre-set limit of aspiration, the user would be notified and/or power to the infusion pump would be cut. Additional safety features within the scope of the present invention will be apparent to one skilled in the art.

(00063) A specific embodiment of an automated blood drawing apparatus according to the present invention has been described for the purpose of illustrating the manner in which the invention is made and used. It should be understood that the implementation of other variations and modifications of the invention and its various aspects will be apparent to one skilled in the art, and that the



invention is not limited by the specific embodiments described. Therefore, it is contemplated to cover the present invention and any and all modifications, variations, or equivalents that fall within the true spirit and scope of the basic underlying principles disclosed and claimed herein.

o

o

## CLAIMS

1. An automated blood drawing apparatus for drawing blood samples at scheduled time intervals from a human or animal, comprising:

a branching element capable of transmitting fluid and engaging at least three fluid lines;

the first fluid line being capable of transmitting blood from a human or animal to the branching element;

the second fluid line being capable of delivering a flushing solution from a flushing solution source to the branching element;

the third fluid line being capable of transmitting fluid arriving at the branching element from either the first or second fluid line to collection means located at the terminus of the third fluid line;

the collection means comprising at least one collection receptacle and a waste container;

the collection means being capable of moving the collection receptacle to a first position to allow fluid exiting the third fluid line to empty into the collection receptacle or to a second position to allow the fluid exiting the third fluid line to empty into the waste container, wherein the collection receptacle is moved to a first or second position in response to an input signal;

at least one pumping means capable of initiating fluid flow through the branching element and the plurality of fluid lines upon activation, the pumping means being selectively activated or deactivated in response to an input signal;

at least one selection means for selectively inhibiting fluid flow in at least one of the fluid lines while the pumping means is activated, the selection means being capable of selective activation in response to an input signal;

wherein activation of one or more selection means allows blood to flow from the first fluid line through the branching element and into the third fluid line or allows flushing solution to flow from the second fluid line through the branching element and into either the first or third fluid line;

computer means capable of providing an input signal to the pumping means, the selection means, and the collecting means in response to system generated information;

the system generated information being produced by the computer means in response to programming information entering the computer means from at least one user interface and from at least one monitoring device;

the system generated information resulting in output signals allowing for coordination of the pumping means, selection means, and the collecting means such that efficient blood sampling occurs at scheduled time intervals without excessive blood waste.

2. An automated blood drawing apparatus according to claim 1, wherein the collection means is comprised of a fraction collector and a waste receptacle;

the fraction collector being comprised of a carousel tray and a plurality of collection receptacles;

wherein in response to an input signal, the carousel tray is moved to a first position whereby one of a plurality of collection receptacles is placed into a stream of fluid exiting the third fluid line;

wherein in response to a second input signal, the carousel tray is moved to a second position whereby the first collection receptacle is moved out of the stream of fluid exiting the third fluid line, fluid exiting the fluid line thereby being collected in a waste container located beneath the carousel tray;

wherein subsequent input signals result in the carousel tray being moved so as to place additional collection vials sequentially in and out of the stream of fluid exiting the third fluid line.

3. An automated blood drawing apparatus according to claim 1, wherein a monitoring device determines the volume of fluid in the waste receptacle;

said monitoring device being capable of generating an output signal to the computer means when the fluid level in the waste container exceeds a pre-determined level;

said output signal resulting in sounding of an alarm and deactivation of the pumping means, thereby preventing excessive blood or flushing solution aspiration.

4. An automated blood drawing apparatus according to claim 1, wherein the blood is captured in a bolus of pliable tubing.

5. An automated blood drawing apparatus according to claim 4, wherein the pliable tubing is sealed at one end and the collection means is further comprised of sealing means, cutting means and advancement means;

the pliable tubing material being capable of softening in response to an application of a specific temperature stimulus, whereby removal of the temperature stimulus results in the pliable material hardening relative to its softened state;

the sealing means being comprised of at least two heating elements, each capable of applying heat or pressure at two positions tangent to the pliable tubing, said tangents being parallel one to the other;

the advancement means being capable of advancing a section of pliable tubing into a position relative to the sealing means such that the first heating element is located at a position adjacent a cut end of the pliable tubing and the second heating element is located at position below the first heating element;

the second heating element is capable of applying heat and pressure to the pliable tubing in response to an input signal, whereby application of heat and pressure to the pliable tubing results in melting of the pliable tubing and a sealing of the tubing upon cooling;

the collection receptacle formed by sealing at the second heating element is capable of accepting fluid from the open end of the third fluid line when placed in the stream of fluid;

the first heating element is capable of applying heat and pressure to the pliable tubing of the collection receptacle in response to an input signal generated once fluid has been introduced into the receptacle, whereby application of heat and pressure to the open end of the collection receptacle results in melting of the pliable tubing and sealing of the collection receptacle, thereby creating a bolus of fluid;

the cutting means is capable of cutting the sealed bolus from the remainder of the pliable tubing;

after cutting, the advancement means is capable moving the bolus out of proximity of the sealing means and advancing additional pliable tubing into a position relative to the sealing means.

6. An automated blood drawing apparatus according to claim 4, wherein fluid exiting the third fluid tube enters a length of pliable tubing and exits into a waste receptacle;

the pliable tubing being positioned along a surface;

first and second heat sealing elements are positioned along a length of pliable tubing,

the heat sealing elements being capable of pressing the pliable tubing down on the flat surface, thereby heating the pliable material and adhering it to itself upon cooling;

the pliable tubing is sealed so as to obtain a bolus of blood in the tubing between the first and second sealed portion;

cutting means cutting the pliable tubing adjacent the sealed portion so as to free the bolus of blood from the remaining tubing material;

a cutting means further cutting the pliable tubing so as to allow fluid to flow through the remaining pliable tubing and into a waste container.

7. An automated blood drawing apparatus according to either of claims 5 and 6, wherein system generated information is affixed or stamped to the bolus.

8. An automated blood drawing apparatus according to claim 1, wherein a monitoring device is comprised of at least two optical sensors in communication with a timing means;

the first optical sensor being located at a position along the third fluid line and adjacent the branching means;

the second optical sensor being located at a position along the third fluid line downstream of the first optical sensor;

the timing means being capable of monitoring time;

the first and second optical sensors being capable of generating an output signal to the timing means in response to changes in the opacity of fluid flowing through the third fluid line;

the first output signal being generated when a change in opacity indicates either blood or flushing solution has entered the third fluid line, said output signal resulting in the timing means polling time;

the second output signal being generated when a change in opacity indicates either blood or flushing solution has reached a position along the third fluid line corresponding to the location of the second optical sensor, said output signal resulting in the cessation of time polling by the timing means, whereby the polled time may be used by the computer to generate system generated information.

9. An automated blood drawing apparatus for drawing blood samples at scheduled time intervals from a human or animal, comprising:

at least two branching elements each capable of transmitting fluid and engaging at least three fluid lines;

the first fluid line of the first branching element is comprised of a blood line being capable of transmitting blood from a human or animal to the first branching element;

the second fluid line of the first branching element being capable of delivering a flushing solution from a flushing solution source to the first branching element;

the third fluid line of the first branching element being comprised of an aspiration line being capable of transmitting fluid arriving at the first branching element from either the blood or second fluid line to collection means located at the terminus of the aspiration line;

the second branching element being incorporated upstream of the second fluid line, such that the second branching element also engages the second fluid line;

the first fluid line of the second branching element is comprised of a flushing line capable of delivering a flushing solution from a flushing solution source through the second branching element to the second fluid line;

the third fluid line of the second branching element is comprised of a monitoring line attached to a blood pressure monitoring device capable of monitoring the blood pressure of a human or animal;

the collection means comprising at least one collection receptacle and a waste container;



the collection means being capable of moving the collection receptacle to a first position to allow fluid exiting the third fluid line to empty into the collection receptacle or to a second position to allow the fluid exiting the third fluid line to empty into the waste container, wherein the collection receptacle is moved to a first or second position in response to an input signal;

at least one pumping means capable of initiating fluid flow through the branching elements and the plurality of fluid lines upon activation, the pumping means being selectively activated or deactivated in response to an input signal;

at least two selection means for selectively inhibiting fluid flow in at least two of the fluid lines while the pumping means is activated, the selection means being capable of selective activation in response to an input signal;

wherein activation of one or more selection means allows blood to flow from the blood fluid line through the first branching element and into the aspiration line or allows flushing solution to flow from the flushing line, through the second branching element, into the second fluid line, through the first branching element and into either the blood or third aspiration line, or allows the blood pressure monitoring device to monitor the blood pressure of a human or animal, the blood line, second fluid line, and monitor line forming a continuous fluid line when the blood pressure monitoring device is active;

computer means capable of providing an input signal to the pumping means, the selection means, and the collecting means in response to system generated information;

the system generated information being produced by the computer means in response to programming information entering the computer means from at least one user interface and from at least one monitoring device;

the system generated information resulting in output signals allowing for coordination of the pumping means, selection means, and the collecting means such that efficient blood sampling occurs at scheduled time intervals without excessive blood waste.

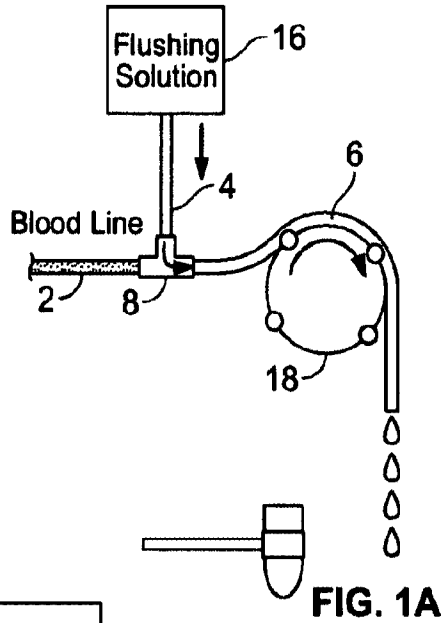


FIG. 1A

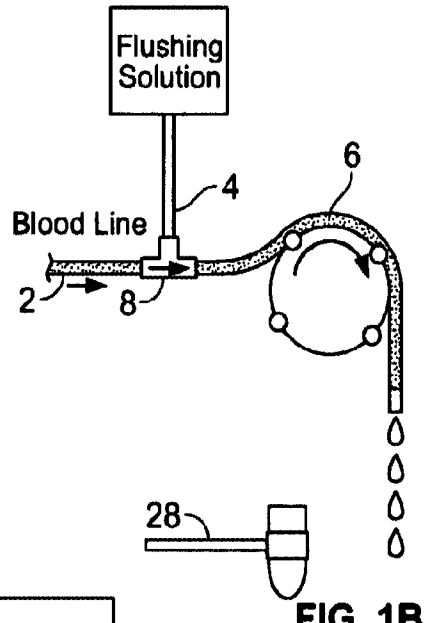


FIG. 1B

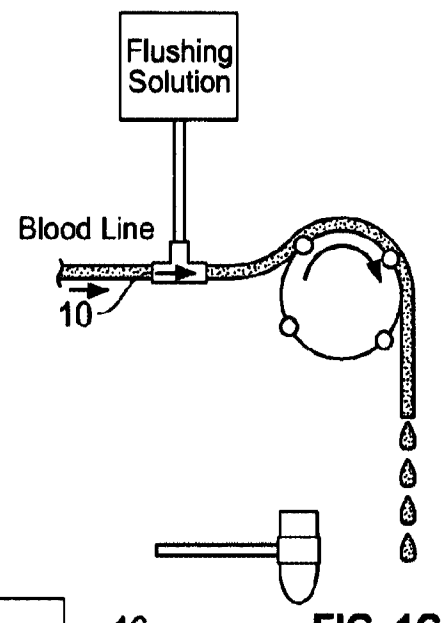


FIG. 1C

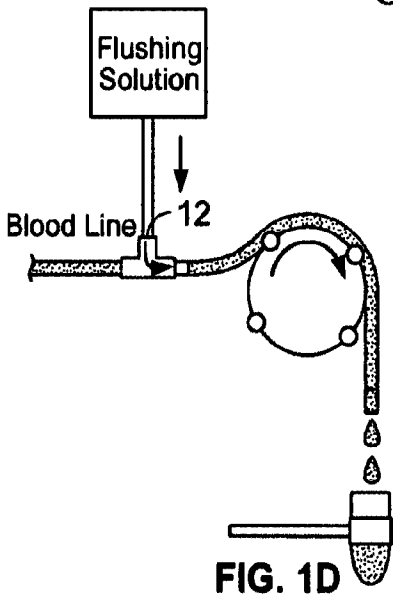


FIG. 1D

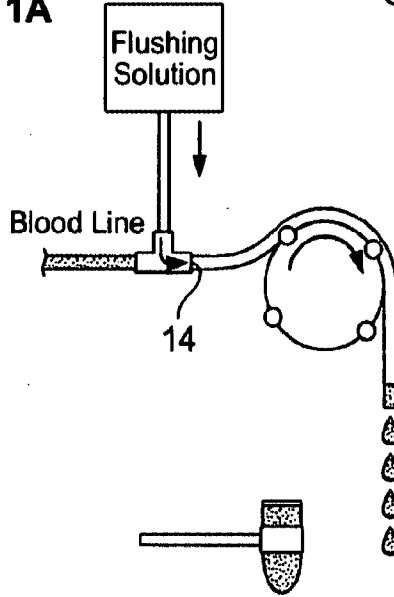


FIG. 1E

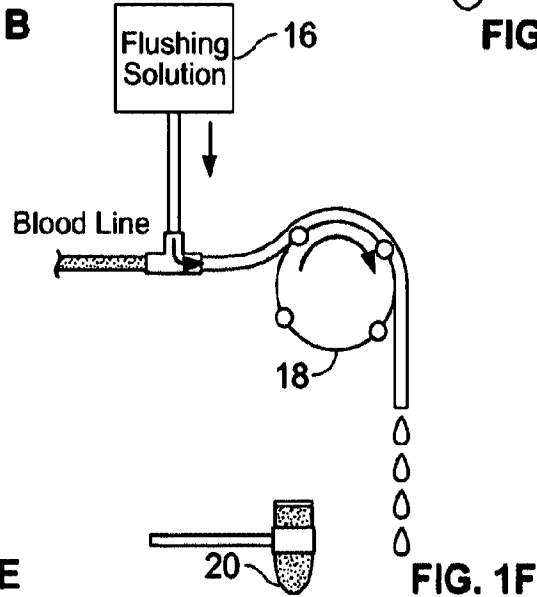


FIG. 1F

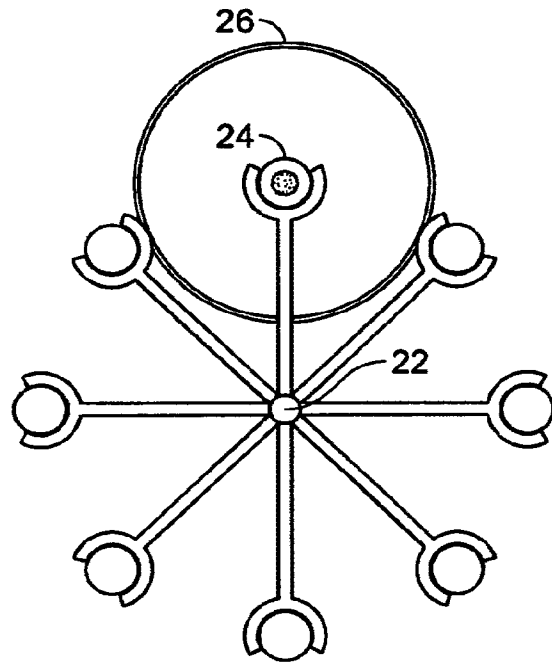


FIG. 2A

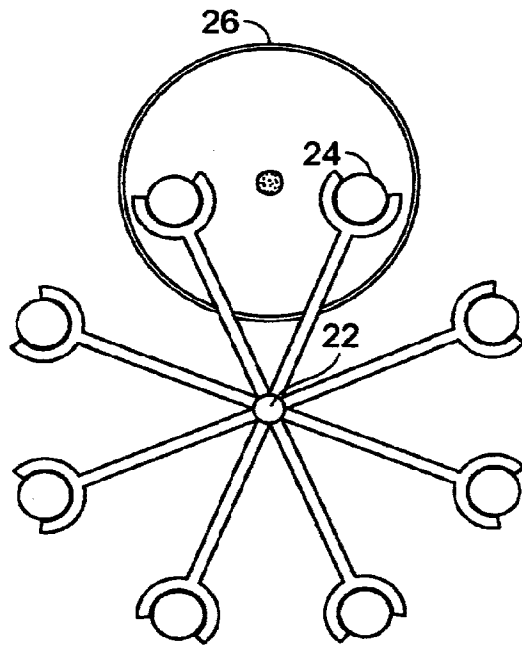


FIG. 2B

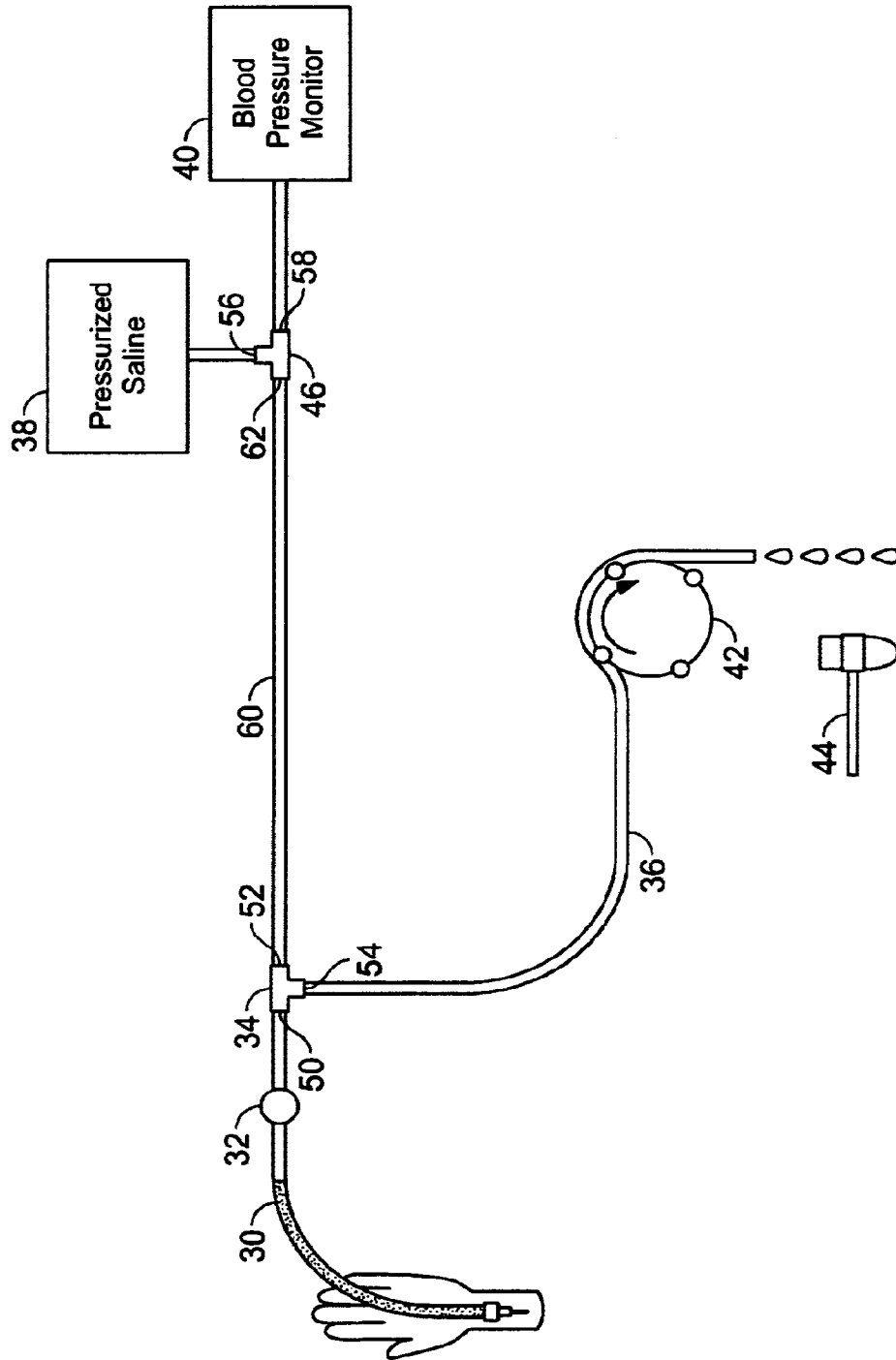


FIG. 3

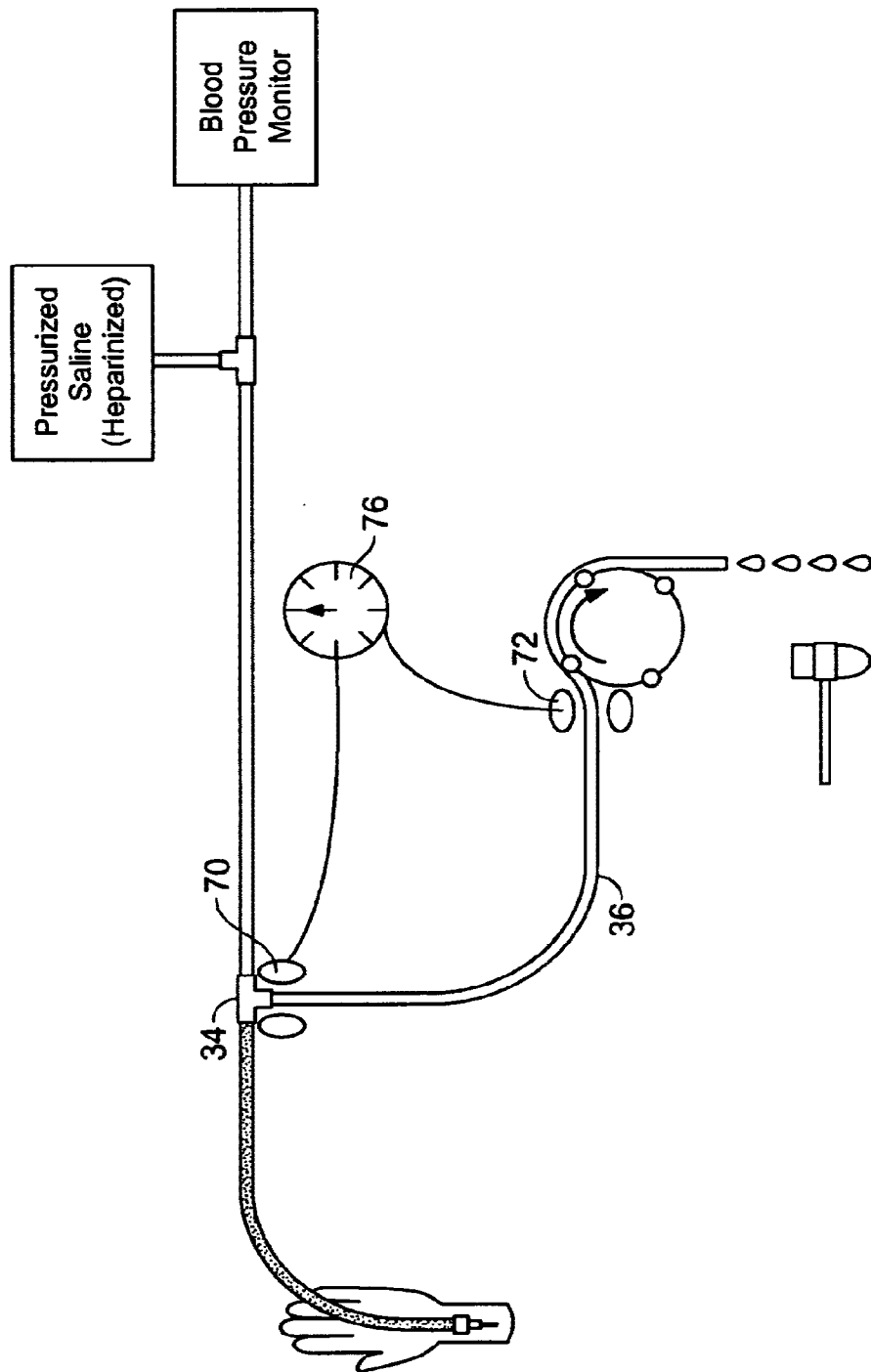


FIG. 4

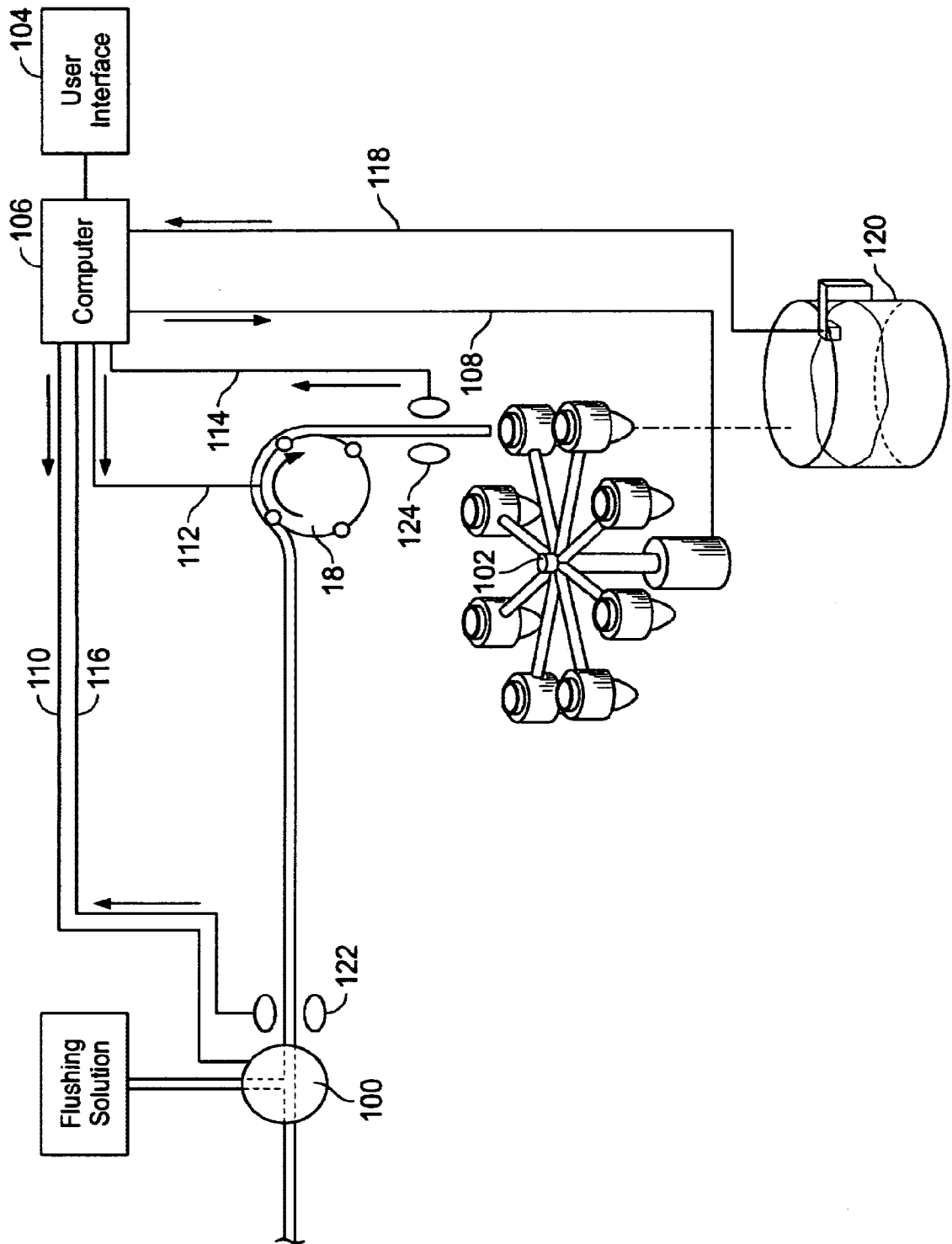


FIG. 5

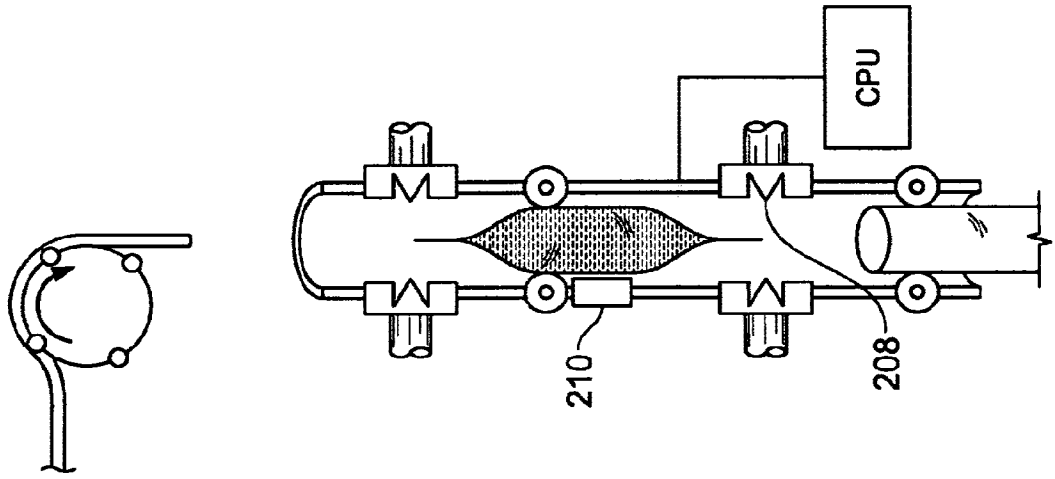


FIG. 6C

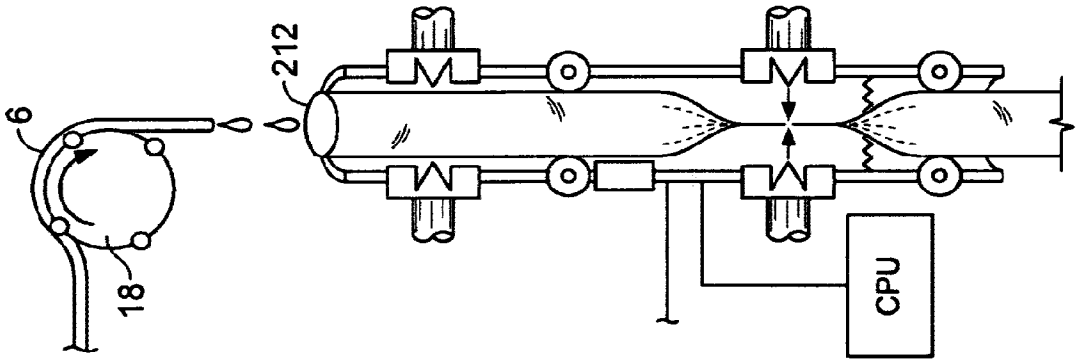


FIG. 6B

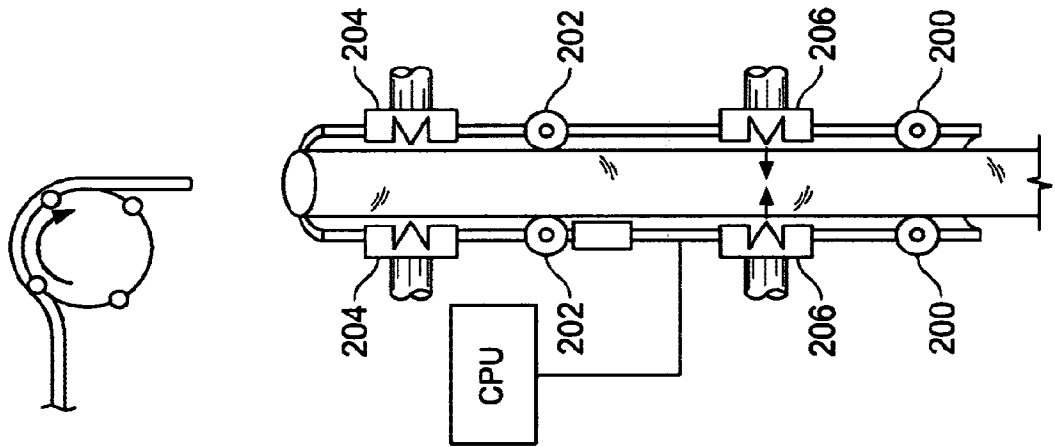
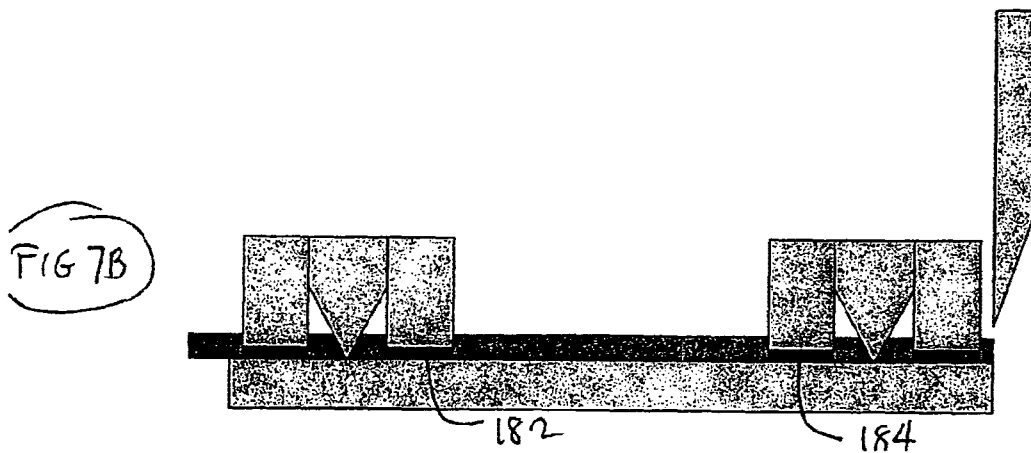
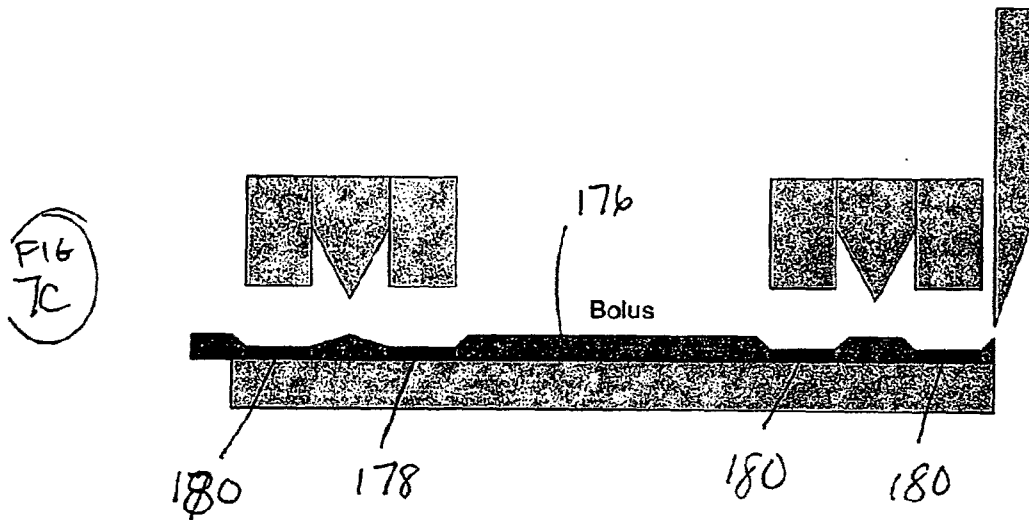
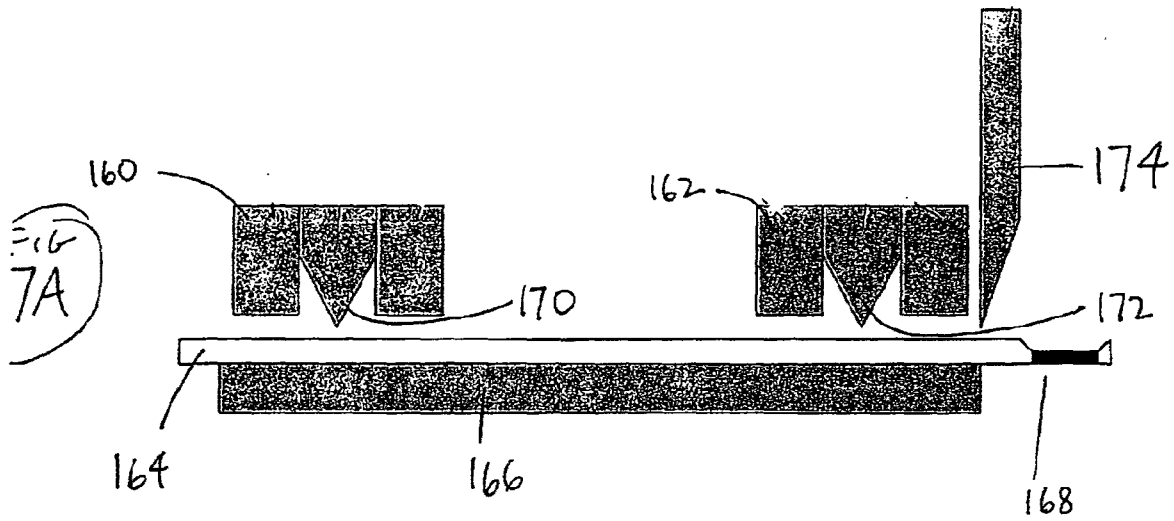


FIG. 6A





PATENT COOPERATION TREATY

PCT

INTERNATIONAL SEARCH REPORT

(PCT Article 18 and Rules 43 and 44)

Applicant's or agent's file reference 56782.1.5.1	<b>FOR FURTHER ACTION</b> see Form PCT/ISA/220 as well as, where applicable, item 5 below.	
International application No. PCT/US2009/047027	International filing date (day/month/year) 11/06/2009	(Earliest) Priority Date (day/month/year) 11/06/2008
Applicant BRACCO DIAGNOSTICS INC.		

This international search report has been prepared by this International Searching Authority and is transmitted to the applicant according to Article 18. A copy is being transmitted to the International Bureau.

This international search report consists of a total of 8 sheets.

It is also accompanied by a copy of each prior art document cited in this report.

1. Basis of the report

a. With regard to the **language**, the international search was carried out on the basis of:

- the international application in the language in which it was filed  
 a translation of the international application into \_\_\_\_\_, which is the language of a translation furnished for the purposes of international search (Rules 12.3(a) and 23.1(b))

b.  This international search report has been established taking into account the **rectification of an obvious mistake** authorized by or notified to this Authority under Rule 91 (Rule 43.6bis(a)).

c.  With regard to any **nucleotide and/or amino acid sequence** disclosed in the international application, see Box No. I.

2.  **Certain claims were found unsearchable** (See Box No. II)

3.  **Unity of invention is lacking** (see Box No III)

4. With regard to the **title**,

- the text is approved as submitted by the applicant  
 the text has been established by this Authority to read as follows:

5. With regard to the **abstract**,

- the text is approved as submitted by the applicant  
 the text has been established, according to Rule 38.2(b), by this Authority as it appears in Box No. IV. The applicant may, within one month from the date of mailing of this international search report, submit comments to this Authority

6. With regard to the **drawings**,

- a. the figure of the **drawings** to be published with the abstract is Figure No. 1c  
 as suggested by the applicant  
 as selected by this Authority, because the applicant failed to suggest a figure  
 as selected by this Authority, because this figure better characterizes the invention
- b.  none of the figures is to be published with the abstract

**A. CLASSIFICATION OF SUBJECT MATTER**  
 INV. A61M5/14 G21F5/015  
 ADD. A61M36/00

According to International Patent Classification (IPC) or to both national classification and IPC

**B. FIELDS SEARCHED**

Minimum documentation searched (classification system followed by classification symbols)  
 A61M G21F

Documentation searched other than minimum documentation to the extent that such documents are included in the fields searched

Electronic data base consulted during the international search (name of data base and, where practical, search terms used)

EPO-Internal, WPI Data

**C. DOCUMENTS CONSIDERED TO BE RELEVANT**

Category*	Citation of document, with indication, where appropriate, of the relevant passages	Relevant to claim No.
X	WO 2005/002971 A1 (IPHASE TECHNOLOGIES PTY LTD [AU]; TOCHON-DANGUY HENRI-JACQUES [AU]; PO) 13 January 2005 (2005-01-13) figures 1-4 page 5, paragraph 4 - page 11, paragraph 3	1-15, 34-37
X	US 2003/004463 A1 (REILLY DAVID M [US] ET AL) 2 January 2003 (2003-01-02) figures 1-4 paragraph [0049] - paragraph [0072]	1-15, 34-37
X	JP 2000 350783 A (SUMITOMO HEAVY INDUSTRIES) 19 December 2000 (2000-12-19) figures 1-5 paragraph [0014] - paragraph [0033]	1-15, 22-37
	-/--	

Further documents are listed in the continuation of Box C.

See patent family annex.

\* Special categories of cited documents :

- \*A\* document defining the general state of the art which is not considered to be of particular relevance
- \*E\* earlier document but published on or after the international filing date
- \*L\* document which may throw doubts on priority claim(s) or which is cited to establish the publication date of another citation or other special reason (as specified)
- \*O\* document referring to an oral disclosure, use, exhibition or other means
- \*P\* document published prior to the international filing date but later than the priority date claimed

- \*T\* later document published after the international filing date or priority date and not in conflict with the application but cited to understand the principle or theory underlying the invention
- \*X\* document of particular relevance; the claimed invention cannot be considered novel or cannot be considered to involve an inventive step when the document is taken alone
- \*Y\* document of particular relevance; the claimed invention cannot be considered to involve an inventive step when the document is combined with one or more other such documents, such combination being obvious to a person skilled in the art.
- \*Z\* document member of the same patent family

Date of the actual completion of the international search

15 February 2010

Date of mailing of the international search report

25/02/2010

Name and mailing address of the ISA/

European Patent Office, P.B. 5818 Patentlaan 2  
 NL - 2280 HV Rijswijk  
 Tel. (+31-70) 340-2040,  
 Fax: (+31-70) 340-3016

Authorized officer

Reinbold, Sylvie

C(Continuation). DOCUMENTS CONSIDERED TO BE RELEVANT		
Category*	Citation of document, with indication, where appropriate, of the relevant passages	Relevant to claim No.
X	WO 2008/037939 A2 (LEMER PROT ANTI X PAR ABREVIAT [FR]; LEMER PIERRE-MARIE [FR]) 3 April 2008 (2008-04-03) the whole document	22-27
Y A		28-33 1-15
X,P	WO 2008/082966 A2 (MEDRAD INC [US]) 10 July 2008 (2008-07-10) figures 1-45 paragraph [0068] - paragraph [0273]	1,22,27, 34
X	EP 0 102 121 A1 (BYK MALLINCKRODT CIL BV [NL]) 7 March 1984 (1984-03-07) figures 1-4 page 9, line 6 - page 12, line 11	22-36
Y	JP 2006 325826 A (UNIVERSAL GIKEN KK; SD GIKEN KK) 7 December 2006 (2006-12-07) figures 1-10 paragraph [0020] - paragraph [0072]	28-33

**FURTHER INFORMATION CONTINUED FROM PCT/ISA/ 210**

Continuation of Box II.1

Claims Nos.: 16-21

The methods of claims 16 to 21 for setting up an infusion device is carried out within a human body. It is implicit that the methods are during a medical therapy because the infusion tubing is connected to a patient. The application does not meet the requirement of Rule 39.1(iv), because these claims are methods of treatment of the human body.

# INTERNATIONAL SEARCH REPORT

International application No.  
PCT/US2009/047027

## Box No. II Observations where certain claims were found unsearchable (Continuation of item 2 of first sheet)

This international search report has not been established in respect of certain claims under Article 17(2)(a) for the following reasons:

1.  Claims Nos.: 16-21  
because they relate to subject matter not required to be searched by this Authority, namely:  
see FURTHER INFORMATION sheet PCT/ISA/210
2.  Claims Nos.:  
because they relate to parts of the international application that do not comply with the prescribed requirements to such an extent that no meaningful international search can be carried out, specifically:
3.  Claims Nos.:  
because they are dependent claims and are not drafted in accordance with the second and third sentences of Rule 6.4(a).

## Box No. III Observations where unity of invention is lacking (Continuation of item 3 of first sheet)

This International Searching Authority found multiple inventions in this international application, as follows:

see additional sheet

1.  As all required additional search fees were timely paid by the applicant, this international search report covers all searchable claims.
2.  As all searchable claims could be searched without effort justifying an additional fees, this Authority did not invite payment of additional fees.
3.  As only some of the required additional search fees were timely paid by the applicant, this international search report covers only those claims for which fees were paid, specifically claims Nos.:
4.  No required additional search fees were timely paid by the applicant. Consequently, this international search report is restricted to the invention first mentioned in the claims; it is covered by claims Nos.:

### Remark on Protest

- The additional search fees were accompanied by the applicant's protest and, where applicable, the payment of a protest fee.
- The additional search fees were accompanied by the applicant's protest but the applicable protest fee was not paid within the time limit specified in the invitation.
- No protest accompanied the payment of additional search fees.

## FURTHER INFORMATION CONTINUED FROM PCT/ISA/ 210

This International Searching Authority found multiple (groups of) inventions in this international application, as follows:

## 1. claims: 1-15, 37

These claims disclose a shielding assembly for an infusion system comprising:

- a first compartment sized to contain more radioisotope generators and enclosed by a first sidewall including an opening extending therethrough and including an opening and lid, the opening being oriented upward and located at a first elevation
- a second compartment sized to contain a portion of an infusion tubing circuit and being enclosed by a second sidewall and including a base portion and a lid
- a third compartment sized to contain a waste bottle of the infusion system and being enclosed by a third sidewall that forms a barrier to radioactive radiation, including an opening and a lid, the opening of the third sidewall being oriented upward and located at a second elevation, the second elevation being greater than the first elevation of the opening of the first sidewall (technical problem: to facilitate an ergonomic stance for technical personnel to lift generator out from the compartment)

---

## 2. claims: 22-26

These claims disclose a shielding assembly for an infusion system comprising:

- a first door to contain one or more radioisotope generators
- a second door to provide access to a second compartment being sized to contain an infusion tubing
- the second door, when enclosing the second compartment preventing the first door from the opening to provide access to the first compartment  
(technical problem: provide access to the corresponding compartments)

---

## 3. claims: 27-33

These claims disclose an infusion system comprising:

- a cabinet structure including a shell and an access panel
- a lock engaging the access panel
- an eluant source
- a shielding assembly comprising a plurality of compartments and including a corresponding plurality of doors  
(technical problem: to provide a relatively ergonomic and organized work area to operate the infusion system)

---

## 4. claims: 34-36

FURTHER INFORMATION CONTINUED FROM PCT/ISA/ 210

These claims disclose a shielding assembly for an infusion system comprising:

- a plurality of compartments
- a corresponding plurality of doors
- a first compartment sized to contain a radioisotope generator including a first sidewall with a first sidewall opening oriented upward and aligned with a first upper opening through a shell of the cabinet structure,
- wherein an upper surface of the shell is located at an elevation which is substantially greater than that of the first sidewall opening and the first upper opening  
(technical problem: to provide an alternative access to the compartment)

---



Information on patent family members

International application No  
PCT/US2009/047027

Patent document cited in search report	Publication date	Patent family member(s)	Publication date	
WO 2005002971	A1	13-01-2005	EP 1644247 A1 US 2006151048 A1	12-04-2006 13-07-2006
US 2003004463	A1	02-01-2003	US 2005238576 A1 US 2003216609 A1	27-10-2005 20-11-2003
JP 2000350783	A	19-12-2000	NONE	
WO 2008037939	A2	03-04-2008	AU 2007301772 A1 CA 2664760 A1 CN 101516420 A EP 2077873 A2 FR 2906475 A1 KR 20090057979 A US 2010030009 A1	03-04-2008 03-04-2008 26-08-2009 15-07-2009 04-04-2008 08-06-2009 04-02-2010
WO 2008082966	A2	10-07-2008	US 2008177126 A1	24-07-2008
EP 0102121	A1	07-03-1984	NONE	
JP 2006325826	A	07-12-2006	NONE	

# PATENT COOPERATION TREATY

From the  
INTERNATIONAL SEARCHING AUTHORITY

## PCT

**WRITTEN OPINION OF THE  
INTERNATIONAL SEARCHING AUTHORITY  
(PCT Rule 43bis.1)**

To:

see form PCT/ISA/220

Date of mailing  
(day/month/year) see form PCT/ISA/210 (second sheet)

Applicant's or agent's file reference  
see form PCT/ISA/220

**FOR FURTHER ACTION**  
See paragraph 2 below

International application No.  
PCT/US2009/047027

International filing date (day/month/year)  
11.06.2009

Priority date (day/month/year)  
11.06.2008

International Patent Classification (IPC) or both national classification and IPC  
INV. A61M5/14 G21F5/015  
ADD. A61M36/00

Applicant  
BRACCO DIAGNOSTICS INC.

**1. This opinion contains indications relating to the following items:**

- Box No. I Basis of the opinion
- Box No. II Priority
- Box No. III Non-establishment of opinion with regard to novelty, inventive step and industrial applicability
- Box No. IV Lack of unity of invention
- Box No. V Reasoned statement under Rule 43bis.1(a)(i) with regard to novelty, inventive step or industrial applicability; citations and explanations supporting such statement
- Box No. VI Certain documents cited
- Box No. VII Certain defects in the international application
- Box No. VIII Certain observations on the international application


**2. FURTHER ACTION**

If a demand for international preliminary examination is made, this opinion will usually be considered to be a written opinion of the International Preliminary Examining Authority ("IPEA") except that this does not apply where the applicant chooses an Authority other than this one to be the IPEA and the chosen IPEA has notified the International Bureau under Rule 66.1bis(b) that written opinions of this International Searching Authority will not be so considered.

If this opinion is, as provided above, considered to be a written opinion of the IPEA, the applicant is invited to submit to the IPEA a written reply together, where appropriate, with amendments, before the expiration of 3 months from the date of mailing of Form PCT/ISA/220 or before the expiration of 22 months from the priority date, whichever expires later.

For further options, see Form PCT/ISA/220.

**3. For further details, see notes to Form PCT/ISA/220.**

<p>Name and mailing address of the ISA:</p> <div style="text-align: center;">  <p>European Patent Office D-80298 Munich Tel. +49 89 2399 - 0 Fax: +49 89 2399 - 4465</p> </div>	<p>Date of completion of this opinion</p> <p>see form PCT/ISA/210</p>	<p>Authorized Officer</p> <p>Reinbold, Sylvie</p> <p>Telephone No. +49 89 2399-7918</p>
--	---	---



---

**Box No. I Basis of the opinion**

---

1. With regard to the **language**, this opinion has been established on the basis of:
  - the international application in the language in which it was filed
  - a translation of the international application into , which is the language of a translation furnished for the purposes of international search (Rules 12.3(a) and 23.1 (b)).
2.  This opinion has been established taking into account the **rectification of an obvious mistake** authorized by or notified to this Authority under Rule 91 (Rule 43bis.1(a))
3. With regard to any **nucleotide and/or amino acid sequence** disclosed in the international application and necessary to the claimed invention, this opinion has been established on the basis of:
  - a. type of material:
    - a sequence listing
    - table(s) related to the sequence listing
  - b. format of material:
    - on paper
    - in electronic form
  - c. time of filing/furnishing:
    - contained in the international application as filed.
    - filed together with the international application in electronic form.
    - furnished subsequently to this Authority for the purposes of search.
4.  In addition, in the case that more than one version or copy of a sequence listing and/or table relating thereto has been filed or furnished, the required statements that the information in the subsequent or additional copies is identical to that in the application as filed or does not go beyond the application as filed, as appropriate, were furnished.
5. Additional comments:

**Box No. III Non-establishment of opinion with regard to novelty, inventive step and industrial applicability**

The questions whether the claimed invention appears to be novel, to involve an inventive step (to be non obvious), or to be industrially applicable have not been examined in respect of

- the entire international application
- claims Nos. 16-21

because:

- the said international application, or the said claims Nos. relate to the following subject matter which does not require an international search (*specify*):
- the description, claims or drawings (*indicate particular elements below*) or said claims Nos. are so unclear that no meaningful opinion could be formed (*specify*):
- the claims, or said claims Nos. are so inadequately supported by the description that no meaningful opinion could be formed (*specify*):
- no international search report has been established for the whole application or for said claims Nos. 16-21
- a meaningful opinion could not be formed without the sequence listing; the applicant did not, within the prescribed time limit:
  - furnish a sequence listing on paper complying with the standard provided for in Annex C of the Administrative Instructions, and such listing was not available to the International Searching Authority in a form and manner acceptable to it.
  - furnish a sequence listing in electronic form complying with the standard provided for in Annex C of the Administrative Instructions, and such listing was not available to the International Searching Authority in a form and manner acceptable to it.
  - pay the required late furnishing fee for the furnishing of a sequence listing in response to an invitation under Rules 13ter.1(a) or (b).
- a meaningful opinion could not be formed without the tables related to the sequence listings; the applicant did not, within the prescribed time limit, furnish such tables in electronic form complying with the technical requirements provided for in Annex C-bis of the Administrative Instructions, and such tables were not available to the International Searching Authority in a form and manner acceptable to it.
- the tables related to the nucleotide and/or amino acid sequence listing, if in electronic form only, do not comply with the technical requirements provided for in Annex C-bis of the Administrative Instructions.
- See Supplemental Box for further details

---

**Box No. IV Lack of unity of invention**

---

1.  In response to the invitation (Form PCT/ISA/206) to pay additional fees, the applicant has, within the applicable time limit:
- paid additional fees
  - paid additional fees under protest and, where applicable, the protest fee
  - paid additional fees under protest but the applicable protest fee was not paid
  - not paid additional fees
2.  This Authority found that the requirement of unity of invention is not complied with and chose not to invite the applicant to pay additional fees.
3. This Authority considers that the requirement of unity of invention in accordance with Rule 13.1, 13.2 and 13.3 is
- complied with
  - not complied with for the following reasons:  
**see separate sheet**
4. Consequently, this report has been established in respect of the following parts of the international application:
- all parts.
  - the parts relating to claims Nos. 1-15, 22-37

---

**Box No. V Reasoned statement under Rule 43bis.1(a)(i) with regard to novelty, inventive step or industrial applicability; citations and explanations supporting such statement**

---

1. Statement

Novelty (N)	Yes: Claims	<u>2-15, 23-26, 28-33, 35-36</u>
	No: Claims	<u>1, 22, 27, 34, 37</u>
Inventive step (IS)	Yes: Claims	
	No: Claims	<u>1-15, 22-37</u>
Industrial applicability (IA)	Yes: Claims	<u>1-15, 22-37</u>
	No: Claims	

2. Citations and explanations

**see separate sheet**

---

**Box No. VI Certain documents cited**

---

1. Certain published documents (Rules 43*bis*.1 and 70.10)  
and / or
2. Non-written disclosures (Rules 43*bis*.1 and 70.9)  
see form 210

**Re Item III**

**Non- establishment of opinion with regard to novelty, inventive step and industrial applicability**

The methods of **claims 16 to 21** for setting up an infusion device is carried out within a human body. It is implicit that the methods are during a medical therapy because the infusion tubing is connected to a patient. The application does not meet the requirement of Rule 39.1 (iv), because these claims are methods of treatment of the human body.

Consequently, no opinion will be formulated with respect to the industrial applicability of the subject matter of these claims. (Article 34(4)(a)(i)PCT)

**Re Item IV**

**Lack of unity of invention**

The inventions in this international application, as follows:

**1. Claims 1-15.37**

These claims disclose a shielding assembly for an infusion system comprising:

- a first compartment sized to contain more radioisotope generators and enclosed by a first sidewall including an opening extending therethrough and including an opening and lid, the opening being oriented upward and located at a first elevation
- a second compartment sized to contain a portion of an infusion tubing circuit and being enclosed by a second sidewall and including a base portion and a lid
- a third compartment sized to contain a waste bottle of the infusion system and being enclosed by a third sidewall that forms a barrier to radioactive radiation, including an opening and a lid, the opening of the third sidewall being oriented upward and located at a second elevation, the second elevation being greater than the first elevation of the opening of the first sidewall (technical problem: to facilitate an ergonomic stance for technical personnel to lift generator out from the compartment)

**2. Claims 22-26:**

These claims disclose a shielding assembly for an infusion system comprising:

- a first door to contain one or more radioisotope generators
- a second door provide access to a second compartment being sized to contain an infusion tubing
- the second door, when enclosing the second compartment preventing the first door from the opening to provide access to the first compartment

(technical problem: provide access to the corresponding compartments)

**3. Claims 27-33:**

These claims disclose an infusion system comprising:

- a cabinet structure including a shell and an access panel
- a lock engaging the access panel, an eluant source
- a shielding assembly comprising a plurality of compartments and including a corresponding plurality of doors

(technical problem: to provide a relatively ergonomic and organized work area to operate the infusion system)

**4. Claims 34-36:**

These claims disclose a shielding assembly for an infusion system comprising:

- a plurality of compartments, a corresponding plurality of doors
- a first compartment sized to contain a radioisotope generator including a first sidewall with a first sidewall opening oriented upward and aligned with a first upper opening through a shell of the cabinet structure,
- wherein an upper surface of the shell is located at an elevation which is substantially greater than that of the first sidewall opening and the first upper opening

(technical problem: to provide an alternative access to the compartment)

The differences between the disclosure of Document D1 (WO2005002971) and the 4 inventions can be defined as follows:

**claim 1:** all the features of claim 1 are disclosed in D1

**claim 22:** the difference between the subject matter of claim 22 and D1 is the second door, when enclosing the second compartment, preventing the first door from opening to provide access to the first compartment. In D1 there is no such a door.

**claim 27:** the difference between the subject matter of claim 27 and D1 is a lock for an access panel, an infusion system with an eluant source. In D1 there is no such a lock.

**claim 34:** the difference between the subject matter of claim 34 and D1 is wherein an upper surface of the shell is located at an elevation which is substantially greater than that of the first sidewall opening and the first upper opening. In D1 there is no such a technical feature.

The special technical features are not identical. The effects of three compounds are different.

The use of the shielding assembly for an infusion device in claim 22 provides access to the corresponding compartments.

The use of the infusion system in claim 27 permits to provide a relatively ergonomic and organized work area to operate the infusion system.



The use of the shielding assembly in claim 34 permits to provide in an alternative way an access to the compartment.

In conclusion, the groups of claims are not linked by common or corresponding special technical features and define 4 different inventions not linked by a single general inventive concept. Therefore the application claims 4 inventions not so linked to form a single general inventive concept. The requirement of unity is not fulfilled, according to Rule 13 PCT.

**Re Item V**

**Reasoned statement under Rule 66.2(a)(ii) with regard to novelty, inventive step or industrial applicability; citations and explanations supporting such statement**

1 Reference is made to the following documents:

- D1 WO 2005/002971 A1
- D2 US 2003/004463 A1
- D3 JP 2000 350783 A
- D4 WO 2008/037939 A2
- D5 WO 2008/082966 A2
- D6 EP 0 102 121 A1
- D7 JP 2006 325826 A

**Novelty Article 33(2) PCT**

**Invention 1: Claims 1 - 15,37**

2 The present application does not meet the criteria of Article 33 (1) PCT, because the subject-matter of **claim 1** is not new in the sense of Article 33(2) PCT.

2.1 The document D1 is regarded as being the closest prior art and discloses (the references in parentheses applying to this document) discloses a shielding assembly for an infusion system, the shielding assembly being mounted within a cabinet structure comprising (figure 1-4):

- a first compartment (30) sized to contain one or more radioisotope generators (34) of the infusion system, the first compartment being enclosed by a first sidewall (sidewall 31) that forms a barrier to radioactive radiation, the first sidewall including an opening extending therethrough and a lid (32), the lid mating with the opening to alternately enclose the first compartment and

provide access to the first compartment, via the opening, and the opening being oriented upward and located at a first elevation, with respect to a lowermost portion of the cabinet structure;

- a second compartment (2) sized to contain a portion of an infusion tubing circuit (tubing 57) of the infusion system that is downstream of the one or more generators, the second compartment being enclosed by a second sidewall that forms a barrier to radioactive radiation, the second sidewall including a base portion and a lid portion (9), the lid portion mating with the base portion to alternately enclose the second compartment and provide access to the second compartment; and

- a third compartment (52) sized to contain a waste bottle (53) of the infusion system, the third compartment being enclosed by a third sidewall that forms a barrier to radioactive radiation, the third sidewall including an opening, extending through the third sidewall, and a lid (41), the lid of the third sidewall mating with the opening of the third sidewall to alternately enclose the third compartment and provide access to the third compartment, via the opening of the third sidewall, the opening of the third sidewall being oriented upward and located at a second elevation, with respect to the lowermost portion of the cabinet structure, and the second elevation being greater than the first elevation of the opening of the first sidewall.

The subject matter of claim 1 is not novel document D1.

2.2 The technical feature of claim 37 is also disclosed in Document D1.

2.3 The technical feature of claims 1 and 37 is shown in Documents D2 and D3.

### **Invention 2: Claims 22-26**

3 The present application does not meet the criteria of Article 33 (1) PCT, because the subject-matter of **claim 22** is not new in the sense of Article 33(2) PCT.

3.1 The document D4 is regarded as being the closest prior art and discloses (the references in parentheses applying to this document) discloses a shielding assembly for an infusion system (6) comprising (figure 1-2):

- a plurality of compartments (2a,2b,2c) and providing a radioactive radiation barrier for the compartments, the assembly further comprising:

- a first door (2b) to alternately enclose and provide access to a first compartment of the plurality of compartments, the first compartment sized to contain one or more radioisotope generators (11) of the infusion system; and

- second door (41) to alternately enclose and provide access to a second compartment (2) of the plurality of compartments, the second compartment being separate from, and outside of, the first compartment, the second

compartment being sized to contain a portion of an infusion tubing circuit (22) of the infusion system that is downstream of the one or more generators, and the second door, when enclosing the second compartment, preventing the first door from opening to provide access to the first compartment.

The subject matter of claim 22 is not new over document D4.

3.2 The technical feature of claim 1 is revealed in Document D3.

**Invention 3: Claims 27-33**

4 The present application does not meet the criteria of Article 33 (1) PCT, because the subject-matter of **claim 27** is not new in the sense of Article 33(2) PCT.

4.1 The document D4 is regarded as being the closest prior art and discloses (the references in parentheses applying to this document) discloses an infusion system comprising (figure 1-2):

- a cabinet structure (figure 2) including a shell defining an interior space thereof, the shell including a first opening (21), a second opening (2b) and an access panel (41), the access panel mating with the second opening and being removable therefrom;
- a lock reversibly (it is implicit that the access panel has a lock) engaging the access panel to secure access to the interior space of the cabinet structure;
- an eluant source (16);
- a shielding assembly located within the interior space of the cabinet structure, the shielding assembly including a sidewall defining a plurality of compartments and providing a barrier to radioactive radiation for the compartments, the shielding assembly further including a corresponding plurality of doors (41,2b), each door, when open, providing access to the corresponding compartment via an opening in the sidewall, and, when closed, providing further barrier to radioactive radiation for the corresponding compartment;
- one or more radioisotope generators (11) contained within a first compartment of the plurality of compartments (2c) of the shielding assembly and being accessible through the second opening (2b) of the shell of the cabinet structure, when the access panel (41) is unlocked, and when a first door (2b) of the plurality of doors, which corresponds to the first compartment, is open;
- an eluant line (23) coupled to the eluant source and to the one or more generators; an eluate line coupled to the one or more generators; and a patient line (17) coupled to the eluate line and extending out from the interior space of the cabinet structure through the first opening of the shell.

The subject matter of claim 27 is not new over Document D4.

4.2 The technical feature of claim 27 is disclosed in Document D3.

**Invention 4: Claims 34-36**

5 The present application does not meet the criteria of Article 33 (1) PCT, because the subject-matter of **claim 34** is not new in the sense of Article 33(2) PCT.

5.1 The document D1 is regarded as being the closest prior art and discloses (the references in parentheses applying to this document) discloses a shielding assembly comprising (figure 1-4):

- a plurality of compartments (2,30) having sidewalls providing barriers to radioactive radiation for the compartments;

- a corresponding plurality of doors (9,32), each door, when open, providing access to the corresponding compartment via an opening in its sidewall, and, when closed, providing further barrier to radioactive radiation for the corresponding compartment;

- a first compartment (2) of the plurality of compartments enclosed by a first sidewall of the sidewalls and sized to contain one or more radioisotope generators (62) of the infusion system, the first sidewall including a first sidewall opening oriented upward and aligned with a first upper opening through a shell of the cabinet structure;

- wherein an upper surface of the shell is located at an elevation, with respect to a lowermost portion of the cabinet structure, such that the elevation of the upper surface is substantially greater than that of the first sidewall opening and the first upper opening (see figure 1)

The subject matter of claim 34 is not new over Document D1.

5.2 Furthermore the technical features of claims 34 are revealed by documents D2,D3 and D6.

**Inventive step Article 33(3) PCT**

**Invention 1: Claims 1 - 15,37**

6 The present application does not meet the criteria of Article 33 (1) PCT, because the subject-matter of **claims 2 to 15** does not seem to involve an inventive step in the sense of Article 33(3) PCT. Document D1 is the closest prior art.

In claims 2 to 15 a slight constructional change in the shielding assembly is defined which comes within the scope of the customary practice followed by persons skilled in the art, especially as the advantages thus achieved can readily be foreseen. Consequently, the subject-matter of these claims also lacks an inventive step.

**Invention 2: Claims 22-26**

7 The present application does not meet the criteria of Article 33 (1) PCT, because the subject-matter of **claims 23 to 26** does not seem to involve an inventive step in the sense of Article 33(3) PCT. Document D4 is the closest prior art.

In claims 23 to 26 a slight constructional change in the shielding assembly is defined which comes within the scope of the customary practice followed by persons skilled in the art, especially as the advantages thus achieved can readily be foreseen. Consequently, the subject-matter of these claims also lacks an inventive step.

**Invention 3: Claims 27-33**

8 The present application does not meet the criteria of Article 33 (1) PCT, because the subject-matter of **claims 28 to 33** does not seem to involve an inventive step in the sense of Article 33(3) PCT. Document D4 is the closest prior art.

The features of claims 28 to 33 are merely one of several straightforward possibilities from which the skilled person would select, in accordance with circumstances, without the exercise of inventive skill, in order to solve the problem posed. (see Document D7 for using a latch component) Consequently, the subject-matter of these claims also lacks an inventive step.

**Invention 4: Claims 34-36**

9 The present application does not meet the criteria of Article 33 (1) PCT, because the subject-matter of **claims 35 and 36** does not seem to involve an inventive step in the sense of Article 33(3) PCT. Document D1 is the closest prior art.

In claims 35 and 36 a slight constructional change in the shielding assembly (elevation) is defined which comes within the scope of the customary practice followed by persons skilled in the art, especially as the advantages thus achieved can readily be foreseen. Consequently, the subject-matter of these claims also lacks an inventive step.

**Further comments**

**Invention 1: Claims 1 - 15,37**

10 Contrary to the requirements of Rule 5.1(a)(ii) PCT, the **relevant background** art disclosed in the documents D1-D4 are not mentioned in the description, nor are these documents identified therein.

- 11 Independent claim 1 is not in the **two-part form** in accordance with Rule 6.3 (b) PCT, which in the present case would be appropriate, with those features known in combination from the prior art (document D1) being placed in the preamble (Rule 6.3(b)(I) PCT) and with the remaining features being included in the characterising part (Rule 6.3(b)(ii) PCT).
- 12 The features of the claims are not provided with **reference signs** placed in parentheses (Rule 6.2(b) PCT).
- 13 The unit employed in claims 4 and 5 and in description is not recognised in international practice, contrary to the requirements of Rule 10.1(d) PCT.

**Invention 2: Claims 22-26**

- 14 Contrary to the requirements of Rule 5.1(a)(ii) PCT, the **relevant background** art disclosed in the documents D3,D4 and D6 are not mentioned in the description, nor are these documents identified therein.
- 15 Independent claim 22 is not in the **two-part form** in accordance with Rule 6.3 (b) PCT, which in the present case would be appropriate, with those features known in combination from the prior art (document D4) being placed in the preamble (Rule 6.3(b)(I) PCT) and with the remaining features being included in the characterising part (Rule 6.3(b)(ii) PCT).
- 16 The features of the claims are not provided with **reference signs** placed in parentheses (Rule 6.2(b) PCT).

**Invention 3: Claim 27-33**

- 17 Contrary to the requirements of Rule 5.1(a)(ii) PCT, the **relevant background** art disclosed in the documents D3,D4 and D7 are not mentioned in the description, nor are these documents identified therein.
- 18 Independent claim 27 is not in the **two-part form** in accordance with Rule 6.3 (b) PCT, which in the present case would be appropriate, with those features known in combination from the prior art (document D4) being placed in the preamble (Rule 6.3(b)(I) PCT) and with the remaining features being included in the characterising part (Rule 6.3(b)(ii) PCT).
- 19 The features of the claims are not provided with **reference signs** placed in parentheses (Rule 6.2(b) PCT).

**Invention 4: Claim 34-36**

- 20 Contrary to the requirements of Rule 5.1(a)(ii) PCT, the **relevant background** art disclosed in the documents D1,D2,D3 and D6 are not mentioned in the description, nor are these documents identified therein.

- 21 Independent claim 34 is not in the **two-part form** in accordance with Rule 6.3 (b) PCT, which in the present case would be appropriate, with those features known in combination from the prior art (document D1) being placed in the preamble (Rule 6.3(b)(I) PCT) and with the remaining features being included in the characterising part (Rule 6.3(b)(ii) PCT).
- 22 The features of the claims are not provided with **reference signs** placed in parentheses (Rule 6.2(b) PCT).
- 23 The unit employed in claims 35 and 36 and in description is not recognised in international practice, contrary to the requirements of Rule 10.1(d) PCT.

**Re Item VI**

**Certain documents cited**

Certain published documents

Application No Patent No	Publication date (day/month/year)	Filing date (day/month/year)	Priority date ( <i>valid claim</i> ) (day/month/year)
WO2008082966	10.07.2008	20.12.2007	31.10.2007

Document D5 discloses the technical feature of claims 1,22,27 and 34. This document will be considered during the European phase.

PATENT COOPERATION TREATY

PCT

INTERNATIONAL SEARCH REPORT

(PCT Article 18 and Rules 43 and 44)

Applicant's or agent's file reference 56782.1.6.1	<b>FOR FURTHER ACTION</b> see Form PCT/ISA/220 as well as, where applicable, item 5 below.	
International application No. PCT/US2009/047030	International filing date (day/month/year) 11/06/2009	(Earliest) Priority Date (day/month/year) 11/06/2008
Applicant  BRACCO DIAGNOSTICS INC.		

This international search report has been prepared by this International Searching Authority and is transmitted to the applicant according to Article 18. A copy is being transmitted to the International Bureau.

This international search report consists of a total of 6 sheets.

It is also accompanied by a copy of each prior art document cited in this report.

1. Basis of the report

a. With regard to the **language**, the international search was carried out on the basis of:

- the international application in the language in which it was filed
- a translation of the international application into \_\_\_\_\_, which is the language of a translation furnished for the purposes of international search (Rules 12.3(a) and 23.1(b))

b.  This international search report has been established taking into account the **rectification of an obvious mistake** authorized by or notified to this Authority under Rule 91 (Rule 43.6bis(a)).

c.  With regard to any **nucleotide and/or amino acid sequence** disclosed in the international application, see Box No. I.

2.  **Certain claims were found unsearchable** (See Box No. II)

3.  **Unity of invention is lacking** (see Box No III)

4. With regard to the **title**,

- the text is approved as submitted by the applicant
- the text has been established by this Authority to read as follows:

5. With regard to the **abstract**,

- the text is approved as submitted by the applicant
- the text has been established, according to Rule 38.2(b), by this Authority as it appears in Box No. IV. The applicant may, within one month from the date of mailing of this international search report, submit comments to this Authority

6. With regard to the **drawings**,

- a. the figure of the **drawings** to be published with the abstract is Figure No. 1d
  - as suggested by the applicant
  - as selected by this Authority, because the applicant failed to suggest a figure
  - as selected by this Authority, because this figure better characterizes the invention
- b.  none of the figures is to be published with the abstract



**A. CLASSIFICATION OF SUBJECT MATTER**

INV. A61M5/00  
ADD. A61M5/14

According to International Patent Classification (IPC) or to both national classification and IPC

**B. FIELDS SEARCHED**

Minimum documentation searched (classification system followed by classification symbols)  
A61M

Documentation searched other than minimum documentation to the extent that such documents are included in the fields searched

Electronic data base consulted during the international search (name of data base and, where practical, search terms used)

EPO-Internal, WPI Data, INSPEC

**C. DOCUMENTS CONSIDERED TO BE RELEVANT**

Category*	Citation of document, with indication, where appropriate, of the relevant passages	Relevant to claim No.
X	FR 2 867 084 A1 (GEN ELECTRIC [US]) 9 September 2005 (2005-09-09) figures 1-12 page 6, line 16 - page 30, line 11	1-2, 5-9
X	EP 0 102 121 A1 (BYK MALLINCKRODT CIL BV [NL]) 7 March 1984 (1984-03-07)  figures 1-4 page 9, line 15 - page 12, line 11	1, 5-9, 17-25, 27-32, 36-38
X	WO 99/56117 A1 (GEN HOSPITAL CORP [US]; LAYFIELD DOMINICK [US]; VENEGAS JOSE [US]) 4 November 1999 (1999-11-04) page 4, line 20 - page 16, line 13; figures 1-6	1-3, 15-17, 31-38
	----- -/--	

Further documents are listed in the continuation of Box C.

See patent family annex.

\* Special categories of cited documents :

- \*A\* document defining the general state of the art which is not considered to be of particular relevance
- \*E\* earlier document but published on or after the international filing date
- \*L\* document which may throw doubts on priority claim(s) or which is cited to establish the publication date of another citation or other special reason (as specified)
- \*O\* document referring to an oral disclosure, use, exhibition or other means
- \*P\* document published prior to the international filing date but later than the priority date claimed

- \*T\* later document published after the international filing date or priority date and not in conflict with the application but cited to understand the principle or theory underlying the invention
- \*X\* document of particular relevance; the claimed invention cannot be considered novel or cannot be considered to involve an inventive step when the document is taken alone
- \*Y\* document of particular relevance; the claimed invention cannot be considered to involve an inventive step when the document is combined with one or more other such documents, such combination being obvious to a person skilled in the art.
- \*&\* document member of the same patent family

Date of the actual completion of the international search

10 February 2010

Date of mailing of the international search report

17/02/2010

Name and mailing address of the ISA/

European Patent Office, P.B. 5818 Patentlaan 2  
NL - 2280 HV Rijswijk  
Tel. (+31-70) 340-2040,  
Fax: (+31-70) 340-3016

Authorized officer

Reinbold, Sylvie

C(Continuation). DOCUMENTS CONSIDERED TO BE RELEVANT		
Category*	Citation of document, with indication, where appropriate, of the relevant passages	Relevant to claim No.
X	EP 0 160 303 A2 (SQUIBB & SONS INC [US]) 6 November 1985 (1985-11-06) figures 1-12 page 7, line 28 - line 15 -----	1-2
X	JP 2000 350783 A (SUMITOMO HEAVY INDUSTRIES) 19 December 2000 (2000-12-19) paragraph [0014] - paragraph [0032]; figures 1-5 -----	18-25, 27-30
X	US 2008/093564 A1 (TARTAGLIA DANIEL [CA] ET AL) 24 April 2008 (2008-04-24) figures 1-7 paragraph [0023] - paragraph [0035] -----	18-30
X	WO 2007/149108 A2 (MALLINCKRODT INC [US]; POLLARD RALPH E JR [US]) 27 December 2007 (2007-12-27) figures 1-18 paragraph [0031] - paragraph [0053] -----	18-30
X	US 2003/004463 A1 (REILLY DAVID M [US] ET AL) 2 January 2003 (2003-01-02) paragraph [0049] - paragraph [0072]; figures 1-4 -----	31-38

# INTERNATIONAL SEARCH REPORT

International application No.  
PCT/US2009/047030

## Box No. II Observations where certain claims were found unsearchable (Continuation of item 2 of first sheet)

This international search report has not been established in respect of certain claims under Article 17(2)(a) for the following reasons:

1.  Claims Nos.:  
because they relate to subject matter not required to be searched by this Authority, namely:
  
2.  Claims Nos.:  
because they relate to parts of the international application that do not comply with the prescribed requirements to such an extent that no meaningful international search can be carried out, specifically:
  
3.  Claims Nos.:  
because they are dependent claims and are not drafted in accordance with the second and third sentences of Rule 6.4(a).

## Box No. III Observations where unity of invention is lacking (Continuation of item 3 of first sheet)

This International Searching Authority found multiple inventions in this international application, as follows:

see additional sheet

1.  As all required additional search fees were timely paid by the applicant, this international search report covers all searchable claims.
2.  As all searchable claims could be searched without effort justifying an additional fees, this Authority did not invite payment of additional fees.
3.  As only some of the required additional search fees were timely paid by the applicant, this international search report covers only those claims for which fees were paid, specifically claims Nos.:
4.  No required additional search fees were timely paid by the applicant. Consequently, this international search report is restricted to the invention first mentioned in the claims; it is covered by claims Nos.:

### Remark on Protest

- The additional search fees were accompanied by the applicant's protest and, where applicable, the payment of a protest fee.
- The additional search fees were accompanied by the applicant's protest but the applicable protest fee was not paid within the time limit specified in the invitation.
- No protest accompanied the payment of additional search fees.

## FURTHER INFORMATION CONTINUED FROM PCT/ISA/ 210

This International Searching Authority found multiple (groups of) inventions in this international application, as follows:

## 1. claims: 1-17

These claims essentially define an infusion system comprising an eluant source, a shielding assembly having a plurality of compartments and plurality of doors, a radioisotope generator, a eluate line and a patient line.  
(technical effect: to provide an infusion system to infuse an radioactive eluate)

---

## 2. claims: 18-30

These claims essentially define a shielding assembly comprising a sidewall defining a plurality of compartments, a first passageway formed in an upper surface of a first portion of the sidewall and defining a first compartment sized to contain a radioisotope and a second passageway with a second compartment.  
(technical effect: to provide a shielding assembly to permit a more effective operation)

---

## 3. claims: 31-38

These claims essentially define a disposable infusion circuit subassembly comprising: an eluate line, a patient line, a waste line, a valve member and a support frame.  
(technical effect: to facilitate the positioning of the components of a portion of infusion circuit in an infusion system)

---

Patent document cited in search report	Publication date	Patent family member(s)	Publication date	
FR 2867084	A1	09-09-2005	DE 102005010152 A1	15-09-2005
			DE 102005010154 A1	15-09-2005
			FR 2867294 A1	09-09-2005
			JP 2005326398 A	24-11-2005
			JP 2005324007 A	24-11-2005
			US 2008242915 A1	02-10-2008
EP 0102121	A1	07-03-1984	NONE	
WO 9956117	A1	04-11-1999	EP 1075654 A1	14-02-2001
			US 6773673 B1	10-08-2004
EP 0160303	A2	06-11-1985	AU 581218 B2	16-02-1989
			CA 1250504 A1	28-02-1989
			CA 1233274 A2	23-02-1988
			DE 3581653 D1	14-03-1991
			JP 2568169 B2	25-12-1996
			JP 60241454 A	30-11-1985
			US 4562829 A	07-01-1986
JP 2000350783	A	19-12-2000	NONE	
US 2008093564	A1	24-04-2008	WO 2009003290 A1	08-01-2009
WO 2007149108	A2	27-12-2007	CA 2627429 A1	27-12-2007
			CN 101253577 A	27-08-2008
			EP 1938339 A2	02-07-2008
			JP 2009506343 T	12-02-2009
			US 2008224065 A1	18-09-2008
US 2003004463	A1	02-01-2003	US 2005238576 A1	27-10-2005
			US 2003216609 A1	20-11-2003

**PATENT COOPERATION TREATY**

From the  
INTERNATIONAL SEARCHING AUTHORITY

**PCT**

**WRITTEN OPINION OF THE  
INTERNATIONAL SEARCHING AUTHORITY  
(PCT Rule 43bis.1)**

To:

see form PCT/ISA/220

Date of mailing  
(day/month/year) see form PCT/ISA/210 (second sheet)

Applicant's or agent's file reference  
see form PCT/ISA/220

**FOR FURTHER ACTION**  
See paragraph 2 below

International application No.  
PCT/US2009/047030

International filing date (day/month/year)  
11.06.2009

Priority date (day/month/year)  
11.06.2008

International Patent Classification (IPC) or both national classification and IPC  
INV. A61M5/00  
ADD. A61M5/14

Applicant  
BRACCO DIAGNOSTICS INC.

1. This opinion contains indications relating to the following items:

- Box No. I Basis of the opinion
- Box No. II Priority
- Box No. III Non-establishment of opinion with regard to novelty, inventive step and industrial applicability
- Box No. IV Lack of unity of invention
- Box No. V Reasoned statement under Rule 43bis.1(a)(i) with regard to novelty, inventive step or industrial applicability; citations and explanations supporting such statement
- Box No. VI Certain documents cited
- Box No. VII Certain defects in the international application
- Box No. VIII Certain observations on the international application



2. **FURTHER ACTION**

If a demand for international preliminary examination is made, this opinion will usually be considered to be a written opinion of the International Preliminary Examining Authority ("IPEA") except that this does not apply where the applicant chooses an Authority other than this one to be the IPEA and the chosen IPEA has notified the International Bureau under Rule 66.1bis(b) that written opinions of this International Searching Authority will not be so considered.

If this opinion is, as provided above, considered to be a written opinion of the IPEA, the applicant is invited to submit to the IPEA a written reply together, where appropriate, with amendments, before the expiration of 3 months from the date of mailing of Form PCT/ISA/220 or before the expiration of 22 months from the priority date, whichever expires later.

For further options, see Form PCT/ISA/220.

3. For further details, see notes to Form PCT/ISA/220.

<p>Name and mailing address of the ISA:</p>  <p>European Patent Office D-80298 Munich Tel. +49 89 2399 - 0 Fax: +49 89 2399 - 4465</p>	<p>Date of completion of this opinion</p> <p>see form PCT/ISA/210</p>	<p>Authorized Officer</p> <p>Reinbold, Sylvie</p> <p>Telephone No. +49 89 2399-7918</p> 
---	---	---

---

**Box No. I Basis of the opinion**

---

1. With regard to the **language**, this opinion has been established on the basis of:
  - the international application in the language in which it was filed
  - a translation of the international application into , which is the language of a translation furnished for the purposes of international search (Rules 12.3(a) and 23.1 (b)).
2.  This opinion has been established taking into account the **rectification of an obvious mistake** authorized by or notified to this Authority under Rule 91 (Rule 43bis.1(a))
3. With regard to any **nucleotide and/or amino acid sequence** disclosed in the international application and necessary to the claimed invention, this opinion has been established on the basis of:
  - a. type of material:
    - a sequence listing
    - table(s) related to the sequence listing
  - b. format of material:
    - on paper
    - in electronic form
  - c. time of filing/furnishing:
    - contained in the international application as filed.
    - filed together with the international application in electronic form.
    - furnished subsequently to this Authority for the purposes of search.
4.  In addition, in the case that more than one version or copy of a sequence listing and/or table relating thereto has been filed or furnished, the required statements that the information in the subsequent or additional copies is identical to that in the application as filed or does not go beyond the application as filed, as appropriate, were furnished.
5. Additional comments:

---

**Box No. IV Lack of unity of invention**

---

1.  In response to the invitation (Form PCT/ISA/206) to pay additional fees, the applicant has, within the applicable time limit:
- paid additional fees
  - paid additional fees under protest and, where applicable, the protest fee
  - paid additional fees under protest but the applicable protest fee was not paid
  - not paid additional fees
2.  This Authority found that the requirement of unity of invention is not complied with and chose not to invite the applicant to pay additional fees.
3. This Authority considers that the requirement of unity of invention in accordance with Rule 13.1, 13.2 and 13.3 is
- complied with
  - not complied with for the following reasons:  
**see separate sheet**
4. Consequently, this report has been established in respect of the following parts of the international application:
- all parts.
  - the parts relating to claims Nos. 1-38

---

**Box No. V Reasoned statement under Rule 43bis.1(a)(i) with regard to novelty, inventive step or industrial applicability; citations and explanations supporting such statement**

---

1. Statement

Novelty (N)	Yes: Claims	<u>4, 10-14, 24-26, 29-30, 33, 35</u>
	No: Claims	<u>1-3, 5-9, 15-23, 27-28, 31-32, 34, 36-38</u>
Inventive step (IS)	Yes: Claims	<u>4, 10-14</u>
	No: Claims	<u>1-3, 5-9, 15-38</u>
Industrial applicability (IA)	Yes: Claims	<u>1-38</u>
	No: Claims	

2. Citations and explanations

**see separate sheet**



---

**Box No. VIII Certain observations on the international application**

---

The following observations on the clarity of the claims, description, and drawings or on the question whether the claims are fully supported by the description, are made:

**see separate sheet**

**Re Item IV**

**Lack of unity of invention**

The inventions in this international application, as follows:

**1. Claims 1 - 17**

These claims essentially define an infusion system comprising an eluant source, a shielding assembly having a plurality of compartments and plurality of doors, a radioisotope generator, a eluate line and a patient line.

(technical effect: to provide an infusion system to infuse an radioactive eluate)

**2. Claims 18-30:**

These claims essentially define a shielding assembly comprising a sidewall defining a plurality of compartments, a first passageway formed in an upper surface of a first portion of the sidewall and defining a first compartment sized to contain a radioisotope and a second passageway with a second compartment.

(technical effect: to provide a shielding assembly to permit a more effective operation)

**3. Claims 31-38:**

These claims essentially define a disposable infusion circuit subassembly comprising: an eluate line, a patient line, a waste line, a valve member and a support frame.

(technical effect: to facilitate the positioning of the components of a portion of infusion circuit in an infusion system)

The only common concept between the invention 1 and 2 is a shielding assembly having a plurality of compartments. This is already known from the person skilled in the art. (FR2867084)

The only common concept between the invention 1 and 3 is an eluate line and a patient line. This is already know from the person skilled in the art. (FR2867084)

There is no common concept between the invention 2 and 3.

The special technical features are not identical. The effects of both compounds are different. The problems posed when using a shielding assembly and a disposable infusion circuit subassembly are also quite different. Consequently the special technical features cannot be regarded as being corresponding. Therefore the application claims 3 inventions not so linked to form a single general inventive concept. The requirement of unity is not fulfilled, according to Rule 13PCT.

**Re Item V**

**Reasoned statement under Rule 66.2(a)(ii) with regard to novelty, inventive step or industrial applicability; citations and explanations supporting such statement**

1 Reference is made to the following documents:

D1 FR 2 867 084 A1

D2	EP 0 102 121 A1
D3	WO 99/56117 A1
D4	EP 0 160 303 A2
D5	JP 2000 350783 A
D6	US 2008/093564 A1
D7	WO 2007/149108 A2
D8	US 2003/004463 A1

**Novelty Article 33(2) PCT**

**Invention 1: Claims 1 - 17**

- 2 The present application does not meet the criteria of Article 33 (1) PCT, because the subject-matter of claims **1-3,5-9 and 15-17** is not new in the sense of Article 33(2) PCT.
- 2.1 The document D1 is regarded as being the closest prior art and discloses (the references in parentheses applying to this document) discloses an infusion system comprising:
- a cabinet structure (page 20 line 25-30) including a shell defining an interior space thereof;
  - an eluant source (412)
  - a shielding assembly (509+404) located within the interior space of the cabinet structure, the shielding assembly including a sidewall defining a plurality of compartments (509,404,418) and providing a barrier to radioactive radiation for the compartments, the shielding assembly further including a corresponding plurality of doors, each door, when open, providing access to the corresponding compartment via an opening in the sidewall, and, when closed, providing further barrier to radioactive radiation for the corresponding compartment;
  - radioisotope generator (502) contained within a first compartment (509) of the plurality of compartments of the shielding assembly;
  - an eluant line (figure 6) coupled to the eluant source (412) and to the generator (104,502), the eluant line extending from the eluant source to the generator, through the shielding assembly, at a first location between the sidewall and a first door of the plurality of doors, which first door corresponds to the first compartment;

- an eluate line coupled to the generator and extending out from the first compartment and into a second compartment (418) of the plurality of compartments of the shielding assembly, at a second location between the sidewall and both the first door and a second door of the plurality of doors, which corresponds to the second compartment, the second compartment being located immediately adjacent the first compartment;
- a patient line (428) coupled to the eluate line, within the second compartment, the patient line extending out from the second compartment at a third location between the sidewall and the second door, and out from the interior space through an opening in the shell of the cabinet structure.

The subject matter of claim 1 is not novel document D1.

- 2.2 Document D1 shows the technical features of claims 2 and 5 to 9.
- 2.3 Furthermore document D2 reveals the technical features of claims 1,5-9 and 17. (figure 1 to 4)
- 2.4 The technical features of claims 1-3 and 15-17 are disclosed in document D3.
- 2.5 Finally document D4 shows the technical features of claims 1 and 2.

#### **Invention 2: Claims 18-30**

- 3 Furthermore, the above-mentioned lack of clarity notwithstanding, the subject-matter of **claim 18-23 and 27-28** is not new in the sense of Article 33(2) PCT, and therefore the criteria of Article 33(1) PCT are not met.
- 3.1 The document D5 is regarded as being the closest prior art and discloses (the references in parentheses applying to this document) discloses a shielding assembly (40+84) comprising:
  - a sidewall defining a plurality of compartments and providing a radioactive radiation barrier for the compartments;
  - a first passageway (bore between wagon (40) and casing (52)) formed in an upper surface of a first portion of the sidewall, the first portion of the sidewall defining a first compartment (62) of the plurality of compartments, the first compartment being sized to contain a radioisotope generator (30) of the infusion system, and the first passageway (bore) being sized to accommodate routing of an eluate line (see figure 2) from the generator;
  - a second passageway (passage for the tube 80) formed along a second portion of the sidewall, the second portion of the sidewall extending upward relative to the first portion of the sidewall and defining a second compartment (84) of the plurality of compartments, the second compartment (84) being sized to accommodate a waste bottle (82) of the infusion system and the second compartment being located on a side of the second portion of the

sidewall that is opposite the second passageway, and the second passageway being sized to accommodate routing of at least one extension of the eluate line (see figure 5) from the generator.

The subject matter of claim 18 is not novel document D5.

3.2 Document D5 shows the technical features of claims 18-23,27 and 28.

3.3 The document D2 discloses a shielding assembly (41+26) comprising:

- a sidewall defining a plurality of compartments and providing a radioactive radiation barrier for the compartments;

- a first passageway (bore 32) formed in an upper surface of a first portion of the sidewall, the first portion of the sidewall defining a first compartment (26) of the plurality of compartments, the first compartment being sized to contain a radioisotope generator (31) of the infusion system, and the first passageway (32) being sized to accommodate routing of an eluate line (see figure 1) from the generator;

- a second passageway (passage between the shield (26) and cover (43)) formed along a second portion of the sidewall, the second portion of the sidewall extending upward relative to the first portion of the sidewall and defining a second compartment (41) of the plurality of compartments, the second compartment (41) being sized to accommodate a waste bottle (12a) of the infusion system and the second compartment being located on a side of the second portion of the sidewall that is opposite the second passageway, and the second passageway being sized to accommodate routing of at least one extension of the eluate line (see figure 1) from the generator.

The subject matter of claim 18 is not novel document D2.

3.4 Document D2 shows the technical features of claims 18-21,27 and 28.

3.5 Furthermore documents D6 and D7 reveal the technical features of claim 18.

### **Invention 3: Claims 31-38**

4 The present application does not meet the criteria of Article 33 (1) PCT, because the subject-matter of **claims 31,32,34 and 36-38** is not new in the sense of Article 33(2) PCT.

4.1 The document D8 is regarded as being the closest prior art and discloses (the references in parentheses applying to this document) discloses a disposable infusion circuit comprising (figures 1-5):

- an eluate line (line from the syringe (20)) ;
- a patient line (100);
- a waste line (line in connection with waste (161));

- a valve member (171) coupling the patient line and the waste line to the eluate line; and
- a support frame (15) including a perimeter edge, the support frame holding the valve member (16) and a portion of each of: the eluate line, the patient line and the waste line in approximately fixed relation with respect to the perimeter edge;
- wherein the perimeter edge of the support frame is sized to fit within a compartment of a shielding assembly (18) of the infusion system; and
- an end of each of the eluate line, the patient line and the waste line extends out from the perimeter edge.

Therefore the subject matter of claim 31 is not novel over document D8.

4.2 Document D8 shows the technical features of claims 32,34 and 36-38.

4.3 Furthermore documents D2 and D3 reveal the technical features of claims 31,32 and 36-38.

Document D2: (figures 1 to 5), eluate line (6), patient line (line next to the valve 4b), waste line (11a), valve member (4b), support frame (operating block 46)

Document D3: (figures 1 to 56, eluate line (saline), patient line (to patient), waste line (dump), valve member (27), support frame (figure 5a-5c)

### **Inventive step Article 33(3) PCT**

#### **Invention 1: Claims 1 - 17**

5 The present application does not meet the criteria of Article 33 (1) PCT, because the subject-matter of **claims 4 and 10 to 14** does not seem to involve an inventive step in the sense of Article 33(3) PCT. Document D1 is the closest prior art. In claims 4 and 10 to 14 a slight constructional change in the infusion system is defined which comes within the scope of the customary practise followed by persons skilled in the art, especially as the advantages thus achieved can readily be foreseen. Consequently, the subject-matter of these claims also lacks an inventive step.

#### **Invention 2: Claims 18-30**

6 The present application does not meet the criteria of Article 33 (1) PCT, because the subject-matter of **claims 24-26,29 and 30** does not seem to involve an inventive step in the sense of Article 33(3) PCT. Document D2 is the closest prior art. In claims 24-26,29 and 30 a slight constructional change in the shielding assembly is defined which comes within the scope of the

customary practise followed by persons skilled in the art, especially as the advantages thus achieved can readily be foreseen. Consequently, the subject-matter of these claims also lacks an inventive step.

**Invention 3: Claims 31-38**

- 7 The present application does not meet the criteria of Article 33 (1) PCT, because the subject-matter of **claims 33 and 35** does not seem to involve an inventive step in the sense of Article 33(3) PCT. Document D8 is the closest prior art. In claims 33 and 35 a slight constructional change in the disposable infusion circuit (eluant line extends out from a third side of the perimeter edge) is defined which comes within the scope of the customary practise followed by persons skilled in the art, especially as the advantages thus achieved can readily be foreseen. Consequently, the subject-matter of these claims also lacks an inventive step.

**Further comments**

**Invention 1: Claims 1 - 17**

- 8 Contrary to the requirements of Rule 5.1(a)(ii) PCT, the **relevant background** art disclosed in the documents D1-D4 are not mentioned in the description, nor are these documents identified therein.
- 9 Independent claim 1 is not in the **two-part form** in accordance with Rule 6.3 (b) PCT, which in the present case would be appropriate, with those features known in combination from the prior art (document D1) being placed in the preamble (Rule 6.3(b)(I) PCT) and with the remaining features being included in the characterising part (Rule 6.3(b)(ii) PCT).
- 10 The features of the claims are not provided with **reference signs** placed in parentheses (Rule 6.2(b) PCT).

**Invention 2: Claims 18-30**

- 11 Contrary to the requirements of Rule 5.1(a)(ii) PCT, the **relevant background** art disclosed in the documents D2,D5-D7 are not mentioned in the description, nor are these documents identified therein.
- 12 Independent claim 18 is not in the **two-part form** in accordance with Rule 6.3 (b) PCT, which in the present case would be appropriate, with those features known in combination from the prior art (document D5) being placed in the preamble (Rule 6.3(b)(I) PCT) and with the remaining features being included in the characterising part (Rule 6.3(b)(ii) PCT).
- 13 The features of the claims are not provided with **reference signs** placed in parentheses (Rule 6.2(b) PCT).

**Invention 3: Claims 31-38**

- 14 Contrary to the requirements of Rule 5.1(a)(ii) PCT, the **relevant background** art disclosed in the documents D2,D3 and D8 are not mentioned in the description, nor are these documents identified therein.
- 15 Independent claim 31 is not in the **two-part form** in accordance with Rule 6.3 (b) PCT, which in the present case would be appropriate, with those features known in combination from the prior art (document D8) being placed in the preamble (Rule 6.3(b)(I) PCT) and with the remaining features being included in the characterising part (Rule 6.3(b)(ii) PCT).
- 16 The features of the claims are not provided with **reference signs** placed in parentheses (Rule 6.2(b) PCT).

### Re Item VIII

#### **Certain observations on the international application**

#### **Invention 2: Claims 18-30**

#### **Clarity Article 6 PCT**

- 17 Although **claims 18 and 27** have been drafted as separate independent claims, they appear to relate effectively to the same subject-matter and to differ from each other only with regard to the definition of the subject-matter for which protection is sought.

The aforementioned claims therefore lack conciseness. Moreover, lack of clarity of the claims as a whole arises, since the plurality of independent claims makes it difficult, if not impossible, to determine the matter for which protection is sought, and places an undue burden on others seeking to establish the extent of the protection.

Hence, these claims do not appear to meet the requirements of Article 6 PCT.

It appears to be appropriate to file an amended set of claims taking account of the above comments and Article 34(2)(b) PCT. The relevant subject-matter should be defined in **a single independent claim** followed by dependent claims covering features which are merely optional (Rules 6.3 and 6.4 PCT)



PATENT COOPERATION TREATY

PCT

INTERNATIONAL SEARCH REPORT

(PCT Article 18 and Rules 43 and 44)

Applicant's or agent's file reference 56782.1.7.1	<b>FOR FURTHER ACTION</b>		see Form PCT/ISA/220 as well as, where applicable, item 5 below.
International application No. PCT/US2009/047031	International filing date (day/month/year) 11/06/2009	(Earliest) Priority Date (day/month/year) 11/06/2008	
Applicant  BRACCO DIAGNOSTICS INC.			

This international search report has been prepared by this International Searching Authority and is transmitted to the applicant according to Article 18. A copy is being transmitted to the International Bureau.

This international search report consists of a total of 7 sheets.

It is also accompanied by a copy of each prior art document cited in this report.

1. Basis of the report

a. With regard to the **language**, the international search was carried out on the basis of:

- the international application in the language in which it was filed  
 a translation of the international application into \_\_\_\_\_, which is the language of a translation furnished for the purposes of international search (Rules 12.3(a) and 23.1(b))

b.  This international search report has been established taking into account the **rectification of an obvious mistake** authorized by or notified to this Authority under Rule 91 (Rule 43.6 bis(a)).

c.  With regard to any **nucleotide and/or amino acid sequence** disclosed in the international application, see Box No. I.

2.  **Certain claims were found unsearchable** (See Box No. II)

3.  **Unity of invention is lacking** (see Box No III)

4. With regard to the **title**,

- the text is approved as submitted by the applicant  
 the text has been established by this Authority to read as follows:

INFUSION SYSTEMS INCLUDING COMPUTER-FACILITATED MAINTENANCE AND/OR OPERATION

5. With regard to the **abstract**,

- the text is approved as submitted by the applicant  
 the text has been established, according to Rule 38.2(b), by this Authority as it appears in Box No. IV. The applicant may, within one month from the date of mailing of this international search report, submit comments to this Authority

6. With regard to the **drawings**,

- a. the figure of the **drawings** to be published with the abstract is Figure No. 1d  
 as suggested by the applicant  
 as selected by this Authority, because the applicant failed to suggest a figure  
 as selected by this Authority, because this figure better characterizes the invention
- b.  none of the figures is to be published with the abstract

**A. CLASSIFICATION OF SUBJECT MATTER**  
 INV. A61M5/00  
 ADD. A61M5/14

According to International Patent Classification (IPC) or to both national classification and IPC

**B. FIELDS SEARCHED**

Minimum documentation searched (classification system followed by classification symbols)  
 A61M

Documentation searched other than minimum documentation to the extent that such documents are included in the fields searched

Electronic data base consulted during the international search (name of data base and, where practical, search terms used)  
 EPO-Internal, INSPEC

**C. DOCUMENTS CONSIDERED TO BE RELEVANT**

Category*	Citation of document, with indication, where appropriate, of the relevant passages	Relevant to claim No.
X	EP 0 310 148 A2 (SQUIBB & SONS INC [US]) 5 April 1989 (1989-04-05) figures 1-6 column 3, line 37 - column 15, line 43	1-5
X	US 2007/140958 A1 (DEKEMP ROBERT A [CA]) 21 June 2007 (2007-06-21) figures 1-5 paragraph [0003] paragraph [0018] - paragraph [0035]	1-5
X	WO 2006/129301 A2 (SPECTRUM DYNAMICS [IL]; ROUSSO BENNY [IL]; BEN-HAIM SHLOMO [GB]; BRONS) 7 December 2006 (2006-12-07) figures 1-14 page 40, line 3 - page 41, line 16 page 90, line 10 - page 97, line 26 ----- -/--	1

Further documents are listed in the continuation of Box C.       See patent family annex.

- \* Special categories of cited documents :
- \*A\* document defining the general state of the art which is not considered to be of particular relevance
  - \*E\* earlier document but published on or after the international filing date
  - \*L\* document which may throw doubts on priority claim(s) or which is cited to establish the publication date of another citation or other special reason (as specified)
  - \*O\* document referring to an oral disclosure, use, exhibition or other means
  - \*P\* document published prior to the international filing date but later than the priority date claimed
  - \*T\* later document published after the international filing date or priority date and not in conflict with the application but cited to understand the principle or theory underlying the invention
  - \*X\* document of particular relevance; the claimed invention cannot be considered novel or cannot be considered to involve an inventive step when the document is taken alone
  - \*Y\* document of particular relevance; the claimed invention cannot be considered to involve an inventive step when the document is combined with one or more other such documents, such combination being obvious to a person skilled in the art.
  - \*&\* document member of the same patent family

Date of the actual completion of the international search  12 February 2010	Date of mailing of the international search report  01/03/2010
---	--

Name and mailing address of the ISA/ European Patent Office, P.B. 5818 Patentlaan 2 NL - 2280 HV Rijswijk Tel. (+31-70) 340-2040. Fax: (+31-70) 340-3016	Authorized officer  Reinbold, Sylvie
--	--

2

C(Continuation). DOCUMENTS CONSIDERED TO BE RELEVANT

Category*	Citation of document, with indication, where appropriate, of the relevant passages	Relevant to claim No.
X	<p>US 2007/213848 A1 (DEKEMP ROBERT A [CA] ET AL) 13 September 2007 (2007-09-13) figures 1-8 paragraph [0006] paragraph [0024] - paragraph [0056]</p>	<p>1-7, 32-35</p>
X	<p>NEIL J. EPSTEIN, AHMED BENELFASSI, ROB S.B. BEANLANDS, ROBERT A. DEKEMP: "A Rb82 infusion system for quantitative perfusion imaging with 3D PET" APPLIED RADIATION AND ISOTOPES, vol. 60, 9 February 2004 (2004-02-09), pages 921-927, XP002557544 DOI: 10.1016/j.apradiso.2004.02.002 the whole document</p>	<p>1-7, 32-35</p>
X	<p>R KLEIN, A ADLER, R S BEANLANFS AND R A DEKEMP: "Precision controlled elution of a Sr82/Rb82 generator for cardiac perfusion imaging with positron emission tomography" PHYSICS IN MEDICINE AND BIOLOGY, vol. 52, 11 January 2007 (2007-01-11), pages 659-673, XP002557545 DOI: 10.1088/0031-9155/52/3/009 the whole document</p>	<p>1-7, 32-35</p>
X	<p>WO 2008/028165 A2 (CATHOLIC HEALTHCARE WEST D B A [US]; DESHMUKH VIVEK R [US]; CRAWFORD N) 6 March 2008 (2008-03-06) paragraph [0060]; figures 1-5</p>	<p>30-31</p>

**FURTHER INFORMATION CONTINUED FROM PCT/ISA/ 210**

Continuation of Box II.1

Claims Nos.: 8-29, 36

The methods of claims 8 to 29 for operating an infusion system is carried out within a human body. As stated in the claims, the method is during a medical therapy. Furthermore the method of claim 36 for purging a tubing circuit of an infusion system with air is carried out within a human body. As stated in the claim, the method is during a medical therapy. These methods are forming part of a therapeutic procedure and can therefore not be regarded as an invention which is susceptible of industrial application. The application does not meet the requirement of Rule 39.1 (iv), because these claims are a method of treatment of the human body.

# INTERNATIONAL SEARCH REPORT

International application No.  
PCT/US2009/047031

## Box No. II Observations where certain claims were found unsearchable (Continuation of item 2 of first sheet)

This international search report has not been established in respect of certain claims under Article 17(2)(a) for the following reasons:

1.  Claims Nos.: **8-29, 36**  
because they relate to subject matter not required to be searched by this Authority, namely:  
**see FURTHER INFORMATION sheet PCT/ISA/210**
  
2.  Claims Nos.:  
because they relate to parts of the international application that do not comply with the prescribed requirements to such an extent that no meaningful international search can be carried out, specifically:
  
3.  Claims Nos.:  
because they are dependent claims and are not drafted in accordance with the second and third sentences of Rule 6.4(a).

## Box No. III Observations where unity of invention is lacking (Continuation of item 3 of first sheet)

This International Searching Authority found multiple inventions in this international application, as follows:

**see additional sheet**

1.  As all required additional search fees were timely paid by the applicant, this international search report covers all searchable claims.
  
2.  As all searchable claims could be searched without effort justifying an additional fees, this Authority did not invite payment of additional fees.
  
3.  As only some of the required additional search fees were timely paid by the applicant, this international search report covers only those claims for which fees were paid, specifically claims Nos.:
  
4.  No required additional search fees were timely paid by the applicant. Consequently, this international search report is restricted to the invention first mentioned in the claims; it is covered by claims Nos.:

### Remark on Protest

- The additional search fees were accompanied by the applicant's protest and, where applicable, the payment of a protest fee.
- The additional search fees were accompanied by the applicant's protest but the applicable protest fee was not paid within the time limit specified in the invitation.
- No protest accompanied the payment of additional search fees.

FURTHER INFORMATION CONTINUED FROM PCT/ISA/ 210

This International Searching Authority found multiple (groups of) inventions in this international application, as follows:

1. claims: 1-5

These claims essentially define an infusion system with an eluant reservoir, a pump, a radioisotope generator, an activity detector, a waste bottle, a computer, an eluant line and an user interface.

(technical effect: to provide an infusion pump which permits a quality control of a dose)

---

2. claims: 6-7

These claims essentially define an infusion system with an eluate line, a pump, an activity sensor, a waste bottle, a computer, a patient line, a by pass line coupled to the eluant line via a divergence valve and a radioisotope generator.

(technical effect: to provide an infusion system which permits to flush or to push any eluate remaining in patient line)

---

3. claims: 30-35

These claims essentially define a computer readable medium.  
(technical effect: to execute computer instructions)

---

Information on patent family members

International application No  
PCT/US2009/047031

Patent document cited in search report	Publication date	Patent family member(s)	Publication date			
EP 0310148	A2	05-04-1989	AT 53305 T 15-06-1990			
			AU 570429 B2 17-03-1988			
			CA 1237539 A1 31-05-1988			
			DE 3482410 D1 12-07-1990			
			EP 0117752 A2 05-09-1984			
			JP 5249245 A 28-09-1993			
			JP 1856747 C 07-07-1994			
			JP 5062314 B 08-09-1993			
			JP 59163584 A 14-09-1984			
			US 4585941 A 29-04-1986			
			US 4585009 A 29-04-1986			
			US 2007140958	A1	21-06-2007	AU 2006326814 A1 28-06-2007
						CA 2562340 A1 21-06-2007
WO 2007071022 A1 28-06-2007						
EP 1973624 A1 01-10-2008						
JP 2009520953 T 28-05-2009						
WO 2006129301	A2	07-12-2006	CA 2610256 A1 07-12-2006			
			EP 1891597 A2 27-02-2008			
US 2007213848	A1	13-09-2007	AU 2007224955 A1 20-09-2007			
			CA 2562453 A1 10-09-2007			
			WO 2007104133 A1 20-09-2007			
			EP 1996276 A1 03-12-2008			
			JP 2009529682 T 20-08-2009			
			KR 20090071512 A 01-07-2009			
WO 2008028165	A2	06-03-2008	NONE			

# PATENT COOPERATION TREATY

From the  
INTERNATIONAL SEARCHING AUTHORITY

## PCT

**WRITTEN OPINION OF THE  
INTERNATIONAL SEARCHING AUTHORITY  
(PCT Rule 43bis.1)**

To:

see form PCT/ISA/220

Date of mailing  
(day/month/year) see form PCT/ISA/210 (second sheet)

Applicant's or agent's file reference  
see form PCT/ISA/220

**FOR FURTHER ACTION**  
See paragraph 2 below

International application No. PCT/US2009/047031	International filing date (day/month/year) 11.06.2009	Priority date (day/month/year) 11.06.2008
--	--	--

International Patent Classification (IPC) or both national classification and IPC  
INV. A61M5/00  
ADD. A61M5/14

Applicant  
BRACCO DIAGNOSTICS INC.

**1. This opinion contains indications relating to the following items:**

- Box No. I Basis of the opinion
- Box No. II Priority
- Box No. III Non-establishment of opinion with regard to novelty, inventive step and industrial applicability
- Box No. IV Lack of unity of invention
- Box No. V Reasoned statement under Rule 43bis.1(a)(i) with regard to novelty, inventive step or industrial applicability; citations and explanations supporting such statement
- Box No. VI Certain documents cited
- Box No. VII Certain defects in the international application
- Box No. VIII Certain observations on the international application



**2. FURTHER ACTION**

If a demand for international preliminary examination is made, this opinion will usually be considered to be a written opinion of the International Preliminary Examining Authority ("IPEA") except that this does not apply where the applicant chooses an Authority other than this one to be the IPEA and the chosen IPEA has notified the International Bureau under Rule 66.1bis(b) that written opinions of this International Searching Authority will not be so considered.

If this opinion is, as provided above, considered to be a written opinion of the IPEA, the applicant is invited to submit to the IPEA a written reply together, where appropriate, with amendments, before the expiration of 3 months from the date of mailing of Form PCT/ISA/220 or before the expiration of 22 months from the priority date, whichever expires later.

For further options, see Form PCT/ISA/220.

**3. For further details, see notes to Form PCT/ISA/220.**

<p>Name and mailing address of the ISA:</p> <div style="text-align: center;">  </div> <p>European Patent Office D-80298 Munich Tel. +49 89 2399 - 0 Fax: +49 89 2399 - 4465</p>	<p>Date of completion of this opinion</p> <p>see form PCT/ISA/210</p>	<p>Authorized Officer</p> <p>Reinbold, Sylvie Telephone No. +49 89 2399-7918</p> <div style="text-align: right;">  </div>
--	---	--



---

**Box No. I Basis of the opinion**

---

1. With regard to the **language**, this opinion has been established on the basis of:
  - the international application in the language in which it was filed
  - a translation of the international application into , which is the language of a translation furnished for the purposes of international search (Rules 12.3(a) and 23.1 (b)).
2.  This opinion has been established taking into account the **rectification of an obvious mistake** authorized by or notified to this Authority under Rule 91 (Rule 43bis.1(a))
3. With regard to any **nucleotide and/or amino acid sequence** disclosed in the international application and necessary to the claimed invention, this opinion has been established on the basis of:
  - a. type of material:
    - a sequence listing
    - table(s) related to the sequence listing
  - b. format of material:
    - on paper
    - in electronic form
  - c. time of filing/furnishing:
    - contained in the international application as filed.
    - filed together with the international application in electronic form.
    - furnished subsequently to this Authority for the purposes of search.
4.  In addition, in the case that more than one version or copy of a sequence listing and/or table relating thereto has been filed or furnished, the required statements that the information in the subsequent or additional copies is identical to that in the application as filed or does not go beyond the application as filed, as appropriate, were furnished.
5. Additional comments:

**Box No. III Non-establishment of opinion with regard to novelty, inventive step and industrial applicability**

The questions whether the claimed invention appears to be novel, to involve an inventive step (to be non obvious), or to be industrially applicable have not been examined in respect of

- the entire international application
- claims Nos. 8-29, 36

because:

- the said international application, or the said claims Nos. relate to the following subject matter which does not require an international search (*specify*):
- the description, claims or drawings (*indicate particular elements below*) or said claims Nos. are so unclear that no meaningful opinion could be formed (*specify*):
- the claims, or said claims Nos. are so inadequately supported by the description that no meaningful opinion could be formed (*specify*):
- no international search report has been established for the whole application or for said claims Nos. 8-29, 36
- a meaningful opinion could not be formed without the sequence listing; the applicant did not, within the prescribed time limit:
  - furnish a sequence listing on paper complying with the standard provided for in Annex C of the Administrative Instructions, and such listing was not available to the International Searching Authority in a form and manner acceptable to it.
  - furnish a sequence listing in electronic form complying with the standard provided for in Annex C of the Administrative Instructions, and such listing was not available to the International Searching Authority in a form and manner acceptable to it.
  - pay the required late furnishing fee for the furnishing of a sequence listing in response to an invitation under Rules 13ter.1(a) or (b).
- a meaningful opinion could not be formed without the tables related to the sequence listings; the applicant did not, within the prescribed time limit, furnish such tables in electronic form complying with the technical requirements provided for in Annex C-bis of the Administrative Instructions, and such tables were not available to the International Searching Authority in a form and manner acceptable to it.
- the tables related to the nucleotide and/or amino acid sequence listing, if in electronic form only, do not comply with the technical requirements provided for in Annex C-bis of the Administrative Instructions.
- See Supplemental Box for further details

---

**Box No. IV Lack of unity of invention**

---

1.  In response to the invitation (Form PCT/ISA/206) to pay additional fees, the applicant has, within the applicable time limit:
- paid additional fees
  - paid additional fees under protest and, where applicable, the protest fee
  - paid additional fees under protest but the applicable protest fee was not paid
  - not paid additional fees
2.  This Authority found that the requirement of unity of invention is not complied with and chose not to invite the applicant to pay additional fees.
3. This Authority considers that the requirement of unity of invention in accordance with Rule 13.1, 13.2 and 13.3 is
- complied with
  - not complied with for the following reasons:  
see separate sheet
4. Consequently, this report has been established in respect of the following parts of the international application:
- all parts.
  - the parts relating to claims Nos. 1-5

---

**Box No. V Reasoned statement under Rule 43bis.1(a)(i) with regard to novelty, inventive step or industrial applicability; citations and explanations supporting such statement**

---

1. Statement

Novelty (N)	Yes: Claims	<u>7, 35</u>
	No: Claims	<u>1-6, 30-34</u>
Inventive step (IS)	Yes: Claims	
	No: Claims	<u>1-7, 30-35</u>
Industrial applicability (IA)	Yes: Claims	<u>1-7, 30-35</u>
	No: Claims	

2. Citations and explanations

see separate sheet

---

**Box No. VIII Certain observations on the international application**

---

The following observations on the clarity of the claims, description, and drawings or on the question whether the claims are fully supported by the description, are made:

see separate sheet

**Re Item III**

**Non- establishment of opinion with regard to novelty, inventive step and industrial applicability**

The methods of **claims 8 to 29** for operating an infusion system is carried out within a human body. As stated in the claims, the method is during a medical therapy.

Furthermore the method of **claim 36** for purging a tubing circuit of an infusion system with air is carried out within a human body. As stated in the claim, the method is during a medical therapy.

These methods are forming part of a therapeutic procedure and can therefore not be regarded as an invention which is susceptible of industrial application. The application does not meet the requirement of Rule 39.1 (iv), because these claims are a method of treatment of the human body. Consequently, no opinion will be formulated with respect to the industrial applicability of the subject matter of these claims. (Article 34 (4)(a)(i)PCT)

**Re Item IV**

**Lack of unity of invention**

The inventions in this international application, as follows:

**1. Claims 1-5**

These claims essentially define an infusion system with an eluant reservoir, a pump, a radioisotope generator, an activity detector, a waste bottle, a computer, an eluant line and an user interface. (technical effect: to provide an infusion pump which permits a quality control of a dose)

**2. Claims 6-7**

These claims essentially define an infusion system with an eluate line, a pump, an activity sensor, a waste bottle, a computer, a patient line, a by pass line coupled to the eluant line via a divergence valve and a radioisotope generator. (technical effect: to provide an infusion system which permits to flush or to push any eluate remaining in patient line)

**3. Claims 30-35:**

These claims essentially define a computer readable medium. (technical effect: to execute computer instructions)

The only common concept between the invention 1 and 2 is an infusion system comprising an eluant reservoir, a pump, a radioisotope generator, an activity detector, a waste bottle, a computer and an eluant line. This is already known from the person skilled in the art. (EP0310148)

There is no common concept between the invention 1 and 3 and 2 and 3.

The special technical features are not identical. The effects of both compounds are different. The use of the infusion system in claim 6 is to flush or push any eluate remaining in the patient line. The use of a computer readable medium is to execute computer instructions.

The groups of claims are not linked by common or corresponding special technical features and define 3 different inventions not linked by a single general inventive concept. Therefore the application claims 3 inventions not so linked to form a single general inventive concept. The requirement of unity is not fulfilled, according to Rule 13 PCT.

**Re Item V**

**Reasoned statement under Rule 66.2(a)(ii) with regard to novelty, inventive step or industrial applicability; citations and explanations supporting such statement**

1 Reference is made to the following documents:

- D1 EP 0 310 148
- D2 US 2007/140958
- D3 WO 2006/129301
- D4 US 2007/213848
- D5 NEIL J. EPSTEIN "A Rb82 infusion system for quantitative perfusion imaging with 3D PET"
- D6 R KLEIN "Precision controlled elution of a Sr82/Rb82 generator for cardiac perfusion imaging with positron emission tomography"
- D7 WO2008/028165

**Novelty Article 33(2) PCT**

**Invention 1: Claims 1 - 5**

2 Furthermore, the above-mentioned lack of clarity notwithstanding, the subject-matter of **claims 1 to 5** is not new in the sense of Article 33(2) PCT, and therefore the criteria of Article 33(1) PCT are not met.

2.1 The document D1 is regarded as being the closest prior art and discloses (the references in parentheses applying to this document) an infusion system comprising (figure 1-6):

-an eluant reservoir (10), a pump (64) coupled to the reservoir, an infusion tubing circuit (26,30,44,38), a radioisotope generator (28), an activity detector (58), a waste bottle (42) and a computer (60);

- the infusion tubing circuit including an eluant line (26) coupled to the pump and to the generator and an eluate line (30) coupled to the generator and to the activity detector; and the computer being coupled to a user interface (figure 2), to the pump and to the activity detector and being preprogrammed to receive input from a user of the system, via the user interface, to collect information, from the pump and the activity detector, and to provide output to the user, via the user interface (column 6 line 12 to 42), according to a method, the method comprising
- activating the pump to pump a volume of eluant from the reservoir, through the eluant line and through the generator, in order to generate a sample or a dose of eluate in the eluate line, via an elution within the generator, the sample (probe 58) being intended for a quality control measurement, and the dose being intended for diagnostic imaging;
- providing an indication, via the computer interface, that the elution is completed, when the pump has completed pumping the volume of eluant through the generator; and
- providing an indication, via the computer interface, of a time lapse since the elution was completed.

The subject matter of claim 1 is not novel document D1.

- 2.2 Document D1 shows the technical features of claims 2 to 5.
- 2.3 The technical features of claims 1 to 5 are also disclosed in Documents D2 to D6.

### **Invention 2: Claims 6-7**

- 3 Furthermore, the above-mentioned lack of clarity notwithstanding, the subject-matter of **claim 6** is not new in the sense of Article 33(2) PCT, and therefore the criteria of Article 33(1) PCT are not met.
- 3.1 The document D4 is regarded as being the closest prior art and discloses (the references in parentheses applying to this document) an infusion system comprising (figure 1-8):
  - an eluant reservoir (4), a pump (6) coupled to the reservoir, an infusion tubing circuit, a radioisotope generator (8), an activity detector (20), a waste bottle (26) and a computer (28); the infusion tubing circuit including an eluant line coupled to the pump and to the generator (figure 6), an eluate line coupled to the generator and to the activity detector, a patient line coupled to the eluate line, a by-pass line (18) coupled to the eluant line, via a divergence valve (16), and to the patient line, the by-pass line (18) accommodating flow of eluant to the patient line, when the divergence valve is set to direct the flow to by-pass the generator; and the computer being coupled to the pump and to

the activity detector and being pre-programmed to collect information, from the pump and the activity detector and to control the divergence valve and the pump (paragraph 29 to 32) according to a method, the method comprising:

- activating the pump a first time to pump a portion of a volume of eluant from the reservoir, through the eluant line and through the generator at a first flow rate, in order to generate eluate in the eluate line, via an elution within the generator, and to push a dose of the eluate into the patient line (figure 6c);
- setting the divergence valve (16) to direct flow through the by-pass line, once the dose has been pushed into the patient line (figure 6d); and
- activating the pump a second time to pump a second portion of the volume of eluant from the reservoir, through the eluant line, through the by-pass line and into the patient line to inject the dose out from the patient line (figure 6d);
- wherein the pump, when activated the second time, is controlled to pump the second portion of the volume of eluant at a second flow rate, the second flow rate being higher than the first flow rate, in order to increase a flow rate of the injection of the dose. (the flow rate can be variable: desired flow)

The subject matter of claim 6 is not novel document D4.

- 3.2 The technical feature of claim 6 is also disclosed in Documents D5 (figure 1) and D6. (figure 1)

### **Invention 3: Claims 30-35**

- 4 Furthermore, the above-mentioned lack of clarity notwithstanding, the subject-matter of **claims 30-34** is not new in the sense of Article 33(2) PCT, and therefore the criteria of Article 33(1) PCT are not met.

- 4.1 The document D7 is regarded as being the closest prior art and discloses (the references in parentheses applying to this document) a computer readable medium (106) comprising (figure 1-5):

- having computer executable instructions for executing a method for maintaining an infusion system (18), the method comprising:
- tracking a portion of a volume of eluant (saline) that is pumped from a reservoir (38) of the system and through a generator of the system, in order to generate, via elution, an eluate; providing an indication of the volume of eluant within the reservoir to a user of the system; tracking a volume of the eluate that is diverted from the generator to a waste bottle (120) of the system; and providing an indication to the user that the waste bottle needs to be emptied (paragraph 60).

The subject matter of claim 30 is not novel document D7.

- 4.2 Document D7 also reveals the technical feature of claim 31.



- 4.3 The document D4 is regarded as being the closest prior art and discloses (the references in parentheses applying to this document) a computer readable medium (28) comprising (figure 1-8) computer executable instructions for executing a method of calibrating an activity detector (20) of an infusion system. (see paragraph 29-32 and paragraph 55). The subject matter of claim 32 is not novel over document D4.
- 4.4 Moreover Document D4 shows the technical features of claims 33 and 34.
- 4.5 Finally the technical features of claims 32 to 34 are also disclosed in Documents D5 and D6.

### **Inventive Step Article 33(3) PCT**

#### **Invention 2: Claims 6-7**

- 5 The present application does not meet the criteria of Article 33 (1) PCT, because the subject-matter of **claim 7** does not seem to involve an inventive step in the sense of Article 33(3) PCT. Document D4 is the prior art. In **claim 7** a slight constructional change (flow rate) in device of D4 is defined which comes within the scope of the customary practice followed by persons skilled in the art, especially as the advantages thus achieved can readily be foreseen. Consequently, the subject-matter of this claim also lacks an inventive step.

#### **Invention 3: Claims 30-35**

- 6 The present application does not meet the criteria of Article 33 (1) PCT, because the subject-matter of **claim 35** does not seem to involve an inventive step in the sense of Article 33(3) PCT. Document D4 is the prior art. In **claim 35** a slight constructional change (time period) in device of D4 is defined which comes within the scope of the customary practice followed by persons skilled in the art, especially as the advantages thus achieved can readily be foreseen. Consequently, the subject-matter of this claim also lacks an inventive step.

### **Further comments**

#### **Invention 1: Claims 1 - 5**

- 7 Contrary to the requirements of Rule 5.1(a)(ii) PCT, the **relevant background** art disclosed in the documents D1-D3 are not mentioned in the description, nor are these documents identified therein.
- 8 Independent claim 1 is not in the **two-part form** in accordance with Rule 6.3 (b) PCT, which in the present case would be appropriate, with those features known in combination from the prior art (document D1) being placed in the preamble (Rule 6.3(b)(i) PCT) and with the remaining features being included in the characterising part (Rule 6.3(b)(ii) PCT).

- 9 The features of the claims are not provided with **reference signs** placed in parentheses (Rule 6.2(b) PCT).

**Invention 2: Claims 6-7**

- 10 Contrary to the requirements of Rule 5.1(a)(ii) PCT, the **relevant background art** disclosed in the documents D4-D6 are not mentioned in the description, nor are these documents identified therein.
- 11 Independent claim 6 is not in the **two-part form** in accordance with Rule 6.3 (b) PCT, which in the present case would be appropriate, with those features known in combination from the prior art (document D4) being placed in the preamble (Rule 6.3(b)(I) PCT) and with the remaining features being included in the characterising part (Rule 6.3(b)(ii) PCT).
- 12 The features of the claims are not provided with **reference signs** placed in parentheses (Rule 6.2(b) PCT).

**Invention 3: Claims 30-35**

- 13 Contrary to the requirements of Rule 5.1(a)(ii) PCT, the **relevant background art** disclosed in the documents D4-D7 are not mentioned in the description, nor are these documents identified therein.
- 14 Independent claim 30 is not in the **two-part form** in accordance with Rule 6.3 (b) PCT, which in the present case would be appropriate, with those features known in combination from the prior art (document D7) being placed in the preamble (Rule 6.3(b)(I) PCT) and with the remaining features being included in the characterising part (Rule 6.3(b)(ii) PCT).
- 15 The features of the claims are not provided with **reference signs** placed in parentheses (Rule 6.2(b) PCT).

**Re Item VIII**

**Certain observations on the international application**

**Clarity Article 6 PCT**

**Invention 1: Claims 1 - 5**

- 16 Some of the features in the apparatus **claim 1** relate to a method of using the apparatus (method comprising activating the pump, providing an indication and providing an indication) rather than clearly defining the apparatus in terms of its technical features. The intended limitations are therefore not clear from this claim, contrary to the requirements of Article 6 PCT.
- Furthermore such a method of using an infusion system is not allowed because this is a method of treatment of the human body. (Rule 39.1 (iv))

**Invention 2: Claims 6-7**

- 17 Some of the features in the infusion system **claim 6** relate to a method of using the apparatus (method comprising activating the pump, setting the valve and providing an indication) rather than clearly defining the apparatus in terms of its technical features. The intended limitations are therefore not clear from this claim, contrary to the requirements of Article 6 PCT.

Furthermore such a method of using an infusion system is not allowed because this is a method of treatment of the human body. (Rule 39.1 (iv)). The method is carried out within a human body, because a dose of eluate is injected to the patient line into the patient.

**Invention 3: Claims 30-35**

- 18 Although **claims 30,32 and 33** have been drafted as separate independent claims, they appear to relate effectively to the **same subject-matter** and to differ from each other only with regard to the definition of the subject-matter for which protection is sought.

The aforementioned claims therefore lack conciseness. Moreover, lack of clarity of the claims as a whole arises, since the plurality of independent claims makes it difficult, if not impossible, to determine the matter for which protection is sought, and places an undue burden on others seeking to establish the extent of the protection. Hence, these claims do not meet the requirements of Article 6 PCT.

- 19 Some of the features in the computer readable medium of **claim 30** relate to a method for maintaining an infusion system rather than clearly defining the apparatus in terms of its technical features. The intended limitations are therefore not clear from this claim, contrary to the requirements of Article 6 PCT.

Furthermore such a method for maintaining an infusion system is not allowed because this is during a method of treatment of the human body. (Rule 39.1 (iv)). It is implicit that to generate an eluate, the infusion pump is activated and is during a method of treatment of the human body.

- 20 Some of the features in the computer readable medium of **claim 32** relate to a method for calibrating an activity detector of an infusion system, rather than clearly defining the apparatus in terms of its technical features. The intended limitations are therefore not clear from this claim, contrary to the requirements of Article 6 PCT.

Furthermore such a method for calibrating an activity detector of an infusion system is not allowed because this is during a method of treatment of the human body. (Rule 39.1 (iv)). It is implicit that to generate an eluate, the infusion pump is activated and is during a method of treatment of the human body.

- 21 Some of the features in the computer readable medium of **claim 33** relate to a method for conducting a breakthrough test of a radioisotope generator of an infusion system rather than clearly defining the apparatus in terms of its technical features. The intended limitations are therefore not clear from this claim, contrary to the requirements of Article 6 PCT.

Furthermore such a method for conducting a breakthrough test of a radioisotope generator of an infusion system is not allowed because this is during a method of treatment of the human body. (Rule 39.1 (iv)). It is implicit that to generate an eluate, the infusion pump is activated and is during a method of treatment of the human body.

PATENT COOPERATION TREATY

PCT

INTERNATIONAL SEARCH REPORT

(PCT Article 18 and Rules 43 and 44)

Applicant's or agent's file reference 56782.1.8.1	<b>FOR FURTHER ACTION</b>		see Form PCT/ISA/220 as well as, where applicable, item 5 below.
International application No. PCT/US2009/047034	International filing date (day/month/year) 11/06/2009	(Earliest) Priority Date (day/month/year) 11/06/2008	
Applicant  BRACCO DIAGNOSTICS INC.			

This international search report has been prepared by this International Searching Authority and is transmitted to the applicant according to Article 18. A copy is being transmitted to the International Bureau.

This international search report consists of a total of 6 sheets.

It is also accompanied by a copy of each prior art document cited in this report.

1. Basis of the report

a. With regard to the **language**, the international search was carried out on the basis of:

- the international application in the language in which it was filed  
 a translation of the international application into \_\_\_\_\_, which is the language of a translation furnished for the purposes of international search (Rules 12.3(a) and 23.1(b))

b.  This international search report has been established taking into account the **rectification of an obvious mistake** authorized by or notified to this Authority under Rule 91 (Rule 43.6bis(a)).

c.  With regard to any **nucleotide and/or amino acid sequence** disclosed in the international application, see Box No. I.

2.  **Certain claims were found unsearchable** (See Box No. II)

3.  **Unity of invention is lacking** (see Box No III)

4. With regard to the **title**,

- the text is approved as submitted by the applicant  
 the text has been established by this Authority to read as follows:

5. With regard to the **abstract**,

- the text is approved as submitted by the applicant  
 the text has been established, according to Rule 38.2(b), by this Authority as it appears in Box No. IV. The applicant may, within one month from the date of mailing of this international search report, submit comments to this Authority

6. With regard to the **drawings**,

- a. the figure of the **drawings** to be published with the abstract is Figure No. 1c  
 as suggested by the applicant  
 as selected by this Authority, because the applicant failed to suggest a figure  
 as selected by this Authority, because this figure better characterizes the invention
- b.  none of the figures is to be published with the abstract

**A. CLASSIFICATION OF SUBJECT MATTER**  
 INV. A61M5/14 A61G12/00  
 ADD. A61M5/00

According to International Patent Classification (IPC) or to both national classification and IPC

**B. FIELDS SEARCHED**

Minimum documentation searched (classification system followed by classification symbols)  
 A61M G21F

Documentation searched other than minimum documentation to the extent that such documents are included in the fields searched

Electronic data base consulted during the international search (name of data base and, where practical, search terms used)

EPO-Internal, WPI Data, INSPEC

**C. DOCUMENTS CONSIDERED TO BE RELEVANT**

Category*	Citation of document, with indication, where appropriate, of the relevant passages	Relevant to claim No.
X	JP 2000 350783 A (SUMITOMO HEAVY INDUSTRIES) 19 December 2000 (2000-12-19) figures 1-5 paragraph [0013] - paragraph [0032]	1-35
X	WO 2008/037939 A2 (LEMER PROT ANTI X PAR ABREVIAT [FR]; LEMER PIERRE-MARIE [FR]) 3 April 2008 (2008-04-03) figures 1-2 page 5, line 27 - page 11, line 19	1-23
X	EP 0 102 121 A1 (BYK MALLINCKRODT CIL BV [NL]) 7 March 1984 (1984-03-07) figures 1-4 page 9, line 16 - page 12, line 11	1,8-10, 12, 14-16, 19,22-23
	-/--	

Further documents are listed in the continuation of Box C.

See patent family annex.

\* Special categories of cited documents :

- "A" document defining the general state of the art which is not considered to be of particular relevance
- "E" earlier document but published on or after the international filing date
- "L" document which may throw doubts on priority claim(s) or which is cited to establish the publication date of another citation or other special reason (as specified)
- "O" document referring to an oral disclosure, use, exhibition or other means
- "P" document published prior to the international filing date but later than the priority date claimed

"T" later document published after the international filing date or priority date and not in conflict with the application but cited to understand the principle or theory underlying the invention

"X" document of particular relevance; the claimed invention cannot be considered novel or cannot be considered to involve an inventive step when the document is taken alone

"Y" document of particular relevance; the claimed invention cannot be considered to involve an inventive step when the document is combined with one or more other such documents, such combination being obvious to a person skilled in the art.

"&" document member of the same patent family

Date of the actual completion of the international search

11 February 2010

Date of mailing of the international search report

25/02/2010

Name and mailing address of the ISA/  
 European Patent Office, P.B. 5818 Patentlaan 2  
 NL - 2280 HV Rijswijk  
 Tel. (+31-70) 340-2040,  
 Fax: (+31-70) 340-3016

Authorized officer

Reinbold, Sylvie

C(Continuation). DOCUMENTS CONSIDERED TO BE RELEVANT

Category*	Citation of document, with indication, where appropriate, of the relevant passages	Relevant to claim No.
X	JP 2006 325826 A (UNIVERSAL GIKEN KK; SD GIKEN KK) 7 December 2006 (2006-12-07) figures 1-10 paragraph [0020] - paragraph [0069]	1-23
X	FR 2 867 084 A1 (GEN ELECTRIC [US]) 9 September 2005 (2005-09-09)  figures 1-12 page 13, line 23 - page 27, line 9	1,8-12, 14-15, 17,19
X	WO 2006/074473 A2 (ATLAS SYSTEMS INC [US]; LIVENGOOD AMY L [US]; LIVENGOOD JOSEPH C [US];) 13 July 2006 (2006-07-13) figures 1-6 page 16, line 4 - page 27, line 4	24-35
X	US 5 590 648 A (MITCHELL ANDREW [US] ET AL) 7 January 1997 (1997-01-07) figures 1-9 column 3, line 65 - column 8, line 5	24,28-35
X A	WO 02/096335 A2 (HILL ROM SERVICES INC [US]; GALLANT DENNIS J [US]; LANCI DENNIS M [US]) 5 December 2002 (2002-12-05) figure 18 page 22, line 6 - page 23, line 3	24, 28-29, 33-34 35
X	WO 96/15337 A1 (NILSSON AGNE [CY]) 23 May 1996 (1996-05-23) figures 1-26 page 4, line 4 - page 12, line 34	28-35

# INTERNATIONAL SEARCH REPORT

International application No.  
PCT/US2009/047034

## Box No. II Observations where certain claims were found unsearchable (Continuation of item 2 of first sheet)

This international search report has not been established in respect of certain claims under Article 17(2)(a) for the following reasons:

1.  Claims Nos.:  
because they relate to subject matter not required to be searched by this Authority, namely:
  
2.  Claims Nos.:  
because they relate to parts of the international application that do not comply with the prescribed requirements to such an extent that no meaningful international search can be carried out, specifically:
  
3.  Claims Nos.:  
because they are dependent claims and are not drafted in accordance with the second and third sentences of Rule 6.4(a).

## Box No. III Observations where unity of invention is lacking (Continuation of item 3 of first sheet)

This International Searching Authority found multiple inventions in this international application, as follows:

see additional sheet

1.  As all required additional search fees were timely paid by the applicant, this international search report covers all searchable claims.
2.  As all searchable claims could be searched without effort justifying an additional fees, this Authority did not invite payment of additional fees.
3.  As only some of the required additional search fees were timely paid by the applicant, this international search report covers only those claims for which fees were paid, specifically claims Nos.:
4.  No required additional search fees were timely paid by the applicant. Consequently, this international search report is restricted to the invention first mentioned in the claims; it is covered by claims Nos.:

### Remark on Protest

- The additional search fees were accompanied by the applicant's protest and, where applicable, the payment of a protest fee.
- The additional search fees were accompanied by the applicant's protest but the applicable protest fee was not paid within the time limit specified in the invitation.
- No protest accompanied the payment of additional search fees.



## FURTHER INFORMATION CONTINUED FROM PCT/ISA/ 210

This International Searching Authority found multiple (groups of) inventions in this international application, as follows:

## 1. claims: 1-23

These claims essentially define a cabinet structure for an infusion system comprising:

- a platform
  - a shell, wherein the shell comprises a first upper opening, a second upper opening and an access panel
  - the access panel mating with the upper opening and being removable therefrom
  - the upper opening is sized and oriented to allow a lowering of one or more radioisotope generators
  - the upper opening being located at an elevation which is substantially lower than an elevation of an uppermost portion of the upper surface  
(technical problem: to provide a better ergonomic)
- 

## 2. claims: 24-35

These claims essentially define a cabinet structure for an infusion system comprising:

- a platform
  - a shell
  - at least one external recess  
(technical problem: to provide a cabinet structure to hold articles pertaining to operation of the infusion system)
-

Information on patent family members

International application No  
PCT/US2009/047034

Patent document cited in search report		Publication date	Patent family member(s)	Publication date
JP 2000350783	A	19-12-2000	NONE	
WO 2008037939	A2	03-04-2008	AU 2007301772 A1 CA 2664760 A1 CN 101516420 A EP 2077873 A2 FR 2906475 A1 KR 20090057979 A US 2010030009 A1	03-04-2008 03-04-2008 26-08-2009 15-07-2009 04-04-2008 08-06-2009 04-02-2010
EP 0102121	A1	07-03-1984	NONE	
JP 2006325826	A	07-12-2006	NONE	
FR 2867084	A1	09-09-2005	DE 102005010152 A1 DE 102005010154 A1 FR 2867294 A1 JP 2005326398 A JP 2005324007 A US 2008242915 A1	15-09-2005 15-09-2005 09-09-2005 24-11-2005 24-11-2005 02-10-2008
WO 2006074473	A2	13-07-2006	US 2006163829 A1	27-07-2006
US 5590648	A	07-01-1997	NONE	
WO 02096335	A2	05-12-2002	AU 2002305689 A1 AU 2002309987 A1 AU 2002310044 A1 CA 2447655 A1 CA 2447656 A1 CA 2447661 A1 EP 1389995 A2 EP 1395220 A1 EP 1397103 A2 JP 2005515800 T JP 2005516635 T JP 2005514080 T WO 02096339 A1 WO 02096338 A2 US 2008236054 A1 US 2003014817 A1 US 2007068089 A1 US 2004237202 A1	09-12-2002 09-12-2002 09-12-2002 05-12-2002 05-12-2002 05-12-2002 25-02-2004 10-03-2004 17-03-2004 02-06-2005 09-06-2005 19-05-2005 05-12-2002 05-12-2002 02-10-2008 23-01-2003 29-03-2007 02-12-2004
WO 9615337	A1	23-05-1996	AT 288000 T AU 3943695 A	15-02-2005 06-06-1996
WO 9615337	A1		CN 1173211 A DE 69533965 D1 EP 0797712 A1 JP 10508770 T JP 4061657 B2 US 6089518 A	11-02-1998 03-03-2005 01-10-1997 02-09-1998 19-03-2008 18-07-2000

# PATENT COOPERATION TREATY

From the  
INTERNATIONAL SEARCHING AUTHORITY

## PCT

**WRITTEN OPINION OF THE  
INTERNATIONAL SEARCHING AUTHORITY  
(PCT Rule 43bis.1)**

To:

see form PCT/ISA/220

Date of mailing  
(day/month/year) see form PCT/ISA/210 (second sheet)

Applicant's or agent's file reference  
see form PCT/ISA/220

**FOR FURTHER ACTION**  
See paragraph 2 below

International application No.  
PCT/US2009/047034

International filing date (day/month/year)  
11.06.2009

Priority date (day/month/year)  
11.06.2008

International Patent Classification (IPC) or both national classification and IPC  
INV. A61M5/14 A61G12/00  
ADD. A61M5/00

Applicant  
BRACCO DIAGNOSTICS INC.

**1. This opinion contains indications relating to the following items:**

- Box No. I Basis of the opinion
- Box No. II Priority
- Box No. III Non-establishment of opinion with regard to novelty, inventive step and industrial applicability
- Box No. IV Lack of unity of invention
- Box No. V Reasoned statement under Rule 43bis.1(a)(i) with regard to novelty, inventive step or industrial applicability; citations and explanations supporting such statement
- Box No. VI Certain documents cited
- Box No. VII Certain defects in the international application
- Box No. VIII Certain observations on the international application


**2. FURTHER ACTION**

If a demand for international preliminary examination is made, this opinion will usually be considered to be a written opinion of the International Preliminary Examining Authority ("IPEA") except that this does not apply where the applicant chooses an Authority other than this one to be the IPEA and the chosen IPEA has notified the International Bureau under Rule 66.1bis(b) that written opinions of this International Searching Authority will not be so considered.

If this opinion is, as provided above, considered to be a written opinion of the IPEA, the applicant is invited to submit to the IPEA a written reply together, where appropriate, with amendments, before the expiration of 3 months from the date of mailing of Form PCT/ISA/220 or before the expiration of 22 months from the priority date, whichever expires later.

For further options, see Form PCT/ISA/220.

**3. For further details, see notes to Form PCT/ISA/220.**

<p>Name and mailing address of the ISA:</p> <div style="text-align: center;">  <p>European Patent Office D-80298 Munich Tel. +49 89 2399 - 0 Fax: +49 89 2399 - 4465</p> </div>	<p>Date of completion of this opinion</p> <p>see form PCT/ISA/210</p>	<p>Authorized Officer</p> <p>Reinbold, Sylvie Telephone No. +49 89 2399-7918</p>
--	---	--



---

**Box No. I Basis of the opinion**

---

1. With regard to the **language**, this opinion has been established on the basis of:
  - the international application in the language in which it was filed
  - a translation of the international application into , which is the language of a translation furnished for the purposes of international search (Rules 12.3(a) and 23.1 (b)).
2.  This opinion has been established taking into account the **rectification of an obvious mistake** authorized by or notified to this Authority under Rule 91 (Rule 43bis.1(a))
3. With regard to any **nucleotide and/or amino acid sequence** disclosed in the international application and necessary to the claimed invention, this opinion has been established on the basis of:
  - a. type of material:
    - a sequence listing
    - table(s) related to the sequence listing
  - b. format of material:
    - on paper
    - in electronic form
  - c. time of filing/furnishing:
    - contained in the international application as filed.
    - filed together with the international application in electronic form.
    - furnished subsequently to this Authority for the purposes of search.
4.  In addition, in the case that more than one version or copy of a sequence listing and/or table relating thereto has been filed or furnished, the required statements that the information in the subsequent or additional copies is identical to that in the application as filed or does not go beyond the application as filed, as appropriate, were furnished.
5. Additional comments:

---

**Box No. IV Lack of unity of invention**

---

1.  In response to the invitation (Form PCT/ISA/206) to pay additional fees, the applicant has, within the applicable time limit:
- paid additional fees
  - paid additional fees under protest and, where applicable, the protest fee
  - paid additional fees under protest but the applicable protest fee was not paid
  - not paid additional fees
2.  This Authority found that the requirement of unity of invention is not complied with and chose not to invite the applicant to pay additional fees.
3. This Authority considers that the requirement of unity of invention in accordance with Rule 13.1, 13.2 and 13.3 is
- complied with
  - not complied with for the following reasons:  
**see separate sheet**
4. Consequently, this report has been established in respect of the following parts of the international application:
- all parts.
  - the parts relating to claims Nos. 1-23

---

**Box No. V Reasoned statement under Rule 43bis.1(a)(i) with regard to novelty, inventive step or industrial applicability; citations and explanations supporting such statement**

---

1. Statement

Novelty (N)	Yes: Claims	<u>2-7, 13, 20-21, 26-27</u>
	No: Claims	<u>1, 8-12, 14-19, 22-25, 28-35</u>
Inventive step (IS)	Yes: Claims	
	No: Claims	<u>1-35</u>
Industrial applicability (IA)	Yes: Claims	<u>1-35</u>
	No: Claims	

2. Citations and explanations

**see separate sheet**

---

**Box No. VIII Certain observations on the international application**

---

The following observations on the clarity of the claims, description, and drawings or on the question whether the claims are fully supported by the description, are made:

see separate sheet

**Re Item IV**

**Lack of unity of invention**

The inventions in this international application, as follows:

**1. Claims 1 - 23**

These claims essentially define a cabinet structure for an infusion system comprising:

- a platform, a shell, wherein the shell comprises a first upper opening, a second upper opening and an access panel
- the access panel mating with the upper opening and being removable therefrom
- the upper opening is sized and oriented to allow a lowering of one or more radioisotope generators
- the upper opening being located at an elevation which is substantially lower than an elevation of an uppermost portion of the upper surface

(technical problem: to provide a better ergonomic)

**2. Claims 24-35:**

These claims essentially define a cabinet structure for an infusion system comprising:

- a platform, a shell
- at least one external recess

(technical problem: to provide a cabinet structure to hold articles pertaining to operation of the infusion system)

The only common concept between the invention 1 and 2 is a cabinet structure for an infusion system having a platform and a shell. This is already known from the person skilled in the art. (see JP200350783).

The special technical features are not identical. The effects of both compounds are different. The use of the cabinet structure in claim 24 or 28 permit to hold articles pertaining to operation of the infusion system.

In conclusion, the groups of claims are not linked by common or corresponding special technical features and define 2 different inventions not linked by a single general inventive concept. Therefore the application claims 2 inventions not so linked to form a single general inventive concept. The requirement of unity is not fulfilled, according to Rule 13 PCT.

**Re Item V**

**Reasoned statement under Rule 66.2(a)(ii) with regard to novelty, inventive step or industrial applicability; citations and explanations supporting such statement**

1 Reference is made to the following documents:

- D1 JP 2000 350783
- D2 WO 2008/037939
- D3 EP 0 102 121
- D4 JP 2006 325826
- D5 FR 2 867 084
- D6 WO 2006/074473
- D7 US 5 590 648
- D8 WO 02/096335
- D9 WO 96/15337

**Novelty Article 33(2) PCT**

**Invention 1: claims 1 - 23**

- 2 The present application does not meet the criteria of Article 33 (1) PCT, because the subject-matter of claims **1,8-12,14-19,22 and 23** is not new in the sense of Article 33(2) PCT.
- 2.1 The document D1 is regarded as being the closest prior art and discloses (the references in parentheses applying to this document) discloses a cabinet structure for an infusion system comprising (figure 1-5):
- a platform on which the infusion system is mounted; and
  - a shell (40+74) surrounding an interior space of the structure, the interior space containing at least a portion of the infusion system;
  - wherein the shell comprises a first upper opening (84) into the interior space, a second upper opening (opening where the panel (64) is fixed) into the interior space and an access panel;
  - the access panel (64) mates with the second upper opening and is removable therefrom;
  - the first upper opening is sized to provide access to a waste bottle (syringe) of the infusion system within the interior space; and
  - the second upper opening is sized and oriented to allow a lowering of one or more radioisotope generators, for the system, into the interior space, and a lifting of the one or more generators out from the interior space, the second upper opening being located at an elevation, with respect to a lowermost



portion of the cabinet structure, which is lower than an elevation, with respect to the lowermost portion of the cabinet structure, of the first upper opening (see figure 2).

The subject matter of claim 1 is not novel over document D1.

- 2.2 Document D1 shows the technical features of claims 8,10,11,12,14,15,17-19, 22 and 23.
- 2.3 The technical feature of claims 1,8-12,14-19,22 and 23 is disclosed in Documents D2,D3,D4 and D5.

### **Invention 2: claims 24 - 35**

3 The present application does not meet the criteria of Article 33 (1) PCT, because the subject-matter of claims **24,25 and 28-35** is not new in the sense of Article 33(2) PCT.

3.1 The document D6 is regarded as being the closest prior art and discloses (the references in parentheses applying to this document) discloses a cabinet structure (100) for an infusion system (124, page 16 line 21), the structure comprising (figures 1-15):

- a platform (120) on which the infusion system is mounted; and
- a shell (204) surrounding an interior space of the structure and including an upper surface (112) in which at least one opening (138,124) and an external recess (192) is formed;
- wherein the interior space contains at least a portion of the infusion system (IV pump);
- the at least one opening provides a passageway (138) for a tubing line of the infusion system to extend out from the interior space; and the external recess (192) is sized to contain a spill from the infusion system.

Therefore the subject matter of claim 24 is not novel over document D6.

- 3.2 Document D6 also shows the technical features of claims 25 and 28 to 35.
- 3.3 Moreover the technical feature of **claims 24,25 and 28-35** is disclosed in Documents D1,D7,D8 and D9.

### **Inventive step Article 33(3) PCT**

#### **Invention 1: claims 1 - 23**

4 The present application does not meet the criteria of Article 33 (1) PCT, because the subject-matter of **claims 2-7,13 and 20-21** does not seem to involve an inventive step in the sense of Article 33(3) PCT. Document D1 is the closest prior art.

In claims 2-7,9,13 and 20-21 a slight constructional change in the cabinet structure is defined which comes within the scope of the customary practice followed by persons skilled in the art, especially as the advantages thus achieved can readily be foreseen. Consequently, the subject-matter of these claims also lacks an inventive step.

**Invention 2: claims 24 - 35**

5 The present application does not meet the criteria of Article 33 (1) PCT, because the subject-matter of **claims 26 and 27** does not seem to involve an inventive step in the sense of Article 33(3) PCT. Document D6 is the closest prior art.

In claims 26 and 27 a slight constructional change in the cabinet structure is defined which comes within the scope of the customary practice followed by persons skilled in the art, especially as the advantages thus achieved can readily be foreseen. Consequently, the subject-matter of these claims also lacks an inventive step.

**Further comments**

**Invention 1: claims 1 - 23**

6 Contrary to the requirements of Rule 5.1(a)(ii) PCT, the **relevant background** art disclosed in the documents D1- D4 are not mentioned in the description, nor are these documents identified therein.

7 Independent claim 1 is not in the **two-part form** in accordance with Rule 6.3 (b) PCT, which in the present case would be appropriate, with those features known in combination from the prior art (document D1) being placed in the preamble (Rule 6.3(b)(I) PCT) and with the remaining features being included in the characterising part (Rule 6.3(b)(ii) PCT).

8 The features of the claims are not provided with **reference signs** placed in parentheses (Rule 6.2(b) PCT).

**Invention 2: claims 24 - 35**

9 Contrary to the requirements of Rule 5.1(a)(ii) PCT, the **relevant background** art disclosed in the documents D1, D6 to D9 are not mentioned in the description, nor are these documents identified therein.

10 Independent claim 24 is not in the **two-part form** in accordance with Rule 6.3 (b) PCT, which in the present case would be appropriate, with those features known in combination from the prior art (document D1) being placed in the preamble (Rule 6.3(b)(I) PCT) and with the remaining features being included in the characterising part (Rule 6.3(b)(ii) PCT).

- 11 The features of the claims are not provided with **reference signs** placed in parentheses (Rule 6.2(b) PCT).

**Re Item VIII**

**Certain observations on the international application**

**Clarity Article 6 PCT**

**Invention 1: claims 1 - 23**

- 12 Although **claims 1 and 19** have been drafted as separate independent claims, they appear to relate effectively to the **same subject-matter** and to differ from each other only with regard to the definition of the subject-matter for which protection is sought.

The aforementioned claims therefore lack conciseness. Moreover, lack of clarity of the claims as a whole arises, since the plurality of independent claims makes it difficult, if not impossible, to determine the matter for which protection is sought, and places an undue burden on others seeking to establish the extent of the protection.

Hence, these claims do not meet the requirements of Article 6 PCT.

It appears to be appropriate to file an amended set of claims taking account of the above comments and Article 34(2)(b) PCT. The relevant subject-matter should be defined in **a single independent claim** followed by dependent claims covering features which are merely optional (Rules 6.3 and 6.4 PCT).

**Invention 2: claims 24 - 35**

- 13 Although **claims 24 and 28** have been drafted as separate independent claims, they appear to relate effectively to the **same subject-matter** and to differ from each other only with regard to the definition of the subject-matter for which protection is sought.

The aforementioned claims therefore lack conciseness. Moreover, lack of clarity of the claims as a whole arises, since the plurality of independent claims makes it difficult, if not impossible, to determine the matter for which protection is sought, and places an undue burden on others seeking to establish the extent of the protection.

Hence, these claims do not meet the requirements of Article 6 PCT.

It appears to be appropriate to file an amended set of claims taking account of the above comments and Article 34(2)(b) PCT. The relevant subject-matter should be defined in **a single independent claim** followed by dependent claims covering features which are merely optional (Rules 6.3 and 6.4 PCT).

## Electronic Acknowledgement Receipt

<b>EFS ID:</b>	7196693
<b>Application Number:</b>	12137356
<b>International Application Number:</b>	
<b>Confirmation Number:</b>	7360
<b>Title of Invention:</b>	SHIELDING ASSEMBLIES FOR INFUSION SYSTEMS
<b>First Named Inventor/Applicant Name:</b>	Charles R. Quirico
<b>Customer Number:</b>	22859
<b>Filer:</b>	Elisabeth Lacy Belden
<b>Filer Authorized By:</b>	
<b>Attorney Docket Number:</b>	56782.1.5
<b>Receipt Date:</b>	12-MAR-2010
<b>Filing Date:</b>	11-JUN-2008
<b>Time Stamp:</b>	12:26:01
<b>Application Type:</b>	Utility under 35 USC 111(a)

### Payment information:

Submitted with Payment	no
------------------------	----

### File Listing:

Document Number	Document Description	File Name	File Size(Bytes)/ Message Digest	Multi Part /.zip	Pages (if appl.)
1		5thSIDS_56782-1-5.pdf	856876 <small>97fc4ff2fd02e509da533fd4b0e118db23cc15d1</small>	yes	5

Multipart Description/PDF files in .zip description					
Document Description			Start	End	
Information Disclosure Statement (IDS) Filed (SB/08)			1	3	
Transmittal Letter			4	5	
<b>Warnings:</b>					
<b>Information:</b>					
2	Foreign Reference	WO9615337A1.pdf	1486044 3f0a489957d75fe17b634665cba1dca9a555959d	no	36
<b>Warnings:</b>					
<b>Information:</b>					
3	Foreign Reference	WO02096335A2.pdf	2874922 0123b0873d007d1e9c2963ddecc35337455e36de	no	57
<b>Warnings:</b>					
<b>Information:</b>					
4	Foreign Reference	WO200674473A2.pdf	3009340 b2dd51851cfcee42a881fc6b1edbf0729b389e96	no	79
<b>Warnings:</b>					
<b>Information:</b>					
5	Foreign Reference	WO2008028165A2.pdf	1831913 875573dee4f641eff4007e9ffa8ce768088784bc	no	45
<b>Warnings:</b>					
<b>Information:</b>					
6	NPL Documents	Article-Epstein.pdf	1242548 4d1ae76a39290b7146438b33486c7d98821ec552	no	7
<b>Warnings:</b>					
<b>Information:</b>					
7	NPL Documents	Article-Klein.pdf	2007175 3e644852e664ae035f2776e9ac7322fa45a539c5	no	15
<b>Warnings:</b>					
<b>Information:</b>					
8	NPL Documents	ISR-WO_56782_1_5_1.pdf	3081572 773bbb06580bc6dbfbafe2f645d6b37ceaebe442	no	22
<b>Warnings:</b>					
<b>Information:</b>					

9	NPL Documents	ISR-WO_56782_1_6_1.pdf	2732881	no	17
			70698277b5883d4afed71695b799561e78095ddb		
<b>Warnings:</b>					
<b>Information:</b>					
10	NPL Documents	ISR-WO_56782_1_7_1.pdf	3013153	no	20
			08067db8c7b81d3142e5ad89e5ab72e32d751231		
<b>Warnings:</b>					
<b>Information:</b>					
11	NPL Documents	ISR-WO_56782_1_8_1.pdf	2323105	no	15
			384268c2cb35b512f07968afcebbccf9cf908b3		
<b>Warnings:</b>					
<b>Information:</b>					
<b>Total Files Size (in bytes):</b>				24459529	

**This Acknowledgement Receipt evidences receipt on the noted date by the USPTO of the indicated documents, characterized by the applicant, and including page counts, where applicable. It serves as evidence of receipt similar to a Post Card, as described in MPEP 503.**

**New Applications Under 35 U.S.C. 111**

**If a new application is being filed and the application includes the necessary components for a filing date (see 37 CFR 1.53(b)-(d) and MPEP 506), a Filing Receipt (37 CFR 1.54) will be issued in due course and the date shown on this Acknowledgement Receipt will establish the filing date of the application.**

**National Stage of an International Application under 35 U.S.C. 371**

**If a timely submission to enter the national stage of an international application is compliant with the conditions of 35 U.S.C. 371 and other applicable requirements a Form PCT/DO/EO/903 indicating acceptance of the application as a national stage submission under 35 U.S.C. 371 will be issued in addition to the Filing Receipt, in due course.**

**New International Application Filed with the USPTO as a Receiving Office**

**If a new international application is being filed and the international application includes the necessary components for an international filing date (see PCT Article 11 and MPEP 1810), a Notification of the International Application Number and of the International Filing Date (Form PCT/RO/105) will be issued in due course, subject to prescriptions concerning national security, and the date shown on this Acknowledgement Receipt will establish the international filing date of the application.**



UNITED STATES PATENT AND TRADEMARK OFFICE

UNITED STATES DEPARTMENT OF COMMERCE
United States Patent and Trademark Office
Address: COMMISSIONER FOR PATENTS
P.O. Box 1450
Alexandria, Virginia 22313-1450
www.uspto.gov

Table with 4 columns: APPLICATION NUMBER (12/137,356), FILING OR 371(C) DATE (06/11/2008), FIRST NAMED APPLICANT (Charles R. Quirico), ATTY. DOCKET NO./TITLE (56782.1.5)

CONFIRMATION NO. 7360

PUBLICATION NOTICE

22859
INTELLECTUAL PROPERTY GROUP
FREDRIKSON & BYRON, P.A.
200 SOUTH SIXTH STREET, SUITE 4000
MINNEAPOLIS, MN 55402



Title:SHIELDING ASSEMBLIES FOR INFUSION SYSTEMS

Publication No.US-2009-0318745-A1
Publication Date:12/24/2009

NOTICE OF PUBLICATION OF APPLICATION

The above-identified application will be electronically published as a patent application publication pursuant to 37 CFR 1.211, et seq. The patent application publication number and publication date are set forth above.

The publication may be accessed through the USPTO's publically available Searchable Databases via the Internet at www.uspto.gov. The direct link to access the publication is currently http://www.uspto.gov/patft/.

The publication process established by the Office does not provide for mailing a copy of the publication to applicant. A copy of the publication may be obtained from the Office upon payment of the appropriate fee set forth in 37 CFR 1.19(a)(1). Orders for copies of patent application publications are handled by the USPTO's Office of Public Records. The Office of Public Records can be reached by telephone at (703) 308-9726 or (800) 972-6382, by facsimile at (703) 305-8759, by mail addressed to the United States Patent and Trademark Office, Office of Public Records, Alexandria, VA 22313-1450 or via the Internet.

In addition, information on the status of the application, including the mailing date of Office actions and the dates of receipt of correspondence filed in the Office, may also be accessed via the Internet through the Patent Electronic Business Center at www.uspto.gov using the public side of the Patent Application Information and Retrieval (PAIR) system. The direct link to access this status information is currently http://pair.uspto.gov/. Prior to publication, such status information is confidential and may only be obtained by applicant using the private side of PAIR.

Further assistance in electronically accessing the publication, or about PAIR, is available by calling the Patent Electronic Business Center at 1-866-217-9197.

Office of Data Management, Application Assistance Unit (571) 272-4000, or (571) 272-4200, or 1-888-786-0101

<b>INFORMATION DISCLOSURE STATEMENT BY APPLICANT</b> ( Not for submission under 37 CFR 1.99)	Application Number		12137356	
	Filing Date		2008-06-11	
	First Named Inventor	Charles R. Quirico		
	Art Unit	3735		
	Examiner Name			
	Attorney Docket Number	56782.1.5		

U.S.PATENTS							Remove
Examiner Initial*	Cite No	Patent Number	Kind Code <sup>1</sup>	Issue Date	Name of Patentee or Applicant of cited Document	Pages,Columns,Lines where Relevant Passages or Relevant Figures Appear	
	1						

If you wish to add additional U.S. Patent citation information please click the Add button. Add

U.S.PATENT APPLICATION PUBLICATIONS							Remove
Examiner Initial*	Cite No	Publication Number	Kind Code <sup>1</sup>	Publication Date	Name of Patentee or Applicant of cited Document	Pages,Columns,Lines where Relevant Passages or Relevant Figures Appear	
	1	20030004463	A1	2003-01-02	Reilly		
	2	20070140958	A1	2007-06-21	DeKemp		

If you wish to add additional U.S. Published Application citation information please click the Add button. Add

FOREIGN PATENT DOCUMENTS								Remove
Examiner Initial*	Cite No	Foreign Document Number <sup>3</sup>	Country Code <sup>2</sup> j	Kind Code <sup>4</sup>	Publication Date	Name of Patentee or Applicant of cited Document	Pages,Columns,Lines where Relevant Passages or Relevant Figures Appear	T <sup>5</sup>
	1	9956117	WO		1999-11-04	General Hospital Corp		<input type="checkbox"/>
	2	20050002971	WO		2005-01-13	Iphase Technologies		<input type="checkbox"/>



**INFORMATION DISCLOSURE  
STATEMENT BY APPLICANT**  
( Not for submission under 37 CFR 1.99)

Application Number	12137356
Filing Date	2008-06-11
First Named Inventor	Charles R. Quirico
Art Unit	3735
Examiner Name	
Attorney Docket Number	56782.1.5

3	2006129301	WO		2006-12-07	Spec-Trum Dynamics	<input type="checkbox"/>
4	2008037939	WO		2008-04-03	Lemer Protection	<input type="checkbox"/>
5	2008082966	WO		2008-07-10	Medrad, Inc.	<input type="checkbox"/>
6	0160303	EP		1985-11-06	E.R. Squibb	<input type="checkbox"/>
7	0310148	EP		1989-04-05	E.R. Squibb	<input type="checkbox"/>
8	2867084	FR		2005-09-09	General Electric Company	<input type="checkbox"/>
9	2006325826	JP		2006-12-07	S.D. Giken	<input type="checkbox"/>
10	2000350783	JP		2000-12-19	Sumitomo Heavy Ind Ltd	<input type="checkbox"/>

If you wish to add additional Foreign Patent Document citation information please click the Add button

**NON-PATENT LITERATURE DOCUMENTS**

Examiner Initials*	Cite No	Include name of the author (in CAPITAL LETTERS), title of the article (when appropriate), title of the item (book, magazine, journal, serial, symposium, catalog, etc), date, pages(s), volume-issue number(s), publisher, city and/or country where published.	T <sup>5</sup>
	1		<input type="checkbox"/>

If you wish to add additional non-patent literature document citation information please click the Add button

<b>INFORMATION DISCLOSURE STATEMENT BY APPLICANT</b> ( Not for submission under 37 CFR 1.99)	Application Number	12137356
	Filing Date	2008-06-11
	First Named Inventor	Charles R. Quirico
	Art Unit	3735
	Examiner Name	
	Attorney Docket Number	56782.1.5

**EXAMINER SIGNATURE**

Examiner Signature		Date Considered	
--------------------	--	-----------------	--

\*EXAMINER: Initial if reference considered, whether or not citation is in conformance with MPEP 609. Draw line through a citation if not in conformance and not considered. Include copy of this form with next communication to applicant.

<sup>1</sup> See Kind Codes of USPTO Patent Documents at [www.USPTO.GOV](http://www.USPTO.GOV) or MPEP 901.04. <sup>2</sup> Enter office that issued the document, by the two-letter code (WIPO Standard ST.3). <sup>3</sup> For Japanese patent documents, the indication of the year of the reign of the Emperor must precede the serial number of the patent document. <sup>4</sup> Kind of document by the appropriate symbols as indicated on the document under WIPO Standard ST.16 if possible. <sup>5</sup> Applicant is to place a check mark here if English language translation is attached.

**INFORMATION DISCLOSURE  
STATEMENT BY APPLICANT**  
( Not for submission under 37 CFR 1.99)

Application Number	12137356
Filing Date	2008-06-11
First Named Inventor	Charles R. Quirico
Art Unit	3735
Examiner Name	
Attorney Docket Number	56782.1.5

**CERTIFICATION STATEMENT**

Please see 37 CFR 1.97 and 1.98 to make the appropriate selection(s):

That each item of information contained in the information disclosure statement was first cited in any communication from a foreign patent office in a counterpart foreign application not more than three months prior to the filing of the information disclosure statement. See 37 CFR 1.97(e)(1).

**OR**

That no item of information contained in the information disclosure statement was cited in a communication from a foreign patent office in a counterpart foreign application, and, to the knowledge of the person signing the certification after making reasonable inquiry, no item of information contained in the information disclosure statement was known to any individual designated in 37 CFR 1.56(c) more than three months prior to the filing of the information disclosure statement. See 37 CFR 1.97(e)(2).

See attached certification statement.

Fee set forth in 37 CFR 1.17 (p) has been submitted herewith.

None

**SIGNATURE**

A signature of the applicant or representative is required in accordance with CFR 1.33, 10.18. Please see CFR 1.4(d) for the form of the signature.

Signature	/Elisabeth L. Belden/	Date (YYYY-MM-DD)	2009-10-16
Name/Print	Elisabeth L. BELDEN	Registration Number	50,751

This collection of information is required by 37 CFR 1.97 and 1.98. The information is required to obtain or retain a benefit by the public which is to file (and by the USPTO to process) an application. Confidentiality is governed by 35 U.S.C. 122 and 37 CFR 1.14. This collection is estimated to take 1 hour to complete, including gathering, preparing and submitting the completed application form to the USPTO. Time will vary depending upon the individual case. Any comments on the amount of time you require to complete this form and/or suggestions for reducing this burden, should be sent to the Chief Information Officer, U.S. Patent and Trademark Office, U.S. Department of Commerce, P.O. Box 1450, Alexandria, VA 22313-1450. **DO NOT SEND FEES OR COMPLETED FORMS TO THIS ADDRESS. SEND TO: Commissioner for Patents, P.O. Box 1450, Alexandria, VA 22313-1450.**

## Privacy Act Statement

The Privacy Act of 1974 (P.L. 93-579) requires that you be given certain information in connection with your submission of the attached form related to a patent application or patent. Accordingly, pursuant to the requirements of the Act, please be advised that: (1) the general authority for the collection of this information is 35 U.S.C. 2(b)(2); (2) furnishing of the information solicited is voluntary; and (3) the principal purpose for which the information is used by the U.S. Patent and Trademark Office is to process and/or examine your submission related to a patent application or patent. If you do not furnish the requested information, the U.S. Patent and Trademark Office may not be able to process and/or examine your submission, which may result in termination of proceedings or abandonment of the application or expiration of the patent.

The information provided by you in this form will be subject to the following routine uses:

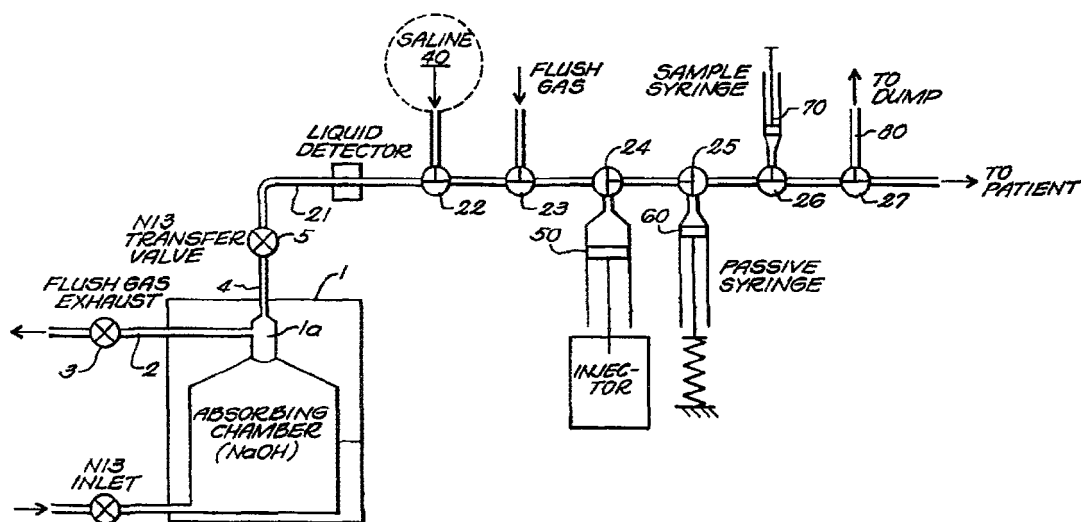
1. The information on this form will be treated confidentially to the extent allowed under the Freedom of Information Act (5 U.S.C. 552) and the Privacy Act (5 U.S.C. 552a). Records from this system of records may be disclosed to the Department of Justice to determine whether the Freedom of Information Act requires disclosure of these records.
2. A record from this system of records may be disclosed, as a routine use, in the course of presenting evidence to a court, magistrate, or administrative tribunal, including disclosures to opposing counsel in the course of settlement negotiations.
3. A record in this system of records may be disclosed, as a routine use, to a Member of Congress submitting a request involving an individual, to whom the record pertains, when the individual has requested assistance from the Member with respect to the subject matter of the record.
4. A record in this system of records may be disclosed, as a routine use, to a contractor of the Agency having need for the information in order to perform a contract. Recipients of information shall be required to comply with the requirements of the Privacy Act of 1974, as amended, pursuant to 5 U.S.C. 552a(m).
5. A record related to an International Application filed under the Patent Cooperation Treaty in this system of records may be disclosed, as a routine use, to the International Bureau of the World Intellectual Property Organization, pursuant to the Patent Cooperation Treaty.
6. A record in this system of records may be disclosed, as a routine use, to another federal agency for purposes of National Security review (35 U.S.C. 181) and for review pursuant to the Atomic Energy Act (42 U.S.C. 218(c)).
7. A record from this system of records may be disclosed, as a routine use, to the Administrator, General Services, or his/her designee, during an inspection of records conducted by GSA as part of that agency's responsibility to recommend improvements in records management practices and programs, under authority of 44 U.S.C. 2904 and 2906. Such disclosure shall be made in accordance with the GSA regulations governing inspection of records for this purpose, and any other relevant (i.e., GSA or Commerce) directive. Such disclosure shall not be used to make determinations about individuals.
8. A record from this system of records may be disclosed, as a routine use, to the public after either publication of the application pursuant to 35 U.S.C. 122(b) or issuance of a patent pursuant to 35 U.S.C. 151. Further, a record may be disclosed, subject to the limitations of 37 CFR 1.14, as a routine use, to the public if the record was filed in an application which became abandoned or in which the proceedings were terminated and which application is referenced by either a published application, an application open to public inspections or an issued patent.
9. A record from this system of records may be disclosed, as a routine use, to a Federal, State, or local law enforcement agency, if the USPTO becomes aware of a violation or potential violation of law or regulation.



## INTERNATIONAL APPLICATION PUBLISHED UNDER THE PATENT COOPERATION TREATY (PCT)

(51) International Patent Classification <sup>6</sup> : <b>G01N 24/00, 37/00</b>	<b>A1</b>	(11) International Publication Number: <b>WO 99/56117</b> (43) International Publication Date: 4 November 1999 (04.11.99)
<p>(21) International Application Number: PCT/US99/08981</p> <p>(22) International Filing Date: 26 April 1999 (26.04.99)</p> <p>(30) Priority Data: 60/083,133 27 April 1998 (27.04.98) US</p> <p>(63) Related by Continuation (CON) or Continuation-in-Part (CIP) to Earlier Application US 60/083,133 (CON) Filed on 27 April 1998 (27.04.98)</p> <p>(71) Applicant (for all designated States except US): THE GENERAL HOSPITAL CORPORATION [US/US]; 55 Fruit Street, Boston, MA 02114 (US).</p> <p>(72) Inventors; and (75) Inventors/Applicants (for US only): LAYFIELD, Dominick [US/US]; 53 Park Street, Somerville, MA 02143 (US). VENEGAS, José [US/US]; 12 Laurel Road, Swampscott, MA 01907 (US).</p> <p>(74) Agents: FALKOFF, Michael, I. et al.; Nutter, McClen- nen &amp; Fish, LLP, One International Place, Boston, MA 02110-2699 (US).</p>		<p>(81) Designated States: JP, US, European patent (AT, BE, CH, CY, DE, DK, ES, FI, FR, GB, GR, IE, IT, LU, MC, NL, PT, SE).</p> <p><b>Published</b> <i>With international search report.</i></p>

(54) Title: RADIATION HANDLING SYSTEM AND SET



(57) Abstract

A radioactive material such as an unstable isotopic gas is provided to a receiving chamber (1) directly from a source to form a purified or enriched bubble. The bubble is passed to a fluid handling set for preparation of the reagent or other delivery system. In an exemplary embodiment trace amounts of nitrogen-13 are concentrated in a receiving chamber and passed into a small bubble of carrier gas. The carrier gas is then delivered into a fluid handling set. The fluid handling set connects to a pressure syringe (50) and a passive syringe (60), and further includes a plurality of flushable valves (22-27) interconnected as a closed unit by tubing (21) to form a switchable or finite state flow network in which the pressure syringe may back flush the tubing, mix the isotope in a delivery liquid, and transfer the mixed liquid to an output for diagnostic imaging or other use.

**FOR THE PURPOSES OF INFORMATION ONLY**

Codes used to identify States party to the PCT on the front pages of pamphlets publishing international applications under the PCT.

<b>AL</b>	Albania	<b>ES</b>	Spain	<b>LS</b>	Lesotho	<b>SI</b>	Slovenia
<b>AM</b>	Armenia	<b>FI</b>	Finland	<b>LT</b>	Lithuania	<b>SK</b>	Slovakia
<b>AT</b>	Austria	<b>FR</b>	France	<b>LU</b>	Luxembourg	<b>SN</b>	Senegal
<b>AU</b>	Australia	<b>GA</b>	Gabon	<b>LV</b>	Latvia	<b>SZ</b>	Swaziland
<b>AZ</b>	Azerbaijan	<b>GB</b>	United Kingdom	<b>MC</b>	Monaco	<b>TD</b>	Chad
<b>BA</b>	Bosnia and Herzegovina	<b>GE</b>	Georgia	<b>MD</b>	Republic of Moldova	<b>TG</b>	Togo
<b>BB</b>	Barbados	<b>GH</b>	Ghana	<b>MG</b>	Madagascar	<b>TJ</b>	Tajikistan
<b>BE</b>	Belgium	<b>GN</b>	Guinea	<b>MK</b>	The former Yugoslav Republic of Macedonia	<b>TM</b>	Turkmenistan
<b>BF</b>	Burkina Faso	<b>GR</b>	Greece			<b>TR</b>	Turkey
<b>BG</b>	Bulgaria	<b>HU</b>	Hungary	<b>ML</b>	Mali	<b>TT</b>	Trinidad and Tobago
<b>BJ</b>	Benin	<b>IE</b>	Ireland	<b>MN</b>	Mongolia	<b>UA</b>	Ukraine
<b>BR</b>	Brazil	<b>IL</b>	Israel	<b>MR</b>	Mauritania	<b>UG</b>	Uganda
<b>BY</b>	Belarus	<b>IS</b>	Iceland	<b>MW</b>	Malawi	<b>US</b>	United States of America
<b>CA</b>	Canada	<b>IT</b>	Italy	<b>MX</b>	Mexico	<b>UZ</b>	Uzbekistan
<b>CF</b>	Central African Republic	<b>JP</b>	Japan	<b>NE</b>	Niger	<b>VN</b>	Viet Nam
<b>CG</b>	Congo	<b>KE</b>	Kenya	<b>NL</b>	Netherlands	<b>YU</b>	Yugoslavia
<b>CH</b>	Switzerland	<b>KG</b>	Kyrgyzstan	<b>NO</b>	Norway	<b>ZW</b>	Zimbabwe
<b>CI</b>	Côte d'Ivoire	<b>KP</b>	Democratic People's Republic of Korea	<b>NZ</b>	New Zealand		
<b>CM</b>	Cameroon			<b>PL</b>	Poland		
<b>CN</b>	China	<b>KR</b>	Republic of Korea	<b>PT</b>	Portugal		
<b>CU</b>	Cuba	<b>KZ</b>	Kazakstan	<b>RO</b>	Romania		
<b>CZ</b>	Czech Republic	<b>LC</b>	Saint Lucia	<b>RU</b>	Russian Federation		
<b>DE</b>	Germany	<b>LI</b>	Liechtenstein	<b>SD</b>	Sudan		
<b>DK</b>	Denmark	<b>LK</b>	Sri Lanka	<b>SE</b>	Sweden		
<b>EE</b>	Estonia	<b>LR</b>	Liberia	<b>SG</b>	Singapore		

## RADIATION HANDLING SYSTEM AND SET

## CROSS-REFERENCE TO RELATED APPLICATIONS

Not Applicable.

## STATEMENT REGARDING FEDERALLY SPONSORED RESEARCH

5 Not Applicable.

## BACKGROUND OF THE INVENTION

The present invention relates to the preparation and use of radioactive isotopes for biological purposes such as labeling, marking, imaging and diagnostics. Such applications generally utilize a single element containing minor amounts of an unstable isotope, which must be generally formed into a simple compound that is incorporated into a solution or reagent which undergoes a known or predictable interaction with the biological system being studied. Thus, for example, radionuclides are often added as labels to a substance that binds to a nucleic acid to indicate the presence of a particular substrate, termination or functional group. Similarly, materials which are taken up by particular biological systems may be labeled for treatment or imaging purposes. Aerosols or radio-labeled fluids may also be used for blood flow or lung function diagnostic imaging studies.

In general, it is necessary that radioactive materials be handled in such a way as to not expose the operator to radiation. Thus they are preferably handled under robotic control or automated conditions. It is desirable that the radioisotopes involved have a short half life, so as to automatically limit the exposure of the subject to radiation, and to facilitate proper disposal. However, materials with a short half life cannot be compounded in advance or stored for lengthy times. Such radionuclides must therefore be manufactured at or near to the site of intended use. In these cases the purification and preparation of the radionuclide in a suitable delivery system must also be accomplished locally. The brevity of the nuclide half life may further complicate its handling and processing. These factors have sometimes prevented the acceptance or use of otherwise worthwhile radionuclide-based procedures.

It would therefore be desirable to provide a convenient system for preparing radionuclides for biological use.

It would also be desirable to provide such a system for handling a radionuclide in an automated fashion without exposing the operator to radiation.

5 It would further be desirable to provide such a system useful for short-lived materials or small batches to enable the routine use of such materials in individual procedures.

#### SUMMARY OF THE INVENTION

10 These and other desirable features are achieved in a system in accordance with the present invention by providing a radioactive marker material such as an unstable isotopic gas to a receiving chamber directly from a source to undergo initial cleansing or concentration, and passing the material into a fluid handling set for automated preparation of the reagent or actual delivery system. In an exemplary embodiment, trace  
15 amounts of  $^{13}\text{N}$ , created by proton bombardment of a target at a cyclotron, pass to a receiving chamber, are cleansed and pass into a small bubble of carrier gas. The carrier gas is then delivered into a fluid handling set. The fluid handling set includes or connects to a pressure syringe and a passive syringe, and further includes a plurality of flushable valves interconnected by tubing in a closed unit to form a flow network in  
20 which the pressure syringe may back-flush the tubing, mix the isotope in a delivery liquid, and transfer the mixed liquid to an output for diagnostic imaging or other use. The fluid handling set, which is a closed and preferably sterile unit, may include the receiving chamber 1, and it mounts in a fixed console of operating motors and condition sensors to control the various steps of fluid handling and delivery, and to effect safety  
25 functions which enable the system to connect directly to a catheter or to a vascular injection system for use on human beings.

In a preferred embodiment, the receiving chamber 1 is substantially rigid, but has a region of limited or unidirectional compliance. The chamber receives a flow of trace



isotope in a bulk gas, operating to remove the bulk gas while the radionuclide accumulates in a bubble at the outlet port of the chamber. Compliance of the receiving chamber may be effected by means of an elastic wall tensioned against a rigid support such that the wall flexes outwardly under pressure to accommodate the inflow of carrier gas but may not bow inwardly. This maintains the chamber volume above a fixed minimum, and prevents liquid from leaving the chamber when suction is applied at the top. In an illustrative system, nitrogen-13 is generated by cyclotron bombardment of a target with accelerated particles, and when the target has attained a sufficient level of radioactivity, the sample is passed to the receiving chamber and the CO<sub>2</sub> with trace <sup>13</sup>NN is bubbled into a sodium hydroxide solution. The one-way compliant wall allows a large flow to be received and maintained under pressure to accommodate the different rates of carrier delivery and carrier removal effected at this stage. The CO<sub>2</sub> reacts with and is effectively taken up by the sodium hydroxide solution, while the desired nuclide concentrates at a gas-filled plenum at the top of the receiving chamber, where it is accessed at the outlet port using a closed sterile set to effect transfer, mixing and delivery in a form useful for medical imaging. The fluid handling set includes a plurality of three way valves or medical infusion stopcocks that are preconnected together via small bore tubing to form a flow path. Two of the stopcocks each have a third port, which are attached to syringe bodies. One operates as an active bidirectional pump, while various motors and sensors in the console operate and control the position of the stopcock handles to achieve transfer, mixing and delivery of the radionuclide.

#### BRIEF DESCRIPTION OF THE DRAWINGS

The invention will be more fully understood from the following detailed description taken in conjunction with the accompanying drawings, in which:

Figure 1 is a flow chart illustrating major steps of the preparation process of the present system:

Figure 1A illustrates the system showing representative components in use for positron emission tomography;

Figure 2 illustrates system architecture as applied to a nitrogen 13 radionuclide;

5

Figure 3 illustrates a preferred construction of a receiving chamber for the system of Figure 2;

Figures 4A through 4D illustrate details of valve operation and flow for transfer of the radionuclide into a fluid handling set of the present invention;

10

Figure 5 illustrates an operating console for the set of the invention;

Figures 5A-5C illustrate stopcock mounting and control blocks of the console for use with a closed sterile set; and

15

Figure 6 illustrates another embodiment of the system and set.

#### DETAILED DESCRIPTION OF THE DRAWINGS

20

In accordance with a principal aspect of the present invention, there is provided a system for automated and isolated handling of a hazardous material, such as a radionuclide, for biological or medical use. The system includes a sterile set defining the path of the nuclide from a source or process chamber to its end use which, in the illustrated embodiment, involves injection into a patient. Other potential end uses may include specialized labeling, microanalytic or synthesis applications. As shown in Figure 1 for a representative system, the radionuclide, which in this case is nitrogen-13, passes from a source to a conditioning or purification chamber 1 which produces a small mass or bubble of the concentrated radionuclide for delivery to the preparation portion 10 of the system. The preparation portion 10 dissolves the nuclide in

25

a saline solution for injection in a patient, and may directly inject the prepared solution into the patient.

By way of technical background for this embodiment, the use of nitrogen-13 in gaseous form for medical imaging procedures was pioneered at the Hammersmith Hospital, in London, several decades ago. The radionuclide is produced by bombardment in a cyclotron using a number of possible target systems and sweep gases. Further details may be found in the text Short-lived Radioactive Gases for Clinical Use of J. C. Clark and P. D. Buckingham (Butterworth, London and Boston) pp 190-200. That text is hereby incorporated herein by reference. Nitrogen-13 is only very slightly soluble in blood, and when injected in solution in the blood stream, quickly leaves the blood and accumulates at the blood-air exchange interface in the lung. Its decay creates positrons which may provide excellent three dimensional PET images of the lung, for evaluation of both perfusion and ventilation. However, the difficulties of using this radionuclide have effectively prevented its adoption in hospital settings. Much of the discussion below is applicable to other gaseous radionuclides such as oxygen-15, or radionuclides incorporated in a gaseous medium, or in a liquid with appropriate modifications. However, the preparation and use of nitrogen-13 presents a number of technical difficulties and will therefore be discussed more fully to illustrate aspects of a system and components of the present invention.

In accordance with a principal aspect of the present invention the source radionuclide is provided in a relatively crude or bulk form, for example in a sweep gas or target fluid from a cyclotron, or in other primitive or intermediate form, and flows through the system to directly enter the patient or be applied to some other sterile or purified application such as marking, analysis or synthesis of a pure product. As shown in Figure 1A it is generally contemplated that the system 20 will be a small cabinet, desktop or other stand-alone unit containing the sub-assemblies 1, 10 (Figure 1), and which attaches to the source and to the patient either directly or via a small intermediate assembly. For example, the unit 20 may connect to the source through a filtration unit or the like, and to the patient via an infusion line, port or pressurized timed injector or the

like. However, most preferably the connection to the source and to the patient are as direct as possible so that little dead space, wasted volume, delay time or regions of radiation exposure are interposed between the source and the patient.

As further shown in Figure 1A, the invention generally contemplates that the unit  
5 20 will be controlled as to several parameters discussed below by a connection to a keyboard/processor assembly 21. Also the specific nitrogen-13 embodiment is used in conjunction with an imaging or detection assembly 25. The assembly 25 of Figure 1A is a detector array which encircles the patient and is configured for positron emission tomography, to simultaneously detect the pair of annihilation photons emitted in opposite  
10 directions by positron-electron annihilations as the radionuclide decays. The detector 25 provides its detection signals to a processor for construction of a three dimensional image of the distribution of the positron-emitting radionuclide. Other suitable detectors include single-sided detector arrays, or even photographic plate cameras which register and record the received annihilation photons on a plate of film. However, a positron  
15 emission tomography (PET) instrument is the preferred detection instrument for the illustrated process.

Figure 2 illustrates functional component of the units 1, 10 of Figure 1. As shown, the unit 1 for carrying out preliminary cleansing or refinement of the radionuclide in this case includes an absorbing chamber through which the nitrogen-13  
20 bubbles to remove the CO<sub>2</sub> sweep or residual target gas as the material arrives from the cyclotron source. The absorbing chamber 1 is filled with sodium hydroxide solution and is shaped with an inverted funnel cap that channels unabsorbed gas upward to a plenum 1a at the top of the chamber. Plenum 1a connects on the one hand to an exhaust port 2 controlled by an exhaust valve 3 and, on the other hand, to an outlet port 4 controlled by  
25 transfer valve 5. The outlet port connects to the main process line 21 of the sub-assembly 10, which as noted above resides within the preparation console 20 (Figure 1A) forming an inlet thereof and extending therethrough to the patient or end use. As described further below, chamber 1 may also be located within the console 20.

As further shown in Figure 2, the functional flow control and handling units appearing in the preparation console 20 include in addition to the flow line 21 a plurality of sterile three-way valves or stopcocks 22,... 27 each of which has two of its three ports connected to the line 21, and its third port connected to an inlet, outlet or syringe. The distal end of line 21 forms the output path from console 20. Each of the stopcocks 22-27 may be identical, and advantageously the stopcocks together with tube 21 are connected together and initially provided as a closed and sterile unit packaged in a manner similar, for example, to a medical infusion set. Each stopcock thus has one "free" port which is connected to allow material to enter, leave, or be moved along line 21. These third ports are attached to a source of sterile saline fluid 40, an active injector syringe 50, a source of flush fluid, and a passive holding syringe 60. In addition, a sample syringe 70 connects at stopcock 26, and an outlet line 80 to a dump, or waste vessel, extends from stopcock 27. These elements may also be connected as part of the set, although, as will be understood from the discussion below, variations are possible. The function of the sample syringe may be implemented instead by providing a small plenum with a pierceable septum connected to the third port of stopcock 26, and the line 80 may simply terminate with a spike port for attaching to a suitable collection vessel or transfer mechanism.

As further illustrated in Figure 2, the passive syringe is spring loaded so that it is normally biased to a non-extended, closed or minimal volume configuration. Thus, when a pressurized flow appears along line 21 and is directed into the syringe 60 by stopcock 25, its piston moves outwardly to form an adaptive chamber that changes volume under pressure for receiving the fluid in the line 21.

In accordance with a principal aspect of the present invention, the sterile set 21 includes a set of connected stopcocks and a syringe 50 all configured to fit within the control console (described further below) and to be manipulated by servomotor elements therein to carry out the radionuclide preparation and delivery to the patient. In a representative preparation and delivery protocol, the stopcocks are set to positions such that one or more stopcocks block the inlet, outlet or intermediate portion of the set, while

one or more stopcocks are open to interconnect various portions of the path for receiving, preparing or delivering the radionuclide. In particular, the set 21 defines a finite state flow path formed of sterile single use disposable elements that fit within a console adapted to secure and control both sets of elements. Advantageously, the console 20 may be configured as a cabinet having separate compartments and which may, for example, be hinged to open for inserting and changing the set. In the prototype, the receiving chamber 1 is housed in the back half with its outlet line 4 (Figure 1A) connecting through the middle wall of the cabinet so that the fluid line 21 (Figure 2), runs through an array of stopcock or syringe receiving recesses and control elements laid out along a path in the front half of the cabinet.

In this embodiment, the apparatus is conveniently divided into those parts that do not contact the sterile solution, and those parts which do. The parts which contact the saline directly are sterile, and are assembled from disposable medical components. These include all of the tubing downstream of the liquid detector, the stopcocks, and the three syringes 50, 60, 70 which are disposable, and are to be replaced for each patient. These components are mounted on the front panel of the main unit, so that they can be changed quickly. The remaining parts of the system do not contact the saline, and may advantageously be made of reusable components. Thus the absorbing chamber 1, and the various solenoid valves and tubing that connect to it may be permanently installed. Preferably, the system is enclosed in a cabinet which is connected to a high flow-rate vacuum to maintain a steady flow into the cabinet through its small openings, so that any leaks of radioactivity within the system are contained and the radioactive material is removed.

The cabinet is divided into three compartments. The rear compartment, accessible via a rear door, contains the absorbing chamber and a dump tank. This compartment is watertight so that a catastrophic failure of the absorbing chamber will not result in escape of sodium hydroxide. A central compartment houses all of the electronics of the apparatus, and is protected from contact with any liquid that may leak from a failing component or connection. The front of the cabinet forms a door which

encloses the front panel, allowing easy access to components of the system that need to be changed frequently. Preferably the syringes mount on this panel.

Figure 3 shows a preferred construction for the receiving chamber 1, which may be formed of a strong medical grade polymer. As shown, the receiving vessel 1 is configured with a rigid housing 101 which may for example be formed of a hard plastic and having an interior with a major lower portion configured with a sloped roof leading to a chimney-like upper portion or outlet plenum 109 of defined volume. The vessel 101 is configured to fit on a magnetic base such as a stand having an internally mounted rotating permanent magnet driver mechanism positioned below the chamber support surface, and a magnetic stirring rod 107 is positioned in the bottom of the vessel 1. The main chamber communicates through a passage 102 to a secondary chamber 101a bounded by a flexible elastic membrane or wall 104 positioned over the passage 102. This serves as a compliant chamber; the membrane 104 bends outwardly as pressure increases in the chamber 1 and fluid flows through the passage into the secondary chamber. However, housing 101 is rigid and the passage 102 is relatively small, or else may consist of a number of small passages such that the wall below the flexible sheet 104 forms a perforated plate that supports the sheet and effectively prevents the sheet 104 from moving inwardly in response to negative pressure. This arrangement provides a stable volume within chamber 1, and accommodates a large influx of fluid so that when radioactive material from the cyclotron enters the inlet, a large bolus of material may be received, increasing the pressure and allowing the material to more effectively react in the absorbing chamber at the slower process rate of absorption therein. As discussed briefly above for the illustrated CO<sub>2</sub>/nitrogen-13 material, chamber 1 is filled with a sodium hydroxide solution and is gently stirred by a magnetic stirring rod, so the solution quickly reacts with and effectively removes all the CO<sub>2</sub> while the unreactive nitrogen tracer rises into the outlet plenum 109 at the top of the chamber.

Preferably, for this process, the plenum 109 is initially loaded with a small volume, e.g. a few cubic centimeters, of a carrier gas in which the nitrogen-13 is soluble. This carrier may, for example, be nitrous oxide or other suitable biocompatible

gas. It is also advantageous that the carrier be highly soluble in blood or aqueous solutions, so that as discussed further below, problems of bubble formation or potential danger of bends are avoided. Thus, operation of the receiving chamber 1 is such that the sweep gas or target predecessor material from the source is removed, and the cleansed or concentrated radionuclide resides in the plenum 109 with a carrier gas for transfer through the transfer valve to the flow path 21. The architecture of vessel 1 therefore retains the pocket of gas at the top of the chamber intact. In this way, no liquid infiltrates the tubing leading to the rest of the apparatus, where small droplets of liquid might cause false triggering of the liquid detector or blocking of the hydrophobic filter.

An important aspect of the design of the compliant compartment is that it is only compliant to positive volumes. That is, volume can be added to the chamber, but not withdrawn. Once the carbon dioxide is absorbed, and the bubble of nitrogen withdrawn, the membrane wall lies flat against the side wall of the chamber, and the chamber becomes rigid. Thus it is impossible to suck significant volumes of sodium hydroxide out of the absorbing chamber and into the rest of the system.

Skipping ahead to Figure 5, there is shown a representative front panel of the console assembly 20 with the radionuclide entry port and elements of the flow path 21 laid out thereon. As shown, the flow line 21 first passes through a liquid detector which detects the arrival of liquid in the flow line from the chamber 1 and provides a control signal used, as described further below, for switching the states of the various stopcocks and transporting the bubble of radionuclide through the processing stages of the preparation assembly 10.

As further shown in Figure 5 a hydrophobic filter 29b is placed in the flow line 21 as a barrier to entry of liquid from chamber 1 into the system 10. As shown, the fluid preparation line 21 or set, is positioned in the console 20 such that each of the stopcocks 22-27 fits within a corresponding receiving block 22a through 27a, and the injection syringe 50 and passive syringe 60 fit within a driver mounting 50a and a syringe support 60a, respectively. By way of example, the driver assembly for the injector syringe may be that of, or similar to, a manual or programmed contrast agent injector system capable



of operation to drive a standard disposable syringe at high pressures through one or more precisely timed and controlled displacements to inject preset doses or volumes into the vascular system of a patient. The mounting 60a for the passive syringe may include a spring-loaded or counter-weighted platform or pushing member against which the distal end of the plunger of the injection syringe rides, so that the biased member returns the piston to its upper position (as shown) when the state of the stopcocks allows flow and the pressure in line 21 drops below the spring bias threshold.

In the prototype embodiment, the injector drive consisted of a MedRad radiographic contrast injection instrument, and the remainder of the cabinet and control mechanism of unit 20 was built atop the injector mount so that the active syringe was conveniently located in immediate proximity to the other elements shown in Figure 2. The stopcock mounting assemblies were prepared as shown in Figures 5A through 5C, by constructing shaped plastic receiving blocks having recesses each shaped to accept a standard disposable stopcock assembly therein and to mount on a plate so that each stopcock engages a position reporting actuator mechanism, which turns the handle of the stopcock. The stopcock was placed into the housing with the handle facing forward and the housing was designed to grip the three fluid connecting stubs of the stopcock, thus securely holding the stopcock body in a fixed position that allowed stopcock position to be controlled to within about one degree. A molded coupling was used to connect the stopcock handle to a standard servomotor, which in turn was controlled by a microcontroller board connected via a serial line to a computer used to control the apparatus. The computer was programmed to control operation of the stopcocks to define different segments for receiving, transferring, mixing and delivering the material. It was also programmed to control the injection regimen of the syringe for delivery of prepared doses to the patient.

In the prototype embodiment, the servomotor assemblies were modified so that the output of an internal potentiometer was passed to an A/D converter on the microcontroller board, and this output was used to calibrate the stopcock positions and then continuously monitor the position of each stopcock. Control software in the

microprocessor with a graphical user interface allowed the user to set the position of the stopcock and displayed the position on the screen, signaling an alarm if a motor fails to drive a stopcock element to the programmed position. For preparing the nitrogen-13 tracer, the program was written to effect a sequence of control steps as described below, and delivery steps were controlled by using the injector both to control the preparation of the solution and the injection into the patient.

Figure 4 illustrates a particular sequence for transfer of the tracer bubble from the absorbing chamber 1 into the mixing syringe, which is performed by encapsulating the tracer bubble with a saline solution. In broad terms, the operating sequence proceeded as follows. Before gas is received from the cyclotron the system is readied for production. The tubing from the absorbing chamber is flushed with a gas and the remainder of the apparatus is flushed and filled with de-gassed saline solution. One suitable flush gas is nitrous oxide but many other gases may be used. The chief requirements are that the gas be biologically safe, soluble in water and be non-reactive with the reagents used (sodium hydroxide, in this case). The radioactive gas is then admitted to the absorbing chamber and is stirred with a magnetic stirrer until all carbon dioxide is absorbed. Stirring is performed gently to avoid generation of droplets which might clog the hydrophobic filter 29b (Figure 5). The bubble of remaining gas at the top of the absorbing chamber is then transferred to the injector syringe which is otherwise filled with an appropriate amount of de-gassed saline for the contemplated infusion regiment or for the amount or available radionuclide. The mixture in the injector is next dissolved by repeatedly ejecting it into the passive syringe allowing its return and again ejecting it, so that by the vigorous flow and atomizing action of ejection the tracer is quickly dissolved in the saline solution. This process of vigorous atomization mixing by repeated passage through a flow segment between syringes in a closed set thus effectively addresses the difficult problem of preparing the radionuclide solution in a manner that is both safe and quick.

Next, with the stopcocks reset to define a different flow segment, a sample of the injectate so prepared is expelled from the syringe into the sampling syringe 80. Preferably a pH sensor is also present in the apparatus downstream of the injector

syringe to detect any sodium hydroxide contamination which may have occurred, and to actuate a shutdown in that event. The strength of the prepared solution is determined and this data is entered in suitable program for the injection control or image processing. The stopcock configurations are again changed, and the injector then gives a rapid bolus  
5 of tracer solution along its output line into the patient.

Returning now to Figure 4, there is shown a representative sequence of states of the finite state flow segment operating sequence of the device, illustrating in this case the initial radionuclide transfer from the receiving chamber 1 into the preparation set 10. After the initial system preparation and cleansing in chamber 1 are completed, the state  
10 of the apparatus is as depicted in Figure 4A. The upstream tubing (on the left) of stopcock 22 is filled with flush gas and the downstream tubing (to the right) is filled with degassed saline. The syringe 50 is then operated to draw along line 21 so that, as shown in Figure 4B the bubble of radioactive gas is drawn out of the pocket 109 (Figure 3), and toward the injector syringe 50. Sodium hydroxide solution is also drawn out of the  
15 absorbing chamber 1 at the trailing edge of the bubble of carrier/tracer gas. A liquid detector 29a is installed in the assembly 10 about the line 21 just upstream of the first stopcock 22 to provide a signal when the sodium hydroxide reaches this point. The transfer valve (Figure 3) is then closed, and the controller moves the first stopcock (Figure 4C) to connect the saline reservoir and fill in behind the bubble with saline  
20 solution from the reservoir. The bubble of tracer is thus "encapsulated" by saline solution as shown in Figure 4D. This allows controlled transfer through the apparatus by operation of the injector syringe. A slight amount of tracer gas still residing in the first stopcock and liquid detector is wasted. However, it will be understood that all tubing interconnecting the various components in the processing section 10 is of small size  
25 (under one millimeter), of the type customarily used for transfer of small volumes of fluid, and thus the wasted tracer represents a very small proportion of the carrier/tracer bubble being processed.

After the bubble of gas is completely drawn into the injector syringe, the stopcocks are moved to define a new flow/transfer segment such that the injector outlet

communicates only with the adjacent passive syringe. The mixture is then vigorously expelled into the passive syringe, then again drawn back into the active syringe and re-expelled. This process of repeated ejection promotes dissolution of the gas in several ways. Firstly, the surface area of the interface is increased exponentially by atomizing the fluid and in subsequent ejections breaking bubbles of gas into many smaller bubbles. Secondly, the ejection occurs at elevated pressure, thus enhancing the mechanisms of diffusion. Finally, the strong current and highly turbulent flow during ejection mixes the liquid very well, reducing any concentration gradients that might otherwise limit the process.

After the mixing process is complete, the stopcocks are again repositioned and the syringe 50 is operated to expel to the dump a volume equal to the volume of gas originally drawn into the syringe. This assures that any undissolved gas is ejected from the system. The lines to the patient are then flushed with the prepared tracer solution, and a small (1 ml) sample is taken. For the illustrated system, the sample is used primarily to assess the activity of the solution, but it could be additionally analyzed to check the composition of the injectate, or when applied to other radionuclide systems could determine other relevant conditions or parameters.

The pH of the solution is preferably measured by a sensor installed on the line to the dump tank. Any sodium hydroxide contamination is detected at this point, before injection to a patient.

In the foregoing system, it is important that the solution injected into the patient not be super-saturated and not contain any gas bubbles. If the solution were super-saturated, there would be a risk that bubbles could spontaneously appear in the solution before infusion or that microbubbles of nitrogen would form in the bloodstream causing an artificially-induced form of decompression sickness ('the bends'). To assure that supersaturation does not occur, the volume of nitrogen withdrawn from the absorbing chamber is limited to that volume which is known to dissolve in the volume of saline being prepared, and following dissolution, the mixture is allowed to equilibrate at atmospheric pressure. Thus, even if the solution is super-saturated, excess gas will

diffuse out of the solution. Further, when, following the mixing described above, the volume at least as great as the volume of gas originally drawn in from the absorbing chamber is ejected from the top of the injector syringe to dump, both the excess undissolved gas and the gas that has come out of solution are expelled.

5            Preferably, an ultrasonic bubble detector is also installed on the line to the patient, as well as a bubble-trap filter. Prior to injection, the lines are flushed, and a final, visual check for microbubbles is performed.

10            Figure 6 illustrates another embodiment of the system and set of the present invention. In this embodiment, the compliance chamber or flexible-walled side chamber may be actively pressed. This may be done to assure complete return of the flexible wall, and thus further guard against expulsion of the sodium hydroxide solution. Furthermore, the stopcocks are located somewhat differently to provide a short direct infusion path to the patient, and to separate or shift other paths or path segments. As in the first embodiment, the pressure syringe is centrally located, and serves as a hub for  
15            drawing, expelling or moving fluid along the various segment defined by the states of the stopcock valves. Advantageously, the pressure syringe mounts vertically, so that it initially receives and segregates the gas, and subsequently expels residual bubbles to the dump.

20            For operation of the system, the saline may be drawn from a USP-standard infusion bag, and all parts of the apparatus that contact the solution are assembled using aseptic technique from sterile, disposable medical components. Microporous filters are installed on the line entering the system from the saline bag, and on the line out of the system to the patient. Preferably a batch of tracer solution is prepared before the batch intended for infusion, and a sample is assayed.

25            Preferably, the bolus infusion of tracer is given by the injector under computer control, with the computer programmed to accurately control the infusate volume and rate, to effectively synchronize with a PET camera, and to automatically adjust dosage as the tracer decays. However, preferably the hardware is designed so that if necessary, the injector can be disconnected and operated manually. In the prototype embodiment using

an existing, manually-operated contrast media injector, the addition of a microprocessor-based controller and other modifications made to the injector were such that all of its safety-features function normally, and when manually-operated, the injector was fundamentally the same device as an unmodified, FDA-approved original. The series  
5 architecture of the treatment vessel and mixing assembly, together with the unique bubble transfer mechanism and multiple redundant stops and operation safety checks thus forms a system that is safely interposed between a cyclotron target and the patient's vasculature. Repetitive ejection between syringes produces a highly effective mixing/solution mechanism using fungible disposables. Moreover, the provision of a closed, disposable  
10 set for handling and compounding the radionuclide in an automated negative pressure safety cabinet allows the operator to maintain a safe distance from radiation, and provides a convenient system for the remote handling and preparation of diverse medicines, reagents and tracer materials.

The invention has been described above in a particular application for receiving,  
15 preparing and injecting a gaseous radionuclide for pulmonary PET imaging. However, the unique remote handling, sterile mixing, and volumetric control achieved by the set and the operating console are applicable with slight changes to compounding and delivering medications, marking and synthesizing materials and other radiation-handling tasks. Thus, it should be understood that the invention is not to be limited by the  
20 particular embodiments shown and discussed above, but may take other forms and be embodied in diverse systems for preparing, reacting, formulating or delivering radionuclides or biologically active materials. The invention and its principals of operation being thus disclosed, one skilled in the art will appreciate further features and advantages of the invention, and will be lead to further variations and modifications of  
25 the invention. Accordingly, all such variations and modifications are considered to be within the spirit and scope of applicant's invention as defined by claims appended hereto and equivalents thereof. All publications and references cited herein are expressly incorporated herein by reference in their entirety.

**Claims**

1. A system for preparation and delivery of a biologically active, hazardous or radioactive fluid, the system comprising

5 a receiving system having a first port for receiving said fluid and a second port positioned for delivering said fluid

a fluid handling set including a syringe and a plurality of flushable valves interconnected as a closed unit by tubing extending to an outlet

10 the syringe connecting via said fluid handling set to said second port and to said outlet for drawing the fluid into the tubing and transferring said fluid to the outlet as a prepared liquid

and the fluid handling set being configured for operation of said valves to define a finite set of flow segments at different times in said set such that the syringe flushes, fills, prepares and delivers the prepared fluid without exposing the operator to radiation.

15 2. A system for preparation and delivery of a biologically active, hazardous or radioactive material such as a gas, the system comprising

a receiving chamber having a first port for receiving said fluid and a second port positioned for accessing an active gas present in said material

20 an operating assembly for mounting a fluid handling set including a pressure syringe, a passive syringe and a plurality of flushable valves interconnected as a closed unit by tubing such that the tubing connects to said second port, and the operating assembly being configured to secure and operate the pressure syringe and the plurality of valves in sequence such that the pressure syringe draws the material into the pressure syringe and  
25 transfers the material with liquid to said passive syringe so as to form a prepared liquid, and furtheroperating said valves to define a finite set of flow segments at different times in said set for flushing, filling, preparing and delivering the prepared liquid, to receive the material from a source and provide the prepared liquid to a patient.

3. A system for preparation and delivery of a biologically active, hazardous or radioactive material, the system comprising

a receiving chamber having a first port for receiving said material and a second port positioned for accumulating a desired portion of the material

5 a fluid handling set including a plurality of flushable valves interconnected as a closed unit by tubing and configured for automated remote operation of said valves to form a finite state flow path effective to receive and encapsulate said desired portion as a bubble, prepare said portion in a delivery liquid and transfer the delivery liquid to an output.

10 4. The system of claim 3, wherein said valves define flow segments at different times in said set for flushing, filling, preparing and delivering the material such that the set receives the material as a gas from a source and safely delivers the delivery liquid to the bloodstream of a patient.

15 5. The system of claim 4, wherein the fluid handling set includes a pressure syringe operable for drawing the material into the set, mixing the delivery liquid, and delivering the delivery liquid into the bloodstream of a patient.

20 6. The system of claim 3 or 4, wherein the system prepares a gaseous radionuclide for injection to perform positron emission tomographic images of the patient.

7. The system of claim 3, wherein the fluid handling set is sterile assembly and further comprises an active syringe connected to one of said valves, and a passive syringe connected to another of said valves for receiving liquid such that the set is operable to  
25 prepare said portion in said delivery liquid by ejecting said portion and delivery liquid from the active syringe into the passive syringe.

8. A system for sterile preparation of a fluid radionuclide for use, such system comprising a sterile flow set including an inlet, an outlet, a plurality of stopcocks arranged  
30 in a sequence along a flow line to define a plurality of fluid transport segments, and first



and second syringes connected to the flow line being operable to form a sterile liquid solution of said radionuclide while it remains in the flow set by repeated ejection from said first syringe to said second syringe and return to said first syringe.

5

9. A system according to claim 8, wherein the sterile flow set includes at least five stopcocks.

10

10. A system according to claim 8, wherein at least one of said syringes attaches directly to a port of one of the stopcocks.

15

11. A fluid handling set for use in receiving a hazardous fluid material and forming a delivery liquid, such set comprising a plurality of at least five stopcocks and tubing interconnecting said plurality of stopcocks to form a closed transport path for handling the hazardous fluid material, each stopcock further having a port for admitting material to or expelling material from said closed transport path.

20

12. A device for receiving a hazardous fluid material and forming a delivery liquid such as a reagent, medicine or imaging agent containing said fluid material, such device comprising

a plurality of stopcock receptacles arranged along a path,

a corresponding plurality of servomotors positioned and configured for individually controlling a stopcock each being positioned in one of the receptacles,

a syringe driver, and

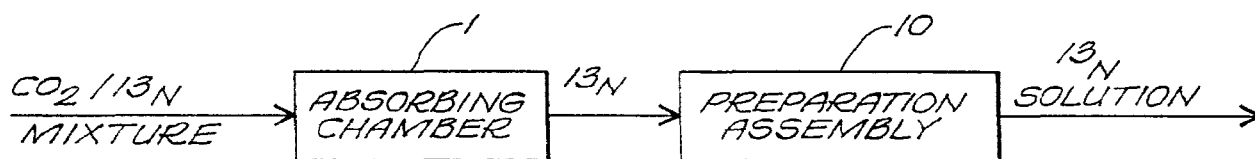
25

a controller operative to control said servomotors to form a set of flow segments along a closed transport path for handling the hazardous fluid material, and to control said syringe driver to drive a syringe so that the syringe draws said fluid material into the transport path and moves the fluid material along ones of said flow segments so as to prepare and deliver the delivery fluid.

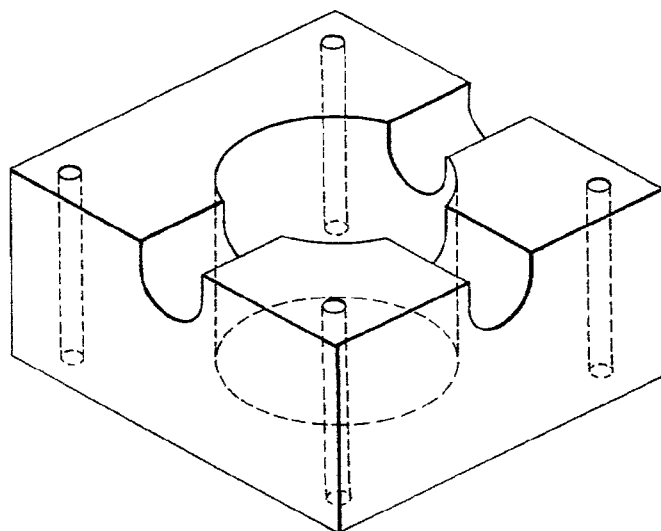
30

13. The device of claim 12, further comprising a flow set including a plurality of stopcocks interconnected by tubing to form a sterile flow path, an active syringe connected to said flow path, and a passive syringe connected to said flow path.

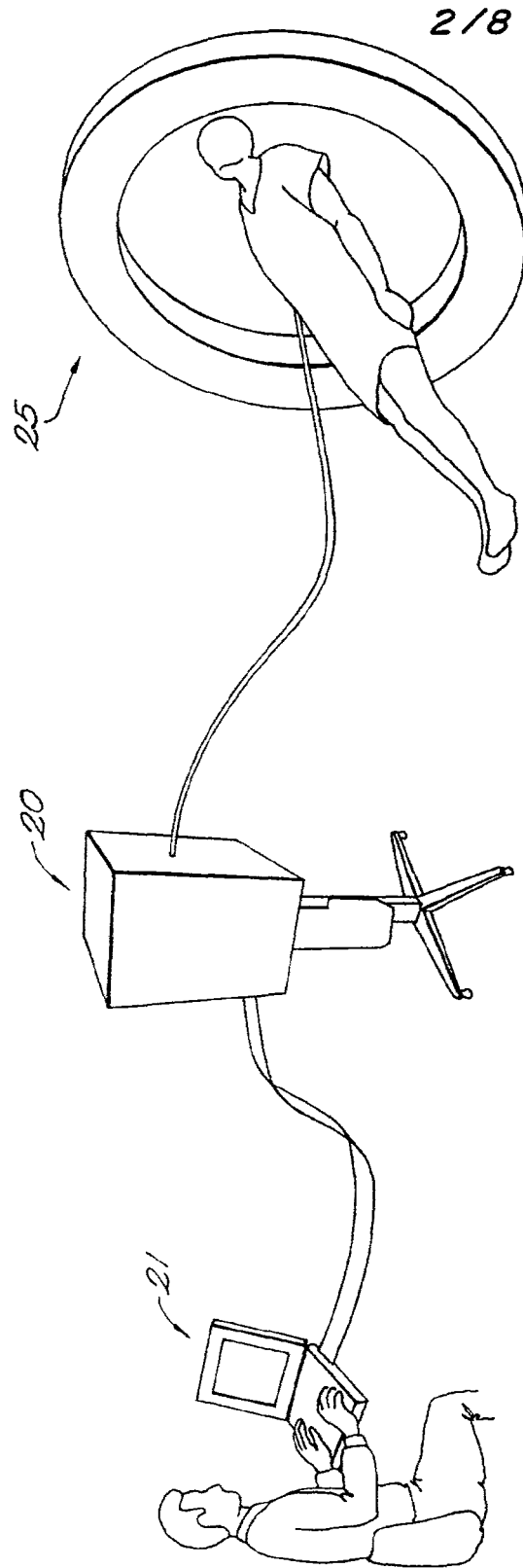
5 14. The device of claim 13, wherein the controller is operative to control said servomotors to define a path between the active syringe and the passive syringe, and to prepare the fluid material by repeated ejection of the material from the active syringe to the passive syringe.



**FIG. 1**



**FIG. 5A**



**FIG. 1A**

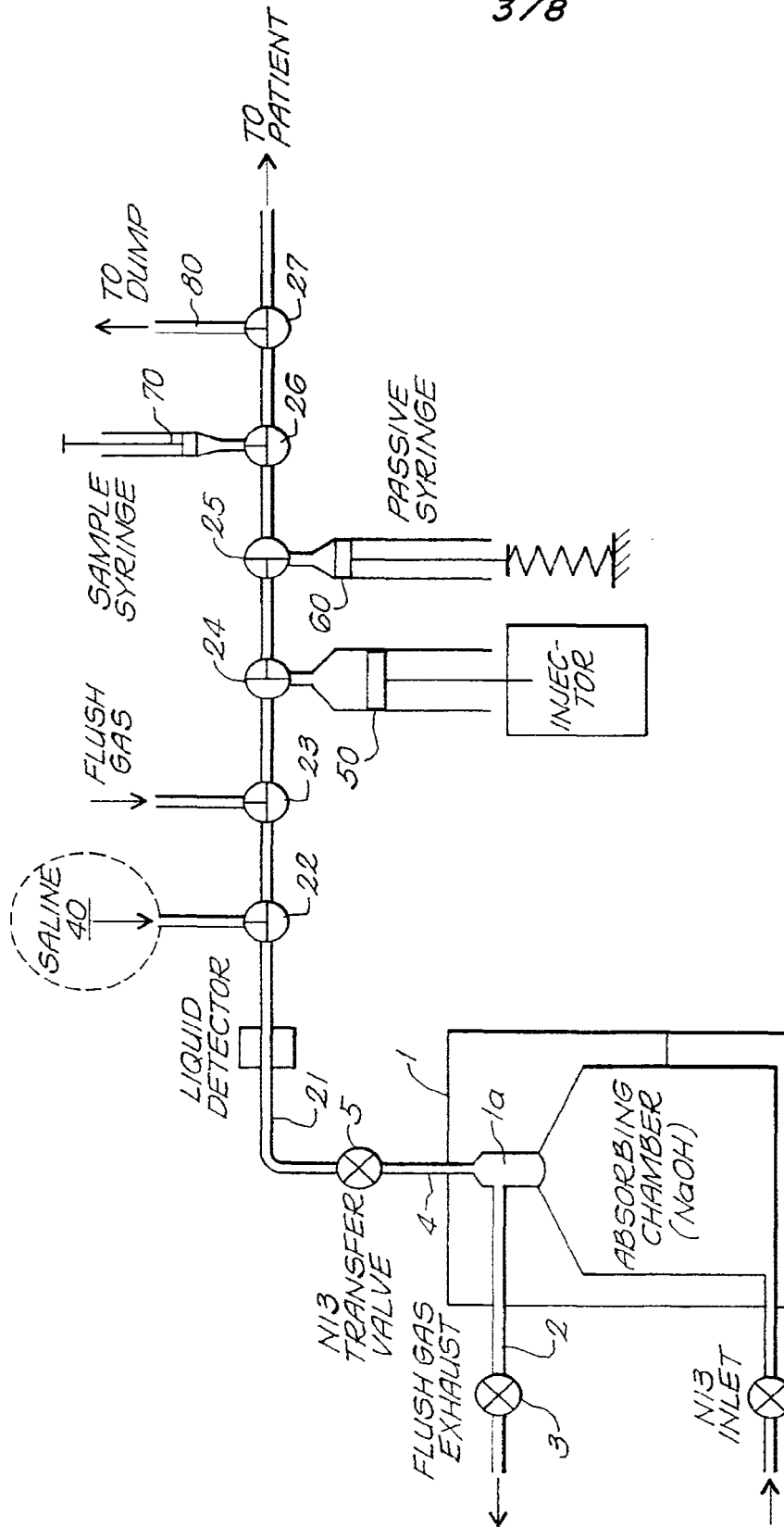


FIG. 2

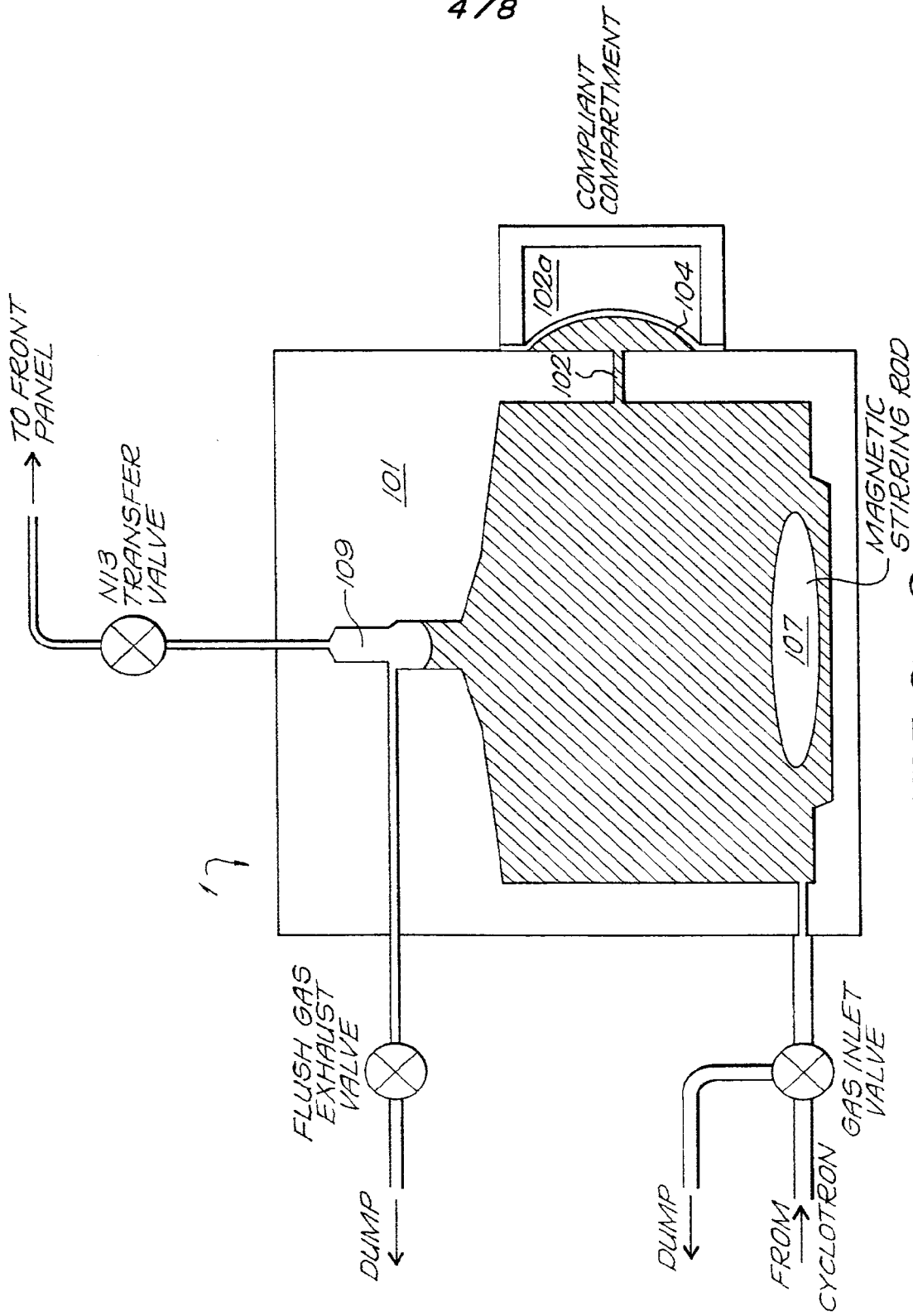
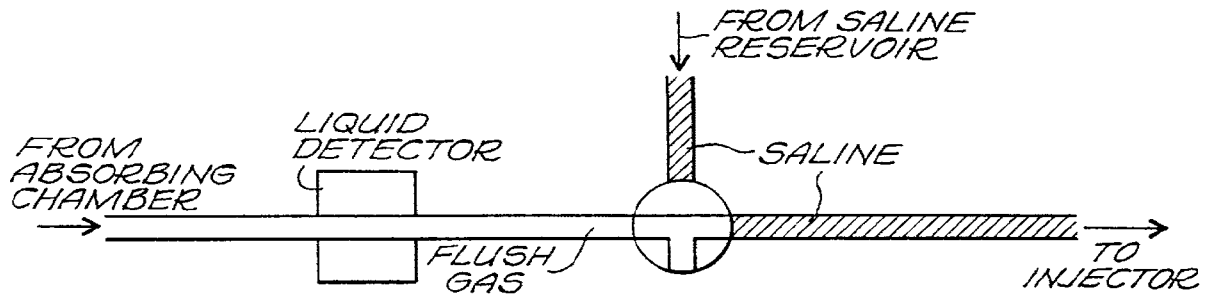
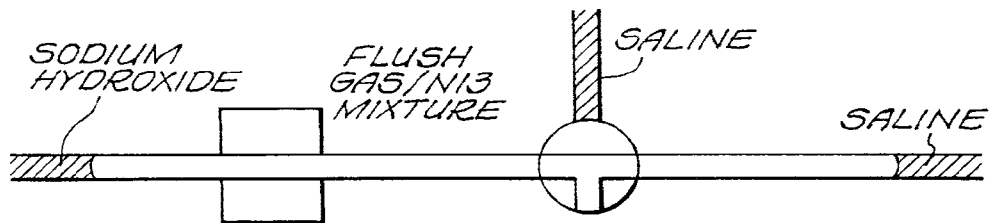


FIG. 3

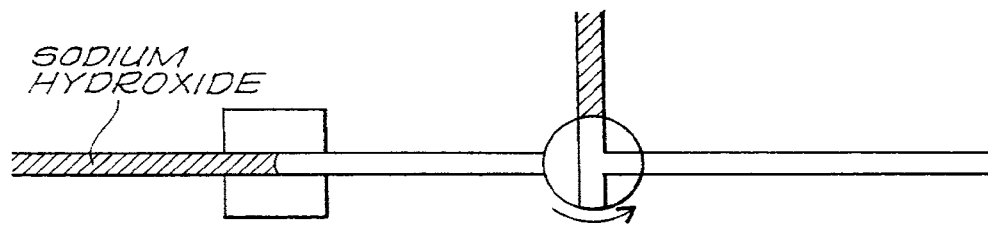
5 / 8



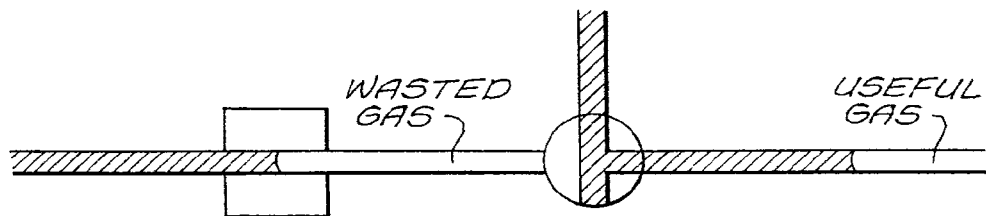
**FIG. 4A**



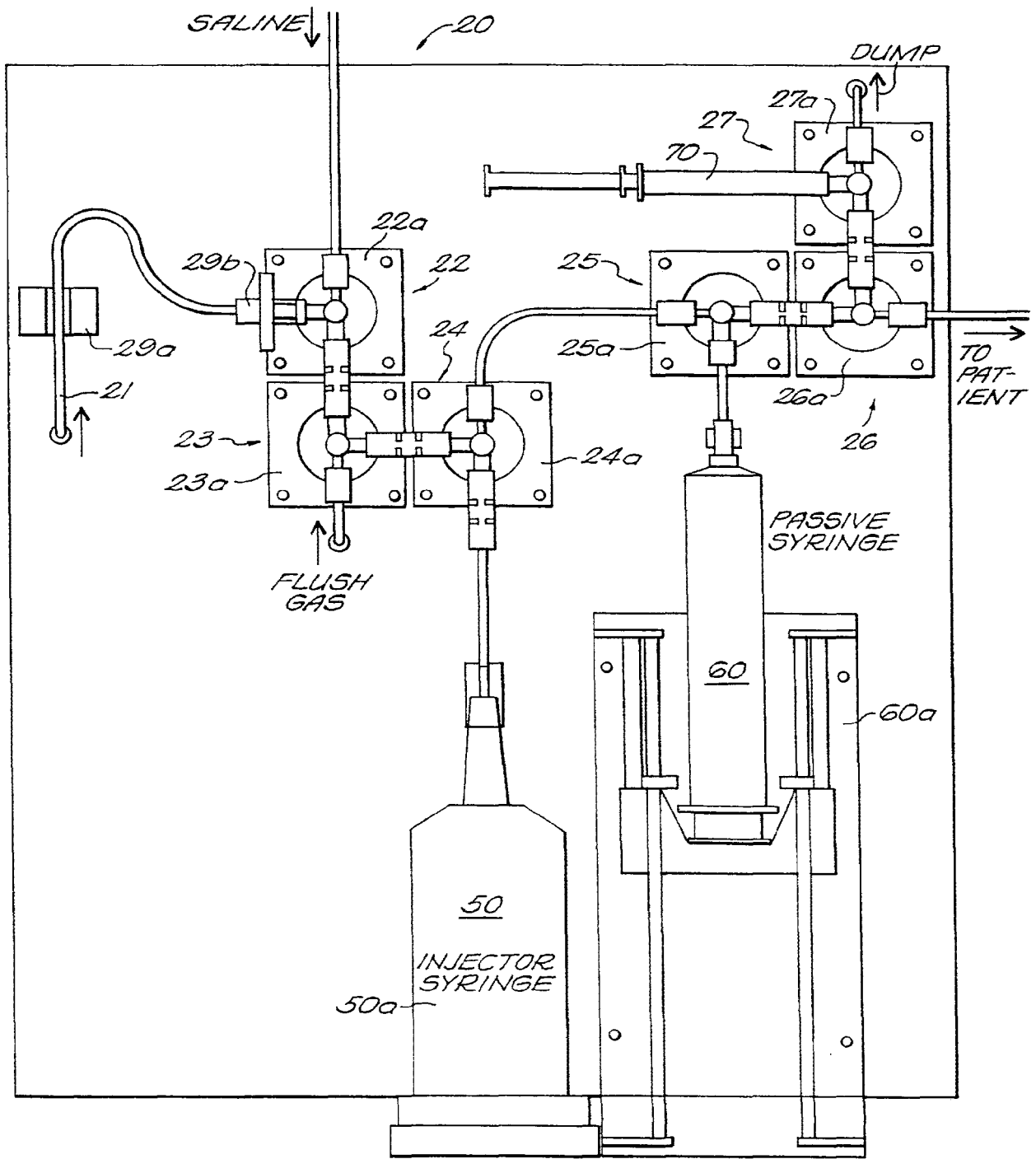
**FIG. 4B**



**FIG. 4C**



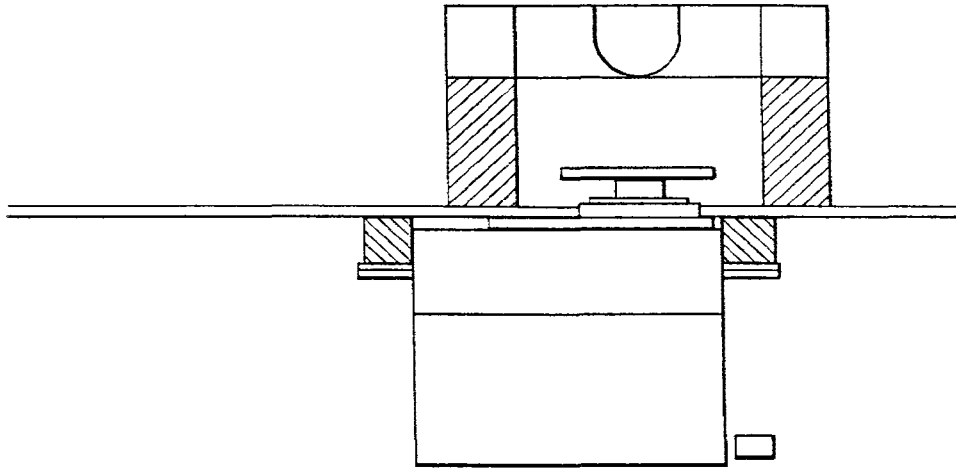
**FIG. 4D**



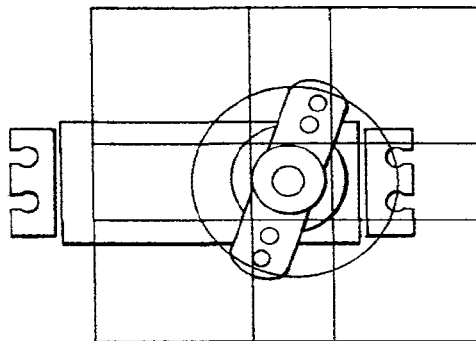
**FIG. 5**



7/8



*FIG. 5B*



*FIG. 5C*

8 / 8

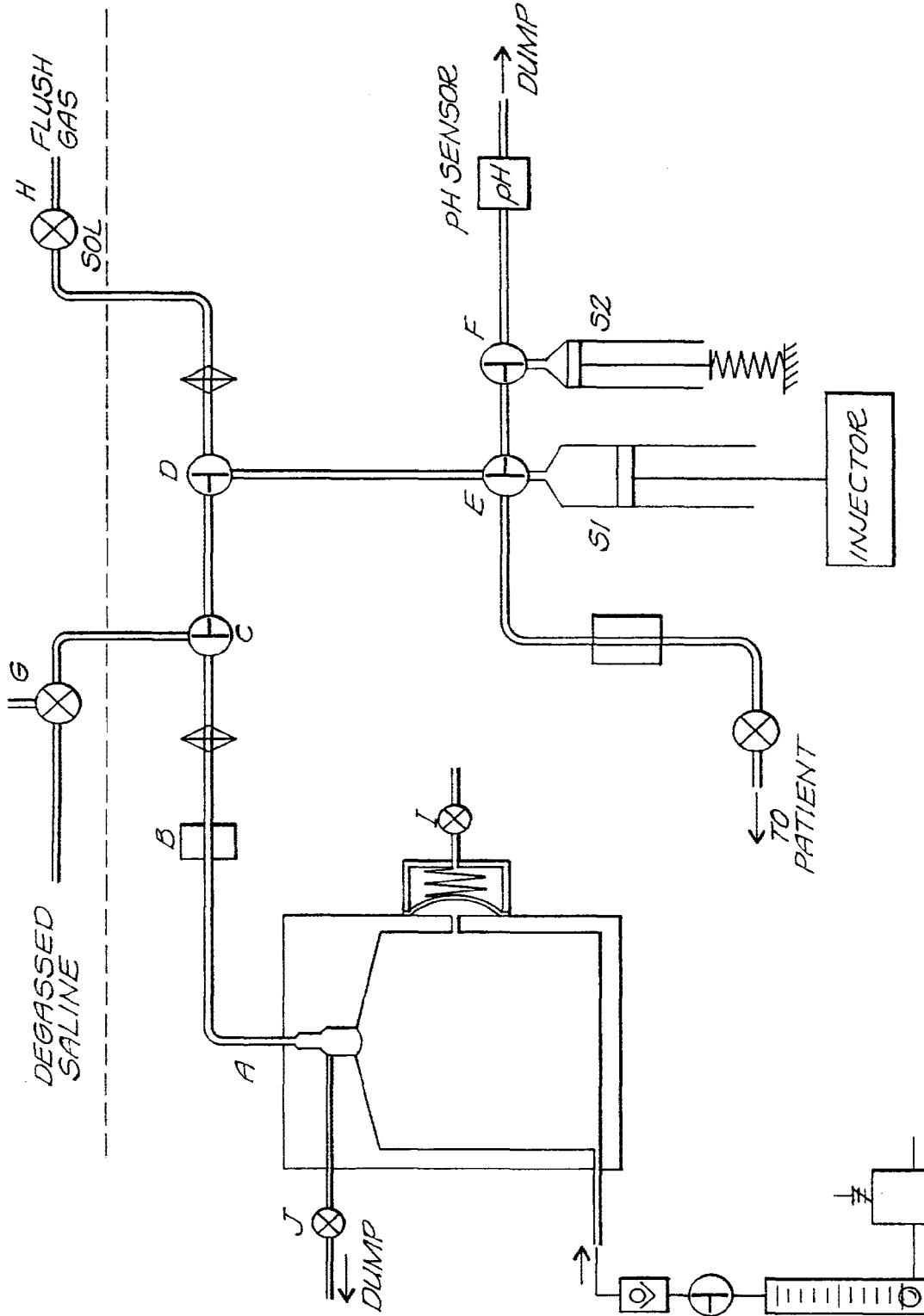


FIG. 6

INTERNATIONAL SEARCH REPORT

International application No.  
PCT/US99/08981

A. CLASSIFICATION OF SUBJECT MATTER

IPC(6) :G01N 24/00, 37/00  
US CL :436/57, 174, 180; 422/81, 100, 903  
According to International Patent Classification (IPC) or to both national classification and IPC

B. FIELDS SEARCHED

Minimum documentation searched (classification system followed by classification symbols)  
U.S. : 436/57, 174, 180; 422/81, 100, 903

Documentation searched other than minimum documentation to the extent that such documents are included in the fields searched

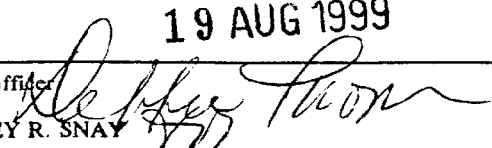
Electronic data base consulted during the international search (name of data base and, where practicable, search terms used)

C. DOCUMENTS CONSIDERED TO BE RELEVANT

Category*	Citation of document, with indication, where appropriate, of the relevant passages	Relevant to claim No.
A	US 5,482,865 A (FERRIERI et al) 09 January 1996, entire document.	1-14
A	US 5,514,071 A (SIELAFF, JR. et al) 07 May 1996, entire document.	1-14
A	US 5,468,355 A (SHEFER et al) 21 November 1995, entire document.	1-14
A	US 5,223,434 A (KANNO et al) 29 June 1993, entire document.	1-14

Further documents are listed in the continuation of Box C.  See patent family annex.

* Special categories of cited documents:	"T" later document published after the international filing date or priority date and not in conflict with the application but cited to understand the principle or theory underlying the invention
"A" document defining the general state of the art which is not considered to be of particular relevance	"X" document of particular relevance; the claimed invention cannot be considered novel or cannot be considered to involve an inventive step when the document is taken alone
"E" earlier document published on or after the international filing date	"Y" document of particular relevance; the claimed invention cannot be considered to involve an inventive step when the document is combined with one or more other such documents, such combination being obvious to a person skilled in the art
"L" document which may throw doubts on priority claim(s) or which is cited to establish the publication date of another citation or other special reason (as specified)	"&" document member of the same patent family
"O" document referring to an oral disclosure, use, exhibition or other means	
"P" document published prior to the international filing date but later than the priority date claimed	

Date of the actual completion of the international search 19 JULY 1999	Date of mailing of the international search report 19 AUG 1999
Name and mailing address of the ISA/US Commissioner of Patents and Trademarks Box PCT Washington, D.C. 20231 Facsimile No. (703) 305-3230	Authorized officer  JEFFREY R. SNAY Telephone No. (703) 305-0661

(19) World Intellectual Property Organization  
International Bureau



(43) International Publication Date  
13 January 2005 (13.01.2005)

PCT

(10) International Publication Number  
WO 2005/002971 A1

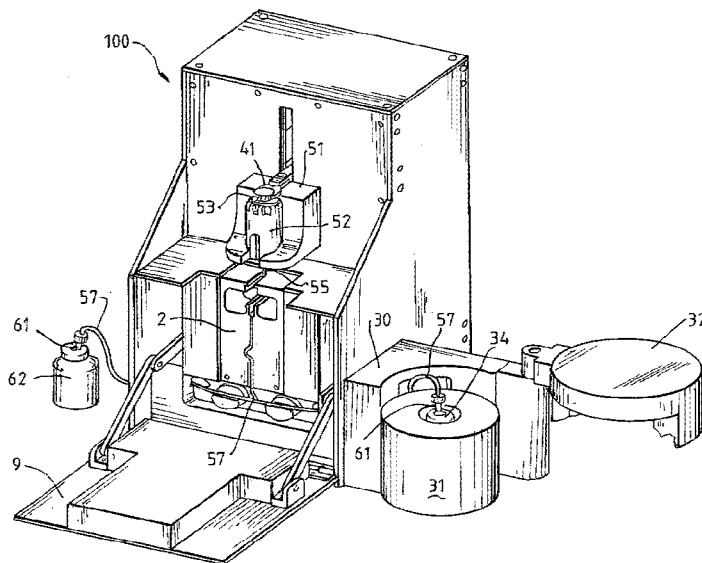
- (51) International Patent Classification<sup>7</sup>: **B65B 3/30**
- (21) International Application Number: PCT/AU2004/000897
- (22) International Filing Date: 2 July 2004 (02.07.2004)
- (25) Filing Language: English
- (26) Publication Language: English
- (30) Priority Data: 2003903404 2 July 2003 (02.07.2003) AU
- (71) Applicant (for all designated States except US): **IPHASE TECHNOLOGIES PTY. LIMITED** [AU/AU]; 428 Waverley Road, Mount Waverley, VIC 3149 (AU).
- (72) Inventors; and
- (75) Inventors/Applicants (for US only): **TOCHON-DAN-GUY, Henri-Jacques** [FR/AU]; 17 Thompson Drive, Rosanna, VIC 3084 (AU). **PONIGER, Stanislaw, Samuel** [AU/AU]; 428 Waverley Road, Mount Waverley, VIC 3149 (AU).
- (74) Agent: **A TATLOCK & ASSOCIATES**; PO Box 155, Carlton South, VIC 3053 (AU).
- (81) Designated States (unless otherwise indicated, for every kind of national protection available): AE, AG, AL, AM, AT, AU, AZ, BA, BB, BG, BR, BW, BY, BZ, CA, CH, CN, CO, CR, CU, CZ, DE, DK, DM, DZ, EC, EE, EG, ES, FI, GB, GD, GE, GH, GM, HR, HU, ID, IL, IN, IS, JP, KE, KG, KP, KR, KZ, LC, LK, LR, LS, LT, LU, LV, MA, MD, MG, MK, MN, MW, MX, MZ, NA, NI, NO, NZ, OM, PG, PH, PL, PT, RO, RU, SC, SD, SE, SG, SK, SL, SY, TJ, TM, TN, TR, TT, TZ, UA, UG, US, UZ, VC, VN, YU, ZA, ZM, ZW.
- (84) Designated States (unless otherwise indicated, for every kind of regional protection available): ARIPO (BW, GH, GM, KE, LS, MW, MZ, NA, SD, SL, SZ, TZ, UG, ZM, ZW), Eurasian (AM, AZ, BY, KG, KZ, MD, RU, TJ, TM), European (AT, BE, BG, CH, CY, CZ, DE, DK, EE, ES, FI, FR, GB, GR, HU, IE, IT, LU, MC, NL, PL, PT, RO, SE, SI, SK, TR), OAPI (BF, BJ, CF, CG, CI, CM, GA, GN, GQ, GW, ML, MR, NE, SN, TD, TG).

**Declarations under Rule 4.17:**

— as to applicant's entitlement to apply for and be granted a patent (Rule 4.17(ii)) for the following designations AE, AG, AL, AM, AT, AU, AZ, BA, BB, BG, BR, BW, BY, BZ, CA, CH, CN, CO, CR, CU, CZ, DE, DK, DM, DZ, EC, EE, EG, ES, FI, GB, GD, GE, GH, GM, HR, HU, ID, IL, IN, IS,

[Continued on next page]

(54) Title: PROCESS AND DEVICE FOR THE DOSE DISPENSING OF A RADIOACTIVE SOLUTION



(57) Abstract: A method of and a device (100) for automatically dispensing radioactive doses by filling a container (53), being a vial or disposable syringe, with a required radioactive dose in a sterile environment, the device (100) being stand alone and radiation shielded. The device (100) further includes control means to accurately dispense and dilute the requested radioactive dose using an on-line radioactivity measurement without any need for knowledge of the volumetric radioactivity of the stock solution.

WO 2005/002971 A1



JP, KE, KG, KP, KR, KZ, LC, LK, LR, LS, LT, LU, LV, MA, MD, MG, MK, MN, MW, MX, MZ, NA, NI, NO, NZ, OM, PG, PH, PL, PT, RO, RU, SC, SD, SE, SG, SK, SL, SY, TJ, TM, TN, TR, TT, TZ, UA, UG, UZ, VC, VN, YU, ZA, ZM, ZW, ARIPO patent (BW, GH, GM, KE, LS, MW, MZ, NA, SD, SL, SZ, TZ, UG, ZM, ZW), Eurasian patent (AM, AZ, BY, KG, KZ, MD, RU, TJ, TM), European patent (AT, BE, BG, CH, CY, CZ, DE, DK, EE, ES, FI, FR, GB, GR, HU, IE, IT, LU, MC, NL, PL, PT, RO, SE, SI, SK, TR), OAPI patent (BF, BJ, CF, CG, CI, CM, GA, GN, GQ, GW, ML, MR, NE, SN, TD, TG)

- as to the applicant's entitlement to claim the priority of the earlier application (Rule 4.17(iii)) for the following designations AE, AG, AL, AM, AT, AU, AZ, BA, BB, BG, BR, BW, BY, BZ, CA, CH, CN, CO, CR, CU, CZ, DE, DK, DM, DZ, EC, EE, EG, ES, FI, GB, GD, GE, GH, GM, HR, HU, ID, IL, IN, IS, JP, KE, KG, KP, KR, KZ, LC, LK, LR, LS, LT, LU, LV, MA, MD, MG, MK, MN, MW, MX, MZ, NA, NI, NO, NZ,

OM, PG, PH, PL, PT, RO, RU, SC, SD, SE, SG, SK, SL, SY, TJ, TM, TN, TR, TT, TZ, UA, UG, UZ, VC, VN, YU, ZA, ZM, ZW, ARIPO patent (BW, GH, GM, KE, LS, MW, MZ, NA, SD, SL, SZ, TZ, UG, ZM, ZW), Eurasian patent (AM, AZ, BY, KG, KZ, MD, RU, TJ, TM), European patent (AT, BE, BG, CH, CY, CZ, DE, DK, EE, ES, FI, FR, GB, GR, HU, IE, IT, LU, MC, NL, PL, PT, RO, SE, SI, SK, TR), OAPI patent (BF, BJ, CF, CG, CI, CM, GA, GN, GQ, GW, ML, MR, NE, SN, TD, TG)

- of inventorship (Rule 4.17(iv)) for US only

**Published:**

- with international search report

For two-letter codes and other abbreviations, refer to the "Guidance Notes on Codes and Abbreviations" appearing at the beginning of each regular issue of the PCT Gazette.

## **PROCESS AND DEVICE FOR THE DOSE DISPENSING OF A RADIOACTIVE SOLUTION**

### **Area Of The Invention**

This invention relates to apparatus used in nuclear medicine and in particular to a means whereby a radioactive dose required can be provided to a syringe in an automated fashion which obviates the need for a person to actually handle the radioactive material.

### **Background To The Invention**

Radioactive solutions called radiotracers or radiopharmaceuticals, have found applications in various medical fields, in particular in medical diagnostic and therapeutic fields. In recent years the advance of Positron Emission Tomography (PET), which use radionuclides (radioisotopes) of significant higher radiation energy than more conventional nuclear medicine isotopes, has raised some concerns about hand and body radiation exposure received by the persons preparing the dose.

The dangers of ionising radiation are well known and apply to all persons being exposed to radiation, including the staff involved in the preparation of radioactive solutions. Dose fractionation of the radioactive solutions is usually a manual process, performed behind a lead shielded screen to minimal exposure to radiation. However, the performance of this task is time consuming, as the operator needs to withdraw

by successive iterations, small volumes of the radiotracer, until he reaches the targeted dose.

After each withdrawal the needle needs to be re-capped and the syringe placed in a dose calibrator to determine if more or less of the radioactive solution should be processed in or out of the syringe. When the targeted dose has been achieved (within  $\pm 10\%$ ), the syringe may be topped up with saline to obtain a reasonable volume.

Before being released or dispatched for clinical use, the syringe is placed again in the dose calibrator to print out the accurate dose record. To date, very little attempt has been made by manufacturers to design automated equipment capable of withdrawing a dedicated radioactive dose into a disposable sterile syringe or vial.

The very few systems currently on the market are expensive and bulky and are not widely available. Other more affordable systems are either not technically practical or do not achieve efficient radiation protection and need to be operated in a shielded environment. In addition, most of these apparatus rely on the pre-requisite knowledge of the volumetric radioactivity (Ci/mL or Bq/mL) of the stock solution to determine the corresponding volume and hence the radioactive dose to be dispensed.

### **Outline of The Invention**

It is an object of this invention to provide an accurate means of automatically dispensing individual doses of a radioactive solution into vials or syringes under

aseptically controlled conditions while minimising the exposure to radiation of an operator which would otherwise be associated with the manipulation of radioactive solutions.

The invention in one aspect is a radioactive dose dispensing device for automatically filling a container with a required radioactive dose in a sterile environment, said device being stand alone and radiation shielded and including control means to control a mix of radioactive stock solution and dilution stock solution, the radioactivity of which mix is monitored by radiation detection means.

The invention in a second aspect is a method of automatically dispensing a dose of a radioactive solution using a software controlled lead shielded device which includes the steps of

- providing the device with a radioactive stock solution and a dilution stock solution
- using a computer software interface to the device to control the dose dispensed automatically into a syringe or vial in the device.

It is preferred that the radioactive dose dispensing device be used for filling a disposable syringe. It is further preferred that a shielded receptacle be provided to receive the syringe.



It is also preferred that a fork shaped arm be provided to actuate the plunger of the disposable shielded syringe. It is further preferred that a high precision linear drive mechanism to move either the syringe or its plunger in a vertical direction.

It is preferred that a customised disposable T shaped tubing assembly be used to provide a sterile fluid pathway. It is further preferred that pinch valves be provided to switch between the radioactive stock solution and the dilution stock solution.

It is also preferred that the automation of the device be controlled by a programmable logic controller (PLC) in association with a radiation detector which monitors on-line the radioactive dose passing through the tubing and being dispensed into the syringe.

It is further preferred that the PLC controls the automation tasks and relevant mathematical calculations for dispensing a requisite dose and that this be operable by computer means with an associated printer although any desired arrangement could be used.

In order that the invention may be more readily understood an embodiment of it will be described herein by way of non limiting example with reference to the accompanying drawings

### **Brief Description Of The Drawing Figures**

Fig. 1 Shows a perspective view of the components of the radioactive dose dispensing device of the invention in its "open" orientation;

- Fig. 2 Shows a cross-section through the device of the invention as shown in Figure 1.;
- Fig. 3 Shows the pre assembled sterile disposable tubing kit used in the device;
- Fig. 4 Shows the device of the invention in its "closed" orientation;

### **Brief Description of an Embodiment of the Invention**

The invention 100 in one embodiment is a device for the automatic filling of disposable syringes with a radioactive solution (radiopharmaceutical) for injection or infusion into a patient.

The device 100 is a stand alone equipment that does not require any additional lead shielding and can be directly used on a bench or inside a conventional, unshielded, laminar flow cabinet.

The device includes a concave lead block 30 and a swinging lead lid 32 designed to accommodate standard lead shielded pots 31 commonly used for the transport of radioactive solutions. It also includes a receptacle 51 that can accommodate various shapes of commercially available tungsten syringe shields and provides an easy and safe installation of the syringe shield 52.

The device further includes a fork-shape arm 41 that can hold or release the plunger of the syringe and an electro-actuator that can link the linear drive 36 to the receptacle 51, and drive up/down the syringe and its needle 55 to pierce the Luer Slip Injection Site 59.

The device provides a permanent link between the linear drive 36 and the fork-shape arm 41 and allows both the radioactive solution and the diluting solution to be drawn at a constant fluid flow rate through the tubing and into the syringe.

The Luer Slip Injection Site 59 is attached to the upper tubing assembly and two Luer-lock fittings 61 (with needles) are attached to the lower tubes assembly (see Fig.3 for view of the pre-assembled sterile disposable kit).

The tubing assembly is held in its appropriate position by a small groove and a dedicated shaped recess 2 to accurately position the Luer Slip Injection Site 59, in regard to the needle 55.

The device is provided with both radioactive and diluting stock solutions which are dispensed from their respective vials 34 and 62, up to the syringe by passing through a disposable, sterile and non-pyrogenic fluid pathway with the radioactive amount controlled by a radiation detector 63, which in this embodiment of the invention is a Geiger-Muller tube or PIN photodiode and located behind a portion of the tube assembly leading to the injection site (behind the plate holder 2).

The device is automated via a programmable PLC and is connected to a computer serving as a user interface, and preferably is provided with a printer to print the syringe or vial label showing the activity, date, time, batch, patient name, etc. or whatever may be required.

The dispensing of the radioactive dose is done on-line by measuring the true amount of radioactivity passing in front of the radiation detector 63 and the total volume required into the syringe is automatically adjusted by dilution.

The device also includes a safety cross-evaluation of the delivered radioactive dose which is automatically performed using the traditional volumetric dispensing method, and the volumetric method can also be used as the main dispensing method.

It is further envisaged that the device of the invention may include a built-in sterile air flow, designed to allow the device to be operated on a bench in a conventional room but still maintaining full compliance with a 3.5 class (A class) dispensing environment, characterized by a sterile air flow directed towards the Luer Slip Injection Site 59 and needle 55.

It is also envisaged that in another embodiment of the invention a sterile disposable double check-valve could be located between the syringe 53 and needle 55, or underneath the Luer Slip Injection Site 59 to allow the transfer of an accurate dose of radioactive solution through a tube, to externally located vials or containers.

### Operation of the device

When the device is being operated the user opens the door 9 of the device and installs a new tubing kit 57 onto the tubing holder 2. The Luer Slip Injection Site 59 attached to the upper T-shape tube is slid into the appropriate recess and both needles 61 attached to the lower T-shape tubes are fed through each lead channel and connected to the radioactive stock solution 34 and the dilution stock solution 62.

The user then rotates the lid 32 and closes the door 9 and introduces a disposable syringe 53 with its appropriate needle 55 into a tungsten syringe shield 52. At this point the needle is un-capped and the tungsten syringe shield is placed onto the receptacle 51 on the front face of the device. The operator then enters on the computer the requested radioactive dose and total volume.

The device lowers the receptacle 51 enabling the syringe to pierce the Luer Slip Injection Site with the needle. The filling sequence will automatically dispense the desired radioactive dose into the syringe and dilute it to match the requested volume by actuation of the syringe plunger. Once the syringe has been filled (less than one minute), the syringe and syringe shield are lifted away from the Luer Slip Injection Site, and the syringe and syringe shield is removed from the device and needle re-capped. At the end of the process, a syringe label is printed with the appropriate dose data.

### Summary of the embodiment of invention

Traditionally the accurate knowledge of the volumetric radioactivity (specific activity: Ci/mL or Bq/mL) of a radioactive stock solution is required for the accurate dispensing of any radioactive dose.

For example, a dose of 3mCi (111MBq) of a radioactive solution with a volumetric radioactivity of 50 mCi/mL (1850MBq/mL) will be precisely achieved by dispensing a volume of 0.06mL. However, volumetric radioactivity of solutions is not always determined with great accuracy at the time of the manufacturing of the product, and post measurement of the volumetric radioactivity at the customer site is regarded as a critical operation.

The invention has the novel feature in that it can accurately dispense a requested radioactive dose without any knowledge of the volumetric radioactivity of the stock solution by an on-line radioactivity measurement and without exposing an operator to the radiation.

In the invention, a radiation detector 63 being a Geiger-Muller tube, a PIN photodiode or other fast measuring device is located behind a portion of the tubing leading to the injection site 59 and then to the syringe 53. The radiation detector continuously monitors the radioactive dose passing through the tube and into the syringe at a very constant liquid flow rate and the PLC 11 determines the appropriate switching sequence of the valves to dispense the requested dose and volume.

The program also calculates online the corresponding radioactivity contained in the dead volume of the tubing which will be inevitably added-on during the dilution phase of the syringe filling. That corresponding radioactivity is subtracted from the required dose by the PLC 11 to identify the amount of radioactivity allowed to pass the radiation detector 63. At the end of the filling process, the sum of the amount of activity allowed to pass by the detector before the dilution phase and the resultant activity gained during the dilution phase due to the dead volume of the tubing kit, translates to the required dose.

Below is the formula used to determine how much of the stock solution needs to be drawn-up into the syringe to achieve the desired dose (this calculation is performed continuously during the filling process):

Let        RD = Requested dose

ADV = Activity contained in the dead volume of the tubing

RMT = Radioactivity measured passing through the tubing

VA = Volumetric activity of the stock solution

DV = Dead volume of the tubing

SA = Volumetric radioactivity

VSW = Volume of stock solution withdrawn from vial

Therefore the radioactive amount of stock solution to draw-up into syringe:

$$= RD - ADV$$

$$= RD - (DV \times SA)$$

$$= RD - (DV \times (RMT/(VSW-DV)))$$

Using the above method of filling a syringe with a radioactive solution, it is not necessary to know the specific activity of the stock solution prior to the filling process, as it is calculated during the filling process.

The accuracy of the dose dispensed is a function of the volumetric radioactivity of the radioactive stock solution, and experiments have shown accuracy better than 5% for volumetric radioactivity in the range of 0-50 mCi/mL (0-1850MBq/mL) and better than 10% for volumetric radioactivity in the range of 50-100 mCi/mL (0-3700MBq/mL).

The invention lies in an automated means of preparing a dose of a radiopharmaceutical into a disposable syringe under computer control by means of a radiation detector to determine the radioactive dosage and dilution by a non radioactive solution to achieve a desired volume. By this means such a dose can be prepared without unnecessary radiation exposure occurring to the person preparing the dose.

The precise components of the apparatus of the invention may be varied provided they achieve the method of the invention as described. It is further envisaged that other embodiments of the invention will exhibit any number of and any combination of the features of those previously described and whilst we have described herein one specific embodiment of the invention it is to be understood that variations and modifications in this can be made without departing from the spirit and scope thereof.



The claims defining the invention are as follows:

1. A radioactive dose dispensing device for automatically filling a container with a required radioactive dose in a sterile environment, said device being stand alone and radiation shielded and including control means to control a mix of radioactive stock solution and dilution stock solution, the radioactivity of which mix is monitored by radiation detection means.
2. A radioactive dose dispensing device as claimed in claim 1 wherein the container is a plunger operated disposable syringe.
3. A radioactive dose dispensing device as claimed in claim 2 wherein a shielded receptacle is provided in the device to receive the syringe.
4. A radioactive dose dispensing device as claimed in claim 3 wherein drive means are provided to actuate the plunger of the syringe.
5. A radioactive dose dispensing device as claimed in claim 4 wherein the drive means is a linear drive mechanism adapted to move either the syringe or its plunger relative to one and other.
6. A radioactive dose dispenser device as claimed in any one of claims 1 to 5 wherein a disposable tubing assembly is used to provide a sterile fluid pathway for the stock solutions.

7. A radioactive dose dispenser device as claimed in claim 6 wherein pinch valves are provided to switch between the radioactive stock solution and the dilution stock solution.
8. A radioactive dose dispenser device as claimed in any one of claims 1 to 7 wherein the automation of the device and its calculation of a requisite dose is controlled by a programmable logic controller (PLC) in association with a radiation detector which controls the radioactive dose passing through the tubing and being dispensed into the syringe.
9. A radioactive dose dispenser device as claimed in claim 8 wherein the device and its PLC are operable by means of a computer interface.
10. A method of automatically dispensing a dose of a radioactive solution using a software controlled lead shielded device which includes the steps of
  - providing the device with a radioactive stock solution and a dilution stock solution
  - using a computer software interface to the device to control the dose dispensed automatically into a syringe or vial in the device.

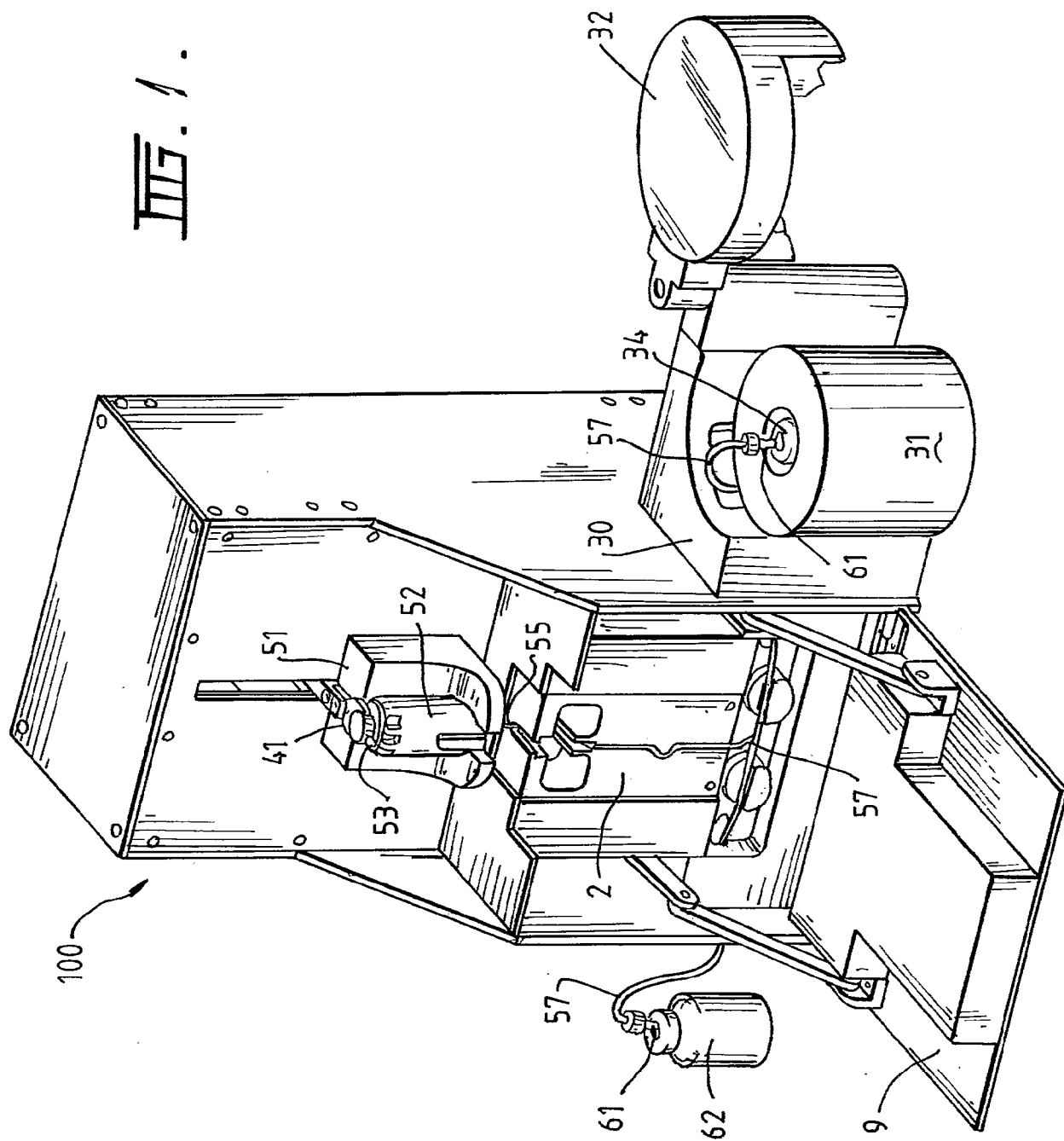
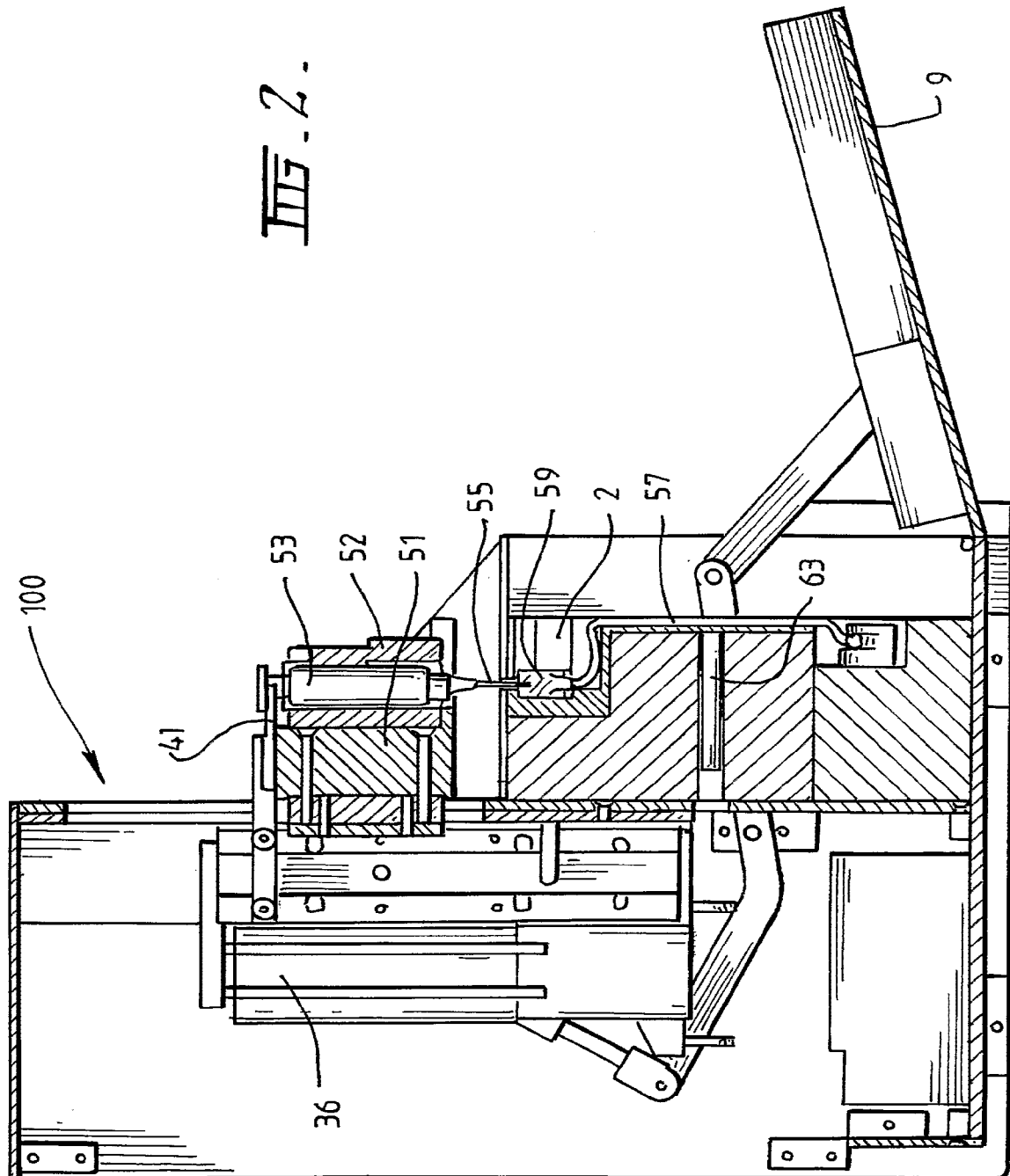
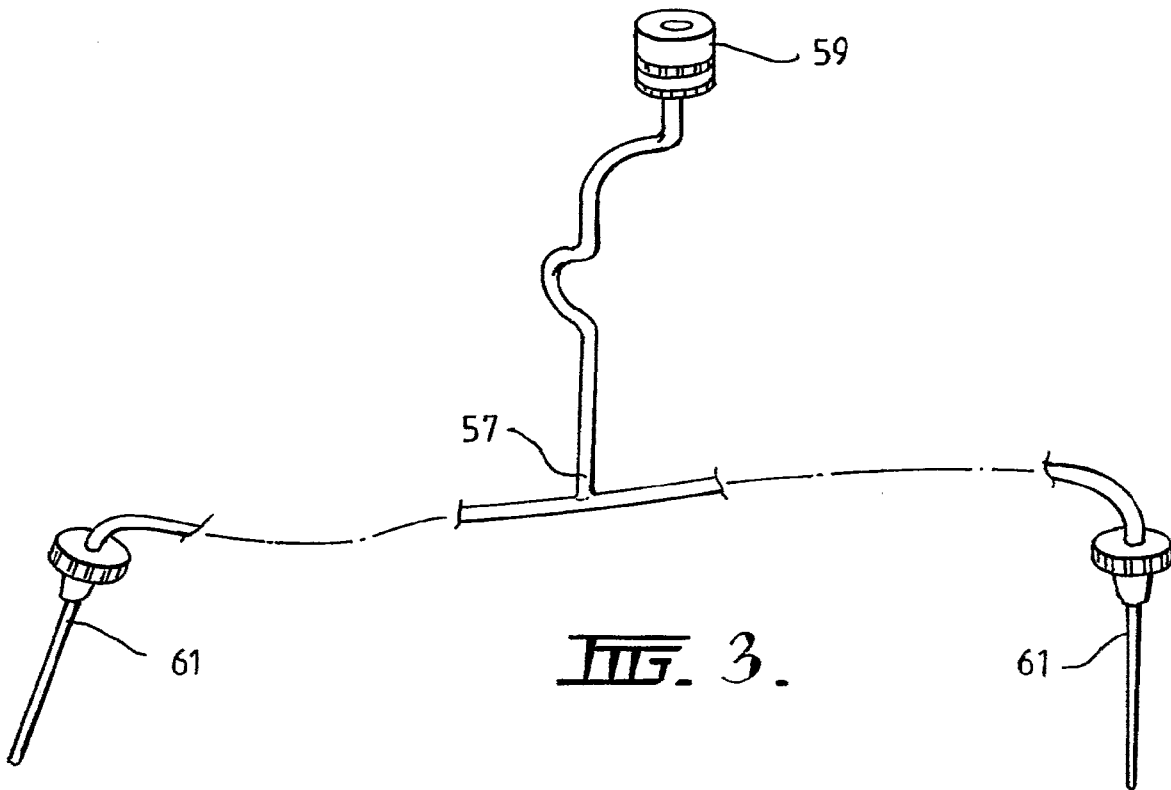


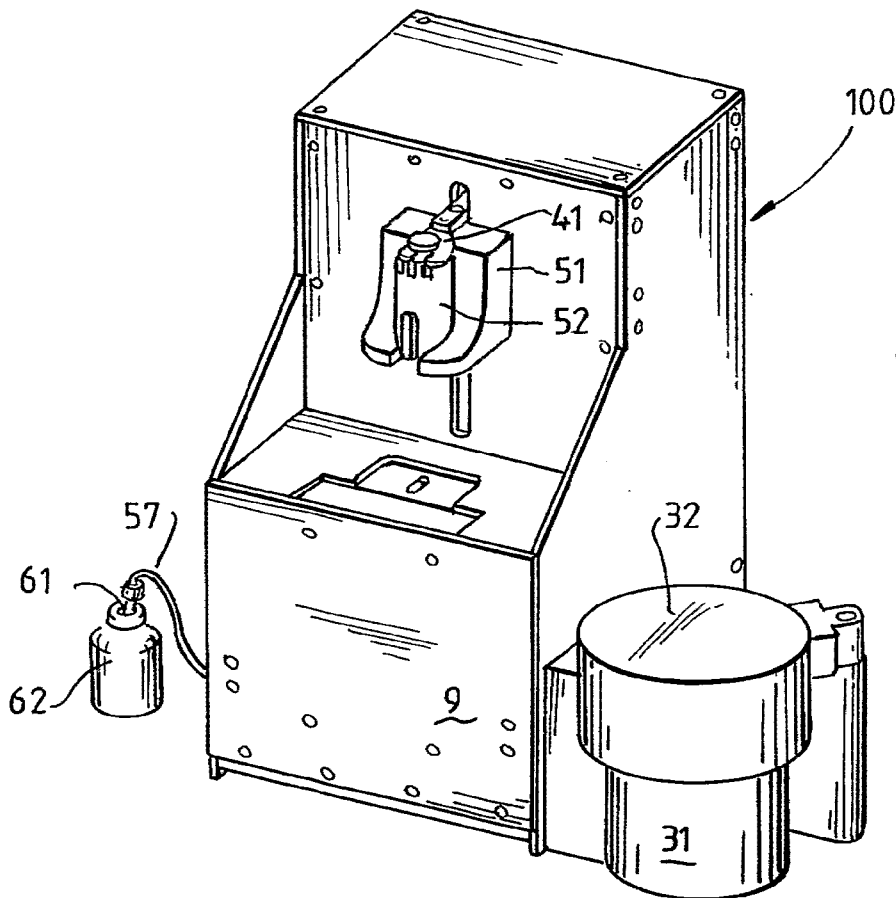
FIG. 1.

FIG. 2.





**FIG. 3.**



**FIG. 4.**

# INTERNATIONAL SEARCH REPORT

International application No.  
**PCT/AU2004/000897**

<b>A. CLASSIFICATION OF SUBJECT MATTER</b> Int. Cl. <sup>7</sup> : B65B 3/30 According to International Patent Classification (IPC) or to both national classification and IPC					
<b>B. FIELDS SEARCHED</b> Minimum documentation searched (classification system followed by classification symbols) See below under "Electronic database consulted" Documentation searched other than minimum documentation to the extent that such documents are included in the fields searched USPTO Electronic data base consulted during the international search (name of data base and, where practicable, search terms used) DWPI: IPC : B65B 3/- with keywords: radioactive, nuclear					
<b>C. DOCUMENTS CONSIDERED TO BE RELEVANT</b>					
Category*	Citation of document, with indication, where appropriate, of the relevant passages	Relevant to claim No.			
X Y	US 5911252A (CASSEL) 15 June 1999 The whole document The whole document	10 1-9			
Y	US 4041994A (HORWITZ et al.) 16 August 1977 The whole document	1-9			
A	US 4662231A (SCHAARSCHMIDT et al.) 5 May 1987	1-10			
A	GB 1415804A (COMMISSARIAT A L'ENERGIE ATOMIQUE) 26 November 1975	1-10			
<input type="checkbox"/> Further documents are listed in the continuation of Box C <input checked="" type="checkbox"/> See patent family annex					
<table style="width: 100%; border: none;"> <tr> <td style="width: 33%; border: none;">                     * Special categories of cited documents:                      "A" document defining the general state of the art which is not considered to be of particular relevance                      "E" earlier application or patent but published on or after the international filing date                      "L" document which may throw doubts on priority claim(s) or which is cited to establish the publication date of another citation or other special reason (as specified)                      "O" document referring to an oral disclosure, use, exhibition or other means                      "P" document published prior to the international filing date but later than the priority date claimed                 </td> <td style="width: 33%; border: none;">                     "T" later document published after the international filing date or priority date and not in conflict with the application but cited to understand the principle or theory underlying the invention                      "X" document of particular relevance; the claimed invention cannot be considered novel or cannot be considered to involve an inventive step when the document is taken alone                      "Y" document of particular relevance; the claimed invention cannot be considered to involve an inventive step when the document is combined with one or more other such documents, such combination being obvious to a person skilled in the art                      "&amp;" document member of the same patent family                 </td> <td style="width: 33%; border: none;"></td> </tr> </table>			* Special categories of cited documents: "A" document defining the general state of the art which is not considered to be of particular relevance "E" earlier application or patent but published on or after the international filing date "L" document which may throw doubts on priority claim(s) or which is cited to establish the publication date of another citation or other special reason (as specified) "O" document referring to an oral disclosure, use, exhibition or other means "P" document published prior to the international filing date but later than the priority date claimed	"T" later document published after the international filing date or priority date and not in conflict with the application but cited to understand the principle or theory underlying the invention "X" document of particular relevance; the claimed invention cannot be considered novel or cannot be considered to involve an inventive step when the document is taken alone "Y" document of particular relevance; the claimed invention cannot be considered to involve an inventive step when the document is combined with one or more other such documents, such combination being obvious to a person skilled in the art "&" document member of the same patent family	
* Special categories of cited documents: "A" document defining the general state of the art which is not considered to be of particular relevance "E" earlier application or patent but published on or after the international filing date "L" document which may throw doubts on priority claim(s) or which is cited to establish the publication date of another citation or other special reason (as specified) "O" document referring to an oral disclosure, use, exhibition or other means "P" document published prior to the international filing date but later than the priority date claimed	"T" later document published after the international filing date or priority date and not in conflict with the application but cited to understand the principle or theory underlying the invention "X" document of particular relevance; the claimed invention cannot be considered novel or cannot be considered to involve an inventive step when the document is taken alone "Y" document of particular relevance; the claimed invention cannot be considered to involve an inventive step when the document is combined with one or more other such documents, such combination being obvious to a person skilled in the art "&" document member of the same patent family				
Date of the actual completion of the international search <b>22 July 2004</b>		Date of mailing of the international search report <b>- 3 AUG 2004</b>			
Name and mailing address of the ISA/AU AUSTRALIAN PATENT OFFICE PO BOX 200, WODEN ACT 2606, AUSTRALIA E-mail address: pct@ipaustrialia.gov.au Facsimile No. (02) 6285 3929		Authorized officer  <b>ASANKA PERERA</b> Telephone No : (02) 6283 2373			

# INTERNATIONAL SEARCH REPORT

International application No.

PCT/AU2004/000897

## Box No. II Observations where certain claims were found unsearchable (Continuation of item 2 of first sheet)

This international search report has not been established in respect of certain claims under Article 17(2)(a) for the following reasons:

1.  Claims Nos.:  
because they relate to subject matter not required to be searched by this Authority, namely:
  
2.  Claims Nos.:  
because they relate to parts of the international application that do not comply with the prescribed requirements to such an extent that no meaningful international search can be carried out, specifically:
  
3.  Claims Nos.:  
because they are dependent claims and are not drafted in accordance with the second and third sentences of Rule 6.4(a)

## Box No. III Observations where unity of invention is lacking (Continuation of item 3 of first sheet)

This International Searching Authority found multiple inventions in this international application, as follows:  
See the Supplemental Box

1.  As all required additional search fees were timely paid by the applicant, this international search report covers all searchable claims.
2.  As all searchable claims could be searched without effort justifying an additional fee, this Authority did not invite payment of any additional fee.
3.  As only some of the required additional search fees were timely paid by the applicant, this international search report covers only those claims for which fees were paid, specifically claims Nos.:
  
4.  No required additional search fees were timely paid by the applicant. Consequently, this international search report is restricted to the invention first mentioned in the claims; it is covered by claims Nos.:

Remark on Protest

- The additional search fees were accompanied by the applicant's protest.
- No protest accompanied the payment of additional search fees.

## INTERNATIONAL SEARCH REPORT

International application No.

PCT/AU2004/000897

### Supplemental Box

(To be used when the space in any of Boxes I to VIII is not sufficient)

#### Continuation of Box No: III

The international application does not comply with the requirements of unity of invention because it does not relate to one invention or to a group of inventions so linked as to form a single general inventive concept. In coming to this conclusion the International Searching Authority has found that there are different inventions as follows:

1. Claims 1-9 is directed to a radioactive dose dispensing device including control means to control a mix of radioactive stock solution and dilution solution. It is considered that the monitoring the radioactivity of a mix by radiation detection means comprises a first "special technical feature".
2. Claim 10 is directed to a method of automatically dispensing a dose of radioactive solution. It is considered that the steps providing the device with a radioactive stock solution and dilution solution and using a computer software interface to control the dispensed dose comprises a second "special technical feature".

These groups are not so linked as to form a single general inventive concept, that is, they do not have any common inventive features, which define a contribution over the prior art. The common concept linking together these groups of claims is controlling a mix of radioactive stock solution and dilution solution in a dispensing device. However this concept is not novel in the light of US 5911252A. Therefore these claims lack unity a posteriori.



# INTERNATIONAL SEARCH REPORT

International application No. <b>PCT/AU2004/000897</b>
---

This Annex lists the known "A" publication level patent family members relating to the patent documents cited in the above-mentioned international search report. The Australian Patent Office is in no way liable for these particulars which are merely given for the purpose of information.

Patent Document Cited in Search Report	Patent Family Member					
US 5911252						
US 4041994						
US 4662231	BE 900719	BE 902407	BR 8405970			
	BR 8505220	DE 3342470	DE 3438303			
	FR 2555746	FR 2572179	GB 2151780			
	GB 2167736	JP 60179624	JP 61099836			
	US 4665758					
GB 1415804	BE 805777	CH 576845	FR 2205038			

Due to data integration issues this family listing may not include 10 digit Australian applications filed since May 2001.

END OF ANNEX

(19) World Intellectual Property Organization  
International Bureau



(43) International Publication Date  
7 December 2006 (07.12.2006)

PCT

(10) International Publication Number  
WO 2006/129301 A2

(51) International Patent Classification: Not classified

(21) International Application Number:  
PCT/IL.2006/000562

(22) International Filing Date: 11 May 2006 (11.05.2006)

(25) Filing Language: English

(26) Publication Language: English

(30) Priority Data:

PCT/IL2005/000572	1 June 2005 (01.06.2005)	IL
PCT/IL2005/000575	1 June 2005 (01.06.2005)	IL
60/691,780	20 June 2005 (20.06.2005)	US
60/700,318	19 July 2005 (19.07.2005)	US
60/700,299	19 July 2005 (19.07.2005)	US
60/700,317	19 July 2005 (19.07.2005)	US
60/700,753	20 July 2005 (20.07.2005)	US
60/700,752	20 July 2005 (20.07.2005)	US
60/702,979	28 July 2005 (28.07.2005)	US
60/720,034	26 September 2005 (26.09.2005)	US
60/720,652	27 September 2005 (27.09.2005)	US
60/720,541	27 September 2005 (27.09.2005)	US
171346	10 October 2005 (10.10.2005)	IL
PCT/IL2005/001173	9 November 2005 (09.11.2005)	IL
PCT/IL2005/001215	16 November 2005 (16.11.2005)	IL
172349	27 November 2005 (27.11.2005)	IL
60/741,440	2 December 2005 (02.12.2005)	US
60/750,287	13 December 2005 (13.12.2005)	US
60/750,294	13 December 2005 (13.12.2005)	US
60/750,597	15 December 2005 (15.12.2005)	US
60/750,334	15 December 2005 (15.12.2005)	US
PCT/IL2006/000059	15 January 2006 (15.01.2006)	IL
67/763,458	31 January 2006 (31.01.2006)	US

(72) Inventors; and

(75) Inventors/Applicants (for US only): ROUSSO, Benny [IL/IL]; 12 Henri Bergson Street, 75801 Rishon-leZion (IL). BEN-HAIM, Shlomo [IL/GB]; 8 Kensington Palace Gardens, London, Greater London W8 4QP (GB). BRON-SHTINE, Zohar [IL/IL]; #46, 38&12 Talmei Elazar (IL). ZILBERSTIEN, Yoel [IL/IL]; 13 Zrubavel Street, 34671 Haifa (IL). NAGLER, Michael [IL/IL]; 4 Avshalom Haviv Street, 69495 Tel Aviv (IL). DICKMAN, Dalia [IL/IL]; 175, 20184 Moshav Manof (IL). EINAV, Omer [IL/IL]; 273, 42875 Moshav Kfar Monash (IL).

(74) Agents: SANFORD T. COLB & CO. et al.; P.o. Box 2273, 76122 Rehovot (IL).

(81) Designated States (unless otherwise indicated, for every kind of national protection available): AE, AG, AL, AM, AT, AU, AZ, BA, BB, BG, BR, BW, BY, BZ, CA, CH, CN, CO, CR, CU, CZ, DE, DK, DM, DZ, EC, EE, EG, ES, FI, GB, GD, GE, GH, GM, HR, HU, ID, IL, IN, IS, JP, KE, KG, KM, KN, KP, KR, KZ, LC, LK, LR, LS, LT, LU, LV, LY, MA, MD, MG, MK, MN, MW, MX, MZ, NA, NG, NI, NO, NZ, OM, PG, PH, PL, PT, RO, RU, SC, SD, SE, SG, SK, SL, SM, SY, TJ, TM, TN, TR, TT, TZ, UA, UG, US, UZ, VC, VN, YU, ZA, ZM, ZW.

(84) Designated States (unless otherwise indicated, for every kind of regional protection available): ARIPO (BW, GH, GM, KE, LS, MW, MZ, NA, SD, SL, SZ, TZ, UG, ZM, ZW), Eurasian (AM, AZ, BY, KG, KZ, MD, RU, TJ, TM), European (AT, BE, BG, CH, CY, CZ, DE, DK, EE, ES, FI, FR, GB, GR, HU, IE, IS, IT, LT, LU, LV, MC, NL, PL, PT, RO, SE, SI, SK, TR), OAPI (BF, BJ, CF, CG, CI, CM, GA, GN, GQ, GW, ML, MR, NE, SN, TD, TG).

Published:

— without international search report and to be republished upon receipt of that report

(71) Applicant (for all designated States except US): SPEC-TRUM DYNAMICS [IL/IL]; P.o. Box 2026, 39120 Tirat Hacarmel (IL).

For two-letter codes and other abbreviations, refer to the "Guidance Notes on Codes and Abbreviations" appearing at the beginning of each regular issue of the PCT Gazette.

(54) Title: UNIFIED MANAGEMENT OF RADIOPHARMACEUTICAL DISPENSING, ADMINISTRATION, AND IMAGING

(57) Abstract: Apparatus is provided for use with at least one labeled radiopharmaceutical agent, the apparatus including a container (22) containing the at least one labeled radiopharmaceutical agent, and a portable computer-communicatable data carrier (120, 24) associated with the container (22), the data carrier (120, 24) containing imaging protocol information for use with the at least one labeled radiopharmaceutical agent. Other embodiments are also described.



WO 2006/129301 A2

UNIFIED MANAGEMENT OF RADIOPHARMACEUTICAL DISPENSING,  
ADMINISTRATION, AND IMAGING

**CROSS-REFERENCES TO RELATED APPLICATIONS**

The present patent application is a continuation-in-part of:

5 (i) International Application PCT/IL2005/001215, filed November 16, 2005;  
and

(ii) International Application PCT/IL2005/001173, filed November 9, 2005,  
which:

(a) claims the benefit of the following US Provisional Patent Applications:

- 10 • 60/625,971, filed November 9, 2004;  
• 60/628,105, filed November 17, 2004;  
• 60/630,561, filed November 26, 2004;  
• 60/632,236, filed December 2, 2004;  
• 60/632,515, filed December 3, 2004;  
15 • 60/635,630, filed December 14, 2004;  
• 60/636,088, filed December 16, 2004;  
• 60/640,215, filed January 3, 2005;  
• 60/648,385, filed February 1, 2005;  
• 60/648,690, filed February 2, 2005;  
20 • 60/675,892, filed April 29, 2005;  
• 60/691,780, filed June 20, 2005;  
• 60/700,318, filed July 19, 2005;  
• 60/700,299, filed July 19, 2005;  
• 60/700,317, filed July 19, 2005;  
25 • 60/700,753, filed July 20, 2005;  
• 60/700,752, filed July 20, 2005;

- 60/702,979, filed July 28, 2005;
- 60/720,034, filed September 26, 2005;
- 60/720,652, filed September 27, 2005; and
- 60/720,541, filed September 27, 2005, and

5 (b) is a continuation-in-part of the following International Patent Applications:

- PCT/IL2005/000572, filed June 1, 2005; and
- PCT/IL2005/000575, filed June 1, 2005.

The present patent application claims the benefit of the following US Provisional Applications:

- 10
- 60/750,287, filed December 13, 2005;
  - 60/750,334, filed December 15, 2005; and
  - 60/750,597, filed December 15, 2005.

The present patent application is related to a US provisional patent application filed on even date herewith, entitled, "Imaging protocols."

15 All of the above-mentioned applications are assigned to the assignee of the present application and are incorporated herein by reference.

#### **FIELD OF THE INVENTION**

The present invention relates generally to pharmaceutical management and control, and specifically to systems and methods for radiopharmaceutical dispensing, administration, and imaging.

20

#### **BACKGROUND OF THE INVENTION**

US Patent Application Publication 2005/0277833 to Williams, Jr., which is incorporated herein by reference, describes techniques for handling, mixing, dispensing and/or injecting a mixture into an individual during a medical procedure. The mixture contains pharmaceutical agents and/or radiopharmaceutical agents. Also described is a mixing device capable of diluting a radiopharmaceutical agent with, for instance, a diluent, for altering a radiation dose emitted by the radiopharmaceutical agent.

25

US Patent Application Publication 2005/0203389 to Williams, Jr., which is incorporated herein by reference, describes techniques for an operator to control an injection device and imaging equipment from a common control console. The injection device may be used to administer a contrast medium into a patient so that imaging  
5 equipment can acquire internal images of the patient. An injection system is bundled with software and/or hardware that is used to modify an existing imaging control console so that it can be used to operate both the injection device and imaging device. In one embodiment, the common control console can access stored protocols that can contain operational parameters for the injection device, the imaging device, or both.

10 US Patent 4,679,142 to Lee, which is incorporated herein by reference, describes techniques for dispersing quantities of radioactive material at a user location. Billing is accomplished by monitoring the decay of material and the degree of activity following each user withdrawal.

US Patent Application Publication 2005/0261938 to Silverbrook et al., which is  
15 incorporated herein by reference, describes a method for authenticating a pharmaceutical product, the pharmaceutical product being associated with packaging having disposed thereon or therein coded data including a number of coded data portions, each coded data portion being indicative of an identity of the pharmaceutical product and at least part of a digital signature of at least part of the identity. The method includes having a computer  
20 system receive indicating data from a sensing device, the sensing device being responsive to sensing of the coded data to generate indicating data at least partially indicative of the identity of the pharmaceutical product and the signature part. The computer system determines the identity at least one determined signature part and uses these to authenticate the pharmaceutical product.

25 US Patent Application Publication 2005/0261936 to Silverbrook et al., which is incorporated herein by reference, describes a method for allowing a user to interact with a pharmaceutical product, the pharmaceutical product associated with packaging having disposed thereon or therein coded data, at least some of the coded data being indicative of at least an identity. The method includes having a computer system receive indicating  
30 data from a sensing device, in response to sensing of the coded data, and determine, using the indicating data, at least one action. The computer system then performs the action associated with the pharmaceutical product, the action including at least one of providing

information to a user; updating tracking information relating to the pharmaceutical product; performing a transaction relating to the pharmaceutical product; authenticating the pharmaceutical product; and receiving feedback from the user.

5 US Patents 5,882,338 and 6,019,745 to Gray, which are incorporated herein by reference, describe a medical syringe comprising a cylindrical barrel having therein a plunger which can be axially driven by a plunger rod. The plunger rod passes through an aperture in the center of a finger grip having two finger grip projections at opposite sides thereof. A data carrier means in the form of an electrically or magnetically operable device is mounted near the end of one of the two finger grip projections, with preferably a  
10 device mounted near the end of each finger grip projection. The device carries data relating to the medicament contained or to be contained within the syringe, and can be read by a suitably adapted syringe pump when the syringe is mounted thereon to be driven by the syringe pump.

US Patent 6,970,735 to Uber, III et al., which is incorporated herein by reference,  
15 describes a system for producing a contrast-enhanced medical image of a patient, including a source of a contrast or enhancement medium, a pressurizing unit in fluid connection with the source of contrast or enhancement medium, an energy source operable to apply energy to a region of the patient, an imaging unit providing a visual display of an internal view of the patient based upon a signal resulting from the energy  
20 applied to the region of the patient, and a control unit. In an embodiment, the signal is affected by a condition of the contrast or enhancement medium in the patient. To control an imaging procedure, the control unit adjusts the condition of the contrast or enhancement medium in the patient based upon the signal. A communication interface preferably enables information between an injector subsystem and an imaging subsystem.

25 US Patents 5,781,442, 6,671,563, 6,915,170, and 6,731,989 to Engleson et al., which are incorporated herein by reference, describe a care management system in which the management of the administration of care for patients is automated. Hospital information systems are monitored and the information from those systems is used in verifying the administrations of care to patients. The care management system monitors  
30 ongoing administrations for progress and automatically updates records and provides alarms when necessary. The care management system is modular in nature but is fully integrated among its modules. Particular lists of data, such as the termination times of all

ongoing infusions, provide hospital staff current information for increased accuracy and efficiency in planning. Features include the automatic provision of infusion parameters to pumps for accurate and efficient configuration of the pump, and providing an alarm when an unscheduled suspension of an infusion exceeds a predetermined length of time. A  
5 passive recognition system for identifying patients and care givers is described.

US Patent Application Publication 2003/0055685 to Cobb et al., which is incorporated herein by reference, describes techniques for monitoring administration of a medical product within a delivery device using a medicine data storage device attached to the delivery device, which includes a product identifier identifying the medical product  
10 and an intended patient identifier identifying a patient intended to receive the medical product. Before administering the medical product to an individual patient, the product identifier and the intended patient identifier are uploaded into a reader, and a patient identifier is accessed from the reader's memory or uploaded from a patient identification device associated with the individual patient into the reader. The patient identifier is  
15 compared with the intended patient identifier to determine whether the individual patient is intended to receive the medical product. Once it is confirmed that the individual patient is intended to receive the medical product, the medical product is administered to the individual patient.

US Patent Application Publication 2005/0131270 to Weil et al., which is  
20 incorporated herein by reference, describes a system including a radiation treatment agent to treat tissue in response to received X-ray radiation and an identifier associated with the radiation treatment agent. The identifier may be usable to identify a radiation treatment plan. In some embodiments, a radiation treatment plan associated with a patient is generated, the radiation treatment plan is associated with an identifier and a patient  
25 identifier identifying the patient, a radiation treatment agent is prepared for delivery to the patient according to the radiation treatment plan, and the radiation treatment agent is associated with the identifier.

US Patent 6,985,870 to Martucci et al., which is incorporated herein by reference, describes a medication delivery system comprising a medical container holding a  
30 prescribed medication to be delivered to a patient, a tag adapted to be worn by the patient, a handheld computing device, and an electronic medication delivery device. Data on the medication is contained in a first label on the medication container. The first label also

contains the instruction on how the medication is delivered to the patient, including the appropriate settings for an electronic medication delivery device for delivering the medication to the patient. Patient data is contained in a second label on the tag worn by the patient. The medication data, medication delivery instruction, and patient data are provided in machine readable formats. The handheld computing device reads the medication data and the medication delivery instruction on the medication container and the patient data on the patient tag. The handheld computing device stores the information obtained and performs a matching check to confirm that the medication data matches with the patient data. Upon a confirmed match, it transmits the medication delivery instruction to the electronic medication delivery device, which downloads the instruction, programs the delivery device, and prompts an operator to begin delivering the medication to the patient according to the downloaded instruction.

US Patent Application Publication 2005/0029277 to Tachibana, which is incorporated herein by reference, describes a drug container having an identification tag fixed or detachably provided at a predetermined position of the container, the tag having recorded thereon drug data on a kind and a concentration of a drug, and upper and/or lower limits of a flow rate for continuous infusion, or time and flow rate for one-shot administration.

US Patent Application Publication 2005/0277911 to Stewart et al., which is incorporated herein by reference, describes techniques for programming a medical therapy in a medical device. The medical device has a controller, a memory, a processor, and an input device. The memory is preloaded with at least one of a plurality of patient profiles and condition profiles. The memory is further preloaded with an associated medication therapy for a plurality of the profiles. The input device receives profile data, comprising at least one of a patient profile data and a condition profile data for a specific patient, and the processor processes the received profile data and provides as output one of the preloaded medication therapies based on the processed profile data.

US Patent 6,506,155 to Sluis, which is incorporated herein by reference, describes an ultrasound imaging system including a data entry device that reads storage media that is assigned to each patient on which the system is to be used or the operator of the system to obtain ultrasound images. The storage media, which comprises a barcode, smartcard, or personal digital assistant, contains patient identifying information. The patient or



procedure identifying information is used to access a digital requisition that is referenced by the patient identifying information. The digital requisition is stored in a disk drive included in the ultrasound imaging system or in a clinical information system accessed through a communication link included in the ultrasound imaging system. The digital  
5 requisition includes information pertaining to an ultrasound examination procedure that is to be performed on the patient, which is used to automatically set up the ultrasound imaging system. The digital requisition may also include the patient's medical history or information about the patient that can be associated with ultrasound images obtained from the patient.

10 US Patent Application Publication 2005/0121505 to Metz et al., which is incorporated herein by reference, describes patient-centric data acquisition protocol selection systems and methods, and identification tags therefor. A patient-centric data acquisition protocol selection system comprises a programmable identification tag capable of allowing predetermined information about a patient to be stored therein and  
15 retrieved therefrom; a medical imaging system capable of communicating with the programmable identification tag; and programming associated with the medical imaging system for selecting an optimal data acquisition protocol. The medical imaging system reads information from the programmable identification tag and then the programming selects an optimal data acquisition protocol based, at least in part, on the predetermined  
20 information about the patient that is stored in the programmable identification tag.

PCT Publication WO 04/004787 to Van Naemen et al., which is incorporated herein by reference, describes a method for dispensing individual doses of a radiopharmaceutical solution, which consists of a radioactive parent solution diluted with a diluting solution. Also described is a computer-generated dose dispenser for dispensing  
25 individual doses of a radiopharmaceutical solution at a specified speed. The method and device are described as being particularly suitable for use in the field of nuclear medicine, and more in particular for use for PET scan applications.

US Patent 6,032,155 to de la Huerga, which is incorporated herein by reference, describes techniques for administering a prescribed medication to a patient. A medication  
30 administration system and apparatus dispense the prescribed medication, verify that the medication is given to a correct patient by an authorized healthcare worker, and track and record the administration of the medication. The system utilizes a workstation connected

to a database containing prescribed medication dose information for various patients. A healthcare worker uses the workstation to manually or automatically dispenses the medication the portable container. An information device is secured to the portable container during transport and administration of the medication to the intended patient.

5 The information device prevents access to the medication or warns the healthcare worker of a potential error if the medication is delivered to the wrong patient or administered by an unauthorized healthcare worker. The information device records actual consumption information, and delivers this information back the workstation database or to a hospital or pharmacy database.

10 US Patent 5,317,506 to Coutre et al., which is incorporated herein by reference, describes an infusion management and pumping system. Infusion prescriptions are generated and monitored by a pharmacy management system. Labels for each infusion to be given to a patient are generated and printed in a barcode format. Each label contains data regarding a prescribed infusion program, including the drug or drugs to be infused,  
15 the infusion regimen, the expiration date, and the patient to whom the infusion is to be administered. The management system checks for incompatibilities between drugs that are being prescribed for simultaneous infusion. Each label generated by the management system is attached to the container which holds the infusion solution. The data on the label is transferred to an infusion pumping system by a barcode reader at the infusion  
20 pumping system. The pumping system checks that all necessary data has been entered. During operation, the pumping system checks for a variety of alarm conditions and stores any alarms in a ranking according to urgency. The infusion pumping system is responsive to remote or biofeedback instructions to alter the planned infusion program. Central computer records processing receives infusion data and provides infusion,  
25 inventory, and use analysis.

US Patent 5,039,863 to Matsuno et al., which is incorporated herein by reference, describes an automatic radioisotope filling apparatus, which is equipped with a radioisotope vial containing a radioisotope solution, a saline vial containing a physiological saline solution, a dilution vial to which a predetermined amount of the  
30 radioisotope solution and a predetermined amount of the physiological saline solution are to be transferred to prepare a diluted radioisotope solution, a radiation detector for measuring the radioactive intensity of the diluted radioisotope solution prepared in the dilution vial, and a plurality of label vials containing a drug to be labeled.

US Patent Application Publication 2004/0051368 to Caputo et al., which is incorporated herein by reference, describes a system for delivering medical fluid to a patient. The system includes a medical container including a Radio Frequency Identification (RFID) tag storing data related to the medical fluid therein. A RF reader  
5 receives data signals transmitted from the RFID tag that include a desired flow rate for delivering the fluid to the intended patient. A pump coupled to the reader includes a pumping mechanism for pumping the medical fluid from the container, and a pump controller for receiving the data including the desired flow rate from the reader. The pump controller automatically controls the pumping mechanism to pump the medical  
10 fluid from the medical container at the desired flow rate based upon the data.

US Patent Application Publication 2005/0171815 to Vanderveen, which is incorporated herein by reference, describes a centralized medication management system for monitoring, managing and controlling medication delivery from a central location. A central computer displays medication orders and ongoing medication administrations for  
15 a health care facility. The central computer checks medication delivery against a database of medication administration guidelines, including guidelines for medication interactions with other medications and with patient conditions, and provides an indication of any detected incompatibilities. A clinician at the central location may adjust the medication administration parameters in response to detected incompatibilities and communicate  
20 with a caregiver at the point of care to provide decision support. In an embodiment, the central location is a pharmacy at the healthcare facility.

US Patent Application Publication 2005/0240441 to Suzuki, which is incorporated herein by reference, describes a hospital information system. The system enables an RF reader, comprising a personal digital assistant (PDA), to read tag information recorded by  
25 RF tags either attached to, or embedded in, various types of a patient wrist bands, injection medicine bottles, patient charts, and medical instrument cases. The PDA transmits a query to a server via a wireless LAN for confirmation from the server. The server collates the query with the content of a medical practice order recorded in its data base, and registers a completion of instructed operation for an instructed item in the  
30 database, and replies with a notification if the transmitted readout data from the PDA is correct. If the readout data is incorrect, the PDA is notified and instructed to perform another reading.

US Patent Application Publication 2001/0049608 to Hochman, which is incorporated herein by reference, describes an automated drug administering system such as an injection device or infusion pump, which is provided with means for reading information from a container holding the drug. The information is then checked for accuracy before the administration of the drug. Optionally, an ID tag on the patient and/or the health care professional providing the drug may also be scanned and checked. The information thus gathered is sent to another station where it is logged for future use and analyzed.

US Patent 6,743,202 to Hirschman et al., which is incorporated herein by reference, describes apparatus for sharing information on syringe configuration between syringes and injector systems, comprising a storage system to store encoded information on syringe configuration. The encoded information is readable by a detection circuit in an injector. In one embodiment, the storage system is an electronic storage system in which information relevant to the syringe configuration is encoded. A method comprises the step of conveying syringe configuration information to a detector in an injector for use with the syringe.

US Patent Application Publication 2005/0148869 to Masuda, which is incorporated herein by reference, describes a liquid syringe having various kinds of data items recorded in a two-dimensional code format. A liquid injector optically reads the two-dimensional codes, decodes them, and executes a predetermined operations corresponding to the decoded results. Recording, for example, a variable pattern for the liquid of interest in the two-dimensional code format on the liquid syringe makes it possible for the liquid injector to inject the liquid in accordance with the predetermined variable pattern.

US Patent 6,346,886 de la Huerga, which is incorporated herein by reference, describes an electronic identification apparatus having data storage memory on board a removable transceiver device. The transceiver device also includes a processor and a transponder for receiving information pertaining to the object/person to which it is attached and storing the information in memory. The transceiver also transmits stored data to a control computer or the external devices. The transceiver is mounted on a base, such as a wristband, and the apparatus includes an attachment sensor indicating whether the transceiver is attached to the base. If the transceiver has been removed from the base,

the processor performs one or more lockdown operations to prevent the stored data from being used in connection with another object or person. The lockdown operations include clearing the contents of the memory, disabling access to the memory, suppressing the display of stored data and activating an alarm.

5 US Patent Application Publication 2004/0156081 to Brill et al., which is incorporated herein by reference, describes a color-coded signature, for securing documents or encrypting images. The encrypted image comprises an array of printed positions formed using a group of inks each of which has a predetermined spectrum. The positions are selected to form a predetermined image, either real or virtual, when the  
10 image is viewed through an optical processor. The optical processor may further use a distorted grating or a distorted lens. The correct image is the spectrum, as distorted by the optical processor. An image formed using inks having the same colors as experienced by the human eye, or even by a standard spectrometer will fail to form the correct predetermined image.

15 The following patents and patent application publications, all of which are incorporated herein by reference, may be of interest:

US Patent Applications 2005/0131579 and 2005/0088306, and US Patent 6,935,560, all to Andreasson

US Patent 6,851,615 to Jones

20 US Patent application 2005/0131397 and US Patent 6,861,954 to Levin

US Patent 6,519,569 to White et al.

US Patent 5,692,640 to Caulfield et al.

US Patents 6,475,192 and 6,733,478 to Reilly et al.

US Patent 6,958,053 to Reilly

25 US Patent Application Publications 2005/0261937 and 2005/0261938 to Silverbrook et al.

US Patent 6,994,249 to Peterka et al.

US Patent 6,843,357 to Bybee et al.

US Patent 6,425,174 to Reich

- US Patent 6,722,499 to Reich
- US Patent 5,536,945 to Reich
- US Patent RE36,693 to Reich
- US Patent 5,519,931 to Reich
- 5 US Patent Application Publication 2005/0198800 to Reich
- US Patent 6,576,918 to Fu et al.
- US Patent Application Publication 2005/0247893 to Fu et al.
- US Patent 5,927,351 to Zhu et al.
- US Patent 5,828,073 to Zhu et al.
- 10 US Patent 6,162,198 to Coffey et al.
- US Patents 6,338,007 and 6,116,461 to Broadfield et al.
- US Patent 5,944,190 to Edelen
- PCT Publication WO 04/032151 to Besing et al.
- US Patent Application Publication 2005/0234424 to Besing et al.
- 15 US Patent 4,296,785 to Vitello et al.
- US Patent 3,446,965 to Ogier et al.
- US Patent 6,355,024 to Small et al.
- US Patent 6,468,261 to Small et al.
- US Patent 5,580,541 to Wells et al.
- 20 US Patent 3,535,085 to Shumate
- US Patent 4,853,546 to Abe et al.
- US Patent 5,329,976 to Haber et al.
- US Patent 5,304,165 to Haber et al.
- US Patent 5,911,252 to Cassel
- 25 US Patent 5,475,232 to Powers et al.
- PCT Publication WO 05/002971 to Tochon-Danguy et al.

- US Patent Application Publication 2005/0278066 to Graves
- US Patent 5,479,969 to Hardie et al.
- US Patent 5,309,959 to Shaw et al.
- US Patent 6,870,175 to Dell et al.
- 5 US Patent 6,767,319 to Reilly et al.
- US Patent 6,976,349 to Baldwin et al.
- US Patent 6,957,522 to Baldwin et al.
- US Patent 6,915,619 to Baldwin
- US Patent 6,813,868 to Baldwin et al.
- 10 US Patent 5,893,397 to Peterson et al.
- US Patents 5,885,216, 5,806,519, and 6,901,283 to Evans, III et al.
- US Patent Application Publication 2004/0084340 to Morelle et al.
- US Patent 6,269,340 to Ford et al.
- US Patent Application Publication 2004/0193453 to Butterfield et al.
- 15 US Patent 4,476,381 to Rubin
- US Patent 6,643,537 to Zatezalo et al.
- US Patent Application Publication 2005/0108044 to Koster
- US Patent 6,851,615 to Jones
- US Patent 5,840,026 to Uber, III et al.
- 20 US Patent 6,685,678 to Evans et al.
- US Patent Application Publication 2003/0183226 to Brand et al.
- US Patent Application Publications 2005/0107914 and 2005/0113945 to Engleson  
et al.
- US Patent Application Publication 2002/0198738 to Osborne
- 25 US Patent Application Publication 2002/0099334 to Hanson et al.
- US Patents 6,317,648 and 6,522,945 to Sleep et al.

US Patent 6,155,485 and 6,318,630 to Coughlin et al.

US Patent 6,202,923 to Boyer et al.

US Patent 6,915,823 to Osborne et al.

US Patent Application Publication 2004/0205343 to Forth et al.

5 US Patent 5,493,805 to Penuela et al.

US Patent 5,973,598 to Beigel

US Patent Application Publication 2005/0149350 to Kerr et al.

US Patent 5,884,457 to Ortiz et al.

The following patents and patent application publications, which describe gamma  
10 cameras and imaging processing techniques, and which are incorporated herein by  
reference, may be of interest:

US Patent Application Publication 2005/0205792 to Rousso et al.

PCT Publication WO 05/118659 to Dichterman et al.

PCT Publication WO 05/119025 to Nagler et al.

15 US Patent Application Publication 2004/0204646 to Nagler et al.

PCT Publication WO 04/042546 to Kimchy et al.

US Patent Application Publication 2004/0054248 to Kimchy et al.

US Patent Application Publication 2004/0015075 to Kimchy et al.

US Patent Application Publication 2004/0054278 to Kimchy et al.

20 US Patent Application Publication 2005/0266074 to Zilberstein et al.

US Patents 5,939,724, 5,587,585, and 5,365,069 to Eisen et al.

US Patent 6,943,355 to Shwartz et al.

US Patents 6,242,743 and 5,757,006 to DeVito et al.

US Patent 6,137,109 to Hayes

25 US Patent 6,388,258 to Berlad et al.

US Patent 6,429,431 to Wilk



US Patent 6,838,672 to Wagenaar et al.

US Patents 6,740,882, 6,545,280, 6,229,145, 5,519,221, and 5,252,830 to Weinberg

US Patent 6,713,766 to Garrard et al.

5 US Patent 6,765,981 to Heumann

US Patent 6,664,542 to Ye et al.

US Patent 6,080,984 to Friesenhahn

US Patent 5,818,050 to Dilmanian et al.

US Patent 6,728,583 to Hallett

10 US Patent 5,481,115 to Hsieh et al.

US Patent 6,723,988 to Wainer

US Patent 6,940,070 to Tumer

US Patent 6,635,879 to Jimbo et al.

US Patent 6,353,227 to Boxen

15 US Patent 6,184,530 to Hines et al.

US Patent Application Publication 2005/0145797 to Oaknin et al.

US Patent Application Publication 2004/0251419 to Nelson et al.

US Patent Application Publication 2003/0001098 to Stoddart et al.

PCT Publication WO 98/16852 to DeVito et al.

20 PCT Publication WO 05/059840 to Nielsen et al.

### SUMMARY OF THE INVENTION

In some embodiments of the present invention, an end-to-end automated system for medical imaging comprises a plurality of integrated elements that are configured to electronically exchange information among one another. The elements include an automated radiopharmaceutical dispensing system, a portable information-bearing radiopharmaceutical agent container, a patient management system, a portable patient-specific data carrier, an automated administration system, and an automated

imaging system. The systems perform their respective automated functions at least in part responsively to the exchanged information. The elements typically authenticate one another via the exchanged information, in order to ensure that only authorized elements participate in the system, and that the systems perform only authorized and appropriate functions.

The exchanged information typically includes patient-specific data, radiopharmaceutical agent-specific data, and/or patient- or radiopharmaceutical agent-specific imaging protocol data. Such data enable the systems to customize their respective automated functions for specific patients, radiopharmaceutical agents, indications, and/or imaging procedures. For some applications, the exchanged information includes commercial license information relating to the use of a specific protocol with a specific radiopharmaceutical agent, and one or more of the systems are configured to verify the license information before performing their respective functions.

In some embodiments of the present invention, the information-bearing radiopharmaceutical agent container and/or the patient-specific data carrier is configured to contain protocol information for performing an imaging procedure using the labeled radiopharmaceutical agent held by the container. For some applications, the protocol information includes SPECT imaging protocol information, and the imaging system uses the protocol information to perform a SPECT imaging procedure using the labeled radiopharmaceutical agent contained in the container. For some applications, the agent container contains a single dose of the labeled radiopharmaceutical agent, which dose is appropriate for use with the imaging protocol.

In some embodiments of the present invention, the information-bearing radiopharmaceutical agent container or the patient-specific data carrier is configured to contain at least one kinetic parameter of the labeled radiopharmaceutical agent contained in the container. The imaging system uses the kinetic parameter to perform a dynamic SPECT imaging procedure.

In some embodiments of the present invention, the information-bearing radiopharmaceutical agent container contains radiopharmaceutical information regarding the labeled radiopharmaceutical agent contained in the container. The portable patient-specific data carrier is configured to contain patient information regarding the patient, and imaging protocol information for use with the labeled radiopharmaceutical

agent, such as SPECT imaging protocol information. The imaging system uses the protocol information to perform an imaging procedure, such as a dynamic SPECT imaging procedure. For some applications, the patient-specific data carrier comprises a coupling mechanism configured to be coupled to the patient. For example, the coupling  
5 mechanism may comprise a bracelet, a watch, a necklace, or another wearable article.

In some embodiments of the present invention, the information-bearing radiopharmaceutical agent container contains a first identifier value, and the patient-specific data carrier contains a second identifier value. The imaging system is configured to perform an imaging procedure responsively to a detection of a  
10 correspondence between the first and second identifier values. For some applications, the first identifier value equals the second identifier value, while for other applications the values do not equal one another, but instead correspond to one another based on information provided by an element of the end-to-end system. For some applications, the  
15 first and/or second identifier values are arbitrarily assigned, or pre-loaded into the data carrier by a manufacturer or distributor, while for other applications at least one of the identifier values comprises a patient identifier, or another meaningful value. For some applications, at least one of the information-bearing agent container and the patient-specific data carrier performs the detection of the correspondence, while for other applications the imaging system or another element of the end-to-end system performs the  
20 detection of the correspondence.

In some embodiments of the present invention, the imaging system comprises a SPECT imaging system configured to utilize the information contained in the labeled radiopharmaceutical agent container and/or the patient-specific data carrier to customize at least one function of the system selected from the group consisting of: administration of  
25 the labeled radiopharmaceutical agent, acquisition of a SPECT image of the patient to whom the labeled radiopharmaceutical agent is administered, reconstruction of the SPECT image, analysis of the SPECT image, and diagnosis of a condition of the patient based at least in part on the analysis.

The integration of the elements of the end-to-end system, and the exchange of  
30 authenticatable information among the elements generally increase patient safety, by ensuring that each patient receives the prescribed labeled radiopharmaceutical agent and dosage, and undergoes the desired imaging protocol. For some applications, one or more

elements of the end-to-end system are configured to perform their respective function only upon being triggered by another element of the system. For example, the administration or imaging system may perform its function only upon being triggered by the information-bearing radiopharmaceutical agent container, by the patient-specific data carrier, and/or, in the case of the administration system, by the imaging system.

In some embodiments of the present invention, the automated radiopharmaceutical dispensing system comprises an information manager that is configured to receive radiopharmaceutical information regarding a labeled radiopharmaceutical agent and patient information regarding a patient. Responsively to the information, the dispensing system automatically dispenses a dose of the labeled radiopharmaceutical agent to an agent container, and stores the radiopharmaceutical information and at least a portion of the patient information in a data carrier associated with the container. For some applications, the radiopharmaceutical information is selected from the group consisting of: imaging protocol information for use with the labeled radiopharmaceutical agent, such as a SPECT imaging protocol; at least one kinetic parameter useful for performing a dynamic SPECT imaging procedure using the at least one labeled radiopharmaceutical agent; and authenticatable information regarding a commercial license for use of a SPECT imaging protocol with the at least one labeled radiopharmaceutical agent.

In some embodiments of the present invention, the dispensing system is configured to receive a mother vial containing a labeled radiopharmaceutical agent in a quantity sufficient for preparation of a plurality of doses of the labeled radiopharmaceutical agent. Associated with the mother vial is a data carrier containing information regarding the labeled radiopharmaceutical agent, such as the formulation, radioactivity information, and protocol information. The information manager of the dispensing system receives at least a portion of the labeled radiopharmaceutical agent information from the data carrier.

In some embodiments of the present invention, use of the end-to-end automated system enables customization of one or more aspects of the imaging process, from dispensing to diagnosis. Customization typically includes one or more of the following:

- The dispensing system customizes the dispensed dose for a specific patient, based on radiopharmaceutical information and patient-specific information. Typically, the dispensing system customizes the dispensed

dose (e.g., the radioactivity level thereof) based in part on the scheduled time of the scheduled time of administration of the dose, and/or the scheduled time of the imaging procedure to be performed using the dose.

- 5       • The administration system customizes the administered dose for a specific patient, based on radiopharmaceutical information and patient-specific information. For some applications in which the administration system customizes the administered dose, the radiopharmaceutical agent container contains a standard, non-customized dose.
- 10       • The imaging system customizes image acquisition, image reconstruction, image analysis, and/or diagnosis, based on radiopharmaceutical information and patient-specific information, such as patient physiology and/or known and/or suspected disease of the patient.

Such customization is typically based at least in part on information provided by the manufacturer or distributor of the radiopharmaceutical agent. Such information may  
15 be in the form of lookup tables and/or expert system rules.

As used in the present application, including in the claims, "labeled" means radiolabeled, and "unlabeled" means not radiolabeled.

There is therefore provided, in accordance with an embodiment of the present  
20 invention, apparatus for use with at least one labeled radiopharmaceutical agent, the apparatus comprising:

- a container containing the at least one labeled radiopharmaceutical agent; and
- a portable computer-communicatable data carrier associated with the container, the data carrier containing imaging protocol information for use with the at least one  
25 labeled radiopharmaceutical agent.

For some applications, the apparatus comprises a device configured to write the imaging protocol information to the data carrier.

For some applications, the data carrier additionally contains administration  
30 protocol information useful for administering the at least one labeled radiopharmaceutical agent.

In an embodiment, the imaging protocol information comprises instructions for performing an imaging procedure using the at least one labeled radiopharmaceutical agent. Alternatively or additionally, the imaging protocol information comprises an identifier of an imaging protocol. Further alternatively or additionally, the imaging protocol information comprises a parameter of the at least one labeled radiopharmaceutical agent. Still further alternatively or additionally, the imaging protocol information comprises a parameter useful for configuring at least one aspect of an imaging procedure performed using the at least one labeled radiopharmaceutical agent.

In an embodiment, the container contains a single dose of the radiopharmaceutical agent, which dose is appropriate for use with the imaging protocol information. Alternatively, the container contains a plurality of labeled radiopharmaceutical agents mixed together. For some applications, the container is shaped so as to define a plurality of chambers, each of which contains a respective one of a plurality of labeled radiopharmaceutical agents.

In an embodiment, the data carrier comprises a first data carrier, which contains a first identifier value, the apparatus further comprises a second computer-communicatable data carrier, which contains a second identifier value, and the apparatus is configured to operate responsively to a detection of a correspondence between the first and second identifier values. For some applications, at least one of the first and second data carriers is configured to perform the detection of the correspondence. Alternatively or additionally, the apparatus comprises a correspondence-detection element configured to perform the detection of the correspondence.

In an embodiment, at least one of the first and second data carriers contains an identifier of a patient to whom the labeled radiopharmaceutical agent is to be administered.

For some applications, at least one of the first and second identifier values comprises an identifier of a patient to whom the labeled radiopharmaceutical agent is to be administered.

In an embodiment, exactly one of the first and second data carriers comprises a coupling mechanism configured to be coupled to a patient to whom the labeled radiopharmaceutical agent is to be administered.

In an embodiment, the apparatus comprises an imaging system comprising imaging functionality, the imaging system configured, responsively to the detection of the correspondence, to drive the imaging functionality to perform an imaging procedure using the at least one labeled radiopharmaceutical agent.

5 In an embodiment, the data carrier is physically coupled to the container. For some applications, the data carrier contains an identifier of a patient to whom the labeled radiopharmaceutical agent is to be administered, and the imaging protocol information comprises imaging protocol information selected for the patient. For some applications, the imaging protocol information comprises an identifier of an imaging protocol.

10 For some applications, the imaging protocol information comprises imaging protocol information customized for the patient.

In an embodiment, the imaging protocol information comprises SPECT imaging protocol information, such as dynamic SPECT imaging protocol information. For some applications, the SPECT imaging protocol information comprises at least one kinetic parameter of the at least one labeled radiopharmaceutical agent, the at least one kinetic parameter useful for performing a dynamic SPECT imaging procedure using the at least one labeled radiopharmaceutical agent.

15 In an embodiment, the apparatus comprises an imaging system, which comprises a communication element, configured to read the imaging protocol information from the data carrier; and a control unit, comprising imaging functionality, which is configured to perform an imaging procedure, and to configure the procedure at least in part responsively to the imaging protocol information read from the data carrier by the communication element.

25 In an embodiment, the imaging system comprises a camera, wherein the imaging functionality comprises image acquisition functionality, and wherein the image acquisition functionality is configured to perform an image acquisition procedure using the camera, and to configure the procedure at least in part responsively to the imaging protocol information read from the data carrier by the communication element. For some applications, the image acquisition functionality configures a total acquisition time of the image acquisition procedure at least in part responsively to the imaging protocol information. Alternatively or additionally, the camera comprises a plurality of detectors, and wherein the image acquisition functionality is configured to configure, at least in part

responsively to the imaging protocol information, at least one motion of at least one of the detectors during the image acquisition procedure. For some applications, the control unit is configured to configure, at least in part responsively to the imaging protocol information, a waiting time between administration of the labeled radiopharmaceutical agent and commencement of the image acquisition procedure. For some applications, the image acquisition functionality is configured to perform a gated image acquisition procedure at least in part responsively to the imaging protocol information.

In an embodiment, the imaging functionality comprises image reconstruction functionality, and wherein the image reconstruction functionality is configured to perform an image reconstruction procedure, and to configure the procedure at least in part responsively to the imaging protocol information read from the data carrier by the communication element.

In an embodiment, the imaging functionality comprises image analysis functionality, and wherein the image analysis functionality is configured to perform an image analysis procedure, and to configure the procedure at least in part responsively to the imaging protocol information read from the data carrier by the communication element.

In an embodiment, the imaging functionality comprises diagnosis functionality, and wherein the diagnosis functionality is configured to perform a diagnostic procedure, and to configure the procedure at least in part responsively to the imaging protocol information read from the data carrier by the communication element.

In an embodiment, the imaging procedure includes a three-dimensional dynamic imaging study, and wherein the imaging functionality is configured to perform the three-dimensional dynamic imaging study, and to configure the study at least in part responsively to the imaging protocol information read from the data carrier by the communication element.

In an embodiment, the data carrier is not physically coupled to the container, and wherein the data carrier contains an identifier of a patient to whom the labeled radiopharmaceutical agent is to be administered. For some applications, the data carrier comprises a coupling mechanism configured to be coupled to the patient. In an embodiment, the data carrier comprises a first data carrier, and wherein the apparatus further comprises a second computer-communicatable data carrier physically coupled to



the container, the second data carrier containing radiopharmaceutical information regarding the at least one labeled radiopharmaceutical agent.

There is also provided, in accordance with an embodiment of the present invention, apparatus for use with at least one labeled radiopharmaceutical agent, the apparatus comprising:

5 a container containing the at least one labeled radiopharmaceutical agent; and  
a computer-communicatable data carrier associated with the container, the data carrier containing authenticatable information regarding a commercial license for use of SPECT imaging protocol information with the at least one labeled radiopharmaceutical  
10 agent.

In an embodiment, the apparatus comprises an imaging system, which comprises:  
a communication element, configured to read the authenticatable license information from the data carrier;  
a control unit, comprising imaging functionality, the control unit configured to:  
15 authenticate the authenticatable license information, and  
only upon authentication, drive the imaging functionality to perform an imaging procedure using the SPECT imaging protocol information.

For some applications, the apparatus comprises a device configured to write the authenticatable license information to the data carrier.

20 For some applications, the data carrier is physically coupled to the container.

There is further provided, in accordance with an embodiment of the present invention, apparatus comprising a portable computer-communicatable data carrier containing authenticatable information regarding a commercial license for use of SPECT imaging protocol information.

25 For some applications, the data carrier additionally contains patient information regarding a patient upon whom an imaging procedure using the SPECT imaging protocol information is to be performed.

For some applications, the authenticatable license information is encrypted.

In an embodiment, the apparatus comprises an imaging system, which comprises:  
30 a communication element, configured to read the authenticatable license

information from the data carrier;

a control unit, comprising imaging functionality, the control unit configured to:  
authenticate the authenticatable license information, and  
only upon authentication, drive the imaging functionality to perform an imaging  
5 procedure using the SPECT imaging protocol information.

For some applications, the apparatus comprises a device configured to write the  
authenticatable license information to the data carrier.

For some applications, the data carrier comprises a coupling mechanism  
configured to be coupled to a patient upon whom an imaging procedure using the SPECT  
10 imaging protocol information is to be performed.

There is still further provided, in accordance with an embodiment of the present  
invention, apparatus comprising:

a first portable computer-communicatable data carrier containing a first identifier  
value;  
15 a second portable computer-communicatable data carrier containing a second  
identifier value; and  
an imaging system comprising imaging functionality, the imaging system  
configured, responsively to a detection of a correspondence between the first and second  
identifier values, to drive the imaging functionality to perform an imaging procedure on a  
20 patient.

For some applications, at least one of the first and second data carriers is  
configured to perform the detection of the correspondence. Alternatively or additionally,  
the imaging system comprises a correspondence-detection element configured to perform  
the detection of the correspondence.

25 For some applications, at least one of the first and second data carriers contains an  
identifier of a patient to whom the labeled radiopharmaceutical agent is to be  
administered.

For some applications, at least one of the first and second identifier values  
comprises an identifier of a patient to whom the labeled radiopharmaceutical agent is to  
30 be administered.

In an embodiment, one of the first and second data carriers comprises a coupling

mechanism configured to be coupled to a patient to whom the labeled radiopharmaceutical agent is to be administered.

For some applications, the apparatus comprises a device configured to write at least one of the first and second identifier values to the respective first and second data carriers.

In an embodiment, at least one of the first and second data carriers contains radiopharmaceutical information regarding at least one labeled radiopharmaceutical agent, the imaging system comprises a communication element, configured to read the radiopharmaceutical information from the at least one of the data carriers, and the imaging system is configured to configure the imaging procedure at least in part responsively to the read radiopharmaceutical information. For some applications, the apparatus comprises a container containing the at least one labeled radiopharmaceutical agent. For some applications, one of the first and second data carriers is physically coupled to the container.

In an embodiment, the imaging functionality comprises a nuclear camera. For some applications, the nuclear camera comprises a SPECT camera.

There is yet further provided, in accordance with an embodiment of the present invention, apparatus for use with first and second portable computer-communicable data carriers containing first and second identifier values, respectively, the apparatus comprising an imaging system, which comprises:

imaging functionality; and

a control unit configured to drive the imaging functionality to perform an imaging procedure on a patient, responsively to a detection of a correspondence between the first and second identifier values.

For some applications, the imaging system comprises a correspondence-detection element configured to perform the detection of the correspondence.

There is additionally provided, in accordance with an embodiment of the present invention, apparatus for use with at least one labeled radiopharmaceutical agent for administration to a patient, the apparatus comprising:

a container containing the at least one labeled radiopharmaceutical agent;

a first computer-communicable data carrier physically coupled to the container,

the first data carrier containing radiopharmaceutical information regarding the at least one labeled radiopharmaceutical agent; and

a second portable computer-communicatable data carrier containing patient information regarding the patient, and imaging protocol information for use with the at least one labeled radiopharmaceutical agent.

For some applications, the imaging protocol information comprises SPECT imaging protocol information.

For some applications, the patient information comprises an identifier of the patient.

For some applications, the second data carrier comprises a coupling mechanism configured to be coupled to the patient.

For some applications, the first data carrier contains a first patient identifier, the patient information contained in the second data carrier comprises a second patient identifier, and the apparatus comprises an administration system, which comprises:

a first communication element, configured to read the first patient identifier from the first data carrier;

a second communication element, configured to read the second patient identifier from the second data carrier; and

a control unit, configured to compare the first patient identifier to the second patient identifier, and, upon detecting a match, generate an administration signal that triggers administration to the patient of the at least one labeled radiopharmaceutical agent contained in the container.

For some applications, the first data carrier contains a first protocol identifier, the imaging protocol information contained in the second data carrier comprises a second protocol identifier, and the apparatus comprises an administration system, which comprises:

a communication element, configured to read the first and second protocol identifiers from the first and second data carriers, respectively; and

a control unit, configured to compare the first protocol identifier to the second protocol identifier, and, upon detecting a match, generate an administration signal that triggers administration to the patient of the at least one labeled radiopharmaceutical agent contained in the container.

For some applications, the first data carrier contains a first protocol identifier, the imaging protocol information contained in the second data carrier comprises a second protocol identifier, and the apparatus comprises an administration system, which comprises:

5 a first communication element, configured to read the first protocol identifier from the first data carrier;

a second communication element, configured to read the second protocol identifier from the second data carrier; and

10 a control unit, configured to compare the first protocol identifier to the second protocol identifier, and, upon detecting a match, generate an administration signal that triggers administration to the patient of the at least one labeled radiopharmaceutical agent contained in the container.

In an embodiment, the apparatus comprises an administration system, which comprises:

15 a communication element; and

a control unit, configured to:

generate an administration signal that triggers administration to the patient of the at least one labeled radiopharmaceutical agent contained in the container, and

20 drive the communication element to transmit information regarding the administration to the second data carrier.

For some applications, the apparatus comprises a device configured to write the imaging protocol information to the first data carrier. Alternatively or additionally, the apparatus comprises a device configured to write the patient information to the second data carrier.

25 In an embodiment, the imaging protocol information comprises imaging protocol information selected for the patient. For some applications, the imaging protocol information comprises an identifier of an imaging protocol. For some applications, the imaging protocol information comprises imaging protocol information customized for the patient.

30 In an embodiment, the first data carrier contains a first patient identifier, the patient information contained in the second data carrier includes a second patient identifier, and the apparatus comprises an administration system, which comprises:

a communication element, configured to read the first and second patient identifiers from the first and second data carriers, respectively; and

a control unit, configured to compare the first patient identifier to the second patient identifier, and, upon detecting a match, generate an administration signal that triggers administration to the patient of the at least one labeled radiopharmaceutical agent contained in the container.

For some applications, the administration system comprises an automated administration device, configured to administer the at least one labeled radiopharmaceutical agent to the patient upon being triggered by the administration signal.

For some applications, the control unit is configured to generate the administration signal to trigger the administration of the at least one labeled radiopharmaceutical agent by instructing a healthcare worker to administer the at least one labeled radiopharmaceutical agent to the patient.

There is yet additionally provided, in accordance with an embodiment of the present invention, apparatus for use with at least one labeled radiopharmaceutical agent for administration to a patient, the apparatus comprising:

a container containing the at least one labeled radiopharmaceutical agent;

a computer-communicatable data carrier associated with the container, the data carrier containing data regarding at least one of: the labeled radiopharmaceutical agent and the patient; and

a SPECT imaging system comprising:

a communication element, configured to read the data; and

a control unit, configured to utilize the read data to customize at least one function of the system selected from the group consisting of: administration of the labeled radiopharmaceutical agent, acquisition of a SPECT image of the patient to whom the labeled radiopharmaceutical agent is administered, reconstruction of the SPECT image, analysis of the SPECT image, and diagnosis of a condition of the patient based at least in part on the analysis.

For some applications, the data carrier contains the data regarding the labeled radiopharmaceutical agent. Alternatively or additionally, the data carrier contains the data regarding the patient.

For some applications, the control unit is configured to utilize the read data to customize the administration of the labeled radiopharmaceutical agent. Alternatively or additionally, the control unit is configured to utilize the read data to customize the acquisition of a SPECT image of the patient to whom the labeled radiopharmaceutical agent is administered. Further alternatively or additionally, control unit is configured to utilize the read data to customize the reconstruction of the SPECT image. Still further alternatively or additionally, the control unit is configured to utilize the read data to customize the analysis of the SPECT image. Alternatively or additionally, the control unit is configured to utilize the read data to customize the diagnosis of a condition of the patient based at least in part on the analysis.

For some applications, the apparatus comprises a device configured to write the data to the data carrier.

There is also provided, in accordance with an embodiment of the present invention, a SPECT imaging system for use with a container containing at least one labeled radiopharmaceutical agent for administration to a patient, and data regarding at least one of: the labeled radiopharmaceutical agent and the patient, the system comprising:

a communication element, configured to read the data; and

a control unit, configured to utilize the read data to customize at least one function of the system selected from the group consisting of: administration of the labeled radiopharmaceutical agent, acquisition of a SPECT image of the patient to whom the labeled radiopharmaceutical agent is administered, reconstruction of the SPECT image, analysis of the SPECT image, and diagnosis of a condition of the patient based at least in part on the analysis.

For some applications, the system comprises a device configured to write the data to the container.

There is further provided, in accordance with an embodiment of the present invention, an automated radiopharmaceutical dispensing system for use with a container and a computer-communicatable container data carrier associated with the container, the system comprising:

a robot, configured to manipulate the container;

a communication element; and

a control unit, configured to:

5 receive radiopharmaceutical information regarding at least one labeled radiopharmaceutical agent, the radiopharmaceutical information selected from the group consisting of: imaging protocol information for use with the at least one labeled radiopharmaceutical agent, and authenticatable information regarding a commercial license for use of an imaging protocol with the at least one labeled radiopharmaceutical agent,

receive patient information regarding a patient,

10 drive the robot to automatically dispense a dose of the labeled radiopharmaceutical agent to the container, and

drive the communication element to transmit to the container data carrier at least a portion of the radiopharmaceutical information and at least a portion of the patient information.

15 For some applications, the control unit is configured to receive the radiopharmaceutical information regarding a plurality of labeled radiopharmaceutical agents, and drive the robot to automatically dispense respective doses of the labeled radiopharmaceutical agents to the container.

20 For some applications, the patient information includes an identifier of an imaging protocol assigned to the patient for performance using the dose, and wherein the control unit is configured to drive the communication element to transmit the imaging protocol identifier to the container data carrier.

25 For some applications, the control unit is configured to drive the communication element to transmit to the container data carrier at least one of: a time of dispensing of the labeled radiopharmaceutical agent to the container, and information regarding a radioactivity of the dose at the time of dispensing.

In an embodiment, the apparatus comprises:

a mother vial that contains the labeled radiopharmaceutical agent prior to dispensing thereof; and

30 a computer-communicatable mother vial data carrier associated with the mother vial, which mother vial data carrier contains the radiopharmaceutical information,

wherein the control unit is configured to receive the radiopharmaceutical



information from the mother vial data carrier.

For some applications, the radiopharmaceutical information comprises the imaging protocol information. For some applications, the imaging protocol information comprises SPECT imaging protocol information, which may comprise at least one kinetic  
5 parameter of the at least one labeled radiopharmaceutical agent.

In an embodiment, the radiopharmaceutical information comprises the authenticatable information regarding the commercial license. For some applications, the information regarding the commercial license comprises information regarding the commercial license for use of a SPECT imaging protocol with the at least one labeled  
10 radiopharmaceutical agent. For some applications, the control unit is configured to authenticate the authenticatable license information, and to drive the robot to automatically dispense the dose only upon authentication.

There is still further provided, in accordance with an embodiment of the present invention, apparatus for use with a container, the apparatus comprising:  
15 a mother vial having a volume of at least 10 ml, which contains at least 5 ml of a non-diluted labeled radiopharmaceutical agent, and at least 5 ml of saline solution; and  
an automated radiopharmaceutical dispensing system, configured to contain the mother vial, and to dispense at least one dose from the mother vial to the container.

There is additionally provided, in accordance with an embodiment of the present  
20 invention, a method comprising:  
placing at least one labeled radiopharmaceutical agent in a container;  
associating a portable computer-communicatable data carrier with the container;  
and  
writing, to the data carrier, imaging protocol information for use with the at least  
25 one labeled radiopharmaceutical agent.

There is yet additionally provided, in accordance with an embodiment of the present invention, a method comprising:  
placing at least one labeled radiopharmaceutical agent in a container;  
associating a computer-communicatable data carrier with the container; and  
30 writing, to the data carrier, authenticatable information regarding a commercial license for use of SPECT imaging protocol information with the at least one labeled

radiopharmaceutical agent.

There is also provided, in accordance with an embodiment of the present invention, a method comprising:

- providing a portable computer-communicatable data carrier; and
- 5 writing, to the data carrier, authenticatable information regarding a commercial license for use of SPECT imaging protocol information.

There is further provided, in accordance with an embodiment of the present invention, a method comprising:

- writing first and second identifier values to first and second
- 10 computer-communicatable data carriers, respectively;
- detecting a correspondence between the first and second identifier values; and
- perform an imaging procedure on a patient responsively to the detecting.

There is still further provided, in accordance with an embodiment of the present invention, a method for use with at least one labeled radiopharmaceutical agent for

15 administration to a patient, the method comprising:

- placing at least one labeled radiopharmaceutical agent in a container;
- physically coupling a first computer-communicatable data carrier to the container;
- writing, to the first data carrier, radiopharmaceutical information regarding the at
- least one labeled radiopharmaceutical agent; and
- 20 writing, to a second portable computer-communicatable data carrier, patient information regarding the patient, and imaging protocol information for use with the at least one labeled radiopharmaceutical agent.

There is additionally provided, in accordance with an embodiment of the present invention, a method comprising:

- 25 placing, in a container, at least one labeled radiopharmaceutical agent for administration to a patient;
- associating a computer-communicatable data carrier with the container;
- writing data to the data carrier regarding at least one of: the labeled radiopharmaceutical agent and the patient;
- 30 reading the data from the data carrier at a SPECT imaging system;
- utilizing the read data to customize at least one function of the system selected

from the group consisting of: administration of the labeled radiopharmaceutical agent, acquisition of a SPECT image of the patient to whom the labeled radiopharmaceutical agent is administered, reconstruction of the SPECT image, analysis of the SPECT image, and diagnosis of a condition of the patient based at least in part on the analysis.

5           There is yet additionally provided, in accordance with an embodiment of the present invention, a method for use with a container containing at least one labeled radiopharmaceutical agent for administration to a patient, and data regarding at least one of: the labeled radiopharmaceutical agent and the patient, the method comprising:

          reading the data at a SPECT imaging system; and

10           utilizing the read data to customize at least one function of the system selected from the group consisting of: administration of the labeled radiopharmaceutical agent, acquisition of a SPECT image of the patient to whom the labeled radiopharmaceutical agent is administered, reconstruction of the SPECT image, analysis of the SPECT image, and diagnosis of a condition of the patient based at least in part on the analysis.

15           There is also provided, in accordance with an embodiment of the present invention, a method for use with a container and a computer-communicatable container data carrier associated with the container, the method comprising:

          receiving, by an automated radiopharmaceutical dispensing system, radiopharmaceutical information regarding at least one labeled radiopharmaceutical agent,  
20           the radiopharmaceutical information selected from the group consisting of: imaging protocol information for use with the at least one labeled radiopharmaceutical agent, and authenticatable information regarding a commercial license for use of an imaging protocol with the at least one labeled radiopharmaceutical agent;

          receiving, by the dispensing system, patient information regarding a patient;  
25           automatically robotically dispensing, by the dispensing system, a dose of the labeled radiopharmaceutical agent to the container; and

          transmitting to the container data carrier, by the dispensing system, at least a portion of the radiopharmaceutical information and at least a portion of the patient information.

30           There is further provided, in accordance with an embodiment of the present invention, a method for automatically dispensing a labeled radiopharmaceutical agent to a

container, comprising:

- providing a mother vial having a volume of at least 10 ml;
- filling the mother vial with at least 5 ml of a non-diluted labeled radiopharmaceutical agent, and with at least 5 ml of saline solution;
- 5 placing the mother vial in an automated radiopharmaceutical dispensing system;
- and
- dispensing at least one dose from the mother vial to the container.

There is also provided, in accordance with an embodiment of the present invention, a method for setting a dose of a labeled radiopharmaceutical agent for use for  
10 performing an imaging procedure on a patient for studying a physiological characteristic of the patient, the method including:

- selecting the radiopharmaceutical agent;
- receiving information regarding a medical parameter of the patient not directly related to the physiological characteristic of the patient; and
- 15 setting the dose at least in part responsively to the received information.

There is further provided, in accordance with an embodiment of the present invention, a substance associated with a time-dependent substance intake program generated by a computer controlled functionality employing a machine readable multi-parameter human physiological profile including at least one of a kinetic and  
20 intra-body location dependent parameter and a machine readable multi-parameter substance profile, including at least one kinetic parameter.

There is still further provided, in accordance with an embodiment of the present invention, a computer controlled functionality employing a machine readable multi-parameter human physiological profile including at least one of a kinetic and  
25 intra-body location dependent parameter and a machine readable multi-parameter substance profile, including at least one kinetic parameter, for indicating a time-dependent substance intake program.

There is yet further provided, in accordance with an embodiment of the present invention, a substance associated with a time-dependent substance intake program  
30 generated by a computer controlled functionality employing a machine readable multi-parameter human physiological profile including at least one of a kinetic and

intra-body location dependent parameter and a machine readable multi-parameter substance profile, including at least one kinetic parameter.

There is also provided, in accordance with an embodiment of the present invention, a time-dependent substance intake program generated by a computer controlled functionality employing a machine readable multi-parameter human physiological profile  
5 including at least one of a kinetic and intra-body location dependent parameter and a machine readable multi-parameter substance profile, including at least one kinetic parameter.

There is further provided, in accordance with an embodiment of the present invention, a substance formulated in accordance with a time-dependent substance intake  
10 program generated by a computer controlled functionality employing a machine readable multi-parameter human physiological profile including at least one of a kinetic and intra-body location dependent parameter and a machine readable multi-parameter substance profile, including at least one kinetic parameter.

There is still further provided, in accordance with an embodiment of the present invention, an apparatus, method, and/or functionality for generation of a machine readable multi-parameter human physiological profile including at least one of a kinetic and  
15 intra-body location dependent parameter, including providing a time-dependent substance intake program; a data acquisition system which acquires data from the patient passing through the intake program; and a computerized analysis using a machine readable  
20 multi-parameter substance profile, including at least one kinetic parameter.

There is yet further provided, in accordance with an embodiment of the present invention, an apparatus, method, and/or functionality for generation of a human physiological profile, including providing a substance intake program; a data acquisition  
25 system which acquires data from the patient passing through the intake program; and a computerized analysis using a substance profile, including at least one kinetic parameter.

There is also provided, in accordance with an embodiment of the present invention, an interactive pharmaceutical-containing, machine-readable information-bearing, customized medicine module suitable for use in computerized  
30 customized medicine, said customized medicine module including a computerized

customized medicine machine-interfaceable pharmaceutical-containing delivery module and a computerized individualized medicine machine-readable information-containing carrier containing at least data regarding said pharmaceutical which is required for use of said pharmaceutical in computerized customized medicine, said data being useful in  
5 computerized customized medicine machine actuation of said pharmaceutical-containing delivery module.

There is additionally provided, in accordance with an embodiment of the present invention, a computerized customized medicine machine including:

- a computerized patient imager;
- 10 a computerized pharmaceutical deliverer employing a pharmaceutical-containing, machine-readable information-bearing, customized medicine module; and
- a customized medicine protocol controller including:
  - an interactive patient imager interface including patient information receiving functionality and patient imaging actuation functionality; and
  - 15 an interactive pharmaceutical deliverer interface including patient information receiving functionality and patient information-responsive pharmaceutical delivery actuation functionality.

There is also provided, in accordance with an embodiment of the present invention, an interactive pharmaceutical-containing, machine-readable authenticated, authenticated customized medicine module suitable for use in computerized customized  
20 medicine, said customized medicine module including a computerized customized medicine machine-interfaceable pharmaceutical-containing module and a computerized individualized medicine machine-readable authentication-containing carrier containing at least authentication data regarding said pharmaceutical which is required for use of said  
25 pharmaceutical in computerized customized medicine, said data being useful in said computerized customized medicine machine.

There is further provided, in accordance with an embodiment of the present invention, a computerized customized medicine preparation machine including:

- a computerized patient information manager;
- 30 a computerized customized medicine pharmaceutical information manager;
- a computerized authenticated customized medicine module authenticator; and

a computerized pharmaceutical-containing, machine-readable information-bearing, customized medicine module generator including:

5 a computerized generator protocol manager operative to receive patient information from said patient information manager, to receive authentication of an authenticated customized medicine module from said authenticator, to receive customized medicine pharmaceutical information relating to at least one pharmaceutical contained in said authenticated customized medicine module from said pharmaceutical information manager and to prepare customized medicine information to be included in said customized medicine module; and

10 a computerized pharmaceutical-containing, machine-readable information-bearing, customized medicine module preparer operative to associate said customized medicine information prepared by said protocol manager in an authenticatable machine readable form with a quantity of said pharmaceutical contained in said authenticated customized medicine module, thereby providing a  
15 pharmaceutical-containing, machine-readable information-bearing, customized medicine module.

There is still further provided, in accordance with an embodiment of the present invention, an interactive pharmaceutical-containing, machine-readable information-bearing, individualized medicine module suitable for use in computerized  
20 individualized medicine, said individualized medicine module including a computerized individualized medicine machine actuatable pharmaceutical-containing delivery module and a computerized individualized medicine machine-readable information-containing carrier containing at least data regarding said pharmaceutical which is required for use of said pharmaceutical in computerized individualized medicine, said data being useful in  
25 computerized individualized medicine machine actuation of said pharmaceutical-containing delivery module.

For some applications, said data is in an encrypted format, readable by said computerized individualized medicine machine upon receipt of a predetermined authentication.

30 There is also provided, in accordance with an embodiment of the present invention, a computerized individualized medicine machine including:

a computerized patient imager;

a computerized pharmaceutical deliverer employing a pharmaceutical-containing, machine-readable information-bearing, individualized medicine module; and

an individualized medicine protocol controller including:

an interactive patient imager interface including patient image receiving  
5 functionality and patient imaging actuation functionality; and

an interactive pharmaceutical deliverer interface including patient image receiving functionality and patient image-responsive pharmaceutical delivery actuation functionality.

There is further provided, in accordance with an embodiment of the present  
10 invention, use of a high definition, high sensitivity camera for determination of an optimal parameter for a labeled radiopharmaceutical agent, the optimal parameter selected from the group consisting of: optimal dose, optimal mode of administration, optimal mode of acquisition of data with respect to the labeled radiopharmaceutical agent, optimal mode of data processing with respect to the labeled radiopharmaceutical agent, and optimal mode  
15 of presentation of information acquired with respect to the labeled radiopharmaceutical agent.

There is still further provided, in accordance with an embodiment of the present invention, a labeled radiopharmaceutical agent that is manufactured or designed or indicated for use with or sold with any one of the above techniques.

20 The present invention will be more fully understood from the following detailed description of embodiments thereof, taken together with the drawings, in which:

#### **BRIEF DESCRIPTION OF THE DRAWINGS**

Fig. 1 is a schematic illustration of an end-to-end automated system for medical imaging, in accordance with an embodiment of the present invention;

25 Fig. 2 is a flow chart showing an end-to-end method for medical imaging, in accordance with an embodiment of the present invention;

Fig. 3 is a schematic illustration of a patient-specific data carrier, in accordance with an embodiment of the present invention;

30 Fig. 4 is a schematic illustration of a patient management system, in accordance with an embodiment of the present invention;



Fig. 5 is a schematic illustration of a radiopharmaceutical dose calculation system, in accordance with an embodiment of the present invention;

Figs. 6A-E are tables showing exemplary preconfigured SPECT protocols and parameters thereof, in accordance with respective embodiments of the present invention;

5 Fig. 7 is a schematic illustration of a mother vial and attached data carrier, in accordance with an embodiment of the present invention;

Fig. 8 is a schematic illustration of a data carrier coupled to a radiopharmaceutical agent container, in accordance with an embodiment of the present invention;

10 Figs. 9A-H are schematic illustrations of respective embodiments of a radiopharmaceutical agent container and data carrier coupled thereto, in accordance with respective embodiments of the present invention;

Fig. 10 is a schematic illustration of an administration system, in accordance with an embodiment of the present invention;

15 Fig. 11 is a schematic illustration of an imaging system, in accordance with an embodiment of the present invention;

Fig. 12 is a schematic illustration of an automated radiopharmaceutical dispensing system, in accordance with an embodiment of the present invention;

Figs. 13A-C are schematic illustrations of a system for carrying out a data transfer process, in accordance with an embodiment of the present invention;

20 Fig. 14 is a schematic illustration of a radioisotope automatic elution system, in accordance with an embodiment of the present invention;

Fig. 15 is a schematic illustration of a mother vial preparation system, in accordance with an embodiment of the present invention;

25 Figs. 16A-B are illustrations of color spectra and a color-coded signature, respectively, in accordance with an embodiment of the present invention;

Fig. 17 is a schematic illustration of a computer-readable medium, a portion of which is shaped so as to define a physical key, in accordance with an embodiment of the present invention; and

Fig. 18 is a graph showing particle energy vs. photon count at a detector of a

camera, in accordance with an embodiment of the present invention.

### DETAILED DESCRIPTION OF EMBODIMENTS

Fig. 1 is a schematic illustration of an end-to-end automated system 10 for medical imaging, in accordance with an embodiment of the present invention. System 10  
5 comprises a plurality of integrated elements that are configured to electronically exchange information among one another. The elements include an automated radiopharmaceutical dispensing system 20, a portable information-bearing radiopharmaceutical agent container 22, a portable patient-specific data carrier 24, an automated administration system 26, and  
10 an automated imaging system 28. The systems perform their respective automated functions at least in part responsively to the exchanged information. The elements typically authenticate one another via the exchanged information, in order to ensure that only authorized elements participate in the system, and that only authorized and appropriate functions are performed. Each of the elements is described in detail hereinbelow.

#### 15 *End-to-end imaging method*

Fig. 2 is a flow chart showing an end-to-end method for medical imaging, in accordance with an embodiment of the present invention. At a radiopharmaceutical provisioning step 100, a manufacturer 102 (Fig. 1) or distributor provides a mother vial 104 (Fig. 1) containing an unlabeled radiopharmaceutical agent, and information  
20 associated with the radiopharmaceutical agent. Such an unlabeled radiopharmaceutical agent typically comprises a pharmaceutical substance, for example an antibody such as Capromab Pendetide marketed by Cytogen Corp. under the name ProstaScint and used in the detection of prostate cancer metastases, or sestamibi used in cardiac perfusion studies and marketed under the name of Cardiolite by Bristol Meyers Squibb Corporation, an ion,  
25 or another biological metabolized substance, or a substance which is not metabolized but nevertheless undergoes an interaction with the body. The information is stored in a mother vial data carrier 106 associated with mother vial 104, as described hereinbelow with reference to Fig. 7. For some applications, data carrier 106 is physically coupled to mother vial 104, while for other applications the data carrier is provided as a separate  
30 element associated with the mother vial. As described hereinbelow with reference to Fig. 7, the information stored in data carrier 106 typically includes information regarding the

radiopharmaceutical agent, such as the formulation, pharmacologic kinetic parameters, radioactivity information, and/or protocol information.

At a labeling step 110, the unlabeled radiopharmaceutical agent is labeled with an appropriate radioisotope, to produce a labeled radiopharmaceutical agent. Such labeling  
5 is typically performed using conventional methods, including mixing the agent with a solution containing the radioisotope, heating the mixture, and performing quality testing on the labeled radiopharmaceutical agent. For some applications, step 110 is performed using conventional radiopharmacy labeling techniques, while for other applications system 10 comprises a mother vial preparation system 700, which automatically performs  
10 all or a portion of the labeling, as described hereinbelow with reference to Fig. 15. The radioisotopes are provided by a radioisotope supplier 111, such as a conventional radiopharmacy or an automatic elution system 600, described hereinbelow with reference to Fig. 14. Data carrier 106 is typically updated with radioactivity-related information, including the time of labeling, the radioactivity of the radioisotope at the time of labeling,  
15 and the volume of the labeled radiopharmaceutical agent, as described hereinbelow with reference to Fig. 7.

For some applications, the only active constituent of the labeled radiopharmaceutical agent is the radioisotope; in other words, the radioisotope is not bound to a biologically active substance. For example, the labeled radiopharmaceutical  
20 agent may consist essentially of thallium (as well as pH-balancing constituents, salt ions, and preservatives). As used in the present application, including in the claims, a "labeled radiopharmaceutical agent" means either: (a) an agent comprising a diagnostic radioisotope, such as thallium, or (b) an agent comprising a radioisotope bound to a biologically active substance, such as an antibody, a pharmaceutical compound, an ion, or  
25 another biological metabolized substance, or a substance which is not metabolized but nevertheless undergoes an interaction with the body.

At a patient registration and imaging protocol assignment step 112, a healthcare worker 206 uses a patient management system 160 to register a patient into system 10, and to assign appropriate administration and imaging protocols for the patient, as  
30 described in detail hereinbelow with reference to Fig. 4. At an information transfer step 114, patient management system 160 assigns a portable patient-specific data carrier 24 to the patient, and transmits information to data carrier 24, including at least a patient

identifier (typically, the patient's identification code and/or name), and the assigned administration and imaging protocols. Additional patient data parameters recorded may include physiological data such as girth, height and weight. The patient management system additionally transmits an order for one or more patient-specific doses of the appropriate labeled radiopharmaceutical agent(s) to dispensing system 20 or a  
5 conventional radiopharmacy.

At a dose dispensing step 116, dispensing system 20 dispenses the ordered customized dose of the labeled radiopharmaceutical agent from mother vial 104, as described in detail hereinbelow with reference to Fig. 12. Prior to dispensing the dose,  
10 dispensing system 20 typically authenticates the mother vial using information stored in mother vial data carrier 106. For some applications, dispensing system 20 verifies the authenticity of a commercial license contained in data carrier 106. Typically, all or a portion of the information used for such verification is encrypted, and dispensing system 20 decrypts the information during the verification procedure. Alternatively or  
15 additionally, dispensing system 20 accesses, over a network, information stored at a remote site, and utilizes the information for such verification. The dispensing system dispenses the dose based on patient-specific prescription information, radiopharmaceutical agent-related information stored in data carrier 106, and/or patient-specific information provided by an element of system 10. Such patient-specific  
20 information may include, for example, age, weight, Body Mass Index (BMI), body dimensions, metabolic rate, hemodynamic state, and/or kinetic parameters of the labeled radiopharmaceutical agent as determined during previous imaging procedures performed on the patient. For some applications, dosage information is provided directly or indirectly by patient management system 160 and/or a radiopharmaceutical dose  
25 calculation system 152, which are described hereinbelow with reference to Figs. 4 and 5, respectively.

At an information transfer step 118, dispensing system 20 transfers patient-specific information and radiopharmaceutical-related information to a data carrier 120 physically coupled to container 22, as described hereinbelow with reference to Figs.  
30 9A-H and 10. "Physically coupled," as used in the present application, including the claims, includes both direct and indirect physical coupling. For example, data carrier 120 may be indirectly physically coupled to container 22 via shielding of container 22, or shielding of a cylinder in which container 22 is stored during transport and handling

thereof. The patient-specific information includes the patient's identification code and/or name, and the assigned administration and imaging protocols. The radiopharmaceutical-related information typically includes: (a) all or a portion of the information provided by the manufacturer in data carrier 106, such as described  
5 hereinbelow with reference to Fig. 7, e.g., intended use, formulation, pharmacologic kinetic parameters, and protocol information; (b) information regarding the radioactivity and volume of the dose; and (c) time of dispensing, as described in detail hereinbelow with reference to Fig. 8. In addition, the dispensing system typically prints and attaches a  
10 conventional information label to container 22, such as in order to comply with regulatory labeling requirements. For applications in which the labeled radiopharmaceutical agent(s) is dispensed using conventional radiopharmacy techniques, dispensing system 20, or another element of system 10, such as dose calculation system 152, typically transfers the radiopharmaceutical-related information to data carrier 120. Alternatively, all or a portion  
15 of the information is transferred directly from mother vial data carrier 106 to container data carrier 120.

At an administration step 122, administration system 26 receives radiopharmaceutical agent container 22, and administers the labeled radiopharmaceutical agent contained therein to the appropriate patient. As described hereinbelow with  
20 reference to Fig. 10, for some applications, administration system 26 comprises an automated administration device, which is configured to administer the labeled radiopharmaceutical agent, while for other applications, a healthcare worker manually administers the agent upon receiving a signal to do so from system 26. Prior to administration, system 26 authenticates container 22 and verifies the identity of the patient, using information provided by patient-specific data carrier 24 and container data  
25 carrier 120, and, optionally, another element of system 10, such as a physician station 115. Typically, all or a portion of the information used for such verification is encrypted, and administration system 26 decrypts the information during the verification procedure. Alternatively or additionally, administration system 26 accesses, over a network, information stored at a remote site, and utilizes the information for such verification.  
30 Administration system 26 verifies that the patient identification codes contained in patient-specific data carrier 24 and container data carrier 120 match one another, and, typically, verifies that the administration and/or imaging protocols contained in the data carriers match one another. Typically, at least a portion of the information stored in data

carrier 120 of container 22 is transferred to data carrier 24, either directly, via administration system 26, or via a communication element. For some applications, system 26 generates a signal for a healthcare worker confirming that a proper match has been made between agent container 22 and the patient. The system also typically verifies that the current time is the proper administration time, as per the administration protocol, and that container 22 contains the proper dose, as per the selected protocol. Optionally, system 26 is configured to administer the labeled radiopharmaceutical agent only if such matches are confirmed by the system. For some applications, administration system 26 verifies the authenticity of a commercial license contained in data carrier 120, and performs the administration only upon verification of the authenticity.

For some applications, administration system 26 customizes the administration of the labeled radiopharmaceutical agent using information provided by data carrier 24, data carrier 120, physician station 115, and/or patient management system 160. For example, system 26 may customize a time-dependent administration profile of the labeled radiopharmaceutical agent, such as a rate of administration. Alternatively or additionally, system 26 may administer less than the entire dose of the labeled radiopharmaceutical agent, e.g., based on feedback from imaging system 28 during an imaging procedure.

For some applications, such as dynamic studies, administration system 26 administers the labeled radiopharmaceutical agent during an imaging procedure performed by imaging system 28. For these applications, the administration system is in communication with the imaging system during the administration, in order to assure information regarding time-dependent administration is accurately communicated between the administration system and the imaging system. For some applications, imaging system 28 reads information from patient-specific data carrier 24, and transmits at least a portion of the information to administration system 26, thereby obviating the need for the administration system to directly read such information from the data carrier. For some applications, imaging system 28 triggers the commencement of administration. (It is to be understood that although the imaging system triggers administration of the agent, for some applications the agent is not administered until a healthcare worker provides a final authorization to do so, such as to comply with regulatory safety requirements.) For some applications, the labeled radiopharmaceutical agent(s) is administered in a closed loop with an imaging procedure performed by imaging system 28; administration system 28 modifies one or more parameters of the administration in

real time based on feedback received from imaging system 28, and/or based on real-time measurements of physiological parameters of the patient (e.g., systemic blood concentrations) during the imaging procedure. For some protocols, the administration system administers a preliminary bolus injection, and, based on feedback from imaging system 28 and/or on physiological parameters of the patient, configures one or more parameters of a subsequent administration of the same or a different labeled radiopharmaceutical agent.

At an information transfer step 123, before, during and/or after administration of the labeled radiopharmaceutical agent, system 26 electronically updates patient-specific data carrier 24 with details of the administration, such as:

- an identification code of container 22 and/or an administration device;
- an identification code of the patient to which the labeled radiopharmaceutical agent was dispensed, which should match the patient code already stored in data carrier 24;
- the administered labeled radiopharmaceutical agent;
- the volume of the labeled radiopharmaceutical agent administered;
- the time of administration;
- the time profile of administration;
- the radioactivity of the labeled radiopharmaceutical agent at the time of administration;
- the radioactivity of the labeled radiopharmaceutical agent when dispensed to container 22;
- the time of measurement of the radioactivity when dispensed to container 22; and/or
- at least a portion of the radiopharmaceutical information provided by data carrier 106 of mother vial 104.

For some applications, data carrier 120 of container 22 communicates administration information to patient-specific data carrier 24, either directly or via administration system 26. For some applications, system 26 provides similar updates to

other elements of system 10, such as patient management system 160, management control component 150, physician station 115, and/or imaging system 28. Alternatively or additionally, a healthcare worker manually updates one or more of the data carrier and/or system elements. Typically, for safety purposes, after administration system 26  
5 has read all necessary information from data carrier 120, administration system 26 permanently disables data carrier 120 of container 22, in order to ensure that the data carrier is not accidentally reused for another patient.

Reference is still made to Fig. 2. After or during administration of the labeled radiopharmaceutical agent, imaging system 28 performs an imaging procedure on the  
10 patient, at an imaging step 124. Imaging system 28 is described hereinbelow with reference to Fig. 11. Prior to performing the imaging procedure, system 28 verifies one or more of the following:

- the identity of the patient, using information provided by patient-specific data carrier 24;
- 15 • the authenticity of patient-specific data carrier 24, typically using information provided by the data carrier itself, a coded signature 256, as described hereinbelow in the section entitled "Signature," and/or a key 852, as described hereinbelow with reference to Fig. 17;
- that patient-specific data carrier 24 has been brought within a certain  
20 distance of imaging system 28, e.g., within about 30 cm;
- the identity of the manufacturer or distributor of the radiopharmaceutical agent, using information stored in data carrier 120;
- that a selected camera of imaging system 28, imaging protocol, and patient  
25 identification code, as provided to imaging system 28 by one or more elements of system 10, match those stored in patient-specific data carrier 24;
- the authenticity of a commercial license contained in patient-specific data  
30 carrier 24. For some applications, system 28 verifies that the license has not been previously used, for example by verifying that a registration code associated with the license has not been previously received by system 28 and/or system 10; and/or



- that administration system 26 used (or is about to use, for procedures in which administration occurs during imaging) the correct container 22 and associated data carrier 120 for the prescribed imaging procedure, and administered (or is about to administer) the appropriate dose of the labeled radiopharmaceutical agent(s) at time(s) appropriate for performance of the imaging procedure.

Typically, all or a portion of the information used for such verification is encrypted, and imaging system 28 decrypts the information during the verification procedure. Alternatively or additionally, imaging system 28 accesses, over a network, information stored at a remote site, and utilizes the information for such verification.

For some applications, system 28 generates a signal for a healthcare worker confirming that a proper match has been made between the patient and one or more of the components described above. Optionally, system 28 is configured to perform the imaging procedure only if such a match is confirmed by the system.

Typically, system 28 customizes the imaging procedure using information provided by administration system 26, data carrier 24, and/or physician station 115. Such information typically includes information regarding the time of labeled radiopharmaceutical administration, the labeled radiopharmaceutical agent (e.g., radioactive strength, time of preparation, and/or kinetic parameters), patient-specific physiological information, and/or imaging protocol information. Parameters of the imaging procedure that are typically customized include, but are not limited to: total acquisition time; detector motions, such as detector angular and translational motions, detector step size (i.e., the density of the step size, typically expressed in degrees), and detector dwell time at each view; type of study, such as standard, active vision (as described in the above-mentioned International Application PCT/IL2005/001173), or gated; definition of the region of interest (ROI), for example, based on the size of the heart; and/or attenuation correction parameters, which are typically based on physiological parameters such as body mass, BMI, and girth.

At an image reconstruction step 126, imaging system 28 uses the acquired imaging data for image reconstruction. For some applications, system 28 customizes the image reconstruction procedure using information provided by administration system 26, data carrier 24, and/or physician station 115.

Imaging system 28 analyzes the reconstructed image, at an analysis step 128. For some applications, system 28 customizes the analysis procedure using information provided by administration system 26, data carrier 24, and/or physician station 115.

5 The imaging system, or a separate diagnostic system of system 10, assists with developing a diagnosis based on the analysis, at a diagnosis step 130. Typically, system 28 customizes the diagnostic procedure using information provided by administration system 26, data carrier 24, and/or physician station 115. For some applications, authentication is performed to verify that the imaging was performed as intended. Reconstruction and analysis are preferably based on lookup tables and expert system  
10 rules, for example, as provided by the radiopharmaceutical manufacturer, and may be patient customized, taking into account known patient physiology and/or suspected disease. Alternatively or additionally, the lookup tables and/or expert system diagnostic rules are configured to provide such customization. For some applications, customization and/or diagnostic techniques are performed that are described in the above-mentioned  
15 International Application PCT/IL2005/001173.

The diagnosis and/or the results of the imaging procedure are typically transmitted to physician station 115, for use by an attending healthcare worker 206. Alternatively or additionally, the diagnosis and/or the results of the imaging procedure are transmitted to a database 132 (Fig. 1). The accumulated results of a number of such imaging procedures  
20 for a large population are analyzed in order to develop, optimize, update, or otherwise re-evaluate imaging protocols, and update appropriate lookup tables and/or expert system rules for the use of the radiopharmaceutical agent. For example, the database may contain quantitative data regarding absolute blood flow measurements from healthy patients and patients with varying level of diseases. For some applications, such data is used to obtain  
25 disease-specific tissue signatures by performing quantitative analysis of normal and diseased tissue. Alternatively or additionally, the information in database 132 is used for: (a) comparing the results of an imaging procedure (images, and/or quantitative information and/or analyses) with historical results of the patient, in order to classify disease state and/or (b) comparing the results of an imaging procedure with similar results  
30 from a patient population, in order to classify disease state.

Typically, physician station 115 comprises one or more standard personal computers or servers with appropriate memory, communication interfaces and software

for carrying out the functions prescribed by relevant embodiments of the present invention. This software may be downloaded to the physician station in electronic form over a network, for example, or it may alternatively be supplied on tangible media, such as CD-ROM.

5           During or after steps 124 through 128, imaging system 28 updates the data stored in patient-specific data carrier 24 and/or other elements of system 10, such as patient information system 160, and/or physician station 115, to reflect details of the imaging procedure performed. In addition, for some applications, imaging system 28 transfers data to the specific camera used for the procedure, such as patient details,  
10 radiopharmaceutical information, and/or administration information, which information is received from data carrier 24, or from other elements of system 10.

*The patient-specific data carrier*

Reference is made to Fig. 3, which is a schematic illustration of patient-specific data carrier 24, in accordance with an embodiment of the present invention. Data carrier  
15 24 is configured to be held or worn by the patient, and, for some applications, comprises a coupling mechanism configured to be coupled to the patient, which coupling mechanism, comprises, for example, a bracelet, watch, or necklace (Fig. 3A shows the data carrier integrated into a watch or bracelet 170). Data carrier 24 is computer-communicatable, and typically comprises an RFID tag, smart card, disk-on-key (e.g., a USB key), or other  
20 electronic memory, as described below. Data carrier 24 is configured to hold information regarding the patient and a selected imaging procedure, as described immediately hereinbelow with reference to Fig. 4.

One or more communication elements 240 are provided for reading data from and transmitting data to data carrier 24 e.g., using a proprietary or standard wireless protocol,  
25 e.g., Bluetooth, WiFi, W-LAN, or IEEE 802.11. Alternatively, the communication element is brought into physical contact with data carrier 24, and reads and/or writes the information using an electrical contact, or other coupling technique, such as inductive coupling. Respective communication elements 240 are typically in data communication with patient management system 160, physician station 115, dispensing system 20,  
30 administration system 26, and/or imaging system 28. For some applications, communication elements 240 comprise one or more coils for transmitting and receiving electromagnetic radiation. Typically, the communication elements are configured to have

a short effective transmission range, e.g., no more than between about 20 and 40 cm, such as about 30 cm. Such a short range reduces the likelihood of accidental communication with a data carrier other than the intended data carrier.

5 For some applications, a portion of the patient information stored in the data carrier is also printed in human- and/or machine-readable form on the data carrier. For example, a name 172 and identification code 174 of the patient, and/or a barcode 176 may be printed on the data carrier.

10 Data carrier 24 comprises circuitry 178, which comprises memory and logic. For some applications, data carrier 24 is passive, in which case it is configured to receive energy from communication element 240. For other applications, data carrier 24 comprises a power source (not shown). For some applications in which the data carrier comprises a power source, the data carrier comprises a communication element for communicating and/or energizing another electronic apparatus. Alternatively or additionally, the data carrier comprises a communication element configured for wireless  
15 communication.

For some applications, data carrier 24 further comprises a user output 180 for outputting information to the patient or healthcare workers. For example, output 180 may comprise a display screen, light, and/or sound generator, which circuitry 178 drives to communicate information, such as when communications have been established with  
20 other elements of system 10, e.g., data carrier 120, administration system 26, imaging system 28, and/or patient management system 160. For some applications, circuitry 178 is configured to additionally function as an alarm clock; for example, the circuitry may drive display 180 to alert the patient prior to a scheduled administration or imaging procedure.

25 Typically, for safety purposes, upon completion of all the imaging procedures associated with a given patient-specific data carrier 24, system 10 permanently disables the data carrier, in order to ensure that the data carrier is not accidentally reused for another patient.

#### *The patient management system*

30 Reference is made to Fig. 4, which is a schematic illustration of patient management system 160, in accordance with an embodiment of the present invention.

Patient management system 160 manages patient-related administrative and medical information, and typically comprises at least one workstation 200 in communication with one or more servers 202. Typically, workstation 200 and servers 202 comprise standard personal computers and/or computer servers with appropriate memory, communication  
5 interfaces and software for carrying out the functions prescribed by relevant embodiments of the present invention. This software may be downloaded to the workstation and servers in electronic form over a network, for example, or it may alternatively be supplied on tangible media, such as CD-ROM.

System 160 performs the following functions:

- 10 • receives and registers new patients into system 10, typically into management and control component 150 thereof;
- assigns patient identification codes;
- assigns, issues, and transfers information to patient-specific data carriers  
24;
- 15 • receives and tracks patient prescriptions for radiopharmaceuticals, and communicates the prescriptions to other elements of system 10, such as dispensing system 20, administration system 26, and/or management and control component 150; and/or
- suggests and assigns imaging protocols based on the patient's imaging  
20 needs and patient-specific information.

During reception of a new patient 204, healthcare worker 206 manually enters patient information into workstation 200. Alternatively or additionally, all or a portion of the patient information is provided electronically by another healthcare system or electronic information source. System 160 typically verifies the healthcare worker's  
25 identity and access privileges by interrogating a computer-communicatable identity tag 208 held by the worker, and/or by checking the validity of a password entered into workstation 200 by the healthcare worker.

The patient information provided to system 160 typically includes:

- 30 • the patient's general details, such as name, age, gender, address, telephone number, profession, attending and/or treating physician, health insurance plan, and next of

kin;

- the patient's medical profile, such as medical condition, medical history, family medical history, BMI, weight, allergies, sensitivity to one or more chemical compounds, metabolic rate, and other physiological conditions;
- 5
- medications prescribed to the patient;
  - the patient's imaging history; and/or
  - information regarding the desired imaging, including reason for imaging, type of imaging, body structure or organ to be imaged, and known or suspected pathology.

In an embodiment of the present invention, upon entry of such patient information  
10 into patient management system 160, the system automatically suggests one or more imaging protocols that may be appropriate for the patient's imaging needs and medical condition. When making such suggestion, the system takes into consideration, in addition to the information regarding the desired imaging, such factors as the patient's general details, medical profile, imaging history, and guidelines for medication interactions. The  
15 system typically selects the suggested protocol(s) from a database of preconfigured protocols, which is described hereinbelow with reference to Figs. 6A-E. Healthcare worker 206 selects one of the suggested protocols, or selects another non-suggested protocol directly from the protocol database.

For some applications, the system suggests one or more customizations of the  
20 selected protocol, as described hereinbelow with reference to Figs. 6A-E, which the healthcare worker may accept, decline, or modify, in whole or in part. These suggested customizations are typically based on (a) physiological parameters of the patient, such as age, weight, BMI, metabolic rate, and/or hemodynamic state, and/or kinetic parameters of the radiopharmaceutical agent as determined during previous imaging procedures  
25 performed on the patient, and/or (b) a medical profile group to which the patient is assigned, such as high, normal, or low BMI, or high BMI - diabetic, or high BMI - normal metabolic rate. (For some applications, such profile groups are stored in a database of management and control component 150.) Alternatively or additionally, the healthcare worker may customize the protocol manually.

30 Upon selection and customization of the protocol, patient management system 160 schedules, typically automatically:

- a specific imaging system 28 capable of performing the selected imaging procedure;
- a date and time for performing the imaging procedure; and
- a date(s) and time(s) for administration of labeled radiopharmaceutical agent(s).

5 Patient management system 160 transmits the entered and generated patient-specific information, including the selected protocol, to the patient's patient-specific data carrier 24. The transmitted patient-specific information typically includes:

- 10 • the patient's identification code and name;
- an identifier of the selected imaging protocol(s), such as a name and/or an identification code thereof, and/or additional imaging protocol information, such as described hereinbelow with reference to Figs. 6A-E;
- an identifier of the selected administration protocol(s), such as a name  
15 and/or an identification code thereof;
- the scheduled imaging system 28;
- the scheduled imaging date and time;
- the scheduled administration date(s) and time(s);
- the patient's personal details;
- 20 • the patient's medical profile; and/or
- the patient's imaging history.

The patient management system transmits an order for one or more patient-specific doses of the appropriate labeled radiopharmaceutical agent(s) to dispensing system 20, such as via management and control component 150. Typically,  
25 the patient management system additionally transmits at least a portion of the entered and generated patient-specific information to one or more of: (a) management and control component 150, (b) dose calculation system 152, (c) administration system 26, and/or (d) imaging system 28. Typically, a different subset of the information is transmitted to each of these entities.

As described hereinabove with reference to Fig. 3, for some applications, a portion of the patient information stored in data carrier 24 is also printed in human- and/or machine-readable form on the data carrier. For example, a name 172 and identification code 174 of the patient, and/or a barcode 176 may be printed on the data carrier. For such applications, system 160 comprises a printer 210, which is configured to print the information directly on data carrier 24, or to print the information on an adhesive label, which healthcare worker 206 attaches to data carrier 24. For some applications, printer 210 comprises communication element 240, and the printer is configured to both print the information on the data carrier and transmit the information to the data carrier, typically generally at the same time.

In an embodiment of the present invention, system 10 comprises at least one web server, which is configured to accept orders for an imaging procedure over an intranet or the Internet, placed by a physician or other healthcare worker. Such orders can typically be modified up until a deadline, such as midnight before the day of the scheduled imaging procedure.

#### *The management and control component*

Reference is again made to Fig. 1. In an embodiment of the present invention, system 10 comprises management and control component 150, which coordinates a portion of the interaction and communication among the elements of system 10. The remainder of the interaction and communication occurs directly between the elements of the system, and/or via other elements of the system. For some applications, component 150 issues a password and/or computer-communicatable identity tags 208 to healthcare workers 206 authorized to interact with one or more elements of system 10. For example, tag 208 may comprise an RFID tag, smart card, disk-on-key (e.g., a USB key), minidisk, or other electronic memory, or a machine-readable code, e.g., a barcode. As appropriate, healthcare workers 206 may be assigned various permission levels, such as permission to view or modify particular system and/or patient data.

Typically, management and control component 150 comprises one or more standard personal computers or servers with appropriate memory, communication interfaces and software for carrying out the functions prescribed by relevant embodiments of the present invention. This software may be downloaded to the management and control component in electronic form over a network, for example, or it may alternatively



be supplied on tangible media, such as CD-ROM.

*The dose calculation system*

Reference is made to Fig. 5, which is a schematic illustration of radiopharmaceutical dose calculation system 152, in accordance with an embodiment of the present invention. The dose calculation system manages and tracks, typically automatically, radiopharmaceutical inventory, ordering, dose dispensing, and disposal. Typically, the dose calculation system comprises one or more standard personal computers or servers with appropriate memory, communication interfaces and software for carrying out the functions prescribed by relevant embodiments of the present invention. This software may be downloaded to the dose calculation system in electronic form over a network, for example, or it may alternatively be supplied on tangible media, such as CD-ROM. The dose calculation system receives information from dispensing system 20 regarding doses drawn from the inventory.

Dose calculation system 152 typically comprises:

- 15     • an ordering sub-system 154, which orders radiopharmaceutical products from radiopharmaceutical manufacturers, distributors, and/or radiopharmacies, typically automatically, such as when the dose calculation system identifies that inventories of a given radiopharmaceutical are lower than needed;
- 20     • a receipt and verification sub-system 155, which manages the receipt and registration of radiopharmaceutical products. The receipt and verification sub-system checks the received products against orders placed by the ordering sub-system, and typically performs license management. When a received mother vial 104 includes a mother vial data carrier 106, the  
25     sub-system reads information contained in the data carrier to verify that the order has been accurately fulfilled, and, typically, verifies the authenticity of the mother vial;
- 30     • a dose calculation sub-system 156, which calculates customized doses of labeled radiopharmaceutical agents for patients based on patient-specific information, protocol information, and/or prescription information, and communicates the customized doses to patient management system 160

and/or dispensing system 20; and/or

- a waste-disposal sub-system 157, which tracks radioactive waste disposal by system 10, such as disposal of radioactive materials contained in waste container 512, described hereinbelow with reference to Fig. 12. For some applications, sub-system 157 additionally tracks radioactive waste disposal of materials in the clinical environment not associated with system 10.

Ordering sub-system 154 and waste-disposal sub-system 157 typically operate in accordance with per country requirements for radiopharmaceutical use. A reporting sub-system reports to relevant nuclear regulatory commissions as required, based on information obtained from the other sub-systems.

In an embodiment of the present invention, dose calculation sub-system 156 designs a cocktail of labeled radiopharmaceutical agents or a series of labeled radiopharmaceutical agents to carry out the desired imaging. When designing such a cocktail or series, the sub-system considers constraints imposed by the physical properties of the agents and by the patient history, and other requirements, such as safety and efficacy requirements. The sub-system determines an appropriate dose for the specific patient having particular physiological parameters (e.g., weight, BMI, and age), and determines the times at which multiple agents are to be administered to the patient in order to achieve optimal imaging.

For some applications, sub-system 156 determines that a plurality of labeled radiopharmaceutical agents are to be administered together and thus must be combined in a single preparation, i.e., a cocktail. For other applications, the sub-system determines that a plurality of labeled radiopharmaceutical agents are to be administered separately at different times and thus must be contained in separate containers 22. As appropriate, sub-system 156 takes into consideration differing half-lives of the plurality of labeled radiopharmaceutical agents, in conjunction with the prescribed time of the imaging procedure. For example, a simultaneous imaging protocol is provided for assessing cardiac perfusion using a cocktail comprising Tc-99m sestamibi injected at rest, and thallium-201 injected at stress, wherein the desired activities at imaging time of the Tc-99m sestamibi and the thallium are 6 mCi and 4 mCi, respectively. When calculating the necessary activity of the dispensed dose, sub-system 156 accounts for the respective half-lives of Tc-99m (6 hours) and thallium-201 (64 hours) in view of the planned time

interval between the dispensing time and administration time. For example, if dispensing is performed 24 hours before administration, sub-system 156 calculates the activities of the Tc-99m and thallium-201 at the time of dispensing to be 96 mCi and 5.5 mCi, respectively.

#### 5 *Protocol information*

Reference is made to Figs. 6A-E, which is a table showing exemplary preconfigured SPECT protocols and parameters thereof, in accordance with respective embodiments of the present invention. These protocols are appropriate, for example, for use with the SPECT imaging methods and apparatus described hereinbelow with  
10 reference to Fig. 11, and/or in the co-assigned patent applications and/or patent application publications incorporated herein by reference hereinabove. For some applications, the techniques described herein utilize additional protocols described in above-mentioned International Application PCT/IL2005/001173, International  
15 Application PCT/IL2005/001215, filed November 16, 2005, above-mentioned US Provisional Patent Application 60/628,105, above-mentioned US Provisional Patent Application 60/675,892, or in one or more of the other co-assigned patent applications and/or patent application publications incorporated herein by reference. Alternatively or additionally, the techniques described herein utilize protocols for non-SPECT imaging modalities, such as PET or CT, or other imaging modalities known in the art. The  
20 preconfigured protocols are stored in a database, which is typically used by patient management system 160 for suggesting protocols and/or by dose calculation sub-system 156, as described hereinabove with reference to Figs. 4 and 5, respectively.

For each of the exemplary protocols shown in Fig. 6A, the table indicates general parameters for a rest phase and a stress phase of the protocol. For example, for the "single  
25 isotope / low dose / fast imaging" protocol, the table shows that the radiopharmaceutical (RP) for the rest phase of the protocol is less than 0.3 mCi of Thallium, that the waiting time after injection of the radiopharmaceutical is 2 minutes, and that the image acquisition duration is 15 minutes. Parameters for the stress phase are similarly indicated, with the addition of the type of stress (exercise, e.g., treadmill or bicycle, or pharmaceutical, e.g.,  
30 adenosine). The "thallium stress perfusion" and "simultaneous dual isotope stress perfusion" protocols are optionally dynamic.

For each of the exemplary protocols shown in Figs. 6B-E, the table indicates

administration parameters, detector parameters, scanning parameters, and analysis parameters for the protocol. For example, for Protocol A of Figs. 6B-C ("Cardiac mapping"), the table indicates:

- the labeled radiopharmaceutical agent is Tc-99-sestamibi (MIBI);
- 5 • the protocol is a fast protocol, with image acquisition completed prior to substantial uptake of the agent by the liver;
- the injection is by a single bolus;
- image acquisition begins either about 2 minutes after injection, or during or immediately administration, for applications in which the administration  
10 is performed while the patient is already placed at camera 452 (Fig. 11);
- the detected photon energy is 140 KeV with an energy resolution of 15%, i.e., the total range of energy levels detected by the detectors 454 of camera 452 (Fig. 11) is set to be 15% of the emitted energy level of the labeled radiopharmaceutical agent (140 Kev). Typically, this range is not  
15 centered around the emitted energy level, but instead is shifted towards lower energy levels;
- the total scan time is 120 seconds;
- four detectors 454 of camera 452 are assigned as outer (distal) detectors, and six detectors 454 are assigned as inner (proximal) detectors, as  
20 described hereinbelow with reference to Fig. 11;
- each of the inner detectors has an angular range of between 90 and 120 degrees, and each of the outer detectors has an angular range of between 40 and 60 degrees;
- the total number of angular orientations assumed by the detectors in  
25 aggregate is 1200, i.e., 10 detectors times 120 orientations each;
- each angular step of the inner detectors is one degree, and each angular step of the outer detectors is 0.3 to 0.5 degrees (corresponding to the range of 40 to 60 degrees described above);
- the dwell time at each step is one second, for both the inner and outer  
30 detectors;

- the imaging procedure is gated using 16 to 32 frames;
- the analyses to be performed include intensity image and ejection fraction.

For some applications, the protocol information includes additional information not shown in Figs. 6B-E, such as:

- 5
- additional scanning parameters, such as whether the detectors perform multiple scans (in all the protocols shown in the table, the detectors typically perform a single scan); and
  - additional analysis parameters, such as:
    - saturation handling (in the first cardiac mapping protocol shown in the  
10 table, no saturation handling is performed, while in the second cardiac mapping protocol shown in the table, the analysis is configured to dismiss saturated pixels);
    - whether the analysis handles scatter from multiple sources (in the  
15 protocols shown in the table, the analysis does not handle scatter from multiple sources);
    - reconstruction resolution (in all of the protocols shown in the table, the image reconstruction resolution is 2.5 mm in the z-direction, and 5 mm in the x- and y-directions); and
    - parameters that provide the diagnosis system (e.g., expert system) with  
20 information regarding how to interpret the results of the imaging study, such as kinetic parameters, predefined pathological values, or patient-specific physiological parameters (e.g., BMI, age, or a group to which the patient is assigned).

Reference is made to Protocol E of Figs. 6B-C. In this cardiac mapping protocol,  
25 simultaneous image acquisition is performed using, typically using full conventional doses of both thallium and MIBI-Tc. The detected photon energy of the thallium is 167 KeV, rather than the 72 KeV that is conventionally detected during nuclear imaging procedures. Unlike conventional SPECT cameras, the camera described hereinbelow with reference to Fig. 11 is sufficiently sensitive to detect a clinically-relevant count of the  
30 relatively low percentage (8%) of photons emitted at the 167 KeV energy level.

(Detection of 72 KeV energy is generally not practical when a conventional dose of MIBI-Tc is used, because the scatter from the 140 KeV energy level of MIBI-Tc masks the 72 KeV photons emitted by the thallium.)

Reference is made to Protocol I of Figs. 6D-E. In this cardiac dynamic mapping protocol, image acquisition typically begins prior to administration of the radiopharmaceutical agent, such as at one minute prior to administration, as shown in the table. This allows the imaging system to complete one full scan of the region of interest prior to administration of the radiopharmaceutical agent, in order to ensure that the imaging system is able to acquire photons of radiation beginning immediately after the radiopharmaceutical agent is administered.

Typically, a selected preconfigured protocol is customized based on physiological parameters of the specific patient, and/or a medical profile group of the patient, as described hereinabove with reference to Fig. 4. Such customization typically includes customization of the radiopharmaceutical agent, administration parameters, and/or imaging parameters.

For some applications, one or more of the following parameters of the radiopharmaceutical agent are customized:

- the dose, or for multiple radiopharmaceutical agents, the respective doses;
- the radioactivity;
- for cocktails, the ratio of the different radiopharmaceutical agents; and/or
- the volume of the dose, or for multiple radiopharmaceutical agents, the volumes of the respective doses.

For some applications, one or more of the following parameters of the administration are customized:

- the dose administered, or for multiple radiopharmaceutical agents, the respective doses per administration;
- the type of administration, e.g., a single bolus, a plurality of boluses (e.g., two boluses), pulsatile administration, or constant drip administration;
- the labeled radiopharmaceutical agent for each administration, whether a single agent or a cocktail of agents;

- the time of the administration with respect to the time of imaging;
- the timings of multiple administrations with respect to each other and with respect to other activities, such as rest or stress (physical or pharmacological);
- 5     • the administration device, e.g., a syringe, a dual-needle syringe, a pump, or an IV line; and/or
- the mode of administration, e.g., manual, automatic, or computer driven.

For some applications, one or more of the following parameters of the imaging procedure are customized. For some applications, such parameters are separately  
10 specified for individual components of camera 452 of imaging system 28, or groups of components, such as for individual detectors 454 or groups of detectors of camera 452, described hereinbelow with reference to Fig. 11.

- total acquisition time, and/or acquisition time for a plurality of phases of acquisition;
- 15     • detector scanning plan, including detector motions, such as detector angular and translational motions, detector step size (i.e., the density of the step size, typically expressed in degrees), number of detectors utilized for image acquisition, and detector dwell time at each view;
- detector sensitivity;
- 20     • detection energy resolution;
- detector calibration plan;
- definition of the region of interest (ROI);
- gating parameters;
- energy bands, i.e., a plurality of non-overlapping energy windows;
- 25     • collimator positioning, shape, structure, and orientation;
- multiple/interlaced scans;
- zooming parameters;
- uniformity/non-uniformity of scan;

- Compton scatter map calculation and correction parameters;
- optimal energy window;
- optimal energy resolution, i.e., the range of energy level windows for which detection is enabled; and/or
- 5     • adaptivity of scan pattern to acquired counts, e.g., active vision parameters (as described in the above-mentioned International Application PCT/IL2005/001173).

In an embodiment of the present invention, system 10 uses high definition protocols in conjunction with SPECT imaging techniques to enable personalized functional imaging at higher speeds and resolutions than can be achieved using conventional radiopharmaceutical protocols and imaging technology, using imaging techniques described herein and/or incorporated herein by reference. Alternatively or additionally, the system uses low dose protocols that enable personalized functional imaging at higher resolutions but with substantially lower doses than possible using conventional methods.

In an embodiment of the present invention, system 10 uses a protocol pursuant to which a patient undergoes a rest thallium (TI-201-thallos chloride) and stress Tc-99-sestamibi (MIBI) study having a total study duration of between about 60 and about 90 minutes, and a total image acquisition duration of between about 0.5 and about 6 minutes, e.g., about four minutes. For example, pursuant to the protocol:

- about 3 mCi of thallium may be administered to the patient as a bolus IV injection,
- the patient may rest for between about 10 and about 15 minutes,
- an image acquisition having a duration of about two minutes may be performed,
- the patient may be physically stressed,
- about 20-30 mCi of Tc-99-sestamibi may be administered as a bolus IV injection, and
- a second image acquisition having a duration of about two minutes may be performed.



Such dual-isotope imaging is generally useful for assessing myocardial perfusion of patients with suspected ischemic syndromes and a variety of other conditions. Alternatively, in an embodiment, the rest phase is performed using an approximately 8 to 10 mCi dose of Tc-99-sestamibi, in which case image acquisition typically commences  
5 about 30 minutes after injection of the sestamibi. Further alternatively, in an embodiment, image acquisition for the rest phase is performed about two minutes after injection of the thallium, the stress is pharmacological (e.g., using adenosine), and image acquisition for the stress phase is performed essentially immediately after injection of the sestamibi. Still further alternatively, in an embodiment, the rest phase is performed using  
10 Tc-99-sestamibi, and image acquisition commences essentially immediately upon injection of a dose of about 8 to 10 mCi.

In accordance with respective embodiments of the present invention, dual-radiopharmaceutical protocols include the administration and simultaneous imaging of the following combinations of labeled radiopharmaceutical agents. Typically, the  
15 labeled radiopharmaceutical agents are administered as a mixture (i.e., a cocktail) before or during a simultaneous imaging procedure; alternatively, the labeled radiopharmaceutical agents are administered separately before or during a simultaneous imaging procedure.

- (a) I-123 BMIPP, a fatty acid imaging agent that has been available in  
20 Japan for many years, and is currently in Phase III clinical trials in the United States, and (b) a myocardial perfusion agent (e.g., Tc-99m sestamibi, Tc-99m tetrofosmin, or Tl-201-thallos chloride), for simultaneously studying myocardial perfusion and fatty acid metabolism;
- (a) Tl-201-thallos chloride and (b) Tc-99m pertechnetate, for  
25 differentiating an organ from its anatomical surroundings, such as differentiating parathyroid glands from the thyroid gland;
- (a) In-111 DTPA, and (b) Tc-99m-MAG3, for differentiating pathological processes in a given organ, such as performing differential diagnosis of a hypo-perfused kidney, e.g., to study true glomerular filtration rate and  
30 tubular secretion simultaneously;
- a cocktail of labeled radiopharmaceutical agents, for studying cancer, including simultaneous diagnosis, prediction of therapy response, and

monitoring of therapy, such as simultaneously identifying a tumor, and characterizing tumor perfusion and metabolic activity, e.g., in order to provide a disease signature; and

- the combinations shown in the following table.

TABLE 1

First radiopharmaceutical	First application	Second radiopharmaceutical	Second application
$^{201}\text{Tl}$	Myocardial perfusion	Tc-99m-teboroxime	Myocardial perfusion
		Tc-99m-sestamibi	
		Tc-99m-tetrophosmin	
$^{201}\text{Tl}$	Myocardial perfusion	Tc-99m-PYP	Infarct Imaging
$^{201}\text{Tl}$	Myocardial perfusion	Tc-99m-Annexin	Apoptosis
$^{201}\text{Tl}$	Myocardial perfusion	$^{123}\text{I}$ -BMIPP	Hypoxia
Tc-99m-teboroxime	Myocardial perfusion	$^{111}\text{In}$ -Annexin	Apoptosis
Tc-99m-teboroxime	Myocardial perfusion	$^{123}\text{I}$ -Fatty acid	Metabolism
$^{111}\text{In}$ -WBC	Infection	Tc-99m-SC	Bone Marrow
$^{111}\text{In}$ -DTPA	Kidney (GFR)	Tc-99m-MAG3	Kidney (tubular secretion)
Tc-99m-RBC	Blood pool	$^{111}\text{In}$ -Prostascint	Prostate cancer
Tc-99m-HMPAO	Cerebral blood flow	$^{123}\text{I}$ -IBZM	Dopamine D2 receptors

In an embodiment of the present invention, system 10 uses protocols for studying the kinetics of thallium. For some applications, such protocols provide dynamic information regarding myocardial function, such as blood flow, rate of thallium uptake, thallium accumulation/redistribution, thallium metabolism, and/or thallium and/or metabolite secretion and/or wash-out (active or passive). Kinetic perfusion

radiopharmaceutical modeling provides absolute myocardial perfusion measurements, coronary flow reserve, and parametric representation of cellular function.

In accordance with respective embodiments of the present invention, thallium protocols include:

- 5       • protocols using a conventional dose of thallium, with a substantially reduced SPECT image acquisition duration, e.g., less than about 6 minutes, such as less than about 2 minutes, e.g., about 0.5 minutes. By way of comparison, conventional thallium SPECT imaging procedures generally have image acquisition durations of between about 10 and about  
10       20 minutes. For some applications, the thallium protocol is customized for a specific patient, as described hereinabove;
- protocols using a conventional dose of thallium and a conventional image acquisition duration, with a substantially increased image resolution. For some applications, acquired photon counts are at least 5 times greater than  
15       those acquired using conventional SPECT techniques, e.g., at least 10 times greater, resulting in an image with substantially higher resolution; and
- dynamic protocols for myocardial perfusion studies that provide absolute quantitative measurements. For example, images of the heart may be  
20       reconstructed from list mode data, with a temporal resolution of 5-10 seconds. This temporal resolution is typically appropriate for the measurement of the kinetics of uptake and wash-out of thallium from the myocardium, as well as those of an input bolus as it passes through the left ventricle. Such data enables the measurement of absolute myocardial  
25       blood flow at rest and during peak stress.

In an embodiment of the present invention, system 10 uses protocols for cardiac stress testing studies, using, for example, Tc99m-sestamibi, Tc-99m tetrofosmin, or thallium. Such protocols differentiate between healthy cardiac tissue and scarred or poorly perfused cardiac tissue. Perfusion defects that appear after exercise or  
30       pharmacologic stress suggest either vascular occlusion or myocardial infarction. For some applications, such studies are performed gated to the patient's ECG, in order to study cardiac wall motion. Wall motion studies allow calculation of key cardiac function

parameters, such as ejection fraction and estimated cardiac output.

In accordance with respective embodiments of the present invention, cardiac stress testing protocols, which use, for example, Tc99m-sestamibi, Tc-99m tetrofosmin, or thallium, include:

- 5       • protocols using a conventional dose, with a substantially reduced SPECT image acquisition duration, e.g., less than about 6 minutes, such as less than about 2 minutes, e.g., about 0.5 minutes. By way of comparison, conventional cardiac stress testing SPECT imaging procedures generally have image acquisition durations of between about 10 and about 20  
10       minutes. For some applications, the protocol is customized for a specific patient, as described hereinabove. For some applications, such as when the protocol uses Tc99m-sestamibi, image acquisition is performed immediately following administration of the labeled radiopharmaceutical agent, before the agent reaches the liver, thereby reducing interference by  
15       the liver on the resulting images.
- protocols using a dose of the labeled radiopharmaceutical agent that is substantially lower than conventional SPECT protocols using the agent. For example, the dose may be between about 50% and about 90% lower than a conventional dose, e.g., about 50% lower than a conventional dose.  
20       By using the image acquisition techniques described herein and/or incorporated herein by reference, even at such reduced doses, acquired photon counts are typically at least 5 times greater than those acquired using conventional SPECT techniques at conventional SPECT doses, e.g., at 10 times greater, and image acquisition duration is typically about 50%  
25       less than conventional durations, e.g., about 80% less (such as four minutes instead of 20 minutes). Alternatively, the dose may be reduced by about 90%, and the image acquisition duration is approximately the same as conventional image acquisition durations.

In an embodiment of the present invention, system 10 uses Tc-99m teboroxime for  
30       performing a SPECT myocardial perfusion study. This radiopharmaceutical is extracted by the myocardium in proportion to myocardial blood flow throughout the entire range of achievable flow rates. When conventional imaging techniques are used, the wash-out rate

of Tc-99m teboroxime from cardiac tissue is so rapid that there is inadequate time for imaging, because the radiopharmaceutical rapidly and avidly accumulates in the liver, which emits gamma rays that blind the imaging of the heart. By using the imaging techniques described herein and/or incorporated herein by reference, sufficient photon counts are obtained in an image acquisition period of no more than approximately two minutes, immediately following administration. The use of such a short period enables the completion of image acquisition prior to substantial uptake of the radiopharmaceutical by the liver, thereby enabling the effective clinical use of Tc-99m teboroxime for cardiac imaging.

10 In an embodiment of the present invention, a dynamic multiple isotope combination protocol is provided for studying different pathological processes of the same organ, such as studying acute myocardial ischemia. In accordance with this protocol, the following labeled radiopharmaceutical agents are administered as bolus IV injections:

- 15 (a) an approximately 2 mCi dose of I-123-BMIPP, followed by a wait of about 48 hours;
- (b) an approximately 1 mCi dose of Tl-201-thallous chloride; and
- (c) either (i) an approximately 10 mCi dose of Tc-99m-sestamibi or (ii) an approximately 10 mCi dose of Tc-99m-teboroxime.

20 Agents (b) and (c) are administered as a cocktail, or as separate injections at approximately the same time. Simultaneous image acquisition of all three radiopharmaceutical agents is performed during or soon after administration of agents (b) and (c), typically using an up to about 30 minute acquisition time, such as between about 5 and about 15 minutes, which is faster than that of standard imaging protocols.

25 Typically, camera 452 of imaging system 28, described hereinbelow with reference to Fig. 11, performs image acquisition using an energy window of between about 2% and about 10% of the emitted energy levels of the radiopharmaceutical agents. Typically, detectors 454 of camera 452 sweep the region of interest once every approximately 10 to approximately 15 seconds. The I-123-BMIPP identifies the ischemic/infarcted area of the

30 myocardium, while the other radiopharmaceutical agents identify the perfused area of the myocardium. Simultaneous imaging provides more accurate identification of myocardial perfusion pathologies than is generally possible using conventional imaging techniques

and protocols.

In an embodiment of the present invention, system 10 uses one or more of the protocols described in the above-mentioned US provisional application filed on even date herewith, entitled, "Imaging protocols."

5 In some embodiments of the present invention, the protocols described herein (including those shown in Figs. 6A-E), and in the co-assigned patent applications incorporated herein by reference, are performed using values that vary from those provided in the protocols by +/- 20%, e.g., +/- 5%, +/- 10%, or +/- 15%. Furthermore, in some embodiments, the protocols are performed with a range of doses from 50%, 75%,  
10 90%, or 100% of the dosage value given for the respective protocol, up to 10 times the dosage value given for the respective protocol (such as up to 2, 4, 6, or 8 times the given dosage value). For example, a dose shown as 3 mCi for a given protocol may, in some embodiments, have a range of 1.5 mCi to 30 mCi, or from 2.7 mCi to 6 mCi. Similarly, in some embodiments, the protocols are performed with a range of acquisition durations  
15 (total scan times) from 50%, 75%, 90%, or 100% of the duration value given for the respective protocol, up to 5 times the duration value given for the respective protocol, such as up to 1.5, 2, 3, or 4 times the given duration value. Other protocol values, such as waiting times, energy windows/resolution, angular range, angular step, and dwell time, may also have a range from 50%, 75%, 90%, or 100% of the value given for the  
20 respective protocol, up to 5 times the value given for the respective protocol, such up to 1.5, 2, 3, or 4 times the given value.

In respective embodiments of the present invention, all of the protocols described herein and/or in the co-assigned patent applications incorporated herein by reference are enabled to generate clinically-valuable images. A "clinically-valuable image" is an image  
25 of an intra-body region of interest (ROI) containing the labeled radiopharmaceutical agent(s), which image fulfills one or more of the following criteria:

- the image is generated according to a protocol, including at the radiopharmaceutical dose specified by the protocol, using a high-definition SPECT camera, for example, camera 452 of imaging system 28, described  
30 hereinbelow with reference to Fig. 11, which camera, during the imaging of the ROI, is capable of acquiring at least one of 5000 photons emitted from the ROI during the image acquisition procedure, such as at least one

of 4000, 3000, 2500, 2000, 1500, 1200, 1000, 800, 600, 400, 200, 100, or 50 photons emitted from the ROI. In one particular embodiment, the camera is capable of acquiring at least one of 2000 photons emitted from the ROI during the image acquisition procedure;

- 5
- the image is generated according to a protocol, including at the radiopharmaceutical dose and image acquisition duration specified by the protocol, using a high-definition SPECT camera, for example, camera 452, which, during the imaging of the ROI, is capable of acquiring at least 200,000 photons, such as at least 500,000, 1,000,000, 2,000,000, 10
- 10
- 3,000,000, 4,000,000, 5,000,000, 8,000,000, or 10,000,000 photons, emitted from a portion of the ROI having a volume of no more than 500 cc, such as a volume of no more than 500 cc, 400 cc, 300 cc, 200 cc, 150 cc, 100cc, or 50 cc. In one particular embodiment, the camera is capable of acquiring at least 1,000,000 photons emitted from a volume of the ROI
- 15
- having a volume of no more than 200 cc;
- the image has a resolution of at least 7x7x7 mm, such as at least 6x6x6 mm, 5x5x5 mm, 4x4x4 mm, 4x3x3 mm, or 3x3x3 mm, in at least 50% of the reconstructed volume, wherein the labeled radiopharmaceutical agent as distributed within the ROI has a range of emission-intensities R (which
- 20
- is measured as emitted photons / unit time / volume), and wherein at least 50% of the voxels of the reconstructed three-dimensional emission-intensity image of the ROI have inaccuracies of less than 30% of range R, such as less than 25%, 20%, 15%, 10%, 5%, 2%, 1%, or 0.5% of range R. For example, the agent may emit over a range from 0
- 25
- photons/second/cc to  $10^5$  photons/second/cc, such that the range R is  $10^5$  photons/second/cc, and at least 50% of the voxels of the reconstructed three-dimensional intensity image of the ROI have inaccuracies of less than 15% of range R, i.e., less than  $1.5 \times 10^4$  photons/second/cc. For some applications, the study produce a parametric
- 30
- image related to a physiological process occurring in each voxel. In one particular embodiment, the image has a resolution of at least 5x5x5 mm, and at least 50% of the voxel have inaccuracies of less than 15% of range R;



- the image is generated according to a protocol, including at the radiopharmaceutical dose and image acquisition duration specified by the protocol, the image has a resolution of at least 7x7x7 mm, such as at least 6x6x6 mm, 5x5x5 mm, 4x4x4 mm, 4x3x3 mm, or 3x3x3 mm, wherein the labeled radiopharmaceutical agent has a range of intensities R (photons / unit time / volume), and wherein at least 50% of the voxels of the reconstructed three-dimensional intensity image of the ROI have inaccuracies of less than 30% of range R, such as less than 25%, 20%, 15%, 10%, 5%, 2%, 1%, or 0.5% of range R. For some applications, the study produce a parametric image related to a physiological process occurring in each voxel; and/or
- the image has a resolution of at least 20x20x20 mm, such as at least 15x15x15 mm, 10x10x10 mm, 7x7x7 mm, 5x5x5 mm, 4x4x4 mm, 4x3x3 mm, or 3x3x3 mm, wherein values of parameters of a physiological process modeled by a parametric representation have a range of physiological parameter values R, and wherein at least 50% of the voxels of the reconstructed parametric three-dimensional image have inaccuracies less than 100% of range R, such as less than 70%, 50%, 40%, 30%, 25%, 20%, 15%, 10%, 5%, 2%, 1%, or 0.5% of range R. For example, the physiological process may include blood flow, the values of the parameters of the physiological process may have a range from 0 to 100 cc / minute, such that the range R is 100 cc / minute, and at least 50% of the voxels of the reconstructed parametric three-dimensional image have inaccuracies less than 25% of range R, i.e., less than 25 cc / minute. In one particular embodiment, the image has a resolution of at least 5x5x5 mm, and at least 50% of the voxels have inaccuracies of less than 25% of range R.

#### *The mother vial*

Reference is made to Fig. 7, which is a schematic illustration of mother vial 104 and attached data carrier 106, in accordance with an embodiment of the present invention. Data carrier 106 is computer-communicatable, and typically comprises an RFID tag, smart card, disk-on-key (e.g., a USB key), compact disc, minidisk, disposable

computer-readable medium, or other electronic memory, or a machine-readable code, e.g., a barcode. Mother vial 104 is shown contained within shielding 272, to which data carrier 106 is attached. Alternatively, the data carrier is attached directly to the mother vial, or otherwise associated with the mother vial, such as by being stored in proximity to the  
5 mother vial, e.g., in a tray that also contains the mother vial.

Data carrier 106 typically contains at least some of the following information:

- a coded signature 256, for authenticating mother vial 104;
- radiopharmaceutical information, a portion of which is typically supplied by the manufacturer, and a portion of which is typically generated by  
10 dispensing system 20 in conjunction with dispensing the radiopharmaceutical agent(s). For some applications, a portion of the information is generated by mother vial preparation system 700, described hereinbelow with reference to Fig. 15, in conjunction with preparing the radiopharmaceutical. The information includes, for example:  
15
  - the name of and/or information regarding the manufacturer;
  - the indicated use(s) (e.g., "Formulation for Cardiac Dynamic Studies");
  - the pre-labeled composition;
  - the time of preparation of the labeled radiopharmaceutical agent(s);
  - the radioactivity at the time of preparation;
  - 20
    - the total solution volume;
    - the pre-labeled-composition expiration date;
    - the appropriate labeling isotope(s);
    - the decay scheme(s) of the appropriate labeling isotope(s);
    - the radiopharmaceutical biodistribution as a function of time;
    - 25
      - the radiopharmaceutical clearance rate;
      - the percent clearance by the liver;
      - the percent clearance by the kidneys;
      - the breakdown rate;

- the liver uptake as a function of time; and/or
  - radiopharmaceutical kinetic parameters, such as described hereinbelow, which parameters may be stored in one or more lookup tables;
- 5
- administration protocol information, such as described hereinbelow;
  - image acquisition protocol information, such as described hereinbelow;
  - image reconstruction protocol information, such as described hereinbelow;
  - image analysis protocol information, such as described hereinbelow;
  - expert system protocol information, such as described hereinbelow;
- 10
- radiolabeling information, which, for some applications, is generated by mother vial preparation system 700, described hereinbelow with reference to Fig. 15. Such information includes, for example:
    - the labeling radioisotope(s), e.g., Tc-99m;
    - time of labeling;
- 15
- activity of the radioisotope(s) per volume at the time of labeling;
  - total solution volume in the mother vial; and/or
  - ratio of radioisotopes (e.g., Tc-99m to Tc-99) at the time of labeling.

If the labeled radiopharmaceutical agent stored in the mother vial is radiolabeled by mother vial preparation system 700, as described hereinbelow with reference to Fig. 15, the labeling information is provided by the mother vial preparation system. Otherwise, the labeling information is provided by the pharmacist and/or conventional labeling system that radiolabels the unlabeled radiopharmaceutical agent.

The radiopharmaceutical kinetic parameters are used by imaging system 28 for performing dynamic imaging studies, for example as described in the above-mentioned International Patent Application PCT/IL2005/001173, and/or in the above-mentioned US provisional application filed on even date herewith, entitled, "Imaging protocols". For some applications, respective sets of these parameters are provided for:

- different patient populations, such as a healthy population and populations which suffer from various pathologies;

- different organs and/or tissue types, for example, brain tissue, cardiac tissue, liver tissue, and tumor tissue;
- different pathologies;
- different patient physiologies;
- 5   • different organs, according to the physiology of the specific patient;
- different patient groups, as expected according to the physiology of the specific patient;
- different pathologies, as expected according to the physiology of the specific patient;
- 10   • different organs, as measured for the specific patient;
- different patient groups, as measured for the specific patient; and/or
- different pathologies, as measured for the specific patient.

Such kinetic parameters may include, for example:

- volume of blood in a voxel;
- 15   • density of blood in a tissue within a voxel;
- labeled radiopharmaceutical agent concentration in the blood within a voxel;
- labeled radiopharmaceutical agent concentration in a tissue within a voxel;
- total labeled radiopharmaceutical agent concentration in a voxel;
- 20   • labeled radiopharmaceutical agent concentration in the systemic blood circulation;
- linearity with blood flow;
- receptor binding for molecular radiotracers;
- labeled radiopharmaceutical accumulation/redistribution in tissue;
- 25   • labeled radiopharmaceutical metabolic rate;
- diffusion coefficient from the blood to the tissue (i.e., rate of wash-out,

passive or active);

- diffusion coefficient from the tissue to the blood (i.e., rate of uptake, passive or active); and/or
- accumulation rate in a tissue within a voxel.

5           The administration protocol information is used by administration system 26 to set parameters of administration of the labeled radiopharmaceutical agent(s) contained in container 22. This protocol information may include, for example:

- the dose administered, or for multiple radiopharmaceutical agents, the respective doses per administration;
- 10   • the type of administration, e.g., a single bolus, a plurality of boluses (e.g., two boluses), pulsatile administration, or constant drip administration;
- the labeled radiopharmaceutical agent for each administration, whether a single agent or a cocktail of agents;
- the time of the administration with respect to the time of imaging;
- 15   • the timings of multiple administrations with respect to each other and with respect to other activities, such as rest or stress (physical or pharmacological);
- the administration device, e.g., a syringe, a dual-needle syringe, a pump, or an IV line;
- 20   • the mode of administration, e.g., manual, automatic, or computer driven; and/or
- an algorithm for customizing the administration based on physiological parameters of the specific patient.

25           The image acquisition protocol information is used by imaging system 28 to set parameters of the image acquisition process. For some applications, such parameters are separately specified for individual components of camera 452 of imaging system 28, or groups of components, such as for individual detectors 454 or groups of detectors. Such acquisition protocol information may include, for example:

- the name(s) and/or identification code(s) of one or more protocols for

which the radiopharmaceutical agent contained in mother vial 104 is suitable;

- total acquisition time, and/or acquisition time for a plurality of phases of acquisition;
- 5
- detector scanning plan, including detector motions, such as detector angular and translational motions, detector step size (typically expressed in degrees), and detector dwell time at each view;
  - detector sensitivity;
  - detector energy resolution;
- 10
- detector calibration plan;
  - definition of the region of interest (ROI);
  - gating parameters;
  - energy bands, i.e., a plurality of non-overlapping energy windows;
  - collimator positioning, shape, structure, and orientation;
- 15
- multiple/interlaced scans;
  - zooming parameters;
  - uniformity/non-uniformity of scan;
  - Compton scatter map calculation and correction parameters;
  - optimal energy window;
- 20
- optimal energy resolution, i.e., the range of energy window levels detected; and/or
  - adaptivity of scan pattern to acquired counts, e.g., active vision parameters (as described in the above-mentioned International Application PCT/IL2005/001173).

25 For some applications, the optimal energy window is set at least in part responsively to the BMI of the patient. For example, the width of the energy window (i.e., the energy resolution) may be inversely related to the BMI, because the tissue of patients with higher BMIs tends to create more scatter. To compensate for narrower

energy windows, a longer acquisition time and/or a higher dose of radiopharmaceutical agent is typically used. For some applications, the protocol information includes a look-up table of BMIs and associated energy windows. For some applications, the energy window is non-symmetrical around a peak of the energy curve.

- 5           The image reconstruction protocol information is used by imaging system 28 to set parameters of the image reconstruction process. Such parameters may include, for example:
- calibration parameters;
  - timing of acquisition;
  - 10           • reconstruction parameters and algorithms;
  - priors, i.e., mathematical constants signifying pre-imaging phase knowledge about system behavior;
  - multi-resolution reconstruction parameters;
  - non-uniform reconstruction grid;
  - 15           • filters;
  - noise modeling and handling;
  - mode selection;
  - information derived during image acquisition and/or gating;
  - protocols for handling interfering organs;
  - 20           • protocols describing the precise procedure to be followed in radiopharmaceutical administration, time management, patient activity status, imaging process, and other parameters that can affect imaging results;
  - optimization parameters per dose and/or cocktail of doses; and/or
  - 25           • attenuation correction parameters, which are typically based on physiological parameters such as body mass, BMI, and girth.

For some applications, imaging system 28 uses one or more of these parameters to perform the image reconstruction process using techniques described in one or more of

the co-assigned patent applications incorporated herein by reference.

The image analysis protocol information includes analysis algorithms and/or parameters of the image analysis process, which are used by imaging system 28 for performing diagnostic analysis of the reconstructed image. For some applications, such analysis includes tracer kinetics analysis. Such parameters may include, for example:

- information for selection of a model of tracer kinetics;
- information for selection of one or more time scales for tracer kinetics;
- tracer parameters;
- information for analysis of multiple time points;
- 10 • information for analysis regarding the clinical meaning of radiation distribution within the patient's body for the purpose of making a clinical diagnosis regarding the patient's health state;
- information for identifying the signatures of multiple labeled radiopharmaceutical agents; and/or
- 15 • optimization parameters per dose and/or cocktail of doses.

The expert system protocol information, such as expert system rules, is used by imaging system 28 to set parameters of the expert system used for assisting with diagnosis. For some applications, the expert system is implemented using techniques described in the above-mentioned International Application PCT/IL2005/001173, or in one or more of the other co-assigned patent applications incorporated by reference. Such parameters may include, for example:

- classification of the patient into a patient population;
- multi-parameter vectors of radiopharmaceutical kinetic parameters for different patient populations, such as a healthy population and populations which suffer from various pathologies, and for different tissue types, for example, brain tissue, cardiac tissue, liver tissue, or tumor tissue;
- 25 • patient history;
- multi-dimensional thresholds for defining healthy-disease state;
- disease signature classifications per pathology and/or organ (typically per



patient population); and/or

- optimization parameters per dose and/or cocktail of doses.

*The portable information-bearing radiopharmaceutical agent container*

Fig. 8 is a schematic illustration of data carrier 120, in accordance with an embodiment of the present invention. As mentioned above, data carrier 120 is physically coupled to radiopharmaceutical agent container 22. Data carrier 120 is computer-communicatable, and typically comprises an RFID tag, smart card, disk-on-key (e.g., a USB key), compact disc, minidisk, disposable computer-readable medium, or other electronic memory, or a machine-readable code, e.g., a barcode. One or more communication elements 240 are provided for reading data from and transmitting data to data carrier 24. Respective communication elements 240 are typically in data communication with dispensing system 20 and administration system 26. For some applications, communication elements 240 comprise one or more coils for transmitting and receiving electromagnetic radiation. Typically, the communication elements are configured to have a short effective transmission range, e.g., no more than between about 20 and 40 cm, such as about 30 cm. Such a short range reduces the likelihood of accidental communication with a data carrier other than the intended data carrier.

Data carrier 120 comprises circuitry 250, which comprises memory and logic. For some applications, data carrier 120 is passive, in which case it is configured to receive energy from communication element 240. For other applications, data carrier 120 comprises a power source (not shown). For some applications in which the data carrier comprises a power source, the data carrier comprises a communication element for communicating and/or energizing another electronic apparatus. Alternatively or additionally, the data carrier comprises a communication element 252 configured for wireless communication. For some applications, data carrier 24 further comprises a user output 254 for outputting information to the patient or healthcare workers. For example, output 254 may comprise a display screen, light, and/or sound generator, which the circuitry drives to communicate information, such as when communications have been established with other elements of system 10, e.g., data carrier 120, administration system 26, or imaging system 28. For some applications, data carrier 120 further comprises coded signature 256, which is typically encrypted, color-coded, or both encrypted and color-coded, as described hereinbelow in the section entitled "Signature."

The information contained in data carrier 120 typically includes some or all of the following:

- an administration-device identification code;
- an identifier, such as an identification code and/or name, of the patient for  
5 which the specific attached radiopharmaceutical agent container 22 is intended;
- the formulation of the labeled radiopharmaceutical agent(s) contained in attached container 22;
- the time of dispensing of the labeled radiopharmaceutical agent(s) to  
10 container 22;
- activity of the labeled radiopharmaceutical agent(s), at the time of dispensing of the labeled radiopharmaceutical agent(s) to container 22;
- the assigned protocol(s) for use with the labeled radiopharmaceutical agent(s) contained in attached container 22;
- the intended time(s) and date(s) of administration of the labeled  
15 radiopharmaceutical agent(s) contained in container 22;
- the intended activity(ies) of the labeled radiopharmaceutical agent(s) at the time of administration thereof;
- the intended time profile of administration (single bolus, slow-drip  
20 administration, or any other form of administration);
- the identification code of mother vial 104 from which the labeled radiopharmaceutical agent(s) contained in container 22 were dispensed; and/or
- at least a portion of the radiopharmaceutical information stored in data  
25 carrier 106 of mother vial 104, as described hereinabove with reference to Fig. 7. This information is typically electronically transferred from data carrier 106 during dispensing of the labeled radiopharmaceutical agent(s) to container 22, as described hereinabove with reference to step 118 of Fig. 2 and hereinbelow with reference to Fig. 12.

As mentioned above, for some applications, all or a portion of the information contained in patient-specific data carrier 24 is alternatively or additionally stored in data carrier 120. Such information is described hereinabove with reference to Fig. 7. For some applications, a portion of the information stored in the data carrier is also printed in human- and/or machine-readable form on the data carrier and/or on the container, for example as a barcode 260, as shown below in Figs. 9A-H.

In an embodiment of the present invention, radiopharmaceutical agent container 22 comprises all or a portion of a drug administration device, such as a syringe or an inhalation device, packaging for an oral dosage form, or radiopharmaceutical packaging.

Reference is made to Figs. 9A-H, which are schematic illustrations of respective embodiments of radiopharmaceutical agent container 22 and data carrier 120, in accordance with respective embodiments of the present invention. In all of these embodiments, data carrier 120 is physically coupled to agent container 22.

Fig. 9A is a schematic illustration of radiopharmaceutical agent container 22 comprising a manual syringe 270, in accordance with an embodiment of the present invention. Syringe 270 is protected by shielding 272, to which data carrier 120 is coupled. Alternatively, the data carrier is coupled directly to an exposed portion of the syringe, such as the end of the plunger of the syringe, as shown in the figure.

Fig. 9B is a schematic illustration of radiopharmaceutical agent container 22 comprising an automatic administration device 280, in accordance with an embodiment of the present invention. Device 280 comprises a chamber 282 for containing the labeled radiopharmaceutical agent(s), a needle 283, a controller 284, a drive 286, and a power source 288. For some applications, controller 284 is preprogrammed with administration instructions, while for other applications, the controller is coupled to administration system 26 and receives an administration signal therefrom prior to administration, or in real time during administration. Administration device 280 typically includes an interlock 290 to prevent administration without verification, for example, of the patient's identity. For some applications, device 180 comprises a flow meter 292, which measures the volume of labeled radiopharmaceutical agent administered. Controller 284 uses this flow information for regulating parameters of the administration, such as rate of administration and total amount of agent administered. Shielding 272 protects medical personnel from the radioactivity of the labeled radiopharmaceutical agent.

Fig. 9C is a schematic illustration of a multi-chamber embodiment of radiopharmaceutical agent container 22, in accordance with an embodiment of the present invention. In this embodiment, container 22 comprises a plurality of chambers in fluid isolation from one another, each of which chambers contains a labeled radiopharmaceutical agent. In the embodiment shown in Fig. 9C, the container comprises two such chambers, a first chamber 282A and a second chamber 282B. Alternatively, the container comprises more than two chambers (configuration not shown). For some multi-chamber applications, container 22 comprises automatic administration device 280, as shown in Fig. 9C, while for other multi-chamber applications, container 22 comprises a plurality of manual syringes 270, as described hereinabove with reference to Fig. 9A (multi-chamber configuration not shown). For some applications, a separate needle 283 is provided for each injection, while for other applications, container 22 is configured to utilize a single needle 283 for the plurality of injections. For example, needle 283 may be configured to slide along a needle mount 294, so as to service the plurality of chambers.

Fig. 9D is a schematic illustration of another configuration of radiopharmaceutical agent container 22, in accordance with an embodiment of the present invention. In this embodiment, container 22 comprises automatic administration device 280, as described hereinabove with reference to Fig. 9B, and controller 284 is configured to perform all or a portion of the functions of data carrier 120. For some applications, one or more of the elements of data carrier 120 are provided separately from the controller. For example, communication element 252 or user output 254 may be provided separately from the controller.

Figs. 9E-G are schematic illustrations of another configuration of radiopharmaceutical agent container 22 comprising manual syringe 270, in accordance with an embodiment of the present invention. In this embodiment, syringe 270 comprises a transmitter 296 fixed with respect to a plunger 298 of the syringe, and shielding 272 is configured so as to modulate effective transmission by transmitter 296. For example, shielding 272 may be shaped so as to define a longitudinal slot 300 along a portion of the shielding. This modulation serves to send, from syringe 270 to administration system 26 and/or imaging system 28, a signal indicative of a time of administration of the labeled radiopharmaceutical agent(s) contained in container 22. The techniques of this embodiment are typically useful when registration of the time of administration with imaging system 28 is important, such as for dynamic studies.

Figs. 9E-G respectively illustrate three steps for administration using these techniques. Fig. 9E shows a first step, during which transmitter 296 is exposed, and therefore effectively transmits a signal. Fig. 9F shows a second step, during which transmitter 296 is shielded by shield 272. Fig. 9G shows a third step, in which transmitter 296 is again exposed. This sequence of exposing, shielding, and again exposing the transmitter serves to signal that administration has occurred. The receiver of the signal (administration system 26 and/or imaging system 28) records the time that this signal is detected. For some applications, other techniques are used to automatically transmit an indication of when the labeled radiopharmaceutical agent(s) are administered. For example, a transmitter may be mounted on shield 272, and may send a signal when electrical contact is established between electrodes (not shown) on plunger 298 and shield 272 at the end of complete motion of the plunger into syringe 270.

Fig. 9H is a schematic illustration of a syringe adaptor 320, in accordance with an embodiment of the present invention. Adaptor 320 comprises shielding 272 and data carrier 120 coupled thereto. The adaptor is configured to be placed on a standard administration device, such as a standard syringe. In an embodiment of the present invention, an adaptor similar to adaptor 320 is provided for use with other components of an end-to-end imaging system, such as Tc-99m vials, mother vials, dispensing tools, and dilution containers. Alternatively or additionally, data carrier 120 is configured to be couplable to such other components.

In an embodiment of the present invention, data carrier 120 is configured to be couplable to a standard administration device, such as a syringe. For example, the data carrier may be couplable to the barrel, plunger, or conventional shielding of a conventional syringe, or another syringe known in the art.

#### 25 *The administration system*

Reference is made to Fig. 10, which is a schematic illustration of administration system 26, in accordance with an embodiment of the present invention. Administration system 26 comprises a control unit 350, at least one communication element 240, and, for some applications, an automated administration device 352. Typically, control unit 350 comprises a standard personal computer or server with appropriate memory, communication interfaces and software for carrying out the functions prescribed by relevant embodiments of the present invention. This software may be downloaded to the

control unit in electronic form over a network, for example, or it may alternatively be supplied on tangible media, such as CD-ROM. For some applications, administration system 26 comprises a single communication element 240 that communicates with both patient-specific data carrier 24 and data carrier 120 of container 22, while for other applications the administration system comprises separate communication elements 240 for communicating with data carriers 120 and 24 respectively. For example, a communication element for communicating with data carrier 120 may be integrated into or coupled to automated administration device 352.

Upon authenticating container 22, verifying the identity of the patient, and performing additional verifications, as described hereinabove with reference to step 122 of Fig. 2, control unit 350 generates an administration signal that triggers administration to the patient of the labeled radiopharmaceutical agent(s) stored in container 22. For applications in which administration system 26 comprises automated administration device 352, container 22 is operatively coupled to device 352, and the signal drives administration device 352 to administer the labeled radiopharmaceutical agent(s) stored therein to the patient. Automated administration device 352 is configured to perform intravenous (IV) injection, intramuscular (IM) injection, subcutaneous injection, transdermal application, oral administration, nasal administration, inhalation, transcervical application, transrectal administration, or another type of administration known in the art. (It is to be understood that although the administration signal triggers administration of the agent, for some applications automated administration device 352 does not administer the agent until a healthcare worker provides a final authorization to do so, such as to comply with regulatory safety requirements.) For applications in which administration system 26 does not comprise automated administration device 352, the administration signal triggers administration of the agent by instructing a healthcare worker to manually administer the agent to the patient.

For some applications, based on administration protocol information received from data carrier 120 of radiopharmaceutical agent container 22 and/or patient-specific data carrier 24, control unit 350 customizes the administration of the labeled radiopharmaceutical agent(s) contained in agent container 22. Such administration protocol information typically includes all or a portion of the administration protocol information described hereinabove with reference to Fig. 7. For some applications, administration system 26 administers a plurality of labeled radiopharmaceutical agents,

either sequentially or premixed together within a single agent container 22 (i.e., as a cocktail).

For some applications, administration system 26 administers the labeled radiopharmaceutical agent(s) responsively at least in part to acquisition of a signal associated with the agent(s). For example, acquisition of the signal may comprise  
5 detection of photons emitted from the agent(s), in order to determine a radioactivity level.

For some applications, administration system 26 monitors uptake and/or clearance of the labeled radiopharmaceutical agent(s) by (a) measuring physiological parameters, e.g., from samples of blood, saliva, or secretions, e.g., urine, breath, feces, or sweat, or (b)  
10 by performing an imaging procedure using imaging system 28. For some applications, these measurements are used to estimate pharmacokinetics of the radiopharmaceutical agent(s) in organs, and/or to predict optimal imaging timing (the optimal time to perform the imaging, and/or the optimal timing parameters of the imaging procedure). For some applications, based on these estimates, an expected level of uptake of the  
15 radiopharmaceuticals in a target organ is determined, enabling diagnosis of pathologies based on absolute uptake levels in the target organ.

#### *The imaging system*

Reference is made to Fig. 11, which is a schematic illustration of imaging system 28, in accordance with an embodiment of the present invention. Imaging system 28  
20 comprises a control unit 450, a communication element 240, a camera 452, and an imaging workstation 453. Typically, control unit 450 and imaging workstation 453 comprise one or more standard personal computers or servers with appropriate memory, communication interfaces and software for carrying out the functions prescribed by relevant embodiments of the present invention. This software may be downloaded to the  
25 control unit and imaging workstation in electronic form over a network, for example, or it may alternatively be supplied on tangible media, such as CD-ROM.

Control unit 450 typically comprises: (a) image acquisition functionality, which is configured to drive camera 452 to perform image acquisition of the patient; (b) image reconstruction functionality, which is configured to perform an image reconstruction  
30 procedure on the acquired image; (c) image analysis functionality, which is configured to perform an image analysis procedure on the reconstructed image; and (d) diagnosis

functionality, which is configured to perform a diagnostic procedure using the results of the image analysis procedure. It will be appreciated that control unit 450 may comprise a plurality of personal computers or servers, each of which performs one or more of these procedures, and that one or more of these computers or servers may be located remotely  
5 from camera 452. Imaging workstation 453 displays the reconstructed images and allows the attending healthcare worker to view and manipulate the images.

As mentioned above with reference to steps 124 through 130 of Fig. 2, imaging system 28 typically customizes one or more of these procedures at least in part responsively to imaging protocol information and/or patient-specific information read by  
10 communication element 240 from patient-specific data carrier 24.

For some applications, camera 452 comprises a commercially available diagnostic structural or functional camera, such as a SPECT or PET camera, and/or utilizes imaging techniques described in one or more of the patents and patent applications described hereinabove in the section entitled "Background of the Invention." Alternatively, camera  
15 452 utilizes techniques described in the above-mentioned International Application PCT/IL2005/001173, in above-mentioned PCT Publication WO 05/119025, and/or in the other above-mentioned co-assigned patent applications and/or patent application publications.

In an embodiment of the present invention, camera 452 comprises a plurality of  
20 detectors 454, each of which is coupled to a respective angular orientator 456. Each of the detectors comprises a plurality of gamma ray sensors, such as a pixelated CZT array, and a collimator. For example, the array may include 16x64 pixels. Control unit 450 drives, typically separately, each of the orientators to orient its respective detector in a plurality of orientations with respect to a region of interest (ROI). Control unit 450  
25 produces a SPECT image from a plurality of radiation acquisitions acquired with the detectors in different relative orientations.

In an embodiment of the present invention, camera 452 is configured to begin an image acquisition procedure by performing a relatively brief, preliminary scan, and, based on the results of this preliminary scan, to determine one or more parameters of the full  
30 image acquisition procedure, such as dwell time per orientation of each detector 454. Typically, this determination further takes into account imaging protocol and/or patient-specific information received by imaging system 28 from patient-specific data



carrier 24, such as the activity of the labeled radiopharmaceutical agent at the time of administration, the time of administration, the patient's BMI (which may be used to estimate a perfusion percentage), and the pharmacokinetics of the labeled radiopharmaceutical agent.

5           In an embodiment of the present invention, camera 452 is configured to individually set a total angular range of each of detectors 454 responsively to the detector's orientation with respect to the ROI. For example, at least one detector closer to the ROI (a "proximal detector" or an "inner detector") may have a greater total angular  
10           range than at least one detector further from the ROI (a "distal detector" or an "outer detector"). The distal detectors are typically located nearer to the ends of a frame holding the detectors, while the proximal detectors are typically located nearer to center of the frame. The use of narrower angular ranges for some of the detectors generally reduces the photon acquisition time spent by these detectors in orientations aimed outside of the ROI. Alternatively, at least one distal detector has a greater total angular range than at least one  
15           proximal detector. In order to reduce the total angular range for a given detector, camera 452 typically drives the associated angular orientator 456 to: (a) increase the dwell time of the detector in at least a portion of its orientations, and/or (b) reduce the angle by which the detector is moved during each orienting of the detector. For some applications, camera 452 sets the angular range of the detectors based on protocol information received  
20           by imaging system 28 from patient-specific data carrier 24. For example, the number of distal and proximal detectors, and their respective angular ranges, may be specified by the protocol information, as described hereinabove with reference to Figs. 6B-E.

          In an embodiment of the present invention, camera 452 comprises a plurality of detectors 454, each of which is coupled to a respective angular orientator 456. Each of  
25           the detectors comprises a plurality of gamma ray sensors, such as a pixelated CZT array, and a collimator. Control unit 450 drives, typically separately, each of the orientators to orient its respective detector in a plurality of orientations with respect to a region of interest (ROI). Control unit 450 produces a SPECT image from a plurality of radiation acquisitions acquired with the detectors in different relative orientations.

30           In an embodiment, camera 452 is configured to drive one of orientators 456 to move its respective detector 454 through a plurality of sequential angular positions, e.g., positions 1, 2, 3, ..., 18, 19, and 20. Typically, a linear relationship relates the sequential

positions, such that, for example, positions 1, 2, 3, ..., 20 represent 1°, 2°, 3°, ..., 20°, or, 2°, 4°, 6°, ..., 40°. Alternatively, a non-linear relationship relates the sequential positions. Higher or lower angular resolutions are typically obtainable, as well.

For some applications, camera 452 steps the orientator in a first pass through a  
5 subset of the positions spanning most of the range of positions, and in a second pass the camera steps the orientator through a different subset of the positions. At each position, data are acquired by the detector. For example, during the first pass, the camera may drive the orientator to step through positions 1, 5, 9, 13, and 17, and the detector acquires data at each of these positions. During the second pass, the orientator steps through  
10 positions 2, 6, 10, 14, and 18. During two subsequent passes, data are acquired at the remainder of the positions. In this manner, a single-direction interlaced scan of the data is acquired by camera 452.

In an embodiment, a back-and-forth interlaced scan is acquired in which data are sampled when the orientator is moving in both directions. For example, during the first  
15 pass, the camera may drive the orientator to step through positions 1, 5, 9, 13, and 17. During the second pass, the orientator steps through positions 18, 14, 10, 6, and 2. During the third pass, the orientator steps through positions 3, 7, 11, 15, and 19, while during the fourth pass, the orientator steps through positions 20, 16, 12, 8, and 4. Fifth and higher passes, if desired, typically repeat the motions used in the earlier passes.

For some applications, the positions in a pass are not ordered from  
20 lowest-to-highest or highest-to-lowest. For example the positions of a pass may be 1, 15, 11, 19, and 17. Typically, the positions are, however, distributed generally evenly throughout the range of positions, in order to acquire photon counts representative of the entire region of interest.

As appropriate for a given scanning protocol using interlaced scanning, one or  
25 more, or even all of orientators 456 are driven to step through their respective positions in an interlaced fashion.

Typically, execution of an interlaced scan as provided by these embodiments of  
the present invention allows an operator of camera 452, such as an imaging technician or  
30 other healthcare worker, to acquire a high-resolution image of the ROI in about 105% to 115% of the amount of time as would be used if orientator 456 were stepped through the positions sequentially. (Typically, each orientation takes between about 50 and about 200

msec, depending upon the angle of the step.) The high-resolution image is completely acquired after the orientator has stepped through each of its positions. In some cases, additional value is attained by interlacing the scanning, however, as this allows the performance of dynamic studies, in which a plurality of images are acquired during a  
5 respective plurality of the time periods, i.e., during each complete pass of the orientator. Although each these images is typically of lower resolution than the high-resolution image acquired using photon counts acquired during all of the passes, the images nevertheless have sufficient resolution to produce clinically-meaningful data for each time period of a dynamic study.

10 For some applications, interlacing the scanning allows an operator to see an initial, lower-resolution scan of the ROI. If, for example, an adjustment of any form is desired, this can often be seen within the first few seconds of a scan. The present scan is terminated, the adjustment made, and a second scan initiated. In the absence of interlacing, it is typically necessary to wait until a scan has completed until an assessment  
15 of the scan's results can be made.

For some applications, it is desirable to know whether the patient has moved during a scan. Patient movement is one reason for lower quality images, and when identified it can typically be corrected by suitable instruction and then a second scanning procedure initiated. Interlaced scanning, as provided by these embodiments of the present  
20 invention, allows the operator to immediately assess whether there has been patient movement between one pass and a subsequent pass. In an embodiment, the imaging system displays to an operator the scans obtained from the various passes in rapid succession at the same location on a monitor. As appropriate, the imaging system cycles quickly through the scans repeatedly (e.g., pass 1, pass 2, pass 3, pass 4, pass 1, pass 2,  
25 pass 3, pass 4...), e.g., displaying each scan for between about 0.2 and about 2 seconds, allowing an operator to see whether there is jitter between successive scans. If so, patient movement is typically the cause and image acquisition is repeated. For some applications, the scan is acquired in exactly two passes, e.g., the orientator steps through positions 1, 3, 5, ..., 19 during a first pass, and through positions 2, 4, 6, ..., 20 during a  
30 second pass, or through positions 20, 18, 16, ..., 2 during the second pass.

Images acquired using these techniques, or other non-interlacing techniques described herein, are generally used to perform one or more of the following image

reconstructions: (a) reconstruction of intensity image, (b) reconstruction of intensity over time, followed by fitting a model of the kinetics (which describe for each voxel a parameter set describing its time curve), and followed by presenting a three-dimensional map of the parameters, and/or (c) direct reconstruction of a three-dimensional parametric representation, without performing a reconstruction of an intensity map, typically by  
5 plugging an equation of a kinetic model into a reconstruction algorithm, and generating a result directly in terms of the value of the parameters per voxel (the parameters may include, for example, flow, diffusion coefficients, metabolism rate, or bio-clearance rate).

*The radiopharmaceutical dispensing system*

10 Reference is made to Fig. 12, which is a schematic illustration of automated radiopharmaceutical dispensing system 20, in accordance with an embodiment of the present invention. System 20 comprises a control unit 500, at least one robot 502, and at least one communication element 504, which, for some applications, is coupled to robot 502. Control unit 500 typically comprises a conventional personal computer running a  
15 conventional operating system, such as Windows XP, with appropriate memory, communication interfaces and software for carrying out the functions described herein. This software may be downloaded to the control unit in electronic form over a network, for example, or it may alternatively be supplied on tangible media, such as CD-ROM. Control unit 500 is in communication with other elements of system 10, for example via  
20 management and control component 150. The control unit notifies appropriate elements of the system upon successful completion of dispensing of a dose.

At least one radiolabeled mother vial 104 is placed in a shielded vials complex 505 of dispensing system 20. Control unit 500 authenticates the mother vial, by actuating communication element 504 to read authentication information stored in data carrier 106,  
25 and/or by verifying a coded signature 256 coupled to the mother vial, as described hereinbelow in the section entitled "Signature." Upon successful authentication, control unit 500 actuates communication element 504 to read radiopharmaceutical-related information from data carrier 106 of the mother vial, including the radiopharmaceutical agent type, isotope type, batch, lot, radiochemical purity (RCP), preparation time, and  
30 half-life information. Dispensing system 20 assays the radioactivity per unit volume of the labeled radiopharmaceutical agent contained in the mother vial. Robot 502 picks up an empty syringe 506 from a syringe tray 508, draws a predetermined amount of solution

from mother vial 104, and brings the syringe to a dose calibrator 510. The syringe used for the assaying is typically discarded into a waste container 512. Typically, robot 502 brings the mother vial to a weighing station 507 for verification that the vial contains the indicated solution volume.

5           Dispensing system 20 receives a patient-specific dose request for at least one specific labeled radiopharmaceutical agent, having a specific dose, radioactivity, and solution volume. Such a dose is typically calculated by dose calculation sub-system 156 of dose calculation system 152, as described hereinabove with reference to Fig. 5, and/or by patient management system 160, described hereinabove with reference to Fig. 4.  
10           Alternatively or additionally, dispensing system 20 is configured to customize, modify, or verify the dose. Further alternatively, dispensing system 20 receives the order from another hospital or radiopharmacy information system, or the order is manually inputted into system 20.

          To fill the request, control unit 500 calculates a required volume of the labeled  
15           radiopharmaceutical agent and a required volume of saline solution for dilution, if any. To perform this calculation, control unit 500 uses (a) information read from data carrier 106 (such as the half-life of the labeling isotope of the labeled radiopharmaceutical agent), and (b) the assayed radioactivity of the labeled radiopharmaceutical agent. Alternatively, dose calculation sub-system 156 performs all or a portion of this calculation.

20           For some applications, control unit 500 authenticates mother vial license information read from data carrier 106, in order to verify that a license is available for dispensing the requested dose. Dispensing proceeds only if a license is available and authenticated. The use of such a license generally provides increased quality control of the imaging process, by verifying that only approved manufacturers (or distributors) are  
25           able to provide radiopharmaceutical agents for use with system 10. A lack of precision in any aspect of an imaging procedure, which may result from the use of an agent that has not been tested and approved for use with system 10, often causes a deterioration of the resultant image quality and/or ability to make accurate and/or quantitative diagnoses.

          Control unit 500 actuates robot 502 to pick up an empty radiopharmaceutical agent  
30           container 22 from tray 508. Typically, but not necessarily, container 22 comprises a syringe, such as described hereinabove with reference to Figs. 9A-H. Container 22 has coupled thereto a data carrier 120. For some applications, syringes 506 and containers 22

are stored in a single tray, as shown in Fig. 12, while for other applications, they are stored in separate trays. Robot 502 typically authenticates container 22, by actuating communication element 504 to read authentication information stored in data carrier 120 and/or verifying coded signature 245 coupled to the container, as described hereinbelow  
5 in the section entitled "Signature."

Robot 502 removes the needle cap from container 22, turns the container over, and brings container 22 to the appropriate mother vial 104. The robot actuates the container to draw the calculated volume of labeled radiopharmaceutical agent from the mother vial, typically by inserting the needle of container 22 through a membrane of mother vial 104,  
10 and withdrawing a plunger of container 22 until the desired volume of agent has been drawn from the mother vial. The robot typically brings the syringe to dose calibrator 510 for quality control assaying of radioactivity. If necessary, robot 502 brings container 22 to a saline vial 514, and actuates the container to draw the required volume of saline solution into the container. Robot 502 replaces the needle cap on the container, and turns  
15 the container over. Alternatively, saline solution is drawn prior to drawing the labeled radiopharmaceutical agent from mother vial 104. For some applications, a needle of the container 22 is changed between drawings.

For dispensing a cocktail of labeled radiopharmaceutical agents, each having a respective dose, robot 502 repeats these steps for a plurality of mother vials 104, typically  
20 changing the needle of container 22 between drawings. During dispensing of such a cocktail, robot 502 typically draws first from the mother vial containing the lower or lowest radiation labeled radiopharmaceutical agent, such as to reduce any effect the assaying of the first agent may have on the assaying of the subsequent agent(s).

System 20 typically performs a quality control check on the dispensed radiopharmaceutical solution to confirm that the solution contains the desired dose(s) of  
25 the radiopharmaceutical agent(s) and radioactivity level.

Control unit 500 activates communication element 504 to write radiopharmaceutical information to data carrier 120 of container 22, as described hereinabove with reference to Fig. 8 and step 118 of Fig. 2. For some applications, the  
30 data carrier is coupled to the container prior to placement of the container in dispensing system 20, while for other applications, robot 502 couples a data carrier to each container during or after the dispensing process. Similarly, for some applications in which coded

signature 256 is provided, the coded signature is attached to container 22 prior to placement of the container in dispensing system 20, while for other applications, robot 502 couples a coded signature to each container during or after the dispensing process.

5 Robot 502 brings the filled container to a shield body tray 530, and inserts the container into a container shield 532. The robot picks up a shield cap 534 from a shield cap tray 536, and secures it to container shield 532. For some applications, data carrier 120 is coupled to shield 532 or cap 534, rather than directly to container 22. Alternatively, separate data carriers 120 are coupled to the container and the shield or cap.

10 In an embodiment of the present invention, dispensing system 20 comprises a print area 540, at which dispensing system 20 prints and attaches at least one conventional label to container 22, shield 532, and/or cap 534, in order to comply with regulatory labeling requirements. The dispensing system typically prints yet another conventional label for placement on a basket that holds a plurality of containers 22 for transport within or between healthcare facilities.

15 After the dispensing of container 22 has been completed, robot 502 brings the container to a completed container tray (tray not shown in the figure).

In an embodiment of the present invention, dispensing system 20 comprises at least one diluted mother vial which has a greater volume than a conventional mother vial. For example, the diluted mother vial may have a volume of at least about 10 ml, e.g., at 20 least about 20 ml, such as 21 ml, while a conventional mother vial may have a volume of less than 10 ml, e.g., less than 7 ml, such as 5.8 ml. The labeled radiopharmaceutical agent solution from a conventionally-sized mother vial 104 is transferred to the diluted mother vial, and the balance of the additional volume of the diluted mother vial is filled with saline solution. The resulting diluted solution is used by dispensing system 20 to fill 25 containers 22 with low-dose labeled radiopharmaceutical agents useful for performing low-dose imaging procedures, such as those described in the above-mentioned International Application IL/2005/001173, in above-mentioned PCT Publication WO 05/119025, or in one or more of the other co-assigned patent applications incorporated herein by reference. Alternatively, the resulting lower-dose solution is used for 30 time-dependent administration protocols, pursuant to which a desired total dose is divided into several sub-doses for sequential administration over time. For mechanical handling and administration reasons, each sub-dose must have a minimum volume, e.g., at least 1

ml.

The information contained in data carrier 106 of conventionally-sized mother vial 104 is transferred to a data carrier 106 of the dilution mother vial, with appropriate adjustments to reflect the diluted dose of the labeled radiopharmaceutical agent.

5 In an embodiment of the present invention, a method for automatically dispensing a labeled radiopharmaceutical agent comprises providing a mother vial having a volume of at least 10 ml, e.g., at least 20 ml; filling the mother vial with at least 5 ml of a non-diluted labeled radiopharmaceutical agent, and with at least 5 ml of saline solution; placing the mother vial in automated radiopharmaceutical dispensing system 20; and  
10 dispensing at least one dose from the mother vial to a container. For some applications, dispensing system 20 further dilutes the dose by dispensing saline solution to the container from a saline solution container.

It is noted that dispensing system 20 is theoretically able to dispense similar low doses to containers 22 by drawing a small volume of labeled radiopharmaceutical agent  
15 from a conventionally-sized mother vial, and diluting the agent with saline solution drawn from saline vial 512, as described above. However, the drawing of such a small volume may present mechanical challenges for achieving precise volumes within acceptable variations.

Reference is made to Figs. 13A-C, which are schematic illustrations of a system  
20 for carrying out a data transfer process, in accordance with an embodiment of the present invention. In this embodiment, information is transferred directly from data carrier 106 of mother vial 104 to data carrier 120 of container 22 while container 22 draws the labeled radiopharmaceutical agent from mother vial 104. As shown in Fig. 13A, container 22 is lowered to mother vial 104 (which is contained within shielding 520 of vials complex  
25 505), as indicated by an arrow 522. As shown in Fig. 13B, as container 22 draws labeled radiopharmaceutical solution from mother vial 104, data carrier 120 of the container is positioned in a vicinity of data carrier 106 of the mother vial. Container 22 is raised from mother vial 104, as indicated by an arrow 524 in Fig. 13C. Information transfer takes place during one or more of the steps illustrated in Figs. 13A-C.

30 For some applications, information is transferred to data carrier 120 of container 22 during assaying of the contents of the container at dose calibrator 510.



In an embodiment of the present invention, dispensing system 20 is configured to dispense to a plurality of containers 22 for a single patient, or to a plurality of independent chambers within a single container 22 (such as first and second chambers 282A and 282B, described hereinabove with reference to Fig. 9C). For some applications, the plurality of  
5 containers are permanently coupled to one another, while for other applications the plurality of containers are removably coupled to one another. Alternatively, the plurality of containers are not coupled to one another, in which case they may be stored in association with one another, e.g., in a single tray.

For some applications, dispensing system 20 utilizes one or more of the dispensing  
10 techniques described in the references mentioned hereinabove in the Background of the Invention section, *mutatis mutandis*.

In an embodiment of the present invention, system 10 does not comprise dispensing system 20. System 10 is instead electronically or manually interfaced with a conventional radiopharmacy. Patient management system 160 places orders with the  
15 radiopharmacy for a particular dose of a labeled radiopharmaceutical agent for a particular patient. Upon dispensing of the dose into a conventional container, such as a syringe, data carrier 120 is physically coupled to the container, and information is written to the data carrier, such as the identity of the labeled radiopharmaceutical agent, the time of dispensing, the measured radioactivity level, and/or other information described herein as  
20 being contained in the data carrier, such as with reference to Fig. 8. For some applications, system 10 comprises a module for automatically measuring the radioactivity level and recording the information in the data carrier. Optionally, the module is in communication with system 10, such as via management control component 150, and receives additional patient-specific or protocol-related information from system 10, and  
25 records the information in data carrier 120. For some applications, the radiopharmacy dispenses the labeled radiopharmaceutical agent to one of the novel radiopharmaceutical agent containers 22 described herein.

#### *The radioisotope elution system*

Reference is made to Fig. 14, which is a schematic illustration of a radioisotope  
30 automatic elution system 600, in accordance with an embodiment of the present invention. System 600 automatically elutes a radioisotope, such as technetium Tc-99m, into radioisotope vials 610. The radioisotope is used for radiolabeling the unlabeled

radiopharmaceutical agent, as described hereinabove with reference to step 110 of Fig. 2. Vials 610 are coupled to radioisotope data carriers 612 containing information about the radioisotope, such as a vial code, the time of preparation, the activity at the time of preparation, and total solution volume. Labels 612 are computer-communicatable, and typically comprise an RFID tag, smart card, disk-on-key (e.g., a USB key), compact disc, 5 minidisk, disposable computer-readable medium, or other electronic memory, or a machine-readable code, e.g., a barcode. For some applications, information contained in data carrier 612 is encrypted for enabling authentication. Alternatively or additionally, data carrier 612 and/or vial 610 comprise coded signature 256, as described hereinabove. 10 The coded signature typically comprises an encrypted signature and/or a color-coded signature, as described hereinbelow in the section entitled "Signature."

The automatic elution process typically begins with a determination by dose calculation system 152 (Fig. 5) of an optimal elution frequency, for example:

- 18 hours, 6 hours, 18 hours, 6 hours, ... ;
  - 15 • 23 hours, 1 hour, 23 hours, 1 hour, ... ;
  - 18 hours, 1 hour, 5 hours, 18 hours, 1 hour, 5 hours, ... ; or
  - 18 hours, 6 hours, 23 hours, 1 hour, 18 hours, 6 hours, 23 hours, 1 hour, ...
- ..

Dose calculation system 152 electronically notifies a control system 616 of elution 20 system 600 of the desired elution frequency. For applications in which the radioisotope comprises Tc-99m, it will be appreciated that the ratio of Tc-99 to Tc-99m, which is determined by the elution frequency, is important for molecular imaging by an antibody, and there is generally an optimal range of the ratio of Tc-99 to Tc-99m, which should be taken into consideration when preparing Tc-99m with an antibody. Typically, control 25 system 616 comprises one or more standard personal computers or servers with appropriate memory, communication interfaces and software for carrying out the functions prescribed by relevant embodiments of the present invention. This software may be downloaded to the control system in electronic form over a network, for example, or it may alternatively be supplied on tangible media, such as CD-ROM.

30 Sterile, empty vials 610 of predetermined volumes (e.g., 10 ml or 20 ml), and typically comprising caps 618, are placed on a conveyor belt 620. A first robot 622 places

a shield 624 on each vial 610. Alternatively, the vials 610 are manually shielded. Conveyor belt 620 moves shielded vial 610 into position under a radioisotope generator 626, such as a TC-99m generator. At a required elution time, a second robot 628 lifts the shielded empty vial 610, and, under sterile conditions, removes cap 618 and engages the shielded empty vial 610 with generator 626.

Upon engagement of vial 610 with generator 626, both a first electronic valve 630 of a saline tank 632 and a second electronic valve 634 of generator 626 open, and vial 610 is filled, while a flow meter 636 monitors the amount of saline flow. After flow of a predetermined volume, control system 616 automatically shuts first electronic valve 630 of saline tank 632 and second electronic valve 634 of generator 626.

Filled, shielded vial 610 is automatically disengaged from generator 626, and is automatically sealed under sterile conditions with a shielded seal 638. Filled, shielded vial 610 is lowered back to conveyor belt 620. The conveyor belt moves filled, shielded vial 610 past an assaying and labeling station 640, which assays and labels the vial with data carrier 612, a barcode 642, and/or coded signature 256. For some applications, coded signature 256 is placed on data carrier 612, while for other applications it is placed on vial 610. For still other applications, separate coded signatures 256 are placed on both vial 610 and data carrier 612, and are used to match the vial with the data carrier. For example, a color-coded signature may be printed on vial 610, either prior to the elution or together with the application of data carrier 612, and an encrypted signature may be stored in the data carrier 612. Alternatively, the encrypted signature may be printed.

It will be appreciated that the elution process is subject to modifications and alterations based on communication and information that is received from system 10. For example, a log book of elution system 600 may specify a Tc-99m vial of 1000 mCi, yet a communication request from dose calculation system 152 may modify the order to be a Tc-99m vial of 200 mCi, based on new requirements, e.g., low-dose administration.

#### *The mother vial preparation system*

Reference is made to Fig. 15, which is a schematic illustration of a mother vial preparation system 700, in accordance with an embodiment of the present invention. System 700 automatically labels mother vials 104, containing unlabeled radiopharmaceutical agents, with appropriate radioisotopes. System 700 attaches a data

carrier 106 to each mother vial 104, and writes the information to the data carrier that is described hereinabove with reference to Fig. 7. Alternatively, the manufacturer or distributor attaches data carrier 106 to mother vial 104, and writes at least a portion of the information to the carrier.

5           Prior to beginning the radiolabeling process, a control unit 702 of system 700 authenticates radioisotope vial 610 and mother vial 104, and verifies that radioisotope vial 610 contains the correct radioisotope at the correct radioactivity, and that mother vial 104 contains the correct unlabeled radiopharmaceutical agent. For some applications, such authentication and/or verification is performed by authenticating coded signature 256 of data carrier 612 of radioisotope vial 610. For some applications, such authentication includes authentication of a commercial license associated with the use of mother vial 104. Typically, control unit 702 comprises one or more standard personal computers or servers with appropriate memory, communication interfaces and software for carrying out the functions prescribed by relevant embodiments of the present invention. This software may be downloaded to the control unit in electronic form over a network, for example, or 15 it may alternatively be supplied on tangible media, such as CD-ROM.

Conveyor belt 620 carries shielded radioisotope vial 610 from radioisotope automatic elution system 600 to mother vial preparation system 700. Alternatively, for embodiments in which elution system 600 is not provided, the radioisotope vial is 20 manually placed on conveyor belt 620. The conveyor belt brings vial 610 to a radioisotope filling point 710.

System 700 typically comprises a plurality of dose preparation platforms 712, each of which contains premixed mother vials 104 containing unlabeled radiopharmaceutical agents that require radiolabeling with the radioisotope contained in radioisotope vial 610, 25 e.g., Tc-99m. In the example shown in Fig. 15, preparation platforms 712 comprise a Tc-99m-teboroxime dose preparation platform, a Tc-99m-pertechnetate dose preparation platform, a Tc-99m-sestamibi dose preparation platform, and a Tc-99m-MDP dose preparation platform.

A robot 720 picks up a syringe 722 from a first syringe platform 724, or a 30 micro-syringe 726 from a second syringe platform 728, and travels along a second conveyer belt 730 to filling point 710. It will be appreciated that other types syringes and/or other dispensing tools may also be used. Upon reaching filling point 710, syringe

722 or 726 draws a predetermined amount of radioisotope solution from radioisotope vial 610. The robot typically travels to an assay station 732, which assays the radioisotope solution. Syringe 722 or 726 is then discarded at a discard station 734.

5 Robot 720 picks up another syringe 722 or 726 from the platform 724 or 728, fills the syringe with a predetermined amount of the radioisotope from vial 610, and travels along second conveyor belt 730 to one of dose preparation platforms 712. At the dose preparation platform, the syringe injects a predetermined amount of radioisotope into mother vial 104 of the dose preparation platform, thereby labeling the unlabeled radiopharmaceutical agent contained in the mother vial.

10 Robot 720 discards the syringe at discard station 734, picks up a new syringe, draws a predetermined amount of solution from labeled mother vial 104, and assays the solution at assay station 732, in order to determine the radioactivity of the labeled radiopharmaceutical agent contained in mother vial 104. Following the assaying, robot 720 discards the syringe at discard station 734. Typically, system 700 performs one or  
15 more quality control procedures on the labeled radiopharmaceutical agent.

System 700 updates data carrier 106 of mother vial 104 with radiolabeling information, such as the time of labeling, and the activity of the radioisotope at the time of labeling, the total solution volume in the mother vial, and the ratio of radioisotopes (e.g., Tc-99m to Tc-99) at the time of labeling, for applications in which the unlabeled  
20 radiopharmaceutical agent is labeled with more than one radioisotope.

It is noted that system 700 is configurable to vary a radioactivity of the radioisotope used to label a given radiopharmaceutical agent in order to produce labeled radiopharmaceutical agents of various levels of radioactivity (for example, Tc-99m-teboroxime of 500 mCi and Tc-99m-teboroxime of 50 mCi). For some  
25 applications, system 700 comprises at least one cocktail dose preparation platform 736, for labeling a cocktail of radiopharmaceutical agents (for example, Tl-201-thallous chloride, Tc-99m-sestamibi, and I-123-BMIPP).

It will be appreciated that the mother vial preparation process is subject to modifications and alterations based on communication and information that is received  
30 from system 10. For example, a log book of system 700 may specify a mother vial of 500 mCi, yet a communication request from dose calculation system 152 may modify the order to be a mother vial of 200 mCi, based on new requirements, e.g., low-dose

administration.

*The exercise room*

In an embodiment of the present invention, system 10 comprises at least one exercise room, which comprises one or more pieces of exercise equipment, typically including at least one treadmill. The exercise room, and the equipment therein, is typically in communication with one or more elements of system 10, such as patient-specific data carrier 24, management and control component 150, administration system 26, data carrier 120 of radiopharmaceutical agent container 22, and/or imaging system 28. For example, the exercise room may report the duration, time, and type of exercise to imaging system 28, administration system 26, and/or management control component 150, for synchronizing the exercise with administration and imaging. For some applications, the exercise room receives instructions regarding the duration, time, and/or type of exercise to be performed for a given patient, and schedules an appropriate exercise session in a log book. For some applications, the exercise room sends the patient an SMS-like message notifying the patient of the scheduled session, and/or reminding the patient about a scheduled session. For some applications in which data carrier 24 is integrated into watch or bracelet 170, as described hereinabove with reference to Fig. 3, watch or bracelet 170 is configured to receive and display the SMS-like message to the patient.

20 *Signature*

In accordance with an embodiment of the present invention, coded signature 256 comprises a signature encrypted using an encryption algorithm, which is either proprietary or known in the art, e.g., Advanced Encryption Standard (AES), Data Encryption Standard (DES), or Triple DES (3DES). Typically, the encryption algorithm utilizes a symmetric key cipher, as is known in the art.

For some applications, coded signature 256 is stored in one of the data carriers described herein. Alternatively or additionally, the coded signature is printed on the apparatus, e.g., as a barcode.

For some applications, coded signature 256 comprises a color-coded signature, which is implemented using techniques described in the above-mentioned US Patent Application Publication 2004/0156081 to Brill et al. Techniques described in the '081

publication include the use of an encrypted image comprising an array of printed positions formed using a group of inks each of which has a predetermined spectrum. The positions are selected to form a predetermined image, either real or virtual, when the image is viewed through an optical processor. The optical processor may further use a distortion, such as a distorted grating or a distorted lens. The correct image is the spectrum, as distorted by the optical processor. An image formed using inks having the same colors as experienced by the human eye, or even by a standard spectrometer, will fail to form the correct predetermined image. Alternatively or additionally, special inks may be used, so that no two ink combinations are exactly alike, and only registered ink combinations provide the correct spectrum. Furthermore, the special inks may be mixtures of 5 or more colors.

Fig. 16A illustrates color spectra 800 of several dyes, for example dyes B, D1, G, D2, and R, each having a well-defined spectral peak, as described in the '081 publication. When dye B and dye G are mixed, the human eye may see a color substantially the same as the color of dye D1. When dye D1 and dye D2 are mixed, the human eye may see a color substantially the same as the color of dye G.

Fig. 16B illustrates a color-coded signature 802, as described in the '081 publication. A color patch 804, which to the human eye may seem a plain orange, for example, may have a first portion 806A, consisting of dye B and dye G, combined to form a hue which is substantially the same as that of dye D1, and a second portion 806B, consisting of dye D1. To the human eye, the color-coded signature 802 appears as a homogeneous patch.

An optical processor 820 comprises an imaging spectrograph, which comprises a grating 822 and, typically, a lens 824. In the example shown in Fig. 16B, the spectrograph produces three structures: a structure 821 formed by diffraction of dye D1 through the grating, a structure 823 formed by diffraction of dye G, and a structure 825 formed by diffraction of dye B. Optical processor 220 thus reveals the authentic spectra of the color-coded signature 802.

For some applications, optical processor 820 comprises two lenses 824 of substantially equal power, one to create a parallel beam at the input to the grating, just before the grating, and one to create an image at the focal point after the grating. Alternatively, a single lens 824, having twice the power of the two lenses, may be placed

just before or just after the grating.

For some applications, a more complex color coding is achieved by using a distorted lens or a distorted grating, such that spectral structure 821, 823, and 825 may be reproduced only when an optical processor having the exact distortion is used. It will be appreciated that a single hue may be produced by mixing several dyes, for example, 3, 5,  
5 or 10. It will be appreciated that each printing house may be allocated only a specific mix of dyes, so that no two printing houses may have identical dye combinations, and no two printing houses may reproduce the same color-coded signatures 802.

For some applications, color-coded signature 802 is printed directly on an element  
10 of system 10, for example, on radiopharmaceutical agent container 22 (Fig. 1), or on radioisotope vial 610 (Fig. 14). Alternatively or additionally, a label, for example, mother vial data carrier 106 or data carrier 120 (Fig. 1) is color-coded, or includes a color-coded patch or pattern, operative as color-coded signature 802.

For some applications, an encrypted signature 256 and a color-coded signature 802  
15 are combined. The resulting color-coded machine-readable signature 256 is authenticated by optical processor 820. For example, an encrypted signature may be provided on a label colored with a coded color. Alternatively or additionally, encrypted signature 256 is printed on a color-coded background, or with color-coded dyes. Alternatively or additionally, coded signature 256 comprises a color-coded barcode. For some  
20 applications, the color-coded barcode may appear black or another color to the eye, but reveal a unique spectrum to optical processor 820. For some applications, the color-coded machine-readable signature further comprises a date, to prevent the recycling or re-use of signatures.

#### *Physical key*

Reference is made to Fig. 17, which is a schematic illustration of a  
25 computer-readable medium 850, a portion of which is shaped so as to define a physical key 852, in accordance with an embodiment of the present invention. A communication element 854 is shaped so as to define a dedicated slot 856 having a geometry matching that of key 852. Only keys having the particular geometry of slot 856 can be inserted into  
30 the slot. Key 852 thus enables authentication of computer-readable medium 850. Computer-readable medium 850 may comprise, for example, a disk-on-key apparatus or a



chip, having, for example, a USB-type connector.

For some applications, patient-specific data carrier 24 comprises computer-readable medium 850, and a communication element of imaging system 28 and/or administration system 26 is shaped so as to define slot 856. Alternatively or  
5 additionally, healthcare worker identity tag 208 comprises computer-readable medium 850, and workstation 200, elution system 600, dispensing system 20, administration system 26, and/or imaging system 28 is shaped so as to define slot 856. For some applications, computer-readable medium 850 further comprises coded signature 256, as described hereinabove, while for other applications, key 852 is relied upon in lieu of  
10 coded signature 256.

For some applications, authentication, as described herein, is alternatively or additionally based on additional parameters, such as a manufacturer's attribute.

In an embodiment of the present invention, information is transferred from one element of system 10 to another element thereof by physically transferring an electronic  
15 information-carrying chip from one element to the other. For example, upon administration of the labeled radiopharmaceutical agent contained in container 22, information may be transferred from data carrier 120 to patient-specific data carrier 24 by physically transferring a memory chip of data carrier 120 to data carrier 24.

#### *Managing Compton residuals*

Reference is made to Fig. 18, which is a graph showing particle energy vs. photon  
20 count at a detector 454 of camera 452 of imaging system 28 (Fig. 11), in accordance with an embodiment of the present invention. In this embodiment, dose calculation sub-system 156 of radiopharmaceutical dose calculation system 152, described hereinabove with reference to Fig. 5, takes Compton residuals into consideration when calculating doses of  
25 a first and a second labeled radiopharmaceutical agent to be mixed together in a cocktail, or to be separately administered for the same image acquisition procedure. If the first agent were to be provided at a relatively high dose and the second agent were to be provided at a lower dose, the first agent would produce a first peak 900A around a first energy level  $E^1$ , and the second agent would produce a second peak 902 around a second  
30 energy level  $E^2$ . A Compton residual 904A produced by the first agent at least partially masks second peak 902. For some applications, in order to prevent such masking, dose

calculation sub-system 156 reduces the dose of the first agent, thereby producing a first peak 900B and a corresponding Compton residual 904B having lower counts than initial first peak 900A and Compton residual 904A, respectively. Compton residual 904B is sufficiently low so as not to mask second peak 902. By using techniques described  
5 hereinabove and/or incorporated herein by reference, camera 452 is sufficiently sensitive to acquire sufficient counts emitted from the lower dose of the second agent. For example, the first and second agents may comprise MIBI-Tc and thallium, respectively, which emit energy at 140 KeV and 72 KeV, respectively.

Alternatively, calculation sub-system 156 determines that the dose of the first  
10 labeled radiopharmaceutical agent cannot be reduced sufficiently to prevent such Compton masking. To make such a determination, the sub-system typically takes into consideration constraints applied by the physical properties of the first agent, patient-specific information, and/or camera 452. The sub-system may thus determine that the two agents must be prepared as separate doses for non-simultaneous administration.  
15 Alternatively, the sub-system determines that the dose of the second agent is to be increased, so as to prevent the masking. To make such a determination, the sub-system typically takes into consideration constraints applied by the physical properties of the first agent, patient-specific information, camera 452, and/or safety and/or regulatory requirements.

#### 20 *Information-bearing radiopharmaceuticals*

In an embodiment of the present invention, a portion of the patient, radiopharmaceutical, and/or protocol information described herein is chemically stored together with a labeled radiopharmaceutical agent in a container, such as radiopharmaceutical agent container 22 or mother vial 104. For some applications, such  
25 information is chemically stored by providing a chemical indicative of and/or encoding the information, and mixing the chemical with the radiopharmaceutical agent. Alternatively, such information is chemically stored by attaching a chemical marker indicative of the information to the radiopharmaceutical agent, or otherwise chemically modifying the radiopharmaceutical agent to store the information. The  
30 information-indicative chemical indicator (i.e., chemical or chemical marker) has properties which are machine-readable, for example, using optical, spectral, fluorescence, or isotope emission techniques.

For some applications, the information is stored by setting a level of a parameter of the chemical indicator, such as concentration or radioactivity, which level is indicative of the information. For example, a plurality of concentrations  $0, A_1, A_2, A_3, \dots, A_{\max}$  may be defined, each of which represents a respective value. At all of the defined  
5 concentrations, the chemical indicator is biologically inert and/or safe in the body, and does not affect the sterility and/or properties of the radiopharmaceutical agent. The plurality of concentrations are sufficiently different from one another so as to be independently measurable and identifiable, such as by measuring a spectral signature of the chemical indicator. For some applications, a plurality of different chemical indicators  
10 are used, each of which has defined levels of a parameter representing respective values. The values represented by the plurality of chemical indicators together represent the information.

For some applications, the level of the parameter of the chemical indicator changes over time, e.g., the radioactivity of the chemical indicator declines because of  
15 radioactive decay, thereby providing an indication of elapsed time. Such elapsed time may be used, for example, to determine the timing of preparation of the radiopharmaceutical agent and/or subsequent processes, as well as validating whether such timing is within an allowed time window.

For some applications, dispensing system 20 applies the code to the labeled  
20 radiopharmaceutical agent and/or container 22 during the dispensing process, and administration system 26 and/or imaging system 28 reads and verifies the stored information. A dedicated reader may be provided for such reading, or a camera of imaging system 28 may be configured to perform such reading.

The scope of the present invention includes embodiments described in the  
25 following applications, which are assigned to the assignee of the present application and are incorporated herein by reference. In an embodiment, techniques and apparatus described in one or more of the following applications are combined with techniques and apparatus described herein:

- International Application PCT/IL2005/001173, filed November 9, 2005;
- 30 • International Application PCT/IL2005/000572, filed June 1, 2005;
- International Application PCT/IL2005/000575, filed June 1, 2005;

- International Application PCT/IL2005/001215, filed November 16, 2005;
- US Provisional Application 60/625,971, filed November 9, 2004;
- US Provisional Application 60/628,105, filed November 17, 2004;
- US Provisional Application 60/630,561, filed November 26, 2004;
- 5 • US Provisional Application 60/632,236, filed December 2, 2004;
- US Provisional Application 60/632,515, filed December 3, 2004;
- US Provisional Application 60/635,630, filed December 14, 2004;
- US Provisional Application 60/636,088, filed December 16, 2004;
- US Provisional Application 60/640,215, filed January 3, 2005;
- 10 • US Provisional Application 60/648,385, filed February 1, 2005;
- US Provisional Application 60/648,690, filed February 2, 2005;
- US Provisional Application 60/675,892, filed April 29, 2005;
- US Provisional Application 60/691,780, filed June 20, 2005;
- US Provisional Application 60/700,318, filed July 19, 2005;
- 15 • US Provisional Application 60/700,299, filed July 19, 2005;
- US Provisional Application 60/700,317, filed July 19, 2005;
- US Provisional Application 60/700,753, filed July 20, 2005;
- US Provisional Application 60/700,752, filed July 20, 2005;
- US Provisional Application 60/702,979, filed July 28, 2005;
- 20 • US Provisional Application 60/720,034, filed September 26, 2005;
- US Provisional Application 60/720,652, filed September 27, 2005;
- US Provisional Application 60/720,541, filed September 27, 2005;
- US Provisional Application 60/750,287, filed December 13, 2005;
- US Provisional Application 60/750,334, filed December 15, 2005; and/or
- 25 • US Provisional Application 60/750,597, filed December 15, 2005.

As used in the present application, including in the claims, a "clinical

environment" means any facility or institution in which at least one of radiopharmaceutical preparation, dispensing, and administration occur, including, for example, a radiopharmaceutical manufacturing facility, a pharmacy, a hospital, a doctor's clinic, a day clinic, an out-patient clinic, a laboratory, and a geriatric center.

5           It will be appreciated by persons skilled in the art that the present invention is not limited to what has been particularly shown and described hereinabove. Rather, the scope of the present invention includes both combinations and subcombinations of the various features described hereinabove, as well as variations and modifications thereof that are not in the prior art, which would occur to persons skilled in the art upon reading the  
10 foregoing description.

## CLAIMS

1. Apparatus for use with at least one labeled radiopharmaceutical agent, the apparatus comprising:
  - a container containing the at least one labeled radiopharmaceutical agent; and
  - 5 a portable computer-communicatable data carrier associated with the container, the data carrier containing imaging protocol information for use with the at least one labeled radiopharmaceutical agent.
2. The apparatus according to claim 1, wherein the apparatus comprises a device configured to write the imaging protocol information to the data carrier.
- 10 3. The apparatus according to claim 1, wherein the data carrier additionally contains administration protocol information useful for administering the at least one labeled radiopharmaceutical agent.
4. The apparatus according to claim 1, wherein the imaging protocol information comprises instructions for performing an imaging procedure using the at least one labeled  
15 radiopharmaceutical agent.
5. The apparatus according to claim 1, wherein the imaging protocol information comprises an identifier of an imaging protocol.
6. The apparatus according to claim 1, wherein the imaging protocol information comprises a parameter of the at least one labeled radiopharmaceutical agent.
- 20 7. The apparatus according to claim 1, wherein the imaging protocol information comprises a parameter useful for configuring at least one aspect of an imaging procedure performed using the at least one labeled radiopharmaceutical agent.
8. The apparatus according to claim 1, wherein the container contains a single dose of the radiopharmaceutical agent, which dose is appropriate for use with the imaging  
25 protocol information.
9. The apparatus according to claim 1, wherein the container contains a plurality of labeled radiopharmaceutical agents mixed together.
10. The apparatus according to claim 1, wherein the container is shaped so as to define a plurality of chambers, each of which contains a respective one of a plurality of labeled  
30 radiopharmaceutical agents.

11. The apparatus according to any one of claims 1-10,  
wherein the data carrier comprises a first data carrier, which contains a first  
identifier value,  
wherein the apparatus further comprises a second computer-communicatable data  
carrier, which contains a second identifier value, and  
5 wherein the apparatus is configured to operate responsively to a detection of a  
correspondence between the first and second identifier values.
12. The apparatus according to claim 11, wherein at least one of the first and second  
data carriers is configured to perform the detection of the correspondence.
- 10 13. The apparatus according to claim 11, wherein the apparatus comprises a  
correspondence-detection element configured to perform the detection of the  
correspondence.
14. The apparatus according to claim 11, wherein at least one of the first and second  
data carriers contains an identifier of a patient to whom the labeled radiopharmaceutical  
15 agent is to be administered.
15. The apparatus according to claim 11, wherein at least one of the first and second  
identifier values comprises an identifier of a patient to whom the labeled  
radiopharmaceutical agent is to be administered.
16. The apparatus according to claim 11, wherein exactly one of the first and second  
20 data carriers comprises a coupling mechanism configured to be coupled to a patient to  
whom the labeled radiopharmaceutical agent is to be administered.
17. The apparatus according to claim 11, wherein the apparatus comprises an imaging  
system comprising imaging functionality, the imaging system configured, responsively to  
the detection of the correspondence, to drive the imaging functionality to perform an  
25 imaging procedure using the at least one labeled radiopharmaceutical agent.
18. The apparatus according to any one of claims 1-10, wherein the data carrier is  
physically coupled to the container.
19. The apparatus according to claim 18, wherein the data carrier contains an  
identifier of a patient to whom the labeled radiopharmaceutical agent is to be  
30 administered, and wherein the imaging protocol information comprises imaging protocol  
information selected for the patient.

20. The apparatus according to claim 19, wherein the imaging protocol information comprises an identifier of an imaging protocol.
21. The apparatus according to claim 19, wherein the imaging protocol information comprises imaging protocol information customized for the patient.
- 5 22. The apparatus according to any one of claims 1-10, wherein the imaging protocol information comprises SPECT imaging protocol information.
23. The apparatus according to claim 22, wherein the SPECT imaging protocol information comprises dynamic SPECT imaging protocol information.
24. The apparatus according to claim 23, wherein the SPECT imaging protocol  
10 information comprises at least one kinetic parameter of the at least one labeled radiopharmaceutical agent, the at least one kinetic parameter useful for performing a dynamic SPECT imaging procedure using the at least one labeled radiopharmaceutical agent.
25. The apparatus according to any one of claims 1-10, comprising an imaging  
15 system, which comprises:
- a communication element, configured to read the imaging protocol information from the data carrier; and
  - a control unit, comprising imaging functionality, which is configured to perform an imaging procedure, and to configure the procedure at least in part responsively to  
20 the imaging protocol information read from the data carrier by the communication element.
26. The apparatus according to claim 25, wherein the imaging system comprises a camera, wherein the imaging functionality comprises image acquisition functionality, and wherein the image acquisition functionality is configured to perform an image acquisition  
25 procedure using the camera, and to configure the procedure at least in part responsively to the imaging protocol information read from the data carrier by the communication element.
27. The apparatus according to claim 26, wherein the image acquisition functionality configures a total acquisition time of the image acquisition procedure at least in part responsively to the imaging protocol information.
- 30 28. The apparatus according to claim 26, wherein the camera comprises a plurality of detectors, and wherein the image acquisition functionality is configured to configure, at



least in part responsively to the imaging protocol information, at least one motion of at least one of the detectors during the image acquisition procedure.

29. The apparatus according to claim 26, wherein the control unit is configured to configure, at least in part responsively to the imaging protocol information, a waiting time  
5 between administration of the labeled radiopharmaceutical agent and commencement of the image acquisition procedure.

30. The apparatus according to claim 26, wherein the image acquisition functionality is configured to perform a gated image acquisition procedure at least in part responsively to the imaging protocol information.

10 31. The apparatus according to claim 25, wherein the imaging functionality comprises image reconstruction functionality, and wherein the image reconstruction functionality is configured to perform an image reconstruction procedure, and to configure the procedure at least in part responsively to the imaging protocol information read from the data carrier by the communication element.

15 32. The apparatus according to claim 25, wherein the imaging functionality comprises image analysis functionality, and wherein the image analysis functionality is configured to perform an image analysis procedure, and to configure the procedure at least in part responsively to the imaging protocol information read from the data carrier by the communication element.

20 33. The apparatus according to claim 25, wherein the imaging functionality comprises diagnosis functionality, and wherein the diagnosis functionality is configured to perform a diagnostic procedure, and to configure the procedure at least in part responsively to the imaging protocol information read from the data carrier by the communication element.

25 34. The apparatus according to claim 25, wherein the imaging procedure includes a three-dimensional dynamic imaging study, and wherein the imaging functionality is configured to perform the three-dimensional dynamic imaging study, and to configure the study at least in part responsively to the imaging protocol information read from the data carrier by the communication element.

30 35. The apparatus according to any one of claims 1-10, wherein the data carrier is not physically coupled to the container, and wherein the data carrier contains an identifier of a patient to whom the labeled radiopharmaceutical agent is to be administered.

36. The apparatus according to claim 35, wherein the data carrier comprises a coupling mechanism configured to be coupled to the patient.
37. The apparatus according to claim 35, wherein the data carrier comprises a first data carrier, and wherein the apparatus further comprises a second  
5 computer-communicatable data carrier physically coupled to the container, the second data carrier containing radiopharmaceutical information regarding the at least one labeled radiopharmaceutical agent.
38. Apparatus for use with at least one labeled radiopharmaceutical agent, the apparatus comprising:  
10 a container containing the at least one labeled radiopharmaceutical agent; and  
a computer-communicatable data carrier associated with the container, the data carrier containing authenticatable information regarding a commercial license for use of SPECT imaging protocol information with the at least one labeled radiopharmaceutical agent.
- 15 39. The apparatus according to claim 38, comprising an imaging system, which comprises:  
a communication element, configured to read the authenticatable license information from the data carrier;  
a control unit, comprising imaging functionality, the control unit configured to:  
20 authenticate the authenticatable license information, and  
only upon authentication, drive the imaging functionality to perform an imaging procedure using the SPECT imaging protocol information.
40. The apparatus according to claim 38, wherein the apparatus comprises a device configured to write the authenticatable license information to the data carrier.
- 25 41. The apparatus according to any one of claims 38-40, wherein the data carrier is physically coupled to the container.
42. Apparatus comprising a portable computer-communicatable data carrier containing authenticatable information regarding a commercial license for use of SPECT imaging protocol information.
- 30 43. The apparatus according to claim 42, wherein the data carrier additionally contains patient information regarding a patient upon whom an imaging procedure using the

SPECT imaging protocol information is to be performed.

44. The apparatus according to claim 42, wherein the authenticatable license information is encrypted.

45. The apparatus according to claim 42, wherein the apparatus comprises a device  
5 configured to write the authenticatable license information to the data carrier.

46. The apparatus according to claim 42, wherein the data carrier comprises a coupling mechanism configured to be coupled to a patient upon whom an imaging procedure using the SPECT imaging protocol information is to be performed.

47. The apparatus according to any one of claims 42-46, comprising an imaging  
10 system, which comprises:

a communication element, configured to read the authenticatable license information from the data carrier;

a control unit, comprising imaging functionality, the control unit configured to:  
authenticate the authenticatable license information, and

15 only upon authentication, drive the imaging functionality to perform an imaging procedure using the SPECT imaging protocol information.

48. Apparatus comprising:

a first portable computer-communicatable data carrier containing a first identifier value;

20 a second portable computer-communicatable data carrier containing a second identifier value; and

an imaging system comprising imaging functionality, the imaging system configured, responsively to a detection of a correspondence between the first and second identifier values, to drive the imaging functionality to perform an imaging procedure on a  
25 patient.

49. The apparatus according to claim 48, wherein at least one of the first and second data carriers is configured to perform the detection of the correspondence.

50. The apparatus according to claim 48, wherein the imaging system comprises a correspondence-detection element configured to perform the detection of the  
30 correspondence.

51. The apparatus according to claim 48, wherein at least one of the first and second

data carriers contains an identifier of a patient to whom the labeled radiopharmaceutical agent is to be administered.

52. The apparatus according to claim 48, wherein at least one of the first and second identifier values comprises an identifier of a patient to whom the labeled  
5 radiopharmaceutical agent is to be administered.

53. The apparatus according to claim 48, wherein one of the first and second data carriers comprises a coupling mechanism configured to be coupled to a patient to whom the labeled radiopharmaceutical agent is to be administered.

54. The apparatus according to claim 48, wherein the apparatus comprises a device  
10 configured to write at least one of the first and second identifier values to the respective first and second data carriers.

55. The apparatus according to any one of claims 48-54,  
wherein at least one of the first and second data carriers contains  
radiopharmaceutical information regarding at least one labeled radiopharmaceutical agent,  
15 wherein the imaging system comprises a communication element, configured to read the radiopharmaceutical information from the at least one of the data carriers, and  
wherein the imaging system is configured to configure the imaging procedure at least in part responsively to the read radiopharmaceutical information.

56. The apparatus according to claim 55, wherein the apparatus comprises a container  
20 containing the at least one labeled radiopharmaceutical agent.

57. The apparatus according to claim 56, wherein one of the first and second data carriers is physically coupled to the container.

58. The apparatus according to any one of claims 48-54, wherein the imaging functionality comprises a nuclear camera.

25 59. The apparatus according to claim 58, wherein the nuclear camera comprises a SPECT camera.

60. Apparatus for use with first and second portable computer-communicatable data carriers containing first and second identifier values, respectively, the apparatus comprising an imaging system, which comprises:

30 imaging functionality; and

a control unit configured to drive the imaging functionality to perform an imaging procedure on a patient, responsively to a detection of a correspondence between the first and second identifier values.

61. The apparatus according to claim 60, wherein the imaging system comprises a  
5 correspondence-detection element configured to perform the detection of the correspondence.

62. Apparatus for use with at least one labeled radiopharmaceutical agent for administration to a patient, the apparatus comprising:

a container containing the at least one labeled radiopharmaceutical agent;

10 a first computer-communicatable data carrier physically coupled to the container, the first data carrier containing radiopharmaceutical information regarding the at least one labeled radiopharmaceutical agent; and

a second portable computer-communicatable data carrier containing patient information regarding the patient, and imaging protocol information for use with the at  
15 least one labeled radiopharmaceutical agent.

63. The apparatus according to claim 62, wherein the imaging protocol information comprises SPECT imaging protocol information.

64. The apparatus according to claim 62, wherein the patient information comprises an identifier of the patient.

20 65. The apparatus according to claim 62, wherein the second data carrier comprises a coupling mechanism configured to be coupled to the patient.

66. The apparatus according to claim 62, wherein the first data carrier contains a first patient identifier, wherein the patient information contained in the second data carrier comprises a second patient identifier, and comprising an administration system, which  
25 comprises:

a first communication element, configured to read the first patient identifier from the first data carrier;

a second communication element, configured to read the second patient identifier from the second data carrier; and

30 a control unit, configured to compare the first patient identifier to the second patient identifier, and, upon detecting a match, generate an administration signal that

triggers administration to the patient of the at least one labeled radiopharmaceutical agent contained in the container.

67. The apparatus according to claim 62, wherein the first data carrier contains a first protocol identifier, wherein the imaging protocol information contained in the second data carrier comprises a second protocol identifier, and comprising an administration system, which comprises:

a communication element, configured to read the first and second protocol identifiers from the first and second data carriers, respectively; and

a control unit, configured to compare the first protocol identifier to the second protocol identifier, and, upon detecting a match, generate an administration signal that triggers administration to the patient of the at least one labeled radiopharmaceutical agent contained in the container.

68. The apparatus according to claim 62, wherein the first data carrier contains a first protocol identifier, wherein the imaging protocol information contained in the second data carrier comprises a second protocol identifier, and comprising an administration system, which comprises:

a first communication element, configured to read the first protocol identifier from the first data carrier;

a second communication element, configured to read the second protocol identifier from the second data carrier; and

a control unit, configured to compare the first protocol identifier to the second protocol identifier, and, upon detecting a match, generate an administration signal that triggers administration to the patient of the at least one labeled radiopharmaceutical agent contained in the container.

69. The apparatus according to claim 62, comprising an administration system, which comprises:

a communication element; and

a control unit, configured to:

generate an administration signal that triggers administration to the patient of the at least one labeled radiopharmaceutical agent contained in the container, and

drive the communication element to transmit information regarding the administration to the second data carrier.

70. The apparatus according to claim 62, wherein the apparatus comprises a device configured to write the imaging protocol information to the first data carrier.
71. The apparatus according to claim 62, wherein the apparatus comprises a device configured to write the patient information to the second data carrier.
- 5 72. The apparatus according to any one of claims 62-71, wherein the imaging protocol information comprises imaging protocol information selected for the patient.
73. The apparatus according to claim 72, wherein the imaging protocol information comprises an identifier of an imaging protocol.
74. The apparatus according to claim 72, wherein the imaging protocol information  
10 comprises imaging protocol information customized for the patient.
75. The apparatus according to any one of claims 62-71, wherein the first data carrier contains a first patient identifier, wherein the patient information contained in the second data carrier includes a second patient identifier, and comprising an administration system, which comprises:
- 15 a communication element, configured to read the first and second patient identifiers from the first and second data carriers, respectively; and  
a control unit, configured to compare the first patient identifier to the second patient identifier, and, upon detecting a match, generate an administration signal that triggers administration to the patient of the at least one labeled radiopharmaceutical agent  
20 contained in the container.
76. The apparatus according to claim 75, wherein the administration system comprises an automated administration device, configured to administer the at least one labeled radiopharmaceutical agent to the patient upon being triggered by the administration signal.
- 25 77. The apparatus according to claim 75, wherein the control unit is configured to generate the administration signal to trigger the administration of the at least one labeled radiopharmaceutical agent by instructing a healthcare worker to administer the at least one labeled radiopharmaceutical agent to the patient.
78. Apparatus for use with at least one labeled radiopharmaceutical agent for  
30 administration to a patient, the apparatus comprising:  
a container containing the at least one labeled radiopharmaceutical agent;

a computer-communicatable data carrier associated with the container, the data carrier containing data regarding at least one of: the labeled radiopharmaceutical agent and the patient; and

a SPECT imaging system comprising:

5 a communication element, configured to read the data; and

a control unit, configured to utilize the read data to customize at least one function of the system selected from the group consisting of: administration of the labeled radiopharmaceutical agent, acquisition of a SPECT image of the patient to whom the labeled radiopharmaceutical agent is administered, reconstruction of the SPECT image, analysis of the SPECT image, and diagnosis of a condition of the patient based at least in part on the analysis.

10

79. The apparatus according to claim 78, wherein the data carrier contains the data regarding the labeled radiopharmaceutical agent.

80. The apparatus according to claim 78, wherein the data carrier contains the data regarding the patient.

15

81. The apparatus according to claim 78, wherein the control unit is configured to utilize the read data to customize the administration of the labeled radiopharmaceutical agent.

82. The apparatus according to claim 78, wherein the control unit is configured to utilize the read data to customize the acquisition of a SPECT image of the patient to whom the labeled radiopharmaceutical agent is administered.

20

83. The apparatus according to claim 78, wherein the control unit is configured to utilize the read data to customize the reconstruction of the SPECT image.

84. The apparatus according to claim 78, wherein the control unit is configured to utilize the read data to customize the analysis of the SPECT image.

25

85. The apparatus according to claim 78, wherein the control unit is configured to utilize the read data to customize the diagnosis of a condition of the patient based at least in part on the analysis.

86. The apparatus according to any one of claims 78-85, wherein the apparatus comprises a device configured to write the data to the data carrier.

30



87. A SPECT imaging system for use with a container containing at least one labeled radiopharmaceutical agent for administration to a patient, and data regarding at least one of: the labeled radiopharmaceutical agent and the patient, the system comprising:
- a communication element, configured to read the data; and
  - 5 a control unit, configured to utilize the read data to customize at least one function of the system selected from the group consisting of: administration of the labeled radiopharmaceutical agent, acquisition of a SPECT image of the patient to whom the labeled radiopharmaceutical agent is administered, reconstruction of the SPECT image, analysis of the SPECT image, and diagnosis of a condition of the patient based at least in
- 10 part on the analysis.
88. The system according to claim 87, wherein the system comprises a device configured to write the data to the container.
89. An automated radiopharmaceutical dispensing system for use with a container and a computer-communicatable container data carrier associated with the container, the
- 15 system comprising:
- a robot, configured to manipulate the container;
  - a communication element; and
  - a control unit, configured to:
    - 20 receive radiopharmaceutical information regarding at least one labeled radiopharmaceutical agent, the radiopharmaceutical information selected from the group consisting of: imaging protocol information for use with the at least one labeled radiopharmaceutical agent, and authenticatable information regarding a commercial license for use of an imaging protocol with the at least one labeled radiopharmaceutical agent,
    - 25 receive patient information regarding a patient,
    - drive the robot to automatically dispense a dose of the labeled radiopharmaceutical agent to the container, and
    - drive the communication element to transmit to the container data carrier at least a portion of the radiopharmaceutical information and at least a portion of the patient
- 30 information.
90. The system according to claim 89, wherein the control unit is configured to receive the radiopharmaceutical information regarding a plurality of labeled

radiopharmaceutical agents, and drive the robot to automatically dispense respective doses of the labeled radiopharmaceutical agents to the container.

91. The system according to claim 89, wherein the patient information includes an identifier of an imaging protocol assigned to the patient for performance using the dose,  
5 and wherein the control unit is configured to drive the communication element to transmit the imaging protocol identifier to the container data carrier.

92. The system according to claim 89, wherein the control unit is configured to drive the communication element to transmit to the container data carrier at least one of: a time of dispensing of the labeled radiopharmaceutical agent to the container, and information  
10 regarding a radioactivity of the dose at the time of dispensing.

93. The system according to claim 89, comprising:

a mother vial that contains the labeled radiopharmaceutical agent prior to dispensing thereof; and

a computer-communicatable mother vial data carrier associated with the mother  
15 vial, which mother vial data carrier contains the radiopharmaceutical information,

wherein the control unit is configured to receive the radiopharmaceutical information from the mother vial data carrier.

94. The system according to any one of claims 89-93, wherein the radiopharmaceutical information comprises the imaging protocol information.

20 95. The system according to claim 94, wherein the imaging protocol information comprises SPECT imaging protocol information.

96. The system according to claim 95, wherein the imaging protocol information comprises at least one kinetic parameter of the at least one labeled radiopharmaceutical agent.

25 97. The system according to any one of claims 89-93, wherein the radiopharmaceutical information comprises the authenticatable information regarding the commercial license.

98. The system according to claim 97, wherein the information regarding the commercial license comprises information regarding the commercial license for use of a  
30 SPECT imaging protocol with the at least one labeled radiopharmaceutical agent.

99. The system according to claim 97, wherein the control unit is configured to

authenticate the authenticatable license information, and to drive the robot to automatically dispense the dose only upon authentication.

100. Apparatus for use with a container, the apparatus comprising:  
a mother vial having a volume of at least 10 ml, which contains at least 5 ml of a  
5 non-diluted labeled radiopharmaceutical agent, and at least 5 ml of saline solution; and  
an automated radiopharmaceutical dispensing system, configured to contain the  
mother vial, and to dispense at least one dose from the mother vial to the container.
101. A method comprising:  
placing at least one labeled radiopharmaceutical agent in a container;  
10 associating a portable computer-communicatable data carrier with the container;  
and  
writing, to the data carrier, imaging protocol information for use with the at least  
one labeled radiopharmaceutical agent.
102. The method according to claim 101, comprising writing, to the data carrier,  
15 administration protocol information useful for administering the at least one labeled  
radiopharmaceutical agent.
103. The method according to claim 101, wherein writing the imaging protocol  
information comprises writing instructions for performing an imaging procedure using the  
at least one labeled radiopharmaceutical agent.
- 20 104. The method according to claim 101, wherein writing the imaging protocol  
information comprises writing an identifier of an imaging protocol.
105. The method according to claim 101, wherein writing the imaging protocol  
information comprises writing a parameter of the at least one labeled radiopharmaceutical  
agent.
- 25 106. The method according to claim 101, wherein writing the imaging protocol  
information comprises writing a parameter useful for configuring at least one aspect of an  
imaging procedure performed using the at least one labeled radiopharmaceutical agent.
107. The method according to claim 101, wherein placing comprises placing a single  
dose of the radiopharmaceutical agent in the container, which dose is appropriate for use  
30 with the imaging protocol information.

108. The method according to claim 101, wherein placing comprises placing, in the container, a plurality of labeled radiopharmaceutical agents mixed together.

109. The method according to claim 101, wherein the container is shaped so as to define a plurality of chambers, and wherein placing the at least one labeled  
5 radiopharmaceutical agent in the container comprises placing a plurality of labeled radiopharmaceutical agents in respective chambers.

110. The method according to any one of claims 101-109, wherein associating the data carrier comprises associating a first data carrier with the container, and wherein the method comprises:

10 writing a first identifier value to the first data carrier;  
writing a second identifier to a second computer-communicatable data carrier;  
detecting a correspondence between the first and second identifier values; and  
performing an operation responsively to the detecting.

111. The method according to claim 110, wherein detecting comprises detecting the  
15 correspondence by at least one of the first and second data carriers.

112. The method according to claim 110, wherein detecting comprises detecting by a correspondence-detection element separate from the first and second data carriers.

113. The method according to claim 110, comprising writing, to at least one of the first and second data carriers, an identifier of a patient to whom the labeled  
20 radiopharmaceutical agent is to be administered.

114. The method according to claim 110, wherein writing at least one of the first and second identifier values comprises writing an identifier of a patient to whom the labeled radiopharmaceutical agent is to be administered.

115. The method according to claim 110, comprising coupling exactly one of the first  
25 and second data carriers to a patient to whom the labeled radiopharmaceutical agent is to be administered.

116. The method according to claim 110, wherein performing the operation comprises, responsively to the detecting of the correspondence, performing an imaging procedure using the at least one labeled radiopharmaceutical agent.

30 117. The method according to any one of claims 101-109, wherein associating the data carrier with the container comprises physically coupling the data carrier to the container.

118. The method according to claim 117, wherein the data carrier contains an identifier of a patient to whom the labeled radiopharmaceutical agent is to be administered, and wherein writing the imaging protocol information comprises writing imaging protocol information selected for the patient.
- 5 119. The method according to claim 118, wherein writing the imaging protocol information comprises writing an identifier of an imaging protocol.
120. The method according to claim 118, wherein writing the imaging protocol information comprises writing imaging protocol information customized for the patient.
121. The method according to any one of claims 101-109, wherein writing the imaging  
10 protocol information comprises writing SPECT imaging protocol information.
122. The method according to claim 121, wherein writing the SPECT imaging protocol information comprises writing dynamic SPECT imaging protocol information.
123. The method according to claim 122, wherein writing the SPECT imaging protocol  
15 information comprises writing at least one kinetic parameter of the at least one labeled radiopharmaceutical agent, the at least one kinetic parameter useful for performing a dynamic SPECT imaging procedure using the at least one labeled radiopharmaceutical agent.
124. The method according to any one of claims 101-109, comprising:  
reading the imaging protocol information from the data carrier; and  
20 performing an imaging procedure, and configuring the procedure at least in part responsively to the imaging protocol information read from the data carrier.
125. The method according to claim 124, wherein performing the imaging procedure comprises performing an image acquisition procedure, and configuring the procedure at least in part responsively to the imaging protocol information read from the data carrier.
- 25 126. The method according to claim 125, wherein performing the image acquisition procedure comprises configuring a total acquisition time of the image acquisition procedure at least in part responsively to the imaging protocol information.
127. The method according to claim 125, wherein performing the image acquisition  
30 procedure comprises performing the image acquisition procedure using a camera having a plurality of detectors, and configuring, at least in part responsively to the imaging protocol information, at least one motion of at least one of the detectors during the image

acquisition procedure.

128. The method according to claim 125, wherein performing the image acquisition procedure comprises configuring, at least in part responsively to the imaging protocol information, a waiting time between administration of the labeled radiopharmaceutical agent and commencement of the image acquisition procedure.

129. The method according to claim 125, wherein performing the image acquisition procedure comprises performing a gated image acquisition procedure at least in part responsively to the imaging protocol information.

130. The method according to claim 124, wherein performing the imaging procedure comprises performing an image reconstruction procedure, and configuring the procedure at least in part responsively to the imaging protocol information read from the data carrier.

131. The method according to claim 124, wherein performing the imaging procedure comprises performing an image analysis procedure, and configuring the procedure at least in part responsively to the imaging protocol information read from the data carrier.

132. The method according to claim 124, wherein performing the imaging procedure comprises performing a diagnostic procedure, and configuring the procedure at least in part responsively to the imaging protocol information read from the data carrier.

133. The method according to claim 124, wherein performing the imaging procedure comprises performing a three-dimensional dynamic imaging study, and configuring the study at least in part responsively to the imaging protocol information read from the data carrier.

134. The method according to any one of claims 101-109, wherein associating the data carrier with the container does not comprise physically coupling the data carrier to the container, and comprising writing, to the data carrier, an identifier of a patient to whom the labeled radiopharmaceutical agent is to be administered.

135. The method according to claim 134, comprising coupling the data carrier to the patient.

136. The method according to claim 134, wherein associating the data carrier comprises associating a first data carrier with the container, and comprising writing, to a second computer-communicatable data carrier, radiopharmaceutical information regarding the at least one labeled radiopharmaceutical agent, and physically coupling the second data

carrier to the container.

137. A method comprising:

placing at least one labeled radiopharmaceutical agent in a container;  
associating a computer-communicatable data carrier with the container; and

5 writing, to the data carrier, authenticatable information regarding a commercial license for use of SPECT imaging protocol information with the at least one labeled radiopharmaceutical agent.

138. The method according to claim 137, comprising:

reading the authenticatable license information from the data carrier;

10 authenticating the authenticatable license information; and

only upon authentication, performing an imaging procedure using the SPECT imaging protocol information.

139. The method according to any one of claims 137-138, wherein associating comprises physically coupling the data carrier to the container.

15 140. A method comprising:

providing a portable computer-communicatable data carrier; and

writing, to the data carrier, authenticatable information regarding a commercial license for use of SPECT imaging protocol information.

141. The method according to claim 140, comprising writing, to the data carrier, patient  
20 information regarding a patient upon whom an imaging procedure using the SPECT imaging protocol information is to be performed.

142. The method according to claim 140, wherein writing the authenticatable license information comprises encrypting the authenticatable license information.

143. The method according to claim 140, comprising:

25 reading the authenticatable license information from the data carrier;

authenticating the authenticatable license information; and

only upon authentication, performing an imaging procedure using the SPECT imaging protocol information.

144. The method according to any one of claims 140-143, comprising coupling the data  
30 carrier to a patient upon whom an imaging procedure using the SPECT imaging protocol

information is to be performed.

145. A method comprising:

writing first and second identifier values to first and second computer-communicatable data carriers, respectively;

5 detecting a correspondence between the first and second identifier values; and perform an imaging procedure on a patient responsively to the detecting.

146. The method according to claim 145, wherein detecting comprises detecting the correspondence by at least one of the first and second data carriers.

147. The method according to claim 145, wherein detecting comprises detecting by a  
10 correspondence-detection element separate from the first and second data carriers.

148. The method according to claim 145, comprising writing, to at least one of the first and second data carriers, an identifier of a patient to whom the labeled radiopharmaceutical agent is to be administered.

149. The method according to claim 145, wherein writing at least one of the first and  
15 second identifier values comprises writing an identifier of a patient to whom the labeled radiopharmaceutical agent is to be administered.

150. The method according to claim 145, comprising coupling one of the first and second data carriers to a patient to whom the labeled radiopharmaceutical agent is to be administered.

20 151. The method according to any one of claims 145-150, comprising:

writing, to at least one of the first and second data carriers, radiopharmaceutical information regarding at least one labeled radiopharmaceutical agent;

reading the radiopharmaceutical information from the at least one of the data carriers; and

25 configuring the imaging procedure at least in part responsively to the read radiopharmaceutical information.

152. The method according to claim 151, comprising placing the at least one labeled radiopharmaceutical agent in a container.

153. The method according to claim 152, comprising physically coupling one of the  
30 first and second data carriers to the container.



154. The method according to any one of claims 145-150, wherein performing the imaging procedure comprises performing a nuclear imaging procedure.
155. The method according to claim 154, wherein performing the nuclear imaging procedure comprises performing a SPECT imaging procedure.
- 5 156. A method for use with at least one labeled radiopharmaceutical agent for administration to a patient, the method comprising:
- placing at least one labeled radiopharmaceutical agent in a container;
  - physically coupling a first computer-communicatable data carrier to the container;
  - writing, to the first data carrier, radiopharmaceutical information regarding the at
- 10 least one labeled radiopharmaceutical agent; and
- writing, to a second portable computer-communicatable data carrier, patient information regarding the patient, and imaging protocol information for use with the at least one labeled radiopharmaceutical agent.
157. The method according to claim 156, wherein writing the imaging protocol
- 15 information comprises writing SPECT imaging protocol information.
158. The method according to claim 156, wherein writing the patient information comprises writing an identifier of the patient.
159. The method according to claim 156, comprising coupling the second data carrier to the patient.
- 20 160. The method according to claim 156, wherein writing the patient information to the second data carrier comprises writing a second patient identifier to the second data carrier, and comprising:
- writing a first patient identifier to the first data carrier;
  - reading the first and second patient identifiers from the first and second data
- 25 carriers, respectively; and
- comparing the first patient identifier to the second patient identifier, and, upon detecting a match, generating an administration signal that triggers administration to the patient of the at least one labeled radiopharmaceutical agent contained in the container.
161. The method according to claim 156, wherein writing the imaging protocol
- 30 information to the second data carrier comprises writing a second protocol identifier to the second data carrier, and comprising:

writing a first protocol identifier to the first data carrier;  
reading the first and second protocol identifiers from the first and second data carriers, respectively; and

5 comparing the first protocol identifier to the second protocol identifier, and, upon detecting a match, generating an administration signal that triggers administration to the patient of the at least one labeled radiopharmaceutical agent contained in the container.

162. The method according to claim 156, comprising:

generating an administration signal that triggers administration to the patient of the at least one labeled radiopharmaceutical agent contained in the container; and

10 transmitting information regarding the administration to the second data carrier.

163. The method according to any one of claims 156-162, wherein writing the imaging protocol information to the second data carrier comprises writing imaging protocol information selected for the patient.

164. The method according to claim 163, wherein writing the imaging protocol information comprises writing an identifier of an imaging protocol.

165. The method according to claim 163, wherein writing the imaging protocol information comprises writing imaging protocol information customized for the patient.

166. The method according to any one of claims 156-162, wherein writing the patient information to the second data carrier comprises writing a second patient identifier to the second data carrier, and comprising:

writing a first patient identifier to the first data carrier;

reading the first and second patient identifiers from the first and second data carriers, respectively; and

25 comparing the first patient identifier to the second patient identifier, and, upon detecting a match, generating an administration signal that triggers administration to the patient of the at least one labeled radiopharmaceutical agent contained in the container.

167. The method according to claim 166, comprising automatically administering the at least one labeled radiopharmaceutical agent to the patient upon triggering by the administration signal.

30 168. The method according to claim 166, wherein generating the administration signal comprises instructing a healthcare worker to administer the at least one labeled

radiopharmaceutical agent to the patient.

169. A method comprising:

placing, in a container, at least one labeled radiopharmaceutical agent for administration to a patient;

5 associating a computer-communicatable data carrier with the container;

writing data to the data carrier regarding at least one of: the labeled radiopharmaceutical agent and the patient;

reading the data from the data carrier at a SPECT imaging system;

10 utilizing the read data to customize at least one function of the system selected from the group consisting of: administration of the labeled radiopharmaceutical agent, acquisition of a SPECT image of the patient to whom the labeled radiopharmaceutical agent is administered, reconstruction of the SPECT image, analysis of the SPECT image, and diagnosis of a condition of the patient based at least in part on the analysis.

170. The method according to claim 169, wherein writing the data comprises writing the data regarding the labeled radiopharmaceutical agent.

171. The method according to claim 169, wherein writing the data comprises writing the data regarding the patient.

172. The method according to claim 169, wherein utilizing the read data comprises utilizing the read data to customize the administration of the labeled radiopharmaceutical agent.

173. The method according to claim 169, wherein utilizing the read data comprises utilizing the read data to customize the acquisition of a SPECT image of the patient to whom the labeled radiopharmaceutical agent is administered.

174. The method according to claim 169, wherein utilizing the read data comprises utilizing the read data to customize the reconstruction of the SPECT image.

175. The method according to claim 169, wherein utilizing the read data comprises utilizing the read data to customize the analysis of the SPECT image.

176. The method according to any one of claims 169-175, wherein utilizing the read data comprises utilizing the read data to customize the diagnosis of a condition of the patient based at least in part on the analysis.

177. A method for use with a container containing at least one labeled radiopharmaceutical agent for administration to a patient, and data regarding at least one of: the labeled radiopharmaceutical agent and the patient, the method comprising:

reading the data at a SPECT imaging system; and

5 utilizing the read data to customize at least one function of the system selected from the group consisting of: administration of the labeled radiopharmaceutical agent, acquisition of a SPECT image of the patient to whom the labeled radiopharmaceutical agent is administered, reconstruction of the SPECT image, analysis of the SPECT image, and diagnosis of a condition of the patient based at least in part on the analysis.

10 178. The method according to claim 177, comprising writing the data to the container.

179. A method for use with a container and a computer-communicatable container data carrier associated with the container, the method comprising:

receiving, by an automated radiopharmaceutical dispensing system, radiopharmaceutical information regarding at least one labeled radiopharmaceutical agent, the radiopharmaceutical information selected from the group consisting of: imaging protocol information for use with the at least one labeled radiopharmaceutical agent, and authenticatable information regarding a commercial license for use of an imaging protocol with the at least one labeled radiopharmaceutical agent;

receiving, by the dispensing system, patient information regarding a patient;

20 automatically robotically dispensing, by the dispensing system, a dose of the labeled radiopharmaceutical agent to the container; and

transmitting to the container data carrier, by the dispensing system, at least a portion of the radiopharmaceutical information and at least a portion of the patient information.

25 180. The method according to claim 179, wherein receiving the radiopharmaceutical information comprises receiving the radiopharmaceutical information regarding a plurality of labeled radiopharmaceutical agents, and wherein dispensing comprises dispensing respective doses of the labeled radiopharmaceutical agents to the container.

30 181. The method according to claim 179, wherein the patient information includes an identifier of an imaging protocol assigned to the patient for performance using the dose, and wherein transmitting comprises transmitting the imaging protocol identifier to the container data carrier.

182. The method according to claim 179, wherein transmitting comprises transmitting to the container data carrier at least one of: a time of dispensing of the labeled radiopharmaceutical agent to the container, and information regarding a radioactivity of the dose at the time of dispensing.

5 183. The method according to claim 179, wherein receiving the radiopharmaceutical information comprises:

providing, to the dispensing system, a mother vial that contains the labeled radiopharmaceutical agent prior to dispensing thereof, and a computer-communicatable mother vial data carrier associated with the mother vial, which mother vial data carrier  
10 contains the radiopharmaceutical information; and

receiving the radiopharmaceutical information from the mother vial data carrier.

184. The method according to any one of claims 179-183, wherein receiving the radiopharmaceutical information comprises receiving the imaging protocol information.

185. The method according to claim 184, wherein receiving the imaging protocol  
15 information comprises receiving SPECT imaging protocol information.

186. The method according to claim 185, wherein receiving the imaging protocol information comprises receiving at least one kinetic parameter of the at least one labeled radiopharmaceutical agent.

187. The method according to any one of claims 179-183, wherein receiving the  
20 radiopharmaceutical information comprises receiving the authenticatable information regarding the commercial license.

188. The method according to claim 187, wherein receiving the information regarding the commercial license comprises receiving information regarding the commercial license for use of a SPECT imaging protocol with the at least one labeled radiopharmaceutical  
25 agent.

189. The method according to claim 187, wherein dispensing comprises authenticating the authenticatable license information, and dispensing the dose only upon authentication.

190. A method for automatically dispensing a labeled radiopharmaceutical agent to a container, comprising:

30 providing a mother vial having a volume of at least 10 ml;

filling the mother vial with at least 5 ml of a non-diluted labeled

radiopharmaceutical agent, and with at least 5 ml of saline solution;

placing the mother vial in an automated radiopharmaceutical dispensing system;

and

dispensing at least one dose from the mother vial to the container.

FIG. 1

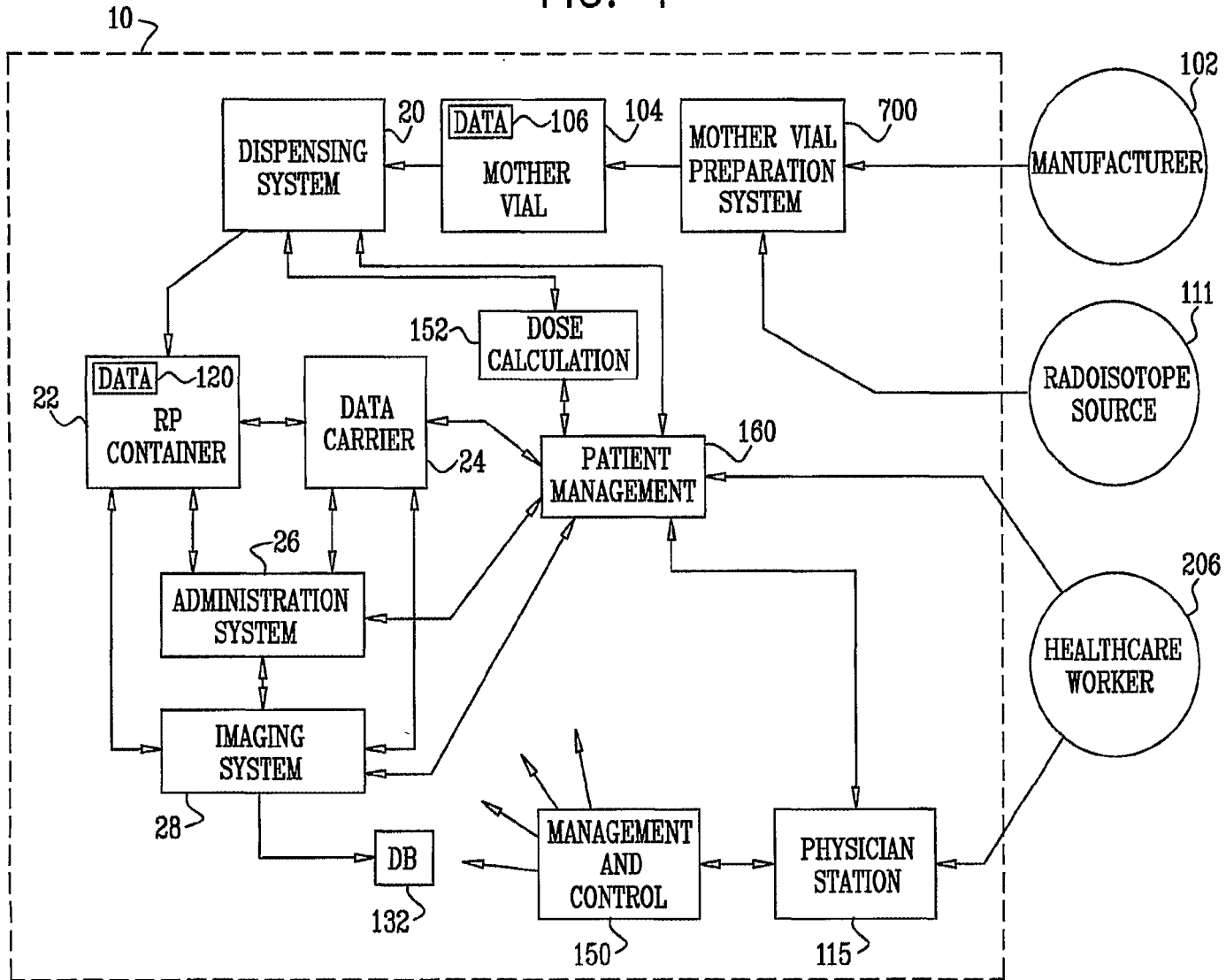


FIG. 2

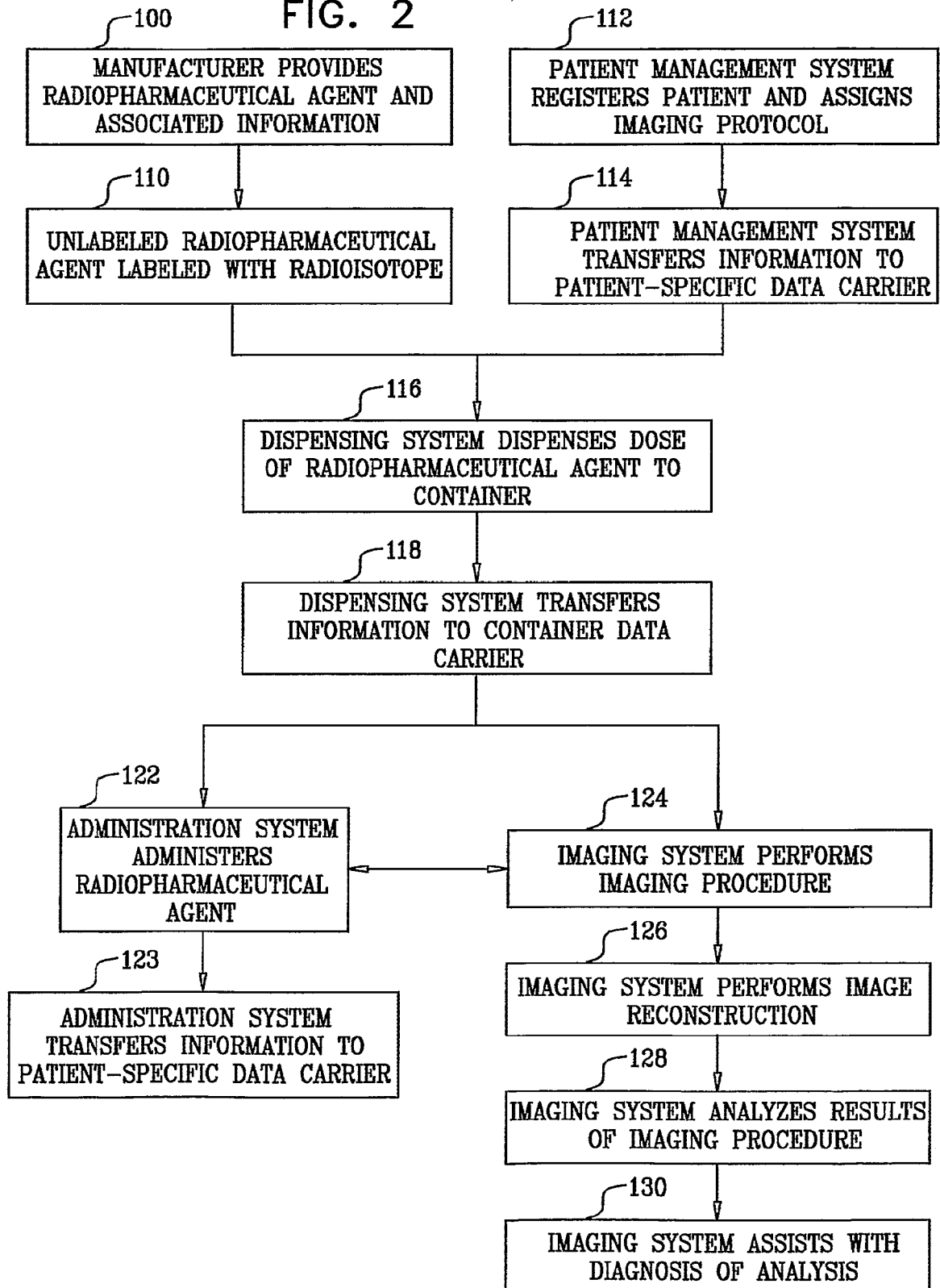




FIG. 3

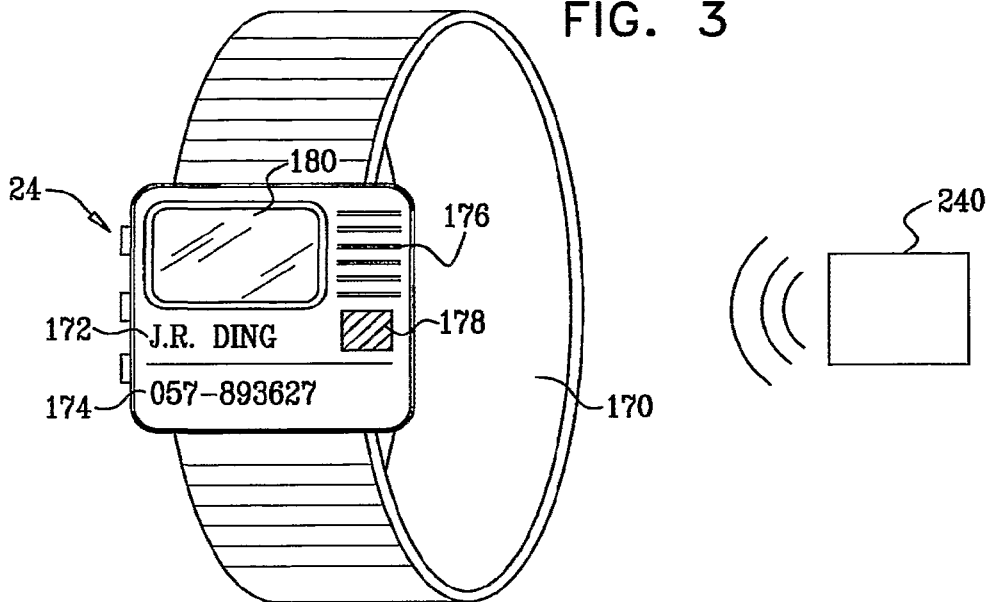


FIG. 4

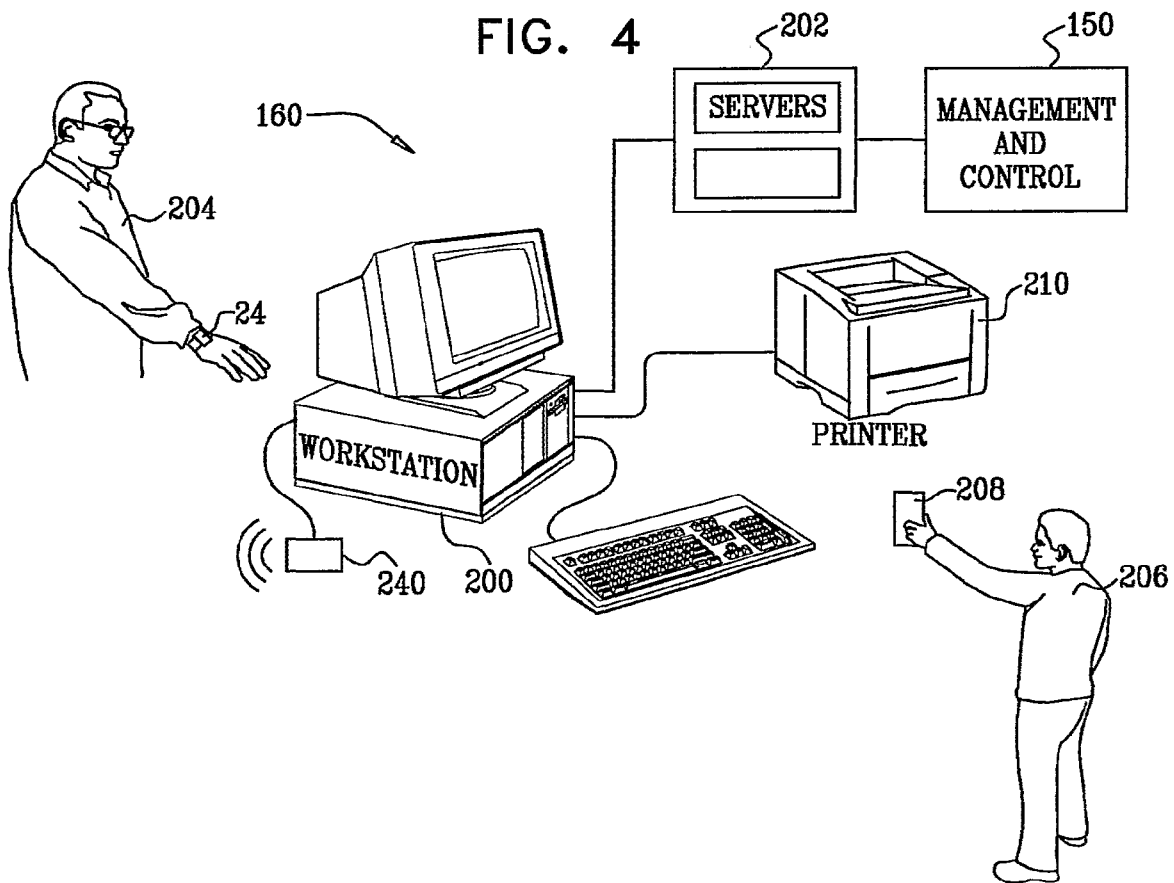


FIG. 5

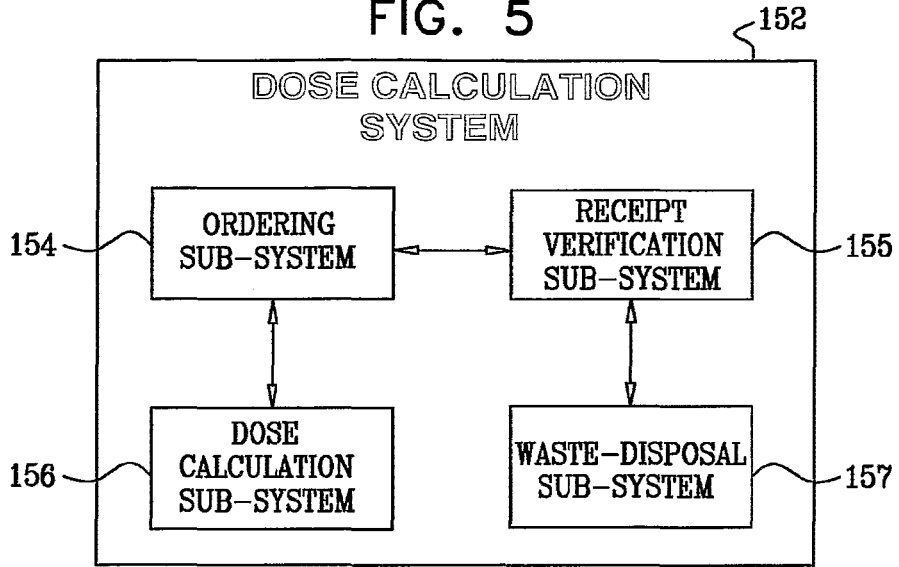


FIG. 6A

	REST PHASE				STRESS PHASE				
	INJECTION		WAITING TIME [MIN]	ACQUISITION DURATION [MIN]	STRESS	INJECTION		WAITING TIME [MIN]	GATED ACQUISITION DURATION [MIN]
	RP	DOSE [mCi]				RP	DOSE [mCi]		
SINGLE ISOTOPE/ LOW DOSE/FAST IMAGING	TL	<0.3	2	15	EXERCISE	TL	<3	10-15	1.5
DUAL ISOTOPE/ LOW DOSE/FAST IMAGING	TL	<0.3	2	15	EXERCISE	Tc- MIBI	30	30-60	1.5
GATED REST THALLIUM (STUNNING)	TL	1.5	2	5 (GATED)	EXERCISE	Tc- MIBI	30	30-60	1.5
THALLIUM STRESS PERFUSION	Tc- MIBI	3	30	1.5	PHARMA	TL	3	0	10 (DYNAMIC)
SIMULTANEOUS DUAL ISOTOPE STRESS PERFUSION	Tc- MIBI	3	20		EXERCISE/PHARMA	TL	3		10 (DYNAMIC)
DYNAMIC IMAGING	TL	0.3			PHARMA (ADENOSINE)	TL	3		10 (DYNAMIC)

5/19

FIG. 6B

NO.	PROTOCOL NAME	KEY FEATURES AND PROPERTIES	ADMINISTRATION PARAMETERS			DETECTOR PARAMETERS
			DOSE (mCi)	INJECTION PROFILE	INJECT TO ACQUISITION TIME	DETECTED PHOTON ENERGY / RESOLUTION
A	CARDIAC MAPPING	MIBI-TC, FAST, BEFORE LIVER UPTAKE	20-40	BOLUS	2 MIN, OR ADMIN UNDER THE CAMERA	140 KeV / 15%
B	CARDIAC MAPPING	MIBI-TC AFTER LIVER UPTAKE	20-40	BOLUS	30+ MIN	140 KeV / 15%
C	CARDIAC MAPPING	SIMULTANEOUS FAST DUAL-ISOTOPE TL-201+ LOW DOSE MIBI-TC	TL-201: 3.5-5; MIBI-Tc-99m: 4-8	2 BOLUS (BEFORE AND AT PEAK STRESS)	TL INJECTED PREVIOUSLY AT REST, TC UNDER CAMERA OR 2 MIN	Tc-140 KeV, Tl-72 KeV / 15%
D	CARDIAC MAPPING	SIMULTANEOUS DUAL-ISOTOPE TL-201+ LOW DOSE MIBI-TC	TL-201: 3.5-5; MIBI-Tc-99m: 4-8	2 BOLUS (BEFORE AND AT PEAK STRESS)	SAME AS ONE OF FIRST 2 CARDIAC MAPPING PROTOCOLS	Tc-140 KeV, Tl-72 KeV / 15%
E	CARDIAC MAPPING	SIMULTANEOUS DUAL-ISOTOPE FULL TL-201+ FULL DOSE MIBI-TC	TL-201: 3.5-5; MIBI-Tc-99m: 20-40	2 BOLUS (BEFORE AND AT PEAK STRESS)	SAME AS ONE OF PROTOCOLS A OR B	Tc-140 KeV, Tl-167 KeV / 10%
F	CARDIAC MAPPING - UNDERWEIGHT (BMI<18.5)	MIBI-TC-99M AFTER LIVER UPTAKE	15-20	BOLUS	30+ MIN	140 KeV / 15%
G1	CARDIAC MAPPING - NORMAL (18.6<BMI<24.9)	MIBI-TC-99M AFTER LIVER UPTAKE	20-30	BOLUS	30+ MIN	140 KeV / 10%
G2	CARDIAC MAPPING - OVERWEIGHT (25<BMI<29.9)	MIBI-TC-99M AFTER LIVER UPTAKE	30-35	BOLUS	30+ MIN	140 KeV / 10%

6 / 19

FIG. 6C

NO.	SCANNING PARAMETERS						ANALYSIS PARAMETERS	
	TOTAL SCAN TIME	COLUMNS DIFFERENCES / UNIFORM SCAN	ANGULAR RANGE	TOTAL # ANGULAR ORIENTATIONS	ANGULAR STEP / INTERLACE	DWELL TIME	GATED ANALYSIS OF VOLUMES	ANALYSIS ALGORITHM / PARAMETERS
A	120 SEC	a) 4 X OUTER b) 6 X INNER	a) 40-60 DEG b) 90-120 DEG	120X10	a) 0.3-0.5 DEG b) 0.75-1 DEG	1 SEC	YES, 16-32 FRAMES	INTENSITY IMAGE, EJECTION FRACTION
B	120 SEC	a) 4 X OUTER b) 6 X INNER	a) 40-60 DEG b) 90-120 DEG	120X10	a) 0.3-0.5 DEG b) 0.75-1 DEG	1 SEC	YES, 16-32 FRAMES	INTENSITY IMAGE, EJECTION FRACTION
C	120 SEC	a) 4 X OUTER b) 6 X INNER	a) 40-60 DEG b) 90-120 DEG	120X10	a) 0.3-0.5 DEG b) 0.75-1 DEG	1 SEC	YES, 16-32 FRAMES	INTENSITY IMAGE, EJECTION FRACTION
D	120 SEC	a) 4 X OUTER b) 6 X INNER	a) 40-60 DEG b) 90-120 DEG	120X10	a) 0.3-0.5 DEG b) 0.75-1 DEG	1 SEC	YES, 16-32 FRAMES	INTENSITY IMAGE, EJECTION FRACTION
E	UP TO 1200 SEC	a) 4 X OUTER b) 6 X INNER	a) 40-60 DEG b) 90-120 DEG	240X10	a) 0.15-0.25 DEG b) 0.375-0.5 DEG	5 SEC	YES, 16-32 FRAMES	INTENSITY IMAGE, EJECTION FRACTION
F	90 SEC	a) 4 X OUTER b) 6 X INNER	a) 20-35 DEG b) 45-60 DEG	60X10	a) .3-0.75 DEG b) 0.75-1 DEG	1 SEC	YES, 16-32 FRAMES	INTENSITY IMAGE, EJECTION FRACTION
G1	120 SEC	a) 4 X OUTER b) 6 X INNER	a) 30-45 DEG b) 75-90 DEG	120X10	a) 0.5-0.75 DEG b) 0.625-1 DEG	1.5 SEC	YES, 16-32 FRAMES	INTENSITY IMAGE, EJECTION FRACTION
G2	120 SEC	a) 4 X OUTER b) 6 X INNER	a) 40-60 DEG b) 90-120 DEG	120X10	a) 0.3-0.5 DEG b) 0.75-1 DEG	2 SEC	YES, 16-32 FRAMES	INTENSITY IMAGE, EJECTION FRACTION

7 / 19

FIG. 6D

NO.	PROTOCOL NAME	KEY FEATURES AND PROPERTIES	ADMINISTRATION PARAMETERS			DETECTOR PARAMETERS
			DOSE (mCi)	INJECTION PROFILE	INJECT TO ACQUISITION TIME	DETECTED PHOTON ENERGY / RESOLUTION
H	CARDIAC MAPPING - OBESE (BMI>30)	MIBI-TC AFTER LIVER UPTAKE	35-40	BOLUS	30+ MIN	140 KeV / 6%
I	CARDIAC DYNAMIC MAPPING	TEBOROXIME-TC	20-40	BOLUS	-1 MIN (IMAGE BEFORE INJECT), OR SIMULTANEOUSLY WITH INJECT	140 KeV / 15%
J	CARDIAC DYNAMIC MAPPING (2-STEP)	TEBOROXIME-TC	20-40	(i) INITIAL SMALL BOLUS FOR IDENTIFYING ROI, (ii) FULL BOLUS FOR DYNAMIC STUDY	(i) 5+ MIN (ii) -1 MIN (IMAGE BEFORE INJECT)	140 KeV / 15%
K	TUMOR SCAN (MULTIPLE BODY SEGMENTS - HEAD TO LEGS)	MDP-TC-99M AFTER LIVER UPTAKE	20-40	BOLUS	30+ MIN	140 KeV / 15%
L	TUMOR SCAN (MULTIPLE BODY SEGMENTS - HEAD TO LEGS), FOCUSED SCAN	MDP-TC-99M AFTER LIVER UPTAKE	20-40	BOLUS	30+ MIN	140 KeV / 15%
M	TUMOR SCAN WITH COCKTAIL (MULTIPLE BODY SEGMENTS - HEAD TO LEGS), FOCUSED SCAN	FDG (METABOLISM), MIBI-TC-99M AND TL (PERFUSION)	TL-201: 3.5-5; MIBI-TC-99M: 20-40; 18-F FDG 10-30	BOLUS	30+ MIN	Tc-140 KeV, Tl-72 KeV, FDG 511 KeV / 10%

8 / 19

FIG. 6E

NO.	SCANNING PARAMETERS						ANALYSIS PARAMETERS	
	TOTAL SCAN TIME	COLUMNS DIFFERENCES / UNIFORM SCAN	ANGULAR RANGE	TOTAL # ANGULAR ORIENTATIONS	ANGULAR STEP / INTERLACE	DWELL TIME	GATED ANALYSIS OF VOLUMES	ANALYSIS ALGORITHM / PARAMETERS
H	180 SEC	a) 4 X OUTER b) 6 X INNER	a) 40-60 DEG b) 90-120 DEG	160X10	a) 0.25-0.375 DEG b) 0.6-0.75 DEG	1.2 SEC	YES, 8-16 FRAMES	INTENSITY IMAGE, EJECTION FRACTION
I	<= 600 SEC	a) 2 X OUTER b) 8 X INNER	a) 40-60 DEG b) 90-120 DEG	600X10	a) continuous b) continuous INTERLACED SCAN	1 SEC	YES, 8 FRAMES	KINETIC PARAMETES, PREDEFINED PATHOLOGICAL VALUES
J	(i) 60 SEC FOR IDENTIFYING ROI (ii) 600 SEC DYNAMIC STUDY	a) 2 X OUTER b) 8 X INNER	a) 40-60 DEG b) 90-120 DEG	(i) 60X10 (ii) 600X10	(i) a) 0.75-1 DEG b) 0.75-0.75-1 DEG (ii) a) continuous b) continuous INTERLACED SCAN	1 SEC	YES, 8 FRAMES	KINETIC PARAMETES, PREDEFINED PATHOLOGICAL VALUES
K	240 SEC PER BODY SEGMENT	16	40-60 DEG	120X16	0.3-0.5 DEG	2 SEC	NO	INTENSITY IMAGE, PREDEFINED PATHOLOGICAL VALUES
L	(i) 120 SEC PER BODY SEGMENT (ii) 60 SEC PER ROI	16	(i) 45-60 DEG (ii) 15-20 DEG	(i) 120X16 (ii) 60x16	(i) 0.375-0.5 DEG (ii) 0.25-0.3	1 SEC	NO	INTENSITY IMAGE, PREDEFINED PATHOLOGICAL VALUES
M	(i) 120 SEC PER BODY SEGMENT (ii) 60 SEC PER ROI	16	(i) 45-60 DEG (ii) 15-20 DEG	(i) 120X16 (ii) 60x16	(i) 0.375-0.5 DEG (ii) 0.25-0.4	1 SEC	NO	INTENSITY IMAGE, PREDEFINED PATHOLOGICAL VALUES

9 / 19

10/19

FIG. 7

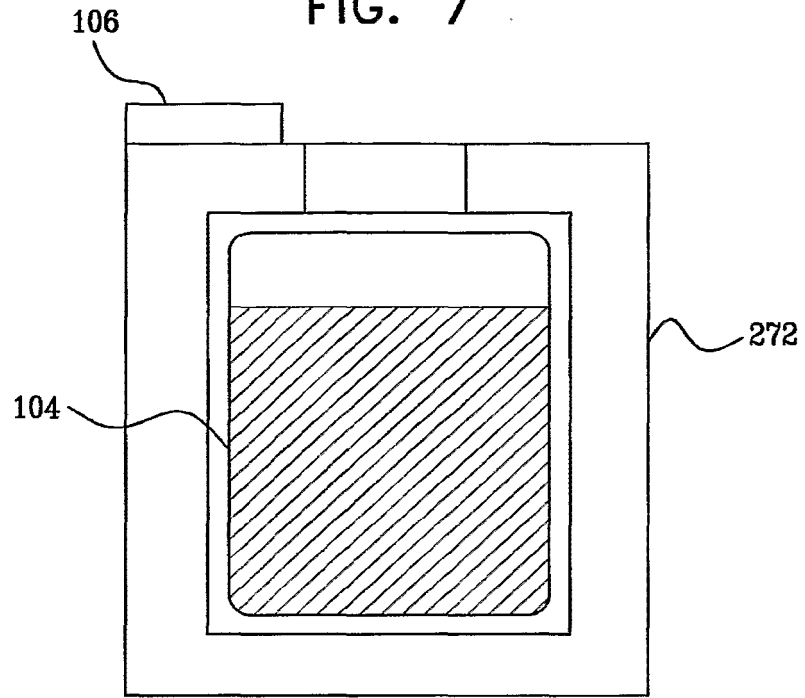
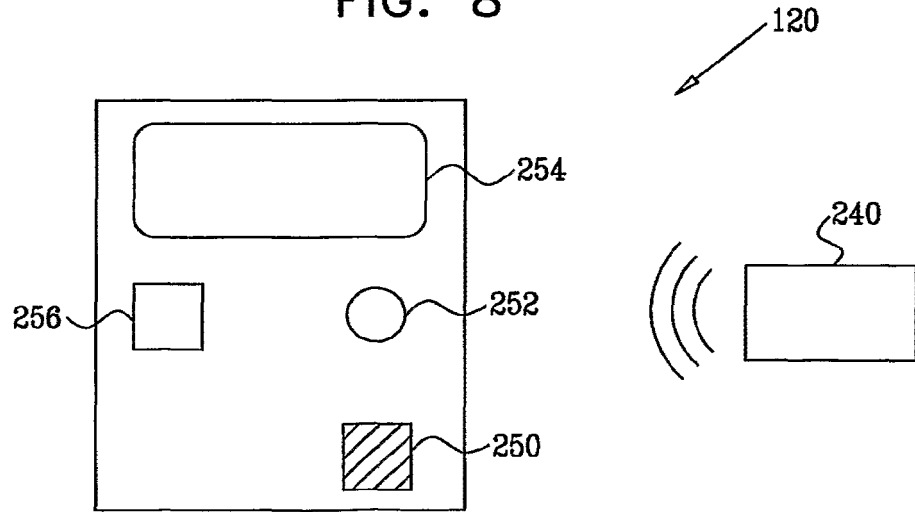


FIG. 8





11/19

FIG. 9A

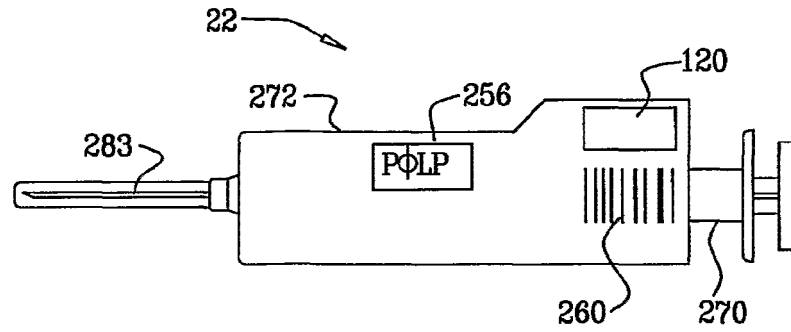


FIG. 9B

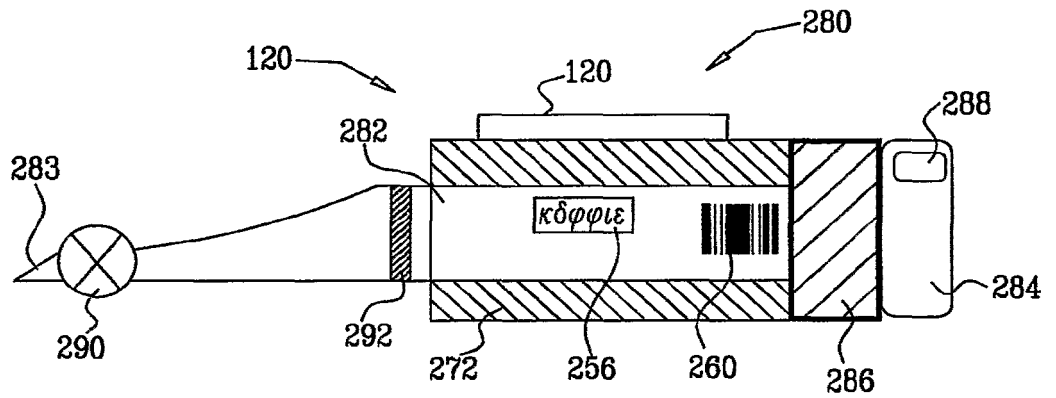
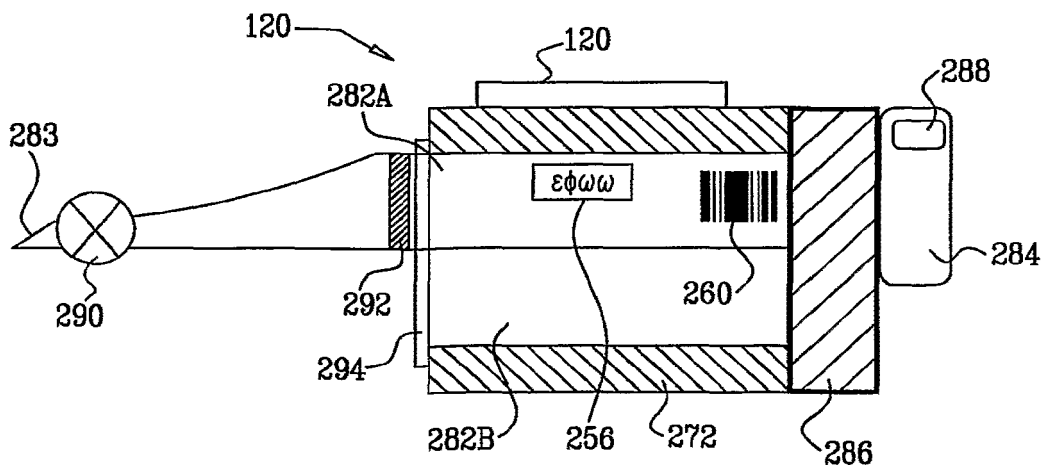


FIG. 9C



12/19

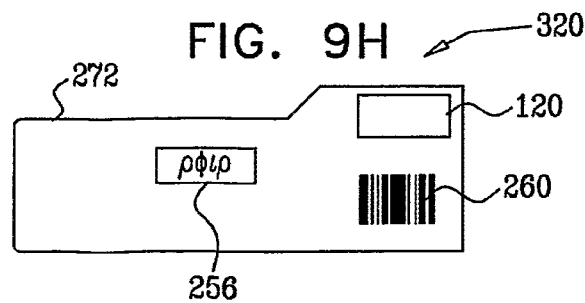
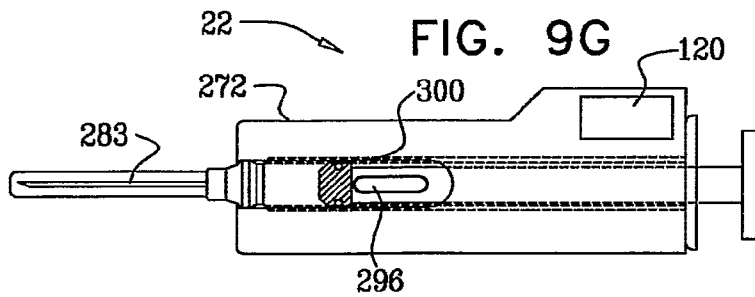
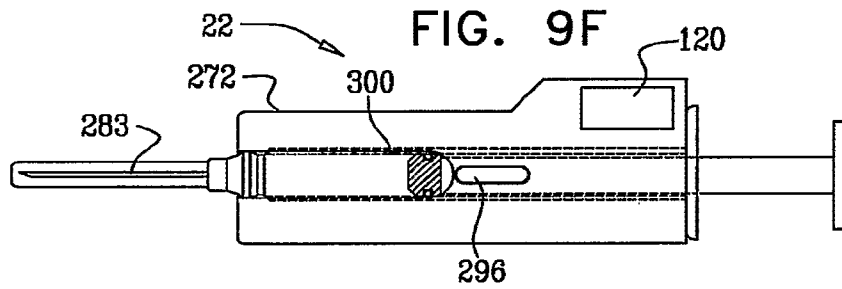
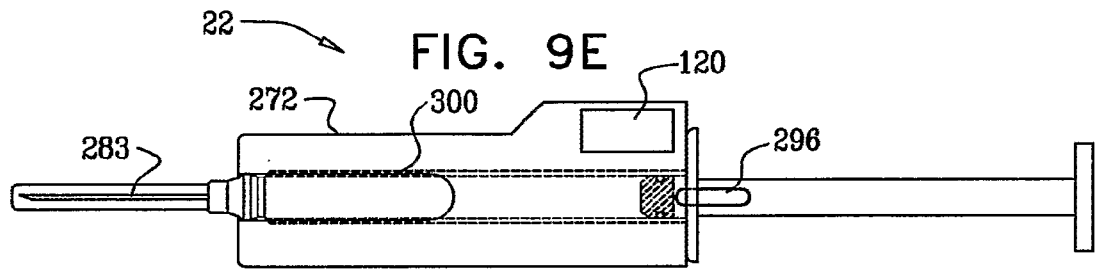
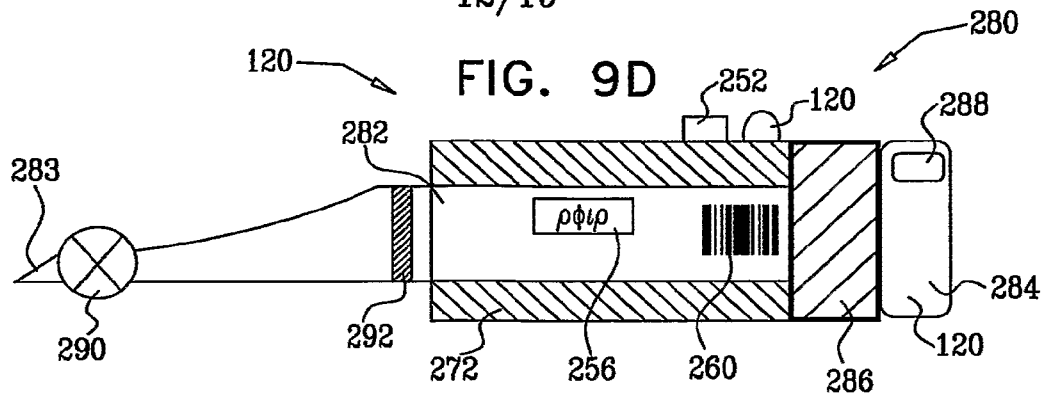


FIG. 10 13/19

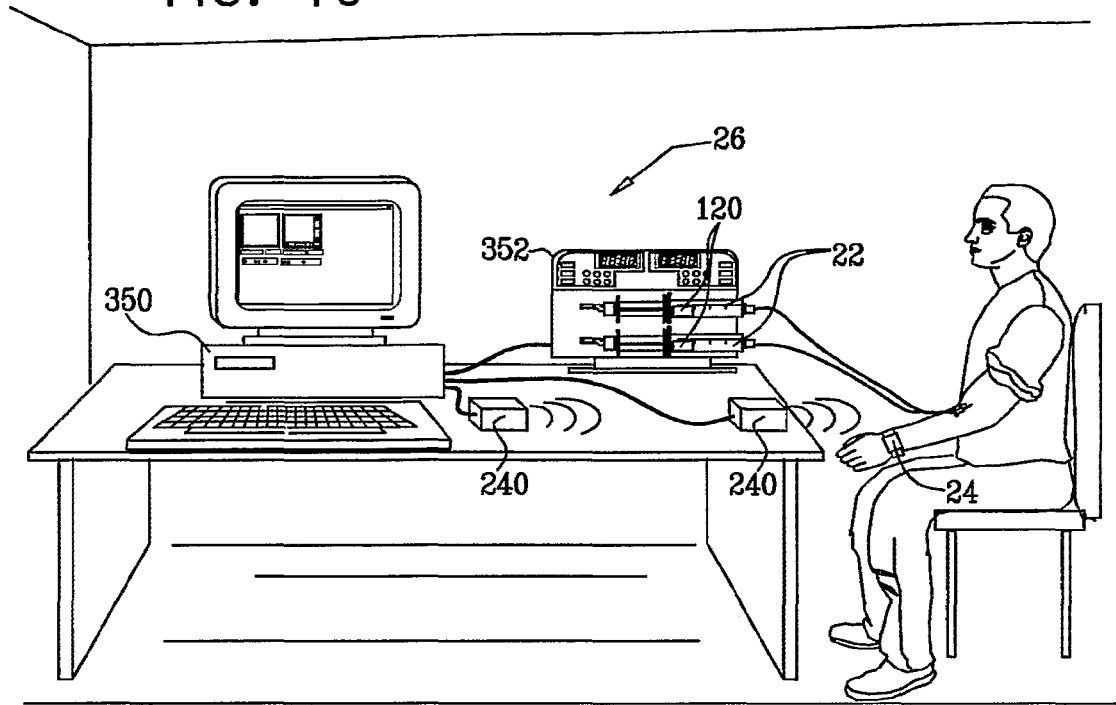


FIG. 11

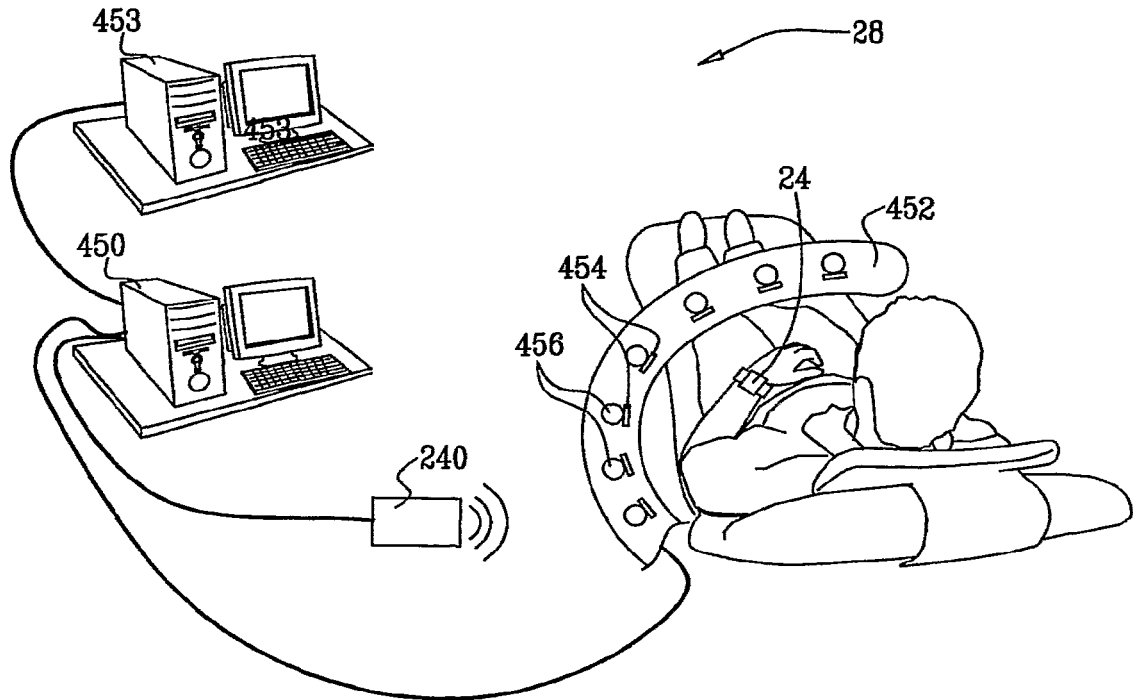
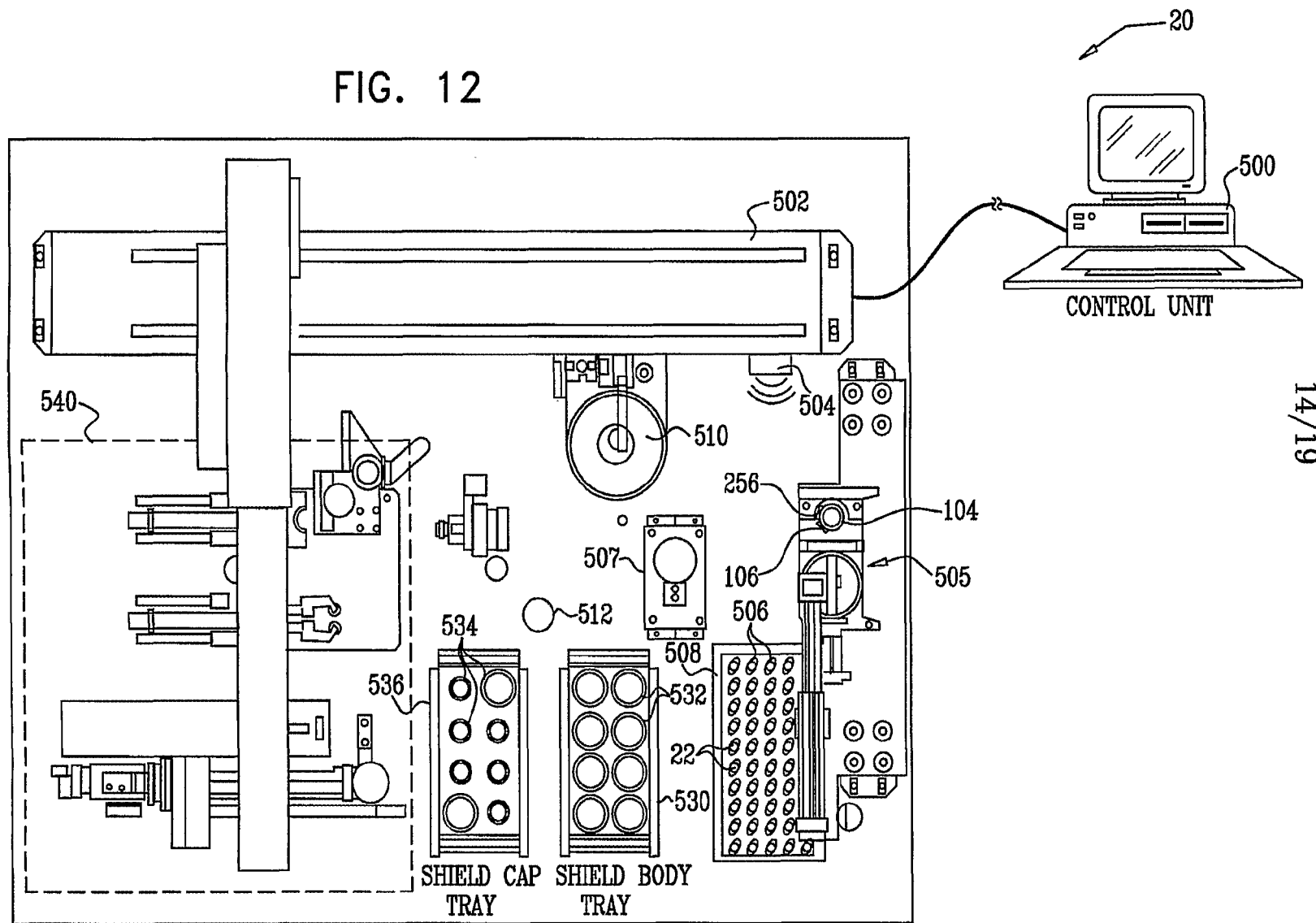


FIG. 12



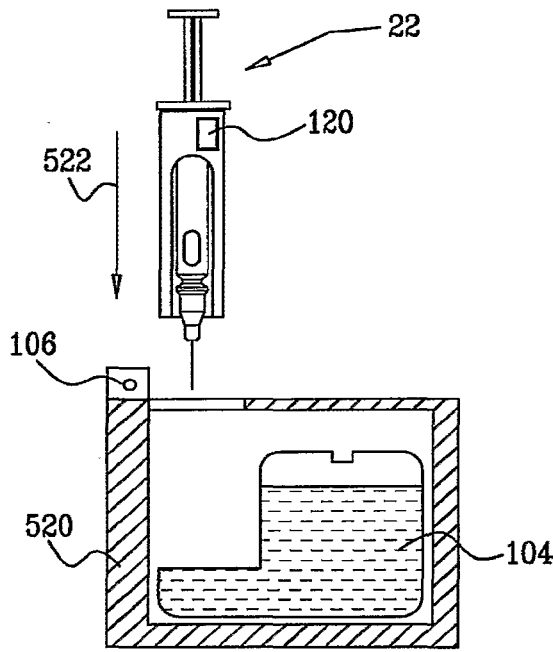


FIG. 13A

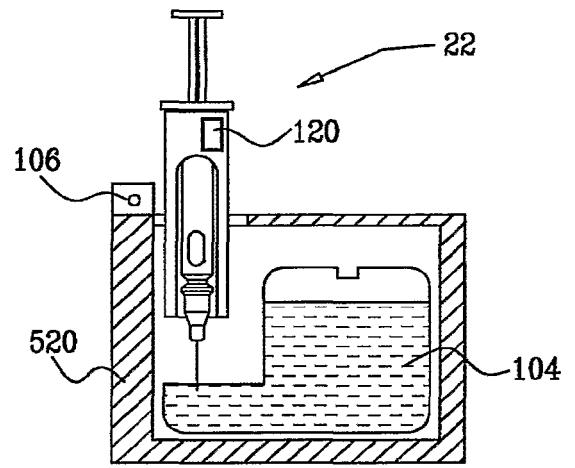


FIG. 13B

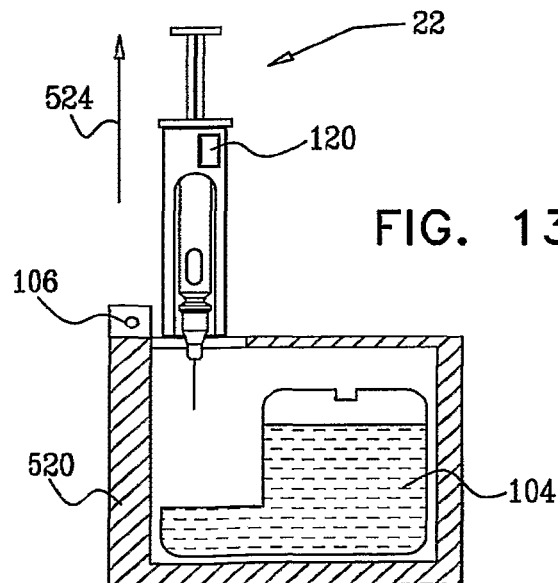


FIG. 13C

FIG. 14

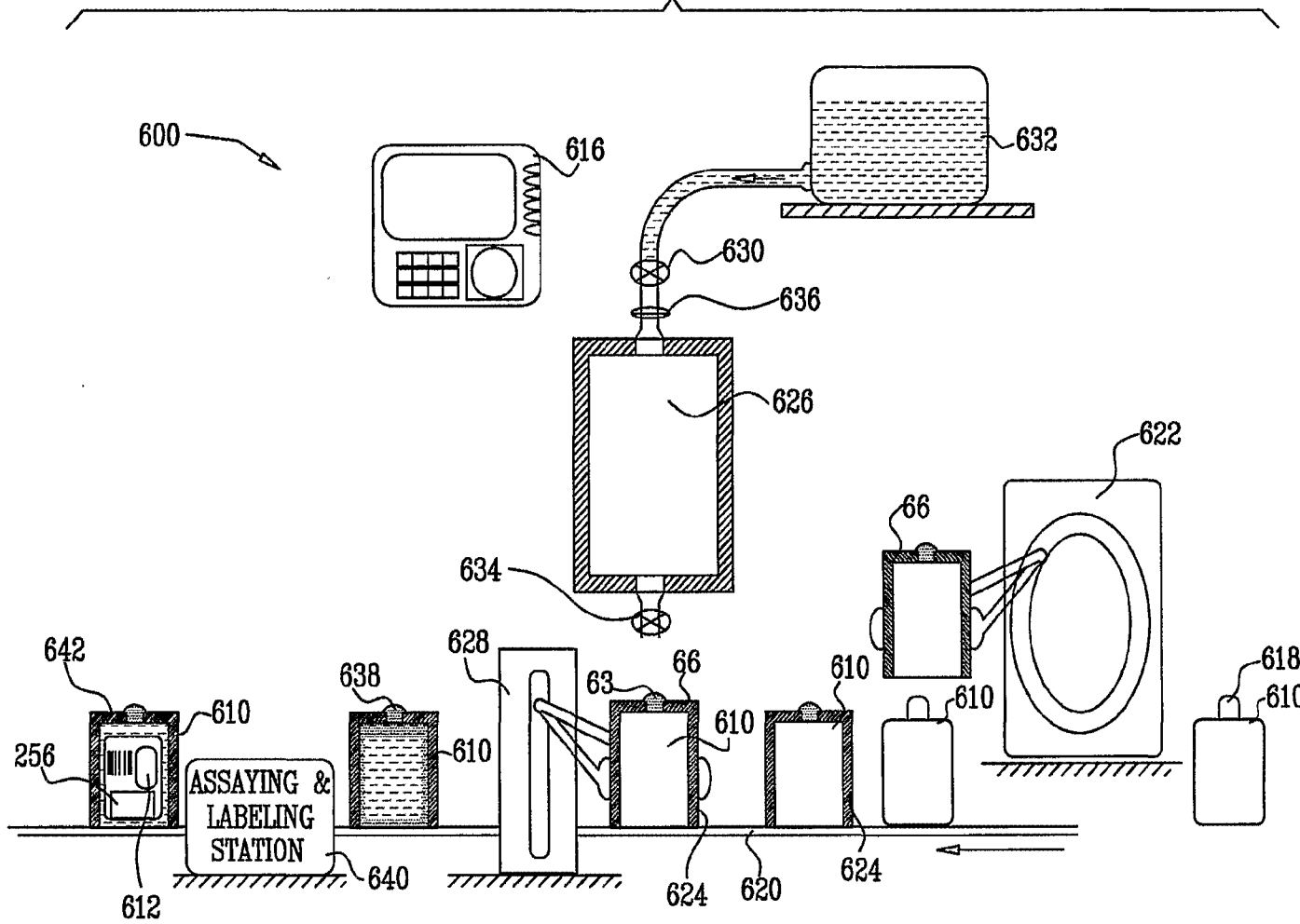


FIG. 15

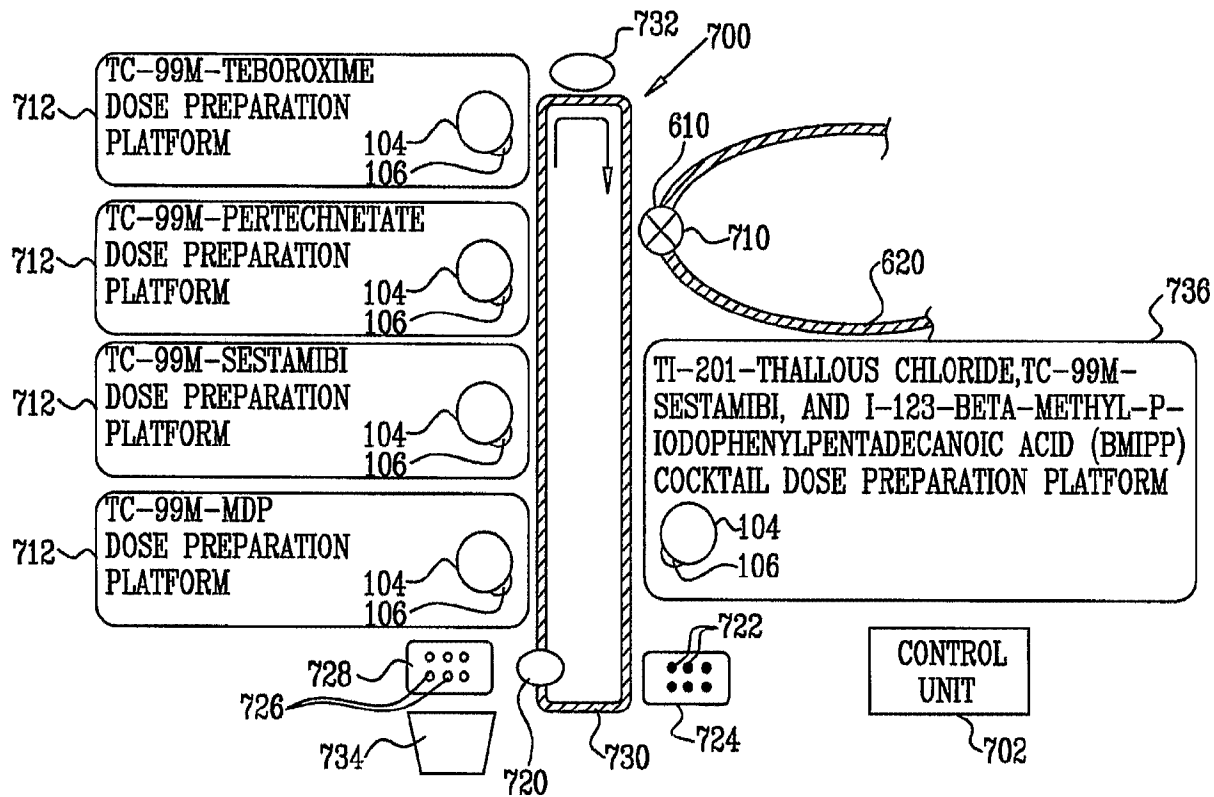


FIG. 16A

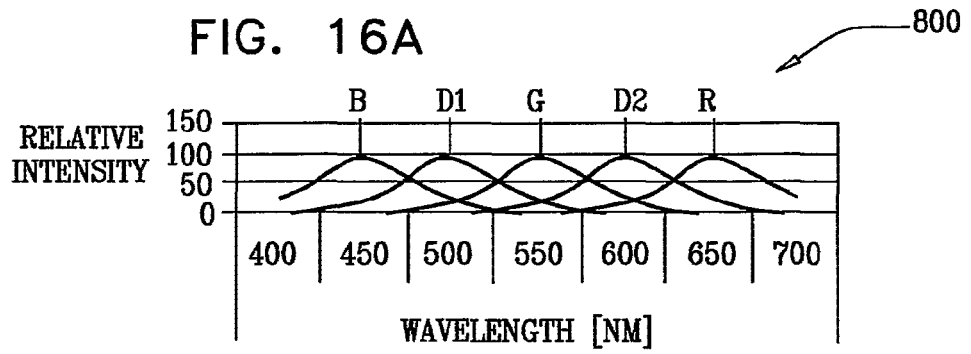


FIG. 16B

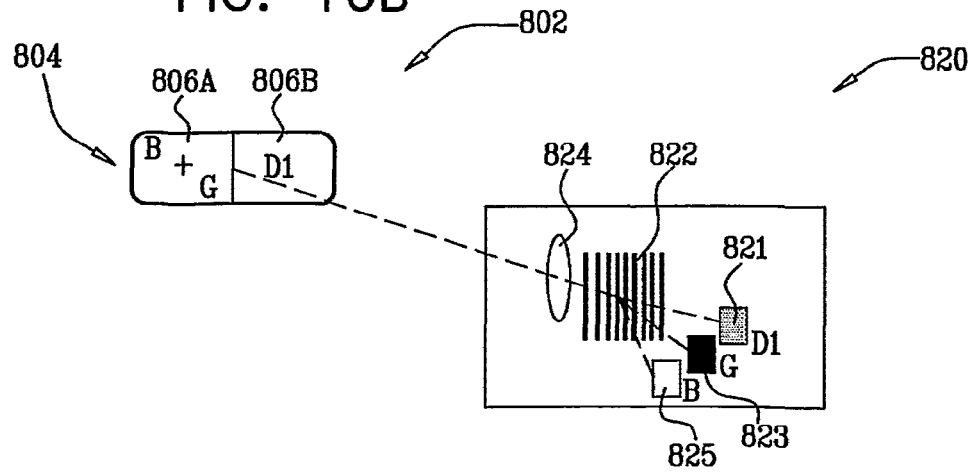




FIG. 17

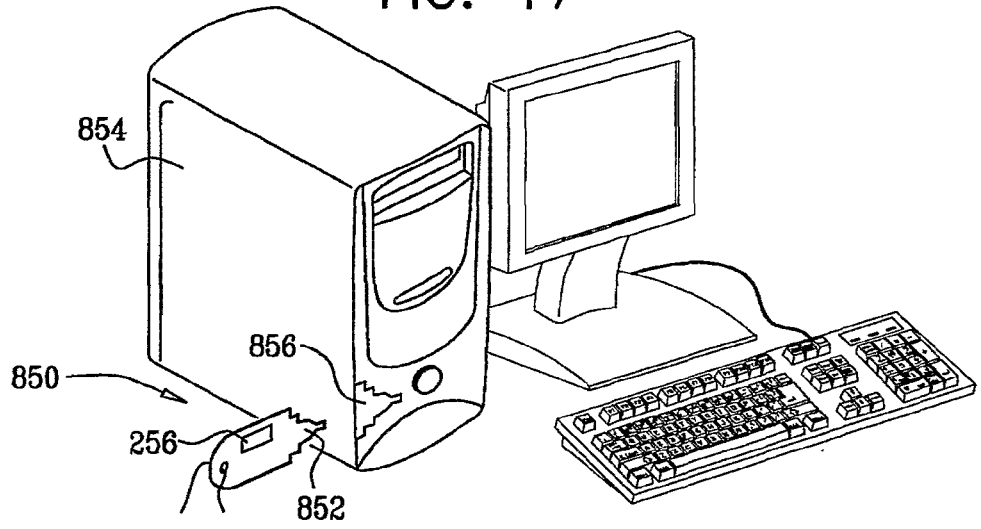
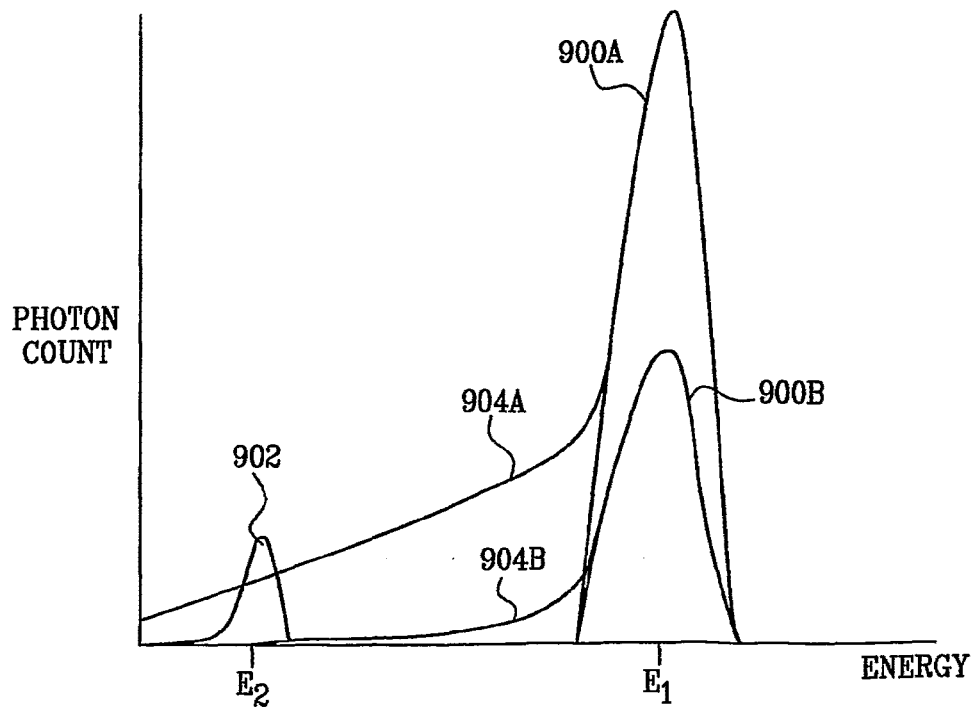


FIG. 18



(12) DEMANDE INTERNATIONALE PUBLIÉE EN VERTU DU TRAITÉ DE COOPÉRATION  
EN MATIÈRE DE BREVETS (PCT)

(19) Organisation Mondiale de la Propriété  
Intellectuelle  
Bureau international



(43) Date de la publication internationale  
3 avril 2008 (03.04.2008)

PCT

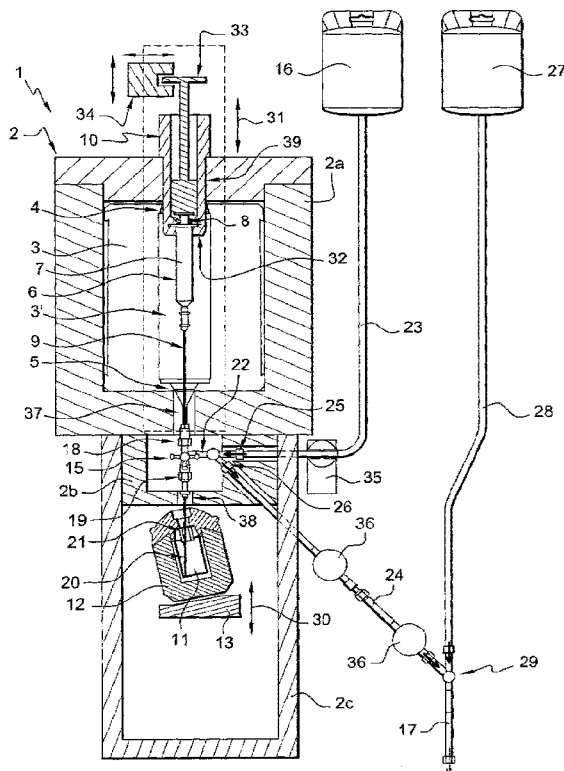
(10) Numéro de publication internationale  
**WO 2008/037939 A2**

- (51) Classification internationale des brevets :  
A61M 5/14 (2006.01) G21F 5/00 (2006.01)  
A61M 5/168 (2006.01) G01T 1/161 (2006.01)
- (21) Numéro de la demande internationale : PCT/FR2007/052048
- (22) Date de dépôt international : 28 septembre 2007 (28.09.2007)
- (25) Langue de dépôt : français
- (26) Langue de publication : français
- (30) Données relatives à la priorité :  
0608586 29 septembre 2006 (29.09.2006) FR
- (71) Déposant (pour tous les États désignés sauf US) : LEMER PROTECTION ANTI-X PAR ABBREVIATION SOCIETE LEMER PAX [FR/FR]; 3 rue de l'Europe, Z.I. de Carquefou, F-44470 Carquefou (FR).
- (72) Inventeur; et
- (75) Inventeur/Déposant (pour US seulement) : LEMER, Pierre-Marie [FR/FR]; 4 rue de Grillaud, F-44100 Nantes (FR).
- (74) Mandataires : MICHELET, Alain etc.: Cabinet HARLE et PHELIP, 7 rue de Madrid, F-75008 Paris (FR).
- (81) États désignés (sauf indication contraire, pour tout titre de protection nationale disponible) : AE, AG, AL, AM, AT, AU, AZ, BA, BB, BG, BH, BR, BW, BY, BZ, CA, CH, CN, CO, CR, CU, CZ, DE, DK, DM, DO, DZ, EC, EE, EG, ES, FI, GB, GD, GE, GH, GM, GT, HN, HR, HU, ID, IL, IN, IS, JP, KE, KG, KM, KN, KP, KR, KZ, LA, LC, LK, LR, LS, LT, LU, LY, MA, MD, ME, MG, MK, MN, MW, MX, MY, MZ, NA, NG, NI, NO, NZ, OM, PG, PH, PL, PT, RO, RS, RU, SC, SD, SE, SG, SK, SL, SM, SV, SY, TJ, TM, TN, TR, TT, TZ, UA, UG, US, UZ, VC, VN, ZA, ZM, ZW.

[Suite sur la page suivante]

(54) Title: MEDICAL UNIT FOR THE COLLECTION, CALIBRATION, DILUTION AND/OR INJECTION OF AN INJECTABLE RADIOACTIVE PRODUCT

(54) Titre : UNITE MEDICALE POUR LE PRELEVEMENT, LE CALIBRAGE, LA DILUTION ET/OU L'INJECTION D'UN PRODUIT RADIOACTIF INJECTABLE



(57) Abstract: The medical unit according to the invention comprises a shielded enclosure (2) that accommodates means (13) for supporting a container (12) comprising a source or a generator of radioactive product (11), means (10) for supporting a syringe (6), a device of the activity meter type (3), and a system of conduits (9, 23, 24) joined to at least one valve (15). The syringe support (10), the valve (15) and the radioactive source support (13) are arranged vertically relative to one another, each facing downwards, said syringe support (10) being designed to support said syringe (6) with its plunger (8) oriented upwards. The valve (15) and the syringe plunger (8) can be manoeuvred for performing the operations of collection, dilution and injection.

(57) Abrégé : L'unité médicale selon l'invention comporte une enceinte blindée (2) dans laquelle sont logés : des moyens (13) support d'un conteneur (12) comprenant une source ou un générateur de produit radioactif (11); des moyens (10) pour le support d'une seringue (6); un dispositif de type activimètre (3); et un système de conduites (9, 23, 24) associé à au moins une vanne (15). Le support de seringue (10), la vanne (15) et le support de source radioactive (13) sont agencés verticalement les uns par rapport aux autres, respectivement du haut vers le bas, ledit support de seringue (10) étant agencé pour supporter ladite seringue (6) avec son piston (8) orienté vers le haut. La vanne (15) et le piston de seringue (8) sont manoeuvrables pour assurer les opérations de prélèvement, de dilution et d'injection.

WO 2008/037939 A2



(84) États désignés (sauf indication contraire, pour tout titre de protection régionale disponible) : ARIPO (BW, GH, GM, KE, LS, MW, MZ, NA, SD, SL, SZ, TZ, UG, ZM, ZW), eurasien (AM, AZ, BY, KG, KZ, MD, RU, TJ, TM), européen (AT, BE, BG, CH, CY, CZ, DE, DK, EE, ES, FI, FR, GB, GR, HU, IE, IS, IT, LT, LU, LV, MC, MT, NL, PL, PT, RO, SE, SI, SK, TR), OAPI (BF, BJ, CF, CG, CI, CM, GA, GN, GQ, GW, ML, MR, NE, SN, TD, TG).

**Déclaration en vertu de la règle 4.17 :**

— relative à la qualité d'inventeur (règle 4.17.iv)

**Publiée :**

— sans rapport de recherche internationale, sera republiée dès réception de ce rapport

## UNITE MEDICALE POUR LE PRELEVEMENT, LE CALIBRAGE, LA DILUTION ET/OU L'INJECTION D'UN PRODUIT RADIOACTIF INJECTABLE

La présente invention concerne le domaine général de la médecine nucléaire. Elle concerne plus particulièrement une unité médicale employée pour le prélèvement,  
5 le calibrage, la dilution et/ou l'injection d'une substance radioactive destinée à être injectée à un patient.

Certaines substances radioactives sont particulièrement utiles dans le domaine médical, par exemple dans les procédures d'imagerie, à titre d'agents de contraste, ou comme agents thérapeutiques.

10 Pour limiter les doses de radiations reçues par le patient et par le personnel chargé des manipulations, on utilise des radioéléments de courtes demi-vies à usage médical, c'est-à-dire que le niveau de radiation émis par ces produits radioactifs décroît rapidement avec le temps.

Mais de tels produits radioactifs à courte demi-vie rendent problématique  
15 l'administration d'une dose appropriée au patient. Le dosage correspondant doit en effet être très précis ; il doit tenir compte du temps nécessaire pour la préparation de la dose à injecter, et aussi du temps susceptible de séparer le moment de la préparation de la dose de produit et le moment de l'injection proprement dite de cette dose au patient.

20 En outre, malgré le type de produits mis en œuvre (courte demi-vie), une autre contrainte à prendre en compte concerne la radioprotection du personnel médical chargé de préparer la dose radioactive et de l'injecter au patient. Cette radioprotection doit aussi être effective pour le patient.

De manière classique, les doses à injecter sont prélevées dans une seringue  
25 munie d'un blindage approprié, placée elle-même dans une enceinte blindée équipée de moyens de mesure et de contrôle appropriés, permettant de prélever dans la seringue la dose de produit radioactif recherchée. Ensuite, un opérateur récupère la seringue blindée et il se rend auprès du patient pour réaliser l'injection.

Cependant, cette manière d'opérer n'offre pas une sécurité optimale, tant sur le  
30 plan de la radioprotection pour l'opérateur que sur le plan de la précision de la dose injectée au patient.

Le document US-6 767 319 décrit un matériel de calibrage et d'injection de produit radioactif visant à limiter l'exposition du personnel à la substance radioactive et aussi optimiser la sécurité du patient.

L'installation correspondante comprend trois enceintes radioprotectrices indépendantes, contenant respectivement :

- des moyens pour le support d'une source en produit radioactif injectable,
- des moyens pour le support d'une seringue, qui sont équipés de moyens pour la manœuvre automatique de son piston, et qui sont associés à un dispositif de type 5 activimètre pour la mesure en temps réel de l'activité radio-isotopique émise par le produit contenu dans la seringue, et
- un système de vannes.

Ce système de vannes est raccordé hydrauliquement, par le biais de tubulures, à 10 l'enceinte contenant la source mère radioactive, à l'enceinte contenant la seringue, à une source de sérum physiologique et à un cathéter d'injection destiné à être connecté au patient.

Ce matériel comprend encore des moyens destinés à piloter le système de vannes et les moyens de manœuvre du piston de seringue, cela de manière adaptée pour 15 assurer, dans un premier temps, le prélèvement d'une dose de produit radioactif et/ou de sérum physiologique au sein de la seringue, et dans un second temps l'éjection au travers du cathéter d'injection, du produit radioactif et/ou du sérum physiologique préalablement prélevés. La dose de produit radioactif est mesurée par le dispositif activimètre au cours du prélèvement dans la seringue.

20 Dans ce matériel, les tubulures reliant l'enceinte contenant le système de vannes et celles contenant la seringue ou la source radioactive, ne sont pas protégées et sont source d'émissions radioactives dans l'environnement.

De plus, du fait de sa structure, le matériel correspondant est encombrant. En outre, la complexité du réseau de tubulures entraîne la présence de volumes morts importants.

25 La présente invention propose une unité médicale originale de calibration et d'injection de produits radioactifs, très compacte, permettant le prélèvement, la mesure et l'injection des produits avec une grande précision, en toute sécurité, et avec des volumes morts réduits.

Cette unité médicale est du type comprenant :

- 30 - des moyens pour le support d'un conteneur en matériau radioprotecteur dans lequel est logée une source ou un générateur de produit radioactif injectable,
- des moyens pour le support d'une seringue équipée d'un piston,
- un dispositif de type activimètre pour la mesure en temps réel de l'activité radio-isotopique émise par le contenu de ladite seringue, et

- un système de conduites associé à au moins une vanne pour le raccordement hydraulique de ladite source radioactive, de ladite seringue, d'une source de sérum physiologique et d'un cathéter d'injection destiné à être connecté au patient, ladite vanne et ledit piston de seringue étant manoeuvrables pour assurer, d'une part, 5 une aspiration dudit produit radioactif ou dudit sérum physiologique au sein de ladite seringue, et d'autre part, une éjection dudit produit radioactif, dudit sérum physiologique ou d'un mélange de ces deux produits, préalablement aspirés au sein de ladite seringue, cela au travers dudit cathéter d'injection, la dose de produit radioactif prélevée et injectée par ladite seringue étant mesurée par ledit activimètre.

10 Conformément à l'invention, l'unité médicale comporte encore une enceinte blindée réalisée en au moins un matériau radioprotecteur, dans laquelle sont logés le support de source radioactive, au moins une partie des moyens support de la seringue, l'activimètre, la vanne, et au moins une partie du système de conduites.

De plus, le support de seringue, la vanne et le support de source radioactive sont 15 agencés verticalement les uns par rapport aux autres, respectivement du haut vers le bas, le support de seringue étant agencé pour porter la seringue verticalement avec son piston orienté vers le haut.

Cet agencement particulier permet à la seringue de prélèvement/injection et à la source de produit radioactif d'être très proches de la vanne, pour obtenir un ensemble 20 très compact, avec des volumes morts minimisés.

Selon une caractéristique de réalisation, la vanne consiste en une vanne trois voies comprenant :

- une voie supérieure, destinée à être raccordée à la seringue de prélèvement et d'injection,
- 25 - une voie inférieure, destinée à être raccordée à la source de produit radioactif injectable, et
- une voie latérale, destinée à être raccordée à une première conduite connectée à la source de sérum physiologique et à une seconde conduite connectée au cathéter d'injection, lesdites conduites étant équipées chacune d'un clapet anti-retour 30 convenablement orienté.

Dans ce cas, l'activimètre a avantageusement une forme générale tubulaire délimitant un puits central, d'axe vertical, destiné à contenir la seringue, ledit 35 activimètre étant muni de deux ouvertures, l'une supérieure et l'autre inférieure, cette dernière étant orientée en regard de la vanne trois voies et du support de la source radioactive.

Pour réduire les volumes morts dans les conduits de ce matériel, la voie supérieure de la vanne, destinée à être raccordée à la seringue, comporte avantageusement un opercule hermétique destiné à être percé par l'aiguille équipant ladite seringue montée sur son support ; de même, la voie inférieure de la vanne, destinée à être raccordée à la source de produit radioactif est avantageusement prolongée par une aiguille destinée à percer un opercule obturant le flacon contenant ladite source radioactive.

Encore selon une caractéristique de réalisation de l'invention, les supports de source radioactive et de seringue sont portés chacun par des moyens assurant leur(s) déplacement(s) selon un axe vertical ou sensiblement vertical, cela entre deux positions :

- une première position, dans laquelle un opérateur peut charger la source radioactive et la seringue sur leurs supports respectifs, ou à l'inverse les décharger, et
- une seconde position dans laquelle la source radioactive et la seringue sont raccordées à la vanne.

Selon cette caractéristique, les moyens de déplacement du support de seringue permettent avantageusement son cheminement verticalement au travers d'un orifice ménagé dans l'enceinte blindée, entre :

- une position supérieure de chargement/déchargement, dans laquelle ledit support se situe au moins partiellement hors de ladite enceinte, et
- une position inférieure de raccordement, dans laquelle la seringue se positionne au sein du logement central de l'activimètre et est raccordée à la vanne.

De plus, le support de source radioactive chemine avantageusement au sein de l'enceinte blindée entre ses positions de chargement/déchargement et de raccordement ; cette enceinte est encore munie d'une trappe frontale pour permettre l'accès d'un opérateur au support de source radioactive au moins dans sa position de chargement/déchargement.

Encore selon une autre caractéristique, l'unité médicale comprend des moyens de commande informatiques et/ou électroniques aptes à piloter la vanne et les moyens de manœuvre du piston de seringue, cela de manière à mettre en œuvre les opérations de prélèvement et d'éjection par la seringue. De même, les moyens de commande informatiques/électroniques pilotent également éventuellement les moyens de déplacement du support de seringue et du support de source radioactive.

Dans ce cas, les moyens de manœuvre du piston de la seringue sont avantageusement de type motoréducteur débrayable, contrôlés par les moyens

informatiques/électroniques, pour assurer, d'une part, le prélèvement automatique d'une dose déterminée de produit radioactif au sein de la seringue et, d'autre part, pour assurer l'injection de cette dose au patient, soit automatiquement, soit manuellement. L'opérateur peut en effet, s'il le souhaite, débrayer les moyens motoréducteurs et

5 contrôler manuellement l'injection de la dose radioactive au patient.

Selon toujours une forme de réalisation intéressante, l'enceinte se compose de trois sous-enceintes alignées verticalement les unes par rapport aux autres, à savoir :

- une sous-enceinte supérieure contenant la seringue et l'activimètre,
- une sous-enceinte intermédiaire contenant la vanne, et
- 10 - une sous-enceinte inférieure contenant la source de produit radioactif.

Ces sous-enceintes sont raccordées deux à deux par des ouvertures traversantes au travers desquelles passent certaines des conduites de raccordement hydraulique.

Pour optimiser encore le traitement des données des médicales, les moyens de commande informatiques/électroniques sont pourvus d'une connectique pour l'envoi

15 et/ou la réception de données, en particulier pour les échanges avec un serveur informatique.

L'unité médicale selon l'invention peut être rendue mobile. Pour cela, elle est montée sur des roues avantageusement motorisées ; elle intègre éventuellement un système de géolocalisation, par exemple de type GPS.

20 L'invention sera encore illustrée, sans être aucunement limitée, par la description suivante d'un mode de réalisation particulier, donné uniquement à titre d'exemple et représenté sur les dessins annexés dans lesquels :

- la figure 1 est une représentation schématique, en coupe, d'une unité médicale conforme à l'invention ;
- 25 - la figure 2 est une vue en perspective de la structure externe d'une forme de réalisation possible de l'unité médicale illustrée figure 1.

Tel que représenté sur la figure 1, l'unité médicale 1 conforme à l'invention comprend une enceinte blindée 2 réalisée en matériau radioprotecteur dans laquelle on trouve un dispositif 3 pour la mesure en temps réel de l'activité radio-isotopique

30 (activimètre de type ACAD (marque déposée)), de forme générale cylindrique d'axe vertical, muni d'une ouverture supérieure 4 et d'une ouverture inférieure 5.

Une seringue classique 6, comprenant un corps 7, un piston 8 et une aiguille 9, est installée dans le puits de mesure 3' de l'activimètre 3 (connectée à une unité de traitement appropriée) ; cette seringue 6 est montée verticalement sur un support



supérieur 10, son piston 8 étant orienté vers le haut, et donc son aiguille 9 étant orientée vers le bas.

Une source ou générateur 11 de produit radioactif est placé sous l'activimètre 3, en regard de son ouverture inférieure 5. Cette source de produit radioactif 11 est  
5 contenue dans un flacon conditionné dans un conteneur blindé 12 réalisé en matériau radioprotecteur. Le conteneur blindé 12 est logé dans l'enceinte blindée 2, posé sur un support 13.

Une vanne trois voies motorisée 15, logée dans l'enceinte blindée 2 entre la seringue 6 et le flacon de source radioactive 11, assure une connexion hydraulique  
10 appropriée entre ladite seringue 6, ledit flacon de source radioactive 11, une poche de sérum physiologique 16 (extérieure à l'enceinte blindée 2) et un cathéter 17 d'injection au patient (également extérieur à l'enceinte blindée 2). Cette vanne 15 est localisée en regard de l'ouverture inférieure 5 de l'activimètre 3, et en regard de la source radioactive 11.

La voie supérieure 18 de cette vanne trois voies 15 comporte un opercule  
15 hermétique destiné à être percé par l'aiguille 9 de la seringue 6. La voie inférieure 19 de la vanne 15 se prolonge par une aiguille 20 destinée à percer l'opercule hermétique 21 qui obture le flacon de source radioactive 11. La voie latérale 22 de la vanne 15 est connectée, par un raccordement en Y, à une tubulure 23 aboutissant à la poche de sérum physiologique 16, et à une tubulure 24 aboutissant au cathéter d'injection 17.  
20 La tubulure 23 est équipée d'un clapet anti-retour 25 empêchant un retour de liquide en direction de la poche de sérum physiologique 16. La tubulure 24 est également équipée d'un clapet anti-retour 26 imposant le passage de liquide en direction du patient.

Sur la figure 1, on remarque que le cathéter 17 est également en  
25 communication avec une seconde poche 27 de sérum physiologique, par le biais d'une tubulure 28 et d'un raccordement en Y 29.

La vanne trois voies 15 a deux positions principales : - une première mettant en  
30 communication ses voies supérieure 18 et inférieure 19 (permettant la mise en communication de la seringue 6 avec la source de produit radioactif 11 pour assurer le prélèvement d'une dose de produit radioactif dans le corps de seringue 7), et - une seconde position, mettant en communication la voie supérieure 18 et la voie latérale 22 (soit pour aspirer du sérum physiologique venant de la poche 16 dans le corps de seringue 7, lors d'une opération d'aspiration par la seringue 6, soit pour éjecter le

liquide contenu dans le corps de seringue 7 dans le cathéter d'injection 17, par une manœuvre de vidange du corps de seringue 7).

Une troisième position possible de la vanne 15 consiste à mettre en communication la source de radioéléments 11 et les tubulures 23 et 24, cela pour casser la dépression du flacon de source radioactive 11 en autorisant l'aspiration du sérum physiologique provenant de la poche 16.

La vanne trois voies 15 est montée fixe à l'intérieur de l'enceinte 2 sur l'axe vertical ou sensiblement sur l'axe vertical passant par la seringue 6 et la source 11 de produit radioactif.

Le support 13 de la source de produit radioactif 11 est mobile verticalement, conformément à la flèche d'orientation 30, sous l'action de moyens mécaniques appropriés (non représentés) actionnés manuellement (ou au pied), ou par des moyens moteurs (également non représentés) de manière à permettre l'intégration de l'aiguille 20 dans le flacon de source radioactive 11, ou le retrait de cette aiguille 20 dudit flacon.

L'opérateur manœuvre le support mobile 13 dans cette dernière position « extraite » lorsqu'il souhaite changer la source de produit radioactif.

D'autre part, le support 10 de la seringue 6 est également mobile verticalement, conformément à la flèche d'orientation 31, sous l'action de moyens mécaniques appropriés (non représentés) actionnés manuellement ou par des moyens moteurs (également non représentés), de manière à permettre l'intégration de l'aiguille 9 de la seringue 6 dans la vanne trois voies 15, ou l'extraction de la seringue 6 au-dessus de l'activimètre 3 et hors du conteneur blindé 2, pour réaliser les opérations de mise en place et de retrait de la seringue 6.

Le support 10 de la seringue 6 est également structuré pour permettre une manœuvre du piston 8 de la seringue depuis l'extérieur du conteneur blindé 2, alors que ladite seringue 6 est centrée dans le puits de mesure 3' de l'activimètre 3. Pour cela, le support 10 comporte une partie cylindrique 32 en prise avec la partie arrière du corps de seringue 7, et une partie centrale 33, en forme de piston coulissant dans la partie cylindrique 32, en prise avec la partie arrière du piston de seringue 8.

Lorsque le corps de seringue 7 est en position dans le puits de mesure 3' de l'activimètre 3, l'extrémité supérieure du piston coulissant 33 est accessible depuis l'extérieur de l'enceinte blindée 2. Cette extrémité supérieure de piston 33 est associée à une motorisation débrayable 34 qui, une fois embrayée, permet l'actionnement

automatique du piston de seringue 8 et qui, lorsqu'elle est débrayée, permet l'actionnement manuel de ce piston 8.

Cette particularité offre à l'opérateur un choix de gestion, automatique ou manuelle, du prélèvement de produit radioactif par la seringue 6 et/ou de l'éjection du produit dans le cathéter 17.

Sur la figure 1, on remarque encore la présence d'une électrovanne à pincement 35, positionnée sur la tubulure 23 de la poche de sérum physiologique 16. Cette électrovanne 35 a pour fonction d'empêcher la circulation intempestive de sérum physiologique au travers de la tubulure 23, avant la connexion du cathéter d'injection 17 au patient.

Sur la tubulure 24 d'alimentation du cathéter 17, on remarque aussi la présence de deux moyens anti-bulles/antibactérien 36 qui se présentent, par exemple, sous la forme de filtres, garantissant la stérilité du processus d'injection.

Toujours sur la figure 1, on remarque que l'enceinte blindée 2 se présente sous la forme de trois sous-ensembles blindés :

- un premier ensemble 2<sub>a</sub> intègre l'activimètre 3 et une partie du support de seringue 10,
- un second ensemble 2<sub>b</sub> cloisonne la vanne trois voies motorisée 15, et
- un troisième ensemble 2<sub>c</sub> cloisonne le support mobile 13 avec son conteneur blindé 12.

Les trois sous-enceintes 2<sub>a</sub>, 2<sub>b</sub> et 2<sub>c</sub> sont superposées ; la connexion entre la seringue 6 et la vanne 15 s'effectue au travers d'une ouverture 37 ménagée entre lesdits sous-ensembles 2<sub>a</sub> et 2<sub>b</sub>. La connexion entre la vanne 15 et la source de produit radioactif 11 est réalisée au travers d'une ouverture 38 ménagée entre les sous-ensembles 2<sub>b</sub> et 2<sub>c</sub>.

Le support 10 de la seringue 6 est réalisé en matériau radioprotecteur. Ses dimensions sont ajustées au mieux dans une ouverture 39 ménagée dans la partie supérieure du sous-ensemble 2<sub>a</sub>, pour obtenir une continuité de blindage en position abaissée (c'est-à-dire lorsque la seringue 6 est centrée dans le puits de mesure 3' de l'activimètre 3).

L'enceinte blindée 2 comporte encore des ouvertures appropriées pour le passage des tubulures 23 et 24 reliées, respectivement, à la poche de sérum physiologique 16 et au cathéter 17.

Les principales étapes mises en œuvre au sein de l'unité médicale 1, pour la préparation d'une dose déterminée de produit radioactif, puis son injection au patient, sont détaillées ci-dessous.

5 Tout d'abord, la dose de produit radioactif à injecter au patient est préparée au sein de la seringue 6.

Pour cela, la seringue 6 (avec son piston 8 en position basse) et la source de produit radioactif 11 sont connectées à la vanne trois voies 15 ; ensuite, cette vanne 15 est pilotée de sorte que ses voies supérieure 18 et inférieure 19 soient raccordées hydrauliquement, permettant la mise en communication respectivement de l'aiguille de seringue 9 avec la source 11 de produit radioactif.

10 Le piston de seringue 8 est ensuite manœuvré, vers le haut, pour aspirer la dose voulue de produit radioactif dans le corps de seringue 7, qui est mesurée en temps réel par l'activimètre 3. Cette dose est notamment fonction du poids du patient.

15 La dose préparée au sein de la seringue peut ensuite être administrée au patient.

A cet effet, la vanne 15 est à nouveau pilotée, cela de sorte que ses voies supérieure 18 et latérale 22 soient respectivement en communication avec l'aiguille de seringue 9, et avec les tubulures 23 et 24 (connectées à la poche 16 de sérum physiologique et au cathéter d'injection 17).

20 Avant la phase d'injection proprement dite, le piston de seringue 8 peut, si nécessaire, être piloté (vers le haut) pour aspirer un volume complémentaire de sérum physiologique provenant de la poche 16 ; ce volume de sérum permet de diluer le produit radioactif, et aussi d'obtenir un volume d'injection suffisant.

25 La seringue 6 est ensuite vidangée par le déplacement adapté du piston de seringue 8 (vers le bas). Le produit radioactif, éventuellement dilué par le volume complémentaire de sérum physiologique, chemine alors au travers de la tubulure 24 où il est filtré par les dispositifs 36, puis le long du cathéter d'injection 17 jusqu'au patient.

30 Suite à cette phase d'injection, l'opérateur peut éventuellement mettre en œuvre une phase complémentaire de rinçage du corps de seringue 7, de la vanne 15, et des conduites aval 17 et 24, avec un volume adapté de sérum physiologique pour assurer l'administration au patient de la totalité de la dose radioactive souhaitée.

35 A cet effet, le piston de seringue 8 est manœuvré successivement en aspiration (vers le haut) pour prélever un volume déterminé de sérum physiologique en provenance de la poche 16, puis manœuvré en éjection (vers le bas) pour éjecter ce volume au travers de la conduite 24 et du cathéter d'éjection 17.

Lorsque l'opérateur souhaite remplacer la seringue 6 ou la source de produit radioactif 11, il lui suffit de manœuvrer leurs structures supports respectives 10 et 13. A titre indicatif, la seringue 6 et la vanne 15 avec ses différentes conduites peuvent être remplacées suite à chaque injection. La seringue 6, d'une part, et la vanne 15  
5 avec son aiguille 20, ses tubulures 23, 24, la poche de sérum physiologique 16 et le cathéter 17, d'autre part, constituent un ensemble stérile à usage unique, remplaçable très facilement après chaque utilisation.

Les différents cycles précités de prélèvement, de dilution et d'injection de ce matériel sont gérés par des moyens de commande électroniques/informatiques de type automate programmable, aptes à piloter automatiquement les moyens de manœuvre  
10 34 du piston de seringue 8 et la vanne trois voies 15, de manière appropriée. L'ensemble de ces cycles peut être totalement automatisé. En fonction des besoins, ou des souhaits de l'utilisateur, l'injection de la dose radioactive au patient peut aussi être réalisée manuellement grâce aux moyens débrayables du motoréducteur 34.

15 Une forme particulièrement intéressante de l'unité médicale illustrée schématiquement sur la figure 1, est représentée sur la figure 2.

Sur cette figure 2, l'enceinte blindée 2 qui intègre l'ensemble du matériel fonctionnel décrit ci-dessus, est montée sur un châssis équipé de quatre roues 40. De préférence, certaines au moins des roues 40 sont associées à une motorisation,  
20 constituant une simple assistance aux déplacements, ou assurant elle-même le déplacement autonome de l'unité mobile, pilotée à distance par un boîtier à manette adapté.

L'unité mobile 1 peut aussi intégrer un système de géolocalisation, par exemple de type GPS, pour connaître en permanence son positionnement à distance dans un  
25 bâtiment.

Dans la partie inférieure de l'enceinte 2, on remarque la présence d'une trappe blindée 41 donnant accès à l'intérieur de la sous-enceinte 2c, pour le chargement ou le déchargement sur son support 13 du conteneur blindé 12 renfermant la source de produit radioactif 11 (en particulier lorsque ce support 13 est en position basse de  
30 chargement/déchargement).

Dans la partie supérieure, on remarque le support de seringue 10, la poche de sérum physiologique 16 accrochée à un support 42, ainsi qu'un tableau 43 de commande et de visualisation, à écran tactile, intégrant l'automate programmable de gestion des cycles, ou en relation directe avec celui-ci (par exemple déporté au sein du  
35 châssis de l'unité). Ce tableau de commande, de dialogue et de visualisation 43

permet d'effectuer les opérations de calibration (mesure d'activité), et la visualisation en temps réel des diverses phases de préparation du transfert (dilution ...) et d'injection du produit radioactif.

5 Les moyens de commande électroniques/informatiques correspondants sont équipés d'une connectique 44 pour l'envoi et/ou la réception de données, en particulier pour réaliser certains échanges avec un serveur informatique situé à proximité ou à distance (par exemple par l'intermédiaire d'un réseau intranet ou du réseau internet), notamment pour réaliser une télémaintenance à distance et collecter certaines données concernant le patient (nécessaires notamment à la détermination de la dose  
10 de radioéléments qui doit lui être administrée).

Le châssis de l'unité 1 porte également des moyens propres d'énergie, par exemple de type batteries rechargeables, assurant l'alimentation électrique notamment des roues motorisées 40 et des moyens de commande électroniques/informatiques.

15 Cette unité mobile blindée 1 constitue une unité autonome permettant la calibration et l'injection de tous produits radioactifs (en particulier de FDG). Elle est très compacte du fait de la superposition de l'activimètre, de la vanne trois voies et de la source de produit radioactif sur le même axe vertical ou sensiblement sur le même axe vertical, et du fait de la superposition des sous-enceintes 2a, 2b et 2c. Cette unité permet un prélèvement, une mesure et une injection en toute sécurité.

- REVENDICATIONS -

- 1.- Unité médicale pour le prélèvement, le calibrage, la dilution et/ou l'injection d'un produit radioactif, injectable à un patient, laquelle unité (1) comprend au moins :
- 5 - des moyens (13) pour le support d'un conteneur (12) en matériau radioprotecteur dans lequel est logée une source ou un générateur de produit radioactif injectable (11),
  - des moyens (10) pour le support d'une seringue (6) équipée d'un piston (8),
  - un dispositif (3) de type activimètre pour la mesure en temps réel de l'activité radio-isotopique émise par le contenu de ladite seringue (6), et
  - 10 - un système de conduites (9, 20, 23, 24) associé à au moins une vanne (15) pour le raccordement hydraulique de ladite source radioactive (11), de ladite seringue (6), d'une source de sérum physiologique (16) et d'un cathéter d'injection (17) destiné à être connecté au patient,
- ladite vanne (15) et ledit piston de seringue (8) étant manoeuvrables pour assurer, d'une part, une aspiration dudit produit radioactif (11) ou dudit sérum physiologique
- 15 (16) au sein de ladite seringue (6), et d'autre part, une éjection dudit produit radioactif (11), dudit sérum physiologique ou d'un mélange de ces deux produits, préalablement aspiré(s) au sein de ladite seringue (6), cela au travers dudit cathéter d'injection (17), la dose de produit radioactif prélevée et injectée par ladite seringue (6) étant mesurée par ledit activimètre (3),
  - 20 caractérisée en ce qu'elle comporte une enceinte blindée (2) réalisée en au moins un matériau radioprotecteur, dans laquelle sont logés ledit support (13) de source radioactive (11), au moins une partie des moyens supports (10) de la seringue (6), ledit activimètre (3), ladite vanne (15) et au moins une partie dudit système de conduites (9, 20, 23, 24), et en ce que ledit support de seringue (10), ladite vanne (15) et ledit
  - 25 support (13) de source radioactive (11) sont agencés verticalement les uns par rapport aux autres, respectivement du haut vers le bas, ledit support de seringue (10) étant agencé pour porter ladite seringue (6) avec son piston (8) orienté vers le haut.
- 2.- Unité médicale selon la revendication 1, caractérisée en ce que la vanne (15) consiste en une vanne trois voies comprenant :
- 30 - une voie supérieure (18), destinée à être raccordée à la seringue (6) de prélèvement et d'injection,
  - une voie inférieure (19), destinée à être raccordée à la source de produit radioactif injectable (11), et
  - une voie latérale (22), destinée à être raccordée à une première conduite (23)
  - 35 connectée à la source de sérum physiologique (16) et à une seconde conduite (24)

connectée au cathéter d'injection (17), lesdites conduites (23, 24) étant équipées chacune d'un clapet anti-retour (25, 26) convenablement orienté.

3.- Unité médicale selon la revendication 2, caractérisée en ce que l'activimètre (3) a une forme générale tubulaire délimitant un puits central (3') d'axe vertical, destiné à contenir la seringue (6), ledit activimètre (3) étant muni de deux ouvertures, l'une supérieure (4) et l'autre inférieure (5), cette dernière étant orientée en regard de la vanne trois voies (15) et du support (13) de la source radioactive (11).

4.- Unité médicale selon l'une quelconque des revendications 2 ou 3, caractérisée en ce que la voie supérieure (18) de la vanne (15), destinée à être raccordée à la seringue (6), comporte un opercule hermétique destiné à être percé par l'aiguille (9) équipant ladite seringue (6).

5.- Unité médicale selon l'une quelconque des revendications 2 à 4, caractérisée en ce que la voie inférieure (19) de la vanne (15), destinée à être raccordée à la source de produit radioactif injectable (11), est prolongée par une aiguille (20) destinée à percer un opercule (21) obturant le flacon contenant ladite source radioactive (11).

6.- Unité médicale selon l'une quelconque des revendications 1 à 5, caractérisée en ce que les supports (13, 10) de source radioactive (11) et de seringue (6) sont portés chacun par des moyens assurant leur(s) déplacement(s) selon un axe vertical ou sensiblement vertical, cela entre deux positions :

- une première position, dans laquelle un opérateur peut charger la source radioactive (11) et la seringue (6) sur leurs supports respectifs (13, 10), ou à l'inverse les décharger, et
- une seconde position dans laquelle la source radioactive (11) et la seringue (6) sont raccordées à la vanne (15).

7.- Unité médicale selon la revendication 6, caractérisée en ce que les moyens de déplacement du support de seringue (10) permettent son cheminement verticalement au travers d'un orifice (39) ménagé dans l'enceinte blindée (2), entre :

- une position supérieure de chargement/déchargement, dans laquelle ledit support (10) se situe au moins partiellement hors de ladite enceinte (2), et
- une position inférieure de raccordement, dans laquelle la seringue (6) se positionne au sein du puits central (3') de l'activimètre (3) et est raccordée à la vanne (15).

8.- Unité médicale selon l'une quelconque des revendications 6 ou 7, caractérisée en ce que le support (13) de source radioactive (11) chemine au sein de l'enceinte blindée (2) entre ses positions de chargement/déchargement et de



raccordement, ladite enceinte (2) étant encore munie d'une trappe (41) frontale pour permettre l'accès d'un opérateur audit support (13) de source radioactive (11) au moins dans sa position de chargement/déchargement.

5 9.- Unité médicale selon l'une quelconque des revendications 1 à 8, caractérisée en ce qu'elle comprend encore des moyens de commande informatiques et/ou électroniques aptes à piloter la vanne (15) et les moyens (33, 34) de manœuvre du piston de seringue (8), cela de manière à mettre en œuvre les opérations de prélèvement et d'éjection par ladite seringue (6), lesquels moyens de commande informatiques/électroniques pilotent également éventuellement les moyens de  
10 déplacement du support de seringue (10) et du support de source radioactive (13).

10.- Unité médicale selon la revendication 9, caractérisée en ce que les moyens de manœuvre du piston (8) de la seringue (6) sont de type motoréducteurs débrayables (34), contrôlés par les moyens de commande informatiques/électroniques, pour assurer, d'une part, le prélèvement automatique d'une dose déterminée de  
15 produit radioactif au sein de ladite seringue (6), et d'autre part, pour assurer l'injection de cette dose au patient, soit automatiquement, soit manuellement.

11.- Unité médicale selon l'une quelconque des revendications 1 à 10, caractérisée en ce que l'enceinte (2) se compose de trois sous-enceintes (2a, 2b, 2c) alignées verticalement les unes par rapport aux autres, à savoir - une sous-enceinte  
20 supérieure (2a) contenant la seringue (6) et l'activimètre (3), - une sous-enceinte intermédiaire (2b) contenant la vanne (15), et - une sous-enceinte inférieure (2c) contenant la source de produit radioactif (11), lesquelles sous-enceintes (2a, 2b, 2c) sont raccordées deux à deux par des ouvertures traversantes (37, 38) au travers desquelles passent certaines des conduites (9, 20) de raccordement hydraulique.

25 12.- Unité médicale selon l'une quelconque des revendications 1 à 11, caractérisée en ce que les moyens de commande informatiques/électroniques sont pourvus d'une connectique (44) pour l'envoi et/ou la réception de données, en particulier pour les échanges avec un serveur informatique.

30 13.- Unité médicale selon l'une quelconque des revendications 1 à 12, caractérisée en ce qu'elle est montée sur des roues (40) pour la rendre mobile, et en ce qu'elle intègre éventuellement un système de géolocalisation, par exemple de type GPS.

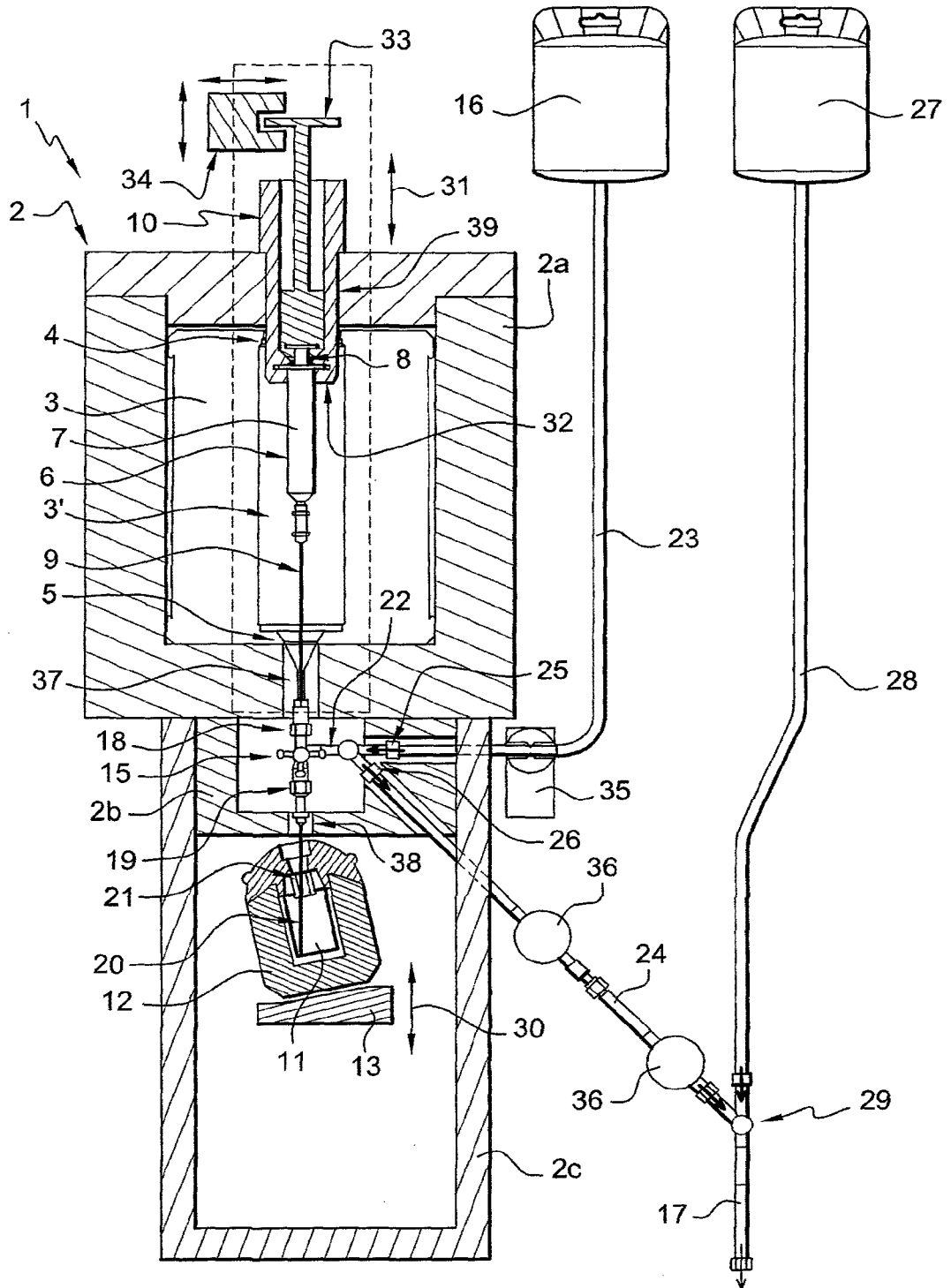
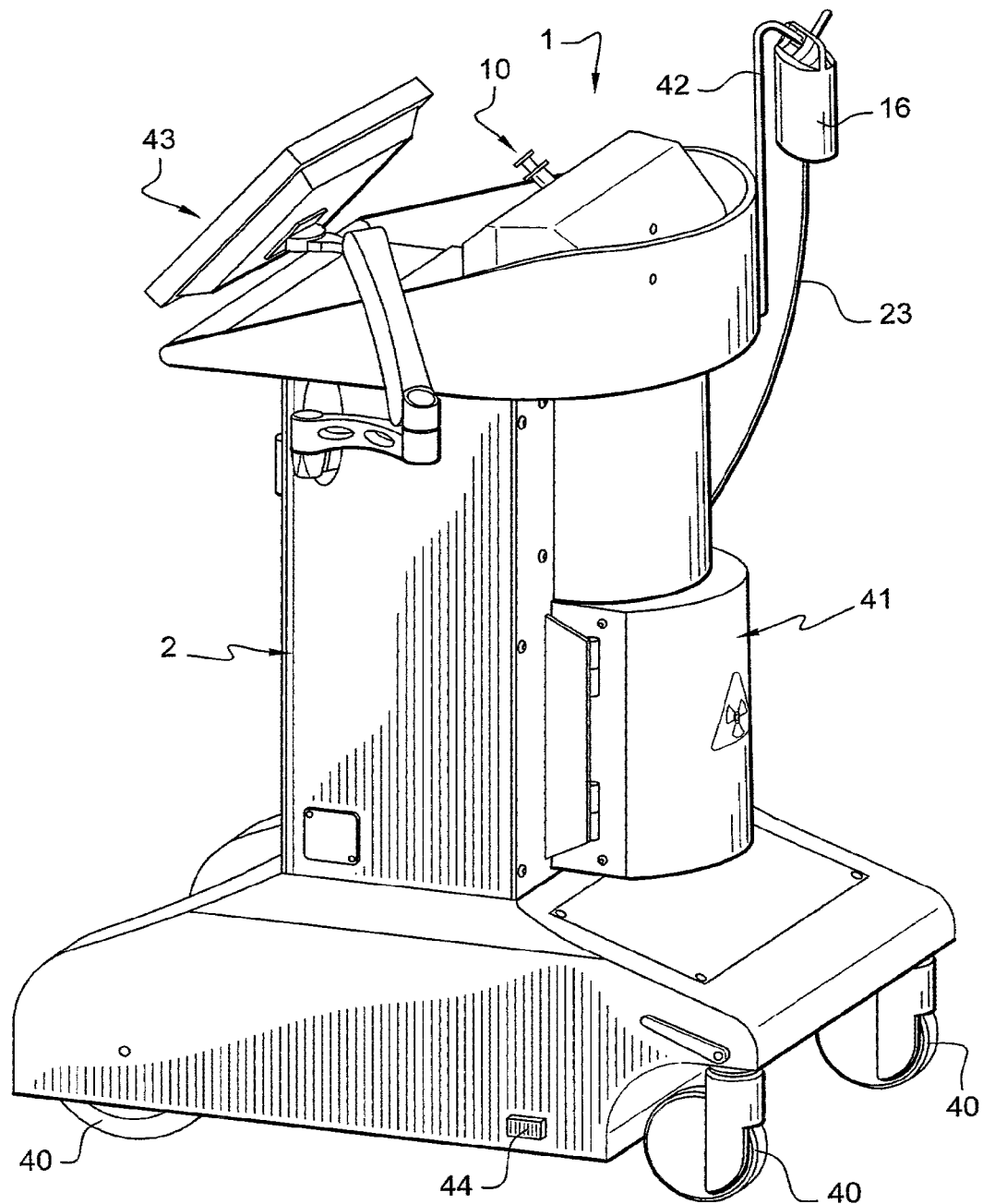


Fig. 1



**Fig. 2**

(19) World Intellectual Property Organization  
International Bureau



(43) International Publication Date  
10 July 2008 (10.07.2008)

PCT

(10) International Publication Number  
**WO 2008/082966 A2**

(51) International Patent Classification:  
A61M 36/08 (2006.01)

15216 (US). MILLER, Paul, J.; 5714 Elgin Street, Pittsburgh, PA 15206 (US). YANKE, Scott H.; S64 W.39064 County Highway CL, Dousman, Wisconsin 53118 (US).

(21) International Application Number:  
PCT/US2007/088028

(74) Agent: BRADLEY, Gregory, L.; Medrad, Inc., One Medrad Drive, Indianola, PA 15051 (US).

(22) International Filing Date:  
20 December 2007 (20.12.2007)

(81) Designated States (unless otherwise indicated, for every kind of national protection available): AE, AG, AL, AM, AT, AU, AZ, BA, BB, BG, BH, BR, BW, BY, BZ, CA, CH, CN, CO, CR, CU, CZ, DE, DK, DM, DO, DZ, EC, EE, EG, ES, FI, GB, GD, GE, GH, GM, GT, HN, HR, HU, ID, IL, IN, IS, JP, KE, KG, KM, KN, KP, KR, KZ, LA, LC, LK, LR, LS, LT, LU, LY, MA, MD, ME, MG, MK, MN, MW, MX, MY, MZ, NA, NG, NI, NO, NZ, OM, PG, PH, PL, PT, RO, RS, RU, SC, SD, SE, SG, SK, SL, SM, SV, SY, TJ, TM, TN, TR, TT, TZ, UA, UG, US, UZ, VC, VN, ZA, ZM, ZW.

(25) Filing Language: English

(26) Publication Language: English

(30) Priority Data:  
60/878,304 1 January 2007 (01.01.2007) US  
60/979,541 12 October 2007 (12.10.2007) US  
11/981,429 31 October 2007 (31.10.2007) US

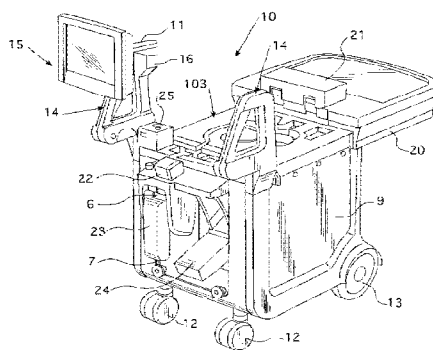
(71) Applicant (for all designated States except US):  
MEDRAD, INC. [US/US]; One Medrad Drive, Indianola, PA 15051 (US).

(84) Designated States (unless otherwise indicated, for every kind of regional protection available): ARIPO (BW, GH, GM, KE, LS, MW, MZ, NA, SD, SL, SZ, TZ, UG, ZM, ZW), Eurasian (AM, AZ, BY, KG, KZ, MD, RU, TJ, TM), European (AT, BE, BG, CH, CY, CZ, DE, DK, EE, ES, FI, FR, GB, GR, HU, IE, IS, IT, LT, LU, LV, MC, MT, NL, PL, PT, RO, SE, SI, SK, TR), OAPI (BF, BJ, CF, CG, CI, CM, GA, GN, GQ, GW, ML, MR, NE, SN, TD, TG).

(72) Inventors: TATE, Leon, J.; 210 D'Orsay Valley Drive, Cranberry Townshi, PA 16066 (US). SHIGENO, James; 163 Lloyd Ave., Pittsburgh, PA 15218 (US). RYGG, Steven, C.; 121 Maplewood Drive, Irwin, PA 15642 (US). NEFF, Jared E.; 319 Finin Road, New Kensington, PA 15068 (US). GRIFFITH, Scott; 61 Bel Aire Drive, Delmont, Pennsylvania 15626 (US). BISEGNA, Joseph, E.; 63 Outlook Place, Cheswick, PA 15024 (US). ILGENFRITZ, Edward; 2309 Candace Street, Pittsburgh, PA

Published:  
— without international search report and to be republished upon receipt of that report

(54) Title: RADIOPHARMACEUTICAL ADMINISTRATION METHODS, FLUID DELIVERY SYSTEMS AND COMPONENTS THEREOF



(57) Abstract: A fluid path set for a fluid delivery system includes a tube coil that is designed to optimally position one or more volumes of a pharmaceutical within an ionization chamber to optimally measure and prepare a pharmaceutical dose for administration to a patient. The tube coil may be maintained in a desired dimensional geometry by means of a core structure around which the tube coil is positioned. Novel developments in radiopharmaceutical administration methods and systems include, but are not limited to, the configuration and layout of a fluid path set for use in a fluid delivery system, arrangements for piercing and drawing fluid from a pharmaceutical container (such as a vial), arrangements for optimizing the positioning of a tube coil within an ionization chamber, a handling system for transporting vial shields that maintain an operator's hand and fingers at a safe distance from a pharmaceutical vial, a method for calibrating a radiopharmaceutical delivery system in which the difference between the expected and measured activities of two radioisotopes are used to calculate an estimated error in the measured activity of a third radioisotope and a vial access system that ensures an optimal draw of fluid from a radiopharmaceutical container.



WO 2008/082966 A2

**RADIOPHARMACEUTICAL ADMINISTRATION METHODS, FLUID  
DELIVERY SYSTEMS AND COMPONENTS THEREOF**

**BACKGROUND OF THE INVENTION**

- [1] The present invention relates to methods, systems and components thereof for delivering pharmaceutical substances to patients for imaging procedures and, more particularly, for delivering radiopharmaceuticals to patients for positron emission tomography (PET) or single-photon emission computerized tomography (SPECT) procedures.
- [2] PET and SPECT are noninvasive, three-dimensional, imaging procedures that provide information regarding physiological and biochemical processes in patients. PET and SPECT images of, for example, the brain or another organ, are produced by injecting the patient with a dose of a radiopharmaceutical (using, for example, fluid delivery systems such as those disclosed in U.S. Patent No. 6,767,319, JP Publication Nos. 2000-350783 and 2002-306609 and PCT Publication Nos. WO 2004/091688, WO 2006/007750 and 2004/004787, the disclosures of which are incorporated herein by reference) and then creating an image based on the radiation emitted by the radiopharmaceutical. The radiopharmaceutical generally includes a radioactive substance, such as a radioisotope, that can be absorbed by certain cells in the brain or other organs, concentrating it there.
- [3] Radioisotopes, especially those with short half-lives, can be relatively safely administered to patients in the form of a labeled substrate, ligand, drug, antibody, neurotransmitter or other compound or molecule that is normally processed or used by the body (for example, glucose). The radioisotope acts as a tracer of specific physiological or biological processes. For example, fluorodeoxyglucose (FDG) is a normal molecule of glucose, the basic energy fuel of cells, to which is attached a radioisotope or radioactive fluor (i.e., F-18). The F-18 radioisotope is produced in a cyclotron equipped with a unit to synthesize the FDG molecule.
- [4] Cells (for example, in the brain) that are more active in a given period of time after an injection of FDG will absorb more FDG because they have a higher metabolism and require more energy. The F-18 radioisotope in the FDG molecule experiences a radioactive decay, emitting a positron. When a positron collides with an electron, annihilation occurs, liberating a burst of energy in the form of two beams of gamma rays in opposite directions. The PET scanner detects the emitted gamma rays to compile a three dimensional image.

- [5] To allow for cell uptake of the radiopharmaceutical, the patient typically rests for a period of time (45-90 minutes for FDG) after the radiopharmaceutical is injected. After sufficient time for cell uptake has elapsed, the patient is typically placed on a movable bed that slides into the PET (or SPECT or other suitable) scanner. The PET scanner includes several rings of radiation detectors. Each detector emits a brief pulse of light every time it is struck with a gamma ray coming from the radioisotope within the patient's body. The pulse of light is amplified, by for example a photomultiplier, and the information is sent to the computer for forming images of the patient.
- [6] To minimize the radiation dose to patients, radiopharmaceuticals containing radioisotopes, such as Flourine-18, Technetium-99, Carbon-11, Copper-64, Gallium-67, Iodine-123, Nitrogen-13, Oxygen-15, Rubidium-82, Thallium-201, Chromium-51, Iodine-131, Iodine-151, Iridium-192, Phosphorus-32, Samarium-153, and Yttrium-90, having relatively short half-lives are typically used for PET and SPECT imaging procedures and other radio-therapies. F-18, for example, has a half-life of 109.7 minutes.
- [7] Because of its short half-life, the radioactivity level of the radioisotope will quickly decrease after it is manufactured in a cyclotron or a reactor. Consequently, the elapsed time (and corresponding decrease in radioactivity level of the radioisotope) after synthesis of the radiopharmaceutical must be factored into calculating the volume of radiopharmaceutical required to be injected into the patient to deliver the desired radioactivity dose. If the time delay after synthesis is long in relation to the radioisotope's half-life or if the calculated volume of radiopharmaceutical to be injected into the patient is insufficient to deliver the desired radioactivity dose, the delivered radioactivity dose may be too low to provide diagnostic-quality images, resulting in wasted time and effort and exposing the patient and medical personnel to unnecessary radiation.
- [8] Further, long-term radiation exposure to technologists and other personnel working in the scanner room can pose a significant health risk. Although the half-life of the radiopharmaceutical is rather short and the applied dosages are considered an acceptable risk to the patient, under current procedures administering personnel are exposed each time they work with the radiopharmaceuticals and other contaminated materials, such as tubing and syringes, used to inject the radiopharmaceuticals into patients. Constant and repeated exposure over an extended period of time can be harmful.

[9] A number of techniques are used to reduce radiation exposure to medical personnel, including minimizing the time of exposure of personnel, maintaining distance between personnel and the source of radiation and shielding personnel from the source of radiation. In general, the radiopharmaceuticals are typically delivered to a nuclear medicine hospital suite or other medical facility from a radiopharmaceutical synthesis facility (within or outside the hospital or medical facility) equipped with a cyclotron in, for example, a lead-shielded container (often called a "PIG"). Often, the radiopharmaceutical is manually drawn from such containers into a shielded syringe. See, for example, U.S. Pat. No. 5,927,351, disclosing a drawing station for handling radiopharmaceuticals for use in syringes. Remote injection mechanisms can also be used to maintain distance between the operator and the radiopharmaceutical. See, for example, U.S. Pat. No. 5,514,071, disclosing an apparatus for remotely administering radioactive material from a lead encapsulated syringe. Nevertheless, these current procedures and systems still result in unnecessary and repeated exposure of technicians and other medical personnel to radiation.

[10] It has long been recognized as very desirable to develop devices, systems, components and methods for calculating and delivering accurate and effective doses of radiopharmaceuticals to patients, while reducing the exposure of administering or other medical personnel to such hazardous pharmaceuticals.

#### SUMMARY OF THE INVENTION

[11] The present invention broadly contemplates and provides devices, systems, components and methods for accurately calculating or delivering effective doses of pharmaceuticals to patients.

[12] In a first aspect, the invention provides a fluid path set including a tube coil that is designed to optimally position one or more volumes of a pharmaceutical within an ionization chamber to optimally measure and prepare a pharmaceutical dose for administration to a patient. The tube coil may be maintained in a desired dimensional geometry by means of a core structure around which the tube coil is positioned or coiled.

[13] The fluid path set includes a medical fluid component comprising a first tubing section for connection to a source of a medical fluid, a pharmaceutical component comprising a second tubing section for connection to a source of a pharmaceutical, a coil assembly component comprising a tube coil having a height of approximately 1.53 inches, a diameter of approximately 1.95 inches and a volume capacity of

- approximately 12.5 ml, and a connector comprising a first port for connecting the first tubing section of the medical fluid component, a second port for connecting the second tubing section of the pharmaceutical component and a third port for connecting the tube coil of the coil assembly component.
- [14] In a second aspect, the present invention provides a vial access system for inserting a cannula into a pharmaceutical container, such as a vial. The vial access system includes structures that shields the operator from exposure to hazardous pharmaceuticals, such as radiopharmaceuticals, and is designed with an inclined bottom surface to tilt the pharmaceutical container from the horizontal and thereby allow the cannula to optimally extract the pharmaceutical from the container.
- [15] The vial access system includes a base portion comprising a substantially horizontal lower surface and a sloped upper surface adapted to support a vial comprising a bottom wall and a substantially cylindrical wall connected thereto. The sloped upper surface is adapted to ensure that a residual volume of fluid in the vial gathers in an area defined at least partially by a portion of the junction between the bottom wall and the cylindrical wall of the vial.
- [16] In a third aspect, the present invention provides a vented cannula for insertion into a pharmaceutical container, such as a vial. The vented cannula may be used in the vial access system of the present invention or may be fluidly connected to a shielded syringe to provide an alternate fluid delivery system.
- [17] The vented cannula includes a main hub comprising two opposed lateral sides and defining a fluid port and a vent, a fluid draw needle in connection with the fluid port and adapted to be placed within the container, a vent needle in connection with the vent and adapted to be placed within the container; and two resilient arms connected to the opposed lateral sides of the main hub. Each of the two arms includes a top edge and a hook member formed thereon and extending outwardly therefrom.
- [18] In a fourth aspect, the present invention provides a fluid delivery system having a retractable shielded cover to shield operators of the system from the fluid path components and the pharmaceutical contained therein. In another aspect, the fluid path components and the pharmaceutical may be disposed in a slidable drawer that may be removed from the shielded system to allow access thereto.
- [19] The fluid delivery system includes a housing having an upper surface defining a plurality of recessed portions for accommodating one or more components of a fluid path set, a cover movably connected to the housing and a locking mechanism



associated with the cover. The cover is adapted to move between a first position that exposes the upper surface and a second position that overlies the upper surface, and the locking mechanism is adapted to lock the cover in the second position.

- [20] In another aspect, the fluid delivery system includes a syringe comprising a body defining a discharge outlet and a plunger movably disposed within the body, a connector comprising a valve member and defining first, second and third ports, a first tubing segment connected between the discharge outlet of the syringe and the first port of the connector, a cannula defining a fluid port, a second tubing segment connected between the fluid port of the cannula and the second port of the connector, a third tubing segment comprising a first end connected to the third port of the connector and a second end comprising a second connector, and a per-patient tubing set comprising a first end that is adapted to be connected to the second connector on the second end of the third tubing segment and a patient end that is adapted to be connected to venous access device in a patient.
- [21] In a fifth aspect, the present invention provides a method of priming the fluid path components of the fluid delivery system to remove air therefrom and to prepare the system to administer a pharmaceutical dose to a patient.
- [22] A method of priming at least a portion of a fluid path set in a fluid delivery system includes: (1) placing a tubing section of the fluid path set in fluid connection with a source of a radiopharmaceutical; (2) placing a portion of the tubing section within a dose calibrator of the fluid delivery system; (3) pumping a volume of the radiopharmaceutical through the tubing section; (4) monitoring the dose calibrator to determine if a measured activity level is substantially equal to or above a predetermined activity level; and (5) if the measured activity level is substantially equal to or above the predetermined activity level, then concluding that the tubing section of the fluid path set has been primed.
- [23] In a sixth aspect, the present invention provides a carrying system for connecting to and transporting a vial shield (containing a pharmaceutical vial). The carrying system may be used to transport the vial shield to and place the vial shield within the fluid delivery system of the present invention. In another aspect, the carrying system may be used to position the vial shield within the vial access device of the present invention.
- [24] The vial shield carrying system includes a collar unit adapted to removably engage a flange on the vial shield and a handle unit adapted to engage the collar unit. The collar unit defines two elongated slots formed in a top surface thereof, each of the

slots including a pin disposed therein and extending between two opposing walls thereof. The handle unit includes a handle connected to a U-shaped cross piece that defines two, downwardly extending arms having hook members formed therein. The open ends of the hook members are formed on opposite ends of the arms and are adapted to engage the pins in the slots of the collar unit through rotation of the handle.

- [25] In a seventh aspect, the present invention provides a system and a method for calibrating a radiopharmaceutical delivery system in which the difference between the expected (based on decay from the initial activity) and measured activities of two radioisotopes are used to calculate an estimated error in the measured activity of a third radioisotope. In response to a difference between the expected and measured activity of the first or the second radioisotope, the gain of the ionization chamber is adjusted to eliminate or reduce the error for that radioisotope. When the estimated error of the third radioisotope falls within an acceptable range, the activity of the third radioisotope is measured to check that the actual error between the expected and measured activity of the third radioisotope is substantially similar to the estimated error.
- [26] Preferably, the energy levels of the first, second and third radioisotopes are less than, greater than, and relatively close to, respectively, the energy level of the radioisotope to be delivered by the system to the patient. In addition, the operator may take consecutive measurements of the first and second radioisotopes (i.e., in an iterative fashion) and adjust the gain of the ionization chamber in response thereto, before measuring the activity of the third radioisotope and comparing it against the estimated error of the third radioisotope.
- [27] A method of calibrating includes (1) measuring an activity level of a first radioisotope in an ionization chamber of the fluid delivery system, the first radioisotope having an energy level less than that of the radioisotope to be delivered to the patient; (2) comparing the measured activity level of the first radioisotope to an expected activity level of the first radioisotope; (3) adjusting the gain of the ionization chamber to compensate for the difference, if any, between the measured activity and the expected activity of the first radioisotope; (4) measuring an activity level of a second radioisotope in the ionization chamber of the fluid delivery system, the second radioisotope having an energy level similar to or greater than that of the radioisotope to be delivered to the patient; (5) comparing the measured activity level of the second radioisotope to an expected activity level of the second radioisotope; (6) adjusting the gain of the ionization chamber to compensate for the difference, if

any, between the measured activity and the expected activity of the second radioisotope; and (7) calculating an estimated error in a measured activity of a third radioisotope based on the differences, if any, between the measured activity and the expected activity of the first radioisotope and the measured activity and the expected activity of the second radioisotope.

[28] Broadly contemplated herein are improvements in radiopharmaceutical administration methods and systems. These inventions include, but are not limited to, the configuration and layout of a fluid path set for use in a fluid delivery system, arrangements for piercing and drawing fluid from a radiopharmaceutical container (such as a vial), arrangements for optimizing the positioning of a tube coil within an ionization chamber, a handle / carrying system for transporting vial shields or "pigs" that keeps an operator's hand and fingers at a safe distance from a vial access cap, and a vial access system that ensures an optimal draw of fluid from a radiopharmaceutical container.

[29] The novel features which are considered characteristic of the present invention are set forth herebelow. The invention itself, however, both as to its construction and its method of operation, together with additional objects and advantages thereof, will be best understood from the following description of the specific embodiments when read in connection with the accompanying drawings.

#### BRIEF DESCRIPTION OF THE DRAWINGS

[30] For the present invention to be clearly understood and readily practiced, the present invention will be described in conjunction with the following figures, wherein like reference characters designate the same or similar elements, which figures are incorporated into and constitute a part of the specification.

[31] Fig. 1A is a perspective view of a fluid delivery system of the present invention.

[32] Fig. 1B is another perspective view of the fluid delivery system of Fig. 1A with the shielded cover thereof in a retracted position.

[33] Fig. 1C is a top plan view of the fluid delivery system shown in Figs. 1A and 1B with various fluid path components positioned therein.

[34] Fig. 1D is a cross-sectional view taken along line 1D-1D of Fig. 1A.

[35] Fig. 1E is a cross-sectional view taken along line 1E-1E of Fig. 1A.

- [36] Fig. 2A is a schematic illustration of the multi-patient fluid path set and components thereof of the present invention.
- [37] Fig. 2B is an exploded view showing the multi-patient fluid path set shown in Fig. 2A connected to a fluid source and disposed above the fluid delivery system shown in Figs. 1A-1E.
- [38] Fig. 2C is a perspective view of an alternate embodiment of the multi-patient fluid path set of the present invention.
- [39] Fig. 3A is an elevational view of a preferred embodiment of a coil assembly of the present invention.
- [40] Fig. 3B is a partial cross-sectional view of Fig. 3A.
- [41] Fig. 3C is a plan view (in partial cross-section) taken along line 3C-3C of Fig. 3A.
- [42] Fig. 3D is a cross-sectional view taken along line 3D-3D of Fig. 3A.
- [43] Fig. 3E is a perspective view of the core element of the coil assembly shown in Fig. 3A.
- [44] Fig. 3F is an enlarged view of Fig. 1D showing the coil assembly in the ionization chamber of the fluid delivery system.
- [45] Fig. 4A is an elevational view of preferred embodiments of a vial shield carrying system and a vial access system of the present invention.
- [46] Fig. 4B is a perspective view showing the vial shield, the vial shield carrying system and the vial access system of Fig. 4A.
- [47] Fig. 4C is an elevational view of a pharmaceutical vial that may be used in the fluid delivery system of the present invention.
- [48] Figs. 5A-5D are various views of an alternate embodiment of a vial shield carrying system of the present invention.
- [49] Fig. 6A is a bottom perspective view of a preferred embodiment of a vial access system of the present invention.
- [50] Fig. 6B is a top perspective view of the vial access system shown in Fig. 6A.

- [51] Fig. 6C is an exploded, perspective view of a preferred embodiment of the vented cannula of the multi-patient fluid path set of the present invention oriented to be connected to the cap of the vial access system shown in Figs. 6A-6B.
- [52] Fig. 6D is a perspective view (similar to Fig. 4B) showing the vial access system and the vial-carrying shield disposed in a well of the fluid delivery system, and the vented cannula connected to the cap of the vial access system and in position to be lowered and inserted through the septum cap of the vial shield into the radiopharmaceutical vial.
- [53] Fig. 6E is another perspective view (similar to Fig. 6D) showing the cap of the vial access system lowered into position and the vented cannula thereby inserted into the pharmaceutical vial.
- [54] Fig. 6F is an enlarged view of Fig. 1E showing the vial access system and the vented cannula of the present invention.
- [55] Fig. 6G is a perspective view of the vented cannula shown in Fig. 6C.
- [56] Fig. 6H is an elevational view of the vented cannula shown in Fig. 6G.
- [57] Fig. 6I is a left-side view of the vented cannula shown in Fig. 6H.
- [58] Fig. 6J is a right-side view of the vented cannula shown in Fig. 6H.
- [59] Fig. 7 shows a main screen of a graphical user interface of the present invention.
- [60] Figs. 8, 9, 10, 11, 12A, 12B, 13, 14, 15, 16A, 16B, 17, 18, 19, 20, 21 and 22 are various depictions of a graphical user interface for use in system preparation tasks.
- [61] Figs. 23, 24A-F, 25A, 25B, 26A, 26B, 27A, 27B, 28A, 28B, 29, 30A, 30B, 31, 32A and 32B are various depictions of a graphical user interface for use in patient treatment tasks.
- [62] Figs. 33A-C, 34A and 34B are various depictions of a graphical user interface for use in injection history/recall operations or tasks.
- [63] Figs. 35, 36, 37, 38, 39A, 39B, 40, 41, 42, 43, 44A-D, 45A-D and 46 are various depictions of a graphical user interface for use in system configuration tasks.
- [64] Fig. 47A is a perspective view of the vented cannula shown in Figs. 6C and 6G-6J being utilized as part of a first alternate fluid delivery system.

- [65] Fig. 47B is another perspective view showing the first alternate fluid delivery system of Fig. 47A.
- [66] Fig. 47C is an elevational view of the first alternate fluid delivery system of Figs. 47A and 47B.
- [67] Fig. 48 is a perspective view of the vented cannula shown in Figs. 6C and 6G-6J being utilized as part of a second alternate fluid delivery system.

#### DETAILED DESCRIPTION OF THE PREFERRED EMBODIMENTS

- [68] As used herein, the term "pharmaceutical" refers to any substance or drug to be injected or otherwise delivered into the body (either human or animal) in a medical procedure and includes, but is not limited to, substances used in imaging procedures (for example, contrast media) and therapeutic substances. A number of such pharmaceutical substances pose a danger to both the patient and the personnel administering the substance if not handled and/or injected properly. Examples of hazardous pharmaceuticals include, but are not limited to, radiopharmaceuticals, biological pharmaceuticals, chemotherapeutic pharmaceuticals and gene therapeutic pharmaceuticals.
- [69] Turning now to the drawings, Figs. 1A-1E show a preferred embodiment of the administration, injector or fluid delivery system 10 of the present invention. The fluid delivery 10 is preferably a cart-like apparatus 9 having wheels 13 and/or casters 12 for allowing the system to be movable. One or more of the wheels 13 may be lockable to prevent the system 10 from moving once it is in position. The system 10 also preferably includes one or more handles 14 for allowing an operator to move or position the system 10. Alternately, the fluid delivery system 10 may be a stand-alone or fixed-position apparatus.
- [70] The fluid delivery system 10 includes a display or graphical user interface (GUI) 15 for programming and operating the system 10. The GUI display 15 is preferably attached to one of the handles 14 (as shown) of the system 10. The display 15 may be a color display and incorporate touch-screen capability, as known in the art, for ease of use. The display 15 may be fixed, but is preferably pivotally connected to the fluid delivery system 10 (as shown), by means of a movable arm 11 that is pivotally connected to a joint 16. Further, the display 15 may be tilted or swiveled with respect to the arm 11 to allow for optimal positioning of the display 15 by an operator.

- [71] The fluid delivery system 10 preferably includes a retractable lid or cover 20 having a primary handle including a latch release 1 (see Figs. 1D and 1E) and a secondary handle 21. The lid 20 preferably covers an upper surface 103 that defines a number of recessed portions, such as wells and troughs, into which a vial or container (see 902 in Fig. 4C) of a pharmaceutical or a radiopharmaceutical (discussed in more detail below) and various components of a multi-patient fluid path set (hereinafter MPDS; discussed in more detail below) may be positioned during an injection procedure. A locking mechanism, such as a combination or a key lock (not shown), may be used to lock the lid 20 in a closed position to, for example, prevent use or access of the system 10 by unauthorized personnel. In another embodiment, the locking mechanism may be a software-implemented lock, such as a password-protected access point, that is accessible through the display 15 and is adapted to lock the cover in a closed position and/or to prevent unauthorized personnel from accessing or operating the system 10.
- [72] The lid 20 is slidable or retractable (by, for example, using primary handle and latch release 1) with respect to the cart 9 to allow for insertion and removal of the vial or container 902 and MPDS from the fluid delivery system 10. The lid 20, upper surface 103 and various other portions of the cart 9 preferably include suitable radioactive shielding (such as lead) for minimizing potential radiation exposure from the radiopharmaceutical to the operator. In this manner, the radiopharmaceutical vial 902 and the components of the MPDS can lie below the plane of surface 103, whereupon the surface 103 or one or more portions thereof can be covered by the lid 20 during use to limit radiation exposure to the operator or other medical personnel. Further, instead of a retractable lid 20, surface 103 itself could be disposed on a portion of the injector apparatus 10 (e.g., a drawer-type mechanism) that slidably displaces with respect to a remainder of the injector apparatus 10.
- [73] As further shown in Figs. 1A, 1B and 1D, the fluid delivery system 10 includes a pumping mechanism, such as a peristaltic pump 22, a removable/replaceable source of medical fluid 23 (such as saline), a printer 24 and an interrupt button 25. The peristaltic pump 22 is shown in a closed position in Fig. 1A, but may be opened (see Figs. 1B, 1C and 2B) to receive a length of tubing 27 (see Figs. 1C and 2) in fluid connection with the source of medical fluid 23 to inject the fluid into a patient (discussed in more detail below). While a peristaltic pump 22 is currently preferred, any suitable type of pumping mechanism, such as a piston-driven syringe pump, gear pump, rotary pump or in-line pump, may be used.

- [74] The printer 24 may be used to generate records of the injection and/or imaging procedures performed on patients, for inclusion in patients' medical records or for billing or inventory purposes. The printer 24 may be pivotally connected to the system 10 (see Fig. 1B) to allow an operator to load paper or labels into the printer 24.
- [75] The interrupt button 25 allows an operator to quickly and easily pause or abort an injection procedure in the event of, for example, patient discomfort or an emergency, without having to resort to the GUI display 15 (which also can be manipulated to pause or abort an injection procedure). The interrupt button 25 may be connected to LEDs and/or a printed circuit board to provide visual and/or auditory alarms when the interrupt button 25 has been activated.
- [76] Turning to Figs. 1C-1E, 2A and 2B, additional features and components of the fluid delivery system 10, including the upper surface 103, the MPDS 200, a vial access device 600 and a single-patient fluid path set 700 (hereinafter SPDS), will be discussed.
- [77] As shown in Fig. 1C, the upper surface 103 generally defines wells and recesses or troughs into which various components of the MPDS are situated. Specifically, a first recess or trough 107 accommodates a first tubing section 204 of the MPDS 200 and a tubing holder 150 for holding the tubing section 204 and preventing it from getting kinked or tangled with, for example, the SPDS 700. The first tubing section 204 may also include the tubing length 27 that is placed within the peristaltic pump 22 and is in fluid connection with the medical fluid source 23.
- [78] The first trough 107 leads into a second recess or trough 113 that accommodates a second pumping mechanism 180, such as a peristaltic pump, and a T-connector 205 (preferably including check valves 214, 215) of the MPDS 200. As shown in Fig. 1C, the second trough 113 also leads to a first well 111 that accommodates a vial access device 600 and a radiopharmaceutical vial or container 902 disposed in a vial shield or PIG 554 (discussed in more detail below) and to a second well 121 that accommodates a dose calibrator or ionization chamber 160 for the fluid delivery system 10. As shown in Figs. 1D and 3F, the ionization chamber 160 preferably accommodates a coil assembly 400 of the MPDS 200 (discussed in more detail below).
- [79] A third recess or trough 125 extends from the second well 121 to a third well 127 and further along the surface 103 of the fluid delivery system 10. The trough 125 accommodates a T-connector 222 of the MPDS 200, two pinch valves 170, 172, an



air detector 174 and a mount or retainer 176 for holding the connector end 228 of the MPDS 200. The pinch valves are preferably powered and controlled by the fluid delivery system 10, but alternately could be manually-operated. In another alternate embodiment, the pinch valves 170, 172 and the T-connector 222 of the MPDS 200 may be replaced with a manual or automated 3-way stopcock.

- [80] The third well 127 accommodates a waste receptacle or bag 224 for receiving medical fluid and/or pharmaceutical that is discarded during, for example, a priming procedure (discussed in more detail below) to prepare the system 10 for an injection procedure.
- [81] As shown in Fig. 1C, the SPDS 700 includes a length of tubing (preferably coiled, as shown) having a first end 702 that is attachable to the connector end 228 of the MPDS 200 and a patient end 704 having a luer connector that is attachable to, for example, a catheter (not shown) placed in a venous structure of a patient. As discussed in more detail below, the MPDS 200 may be used for multiple patients but the SPDS 700 is intended to be used on a per-patient basis and discarded after use with a single patient to prevent, for example, cross-contamination between patients.
- [82] As can be appreciated after reviewing Fig. 1A-1E, the secondary handle 21 of lid 20 overlies the tubing holder 150 and the mount 176 when the lid 20 and handle 21 are closed to cover the MPDS 200. The secondary handle 21 may be flipped open (from the closed position shown in Fig. 1A) without retracting the cover 20 to allow an operator to connect the SPDS 700 to the MPDS 200 (as discussed in more detail below). As best shown in Fig. 1C, the SPDS 700 may be placed under the secondary handle 21 when it is closed.
- [83] The fluid delivery system 10 further includes a system controller 5 (see Figs. 1D and 1E) in communication with the various components thereof, including the GUI 15, the pumps 22, 180, the dose calibrator or ionization chamber 160, the stop button 25, the air detector 176, the printer 24 and the motors 30, 31 (see Fig. 3F) for pinch valves 170, 172, respectively, for controlling the operation of the system 10. The system controller 5 is preferably a single-board computer, including a CPU having a main memory.
- [84] As can be appreciated, the wells and troughs formed in the upper surface 103 can be sized, configured or arranged as suitable for the length, design or configuration of the MPDS 200 or other components thereof, including the radiopharmaceutical vial 902, vial shield 554, vial access device 600, ionization chamber 160, waste receptacle 224, etc.

- [85] It should be understood that Fig. 1C in no way is intended to convey dimensions or relative dimensions of the aforementioned recessed portions or MPDS components; instead, Fig. 1C conveys general positional relationships of such recessed portions with respect to one another.
- [86] It should further be understood and appreciated that the recessed portions shown and described with respect to Fig. 1C are preferably encased throughout with suitable radioactive shielding to further minimize exposure to an operator.
- [87] Turning now to Figs. 2A and 2B, a preferred embodiment of the MPDS 200 and components thereof will be discussed. In addition, specific details of the coil assembly 400 employed in the MPDS 200 are shown and described with respect to Figs. 3A-3F and Fig. 1D.
- [88] By way of a general overview, the MPDS 200 in accordance with at least one presently preferred embodiment of the present invention allows for FDG (or other radiopharmaceutical) to be drawn from a bulk radiopharmaceutical vial 902 and placed into a coil assembly 400 that allows an ionization chamber 160 to measure the amount of activity in the coil assembly 400. Once the system prepares a dose having the desired activity level, the fluid delivery system 10 will deliver the FDG dose to the patient (through the SPDS 700).
- [89] Generally, the MPDS 200 can be considered in terms of four components: (1) a medical fluid or saline component; (2) an FDG or pharmaceutical component; (3) a coil assembly component; and (4) a waste component. The saline component preferably draws saline out of a bulk source 23 (e.g., via peristaltic pump 22). This is then used to prime the MPDS (i.e., remove air therefrom), position FDG in the coil assembly 400 in the ionization chamber 160, and then deliver the dose to the patient.
- [90] The FDG component preferably serves to draw FDG out of a bulk radiopharmaceutical vial 902 (e.g., via peristaltic pump 180) and place the same into the fluid path to the ionization chamber 160.
- [91] The coil assembly component preferably is employed to position the radiopharmaceutical to allow its radioactivity level to be optimally measured by the ionization chamber 160. Through the arrangement of the coil assembly 400 (as discussed in more detail below), the radiopharmaceutical can be optimally oriented and located within the "linear region" of the ionization chamber 160 to more accurately measure its activity level and prepare an optimal dose for injection into a patient.

- [92] The waste component preferably holds the saline fluid and/or radiopharmaceutical that are discarded during the prime and dose preparation procedures, which are conducted to prepare the fluid path and the pharmaceutical dose for injection into a patient.
- [93] Fig. 2A schematically illustrates the MPDS 200 in accordance with a preferred embodiment of the present invention. The MPDS shown in Fig. 2A may preferably be pre-connected as shown and may originally be stored in a sterile packet or container for use in an injector apparatus, such as fluid delivery system 10, when desired. For a non-restrictive and illustrative appreciation of a manner in which MPDS 200 can be incorporated in an injector apparatus, simultaneous reference may be made to Figs. 1A-1E and 2B (and the discussion thereof hereinabove).
- [94] Primary components of MPDS 200 include, as shown, a spike 202 for connecting the MPDS to the medical fluid or saline source 23, a vented cannula 208 for connecting with a source of FDG or other radiopharmaceutical, a coil assembly 400, a T-connector 205 with check valves 214, 215 for fluidly connecting the saline source 23, the radiopharmaceutical source and the coil assembly 400, a waste bag 224, a connector end 228, and a T-connector 222 for fluidly connecting the coil assembly 400, the waste bag 224 and the connector end 228.
- [95] In general, MPDS 200 and fluid delivery system 10 are configured for priming (i.e., purging air from) the MPDS 200, delivering pharmaceutical (e.g., FDG) to a patient, and providing a saline flush, while minimizing or eliminating exposure of administering or operating personnel to the detrimental effects of the pharmaceutical and minimizing or eliminating creation of contaminated waste. Moreover, MPDS 200 and other elements of the present invention also facilitate safe delivery of the pharmaceutical to multiple destinations (for example, dose delivery to a series of patients).
- [96] A T-connector 205 and check valves 214, 215 preferably accommodate a first tubing section 204 that is in fluid connection with spike 202 and a second tubing section 210 in fluid connection with cannula 208. The check valves 214, 215 may be integrally formed with the T-connector 205 or may be separate components, or they could be combined into a single dual check valve. The check valves 214, 215 prevent saline from being pumped by peristaltic pump 22 into second tubing section 210 and the pharmaceutical from being pumped by peristaltic pump 180 into the first tubing section 204.

- [97] A third tubing section 216 thence preferably leads to coil assembly 400 (including tube coil 444), and a fourth tubing section 220 preferably leads from the coil assembly 400 to the T-connector 222. As described below, in a preferred embodiment the tube coil 444 is formed from a tubing section 217 that has dimensions different from those of the third tubing section 216 and the fourth tubing section 220. In an alternate embodiment, the third tubing section 216, the tube coil 444 and the fourth tubing section 220 are formed from the same length of tubing.
- [98] A fifth tubing section 226 leads from the T-connector 222 to the waste receptacle 224 and a sixth tubing section 230 leads from the T-connector 222 to the connector end 228. As shown above in Fig. 1C, the connector end 228 mates with the first end 702 of the SPDS 700 for delivery of a pharmaceutical to a patient.
- [99] In a preferred embodiment, the connector end 228 is a swabable luer valve (Part No. 245204024 provided by Halkey-Roberts Corporation of St. Petersburg, FL) that is biased to close or seal off the connector end 228 of the MPDS 200 when the SPDS 700 is not connected thereto. The swabable luer valve prevents the MPDS 200 from being contaminated and allows an operator to swab or clean (by, for example, an alcohol wipe) the connector end 228 prior to connecting an SPDS 7000 thereto. Alternately, however, the connector end 228 may be a standard luer connector as known in the art.
- [100] As schematically shown in Fig. 2A, the tubing length 27 of the first tubing section 204 can be placed within pump 22 (indicated by dotted lines) to pump saline or other medical fluid from source 23 and a portion of the second tubing section 210 can be placed within pump 180 (indicated by dotted lines) to pump a radiopharmaceutical from a radiopharmaceutical source.
- [101] Absolute and relative dimensions of the components shown in Fig. 2A, including tubing, may be chosen to best suit the applications at hand. Preferably, the first tubing section 204 is approximately 56.75 inches in length, has an outer diameter (OD) of approximately 0.188 inches and an inner diameter (ID) of approximately 0.062 inches and has a 45 durometer, the third tubing section 216 is approximately 15 inches in length, has an OD of approximately 0.163 inches and an ID of approximately 0.062 inches and has a 60 durometer, the fourth tubing section 220 is approximately 12 inches in length, has an OD of approximately 0.163 inches and an ID of approximately 0.062 inches and has a 60 durometer, and the fifth tubing section 226 and the sixth tubing section 230 are each approximately 5 inches in length, have an OD of approximately 0.163 inches and an ID of approximately 0.062 inches and have a 60 durometer. The second tubing section 210 is approximately

8.75 inches in length and is formed of microbore tubing having an OD of about 0.094 inches and an ID of about 0.032 inches and a 45 durometer. The tubing in tube coil 444 preferably is approximately 41 inches in length, has an OD of about 0.218 inches and an ID of about 0.156 inches and an 80 durometer.

- [102] Preferably, the microbore tubing of second tubing section 210 is formed of, for example, silicone, C-Flex, or silicone-like PVC material. Essentially, the use of microbore tubing in second tubing section 210 improves volume accuracy and thereby improves measured activity accuracy (i.e., of pharmaceutical delivered to the patient) and reduces radiopharmaceutical waste.
- [103] By way of tubing material for the other tubing sections 204, 216, 220, 226, 230 and tube coil 444, essentially any suitable polymeric material, including standard PVC or pump tubing, may be employed.
- [104] In an alternate embodiment of the MPDS 200' shown in Fig. 2C, a conventional manifold 228' or stopcock may be substituted for the connector end 228 of the MPDS 200 (all other components of the MPDS 200' may be identical or similar to those shown in Fig. 2A and are denoted in Fig. 2C by prime notations). As shown in Fig. 2C, the manifold 228' includes three outlet ports (preferably including swabable valves) to which respective first ends 702' of the SPDSs 700' are connected. By connecting the respective patient ends 704 of the SPDSs 700' to, for example, catheters placed in patients, pharmaceutical doses can be delivered sequentially or concurrently to three separate patients. While the manifold 228' shown in Fig. 2C includes three ports for connection to three SPDSs 700', two, four, five or any suitable number of ports may be included in manifold 228' for connection with a like number of SPDSs 700'.
- [105] Referring again to Figs. 1A-2B, the placement of the MPDS 200 in the fluid delivery system 10 and the connection of the SPDS will now be discussed. To set up the system 10 at, for example, the beginning of the day, the operator lifts the secondary handle 21, grasps the primary handle and latch release 1 and retracts the lid 20 to reveal the upper surface 103 of the system 10. If a used MPDS 200 is present in the system 10, the operator will remove and discard it.
- [106] A new MPDS 200 may be removed from its (typically sterile) packaging and placed in the system 10 as shown in Fig. 1C. This includes placing the waste receptacle 224 into well 127, placing coil assembly 400 into ionization chamber 160, placing second tubing section 210 into operative connection with pump 180, placing the tubing length 27 of the first tubing section 204 into operative connection with pump

22 and tubing holder 150, placing vented cannula 208 into fluid connection with radiopharmaceutical source or vial 902 located in well 111, placing fifth tubing section 226 in operative connection with pinch valve 170, and placing sixth tubing section 230 in operative connection with pinch valve 172, air detector 174 and mount 176. A saline source 23 may be hung on hook 6 (see Figs. 1A, 1B and 2B) or otherwise mounted on fluid delivery system 10, and spike 202 is inserted into port 7 (see Figs. 1A, 1B and 2B) of source 23 to fluidly connect the MPDS 200 to the source 23. Of course, this installation procedure does not need to be completed in the order described above, but may be completed in any suitable order consistent with the description or drawings hereof.

- [107] After the MPDS 200 is installed and preferably primed (as discussed below), the first end 702 of the SPDS 700 is connected to the connector end 228 of the MPDS 200 and the SPDS 700 is preferably primed to provide a wet connection at the patient end 704 of the SPDS 700, which is then connected to a catheter (not shown) located in a patient. The SPDS 700 is preferably a coiled tubing formed of standard PVC, approximately 60 inches in length and having an OD of approximately 0.100 inches and an ID of approximately 0.060 inches and a 90 durometer.
- [108] As shown in Figs. 2A and 2B, the MPDS 200 includes a coil assembly 400. In the broadest sense, coil assembly 400 may include a section of tubing (including portions of third and fourth tubing sections 216, 220) that is simply gathered (in a coiled or an uncoiled, amorphous fashion) and placed inside ionization chamber 160.
- [109] As shown in Figs. 3A-3F, however, a preferred embodiment of coil assembly 400 includes a (preferably thermoformed) core element or structure 446 that is preferably configured for allowing a tubing section 217 to be wrapped thereupon and to assume the coiled tube section indicated at 444. As such, the coiled tube section or tube coil 444 is preferably formed on the core element 446 to facilitate optimal positioning of the tube coil 444 within the ionization chamber 160.
- [110] To facilitate positioning of the tube coil 444, the core element 446 preferably includes a tube channel 410 defined by shoulders 412, 414 (see Fig. 3B) that retain tube coil 444 therebetween to hold the tube coil 444 in position and to prevent tube kinking. Further, the upper surface 420 of core element 446 defines an inlet channel or groove 422 and an outlet channel or groove 424 to accommodate third tubing section 216 and fourth tubing section 220, respectively.

- [111] In an alternate embodiment, the core element 446 could include a coiled tube channel (not shown) formed therealong to further guide and retain the tubing segments or turns that form tube coil 444 between shoulders 412, 414.
- [112] The core element 446 preferably is self-centering when inserted into the sleeve 162 of the ionization chamber 160 of the fluid delivery system 10 to thereby facilitate optimal performance (see Fig. 3F). This may be achieved either through structural features of the coil assembly 400, the structure of core element 446 itself, or a combination thereof when used with the sleeve 162 of the ionization chamber 160.
- [113] As best shown in Fig. 3E, the core element 446 is preferably formed by folding two elements (450, 452) together along an integral hinge 455. Suitable form-locking mechanisms can be molded onto the core element 446 to facilitate clasping of the elements 450, 452 together.
- [114] Figs. 1C, 1D and 3F show coil assembly 400 positioned concentrically in the sleeve 162 of the ionization chamber 160. The core element 446 and the tube coil 444 are sized and dimensioned so that the coil assembly 400 is optimally positioned within the "linear region" of the ionization chamber 160 so that the ionization chamber 160 can accurately determine the activity level of one or more volumes of radiopharmaceutical that is located within the tube coil 444. The "linear region" of an ionization chamber is the region in which activity level measurements are repeatable and predictable. For the preferred ionization chamber (Model IK-102 Short Ionization Chamber provided by Veenstra Instruments) used in system 10, the "linear region" is located within a window of 5 mm to 65 mm measured from the base or bottom wall 160a of the ionization chamber 160 (see Fig. 3F).
- [115] In a preferred embodiment, the tube coil 444 is comprised of approximately 7 turns (see Figs. 3A and 3B) formed from a length of tubing that is approximately 41.0 inches. As shown in Fig. 3B, the height H of the tube coil 444 is approximately 1.53 inches and the diameter D of the tube coil 444 is approximately 1.95 inches. The tube coil 444 is preferably formed from a tube having an OD of 0.218 inches and an ID of 0.156 inches. Further, based on the length and ID of the tubing, the tube coil 444 preferably has a volume capacity of approximately 12.5 ml.
- [116] As discussed heretofore, a source, container or vial 902 (see Fig. 4C) of a pharmaceutical or radiopharmaceutical is placed into the fluid delivery system 10 (e.g., in well 111 formed in upper surface 103) to prepare and perform an injection procedure. A radiopharmaceutical container or vial 902 is typically placed in a conventional vial shield or PIG 554 for transport by personnel.

- [117] Turning now to Figs. 4A and 4B, preferred embodiments of a vial shield carrying device or system 500 and a vial access system 600 of the present invention are shown. Vial access system 600 is removably disposed within well 111 of fluid delivery system 10 and operates to hold vial shield 554 and to access the contents of the vial 902 contained therein. (Vial access system 600 will be described in more detail below with reference to Figs. 6A-6J).
- [118] As best shown in Fig. 4A, the vial shield 544 (containing a radiopharmaceutical vial 902) includes a flange 504 formed along a top end thereof and a removable septum cap 562 that is securely and removably engaged with the vial shield 544 (e.g., via threading) to allow insertion and removal of the vial 902 therefrom.
- [119] As shown in Figs. 4A and 4B, the carrying system 500 includes a collar unit 502 that removably engages the flange 504 formed on the vial shield 554. The collar 502 may be formed in two pieces 506, 508 that are pivotally connected together (e.g., at one end thereof) to allow the collar 502 to engage and disengage the flange 504.
- [120] The collar 502 includes two elongated slots 510 formed in a top surface therein. As best shown in Fig. 4B, the slots 510 each include a pin 512 disposed therein and extending between two opposing walls 514 thereof.
- [121] The carrying system 500 further includes a handle unit 520 that engages with the collar unit 502 and the septum cap 562 to allow the vial shield 554 (and vial 902) to be carried and installed in the fluid delivery system 10. The handle unit 520 includes a handle 556 that is rigidly connected to a generally U-shaped cross piece 564a. The cross-piece 564a defines two, downwardly extending arms 530 having slots 532 formed thereon.
- [122] The slots 523 each form a slight hook on the ends thereof and are adapted to engage and retain a second cross piece 564b that supports a plunger 566 having a generally frustoconical shape that mates with a generally frustoconical recess of the septum cap 562 (see Fig. 4B).
- [123] The second cross piece 564b is also generally U-shaped and defines two downwardly extending arms 534 having hooks 536 formed therein. The open ends of the hooks 536 are formed on opposite ends of the arms 534 and are adapted to accept and retain the pins 512 in slots 510 of collar 502. The slots 510 are sized to provide sufficient clearance for the arms 534 to be inserted thereinto (in a downward direction) and for the hooks 536 to engage pins 512 (through rotation of handle 556).



- [124] The plunger 566 is connected to the second cross piece 564b by means of a connector (such as a screw 540) and a spring 538. The plunger 566 is biased by spring 538 to ensure a tight fit between the plunger 566 and the septum cap 562.
- [125] To engage and carry the vial shield 554, the collar 502 is connected to the flange 504 of the vial shield 554 as described above. The handle unit 520 is then moved into proximity to the vial shield 554 (by an operator grasping the handle 556 and moving the unit 520 into position) and the arms 534 are lowered into the slots 510 of the collar 502. At substantially the same time, the plunger 566 is engaged with the septum cap 562, with the spring 538 insuring a tight fit between the two. The operator then turns the handle unit 520 in a clockwise direction (see Arrow A in Fig. 4A) to seat the pins 512 in slots 510 into the hooks 536 of arms 534.
- [126] The operator then lifts the combined vial shield 554 and vial carrying system 500 (by moving the handle unit 520 in an upward direction) and transports it to, for example, the fluid delivery system 10. The operator then lowers the vial shield 554 into the vial access system 600 disposed in well 111 (see Fig. 4A) and rotates the handle unit 520 in a counter-clockwise direction to disengage the hooks 536 from the pins 512. The operator then lifts the handle 556 in an upward direction to remove the arms 534 from the slots 510 and the plunger 566 from the septum cap 562, thereby leaving the vial shield 554 (with septum cap 562 and collar 502) in vial access device 600 in well 111 (see Fig. 4B).
- [127] In a preferred embodiment, the plunger 566 includes radioactive shielding (such as lead) to shield the operator from radiation that would otherwise leak through or be emitted from the septum of the septum cap 562. Together with the vial shield 554 and the septum cap 562, the plunger 556 of the vial carrying system 500 shields the operator from the radiation emitted by the radiopharmaceutical and prevents unnecessary radiation exposure. Further by extending the handle 556 from the vial shield 554, the distance between the two functions to also lessen any possible radiation exposure to the operator.
- [128] An alternate embodiment of the carrying system is shown in Figs. 5A-5D. As with the preferred embodiment described above with respect to Figs. 4A and 4B, the carrying system 1500 helps minimize operator exposure to radiation. Dimensions shown in Fig. 5A are for illustrative and non-restrictive purposes; here they are given in inches. As with Figs. 4A and 4B, generally contemplated here is an integral carrying system 1500 that enables the vial shield 1554 to be carried and placed in the fluid delivery system 10 with minimal operator finger/hand radiation exposure

because the design of the carrying system 1500 increases the distance from the vial 902 contained within the vial shield 1554.

- [129] Shown in Figs. 5A and 5C is a vial shield 1554 with a plunger 1566 of the carrying/installation handle system 1500 engaged with the septum cap 1562 of the vial shield 1544. The septum cap 1562 engages securely with the vial shield 1554 (e.g., via threading) to provide suitable radioactive shielding.
- [130] As shown in Figs. 5A-5D, a crosspiece 1564a with a central aperture is rigidly connected to handle 1556 and is preferably configured to slidably accommodate an extension tube 1558. At a free end of extension tube 1558, the plunger 1566 is preferably disposed to engage with septum cap 1562. Though this engagement may be embodied in essentially any suitable way, here plunger 1566 has a generally frustoconical shape that engages with a generally frustoconical recess of septum cap 1562.
- [131] As further shown in Figs. 5A and 5B (and as can be better appreciated by the perspective views in Figs. 5C and 5D), handle 1556 preferably terminates in a ring 1564b that is configured for engaging with structural features of cap 1562 (to be described more fully below).
- [132] As shown in Fig. 5B, plunger 1566 may be hingedly or pivotably connected to extension tube 1558 via a hinge or pivot connection 1568, which provides freedom of motion to allow the plunger 1566 to mate with the septum cap 1562 without the operator having to otherwise place her hand and fingers directly above the septum cap 1562 before it is covered by the plunger 1566 (thereby reducing the possibility of radiation exposure to the operator).
- [133] While Figs. 5A-5C show handle 1556 in a retracted position, i.e., maximally displaced away from plunger 1566, Fig. 5D shows in perspective view a different stage of the engagement of handle 1556 with vial shield 1554. As such, Figs. 5A-5C shows handle 1556 maximally retracted from plunger 1566 (and, by extension, cap 1562), while Fig. 5D shows handle 1556 in a "fully engaged" configuration with respect to cap 1562.
- [134] Preferably, plunger 1566 will initially mate with cap 1562. Thence, handle 1556 is preferably moved towards cap 1562 (conceptually progressing from Fig. 5B to 5D) such that slots 1570 on ring 1564b fit over and capture posts 1572 (through clockwise rotation of handle 1556) on cap 1562. The handle 1556 may then be lifted to carry and deposit the vial shield 1554 in the well 111, as described above.

The carrying system 1500 is disengaged from the vial shield 1554 through counter-clockwise rotation of the handle 1556 to disengage the capture posts 1572 from the slots 1570 on the ring 1564b. Of course, after the contents of the vial 902 are depleted, the carrying system 1500 can be attached to the vial shield 1554 as described above to remove the vial shield 1554 and the vial 902 from the fluid delivery system 10.

- [135] As discussed above with respect to Figs. 4A-4B, the fluid delivery system 10 includes a vial access system 600 that is removably disposed within well 111 of fluid delivery system 10 and is adapted to hold vial shield 554, 1554 and to provide access to the contents of the vial 902 within vial shield 554, 1554.
- [136] Because vials (such as vial 902 described herein) typically come in various sizes, such as 10 ml, 15 ml, 20 ml and 30 ml, the fluid delivery system 10 of the present invention is intended to accommodate various vial sizes. To do so, the fluid delivery system 10 may include one or more vial shields and vial access systems (varying primarily in size in relation to the preferred embodiment of the vial shields 554, 1554 and vial access system 600 disclosed and described herein) that are specifically sized to accommodate known vial sizes. In a preferred embodiment, three vial shields and vial access systems 600 are provided with the fluid delivery system 10, and the well 111 is configured and designed to accept each of the vial access systems 600. However, the fluid delivery system 10 can be provided with one, four, five or any suitable number of vial shields and vial access systems depending on evolving needs or changes in the size or shape of the vials. Thus, depending on the size of the vial used at a clinical site or for a particular procedure, an operator of the fluid delivery system 10 can select the appropriate vial shield and vial access system and place it in the well 111 of the fluid delivery system to enable a fluid injection procedure.
- [137] Preferred embodiments of the vial access system 600 and the vented cannula 208 of the MPDS 200 are described below in relation to Figs. 6A-6J (and with reference to Figs. 4A and 4B). Generally, as best shown in Figs. 6A, 6B and 6F, the vial access system 600 includes a base portion 670 that preferably includes a sloped surface 672, the function of which will be more fully appreciated herebelow. Two (preferably removable and extendable) support members or pins 674 are provided to support and retain a vial shield 554 (i.e., enclosing a vial 902; see Fig. 4C) when it is placed on the sloped surface 672 (e.g., after being carried and disposed there using the vial shield carrying systems 500, 1500 discussed above).

- [138] As shown, the vial access system 600 further includes a vertical support arm 676 that is disposed within a housing 678. A cap member 684 and a handle member 682 are connected to an upper end of the vertical support arm 676. The vertical support arm 676 is preferably slidably and rotationally displaceable with respect to the housing 678. That is, the arm 676 may slide and rotate with respect to the housing 678 (see e.g., Figs. 4B and 6D) to allow the vial shield 554 to be readily inserted and removed therefrom and to lower the vented cannula 208 into the vial 902 contained within the vial shield 554 (as discussed in more detail below).
- [139] The handle 682 is used by an operator or technician to insert and remove the vial access system 600 from the well 111 of the fluid delivery system 10. The handle 682 is preferably connected to the vertical support arm 676 via a suitable pivot connection (such as a hinge or bolt connection) 680 to permit movement of the handle 682 between an extended, carrying position (see Fig. 6D) for carrying the vial access system 600 and a horizontal or operating position (see Figs. 6B and 6E) in which the handle 682 rests on top of the cap 684 (e.g., when the vial access system 600 is disposed in the well 111), thereby allowing the cover 20 of the fluid delivery system 10 to be closed.
- [140] The cap 684 is preferably rigidly connected to the vertical support arm 676 via an arm 650 (see Figs. 6A and 6D), but it may be pivotally connected to the vertical support arm 676 via, for example, a pivot connection (not shown) or adjustably connected to the vertical support arm 676 via, for example, a slot (not shown) formed in the arm 650. As best shown in Figs. 6E and 6F, when the cap 684 is lowered (by sliding the vertical support arm 676 within the housing 678) to insert the cannula 208 into the vial 902 within the vial shield 554, and the handle 682 is pivoted to a horizontal position atop the cap 684, the cap 684 and the handle 682 (and thus the remainder of the vial access system 600) lies below or flush with the upper surface 103 of the fluid delivery system 10, thereby allowing the cover 20 to close over the upper surface 103 of the fluid delivery system 10 and the MPDS 200 installed therein. The cap 684 preferably includes or is formed with radioactive shielding material (e.g., lead) to minimize radiation exposure to personnel from the FDG or other radioactive solution contained within the vial 902 in the vial shield 554.
- [141] As best shown in Figs. 6A and 6C, the underside of cap 684 includes a mounting mechanism 686 for accepting the cannula 208 (or other suitable type of spike, cannula or needle) for piercing the septum of a vial 902 or other pharmaceutical container in the vial shield 554. The mounting mechanism 686 preferably includes

two arms 687 that define a groove or slot 688 therebetween. Each of the arms 687 includes a tab member 690 extending downwardly therefrom.

- [142] The vented cannula 208, in accordance with a preferred embodiment of the present invention, may be employed for spiking a pharmaceutical source (such as the radiopharmaceutical vial 902 discussed above) and preferably includes a main hub 332 to which are connected (or integrally formed) two, resilient spring arms 350. The spring arms 350 and the main hub 332 cooperate to define two U-shaped channels 352 on lateral sides of the main hub 332.
- [143] As shown in Figs. 6C and 6G-6J, each of the spring arms 350 includes a flange or hook member 370 formed thereon and extending outwardly therefrom. The hook members 370 each defines an inclined surface or edge 372 formed thereon.
- [144] The vented cannula 208 further includes a ledge or flange 338 that is connected to or integrally formed with the main hub 332 and is disposed in a horizontal plane above the two spring arms 350. The ledge 338 and the top edges of the spring arms 350 cooperate to define horizontal grooves or slots 360 therebetween for accommodating the arms 687 of the mounting mechanism 686 on the cap 684 of the vial access system 600.
- [145] To connect the cannula 208 to the mounting mechanism 686 on the cap 684, the main hub 332 of the cannula 208 is aligned with the slot 688 of the mounting mechanism 686 and the arms 687 of the mounting mechanism 686 are aligned with the grooves 360 defined between the spring arms 350 and the top ledge 338 of the main hub 332. Once the structural elements of the cannula 208 and the mounting mechanism 686 are aligned, the cannula 208 is inserted into the mounting mechanism 686 until the hook members 370 of the spring arms 350 engage the front edges 691 of the tab members 690. Upon further insertion of the cannula 208, the front edges 691 of the tab members 690 engage and ride along the inclined surfaces 372 of the hook members 370, thereby moving the spring arms 350 in an inward direction (i.e., toward the vertical axis of cannula 208). This inward movement of the hook members 370 allows them to clear the front edges 691 of the tab members 690 and ride along the inner sides 693 thereof until the hook members 370 clear the tab members 690 and move or snap back into their original position to engage the rear edges 692 of the tab members 690. At this point, the cannula 208 is fully inserted into and retained by the mounting mechanism 686. To remove the cannula 208 from the mounting mechanism 686 (e.g., when the MPDS 200 is removed from the fluid delivery system 10), the operator pinches the hook members 370 together (i.e., moves them toward the vertical axis of the cannula 208) until they clear the

rear edges 692 of the tab members 690, and then slides the cannula 208 out of engagement with the mounting mechanism 686.

- [146] Referring again to Figs. 6C and 6G-6J, the vented cannula 208 includes a longer, fluid draw needle 340 in fluid connection with the second tubing section 210 of the MPDS 200 via a fluid port 384 and a shorter, vent needle 342 in fluid connection with a vent 334. As known in the art, the vent 334 may include a suitable filter for filtering the ambient air that is drawn into the vial 902 to allow fluid to be drawn therefrom.
- [147] The description now turns to the preferred operation and use of the vial access system 600 and the vented cannula 208 of the present invention. When a vial shield 554 (holding a pharmaceutical vial 902) is to be placed in the vial access system 600, the vertical support arm 676 is raised to an extended position and rotated (see Figs. 2B and 4A) to move the cap 684 out of its normal position above the sloped surface 672. The vial shield 554 is then inserted into the well 111 and placed on the sloped surface 672 (see Fig. 6F). The support pins 674 engage the vial shield 554 to hold it in position on the sloped surface 672.
- [148] After the vial shield 554 is inserted into the vial access system 600 (see Fig. 4B), the vented cannula 208 of the MPDS 200 is inserted into the mounting mechanism 686 on the cap 684 and the cap 684 is rotated back into position (e.g., by turning the handle 682) above the septum cap 562 of the vial shield 554 (see Fig. 6D). Then the cap 684 is lowered (e.g., by using the handle 682 to urge the vertical support arm 676 into the housing 678) to insert the fluid draw needle 340 and the vent needle 342 of the cannula 208 through the septum of the septum cap 562 and into the pharmaceutical vial 902 (see Fig. 6F). The handle 682 is then rotated to lie in a substantially horizontal orientation on or above the cap 684 (see Figs. 1C and 6E), thereby allowing the cover 20 of the fluid delivery system 10 to be closed. While the preferred method of operating the vial access system 600 and the vented cannula 208 is provided above, the method and steps can be conducted in any suitable order or arrangement to achieve the desired results.
- [149] As best shown in Fig. 6F, the support surface 672 is preferably configured such that when a vial is pierced by the fluid draw and vent needles 340, 342 of the cannula 208, the bottom end of the fluid draw needle 340 will be placed at or near the location where the cylindrical wall of the vial meets the bottom (floor) of the vial. Thus, to the extent that some vials may not have a completely flat bottom or floor (e.g., may have a rounded bump with a maximum height at the central longitudinal axis of the vial), the fluid draw needle 340 will be in a position to maximally draw

fluid from the vial as it collects at the junction of the vial's bottom and cylindrical wall (i.e., to avoid waste of the pharmaceutical). Or, even in a flat-bottomed vial, such an orientation of the vial will help ensure that fluid maximally gathers and is drawn in a closely defined area.

- [150] As discussed above, the dimensions of the vial access system(s) 600 provided with the fluid delivery system 10 can preferably be chosen in accordance with dimensions of the vial shields and vials to be employed, to ensure that as much fluid from the vial is drawn as possible. By way of a non-restrictive example, the sloped surface 672 could be sloped at an angle of about 10-13 degrees with respect to the horizontal.
- [151] Instead of being incorporated into and as part of the MPDS 200 for use with the fluid delivery system 10, the vented cannula 208 of the present invention may be used in other fluid delivery systems, including ones that use shielded syringes (see e.g., U.S. Patent Nos. 5,927,351 and 5,514,071, the contents of which are incorporated herein by reference), for injecting pharmaceuticals or other medical fluids into patients.
- [152] As shown in Figs. 47A-C, the vented cannula 208 may be used with a hand-held syringe 380 (preferably held within a conventional lead-shielded container (not shown for ease of illustration)) having a discharge outlet 386 and a plunger 381 slidably disposed therein. The fluid draw needle 340 of the cannula 208 is in fluid connection with the shielded syringe 380 by means of a tube 383 connected between the discharge outlet 386 of the syringe 380 and the fluid port 384 of the cannula 208. The tube 383 preferably includes a connector 387, such as a standard luer connector, for removably connecting the tube 383 to the shielded syringe 380. The other end of the tube 383 may be non-removably attached to the fluid port 384 of the cannula 208 by use of, for example, an adhesive. Alternately, the tube 383 may include a connector (not shown) for removable connection to the fluid port 384 or may be press fit and held by friction forces onto the fluid port 384.
- [153] The tube 383 may be fashioned in any length or diameter suitable for the application. In use, the fluid draw and vent needles 340, 342 of the cannula 208 are inserted into a vial (not shown) containing a pharmaceutical or other fluid. The plunger 381 is retracted (moved away from the discharge outlet 386 of the syringe 380) to aspirate fluid from the vial into the syringe 380. The connector 387 is disconnected from the shielded syringe 380 and the syringe 380 is then connected, generally via an intermediate tubing (not shown), to a catheter disposed in a patient.

- The plunger 381 is then advanced (moved toward the discharge outlet 386) to inject fluid into the patient.
- [154] As shown in Fig. 48, the vented cannula 208 may also be utilized as part of a second alternate fluid delivery system 399 including a shielded (not shown for ease of illustration), hand-held syringe 380' having a discharge outlet 386' and a plunger 381' slidably disposed therein. In addition to like elements shown in Figs 47A-C, the system 399 includes first, second and third tubing segments 390, 391, 392 that are connected via a T-connector 393 having an integral stopcock 394. The third tubing segment 392 also preferably includes a swabable valve 395 to which the first end 702 of the SPDS 700 described above could be connected. Instead of a swabable valve 395, it is contemplated that a conventional luer connector could be used for suitable applications.
- [155] After the vented cannula 208 is placed in a pharmaceutical source (not shown), the stopcock 394 is actuated to open the fluid path between the vented cannula 208 and the syringe 380' and to close the path to the third tubing segment 392. The plunger is then retracted to aspirate fluid into the syringe 380' from the pharmaceutical source. The stopcock 394 is then actuated to open the fluid path between the syringe 380' and the third tubing segment 392 and to close the path to the second tubing segment 391. The first end 702 of the SPDS 700 is then preferably connected to the swabable valve or luer connector 395, and the plunger 381' is advanced to pump fluid to the patient end 704 of the SPDS 700 (e.g., to purge air from the tubing and to thereby provide a wet connection between the patient end 704 of the SPDS 700 and the catheter (not shown) in a patient). The patient end 704 is then connected to the catheter and the plunger 381' is advanced again to pump or deliver fluid through the SPDS 700 to the patient.
- [156] After the fluid is delivered to the patient, the SPDS 700 is disconnected from the patient and the valve or luer connector 395 and is discarded. If another injection is to be performed, a new SPDS 700 can be connected to the valve or connector 395 and the system 399 can be primed to again provide a wet connection at the patient end 704 of the SPDS 700.
- [157] The disclosure now turns to the operation of the fluid delivery system 10 and its various components. As known in the art, in injection procedures and other fluid delivery operations in which pharmaceuticals are delivered to a patient, air is purged from the fluid path by pumping an amount of the pharmaceutical and/or a diluent, such as saline, through the fluid path to the end of a tubing set (e.g., MPDS 200 or SPDS 700) before connecting the tubing set to a catheter in the patient. Such an air



purging or "priming" procedure is standard practice to prevent the occurrence of an air embolism in a patient, which can cause serious injury or death. Further, the dimensions (e.g., length and ID) of the SPDS 700 and the various tubing sections of the MPDS 200 (provided above) are necessary for accurate priming, activity measurement and delivery of the pharmaceutical to the patient because the system 10 relies on those dimensions to accurately determine and monitor the volume of pharmaceutical and saline that is required for those various operations.

- [158] Referring again to Figs. 1C and 2A, once the MPDS 200 is installed in the fluid delivery system 10, the spike 202 is placed in fluid connection with the saline source 23 and the cannula 208 is inserted into the vial 902 and placed in fluid connection with the pharmaceutical therein, the MPDS 200 is primed to remove air therefrom.
- [159] In a preferred method of priming the MPDS 200, the pump 22 is activated to draw saline out of source 23 and to move the saline through first tubing section 204, check valve 215, T-connector 205 and into third tubing section 216. The pump 180 is then activated to draw a small amount of pharmaceutical out of vial 902 and to move the pharmaceutical through second tubing section 210, check valve 214, T-connector 205 and into third tubing section 216. The pump 23 is then activated again to draw additional saline from saline source 23 to thereby move the volume of pharmaceutical present in third tubing section 216 into the tube coil 444 of coil assembly 400 located in the dose calibrator 160.
- [160] To ensure that the second tubing section 210 is primed, the dose calibrator 160 is monitored to measure the level of radioactivity in the coil 444. If the dose calibrator measures no activity (or an activity level below a predetermined, baseline activity level), then the second tubing section 210 has not been appropriately primed and the priming process described above needs to be reinitiated by the operator. If the dose calibrator measures any activity level (or an activity level above the predetermined, baseline activity level), then the system 10 concludes that the second tubing section 210 has been correctly primed.
- [161] After the second tubing section 210 is primed, the motor 30 is activated to open the pinch valve 170 and thereby open the fluid path from the fourth tubing section 220 through the T-connector 222 and the fifth tubing section 226 to the waste receptacle 224, the motor 31 is activated to close the pinch valve 172 and thereby close the fluid path along the sixth tubing section 230, and pump 22 is activated again to move the saline and the pharmaceutical in tube coil 444 through fourth tubing section 220, T-connector 222, fifth tubing section 226 and into waste receptacle 224.

- [162] Subsequently, the first end 702 of the SPDS 700 is connected to the connector end 228 of the MPDS 200. The motor 30 is activated to close the pinch valve 170 (and thereby close the fluid path from the fourth tubing section 220 through the T-connector 222 and the fifth tubing section 226 to the waste receptacle 224), the motor 31 is activated to open the pinch valve 172 (and thereby open the fluid path along the sixth tubing section 230), and the pump 22 is activated again to move the saline through the T-connector 222 and the sixth tubing section 230 to the patient end 704 of the SPDS 700. At this point, the entire length of the MPDS 200 and the SPDS 700 is primed and the patient end 704 of the SPDS 700 can be connected to the catheter or other venous access device placed in a patient.
- [163] In an alternate embodiment, after the pharmaceutical is moved into the waste receptacle 224, the remainder of the MPDS 200 is primed prior to the SPDS 700 being connected to connector end 228 of the MPDS 200. (This alternate priming method may be accomplished if the connector end 228 of the MPDS 200 is not the preferred swabable luer valve but rather is, for example, a standard luer connector or another connector that is not biased to a closed position when disconnected from the first end 702 of the SPDS 700.) Then, the first end 702 of the SPDS 700 is connected to the connector end 228 of the MPDS 200 and the SPDS 200 is primed to provide a wet connection at the patient end 704 of the SPDS 700.
- [164] To accomplish this alternate priming method, the motor 30 is activated to close the pinch valve 170 (and thereby close the fluid path from the fourth tubing section 220 through the T-connector 222 and the fifth tubing section 226 to the waste receptacle 224), the motor 31 is activated to open the pinch valve 172 (and thereby open the fluid path along the sixth tubing section 230), and the pump 22 is activated again to move the saline through the T-connector 222 and the sixth tubing section 230 to the connector end 228 of the MPDS 200. Then, after the first end 702 of the SPDS 700 is connected to the connector end 228 of the MPDS 200, the pump 22 is activated again to move saline through the SPDS 700 to the patient end 704 thereof.
- [165] After the MPDS 200 and the SPDS 700 are primed and the patient end 704 of the SPDS 700 is connected to the patient, the system 10 is ready for an injection procedure. While preferred and alternate methods of priming the MPDS 200 and the SPDS 200 are described above, other methods or steps may be employed or the steps above may be rearranged in any suitable manner to purge air from the MPDS 200 and the SPDS 700.

- [166] In an alternate embodiment of the MPDS 200, the T-connector 205 and the check valves 214, 215 can be replaced with an automated, motor-driven stopcock. T-connector 222 also can be replaced with an automated stopcock as well.
- [167] The disclosure now turns to embodiments of the present invention, as illustrated in Figures 7-46, that could conceivably be employed in programming and operating a fluid delivery system as broadly contemplated herein.
- [168] Shown schematically in Figures 7-46 are various incarnations of a touch screen arrangement 1000 displayed on a graphical user interface, such as GUI 15, that could be employed with the fluid delivery system 10. As a non-restrictive example, such a touch screen arrangement could be utilized in conjunction with a system controller 5 and/or computer of any of a variety of fluid delivery systems as broadly contemplated herein.
- [169] In order to clearly and unambiguously communicate to an operator the current status of the system 10, a graphical user interface with easily legible symbols and icons, including exceedingly user-friendly data entry mechanisms, is broadly contemplated. An operator will thus be able to intuitively understand and undertake various tasks for operating system 10.
- [170] While a touch screen arrangement is contemplated in connection with Figures 7-46, it is to be understood that other types of data entry arrangements are conceivable that would achieve an equivalent purpose. For example, soft or hard key entry could be used, as well as trackball arrangements, mouse arrangements, or a cursor control touch pad (remote from the screen).
- [171] The touch screen arrangement 1000 shown in Figures 7-46 can preferably be employed for four categories of tasks, namely: (1) system preparation, (2) patient treatment, (3) injection history (i.e., obtaining information regarding previous treatments) and (4) system configuration. Preferably, a touch screen arrangement 1000 will be flexibly and selectably manipulable to accommodate and undertake any and all of these tasks as desired.

### **System Preparation**

- [172] The "system preparation" category includes a number of tasks that are preferably performed in the following order to prepare the system 10 for a fluid injection or delivery procedure: (1) disposing of a used MPDS 200 and vial 902 from, for example, the previous day or previous use of the system 10 (if still present in the system 10); (2) conducting a quality control check or "daily QC" of the system 10;

(3) installing a new pharmaceutical vial 902 and a new MPDS 200 in the system 10; and (4) priming the MPDS 200 to remove air therefrom. While the above order is the preferred one for preparing the system 10, the tasks may be performed in any suitable manner and order for the intended application.

- [173] Fig. 7 conveys a “main” screen visible on touch screen arrangement 1000, which may be an initial screen presented to an operator when the system 10 is initially activated.
- [174] As such, and as shown in Fig. 7, touch screen arrangement 1000 preferably generally depicts at a very high level the fluid path (e.g., MPDS 200 and SPDS 700) of the fluid delivery system 10. It can be appreciated that touch screen 1000 can easily be “mapped” (i.e., provide a one-to-one correspondence) to major components of the MPDS 200, the SPDS 700 and other components of the system 10 such as that discussed and illustrated herein with respect to Figs. 1A-6J, but that level of detail is generally not required for programming and use of the system 10.
- [175] As shown in Fig. 7, the touch screen shows a saline field 1002 (here in the stylized shape of an IV bag), a pharmaceutical or FDG field 1004 (here in the stylized shape of a vial) and an ionization chamber graphic 1010. A tubing graphic 1008, as shown, encompasses a three-way junction with branches leading, respectively, to saline field 1002, FDG field 1004 and ionization chamber graphic 1010. As shown, the tubing graphic 1008 is coiled inside the ionization chamber graphic 1010 to indicate the tube coil 444 described above.
- [176] Touch screen arrangement 1000 in Fig. 7 shows the system 10 as being in an “idle” state. As such, no fluid is shown as being disposed in or moving through tubing graphic 1008 and ionization chamber graphic 1010. Further, saline and FDG fields 1002, 1004 in Fig. 7 both convey an “empty” status, to indicate that the system 10 has not yet been provided with information regarding the presence and/or amount of fluid in the saline source 23 and the vial 902.
- [177] Indicated at 1006 is a touch field showing desired activity (currently displayed as 15.0 mCi) for an injection procedure to be performed. When the system 10 is activated, the desired activity field 1006 preferably displays a default activity value that can be pre-programmed into the system 10 or pre-set by the operator. Alternately, the desired activity field 1006 can default to the last activity level that was programmed into the system 10. Further, a display (read-only) system preparation field 1020 includes an associated “setup” button 1022a that, when activated, permits system preparation tasks to be performed.

- [178] Indicated at 1012, 1014, 1016 and 1018, respectively, in Fig. 7 are circular status icons that provide quick and easy reference to different aspects of system status and, as such, will highlight when an aspect of system status is “on” or “active” or provide status information on the system 10. Thus, icons 1012-1018 from left to right, respectively, convey information on the following system aspects: activity present 1012, fluid motion / injection status 1014, check for air / priming status 1016, and system battery status 1018.
- [179] The system battery (not shown) provides power to the system controller 5 and to the ionization chamber 160 (to maintain the ionization chamber at its normal operating state) in the event that the system 10 is disconnected from an AC power source. The system battery is charged while the system 10 is connected to an AC power source.
- [180] Fig. 7 also shows four rectangular touch fields 1020-1023 along the bottom thereof. Reset button 1020 is activated to reset or clear information, such as case identification information, desired activity level, etc., from the treatment screens (as described in more detail below). Configuration button 1021 is activated to access the configuration screens for the system 10 (as described in more detail below). Records or Injection History button 1022 is activated to access information regarding prior injection procedures (as described in more detail below). Help button 1023 is activated to access searchable text, FAQs or other information that might be provided about the use and operation of the system 10.
- [181] When the setup button 1022a is activated, the touch screen changes to that shown in Fig. 8. and “summary” 1030, “setup guide” 1032 and “daily QC” (quality control) 1034 touch fields preferably appear and the “summary” touch field 1030 is activated, prompting the appearance of a summary display 1038. As shown, summary display 1038 provides FDG and saline fields 1040, 1044, respectively, as well as MPDS tubing field 1048 and waste field 1050.
- [182] In the saline field 1044, a “replace” button 1046 can be activated by the user to inform the system 10 that the saline source 23 has been replaced and to allow the user to input the volume of the saline source into the system 10 (see Fig. 13). After the saline volume is input via pop-up screen 1110 including keypad 1114 in Fig. 13, the saline volume is displayed as shown in Fig. 11. In a preferred embodiment, the saline source 23 is replaced at the same time that a new vial 902 is placed into the system 10.
- [183] As part of the FDG field 1040 in Fig. 8, there are shown a number of informational displays (shown here as blank) regarding assay information that can be input by a

user into the system 10. An edit button 1042 can be activated by the user to facilitate the entry of such information. When the edit button 1042 is activated, the display shown in Fig. 10 appears. The user can then input the noted assay information (typically provided on the pharmaceutical vial 902) into the system 10. Specifically, a lot number can be entered into field 1072, while the activity and volume of, for example, FDG or other radiopharmaceutical in the vial can be entered into touch fields 1080 and 1082, respectively. In a manner well known to those of ordinary skill in the art, the activation of any of these fields can prompt a numerical keypad pop-up to assist in data entry, or data can be entered in essentially any other suitable manner (e.g., directly via a physical keyboard).

[184] Further, the assay date of the radiopharmaceutical in the vial is entered in field 1074 via a calendar button 1074a (which prompts the appearance of a pop-up calendar in known manner), or a simplified entry touch field 1074 which selectively permits the entry of a day such as “today” or “yesterday” (which is useful for radiopharmaceuticals, such as FDG, that have very short half-lives).

[185] The assay time is entered into touch field 1076 (via a pop-up time field or keyboard/keypad entry) and an AM/PM toggle field 1076a. Other functional buttons are present, such as “clear all” 1078, “cancel” 1084 and “OK” 1086 buttons, to facilitate entry, deletion and/or acceptance of inputted values of the requested assay information. When the OK button 1086 is activated to accept the assay information shown in Fig. 10, the display shown in Fig. 11 appears.

[186] Finally, as shown in both Figs. 8 and 11, information regarding the amount of radioactivity present in the MPDS tubing 200 is displayed at area 1048, while a waste field 1050 is preferably provided to graphically display the quantity of fluid and the activity level in the waste receptacle 224. Further, an “OK” button 1036 is activated to notify the system 10 that the system preparation tasks have been completed.

[187] Fig. 9 illustrates the display screen that is shown when the “setup guide” touch field 1032 shown in Fig. 8 is activated. As shown, setup guide 1032 prompts the appearance of a setup screen 1053 to assist an operator in physically preparing the system 10 for a procedure. Setup screen 1053 preferably includes four tabs 1054, 1056, 1058, 1060), which each, respectively, assist an operator in a different aspect of system setup (here, FDG removal, saline source installation, FDG installation, and MPDS installation, respectively).

- [188] Fig. 9 also shows that FDG tab 1058 has been activated, prompting the appearance of display 1062. Up and down arrows 1066, 1068 preferably permit an operator to go through numbered procedure steps 1-4 as shown to install FDG vial 902 into the system 10, and a graphical image 1064 of the fluid delivery system 10 preferably graphically relates each of the numbered procedure steps. Here, for instance, "step 1" is shown graphically for the unlocking and opening of the cart. After the FDG vial 902 is installed in the system 10, status icon 1012a is highlighted (see Fig. 11) because activity is now present in the system 10.
- [189] After the FDG vial 902, the saline source 23 and the MPDS 200 have been installed using, for example, the display shown in Fig. 9, and the FDG assay information and the saline volume information have been provided to the system (as shown in Fig. 11), the "purge air" button 1052 shown in Fig. 11 can be activated to prime the MPDS 200. When purge air button 1052 is activated, the "Prime MPDS" query prompt 1100 shown in Fig. 12A is displayed. When the "Yes" button 1101 in Fig. 12A is activated, the MPDS priming operation described in detail above is performed by the system 10 and a "Priming MPDS" status display 1102 is shown (see Fig. 12B) to indicate the status and completion of the MPDS priming operation to the user.
- [190] After the MPDS 200 is primed by the system 10, a volume of fluid (i.e., a mixture of saline and a pharmaceutical (e.g., FDG)) is present in the waste receptacle 224 (as described in detail above). The outcome of the MPDS priming operation and the current status of the system 10 is displayed to the user, as shown in Fig. 14.
- [191] As Fig. 14 shows, and as compared to the pre-MPDS priming system status shown in Fig. 11, the waste receptacle 224 contains 20 ml of waste (i.e., saline and pharmaceutical) and has an activity level of 15 mCi, the MPDS tubing has an activity level of 2 mCi, the saline source 23 contains 485 ml of saline (compared to 500 ml in Fig. 11) and the vial 902 contains 15 ml of FDG and has an activity level of 374 mCi (compared to 30 ml and an activity level of 700 mCi in Fig. 11).
- [192] As shown in Fig. 14, the "Activity" (i.e., 700.0 mCi) listed in the Assay Information section of display 1038 is the amount of radioactivity provided by the radiopharmaceutical at the time it was assayed. The "Total Activity" (i.e., 415 mCi) shown next to the FDG display 1040 is the amount of radioactivity currently provided by the radiopharmaceutical present in the vial 902. The difference (i.e., 285 mCi) between the "Activity" and the "Total Activity" is calculated from the decay rate of the radioisotope and the elapsed time since the radiopharmaceutical was assayed. The activity level (i.e., 374 mCi) displayed within the FDG display

1040 is the 'extractable activity'; that is, the amount of activity that can be extracted from the vial 902. The "extractable activity" is less than the "total activity" because there is a small volume of radiopharmaceutical (e.g., approximately 1-2 ml) that cannot be extracted from pharmaceutical vials or containers and becomes discarded waste.

- [193] Preferably prior to installing and priming the MPDS 200, the operator or other personnel should perform a quality control check on the fluid delivery system 10. In a preferred embodiment, the quality control check is performed daily, for example at the beginning of a work day, to ensure that the fluid delivery system 10 is in good working order. The quality control check is initiated by activating the "Daily QC" field or button 1034, as shown in Fig. 15. When activated, the "daily QC" touch field 1034 prompts the appearance of a QC display 1120 to assist an operator in performing a quality control check. A menu of checks to be performed preferably appears via the following touch fields: zero check (1122), bias adjustment (1124), background check (1126), constancy/accuracy test (1128) and ionization chamber battery (i.e., high voltage) measurement check (1130). In addition, the QC display 1120 provides a warning prompt 1121 to the operator that no activity (i.e., no radiopharmaceutical) should be inside the ionization chamber 160 when the quality control check is conducted.
- [194] To the left of each touch field, preferably, is a "check box" or "pass/fail" indicator that preferably indicates one of the following four states, as appropriate: highlighted (if the corresponding touch field 1122-1130 is activated) to indicate an active test or check; not highlighted and blank to indicate an unexecuted test or check; checked with a checkmark to indicate a successful test or check; and an "X" to indicate a failed test or check.
- [195] The QC display 1120 also includes a "Previous Test" button 1132 and a "Start" button 1134. The Previous Test button 1132 is activated to display the results of the previous quality control check of the system 10. When the Start button 1134 is activated, the tests or checks displayed in the QC display 1120 are initiated. Preferably, the checks are conducted in the order presented (i.e., from top to bottom) but they may be performed in any suitable order.
- [196] Upon activating the Start button 1134, the "Zero Check" test 1122 is initiated. As shown in Fig. 16A, when the Zero Check test is initiated, the system 10 creates a pop-up 1136 that queries the operator as to whether there is activity (i.e., a radiopharmaceutical) inside of the ionization chamber 160 of the fluid delivery system 10. If the operator activates the "No" touch button 1137 in pop-up 1136,



- system 10 “zeros out” the ionization chamber by automatically adjusting internal parameters so that the output from the ionization chamber indicates no activity. This check primarily accounts for environmental background radiation. When the check is completed, the system 10 displays a checkmark (see Fig. 16B) in the Zero Check display 1122.
- [197] As shown in Fig. 17, the quality control check continues on to the Bias Adjustment check, which is similar to the Zero Check above but makes finer adjustments to internal biasing parameters to offset the effects of minor current fluctuations due to noise within the circuitry of the ionization chamber. The fine adjustments are made to ensure consistent activity readings from one measurement to the next. Fig. 17 shows a checkmark in the Bias Adjustment display 1124, thereby indicating that the system 10 has successfully adjusted the bias setting.
- [198] Fig. 17 further shows that the Background Check is in progress. As such, field 1126 is highlighted and a progress bar 1126a indicates the degree of progress (here, 20%). The Background Check basically completes the ionization chamber “zeroing” steps conducted during the Zero and Bias Adjustment checks. The system 10 takes several readings (e.g., 10) from the ionization chamber and captures the average of those readings for display to the user. This allows the user to determine whether the ionization chamber has been sufficiently zeroed out.
- [199] The next system check is the “Constancy/Accuracy” test, which is used to monitor the performance of the ionization chamber by measuring the same check source at intervals over a long period of time. The check source (e.g., Cs-137) is placed in the ionization chamber and the measured activity is compared to the expected activity based on the original assay information (decayed for time) of the check source. This ensures that the ionization chamber is providing accurate readings. The measured activity is also compared to previous readings of the same check source (decayed for time) by the ionization chamber. This ensures that the readings provided by the ionization chamber are consistent over time.
- [200] When the system 10 initiates the “Constancy / Accuracy” test, a pop-up 1140 is generated (see Fig. 18) to prompt the operator to place a suitable pharmaceutical (in this example, Cs-137) in the ionization chamber 160 and to input information about the radiopharmaceutical (see data fields in pop-up 1140) into the system 10. In a preferred embodiment, the pop-up 1140 automatically includes the radiopharmaceutical information from the most recent “Constancy/Accuracy” test, and the operator activates the “Edit” button 1144 to input new and accurate

information when necessary. In an alternate embodiment the data fields in pop-up 1140 could be left blank for filling by the operator.

- [201] After the pharmaceutical is placed in the ionization chamber 160 and the data fields in pop-up 1140 are complete and accurate, the operator activates the “OK” button 1146 to initiate the “Constancy/Accuracy” test. The “Constancy/Accuracy” display bar 1128 preferably includes a test progress bar (not shown) similar to bar 1126a in Fig. 17 that indicates the degree of progress to the operator. If the operator wishes to bypass the “Constancy/Accuracy” test, she may activate the “Skip” button 1142 to bypass the test and proceed to the “Battery Measurement” test (discussed below with respect to Fig. 20). Once the “Constancy/Accuracy” test is completed, another pop-up 1148 is generated by the system 10 (see Fig. 19) to prompt the operator to remove the pharmaceutical from the ionization chamber 160. After the operator activates the “OK” button 1149 in pop-up 1148 to inform the system 10 that the radiopharmaceutical has been removed from the ionization chamber 160, the system 10 then initiates the ionization chamber “Battery Measurement” check.
- [202] As shown in Fig. 20, the four previous system checks (see displays 1122-1128) are indicated by checkmarks as having been successfully completed. The ionization chamber “Battery Measurement” check measures the voltage output provided by a battery pack internal to the ionization chamber to ensure that the voltage output is sufficient to produce accurate readings from the ionization chamber. The ionization chamber “Battery Measurement” check is shown as being 84% completed by progress bar 1130a.
- [203] After the “Battery Measurement” check is completed, the system 10 generates a “Summary” display screen 1150, as shown in Fig. 21, with specific results for all of the checks. If the “Constancy/Accuracy” test was bypassed by the operator (by activating Skip button 1142 in Fig. 18), the system 10 generates “Summary” display 1150a shown in Fig. 22, which indicates that the “Constancy/Accuracy” test was skipped.
- [204] Screen 1150 also includes a print button 1152 that is activated to, for example, print out the test results (via printer 24 of system 10) for the system’s maintenance file. In addition, the Summary display 1150 includes a New Test button 1154, which is activated by the operator to initiate a new series of quality control checks. When the New Test button is activated, the display 1120 shown in Fig. 15 is generated and the quality control check is conducted again by the system 10.

### **Patient Treatment**

- [205] The "Patient Treatment" category of tasks is described below in relation to Figs. 23-32B. The "Patient Treatment" category includes a number of tasks that are preferably performed in the following order to administer or inject a radiopharmaceutical into a patient: (1) setting the desired activity level to be delivered to the patient; (2) inputting patient and/or case identification information into the system 10; (3) connecting the first end 702 of the SPDS 700 to the connector end 228 of the MPDS 200; (4) priming the SPDS 700 to remove air therefrom; (5) connecting the patient end 704 of the SPDS 700 to the patient; (6) conducting a test injection to ensure the integrity of the fluid path to the patient; (7) preparing the radiopharmaceutical dose to be administered or injected into the patient; (8) measuring the activity level of the radiopharmaceutical dose in the dose calibrator 160 to ensure that it is equal or substantially equal to the desired activity level to be delivered to the patient; (9) discarding the radiopharmaceutical dose if, for example, the patient is experiencing discomfort or the measured activity level is not equal or substantially equal to the desired activity level; and (10) administering or injecting the radiopharmaceutical dose to the patient if the measured activity level is equal or substantially equal to the desired activity level. While the above order is the preferred one for the "Patient Treatment" tasks, the tasks may be performed in any suitable manner and order for the intended application.
- [206] After the operator prepares the system 10 for a fluid delivery procedure by, for example, completing the steps set forth above in the "System Preparation" tasks, the system 10 generates the display 1000 shown in Fig. 23 which indicates in the upper left hand side thereof that the "System is ready." The saline field 1002 indicates that 500 ml of saline is available and the FDG field 1004 indicates that 700 mCi of FDG are available, as shown.
- [207] As further shown in Fig. 23, the Desired Activity field 1006 indicates that 15.0 mCi is the current desired activity level. This 15.0 mCi activity level is preferably an operator-defined, default setting in the system 10, but also could be the desired activity level that was programmed for the last injection procedure.
- [208] The desired activity level is preferably set by the operator in one of two ways: (1) manual input; or (2) a calculation based on patient weight. If the operator wants to set the desired activity level by manual input rather than by patient weight, the operator activates the "No" button 1202a in display 1006. In response thereto, the system 10 generates the display and keypad 1204 shown in Fig. 24A. The operator uses the keypad 1204 to input the desired activity level.

- [209] If instead the operator wants to set the desired activity level based on patient weight, the operator activates the “Yes” button 1202b in Fig. 23. Upon activation of the “Yes” button 1202b, the system 10 generates the display 1000 and pop-up 1205 shown in Fig. 24B, which prompts the operator to “Enter patient weight” (displayed in pounds or kilograms in data field 1003) using pop-up 1205. Further, the operator can select the formula to be used in calculating the weight-based activity level by activating formula touch field 1011. When formula touch field 1011 is activated, the pop-up table 1013 shown in Fig. 24C is displayed and the operator is prompted to “Select formula.” In a preferred embodiment the operator can select up to five operator-defined formulas. For example, as shown in Fig. 24C, the operator can select among three predefined formulas: (1) Standard (0.1 mCi/lb.); (2) Melanoma (0.13 mCi/lb.); and (3) Pediatric (0.07 mCi/lb.). However, the system 10 can include more than pre-set or predefined weight-based formulas. For example, the system 10 can also include formulas based on other patient parameters, such as glucose-level or cardiac output, or scanner parameters, such as acquisition time or crystal type.
- [210] Once the formula is selected, the desired activity level is calculated using the formula and the patient’s weight. The desired activity level (e.g., 13.5 mCi), the patient’s weight (e.g., 135 lb.) and the formula (e.g., 0.1 mCi/lb.) are displayed in field 1006 and the screen display 100 indicates that the “System is ready”, as shown in Fig. 24D.
- [211] In addition, as displayed in display and keypad 1204 shown in Fig. 24A, in a preferred embodiment the system 10 includes pre-defined minimum and maximum activity levels that define the operating range (i.e., 5-25 mCi) of the system 10. The operating range of the system 10 cannot be altered by the operator, and the system 10 preferably will not accept a desired activity level (whether manually input or calculated based on patient weight or other patient or scanner parameter) that falls outside of the system’s operating range. In a preferred embodiment, the system will default to the maximum or the minimum activity level (i.e., 25 mCi or 5 mCi) if the operator attempts to input or the system calculates a desired activity level that is greater than the maximum activity level or less than the minimum activity level, respectively.
- [212] Furthermore, if desired for safety or medical practice or preference reasons, the operator preferably can define her own minimum and maximum desired activity levels for the system, as long as they fall within the operating range of the system 10. For example, the operator can define a minimum desired activity level of 10.0

mCi and a maximum desired activity level of 17.5 mCi for the system 10 because those two parameters fall within the 5-25 mCi operating range of the system 10. In such a case, as shown in Fig 24E, even though the operator inputted a patient weight of 5 lb. and chose a formula of 0.1 mCi/lb. (which would result in a calculated desired activity level of 0.5 mCi), the system 10 sets the desired activity level to the minimum desired activity level of 10.0 mCi. When the system 10 uses the minimum desired activity level instead of a manually input activity level or a calculated weight-based activity level, the system 10 indicates that to the operator by using, for example, the downward arrow icon 1006a shown in display field 1006 of Fig. 24E.

[213] Likewise, as shown in Fig. 24F, even though the operator inputted a patient weight of 999 lb. and chose a formula of 0.1 mCi/lb. (which would result in a calculated desired activity level of 99.9 mCi), the system 10 set the desired activity level to the maximum desired activity level of 17.5 mCi. When the system 10 uses the maximum desired activity level instead of a manually input activity level or a calculated weight-based activity level, the system 10 indicates that to the operator by using, for example, the upward arrow icon 1006b shown in display field 1006 of Fig. 24F.

[214] After the desired activity level is programmed or set by the system 10, preferably the operator inputs case information including patient identification and injection site information into the system 10, as shown in Figs. 25A and 25B. When the operator activates the Edit button 1208 in the Case ID field 1206 (see e.g., Fig. 23), the "Case Information" pop-up display 1217 shown in Fig. 25A appears. The display 1217 includes an "Identification" field 1217a and a keypad 1217j for inputting a patent or other identification number in field 1217a. In addition, the display 1217 includes a number of "Injection Site" touch buttons 1217b-1217i for identifying and recording in the system 10 the site on the patient at which the radiopharmaceutical will be administered or injected, including 'Left Antecubital' 1217b, 'Right Antecubital' 1217c, 'Left Hand' 1217d, 'Right Hand' 1217e, 'Left Foot' 1217f, 'Right Foot' 1217g, 'Access Port' 1217h and 'Other' 1217i.

[215] Once the Identification and Injection Site information is input into the system 10, the information is displayed in the Case ID field 1206, as shown in Fig. 25B. Further, as shown in Fig. 25B, after the requisite information is input into the system 10 and displayed in the Case ID field 1206, a Patient Preparation field 1210 including a Prime touch button 1212 is generated and displayed for the operator.

[216] Before the Prime button is 1212 is activated, the first end 702 of the SPDS 700 should be attached to the connector end 228 of the MPDS 200, as discussed in detail

above. When the SPDS 700 is connected to the MPDS 700, the operator can activate the prime button 1212 to cause the system 10 to prime the SPDS 700 to remove air therefrom.

[217] As shown in Fig. 26A, after the Prime button 1212 is activated the system 10 indicates that the system is “Priming” the SPDS 700 and generates a progress bar 1213 (which indicates in Fig. 26A that the priming operation is 17% completed). Further, the system 10 highlights the fluid path field 1008 and the coil field 1010 in display 1000 to indicate that saline is being pumped from saline source 23 (indicated by saline field 1002) through the MPDS 200 and the SPDS 700 to prime the SPDS 700. After the SPDS priming operation is completed, the system 10 generates a prompt display 1215, as shown in Fig. 26B, that queries the operator as to whether all air has been expelled or purged from the SPDS 700. If the “Yes” button 1215a is activated, the SPDS priming operation is completed and the system 10 is ready to conduct a test injection and/or to prepare the pharmaceutical dose for injection into the patient, as discussed in more detail below. If, on the other hand, the “No” button 1215b is activated, the SPDS priming operation is preferably conducted again.

[218] After the SPDS priming operation is completed, the patient end 704 of the SDPS 700 is connected to the patient (as described above) and the Patient Preparation display field 1210 on the touch screen 1000 includes a “Test Inject” button 1212a, as shown in Fig. 28A. If the operator desires to conduct a test injection to, for example, ensure the integrity of the fluid path along the MPDS 700, the SPDS 200 and the patient’s vasculature, the operator activates the “Test Injection” button 1212a and the system 10 pumps saline from the saline source 23 through the MPDS 200 and the SPDS 700 to the patient. Concurrently, the system 10 generates the display shown in Fig. 27A to inform the operator that the system 10 is “Test Injecting” and highlights the fluid path display 1008 from the saline source icon 1002 to the ionization chamber display 1010. The display 1000 also includes a progress bar 1213a to indicate the degree of progress made (here 45%) in completing the test injection procedure.

[219] If the operator needs to pause the test injection due to, for example, patient discomfort or incorrect positioning of the catheter in the patient, she can activate the “Pause” button 1212d in the Patient Preparation display 1210 (see Fig. 27A) to pause the procedure. When the test injection procedure is paused, the system 10 generates the display shown in Fig. 27B, indicating that the test injection is “Paused” and providing a “Resume” button 1212b and a “Stop” button 1212c in the Patient Preparation display 1210. To resume or stop the test injection, the operator

can activate the corresponding “Resume” and “Stop” buttons, 1212b, 1212c, respectively.

[220] In addition to using the various “Pause” and “Stop” buttons provided by the GUI display 15, an operator can also depress the interrupt button 25 on the cabinet 9 of the system 10 to at any time pause or stop a procedure or operation being conducted by the system.

[221] After the test injection is completed or terminated the system 10 generates the display 1000 shown in Fig. 28A, which includes an FDG Dose display 1216 and a corresponding “Prepare” button 1218. After the operator activates the “Prepare” button 1218, the system 10 generates the display shown in Fig. 28B and begins to pump a volume of FDG (or other suitable pharmaceutical or radiopharmaceutical) from the vial 902 through the MPDS 200 to the tube coil 444 thereof disposed in the ionization chamber 160. As shown in Fig. 28B, to reflect this operation the display 1000 informs the operator that the system 10 is “Measuring Dose” and highlights the fluid path display 1008 from the FDG source display 1004 to the ionization chamber display 1010. The display also includes a progress bar 1214a that shows the system’s progress (here 78%) in measuring the pharmaceutical dose.

[222] In a preferred embodiment, the system 10 prepares the pharmaceutical dose in accord with the methodology described in PCT Publication No. WO 2006/007750, in which the activity level of a first amount of a radioactive liquid is measured and used to calculate a second amount of the radioactive liquid that is required for the combined amounts to have a pre-determined level of radioactivity to be delivered to a patient. The contents of PCT Publication No. 2006/007750 are incorporated herein by reference. The dimensions of the coil assembly 400 and the core structure 446, including the height, diameter and volume of the tube coil 444, the length, number of turns, OD and ID of the tubing that forms the tube coil 444, and the dimensional location of the “linear region” of the Veenstra IK-102 ionization chamber, provided above are necessary to optimally and accurately prepare the pharmaceutical dose, whether in accord with the preferred methodology described in PCT Publication No. WO 2006/007750 or using another suitable dose preparation methodology.

[223] The stated tube coil 444 dimensions are necessary to optimally position within the “linear region” of ionization chamber: (1) the volume(s) of pharmaceutical required to deliver the desired activity level to the patient; and (2) the volume of saline necessary to position the total volume of pharmaceutical in the tube coil. The tube coil 444 could be formed from tubing having a larger ID than that stated above (i.e.,

0.156 inches), but larger IDs tend to allow the radiopharmaceutical to be diffused with the saline (which is used to 'place' or 'position' the radiopharmaceutical within the tube coil 444), which may result in the radiopharmaceutical volume or a portion thereof being positioned outside of the tube coil 444 and thus outside of the "linear region" of the ionization chamber (resulting in inaccurate activity level measurements and delivery). Likewise, the tube coil 44 could be formed from tubing having a smaller ID than 0.156 inches (which would possibly further decrease or prevent the diffusion of the radiopharmaceutical with the saline), but the dimensions of the tube coil 444 (e.g., length of tubing, coil tube height, number of turns) required to maintain a tube coil volume of 12.5 ml would result in the tube coil 444 extending beyond the "linear region" of the ionization chamber (resulting in inaccurate activity level measurements and delivery).

- [224] Further, the core structure 446 operates to maintain the desired tube coil geometry (e.g., tube coil diameter and height) and to properly position the tube coil 444 axially and vertically within the sleeve 162 so that the tube coil 444 thereby resides within the "linear region" of the ionization chamber 160 (see e.g., Fig. 3F).
- [225] With specific reference to the dose preparation methodology described in PCT Publication No. WO 2006/007750, the 12.5 ml volume of the tube coil 444 is designed to accommodate two volumes of a radiopharmaceutical from vial 902 separated by a volume of saline from source 23, regardless of whether the dose is prepared shortly after the radiopharmaceutical was assayed (when a small volume of the radiopharmaceutical is required to deliver a desired activity level) or after a significant amount of time has passed (e.g., in relation to the radioisotope's half-life) since the radiopharmaceutical was assayed (when a greater volume of the radiopharmaceutical is required to deliver the same desired activity level). As a specific example of the above, the 12.5 ml tube coil 444 is designed to accommodate: (1) two 1/16 ml volumes or "slugs" of a pharmaceutical (for a total volume of 1/8 ml) at a concentration of 40 mCi/ml (i.e., highest concentration that the system 10 is designed to handle), separated by a calculated volume of saline necessary to fill or substantially fill the remaining tube coil volume; and (2) two 1.5 ml "slugs" of a pharmaceutical (for a total volume of 3 ml) at a concentration of 1.67 mCi/ml (i.e., lowest concentration that the system 10 is designed to handle), separated by a calculated volume of saline necessary to fill or substantially fill the remaining tube coil volume.
- [226] After the dose is pumped by the system 10 into the tube coil 444 disposed within the ionization chamber 160, the activity level of the dose is measured by the system 10.



The measured activity level is then displayed to the operator and the ionization chamber display 1010 is highlighted, as shown in Fig. 29. A new display field 1006a is generated by the system, showing the measured “Calibrated Activity” (here 13.5 mCi) of the prepared dose. Just below field 1006a is a “plus/minus” range indicator 1224. Range indicator 1224, as shown, includes a center circle 1224a, flanked on each side by 10 rectangles. Left and right arrows are also included, respectively, at the far left and far right of indicator 1224. Preferably, as shown in Fig. 29, center circle highlights when the measured “Calibrated Activity” level is the same as the previously programmed, desired activity level (which is the case in Fig. 29). Otherwise, if the measured activity level is greater or lesser than the desired activity level, corresponding rectangles or, in some cases, arrows will highlight to the right of the center circle 1224a (for measured activity > desired activity) or to the left of the center circle 1224a (for measured activity < desired activity) to visually indicate to the operator the difference between the measured and desired activity levels.

[227] In a preferred embodiment, each of the rectangles represents a default value of a 1% discrepancy in the desired to measured activity level, such that three rectangles to the right of the center circle 1224a would be highlighted if the measured activity level was 3% greater than the desired activity level of 13.5 mCi. If the measured activity exceeds the desired activity by more than 10%, then all the rectangles to the right of the center circle 1224a and the right arrow would highlight. Preferably, the extent of the rectangles in indicator 1224 will convey an acceptable range within which the measured activity may fall. Thus, such an acceptable range could be plus or minus ten percent or could be another range as deemed appropriate, with each rectangle representing one tenth of the positive or negative extent of that range. Alternately, however, the default value of each rectangular could be pre-set to another value (such as 0.1 mCi) or could be changed by the operator to another value more suitable for the intended application.

[228] In addition to displaying the measured activity level, as shown in Fig. 29 the display 1000 also generates a “Discard” button 1222 and an “Inject” button 1220 in the FDG Dose display 1216. If for example the measured activity is outside of a clinically acceptable range for the intended procedure, the operator can activate the “Discard” button 1222 to have the system 10 discard the measured dose (i.e., by pumping the dose to the waste receptacle 224, as discussed in detail above) and to prepare another dose for delivery to the patient. Specifically, when the “Discard” button 1222 is activated the system generates the dialog box 1231 shown in Fig. 30A, which queries the operator to confirm that the measured dose is to be discarded. If the

operator confirms that the measured dose is to be discarded by activating the “Yes” button 1231a, the system 10 generates the display shown in Fig. 30B, which indicates to the operator that the system is “Discarding” and creates a progress bar 1233 that indicates the status of the “discarding” operation (here 86% completed). The display 1000 also highlights the fluid path display 1008 from the saline source display 1002 to the ionization chamber display 1010 to indicate that the system 10 is pumping saline through the MPDS 200 to push the dose from the tube coil 444 to the waste receptacle 224 (as described above).

- [229] If, on the other hand, the operator activates the “No” button 1231b in Fig. 30A to inform the system 10 that she does not want to discard the measured dose, the system 10 reverts to the display shown in Fig. 29 and the “Discard” button 1222 and the “Inject” button 1220 are again made available to prompt the operator to decide whether to discard or to inject the measured pharmaceutical dose.
- [230] If the operator desires to inject the measured dose and thus activates the “Inject” button 1220 shown in Fig. 29, the system 10 generates the display shown in Fig. 31 which indicates to the operator that the system 10 is “Injecting” and, via progress bar 1223, that the injection operation (in Fig. 31) is 27% completed. The fluid path display 1008 between the saline source display 1002 and through the ionization chamber display 1010 to the arrow at the end of the fluid path display 1008 is highlighted to indicate that the system 10 is pumping saline from the saline source 23 to push the dose in the ionization chamber 160 through the remainder of the MPDS 200 and the SPDS 700 to the patient (as described above). Further, the system 10 generates a “Pause” button 1230 in FDG Dose display 1216. As with the test injection operation discussed above (see Fig. 27A), the operator can activate the “Pause” button 1230 or the interrupt button 25 to pause the injection procedure.
- [231] After the “Pause” button 1221 is activated, the display shown in Fig. 32A is generated and displayed to the operator. The display shown in Fig. 32A informs the operator that the system 10 is “Paused” and includes a “Discard” button 1222a and a “Resume” button 1230a in the FDG Dose display 1216.
- [232] If the injection needs to be terminated, the operator activates the “Discard” button 1222a and the system reverts to that shown and described above with respect to Figs. 30A and 30B to discard the dose into the waste receptacle 224. However, if the procedure can be resumed, the operator activates the “Resume” button 1230a in Fig. 32A and the injection procedure continues to deliver the measured dose to the patient.

- [233] When the injection procedure is completed, a pop-up 1240 preferably appears as shown in Fig. 32B. This pop-up 1240, as shown, preferably contains information about the activity and volume of the dose (e.g., FDG) just delivered to the patient, the total fluid delivered (which would include saline) and other identifying information including, for example, the patient identification number, radiopharmaceutical lot number and patient injection site (as shown on the right of pop-up 1240). Activating the “OK” button 1242 causes pop-up 1240 to disappear and the system to revert to an “Idle” state (as shown in Fig. 7) or a “Ready” state (as shown in Fig. 23), while activating the “print” button 1244 prompts the injection information to be printed out by the printer 24 for patient, billing, inventory or other suitable records.
- [234] Other capabilities and functions not expressly discussed hereinabove or shown in the drawings are of course conceivable in accordance with the embodiments of the present invention. For instance, if the extraction of a pharmaceutical dose (e.g., FDG) from a vial is interrupted for an unforeseeable reason and is not prompted by a desired “pause”, the system could alert the operator to discard the dose (and in that connection present a button for the purpose).

#### **Injection History**

- [235] The disclosure now turns to a discussion of the injection history operations or tasks that can be performed using the display 1000, as depicted in Figs. 33A-C, 34A and 34B.
- [236] The injection history operations or tasks may be prompted by activating the Records / Injection History button 1022, which is displayed when the system 10 is in an “Idle” state (see e.g., Fig. 7) or a “Ready” state (see e.g., Figs. 23, 24D and 28A). Activation of Records button 1022 preferably prompts the appearance of the calendar display 1302 shown in Fig. 33A (here ‘October 2006’). Highlighted touch fields within the calendar display 1302 preferably correspond to those dates of the displayed month (here ‘October 2006’ in field 1309) on which the system 10 was used to perform an injection procedure, while those other days of the displayed month in which the system 10 was not used are not highlighted. Arrow buttons to the left 1309a and right (not shown), respectively, of field 1309 preferably permit the operator to scroll through different months to access and retrieve injection history information.
- [237] The calendar display 1302 also includes a “Print Summary” button 1304, a “Print Days” button 1306 and a “Done” button 1308. Activation of the “Print Summary”

button 1304 provides a high-level summary of the injection procedures conducted for the specified month (here 'October 2006'), similar to the injection procedure information displayed in Fig. 34A. The "Print Days" button 1306 preferably prompts the appearance of the display 1302a shown in Fig. 33B. The "Done" button 1308 can be activated once the operator has completed the necessary injection history retrieval operation or task, and the display 1000 then preferably reverts to the "Idle" state display (see e.g., Fig. 7) or the "Ready" state display (see e.g., Figs. 23, 24D and 28A) as appropriate.

- [238] Referring now to Fig. 33B (prompted by activation of "Print Days" button 1306), the display 1302a includes an "All Days" touch field 1330 (which is activated in Fig. 33B) including a "Print" button 1334, and a "Range" touch field 1332. If the operator mistakenly activated the "Print Days" button 1309 on display 1302 (see Fig. 33A), she can activate the "Cancel" button 1336 to return to the display 1302 shown in Fig. 33A. If the operator wishes to print the injection history information for all the days in the selected month (here 'October 2006'), "Print" button 1334 can be activated and the printer 24 will print the injection history records for the days in which the system 10 performed injection procedures. If the operator instead wants to access injection history information for a range of days in the selected month, the operator can activate the "Range" touch field 1332, which prompts the appearance of the display 1302b shown in Fig. 33C.
- [239] As shown in Fig. 33C, the display 1302b includes a "From" touch field 1332a and a "To" touch field 1332b which the operator activates to select the "From" and "To" dates in the selected month to establish the range of dates for which injection history information is to be accessed. Once the date range is selected, the "Print" button 1334 is activated to prompt the printer 24 to print the injection history information.
- [240] Referring back to Fig. 33A, in addition to activating the "Print Summary" button 1304 or the "Print Days" button 1306, the operator is also able to activate any of the highlighted calendar buttons to access injection history information for that day of the selected month. For example, if the operator wanted to retrieve injection history information for 10 October 2006, the operator would activate the "10" button 1340 shown in Fig. 33A and the system 10 would generate the display 1310 (including selected date field 1310a) shown in Fig. 34A.
- [241] As shown in Fig. 34A, a series of display fields 1312 includes information on the lot number, case ID, delivery time and delivered activity of a given injection procedure conducted on the selected day (here '10 October 2006 (Tuesday)'). Page up 1316 and page down 1318 arrow buttons are provided to allow the operator to scroll

through the procedures conducted on the selected day. Page left 1350 and page right 1351 arrow buttons are also provided to allow the operator to scroll through and select dates prior to or subsequent to the selected '10 October 2006' date displayed in date field 1310a. A "Month View" button 1320 can be activated to revert to a "month view" as shown in Fig. 33A, while the "Print Day" button 1306a can be activated to print the injection history details of all injection procedures on the day in question (i.e., the day currently being displayed). Further, "magnifying glass" touch fields 1314 are provided for each procedure and, upon activation, preferably prompts a detailed injection history display 1360 (see Fig. 34B) for the selected procedure.

- [242] As shown in Fig. 34B, the detailed injection history display 1360 provides details on the specific pharmaceutical injected (here "FDG"), the date (10 October 2006) and time (09:15) of injection and the activity level (15.1 mCi) and volume (5 ml) of the injected pharmaceutical. Further, the display 1360 indicates the total volume (35.0 ml) of injected fluid (pharmaceutical and saline), the Patient Identification number, the Lot number of the pharmaceutical and the IV Injection Site on the patient. The "Print" button 1363 is activated to print the injection details and the "OK" button 1362 is activated to revert to the display 1310 shown in Fig. 34A.

#### **System Configuration**

- [243] The disclosure now turns to a discussion of system configuration tasks, as depicted in Figures 35-46. The configuration tasks are undertaken to permit an operator to set various system preferences, including but not limited to preferences related to the following: (1) Language; (2) Date / Time display; (3) Units; (4) Audio; (5) FDG / Pharmaceutical dose preparation formulas; (6) Saline volumes; (7) Case Information display; (8) Printing; (9) Daily QC isotope reference information; (10) Linearity measurement tests; (11) Calibration tests; and (12) Field Service reminders.
- [244] The system configuration tasks may be prompted by activating the Configuration button 1021, which is displayed when the system 10 is in an "Idle" state (see e.g., Fig. 7) or a "Ready" state (see e.g., Figs. 23, 24D and 28A). Activation of Configuration button 1021 preferably prompts the appearance of the "System", "Treatment" and "Maintenance" touch fields (1402, 1404 and 1406, respectively) shown in Fig. 35, each of which when activated prompts the appearance of a distinct tabbed menu display 1400a-c (as explained in more detail below). An "OK" button 1418 may be activated when the system configuration tasks are completed, while a "default" button 1416 may be activated to reset the system 10 to the default configuration settings.

- [245] As shown in Fig. 35, the “System” touch field 1402 is activated and the tabbed menu display 1400a is provided. On menu display 1400a, tabs for language, date/time, units and audio are provided (1408, 1410, 1412, and 1414, respectively), and language tab 1408 is activated to prompt a language menu 1420. Preferably, language menu 1420 will permit the selection of any of a number of languages to be used with the system 10 in accordance with operator or local preferences.
- [246] Fig. 36 shows date/time tab 1410 activated to prompt a date/time display 1422. Via a calendar button 1422a, a current date can be set, while date format preferences (e.g., European vs. American, etc.) can be set via touch field 1422b. A time display field 1422c preferably shows the current time and a time edit button 1422d may be activated to set the time as well as to select a 12- or 24-hour time format.
- [247] Fig. 37 shows units tab 1412 activated to prompt a display 1424. Display 1424 preferably permits, via buttons 1426a, 1426b, 1428a, 1428b, a choice of units for weight (lbs. vs. kg) and activity (Curies vs. Becquerels), respectively.
- [248] Fig. 38 shows audio tab 1414 activated to prompt a display 1444. “High”, “normal” and “low” audio volumes (e.g., for prompts or alarms) can be selected via buttons 1444a, 1444b and 1444c, respectively.
- [249] Fig. 39A shows the treatment touch field 1404 activated, which generates a second tabbed menu display 1400b. On menu display 1400b, tabs for “FDG”, “saline”, “case” and “printing” are provided (1450, 1452, 1454, and 1456, respectively). In Fig. 39A, FDG tab 1450 is activated to prompt a display 1460. Preferably, display 1460 includes an entry field 1462 for entering a default desired activity level (which may then automatically appear in field 1006 of Fig. 7).
- [250] The display 1460 further includes a weight-based dosing sub-menu 1460a that includes on/off buttons 1464a, 1464b and an “Edit Formulas” button 1466. If the operator would like the system 10 to default to a weight-based calculation for desired activity level, the operator activates the “On” button 1464a. If a default, weight-based calculation for desired activity level is not desired, the operator can select the “Off” button 1464b (as shown in Fig. 39A). Further, upon activation of the “Edit Formulas” button 1466, the system 10 generates the pop-up edit display 1470 shown in Fig. 39B to allow the operator to edit existing or add new formulas for calculating desired activity level based on, for example, patient weight.
- [251] As shown in Fig. 39B, the edit display 1470 may include a column of five buttons 1476, each preferably corresponding to a predetermined formula for a procedure

type that, for instance, may commonly be repeated. Here, a “Melanoma” button 1476a is activated to then present a sub-display 1478 which can afford an editing of any or all of the following: name of the formula (via button 1478a), multiplier to be used in calculating weight-based desired activity level (via touch field 1478b), and minimum and maximum desired activity levels (via touch fields 1478c and 1478d, respectively). Also, the entire formula can be deleted (via button 1478e) from the set 1476, if desired. Further, the operator may enter new formulas into the system 10 by activating the “New Formula” buttons 1476b

- [252] Fig. 40 shows Saline tab 1452 activated to prompt a display 1480. Display 1480 preferably contains touch fields 1482, 1484 and 1486, respectively, for pre-selecting a default saline bulk size (here 500 ml) for the saline source 23 (if, for example, the facility generally uses or will use the same bulk size of saline), an additional saline flush volume (e.g., to account for the additional tubing length if the SPDS 700 is connected to an IV instead of directly to a catheter in a patient) and a test inject volume (here 30 ml). The Default Bulk Size volume entered in 1482, for example, can be a quantity that initially appears to an operator at a time when saline is installed in the system 10, which can be changed or left alone as appropriate. Any data entry in touch fields 1482, 1484, 1486 can be accomplished, e.g., via a keypad 1488.
- [253] Fig. 41 shows case tab 1454 activated to prompt a display 1490. Display 1490 preferably permits the operator to set a default preference (via on/off buttons 1492) as to whether Case ID information (i.e., for a given patient) can be edited as appropriate. Further, the display 1490 allows the operator to set a default injection site for the system 10 by activating one of the injection site buttons 1494 provided in display 1490. Of course, the default injection site location can be changed by the operator during the preparation steps for the fluid delivery procedure if the actual injection site is different from the default injection site.
- [254] Fig. 42 shows printing tab 1456 activated to prompt a display 1502 which allows an operator to establish an automatic printing of record labels (e.g., as may be printed at the end of an injection procedure) and the quantity of record labels to be printed.
- [255] Finally, Fig. 43A shows maintenance touch field 1406 activated, which generates a third tabbed menu display 1400c. On menu display 1400c, tabs for “Daily QC”, “Linearity”, “Calibration” and “Field Service” (1510, 1512, 1514, 1516, respectively) are provided. The maintenance tabs relate to general maintenance and calibration of the system 10.

- [256] As shown in Fig. 43, Daily QC tab 1510 is activated to prompt a display 1518. Display 1518 allows the operator to input information related to the radioisotope to be used to conduct daily QC tests (described above) of the system 10. Specifically, Isotope touch field 1520 and Lot Number touch field 1522 permit the operator to input the specific radioisotope to be used (here Cs-137) and the lot number thereof, respectively. Further, the operator can input the time and date that the radioisotope was created (e.g., in a cyclotron or a reactor), as well as the activity level of the radioisotope when it was created, in the Time and Activity touch fields 1526, 1524, respectively. The Edit button 1526a can be activated to edit the previously entered time and date information.
- [257] Fig. 44A shows linearity tab 1512 activated to prompt a display 1530. Display 1530 prompts the operator for information and assists in conducting a linearity measurement for the system 10, which should be conducted every quarter (as noted in display 1530). Linearity measurements are based on the known decay of radioisotopes and are conducted to ensure that the ionization chamber 160 in the system 10 is reliably measuring the activity level of a radioisotope placed therein. Specifically, during a linearity measurement the measured activity level of a radioisotope is compared to the known activity level of the radioisotope (based on its half-life decay) at selected intervals (e.g., every 15 minutes) over a period of time (e.g., 24 hours) to determine whether the measured activity level falls within an acceptable error range.
- [258] When the linearity tab 1512 is activated, details from the most recent linearity measurement are shown in sub-display 1532, while a button 1534 can be activated to prompt the appearance of a related graph (of, for example, measured vs. known activity level over the measurement period). To conduct a new linearity measurement, button 1536 is activated, which preferably generates the display 1540 shown in Fig. 44B.
- [259] As shown in Fig. 44B, isotope field 1542 may be activated to identify the radioisotope to be used for the linearity measurement (here F-18). While isotope field 1542 preferably conveys the reference isotope, the activity level of the radioisotope (e.g., at the time it was drawn) can be input into activity level field 1544. In addition, the reference date and time for the activity level (e.g., the date and time that the radioisotope was drawn) is input into touch fields 1546 and 1548, respectively, by using, for example, a calendar button 1546a and a AM/PM time button 1548a. Once the requisite radioisotope information is inputted into display 1540, the operator can activate the "Begin Measurement" button 1543 to start the



linearity measurement. Of course, the operator can activate the “Cancel” button 1541 to cancel the linearity measurement and return to the display 1530 shown in Fig. 44A

- [260] After the “Begin Measurement” button 1543 is activated, the pop-up display 1545 shown in Fig. 44C is generated to prompt the operator to confirm that the reference radioisotope has been placed in the ionization chamber 160. If the operator activates the “Yes” button 1545a (as shown in Fig. 44C) to confirm that the F-18 radioisotope has been placed in the ionization chamber 160, the system 10 will begin the linearity measurement.
- [261] If the operator activates the “No” button 1545b, the display reverts to the display 1540 shown in Fig. 44B, and the operator can then load the reference radioisotope source into the ionization chamber and once again activate the “Begin Measurement” button 1543 to start the linearity measurement.
- [262] After the operator activates the “Yes” button 1545a, the display 1547 shown in Fig. 44D is generated. In addition to displaying the radioisotope in field 1542 and the maximum allowable error for the linearity measurement in field 1552, the display 1547 also shows the estimated time for completion of the linearity measurement (here “23:15:03” hours) and the measured activity (in field 1554), the calculated activity (in field 1558) and the current error (in percentage format) (in field 1556). The linearity measurement may be aborted via an “Abort” button 1560 and the results of the linearity measurement, including a graph of the results, may be printed by selecting a “Print” button (not shown).
- [263] As shown in Fig. 45A, activation of calibration tab 1514 prompts the system 10 to generate a calibration display 1570, which shows the results of a previous ionization chamber calibration routine. Ionization chamber calibration routines are preferably conducted upon installation of the system 10 (at, for example, a medical facility) and approximately once a year thereafter to ensure that the ionization chamber 160 of the system 10 is properly calibrated to operate over the range of energies and activity levels of the radiopharmaceuticals for which the ionization chamber 160 is intended to be used. In a preferred calibration routine, the gain of the ionization chamber is increased or decreased to best fit or adjust the measured activity levels of two or three radioisotopes (preferably having energy levels different from (e.g., lower than and greater than) the energy levels of the radiopharmaceuticals to be used with the system 10) against their known activity levels.

- [264] By way of a specific example, the system 10 is currently intended to be used to administer FDG (which contains the radioisotope F-18) to patients. The energy level of F-18 is 511 KeV. In a first preferred embodiment, three radioisotopes are used to calibrate the ionization chamber 160: (1) Co-57 (energy level of 122 KeV; less than that of F-18); (2) Co-60 (energy level of 1333 KeV; greater than that of F-18); and (3) Cs-137 (energy level of 662 KeV; relatively close to that of F-18). In a second preferred embodiment, two radioisotopes are used for the calibration routine: (1) Co-57; and (2) Cs-137.
- [265] Returning to Fig. 45A, the calibration display 1570 includes a sub-display 1571 conveying previous calibration results for Co-57 (field 1571a), Co-60 (field 1571b) and Cs-137 (field 1571c), while a button 1574 can be activated to begin a new calibration routine. Previous results can also be printed, e.g., via a button 1572.
- [266] Upon activating button 1574, a display 1573 is generated (see Fig. 45B) that prompts the operator to place the radioisotope source (here Co-57) in the ionization chamber 160. The display 1573 includes a sub-display 1573a that lists various information about the isotope, including the isotope's name, the lot number, the date and time that the isotope was drawn and the activity level of the isotope when it was drawn. Further, the display 1573 includes "Cancel" button 1573b, "Edit" button 1573c and "OK" button 1573d. The cancel button 1573b is activated to cancel the calibration routine, the edit button 1573c is activated to edit the isotope information provided in sub-display 1573a and the OK button 1573d is activated (as shown in Fig. 45B) to commence the calibration routine with respect to the noted radioisotope (here Co-57), as discussed in more detail below.
- [267] If the edit button 1573c in display 1573 is activated, the edit source display 1576 shown in Fig. 45C appears. The operator can edit the isotope information in display 1576 by entering the isotope name in field 1580, the lot number in field 1582, the activity level (at isotope creation) in field 1584 and the reference time and date (of isotope creation) in field 1586 via edit button 1586a. After the isotope information is entered, the operator activates the OK button 1578 and the display 1000 reverts to the display 1573 shown in Fig. 45B. If the isotope information is now correct, the operator can activate the OK button 1573d in display 1573 to commence the calibration routine for the noted radioisotope (here Co-57).
- [268] After the OK button 1573d is activated, a tabbed calibration display 1590, including touch tabs for Co-57 (tab 1592), Co-60 (tab 1594) and Cs-137 (tab 1596), appears (as shown in Fig. 45D) and shows the results of the calibration routine for the noted radioisotope (here Co-57). Specifically, the display 1590a for Co-57 tab 1592

shows the target or expected activity for Co-57 (in field 1598), the actual measured activity for the Co-57 placed in the ionization chamber 160 (in field 1600) and the error between the target and measured activity (in field 1602). To thereafter compensate for the error (here 1%), the low gain of the ionization chamber (displayed in field 1604) is adjusted by using the 'plus' and 'minus' buttons 1606, respectively. Further, as shown in Fig. 45D, based on the error for Co-57 the system 10 calculates an estimated error (here 1%) for Cs-137 and displays it in field 1612. Based on the target or expected activity for Cs-137 (entered by the operator and displayed in field 1608) and the estimated error, the estimated measured activity is calculated by the system 10 and displayed in field 1610.

[269] The calibration routine is continued by thereafter activating the tab 1594 for the Co-60 isotope and repeating the steps described above with respect to Figs. 45B-45D. To compensate for the error (not shown) between the expected activity and the measured activity for Co-60, the high gain of the ionization chamber is adjusted (in the same way as shown in Fig. 45D for Co-57). The system 10 then uses the error for Co-60 to revise the estimated error for Cs-137, which is then displayed in field 1612 for the operator.

[270] The operator may continue the process above (i.e., iteratively conducting Co-57 and Co-60 activity measurements and adjusting the low and high gain of the ionization chamber) until the estimated error for Cs-137 (whose energy level of 662 KeV is relatively close to the 511 KeV energy level of F-18) is within an acceptable range (e.g., 1%). At that time, the operator activates the tab 1596 for the Cs-137 isotope and places the Cs-137 source in the ionization chamber to confirm that the difference between the expected and measured activity of the Cs-137 isotope is substantially similar to or within an acceptable range from the estimated error displayed in field 1612. At this point the calibration routine is completed, and the results may be printed and/or stored for later accessing by system maintenance personnel. As shown, an "abort" button 1614 for terminating the calibration procedure is provided for the operator.

[271] Finally, Fig. 46 shows field service tab 1516 activated to prompt a display 1620 which can be used to pre-set one or more future reminder dates to undertake preventative maintenance for the system 10.

[272] It is to be appreciated that the systems, devices and methods of the present invention can be used in a very wide variety of drug delivery and therapeutic procedures. In general, the systems, devices and methods of the present invention are particularly suited for use in connection with any hazardous pharmaceutical or substance to be

injected into a patient (human or animal). Even pharmaceuticals, such as contrast agents or thrombolytic agents, that are not considered to be especially hazardous can be beneficially administered via systems broadly contemplated herein and provide hospital personnel additional protection against adverse effects.

- [273] To the extent that systems of the present invention can be applicable to radiotherapy drugs or pharmaceuticals wherein the drug or pharmaceutical itself is radioactive, it is to be appreciated that, as clear to one skilled in the art, maintaining containment of radiotherapy pharmaceuticals promotes safety. If the drug or pharmaceutical is radioactive, the use of radiation absorbing or leaded shielding will help protect the operator and patient from unnecessary radiation. Containment of radiotherapy pharmaceutical is discussed in U.S. Patent Application Publication No. 2003-0004463, the contents of which are incorporated herein by reference.
- [274] While procedures discussed herein in accordance with embodiments of the present invention have generally been described with respect to liquid drugs, it is to be understood that they can also apply to powdered drugs with either a liquid or gaseous vehicle, or gaseous drugs that are to be delivered to a recipient.
- [275] If not otherwise stated herein, it may be assumed that all components and/or processes described heretofore may, if appropriate, be considered to be interchangeable with similar components and/or processes disclosed elsewhere in the specification, unless an express indication is made to the contrary.
- [276] If not otherwise stated herein, any and all patents, patent publications, articles and other printed publications discussed or mentioned herein are hereby incorporated by reference as if set forth in their entirety herein.
- [277] It should be appreciated that the apparatus, systems, components and methods of the present invention may be configured and conducted as appropriate for any context at hand. The embodiments described above are to be considered in all respects only as illustrative and not restrictive.

## WHAT IS CLAIMED IS:

1. A fluid path set for use in a fluid delivery system, the fluid path set comprising:
  - a medical fluid component comprising a first tubing section for connection to a source of a medical fluid;
  - a pharmaceutical component comprising a second tubing section for connection to a source of a pharmaceutical;
  - a coil assembly component comprising a tube coil having a height of approximately 1.53 inches, a diameter of approximately 1.95 inches and a volume capacity of approximately 12.5 ml; and
  - a connector comprising a first port for connecting the first tubing section of the medical fluid component, a second port for connecting the second tubing section of the pharmaceutical component and a third port for connecting the tube coil of the coil assembly component.
  
2. The fluid path set of Claim 1 wherein the tube coil comprises a tubing section having an outer diameter of approximately 0.218 inches, an inner diameter of approximately 0.156 inches and a length of approximately 41 inches.
  
3. The fluid path set of Claim 2 wherein the tube coil is formed in a helical coil of approximately 7 turns of the tubing section.
  
4. The fluid path set of Claim 3 wherein the coil assembly further comprises a core structure around which the tube coil is formed, the core structure comprising an upper shoulder and a lower shoulder that define a tube channel therebetween, the upper and lower shoulders adapted to retain the tube coil therebetween within the tube channel.
  
5. The fluid path set of Claim 4 wherein the core structure further comprises an upper surface defining an inlet for accommodating a first end of the tubing section and an outlet for accommodating a second end of the tubing section.
  
6. The fluid path set of Claim 5 wherein the coil assembly component further comprises a third tubing section connected to the third port of the connector and the first end of the tubing section and a fourth tubing section connected to the second end of the tubing section.

7. The fluid path set of Claim 6, further comprising:
- a waste component comprising a fifth tubing section in connection with a waste receptacle;
  - a sixth tubing section having a connector end that is adapted to be connected to a single-patient tubing set; and
  - a second connector comprising a first port for connecting the fourth tubing section of the coil assembly component, a second port for connecting the fifth tubing section of the waste component and a third port for connecting the sixth tubing section.
8. The fluid path set of Claim 7 wherein the connector end comprises a swabable luer valve that is biased to a closed position when the single-patient tubing set is not connected thereto.
9. The fluid path set of Claim 7 wherein the connector end comprises a manifold or a stopcock each having two or more outlet ports for connection to respective single-patient tubing sets.
10. The fluid path set of Claim 7 wherein the first tubing section is approximately 56.75 inches in length and has an outer diameter of approximately 0.188 inches, an inner diameter of approximately 0.062 inches and a durometer of 45, the second tubing section is approximately 8.75 inches in length and has an outer diameter of approximately 0.094 inches, an inner diameter of approximately 0.032 inches and a durometer of 45, the third tubing section is approximately 15 inches in length and has an outer diameter of approximately 0.163 inches, an inner diameter of approximately 0.062 inches and a durometer of 60, the fourth tubing section is approximately 12 inches in length and has an outer diameter of approximately 0.163 inches, an inner diameter of approximately 0.062 inches and a durometer of 60, and the fifth tubing section and the sixth tubing section are each approximately 5 inches in length and have an outer diameter of approximately 0.163 inches, an inner diameter of approximately 0.062 inches and a durometer of 60.
11. The fluid path set of Claim 1 wherein the first tubing section comprises a first check valve and a spike for connecting to the source of a medical fluid and the second tubing

section comprises a second check valve and a vented cannula for connecting to the source of a pharmaceutical.

12. The fluid path set of Claim 1 wherein the second tubing section comprises a vented cannula comprising:

- a main hub comprising two opposed lateral sides and defining a fluid port and a vent;
- a fluid draw needle in connection with the second tubing section through the fluid port and adapted to be placed within the source of a pharmaceutical;
- a vent needle in connection with the vent and adapted to be placed within the source of a pharmaceutical; and
- two resilient arms connected to the opposed lateral sides of the main hub, each of the two arms comprising a top edge and a hook member formed thereon and extending outwardly therefrom.

13. The fluid path set of Claim 12 wherein the fluid draw needle is longer than the vent needle.

14. The fluid path set of Claim 12 wherein the vent comprises a filter.

15. The fluid path set of Claim 12 wherein the main hub of the vented cannula further comprises a ledge extending therefrom in a horizontal plane above the two arms, the ledge and the top edges of the two arms cooperating to define horizontal slots therebetween.

16. The fluid path set of Claim 15 wherein the hook members extend outwardly from the arms in a plane substantially normal to the horizontal plane of the ledge.

17. The fluid path set of Claim 12 wherein the main hub and each of the arms cooperate to define substantially U-shaped grooves extending along the lateral sides of the main hub.

18. A vented cannula for drawing fluid from a container, the vented cannula comprising:

a main hub comprising two opposed lateral sides and defining a fluid port and a vent;  
a fluid draw needle in connection with the fluid port and adapted to be placed within the container;  
a vent needle in connection with the vent and adapted to be placed within the container;  
and  
two resilient arms connected to the opposed lateral sides of the main hub, each of the two arms comprising a top edge and a hook member formed thereon and extending outwardly therefrom.

19. The vented cannula of Claim 18 wherein the fluid draw needle is longer than the vent needle.

20. The vented cannula of Claim 18 wherein the vent comprises a filter.

21. The vented cannula of Claim 18 wherein the main hub of the vented cannula further comprises a ledge extending therefrom in a horizontal plane above the two arms, the ledge and the top edges of the two arms cooperating to define horizontal slots therebetween.

22. The vented cannula of Claim 21 wherein the hook members extend outwardly from the arms in a plane substantially normal to the horizontal plane of the ledge.

23. The vented cannula of Claim 18 wherein the main hub and each of the arms cooperate to define substantially U-shaped grooves extending along the lateral sides of the main hub.

24. A method of calibrating a fluid delivery system for delivering a pharmaceutical containing a radioisotope to a patient, the method comprising:

measuring an activity level of a first radioisotope in an ionization chamber of the fluid delivery system, the first radioisotope having an energy level less than that of the radioisotope to be delivered to the patient;

comparing the measured activity level of the first radioisotope to an expected activity level of the first radioisotope;



adjusting the gain of the ionization chamber to compensate for the difference, if any, between the measured activity and the expected activity of the first radioisotope;

measuring an activity level of a second radioisotope in the ionization chamber of the fluid delivery system, the second radioisotope having an energy level similar to or greater than that of the radioisotope to be delivered to the patient;

comparing the measured activity level of the second radioisotope to an expected activity level of the second radioisotope;

adjusting the gain of the ionization chamber to compensate for the difference, if any, between the measured activity and the expected activity of the second radioisotope; and

calculating an estimated error in a measured activity of a third radioisotope based on the differences, if any, between the measured activity and the expected activity of the first radioisotope and the measured activity and the expected activity of the second radioisotope.

25. The method of Claim 24, further comprising:

comparing the estimated error in a measured activity of the third radioisotope to a predetermined acceptable error or error range;

if the estimated error is the same as or similar to the predetermined acceptable error or is within the predetermined acceptable error range, then measuring an activity level of the third radioisotope in the ionization chamber of the fluid delivery system;

calculating the difference, if any, between the measured activity level of the third radioisotope and an expected activity level of the third radioisotope to derive an actual error; and

determining whether the actual error is the same or similar to the predetermined acceptable error or is within the predetermined acceptable error range.

26. The method of Claim 24 wherein the calculating step comprises:

calculating an initial estimated error in a measured activity of a third radioisotope based on the difference, if any, between the measured activity and the expected activity of the first radioisotope; and

calculating a revised estimated error in a measured activity of the third radioisotope based on the difference, if any, between the measured activity and the expected activity of the second radioisotope.

27. The method of Claim 26, further comprising:

comparing the revised estimated error in a measured activity of the third radioisotope to a predetermined acceptable error or error range;

if the revised estimated error is the same or similar to the predetermined acceptable error or is within the predetermined acceptable error range, then measuring an activity level of the third radioisotope in the ionization chamber of the fluid delivery system;

calculating the difference, if any, between the measured activity level of the third radioisotope and an expected activity level of the third radioisotope to derive an actual error; and

determining whether the actual error is the same or similar to the predetermined acceptable error or is within the predetermined acceptable error range.

28. The method of Claim 27, further comprising:

if the revised estimated error is not the same or similar to the predetermined acceptable error or is not within the predetermined acceptable error range, then remeasuring the activity level of the first radioisotope in the ionization chamber of the fluid delivery system;

comparing the remeasured activity level of the first radioisotope to the expected activity level of the first radioisotope;

adjusting the gain of the ionization chamber to compensate for the difference, if any, between the remeasured activity and the expected activity of the first radioisotope;

calculating a second revised estimated error in a measured activity of the third radioisotope based on the difference, if any, between the remeasured activity and the expected activity of the first radioisotope;

remeasuring the activity level of the second radioisotope in the ionization chamber of the fluid delivery system;

comparing the remeasured activity level of the second radioisotope to the expected activity level of the second radioisotope;

adjusting the gain of the ionization chamber to compensate for the difference, if any, between the remeasured activity and the expected activity of the second radioisotope; and

calculating a third revised estimated error in a measured activity of the third radioisotope based on the difference, if any, between the remeasured activity and the expected activity of the second radioisotope.

29. The method of Claim 28, further comprising:

comparing the third revised estimated error in a measured activity of the third radioisotope to a predetermined acceptable error or error range;

if the third revised estimated error is the same or similar to the predetermined acceptable error or is within the predetermined acceptable error range, then measuring an activity level of the third radioisotope in the ionization chamber of the fluid delivery system;

calculating the difference, if any, between the measured activity level of the third radioisotope and an expected activity level of the third radioisotope to derive an actual error; and

determining whether the actual error is the same or similar to the predetermined acceptable error or is within the predetermined acceptable error range.

30. The method of Claim 27, further comprising:

if the revised estimated error is not the same or similar to the predetermined acceptable error or is not within the predetermined acceptable error range, then remeasuring the activity level of the first radioisotope in the ionization chamber of the fluid delivery system;

comparing the remeasured activity level of the first radioisotope to the expected activity level of the first radioisotope;

adjusting the gain of the ionization chamber to compensate for the difference, if any, between the remeasured activity and the expected activity of the first radioisotope;

calculating a second revised estimated error in a measured activity of the third radioisotope based on the difference, if any, between the remeasured activity and the expected activity of the first radioisotope;

comparing the second revised estimated error in a measured activity of the third radioisotope to a predetermined acceptable error or error range;

if the second revised estimated error is the same or similar to the predetermined acceptable error or is within the predetermined acceptable error range, then measuring an activity level of the third radioisotope in the ionization chamber of the fluid delivery system;

calculating the difference, if any, between the measured activity level of the third radioisotope and an expected activity level of the third radioisotope to derive an actual error;

determining whether the actual error is the same or similar to the predetermined acceptable error or is within the predetermined acceptable error range;

if the second revised estimated error is not the same or similar to the predetermined acceptable error or is not within the predetermined acceptable error range, then remeasuring the activity level of the second radioisotope in the ionization chamber of the fluid delivery system;

comparing the remeasured activity level of the second radioisotope to the expected activity level of the second radioisotope;

adjusting the gain of the ionization chamber to compensate for the difference, if any, between the remeasured activity and the expected activity of the second radioisotope; and

calculating a third revised estimated error in a measured activity of the third radioisotope based on the difference, if any, between the remeasured activity and the expected activity of the second radioisotope.

31. The method of Claim 30, further comprising:

comparing the third revised estimated error in a measured activity of the third radioisotope to a predetermined acceptable error or error range;

if the third revised estimated error is the same or similar to the predetermined acceptable error or is within the predetermined acceptable error range, then measuring an activity level of the third radioisotope in the ionization chamber of the fluid delivery system;

calculating the difference, if any, between the measured activity level of the third radioisotope and an expected activity level of the third radioisotope to derive an actual error; and

determining whether the actual error is the same or similar to the predetermined acceptable error or is within the predetermined acceptable error range.

32. The method of Claim 24 wherein the radioisotope to be delivered to the patient is F-18.

33. The method of Claim 32 wherein the first radioisotope is Co-57, the second radioisotope is Co-60 and the third radioisotope is Cs-137.

34. The method of Claim 24 wherein the low gain of the ionization chamber is adjusted to compensate for the difference, if any, between the measured activity and the expected activity of the first radioisotope and the high gain of the ionization chamber is adjusted to compensate for the difference, if any, between the measured activity and the expected activity of the second radioisotope.

35. A vial access system comprising:

a base portion comprising a substantially horizontal lower surface and a sloped upper surface adapted to support a vial comprising a bottom wall and a substantially cylindrical wall connected thereto, the sloped upper surface adapted to ensure that a residual volume of fluid in the vial gathers in an area defined at least partially by a portion of the junction between the bottom wall and the cylindrical wall of the vial.

36. The vial access system of Claim 35, further comprising:  
a housing extending vertically from the base portion;  
a vertical support arm comprising an upper end, the vertical support arm movably disposed within the housing; and  
a cap member connected to the upper end of the vertical support arm and adapted to overlie a septum of the vial.

37. The vial access system of Claim 36 wherein the cap member comprises a mounting mechanism disposed on an underside thereof, the mounting mechanism adapted to retain a cannula therein for insertion through the septum of the vial.

38. The vial access system of Claim 37 wherein the vertical support arm is slidably disposed within the housing to allow the cannula to be inserted into and removed from the vial.

39. The vial access system of Claim 38 wherein the vertical support arm is rotatably disposed within the housing to allow the cap member to be rotated into and out of a position that overlies the septum of the vial.

40. The vial access system of Claim 37 wherein the mounting mechanism comprises two arms that cooperate to define a slot therebetween, each of the two arms comprising a tab member extending downwardly therefrom, each of the tab members comprising a front edge and a rear edge.

41. The vial access system of Claim 36, further comprising a handle member pivotally connected to the upper end of the vertical support arm.

42. The vial access system of Claim 36 wherein the cap member includes or is formed from radioactive shielding material.

43. The vial access system of Claim 35, further comprising at least one support member connected to the base portion for retaining the vial on the sloped upper surface of the base portion.

44. The vial access system of Claim 43 wherein the at least one support member comprises two support pins that are connected to the sloped upper surface of the base portion.

45. The vial access system of Claim 35 wherein the vial is contained within a vial shield and the fluid is a radiopharmaceutical.

46. The vial access system of Claim 35 wherein the sloped upper surface is sloped at an angle of approximately 10-13 degrees with respect to a horizontal plane.

47. A method of priming at least a portion of a fluid path set in a fluid delivery system, the method comprising:

placing a tubing section of the fluid path set in fluid connection with a source of a radiopharmaceutical;

placing a portion of the tubing section within a dose calibrator of the fluid delivery system;

pumping a volume of the radiopharmaceutical through the tubing section;

monitoring the dose calibrator to determine if a measured activity level is substantially equal to or above a predetermined activity level; and

if the measured activity level is substantially equal to or above the predetermined activity level, then concluding that the tubing section of the fluid path set has been primed.

48. The method of Claim 47, further comprising:

if the measured activity level is zero or below the predetermined activity level, then concluding that the tubing section of the fluid path has not been primed; and

pumping a second volume of the radiopharmaceutical through the tubing section.

49. The method of Claim 47, further comprising:

placing a second tubing section in fluid connection with a source of medical fluid and the tubing section;

pumping a volume of the medical fluid through the second tubing section and at least a portion of the tubing section to move the volume of the radiopharmaceutical to the portion of the tubing section that is positioned within the dose calibrator.

50. The method of Claim 49, further comprising:

placing the tubing section in fluid connection with a waste receptacle;

pumping a second volume of the medical fluid through the second tubing section and at least a portion of the tubing section to move the volume of the radiopharmaceutical into the waste receptacle.

51. A fluid delivery system, comprising:

a housing having an upper surface defining a plurality of recessed portions for accommodating one or more components of a fluid path set;

a cover movably connected to the housing and adapted to move between a first position that exposes the upper surface and a second position that overlies the upper surface; and

a locking mechanism associated with the cover and adapted to lock the cover in the second position.

52. The fluid delivery system of Claim 51 wherein the cover is slidably connected to the housing.

53. The fluid delivery system of Claim 51 wherein the first position allows an operator to insert or remove the one or more components of the fluid path set.

54. The fluid delivery system of Claim 51 wherein the plurality of recessed portions includes wells and troughs.

55. The fluid delivery system of Claim 51, further comprising:

one or more handles connected to the housing;  
a plurality of wheels or casters connected to the housing; and  
a display connected to the housing.

56. The fluid delivery system of Claim 51 wherein the cover and the upper surface comprises or is formed from a radioactive shielding material.

57. The fluid delivery system of Claim 51, further comprising:  
a dose calibrator for measuring the radioactivity level of a radiopharmaceutical;  
a pumping mechanism for pumping the radiopharmaceutical; and  
a controller in communication with the dose calibrator and the pumping mechanism.

58. The fluid delivery system of Claim 51 wherein the locking mechanism comprises a mechanical lock that locks the cover to the housing in the second position.

59. The fluid delivery system of Claim 57 wherein the locking mechanism is a software-implemented lock that is in communication with the controller, the software implemented lock adapted to lock the cover to the housing in the second position.

60. The fluid delivery system of Claim 51, further comprising a printer associated with the housing.

61. A vial shield carrying system for carrying a vial shield containing a pharmaceutical vial, the vial shield carrying system comprising in combination:

a collar unit adapted to removably engage a flange on the vial shield, the collar unit defining two elongated slots formed in a top surface thereof, each of the slots including a pin disposed therein and extending between two opposing walls thereof; and

a handle unit adapted to engage the collar unit, the handle unit comprising a handle connected to a U-shaped cross piece defining two, downwardly extending arms having hook members formed therein, the open ends of the hook members formed on opposite ends of the arms and adapted to engage the pins in the slots of the collar unit through rotation of the handle.



62. The vial shield carrying system of Claim 61, further comprising a plunger connected to the U-shaped cross piece and adapted to mate with a septum cap of the vial shield when the handle unit engages the collar unit on the vial shield.

63. The vial shield carrying system of Claim 62, further comprising a spring disposed between the plunger and the U-shaped cross piece, the spring adapted to bias the plunger into engagement with the septum cap of the vial shield.

64. The vial shield carrying system of Claim 63 wherein the arms are lowered into the slots of the collar unit, the plunger is engaged with the septum cap of the vial shield and the handle is rotated in a clockwise direction to seat the pins of the collar unit in the hook members of the handle unit.

65. The vial shield carrying system of Claim 64 wherein the handle is rotated in a counter-clockwise direction to disengage the hook members of the handle unit from the pins of the collar unit.

66. The vial shield carrying system of Claim 62 wherein the plunger comprises or is formed from a radioactive shielding material.

67. The vial shield carrying system of Claim 61 wherein the collar unit comprises two members that are pivotally connected to allow the collar unit to engage and disengage the flange of the vial shield.

68. A fluid delivery system, comprising:

a syringe comprising a body defining a discharge outlet and a plunger movably disposed within the body;

a connector comprising a valve member and defining first, second and third ports;

a first tubing segment connected between the discharge outlet of the syringe and the first port of the connector;

a cannula defining a fluid port;

a second tubing segment connected between the fluid port of the cannula and the second port of the connector;

a third tubing segment comprising a first end connected to the third port of the connector and a second end comprising a second connector; and

a per-patient tubing set comprising a first end that is adapted to be connected to the second connector on the second end of the third tubing segment and a patient end that is adapted to be connected to venous access device in a patient.

69. The fluid delivery system of Claim 68 wherein the connector comprises a T-connector and the valve member comprises a stopcock.

70. The fluid delivery system of Claim 68 wherein the second connector comprises a swabable valve or a luer connector.

71. The fluid delivery system of Claim 68 wherein the syringe contains a radiopharmaceutical and is disposed within a lead-shielded container.

72. The fluid delivery system of Claim 68 wherein the syringe is a hand-held syringe.

73. The fluid delivery system of Claim 68 wherein the cannula further comprises:  
a main hub comprising two opposed lateral sides and defining a vent;  
a fluid draw needle in connection with the fluid port and adapted to be placed within a fluid container;

a vent needle in connection with the vent and adapted to be placed within the fluid container; and

two resilient arms connected to the opposed lateral sides of the main hub, each of the two arms comprising a top edge and a hook member formed thereon and extending outwardly therefrom.

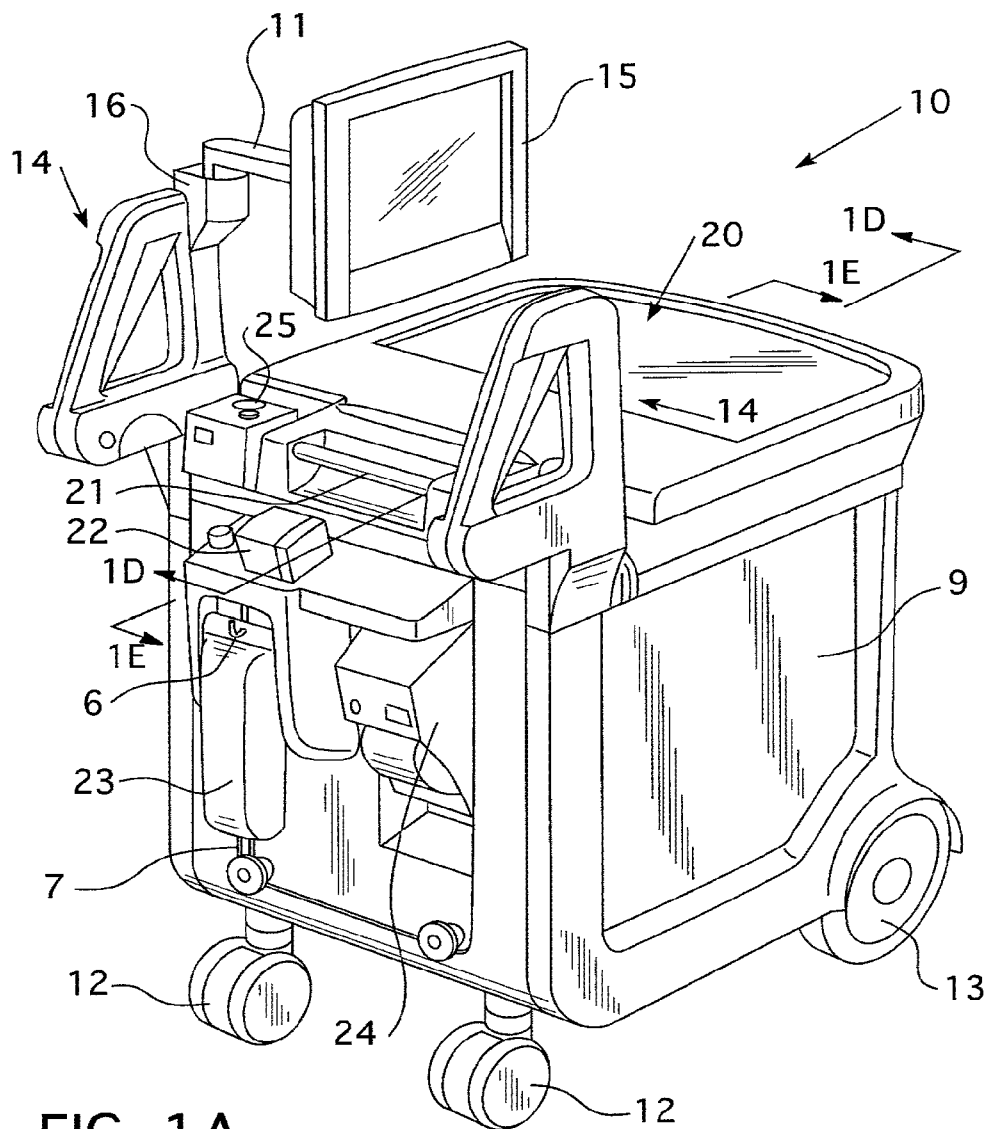


FIG. 1A

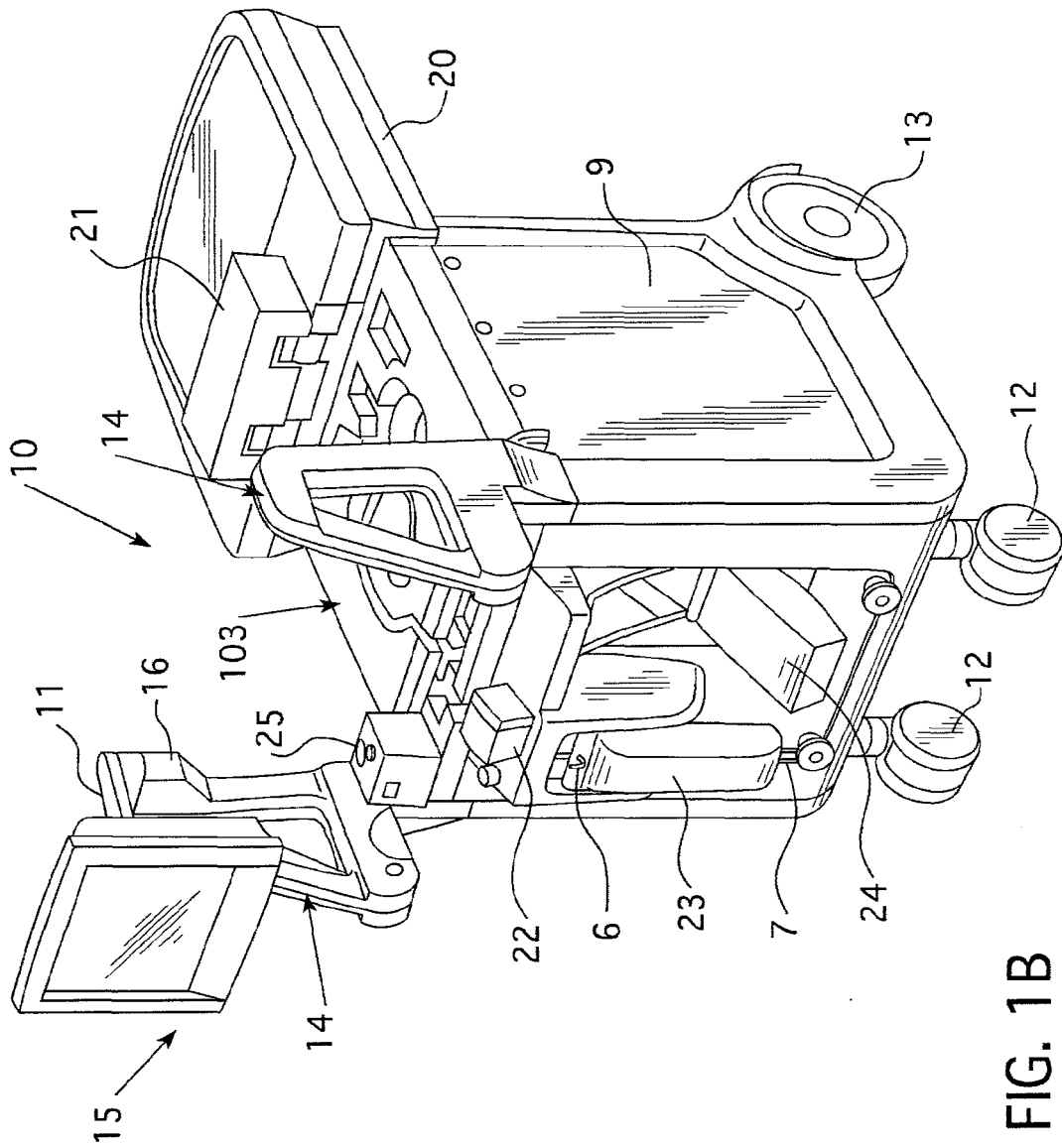


FIG. 1B