

## Electronic Acknowledgement Receipt

<b>EFS ID:</b>	26475067
<b>Application Number:</b>	14876276
<b>International Application Number:</b>	
<b>Confirmation Number:</b>	3403
<b>Title of Invention:</b>	Video Data Compression Systems
<b>First Named Inventor/Applicant Name:</b>	James J. FALLON
<b>Customer Number:</b>	26111
<b>Filer:</b>	Michael V. Messinger/William Flanigen
<b>Filer Authorized By:</b>	Michael V. Messinger
<b>Attorney Docket Number:</b>	3421.005000C
<b>Receipt Date:</b>	27-JUL-2016
<b>Filing Date:</b>	06-OCT-2015
<b>Time Stamp:</b>	19:45:13
<b>Application Type:</b>	Utility under 35 USC 111(a)

### Payment information:

Submitted with Payment	no
------------------------	----

### File Listing:

Document Number	Document Description	File Name	File Size(Bytes)/ Message Digest	Multi Part /.zip	Pages (if appl.)
1	Non Patent Literature	NPL1_Teradata_Amended_Co mplaint_05172016.pdf	560550  1d54993756f1ce46f94d7f594e74d05a7666886b	no	58

### Warnings:

<b>Information:</b>					
2	Non Patent Literature	NPL2_HP_Answer_05202016.pdf	69721 07c16abfe547425e159030866263f5a01508e8b9	no	20
<b>Warnings:</b>					
<b>Information:</b>					
3	Non Patent Literature	NPL3_Realttime_Opening_CC_Brief_05232016.pdf	408358 9cfbfe7e5de4e570716827f79a440c13be66945	no	37
<b>Warnings:</b>					
<b>Information:</b>					
4	Non Patent Literature	NPL4_Agreed_and_Disputed_Construction_05232016.pdf	41230 b3370fdee4fa0375760e2ba46898759417ac17f31	no	4
<b>Warnings:</b>					
The page size in the PDF is too large. The pages should be 8.5 x 11 or A4. If this PDF is submitted, the pages will be resized upon entry into the Image File Wrapper and may affect subsequent processing					
<b>Information:</b>					
5	Non Patent Literature	NPL5_Zeger_Declaration_05232016.pdf	293212 0e812d9edcfcdf9bbf3855ea30278376327d544b5	no	21
<b>Warnings:</b>					
<b>Information:</b>					
6	Non Patent Literature	NPL6_Silver_Peak_Answer_06032016.pdf	71185 3e746586b967b348f06a171916f95fad19574cdc	no	23
<b>Warnings:</b>					
<b>Information:</b>					
7	Non Patent Literature	NPL7_Veritas_Answer_06062016.pdf	105541 8149e418d163c1853152368d5053f5b1a473a6e	no	30
<b>Warnings:</b>					
<b>Information:</b>					
8	Non Patent Literature	NPL8_Dell_Amended_Complaint_06092016.pdf	664764 a53bde5dd66223b2cf0372045f77d3c297ccca4	no	47
<b>Warnings:</b>					

<b>Information:</b>					
9	Non Patent Literature	NPL9_Savvis_Answer_06132016.pdf	56171 c31a5ab43c2842cbf00285cf7946946cf66abb97	no	16
<b>Warnings:</b>					
<b>Information:</b>					
10	Non Patent Literature	NPL10_Responsive_CC_Brief_06132016.pdf	364043 451374d710e75fde0ccd30e2cfa7e00444779e9f3	no	39
<b>Warnings:</b>					
<b>Information:</b>					
11	Non Patent Literature	NPL11_Dell_Creusere_Declaration_06132016.pdf	80785 517fc05ff1004b672667f3522a407e0926c1148	no	10
<b>Warnings:</b>					
<b>Information:</b>					
12	Non Patent Literature	NPL12_Dict_of_Electronics.pdf	372969 63986a44980d59880cd41a99807b69143b1a7745	no	5
<b>Warnings:</b>					
<b>Information:</b>					
13	Non Patent Literature	NPL13_Dell_Motion_Summary_Judgment_06132016.pdf	126631 ed2837ba385fcd33237c99be4e758f9d7ab7c316	no	15
<b>Warnings:</b>					
<b>Information:</b>					
14	Non Patent Literature	NPL14_Prov_App_60136561.pdf	434579 c61826cc7a4ebca168dabc0407d5f4371646613	no	24
<b>Warnings:</b>					
<b>Information:</b>					
15	Non Patent Literature	NPL15_Storer_Declaration_06132016.pdf	374050 cd8a9e551239e6d97892fa04f8bf389f82b6f12f	no	37
<b>Warnings:</b>					
<b>Information:</b>					

16	Non Patent Literature	NPL16_Dell_Answer_to_Amended_Complaint_06232016.pdf	52095 a37d3707dcd004aada3f2b1126189f396369c9d4	no	17
<b>Warnings:</b>					
<b>Information:</b>					
17	Non Patent Literature	NPL17_Actian_Motion_Supplement_Invalidity_06242016.pdf	58501 97ef2ed50e3c76b928e7093fd5cab286731a4f4	no	12
<b>Warnings:</b>					
<b>Information:</b>					
18	Non Patent Literature	NPL18_Actian_Motion_Amend_Invalidity_Ex_A_06242016.pdf	376668 993fca0064386666a1ff17d74459b95bde680baa	no	19
<b>Warnings:</b>					
The page size in the PDF is too large. The pages should be 8.5 x 11 or A4. If this PDF is submitted, the pages will be resized upon entry into the Image File Wrapper and may affect subsequent processing					
<b>Information:</b>					
19	Non Patent Literature	NPL19_Actian_Motion_Amend_Invalidity_Ex_B_06242016.pdf	53800 076ff3fce63663c67a39fb96ce8ea9d12a73208	no	5
<b>Warnings:</b>					
The page size in the PDF is too large. The pages should be 8.5 x 11 or A4. If this PDF is submitted, the pages will be resized upon entry into the Image File Wrapper and may affect subsequent processing					
<b>Information:</b>					
20	Non Patent Literature	NPL20_Actian_Motion_Amend_Invalidity_Ex_C_06242016.pdf	387569 665cdd85953b85ccfb38c3566ab4e2a952519b10	no	20
<b>Warnings:</b>					
The page size in the PDF is too large. The pages should be 8.5 x 11 or A4. If this PDF is submitted, the pages will be resized upon entry into the Image File Wrapper and may affect subsequent processing					
<b>Information:</b>					
21	Non Patent Literature	NPL21_Actian_Motion_Amend_Invalidity_Ex_D_06242016.pdf	388930 a7676d2d5081b37e1d695d46f1563afd17b16e2	no	20
<b>Warnings:</b>					
The page size in the PDF is too large. The pages should be 8.5 x 11 or A4. If this PDF is submitted, the pages will be resized upon entry into the Image File Wrapper and may affect subsequent processing					
<b>Information:</b>					

22	Non Patent Literature	NPL22_Actian_Motion_Amend _Invalidity_Ex_E_06242016.pdf	995487	no	53
			05fbbd80e279aa8fabbb4bd3bf64930c1cc271929		
<b>Warnings:</b>					
The page size in the PDF is too large. The pages should be 8.5 x 11 or A4. If this PDF is submitted, the pages will be resized upon entry into the Image File Wrapper and may affect subsequent processing					
<b>Information:</b>					
23	Non Patent Literature	NPL23_Actian_Motion_Amend _Invalidity_Ex_F_06242016.pdf	266079	no	16
			5afdc5ecf38ebc4f1d6d65e6c216514d2c9ff12		
<b>Warnings:</b>					
The page size in the PDF is too large. The pages should be 8.5 x 11 or A4. If this PDF is submitted, the pages will be resized upon entry into the Image File Wrapper and may affect subsequent processing					
<b>Information:</b>					
24	Non Patent Literature	NPL24_Actian_Motion_Amend _Invalidity_Ex_M_06242016. pdf	79670	no	20
			001716bc494521a8c1ec11fe3903721d87a06518		
<b>Warnings:</b>					
<b>Information:</b>					
25	Non Patent Literature	NPL25_Realtime_Reply_CC_Bri ef_06272016.pdf	82606	no	15
			999579ac3b24dc5d9b6225c1f39add513bc15d2f		
<b>Warnings:</b>					
<b>Information:</b>					
26	Non Patent Literature	NPL26_Realtime_Response_M otion_Partial_Summary_Judg ment_06272016.pdf	113587	no	20
			819a159f84b6c0be7d0b5f41765260634954da6		
<b>Warnings:</b>					
<b>Information:</b>					
27	Non Patent Literature	NPL27_Brief_Supporting_Moti on_for_Summary_Judgment_0 6302016.pdf	81616	no	9
			91effdbad9ac720cb044a7147072e18e19906a54		
<b>Warnings:</b>					
<b>Information:</b>					
28	Non Patent Literature	NPL28_Joint_CC_Chart_A_063 02016.pdf	38715	no	3
			e444c8884a637c13592b50b8803dbed7ad0da90d		

<b>Warnings:</b>					
The page size in the PDF is too large. The pages should be 8.5 x 11 or A4. If this PDF is submitted, the pages will be resized upon entry into the Image File Wrapper and may affect subsequent processing					
<b>Information:</b>					
29	Non Patent Literature	NPL29_Joint_CC_Chart_B_063 02016.pdf	193122  638a306cb0736d61c9f7671b40fa56708d0 3ac0	no	18
<b>Warnings:</b>					
The page size in the PDF is too large. The pages should be 8.5 x 11 or A4. If this PDF is submitted, the pages will be resized upon entry into the Image File Wrapper and may affect subsequent processing					
<b>Information:</b>					
30	Non Patent Literature	NPL30_Realtime_Notice_of_Su ppl_Facts_07052016.pdf	32032  0c5733ca39d782c005e76bd40be00ad8e14 3e504	no	3
<b>Warnings:</b>					
<b>Information:</b>					
31	Non Patent Literature	NPL31_Oracle_Motion_to_Sup pl_CC_Record_07112016.pdf	45822  7a941dde376b1fa66ceb46b6b48b06037af 7cc2c	no	10
<b>Warnings:</b>					
<b>Information:</b>					
32	Non Patent Literature	NPL32_Joint_CC_Statement_0 7132016.pdf	43308  f7f46af5287fcf996e263cb443a422762e678 e7d	no	5
<b>Warnings:</b>					
<b>Information:</b>					
33	Non Patent Literature	NPL33_Joint_CC_Statement_E x_A_07132016.pdf	56485  c7de7bfc8b56d7062b484c18786259f94eb 5703e	no	5
<b>Warnings:</b>					
The page size in the PDF is too large. The pages should be 8.5 x 11 or A4. If this PDF is submitted, the pages will be resized upon entry into the Image File Wrapper and may affect subsequent processing					
<b>Information:</b>					
34	Non Patent Literature	NPL34_Realtime_Response_to _Motion_to_Suppl_CC_Record _07142016.pdf	99668  6de08fdeb265cc3bf9bbebc1057a7c7e0365a 1f93	no	14
<b>Warnings:</b>					
<b>Information:</b>					

35	Non Patent Literature	NPL35_Rackspace_Complaint_06292016.pdf	2270488	no	216
			c7a94e99cf67811961206b0a2be233e27cc56acc		
<b>Warnings:</b>					
<b>Information:</b>					
36	Non Patent Literature	NPL36_Fujitsu_Complaint_07212016.pdf	1302477	no	137
			2c54d914d8a179380b3308dfac5df24be45e9ecf		
<b>Warnings:</b>					
<b>Information:</b>					
37	Non Patent Literature	NPL37_Vembu_Complaint_07222016.pdf	836346	no	86
			badaa78f5637ce5a98877af817591fd12d77578e		
<b>Warnings:</b>					
<b>Information:</b>					
38	Non Patent Literature	NPL38_NFOA_14844973_05172016.pdf	83435	no	18
			20f5605117c0069f1ab06f69b98267cda74a1930		
<b>Warnings:</b>					
<b>Information:</b>					
39	Non Patent Literature	NPL39_NFOA_14727309_06072016.pdf	72208	no	15
			cdae208ecec6c6c6c23cc23713897f799b527e494		
<b>Warnings:</b>					
<b>Information:</b>					
40	Non Patent Literature	NPL40_NIIRC_95001581_06022016.pdf	34078	no	5
			297766e3a222eb4d72696c8adf3b25d8f1199b1b		
<b>Warnings:</b>					
<b>Information:</b>					
41	Non Patent Literature	NPL41_NIIRC_95001533_06142016.pdf	40745	no	6
			e3d32e225ac506ba2b0ae8bab117d2c7ce0c49f3		
<b>Warnings:</b>					
<b>Information:</b>					

42	Non Patent Literature	NPL42_Reexam_Cert_95001581_07082016.pdf	22619	no	2
			2fad885064df03593c0b8881849498f5d8af aled		
<b>Warnings:</b>					
<b>Information:</b>					
43	Non Patent Literature	NPL43_NIIRC_95001544_07152016.pdf	38704	no	5
			fd4355802a38025ba54a44461f9c683c186a 284c		
<b>Warnings:</b>					
<b>Information:</b>					
44	Non Patent Literature	NPL44_Reexam_Cert_95001533_07222016.pdf	25517	no	2
			1f54453805b0f1ff9b32ceae2d490a3518e9 89b		
<b>Warnings:</b>					
<b>Information:</b>					
45	Non Patent Literature	NPL45_IPR201600373_Institution_Decision_06272016.pdf	192996	no	32
			ea63ae92cce57810e90343eb59fda2246 22ec0		
<b>Warnings:</b>					
<b>Information:</b>					
46	Non Patent Literature	NPL46_IPR201600374_Institution_Decision_06272016.pdf	168181	no	28
			03a772d3b380d25849a46f6c8a16a688c09d 463df		
<b>Warnings:</b>					
<b>Information:</b>					
47	Non Patent Literature	NPL47_IPR201600375_Institution_Decision_07012016.pdf	61002	no	13
			24a411a4b2ac7cee6fc3d85746f47436887f 497f		
<b>Warnings:</b>					
<b>Information:</b>					
48	Non Patent Literature	NPL48_IPR201600376_Institution_Decision_07012016.pdf	90606	no	18
			a3c357c0b405f14d783c41ddaafda4675ff8 a647		
<b>Warnings:</b>					
<b>Information:</b>					



49	Non Patent Literature	NPL49_IPR201600377_Institution_Decision_07012016.pdf	93218	no	16
			1b2d476e6c66f93933aa0ce029eac43443b4e45		
<b>Warnings:</b>					
<b>Information:</b>					
50	Non Patent Literature	NPL50_IPR201601365_Petition_07082016.pdf	505563	no	77
			c8e045c0d4ace1b54c8ae60f9d19826eb39da9dd		
<b>Warnings:</b>					
<b>Information:</b>					
51	Non Patent Literature	NPL51_IPR201601365_1002_608_FH.pdf	6197849	no	507
			61beec8010bb75a611dad81d873cb68618c781ec		
<b>Warnings:</b>					
<b>Information:</b>					
52	Non Patent Literature	NPL52_IPR201601365_1003_Neuhauser_Decl_07082016.pdf	676680	no	174
			2a0455dae701f094a84816cc7a2977b06d5d515c		
<b>Warnings:</b>					
<b>Information:</b>					
53	Non Patent Literature	NPL53_IPR201601365_1007_Burrows_1992.pdf	113409	no	27
			7871707c76ce07cdaba28f2fc0f4d11b4a0b357		
<b>Warnings:</b>					
<b>Information:</b>					
54	Non Patent Literature	NPL54_IPR201601365_1010_Hennessy_1990.pdf	1728887	no	36
			7d4e76e92fd63e95bca4b745257bd3e63b24a8f6		
<b>Warnings:</b>					
<b>Information:</b>					
55	Non Patent Literature	NPL55_IPR201601365_1010_Part1of2_Prosise_1993.pdf	8488160	no	29
			f3d6e281aa8143252c1b5dcb250d664a0abb005		
<b>Warnings:</b>					
<b>Information:</b>					

56	Non Patent Literature	NPL55_IPR201601365_1010_Pa rt2of2_Proprise_1993.pdf	1764954	no	13
			9d71292d5c403a2dd8f781098e258557333 815c5		
<b>Warnings:</b>					
<b>Information:</b>					
57	Non Patent Literature	NPL56_IPR201601365_1013_M icrosoft_Comp_Dict_1997.pdf	263628	no	5
			2b91111185f5844530cf4481210bb64979a 0f3e7		
<b>Warnings:</b>					
<b>Information:</b>					
58	Non Patent Literature	NPL57_IPR201601365_1014_P CI_System_Architecture_1999. pdf	537938	no	11
			2becc04cf1dbd5e79d8928624dd3bfaaa82 697a5		
<b>Warnings:</b>					
<b>Information:</b>					
59	Non Patent Literature	NPL58_IPR201601365_1016_St orer_1982.pdf	1029964	no	24
			a344b55850ca50f6ffdd20699413b8cb1b82 7383		
<b>Warnings:</b>					
<b>Information:</b>					
60	Non Patent Literature	NPL59_IPR201601366_Petition _07082016.pdf	542493	no	77
			ef858a6828e549cbcdca57bbac1ffe7518578 0890		
<b>Warnings:</b>					
<b>Information:</b>					
<b>Total Files Size (in bytes):</b>			34651694		

**This Acknowledgement Receipt evidences receipt on the noted date by the USPTO of the indicated documents, characterized by the applicant, and including page counts, where applicable. It serves as evidence of receipt similar to a Post Card, as described in MPEP 503.**

**New Applications Under 35 U.S.C. 111**

**If a new application is being filed and the application includes the necessary components for a filing date (see 37 CFR 1.53(b)-(d) and MPEP 506), a Filing Receipt (37 CFR 1.54) will be issued in due course and the date shown on this Acknowledgement Receipt will establish the filing date of the application.**

**National Stage of an International Application under 35 U.S.C. 371**

**If a timely submission to enter the national stage of an international application is compliant with the conditions of 35 U.S.C. 371 and other applicable requirements a Form PCT/DO/EO/903 indicating acceptance of the application as a national stage submission under 35 U.S.C. 371 will be issued in addition to the Filing Receipt, in due course.**

**New International Application Filed with the USPTO as a Receiving Office**

**If a new international application is being filed and the international application includes the necessary components for an international filing date (see PCT Article 11 and MPEP 1810), a Notification of the International Application Number and of the International Filing Date (Form PCT/RO/105) will be issued in due course, subject to prescriptions concerning national security, and the date shown on this Acknowledgement Receipt will establish the international filing date of the application.**

Under the Paperwork Reduction Act of 1995, no persons are required to respond to a collection of information unless it displays a valid OMB control number.

<b>PATENT APPLICATION FEE DETERMINATION RECORD</b> Substitute for Form PTO-875			Application or Docket Number <b>14/876,276</b>	Filing Date <b>10/06/2015</b>	<input type="checkbox"/> To be Mailed
<b>ENTITY:</b> <input checked="" type="checkbox"/> LARGE <input type="checkbox"/> SMALL <input type="checkbox"/> MICRO					
<b>APPLICATION AS FILED – PART I</b>					
(Column 1)		(Column 2)			
FOR	NUMBER FILED	NUMBER EXTRA	RATE (\$)	FEE (\$)	
<input type="checkbox"/> BASIC FEE <small>(37 CFR 1.16(a), (b), or (c))</small>	N/A	N/A	N/A		
<input type="checkbox"/> SEARCH FEE <small>(37 CFR 1.16(k), (l), or (m))</small>	N/A	N/A	N/A		
<input type="checkbox"/> EXAMINATION FEE <small>(37 CFR 1.16(o), (p), or (q))</small>	N/A	N/A	N/A		
TOTAL CLAIMS <small>(37 CFR 1.16(i))</small>	minus 20 =	*	X \$ =		
INDEPENDENT CLAIMS <small>(37 CFR 1.16(h))</small>	minus 3 =	*	X \$ =		
<input type="checkbox"/> APPLICATION SIZE FEE <small>(37 CFR 1.16(s))</small>	If the specification and drawings exceed 100 sheets of paper, the application size fee due is \$310 (\$155 for small entity) for each additional 50 sheets or fraction thereof. See 35 U.S.C. 41(a)(1)(G) and 37 CFR 1.16(s).				
<input type="checkbox"/> MULTIPLE DEPENDENT CLAIM PRESENT <small>(37 CFR 1.16(j))</small>					
* If the difference in column 1 is less than zero, enter "0" in column 2.			TOTAL		

<b>APPLICATION AS AMENDED – PART II</b>								
(Column 1)		(Column 2)		(Column 3)				
<b>AMENDMENT</b>	<b>07/27/2016</b>	CLAIMS REMAINING AFTER AMENDMENT		HIGHEST NUMBER PREVIOUSLY PAID FOR	PRESENT EXTRA	RATE (\$)	ADDITIONAL FEE (\$)	
	Total (37 CFR 1.16(i))	* 30	Minus	** 30	= 0	X \$80 =	0	
	Independent (37 CFR 1.16(h))	* 2	Minus	*** 3	= 0	X \$420 =	0	
	<input type="checkbox"/> Application Size Fee (37 CFR 1.16(s))							
	<input type="checkbox"/> FIRST PRESENTATION OF MULTIPLE DEPENDENT CLAIM (37 CFR 1.16(j))							
TOTAL ADD'L FEE						<b>0</b>		

(Column 1)		(Column 2)		(Column 3)				
<b>AMENDMENT</b>		CLAIMS REMAINING AFTER AMENDMENT		HIGHEST NUMBER PREVIOUSLY PAID FOR	PRESENT EXTRA	RATE (\$)	ADDITIONAL FEE (\$)	
	Total (37 CFR 1.16(i))	*	Minus	**	=	X \$ =		
	Independent (37 CFR 1.16(h))	*	Minus	***	=	X \$ =		
	<input type="checkbox"/> Application Size Fee (37 CFR 1.16(s))							
	<input type="checkbox"/> FIRST PRESENTATION OF MULTIPLE DEPENDENT CLAIM (37 CFR 1.16(j))							
TOTAL ADD'L FEE								
* If the entry in column 1 is less than the entry in column 2, write "0" in column 3.						LIE /DEBRA SAVOY/		
** If the "Highest Number Previously Paid For" IN THIS SPACE is less than 20, enter "20".								
*** If the "Highest Number Previously Paid For" IN THIS SPACE is less than 3, enter "3".								
The "Highest Number Previously Paid For" (Total or Independent) is the highest number found in the appropriate box in column 1.								

This collection of information is required by 37 CFR 1.16. The information is required to obtain or retain a benefit by the public which is to file (and by the USPTO to process) an application. Confidentiality is governed by 35 U.S.C. 122 and 37 CFR 1.14. This collection is estimated to take 12 minutes to complete, including gathering, preparing, and submitting the completed application form to the USPTO. Time will vary depending upon the individual case. Any comments on the amount of time you require to complete this form and/or suggestions for reducing this burden, should be sent to the Chief Information Officer, U.S. Patent and Trademark Office, U.S. Department of Commerce, P.O. Box 1450, Alexandria, VA 22313-1450. DO NOT SEND FEES OR COMPLETED FORMS TO THIS ADDRESS. **SEND TO: Commissioner for Patents, P.O. Box 1450, Alexandria, VA 22313-1450.**  
 If you need assistance in completing the form, call 1-800-PTO-9199 and select option 2.



UNITED STATES PATENT AND TRADEMARK OFFICE

UNITED STATES DEPARTMENT OF COMMERCE
United States Patent and Trademark Office
Address: COMMISSIONER FOR PATENTS
P.O. Box 1450
Alexandria, Virginia 22313-1450
www.uspto.gov

NOTICE OF ALLOWANCE AND FEE(S) DUE

26111 7590 06/06/2016
STERNE, KESSLER, GOLDSTEIN & FOX P.L.L.C.
1100 NEW YORK AVENUE, N.W.
WASHINGTON, DC 20005

EXAMINER

BOCURE, TESFALDET

ART UNIT PAPER NUMBER

2634

DATE MAILED: 06/06/2016

Table with 5 columns: APPLICATION NO., FILING DATE, FIRST NAMED INVENTOR, ATTORNEY DOCKET NO., CONFIRMATION NO.
14/876,276 10/06/2015 James J. FALLON 3421.005000C 3403

TITLE OF INVENTION: Video Data Compression Systems

Table with 7 columns: APPLN. TYPE, ENTITY STATUS, ISSUE FEE DUE, PUBLICATION FEE DUE, PREV. PAID ISSUE FEE, TOTAL FEE(S) DUE, DATE DUE
nonprovisional UNDISCOUNTED \$960 \$0 \$0 \$960 09/06/2016

THE APPLICATION IDENTIFIED ABOVE HAS BEEN EXAMINED AND IS ALLOWED FOR ISSUANCE AS A PATENT. PROSECUTION ON THE MERITS IS CLOSED. THIS NOTICE OF ALLOWANCE IS NOT A GRANT OF PATENT RIGHTS. THIS APPLICATION IS SUBJECT TO WITHDRAWAL FROM ISSUE AT THE INITIATIVE OF THE OFFICE OR UPON PETITION BY THE APPLICANT. SEE 37 CFR 1.313 AND MPEP 1308.

THE ISSUE FEE AND PUBLICATION FEE (IF REQUIRED) MUST BE PAID WITHIN THREE MONTHS FROM THE MAILING DATE OF THIS NOTICE OR THIS APPLICATION SHALL BE REGARDED AS ABANDONED. THIS STATUTORY PERIOD CANNOT BE EXTENDED. SEE 35 U.S.C. 151. THE ISSUE FEE DUE INDICATED ABOVE DOES NOT REFLECT A CREDIT FOR ANY PREVIOUSLY PAID ISSUE FEE IN THIS APPLICATION. IF AN ISSUE FEE HAS PREVIOUSLY BEEN PAID IN THIS APPLICATION (AS SHOWN ABOVE), THE RETURN OF PART B OF THIS FORM WILL BE CONSIDERED A REQUEST TO REAPPLY THE PREVIOUSLY PAID ISSUE FEE TOWARD THE ISSUE FEE NOW DUE.

HOW TO REPLY TO THIS NOTICE:

I. Review the ENTITY STATUS shown above. If the ENTITY STATUS is shown as SMALL or MICRO, verify whether entitlement to that entity status still applies.

If the ENTITY STATUS is the same as shown above, pay the TOTAL FEE(S) DUE shown above.

If the ENTITY STATUS is changed from that shown above, on PART B - FEE(S) TRANSMITTAL, complete section number 5 titled "Change in Entity Status (from status indicated above)".

For purposes of this notice, small entity fees are 1/2 the amount of undiscounted fees, and micro entity fees are 1/2 the amount of small entity fees.

II. PART B - FEE(S) TRANSMITTAL, or its equivalent, must be completed and returned to the United States Patent and Trademark Office (USPTO) with your ISSUE FEE and PUBLICATION FEE (if required). If you are charging the fee(s) to your deposit account, section "4b" of Part B - Fee(s) Transmittal should be completed and an extra copy of the form should be submitted. If an equivalent of Part B is filed, a request to reapply a previously paid issue fee must be clearly made, and delays in processing may occur due to the difficulty in recognizing the paper as an equivalent of Part B.

III. All communications regarding this application must give the application number. Please direct all communications prior to issuance to Mail Stop ISSUE FEE unless advised to the contrary.

IMPORTANT REMINDER: Utility patents issuing on applications filed on or after Dec. 12, 1980 may require payment of maintenance fees. It is patentee's responsibility to ensure timely payment of maintenance fees when due.

**PART B - FEE(S) TRANSMITTAL**

**Complete and send this form, together with applicable fee(s), to: Mail Mail Stop ISSUE FEE  
 Commissioner for Patents  
 P.O. Box 1450  
 Alexandria, Virginia 22313-1450  
 or Fax (571)-273-2885**

**INSTRUCTIONS:** This form should be used for transmitting the ISSUE FEE and PUBLICATION FEE (if required). Blocks 1 through 5 should be completed where appropriate. All further correspondence including the Patent, advance orders and notification of maintenance fees will be mailed to the current correspondence address as indicated unless corrected below or directed otherwise in Block 1, by (a) specifying a new correspondence address; and/or (b) indicating a separate "FEE ADDRESS" for maintenance fee notifications.

CURRENT CORRESPONDENCE ADDRESS (Note: Use Block 1 for any change of address)

26111                      7590                      06/06/2016  
**STERNE, KESSLER, GOLDSTEIN & FOX P.L.L.C.**  
 1100 NEW YORK AVENUE, N.W.  
 WASHINGTON, DC 20005

Note: A certificate of mailing can only be used for domestic mailings of the Fee(s) Transmittal. This certificate cannot be used for any other accompanying papers. Each additional paper, such as an assignment or formal drawing, must have its own certificate of mailing or transmission.

**Certificate of Mailing or Transmission**  
 I hereby certify that this Fee(s) Transmittal is being deposited with the United States Postal Service with sufficient postage for first class mail in an envelope addressed to the Mail Stop ISSUE FEE address above, or being facsimile transmitted to the USPTO (571) 273-2885, on the date indicated below.

(Depositor's name)
(Signature)
(Date)

APPLICATION NO.	FILING DATE	FIRST NAMED INVENTOR	ATTORNEY DOCKET NO.	CONFIRMATION NO.
14/876,276	10/06/2015	James J. FALLON	3421.005000C	3403

TITLE OF INVENTION: Video Data Compression Systems

APPLN. TYPE	ENTITY STATUS	ISSUE FEE DUE	PUBLICATION FEE DUE	PREV. PAID ISSUE FEE	TOTAL FEE(S) DUE	DATE DUE
nonprovisional	UNDISCOUNTED	\$960	\$0	\$0	\$960	09/06/2016

EXAMINER	ART UNIT	CLASS-SUBCLASS
BOCURE, TESFALDET	2634	375-240100

<p>1. Change of correspondence address or indication of "Fee Address" (37 CFR 1.363).</p> <p><input type="checkbox"/> Change of correspondence address (or Change of Correspondence Address form PTO/SB/122) attached.</p> <p><input type="checkbox"/> "Fee Address" indication (or "Fee Address" Indication form PTO/SB/47; Rev 03-02 or more recent) attached. <b>Use of a Customer Number is required.</b></p>	<p>2. For printing on the patent front page, list</p> <p>(1) The names of up to 3 registered patent attorneys or agents OR, alternatively, _____ 1</p> <p>(2) The name of a single firm (having as a member a registered attorney or agent) and the names of up to 2 registered patent attorneys or agents. If no name is listed, no name will be printed. _____ 2</p> <p>_____ 3</p>
-------------------------------------------------------------------------------------------------------------------------------------------------------------------------------------------------------------------------------------------------------------------------------------------------------------------------------------------------------------------------------------------------------------------	---------------------------------------------------------------------------------------------------------------------------------------------------------------------------------------------------------------------------------------------------------------------------------------------------------------------------------------------------------------------------------------

3. ASSIGNEE NAME AND RESIDENCE DATA TO BE PRINTED ON THE PATENT (print or type)

PLEASE NOTE: Unless an assignee is identified below, no assignee data will appear on the patent. If an assignee is identified below, the document has been filed for recordation as set forth in 37 CFR 3.11. Completion of this form is NOT a substitute for filing an assignment.

(A) NAME OF ASSIGNEE \_\_\_\_\_ (B) RESIDENCE: (CITY and STATE OR COUNTRY) \_\_\_\_\_

Please check the appropriate assignee category or categories (will not be printed on the patent):  Individual  Corporation or other private group entity  Government

<p>4a. The following fee(s) are submitted:</p> <p><input type="checkbox"/> Issue Fee</p> <p><input type="checkbox"/> Publication Fee (No small entity discount permitted)</p> <p><input type="checkbox"/> Advance Order - # of Copies _____</p>	<p>4b. Payment of Fee(s): (<b>Please first reapply any previously paid issue fee shown above</b>)</p> <p><input type="checkbox"/> A check is enclosed.</p> <p><input type="checkbox"/> Payment by credit card. Form PTO-2038 is attached.</p> <p><input type="checkbox"/> The director is hereby authorized to charge the required fee(s), any deficiency, or credits any overpayment, to Deposit Account Number _____ (enclose an extra copy of this form).</p>
-------------------------------------------------------------------------------------------------------------------------------------------------------------------------------------------------------------------------------------------------	------------------------------------------------------------------------------------------------------------------------------------------------------------------------------------------------------------------------------------------------------------------------------------------------------------------------------------------------------------------------------------------------------------------------------------------------------------------

5. **Change in Entity Status** (from status indicated above)

Applicant certifying micro entity status. See 37 CFR 1.29

Applicant asserting small entity status. See 37 CFR 1.27

Applicant changing to regular undiscounted fee status.

**NOTE:** Absent a valid certification of Micro Entity Status (see forms PTO/SB/15A and 15B), issue fee payment in the micro entity amount will not be accepted at the risk of application abandonment.

**NOTE:** If the application was previously under micro entity status, checking this box will be taken to be a notification of loss of entitlement to micro entity status.

**NOTE:** Checking this box will be taken to be a notification of loss of entitlement to small or micro entity status, as applicable.

NOTE: This form must be signed in accordance with 37 CFR 1.31 and 1.33. See 37 CFR 1.4 for signature requirements and certifications.

Authorized Signature _____	Date _____
Typed or printed name _____	Registration No. _____



UNITED STATES PATENT AND TRADEMARK OFFICE

UNITED STATES DEPARTMENT OF COMMERCE
United States Patent and Trademark Office
Address: COMMISSIONER FOR PATENTS
P.O. Box 1450
Alexandria, Virginia 22313-1450
www.uspto.gov

Table with 5 columns: APPLICATION NO., FILING DATE, FIRST NAMED INVENTOR, ATTORNEY DOCKET NO., CONFIRMATION NO.

26111 7590 06/06/2016
STERNE, KESSLER, GOLDSTEIN & FOX P.L.L.C.
1100 NEW YORK AVENUE, N.W.
WASHINGTON, DC 20005

EXAMINER

BOCURE, TESHALDET

ART UNIT PAPER NUMBER

2634

DATE MAILED: 06/06/2016

Determination of Patent Term Adjustment under 35 U.S.C. 154 (b)
(Applications filed on or after May 29, 2000)

The Office has discontinued providing a Patent Term Adjustment (PTA) calculation with the Notice of Allowance.

Section 1(h)(2) of the AIA Technical Corrections Act amended 35 U.S.C. 154(b)(3)(B)(i) to eliminate the requirement that the Office provide a patent term adjustment determination with the notice of allowance. See Revisions to Patent Term Adjustment, 78 Fed. Reg. 19416, 19417 (Apr. 1, 2013). Therefore, the Office is no longer providing an initial patent term adjustment determination with the notice of allowance. The Office will continue to provide a patent term adjustment determination with the Issue Notification Letter that is mailed to applicant approximately three weeks prior to the issue date of the patent, and will include the patent term adjustment on the patent. Any request for reconsideration of the patent term adjustment determination (or reinstatement of patent term adjustment) should follow the process outlined in 37 CFR 1.705.

Any questions regarding the Patent Term Extension or Adjustment determination should be directed to the Office of Patent Legal Administration at (571)-272-7702. Questions relating to issue and publication fee payments should be directed to the Customer Service Center of the Office of Patent Publication at 1-(888)-786-0101 or (571)-272-4200.

## OMB Clearance and PRA Burden Statement for PTOL-85 Part B

The Paperwork Reduction Act (PRA) of 1995 requires Federal agencies to obtain Office of Management and Budget approval before requesting most types of information from the public. When OMB approves an agency request to collect information from the public, OMB (i) provides a valid OMB Control Number and expiration date for the agency to display on the instrument that will be used to collect the information and (ii) requires the agency to inform the public about the OMB Control Number's legal significance in accordance with 5 CFR 1320.5(b).

The information collected by PTOL-85 Part B is required by 37 CFR 1.311. The information is required to obtain or retain a benefit by the public which is to file (and by the USPTO to process) an application. Confidentiality is governed by 35 U.S.C. 122 and 37 CFR 1.14. This collection is estimated to take 12 minutes to complete, including gathering, preparing, and submitting the completed application form to the USPTO. Time will vary depending upon the individual case. Any comments on the amount of time you require to complete this form and/or suggestions for reducing this burden, should be sent to the Chief Information Officer, U.S. Patent and Trademark Office, U.S. Department of Commerce, P.O. Box 1450, Alexandria, Virginia 22313-1450. DO NOT SEND FEES OR COMPLETED FORMS TO THIS ADDRESS. SEND TO: Commissioner for Patents, P.O. Box 1450, Alexandria, Virginia 22313-1450. Under the Paperwork Reduction Act of 1995, no persons are required to respond to a collection of information unless it displays a valid OMB control number.

### Privacy Act Statement

**The Privacy Act of 1974 (P.L. 93-579)** requires that you be given certain information in connection with your submission of the attached form related to a patent application or patent. Accordingly, pursuant to the requirements of the Act, please be advised that: (1) the general authority for the collection of this information is 35 U.S.C. 2(b)(2); (2) furnishing of the information solicited is voluntary; and (3) the principal purpose for which the information is used by the U.S. Patent and Trademark Office is to process and/or examine your submission related to a patent application or patent. If you do not furnish the requested information, the U.S. Patent and Trademark Office may not be able to process and/or examine your submission, which may result in termination of proceedings or abandonment of the application or expiration of the patent.

The information provided by you in this form will be subject to the following routine uses:

1. The information on this form will be treated confidentially to the extent allowed under the Freedom of Information Act (5 U.S.C. 552) and the Privacy Act (5 U.S.C. 552a). Records from this system of records may be disclosed to the Department of Justice to determine whether disclosure of these records is required by the Freedom of Information Act.
2. A record from this system of records may be disclosed, as a routine use, in the course of presenting evidence to a court, magistrate, or administrative tribunal, including disclosures to opposing counsel in the course of settlement negotiations.
3. A record in this system of records may be disclosed, as a routine use, to a Member of Congress submitting a request involving an individual, to whom the record pertains, when the individual has requested assistance from the Member with respect to the subject matter of the record.
4. A record in this system of records may be disclosed, as a routine use, to a contractor of the Agency having need for the information in order to perform a contract. Recipients of information shall be required to comply with the requirements of the Privacy Act of 1974, as amended, pursuant to 5 U.S.C. 552a(m).
5. A record related to an International Application filed under the Patent Cooperation Treaty in this system of records may be disclosed, as a routine use, to the International Bureau of the World Intellectual Property Organization, pursuant to the Patent Cooperation Treaty.
6. A record in this system of records may be disclosed, as a routine use, to another federal agency for purposes of National Security review (35 U.S.C. 181) and for review pursuant to the Atomic Energy Act (42 U.S.C. 218(c)).
7. A record from this system of records may be disclosed, as a routine use, to the Administrator, General Services, or his/her designee, during an inspection of records conducted by GSA as part of that agency's responsibility to recommend improvements in records management practices and programs, under authority of 44 U.S.C. 2904 and 2906. Such disclosure shall be made in accordance with the GSA regulations governing inspection of records for this purpose, and any other relevant (i.e., GSA or Commerce) directive. Such disclosure shall not be used to make determinations about individuals.
8. A record from this system of records may be disclosed, as a routine use, to the public after either publication of the application pursuant to 35 U.S.C. 122(b) or issuance of a patent pursuant to 35 U.S.C. 151. Further, a record may be disclosed, subject to the limitations of 37 CFR 1.14, as a routine use, to the public if the record was filed in an application which became abandoned or in which the proceedings were terminated and which application is referenced by either a published application, an application open to public inspection or an issued patent.
9. A record from this system of records may be disclosed, as a routine use, to a Federal, State, or local law enforcement agency, if the USPTO becomes aware of a violation or potential violation of law or regulation.



<b>Notice of Allowability</b>	<b>Application No.</b> 14/876,276	<b>Applicant(s)</b> FALLON ET AL.	
	<b>Examiner</b> TESFALDET BOCURE	<b>Art Unit</b> 2634	<b>AIA (First Inventor to File) Status</b> No

**-- The MAILING DATE of this communication appears on the cover sheet with the correspondence address--**

All claims being allowable, PROSECUTION ON THE MERITS IS (OR REMAINS) CLOSED in this application. If not included herewith (or previously mailed), a Notice of Allowance (PTOL-85) or other appropriate communication will be mailed in due course. **THIS NOTICE OF ALLOWABILITY IS NOT A GRANT OF PATENT RIGHTS.** This application is subject to withdrawal from issue at the initiative of the Office or upon petition by the applicant. See 37 CFR 1.313 and MPEP 1308.

1.  This communication is responsive to RCE and IDS of 05/16/2016.  
 A declaration(s)/affidavit(s) under **37 CFR 1.130(b)** was/were filed on \_\_\_\_\_.

2.  An election was made by the applicant in response to a restriction requirement set forth during the interview on \_\_\_\_\_; the restriction requirement and election have been incorporated into this action.

3.  The allowed claim(s) is/are 1-30. As a result of the allowed claim(s), you may be eligible to benefit from the **Patent Prosecution Highway** program at a participating intellectual property office for the corresponding application. For more information, please see [http://www.uspto.gov/patents/init\\_events/poh/index.jsp](http://www.uspto.gov/patents/init_events/poh/index.jsp) or send an inquiry to [PPHfeedback@uspto.gov](mailto:PPHfeedback@uspto.gov).

4.  Acknowledgment is made of a claim for foreign priority under 35 U.S.C. § 119(a)-(d) or (f).

**Certified copies:**

a)  All    b)  Some    \*c)  None of the:

1.  Certified copies of the priority documents have been received.

2.  Certified copies of the priority documents have been received in Application No. \_\_\_\_\_.

3.  Copies of the certified copies of the priority documents have been received in this national stage application from the International Bureau (PCT Rule 17.2(a)).

\* Certified copies not received: \_\_\_\_\_.

Applicant has THREE MONTHS FROM THE "MAILING DATE" of this communication to file a reply complying with the requirements noted below. Failure to timely comply will result in ABANDONMENT of this application.  
**THIS THREE-MONTH PERIOD IS NOT EXTENDABLE.**

5.  CORRECTED DRAWINGS ( as "replacement sheets") must be submitted.  
 including changes required by the attached Examiner's Amendment / Comment or in the Office action of Paper No./Mail Date \_\_\_\_\_.

**Identifying indicia such as the application number (see 37 CFR 1.84(c)) should be written on the drawings in the front (not the back) of each sheet. Replacement sheet(s) should be labeled as such in the header according to 37 CFR 1.121(d).**

6.  DEPOSIT OF and/or INFORMATION about the deposit of BIOLOGICAL MATERIAL must be submitted. Note the attached Examiner's comment regarding REQUIREMENT FOR THE DEPOSIT OF BIOLOGICAL MATERIAL.

**Attachment(s)**

1. <input type="checkbox"/> Notice of References Cited (PTO-892)	5. <input checked="" type="checkbox"/> Examiner's Amendment/Comment
2. <input checked="" type="checkbox"/> Information Disclosure Statements (PTO/SB/08), Paper No./Mail Date _____	6. <input type="checkbox"/> Examiner's Statement of Reasons for Allowance
3. <input type="checkbox"/> Examiner's Comment Regarding Requirement for Deposit of Biological Material	7. <input type="checkbox"/> Other _____
4. <input type="checkbox"/> Interview Summary (PTO-413), Paper No./Mail Date _____	

/TESFALDET BOCURE/ Primary Examiner, Art Unit 2634	
-------------------------------------------------------	--

### **DETAILED ACTION**

1. The present application is being examined under the pre-AIA first to invent provisions.
2. This office action (Notice of Allowance) is in response to the IDS and RCE filed on 05/16/2016. The pending claims 1-30 are now allowed.

### ***Information Disclosure Statement***

3. The information disclosure statements (IDS) submitted on 05/16/2016 (two IDSs filed on the same date) are in compliance with the provisions of 37 CFR 1.97. Accordingly, the information disclosure statement is being considered by the examiner. Attached with this correspondence are the initialed copies of the IDSs.

### ***Conclusion***

4. Any inquiry concerning this communication or earlier communications from the examiner should be directed to TESHALDET BOCURE whose telephone number is (571)272-3015. The examiner can normally be reached on 8:30am-to-5:00pm.

If attempts to reach the examiner by telephone are unsuccessful, the examiner's supervisor, Daniel C. Washburn can be reached on 571-272-5551. The fax phone number for the organization where this application or proceeding is assigned is 571-273-8300.

Information regarding the status of an application may be obtained from the Patent Application Information Retrieval (PAIR) system. Status information for published applications may be obtained from either Private PAIR or Public PAIR. Status information for unpublished applications is available through Private PAIR only. For more information about the PAIR system, see <http://pair-direct.uspto.gov>. Should you have questions on access to the Private PAIR system, contact the Electronic Business Center (EBC) at 866-217-9197 (toll-free). If you would like assistance from a USPTO Customer Service Representative or access to the automated information system, call 800-786-9199 (IN USA OR CANADA) or 571-272-1000.

/TESFALDET BOCURE/  
Primary Examiner, Art Unit 2634

/T. B./  
Primary Examiner, Art Unit 2634

## WEST Search History for Application 14876276

Creation Date: 2016052921:02

### Prior Art Searches

Query	DB	Hits	Op.	Plur.	Thes.	Date
((Fallen adj James).in. or (McErlain adj Stephen).in.)	PGPB, USPT, USOC, EPAB, JPAB, DWPI, TDBD	n/a	OR	YES		05-29-2016
((Fallen).in. or (McErlain).in.)	PGPB, USPT, USOC, EPAB, JPAB, DWPI, TDBD	n/a	OR	YES		05-29-2016
(select\$4 or choos\$4) near4 ((multiple or plural\$4 or two or three or four or five) near5 encoder\$) same ((assymetric\$ or (lempel adj2 ziv)) near4 (compressing or compression))	PGPB, USPT, USOC, EPAB, JPAB, DWPI, TDBD	n/a	OR	YES		05-29-2016
(select\$4 or choos\$4) near4 ((multiple or plural\$4 or two or three or four or five) near5 encoder\$) and ((assymetric\$ or (lempel adj2 ziv)) near4 (compressing or compression))	PGPB, USPT, USOC, EPAB, JPAB, DWPI, TDBD	n/a	OR	YES		05-29-2016
((select\$4 or choos\$4) near4 ((multiple or plural\$4 or two or three or four or five) near5 encoder\$) and ((assymetric\$ or (lempel adj2 ziv)) near4 (compressing or compression)) ) and @ad<=20010213	PGPB, USPT, USOC, EPAB, JPAB, DWPI, TDBD	n/a	OR	YES		05-29-2016
((select\$4 or choos\$4) near4 ((multiple or plural\$4 or two or three or four or five) near5 encoder\$) and ((assymetric\$ or (lempel adj2 ziv)) near4	PGPB, USPT, USOC,	n/a	OR	YES		05-29-2016

<b>((compressing or compression)) ) and ( ((Fallen adj James).in. or (McErlain adj Stephen).in.) ) or (((Fallen).in. or (McErlain).in.) ) )</b>	EPAB, JPAB, DWPI, TDBD					
<b>((select\$4 or choos\$4) near4 ((multiple or plural\$4 or two or three or four or five) near5 encoder\$) and ((assymetric\$ or (lempel adj2 ziv)) near4 (compressing or compression)) ) and ( ((Fallen adj James).in. or (McErlain adj Stephen).in.) ) )</b>	PGPB, USPT, USOC, EPAB, JPAB, DWPI, TDBD	n/a	OR	YES		05-29-2016
<b>(selecting or select or choose or choosing) near4 ((compress or compression or compressing) near4 (algorithm or algorithms or mode or modes)) same ((assymetric\$4 or (lempel adj2 ziv)) near4 (compressing or compression))</b>	PGPB, USPT, USOC, EPAB, JPAB, DWPI, TDBD	n/a	OR	YES		05-29-2016
<b>((compress or compression or compressing) near4 (algorithm or algorithms or mode or modes)) same (parameter or parameters or attribute or attributes) same (assymetric \$4near4 (compressing or compression))</b>	PGPB, USPT, USOC, EPAB, JPAB, DWPI, TDBD	n/a	OR	YES		05-29-2016
<b>((compress or compression or compressing) near4 (algorithm or algorithms or mode or modes)) same (parameter or parameters or attribute or attributes) same (assymetric\$4 near4 (compressing or compression))</b>	PGPB, USPT, USOC, EPAB, JPAB, DWPI, TDBD	n/a	OR	YES		05-29-2016
<b>((compress or compression or compressing) near4 (algorithm or algorithms or mode or modes)) same (parameter or parameters or attribute or attributes) same ((fast near4 slow) near4 (compressing or compression))</b>	PGPB, USPT, USOC, EPAB, JPAB, DWPI, TDBD	n/a	OR	YES		05-29-2016
<b>((multiple or plural\$4 or two or three or four or five) near5 encoder\$) same ((assymetric\$ or (lempel adj2 ziv)) near4 (compressing or compression))</b>	PGPB, USPT, USOC, EPAB, JPAB, DWPI, TDBD	n/a	OR	YES		05-29-2016

<p>((selecting or select or choose or choosing) near4 ((compress or compression or compressing) near4 (algorithm or algorithms or mode or modes)) same ((assymmetric\$4 or (lempel adj2 ziv)) near4 (compressing or compression)) ) and (((((H03M7/30))))   (((H03M7/3084))))   (((H03M7/6094))))   (((G06F15/7867))))   (((G06T1/60))))   (((H04N19/136))))).CPC. )</p>	PGPB, USPT, USOC, EPAB, JPAB, DWPI, TDBD	n/a	OR	YES		05-29-2016
<p>((multiple or plural\$4 or two or three or four or five) near5 encoder\$) same ((assymmetric\$ or (lempel adj2 ziv)) near4 (compressing or compression)) ) and (((((H03M7/30))))   (((H03M7/3059))))   (((H03M7/3093))))   (((H04L69/04))))   (((H04N19/152))))   (((H04N9/8042))))).CPC. )</p>	PGPB, USPT, USOC, EPAB, JPAB, DWPI, TDBD	n/a	OR	YES		05-29-2016
<p>("20010019630"   "20010031092"   "20010032128"   "20010047473"   "20010052038"   "20020037035"   "20020069354"   "20020078241"   "20020080871"   "20020097172"   "20020101367"   "20020104891"   "20020126755"   "20020169950"   "20020191692"   "20030030575"   "20030034905"   "20030058873"   "20030084238").PN.</p>	PGPB, USPT, USOC, EPAB, JPAB, DWPI, TDBD	n/a	OR	YES		05-29-2016
<p>((((375/\$8))).ccls. or ((370/\$8)).ccls. or ((348/\$8)).ccls. or ((341/\$8)).ccls. or ((711/\$8)).ccls. or ((701/\$8)).ccls. or ((381/\$8)).ccls. or ((375/382)).ccls. )</p>	PGPB, USPT, USOC, EPAB, JPAB, DWPI, TDBD	n/a	OR	YES		05-29-2016
<p>((((375/\$8))).ccls. or ((370/\$8)).ccls. or ((348/\$8)).ccls. or ((341/\$8)).ccls. or ((711/\$8)).ccls. or ((701/\$8)).ccls. or ((381/\$8)).ccls. or ((375/382)).ccls. ) and ( ((select\$4 or choos\$4) near4 ((multiple or plural\$4 or two or three or four or five) near5 encoder\$) and ((assymmetric\$ or (lempel adj2 ziv)) near4 (compressing or compression)) ) or ((selecting or select or choose or choosing) near4 ((compress or compression or compressing) near4 (algorithm or algorithms or mode or modes)) same ((assymmetric\$4 or (lempel adj2 ziv)) near4 (compressing or compression)) ) or (((multiple or plural\$4 or two or three or four or five) near5 encoder\$) same ((assymmetric\$ or (lempel adj2 ziv)) near4 (compressing or compression)) ) )</p>	PGPB, USPT, USOC, EPAB, JPAB, DWPI, TDBD	n/a	OR	YES		05-29-2016
<p>((((375/240))).ccls. or ((375/240.01)).ccls. or ((375/240.02)).ccls. or ((341/50)).ccls. or</p>	PGPB, USPT,	n/a	OR	YES		05-29-2016

(((341/51))).cls. or (((341/126))).cls. ) and ( (select\$4 or choos\$4) near4 ((multiple or plural\$4 or two or three or four or five) near5 encoder\$) and ((assymetric\$ or (lempel adj2 ziv)) near4 (compressing or compression)) ) or ((selecting or select or choose or choosing) near4 ((compress or compression or compressing) near4 (algorithm or algorithms or mode or modes)) same ((assymetric\$4 or (lempel adj2 ziv)) near4 (compressing or compression)) ) or (((multiple or plural\$4 or two or three or four or five) near5 encoder\$) same ((assymetric\$ or (lempel adj2 ziv)) near4 (compressing or compression)) ) )	USOC, EPAB, JPAB, DWPI, TDBD					
((multiple or plural\$4 or two or three or four or five) near5 encoder\$) same ((assymetric\$3 or (lempel adj2 ziv) and (arithmetic)) near4 (compressing or compression))	PGPB, USPT, USOC, EPAB, JPAB, DWPI, TDBD	n/a	OR	YES		05-29-2016
( (select\$4 or choos\$4) near4 ((multiple or plural\$4 or two or three or four or five) near5 encoder\$) and ((assymetric\$ or (lempel adj2 ziv)) near4 (compressing or compression)) ) or ((selecting or select or choose or choosing) near4 ((compress or compression or compressing) near4 (algorithm or algorithms or mode or modes)) same ((assymetric\$4 or (lempel adj2 ziv)) near4 (compressing or compression)) ) or (((multiple or plural\$4 or two or three or four or five) near5 encoder\$) same ((assymetric\$ or (lempel adj2 ziv)) near4 (compressing or compression)) ) or (((multiple or plural\$4 or two or three or four or five) near5 encoder\$) same ((assymetric\$3 or (lempel adj2 ziv) and (arithmetic)) near4 (compressing or compression)) ) )	PGPB, USPT, USOC, EPAB, JPAB, DWPI, TDBD	n/a	OR	YES		05-29-2016
((select\$4 or choos\$4) near4 ((multiple or plural\$4 or two or three or four or five) near5 encoder\$) and ((assymetric\$ or (lempel adj2 ziv)) near4 (compressing or compression)) or (selecting or select or choose or choosing) near4 ((compress or compression or compressing) near4 (algorithm or algorithms or mode or modes)) same ((assymetric\$4 or (lempel adj2 ziv)) near4 (compressing or compression)) or ((multiple or plural\$4 or two or three or four or five) near5 encoder\$) same ((assymetric\$ or (lempel adj2 ziv)) near4 (compressing or compression)) or ((multiple or plural\$4 or two or three or four or five) near5 encoder\$) same ((assymetric\$3 or (lempel adj2 ziv) and (arithmetic)) near4 (compressing or compression)) ) )	PGPB, USPT, USOC, EPAB, JPAB, DWPI, TDBD	n/a	OR	YES		05-29-2016

<p>encoder\$) same ((asymmetric\$3 or (lempel adj2 ziv) and (arithmetic)) near4 (compressing or compression)) ) and (((375/240)).ccls. or ((375/240.01)).ccls. or ((375/240.02)).ccls. or ((341/50)).ccls. or ((341/51)).ccls. or ((341/126)).ccls. ) and ((select\$4 or choos\$4) near4 ((multiple or plural\$4 or two or three or four or five) near5 encoder\$) and ((asymmetric\$ or (lempel adj2 ziv)) near4 (compressing or compression)) or (selecting or select or choose or choosing) near4 ((compress or compression or compressing) near4 (algorithm or algorithms or mode or modes)) same ((asymmetric\$4 or (lempel adj2 ziv)) near4 (compressing or compression)) or ((multiple or plural\$4 or two or three or four or five) near5 encoder\$) same ((asymmetric\$ or (lempel adj2 ziv)) near4 (compressing or compression)) ) )</p>						
<p>((select\$4 or choos\$4) near4 ((multiple or plural\$4 or two or three or four or five) near5 encoder\$) and ((asymmetric\$ or (lempel adj2 ziv)) near4 (compressing or compression)) or (selecting or select or choose or choosing) near4 ((compress or compression or compressing) near4 (algorithm or algorithms or mode or modes)) same ((asymmetric\$4 or (lempel adj2 ziv)) near4 (compressing or compression)) or ((multiple or plural\$4 or two or three or four or five) near5 encoder\$) same ((asymmetric\$ or (lempel adj2 ziv)) near4 (compressing or compression)) or ((multiple or plural\$4 or two or three or four or five) near5 encoder\$) same ((asymmetric\$3 or (lempel adj2 ziv) and (arithmetic)) near4 (compressing or compression)) ) and (((375/\$8)).ccls. or ((370/\$8)).ccls. or ((348/\$8)).ccls. or ((341/\$8)).ccls. or ((711/\$8)).ccls. or ((701/\$8)).ccls. or ((381/\$8)).ccls. or ((375/382)).ccls. ) )</p>	<p>PGPB, USPT, USOC, EPAB, JPAB, DWPI, TDBD</p>	<p>n/a</p>	<p>OR</p>	<p>YES</p>		<p>05-29-2016</p>
<p>((select\$4 or choos\$4) near4 ((multiple or plural\$4 or two or three or four or five) near5 encoder\$) and ((asymmetric\$ or (lempel adj2 ziv)) near4 (compressing or compression)) or (selecting or select or choose or choosing) near4 ((compress or compression or compressing) near4 (algorithm or algorithms or mode or modes)) same ((asymmetric\$4 or (lempel adj2 ziv)) near4 (compressing or compression)) or ((multiple or plural\$4 or two or three or four or five) near5 encoder\$) same ((asymmetric\$ or (lempel adj2 ziv))</p>	<p>PGPB, USPT, USOC, EPAB, JPAB, DWPI, TDBD</p>	<p>n/a</p>	<p>OR</p>	<p>YES</p>		<p>05-29-2016</p>



near4 (compressing or compression)) or ((multiple or plural\$4 or two or three or four or five) near5 encoder\$) same ((assymetric\$3 or (lempel adj2 ziv) and (arithmetic)) near4 (compressing or compression)) ) ) and (((H03M7/30))   ((H03M7/3059))   ((H03M7/3084))   ((H03M7/6094))   ((H03M7/3088))   ((H03M7/6023))   ((H03M7/6064))   ((H04N19/152))   ((G11B20/00007))),CPC. )						
("20150334390"   "3394352"   "3490690"   "4021782"   "4032893"   "4054951"   "4127518"   "4302775"   "4325085"   "4360840"   "4386416"   "4394774"   "4464650"   "4494108"   "4499499"   "4574351"   "4626829"   "4646061"   "4682150"   "4701745").PN.	PGPB, USPT, USOC, EPAB, JPAB, DWPI, TDBD	n/a	OR	YES		05-29-2016
("20150334390"   "3394352"   "3490690"   "4021782"   "4032893"   "4054951"   "4127518"   "4302775"   "4325085"   "4360840"   "4386416"   "4394774"   "4464650"   "4494108"   "4499499"   "4574351"   "4626829"   "4646061"   "4682150"   "4701745").PN. ) and ((select\$4 or choos\$4) near4 ((multiple or plural\$4 or two or three or four or five) near5 encoder\$) and ((assymetric\$ or (lempel adj2 ziv)) near4 (compressing or compression)) or (selecting or select or choose or choosing) near4 ((compress or compression or compressing) near4 (algorithm or algorithms or mode or modes)) same ((assymetric\$4 or (lempel adj2 ziv)) near4 (compressing or compression)) or ((multiple or plural\$4 or two or three or four or five) near5 encoder\$) same ((assymetric\$ or (lempel adj2 ziv)) near4 (compressing or compression)) or ((multiple or plural\$4 or two or three or four or five) near5 encoder\$) same ((assymetric\$3 or (lempel adj2 ziv) and (arithmetic)) near4 (compressing or compression)) ) )	PGPB, USPT, USOC, EPAB, JPAB, DWPI, TDBD	n/a	OR	YES		05-29-2016
("4558302"   "4568983"   "5046119"   "5227878"   "5333212"   "5379351"   "5379356"   "5402146"   "5408542"   "5684478"   "5870036"   "6023233"   "6092071"   "6169499"   "6215983"   "6370631"   "6404919"   "20160029018"   "5479210"   "5590317"   "5710562"   "6233017"   "6744926"   "7496586"   "5479210"   "5590317"   "5710562"   "6233017"   "6744926"   "7496586"   "3560639"   "5467134"   "5623483"   "5664226").PN.	PGPB, USPT, USOC, EPAB, JPAB, DWPI, TDBD	n/a	OR	YES		05-29-2016
((select\$4 or choos\$4) near4 ((multiple or plural\$4 or two or three or four or five) near5 encoder\$)	PGPB, USPT,	60	OR	YES		05-29-2016

<p>and ((assymetric\$ or (lempel adj2 ziv)) near4 (compressing or compression)) or (selecting or select or choose or choosing) near4 ((compress or compression or compressing) near4 (algorithm or algorithms or mode or modes)) same ((assymetric\$4 or (lempel adj2 ziv)) near4 (compressing or compression)) or ((multiple or plural\$4 or two or three or four or five) near5 encoder\$) same ((assymetric\$ or (lempel adj2 ziv)) near4 (compressing or compression)) or ((multiple or plural\$4 or two or three or four or five) near5 encoder\$) same ((assymetric\$3 or (lempel adj2 ziv) and (arithmetic)) near4 (compressing or compression)) ) ) and ((H03M7/30)   (H03M7/3084)   (H03M7/6094)   (H04N19/164)   HO4N19/176   (H04N19/103)).CPC.</p>	<p>USOC, EPAB, JPAB, DWPI, TDBD</p>					
<p>("20160127512"   "20160127513"   "5479638"   "5771354").PN.</p>	<p>PGPB, USPT, USOC, EPAB, JPAB, DWPI, TDBD</p>	<p>8</p>	<p>OR</p>	<p>YES</p>		<p>05-29-2016</p>


**UNITED STATES PATENT AND TRADEMARK OFFICE**

UNITED STATES DEPARTMENT OF COMMERCE  
**United States Patent and Trademark Office**  
 Address: COMMISSIONER FOR PATENTS  
 P.O. Box 1450  
 Alexandria, Virginia 22313-1450  
 www.uspto.gov

**BIB DATA SHEET**
**CONFIRMATION NO. 3403**

SERIAL NUMBER	FILING or 371(c) DATE RULE	CLASS	GROUP ART UNIT	ATTORNEY DOCKET NO.	
14/876,276	10/06/2015	375	2634	3421.005000C	
<b>APPLICANTS</b> Realtime Data, LLC, Armonk, NY; <b>INVENTORS</b> James J. FALLON, Armonk, NY; Stephen J. MCERLAIN, Astoria, NY; <b>** CONTINUING DATA *****</b> This application is a CON of 14/733,565 06/08/2015 which is a CON of 14/577,286 12/19/2014 ABN which is a CON of 14/134,933 12/19/2013 PAT 8929442 which is a CON of 14/033,245 09/20/2013 PAT 8934535 which is a CON of 13/154,239 06/06/2011 PAT 8553759 which is a CON of 12/123,081 05/19/2008 PAT 8073047 which is a CON of 10/076,013 02/13/2002 PAT 7386046 which claims benefit of 60/268,394 02/13/2001 <b>** FOREIGN APPLICATIONS *****</b> <b>** IF REQUIRED, FOREIGN FILING LICENSE GRANTED **</b> 10/20/2015					
Foreign Priority claimed <input type="checkbox"/> Yes <input checked="" type="checkbox"/> No 35 USC 119(a-d) conditions met <input type="checkbox"/> Yes <input checked="" type="checkbox"/> No Verified and /TESFALDET BOCCURE/ Acknowledged _____ Examiner's Signature	<input type="checkbox"/> Met after Allowance _____ Initials	<b>STATE OR            COUNTRY</b> NY	<b>SHEETS            DRAWINGS</b> 4	<b>TOTAL            CLAIMS</b> 30	<b>INDEPENDENT            CLAIMS</b> 2
<b>ADDRESS</b> STERNE, KESSLER, GOLDSTEIN & FOX P.L.L.C. 1100 NEW YORK AVENUE, N.W. WASHINGTON, DC 20005 UNITED STATES					
<b>TITLE</b> Video Data Compression Systems					
<b>FILING FEE            RECEIVED</b> 2400	FEES: Authority has been given in Paper No. _____ to charge/credit DEPOSIT ACCOUNT No. _____ for following:		<input type="checkbox"/> All Fees <input type="checkbox"/> 1.16 Fees (Filing) <input type="checkbox"/> 1.17 Fees (Processing Ext. of time) <input type="checkbox"/> 1.18 Fees (Issue) <input type="checkbox"/> Other _____ <input type="checkbox"/> Credit		

IN THE UNITED STATES PATENT AND TRADEMARK OFFICE

Inventors: FALLON *et al.*

Confirmation No.: 3403

Applicant: Realtime Data, LLC

Art Unit: 2634

Application No.: 14/876,276

Examiner: BOCURE, TESFALDET

Filing Date: October 6, 2015

Atty. Docket: 3421.005000C

Title: **Video Data Compression Systems**

**Sixth Supplemental Information Disclosure Statement**

*Mail Stop RCE*

Commissioner for Patents  
PO Box 1450  
Alexandria, VA 22313-1450

Commissioner:

Notice of Prior and Concurrent Proceedings

Applicant hereby calls to the attention of the Patent and Trademark Office the following reexamination proceedings involving patents that are commonly-assigned with the patent in the above-identified patent application:

<b>Proceeding</b>	<b>Status</b>
Inter Partes Reexamination of U.S. Patent No. 6,604,158 (Control No. 95/000,486)	Inter Partes Reexamination Certificate issued 10/10/2012
Inter Partes Reexamination of U.S. Patent No. 7,321,937 (Control No. 95/000,466)	Inter Partes Reexamination Certificate issued 05/15/2012
Inter Partes Reexamination of U.S. Patent No. 6,604,158 (Control No. 95/000,453)	Terminated
Ex Parte Reexamination of U.S. Patent No. 6,601,104 (Control No. 90/009,428)	Ex Parte Reexamination Certificate issued 02/28/2012
Inter Partes Reexamination of U.S. Patent No. 7,378,992 (Control No. 95/000,478)	Inter Partes Reexamination Certificate issued 10/04/2012
Inter Partes Reexamination of U.S. Patent No. 6,624,761 (Control No. 95/000,464)	Inter Partes Reexamination Certificate issued 06/12/2012
Inter Partes Reexamination of U.S. Patent No. 7,161,506 (Control No. 95/000,479)	Inter Partes Reexamination Certificate issued 05/22/2012

/Tesfaldet Bocure/

05/29/2016

ALL REFERENCES CONSIDERED EXCEPT WHERE LINED THROUGH. /T.B./

<b>Proceeding</b>	<b>Status</b>
Inter Partes Reexamination of U.S. Patent No. 7,714,747 (Control No. 95/001,517)	Appeal to the Court of Appeals for the Federal Circuit dismissed 6/4/2015
Inter Partes Reexamination of U.S. Patent No. 7,417,568 (Control No. 95/001,533)	Decision on Appeal mailed 10/29/2015
Inter Partes Reexamination of U.S. Patent No. 7,777,651 (Control No. 95/001,581)	Decision on Appeal mailed 10/29/2015
Inter Partes Reexamination of U.S. Patent No. 7,400,274 (Control No. 95/001,544)	Decision on Appeal mailed 10/29/2015

Applicant hereby calls to the attention of the Patent and Trademark Office the following reexamination proceedings filed by Cellco Partnership d/b/a Verizon Wireless, involving patents that are commonly-assigned with the patent in the above-identified patent application:

<b>Proceeding</b>	<b>Status</b>
Inter Partes Reexamination of U.S. Patent No. 7,321,937 (Control No. 95/001,922)	Inter Partes Reexamination Certificate issued 12/05/2013
Inter Partes Reexamination of U.S. Patent No. 6,604,158 (Control No. 95/001,923)	Inter Partes Reexamination Certificate issued 04/17/2015
Inter Partes Reexamination of U.S. Patent No. 7,352,300 (Control No. 95/001,924)	Inter Partes Reexamination Certificate issued 08/04/2014
Inter Partes Reexamination of U.S. Patent No. 7,395,345 (Control No. 95/001,925)	Inter Partes Reexamination Certificate issued 11/03/2014
Inter Partes Reexamination of U.S. Patent No. 7,161,506 (Control No. 95/001,926)	Inter Partes Reexamination Certificate issued 01/08/2014
Inter Partes Reexamination of U.S. Patent No. 7,415,530 (Control No. 95/001,927)	Inter Partes Reexamination Certificate issued 08/16/2013
Inter Partes Reexamination of U.S. Patent No. 7,378,992 (Control No. 95/001,928)	Inter Partes Reexamination Certificate issued 01/08/2014

Applicant invites the Examiner to review the Requests for Reexamination, issued Office Actions, replies, and any other papers in the above-identified reexamination proceedings. If the Examiner is unable to obtain copies of papers in any reexamination proceeding, copies can be

/Tsfaldet Bocure/

05/29/2016

Atty. Dkt. No. 3421.005000C

ALL REFERENCES CONSIDERED EXCEPT WHERE LINED THROUGH. /T.B./

provided to the Examiner upon request. Those documents which may be material that are not already of record in this patent application are listed on the accompanying Form PTO/SB/08.

Applicant hereby calls to the attention of the Patent and Trademark Office the following *inter partes* review proceedings involving patents that are commonly-assigned with the patent in the above-identified patent application:

Proceeding	Patent	Status
<i>Oracle America, Inc. v. Realtime Data, LLC</i> , IPR2016-00373	7,378,992	Patent Owner Preliminary Response filed April 7, 2016
<i>Oracle America, Inc. v. Realtime Data, LLC</i> , IPR2016-00374	8,643,513	Patent Owner Preliminary Response filed April 8, 2016
<i>Oracle America, Inc. v. Realtime Data, LLC</i> , IPR2016-00375	7,415,530	Patent Owner Preliminary Response filed April 11, 2016
<i>Oracle America, Inc. v. Realtime Data, LLC</i> , IPR2016-00376	7,415,530	Patent Owner Preliminary Response filed April 11, 2016
<i>Oracle America, Inc. v. Realtime Data, LLC</i> , IPR2016-00377	9,116,908	Patent Owner Preliminary Response filed April 11, 2016
<i>SAP America Inc., et al. v. Realtime Data, LLC d/b/a IXO</i> , IPR2016-00783	6,597,812	Petition filed April 1, 2016
<i>Dell Inc., et al. v. Realtime Data, LLC</i> , IPR2016-00878	7,415,530	Petition filed April 22, 2016
<i>Dell Inc., et al. v. Realtime Data, LLC</i> , IPR2016-00972	7,415,530	Petition filed April 29, 2016
<i>Riverbed Technology, Inc. et al. v. Realtime Data, LLC</i> , IPR2016-00978	8,643,513	Petition filed April 29, 2016
<i>Riverbed Technology, Inc. et al. v. Realtime Data, LLC</i> , IPR2016-00980	7,378,992	Petition filed April 29, 2016
<i>Dell Inc., et al. v. Realtime Data, LLC</i> , IPR2016-01002	9,116,908	Petition filed May 5, 2016

/Tsfaldet Bocure/

05/29/2016

Atty. Dkt. No. 3421.005000C

ALL REFERENCES CONSIDERED EXCEPT WHERE LINED THROUGH. /T.B./

Applicant invites the Examiner to review the petitions for *inter partes* review and any other papers in the above-identified *inter partes* review proceedings. If the Examiner is unable to obtain copies of papers in any *inter partes* review proceeding, copies can be provided to the Examiner upon request. Those documents which may be material that are not already of record in this patent application are listed on the accompanying Form PTO/SB/08 as documents **US1-US2, FP1-FP2, and NPL8-NPL19.**

Notice of Related Litigation

Applicant notifies the Patent and Trademark Office of the following litigation involving U.S. Patents commonly-owned with the current patent application, the subject matter of which may be related to the present patent application:

No.	Case	Status
1	<i>Realtime Data LLC d/b/a IXO v. Packeteer, Inc. et al.</i> , No. 6:08-cv-00144-LED (E.D. Texas)	Dismissed

Applicant also notifies the Patent and Trademark Office of the following additional litigation involving U.S. Patents commonly-owned with the current patent application, the subject matter of which may be related to the present patent application:

No.	Case	Status
2	<i>Realtime Data LLC d/b/a IXO v. Thomson Reuters Corporation et al.</i> No. 1:11-cv-06698-RJH (S.D. New York) (transferred from E.D. Texas; 6:09-cv-00333-LED)	Case Terminated 11/9/2012; Opinion of the Court of Appeals for the Federal Circuit received 01/27/2014

/Tsfaldet Bocure/

05/29/2016

Atty. Dkt. No. 3421.005000C

ALL REFERENCES CONSIDERED EXCEPT WHERE LINED THROUGH. /T.B./

3	<i>Realtime Data LLC d/b/a IXO v. Morgan Stanley et al.</i> , No. 1:11-cv-06696-RJH (S.D. New York) (transferred from E.D. Texas; 6:09-cv-00326-LED)	Case Terminated 11/9/2012; Opinion of the Court of Appeals for the Federal Circuit received 01/27/2014
4	<i>Realtime Data LLC d/b/a IXO v. CME Group Inc., et al.</i> , No. 1:11-cv-06697-RJH (S.D. New York) (transferred from E.D. Texas; No. 6:09-cv-00327-LED)	Case Terminated 11/9/2012; Opinion of the Court of Appeals for the Federal Circuit received 01/27/2014
5	<i>Chicago Board Options Exchange, Inc., v. Realtime Data LLC d/b/a IXO</i> , No. 09-cv-4486 (N.D. Ill.)	Dismissed
6	<i>Thomson Reuters Corporation v. Realtime Data, LLC d/b/a IXO</i> , No. 1:09-cv-07868-RMB (S.D.N.Y)	Consolidated with Case No. 2
7	<i>Realtime Data, LLC d/b/a IXO v. CME Group Inc., et al. (II)</i> , No. 6:10-cv-246 (E.D. Texas)	Consolidated with Case No. 4
8	<i>Realtime Data LLC d/b/a IXO v. Thomson Reuters Corporation et al. (II)</i> , No. 6:10-cv-247 (E.D. Texas)	Consolidated with Case No. 2
9	<i>Realtime Data, LLC d/b/a IXO v. Morgan Stanley, et al. (II)</i> , No. 6:10-cv-248 (E.D. Texas)	Consolidated with Case No. 3
10	<i>Realtime Data, LLC d/b/a IXO v. MetroPCS Texas, LLC et al.</i> , No. 6:10-cv-00493 (E.D. Texas)	Appeal Terminated
11	<i>Realtime Data, LLC d/b/a IXO v. Microsoft Corporation, et al.</i> , No. 4:14-cv-00827 (E.D. Texas)	Dismissed May 1, 2015
12	<i>Realtime Data, LLC d/b/a IXO v. Actian Corporation, et al.</i> , No. 6:15-cv-00463 (E.D. Texas)	Amended Complaints for Patent Infringement filed September 14, 2015
13	<i>Realtime Data, LLC d/b/a IXO v. Dropbox, Inc.</i> , No. 6:15-cv-00465 (E.D. Texas)	Transferred to the Northern District of California, January 16, 2016; Answer to Amended Complaint filed February 4, 2016
14	<i>Realtime Data, LLC d/b/a IXO v. Echostar Corporation, et al.</i> , No. 6:15-cv-00466 (E.D. Texas)	Consolidated with Case No. 12; Answer to Amended Complaint filed February 4, 2016

/Tesfaldet Bocure/

05/29/2016

Atty. Dkt. No. 3421.005000C

ALL REFERENCES CONSIDERED EXCEPT WHERE LINED THROUGH. /T.B./



15	<i>Realtime Data, LLC d/b/a IXO v. Riverbed Technology, Inc., et al.</i> , No. 6:15-cv-00468 (E.D. Texas)	Consolidated with Case No. 12; Second Amended Complaint for Infringement filed February 2, 2016
16	<i>Realtime Data, LLC d/b/a IXO v. BMC Software, Inc.</i> , No. 6:15-cv-00464 (E.D. Texas)	Terminated October 5, 2015
17	<i>Realtime Data, LLC d/b/a IXO v. Oracle America, Inc., et al.</i> , No. 6:15-cv-00467 (E.D. Texas)	Consolidated with Case No. 12
18	<i>Realtime Data, LLC d/b/a IXO v. SAP America, Inc., et al.</i> , No. 6:15-cv-00469 (E.D. Texas)	Consolidated with Case No. 12; Answers to Amended Complaint filed February 4, 2016
19	<i>Realtime Data, LLC d/b/a IXO v. Teradata Corporation, et al.</i> , No. 5:16-cv-01836 (N.D. Cal.) (formerly no. 6:15-cv-00470 (E.D. Texas))	Transferred to the Northern District of California, January 19, 2016
20	<i>Realtime Data, LLC d/b/a IXO v. Apple Inc.</i> , No. 6:15-cv-00885 (E.D. Texas)	Order Granting Motion to Stay entered February 11, 2016
21	<i>Realtime Data LLC d/b/a IXO v. Hewlett Packard Enterprise Co., et al.</i> , No. 6:16-cv-00086 (E.D. Texas)	Complaint filed February 26, 2016
22	<i>Realtime Data LLC d/b/a IXO v. Oracle America, Inc.</i> , No. 6:16-cv-00088 (E.D. Texas)	Complaint filed February 26, 2016
23	<i>Realtime Data LLC d/b/a IXO v. CenturyLink, Inc., et al.</i> , No. 6:16-cv-00087 (E.D. Texas)	Complaint filed February 26, 2016
24	<i>Realtime Data LLC d/b/a IXO v. Dell, Inc., et al.</i> , No. 6:16-cv-00089 (E.D. Texas)	Complaint filed February 26, 2016
25	<i>Realtime Data LLC d/b/a IXO v. Teradata Operations, Inc.</i> , No. 2:16-cv-02743 (C.D. Cal.)	Complaint filed April 21, 2016

An updated court docket for a pending litigation is submitted herewith as document **NPL20**.

Information Disclosure Statement

Listed on accompanying IDS Forms PTO/SB/08a equivalent and PTO/SB/08b equivalent are documents that may be considered material to the patentability of this application as defined in

/Tesfaldet Bocure/

05/29/2016

Atty. Dkt. No. 3421.005000C

ALL REFERENCES CONSIDERED EXCEPT WHERE LINED THROUGH. /T.B./

37 C.F.R. §1.56, and in compliance with the duty of disclosure requirements of 37 C.F.R. §§ 1.97 and 1.98.

Applicant has listed publication dates on the attached IDS Forms based on information presently available to the undersigned. However, the listed publication dates should not be construed as an admission that the information was actually published on the date indicated.

Applicant reserves the right to establish the patentability of the claimed invention over any of the information provided herewith, and/or to prove that this information may not be prior art, and/or to prove that this information may not be enabling for the teachings purportedly offered.

This statement should not be construed as a representation that a search has been made, or that information more material to the examination of the present patent application does not exist. The Examiner is specifically requested not to rely solely on the material submitted herewith.

Filing under 37 C.F.R. § 1.97(b). This Information Disclosure Statement is being filed before the mailing of a first Office Action after the filing of a request for continued examination under 37 C.F.R. § 1.114. No statement or fee is required.

Copies of documents **FP1-FP2** and **NPL1-NPL20** are submitted. However, in accordance with 37 C.F.R. § 1.98(a)(2)(ii), no copies of the U.S. patents and patent application publications cited as documents **US1-US4** on the attached IDS Forms are submitted.

Applicant submits herewith Office Actions from the co-pending U.S. Patent Application Nos.:

Document **NPL6** is a copy of a Notice of Allowance mailed April 26, 2016, in the prosecution of co-pending, commonly-assigned U.S. Patent Application No. 14/727,309.

/Tsfaldet Bocure/

05/29/2016

Atty. Dkt. No. 3421.005000C

ALL REFERENCES CONSIDERED EXCEPT WHERE LINED THROUGH. /T.B./

Document **NPL7** is a copy of a Notice of Allowance mailed May 6, 2016, in the prosecution of co-pending, commonly-assigned U.S. Patent Application No. 14/733,565.

The identification of these Office Actions is not to be construed as a waiver of secrecy as to those applications now or upon issuance of the present application as a patent. The Examiner is respectfully requested to consider the cited applications and the art cited therein during examination.

It is expected that the examiner will review the prosecution and cited art in the parent application nos. 14/733,565, filed June 8, 2015 (now pending); 14/577,286, filed December 19, 2014 (now abandoned); 14/134,933, filed December 19, 2013 (now U.S. Patent No. 8,929,442); 14/033,245, filed September 20, 2013 (now U.S. Patent No. 8,934,535); 13/154,239, filed June 6, 2011 (now U.S. Patent No. 8,553,759); 12/123,081, filed May 19, 2008 (now U.S. Patent No. 8,073,047); and 10/076,013, filed February 13, 2002 (now U.S. Patent No. 7,386,046), in accordance with MPEP 2001.06(b), and indicate in the next communication from the office that the art cited in the earlier prosecution history has been reviewed in connection with the present application.

It is respectfully requested that the Examiner initial and return a copy of the enclosed IDS Forms, and indicate in the official file wrapper of this patent application that the documents have been considered.

/Tsfaldet Bocure/

05/29/2016

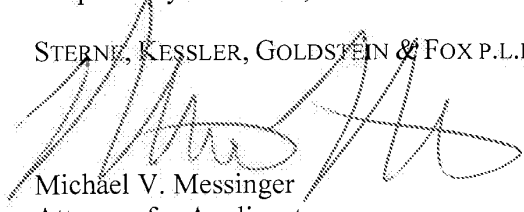
Atty. Dkt. No. 3421.005000C

ALL REFERENCES CONSIDERED EXCEPT WHERE LINED THROUGH. /T.B./

The U.S. Patent and Trademark Office is hereby authorized to charge any fee deficiency, or credit any overpayment, to our Deposit Account No. 19-0036.

Respectfully submitted,

STERNE, KESSLER, GOLDSTEIN & FOX P.L.L.C.



Michael V. Messinger  
Attorney for Applicant  
Registration No. 37,575

Date: \_\_\_\_\_

May 16, 2016

1100 New York Avenue, N.W.  
Washington, D.C. 20005-3934  
(202) 371-2600

2810062\_1.DOCX

Atty. Dkt. No. 3421.005000C

ALL REFERENCES CONSIDERED EXCEPT WHERE LINED THROUGH. /T.B./

Substitute for form 1449/PTO		<b>Complete if Known</b>	
<b>SIXTH SUPPLEMENTAL INFORMATION DISCLOSURE STATEMENT BY APPLICANT</b> <i>(Use as many sheets as necessary)</i>		Application Number	14/876,276
		Filing Date	October 6, 2015
		First Named Inventor	James J. FALLON
		Art Unit	2634
		Examiner Name	BOCURE, TESFALDET
		Attorney Docket Number	3421.005000C
Sheet	1	of	1

U.S. PATENT DOCUMENTS						
Examiner initials*	Cite No. <sup>1</sup>	Document Number		Publication Date MM-DD-YYYY	Name of Patentee or Applicant of Cited Document	Pages, Columns, Lines, Where Relevant Passages or Relevant Figures Appear
		Number-Kind Code <sup>2</sup> (if known)				
	US1	5,479,638		12-26-1995	Assar et al.	
	US2	5,771,354		06-23-1998	Crawford	
	US3	2016/0127512 A1		05-05-2016	Fallon et al.	
	US4	2016/0127513 A1		05-05-2016	Fallon et al.	

FOREIGN PATENT DOCUMENTS							
Examiner initials*	Cite No. <sup>1</sup>	Foreign Patent Document		Publication Date MM-DD-YYYY	Name of Patentee or Applicant of Cited Document	Pages, Columns, Lines, Where Relevant Passages or Relevant Figures Appear	T 6
		Country Code <sup>3</sup> -Number <sup>4</sup> -Kind Code <sup>5</sup> (if known)					
	FP1	WO 00/46688		08-10-2000	Wang		
	FP2	WO 97/39421		10-23-1997	The Regents of the University of California		

2809984\_1.DOCX

Examiner Signature	/Tesfaldet Bocure/	Date Considered	05/29/2016
--------------------	--------------------	-----------------	------------

\*EXAMINER: Initial if reference considered, whether or not citation is in conformance with MPEP 609. Draw line through citation if not in conformance and not considered. Include copy of this form with next communication to applicant. <sup>1</sup> Applicant's unique citation designation number (optional). <sup>2</sup> See Kinds Codes of USPTO Patent Documents at www.uspto.gov or MPEP 901.04. <sup>3</sup> Enter Office that issued the document, by the two-letter code (WIPO Standard ST.3). <sup>4</sup> For Japanese patent documents, the indication of the year of the reign of the Emperor must precede the serial number of the patent document. <sup>5</sup> Kind of document by the appropriate symbols as indicated on the document under WIPO Standard ST.16 if possible. <sup>6</sup> Applicant is to place a

**ALL REFERENCES CONSIDERED EXCEPT WHERE LINED THROUGH. /T.B./**

Substitute for form 1449/PTO		<b>Complete if Known</b>	
<b>SIXTH SUPPLEMENTAL INFORMATION DISCLOSURE STATEMENT BY APPLICANT</b> <i>(Use as many sheets as necessary)</i>		Application Number	14/876,276
		Filing Date	October 6, 2015
		First Named Inventor	James J. FALLON
		Art Unit	2634
		Examiner Name	BOCURE, TESFALDET
		Attorney Docket Number	3421.005000C
Sheet	1	of	2

NON PATENT LITERATURE DOCUMENTS			
Examiner Initials*	Cite No. <sup>1</sup>	Include name of the author (in CAPITAL LETTERS), title of the article (when appropriate), title of the item (book, magazine, journal, serial, symposium, catalog, etc.), date, page(s), volume-issue number(s), publisher, city and/or country where published	T <sup>2</sup>
	NPL1	Joint Claim Construction and Prehearing Statement, filed in Realtime Data LLC d/b/a IXO v. Actian Corporation, et al., Case No. 6:15-cv-00463-RWS-JDL (E.D. Tex.), filed April 18, 2016; 26 pages.	
	NPL2	Complaint for Patent Infringement against Teradata Operations, Inc., filed in Realtime Data LLC d/b/a IXO v. Teradata Operations, Inc., Case No. 2:16-cv-02743 (C.D. Cal.), filed April 21, 2016; 31 pages.	
	NPL3	Defendant Oracle America, Inc.'s Answer to Realtime Data LLC's Complaint and Counterclaims, filed in Realtime Data LLC d/b/a IXO v. Oracle America, Inc., Case No. 6:16-cv-00088-RWS-JDL (E.D. Tex.), filed May 3, 2016; 22 pages.	
	NPL4	Defendants' Letter Requesting Permission to File a Motion for Partial Summary Judgment of Invalidity, filed in Realtime Data LLC d/b/a IXO v. Actian Corporation, et al., Case No. 6:15-cv-00463-RWS-JDL (E.D. Tex.) filed April 20, 2016; 6 pages.	
	NPL5	Plaintiff's Letter in Opposition to Moving Defendants' Letter Requesting Permission to File a Motion for Partial Summary Judgment, filed in Realtime Data LLC d/b/a IXO v. Actian Corporation, et al., Case No. 6:15-cv-00463-RWS-JDL (E.D. Tex.) filed May 9, 2016; 6 pages.	
	NPL6	Copy of Notice of Allowance for U.S. Pat. Appl. No. 14/727,309, mailed April 26, 2016; 7 pages.	
	NPL7	Copy of Notice of Allowance for U.S. Patent Appl. No. 14/733,565, mailed May 6, 2016; 6 pages.	
	NPL8	Petition for Inter Partes Review of U.S. Patent No. 7,415,530, filed in Dell Inc., et al. v. Realtime Data LLC d/b/a IXO, Case No. IPR2016-00878 (P.T.A.B.), filed April 22, 2016; 69 pages.	
	NPL9	Declaration of Charles D. Creusere, filed in Dell Inc., et al. v. Realtime Data LLC d/b/a IXO, Case No. IPR2016-00878 (P.T.A.B.), filed April 22, 2016; 124 pages.	
	NPL10	SOBH, et al., "A Comparison of Compressed and Uncompressed Transmission Modes," University of Pennsylvania Department of Computer and Information Science Technical Report No. MS-CIS-91-41, May 1991; 15 pages.	

Examiner Signature	/Tesfaldet Bocure/	Date Considered	05/29/2016
-----------------------	--------------------	--------------------	------------

\*EXAMINER: Initial if reference considered, whether or not citation is in conformance with MPEP 609. Draw line through citation if not in conformance and not considered. Include copy of this form with next communication to applicant.

<sup>1</sup> Applicant's unique citation designation number (optional). <sup>2</sup> Applicant is to place a check mark here if English language Translation is attached.

**ALL REFERENCES CONSIDERED EXCEPT WHERE LINED THROUGH. /T.B./**

Substitute for form 1449/PTO		<b>Complete if Known</b>	
<b>SIXTH SUPPLEMENTAL INFORMATION DISCLOSURE STATEMENT BY APPLICANT</b> <i>(Use as many sheets as necessary)</i>		Application Number	14/876,276
		Filing Date	October 6, 2015
		First Named Inventor	James J. FALLON
		Art Unit	2634
		Examiner Name	BOCURE, TESFALDET
		Attorney Docket Number	3421.005000C
Sheet	2	of	2

NON PATENT LITERATURE DOCUMENTS			
Examiner Initials*	Cite No. <sup>1</sup>	Include name of the author (in CAPITAL LETTERS), title of the article (when appropriate), title of the item (book, magazine, journal, serial, symposium, catalog, etc.), date, page(s), volume number, publisher, city and/or country where published	T <sup>2</sup>
	NPL11	9704 Data Compression Coprocessor Data Sheet, Stac Electronics, September, 1991; 56 pages.	
	NPL12	Petition for Inter Partes Review of U.S. Patent No. 8,643,513, filed in Riverbed Technology, Inc., et al. v. Realtime Data, LLC, Case No. IPR2016-00978 (P.T.A.B.), filed April 29, 2016; 65 pages.	
	NPL13	Declaration of Charles D. Creusere, Ph.D. Under 37 C.F.R. § 1.68, filed in Riverbed Technology, Inc., et al. v. Realtime Data, LLC, Case No. IPR2016-00978 (P.T.A.B.), filed April 29, 2016; 139 pages.	
	NPL14	Petition for Inter Partes Review of U.S. Patent No. 9,116,908, filed in Dell Inc. al. v. Realtime Data, LLC, Case No. IPR2016-01002 (P.T.A.B.), filed May 5, 2016; 68 pages.	
	NPL15	Declaration of Charles D. Creusere, Ph.D., filed in Dell Inc. al. v. Realtime Data, LLC, Case No. IPR2016-01002 (P.T.A.B.), filed May 5, 2016; 105 pages.	
	NPL16	Petition for Inter Partes Review of U.S. Patent No. 7,415,530, filed in Dell Inc. al. v. Realtime Data, LLC, Case No. IPR2016-00972 (P.T.A.B.), filed April 29, 2016; 69 pages.	
	NPL17	Declaration of Charles D. Creusere, Ph.D., filed in Dell Inc. al. v. Realtime Data, LLC, Case No. IPR2016-00972 (P.T.A.B.), filed April 29, 2016; 124 pages.	
	NPL18	Petition for Inter Partes Review of U.S. Patent No. 7,378,992, filed in Riverbed Technology, Inc. v. Realtime Data, LLC, Case No. IPR2016-00980 (P.T.A.B.), filed April 29, 2016; 57 pages.	
	NPL19	Declaration of Charles D. Creusere, Ph.D., filed in Dell Inc. al. v. Realtime Data, LLC, Case No. IPR2016-00980 (P.T.A.B.), filed April 29, 2016; 105 pages.	
	NPL20	Court Docket History for Realtime Data LLC d/b/a IXO v. Teradata Operations, Inc., Case No. 2:16-cv-02743 (C.D. Cal), downloaded April 26, 2016; 2 pages.	


2810041\_1.DOCX

Examiner Signature	/Tesfaldet Bocure/	Date Considered	05/29/2016
-----------------------	--------------------	--------------------	------------

\*EXAMINER: Initial if reference considered, whether or not citation is in conformance with MPEP 609. Draw line through citation if not in conformance and not considered. Include copy of this form with next communication to applicant.

<sup>1</sup> Applicant's unique citation designation number (optional). <sup>2</sup> Applicant is to place a check mark here if English language Translation is attached.

ALL REFERENCES CONSIDERED EXCEPT WHERE LINED THROUGH. /T.B./


<b>Issue Classification</b> 	<b>Application/Control No.</b> 14876276	<b>Applicant(s)/Patent Under Reexamination</b> FALLON ET AL.
	<b>Examiner</b> TESFALDET BOCURE	<b>Art Unit</b> 2634

CPC					
Symbol				Type	Version
H04N	19		103	F	2014-11-01
H04N	19		164	I	2014-11-01
H04N	19		176	I	2014-11-01
H03M	7		30	I	2013-01-01
H03M	7		3084	I	2013-01-01
H03M	7		6094	I	2013-01-01

CPC Combination Sets				
Symbol	Type	Set	Ranking	Version


NONE		<b>Total Claims Allowed:</b>	
(Assistant Examiner)	(Date)	30	
/TESFALDET BOCURE/ Primary Examiner.Art Unit 2634	05/29/2016	O.G. Print Claim(s)	O.G. Print Figure
(Primary Examiner)	(Date)	1	1



<b>Issue Classification</b> 	<b>Application/Control No.</b> 14876276	<b>Applicant(s)/Patent Under Reexamination</b> FALLON ET AL.
	<b>Examiner</b> TESFALDET BOCURE	<b>Art Unit</b> 2634


US ORIGINAL CLASSIFICATION						INTERNATIONAL CLASSIFICATION								
CLASS			SUBCLASS			CLAIMED			NON-CLAIMED					
375			240.1			H	0	4	N	7 / 12 (2006.01.01)				
<b>CROSS REFERENCE(S)</b>														
CLASS	SUBCLASS (ONE SUBCLASS PER BLOCK)													

NONE		<b>Total Claims Allowed:</b>	
(Assistant Examiner)	(Date)	30	
/TESFALDET BOCURE/ Primary Examiner.Art Unit 2634	05/29/2016	O.G. Print Claim(s)	O.G. Print Figure
(Primary Examiner)	(Date)	1	1

<b>Issue Classification</b> 	<b>Application/Control No.</b> 14876276	<b>Applicant(s)/Patent Under Reexamination</b> FALLON ET AL.
	<b>Examiner</b> TESFALDET BOCURE	<b>Art Unit</b> 2634

<input checked="" type="checkbox"/> <b>Claims renumbered in the same order as presented by applicant</b> <input type="checkbox"/> <b>CPA</b> <input type="checkbox"/> <b>T.D.</b> <input type="checkbox"/> <b>R.1.47</b>															
Final	Original	Final	Original	Final	Original	Final	Original	Final	Original	Final	Original	Final	Original	Final	Original
1	1	17	17												
2	2	18	18												
3	3	19	19												
4	4	20	20												
5	5	21	21												
6	6	22	22												
7	7	23	23												
8	8	24	24												
9	9	25	25												
10	10	26	26												
11	11	27	27												
12	12	28	28												
13	13	29	29												
14	14	30	30												
15	15														
16	16														


NONE		<b>Total Claims Allowed:</b>	
		30	
(Assistant Examiner)	(Date)	O.G. Print Claim(s)	O.G. Print Figure
/TESFALDET BOCURE/ Primary Examiner. Art Unit 2634	05/29/2016	1	1
(Primary Examiner)	(Date)		

<b>Index of Claims</b> 	<b>Application/Control No.</b> 14876276	<b>Applicant(s)/Patent Under Reexamination</b> FALLON ET AL.
	<b>Examiner</b> TESFALDET BOCURE	<b>Art Unit</b> 2634

✓	<b>Rejected</b>	-	<b>Cancelled</b>	N	<b>Non-Elected</b>	A	<b>Appeal</b>
=	<b>Allowed</b>	÷	<b>Restricted</b>	I	<b>Interference</b>	O	<b>Objected</b>

Claims renumbered in the same order as presented by applicant
  CPA
  T.D.
  R.1.47

CLAIM		DATE							
Final	Original	01/23/2016	04/18/2016	05/29/2016					
1	1	✓	=	=					
2	2	✓	=	=					
3	3	✓	=	=					
4	4	✓	=	=					
5	5	✓	=	=					
6	6	✓	=	=					
7	7	✓	=	=					
8	8	✓	=	=					
9	9	✓	=	=					
10	10	✓	=	=					
11	11	✓	=	=					
12	12	✓	=	=					
13	13	✓	=	=					
14	14	✓	=	=					
15	15	✓	=	=					
16	16	✓	=	=					
17	17	✓	=	=					
18	18	✓	=	=					
19	19	✓	=	=					
20	20	✓	=	=					
21	21	✓	=	=					
22	22	✓	=	=					
23	23	✓	=	=					
24	24	✓	=	=					
25	25	✓	=	=					
26	26	✓	=	=					
27	27	✓	=	=					
28	28	✓	=	=					
29	29	✓	=	=					
30	30	✓	=	=					

<b>Search Notes</b>  	<b>Application/Control No.</b>  14876276	<b>Applicant(s)/Patent Under Reexamination</b>  FALLON ET AL.
	<b>Examiner</b>  TESFALDET BOCURE	<b>Art Unit</b>  2634

<b>CPC- SEARCHED</b>		
Symbol	Date	Examiner
((H03M7/30))   ((H03M7/3084))   ((H03M7/6094))   ((G06F15/7867))   ((G06T1/60))   ((H04N19/136).CPC.)	01/22/2016	TB
((H03M7/30))   ((H03M7/3059))   ((H03M7/3093))   ((H04L69/04))   ((H04N19/152))   ((H04N9/8042).CPC.)	01/22/2016	TB
( ( H03M7/30   H03M7/3059   H03M7/3084   H03M7/6094   H03M7/3088   H03M7/6023   H03M7/6064   H04N19/152   G11B20/00007 ).CPC.)	01/23/2016	TB
(H03M7/30 H03M7/3084 H03M7/6094 H04N19/164 H04N19/176 H04N19/103).CPC.	04/17/2016	TB
CPC Updated	04/18/2016	TB
CPC Updated	05/29/2016	TB

<b>CPC COMBINATION SETS - SEARCHED</b>		
Symbol	Date	Examiner

<b>US CLASSIFICATION SEARCHED</b>			
Class	Subclass	Date	Examiner
375	240, 240.01, 240.02	01/22/2016	TB
341	50, 51, 126	01/22/2016	TB
375, 370, 348, 341, 711, 701, 381	Search ALL (\$8.ccls.)	01/22/2016	TB
375, 370, 348, 341, 711, 701, 381	Search Updated ALL	01/23/2016	TB
375, 370, 348, 341, 711, 701, 381	Search Updated ALL	04/17/2016 & 04/18/2016	TB
375, 370, 348, 341, 711, 701, 381	Search Updated ALL	05/29/2016	TB

	/TESFALDET BOCURE/ Primary Examiner.Art Unit 2634
--	------------------------------------------------------

### SEARCH NOTES

Search Notes	Date	Examiner
WEST and Inventor's Name Searched	01/22/2016	TB
See Related parent application 14/733,565 for further prosecution History	01/22/2016	TB
WEST Search Updated	01/23/2016	TB
WEST Search Updated	04/17/2016	TB
WEST Search Updated	04/18/2016	TB
WEST Search Updated	05/29/2016	TB

### INTERFERENCE SEARCH

US Class/ CPC Symbol	US Subclass / CPC Group	Date	Examiner
375	240, 240.1	04/18/2016	TB
CPC	(H03M7/30 H03M7/3084 H03M7/6094 H04N19/164 H04N19/176 H04N19/103).CPC.	04/18/2016	TB
375	240, 240.1	05/29/2016	TB
CPC	(H03M7/30 H03M7/3084 H03M7/6094 H04N19/164 H04N19/176 H04N19/103).CPC.	05/29/2016	TB

	/TESFALDET BOCURE/ Primary Examiner.Art Unit 2634
--	------------------------------------------------------

Under the Paperwork Reduction Act of 1995, no persons are required to respond to a collection of information unless it contains a valid OMB control number.

**Request  
for  
Continued Examination (RCE)  
Transmittal**

Address to:  
Mail Stop RCE  
Commissioner for Patents  
P.O. Box 1450  
Alexandria, VA 22313-1450

Application Number	14/876,276
Filing Date	October 6, 2015
First Named Inventor	James J. FALLON
Art Unit	2634
Examiner Name	BOCURE, TESFALDET
Attorney Docket Number	3421.005000C

**This is a Request for Continued Examination (RCE) under 37 CFR 1.114 of the above-identified application.**  
Request for Continued Examination (RCE) practice under 37 CFR 1.114 does not apply to any utility or plant application filed prior to June 8, 1995, or to any design application. See Instruction Sheet for RCEs (not to be submitted to the USPTO) on page 2.

1. **Submission required under 37 CFR 1.114** Note: If the RCE is proper, any previously filed unentered amendments and amendments enclosed with the RCE will be entered in the order in which they were filed unless applicant instructs otherwise. If applicant does not wish to have any previously filed unentered amendment(s) entered, applicant must request non-entry of such amendment(s).

a.  Previously submitted. If a final Office action is outstanding, any amendments filed after the final Office action may be considered as a submission even if this box is not checked.

i.  Consider the arguments in the Appeal Brief or Reply Brief previously filed on \_\_\_\_\_

ii.  Other \_\_\_\_\_

b.  Enclosed

i.  Amendment/Reply

iii.  Information Disclosure Statement (IDS)

ii.  Affidavit(s)/ Declaration(s)

iv.  Other \_\_\_\_\_

2. **Miscellaneous**

a.  Suspension of action on the above-identified application is requested under 37 CFR 1.103(c) for a period of \_\_\_\_\_ months. (Period of suspension shall not exceed 3 months; Fee under 37 CFR 1.17(i) required)

b.  Other \_\_\_\_\_

3. **Fees**

The RCE fee under 37 CFR 1.17(e) is required by 37 CFR 1.114 when the RCE is filed.

a.  The Director is hereby authorized to charge the following fees, any underpayment of fees, or credit any overpayments, to Deposit Account No. 19-0036

i.  RCE fee required under 37 CFR 1.17(e)

ii.  Extension of time fee (37 CFR 1.136 and 1.17)

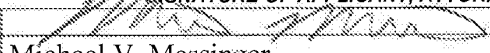
iii.  Other \_\_\_\_\_

b.  Check in the amount of \$ \_\_\_\_\_ enclosed

c.  Payment by credit card (Form PTO-2038 enclosed)

**WARNING: Information on this form may become public. Credit card information should not be included on this form. Provide credit card information and authorization on PTO-2038.**

**SIGNATURE OF APPLICANT, ATTORNEY, OR AGENT REQUIRED**

Signature		Date	10/16/2015
Name (Print/Type)	Michael V. Messinger	Registration No.	37,575

**CERTIFICATE OF MAILING OR TRANSMISSION**

I hereby certify that this correspondence is being deposited with the United States Postal Service with sufficient postage as first class mail in an envelope addressed to: Mail Stop RCE, Commissioner for Patents, P. O. Box 1450, Alexandria, VA 22313-1450 or facsimile transmitted to the U.S. Patent and Trademark Office on the date shown below.

Signature		Date	
Name (Print/Type)			

This collection of information is required by 37 CFR 1.114. The information is required to obtain or retain a benefit by the public which is to file (and by the USPTO to process) an application. Confidentiality is governed by 35 U.S.C. 122 and 37 CFR 1.11 and 1.14. This collection is estimated to take 12 minutes to complete, including gathering, preparing, and submitting the completed application form to the USPTO. Time will vary depending upon the individual case. Any comments on the amount of time you require to complete this form and/or suggestions for reducing this burden, should be sent to the Chief Information Officer, U.S. Patent and Trademark Office, U.S. Department of Commerce, P.O. Box 1450, Alexandria, VA 22313-1450. DO NOT SEND FEES OR COMPLETED FORMS TO THIS ADDRESS. **SEND TO: Mail Stop RCE, Commissioner for Patents, P.O. Box 1450, Alexandria, VA 22313-1450.**

If you need assistance in completing the form, call 1-800-PTO-9199 and select option 2.

2810151

IN THE UNITED STATES PATENT AND TRADEMARK OFFICE

Inventors: FALLON *et al.*

Confirmation No.: 3403

Applicant: Realtime Data, LLC

Art Unit: 2634

Application No.: 14/876,276

Examiner: BOCURE, TESFALDET

Filing Date: October 6, 2015

Atty. Docket: 3421.005000C

Title: **Video Data Compression Systems**

**Sixth Supplemental Information Disclosure Statement**

*Mail Stop RCE*

Commissioner for Patents  
PO Box 1450  
Alexandria, VA 22313-1450

Commissioner:

Notice of Prior and Concurrent Proceedings

Applicant hereby calls to the attention of the Patent and Trademark Office the following reexamination proceedings involving patents that are commonly-assigned with the patent in the above-identified patent application:

<b>Proceeding</b>	<b>Status</b>
Inter Partes Reexamination of U.S. Patent No. 6,604,158 (Control No. 95/000,486)	Inter Partes Reexamination Certificate issued 10/10/2012
Inter Partes Reexamination of U.S. Patent No. 7,321,937 (Control No. 95/000,466)	Inter Partes Reexamination Certificate issued 05/15/2012
Inter Partes Reexamination of U.S. Patent No. 6,604,158 (Control No. 95/000,453)	Terminated
Ex Parte Reexamination of U.S. Patent No. 6,601,104 (Control No. 90/009,428)	Ex Parte Reexamination Certificate issued 02/28/2012
Inter Partes Reexamination of U.S. Patent No. 7,378,992 (Control No. 95/000,478)	Inter Partes Reexamination Certificate issued 10/04/2012
Inter Partes Reexamination of U.S. Patent No. 6,624,761 (Control No. 95/000,464)	Inter Partes Reexamination Certificate issued 06/12/2012
Inter Partes Reexamination of U.S. Patent No. 7,161,506 (Control No. 95/000,479)	Inter Partes Reexamination Certificate issued 05/22/2012

<b>Proceeding</b>	<b>Status</b>
Inter Partes Reexamination of U.S. Patent No. 7,714,747 (Control No. 95/001,517)	Appeal to the Court of Appeals for the Federal Circuit dismissed 6/4/2015
Inter Partes Reexamination of U.S. Patent No. 7,417,568 (Control No. 95/001,533)	Decision on Appeal mailed 10/29/2015
Inter Partes Reexamination of U.S. Patent No. 7,777,651 (Control No. 95/001,581)	Decision on Appeal mailed 10/29/2015
Inter Partes Reexamination of U.S. Patent No. 7,400,274 (Control No. 95/001,544)	Decision on Appeal mailed 10/29/2015

Applicant hereby calls to the attention of the Patent and Trademark Office the following reexamination proceedings filed by Cellco Partnership d/b/a Verizon Wireless, involving patents that are commonly-assigned with the patent in the above-identified patent application:

<b>Proceeding</b>	<b>Status</b>
Inter Partes Reexamination of U.S. Patent No. 7,321,937 (Control No. 95/001,922)	Inter Partes Reexamination Certificate issued 12/05/2013
Inter Partes Reexamination of U.S. Patent No. 6,604,158 (Control No. 95/001,923)	Inter Partes Reexamination Certificate issued 04/17/2015
Inter Partes Reexamination of U.S. Patent No. 7,352,300 (Control No. 95/001,924)	Inter Partes Reexamination Certificate issued 08/04/2014
Inter Partes Reexamination of U.S. Patent No. 7,395,345 (Control No. 95/001,925)	Inter Partes Reexamination Certificate issued 11/03/2014
Inter Partes Reexamination of U.S. Patent No. 7,161,506 (Control No. 95/001,926)	Inter Partes Reexamination Certificate issued 01/08/2014
Inter Partes Reexamination of U.S. Patent No. 7,415,530 (Control No. 95/001,927)	Inter Partes Reexamination Certificate issued 08/16/2013
Inter Partes Reexamination of U.S. Patent No. 7,378,992 (Control No. 95/001,928)	Inter Partes Reexamination Certificate issued 01/08/2014

Applicant invites the Examiner to review the Requests for Reexamination, issued Office Actions, replies, and any other papers in the above-identified reexamination proceedings. If the Examiner is unable to obtain copies of papers in any reexamination proceeding, copies can be

Atty. Dkt. No. 3421.005000C



provided to the Examiner upon request. Those documents which may be material that are not already of record in this patent application are listed on the accompanying Form PTO/SB/08.

Applicant hereby calls to the attention of the Patent and Trademark Office the following *inter partes* review proceedings involving patents that are commonly-assigned with the patent in the above-identified patent application:

<b>Proceeding</b>	<b>Patent</b>	<b>Status</b>
<i>Oracle America, Inc. v. Realtime Data, LLC</i> , IPR2016-00373	7,378,992	Patent Owner Preliminary Response filed April 7, 2016
<i>Oracle America, Inc. v. Realtime Data, LLC</i> , IPR2016-00374	8,643,513	Patent Owner Preliminary Response filed April 8, 2016
<i>Oracle America, Inc. v. Realtime Data, LLC</i> , IPR2016-00375	7,415,530	Patent Owner Preliminary Response filed April 11, 2016
<i>Oracle America, Inc. v. Realtime Data, LLC</i> , IPR2016-00376	7,415,530	Patent Owner Preliminary Response filed April 11, 2016
<i>Oracle America, Inc. v. Realtime Data, LLC</i> , IPR2016-00377	9,116,908	Patent Owner Preliminary Response filed April 11, 2016
<i>SAP America Inc., et al. v. Realtime Data, LLC d/b/a IXO</i> , IPR2016-00783	6,597,812	Petition filed April 1, 2016
<i>Dell Inc., et al. v. Realtime Data, LLC</i> , IPR2016-00878	7,415,530	Petition filed April 22, 2016
<i>Dell Inc., et al. v. Realtime Data, LLC</i> , IPR2016-00972	7,415,530	Petition filed April 29, 2016
<i>Riverbed Technology, Inc. et al. v. Realtime Data, LLC</i> , IPR2016-00978	8,643,513	Petition filed April 29, 2016
<i>Riverbed Technology, Inc. et al. v. Realtime Data, LLC</i> , IPR2016-00980	7,378,992	Petition filed April 29, 2016
<i>Dell Inc., et al. v. Realtime Data, LLC</i> , IPR2016-01002	9,116,908	Petition filed May 5, 2016

Atty. Dkt. No. 3421.005000C

Applicant invites the Examiner to review the petitions for *inter partes* review and any other papers in the above-identified *inter partes* review proceedings. If the Examiner is unable to obtain copies of papers in any *inter partes* review proceeding, copies can be provided to the Examiner upon request. Those documents which may be material that are not already of record in this patent application are listed on the accompanying Form PTO/SB/08 as documents **US1-US2, FP1-FP2, and NPL8-NPL19.**

Notice of Related Litigation

Applicant notifies the Patent and Trademark Office of the following litigation involving U.S. Patents commonly-owned with the current patent application, the subject matter of which may be related to the present patent application:

No.	Case	Status
1	<i>Realtime Data LLC d/b/a IXO v. Packeteer, Inc. et al.</i> , No. 6:08-cv-00144-LED (E.D. Texas)	Dismissed

Applicant also notifies the Patent and Trademark Office of the following additional litigation involving U.S. Patents commonly-owned with the current patent application, the subject matter of which may be related to the present patent application:

No.	Case	Status
2	<i>Realtime Data LLC d/b/a IXO v. Thomson Reuters Corporation et al.</i> No. 1:11-cv-06698-RJH (S.D. New York) (transferred from E.D. Texas; 6:09-cv-00333-LED)	Case Terminated 11/9/2012; Opinion of the Court of Appeals for the Federal Circuit received 01/27/2014

Atty. Dkt. No. 3421.005000C

3	<i>Realtime Data LLC d/b/a IXO v. Morgan Stanley et al.</i> , No. 1:11-cv-06696-RJH (S.D. New York) (transferred from E.D. Texas; 6:09-cv-00326-LED)	Case Terminated 11/9/2012; Opinion of the Court of Appeals for the Federal Circuit received 01/27/2014
4	<i>Realtime Data LLC d/b/a IXO v. CME Group Inc., et al.</i> , No. 1:11-cv-06697-RJH (S.D. New York) (transferred from E.D. Texas; No. 6:09-cv-00327-LED)	Case Terminated 11/9/2012; Opinion of the Court of Appeals for the Federal Circuit received 01/27/2014
5	<i>Chicago Board Options Exchange, Inc., v. Realtime Data LLC d/b/a IXO</i> , No. 09-cv-4486 (N.D. Ill.)	Dismissed
6	<i>Thomson Reuters Corporation v. Realtime Data, LLC d/b/a IXO</i> , No. 1:09-cv-07868-RMB (S.D.N.Y)	Consolidated with Case No. 2
7	<i>Realtime Data, LLC d/b/a IXO v. CME Group Inc., et al. (II)</i> , No. 6:10-cv-246 (E.D. Texas)	Consolidated with Case No. 4
8	<i>Realtime Data LLC d/b/a IXO v. Thomson Reuters Corporation et al. (II)</i> , No. 6:10-cv-247 (E.D. Texas)	Consolidated with Case No. 2
9	<i>Realtime Data, LLC d/b/a IXO v. Morgan Stanley, et al. (II)</i> , No. 6:10-cv-248 (E.D. Texas)	Consolidated with Case No. 3
10	<i>Realtime Data, LLC d/b/a IXO v. MetroPCS Texas, LLC et al.</i> , No. 6:10-cv-00493 (E.D. Texas)	Appeal Terminated
11	<i>Realtime Data, LLC d/b/a IXO v. Microsoft Corporation, et al.</i> , No. 4:14-cv-00827 (E.D. Texas)	Dismissed May 1, 2015
12	<i>Realtime Data, LLC d/b/a IXO v. Actian Corporation, et al.</i> , No. 6:15-cv-00463 (E.D. Texas)	Amended Complaints for Patent Infringement filed September 14, 2015
13	<i>Realtime Data, LLC d/b/a IXO v. Dropbox, Inc.</i> , No. 6:15-cv-00465 (E.D. Texas)	Transferred to the Northern District of California, January 16, 2016; Answer to Amended Complaint filed February 4, 2016
14	<i>Realtime Data, LLC d/b/a IXO v. Echostar Corporation, et al.</i> , No. 6:15-cv-00466 (E.D. Texas)	Consolidated with Case No. 12; Answer to Amended Complaint filed February 4, 2016

Atty. Dkt. No. 3421.005000C

15	<i>Realtime Data, LLC d/b/a IXO v. Riverbed Technology, Inc., et al.</i> , No. 6:15-cv-00468 (E.D. Texas)	Consolidated with Case No. 12; Second Amended Complaint for Infringement filed February 2, 2016
16	<i>Realtime Data, LLC d/b/a IXO v. BMC Software, Inc.</i> , No. 6:15-cv-00464 (E.D. Texas)	Terminated October 5, 2015
17	<i>Realtime Data, LLC d/b/a IXO v. Oracle America, Inc., et al.</i> , No. 6:15-cv-00467 (E.D. Texas)	Consolidated with Case No. 12
18	<i>Realtime Data, LLC d/b/a IXO v. SAP America, Inc., et al.</i> , No. 6:15-cv-00469 (E.D. Texas)	Consolidated with Case No. 12; Answers to Amended Complaint filed February 4, 2016
19	<i>Realtime Data, LLC d/b/a IXO v. Teradata Corporation, et al.</i> , No. 5:16-cv-01836 (N.D. Cal.) (formerly no. 6:15-cv-00470 (E.D. Texas))	Transferred to the Northern District of California, January 19, 2016
20	<i>Realtime Data, LLC d/b/a IXO v. Apple Inc.</i> , No. 6:15-cv-00885 (E.D. Texas)	Order Granting Motion to Stay entered February 11, 2016
21	<i>Realtime Data LLC d/b/a IXO v. Hewlett Packard Enterprise Co., et al.</i> , No. 6:16-cv-00086 (E.D. Texas)	Complaint filed February 26, 2016
22	<i>Realtime Data LLC d/b/a IXO v. Oracle America, Inc.</i> , No. 6:16-cv-00088 (E.D. Texas)	Complaint filed February 26, 2016
23	<i>Realtime Data LLC d/b/a IXO v. CenturyLink, Inc., et al.</i> , No. 6:16-cv-00087 (E.D. Texas)	Complaint filed February 26, 2016
24	<i>Realtime Data LLC d/b/a IXO v. Dell, Inc., et al.</i> , No. 6:16-cv-00089 (E.D. Texas)	Complaint filed February 26, 2016
25	<i>Realtime Data LLC d/b/a IXO v. Teradata Operations, Inc.</i> , No. 2:16-cv-02743 (C.D. Cal.)	Complaint filed April 21, 2016

An updated court docket for a pending litigation is submitted herewith as document **NPL20**.

Information Disclosure Statement

Listed on accompanying IDS Forms PTO/SB/08a equivalent and PTO/SB/08b equivalent are documents that may be considered material to the patentability of this application as defined in

Atty. Dkt. No. 3421.005000C

37 C.F.R. §1.56, and in compliance with the duty of disclosure requirements of 37 C.F.R. §§ 1.97 and 1.98.

Applicant has listed publication dates on the attached IDS Forms based on information presently available to the undersigned. However, the listed publication dates should not be construed as an admission that the information was actually published on the date indicated.

Applicant reserves the right to establish the patentability of the claimed invention over any of the information provided herewith, and/or to prove that this information may not be prior art, and/or to prove that this information may not be enabling for the teachings purportedly offered.

This statement should not be construed as a representation that a search has been made, or that information more material to the examination of the present patent application does not exist. The Examiner is specifically requested not to rely solely on the material submitted herewith.

Filing under 37 C.F.R. § 1.97(b). This Information Disclosure Statement is being filed before the mailing of a first Office Action after the filing of a request for continued examination under 37 C.F.R. § 1.114. No statement or fee is required.

Copies of documents **FP1-FP2** and **NPL1-NPL20** are submitted. However, in accordance with 37 C.F.R. § 1.98(a)(2)(ii), no copies of the U.S. patents and patent application publications cited as documents **US1-US4** on the attached IDS Forms are submitted.

Applicant submits herewith Office Actions from the co-pending U.S. Patent Application Nos.:

Document **NPL6** is a copy of a Notice of Allowance mailed April 26, 2016, in the prosecution of co-pending, commonly-assigned U.S. Patent Application No. 14/727,309.

Atty. Dkt. No. 3421.005000C

Document **NPL7** is a copy of a Notice of Allowance mailed May 6, 2016, in the prosecution of co-pending, commonly-assigned U.S. Patent Application No. 14/733,565.

The identification of these Office Actions is not to be construed as a waiver of secrecy as to those applications now or upon issuance of the present application as a patent. The Examiner is respectfully requested to consider the cited applications and the art cited therein during examination.

It is expected that the examiner will review the prosecution and cited art in the parent application nos. 14/733,565, filed June 8, 2015 (now pending); 14/577,286, filed December 19, 2014 (now abandoned); 14/134,933, filed December 19, 2013 (now U.S. Patent No. 8,929,442); 14/033,245, filed September 20, 2013 (now U.S. Patent No. 8,934,535); 13/154,239, filed June 6, 2011 (now U.S. Patent No. 8,553,759); 12/123,081, filed May 19, 2008 (now U.S. Patent No. 8,073,047); and 10/076,013, filed February 13, 2002 (now U.S. Patent No. 7,386,046), in accordance with MPEP 2001.06(b), and indicate in the next communication from the office that the art cited in the earlier prosecution history has been reviewed in connection with the present application.

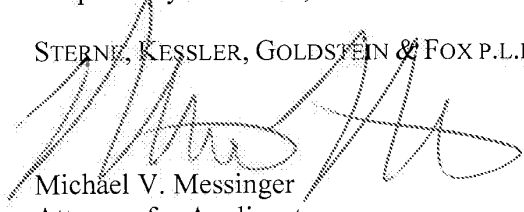
It is respectfully requested that the Examiner initial and return a copy of the enclosed IDS Forms, and indicate in the official file wrapper of this patent application that the documents have been considered.

Atty. Dkt. No. 3421.005000C

The U.S. Patent and Trademark Office is hereby authorized to charge any fee deficiency, or credit any overpayment, to our Deposit Account No. 19-0036.

Respectfully submitted,

STERNE, KESSLER, GOLDSTEIN & FOX P.L.L.C.



Michael V. Messinger  
Attorney for Applicant  
Registration No. 37,575

Date: May 16, 2016

1100 New York Avenue, N.W.  
Washington, D.C. 20005-3934  
(202) 371-2600

2810062\_1.DOCX

Substitute for form 1449/PTO			<b>Complete if Known</b>	
<b>SIXTH SUPPLEMENTAL INFORMATION DISCLOSURE STATEMENT BY APPLICANT</b> <i>(Use as many sheets as necessary)</i>			Application Number	14/876,276
			Filing Date	October 6, 2015
			First Named Inventor	James J. FALLON
			Art Unit	2634
			Examiner Name	BOCURE, TEFALDET
			Attorney Docket Number	3421.005000C
Sheet	1	of	1	

**U.S. PATENT DOCUMENTS**

Examiner initials*	Cite No. <sup>1</sup>	Document Number	Publication Date MM-DD-YYYY	Name of Patentee or Applicant of Cited Document	Pages, Columns, Lines, Where Relevant Passages or Relevant Figures Appear
		Number-Kind Code <sup>2</sup> (if known)			
	US1	5,479,638	12-26-1995	Assar et al.	
	US2	5,771,354	06-23-1998	Crawford	
	US3	2016/0127512 A1	05-05-2016	Fallon et al.	
	US4	2016/0127513 A1	05-05-2016	Fallon et al.	

**FOREIGN PATENT DOCUMENTS**

Examiner initials*	Cite No. <sup>1</sup>	Foreign Patent Document	Publication Date MM-DD-YYYY	Name of Patentee or Applicant of Cited Document	Pages, Columns, Lines, Where Relevant Passages or Relevant Figures Appear	T 6
		Country Code <sup>3</sup> -Number <sup>4</sup> -Kind Code <sup>5</sup> (if known)				
	FP1	WO 00/46688	08-10-2000	Wang		
	FP2	WO 97/39421	10-23-1997	The Regents of the University of California		

2809984\_1.DOCX

Examiner Signature	Date Considered
--------------------	-----------------

\*EXAMINER: Initial if reference considered, whether or not citation is in conformance with MPEP 609. Draw line through citation if not in conformance and not considered. Include copy of this form with next communication to applicant. <sup>1</sup> Applicant's unique citation designation number (optional). <sup>2</sup> See Kinds Codes of USPTO Patent Documents at www.uspto.gov or MPEP 901.04. <sup>3</sup> Enter Office that issued the document, by the two-letter code (WIPO Standard ST.3). <sup>4</sup> For Japanese patent documents, the indication of the year of the reign of the Emperor must precede the serial number of the patent document. <sup>5</sup> Kind of document by the appropriate symbols as indicated on the document under WIPO Standard ST.16 if possible. <sup>6</sup> Applicant is to place a check mark here if English language Translation is attached



Substitute for form 1449/PTO		<b>Complete if Known</b>	
<b>SIXTH SUPPLEMENTAL INFORMATION DISCLOSURE STATEMENT BY APPLICANT</b> <i>(Use as many sheets as necessary)</i>		Application Number	14/876,276
		Filing Date	October 6, 2015
		First Named Inventor	James J. FALLON
		Art Unit	2634
		Examiner Name	BOCURE, TESFALDET
		Attorney Docket Number	3421.005000C
Sheet	1	of	2

NON PATENT LITERATURE DOCUMENTS			
Examiner Initials*	Cite No. <sup>1</sup>	Include name of the author (in CAPITAL LETTERS), title of the article (when appropriate), title of the item (book, magazine, journal, serial, symposium, catalog, etc.), date, page(s), volume-issue number(s), publisher, city and/or country where published	T <sup>2</sup>
	NPL1	Joint Claim Construction and Prehearing Statement, filed in Realtime Data LLC d/b/a IXO v. Actian Corporation, et al., Case No. 6:15-cv-00463-RWS-JDL (E.D. Tex.), filed April 18, 2016; 26 pages.	
	NPL2	Complaint for Patent Infringement against Teradata Operations, Inc., filed in Realtime Data LLC d/b/a IXO v. Teradata Operations, Inc., Case No. 2:16-cv-02743 (C.D. Cal.), filed April 21, 2016; 31 pages.	
	NPL3	Defendant Oracle America, Inc.'s Answer to Realtime Data LLC's Complaint and Counterclaims, filed in Realtime Data LLC d/b/a IXO v. Oracle America, Inc., Case No. 6:16-cv-00088-RWS-JDL (E.D. Tex.), filed May 3, 2016; 22 pages.	
	NPL4	Defendants' Letter Requesting Permission to File a Motion for Partial Summary Judgment of Invalidity, filed in Realtime Data LLC d/b/a IXO v. Actian Corporation, et al., Case No. 6:15-cv-00463-RWS-JDL (E.D. Tex.) filed April 20, 2016; 6 pages.	
	NPL5	Plaintiff's Letter in Opposition to Moving Defendants' Letter Requesting Permission to File a Motion for Partial Summary Judgment, filed in Realtime Data LLC d/b/a IXO v. Actian Corporation, et al., Case No. 6:15-cv-00463-RWS-JDL (E.D. Tex.) filed May 9, 2016; 6 pages.	
	NPL6	Copy of Notice of Allowance for U.S. Pat. Appl. No. 14/727,309, mailed April 26, 2016; 7 pages.	
	NPL7	Copy of Notice of Allowance for U.S. Patent Appl. No. 14/733,565, mailed May 6, 2016; 6 pages.	
	NPL8	Petition for Inter Partes Review of U.S. Patent No. 7,415,530, filed in Dell Inc., et al. v. Realtime Data LLC d/b/a IXO, Case No. IPR2016-00878 (P.T.A.B.), filed April 22, 2016; 69 pages.	
	NPL9	Declaration of Charles D. Creusere, filed in Dell Inc., et al. v. Realtime Data LLC d/b/a IXO, Case No. IPR2016-00878 (P.T.A.B.), filed April 22, 2016; 124 pages.	
	NPL10	SOBH, et al., "A Comparison of Compressed and Uncompressed Transmission Modes," University of Pennsylvania Department of Computer and Information Science Technical Report No. MS-CIS-91-41, May 1991; 15 pages.	

Examiner Signature		Date Considered	
--------------------	--	-----------------	--

\*EXAMINER: Initial if reference considered, whether or not citation is in conformance with MPEP 609. Draw line through citation if not in conformance and not considered. Include copy of this form with next communication to applicant.

<sup>1</sup> Applicant's unique citation designation number (optional). <sup>2</sup> Applicant is to place a check mark here if English language Translation is attached.

Substitute for form 1449/PTO		<b>Complete if Known</b>	
<b>SIXTH SUPPLEMENTAL INFORMATION DISCLOSURE STATEMENT BY APPLICANT</b> <i>(Use as many sheets as necessary)</i>		Application Number	14/876,276
		Filing Date	October 6, 2015
		First Named Inventor	James J. FALLON
		Art Unit	2634
		Examiner Name	BOCURE, TESFALDET
		Attorney Docket Number	3421.005000C
Sheet	2	of	2

NON PATENT LITERATURE DOCUMENTS			
Examiner Initials*	Cite No. <sup>1</sup>	Include name of the author (in CAPITAL LETTERS), title of the article (when appropriate), title of the item (book, magazine, journal, serial, symposium, catalog, etc.), date, page(s), volume number, publisher, city and/or country where published	T <sup>2</sup>
	NPL11	9704 Data Compression Coprocessor Data Sheet, Stac Electronics, September, 1991; 56 pages.	
	NPL12	Petition for Inter Partes Review of U.S. Patent No. 8,643,513, filed in Riverbed Technology, Inc., et al. v. Realtime Data, LLC, Case No. IPR2016-00978 (P.T.A.B.), filed April 29, 2016; 65 pages.	
	NPL13	Declaration of Charles D. Creusere, Ph.D. Under 37 C.F.R. § 1.68, filed in Riverbed Technology, Inc., et al. v. Realtime Data, LLC, Case No. IPR2016-00978 (P.T.A.B.), filed April 29, 2016; 139 pages.	
	NPL14	Petition for Inter Partes Review of U.S. Patent No. 9,116,908, filed in Dell Inc. al. v. Realtime Data, LLC, Case No. IPR2016-01002 (P.T.A.B.), filed May 5, 2016; 68 pages.	
	NPL15	Declaration of Charles D. Creusere, Ph.D., filed in Dell Inc. al. v. Realtime Data, LLC, Case No. IPR2016-01002 (P.T.A.B.), filed May 5, 2016; 105 pages.	
	NPL16	Petition for Inter Partes Review of U.S. Patent No. 7,415,530, filed in Dell Inc. al. v. Realtime Data, LLC, Case No. IPR2016-00972 (P.T.A.B.), filed April 29, 2016; 69 pages.	
	NPL17	Declaration of Charles D. Creusere, Ph.D., filed in Dell Inc. al. v. Realtime Data, LLC, Case No. IPR2016-00972 (P.T.A.B.), filed April 29, 2016; 124 pages.	
	NPL18	Petition for Inter Partes Review of U.S. Patent No. 7,378,992, filed in Riverbed Technology, Inc. v. Realtime Data, LLC, Case No. IPR2016-00980 (P.T.A.B.), filed April 29, 2016; 57 pages.	
	NPL19	Declaration of Charles D. Creusere, Ph.D., filed in Dell Inc. al. v. Realtime Data, LLC, Case No. IPR2016-00980 (P.T.A.B.), filed April 29, 2016; 105 pages.	
	NPL20	Court Docket History for Realtime Data LLC d/b/a IXO v. Teradata Operations, Inc., Case No. 2:16-cv-02743 (C.D. Cal), downloaded April 26, 2016; 2 pages.	

2810041\_1.DOCX

Examiner Signature	Date Considered
-----------------------	--------------------

\*EXAMINER: Initial if reference considered, whether or not citation is in conformance with MPEP 609. Draw line through citation if not in conformance and not considered. Include copy of this form with next communication to applicant.

<sup>1</sup> Applicant's unique citation designation number (optional). <sup>2</sup> Applicant is to place a check mark here if English language Translation is attached.

## Electronic Patent Application Fee Transmittal

<b>Application Number:</b>	14876276			
<b>Filing Date:</b>	06-Oct-2015			
<b>Title of Invention:</b>	Video Data Compression Systems			
<b>First Named Inventor/Applicant Name:</b>	James J. FALLON			
<b>Filer:</b>	Michael V. Messinger/William Flanigen			
<b>Attorney Docket Number:</b>	3421.005000C			
Filed as Large Entity				
<b>Filing Fees for Utility under 35 USC 111(a)</b>				
<b>Description</b>	<b>Fee Code</b>	<b>Quantity</b>	<b>Amount</b>	<b>Sub-Total in USD(\$)</b>
<b>Basic Filing:</b>				
<b>Pages:</b>				
<b>Claims:</b>				
<b>Miscellaneous-Filing:</b>				
<b>Petition:</b>				
<b>Patent-Appeals-and-Interference:</b>				
<b>Post-Allowance-and-Post-Issuance:</b>				
<b>Extension-of-Time:</b>				

Description	Fee Code	Quantity	Amount	Sub-Total in USD(\$)
<b>Miscellaneous:</b>				
Request for Continued Examination	1801	1	1200	1200
<b>Total in USD (\$)</b>				<b>1200</b>

## Electronic Acknowledgement Receipt

<b>EFS ID:</b>	25786529
<b>Application Number:</b>	14876276
<b>International Application Number:</b>	
<b>Confirmation Number:</b>	3403
<b>Title of Invention:</b>	Video Data Compression Systems
<b>First Named Inventor/Applicant Name:</b>	James J. FALLON
<b>Customer Number:</b>	26111
<b>Filer:</b>	Michael V. Messinger/William Flanigen
<b>Filer Authorized By:</b>	Michael V. Messinger
<b>Attorney Docket Number:</b>	3421.005000C
<b>Receipt Date:</b>	16-MAY-2016
<b>Filing Date:</b>	06-OCT-2015
<b>Time Stamp:</b>	14:41:20
<b>Application Type:</b>	Utility under 35 USC 111(a)

### Payment information:

Submitted with Payment	yes
Payment Type	Credit Card
Payment was successfully received in RAM	\$1200
RAM confirmation Number	992
Deposit Account	
Authorized User	

The Director of the USPTO is hereby authorized to charge indicated fees and credit any overpayment as follows:

<b>File Listing:</b>					
<b>Document Number</b>	<b>Document Description</b>	<b>File Name</b>	<b>File Size(Bytes)/ Message Digest</b>	<b>Multi Part /.zip</b>	<b>Pages (if appl.)</b>
1	Foreign Reference	FP1_WO0046688.pdf	1674916 05f949ee977f215f4760b844b779e4a044d5556	no	16
<b>Warnings:</b>					
<b>Information:</b>					
2	Foreign Reference	FP2_WO9739421.pdf	4120200 131adf98eae5bdd3ab06eccaa8cfff4ae0ca90435	no	33
<b>Warnings:</b>					
<b>Information:</b>					
3	Non Patent Literature	NPL1_Actian_Joint_CC_04182016.pdf	243572 594759e2e8d141354c87d30586b305d82f817244	no	26
<b>Warnings:</b>					
<b>Information:</b>					
4	Non Patent Literature	NPL2_Oracle_Answer_05032016.pdf	182401 c7d0495b0c5e7202289499a273551ac0570bf9f9	no	22
<b>Warnings:</b>					
<b>Information:</b>					
5	Non Patent Literature	NPL3_Defendants_Letter_Summary_Judgment_04202016.pdf	142527 7ec4d06e20f5bd6560d330ee557e26226dd43b9b	no	6
<b>Warnings:</b>					
<b>Information:</b>					
6	Non Patent Literature	NPL4_Realtme_Opposition_Defendants_Letter_Summary_Judgment_05092016.pdf	164551 0e7b6a2e87b2b8cf56662b7ace888db3a90d75ef	no	6
<b>Warnings:</b>					
<b>Information:</b>					
7	Non Patent Literature	NPL5_Teradata_Operations_Complaint_04212016.pdf	306859 8f2dd01bc317afb3ccff896c54a79e9499387c7	no	31
<b>Warnings:</b>					
<b>Information:</b>					

8	Non Patent Literature	NPL6_NOA_14727309_04262016.pdf	410266 67b3774e4683895bd05fb4356cb75575f83558d3	no	7
<b>Warnings:</b>					
<b>Information:</b>					
9	Non Patent Literature	NPL7_NOA_14733565_05062016.pdf	146217 2cf6d27590c598e8e71f57f87b57c3f8acc19e16	no	6
<b>Warnings:</b>					
<b>Information:</b>					
10	Non Patent Literature	NPL8_Petition_IPR201600878_04222016.pdf	571890 fefd97410f4430123b92737b8eb9299a7e6ae32e	no	69
<b>Warnings:</b>					
<b>Information:</b>					
11	Non Patent Literature	NPL9_Creusere_Declaration.pdf	1157954 1bbd0c1342b501d1734e13c7f465105ca8f31678	no	124
<b>Warnings:</b>					
<b>Information:</b>					
12	Non Patent Literature	NPL10_Sobh_1991.pdf	2676227 89ff2f6c00cf103e2e63c93d9d01b05f2a72053	no	15
<b>Warnings:</b>					
<b>Information:</b>					
13	Non Patent Literature	NPL11_STAC_Data_Compression_Coprocessor.pdf	10753123 c7bf4a8f450ce91cdc705f8fb0a4929555d966a7	no	56
<b>Warnings:</b>					
<b>Information:</b>					
14	Non Patent Literature	NPL12_IPR201600978_Petition.pdf	662626 faf165924e19de09611a1703d25ddc30a9ae430c	no	65
<b>Warnings:</b>					
<b>Information:</b>					
15	Non Patent Literature	NPL13_IPR201600978_Creuser_Declaration.pdf	1267875 4e789c3dbd5ec22f091fb9b49d281222dfbd0bcd	no	139
<b>Warnings:</b>					
<b>Information:</b>					
16	Non Patent Literature	NPL14_IPR201601002_Petition_05052016.pdf	686824 c938bee1ee1dcbf4e84dbfea796a1e380a3fd2b6	no	68
<b>Warnings:</b>					
<b>Information:</b>					

17	Non Patent Literature	NPL15_IPR201601002_Creuser e_Declaration.pdf	927635 0b9a3910606ba657ac7aa6091372b5af77f6 a430	no	105
<b>Warnings:</b>					
<b>Information:</b>					
18	Non Patent Literature	NPL16_IPR201600972_Petition. pdf	557319 c9ccd727584bd09ecececa23d15ea4921c0 a82a6	no	69
<b>Warnings:</b>					
<b>Information:</b>					
19	Non Patent Literature	NPL17_IPR201500972_Creuser e_Declaration.pdf	1177836 565c05307bab08cce3677c1065702b1d74a 04239	no	124
<b>Warnings:</b>					
<b>Information:</b>					
20	Non Patent Literature	NPL18_IPR201600980_Petition. pdf	603008 ae57b3263342d3894a51c1ce892e7794c15 ad1cf	no	57
<b>Warnings:</b>					
<b>Information:</b>					
21	Non Patent Literature	NPL19_IPR201600980_Creuser e_Declaration.pdf	931189 f208e6c0dda99dc8b9c8b964d794eb6c197 0acaf	no	93
<b>Warnings:</b>					
<b>Information:</b>					
22	Non Patent Literature	NPL20_Teradata_Operations_D ocket_04262016.pdf	99284 f9a417f9b72eec11e3a2fe16b2c5ef8e75e9 7a4	no	2
<b>Warnings:</b>					
<b>Information:</b>					
23		3421005000C_6SIDS.pdf	1992223 96782c667a976885f21f763720b9640f564f 3420	yes	14
	<b>Multipart Description/PDF files in .zip description</b>				
	<b>Document Description</b>		<b>Start</b>	<b>End</b>	
	Miscellaneous Incoming Letter		1	1	
	Request for Continued Examination (RCE)		2	2	
	Transmittal Letter		3	11	
	Information Disclosure Statement (IDS) Form (SB08)		12	14	
<b>Warnings:</b>					



<b>Information:</b>					
24	Fee Worksheet (SB06)	fee-info.pdf	30386	no	2
			9718a7fad8dcd917f18f447e111232eea27fba56		
<b>Warnings:</b>					
<b>Information:</b>					
<b>Total Files Size (in bytes):</b>				31486908	
<p><b>This Acknowledgement Receipt evidences receipt on the noted date by the USPTO of the indicated documents, characterized by the applicant, and including page counts, where applicable. It serves as evidence of receipt similar to a Post Card, as described in MPEP 503.</b></p> <p><b><u>New Applications Under 35 U.S.C. 111</u></b>  <b>If a new application is being filed and the application includes the necessary components for a filing date (see 37 CFR 1.53(b)-(d) and MPEP 506), a Filing Receipt (37 CFR 1.54) will be issued in due course and the date shown on this Acknowledgement Receipt will establish the filing date of the application.</b></p> <p><b><u>National Stage of an International Application under 35 U.S.C. 371</u></b>  <b>If a timely submission to enter the national stage of an international application is compliant with the conditions of 35 U.S.C. 371 and other applicable requirements a Form PCT/DO/EO/903 indicating acceptance of the application as a national stage submission under 35 U.S.C. 371 will be issued in addition to the Filing Receipt, in due course.</b></p> <p><b><u>New International Application Filed with the USPTO as a Receiving Office</u></b>  <b>If a new international application is being filed and the international application includes the necessary components for an international filing date (see PCT Article 11 and MPEP 1810), a Notification of the International Application Number and of the International Filing Date (Form PCT/RO/105) will be issued in due course, subject to prescriptions concerning national security, and the date shown on this Acknowledgement Receipt will establish the international filing date of the application.</b></p>					

PCT

WORLD INTELLECTUAL PROPERTY ORGANIZATION  
International Bureau



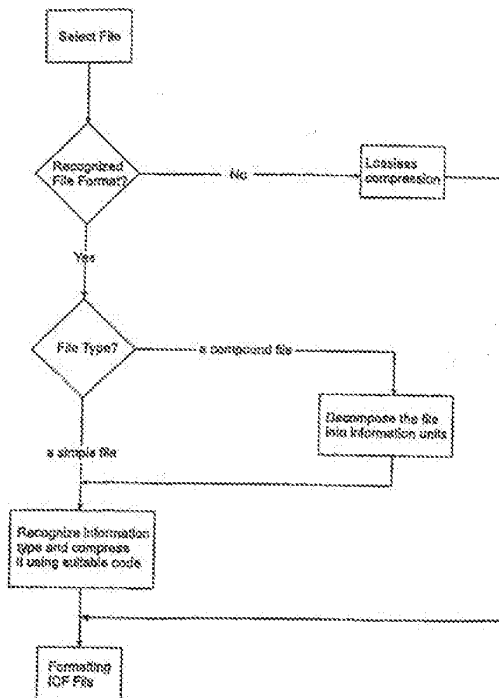
INTERNATIONAL APPLICATION PUBLISHED UNDER THE PATENT COOPERATION TREATY (PCT)

(51) International Patent Classification <sup>7</sup> : <b>G06F 17/00</b>	<b>A1</b>	(11) International Publication Number: <b>WO 00/46688</b>
		(43) International Publication Date: 10 August 2000 (10.08.00)
(21) International Application Number: PCT/CN00/00019		(81) Designated States: AU, CA, CN, JP, European patent (AT, BE, CH, CY, DE, DK, ES, FI, FR, GB, GR, IE, IT, LU, MC, NL, PT, SE).
(22) International Filing Date: 2 February 2000 (02.02.00)		Published With international search report.
(30) Priority Data: 09/241,472 2 February 1999 (02.02.99) US		
(71)(72) Applicant and Inventor: WANG, Jinbo [CN/CN]; Tian Jie Hu Dong Li, Beijing 100026 (CN).		
(74) Agent: CHINA PATENT AGENT (H.K.) LTD., Great Eagle Centre, 22/F, 23 Harbour Road, Wanchai, Hong Kong (CN).		

(54) Title: INTELLIGENT METHOD FOR COMPUTER FILE COMPRESSION

(57) Abstract

The present invention relates to an easy-to-use intelligent method for compressing computer files. In this method, a computer file containing different information types, such as text, image and sound, is automatically compressed by a computer, using suitable lossy or lossless codes. Both appropriate compression ratio and compression quality can be obtained. The present invention also relates to a method for decompressing a compressed file.



FOR THE PURPOSES OF INFORMATION ONLY

Codes used to identify States party to the PCT on the front pages of pamphlets publishing international applications under the PCT.

AL	Albania	ES	Spain	LS	Lesotho	SI	Slovenia
AM	Armenia	FI	Finland	LT	Lithuania	SK	Slovakia
AT	Austria	FR	France	LU	Luxembourg	SN	Senegal
AU	Australia	GA	Gabon	LV	Latvia	SZ	Swaziland
AZ	Azerbaijan	GB	United Kingdom	MC	Monaco	TD	Chad
BA	Bosnia and Herzegovina	GE	Georgia	MD	Republic of Moldova	TG	Togo
BB	Barbados	GH	Ghana	MG	Madagascar	TJ	Tajikistan
BE	Belgium	GN	Guinea	MK	The former Yugoslav Republic of Macedonia	TM	Turkmenistan
BF	Burkina Faso	GR	Greece	ML	Mali	TR	Turkey
BG	Bulgaria	HU	Hungary	MM	Myanmar	TT	Trinidad and Tobago
BJ	Benin	IE	Ireland	MN	Mongolia	UA	Ukraine
BR	Brazil	IL	Israel	MR	Mauritania	UG	Uganda
BY	Belarus	IS	Iceland	MW	Malawi	US	United States of America
CA	Canada	IT	Italy	MX	Mexico	UZ	Uzbekistan
CF	Central African Republic	JP	Japan	NE	Niger	VN	Viet Nam
CG	Congo	KE	Kenya	NL	Netherlands	YU	Yugoslavia
CH	Switzerland	KG	Kyrgyzstan	NO	Norway	ZW	Zimbabwe
CI	Cote d'Ivoire	KP	Democratic People's Republic of Korea	NZ	New Zealand		
CM	Cameroun	KR	Republic of Korea	PL	Poland		
CN	China	KZ	Kazakhstan	PT	Portugal		
CU	Cuba	LC	Saint Lucia	RO	Romania		
CZ	Czech Republic	LI	Liechtenstein	RU	Russian Federation		
DE	Germany	LK	Sri Lanka	SD	Sudan		
DK	Denmark	LR	Liberia	SE	Sweden		
EE	Estonia			SG	Singapore		

INTELLIGENT METHOD FOR COMPUTER FILE COMPRESSION

## FIELD OF THE INVENTION

The present invention relates to a compression method and compression software for computer files. The present invention also relates to method and software for decompression of computer files that are compressed in accordance with the present invention.

## BACKGROUND OF THE INVENTION

Original information, such as text, image and sound, is usually not compressed when it is stored in the form of computer files. Because the size of such non-compressed files can be large, however, it is often necessary to compress the files, before transmitting them electronically over a wide area network, such as the Internet, or storing them in a portable memory device, such as a floppy disk.

There are currently two existing methods for computer file compression. In the first method, an information type of the file is first recognized by a user who wishes to compress the file, and depending on the type of the file, the user then runs one or more specific types of computer file compression software to compress the file. For example, the user may run commercially available compression software ARJ for compression of text files, LeadView for compression of image files and RealAudio for compression of audio files. Although this method allows to obtain required compression ratio, this process may be time-consuming and may require many different types of compression software. It will be readily appreciated that this method of operation can be particularly inefficient when the file to be compressed contains multiple information types, such as text, image and audio, or when the user wishes to compress a large number of files, particularly if they do not all have the same information type.

*CONFIRMATION COPY*

The second compression method is to compress a file using only a lossless code, such as LZW, regardless of what type of information is contained in the file. This is manifest in the adoption of the V.42 bis chip in modems to compress all of the information that passes the modem, or in the use of Winzip software to compress files of different types. While this method can save time spent by the user, it has the inherent weakness that this compression mode is not necessarily well suited for the type of information that is being compressed. As a result, the compression ratios provided by such operation method are generally poor. This method of operation is more suitable for compression of character information, but not suitable for other types of information, such as for image or sound.

#### SUMMARY OF THE INVENTION

The object of the present invention is to provide an intelligent compression method for computer file compression. This object is achieved in the present invention, in which different types of information, such as text, image and sound, in a compute file is automatically compressed by a computer, using suitable lossy or lossless codes. The method of the present invention is easy-to-use and provides both an appropriate compression ratio and compression quality.

In one embodiment, the method of the present invention automatically compresses a computer file using a computer and it comprises the following steps: (1) operating to recognize a format of the file by an extension name of the file and in conjunction with control information of the file; and (2) compressing the file in accordance with the format of the file as follows: (a) if the format of the file is not recognized, compressing the file with a lossless code; (b) if the format of the file is recognized and the file includes only a single type of data information, compressing data information of the file with a suitable lossy or lossless code in accordance with the type of data information contained in the file; and (c) if the format of the file is recognized and the file includes a plurality of types of data

information, first decomposing the file into a plurality of units each containing only a single type of data information, then compressing each unit with a suitable lossy or lossless code in accordance with the type of data information of the unit.

The method of the present invention may be used in any computer hardware and/or software system, such as in modem software or an e-mail system.

In accordance with another embodiment of the present invention, a method for automatically compressing a computer file using a computer is provided. The method comprises the following steps: (1) operating to recognize a format of the file by an extension name of the file and in conjunction with control information of the file; and (2) compressing the file in accordance with the format of the file as follows: (a) if the format of the file is recognized and the file contains only a single type of data information, compressing the data information contained in the file with a suitable lossy or lossless code in accordance with the type of data information contained in the file; (b) if the file format is not recognized or the file contains more than one type of data information type, compressing the file directly with lossless code.

#### BRIEF DESCRIPTION OF THE DRAWINGS

The present invention can be realized by computer software, computer hardware or a combination of computer hardware and software. This invention will be more apparent from the following description in conjunction with the appended drawings, in which:

Figure 1 illustrates, in a flow chart form, a method for compressing a computer file of the present invention; and

Figure 2 depicts, in a flow chart form, a method for decompressing a computer file of the present invention that has previously been compressed with the method of this invention.

## DETAILED DESCRIPTION OF THE INVENTION

The intelligent method for compressing computer files will now be described with reference to the figures, which illustrate, in a flowchart form, a preferred embodiment of the present invention.

Figure 1 depicts, in a flow chart form, a method of compressing a computer file of the present invention. The first action in accordance with Figure 1 is selecting a computer file which is to be compressed. This file selection is carried by the user who wish to compress a particular file. All of the other steps illustrated in Figure 1, except file selection, are automatically carried out by a computer system in accordance with the present invention. These steps are as follows:

- A. The computer system operates to recognize the format of the file by the extension name of the file and in conjunction with the control information of the file to determine whether or not the file format is known.
- B. If the file format is not known, then the system will automatically compress the file with a lossless code, such as LZW.
- C. If the file format is known, the system then determine whether the file is a simple file (*i.e.*, it contains only a single data information type, such as text, Bitmap or Wave), or the file is a compound file (*i.e.*, it contains more than one type of data information).
- D. If the file is a simple file, the system will then automatically recognize the type of data information contained in the file and automatically compress the data information using a suitable code. For example, a lossless code, such as LZW, may be used for compression of character information. A proper lossy code, such as JPEG or G.723, may be used for compression of image or audio information.

E. If the file is a compound file, such as RTF or HTML, and the system will automatically decompose the file into a plurality of units each containing only a single data information type, and then compressing each unit just as in the former case.

In accordance with the present invention, in order to decrease the complexity of the system, the system may also compress the compound file directly with a lossless code without the decomposition step and the followed steps. For reason of simplicity, this option is not depicted in Figure 1.

F. Although it is currently the case that the compressed image information has a standard file format, such as JPEG, but the other information compressed by codes such as LZW or G.723, do not have a standard file format. In order to contain the compressed data and control information, the compressed file format must be defined, which is defined herein as ICF ("Intelligent Compression Format"), with an extension name of icf. In the final step of Figure 1, a compressed file is formatted according to the ICF format.

It is important that it be possible to decompress a file that has been compressed according to the compression method of the present invention described above. A preferred embodiment of the decompression method is described with reference to Figure 2. The first step in Figure 2 is the ICF file selection, that means a user should select a file which must have an icf extension. In accordance with the present invention, the selected icf file is then subjected to the verification step, in which the control information of the file is automatically checked by a computer system to ascertain whether or not the format of the file is truly in the ICF format. All the followed actions are also automatically carried out by the computer system.

If the file is not a proper ICF file, then a termination step is executed. During execution of this step, the user is notified that the file is not in the proper format, and the method ceases.



If the file is determined to be in the ICF format by the verification step, the system will then further determine whether or not the file is a compressed simple file that contains only one type of compressed data information, or the file is a compressed compound file that contains more than one type of compressed data information.

If the ICF file is a compressed simple file, the system will automatically recognize the type of data information of the file, and decompressing the data information using corresponding suitable decode.

If the ICF file is a compressed compound file, such as the ICF file formed by compressing an RTF or HTML file, the system will automatically decomposes the ICF file into a plurality of compressed data information units each containing only a single type of compressed data information, and then decompressing each such unit just as in the above event.

If, in the compression stage, the compound file was compressed directly with a lossless code, in this decompression steps, the file will be decompressed using the corresponding a lossless decode. For reason of simplicity, this step is not illustrated in the Figure 2.

The final action in Figure 2 is to form a decompressed file and reconstruct its original file format.

It will be apparent to one skilled in the art that the method of the present invention can be readily adopted into various application systems, such as modem software and E-mail systems, to improve the speed of file transmission.

In accordance with the present invention, a new type of compression and decompression software has been provided. This software provides a simple-to-use and efficient way for computer file compression and decompression, with both an appropriate compression ratio and compression quality. This software has demonstrated that the

method of the present invention as described herein is advantageous over existing file compression methods.

Although the present invention has been described with reference to a preferred embodiment, it will also be appreciated by those of ordinary skill in the art that modifications can be made to the form of the invention without departing from its spirit and scope, which is defined in the following claims.

## WHAT IS CLAIMED IS:

1. Method for automatically compressing a computer file by a computer, comprising the following steps:
  - (1) operating to recognize a format of the file by an extension name of the file and in conjunction with control information of the file; and
  - (2) compressing the file in accordance with the format of the file as follows:
    - a. if the format of the file is not recognized, compressing the file with a lossless code;
    - b. if the format of the file is recognized and the file includes only a single type of data information, compressing data information of the file with a suitable lossy or lossless code in accordance with the type of data information contained in the file; and
    - c. if the format of the file is recognized and the file includes a plurality of types of data information, first decomposing the file into a plurality of data information units each containing only a single type of data information, then compressing each unit with a suitable lossy or lossless code in accordance with the type of the data information contained in the unit.
  
2. Method for automatically compressing a computer file by a computer, comprising the following steps:
  - (1) operating to recognize a format of the file by an extension name of the file and in conjunction with control information of the file; and
  - (2) compressing the file in accordance with the format of the file as follows:
    - a. if the format of the file is recognized and the file contains only a single type of data information, compressing the data information

- contained in the file with a suitable lossy or lossless code in accordance with the type of data information contained in the file;
- b. if the file format is not recognized or the file contains more than one type of data information type, compressing the file directly with a lossless code.
3. Method for automatically compressing a computer file by a computer, comprising the following steps:
- a. operating to recognize a format of the computer file on the basis of an extension name of the file and control information of the file; and
  - b. compressing the file in accordance with the format of the file.
4. The use of the method of claim 1 in computer software, computer hardware, or a combination of computer hardware and software.
5. The use of the method of claim 2 in computer software, computer hardware, or a combination of computer hardware and software.
6. The use of the method of claim 3 in computer software, computer hardware, or a combination of computer hardware and software.
7. The use of the method of claim 1 as a separate compression tool.
8. The use of the method of claim 2 as a separate compression tool.
9. The use of the method of claim 3 as a separate compression tool.

10. The use of the method of claim 1 in any application system.
11. The use of the method of claim 2 in any application system.
12. The use of the method of claim 3 in any application system.

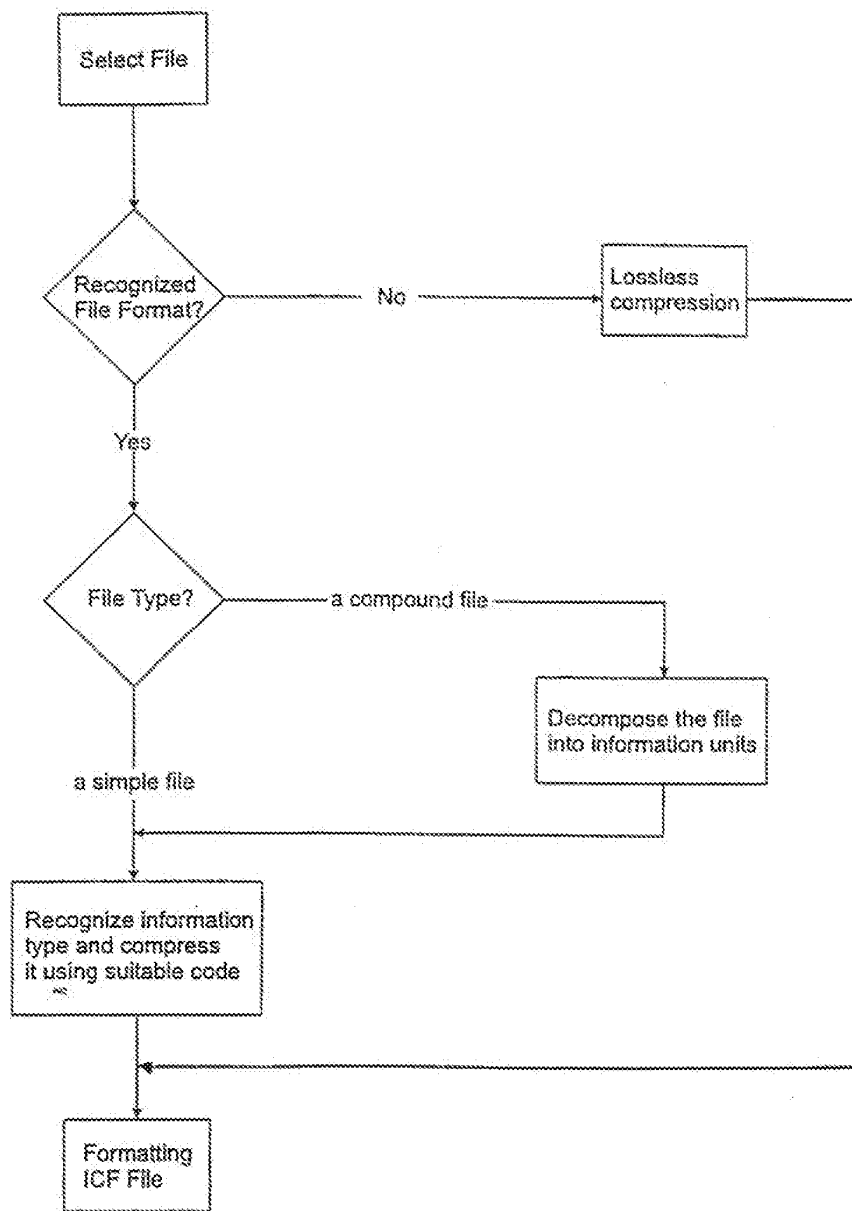


Figure 1

*SUBSTITUTE SHEET (RULE 26)*

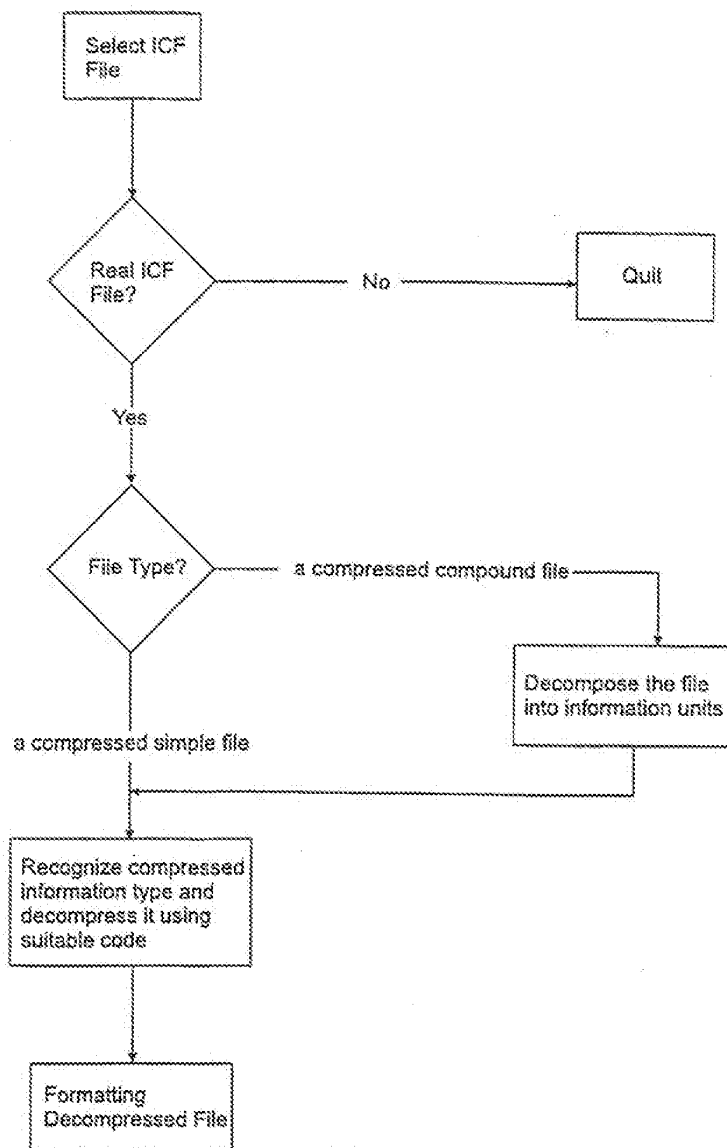


Figure 2

## INTERNATIONAL SEARCH REPORT

International application No.

PCT/CN 09/00919

A. CLASSIFICATION OF SUBJECT MATTER		
G06F 17/00		
According to International Patent Classification (IPC) or to both national classification and IPC		
B. FIELDS SEARCHED		
Minimum documentation searched (classification system followed by classification symbols)		
G06F 17/00, 17/20, 17/21, 17/22, 17/28, 9/00, G06T 9/00, H01N 1/11, H03M 7/30		
Documentation searched other than minimum documentation to the extent that such documents are included in the fields searched		
Electronic data base consulted during the international search (name of data base and, where practicable, search terms used)		
C. DOCUMENTS CONSIDERED TO BE RELEVANT		
Category*	Citation of document, with indication, where appropriate, of the relevant passages	Relevant to claim No.
A	EP0813167A2 the whole document	1-12
A	EP 0411232A2 the whole document	1-12
A	CN 1191355A the whole document	1-12
<input type="checkbox"/> Further documents are listed in the continuation of Box C. <input checked="" type="checkbox"/> See patent family annex.		
* Special categories of cited documents: * A* document defining the general state of the art which is not considered to be of particular relevance * B* earlier application or patent but published on or after the international filing date * L* document which may throw doubts on priority claim(s) or which is cited to establish the publication date of another citation or other special reason (as specified) * O* document referring to an oral disclosure, use, exhibition or other means * P* document published prior to the international filing date but later than the priority date claimed * T* later document published after the international filing date or priority date and not in conflict with the application but cited to understand the principle or theory underlying the invention * X* document of particular relevance; the claimed invention cannot be considered novel or cannot be considered to involve an inventive step when the document is taken alone * Y* document of particular relevance; the claimed invention cannot be considered to involve an inventive step when the document is combined with one or more other such documents, such combination being obvious to a person skilled in the art * Z* document member of the same patent family		
Date of the actual completion of the international search	Date of mailing of the international search report	
20 Apr. 2000 (20.04.00)	18 MAY 2000 (18.05.00)	
Name and mailing address of the ISA/CN	Authorized officer	
6 Xituchong Rd. Jimen Bridge, Haidian District, 100088 Beijing, China	Guohong, Xie	
Facsimile No. 86-10-62019451	Telephone No. 86-10-62093837	

Form PCT/ISA/210(second sheet)(July 1998)



**INTERNATIONAL SEARCH REPORT**  
 Information patent family members

International application No.  
 PCT/CN 00/00015

Patent document cited in search report	Publication date	Patent family member(s)	Publication date
EP 0813167A2	17.12.97	JP 10091110	10.01.98
EP 0111232A2	06.02.91	CA 2019133	01.02.91
		JP 3165181	17.07.91
		US 5254756	20.01.93
		B. 91221	30.02.95
		DE 68925281D	08.02.96
		ES 2081859T	16.03.96
		DE 68925281T	11.07.96
CN 1191355A	26.08.93	none	

Form PCT/ISA/210 (patent family annex) (July 1998)



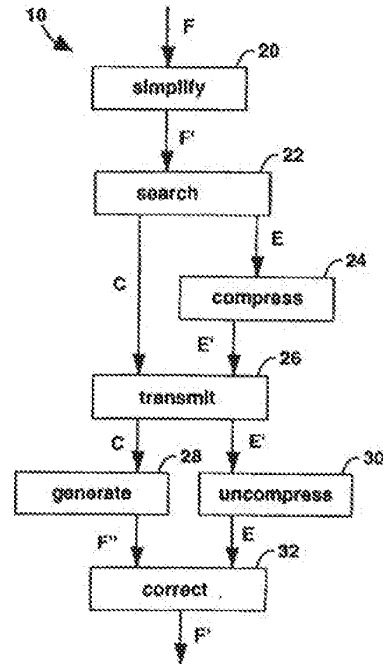
INTERNATIONAL APPLICATION PUBLISHED UNDER THE PATENT COOPERATION TREATY (PCT)

<p>(51) International Patent Classification <sup>6</sup> : <b>G06K 9/36, 9/46</b></p>	<p><b>AI</b></p>	<p>(11) International Publication Number: <b>WO 97/39421</b> (43) International Publication Date: 23 October 1997 (23.10.97)</p>
<p>(21) International Application Number: PCT/US97/05847 (22) International Filing Date: 9 April 1997 (09.04.97) (30) Priority Data: 08/633,386 16 April 1996 (16.04.96) US (71) Applicant: THE REGENTS OF THE UNIVERSITY OF CALIFORNIA [US/US]; 22nd floor, 300 Lakeside Drive, Oakland, CA 94612 (US). (72) Inventors: FEO, John, T.; 11321 Marwick Drive, Dublin, CA 94568 (US); HANKS, David, C.; 2675 Twin Creeks Drive, San Ramon, CA 94583 (US); KRAAY, Thomas, A.; 15192 Harrison Hill Lane, Lzeburg, VA 22075 (US). (74) Agent: SARTORIO, Henry, P.; P.O. Box 508, L-703, Livermore, CA 94530 (US).</p>	<p>(81) Designated States: AU, CA, CN, JP, RU, European patent (AT, BE, CH, DE, DK, ES, FI, FR, GB, GR, IE, IT, LU, MC, NL, PT, SE).  <b>Published</b> <i>With international search report. Before the expiration of the time limit for amending the claims and to be republished in the event of the receipt of amendments.</i></p>	

(54) Title: METHOD FOR DATA COMPRESSION BY ASSOCIATING COMPLEX NUMBERS WITH FILES OF DATA VALUES

(57) Abstract

A method (10) for compressing data for storage or transmission. Given a complex polynomial and a value assigned to each root, a root generated data file (RGDF) is created, one entry at a time. Each entry is mapped to a point in a complex plane. An iterative root finding technique is used to map the coordinates of the point to the coordinates of one of the roots of the polynomial. The value associated with that root is assigned to the entry. An equational data compression (EDC) method reverses this procedure. Given a target data file (F'), the EDC method uses a search algorithm (22) to calculate a set of m complex numbers and a value map that will generate the target data file. The error (E) between a simple target data file and generated data file is typically less than 10 %. Data files can be transmitted or stored without loss by transmitting (26) the m complex numbers, their associated values, and error file (E) whose size is at most one-tenth of the size of the input data file (F').



*FOR THE PURPOSES OF INFORMATION ONLY*

Codes used to identify States party to the PCT on the front pages of pamphlets publishing international applications under the PCT.

AL	Albania	ES	Spain	LS	Lesotho	SI	Slovenia
AM	Armenia	FI	Finland	LT	Lithuania	SK	Slovakia
AT	Austria	FR	France	LU	Luxembourg	SN	Senegal
AU	Australia	GA	Gabon	LV	Latvia	SZ	Switzerland
AZ	Azerbaijan	GB	United Kingdom	MC	Monaco	TD	Chad
BA	Bosnia and Herzegovina	GE	Georgia	MD	Republic of Moldova	TG	Togo
BB	Barbados	GH	Ghana	MG	Madagascar	TJ	Tajikistan
BE	Belgium	GN	Guinea	MK	The former Yugoslav Republic of Macedonia	TM	Turkmenistan
BF	Burkina Faso	GR	Greece			TR	Turkey
BG	Bulgaria	HU	Hungary	ML	Mali	TT	Trinidad and Tobago
BJ	Benin	IE	Ireland	MN	Mongolia	UA	Ukraine
BR	Brazil	IL	Israel	MR	Mauritania	UG	Uganda
BY	Belarus	IS	Iceland	MW	Malawi	US	United States of America
CA	Canada	IT	Italy	MX	Mexico	UZ	Uzbekistan
CF	Central African Republic	JP	Japan	NE	Niger	VN	Viet Nam
CG	Congo	KE	Kenya	NL	Netherlands	YU	Yugoslavia
CH	Switzerland	KG	Kyrgyzstan	NO	Norway	ZW	Zimbabwe
CI	Côte d'Ivoire	KP	Democratic People's Republic of Korea	NZ	New Zealand		
CM	Cameroon		Republic of Korea	PL	Poland		
CN	China	KR	Republic of Korea	PT	Portugal		
CU	Cuba	KZ	Kazakhstan	RO	Romania		
CZ	Czech Republic	LC	Saint Lucia	RU	Russian Federation		
DE	Germany	LI	Liechtenstein	SD	Sudan		
DK	Denmark	LK	Sri Lanka	SE	Sweden		
EE	Estonia	LR	Liberia	SG	Singapore		

METHOD FOR DATA COMPRESSION BY ASSOCIATING  
COMPLEX NUMBERS WITH FILES OF DATA VALUES

The United States Government has rights in this invention pursuant to Contract No. W-7405-ENG-48 between the United States Department of Energy and the University of California for the operation of Lawrence Livermore National Laboratory.

BACKGROUND OF THE INVENTION

Field of the Invention

The present invention relates to data compression and more particularly to methods and systems for representing a computer data file as a set of complex number-value pairs.

Description of the Background Art

A so-called graphics interchange format (GIF) was developed by a telephone-based information source, CompuServe Incorporated. GIF uses Lempel-Ziv and Welch (LZW) compression as its primary source of image compression. The syntax of the GIF data stream provides the information required for the preparation of LZW decoding, such as color maps. GIF compression is lossless, with a compression ratio from 2:1 to 9:1 being possible, depending on the type of data being compressed.

LZW Encoding reduces the size of a data set in one dimension. The compression method developed by Lempel-Ziv and Welch, known as LZW compression, seeks to take advantage of repeated sequences of data values, even when the repetition exists non-contiguously. A unique code replaces a repeated sequence in the encoded data set, saving bytes each time that sequence is repeated.

-2-

Consider the following data stream and its corresponding compressed data stream.

original data set     5 23 7 12 5 23 7 6 12    5 23 7 6 12  
 5 compressed data set   Code1 12 Code1 Code2 Code1 Code2

Given the compressed data set, a table or "codebook" which assigns values to each code is used to decode the data. In the example above, such a codebook would assign "5 23 7" to the entry for Code1. If  
 10 the codebook is large, however, the overhead costs of storing it can greatly reduce the efficiency of compression. LZW compression was developed to avoid this storage requirement. It also has the pleasant characteristics of relatively low memory requirements, due to its  
 15 sequential processing, and simplicity of algorithm, leading to implementations which use a relatively small amount of computer code.

In LZW compression, an encoder and decoder build identical codebooks as the data stream is processed sequentially. The encoder outputs a pattern code only after it has found the pattern more than  
 20 once. The first time it processes a sequence of data, it places that sequence in its codebook and outputs the sequence without any encoding. During decoding, this sequence is output and an entry into the codebook is made for this sequence. The entry is assigned a code in the same manner that the encoder assigned a code, so that when this  
 25 code is encountered later, the decoder will output the correct sequence of values.

To further illustrate LZW compression, the following algorithms for encoding and decoding are presented, together with simulation examples for each. Here, a colon is used to indicate  
 30 concatenation. For example "abc" : "d" = "abcd".

-3-

<u>encoding</u>	
	initialize the codebook - one entry for each possible individual value
	<b>prefix</b> = empty string
5	repeat
	<b>dataValue</b> = next data value in data stream
	if <b>prefix : dataValue</b> is already in codebook
	then <b>prefix</b> = <b>prefix : dataValue</b>
	else {
10	add <b>prefix : dataValue</b> to the codebook
	output the <b>prefix</b> code from the codebook
	<b>prefix</b> = <b>dataValue</b> }
	until all the data values are processed
15	output the code from the codebook for <b>prefix</b>

For the encoding algorithm, a string of data values is built until the string is different from any other previously coded string. New data strings are always made of some previously known strings (which has been entered into the codebook) plus one new data value.

20 When a new pattern is found the new pattern is immediately added to the codebook, the code for the prefix of the new data string is output, and the data string is reinitialized to begin the search for a new data string. Each time a code is output, a new entry is made in the codebook.

```

simulation of encoding
assuming that original data can be one of three different values - a, b, or
c. Consider the sample data stream "a b a b b b c".
5
Initialize the codebook as follows:
Code      Data Value      Prefix : Data Value
   0         a          -: a
   1         b          -: b
10    2         c          -: c

prefix = empty string

   input      prefix:   new codebook entries
15  dataValue  dataValue  code      data string  output  new prefix
   a         -: a      [code 0 already entered]      0
   b         0: b      3         ab         0         1
   a         1: a      4         ba         1         0
   b         0: b      [code 3 already entered]      3
20    b         3: b      5         abb        3         1
   b         1: b      6         bb         1         1
   b         1: b      [code 6 already entered]      6
   c         6: c      7         bbc        6         2

25  output last prefix value:                                2
    
```

-5-

decoding	
	initialize the codebook - one entry for each possible individual value
	code = the first code value in the compressed data stream
5	output the data string that corresponds to code in the codebook
	repeat
	oldCode = code
	code = next code value from compressed data stream
	if code already exists in the codebook
10	then {
	output the data string corresponding to code
	prefix = oldCode
	suffix = first value from output data string }
	else {
15	prefix = oldCode
	suffix = first value from the prefix data string
	output prefix : suffix)
	add prefix : suffix to the codebook
20	until all code values are processed

For the if-statement, when the input code is already in the codebook, it is a straight forward process to output the string corresponding to that code. When a code is encountered which is not yet in the codebook, the immediately preceding data values must form the new data string. The new data string being formed is immediately preceded by itself. Since the preceding suffix starts the current prefix, the new code's data string must begin and end with the same data value. And since the pattern is repeated, the prefix of the new data string must be the string corresponding to the code previously input to the decoder. Therefore, the value of the undefined code is oldCode concatenated with the first value of OldCode.



simulation of decoding

The encoder produced the data stream "013162". This now becomes our input for the decoder.

5 Initialize the codebook as follows:

Code	Data Value	Prefix : Data Value
0	a	- : a
1	b	- : b
2	c	- : c

10 code = 0  
output a (data value of code 0)

oldCode	input Code	in codebook?	new codebook entries						
			prefix	suffix	output	code	string	suffix	
0	1	yes	0	1	b	3	ab	0:1	
1	3	yes	1	0	ab	4	ba	1:0	
3	1	yes	3	1	b	5	abb	3:1	
1	6	no	1	1	bb	6	bb	1:1	
6	2	yes	6	2	c	7	bbc	6:2	

15

20

The string produced by the decoder, "ababbbbc", is the original string which was input into the encoder.

25 The effectiveness of LZW compression is data dependent. Simple line drawings that are stored in raster format can be compressed as much as 16:1 or more. Raster scanned photographs are expected to achieve compression ratios from 2:1 to 9:1.

30 The Joint Photographic Experts Group (JPEG) has issued a suite of standards, with twenty nine distinct coding processes in all. The so-called JPEG compression standard was intended to satisfy a broad range of applications. Its seeks high compression ratios and high image fidelity. Applications can select from a broad range of compression ratios, trading off image quality for higher compression to meet the specific needs of an application. No restrictions are made on

35 the image contents, e.g., complexity or range of colors, or characteristics, such as resolution. A manageable computational complexity allows for reasonable software implementations and fast hardware

-7-

such as resolution. A manageable computational complexity allows for reasonable software implementations and fast hardware implementations. A lossless encoding mode provides for exact image reproduction. A sequential encoding mode provides for image reproduction using multiple passes through the data, where the image is initially blurry and each pass through the data adds further clarity to the image. And a hierarchical encoding mode is provided for image reproduction using a sequence of frames, each at different resolutions.

Other prior art data compression methods exist and some are in wide use. However, all leave the user wanting higher levels of compression with lower losses occurring in such compression. No conventional compression method has thus far proven totally satisfactory, even in particular applications.

#### SUMMARY OF THE INVENTION

An object of the present invention is to provide a method for starting with a data file to compress and finding the roots of the polynomial, assuming such a polynomial exists, that will generate the same data file in a reconstruction either exactly or within some threshold of error.

Briefly, a method embodiment of the present invention compresses data for storage or transmission. For a data file of pixel values organized as an  $n \times n$  grid of pixels, the data file of pixel values, or any computer data file, may be compressed by the method of the present invention. Letting  $G$  be an  $n \times n$  grid superimposed on the complex plane, and  $P$ , an  $m$  degree polynomial. Letting  $A$  be a function of the first derivative of  $P$ , and letting  $B$  be a function of the second derivative of  $P$ . And further letting  $C(i)$  be a map to a unique color for each root of  $P$ , where  $1 \leq i \leq m$ .  $A$  and  $B$  are then iteratively solved for each  $z$  in  $G$ . The solution ultimately converges within some epsilon of one of the roots of  $P$ . When  $z$  converges to root  $i$ ,  $C(i)$  is assigned to  $z$ .  $P$ ,  $A$  and  $B$  can be defined for any  $m$  numbers in the complex plane and

-8-

color function C to generate a data file of pixel values encoded by m complex numbers.

An advantage of the present invention is that a method for compressing data is provided.

5 Another advantage of the present invention is that a method of compressing data with few losses and high compression ratios is provided.

#### BRIEF DESCRIPTION OF THE DRAWINGS

Fig. 1 is a flowchart of an equational data file compression method embodiment of the present invention for data compression;

10 Fig. 2 shows a more detailed flowchart of the method of Fig. 1;

Fig. 3 is a flowchart for a generic search method useful in the method of Fig. 2; and

15 Fig. 4 is a flowchart of a generating method useful in the method of Figs. 2 and 3.

#### DETAILED DESCRIPTION OF THE INVENTION

Figs. 1 illustrates an equational data compression (EDC) method embodiment of the present invention for compressing and decompressing data, and is referred to herein by the general reference numeral 10. The EDC method 10 comprises a compression step 12, a transmission step 14, and a decompression step 16. The compression step 12 takes the data file F and returns a data file F'. The file F is a file of values whose type depends on the data medium. For example, if the file F is a text file, then the values might be octal numbers such that F(i) encodes the i-th character of the text. If the file F is a data file file, then the values might be eight-bit binary numbers such that F(i) encodes the color of the i-th pixel of the data file. The compression step 12 reduces the size of the data file to minimize the amount of data that needs to be transmitted or stored by the transmission step 14.

20

25

The transmission step 14 either transmits or stores the data file  $F'$ . The transmission or storage of data is assumed here to be without error. Any of a number of conventional methods may be used to detect and/or correct errors due to faulty transmission or storage.

5           The decompression step 16 inputs the data file  $F'$  and outputs the data file  $F''$ . It uses an inverse method to that used by the compression step 12 to uncompress the data. Where file  $F''$  equals file  $F$ , then the compression method was lossless. Otherwise, the compression resulted in data loss. The extent to which the  
10           compression method is lossy depends on the methods used steps 12 and 16.

          Fig. 2 illustrates the EDC method 10 in greater detail. A simplify step 20, a search step 22, and a compress step 24 are equivalent to the compression step 12 of Fig. 1. A transmission step 26 is  
15           equivalent to the transmission step 14 of Fig. 1. A generating step 28, a decompression step 30, and a correction step 32 are equivalent to the decompression step 16 in Fig. 1. The simplify step 20 takes the data file  $F$  and returns a simplified data file  $F'$ . This step may or may not be empty. The form of the simplification is data dependent and the  
20           degree of simplification depends on the amount of loss information tolerable by the sender and receiver. For example, this step might reduce the number of colors in a data file file from a maximum of 256 to twenty six by dividing each value in the file  $F$  by 10. The search step 22 takes the data file  $F'$  and returns two outputs,  $C$  and  $E$ . Output  $C$  is a  
25           set of tuples  $\{z, v\}$ , such that  $z$  is complex number, and  $v$  is a value in  $F'$ . The search step 22 uses a search heuristic to find  $C$  such that  $G(C, i) = P'(i)$ . Since it is unlikely that the search heuristic will return a set of numbers that regenerates  $P'$  without loss, the step returns an error file  $E$ . The tuple  $\{i, y\}$  is in  $E$  if and only if  $G(C, i) \neq F'(i)$  and  $F'(i) = y$ . A  
30           conventional genetic algorithm is used to find  $C$ , however, practically any search algorithm can be used. The compression step 24 compresses

-10-

the file E, e.g., using any conventional lossless compression algorithm. Its output is the data file E'. The transmission step 26 either electronically transmits or stores C and E', e.g., across the Internet or into a hard disk file. Such transmission or storage of the data is  
5 assumed here to be without error. The generating step 28 implements the generation of an algorithm G, described in connection with Fig. 4. The generating step 28 inputs a set of complex numbers C and returns the data file P". The decompression step 30 uncompresses the data file E' to regenerate a data file E without loss. The correction step 32 inputs  
10 files F" and E, and returns a data file F'. For each tuple (i, y) in E, the box sets the value of F"(i) to y.

The search step 22 of Fig. 2 searches the complex plane for a set of tuples (z, v) such that a generate method can return a file F" as close as possible to F'. Any discrepancy between F" and F' is returned  
15 in E. The particular search algorithm used is not important. A genetic algorithm whose gross structure is shown in Fig. 3 has been used successfully. The particular mating, mutation, and replacement method used is beyond the scope of this description. Possible choices of methods are well documented in the literature.

Fig. 3 illustrates a generic search method 40. A step 42  
20 generates a population of possible solutions, e.g., it generates two or more possible values for C. Each value is referred to as an individual of the population. A step 44 mates the individuals of the population and thus generates a set of new individuals. As in nature, the method  
25 tends to preserve the best characteristics of the population and to eliminate the worse characteristics. Over the generations, the population includes fitter and fitter individuals, e.g., better and better solutions to the search problem. Typically, the methods implemented by steps 50 and 52 of Fig. 3 are used to evaluate the fitness of  
30 individuals. A step 46 mutates selected individuals. Mutations or random changes to the data are necessary to prevent the method from

-11-

becoming stuck at a local maximum. A step 48 replaces individuals from the previous generation with those born and mutated by steps 44 and 46, respectively. An output of step 48 is the next population of individuals. A step 50 generates a data file for each individual in P.

5 The set of data files is G. The step 50 is equivalent to step 28 of Fig. 2. A step 52 calculates the error between F' and each data file generated by step 50. A typical error function is the sum of  $\text{diff}(i)$ , where  $\text{diff}(i)$  is 1 if the two files have different values at position  $i$ , else 0. Step 52 returns the smallest error value computed ( $e$ ), the individual that generated  
 10 the smallest error value ( $C$ ), and a file of the differences between that individual and F' ( $E$ ). A step 54 compares the error value with some threshold value. If the comparison is true, then the search terminates and  $C$  and  $E$  are returned; else, the new population and control are passed back to step 44.

15 The generation step 28 of Fig. 2 generates the file F'' of  $n$  values,  $1 \leq i \leq n$ , from  $C$ . Letting  $P$  be a  $m$ -th degree complex polynomial whose roots  $r_j$ ,  $1 \leq j \leq m$ ,  $m$  complex numbers in  $C$ , and letting  $T$  be a function that transforms integers to complex numbers, then for each integer  $i$ ,  $1 \leq i \leq n$ , step 28 executes the data flow shown in  
 20 Fig. 4. The inputs to the generating step 28 of Fig. 2 are assumed to be available to all the steps in Fig. 4 and so, do not explicitly show their edges.

Fig. 4 illustrates a generating method 60. A step 62 applies a transform function  $T$  to  $i$  and returns  $z$ . The appropriate transform  
 25 function to use depends on the type of the data file. For example, if the data file is a 2-D data file of size  $n$  by  $n$ , then  $T(i)$  might return the complex number  $\{(i \text{ div } n)/n, (i \text{ mod } n)/n\}$ . A step 64 computes  $P(z)$ . If the computed value is less than some small value, then the step returns yes. Otherwise, the step 64 returns no. If the step 64 returns  
 30 no, then control is passed to a step 66 that computes the displayed expression returning two complex values,  $a^+$  and  $a^-$ . A step 68 passes

-12-

the value with the smallest absolute value to a step 70 that decrements  
 z by this value. The decremented value and control back are passed  
 back to the step 64. If the step 64 returns yes, then control is passed to a  
 step 72 that searches C, and returns the value associated with the  
 5 complex number in C closest to z. The iterative computation of Fig. 4  
 terminates when z is within epsilon of some root of P.

An equational data compression (EDC) method of the present  
 invention reverses the creation data files that used an iterative root  
 finding method. Data files can be created using this method, and  
 10 equations which closely approximates a given data file can also be  
 found.

An iterative root finding method, developed by one of the  
 present inventors, Thomas Kraay, starts with a complex function, P,  
 with m complex roots and an arbitrary initial guess z, in the complex  
 15 plane, the iterative root finding method converges unexpectedly fast to  
 one of the function's roots, usually in two to four iterations. The  
 method has converged over ten million times to within  $10^{-6}$  of a root  
 value.

The iterative root finding method, e.g., illustrated in Fig. 4,  
 20 can be described mathematically, as follows:

Let P(z) be a known polynomial with unknown roots  $r_1, \dots, r_m$ . Then,

$$P(z) = \prod_{i=1}^m (z - r_i).$$

For  $z \in \{r_1, \dots, r_m\}$ , take the natural log of both sides to get,

25 
$$\ln P(z) = \ln \prod_{i=1}^m (z - r_i) = \sum_{i=1}^m \ln(z - r_i).$$

-13-

Taking the derivative of both sides,

$$\frac{d}{dz} \ln P(z) = \frac{d}{dz} \sum_{i=1}^m \ln(z - r_i) = \sum_{i=1}^m \frac{d}{dz} \ln(z - r_i) = \sum_{i=1}^m \frac{1}{(z - r_i)},$$

and since,

$$\frac{d}{dz} \ln P(z) = \frac{P'(z)}{P(z)},$$

5 then,

$$g(z) = \frac{P'(z)}{P(z)} = \sum_{i=1}^m \frac{1}{(z - r_i)}. \quad (\text{eq. 1})$$

Now taking the derivative of  $g(z)$  with respect to  $z$ , provides,

$$\frac{d}{dz} \frac{P'(z)}{P(z)} = \frac{d}{dz} \sum_{i=1}^m \frac{1}{(z - r_i)} = \sum_{i=1}^m \frac{-1}{(z - r_i)^2},$$

and since,

$$10 \quad - \frac{d}{dz} \frac{P'(z)}{P(z)} = \frac{[P'(z)]^2 - P(z)P''(z)}{P^2(z)},$$

then,

$$h(z) = \frac{[P'(z)]^2 - P(z)P''(z)}{P^2(z)} = \sum_{i=1}^m \frac{1}{(z - r_i)^2}. \quad (\text{eq. 2})$$



-14-

Given a complex number  $z$ , the values of  $g(z)$  and  $h(z)$  can be calculated. Let  $r_j$  represent some root of  $P(x)$ , and define the value  $a$  such that,

$$a = z - r_j, \quad (\text{eq. 3})$$

5 The equations (1) and (2) can be rewritten,

$$g(z) = \frac{1}{a} + \sum_{\substack{i=1 \\ i \neq j}}^m \frac{1}{(z - r_i)} \quad \text{and} \quad (\text{eq. 1a})$$

$$h(z) = \frac{1}{a^2} + \sum_{\substack{i=1 \\ i \neq j}}^m \frac{1}{(z - r_i)^2}. \quad (\text{eq. 2a})$$

There exists a complex number  $b$  such that,

$$\sum_{\substack{i=1 \\ i \neq j}}^m \frac{1}{(z - r_i)} = \frac{m-1}{b},$$

10 giving

$$g(z) = \frac{1}{a} + \frac{m-1}{b}. \quad (\text{eq. 1b})$$

Let  $c$  be the complex number, such that,

$$\sum_{\substack{i=1 \\ i \neq j}}^m \frac{1}{(z - r_i)^2} = \frac{m-1}{b^2} + c. \quad (\text{eq. 4})$$

-15-

For  $m > 2$ , discarding  $\epsilon$ , introduces error, but gives,

$$h(z) = \frac{1}{a^2} + \frac{m-1}{b^2} \quad (\text{eq. 2b})$$

There are two equations (1b) and (2b) in two unknowns (a and b). It can be shown that,

$$5 \quad a^{\pm} = \frac{m}{g(z) \mp \sqrt{(m-1)(mh(z) - g^2(z))}} \quad (\text{eq. 5})$$

Which is equivalent to the step 66. To aid in convergence, a is assigned the value of smaller magnitude,

$$a = \begin{cases} a^+ & \text{if } |a^+| < |a^-| \\ a^- & \text{otherwise} \end{cases} \quad (\text{eq. 6})$$

10 Which is equivalent to the step 68. By equation (3),  $r_1 = z - a$  is a root of the equation. However, having discarded  $\epsilon$  this equality no longer holds.  $z - a$  now only approximates  $r_1$ .

Given an initial guess  $z$ ,  $P(Z)$  is calculated. If the absolute value is greater than  $\epsilon$ , a is calculated letting  $z = z - a$ , e.g., step 70. Repeating this process, as in the step 64, until the absolute value of  $P(z)$  is less than  $\epsilon$ , a root of the polynomial is converged within  $\epsilon$ .

15 The iterative root finding method is used to generate data files. A file of size  $n$ ,  $0 \leq i \leq n-1$  is created, using the iterative root finding method. Let  $P(Z)$  be a polynomial with roots  $r_1, \dots, r_m$  and let  $v_1, \dots, v_m$  be a set of  $m$  values. Start by defining a transformation  
20 function from integers to points in the complex plane. Letting  $n = W * H$ , then  $T(i)$ ,  $0 \leq i \leq n-1$ , returns the complex number,

-16-

$$z = \left\{ \frac{i \operatorname{div} W}{H}, \frac{i \operatorname{mod} W}{W} \right\}.$$

Which is equivalent to the step 62.

Using  $z$  as an initial guess, the iterative method is used to calculate a root of  $P(z)$ . As in the step 72, if the  $i$ -th root is returned, then the value  $v_i$  is assigned to the  $i$ -th datum in the file. The resulting file of values is referred to as a root generated data file (RGDF) and the procedure is called a generation process. For example, to create a data file data file of 40,000 pixels. Let  $W = 200$ ,  $H = 200$ ,  $r_1 = 0.0 + 0.0i$ ,  $v_1 = \text{blue}$ ,  $r_2 = 0.75 + 0.75i$ ,  $v_2 = \text{green}$ ,  $r_3 = 0.8 - 0.15i$ ,  $v_3 = \text{gray}$ ,  $r_4 = 1.5 - 0.50i$ , and  $v_4 = \text{purple}$ . Then, the RGDF created corresponds to a particular data file. Such file is uniquely encoded by the four root-value pairs used to create it.

The generation process can be reverse engineered. Since EDC is given a data file  $F$  of size  $n$ ,  $0 \leq i \leq n - 1$ , with  $m$  unique values, the  $m$  complex numbers can be found such that the RGDF returned by the generation process is equivalent to  $F$ . Although reversing the mathematical formulations might appear impossible, an attractive solution method is the use of general purpose search methods. The problem can be viewed as a search for  $m$  points in the complex plane, where the optimality of a set of  $m$  points is defined by a fitness function. The current embodiments use a genetic algorithm to search for the  $m$  points, e.g., as in Fig. 3.

Genetic algorithms are search algorithms that depend on an imitation of nature and use the mechanics of natural selection and natural genetics. The object is to improve a set of initial solutions, referred to as a "population" of individuals, using "recombination" and "mutation" of their "genetic material". The method combines survival of the fittest among solutions with a structured and randomized information exchange.

-17-

Each "generation" creates new solutions that replace old and ineffective solutions in the population. A solution's probability of recombination is directly proportional to its fitness. Only the most effective solutions survive. The selection of solutions for

5 recombination and mutation, as well as the replacement of solutions in the population are driven by genetic operators controlled by probability.

Genetic algorithms can work with several solutions at the same time, improving the solutions in each generation, while

10 simultaneously exploring new solutions in the search space. Genetic algorithms are also easily adapted to a variety of problems requiring adjustments to only the representation of solutions and the fitness function. Because the objective function used to measure fitness is the only information used to guide the search, no auxiliary or derivative

15 information is required.

A simple genetic algorithm (SGA) is described with the aid of the pseudo code of Table I. A solution consists of one, or occasionally more, bit-encoded strings, or chromosomes. Each bit's position is its locus and the value of the bits as its allele (0 or 1 for binary strings). For

20 simplicity, unless otherwise stated, we assume a single chromosome per individual and binary alleles.

TABLE I

25 randomly create and evaluate an initial population of size n  
for gen = 1 to MAX\_GEN  
    create a mating pool selecting individuals from the  
        population using fitness proportionate selection  
    form n/2 pairs from the mating pool and perform  
        crossover and mutation  
    replace current generation with offsprings  
    evaluate the fitness of the new population  
30 end for

-18-

output fittest individual as the solution

5 The first generation of a genetic algorithm consists of individuals whose chromosomes are randomly constructed, e.g., step 42. Assuming that genes may be one of two values, either 0 or 1, and letting  $P_1$  be the probability that a given gene will have the value 1. Each gene of each chromosome in the initial population can be assigned a value 1, with probability  $P_1$ , or a value of 0, with probability  $P_0 = 1 - P_1$ .

10 Once the procedure has defined all genes of a chromosome, it then applies the fitness function to determine the chromosome's fitness value. Once the procedure has created an initial population and determined the fitness of each individual, it then creates the next generation.

15 For successive generations, several mate selection, mating, and replacement are used. The process is continued for an indicated number of generations, or until some other terminating condition is encountered.

20 As the step 44 illustrates, mate selection selects  $n$  individuals to parent offspring in the next generation. The selected individuals create a mating pool. Such individuals are chosen according to their fitness values. On average, those with higher fitness values are selected more often than those with lower fitness values. More exactly, the probability that the algorithm selects individual  $I_i$  with fitness  $F_i$  is,

25 
$$P_i = \frac{F_i}{\sum_{j=1}^n F_j}$$

Such method, known as fitness proportionate reproduction (FPR) selection, is an artificial version of natural selection, a Darwinian "survival of the fittest" among individuals.

Table II represents a sample population of four individuals, their fitness values and selection probabilities, and the results of mate selection. In this example, the string is a binary number and the fitness function is  $f(x) = x^2$ .

5

TABLE II

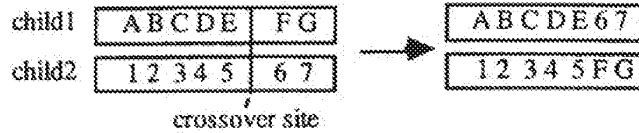
INDIVIDUAL		FITNESS	SEL. PROB.	Mating Pool
i	Ii	Fi	Pi	
1	10011	361	0.310	11001
2	00110	36	0.031	10011
3	01100	144	0.123	01100
4	11001	625	0.536	11011
Total		1166	1.000	

Once the mate selection is complete, the members of the mating pool are randomly divided into pairs for mating. Their chromosomes are manipulated by crossover and mutation with probability  $P_x$  and  $P_m$ , respectively.

10

During the crossover operation, a crossover site, a position between the individuals' genes, is selected at random. The alleles to the right of the crossover site are then swapped between the pair, as in Table III.

TABLE III



As in step 46, when  $P_x < 1.0$ , some pairs may not undergo the crossover operation, but all pairs are subject to mutation. The mutation operation considers each allele in every individual, and changes its value with probability  $P_m$ . When an allele is mutated, its value changes from 0 to 1 or 1 to 0. This operation allows the algorithm to recover genetic material which has been lost and to introduce new genetic material.

Table IV illustrates a full reproduction phase for  $P_x = 0.667$  and  $P_m = 0.033$ .

TABLE IV

i	Mating pairs	fitness	After crossover	After mutation	New generation	fitness
1	11001	625	11 100	11100	11100	784
2	01100	144	01 001	01001	01001	81
3	10011	361	100 11	10011	10111	529
4	11001	625	11001	11001	11001	625
Total		1755				2019

The step 48 includes a steady state genetic algorithm (SSGA) that is a variant of the SGA. In the SSGA, only a subset of individuals in a population, e.g., a "generation gap", are replaced in every

-21-

generation. The size of the generation gap,  $G$ , is usually expressed as a fraction of the overall population size. Thus, if  $n$  is the population size, the number of individual to be replaced each generation is  $G * n$ . A commonly chosen value for  $G$  is  $2/n$ . Only one pair is chosen to mate, and their offspring replace two individuals in the population. When  $G = 1.0$ , the algorithm replaces all individuals, as is equivalent to the SGA. With  $G < 1.0$ , a replacement rule is need to decide which individuals should perish to make room for the new offspring. Such individuals could be those with the lowest fitnesses. In inverse ranking, the individuals are ranked according to their fitnesses. Each individual is considered, starting with the least fit, and individuals are eliminated with probability greater than  $1/n$  until only two individuals remain.

SSGA thus imitates nature more accurately than the SGA, but has several drawbacks. Because low fitness individuals are quickly dismissed, the fitter individuals tend to dominate faster, leading to a greater possibility premature convergence. Also, the SSGA is not easily parallelizable, depending on the size of  $G$ . If  $G=2/n$ , there is no parallelism.

A variation of the SGA with linear fitness scaling has been used with success in embodiments of the present invention. The deviation from ordinary SGA involves the encoding of the problem and the manipulation of roots. Various methods have been attempted, e.g., in the initial population generation and root mutation.

The data file to compress is defined here as the target file. The target file is compressed and encoded with method embodiments of the present invention.

For encoding, an individual is comprised of a chromosome with  $N$  binary alleles, and  $N$  complex numbers and values, one for each locus in the chromosome. Table V represents an individual in this encoding.



TABLE V

allele 0	complex # 0	value 0
allele 1	complex # 1	value 1
allele 2	complex # 2	value 2
...	...	
allele N-1	complex # N-1	value N-1

5 A complex number is active if its corresponding allele in the chromosome is one. The roots of the polynomial associated with the individual are the active complex numbers. Thus, the degree of this polynomial is exactly the number of ones in the chromosome.

Table VI represents a polynomial associated with a sample individual.

10

TABLE VI

0	$5.0 + 3.2i$	blue
1	$3.3 - 1.6i$	red
1	$-2.4 + 10.0i$	grey
0	$4.1 - 5.9i$	purple
1	$-0.1 - 1.7i$	green

$$P(z) = [z - (3.3 - 1.6i)] [z - (-2.4 + 10.0i)] [z - (-0.1 - 1.7i)]$$

15 For the initial population, the value of each allele in each chromosome in the initial population is randomly chosen 0 or 1, with

-23-

equal probability. The complex numbers corresponding to each locus are chosen by creating a vector of random angle and random length (less than some value, L), transforming it to the form  $x+iy$ , and adding it to C, a complex number in the middle of the frame in the complex plane into which pixel locations are translated. Each locus of each chromosome in the population is assigned its own randomly generated root. Values are assigned randomly with equal probability.

For successive generations, mate selection, crossover, and mutation are conventional, except for a few points. No replacement policy is needed since as we use the SGA model. The triplet of allele, root, and color always stay together. Thus, when a crossover occurs, the roots and colors corresponding to each moved allele are also moved. The changing of the value of a root is also different. Like mutation of alleles, each root is considered for adjustment every generation. Adjustment occurs with small probability. When a root is adjusted, it is moved a random distance, e.g., less than some variable length, in the direction of a random angle.

The fitness measurement depends on how many values in the generated file match the corresponding value in the target file. The maximum fitness is n. The fittest file, e.g., file C in Fig. 2, to emerge from the genetic algorithm, referred to as the generated file, is most likely not equivalent to the target file. A greedy algorithm is applied to improve the solution and record the error entries in an error file, e.g., file E in Fig. 2.

For data file improvement, once the genetic algorithm converges, the generated file is improved using a greedy algorithm, that systematically adjusts each active root in the following way. An imaginary circle is placed around the root with a random radius. Fitnesses are sampled around the circle to determine the angle we should move the root to maximize fitness. A line is then drawn at this angle, and fitnesses sampled in order to determine the best distance to

-24-

move the root in this direction. The process is typically repeated until further attempts result in little or no improvement in fitness.

5 Although particular embodiments of the present invention have been described and illustrated, such is not intended to limit the invention. Modifications and changes will no doubt become apparent to those skilled in the art, and it is intended that the invention only be limited by the scope of the appended claims.

THE INVENTION CLAIMED IS

1. A method for compressing and uncompressing data for storage or transmission, wherein a data file is stored as a file of size  $N$ , and letting  $T$  be a function that maps integers to points in the complex plane  $P$ , which is an  $m$  degree polynomial, and letting  $A$  be a function of the first derivative of  $P$ , and  $B$  be a function of the second derivative of  $P$ , and further letting  $C(i)$  be a map to a unique value for each root of  $P$ , where  $1 \leq i \leq m$ , then  $A$  and  $B$  are then iteratively solved for each  $z = T(i)$ ,  $1 \leq i \leq N$ , and a solution ultimately converges within some epsilon of one of the roots of  $P$ , for when  $z$  converges to root  $j$ ,  $C(j)$  is assigned to  $z$ , and  $P$ ,  $A$  and  $B$  can be defined for any  $m$  numbers in the complex plane and color function  $C$  to generate a data file of pixel values encoded by  $m$  complex numbers.

2. The method of claim 1, wherein given a data file of size  $N$ , the  $m$  complex numbers and value function  $C$  are found that encode said data file using an optimization method including conventional genetic algorithms, wherein for a given target data file to compress, a main process is repeated until a solution sufficiently close to the target is found or some arbitrary maximum number of generations is exceeded, wherein said main process comprises producing a data file for each member of the generation, then evaluating each member's fitness against the target, then scaling the fitness values, then creating  $N/2$  couples of polynomials, where each couple is comprised of two polynomials randomly selected from the current generation, and where the probability of a member being assigned to a couple is in

-26-

15 direct proportion to its scaled fitness value, and then, mating each couple to generate two children, allowing for characteristics of each parent to contribute to each child or crossover and allowing for mutation.

3. A method for compressing data for storage or transmission, wherein given a complex polynomial and a value assigned to each root, a root generated data file (RGDF) is created, one entry at a time, and each entry is mapped to a point in a complex plane, then an  
5 iterative root finding technique is used to map the coordinates of the point to the coordinates of one of the roots of the polynomial, then the value associated with that root is assigned to the entry, whereafter an equational data compression (EDC) method is used to reverse such steps, wherein given a target data file, the EDC method uses a search  
10 algorithm to calculate a set of  $m$  complex numbers and a value map that will generate the target data file, wherein data files are transmitted or stored by transmitting the  $m$  complex numbers, their associated values, and an error file.

Fig. 1

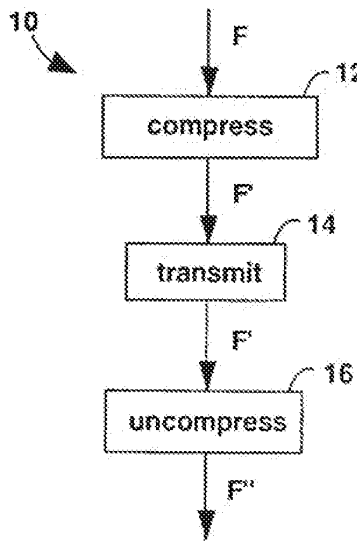


Fig. 2

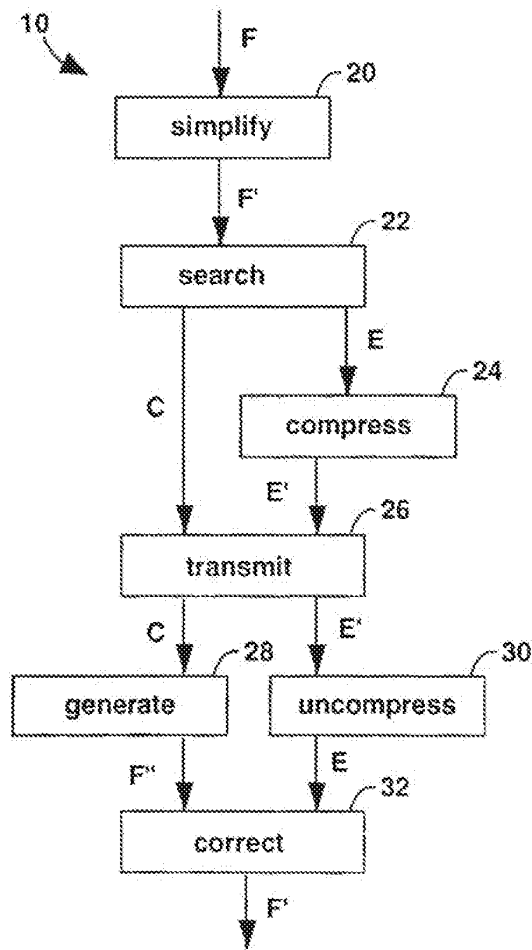


Fig. 3

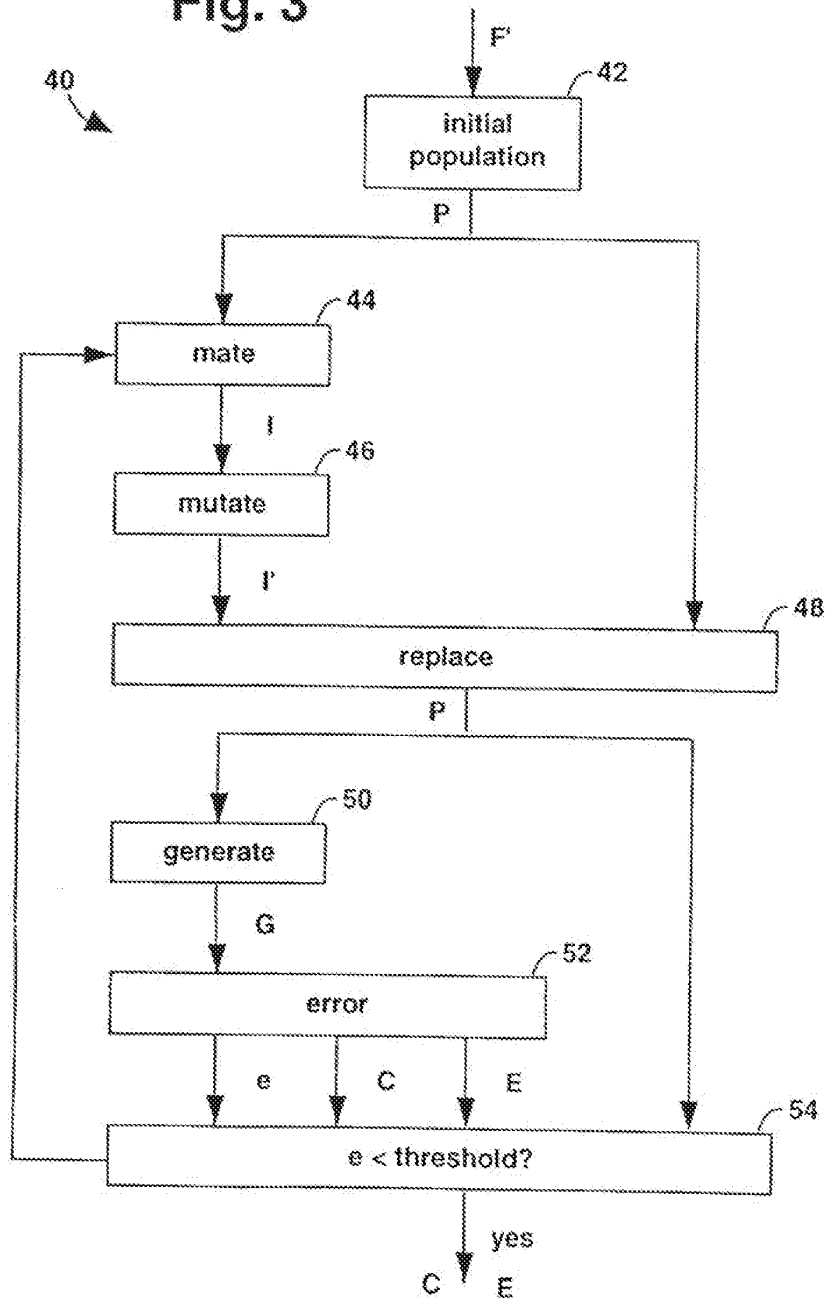
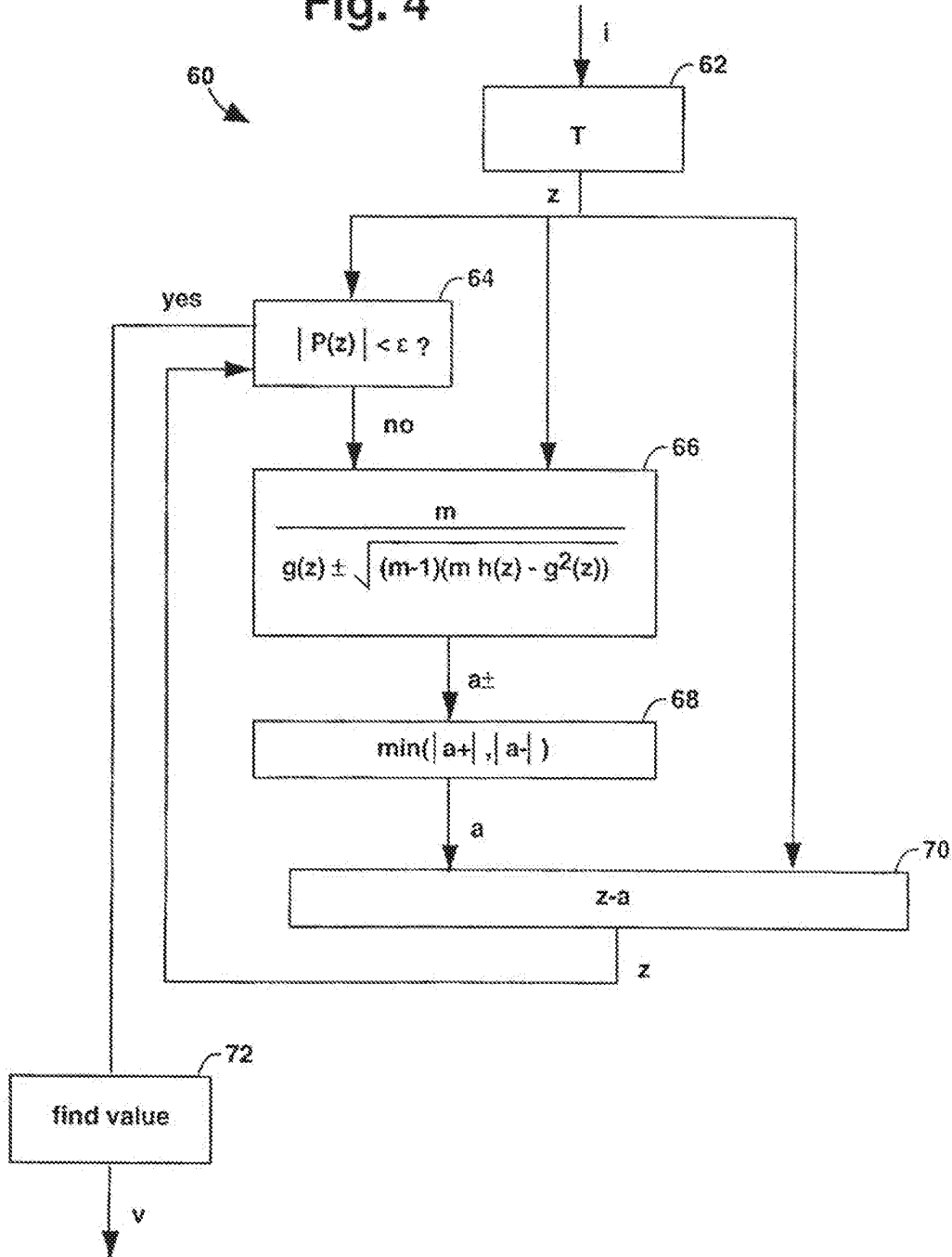




Fig. 4



INTERNATIONAL SEARCH REPORT

International application No.  
PCT/US97/05847

<p><b>A. CLASSIFICATION OF SUBJECT MATTER</b>                  IPC(6) :G06K 9/36, 9/46                  US CL :382/232, 249; 395/13                  According to International Patent Classification (IPC) or to both national classification and IPC</p>																						
<p><b>B. FIELDS SEARCHED</b>                  Minimum documentation searched (classification system followed by classification symbols)                  U.S. : 382/232, 249, 233, 241, 243, 247, 248, 253; 395/13, 612; 364/715.02</p> <p>Documentation searched other than minimum documentation to the extent that such documents are included in the fields searched</p> <p>Electronic data base consulted during the international search (name of data base and, where practicable, search terms used)                  APS, IEEE/IEEE Publications Ondisc Jan 1990 - Nov 1996                  Search terms: complex, polynomial, root, compression, coding, genetic</p>																						
<p><b>C. DOCUMENTS CONSIDERED TO BE RELEVANT</b></p> <table border="1"> <thead> <tr> <th>Category*</th> <th>Citation of document, with indication, where appropriate, of the relevant passages</th> <th>Relevant to claim No.</th> </tr> </thead> <tbody> <tr> <td>A</td> <td>US, A 5,343,554 (KOZA et al) 30 August 1994, col. 78, line 60 - col. 79, line 34.</td> <td>1-3</td> </tr> </tbody> </table>			Category*	Citation of document, with indication, where appropriate, of the relevant passages	Relevant to claim No.	A	US, A 5,343,554 (KOZA et al) 30 August 1994, col. 78, line 60 - col. 79, line 34.	1-3														
Category*	Citation of document, with indication, where appropriate, of the relevant passages	Relevant to claim No.																				
A	US, A 5,343,554 (KOZA et al) 30 August 1994, col. 78, line 60 - col. 79, line 34.	1-3																				
<p><input type="checkbox"/> Further documents are listed in the continuation of Box C. <input type="checkbox"/> See patent family annex.</p>																						
<p>* Special categories of cited documents:</p> <table border="0"> <tr> <td>"A"</td> <td>document defining the general state of the art which is not considered to be part of particular relevance</td> <td>"T"</td> <td>later documents published after the international filing date or priority date and not in conflict with the application but cited to understand the principle or theory underlying the invention</td> </tr> <tr> <td>"B"</td> <td>earlier document published on or after the international filing date</td> <td>"X"</td> <td>document of particular relevance; the claimed invention cannot be considered novel or cannot be considered to involve an inventive step when the document is taken alone</td> </tr> <tr> <td>"L"</td> <td>document which may throw doubt on priority claim(s) or which is cited to establish the publication date of another citation or other special reason (as specified)</td> <td>"Y"</td> <td>document of particular relevance; the claimed invention cannot be considered to involve an inventive step when the document is combined with one or more other such documents, such combination being obvious to a person skilled in the art</td> </tr> <tr> <td>"O"</td> <td>document referring to an oral disclosure, use, exhibition or other means</td> <td>"G"</td> <td>document member of the same patent family</td> </tr> <tr> <td>"P"</td> <td>document published prior to the international filing date but later than the priority date claimed</td> <td></td> <td></td> </tr> </table>			"A"	document defining the general state of the art which is not considered to be part of particular relevance	"T"	later documents published after the international filing date or priority date and not in conflict with the application but cited to understand the principle or theory underlying the invention	"B"	earlier document published on or after the international filing date	"X"	document of particular relevance; the claimed invention cannot be considered novel or cannot be considered to involve an inventive step when the document is taken alone	"L"	document which may throw doubt on priority claim(s) or which is cited to establish the publication date of another citation or other special reason (as specified)	"Y"	document of particular relevance; the claimed invention cannot be considered to involve an inventive step when the document is combined with one or more other such documents, such combination being obvious to a person skilled in the art	"O"	document referring to an oral disclosure, use, exhibition or other means	"G"	document member of the same patent family	"P"	document published prior to the international filing date but later than the priority date claimed		
"A"	document defining the general state of the art which is not considered to be part of particular relevance	"T"	later documents published after the international filing date or priority date and not in conflict with the application but cited to understand the principle or theory underlying the invention																			
"B"	earlier document published on or after the international filing date	"X"	document of particular relevance; the claimed invention cannot be considered novel or cannot be considered to involve an inventive step when the document is taken alone																			
"L"	document which may throw doubt on priority claim(s) or which is cited to establish the publication date of another citation or other special reason (as specified)	"Y"	document of particular relevance; the claimed invention cannot be considered to involve an inventive step when the document is combined with one or more other such documents, such combination being obvious to a person skilled in the art																			
"O"	document referring to an oral disclosure, use, exhibition or other means	"G"	document member of the same patent family																			
"P"	document published prior to the international filing date but later than the priority date claimed																					
<p>Date of the actual completion of the international search 10 JULY 1997</p>		<p>Date of mailing of the international search report <b>20 AUG 1997</b></p>																				
<p>Name and mailing address of the ISA/US Commissioner of Patents and Trademarks Box PCT Washington, D.C. 20231 Facsimile No. (703) 305-3230</p>		<p>Authorized officer B. N. TRAN PHUOC TRAN Telephone No. (703) 305-4861</p>																				

Form PCT/ISA/210 (second sheet)(July 1992)\*

MICHAEL V. MESSINGER  
DIRECTOR  
(202) 772-8667  
MIKEM@SKGF.COM



May 16, 2016

Commissioner for Patents  
PO Box 1450  
Alexandria, VA 22313-1450

Confirmation No. 3403  
*Art Unit 2634*  
*Attn: Mail Stop RCE*

Re: U.S. Utility Patent Application  
Application No. 14/876,276; Filing Date: October 6, 2015  
For: **Video Data Compression Systems**  
Inventors: FALLON *et al.*  
Our Ref: 3421.005000C

Commissioner:

Transmitted herewith for appropriate action are the following documents:

1. Online Credit Card Payment Authorization in the amount of \$1,200.00 in payment of the fee under 37 C.F.R. § 1.17(e)(1);
2. Request for Continued Examination (PTO/SB/30);
3. Sixth Supplemental Information Disclosure Statement;
4. Form PTO/SB/08a (1 sheet) listing 6 documents (**US1-US4** and **FP1-FP2**);
5. Form PTO/SB/08b (2 sheets) listing 20 documents (**NPL1-NPL20**); and
6. Copies of cited documents (**FP1-FP2** and **NPL1-NPL20**).

In the event that extensions of time are necessary to prevent abandonment of this patent application, then such extensions of time are hereby petitioned.

Fee payment is provided through online credit card payment. The U.S. Patent and Trademark Office is hereby authorized to charge any fee deficiency, or credit any overpayment, to our Deposit Account No. 19-0036.

Respectfully submitted,

STERNE, KESSLER, GOLDSTEIN & FOX P.L.L.C.

A handwritten signature in black ink, appearing to read "Michael V. Messinger".

Michael V. Messinger  
Attorney for Applicant  
Registration No. 37,575

MVM/MRM/wcf  
Enclosures



UNITED STATES PATENT AND TRADEMARK OFFICE

UNITED STATES DEPARTMENT OF COMMERCE
United States Patent and Trademark Office
Address: COMMISSIONER FOR PATENTS
P.O. Box 1450
Alexandria, Virginia 22313-1450
www.uspto.gov

NOTICE OF ALLOWANCE AND FEE(S) DUE

26111 7590 04/26/2016
STERNE, KESSLER, GOLDSTEIN & FOX P.L.L.C.
1100 NEW YORK AVENUE, N.W.
WASHINGTON, DC 20005

EXAMINER

BOCURE, TESFALDET

ART UNIT PAPER NUMBER

2634

DATE MAILED: 04/26/2016

Table with 5 columns: APPLICATION NO., FILING DATE, FIRST NAMED INVENTOR, ATTORNEY DOCKET NO., CONFIRMATION NO.

14/876,276 10/06/2015 James J. FALLON 3421.005000C 3403

TITLE OF INVENTION: Video Data Compression Systems

Table with 7 columns: APPLN. TYPE, ENTITY STATUS, ISSUE FEE DUE, PUBLICATION FEE DUE, PREV. PAID ISSUE FEE, TOTAL FEE(S) DUE, DATE DUE

nonprovisional UNDISCOUNTED \$960 \$0 \$0 \$960 07/26/2016

THE APPLICATION IDENTIFIED ABOVE HAS BEEN EXAMINED AND IS ALLOWED FOR ISSUANCE AS A PATENT. PROSECUTION ON THE MERITS IS CLOSED. THIS NOTICE OF ALLOWANCE IS NOT A GRANT OF PATENT RIGHTS. THIS APPLICATION IS SUBJECT TO WITHDRAWAL FROM ISSUE AT THE INITIATIVE OF THE OFFICE OR UPON PETITION BY THE APPLICANT. SEE 37 CFR 1.313 AND MPEP 1308.

THE ISSUE FEE AND PUBLICATION FEE (IF REQUIRED) MUST BE PAID WITHIN THREE MONTHS FROM THE MAILING DATE OF THIS NOTICE OR THIS APPLICATION SHALL BE REGARDED AS ABANDONED. THIS STATUTORY PERIOD CANNOT BE EXTENDED. SEE 35 U.S.C. 151. THE ISSUE FEE DUE INDICATED ABOVE DOES NOT REFLECT A CREDIT FOR ANY PREVIOUSLY PAID ISSUE FEE IN THIS APPLICATION. IF AN ISSUE FEE HAS PREVIOUSLY BEEN PAID IN THIS APPLICATION (AS SHOWN ABOVE), THE RETURN OF PART B OF THIS FORM WILL BE CONSIDERED A REQUEST TO REAPPLY THE PREVIOUSLY PAID ISSUE FEE TOWARD THE ISSUE FEE NOW DUE.

HOW TO REPLY TO THIS NOTICE:

I. Review the ENTITY STATUS shown above. If the ENTITY STATUS is shown as SMALL or MICRO, verify whether entitlement to that entity status still applies.

If the ENTITY STATUS is the same as shown above, pay the TOTAL FEE(S) DUE shown above.

If the ENTITY STATUS is changed from that shown above, on PART B - FEE(S) TRANSMITTAL, complete section number 5 titled "Change in Entity Status (from status indicated above)".

For purposes of this notice, small entity fees are 1/2 the amount of undiscounted fees, and micro entity fees are 1/2 the amount of small entity fees.

II. PART B - FEE(S) TRANSMITTAL, or its equivalent, must be completed and returned to the United States Patent and Trademark Office (USPTO) with your ISSUE FEE and PUBLICATION FEE (if required). If you are charging the fee(s) to your deposit account, section "4b" of Part B - Fee(s) Transmittal should be completed and an extra copy of the form should be submitted. If an equivalent of Part B is filed, a request to reapply a previously paid issue fee must be clearly made, and delays in processing may occur due to the difficulty in recognizing the paper as an equivalent of Part B.

III. All communications regarding this application must give the application number. Please direct all communications prior to issuance to Mail Stop ISSUE FEE unless advised to the contrary.

IMPORTANT REMINDER: Utility patents issuing on applications filed on or after Dec. 12, 1980 may require payment of maintenance fees. It is patentee's responsibility to ensure timely payment of maintenance fees when due.

**PART B - FEE(S) TRANSMITTAL**

**Complete and send this form, together with applicable fee(s), to: Mail Mail Stop ISSUE FEE  
 Commissioner for Patents  
 P.O. Box 1450  
 Alexandria, Virginia 22313-1450  
 or Fax (571)-273-2885**

**INSTRUCTIONS:** This form should be used for transmitting the ISSUE FEE and PUBLICATION FEE (if required). Blocks 1 through 5 should be completed where appropriate. All further correspondence including the Patent, advance orders and notification of maintenance fees will be mailed to the current correspondence address as indicated unless corrected below or directed otherwise in Block 1, by (a) specifying a new correspondence address; and/or (b) indicating a separate "FEE ADDRESS" for maintenance fee notifications.

CURRENT CORRESPONDENCE ADDRESS (Note: Use Block 1 for any change of address)

26111                      7590                      04/26/2016  
**STERNE, KESSLER, GOLDSTEIN & FOX P.L.L.C.**  
 1100 NEW YORK AVENUE, N.W.  
 WASHINGTON, DC 20005

Note: A certificate of mailing can only be used for domestic mailings of the Fee(s) Transmittal. This certificate cannot be used for any other accompanying papers. Each additional paper, such as an assignment or formal drawing, must have its own certificate of mailing or transmission.

**Certificate of Mailing or Transmission**

I hereby certify that this Fee(s) Transmittal is being deposited with the United States Postal Service with sufficient postage for first class mail in an envelope addressed to the Mail Stop ISSUE FEE address above, or being facsimile transmitted to the USPTO (571) 273-2885, on the date indicated below.

_____ (Depositor's name)
_____ (Signature)
_____ (Date)

APPLICATION NO.	FILING DATE	FIRST NAMED INVENTOR	ATTORNEY DOCKET NO.	CONFIRMATION NO.
14/876,276	10/06/2015	James J. FALLON	3421.005000C	3403

TITLE OF INVENTION: Video Data Compression Systems

APPLN. TYPE	ENTITY STATUS	ISSUE FEE DUE	PUBLICATION FEE DUE	PREV. PAID ISSUE FEE	TOTAL FEE(S) DUE	DATE DUE
nonprovisional	UNDISCOUNTED	\$960	\$0	\$0	\$960	07/26/2016

EXAMINER	ART UNIT	CLASS-SUBCLASS
BOCURE, TESFALDET	2634	375-240100

<p>1. Change of correspondence address or indication of "Fee Address" (37 CFR 1.363).</p> <p><input type="checkbox"/> Change of correspondence address (or Change of Correspondence Address form PTO/SB/122) attached.</p> <p><input type="checkbox"/> "Fee Address" indication (or "Fee Address" Indication form PTO/SB/47; Rev 03-02 or more recent) attached. <b>Use of a Customer Number is required.</b></p>	<p>2. For printing on the patent front page, list</p> <p>(1) The names of up to 3 registered patent attorneys or agents OR, alternatively, _____ 1</p> <p>(2) The name of a single firm (having as a member a registered attorney or agent) and the names of up to 2 registered patent attorneys or agents. If no name is listed, no name will be printed. _____ 2</p> <p>_____ 3</p>
-------------------------------------------------------------------------------------------------------------------------------------------------------------------------------------------------------------------------------------------------------------------------------------------------------------------------------------------------------------------------------------------------------------------	---------------------------------------------------------------------------------------------------------------------------------------------------------------------------------------------------------------------------------------------------------------------------------------------------------------------------------------------------------------------------------------

3. ASSIGNEE NAME AND RESIDENCE DATA TO BE PRINTED ON THE PATENT (print or type)

PLEASE NOTE: Unless an assignee is identified below, no assignee data will appear on the patent. If an assignee is identified below, the document has been filed for recordation as set forth in 37 CFR 3.11. Completion of this form is NOT a substitute for filing an assignment.

(A) NAME OF ASSIGNEE \_\_\_\_\_ (B) RESIDENCE: (CITY and STATE OR COUNTRY) \_\_\_\_\_

Please check the appropriate assignee category or categories (will not be printed on the patent):  Individual  Corporation or other private group entity  Government

<p>4a. The following fee(s) are submitted:</p> <p><input type="checkbox"/> Issue Fee</p> <p><input type="checkbox"/> Publication Fee (No small entity discount permitted)</p> <p><input type="checkbox"/> Advance Order - # of Copies _____</p>	<p>4b. Payment of Fee(s): (<b>Please first reapply any previously paid issue fee shown above</b>)</p> <p><input type="checkbox"/> A check is enclosed.</p> <p><input type="checkbox"/> Payment by credit card. Form PTO-2038 is attached.</p> <p><input type="checkbox"/> The director is hereby authorized to charge the required fee(s), any deficiency, or credits any overpayment, to Deposit Account Number _____ (enclose an extra copy of this form).</p>
-------------------------------------------------------------------------------------------------------------------------------------------------------------------------------------------------------------------------------------------------	------------------------------------------------------------------------------------------------------------------------------------------------------------------------------------------------------------------------------------------------------------------------------------------------------------------------------------------------------------------------------------------------------------------------------------------------------------------

5. **Change in Entity Status** (from status indicated above)

Applicant certifying micro entity status. See 37 CFR 1.29

Applicant asserting small entity status. See 37 CFR 1.27

Applicant changing to regular undiscounted fee status.

**NOTE:** Absent a valid certification of Micro Entity Status (see forms PTO/SB/15A and 15B), issue fee payment in the micro entity amount will not be accepted at the risk of application abandonment.

**NOTE:** If the application was previously under micro entity status, checking this box will be taken to be a notification of loss of entitlement to micro entity status.

**NOTE:** Checking this box will be taken to be a notification of loss of entitlement to small or micro entity status, as applicable.

NOTE: This form must be signed in accordance with 37 CFR 1.31 and 1.33. See 37 CFR 1.4 for signature requirements and certifications.

Authorized Signature _____	Date _____
Typed or printed name _____	Registration No. _____



UNITED STATES PATENT AND TRADEMARK OFFICE

UNITED STATES DEPARTMENT OF COMMERCE
United States Patent and Trademark Office
Address: COMMISSIONER FOR PATENTS
P.O. Box 1450
Alexandria, Virginia 22313-1450
www.uspto.gov

Table with 5 columns: APPLICATION NO., FILING DATE, FIRST NAMED INVENTOR, ATTORNEY DOCKET NO., CONFIRMATION NO.
14/876,276 10/06/2015 James J. FALLON 3421.005000C 3403

26111 7590 04/26/2016
STERNE, KESSLER, GOLDSTEIN & FOX P.L.L.C.
1100 NEW YORK AVENUE, N.W.
WASHINGTON, DC 20005

EXAMINER

BOCURE, TESFALDET

ART UNIT PAPER NUMBER

2634

DATE MAILED: 04/26/2016

Determination of Patent Term Adjustment under 35 U.S.C. 154 (b)
(Applications filed on or after May 29, 2000)

The Office has discontinued providing a Patent Term Adjustment (PTA) calculation with the Notice of Allowance.

Section 1(h)(2) of the AIA Technical Corrections Act amended 35 U.S.C. 154(b)(3)(B)(i) to eliminate the requirement that the Office provide a patent term adjustment determination with the notice of allowance. See Revisions to Patent Term Adjustment, 78 Fed. Reg. 19416, 19417 (Apr. 1, 2013). Therefore, the Office is no longer providing an initial patent term adjustment determination with the notice of allowance. The Office will continue to provide a patent term adjustment determination with the Issue Notification Letter that is mailed to applicant approximately three weeks prior to the issue date of the patent, and will include the patent term adjustment on the patent. Any request for reconsideration of the patent term adjustment determination (or reinstatement of patent term adjustment) should follow the process outlined in 37 CFR 1.705.

Any questions regarding the Patent Term Extension or Adjustment determination should be directed to the Office of Patent Legal Administration at (571)-272-7702. Questions relating to issue and publication fee payments should be directed to the Customer Service Center of the Office of Patent Publication at 1-(888)-786-0101 or (571)-272-4200.

## OMB Clearance and PRA Burden Statement for PTOL-85 Part B

The Paperwork Reduction Act (PRA) of 1995 requires Federal agencies to obtain Office of Management and Budget approval before requesting most types of information from the public. When OMB approves an agency request to collect information from the public, OMB (i) provides a valid OMB Control Number and expiration date for the agency to display on the instrument that will be used to collect the information and (ii) requires the agency to inform the public about the OMB Control Number's legal significance in accordance with 5 CFR 1320.5(b).

The information collected by PTOL-85 Part B is required by 37 CFR 1.311. The information is required to obtain or retain a benefit by the public which is to file (and by the USPTO to process) an application. Confidentiality is governed by 35 U.S.C. 122 and 37 CFR 1.14. This collection is estimated to take 12 minutes to complete, including gathering, preparing, and submitting the completed application form to the USPTO. Time will vary depending upon the individual case. Any comments on the amount of time you require to complete this form and/or suggestions for reducing this burden, should be sent to the Chief Information Officer, U.S. Patent and Trademark Office, U.S. Department of Commerce, P.O. Box 1450, Alexandria, Virginia 22313-1450. DO NOT SEND FEES OR COMPLETED FORMS TO THIS ADDRESS. SEND TO: Commissioner for Patents, P.O. Box 1450, Alexandria, Virginia 22313-1450. Under the Paperwork Reduction Act of 1995, no persons are required to respond to a collection of information unless it displays a valid OMB control number.

### Privacy Act Statement

**The Privacy Act of 1974 (P.L. 93-579)** requires that you be given certain information in connection with your submission of the attached form related to a patent application or patent. Accordingly, pursuant to the requirements of the Act, please be advised that: (1) the general authority for the collection of this information is 35 U.S.C. 2(b)(2); (2) furnishing of the information solicited is voluntary; and (3) the principal purpose for which the information is used by the U.S. Patent and Trademark Office is to process and/or examine your submission related to a patent application or patent. If you do not furnish the requested information, the U.S. Patent and Trademark Office may not be able to process and/or examine your submission, which may result in termination of proceedings or abandonment of the application or expiration of the patent.

The information provided by you in this form will be subject to the following routine uses:

1. The information on this form will be treated confidentially to the extent allowed under the Freedom of Information Act (5 U.S.C. 552) and the Privacy Act (5 U.S.C. 552a). Records from this system of records may be disclosed to the Department of Justice to determine whether disclosure of these records is required by the Freedom of Information Act.
2. A record from this system of records may be disclosed, as a routine use, in the course of presenting evidence to a court, magistrate, or administrative tribunal, including disclosures to opposing counsel in the course of settlement negotiations.
3. A record in this system of records may be disclosed, as a routine use, to a Member of Congress submitting a request involving an individual, to whom the record pertains, when the individual has requested assistance from the Member with respect to the subject matter of the record.
4. A record in this system of records may be disclosed, as a routine use, to a contractor of the Agency having need for the information in order to perform a contract. Recipients of information shall be required to comply with the requirements of the Privacy Act of 1974, as amended, pursuant to 5 U.S.C. 552a(m).
5. A record related to an International Application filed under the Patent Cooperation Treaty in this system of records may be disclosed, as a routine use, to the International Bureau of the World Intellectual Property Organization, pursuant to the Patent Cooperation Treaty.
6. A record in this system of records may be disclosed, as a routine use, to another federal agency for purposes of National Security review (35 U.S.C. 181) and for review pursuant to the Atomic Energy Act (42 U.S.C. 218(c)).
7. A record from this system of records may be disclosed, as a routine use, to the Administrator, General Services, or his/her designee, during an inspection of records conducted by GSA as part of that agency's responsibility to recommend improvements in records management practices and programs, under authority of 44 U.S.C. 2904 and 2906. Such disclosure shall be made in accordance with the GSA regulations governing inspection of records for this purpose, and any other relevant (i.e., GSA or Commerce) directive. Such disclosure shall not be used to make determinations about individuals.
8. A record from this system of records may be disclosed, as a routine use, to the public after either publication of the application pursuant to 35 U.S.C. 122(b) or issuance of a patent pursuant to 35 U.S.C. 151. Further, a record may be disclosed, subject to the limitations of 37 CFR 1.14, as a routine use, to the public if the record was filed in an application which became abandoned or in which the proceedings were terminated and which application is referenced by either a published application, an application open to public inspection or an issued patent.
9. A record from this system of records may be disclosed, as a routine use, to a Federal, State, or local law enforcement agency, if the USPTO becomes aware of a violation or potential violation of law or regulation.

<b>Notice of Allowability</b>	<b>Application No.</b> 14/876,276	<b>Applicant(s)</b> FALLON ET AL.	
	<b>Examiner</b> TESFALDET BOCURE	<b>Art Unit</b> 2634	<b>AIA (First Inventor to File) Status</b> No

**-- The MAILING DATE of this communication appears on the cover sheet with the correspondence address--**

All claims being allowable, PROSECUTION ON THE MERITS IS (OR REMAINS) CLOSED in this application. If not included herewith (or previously mailed), a Notice of Allowance (PTOL-85) or other appropriate communication will be mailed in due course. **THIS NOTICE OF ALLOWABILITY IS NOT A GRANT OF PATENT RIGHTS.** This application is subject to withdrawal from issue at the initiative of the Office or upon petition by the applicant. See 37 CFR 1.313 and MPEP 1308.

1.  This communication is responsive to 04/12/2016.  
 A declaration(s)/affidavit(s) under **37 CFR 1.130(b)** was/were filed on \_\_\_\_\_.
2.  An election was made by the applicant in response to a restriction requirement set forth during the interview on \_\_\_\_\_; the restriction requirement and election have been incorporated into this action.
3.  The allowed claim(s) is/are 1-30. As a result of the allowed claim(s), you may be eligible to benefit from the **Patent Prosecution Highway** program at a participating intellectual property office for the corresponding application. For more information, please see [http://www.uspto.gov/patents/init\\_events/poh/index.jsp](http://www.uspto.gov/patents/init_events/poh/index.jsp) or send an inquiry to [PPHfeedback@uspto.gov](mailto:PPHfeedback@uspto.gov).
4.  Acknowledgment is made of a claim for foreign priority under 35 U.S.C. § 119(a)-(d) or (f).

**Certified copies:**

- a)  All    b)  Some    \*c)  None of the:
1.  Certified copies of the priority documents have been received.
  2.  Certified copies of the priority documents have been received in Application No. \_\_\_\_\_.
  3.  Copies of the certified copies of the priority documents have been received in this national stage application from the International Bureau (PCT Rule 17.2(a)).

\* Certified copies not received: \_\_\_\_\_.

Applicant has THREE MONTHS FROM THE "MAILING DATE" of this communication to file a reply complying with the requirements noted below. Failure to timely comply will result in ABANDONMENT of this application.

**THIS THREE-MONTH PERIOD IS NOT EXTENDABLE.**

5.  CORRECTED DRAWINGS ( as "replacement sheets") must be submitted.  
 including changes required by the attached Examiner's Amendment / Comment or in the Office action of Paper No./Mail Date \_\_\_\_\_.  
**Identifying indicia such as the application number (see 37 CFR 1.84(c)) should be written on the drawings in the front (not the back) of each sheet. Replacement sheet(s) should be labeled as such in the header according to 37 CFR 1.121(d).**
6.  DEPOSIT OF and/or INFORMATION about the deposit of BIOLOGICAL MATERIAL must be submitted. Note the attached Examiner's comment regarding REQUIREMENT FOR THE DEPOSIT OF BIOLOGICAL MATERIAL.

**Attachment(s)**

- |                                                                                                                                                                                                                                                                                                                                                                                                                                                                                                 |                                                                                                                                                                                                                                                            |
|-------------------------------------------------------------------------------------------------------------------------------------------------------------------------------------------------------------------------------------------------------------------------------------------------------------------------------------------------------------------------------------------------------------------------------------------------------------------------------------------------|------------------------------------------------------------------------------------------------------------------------------------------------------------------------------------------------------------------------------------------------------------|
| <ol style="list-style-type: none"> <li>1. <input type="checkbox"/> Notice of References Cited (PTO-892)</li> <li>2. <input checked="" type="checkbox"/> Information Disclosure Statements (PTO/SB/08),<br/>Paper No./Mail Date <u>2/1/16, 2/24/16 &amp; 4/2/16</u></li> <li>3. <input type="checkbox"/> Examiner's Comment Regarding Requirement for Deposit of Biological Material</li> <li>4. <input type="checkbox"/> Interview Summary (PTO-413),<br/>Paper No./Mail Date _____.</li> </ol> | <ol style="list-style-type: none"> <li>5. <input checked="" type="checkbox"/> Examiner's Amendment/Comment</li> <li>6. <input type="checkbox"/> Examiner's Statement of Reasons for Allowance</li> <li>7. <input type="checkbox"/> Other _____.</li> </ol> |
|-------------------------------------------------------------------------------------------------------------------------------------------------------------------------------------------------------------------------------------------------------------------------------------------------------------------------------------------------------------------------------------------------------------------------------------------------------------------------------------------------|------------------------------------------------------------------------------------------------------------------------------------------------------------------------------------------------------------------------------------------------------------|

/TESFALDET BOCURE/  
Primary Examiner, Art Unit 2634



### **DETAILED ACTION**

1. The present application is being examined under the pre-AIA first to invent provisions.
2. This office action (Notice of Allowance) is in response to the amendment and remarks filed on 04/12/2016. The pending claims 1-30 are now allowed.

### ***Information Disclosure Statement***

3. The information disclosure statements (IDSs) submitted on 02/01/2016, 02/24/2016 and 04/12/2016 are in compliance with the provisions of 37 CFR 1.97. Accordingly, the information disclosure statement is being considered by the examiner. Attached with this correspondence are the initialed copies of the IDSs.

### ***Response to Amendment***

4. In response to the amendment and remarks filed on 04/12/2016, the following actions have been taken:
  - The objection to the specification to update the status of the parent application indicated in the office action mailed on 01/28/2016 was neither addressed nor amended. However, the above minor informality has been corrected by the Examiner's amendment as shown below.
  - The abstract of the disclosure is withdrawn because of the preliminary amendment, which was overlooked by the Examiner and as indicated in the interview summary of 3/15/2016 and 03/21/2016. Further to the abstract of the

disclosure in the amendment of 04/12/2016 has been considered by the Examiner.

- The objection to claims 1-30 indicated in the office action mailed on 01/28/2016 has been withdrawn.
- The rejection to claims 1-30 under 112 second paragraph indicated in the office action mailed on 01/28/2016 has been withdrawn.

#### **EXAMINER'S AMENDMENT**

5. An examiner's amendment to the record appears below. Should the changes and/or additions be unacceptable to applicant, an amendment may be filed as provided by 37 CFR 1.312. To ensure consideration of such an amendment, it MUST be submitted no later than the payment of the issue fee.

The application has been amended as follows:

In the Specification:

In ¶ [0001], line 3, after "December 19, 2014," ---now abandoned,---has been added.

#### **Remarks:**

6. The above Examiner's Amendment was made to update the status of the parent application S/N 14/577,286.

***Conclusion***


7. Any inquiry concerning this communication or earlier communications from the examiner should be directed to TESHALDET BOCURE whose telephone number is (571)272-3015. The examiner can normally be reached on 8:30am-to-5:00pm.

If attempts to reach the examiner by telephone are unsuccessful, the examiner's supervisor, Daniel C. Washburn can be reached on 571-272-5551. The fax phone number for the organization where this application or proceeding is assigned is 571-273-8300.

Information regarding the status of an application may be obtained from the Patent Application Information Retrieval (PAIR) system. Status information for published applications may be obtained from either Private PAIR or Public PAIR. Status information for unpublished applications is available through Private PAIR only. For more information about the PAIR system, see <http://pair-direct.uspto.gov>. Should you have questions on access to the Private PAIR system, contact the Electronic Business Center (EBC) at 866-217-9197 (toll-free). If you would like assistance from a USPTO Customer Service Representative or access to the automated information system, call 800-786-9199 (IN USA OR CANADA) or 571-272-1000.

/TESHALDET BOCURE/  
Primary Examiner, Art Unit 2634


/T. B./  
Primary Examiner, Art Unit 2634

<b>Issue Classification</b> 	<b>Application/Control No.</b> 14876276	<b>Applicant(s)/Patent Under Reexamination</b> FALLON ET AL.
	<b>Examiner</b> TESFALDET BOCURE	<b>Art Unit</b> 2634

CPC					
Symbol				Type	Version
H04N	19		103	F	2014-11-01
H04N	19		164	I	2014-11-01
H04N	19		176	I	2014-11-01
H03M	7		30	I	2013-01-01
H03M	7		3084	I	2013-01-01
H03M	7		6094	I	2013-01-01


CPC Combination Sets				
Symbol	Type	Set	Ranking	Version

NONE		<b>Total Claims Allowed:</b>	
(Assistant Examiner)	(Date)	30	
/TESFALDET BOCURE/ Primary Examiner. Art Unit 2634	04/18/2016	O.G. Print Claim(s)	O.G. Print Figure
(Primary Examiner)	(Date)	1	1

<b>Issue Classification</b> 	<b>Application/Control No.</b> 14876276	<b>Applicant(s)/Patent Under Reexamination</b> FALLON ET AL.
	<b>Examiner</b> TESFALDET BOCURE	<b>Art Unit</b> 2634


US ORIGINAL CLASSIFICATION						INTERNATIONAL CLASSIFICATION								
CLASS			SUBCLASS			CLAIMED				NON-CLAIMED				
375			240.1			H	0	4	N	7 / 12 (2006.01.01)				
<b>CROSS REFERENCE(S)</b>														
CLASS	SUBCLASS (ONE SUBCLASS PER BLOCK)													

NONE			<b>Total Claims Allowed:</b>	
(Assistant Examiner)			30	
(Date)				
/TESFALDET BOCURE/ Primary Examiner. Art Unit 2634			04/18/2016	O.G. Print Claim(s)
(Primary Examiner)			(Date)	O.G. Print Figure
			1	1

<b>Issue Classification</b> 	<b>Application/Control No.</b> 14876276	<b>Applicant(s)/Patent Under Reexamination</b> FALLON ET AL.
	<b>Examiner</b> TESFALDET BOCURE	<b>Art Unit</b> 2634

<input checked="" type="checkbox"/> <b>Claims renumbered in the same order as presented by applicant</b> <input type="checkbox"/> <b>CPA</b> <input type="checkbox"/> <b>T.D.</b> <input type="checkbox"/> <b>R.1.47</b>															
Final	Original	Final	Original	Final	Original	Final	Original	Final	Original	Final	Original	Final	Original	Final	Original
1	1	17	17												
2	2	18	18												
3	3	19	19												
4	4	20	20												
5	5	21	21												
6	6	22	22												
7	7	23	23												
8	8	24	24												
9	9	25	25												
10	10	26	26												
11	11	27	27												
12	12	28	28												
13	13	29	29												
14	14	30	30												
15	15														
16	16														

NONE		<b>Total Claims Allowed:</b>	
		30	
(Assistant Examiner)	(Date)		
/TESFALDET BOCURE/ Primary Examiner. Art Unit 2634	04/18/2016	O.G. Print Claim(s)	O.G. Print Figure
(Primary Examiner)	(Date)	1	1

<b>Search Notes</b>  	<b>Application/Control No.</b>  14876276	<b>Applicant(s)/Patent Under Reexamination</b>  FALLON ET AL.
	<b>Examiner</b>  TESFALDET BOCURE	<b>Art Unit</b>  2634

<b>CPC- SEARCHED</b>		
Symbol	Date	Examiner
((H03M7/30))   ((H03M7/3084))   ((H03M7/6094))   ((G06F15/7867))   ((G06T1/60))   ((H04N19/136).CPC.)	01/22/2016	TB
((H03M7/30))   ((H03M7/3059))   ((H03M7/3093))   ((H04L69/04))   ((H04N19/152))   ((H04N9/8042).CPC.)	01/22/2016	TB
(( H03M7/30   H03M7/3059   H03M7/3084   H03M7/6094   H03M7/3088   H03M7/6023   H03M7/6064   H04N19/152   G11B20/00007 ).CPC.)	01/23/2016	TB
(H03M7/30 H03M7/3084 H03M7/6094 H04N19/164 H04N19/176 H04N19/103).CPC.	04/17/2016	TB
CPC Updated	04/18/2016	TB

<b>CPC COMBINATION SETS - SEARCHED</b>		
Symbol	Date	Examiner

<b>US CLASSIFICATION SEARCHED</b>			
Class	Subclass	Date	Examiner
375	240, 240.01, 240.02	01/22/2016	TB
341	50, 51, 126	01/22/2016	TB
375, 370, 348, 341, 711, 701, 381	Search ALL (\$8.ccls.)	01/22/2016	TB
375, 370, 348, 341, 711, 701, 381	Search Updated ALL	01/23/2016	TB
375, 370, 348, 341, 711, 701, 381	Search Updated ALL	04/17/2016 & 04/18/2016	TB

<b>SEARCH NOTES</b>		
Search Notes	Date	Examiner
		/TESFALDET BOCURE/ Primary Examiner.Art Unit 2634

### SEARCH NOTES

Search Notes	Date	Examiner
WEST and Inventor's Name Searched	01/22/2016	TB
See Related parent application 14/733,565 for further prosecution History	01/22/2016	TB
WEST Search Updated	01/23/2016	TB
WEST Search Updated	04/17/2016	TB
WEST Search Updated	04/18/2016	TB

### INTERFERENCE SEARCH

US Class/ CPC Symbol	US Subclass / CPC Group	Date	Examiner
375	240, 240.1	04/18/2016	TB
CPC	(H03M7/30 H03M7/3084 H03M7/6094 H04N19/164 H04N19/176 H04N19/103).CPC.	04/18/2016	TB

/TESFALDET BOCURE/  
Primary Examiner.Art Unit 2634



Substitute for form 1449/PTO			<i>Complete if Known</i>	
<b>FIFTH SUPPLEMENTAL INFORMATION DISCLOSURE STATEMENT BY APPLICANT</b> <i>(Use as many sheets as necessary)</i>			Application Number	14/876,276
			Filing Date	October 6, 2015
			First Named Inventor	James J. FALLON
			Art Unit	2634
			Examiner Name	BOCURE, TESHALDET
			Attorney Docket Number	3421.005000C
Sheet	1	of	1	

U.S. PATENT DOCUMENTS						
Examiner initials*	Cite No. <sup>1</sup>	Document Number		Publication Date MM-DD-YYYY	Name of Patentee or Applicant of Cited Document	Pages, Columns, Lines, Where Relevant Passages or Relevant Figures Appear
		Number-Kind Code <sup>2</sup> (if known)				
	US1	3,560,639		02-02-1971	Centanni	
	US2	5,467,134		11-14-1995	Laney et al.	
	US3	5,623,483		04-22-1997	Agrawal et al.	
	US4	5,664,226		09-02-1997	Czako et al.	

FOREIGN PATENT DOCUMENTS							
Examiner initials*	Cite No. <sup>1</sup>	Foreign Patent Document		Publication Date MM-DD-YYYY	Name of Patentee or Applicant of Cited Document	Pages, Columns, Lines, Where Relevant Passages or Relevant Figures Appear	T 6
		Country Code <sup>3</sup> -Number <sup>4</sup> -Kind Code <sup>5</sup> (if known)					

2792778\_1.DOCX

Examiner Signature	/Teshaldet Bocure/	Date Considered	04/18/2016
--------------------	--------------------	-----------------	------------

\*EXAMINER: Initial if reference considered, whether or not citation is in conformance with MPEP 609. Draw line through citation if not in conformance and not considered. Include copy of this form with next communication to applicant. <sup>1</sup> Applicant's unique citation designation number (optional). <sup>2</sup> See Kinds Codes of USPTO Patent Documents at [www.uspto.gov](http://www.uspto.gov) or MPEP 901.04. <sup>3</sup> Enter Office that issued the document, by the two-letter code (WIPO Standard ST.3). <sup>4</sup> For Japanese patent documents, the indication of the year of the reign of the Emperor must precede the serial number of the patent document. <sup>5</sup> Kind of document by the appropriate symbols as indicated on the document under WIPO Standard ST.16 if possible. <sup>6</sup> Applicant is to place a

Substitute for form 1449/PTO		<b>Complete if Known</b>	
<b>FIFTH SUPPLEMENTAL INFORMATION DISCLOSURE STATEMENT BY APPLICANT</b> <i>(Use as many sheets as necessary)</i>		Application Number	14/876,276
		Filing Date	October 6, 2015
		First Named Inventor	James J. FALLON
		Art Unit	2634
		Examiner Name	BOCURE, TESHALDET
		Attorney Docket Number	3421.005000C
Sheet	1	of	3

NON PATENT LITERATURE DOCUMENTS			
Examiner Initials*	Cite No. <sup>1</sup>	Include name of the author (in CAPITAL LETTERS), title of the article (when appropriate), title of the item (book, magazine, journal, serial, symposium, catalog, etc.), date, page(s), volume-issue number(s), publisher, city and/or country where published	T <sup>2</sup>
	NPL1	Dell Inc.'s Answer, Defenses, and Counterclaims to Plaintiff's Second Amended Complaint, filed in Realtime Data, LLC d/b/a IXO v. Actian Corporation, et al., Case No. 6:15-cv-00463-RWS-JDL (E.D. Tex.), filed February 19, 2016; 18 pages.	
	NPL2	Riverbed Technology's Answer, Defenses, and Counterclaims, filed in Realtime Data, LLC d/b/a IXO v. Actian Corporation, et al., Case No. 6:15-cv-00463-RWS-JDL (E.D. Tex.), filed February 19, 2016; 26 pages.	
	NPL3	Complaint for Patent Infringement Against Dell Inc., EMC Corporation, iland Internet Solutions Corporation, and Veeam Software Corporation, filed in Realtime Data d/b/a IXO v. Dell Inc., et al., Case No. 6:16-cv-00089 (E.D. Texas), filed February 26, 2016; 67 pages.	
	NPL4	Complaint for Patent Infringement Against Hewlett Packard Enterprise Co., HP Enterprise Services, LLC, and Silver Peak Systems, Inc., filed in Realtime Data d/b/a IXO v. Hewlett Packard Enterprise, Co., et al., Case No. 6:16-cv-00086 (E.D. Texas), filed February 26, 2016; 49 pages.	
	NPL5	Complaint for Patent Infringement Against CenturyLink, Inc. and Veritas Technologies LLC, filed in Realtime Data d/b/a IXO v. CenturyLink, Inc., et al., Case No. 6:16-cv-00087 (E.D. Texas), filed February 26, 2016; 46 pages.	
	NPL6	Complaint for Patent Infringement Against Oracle America, Inc., filed in Realtime Data d/b/a IXO v. Oracle America, Inc., Case No. 6:16-cv-00088 (E.D. Texas), filed February 26, 2016; 40 pages.	
	NPL7	Realtime Data LLC d/b/a IXO's Answer to Echostar Corporation's and Hughes Network Systems, LLC's Counterclaims, filed Realtime Data LLC d/b/a IXO v. Actian Corporation, et al., Case No. 6:15-cv-000463-RWS-JDL (E.D. Texas), filed February 25, 2016; 8 pages.	
	NPL8	Realtime Data LLC d/b/a IXO's Answer to SAP America Inc.'s and Sybase, Inc.'s Counterclaims, filed Realtime Data LLC d/b/a IXO v. Actian Corporation, et al., Case No. 6:15-cv-000463-RWS-JDL (E.D. Texas), filed February 25, 2016; 5 pages.	
	NPL9	Realtime Data LLC d/b/a IXO's Answer to Dell, Inc.'s Counterclaims, filed Realtime Data LLC d/b/a IXO v. Actian Corporation, et al., Case No. 6:15-cv-000463-RWS-JDL (E.D. Texas), filed February 25, 2016; 5 pages.	
	NPL10	Copy of Non-Final Office Action for U.S. Appl. No.14/853,581, mailed March 15, 2016; 5 pages.	

Examiner Signature	/Teshaldet Bocure/	Date Considered	04/18/2016
-----------------------	--------------------	--------------------	------------

\*EXAMINER: Initial if reference considered, whether or not citation is in conformance with MPEP 609. Draw line through citation if not in conformance and not considered. Include copy of this form with next communication to applicant.

<sup>1</sup> Applicant's unique citation designation number (optional). <sup>2</sup> Applicant is to place a check mark here if English language Translation is attached.

ALL REFERENCES CONSIDERED EXCEPT WHERE LINED THROUGH. /T.B./

Substitute for form 1449/PTO		<b>Complete if Known</b>	
<b>FIFTH SUPPLEMENTAL INFORMATION DISCLOSURE STATEMENT BY APPLICANT</b> <i>(Use as many sheets as necessary)</i>		Application Number	14/876,276
		Filing Date	October 6, 2015
		First Named Inventor	James J. FALLON
		Art Unit	2634
		Examiner Name	BOCURE, TESFALDET
		Attorney Docket Number	3421.005000C
Sheet	2	of	3

NON PATENT LITERATURE DOCUMENTS			
Examiner Initials*	Cite No. <sup>1</sup>	Include name of the author (in CAPITAL LETTERS), title of the article (when appropriate), title of the item (book, magazine, journal, serial, symposium, catalog, etc.), date, page(s), volume number, publisher, city and/or country where published	T <sup>2</sup>
	NPL11	Copy of Notice of Allowance for U.S. Patent Appl. No. 14/733,565, mailed March 25, 2016; 8 pages.	
	NPL12	Petition for Inter Partes Review of Claims 1-4, 8, 14-17, 21 and 28 of U.S. Patent No. 6,597,812, filed in SAP America Inc., et al. v. Realtime Data, LLC d/b/a IXO, Case No. IPR2016-00783 (P.T.A.B.), filed April 1, 2016; 67 pages.	
	NPL13	Declaration of Scott Bennett, Ph.D., filed in SAP America Inc., et al. v. Realtime Data LLC d/b/a IXO, Case No. IPR2016-00783 (P.T.A.B.), filed April 1, 2016; 45 pages.	
	NPL14	Declaration of Charles D. Creusere in Support of Petition for Inter Partes Review of Claims 1-4, 8, 14-17, 21 and 28 of U.S. Patent No. 6,597,812, filed in SAP America Inc., et al. v. Realtime Data LLC d/b/a IXO, Case No. IPR2016-00783 (P.T.A.B.), filed April 1, 2016; 82 pages.	
	NPL15	NELSON, M., The Data Compression Book, 1st Edition, San Mateo, CA: M&T Books, 1992; 534 pages.	
	NPL16	RANDELL, B., "Hardware/Software Tradeoffs: A General Design Principle?", Computing Laboratory, The University of Newcastle Upon Tyne, January 25, 1985; 2 pages.	
	NPL17	Definition of "consecutive", Random House Webster's College Dictionary, 2nd Edition, New York: Random House, 1998; p. 281.	
	NPL18	ROBINSON, et al., "Results of a Prototype Television Bandwidth Compression Scheme," Proceedings of the IEEE, Vol. 55, No. 3, March 1967; pp. 356-364.	
	NPL19	Court Docket History for Realtime Data LLC d/b/a IXO v. Hewlett Packard Enterprise Co., et al., No. 6:16-cv-00086 (E.D. Texas), downloaded March 1, 2016, 2 pages.	
	NPL20	Court Docket History for Realtime Data LLC d/b/a IXO v. Oracle America, Inc., No. 6:16-cv-00088 (E.D. Texas), downloaded March 1, 2016; 2 pages.	

Examiner Signature	/Tesfaldet Bocure/	Date Considered	04/18/2016
-----------------------	--------------------	--------------------	------------

\*EXAMINER: Initial if reference considered, whether or not citation is in conformance with MPEP 609. Draw line through citation if not in conformance and not considered. Include copy of this form with next communication to applicant.

<sup>1</sup> Applicant's unique citation designation number (optional). <sup>2</sup> Applicant is to place a check mark here if English language Translation is attached.

ALL REFERENCES CONSIDERED EXCEPT WHERE LINED THROUGH. /T.B./

Substitute for form 1449/PTO		<i>Complete if Known</i>	
<b>FIFTH SUPPLEMENTAL INFORMATION DISCLOSURE STATEMENT BY APPLICANT</b> <i>(Use as many sheets as necessary)</i>		Application Number	14/876,276
		Filing Date	October 6, 2015
		First Named Inventor	James J. FALLON
		Art Unit	2634
		Examiner Name	BOCURE, TESFALDET
		Attorney Docket Number	3421.005000C
Sheet	3 of 3		

NON PATENT LITERATURE DOCUMENTS			
Examiner Initials*	Cite No. <sup>1</sup>	Include name of the author (in CAPITAL LETTERS), title of the article (when appropriate), title of the item (book, magazine, journal, serial, symposium, catalog, etc.), date, page(s), volume number, publisher, city and/or country where published	T <sup>2</sup>
	NPL21	Court Docket History for Realtime Data LLC d/b/a IXO v. CenturyLink, Inc., et al., No. 6:16-cv-00087 (E.D. Texas), downloaded March 1, 2016; 2 pages.	
	NPL22	Court Docket History for Realtime Data LLC d/b/a IXO v. Dell, Inc., et al., No. 6:16-cv-00089 (E.D. Texas), downloaded March 1, 2016; 2 pages.	

2792785\_1.DOCX

Examiner Signature	/Tesfaldet Bocure/	Date Considered	04/18/2016
--------------------	--------------------	-----------------	------------

\*EXAMINER: Initial if reference considered, whether or not citation is in conformance with MPEP 609. Draw line through citation if not in conformance and not considered. Include copy of this form with next communication to applicant.  
<sup>1</sup> Applicant's unique citation designation number (optional). <sup>2</sup> Applicant is to place a check mark here if English language Translation is attached.

ALL REFERENCES CONSIDERED EXCEPT WHERE LINED THROUGH. /T.B./

## WEST Search History for Application 14876276

Creation Date: 2016041809:16

### Prior Art Searches

Query	DB	Hits	Op.	Plur.	Thes.	Date
((Fallen adj James).in. or (McErlain adj Stephen).in.)	PGPB, USPT, USOC, EPAB, JPAB, DWPI, TDBD	n/a	OR	YES		04-18-2016
((Fallen).in. or (McErlain).in.)	PGPB, USPT, USOC, EPAB, JPAB, DWPI, TDBD	n/a	OR	YES		04-18-2016
(select\$4 or choos\$4) near4 ((multiple or plural\$4 or two or three or four or five) near5 encoder\$) same ((assymetric\$ or (lempel adj2 ziv)) near4 (compressing or compression))	PGPB, USPT, USOC, EPAB, JPAB, DWPI, TDBD	n/a	OR	YES		04-18-2016
(select\$4 or choos\$4) near4 ((multiple or plural\$4 or two or three or four or five) near5 encoder\$) and ((assymetric\$ or (lempel adj2 ziv)) near4 (compressing or compression))	PGPB, USPT, USOC, EPAB, JPAB, DWPI, TDBD	n/a	OR	YES		04-18-2016
((select\$4 or choos\$4) near4 ((multiple or plural\$4 or two or three or four or five) near5 encoder\$) and ((assymetric\$ or (lempel adj2 ziv)) near4 (compressing or compression)) ) and @ad<=20010213	PGPB, USPT, USOC, EPAB, JPAB, DWPI, TDBD	n/a	OR	YES		04-18-2016
((select\$4 or choos\$4) near4 ((multiple or plural\$4 or two or three or four or five) near5 encoder\$) and ((assymetric\$ or (lempel adj2 ziv)) near4	PGPB, USPT, USOC,	n/a	OR	YES		04-18-2016

<b>((compressing or compression)) ) and ( ((Fallen adj James).in. or (McErlain adj Stephen).in.) ) or (((Fallen).in. or (McErlain).in.) ) )</b>	EPAB, JPAB, DWPI, TDBD					
<b>((select\$4 or choos\$4) near4 ((multiple or plural\$4 or two or three or four or five) near5 encoder\$) and ((assymetric\$ or (lempel adj2 ziv)) near4 (compressing or compression)) ) and ( ((Fallen adj James).in. or (McErlain adj Stephen).in.) ) )</b>	PGPB, USPT, USOC, EPAB, JPAB, DWPI, TDBD	n/a	OR	YES		04-18-2016
<b>(selecting or select or choose or choosing) near4 ((compress or compression or compressing) near4 (algorithm or algorithms or mode or modes)) same ((assymetric\$4 or (lempel adj2 ziv)) near4 (compressing or compression))</b>	PGPB, USPT, USOC, EPAB, JPAB, DWPI, TDBD	n/a	OR	YES		04-18-2016
<b>((compress or compression or compressing) near4 (algorithm or algorithms or mode or modes)) same (parameter or parameters or attribute or attributes) same (assymetric \$4near4 (compressing or compression))</b>	PGPB, USPT, USOC, EPAB, JPAB, DWPI, TDBD	n/a	OR	YES		04-18-2016
<b>((compress or compression or compressing) near4 (algorithm or algorithms or mode or modes)) same (parameter or parameters or attribute or attributes) same (assymetric\$4 near4 (compressing or compression))</b>	PGPB, USPT, USOC, EPAB, JPAB, DWPI, TDBD	n/a	OR	YES		04-18-2016
<b>((compress or compression or compressing) near4 (algorithm or algorithms or mode or modes)) same (parameter or parameters or attribute or attributes) same ((fast near4 slow) near4 (compressing or compression))</b>	PGPB, USPT, USOC, EPAB, JPAB, DWPI, TDBD	n/a	OR	YES		04-18-2016
<b>((multiple or plural\$4 or two or three or four or five) near5 encoder\$) same ((assymetric\$ or (lempel adj2 ziv)) near4 (compressing or compression))</b>	PGPB, USPT, USOC, EPAB, JPAB, DWPI, TDBD	n/a	OR	YES		04-18-2016

<p>((selecting or select or choose or choosing) near4 ((compress or compression or compressing) near4 (algorithm or algorithms or mode or modes)) same ((assymmetric\$4 or (lempel adj2 ziv)) near4 (compressing or compression)) ) and (((H03M7/30)))   (((H03M7/3084)))   (((H03M7/6094)))   (((G06F15/7867)))   (((G06T1/60)))   (((H04N19/136))).CPC. )</p>	PGPB, USPT, USOC, EPAB, JPAB, DWPI, TDBD	n/a	OR	YES		04-18-2016
<p>(((multiple or plural\$4 or two or three or four or five) near5 encoder\$) same ((assymmetric\$ or (lempel adj2 ziv)) near4 (compressing or compression)) ) and (((H03M7/30)))   (((H03M7/3059)))   (((H03M7/3093)))   (((H04L69/04)))   (((H04N19/152)))   (((H04N9/8042))).CPC. )</p>	PGPB, USPT, USOC, EPAB, JPAB, DWPI, TDBD	n/a	OR	YES		04-18-2016
<p>("20010019630"   "20010031092"   "20010032128"   "20010047473"   "20010052038"   "20020037035"   "20020069354"   "20020078241"   "20020080871"   "20020097172"   "20020101367"   "20020104891"   "20020126755"   "20020169950"   "20020191692"   "20030030575"   "20030034905"   "20030058873"   "20030084238").PN.</p>	PGPB, USPT, USOC, EPAB, JPAB, DWPI, TDBD	n/a	OR	YES		04-18-2016
<p>(((375/\$8)).ccls. or ((370/\$8)).ccls. or ((348/\$8)).ccls. or ((341/\$8)).ccls. or ((711/\$8)).ccls. or ((701/\$8)).ccls. or ((381/\$8)).ccls. or ((375/382)).ccls. )</p>	PGPB, USPT, USOC, EPAB, JPAB, DWPI, TDBD	n/a	OR	YES		04-18-2016
<p>(((375/\$8)).ccls. or ((370/\$8)).ccls. or ((348/\$8)).ccls. or ((341/\$8)).ccls. or ((711/\$8)).ccls. or ((701/\$8)).ccls. or ((381/\$8)).ccls. or ((375/382)).ccls. ) and ((select\$4 or choos\$4) near4 ((multiple or plural\$4 or two or three or four or five) near5 encoder\$) and ((assymmetric\$ or (lempel adj2 ziv)) near4 (compressing or compression)) ) or ((selecting or select or choose or choosing) near4 ((compress or compression or compressing) near4 (algorithm or algorithms or mode or modes)) same ((assymmetric\$4 or (lempel adj2 ziv)) near4 (compressing or compression)) ) or (((multiple or plural\$4 or two or three or four or five) near5 encoder\$) same ((assymmetric\$ or (lempel adj2 ziv)) near4 (compressing or compression)) ) )</p>	PGPB, USPT, USOC, EPAB, JPAB, DWPI, TDBD	n/a	OR	YES		04-18-2016
<p>(((375/240)).ccls. or ((375/240.01)).ccls. or ((375/240.02)).ccls. or ((341/50)).ccls. or ((341/51)).ccls. or ((341/126)).ccls. ) and ((select\$4</p>	PGPB, USPT, USOC,	n/a	OR	YES		04-18-2016

or choos\$4) near4 ((multiple or plural\$4 or two or three or four or five) near5 encoder\$) and ((assymmetric\$ or (lempel adj2 ziv)) near4 (compressing or compression)) ) or ((selecting or select or choose or choosing) near4 ((compress or compression or compressing) near4 (algorithm or algorithms or mode or modes)) same ((assymmetric\$4 or (lempel adj2 ziv)) near4 (compressing or compression)) ) or (((multiple or plural\$4 or two or three or four or five) near5 encoder\$) same ((assymmetric\$ or (lempel adj2 ziv)) near4 (compressing or compression)) ) )	EPAB, JPAB, DWPI, TDBD					
((multiple or plural\$4 or two or three or four or five) near5 encoder\$) same ((assymmetric\$3 or (lempel adj2 ziv) and (arithmetic)) near4 (compressing or compression))	PGPB, USPT, USOC, EPAB, JPAB, DWPI, TDBD	n/a	OR	YES		04-18-2016
((select\$4 or choos\$4) near4 ((multiple or plural\$4 or two or three or four or five) near5 encoder\$) and ((assymmetric\$ or (lempel adj2 ziv)) near4 (compressing or compression)) ) or ((selecting or select or choose or choosing) near4 ((compress or compression or compressing) near4 (algorithm or algorithms or mode or modes)) same ((assymmetric\$4 or (lempel adj2 ziv)) near4 (compressing or compression)) ) or (((multiple or plural\$4 or two or three or four or five) near5 encoder\$) same ((assymmetric\$ or (lempel adj2 ziv)) near4 (compressing or compression)) ) or (((multiple or plural\$4 or two or three or four or five) near5 encoder\$) same ((assymmetric\$3 or (lempel adj2 ziv) and (arithmetic)) near4 (compressing or compression)) ) )	PGPB, USPT, USOC, EPAB, JPAB, DWPI, TDBD	n/a	OR	YES		04-18-2016
((select\$4 or choos\$4) near4 ((multiple or plural\$4 or two or three or four or five) near5 encoder\$) and ((assymmetric\$ or (lempel adj2 ziv)) near4 (compressing or compression)) or (selecting or select or choose or choosing) near4 ((compress or compression or compressing) near4 (algorithm or algorithms or mode or modes)) same ((assymmetric\$4 or (lempel adj2 ziv)) near4 (compressing or compression)) or ((multiple or plural\$4 or two or three or four or five) near5 encoder\$) same ((assymmetric\$ or (lempel adj2 ziv)) near4 (compressing or compression)) or ((multiple or plural\$4 or two or three or four or five) near5 encoder\$) same ((assymmetric\$3 or (lempel adj2 ziv) and (arithmetic)) near4 (compressing or compression)) ) )	PGPB, USPT, USOC, EPAB, JPAB, DWPI, TDBD	n/a	OR	YES		04-18-2016



<p>and (arithmetic)) near4 (compressing or compression)) ) and (((375/240)).ccls. or ((375/240.01)).ccls. or ((375/240.02)).ccls. or ((341/50)).ccls. or ((341/51)).ccls. or ((341/126)).ccls. ) and ((select\$4 or choos\$4) near4 ((multiple or plural\$4 or two or three or four or five) near5 encoder\$) and ((assymetric\$ or (lempel adj2 ziv)) near4 (compressing or compression)) or (selecting or select or choose or choosing) near4 ((compress or compression or compressing) near4 (algorithm or algorithms or mode or modes)) same ((assymetric\$4 or (lempel adj2 ziv)) near4 (compressing or compression)) or ((multiple or plural\$4 or two or three or four or five) near5 encoder\$) same ((assymetric\$ or (lempel adj2 ziv)) near4 (compressing or compression)) ) )</p>						
<p>((select\$4 or choos\$4) near4 ((multiple or plural\$4 or two or three or four or five) near5 encoder\$) and ((assymetric\$ or (lempel adj2 ziv)) near4 (compressing or compression)) or (selecting or select or choose or choosing) near4 ((compress or compression or compressing) near4 (algorithm or algorithms or mode or modes)) same ((assymetric\$4 or (lempel adj2 ziv)) near4 (compressing or compression)) or ((multiple or plural\$4 or two or three or four or five) near5 encoder\$) same ((assymetric\$ or (lempel adj2 ziv)) near4 (compressing or compression)) or ((multiple or plural\$4 or two or three or four or five) near5 encoder\$) same ((assymetric\$3 or (lempel adj2 ziv)) and (arithmetic)) near4 (compressing or compression)) ) ) and (((375/\$8)).ccls. or ((370/\$8)).ccls. or ((348/\$8)).ccls. or ((341/\$8)).ccls. or ((711/\$8)).ccls. or ((701/\$8)).ccls. or ((381/\$8)).ccls. or ((375/382)).ccls. ) )</p>	<p>PGPB, USPT, USOC, EPAB, JPAB, DWPI, TDBD</p>	<p>n/a</p>	<p>OR</p>	<p>YES</p>		<p>04-18-2016</p>
<p>((select\$4 or choos\$4) near4 ((multiple or plural\$4 or two or three or four or five) near5 encoder\$) and ((assymetric\$ or (lempel adj2 ziv)) near4 (compressing or compression)) or (selecting or select or choose or choosing) near4 ((compress or compression or compressing) near4 (algorithm or algorithms or mode or modes)) same ((assymetric\$4 or (lempel adj2 ziv)) near4 (compressing or compression)) or ((multiple or plural\$4 or two or three or four or five) near5 encoder\$) same ((assymetric\$ or (lempel adj2 ziv)) near4 (compressing or compression)) or ((multiple or plural\$4 or two or three or four or five) near5 encoder\$) same ((assymetric\$3 or (lempel adj2 ziv))</p>	<p>PGPB, USPT, USOC, EPAB, JPAB, DWPI, TDBD</p>	<p>n/a</p>	<p>OR</p>	<p>YES</p>		<p>04-18-2016</p>

and (arithmetic)) near4 (compressing or compression)) ) and ((H03M7/30)   (H03M7/3059)   (H03M7/3084)   (H03M7/6094)   (H03M7/3088)   (H03M7/6023)   (H03M7/6064)   (H04N19/152)   (G11B20/00007)).CPC. )						
("20150334390"   "3394352"   "3490690"   "4021782"   "4032893"   "4054951"   "4127518"   "4302775"   "4325085"   "4360840"   "4386416"   "4394774"   "4464650"   "4494108"   "4499499"   "4574351"   "4626829"   "4646061"   "4682150"   "4701745").PN.	PGPB, USPT, USOC, EPAB, JPAB, DWPI, TDBD	n/a	OR	YES		04-18-2016
("20150334390"   "3394352"   "3490690"   "4021782"   "4032893"   "4054951"   "4127518"   "4302775"   "4325085"   "4360840"   "4386416"   "4394774"   "4464650"   "4494108"   "4499499"   "4574351"   "4626829"   "4646061"   "4682150"   "4701745").PN. ) and ((select\$4 or choos\$4) near4 ((multiple or plural\$4 or two or three or four or five) near5 encoder\$) and ((assymetric\$ or (lempel adj2 ziv)) near4 (compressing or compression)) or (selecting or select or choose or choosing) near4 ((compress or compression or compressing) near4 (algorithm or algorithms or mode or modes)) same ((assymetric\$4 or (lempel adj2 ziv)) near4 (compressing or compression)) or ((multiple or plural\$4 or two or three or four or five) near5 encoder\$) same ((assymetric\$ or (lempel adj2 ziv)) near4 (compressing or compression)) or ((multiple or plural\$4 or two or three or four or five) near5 encoder\$) same ((assymetric\$3 or (lempel adj2 ziv)) and (arithmetic)) near4 (compressing or compression)) ) )	PGPB, USPT, USOC, EPAB, JPAB, DWPI, TDBD	1	OR	YES		04-18-2016
("4558302"   "4568983"   "5046119"   "5227878"   "5333212"   "5379351"   "5379356"   "5402146"   "5408542"   "5684478"   "5870036"   "6023233"   "6092071"   "6169499"   "6215983"   "6370631"   "6404919"   "20160029018"   "5479210"   "5590317"   "5710562"   "6233017"   "6744926"   "7496586"   "5479210"   "5590317"   "5710562"   "6233017"   "6744926"   "7496586"   "3560639"   "5467134"   "5623483"   "5664226").PN.	PGPB, USPT, USOC, EPAB, JPAB, DWPI, TDBD	74	OR	YES		04-18-2016
((select\$4 or choos\$4) near4 ((multiple or plural\$4 or two or three or four or five) near5 encoder\$) and ((assymetric\$ or (lempel adj2 ziv)) near4 (compressing or compression)) or (selecting or select or choose or choosing) near4 ((compress or compression or compressing) near4 (algorithm or	PGPB, USPT, USOC, EPAB, JPAB, DWPI,	59	OR	YES		04-18-2016

<p>algorithms or mode or modes) same        ((asymmetric\$4 or (lempel adj2 ziv)) near4        (compressing or compression)) or ((multiple or        plural\$4 or two or three or four or five) near5        encoder\$) same ((asymmetric\$ or (lempel adj2 ziv))        near4 (compressing or compression)) or ((multiple        or plural\$4 or two or three or four or five) near5        encoder\$) same ((asymmetric\$3 or (lempel adj2 ziv)        and (arithmetic)) near4 (compressing or        compression)) ) ) and (H03M7/30   H03M7/3084          H03M7/6094   H04N19/164   H04N19/176          H04N19/103).CPC.</p>	<p>TDBD</p>					
------------------------------------------------------------------------------------------------------------------------------------------------------------------------------------------------------------------------------------------------------------------------------------------------------------------------------------------------------------------------------------------------------------------------------------------------------------------------------------------------------------------------------------------------------------------------------------------------------------------------------------------------------------------------------	-------------	--	--	--	--	--

Substitute for form 1449/PTO			<b>Complete if Known</b>		
<b>THIRD SUPPLEMENTAL INFORMATION DISCLOSURE STATEMENT BY APPLICANT</b> <i>(Use as many sheets as necessary)</i>			Application Number	14/876,276	
			Filing Date	October 6, 2015	
			First Named Inventor	James J. FALLON	
			Art Unit	2634	
			Examiner Name	BOCURE, TESFALDET	
Sheet	1	of	1	Attorney Docket Number	3421.005000C

U.S. PATENT DOCUMENTS						
Examiner initials*	Cite No. <sup>1</sup>	Document Number		Publication Date MM-DD-YYYY	Name of Patentee or Applicant of Cited Document	Pages, Columns, Lines, Where Relevant Passages or Relevant Figures Appear
		Number-Kind Code <sup>2</sup> (if known)				
	US1	4,558,302		12-10-1985	Welch	
	US2	4,568,983		02-04-1986	Bobick	
	US3	5,046,119		09-03-1991	Hoffert et al.	
	US4	5,227,878		07-13-1993	Puri et al.	
	US5	5,333,212		07-26-1994	Ligtenberg	
	US6	5,379,351		01-03-1995	Fandrianto et al.	
	US7	5,379,356		01-03-1995	Purcell et al.	
	US8	5,402,146		03-28-1995	Rodriguez et al.	
	US9	5,408,542		04-18-1995	Callahan	
	US10	5,684,478		11-04-1997	Panaoussis	
	US11	5,870,036		02-09-1999	Franaszek et al.	
	US12	6,023,233		02-08-2000	Craven et al.	
	US13	6,092,071		07-18-2000	Bolan et al.	
	US14	6,169,499 B1		01-02-2001	Cooper	
	US15	6,215,983 B1		04-10-2001	Dogan et al.	
	US16	6,370,631 B1		04-09-2002	Dye	
	US17	6,404,919 B1		06-11-2002	Nishigaki et al.	

FOREIGN PATENT DOCUMENTS							
Examiner initials*	Cite No. <sup>1</sup>	Foreign Patent Document		Publication Date MM-DD-YYYY	Name of Patentee or Applicant of Cited Document	Pages, Columns, Lines, Where Relevant Passages or Relevant Figures Appear	T 6
		Country Code <sup>3</sup> -Number <sup>4</sup> -Kind Code <sup>5</sup> (if known)					
	FP1	WO	98/19450	05-07-1998	Sensormatic Electronics Corporation		

2763213\_1.DOCX

Examiner Signature	/Tesfaldet Bocure/	Date Considered	04/18/2016
--------------------	--------------------	-----------------	------------

\*EXAMINER: Initial if reference considered, whether or not citation is in conformance with MPEP 609. Draw line through citation if not in conformance and not considered. Include copy of this form with next communication to applicant. <sup>1</sup> Applicant's unique citation designation number (optional). <sup>2</sup> See Kinds Codes of USPTO Patent Documents at www.uspto.gov or MPEP 901.04. <sup>3</sup> Enter Office that issued the document, by the two-letter code (WIPO Standard ST.3). <sup>4</sup> For Japanese patent documents, the indication of the year of the reign of the Emperor must precede the serial number of the patent document. <sup>5</sup> Kind of document by the appropriate symbols as indicated on the document under WIPO Standard ST.16 if possible. <sup>6</sup> Applicant is to place a

ALL REFERENCES CONSIDERED EXCEPT WHERE LINED THROUGH. /T.B./

Substitute for form 1449/PTO		<i>Complete if Known</i>	
<b>THIRD SUPPLEMENTAL INFORMATION DISCLOSURE STATEMENT BY APPLICANT</b> <i>(Use as many sheets as necessary)</i>		Application Number	14/876,276
		Filing Date	October 6, 2015
		First Named Inventor	James J. FALLON
		Art Unit	2634
		Examiner Name	BOCURE, TESFALDET
		Attorney Docket Number	3421.005000C
Sheet	1	of	4

NON PATENT LITERATURE DOCUMENTS			
Examiner Initials*	Cite No. <sup>1</sup>	Include name of the author (in CAPITAL LETTERS), title of the article (when appropriate), title of the item (book, magazine, journal, serial, symposium, catalog, etc.), date, page(s), volume-issue number(s), publisher, city and/or country where published	T <sup>2</sup>
	NPL1	Order Adopting Report and Recommendation of United States Magistrate Judge, filed in Realtime Data, LLC d/b/a IXO v. Actian Corporation, et al., Case No. 6:15-cv-00463-RWS-JDL (E.D. Texas), filed January 21, 2016; 4 pages.	
	NPL2	Defendants' Preliminary Invalidation Contentions, submitted in Realtime Data, LLC d/b/a IXO v. Actian Corporation, et al., Case No. 6:15-cv-0063-RWS-JDL (E.D. Texas), served December 4, 2015; 138 pages.	
	NPL3	Non-Confidential Exhibits A1-A7 and A9-A10 to Defendants' Preliminary Invalidation Contentions, submitted in Realtime Data, LLC d/b/a IXO v. Actian Corporation, et al., Case No. 6:15-cv-0063-RWS-JDL (E.D. Texas), served December 4, 2015; 743 pages.	
	NPL4	Non-confidential Exhibits B1-B17 and B19 to Defendants' Preliminary Invalidation Contentions, submitted in Realtime Data, LLC d/b/a IXO v. Actian Corporation, et al., Case No. 6:15-cv-0063-RWS-JDL (E.D. Texas), served December 4, 2015; 506 pages.	
	NPL5	Non-Confidential Exhibits C1-C36 to Defendants' Preliminary Invalidation Contentions, submitted in Realtime Data, LLC d/b/a IXO v. Actian Corporation, et al., Case No. 6:15-cv-0063-RWS-JDL (E.D. Texas), served December 4, 2015; 1,445 pages.	
	NPL6	Non-Confidential Exhibits D1-D14 and D16 to Defendants' Preliminary Invalidation Contentions, submitted in Realtime Data, LLC d/b/a IXO v. Actian Corporation, et al., Case No. 6:15-cv-0063-RWS-JDL (E.D. Texas), served December 4, 2015; 1,052 pages.	
	NPL7	Non-Confidential Exhibits E1-E36 to Defendants' Preliminary Invalidation Contentions, submitted in Realtime Data, LLC d/b/a IXO v. Actian Corporation, et al., Case No. 6:15-cv-0063-RWS-JDL (E.D. Texas), served December 4, 2015; 1,205 pages.	
	NPL8	KATZ, ET AL., "The Bay Area Research Wireless Access Network (BARWAN)," Proceedings of COMPCON '96, 1996; pp. 15-20.	
	NPL9	U.S. Provisional Patent Application No. 60/100,671, "Hybrid Compression Method with Compression Ratio Control," filed September 16, 1998; 50 pages.	
	NPL10	WELCH, T., "A Technique for High-Performance Data Compression," Computer, Vol. 18, Issue 6, 1984; pp. 8-19.	

Examiner Signature	/Tesdalet Bocure/	Date Considered	04/18/2016
--------------------	-------------------	-----------------	------------

\*EXAMINER: Initial if reference considered, whether or not citation is in conformance with MPEP 609. Draw line through citation if not in conformance and not considered. Include copy of this form with next communication to applicant.

<sup>1</sup> Applicant's unique citation designation number (optional). <sup>2</sup> Applicant is to place a check mark here if English language Translation is attached.

ALL REFERENCES CONSIDERED EXCEPT WHERE LINED THROUGH. /T.B./

Substitute for form 1449/PTO		<b>Complete if Known</b>	
<b>THIRD SUPPLEMENTAL INFORMATION DISCLOSURE STATEMENT BY APPLICANT</b> <i>(Use as many sheets as necessary)</i>		Application Number	14/876,276
		Filing Date	October 6, 2015
		First Named Inventor	James J. FALLON
		Art Unit	2634
		Examiner Name	BOCURE, TESFALDET
		Attorney Docket Number	3421.005000C
Sheet	2	of	4

NON PATENT LITERATURE DOCUMENTS			
Examiner Initials*	Cite No. <sup>1</sup>	Include name of the author (in CAPITAL LETTERS), title of the article (when appropriate), title of the item (book, magazine, journal, serial, symposium, catalog, etc.), date, page(s), volume number, publisher, city and/or country where published	T <sup>2</sup>
	NPL11	Internet Archive version of the web page www.imatix.com/index.htm, dated May 20, 1998, available at <a href="http://web.archive.org/web/19980520033922/http://imatix.com/index.htm">http://web.archive.org/web/19980520033922/http://imatix.com/index.htm</a> ; 1 page.	
	NPL12	Internet Archive version of the web page www.imatix.com/index.htm, dated January 10, 1998, available at <a href="http://web.archive.org/web/19980110141513/http://imatix.com/index.htm">http://web.archive.org/web/19980110141513/http://imatix.com/index.htm</a> ; 1 page.	
	NPL13	Internet Archive version of the web page www.imatix.com/, dated January 9, 1998, available at <a href="https://web.archive.org/web/19980109064903/http://imatix.com/">https://web.archive.org/web/19980109064903/http://imatix.com/</a> ; 1 page.	
	NPL14	Internet Archive version of the web page www.imatix.com/, dated October 14, 1997, available at <a href="https://web.archive.org/web/19971014195839/http://www.imatix.com/">https://web.archive.org/web/19971014195839/http://www.imatix.com/</a> ; 1 page.	
	NPL15	Internet Archive version of the web page www.imatix.com/, dated June 29, 1997, available at <a href="https://web.archive.org/web/19970629063852/http://www.imatix.com/">https://web.archive.org/web/19970629063852/http://www.imatix.com/</a> ; 2 pages.	
	NPL16	Internet Archive version of the web page www.imatix.com/, dated April 16, 1997, available at <a href="https://web.archive.org/web/19970416061218/http://imatix.com/">https://web.archive.org/web/19970416061218/http://imatix.com/</a> ; 2 pages.	
	NPL17	Internet Archive version of the web page www.imatix.com/, dated December 21, 1996, available at <a href="https://web.archive.org/web/19961221064553/http://imatix.com/">https://web.archive.org/web/19961221064553/http://imatix.com/</a> ; 2 pages.	
	NPL18	Internet Archive version of the web page www.imatix.com/, dated November 6, 1996, available at <a href="https://web.archive.org/web/19961106161211/http://imatix.com/">https://web.archive.org/web/19961106161211/http://imatix.com/</a> ; 2 pages.	
	NPL19	"Liberetto, The iMatix Newsletter," vol. III, issue 9, September 1998, available at <a href="http://legacy.imatix.com/html/libero/doc/news9809.txt">http://legacy.imatix.com/html/libero/doc/news9809.txt</a> ; 9 pages.	
	NPL20	"Liberetto, The iMatix Newsletter," vol. III, issue 4, April 1998, available at <a href="http://legacy.imatix.com/html/libero/doc/news9804.txt">http://legacy.imatix.com/html/libero/doc/news9804.txt</a> ; 8 pages.	

Examiner Signature	/Tesfaldet Bocure/	Date Considered	04/18/2016
--------------------	--------------------	-----------------	------------

\*EXAMINER: Initial if reference considered, whether or not citation is in conformance with MPEP 609. Draw line through citation if not in conformance and not considered. Include copy of this form with next communication to applicant.  
<sup>1</sup> Applicant's unique citation designation number (optional). <sup>2</sup> Applicant is to place a check mark here if English language Translation is attached.

ALL REFERENCES CONSIDERED EXCEPT WHERE LINED THROUGH. /T.B./

Substitute for form 1449/PTO		<b>Complete if Known</b>	
<b>THIRD SUPPLEMENTAL INFORMATION DISCLOSURE STATEMENT BY APPLICANT</b> <i>(Use as many sheets as necessary)</i>		Application Number	14/876,276
		Filing Date	October 6, 2015
		First Named Inventor	James J. FALLON
		Art Unit	2634
		Examiner Name	BOCURE, TESFALDET
		Attorney Docket Number	3421.005000C
Sheet	3	of	4

NON PATENT LITERATURE DOCUMENTS			
Examiner Initials*	Cite No. <sup>1</sup>	Include name of the author (in CAPITAL LETTERS), title of the article (when appropriate), title of the item (book, magazine, journal, serial, symposium, catalog, etc.), date, page(s), volume number, publisher, city and/or country where published	T <sup>2</sup>
	NPL21	"Liberetto, The iMatix Newsletter," vol. III, issue 1, January 1998, available at <a href="http://legacy.imatix.com/html/libero/doc/news9801.txt">http://legacy.imatix.com/html/libero/doc/news9801.txt</a> ; 7 pages.	
	NPL22	"Liberetto, The iMatix Newsletter," vol. II, issue 8, August 1997, available at <a href="http://legacy.imatix.com/html/libero/doc/news9708.txt">http://legacy.imatix.com/html/libero/doc/news9708.txt</a> ; 8 pages.	
	NPL23	"Liberetto, The iMatix Newsletter," vol. II, issue 6, June 1997, available at <a href="http://legacy.imatix.com/html/libero/doc/news9706.txt">http://legacy.imatix.com/html/libero/doc/news9706.txt</a> ; 6 pages.	
	NPL24	"Liberetto, The iMatix Newsletter," vol. II, issue 2, February 1997, available at <a href="http://legacy.imatix.com/html/libero/doc/news9702.txt">http://legacy.imatix.com/html/libero/doc/news9702.txt</a> ; 9 pages.	
	NPL25	Internet Archive version of the web page <a href="http://www.seas.upenn.edu/~liefke/">www.seas.upenn.edu/~liefke/</a> , dated October 5, 1999, available at <a href="https://web.archive.org/web/19991005050552/http://www.seas.upenn.edu/~liefke/">https://web.archive.org/web/19991005050552/http://www.seas.upenn.edu/~liefke/</a> ; 2 pages.	
	NPL26	Internet Archive version of the web page <a href="http://www.seas.upenn.edu/~liefke/research.html">www.seas.upenn.edu/~liefke/research.html</a> , dated January 18, 2000, available at <a href="https://web.archive.org/web/20000118224540/http://www.seas.upenn.edu/~liefke/research.html">https://web.archive.org/web/20000118224540/http://www.seas.upenn.edu/~liefke/research.html</a> ; 2 pages.	
	NPL27	Internet Archive version of the web page <a href="http://www.seas.upenn.edu/~liefke/xmlzip.html">www.seas.upenn.edu/~liefke/xmlzip.html</a> , dated January 19, 2000, available at <a href="https://web.archive.org/web/20000119051403/http://www.seas.upenn.edu/~liefke/xmlzip.html">https://web.archive.org/web/20000119051403/http://www.seas.upenn.edu/~liefke/xmlzip.html</a> ; 4 pages.	
	NPL28	Internet Archive version of the web page <a href="http://www.research.att.com/~suciu/strudel/external/NodeExternal,internal.genoid_3.html">www.research.att.com/~suciu/strudel/external/NodeExternal,internal.genoid_3.html</a> , dated March 10, 2000, available at <a href="https://web.archive.org/web/20000310042016/http://www.research.att.com/~suciu/strudel/external/NodeExternal,internal.genoid_3.html">https://web.archive.org/web/20000310042016/http://www.research.att.com/~suciu/strudel/external/NodeExternal,internal.genoid_3.html</a> ; 12 pages.	
	NPL29	Internet Archive version of the web page <a href="http://www.research.att.com/sw/tools/xmill/">www.research.att.com/sw/tools/xmill/</a> , dated August 31, 2000, available at <a href="https://web.archive.org/web/20000831200854/http://www.research.att.com/sw/tools/xmill/">https://web.archive.org/web/20000831200854/http://www.research.att.com/sw/tools/xmill/</a> ; 2 pages.	
	NPL30	Internet Archive version of the web page <a href="http://www.research.att.com/sw/tools/xmill/download.html">www.research.att.com/sw/tools/xmill/download.html</a> , dated September 25, 2000, available at <a href="https://web.archive.org/web/20000925084557/http://www.research.att.com/sw/tools/xmill/download.html">https://web.archive.org/web/20000925084557/http://www.research.att.com/sw/tools/xmill/download.html</a> ; 1 page.	
Examiner Signature	/Tesdalet Bocure/		Date Considered 04/18/2016

\*EXAMINER: Initial if reference considered, whether or not citation is in conformance with MPEP 609. Draw line through citation if not in conformance and not considered. Include copy of this form with next communication to applicant.

<sup>1</sup> Applicant's unique citation designation number (optional). <sup>2</sup> Applicant is to place a check mark here if English language Translation is attached.

ALL REFERENCES CONSIDERED EXCEPT WHERE LINED THROUGH. /T.B./

Substitute for form 1449/PTO		<i>Complete if Known</i>	
<b>THIRD SUPPLEMENTAL INFORMATION DISCLOSURE STATEMENT BY APPLICANT</b> <i>(Use as many sheets as necessary)</i>		Application Number	14/876,276
		Filing Date	October 6, 2015
		First Named Inventor	James J. FALLON
		Art Unit	2634
		Examiner Name	BOCURE, TESHFALDET
		Attorney Docket Number	3421.005000C
		Sheet	4

NON PATENT LITERATURE DOCUMENTS			
Examiner Initials*	Cite No. <sup>1</sup>	Include name of the author (in CAPITAL LETTERS), title of the article (when appropriate), title of the item (book, magazine, journal, serial, symposium, catalog, etc.), date, page(s), volume number, publisher, city and/or country where published	T <sup>2</sup>
	NPL31	LIEFKE, ET AL., "Xmill: an Efficient Compressor for XML Data," Proceedings of the 2000 ACM SIGMOD International Conference on the Management of Data, 2000; pp. 153-164.	
	NPL32	"User Manual for XMill," XMill Version 0.7 (1999); 16 pages.	

2763226\_1.DOCX

Examiner Signature	/Teshfaldet Bocure/	Date Considered	04/18/2016
--------------------	---------------------	-----------------	------------

\*EXAMINER: Initial if reference considered, whether or not citation is in conformance with MPEP 609. Draw line through citation if not in conformance and not considered. Include copy of this form with next communication to applicant.  
<sup>1</sup> Applicant's unique citation designation number (optional). <sup>2</sup> Applicant is to place a check mark here if English language Translation is attached.

ALL REFERENCES CONSIDERED EXCEPT WHERE LINED THROUGH. /T.B./



Substitute for form 1449/PTO		<i>Complete if Known</i>	
<b>FOURTH SUPPLEMENTAL INFORMATION DISCLOSURE STATEMENT BY APPLICANT</b> <i>(Use as many sheets as necessary)</i>		Application Number	14/876,276
		Filing Date	October 6, 2015
		First Named Inventor	James J. FALLON
		Art Unit	2634
		Examiner Name	BOCURE, TESFALDET
Sheet	1	of	1
		Attorney Docket Number	3421.005000C

U.S. PATENT DOCUMENTS					
Examiner initials*	Cite No. <sup>1</sup>	Document Number	Publication Date MM-DD-YYYY	Name of Patentee or Applicant of Cited Document	Pages, Columns, Lines, Where Relevant Passages or Relevant Figures Appear
		Number-Kind Code <sup>2</sup> (if known)			
	US1	5,479,210	12-26-1995	Cawley et al.	
	US2	5,590,317	12-31-1996	Iguchi et al.	
	US3	5,710,562	01-20-1998	Gormish et al.	
	US4	6,233,017 B1	05-15-2001	Chaddha	
	US5	6,744,926 B1	06-01-2004	Nishigaki	
	US6	7,496,586 B1	02-24-2009	Bonwick et al.	

FOREIGN PATENT DOCUMENTS						
Examiner initials*	Cite No. <sup>1</sup>	Foreign Patent Document	Publication Date MM-DD-YYYY	Name of Patentee or Applicant of Cited Document	Pages, Columns, Lines, Where Relevant Passages or Relevant Figures Appear	T 6
		Country Code <sup>3</sup> -Number <sup>4</sup> -Kind Code <sup>5</sup> (if known)				

2774120\_1.DOCX

Examiner Signature	/Tesfaldet Bocure/	Date Considered	04/18/2016
--------------------	--------------------	-----------------	------------

\*EXAMINER: Initial if reference considered, whether or not citation is in conformance with MPEP 609. Draw line through citation if not in conformance and not considered. Include copy of this form with next communication to applicant. <sup>1</sup> Applicant's unique citation designation number (optional). <sup>2</sup> See Kinds Codes of USPTO Patent Documents at www.uspto.gov or MPEP 901.04. <sup>3</sup> Enter Office that issued the document, by the two-letter code (WIPO Standard ST.3). <sup>4</sup> For Japanese patent documents, the indication of the year of the reign of the Emperor must precede the serial number of the patent document. <sup>5</sup> Kind of document by the appropriate symbols as indicated on the document under WIPO Standard ST.16 if possible. <sup>6</sup> Applicant is to place a check mark in the English language translation column.

**ALL REFERENCES CONSIDERED EXCEPT WHERE LINED THROUGH. /T.B./**

Substitute for form 1449/PTO		<b>Complete if Known</b>	
<b>FOURTH SUPPLEMENTAL INFORMATION DISCLOSURE STATEMENT BY APPLICANT</b> <i>(Use as many sheets as necessary)</i>		Application Number	14/876,276
		Filing Date	October 6, 2015
		First Named Inventor	James J. FALLON
		Art Unit	2634
		Examiner Name	BOCURE, TESFALDET
		Attorney Docket Number	3421.005000C
Sheet	1	of	14

NON PATENT LITERATURE DOCUMENTS			
Examiner Initials*	Cite No. <sup>1</sup>	Include name of the author (in CAPITAL LETTERS), title of the article (when appropriate), title of the item (book, magazine, journal, serial, symposium, catalog, etc.), date, page(s), volume-issue number(s), publisher, city and/or country where published	T <sup>2</sup>
	NPL1	Second Amended Complaint for Patent Infringement Against Riverbed Technology, Inc. and Dell, Inc., filed in Realtime Data LLC d/b/a IXO v. Actian Corporation, et al., Case No. 6:15-cv-00463-RWS-JDL (E.D. Texas), filed February 2, 2016; 37 pages.	
	NPL2	Defendant Dropbox's Answer to Plaintiff Realtime Data LLC d/b/a IXO's Amended Complaint, filed in Realtime Data LLC d/b/a IXO v. Actian Corporation, et al., Case No. 6:15-cv-00463-RWS-JDL (E.D. Texas), filed February 4, 2016; 10 pages.	
	NPL3	Defendants Echostar Corporation's and Hughes Network Systems, LLC's Answer, Affirmative Defenses, and Counterclaims to Plaintiff Realtime Data LLC d/b/a IXO's Amended Complaint, filed in Realtime Data LLC d/b/a IXO v. Actian Corporation, et al., Case No. 6:15-cv-00463-RWS-JDL (E.D. Texas), filed February 4, 2016; 23 pages.	
	NPL4	Defendants SAP America Inc. and SyBase, Inc.'s Answer, Affirmative Defenses, and Counterclaims to Plaintiff's Second Amended Complaint, filed in Realtime Data LLC d/b/a IXO v. Actian Corporation, et al., Case No. 6:15-cv-00463-RWS-JDL (E.D. Texas), filed February 4, 2016; 35 pages.	
	NPL5	Dell Inc.'s Answer, Defenses, and Counterclaims to Plaintiff's Amended Complaint, filed in Realtime Data LLC d/b/a IXO v. Actian Corporation, et al., Case No. 6:15-cv-00463-RWS-JDL (E.D. Texas), filed February 4, 2016; 28 pages.	
	NPL6	Standard Function Library (SFL) Code, Version 1.4, written March 29, 1993, revised January 2, 1997; 190 pages.	
	NPL7	Standard Function Library Documentation, written June 4, 1997, revised November 17, 1997; 1,102 pages. (Submitted in 6 parts.)	
	NPL8	Defendants Oracle America, Inc., Hewlett-Packard Company, and HP Enterprise Services, LLC's Invalidity Contentions, submitted in Realtime Data, LLC d/b/a IXO v. Actian Corporation, et al., Case No. 6:15-cv-00463-RWS-JDL (E.D. Texas), served December 4, 2015; 62 pages.	
	NPL9	Non-Confidential Exhibits A3-A4 to Defendants Oracle America, Inc., Hewlett-Packard Company, and HP Enterprise Services, LLC's Invalidity Contentions, submitted in Realtime Data, LLC d/b/a IXO v. Actian Corporation, et al., Case No. 6:15-cv-00463-RWS-JDL (E.D. Texas), served December 4, 2015; 296 pages.	
	NPL10	Non-Confidential Exhibits B3-B4 to Defendants Oracle America, Inc., Hewlett-Packard Company, and HP Enterprise Services, LLC's Invalidity Contentions, submitted in Realtime Data, LLC d/b/a IXO v. Actian Corporation, et al., Case No. 6:15-cv-00463-RWS-JDL (E.D. Texas), served December 4, 2015; 1,179 pages.	
Examiner Signature	/Tesfaldet Bocure/		Date Considered
			04/18/2016

\*EXAMINER: Initial if reference considered, whether or not citation is in conformance with MPEP 609. Draw line through citation if not in conformance and not considered. Include copy of this form with next communication to applicant.

<sup>1</sup> Applicant's unique citation designation number (optional). <sup>2</sup> Applicant is to place a check mark here if English language Translation is attached.

ALL REFERENCES CONSIDERED EXCEPT WHERE LINED THROUGH. /T.B./

Substitute for form 1449/PTO		<b>Complete if Known</b>	
<b>FOURTH SUPPLEMENTAL INFORMATION DISCLOSURE STATEMENT BY APPLICANT</b> <i>(Use as many sheets as necessary)</i>		Application Number	14/876,276
		Filing Date	October 6, 2015
		First Named Inventor	James J. FALLON
		Art Unit	2634
		Examiner Name	BOCURE, TESFALDET
		Attorney Docket Number	3421.005000C
Sheet	2	of	14

NON PATENT LITERATURE DOCUMENTS			
Examiner Initials*	Cite No. <sup>1</sup>	Include name of the author (in CAPITAL LETTERS), title of the article (when appropriate), title of the item (book, magazine, journal, serial, symposium, catalog, etc.), date, page(s), volume number, publisher, city and/or country where published	T <sup>2</sup>
	NPL11	Non-Confidential Exhibits C4-C7 and C9 to Defendants Oracle America, Inc., Hewlett-Packard Company, and HP Enterprise Services, LLC's Invalidation Contentions, submitted in Realtime Data, LLC d/b/a IXO v. Actian Corporation, et al., Case No. 6:15-cv-00463-RWS-JDL (E.D. Texas), served December 4, 2015; 3,029 pages.	
	NPL12	Non-Confidential Exhibits D4-D7 and D9 to Defendants Oracle America, Inc., Hewlett-Packard Company, and HP Enterprise Services, LLC's Invalidation Contentions, submitted in Realtime Data, LLC d/b/a IXO v. Actian Corporation, et al., Case No. 6:15-cv-00463-RWS-JDL (E.D. Texas), served December 4, 2015; 3,125 pages.	
	NPL13	Non-Confidential Exhibits E1-E4 to Defendants Oracle America, Inc., Hewlett-Packard Company, and HP Enterprise Services, LLC's Invalidation Contentions, submitted in Realtime Data, LLC d/b/a IXO v. Actian Corporation, et al., Case No. 6:15-cv-00463-RWS-JDL (E.D. Texas), served December 4, 2015; 1,657 pages.	
	NPL14	"Adaptive Lossless Data Compression Algorithm," ECMA Standard ECMA-222, June 1995; 20 pages.	
	NPL15	"ALDC1-40S Adaptive Lossless Data Compression," IBM Microelectronics Data Compression Technologies, May 1994; 2 pages.	
	NPL16	AMIR, ET AL., "An Application Level Video Gateway," ACM Multimedia, San Francisco, November 1995; 11 pages.	
	NPL17	ANDREWS, ET AL., "A Mean-Removed Variation of Weighted Universal Vector Quantization for Image Coding," IEEE Data Compression Conference, 1993; pp. 302-309.	
	NPL18	AX.25 Link Access Protocol for Amateur Packet Radio, Version 2.2, Tuscon Amateur Packet Radio Corporation, Revision: July 1998; 143 pages.	
	NPL19	BAKER, ET AL., "Lossless Data Compression for Short Duration 3D Frames in Positron Emission Tomography," IEEE Nuclear Science Symposium and Medical Imaging Conference, 1993; pp. 1831-1834.	
	NPL20	BASSIOUNI, ET AL., "A Scheme for Data Compression in Supercomputers," IEEE Supercomputing '88, 1988; pp. 272-278.	
Examiner Signature	/Tesfaldet Bocure/		Date Considered
			04/18/2016

\*EXAMINER: Initial if reference considered, whether or not citation is in conformance with MPEP 609. Draw line through citation if not in conformance and not considered. Include copy of this form with next communication to applicant.

<sup>1</sup> Applicant's unique citation designation number (optional). <sup>2</sup> Applicant is to place a check mark here if English language Translation is attached.

ALL REFERENCES CONSIDERED EXCEPT WHERE LINED THROUGH. /T.B./

Substitute for form 1449/PTO		<b>Complete if Known</b>	
<b>FOURTH SUPPLEMENTAL INFORMATION DISCLOSURE STATEMENT BY APPLICANT</b> <i>(Use as many sheets as necessary)</i>		Application Number	14/876,276
		Filing Date	October 6, 2015
		First Named Inventor	James J. FALLON
		Art Unit	2634
		Examiner Name	BOCURE, TESFALDET
		Attorney Docket Number	3421.005000C
Sheet	3	of	14

NON PATENT LITERATURE DOCUMENTS			
Examiner Initials*	Cite No. <sup>1</sup>	Include name of the author (in CAPITAL LETTERS), title of the article (when appropriate), title of the item (book, magazine, journal, serial, symposium, catalog, etc.), date, page(s), volume number, publisher, city and/or country where published	T <sup>2</sup>
	NPL21	BRUCKMANN, ET AL., "Selective Medical Image Compression Using Wavelet Techniques," Journal of Computing and Information Technology, Vol. 6, No. 2 (1998); 23 pages.	
	NPL22	CHENG, ET AL., "A fast, highly reliable data compression chip and algorithm for storage systems," IBM Journal of Research and Development, Vol. 40, No. 6, November 1996; pp. 603-613.	
	NPL23	ZHANG, ET AL., "Content-based video retrieval and compression: a unified solution," IEEE Proceedings of the International Conference on Image Processing, October 1997; pp. 13-16.	
	NPL24	CRAFT, D., "A fast hardware data compression algorithm and some algorithmic extensions," IBM Journal of Research and Development, Vol. 42, No. 6, November 1998; pp. 733-745.	
	NPL25	SATTLER, M., Internet TV with CU-SeeMe, Indianapolis, IN: sams.net, 1995; 172 pages.	
	NPL26	DANSKIN, J., "Compressing The X Graphics Protocol," Dissertation, Princeton University Department of Computer Science, January 1995; 147 pages.	
	NPL27	FOX, ET AL., "Adapting to Network and Client Variability via On-Demand Dynamic Distillation," Proceedings of the Seventh International Conference on Architectural Support for Programming Languages and Operating Systems, 1996; pp. 160-170.	
	NPL28	FOX, ET AL., "Adapting to Network and Client Variability Using Infrastructural Proxies: Lessons and Perspectives," Abstract, IEEE Personal Communications, Vol. 5, No. 4, August 1998; 2 pages.	
	NPL29	BOTTOU, ET AL., "High Quality Document Image Compression with DjVu," Journal of Electronic Imaging, Vol. 7, No. 3, 1998; pp. 410-425.	
	NPL30	HOWARD, ET AL., "Parallel Lossless Image Compression Using Huffman and Arithmetic Coding," IEEE Data Compression Conference, March 1992; pp. 299-308.	
Examiner Signature	/Tesfaldet Bocure/		Date Considered
			04/18/2016

\*EXAMINER: Initial if reference considered, whether or not citation is in conformance with MPEP 609. Draw line through citation if not in conformance and not considered. Include copy of this form with next communication to applicant.

<sup>1</sup> Applicant's unique citation designation number (optional). <sup>2</sup> Applicant is to place a check mark here if English language Translation is attached.

ALL REFERENCES CONSIDERED EXCEPT WHERE LINED THROUGH. /T.B./

Substitute for form 1449/PTO		<b>Complete if Known</b>	
<b>FOURTH SUPPLEMENTAL INFORMATION DISCLOSURE STATEMENT BY APPLICANT</b> <i>(Use as many sheets as necessary)</i>		Application Number	14/876,276
		Filing Date	October 6, 2015
		First Named Inventor	James J. FALLON
		Art Unit	2634
		Examiner Name	BOCURE, TESFALDET
		Attorney Docket Number	3421.005000C
Sheet	4	of	14

NON PATENT LITERATURE DOCUMENTS			
Examiner Initials*	Cite No. <sup>1</sup>	Include name of the author (in CAPITAL LETTERS), title of the article (when appropriate), title of the item (book, magazine, journal, serial, symposium, catalog, etc.), date, page(s), volume number, publisher, city and/or country where published	T <sup>2</sup>
	NPL31	"Hewlett-Packard Journal," Hewlett-Packard Corporation, June 1989; 84 pages.	
	NPL32	HSU, ET AL., "Automatic Synthesis of Compression Techniques for Heterogeneous Files," Software - Practice and Experience, Vol. 25, No. 10, October 1995; pp. 1097-1116.	
	NPL33	"Guide to Sharing and Partitioning IBM Tape Library Dataservers," IBM International Technical Support Organization, San Jose Center, November 1996; 276 pages. (Submitted in 2 parts.)	
	NPL34	"Add-On Options for the XpressFiles," Intelligent Compression Technologies, 1998, accessible at < <a href="http://web.archive.org/web/19980518053418/ictcompress.com/options_X.html">http://web.archive.org/web/19980518053418/ictcompress.com/options_X.html</a> >; 2 pages.	
	NPL35	"Introducing XpressFiles," Intelligent Compression Technologies, 1998, accessible at < <a href="http://web.archive.org/web/19980518053310/ictcompress.com/xpressfiles.html">http://web.archive.org/web/19980518053310/ictcompress.com/xpressfiles.html</a> >; 1 page.	
	NPL36	"The Technology Behind XpressFiles," Intelligent Compression Technologies, 1998, accessible at < <a href="http://web.archive.org/web/19980518053634/ictcompress.com/technical_X.html">http://web.archive.org/web/19980518053634/ictcompress.com/technical_X.html</a> >; 1 page.	
	NPL37	XpressFiles White Paper, Intelligent Compression Technologies, 1999; 3 pages.	
	NPL38	"XML-Xpress Product Overview," Intelligent Compression Technologies, 2001, accessible at < <a href="http://web.archive.org/web/20020818002535/www.ictcompress.com/products_xmlxpress.html">http://web.archive.org/web/20020818002535/www.ictcompress.com/products_xmlxpress.html</a> >; 2 pages.	
	NPL39	"ICT's XML-Xpress," Intelligent Compression Technologies, December 2000; 6 pages.	
	NPL40	LARMOUTH, J., "ASN. 1 Complete," Open Systems Solutions, 1999; 387 pages. (Submitted in 4 parts.)	
Examiner Signature	/Tsfaldet Bocure/		Date Considered
			04/18/2016

\*EXAMINER: Initial if reference considered, whether or not citation is in conformance with MPEP 609. Draw line through citation if not in conformance and not considered. Include copy of this form with next communication to applicant.

<sup>1</sup> Applicant's unique citation designation number (optional). <sup>2</sup> Applicant is to place a check mark here if English language Translation is attached.

ALL REFERENCES CONSIDERED EXCEPT WHERE LINED THROUGH. /T.B./

Substitute for form 1449/PTO		<b>Complete if Known</b>	
<b>FOURTH SUPPLEMENTAL INFORMATION DISCLOSURE STATEMENT BY APPLICANT</b> <i>(Use as many sheets as necessary)</i>		Application Number	14/876,276
		Filing Date	October 6, 2015
		First Named Inventor	James J. FALLON
		Art Unit	2634
		Examiner Name	BOCURE, TESFALDET
		Attorney Docket Number	3421.005000C
Sheet	5	of	14

NON PATENT LITERATURE DOCUMENTS			
Examiner Initials*	Cite No. <sup>1</sup>	Include name of the author (in CAPITAL LETTERS), title of the article (when appropriate), title of the item (book, magazine, journal, serial, symposium, catalog, etc.), date, page(s), volume number, publisher, city and/or country where published	T <sup>2</sup>
	NPL41	"Magstar and IBM 3590 High Performance Tape Subsystem Technical Guide," IBM International Technical Support Organization, San Jose Center, November 1996; 287 pages. (Submitted in 2 parts.)	
	NPL42	McGREGOR, ET AL., "Performance Impact of Data Compression on Virtual Private Network Transactions," IEEE Proceedings of the 25th Annual Conference on Local Computer Networks, 2000; 11 pages.	
	NPL43	SUMMERS, B., "Official Microsoft NetMeeting Book," Redmond, WA: Microsoft Press, 1998; 374 pages. (Submitted in 5 parts.)	
	NPL44	BRITTON, ET AL., Discover Desktop Conferencing with NetMeeting 2.0, Foster City, CA: IDG Books Worldwide, Inc., 1998; 304 pages. (Submitted in 4 parts.)	
	NPL45	RANGANATHAN, N., "High-Speed VLSI Designs for Lempel-Ziv-Based Data Compression," IEEE Transactions on Circuits and Systems - II: Analog and Digital Signal Processing, Vol. 40, No. 2, February 1993; pp. 96-106.	
	NPL46	User's Guide, Sidewinder 50 AIT-1 Tape Drive, Seagate Technology, Inc., 1997; 19 pages.	
	NPL47	PROSISE, J., "Understanding Data Compression," PC Magazine, May 25, 1993; pp. 305-308.	
	NPL48	WELCH, T., Source Code, University of California, 1985; 23 pages.	
	NPL49	ABALI, ET AL., "Memory Expansion Technology (MXT): Software Support and Performance," IBM Journalist of Research and Development, Vol. 45, No. 2, March 2001; pp. 287-301.	
	NPL50	ANDERSON, ET AL., "Codec Squeezes Color Teleconferencing Through Digital Telephone Lines," Electronics, January 26, 1984; pp. 113-115.	
Examiner Signature	/Tesfaldet Bocure/		Date Considered
			04/18/2016

\*EXAMINER: Initial if reference considered, whether or not citation is in conformance with MPEP 609. Draw line through citation if not in conformance and not considered. Include copy of this form with next communication to applicant.

<sup>1</sup> Applicant's unique citation designation number (optional). <sup>2</sup> Applicant is to place a check mark here if English language Translation is attached.

ALL REFERENCES CONSIDERED EXCEPT WHERE LINED THROUGH. /T.B./

Substitute for form 1449/PTO		<b>Complete if Known</b>	
<b>FOURTH SUPPLEMENTAL INFORMATION DISCLOSURE STATEMENT BY APPLICANT</b> <i>(Use as many sheets as necessary)</i>		Application Number	14/876,276
		Filing Date	October 6, 2015
		First Named Inventor	James J. FALLON
		Art Unit	2634
		Examiner Name	BOCURE, TESFALDET
		Attorney Docket Number	3421.005000C
Sheet	6	of	14

NON PATENT LITERATURE DOCUMENTS			
Examiner Initials*	Cite No. <sup>1</sup>	Include name of the author (in CAPITAL LETTERS), title of the article (when appropriate), title of the item (book, magazine, journal, serial, symposium, catalog, etc.), date, page(s), volume number, publisher, city and/or country where published	T <sup>2</sup>
	NPL51	COENE, ET AL., "A Fast Route For Application of Rate-Distortion Optimal Quantization in an MPEG Encoder," IEEE Proceedings of the International Conference on Image Processing, 1996; pp. 825-828.	
	NPL52	FRANASZEK, ET AL., "Algorithms and Data Structures for Compressed-Memory Machines," IBM Journal of Research and Development, Vol. 45, No. 2, March 2001; pp. 245-258.	
	NPL53	FRANASZEK, ET AL., "On Internal Organization in Compressed Random-Access Memories," IBM Journal of Research and Development, Vol. 45, No. 2, March 2001; pp. 259-270.	
	NPL54	IBM Technical Disclosure Bulletin, Vol. 38, No. 2, February 1995; 3 pages.	
	NPL55	"IBM Boosts Your Memory," Geek.com, accessible at <http://www.geek.com/ibm-boosts-your-memory/>, June 26, 2000; 3 pages.	
	NPL56	"IBM Research Breakthrough Doubles Computer Memory Capacity," IBM Press Release, June 26, 2000; 3 pages.	
	NPL57	IBM Technical Disclosure Bulletin, Vol. 37, No. 2B, February 1994; 3 pages.	
	NPL58	International Search Reports directed to International Patent Application Nos. PCT/US01/03711 and PCT/US01/03712, January 28, 2001 and May 10, 2002; 9 pages.	
	NPL59	MURASHITA, ET AL., "High-Speed Statistical Compression Using Self-Organized Rules and Predetermined Code Tables," IEEE Proceedings of Data Compression Conference, 1996; p. 449.	
	NPL60	RICE, ET AL., "Lossless Coding Standards for Space Data Systems," IEEE Conference Record of the Thirtieth Asilomar Conference on Signals, Systems and Computers, 1996; pp. 577-585.	

Examiner Signature	/Tesfaldet Bocure/	Date Considered	04/18/2016
-----------------------	--------------------	--------------------	------------

\*EXAMINER: Initial if reference considered, whether or not citation is in conformance with MPEP 609. Draw line through citation if not in conformance and not considered. Include copy of this form with next communication to applicant.

<sup>1</sup> Applicant's unique citation designation number (optional). <sup>2</sup> Applicant is to place a check mark here if English language Translation is attached.

ALL REFERENCES CONSIDERED EXCEPT WHERE LINED THROUGH. /T.B./

Substitute for form 1449/PTO		<b>Complete if Known</b>	
<b>FOURTH SUPPLEMENTAL INFORMATION DISCLOSURE STATEMENT BY APPLICANT</b> <i>(Use as many sheets as necessary)</i>		Application Number	14/876,276
		Filing Date	October 6, 2015
		First Named Inventor	James J. FALLON
		Art Unit	2634
		Examiner Name	BOCURE, TESFALDET
		Attorney Docket Number	3421.005000C
Sheet	7	of	14

NON PATENT LITERATURE DOCUMENTS			
Examiner Initials*	Cite No. <sup>1</sup>	Include name of the author (in CAPITAL LETTERS), title of the article (when appropriate), title of the item (book, magazine, journal, serial, symposium, catalog, etc.), date, page(s), volume number, publisher, city and/or country where published	T <sup>2</sup>
	NPL61	RICE, R., "Some Practical Universal Noiseless Coding Techniques," National Aeronautics and Space Administration, JPL Publication 79-22, 1979; 149 pages.	
	NPL62	"ServerWorks To Deliver IBM's Memory eXpansion Technology in Next-Generation Core Logic for Servers," ServerWorks press release, accessible at < <a href="http://www.serverworks.com/news/press/000627.html">http://www.serverworks.com/news/press/000627.html</a> >, June 27, 2000; 1 page.	
	NPL63	SMITH, ET AL., "Memory Expansion Technology (MXT): Competitive Impact," IBM Journal of Research and Development, Vol. 45, No. 2, March 2001; pp. 303-309.	
	NPL64	TREMAINE, ET AL., "IBM Memory Expansion Technology (MXT)," IBM Journal of Research and Development, Vol. 45, No. 2, March 2001; pp. 271-285.	
	NPL65	VENBRUX, ET AL., "A VLSI Chip Set for High-Speed Lossless Data Compression," IEEE Transactions on Circuits and Systems for Video Technology, Vol. 2, No. 4, December 1992; pp. 381-391.	
	NPL66	YEH, P., "The CCSDS Lossless Data Compression Recommendation for Space Applications," Chapter 16, Lossless Compression Handbook, SAYOOD, K., ed., Academic Press, 2003; pp. 311-326.	
	NPL67	MARTIN, J., "HP drive offers data compression," COMPUTERWORLD, May 9, 1988; p. 76.	
	NPL68	MILLMAN, H., "Image and Video Compression," COMPUTERWORLD, January 18, 1999; p. 78.	
	NPL69	"MegaRam Disc Emulator: Revolutionary, Non-rotating, Solid-state Replacement for Fixed and Moving Head Discs," Imperial Technology, Inc., October 1985; 4 pages.	
	NPL70	"MegaRam-PC: Solid-State Disk Emulator For The IBM And IBM Compatible Personal Computers," Imperial Technology, Inc., October 1985; 2 pages.	

Examiner Signature	/Tsfaldet Bocure/	Date Considered	04/18/2016
-----------------------	-------------------	--------------------	------------

\*EXAMINER: Initial if reference considered, whether or not citation is in conformance with MPEP 609. Draw line through citation if not in conformance and not considered. Include copy of this form with next communication to applicant.

<sup>1</sup> Applicant's unique citation designation number (optional). <sup>2</sup> Applicant is to place a check mark here if English language Translation is attached.

ALL REFERENCES CONSIDERED EXCEPT WHERE LINED THROUGH. /T.B./



Substitute for form 1449/PTO		<b>Complete if Known</b>	
<b>FOURTH SUPPLEMENTAL INFORMATION DISCLOSURE STATEMENT BY APPLICANT</b> <i>(Use as many sheets as necessary)</i>		Application Number	14/876,276
		Filing Date	October 6, 2015
		First Named Inventor	James J. FALLON
		Art Unit	2634
		Examiner Name	BOCURE, TESFALDET
		Attorney Docket Number	3421.005000C
Sheet	8	of	14

NON PATENT LITERATURE DOCUMENTS			
Examiner Initials*	Cite No. <sup>1</sup>	Include name of the author (in CAPITAL LETTERS), title of the article (when appropriate), title of the item (book, magazine, journal, serial, symposium, catalog, etc.), date, page(s), volume number, publisher, city and/or country where published	T <sup>2</sup>
	NPL71	"MegaRam Solid State Disks," Imperial Technology, Inc., accessible via the Internet Archive at < <a href="https://web.archive.org/web/19990501183337/http://imperialtech.com/SolidState.html">https://web.archive.org/web/19990501183337/http://imperialtech.com/SolidState.html</a> >, May 1, 1999; 3 pages.	
	NPL72	"Quantum Rushmore Solid State Disk Drives," Quantum Corporation, accessible via the Internet Archive at < <a href="http://web.archive.org/web/19990508051125/http://www.quantum.com/products/ssd/">http://web.archive.org/web/19990508051125/http://www.quantum.com/products/ssd/</a> >, May 8, 1999; 3 pages.	
	NPL73	"Lucent Opts for Hi/fn Compression and Encryption In Latest Portmaster Products," PR Newswire, May 11, 1999; 2 pages.	
	NPL74	7711 to 7751 Migration Application Note, Hi/fn Network Security Processors, Application Note AN-0002-00, October 1, 1998; 8 pages.	
	NPL75	9705 Network Software Design Guide Application Note, Stac Electronics, Inc., APP-0012 Revision 1.0, May 1993; 30 pages.	
	NPL76	9705/9705A Data Compression Coprocessor Data Sheet, Hi/fn, May 1996; 87 pages.	
	NPL77	9711 to 7711 Migration Application Note, Hi/fn Network Security Processors, Application Note AN-0007-00, October 1, 1998; 7 pages.	
	NPL78	9732AM Data Compression Coprocessor Data Sheet, Hi/fn, PRS-0055 Revision 0.1, May 1999; 58 pages.	
	NPL79	BLELLOCH, G., "Algorithms in the Real World: Lecture Notes (Fall 1997)," Lecture Notes, UC Berkeley, April 23, 1998; 303 pages. (Submitted in 2 parts.)	
	NPL80	LeCUN, ET AL., "DjVu: a Compression Method for Distributing Scanned Documents in Color over the Internet," AT&T Labs-Research, January 1999; 2 pages.	

Examiner Signature	/Tsfaldet Bocure/	Date Considered	04/18/2016
-----------------------	-------------------	--------------------	------------

\*EXAMINER: Initial if reference considered, whether or not citation is in conformance with MPEP 609. Draw line through citation if not in conformance and not considered. Include copy of this form with next communication to applicant.

<sup>1</sup> Applicant's unique citation designation number (optional). <sup>2</sup> Applicant is to place a check mark here if English language Translation is attached.

ALL REFERENCES CONSIDERED EXCEPT WHERE LINED THROUGH. /T.B./

Substitute for form 1449/PTO		<b>Complete if Known</b>	
<b>FOURTH SUPPLEMENTAL INFORMATION DISCLOSURE STATEMENT BY APPLICANT</b> <i>(Use as many sheets as necessary)</i>		Application Number	14/876,276
		Filing Date	October 6, 2015
		First Named Inventor	James J. FALLON
		Art Unit	2634
		Examiner Name	BOCURE, TESFALDET
		Attorney Docket Number	3421.005000C
Sheet	9	of	14

NON PATENT LITERATURE DOCUMENTS			
Examiner Initials*	Cite No. <sup>1</sup>	Include name of the author (in CAPITAL LETTERS), title of the article (when appropriate), title of the item (book, magazine, journal, serial, symposium, catalog, etc.), date, page(s), volume number, publisher, city and/or country where published	T <sup>2</sup>
	NPL81	9732A Data Compression Coprocessor Data Sheet, Hi/fn, October 1999; 50 pages.	
	NPL82	7711 Encryption Processor Data Sheet, Hi/fn Network Security Processors, June 1999; 77 pages.	
	NPL83	7751 Encryption Processor Data Sheet, Hi/fn Network Security Processors, June 1999; 84 pages.	
	NPL84	9751 Data Compression Processor Data Sheet, Hi/fn, June 1999; 66 pages.	
	NPL85	"Hi/fn Encryption Products Power Network Alchemy's Revolutionary VPN Products," Business Wire, January 26, 1999; 2 pages.	
	NPL86	"Hi/fn Provides Hardware Encryption for Xedia's New Access Point QPVN Internet Access Platform," Business Wire, October 19, 1998; 2 pages.	
	NPL87	"LZW Data Compression," Dr. Dobb's, October 1, 1989; 14 pages.	
	NPL88	"New Accelerator Chip From Hi/fn to Speed-Up Virtual Private Networks - 'VPNs'," Business Wire, January 26, 1999; 3 pages.	
	NPL89	Programming the 7711 For IPSEC Applications Application Note, Hi/fn Network Security Processors, Application Note AN-0002-00, October 1, 1998; 15 pages.	
	NPL90	FRIEND, R., "IP Payload Compression Using LZS, Request for Comments" The Internet Society, Network Working Group, Hi/fn, Inc., December 1998; 9 pages.	

Examiner Signature	/Tesfaldet Bocure/	Date Considered	04/18/2016
-----------------------	--------------------	--------------------	------------

\*EXAMINER: Initial if reference considered, whether or not citation is in conformance with MPEP 609. Draw line through citation if not in conformance and not considered. Include copy of this form with next communication to applicant.

<sup>1</sup> Applicant's unique citation designation number (optional). <sup>2</sup> Applicant is to place a check mark here if English language Translation is attached.

ALL REFERENCES CONSIDERED EXCEPT WHERE LINED THROUGH. /T.B./

Substitute for form 1449/PTO		<b>Complete if Known</b>	
<b>FOURTH SUPPLEMENTAL INFORMATION DISCLOSURE STATEMENT BY APPLICANT</b> <i>(Use as many sheets as necessary)</i>		Application Number	14/876,276
		Filing Date	October 6, 2015
		First Named Inventor	James J. FALLON
		Art Unit	2634
		Examiner Name	BOCURE, TESFALDET
		Attorney Docket Number	3421.005000C
Sheet	10	of	14

NON PATENT LITERATURE DOCUMENTS			
Examiner Initials*	Cite No. <sup>1</sup>	Include name of the author (in CAPITAL LETTERS), title of the article (when appropriate), title of the item (book, magazine, journal, serial, symposium, catalog, etc.), date, page(s), volume number, publisher, city and/or country where published	T <sup>2</sup>
	NPL91	Screenshot of hifn.com, accessible via the Internet Archive at < <a href="https://web.archive.org/web/19981212025553/http://www.hifn.com/">https://web.archive.org/web/19981212025553/http://www.hifn.com/</a> >, December 12, 1998; 1 page.	
	NPL92	WIRBEL, L., "Volume shipment for Hi/fn encryption processor," Electronic Engineering Times, Issue 1005, May 4, 1998; 2 pages.	
	NPL93	"Intelligent Compression Technologies: Intelligent Compression Technologies releases XML compressor, XML-Xpress," M2 Presswire, January 30, 2001; 5 pages.	
	NPL94	Form 10 - General Form for Registration of Securities, hi/fn, inc., United States Securities and Exchange Commission, filed December 8, 1998; 387 pages. (Submitted in 3 parts.)	
	NPL95	Form S-3 - Registration Statement Under The Securities Act of 1913, hi/fn, inc., United States Securities and Exchange Commission, filed February 17, 1999; 151 pages.	
	NPL96	HP 7979A/7980A/7980XC Tape Drive User's Guide, Hewlett-Packard Corporation, HP Computer Museum, October 1988; 76 pages.	
	NPL97	7980A Tape Drive - Documentation, HP Computer Museum, accessible at < <a href="http://www.hp.com/museum/exhibit.php?hwdoc=390">http://www.hp.com/museum/exhibit.php?hwdoc=390</a> >, September 22, 2015; 1 page.	
	NPL98	The HP 7980A/7979A 1/2-inch Tape Drives, Hewlett-Packard Product Specifications, June 1, 1987; 2 pages.	
	NPL99	9145A Tape Drive - Documentation, HP Computer Museum, accessible at < <a href="http://www.hp.com/museum/exhibit.php?hwdoc=258">http://www.hp.com/museum/exhibit.php?hwdoc=258</a> >, September 22, 2015; 1 page.	
	NPL100	HP 9145A Tape Drive User's Manual, Edition 1, Hewlett-Packard Corporation, July 1988; 61 pages.	

Examiner Signature	/Teskaldet Bocure/	Date Considered	04/18/2016
-----------------------	--------------------	--------------------	------------

\*EXAMINER: Initial if reference considered, whether or not citation is in conformance with MPEP 609. Draw line through citation if not in conformance and not considered. Include copy of this form with next communication to applicant.

<sup>1</sup> Applicant's unique citation designation number (optional). <sup>2</sup> Applicant is to place a check mark here if English language Translation is attached.

ALL REFERENCES CONSIDERED EXCEPT WHERE LINED THROUGH. /T.B./

Substitute for form 1449/PTO		<b>Complete if Known</b>	
<b>FOURTH SUPPLEMENTAL INFORMATION DISCLOSURE STATEMENT BY APPLICANT</b> <i>(Use as many sheets as necessary)</i>		Application Number	14/876,276
		Filing Date	October 6, 2015
		First Named Inventor	James J. FALLON
		Art Unit	2634
		Examiner Name	BOCURE, TESFALDET
		Attorney Docket Number	3421.005000C
Sheet	11	of	14

NON PATENT LITERATURE DOCUMENTS			
Examiner Initials*	Cite No. <sup>1</sup>	Include name of the author (in CAPITAL LETTERS), title of the article (when appropriate), title of the item (book, magazine, journal, serial, symposium, catalog, etc.), date, page(s), volume number, publisher, city and/or country where published	T <sup>2</sup>
	NPL101	Peripheral Products, HP Computer Museum, accessible at < <a href="http://www.hpmuseum.net/exhibit.php?class=4&amp;cat=85">http://www.hpmuseum.net/exhibit.php?class=4&amp;cat=85</a> >, September 22, 2015; 3 page.	
	NPL102	PALL, G., "Microsoft Point-To-Point Compression (MPPC) Protocol, Request for Comments," The Internet Society, Network Working Group, Hi/fn, Inc., December 1998; 9 pages.	
	NPL103	"Cisco IOS Data Compression," Cisco Systems White Paper, 1997; 10 pages.	
	NPL104	"Reference Software 7751 Encryption Processor," Hi/fn Network Security Processors, Reference Software RS-0001-00, October 1, 1998; 38 pages.	
	NPL105	Screenshot of hifn.com, accessible via the Internet Archive at < <a href="https://web.archive.org/web/19981205163011/http://www.hifn.com">https://web.archive.org/web/19981205163011/http://www.hifn.com</a> >, December 5, 1998; 1 page.	
	NPL106	TESS Record for Serial No. 78040025, filed December 20, 2000, "Typed Drawing," accessed November 10, 2015; 1 page.	
	NPL107	"Compaq Professional Workstation AP500 Key Technologies White Paper," Compaq Computer Corporation, August 1998; 21 pages.	
	NPL108	LANGDON, G., "An Introduction to Arithmetic Coding," IBM Journal of Research and Development, Vol. 28, No. 2, March 1984; pp. 135-149.	
	NPL109	"Connecting Your HP SureStore CD-Writer Plus Drive: Windows 95 and Windows NT 4.0," Hewlett-Packard Corporation, 1997; 50 pages.	
	NPL110	"Quantum Rushmore Solid State Disk Drives," Quantum Corporation, accessible via the Internet Archive at < <a href="http://web.archive.org/web/19980220122303/http://www.quantum.com/products/ssd/">http://web.archive.org/web/19980220122303/http://www.quantum.com/products/ssd/</a> >, February 20, 1998; 2 pages.	

Examiner Signature	/Tesfaldet Bocure/	Date Considered	04/18/2016
-----------------------	--------------------	--------------------	------------

\*EXAMINER: Initial if reference considered, whether or not citation is in conformance with MPEP 609. Draw line through citation if not in conformance and not considered. Include copy of this form with next communication to applicant.

<sup>1</sup> Applicant's unique citation designation number (optional). <sup>2</sup> Applicant is to place a check mark here if English language Translation is attached.

ALL REFERENCES CONSIDERED EXCEPT WHERE LINED THROUGH. /T.B./

Substitute for form 1449/PTO		<i>Complete if Known</i>	
<b>FOURTH SUPPLEMENTAL INFORMATION DISCLOSURE STATEMENT BY APPLICANT</b> <i>(Use as many sheets as necessary)</i>		Application Number	14/876,276
		Filing Date	October 6, 2015
		First Named Inventor	James J. FALLON
		Art Unit	2634
		Examiner Name	BOCURE, TESHALDET
		Attorney Docket Number	3421.005000C
Sheet	12	of	14

NON PATENT LITERATURE DOCUMENTS			
Examiner Initials*	Cite No. <sup>1</sup>	Include name of the author (in CAPITAL LETTERS), title of the article (when appropriate), title of the item (book, magazine, journal, serial, symposium, catalog, etc.), date, page(s), volume number, publisher, city and/or country where published	T <sup>2</sup>
	NPL111	"MegaRam Solid State Disks," Imperial Technology, Inc., accessible via the Internet Archive at < <a href="https://web.archive.org/web/19980206055558/http://imperialtech.com/SolidState.html">https://web.archive.org/web/19980206055558/http://imperialtech.com/SolidState.html</a> >, February 6, 1998; 2 pages.	
	NPL112	"Replica - The Fastest, Most Reliable Data Protection For Servers," accessible via the Internet Archive at < <a href="http://web.archive.org/web/19970226213335/http://www1.stac.com/soft/replfct.html">http://web.archive.org/web/19970226213335/http://www1.stac.com/soft/replfct.html</a> >, February 26, 1997; 4 pages.	
	NPL113	"Object Replication: A Revolutionary Advance in Distributed Data Protection and Recovery," Stac White Paper, 1999; 7 pages.	
	NPL114	"Features and Benefits for Replica," Replica for NetWare, 1999; 3 pages.	
	NPL115	DjVu 2.2 Reference Library, August 2000 (submitted on compact disc).	
	NPL116	"Replica - The Fastest, Most Reliable Data Protection for Servers," accessible via the Internet Archive at < <a href="http://web.archive.org/web/19970226213335/http://www1.stac.com/soft/replcont.html">http://web.archive.org/web/19970226213335/http://www1.stac.com/soft/replcont.html</a> >, February 26, 1997; 1 page.	
	NPL117	"Stac Products & Technology," accessible via the Internet Archive at < <a href="http://web.archive.org/web/19970226213054/http://www1.stac.com/soft/softprod.html">http://web.archive.org/web/19970226213054/http://www1.stac.com/soft/softprod.html</a> >, February 26, 1997; 1 page.	
	NPL118	"Hi/fn Product Catalog," accessible via the Internet Archive at < <a href="http://web.archive.org/19971010233632/http://www.hifn.com/products/product/index.htm">http://web.archive.org/19971010233632/http://www.hifn.com/products/product/index.htm</a> >, October 10, 1997; 1 page.	
	NPL119	"Hi/fn Products," accessible via the Internet Archive at < <a href="http://web.archive.org/19971010233115/http://www.hifn.com/products/index.htm">http://web.archive.org/19971010233115/http://www.hifn.com/products/index.htm</a> >, October 10, 1997; 1 page.	
	NPL120	"Replica Family," accessible via the Internet Archive at < <a href="http://web.archive.org/19980212174817/http://www.stac.com/replica/rep_overview.html">http://web.archive.org/19980212174817/http://www.stac.com/replica/rep_overview.html</a> >, February 12, 1998; 1 page.	
Examiner Signature	/Teshaldet Bocure/		Date Considered 04/18/2016

\*EXAMINER: Initial if reference considered, whether or not citation is in conformance with MPEP 609. Draw line through citation if not in conformance and not considered. Include copy of this form with next communication to applicant.

<sup>1</sup> Applicant's unique citation designation number (optional). <sup>2</sup> Applicant is to place a check mark here if English language Translation is attached.

ALL REFERENCES CONSIDERED EXCEPT WHERE LINED THROUGH. /T.B./

Substitute for form 1449/PTO		<b>Complete if Known</b>	
<b>FOURTH SUPPLEMENTAL INFORMATION DISCLOSURE STATEMENT BY APPLICANT</b> <i>(Use as many sheets as necessary)</i>		Application Number	14/876,276
		Filing Date	October 6, 2015
		First Named Inventor	James J. FALLON
		Art Unit	2634
		Examiner Name	BOCURE, TESFALDET
		Attorney Docket Number	3421.005000C
Sheet	13	of	14

NON PATENT LITERATURE DOCUMENTS			
Examiner Initials*	Cite No. <sup>1</sup>	Include name of the author (in CAPITAL LETTERS), title of the article (when appropriate), title of the item (book, magazine, journal, serial, symposium, catalog, etc.), date, page(s), volume number, publisher, city and/or country where published	T <sup>2</sup>
	NPL121	"Stac Web Site Cotents," accessible via the Internet Archive at < <a href="http://web.archive.org/19990827224836/http://www.stac.com/subcontents/sitemap.asp?sitemap">http://web.archive.org/19990827224836/http://www.stac.com/subcontents/sitemap.asp?sitemap</a> >, August 27, 1999; 4 pages.	
	NPL122	"Data Compression Procedures for Data Circuit Terminating Equipment (DCE) Using Error Correcting Procedures," International Telecommunication Union Recommendation V.42 bis, 1990; 29 pages.	
	NPL123	Stac, Inc., News Articles, dated March 10, 1997 to February 2, 1999; 41 pages.	
	NPL124	Orost Archive of Welch Source Code, University of California, 1985; 54 pages.	
	NPL125	Sidewinder 50 Product Manual, Rev. A, Seagate Technology, Inc., 1997; 189 pages. (Submitted in 3 parts.)	
	NPL126	Form 10-Q Quarterly Report Pursuant to Section 13 or 15(d) of the Security Exchange Act of 1934, Stac Software, Inc., filed August 13, 1999; 16 pages.	
	NPL127	"Hi/Fn™ 7711 Encryption Processor™ Shipping in Volume," PR Newswire, April 20, 1998; 2 pages.	
	NPL128	"Lucent Technologies Selects," PR Newswire, March 1, 1999; 2 pages.	
	NPL129	"Stac backs it up with Replica," INFOSTOR, May 1, 1998; 2 pages.	
	NPL130	Court Docket History for Realtime Data, LLC d/b/a IXO v. Actian Corporation, et al., Case No. 6:15-cv-00463 (E.D. Texas), downloaded February 17, 2016, 29 pages.	
Examiner Signature	/Tesfaldet Bocure/		Date Considered 04/18/2016

\*EXAMINER: Initial if reference considered, whether or not citation is in conformance with MPEP 609. Draw line through citation if not in conformance and not considered. Include copy of this form with next communication to applicant.

<sup>1</sup> Applicant's unique citation designation number (optional). <sup>2</sup> Applicant is to place a check mark here if English language Translation is attached.

ALL REFERENCES CONSIDERED EXCEPT WHERE LINED THROUGH. /T.B./

Substitute for form 1449/PTO		<b>Complete if Known</b>	
<b>FOURTH SUPPLEMENTAL INFORMATION DISCLOSURE STATEMENT BY APPLICANT</b> <i>(Use as many sheets as necessary)</i>		Application Number	14/876,276
		Filing Date	October 6, 2015
		First Named Inventor	James J. FALLON
		Art Unit	2634
		Examiner Name	BOCURE, TESFALDET
		Attorney Docket Number	3421.005000C
Sheet	14 of 14		

NON PATENT LITERATURE DOCUMENTS			
Examiner Initials*	Cite No. <sup>1</sup>	Include name of the author (in CAPITAL LETTERS), title of the article (when appropriate), title of the item (book, magazine, journal, serial, symposium, catalog, etc.), date, page(s), volume number, publisher, city and/or country where published	T <sup>2</sup>
	NPL131	Court Docket History for Realtime Data, LLC d/b/a IXO v. Dropbox, Inc., Case No. 6:15-cv-00465 (E.D. Texas), downloaded February 17, 2016, 6 pages.	
	NPL132	Court Docket History for Realtime Data, LLC d/b/a IXO v. Echostar Corporation, et al., Case No. 6:15-cv-00466 (E.D. Texas), downloaded February 17, 2016, 3 pages.	
	NPL133	Court Docket History for Realtime Data, LLC d/b/a IXO v. Riverbed Technology, Inc., et al., Case No. 6:15-cv-00468 (E.D. Texas), downloaded February 17, 2016, 3 pages.	
	NPL134	Court Docket History for Realtime Data, LLC d/b/a IXO v. BMC Software, Inc., Case No. 6:15-cv-00464 (E.D. Texas), downloaded February 17, 2016, 3 pages.	
	NPL135	Court Docket History for Realtime Data, LLC d/b/a IXO v. Oracle America, Inc., et al., Case No. 6:15-cv-00467 (E.D. Texas), downloaded February 17, 2016, 4 pages.	
	NPL136	Court Docket History for Realtime Data, LLC d/b/a IXO v. SAP America, Inc., et al., Case No. 6:15-cv-00469 (E.D. Texas), downloaded February 17, 2016, 5 pages.	
	NPL137	Court Docket History for Realtime Data, LLC d/b/a IXO v. Teradata Corporation, et al., Case No. 6:15-cv-00470 (E.D. Texas), downloaded February 17, 2016, 6 pages.	
	NPL138	Court Docket History for Realtime Data, LLC d/b/a IXO v. Apple, Inc., Case No. 6:15-cv-00885 (E.D. Texas), downloaded February 17, 2016, 6 pages.	


2774134\_1.DOCX

Examiner Signature	/Tesfaldet Bocure/	Date Considered	04/18/2016
--------------------	--------------------	-----------------	------------

\*EXAMINER: Initial if reference considered, whether or not citation is in conformance with MPEP 609. Draw line through citation if not in conformance and not considered. Include copy of this form with next communication to applicant.

<sup>1</sup> Applicant's unique citation designation number (optional). <sup>2</sup> Applicant is to place a check mark here if English language Translation is attached.

**ALL REFERENCES CONSIDERED EXCEPT WHERE LINED THROUGH. /T.B./**

<b>Index of Claims</b> 	<b>Application/Control No.</b> 14876276	<b>Applicant(s)/Patent Under Reexamination</b> FALLON ET AL.
	<b>Examiner</b> TESFALDET BOCURE	<b>Art Unit</b> 2634

✓	<b>Rejected</b>	-	<b>Cancelled</b>	N	<b>Non-Elected</b>	A	<b>Appeal</b>
=	<b>Allowed</b>	÷	<b>Restricted</b>	I	<b>Interference</b>	O	<b>Objected</b>

Claims renumbered in the same order as presented by applicant
  CPA
  T.D.
  R.1.47

CLAIM		DATE							
Final	Original	01/23/2016	04/18/2016						
1	1	✓	=						
2	2	✓	=						
3	3	✓	=						
4	4	✓	=						
5	5	✓	=						
6	6	✓	=						
7	7	✓	=						
8	8	✓	=						
9	9	✓	=						
10	10	✓	=						
11	11	✓	=						
12	12	✓	=						
13	13	✓	=						
14	14	✓	=						
15	15	✓	=						
16	16	✓	=						
17	17	✓	=						
18	18	✓	=						
19	19	✓	=						
20	20	✓	=						
21	21	✓	=						
22	22	✓	=						
23	23	✓	=						
24	24	✓	=						
25	25	✓	=						
26	26	✓	=						
27	27	✓	=						
28	28	✓	=						
29	29	✓	=						
30	30	✓	=						



## WEST Search History for Application 14876276

Creation Date: 2016041808:24

### Prior Art Searches

Query	DB	Hits	Op.	Plur.	Thes.	Date
<b>((Fallen adj James).in. or (McErlain adj Stephen).in.)</b>	PGPB, USPT, USOC, EPAB, JPAB, DWPI, TDBD	n/a	OR	YES		04-18-2016
<b>((Fallen).in. or (McErlain).in.)</b>	PGPB, USPT, USOC, EPAB, JPAB, DWPI, TDBD	n/a	OR	YES		04-18-2016
<b>(select\$4 or choos\$4) near4 ((multiple or plural\$4 or two or three or four or five) near5 encoder\$) same ((assymetric\$ or (lempel adj2 ziv)) near4 (compressing or compression))</b>	PGPB, USPT, USOC, EPAB, JPAB, DWPI, TDBD	n/a	OR	YES		04-18-2016
<b>(select\$4 or choos\$4) near4 ((multiple or plural\$4 or two or three or four or five) near5 encoder\$) and ((assymetric\$ or (lempel adj2 ziv)) near4 (compressing or compression))</b>	PGPB, USPT, USOC, EPAB, JPAB, DWPI, TDBD	n/a	OR	YES		04-18-2016
<b>((select\$4 or choos\$4) near4 ((multiple or plural\$4 or two or three or four or five) near5 encoder\$) and ((assymetric\$ or (lempel adj2 ziv)) near4 (compressing or compression)) ) and @ad&lt;=20010213</b>	PGPB, USPT, USOC, EPAB, JPAB, DWPI, TDBD	n/a	OR	YES		04-18-2016
<b>((select\$4 or choos\$4) near4 ((multiple or plural\$4 or two or three or four or five) near5 encoder\$) and ((assymetric\$ or (lempel adj2 ziv)) near4</b>	PGPB, USPT, USOC,	n/a	OR	YES		04-18-2016

<b>((compressing or compression)) ) and ( ((Fallen adj James).in. or (McErlain adj Stephen).in.) ) or (((Fallen).in. or (McErlain).in.) ) )</b>	EPAB, JPAB, DWPI, TDBD					
<b>((select\$4 or choos\$4) near4 ((multiple or plural\$4 or two or three or four or five) near5 encoder\$) and ((assymetric\$ or (lempel adj2 ziv)) near4 (compressing or compression)) ) and ( ((Fallen adj James).in. or (McErlain adj Stephen).in.) ) )</b>	PGPB, USPT, USOC, EPAB, JPAB, DWPI, TDBD	n/a	OR	YES		04-18-2016
<b>(selecting or select or choose or choosing) near4 ((compress or compression or compressing) near4 (algorithm or algorithms or mode or modes)) same ((assymetric\$4 or (lempel adj2 ziv)) near4 (compressing or compression))</b>	PGPB, USPT, USOC, EPAB, JPAB, DWPI, TDBD	n/a	OR	YES		04-18-2016
<b>((compress or compression or compressing) near4 (algorithm or algorithms or mode or modes)) same (parameter or parameters or attribute or attributes) same (assymetric \$4near4 (compressing or compression))</b>	PGPB, USPT, USOC, EPAB, JPAB, DWPI, TDBD	n/a	OR	YES		04-18-2016
<b>((compress or compression or compressing) near4 (algorithm or algorithms or mode or modes)) same (parameter or parameters or attribute or attributes) same (assymetric\$4 near4 (compressing or compression))</b>	PGPB, USPT, USOC, EPAB, JPAB, DWPI, TDBD	n/a	OR	YES		04-18-2016
<b>((compress or compression or compressing) near4 (algorithm or algorithms or mode or modes)) same (parameter or parameters or attribute or attributes) same ((fast near4 slow) near4 (compressing or compression))</b>	PGPB, USPT, USOC, EPAB, JPAB, DWPI, TDBD	n/a	OR	YES		04-18-2016
<b>((multiple or plural\$4 or two or three or four or five) near5 encoder\$) same ((assymetric\$ or (lempel adj2 ziv)) near4 (compressing or compression))</b>	PGPB, USPT, USOC, EPAB, JPAB, DWPI, TDBD	n/a	OR	YES		04-18-2016

<p>((selecting or select or choose or choosing) near4 ((compress or compression or compressing) near4 (algorithm or algorithms or mode or modes) same ((assymmetric\$4 or (lempel adj2 ziv)) near4 (compressing or compression)) ) and (((H03M7/30)))   (((H03M7/3084)))   (((H03M7/6094)))   (((G06F15/7867)))   (((G06T1/60)))   (((H04N19/136))).CPC. )</p>	PGPB, USPT, USOC, EPAB, JPAB, DWPI, TDBD	n/a	OR	YES		04-18-2016
<p>(((multiple or plural\$4 or two or three or four or five) near5 encoder\$) same ((assymmetric\$ or (lempel adj2 ziv)) near4 (compressing or compression)) ) and (((H03M7/30)))   (((H03M7/3059)))   (((H03M7/3093)))   (((H04L69/04)))   (((H04N19/152)))   (((H04N9/8042))).CPC. )</p>	PGPB, USPT, USOC, EPAB, JPAB, DWPI, TDBD	n/a	OR	YES		04-18-2016
<p>("20010019630"   "20010031092"   "20010032128"   "20010047473"   "20010052038"   "20020037035"   "20020069354"   "20020078241"   "20020080871"   "20020097172"   "20020101367"   "20020104891"   "20020126755"   "20020169950"   "20020191692"   "20030030575"   "20030034905"   "20030058873"   "20030084238").PN.</p>	PGPB, USPT, USOC, EPAB, JPAB, DWPI, TDBD	n/a	OR	YES		04-18-2016
<p>(((375/\$8)).ccls. or ((370/\$8)).ccls. or ((348/\$8)).ccls. or ((341/\$8)).ccls. or ((711/\$8)).ccls. or ((701/\$8)).ccls. or ((381/\$8)).ccls. or ((375/382)).ccls. )</p>	PGPB, USPT, USOC, EPAB, JPAB, DWPI, TDBD	n/a	OR	YES		04-18-2016
<p>(((375/\$8)).ccls. or ((370/\$8)).ccls. or ((348/\$8)).ccls. or ((341/\$8)).ccls. or ((711/\$8)).ccls. or ((701/\$8)).ccls. or ((381/\$8)).ccls. or ((375/382)).ccls. ) and ( ((select\$4 or choos\$4) near4 ((multiple or plural\$4 or two or three or four or five) near5 encoder\$) and ((assymmetric\$ or (lempel adj2 ziv)) near4 (compressing or compression)) ) or ((selecting or select or choose or choosing) near4 ((compress or compression or compressing) near4 (algorithm or algorithms or mode or modes) same ((assymmetric\$4 or (lempel adj2 ziv)) near4 (compressing or compression)) ) or (((multiple or plural\$4 or two or three or four or five) near5 encoder\$) same ((assymmetric\$ or (lempel adj2 ziv)) near4 (compressing or compression)) ) )</p>	PGPB, USPT, USOC, EPAB, JPAB, DWPI, TDBD	n/a	OR	YES		04-18-2016
<p>(((375/240)).ccls. or ((375/240.01)).ccls. or ((375/240.02)).ccls. or ((341/50)).ccls. or ((341/51)).ccls. or ((341/126)).ccls. ) and ( ((select\$4</p>	PGPB, USPT, USOC,	n/a	OR	YES		04-18-2016

<p>or choos\$4) near4 ((multiple or plural\$4 or two or three or four or five) near5 encoder\$) and ((assymmetric\$ or (lempel adj2 ziv)) near4 (compressing or compression)) ) or ((selecting or select or choose or choosing) near4 ((compress or compression or compressing) near4 (algorithm or algorithms or mode or modes)) same ((assymmetric\$4 or (lempel adj2 ziv)) near4 (compressing or compression)) ) or (((multiple or plural\$4 or two or three or four or five) near5 encoder\$) same ((assymmetric\$ or (lempel adj2 ziv)) near4 (compressing or compression)) ) )</p>	<p>EPAB, JPAB, DWPI, TDBD</p>					
<p>((multiple or plural\$4 or two or three or four or five) near5 encoder\$) same ((assymmetric\$3 or (lempel adj2 ziv) and (arithmetic)) near4 (compressing or compression))</p>	<p>PGPB, USPT, USOC, EPAB, JPAB, DWPI, TDBD</p>	<p>n/a</p>	<p>OR</p>	<p>YES</p>		<p>04-18-2016</p>
<p>((select\$4 or choos\$4) near4 ((multiple or plural\$4 or two or three or four or five) near5 encoder\$) and ((assymmetric\$ or (lempel adj2 ziv)) near4 (compressing or compression)) ) or ((selecting or select or choose or choosing) near4 ((compress or compression or compressing) near4 (algorithm or algorithms or mode or modes)) same ((assymmetric\$4 or (lempel adj2 ziv)) near4 (compressing or compression)) ) or (((multiple or plural\$4 or two or three or four or five) near5 encoder\$) same ((assymmetric\$ or (lempel adj2 ziv)) near4 (compressing or compression)) ) or (((multiple or plural\$4 or two or three or four or five) near5 encoder\$) same ((assymmetric\$3 or (lempel adj2 ziv) and (arithmetic)) near4 (compressing or compression)) ) )</p>	<p>PGPB, USPT, USOC, EPAB, JPAB, DWPI, TDBD</p>	<p>n/a</p>	<p>OR</p>	<p>YES</p>		<p>04-18-2016</p>
<p>((select\$4 or choos\$4) near4 ((multiple or plural\$4 or two or three or four or five) near5 encoder\$) and ((assymmetric\$ or (lempel adj2 ziv)) near4 (compressing or compression)) or (selecting or select or choose or choosing) near4 ((compress or compression or compressing) near4 (algorithm or algorithms or mode or modes)) same ((assymmetric\$4 or (lempel adj2 ziv)) near4 (compressing or compression)) or ((multiple or plural\$4 or two or three or four or five) near5 encoder\$) same ((assymmetric\$ or (lempel adj2 ziv)) near4 (compressing or compression)) or ((multiple or plural\$4 or two or three or four or five) near5 encoder\$) same ((assymmetric\$3 or (lempel adj2 ziv) and (arithmetic)) near4 (compressing or compression)) ) )</p>	<p>PGPB, USPT, USOC, EPAB, JPAB, DWPI, TDBD</p>	<p>n/a</p>	<p>OR</p>	<p>YES</p>		<p>04-18-2016</p>

<p>and (arithmetic)) near4 (compressing or compression)) ) ) and (((375/240)).ccls. or ((375/240.01)).ccls. or ((375/240.02)).ccls. or ((341/50)).ccls. or ((341/51)).ccls. or ((341/126)).ccls. ) and ((select\$4 or choos\$4) near4 ((multiple or plural\$4 or two or three or four or five) near5 encoder\$) and ((assymetric\$ or (lempel adj2 ziv)) near4 (compressing or compression)) or (selecting or select or choose or choosing) near4 ((compress or compression or compressing) near4 (algorithm or algorithms or mode or modes)) same ((assymetric\$4 or (lempel adj2 ziv)) near4 (compressing or compression)) or ((multiple or plural\$4 or two or three or four or five) near5 encoder\$) same ((assymetric\$ or (lempel adj2 ziv)) near4 (compressing or compression)) ) )</p>						
<p>((select\$4 or choos\$4) near4 ((multiple or plural\$4 or two or three or four or five) near5 encoder\$) and ((assymetric\$ or (lempel adj2 ziv)) near4 (compressing or compression)) or (selecting or select or choose or choosing) near4 ((compress or compression or compressing) near4 (algorithm or algorithms or mode or modes)) same ((assymetric\$4 or (lempel adj2 ziv)) near4 (compressing or compression)) or ((multiple or plural\$4 or two or three or four or five) near5 encoder\$) same ((assymetric\$ or (lempel adj2 ziv)) near4 (compressing or compression)) or ((multiple or plural\$4 or two or three or four or five) near5 encoder\$) same ((assymetric\$3 or (lempel adj2 ziv)) and (arithmetic)) near4 (compressing or compression)) ) ) and (((375/\$8)).ccls. or ((370/\$8)).ccls. or ((348/\$8)).ccls. or ((341/\$8)).ccls. or ((711/\$8)).ccls. or ((701/\$8)).ccls. or ((381/\$8)).ccls. or ((375/382)).ccls. ) )</p>	<p>PGPB, USPT, USOC, EPAB, JPAB, DWPI, TDBD</p>	<p>n/a</p>	<p>OR</p>	<p>YES</p>		<p>04-18-2016</p>
<p>((select\$4 or choos\$4) near4 ((multiple or plural\$4 or two or three or four or five) near5 encoder\$) and ((assymetric\$ or (lempel adj2 ziv)) near4 (compressing or compression)) or (selecting or select or choose or choosing) near4 ((compress or compression or compressing) near4 (algorithm or algorithms or mode or modes)) same ((assymetric\$4 or (lempel adj2 ziv)) near4 (compressing or compression)) or ((multiple or plural\$4 or two or three or four or five) near5 encoder\$) same ((assymetric\$ or (lempel adj2 ziv)) near4 (compressing or compression)) or ((multiple or plural\$4 or two or three or four or five) near5 encoder\$) same ((assymetric\$3 or (lempel adj2 ziv))</p>	<p>PGPB, USPT, USOC, EPAB, JPAB, DWPI, TDBD</p>	<p>n/a</p>	<p>OR</p>	<p>YES</p>		<p>04-18-2016</p>

<p><b>and (arithmetic)) near4 (compressing or compression)) ) and ((H03M7/30)   (H03M7/3059)   (H03M7/3084)   (H03M7/6094)   (H03M7/3088)   (H03M7/6023)   (H03M7/6064)   (H04N19/152)   (G11B20/00007)).CPC. )</b></p>						
<p><b>("20150334390"   "3394352"   "3490690"   "4021782"   "4032893"   "4054951"   "4127518"   "4302775"   "4325085"   "4360840"   "4386416"   "4394774"   "4464650"   "4494108"   "4499499"   "4574351"   "4626829"   "4646061"   "4682150"   "4701745").PN.</b></p>	<p>PGPB, USPT, USOC, EPAB, JPAB, DWPI, TDBD</p>	<p>n/a</p>	<p>OR</p>	<p>YES</p>		<p>04-18-2016</p>
<p><b>("20150334390"   "3394352"   "3490690"   "4021782"   "4032893"   "4054951"   "4127518"   "4302775"   "4325085"   "4360840"   "4386416"   "4394774"   "4464650"   "4494108"   "4499499"   "4574351"   "4626829"   "4646061"   "4682150"   "4701745").PN. ) and (((select\$4 or choos\$4) near4 ((multiple or plural\$4 or two or three or four or five) near5 encoder\$) and ((assymetric\$ or (lempel adj2 ziv)) near4 (compressing or compression)) or (selecting or select or choose or choosing) near4 ((compress or compression or compressing) near4 (algorithm or algorithms or mode or modes)) same ((assymetric\$4 or (lempel adj2 ziv)) near4 (compressing or compression)) or ((multiple or plural\$4 or two or three or four or five) near5 encoder\$) same ((assymetric\$ or (lempel adj2 ziv)) near4 (compressing or compression)) or ((multiple or plural\$4 or two or three or four or five) near5 encoder\$) same ((assymetric\$3 or (lempel adj2 ziv) and (arithmetic)) near4 (compressing or compression)) ) )</b></p>	<p>PGPB, USPT, USOC, EPAB, JPAB, DWPI, TDBD</p>	<p>1</p>	<p>OR</p>	<p>YES</p>		<p>04-18-2016</p>

IN THE UNITED STATES PATENT AND TRADEMARK OFFICE

Inventors: FALLON *et al.*

Applicant: Realtime Data, LLC

Application No.: 14/876,276

Filing Date: October 6, 2015

Title: **Video Data Compression Systems**

Confirmation No.: 3403

Art Unit: 2634

Examiner: BOCURE, TESFALDET

Atty. Docket: 3421.005000C

**Amendment and Reply Under 37 C.F.R. § 1.111**

***Mail Stop Amendment***

Commissioner for Patents  
PO Box 1450  
Alexandria, VA 22313-1450

Commissioner:

In reply to the Office Action dated January 28, 2016 ("Office Action"), Applicant submits the following Amendment and Remarks.

It is not believed that extensions of time are required beyond those that may otherwise be provided for in documents accompanying this paper. However, if additional extensions of time are necessary to prevent abandonment of this Application, then such extensions of time are hereby petitioned under 37 C.F.R. § 1.136(a), and any additional fees required to continue prosecution or appeal of this Application (including issue fee, fees for net addition of claims or forwarding to appeal) are hereby authorized to be charged to our Deposit Account No. 19-0036.

*Amendments to the Claims*

This listing of claims will replace all prior versions, and listings, of claims in this Application.

1. (Currently Amended) A system ~~for compressing video data~~, comprising:  
a plurality of different asymmetric data compression algorithms, wherein a first asymmetric data compression algorithm of the plurality of different asymmetric data compression algorithms is configured to compress data at a higher data compression rate than a second asymmetric data compression algorithm of the plurality of different asymmetric data compression algorithms, wherein compression rate is measured in bits per second; and  
one or more processors configured to:  
determine one or more data parameters from one or more data blocks containing video data, at least one of the one or more data parameters relating to a throughput of a communications channel; and  
select one or more asymmetric data compression algorithms from among the plurality of different asymmetric data compression algorithms based upon, at least in part, the determined one or more data parameters.

2. (Currently Amended) The system of claim 1 wherein at least one of the plurality of different asymmetric data compression algorithms is an arithmetic ~~encoder~~ algorithm.

3. (Original) The system of claim 1, wherein the throughput of the communications

Atty. Dkt. No. 3421.005000C



Reply to Office Action of January 28, 2016

FALLON *et al.*  
Application No. 14/876,276

channel comprises:

an actual throughput of the communications channel.

4. (Original) The system of claim 1, wherein the throughput of the communications channel comprises:

an estimated throughput of the communications channel.

5. (Original) The system of claim 1, wherein the throughput of the communications channel comprises:

an expected throughput of the communications channel.

6. (Previously Presented) The system of claim 1, wherein the one or more different asymmetric data compression algorithms are configured to compress the one or more data blocks containing video data for different data transmission rates to produce a plurality of compressed data blocks.

7. (Previously Presented) The system of claim 1, wherein at least one of the plurality of different asymmetric data compression algorithms comprises:

a lossless data compression algorithm.

8. (Original) The system of claim 1, wherein at least one of the one or more data parameters comprises:

Atty. Dkt. No. 3421.005000C

a resolution of the one or more data blocks containing video data.

9. (Original) The system of claim 1, wherein at least one of the one or more data parameters comprises:

a data transmission rate of the one or more data blocks containing video data.

10. (Original) The system of claim 1, wherein at least one of the one or more data parameters comprises:

an attribute or a value related to a format or a syntax of video data contained in the one or more data blocks containing video data.

11. (Previously Presented) The system of claim 1, wherein the selected one or more asymmetric data compression algorithms comprise:

a content-dependent data compression algorithm.

12. (Previously Presented) The system of claim 11, wherein the content-dependent data compression algorithm comprises:

an arithmetic algorithm.

13. (Previously Presented) The system of claim 1, wherein the selected one or more asymmetric data compression algorithms are configured to perform compression in real-time or substantially real-time.

14. (Original) The system of claim 1, wherein the communications channel comprises:

a distributed network.

15. (Original) The system of claim 14, wherein the distributed network comprises:  
the Internet.

16. (Previously Presented) The system of claim 1, wherein the selected one or more asymmetric data compression algorithms are utilized to compress the one or more data blocks containing video data to create one or more compressed data blocks, and

wherein a descriptor is associated with the one or more compressed data blocks that indicates the selected one or more asymmetric data compression algorithms.

17. (Previously Presented) The system of claim 1, wherein the selected one or more asymmetric data compression algorithms are utilized to compress the one or more data blocks containing video data to create one or more compressed data blocks, and

wherein a descriptor indicating the selected one or more asymmetric data compression algorithms is included with the one or more compressed data blocks.

18. (Original) The system of claim 1, wherein at least one of the one or more data parameters comprises:

a video data profile.

19. (Currently Amended) A system ~~for compressing video data~~, comprising:

a plurality of data compression algorithms;

wherein at least one of the plurality of data compression algorithms comprises an asymmetric data compression algorithm, and

wherein at least one of the plurality of data compression algorithms comprises an arithmetic data compression algorithm,

wherein a first data compression algorithm of the plurality of data compression algorithms is configured to compress more bits per second of data than a second data compression algorithm of the plurality of data compression algorithms; and

one or more processors configured to:

determine one or more data parameters from one or more data blocks containing video data, at least one of the one or more data parameters relating to a throughput of a communications channel; and

select one or more data compression algorithms from among the plurality of data compression algorithms based upon, at least in part, the determined one or more data parameters.

20. (Original) The system of claim 19, wherein the throughput of the communications channel comprises:

an actual throughput of the communications channel.

21. (Original) The system of claim 19, wherein the throughput of the communications channel comprises:

an estimated or expected throughput of the communications channel.

22. (Previously Presented) The system of claim 19, wherein the selected one or more data compression algorithms are configured to compress the one or more data blocks containing video data for different data transmission rates to produce a plurality of compressed data blocks.

23. (Previously Presented) The system of claim 19, wherein at least one of the plurality of data compression algorithms comprises:

a lossless data compression algorithm.

24. (Original) The system of claim 19, wherein at least one of the one or more data parameters are related to a resolution of the one or more data blocks containing video data.

25. (Original) The system of claim 19, wherein at least one of the one or more data parameters comprises:

a data transmission rate of the one or more data blocks containing video data.

26. (Original) The system of claim 19, wherein at least one of the one or more data parameters comprises:

an attribute or a value related to a format or a syntax of video data contained in the one or more data blocks containing video data.

27. (Previously Presented) The system of claim 19, wherein the selected one or more data compression algorithms perform data compression in real-time or substantially real-time.

28. (Original) The system of claim 19, wherein the communications channel comprises:

a distributed network or the Internet.

29. (Previously Presented) The system of claim 19, wherein the one or more data blocks are compressed with the selected the one or more selected data compression algorithms to create one or more compressed data blocks, and

wherein a descriptor is associated with the one or more compressed data blocks that indicates the selected data compression algorithm.

30. (Original) The system of claim 19, wherein at least one of the one or more data parameters comprises:

a video data profile.

*Amendments to the Abstract*

1. Applicant respectfully requests the Abstract of the Disclosure as amended in the Preliminary Amendment Under 37 C.F.R. § 1.115 that was filed on December 11, 2015 be further amended as follows:

A system and method ~~for compressing data is disclosed. The system and method include~~ including one or more ~~[[of]]~~ asymmetric data compression algorithms is disclosed. A first asymmetric data compression algorithm of the one or more asymmetric data compression algorithms compresses data at a higher data compression rate than a second asymmetric data compression algorithm of the one or more asymmetric data compression algorithms. The system and method also include one or more processors that determine one or more data parameters from one or more data blocks and select one or more asymmetric data compression algorithms from among the one or more asymmetric data compression algorithms based upon, at least in part, the determined one or more data parameters.

*Remarks*

Reconsideration of this Application is respectfully requested.

Upon entry of the foregoing amendment, claims 1-30 are pending in this Application, with claims 1 and 19 being the independent claims. Claims 1, 2, and 19 are sought to be amended. Applicant reserves the right to prosecute similar or broader claims, with respect to the amended claims, in the future. The Abstract of the Disclosure as amended in the Preliminary Amendment Under 37 C.F.R. § 1.115 that was filed on December 11, 2015 is sought to be further amended. These changes are believed to introduce no new matter, and their entry is respectfully requested.

Based on the above amendment and the following remarks, Applicant respectfully requests that the Examiner reconsider all outstanding objections and rejections and that they be withdrawn.

*Statement of the Substance of the Interview*

Pursuant to 37 C.F.R. § 1.133, Applicant provides the following statement of substance of the interview. Applicant expresses their appreciation to Examiner Tesfaldet Bocure for the courtesy of telephonic interviews with Applicant's representative, Michael R. Malek, Reg. No. 65,211, on March 15, 2016 and March 21, 2016. During the interviews, an agreement was reached that the amendments to independent claims 1 and 16 presented herewith overcome the objections to claims 1-30 and the rejections to claims 1-30 under U.S.C. § 112, second paragraph, as presented in the Office Action. Furthermore, the Examiner also agreed that the Amendment to the Specification in the Preliminary Amendment Under 37 C.F.R. § 1.115 that was filed on December 11, 2015 ("Preliminary Amendment") overcomes the objection to the Specification as presented in the Office Action.

Atty. Dkt. No. 3421.005000C



***Objection to the Specification***

The Specification stands objected to because of alleged informalities. As discussed in the Statement of the Substance of the Interview above, the Examiner agreed that the Amendment to the Specification in the Preliminary Amendment overcomes this objection to the Specification. (*See*, Preliminary Amendment, p. 2) Accordingly, Applicant respectfully request the objection to the Specification be reconsidered and withdrawn.

***Objection to the Claims***

Claims 1-30 stand objected to because of alleged informalities. Without acquiescing to the merits of this allegation, Applicant has amended independent claims 1 and 19 herewith to overcome this objection for the sole purpose of advancing prosecution of this Application. As discussed in the Statement of the Substance of the Interview above, the Examiner agreed that these amendments to independent claims 1 and 19 overcome this objection. Accordingly, Applicant respectfully request the objection to claims 1-30 be reconsidered and withdrawn.

***Rejections under 35 U.S.C. § 112***

Claim 1-30 stand rejected under 35 U.S.C. § 112, second paragraph, for allegedly being indefinite. Without acquiescing to the merits of this allegation, Applicant has amended independent claims 1 and 19 herewith to overcome this rejection for the sole purpose of advancing prosecution of this Application. As discussed in the Statement of the Substance of the Interview above, the Examiner agreed that these amendments to independent claims 1 and 19 overcome this rejection.

Atty. Dkt. No. 3421.005000C

Reply to Office Action of January 28, 2016

FALLON *et al.*  
Application No. 14/876,276

Accordingly, Applicant respectfully requests the rejection to claims 1-30 under 35 U.S.C. § 112, second paragraph, be reconsidered and withdrawn.

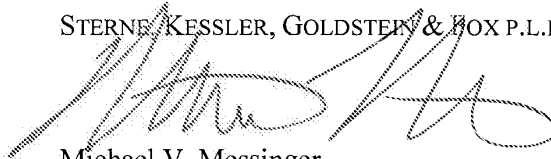
***Conclusion***

All of the stated grounds of objection and rejection have been properly traversed, accommodated, or rendered moot. Applicant therefore respectfully requests that the Examiner reconsider all presently outstanding objections and rejections and that they be withdrawn. Applicant believes that a full and complete reply has been made to the outstanding Office Action and, as such, this Application is in condition for allowance. If the Examiner believes, for any reason, that personal communication will expedite prosecution of this Application, the Examiner is invited to telephone the undersigned at the number provided.

Prompt and favorable consideration of this Amendment and Reply is respectfully requested.

Respectfully submitted,

STERNE, KESSLER, GOLDSTEIN & FOX P.L.L.C.



Michael V. Messinger  
Attorney for Applicant  
Registration No. 37,575

Date: April 12, 2016

1100 New York Avenue, N.W.  
Washington, D.C. 20005-3934  
(202) 371-2600

2764988\_1

Atty. Dkt. No. 3421.005000C

IN THE UNITED STATES PATENT AND TRADEMARK OFFICE

Inventors: FALLON *et al.*

Confirmation No.: 3403

Applicant: Realtime Data, LLC

Art Unit: 2634

Application No.: 14/876,276

Examiner: BOCURE, TESFALDET

Filing Date: October 6, 2015

Atty. Docket: 3421.005000C

Title: **Video Data Compression Systems**

**Fifth Supplemental Information Disclosure Statement**

*Mail Stop Amendment*

Commissioner for Patents  
PO Box 1450  
Alexandria, VA 22313-1450

Commissioner:

Notice of Prior and Concurrent Proceedings

Applicant hereby calls to the attention of the Patent and Trademark Office the following reexamination proceedings involving patents that are commonly-assigned with the patent in the above-identified patent application:

<b>Proceeding</b>	<b>Status</b>
Inter Partes Reexamination of U.S. Patent No. 6,604,158 (Control No. 95/000,486)	Inter Partes Reexamination Certificate issued 10/10/2012
Inter Partes Reexamination of U.S. Patent No. 7,321,937 (Control No. 95/000,466)	Inter Partes Reexamination Certificate issued 05/15/2012
Inter Partes Reexamination of U.S. Patent No. 6,604,158 (Control No. 95/000,453)	Terminated
Ex Parte Reexamination of U.S. Patent No. 6,601,104 (Control No. 90/009,428)	Ex Parte Reexamination Certificate issued 02/28/2012
Inter Partes Reexamination of U.S. Patent No. 7,378,992 (Control No. 95/000,478)	Inter Partes Reexamination Certificate issued 10/04/2012
Inter Partes Reexamination of U.S. Patent No. 6,624,761 (Control No. 95/000,464)	Inter Partes Reexamination Certificate issued 06/12/2012
Inter Partes Reexamination of U.S. Patent No. 7,161,506 (Control No. 95/000,479)	Inter Partes Reexamination Certificate issued 05/22/2012

<b>Proceeding</b>	<b>Status</b>
Inter Partes Reexamination of U.S. Patent No. 7,714,747 (Control No. 95/001,517)	Appeal to the Court of Appeals for the Federal Circuit dismissed 6/4/2015
Inter Partes Reexamination of U.S. Patent No. 7,417,568 (Control No. 95/001,533)	Decision on Appeal mailed 10/29/2015
Inter Partes Reexamination of U.S. Patent No. 7,777,651 (Control No. 95/001,581)	Decision on Appeal mailed 10/29/2015
Inter Partes Reexamination of U.S. Patent No. 7,400,274 (Control No. 95/001,544)	Decision on Appeal mailed 10/29/2015

Applicant hereby calls to the attention of the Patent and Trademark Office the following reexamination proceedings filed by Cellco Partnership d/b/a Verizon Wireless, involving patents that are commonly-assigned with the patent in the above-identified patent application:

<b>Proceeding</b>	<b>Status</b>
Inter Partes Reexamination of U.S. Patent No. 7,321,937 (Control No. 95/001,922)	Inter Partes Reexamination Certificate issued 12/05/2013
Inter Partes Reexamination of U.S. Patent No. 6,604,158 (Control No. 95/001,923)	Inter Partes Reexamination Certificate issued 04/17/2015
Inter Partes Reexamination of U.S. Patent No. 7,352,300 (Control No. 95/001,924)	Inter Partes Reexamination Certificate issued 08/04/2014
Inter Partes Reexamination of U.S. Patent No. 7,395,345 (Control No. 95/001,925)	Inter Partes Reexamination Certificate issued 11/03/2014
Inter Partes Reexamination of U.S. Patent No. 7,161,506 (Control No. 95/001,926)	Inter Partes Reexamination Certificate issued 01/08/2014
Inter Partes Reexamination of U.S. Patent No. 7,415,530 (Control No. 95/001,927)	Inter Partes Reexamination Certificate issued 08/16/2013
Inter Partes Reexamination of U.S. Patent No. 7,378,992 (Control No. 95/001,928)	Inter Partes Reexamination Certificate issued 01/08/2014

Applicant invites the Examiner to review the Requests for Reexamination, issued Office Actions, replies, and any other papers in the above-identified reexamination proceedings. If the Examiner is unable to obtain copies of papers in any reexamination proceeding, copies can be

Atty. Dkt. No. 3421.005000C

provided to the Examiner upon request. Those documents which may be material that are not already of record in this patent application are listed on the accompanying Form PTO/SB/08.

Applicant hereby calls to the attention of the Patent and Trademark Office the following *inter partes* review proceedings involving patents that are commonly-assigned with the patent in the above-identified patent application:

Proceeding	Patent	Status
<i>Oracle America, Inc. v. Realtime Data, LLC</i> , IPR2016-00373	7,378,992	Patent Owner Preliminary Response Filed April 7, 2016
<i>Oracle America, Inc. v. Realtime Data, LLC</i> , IPR2016-00374	8,643,513	Patent Owner Preliminary Response Filed April 8, 2016
<i>Oracle America, Inc. v. Realtime Data, LLC</i> , IPR2016-00375	7,415,530	Patent Owner Preliminary Response Filed April 11, 2016
<i>Oracle America, Inc. v. Realtime Data, LLC</i> , IPR2016-00376	7,415,530	Patent Owner Preliminary Response Filed April 11, 2016
<i>Oracle America, Inc. v. Realtime Data, LLC</i> , IPR2016-00377	9,116,908	Patent Owner Preliminary Response Filed April 11, 2016
<i>SAP America Inc., et al. v. Realtime Data, LLC d/b/a IXO</i> , IPR2016-00783	6,597,812	Petition filed April 1, 2016

Applicant invites the Examiner to review the petitions for *inter partes* review and any other papers in the above-identified *inter partes* review proceedings. If the Examiner is unable to obtain copies of papers in any *inter partes* review proceeding, copies can be provided to the Examiner upon request. Those documents which may be material that are not already of record in this patent application are listed on the accompanying Form PTO/SB/08 as documents **US1-US2** and **NPL12-NPL18**.

Atty. Dkt. No. 3421.005000C

Notice of Related Litigation

Applicant notifies the Patent and Trademark Office of the following litigation involving U.S. Patents commonly-owned with the current patent application, the subject matter of which may be related to the present patent application:

No.	Case	Status
1	<i>Realtime Data LLC d/b/a IXO v. Packeteer, Inc. et al.</i> , No. 6:08-cv-00144-LED (E.D. Texas)	Dismissed

Applicant also notifies the Patent and Trademark Office of the following additional litigation involving U.S. Patents commonly-owned with the current patent application, the subject matter of which may be related to the present patent application:

No.	Case	Status
2	<i>Realtime Data LLC d/b/a IXO v. Thomson Reuters Corporation et al.</i> No. 1:11-cv-06698-RJH (S.D. New York) (transferred from E.D. Texas; 6:09-cv-00333-LED)	Case Terminated 11/9/2012; Opinion of the Court of Appeals for the Federal Circuit received 01/27/2014
3	<i>Realtime Data LLC d/b/a IXO v. Morgan Stanley et al.</i> , No. 1:11-cv-06696-RJH (S.D. New York) (transferred from E.D. Texas; 6:09-cv-00326-LED)	Case Terminated 11/9/2012; Opinion of the Court of Appeals for the Federal Circuit received 01/27/2014
4	<i>Realtime Data LLC d/b/a IXO v. CME Group Inc., et al.</i> , No. 1:11-cv-06697-RJH (S.D. New York) (transferred from E.D. Texas; No. 6:09-cv-00327-LED)	Case Terminated 11/9/2012; Opinion of the Court of Appeals for the Federal Circuit received 01/27/2014
5	<i>Chicago Board Options Exchange, Inc., v. Realtime Data LLC d/b/a IXO</i> , No. 09-cv-4486 (N.D. Ill.)	Dismissed

6	<i>Thomson Reuters Corporation v. Realtime Data, LLC d/b/a IXO</i> , No. 1:09-cv-07868-RMB (S.D.N.Y)	Consolidated with Case No. 2
7	<i>Realtime Data, LLC d/b/a IXO v. CME Group Inc., et al. (II)</i> , No. 6:10-cv-246 (E.D. Texas)	Consolidated with Case No. 4
8	<i>Realtime Data LLC d/b/a IXO v. Thomson Reuters Corporation et al. (II)</i> , No. 6:10-cv-247 (E.D. Texas)	Consolidated with Case No. 2
9	<i>Realtime Data, LLC d/b/a IXO v. Morgan Stanley, et al. (II)</i> , No. 6:10-cv-248 (E.D. Texas)	Consolidated with Case No. 3
10	<i>Realtime Data, LLC d/b/a IXO v. MetroPCS Texas, LLC et al.</i> , No. 6:10-cv-00493 (E.D. Texas)	Appeal Terminated
11	<i>Realtime Data, LLC d/b/a IXO v. Microsoft Corporation, et al.</i> , No. 4:14-cv-00827 (E.D. Texas)	Dismissed May 1, 2015
12	<i>Realtime Data, LLC d/b/a IXO v. Actian Corporation, et al.</i> , No. 6:15-cv-00463 (E.D. Texas)	Amended Complaints for Patent Infringement filed September 14, 2015
13	<i>Realtime Data, LLC d/b/a IXO v. Dropbox, Inc.</i> , No. 6:15-cv-00465 (E.D. Texas)	Transferred to the Northern District of California, January 16, 2016; Answer to Amended Complaint filed February 4, 2016
14	<i>Realtime Data, LLC d/b/a IXO v. Echostar Corporation, et al.</i> , No. 6:15-cv-00466 (E.D. Texas)	Consolidated with Case No. 12; Answer to Amended Complaint filed February 4, 2016
15	<i>Realtime Data, LLC d/b/a IXO v. Riverbed Technology, Inc., et al.</i> , No. 6:15-cv-00468 (E.D. Texas)	Consolidated with Case No. 12; Second Amended Complaint for Infringement filed February 2, 2016
16	<i>Realtime Data, LLC d/b/a IXO v. BMC Software, Inc.</i> , No. 6:15-cv-00464 (E.D. Texas)	Terminated October 5, 2015
17	<i>Realtime Data, LLC d/b/a IXO v. Oracle America, Inc., et al.</i> , No. 6:15-cv-00467 (E.D. Texas)	Consolidated with Case No. 12

18	<i>Realtime Data, LLC d/b/a IXO v. SAP America, Inc., et al.</i> , No. 6:15-cv-00469 (E.D. Texas)	Consolidated with Case No. 12; Answers to Amended Complaint filed February 4, 2016
19	<i>Realtime Data, LLC d/b/a IXO v. Teradata Corporation, et al.</i> , No. 6:15-cv-00470 (E.D. Texas)	Transferred to the Northern District of California, January 19, 2016
20	<i>Realtime Data, LLC d/b/a IXO v. Apple, Inc.</i> , No. 6:15-cv-00885 (E.D. Texas)	Order Granting Motion to Stay entered February 11, 2016
21	<i>Realtime Data LLC d/b/a IXO v. Hewlett Packard Enterprise Co., et al.</i> , No. 6:16-cv-00086 (E.D. Texas)	Complaint filed February 26, 2016
22	<i>Realtime Data LLC d/b/a IXO v. Oracle America, Inc.</i> , No. 6:16-cv-00088 (E.D. Texas)	Complaint filed February 26, 2016
23	<i>Realtime Data LLC d/b/a IXO v. CenturyLink, Inc., et al.</i> , No. 6:16-cv-00087 (E.D. Texas)	Complaint filed February 26, 2016
24	<i>Realtime Data LLC d/b/a IXO v. Dell, Inc., et al.</i> , No. 6:16-cv-00089 (E.D. Texas)	Complaint filed February 26, 2016

Updated court dockets for pending litigations are submitted herewith as documents **NPL19-NPL22**.

Information Disclosure Statement

Listed on accompanying IDS Forms PTO/SB/08a equivalent and PTO/SB/08b equivalent are documents that may be considered material to the patentability of this application as defined in 37 C.F.R. §1.56, and in compliance with the duty of disclosure requirements of 37 C.F.R. §§ 1.97 and 1.98.

Applicant has listed publication dates on the attached IDS Forms based on information presently available to the undersigned. However, the listed publication dates should not be construed as an admission that the information was actually published on the date indicated.

Atty. Dkt. No. 3421.005000C



Applicant reserves the right to establish the patentability of the claimed invention over any of the information provided herewith, and/or to prove that this information may not be prior art, and/or to prove that this information may not be enabling for the teachings purportedly offered.

This statement should not be construed as a representation that a search has been made, or that information more material to the examination of the present patent application does not exist. The Examiner is specifically requested not to rely solely on the material submitted herewith.

Filing under 37 C.F.R. § 1.97(c). This Information Disclosure Statement is being filed more than three months after the U.S. filing date AND after the mailing date of the first Office Action on the merits, but before the mailing date of a Final Rejection, or Notice of Allowance, or an action that otherwise closes prosecution in the application. The required fee is provided through online credit card payment authorization in the amount of \$180.00 in payment of the fee under 37 C.F.R. § 1.17(p).

A copy of document **NPL11** is submitted. However, in accordance with 37 C.F.R. § 1.98(a)(2)(ii), no copies of the U.S. patents cited as documents **US1-US4** on the attached IDS Forms are submitted.

Copies of documents **NPL1-NPL10** and **NPL12-NPL22** were cited by or submitted to the Office in an IDS that complies with 37 C.F.R. § 1.98(a)-(c) in Application No. 14/733,565, filed June 8, 2015 (now pending), which is relied upon for an earlier filing date under 35 U.S.C. § 120. Thus, copies of these documents are not attached. 37 C.F.R. § 1.98(d).

It is expected that the examiner will review the prosecution and cited art in the parent application nos. 14/733,565, filed June 8, 2015 (now pending); 14/577,286, filed December 19,

Atty. Dkt. No. 3421.005000C

2014 (now abandoned); 14/134,933, filed December 19, 2013 (now U.S. Patent No. 8,929,442); 14/033,245, filed September 20, 2013 (now U.S. Patent No. 8,934,535); 13/154,239, filed June 6, 2011 (now U.S. Patent No. 8,553,759); 12/123,081, filed May 19, 2008 (now U.S. Patent No. 8,073,047); and 10/076,013, filed February 13, 2002 (now U.S. Patent No. 7,386,046), in accordance with MPEP 2001.06(b), and indicate in the next communication from the office that the art cited in the earlier prosecution history has been reviewed in connection with the present application.

Applicant submits herewith an Office Action from the co-pending U.S. Patent Application No.:

Document **NPL11** is a copy of a Notice of Allowance mailed March 25, 2016 in the prosecution of co-pending, commonly-assigned U.S. Patent Application No. 14/733,565.

The identification of this Office Action is not to be construed as a waiver of secrecy as to that application now or upon issuance of the present application as a patent. The Examiner is respectfully requested to consider the cited application and the art cited therein during examination.

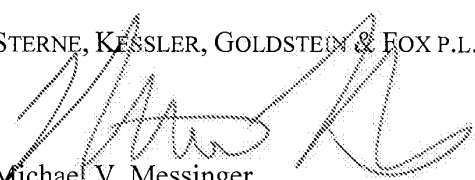
It is respectfully requested that the Examiner initial and return a copy of the enclosed IDS Forms, and indicate in the official file wrapper of this patent application that the documents have been considered.

Atty. Dkt. No. 3421.005000C

The U.S. Patent and Trademark Office is hereby authorized to charge any fee deficiency, or credit any overpayment, to our Deposit Account No. 19-0036.

Respectfully submitted,

STERNE, KESSLER, GOLDSTEIN & FOX P.L.L.C.

  
Michael V. Messinger  
Attorney for Applicant  
Registration No. 37,575

Date: April 12, 2016

1100 New York Avenue, N.W.  
Washington, D.C. 20005-3934  
(202) 371-2600

2792811\_1.DOCX

Atty. Dkt. No. 3421.005000C

Substitute for form 1449/PTO			<i>Complete if Known</i>		
<b>FIFTH SUPPLEMENTAL INFORMATION DISCLOSURE STATEMENT BY APPLICANT</b> <i>(Use as many sheets as necessary)</i>			Application Number	14/876,276	
			Filing Date	October 6, 2015	
			First Named Inventor	James J. FALLON	
			Art Unit	2634	
			Examiner Name	BOCURE, TEFALDET	
Sheet	1	of	1	Attorney Docket Number	3421.005000C

U.S. PATENT DOCUMENTS						
Examiner initials*	Cite No. <sup>1</sup>	Document Number		Publication Date MM-DD-YYYY	Name of Patentee or Applicant of Cited Document	Pages, Columns, Lines, Where Relevant Passages or Relevant Figures Appear
		Number-Kind Code <sup>2</sup> (if known)				
	US1	3,560,639		02-02-1971	Centanni	
	US2	5,467,134		11-14-1995	Laney et al.	
	US3	5,623,483		04-22-1997	Agrawal et al.	
	US4	5,664,226		09-02-1997	Czako et al.	

FOREIGN PATENT DOCUMENTS							
Examiner initials*	Cite No. <sup>1</sup>	Foreign Patent Document		Publication Date MM-DD-YYYY	Name of Patentee or Applicant of Cited Document	Pages, Columns, Lines, Where Relevant Passages or Relevant Figures Appear	T 6
		Country Code <sup>3</sup> -Number <sup>4</sup> - Kind Code <sup>5</sup> (if known)					

2792778\_1.DOCX

Examiner Signature	Date Considered
--------------------	-----------------

\*EXAMINER: Initial if reference considered, whether or not citation is in conformance with MPEP 609. Draw line through citation if not in conformance and not considered. Include copy of this form with next communication to applicant. <sup>1</sup> Applicant's unique citation designation number (optional). <sup>2</sup> See Kinds Codes of USPTO Patent Documents at www.uspto.gov or MPEP 901.04. <sup>3</sup> Enter Office that issued the document, by the two-letter code (WIPO Standard ST.3). <sup>4</sup> For Japanese patent documents, the indication of the year of the reign of the Emperor must precede the serial number of the patent document. <sup>5</sup> Kind of document by the appropriate symbols as indicated on the document under WIPO Standard ST.16 if possible. <sup>6</sup> Applicant is to place a check mark here if English language Translation is attached.

Substitute for form 1449/PTO		<b>Complete if Known</b>	
<b>FIFTH SUPPLEMENTAL INFORMATION DISCLOSURE STATEMENT BY APPLICANT</b> <i>(Use as many sheets as necessary)</i>		Application Number	14/876,276
		Filing Date	October 6, 2015
		First Named Inventor	James J. FALLON
		Art Unit	2634
		Examiner Name	BOCURE, TESFALDET
		Attorney Docket Number	3421.005000C
Sheet	1	of	3

NON PATENT LITERATURE DOCUMENTS			
Examiner Initials*	Cite No. <sup>1</sup>	Include name of the author (in CAPITAL LETTERS), title of the article (when appropriate), title of the item (book, magazine, journal, serial, symposium, catalog, etc.), date, page(s), volume-issue number(s), publisher, city and/or country where published	T <sup>2</sup>
	NPL1	Dell Inc.'s Answer, Defenses, and Counterclaims to Plaintiff's Second Amended Complaint, filed in Realtime Data, LLC d/b/a IXO v. Actian Corporation, et al., Case No. 6:15-cv-00463-RWS-JDL (E.D. Tex.), filed February 19, 2016; 18 pages.	
	NPL2	Riverbed Technology's Answer, Defenses, and Counterclaims, filed in Realtime Data, LLC d/b/a IXO v. Actian Corporation, et al., Case No. 6:15-cv-00463-RWS-JDL (E.D. Tex.), filed February 19, 2016; 26 pages.	
	NPL3	Complaint for Patent Infringement Against Dell Inc., EMC Corporation, iland Internet Solutions Corporation, and Veeam Software Corporation, filed in Realtime Data d/b/a IXO v. Dell Inc., et al., Case No. 6:16-cv-00089 (E.D. Texas), filed February 26, 2016; 67 pages.	
	NPL4	Complaint for Patent Infringement Against Hewlett Packard Enterprise Co., HP Enterprise Services, LLC, and Silver Peak Systems, Inc., filed in Realtime Data d/b/a IXO v. Hewlett Packard Enterprise, Co., et al., Case No. 6:16-cv-00086 (E.D. Texas), filed February 26, 2016; 49 pages.	
	NPL5	Complaint for Patent Infringement Against CenturyLink, Inc. and Veritas Technologies LLC, filed in Realtime Data d/b/a IXO v. CenturyLink, Inc., et al., Case No. 6:16-cv-00087 (E.D. Texas), filed February 26, 2016; 46 pages.	
	NPL6	Complaint for Patent Infringement Against Oracle America, Inc., filed in Realtime Data d/b/a IXO v. Oracle America, Inc., Case No. 6:16-cv-00088 (E.D. Texas), filed February 26, 2016; 40 pages.	
	NPL7	Realtime Data LLC d/b/a IXO's Answer to Echostar Corporation's and Hughes Network Systems, LLC's Counterclaims, filed Realtime Data LLC d/b/a IXO v. Actian Corporation, et al., Case No. 6:15-cv-000463-RWS-JDL (E.D. Texas), filed February 25, 2016; 8 pages.	
	NPL8	Realtime Data LLC d/b/a IXO's Answer to SAP America Inc.'s and Sybase, Inc.'s Counterclaims, filed Realtime Data LLC d/b/a IXO v. Actian Corporation, et al., Case No. 6:15-cv-000463-RWS-JDL (E.D. Texas), filed February 25, 2016; 5 pages.	
	NPL9	Realtime Data LLC d/b/a IXO's Answer to Dell, Inc.'s Counterclaims, filed Realtime Data LLC d/b/a IXO v. Actian Corporation, et al., Case No. 6:15-cv-000463-RWS-JDL (E.D. Texas), filed February 25, 2016; 5 pages.	
	NPL10	Copy of Non-Final Office Action for U.S. Appl. No.14/853,581, mailed March 15, 2016; 5 pages.	

Examiner Signature		Date Considered	
--------------------	--	-----------------	--

\*EXAMINER: Initial if reference considered, whether or not citation is in conformance with MPEP 609. Draw line through citation if not in conformance and not considered. Include copy of this form with next communication to applicant.  
<sup>1</sup> Applicant's unique citation designation number (optional). <sup>2</sup> Applicant is to place a check mark here if English language Translation is attached.

Substitute for form 1449/PTO		<b>Complete if Known</b>	
<b>FIFTH SUPPLEMENTAL INFORMATION DISCLOSURE STATEMENT BY APPLICANT</b> <i>(Use as many sheets as necessary)</i>		Application Number	14/876,276
		Filing Date	October 6, 2015
		First Named Inventor	James J. FALLON
		Art Unit	2634
		Examiner Name	BOCURE, TESFALDET
		Attorney Docket Number	3421.005000C
Sheet	2	of	3

NON PATENT LITERATURE DOCUMENTS			
Examiner Initials*	Cite No. <sup>1</sup>	Include name of the author (in CAPITAL LETTERS), title of the article (when appropriate), title of the item (book, magazine, journal, serial, symposium, catalog, etc.), date, page(s), volume number, publisher, city and/or country where published	T <sup>2</sup>
	NPL11	Copy of Notice of Allowance for U.S. Patent Appl. No. 14/733,565, mailed March 25, 2016; 8 pages.	
	NPL12	Petition for Inter Partes Review of Claims 1-4, 8, 14-17, 21 and 28 of U.S. Patent No. 6,597,812, filed in SAP America Inc., et al. v. Realtime Data, LLC d/b/a IXO, Case No. IPR2016-00783 (P.T.A.B.), filed April 1, 2016; 67 pages.	
	NPL13	Declaration of Scott Bennett, Ph.D., filed in SAP America Inc., et al. v. Realtime Data LLC d/b/a IXO, Case No. IPR2016-00783 (P.T.A.B.), filed April 1, 2016; 45 pages.	
	NPL14	Declaration of Charles D. Creusere in Support of Petition for Inter Partes Review of Claims 1-4, 8, 14-17, 21 and 28 of U.S. Patent No. 6,597,812, filed in SAP America Inc., et al. v. Realtime Data LLC d/b/a IXO, Case No. IPR2016-00783 (P.T.A.B.), filed April 1, 2016; 82 pages.	
	NPL15	NELSON, M., The Data Compression Book, 1st Edition, San Mateo, CA: M&T Books, 1992; 534 pages.	
	NPL16	RANDELL, B., "Hardware/Software Tradeoffs: A General Design Principle?", Computing Laboratory, The University of Newcastle Upon Tyne, January 25, 1985; 2 pages.	
	NPL17	Definition of "consecutive", Random House Webster's College Dictionary, 2nd Edition, New York: Random House, 1998; p. 281.	
	NPL18	ROBINSON, et al., "Results of a Prototype Television Bandwidth Compression Scheme," Proceedings of the IEEE, Vol. 55, No. 3, March 1967; pp. 356-364.	
	NPL19	Court Docket History for Realtime Data LLC d/b/a IXO v. Hewlett Packard Enterprise Co., et al., No. 6:16-cv-00086 (E.D. Texas), downloaded March 1, 2016, 2 pages.	
	NPL20	Court Docket History for Realtime Data LLC d/b/a IXO v. Oracle America, Inc., No. 6:16-cv-00088 (E.D. Texas), downloaded March 1, 2016; 2 pages.	

Examiner Signature		Date Considered	
-----------------------	--	--------------------	--

\*EXAMINER: Initial if reference considered, whether or not citation is in conformance with MPEP 609. Draw line through citation if not in conformance and not considered. Include copy of this form with next communication to applicant.

<sup>1</sup> Applicant's unique citation designation number (optional). <sup>2</sup> Applicant is to place a check mark here if English language Translation is attached.

Substitute for form 1449/PTO		<i>Complete if Known</i>	
<b>FIFTH SUPPLEMENTAL INFORMATION DISCLOSURE STATEMENT BY APPLICANT</b> <i>(Use as many sheets as necessary)</i>		Application Number	14/876,276
		Filing Date	October 6, 2015
		First Named Inventor	James J. FALLON
		Art Unit	2634
		Examiner Name	BOCURE, TEFALDET
		Attorney Docket Number	3421.005000C
Sheet	3	of	3

NON PATENT LITERATURE DOCUMENTS			
Examiner Initials*	Cite No. <sup>1</sup>	Include name of the author (in CAPITAL LETTERS), title of the article (when appropriate), title of the item (book, magazine, journal, serial, symposium, catalog, etc.), date, page(s), volume number, publisher, city and/or country where published	T <sup>2</sup>
	NPL21	Court Docket History for Realtime Data LLC d/b/a IXO v. CenturyLink, Inc., et al., No. 6:16-cv-00087 (E.D. Texas), downloaded March 1, 2016; 2 pages.	
	NPL22	Court Docket History for Realtime Data LLC d/b/a IXO v. Dell, Inc., et al., No. 6:16-cv-00089 (E.D. Texas), downloaded March 1, 2016; 2 pages.	

2792785\_1.DOCX

Examiner Signature		Date Considered	
--------------------	--	-----------------	--

\*EXAMINER: Initial if reference considered, whether or not citation is in conformance with MPEP 609. Draw line through citation if not in conformance and not considered. Include copy of this form with next communication to applicant.  
<sup>1</sup> Applicant's unique citation designation number (optional). <sup>2</sup> Applicant is to place a check mark here if English language Translation is attached.

## Electronic Patent Application Fee Transmittal

<b>Application Number:</b>	14876276				
<b>Filing Date:</b>	06-Oct-2015				
<b>Title of Invention:</b>	Video Data Compression Systems				
<b>First Named Inventor/Applicant Name:</b>	James J. FALLON				
<b>Filer:</b>	Michael V. Messinger/William Flanigen				
<b>Attorney Docket Number:</b>	3421.005000C				
Filed as Large Entity					
<b>Filing Fees for Utility under 35 USC 111(a)</b>					
<b>Description</b>	<b>Fee Code</b>	<b>Quantity</b>	<b>Amount</b>	<b>Sub-Total in USD(\$)</b>	
<b>Basic Filing:</b>					
<b>Pages:</b>					
<b>Claims:</b>					
<b>Miscellaneous-Filing:</b>					
<b>Petition:</b>					
<b>Patent-Appeals-and-Interference:</b>					
<b>Post-Allowance-and-Post-Issuance:</b>					
<b>Extension-of-Time:</b>					



Description	Fee Code	Quantity	Amount	Sub-Total in USD(\$)
<b>Miscellaneous:</b>				
Submission- Information Disclosure Stmt	1806	1	180	180
<b>Total in USD (\$)</b>				<b>180</b>

## Electronic Acknowledgement Receipt

<b>EFS ID:</b>	25471402
<b>Application Number:</b>	14876276
<b>International Application Number:</b>	
<b>Confirmation Number:</b>	3403
<b>Title of Invention:</b>	Video Data Compression Systems
<b>First Named Inventor/Applicant Name:</b>	James J. FALLON
<b>Customer Number:</b>	26111
<b>Filer:</b>	Michael V. Messinger/William Flanigen
<b>Filer Authorized By:</b>	Michael V. Messinger
<b>Attorney Docket Number:</b>	3421.005000C
<b>Receipt Date:</b>	12-APR-2016
<b>Filing Date:</b>	06-OCT-2015
<b>Time Stamp:</b>	20:42:45
<b>Application Type:</b>	Utility under 35 USC 111(a)

### Payment information:

Submitted with Payment	yes
Payment Type	Credit Card
Payment was successfully received in RAM	\$180
RAM confirmation Number	5884
Deposit Account	
Authorized User	

The Director of the USPTO is hereby authorized to charge indicated fees and credit any overpayment as follows:

<b>File Listing:</b>					
<b>Document Number</b>	<b>Document Description</b>	<b>File Name</b>	<b>File Size(Bytes)/ Message Digest</b>	<b>Multi Part /.zip</b>	<b>Pages (if appl.)</b>
1		3421005000C_5SIDS.pdf	3266514 3e9173c8ea977fb5b192cc859923dad2273c1972	yes	27
<b>Multipart Description/PDF files in .zip description</b>					
	<b>Document Description</b>		<b>Start</b>		<b>End</b>
	Miscellaneous Incoming Letter		1		2
	Amendment/Req. Reconsideration-After Non-Final Reject		3		3
	Claims		4		10
	Abstract		11		11
	Applicant Arguments/Remarks Made in an Amendment		12		14
	Transmittal Letter		15		23
	Information Disclosure Statement (IDS) Form (SB08)		24		27
<b>Warnings:</b>					
<b>Information:</b>					
2	Non Patent Literature	NPL11_NOA_14733565_03252016.pdf	424910 72bf51aaf73ba3e6bad68be339876334c07acfe1	no	8
<b>Warnings:</b>					
<b>Information:</b>					
3	Fee Worksheet (SB06)	fee-info.pdf	30302 b971bd71861ccb8de5b3223436bdf2654e24569	no	2
<b>Warnings:</b>					
<b>Information:</b>					
<b>Total Files Size (in bytes):</b>			3721726		

**This Acknowledgement Receipt evidences receipt on the noted date by the USPTO of the indicated documents, characterized by the applicant, and including page counts, where applicable. It serves as evidence of receipt similar to a Post Card, as described in MPEP 503.**

**New Applications Under 35 U.S.C. 111**

**If a new application is being filed and the application includes the necessary components for a filing date (see 37 CFR 1.53(b)-(d) and MPEP 506), a Filing Receipt (37 CFR 1.54) will be issued in due course and the date shown on this Acknowledgement Receipt will establish the filing date of the application.**

**National Stage of an International Application under 35 U.S.C. 371**

**If a timely submission to enter the national stage of an international application is compliant with the conditions of 35 U.S.C. 371 and other applicable requirements a Form PCT/DO/EO/903 indicating acceptance of the application as a national stage submission under 35 U.S.C. 371 will be issued in addition to the Filing Receipt, in due course.**

**New International Application Filed with the USPTO as a Receiving Office**

**If a new international application is being filed and the international application includes the necessary components for an international filing date (see PCT Article 11 and MPEP 1810), a Notification of the International Application Number and of the International Filing Date (Form PCT/RO/105) will be issued in due course, subject to prescriptions concerning national security, and the date shown on this Acknowledgement Receipt will establish the international filing date of the application.**

MICHAEL V. MESSINGER  
DIRECTOR  
(202) 772-8667  
MIKEM@SKGF.COM



April 12, 2016

Commissioner for Patents  
PO Box 1450  
Alexandria, VA 22313-1450

**Confirmation No. 3403**  
**Art Unit 2634**  
**Attn: Mail Stop Amendment**

Re: U.S. Utility Patent Application  
Application No. 14/876,276; Filing Date: October 6, 2015  
For: **Video Data Compression Systems**  
Inventors: FALLON *et al.*  
Our Ref: 3421.005000C

Commissioner:

Transmitted herewith for appropriate action are the following documents:

1. Online Credit Card Payment Authorization in the amount of \$180.00 in payment of the fee under 37 C.F.R. § 1.17(p);
2. Amendment and Reply Under 37 C.F.R. §1.111;
3. Fifth Supplemental Information Disclosure Statement;
4. Form PTO/SB/08a (1 sheet) listing 4 documents (**US1-US4**);
5. Form PTO/SB/08b (3 sheets) listing 22 documents (**NPL1-NPL22**); and
6. A copy of the cited document (**NPL11**).

***The above-listed documents are filed electronically through EFS-Web.***

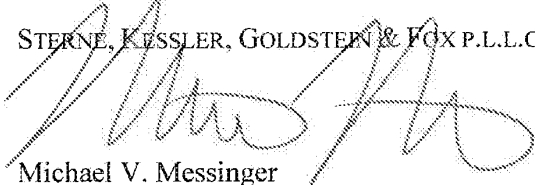
In the event that extensions of time are necessary to prevent abandonment of this patent application, then such extensions of time are hereby petitioned.

Commissioner for Patents  
April 12, 2016  
Page 2

Fee payment is provided through online credit card payment. The U.S. Patent and Trademark Office is hereby authorized to charge any fee deficiency, or credit any overpayment, to our Deposit Account No. 19-0036.

Respectfully submitted,

STERNE, KESSLER, GOLDSTEIN & FOX P.L.L.C.



Michael V. Messinger  
Attorney for Applicant  
Registration No. 37,575

MVM/MRM/wcf  
Enclosures

2792822\_1.DOCX

Under the Paperwork Reduction Act of 1995, no persons are required to respond to a collection of information unless it displays a valid OMB control number.

<b>PATENT APPLICATION FEE DETERMINATION RECORD</b> Substitute for Form PTO-875			Application or Docket Number <b>14/876,276</b>	Filing Date <b>10/06/2015</b>	<input type="checkbox"/> To be Mailed
<b>ENTITY:</b> <input checked="" type="checkbox"/> LARGE <input type="checkbox"/> SMALL <input type="checkbox"/> MICRO					
<b>APPLICATION AS FILED – PART I</b>					
(Column 1)		(Column 2)			
FOR	NUMBER FILED	NUMBER EXTRA	RATE (\$)	FEE (\$)	
<input type="checkbox"/> BASIC FEE <small>(37 CFR 1.16(a), (b), or (c))</small>	N/A	N/A	N/A		
<input type="checkbox"/> SEARCH FEE <small>(37 CFR 1.16(k), (l), or (m))</small>	N/A	N/A	N/A		
<input type="checkbox"/> EXAMINATION FEE <small>(37 CFR 1.16(o), (p), or (q))</small>	N/A	N/A	N/A		
TOTAL CLAIMS <small>(37 CFR 1.16(i))</small>	minus 20 =	*	X \$ =		
INDEPENDENT CLAIMS <small>(37 CFR 1.16(h))</small>	minus 3 =	*	X \$ =		
<input type="checkbox"/> APPLICATION SIZE FEE <small>(37 CFR 1.16(s))</small>	If the specification and drawings exceed 100 sheets of paper, the application size fee due is \$310 (\$155 for small entity) for each additional 50 sheets or fraction thereof. See 35 U.S.C. 41(a)(1)(G) and 37 CFR 1.16(s).				
<input type="checkbox"/> MULTIPLE DEPENDENT CLAIM PRESENT <small>(37 CFR 1.16(j))</small>					
* If the difference in column 1 is less than zero, enter "0" in column 2.			TOTAL		

<b>APPLICATION AS AMENDED – PART II</b>								
(Column 1)		(Column 2)		(Column 3)				
<b>AMENDMENT</b>	<b>04/12/2016</b>	CLAIMS REMAINING AFTER AMENDMENT		HIGHEST NUMBER PREVIOUSLY PAID FOR	PRESENT EXTRA	RATE (\$)	ADDITIONAL FEE (\$)	
	Total (37 CFR 1.16(i))	* 30	Minus	** 30	= 0	X \$80 =	0	
	Independent (37 CFR 1.16(h))	* 2	Minus	***3	= 0	X \$420 =	0	
	<input type="checkbox"/> Application Size Fee (37 CFR 1.16(s))							
	<input type="checkbox"/> FIRST PRESENTATION OF MULTIPLE DEPENDENT CLAIM (37 CFR 1.16(j))							
TOTAL ADD'L FEE						<b>0</b>		

(Column 1)		(Column 2)		(Column 3)				
<b>AMENDMENT</b>		CLAIMS REMAINING AFTER AMENDMENT		HIGHEST NUMBER PREVIOUSLY PAID FOR	PRESENT EXTRA	RATE (\$)	ADDITIONAL FEE (\$)	
	Total (37 CFR 1.16(i))	*	Minus	**	=	X \$ =		
	Independent (37 CFR 1.16(h))	*	Minus	***	=	X \$ =		
	<input type="checkbox"/> Application Size Fee (37 CFR 1.16(s))							
	<input type="checkbox"/> FIRST PRESENTATION OF MULTIPLE DEPENDENT CLAIM (37 CFR 1.16(j))							
TOTAL ADD'L FEE								
* If the entry in column 1 is less than the entry in column 2, write "0" in column 3.						LIE		
** If the "Highest Number Previously Paid For" IN THIS SPACE is less than 20, enter "20".						/DOROTHY BELL/		
*** If the "Highest Number Previously Paid For" IN THIS SPACE is less than 3, enter "3".								
The "Highest Number Previously Paid For" (Total or Independent) is the highest number found in the appropriate box in column 1.								

This collection of information is required by 37 CFR 1.16. The information is required to obtain or retain a benefit by the public which is to file (and by the USPTO to process) an application. Confidentiality is governed by 35 U.S.C. 122 and 37 CFR 1.14. This collection is estimated to take 12 minutes to complete, including gathering, preparing, and submitting the completed application form to the USPTO. Time will vary depending upon the individual case. Any comments on the amount of time you require to complete this form and/or suggestions for reducing this burden, should be sent to the Chief Information Officer, U.S. Patent and Trademark Office, U.S. Department of Commerce, P.O. Box 1450, Alexandria, VA 22313-1450. DO NOT SEND FEES OR COMPLETED FORMS TO THIS ADDRESS. **SEND TO: Commissioner for Patents, P.O. Box 1450, Alexandria, VA 22313-1450.**  
 If you need assistance in completing the form, call 1-800-PTO-9199 and select option 2.



UNITED STATES PATENT AND TRADEMARK OFFICE

UNITED STATES DEPARTMENT OF COMMERCE  
United States Patent and Trademark Office  
Address: COMMISSIONER FOR PATENTS  
P. O. Box 1450  
Alexandria, Virginia 22313-1450  
www.uspto.gov

APPLICATION NO.	FILING DATE	FIRST NAMED INVENTOR	ATTORNEY DOCKET NO.	CONFIRMATION NO.
14/876,276	10/06/2015	James J. FALLON	3421.005000C	3403

26111 7590 03/29/2016  
STERNE, KESSLER, GOLDSTEIN & FOX P.L.L.C.  
1100 NEW YORK AVENUE, N.W.  
WASHINGTON, DC 20005

EXAMINER
----------

BOCURE, TEFALDET

ART UNIT	PAPER NUMBER
2634	

MAIL DATE	DELIVERY MODE
03/29/2016	PAPER

**Please find below and/or attached an Office communication concerning this application or proceeding.**

The time period for reply, if any, is set in the attached communication.



<b>Applicant-Initiated Interview Summary</b>	<b>Application No.</b>	<b>Applicant(s)</b>	
	14/876,276	FALLON ET AL.	
	<b>Examiner</b>	<b>Art Unit</b>	
	TESFALDET BOCURE	2634	

All participants (applicant, applicant's representative, PTO personnel):

(1) TESFALDET BOCURE. (3)\_\_\_\_\_.

(2) Mr. Malek Michael (Mike), Attorney Reg. # 65211. (4)\_\_\_\_\_.

Date of Interview: 23 March 2016.

Type:    Telephonic    Video Conference  
 Personal [copy given to:    applicant    applicant's representative]

Exhibit shown or demonstration conducted:    Yes    No.  
If Yes, brief description: \_\_\_\_\_.

Issues Discussed   101   112   102   103   Others  
(For each of the checked box(es) above, please describe below the issue and detailed description of the discussion)

Claim(s) discussed: 1 and 19.

Identification of prior art discussed: none.

**Substance of Interview**  
(For each issue discussed, provide a detailed description and indicate if agreement was reached. Some topics may include: identification or clarification of a reference or a portion thereof, claim interpretation, proposed amendments, arguments of any applied references etc...)

See attached detail action.

**Applicant recordation instructions:** The formal written reply to the last Office action must include the substance of the interview. (See MPEP section 713.04). If a reply to the last Office action has already been filed, applicant is given a non-extendable period of the longer of one month or thirty days from this interview date, or the mailing date of this interview summary form, whichever is later, to file a statement of the substance of the interview

**Examiner recordation instructions:** Examiners must summarize the substance of any interview of record. A complete and proper recordation of the substance of an interview should include the items listed in MPEP 713.04 for complete and proper recordation including the identification of the general thrust of each argument or issue discussed, a general indication of any other pertinent matters discussed regarding patentability and the general results or outcome of the interview, to include an indication as to whether or not agreement was reached on the issues raised.

Attachment

/TESFALDET BOCURE/ Primary Examiner, Art Unit 2634	
-------------------------------------------------------	--

## Summary of Record of Interview Requirements

### Manual of Patent Examining Procedure (MPEP), Section 713.04, Substance of Interview Must be Made of Record

A complete written statement as to the substance of any face-to-face, video conference, or telephone interview with regard to an application must be made of record in the application whether or not an agreement with the examiner was reached at the interview.

### Title 37 Code of Federal Regulations (CFR) § 1.133 Interviews

Paragraph (b)

In every instance where reconsideration is requested in view of an interview with an examiner, a complete written statement of the reasons presented at the interview as warranting favorable action must be filed by the applicant. An interview does not remove the necessity for reply to Office action as specified in §§ 1.111, 1.135. (35 U.S.C. 132)

37 CFR §1.2 Business to be transacted in writing.

All business with the Patent or Trademark Office should be transacted in writing. The personal attendance of applicants or their attorneys or agents at the Patent and Trademark Office is unnecessary. The action of the Patent and Trademark Office will be based exclusively on the written record in the Office. No attention will be paid to any alleged oral promise, stipulation, or understanding in relation to which there is disagreement or doubt.

The action of the Patent and Trademark Office cannot be based exclusively on the written record in the Office if that record is itself incomplete through the failure to record the substance of interviews.

It is the responsibility of the applicant or the attorney or agent to make the substance of an interview of record in the application file, unless the examiner indicates he or she will do so. It is the examiner's responsibility to see that such a record is made and to correct material inaccuracies which bear directly on the question of patentability.

Examiners must complete an Interview Summary Form for each interview held where a matter of substance has been discussed during the interview by checking the appropriate boxes and filling in the blanks. Discussions regarding only procedural matters, directed solely to restriction requirements for which interview recordation is otherwise provided for in Section 812.01 of the Manual of Patent Examining Procedure, or pointing out typographical errors or unreadable script in Office actions or the like, are excluded from the interview recordation procedures below. Where the substance of an interview is completely recorded in an Examiners Amendment, no separate Interview Summary Record is required.

The Interview Summary Form shall be given an appropriate Paper No., placed in the right hand portion of the file, and listed on the "Contents" section of the file wrapper. In a personal interview, a duplicate of the Form is given to the applicant (or attorney or agent) at the conclusion of the interview. In the case of a telephone or video-conference interview, the copy is mailed to the applicant's correspondence address either with or prior to the next official communication. If additional correspondence from the examiner is not likely before an allowance or if other circumstances dictate, the Form should be mailed promptly after the interview rather than with the next official communication.

The Form provides for recordation of the following information:

- Application Number (Series Code and Serial Number)
- Name of applicant
- Name of examiner
- Date of interview
- Type of interview (telephonic, video-conference, or personal)
- Name of participant(s) (applicant, attorney or agent, examiner, other PTO personnel, etc.)
- An indication whether or not an exhibit was shown or a demonstration conducted
- An identification of the specific prior art discussed
- An indication whether an agreement was reached and if so, a description of the general nature of the agreement (may be by attachment of a copy of amendments or claims agreed as being allowable). Note: Agreement as to allowability is tentative and does not restrict further action by the examiner to the contrary.
- The signature of the examiner who conducted the interview (if Form is not an attachment to a signed Office action)

It is desirable that the examiner orally remind the applicant of his or her obligation to record the substance of the interview of each case. It should be noted, however, that the Interview Summary Form will not normally be considered a complete and proper recordation of the interview unless it includes, or is supplemented by the applicant or the examiner to include, all of the applicable items required below concerning the substance of the interview.

A complete and proper recordation of the substance of any interview should include at least the following applicable items:

- 1) A brief description of the nature of any exhibit shown or any demonstration conducted,
- 2) an identification of the claims discussed,
- 3) an identification of the specific prior art discussed,
- 4) an identification of the principal proposed amendments of a substantive nature discussed, unless these are already described on the Interview Summary Form completed by the Examiner,
- 5) a brief identification of the general thrust of the principal arguments presented to the examiner,  
(The identification of arguments need not be lengthy or elaborate. A verbatim or highly detailed description of the arguments is not required. The identification of the arguments is sufficient if the general nature or thrust of the principal arguments made to the examiner can be understood in the context of the application file. Of course, the applicant may desire to emphasize and fully describe those arguments which he or she feels were or might be persuasive to the examiner.)
- 6) a general indication of any other pertinent matters discussed, and
- 7) if appropriate, the general results or outcome of the interview unless already described in the Interview Summary Form completed by the examiner.

Examiners are expected to carefully review the applicant's record of the substance of an interview. If the record is not complete and accurate, the examiner will give the applicant an extendable one month time period to correct the record.

### Examiner to Check for Accuracy

If the claims are allowable for other reasons of record, the examiner should send a letter setting forth the examiner's version of the statement attributed to him or her. If the record is complete and accurate, the examiner should place the indication, "Interview Record OK" on the paper recording the substance of the interview along with the date and the examiner's initials.

1. The present application is being examined under the pre-AIA first to invent provisions.

***Applicant Initiated Interview Summary***

2. Applicant's representative Mr. Malek Michael (Mike), Attorney Reg. # 65211, called Examiner on 03/17/2017 and proposed to delete the claimed limitation, "for compressing video data, "in the preamble of the independent claims 1 and 19 in order to overcome the 112 2<sup>nd</sup> paragraph rejection indicated in the office action mailed on 01/28/2016. After reviewing the proposed amendment, Examiner called back on 03/23/2016 and agreed that the proposed amendment will overcome the 112 second paragraph rejection. Examiner suggests Mr. Malek that the proposed amendment would not guarantee that there would not be any applicable art to reject the claims.

Further Mr. Malek argued that the proposed amendment to the abstract filed in the preliminary amendment of 12/11/2015 reflects to the claimed invention of the instant application. The abstract was not properly indexed in the file (eDAN), where Examiner did not locate the preliminary amendment when the case was first examined. Examiner agreed that the amendment to abstract reflects the claimed invention and the objection will be withdrawn.

***Conclusion***

3. Any inquiry concerning this communication or earlier communications from the examiner should be directed to TESHALDET BOCURE whose telephone number is (571)272-3015. The examiner can normally be reached on 8:30am-to-5:00pm.

If attempts to reach the examiner by telephone are unsuccessful, the examiner's supervisor, Daniel C. Washburn can be reached on 571-272-5551. The fax phone number for the organization where this application or proceeding is assigned is 571-273-8300.

Information regarding the status of an application may be obtained from the Patent Application Information Retrieval (PAIR) system. Status information for published applications may be obtained from either Private PAIR or Public PAIR. Status information for unpublished applications is available through Private PAIR only. For more information about the PAIR system, see <http://pair-direct.uspto.gov>. Should you have questions on access to the Private PAIR system, contact the Electronic Business Center (EBC) at 866-217-9197 (toll-free). If you would like assistance from a USPTO Customer Service Representative or access to the automated information system, call 800-786-9199 (IN USA OR CANADA) or 571-272-1000.

/TESHALDET BOCURE/  
Primary Examiner, Art Unit 2634

/T. B./  
Primary Examiner, Art Unit 2634

Substitute for form 1449/PTO		<b>Complete if Known</b>	
<b>FOURTH SUPPLEMENTAL INFORMATION DISCLOSURE STATEMENT BY APPLICANT</b> <i>(Use as many sheets as necessary)</i>		Application Number	14/876,276
		Filing Date	October 6, 2015
		First Named Inventor	James J. FALLON
		Art Unit	2634
		Examiner Name	BOCURE, TESFALDET
Sheet	1	of	1
		Attorney Docket Number	3421.005000C

**U.S. PATENT DOCUMENTS**

Examiner initials*	Cite No. <sup>1</sup>	Document Number	Publication Date MM-DD-YYYY	Name of Patentee or Applicant of Cited Document	Pages, Columns, Lines, Where Relevant Passages or Relevant Figures Appear
		Number-Kind Code <sup>2</sup> (if known)			
	US1	5,479,210	12-26-1995	Cawley et al.	
	US2	5,590,317	12-31-1996	Iguchi et al.	
	US3	5,710,562	01-20-1998	Gormish et al.	
	US4	6,233,017 B1	05-15-2001	Chaddha	
	US5	6,744,926 B1	06-01-2004	Nishigaki	
	US6	7,496,586 B1	02-24-2009	Bonwick et al.	

**FOREIGN PATENT DOCUMENTS**

Examiner initials*	Cite No. <sup>1</sup>	Foreign Patent Document	Publication Date MM-DD-YYYY	Name of Patentee or Applicant of Cited Document	Pages, Columns, Lines, Where Relevant Passages or Relevant Figures Appear	T 6
		Country Code <sup>3</sup> -Number <sup>4</sup> -Kind Code <sup>5</sup> (if known)				

2774120\_1.DOCX

Examiner Signature	Date Considered
--------------------	-----------------

\*EXAMINER: Initial if reference considered, whether or not citation is in conformance with MPEP 609. Draw line through citation if not in conformance and not considered. Include copy of this form with next communication to applicant. <sup>1</sup> Applicant's unique citation designation number (optional). <sup>2</sup> See Kinds Codes of USPTO Patent Documents at www.uspto.gov or MPEP 901.04. <sup>3</sup> Enter Office that issued the document, by the two-letter code (WIPO Standard ST.3). <sup>4</sup> For Japanese patent documents, the indication of the year of the reign of the Emperor must precede the serial number of the patent document. <sup>5</sup> Kind of document by the appropriate symbols as indicated on the document under WIPO Standard ST.16 if possible. <sup>6</sup> Applicant is to place a check mark here if English language Translation is attached.

Substitute for form 1449/PTO		<b>Complete if Known</b>	
<b>FOURTH SUPPLEMENTAL INFORMATION DISCLOSURE STATEMENT BY APPLICANT</b> <i>(Use as many sheets as necessary)</i>		Application Number	14/876,276
		Filing Date	October 6, 2015
		First Named Inventor	James J. FALLON
		Art Unit	2634
		Examiner Name	BOCURE, TESFALDET
		Attorney Docket Number	3421.005000C
Sheet	1	of	14

NON PATENT LITERATURE DOCUMENTS			
Examiner Initials*	Cite No. <sup>1</sup>	Include name of the author (in CAPITAL LETTERS), title of the article (when appropriate), title of the item (book, magazine, journal, serial, symposium, catalog, etc.), date, page(s), volume-issue number(s), publisher, city and/or country where published	T <sup>2</sup>
	NPL1	Second Amended Complaint for Patent Infringement Against Riverbed Technology, Inc. and Dell, Inc., filed in Realtime Data LLC d/b/a IXO v. Actian Corporation, et al., Case No. 6:15-cv-00463-RWS-JDL (E.D. Texas), filed February 2, 2016; 37 pages.	
	NPL2	Defendant Dropbox's Answer to Plaintiff Realtime Data LLC d/b/a IXO's Amended Complaint, filed in Realtime Data LLC d/b/a IXO v. Actian Corporation, et al., Case No. 6:15-cv-00463-RWS-JDL (E.D. Texas), filed February 4, 2016; 10 pages.	
	NPL3	Defendants Echostar Corporation's and Hughes Network Systems, LLC's Answer, Affirmative Defenses, and Counterclaims to Plaintiff Realtime Data LLC d/b/a IXO's Amended Complaint, filed in Realtime Data LLC d/b/a IXO v. Actian Corporation, et al., Case No. 6:15-cv-00463-RWS-JDL (E.D. Texas), filed February 4, 2016; 23 pages.	
	NPL4	Defendants SAP America Inc. and SyBase, Inc.'s Answer, Affirmative Defenses, and Counterclaims to Plaintiff's Second Amended Complaint, filed in Realtime Data LLC d/b/a IXO v. Actian Corporation, et al., Case No. 6:15-cv-00463-RWS-JDL (E.D. Texas), filed February 4, 2016; 35 pages.	
	NPL5	Dell Inc.'s Answer, Defenses, and Counterclaims to Plaintiff's Amended Complaint, filed in Realtime Data LLC d/b/a IXO v. Actian Corporation, et al., Case No. 6:15-cv-00463-RWS-JDL (E.D. Texas), filed February 4, 2016; 28 pages.	
	NPL6	Standard Function Library (SFL) Code, Version 1.4, written March 29, 1993, revised January 2, 1997; 190 pages.	
	NPL7	Standard Function Library Documentation, written June 4, 1997, revised November 17, 1997; 1,102 pages. (Submitted in 6 parts.)	
	NPL8	Defendants Oracle America, Inc., Hewlett-Packard Company, and HP Enterprise Services, LLC's Invalidity Contentions, submitted in Realtime Data, LLC d/b/a IXO v. Actian Corporation, et al., Case No. 6:15-cv-00463-RWS-JDL (E.D. Texas), served December 4, 2015; 62 pages.	
	NPL9	Non-Confidential Exhibits A3-A4 to Defendants Oracle America, Inc., Hewlett-Packard Company, and HP Enterprise Services, LLC's Invalidity Contentions, submitted in Realtime Data, LLC d/b/a IXO v. Actian Corporation, et al., Case No. 6:15-cv-00463-RWS-JDL (E.D. Texas), served December 4, 2015; 296 pages.	
	NPL10	Non-Confidential Exhibits B3-B4 to Defendants Oracle America, Inc., Hewlett-Packard Company, and HP Enterprise Services, LLC's Invalidity Contentions, submitted in Realtime Data, LLC d/b/a IXO v. Actian Corporation, et al., Case No. 6:15-cv-00463-RWS-JDL (E.D. Texas), served December 4, 2015; 1,179 pages.	
Examiner Signature		Date Considered	

\*EXAMINER: Initial if reference considered, whether or not citation is in conformance with MPEP 609. Draw line through citation if not in conformance and not considered. Include copy of this form with next communication to applicant.

<sup>1</sup> Applicant's unique citation designation number (optional). <sup>2</sup> Applicant is to place a check mark here if English language Translation is attached.

Substitute for form 1449/PTO		<b>Complete if Known</b>	
<b>FOURTH SUPPLEMENTAL INFORMATION DISCLOSURE STATEMENT BY APPLICANT</b> <i>(Use as many sheets as necessary)</i>		Application Number	14/876,276
		Filing Date	October 6, 2015
		First Named Inventor	James J. FALLON
		Art Unit	2634
		Examiner Name	BOCURE, TESFALDET
		Attorney Docket Number	3421.005000C
Sheet	2	of	14

NON PATENT LITERATURE DOCUMENTS			
Examiner Initials*	Cite No. <sup>1</sup>	Include name of the author (in CAPITAL LETTERS), title of the article (when appropriate), title of the item (book, magazine, journal, serial, symposium, catalog, etc.), date, page(s), volume number, publisher, city and/or country where published	T <sup>2</sup>
	NPL11	Non-Confidential Exhibits C4-C7 and C9 to Defendants Oracle America, Inc., Hewlett-Packard Company, and HP Enterprise Services, LLC's Invalidation Contentions, submitted in Realtime Data, LLC d/b/a IXO v. Actian Corporation, et al., Case No. 6:15-cv-00463-RWS-JDL (E.D. Texas), served December 4, 2015; 3,029 pages.	
	NPL12	Non-Confidential Exhibits D4-D7 and D9 to Defendants Oracle America, Inc., Hewlett-Packard Company, and HP Enterprise Services, LLC's Invalidation Contentions, submitted in Realtime Data, LLC d/b/a IXO v. Actian Corporation, et al., Case No. 6:15-cv-00463-RWS-JDL (E.D. Texas), served December 4, 2015; 3,125 pages.	
	NPL13	Non-Confidential Exhibits E1-E4 to Defendants Oracle America, Inc., Hewlett-Packard Company, and HP Enterprise Services, LLC's Invalidation Contentions, submitted in Realtime Data, LLC d/b/a IXO v. Actian Corporation, et al., Case No. 6:15-cv-00463-RWS-JDL (E.D. Texas), served December 4, 2015; 1,657 pages.	
	NPL14	"Adaptive Lossless Data Compression Algorithm," ECMA Standard ECMA-222, June 1995; 20 pages.	
	NPL15	"ALDC1-40S Adaptive Lossless Data Compression," IBM Microelectronics Data Compression Technologies, May 1994; 2 pages.	
	NPL16	AMIR, ET AL., "An Application Level Video Gateway," ACM Multimedia, San Francisco, November 1995; 11 pages.	
	NPL17	ANDREWS, ET AL., "A Mean-Removed Variation of Weighted Universal Vector Quantization for Image Coding," IEEE Data Compression Conference, 1993; pp. 302-309.	
	NPL18	AX.25 Link Access Protocol for Amateur Packet Radio, Version 2.2, Tuscon Amateur Packet Radio Corporation, Revision: July 1998; 143 pages.	
	NPL19	BAKER, ET AL., "Lossless Data Compression for Short Duration 3D Frames in Positron Emission Tomography," IEEE Nuclear Science Symposium and Medical Imaging Conference, 1993; pp. 1831-1834.	
	NPL20	BASSIOUNI, ET AL., "A Scheme for Data Compression in Supercomputers," IEEE Supercomputing '88, 1988; pp. 272-278.	
Examiner Signature		Date Considered	

\*EXAMINER: Initial if reference considered, whether or not citation is in conformance with MPEP 609. Draw line through citation if not in conformance and not considered. Include copy of this form with next communication to applicant.

<sup>1</sup> Applicant's unique citation designation number (optional). <sup>2</sup> Applicant is to place a check mark here if English language Translation is attached.

Substitute for form 1449/PTO		<b>Complete if Known</b>	
<b>FOURTH SUPPLEMENTAL INFORMATION DISCLOSURE STATEMENT BY APPLICANT</b> <i>(Use as many sheets as necessary)</i>		Application Number	14/876,276
		Filing Date	October 6, 2015
		First Named Inventor	James J. FALLON
		Art Unit	2634
		Examiner Name	BOCURE, TESFALDET
		Attorney Docket Number	3421.005000C
Sheet	3	of	14

NON PATENT LITERATURE DOCUMENTS			
Examiner Initials*	Cite No. <sup>1</sup>	Include name of the author (in CAPITAL LETTERS), title of the article (when appropriate), title of the item (book, magazine, journal, serial, symposium, catalog, etc.), date, page(s), volume number, publisher, city and/or country where published	T <sup>2</sup>
	NPL21	BRUCKMANN, ET AL., "Selective Medical Image Compression Using Wavelet Techniques," Journal of Computing and Information Technology, Vol. 6, No. 2 (1998); 23 pages.	
	NPL22	CHENG, ET AL., "A fast, highly reliable data compression chip and algorithm for storage systems," IBM Journal of Research and Development, Vol. 40, No. 6, November 1996; pp. 603-613.	
	NPL23	ZHANG, ET AL., "Content-based video retrieval and compression: a unified solution," IEEE Proceedings of the International Conference on Image Processing, October 1997; pp. 13-16.	
	NPL24	CRAFT, D., "A fast hardware data compression algorithm and some algorithmic extensions," IBM Journal of Research and Development, Vol. 42, No. 6, November 1998; pp. 733-745.	
	NPL25	SATTLER, M., Internet TV with CU-SeeMe, Indianapolis, IN: sams.net, 1995; 172 pages.	
	NPL26	DANSKIN, J., "Compressing The X Graphics Protocol," Dissertation, Princeton University Department of Computer Science, January 1995; 147 pages.	
	NPL27	FOX, ET AL., "Adapting to Network and Client Variability via On-Demand Dynamic Distillation," Proceedings of the Seventh International Conference on Architectural Support for Programming Languages and Operating Systems, 1996; pp. 160-170.	
	NPL28	FOX, ET AL., "Adapting to Network and Client Variability Using Infrastructural Proxies: Lessons and Perspectives," Abstract, IEEE Personal Communications, Vol. 5, No. 4, August 1998; 2 pages.	
	NPL29	BOTTOU, ET AL., "High Quality Document Image Compression with DjVu," Journal of Electronic Imaging, Vol. 7, No. 3, 1998; pp. 410-425.	
	NPL30	HOWARD, ET AL., "Parallel Lossless Image Compression Using Huffman and Arithmetic Coding," IEEE Data Compression Conference, March 1992; pp. 299-308.	
Examiner Signature		Date Considered	

\*EXAMINER: Initial if reference considered, whether or not citation is in conformance with MPEP 609. Draw line through citation if not in conformance and not considered. Include copy of this form with next communication to applicant.

<sup>1</sup> Applicant's unique citation designation number (optional). <sup>2</sup> Applicant is to place a check mark here if English language Translation is attached.



Substitute for form 1449/PTO		<b>Complete if Known</b>	
<b>FOURTH SUPPLEMENTAL INFORMATION DISCLOSURE STATEMENT BY APPLICANT</b> <i>(Use as many sheets as necessary)</i>		Application Number	14/876,276
		Filing Date	October 6, 2015
		First Named Inventor	James J. FALLON
		Art Unit	2634
		Examiner Name	BOCURE, TESFALDET
		Attorney Docket Number	3421.005000C
Sheet	4	of	14

NON PATENT LITERATURE DOCUMENTS			
Examiner Initials*	Cite No. <sup>1</sup>	Include name of the author (in CAPITAL LETTERS), title of the article (when appropriate), title of the item (book, magazine, journal, serial, symposium, catalog, etc.), date, page(s), volume number, publisher, city and/or country where published	T <sup>2</sup>
	NPL31	"Hewlett-Packard Journal," Hewlett-Packard Corporation, June 1989; 84 pages.	
	NPL32	HSU, ET AL., "Automatic Synthesis of Compression Techniques for Heterogeneous Files," Software - Practice and Experience, Vol. 25, No. 10, October 1995; pp. 1097-1116.	
	NPL33	"Guide to Sharing and Partitioning IBM Tape Library Dataservers," IBM International Technical Support Organization, San Jose Center, November 1996; 276 pages. (Submitted in 2 parts.)	
	NPL34	"Add-On Options for the XpressFiles," Intelligent Compression Technologies, 1998, accessible at < <a href="http://web.archive.org/web/19980518053418/ictcompress.com/options_X.html">http://web.archive.org/web/19980518053418/ictcompress.com/options_X.html</a> >; 2 pages.	
	NPL35	"Introducing XpressFiles," Intelligent Compression Technologies, 1998, accessible at < <a href="http://web.archive.org/web/19980518053310/ictcompress.com/xpressfiles.html">http://web.archive.org/web/19980518053310/ictcompress.com/xpressfiles.html</a> >; 1 page.	
	NPL36	"The Technology Behind XpressFiles," Intelligent Compression Technologies, 1998, accessible at < <a href="http://web.archive.org/web/19980518053634/ictcompress.com/technical_X.html">http://web.archive.org/web/19980518053634/ictcompress.com/technical_X.html</a> >; 1 page.	
	NPL37	XpressFiles White Paper, Intelligent Compression Technologies, 1999; 3 pages.	
	NPL38	"XML-Xpress Product Overview," Intelligent Compression Technologies, 2001, accessible at < <a href="http://web.archive.org/web/20020818002535/www.ictcompress.com/products_xmlxpress.html">http://web.archive.org/web/20020818002535/www.ictcompress.com/products_xmlxpress.html</a> >; 2 pages.	
	NPL39	"ICT's XML-Xpress," Intelligent Compression Technologies, December 2000; 6 pages.	
	NPL40	LARMOUTH, J., "ASN. 1 Complete," Open Systems Solutions, 1999; 387 pages. (Submitted in 4 parts.)	
Examiner Signature		Date Considered	

\*EXAMINER: Initial if reference considered, whether or not citation is in conformance with MPEP 609. Draw line through citation if not in conformance and not considered. Include copy of this form with next communication to applicant.

<sup>1</sup> Applicant's unique citation designation number (optional). <sup>2</sup> Applicant is to place a check mark here if English language Translation is attached.

Substitute for form 1449/PTO		<b>Complete if Known</b>	
<b>FOURTH SUPPLEMENTAL INFORMATION DISCLOSURE STATEMENT BY APPLICANT</b> <i>(Use as many sheets as necessary)</i>		Application Number	14/876,276
		Filing Date	October 6, 2015
		First Named Inventor	James J. FALLON
		Art Unit	2634
		Examiner Name	BOCURE, TESFALDET
		Attorney Docket Number	3421.005000C
Sheet	5	of	14

NON PATENT LITERATURE DOCUMENTS			
Examiner Initials*	Cite No. <sup>1</sup>	Include name of the author (in CAPITAL LETTERS), title of the article (when appropriate), title of the item (book, magazine, journal, serial, symposium, catalog, etc.), date, page(s), volume number, publisher, city and/or country where published	T <sup>2</sup>
	NPL41	"Magstar and IBM 3590 High Performance Tape Subsystem Technical Guide," IBM International Technical Support Organization, San Jose Center, November 1996; 287 pages. (Submitted in 2 parts.)	
	NPL42	McGREGOR, ET AL., "Performance Impact of Data Compression on Virtual Private Network Transactions," IEEE Proceedings of the 25th Annual Conference on Local Computer Networks, 2000; 11 pages.	
	NPL43	SUMMERS, B., "Official Microsoft NetMeeting Book," Redmond, WA: Microsoft Press, 1998; 374 pages. (Submitted in 5 parts.)	
	NPL44	BRITTON, ET AL., Discover Desktop Conferencing with NetMeeting 2.0, Foster City, CA: IDG Books Worldwide, Inc., 1998; 304 pages. (Submitted in 4 parts.)	
	NPL45	RANGANATHAN, N., "High-Speed VLSI Designs for Lempel-Ziv-Based Data Compression," IEEE Transactions on Circuits and Systems - II: Analog and Digital Signal Processing, Vol. 40, No. 2, February 1993; pp. 96-106.	
	NPL46	User's Guide, Sidewinder 50 AIT-1 Tape Drive, Seagate Technology, Inc., 1997; 19 pages.	
	NPL47	PROSISE, J., "Understanding Data Compression," PC Magazine, May 25, 1993; pp. 305-308.	
	NPL48	WELCH, T., Source Code, University of California, 1985; 23 pages.	
	NPL49	ABALI, ET AL., "Memory Expansion Technology (MXT): Software Support and Performance," IBM Journalist of Research and Development, Vol. 45, No. 2, March 2001; pp. 287-301.	
	NPL50	ANDERSON, ET AL., "Codec Squeezes Color Teleconferencing Through Digital Telephone Lines," Electronics, January 26, 1984; pp. 113-115.	
Examiner Signature		Date Considered	

\*EXAMINER: Initial if reference considered, whether or not citation is in conformance with MPEP 609. Draw line through citation if not in conformance and not considered. Include copy of this form with next communication to applicant.

<sup>1</sup> Applicant's unique citation designation number (optional). <sup>2</sup> Applicant is to place a check mark here if English language Translation is attached.

Substitute for form 1449/PTO		<b>Complete if Known</b>	
<b>FOURTH SUPPLEMENTAL INFORMATION DISCLOSURE STATEMENT BY APPLICANT</b> <i>(Use as many sheets as necessary)</i>		Application Number	14/876,276
		Filing Date	October 6, 2015
		First Named Inventor	James J. FALLON
		Art Unit	2634
		Examiner Name	BOCURE, TESFALDET
		Attorney Docket Number	3421.005000C
Sheet	6	of	14

NON PATENT LITERATURE DOCUMENTS			
Examiner Initials*	Cite No. <sup>1</sup>	Include name of the author (in CAPITAL LETTERS), title of the article (when appropriate), title of the item (book, magazine, journal, serial, symposium, catalog, etc.), date, page(s), volume number, publisher, city and/or country where published	T <sup>2</sup>
	NPL51	COENE, ET AL., "A Fast Route For Application of Rate-Distortion Optimal Quantization in an MPEG Encoder," IEEE Proceedings of the International Conference on Image Processing, 1996; pp. 825-828.	
	NPL52	FRANASZEK, ET AL., "Algorithms and Data Structures for Compressed-Memory Machines," IBM Journal of Research and Development, Vol. 45, No. 2, March 2001; pp. 245-258.	
	NPL53	FRANASZEK, ET AL., "On Internal Organization in Compressed Random-Access Memories," IBM Journal of Research and Development, Vol. 45, No. 2, March 2001; pp. 259-270.	
	NPL54	IBM Technical Disclosure Bulletin, Vol. 38, No. 2, February 1995; 3 pages.	
	NPL55	"IBM Boosts Your Memory," Geek.com, accessible at <http://www.geek.com/ibm-boosts-your-memory/>, June 26, 2000; 3 pages.	
	NPL56	"IBM Research Breakthrough Doubles Computer Memory Capacity," IBM Press Release, June 26, 2000; 3 pages.	
	NPL57	IBM Technical Disclosure Bulletin, Vol. 37, No. 2B, February 1994; 3 pages.	
	NPL58	International Search Reports directed to International Patent Application Nos. PCT/US01/03711 and PCT/US01/03712, January 28, 2001 and May 10, 2002; 9 pages.	
	NPL59	MURASHITA, ET AL., "High-Speed Statistical Compression Using Self-Organized Rules and Predetermined Code Tables," IEEE Proceedings of Data Compression Conference, 1996; p. 449.	
	NPL60	RICE, ET AL., "Lossless Coding Standards for Space Data Systems," IEEE Conference Record of the Thirtieth Asilomar Conference on Signals, Systems and Computers, 1996; pp. 577-585.	

Examiner Signature	Date Considered
-----------------------	--------------------

\*EXAMINER: Initial if reference considered, whether or not citation is in conformance with MPEP 609. Draw line through citation if not in conformance and not considered. Include copy of this form with next communication to applicant.

<sup>1</sup> Applicant's unique citation designation number (optional). <sup>2</sup> Applicant is to place a check mark here if English language Translation is attached.

Substitute for form 1449/PTO		<b>Complete if Known</b>	
<b>FOURTH SUPPLEMENTAL INFORMATION DISCLOSURE STATEMENT BY APPLICANT</b> <i>(Use as many sheets as necessary)</i>		Application Number	14/876,276
		Filing Date	October 6, 2015
		First Named Inventor	James J. FALLON
		Art Unit	2634
		Examiner Name	BOCURE, TESFALDET
		Attorney Docket Number	3421.005000C
Sheet	7	of	14

NON PATENT LITERATURE DOCUMENTS			
Examiner Initials*	Cite No. <sup>1</sup>	Include name of the author (in CAPITAL LETTERS), title of the article (when appropriate), title of the item (book, magazine, journal, serial, symposium, catalog, etc.), date, page(s), volume number, publisher, city and/or country where published	T <sup>2</sup>
	NPL61	RICE, R., "Some Practical Universal Noiseless Coding Techniques," National Aeronautics and Space Administration, JPL Publication 79-22, 1979; 149 pages.	
	NPL62	"ServerWorks To Deliver IBM's Memory eXpansion Technology in Next-Generation Core Logic for Servers," ServerWorks press release, accessible at < <a href="http://www.serverworks.com/news/press/000627.html">http://www.serverworks.com/news/press/000627.html</a> >, June 27, 2000; 1 page.	
	NPL63	SMITH, ET AL., "Memory Expansion Technology (MXT): Competitive Impact," IBM Journal of Research and Development, Vol. 45, No. 2, March 2001; pp. 303-309.	
	NPL64	TREMAINE, ET AL., "IBM Memory Expansion Technology (MXT)," IBM Journal of Research and Development, Vol. 45, No. 2, March 2001; pp. 271-285.	
	NPL65	VENBRUX, ET AL., "A VLSI Chip Set for High-Speed Lossless Data Compression," IEEE Transactions on Circuits and Systems for Video Technology, Vol. 2, No. 4, December 1992; pp. 381-391.	
	NPL66	YEH, P., "The CCSDS Lossless Data Compression Recommendation for Space Applications," Chapter 16, Lossless Compression Handbook, SAYOOD, K., ed., Academic Press, 2003; pp. 311-326.	
	NPL67	MARTIN, J., "HP drive offers data compression," COMPUTERWORLD, May 9, 1988; p. 76.	
	NPL68	MILLMAN, H., "Image and Video Compression," COMPUTERWORLD, January 18, 1999; p. 78.	
	NPL69	"MegaRam Disc Emulator: Revolutionary, Non-rotating, Solid-state Replacement for Fixed and Moving Head Discs," Imperial Technology, Inc., October 1985; 4 pages.	
	NPL70	"MegaRam-PC: Solid-State Disk Emulator For The IBM And IBM Compatible Personal Computers," Imperial Technology, Inc., October 1985; 2 pages.	

Examiner Signature	Date Considered
-----------------------	--------------------

\*EXAMINER: Initial if reference considered, whether or not citation is in conformance with MPEP 609. Draw line through citation if not in conformance and not considered. Include copy of this form with next communication to applicant.

<sup>1</sup> Applicant's unique citation designation number (optional). <sup>2</sup> Applicant is to place a check mark here if English language Translation is attached.

Substitute for form 1449/PTO		<b>Complete if Known</b>	
<b>FOURTH SUPPLEMENTAL INFORMATION DISCLOSURE STATEMENT BY APPLICANT</b> <i>(Use as many sheets as necessary)</i>		Application Number	14/876,276
		Filing Date	October 6, 2015
		First Named Inventor	James J. FALLON
		Art Unit	2634
		Examiner Name	BOCURE, TESFALDET
		Attorney Docket Number	3421.005000C
Sheet	8	of	14

NON PATENT LITERATURE DOCUMENTS			
Examiner Initials*	Cite No. <sup>1</sup>	Include name of the author (in CAPITAL LETTERS), title of the article (when appropriate), title of the item (book, magazine, journal, serial, symposium, catalog, etc.), date, page(s), volume number, publisher, city and/or country where published	T <sup>2</sup>
	NPL71	"MegaRam Solid State Disks," Imperial Technology, Inc., accessible via the Internet Archive at < <a href="https://web.archive.org/web/19990501183337/http://imperialtech.com/SolidState.html">https://web.archive.org/web/19990501183337/http://imperialtech.com/SolidState.html</a> >, May 1, 1999; 3 pages.	
	NPL72	"Quantum Rushmore Solid State Disk Drives," Quantum Corporation, accessible via the Internet Archive at < <a href="http://web.archive.org/web/19990508051125/http://www.quantum.com/products/ssd/">http://web.archive.org/web/19990508051125/http://www.quantum.com/products/ssd/</a> >, May 8, 1999; 3 pages.	
	NPL73	"Lucent Opts for Hi/fn Compression and Encryption In Latest Portmaster Products," PR Newswire, May 11, 1999; 2 pages.	
	NPL74	7711 to 7751 Migration Application Note, Hi/fn Network Security Processors, Application Note AN-0002-00, October 1, 1998; 8 pages.	
	NPL75	9705 Network Software Design Guide Application Note, Stac Electronics, Inc., APP-0012 Revision 1.0, May 1993; 30 pages.	
	NPL76	9705/9705A Data Compression Coprocessor Data Sheet, Hi/fn, May 1996; 87 pages.	
	NPL77	9711 to 7711 Migration Application Note, Hi/fn Network Security Processors, Application Note AN-0007-00, October 1, 1998; 7 pages.	
	NPL78	9732AM Data Compression Coprocessor Data Sheet, Hi/fn, PRS-0055 Revision 0.1, May 1999; 58 pages.	
	NPL79	BLELLOCH, G., "Algorithms in the Real World: Lecture Notes (Fall 1997)," Lecture Notes, UC Berkeley, April 23, 1998; 303 pages. (Submitted in 2 parts.)	
	NPL80	LeCUN, ET AL., "DjVu: a Compression Method for Distributing Scanned Documents in Color over the Internet," AT&T Labs-Research, January 1999; 2 pages.	

Examiner Signature	Date Considered
-----------------------	--------------------

\*EXAMINER: Initial if reference considered, whether or not citation is in conformance with MPEP 609. Draw line through citation if not in conformance and not considered. Include copy of this form with next communication to applicant.

<sup>1</sup> Applicant's unique citation designation number (optional). <sup>2</sup> Applicant is to place a check mark here if English language Translation is attached.

Substitute for form 1449/PTO		<b>Complete if Known</b>	
<b>FOURTH SUPPLEMENTAL INFORMATION DISCLOSURE STATEMENT BY APPLICANT</b> <i>(Use as many sheets as necessary)</i>		Application Number	14/876,276
		Filing Date	October 6, 2015
		First Named Inventor	James J. FALLON
		Art Unit	2634
		Examiner Name	BOCURE, TESFALDET
		Attorney Docket Number	3421.005000C
Sheet	9	of	14

NON PATENT LITERATURE DOCUMENTS			
Examiner Initials*	Cite No. <sup>1</sup>	Include name of the author (in CAPITAL LETTERS), title of the article (when appropriate), title of the item (book, magazine, journal, serial, symposium, catalog, etc.), date, page(s), volume number, publisher, city and/or country where published	T <sup>2</sup>
	NPL81	9732A Data Compression Coprocessor Data Sheet, Hi/fn, October 1999; 50 pages.	
	NPL82	7711 Encryption Processor Data Sheet, Hi/fn Network Security Processors, June 1999; 77 pages.	
	NPL83	7751 Encryption Processor Data Sheet, Hi/fn Network Security Processors, June 1999; 84 pages.	
	NPL84	9751 Data Compression Processor Data Sheet, Hi/fn, June 1999; 66 pages.	
	NPL85	"Hi/fn Encryption Products Power Network Alchemy's Revolutionary VPN Products," Business Wire, January 26, 1999; 2 pages.	
	NPL86	"Hi/fn Provides Hardware Encryption for Xedia's New Access Point QPVN Internet Access Platform," Business Wire, October 19, 1998; 2 pages.	
	NPL87	"LZW Data Compression," Dr. Dobb's, October 1, 1989; 14 pages.	
	NPL88	"New Accelerator Chip From Hi/fn to Speed-Up Virtual Private Networks - 'VPNs'," Business Wire, January 26, 1999; 3 pages.	
	NPL89	Programming the 7711 For IPSEC Applications Application Note, Hi/fn Network Security Processors, Application Note AN-0002-00, October 1, 1998; 15 pages.	
	NPL90	FRIEND, R., "IP Payload Compression Using LZS, Request for Comments" The Internet Society, Network Working Group, Hi/fn, Inc., December 1998; 9 pages.	

Examiner Signature	Date Considered
-----------------------	--------------------

\*EXAMINER: Initial if reference considered, whether or not citation is in conformance with MPEP 609. Draw line through citation if not in conformance and not considered. Include copy of this form with next communication to applicant.

<sup>1</sup> Applicant's unique citation designation number (optional). <sup>2</sup> Applicant is to place a check mark here if English language Translation is attached.

Substitute for form 1449/PTO		<b>Complete if Known</b>	
<b>FOURTH SUPPLEMENTAL INFORMATION DISCLOSURE STATEMENT BY APPLICANT</b> <i>(Use as many sheets as necessary)</i>		Application Number	14/876,276
		Filing Date	October 6, 2015
		First Named Inventor	James J. FALLON
		Art Unit	2634
		Examiner Name	BOCURE, TEFALDET
		Attorney Docket Number	3421.005000C
Sheet	10 of 14		

NON PATENT LITERATURE DOCUMENTS			
Examiner Initials*	Cite No. <sup>1</sup>	Include name of the author (in CAPITAL LETTERS), title of the article (when appropriate), title of the item (book, magazine, journal, serial, symposium, catalog, etc.), date, page(s), volume number, publisher, city and/or country where published	T <sup>2</sup>
	NPL91	Screenshot of hifn.com, accessible via the Internet Archive at < <a href="https://web.archive.org/web/19981212025553/http://www.hifn.com/">https://web.archive.org/web/19981212025553/http://www.hifn.com/</a> >, December 12, 1998; 1 page.	
	NPL92	WIRBEL, L., "Volume shipment for Hi/fn encryption processor," Electronic Engineering Times, Issue 1005, May 4, 1998; 2 pages.	
	NPL93	"Intelligent Compression Technologies: Intelligent Compression Technologies releases XML compressor, XML-Xpress," M2 Presswire, January 30, 2001; 5 pages.	
	NPL94	Form 10 - General Form for Registration of Securities, hi/fn, inc., United States Securities and Exchange Commission, filed December 8, 1998; 387 pages. (Submitted in 3 parts.)	
	NPL95	Form S-3 - Registration Statement Under The Securities Act of 1913, hi/fn, inc., United States Securities and Exchange Commission, filed February 17, 1999; 151 pages.	
	NPL96	HP 7979A/7980A/7980XC Tape Drive User's Guide, Hewlett-Packard Corporation, HP Computer Museum, October 1988; 76 pages.	
	NPL97	7980A Tape Drive - Documentation, HP Computer Museum, accessible at < <a href="http://www.hp.com/museum/exhibit.php?hwdoc=390">http://www.hp.com/museum/exhibit.php?hwdoc=390</a> >, September 22, 2015; 1 page.	
	NPL98	The HP 7980A/7979A 1/2-inch Tape Drives, Hewlett-Packard Product Specifications, June 1, 1987; 2 pages.	
	NPL99	9145A Tape Drive - Documentation, HP Computer Museum, accessible at < <a href="http://www.hp.com/museum/exhibit.php?hwdoc=258">http://www.hp.com/museum/exhibit.php?hwdoc=258</a> >, September 22, 2015; 1 page.	
	NPL100	HP 9145A Tape Drive User's Manual, Edition 1, Hewlett-Packard Corporation, July 1988; 61 pages.	

Examiner Signature	Date Considered
--------------------	-----------------

\*EXAMINER: Initial if reference considered, whether or not citation is in conformance with MPEP 609. Draw line through citation if not in conformance and not considered. Include copy of this form with next communication to applicant.

<sup>1</sup> Applicant's unique citation designation number (optional). <sup>2</sup> Applicant is to place a check mark here if English language Translation is attached.

Substitute for form 1449/PTO		<b>Complete if Known</b>	
<b>FOURTH SUPPLEMENTAL INFORMATION DISCLOSURE STATEMENT BY APPLICANT</b> <i>(Use as many sheets as necessary)</i>		Application Number	14/876,276
		Filing Date	October 6, 2015
		First Named Inventor	James J. FALLON
		Art Unit	2634
		Examiner Name	BOCURE, TESFALDET
		Attorney Docket Number	3421.005000C
Sheet	11	of	14

NON PATENT LITERATURE DOCUMENTS			
Examiner Initials*	Cite No. <sup>1</sup>	Include name of the author (in CAPITAL LETTERS), title of the article (when appropriate), title of the item (book, magazine, journal, serial, symposium, catalog, etc.), date, page(s), volume number, publisher, city and/or country where published	T <sup>2</sup>
	NPL101	Peripheral Products, HP Computer Museum, accessible at < <a href="http://www.hpmuseum.net/exhibit.php?class=4&amp;cat=85">http://www.hpmuseum.net/exhibit.php?class=4&amp;cat=85</a> >, September 22, 2015; 3 page.	
	NPL102	PALL, G., "Microsoft Point-To-Point Compression (MPPC) Protocol, Request for Comments," The Internet Society, Network Working Group, Hi/fn, Inc., December 1998; 9 pages.	
	NPL103	"Cisco IOS Data Compression," Cisco Systems White Paper, 1997; 10 pages.	
	NPL104	"Reference Software 7751 Encryption Processor," Hi/fn Network Security Processors, Reference Software RS-0001-00, October 1, 1998; 38 pages.	
	NPL105	Screenshot of hifn.com, accessible via the Internet Archive at < <a href="https://web.archive.org/web/19981205163011/http://www.hifn.com">https://web.archive.org/web/19981205163011/http://www.hifn.com</a> >, December 5, 1998; 1 page.	
	NPL106	TESS Record for Serial No. 78040025, filed December 20, 2000, "Typed Drawing," accessed November 10, 2015; 1 page.	
	NPL107	"Compaq Professional Workstation AP500 Key Technologies White Paper," Compaq Computer Corporation, August 1998; 21 pages.	
	NPL108	LANGDON, G., "An Introduction to Arithmetic Coding," IBM Journal of Research and Development, Vol. 28, No. 2, March 1984; pp. 135-149.	
	NPL109	"Connecting Your HP SureStore CD-Writer Plus Drive: Windows 95 and Windows NT 4.0," Hewlett-Packard Corporation, 1997; 50 pages.	
	NPL110	"Quantum Rushmore Solid State Disk Drives," Quantum Corporation, accessible via the Internet Archive at < <a href="http://web.archive.org/web/19980220122303/http://www.quantum.com/products/ssd/">http://web.archive.org/web/19980220122303/http://www.quantum.com/products/ssd/</a> >, February 20, 1998; 2 pages.	

Examiner Signature	Date Considered
-----------------------	--------------------

\*EXAMINER: Initial if reference considered, whether or not citation is in conformance with MPEP 609. Draw line through citation if not in conformance and not considered. Include copy of this form with next communication to applicant.

<sup>1</sup> Applicant's unique citation designation number (optional). <sup>2</sup> Applicant is to place a check mark here if English language Translation is attached.



Substitute for form 1449/PTO		<i>Complete if Known</i>	
<b>FOURTH SUPPLEMENTAL INFORMATION DISCLOSURE STATEMENT BY APPLICANT</b> <i>(Use as many sheets as necessary)</i>		Application Number	14/876,276
		Filing Date	October 6, 2015
		First Named Inventor	James J. FALLON
		Art Unit	2634
		Examiner Name	BOCURE, TESHALDET
		Attorney Docket Number	3421.005000C
Sheet	12	of	14

NON PATENT LITERATURE DOCUMENTS			
Examiner Initials*	Cite No. <sup>1</sup>	Include name of the author (in CAPITAL LETTERS), title of the article (when appropriate), title of the item (book, magazine, journal, serial, symposium, catalog, etc.), date, page(s), volume number, publisher, city and/or country where published	T <sup>2</sup>
	NPL111	"MegaRam Solid State Disks," Imperial Technology, Inc., accessible via the Internet Archive at < <a href="https://web.archive.org/web/19980206055558/http://imperialtech.com/SolidState.html">https://web.archive.org/web/19980206055558/http://imperialtech.com/SolidState.html</a> >, February 6, 1998; 2 pages.	
	NPL112	"Replica - The Fastest, Most Reliable Data Protection For Servers," accessible via the Internet Archive at < <a href="http://web.archive.org/web/19970226213335/http://www1.stac.com/soft/replfct.html">http://web.archive.org/web/19970226213335/http://www1.stac.com/soft/replfct.html</a> >, February 26, 1997; 4 pages.	
	NPL113	"Object Replication: A Revolutionary Advance in Distributed Data Protection and Recovery," Stac White Paper, 1999; 7 pages.	
	NPL114	"Features and Benefits for Replica," Replica for NetWare, 1999; 3 pages.	
	NPL115	DjVu 2.2 Reference Library, August 2000 (submitted on compact disc).	
	NPL116	"Replica - The Fastest, Most Reliable Data Protection for Servers," accessible via the Internet Archive at < <a href="http://web.archive.org/web/19970226213335/http://www1.stac.com/soft/replcont.html">http://web.archive.org/web/19970226213335/http://www1.stac.com/soft/replcont.html</a> >, February 26, 1997; 1 page.	
	NPL117	"Stac Products & Technology," accessible via the Internet Archive at < <a href="http://web.archive.org/web/19970226213054/http://www1.stac.com/soft/softprod.html">http://web.archive.org/web/19970226213054/http://www1.stac.com/soft/softprod.html</a> >, February 26, 1997; 1 page.	
	NPL118	"Hi/fn Product Catalog," accessible via the Internet Archive at < <a href="http://web.archive.org/19971010233632/http://www.hifn.com/products/product/index.htm">http://web.archive.org/19971010233632/http://www.hifn.com/products/product/index.htm</a> >, October 10, 1997; 1 page.	
	NPL119	"Hi/fn Products," accessible via the Internet Archive at < <a href="http://web.archive.org/19971010233115/http://www.hifn.com/products/index.htm">http://web.archive.org/19971010233115/http://www.hifn.com/products/index.htm</a> >, October 10, 1997; 1 page.	
	NPL120	"Replica Family," accessible via the Internet Archive at < <a href="http://web.archive.org/19980212174817/http://www.stac.com/replica/rep_overview.html">http://web.archive.org/19980212174817/http://www.stac.com/replica/rep_overview.html</a> >, February 12, 1998; 1 page.	
Examiner Signature		Date Considered	

\*EXAMINER: Initial if reference considered, whether or not citation is in conformance with MPEP 609. Draw line through citation if not in conformance and not considered. Include copy of this form with next communication to applicant.

<sup>1</sup> Applicant's unique citation designation number (optional). <sup>2</sup> Applicant is to place a check mark here if English language Translation is attached.

Substitute for form 1449/PTO		<b>Complete if Known</b>	
<b>FOURTH SUPPLEMENTAL INFORMATION DISCLOSURE STATEMENT BY APPLICANT</b> <i>(Use as many sheets as necessary.)</i>		Application Number	14/876,276
		Filing Date	October 6, 2015
		First Named Inventor	James J. FALLON
		Art Unit	2634
		Examiner Name	BOCURE, TESFALDET
		Attorney Docket Number	3421.005000C
Sheet	13	of	14

NON PATENT LITERATURE DOCUMENTS			
Examiner Initials*	Cite No. <sup>1</sup>	Include name of the author (in CAPITAL LETTERS), title of the article (when appropriate), title of the item (book, magazine, journal, serial, symposium, catalog, etc.), date, page(s), volume number, publisher, city and/or country where published	T <sup>2</sup>
	NPL121	"Stac Web Site Cotents," accessible via the Internet Archive at < <a href="http://web.archive.org/19990827224836/http://www.stac.com/subcontents/sitemap.asp?sitemap">http://web.archive.org/19990827224836/http://www.stac.com/subcontents/sitemap.asp?sitemap</a> >, August 27, 1999; 4 pages.	
	NPL122	"Data Compression Procedures for Data Circuit Terminating Equipment (DCE) Using Error Correcting Procedures," International Telecommunication Union Recommendation V.42 bis, 1990; 29 pages.	
	NPL123	Stac, Inc., News Articles, dated March 10, 1997 to February 2, 1999; 41 pages.	
	NPL124	Orost Archive of Welch Source Code, University of California, 1985; 54 pages.	
	NPL125	Sidewinder 50 Product Manual, Rev. A, Seagate Technology, Inc., 1997; 189 pages. (Submitted in 3 parts.)	
	NPL126	Form 10-Q Quarterly Report Pursuant to Section 13 or 15(d) of the Security Exchange Act of 1934, Stac Software, Inc., filed August 13, 1999; 16 pages.	
	NPL127	"Hi/Fn™ 7711 Encryption Processor™ Shipping in Volume," PR Newswire, April 20, 1998; 2 pages.	
	NPL128	"Lucent Technologies Selects," PR Newswire, March 1, 1999; 2 pages.	
	NPL129	"Stac backs it up with Replica," INFOSTOR, May 1, 1998; 2 pages.	
	NPL130	Court Docket History for Realtime Data, LLC d/b/a IXO v. Actian Corporation, et al., Case No. 6:15-cv-00463 (E.D. Texas), downloaded February 17, 2016, 29 pages.	
Examiner Signature		Date Considered	

\*EXAMINER: Initial if reference considered, whether or not citation is in conformance with MPEP 609. Draw line through citation if not in conformance and not considered. Include copy of this form with next communication to applicant.

<sup>1</sup> Applicant's unique citation designation number (optional). <sup>2</sup> Applicant is to place a check mark here if English language Translation is attached.

Substitute for form 1449/PTO		<b>Complete if Known</b>	
<b>FOURTH SUPPLEMENTAL INFORMATION DISCLOSURE STATEMENT BY APPLICANT</b> <i>(Use as many sheets as necessary)</i>		Application Number	14/876,276
		Filing Date	October 6, 2015
		First Named Inventor	James J. FALLON
		Art Unit	2634
		Examiner Name	BOCURE, TESFALDET
		Attorney Docket Number	3421.005000C
Sheet	14	of	14

NON PATENT LITERATURE DOCUMENTS			
Examiner Initials*	Cite No. <sup>1</sup>	Include name of the author (in CAPITAL LETTERS), title of the article (when appropriate), title of the item (book, magazine, journal, serial, symposium, catalog, etc.), date, page(s), volume number, publisher, city and/or country where published	T <sup>2</sup>
	NPL131	Court Docket History for Realtime Data, LLC d/b/a IXO v. Dropbox, Inc., Case No. 6:15-cv-00465 (E.D. Texas), downloaded February 17, 2016, 6 pages.	
	NPL132	Court Docket History for Realtime Data, LLC d/b/a IXO v. Echostar Corporation, et al., Case No. 6:15-cv-00466 (E.D. Texas), downloaded February 17, 2016, 3 pages.	
	NPL133	Court Docket History for Realtime Data, LLC d/b/a IXO v. Riverbed Technology, Inc., et al., Case No. 6:15-cv-00468 (E.D. Texas), downloaded February 17, 2016, 3 pages.	
	NPL134	Court Docket History for Realtime Data, LLC d/b/a IXO v. BMC Software, Inc., Case No. 6:15-cv-00464 (E.D. Texas), downloaded February 17, 2016, 3 pages.	
	NPL135	Court Docket History for Realtime Data, LLC d/b/a IXO v. Oracle America, Inc., et al., Case No. 6:15-cv-00467 (E.D. Texas), downloaded February 17, 2016, 4 pages.	
	NPL136	Court Docket History for Realtime Data, LLC d/b/a IXO v. SAP America, Inc., et al., Case No. 6:15-cv-00469 (E.D. Texas), downloaded February 17, 2016, 5 pages.	
	NPL137	Court Docket History for Realtime Data, LLC d/b/a IXO v. Teradata Corporation, et al., Case No. 6:15-cv-00470 (E.D. Texas), downloaded February 17, 2016, 6 pages.	
	NPL138	Court Docket History for Realtime Data, LLC d/b/a IXO v. Apple, Inc., Case No. 6:15-cv-00885 (E.D. Texas), downloaded February 17, 2016, 6 pages.	

2774134\_1.DOCX

Examiner Signature	Date Considered
-----------------------	--------------------

\*EXAMINER: Initial if reference considered, whether or not citation is in conformance with MPEP 609. Draw line through citation if not in conformance and not considered. Include copy of this form with next communication to applicant.

<sup>1</sup> Applicant's unique citation designation number (optional). <sup>2</sup> Applicant is to place a check mark here if English language Translation is attached.

## Electronic Patent Application Fee Transmittal

<b>Application Number:</b>	14876276			
<b>Filing Date:</b>	06-Oct-2015			
<b>Title of Invention:</b>	Video Data Compression Systems			
<b>First Named Inventor/Applicant Name:</b>	James J. FALLON			
<b>Filer:</b>	Michael V. Messinger/William Flanigen			
<b>Attorney Docket Number:</b>	3421.005000C			
Filed as Large Entity				
<b>Filing Fees for Utility under 35 USC 111(a)</b>				
<b>Description</b>	<b>Fee Code</b>	<b>Quantity</b>	<b>Amount</b>	<b>Sub-Total in USD(\$)</b>
<b>Basic Filing:</b>				
<b>Pages:</b>				
<b>Claims:</b>				
<b>Miscellaneous-Filing:</b>				
<b>Petition:</b>				
<b>Patent-Appeals-and-Interference:</b>				
<b>Post-Allowance-and-Post-Issuance:</b>				
<b>Extension-of-Time:</b>				

Description	Fee Code	Quantity	Amount	Sub-Total in USD(\$)
<b>Miscellaneous:</b>				
Submission- Information Disclosure Stmt	1806	1	180	180
<b>Total in USD (\$)</b>				<b>180</b>

## Electronic Acknowledgement Receipt

<b>EFS ID:</b>	25008950
<b>Application Number:</b>	14876276
<b>International Application Number:</b>	
<b>Confirmation Number:</b>	3403
<b>Title of Invention:</b>	Video Data Compression Systems
<b>First Named Inventor/Applicant Name:</b>	James J. FALLON
<b>Customer Number:</b>	26111
<b>Filer:</b>	Michael V. Messinger/William Flanigen
<b>Filer Authorized By:</b>	Michael V. Messinger
<b>Attorney Docket Number:</b>	3421.005000C
<b>Receipt Date:</b>	24-FEB-2016
<b>Filing Date:</b>	06-OCT-2015
<b>Time Stamp:</b>	15:47:36
<b>Application Type:</b>	Utility under 35 USC 111(a)

### Payment information:

Submitted with Payment	yes
Payment Type	Credit Card
Payment was successfully received in RAM	\$180
RAM confirmation Number	2258
Deposit Account	
Authorized User	

The Director of the USPTO is hereby authorized to charge indicated fees and credit any overpayment as follows:

--	--	--	--	--	--

**File Listing:**

Document Number	Document Description	File Name	File Size(Bytes)/ Message Digest	Multi Part /.zip	Pages (if appl.)
1		3421005000C_4SIDS.pdf	3352683 f9c9821beaae2272a54a26e5ee3896e8a94f a1f2	yes	24

Multipart Description/PDF files in .zip description			
Document Description	Start	End	
Miscellaneous Incoming Letter	1	1	
Transmittal Letter	2	9	
Information Disclosure Statement (IDS) Form (SB08)	10	24	

**Warnings:**

**Information:**

2	Fee Worksheet (SB06)	fee-info.pdf	30303 623cac326255916873df9d2283dff990947f d565	no	2
---	----------------------	--------------	-------------------------------------------------------	----	---

**Warnings:**

**Information:**

<b>Total Files Size (in bytes):</b>	3382986
-------------------------------------	---------

**This Acknowledgement Receipt evidences receipt on the noted date by the USPTO of the indicated documents, characterized by the applicant, and including page counts, where applicable. It serves as evidence of receipt similar to a Post Card, as described in MPEP 503.**

**New Applications Under 35 U.S.C. 111**

If a new application is being filed and the application includes the necessary components for a filing date (see 37 CFR 1.53(b)-(d) and MPEP 506), a Filing Receipt (37 CFR 1.54) will be issued in due course and the date shown on this Acknowledgement Receipt will establish the filing date of the application.

**National Stage of an International Application under 35 U.S.C. 371**

If a timely submission to enter the national stage of an international application is compliant with the conditions of 35 U.S.C. 371 and other applicable requirements a Form PCT/DO/EO/903 indicating acceptance of the application as a national stage submission under 35 U.S.C. 371 will be issued in addition to the Filing Receipt, in due course.

**New International Application Filed with the USPTO as a Receiving Office**

If a new international application is being filed and the international application includes the necessary components for an international filing date (see PCT Article 11 and MPEP 1810), a Notification of the International Application Number and of the International Filing Date (Form PCT/RO/105) will be issued in due course, subject to prescriptions concerning national security, and the date shown on this Acknowledgement Receipt will establish the international filing date of the application.

MICHAEL V. MESSINGER  
DIRECTOR  
(202) 772-8667  
MIKEM@SKGF.COM



February 24, 2016

Commissioner for Patents  
PO Box 1450  
Alexandria, VA 22313-1450

**Confirmation No. 3403**  
**Art Unit 2634**  
**Attn: Mail Stop Amendment**

Re: U.S. Utility Patent Application  
Application No. 14/876,276; Filing Date: October 6, 2015  
For: **Video Data Compression Systems**  
Inventors: FALLON *et al.*  
Our Ref: 3421.005000C

Commissioner:

Transmitted herewith for appropriate action are the following documents:

1. Online Credit Card Payment Authorization in the amount of \$180.00 in payment of the fee under 37 C.F.R. § 1.17(p);
2. Fourth Supplemental Information Disclosure Statement;
3. Form PTO/SB/08a (1 sheet) listing 6 documents (US1-US6);
4. Form PTO/SB/08b (14 sheets) listing 138 documents (NPL1-NPL138).

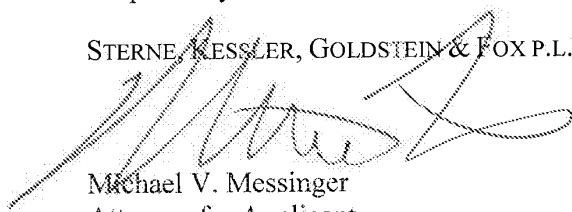
***The above-listed documents are filed electronically through EFS-Web.***

In the event that extensions of time are necessary to prevent abandonment of this patent application, then such extensions of time are hereby petitioned.

Fee payment is provided through online credit card payment. The U.S. Patent and Trademark Office is hereby authorized to charge any fee deficiency, or credit any overpayment, to our Deposit Account No. 19-0036.

Respectfully submitted,

STERNE, KESSLER, GOLDSTEIN & FOX P.L.L.C.



Michael V. Messinger  
Attorney for Applicant  
Registration No. 37,575

MVM/MRM/wcf  
Enclosures

2774149\_1.DOCX



IN THE UNITED STATES PATENT AND TRADEMARK OFFICE

Inventors: FALLON *et al.*

Confirmation No.: 3403

Applicant: Realtime Data, LLC

Art Unit: 2634

Application No.: 14/876,276

Examiner: BOCURE, TESFALDET

Filing Date: October 6, 2015

Atty. Docket: 3421.005000C

Title: **Video Data Compression Systems**

**Fourth Supplemental Information Disclosure Statement**

*Mail Stop Amendment*

Commissioner for Patents  
PO Box 1450  
Alexandria, VA 22313-1450

Commissioner:

Notice of Prior and Concurrent Proceedings

Applicant hereby calls to the attention of the Patent and Trademark Office the following reexamination proceedings involving patents that are commonly-assigned with the patent in the above-identified patent application:

<b>Proceeding</b>	<b>Status</b>
Inter Partes Reexamination of U.S. Patent No. 6,604,158 (Control No. 95/000,486)	Inter Partes Reexamination Certificate issued 10/10/2012
Inter Partes Reexamination of U.S. Patent No. 7,321,937 (Control No. 95/000,466)	Inter Partes Reexamination Certificate issued 05/15/2012
Inter Partes Reexamination of U.S. Patent No. 6,604,158 (Control No. 95/000,453)	Terminated
Ex Parte Reexamination of U.S. Patent No. 6,601,104 (Control No. 90/009,428)	Ex Parte Reexamination Certificate issued 02/28/2012
Inter Partes Reexamination of U.S. Patent No. 7,378,992 (Control No. 95/000,478)	Inter Partes Reexamination Certificate issued 10/04/2012
Inter Partes Reexamination of U.S. Patent No. 6,624,761 (Control No. 95/000,464)	Inter Partes Reexamination Certificate issued 06/12/2012
Inter Partes Reexamination of U.S. Patent No. 7,161,506 (Control No. 95/000,479)	Inter Partes Reexamination Certificate issued 05/22/2012

<b>Proceeding</b>	<b>Status</b>
Inter Partes Reexamination of U.S. Patent No. 7,714,747 (Control No. 95/001,517)	Appeal to the Court of Appeals for the Federal Circuit dismissed 6/4/2015
Inter Partes Reexamination of U.S. Patent No. 7,417,568 (Control No. 95/001,533)	Decision on Appeal mailed 10/29/2015
Inter Partes Reexamination of U.S. Patent No. 7,777,651 (Control No. 95/001,581)	Decision on Appeal mailed 10/29/2015
Inter Partes Reexamination of U.S. Patent No. 7,400,274 (Control No. 95/001,544)	Decision on Appeal mailed 10/29/2015

Applicant hereby calls to the attention of the Patent and Trademark Office the following reexamination proceedings filed by Cellco Partnership d/b/a Verizon Wireless, involving patents that are commonly-assigned with the patent in the above-identified patent application:

<b>Proceeding</b>	<b>Status</b>
Inter Partes Reexamination of U.S. Patent No. 7,321,937 (Control No. 95/001,922)	Inter Partes Reexamination Certificate issued 12/05/2013
Inter Partes Reexamination of U.S. Patent No. 6,604,158 (Control No. 95/001,923)	Inter Partes Reexamination Certificate issued 04/17/2015
Inter Partes Reexamination of U.S. Patent No. 7,352,300 (Control No. 95/001,924)	Inter Partes Reexamination Certificate issued 08/04/2014
Inter Partes Reexamination of U.S. Patent No. 7,395,345 (Control No. 95/001,925)	Inter Partes Reexamination Certificate issued 11/03/2014
Inter Partes Reexamination of U.S. Patent No. 7,161,506 (Control No. 95/001,926)	Inter Partes Reexamination Certificate issued 01/08/2014
Inter Partes Reexamination of U.S. Patent No. 7,415,530 (Control No. 95/001,927)	Inter Partes Reexamination Certificate issued 08/16/2013
Inter Partes Reexamination of U.S. Patent No. 7,378,992 (Control No. 95/001,928)	Inter Partes Reexamination Certificate issued 01/08/2014

Applicant invites the Examiner to review the Requests for Reexamination, issued Office Actions, replies, and any other papers in the above-identified reexamination proceedings. If the Examiner is unable to obtain copies of papers in any reexamination proceeding, copies can be

Atty. Dkt. No. 3421,005000C

provided to the Examiner upon request. Those documents which may be material that are not already of record in this patent application are listed on the accompanying Form PTO/SB/08.

Applicant hereby calls to the attention of the Patent and Trademark Office the following *inter partes* review proceedings involving patents that are commonly-assigned with the patent in the above-identified patent application:

Proceeding	Patent	Status
<i>Oracle America, Inc. v. Realtime Data, LLC</i> , IPR2016-00373	7,378,992	Petition filed December 22, 2015
<i>Oracle America, Inc. v. Realtime Data, LLC</i> , IPR2016-00374	8,643,513	Petition filed December 22, 2015
<i>Oracle America, Inc. v. Realtime Data, LLC</i> , IPR2016-00375	7,415,530	Petition filed December 28, 2015
<i>Oracle America, Inc. v. Realtime Data, LLC</i> , IPR2016-00376	7,415,530	Petition filed December 28, 2015
<i>Oracle America, Inc. v. Realtime Data, LLC</i> , IPR2016-00377	9,116,908	Petition filed December 28, 2015

Applicant invites the Examiner to review the petitions for *inter partes* review and any other papers in the above-identified *inter partes* review proceedings. If the Examiner is unable to obtain copies of papers in any *inter partes* review proceeding, copies can be provided to the Examiner upon request. Those documents which may be material that are not already of record in this patent application are listed on the accompanying Form PTO/SB/08.

Notice of Related Litigation

Applicant notifies the Patent and Trademark Office of the following litigation involving U.S. Patents commonly-owned with the current patent application, the subject matter of which may be related to the present patent application:

Atty. Dkt. No. 3421.005000C

No.	Case	Status
1	<i>Realtime Data LLC d/b/a IXO v. Packeteer, Inc. et al.</i> , No. 6:08-cv-00144-LED (E.D. Texas)	Dismissed

Applicant also notifies the Patent and Trademark Office of the following additional litigation involving U.S. Patents commonly-owned with the current patent application, the subject matter of which may be related to the present patent application:

No.	Case	Status
2	<i>Realtime Data LLC d/b/a IXO v. Thomson Reuters Corporation et al.</i> No. 1:11-cv-06698-RJH (S.D. New York) (transferred from E.D. Texas; 6:09-cv-00333-LED)	Case Terminated 11/9/2012; Opinion of the Court of Appeals for the Federal Circuit received 01/27/2014
3	<i>Realtime Data LLC d/b/a IXO v. Morgan Stanley et al.</i> , No. 1:11-cv-06696-RJH (S.D. New York) (transferred from E.D. Texas; 6:09-cv-00326-LED)	Case Terminated 11/9/2012; Opinion of the Court of Appeals for the Federal Circuit received 01/27/2014
4	<i>Realtime Data LLC d/b/a IXO v. CME Group Inc., et al.</i> , No. 1:11-cv-06697-RJH (S.D. New York) (transferred from E.D. Texas; No. 6:09-cv-00327-LED)	Case Terminated 11/9/2012; Opinion of the Court of Appeals for the Federal Circuit received 01/27/2014
5	<i>Chicago Board Options Exchange, Inc., v. Realtime Data LLC d/b/a IXO</i> , No. 09-cv-4486 (N.D. Ill.)	Dismissed
6	<i>Thomson Reuters Corporation v. Realtime Data, LLC d/b/a IXO</i> , No. 1:09-cv-07868-RMB (S.D.N.Y)	Consolidated with Case No. 2
7	<i>Realtime Data, LLC d/b/a IXO v. CME Group Inc., et al. (II)</i> , No. 6:10-cv-246 (E.D. Texas)	Consolidated with Case No. 4
8	<i>Realtime Data LLC d/b/a IXO v. Thomson Reuters Corporation et al. (II)</i> , No. 6:10-cv-247 (E.D. Texas)	Consolidated with Case No. 2
9	<i>Realtime Data, LLC d/b/a IXO v. Morgan Stanley, et al. (II)</i> , No. 6:10-cv-248 (E.D. Texas)	Consolidated with Case No. 3
10	<i>Realtime Data, LLC d/b/a IXO v. MetroPCS Texas, LLC et al.</i> , No. 6:10-cv-00493 (E.D. Texas)	Appeal Terminated

Atty. Dkt. No. 3421.005000C

11	<i>Realtime Data, LLC d/b/a IXO v. Microsoft Corporation, et al.</i> , No. 4:14-cv-00827 (E.D. Texas)	Dismissed May 1, 2015
12	<i>Realtime Data, LLC d/b/a IXO v. Actian Corporation, et al.</i> , No. 6:15-cv-00463 (E.D. Texas)	Amended Complaints for Patent Infringement filed September 14, 2015
13	<i>Realtime Data, LLC d/b/a IXO v. Dropbox, Inc.</i> , No. 6:15-cv-00465 (E.D. Texas)	Dismissed February 22, 2016
14	<i>Realtime Data, LLC d/b/a IXO v. Echostar Corporation, et al.</i> , No. 6:15-cv-00466 (E.D. Texas)	Consolidated with Case No. 12; Answer to Amended Complaint filed February 4, 2016
15	<i>Realtime Data, LLC d/b/a IXO v. Riverbed Technology, Inc., et al.</i> , No. 6:15-cv-00468 (E.D. Texas)	Consolidated with Case No. 12; Second Amended Complaint for Infringement filed February 2, 2016
16	<i>Realtime Data, LLC d/b/a IXO v. BMC Software, Inc.</i> , No. 6:15-cv-00464 (E.D. Texas)	Terminated October 5, 2015
17	<i>Realtime Data, LLC d/b/a IXO v. Oracle America, Inc., et al.</i> , No. 6:15-cv-00467 (E.D. Texas)	Consolidated with Case No. 12
18	<i>Realtime Data, LLC d/b/a IXO v. SAP America, Inc., et al.</i> , No. 6:15-cv-00469 (E.D. Texas)	Consolidated with Case No. 12; Answers to Amended Complaint filed February 4, 2016
19	<i>Realtime Data, LLC d/b/a IXO v. Teradata Corporation, et al.</i> , No. 6:15-cv-00470 (E.D. Texas)	Transferred to the Northern District of California, January 19, 2016
20	<i>Realtime Data, LLC d/b/a IXO v. Apple, Inc.</i> , No. 6:15-cv-00885 (E.D. Texas)	Order Granting Motion to Stay entered February 11, 2016

Updated court docket histories for pending litigations are submitted herewith as documents  
**NPL130-NPL138.**

Information Disclosure Statement

Listed on accompanying IDS Forms PTO/SB/08a equivalent and PTO/SB/08b equivalent are documents that may be considered material to the patentability of this application as defined in 37 C.F.R. §1.56, and in compliance with the duty of disclosure requirements of 37 C.F.R. §§ 1.97 and 1.98.

Applicant has listed publication dates on the attached IDS Forms based on information presently available to the undersigned. However, the listed publication dates should not be construed as an admission that the information was actually published on the date indicated.

Applicant reserves the right to establish the patentability of the claimed invention over any of the information provided herewith, and/or to prove that this information may not be prior art, and/or to prove that this information may not be enabling for the teachings purportedly offered.

This statement should not be construed as a representation that a search has been made, or that information more material to the examination of the present patent application does not exist. The Examiner is specifically requested not to rely solely on the material submitted herewith.

Filing under 37 C.F.R. § 1.97(c). This Information Disclosure Statement is being filed more than three months after the U.S. filing date AND after the mailing date of the first Office Action on the merits, but before the mailing date of a Final Rejection, or Notice of Allowance, or an action that otherwise closes prosecution in the application. The required fee is provided through online

Atty. Dkt. No. 3421.005000C

credit card payment authorization in the amount of \$180.00 in payment of the fee under 37 C.F.R. § 1.17(p).

In accordance with 37 C.F.R. § 1.98(a)(2)(ii), no copies of the U.S. patents and patent application publication cited as documents **US1-US6** on the attached IDS Forms are submitted.

Copies of documents **NPL1-NPL138** were cited by or submitted to the Office in an IDS that complies with 37 C.F.R. § 1.98(a)-(c) in Application No. 14/733,565, filed June 8, 2015 (now pending), which is relied upon for an earlier filing date under 35 U.S.C. § 120. Thus, copies of these documents are not attached. 37 C.F.R. § 1.98(d).

It is expected that the examiner will review the prosecution and cited art in the parent application nos. 14/733,565, filed June 8, 2015 (now pending); 14/577,286, filed December 19, 2014 (now abandoned); 14/134,933, filed December 19, 2013 (now U.S. Patent No. 8,929,442); 14/033,245, filed September 20, 2013 (now U.S. Patent No. 8,934,535); 13/154,239, filed June 6, 2011 (now U.S. Patent No. 8,553,759); 12/123,081, filed May 19, 2008 (now U.S. Patent No. 8,073,047); and 10/076,013, filed February 13, 2002 (now U.S. Patent No. 7,386,046), in accordance with MPEP 2001.06(b), and indicate in the next communication from the office that the art cited in the earlier prosecution history has been reviewed in connection with the present application.

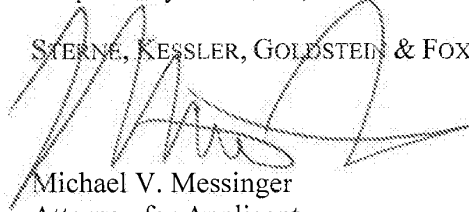
It is respectfully requested that the Examiner initial and return a copy of the enclosed IDS Forms, and indicate in the official file wrapper of this patent application that the documents have been considered.

Atty. Dkt. No. 3421.005000C

The U.S. Patent and Trademark Office is hereby authorized to charge any fee deficiency, or credit any overpayment, to our Deposit Account No. 19-0036.

Respectfully submitted,

STERNE, KESSLER, GOLDSTEIN & FOX P.L.L.C.



Michael V. Messinger  
Attorney for Applicant  
Registration No. 37,575

Date: February 24, 2016

1100 New York Avenue, N.W.  
Washington, D.C. 20005-3934  
(202) 371-2600

2774143\_1.DOCX



Substitute for form 1449/PTO			<b>Complete if Known</b>		
<b>THIRD SUPPLEMENTAL INFORMATION DISCLOSURE STATEMENT BY APPLICANT</b> <i>(Use as many sheets as necessary)</i>			Application Number	14/876,276	
			Filing Date	October 6, 2015	
			First Named Inventor	James J. FALLON	
			Art Unit	2634	
			Examiner Name	BOCURE, TESFALDET	
Sheet	1	of	1	Attorney Docket Number	3421.005000C

U.S. PATENT DOCUMENTS						
Examiner initials*	Cite No. <sup>1</sup>	Document Number		Publication Date MM-DD-YYYY	Name of Patentee or Applicant of Cited Document	Pages, Columns, Lines, Where Relevant Passages or Relevant Figures Appear
		Number-Kind Code <sup>2</sup> (if known)				
	US1	4,558,302		12-10-1985	Welch	
	US2	4,568,983		02-04-1986	Bobick	
	US3	5,046,119		09-03-1991	Hoffert et al.	
	US4	5,227,878		07-13-1993	Puri et al.	
	US5	5,333,212		07-26-1994	Ligtenberg	
	US6	5,379,351		01-03-1995	Fandrianto et al.	
	US7	5,379,356		01-03-1995	Purcell et al.	
	US8	5,402,146		03-28-1995	Rodriguez et al.	
	US9	5,408,542		04-18-1995	Callahan	
	US10	5,684,478		11-04-1997	Panaoussis	
	US11	5,870,036		02-09-1999	Franaszek et al.	
	US12	6,023,233		02-08-2000	Craven et al.	
	US13	6,092,071		07-18-2000	Bolan et al.	
	US14	6,169,499 B1		01-02-2001	Cooper	
	US15	6,215,983 B1		04-10-2001	Dogan et al.	
	US16	6,370,631 B1		04-09-2002	Dye	
	US17	6,404,919 B1		06-11-2002	Nishigaki et al.	

FOREIGN PATENT DOCUMENTS							
Examiner initials*	Cite No. <sup>1</sup>	Foreign Patent Document		Publication Date MM-DD-YYYY	Name of Patentee or Applicant of Cited Document	Pages, Columns, Lines, Where Relevant Passages or Relevant Figures Appear	T 6
		Country Code <sup>3</sup> -Number <sup>4</sup> -Kind Code <sup>5</sup> (if known)					
	FP1	WO	98/19450	05-07-1998	Sensormatic Electronics Corporation		

2763213\_1.DOCX

Examiner Signature		Date Considered	
--------------------	--	-----------------	--

\*EXAMINER: Initial if reference considered, whether or not citation is in conformance with MPEP 609. Draw line through citation if not in conformance and not considered. Include copy of this form with next communication to applicant. <sup>1</sup> Applicant's unique citation designation number (optional). <sup>2</sup> See Kinds Codes of USPTO Patent Documents at www.uspto.gov or MPEP 901.04. <sup>3</sup> Enter Office that issued the document, by the two-letter code (WIPO Standard ST.3). <sup>4</sup> For Japanese patent documents, the indication of the year of the reign of the Emperor must precede the serial number of the patent document. <sup>5</sup> Kind of document by the appropriate symbols as indicated on the document under WIPO Standard ST.16 if possible. <sup>6</sup> Applicant is to place a check mark here if English language Translation is attached.

Substitute for form 1449/PTO		<i>Complete if Known</i>	
<b>THIRD SUPPLEMENTAL INFORMATION DISCLOSURE STATEMENT BY APPLICANT</b> <i>(Use as many sheets as necessary)</i>		Application Number	14/876,276
		Filing Date	October 6, 2015
		First Named Inventor	James J. FALLON
		Art Unit	2634
		Examiner Name	BOCURE, TESFALDET
		Attorney Docket Number	3421.005000C
Sheet	1	of	4

NON PATENT LITERATURE DOCUMENTS			
Examiner Initials*	Cite No. <sup>1</sup>	Include name of the author (in CAPITAL LETTERS), title of the article (when appropriate), title of the item (book, magazine, journal, serial, symposium, catalog, etc.), date, page(s), volume-issue number(s), publisher, city and/or country where published	T <sup>2</sup>
	NPL1	Order Adopting Report and Recommendation of United States Magistrate Judge, filed in Realtime Data, LLC d/b/a IXO v. Actian Corporation, et al., Case No. 6:15-cv-00463-RWS-JDL (E.D. Texas), filed January 21, 2016; 4 pages.	
	NPL2	Defendants' Preliminary Invalidation Contentions, submitted in Realtime Data, LLC d/b/a IXO v. Actian Corporation, et al., Case No. 6:15-cv-0063-RWS-JDL (E.D. Texas), served December 4, 2015; 138 pages.	
	NPL3	Non-Confidential Exhibits A1-A7 and A9-A10 to Defendants' Preliminary Invalidation Contentions, submitted in Realtime Data, LLC d/b/a IXO v. Actian Corporation, et al., Case No. 6:15-cv-0063-RWS-JDL (E.D. Texas), served December 4, 2015; 743 pages.	
	NPL4	Non-confidential Exhibits B1-B17 and B19 to Defendants' Preliminary Invalidation Contentions, submitted in Realtime Data, LLC d/b/a IXO v. Actian Corporation, et al., Case No. 6:15-cv-0063-RWS-JDL (E.D. Texas), served December 4, 2015; 506 pages.	
	NPL5	Non-Confidential Exhibits C1-C36 to Defendants' Preliminary Invalidation Contentions, submitted in Realtime Data, LLC d/b/a IXO v. Actian Corporation, et al., Case No. 6:15-cv-0063-RWS-JDL (E.D. Texas), served December 4, 2015; 1,445 pages.	
	NPL6	Non-Confidential Exhibits D1-D14 and D16 to Defendants' Preliminary Invalidation Contentions, submitted in Realtime Data, LLC d/b/a IXO v. Actian Corporation, et al., Case No. 6:15-cv-0063-RWS-JDL (E.D. Texas), served December 4, 2015; 1,052 pages.	
	NPL7	Non-Confidential Exhibits E1-E36 to Defendants' Preliminary Invalidation Contentions, submitted in Realtime Data, LLC d/b/a IXO v. Actian Corporation, et al., Case No. 6:15-cv-0063-RWS-JDL (E.D. Texas), served December 4, 2015; 1,205 pages.	
	NPL8	KATZ, ET AL., "The Bay Area Research Wireless Access Network (BARWAN)," Proceedings of COMPCON '96, 1996; pp. 15-20.	
	NPL9	U.S. Provisional Patent Application No. 60/100,671, "Hybrid Compression Method with Compression Ratio Control," filed September 16, 1998; 50 pages.	
	NPL10	WELCH, T., "A Technique for High-Performance Data Compression," Computer, Vol. 18, Issue 6, 1984; pp. 8-19.	

Examiner Signature	Date Considered
--------------------	-----------------

\*EXAMINER: Initial if reference considered, whether or not citation is in conformance with MPEP 609. Draw line through citation if not in conformance and not considered. Include copy of this form with next communication to applicant.

<sup>1</sup> Applicant's unique citation designation number (optional). <sup>2</sup> Applicant is to place a check mark here if English language Translation is attached.

Substitute for form 1449/PTO		<b>Complete if Known</b>	
<b>THIRD SUPPLEMENTAL INFORMATION DISCLOSURE STATEMENT BY APPLICANT</b> <i>(Use as many sheets as necessary)</i>		Application Number	14/876,276
		Filing Date	October 6, 2015
		First Named Inventor	James J. FALLON
		Art Unit	2634
		Examiner Name	BOCURE, TESFALDET
		Attorney Docket Number	3421.005000C
Sheet	2	of	4

NON PATENT LITERATURE DOCUMENTS			
Examiner Initials*	Cite No. <sup>1</sup>	Include name of the author (in CAPITAL LETTERS), title of the article (when appropriate), title of the item (book, magazine, journal, serial, symposium, catalog, etc.), date, page(s), volume number, publisher, city and/or country where published	T <sup>2</sup>
	NPL11	Internet Archive version of the web page www.imatix.com/index.htm, dated May 20, 1998, available at <a href="http://web.archive.org/web/19980520033922/http://imatix.com/index.htm">http://web.archive.org/web/19980520033922/http://imatix.com/index.htm</a> ; 1 page.	
	NPL12	Internet Archive version of the web page www.imatix.com/index.htm, dated January 10, 1998, available at <a href="http://web.archive.org/web/19980110141513/http://imatix.com/index.htm">http://web.archive.org/web/19980110141513/http://imatix.com/index.htm</a> ; 1 page.	
	NPL13	Internet Archive version of the web page www.imatix.com/, dated January 9, 1998, available at <a href="https://web.archive.org/web/19980109064903/http://imatix.com/">https://web.archive.org/web/19980109064903/http://imatix.com/</a> ; 1 page.	
	NPL14	Internet Archive version of the web page www.imatix.com/, dated October 14, 1997, available at <a href="https://web.archive.org/web/19971014195839/http://www.imatix.com/">https://web.archive.org/web/19971014195839/http://www.imatix.com/</a> ; 1 page.	
	NPL15	Internet Archive version of the web page www.imatix.com/, dated June 29, 1997, available at <a href="https://web.archive.org/web/19970629063852/http://www.imatix.com/">https://web.archive.org/web/19970629063852/http://www.imatix.com/</a> ; 2 pages.	
	NPL16	Internet Archive version of the web page www.imatix.com/, dated April 16, 1997, available at <a href="https://web.archive.org/web/19970416061218/http://imatix.com/">https://web.archive.org/web/19970416061218/http://imatix.com/</a> ; 2 pages.	
	NPL17	Internet Archive version of the web page www.imatix.com/, dated December 21, 1996, available at <a href="https://web.archive.org/web/19961221064553/http://imatix.com/">https://web.archive.org/web/19961221064553/http://imatix.com/</a> ; 2 pages.	
	NPL18	Internet Archive version of the web page www.imatix.com/, dated November 6, 1996, available at <a href="https://web.archive.org/web/19961106161211/http://imatix.com/">https://web.archive.org/web/19961106161211/http://imatix.com/</a> ; 2 pages.	
	NPL19	"Liberetto, The iMatix Newsletter," vol. III, issue 9, September 1998, available at <a href="http://legacy.imatix.com/html/libero/doc/news9809.txt">http://legacy.imatix.com/html/libero/doc/news9809.txt</a> ; 9 pages.	
	NPL20	"Liberetto, The iMatix Newsletter," vol. III, issue 4, April 1998, available at <a href="http://legacy.imatix.com/html/libero/doc/news9804.txt">http://legacy.imatix.com/html/libero/doc/news9804.txt</a> ; 8 pages.	

Examiner Signature	Date Considered
--------------------	-----------------

\*EXAMINER: Initial if reference considered, whether or not citation is in conformance with MPEP 609. Draw line through citation if not in conformance and not considered. Include copy of this form with next communication to applicant.

<sup>1</sup> Applicant's unique citation designation number (optional). <sup>2</sup> Applicant is to place a check mark here if English language Translation is attached.

Substitute for form 1449/PTO		<b>Complete if Known</b>	
<b>THIRD SUPPLEMENTAL INFORMATION DISCLOSURE STATEMENT BY APPLICANT</b> <i>(Use as many sheets as necessary)</i>		Application Number	14/876,276
		Filing Date	October 6, 2015
		First Named Inventor	James J. FALLON
		Art Unit	2634
		Examiner Name	BOCURE, TEFALDET
		Attorney Docket Number	3421.005000C
Sheet	3	of	4

NON PATENT LITERATURE DOCUMENTS			
Examiner Initials*	Cite No. <sup>1</sup>	Include name of the author (in CAPITAL LETTERS), title of the article (when appropriate), title of the item (book, magazine, journal, serial, symposium, catalog, etc.), date, page(s), volume number, publisher, city and/or country where published	T <sup>2</sup>
	NPL21	"Liberetto, The iMatix Newsletter," vol. III, issue 1, January 1998, available at <a href="http://legacy.imatix.com/html/libero/doc/news9801.txt">http://legacy.imatix.com/html/libero/doc/news9801.txt</a> ; 7 pages.	
	NPL22	"Liberetto, The iMatix Newsletter," vol. II, issue 8, August 1997, available at <a href="http://legacy.imatix.com/html/libero/doc/news9708.txt">http://legacy.imatix.com/html/libero/doc/news9708.txt</a> ; 8 pages.	
	NPL23	"Liberetto, The iMatix Newsletter," vol. II, issue 6, June 1997, available at <a href="http://legacy.imatix.com/html/libero/doc/news9706.txt">http://legacy.imatix.com/html/libero/doc/news9706.txt</a> ; 6 pages.	
	NPL24	"Liberetto, The iMatix Newsletter," vol. II, issue 2, February 1997, available at <a href="http://legacy.imatix.com/html/libero/doc/news9702.txt">http://legacy.imatix.com/html/libero/doc/news9702.txt</a> ; 9 pages.	
	NPL25	Internet Archive version of the web page <a href="http://www.seas.upenn.edu/~liefke/">www.seas.upenn.edu/~liefke/</a> , dated October 5, 1999, available at <a href="https://web.archive.org/web/19991005050552/http://www.seas.upenn.edu/~liefke/">https://web.archive.org/web/19991005050552/http://www.seas.upenn.edu/~liefke/</a> ; 2 pages.	
	NPL26	Internet Archive version of the web page <a href="http://www.seas.upenn.edu/~liefke/research.html">www.seas.upenn.edu/~liefke/research.html</a> , dated January 18, 2000, available at <a href="https://web.archive.org/web/20000118224540/http://www.seas.upenn.edu/~liefke/research.html">https://web.archive.org/web/20000118224540/http://www.seas.upenn.edu/~liefke/research.html</a> ; 2 pages.	
	NPL27	Internet Archive version of the web page <a href="http://www.seas.upenn.edu/~liefke/xmlzip.html">www.seas.upenn.edu/~liefke/xmlzip.html</a> , dated January 19, 2000, available at <a href="https://web.archive.org/web/20000119051403/http://www.seas.upenn.edu/~liefke/xmlzip.html">https://web.archive.org/web/20000119051403/http://www.seas.upenn.edu/~liefke/xmlzip.html</a> ; 4 pages.	
	NPL28	Internet Archive version of the web page <a href="http://www.research.att.com/~suciu/strudel/external/NodeExternal,internal.genoid_3.html">www.research.att.com/~suciu/strudel/external/NodeExternal,internal.genoid_3.html</a> , dated March 10, 2000, available at <a href="https://web.archive.org/web/20000310042016/http://www.research.att.com/~suciu/strudel/external/NodeExternal,internal.genoid_3.html">https://web.archive.org/web/20000310042016/http://www.research.att.com/~suciu/strudel/external/NodeExternal,internal.genoid_3.html</a> ; 12 pages.	
	NPL29	Internet Archive version of the web page <a href="http://www.research.att.com/sw/tools/xmill/">www.research.att.com/sw/tools/xmill/</a> , dated August 31, 2000, available at <a href="https://web.archive.org/web/20000831200854/http://www.research.att.com/sw/tools/xmill/">https://web.archive.org/web/20000831200854/http://www.research.att.com/sw/tools/xmill/</a> ; 2 pages.	
	NPL30	Internet Archive version of the web page <a href="http://www.research.att.com/sw/tools/xmill/download.html">www.research.att.com/sw/tools/xmill/download.html</a> , dated September 25, 2000, available at <a href="https://web.archive.org/web/20000925084557/http://www.research.att.com/sw/tools/xmill/download.html">https://web.archive.org/web/20000925084557/http://www.research.att.com/sw/tools/xmill/download.html</a> ; 1 page.	
Examiner Signature		Date Considered	

\*EXAMINER: Initial if reference considered, whether or not citation is in conformance with MPEP 609. Draw line through citation if not in conformance and not considered. Include copy of this form with next communication to applicant.

<sup>1</sup> Applicant's unique citation designation number (optional). <sup>2</sup> Applicant is to place a check mark here if English language Translation is attached.

Substitute for form 1449/PTO		<i>Complete if Known</i>	
<b>THIRD SUPPLEMENTAL          INFORMATION DISCLOSURE          STATEMENT BY APPLICANT</b> <i>(Use as many sheets as necessary)</i>		Application Number	14/876,276
		Filing Date	October 6, 2015
		First Named Inventor	James J. FALLON
		Art Unit	2634
		Examiner Name	BOCURE, TESFALDET
		Attorney Docket Number	3421.005000C
		Sheet	4 of 4

NON PATENT LITERATURE DOCUMENTS			
Examiner Initials*	Cite No. <sup>1</sup>	Include name of the author (in CAPITAL LETTERS), title of the article (when appropriate), title of the item (book, magazine, journal, serial, symposium, catalog, etc.), date, page(s), volume number, publisher, city and/or country where published	T <sup>2</sup>
	NPL31	LIEFKE, ET AL., "Xmill: an Efficient Compressor for XML Data," Proceedings of the 2000 ACM SIGMOD International Conference on the Management of Data, 2000; pp. 153-164.	
	NPL32	"User Manual for XMill," XMill Version 0.7 (1999); 16 pages.	

2763226\_1.DOCX

Examiner Signature		Date Considered	
-----------------------	--	--------------------	--

\*EXAMINER: Initial if reference considered, whether or not citation is in conformance with MPEP 609. Draw line through citation if not in conformance and not considered. Include copy of this form with next communication to applicant.

<sup>1</sup> Applicant's unique citation designation number (optional). <sup>2</sup> Applicant is to place a check mark here if English language Translation is attached.



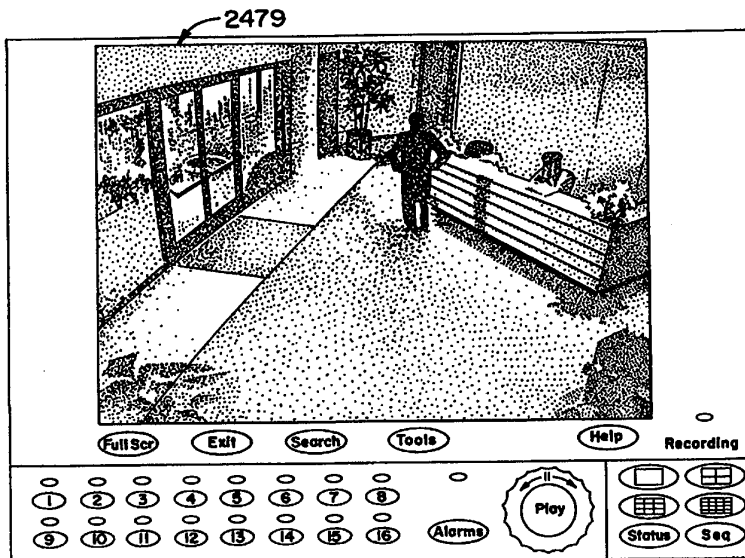
INTERNATIONAL APPLICATION PUBLISHED UNDER THE PATENT COOPERATION TREATY (PCT)

<p>(51) International Patent Classification <sup>6</sup> : <b>H04N</b></p>	<p><b>A2</b></p>	<p>(11) International Publication Number: <b>WO 98/19450</b> (43) International Publication Date: 7 May 1998 (07.05.98)</p>																																	
<p>(21) International Application Number: PCT/US97/17886 (22) International Filing Date: 1 October 1997 (01.10.97)</p> <p>(30) Priority Data:</p> <table border="0"> <tr><td>08/742,017</td><td>31 October 1996 (31.10.96)</td><td>US</td></tr> <tr><td>08/741,715</td><td>31 October 1996 (31.10.96)</td><td>US</td></tr> <tr><td>08/740,628</td><td>31 October 1996 (31.10.96)</td><td>US</td></tr> <tr><td>08/741,982</td><td>31 October 1996 (31.10.96)</td><td>US</td></tr> <tr><td>08/741,914</td><td>31 October 1996 (31.10.96)</td><td>US</td></tr> <tr><td>08/741,983</td><td>31 October 1996 (31.10.96)</td><td>US</td></tr> <tr><td>08/729,620</td><td>31 October 1996 (31.10.96)</td><td>US</td></tr> <tr><td>08/740,651</td><td>31 October 1996 (31.10.96)</td><td>US</td></tr> <tr><td>08/742,015</td><td>31 October 1996 (31.10.96)</td><td>US</td></tr> <tr><td>08/741,650</td><td>31 October 1996 (31.10.96)</td><td>US</td></tr> <tr><td>08/740,627</td><td>31 October 1996 (31.10.96)</td><td>US</td></tr> </table> <p>(71) Applicant: SENSORMATIC ELECTRONICS CORPORATION [US/US]; 951 Yamato Road, Boca Raton, FL 33431-0700 (US).</p> <p>(72) Inventors: MACCORMACK, David, Ross; 3344 31st Street, San Diego, CA 92104 (US). NUNALLY, Patrick, O.; 2989 Racetrack View, Delmar, CA 92014 (US). WILSON, Charles, Park; 9807 Highdale Road, Santee, CA 92071 (US). WINTER, Gerhard, Josef; 7408 Park Village Road, San</p>		08/742,017	31 October 1996 (31.10.96)	US	08/741,715	31 October 1996 (31.10.96)	US	08/740,628	31 October 1996 (31.10.96)	US	08/741,982	31 October 1996 (31.10.96)	US	08/741,914	31 October 1996 (31.10.96)	US	08/741,983	31 October 1996 (31.10.96)	US	08/729,620	31 October 1996 (31.10.96)	US	08/740,651	31 October 1996 (31.10.96)	US	08/742,015	31 October 1996 (31.10.96)	US	08/741,650	31 October 1996 (31.10.96)	US	08/740,627	31 October 1996 (31.10.96)	US	<p>Diego, CA 92129 (US). KLEIN, Harry, Eric; 9627 Babuata Road, San Diego, CA 92129 (US). NGUYEN, William, Thanh; 13750 Caminito Vizzini, San Diego, CA 92129 (US). LIN-LIU, Sen; 13005 Brixton Place, San Diego, CA 92130 (US). NGUYEN, Lyn; 3114 Chollas Road, San Diego, CA 92105 (US). AUYEUNG, Alex, Kamlun; 13446 Little Dawn Lane, Poway, CA 92046 (US). PEDERSEN, Chris, Harvey, Jr.; 9621 Pebble Beach Drive, Santee, CA 92071 (US). SMITH, Gordon, W.; 1331 Hampton Road, San Marcos, CA 92069 (US). OUSLEY, David, James; 10030-58 Scripps Vista Way, San Diego, CA 92131 (US). WANG, Sherwin, Sheng-shu; 13124 Polvera Way, San Diego, CA 92128 (US).</p> <p>(74) Agent: LEVIN, Nathaniel; Robin, Blecker, Daley &amp; Driscoll, 330 Madison Avenue, New York, NY 10017 (US).</p> <p>(81) Designated States: AL, AM, AT, AU, AZ, BA, BB, BG, BR, BY, CA, CH, CN, CU, CZ, DE, DK, EE, ES, FI, GB, GE, GH, HU, IL, IS, JP, KE, KG, KP, KR, KZ, LC, LK, LR, LS, LT, LU, LV, MD, MG, MK, MN, MW, MX, NO, NZ, PL, PT, RO, RU, SD, SE, SG, SI, SK, SL, TJ, TM, TR, TT, UA, UG, UZ, VN, YU, ZW, ARIPO patent (GH, KE, LS, MW, SD, SZ, UG, ZW), European patent (AT, BE, CH, DE, DK, ES, FI, FR, GB, GR, IE, IT, LU, MC, NL, PT, SE), OAPI patent (BF, BJ, CF, CG, CI, CM, GA, GN, ML, MR, NE, SN, TD, TG).</p> <p><b>Published</b> Without international search report and to be republished upon receipt of that report.</p>
08/742,017	31 October 1996 (31.10.96)	US																																	
08/741,715	31 October 1996 (31.10.96)	US																																	
08/740,628	31 October 1996 (31.10.96)	US																																	
08/741,982	31 October 1996 (31.10.96)	US																																	
08/741,914	31 October 1996 (31.10.96)	US																																	
08/741,983	31 October 1996 (31.10.96)	US																																	
08/729,620	31 October 1996 (31.10.96)	US																																	
08/740,651	31 October 1996 (31.10.96)	US																																	
08/742,015	31 October 1996 (31.10.96)	US																																	
08/741,650	31 October 1996 (31.10.96)	US																																	
08/740,627	31 October 1996 (31.10.96)	US																																	

(54) Title: INTELLIGENT VIDEO INFORMATION MANAGEMENT SYSTEM

(57) Abstract

A flexible video information storage and analysis apparatus stores a video information data base and a plurality of moving image content analysis algorithms for analyzing the video information in the data base. A user can manipulate a mouse to select one of the analysis algorithms. The selected algorithm is used to analyze video information in the data base. The apparatus records and displays plural streams of video information. Content analysis algorithms may be downloaded from a remote location. The apparatus takes appropriate actions in response to detected features in incoming video streams. Tile-based conditional-refresh video data compression is employed. A support structure efficiently supports several record-medium drive units. A tape back-up drive serves as an archiving mechanism for video data stored on hard disks. Recording of incoming video, and archiving and displaying of stored video, all proceed simultaneously.



**FOR THE PURPOSES OF INFORMATION ONLY**

Codes used to identify States party to the PCT on the front pages of pamphlets publishing international applications under the PCT.

<b>AL</b>	Albania	<b>ES</b>	Spain	<b>LS</b>	Lesotho	<b>SI</b>	Slovenia
<b>AM</b>	Armenia	<b>FI</b>	Finland	<b>LT</b>	Lithuania	<b>SK</b>	Slovakia
<b>AT</b>	Austria	<b>FR</b>	France	<b>LU</b>	Luxembourg	<b>SN</b>	Senegal
<b>AU</b>	Australia	<b>GA</b>	Gabon	<b>LV</b>	Latvia	<b>SZ</b>	Swaziland
<b>AZ</b>	Azerbaijan	<b>GB</b>	United Kingdom	<b>MC</b>	Monaco	<b>TD</b>	Chad
<b>BA</b>	Bosnia and Herzegovina	<b>GE</b>	Georgia	<b>MD</b>	Republic of Moldova	<b>TG</b>	Togo
<b>BB</b>	Barbados	<b>GH</b>	Ghana	<b>MG</b>	Madagascar	<b>TJ</b>	Tajikistan
<b>BE</b>	Belgium	<b>GN</b>	Guinea	<b>MK</b>	The former Yugoslav Republic of Macedonia	<b>TM</b>	Turkmenistan
<b>BF</b>	Burkina Faso	<b>GR</b>	Greece	<b>ML</b>	Mali	<b>TR</b>	Turkey
<b>BG</b>	Bulgaria	<b>HU</b>	Hungary	<b>MN</b>	Mongolia	<b>TT</b>	Trinidad and Tobago
<b>BJ</b>	Benin	<b>IE</b>	Ireland	<b>MR</b>	Mauritania	<b>UA</b>	Ukraine
<b>BR</b>	Brazil	<b>IL</b>	Israel	<b>MW</b>	Malawi	<b>UG</b>	Uganda
<b>BY</b>	Belarus	<b>IS</b>	Iceland	<b>MX</b>	Mexico	<b>US</b>	United States of America
<b>CA</b>	Canada	<b>IT</b>	Italy	<b>NE</b>	Niger	<b>UZ</b>	Uzbekistan
<b>CF</b>	Central African Republic	<b>JP</b>	Japan	<b>NL</b>	Netherlands	<b>VN</b>	Viet Nam
<b>CG</b>	Congo	<b>KE</b>	Kenya	<b>NO</b>	Norway	<b>YU</b>	Yugoslavia
<b>CH</b>	Switzerland	<b>KG</b>	Kyrgyzstan	<b>NZ</b>	New Zealand	<b>ZW</b>	Zimbabwe
<b>CI</b>	Côte d'Ivoire	<b>KP</b>	Democratic People's Republic of Korea	<b>PL</b>	Poland		
<b>CM</b>	Cameroon	<b>KR</b>	Republic of Korea	<b>PT</b>	Portugal		
<b>CN</b>	China	<b>KZ</b>	Kazakistan	<b>RO</b>	Romania		
<b>CU</b>	Cuba	<b>LC</b>	Saint Lucia	<b>RU</b>	Russian Federation		
<b>CZ</b>	Czech Republic	<b>LI</b>	Liechtenstein	<b>SD</b>	Sudan		
<b>DE</b>	Germany	<b>LK</b>	Sri Lanka	<b>SE</b>	Sweden		
<b>DK</b>	Denmark	<b>LR</b>	Liberia	<b>SG</b>	Singapore		
<b>EE</b>	Estonia						

**INTELLIGENT VIDEO INFORMATION MANAGEMENT SYSTEM**5                                    FIELD OF THE INVENTION

The present invention is related to closed circuit video security surveillance systems, but also is more generally concerned with application of machine intelligence to management, interpretation and use of video information. The system disclosed herein can therefore be referred to as an "intelligent video information management" (IVIM) system. The IVIM field has not hitherto been recognized as distinct from other related endeavors, and it is among the primary purposes of the present disclosure to teach fundamental principles of general application to the emerging art of intelligent video information management.

10                                   BACKGROUND OF THE INVENTION

It is well known to provide video security systems in which video cameras are used to generate video signals representative of locations for which security surveillance is desired. In a typical system, some or all of the video signals are displayed on video screens for monitoring by security personnel. It is also known to record some or all of the video signals on video tape, either to provide evidentiary support for the observations of security personnel or in cases where "real-time" human monitoring of the signals is impractical or is not desired.

30                                   However, video tape suffers from serious drawbacks as a storage medium, particularly in view of the large quantity of video information generated by video security systems. A major concern is the sheer quantity of tapes to be stored, especially when it is desired to record signals generated by a large number of surveillance cameras. Moreover, in a large system many video tape recorders may be required, resulting in a large capital expenditure, and also the need to allocate space for the



recorders. Another problem is the need to frequently change tape cassettes.

Retrieving information of interest from recorded tapes presents additional challenges. It is the nature of  
5 video surveillance that a large part of the tape-recorded video surveillance signal is of no interest whatsoever, since it typically represents a static image of a hall-way or the like. Finding a particular sequence representing a significant event can be extremely difficult and time-  
10 consuming, requiring tedious human review of hours or days of tape-recorded signals.

Another problem occurs when the video signals of interest were generated so recently that the tape on which the signals were recorded is still being used in current  
15 recording operations. In such a case, it is necessary to interrupt recording to remove the tape from the tape deck and to insert another tape. Then the signals of interest are played back using a separate tape deck. As is evident, this procedure entails inconvenient and time-  
20 consuming tape cassette handling, and there is a risk that new signals of interest will fail to be recorded while the exchange of tape cassettes takes place.

There have been a number of attempts to overcome these disadvantages, but so far with limited success, or  
25 at the cost of additional drawbacks. For example, it is known to use "quad multiplexers" to combine signals from four video cameras into a single dynamic image, having four quadrants each dedicated to a respective one of the cameras. The resultant space-multiplexed signal can then  
30 be recorded, realizing a four-to-one compression ratio in terms of required storage capacity. However, the multiplexed image suffers from a corresponding loss of spatial resolution, which may impair the value of the recorded images as evidence or may interfere with  
35 subsequent review. Also, recording of multiplexed images does not address the problems involved in finding sequences of interest on the recorded tapes.

It is also known to record the surveillance video

signals selectively in response to input from a human operator who is monitoring the signals or in response to signals generated by sensor devices arranged to detect events such as opening of doors or windows. This  
5 technique reduces the total information to be recorded, while preventing storage of much uninteresting information, but at the risk of failing to record significant events which cannot readily or timely be detected by sensors or human operators. Also, the  
10 reliance on external input can result in unreliability and increased expense, particularly where human operators are to initiate recording.

The OPTIMA II video surveillance multiplexer introduced by the assignee of the present application  
15 employs a more sophisticated technique for culling out uninteresting information prior to storage. In the OPTIMA II multiplexer, respective streams of video image information are received from a plurality of cameras and a combined stream of images is formed by time-division  
20 multiplexing of the images from the cameras. The combined stream is then output to a conventional video tape recorder for storage on tape. The OPTIMA II multiplexer applies motion detection analysis to the respective input streams and adaptively allocates the "time slots" in the  
25 output stream by allocating a larger number of slots to images from an input stream in which motion is detected. In this way, a relatively large portion of the system's storage capacity is allocated to image streams which contain moving objects and are therefore more likely to  
30 include significant information.

The OPTIMA II multiplexer represents a significant advance over conventional tape-based surveillance video storage techniques, but still greater efficiency and flexibility are to be desired.

35 The "MultiScop" video disc recorder sold by Geutebrück GmbH is an application of digital recording to the problem of storing video surveillance information. The MultiScop system employs the above-mentioned selective

recording technique to minimize recording of "uninteresting" information. In addition, some redundant information is excluded from recording by use of a conventional digital image compression technique. Random  
5 access to stored information based on date and time indexing, or based on indexing indicative of an externally sensed alarm condition, provides a modest improvement over conventional tape-based systems in terms of convenience in retrieving stored video.

10 Although the random-access retrieval aspect of the MultiScop recorder is undoubtedly beneficial, it is a less desirable feature of this recorder that all recording is interrupted during retrieval operations. To mitigate the potential for missing new video information that should be  
15 recorded, the MultiScop recorder can be programmed to automatically interrupt retrieval in response to an alarm condition, so as to return immediately to recording mode. When this automatic interrupt feature is not actuated, either for lack of an alarm condition, or because the  
20 feature was not selected, new video information goes unrecorded. Although the MultiScop avoids tape-swapping, recording by the MultiScop recorder is interrupted during the entire duration of retrieval operations, instead of the relatively brief time required to swap tapes in tape-  
25 based systems that have a separate VCR for playback.

It would be most desirable that an intelligent video information management system avoid the mutual interference between record and playback operations that has characterized prior systems, while in general  
30 providing greater efficiency and flexibility than have previously been known.

Greater efficiency and flexibility than are provided by the MultiScop system are greatly to be desired. In particular, it would be most useful to exclude  
35 uninteresting information from recording while minimizing the chance of missing significant information. Also, more efficient information retrieval techniques are needed.

It is believed that the MultiScop system employs a

transform-based compression encoding technique, such as the well-known JPEG standard, which provides a compression factor on the order of 40:1 or 50:1. Given data storage capacity of, say, 2,000 megabytes and a recording rate of 5 25 fields/sec., the MultiScop system is able to record video signals over a period of little more than one hour. It would be desirable to provide a higher degree of compression so that higher recording rates and/or longer recording times can be provided for a given data storage 10 capacity.

It would be another desirable feature of a video data compression technique, for the purpose of IVIM and video surveillance operations, if the respective computational complexities for compression and decompression were 15 roughly in balance, to accommodate an implementation in which both compression and decompression may be performed using a general purpose processor device. Also, it would be most helpful if the compression technique were to facilitate machine analysis and reverse-direction playback 20 of the video image streams.

It also has been observed by the inventors that the most widely supported video data compression techniques have not taken into account particular characteristics of surveillance video that may allow for high rates of 25 compression, while preserving image quality adequate for surveillance purposes. The well-known MPEG techniques, for example, can provide a high level of compression and the high image quality required for consumer broadcast applications, but at the cost of great complexity. 30 Moreover, techniques of the MPEG type are poorly adapted for features such as reverse playback, or simultaneous compression of plural input video streams.

The large quantity of information (useful or otherwise) present in a stream of video signals places 35 great demands not only on digital data storage devices, but also on the circuitry arrangements employed to route and manipulate the video information before storage on, or after retrieval from, a storage device. These demands are

much greater when, as is often the case, it is desired to record a number of video signal streams simultaneously. Moreover, compressing the video information promotes efficient use of storage capacity, but adds to the burdens  
5 on routing and processing circuits.

Another disadvantage of existing systems is the requirement that the user be physically present at the recorder in order to gain access to video data stored by the recorder. Moreover, the user's options for searching  
10 the video data are limited to capabilities provided by the recorder.

Another design issue in connection with video data storage is the total storage capacity to be provided. Known systems include only a single internal hard disk  
15 drive, and require use of external storage medium drives when the user needs more storage than is available on the internal drive. Given that a recorder comprising several internal drive units would allow for greater storage capacity and would provide other benefits, it is also  
20 desirable that the internal drive units be mounted securely in a structure that is easy to manufacture and assemble. Further, other internal electronic components of a digital video recorder should be arranged so as to minimize manufacturing cost while facilitating capture and  
25 processing of video information.

Supposing that an intelligent video information management system may have a larger effective hard disk storage capacity than prior art devices, even so that disk storage capacity will remain finite and may need to be  
30 reused as time passes and more current video information is captured and recorded. It will therefore still be desirable to permit permanent or "archival" video information storage on removable media even though fixed magnetic disks are used instead of videotape as the  
35 primary storage medium. The system archiving capabilities should be easy for users to manage and should dovetail effectively with other system features.

While it is probably inescapable that increased

flexibility in a recording system will be accompanied by increased complexity, it is also important that the system not become difficult to use. Ease of use may be a crucial factor in determining whether an IVIM system  
5 satisfactorily performs its intended functions.

The intelligent video information management system disclosed hereinafter represents a novel fusion of video recording and personal computer technologies, to realize an over-all improvement in capabilities for capturing and  
10 retrieving video information. Certain user-settable options are presented which enhance the flexibility of the system and permit the user to tailor the system to particular applications.

There have been proposed many techniques for  
15 filtering video image data in order to detect significant features of the image represented by the image data. Writings in this field include the following: M.P. Cagigal, et al., "Object movement characterization from low-light-level images", Optical Engineering, Aug. 1994,  
20 vol. 33, no. 8, pp. 2810-2812; S.J. Nowlan, et al., "Filter selection model for motion segmentation and velocity integration," J. Opt. Soc. Am. A, Dec. 1994, vol. 11, no. 12, pp. 3177-3200; T.G. Allen, et al., "Multiscale approaches to moving target detection in image sequences,"  
25 Optical Engineering, Jul. 1994, vol. 33, no. 7, pp. 2248-2254; M.-P. Dubuisson, et al., "Contour Extraction of Moving Objects in Complex Outdoor Scenes," International Journal of Computer Vision, 14, pp. 83-105 (1995); M. Bichsel, "Segmenting Simply Connected Moving Objects in a  
30 Static Scene," IEEE Transactions on Pattern Analysis and Machine Intelligence, Nov. 1994, vol. 16, no. 11, pp. 1138-1142; M. Irani, et al., "Computing Occluding and Transparent Motions," International Journal of Computer Vision, 12:1, pp. 5-16 (1994); I.J. Cox, "A Review of  
35 Statistical Data Association Techniques for Motion Correspondence," International Journal of Computer Vision, 10:1, pp. 53-66 (1993); D. Koller, et al., "Model-Based Object Tracking in Monocular Image Sequences of Road

Traffic Scenes," International Journal of Computer Vision, 10:3, pp. 257-281 (1993); J.H. Lee, et al., "A VLSI Chip for motion estimation of HDTV Signals," IEEE Transactions on Consumer Electronics, May 1994, vol. 40, no. 2, pp. 2154-160; T. Koivunen, "Motion detection of an interlaced video signal," IEEE Transactions on Consumer Electronics, Aug. 1994, vol. 40, no. 3, pp. 753-760; S.-I. Jang, et al., "A real-time identification method on motion and out-of-focus blur for a video camera," IEEE Transactions on Consumer Electronics, May 1994, vol. 40, no. 2, pp. 145-153. However, commercial applications of these proposed filtering techniques have been rare, and for the most part have been limited to analysis of static images, rather than attempting to acquire information by analyzing a dynamic stream of images.

Advances in management and use of the information contained in single or concurrent video image streams are to be desired. It would be especially desirable to permit a user of a video surveillance system, or other system which stores dynamic image information, increased flexibility in the management of incoming video information and in the use of both incoming and stored video streams.

In addition to the above-mentioned OPTIMA II multiplexer, other devices intended to provide automatic response to detected features of video information have been directed primarily to detecting motion and to actuating an alarm condition when motion is detected. Such devices are disclosed in U.S. Patent Nos. 4,737,847 (Araki et al.); 4,160,998 (Kamin); 4,198,653 (Kamin); 3,988,533 (Mick et al.); 4,081,830 (Mick et al.); 3,743,768 (Copeland); and 4,249,207 (Harmon et al.).

It would be desirable to extend application of machine intelligence to detection of video information features, and automatic performance of functions, beyond those contemplated in the prior art.

OBJECTS AND SUMMARY OF THE INVENTION

It is an object of the invention to provide an apparatus which permits the user to select a desired one or ones from among a plurality of video data analysis options available by use of the apparatus.

It is a further object of the invention to permit the user of such apparatus to tailor a selected video information analysis algorithm to known or anticipated features represented by the information to be analyzed.

It is still another objection of the invention to provide an intelligent video information management system having a number of user-selectable operating modes which enhance the flexibility and ease of use of the system.

It is yet another object of the invention to provide a distributed video information data base system. It is a further object to provide a capability for performing content-based searches for video information stored at a location that is remote from the individual desiring to retrieve the video information.

It is a further object of the invention to provide an intelligent video information management system which detects significant features of an incoming video information stream, and takes appropriate action in response to detection of features of interest.

It is yet another object of the invention to provide a method and apparatus for compressing, with a high degree of efficiency, video data representing streams of dynamic video images.

It is another object of the invention to provide a video data compression technique that is well suited for video surveillance security applications.

It is still another object of the invention to provide compressed video data in a form that is suitable for machine analysis of the data.

It is still a further object of the invention to compress a stream of video images in a form which facilitates reverse playback of the image stream.

It is yet another object of the invention to provide



techniques for capture, formatting and temporary storage of video information so as to facilitate processing and routing of the video information in an intelligent video information management system.

5 It is still a further object of the invention to provide a support structure for several record-medium drive units that are to be mounted within a digital video recorder.

10 It is another object to provide such a support structure in a configuration that is convenient to manufacture and assemble.

15 It is still another object of the invention to provide an efficient and cost effective architecture for data processing circuitry included in a digital video recording apparatus.

It is a further object of the invention to provide an intelligent video information management system having video information archiving capabilities.

20 It is still a further object to provide an IVIM system in which the archiving capabilities are flexible and user-friendly.

25 It is another object of the invention to provide an intelligent video information management system in which information concerning the status of the system is provided in an intelligible and useful form to a user of the system.

30 It is also an object of the invention to employ parallel processing and multi-tasking techniques in an intelligent video information system so that the system may carry out basic functions simultaneously while eliminating or minimizing interference between the functions.

35 It is a further object of the invention to provide techniques for identifying, marking and indexing respective portions of video information to support flexible and efficient storage and retrieval of the video information.

According to an aspect of the invention, there is

provided a flexible video information analysis apparatus including first storage capability for storing a video information data base, second storage capability for storing a plurality of moving image content analysis algorithms for analyzing the video information in the data base, a mechanism actuatable by a user of the apparatus for selecting one of the algorithms, and circuitry, responsive to the user actuatable mechanism, for analyzing the video information in the data base in accordance with the one of the algorithms selected by the user actuatable mechanism.

The apparatus may further include a plurality of video cameras for generating respective sequences of video signals, and circuitry for digitizing the respective sequences of video signals generated by the video cameras and for supplying the digitized sequences of video signals to the first storage capability. There may also be included in the apparatus a display device for displaying a plurality of word designations or icons each representing a respective one of the algorithms for analyzing video information and the user actuatable mechanism may include a mouse or other device for selecting one of the displayed icons or word designations. A touch-sensitive screen is an alternative that may be employed to both display the word designations or icons and to implement the user actuatable mechanism.

The user actuatable mechanism may also include circuitry for setting a parameter for constraining execution of a selected one of the algorithms. The circuitry for setting the parameter may include location circuitry for selecting a portion of an image plane which corresponds to the video information, with the analysis circuitry responding to the location circuitry by analyzing the video information with respect to the portion of the image plane selected by the location circuitry.

In a preferred embodiment of the invention, more than one analysis algorithm may be selected for application to

a single image stream, and/or each of a plurality of streams may be analyzed using the same algorithm or respective algorithms. One or more of the stored algorithms may be for detecting moving objects represented  
5 by data in the stored video information data base. The analysis circuitry may generate analysis data indicative of results of the analysis performed by the analysis circuitry in accordance with the selected one of the algorithms, and the first storage capability may include  
10 capability for storing the analysis data generated by the analysis circuitry.

According to another aspect of the invention, there is provided a method of storing and retrieving video data, including the steps of storing data representing plural  
15 images of a dynamic video image stream, selecting a search algorithm to be used for a desired image among the images represented by the stored data, setting a parameter for constraining execution of the selected search algorithm, and searching the stored data in accordance with the  
20 selected search algorithm and the parameter as set during the setting step.

According to still another aspect of the invention, there is provided a method of carrying out an algorithm for detecting features represented by video data stored in  
25 a video information data base, including the steps of setting a parameter for constraining execution of the algorithm, and executing the algorithm in accordance with the parameter as set in the setting step. The algorithm in question may be for detecting at least one moving  
30 object represented by the stored video data and the setting step may include selecting a portion of an image plane which corresponds to the video data, that portion being a portion at which the moving object is to be detected by execution of the algorithm.

35 The portion of the image plane may be selected by displaying an image which corresponds to an image represented by the stored video data and superimposing a line or polygon on the displayed image, where the

superimposed line represents the selected portion of the image plane. The image displayed during selection of the portion of the image plane may be provided by retrieving data representing the image from the video information data base, or the image may be supplied as a live image  
5 based on a signal currently being generated by a video camera.

Where the algorithm is for detecting at least one moving object, the step of setting the parameter may  
10 include indicating at least one of a maximum size and a minimum size of the object to be detected. This may be done by displaying an image corresponding to an image represented by the stored video data and superimposing on the displayed image an image element indicative of the  
15 maximum or minimum object size. An image element representing the maximum size may be displayed in a first color, and an image element indicative of the minimum size of the object to be detected may be displayed in a second color that is different from the first color, the image  
20 elements being superimposed on the displayed image. Both image elements may be displayed simultaneously. Somewhat more generally, the parameter setting step may include displaying a graphical user interface element and adjusting the displayed graphical user interface element  
25 by means of a user input device. For example, a slide bar or dial interface element may be displayed, and may be adjusted by user manipulation of a mouse.

According to still another aspect of the invention, there is provided a flexible video information analysis  
30 apparatus, including a video information source for providing video information which includes at least one dynamic sequence of video information frames, a storage device for storing a plurality of algorithms for analyzing the video information provided by the video information  
35 source, a user actuatable mechanism for selecting one of the algorithms, and analysis circuitry responsive to the user actuatable mechanism for receiving the video information provided by the video information source and

for analyzing the received video information provided by the video information source in accordance with the one of the algorithms selected by the user actuatable mechanism. The video information source may be a video camera which  
5 generates a dynamic sequence of video information frames, a plurality of video cameras which generate respective sequences of video information frames, or a video information storage and playback device which provides to the analysis circuitry video information which was  
10 previously generated and stored on the video information storage device.

According to yet another aspect of the invention, there is provided a method of analyzing video information, including the steps of receiving an analog video signal  
15 which represents a dynamic sequence of images, digitizing the received analog video signal to form a sequence of video data frames which represent the dynamic sequence of images, first analyzing the sequence of video data frames using a first predetermined video data analysis algorithm  
20 and generating first analysis data indicative of results of the first analyzing, storing the sequence of video data frames in a data base, storing the first analysis data in the data base in association with the stored sequence of video data frames, retrieving from the data base the  
25 stored sequence of video frames, second analyzing the retrieved sequence of video data frames using a second predetermined video data analysis algorithm and generating second analysis data indicative of results of the second analyzing, and storing the second analysis data in the  
30 data base in association with the stored sequence of video data frames.

According to still another aspect of the invention, there is provided an apparatus for analyzing video information, including receiving circuitry for receiving  
35 an analog video signal which represents a dynamic sequence of images, A/D circuitry, connected to the receiving circuitry for digitizing the analog video signal to form a sequence of video data frames which represent the

dynamic sequence of images, first analysis circuitry, connected to the A/D circuitry, for analyzing the sequence of video data frames using a first predetermined video data analysis algorithm to generate first analysis data, a storage device connected to the A/D circuitry and the first analysis means, for storing the sequence of video data frames formed by the A/D circuitry and the first analysis data generated by the first analysis circuitry, and second analysis circuitry, connected to the storage device, for retrieving the sequence of video data frames stored in the storage device and for analyzing the retrieved sequence of video data frames using a second predetermined video data analysis algorithm to generate second analysis data, the second analysis data being stored in the storage device. The apparatus may also include a display device, connected to the storage device, for displaying at least one image represented by the stored sequence of images. The storage device may include compression circuitry for receiving the sequence of video data frames from the A-D circuitry and for applying a compression algorithm to the sequence of video data frames to form compression video data, and a storage medium on which the compression video data is stored. The storage medium may be a hard disk, magneto-optical disk, writable optical disk or other conventional mass storage device. The first analysis circuitry may include a first processing device and the second analysis circuitry may include a second processing device different from the first processing device. It is also contemplated that both of the first and second analysis devices be realized using a single processor which performs a first analysis on the video data prior to storage and performs a second analysis on the video data after the video data has been stored and then retrieved from the storage device.

According to yet a further aspect of the invention, there is provided a video information analysis apparatus, including circuitry for receiving video information, analysis circuitry for analyzing the received video

information in accordance with a predetermined analysis algorithm, and a parameter mechanism, actuatable by the user of the apparatus, for setting a parameter to constrain execution of the analysis algorithm, the analysis circuitry being responsive to the parameter mechanism so as to execute the analysis algorithm in accordance with the parameter set by the parameter mechanism.

According to still another aspect of the invention, there is provided a method of searching an image information data base, including the steps of storing a plurality of algorithms for identifying respective features in images represented by the image information in the data base, selecting two of the stored algorithms for respectively identifying a first feature and a second feature, selecting a logical operator to form a logical combination of the two selected algorithms, and searching the data base to identify images which satisfy the logical combination of the two selected algorithms. The information in the image information data base may include data representative of at least one dynamic sequence of video image frames and at least one of the selected algorithms may be for detecting a moving object in the sequence of video information frames. The logical operators may include the well known "AND", "OR" operators or the like. For example, an image may be identified as satisfying a combination of two algorithms where either one of the respective features detected by the algorithms is present ("OR" operation) or, alternatively, only those images are identified as satisfying the combination where both of the respective features are present ("AND" operation). Similarly, the image may be identified as satisfying the combination where either one, but not both of the respective features are present ("XOR" operation). "NOR", "NAND", and other logical operations may also be implemented, and more than two search algorithms may be subjected to logical operations in order to construct criteria for determining whether images are to be

identified.

According to still another aspect of the invention, there is provided apparatus for analyzing video information, including a first video information source  
5 for providing a first stream of video data frames, a second video information source for providing a second stream of video data frames, first analysis circuitry for receiving the first stream of video data frames provided  
10 by the first video information source and performing a first moving image content analysis algorithm with respect to the received first stream of video data frames, and second analysis circuitry for receiving the second stream of video data frames provided by the second video information source and performing a second moving image  
15 content analysis algorithm with respect to the received second stream of video data frames. The first and second analysis circuitry may operate simultaneously in performing the first and second moving image content analysis algorithms. The first and second analysis  
20 circuitry may respectively be implemented by first and second signal processing integrated circuits that are distinct from each other, or both of the first and second analysis circuitry may be implemented using a single processor IC. The first analysis circuitry may be a  
25 digital signal processing IC which processes live video currently being generated by a video camera, and the second signal processing circuitry may be a general purpose microprocessor operating under a standard operating system and performing the second moving content  
30 analysis algorithm with respect to a stream of video data frames played back from a memory device such as a hard disk.

The apparatus according to this aspect of the invention may include compression circuitry for applying  
35 a data compression algorithm to the first stream of video data frames to produce compressed video data and circuitry for transmitting the compressed video data from the compression circuitry to the hard disk for storage on the



hard disk. Also included in the apparatus may be circuitry for retrieving the stored compressed video data from the hard disk and applying a data decompression algorithm to the retrieved compressed video data to form the second stream of video data frames. Each of the first and second video information sources may be a respective video camera in which case the first and second analysis circuitry may operate simultaneously in performing the first and second moving image content analysis algorithms. Moreover, the first and second streams of video data may be retrieved simultaneously or virtually simultaneously from the hard disk and then respectively supplied to the first and second analysis circuitry. As noted before, the first and second analysis circuitry may be constituted by separate processing IC's or may be provided by time-division multiplexing processing using a single processing IC or by task-switching multiplexing or other multiplexing techniques.

According to yet another aspect of the invention, there is provided a video information analysis apparatus, including circuitry for generating a first stream of dynamic images and a second stream of dynamic images, variable-rate image selection circuitry for selecting images for storage from the first stream of images at a first image interval rate, and for selecting images for storage from the second stream of images at a second image interval rate that is different from the first image interval rate, a storage device for storing the images selected for storage from the first stream of images by the image selection circuitry and for storing the images selected for storage in the second stream of images by the image selection circuitry, playback circuitry for selectively retrieving from the storage device the stored images from the first and second streams of images, and analysis circuitry for applying a moving image content analysis algorithm to images retrieved by the playback circuitry from a selected one of the first and second streams of images, the analysis circuitry adapting the

moving image content analysis algorithm to the respective image interval rate of the selected stream of images.

The generating circuitry may include a first video camera for generating the first stream of dynamic images and a second video camera for generating the second stream of dynamic images. Alternatively, both of the first and second streams may be generated by the same video camera, the first having been generated at a first time period which is earlier than a second time period during which the second stream of dynamic stream of images was generated.

The moving image content analysis algorithm may be for detecting moving objects represented by the selected stream of images. The apparatus may include a display device for displaying images retrieved from the storage means and the moving image content analysis algorithm may be for detecting moving objects at a selected portion of an image plane displayed on the display device.

According to yet a further aspect of the invention, there is provided a method of analyzing video information, including the steps of generating a first stream of dynamic images, selecting images for storage from the first stream of images at a first image interval rate, generating a second stream of dynamic images, selecting images for storage from the second stream of images at a second image interval rate that is different from the first image interval rate, storing the selected images from the first and second streams of dynamic images, retrieving the stored images from the selected stream of dynamic images, and applying a moving image content analysis algorithm to the retrieved images from the selected stream of dynamic images, the algorithm being adapted to the image interval rate of the selected stream of dynamic images.

According to still another aspect of the invention, there is provided a method of detecting moving objects represented by a sequence of dynamic images, the sequence of dynamic images being represented by stored video data,

at least 75% of the dynamic images having been compression-encoded using an inter-image encoding algorithm such that the video data representing each inter-image encoded image includes image data consists of  
5 a plurality of image data portions each corresponding to a respective region of an image plane, the video data for each inter-image encoded image also including mapping data indicative of the regions of the image plane to which the image data portions of the video data correspond, the  
10 method comprising the steps of retrieving at least the mapping data included in the stored video data, and applying a motion detection algorithm to the retrieved mapping data to detect the moving objects.

It is contemplated to apply this aspect of the  
15 invention to a stream of dynamic images in which at least 19 out of each 20 consecutive dynamic images has been compression-encoding using the inter-image encoding algorithm. In a preferred embodiment of the invention 32  
20 out of each sequence of 33 images is inter-image encoded.

According to yet another aspect of the invention, there is provided a method of analyzing a sequence of video information frames to detect changes in the video information frames, including the steps of designating an object represented by the video information frames,  
25 selecting portions of the designated object, and sequentially examining portions of the video information frames corresponding to the selected portions of the designated object to determine whether the designated  
30 object remains in a predetermined position in the video information frames. The step of designating the object may include defining a periphery of the object, and the selected portions of the designated object may be portions of the object at mutually remote locations at the periphery of the object. For instance, the mutually  
35 remote locations may represent respective corners of the object as viewed in an image plane.

This aspect of the invention may be operated as a "museum tool" which permits automatic analysis of a video

information stream to assure that a valuable object is not removed from its location in a museum, art gallery or the like.

According to another aspect of the invention, there is provided a video data storage apparatus, including circuitry for receiving video data which represents an image in an image plane, discard circuitry for selecting a portion of the image plane as to which data storage is not required, and a storage device, responsive to the discard circuitry, for storing such portions of the received video data as do not correspond to the selected portion of the image plane, it being understood that the portions of the received video data which correspond to the selected portion of the image plane are not stored in the storage device. The portion of the image plane as to which the data is to be discarded may be selected by using a display device which displays an image which corresponds to an image represented by the received video data, and a drawing device which is operable to superimpose on the image displayed by the display means an image element such as a polygon to indicate the portion of the image plane as to which data storage is not required. The drawing device may be a mouse, and the storage device may be a hard disk, magneto-optical disk or a writable optical disk.

This aspect of the invention permits a user of the system to pre-edit the images to be stored on the system so as to exclude portions of the image not expected to be of interest, thereby conserving storage capacity in the system.

According to another aspect of the invention, there is provided a video signal processing apparatus, including circuitry for receiving a video signal which represents an image in an image plane, a selection mechanism for selecting a portion of the image plane for contrast enhancement, and enhancement circuitry, connected to the receiving circuitry and responsive to the selection mechanism, for expanding a dynamic range of portions of the received video signal which correspond to the selected

portion of the image plane, and for outputting a selectively enhanced video signal. Again, the selection mechanism may include a drawing means for superimposing on an image displayed by a display device, an image element  
5 indicative of the portion of the image plane selected for contrast enhancement.

This aspect of the invention permits a user to select portions of the image plane, such as areas in shadow, for an automatic increase in the dynamic range in the selected  
10 portion of the image prior to display and storage of the image information.

According to a further aspect of the invention, there is provided a video information storage apparatus, including a video information source for generating a  
15 dynamic video signal formed of a sequence of video signal frames, each frame representing a respective image in an image plane, the dynamic video signal having a time resolution corresponding to a frame rate at which successive frames of the sequence are produced, the  
20 dynamic video signal also having a space resolution corresponding to a density at which pixels in the signal are formed in the image plane, the apparatus also including signal processing circuitry for receiving the dynamic video signal generated by the video information  
25 source and for selectively varying at least one of the time resolution and the space resolution of the received dynamic video signal, a user adjustable mechanism for entering a control signal for controlling whether and to what degree the signal processing circuitry varies the  
30 time resolution or the space resolution of the received dynamic video signal, the signal processing means outputting a processed dynamic video signal having a time resolution and a space resolution at least one of which is determined in accordance with the control signal, and a  
35 storage device for storing the processed dynamic video signal.

This aspect of the invention permits the user to make a tradeoff between time resolution (i.e., image rate)

and/or space resolution vis-a-vis the quantity of storage capacity to be used in storing the video signal.

According to still a further aspect of the invention, there is provided a method of performing data compression with respect to a sequence of image data frames which represents a dynamic sequence of video images, including the steps of encoding every nth frame of the sequence of image data frames in accordance with an intra-frame compression algorithm in which each of the every nth frame is encoded without reference to any other image data frame, n being an integer greater than 1; encoding every frame other than the intra-frame encoded frames in accordance with a difference-encoding compression algorithm which includes forming difference data by reference to at least one data frame which precedes the frame which is being difference-encoded, receiving a compression parameter setting signal input by a user, and varying a value of n in accordance with the received compression parameter setting signal.

This aspect of the invention allows the user of the system to make a trade-off between image quality and amount of storage capacity consumed, by varying the degree of compression applied to an input video image stream.

According to yet another aspect of the invention, there is provided a method of assigning regions of an image plane among streams of dynamic images each generated by a respective one of a plurality of video cameras, the method including the steps of displaying in a first portion of a display screen a plurality of icons each representing a respective one of the plurality of video cameras, displaying in a second portion of the display screen a representation of the image plane including regions of the second portion of the display screen corresponding to the regions of the image plane, and moving at least one of the icons from the first portion of the display screen to the second portion of the display screen to position the moved icon in a respective one of the regions of the second portion to indicate that the

image screen generated by the video camera represented by the moved icon is to be displayed in the image plane region corresponding to the respective one of the regions of the second portion.

5 This aspect of the invention permits a user to conveniently allocate display windows among various cameras providing video image streams to the system.

According to still a further aspect of the invention, there is provided apparatus for storing video information, including a plurality of video cameras, a recording device for recording on a recording medium video information generated by the plurality of video cameras, the recording device being selectively operable in accordance with a plurality of recording modes with respect to each one of 10 the plurality of video cameras, a storage device for storing scheduling information, the scheduling information including a plurality of scheduling information portions each corresponding to a respective 24-hour period, each of the scheduling information portions including a plurality of sub-portions each corresponding to a respective one of 15 the plurality of video cameras, each of the sub-portions defining times during the respective 24-hour period for which ones of the recording modes have been selected for the respective one of the plurality of video cameras, and 20 control circuitry for controlling the recording device in accordance with the scheduling information stored in the storage device. One of the scheduling information portions may correspond to weekdays, a second one of the scheduling information portions may correspond to weekend-days, and a third one of the scheduling information 25 portions may correspond to holidays. Also included in the scheduling information may be additional information for defining the holidays by month and day of the month. Still further information included in the scheduling information may include information for partitioning each 30 of the 24-hour periods into day and night parts. The recording modes may include a first mode in which images generated by a respective one of the video cameras are

continuously recorded at intervals that do not exceed a maximum interval, a second recording mode in which images generated by the respective video camera are only recorded in response to detection of an alarm condition, and a  
5 third recording mode in which the images generated by the respective video camera are not recorded.

This aspect of the invention permits the user to pre-schedule a plurality of different operating modes for the system, extending over many days and with different  
10 operating mode schedules on different days.

According to still another aspect of the invention, there is provided a method of storing video information, including the steps of simultaneously generating a plurality of dynamic video signals each formed of a  
15 sequence of video signal fields, each of the fields representing a respective image, recording each of the sequences of video signal fields at regular intervals at a field storage rate which is variable from sequence to sequence, the field storage rate defining a duration of  
20 the regular intervals at which the respective sequence of video signals is recorded, and selectively manipulating a user input device to generate selection signals for selecting with respect to each of the sequences of video signal fields, the field storage rate for the respective  
25 sequence. The selection signal generated by the user input device may include numerical data indicative of a selected field storage rate for the respective sequence of video signal fields and camera identification data for identifying a video camera which is generating the  
30 respective sequence.

This feature of the invention allows the user to directly control allocation of recording "bandwidth" among incoming video streams.

According to yet another aspect of the invention,  
35 there is provided apparatus for analyzing video information, including a video camera, analysis circuitry for analyzing video information generated by the video camera in accordance with a moving image content analysis



algorithm, the analysis circuitry being selectively operable in accordance with a plurality of operating modes, a storage device for storing scheduling information, the scheduling information including a plurality of scheduling information portions each corresponding to a respective different future period of time, and each indicating an operating mode of said analysis circuitry that has been selected for the period of time, and control circuitry for controlling the analysis circuitry so as to operate in accordance with the selected operating modes during the periods of time indicated by the scheduling information stored in the storage device.

This aspect of the invention permits the user to schedule various image analysis functions of the system ahead of time, to be carried out automatically in accordance with stored scheduling information.

According to an additional aspect of the invention, there is provided a method of storing and retrieving video data, including the steps of storing, in a data storage device located at a first location, data representing plural images of a dynamic video image stream, and also storing, in a host processor located at a second location remote from the first location, a program file representing a search algorithm for searching for a desired image among the images represented by the data stored at the first location. The method further includes downloading the program file representing the search algorithm from the host processor to the data storage device, and using the downloaded program file to search for the desired image in the video data stored in the data storage device.

Further in accordance with this aspect of the invention, the method may include the additional steps of using the downloaded program file to select an image from among images represented by the video data stored in the data storage device, and uploading from the data storage device to the host processor data representative of the

image selected by using the downloaded program file. The method may also include uploading from the data storage device to the host processor data representative of an image which corresponds to an image represented by the data stored in the data storage device and displaying at the second location the image represented by the uploaded data. The image displayed at the second location may be simultaneously displayed at the first location and respective human operators at the first and second locations may exchange oral telephone communication and/or text or other data communication at the same time that the image is being displayed at the first and second locations. There may also be included in the method the steps of setting a parameter for constraining execution of the search algorithm and executing the search algorithm at the first location and in accordance with the set parameter. The parameter setting step may be performed before or after the program file is downloaded from the host processor to the data storage device. The search algorithm may be an algorithm for detecting at least one moving object represented by the data stored in the data storage device, and the parameter setting step may include selecting a portion of an image plane which corresponds to the stored data, that portion being a portion at which the moving object is to be detected by execution of the algorithm. The portion of the image plane may be selected by superimposing a line on the image displayed at either the second or the first location.

This aspect of the invention allows a system user at the location where the data of interest is stored to engage in a consultation with an expert located at a host computer location to receive advice and assistance from the expert concerning approaches for retrieving the data at the first user's location. The expert may download a suitable search algorithm program to the first user's location. Before doing so, the expert may set parameters for the search algorithm or otherwise customize it so as to meet the first user's needs. In this way, search

capabilities not previously present at the first user's location may be imported into the video information storage device at the first user's location and the first user may benefit from system operating knowledge not in  
5 the possession of the first user.

According to another aspect of the invention, there is provided apparatus for storing a distributed video data base, including a first video information source, at a first location, for providing first video information  
10 which includes at least one dynamic sequence of video information frames, a first analysis device for receiving the first video information provided by the first video information source and for analyzing the received first video information in accordance with a first image  
15 analysis algorithm to generate first analysis data, a first storage device for storing, in the form of digital data, the first video information provided by the first video information source and the first analysis data generated by the first analysis device, a second video  
20 information source, at a second location remote from the first location, for providing second video information which includes at least one dynamic sequence of video information frames, a second analysis device for receiving the second video information provided by the second video  
25 information source and for analyzing the received second video information in accordance with a second image analysis algorithm to generate second analysis data, a second storage device, provided at a location remote from the first storage device, for storing, in the form of  
30 digital data, the second video information provided by the second video information source and the second analysis data generated by the second analysis device, and a device operatively connectable to the first and second storage devices for selectively retrieving the first and second  
35 video information from the first and second storage devices, respectively.

In the system apparatus provided in accordance with this aspect of the invention, a user at a central site can

access and retrieve video information stored at remote sites, where the remote sites have a capability for providing indexing information based on the content of the video information stored at the respective remote site.

5 The apparatus provided in accordance with this aspect of the invention may be arranged so that the first and second video information sources are respectively a first and second video camera, or each of the first and second video information sources may include a respective plurality of

10 the video cameras. The device provided for selectively retrieving the first and second video information may include a processor located remotely from the first and second storage devices, circuitry for selectively establishing a data communication path between the

15 processor and the first storage device, and circuitry for selectively establishing a data communication path between the processor and the second storage device. The device for selectively retrieving the first and second video information may do so on the basis of the stored first and

20 second analysis data, respectively. The first and second analysis algorithms may be for respectively assigning to portions of the video information analyzed by the algorithm analysis scores indicative of respective degrees to which the portions of the video information represent

25 a predetermined analysis feature. The scores may be permitted to range over a set of values that may be defined over eight bits, i.e., 256 distinct analysis score values.

According to still another aspect of the invention,

30 there is provided apparatus for storing a distributed video data base, including a first video information source, at a first location, for providing first video information which includes at least one dynamic sequence of video information frames, a first storage device for

35 storing in the form of digital data, the first video information provided by the first video information source, a second video information source, at a second location remote from the first location, for providing

second video information which includes at least one dynamic sequence of video information frames, a second storage device, provided at a location remote from the first storage device, for storing, in the form of digital data, the second video information provided by the second video information source, a third storage device, located remotely from the first and second storage devices, for storing an image analysis algorithm, a first processor operatively connected to and co-located with the first storage device, a second processor operatively connected to and co-located with the second storage device, and circuitry for sequentially downloading the image analysis algorithm from the third storage device to the first processor and to the second processor. According to further features of the apparatus, the first processor responds to the downloading to the first processor of the analysis algorithm by retrieving the first video information from the first storage device and analyzing the retrieved first video information in accordance with the downloaded analysis algorithm, and the second processor responds to the downloading by the second processor of the analysis algorithm by retrieving the second video information from the second storage device and analyzing the retrieved second video information in accordance with the downloaded analysis algorithm.

The third storage device may store a plurality of image analysis algorithms, with the first and second processors each including circuitry for selecting one of the algorithms to be downloaded to the respective processor from the third storage device. Each of the first and second processors may also include a mechanism for setting a parameter for constraining execution of the image analysis algorithm downloaded to the respective processor. The image analysis algorithm may assign respective analysis scores to portions of the first and second video information, the analysis scores being indicative of respective degrees to which the portions of the video information represent a predetermined analysis

feature, with the analysis scores ranging over 256 values.

This aspect of the invention provides for maintenance of a library of analysis algorithms, accessible from remote locations, so that a desired search algorithm can  
5 be downloaded to the remote location on demand and used at the remote location to analyze video data stored at the remote location.

According to an additional aspect of the invention, there is provided apparatus for analyzing and storing  
10 video data, including a device for generating the video data, an analysis device for analyzing the video data generated by the video data generating device to detect a predetermined characteristic of the video data, and a storage facility for storing the analyzed video data, with  
15 the storage facility including a first data storage device and a second data storage device, and the storage facility routing the analyzed video data to a selected one of the first and second data storage devices in response to detection by the analysis device of the predetermined  
20 characteristic of the video data. The second storage device may be selectively connectable to the video data generating device, with the storage facility establishing a data communication path connection between the video data generating device and the second data storage device  
25 in response to detection by the analysis device of the characteristic of the video data. The communication path connection may include a dial-up telephone connection between the video data generating device and the second data storage device. Alternatively, the data  
30 communication between the video data generating device and the second storage device may be by ISDN link, satellite link, local area network, or wireless infra red communication.

The characteristic of the video data to be detected  
35 by the analysis device may include a characteristic of an object represented by the video data, including a characteristic selected from the group consisting of size of the object, change of size of the object, motion of the

object, velocity of the object, acceleration of the object, change in rate of acceleration of the object, shape of the object, change of shape of the object, and texture of the object. Alternatively, or in addition, the  
5 predetermined characteristic of the video data to be detected by the analysis device may be a chrominance characteristic of the video data and/or a change of the chrominance characteristic of the video data.

According to another aspect of the invention, there  
10 is provided apparatus for analyzing video data, including a first video camera for generating first video data, an analysis device for analyzing the first video data generated by the first video camera to detect a predetermined characteristic of the first video data, a  
15 second video camera for generating second video data, and circuitry, responsive to the analysis device, for selectively storing the second video data generated by the second video camera in response to detection of the predetermined characteristic of the first video data by  
20 the analysis device. The predetermined characteristics to be detected by the analysis device may be as indicated above in connection with the first aspect of the invention. According to still another aspect of the invention, there is provided apparatus for analyzing video  
25 data, including a first video camera for generating first video data, an analysis device for analyzing the first video data generated by the first video camera to detect a predetermined characteristic of the first video data, where the analysis device selectively performs a  
30 predetermined analysis algorithm with respect to the second video data generated by the second video camera when the analysis device detects the predetermined characteristic of the first video data. The predetermined characteristic of the first video data to be detected by  
35 the analysis device may be as described above in connection with the first aspect of the invention.

According to still a further aspect of the invention, there is provided apparatus for analyzing video data,

including a source of video data and a device for analyzing the video data provided by the source of video data to detect a first predetermined characteristic of the video data by performing a first predetermined analysis  
5 algorithm, and for performing a second predetermined analysis algorithm to detect a second predetermined characteristic of the video data when the analysis device detects the first predetermined characteristic.

Further in accordance with this aspect of the  
10 invention, the source of video data may include a video camera, and the apparatus may also include a storage device for storing the video data and for supplying the stored video data for analysis in accordance with the second predetermined analysis algorithm when the analysis  
15 device detects the first predetermined characteristic of the video data.

According to this aspect of the invention, the apparatus has the capability not only of detecting features of interest in an incoming live video data  
20 stream, but also is able, upon detecting the feature of interest, to play back and further analyze the video data to see if a second characteristic of interest was also present in the video data.

According to still another aspect of the invention,  
25 there is provided apparatus for analyzing and storing video data, including a video camera for generating video data, an alarm device for detecting an alarm condition, a compression device for performing compression processing on the video data generated by the video camera according  
30 to a predetermined compression algorithm to form compressed video data, and a storage device for storing the compressed video data formed by the compression device, where the compression device is responsive to the alarm device so as to vary the compression algorithm in  
35 dependence upon whether the alarm device detects an alarm condition. The compression algorithm may include comparing predetermined portions of a present field of the video data to corresponding portions of a reference image



generated by the video camera, to form comparison statistics, comparing the comparison statistics with a threshold that is set at a first value when the alarm device does not detect an alarm condition and that is set  
5 at a second value, different from the first value, when the alarm device detects an alarm condition, and selectively discarding the predetermined portions of the present field on the basis of the comparing of the comparison statistics with the threshold. The alarm  
10 device may include circuitry for analyzing the video data generated by the video camera to detect a predetermined characteristic of the video data. The predetermined characteristic may be a spectral characteristic of the data or a measure of information content per unit quantity  
15 of the data.

According to a further aspect of the invention, there is provided apparatus for analyzing and storing video data, including a first video camera for generating first video data, a second video camera for generating second  
20 video data, a storage device for storing the second video data generated by the second video camera and a device for analyzing the first video data generated by the first video camera to detect a predetermined characteristic of the first video data, and for selectively analyzing the  
25 second video data stored in the storage device to detect a predetermined characteristic of the second stored video data in dependence upon whether the predetermined characteristic of the first video data is detected by the analysis device.

30 According to still another aspect of the invention, there is provided apparatus for analyzing and storing video data, including a first video camera for generating first video data, a second video camera for generating second video data, a storage device for storing the second  
35 video data generated by the second video camera, and a device for analyzing the first video data generated by the first video camera to detect a predetermined characteristic of the first video data, with the storage

device storing a first predetermined number of fields of the second video data per unit time during periods in which the analysis device does not detect the predetermined characteristic of the first video data, and  
5 storing a second predetermined number of fields, larger than the first predetermined number of fields, of the second video data per unit time during periods in which the analysis device detects the predetermined characteristic of the first video data.

10 According to still a further aspect of the invention, there is provided an apparatus for analyzing, storing and displaying video information, including a first camera for generating a first stream of video data, a second camera for generating a second stream of video data, a first  
15 storage device for selectively storing at least one of the first and second streams of video data, a second storage device for selectively storing at least one of the first and second streams of video data, transmission circuitry for selecting one of the first and second storage devices  
20 to receive the first stream of video data, a display device for selectively displaying at least one of the first and second streams of video data, an analysis device for analyzing the first stream of video data to detect a predetermined characteristic of the first stream of video  
25 data, and an action device, responsive to the analysis device, for performing at least one of a selected group of actions, in dependence upon whether the analysis device detects the predetermined characteristic of the first stream of video data. The predetermined characteristic of  
30 the first stream of video data to be detected by the analysis means is selected from the group consisting of acceleration of an object represented by the first stream of video data, change in acceleration of an object represented by the first stream of video data, shape of an  
35 object represented by the first stream of video data, change of shape of an object represented by the first stream of video data, and texture of an object represented by the first stream of video data. The action to be

performed by the action device upon detection of the predetermined characteristic is one or more of changing a characteristic of an image displayed on the display means, where at least part of the image represents the first  
5 stream of video data, controlling the transmission circuitry to change over between the first and second storage devices, changing a field of view of at least one of the first camera and the second camera, causing the analysis device to carry out a video data analysis  
10 algorithm with respect to the second stream of video data, selecting the second stream of video data for storage in at least one of the first and second storage devices, causing the display device to display an image at least part of which is representative of the second stream of  
15 video data, and causing the analysis device to carry out a video data analysis algorithm with respect to video data stored in and read out from one of the first and second storage devices.

According to yet another aspect of the invention,  
20 there is provided apparatus for analyzing, storing and displaying video information, including a first camera for generating a first stream of video data, a second camera for generating a second stream of video data, a first storage device for selectively storing at least one of the  
25 first and second streams of video data, a second storage device for selectively storing at least one of the first and second streams of video data, a transmission device for selecting one of the first and second storage device to receive the first stream of video data, a display  
30 device for selectively displaying at least one of the first and second video data, an analysis device for analyzing the first stream of video data to detect a plurality of predetermined characteristics of the stream of video data, and an action device, responsive to the  
35 analysis device, for performing at least one of a group of actions in dependence upon whether the analysis device detects the plurality of predetermined characteristics of the first stream of video data. The plurality of

characteristics to be detected by the analysis device are selected from the group consisting of motion of an object represented by the first stream of video data, acceleration of an object represented by the first stream of video data, change in acceleration of an object represented by the first stream of video data, shape of an object represented by the first stream of video data, change of shape of an object represented by the first stream of video data, and texture of an object represented by the first stream of video data. The action device performs at least one action, depending upon whether the analysis means detects the plurality of predetermined characteristics of the first stream of video data, selected from the group consisting of changing a characteristic of an image displayed on the display device, at least part of that image representing the first stream of video data, controlling the transmission device to change over between the first and second storage devices, changing a field of view of at least one of the first camera and the second camera, causing the analysis device to carry out a video data analysis algorithm with respect to the second stream of video data, selecting the second stream of video data for storage in at least one of the first and second storage devices, causing the display device to display an image at least part of which is representative of the second stream of video data, and causing the analysis device to carry out a video data analysis algorithm with respect to video data stored in and read out from one of the first and second storage devices.

According to yet another aspect of the invention, there is provided an apparatus for storing, analyzing and displaying video information, including a storage device for storing a stream of video data, the stream of video data representing a dynamic video image, a detecting device for detecting a predetermined characteristic of the stream of video data stored in the storage device, a display device for displaying images corresponding to the

stream of video data stored in the storage device, a display buffer for storing image data transferred from the storage device and for reading out image data stored in the display buffer, the image data read out from the display buffer being supplied to the display device to cause the display device to display an image corresponding to the supplied image data, and an action device, responsive to the detecting device, for performing at least one of a group of actions in dependence upon whether the detecting device detects the predetermined characteristic of the stream of video data stored in the storage device. The predetermined characteristic of the stream of video data to be detected by the detecting device is selected from the group consisting of motion of an object represented by the stream of video data stored in the storage device, texture of an object represented by the stream of video data stored in the storage device, amplitude of a high frequency component of the stream of video data stored in the storage device, a degree to which the stream of video data stored in the storage device has been compressed, a degree to which the stream of video data stored in the storage means exhibits spatial correlation, and a degree to which the stream of video data stored in the storage means exhibits temporal correlation. The group of actions, at least one of which is performed by the action device, includes selecting between a first display buffer update mode in which the data stored in the display buffer is updated according to a progressive image scan, selecting a rate at which data stored in the display buffer is updated, selecting a spatial resolution with which the display device displays the images corresponding to the stream of video data stored in the storage device, and selecting for updating a portion of an image plane corresponding to the image plane displayed on the display device.

According to still another aspect of the invention, there is provided a method of analyzing video data, including the steps of generating a stream of dynamic

images, applying a moving image content analysis algorithm to the stream of dynamic images, and inhibiting application of the analysis algorithm to the stream of dynamic images, in response to detection of an alarm  
5 condition. The alarm condition may be detected by application of the analysis algorithm, and the algorithm may be for detecting a moving object represented by the stream of dynamic images.

According to still a further aspect of the invention,  
10 there is provided a method of simultaneously recording on a recording medium a plurality of streams of video information each generated by a respective video camera, including the steps of determining whether an alarm condition is present, and in the case that no alarm  
15 condition is present, recording images generated by the video cameras on the recording medium at a first aggregate image rate, the aggregate image rate defining a total number of images currently being recorded on the recording medium per unit time, and in the case that an alarm  
20 condition is determined to be present, recording images generated by the video cameras on the recording medium at a second aggregate image rate that is higher than the first aggregate image rate. The step of determining whether an alarm condition is present may include  
25 analyzing content of at least one of the streams of video information and/or receiving a signal from an alarm sensor. In one embodiment of the invention, the aggregate image recording rate is 30 images per second when no alarm condition is present and is 45 images per second when an  
30 alarm condition is present.

According to an additional aspect of the invention, there is provided a method of performing data compression with respect to a frame of image data, the image data being representative of pixels arrayed in an image plane,  
35 the method including the steps of dividing the image data into a plurality of data blocks, each data block representing a respective rectangular part of the image plane, comparing each of the data blocks with a

corresponding data block of a preceding frame of image data to generate a similarity metric indicative of a degree of similarity between the data block and the corresponding block of the preceding frame, comparing the  
5 similarity metric with a predetermined threshold value, selecting, on the basis of the comparison of the similarity metric with the threshold value, one of a first mode for generating and coding values for the data block and a second mode for generating and coding values for the  
10 data block, generating and coding values for each data block in accordance with the selected one of the first mode and the second mode, and applying a transformation to the encoding values of the data block to form a respective block of coefficient values.

15 According to another aspect of the invention, there is provided a method of reconstituting compressed image data, where the compressed image data includes image data frames representative of a dynamic sequence of  $m$  images, every  $n$ th one of the  $m$  image data frames having been  
20 compression-encoded using an intra-frame compression algorithm in which each of every  $n$ th frame is encoded without reference to any other image frame,  $n$  being an integer greater than 2,  $m$  being an integral multiple of  $n$  and at least twice as large as  $n$ , all of the image data  
25 frames other than the every  $n$ th frame having been compression-encoded using a difference encoding algorithm such that the other image data frames are formed of data representing differences relative to a preceding image data frame, and the method including the steps of  
30 reconstituting all of the difference-encoded image data frames, storing all of the reconstituted image data frames in a storage device, and retrieving the reconstituted image data frames from the storage device and displaying the retrieved image data frames, with a plurality of the  
35 reconstituted difference-encoded image data frames being stored in the storage device before any of the reconstituted difference-encoded image data frames are retrieved from the storage device and displayed.

According to still another aspect of the invention, there is provided a method of reconstituting compressed image data, with the compressed image data including image data frames representative of a dynamic sequence of  
5 images, every nth one of the image data frames having been compression-encoded using an intra-frame compression algorithm in which each of the every nth frames is encoded without reference to any other image frame, n being an integer greater than one, all others of the image data  
10 frames having been compression-encoded using a difference encoding algorithm such that the other image data frames are formed of difference data representing differences relative to a respective preceding image data frame, and the method including the steps of reconstituting all of  
15 the intra-frame-encoded image data frames, forming, for each of the difference-encoded image data frames, second difference data representing differences relative to a respective succeeding reconstituted image data frame, and storing the second difference data in association with the  
20 respective difference-encoded image data frame.

According to yet another aspect of the invention, there is provided a method of representing video data in compressed form, including the steps of dividing into rectangular blocks a present image to be compressed, the  
25 present image being formed in an image plane, comparing each of the rectangular blocks of the present image with a corresponding rectangular block of a reference image to generate comparison data from the block of the present image, selecting for representation the rectangular blocks  
30 of the present image for which the generated comparison data meets a selection criterion, generating mapping data indicative of locations in the image plane which correspond to the selected rectangular blocks for the present image, and representing the present image in  
35 compressed form by use of header data for identifying the present image, the mapping data generated for the present image, and image data representative of the selected rectangular blocks of the present frame. Preferably,



blocks of pixels corresponding to the selected rectangular blocks of the present frame are subjected to an orthogonal transform and then the resulting coefficient data is quantized. For example, JPEG compression may be applied to the blocks of pixels in the selected rectangular blocks. (In a conceptual sense, the latter aspect of the invention contemplates dividing the image plane into "postage stamps", selecting for further compression processing and storage only those "stamps" which differ significantly from a reference image, and then, when the present image is to be reconstituted, the compressed "postage stamp" data is reconstituted and then "pasted" at the appropriate points on the reference image, according to mapping data generated at the time of selection of the "postage stamps".)

The mapping data represents, for each image, a coarse indication of changes vis-a-vis the reference image. The mapping data therefore is suitable for analysis to detect motion, moving objects, or other features of interest in the stream of video images.)

According to still a further aspect of the invention, there is provided a method of representing video data in compressed form, including the steps of dividing an image plane into a plurality of rectangular areas, processing a first video image to generate a first set of characteristic statistics including at least one characteristic statistic corresponding to each of the plurality of rectangular areas, storing the first set of characteristic statistics, processing a second video image to generate a second set of characteristic statistics including at least one characteristic statistic corresponding to each of the plurality of rectangular areas, comparing, for each of the plurality of rectangular areas, corresponding ones of the first and second sets of characteristic statistics, selecting, on the basis of the comparing step, ones of the rectangular areas for which the corresponding ones of the first and second sets of characteristic statistics differ from each other by at

least a predetermined degree of difference, updating the stored set of characteristics statistics by replacing the stored characteristics statistics corresponding to the selected rectangular areas with the characteristics of the second set which correspond to the selected rectangular areas, processing a third video image to generate a third set of characteristics statistics including at least one characteristic statistic corresponding to each of the plurality of rectangular areas, and comparing, for each of the plurality of rectangular areas, corresponding ones of the updated set of characteristic statistics and the third set of characteristic statistics.

According to yet another aspect of the invention, there is provided a method of displaying in an image plane a video image represented by compressed video data, the compressed video data including replacement image data consisting of a plurality of image data portions each corresponding to a respective region of the image plane, the compressed video data also including mapping data indicative of the regions of the image plane to which the image data portions correspond, and the method including the steps of storing in a buffer reference data representative of a reference video image, performing a first displaying step consisting of displaying the referenced video image, reading the mapping data, updating, on the basis of the mapping data, the stored reference data by replacing portions of the stored reference data corresponding to the image plane regions indicated by the mapping data with the corresponding replacement image data portions of the compressed video data, and performing a second displaying step consisting of displaying the second video image corresponding to the updated stored reference data. The reference image displayed at the first displaying step may correspond to an image that was generated either earlier in time or later in time by the same video camera which generated the image displayed at the second displaying step. Thus, the "postage stamp replacement" technique for providing the

reconstituted images may be applied either to forward or reverse playback operations.

According to an additional aspect of the invention, there is provided a random-access data storage device in which is stored compressed video data representing a sequence of images formed in an image plane by a video camera, the compressed video data including a plurality of first compressed data portions representing reference images consisting of every  $n$ th one of the sequence of images, the first data portions having been respectively formed by applying an intra-image compression process to data representing each one of the reference images,  $n$  being an integer greater than 3, the compressed video data also including a plurality of second compressed data portions, each representing a respective one of the sequence of images that is not one of the reference images, each of the compressed data portions including replacement image data corresponding to selected portions of the image plane and mapping data indicative of the selected portions of the image plane.

According to another aspect of the invention, there is provided video information storage apparatus, including a plurality of video images, each for generating a respective stream of dynamic images, a multiplexer for multiplexing the streams of dynamic images to form a combined sequence of video images, images generated by respective ones of the video cameras being interspersed with each other in the combined sequence, compression circuitry for receiving the combined sequence of video images and for applying a data compression algorithm to the images of the combined sequence, the compression algorithm applied to each of the images of the combined sequence being subject to variation depending on which camera generated the image to which the algorithm is applied, and a storage device for storing compressed video images formed by the compression circuitry.

According to a further aspect of the invention there is provided video data storage apparatus, including a

video information source for outputting a sequence of fields of video data, each field of video data representing a respective image, a storage device for storing the video data fields in the form of compressed video data, a microprocessor for controlling storage of compressed video data by the storage device, and a digital signal processing integrated circuit (DSP-IC) for exchanging data with the microprocessor and for applying a data compression algorithm to the fields of video data, the DSP-IC applying the data compression algorithm to a first field of the sequence of fields in accordance with a parameter which constrains operation of the data compression algorithm, and the DSP-IC receiving a signal from the microprocessor to change the parameter when the DSP-IC completes compression-processing of the first field; and then the DSP-IC applying the data compression algorithm to a second field, immediately following the first field, in accordance with the changed parameter, and then receiving a signal from the microprocessor to again change the parameter after completing compression-processing of the second field, and then applying the data compression algorithm to a third field of the sequence of fields in accordance with the again-changed parameter, with the third field immediately following the second field in the sequence of fields.

According to still a further aspect of the invention, there is provided a method of characterizing a block of video data in a first field of video data, the block of video data being provided to be characterized in comparison with a corresponding block of video data in another field of video data, the block of video data in the first field being in the form of an 8 x 8 pixel data array, the method including the steps of dividing the 8 x 8 pixel data into four quadrants each consisting of a 4 x 4 pixel data array, selecting pixels from each of the quadrants in accordance with a checker-board sampling pattern, summing, with respect to each of the quadrants, the pixels selected from the quadrant and dividing the

resulting sum by a scaling factor to generate a characterizing statistic for the respective quadrant, subtracting each of the respective characterizing statistics from a characterizing statistic for a corresponding quadrant of the corresponding block of video data in the other field to generate a difference value for each quadrant of the block of video data in the first field, comparing each of the difference values with a threshold level, and characterizing the block of video data in the first field as different from the corresponding block of video data in the other field if the absolute value of any one of the difference values for the four quadrants of the block of video data in the first field exceeds the threshold level.

According to still another aspect of the invention, there is provided a method of performing data compression with respect to a plurality of streams of dynamic video images, each of the streams being generated by a respective video camera, images from the streams being interspersed with each other to form a composite stream, the method including the steps of storing statistics characterizing a respective reference image from each of the plurality of streams, and performing compression-encoding with respect to later images of each of the plurality of streams by comparing each of the later images with the statistics characterizing a reference image corresponding to the respective stream.

According to an additional aspect of the invention, there is provided an apparatus for storing video signals, including at least four video cameras, first, second and third video decoding circuits each for receiving a field of a video signal generated by a respective one of the video cameras concurrently connected to the video decoding circuit and for extracting luminance, chrominance and reference signal components from the received video signal, circuitry for selectively connecting each of the video decoding circuits to every one of the video cameras, first and second signal conversion circuits, each for

converting into digital form the luminance and chrominance signal components extracted by a respective one of the video decoding circuits currently connected to the signal conversion circuit, circuitry for selectively connecting  
5 each of the signal conversion circuits to every one of the first, second and third video decoding circuits, a first storage device connected to the first signal conversion circuit for sequentially storing fields of the luminance and chrominance signal components converted into digital  
10 form by the first conversion circuit, and a second storage device connected to the second signal conversion circuit for sequentially storing fields of the luminance and chrominance signal components converted into digital form by the second conversion circuit.

15 The apparatus provided in accordance with this aspect of the invention may also include a data compression circuit for applying a data compression algorithm to the digital components stored in the first and second storage devices to form compressed video data, and circuitry for  
20 selectively connecting the data compression circuit to each of the first and second storage devices. There may further be included in the apparatus a mass storage device, such as a hard disk drive, magneto-optical disk drive, writable optical drive, etc., connected to the data  
25 compression circuit for storing the compressed video data formed by the data compression circuit. The chrominance signal components may include first and second chrominance signal components, and each of the first and second signal conversion circuits may include circuitry for formatting  
30 digital data representing the luminance signal component and the first and second chrominance signal components according to a 4:1:1 data format. Alternatively, 4:2:2 or 4:4:4 formats may be used.

In a preferred embodiment of the invention, 16 video  
35 cameras are selectively connectable to the three decoding circuits, and fields of the video signals from the cameras are captured and converted to digital form at an aggregate rate of 45 fields per second.

According to another aspect of the invention, there is provided a method of updating a display buffer, the display buffer being for storing image data to be supplied to a display device to cause the display device to display  
5 an image corresponding to the image data, the display device displaying the image in the form of a plurality of rows of picture elements, the rows of picture elements consisting of a first set of rows that are alternate ones of the rows of picture elements and a second set of rows  
10 that are all of the rows of picture elements not included in the first set of rows, the display buffer including a first set of memory locations corresponding to the first set of rows and a second set of memory locations corresponding to the second set of rows, the method  
15 including the steps of first updating the image data stored in the first set of memory locations, and then following completion of the first updating step, second updating the image data stored in the second set of memory locations, and then sequentially repeating the first and  
20 second updating steps.

According to still another aspect of the invention, there is provided apparatus for formatting an image plane represented as a two-dimensional array of pixel locations according to a 4:1:1 digital color video format, including  
25 circuitry for dividing the image plane into  $n$  rectangular regions having a vertical dimension of  $m$  pixels and a horizontal dimension of  $4m$  pixels,  $n$  being an integer greater than 1,  $m$  being an even integer greater than 1, a luma block circuit for forming with respect to each of the  
30  $n$  rectangular regions four  $m \times m$  luminance-value pixel blocks arranged in a horizontal sequence in the rectangular region, and a chroma block circuit for forming exactly two  $m \times m$  chrominance value blocks with respect to each of the  $n$  rectangular regions, a first one of the two  
35 chrominance-value blocks corresponding to a first chrominance signal, and each value of the first chrominance-value block representing an area corresponding to four horizontally sequential pixels of the respective

rectangular region, the second one of the two chrominance-value blocks corresponding to a second chrominance signal different from the first chrominance signal, each value of the second chrominance-value block representing an area  
5 corresponding to four horizontally-sequential pixels of the respective rectangular region.

In a preferred embodiment of the invention, each of the pixel blocks is made up of an 8 x 8 block of pixels, each of the regions is made up of four, horizontally-  
10 sequential, 8 x 8 pixel blocks, and the entire image plane is formed of 600 of the rectangular regions, having a horizontal dimension equivalent to 20 of the rectangular regions and a vertical dimension equivalent to 30 of the rectangular regions. The first chrominance signal may be  
15 a U signal, in which case the second chrominance signal is a V signal.

According to still a further aspect of the invention, there is provided a method of transmitting a field of video data on a multi-bit parallel data bus, the field of  
20 video data corresponding to an image, the method including the steps of dividing the field of video data into first video data portions each corresponding to at least one and no more than m raster-scan lines of the field, m being a positive integer that is less than a number of raster-scan  
25 lines making up said field of video data, transmitting each of the first video data portions in a respective one of a first sequence of discrete time intervals, formatting the field of video data into a plurality of n x p data blocks, each of the data blocks corresponding to a  
30 respective rectangular portion of the image that overlaps at least two raster-scan lines, n and p both being positive integers greater than 1, dividing the block-formatted video data into second data portions, each consisting of a plurality of the n x p data blocks, and  
35 transmitting each of the second data portions in a respective one of a second sequence of discrete time intervals, the second sequence of discrete time intervals being interleaved with the first sequence of discrete time



intervals. In a preferred embodiment of the invention,  $m = 1$  (i.e., exactly 1 raster-scan line is sent during each interval of the first sequence of intervals), while  $n = p = 8$ , and each of the second data portions consists of 15  
5 of the  $8 \times 8$  data blocks (i.e., 15 of the  $8 \times 8$  data blocks are transmitted during each interval of the second sequence of intervals). In short, this aspect of the invention contemplates transmitting all of the pixels of the field of video data twice, with raster-scan lines  
10 being interspersed with rectangular blocks. As will be seen from subsequent disclosure herein, this video data transmission technique facilitates parallel processing of fields of video data.

According to still a further aspect of the invention,  
15 there is provided a method of updating a display buffer, the display buffer being for storing image data to be supplied to a display device to cause the display device to display an image corresponding to the image data, the display device displaying the image in the form of a two-  
20 dimensional array of picture elements, the array of picture elements defining an image plane, the method including steps of dividing the image plane into a plurality of rectangular regions, generating a present field of video data representative of an image formed in  
25 the image plane, and, for each one of the rectangular regions of the image plane, detecting a characteristic of a portion of the present field of video data, that portion corresponding to the respective one of the rectangular regions, comparing the detected characteristic with a  
30 reference characteristic, and selectively storing the portion of the present field of video data in the display buffer, in dependence upon a result of the comparing step.

According to an additional aspect of the invention, there is provided a video data storage apparatus,  
35 including a plurality of video cameras each for generating a respective stream of video information, one or more hard disks for storing video data, a housing in which the hard disk(s) is contained, a motherboard mounted in the housing

and having mounted thereon a microprocessor for controlling storage of video data on the hard disks, a second printed circuit board mounted in the housing and having integrated circuits mounted thereon for receiving  
5 the streams of video information generated by the video cameras, the integrated circuits on the second printed circuit board being for selecting for storage ones of fields of video information included in the streams of video information, and a third printed circuit board  
10 mounted in the housing and connected to the motherboard and the third printed circuit board, with the second printed circuit board being connected to the motherboard only through the third printed circuit board, and the third circuit board having mounted thereon integrated  
15 circuitry for digitizing the selected fields of video information and for applying data compression processing to the selected fields of video information. Filtering circuitry for performing analog signal conditioning on the fields of video information may be mounted on the second  
20 printed circuit board, and an integrated circuit processing device for applying a moving image content analysis algorithm to the digitized fields of video information may be mounted on the third printed circuit board. The apparatus may also include an archive device,  
25 such as a DAT drive or other removable recording medium drive unit, for recording video data copied from the hard disk. The archive device may be mounted within the housing.

In a preferred embodiment of the invention, the  
30 motherboard may have a configuration, including a population of IC components and connecting traces, like those found in standard personal computer motherboards, to minimize the component and manufacturing cost for the motherboard. The novel and customized front-end  
35 processing circuitry, provided on the second and third printed circuit boards, permits rapid and flexible pre-processing of the video information.

According to another aspect of the invention, there

is provided a video data storage apparatus, including a video information source for outputting at least one stream of video data fields, a storage device for storing the video data fields in the form of compressed video data, a housing, a motherboard mounted in the housing, the motherboard having mounted thereon a microprocessor for controlling storage of the compressed video data by the storage device, a second printed circuit board mounted in the housing and connected to the motherboard, a first digital signal processing integrated circuit (DSP-IC), mounted on the second printed circuit board, for exchanging data with the microprocessor and for applying a data compression algorithm to the at least one stream of video data fields, the second printed circuit board also having mounted thereon display processing circuitry for applying scaling processing and overlay mixing to the stream of video data fields, a second DSP-IC for controlling the display processing circuitry, and a third DSP-IC for applying a moving image content analysis algorithm to the stream of video data fields, with the first DSP-IC transmitting command messages to, and receiving status messages from, the second and third DSP-IC's.

According to still another aspect of the invention, there is provided a structure for supporting a plurality of recording medium drive units in a video data storage apparatus, the structure including a base member for supporting at least one of the drive units, a second member, supported on the base member, for supporting at least a second one of the drive units, and a third member, supported on the second member, for securing the at least second one of the drive units on the second member. Preferably, the structure is arranged to support up to six drive units, with up to two drive units being mounted on each of the base member, the second member and the third member. The drive units may include a floppy disk drive unit and a DAT drive unit supported on the base member, two hard disk drive units supported on the second member,

and one or two additional hard disk drive units supported on the third member. Instead of the DAT drive, a digital video disk (DVD) drive, a writable optical disk drive or a magneto-optical disk drive may be mounted on the base member. The base member preferably includes a substantially planar and horizontal bottom plate and two vertical end walls emerging upwardly and integrally from respective opposite side edges of the bottom plate. Also, the second member is preferably substantially planar and a vertical end wall of the base member has a pair of slots formed therein, with the second member having a pair of hinge-tabs formed therein at respective positions that correspond to the respective positions of the slots of the base member, each of the hinge-tabs being for pivotally engaging a respective one of the slots. Preferably the third member includes a substantially planar and horizontal top plate and two vertical end walls emerging downwardly and integrally from respective opposite side edges of the top plate. The base member, the second member and the third member preferably all have a respective attachment tab formed thereon with the attachment tabs each having a hole formed therein for accommodating a fastener, and the three members being positioned with respect to each other so that the three holes in the attachment tabs are aligned to permit simultaneous insertion of the fastener through all three holes. In this way, the three members may be fastened together to form the drive unit support structure by means of a single fastener.

According to an aspect of the invention, there is provided a video data storage apparatus, including a source device for providing video data, a first storage device including a first storage medium for storing the video data provided by the source device, a second storage device including a second storage medium on which video data provided by the source device has been recorded, a third storage device including a third storage medium for storing video data to be archived, and a control device

for controlling the first storage device to store video data provided by the source device, while controlling the second and third storage devices to transfer the video data stored on the second storage medium from the second  
5 storage medium to the third storage medium.

The first and second storage media may respectively be a first hard disk and a second hard disk, and the third storage medium may be a magnetic tape, with the third storage device being a helical-scan tape recorder such as  
10 a recorder employing the standard DAT format. Alternatively, the third storage medium may be a writable optical disk, a magneto-optical disk, a DVD (digital video disk), or a removable hard drive.

The apparatus may include plural video cameras, each  
15 generating respective sequences of frames of video signals, and conversion facilities for converting the respective sequences of frames of video signals into sequences of frames of digital video data for storage on the storage media. There may also be included in the  
20 apparatus facilities for generating index data with respect to the frames of digital video data, the index data being indicative of respective times at which the frames of digital video data were generated, as well as identifying which camera generated each frame of digital  
25 video data and locations on the first storage medium at which the frames of digital video data are recorded. The index data may also include data indicative of events represented by the sequences of frames of the digital video data. Such events may include alarm conditions,  
30 either indicated by alarm sensing devices, or generated by analysis of the data itself. A fourth hard disk drive may be provided in the apparatus for storing the index data, which is also stored on the first hard disk. When video data is transferred from one of the hard disks to the  
35 archiving medium (e.g. the DAT), it is accompanied by corresponding index data, including index data previously stored on one of the hard disks.

The control device may be operable to determine what

portion of the first hard disk remains available for storing video data provided by the source device and for determining what quantity of the video data recorded on the second hard disk remains to be transferred to tape for permanent storage, the control means also being arranged to compare the available proportion of the first hard disk and the quantity of video data remaining to be transferred from the second hard disk, and then selecting, as a result of the comparison, a rate at which video data from the source device is stored on the first hard disk. For example, the storage rate may be a frame rate at which the video data from the source device is stored on the first hard disk.

According to another aspect of the invention, there is provided a method of archiving video data stored in a video data storage apparatus, the apparatus including a plurality of video cameras, first and second video data storage hard disks, an index data storage hard disk, an archive recording medium and a drive unit for the archive recording medium, the method including the steps of (A) storing on the first video data storage hard disk video data representative of dynamic video signal streams generated by the video cameras, while storing on the index data storage hard disk, index data indicative of times of recording and sources of the video data being stored on the first video data storage hard disk, (B) concurrently with step (A), recording on the archive recording medium all video data stored on the second video data storage hard disk and index data stored on the index data storage hard disk and indicative of times of recording and sources of the video data stored on the second video data storage hard disk, and (C) after completion of step (B) storing on the second video data storage hard disk video data representative of dynamic video signal streams generated by the video cameras, and concurrently recording on the archive recording medium index data stored on the index data storage hard disk and indicative of times of recording and sources of the video data stored on the

first video data storage hard disk during step (A) and also storing on the archive recording medium the video data stored on the first video data storage hard disk during step (A).

5           The above-recited step (C) may be performed immediately upon completion of step (B) (i.e. as soon as archiving of the data from the second hard disk is complete) or may be deferred until all or a predetermined proportion of the storage capacity of the first hard disk  
10 has been filled.

          According to still another aspect of the invention, there is provided an apparatus for storing and retrieving video data, including a plurality of video cameras generating respective sequences of video signals, a first  
15 hard disk for selectively storing video data corresponding to the video signals generated by the video cameras, and for selectively outputting the video data stored on the first hard disk, a second hard disk for selectively storing video data corresponding to the video signals  
20 generated by the video cameras, and for selectively outputting the video data stored on the second hard disk, an archive medium drive unit for selectively recording on an archive recording medium video data stored on and outputted from the first and second hard disks, a display  
25 device for selectively displaying an image corresponding to video data stored on and outputted from the first and second hard disks, and a control device for controlling the first and second hard disks, the archive medium drive unit and the display device, wherein the control device  
30 selectively performs recording operations in which video data corresponding to the video signals generated by the video cameras is recorded on a selected one of the hard disks, playback operations in which the display device displays an image corresponding to video data read from a  
35 selected one of the hard disks and archiving operations in which video data outputted from a selected one of the hard disks is recorded on the archive recording medium, at least some of the recording, playback and archiving

operations exhibiting dynamic variations in a quantity of video data involved in the operations, and the control device having a finite processing capacity and allocating its processing capacity so as to give priority to the recording operations relative to the playback operations and so as to give priority to the playback operations relative to the archiving operations.

According to yet a further aspect of the invention, there is provided a video data storage apparatus, including a video information source for providing a sequence of frames of video data, a primary storage device including a storage medium for storing video data provided by the video information source, an archive storage device for storing video data to be archived, and a control device for controlling the primary storage device to store the video data provided by the video information source at a storage rate selected by the control device, the control device also controlling the primary storage device and the archive storage device to transfer to the archive storage device video data stored by the primary storage device, the control device calculating a first time for completion of transferring of a predetermined quantity of stored video data from the primary storage device to the archive storage device, and calculating a second time for completion of storing on the primary storage device of a predetermined number of fields of video data to be provided by the video information source, the control means comparing the calculated first and second times and, on the basis of a result of the comparison, selecting the storage rate at which the primary storage device stores the video data provided by the video information source. For example, when the control device calculates that the primary storage device will be filled before archiving of the data from the primary storage device is completed, the control device may select a first field rate for the primary storage device that is slower than a second field rate that would otherwise be used. The first storage device may be a hard disk drive storing the video data on



a hard disk and the archive storage device may be a DAT drive. Alternatively, the archive storage device may be a writable optical disk, a magneto-optical disk, a DVD (digital video disk), or a removable hard drive.

5           According to still a further aspect of the invention, there is provided a video information storage apparatus, including a plurality of video cameras each for generating a respective stream of video information, a housing, a storage device including first and second hard disk drives  
10 fixedly mounted in the housing for storing the streams of video information, an archive device for driving a removable recording medium such as a DAT, the archive device being operated to copy onto a sequence of DATs video information sequentially stored on the hard disk  
15 drives, and circuitry for generating removable media data and for recording the removable media data on one of the hard disk drives, the removable media data including data corresponding to each of a plurality of the DATs upon which video information was copied, the data corresponding  
20 to each of the DAT's including data indicative of the video cameras by which and the times at which the video information copied on the DAT was generated. It should be understood that other removable media, such as digital video disks, may be employed instead of or in addition to  
25 magnetic tape (DAT format) for the purposes of archival storage. The latter aspect of the invention provides quasi-permanent data storage within the apparatus itself of index information relating to video data that has previously been archived on the removable media.

30           According to an additional aspect of the invention, there is provided a closed-circuit video surveillance system, including a plurality of video cameras, a selection device for selecting one or more of the video cameras, a display device for displaying video images  
35 generated by ones of the video cameras selected by the selection device, and a control device for controlling the display device, the control device causing the display device to display a plurality of symbols each

representative of a respective one of the video cameras, the control device also causing the display device to display an indication in association with at least one of the symbols to indicate that the camera or cameras  
5 corresponding to the at least one of the symbols have been selected by the selection device. The display device may display the video images generated by the selected video camera or cameras in a first portion of a display screen and the symbols representative of the plurality of video  
10 cameras in a second portion of the display screen. The symbols representative of the plurality of video cameras may be buttons on which a cursor is selectively positioned to select corresponding ones of the video cameras. The second portion of the display screen may be displaced  
15 downwardly from the first portion of the display screen.

According to another aspect of the invention, there is provided a closed-circuit video surveillance system, including a plurality of video cameras, display-selection means for display-selecting one or more of the video  
20 cameras, a display device including a display screen for displaying respective streams of video images generated by ones of the video cameras display-selected by the display-selection device, each respective display stream of video images being displayed in a respective display window on  
25 the display screen, a record-selection mechanism for record-selecting one or more of the video cameras, a recording device for recording video information corresponding to the video images generated by ones of the video cameras record-selected by the record-selection  
30 mechanism, and a control device for controlling the display device, the control device causing the display device to display a record-enable indicia at a border of each display window, the record-enable indicia being for indicating whether the display-selected video camera  
35 corresponding to the respective display window is currently record-selected by the record-selection means.

According to still another aspect of the invention, there is provided, in a closed-circuit video surveillance

system including a video camera, a method of automatically  
diagnosing the video camera, including the steps of  
storing a reference image generated by the video camera,  
analyzing the stored reference image to form reference  
5 parameters indicative of characteristics of the stored  
reference image, analyzing the reference parameters,  
automatically and periodically operating the video camera  
to generate comparison images, storing and analyzing the  
comparison images to generate comparison parameters  
10 indicative of characteristics of respective comparison  
images, and comparing the comparison parameters with the  
stored reference parameters.

The automatic camera diagnosis technique provided in  
accordance with this aspect of the invention makes it  
15 possible for the system to automatically and periodically  
compare the performance of each camera against a base line  
set of performance parameters. The capture and analysis  
of the images for diagnosis may occur at regular  
intervals, say monthly, after the base line parameters are  
20 generated. The reference parameters may include a color  
histogram and a spatial frequency distribution, to detect  
"blooming" or loss of resolution, which may occur as a  
camera ages.

According to yet a further aspect of the invention,  
25 there is provided a method of displaying status  
information relating to a video surveillance system, the  
system including at least one hard disk for storing in  
digital form video image information generated by a  
plurality of video cameras, the system also including an  
30 archive storage device for driving a removable recording  
medium and copying video image information onto the  
removable recording medium from the hard disk, and the  
method including the steps of displaying on a display  
screen first information indicative of unused recording  
35 space available on the at least one hard disk, displaying  
on the display screen second information indicative of  
unused recording space available on the removable  
recording medium, displaying additional information

indicative of a number of alarm events with respect to which alarm information has been stored in the video surveillance system, and the alarm information has been reviewed, within a predetermined period of time, and displaying further additional information indicative of a number of alarm events with respect to which alarm information has been stored in the video surveillance system and has not been reviewed, displaying still further additional information indicative of how many video cameras are connected to the video surveillance system, and displaying yet further additional information indicative of a number of video cameras currently selected for recording by the video surveillance system, and further displaying information indicative of a one of a plurality of image display configurations currently selected in the video surveillance system.

According to still another aspect of the invention, there is provided a video data storage apparatus for simultaneously recording a plurality of streams of video images each generated by a respective video camera, including a plurality of video cameras, a housing having a front panel, a storage device disposed within the housing for storing video information generated by the video cameras, a display device including a display screen for displaying the video information generated by the video cameras, a control device disposed within the housing for receiving the video information generated by the video cameras and transmitting the video information to the storage device and to the display device, a plurality of manually-operable switches, mounted in a layout pattern on the front panel of the housing, for inputting respective command signals to the control device, and a cursor device for transmitting signals to the control device to control positioning of a cursor on the display screen, the control device being arranged to control the display device to display a plurality of switch areas on the display screen in accordance with the switch layout pattern on the front panel, each of the

switch areas on the display screen corresponding to one of the switches on the front panel and being actuatable by the cursor device to generate a command signal which is the same as the command signal generated by actuation of  
5 the corresponding switch on the front panel.

In a preferred embodiment, the switches on the front panel include camera selection switches, each corresponding to one of the video cameras, for selecting the respective video camera so that the video information  
10 generated by the camera is displayed by the display device, and the switch areas on the display screen include camera switch areas corresponding to the camera selection switches on the front panel. Also, the switches on the front panel include a circular jog-shuttle switch manually  
15 rotatable by a user to generate command signals for controlling playback and display of video information stored by the storage device, and the switch areas on the display screen include a circular switch area corresponding to the jog-shuttle switch on the front panel  
20 and having a control point actuatable by the cursor device for controlling playback and display of the video information stored by the storage device. There may also be a plurality of light-emitting diodes mounted on the front panel, each adjacent to a respective one of the  
25 camera selection switches, for indicating that the respective video camera is selected for display, and the display screen displays adjacent to each of the camera switch areas a camera selection indication corresponding to a respective one of the LEDs on the front panel.

30 According to an additional aspect of the invention, there is provided a method of processing fields of video data, including the steps of dividing each of the fields of video data into a plurality of rectangular data blocks, each data block consisting of an  $n \times m$  array of picture  
35 elements, where  $n$  and  $m$  are positive integers greater than 1, comparing each data block with a corresponding data block in a preceding field to generate comparison data, performing a data compression algorithm with respect to

the data blocks on the basis of the comparison data, and performing a data analysis algorithm with respect to the data blocks on the basis of the comparison data.

According to another aspect of the invention, there is provided a video information storage and analysis apparatus, including a video information source for generating a dynamic sequence of video data frames, a compression circuit for applying a data compression algorithm to the dynamic sequence of video data frames to form compression video data, a display device for displaying a dynamic image which corresponds to the dynamic sequence of video data frames, an analysis circuit for receiving the dynamic sequence of video data frames and performing a moving image content analysis algorithm with respect to the received dynamic sequence of video data frames, and signal transmission circuitry for simultaneously transmitting the dynamic sequence of video data frames from the video information source to all three of the compression circuit, the display device and the analysis circuit.

According to a further aspect of the invention, there is provided an apparatus for storing video data, including a plurality of signal sources each for providing a respective stream of video signals, a difference circuit for detecting differences between successive frames in each of the streams of video signals and for generating difference data indicative of the detected differences, a compression device for processing the difference data to form compression-encoded data representative of the streams of video signals, and a storage device for storing the compression-encoded data formed by the compression circuit.

The apparatus provided in accordance with this aspect of the invention may further include an analysis circuit for processing the difference data in accordance with a moving image content analysis algorithm to form analysis data indicative of respective characteristics of the streams of video signals.

According to still a further aspect of the invention, there is provided an apparatus for storing and displaying video information, including a first video camera for generating first video information, a second video camera  
5 for generating second video information, a recording device for recording, on a first occasion, first and second video information simultaneously generated by the first and second video cameras on the first occasion, a storage device for storing the recorded first and second  
10 video information, circuitry for retrieving from the storage device and displaying, on a second occasion later in time than the first occasion, the first video information generated on the first occasion by the first video camera, a selection device actuatable by a user of  
15 the apparatus on the second occasion for selecting the second video camera while the first video information generated on the first occasion by the first camera is being displayed, search circuitry, responsive to selection of the second video camera by the selection device while  
20 the first video information generated on the first occasion by the first video camera is being displayed, for searching the storage device to locate the second video information generated by the second video camera on the first occasion and stored on the storage device, and an  
25 arrangement for displaying the located second video information.

According to yet another aspect of the invention, there is provided a method of analyzing video information, including the steps of receiving an analog video signal  
30 which represents a dynamic sequence of images, digitizing the received analog video signal to form a sequence of digitized video data fields which represent the dynamic sequence of images, transmitting on a video bus the sequence of digitized video data fields according to a  
35 timing sequence which includes a vertical blanking interval between each two adjacent video data fields, receiving the sequence of digitized video data fields which were transmitted according to the timing sequence,

and applying a moving image content analysis algorithm to each received video data field during the vertical blanking interval which follows receipt of the video data field.

5           According to still a further aspect of the invention, there is provided an apparatus for storing and analyzing video information, including a video camera for generating a sequence of video fields, circuitry for comparing predetermined portions of a present field of the sequence  
10 of video fields with a reference field of the sequence of video fields to form comparison statistics, the reference field having preceded the present field in the sequence of video fields, a compression circuit for comparing the comparison statistics with a first threshold, and for  
15 selectively discarding the predetermined portions of the present field on the basis of the comparing of the comparison statistics with the first threshold, a storage device for storing the predetermined portions of the present field which were not discarded by the compression  
20 circuit, and an analysis circuit for comparing the comparison statistics with a second threshold, different from the first threshold, to generate analysis statistics, and for analyzing the sequence of video fields, on the basis of the analysis statistics, to detect moving objects  
25 represented by the sequence of video fields.

          According to still a further aspect of the invention, there is provided a video camera for generating a first stream of dynamic images, a hard disk drive unit including a hard disk for storing data representing the first stream  
30 of data images, data representing a second stream of dynamic images having previously been stored on the hard disk, a display device for displaying a selected one of the first stream of images and the second stream of images, and a control device for controlling the hard disk  
35 drive unit and the display device so that data representing the first stream of dynamic images is being recorded on the hard disk while the second stream of dynamic images is simultaneously played back from the hard



disk and displayed by the display device.

The second stream of dynamic images (i.e. the played-back stream) may have been generated by the same camera currently generating the first stream of dynamic images,  
5 or may have been generated by a different camera.

Further in accordance with this aspect of the invention, data representing a third stream of dynamic images, different from the first and second streams, may have been stored on the hard disk, and the system may  
10 include an output device for transmitting data reproduced from the hard disk to a remote device, with the control device controlling the hard disk unit and the output device so that the data representing the third stream of dynamic images is reproduced from the hard disk and  
15 transmitted to the remote device by the output device, simultaneously with the recording of the first stream of dynamic images and the displaying of the second stream of images.

There may further be included in the apparatus an  
20 archive device for receiving video data reproduced from the hard disk and for recording the received video data on a removable recording medium, and the video data to be recorded on the removable recording medium may be reproduced from the hard disk simultaneously with the  
25 recording of the first stream of dynamic images and displaying of the second stream of dynamic images.

It is to be understood that the term "simultaneously" as used herein encompasses actual simultaneity, as in the case where a played back image is being displayed on a  
30 display screen at the same time that newly generated video information is being recorded on a hard disk, as well as "virtual" simultaneity, which may be achieved by multi-tasking. As is commonly understood by the term, "multi-tasking" implies time-division multiplexing of functions  
35 which are performed in discrete but rapidly alternated (i.e., densely interleaved in the time dimension) time slots such that each of the "virtually simultaneous" functions is performed a plurality of times within a short

period such as one second.

It should further be understood that, when a hard disk is referred to herein, another type of record medium drive, such as a DVD, writable optical disk, or magneto-  
5 optical disk drive, may be employed.

According to another aspect of the invention, there is provided a method of storing and retrieving video information, including the steps of generating a first sequence of dynamic video images on a first occasion and  
10 recording the first sequence of video images on a recording medium, generating a second sequence of dynamic video images on a second occasion that is later than the first occasion, and recording the second sequence of video images on the recording medium, and simultaneously  
15 reproducing from the recording medium both the first and second sequences of video images. The simultaneously reproduced sequences may also be simultaneously displayed, either on different respective display screens, or in respective display windows on the same display screen.  
20 The two sequences may have been generated at different times by different video cameras, or at different times by the same video camera.

According to still another aspect of the invention, there is provided a method of storing and retrieving video  
25 information, including the steps of storing on a recording medium a plurality of segments of video information, each segment of video information having been generated at a different respective period of time, inputting a first parameter signal indicative of a first one of the periods  
30 of time, displaying the segment of video information generated during the period of time indicated by the first parameter signal, and, while performing the displaying step, inputting a second parameter signal indicative of a second one of the periods of time and also displaying the  
35 segment of video information generated during the period of time indicated by the second parameter signal.

According to an aspect of the invention, there is provided a video information analysis apparatus, including

a storage device for storing a video information database, and an analysis circuit for analyzing video information in the database in accordance with a predetermined analysis algorithm, the algorithm being for assigning to respective portions of the video information analysis scores each indicative of a degree to which the respective portion of the video information represents a predetermined analysis feature, each analysis score being a value within a predetermined range of values which may encompass 256 values (indicated by an eight-bit analysis score). The apparatus may also include a selection mechanism for selecting a specific one of the range of values, and a search circuit for identifying portions of the video information having analysis scores greater than or equal to the selected one of the range of values.

According to another aspect of the invention there is provided a video information storage apparatus, including circuitry for receiving video information, a circuit for analyzing the received video information to detect a predetermined feature in the received video information, and for generating a detection signal indicative of the detected feature, a memory device for storing the received video information, and circuitry for storing the detection signal as an index signal in association with the stored video information. The memory device may include a facility for storing the received video information in the form of digital data, with the stored video information being in the form of plural frames of video data, each frame of video data having header data stored in association with the frame of video data, and the index signal being included in the header data. The apparatus may also include a facility for reading the stored index signal, and a facility for retrieving from the memory device a selected portion of the stored video information in accordance with the index signal read by the reading facility.

According to still another aspect of the invention, there is provided a video information storage apparatus,

including a storage device for storing video information, circuitry for retrieving the stored video information from the storage device, circuitry for analyzing the retrieved video information to detect a predetermined feature in the  
5 retrieved video information, and for generating a detection signal indicative of the detected feature, and circuitry for transmitting the detection signal to the storage device to store the detection signal as an index signal in association with the stored video information.  
10 Assuming that the video information is stored in the form of digital data, and includes plural frames of video data, header data is stored with each frame of video data and includes an index signal generated by the analysis circuitry. The header may include separate index signals  
15 generated by analyzing the video information both before and after storage.

According to still a further aspect of the invention, there is provided a method of operating an apparatus for storing and retrieving video data, the method including  
20 the steps of storing a plurality of frames of video data on a first hard disk, storing index data on the first hard disk, the index data including data indicative of respective times at which the frames of video data were generated and respective locations on the first hard disk  
25 at which frames of video data are stored, and storing the index data on a second hard disk. A desired frame of video data stored on the first hard disk may be searched on the basis of index data read out from the second hard disk. Further, a quantity of video data read out from the  
30 first hard disk may be cached (i.e., temporarily stored) on the second hard disk.

The above described storage and retrieval techniques may be applied to plural streams of video signals each generated by a different respective video cameras and  
35 stored together on the first hard disk, in which case the index data is indicative of the respective camera which generated each frame of video data.

According to yet another aspect of the invention,

there is provided a video data storage apparatus, including a video data source for providing a dynamic stream of video data frames, a data memory device for storing the dynamic stream of video data frames provided  
5 by the video data source, and a control device for designating a main portion of the data memory device, the main portion being for recording the dynamic stream of video data frames at a first frame rate, the control device also designating a buffer portion on the data  
10 memory device, the buffer portion being for recording the dynamic stream of video data frames at a second frame rate that is higher than the first frame rate. The data memory device may be a hard disk drive including a hard disk, and the apparatus may further include a detection device for  
15 detecting an alarm condition. The control device may designate the buffer portion of the data memory device by maintaining a pointer indicative of where the buffer portion is located in the data memory device, and may respond to detection of the alarm condition by the  
20 detection device by changing a value of the pointer, so that the buffer portion is thereby moved to a new location in the data memory device.

According to yet a further aspect of the invention, there is provided a data storage medium on which is stored  
25 video data representing a plurality of video image frames, frame identification data indicative of respective times at which the video image frames were generated, and characteristic data indicative of respective characteristics of the video image frames represented by  
30 the video data, the respective characteristics having been detected by applying an image analysis algorithm to the video data. The characteristic data may include first sub-data indicative of a type of characteristic represented by the characteristic data, and second sub-  
35 data indicative of a degree to which a respective video image frame exhibits the type of characteristic represented by the characteristic data. The image analysis algorithm may have been applied to the video data

before the data was stored on the storage medium or may have been applied to the video data by reading the video data from the storage medium. The characteristic data may include first characteristic data generated by applying a first image analysis algorithm to the video data and  
5 second characteristic data generated by applying a second image analysis algorithm, different from the first image analysis algorithm, to the video data. There may also be stored on the data storage medium audio data indicative of  
10 audio signals generated at times when the video image frames were generated. Video data representative of respective streams of video image frames generated by a plurality of video cameras may also be stored on the data storage medium, together with data identifying the  
15 respective one of the plurality of video cameras which generated each of the video image frames. The storage medium may be a hard disk, a magnetic tape (including a helical-scan magnetic tape) or another type of data storage medium.

20 According to still another aspect of the invention, there is provided a video information storage apparatus, including a video camera for generating a stream of dynamic images, a storage device for storing respective video data portions each of which represents an image from  
25 the stream of dynamic images, each video data portion including header data, a mechanism for moving the video camera to change a field of view of the video camera, and a control device for providing control signals to the movement mechanism to control movement of the video  
30 camera, the control device being connected to the storage device to provide to the storage device signals indicative of times when the control device is causing the camera to be moved, the storage device responding to the signals provided thereto, by including a motion signal in the  
35 header data included in the video data portions corresponding to images generated at the times when the camera is being moved, the motion signal indicating that the respective image was taken by the camera when the

camera was moving.

The apparatus provided in accordance with this aspect of the invention may further include circuitry for retrieving the stored video data portions from the storage device, an analysis circuit for analyzing the retrieved video data portions to detect a predetermined feature in the images represented by the retrieved video data portions, and for generating a detection signal indicative of the detected feature, circuitry for transmitting the detection signal to the storage device to store the detection signal as an index signal in association with the stored video data portions, and inhibit circuitry for reading the movement signal included in the header data of respective ones of the stored video data portions and for inhibiting the analysis circuitry from analyzing the respective ones of the stored video data portions for which the movement signal is included in the respective header data. The predetermined feature to be detected by the analysis circuitry may be a moving object represented by the stream of dynamic images.

According to still another aspect of the invention there is provided a method of transmitting and displaying video information, including the steps of receiving a plurality of streams of video information each generated by a respective video camera, transmitting the plural streams of video information to a display device field-by-field, and displaying each of the plural streams of video information in a respective display window on a display screen, the transmitting step including appending, to each field of the plural streams of video information, header data which includes data indicative of the one of the display windows in which the field is to be displayed. The appended header data may also include data for identifying the one of the video cameras which generated the field.

According to still another aspect of the invention, there is provided a method of storing video information, including the steps of recording plural fields of video

data on a recording medium, each of the fields of video data representing a respective image, recording on the recording medium, in association with each of the fields of video data, header data including data indicative of a source of the image represented by the respective field, reproducing from the recording medium the recorded fields of video data, processing the reproduced fields of video data to obtain a processing result, and, on the basis of the processing result, recording processed result data on the recording medium in the header data for at least one of the reproduced fields of video data.

The processing step may include applying a moving image content analysis algorithm to the reproduced fields of video data, in which case the analysis algorithm may be for detecting moving objects represented by the reproduced fields of video data, and the processed result data would constitute data indicative of detection of the moving object. The recording medium may be a hard disk, and the header data may include data for identifying a camera which generated the respective field of video data, and data indicative of a time at which the field of video data was generated.

The foregoing and other objects, features and advantages of the invention will be further understood from the following detailed description of preferred embodiments and practices thereof and from the drawings, wherein like reference numerals identify like components and parts throughout.

#### BRIEF DESCRIPTION OF THE DRAWINGS

Fig. 1 presents in block diagram form an overview of a distributed intelligent video information management system provided in accordance with the invention.

Fig. 2 represents, in functional block form, a video analysis and storage apparatus forming a functional part of the system of Fig. 1.

Fig. 3 is a block diagram of electronic components of a video recording/personal computer (VR/PC) unit provided



in accordance with the invention and used in the system of Fig. 1.

Fig. 4 is a pictorial representation of a circuit board architecture employed in the VR/PC unit of Fig. 3.

5 Fig. 5 is a perspective view showing the housing and front panel of the VR/PC unit.

Fig. 6 is an elevational view of the front panel of the VR/PC unit.

Fig. 7 is a rear elevational view of the VR/PC unit.

10 Fig. 8 is an isometric view of a structural support assembly provided within the VR/PC unit for the purpose of supporting disk drive units and the like.

Fig. 9 is an exploded representation of the disk drive support structure of Fig. 8.

15 Fig. 10 is an isometric view of the drive support structure of Fig. 8, as assembled and supporting hard disk drive units and other media drive units.

Fig. 11 is a print of a screen display generated by the VR/PC unit when operating in a live display mode, and including cursor-actuatable control regions.

20 Fig. 12 is a print of a screen display generated by the VR/PC unit when operating in a playback mode, and also having cursor-actuatable control regions.

Fig. 13 is a schematic block diagram of an analog processing/multiplexing circuit board shown in Fig. 4.

Fig. 14 is a block diagram of a digitizing/compression/analysis circuit board shown in Fig. 4.

30 Fig. 15 represents functional blocks of an analog-to-digital conversion, field buffering and video bus control block shown in Fig. 14.

Fig. 16 shows some details of the analog-to-digital conversion function shown in Fig. 15.

35 Fig. 17 shows some details of a video digitizing control function shown in Fig. 15.

Fig. 17A illustrates in flow-chart form processing carried out in a controller logic block shown in Fig. 17.

Fig. 18 shows some details of a field buffering

function shown in Fig. 15.

Fig. 19 shows some details of a video output control function shown in Fig. 15.

5 Figs. 20A and 20B represent, respectively, raster-scan and rectangular tile formats of an image plane (field) of video data formed in the VR/PC unit.

Fig. 21 illustrates a rectangular tile format employed in the VR/PC unit.

10 Fig. 22 represents the format of a minimum coding unit (MCU) employed in the VR/PC unit.

Fig. 23 represents a 4:1:1 color video data format employed in the VR/PC unit.

Fig. 24 is indicative of a color data format used for each MCU.

15 Fig. 25 is a pictorial representation of a first mode of transmitting video data on a video bus shown in Fig. 14.

Fig. 26 pictorially represents a second mode of transmitting video data on the video bus.

20 Fig. 27 pictorially represents a third mode of transmitting video data on the video bus.

Fig. 28 pictorially represents a data format for raster-scan lines of video data transmitted on the video bus.

25 Fig. 29 is a pictorial representation of a format for video data tiles transmitted on the video bus.

Fig. 30 indicates a format for header data bits included in headers for fields of video data transmitted on the video data bus.

30 Fig. 31 indicates in functional block form processing performed by an output control logic block shown on Fig. 19.

Fig. 31A represents, as a flow diagram, processing performed by the output control logic block of Fig. 31 for the purpose of forming field header data.

35 Fig. 31B illustrates in flow diagram form processing performed by the output control logic block of Fig. 31 for the purpose of using line and tile header data to control

line and tile output operations.

Fig. 32 illustrates in flow diagram form processing performed by the output control logic block of Fig. 31 for the purpose of generating raster-scan lines of video data.

5 Fig. 33 illustrates in flow diagram form processing performed by the output control logic block of Fig. 31 for the purpose of forming rectangular tiles of video data.

Fig. 34 illustrates in flow diagram form processing performed by the output control logic block of Fig. 31 for  
10 the purpose of generating an interleaved sequence of raster-scan lines and rectangular tiles of video data.

Fig. 35 is a state machine diagram which represents operation of the output control logic block of Fig. 31.

Fig. 36 is a schematic block diagram representation  
15 of a digital signal processing chip, and associated circuitry, which together perform control functions for the video front end processing, and initial processing with respect to video data compression.

Fig. 37 represents in block form certain details of  
20 the live video data analysis processing block of Fig. 14.

Fig. 38 illustrates in block diagram form certain details of the live display processing block of Fig. 14.

Fig. 39 is a schematic representation of major software modules which program the operation of the  
25 control DSP chip of Figs. 36 and 14.

Fig. 39A represents in flow-chart form the "changed tile" map generator module of the software for the control DSP.

Fig. 40 is a flow chart representation of the PCI  
30 interface driver module of the software for the control DSP.

Figs. 41A and 41B together form a flow-chart representation of the compressor manager module of the software for the control DSP.

35 Fig. 42 represents in flow-chart form the video data tile comparison function carried out by the control DSP.

Fig. 43A is a pictorial representation of a video data tile format utilized in the present invention.

Figs. 43B and 43C pictorially represent division of the video data tile format of Fig. 42A into quadrants, and a checker-board subsampling pattern applied to the data elements in each quadrant.

5 Fig. 44 is a representation of a data format used for compressed video data generated by the front end processing board of Fig. 14.

Fig. 45 represents an overview of major software components which control operations of the motherboard microprocessor shown in Fig. 3.

10 Fig. 46A is a COM (Component Object Model) representation of the system director module of the motherboard CPU software.

Fig. 46B is a COM representation of a generalized form of other components of the CPU software.

Fig. 47 is a flow-chart representation of the security manager software module for the motherboard CPU.

20 Fig. 48 represents a typical remote object which may be instantiated from time to time in the processing performed by the motherboard CPU.

Fig. 49 represents a software object which handles interaction between the motherboard CPU and the physical front panel of the VR/PC unit of Fig. 5.

25 Fig. 50 shows in flow-chart form a setup manager software module for the motherboard CPU.

Fig. 51 illustrates video data and index data formats utilized by the VR/PC unit in storing video data on the hard disk provided therein.

30 Fig. 52 illustrates in flow-chart form a video storage processing software module for the motherboard CPU.

Fig. 53 illustrates in flow-chart form a video search processing software module for the motherboard CPU.

35 Fig. 54 illustrates in flow-chart form the "perform search" block of Fig. 53.

Fig. 55 illustrates in flow-chart form processing performed by the motherboard CPU in connection with video playback operations.

Fig. 56 illustrates in flow-chart form the "restart decompressor" block of Fig. 55.

Fig. 57 illustrates in flow-chart form the "decompress reference image" block of Fig. 56.

5 Fig. 58 illustrates in flow-chart form the "stop decompressor" block of Fig. 55.

Fig. 59 illustrates in flow-chart form the "decompress difference image" blocks of Fig. 56.

10 Fig. 60 illustrates in flow-chart form the portion of the process of Fig. 59 which relates to decoding of certain blocks of video data.

Fig. 61 is a pictorial representation of a technique used in the VR/PC unit for reconstituting a field of compressed video data.

15 Figs. 62A and 62b illustrate, respectively, alternative techniques for refreshing a video display buffer in connection with the VR/PC unit.

Figs. 63A and 63B illustrate, respectively, lower-resolution and higher-resolution video data storage and 20 playback techniques that may be used in the VR/PC.

Fig. 64 is a pictorial illustration of a technique used for reconstituting compressed video data when the VR/PC is operated to provide a reverse-direction playback function.

25 Fig. 65 is a high-level flow-chart representation of the reverse playback decompression technique of Fig. 64.

Fig. 66 illustrates in flow-chart form the "build backward history buffer" blocks of Fig. 65.

30 Fig. 67 is a flow-chart representation of the processing employed to decompress and re-code reference image data as part of the reverse direction decompression process.

Fig. 68 illustrates in flow-chart form the "decompress & re-code tile" block of Fig. 67.

35 Fig. 69 illustrates in flow-chart form a command handling portion of a software module which programs the motherboard CPU to interact with the front-end processing electronics.

Fig. 70 is a flow-chart illustration of the status message handling portion of a software module which programs the motherboard CPU to interact with the front end processing electronics.

5 Fig. 71 is a flow-chart representation of video data handling processing carried out by the motherboard CPU with respect to video data transferred thereto from the front end processing electronics.

10 Fig. 72 illustrates processing carried out by the motherboard CPU in connection with initiating recording of incoming video data on a hard disk of the VR/PC unit.

Fig. 73 illustrates processing carried out by the archive manager software module in connection with handling search requests.

15 Fig. 74 illustrates in flow-chart form processing carried out by the motherboard CPU in connection with recording and/or playback of video data on or from a removable archive recording medium.

20 Fig. 75 illustrates processing carried on by the motherboard CPU in response to an indication of an alarm condition.

25 Fig. 76 is a pictorial representation of an allocation of a time-sequence of video data field recording slots provided as a standard response to an alarm condition.

Fig. 77 illustrates in flow-chart form processing performed by the motherboard CPU in connection with image processing utility features of the VR/PC.

30 Fig. 78 schematically illustrates operation of the motherboard CPU in connection with operation of the graphical user interface.

Fig. 79 illustrates in flow-chart form software which programs the motherboard CPU for selection of main scheduling options.

35 Fig. 80 illustrates in flow-chart form operation of the motherboard CPU in connection with setting up a selection of holidays for the purpose of scheduling operation of the system.

Fig. 81 is a pictorial representation of a screen display used to define "day" versus "night" periods of a 24-hour calendar day interval.

5 Fig. 82 illustrates in flow-chart form programming of the motherboard CPU to carry out the day/night partition function pictorially illustrated in Fig. 81.

Fig. 83 illustrates in flow-chart form programming of the motherboard CPU to carry out option selections in connection with scheduling of system operations.

10 Fig. 84 illustrates in flow-chart form programming of the motherboard CPU in connection with generating scripts for controlling pre-scheduled system operations.

Fig. 85 illustrates a data format for a queue that controls pre-scheduled operations of the system.

15 Fig. 86 is a data format which illustrates a scheduling script table of the kind generated by the processing of Fig. 84.

20 Fig. 87 illustrates in flow-chart form programming of the motherboard CPU to control system operation in accordance with pre-set scheduling parameters.

Fig. 88 illustrates in summary form operations carried out by the motherboard CPU in performing a typical image analysis algorithm.

25 Fig. 89 illustrates in flow-chart form the select and setup portions of the image analysis tool operation of Fig. 88.

30 Figs. 90A-90D are flow-charts representing parameter setting operations in connection with a perimeter violation detection image analysis tool provided in the system disclosed herein.

Fig. 91 is a flow-charts based illustration of preparatory steps required before performing an image analysis.

35 Fig. 92 illustrates in flow-chart form an initialization phase of an image analysis algorithm performed on an incoming video image.

Fig. 93A illustrates processing performed by the live image analysis processor of the front end video board of

Fig. 14, and Figs. 93B and 93C are associated processing steps carried on by the video board controller.

Figs. 93D and 93E illustrate in flow-chart form further processing carried on by the live image analysis  
5 processor.

Fig. 94 is a flow-charts illustrating initialization steps carried on in connection with image analysis applied to a reproduced video image stream.

Figs. 95A-95C are flow-charts illustrating processing  
10 carried out by the motherboard CPU for the purpose of applying an image analysis algorithm to a reproduced video stream.

Fig. 96 is a pictorial illustration used in explaining a curve-fitting analysis performed on a  
15 reproduced video stream.

Fig. 97 illustrates in flow-chart form application of a perimeter violation detection image analysis algorithm to a reproduced video stream.

Fig. 98 illustrates in flow-chart form actuation of a live video analysis algorithm in response to occurrence  
20 of an event.

Fig. 99 illustrates in flow-chart form a video data compression technique provided in an alternative embodiment of the invention.

Fig. 100 illustrates in flow-chart form a decompression technique carried out with respect to data  
25 compressed according to the processing of Fig. 99.

Figs. 101A and 101B illustrate in flow-chart form system operations which permit a user to adjust video  
30 display time resolution and/or space resolution settings.

Fig. 102 illustrates in flow-chart form operation of the system to permit a user to adjust video data compression parameters.

Figs. 103A-103C are flow-charts illustrating system  
35 operations in connection with downloading of image analysis algorithms from one system device to another.

Fig. 104 is a flow-chart illustrating selective transmission of an incoming video stream in response to a



condition detected by a live video analysis algorithm.

Fig. 105 is a flow-chart illustrating a change in camera-stream storage sequencing in response to detection of a predetermined characteristic by a live video analysis algorithm.

Fig. 106 illustrates in flow-chart form actuation of a second live video stream analysis algorithm in response to detection of a predetermined characteristic by a first live video analysis algorithm.

Fig. 107 is a flow-chart which illustrates an automatic change in a video data compression parameter in response to detection of an alarm condition.

Fig. 108 is a flow-chart which illustrates an automatically actuated software zoom-in operation in response to detection of a predetermined condition by a live video analysis algorithm.

Fig. 109 is a flow-chart which illustrates operation of the system to automatically actuate a movement of a video camera in response to detection of a predetermined condition by live video analysis.

Fig. 110 is a flow-chart which illustrates operation of the system to take a predetermined action when respective predetermined conditions are detected by two different live video analysis algorithms.

Fig. 111 is a flow-chart which illustrates operation of the system to inhibit live video stream analysis when the camera providing the video stream is in motion or an alarm condition is detected.

Fig. 112 is a flow-chart which illustrates operation of the system to store header data indicating that a camera which is generating an input video stream is in motion.

Fig. 112A is a flow-chart illustrating operation of the system to inhibit application of an image analysis algorithm to a reproduced video stream that was generated by a moving camera.

Fig. 113 is a flow-chart which illustrates operation of the system to increase aggregate field through-put rate

when an alarm condition is detected.

Fig. 114 is a flow-chart illustrating operation of the system to provide for compression parameters that vary among different incoming video data streams.

5 Fig. 115 is a flow-chart illustrating operation of the system to vary a display-buffer updating technique in dependence upon whether an alarm condition is detected.

Fig. 116 is a flow-chart which illustrates system priorities with respect to recording, reproduction and  
10 archiving of video data streams.

Figs. 117A and 117B are flow-charts which respectively illustrate alternative archiving operational modes of the system.

Fig. 118 is a flow-chart illustrating operation of  
15 the system to reduce the rate at which incoming video signals are stored in order to prevent over-running of an archiving operation.

Fig. 119 is a flow-chart illustrating operation of the system to store data relating to previously archived  
20 video signals.

Fig. 120 is a flow-chart illustrating operation of an automatic camera diagnosis function.

Fig. 121 is a flow-chart which illustrates operation of the system to provide a system status display to the  
25 user.

Fig. 122 is a flow-chart illustrating operation of the system to automatically search for and display a reproduced video stream generated contemporaneously with a currently displayed reproduced video stream.

30 Fig. 123 illustrates, in the form of a flow-chart, operation of the system for simultaneously recording incoming video signals while displaying a reproduced video image stream.

Fig. 124 is a flow-chart illustrating operation of  
35 the system to simultaneously display two reproduced video image streams.

Fig. 125 is a flow-chart illustrating operation of the system to record video data indexing information

simultaneously on two different hard disks.

Fig. 126 is a flow-chart illustrating operation of the system to provide pre-alarm buffering with respect to a video image stream that is being recorded at a time-lapse rate.

Fig. 127 is a flow-chart showing operation of the system to change and/or supplement video data header information on the basis of a machine analysis of reproduced video information.

Figs. 128(a) and (b) are together illustrative of a user-operable image enhancement utility.

Fig. 129 is a screen display presented to a user in connection with searching for recorded video information.

Fig. 130 is a screen display presented to a user in connection with searching for recorded video information.

Fig. 131 is a screen display presented to a user in connection with searching for recorded video information.

Fig. 132 is a screen display presented to a user in connection with searching for recorded video information.

Fig. 133 is a screen display presented to a user in connection with searching for recorded video information.

Fig. 134 is a screen display presented to the user to allow the user to select a setup operation.

Fig. 135 is a screen display presented to the user to permit the user to select a video data recording mode.

Fig. 136 is a screen display presented to the user to permit the user to select a video data recording mode.

Fig. 137 is a screen display presented to the user to permit the user to login to the system.

Fig. 138 is a screen display presented to a user to permit the user to add an authorized user to the system.

Fig. 139 is a screen display presented to a user to permit selection of system functionality that is to be accessible to an authorized user.

Fig. 140 is a screen display presented to a user to permit selection of system functionality that is to be accessible to an authorized user.

Fig. 141 is a screen display presented to a user to

permit selection of system functionality that is to be accessible to an authorized user.

Fig. 142 is a screen display presented to a user to permit selection of system functionality that is to be  
5 accessible to an authorized user.

Fig. 143 is a screen display presented to a user to permit selection of system functionality that is to be accessible to an authorized user.

Fig. 144 is a screen display presented to the user to  
10 configure security functions of the system.

Fig. 145 is a screen display presented to a user to permit the user to assign names to cameras connected to the system.

Fig. 146 is a screen display presented to the user to  
15 permit the user to assign names to alarm signal outputs provided by the system.

Fig. 147 is a screen display presented to a user to permit the user to assign names to alarm signal inputs that may be received by the system.

Fig. 148 is a screen display presented to the user to  
20 permit the user to select among a number of utility functions which the system is capable of performing.

Fig. 149 is a screen display which presents to the user system status information.

Figs. 150 and 151 are screen displays presented to  
25 the user to permit the user to assign video display windows among a plurality of cameras connected to the system.

Fig. 152 is a screen display presented to the user to  
30 permit the user to designate calendar dates as holidays for the purpose of scheduling system operating modes.

Fig. 153 is a screen display presented to the user to permit the user to adjust parameters with respect to an image analysis algorithm which detects changes in lighting  
35 in a scene represented by a video image stream.

Fig. 154 is a screen display presented to the user to permit the user to adjust parameters of an image analysis algorithm which detects motion in a scene represented by

a video image stream.

Fig. 155 is a screen display presented to a user to permit the user to adjust parameters of an image analysis algorithm which determines whether a perimeter boundary  
5 has been crossed by a moving object.

Fig. 156 is a screen display presented to a user to permit the user to adjust parameters of an image analysis algorithm which detects removal of an object of interest.

Fig. 157 is a screen display presented to a user to  
10 permit the user to define a list of holidays for the purpose of pre-scheduling system operating modes.

Fig. 158 is a screen display presented to the user to permit the user to schedule recording modes for each of a plurality of cameras.

15 Fig. 159 is a screen display presented to a user to permit the user to define scheduling periods with regard to pre-scheduled system operating modes.

Fig. 160 is a screen display presented to a user to permit the user to define scheduling periods with regard  
20 to pre-scheduled system operating modes.

Fig. 161 is a screen display presented to a user in connection with operation of the image enhancement utility illustrated in Figs. 128(a) and (b).

Fig. 162 is a screen display presented to the user to  
25 permit the user to instruct the system to discard video data corresponding to a user-selected portion of an image plane.

Fig. 163 is a live display screen format similar to Fig. 11, except that a live video region of the screen is  
30 divided in a quad configuration with recording indications for each display window.

Fig. 164 is a screen display presented to a user in connection with selecting an archiving operation mode.

Fig. 165 is an alternative format of the display of  
35 Fig. 164.

Fig. 166 is a screen display presented to the user in connection with searching for video data recorded on a removable archive recording medium.

Fig. 167 is a screen display presented to the user to permit access to a database of index information for previously recorded removable archive recording media.

Fig. 168 is a screen display presented to the user to  
5 update a listing of archive media drive devices installed with the VR/PC unit.

Fig. 169 is a screen display presented to the user to permit selection of an image analysis algorithm to be used in searching the video database stored in the VR/PC unit.

10 Fig. 170 is a screen display like that shown in Fig. 169, but also showing a pull-down menu listing image analysis algorithms available for selection by the user.

Fig. 171 and 172 are screen displays which permit the user to select, in connection with pre-scheduled system  
15 operating modes, an image analysis algorithm to be applied to a live incoming video stream.

Fig. 173 is an example of a hard-copy screen print generated in response to actuation of a "print" option provided at Fig. 161.

20

#### DESCRIPTION OF PREFERRED EMBODIMENTS

##### IVIM SYSTEM OVERVIEW

Fig. 1 presents an overview of an intelligent video information management (IVIM) system, generally indicated  
25 by reference numeral 500. The system 500 is shown as extending over multiple locations and a plurality of business enterprises. For example, the business enterprises may include a multi-branch bank 502 and a multi-location retailer 504. The bank 502 and retailer  
30 504 are, respectively, served by IVIM systems 506 and 508, which are quasi-independent from each other, but are at least selectively interactive with a master node facility 510 provided by a security service organization 512. For example, the service organization 512 may provide, install  
35 and service intelligent video information management systems and other video security systems.

The master node 510 is preferably in the form of a host computer which provides support functions and

downloadable software resources to the IVIM systems 506 and 508. Although only two business enterprise IVIM's are shown in Fig. 1, it is contemplated that the master node 510 may provide support for a large number of businesses each maintaining its own IVIM system. The business enterprises may be located and have branches across the United States (for example), and in other countries as well. It is contemplated that the system disclosed herein will be used in many other types of enterprises in addition to banks and retailers.

As shown in Fig. 1, each of the IVIM systems 506 and 508 includes a local node 514 which provides oversight and management functions for the respective IVIM system. Each of the local nodes 514 is connected via a respective data communication channel 516 to the master node 510. Each data communication channel 516 may, for example, be constituted by a dedicated telecommunication channel, or the channel 516 may be implemented upon demand on a dial-up basis. The local nodes 514 are preferably implemented using standard personal computer hardware and software, augmented with novel software capabilities which will be described below.

Key components of each IVIM system are video analysis and storage units 518 connected by data communication paths 519 to the respective local node 516. Each unit 518 has connected thereto one or more video cameras, indicated as cameras 520-1 through 520-N. Each video analysis and storage unit 518 provides storage, analysis and selective retrieval of video information streams generated by the video cameras 520 connected thereto.

The number of video cameras connected to each unit 518 may vary from one analysis and storage unit to another. For example, the number of cameras may vary from one to more than a dozen. As will be seen, a preferred embodiment of the unit 518 supports up to 16 video cameras.

It should also be recognized that the number of analysis and storage units 518 in each IVIM system may

vary. Although only 2 or 3 of the units 518 are shown per IVIM system in Fig. 1, the actual number of analysis and storage units in each enterprise may number in the dozens or higher.

5 Associated with each analysis and storage unit 518 are other components typically found in video security systems, as indicated by dotted-line boxes 522. The other security components 522 associated with each unit 518 may vary from unit to unit. An example of such other  
10 components is shown in the lower left hand corner of Fig. 1 as including two video display monitors 524, mechanically actuatable alarm sensors 526, and a camera control device 528.

Streams of video signals respectively generated by  
15 the video cameras 520 and received at the analysis and storage unit 518 are selectively directed from the unit 518 for display on the monitors 524. As will be seen, the signals may be displayed in a variety of formats including full screen, or in windows taking up only a portion of the  
20 image plane. Plural display windows may be formed on one or both of the displays 524 so that plural video streams are displayed simultaneously on a single video display 524. Preferably, the displays 524 are conventional items  
25 such as the NTSC monitor model JC-1215MA available from NEC and/or the SVGA monitor model C1591E available from Panasonic. One advantage provided by the analysis and storage units 518 of the novel system disclosed herein is that the units 518 perform the video stream distribution  
30 function which is performed in conventional video surveillance systems by a video switch. Therefore, in a practical embodiment of the IVIM system, no video switch is required to be included in the "other security system components" 522.

The alarm sensors 526 are preferably conventional  
35 items which detect events such as opening or closing of doors, windows, display cases, etc., and generate signals indicative of such events and alarm signals. The alarm signals are provided to the analysis and storage unit 518



and to the camera control device 528.

The camera control unit 528 may be, for example, a conventional device such as the "TOUCHTRACK'R" camera control pad commercially available from the assignee of this application. The camera control device 528 and the analysis and storage unit 518 are connected for exchange of data messages therebetween.

It is assumed that some of the video cameras 520 are movable. That is, some of the cameras 520 are conventional items, such as dome cameras marketed by the assignee of this application, which have a direction of view that is adjusted in response to control signals. Movable ones of the video cameras 520 may also include cameras movable along a rail. Typically in movable cameras the zoom and focus settings thereof are also controllable by control signals. As indicated at 530, the camera control device 528 is arranged to supply control signals to the movable ones of the video cameras 520.

It is also assumed that some of the video cameras 520 are fixed as to field of view. It should be understood that it is contemplated that all cameras connected to a particular analysis and storage unit 518 may be movable, or all may be fixed.

As indicated at 532, the analysis and storage unit 518 and the camera control device 528 are connected for exchange of data therebetween. The control device 528 may be arranged so that, in response either to outputs from alarm sensors 526 or in response to a data message from the analysis and storage unit 518, control signals are automatically transmitted over the control signal path 530 to a selected one of the movable cameras 520 so that the movable camera is automatically positioned in response to an event detected by the alarm sensor 520 or by the analysis and storage unit 518.

The additional component configuration 522 described above is only exemplary, and may be subject to numerous variations. For example, the number of monitors may be reduced to one or increased to a number larger than two.

As another possibility, both the alarm sensors 526 and the camera control device 528 may be omitted. Particularly, it will be understood that if all of the cameras 520 are fixed, no camera control device 528 would be required.

5 Other peripheral devices, such as printers, may be present, and there may also be alarm enunciating devices such as flashing lights, sirens or the like. There may also be auxiliary data storage devices in addition to those included within the analysis and storage unit 518.

10 There may also be included in the additional components 522 a Point Of Sale Exception Monitoring system of the type marketed by the assignee of this application under the trademark POS/EM.

In addition to the communication links that have previously been described as being in place between the local nodes 514 and associated analysis and storage units 518, there may be direct communication links, as indicated at 534, between the master node 510 and the analysis and storage units 518. The data links may be formed by conventional dedicated lines, dial-up connections, satellite, LAN, WAN and/or via the Internet. If the Internet is used, the nodes and storage units are preferably arranged to support "streaming" protocols for efficient data transmission.

25

#### VR/PC UNIT OVERVIEW

Fig. 2 provides a functional overview of the video analysis and storage block 518. A main unit 550, which will be described in detail below, provides a control function 552, an analysis function 554, a storage function 556, an archiving function 558, and a video processing function 560.

Inputs to the unit 550 include video inputs 562 from the cameras 520 (Fig. 1) and auxiliary inputs 564 such as the alarm condition detection signals provided from alarm sensors 526 (Fig. 1).

Continuing to refer to Fig. 2, user control signals for the main unit 550 may be provided from a cursor

positioning and feature selection device 566. The device 566 is preferably a conventional mouse, such as those commercially available from Microsoft, but may alternatively be a track ball, touch screen, light pen, and so forth. A preferred embodiment of the unit 550 also includes a front panel (not shown in Fig. 2) including switches for manipulation by the user.

Outputs from the unit 550 include live video data 568, provided through a video display buffer 570 to a display unit 524. Another output of the unit 550 is a reproduced video signal as indicated at 572. Although the reproduced video output 572 is shown as separate from the live video output 568, it should be understood that the reproduced video may be transmitted through video display buffer 570 for display on the video display unit 524. Further outputs from the unit 550 include control signals 574 and reproduced video data and accompanying indexing information, as indicated at 576, for storage on external storage devices. Such devices, which are not shown, may include digital or analog tape recorders, write-once or re-writable video disk recorders, and/or DVD recorders, whether connected by dedicated lines or on a dial up basis to the main unit 550.

Data communication links 578 provide for data communication between the main unit 550 and other computing devices, and include, for example, the communication channels 516, 519 and 534 shown in Fig. 1. Although not shown in the drawing, a conventional modem may be incorporated in or attached to the VR/PC unit.

Fig. 3 illustrates the hardware architecture of the main unit 550. The unit 550 shown in Fig. 3 incorporates unique hardware and software features that provide an unprecedented fusion of PC and video recording capabilities, and will therefore be referred to as a 'VR/PC' (Video Recorder/PC) unit. In addition to novel video data compression and recording techniques, the VR/PC unit 550 performs data management, routing and analysis functions that have not previously been proposed. The

VR/PC unit 550 also implements unique user interface features that make the unit's capabilities conveniently available for selection and operation by the user.

The VR/PC unit 550 includes a motherboard 580, front  
5 end video processing and video data compression hardware  
582, a back panel 584 and a front panel 586 (Figs. 5 and  
6).

As somewhat schematically illustrated on Fig. 4, the  
front end processing and compression hardware 582 is made  
10 up of two separate printed wiring boards: an analog  
processing/multiplexing board 588, which receives video  
signals directly from the back panel 584, and a  
digitizing/compression/analysis board 590 connected  
between the analog board 588 and the motherboard 580.

15 In an alternative embodiment of the invention, the  
digitizing/compression/analysis components of board 590  
are arranged on two separate PWB's connected between the  
analog board 588 and the motherboard 580.

Referring again to Fig. 3, the motherboard 580  
20 preferably is similar in architecture to standard personal  
computer motherboards and is populated entirely with  
standard, commercially available components. Thus, the  
VR/PC hardware is essentially implemented as a standard PC  
platform, although with novel front end electronics, as  
25 described in detail below. The components on the  
motherboard 580 include a microprocessor 592, functioning  
as a CPU. The microprocessor 592 is preferably a Pentium  
P5-120C from Intel, operating at 100 megahertz with the  
Windows 95 operating system. Other processors, including  
30 those operating at higher speed, may be used. A bus 594,  
provided in accordance with the PCI standard,  
interconnects the CPU 592 with other components on the  
motherboard 580. As indicated at 596, the PCI bus 594 is  
extended to interconnect the motherboard 580 with the  
35 front end electronics 582. Other components on the  
motherboard 580 include a program memory ROM 598, and a  
working memory 602. In a preferred embodiment, the  
working memory 602 is constituted by 16 megabytes of RAM.

Also provided on the motherboard 580 is an SVGA chip set 604, which may be the "Alpine" chip set marketed by Cirrus Logic. An SVGA video data input path 606 is provided directly from the front end electronics 582 to the SVGA chip set 604. The SVGA chip set provides an output 608 to drive one or more SVGA monitors. (An NTSC output is provided directly from the front end electronics 582 for driving NTSC monitors. If the presence of an NTSC monitor is sensed (by conventional means, not shown), then the SVGA output may be disabled.)

The motherboard 580 also includes a number of serial ports 612, to handle data communication between the motherboard and auxiliary devices. The auxiliary devices may include the above-mentioned alarm sensors, as well as alarm enunciators, electronically controlled door locks, conventional POSEM (point of sale exception monitoring) devices, and so forth. A mouse port 614 is included on the motherboard 580 for the purpose of receiving user-actuated control signals from the mouse 566 (Fig. 2). Continuing to refer to Fig. 3, a parallel port 616 is provided on the motherboard 580 as a source of data used to drive a report printer (not shown). Also connected to the motherboard 580 is a conventional floppy disk drive 618, which preferably is arranged to accept 3 1/2 inch disks.

Also provided on the motherboard 580 is an IDE (integrated drive electronics) controller 620 which provides an interface to a plurality of IDE hard drives 622, mounted within the VR/PC unit 550. The hard drives 622 provide mass storage for video data, indexing information, programs and so forth. Preferred embodiments of the VR/PC unit include two, three or more hard drives 622. A suitable hard drive unit for use in the VR/PC 550 is the "Caviar" 2 or 2.5 gigabyte drive available from Western Digital. Hard drives from Seagate or other suppliers may also be used.

A SCSI interface 624 is also present on the motherboard 580. A DAT (digital audio tape) drive 626 is

connected to the motherboard 580 through the SCSI interface 624, and constitutes the primary archive medium drive device for the VR/PC unit. The DAT drive may, for example, be a Sony model SDT-7000/BM, which stores 2 gigabytes of data on a 4 mm x 90 m magnetic tape. Other known DAT recorders may also be used. It is contemplated to use other archive medium drive devices in addition to or instead of the DAT drive 626. For instance, a digital video disk (DVD) drive or a linear digital tape drive may be employed.

Also provided through the SCSI interface 624 is a SCSI output port 628.

The outward physical appearance of the VR/PC unit 550 is illustrated by Figs. 5 and 6. Fig. 5 shows a molded plastic housing 630 having a front elevation 632, which includes the front panel 586 and a hinged dust-shield 634. The dust-shield 634, shown in a closed position in Figs. 5 and 6, may selectively be opened by the user to permit access to the floppy and DAT drives, which are contained within the housing 630.

As an alternative to the stand alone housing configuration shown in Fig. 5, it is contemplated to provide a housing configured with suitable hardware for rack mounting.

Switches 636, provided on the front panel 586, permit the user to control much of the functionality of the VR/PC unit. The switches 636 include display format switches 638, 640, 642 and 644. As indicated by the labels on these four switches, the user may use these switches to select among display formats in which 1, 4, 9 or 16 video image streams are displayed on the monitor or monitors. Switch 646 allows the user to select a display screen which provides information indicative of the status of the VR/PC unit, and switch 648 permits the user to select a mode of operation in which a plurality of video streams are presented one at a time, but in accordance with a predetermined sequence.

The front panel 586 also has mounted thereon camera

selection switches 650, labeled from "1" to "16". Each of the camera selection switches 650, when actuated, calls up for display on the monitor the video signal currently generated by the corresponding video camera. Associated  
5 with each one of the camera selection switches 650 is a respective LED 652, which is illuminated when the live signal from the corresponding camera is being displayed. Also mounted on the front panel 586 is an LED 652 which is illuminated when the VR/PC unit is recording one or more  
10 incoming video signals generated by the cameras 520.

Another LED 656 is mounted on the front panel 586 to indicate that an alarm condition has been detected (either through the alarm sensors 526 or by image analysis carried on within the VR/PC unit itself). An alarm switch 658 is  
15 near the alarm indicator 656 and may be actuated by the user to cause the system to display information concerning the detected alarm or alarms.

Another notable feature mounted on the front panel 586 is a jog-shuttle switch 660. The jog-shuttle 660 is  
20 similar in appearance, operability and functionality to switches provided on conventional VCR's, and is provided for controlling playback of video image streams that have been stored on the hard drive or drives within the VR/PC unit 550.

25 The jog-shuttle 660 is arranged to allow the user to control such well-known playback features as forward playback, reverse playback and pause (still image) playback. Preferably, at least two forward and reverse playback rates are provided, corresponding to different  
30 amounts by which the jog-shuttle switch is rotated clockwise or counterclockwise. Preferably, the jog-shuttle switch 660 automatically returns to a "neutral" position after being released by the user and playback or rewind continues at the rate selected by the latest  
35 manipulation of the switch 660.

To summarize the overall layout of the front panel 586, four areas may be defined, proceeding from left to right:

Area 1: two rows of camera selection switches 650 (eight switches per row) with associated camera selection indicators 652 (also forming two rows), and also including the recording indicator 650;

5 Area 2: alarm indicator 656 and selection switch 658;

Area 3: jog-shuttle switch 660; and

Area 4: display control switches 638-648.

As will be seen, a substantially similar switch and  
10 indicator layout, which emulates the front panel 586, is provided in mouse-actuatable screen displays which form part of the graphical user interface (GUI) supported by the VR/PC unit 550. Examples of such screen displays are shown at Figs. 11 and 12 and will be discussed further  
15 below.

According to another embodiment at the VR/PC unit all of the switches, LEDs and other features shown on the front panel 586 may be omitted, so that the VR/PC unit is controlled only through mouse-actuatable screen displays.

20 Turning now to Fig. 7, details of the back panel 584 of the VR/PC unit will now be described.

In an upper central region of the back panel 584 are provided 16 video input ports arranged in two rows of eight ports each, and indicated by reference numeral 662.  
25 Below the video input ports 662 are provided 16 loop-through output ports (also in two rows of eight apiece), indicated by reference numeral 664. Both the input ports 662 and output ports 664 are for analog video. In a lower tier underneath the ports 662 and 664 are provided, from  
30 right to left, a serial port 666, a printer (parallel) port 668, an SVGA (digital video) output port 670 and an SCSI port 672. An additional (analog) video output port 674 is provided adjacent to the input video ports 662.

At an upper left portion of the back panel 584 there  
35 is a multi-position connector jack 676 to permit the VR/PC unit to be connected for digital communication with other devices. Below the data communication port 676 are provided a power-in receptacle 678 and a loop-through



power-out receptacle 680. Adjacent the power receptacles 678 and 680 is a ventilation aperture 682. At the right side of the back panel 584 are three expansion slots 684.

5

#### MEDIA DRIVE SUPPORT STRUCTURE

A compact and efficient media drive support structure is mounted within the housing 630 of the VR/PC unit 550. The medium drive support structure will now be described with reference to Figs. 8-10 and is indicated generally by reference numeral 700 in Fig. 8.

The major components of the support structure 700 are a base member 702, an intermediate member 704 and a top member 706.

15 As best seen from the exploded view shown in Fig. 9, the base member 702 is substantially u-shaped in cross-section, the intermediate member 704 is essentially planar, and the top member 706 is substantially an inverted u-shape. When the support structure 700 is assembled, the intermediate member 704 is supported on the base member 702, and the top member 706 is, in turn, supported on the intermediate member 704. All of the members, 702, 704 and 706 are preferably formed by applying bending and punching operations to sheet metal.

20 The base member 702 includes a substantially planar base plate section 708. The base plate 708 is substantially rectangular, except for an extension portion 710 which extends rearwardly in the plane of the plate 708 from a portion of a rear side 712 of the base plate 708. At opposed end sides of the plate 708, vertical side walls 714 and 716 are formed and extend upwardly from the base plate 708. Positioning studs 718 are mounted in a rightward region of base plate 708. The studs 718 are provided to define a position for a DAT drive unit to be mounted on  
25 base member 702. At a front side of the base plate 708, curved tabs 720 are formed. Additional tabs 720 are formed at respective rear portions of the base plate 708 by means of cutouts 722. (One of the additional tabs 720  
30

and its corresponding cutout 722 is occluded by the side wall 716 and riser member 726 in the view provided in Fig. 9). The tabs 720 are shaped for insertion into bridge lances formed on the chassis (not shown) of the VR/PC unit. By means of these bridge lances and the tabs 720, the base member 702, and consequently the entire media drive support structure (with drives installed therein) is secured within the housing 630 of the VR/PC unit.

A raised access hole 724 is formed in a left-ward portion of the extension portion 710 of the base plate 708. The access hole 724 is provided to permit insertion of a fastener such as a screw used to secure the base plate 708 to a pin nut (not shown) provided on the chassis of the VR/PC unit. A riser member 726 is secured to the base plate 708 at a left-ward portion of the base plate. A plurality of positioning studs 728 (of which only one is shown, Fig. 8) are provided on the riser member 726 to arrange for positioning of a floppy disk drive unit to be supported on the riser member 726. When the drive support structure 700 is assembled, as seen from Figs. 8 and 10, the space provided between the upper surface of the riser member 726 and the lower surface of the intermediate member 704 provides a form factor corresponding to one-half of a standard drive unit form factor, suitable for accommodating a standard floppy disk drive.

Referring again to Fig. 9, the right side wall 714 of the base member 702 has three slots 730 formed therein, extending horizontally adjacent to a top edge 732 of the side wall 714. The left side wall 716 of the base member 702 has a top edge 734, from which short tabs 736 extend vertically upward from, respectively, front and rear portions of the top edge 734. A fastener tab 738 extends horizontally outwardly from a central portion of the top edge 734 of the side wall 716. A hole 740 is formed in the tab 738 to permit insertion of a fastener through the tab 738. Still referring to Fig. 9, the intermediate member 704 carries eight positioning studs 742, arranged in two groups of four, each group for positioning a

respective hard disk drive unit.

Carried on the under side of the intermediate member 704 are pressure pads 744 (shown in phantom). When the support structure is in its assembled condition, as shown in Fig. 10, with drive units mounted therein, the pressure pads 744 exert downward pressure, respectively, on a DAT drive unit 746 and a floppy disk drive unit 748, to maintain those drive units in place in the drive support structure 700. The pressure pads 744 are preferably made of a resilient elastomeric material.

Punched-out fastener tabs 749 extend upwardly from positions at the four corners of the intermediate member 704. Holes formed in the tabs 749 permit insertion of fasteners for securing to the intermediate member 704 hard disk drive units mounted on the member 704. A u-shaped bracket 751 is provided for attachment via a fastener 753 at a central portion of the intermediate member 704. The bracket 751 aids in securing to the intermediate member 704 the hard drive units mounted thereon.

A short tab 750 extends horizontally outwardly from a right side edge 752 of the intermediate member 704. Two hinge tabs 754 curve outwardly and upwardly from the edge 752, and are positioned respectively at front and rear positions on edge 752. The tabs 754 and 750 are spaced along edge 752 of member 704 so as to be simultaneously insertable through the slots 730 in side walls 714 of base member 702. After insertion of the hinge tabs 754 into the outer slots 730, the intermediate member 704 may, during assembly, be swung downwardly toward the base member 702. At the left side of the intermediate member 704, there are provided slots 756 spaced so as to accommodate insertion therein of the short tabs 736 on the side wall 716 of base member 702. Also at the left side of member 704 are downwardly extending flaps 758 and a fastener tab 760 (similar to the fastener tab 738 of member 702) and having a hole 762 formed therein.

Two further pairs of slots 764 are also formed in the member 704, each pair of slots 764 being spaced a short

distance from a respective side edge of the member 704. A short downward flap 766 is formed at each of the front edge and the rear edge of the member 704.

The top member 706, like the intermediate member 704, carries eight positioning studs 742 arranged in two groups of four apiece, each of the groups for positioning a respective hard disk drive unit. These positioning studs 742 are carried on a substantially planar top plate 768 which forms most of the top member 706. As indicated in Fig. 9, the underside of top plate 768 has mounted therein pressure pads 744 which are provided to press down upon hard drives mounted on the intermediate member 704.

Extending downwardly from respective left and right edges of the top plate 768 are side walls 770 and 772. Short tabs 774 extend vertically downwardly from lower edges of the side walls 770 and 772. The tabs 774 are spaced so as to be simultaneously insertable into the slots 764 of the intermediate member 704. (One of the four tabs 774 provided on the top member 706 is occluded by the top plate 768 in the view provided by Fig. 9). A fastener tab 776 extends horizontally outwardly from a central portion of the lower edge of side wall 772. The fastener tab 776 is similar to the above-mentioned fastener tabs 738 and 760 and has a hole 778 formed therein. The members 702, 704 and 706 in general, and particularly the respective fastener tabs 738, 760 and 778, are dimensioned so that when the three members 702, 704 and 706 are assembled as shown in Fig. 8, the respective holes 740, 762 and 778 are brought into vertical juxtaposition with each other, thereby permitting a single fastener 779 to be inserted simultaneously through the three holes and permitting the single fastener to secure the three members 702, 704 and 706 together to form the drive support structure 700.

Fig. 10 shows the media drive support structure 700 in fully assembled form, including media drive units. In addition to the previously mentioned DAT drive 746 and floppy drive 748, hard disk drive units 786 and 788 are

shown mounted side by side on intermediate member 704, and a single hard disk drive unit 790 is shown mounted on top member 706. It will be observed that a space for mounting a fourth hard drive unit (not shown) remains in the right-ward portion of the top plate 768 of the top member 706.

Assembly of the drive units and the support structure may proceed rapidly and efficiently according to the following sequence: 1, mount DAT drive and floppy drive on base member; 2, using hinge tabs mount intermediate member onto base member; 3, mount two hard drive units on intermediate member; 4, using straight tabs extending downward from side walls, mount top member on intermediate member; 5, insert fastener (indicated by reference numeral 779 in Fig. 10) through all three holes in corresponding fastener tabs to form a single stable structure out of members 702, 704 and 706; 6, mount one or two hard drives on top member, using bracket 782 and fasteners through tabs 780. The completed media drive assembly can then be installed on the chassis of the VR/PC unit. If only two hard drives are to be provided in the unit, then step 6 may be omitted.

It is to be understood that the media drive support structure shown in Figs. 8-10 allows the mass storage hardware portion of the VR/PC unit to be assembled in a manner that is convenient as well as cost- and time-effective.

## ANALOG VIDEO HARDWARE

The analog front end circuitry provided on board 588 (Fig. 4) will now be described with reference to Fig. 13.

As seen from Fig. 13, the sixteen analog video signal  
5 streams generated by the sixteen cameras attached to the VR/PC unit are provided in common to three sixteen-to-one multiplexers, together indicated by reference numeral 802. Together the multiplexers 802 provide three outputs, respectively constituting inputs to three field locking  
10 channels 804. Each of the multiplexers 802 is controlled by a respective control signal (the control signals together are indicated at 806) to select a respective one of the cameras 16 for acquisition through the respective locking channel 804. The control signals 806 are provided  
15 from the digital front end board 590 (Fig. 4).

Continuing to refer to Fig. 13, the three locking channels 804 are identical, so that only one of the three channels will be described. The selected input video signal is provided, through amplifiers 808 and 810,  
20 respectively, to a chroma notch filter 812 and a chroma bandpass filter 814. A luminance signal is output from the chroma notch filter 812 and provided to a synchronizing signal separator circuit 816, which outputs a composite sync signal extracted from the luminance  
25 signal. The composite sync signal from the sync separator 816 is provided to a vertical synchronizing signal separation circuit 818, which separates a vertical sync signal from the composite sync. The vertical sync and the composite sync are both provided to the digital front end  
30 board 590. The composite sync output from the sync separator 816 is also provided to a burst gate detection circuit 820, which outputs a burst gate detection signal. The burst gate detection signal and the chrominance signal output from the chroma bandpass filter 814 are provided as  
35 inputs to a phase lock loop (PLL) circuit 822. The PLL

822 outputs a baseband chrominance signal and a reference signal. Another multiplexer block 824 is provided between the field locking channels 804 and two selection channels 826. The multiplexer block 820 is made up of six three-  
5 to-one multiplexers, of which three multiplexers are used for each of the two selection channels. The control signals for the multiplexer block 824 are indicated at 828 and are provided from the digital front end board.

The two selection channels 826 are identical, and  
10 accordingly only one of the two channels will be described. The three inputs to each selection channel are a luminance signal, a chrominance signal and a reference signal, all of which correspond to the video signal provided by a single one of the three input camera signals  
15 selected for locking by one of the three locking channels 804. The output of a respective three-to-one mux from the block 824 is used for each of the luminance, chrominance and reference signals, so that, correspondingly, the three inputs of the respective mux are the three luminance,  
20 chrominance or reference outputs, as the case may be, from the locking channels 804. The selected luminance signal is provided to a luma clamp circuit 830, which outputs a clamped luminance signal for selected channel one. The selected reference and chrominance signals, which  
25 correspond to the selected luminance signal, are provided to a chroma demodulation circuit 832, which outputs R-Y and B-Y signals to a multiplexer 834. The multiplexer 834 is controlled as indicated at 836 (control signal provided by front end digital board), to provide an alternating  
30 sequence of R-Y and B-Y signals as the chrominance signal for selected channel one. The clamped luminance and the sequentially alternating color difference signals making up the chrominance signal are then output for further processing to the digital front end board 590.

35 As noted above, the selection channel 826 corresponding to channel two is identical to that of channel one.

## FRONT END DIGITAL HARDWARE

Fig. 14 provides an overview, in functional block form, of the digital front end board 590. Major functional blocks on the front end board 590 include an analog-to-digital conversion and buffering block 840, a control and compression processing block 842, a live video display processing block 844, a live video image analysis block 846 and a "back end" compression block 848. Also included is an interface 850 to the PCI bus extension 596 (Fig. 3).

Continuing to refer to Fig. 14, the block 840 receives two channels of analog video acquired through and selected by the analog front end 588, digitizes the selected two analog channels, and buffers fields of the digitized video data in buffers 852 and 854, respectively corresponding to the two selected channels. Control signals to be output to the analog front end, and signals indicating the status of the analog front end, including sync signals, are received and transmitted through the block 840. In addition, the block 840 controls a video data bus 852 and distributes the buffered fields of video data, in accordance with a format to be described below, to the blocks 842, 844, 846 and 848. A control/status bus 854 interconnects the control block 842 and other blocks of the digital front end board 590, and permits the control block 842 to control the other blocks and to receive signals indicative of the status of the other blocks. Control and status signals ultimately transmitted to or from the analog front end are also carried on the control/status bus 854.

In addition to providing overall control of the function of the front end boards, the block 842 also performs initial data compression processing with respect to the video data output on video bus 852. Block 844 provides display processing of the video signals carried on video bus 852 and outputs a processed video signal, including overlay information and image plane allocation, in an output signal provided to the motherboard 580 and to



the display monitors. The block 846 performs moving image analysis with respect to the video data carried on the bus 852, according to techniques described below, to permit the VR/PC to detect characteristics of the images  
5 represented by the incoming video data.

The block 848 is preferably implemented as a standard commercially available integrated circuit which performs data compression processing on the video data that has been pre-processed in block 842. In a preferred  
10 embodiment of the invention, the compression-processing carried out by the block 848 is in accordance with the well-known JPEG standard, and is implemented using IC model CL 560, available from the C<sup>3</sup> Corporation. According to this embodiment, only the encoding, but not  
15 the decoding, capability of the JPEG IC is utilized.

The PCI interface 850 is used for providing the incoming, compression-encoded video signal to the motherboard 580 via direct memory access (DMA) techniques, under control by block 842. Control signals received  
20 from, and status signals sent to, the motherboard 580 from the block 842 are also transferred through the PCI interface 850.

#### DIGITIZING AND BUFFERING VIDEO DATA

25 The digitizing and buffering block 840 of Fig. 14 will now be described in more detail, initially with reference to Fig. 15. In Fig. 15, main functional portions of block 840 are shown, schematically, as including analog-to-digital conversion (856), video  
30 digitizing control (858), field buffering (860), video output control (862) and control register access (864). The control register access function 864 is provided to permit the control block 842 (Fig. 14) to write control messages with respect to the block 840 and the analog  
35 front end board, and to read incoming video data and status messages relating to block 840 and the analog front end board. The other portions of block 840 shown in Fig. 15 will be discussed with reference to subsequent drawing

figures.

5           Details of the analog-to-digital conversion function 856 are shown in Fig. 16. Four discrete conversion channels 866-874 are provided. Channels 866 and 868 are  
10           respectively for the luminance signals in channels one and two, and 870 and 872 are respectively for the chrominance signals in channels one and two. Each of the four conversion channels includes a buffer amplifier 174 and an analog-to-digital conversion circuit 876. Each channel is  
15           controlled in accordance with an analog/digital conversion clock (pixel clock), as indicated at 878 and a reference level, as indicated at 880.

          As shown in Fig. 17, the digitized video signal output from the A/D conversion function 856 is provided in  
15           two channels (channel one including luminance one and chrominance one, channel two including luminance two and chrominance two), to video digitizing controller 858. The digitizing is performed so that an eight-bit word represents each pixel. The pixel data is provided to  
20           controlling logic 882 which performs processing as will be described in connection with Fig. 17A. A FIFO memory 884 is provided for each channel to permit timing adjustments required when a video signal according to the PAL standard is being processed.

25           The controller logic 882 performs the process shown in Fig. 17A with respect to each channel independently. With respect to a particular channel, the controller logic waits until the beginning of a video signal field is detected in the particular channel (block 886) and then  
30           waits for a predetermined period of time (to clear the vertical blanking interval) and then waits until the beginning of a line is detected (block 888). When the start of the line is detected, the first pixel value is loaded into the field buffer corresponding to the  
35           particular channel and the logic then performs a loop made up of blocks 892 and 894, whereby all of the subsequent pixel values in the line are loaded until the end of the line is detected. When the end of the line is detected,

the loop is exited to block 896, at which it is determined whether this was the last line of the field. If not, the processing loops back to block 888. Otherwise, the processing loops back to block 886.

5           Advantageously, the processing of Fig. 17A may be implemented using a state machine formed as firmware in a programmable logic device. Design of such firmware is well within the capabilities of those who are skilled in the art, and need not be described further.

10           Referring again to Fig. 17, the control logic block 882 outputs the pixels of video data for the first and second channels, in accordance with the processing of Fig. 17A, and also provides to the following field buffering block a control signal, as indicated at 898.

15           Details of the field buffering block 860 are shown in Fig. 18. In addition to the previously mentioned field buffers 852 and 854 (each implemented using a VRAM), the field buffering block 860 also includes a VRAM controller 902. The VRAM controller 902 controls the buffer VRAMs  
20 852 and 854 and is in turn controlled by signals 898 (from the video digitizing controller 858) and by signals 904 (from video output controller 862). The video data output from the video digitizing controller 858 is stored in the field buffers 852 and 854, and is read out therefrom via  
25 a bus 906. Address and enable signals for the buffers 852 and 854 are carried on an address bus 908 controlled by the VRAM controller 902.

As seen in Fig. 19, the heart of the video output control block 862 is output control logic 910, which  
30 implements an output state machine (Fig. 35, to be discussed below). The output control logic 910 receives the video data from the VRAMs 852 and 854. The VRAM controller 902 generates the control signal 908 for controlling the VRAMs and generating required addresses.  
35 The output control logic 910 controls a delay FIFO 912, a header module 912B, and a FIFO accumulation 914. Data from these modules are buffered onto the video bus by bus drivers 912A. The FIFO 914 accumulates video data to be

used by the control/compression front end block 842 for the purpose of video data compression. This data is made available to the block 842 via the control register access 864 (Fig. 15).

5

## VIDEO DATA FORMATTING

There will now be described aspects of the format in which the output control logic 910 causes the video data to be transmitted on the video bus 852.

10 Figs. 20A and 20B each show an image plane 920, which is divided, for internal data representation purposes, into 240 lines in the vertical direction, and each line is divided into 640 pixels in the horizontal direction. The actual video data used to drive the display monitors is  
15 formed as 480 lines by 640 pixels, with the additional lines being generated by vertical interpolation from the 240 data lines provided for each field in the internal data representation. The image plane is also represented in the form of tiles, each tile measuring eight pixels in  
20 both the horizontal and vertical direction (Fig. 21). The image plane is thus divided into 80 tiles in the horizontal direction and 30 tiles in the vertical direction (Fig. 20B).

A 4:1:1 data format is employed whereby a group of  
25 four pixels is represented by four bytes of luminance data and two bytes of chrominance data. In effect, each line is divided into discrete groups of four pixels, and for each such group four luminance pixel bytes are provided, as well as one pixel byte of U color data and one pixel  
30 byte of V color data (Fig. 23). This format contrasts with conventional 4:1:1 formats, in which each chrominance data byte corresponds to a two pixel by two pixel area of the image plane. The format utilized herein and illustrated in Fig. 23 helps to minimize "smearing" of the  
35 color information in the vertical direction and lessens any adverse effects upon image quality that may result from allocating only 240 horizontal lines to each video data field.

For compression encoding purposes, the image plane is divided into discrete groups of four, horizontally-arrayed eight-by-eight tiles (Fig. 22). Each group of four horizontally sequential tiles constitutes a "minimum coding unit" (MCU). The data required to represent each MCU is made up of four eight-by-eight pixel blocks of luminance data, and one eight-by-eight block each of U data and V data. As shown in Fig. 24, a preferred order for transmitting the data in each MCU is the U data block, the V data block, and then the four luma data blocks.

According to the novel video data format employed in the VR/PC unit, each field of video data output from the block 840 by the video output controller 862 is transmitted twice, once in the form of tiles and once in the form of raster scan lines. The tiles are interleaved with the scan lines, as illustrated in Fig. 25. In a preferred format, 15 8 x 8 tiles are transmitted, preceded by a block of field header data, which identifies the field of video data being transmitted. Then the field header is transmitted again, followed by the pixels corresponding to the first raster scan line of the field. After the first raster scan line of the field, another 15 tiles are transmitted, followed by the second raster scan line, then another 15 tiles and then the third raster scan line, and so forth. This process of interleavedly transmitting raster scan lines and groups of rectangular tiles continues until all of the tiles have been sent and all of the raster scan lines have been sent. As a result, as indicated above, each pixel data word of the field is transmitted twice, once as part of a rectangular tile, and once as part of a raster scan line. According to the timing shown in Fig. 25, a period of about 27 microseconds is required to transmit each raster scan line, and a period of about 40 microseconds is required to transmit each group of 15 tiles.

Fig. 25 represents a transmission mode which nominally corresponds to three-quarters of the NTSC standard 60 fields per second transmission rate. In the

mode shown in Fig. 25, 45 fields of lines, and the same 45 fields in the form of tiles, are transmitted each second. It will be noted that 240 lines per field and 3600 tiles per field are transmitted (2400 luminance data tiles, plus  
5 600 tiles each of U data and V data). Thus, when the video bus 852 is operated as indicated in Fig. 25, the system has an input rate of 45 fields per second, which may be selectively distributed among up to 16 video camera inputs. Referring briefly to Fig. 14, the tiles are  
10 provided on the video bus 852 as the preferred format by which blocks 842 and 846 operate; whereas the raster scan line transmission of the fields is the preferred input format for the live display processing block 844.

Turning now to Fig. 26, another mode of operating the  
15 video bus will be described. In this mode, tiles are sent at the rate of 60 fields per second, but only every other one of the 60 fields is sent as lines. In other words, half of the fields are sent twice, once as lines and once as tiles, and the remaining fields are sent only as tiles.  
20 This mode may be employed, for example, when one or more of the field locking channels 804, and one or both of the selection channels 826 is used exclusively for a single one of the camera inputs. In such a case, the analog front end electronics are able to lock onto that input  
25 channel without any delay between fields, allowing for a throughput rate of 60 fields per second.

In the mode of operation shown in Fig. 26, a first raster line is sent during a period of 27 microseconds, then 30 tiles are sent during a period of 80 microseconds,  
30 then the next raster line is sent, then the next group of 30 tiles is sent and so forth. (The field headers are omitted from Fig. 26 to simplify the drawing.) During the time period in which 240 lines, corresponding to one field, are sent (i.e., approximately one thirtieth of a  
35 second), 7200 tiles, corresponding to two fields, are also sent.

Fig. 27 illustrates another mode of operating the video bus 852. The mode shown in Fig. 27 is utilized when

the field being transmitted is to be displayed with zooming in on a particular portion of the image plane. In this mode only the raster lines required to produce the magnified image are sent, and only the pixels within those  
5 raster lines required for the magnified image are sent. This reduces the bandwidth requirements for storage in the live display frame buffer.

In the example shown in Fig. 27, it is assumed that a two times zoom display is being implemented. If Fig. 27  
10 is compared with Fig. 25, it will be observed in the mode of Fig. 27 that in alternate ones of the raster line transmission time slots, all of the data is omitted from transmission. In the other time slots, only half of the pixels for the each line are transmitted. However, to  
15 maintain proper timing for the bus, the line time slots of 27 microseconds, provided between each pair of tile time slots, is maintained, even though no raster data, or a reduced amount of raster data, is being transmitted. (In Fig. 27, again the field headers are omitted to simplify  
20 the drawing.)

Fig. 28 illustrates the data format used in transmitting the raster line data on the video bus 852. In a preferred embodiment of the system, the video bus 852 consists of 19 parallel signal lines, of which 16 are  
25 devoted to data (two bytes side-by-side) and the remaining three bits are used to identify the bytes concurrently being transmitted. In the example shown in Fig. 28, it is assumed that the line being transmitted is the first line in a field, so that the first four bytes (first two byte  
30 transmission time slots) are devoted to a field header 926. In the field header 926, the two bytes that are initially transmitted make up a 16 bit time code. The next two bytes are indicative of the camera number and other information indicative of the type of field being  
35 transmitted. In the camera number byte, the first four bits are the camera number and the last four bits are indicative of the portion of the image plane in which the field being transmitted is to be displayed ("pane"

number). The pane number may indicate, for example, that the field being transmitted is to be displayed in the second window in the third row of a 4 x 4 multi-window display format. The pane number aids in efficient  
5 composition of multi-window displays in the live display processing block 844 (Fig. 14).

Byte 930 contains field type and other information. In this format, the first through fourth bits and the eighth bit of the byte 930 are unused. The fifth bit  
10 indicates whether or not the incoming video is being captured in a single camera mode (i.e., only video information from one camera is being captured). The sixth bit indicates whether the field is even or odd, and the seventh bit indicates whether frames of fields of the  
15 video signal are being captured.

The next two bytes, indicated by reference numeral 940, constitute the line header, which is a 16 bit line identifying number. There follows the pixel data for the raster line, including first four bytes of luminance data,  
20 then two bytes of U color data, then another four bytes of luminance data, then two bytes of V color data, and so forth. The line is complete when 640 bytes of luminance data and 160 bytes apiece of U and V data have been transmitted. Accompanying the last pair of bytes is an  
25 identifying code indicating the end of the line, as indicated at reference numeral 942. If the line being transmitted is the last line in the field, then the next pair of bytes includes a "next camera" identifying byte 944, which has the same data format as the "camera number"  
30 byte 928 described above. The "next camera" byte 944 provides advance notice to the live display processing block 844, to permit pre-generation of overlay information, appropriate setting of buffer pointers, and so forth.

35 As an alternative to the format shown in Fig. 28, in which two color data bytes of the same type are transmitted together, there could instead be transmitted pairs of color bytes with each pair of bytes consisting of



a U information byte and a V information byte corresponding to the four immediately preceding luminance pixels.

5 The format in which the tile data is transmitted on the video bus will now be described with reference to Figs. 29 and 30. Referring initially to Fig. 29, a typical tile data format is shown. The first two bytes, indicated at 952, constitute the tile header. One byte of the header, indicated at 954, includes a seven bit column  
10 identifying code which indicates, by column, the location of the tile in the image plane. The last bit of the byte 954 indicates whether the tile has been found to be a "changed" tile for the purpose of the data compression processing to be described below. The other byte of the  
15 tile header, indicated at 956, includes six bits to indicate the row position of the tile in the image plane. The last two bits are respectively reserved for indicating whether the tile is considered changed for the purposes of two different image analysis algorithms (i.e., two  
20 different "change thresholds" may be applied for the purpose of image analysis, and both may be different from the threshold applied for the changed tile bit of byte 954, the latter being used for data compression processing.)

25 Following the header bytes 952, are the 64 bytes which correspond to the 8 x 8 tile. In the example shown in Fig. 29, it is assumed that the tile is a U color information tile. The other tiles are made up of either 64 luminance bytes or 64 V color information bytes. For  
30 each minimum coding unit of four horizontally sequential eight pixel by eight pixel regions of the image plane (see Fig. 22), four luminance tiles, one U tile and one V tile are transmitted (Fig. 24). Since the image plane is divided into 2400 eight pixel by eight pixel regions (80  
35 tiles in the horizontal direction, 30 in the vertical direction; see Fig. 20B) a total number of 3600 tiles, including color information, is used to represent each field.

A field header is transmitted for each field of tiles, immediately in advance of the first tile of the field. The tile field header is like the field header shown for the line transmission format of Fig. 28, including two bytes of time code, a "camera number" byte and a "field type" byte, except that the camera number and a field type bytes used in the tile format differ somewhat from those used in the line format. Referring now to Fig. 30, the camera number and field type formats used with the fields of tiles will be described. The tile camera number byte 928' includes, in its first four bytes, the same 16 bit camera identifying code as for the line format. However, since the tiles are not used for live display, there is no need for pane identification information, so that the other four bits of the camera number byte 928' are unused.

As for the field type byte 930' used in the header for the tile field, the last six bits are the same as in the line format field header. The first bit indicates whether the field of tiles is used as a reference image field for the purpose of image analysis, and the second bit indicates whether the field of tiles is used as a reference image for the purpose of data compression processing.

Fig. 31 provides an overview of the processing functions performed by the output control logic 910 of Fig. 19. As seen from Fig. 31, the output control logic 910 includes a controlling state machine 960, a function 962 to build the field headers, header translation logic 964, raster building logic 966, tile building logic 968 and raster/tile sequencing 970. The output control logic functions to generate the data formats and bus operating modes that have been described above in connection with Figs. 25-30. The field header building function 962 is illustrated in flow chart form in Fig. 31A. As indicated at block 972 in Fig. 31A, the field header building function idles until the beginning of a field (first pixel in first line) is detected. Once this occurs, the field

header building function obtains camera identification and time stamp information from the front end board controller 842 (Fig. 14), as indicated at block 974, and then the field header format is assembled (block 976).

5       As shown in Fig. 31B, the header translation logic determines offset and scaling parameters (step 978) and uses these parameters to drive the raster build logic 966 and the tile build logic 968 (step 980).

10       Fig. 32 illustrates the processing carried on by the raster build logic 966. First (step 982), the raster build logic gets the line number on the basis of the current raster number. It is next determined whether this is the first line of a field (step 984). If not, the line header (shown as 940 in Fig. 28) is assembled (step 986)  
15       and then the data making up the raster line is sent to the sequencer 970 (step 988), and the process loops back to step 982. However, if at step 984 it was found that the first line in the field was about to be processed, then step 990 is inserted before step 986. At step 990, the  
20       information for the camera number and field bytes is obtained and the field header bytes are assembled.

      The processing carried on by the tile build logic 968 is shown in Fig. 33. The processing shown in Fig. 33 is indicated as a continuous loop, including a first step  
25       992, in which the tile build logic 966 obtains tile identification data, namely row and column location for the tile in the image plane. Then, at step 994, the data is assembled into the tile header bytes (shown as 952 in Fig. 29).

30       Continuing to refer to Fig. 33, step 996 follows step 994. At step 996, the tile building logic calculates the appropriate VRAM address from the row and column information and precedes to retrieve, from the appropriate one of VRAMS 852 and 854 (Fig. 18), the data required to  
35       construct the tile (step 998). Following step 998 is step 1002, in which the tile building logic 968 forwards to the sequencer 970 the completed tile.

      Fig. 34 illustrates the processing carried on by the

raster/tile sequencer 970.

Initially, at 1004, it is determined whether it is time to send a raster line. If so, the sequencer 970 transmits the data corresponding to the raster line (step 5 1006), preceded by the line header generated by the raster build logic 996, and also preceded by the field header, if this is the first line of the field.

If at step 1004 it was not found to be the time for transmitting raster data, then step 1006 is reached. At 10 step 1006, it is determined whether the sequencer 970 has received from the tile building logic 968 a complete set of the tiles to be transmitted during the period between two raster lines. The number of tiles will be either 15 or 30, depending upon whether the mode of Fig. 25 or Fig. 15 26, respectively, is in effect. If at step 1008 a complete tile set is found to be present, then the tile data, including tile headers generated by the tile build logic 968 (and a field header if appropriate) is transmitted onto the video bus 852 (step 1010). 20 Otherwise, step 1012 follows step 1008. At step 1012, the tile set counter is incremented each time a tile is received from the tile building logic 968, and the process loops back to step 1008.

After either step 1006 or 1010, the process loops 25 back to step 1004.

The controlling state machine 960 (Fig. 31) is illustrated in Fig. 35. As seen from Fig. 35, an idle state 1014 is exited, in favor of a tile handling state 1016, when it is time to start a field. When transmission 30 of 15 tiles is complete (or 30 tiles, as the case may be, depending on the mode of operating the video bus), then the state 1016 is exited in favor of state 1018, in which data corresponding to a raster line is transmitted. When the line is complete, a transition is made from the line 35 handling state 1018 back to the tile handling state 1016. However, at the completion of the last line, the field is complete, in which case the state machine transitions from the line handling state 1018 back to the idle state 1014.

## FRONT END BOARD CONTROL HARDWARE

Turning now to Fig. 36, the control block 842 for the front end electronics will now be described in additional detail. Major components of the control block 842 include  
5 a digital signal processing integrated circuit 1050, a dynamic RAM 1052, a static RAM 1054 and a DMA addressing module 1056. The DSP 1050 (like the digital signal processing devices which respectively supervise the live display processing block and the live image analysis block  
10 846) may be a series TMS-C32 device available from Texas Instruments. The DSP 1050 is the "brains" and "traffic cop" for the front end electronics. Among other functions, the DSP 1050 manages an address bus 1058 and a data bus 1060 which are utilized for management of video  
15 data in connection with data compression processing, and are also used for transfer of compressed video data to the motherboard via PCI interface 850.

The DSP 1050 also manages the control/status bus 854 (Fig. 14; not shown in Fig. 36). The control status bus  
20 854 may be implemented as a high-speed serial link which carries commands from the DSP 1050 to the digitizing, buffering and bus control block 840, the live display processing block 844 and the live image analysis block 846. Status messages from the blocks 840, 844 and 846 to  
25 DSP 1050 are also carried on the control/status bus 854. Control and monitoring of the front end analog board 588 (Figs. 4 and 13) is also handled by DSP 1050, by means of messages relayed through the block 840 (Fig. 14).

Referring again to Fig. 36, the DRAM 1052 stores  
30 statistics generated and used by the DSP 1050 in connection with initial compression processing of the tiles of video data which is accessed by the DSP 1050 via the FIFO 914 of Fig. 19 and the control register access 864 (Fig. 15). The SRAM 1054 serves as the general  
35 purpose working memory for the DSP 1050, and also as an output buffer for compressed video data that is ready for transfer to the motherboard via the PCI interface 850. The DMA addressing module 1056 provides the addresses used

during DMA transfer of the compressed video data from the digital front end board 590 to the motherboard.

Tri-state bus drivers, indicated by reference numerals 1062, are associated with the buses 1058 and 1060  
5 to route signal traffic flow as required on the buses.

#### LIVE IMAGE ANALYSIS HARDWARE

Details of the live image analysis block 846 will now be described with reference to Fig. 37. A live analysis  
10 block 846 includes a digital signal processing integrated circuit 1064, which may be of the type, mentioned above, available from Texas Instruments. Included within the DSP 1064 are functional blocks including an arithmetic and logic unit 1066, a boot code memory 1068, a program cache  
15 memory 1070 and latch and control circuitry 1072. Associated with the DSP 1064 are a serial port 1074, program memory 1076 and image memory 1078. The serial port 1074 receives control signals from the front end controller DSP 1050 and relays the control signals to the  
20 latch and control circuitry 1072. Similarly, status messages are relayed from the latch and control circuitry 1072 through the serial port 1074 and then to the controller DSP 1050. An address and data bus 1080 interconnects the DSP 1064 and the memories 1076 and 1078.

25 The program memory 1076 stores software which controls the DSP 1064 to execute one or more image analysis algorithms. The image analysis algorithm software is loaded in the program memory 1076 by the control DSP 1050. The algorithm software, in turn, may  
30 have been forwarded to the control DSP 1050 from the motherboard. The original source of some or all of the image analysis algorithm software may be a device that is separate from, and located remotely from, the VR/PC unit.

The image memory 1078 stores the video information  
35 which is to be analyzed by the live image analysis block 846. The video information is received in the form of tiles from the video bus 852, and then formatted in format logic 1082 prior to storage in the image memory 1078.

Preferably the image memory 1078 has sufficient storage capacity to store reference images, or statistics derived from reference images, for plural independent streams of video information. For example, it is contemplated that the live image analysis block 846 can contemporaneously apply image analysis to 16 live input video streams, respectively generated by 16 cameras connected to the VR/PC unit. Moreover, the respective image analysis algorithms applied to each incoming video stream may vary in terms of parameters used to constrain operation of the algorithms, and one or more of the algorithms may be directed to image characteristics that are completely different from other contemporaneously applied image algorithms. For example, a perimeter violation detection algorithm may be applied to some incoming image streams, while a "museum" algorithm is applied to one or more other of the incoming video streams. Both the perimeter violation algorithm and the "museum" algorithm will be further described below.

It should be understood that the results of the image analysis processing carried out by the block 846 are reported to the controller DSP 1050 via the serial port 1074.

#### LIVE DISPLAY PROCESSING HARDWARE

Details of the live display processing block 844 will now be described with reference to Fig. 38.

Major components of the live display processing block 844 are a DSP 1084, a first scaling and color space conversion circuit 1086, a display VRAM 1090, an overlay plane generating circuit 1092, an overlay mixer and concatenator 1094, a first in/first out memory 1096, a second scaling and color space conversion circuit 1098, an SVGA feature connector 1102, an NTSC/PAL encoding circuit 1104 and a synchronizing signal generator 1106.

All of the circuit blocks shown in Fig. 38 are preferably implemented using standard commercially available components. For example, the live display

controller DSP 1084 is preferably a Texas Instruments device of the type previously mentioned. The DSP 1084 receives command messages from the controller DSP 1050 and transmits status messages to the controller 1050. Under  
5 supervision of the controller DSP 1050, the live display control DSP 1084 controls operations of the live display processing circuitry 844, and, in particular, controls the two scaling/color space conversion circuits 1086, 1098 and the overlay plane generator 1092.

10 The first scaler/color space converter 1086 receives and processes the raster line data provided on the video bus 852. If the image represented by the received lines of video data is to occupy the entire live video display portion of the display screen, then no scaling is  
15 performed at circuit 1086. However, if a split-screen live image is to be displayed, including images corresponding to two or more live video image streams, then scaling is performed at circuit 1086. For example, if four images are to be displayed in respective windows  
20 in a 2 x 2 format, then each image is reduced by a factor of two, in both the horizontal and vertical directions, at the circuit 1086. In addition, color space conversion is performed at the circuit 1086 so that the YUV color data received from the video bus is converted into RGB data.

25 The converted (and if necessary, scaled) RGB data output from the scaling and color space conversion circuit 1086 is provided to a display VRAM 1090, which functions as a buffer, and then the buffered video data is output to the overlay mixer/concatenator 1094. Meanwhile,  
30 responsive to control signals from the DSP 1084, the overlay plane generator 1092 provides an overlay image, such as alphanumeric characters which may represent captions including "live" or "camera one". The image data representing the overlay image is supplied from the  
35 overlay plane generator 1092 to the overlay mixer 1094 for mixing with the live video image data. After suitable buffering in the concatenator portion of the circuit 1094, including, if appropriate, assignment to a selected



display window, the video image information (which may be a composite of several video image streams), is transferred through FIFO memory 1096 to the second scaling and color space conversion circuit 1098.

5           Scaling of the image output through the FIFO memory 1096 is performed at the circuit 1098 if the image output from the front end electronics is to occupy less than the entire image plane of the display monitor. If the entire display screen on the monitor is to be devoted to the live  
10 image output from the front end electronics, then no scaling is performed at circuit 1098. However, if the live video occupies only a portion of the video screen (as shown, for example, in Fig. 11) then scaling is performed so that the image generated from the front end electronics  
15 fits into the window assigned thereto. It will be observed in the display of Fig. 11 that graphical user interface features are provided in a lower portion of the screen display. As will be explained below, the GUI elements are generated at the motherboard.

20           RGB video data, scaled if necessary at circuit 1098, is provided as the SVGA output from the digital front end board 590 (Fig. 4) to the motherboard by way of the standard SVGA feature connector 1102 (Fig. 38). In addition, the circuit 1098 performs a color space  
25 conversion (after scaling, if necessary) on the RGB data to provide a second output in the form of YUV video data. The YUV video data is provided to an NTSC or PAL encoder 1104 which uses a sync signal generated at sync generator 1106 to form an NTSC (or PAL, as the case may be) analog  
30 output signal, which may be used to drive an NTSC monitor.

#### FRONT END SOFTWARE

Fig. 39 presents an overview of the software which controls operation of the video board controller DSP 1050.  
35 The software which controls the DSP 1050 includes a video board master control software module 1108 which arbitrates among the other software modules for the DSP 1050. The other software modules include an analog board managing

(camera sequencing) module 1110, an event manager 1112, a time keeper module 1114, a live analysis block manager 1116, a live display block manager 1118, a compressor manager module 1120, a tile comparison module 1122, a map generator module 1124 and a driver module 1126 for the PCI interface to the motherboard.

The software modules 1110 through 1118 and 1126 can be thought of as handling the "administrative" duties of the DSP 1050, while the modules 1120-1124 are concerned with functions relating to compression of the video data. Of the "administrative" software modules, all except the PCI interface driver 1126 essentially perform routine functions such as relaying messages from/to the motherboard and to/from other components of the video processing front end electronics. These software components can be readily provided by those of ordinary skill in the art by following standard programming techniques, and therefore need not be further discussed.

The functioning of the PCI interface driver 1126 will, however, now be further described with reference to Fig. 40. Essentially, the PCI interface performs two functions: (1) transfer of compressed video data from the front end board to the motherboard by DMA operations; and (2) transferring command and status messages between the motherboard and the video processing front end board. The one-way video data traffic from the front end board to the motherboard is much greater in volume than the two-way message traffic.

As seen from Fig. 40, the processing carried out by the PCI interface driver commences with a determination as to whether a message is incoming from the motherboard (step 1128). If it is found at step 1128 that a message is coming in from the motherboard, then step 1130 follows, at which the message is decoded. Then the decoded message is placed in a format suitable for handling by the relevant one of the manager modules shown on Fig. 39 (step 1132), and the reformatted message is dispatched to the relevant manager (step 1134). The process then loops back

to step 1128. Typically, messages received at the front end processing board from the motherboard contain programming and/or command data, such as that required to change the sequencing of cameras in the field capture operations by the analog video board, changes in parameters used in connection with video data compression operations, selection or adjustment of live image analysis algorithms to be carried out by the front end board, and so forth.

10 If at step 1128 no message was found to be incoming from the motherboard, the driver processing advances to step 1136, at which it is determined whether there is a message to be sent from the front end board to the motherboard. If so, step 1138 follows, at which the  
15 outgoing message is reformatted for handling by the "system director". The "system director" is, as will be seen, a software module which controls the motherboard CPU and acts as a central clearing house for messaging among the software objects supported by the motherboard CPU.  
20 Following step 1138 is step 1140, at which the reformatted outgoing message is dispatched to the system director via the PCI connection between the front end board and the motherboard. The process then loops back to step 1128.

If at step 1136 no outgoing message was found to be  
25 present, the next step is step 1142. At step 1142 it is determined whether compressed video data is ready for transfer to the motherboard. If not, the process loops back to step 1128. However, if at step 1142 it is found that video data is ready for transfer to the motherboard,  
30 then the process goes on to step 1144, at which a counter in the DMA addressing unit 1056 (Fig. 36) is initialized with the target location in the motherboard memory space to which the video data is to be transferred. Following initialization of the target address, the DMA transfer of  
35 the video data to the motherboard is itself begun (step 1146). While the transfer of the video data is going on, the process of Fig. 40 may detect a time-out condition, as indicated at step 1148. It is noted that a time-out

condition may occur if the DMA transfer fails for some reason. If a time-out is detected, a message is generated to inform the motherboard of the time-out (step 1152). Following the reformatting and message dispatch steps 1138 and 1140, the process then returns to step 1128. Unless a time-out condition is encountered, the interface driver process idles, as indicated at block 1154.

#### VIDEO DATA COMPRESSION

10 The video data compression operations carried out on the digital front end board 590 (Fig. 4) will now be discussed with reference to Figs. 41 through 44 and 39A.

The VR/PC unit disclosed herein employs a novel video data compression technique which, under typical operating conditions for the unit, provides an effective compression ratio of at least about 250:1, while providing an image quality that is at least adequate for video surveillance security applications. This high degree of compression permits efficient use of storage capacity (principally hard disk capacity) while facilitating data transmission and manipulation within the VR/PC unit. Moreover, as will be understood from subsequent portions of the discussion, the novel video data compression technique disclosed herein synergistically accommodates image analysis algorithms that are subsequently performed on the compressed video data. Moreover, even with the remarkably high compression ratio provided by the present compression technique, rather difficult playback functions, such as reverse-direction playback, can be performed relatively efficiently.

An overview of the present video data compression technique, and a description of the format of the compressed video data, will now be provided with reference to Fig. 44.

35 After compression, the stream of video images produced by a given camera is represented as a sequence of data fields 1130. There are two types of fields in the sequence of fields: reference image fields 1132 and

"difference" image fields 1134. The reference fields 1132 occur at regular intervals in the sequence of data fields. For example, in a preferred embodiment of the present compression technique, every 33rd field in the sequence is  
5 a reference field; that is, 32 "difference" fields 1134 are provided between each sequential pair of reference fields 1132. The reference fields 1132 are each compression encoded without reference to any other image. On the other hand, each of the difference fields 1134 is  
10 compression encoded with reference to one or more preceding images.

Each of the reference fields 1132 begins with a field header (not shown in Fig. 44) which may be the same as the tile field header discussed above in connection with Fig.  
15 30 (time code bytes not shown in Fig. 30 would also be included in the field header). The balance of the reference field 1132 is made up of compressed video data corresponding to every one of the 2400 tiles of the image plane. In particular, the compressed video data making up  
20 the balance of the reference field is formed by processing every one of the 3600 data tiles (2400 luminance tiles and 1200 color information tiles) by the compression-encoding circuitry of the JPEG chip 848 (Fig. 14). As is well known to those of ordinary skill in the art, the JPEG  
25 encoding process performed by the chip 848 entails conventional encoding steps such as orthogonal (DCT) transformation, quantization of coefficient values, and run-length encoding. The compression ratio achieved with respect to the reference fields is on the order of 30:1 to  
30 70:1.

On the other hand, in the difference fields, each of the "difference" data fields 1134 include compressed video data only for selected tiles that represent "changes" relative to a preceding image. When there is little or no  
35 motion in the video image stream, very few, or none, of the data tiles are represented in the difference data fields 1134, so that a high degree of compression is realized.

As seen from the lower portion of Fig. 44, a typical difference data field 1134 is made up of a field header 1136, followed by map data 1138 which indicates the portions of the image plane which were considered  
5 "changed" in the current image, and are accordingly represented by video data in the present difference data field 1134. For example, the map data may consist of one bit for each of the 600 minimum coding units (MCUs) in the image plane, it being recalled that an MCU corresponds to  
10 a discrete horizontal sequence of four tiles. For example, a "1" bit corresponding to a particular MCU would indicate that the MCU has been found to be "changed" and is represented by JPEG-compressed video data corresponding to the six data tiles for the MCU. A "0" value for the  
15 bit corresponding to a particular MCU indicates that no data for the MCU is included in the present difference data field.

Following the changed MCU map 1138 are data segments 1140 made up of the JPEG-compressed video data  
20 corresponding to the changed MCUs indicated by the map data 1138. The number of "1" bits in the map data is the same as the number of encoded MCU portions 1140.

The compression technique just described allows for an image reconstruction technique schematically  
25 illustrated in Fig. 61. According to this technique, a reference field 1132 is reconstituted simply by reversing the JPEG compression encoding in a conventional manner. Then, for the immediately following difference field, the changed MCU data segments are each JPEG-decompressed, and  
30 each MCU of the resulting video data is substituted at the appropriate portion of the image plane as indicated by the changed MCU map. One can think of the process of constructing the first difference field as one of "pasting in" postage stamps (reconstituted MCUs) using the MCU map  
35 as a guide. The process is then repeated with respect to each of the succeeding difference fields.

A key portion of the compression encoding process for the difference fields entails determining whether a

particular MCU is to be JPEG-encoded (because it is "different" from a corresponding reference MCU) or discarded (because it is "the same" as the reference MCU). In a preferred embodiment of the invention, each tile in the MCU is compared with a corresponding tile in the reference MCU, and an MCU in the difference field is considered different if any tile is found "different" from the corresponding reference tile. The determination as to whether a tile is different from a reference tile is made by calculating certain statistics from the pixel data making up the reference tile, and comparing the statistics, on the basis of a threshold, with the same statistics previously generated for the reference tile. The threshold level for "sameness" is adjustable by the user, in a preferred embodiment of the system, so that compression ratio and image quality may be traded off against each other by the user.

Figs. 43A-43C schematically illustrate aspects of the tile comparison process. Fig. 43A shows the tile as an eight by eight array of pixels. Fig. 43B indicates how the tile of Fig. 43A is divided up into four quadrants that are discrete from each other and each consist of a four by four array of pixels. A tile comparison statistic is calculated for each of the four quadrants by summing eight of the 16 pixels in the quadrant and then dividing by four (shifting two binary places to the right). The result is a nine-bit quadrant statistic. (The number by which the eight pixel sum is divided may be considered a "scaling factor" and may be a number other than four.)

The eight pixels to be summed are selected by what will be referred to as "checker-board" subsampling, as indicated in Fig. 43C. Two checker-board subsampling techniques are possible: either the pixels marked "x" in Fig. 43C may be selected for summation, or the pixels not marked may be selected. In either case, it will be observed that checker-board subsampling entails subsampling by a factor of two, with offset from line to line. In a preferred embodiment of the invention, only

one of the two checker-board subsampling techniques is applied for all of the quadrants of all of the tiles, so that no pair of vertically or horizontally adjacent pixels is used for calculation of the tile characteristic  
5 statistics.

The same technique is used to calculate the statistics both for the reference tiles and the tiles in the difference fields. If one of the four quadrant statistics for a reference tile differs by more than the  
10 threshold amount from the statistic for the corresponding reference quadrant, then the entire tile, and hence the entire MCU, is considered to be "changed" relative to the reference MCU. It will be understood that this procedure is applied to six tiles (four luminance, two color) for  
15 each MCU.

Processing carried on in connection with compression encoding of the difference video data fields is illustrated in Figs. 39A, 41A, 41B and 42. Referring initially to Fig. 41A, a setup operation for the  
20 compressor manager software module 1120 (Fig. 39) will be described. The setup phase of the compressor manager begins with a step 1142, at which there is received from the motherboard a table of threshold values respectively applicable to the input video streams from the respective  
25 cameras. These threshold values, which correspond to image quality and compression ratio parameters for the respective video signal streams, are stored in an on-board RAM for the front end board control block 842. The threshold values in the table are then loaded for use in  
30 compression processing by the DSP 1050 (step 1146) and the compression process is reset (step 1148). In particular, at step 1148, suitable instructions are sent to the JPEG chip 848 to set desired parameters, such as selection of quantization tables and Huffman encoding tables, selection  
35 of monochrome vs. polychrome encoding, etc.

Operation of the compressor manager software module is illustrated in Fig. 41B. As indicated at block 1152, the same operational process is carried on with respect to



each of the 16 incoming video streams. First, as shown at block 1154, threshold data corresponding to the camera which generated the present difference field to be encoded is retrieved. It is then determined whether the threshold settings are different from those most recently applied (block 1156). If not, the compression process is applied in the same manner as was done for the most recent difference data field. However, if the threshold data is different from that most recently applied, the operating tables for the compression processing are updated (step 1158) and the compression process is reset (step 1160).

It should be understood that the same threshold parameter may be used in processing both luminance and color data tiles, or different thresholds may be used for the luminance data on one hand and the color (U,V) data on the other hand.

The processing carried on by the tile comparison software block 1122 is illustrated in Fig. 42. Initially, the 15 tiles to be transmitted during the tile phase of the video bus operation (see Fig. 25) are read in (step 1162) by accessing the tile data in the FIFO 914 (Fig. 19) and then, as indicated at step 1164, the following procedure is applied to each tile: the reference characteristic statistics for the corresponding reference tile are retrieved (step 1166) and the characteristic statistics for the present tile are calculated according to the technique described in connection with Fig. 43 (step 1168). If, based on the applicable threshold, the retrieved reference characteristics, and the calculated characteristic statistics for the present tile, a tile is found to be "different" from the reference tile, then the tile is marked as different (step 1169) and the calculated characteristic statistics for the present tile are stored in place of the previous reference characteristics and thus serve as updated reference characteristics. However, if at step 1168 the present tile was found to be "the same" as the reference tile (i.e, differing in its characteristics by less than the threshold), then the tile

goes unmarked. As indicated at step 1172, the process of steps 1164 through 1178 continues until all 15 of the tiles have been compared with the reference characteristics. Then the tiles, including the tiles which have been marked as "different" tiles, are returned to the video output block (step 1174). As will be recalled from previous discussion, all tiles that are either marked "different" or are in the same MCU as a "different" tile are provided to the JPEG processing chip 848 for JPEG compression and inclusion in the compressed difference data field. All other tiles are not provided to the JPEG chip, but are simply discarded.

The processing performed by the map generator software module 1124 (Fig. 39) will now be described with reference to Fig. 39A.

As indicated at block 1176, the following procedure is carried out for each tile. First, it is determined whether the tile has been marked "different" (step 1178). Then, as indicated at steps 1180, 1182 and 1184, a flag corresponding to the present tile is set to one if the tile was marked "different" and is set to zero otherwise. As shown at step 1186, the flag is then merged with a map byte which is currently being constructed. If all eight flags from which the map byte is to be constructed have been merged into the map byte (step 1188) then a new map byte is started (step 1190). After map bytes have been constructed for all of the tiles for the image, the resulting map data is transferred to the motherboard through the PCI interface 850 (step 1192).

Although the foregoing discussion of Fig. 39A has indicated use of one mapping bit per tile, it should be understood that as a preferred alternative, one map bit is allocated to each MCU and that the flag for a given MCU is set to "1" if any of the six data tiles for the MCU has been marked as "different".

## MOTHERBOARD SOFTWARE

There will now be discussed the software which controls the operation of the motherboard CPU 592 (Fig. 3) and hence controls the VR/PC unit as a whole. In a preferred embodiment of the VR/PC unit, a standard microprocessor (e.g., a Pentium) is employed, operating with a standard operating system, in order to minimize the cost for the motherboard. The well known Windows 95 operating system is employed for the motherboard CPU in a preferred embodiment of the VR/PC unit, because of the multi-tasking options and software development capabilities supported by Windows 95. The application software modules to be discussed below were implemented in accordance with the Component Object Model (COM) architecture propounded by MicroSoft. The C++ object-oriented programming language was used to create the application modules.

Fig. 45 provides an overview of software components which make up the motherboard CPU application. The illustrated components are enumerated as follows: system director 1202, setup manager component 1204, scheduling component 1206, security manager component 1208, user interface component 1210, alarm handling component 1212, front panel component 1214, compressor manager component 1216, video recording component 1218, image processing utility objects 1220-1 through 1220-P, image processing utilities manager component 1222, video search component 1224, archive manager component 1226, video play component 1228, image analysis (playback) tool objects 1230-1 through 1230-M, database search tool manager component 1232, video storage component 1234, remote device objects 1236-1 through 1236-N and remote object manager component 1238. Except for the remote objects 1236, playback analysis tool objects 1230 and image processing utility objects 1220, all of the components other than the system director 1202 are shown as being in two-way message-passing communication with the system director 1202.

The system director functions as a central message

clearing house to permit message passing between the other application software components. Messages to and from the remote objects 1236 are passed through the remote manager component 1238, messaging to and from the image analysis tool objects 1230 occurs through the database search tool manager 1232, and messaging to and from the image processing utility objects 1220 occurs through the image processing utility manager component 1222. Through the multi-tasking facilities provided by the Windows 95 operating system, it is expected that each software module and object will operate its own processing thread or alternatively utilize the main GUI thread. The application software architecture is message oriented and event driven. The system director 1202 is shown in Fig. 46A. In accordance with the standard approach of the COM architecture, the system director 1202 supports two interfaces, IUnknown (reference number 1240) and INotifySrc (reference numeral 1242). As will be appreciated by those of ordinary skill in the art, the IUnknown interface 1240 is a standard COM interface for the purpose of reference counting, freeing memory, and gaining access to interfaces supported by the other COM objects. The INotifySrc interface is 1242 is modelled after standard COM design guidelines allows software components to indicate interest in receiving certain messages. The system director maintains a mapping which relates messages to interested parties, and when a message comes to the system director, the system director looks up all interested parties and actuates a call to the interested party components through the INotifySrc interface. The system director is the first component that is loaded and initialized by the application software. The system director then determines from a system registry all components to be initialized by the system director and then loads each of the components and calls an initialization function passing the INotifySrc interface pointer so that the component can register itself.

Other software components are illustrated in generalized form in Fig. 46B. It will be noted that the other components typically support interfaces IUnknown and INotify.

5 Background on the COM architecture and messaging between objects by use of interfaces can be found in an article entitled, "How OLE and COM Solve the Problems of Component Software Design," by K. Brockschmidt, Microsoft Systems Journal, May 1996, pp. 63-80, and a related  
10 (sequel) article at pages 19-28 of the June 1996 issue of the Microsoft Systems Journal.

Processing carried out by the security manager component 1208 is illustrated in Fig. 47. As seen from block 1244, the security manager idles until a user  
15 attempts to login. When a login attempt is detected, it is determined (step 1246) whether the login attempt was valid. If not, the component loops back to block 1244. But if the login attempt is valid, then the user is logged in (step 1248), and it is then determined (step 1252) what  
20 system features the person logging in is permitted to operate. This is done by accessing a security database 1254 to retrieve the feature set associated with the person who has logged in. On the basis of the retrieved feature set, the security manager component then sends  
25 permission to operate to each component that the user is allowed to access (step 1256). As also indicated in Fig. 47 at block 1258, the security manager component further provides for a process whereby the feature sets in the security database 1254 can be entered and edited by  
30 authorized supervisory personnel.

Fig. 48 illustrates operation of a typical one of the remote objects 1236. The remote objects function as drivers or interfaces for devices external to the VR/PC unit. Such devices may include external media drive  
35 devices (e.g., an external DAT drive), other VR/PC units, or local or remote nodes like those shown in Fig. 1. Preferably, a remote object is instantiated for each external device which is in communication with the VR/PC

unit.

As indicated at block 1260, data received via a communication link with the remote device is received, and then buffered (step 1262). Received data is then translated into the message protocol in use among the application software components (step 1264) and the resulting message is sent to the remote manager 1238 (Fig. 45). Continuing to refer to Fig. 48, when a message is to be sent from the VR/PC unit to a remote device, the message is received by the appropriate one of the remote objects 1236 from the remote manager 1238. The message is translated by the remote object 1236 into an appropriate format for transmission to the external device (step 1266) and then is placed in an output buffer (step 1268) and transmitted via the communication link (step 1270).

Fig. 49 illustrates processing carried out by the front panel software component 1214 (Fig. 45). When a user of the VR/PC unit manipulates a switch on the front panel 586 (Fig. 6), a corresponding signal is received by the front panel software object 1214 (step 1272, Fig. 49). The switch manipulation signal is then translated into the message protocol used within the application software (step 1274) and the resulting message is forwarded to the system director.

The front panel software object also manages the states of the LEDs provided on the physical front panel 586. When the LED display conditions on the front panel 586 are to be changed, a suitable message is received by the front panel software object 1214 from the system director. The front panel software module then operates to translate the message into LED register commands (step 1276) and outputs the resulting data for storage in the LED register (step 1278; LED register not shown).

Processing carried out by the setup manager component 1204 is illustrated in Fig. 50. Initially (step 1280), it is determined whether a request for previously stored setup information has been received. If so, the request is fulfilled (step 1282). Following step 1282 (or

immediately following step 1280 if no request for setup information was received) is step 1284, at which it is determined whether a request to change the previously stored setup information is received. If so, the setup  
5 information is changed in accordance with the request (step 1286) and the process loops back to 1280. If no request was received at step 1284, then the process loops back to step 1280 directly from step 1284.

There will now be described with reference to Figs.  
10 51 and 52 processing carried on by the video storage software component 1234.

Fig. 51 illustrates a format in which compressed video data is stored on one or more of the hard disk drives of the VR/PC unit.

15 As seen from Fig. 51, the data stored on the hard drives includes compressed video data 1288 and index data 1290. The video data corresponds to the incoming streams from all 16 cameras (if as many as 16 cameras are connected to the VR/PC and in operation) and is in a form  
20 which complies with the Microsoft .AVI (audio/video interleave) standard for audio/video files. Although the embodiment of the VR/PC described herein does not store audio information, it is contemplated to modify the system so that audio pickups (microphones) are provided and  
25 digitized audio data is stored in association with relevant video information. The data corresponding to the streams of incoming video signals are stored interleaved together in the form of fixed length files 1292, of which N files 1292 are shown in Fig. 51 as being recorded on the  
30 hard disk. A preferred size for each of the files 1292 is about 20 megabytes. By dividing up the continuous streams of video data into files, loss of data due to a drop out or data corruption on the hard disk can be limited.

In addition to the quasi-permanent video data files  
35 1292, there is also stored on the hard disk video data maintained in a pre-alarm buffer section of the disk (reference numeral 1294). The pre-alarm buffer 1294 preferably stores video data corresponding to the incoming

video signals from all 16 cameras in an interleaved fashion and at what is substantially the full frame rate for the system (45 fields per second divided among the 16 cameras). By contrast, it should be understood that some  
5 or all of the 16 cameras may not be currently recorded at all in the quasi-permanent files 1292, or may be stored at a "time lapse" rate that is substantially less frequent than 45/16 fields per second. The pre-alarm buffer 1294 is preferably implemented as a ring buffer on the hard  
10 disk and may, for example, store all of the video fields captured at the front end electronics over the past 60 seconds.

Turning now to the index data on the hard disk, overall indexing covering all of the files 1292 is  
15 indicated at reference numeral 1296. For each of the N files 1292, a starting date and time and an ending date and time are provided. An additional, file-specific index is provided with respect to each one of the individual files 1292. This file-specific index is illustrated at  
20 1298 and provides for each field of video data the date and time at which the field was captured, the camera by which the field was captured, event-related information, and the offset within the file at which the field can be found. As indicated at reference numeral 1302, the event  
25 information given for a particular field may include data indicative of the occurrence of more than one type of event at the time that the field was captured. The detection of events may be accomplished through the alarm sensors 526 discussed in connection with Fig. 1 and/or by  
30 analysis of characteristics of the image stream. The analysis may have occurred either at the time the image stream was received or by playing back the image stream at a later time. The image stream analysis algorithms used to detect the events may return confidence factor values  
35 in addition to detecting that an event itself has occurred. In such cases, the data indicating that an event has been detected may be accompanied by the confidence factor provided by the event detection



algorithm, as indicated at reference numeral 1304.

In a preferred embodiment of the invention, the indexing information 1290 is stored on the same hard disk with the associated video data files 1292, and the indexing information is also stored on a second hard disk. The second hard disk may then be accessed in order to search for the locations on the first hard disk of video data that is of interest to the user, while access to the first hard disk for the purpose of storing new video data thereon continues without interruption for index searching. In one embodiment of the invention, two hard disks are provided, of which one is used for video data storage (and associated indexing) while the other hard disk is not used for video data storage, but rather is dedicated to the backup or "shadow" index information and storage of programs or the like. In another embodiment of the invention, three or more hard disk drives are provided. In the latter embodiment, one of the hard drives is dedicated to the shadow index and program information storage, and the other two or more hard disks are available for video data storage.

The video storage software component 1234 performs the functions of managing pre-alarm video data buffering on the hard disk or disks, storing the incoming video streams on the hard disk, and indexing the stored video data on the hard disk. The processing performed by the video storage software module is illustrated in flow-chart form on Fig. 52. Initially, it is determined at step 1306 whether the video storage software component is now engaged in the pre-alarm buffer management portion or regular video data storage portion of its function. If not engaged in pre-alarm buffer management, the process stores in a currently open file on the hard disk the next "chunk" of video data intended for quasi-permanent storage (step 1308). As used in the previous sentence and the subsequent discussion, it should be understood that a "chunk" of video data corresponds to a quantity of data that is conveniently handled and buffered preparatory to

writing onto the hard disk. The corresponding index data is then updated (step 310). Next the process determines whether the end of the current video data file 1292 has been reached. If so, it is then determined whether the  
5 disk or disks available for video data storage are full (step 314). If not, another video data file is opened on the disk or disks (step 316). If the disk or disks are full, then step 318 follows step 314. At step 318, it is determined whether the video data storage disk or disks  
10 are being employed in a ring mode. If not, then the video storage software component sends a message to the system director indicating that the end of the storage capacity has been reached (step 320). However, if at step 318 it was found that the disk storage was being operated in a  
15 ring mode, then the file index list is reset and storage proceeds at the "beginning" of the hard disk (step 1322).

If at step 306 it was found to be time for execution of the pre-alarm buffer management function, then the process advances from 1306 to step 1324. At step 1324, it  
20 is determined whether an alarm condition has been detected. If not, the next chunk of video data to be stored in the pre-alarm buffer is placed at the next storage location in the ring buffer portion of the hard disk (step 1326). Then it is determined whether the end  
25 of the ring buffer portion of the hard disk has been reached (step 328). If so, the pointer indicative of the next storage point on the ring buffer is moved to the front of the ring buffer (step 330). Otherwise, the pointer is simply moved to the next storage location in  
30 the ring buffer portion of the hard disk (step 332).

If at step 1324 an alarm condition was found to have been detected, then step 1334 follows step 1324. At step 1334, the video data stored in the ring buffer is copied into the permanent storage portion of the hard disk. As  
35 indicated at step 1336, the copying of the data from the ring buffer to the permanent storage portion of the hard disk continues until complete, and then the pointer is reset to the beginning of the ring buffer portion.

Alternatively, a new portion of the hard disk may be assigned for use as the ring buffer, with the portion of the hard disk previously assigned to use as a ring buffer having been made a part of the permanent storage portion  
5 in order to preserve the video data recorded in the pre-alarm buffer prior to the detection of the alarm condition.

Fig. 53 illustrates the processing carried on by the video search software component 1224. When a search  
10 operation is initiated by a user (through interaction with the graphical user interface, as will be explained below), the video search software component proceeds to obtain from the user search parameters indicative of the date, time, and source camera for the video information of  
15 interest to the user (step 1340). In addition, the video search component obtains from the user an indication as to whether the search is to employ an image analysis algorithm ("tool"). Step 1342 is a decision block at which it is determined whether an image analysis based  
20 search is requested. If so, the video search software component obtains from the user input indicative of the type of image analysis algorithm to be performed, as well as, if appropriate, one or more parameters to constrain the execution of the image analysis algorithm (step 1344).  
25 On the basis of this information, the process then prepares the image analysis algorithm to operate with respect to the video data to be retrieved during the search (step 1346). Following step 1346 (or immediately following step 1342 if no image analysis is requested by  
30 the user) is step 1348, at which the database is searched to retrieve the video data requested by the user. If image analysis was requested, then the analysis algorithm is applied to the retrieved video data. In either case, the outcome of the search is reported (step 1352).

35 There will now be provided, with reference to Fig. 54, a more detailed description of the process step shown as step 1348 ("perform search") in Fig. 53. The step 1348 initially includes building a list of one or more date and

time files that match the search criteria specified by the user (step 1354, Fig. 54). For each file on the list, the following steps are performed, as indicated at step 1356: A list of the date, time and camera entries is generated  
5 for each of the files (step 1358), and then a decision is made as to whether an image analysis algorithm is to be applied (step 1360). If not, i.e., if no image analysis was requested by the user, then the list is simply submitted for reporting (step 1362). However, if an image  
10 analysis based search has been requested, then for each entry in the list assembled at step 1358, the following procedure is followed, as indicated at step 1364: First the image analysis algorithm is reset (step 1366) and then the sequence of video images corresponding to the entry is  
15 analyzed using the image analysis algorithm (step 1368). It is then determined at step 1370 whether the sequence of images exhibits a characteristic that was to be detected by the image analysis algorithm. If so, the sequence is added to a positive result list (step 1372) and the index  
20 information for the file is updated to indicate detection of the event (step 1374). That is, the event related data shown at 1302 in Fig. 51 is updated to indicate detection of the event, as well as the confidence factor applicable to the event detection decision. It will be appreciated  
25 that if the characteristic of the image stream is not found to be present, the sequence is not added to the result list and the index information is not updated. In any case, following step 1374, or directly following step 1370 if the characteristic of interest was not detected,  
30 it is determined whether more entries are present on the list (step 1376). If not, the results obtained as a result of the image analysis are reported (step 1362). However, if more entries are present, the next entry is retrieved (step 1378), and the loop starting at step 1364  
35 is performed with respect to the next entry.

Fig. 55 presents an overview of the processing carried out by the video play software component 1228. Video playback operations may be initiated through user

manipulation of the jog-shuttle switch 660 on the front panel 586 (Fig. 6) or by user interaction with the graphical user interface, as will be described below. In some cases the video play function is entered  
5 automatically upon completion of a search in order to display the video data requested by the user.

As shown in Fig. 55, an initial step of the video play function is determining what play command has been asserted (step 1380). If a pause command has been  
10 asserted (step 1382), then video data decompression operations are halted (step 1384), and the video play function reports to the system director that video playback has been paused (step 1386). If a forward play command, at a given speed of X fields per second, has been  
15 asserted (step 1388), then again the decompression operation is halted (step 1390) and the forward mode playback image rate is reset (1392). Then the video data decompression operation is restarted (step 1304) and the new requested playback rate is reported to the system  
20 director (step 1396).

If playback in the reverse direction has been selected, at a rate of Y images per second, was asserted (step 1398), then once more the decompression operation is halted (step 1402) and the image rate for the backward  
25 reproduction mode is reset (1404) and a reverse direction decompression operation is initiated (step 1406). Following step 1406 is the aforesaid step 1396, at which the requested playback rate is reported to the system director. If none of the circumstances to be detected at  
30 steps 1382, 1388 and 1398 have occurred, then a playback status unchanged message is sent to the system director (step 1408).

#### VIDEO DATA DECOMPRESSION (FORWARD DIRECTION)

35 The process step 1394 shown in Fig. 55 will now be described in greater detail with reference to Fig. 56.

The process illustrated in Fig. 56 commences with receipt of the restart command for the decompression

engine (step 1410). There follows step 1412, at which the playback rate timer is set in accordance with the applicable X image per second rate, and the quit decompressing flag is cleared.

5           There follows step 1414 which entails locating the first reference image in the video stream to be played back occurring after the point at which playback is to be initiated. The reference image is then decompressed (reconstituted) in a step 1416. Following step 1416 is  
10 step 1418, at which it is determined whether halting of the decompression engine has been requested. If so, a message is sent to the system director to indicate that the decompression engine has halted (block 1420) and the decompression operation ceases. However, if it was not  
15 found at step 1418 that decompression was to be halted, then the process moves on to step 1422, at which it is determined whether the time has come to decompress the next image. If not, the process loops back to step 1418. However, if it is time to decompress the next image, the  
20 process advances to step 1424, at which it is determined whether the next image to be decompressed is a reference image or a difference image. If the next image is a reference image, a procedure for decompressing a reference image (block 1426) is applied, and then the process loops  
25 back to step 1418. If the next image is a difference image, then a procedure for decompressing the difference image (block 1428) is applied and the process again moves back to block 1418.

The procedure used for decompressing reference images  
30 (blocks 1416 and 1426 in Fig. 56), will now be described with reference to Fig. 57. The procedure shown in Fig. 57 is made up of nested loops, of which an outer loop, indicated at block 1430, is applied to each row of minimum coding units in the image (30 rows per image) and the  
35 inner loop, indicated at block 1432, is applied to each MCU in the present row (20 MCU's per row).

At step 1434, each of the six blocks of JPEG-encoded data is processed so as to reverse the JPEG encoding and

recover substantially the original six tiles (four luminance and two color) of video data. Routines for controlling a general purpose microprocessor to decode JPEG-encoded video data are well known and therefore need  
5 not be described herein. The decoded video data corresponding to the MCU is then copied into an output buffer (step 1436). Once all of the MCUs in all of the rows of the reference image have been decoded and placed in the output buffer, the buffered data, representing the  
10 entire decoded image, is bit-level transferred for display on the monitor (step 1438).

Further discussion of blocks 1384, 1390 and 1402 of Fig. 55 will now occur with reference to Figs. 56 and 58. As indicated in Fig. 58, when a stop decompressor command  
15 is received (step 1440) then a "quit-in-progress" flag is set (step 1442). If a forward playback operation is then occurring, then the setting of the quit-in-progress flag triggers an affirmative finding at block 1418 (Fig. 56), leading to shutting down of the decompression engine, with  
20 transmission of an appropriate message to the system director. As will be seen from a subsequent discussion of the processing for reverse-direction reproduction, the quit-in-progress flag has a similar effect with respect to reverse-direction reproduction operations.

25 Processing carried out in connection with block 1428 ("decompress difference image") of Fig. 56 will now be described with reference to Fig. 59 and the representation of difference image data as shown in Fig. 44. The initial step for decompressing the difference image, as indicated  
30 at block 1444, is to read in the data which indicates the locations of the changed MCU data in the image plane corresponding to the difference image. Then nested loops are carried out, of which the outer loop is indicated at block 1446 and is carried out for each row of MCUs in the  
35 image plane (30 rows per image) and the inner loop, indicated step 1448, is carried out for each MCU in the row (20 MCUs per row).

For each MCU, the bit from the map data corresponding

to that MCU is fetched (step 1450), and it is then determined (step 1452) whether that MCU in the image plane is changed in the present image. E.g., if the bit has a "0" value, then the MCU is unchanged, whereas a "1" value  
5 for the bit indicates that the MCU is changed and that updating data corresponding to the MCU is included in the present video data field. If a "0" bit is encountered, then the procedure simply loops back so as to fetch the bit for the next MCU. When there is little or no motion  
10 in the image, the MCU map will normally be quite sparse, so that entire rows of MCUs may go unchanged. However, when a changed MCU is encountered, the process of Fig. 59 advances to block 1454, at which the next block of changed MCU data is decoded. The decoding of the MCU data may be  
15 carried out by the same standard routines referred to in connection with step 1434 of Fig. 57.

Continuing to refer to Fig. 59, after the changed MCU data has been decoded, the process determines on the basis of the current row and column count for the MCUs an  
20 appropriate offset so that the just decoded block of MCU data is "steered" to the appropriate position in the image plane (step 1456). Then, based on the resulting offset, the decoded block of MCU data is output to refresh the display buffer (step 1458). The result of steps 1456 and  
25 1458 is pictorially represented in Fig. 61. Fig. 61 shows that an image that was previously displayed is updated on an MCU by MCU basis to generate the difference image which is presently being decoded. As previously noted, the changed MCUs can be thought of as "postage stamps" that  
30 are to be "pasted" at locations in the image plane determined in accordance with the changed MCU mapping data.

After steps 1456 and 1458, the process loops back to obtain the map data bit for the next MCU in the image  
35 plane.

Additional details of step 1454 of Fig. 59 will now be described with reference to Fig. 60. Initially upon decoding a block of changed MCU data, a buffered quantity



of the compression-encoded video data is fetched (step 1460). It is then determined whether enough of the compressed video data is available to apply the decoding routines (step 1462). If so, the standard decoding  
5 routines previously referred to are employed to reverse the JPEG encoding carried out on the front end board (step 1464). When it is found at step 1462 that insufficient compression-encoded video data is available to begin decoding, then the buffer is refilled, as indicated at  
10 step 1466. Moreover, if, while refilling the buffer, the end of a data storage file is encountered, then the next data file is opened (steps 1468 and 1470). In an alternative and preferred embodiment, the full data complement for the image is retrieved at once, and steps  
15 1462, 1466, 1468 and 1470 can be dispensed with.

Alternative techniques for refreshing the display buffer during playback operations will now be described with reference to Figs. 62A and 62B.

Fig. 62A shows a technique which is utilized in the  
20 VR/PC unit to provide a refresh rate of 18 fields per second. Initially, JPEG decoding is applied to the 600 MCUs of pixel data in a reference image or is applied to the changed MCU data in a difference image (step 1472). Then a vertical interpolation operation is applied by the  
25 motherboard CPU to obtain 480 rows of pixel data (step 1474) from the 640 pixel by 240 row internal data representation. Following a further software processing step in which the YUV data is translated to RGB data (step 1474), the translated data, consisting of 640 pixels in  
30 each of 480 rows, three bytes per pixel, is buffered at 1478 and then bit level transferred at 18 fields per second to drive an SVGA monitor.

An alternative technique which provides a 30 fields per second refresh rate during playback is illustrated in  
35 Fig. 62B. According to this technique, the same initial JPEG decoding step 1472 is employed as in the technique of Fig. 62A, but the decoded data is fed to a hardware module 1480 which applies a two times vertical zoom function and

then passes the resulting 480 lines of data to another hardware module 1482 for color space translation from YUV to RGB. The RGB data is then output directly from the hardware 1482 to drive the SVGA at a 30 fields per second refresh rate. The so-called "direct draw" technique 5 illustrated in Fig. 62B, in addition to providing a faster refresh rate, also reduces the burden on the motherboard CPU, albeit at the cost of providing additional hardware components 1480 and 1482.

10 Alternative recording and playback strategies that may be employed in the VR/PC unit will now be described with reference to Figs. 63A and 63B.

The first alternative, schematically illustrated in Fig. 63A, maximizes the flexibility of the unit in 15 recording simultaneous streams of video signals respectively generated by several (say 16) cameras connected to the unit, but provides only 240 lines of vertical resolution per image, roughly one half of the commercial broadcast standard. Nevertheless, it has been 20 found that with interpolation to produce 480 lines, the vertical resolution is at least adequate for video surveillance applications. In any case, in the technique shown in Fig. 63A a "tri-corder" slot 1484 (which corresponds to one of the three field locking channels 804 25 of the front end analog board (Fig. 13)) is assigned at a given time to a field generated by camera X. The front end analog board is operated so that only odd fields are captured to minimize jitter and false indications of motion or changed MCUs. The captured field from camera X 30 is then pipelined for digitization and compression through the front end electronics as indicated at 1486 and stored as a single .AVI data stream on the hard disk 1488.

When playback of the stream of images generated by camera X is requested, the corresponding .AVI stream is 35 reproduced from the disk 1488, software decoded (decompressed) in the manner discussed herein above (block 1490) and then used to drive an SVGA monitor (block 1492).

Fig. 63B illustrates an alternative technique, in

which the VR/PC unit is operated to provide essentially the standard commercial broadcast vertical resolution upon playback for one camera, but at the cost of greatly reducing the recording resources available for other  
5 cameras that may be connected to the VR/PC unit. In the technique of Fig. 63B, two of the field locking channels 804 of the front end analog board, represented by "tri-corder" slots 1494 and 1496 in Fig. 63B, are dedicated exclusively to capturing both odd and even fields  
10 generated by camera X. The tri-corder slot 1494 captures only the even fields and the tri-corder slot 1496 captures only the odd fields.

In the subsequent processing up to and through storage on the disk, the camera X even fields and the  
15 camera X odd fields are treated as if the same were two unrelated streams of video signals. Thus the even fields are pipelined for digitization and compression separately from the odd fields streams, as indicated at blocks 1498 and 1502. Since a third field capture channel remains  
20 available, the third channel may be used by another camera or shared among other cameras, so that one or more additional streams (not shown in Fig. 63B) are pipelined for digitization and compression along with the odd and even field streams generated from camera X. In any event,  
25 the two separate streams are stored, managed and indexed as two separate .AVI streams on the hard disk 1488. As a result, the arrangement shown in Fig. 63B allows the VR/PC unit to store the images generated by camera X with a vertical resolution of 480 lines.

30 Because of the separate storage of the even and odd field streams, several software decoding options are available upon playback, as indicated at block 1504. For example, since all of the data required for full vertical resolution is present on the hard disk 1488, the two  
35 streams may be played back and interleaved to provide an interlaced 480 line display, as indicated at 1506. A less computationally-intensive approach, which could be referred to "halt and fill" (reference numeral 1508),

entails playing back only one of the two streams, and vertically interpolating to provide 480 lines, when playback with either forward or reverse motion is occurring. But when the playback image stream is paused, 5 the field from the other stream may also be reproduced to generate an image having full vertical resolution.

#### REVERSE DIRECTION VIDEO DATA DECOMPRESSION

Processing required to decompress the compression- 10 encoded video data when the image stream is to be reproduced in a reverse direction will now be described. Initially, a conceptual overview of the process will be provided with reference to Fig. 64.

In Fig. 64 there is shown at reference numeral 1510 15 a sequence of compressed video data fields in the same format discussed on connection with Fig. 44. However, for the purposes of the example illustrated in Fig. 64, it is assumed that only three difference images 1134 are provided between two successive reference images 1132, 20 rather than the 32 difference images actually employed in a preferred embodiment of the VR/PC unit. As would be expected from the format shown in Fig. 44, reference numerals 1138-1 through 1138-3 indicate the changed MCU mapping data included in the difference image data fields 25 1134-1 through 1134-3. By the same token, the reference numerals 1140-1 through 1140-3 indicate the changed MCU data respectively included in the reference fields 1134-1 through 1134-3. It should be understood that the left-to-right direction in the sequence of image fields 1510 30 corresponds to the forward passage of time which occurred as the fields were being recorded. In other words, the time sequence in generating and recording the fields was 1132-1, 1134-1, 1134-2, 1134-3, 1132-2. There is illustrated at reference numeral 1512 in Fig. 64 a 35 sequence of pre-processing steps that are carried out before actually proceeding with reverse direction playback of the sequence of image shown at Fig. 1510.

Having generated an image that corresponds to the

image originally compressed to form the reference data field 1132-1, the pre-processing procedure then reads the "changed" MCU map data 1138-1 corresponding the following image, which is difference image 1134-1. Since the mapping data 1138-2 indicates the MCU portions of the image plane at which the next difference image 1134-1 differs from the present image 1132-1, the mapping data 1138-1 is also indicative of the MCUs in the present image which will be "pasted over" when the next image is formed. For that reason, the MCUs of the image corresponding to the data field 1132-1 are selected on the basis of the mapping data 1138-1, to form "backwards postage stamp" data 1514-0 which will be used to reconstruct the present image in the course of reverse playback. After saving the "to-be-changed" MCUs 1514-0, the mapping data 1138-1 is used again, this time to update the image corresponding to the data field 1132-1 by "pasting on" the changed MCU data 1140-1 to reconstruct the image corresponding to data field 1134-1.

As in the procedure described in connection with Fig. 59, the mapping data 1138-1 is used to "steer" the decoded MCU "postage stamps" in the manner pictorially illustrated in Fig. 61. (Unlike the procedure of Fig. 59, however, the resulting reference image is not output for display.)

At this point the mapping data 1138-2 of data field 1134-2 is consulted to determine which MCUs of the image corresponding to 1134-1 are to be saved as "to-be-changed" MCUs 1514-1 corresponding to the data field 1134-1. Then, as before, the mapping data 1138-2 is used a second time to update the image corresponding to field 1134-1 by pasting in the MCU data 1134-2 to generate a reconstructed image corresponding to the data field 1134-2.

Next, the mapping data field 1138-3 is used to determine which MCUs of the image corresponding to 1134-2 are to be saved as "to be changed" MCUs 1514-2 for the data field 1134-2. Then, once more the mapping data 1138-3 is used to steer the MCU data 1134-3 to generate a reconstructed image corresponding to field 1134-3 by

updating the image for field 1134-2. The resulting reconstructed image, labeled as 1134-3R (reconstructed) in Fig. 64, is then saved for use as a backwards "reference" image during the reverse playback sequence which is to follow. The pre-processing sequence 1512 is now complete, and the reverse playback procedure may go on to a sequence 1514 shown in Fig. 64 as proceeding from the right to left direction.

Initially in sequence 1514, the reconstructed backward "reference" image 1134-3R (corresponding to the image captured immediately earlier in time than reference image 1132-2) is output for display.

Then the image 1134-3R is updated using the mapping data 1138-3 to steer the backward postage stamps ("to-be-changed MCUs") 1514-2 so that the backwards reference image 1134-3R is updated on an MCU by MCU basis to produce an image corresponding to the next-earlier-in-time image, i.e., the image corresponding to difference video data field 1134-2. Then, in turn, the image corresponding to data field 1134-2 is updated using the changed MCU mapping data 1138-2 to steer the to-be-changed "backward direction stamps" 1514-1 to appropriate positions in the image plane so as to form an image corresponding to video data field 1134-1.

Next, the image for field 1134-1 is updated with the to-be-changed MCU 1514-0, steered by mapping data 1138-1, to form an image corresponding to field 1132-1. Alternatively, the entire reference field 1132-1 could be decoded de novo, but this would take longer than using the 'backwards postage stamps' 1514-0. At that point, the procedure which was discussed above with respect to sequence 1512 is again applied, but this time utilizing the reference image which occurs latest in the stream prior to the reference image 1132-1 and the set of difference image data fields immediately preceding reference image 1132-1.

In the remaining portion of Fig. 64, there is presented a simplified pictorial illustration of the

decompression technique employed for reverse playback operations. As a simplified example, a sequence 1516 of images is shown. The sequence 1516 includes images 1132-1E, 1134-1E, 1134-2E, 1134-3E and 1132-2E. The following  
5 assumptions have been made so as to illustrate the principles of the decompression technique without unduly complicated drawings:

(1) It is assumed that each image is made up of a 4 x 4 array of minimum coding units.

10 (2) Each of the minimum coding units is presented as being square in shape, rather than the 4 x 1 rectangle of tiles which is the MCU configuration in an actually preferred implementation of the VR/PC unit.

(3) The initial image 1132-1E is all white.

15 (4) A black object, corresponding exactly in size to an MCU, enters the image field of view at the left-most MCU of the top row of MCUs, and exactly in time for image 1134-1E, and then proceeds in a rightward direction across the image plane at the rate of exactly 1 MCU per frame.

20 Presented at 1518 is the mapping data 1138-1E, 1138-2E, 1138-3E, respectively corresponding to the difference images 1134-1E, 1134-2E and 1134-3E. (However, it should be noted that only the first four bits of the mapping data 1138-(N)E are presented at 1518. Based on the exemplary  
25 images shown in 15-16, the last 12 bits of each of the mapping data would all be "0" and are omitted to simplify the drawing.)

Examining the mapping data presented at 1518, it will be noted that the image 1134-1E has only one changed MCU  
30 (the first in the top row), so that correspondingly only the first bit of the mapping data 1138-1E has the value "1". In the next image, 1134-2E, the first two MCUs in the top row are changed relative to the preceding image, so that the first two bits in the mapping data 1138-2E  
35 have the value "1" and the remaining bits have the value "0". In the next image, 1134-3E, the second and third MCUs in the top row are changed relative to the preceding image, producing the mapping data "0110" as shown at 1138-

3E.

The corresponding changed MCU data is pictorially represented at 1520. As seen from the drawing, only a single block of MCU data (a black "postage stamp") makes up the changed MCU data 1140-1E for the data representation of the first difference image 1134-1E. The changed MCU data 1140-2E for the next image consists of a white "postage stamp" followed by a black "postage stamp." The changed MCU data 1140-3E for the next image is the same, namely a white "postage stamp" followed by a black "postage stamp."

Following the pre-processing sequence discussed above with respect to the sequence 1512, the mapping data 1138-1E is read. The values "1000" mean that only the first MCU of the reference image 1132-1E is to be saved, thereby forming to-be-changed MCU data 1514-0E (one "backward postage stamp" - all white). Next, the reference image 1132-1E is updated using the mapping data 1138-1E to apply the all black postage stamp changed MCU data 1140-1E at the first MCU location in the top row of MCUs, to produce the reconstructed difference image 1134-1E. Then the mapping data 1138-2E for the next difference image is read. The values "1100" indicate that the first two MCUs of the reconstructed image 1134-1E (a black postage stamp followed by a white postage stamp) are to be saved, thereby forming the to-be-changed MCU data 1514-1E ("backward postage stamps"). Then the image 1134-1E is updated, changed MCU by changed MCU, to form the image 1134-2E. In particular, the mapping data 1138-2E is read, bit by bit, and as indicated by the values "1100", the first postage stamp of the MCU data 1140-2E is steered to the first MCU position in the top row, and then the next postage stamp in 1140-2E (all black) is steered to the second MCU location in the top row. It is then once more time to save the "to-be-changed" MCUs. Thus the mapping data 1138-3E is read and it is found that the second and third MCUs in the top row (corresponding to a black postage stamp followed by a white postage stamp) are



selected to form the ("backward direction postage stamp")  
to-be-changed MCU data 1514-2E.

Following is the step of updating the image 1134-2E  
MCU by MCU to form the image 1134-3E. As before, this is  
5 done by using the mapping data 1138-3E to steer the  
forward direction changed MCUs 1140-3E to the appropriate  
positions in the image plane. Since 1134-3E is the last  
difference image before a reference image, the  
reconstructed image 1134-3E is saved for display and then  
10 for use as a backward direction "reference" image.

At this point, the preprocessing stage is complete,  
and actual reverse direction playback may occur.  
Initially, the reconstructed image 1134-3E is displayed.  
Then the mapping data 1138-3E is read and used to steer  
15 the backward direction MCU data 1514-2E so as to update  
the image 1134-3E to form the image 1134-2E. Next, the  
mapping data 1138-2E is read to steer the backward MCU  
data 1514-1E so as to update the image 1134-2E to form the  
image 1134-1E. Finally, the mapping data 1138-1E is used  
20 to steer the backward MCU data 1514-0E to form the  
reference image 1132-1E by updating the difference image  
1134-1E. As will be appreciated from the preceding  
discussion, then the pre-processing sequence is next  
performed as to the reference image and set of difference  
25 images which were originally generated immediately before  
the image 1132-1E.

It should be understood from the foregoing  
description of the decompression technique used for  
reverse direction playback that the mapping data 1138 is  
30 used in connection with reverse-playback decompression as  
well as forward-direction playback. In particular, the  
mapping data 1138 is used for three distinct purposes in  
connection with the reverse-playback decompression  
technique:

- 35 (1) To reconstruct difference images in a forward  
direction during the pre-processing stage, in a similar  
manner as in forward-direction playback decompression.
- (2) To select the "backward direction postage

stamps" (to-be-changed MCUs) 1514.

(3) To steer the changed MCUs during the actual backward direction playback.

It is believed that the multiple and highly efficient use of the mapping data during reverse-direction decompression processing represents a particularly advantageous aspect of the compressed video data format (Fig. 44) and corresponding compression technique disclosed herein.

Against the background of the example illustrated in Fig. 64, there will now be provided, with reference to Figs. 65-68, a more detailed description of the processing represented by block 1406 in Fig. 55.

Referring initially to Fig. 65, the backward decompression process starts by setting the image rate timer in accordance with the desired backward playback rate and clearing the quit flag (step 1522). Then, at step 1524, the reference image corresponding to the point in time at which the reverse direction playback is to occur is located, and the reference image is then decompressed (step 1526). Following step 1526 is step 1528, which corresponds to the pre-processing sequence indicated at 1512 in Fig. 64.

The next step is step 1530, at which it is determined whether the quit-in-progress flag has been set. If so, a suitable message is transmitted to the system director (step 1532), and the backward-direction decompression operation is stopped. If the quit-in-progress flag was not found to be set at step 1530, then the process advances to step 1534, at which it is determined whether, for the desired playback image rate, it is time to decode and display the next image. If not, the process loops back to step 1530. However, if it is time to decode and display the next image, step 1536 follows, at which it is determined whether the next image is a reference or a difference image. If the next image is a reference image, the reference image is decoded according to a suitable procedure (step 1538) and then the next "backward history

buffer" is built (step 1540), that is, the pre-processing procedure shown at 1512 in Fig. 64 is applied to the next (immediately earlier at time of recording) set of difference images.

5        If at step 1536 it is found that the next image to be decoded is a difference image, then the difference image is decoded according to a suitable procedure utilizing the previously generated backward history buffer.

Turning now to Fig. 6, the "build backward history  
10 buffer", steps 1528 and 1540 of Fig. 65 will be further explained. Initially (step 1544), the reference image (shown at 1132-1 in Fig. 64) recorded immediately prior to the set of difference images now to be decoded is decompressed and then stored in re-coded form in a "last  
15 field" buffer. Then, at step 1546, the process fetches the mapping data corresponding to the difference image 1134 recorded immediately later in time than the reference image just decoded. The fetched mapping data is used to update the "last field buffer" on an MCU by MCU basis  
20 using the changed MCU data 1140 corresponding to that first difference field (step 1548). There then follows a loop, as indicated at step 1552, which is applied with respect to each of the other difference images 1134 in the set of difference images now being encoded. As a first  
25 step of the loop, which is step 1554, the mapping data for the difference image following the difference image most recently reconstructed is fetched. Then the to-be-changed MCUs from the difference image just reconstructed (the backward postage stamps 1514) are generated on the basis  
30 of the next-difference-field mapping data (step 1556), and then the last field buffer is updated using the forward direction changed MCU data 1140 to reconstruct the next difference image (step 1558). After all the required iterations of the loop 1552--1558, the backward history  
35 buffer data as represented at 1512 in Fig. 64 has been generated.

Fig. 67 provides a more detailed illustration of the processing corresponding to block 1544 in Fig. 66. The

processing of Fig. 67 takes the form of three nested loops, of which the outer loop, indicated at block 1560 is carried out with respect to each row of MCUs. The intermediate loop, as indicated at step 1562, is carried out with respect to each MCU in the row. The innermost loop, indicated at step 1564 is carried out for each tile in the MCU. As shown at block 1566, for each tile a decompression and then recording process is carried out. Details of block 1566 are shown in Fig. 68. Initially, as shown at step 1568, the compressed video data corresponding to the tile is processed to recover quantized coefficient values. Then the DC coefficient is recorded as an absolute value, rather than as a differential value generated in comparison to a preceding tile DC level.

Then the other coefficients are Huffman and run-length encoded according to standard video data compression techniques (step 1572) and the recorded tile of data is stored (step 1574). (Generation of a backward history buffer, as just described, may also be carried out during forward playback operations, as indicated at block 1575 in Fig. 56, to facilitate rapid changing over from forward- to reverse-direction playback.)

#### COMPRESSOR MANAGER SOFTWARE COMPONENT

The compressor manager software component 1216 shown on Fig. 45 will now be described in further detail with reference to Figs. 69 and 70. It should be understood that the compressor manager software component 1216 handles communication between the motherboard CPU and the front end electronics (particularly front end controller DSP 1050, Fig. 36).

Fig. 69 illustrates the aspects of the compressor manager software component relating to handling commands, i.e., messages sent from the motherboard to the front end electronics. Initially, it is determined at step 1576 whether an alarm command is to be sent. If so, the bit or bits corresponding to the present alarm condition or

conditions are set in alarm condition data bytes (step 1578) and then a message carrying the alarm condition bytes is generated in an appropriate format for receipt by the front end controller DSP (step 1580).

5           If a command relating to the sequence at which camera input streams are to be captured for storage is to be sent to the front end board (step 1582), then a data set indicative of the desired sequence for capturing the camera signal streams is generated (step 1584). The  
10 resulting message is formatted for receipt by the front end board controller (step 1586).

          At step 1588 it is determined whether a field storage rate command is to be sent to the front end electronics. If so, data required to program the front end electronics  
15 to capture video fields at the desired rate is generated (step 1590) and the resulting data is formatted for receipt by the front end electronics (step 1592).

          At step 1594, it is determined whether there is to be sent to the front end electronics a command relating to an  
20 image analysis algorithm to be performed in the live image analysis block 846 (Fig. 14) of the front end electronics. Continuing to refer to Fig. 69, if an image analysis algorithm command is to be sent, then the data relating to the image analysis (e.g., data specifying the algorithm to  
25 be performed, or parameters for constraining the performance of the algorithm) is generated (step 1596), and is then placed in a format appropriate for receipt by the front end electronics (step 1598).

          It is determined at step 1682 whether a command  
30 relating to video data compression is to be sent to the front end electronics. If so, data for selecting a compression parameter is assembled (step 1604). For example, a compression parameter selecting one of a standard tile "sameness" threshold, or a second more  
35 stringent threshold providing better reproduced image quality, or a third parameter, which is less stringent and reduces the average quantity of compressed video data generated per field, may be sent. Alternatively, the

compression parameter may be for setting the number of bits employed for quantization of coefficients in the JPEG chip 848.

5 It should be noted that the data packages assembled at steps 1596 and 1604 preferably include data identifying the camera for which the data is applicable, so that the image analysis algorithm and/or the compression procedure can be varied on a camera by camera basis.

10 Following step 1604 is step 1606, at which the compression parameter package is formatted for receipt by the front end electronics. At step 1608, it is determined whether a message is to be sent to the front end electronics for the purpose of controlling operation of the live display processing block 844 (Fig. 14). For  
15 example, the size of the image output from the live display block 844, the number of video streams to be simultaneously displayed, such as 1, 4, 9, or 16, and/or the assignment of camera streams among display windows, may be varied. If a positive determination is made at  
20 step 1608, then the appropriate live display command sequence is generated at step 1610, and formatted at step 1612 so as to provide a message that can be properly handled at the front end electronics.

Following any one of the steps 1580, 1586, 1592,  
25 1598, 1606 or 1612, there is a step 1614 at which the message in question is coupled onto the PCI bus 596 (Fig. 3) for transmission to the front end electronics.

30 Aspects of the compressor manager software component relating to handling of status messages received by the motherboard from the front end electronics will now be described with reference to Fig. 70. As indicated at step 1616, message data that has come in over the PCI bus is received, and then the type of message is detected.

If the message is found to be an alarm message (step  
35 1618), then the alarm data is decoded (1620) and a message reporting the alarm data is generated in an appropriate format for the motherboard CPU software components (step 1622). The alarm message may specify, for example, a type

of alarm event detected through an alarm sensor 526 (Fig. 1) or by live image analysis carried out by the front end electronics.

Continuing to refer to Fig. 70, if the incoming  
5 message is found to be a message relating to sequencing of camera streams for recording (step 1624), the data including in the message is decoded (step 1626) and the formatted for messaging within the motherboard CPU software (step 1628).

10 If the incoming message relates to a field capture rate implemented by the front end electronics (step 1630), then the field rate data is decoded (step 1632) and formatted in a suitable manner for use in the motherboard CPU software (step 1634).

15 If the incoming message is related to a live image analysis algorithm being carried out in the front end electronics (step 1636), then the data relating to the algorithm is decoded (step 1638) and formatted for use in the motherboard software (step 1640).

20 If the incoming message is related to a parameter used for controlling compression operations being carried out in the front end electronics (step 1642), then the compression parameter data is decoded (step 1644) and formatted for use in the motherboard software (step 1646).

25 If the message relates to live display processing being carried out in the front end electronics (step 1648), then the data is decoded (step 1650) and formatted for use in the motherboard software (step 1652).

Following any one of steps 1622, 1628, 1634, 1640,  
30 1646 or 1652, a step 1654 follows, in which the message in question is forwarded to the system director software component 1202 (Fig. 45), and through the system director is relayed to other software components that have a need to receive the message. Typically, the messages detected  
35 at blocks 1624, 1630, 1636, 1642 and 1648 are status messages indicating that the front end board has implemented commands previously sent from the motherboard to the front end electronics.

Aspects of the compressor manager software component relating to handling of incoming compressed video data will be described with reference to Fig. 71. It is assumed that a DMA transfer of video data is taking place.

5 The compressor manager then determines if the DMA video data transfer is complete (step 1656). If so, the buffered video data which has just been received is transferred for recording on the hard disk (step 1658), and it is then determined whether the end of an image has

10 been reached (step 1660). If not, the process loops back to step 1656. However, if the end of an image has been reached, then the index data corresponding to the video data just received is generated (step 1662), the map indicative of the locations of the video data is generated

15 and stored and the video data is stored in locations following the map (step 1664). Finally, in a step 1666, the received video data and the index data are forwarded to the video storage software component 1234 (Fig. 45).

The video record software component 1218 (Fig. 45)

20 will now be described with reference to Fig. 72. Essentially, the video record software component performs three functions. First, this component sets up the compression operations in the front end electronics by generating parameter setting messages (step 1668) which

25 are forwarded to the front end electronics through the compressor manager software component 1216. Further, appropriate initializing messages are provided to the video storage software component 1234 (Fig. 45), as indicated at step 1670. Finally, operation of the

30 compression processing in the front end electronics is actuated by a suitable message generated at step 1672 and forwarded through the compressor manager software component.

There will now be described, with reference to Fig. 73, aspects of the archive manager software component 1226

35 (Fig. 45) relating to handling of search requests.

Fig. 74 illustrates aspects of the archive manager software component relating to command handling.



Essentially, the commands handled in the processing shown in Fig. 74 relate to those required to carry on "tape recorder" functions or the like.

5 A first step 1674 shown in Fig. 74, indicates that the archive manager component has received a search request. The search request is parsed (step 1676) and then translated into commands in a format suitable for further processing in the archive manager software component (step 1678).

10 If a record start command is detected (step 1680), then a corresponding START message is generated (step 1682). If a stop command is detected (step 1684), then a corresponding STOP message is generated (step 1686). If a load command (step 1688) is detected, then a LOAD  
15 message is generated (step 1690). If a play command is detected (step 1692) then a PLAY message is generated (step 1694). If an eject command is detected (step 1696), then an EJECT message is generated (step 1698). If a resume command is detected (step 1702), then a RESUME  
20 message is generated (step 1704). If a search command is detected (step 1706), then a SEARCH message is generated (step 1708). If a rewind command is detected (step 1710), then a REWIND message is generated (step 1712). If a go to command is detected (step 1714), then a GOTO message is  
25 generated (step 1716). In the case of each of the messages referred to in this paragraph, the message is forwarded to an archive software object (step 1718). The archive object is a driver software function which controls the archive DAT drive 626 (Fig. 3) or an  
30 externally connected archive median drive unit. For example, a separate DAT drive, DVD drive, magneto-optical disk drive, or the like may be connected to the VR/PC unit through the SCSI port 628.

It is contemplated that archive storage and/or  
35 retrieval operations may be carried on simultaneously using two or more archiving devices, including, perhaps, the DAT drive 626 and one or more externally connected devices.

## ALARM HANDLER COMPONENT

There will next be described, with reference to Figs. 75 and 76, operation of the alarm handler software component 1212. For the purposes of Fig. 75, it is assumed that an alarm message has been received from the front end electronics. It is then determined, at step 1720 whether the user has elected to have alarms handled according to a standard protocol or a custom protocol. If a standard protocol has been selected, then step 1722 follows step 1720. At step 1722, the alarm handler causes one or more predetermined alarm out signals to be generated according to the type of alarm message that was received. For example, the alarm out signal or signals may automatically close or lock doors, actuate sirens or visible alarm indications, or the like. Following step 1722, is step 1724, at which a message is generated to cause the front end electronics to change the sequence in which video signal fields are captured from the respective cameras attached to the VR/PC unit.

The next step is step 1726, at which it is determined whether the VR/PC unit is being operated in a pre-alarm buffering mode. If so, then step 1728 follows step 1726. In step 1728, the alarm handler software component dispatches a message which instructs the video storage software component to capture the data in the pre-alarm buffer, as previously described in connection with steps 1334-1338 (Fig. 52). The video storage function may be arranged either so that all of the data in the pre-alarm buffer is transferred to "permanent" storage on the hard disk, or so that only video data fields corresponding to particular cameras are so transferred.

Following step 1728 is step 1730 (which directly follows step 1726 if the VR/PC unit is not being operated in the pre-alarm mode). At step 1730, the alarm timer is set (or extended, if an alarm condition is already in effect), and the detected alarm event is added to a list of alarm events maintained by the alarm handler software component.

Fig. 76 illustrates the camera sequence implemented at step 1724 according to a standard alarm-actuated camera sequencing scheme. The sequence shown in Fig. 76 is analogous to that provided in the MV 200 analog multiplexer marketed by the assignee of the present invention (see page 33 of Multivision Optima II™ Multiplexers, Installation and Operation Manual, Robot Research Inc., 1995). In a sequence of video fields 1732 shown in Figs. 76, the blocks 1734 bearing the label "A" correspond to a field or fields generated by one or more cameras which have been predetermined as likely to generate video signals of interest relative to the detected alarm. Blocks 1736, 1738 and 1740 each respectively represent a video signal field captured from three different cameras that are not particularly of interest relative to the alarm condition. Thus, as in the above-indicated MV 200 multiplexer, the cameras are re-sequenced in response to an alarm so that fields generated by a camera or cameras of relevance to the alarm are accorded more frequent recording slots than other cameras.

Step 1742 follows step 1730. Step 1742 indicates that the recording sequence indicated in Fig. 76 is maintained until the alarm timer times out. The determination as to whether the last alarm has timed out is made at step 1744, and if so, the alarm timer is shut down (step 1746).

Once the time for recording the alarm-relevant cameras with an increased field rate, as per Fig. 76, has elapsed, the field recording rate for those cameras is reduced to whatever had been prescribed for those cameras for the period before the alarm was detected. It should be understood that the previously prescribed recording field rate might have been "zero" (i.e., the camera status would have been record-on-alarm-only), or recording in the ordinary sequence with other cameras in the normal record status, or a "time-lapse" recording status in which the camera is recorded with a lower field rate than cameras being recorded in the normal sequence.

If at step 1720 it was determined that a custom alarm handling mode is in effect, then step 1748 follows step 1720. At step 1748, the alarm handler software component determines the camera, type of event and time relative to the alarm condition which has been detected. There follows step 1749, at which the decoded camera, event type and time data is used to fetch the appropriate event response script from an event response script database 1746. Following step 1749 is a loop, indicated at step 1750, which is carried out for each command in the retrieved event response script. The loop is made up of steps 1752, 1754 and 1756. At step 1752, the command corresponding to the present line in the script is read. At step 1754, a message corresponding to the command is encoded, and at step 1756 the message is sent to the system director software component.

An example of a typical event response script follows:

Event Response Script (Example)

```

20      ALARM1 OUT = ON           (1)
      ALARM2 OUT = ON           (2)
      CAMERA1RATE = 30         (3)
      CAMERA1 = ON             (4)
25      WAIT = 30               (5)
      RESUME                   (6)

```

It will be observed that the exemplary event response script set forth above consists of six lines. The first line indicates that the alarm 1 output signal is to be turned on. This may be, for example, a signal to actuate a visual alarm indicator such as a flashing light. The second line indicates that the second alarm output signal is to be turned on. This may operate, for example, an audible alarm indicator, such as a siren.

The third line indicates that the rate at which fields from camera one are to be captured for recording is set to 30 fields per second. The remaining recording bandwidth will then be allocated among other cameras which had previously been sequenced for recording.

The fourth line indicates that recording status for

camera 1 is to be set to "on". This command would override any previous command that had software-disabled camera 1.

The fifth command indicates that the status defined  
5 by the first four lines of the response script is to be maintained for 30 seconds.

The sixth and final line of the script indicates that the prior operating status of the system is to resume after the 30 second alarm-response.

10 IMAGE PROCESSING UTILITIES

The image processing utilities manager software component 1222 (Fig. 45) will now be described with reference to Fig. 77. Initially, at step 1758, the image processing utilities manager software component operates  
15 to present to the user of the VR/PC unit options available to the user for processing an image or sequence of images being displayed by the system. Following step 1758 is step 1760, at which it is determined whether the user has indicated that selection of an image processing utility  
20 and parameters therefor has been completed. If the user has not indicated completion of the utility and parameter selection process, then step 1762 follows, at which it is determined whether the user has indicated that a currently selected utility and set of parameters therefor is to be  
25 cancelled. If the user has not so indicated, then step 1764 follows step 1762. Step 1764 indicates that for a utility selected by the user, steps 1766 through 1772 are to be performed. As will be understood from subsequent discussion, the image processing utility options available  
30 for the user may be presented in the form of a menu or as a collection of icons representing a "tool kit". Among the image processing utility options contemplated for inclusion in the VR/PC unit are a zoom-in option, a color adjustment option, a contrast adjustment option, a focus  
35 adjustment option, a histogram balance option or an object recognition option.

Step 1766 entails receiving input from the user as to parameters relevant to the image processing utility

selected. The parameters may include a zone or zones in the image plane in which the utility selected is to be applied or is not to be applied. Other parameters may include a degree or intensity of operation of the selected utility or numeric or quantitative controls such as a slide bar. For example, if a zoom utility is selected, the degree of zoom (2, 3, 4 times, etc.) may be selected.

At step 1768, the parameter or parameters selected by the user are translated into units relevant to the image plane, such as pixel location. There may also be translation, if appropriate, to color or contrast or focus adjustment control values or the like. Then, at step 1770, the image processing utilities manager component uses the translated parameter values to generate a "preview" image that will indicate to the user the likely effect of the selected image processing utility. Then, at step 1772, the preview image is displayed.

Following step 1772 is step 1774, at which it is determined whether the user has approved for execution the selected utility and parameters. If so, step 1776 follows, at which the selected utility and parameters are applied to the image or sequence of images. The process then loops back to step 1760. However, if at step 1774 the user indicates that the selected utility and parameter settings are not satisfactory, then the image or sequence of images is restored to the condition prevailing before the image processing utility was applied (step 1778) and the process loops back to step 1760. Furthermore, it will be seen that if at step 1762 it is determined that the user has elected to cancel the utility and parameter selected, again step 1778 is entered.

Of course, if at step 1750 it is determined that the user wishes to end interaction with the image processing utilities manager, then the process terminates, with any selected and not cancelled image processing utility continuing in effect.

#### GRAPHICAL USER INTERFACE

Fig. 78 illustrates operations of the graphical user

interface portion of the motherboard CPU software. As indicated at 1778, a graphical user interface (GUI) engine interprets signals input by a user via a position selection device, such as a mouse, and generates objects  
5 to be displayed on a display monitor. In a preferred embodiment of the VR/PC, the GUI engine 1778 utilizes the capabilities of the well-known Windows 95 operating system. Use of other GUI kernels, such as Windows NT, is contemplated in alternative embodiments. Operation of the  
10 GUI engine 1778 to interpret signals from the position selection device is illustrated by steps 1780-1784 in Fig. 78.

At step 1780, the user input is received and decoded. At step 1782, the decoded input signal data is translated  
15 into a standard message format, and at step 1784, the user interface software component sends a corresponding message or messages to the system director.

#### SCHEDULING SOFTWARE COMPONENT

A portion of the scheduling software component  
20 relating to setup, and in particular, to a main option screen display, will now be described with reference to Fig. 79. At step 1786, it is determined whether the user has elected to setup a holiday scheduling operation. If so, the holiday setup operation is performed (step 1788).

25 At step 1790, it is determined whether the user wishes to setup a definition of "day time" versus "night time" periods. If so, an operation to partition the 24 hours making up a calendar day between day and night is performed (step 1792).

30 At step 1794 it is determined whether the user wishes to perform a scheduling function with respect to a specific time-block (e.g., day-time on weekdays or night-time on weekends). If so, a scheduling operation for the selected time block is performed (step 1796).

35 At step 1798, it is determined whether the user has indicated that the scheduling operation is complete. If not, the process loops back to step 1786. Otherwise, the process is terminated.

Fig. 80 illustrates the processing involved in block 1788 of Fig. 79. The holiday setup process illustrated in Fig. 80 begins with a step 1802 in which a calendar screen display is presented to the user (see, for example, Fig. 5 152).

At step 1804, it is determined whether the user has selected a day from the calendar display. If so, the selected day is decoded (step 1806). It is then determined whether the user has indicated a desire to add 10 the selected day to the list of holidays (step 1808). If so, the selected day is added to the holiday list (step 1810).

At step 1812, it is determined whether the user wishes to cancel a decision to add a selected day to the 15 holiday list. If a selection is not cancelled, it is determined whether the user has indicated that the holiday setup session is complete (step 1814). If the session is indicated as being completed, the list of holidays generated during the session is used to replace the 20 previously existing holiday set (step 1860), and the scheduling session the ends. Until the user indicates completion of the session, the process loops through steps 1804, 1808, 1812, and 1814. If at a step 1812 the user indicates a desire to cancel the selections made by the 25 session, then the session ends without replacing the holiday list as it existed prior to the holiday session.

The process entailed by step 1792 in Fig. 79 will now be described with reference to Figs. 81 and 82. The process illustrated in Fig. 82 begins, as indicated at 30 step 1818 with the display for the current start (night-day) time, and end (day-night) time utilizing two time controls as illustrated in Fig. 81, in display box 1820. Each time control (1822, 1824) consists of an up arrow button (1822A), a down arrow button (1822B) and a time 35 display field (1822C). In addition to those two controls, there is a cancel button (1826), and a "done" button (1828). The entire control box is manipulated using positioner/cursor (1830). Following the initial display



the process sits in an endless loop until the user activates either the cancel button (1826) as indicated in decision box 1832, or the "done" button (1828) as indicated in decision box 1836. If the cancel button  
5 (1826) was activated by the cursor (1830), the process terminates without updating the partition data as indicated in the process box 1834. If the done button (1828) was activated the values in the display portions (1822C) of the controls are read and the partition data  
10 updated as indicated in process boxes 1838 and 1842. If the cursor is used to select either the start time control (1822) or the end time control (1824), then the times may be incremented or decremented by activating the corresponding up arrow button (1822A) or down arrow button  
15 (1822B) using the cursor (1830). The increment or decrement operation results in an updated display value as illustrated in decision boxes 1844 and 1848 and process boxes 1846 and 1850.

Fig. 83 illustrates processing performed during  
20 scheduling setup to permit the user to select from a number of different modes to be selected for scheduling.

At step 1854, it is determined whether the user is performing scheduling with respect to an archiving mode. If so, the time selected for the pre-scheduled archiving  
25 operation is set in a schedule queue (step 1856) and the parameters for the archiving operation, as selected by the user, are fetched (step 1858).

At step 1860, it is determined whether the user has selected for scheduling an operational recording mode. If  
30 so, the relevant operating parameters selected by the user are received (step 1862) and the relevant time for the operational mode is set in the schedule queue.

At step 1866, it is determined whether the user is scheduling one or more cameras to be "off-line", that is  
35 excluded from recording (also referred to as "software disabled"). If so, the relevant time is set in the schedule queue (step 1868).

Further discussion of the processing indicated in

Fig. 83 will now proceed with reference to Figs. 84-86. In particular, Fig. 84 illustrates details of block 1862 ("get operating parameters"). As indicated at step 1870 in Fig. 84, the processing illustrated in Fig. 84 is a loop carried out with respect to each camera connected to the VR/PC unit. Step 1872 shows that, for the particular camera, the recording mode selected by the user is noted. If the selected mode is "off-line" (as determined at step 1874), then a indication to that effect is inserted as an entry in a schedule script (step 1876).

If at step 1874 it was found that the selected mode is not off-line, then the user's selection for the spatial resolution parameter for governing the data to be recorded is obtained (step 1880). It is then determined whether the camera is to be recorded in an ongoing on-line basis or in an event-driven mode. If on-line, such is then indicated in a suitable table entry (step 1876).

If at step 1880 it is determined that the camera has been selected for recording only on an event-driven basis, then step 1882 follows, at which it is determined whether the events are to be detected through external sensors or through image analysis processing carried out by the front end electronics. If the event detection is through alarm sensors, then step 1884 follows, at which the alarm sensor or sensors used to drive the recording of the invention are identified. Otherwise, step 1886 follows step 1882. At step 1886, the image analysis algorithm to be applied by the front end electronics and used to generate event-driven recording for the particular camera is selected.

Following step 1886 is step 1888, at which the parameters for constraining the selected analysis algorithm are received. Following either step 1888 or 1884, as the case may be, is again step 1876, in which the relevant data is provided as an entry in an schedule script or table.

Fig. 85 presents a simplified example of a schedule queue. The schedule queue is made up of entries 1890, 1892, etc. Each of the entries starts with a time and

operational state header, and then data indicative of operational mode parameters or a pointer to a relevant scheduling script or table. An example of a schedule script or table is shown in Fig. 86. In a first entry, 5 indicated at 1894, the system is shown as being taken off-line. At the next entry, shown at 1896, an archiving operation is scheduled and it is indicated that the operation is performed on an interactive basis with a device designated as a "external drive 2". A third entry 10 indicates a time at which the system is made operational and contains a script detailing the operating mode for each camera. For example, at 1902, it is indicated that camera 1 is to be recorded in "real time" (not time lapse), and with a compression parameter that corresponds 15 to a high quality image. Accordingly, camera 1 will be included in the sequence of cameras from which fields are captured at regular intervals for recording. At 1904, it is indicated that camera 2 is to be recorded only on the occurrence of events detected through an alarm sensor. At 20 1906, it is indicated that camera 3 is to be recorded only upon the occurrence of events detected by a motion detection algorithm carried out by image analysis in the front end electronics.

At 1908, it is indicated that camera 4 is to be 25 recorded at a "time lapse" rate that is less frequent than other cameras being recorded, but with high image quality compression.

At 1910, it is indicated that camera 5 is to be recorded in real time, but with video data compression 30 that provides comparatively low image quality. Corresponding script lines (not shown) would also be provided for other cameras (up to a total of 16) connected to the VR/PC unit.

Fig. 87 represents processing carried out in 35 execution of pre-scheduled operating modes that have been stored in the system. At step 1912, it is determined whether the time has arrived to check the schedule. For example, the timer may "go off" at one minute intervals,

so that a schedule change is checked for once a minute. When the timer goes off, the present time is decoded (step 1914) and if there is a match, the time is looked up in the schedule queue (step 1916). In a processing loop  
5 carried out for each line in the schedule queue (as indicated at step 1918), steps 1920-1924 are carried out. At step 1920, the entry line is read. At step 1922, a suitable command message is built in accordance with the entry line. Then, at step 1924, the message is sent to  
10 the system director for forwarding for execution by the relevant software component.

#### MACHINE ANALYSIS OF VIDEO STREAM CONTENT

Software for performing image analysis algorithms will now be discussed, with reference to Figs. 88-98. The  
15 ensuing discussion will have bearing both on application of image analysis to "live" video by the front end electronics and also to image analysis carried on by the motherboard CPU with respect to sequences of video data fields reproduced from the hard disk.

20 Fig. 88 presents an overview of aspects common to all image analysis algorithms provided in the VR/PC unit. Aspects related to the user interface are represented at 1926, and may be divided into those used to select an image analysis algorithm (1928) and those used to set  
25 parameters for a selected algorithm (1930). Block 1932 is indicative of the execution of the algorithm in question, whether performed on "live" video by the front end electronics, or executed by the motherboard CPU with respect to reproduced video signals. Then, as indicated  
30 at 1934, results of the algorithm are reported and/or stored and/or certain actions are taken, depending on the outcome of the image analysis algorithm.

Fig. 89 illustrates processing involved in the selection and setup of an image analysis algorithm or  
35 "tool". As indicated at step 1936, the user is initially presented with a screen display in which a number of tool (analysis algorithm) are available for selection by the user. For example, a respective icon corresponding to

each available tool may be displayed on the screen. Or, a menu listing the available tools by name may be displayed. Then, at step 1938, it is determined whether the user has selected a tool from the tool kit. If so, a  
5 new screen is generated, or the selection screen is altered, in a manner to indicate which tool has been selected (step 1940). It is then determined (step 1942) whether the user wishes to actuate employment of the selected tool. If not, the process loops back to step  
10 1936. However, if the user does wish to actuate use of the tool, then step 1944 follows, at which the user indicates, by camera number or name, the source of the video signal stream to which the selected tool is to be applied. There follows a loop (as indicated at step 1946)  
15 which is to be applied to each parameter relevant to the selected tool. The loop is made up of steps 1948 through 1952. At step 1948, the options selectable by the user with respect to the parameter are indicated to the user. At step 1950, the user's input as to the desired option is  
20 received, and at step 1952 the parameter setting provided by the user is translated into data that is relevant to the image analysis process.

After the tool parameter loop has been carried out as to each parameter, step 1954 follows, at which it is  
25 determined whether the tool in question is to be applied to live video or reproduced video. If live video is to be analyzed by the selected tool, then a suitable command message or set of command messages is generated (step 1956) and transmitted to the front end electronics by way  
30 of the system director (step 1958). On the other hand, if the selected algorithm is to be applied to reproduced video signals, then the image analysis component of the motherboard CPU hardware is loaded (step 1960) and a suitable command message indicative of the selected  
35 algorithm and parameters is sent via the system director (step 1962).

Examples of parameter setting will now be described, in the context of a "perimeter invasion tool", with

reference to Figs. 90A-90D.

Fig. 155 is a screen display of the type that may be presented to the user in connection with setting parameters for execution of a "perimeter violation" image analysis tool.

Turning to Fig. 90A, in an initial step 1964, there is displayed over a video image a drawing element (such as a box or line) which is indicative of a perimeter of an area in the scene represented by the video signal, the purpose of the image analysis algorithm being to detect entry of objects into the indicated area. In the screen display of Fig. 155 the parameter is represented by the box graphic element 1966.

Referring again to Fig. 90A, step 1968 follows step 1964. At step 1968, the user is permitted to drag and/or stretch the perimeter element 1966 in essentially the same manner that a polygon or line may be dragged or stretched in a conventional PC software drawing package. When the user indicates that parameter setting is done (as detected at step 1970), then the end points of the line or box indicating the perimeter 1966 are determined on the basis of the relevant tiles (column and row) in the image plane space (step 1972). The end points are then saved as parameters indicative of the perimeter location.

Another parameter relevant to the perimeter tool is the direction of crossing the perimeter. That is, the image analysis tool may be instructed to detect crossing of the perimeter in both directions, or in only one of the two possible directions. For the purpose of user selection, the crossing direction may be indicated by an arrow (which may be two-headed to indicate crossing in either direction). In Fig. 155, single-direction arrows are indicated at 1976.

The process for selecting the crossing direction or directions to be detected is illustrated in Fig. 90B. In an initial step, the crossing direction arrows 1976 are displayed (step 1978). Following steps 1978 is step 1980, at which it is determined whether the user has indicated

a change in the crossing direction. If so, a crossing direction is toggled to the next direction. For example, the crossing direction may be toggled in a loop such as in, out, both ways, in and so forth (step 1982).

5 As in Fig. 90A, a step 1970 is present in the process of Fig. 90B so that the crossing direction parameter is set (step 1984) when the user indicates that parameter setting is complete.

10 Another parameter relevant to the perimeter violation detection tool is the size of the object found to be crossing the perimeter. For example, it may be desirable to disregard apparent perimeter crossings unless the object which seems to be crossing the perimeter is of a given size or larger. To specify the size of object  
15 another drawing element box, perhaps shaded in a contrasting color such as red, may be displayed, as indicated at 1986 in Fig. 155. Thus, turning to Fig. 90C, the initial step 1988 entails displaying the object size box 1986. Following step 1988 is step 1990, at which it  
20 is determined whether the user has indicated that the object size box is to be changed. If so, the new size setting is determined from user input (step 1992) and the size box is updated on the display screen (step 1994). Again, a step 1970 is provided in Fig. 90C to determine  
25 whether the parameter setting process is complete. If so, the final size setting is determined (step 1996), based on the state of the size box as currently displayed on the screen. Then the final object size setting is translated into tile based units (step 1998) and the corresponding  
30 tile-based object size parameter is stored (step 2002).

Another parameter relevant to the perimeter violation detection algorithm is the "sensitivity", i.e., a video signal contrast level that will be considered to represent motion rather than noise. The setting of the sensitivity  
35 parameter is illustrated in Fig. 90D, and includes a first step 2004, in which a slide bar or similar image element is displayed. The corresponding sensitivity slide bar element is indicated by reference numeral 2006 in Fig.

155.

Turning again to Fig. 90D, a step 2008 follows step 2004. At step 2008, it is determined whether the user has indicated a change in the sensitivity level. If so, the  
5 new slide bar setting is detected (step 2010). As in the Figs. 90A-90C, step 1970 is again present to determine whether the parameter setting process is complete. If so, step 2012 follows, at which the slide bar reading is translated into a video signal contrast ratio, and the  
10 resulting contrast ratio threshold is saved as the sensitivity parameter (step 2014).

A process for loading the image analysis engine is shown in Fig. 91. Initially (step 2016), parameters of general applicability to any analysis tool are loaded.  
15 The parameters loaded at step 2016 may include, for example, data indicative of how to translate GUI input information into tile space and/or velocity space. Then, at step 2018, parameters relevant to velocity are determined, and the velocity-relevant parameters are the  
20 fed to a velocity-analysis component of the image analysis engine (step 2020). Then parameters relevant to clustering of detected motion vectors are determined (step 2022), and the cluster-relevant parameter are fed to a clustering component of the image analysis engine (step  
25 2024). Following step 2024 is step 2026, at which parameter relevant to analysis of individual video data tiles are determined. The resulting tile analysis parameters are then fed to a tile analyzing portion of the image analysis engine (step 2028). To provide examples of  
30 the parameters relevant to the perimeter violation detection tool, the velocity-relevant parameter for the perimeter tool would be detection of any motion (block 2030). The cluster-relevant parameter for the perimeter tool is the object size box, as measured in image plane  
35 tile units (block 2032). The relevant tile analysis parameter for the perimeter tool is the contrast ratio derived from the sensitivity setting (block 2034).

A process for initializing an image analysis



algorithm to be carried out on live video data by the front end electronics is illustrated in Fig. 92. First, one or more reference images (preferably live video images) are obtained (step 2036). From the reference  
5 image, relevant parameter reference values are extracted (step 2038). Following step 2038 is step 2040. At step 2040, the extracted parameter reference values are stored in the memory of live image analysis block 846 (Fig. 14), then counters used in the image analysis engine are set to  
10 zero (step 2042) and a message is sent to the system director component of the motherboard software indicating that the live analysis engine is ready to operate (step 2044). The counters zero'ed at step 2042 are used to determine when enough data is available to apply FFT  
15 processing. In the case of the perimeter violation detection tool, the step 2038 preferably consists of calculating an average luminosity along the perimeter line to provide a base value against which changes will be detected (block 2046).

20 Operation of the live analysis block 846 for the purpose of carrying out the perimeter violation detection algorithm will now be described with reference to Figs. 93A-93E.

First, it is assumed that the live analysis block  
25 uses any of a number of conventional image sequence filtering algorithms which generate data indicative of optical flow. In a preferred embodiment of the invention, motion-related analysis algorithms are implemented using FFT-based spatio-temporal filtering applied to a time-  
30 varying series of changed MCU mapping data so as to generate X- and Y-direction velocity estimates. (The MCU mapping data subjected to FFT analysis may be the same data used for compression processing, or may be generated specifically for motion analysis based on different MCU  
35 'sameness' criteria than those used for compression.) A clustering analysis is applied to the velocity estimates to detect the leading and trailing edges of moving objects. Particular examples of motion-related algorithms

are the motion detection and perimeter violation detection analysis tools discussed below.

Other analysis algorithms, such as the "museum" and "light" tools discussed below, entail tile-by-tile  
5 comparison of the content of a present image data field versus a reference image data field. As indicated in Fig. 93A, data indicative of velocity vectors is obtained (step 2048), and so is data indicative of clustering of the velocity vectors (step 2052). At step 2054, data relating  
10 to analysis of the tiles at the designated perimeter is obtained. Then, as shown at step 2056, it is determined whether enough time is available to complete the analysis. If not, an "analysis aborted" message is sent to the front end controller DSP 1050 (step 2058). If appropriate, the  
15 controller DSP may then issue an event report to the motherboard, which may, in turn, declare an alarm condition.

However, if enough time is available to complete the analysis, then step 2060 follows step 2056. At step 2060,  
20 the velocity vector data is analyzed. If the velocity vector criteria indicative of a perimeter violation are met (step 2062) then the vector clustering data are analyzed (step 2064). It is then determined whether the cluster "object size" criteria required to find a  
25 perimeter violation have been met (step 2066). If so, step 2068 follows, at which the data representing the perimeter tiles themselves is analyzed.

Following step 2068 is step 2070. At 2070, it is determined whether the analysis of the perimeter tiles  
30 indicates that a perimeter violation has occurred. If so, step 2072 is performed. At step 2072, a confidence factor for the violation detection determination is calculated. Then, at step 2074, the occurrence of the perimeter violation and the confidence factor are reported to the  
35 front end controller DSP 1050.

On the other hand, following step 2058, or upon a negative determination at any one of steps 2062, 2066 or 2070, the perimeter violation detection analysis is

terminated without finding that a violation has occurred.

Fig. 93B illustrates action taken by the controller DSP 1050 in response to an "analysis aborted" message generated as step 2058. As shown in Fig. 93B, the controller DSP first receives the "analysis aborted" message (step 2076), then formats a suitable message for receipt by the motherboard (step 2078) and forwards the message to the system director component of the motherboard software via the PCI connection between the front end electronics and the motherboard (step 2082).

Fig. 93C illustrates processing carried out by the front end controller DSP in response to the message generated by the live display analysis block at step 2074. As seen from Fig. 93C, the controller DSP receives the message reporting the detected event (step 2082), formats a suitable message to report the event to the motherboard (step 2084), and then sends the message to the motherboard software system director via the above-mentioned PCI connection (step 2086).

Fig. 93D illustrates in generic terms the processing carried out in connection with each of the decision blocks 2062, 2066 and 2070 the processing of Fig. 93A. The first step in Fig. 93D is a step 2087 which indicates that the processing of Fig. 93D is carried out for each parameter. At a step 2088, it is determined whether the parameter value is below an upper level threshold for the parameter. If so, then at step 2090 it is determined whether the parameter value is above a lower-level threshold for the parameter.

A step 2092 is reached if the response to both of the steps 2088 and 2090 is positive. At step 2092, a flag value indicating that the parameter criteria were met is set, and a confidence level value is returned. On the other hand, a step 2094 is reached if a negative result is obtained at either one of steps 2088 and 2090. At step 2094, the flag is set to indicate that the parameter criteria were not met.

Fig. 93E illustrates details of step 2072 (calculate

confidence factor, Fig. 93A). In the processing shown in Fig. 93E, a confidence weight is applied to the velocity confidence level value (step 2096) then a confidence weight is applied to the confidence level value  
5 corresponding to the clustering determination (step 2098), and then a confidence weight is applied to the tile processing confidence level value (step 2102). At step 2104, the weighted velocity, cluster and tile values are added to obtain an overall confidence level value, and a  
10 message including the resulting value is generated (step 2106). Fig. 94 illustrates a process for initializing an analysis engine included in the motherboard CPU software for the purpose of applying an image analysis algorithm to a reproduced video data stream.

15 In first step shown in Fig. 94, the first reference image in this stream after the point at which analysis is to begin is found (step 2108). Following step 2108 is step 2110, at which the relevant parameter reference values are extracted and stored. Then, at step 2112, the  
20 flags for the image analysis engine are initialized to appropriate starting values and, at step 2114, the analysis engine reports to the system director that it is ready to begin the analysis algorithm.

Figs. 95A-95C illustrate operation of the image  
25 analysis engine which operates on the reproduced video stream. The image analysis engine employed for analyzing reproduced video data is similar to the live video analysis technique described above in connection with Figs. 93A-93E. As indicated at step 2116, the process  
30 shown in Fig. 95A is a loop applied to each difference image field 1134 (Fig. 44) in the reproduced stream of video image fields. Step 2118 indicates that for the present difference image field, the changed MCU mapping data is read, and then the mapping data is used as an  
35 input to a velocity analysis process (step 2120) and also as an input to a cluster analysis process (step 2122). On the basis of the outputs from the velocity analysis and cluster analysis processes, it is determined whether an

analysis of the changed MCU tile data itself is required (step 2124). If so, the tile-data-based analysis proceeds (step 2126). In either case, step 2128 next follows, in which the image is assessed on the basis of the results of  
5 the analysis processes. A determination is then made whether the criteria are met (step 2130). If at step 2130 it is found that the criteria have definitely not been met, then there is no finding that the image characteristic of interest has been detected. If the  
10 criteria have definitely been met, then a step 2132 follows step 2130. At step 2132, detection of the characteristic of interest is reported to the system director along with a confidence level. However, if the confidence level resulting from the analysis is not high  
15 enough to report the detection of the characteristic of interest, nor low enough to definitely rule out the presence of the characteristic, further processing occurs, as indicated at step 2134.

Fig. 95B illustrates further details of the step 2126 of Fig. 95A. As shown in Fig. 95B, the changed MCU data is read in (step 2136), and then decoded using conventional JPEG decompression processing (step 2138).

It is then determined whether the frequency coefficient data is required for further analysis (step  
25 2140) and if so, the DCT coefficients are provided for analysis (step 2142). Then, at step 2144, it is determined whether pixel data (time domain data) is required, and if so, the pixel data is obtained by inverse transform processing and supplied for analysis (step  
30 2146).

Fig. 95C illustrates the processing indicated at step 2134 in Fig. 95A. The first step in Fig. 95C is shown as step 2148, in which the present set of velocity vectors resulting from optical flow analysis is compared with a  
35 history of velocity vectors generated based on previous images in the sequence of images.

Following step 2148 is step 2150, at which it is determined whether the analysis of the velocity vector

history indicates that the velocity may have passed through a velocity vector value that the image analysis algorithm was intended to detect. If so, then objects currently detected by the optical flow analysis are compared with objects detected over the preceding set of images (step 2152). It is then determined at step 2154 whether an object of the type to be detected by the analysis algorithm might have been present. If so, step 2156 follows. At step 2156, an historical analysis of tile data is performed, and then at step 2158 it is determined whether present and past detected tile characteristics indicate that tile characteristics to be detected by the present algorithm may have been present. If a positive determination is made at step 2158, then step 2160 is performed. At step 2160, a confidence factor is generated for the algorithm output, and a flag corresponding to a "maybe" determination is set. Then, at step 2162, the confidence data generated from each analysis portion of the algorithm is assembled and weighted, and next an adjusted confidence factor is calculated (step 2164). Following is step 2166, at which a suitable message including a "maybe" result is forwarded to the system director.

If a negative determination is made at any one of steps 2150, 2154 and 2158, then the processing of Fig. 95C returns a conclusion that the characteristic to be detected by the algorithm was not present (step 2168).

A particular example of operation of an image analysis algorithm applied to reproduced video data will now be described, with reference to Figs. 96 and 97. For the purposes of this example, it is assumed that the analysis algorithm to be applied is of the type mentioned above which detects violations of a "perimeter". Fig. 96 schematically represents a sequence of images generated by a video camera (not shown) which provides a view, from above, of a cash box 2170 kept in a partially enclosed area 2172.

A graphical drawing element 2174 is indicative of a

perimeter assigned by a user for the purpose of carrying out a perimeter violation analysis algorithm. Shapes 2176-1 through 2176-6 are representative of a moving object detected by the analysis algorithm as positioned in  
5 respective fields of the sequence of video signals under analysis.

Turning to Fig. 97, an initial step 2178 indicates that the subsequent processing is carried out with respect to each set of difference fields in the reproduced  
10 sequence of video signals that is being analyzed. For efficiency in processing, preferred embodiments of the motion-based image analysis algorithms, when applied to reproduced video streams, disregard the "reference" images and operate, as noted before, on the changed MCU mapping  
15 data. As a result, a "hole" or "seam" in the sequence of images occurs at each reference image, but this is found not to cause serious shortcomings in the image analysis if a reasonably large number of difference images are provided in each interval between reference images. Of  
20 course, a larger number of difference images also produces a higher compression ratio, while trading off image quality and convenience in the case of reverse-direction reproduction. As noted before, a preferred embodiment of the VR/PC unit generates 32 difference fields between each  
25 pari of reference fields.

Continuing to refer to Fig. 97, the process applied to each set of difference fields includes a step 2180, at which an array of the changed MCU mapping data is generated, and a step 2182, at which a velocity profile  
30 set is formed from the MCU mapping data array, by using FFT (fast Fourier transform) processing or the like. Clusters of velocity vectors which may constitute objects are then assembled at step 2184, and each association of possible objects and velocity vectors is analyzed as per  
35 Fig. 95A to generate a "yes", "no" or "maybe" determination as to each object/velocity set (step 2186). A decision block 2188 follows step 2186. At step 2188, it may be determined that each object/velocity set has been

marked "no", in which case step 2190 follows. Step 2190 is representative of ending the analysis process without detecting any violations of the perimeter.

For each object/velocity set marked yes (as  
5 represented by step 2192), that is, for each  
object/velocity set which met the criteria for indicating  
a violation of the perimeter, it is determined, at step  
2194, whether the sensitivity (luminance) criteria were  
met. If so, a confidence level value is generated (step  
10 2196), and the confidence level, as well as the values  
representing the outcomes of the object and velocity  
analysis, are generated as outputs (step 2198). As to  
each object/velocity set marked "maybe" (i.e., neither  
clearly indicative of a perimeter violation nor clearly  
15 not indicative of a perimeter violation), a process  
beginning at step 2202 is carried out. Initially, a  
spline based on the velocity history is generated (step  
2204). An example of such a spline is shown as dotted  
line 2206 in Fig. 96. Then, an inflection point of the  
20 spline (indicated at 2208 in Fig. 96) is determined (step  
2210) and then the decision is made as to whether the  
inflection of the spline has crossed the perimeter (step  
2212). It will be seen from Fig. 96 that in the example  
shown therein, the inflection point 2208 of the spline  
25 2206 did indeed cross the perimeter 2174.

In the case of a positive determination at step 2212,  
the steps 2196 and 2198, as previously described, are  
carried out. In the case of a negative determination at  
either one of steps 2212 or 2194, step 2190 (end of  
30 processing with no violation detected) takes place.

Fig. 98 illustrates processing steps which cause a  
pre-selected image analysis algorithm to be applied to a  
predetermined live video signal stream upon occurrence of  
certain alarm events. In Fig. 98, step 2214 indicates  
35 that an alarm signal provided by an external alarm sensor  
device or the like has been received. Step 2216 is a  
decision block at 2216 which indicates that a certain  
image analysis algorithm is being applied on a continuous



basis to a live video image stream generated from a camera Y. Occurrence of either step 2214 or a positive determination (detection of image characteristics) at step 2216 causes step 2218 to be carried out. At step 2218, 5 the pre-selected image analysis algorithm is applied to a live video image stream generated from a camera Z in accordance with parameters (such as a perimeter line location) that have been pre-stored. The image analysis algorithm performed in connection with step 2218 may, but 10 need not, be similar to that applied in connection with step 2216. Moreover, camera Z may be considered the same as camera Y. In other words, detection of a feature that is of interest in a live video stream using a first analysis algorithm may automatically lead to application 15 of a second analysis algorithm to the same live video stream.

#### ALTERNATIVE VIDEO DATA COMPRESSION TECHNIQUE

Figs. 99 and 100 illustrate processing performed according to a variation of the "postage stamp" 20 compression technique that has previously been described herein. Essentially, in the variation of Figs. 99 and 100, instead of simply omitting from storage "same" MCUs in difference images, the "same" MCU portions of the difference images may be converted into an all black 25 condition prior to JPEG encoding.

Turning to Fig. 99, an initialization step is performed (step 2220). Following step 2220, is step 2222, at which the next video data field to be encoded is received. After step 2222, is step 2224, at which the 30 least significant bit of each pixel value is forced to assume a value that is inconsistent with a black pixel value. It is next determined (step 2226) whether the field being processed is a reference field. If so, step 2228 follows. At step 2228, JPEG compression is performed 35 as to all of the blocks (as in the compression technique previously described), and the reference statistics for making "sameness" determinations are updated. The process then loops back to step 2222.

If at step 2226 it was found that the field to be processed is a difference field, then the next tile or MCU is fetched (step 2230) and characteristic statistics are calculated (step 2232). The calculation of the statistics  
5 may use the checker-board sub-sampling technique described above, or other suitable techniques, including diagonal sampling in the tiles or quadrants of tiles.

Following step 2232 is step 2234, at which the calculated characteristics are compared with reference  
10 characteristics, and at step 2236 a "sameness" determination is made. If at step 2236 the present MCU or tile is found to be "the same" as the reference tile or MCU, then all of the pixels making up the MCU or tile being processed are forced to values indicating a solid  
15 color black in the MCU or tile (step 2238).

Following step 2238 are steps 2240, 2242 and 2246, which represent the portions of the JPEG encoding technique which include orthogonal transformation, quantization and run length encoding. Accordingly, the  
20 blackened tile or block is JPEG encoded. However, if at step 2236 the tile or MCU being processed was found to be "different" from the reference statistics, then the JPEG encoding steps are performed with respect to the tile or MCU without first forcing the tile or MCU to be black.

25 The decision block indicated as step 2246 shows that the process loops back to step 2230 until the last MCU or tile or in the difference field has been processed, at which point the process loops back to step 2222. The decompression technique which corresponds to the "black-  
30 fill" postage stamp decompression technique of Fig. 99 is shown in Fig. 100. Initially in Fig. 100, is a step 2248, which represents a decision as to whether a reference field is now to be decoded. If so, all of the tiles in the field are JPEG-decompressed and the display buffer  
35 locations corresponding to the entire image plane are updated using the decoded tiles (step 2250). The process then loops back to step 2248.

If at step 2248 it was found that a difference field

is now to be decoded, then a processing loop is performed as to each tile or MCU in the difference field (as indicated at step 2252). A first step in the loop is step 2254, at which the particular tile or MCU is JPEG-  
5 decompressed. It is then determined, at step 2256, whether the entire tile or MCU is black. If so, step 2258 follows, at which the display buffer locations corresponding to the tile or MCU are not updated. However, if at step 2256 it is found that the tile or MCU  
10 is not totally black, then the JPEG-decompression process relative to the block is completed (step 2260) and the "postage stamp" corresponding to the block is used to update the display buffer at the corresponding location in the image plane (step 2262).

15 The decompression technique of Fig. 100 can be summarized by saying that in the difference data fields, the black postage stamps are thrown away, and the non-black postage stamps are used to update the image plane. It will be noted that the technique just described in  
20 connection with Figs. 99 and 100 lacks the changed MCU mapping data 1134 as in the initial "postage stamp" compression technique described, for example, in connection with Fig. 44. Thus, the data format and the processing of the technique shown in Figs. 99 and 100 is  
25 somewhat simpler, but lacks the benefits for motion detection and backward-direction decompression provided by the mapping data. Also, the "black-fill" postage stamp technique provides a lower compression ratio. In addition, the dynamic range of the compressed video data  
30 provided by the technique of Fig. 99 is less than in the pure "postage stamp" technique since no compressed data pixel is permitted to have a true black value.

#### USER SELECTABLE DISPLAY/STORAGE OPTIONS

There will now be described, with reference to Figs.  
35 101A and 101B processing which permits the user to select spatial and temporal resolution options with respect to storage of incoming video signal streams.

First, a setup portion of the processing will be

described with respect to Fig. 101A. At step 2264, the user is presented with temporal and spacial resolution options. Then, at step 2266, it is determined whether the user has selected a non-standard temporal resolution with  
5 respect to a given video signal stream generated by a given camera. An example of a non-standard temporal resolution would be a "time-lapse" recording mode which would cause the respective input stream to be recorded at a lower field rate (lower temporal resolution) than  
10 streams recorded with the standard resolution. If a positive determination is made at step 2266, then a suitable message is sent to the front end electronics (step 2268) so that the non-standard time resolution is implemented for the camera stream in question.

15 It is determined at step 2270 whether a non-standard spatial resolution is requested with respect to a given camera stream. Examples of non-standard spatial resolution would be using more or fewer than the system standard 240 horizontal lines to represent each video  
20 field of the camera stream in question. If a positive determination is made at step 2270, then a suitable message is sent to the video storage software component to implement the selected non-standard spatial resolution (step 2272).

25 Fig. 101B represents processing performed to implement the resolution options discussed in connection with Fig. 101A. In particular, the processing shown in Fig. 101B represents steps entered upon a negative determination at block 1306 ("pre-alarm?") in Fig. 52  
30 ("video storage" software component). In the processing of Fig. 101B, first it is determined whether a non-standard resolution message has been received with respect to the field being stored (step 2274). If such is not the case, then step 1308 of Fig. 52 is entered directly from  
35 step 2274 of Fig. 101B. However, if a positive determination is made at step 2274, then, for example, alternative lines of the field being stored may be omitted from storage (step 2276), and indexing data indicating a

non-standard spatial or temporal resolution for the stored data is generated (step 2278).

Fig. 102 represents processing carried out to set a parameter related to compression of input video signal streams. The first step shown in Fig. 102 is step 2280, at which a screen display is provided to indicate to the user parameter setting options with respect to compression operations. The options will customarily entail trading off image quality against efficient use of the VR/PC unit's storage capacity. The options may include setting bit rates available for quantization operations in the JPEG chip 848 (Fig. 14), increasing the number of difference fields provided in each interval between reference fields, and/or adjusting a tile-sameness threshold used in determining whether to retain or discard tiles in difference fields. It is to be understood that the options presented to the user are settable camera-by-camera.

It is determined at step 2282 whether a non-standard interval between reference fields is selected. Moreover, it is determined at step 2284 whether a non-standard block-sameness threshold is selected. In the case of an affirmative determination at either one of steps 2282 and 2284, then step 2286 follows, at which a suitable message to implement the non-standard compression parameter is sent to the front end electronics. Although not shown in Fig. 102, if the user indicates a change in the quantization bit rate, a message to this effect is also sent to the front end electronics.

30

#### APPLICATIONS OF IMAGE ANALYSIS TOOLS IN DISTRIBUTED IVIM SYSTEM

There will now be described with reference to Figs. 103A through 103C processing involved in downloading image stream analysis algorithms from a remote site, such as a local or master node, to the VR/PC unit.

The processing shown in Fig. 103A is presented from the point of view of the external device, e.g., the master

or remote node. At step 2286, it is determined whether a remotely-located VR/PC unit has requested that a program routine corresponding to an image analysis algorithm be transmitted to the VR/PC unit from the master or local node (step 2286). If so, step 2288 follows, at which it is determined whether parameters to constrain execution of the algorithm will be set at the requesting VR/PC unit. Step 2292 follows step 2290, or directly follows step 2288 if the parameters are not set at the master or local node. At step 2292, the program routine corresponding to the requested analysis algorithm, with set parameters as the case may be, is downloaded to the requesting VR/PC.

Fig. 103B provides additional details regarding the step 2290 of Fig. 103A. In particular, at step 2294 of Fig. 103B, it is indicated that a reference image is uploaded from the requesting VR/PC unit to the master or local node at which the algorithm parameters are to be set. The updated reference image is then used at the master or local node in setting the algorithm parameters (step 2296).

Fig. 103C illustrates processing which takes place at a master or local node when the node operates to initiate analysis-tool-based searches at two or more VR/PC units located remotely from the node device. Step 2302 is the first step shown in Fig. 103C. At step 2302, the node device initiates communication with a VR/PC unit at a first remote site to cause a reference image to be uploaded to the remote device from the first VR/PC unit. An image analysis algorithm is then selected at the node device, and parameter to constrain execution of the algorithm are set using the uploaded reference image (step 2304). Following step 2304 is step 2306. At step 2306, time parameters (begin and end times) are specified to indicate the time period of interest for the ensuing database search to be performed on the video data in the first VR/PC unit. After step 2306 is step 2308. At step 2308, a data message (or more precisely a sequence of data messages) are transmitted from the node device to the

first remote VR/PC unit to download the selected analysis algorithm, the parameters set at the node device, and the time range of interest. Execution of the algorithm-based search of the video database at the first VR/PC unit  
5 proceeds at that point.

Following step 2308 are steps 2310 through 2316, which are the same as steps 2302 through 2308, except that steps 2310 through 2316 are performed with respect to a second VR/PC unit located at a site different from the  
10 location of the first VR/PC unit. As before, a reference image is uploaded (step 2310), analysis algorithm selection and parameter setting proceed at the node device, along with setting of the relevant time range (steps 2312 and 2314) and messages are sent to the second  
15 VR/PC unit to download the selected algorithm, with the parameters including the time parameters, to initiate a video database search carried on within the second VR/PC unit (step 2316). The final step in Fig. 103C is 2318, at which the node device waits for the VR/PC units to report  
20 the results of the respective searches carried on in each VR/PC unit. Another practice contemplated in the distributed IVIM system entails uploading a sequence of dynamic video image data fields from a VR/PC unit to a master or local node for application of an image analysis  
25 algorithm to the uploaded image sequence at the node. It is noted that this practice may not always be desirable because of the considerable transmission bandwidth and/or amount of time required to transmit the video data from the VR/PC unit to the node.

30 Fig. 104 represents processing which occurs to automatically transmit video information of interest upon detection of a characteristic of interest by an image analysis algorithm applied to a live input video stream. It is assumed that the processing in Fig. 104 is carried  
35 out in a VR/PC unit. Initially, in the processing of Fig. 104, it is determined whether an analysis algorithm applied to an input stream generated by camera X has detected a characteristic which the algorithm is intended

to detect (step 2320). If so, the VR/PC unit operates to automatically transmit video data fields from the incoming camera X signal to an external device, such as a local or master node device (step 2322).

5

## INTELLIGENT RESPONSES TO EVENTS

Fig. 105 illustrates processing carried out in a VR/PC unit to change a camera recording sequence upon detection of a characteristic of interest by means of image analysis of a live incoming video stream.

Initially, in Fig. 105 is step 2324 at which it is determined whether a characteristic of interest has been detected in the stream of video signals incoming from a first video camera. When such a characteristic is detected, step 2326 follows. At step 2326, a camera different from the first camera and up to this point not included in the recording sequence, is added to the recording sequence. For example, the two cameras may generate views of the same area from different angles. The first camera may normally be in operation with a motion detection analysis algorithm applied to the incoming stream from the first camera. When motion is detected, the second camera, normally "off line" (not recorded) is added to the recording sequence so that the motion event is captured from both angles. Although not indicated in Fig. 105, the response at step 2326 may also include permanently storing video signals generated through the second camera and present in a pre-alarm buffer as at blocks 1726 and 1728 of Fig. 75.

Fig. 106 illustrates a feature implemented in software by which detection of an image characteristic by an image analysis algorithm causes actuation of an additional image analysis algorithm. An initial block 2328 in Fig. 106 is the same as block 2324 in Fig. 105. If the image analysis algorithm represented by block 2328 detects the characteristic to which it is directed, then step 2330 follow step 2328. At step 2330, a predetermined image analysis algorithm, with pre-stored parameters, is



retrieved from memory. Then step 2332 follows step 2330. At step 2332, the retrieved analysis algorithm is sent to the front end electronics to be applied to the incoming video image stream generated either by the same camera  
5 which was monitored using the algorithm referred to in 2328, or another incoming video stream, or both. The additional algorithm retrieved at step 2330 may be of the same type applied at step 2328, or may be substantially different.

10 Fig. 107 illustrates processing which causes video data compression parameters to be changed in response to detection of an alarm condition. As seen from Fig. 107, it is first determined, at step 2334, whether an alarm  
15 condition is detected. The alarm condition may be detected by input from an alarm sensor device, by analysis carried out on a live video stream using an image analysis algorithm, or by a signal input by a user of this system to declare an alarm condition. In any case, when an alarm  
20 condition is detected, step 2336 follows step 2334. At step 2336, a script is retrieved from memory designating a camera or cameras which are relevant to the detected alarm condition, and also indicating updated compression algorithm parameters which are to be applied because of  
25 the detected alarm condition. Typically, the alarm-actuated compression parameters would be such as to provide improved image quality. Thus, the number of bits available for quantization in the JPEG encoding process would be increased, the number of difference images in each interval between reference images would be reduced,  
30 and/or the "sameness" threshold for comparing difference field tiles with reference tiles would be lowered.

Following step 2336 is step 2338. At step 2338 the updated compression parameter retrieved at step 2336 is sent to the front end electronics with instructions to  
35 compress the designated camera video stream in accordance with the updated compression parameter.

Fig. 108 illustrates an example of how an effective field-of-view of a camera is changed in response to

detection of an image characteristic using an image analysis algorithm applied to a live incoming video stream. It is assumed for the purposes of Fig. 108 that a perimeter violation detection algorithm, as previously  
5 described, is being applied to a live video stream generated by a camera designated as camera X. At step 2340 it is determined whether a perimeter violation has been detected. If so, step 2342 follows. At step 2342, a zoom-in operation is carried out by processing the  
10 incoming video stream from camera X so that the portion of the image plane corresponding to the designated perimeter is magnified. In this way, a larger portion of the image plane is devoted to what is likely to be the most important information in the image stream, namely,  
15 features at or near the designated perimeter.

Fig. 109 illustrates another example of automatically changing a camera's field of view in response to detection of an image characteristic by an image analysis algorithm applied to a live incoming video stream. The initial step  
20 2344 shown in Fig. 109 is the same as step 2324 in Fig. 105. If at step 2344 it is found that the feature of interest has been detected, then step 2346 is carried out. At step 2346, a predetermined alarm output is generated and/or a signal is generated to cause a predetermined  
25 movement of either the camera from which the video stream is monitored at step 2344 and/or predetermined movement of a different camera. The predetermined camera movement or movements may be carried out with a predetermined targeting algorithm as is described in U.S. Patent No.  
30 5,526,041.

Fig. 110 illustrates processing in which a predetermined action or actions are taken in response to detection of two different characteristics of an incoming video stream. It is determined at step 2348 whether a  
35 first characteristic is present in an incoming stream of video images, by application of a first image analysis algorithm. If at step 2348 it is determined that the predetermined characteristic has been detected by the

first analysis algorithm, then step 2350 follows, at which it is determined whether a second predetermined characteristic has been detected in the same incoming video stream using a second analysis algorithm. If so, step 2352 follows. As indicated in Fig. 110, step 2352 is entered only if a positive determination is made at both of steps 2348 and 2350.

Step 2352 represents performance of one or more of the following actions: Changing the displayed image of the incoming video stream (e.g., by increasing the vertical resolution or temporal resolution); selecting a storage medium in which the incoming video stream is to be stored (e.g., transmitting data representing the video stream to an external device such as a local or master node); transmitting a signal to cause an automatic targeting or other movement of the camera generating the incoming video stream or a different camera; and/or selecting an additional image analysis algorithm to be applied to the incoming video stream of a different video stream. The process shown in Fig. 110 can be thought of as applying a logical combination of two analysis "tools", particularly in this case, an AND combination of the two tools. It is further contemplated that other logical combinations of analysis tools could be employed to detect an event condition, or to trigger a predetermined response, and so forth. For example, an event condition could be declared when any one of two or more tool "hits" are detected. This would constitute an OR combination of two or more tools. (As will be understood from the previous sentence, logical combinations of more than two analysis tools are also contemplated.) Moreover, there may be employed other logical operators such as NOR, NAND, XOR, etc., and also complex logical combinations including two or more operators.

The user may be presented with a screen display (not shown) which permits construction of a desired logical combination of analysis tools from available choices of tools and logical operators. The user would also be

permitted to select a camera stream or streams to which the analysis tools are to be employed, and also to set parameters relevant to the selected tools.

Fig. 111 shows a process in which application of a  
5 live image analysis algorithm is inhibited when the camera  
generating the video stream to which the algorithm is to  
be applied is in motion; or when there is an alarm  
condition relevant to the camera. In Fig. 111, step 2354  
indicates a determination whether an alarm condition  
10 relevant to a certain camera (designated camera X) is  
present. The alarm condition may be detected through an  
alarm sensor device, through live image analysis, or may  
be actuated by user input. Step 2356 indicates a  
determination as to whether camera X is in motion. This  
15 determination may be made based on whether a camera  
movement signals is received from the camera control  
device 528 (Fig. 1).

Continuing to refer to Fig. 111, a step 2358 is  
entered if a positive determination is made at either one  
20 of steps 2354 and 2356. In step 2358, a suitable message  
is sent to the front end electronics to inhibit  
application of an image analysis algorithm to the live  
video stream generated by camera X. Where an alarm  
condition relevant to camera X has been detected, it may  
25 be beneficial to inhibit live analysis of the camera X  
video stream so as not to unduly prolong the alarm  
condition. Also, it may be desirable to inhibit live  
analysis of the camera X video stream when camera X is in  
motion, because it may not be possible, depending on the  
30 nature of the image analysis algorithm, to generate a  
meaningful analysis with respect to a video stream  
generated by a moving camera. Fig. 112 illustrates  
another feature designed to handle the situation in which  
a video stream is being generated by a moving camera. In  
35 Fig. 112, the first step, which is step 2360, is the same  
as step 2356 in Fig. 111. If at step 2360 it is  
determined that a camera X is in motion, then step 2362  
follows. At step 2362, a message is sent to the front end

electronics to add an indication (e.g., set a bit value in the video data field headers for the camera X video stream) to show that the video data fields in question were generated while the camera is in motion. The header data may later be used, upon reproduction of the video data fields captured by a moving camera, either to inhibit a post-recording image analysis algorithm, or as a cue for specialized processing by an image analysis algorithm. As an alternative to step 2362, the in-motion indicator in the header data may be added at the motherboard CPU during the recording process, and/or may be added in indexing data generated during recording of the video stream on the hard disk.

Fig. 112A illustrates a process in which the camera-in-motion indicator is used to inhibit subsequent application of an image analysis algorithm. The first step shown in Fig. 112A is step 2364. At step 2364, it is determined whether an image analysis algorithm has been selected, and parameters set, for application of the algorithm to a video image stream reproduced from the hard disk. If so, then the video stream to be analyzed is retrieved from the hard disk (step 2366). Following step 2366 is step 2368. At step 2368, it is determined whether the header data accompanying the reproduced video data fields indicates that the camera which generated the video data fields was in motion at the time the fields were generated. If so, step 2370 follows step 2368. At step 2370, the performance of the selected image analysis algorithm is inhibited, and then a messaging reporting that there was camera motion during the selected video stream is generated (step 2372). On the other hand, if no motion indication is found at step 2368, then the image analysis algorithm is applied, and the results of the algorithm are reported, in accordance with the usual practice as previously disclosed herein (steps 2374 and 2376).

It would be understood that the motion indication may be carried in index data rather than a header data, in

which case step 2368 entails examining the index data for the motion indication.

Fig. 113 illustrates the processing by which an overall rate at which video data fields are captured and stored is increased when an alarm condition is detected.

In Fig. 113, step 2378 indicates a determination as to whether an alarm condition is detected. The alarm condition may be detected based on a signal received from an alarm sensor device, by application of an image analysis algorithm to a live video image stream, or by actuation of an alarm signal by a user of the system. If an alarm condition is found to be present at step 2378, then step 2380 follows. At step 2380, the VR/PC unit, and particularly the front end electronics portion thereof, is switched over from a first mode in which video data fields are captured and stored at a first rate to a second mode in which the video data fields are captured at a higher aggregate rate. For example, it is contemplated that when no alarm condition is present, the VR/PC unit operates to capture and store 30 fields per second. The aggregate 30 fields per second, may, for example, be allocated in sequence to each of the cameras connected to the VR/PC unit. But when an alarm condition is detected, the aggregate field capture rate may be increased to 45 fields per second. The 45 fields per second being captured and stored may be allocated according to the same sequence as before, or, more preferably, 15 or 30 of the fields per second may be allocated to one or two cameras of particular interest, and the remaining field recording slots would then be allocated to a sequence of the other cameras. A sequence in which fields generated by an alarm-relevant camera are interleaved with a sequence of fields from other cameras has been discussed above in connection with Fig. 76.

Fig. 114 illustrates a process by which different compression parameters are applied, respectively, to incoming video streams received from different cameras. Step 2382, which is the first step shown in Fig. 114,

indicates that the subsequent steps 2384 and 2386 are performed for each camera as it is selected for recording in the sequence of cameras to be recorded. At step 2384, the process retrieves for the next camera to be recorded  
5 the compression algorithm parameter which determines how much difference there can be between a tile of a difference video data field and the reference field without considering the difference field tile to be "different" from the reference field tile. At step 2386,  
10 the compression algorithm is applied to the difference field data using the compression parameter retrieved at step 2384.

Fig. 115 represents a process by which detection of an alarm condition causes a display buffer to be updated  
15 in a different manner than when no alarm condition is present. The first step in Fig. 115 is step 2388, which is the same as step 2378 of Fig. 113. If it is determined at step 2388 that an alarm condition is present, then the display buffer is updated so that the entire buffer is  
20 updated at each field display interval (step 2390). On the other hand, when no alarm condition is found to be present, step 2392 is performed. At step 2392, only some of the display buffer locations are updated at each display cycle. For example, an interlace updating  
25 technique may be applied, whereby display buffer locations corresponding to even line pixels are updated at a first display cycle and then in the next display cycle, the remaining (odd line) locations are updated, and that the alternating updating of even and odd line display buffer  
30 locations is carried out for subsequent display cycles.

#### VR/PC UNIT PERFORMS MAJOR FUNCTIONS SIMULTANEOUSLY

Fig. 116 represents a process by which the VR/PC unit resolves conflicts among the recording, playback and  
35 archiving functions carried out in the VR/PC unit. The quantity of data to be handled during recording, playback and archiving is subject to dynamic variations. For example, there may be times when neither playback nor

archiving is carried out. Or, the quantity of video information to be played back or to be archived may vary. In addition, the rate at which video data is generated for recording is subject to variation depending upon the  
5 aggregate rate at which video fields are captured, the degree of compression achievable as to the incoming video streams, the resolution and compression parameters selected by the user, and other factors.

The VR/PC unit disclosed herein is intended to be  
10 operable simultaneously for recording, playback and archiving operations. As used herein and in claims that may be appended hereto, the term "simultaneous" should be understood both literally and in a virtual sense. As an example of a literally simultaneous recording and playback  
15 operations, one may consider a case in which a video display monitor is displaying a signal indicative of a video image stream reproduced from the hard disk, while at precisely the same instant video data generated by one or more cameras connected to the VR/PC unit is being written  
20 onto the hard disk. "Virtual" simultaneity can be achieved by multi-tasking operation of the motherboard CPU by which independent recording, playback and archiving control threads are contemporaneously maintained. As will be understood by those of ordinary skill in the art,  
25 maintenance contemporaneously of the recording, playback and archiving threads involves time division multiplexing of the processing cycles carried by the CPU to serve the recording, playback and archiving threads among others. Through the multi-tasking operations, activities  
30 corresponding to all three of the recording, playback and archiving threads are carried on repeatedly within short periods of time that are, for example, small portions of a second.

Of course, the number of processing cycles carried  
35 out by the motherboard CPU within a given period of time is finite. Moreover, the rates at which data can be written to or read from the hard disk drive(s) are also finite. There accordingly may be situations in which



simultaneous recording, playback and archiving operations are constrained by either CPU processing capacity or hard disk access rates. Fig. 116 indicates how such constraints are managed in a preferred embodiment of the  
5 VR/PC unit.

The first step shown in Fig. 116 is step 2394, at which simultaneous recording, playback and archiving operations are maintained. Following step 2394 is a step 2396, at which it is determined whether the processor  
10 (and/or hard disk access bandwidth) is over burdened by the three simultaneous recording, playback and archiving threads. If not, the process simply loops back to step 2394. However, if the processing capacity is found to be over burdened at step 2396, then step 2398 follows, at  
15 which only simultaneous recording and playback are maintained. Thus, archiving is accorded a lower priority than either one of recording and playback. Following step 2398, is step 2402. At step 2402, it is determined whether the simultaneous recording and playback operations  
20 are overburdening the capabilities of the processor (and/or the hard disk access bandwidth). If such is not the case, then it is determined at step 2404, whether there is sufficient processing and hard disk bandwidth available to support archiving as well as recording and  
25 playback. If so, the process returns to step 2394. Otherwise, the process returns to step 2398.

If at step 2402 it was found that recording and playback were over burdening the processor or exceeding the disk access capabilities, then the playback operation  
30 is halted and recording alone is carried out (step 2406). Thus, it can be seen that recording is accorded a higher priority than both playback and archiving.

Following step 2406 is step 2408. At step 2408, it is determined whether the processor has a predetermined  
35 amount of unused capacity, and if so, step 2398, with simultaneous recording and playback, is reinstated. However, if the predetermined amount of unused capacity is not present, then the recording-only operation of step

2406 is maintained.

The flow-chart presentation of Fig. 116 should be understood as somewhat simplified, in that cases such as simultaneous recording and archiving without playback are not addressed. However, it should be understood that recording is always accorded priority over playback and archiving, and playback is always accorded priority over archiving.

Fig. 117A is illustrative of processing carried out during simultaneous recording and archiving operations. According to the first step of Fig. 117A, which is step 2410, data is copied from a disk drive (designated disk drive B) onto the removable recording medium (e.g., digital audio tape) used for archiving, while simultaneously incoming video stream data is recorded onto another disk drive, designated disk drive A. Following step 2410 is step 2412, at which it is determined whether all of the video data has been copied from disk drive B onto the archive medium. If not, step 2410 continues. However, once the copying of the data from disk drive B is complete, copying of the data from disk drive A onto the archive medium begins, while using disk drive B to record the incoming video data stream (step 2414). At step 2416 it is determined whether all of the video data has been copied from disk drive A onto the archive medium. If not, step 2414 is maintained. However, once the archiving from disk drive A is complete, the process returns to step 2410, with archiving from disk drive B and live recording on disk drive A.

The process carried out in Fig. 117A can be summarized by saying that the point in time at which the disks are switched over from archiving to recording is driven by completion of the archiving. Fig. 117B presents an alternative technique, in which the live data continues to be recorded on a first disk, even after all of the video data on the other disk drive has been archived. The process shown in Fig. 117B starts with a step 2418, which is the same as step 2410 of Fig. 117A. In Fig. 117B, step

2418 is followed by step 2420. Step 2420 is the same as step 2412 of Fig. 117A. That is, it is determined whether all of the video data on disk drive B has been copied onto the archive recording medium. If not, step 2418 is  
5 maintained. However, if the copying from disk drive B is complete, then step 2422 follows, at which the archiving is no longer carried on, but the incoming video data continues to be recorded on disk drive A. Following step 2422 is step 2424. At step 2424, it is determined whether  
10 the entire storage capacity of disk drive A had been utilized (or, alternatively, whether a predetermined proportion of the recording capacity has been used). If not, step 2422 continues. However, if disk drive A is full or the predetermined quantity level has been reached,  
15 then step 2426 follows. Step 2426 is the same as step 2414 of Fig. 117A, and signifies that live recording has been switched over from disk drive A to disk drive B, while copying of the recorded video data from disk drive A onto the archive medium is initiated. At step 2428, it  
20 is determined whether the archiving from disk drive A is complete. If not, step 2426 is continued, but if the archiving from disk drive A is complete, then step 2430 follows, at which archiving is no longer carried out, but live data recording onto disk drive B continues. At step  
25 2432 it is determined whether the disk drive B is full. If not, recording onto disk drive B continues, but otherwise step 2418 is entered again. That is, live recording switches back to disk drive A and archiving from disk drive B begins again.

30 For the purposes of Figs. 117A and 117B it has been assumed that the full recording capacity of one disk drive is never reached before archiving from the other disk drive is complete. If this ever turns out not to be the case, it is contemplated to switch the live recording over  
35 from the full disk drive to the disk drive being archived. It should also be understood that playback operations may be carried on simultaneously with the recording and archiving operations discussed in connection with Figs.

117A and 117B.

A technique to prevent one disk from filling up before the other has been completely archived is presented in Fig. 118. It is assumed for the purposes of Fig. 118  
5 that recording is being carried on one disk drive while archiving of the other disk drive takes place. At step 2434, an estimate is made of the time at which the archiving operation will be completed, taking into account the rate at which archiving is taking place and the  
10 quantity of data remaining to be achieved. At step 2436, an estimate is made as to the time at which the recording capacity of the disk being used for recording will be exhausted. This estimate is made, for example, based on the remaining unused storage capacity, and the rate at  
15 which data is being recorded.

At step 2438, it is determined whether the archiving operation will be completed before the other disk drive becomes full. If the archiving will be completed first, then the process loops back to step 2434. However, if it  
20 appears that the capacity of the other disk will be reached before archiving is complete, a message is sent to the front end electronics to reduce the aggregate rate at which video data fields are being captured for storage (step 2440). In this way, the storage rate is reduced to  
25 permit archiving to be completed on the other disk.

#### USER-FRIENDLY FEATURES OF THE VR/PC UNIT

Fig. 119 shows a process for generating a database, to be maintained on the hard disk of the VR/PC unit, for  
30 storing index information regarding archiving tapes that have previously been recorded by the VR/PC unit. In Fig. 119 the first step, which is step 2442, calls for accumulating index information for an archiving tape while the archiving is going on. At step 2444, it is indicated  
35 that the accumulation of the index information for the archiving tape continues until the archive tape is ejected. At that point, the accumulated index information for the ejected tape is added to the archive database

maintained on at least one of the hard disks in the VR/PC unit (step 2446). The user is permitted to access the archive tape database, so that the VR/PC unit can assist the user in managing the video data stored on the archive  
5 tapes.

Fig. 120 shows a process whereby the VR/PC unit operates to automatically diagnose the onset of malfunctions in cameras connected to the VR/PC unit. Typical video cameras have limited service life and tend  
10 to experience a degradation in function over time. Typical problems encountered in aging video cameras are a loss of focus, and "blooming", i.e. a tendency for a number of pixel locations to generate a brighter output than is actually present in the scene. The process shown  
15 in Fig. 20 enables the VR/PC unit to automatically track and diagnose deterioration in camera characteristics over time.

In a first step in Fig. 120, designated as step 2448, an image generated by the camera is captured immediately  
20 or soon after the camera is first connected to the VR/PC unit. Following step 2448 is step 2450. At step 2450, a statistical analysis of the data corresponding to the image captured at 2448 is carried out to generate a set of baseline statistics to be used when analyzing subsequently  
25 captured images generated by the camera. Preferably, the baseline statistics include one or both of statistics indicative of high-frequency components of the image signal and statistics indicative of a color distribution in the image data. The baseline statistics are then  
30 stored on a hard disk within the VR/PC unit.

It is indicated at step 2452 that periodically after generation of the baseline statistics an automatic diagnosis of the camera is to be carried out. For example, the automatic diagnosis process may be carried  
35 out at regular intervals, such as weekly or monthly, after the initial installation of the camera. The first step in the automatic diagnosis is step 2454, at which an image currently generated by the camera is captured. Then, at

step 2456, statistics corresponding to the baseline statistics are generated from the current image data and are compared with the baseline statistics. Then, as indicated by step 2458, it is determined on the basis of  
5 the comparison of the current image statistics with the baseline statistics whether the camera continues to exhibit satisfactory performance. For example, a substantial reduction in the high frequency component of the current image signal, in comparison to the baseline  
10 high frequency component statistics, may indicate that the camera no longer exhibits satisfactory focus. Similarly, a substantial shift in the distribution of the color data may indicate that there is excessive blooming in the camera's pickup elements. To avoid false findings of  
15 camera malfunctions, it is advisable that the images gathered for diagnosis purposes be generated under the same lighting conditions as for the baseline image. This may be done, for example, by taking both the baseline and subsequent images at night under controlled lighting  
20 conditions.

If at step 2458 it is found that there is a substantial change in the image statistics indicating unsatisfactory camera function, then appropriate steps may be taken, such as displaying a warning (step 2460), to  
25 indicate that the camera is not functioning properly. Although automatic diagnosis of only a single camera is illustrated in Fig. 120, it is to be appreciated that the process of Fig. 120 may be applied to all cameras connected to the VR/PC unit, with appropriate variations  
30 in timing as to the capture of the baseline statistics and subsequent capturing of auto-diagnosis images.

There will now be described, with reference to Fig. 121, a process whereby the VR/PC unit generates data to be used in providing a status information display to a user.  
35 An example of such a status display is provided in Fig. 149.

The process of Fig. 121 commences with a step 2462, at which it is determined whether the user has requested

that system status information be displayed. The request for the status display may be entered, for example, by actuating the status button 646 provided on the front panel (Fig. 6).

5 Continuing to refer to Fig. 121, if a status request display is requested, then step 2464 follows step 2462. At step 2464, the motherboard CPU determines how much recording capacity remains unused on the disk drive or disk drives included within the VR/PC unit. Then, at step  
10 2466, it is determined how much unused recording capacity remains on the recording medium (digital audio tape) loaded within the internal archive DAT drive. Next, at step 2468, it is determined how many alarm event conditions have been noted and not reviewed by the user.  
15 Following step 2468 is step 2470, which generates a count of alarm event reports that have been reviewed but not deleted. Following step 2470 is step 2472. At step 2472, the motherboard CPU generates a count of the number of cameras connected to the VR/PC unit, and at step 2474, the  
20 number of those cameras which are in the active recording sequence are counted. Finally, at step 2476, all of the data gathered at steps 2464 through 2474 is used to generate the status information display screen (Fig. 149).

Fig. 122 illustrates a feature of the VR/PC unit  
25 which permits a user to conveniently shift from viewing a reproduced video image stream generated by a first camera at a given time to a reproduced video image stream generated at the same time by a different camera. A first step shown in Fig. 122 is step 2478. At step 2478, an  
30 image stream generated at a certain point in time in the past by a first camera is reproduced from the hard disk and displayed on the display monitor. An example of a playback display format, such as is provided in step 2478, is shown in Fig. 12. The screen display of Fig. 12  
35 includes a video image display area 2479, in which the reproduced image generated by a camera (assumed to be camera 1) is shown. For the purposes of this example, it is assumed that the image stream displayed in the area

2479 was generated by camera 1 at 10:00 a.m. on the previous day.

Referring again to Fig. 122, step 2480 follows step 2478. At step 2480, it is determined whether a different  
5 camera is selected for playback. If not, the reproduction of the image stream generated on the day before by camera 1 continues (step 2478). However, if the user actuates one of the camera selection buttons 650 (Fig. 6) other than the button corresponding to camera 1, then it is  
10 understood at step 2480 that the other camera (say camera 2) has been selected. In that case, step 2482 follows step 2480. At step 2482, the motherboard CPU operates so as to search for, reproduce and display the video image stream generated by camera 2 (the selected camera) at the  
15 same time (10:00 on the previous day) that the currently displayed playback video was generated by camera 1. Following step 2482 is step 2484, at which the VR/PC unit causes the display monitor to shift to a split-screen display mode (not shown in Fig. 12), in which the video  
20 image streams respectively generated by cameras 1 and 2 at 10:00 a.m. on the previous day are simultaneously displayed.

It should be noted that the camera selection detected at step 2480 may be carried out by using the mouse to  
25 actuate one of the virtual camera selection buttons displayed on Fig. 12, as an alternative to actuating the corresponding front panel camera selection button 650.

Fig. 123 schematically illustrates operation of the VR/PC unit to simultaneously perform recording and  
30 playback operations. Fig. 123 schematically shows contemporaneously maintained control threads 2486 and 2488. Thread 2486 relates to capturing and recording live incoming streams of video signals generated by cameras connected to the VR/PC unit, while thread 2488 is  
35 concerned with receiving and complying with user requests to retrieve and playback video data streams stored on the hard disk in VR/PC unit. Implementation of contemporaneous independent control threads is made



possible by the multi-tasking nature of the operating system software provided for the motherboard CPU.

Thread 2486 is shown as including steps 2490 and 2492. At step 2490, the streams of video images generated  
5 by the cameras connected to the VR/PC unit are sequentially captured in a time-multiplexed fashion, and at step 2492 the resulting sequence of video data fields is recorded on the hard disk.

Playback thread 2488 is shown as including steps 2494  
10 and 2496. At step 2494, the user initiates a request to playback a video data stream that was previously generated by a certain camera at a certain time and recorded on the hard disk. At step 2496, video data corresponding to the requested stream is retrieved from the hard disk and  
15 displayed on the display monitor. For example, a display in the format shown in Fig. 12 may be provided. It should be understood that even as the requested reproduced video data stream is shown in the display area 2479 of the screen display of Fig. 12, ongoing recording of live input  
20 video streams continues without interruption.

Fig. 124 illustrates in generalized form the feature of simultaneously displaying two different reproduced video image streams. The first step in Fig. 124 is step 2502, which corresponds to step 2478 of Fig. 122. It is  
25 then determined, at step 2504 whether the user requests that an additional video stream be reproduced and displayed at the same time as the stream displayed at step 2502. A particular example of step 2504 would be step 2480 in Fig. 122, at which the user requests simultaneous  
30 display of a stream generated by a different camera at the same time that the stream displayed at step 2502 was generated. Another possible request that could be made at step 2504 would be requesting simultaneous display of a recorded video image stream generated at a different time  
35 by the same camera which generated the image stream reproduced at step 2502.

In any case, when playback of an additional stream is requested at step 2504, step 2506 follows, at which the

parameters (camera and time generated) for the requested stream are received or generated. Then, at step 2508, both the image stream displayed at step 2502 and the additional requested stream are simultaneously displayed  
5 in a split-screen format.

There will now be described, with reference to Fig. 125, a process whereby indexing data relating to video data fields to be recorded on a hard disk is recorded both on the same hard disk with the video data fields and on a  
10 separate hard disk. Fig. 125 includes a first step 2510, at which a sequence of live video data fields is received. The next step, which is step 2512, represents generating indexing data which corresponds to the received video data fields. Then, following step 2512 are steps 2514 and 2516  
15 which are carried out contemporaneously with each other. At step 2514, the incoming video data fields are recorded on a hard disk together with the indexing data generated at step 2512. At step 2516, the same indexing data is recorded on a different hard disk from that on which the  
20 video data fields were recorded.

By recording a "shadow" set of index data on the separate hard drive, the index data can be searched on the separate hard drive without impeding ongoing record, playback or archiving operations which require access to  
25 the hard drive on which the video data fields are recorded.

Fig. 126 portrays operation of the VR/PC unit to provide pre-alarm buffer storage of an incoming video signal stream at a field rate that is higher than a  
30 "permanent" field rate that has been assigned to the video stream. The first step in Fig. 126 is step 2518. At step 2518, an incoming video data stream is received and captured in the form of a sequence of video data fields. It is assumed for the purposes of this example that the  
35 video data stream is captured at a rate of about three fields per second.

At step 2520, selected ones of the video data fields captured at step 2518 are recorded at a lower field rate,

say one field per second, in a main "permanent recording" area of a hard drive. (It is to be understood that in a preferred embodiment, only video data on the "permanently" recorded part of the hard drive is archived; and the pre-  
5 alarm buffered material preferably is not archived unless it is first transferred to the "permanent" part of the hard drive.) Meanwhile, at step 2522, all of the captured data fields are recorded in a ring buffer area on the hard disk drive to provide a recording rate equal to the  
10 capture rate, i.e., three fields per second in this example.

Following step 2522 is step 2524, at which it is determined whether an alarm condition has been detected. If so, step 2526 follows, at which a pointer defining the  
15 ring buffer area is moved to provide permanent storage of the three-field-per-second data (alternatively, the three-field-per-second data can be copied from the ring buffer area to the main area for permanent storage at step 2526).

At step 2528, recording at the full field rate  
20 (assumed to be three fields per second) continues for a predetermined period of time after detection of the alarm condition.

It should be understood that the field rates given in the above discussion of Fig. 126 are exemplary only and  
25 are subject to variation, the main pointing being that at the temporal resolution (field rate) provided at steps 2522 and 2528 is greater than that provided at step 2520.

Fig. 127 represents a generalization of the playback image analysis practices that have been previously been  
30 described herein. At a first step in Fig. 127, namely step 2530, video data and/or corresponding indexing data, is retrieved from a recording medium, such as a hard disk. Then, at step 2532, the VR/PC unit analyzes the retrieved data. For example, one or more of the image analysis  
35 algorithms described previously or hereafter may be applied. Alternatively, other image analysis algorithms, including other algorithms relating to motion or acceleration of objects represented in the image stream

may be applied. The machine analysis applied at step 2532 is not limited to detection of image characteristics, however. For example, the indexing data may be surveyed to determine what camera streams were recorded at a given point of time in the past.

At step 2534, header data, indexing data or the like stored on the hard disk or other recording medium is changed or added to indicate the results of the machine analysis carried out at step 2532.

It is to be recognized that the process presented in Fig. 127 generally contemplates application of a machine analysis to a video database stored on a recording medium, and then updating indexing or header data to indicate the results of the machine analysis. There will now be discussed, with reference to Figs. 128(a) and 128(b), an example of the image processing utilities which have previously been referred to. In particular, these drawings relate to a feature which permits the user to enhance the image contrast in a selected part of the image plane.

Fig. 128(a) shows a variable-gain amplifier 808' which may be provided in the front end analog board electronics of Fig. 113 in place of each of the amplifiers 808 shown in Fig. 13.

As indicated at 2536 in Fig. 128(a), the gain provided by the amplifier 808' is controllable by a control signal which originates from the front end controller DSP 1050.

Fig. 128(b) is illustrative of processing which implements the selective contrast enhancement feature. At step 2538, a portion of the image plane is selected for contrast enhancement. Then, at step 2540, a suitable message is sent to the front end electronics to cause each of the variable amplifiers 808' to be operated so as to increase the image contrast (dynamic range) in the selected portion of the image plane.

Fig. 161 is an example of a display screen presented to the user to permit selection of a portion of the image

for contrast enhancement. The rectangular drawing element indicated at 2542 is the region of the image plane selected for image enhancement.

5

## EXAMPLES OF USER INTERFACE SCREENS

Fig. 11 is an example of a screen display format provided in the IVIM system for displaying a live video signal currently generated by one of the cameras connected to the VR/PC unit. The screen display format of Fig. 11 includes an upper area 2546 and a lower area 2548. The upper area 2546 includes a video image stream display window 2550. Six mouse-actuatable switch areas 2552 are provided in a horizontal array below the live video display window 2550. As seen from Fig. 11, the mouse-actuatable switch areas 2552 respectively carry the legends "Full Scr" (full screen), "Sch On" (turn on pre-scheduled operating modes), "Utilities", "Archive", "Setup", and "Help". Actuating the "full screen" switch area causes the two-part display shown in Fig. 11 to be replaced with a display format in which the entire screen area is devoted to the live video image display window. The "scheduling on" switch allows the user to cause the VR/PC unit to enter previously-scheduled operating modes. The "utilities" switch area allows the user to access certain system features, such as transmitting data to other devices, or generating reports of system activities. The "archive" switch area allows the user to access features relating to archiving functions performed by the VR/PC unit. The "setup" switch area allows the user to enter a mode for configuring the VR/PC unit. The "help" switch area provides the user with access to context-sensitive explanatory text displays.

A mock-LED display area 2554 is provided at a lower right hand position in the upper area 2546. A legend "recording" is proximate to the mock-LED 2554. The mock-LED 2554 corresponds to the LED 654 provided on the physical front panel (Fig. 6). The mock-LED 2554 is preferably displayed in a first state (e.g., red) when the

-214-

SUBSTITUTE SHEET (RULE 26)

VR/PC unit is recording live video signals, and is displayed in a separate condition (e.g., black or dark grey) when no recording is taking place.

If the lower area 2548 of the screen display of Fig. 11 is compared with the front panel layout illustrated in Fig. 6, it will be observed that the lower area 2548 has a layout that corresponds to the layout of the front panel. In particular, mouse-actuatable switch areas are provided at respective positions in the area 2548 corresponding to respective positions of the switches 638, 340, 642, 644, 646, 648, 650, 658 and 660 of the front panel (Fig. 6). The camera selection switch areas of the area 2548 bear the legends "1" through "16", respectively, and correspond to the identically numbered camera selection switches 650 on the physical front panel. Moreover, an "alarms" switch area, indicated at 2556 in Fig. 11, corresponds to the "alarms" -labeled switch 658 on the front panel.

At the right side of the lower area 2548, are provided six switch areas arranged in a two across by three down array and corresponding in location and function to the switches 638, 640, 642, 644, 646, and 648 of the front panel. The switch area corresponding to the front panel switch 638 is overlaid with a single rectangle indicated at 2558, which is representative of the single-window display format to be established by actuating either the switch 638 or the switch area bearing the single rectangle. Similarly, an overlay representing a 2 x 2 window format is provided at the switch-area corresponding to switch 640, a 3 x 3 overlay is provided at the switch-area corresponding to switch 642 of the front panel, and a 4 x 4 overlay is provided at the switch area corresponding to the switch 644 on the front panel. All of the above-mentioned switch-areas of the lower part 2548 of the Fig. 11 screen display are actuatable by manipulating the mouse, and with the same effect as physically pressing the corresponding switch buttons on the front panel. Also included in the area 2548 is a

generally circular mouse-actuatable switch area 2560 which bears the legend "play". The circular switch area 2560 corresponds in position as well as function, to the jog-shuttle switch 660 on the front panel. Like the jog-shuttle switch, the switch area 2560 has arrow legends. The region at the arrows of the switch area 2560 is manipulatable by the mouse to provide "rotation" of the switch area 2560 either in a clockwise or counter-clockwise direction. The mouse-actuated rotation of the switch area 2560 has effects that emulate the manual rotation of the jog-shuttle switch 660 of the front panel. The lower area 2548 of the screen display of Fig. 11 also includes mock-LED display regions which emulate in position and function the LEDs 652 and 656 previously discussed with reference to the front panel (Fig. 6).

Another notable feature of the screen display format of Fig. 11 are the alphanumeric character overlays provided in the image display window 2550. The overlays shown in Fig. 11 include date and time information, as well as a legend "live" to make clear to the reader that a live video signal is being provided in the window 2550. A camera identification overlay is provided at a lower left corner of the window 2550.

Fig. 12 shows a display format utilized when the VR/PC unit is operated in a playback mode. The playback mode may be entered by actuating either the play/pause area on the jog-shuttle switch 660 of the front panel, or by mouse-clicking on the "play" legend at the center of the circular switch area 2560 shown in Fig. 11. The screen display format of Fig. 12 is generally similar to that of Fig. 11, and only the differences between those two formats will be discussed. First, it should be understood that the video image stream displayed in the display window 2479 of Fig. 12 represents a previously recorded and currently reproduced image stream, rather than a live, currently-generated image stream.

The switch area features and mock-LED areas in Fig. 12 are the same as those in Fig. 11, except that the

switch areas "schedule on", "utilities", "archive" and "setup" of Fig. 11 are replaced with switch areas labeled "exit", "search" and "tools" in the display format of Fig. 12. Actuation of the "exit" switch area in Fig. 12  
5 returns the system to a live-display mode with the format of Fig. 11. Actuating the "search" switch area in Fig. 12 brings up a menu screen display which permits the user to select among video database search functions. The "tools" switch area gives the user access to image processing  
10 utilities.

Fig. 129 represents a search dialog screen display which can be called up by the user by actuating the "search" switch-area on the screen display of Fig. 12. A major feature of the search dialog display of Fig. 129 is  
15 the selection of tab dialog boxes respectively bearing the legends "date/time", "camera", "alarm" and "tools". In the particular display example shown in Fig. 129, the "data/time" dialog box is uppermost. The other tabbed dialog boxes can be actuated by clicking on the respective  
20 tab.

The date/time dialog box has three mouse-actuatable mode selection settings, indicated as "all recorded images", "images between . . .", and "images within". The first selection implements a video data base search  
25 without any time limit. The second selection provides starting and stopping limits to constrain the search period. The third selection limits the search to a given duration prior to and extending up to the present time.

Below the dialog box area is a "result field" which  
30 is used to display information identifying images found to match the search criteria. To the right of the dialog box area there is a vertical column of five switch-areas, respectively legended "find", "stop", "play", "close", and "help". Immediately below these switch areas is an icon  
35 area in which a "search light" icon is displayed. While a search is being carried out, the search light icon 2562 is moved in an oscillating sweep pattern to indicate to the user that a search is in progress.



Actuation of the "find" search button causes the selected search to be executed. Actuation of the "stop" button causes a search in progress to be stopped. Actuation of the "play" switch area causes the VR/PC unit  
5 to playback a video stream corresponding to a selected item in the result field. Actuation of the "close" switch area returns the user to the playback screen display of Fig. 12. It will be observed in Fig. 129 that the "all recorded images" selection is selected.

10 Fig. 130 is a display screen similar to that of Fig. 129, but indicating selection of the "images between . . ." option instead of the "all recorded images" option. Also shown in Fig. 130 is a pop-up calendar box which allows the user to set a date to limit the search period.  
15 To the left of the pop-up calendar box are user-adjustable time-of-day settings.

Fig. 131 illustrates the search dialog display provided when the "alarm" dialog box is selected. In a left portion of the alarm dialog box, the user may select  
20 search criteria relating to alarm events detected by external alarm sensor devices. On the right side of the alarm dialog box, the user may select search criteria based upon whether image analysis algorithms operated at the time that the video data was generated have detected  
25 predetermined characteristics that were the subject of the analysis algorithms.

Fig. 132 illustrates the search dialog display screen provided when the camera dialog box has been selected. In the example shown in Fig. 132, a pull-down list of cameras  
30 has been actuated to allow the user to specify which camera streams are to be searched.

It is also notable that, in Fig. 132, the results field includes a listing of four matching video data portions which were found in a previous search. The  
35 "play" switch area at the right side of the display in 132 is illuminated (by contrast with Figs. 129-131), to permit the user to playback the video data portions listed in the results field.

In Fig. 133, again the date/time dialog box has been selected. In addition, the first video data portion listed in the results field has been selected and would be played back if the user actuated the "play" switch area.

5 Fig. 134 is the set up option display screen which is generated in response to user actuation of the "setup" switch area of Fig. 11. The setup option display screen provides the user with four setup options, each accessible through a respective switch area. The options are "name"  
10 (applying names to cameras and alarm inputs and outputs), "record" (allowing the user to select recording options), "security" (permitting the user, if authorized, to configure security arrangements for the VR/PC unit), and "login" (permitting the user, if authorized, to add or  
15 delete users permitted to log into the VR/PC unit). Also provided are a "close" switch area which causes the screen display to return to the display format of Fig. 11, as well as the customary "help" switch area.

Fig. 135 is an example of the recording options dialog box displayed in response to actuation of the  
20 "record" switch area of Fig. 134. The dialog box shown in Fig. 135 permits the user to select three types of options: recording mode, recording quality, and recording rate. The two possible recording modes are "linear" and  
25 "circular". In the linear mode, the recording on the hard drive ends when the hard drive storage capacity is exhausted. In the circular recording mode when the end of the hard disk storage area is reached, the next incoming video data is written at the beginning of the hard disk  
30 storage area.

The recording quality options are "normal", "super fidelity", and "extended". The three quality options each correspond to different quantization bit rates carried out in the JPEG chip 848 (Fig. 14). Continuing to refer to  
35 Fig. 135, the "super fidelity" setting uses, on average, more data bytes to represent each video data field than are used in the "normal" setting, so as to provide enhanced image quality. The "extended" setting uses, on

average, fewer data bytes to represent each video data field than the normal setting, providing more efficient use of the hard disk storage capacity, but with somewhat lower image quality.

5       The recording rate options are implemented via a pull-down list, as shown in Fig. 136. The rate options correspond to different field capture rates, and are indicative of the effective recording duration (2, 6, 12 or 24 hours) provided by the hard disk storage capacity at  
10 the respective rate options. Although not indicated by the options presented in Figs. 135 and 136, the rate and quality settings could also be made on a camera-stream by camera-stream basis. Moreover, the quality settings could be used to adjust compression front-end "block sameness"  
15 thresholds and/or reference image frequency rates, instead of or in addition to the JPEG quantization setting adjustment currently driven by the quality setting options. It is also contemplated to display, for each of the quality and rate options, sample video image sequences  
20 to indicate to the user what sort of image quality can be expected from each of the quality and rate settings.

      Fig. 137 is the login dialog box presented in response to actuation of the "login" switch area on Fig. 134. The dialog box in Fig. 137 invites the user to enter  
25 a personal identification number (PIN) utilizing the virtual numeric keypad provided at the right hand side of the dialog box. A backspace switch area 2564 is provided. As each number in the virtual keypad is actuated, an asterisk corresponding to each digit is displayed in the  
30 field under the legend "enter PIN code:". The "okay" switch area implements an enter function, at which the point the entered digits are read to determine whether an authorized user is attempting to login.

      If the user currently logged in is entitled to  
35 reconfigure the unit's security features, then actuation of the "security" switch area in Fig. 134 causes the display screen shown in Fig. 144 to be displayed. The main options shown in the display of Fig. 144 are adding

a new user ("add" switch area), changing the features accessible by an existing user ("edit" switch area) and removing an existing user ("delete"). In the field at the left side of the display of Fig. 144, a list of the  
5 existing authorized users is provided.

Actuating the "edit" switch area on Fig. 144 provides access to the access privileges display of which a first example is shown on Fig. 138. A scroll-bar provided in a vertical orientation at the lower right side of the  
10 display of Fig. 138 permits the user to scroll through the various feature access privilege settings. Setting options shown in Fig. 138 include the ability to override pre-scheduled operating modes ("enable" under "schedule") and configuring the pre-scheduled operating modes  
15 themselves ("configure" under "schedule").

Fig. 139 shows another view of the feature access privileges setting options, including options relating to system setup privileges. The setup privileges shown in Fig. 139 correspond to camera-related setup options,  
20 selecting analysis algorithms to be applied to incoming video streams, live video display format options, and system security features.

Fig. 140 is the same display as Fig. 139, but indicating the security feature access privileges are  
25 being accorded to a particular user. In addition, the illuminated areas to the left of the "cameras" and "analysis tools" feature privileges indicate that those privileges have previously been accorded to the same user.

Fig. 141 represents the same display at another  
30 scrolling position relative to the feature access privileges. The privileges shown in Fig. 141 relate to selecting recording mode options ("configure" under "record"), accessing operating systems software files ("maintenance" under "record"), access to video data  
35 stored on the hard disk ("enable" under "playback") and access to video signals stored on a conventional externally-connected video cassette recorder, which is not shown ("VCR transcript" under "playback").

Further feature access privileges are shown in Fig. 142, namely the ability to configure event handling modes ("configure" under "events"), and the ability to access reports concerning detected events ("reports" under  
5 "events").

Still further feature access privileges are shown in Fig. 143. These relate to retrieving data stored on an archive recording medium ("enable" under "archive") and storage and retrieval of data stored on a hard disk which indexes the contents of archive recording media ("restore"  
10 and "library").

In Fig. 145 represents the screen display brought up in response to actuation of the "name" switch area of Fig. 134. In the display screen of Fig. 145, three tabbed dialog boxes are accessible namely "cameras", "alarms in",  
15 and "alarms out". In the particular display shown in Fig. 145, the "cameras" dialog box has been selected. The cameras dialog box provides naming fields for each of sixteen cameras. Alphanumeric names may be entered into  
20 each of the naming fields utilizing either a keyboard (not shown) connected to the VR/PC unit, or a "virtual keyboard" (not shown) displayed on the display monitor and actuatable by the mouse.

Fig. 146 presents the "alarms out" dialog box accessible at Fig. 145. The alarms out dialog box permits  
25 alphanumeric designation of sixteen alarm output signals.

Fig. 147 presents the "alarms in" dialog box which is also accessible at Fig. 145 (or Fig. 146). At Fig. 147, names may be entered to identify respective external alarm  
30 sensor devices which generate sixteen incoming alarm detection signals.

Fig. 148 is a screen display that is brought up in response to actuation of the "utilities" switch area of Fig. 1. The options presented to the user in the display  
35 of Fig. 148 are transmitting data (including video data) to an external device, such as a local or master node, creating reports concerning operation of the VR/PC unit, to be printed out on a printer (not shown), and generating

signals to control movable cameras connected to the VR/PC unit.

Fig. 149 is a display screen brought up in response to actuation of the "status" switch area of Figs. 11 and 5 12. The status data displayed in Fig. 149 is generated by the process discussed above in connection with Fig. 121. Fig. 149 displays data indicative of the remaining storage capacity available on the hard disk or disks, the storage capacity remaining available on a removable archive 10 recording medium, the number of alarm events that have been detected and not yet reviewed by the user, the number of alarm events that have been reviewed but not deleted from the alarm event file, the number of video cameras connected to the VR/PC unit and the number of cameras from 15 which the video streams are currently being recorded.

Fig. 150 is a display screen provided for the purpose of defining a pre-scheduled live video display format. Tabbed dialog boxes accessible by the user at the display screen of Fig. 150 are, respectively, for 2 x 2, 3 x 3, 4 20 x 4 and "custom" video display window formats. The 2 x 2 dialog box is shown as being active in Fig. 150. The text "weekend day" shown toward the right at the top of the selected dialog box indicates that the user is defining pre-scheduled operational modes to be automatically 25 carried out during time periods defined as day times on weekends. To the left side of the dialog box, a number of icons are provided, each corresponding to a respective camera connected to the VR/PC unit. To the right side of the selected dialog box is a two by two array of empty 30 boxes, representing the four video display windows in the display format that is being set-up. As shown in Fig. 151, a camera icon may be dragged using a cursor 2566 so that the icon is placed in one of the boxes. Placement of the camera in the box indicates assignment of the 35 corresponding camera video stream for display in the corresponding display window. In the particular instance shown in Fig. 151, the "parking lot" camera stream has been designated for display in the upper left hand window

of the 2 x 2 display format.

Fig. 152 is a display screen provided during scheduling setup operations in order to define which calendar days are to be considered holidays. To the left  
5 side of the display in Fig. 152, a calendar display is provided to permit the user to select a particular day of a particular month of a particular year. To the right side of the display in Fig. 152, there is provides a list of the dates which have been designated holidays.  
10 Actuation of the "add" switch area in Fig. 152 causes a date selected in the calendar display to be added to the holiday list.

#### IMAGE ANALYSIS TOOL SETUP SCREENS

15 Fig. 153 represents a screen display provided to the user to permit the user to set parameters for an image analysis algorithm designated as the "light tool". This algorithm is designed to detect selected changes in illumination in the screen of interest. The screen  
20 display in Fig. 153 includes an image display window 2568 in which a static video image is displayed. The static video image is used to define the parameters for the light tool. Displayed within the image is a display element box 2570, which defines the area of the image plane with  
25 respect to which the algorithm is to operate. The box 2570 may be dragged from one location to another in the image plane, and may be decreased or increased in size and changed in shape, by cursor manipulation in like manner to manipulation of similar graphic elements in a conventional  
30 computer drawing software package. The portion of the image within the box 2570 is displayed in a brighter manner than the balance of the image so as to highlight the area within the box 2570. A circular spot 2572 is within the box 2570. The size of the spot 2572 is  
35 indicative of the size of a light spot to be detected if a spot light detection feature of the analysis algorithm is actuated. The spot is preferably displayed in a solid color such as red.

Virtual buttons and switches for selecting features of the algorithm and setting parameters therefore are provided on the right side of the display of Fig. 153. At 2574, the user is permitted to fix the location ("mark") or delete ("erase") the active zone defined by the box 2570. At 2576, the user is permitted to select among three operational modes for the algorithm: detecting a large increase in illumination ("dark to light"), detecting a large decrease in illumination ("light to dark") or detecting a bright spot of light in the active zone ("spot light"). The first option enables the VR/PC unit to determine when lights are turned on, the second to detect when lights are turned off, and the third is intended to detect the presence of a flashlight in a darkened area.

The slide bar at 2578 controls the size of the spot 2572 used as a parameter setting for the spot light operational mode. As the slide bar is manipulated to the left, the size of the spot 2572 is reduced. Manipulating the slide bar to the right causes the spot size to be increased.

Sensitivity setting options for the light tool are provided at 2580. The sensitivity parameters for the light tool constitute the thresholds for determining whether the change over from dark to light or light to dark has taken place, or whether the illuminated area to be detected in the spot light mode is sufficiently bright to constitute an event to be detected. If the "default" switch area is actuated by the user, then threshold settings considered to be optimal by the designers of the VR/PC unit are applied. The sensitivity level can also be adjusted by the user by manipulating the slide bar provided at 2580. Moving the slide bar to the left decreases the sensitivity, which decreases the risk of false alarms, while also increasing the risk that significant events will not be noted. Sliding the slide bar to the right increases the sensitivity, thereby reducing the risk that significant events will go unnoted,



but also increasing the risk of false alarms. The "ADV" switch area allows the user to access a dialog box in which the various sensitivity parameters are unbundled and can be set separately from each other.

5 Above the image display window 2568, there is a legend which identifies the type of analysis algorithm being setup as well as the camera to which it is to be applied. Below the window 2568 are switch areas to actuate application of the algorithm to the selected video  
10 image stream, or to cancel selection of the analysis algorithm.

Fig. 154 presents a screen display which permits the user to set parameters in connection with a motion detection analysis algorithm. As with the light tool  
15 setup screen shown in Fig. 153, the motion detection setup screen of Fig. 154 includes an image display window 2568 and a graphic element box 2570 which defines an area of the image plane within which the motion detection algorithm is to be applied. An upper right portion of the  
20 display in Fig. 154, indicated by reference numeral 2582, provides cursor-actuatable features to allow the user to activate, deactivate or remove one or more active zones corresponding to one or more of the graphic image element boxes 2570. The display shown in Fig. 154 also includes  
25 a sensitivity control area 2580 corresponding to that of Fig. 153. In regard to the motion detection tool, the sensitivity controls provide thresholds for such factors as the amount of motion detected in the active zone and/or luminance levels.

30 Fig. 155 presents the setup screen display for use with the above-described perimeter violation detection analysis algorithm. The display of Fig. 155, includes an image display window 2568 as in the other tool setup screen displays just discussed. Other features of the  
35 display in Fig. 155, including the graphic image element box 1966 representing the perimeter, the crossing direction arrows 1976 and the object size box 1986, have previously been referred to in connection with the

processing algorithm shown in Figs. 90A-90C. Controls provided at 2584 permit the user to mark or erase the perimeter corresponding to the box 1966. The controls at 2586 select whether the directional arrows 1976 point  
5 inwardly, outwardly or in both directions relative to the perimeter. The slide bar at 2588 controls the size of the object box 1986. Manipulating the slide bar 2588 to the left reduces the size of the object box, manipulation in the other direction increases the size of the object box.  
10 It should be understood that, as an alternative, the object size box itself could be subject to cursor manipulation so as to be decreased or increased in size, as can be done with drawing elements in conventional computer drawing software packages.

15 The sensitivity controls 2006 have previously been referred to in connection with Fig. 90D. The sensitivity factors controllable at 2006 may include contrast ratio and degree of confidence in terms of one or more of presence of motion, location of moving object, and size of  
20 the moving object.

Although not shown in Fig. 155, it is also contemplated to allow the user to set as a parameter the speed at which an object crosses the perimeter. A graphic element that oscillates at a speed settable by user input  
25 may be provided. Such a graphic element may, for example, be similar in appearance to the wand of a musical metronome. The VR/PC unit may be programmed to detect image edges to detect perspectives indicative of depth in the image scene, and to adjust tile-space measures of  
30 velocity to take depth into account when estimating the speed of an object. A slide bar control for setting the velocity parameter may be provided in association with the "metronome" element, or in place of the "metronome".

Fig. 156 is the setup screen for the analysis  
35 algorithm known as the "museum tool". The museum tool algorithm is intended to permit automatic detection of the removal of an object, such as a painting, a piece of jewelry or the like. As in the other tool setup screens,

the screen shown in Fig. 156 includes an image display window 2568. A graphic image element box 2590 defines a zone which is to be monitored by the analysis algorithm. The box 2590 can be changed in width and height or both in order to change the monitored zone. Unless the monitored zone is quite small, a preferred embodiment of the museum tool algorithm calls for defining a number of "hot spots" represented by colored rectangles 2592. When hot spots 2592 are provided, it is only the portions of the image plane corresponding to the hot spots themselves that are actually monitored. The number of hot spots provided depends on how large an area in the image plane is occupied by the monitored zone defined by the box 2590. The number of hot spots may be reduced by the user, but may not be increased, in a preferred embodiment. The purpose of monitoring only the hot spots, rather than the entire monitored zone, is to save memory. In a preferred embodiment of the museum tool, the removal of object is detected by noting differences between the content of tiles located in the hot spots and corresponding tiles in a reference image.

Controls at 2594 permit the user to mark or erase the monitored zone corresponding to the box 2590. Controls at 2594 permit the user to mark or erase hot spots. The user is permitted to reposition hot spots within the monitored area by dragging the hot spots with a cursor.

The control at 2598 allows the user to define for how long the monitored area must be missing or occluded before an event is considered to have occurred.

At 2602, sensitivity controls are provided to set thresholds for factors such as variation in chrominance, numbers of hot spots occluded, or the like.

Fig. 157 is a screen display in a format that is an alternative to the display shown in Fig. 152 for generating a list of holidays. In the format shown in Fig. 157, the calendar selection box is implemented as a pull-down element, and the "set holiday" dialog is one of a number of tabbed dialog boxes including "general",

"weekday", "weekend", and "holiday".

Fig. 158 presents the "weekday" dialog accessible at Fig. 157. Fig. 158 provides scheduling of the recording status for sixteen cameras connected to the VR/PC unit. In general, the format of the display in Fig. 158 is a bar chart, with horizontal bars displayed for each of the sixteen cameras. Bars of different colors indicate different operating modes for the camera selected for respective portions of the 24-hour period. The bars can be manipulated, using the cursor so as to stretch or shrink the bar, which has the effect of increasing or decreasing the scheduled period of time for the corresponding operating mode. The available operating mode options for each camera are "active" (ongoing recording), "alarmed" (recording only in the event an alarm condition is detected) and "disabled" (no recording of the camera stream). A pop up element indicated at 2604 states in numeric terms the period of time represented by a selected bar element. The pop up 2604 shown in Fig. 158 corresponds to the bar at camera 7, as shown by the selection indicator 2606. The formats for the "weekend" and "holiday" dialog boxes are like Fig. 158.

Fig. 159 shows the dialog box corresponding to the "general" tab which is visible in Figs. 157 and 158. The controls at 2608 in Fig. 159 allow the user to select between regular scheduling options and custom schedule options. At 2610, the user is permitted to define for weekdays when the "day-time" and "night-time" periods take place. The controls shown at 2610 are an alternative to the display presented in Fig. 81.

Continuing to refer to Fig. 159, controls provided at 2612 permit the user to define the starting and ending times for weekends, and the controls at 2614 permit the user to define starting and ending times for holidays.

Fig. 160 is a variation on the display screen of Fig. 159. It will seen from the controls 2608 in Fig. 160 that "weekend" and "holiday" have not been selected for custom scheduling. As a result, the weekend and holiday tab

dialog boxes shown in Fig. 159 are not presented as options in Fig. 160.

Fig. 161 presents a screen display which permits the user to select and set a parameter for an image processing utility. The display screen of Fig. 161 includes an image display window 2616, for displaying an image which is to be subjected to processing. A box 2542, which has been referred to above, is overlaid at a portion of the window 2616 and defines the portion of the image plane in which a selected processing utility is to be applied. Zoom controls 2618 are provided at an upper right hand portion of the display screen. The zoom controls permit a user to zoom in or out of the portion of the image defined by box 2542, and/or to move the area which is subject to zooming. The switch area marked "1:1" restores the image to an unzoomed condition. The switch area marked "enhance" applies a group of image enhancement processes to the zoomed area, including emphasis of high frequency components, an increase in contrast, normalization of color and intensity distributions, and non-linear interpolation of pixels, instead of linear interpolation. Provided below the controls 2618 are utility selection controls 2620, which permit a user to select from among other image processing utilities in addition to the zoom function. For example, one of the utilities that may be selected using the controls 2620 is the selective contrast enhancement utility previously described with reference to Figs. 128(a) and (b). Other image processing utility options that may be presented to the user include adjustments to brightness, "sharpness" (i.e., the degree to which emphasis is applied to high-frequency components of the image data), and color and/or intensity distributions. A horizontal array of switch areas is provided at the bottom of the display screen. A switch area marked "full scr" switches the screen format of Fig. 161 to a full screen format. The switch area marked "load" causes an image to be retrieved from a floppy disk inserted in the VR/PC unit so that the retrieved image can

be displayed in the window 2616. The switch area marked "save" causes the image displayed in the window 2616, including any modifications applied by processing utilities, to be written onto the floppy disk.

5 The "print" switch area causes the image displayed in window 2616 to be output as hard copy via a printer or to be transmitted as a facsimile. The switch area marked "restore" removes any modifications that resulted from application of processing utilities.

10 Fig. 162 is a screen display which permits a user to implement a process for discarding video data corresponding to certain parts of the image plane. The display screen of Fig. 162 includes an image display window 2622 for displaying a video image. Polygonal  
15 drawing elements such as those indicated at 2624 and 2626 may be formed by the user to define areas in the image plane for which video data need not be stored. Controls relating to the selected areas are provided at 2628. In response to the user's designation of the areas indicated  
20 by the polygonal figures 2624 and 2626, the motherboard CPU instructs the front end electronics that corresponding portions of an image plane in the video signals generated by the selected camera are not to be transmitted for storage, thereby achieving more efficient utilization of  
25 the disk storage capacity. The feature illustrated in Fig. 162 permits the user to select areas of the image plane which are determined not to be of interest with respect to a particular camera image stream. The areas found not to be of interest may be areas like those  
30 indicated in Fig. 162, which are essentially static, or may include areas which include frequent motion (e.g., a highway in the background, or a wind-blown tree) which are also unlikely to provide significant information, although being likely to generate large quantities of data in  
35 difference video data fields if not selected for discarding.

Fig. 163 shows a live video display format, similar to that of Fig. 11, except that the live video display

window 2550 has been divided into four sub-windows in a 2 x 2 configuration. In the particular example of the 2 x 2 configuration shown in Fig. 163, each of two different live input signals is shown in two of the four windows. However, it is contemplated that in the format of Fig. 163, four different live video streams may be displayed simultaneously. In addition, as indicated at 2630, a bright colored box (e.g., in red) is provided in the upper left hand corner of each window to indicate that the image stream in question is being recorded. It should be understood that if an image stream displayed in one of the sub-windows is not being recorded, then the indicator 2630 is not present. Other forms of the record-selection indicator 2630 are also contemplated, including, e.g., a circular indicator positioned at the lower border of the display window.

Fig. 164 is a screen display generated in response to actuation of the "archive" switch area in the display of Fig. 11 (or Fig. 163). Referring to Fig. 164, the user is presented with a choice of two tabbed dialog boxes, corresponding to "archiving" and "searching". The particular example of the display screen shown in Fig. 164 shows the "archiving" dialog as active. The archiving dialog permits the user to select among four modes of archiving operation: "background", in which archiving is carried on continuously in background while other functional operations of the VR/PC unit take place (preferably the archiving background process is lower in priority than either recording or playback operations, as indicated in the above discussion of Fig. 116); "background-silent", which is the same as "background" except that the data relating to archive space is omitted from the status display (Fig. 149); "dedicated-fast", a mode in which no recording or playback operations occur, so that motherboard CPU processing and disk access resources are dedicated to rapidly copying video data from the disk to the archive medium; and "archive off", in which no archiving is taking place.

The archive dialog box also indicates which device is being used for the archiving function; in this case it is the internally installed DAT drive. The switch areas provided in a vertical column at the left side of the screen display in Fig. 164 are analogous to those shown in 5 Figs. 129-133, but are not operational when the archiving dialog box is selected. Rather, these switch areas may be used in connection with the "searching" dialog box which will be referred to below. Also provided in the format of 10 Fig. 164 is a "search light" icon analogous to the icon 2562 which was discussed above in connection with Fig. 129. In addition, a search-results field is provided at the lower part of the screen display.

Fig. 165 presents an alternative version of the 15 display of Fig. 164. Fig. 165 differs from Fig. 164 in that Fig. 165 offers two additional dialog boxes, respectively tabbed "library" and "customize". In addition, the archiving dialog box of Fig. 165 permits the user to select among a number of internal or external 20 record medium drive devices. Among the selections provided in Fig. 165 is an internally-installed magneto-optical disk drive device.

Fig. 166 presents a screen display which is reached by selecting the "searching" dialog box available at Fig. 25 164. The searching dialog box shown in Fig. 166 permits the user to define date and time or alarm parameters to be used in searching for video data of interest that has been stored on the currently inserted archive recording medium.

Fig. 167 is a screen display provided when the 30 "library" dialog box is selected at Fig. 165. The purpose of the library dialog box is to access the previously-recorded archive media database which was discussed above in connection with Fig. 119. The user may request viewing of data corresponding to all previously recorded archiving 35 media, or only those recorded within a user-defined time period. The display field provided at the bottom of the screen display is for displaying the requested information. The "add" switch area permits the user to



add to the database an item corresponding to an additional recorded archive medium. The "delete" switch area permits the user to remove an item from the database. The "details" switch area permits the user to select display  
5 of detailed data relating to one of the items in the database. The "reset" switch area permits the user to clear all data from the recorded archive media data base.

The display screen shown in Fig. 168 illustrates the "customized" dialog box available to the user from the  
10 screen displays of Figs. 165 through 167. In the "customized" dialog box, the user is permitted to update a listing of archiving media drive units that have been installed within or connected to the VR/PC unit. Among the types of archive media drive units that are or may be  
15 installed, the following are indicated in the screen display of Fig. 168: a digital video disk (DVD) drive, an internal DAT drive, a magneto-optical disk drive, a so-called "jazz" drive (removable hard disk), and a DAT carousal. It is, of course, contemplated that any or all  
20 of those types of devices may be connected to the VR/PC unit.

#### ANALYSIS TOOL SELECTION SCREENS

Fig. 169 is a screen display provided in response to  
25 selection of the "tools" dialog box at any one of Figs. 129 through 133. The purpose of the "tools" dialog box is to permit a user to select for a recorded video stream corresponding to a given camera, an image analysis algorithm to be applied to the image stream. The "tools"  
30 dialog box includes a pull-down list 2632 used to select a camera, and another pull-down list 2634, to permit the user to select an image analysis algorithm to be applied to the recorded video stream which was generated by the selected camera. A switch area labeled "setup" allows the  
35 user to bring up the tool setup screen display corresponding to the selected analysis algorithm. Examples of tool setup screen displays have previously been discussed, and are shown at Figs. 153-156. At the

lower part of Fig. 169, information indicating previous assignments of analysis tools to recorded camera streams is shown.

Fig. 170 shows a screen display provided when the pull-down menu under "Tool To Apply:" in Fig. 169 is pulled. As seen at 2636, the menu provides the user with several options as to selection of image analysis algorithms, including "motion tool", "perimeter tool", "museum tool" and "light tool". In addition, the user may elect not to have any analysis tool applied during the search. Thus, the screen display of Fig. 170 permits the user to conveniently select for searching purposes from among a plurality of previously-stored image analysis algorithms. As an alternative to the word-listing of the analysis algorithms options shown in Fig. 170, it is also contemplated to use icons representative of the previously-stored analysis algorithms available for selection by the user.

As can be seen from Figs. 171 and 172, pull-down menus are also presented to the user to permit selection of an analysis algorithm to be applied to live incoming video streams. In the screen display shown in Fig. 171, the analysis algorithms are assigned on a camera-by-camera basis, while even finer "granularity" is provided in Fig. 172, whereby selection of a particular analysis algorithm is not only applicable to a particular camera, but to a particular future time period.

Fig. 173 is an example of a hard copy screen print generated in response to actuation of the "print" switch area shown in Fig. 161. The hard copy print shown in Fig. 173 includes an image 2640, which may be in color, and may represent a zoomed and/or otherwise processed portion of the image shown in the window 2616 of Fig. 161. In addition, as shown at 2642, caption information is provided, indicating times at which the image was generated and printed out, the source of the image, and so forth.

It has previously been mentioned that the preferred

video data file format would also accommodate storage on disk with the video data, of contemporaneously generated audio data. One or more microphones (not shown or other sources of audio information could be connected as inputs  
5 to the VR/PC unit or a modified version thereof. The audio information, after digitation, would be stored on disk, possibly in association with related video data. The VR/PC unit would have a speaker (not shown), built in or attached as a peripheral, to reproduce in audible form,  
10 audio information retrieved from the disk.

It is also contemplated that audio content analysis algorithms ("tools") might be provided in the VR/PC unit to detect audible events such as door openings/closings, footsteps, etc. The audio tools could be operated either  
15 "live", or as "search" tools, i.e. by application to audio data retrieved from disk, and may be applied similarly to the video "tools" described above. For example, a live audio tool or tools could be employed to detect events and actuate alarm conditions. Audio tools could be employed  
20 in logical combinations with each other and/or with video tools. As one example, detection of footsteps by an audio tool, in the absence of detection of light by a video tool, could actuate an alarm condition. Application of a video tool could be triggered by detection of an audio  
25 event, and/or application of an audio tool could be triggered by detection of a video event.

Audio tools preferably would be selectable and configurable in a manner similar to the "video tool kit" features illustrated above at Figs. 170-172 and 153-156.  
30 User-settable parameters to constrain execution of an audio tool might include sound volume, frequency, direction, and so forth. Characteristics of audio surveillance such as low cost, the relatively small quantity of data to need be stored, omnidirectionality,  
35 and independence from illumination, can in many applications make audio a valuable supplement to, or even replacement for, video surveillance. At the same time, application of the information management philosophies

disclosed herein can significantly enhance the usefulness of audio surveillance and the resulting stored data.

It should be understood that the embodiments of the claimed invention disclosed above are to be taken as  
5 illustrative, and not limiting. The true spirit and scope of the invention is set forth in the following claims.

What is claimed is:

1. A flexible video information analysis apparatus, comprising:
  - (a) first storage means for storing a video  
5 information data base;
  - (b) second storage means for storing a plurality of moving image content analysis algorithms for analyzing video information in the data base;
  - (c) user actuatable means for selecting one of  
10 said algorithms; and
  - (d) analysis means, responsive to said user actuatable means, for analyzing said video information in the data base in accordance with said one of said algorithms selected by said user actuatable means.
- 15 2. An apparatus according to claim 1, further comprising:
  - a plurality of video cameras for generating respective sequences of video signals; and
  - means for digitizing the respective sequences of  
20 video signals generated by said video cameras and for supplying the digitized sequences of video signals to said first storage means.
3. An apparatus according to claim 1, further comprising means for displaying a plurality of icons or  
25 alphanumeric labels each representing a respective one of said algorithms for analyzing video information.
4. An apparatus according to claim 3, wherein said user actuatable means comprises means for selecting one of the displayed icons or alphanumeric labels.
- 30 5. An apparatus according to claim 4, wherein said means for selecting one of the displayed icons comprises a mouse.
6. An apparatus according to claim 4, wherein said means for displaying and said means for selecting one of  
35 the displayed icons comprise a touch-sensitive screen.
7. An apparatus according to claim 1, wherein said user actuatable means includes means for setting a parameter for constraining execution of a selected one of

said algorithms.

8. An apparatus according to claim 7, wherein said means for setting said parameter includes location means for selecting a portion of an image plane which  
5 corresponds to said video information, said analysis means responding to said location means by analyzing said video information with respect to the portion of the image plane selected by said location means.

9. An apparatus according to claim 1, wherein at  
10 least one of said stored algorithms is for detecting moving objects represented by data in said stored video information data base.

10. An apparatus according to claim 1, wherein said analysis means generates analysis data indicative of  
15 results of the analysis performed by said analysis means in accordance with said selected one of said algorithms and said first storage means includes means for storing said analysis data generated by said analysis means.

11. A method of storing and retrieving video data,  
20 comprising the steps of:

storing data representing plural images of a dynamic video image stream;

selecting a search algorithm to be used in searching for a desired image among the images represented  
25 by the stored data;

setting a parameter for constraining execution of the selected search algorithm; and

30 searching said stored data in accordance with the selected search algorithm and the set parameter.

12. A method according to claim 11, wherein the selected search algorithm is for detecting moving objects represented by said stored data.

13. A method according to claim 11, wherein the parameter for constraining execution of the selected  
35 search algorithm represents a location in an image plane at which the selected search algorithm is to be performed.

14. A method of carrying out an algorithm for detecting features represented by video data stored in a

video information data base, comprising the steps of:  
    setting a parameter for constraining execution  
of said algorithm; and  
    executing said algorithm in accordance with the  
5 set parameter.

15. A method according to claim 14, wherein said  
algorithm is an algorithm for detecting at least one  
moving object represented by the stored video data, and  
said setting step includes selecting a portion of an image  
10 plane which corresponds to the stored video data, said  
portion being a portion at which said at least one moving  
object is to be detected by execution of said algorithm.

16. A method according to claim 15, wherein said  
portion of an image plane is selected by displaying an  
15 image which corresponds to an image represented by the  
stored video data and superimposing a line or polygon on  
said displayed image, said superimposed line or polygon  
representing said selected portion of said image plane.

17. A method according to claim 16, wherein said  
20 displaying of said image includes retrieving from the  
video information data base data representing said image  
to be displayed.

18. A method according to claim 16, wherein said  
displaying of said image is performed by:

25           generating with a video camera a video signal  
representing an image which corresponds to an image  
represented by said stored video data; and

            displaying the video signal generated by said  
video camera.

30           19. A method according to claim 14, wherein said  
algorithm is an algorithm for detecting at least one  
moving object represented by the stored video data, and  
said setting step includes indicating at least one of a  
maximum size and a minimum size of the object to be  
35 detected.

20. A method according to claim 19, wherein said at  
least one of a maximum size and a minimum size is  
indicated by displaying an image corresponding to an image

represented by the stored video data and superimposing on said displayed image an image element indicative of said at least one of a maximum size and a minimum size.

21. A method according to claim 20, wherein a first  
5 image element indicative of said maximum size of the object to be detected is displayed in a first color superimposed on said displayed image and a second image element indicative of said minimum size of the object to be detected is displayed in a second color, different from  
10 said first color, superimposed on said displayed image.

22. A method according to claim 21, wherein said first and second image elements are displayed simultaneously.

23. A method according to claim 14, wherein said  
15 parameter setting step includes displaying a graphical user interface element and adjusting the displayed graphical user interface element by means of a user input device.

24. A method according to claim 23, wherein the  
20 displayed graphical user interface element is a slide bar.

25. A method according to claim 23, wherein the displayed graphical user interface element is a dial.

26. A method according to claim 23, wherein the user input device is a mouse.

27. A flexible video information analysis apparatus,  
25 comprising:

(a) a video information source for providing video information which includes at least one dynamic sequence of video information frames;

30 (b) storage means for storing a plurality of algorithms for analyzing the video information provided by the video information source;

(c) user actuatable means for selecting one of said algorithms; and

35 (d) analysis means responsive to said user actuatable means, for receiving the video information provided by said video information source and for analyzing the received video information provided by the



video information source in accordance with said one of said algorithms selected by said user actuatable means.

28. An apparatus according to claim 27, wherein said video information source includes a video camera which  
5 generates a dynamic sequence of video information frames.

29. An apparatus according to claim 27, wherein said video information source includes a plurality of video cameras which generate respective sequences of video information frames.

10 30. An apparatus according to claim 27, further comprising display means for displaying a plurality of icons each representing a respective one of said algorithms for analyzing video information.

31. An apparatus according to claim 30, wherein said  
15 user actuatable means comprises means for selecting one of the displayed icons.

32. An apparatus according to claim 31, wherein said means for selecting one of the displayed icons comprises a mouse.

20 33. An apparatus according to claim 31, wherein said means for displaying and said means for selecting one of the displayed icons comprise a touch-sensitive screen.

34. An apparatus according to claim 27, wherein said user actuatable means includes means for setting a  
25 parameter for constraining execution of a selected one of said algorithms.

35. An apparatus according to claim 34, wherein said means for setting said parameter includes location means for selecting a portion of an image plane which  
30 corresponds to said video information, said analysis means responding to said location means by analyzing the received video information with respect to the portion of the image plane selected by said location means.

36. An apparatus according to claim 35, wherein said  
35 apparatus is operative to display on said display means an image which corresponds to an image represented by said video information, and said location means includes drawing means for superimposing on said image displayed by

said display means a line indicative of said selected portion of said image plane.

37. An apparatus according to claim 36, wherein said drawing means includes a mouse.

5 38. An apparatus according to claim 27, wherein at least one of said stored algorithms is for detecting moving objects represented by said received video information.

39. An apparatus according to claim 38, further  
10 comprising object means for selecting at least one of a maximum size and a minimum size of objects to be detected in accordance with said at least one moving object detection algorithm.

40. An apparatus according to claim 39, further  
15 comprising display means for displaying an image which corresponds to an image represented by said video information, and wherein said object means includes drawing means for superimposing on said image displayed by said display means an image element indicative of said at  
20 least one of a maximum size and a minimum size.

41. An apparatus according to claim 40, wherein said drawing means includes a mouse.

42. A method of analyzing video information, comprising the steps of:

25 receiving an analog video signal which represents a dynamic sequence of images;

digitizing the received analog video signal to form a sequence of video data frames which represent the dynamic sequence of images;

30 first analyzing the sequence of video data frames using a first predetermined video data analysis algorithm and generating first analysis data indicative of results of said first analyzing;

35 storing the sequence of video data frames in a data base;

storing the first analysis data in said data base in association with the stored sequence of video data frames;

retrieving from the data base the stored sequence of video frames;

second analyzing the retrieved sequence of video data frames using a second predetermined video data analysis algorithm and generating second analysis data  
5 indicative of results of said second analyzing; and

storing the second analysis data in said data base in association with the stored sequence of video data frames.

10 43. A method according to claim 42, wherein said first analyzing step is performed before said step of storing the sequence of video data frames in the data base.

15 44. An apparatus for analyzing video information, comprising:

receiving means for receiving an analog video signal which represents a dynamic sequence of images;

20 A/D means, connected to said receiving means, for digitizing the analog video signal to form a sequence of video data frames which represent the dynamic sequence of images;

25 first analysis means, connected to said A/D means, for analyzing the sequence of video data frames using a first predetermined video data analysis algorithm to generate first analysis data;

30 storage means, connected to said A/D means and said first analysis means, for storing the sequence of video data frames formed by said A/D means and said first analysis data generated by said first analysis means; and

35 second analysis means, connected to said storage means, for retrieving the sequence of video data frames stored in said storage means and for analyzing the retrieved sequence of video data frames using a second predetermined video data analysis algorithm to generate second analysis data, said second analysis data being stored in said storage means.

45. An apparatus according to claim 44, further

comprising display means, connected to said storage means, for displaying at least one image represented by the stored sequence of images.

46. An apparatus according to claim 44, wherein said  
5 storage means includes:

compression means for receiving the sequence of video data frames from said A/D means and for applying a compression algorithm to the sequence of video data frames to form compressed video data; and

10 a storage medium on which said compressed video data is stored.

47. An apparatus according to claim 46, wherein said storage medium is a hard disk.

48. An apparatus according to claim 44, wherein said  
15 first analysis means includes a first processing device and said second analysis means includes a second processing device different from said first processing device.

49. A video information analysis apparatus,  
20 comprising:

means for receiving video information;

analysis means for analyzing the received video information in accordance with a predetermined analysis algorithm; and

25 parameter means, actuatable by a user of the apparatus, for setting a parameter to constrain execution of said analysis algorithm, said analysis means being responsive to said parameter means so as to execute said analysis algorithm in accordance with the parameter  
30 set by said parameter means.

50. An apparatus according to claim 49, further comprising display means for displaying an image which corresponds to an image represented by said video information, and wherein said parameter means includes  
35 drawing means, actuatable by said user of the apparatus, for superimposing on said displayed image a drawing element to indicate the parameter set by said parameter means.

51. An apparatus according to claim 50, wherein said drawing element is a line or polygon indicative of a location in an image plane at which the analysis algorithm is to be performed.

5 52. An apparatus according to claim 50, wherein said analysis algorithm is for detecting moving objects represented by said video information.

53. An apparatus according to claim 52, wherein said drawing element represents at least one of a maximum size and a minimum size of objects to be detected using said analysis algorithm.

54. An apparatus according to claim 52, wherein said drawing element represents at least one of a maximum velocity and a minimum velocity of objects to be detected by using said analysis algorithm.

55. An apparatus according to claim 52, wherein said drawing means includes a mouse.

56. An apparatus according to claim 49, wherein said parameter means includes display means for displaying a graphical user interface element and user input means for adjusting the graphical user interface element displayed by the display means.

57. An apparatus according to claim 56, wherein the displayed graphical user interface element is a slide bar.

25 58. An apparatus according to claim 56, wherein the displayed graphical user interface element is a dial.

59. An apparatus according to claim 56, wherein the user input device is a mouse.

60. A method of searching an image information data base, comprising the steps of:

a plurality of algorithms for identifying respective features in images represented by the image information in said data base;

35 selecting two of said stored algorithms for respectively identifying a first feature and a second feature;

selecting a logical operator to form a logical combination of said two selected algorithms; and

searching said data base to identify images which satisfy said logical combination of said two selected algorithms.

61. A method according to claim 60, wherein said  
5 image information data base includes data representative of at least one dynamic sequence of video information frames and at least one of said selected algorithms is for detecting a moving object in said at least one sequence of video information frames.

10 62. Apparatus for analyzing video information comprising:

video information source means for providing a first stream of video data frames;

15 second video information source means for providing a second stream of video data frames;

first analysis means for receiving said first stream of video data frames provided by said first video information source means and performing a first moving image content analysis algorithm with respect to the  
20 received first stream of video data frames; and

second analysis means for receiving said second stream of video data frames provided by said second video information source means, and performing a second moving image content analysis algorithm with respect to the  
25 received second stream of video data frames.

63. Apparatus according to claim 62, wherein said first and second analysis means operate simultaneously in performing said first and second moving image content analysis algorithms.

30 64. Apparatus according to claim 62, wherein said first analysis means includes a first signal processing integrated circuit and said second analysis means includes a second signal processing integrated circuit separate from said first signal processing integrated circuit.

35 65. Apparatus according to claim 64, wherein said first signal processing integrated circuit is a digital signal processing integrated circuit and said second signal processing integrated circuit is a general purpose

microprocessor.

66. Apparatus according to claim 62, wherein said first video information source means includes at least one video camera, and said video information source means  
5 includes a memory device from which said second stream of video data frames is retrieved.

67. Apparatus according to claim 66, wherein said memory device is selected from a group consisting of a hard disk, a magneto-optical disk, and a writable optical  
10 disk.

68. Apparatus according to claim 67, further comprising:

means for applying a data compression algorithm to said first stream of video data frames to produce  
15 compressed video data; and

means for transmitting said compressed video data from said compression means to said hard disk for storage on said hard disk.

69. Apparatus according to claim 68, further  
20 comprising means for retrieving said stored compressed video data from said hard disk and for applying a data decompression algorithm to said retrieved compressed video data to form said second stream of video data frames.

70. Apparatus according to claim 66, wherein said  
25 first video information source means is a first video camera and said second video information source means is a second video camera.

71. Apparatus according to claim 70, wherein said first and second analysis means operate simultaneously in  
30 performing said first and second moving image content analysis algorithms.

72. Apparatus according to claim 67, wherein said first and second streams of video data are retrieved simultaneously from said hard disk and then respectively  
35 supplied to said first and second analysis means.

73. Apparatus for analyzing video information comprising:

video camera for generating a stream of video

data fields;

first analysis means for receiving said stream of video data fields provided by said video camera for performing a first moving image content analysis algorithm with respect to the received stream of video data fields; and

second analysis means for receiving said stream of video fields provided by said video camera, and for performing a second moving image content analysis algorithm with respect to the received stream of video data fields, said second moving image content analysis algorithm being different from said first moving image content analysis algorithm.

74. Apparatus according to claim 73, wherein said first and second analysis means operate simultaneously in performing said first and second moving image content analysis algorithms.

75. A video information analysis apparatus, comprising:

for generating a first stream of dynamic images and a second stream of dynamic images;

variable-rate image selection means for selecting images for storage from said first stream of images at a first image interval rate, and for selecting images for storage from said second stream of images at a second image interval rate that is different from said first image interval rate;

storage means for storing said images selected for storage from said first stream of images by said image selection means and for storing said images selected for storage from said second stream of images by said image selection means;

playback means for selectively retrieving from said storage means said stored images from said first and second streams of images; and

analysis means for applying a moving image content analysis algorithm to images retrieved by said playback means from a selected one of said first and



second streams of images, said analysis means adapting said moving image content analysis algorithm to the respective image interval rate of the selected stream of images.

5           76. A video information analysis apparatus according to claim 75, wherein said means for generating includes a first video camera for generating said first stream of dynamic images and a second video camera for generating said second stream of dynamic images.

10           77. A video information analysis apparatus according to claim 75, wherein said means for generating includes a video camera which generates said first stream of dynamic images during a first time period and which generates said second stream of dynamic images during a second time  
15 period that is later than said first time period.

          78. A video information analysis apparatus according to claim 75, wherein said moving image content analysis algorithm is for detecting moving objects represented by the selected stream of images.

20           79. A video information analysis apparatus according to claim 78, further comprising display means for displaying images retrieved from said storage means, and wherein said moving image content analysis algorithm is for detecting moving objects at a selected portion of an  
25 image plane displayed on said display means.

          80. A video information analysis apparatus according to claim 79, further comprising user input means for permitting user of the apparatus to select said portion of the image plane at which moving objects are to be detected  
30 by said moving image analysis algorithm.

          81. A video information analysis apparatus according to claim 75, wherein said storage means comprises a hard disk, a magneto-optical disk and a writable optical disk.

          82. A method of analyzing video information,  
35 comprising the steps of:

          a first stream of dynamic images;  
          selecting images for storage from said first stream of images at a first image interval rate;

generating a second stream of dynamic images;  
selecting images for storage from said second  
stream of images at a second image interval rate that is  
different from said first image interval rate;  
5 storing said selected images from said first and  
second streams of dynamic images;  
retrieving the stored images from the selected  
stream of dynamic images; and  
applying a moving image content analysis  
10 algorithm to the retrieved images from the selected stream  
of dynamic images, said algorithm being adapted to the  
image interval rate of the selected stream of dynamic  
images.

83. A method according to claim 82, wherein said  
15 generating steps are performed by different respective  
video cameras.

84. A method according to claim 82, wherein said  
first and second streams are generated during different  
respective time periods by the same video camera.

20 85. A method according to claim 82, wherein said  
moving image content analysis algorithm is for detecting  
moving objects represented by the selected stream of  
images.

86. A method according to claim 82, wherein said  
25 storing step includes storing said selected images on  
recording medium selected from the group consisting of a  
hard disk, a magneto-optical disk and a writable optical  
disk.

87. A method according to claim 86, wherein said  
30 retrieving step includes retrieving said selected images  
from said recording medium.

88. A method of detecting moving objects represented  
by a sequence of dynamic images, said sequence of dynamic  
images being represented by stored video data, at least  
35 75% of said dynamic images having been compression-encoded  
using an inter-image encoding algorithm such that the  
video data representing each inter-image encoded image  
includes image data consisting of a plurality of image

data portions each corresponding to a respective region of an image plane, said video data for each inter-image encoded image also including mapping data indicative of the regions of the image plane to which the image data portions of said video data correspond, the method comprising the steps of:

at least the mapping data included in said stored video data; and

applying a motion detection algorithm to the retrieved mapping data to detect said moving objects.

89. A method according to claim 88, wherein at least 80% of said dynamic images have been compression-encoded using said inter-image encoding algorithm.

90. A method according to claim 89, wherein at least 90% of said dynamic images have been compression-encoded using said inter-image encoding algorithm.

91. A method according to claim 90, wherein at least 95% of said dynamic images have been compression-encoded using said inter-image encoding algorithm.

92. Apparatus for detecting moving objects represented by a sequence of dynamic images, said sequence of dynamic images being represented by stored video data, at least 75% of said dynamic images having been compressed-encoded using an inter-image encoding algorithm such that the video data representing each inter-image encoded image includes image data consisting of a plurality of image data portions each corresponding to a respective region of an image plane, said video data for each inter-image encoded image also including mapping data indicative of the regions of the image plane to which the image data portions of said video data correspond, the apparatus comprising:

for retrieving at least the mapping data included in said stored video data; and

means for applying a motion detection algorithm to the retrieved mapping data to detect said moving objects.

93. Apparatus according to claim 92, wherein at

least 90% of said dynamic images have been compression-encoded using said inter-image encoding algorithm.

94. A method of analyzing a sequence of video information frames to detect changes in said video information frames, comprising the steps of:

an object represented by said video information frames;

selecting portions of said designated object; and

sequentially examining portions of said video information frames corresponding to said selected portions of said designated object to determine whether said designated object remains in a predetermined position in said video information frames.

95. A method according to claim 94, wherein said step of designating said object includes defining a periphery of said object.

96. A method according to claim 95, wherein said selected portions of said designated object are portions of said object at mutually remote locations at said periphery of said object.

97. A video data storage apparatus, comprising:

for receiving video data which represents an image in an image plane;

discard means for selecting a portion of the image plane as to which data storage is not required; and

storage means, responsive to said discard means, for storing such portions of said received video data as do not correspond to said selected portion of said image plane;

such portions of said received video data as correspond to said selected portion of said image plane are not stored in said storage means.

98. An apparatus according to claim 97, further comprising display means for displaying an image which corresponds to an image represented by said received video data, wherein said discard means includes drawing means

for superimposing on said image displayed by said display means an image element indicative of said portion of an image plane as to which data storage is not required.

99. An apparatus according to claim 98, wherein said  
5 drawing means includes a mouse.

100. A video data storage apparatus according to claim 97, further comprising a video camera for generating the video data received by said means for receiving.

101. A video data storage apparatus according to  
10 claim 97, wherein said storage means includes a recording medium on which are recorded the portions of the video data not selected by said discard means, said recording medium being selected from the group consisting of a hard disk, a magneto-optical disk, and a writable optical disk.

15 102. A method of storing video data, comprising the steps of:

video data which represents an image in an image plane;

20 selecting a portion of the image plane as to which data storage is not required; and

storing on a recording medium only such portions of the received video data as do not correspond to said selected portion of said image plane.

25 103. A method according to claim 102, wherein said selecting step includes manipulating a graphic element on a display screen to indicate the selected portion of the image plane.

30 104. A video signal processing apparatus, comprising:  
for receiving a video signal which represents an image in an image plane;

selection means for selecting a portion of the image plane for contrast enhancement; and

35 enhancement means, connected to said means for receiving, and responsive to said selection means, for expanding a dynamic range of portions of said received video signal which correspond to said selected portion of the image plane, and for outputting a selectively enhanced video signal.

105. An apparatus according to claim 104, further comprising display means for displaying an image which corresponds to an image represented by said received video signal, and wherein said selection means includes drawing  
5 means for superimposing on said image displayed by said display means an image element indicative of said portion of an image plane selected for contrast enhancement.

106. An apparatus according to claim 104, wherein said selection means includes means, connected to said  
10 receiving means, for detecting a contrast characteristic of said received video signal.

107. An apparatus according to claim 104, wherein said selectively enhanced video signal is an analog signal, and further comprising A/D conversion means, for  
15 converting said selectively enhanced video signal into video data corresponding to said selectively enhanced video signal.

108. An apparatus according to claim 107, further comprising storage means, connected to said A/D conversion  
20 means, for storing said video data.

109. A video information storage apparatus, comprising:

information source means for generating a dynamic video signal formed of a sequence of video signal  
25 frames, each of said frames representing a respective image in an image plane, said dynamic video signal having a time resolution corresponding to a frame rate at which successive frames of said sequence are produced, said dynamic video signal also having a space resolution  
30 corresponding to a density at which pixels of said signal are formed in said image plane;

signal processing means for receiving said dynamic video signal generated by said video information source means and for selectively varying at least one of  
35 the time resolution and the space resolution of the received dynamic video signal;

user adjustable means for entering a control signal for controlling whether and to what degree said

signal processing means varies said at least one of the time resolution and the space resolution of the received dynamic video signal, said signal processing means outputting a processed dynamic video signal having a time resolution and a space resolution at least one of which is determined in accordance with said control signal; and storage means for storing said processed dynamic video signal.

110. Apparatus according to claim 109, wherein said video information source means includes a video camera.

111. Apparatus according to claim 109, wherein said signal processing means selectively varies both of the time resolution and the space resolution of the received dynamic video signal in response to the control signal entered by the user adjustable means.

112. Apparatus according to claim 109, further comprising display means for displaying a selected one of said dynamic video signal generated by said video information source means and said processed video signal outputted from said signal processing means.

113. Apparatus according to claim 112, wherein said user adjustable means includes means for generating said control signal by manipulating a cursor displayed on said display means.

114. Apparatus according to claim 113, wherein said user adjustable means includes a mouse.

115. Apparatus according to claim 112, wherein said storage means includes a recording medium selected from the group consisting of a hard disk, a magneto-optical disk and a writable optical disk.

116. Apparatus according to claim 115, wherein said display means selectively displays an image corresponding to a processed dynamic video signal retrieved from said hard disk.

117. A method of performing data compression with respect to a sequence of image data frames which represents a dynamic sequence of video images, comprising the steps of:

every nth frame of said sequence of image data frames in accordance with an intra-frame compression algorithm in which each of said every nth frame is encoded without reference to any other image data frame, n being  
5 an integer greater than 1;

encoding every frame other than said intraframe-encoded frames in accordance with a difference-encoding compression algorithm which includes forming difference data by reference to at least one data frame which  
10 precedes the frame which is being difference-encoded;

receiving a compression parameter setting signal input by a user; and

varying a value of n in accordance with the received compression parameter setting signal.

15 118. A method of performing data compression with respect to a sequence of image data frames which represents a dynamic sequence of video images, comprising the steps of:

a compression parameter setting signal  
20 input by a user;

selecting a frame interval in accordance with the received compression parameter setting signal;

compression-encoding in accordance with a first compression algorithm ones of said image data frames  
25 occurring at said selected frame interval; and

compression-encoding in accordance with a second compression algorithm all other of said image data frames, said second compression algorithm being different from said first compression algorithm.

30 119. A method according to claim 118, wherein said first compression algorithm is an intra-frame compression algorithm and said second compression algorithm is a compression algorithm in which an image is compared with a preceding reference image.

35 120. A method of assigning regions of an image plane among streams of dynamic images each generated by a respective one of a plurality of video cameras, comprising the steps of:



in a first portion of a display screen a plurality of icons each representing a respective one of said plurality of video cameras;

displaying in a second portion of said display  
5 screen a representation of said image plane including regions of said second portion of said display screen corresponding to said regions of said image plane; and

moving at least one of said icons from said first portion of said display screen to said second  
10 portion of said display screen, to position each said moved icon in a respective one of said regions of said second portion to indicate that the image stream generated by the video camera represented by said moved icon is to be displayed in the image plane region corresponding to  
15 said respective one of said regions of said second portion.

121. A method according to claim 120, wherein said plurality of camera-representing icons includes at least four icons.

20 122. A method according to claim 121, wherein said plurality of camera-representing icons includes sixteen icons.

123. A method according to claim 120, wherein said regions of said second portion of said display screen  
25 consist of four regions each occupying a quadrant of said second portion and each representing a respective quadrant of said image plane.

124. A method according to claim 120, wherein said regions of said second portion of said display screen  
30 include at least nine regions.

125. A method according to claim 124, wherein said regions of said second portion of said display screen consist of sixteen regions.

126. A method according to claim 124, wherein said  
35 regions of said second portion of said display screen consist of eight regions including one large region located at a corner of said second portion and seven small regions, all of said small regions being equal in size to

each other, said large region having an area that is nine times as large as the area of each of said small regions.

127. A method according to claim 120, wherein said icon-moving step includes operating a mouse.

5 128. Video display apparatus, comprising:

a plurality of video cameras each for generating a respective stream of dynamic images;

display means including a display screen for displaying at least selected ones of said streams of  
10 dynamic images;

control means for controlling said display means to display in a first portion of said display screen a plurality of icons each representing a respective one of said plurality of video cameras and to display in a second  
15 portion of said display screen a representation of an image plane including regions of said second portion corresponding to respective regions of said image plane; and instruction means for inputting first instructions from a user of the apparatus to said control means to  
20 cause said control means to move at least one of said icons from said first portion of said display screen to said second portion of said display screen, to position each said moved icon in a respective one of said regions of said second portion to indicate that the image stream  
25 generated by the video camera represented by said moved icon is to be displayed in the image plane region corresponding to said respective one of said regions of said second portion, said instruction means also for inputting a second instruction from said user to said  
30 control means to cause said display means to display said image plane in which respective image streams generated by selected ones of said video cameras are displayed in respective regions of said image plane in accordance with said image plane region assignment indicated by said first  
35 instructions.

129. Video display apparatus according to claim 128, wherein said plurality of video cameras includes at least four cameras and said camera-representing icons includes

at least four icons.

130. Video display apparatus according to claim 129, wherein said regions of said second portion of said display screen consist of four regions each occupying a quadrant of said second portion and each representing a  
5 respective quadrant of said image plane.

131. Video display apparatus according to claim 130, wherein said plurality of video cameras includes 16 cameras and said plurality of camera-representing icons  
10 includes 16 icons.

132. Apparatus for storing video information, comprising:

a plurality of video cameras;  
recording means for recording on a recording  
15 medium video information generated by said plurality of video cameras, said recording means being selectively operable in accordance with a plurality of recording modes with respect to each one of said plurality of video cameras;

20 storage means for storing scheduling information, said scheduling information including a plurality of scheduling information portions each corresponding to a respective 24-hour period, each of said scheduling information portions including a plurality of  
25 subportions each corresponding to a respective one of said plurality of video cameras, each of said subportions defining times during the respective 24-hour period for which ones of said recording modes have been selected for the respective one of said plurality of video cameras; and

30 control means for controlling said recording means in accordance with the scheduling information stored in said storage means.

133. Apparatus according to claim 132, wherein a  
35 first one of said scheduling information portions corresponds to weekdays, a second one of said scheduling information portions corresponds to weekend-days, and a third one of said scheduling information portions corresponds to holidays.

134. Apparatus according to claim 133, wherein said scheduling information includes additional information for defining said holidays by month and day of the month.

5 135. Apparatus according to claim 132, wherein said scheduling information includes further information for partitioning each of said 24-hour periods into day and night parts of said 24-hour period.

10 136. Apparatus according to claim 132, wherein said recording modes include a first recording mode in which images generated by a respective one of said video cameras are continuously recorded at intervals that do not exceed a maximum interval, a second recording mode in which images generated by the respective video camera are only recorded in response to detection of an alarm condition,  
15 and a third recording mode in which there is no recording of images generated by the respective video camera.

137. Apparatus according to claim 132, wherein said recording medium is a hard disk.

20 138. Apparatus according to claim 137, wherein said storage means includes a storage device selected from the group consisting of a hard disk, a magneto-optical disk and a writable optical disk.

25 139. Apparatus according to claim 132, further comprising override means, actuatable by a user of the apparatus to select one of said plurality of video cameras, for causing said recording means to operate with respect to the selected camera in a recording mode that is different from the recording mode for the selected camera indicated by the scheduling information as being  
30 applicable to a time at which the override means is actuated.

140. A method of scheduling recording modes with respect to a plurality of video cameras included in a closed-circuit video surveillance system, comprising the  
35 steps of:

storing scheduling information, said scheduling information including a plurality of scheduling information portions each corresponding to a respective

24-hour period, each of said scheduling information portions including a plurality of subportions each corresponding to a respective one of said plurality of video cameras, each of said subportions defining times  
5 during the respective 24-hour period for which ones of said recording modes have been selected for the respective one of said plurality of video cameras; and

controlling, in accordance with the stored scheduling information, recording of images generated by  
10 said plurality of video cameras.

141. A method according to claim 140, wherein a first one of said scheduling information portions corresponds to weekdays, a second one of said scheduling information portions corresponds to weekend-days, and a third one of  
15 said scheduling information portions corresponds to holidays.

142. A method according to claim 141, wherein said scheduling information includes additional information for defining said holidays by month and day of the month.

20 143. A method according to claim 140, wherein said scheduling information includes further information for partitioning each of said 24-hour periods into day and night parts of said 24-hour period.

144. A method according to claim 140, wherein said  
25 recording modes include a first recording mode in which images generated by a respective one of said video cameras are continuously recorded at intervals that do not exceed a maximum interval, a second recording mode in which images generated by the respective video camera are only  
30 recorded in response to detection of an alarm condition, and a third recording mode in which there is no recording of images generated by the respective video camera.

145. A video information storage apparatus, comprising:  
35 a plurality of video cameras each for generating a dynamic video signal formed of a sequence of video signal fields, each of said fields representing a respective image;

recording means for recording each of said sequences of video signal fields at regular intervals at a field storage rate which is variable from sequence to sequence, the field storage rate defining a duration of the regular intervals at which the respective sequence of video signal fields is recorded; and

user actuatable means for selectively inputting to the recording means selection signals for selecting with respect to each of said sequences of video signal fields the field storage rate for the respective sequence.

146. A video information storage apparatus according to claim 145, wherein a selection signal input by said user actuatable means includes numerical data indicative of a selected field storage rate for a respective one of said sequences of video signal fields and camera identification data for identifying the video camera which is generating the respective sequence.

147. A video information storage apparatus according to claim 145, wherein said user actuatable means includes a mouse for inputting cursor control signals to said recording means.

148. A video information storage apparatus according to claim 145, wherein said recording means includes a hard disk on which the sequences of video signal fields are recorded.

149. A method of storing video information, comprising the steps of:

generating a plurality of dynamic video signals each formed of a sequence of video signal fields, each of said fields representing a respective image;

recording each of said sequences of video signal fields at regular intervals at a field storage rate which is variable from sequence to sequence, the field storage rate defining a duration of the regular intervals at which the respective sequence of video signal fields is recorded; and selectively manipulating a user input device to generate selection signals for selecting with respect to each of said sequences of video signal fields the field

storage rate for the respective sequence.

150. A method according to claim 149, wherein a selection signal input by selectively manipulating the user input device includes numerical data indicative of a selected field storage rate for a respective one of said sequences of video signal fields and camera identification data for identifying a video camera which is generating the respective sequence.

151. A method according to claim 150, wherein said user input device is a mouse.

152. Apparatus for analyzing video information, comprising:

video camera;

analysis means for analyzing video information generated by said video camera in accordance with a moving image content analysis algorithm, said analysis means being selectively operable in accordance with a plurality of operating modes;

storage means for storing scheduling information, said scheduling information including a plurality of scheduling information portions each corresponding to a respective different future period of time, and each indicating an operating mode of said analysis means that has been selected for said period of time; and means for controlling said analysis means so as to operate in accordance with the selected operating modes during the periods of time indicated by the scheduling information stored in said storage means.

153. Apparatus according to claim 152, wherein said plurality of operating modes includes a first mode in which said analysis means performs said analysis algorithm according to a first parameter for constraining operation of said algorithm and a second mode in which said analysis means performs said analysis algorithm according to a second parameter for constraining operation of said algorithm, said second algorithm being different from said first algorithm.

154. Apparatus according to claim 152, wherein a

first one of said periods of time corresponds to a part of a 24-hour period and a second one of said periods of time corresponds to all of said 24-hour period except for said part.

5           155. A method of scheduling operating modes of a video information analysis device, comprising the steps of:

                  scheduling information, said scheduling information including a plurality of scheduling information portions each corresponding to a respective  
10           different future period of time, and each indicating an operating mode of said analysis device that has been selected for said period of time; and

                  controlling said analysis device so as to  
15           operate in accordance with the selected operating modes during the periods of time indicated by the stored scheduling information.

          156. A method of storing and retrieving video data, comprising the steps of:

20                   storing, in a data storage device located at a first location, data representing plural images of a dynamic video image stream;

                  storing, in a host processor located at a second location remote from the first location, a program  
25           file representing a search algorithm for searching for a desired image among the images represented by the data stored at the first location;

                  downloading said program file representing said search algorithm from said host processor to said  
30           data storage device; and using said downloaded program file to search for said desired image in said video data stored in said data storage device.

          157. A method according to claim 156, further comprising the steps of:

35                   said downloaded program file to select an image from among images represented by said video data stored in said data storage device; and uploading from said data storage device to said host processor data



representative of said image selected by using said downloaded program file.

158. A method according to claim 156, further comprising the step, performed prior to said downloading  
5 step, of uploading from said data storage device to said host processor data representative of an image which corresponds to an image represented by said data stored in said data storage device.

159. A method according to claim 158, further  
10 comprising the step of displaying at said second location said image represented by said uploaded data.

160. A method according to claim 159, further comprising the step, performed simultaneously with said displaying step of claim 4, of displaying at said first  
15 location an image corresponding to the image displayed at said second location.

161. A method according to claim 160, further comprising the step of exchanging communication between respective human operators viewing said displayed images  
20 at said first and second locations, said exchanged communication including at least one of oral telephone communication and data communication.

162. A method according to claim 159, further comprising the steps of:  
25 a parameter for constraining execution of said search algorithm; and executing said search algorithm at said first location and in accordance with the set parameter.

163. A method according to claim 162, wherein said  
30 parameter setting step is performed before said downloading step.

164. A method according to claim 163, wherein said search algorithm is an algorithm for detecting at least one moving object represented by the data stored in said  
35 data storage device, and said setting step includes selecting a portion of an image plane which corresponds to the stored data, said portion being a portion at which said at least one moving object is to be detected by

execution of said algorithm.

165. A method according to claim 164, wherein said portion of an image plane is selected by superimposing a line or polygon on said image displayed at said second location, said superimposed line or polygon representing  
5 said selected portion of said image plane.

166. Apparatus for storing and retrieving video data, comprising:

10 a data storage device located at a first location for storing data representing plural images of a dynamic video image stream;

a host processor, located at a second location remote from the first location, for storing a program file representing a search algorithm for searching for a  
15 desired image among the images represented by the data stored at the first location; and means for downloading said program file representing said search algorithm from said host processor to said data storage device;

20 said data storage device including means for using said downloaded program file to search for said desired image in said video data stored in said storage device.

167. Apparatus according to claim 166, further comprising:

25 means for using said downloaded program file to select an image from among images represented by said video data stored in said data storage device; and for uploading from said data storage device to said host processor data representative of said image selected by using said downloaded program file.

30 168. Apparatus for storing a distributed video data base, comprising:

a first video information source, at a first location, for providing first video information which includes at least one dynamic sequence of video  
35 information frames;

first analysis means for receiving the first video information provided by said first video information source and for analyzing the received first

video information in accordance with a first image analysis algorithm to generate first analysis data;

first storage means for storing, in the form of digital data, the first video information provided  
5 by said first video information source and the first analysis data generated by the first analysis means;

a second video information source, at a second location remote from said first location, for providing second video information which includes at least  
10 one dynamic sequence of video information frames;

second analysis means for receiving the second video information provided by said second video information source and for analyzing the received second video information in accordance with a second image  
15 analysis algorithm to generate second analysis data;

storage means, provided at a location remote from said first storage means, for storing, in the form of digital data, the second video information provided by said second video information source and the  
20 second analysis data generated by the second analysis means; and operatively connectable to said first and second storage means for selectively retrieving the first and second video information from said first and second storage means, respectively.

25 169. Apparatus according to claim 168, wherein said first video information source includes a first video camera and said second video information source includes a second video camera.

30 170. Apparatus according to claim 169, wherein said first video information source includes a first plurality of video cameras and said second video information source includes a second plurality of video cameras.

35 171. Apparatus according to claim 168, wherein said means for selectively retrieving includes processor means located remotely from said first and second storage means, means for selectively establishing a data communication path between said processor means and said first storage means, and means for selectively establishing a data

communication path between said processor means and said second storage means.

172. Apparatus according to claim 168, wherein said means for selectively retrieving retrieves the first and  
5 second video information on the basis of the stored first and second analysis data, respectively.

173. Apparatus according to claim 168, wherein at least one of said first analysis algorithm and said second analysis algorithm is for assigning to respective portions  
10 of the video information analyzed by said at least one algorithm analysis scores indicative of respective degrees to which said portions of the video information represent a predetermined analysis feature, said analysis scores being values within a predetermined range of values  
15 comprising at least three values.

174. Apparatus according to claim 173, wherein said range of values comprises at least eight values.

175. Apparatus according to claim 174, wherein said range of values comprises at least one hundred values.

20 176. A method of storing and retrieving video data, comprising the steps of:

storing first video information in a first information storage device at a first location;

25 generating first analysis data by analyzing the first video information in accordance with a first image analysis algorithm;

storing said first analysis data in the first information storage device;

30 storing second video information in a second information storage device at a second location remote from the first location;

generating second analysis data by analyzing the second video information in accordance with a second image analysis algorithm;

35 storing said second analysis data in the second information storage device; and

selectively retrieving the first and second video information from said first and second storage

means, for transmission to a retrieval device at a third location remote from said first and second storage devices.

177. A method according to claim 176, wherein said  
5 selective retrieving step includes using the stored first and second analysis data to select portions of said first and second video information to be retrieved.

178. A method according to claim 176, further  
10 comprising the steps of reproducing said first video information from said first information storage device and applying said first analysis algorithm to the reproduced first video information to generate the first analysis data.

179. A method according to claim 178, further  
15 comprising the steps of reproducing said second video information from said second information storage device and applying said second analysis algorithm to the reproduced second video information to generate the second analysis data.

20 180. Apparatus for storing a distributed video data base, comprising:

a first video information source, at a first location, for providing first video information which includes at least one dynamic sequence of video  
25 information frames;

first storage means for storing, in the form of digital data, the first video information provided by said first video information source;

a second video information source, at a  
30 second location remote from said first location, for providing second video information which includes at least one dynamic sequence of video information frames;

second storage means, provided at a location remote from said first storage means, for  
35 storing, in the form of a digital data, the second video information provided by said second video information source and the second analysis data generated by the second analysis means;

....

retrieval means, located remotely from at least one of said first storage means and said second storage means, for selectively retrieving video information frames stored in said first storage means and  
5 said second storage means;

first connection means for forming a first data communication path between said retrieval means and said first storage means; and

second connection means for forming a  
10 second data communication path between said retrieval means and said second storage means.

181. Apparatus according to claim 180, wherein said retrieval means includes means for defining search parameters according to which video information frames  
15 stored in said first and second storage means are retrieved.

182. Apparatus according to claim 181, wherein said search parameters include image characteristics.

183. Apparatus according to claim 182, wherein said  
20 image characteristics include moving object characteristics.

184. Apparatus according to claim 180, wherein said first video information source includes a first video camera and said second video information source includes  
25 a second video camera.

185. Apparatus according to claim 180, wherein said first video information source includes a first plurality of video cameras and said second video information source includes a second plurality of video cameras.

30 186. Apparatus according to claim 180, wherein said first connection means selectively forms said first data communication path and said second connection means selectively forms said second data communication path.

187. Apparatus according to claim 180, further  
35 comprising lock-out means, operatively associated with said first storage means, for selectively preventing the first video information stored in said first storage means from being retrieved by said retrieval means.

188. Apparatus for storing a distributed video data base, comprising:

a first video information source, at a first location, for providing first video information which includes at least one dynamic sequence of video information frames;

first storage means for storing in the form of digital data, the first video information provided by said first video information source;

10 a second video information source, at a second location remote from said first location, for providing second video information which includes at least one dynamic sequence of video information frames;

second storage means, provided at a location remote from said first storage means, for storing, in the form of digital data, the second video information provided by said second video information source;

third storage means, located remotely from said first and second storage means, for storing an image analysis algorithm;

a first processor operatively connected to and co-located with said first storage means;

a second processor operatively connected to and co-located with said second storage means; and

25 means for sequentially downloading said image analysis algorithm from said third storage means to said first processor and to said second processor;

said first processor responding to downloading thereto of said analysis algorithm by retrieving the first video information from said first storage means and analyzing the retrieved first video information in accordance with the downloaded analysis algorithm to detect a moving object represented by the retrieved first video information;

35 said second processor responding to downloading thereto of said analysis algorithm by retrieving the second video information from said second

storage means and analyzing the retrieved second video information in accordance with the downloaded analysis algorithm to detect a moving object represented by the retrieved second video information.

5           189. Apparatus according to claim 188, wherein said third storage means stores a plurality of image analysis algorithms, and each of said first processor and said second processor includes means for selecting one of said algorithms to be downloaded to the respective processor  
10 from said third storage means.

          190. Apparatus according to claim 188, wherein each of said first processor and said second processor includes means for setting a parameter for constraining execution by the respective processor of the image analysis  
15 algorithm downloaded to the respective processor.

          191. Apparatus according to claim 188, wherein said image analysis algorithm is for assigning respective analysis scores to portions of said first and second video information, said analysis scores being indicative of  
20 respective degrees to which said portions of the video information represent a predetermined analysis feature, said analysis scores being values within a predetermined range of values comprising at least three values.

          192. Apparatus according to claim 191, wherein said  
25 range of values comprises at least eight values.

          193. Apparatus according to claim 192, wherein said range of values comprises at least one hundred values.

          194. Apparatus for analyzing and storing video data, comprising:

30                       for generating said video data;  
                          analysis means for analyzing the video data generated by said means for generating to detect a predetermined characteristic of said video data; and  
                          storage means for storing the analyzed  
35 video data, said storage means including a first data storage device and a second data storage device, said storage means routing said analyzed video data to a selected one of said first and second data storage devices



in response to detection by said analysis means of said predetermined characteristic of said video data.

195. Apparatus according to claim 194, wherein said second data storage device is selectively connectable to  
5 said means for generating said video data, and said storage means establishes a data communication path connection between said means for generating and said second data storage device in response to detection by  
10 said analysis means of said characteristic of said video data.

196. Apparatus according to claim 195, wherein said data communication path connection includes a dial-up telephone connection between said means for generating and said second data storage device.

197. Apparatus according to claim 194, wherein said  
15 predetermined characteristic of said video data is a characteristic of an object represented by said video data.

198. Apparatus according to claim 197, wherein said  
20 characteristic of said object represented by said video data is a characteristic selected from the group consisting of size of the object, change of size of the object, motion of the object, velocity of the object, acceleration of the object, change in rate of acceleration  
25 of the object, shape of the object, change of shape of the object, and texture of the object.

199. Apparatus according to claim 194, wherein said  
30 predetermined characteristic of said video data is a characteristic selected from the group consisting of a chrominance characteristic of said video data and a change of a chrominance characteristic of said video data.

200. Apparatus according to claim 194, wherein each  
35 of said first and second data storage devices includes means for storing a plurality of frames of said video data.

201. Apparatus for analyzing video data, comprising:  
a first video camera for generating first  
video data;

analysis means for analyzing the first video data generated by said first video camera to detect a predetermined characteristic of said first video data; a second video camera for generating second  
5 video data; and

means, responsive to said analysis means, for selectively storing the second video data generated by said second video camera in response to detection of said predetermined characteristic of said first video data by  
10 said analysis means.

202. Apparatus according to claim 201, wherein said predetermined characteristic of said first video data is a characteristic of an object represented by said first video data.

15 203. Apparatus according to claim 202, wherein said characteristic of said object represented by said first video data is a characteristic selected from the group consisting of size of the object, change of size of the object, motion of the object, velocity of the object,  
20 acceleration of the object, change in rate of acceleration of the object, shape of the object, change of shape of the object, and texture of the object.

204. Apparatus according to claim 201, wherein said predetermined characteristic of said first video data is  
25 a characteristic selected from the group consisting of a chrominance characteristic of said first video data and a change of a chrominance characteristic of said first video data.

205. Apparatus for analyzing video data, comprising:  
30 a first video camera for generating first video data;

analysis means for analyzing the first video data generated by said first video camera to detect a predetermined characteristic of said first video data;

35 a second video camera for generating second video data; and

said analysis means selectively performing a predetermined analysis algorithm with respect to said

second video data generated by said second video camera when said analysis means detects said predetermined characteristic of said first video data.

206. Apparatus according to claim 205, wherein said  
5 predetermined characteristic of said first video data is a characteristic of an object represented by said first video data.

207. Apparatus according to claim 206, wherein said  
10 characteristic of said object represented by said first video data is a characteristic selected from the group consisting of size of the object, change of size of the object, motion of the object, velocity of the object, acceleration of the object, change in rate of acceleration of the object, shape of the object, change of shape of the  
15 object, and texture of the object.

208. Apparatus according to claim 207, wherein said  
predetermined characteristic of said first video data is a characteristic selected from the group consisting of a chrominance characteristic of said first video data and a  
20 change of a chrominance characteristic of said first video data.

209. Apparatus for analyzing video data, comprising:  
a source of video data; and  
means for analyzing video data provided by  
25 said source of video data to detect a first predetermined characteristic of said video data by performing a first predetermined analysis algorithm, and for performing a second predetermined analysis algorithm to detect a second predetermined characteristic of said video data when said  
30 means for analyzing detects said first predetermined characteristic.

210. Apparatus according to claim 209, wherein said  
source of video data includes a video camera; and  
comprising storage means for storing said  
35 video data, and for supplying said stored video data for analysis in accordance with said second predetermined analysis algorithm when said means for analyzing detects said first predetermined characteristic of said video

data.

211. Apparatus for analyzing and storing video data, comprising:

5 a video camera for generating video data;  
alarm means for detecting an alarm  
condition;  
compression means for performing  
compression processing on the video data generated by said  
video camera according to a predetermined compression  
10 algorithm to form compressed video data; and  
storage means for storing the compressed  
video data formed by said compression means;  
said compression means being responsive to  
said alarm means so as to vary said compression algorithm  
15 in dependence upon whether said alarm means detects an  
alarm condition.

212. Apparatus according to claim 211, wherein said predetermined compression algorithm includes:

20 comparing predetermined portions of a present  
field of said video data to corresponding portions of a  
reference image generated by said video camera, to form  
comparison statistics;

25 comparing said comparison statistics with a  
threshold that is set at a first value when said alarm  
means does not detect an alarm condition and that is set  
at a second value, different from said first value, when  
said alarm means detects an alarm condition; and

30 selectively discarding said predetermined  
portions of the present field on the basis of the  
comparing of the comparison statistics with the threshold.

213. Apparatus according to claim 211, wherein said alarm means includes means for analyzing the video data generated by said video camera to detect a predetermined characteristic of said video data.

35 214. Apparatus according to claim 213, wherein said predetermined characteristic is a spectral characteristic of said video data.

215. Apparatus according to claim 214, wherein said

predetermined characteristic is a measure of information content per unit quantity of the video data.

216. Apparatus for analyzing and storing video data, comprising:

- 5 a first video camera for generating first video data;
- a second video camera for generating second video data;
- 10 storage means for storing the second video data generated by said second video camera; and
- means for analyzing said first video data generated by said first video camera to detect a predetermined characteristic of said first video data, and for selectively analyzing said second video data stored in
- 15 said storage means to detect a predetermined characteristic of said second stored video data in dependence upon whether said predetermined characteristic of said first video data is detected by said means for analyzing.

20 217. Apparatus according to claim 216, wherein said predetermined characteristic of said first video data is a characteristic of an object represented by said first video data.

25 218. Apparatus according to claim 217, wherein said characteristic of said object represented by said first video data is a characteristic selected from the group consisting of size of the object, change of size of the object, motion of the object, velocity of the object, acceleration of the object, change in rate of acceleration

30 of the object, shape of the object, change of shape of the object, and texture of the object.

219. Apparatus according to claim 216, wherein said predetermined characteristic of said first video data is a characteristic selected from the group consisting of a

35 chrominance characteristic of said first video data a change of a chrominance characteristic of said first video data, a luminance characteristic of said first video data, and a change of a luminance characteristic of said first

video data. 220. An apparatus for analyzing and storing  
video data, comprising:  
a first video camera for generating first  
video data;  
5 a second video camera for generating second  
video data;  
storage means for storing the second video  
data generated by said second video camera; and  
means for analyzing said first video data  
10 generated by said first video camera to detect a  
predetermined characteristic of said first video data;  
wherein said storage means stores a first  
predetermined number of fields of said second video data  
per unit time during periods in which said means for  
15 analyzing does not detect said predetermined  
characteristic of said first video data, and said storage  
means stores a second predetermined number of fields,  
larger than said first predetermined number of fields, of  
said second video data per unit time during periods in  
20 which said means for analyzing detects said predetermined  
characteristic of said first video data.

221. An apparatus for analyzing, storing and  
displaying video information, comprising:  
first camera means for generating a first  
25 stream of video data;  
second camera means for generating a second  
stream of video data;  
first storage means for selectively storing  
at least one of said first and second streams of video  
30 data;  
second storage means for selectively  
storing at least one of said first and second streams of  
video data;  
transmission means for selecting one of  
35 said first and second storage means to receive said first  
stream of video data;  
display means for selectively displaying at  
least one of said first and second streams of video data;

analysis means for analyzing said first stream of video data to detect a predetermined characteristic of said first stream of video data; and  
action means, responsive to said analysis  
5 means, for performing at least one of the following actions in dependence upon whether said analysis means detects said predetermined characteristic of said first stream of video data:

- changing a characteristic of an image  
10 displayed on said display means, at least part of said image representing said first stream of video data;
- controlling said transmission means to change over between said first and second storage means;
- changing a field of view of at least  
15 one of said first camera means and said second camera means;
- causing said analysis means to carry out a video data analysis algorithm with respect to said second stream of video data;
- 20 selecting said second stream of video data for storage in at least one of said first and second storage means;
- causing said display means to display an image at least part of which is representative of said  
25 second stream of video data; and
- causing said analysis means to carry out a video data analysis algorithm with respect to video data stored in and read out from one of said first and second storage means;
- 30 wherein said predetermined characteristic of said first stream of video data detected by said analysis means is selected from the group consisting of:
  - acceleration of an object  
35 represented by said first stream of video data;
  - change in acceleration of an object represented by said first stream of video data;
  - shape of an object represented by

said first stream of video data;  
change of shape of an object  
represented by said first stream of video data; and  
texture of an object represented  
5 by said first stream of video data.

222. An apparatus for analyzing, storing and  
displaying video information, comprising:

first camera means for generating a first  
stream of video data;

10 second camera means for generating a second  
stream of video data;

first storage means for selectively storing  
at least one of said first and second streams of video  
data;

15 second storage means for selectively  
storing at least one of said first and second streams of  
video data;

transmission means for selecting one of  
said first and second storage means to receive said first  
20 stream of video data;

display means for selectively displaying at  
least one of said first and second streams of video data;

analysis means for analyzing said first  
stream of video data to detect a plurality of  
25 predetermined characteristics of said first stream of  
video data; and

action means, responsive to said analysis  
means, for performing at least one of the following  
actions in dependence upon whether said analysis means  
30 detects said plurality of predetermined characteristics of  
said first stream of video data:

changing a characteristic of an image  
displayed on said display means, at least part of said  
image representing said first stream of video data;

35 controlling said transmission means to  
change over between said first and second storage means;

changing a field of view of at least  
one of said first camera means and said second camera



means;

causing said analysis means to carry out a video data analysis algorithm with respect to said second stream of video data;

5 selecting said second stream of video data for storage in at least one of said first and second storage means;

causing said display means to display an image at least part of which is representative of said  
10 second stream of video data; and

causing said analysis means to carry out a video data analysis algorithm with respect to video data stored in and read out from one of said first and second storage means;

15 wherein said plurality of predetermined characteristics of said first stream of video data detected by said analysis means are selected from the group consisting of:

20 motion of an object represented by said first stream of video data;

acceleration of an object represented by said first stream of video data;

change in acceleration of an object represented by said first stream of video data;

25 said first stream of video data;

change of shape of an object represented by said first stream of video data; and

30 texture of an object represented by said first stream of video data.

223. An apparatus for storing, analyzing and displaying video information, comprising:

35 storage means for storing a stream of video data, said stream of video data representing a dynamic video image;

detecting means for detecting a predetermined characteristic of said stream of video data stored in said storage means;

display means for displaying images corresponding to said stream of video data stored in said storage means;

5 a display buffer for storing image data transferred from said storage means and for reading out image data stored in said display buffer, said image data read out from said display buffer being supplied to said display means to cause the display means to display an image corresponding to said supplied image data; and

10 action means, responsive to said detecting means, for performing at least one of the following actions in dependence upon whether said detecting means detects said predetermined characteristic of said stream of video data stored in said storage means:

15 selecting between a first display buffer update mode in which the data stored in said display buffer is updated according to a progressive image scan and a second display buffer update mode in which the data stored in said display buffer is updated according to an interlaced image scan;

selecting a rate at which the data stored in said display buffer is updated;

25 selecting a spatial resolution with which said display means displays said images corresponding to said stream of video data stored in said storage means; and

selecting for updating a portion of an image plane corresponding to the image plane displayed on said display means;

30 wherein said predetermined characteristic of said stream of video data stored in said storage means is selected from the group consisting of:

motion of an object represented by said stream of video data stored in said storage means;

35 texture of an object represented by said stream of video data stored in said storage means;

amplitude of a high frequency component of said stream of video data stored in said storage means;

a degree to which said stream of video data stored in said storage means has been compressed;

a degree to which said stream of video data stored in said storage means exhibits spatial correlation;

5 and

a degree to which said stream of video data stored in said storage means exhibits temporal correlation.

224. Apparatus according to claim 223, wherein said storage means includes a hard disk.

225. A method of analyzing video data, comprising the steps of:

generating a stream of dynamic images;

15 applying a moving image content analysis algorithm to said stream of dynamic images; and

inhibiting application of said analysis algorithm to said stream of dynamic images, in response to detection of an alarm condition.

226. A method according to claim 225, wherein said alarm condition is detected by application of said analysis algorithm.

227. A method according to claim 225, wherein said analysis algorithm is for detecting a moving object represented by said stream of dynamic images.

228. Apparatus for analyzing video data, comprising:  
means for generating a stream of dynamic images;  
analysis means for applying a moving image content analysis algorithm to said stream of dynamic images;

30 means for detecting an alarm condition; and  
means, responsive to said means for detecting, for selectively inhibiting said analysis means from applying said analysis algorithm to said stream of dynamic images.

229. Apparatus according to claim 228, wherein said analysis means applied to said stream of dynamic images an analysis algorithm for detecting a moving object represented by said stream of dynamic images.

230. Apparatus according to claim 228, wherein said means for detecting includes means for comparing a result of said analysis algorithm with an alarm detection threshold.

5 231. A method of simultaneously recording on a recording medium a plurality of streams of video information each generated by a respective video camera, comprising the steps of:

10 determining whether an alarm condition is present;

if no alarm condition is present, recording images generated by said video cameras on said recording medium at a first aggregate image rate, said aggregate image rate defining a total number of images currently being recorded on said recording medium per unit time; and

15 if an alarm condition is determined to be present, recording images generated by said video cameras on said recording medium at a second aggregate image rate that is higher than said first aggregate image rate.

20 232. A method according to claim 231, wherein said step of determining whether an alarm condition is present includes analyzing content of at least one of said streams of video information.

25 233. A method according to claim 231, wherein said step of determining whether an alarm condition is present includes receiving a signal from an alarm sensor.

234. A method according to claim 231, wherein said first aggregate image rate is 30 images per second and said second aggregate image rate is 45 images per second.

30 235. Video information recording apparatus, comprising:

a plurality of video cameras each generating a respective stream of video information;

35 recording means for simultaneously recording on a recording medium the plural streams of video information, at a variable aggregate image rate, said aggregate image rate defining a total number of images currently being recorded on said recording medium per unit

time; and

alarm means for determining whether an alarm condition is present;

said recording means operating at a first aggregate image rate when said alarm means does not determine that an alarm condition is present and said recording means operating at second aggregate image rate, higher than said first aggregate image rate, when said alarm means determines that an alarm condition is present.

236. Video information recording apparatus according to claim 235, wherein said alarm means includes means for analyzing content of at least one of said streams of video information.

237. Video information recording apparatus according to claim 235, further comprising at least one alarm sensor for selectively providing an alarm signal to said alarm means.

238. Video information recording apparatus according to claim 235, wherein said first aggregate image rate is 30 images per second and said second aggregate image rate is 45 images per second.

239. Video information recording apparatus according to claim 235, wherein said recording medium is selected from a group consisting of a hard disk, a magneto-optical disk, and a writable optical disk.

240. A method of performing data compression with respect to a frame of image data, said image data being representative of pixels arrayed in an image plane, the method comprising the steps of:

dividing said image data into a plurality of data blocks, each of said data blocks representing a respective rectangular part of said image plane;

comparing each of said data blocks with a corresponding data block of a preceding frame of image data to generate a similarity metric indicative of a degree of similarity between said each data block and the corresponding data block of the preceding frame;

comparing said similarity metric with a

predetermined threshold value;

on the basis of said comparison of said similarity metric with said predetermined threshold value, selecting one of a first mode for generating encoding  
5 values for said each data block and a second mode for generating encoding values for said each data block;

generating encoding values for said each data block in accordance with the selected one of said first mode and said second mode; and

10 applying a transformation to said encoding values of said each data block to form a respective block of coefficient values therefrom.

241. A method according to claim 240, wherein said first mode for generating encoding values for said each  
15 block includes setting to a predetermined value each data element of said each block.

242. A method according to claim 241, wherein said predetermined value to which said data elements are set in  
20 said first mode corresponds to a level representative of a black pixel.

243. A method according to claim 242, further comprising the step of, prior to said comparing steps, changing a value of each data element that is  
representative of a black pixel.

25 244. A method according to claim 240, wherein generating said similarity metric includes summing respective values of data elements selected by checkerboard-subsampling of said each data block.

245. A method according to claim 240, further  
30 comprising the steps of:

receiving a compression parameter setting signal input by a user; and

varying a value of said predetermined threshold value in accordance with the received compression  
35 parameter setting signal.

246. A method of reconstituting compressed image data, said compressed image data including image data frames representative of a dynamic sequence of  $m$  images,

every nth one of said m image data frames having been compression-encoded using an intra-frame compression algorithm in which each of said every nth frame is encoded without reference to any other image frame, n being an integer greater than 2, m being an integral multiple of n and at least twice as large as n, all of said image data frames other than said every nth frame having been compression-encoded using a difference encoding algorithm such that said other image data frames are formed of data representing differences relative to a preceding image data frame, the method comprising the steps of:

reconstituting all of said difference-encoded image data frames;

storing all of said reconstituted image data frames in storage means; and

retrieving said reconstituted image data frames from said storage means and displaying said retrieved image data frames;

wherein a plurality of said reconstituted difference-encoded image data frames are stored in said storage means before any of said reconstituted difference-encoded image data frames are retrieved from said storage means and displayed.

247. A method of reconstituting compressed image data, said compressed image data including image data frames representative of a dynamic sequence of images, every nth one of said image data frames having been compression-encoded using an intra-frame compression algorithm in which each of said every nth frames is encoded without reference to any other image frame, n being an integer greater than 1, all others of said image data frames having been compression-encoded using a difference encoding algorithm such that said other image data frames are formed of difference data representing differences relative to a respective preceding image data frame, the method comprising the steps of:

reconstituting all of said intra-frame-encoded image data frames;

for each of said difference-encoded image data frames, forming second difference data representing differences relative to a respective succeeding reconstituted image data frame; and

5 storing said second difference data in association with the respective difference-encoded image data frame.

248. A method of representing video data in compressed form, comprising the steps of:

10 dividing into rectangular blocks a present image to be compressed, the present image being formed in an image plane;

comparing each of said rectangular blocks of the present image with a corresponding rectangular block of a reference image to generate comparison data for the block of the present image;

15 selecting for representation the rectangular blocks of the present image for which the generated comparison data meets a selection criterion;

20 generating mapping data indicative of locations in the image plane which correspond to the selected rectangular blocks for the present image; and

representing the present image in compressed form by use of:

25 (a) header data for identifying the present image;

(b) said mapping data generated for the present image; and

30 (c) image data representative of the selected rectangular blocks of the present frame.

249. A method according to claim 248, wherein said dividing step includes dividing the present image into  $n$  rectangular blocks all having the same shape and size, said  $n$  rectangular blocks together forming said image plane,  $n$  being an integer greater than 1.

250. A method according to claim 249, wherein each of said  $n$  rectangular blocks corresponds to a horizontal sequence of four  $m \times m$  pixel blocks,  $m$  being an integer



greater than 1.

251. A method according to claim 250, wherein  $m = 8$ .

252. A method according to claim 251, wherein  $n = 600$ .

5 253. A method according to claim 252, wherein said image plane has a horizontal dimension corresponding to 640 pixels and a vertical dimension corresponding to 240 pixels.

254. A method according to claim 251, wherein said  
10 comparing step comprises comparing each of said  $m \times m$  pixel blocks of the present image with a corresponding  $m \times m$  pixel block of said reference image.

255. A method according to claim 254, wherein said  
15 comparing step includes dividing each of said  $m \times m$  pixel blocks of the present image into quadrants and comparing each of said quadrants with a corresponding quadrant of a corresponding  $m \times m$  pixel block of said reference image.

256. A method according to claim 255, wherein said  
20 comparing step includes generating a quadrant statistic corresponding to each of said quadrants of said  $m \times m$  pixel blocks of the present image, and comparing the quadrant statistics for the present image with corresponding quadrant statistics of said reference image.

257. A method according to claim 256, wherein said  
25 generating of said quadrant statistic for each of said quadrants includes selecting eight pixels of the respective quadrant according to a checker-board sampling pattern and summing the eight selected pixels.

258. A method according to claim 257, wherein said  
30 quadrant statistic is obtained by dividing the sum of the eight selected pixels by four.

259. A method according to claim 258, wherein the  
35 same checker-board sampling pattern is used in each of said quadrants for selecting the eight pixels in the respective quadrant.

260. A method according to claim 256, wherein said  
comparing step includes subtracting from the quadrant  
statistic for each quadrant in a respective rectangular

block of the present image a corresponding quadrant statistic of said reference image to produce a respective difference statistic for each quadrant, and said selecting step includes selecting the respective rectangular block  
5 for representation if the difference statistic for any quadrant of the respective rectangular block exceeds a threshold value.

261. A method according to claim 260, further comprising the step of varying said threshold to vary a  
10 degree of compression afforded by said method.

262. A method according to claim 250, wherein four  $m \times m$  luminance pixel arrays and exactly two  $m \times m$  chrominance pixel arrays are formed for each of said  $n$  rectangular blocks.

15 263. A method according to claim 262, wherein one of said two  $m \times m$  chrominance pixel arrays consists of  $U$  pixels and the other said two  $m \times m$  chrominance pixel arrays consist of  $V$  pixels.

264. A method according to claim 248, wherein said  
20 header data includes time and date data for identifying a time and date at which the present image was generated and camera data for identifying a video camera by which the present image was generated.

265. A method according to claim 248, wherein said  
25 image data is obtained by quantizing coefficient data obtained by applying an orthogonal transform of blocks of pixels corresponding to the selected rectangular blocks of the present frame.

266. A method according to claim 248, wherein said  
30 image data is obtained by applying JPEG compression processing to the selected rectangular blocks of the present frame.

267. Apparatus for compressing video data,  
comprising:  
35 means for dividing into rectangular blocks a present image to be compressed, the present image being formed in an image plane;  
means for comparing each of said rectangular

blocks of the present image with a corresponding rectangular block of a reference image to generate compression data from the block of the present image;

means for selecting for representation the  
5 rectangular blocks of the present image for which the generated comparison data meets a selection criterion;

means for generating mapping data indicative of locations in the image plane which correspond to the selected rectangular blocks for the present image; and  
10 storage means for storing a representation of the present image, said representation including:

(a) header data for identifying the present image;

(b) said mapping data generated for the  
15 present image by said means for generating; and

(c) image data representative of the rectangular blocks selected from the present frame by said means for selecting.

268. Apparatus according to claim 267, wherein each  
20 of said rectangular blocks corresponds to a horizontal sequence of four  $m \times m$  pixel blocks,  $m$  being an integer greater than 1.

269. Apparatus according to claim 267, wherein:  
said means for comparing comprises means for  
25 generating at least one comparison statistic for each of said rectangular blocks of the present image; and  
said means for selecting includes means for comparing said at least one comparison statistic with a threshold value;

30 the apparatus further comprising user-actuatable means for permitting a user of the apparatus to vary a level of said threshold value.

270. Apparatus according to claim 267, further comprising transform means for applying an orthogonal  
35 transform to pixel data corresponding to the rectangular blocks selected from the present frame by said means for selecting, and for quantizing the transformed data to produce compression-encoded image data for storage by said

storage means.

271. Apparatus according to claim 270, wherein said transform means includes an JPEG integrated circuit which operates in accordance with the JPEG compression algorithm  
5 to produce said compression-encoded image data.

272. Apparatus according to claim 271, wherein pixel data corresponding to said reference image is provided to said JPEG integrated circuit, said JPEG integrated circuit processes said pixel data corresponding to said reference  
10 image to produce compression-encoded image data representative of said reference image, and said compression-encoded image data representative of said reference image is stored in said storage means.

273. A method of representing video data in  
15 compressed form, comprising the steps of:

dividing an image plane into a plurality of rectangular areas;

processing a first video image to generate a first set of characteristic statistics including at least  
20 one characteristic statistic corresponding to each of said plurality of rectangular areas;

storing said first set of characteristic statistics;

processing a second video image to generate a  
25 second set of characteristic statistics including at least one characteristic statistic corresponding to each of said plurality of rectangular areas;

for each of said plurality of rectangular areas, comparing corresponding ones of said first and second sets  
30 of characteristic statistics;

on the basis of said comparing step, selecting ones of said rectangular areas for which the corresponding ones of said first and second sets of characteristic statistics differ from each other by at least a  
35 predetermined degree of difference;

updating said stored set of characteristic statistics by replacing the stored characteristic statistics corresponding to said selected rectangular

areas with the characteristics of said second set which correspond to said selected rectangular areas;

processing a third video image to generate a third set of characteristic statistics including at least one characteristic statistic corresponding to each of said plurality of rectangular areas; and

for each of said plurality of rectangular areas, comparing corresponding ones of said updated set of characteristic statistics and of said third set of characteristic statistics.

274. A method according to claim 273, wherein the number of said rectangular areas is in excess of 100.

275. A method according to claim 274, wherein the number of said rectangular areas is at least 600.

276. A method according to claim 273, further comprising the steps of:

applying a transform-encoding compression algorithm to pixel data of said first video image corresponding to each of said rectangular areas;

storing the transform-encoded pixel data of said first video image;

applying said transform-encoding compression algorithm to only such pixel data of said second video image as corresponds to said selected ones of said rectangular areas;

storing said transform-encoded pixel data of said second video image; and

storing mapping data indicative of said selected ones of said rectangular areas.

277. A method of displaying in an image plane a video image represented by compressed video data, said compressed video data including replacement image data consisting of a plurality of image data portions each corresponding to a respective region of the image plane, said compressed video data also including mapping data indicative of the regions of the image plane to which the image data portions correspond, the method comprising the steps of:

storing in a buffer reference data representative of a reference video image;

performing a first displaying step consisting of displaying the reference video image;

5 reading said mapping data;

on the basis of said read mapping data, updating said stored reference data by replacing portions of the stored reference data corresponding to the image plane regions indicated by said read mapping data with the corresponding replacement image data portions of said compressed video data; and

10 performing a second displaying step consisting of displaying a second video image corresponding to said updated stored reference data.

15 278. A method according to claim 277, wherein said reference image displayed at said first displaying step corresponds to an image that was generated by a video camera at a point in time prior to a point in time at which said video camera generated an image which is represented by said second video image displayed at said second displaying step.

25 279. A method according to claim 278, wherein said reference image displayed at said first displaying step corresponds to an image that was generated by a video camera at a point in time later than a point in time at which said video camera generated an image which is represented by said second video image displayed at said second displaying step.

30 280. Apparatus for displaying in an image plane a video image represented by compressed video data, said compressed video data including replacement image data consisting of a plurality of image data portions each corresponding to a respective region of the image plane, said compression video data also including mapping data indicative of the regions of the image plane to which the image data portions correspond, the apparatus comprising:

35 a buffer for storing reference data representative of a reference video image;

reading means for reading said mapping data;  
update means, responsive to said reading means,  
for replacing portions of the stored reference data  
corresponding to the image plane regions indicated by said  
5 read mapping data with the corresponding replacement image  
data portions of said compressed video data; and

display means for sequentially displaying said  
reference image and a second image corresponding to said  
updated stored reference data.

10 281. Apparatus according to claim 280, wherein said  
reference image displayed by said display means  
corresponds to an image that was generated by a video  
camera at a point in time prior to a point in time at  
which said video camera generated an image which is  
15 represented by said second video image displayed by said  
display means.

282. Apparatus according to claim 281, wherein said  
reference image displayed by said display means  
corresponds to an image that was generated by a video  
20 camera at a point in time later than a point in time at  
which said video camera generated an image which is  
represented by said second video image displayed by said  
display means.

283. A random-access data storage device in which is  
25 stored compressed video data representing a sequence of  
images formed in an image plane by a video camera;

said compressed video data comprising a  
plurality of first compressed data portions representing  
reference images consisting of every nth one of said  
30 sequence of images, said first data portions having been  
respectively formed by applying an intra-image compression  
process to data representing each one of said reference  
images, n being an integer greater than three;

said compressed video data also comprising a  
35 plurality of second compressed data portions, each  
representing a respective one of said sequence of images  
that is not one of said reference images, each of said  
second compressed data portions including replacement

image data corresponding to selected portions of said image plane and mapping data indicative of said selected portions of said image plane.

284. A random-access data storage device according to  
5 claim 283, wherein the mapping data corresponding to each  
said second compressed data portion is indicative of  
regions of said image plane at which the image represented  
by the respective second compressed data portion differs  
10 from an image that was generated by said video camera  
earlier in time than said image represented by the  
respective second compressed data portion.

285. A random-access data storage device according to  
claim 284, wherein the mapping data corresponding to each  
15 said second compressed data portion is indicative of  
regions of said image plane at which the image represented  
by the respective second compressed data portion differs  
from an image that was generated by said video camera  
later in time than said image represented by the  
respective second compressed data portion.

286. A random-access data storage device according to  
20 claim 283, including a hard disk on which said compressed  
video data is stored.

287. A random-access data storage device according to  
claim 283, wherein  $n \geq 10$ .

288. A random-access data storage device according to  
25 claim 287, wherein  $n \geq 20$ .

289. A random-access data storage device according to  
claim 288, wherein  $n = 33$ .

290. A random-access data storage device according to  
30 claim 283, wherein each of said first and second data  
portions includes header data which includes data  
indicative of a date and time at which the image  
corresponding to the respective data portion was generated  
by said video camera.

291. A random-access data storage device according to  
35 claim 290, wherein said header data further includes data  
identifying the video camera which generated the image  
corresponding to the respective data portion.



292. A method of displaying a sequence of video images in an order that is opposite to an order in which said sequence of video images was generated in an image plane by a video camera, said sequence of video images  
5 having been stored in a data storage device in the form of compressed video data including a first compressed data portion representing a forward reference image generated first in time in said sequence of video images, said first compressed data portion having been formed by applying an  
10 intra-image compression process to data representing said forward reference image, the stored compressed video data further including a sequence of second compressed data portions, each representing a respective one of said sequence of images other than said forward reference  
15 image, each of said second compressed data portions including forward replacement data corresponding to selected regions of said image plane and mapping data indicative of said selected regions of said image plane, the mapping data included in each of said second data  
20 portions having been formed on the basis of differences between the respective image represented by said second data portion and an image representing the image of said sequence generated immediately prior in time to the respective image, the method comprising the steps of:  
25 (a) retrieving said first compressed data portion from said storage device;  
(b) decompressing the retrieved first compressed data portion to form decompressed forward reference video data;  
30 (c) storing the decompressed forward reference data in a buffer;  
(d) retrieving the second compressed data portion representing the image of said sequence that was generated immediately after the forward reference image;  
35 (e) reading the mapping data included in the second compressed data portion retrieved in step (d);  
(f) on the basis of the mapping data read in step (e), updating the decompressed forward reference data

stored in the buffer by replacing portions of the stored forward reference data corresponding to the image plane regions indicated by the read mapping data with the corresponding forward replacement data included in the  
5 retrieved second compressed data portion, to form updated forward reference data;

(g) retrieving the second compressed data portion representing the image of said sequence that was generated immediately after the image corresponding to the  
10 most recently retrieved second compressed data portion;

(h) reading and storing the mapping data included in the second compressed data portion retrieved in step (g);

(i) selecting portions of the updated forward  
15 reference data in accordance with the mapping data read at step (h);

(j) storing the forward reference data portions selected at step (i) as backward replacement data corresponding to the earlier one of the two images  
20 referred to in step (g);

(k) again updating the updated forward reference data by replacing portions thereof corresponding to the image plane regions indicated by the mapping data read at step (h) with the corresponding forward  
25 replacement data included in the second compressed data portion retrieved at step (g), to again form updated forward reference data;

(l) repeating said steps (g)-(k) in sequence until the second compressed data portion representing the  
30 last image in said sequence has been retrieved at the latest step (g) and processed in succeeding steps (h)-(k), the updated forward reference data formed at the last repeated step (k) corresponding to said last image of the sequence and being considered also backward reference  
35 data;

(m) displaying an image corresponding to said backward reference data;

(n) retrieving and reading the mapping data

included in the second compressed data portion corresponding to the image displayed at step (m);

(o) retrieving the backward replacement data corresponding to the image in said sequence generated  
5 immediately prior to the image displayed at step (m);

(p) updating said backward reference data by replacing portions thereof corresponding to the image plane regions indicated by the mapping data read at step (n) with the corresponding backward replacement data  
10 retrieved at step (o);

(q) repeating steps (m)-(p) until the updated backward reference data corresponds to the image of said sequence generated immediately after the forward reference image; and

(r) displaying an image corresponding to the latest updated backward reference data; and

(s) displaying an image corresponding to the forward reference image.

293. A method according to claim 292, further  
20 comprising the steps of:

(e1) selecting portions of the decompressed reference data stored at step (c) in accordance with the mapping data read at step (e); and

(e2) storing the reference data portions  
25 selected at step (e2) as backward replacement data corresponding to the first compressed data portion;

said step (s) comprising:

(s1) retrieving the backward replacement data stored at step (e);

(s2) updating the updated reference data  
30 corresponding to the image displayed at step (r) by replacing portions thereof corresponding to the image plane regions indicated by the mapping data read at step (e) with the corresponding replacement data retrieved at  
35 step (s1); and

(s3) displaying an image corresponding to the updated data formed at step (s2).

294. Video information storage apparatus, comprising:

a plurality of video cameras, each for generating a respective stream of dynamic images;

multiplexing means for multiplexing said streams of dynamic images to form a combined sequence of video images, images generated by respective ones of said video cameras being interspersed with each other in said combined sequence;

compression means for receiving the combined sequence of video images and for applying a data compression algorithm to the images of said combined sequence, the compression algorithm applied to each of said images of said combined sequence being subject to variation depending on which camera generated the image to which the algorithm is applied; and

storage means for storing compressed video images formed by said compression means.

295. Video information storage apparatus according to claim 294, wherein said data compression algorithm applied by said compression means includes:

comparing predetermined portions of a present image of said combined sequence to corresponding portions of a preceding reference image generated by the video camera which generated the present image, to form comparison statistics;

comparing said comparison statistics with a threshold; and

selectively discarding said predetermined portions of the present image on the basis of the comparing of the comparison statistics with the threshold;

the threshold being subject to variation from image to image depending on which camera generated the present image.

296. A method of storing video information, comprising the steps of:

generating a plurality of streams of dynamic images by using a respective video camera to generate each stream;

multiplexing said streams of dynamic images to

form a combined sequence of video images, images generated by respective ones of said video cameras being interspersed with each other in said combined sequence;  
receiving the combined sequence of video images  
5 and applying a data compression algorithm to the images of said combined sequence, the compression algorithm applied to each of said images of said combined sequence being subject to variation depending on which camera generated the image to which the algorithm is applied; and  
10 storing the compressed video images.

297. A method according to claim 296, wherein said applying of the data compression algorithm includes:

comparing predetermined portions of a present image of said combined sequence to corresponding portions  
15 of a preceding reference image generated by the video camera which generated the present image, to form comparison statistics;

comparing said compression statistics with a threshold; and

20 selectively discarding said predetermined portions of the present image on the basis of the comparing of the comparison statistics with the threshold; the threshold being subject to variation from image to image depending on which camera generated the  
25 present image.

298. Video data storage apparatus, comprising:

a video information source for outputting a sequence of fields of video data, each said field of video data representing a respective image;

30 storage means for storing said video data fields in the form of compressed video data;

a microprocessor for controlling storage of said compressed video data by said storage means; and

a digital signal processing integrated circuit  
35 (DSP-IC) for exchanging data with said microprocessor and for applying a data compression algorithm to said fields of video data;

said DSP-IC applying said data compression

algorithm to a first field of said sequence of fields in accordance with a parameter which constrains operation of said data compression algorithm;

5 upon said DSP-IC completing compression-processing of said first field, said DSP-IC receiving a signal from said microprocessor to change said parameter;

10 said DSP-IC applying said data compression algorithm to a second field of said sequence of fields in accordance with the changed parameter, said second field immediately following said first field in said sequence of fields;

15 upon said DSP-IC completing compression-processing of said second field, said DSP-IC receiving a signal from said microprocessor to again change said parameter; and

20 said DSP-IC applying said data compression algorithm to a third field of said sequence of fields in accordance with the again-changed parameter, said third field immediately following said second field in said sequence of fields.

299. Video data storage apparatus according to claim 298, wherein the again-changed parameter is the same as said parameter in accordance with which said data compression algorithm was applied to said first field.

25 300. Video data storage apparatus according to claim 299, wherein said data compression algorithm applied by said DSP-IC includes:

30 comparing predetermined portions of a present field of said sequence of fields to corresponding portions of a reference image, generated by a video camera which subsequently generated the present field, to form comparison statistics;

comparing said comparison statistics with said parameter; and

35 selectively discarding said predetermined portions of the present field on the basis of the comparing of the comparison statistics with said parameter.

301. A method of characterizing a block of video data in a first field of video data, said block of video data to be characterized in comparison with a corresponding block of video data in another field of video data, said  
5 block of video data in the first field being in the form of an  $m \times m$  pixel data array,  $m$  being an even, positive integer, the method comprising the steps of:

dividing said  $m \times m$  pixel data into four quadrants each consisting of an  $(m/2) \times (m/2)$  pixel data  
10 array;

selecting pixels from each of said quadrants in accordance with a checker-board sampling pattern;

with respect to each of said quadrants, summing the pixels selected from said quadrant and dividing the  
15 resultant sum by a scaling factor to generate a characterizing statistic for the respective quadrant;

subtracting each of the respective characterizing statistics from a characterizing statistic for a corresponding quadrant of the corresponding block of  
20 video data in said another field to generate a difference value for each quadrant of the block of video data in the first field;

comparing each of said difference values with a threshold level; and

25 characterizing the block of video data in the first field as different from the corresponding block of video data in said another field if the absolute value of any one of the difference values for the four quadrants of the block of video data in the first field exceeds the  
30 threshold level.

302. A method according to claim 301, wherein  $m = 8$ .

303. A method according to claim 302, wherein said scaling factor is four.

304. A method according to claim 301, wherein the  
35 same checker-board sampling pattern is used to select pixels from all four of said quadrants.

305. A method of characterizing a block of video data in a first field of video data representing a color image,

said block of video data to be characterized in comparison with a corresponding block of video data in another field of video data representing another color image, said block of video data in the first field corresponding to a 4m  
5 pixels by m pixels region in said first field and being in the form of four m x m arrays of luminance data, one m x m array of a first type of chrominance data and one m x m array of a second type of chrominance data, m being an even, positive integer, the method comprising steps of:

10           dividing each of said six m x m arrays into four quadrants each consisting of an  $(m/2) \times (m/2)$  pixel data array;

                  selecting pixels from each of said quadrants in accordance with a checker-board sampling pattern;

15           with respect to each of said quadrants, summing the pixels selected from said quadrant and dividing the resultant sum by a scaling factor to generate a characterizing statistic for the respective quadrant;

                  subtracting each of the respective  
20 characterizing statistics from a characterizing statistic for a corresponding quadrant of a corresponding m x m array of the corresponding block of video data in said another field to generate a difference value for each quadrant of the block of video data in the first field;

25           comparing each of said difference values for said quadrants of luminance data with a first threshold level, and comparing each of said difference values for said quadrants of chrominance data with a second threshold level; and

30           characterizing the block of video data in the first field as different from the corresponding block of video data in said another field if the absolute value of any one of the difference values for the luminance data quadrants exceeds the first threshold level or if any one  
35 of the difference values for the chrominance data quadrants exceeds the second threshold level.

306. A method according to claim 305, wherein  $m = 8$ .

307. A method according to claim 306, wherein said



scaling factor is four.

308. A method according to claim 305, wherein the same checker-board sampling pattern is used to select pixels from all of said quadrants.

5 309. A method according to claim 305, wherein said second threshold is different from said first threshold.

310. A method according to claim 309, wherein said second threshold is twice said first threshold.

311. A method of performing data compression with  
10 respect to a plurality of streams of dynamic video images, each of said streams being generated by a respective video camera, images from said streams being interspersed with each other to form a composite stream, the method comprising the steps of:

15 storing statistics characterizing a respective reference image from each of said plurality of streams; and

performing compression-encoding with respect to later images of each of said plurality of streams by  
20 comparing each of said later images with the statistics characterizing the reference image corresponding to the respective stream.

312. A method according to claim 311, wherein said plurality of streams of dynamic video images includes four  
25 such streams.

313. A method according to claim 312, wherein said plurality of streams of dynamic video images includes sixteen such streams.

314. Apparatus for performing data compression with  
30 respect to a plurality of streams of dynamic video images, each of said streams being generated by a respective video camera, images from said streams being interspersed with each other to form a composite stream, comprising:

35 means for storing statistics characterizing a respective reference image from each of said plurality of streams; and

means for performing compression-encoding with respect to later images of each of said plurality of

streams by comparing each of said later images with the statistics characterizing the reference image corresponding to the respective stream.

315. Apparatus according to claim 314, wherein said  
5 plurality of streams of dynamic video images includes four such streams.

316. Apparatus according to claim 315, wherein said plurality of streams of dynamic video images includes sixteen such streams.

10 317. A method of performing data compression with respect to a plurality of streams of dynamic video images, each of said streams being generated by a respective video camera, images from said streams being interspersed with each other to form a composite stream, the method  
15 comprising the steps of:

storing data representative of a respective reference image from each of said plurality of streams; and

20 performing compression-encoding with respect to later images of each of said plurality of streams by comparing each of said later images with the reference image corresponding to the respective stream.

318. Apparatus for performing data compression with respect to a plurality of streams of dynamic video images,  
25 each of said streams being generated by a respective video camera, images from said streams being interspersed with each other to form a composite stream, comprising:

30 means for storing data representative of a respective reference image from each of said plurality of streams; and

means for performing compression-encoding with respect to later images of each of said plurality of streams by comparing each of said later images with the reference image corresponding to the respective stream.

35 319. Apparatus for storing video signals, comprising: a plurality of video cameras, including at least four video cameras;

first, second and third video decoding circuits

each for receiving a field of a video signal generated by a respective one of said video cameras currently connected to the video decoding circuit and for extracting luminance, chrominance and reference signal components  
5 from the received video signal;

means for selectively connecting each of said video decoding circuits to every one of said plurality of video cameras;

first and second signal conversion circuits,  
10 each for converting into digital form the luminance and chrominance signal components extracted by a respective one of said video decoding circuits currently connected to the signal conversion circuit;

means for selectively connecting each of said  
15 signal conversion circuits to every one of said first, second and third video decoding circuits;

first storage means connected to said first signal conversion circuit for sequentially storing fields of said luminance and chrominance signal components  
20 converted into digital form by said first conversion circuit; and

second storage means connected to said second signal conversion circuit for sequentially storing fields of said luminance and chrominance signal components  
25 converted into digital form by said second conversion circuit.

320. Apparatus according to claim 319, further comprising:

a data compression circuit for applying a data  
30 compression algorithm to the digital components stored in said first and second storage means to form compressed video data; and

means for selectively connecting said data  
compression circuit to each of said first and second  
35 storage means.

321. Apparatus according to claim 320, further comprising a mass storage device connected to said data compression circuit for storing the compressed video data

formed by said data compression circuit.

322. Apparatus according to claim 321, wherein said mass storage device is selected from a group consisting of a hard disk, a magneto-optical disk and a writable optical  
5 disk.

323. Apparatus according to claim 319, wherein said chrominance signal components include first and second chrominance signal components, and each one of said first and second signal conversion circuits includes means for  
10 formatting digital data representing said luminance signal component and said first and second chrominance signal components according to a 4:1:1 data format.

324. Apparatus according to claim 323, wherein each one of said first and second signal conversion circuits  
15 includes:

a first analog-to-digital converter for converting said luminance signal component into luminance data; and

a second analog-to-digital converter for  
20 converting said chrominance signal components into chrominance data.

325. Apparatus according to claim 324, wherein each one of said first and second signal conversion circuits includes means for demodulating the chrominance signal  
25 component extracted by the video decoding circuit currently connected to the signal conversion circuit, on the basis of the reference signal component extracted by the video decoding circuit currently connected to the signal conversion circuit, to form the first and second  
30 chrominance signal components.

326. Apparatus according to claim 319, wherein said plurality of video cameras includes sixteen video cameras.

327. Apparatus according to claim 319; said apparatus being operable in a mode wherein two of said video  
35 decoding circuits respectively receive alternate ones of fields generated by a single one of said video cameras.

328. A method of updating a display buffer, said display buffer for storing image data to be supplied to a

display device to cause the display device to display an image corresponding to the image data, said display device displaying said image in the form of a plurality of rows of picture elements, said rows of picture elements  
5 consisting of a first set of rows that are alternate ones of said rows of picture elements and a second set of rows that are all of the rows of picture elements not included in said first set of rows, said display buffer including a first set of memory locations corresponding to said  
10 first set of rows and a second set of memory locations corresponding to said second set of rows, the method comprising the steps of:

first updating the image data stored in said first set of memory locations;

15 upon completion of said first updating step, second updating the image data stored in said second set of memory locations; and

sequentially repeating said first and second updating steps.

20 329. A method according to claim 328, wherein said image data stored in said display buffer represents a dynamic video image.

330. Apparatus for formatting an image plane represented as a two-dimensional array of pixel locations  
25 according to a 4:1:1 digital color video format, comprising:

means for dividing said image plane into  $n$  rectangular regions having a vertical dimension of  $m$  pixels and a horizontal dimension of  $4m$  pixels,  $n$  being an integer greater than 1,  $m$  being an even integer greater  
30 than 1;

luma block means for forming with respect to each of said  $n$  rectangular regions four  $m \times m$  luminance-value pixel blocks arranged in a horizontal sequence in  
35 the rectangular region; and

chroma block means for forming exactly two  $m \times m$  chrominance-value blocks with respect to each of said  $n$  rectangular regions, a first one of said two chrominance-

value blocks corresponding to a first chrominance signal, and each value of said first chrominance-value block representing an area corresponding to four horizontally-sequential pixels of the respective rectangular region, the second one of said two chrominance-value blocks corresponding to a second chrominance signal different from said first chrominance signal, each value of said second chrominance-value block representing an area corresponding to four horizontally-sequential pixels of the respective rectangular region.

331. Apparatus according to claim 330, wherein  $m = 8$ .

332. Apparatus according to claim 331, wherein  $n = 600$ .

333. Apparatus according to claim 332, wherein said means for dividing divides said image plane into 20 of said rectangular regions in a horizontal direction and into 30 of said rectangular regions in a vertical direction.

334. Apparatus according to claim 330, wherein said first chrominance signal is a U signal and said second chrominance signal is a V signal.

335. A method of formatting an image plane represented as a two-dimensional array of pixel locations according to a 4:1:1 digital color video format, the method comprising the steps of:

dividing said image plane into  $n$  rectangular regions having a vertical dimension of  $m$  pixels and a horizontal dimension of  $4m$  pixels,  $n$  being an integer greater than 1,  $m$  being an even integer greater than 1;

forming with respect to each of said  $n$  rectangular regions four  $m \times m$  luminance-value pixel blocks arranged in a horizontal sequence in the rectangular region; and

forming exactly two  $m \times m$  chrominance-value blocks with respect to each of said  $n$  rectangular regions, a first one of said two chrominance-value blocks corresponding to a first chrominance signal, and each value of said first chrominance-value block representing

an area corresponding to four horizontally-sequential pixels of the respective rectangular regions, the second one of said two chrominance-value blocks corresponding to a second chrominance signal different from said first chrominance signal, each value of said second chrominance-value block representing an area corresponding to four horizontally-sequential pixels of the respective rectangular region.

336. A method according to claim 335, wherein  $m = 8$ .

10 337. A method according to claim 336, wherein  $n = 600$ .

338. A method according to claim 337, wherein said dividing step includes dividing said image plane into 20 of said rectangular regions in a horizontal direction and into 30 of said rectangular regions in a vertical direction.

339. A method according to claim 335, wherein said first chrominance signal is a U signal and said second chrominance signal is a V signal.

20 340. A method of transmitting a field of video data on a multi-bit parallel data bus, said field of video data corresponding to an image, the method comprising the steps of:

25 dividing said field of video data into first video data portions each corresponding to at least one and no more than  $m$  raster-scan lines of said field,  $m$  being a positive integer that is less than a number of raster-scan lines making up said field of video data;

30 transmitting each of said first video data portions in a respective one of a first sequence of discrete time intervals;

formatting said field of video data into a plurality of  $n \times p$  data blocks, each of said data blocks corresponding to a respective rectangular portion of said image that overlaps at least two raster-scan lines,  $n$  and  $p$  both being positive integers greater than one;

35 dividing said block-formatted video data into second data portions each consisting of a plurality of

said  $n \times p$  data blocks; and

transmitting each of said second data portions in a respective one of a second sequence of discrete time intervals, said second sequence of discrete time intervals being interleaved with said first sequence of discrete time intervals.

341. A method according to claim 340, wherein  $m = 1$ .

342. A method according to claim 340, wherein  $n = p = 8$ .

343. A method according to claim 342, wherein each of said second data portions consists of 15 of said  $8 \times 8$  data blocks.

344. A method according to claim 343, wherein  $m = 1$ .

345. A method according to claim 344, wherein each of the intervals of said first sequence is 27 microseconds and each of said intervals of said second sequence is 40 microseconds.

346. A method according to claim 345, wherein said field of video data is made up of 240 raster-scan lines, each including 640 pixels.

347. A method according to claim 340, wherein two-thirds of said data blocks are formed of luminance data, one-sixth of said data blocks are formed of a first kind of chrominance data, and one-sixth of said data blocks are formed of a second kind of chrominance data different from said first kind of chrominance data.

348. A method according to claim 340, further comprising the steps of:

one of a first transmission mode and a second transmission mode; and

varying the number of said  $n \times p$  data blocks which forms each of said second data portions in dependence on the selected transmission mode.

349. A method according to claim 340, further comprising the steps of:

selecting one of a normal display mode and a reduced-resolution display mode; and

when said reduced-resolution display mode is



selected, subsampling said first data portions prior to transmission thereof.

350. A method according to claim 349, wherein said reduced-resolution display mode is a zoom display mode.

5 351. A method according to claim 340, further comprising the step of supplying the transmitted first data portions to a display buffer used for driving a video display device.

10 352. A method according to claim 340, further comprising the step of applying a video data analysis algorithm to said second data portions.

353. A method according to claim 352, further comprising the step of applying a video data compression algorithm to said second data portions.

15 354. A method according to claim 340, further comprising the step of applying a video data compression algorithm to said second data portions.

20 355. A method according to claim 340, further comprising the step of appending header data to each of said transmitted  $n \times p$  data blocks, said appended header data for indicating whether the respective data block is different from a corresponding data block of an earlier field of video data.

25 356. Video data transmission apparatus, comprising:  
a multi-bit parallel data bus;

means for dividing a field of video data into first video data portions each corresponding to at least one and no more than  $m$  raster-scan lines of said field,  $m$  being a positive integer that is less than a number of  
30 raster-scan lines making up said field of video data;

means for transmitting, on said parallel data bus, each of said first data portions in a respective one of a first sequence of discrete line intervals;

35 means for formatting said field of video data into a plurality of  $n \times p$  data blocks, each of said data blocks corresponding to a respective rectangular portion of said image that overlaps at least two raster-scan lines,  $n$  and  $p$  both being positive integers greater than

one;

means for dividing said block-formatted video data into second data portions each consisting of a plurality of said  $n \times p$  data blocks; and

5 means for transmitting, on said parallel data bus, each of said second data portions in a respective one of a second sequence of discrete time intervals, said second sequence of discrete time intervals being interleaved with said first sequence of discrete time  
10 intervals.

357. Video data transmission apparatus according to claim 356, wherein  $m = 1$ .

358. Video data transmission apparatus according to claim 356, wherein  $n = p = 8$ .

15 359. Video data transmission apparatus according to claim 358, wherein each of said second data portions consists of 15 of said  $8 \times 8$  data blocks.

360. Video data transmission apparatus according to claim 359, wherein  $m = 1$ .

20 361. Video data transmission apparatus according to claim 360, wherein each of the intervals of said first sequence is 27 microseconds and each of the intervals of said second sequence is 40 microseconds.

362. Video data transmission apparatus according to  
25 claim 356, further comprising:

for selecting one of a first transmission mode and a second transmission mode; and

30 means for varying the number of said  $n \times p$  data blocks which forms each of said second data portions in dependence on the selected transmission mode.

363. Video data transmission apparatus according to claim 356, further comprising:

means for selecting one of a normal display mode and a reduced-resolution display mode; and

35 means for subsampling said first data portions prior to transmission thereof, when said reduced-resolution display mode is selected.

364. Video data transmission apparatus according to

claim 356, wherein said multi-bit parallel data bus includes:

16 parallel data transmission lines for simultaneously transmitting a pair of eight-bit bytes of said video data; and

3 parallel data transmission lines for transmitting three bits of identifying data simultaneously with each pair of video data bytes.

365. A method of updating a display buffer, said display buffer for storing image data to be supplied to a display device to cause the display device to display an image corresponding to the image data, said display device displaying said image in the form of a two-dimensional array of picture elements, said array of picture elements defining an image plane, the method comprising the steps of:

dividing the image plane into a plurality of rectangular regions;

generating a present field of video data representative of an image formed in the image plane; and

for each respective one of the rectangular regions of the image plane:

detecting a characteristic of a portion of the present field of video data, said portion corresponding to the respective one of the rectangular regions;

comparing the detected characteristic with a reference characteristic; and

selectively storing the portion of the present field of video data in the display buffer, in dependence upon a result of said comparing step.

366. A method according to claim 365, wherein the respective portion of the present field of video data is stored in the display buffer only if the detected characteristic differs from the reference characteristic by more than a threshold amount.

367. A method according to claim 365, wherein each of

said plurality of rectangular regions corresponds to a  $4m \times m$  array of the picture elements,  $m$  being an integer greater than 1.

368. A method according to claim 365, wherein the  
5 portion of said present video field which corresponds to each rectangular region consists of four  $m \times m$  arrays of luminance data, one  $m \times m$  array of a first type of chrominance data, and one  $m \times m$  array of a second type of chrominance data.

10 369. A method according to claim 368, wherein  $m = 8$ .

370. Video data storage apparatus, comprising:  
a plurality of video cameras each for generating  
a respective stream of video information;  
at least one hard disk for storing video data;  
15 a housing in which said at least one hard disk  
is contained;

a motherboard mounted in said housing, said  
motherboard having mounted thereon a microprocessor for  
controlling storage of video data on said hard disk;

20 a second printed circuit board mounted in said  
housing having integrated circuits mounted thereon for  
receiving the streams of video information generated by  
said video cameras, said integrated circuits for selecting  
for storage ones of fields of video information included  
25 in said streams of video information; and

a third printed circuit board mounted in said  
housing and connected to said motherboard and to said  
third printed circuit board, said second printed circuit  
board being connected to said motherboard only through  
30 said third printed circuit board, said third printed  
circuit board having mounted thereon integrated circuitry  
for digitizing said selected fields of video information  
and for applying data compression processing to said  
selected fields of video information.

35 371. Video data storage apparatus according to claim  
370, wherein said second printed circuit board has mounted  
thereon filtering circuitry for performing analog signal  
conditioning on the fields of said video information

generated by said video cameras and selected for storage.

372. Video data storage apparatus according to claim 370, wherein said third printed circuit board has mounted thereon an integrated circuit processing device for  
5 applying a moving image content analysis algorithm to said digitized fields of video information.

373. Video data storage apparatus according to claim 370, further comprising archive means, operatively connected to said microprocessor, for recording on a  
10 removable recording medium video data copied from said hard disk.

374. Video data storage apparatus, comprising:  
a video information source for outputting at least one stream of video data fields;  
15 storage means for storing said video data fields in the form of compressed video data;  
a housing;  
a motherboard mounted in said housing, said motherboard having mounted thereon a microprocessor for  
20 controlling storage of said compressed video data by said storage means;  
a second printed circuit board mounted in said housing and connected to said motherboard;  
a first digital signal processing integrated  
25 circuit (DSP-IC), mounted on said second printed circuit board, for exchanging data with said microprocessor and for applying a data compression algorithm to said at least one stream of video data fields; and  
at least one other DSP-IC mounted on said second  
30 printed circuit board, for processing said at least one stream of video data fields;  
said first DSP-IC transmitting command messages to, and receiving status messages from, said at least one other DSP-IC.

35 375. Video data storage apparatus according to claim 374, wherein:

said second printed circuit board has mounted thereon display processing circuitry for applying scaling

processing and overlay mixing to said at least one stream of video data fields; and

said at least one other DSP-IC mounted on said second printed circuit board includes:

5 a second DSP-IC for controlling said display processing circuitry, and

a third DSP-IC for applying a moving image content analysis algorithm to said at least one stream of video data fields.

10 376. Video data storage apparatus according to claim 375, wherein said data exchanged between said microprocessor and said first DSP-IC includes parameter data transmitted from said microprocessor to said first DSP-IC, said parameter data for constraining execution by  
15 said third DSP-IC of said moving image content analysis algorithm, said first DSP-IC transmitting said parameter data to said third DSP-IC.

20 377. Video data storage apparatus according to claim 374, said first DSP-IC comparing predetermined portions of said video data fields with corresponding portions of a reference video data field to determine whether said predetermined portions are to be stored by said storage means.

25 378. Video data storage apparatus according to claim 377, further including a JPEG integrated circuit, mounted on said second printed circuit board, for applying video data compression processing, in accordance with the JPEG compression standard to said reference video data field and to said predetermined portions of video data fields  
30 which said first DSP-IC determines are to be stored by said storage means.

379. Video data storage apparatus according to claim 374, wherein said storage means includes a hard disk within said housing.

35 380. A printed circuit board for a video data storage apparatus, the printed circuit board having means for receiving at least one stream of video data fields and having mounted thereon:

a first digital signal processing integrated circuit (DSP-IC) for applying a data compression algorithm to said at least one stream of video data fields;

5 a second DSP-IC for controlling scaling and overlay mixing processes applied to said at least one stream of video data fields; and

a third DSP-IC for applying a moving image content analysis algorithm to said at least one stream of video data fields.

10 381. A printed circuit board according to claim 380, wherein said first DSP-IC transmits command messages to, and receives status messages from, each of said second and third DSP-IC's.

15 382. A printed circuit board according to claim 381, wherein said first DSP-IC exchanges data with a microprocessor not located on said printed circuit board.

383. A structure for supporting a plurality of recording medium drive units in a video data storage apparatus, the structure comprising:

20 a base member for supporting at least one of said drive units;

a second member, supported on said base member, for supporting at least a second one of said drive units; and

25 a third member, supported on said second member, for securing said at least second one of said drive units on said second member.

384. A structure according to claim 383, wherein said third member is shaped and sized to support at least a 30 third one of said plurality of drive units.

385. A structure according to claim 384, wherein each of said base member, said second member and said third member is shaped and sized to support at least two of said drive units.

35 386. A structure according to claim 385, wherein each of said second member and said third member is shaped and sized to support two standard hard disk drive units.

387. A structure according to claim 383, wherein said

base member includes a substantially planar and horizontal bottom plate and two vertical end walls emerging upwardly and integrally from respective opposite side edges of said bottom plate.

5           388. A structure according to claim 387, wherein said second member is substantially planar.

          389. A structure according to claim 388, wherein one of said vertical end walls of said base member has a pair of slots formed therein, and said second member has a pair  
10 of hinge-tabs formed thereon at respective positions that correspond to respective positions of said slots on said base member, each of said hinge-tabs for pivotally engaging a respective one of said slots.

          390. A structure according to claim 389, wherein each  
15 of said base member, said second member and said third member has a respective attachment tab formed thereon, each of the attachment tabs having a hole formed therein for accommodating a fastener, said base member, said second member and said third member being positioned with  
20 respect to each other so that the three holes in the attachment tabs are aligned to permit simultaneous insertion of the fastener through all three holes.

          391. A structure according to claim 388, wherein said  
25 second member has a pad mounted on a lower surface of said second member, said pad for pressing against a drive unit supported on said base member.

          392. A structure according to claim 391, wherein said  
30 third member includes a substantially planar and horizontal top plate and two vertical end walls emerging downwardly and integrally from respective opposite side edges of said top plate.

          393. A structure according to claim 392, wherein said  
35 top plate of said third member has a pad mounted on a lower surface of said top plate, said pad on said top plate for pressing against a drive unit supported on said second member.

          394. A multiple record medium drive unit assembly for use in a video data storage apparatus, the assembly



comprising:

a base member;

a pair of record medium drive units mounted on  
said base member;

5 a second support member positioned above said  
drive units and supported on said base member;

a third record medium drive unit mounted on said  
second support member;

a third support member supported on said second  
10 support member; and

means for securing said base member, said second  
support member and said third support member to each  
other.

395. An assembly according to claim 394, further  
15 comprising a fourth record medium drive unit supported on  
said second support member.

396. An assembly according to claim 395, further  
comprising a fifth record medium drive unit supported on  
said third support member.

20 397. An assembly according to claim 396, further  
comprising a sixth recording medium drive unit supported  
on said third support member.

398. An assembly according to claim 394, further  
comprising a fourth record medium drive unit supported on  
25 said third support member.

399. An assembly according to claim 394, wherein one  
of said pair of drive units mounted on said base member is  
for driving a removable recording medium.

400. An assembly according to claim 399, wherein said  
30 other one of said pair of drive units is a floppy disk  
drive and the third drive unit is a hard disk drive.

401. An assembly according to claim 400, wherein said  
removable recording medium is a digital audio tape.

402. An assembly according to claim 400, wherein said  
35 removable recording medium is a DVD.

403. An assembly according to claim 400, wherein said  
removable recording medium is a writable optical disk.

404. An assembly according to claim 400, wherein said

removable recording medium is a magneto-optical disk.

405. A video data storage apparatus, comprising:  
source means for providing video data;  
first storage means including a first  
5 storage medium for storing said video data provided by  
said source means;  
second storage means including a second  
storage medium on which video data provided by said source  
means has been recorded;  
10 third storage means including a third  
storage medium for storing video data to be archived; and  
control means for controlling said first  
storage means to store said video data provided by said  
source means, while controlling said second and third  
15 storage means to transfer said video data recorded on said  
second storage medium from said second storage medium to  
said third storage medium.

406. Apparatus according to claim 405, wherein said  
first storage medium is a first hard disk, said second  
20 storage medium is a second hard disk, and said third  
storage medium is a magnetic tape.

407. Apparatus according to claim 406, wherein said  
third storage means is a helical-scan tape recorder.

408. Apparatus according to claim 407, wherein said  
25 third storage means records said video data to be archived  
on said third storage medium in accordance with a standard  
format for digital audio tape recording.

409. Apparatus according to claim 405, wherein said  
source means includes a plurality of video cameras, each  
30 generating a respective sequence of frames of video  
signals, and conversion means for converting the  
respective sequences of frames of video signals into  
respective sequences of frames of digital video data.

410. Apparatus according to claim 409, further  
35 comprising index generating means for generating, with  
respect to the frames of digital video data, index data  
indicative of respective times at which the frames of  
digital video data were generated, the ones of the

plurality of cameras which generated the frames of digital video data, and locations on said first storage medium at which said frames of digital video data are recorded.

411. Apparatus according to claim 410, wherein said  
5 index data generated by said index data generating means further includes data indicative of events represented by the sequences of frames of digital video data.

412. Apparatus according to claim 410, further  
10 comprising means for receiving signals indicative of alarm conditions, and wherein said index data generated by said index data generating means further includes data indicative of said alarm conditions.

413. Apparatus according to claim 410, further  
15 comprising fourth storage means including a fourth storage medium for storing said index data generated by said index data generating means.

414. Apparatus according to claim 413, wherein said fourth storage medium is a hard disk.

415. Apparatus according to claim 413, wherein said  
20 control means controls said fourth storage means to read out said index data from said fourth storage medium.

416. Apparatus according to claim 415, wherein said  
25 control means controls said third storage means to record on said third storage medium the index data read out from said fourth storage medium.

417. Apparatus according to claim 413, wherein said  
control means controls said first storage means to record on said first storage medium the index data generated by said index data generating means.

30 418. Apparatus according to claim 405, wherein said control means determines what portion of said first storage medium remains available for storing said video data provided by said source means and determines what quantity of the video data recorded on said second storage  
35 medium remains to be transferred to said third storage medium, said control means comparing said available proportion of said first storage medium and said quantity of video data remaining to be transferred from said second

storage medium, and said control means selecting, on the basis of a result of said comparison, a storage rate at which said first storage means stores on said first storage medium said video data provided by said source  
5 means.

419. Apparatus according to claim 418, wherein said storage rate selected by said control means is a frame rate at which said first storage means stores on said first storage medium frames of said video data provided by  
10 said source means.

420. A method of archiving video data stored in a video data storage apparatus, the apparatus including a plurality of video cameras, first and second video data storage hard disks, an index data storage hard disk, an  
15 archive recording medium and a drive unit for the archive recording medium, the method comprising the steps of:

(a) storing on said first video data storage hard disk video data representative of dynamic video signal streams generated by said video cameras,  
20 while storing on said index data storage hard disk index data indicative of times of recording and sources of the video data being stored on said first video data storage hard disk;

(b) concurrently with step (a), recording  
25 on said archive recording medium all video data stored on said second video data storage hard disk and index data stored on said index data storage hard disk and indicative of times of recording and sources of the video data stored on said second video data storage hard disk; and

(c) after completion of step (b),  
30 (i) storing on said second video data storage hard disk video data representative of dynamic video signal streams generated by said video cameras; and  
35 (ii) concurrently with step (c) (i), recording on said archive recording medium index data

5 stored on said index data  
storage hard disk and indicative  
of times of recording and  
sources of the video data stored  
on said first video data storage  
hard disk during step (a) and  
also storing on said archive  
recording medium said video data  
stored on said first video data  
10 storage hard disk during step  
(a).

421. A method according to claim 420, wherein step  
(c) is performed immediately upon completion of step (b).

15 422. A method according to claim 420, wherein step  
(c) is deferred after completion of step (b), until a  
predetermined quantity of video data has been stored on  
said first video data storage hard disk.

423. An apparatus for storing and retrieving video  
data, comprising:

20 a plurality of video cameras generating  
respective sequences of video signals;

a first hard disk for selectively storing  
video data corresponding to the video signals generated by  
said video cameras, and for selectively outputting the  
25 video data stored on said first hard disk;

a second hard disk for selectively storing  
video data corresponding to the video signals generated by  
said video cameras, and for selectively outputting the  
video data stored on said second hard disk;

30 an archive medium drive unit for  
selectively recording on an archive recording medium video  
data stored on and outputted from said first and second  
hard disks;

35 display means for selectively displaying an  
image corresponding to video data stored on and outputted  
from said first and second hard disks; and

control means for controlling said first  
and second hard disks, said archive medium drive unit and

said display means, said control means selectively performing recording operations in which video data corresponding to the video signals generated by said video cameras is recorded on a selected one of said hard disks, 5 playback operations in which said display means displays an image corresponding to video data read from a selected one of said hard disks, and archiving operations in which video data outputted from a selected one of said hard disks is recorded on said archive recording medium, at 10 least some of said recording, playback and archiving operations exhibiting dynamic variations in a quantity of video data involved in said operations, said control means having a finite processing capacity and allocating its said processing capacity so as to give priority to said 15 recording operations relative to said playback operations and so as to give priority to said playback operations relative to said archiving operations.

424. Apparatus according to claim 423, wherein said archive medium drive unit operates in accordance with a 20 standard digital audio tape (DAT) format.

425. Apparatus according to claim 423, wherein said archive medium drive unit is selected from a group consisting of a writable optical disk drive, a DVD drive, a magneto-optical disk drive, and a removable hard disk 25 drive.

426. A video data storage apparatus, comprising:  
video information source means for providing a sequence of frames of video data;  
primary storage means including a storage 30 medium for storing video data provided by said video information source means;  
archive storage means for storing video data to be archived; and  
control means for controlling said primary 35 storage means to store said video data provided by said video information source means at a storage rate selected by said control means, said control means also controlling said primary storage means and said archive storage means

to transfer to said archive storage means video data stored by said primary storage means, said control means calculating a first time for completion of transferring of a predetermined quantity of stored video data from said primary storage means to said archive storage means, and calculating a second time for completion of storing on said primary storage means of a predetermined number of fields of video data to be provided by said video information source means, said control means comparing said calculated first and second times and, on the basis of a result of said comparison, selecting said storage rate at which said primary storage means stores said video data provided by said video information source means.

427. Apparatus according to claim 426, wherein, if said first time is earlier than said second time, said control means selects a first field rate at which said primary storage means stores said video data provided by said video information source means, and if said second time is earlier than said first time, said control means selects a second field rate at which said primary storage means stores said video data provided by said video information source means, said second field rate being slower than said first field rate.

428. Apparatus according to claim 426, wherein said primary storage means includes a first storage medium on which video data currently provided by said video information source means is being stored and a second storage medium from which previously stored video data is currently being transferred to said archive storage means.

429. Apparatus according to claim 428, wherein said first storage medium is a first hard disk, said second storage medium is a second hard disk, and said archive storage means includes a magnetic recording tape on which is recorded the video data transferred from said second hard disk.

430. Video information storage apparatus, comprising:  
a plurality of video cameras each for generating a respective stream of video information;

a housing;

storage means fixedly mounted in said housing for storing the streams of video information;

archive means for driving a recording medium  
5 that is removable from said housing, said archive means being operated to copy onto a sequence of removable recording media video information sequentially stored on said storage means; and

means for generating removable media data and  
10 for recording said removable media data on said storage means, said removable media data including data corresponding to each of a plurality of said removable recording media upon which said video information was copied, said data corresponding to each removable  
15 recording medium including data indicative of the video cameras by which and the times at which the video information copied on the recording medium was generated.

431. Video information storage apparatus according to claim 430, wherein said storage means includes a first  
20 hard disk and a second hard disk, said video information being stored on, and copied onto said removable media from, said first hard disk, and said removable media data being recorded on said second hard disk.

432. Video information storage apparatus according to  
25 claim 430, wherein said storage means includes a hard disk on which said removable media data is recorded and from which said video information is copied onto said removable media.

433. Video information storage apparatus according to  
30 claim 430, wherein said archive means includes a digital audio tape deck.

434. A closed-circuit video surveillance system, comprising:

a plurality of video cameras;  
35 selection means for selecting one or more of said video cameras;

display means for displaying video images generated by ones of said video cameras selected by said



selection means; and

control means for controlling said display means, said control means causing said display means to display a plurality of symbols each representative of a  
5 respective one of said video cameras, said control means also causing said display means to display an indication in association with at least one of said symbols to indicate that the camera or cameras corresponding to said  
at least one of said symbols have been selected by said  
10 selection means.

435. A closed-circuit video surveillance system according to claim 434, wherein said control means causes said display means to display the video images generated by the selected video camera or cameras in a first portion  
15 of a display screen and to display said symbols representative of said plurality of video cameras in a second portion of said display screen.

436. A closed-circuit video surveillance system according to claim 435, wherein said symbols  
20 representative of said plurality of video cameras are buttons on which a cursor is selectively positioned to select corresponding ones of said video cameras.

437. A closed-circuit video surveillance system according to claim 436, wherein said second portion of  
25 said display screen is displaced downwardly from said first position of said display screen.

438. A method of indicating a display status of video cameras selected for display from among a plurality of video cameras included in a closed-circuit video  
30 surveillance system, the method comprising the steps of:

displaying in a window on a display screen images generated by one or more of said cameras, said one or more of said cameras having been selected for display;

displaying, outside of said window on said  
35 display screen, a plurality of symbols each corresponding to a respective one of said plurality of video cameras included in said closed-circuit video surveillance system;  
and

displaying one or more indicia for indicating which one or ones of said plurality of video cameras have been selected for display, each of said one or more indicia being displayed in proximity to one of said symbols which corresponds to a video camera selected for display.

439. A closed-circuit video surveillance system, comprising:

a plurality of video cameras;

display-selection means for display-selecting one or more of said video cameras;

display means including a display screen for displaying respective streams of video images generated by ones of said video cameras display-selected by said display-selection means, each respective displayed stream of video images being displayed in a respective display window on said display screen;

record-selection means for record-selecting one or more of said video cameras;

recording means for recording video information corresponding to the video images generated by ones of said video cameras record-selected by said record-selection means; and

control means for controlling said display means, said control means causing said display means to display a record-enable indicia at a border of each said display window, said record-enable indicia for indicating whether the display-selected video camera corresponding to the respective display window is currently record-selected by said record selection means.

440. A closed-circuit video surveillance system according to claim 439, wherein said display means simultaneously displays in respective display windows the video image streams generated by a plurality of display-selected cameras, said display means simultaneously displaying a respective record-enable indicia at a respective border of each of said simultaneously-displayed display windows.

441. A closed-circuit video surveillance system according to claim 440, wherein said display means simultaneously displays four display windows each corresponding to a respective display-selected video  
5 camera.

442. A closed-circuit video surveillance system according to claim 441, wherein said display means simultaneously displays nine display windows each corresponding to a respective display-selected video  
10 camera.

443. A closed-circuit video surveillance system according to claim 439, wherein said recording means records the video information corresponding to the video images generated by each of said record-selected video  
15 cameras according to a respective selected one of a plurality of recording modes, said plurality of recording modes including a first recording mode in which images generated by the respective record-selected camera are continuously recorded at intervals that do not exceed a  
20 maximum interval, and a second recording mode in which images generated by the respective record-selected camera are only recorded in response to detection of an alarm condition, the record-enable indicia displayed for each video camera that is both record- and display-selected  
25 being displayed in a first state when the first recording mode is currently selected for the respective video camera, and being displayed in a second state different from the first state when the second recording mode is currently selected for the respective video camera.

30 444. A closed-circuit video surveillance system according to claim 439, wherein said recording means includes at least one hard disk on which is recorded the video information corresponding to the video images generated by said record-selected video cameras.

35 445. A method of indicating a recording status with respect to video cameras included in a closed-circuit video surveillance system, the method comprising the steps of:

displaying in a window on a display screen a dynamic image generated by one of said video cameras;

displaying at a border of said window a record-enable indicia to indicate whether signals output by said one of said video cameras have been selected for recording.

446. A method according to claim 445, further comprising the step of simultaneously displaying, in respective windows, a plurality of image streams each generated by a respective one of said video cameras, each of said windows having a border at which a respective record-enable indicia is provided to indicate whether signals of the respective video camera have been selected for recording.

447. In a closed-circuit video surveillance system including a video camera, a method of automatically diagnosing the video camera, comprising the steps of:

storing a reference image generated by the video camera;

analyzing the stored reference image to form reference parameters indicative of characteristics of the stored reference image;

storing the reference parameters;

automatically and periodically operating the video camera to generate comparison images;

storing and analyzing the comparison images to generate comparison parameters indicative of characteristics of the respective comparison images; and comparing the comparison parameters with the

stored reference parameters;

at least one of said comparison images being generated at least five days after said reference image was stored.

448. A method according to claim 447, wherein at least one of said comparison images is generated at least 100 days after said reference image was stored.

449. A method according to claim 447, wherein said reference parameters include a color histogram and a

spatial frequency distribution.

450. A method according to step 447, wherein said step of periodically operating the video camera to generate said comparison images is performed weekly.

5 451. Apparatus for automatically diagnosing a video camera included in a closed-circuit video surveillance system, the apparatus comprising:

means for storing a reference image generated by the video camera;

10 means for analyzing the stored reference image to form reference parameters indicative of characteristics of the stored reference image;

means for storing the reference parameters;

calendar means for generating calendar signals;

15 diagnosis operation means, responsive to said calendar signals, for automatically and periodically operating the video camera to generate comparison images;

means for storing and analyzing the comparison images to generate comparison parameters indicative of characteristics of the respective comparison images; and

20 means for comparing the comparison parameters with the stored reference parameters;

said diagnosis operation means causing said video camera to generate at least one of said comparison images at least five days after said reference image was stored.

452. A method of displaying status information relating to a video surveillance system, the system including at least one hard disk for storing in digital form video image information generated by a plurality of video cameras, the system further including an archive storage device for driving a removable recording medium and copying video image information onto the removable recording medium from the hard disk, the method comprising

30 the steps of:

displaying on a display screen first information indicative of unused recording space available on said at least one hard disk; and

displaying on said display screen second information indicative of unused recording space available on said removable recording medium.

453. A method according to claim 452, wherein said  
5 first and second information is displayed in the form of numeric characters.

454. A method according to claim 452, wherein said first and second information is displayed in the form of first and second graphic display elements, respectively.

10 455. A method according to claim 452, further comprising the step of displaying additional information indicative of a number of alarm events with respect to which alarm information has been stored in said video surveillance system, and said alarm information has been  
15 reviewed, within a predetermined period of time.

456. A method according to claim 452, further comprising the step of displaying additional information indicative of a number of alarm events with respect to which alarm information has been stored in said video  
20 surveillance system, and said alarm information has not been reviewed.

457. A method according to claim 452, further comprising the steps of:

25 displaying first additional information indicative of how many video cameras are connected to said video surveillance system; and

30 displaying second additional information indicative of a number of said video cameras which are currently selected for recording by said video surveillance system.

458. A method according to claim 452, wherein said video surveillance system includes means for selecting one of a plurality of display configurations in which one or more streams of video images, each generated by a  
35 respective video camera, are displayed in respective windows on said display screen, the method further comprising:

displaying additional information indicative of

the one of said plurality of display configurations which is currently selected by said means for selecting.

459. A video surveillance system, comprising:

a plurality of video cameras;

5 at least one hard disk for storing in digital form video image information generated by said video cameras;

archive means for driving a removable recording medium;

10 means for copying video image information from said hard disk onto said removable recording medium; and

a display screen for displaying first information indicative of unused recording space available on said at least one hard disk, and for displaying second  
15 information indicative of unused recording space available on said removable recording medium.

460. A video surveillance system according to claim 459, wherein said display screen displays said first and second information in the form of numeric characters.

20 461. A video surveillance system according to claim 459, wherein said display screen displays said first and second information in the form of first and second graphic display elements, respectively.

462. Video data storage apparatus for simultaneously  
25 recording a plurality of streams of video images each generated by a respective video camera, comprising:

a plurality of video cameras;

a housing having a front panel;

30 storage means disposed within the housing for storing video information generated by the video cameras;

display means including a display screen for displaying the video information generated by the video cameras;

35 control means disposed within the housing for receiving the video information generated by the video cameras and transmitting the video information to the storage means and to the display means;

a plurality of manually-operable switches,

mounted in a layout pattern on the front panel of the housing, for inputting respective command signals to the control means; and

5 cursor means for transmitting signals to the control means to control positioning of a cursor on said display screen;

10 wherein the control means controls the display means to display a plurality of switch areas on the display screen in accordance with the switch layout pattern on the front panel, each of said switch areas on the display screen corresponding to one of the switches on the front panel and being actuatable by the cursor means to generate a command signal which is the same as the command signal generated by actuation of the corresponding  
15 switch on the front panel.

463. Video data storage apparatus according to claim 462, wherein said switches on the front panel include camera selection switches, each corresponding to one of said video cameras, for selecting the respective video  
20 camera so that the video information generated by the camera is displayed by the display means, said switch areas on the display screen including camera switch areas corresponding to said camera selection switches on the front panel.

25 464. Video data storage apparatus according to claim 463, wherein said switches on the front panel include a circular jog-shuttle switch manually rotatable by a user to generate command signals for controlling playback and display of video information stored by the storage means,  
30 said switch areas on the display screen including a circular switch area corresponding to the jog-shuttle switch on the front panel, said circular switch area having a control point actuatable by the cursor means for controlling playback and display of the video information  
35 stored by the storage means.

465. Video data storage apparatus according to claim 463, further comprising a plurality of light-emitting diodes (LEDs) mounted on the front panel, each adjacent to



a respective one of said camera selection switches, for indicating that the respective video camera is selected for display, and said display screen displaying adjacent to each of said camera switch areas a camera selection  
5 indication corresponding to a respective one of the LEDs on the front panel.

466. Video data storage apparatus according to claim 462, wherein said switches on the front panel include a circular jog-shuttle switch manually rotatable by a user  
10 to generate command signals for controlling playback and display of video information stored by the storage means, said switch areas on the display screen including a circular switch area corresponding to the jog-shuttle switch on the front panel, said circular switch area  
15 having a control point actuatable by the cursor means for controlling playback and display of the video information stored by the storage means.

467. A method of processing fields of video data, comprising the steps of:  
20           dividing each of said fields of video data into a plurality of rectangular data blocks, each said data block consisting of an  $n \times m$  array of picture elements, where  $n$  and  $m$  are positive integers greater than 1;  
              comparing each said data block with a  
25 corresponding data block in a preceding field to generate comparison data;  
              performing a data compression algorithm with respect to said data blocks on the basis of said comparison data; and  
30           performing a data analysis algorithm with respect to said data blocks on the basis of said comparison data.

468. A method according to claim 467, wherein said step of performing a data compression algorithm includes  
35 applying an orthogonal transform to said data blocks to produce coefficient data, and quantizing said coefficient data.

469. A method according to claim 467, wherein said

step of performing said data analysis algorithm includes detecting moving objects represented by said fields of video data.

470. A method according to claim 467, wherein  $n = m$   
5 = 8.

471. Video information storage and analysis apparatus, comprising:

video information source means for generating a dynamic sequence of video data frames;

10 compression means for applying a data compression algorithm to said dynamic sequence of video data frames to form compressed video data;

display means for displaying a dynamic image which corresponds to said dynamic sequence of video data  
15 frames;

analysis means for receiving said dynamic sequence of video data frames and performing a moving image content analysis algorithm with respect to the received dynamic sequence of video data frames; and

20 signal transmission means for simultaneously transmitting said dynamic sequence of video data frames from said video information source means to all three of said compression means, said display means and said analysis means.

25 472. Apparatus according to claim 471, wherein said video information source means includes a video camera.

473. Apparatus according to claim 472, wherein said video camera generates a dynamic analog video signal, and said video information source means further includes  
30 conversion means for converting said dynamic analog video signal into said dynamic sequence of video data frames.

474. Apparatus according to claim 471, wherein said compression means applies an orthogonal transform to said dynamic sequence of video data frames.

35 475. Apparatus according to claim 471, further comprising storage means for receiving and storing said compressed video data formed by said compression means.

476. Apparatus according to claim 475, wherein said

storage means includes a hard disk.

477. Apparatus according to claim 471, wherein said display means includes an NTSC monitor.

478. Apparatus according to claim 471, wherein said  
5 display means includes an SVGA monitor.

479. Apparatus according to claim 471, wherein said display means includes an NTSC monitor and an SVGA monitor.

480. Apparatus for storing video data, comprising:  
10 a plurality of source means each for providing a respective stream of video signals;

difference means for detecting differences between successive frames in each of said streams of video signals and for generating difference data indicative of  
15 the detected differences;

compression means for processing said difference data to form compression-encoded data representative of said streams of video signals; and

20 storage means for storing said compression-encoded data formed by said compression means.

481. Apparatus according to claim 480, further comprising analysis means for processing said difference data in accordance with a moving image content analysis algorithm to form analysis data indicative of respective  
25 characteristics of said streams of video signals.

482. Apparatus according to claim 481, wherein said storage means also stores said analysis data formed by said analysis means.

483. Apparatus according to claim 480, wherein said  
30 difference means includes means for storing data indicative of at least one frame of each of said streams of video signals.

484. Apparatus according to claim 483, wherein said difference means further includes comparison means for  
35 comparing data representative of an incoming frame of said streams of video signals with said stored data indicative of at least one frame of a corresponding one of said streams of video signals.

485. Apparatus for storing video data, comprising:  
a plurality of source means each for providing  
a respective stream of video signals;  
difference means for detecting differences  
5 between successive frames in each of said streams of video  
signals and for generating difference data indicative of  
the detected differences;  
analysis means for processing said difference  
data in accordance with a moving image content analysis  
10 algorithm to form analysis data indicative of respective  
characteristics of said streams of video signals; and  
storage means for storing said analysis data  
formed by said analysis means.

486. Apparatus according to claim 485, wherein said  
15 difference means includes means for storing data  
indicative of at least one field of each of said streams  
of video signals.

487. Apparatus according to claim 486, wherein said  
difference means further includes comparison means for  
20 comparing data representative of an incoming field of said  
streams of video signals with said stored data indicative  
of at least one field of a corresponding one of said  
streams of video signals.

488. Apparatus for storing and displaying video  
25 information, comprising:  
a first video camera for generating first video  
information;  
a second video camera for generating second  
video information;  
30 recording means for recording, on a first  
occasion, first and second video information  
simultaneously generated by said first and second video  
cameras on said first occasion;  
storage means for storing the recorded first and  
35 second video information;  
means for retrieving from said storage means and  
displaying, on a second occasion later in time than said  
first occasion, the first video information generated on

said first occasion by said first video camera;

selection means actuatable by a user of the apparatus on said second occasion for selecting said second video camera while said first video information  
5 generated on said first occasion by said first camera is being displayed;

search means, responsive to selection of said second video camera by said selection means while said first video information generated on said first occasion  
10 by said first video camera is being displayed, for searching said storage means to locate said second video information generated by said second video camera on said first occasion and stored on said storage means; and

means for displaying the located second video  
15 information.

489. Apparatus according to claim 488, further comprising a housing in which said storage means is enclosed, said housing including a front panel;

said selection means including a button, located  
20 on said front panel and corresponding to said second video camera.

490. Apparatus according to claim 489, wherein said means for retrieving and displaying includes a display screen on which is displayed said first video information  
25 generated by said first video camera on said first occasion, said display screen displaying simultaneously with said first video information a selection area corresponding to said second video camera, said selection means including means for positioning a cursor on said  
30 selection area to actuate said selection means to select said second video camera.

491. Apparatus according to claim 488, wherein said means for retrieving and displaying includes a display screen on which is displayed said first video information  
35 generated by said first video camera on said first occasion, said display screen displaying simultaneously with said first video information a selection area corresponding to said second video camera, said selection

means including means for positioning a cursor on said selection area to actuate said selection means to select said second video camera.

5 492. Apparatus according to claim 488, wherein said storage means includes a hard disk.

493. Apparatus according to claim 492, wherein said recording means records both said first video information and said second video information on said hard disk on said first occasion.

10 494. A method of retrieving and displaying video information, comprising the steps of:

displaying first video information, said first video information having been generated by a first video camera and stored on a recording medium on a first occasion prior to a time at which said displaying step is being performed;

while said displaying step is being performed, selecting a second video camera;

15 in response to said selection of said second video camera, automatically retrieving second video information generated by said second video camera and stored on a recording medium on said first occasion; and displaying said retrieved second video information.

25 495. A method according to claim 494, wherein said selecting step includes actuating a switch located on a front panel of a video information storage device.

30 496. A method according to claim 495, wherein said selecting step includes positioning a cursor in a selection location displayed on a display screen.

497. A method of analyzing video information, comprising the steps of:

receiving an analog video signal which represents a dynamic sequence of images;

35 digitizing the received analog video signal to form a sequence of digitized video data fields which represent the dynamic sequence of images;

transmitting on a video bus the sequence of

digitized video data fields according to a timing sequence which includes a vertical blanking interval between each two adjacent video data fields;

receiving the sequence of digitized video data  
5 fields which were transmitted according to said timing sequence; and

applying a moving image content analysis algorithm to each received video data field during the vertical blanking interval which follows receipt of the  
10 video data field.

498. A method according to claim 497, wherein said transmitting step includes transmitting on said video bus video data corresponding to lines of each of said digitized video data fields, interspersed with data  
15 corresponding to two-dimensional pixel blocks of the respective digitized video data field.

499. Video information analysis apparatus, comprising:

means for receiving an analog video signal which  
20 represents a dynamic sequence of images;

means for digitizing the received analog video signal to form a sequence of digitized video data fields which represent the dynamic sequence of images;

a multi-bit parallel data bus;

25 transmission means for transmitting on said data bus the sequence of digitized video data fields formed by said means for digitizing, said transmission means transmitting the sequence of digitized video data fields according to a timing sequence which includes a vertical  
30 blanking interval between each two adjacent video data fields;

means for receiving the sequence of digitized video data fields which were transmitted on said data bus according to said timing sequence; and

35 means for applying a moving image content analysis algorithm to each received video data field during the vertical blanking interval which follows receipt of the video data field.

500. Video information analysis apparatus according to claim 499, wherein said transmission means transmits on said data bus video data corresponding to lines of each of said digitized video data fields, interspersed with video data corresponding to two-dimensional pixel blocks of the respective digitized video data field.

501. Apparatus for storing and analyzing video information, comprising:

a video camera for generating a sequence of video fields;

means for comparing predetermined portions of a present field of said sequence of video fields with a reference field of said sequence of video fields to form comparison statistics, said reference field having preceded the present field in said sequence of video fields;

compression means for comparing said comparison statistics with a first threshold, and for selectively discarding said predetermined portions of the present field on the basis of the comparing of the comparison statistics with the first threshold;

storage means for storing the predetermined portions of the present field which were not discarded by said compression means; and

analysis means for comparing said comparison statistics with a second threshold, different from said first threshold, to generate analysis statistics, and for analyzing the sequence of video fields, on the basis of said analysis statistics, to detect moving objects represented by said sequence of video fields.

502. Apparatus according to claim 501, wherein said storage means stores data indicative of results of the analysis performed by said analysis means.

503. Apparatus according to claim 501, wherein said predetermined portions of the present field are  $m \times n$  groups of pixels of the present field, where  $m$  and  $n$  are integers greater than one.

504. Apparatus according to claim 503, wherein  $m = n$



= 8.

505. Apparatus according to claim 501, further comprising JPEG means for applying to said predetermined portions of the present field not discarded by said  
5 compression means a data compression algorithm in accordance with the JPEG standard, to form transform-encoded video data to be stored by said storage means.

506. A method of storing and analyzing video information, comprising:

10           generating a sequence of video fields;  
              comparing predetermined portions of a present field of said sequence of video fields with a reference field of said sequence of video fields to form comparison statistics, said reference field having preceded the  
15 present field in said sequence of video fields;

              comparing said comparison statistics with a first threshold and selectively discarding said predetermined portions of the present field on the basis of the comparing of the comparison statistics with the  
20 first threshold;

              storing the predetermined portions of the present field which were not discarded;

              comparing the comparison statistics with a second threshold, different from said first threshold; and  
25           analyzing the sequence of video fields, on the basis of said analysis statistics, to detect moving objects represented by said sequence of video fields.

507. A method according to claim 506, further comprising the steps of storing data indicative of results  
30 of the analysis performed by said analysis means.

508. A method according to claim 506, further comprising the steps of applying to the predetermined portions of the present field which were not discarded a data compression algorithm in accordance with the JPEG  
35 standard.

509. Video information storage apparatus, comprising:

              a video camera for generating a first stream of dynamic images;

a record medium drive unit including a record medium for storing data representing said first stream of dynamic images, data representing a second stream of dynamic images having previously been stored on said  
5 record medium;

display means for displaying a selected one of said first stream of images and said second stream of images; and

control means for controlling said record medium  
10 drive unit and said display means so that data representing said first stream of dynamic images is being recorded on said record medium while said second stream of dynamic images is simultaneously played back from said record medium and displayed by said display means.

15 510. Video information storage apparatus according to claim 509, wherein said second stream of dynamic images was generated by said video camera which generates said first stream of dynamic images.

20 511. Video information storage apparatus according to claim 509, wherein said second stream of dynamic images was generated by a second video camera different from the video camera which generates said first stream of dynamic images.

25 512. Video information storage apparatus according to claim 509, wherein data representing a third stream of dynamic images, different from said first and second streams, has been stored on said record medium, and further comprising output means for transmitting data reproduced from said record medium to a remote device;  
30 said control means controlling said record medium drive unit and said output means so that said data representing said third stream of dynamic images is reproduced from said record medium and transmitted to said remote device  
35 by said output means, simultaneously with said recording of said first stream of dynamic images and said displaying of said second stream of images.

513. Video information storage apparatus according to claim 509, further comprising archive means for receiving

video data reproduced by said record medium drive unit and for recording the received video data on a removable recording medium.

514. Video information storage apparatus according to claim 513, wherein said video data to be recorded on the removable recording medium is reproduced by said record medium drive unit simultaneously with said recording of said first stream of dynamic images and said displaying of said second stream of images.

515. Video information storage apparatus according to claim 509, wherein said record medium is selected from a group consisting of a hard disk, a DVD, a writable optical disk, and a magneto-optical disk.

516. A method of storing and displaying video images, comprising the steps of:

(a) generating a stream of dynamic images and storing on a hard disk data representative of said stream of dynamic images;

(b) after step (a), generating and storing on said hard disk another stream of dynamic images; and

(c) simultaneously with step (b), reproducing from said hard disk and displaying said stream of dynamic images generated and stored during step (a).

517. A method according to claim 516, further comprising the steps of:

(d) prior to step (b), generating and recording on said hard disk still another stream of dynamic images; and

(e) simultaneously with step (b), reproducing from said hard disk and transmitting to a remote device said stream of dynamic images generated and stored during step (d).

518. A method according to claim 516, further comprising the step of:

(d) simultaneously with step (b), storing on a removable recording medium video data reproduced from said hard disk.

519. A method of storing and retrieving video

information, comprising the steps of:

generating a first sequence of dynamic video images on a first occasion and recording the first sequence of video images on a recording medium;

5 generating a second sequence of dynamic video images on a second occasion that is later than said first occasion, and recording the second sequence of video images on the recording medium; and

10 simultaneously reproducing from the recording medium both the first and second sequences of video images.

520. A method according to claim 519, further comprising the step of simultaneously displaying both of the reproduced first and second sequences of video images.

15 521. A method according to claim 520, wherein the reproduced first and second sequences of video images are displayed in respective display windows on the same display screen.

20 522. A method according to claim 521, wherein the reproduced first and second sequences of video images are displayed on different respective display screens.

25 523. A method according to claim 519, wherein the first sequence of video images is generated using a first video camera, and the second sequence of video images is generated using a second video camera that is different from said first video camera.

30 524. A method according to claim 519, wherein both of the first and second sequences of video images are generated using the same video camera.

525. A method according to claim 519, wherein said recording medium is a hard disk.

526. Apparatus for recording and retrieving video information, comprising:

a recording medium;

35 first means for generating a first sequence of dynamic video images on a first occasion and recording the first sequence of video images on the recording medium;

second means for generating a second sequence of

dynamic video images on a second occasion that is later than said first occasion, and recording the second sequence of video images on the recording medium; and

5 third means for simultaneously reproducing from the recording medium both the first and second sequences of video images.

527. Apparatus according to claim 526, further comprising display means for simultaneously displaying both of the first and second sequences simultaneously reproduced by said third means.

528. Apparatus according to claim 527, wherein said display means includes a display screen on which the reproduced first and second sequences are displayed simultaneously in respective display windows.

15 529. Apparatus according to claim 527, wherein said display means includes a first display screen on which the reproduced first sequence of video images is displayed and a second display screen, separate from said first display screen, on which the reproduced second sequence of video images is displayed.

530. Apparatus according to claim 526, wherein said first means includes a first video camera which generates said first sequence of video images and said second means includes a second video camera which generates said second sequence of video images.

531. Apparatus according to claim 526, wherein a single video camera is used to generate both of said first and second sequences of video images.

532. Apparatus according to claim 526, wherein said recording medium is a hard disk.

533. A method of storing and retrieving video information, comprising the steps of:

storing on a recording medium a plurality of segments of video information, each segment of video information having been generated at a different respective period of time;

inputting a first parameter signal indicative of a first one of said periods of time;

displaying the segment of video information generated during the period of time indicated by the first parameter signal; and,

while performing said displaying step, inputting  
5 a second parameter signal indicative of a second one of said periods of time and also displaying the segment of video information generated during the period of time indicated by the second parameter signal.

534. A video information analysis apparatus,  
10 comprising:

storage means for storing a video information data base;

analysis means for analyzing video information in the data base in accordance with a  
15 predetermined analysis algorithm, said predetermined analysis algorithm for assigning to respective portions of said video information analysis scores each indicative of a degree to which the respective portion of said video information represents a predetermined analysis feature,  
20 each said analysis score being a value within a predetermined range of values comprising at least three values.

535. A video information analysis apparatus according to claim 534, wherein said range of values comprises at  
25 least eight values.

536. A video information analysis apparatus according to claim 535, wherein said range of values comprises at least one hundred values.

537. A video information analysis apparatus according  
30 to claim 534, further comprising:

selection means for selecting a specific one of said range of values; and

search means for identifying portions of said video information having analysis scores greater than  
35 or equal to said selected one of said range of values.

538. A video information storage apparatus, comprising:

means for receiving video information;

means for analyzing the received video information to detect a predetermined feature in the received video information, and for generating a detection signal indicative of the detected feature;

5 memory means for storing the received video information; and

means for storing the detection signal as an index signal in association with the stored video information.

10 539. Apparatus according to claim 538, wherein the memory means includes means for storing the received video information in the form of digital data.

540. Apparatus according to claim 539, wherein the stored video information is in the form of plural frames  
15 of video data, each frame of video data having header data stored in association with the frame of video data, and said index signal is included in said header data.

541. Apparatus according to claim 538, further comprising:

20 means for reading the stored index signal; and

means for retrieving from the memory means a selected portion of the stored video information in accordance with the index signal read by the means for  
25 reading.

542. A video information storage apparatus, comprising:

30 storage means for storing video information;

means for retrieving the stored video information from the storage means;

means for analyzing the retrieved video information to detect a predetermined feature in the retrieved video information, and for generating a  
35 detection signal indicative of the detected feature; and

means for transmitting the detection signal to the storage means to store the detection signal as an index signal in association with the stored video

information.

543. Apparatus according to claim 542, wherein the storage means includes means for storing the video information in the form of digital data.

5 544. Apparatus according to claim 543, wherein the stored video information is in the form of plural frames of video data, each frame of video data having header data stored in association with the frame of video data, and said index signal is included in said header data.

10 545. Apparatus according to claim 542, further comprising:

means for reading the stored index signal;

and

15 means for retrieving from the storage means a selected portion of the stored video information in accordance with the index signal read by the means for reading.

20 546. A method of operating an apparatus for storing and retrieving video data, the method comprising the steps of:

storing a plurality of frames of video data on a first hard disk;

25 storing index data on said first hard disk, said index data including data indicative of respective times at which said frames of video data were generated and respective locations on said first hard disk at which said frames of video data are stored; and

storing said index data on a second hard disk.

30 547. A method according to claim 546, further comprising the steps of searching for a desired frame of the video data stored on the first hard disk on the basis of index data read out from the second hard disk.

35 548. A method according to claim 546, further comprising the step of storing on said second hard disk a quantity of video data read out from said first hard disk.

549. A method according to claim 546, wherein said video data stored on said first hard disk includes video



data representative of respective streams of video signals generated by a plurality of cameras, and said index data stored on said first and second hard disks includes data indicative of respective cameras by which said frames of video data stored on said first hard disk were generated.

5 550. A method according to claim 546, wherein said index data stored on said first and second hard disks includes data indicative of characteristics of said video data stored on said first hard disk, said characteristics of said video data having been detected by applying a video data analysis algorithm to said video data.

10 551. A method according to claim 550, wherein said video data analysis algorithm was applied to said video data before said video data was stored on said first hard disk.

15 552. A method according to claim 550, wherein said video data analysis algorithm was applied to said video data after said video data was stored on said first hard disk.

20 553. A method according to claim 546, wherein said index data stored on said first and second hard disks includes data indicative of alarm conditions detected at times when respective portions of the video data stored on said first hard disk were generated.

25 554. A video data storage apparatus, comprising:  
a video data source for providing a dynamic stream of video data frames;  
a data memory device for storing the dynamic stream of video data frames provided by the video data source; and

30 control means for designating a main portion of said data memory device, said main portion for recording said dynamic stream of video data frames at a first frame rate, said control means also designating a buffer portion of said data memory device, said buffer portion for recording said dynamic stream of video data frames at a second frame rate that is higher than said first frame rate.

555. A video data storage apparatus according to claim 554, wherein said data memory device comprises a hard disk.

556. A video data storage apparatus according to claim 554, further comprising detection means for detecting an alarm condition, and wherein said control means designates said buffer portion of said data memory device by maintaining a pointer indicative of where said buffer portion is located in said data memory device, and said control means responds to detection of said alarm condition by said detection means by changing a value of said pointer, whereby said buffer portion is moved to a new location in said data memory device.

557. A data storage medium on which is stored video data representing a plurality of video image frames, frame identification data indicative of respective times at which said video image frames were generated, and characteristic data indicative of respective characteristics of the video image frames represented by said video data, said respective characteristics having been detected by applying an image analysis algorithm to said video data.

558. A data storage medium according to claim 557, wherein said characteristic data includes first subdata indicative of a type of characteristic represented by said characteristic data, and second subdata indicative of a degree to which a respective video image frame exhibits said type of characteristic represented by said characteristic data.

559. A data storage medium according to claim 557, wherein said image analysis algorithm was applied to said video data before said video data was stored on the storage medium.

560. A data storage medium according to claim 557, wherein said image analysis algorithm was applied to said video data by reading said video data from the storage medium.

561. A data storage medium according to claim 557,

wherein said characteristic data includes first characteristic data generated by applying a first image analysis algorithm to said video data, and second characteristic data generated by applying a second image analysis algorithm, different from said first image analysis algorithm, to said video data.

562. A data storage medium according to claim 561, wherein said first image analysis algorithm was applied to said video data before said video data was stored on the storage medium, and said second image analysis algorithm was applied to said video data after reading said video data from the storage medium.

563. A data storage medium according to claim 557, on which is also stored data indicative of an alarm condition detected at a time at which at least one of said video image frames was generated.

564. A data storage medium according to claim 557, on which is also stored data indicative of audio signals generated at times when said video image frames were generated.

565. A data storage medium according to claim 557, wherein said video data represents respective streams of video image frames generated by a plurality of video cameras, and there is also stored on the storage medium data identifying the respective one of said plurality of video cameras which generated each of the video image frames.

566. A data storage medium according to claim 557, comprising a hard disk.

567. A data storage medium according to claim 557, comprising a magnetic tape.

568. A data storage medium according to claim 567, wherein said video data is recorded in a plurality of parallel oblique recording tracks on said magnetic tape.

569. A video information storage apparatus, comprising:

a video camera for generating a stream of dynamic images;

storage means for storing respective video data portions each of which represents an image from said stream of dynamic images, each said video data portion including header data;

5 means for moving the video camera to change a field of view of the video camera; and

control means for providing control signals to said means for moving to control movement of the video camera;

10 said control means being connected to said storage means to provide to said storage means signals indicative of times when said control means is causing said camera to be moved;

15 said storage means responding to said signals provided to said storage means from said control means, by including a motion signal in the header data included in the video data portions corresponding to images generated at said times when said camera is moved, said motion signal indicating that the respective image was taken by  
20 said camera when said camera was moving.

570. A video information storage apparatus according to claim 569, further comprising:

means for retrieving the stored video data portions from the storage means;

25 analysis means for analyzing the retrieved video data portions to detect a predetermined feature in the images represented by the retrieved video data portions, and for generating a detection signal indicative of the detected feature;

30 means for transmitting the detection signal to the storage means to store the detection signal as an index signal in association with the stored video data portions; and

35 inhibit means for reading the movement signal included in the header data of respective ones of the stored video data portions and for inhibiting the analysis means from analyzing the respective ones of the stored video data portions.

571. A video information storage apparatus according to claim 570, wherein said index signal is included in the header data corresponding to the stored video data portions with respect to which the predetermined feature  
5 was detected by the analysis means.

572. A video information storage apparatus according to claim 570, wherein the predetermined feature detected by said analysis means is a moving object represented by the stream of dynamic images.

10 573. A method of storing and indexing video information, comprising the steps of:

using a movable video camera to generate a stream of dynamic images;

15 storing video data representing the stream of dynamic images; and

storing indexing data in association with the stored video data, said stored indexing data including movement data indicating, as to each image represented by the stored video data, whether the respective image was  
20 generated at a time when the camera was being moved.

574. A method according to claim 573, further comprising the steps of:

reading the movement data; and

25 on the basis of the read movement data, selectively analyzing the stored video data to detect a predetermined feature represented by the stored video data.

575. A method of transmitting and displaying video information, comprising the steps of:

30 receiving a plurality of streams of video information each generated by a respective video camera;

transmitting said plural streams of video information to display means field by field; and

35 displaying each of said plural streams of video information in a respective display window on a display screen;

wherein said transmitting step includes appending, to each field of each of said plural streams of

video information, header data which includes data indicative of the one of said display windows in which the field is to be displayed.

576. A method according to claim 575, wherein the appended header data includes data for identifying the one of said video cameras which generated the field.

577. Apparatus for transmitting and displaying video information, comprising:

means for receiving a plurality of streams of video information each generated by a respective video camera;

display means for simultaneously displaying each of said plural streams of video information in a respective display window on a display screen;

means for appending, to each field of said received plural stream of video information, header data which includes data indicative of the one of said display windows in which the respective field is to be displayed; and

means for transmitting the received fields of video information, with the appended header data, to the display means.

578. Apparatus according to claim 577, wherein said means for transmitting includes a multi-bit parallel data bus.

579. Apparatus according to claim 577, wherein the appended header data includes data for identifying the one of said video cameras which generated the field.

580. Apparatus according to claim 577, wherein said display means simultaneously displays four video information streams in respective windows on said display screen.

581. Apparatus according to claim 580, wherein said display means simultaneously displays nine video information streams in respective windows on said display screen.

582. Apparatus according to claim 581, wherein said display means simultaneously displays sixteen video

information streams in respective windows on said display screen.

583. A method of storing video information, comprising the steps of:

5 recording plural fields of video data on a recording medium, each of said fields of video data representing a respective image;

10 recording on said recording medium, in association with each of said fields of video data, header data including data indicative of a source of the image represented by the respective field;

reproducing from the recording medium the recorded fields of video data;

15 processing at least one of the header data and the reproduced fields of video data to obtain a processing result; and

20 on the basis of said processing result, recording process result data on said recording medium in the header data for at least one of said reproduced fields of video data.

584. A method according to claim 583, wherein said processing step includes applying a moving image content analysis algorithm to the reproduced fields of video data.

25 585. A method according to claim 584, wherein said moving image content analysis algorithm is for detecting moving objects represented by the reproduced fields of video data, and said process result is data indicative of detection of a moving object.

30 586. A method according to claim 583, wherein said recording medium is a hard disk.

587. A method according to claim 583, wherein said header data includes data for identifying a camera which generated the respective field of video data, and data indicative of a time at which the field of video data was  
35 generated.

588. Apparatus for storing video data, comprising:  
means for recording plural fields of video data on a recording medium, each of said fields of video data

representing a respective image;

means for recording on said recording medium, in association with each of said fields of video data, header data including data indicative of a source of the image  
5 represented by the respective field;

means for reproducing from the recording medium the recorded fields of video data;

processing means for processing at least one of the header data and the reproduced fields of video data,  
10 to generate process result data; and

means, responsive to said processing means, for recording the process result data on said recording medium in the header data for at least one of said reproduced fields of video data.

15 589. Apparatus according to claim 588, wherein said processing means includes analysis means for applying a moving image content analysis algorithm to the reproduced fields of video data.

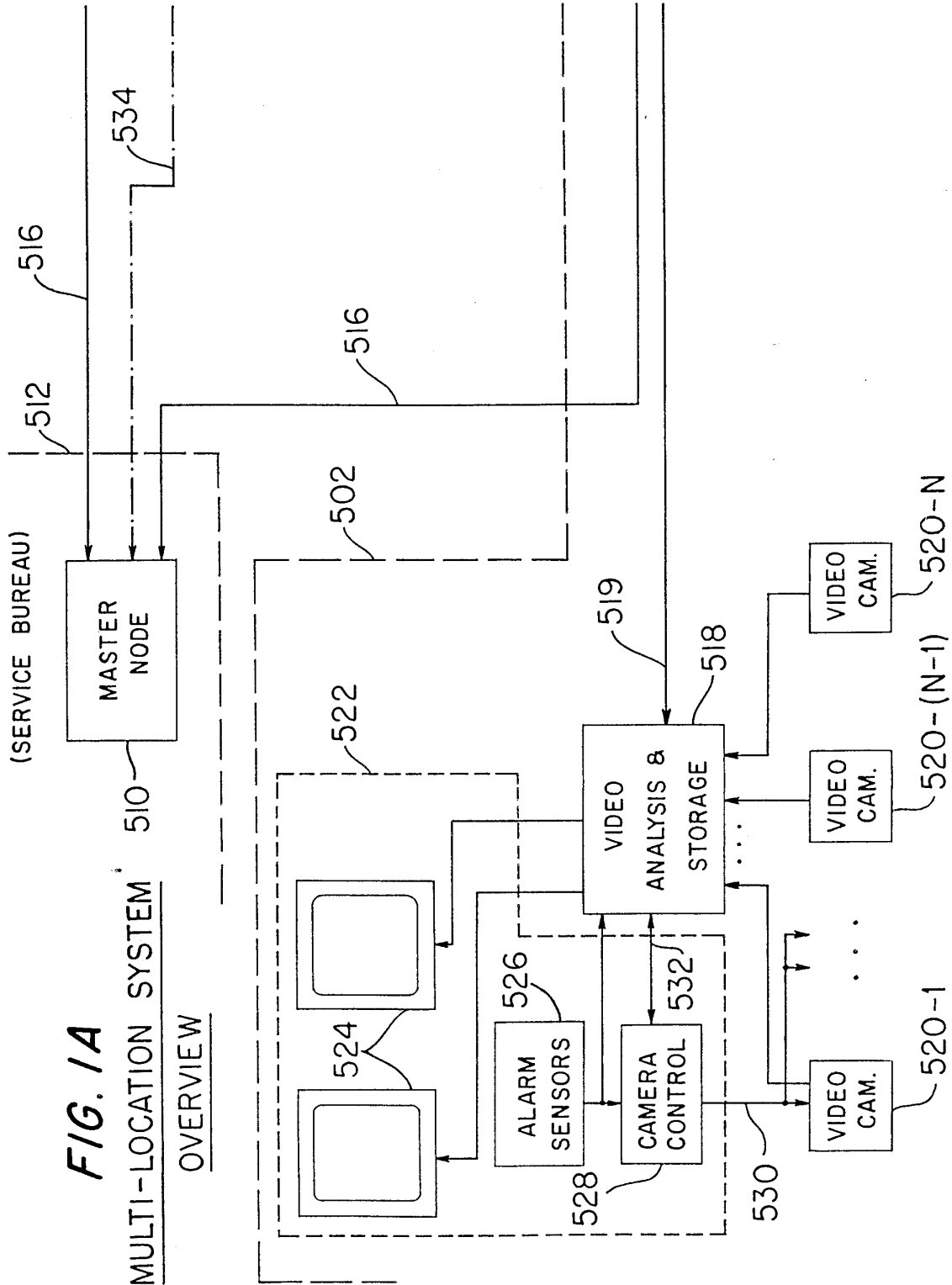
20 590. Apparatus according to claim 56, wherein said moving image content analysis algorithm applied by said analysis means is for detecting moving objects represented by the reproduced fields of video data, and said process result data generated by said processing means is data indicative of detection of a moving object.

25 591. Apparatus according to claim 588, wherein said recording medium is a hard disk.

592. Apparatus according to claim 588, wherein said header data includes data for identifying a camera which generated the respective field of video data, and data  
30 indicative of a time at which the field of video data was generated.

35





2/158

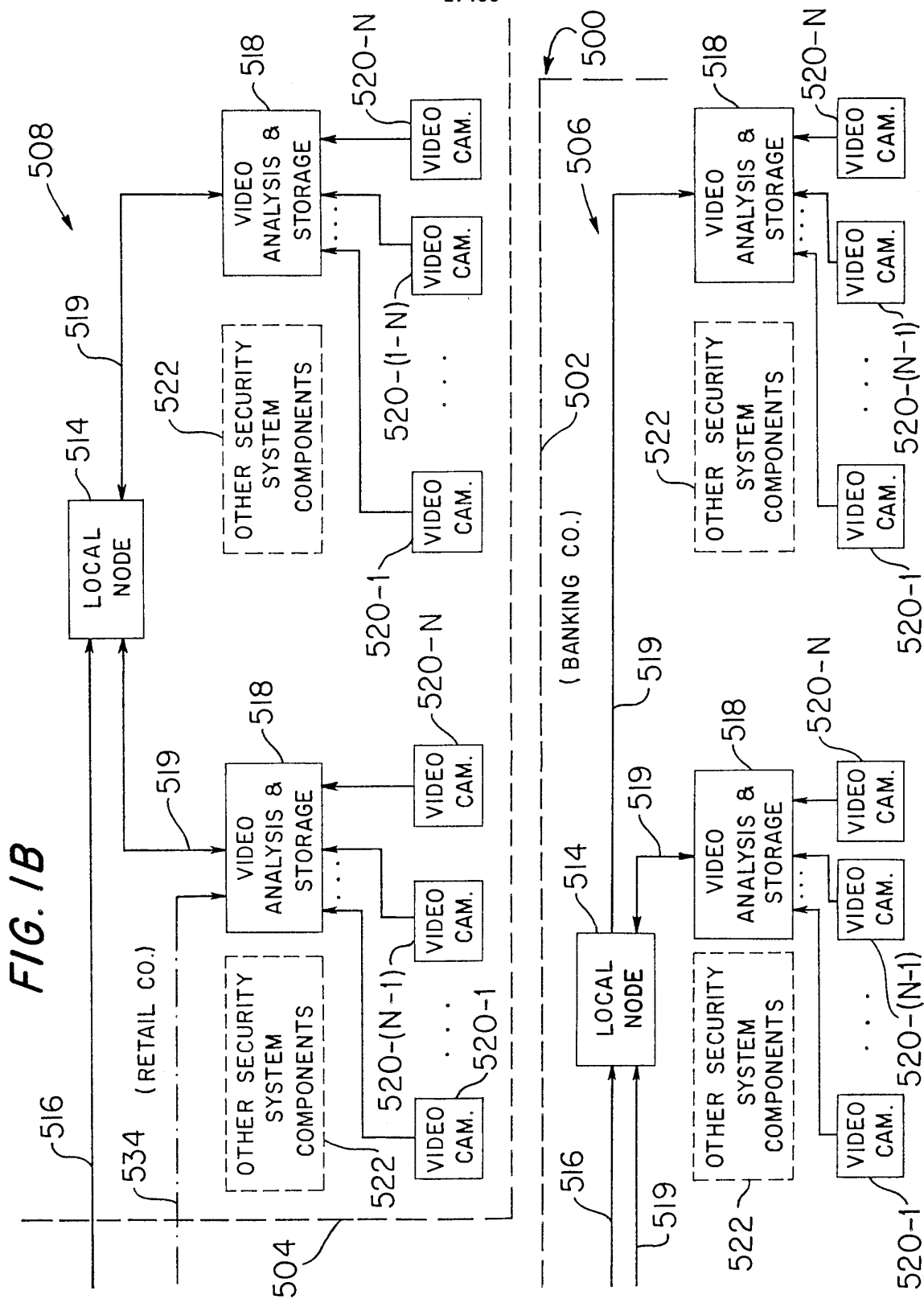
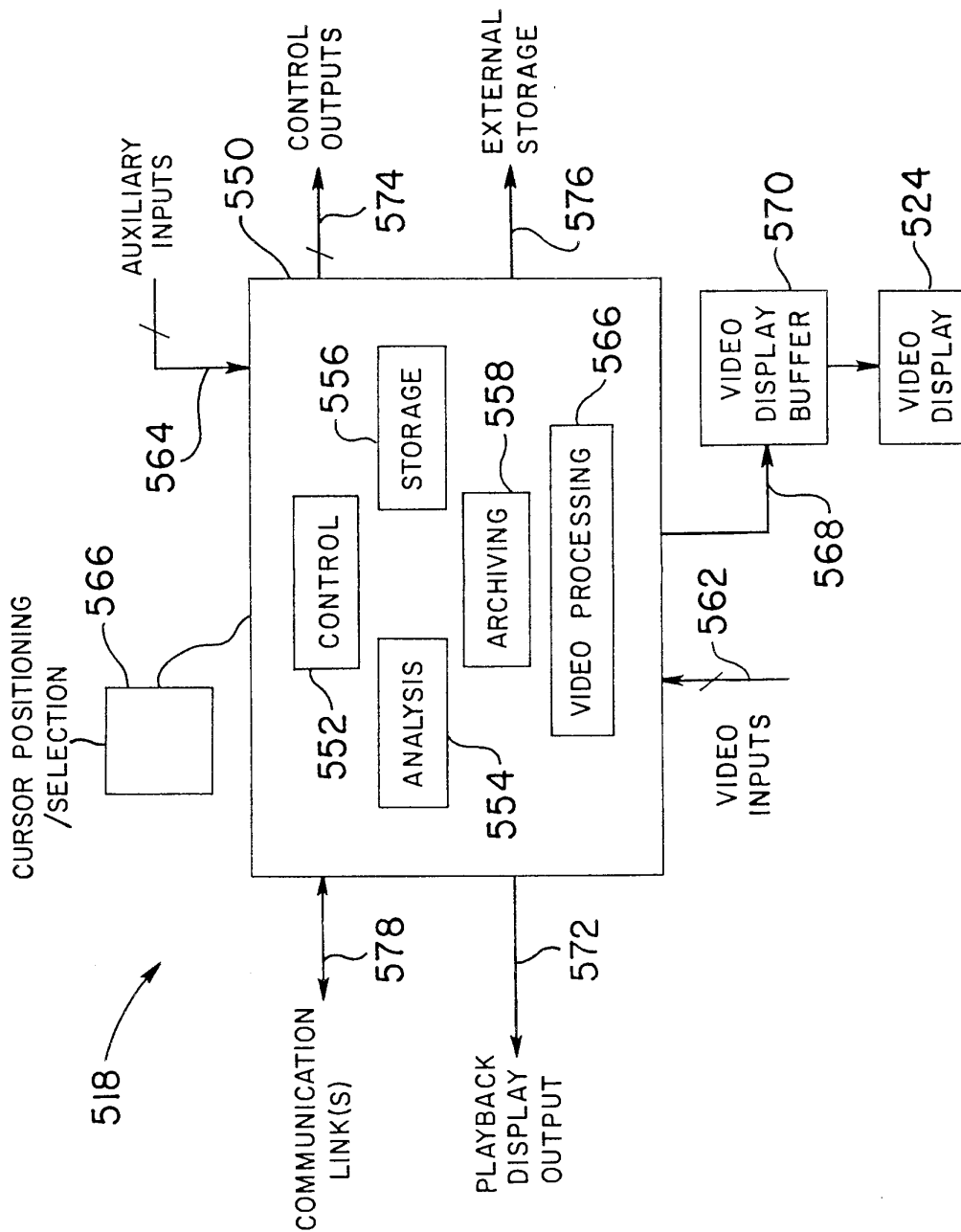
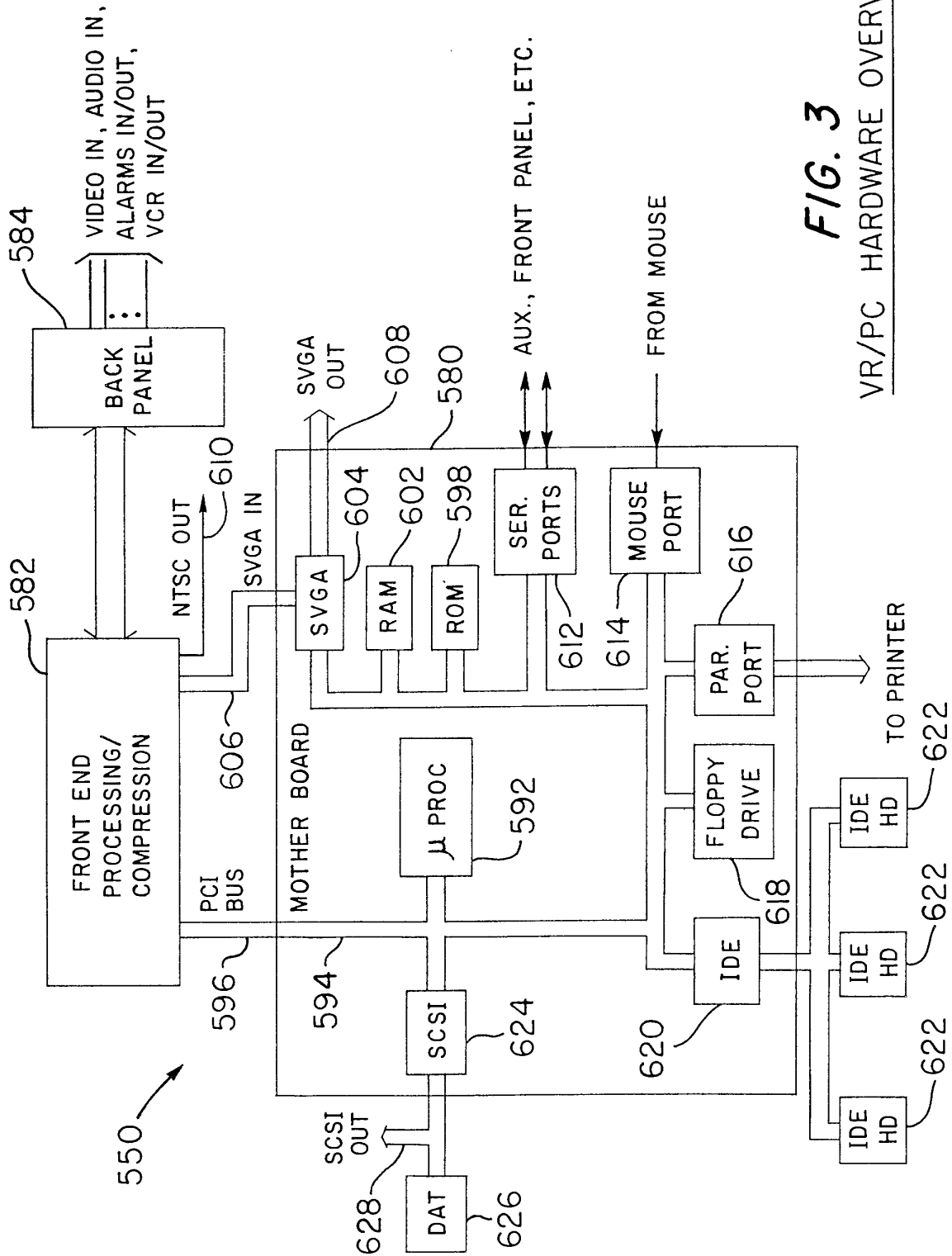


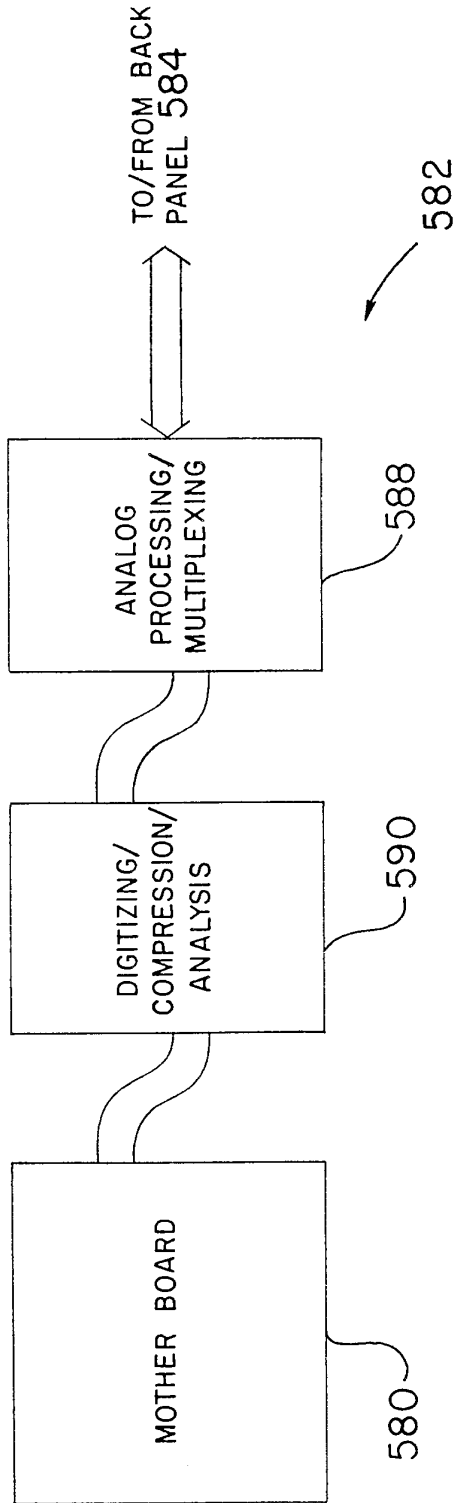
FIG. 1B



**FIG. 2**  
VIDEO ANALYSIS & STORAGE

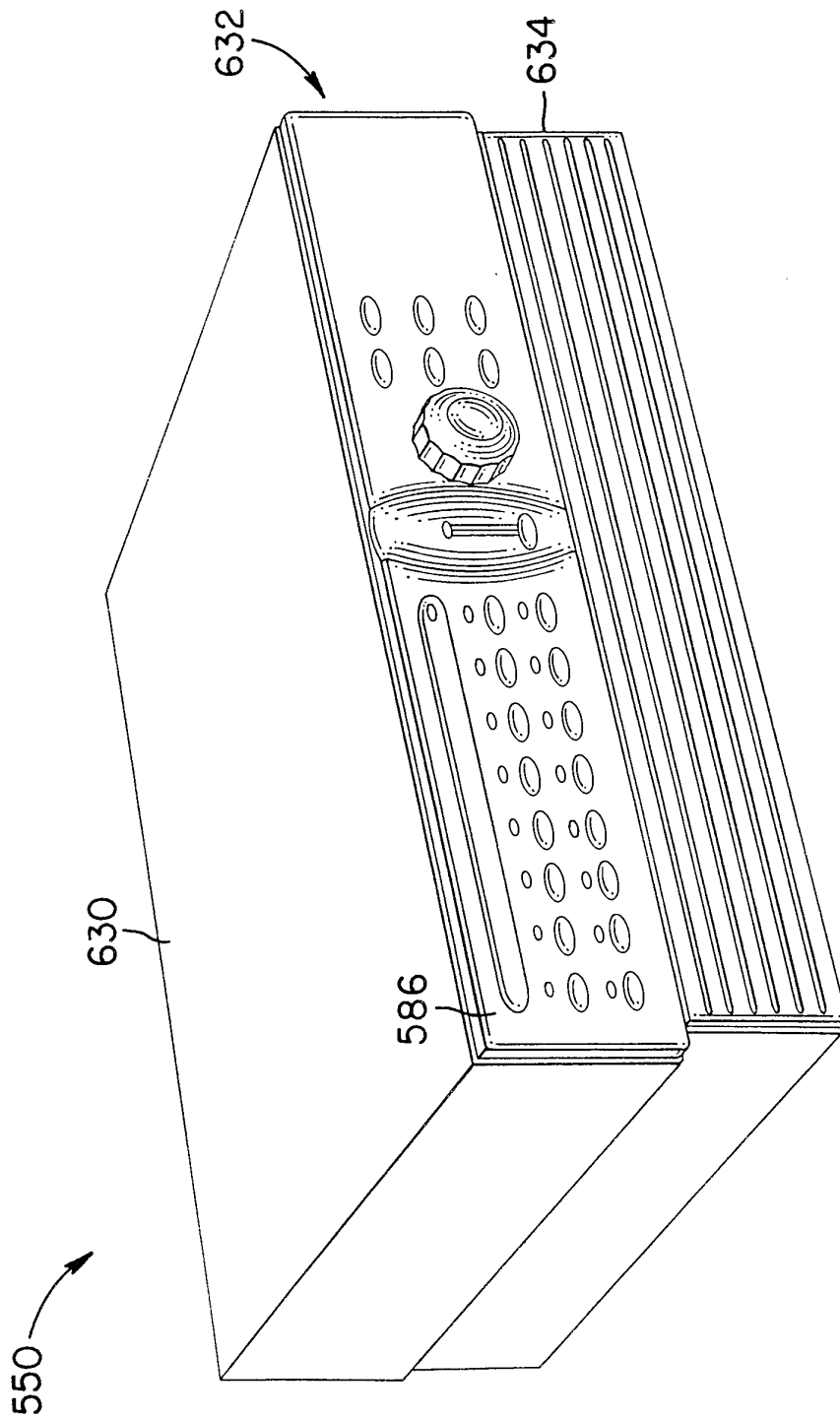


**FIG. 3**  
VR/PC HARDWARE OVERVIEW

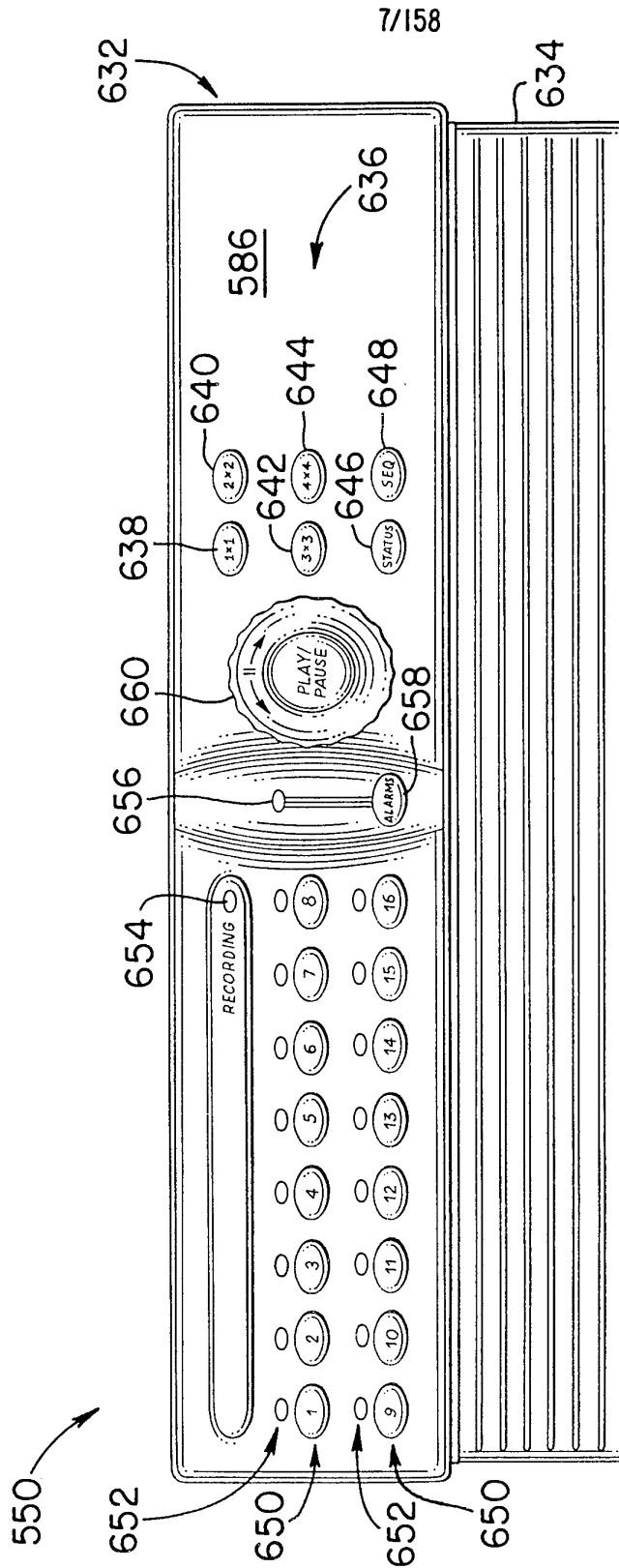


**FIG. 4**  
CIRCUIT BOARD ARCHITECTURE

6/158

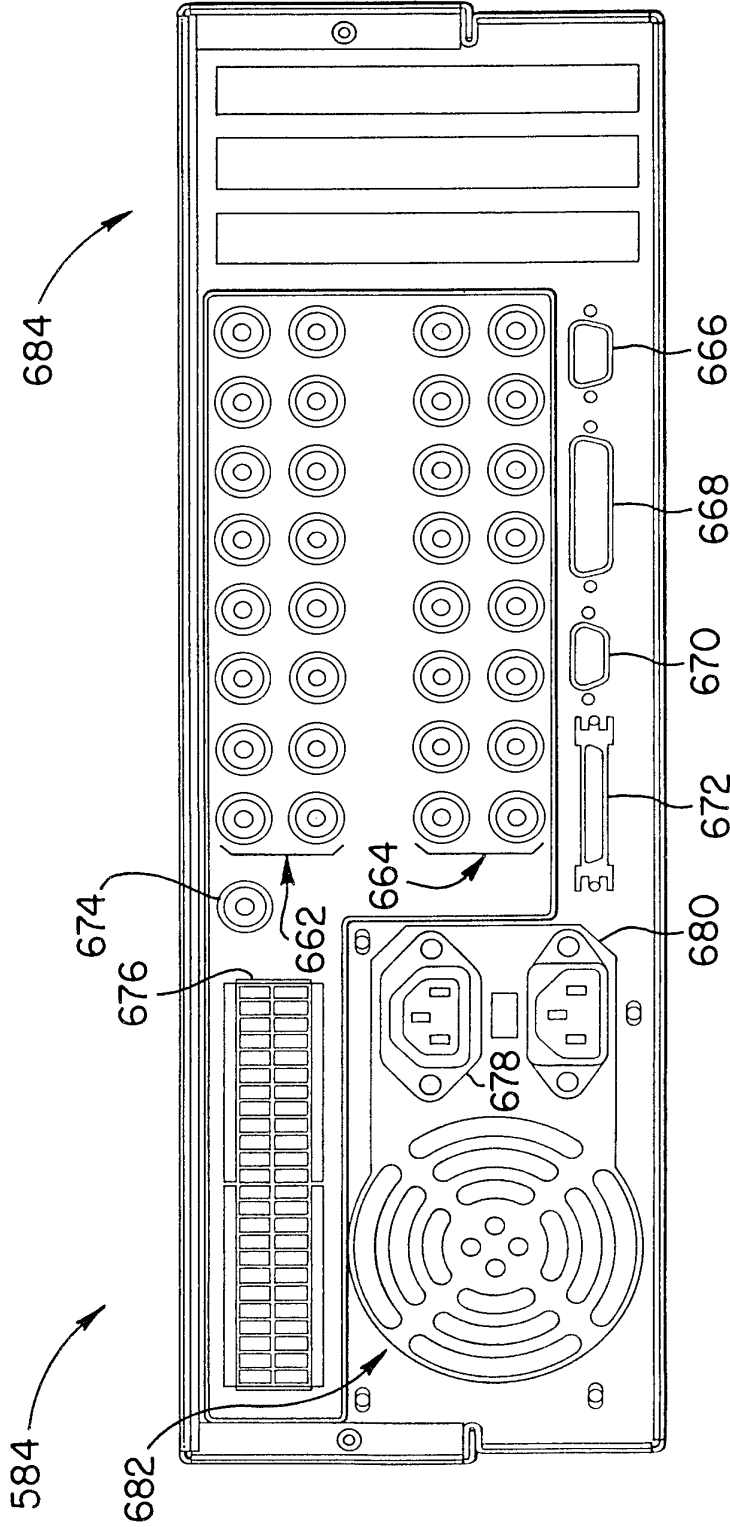


**FIG. 5**  
VR/PC



**FIG. 6**  
FRONT PANEL

8/158



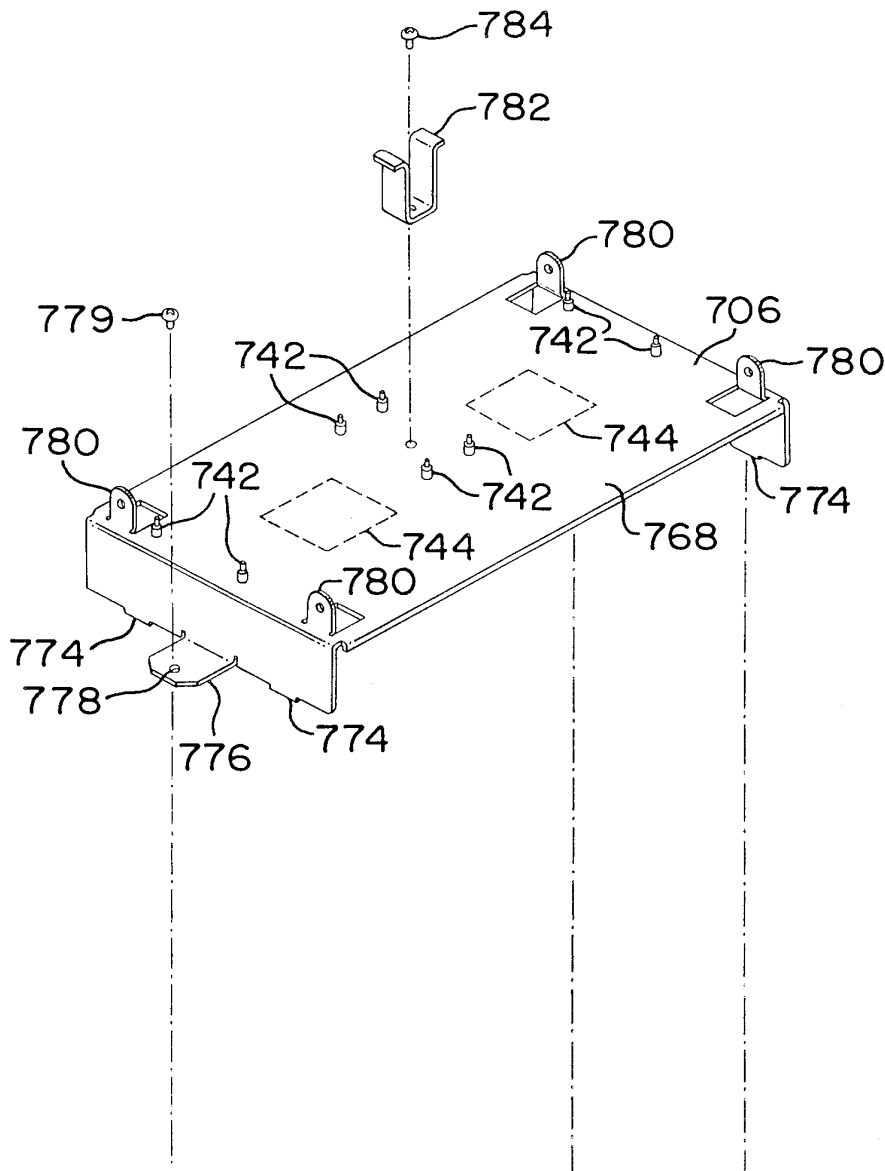
**FIG. 7**  
REAR ELEVATION





10/158

**FIG. 9A**  
**MEDIA DRIVE**  
**SUPPORT ASSEMBLY**



II/158

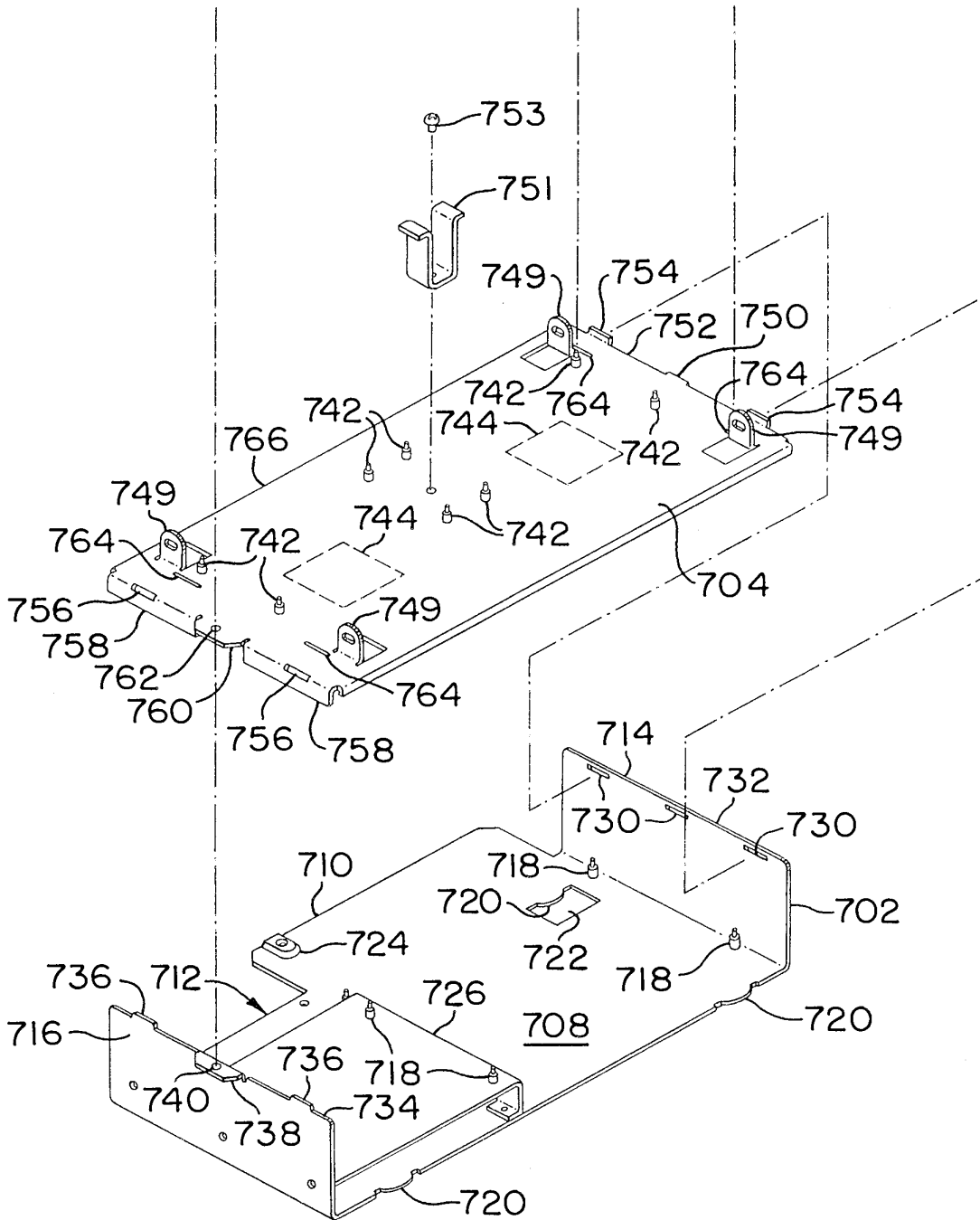
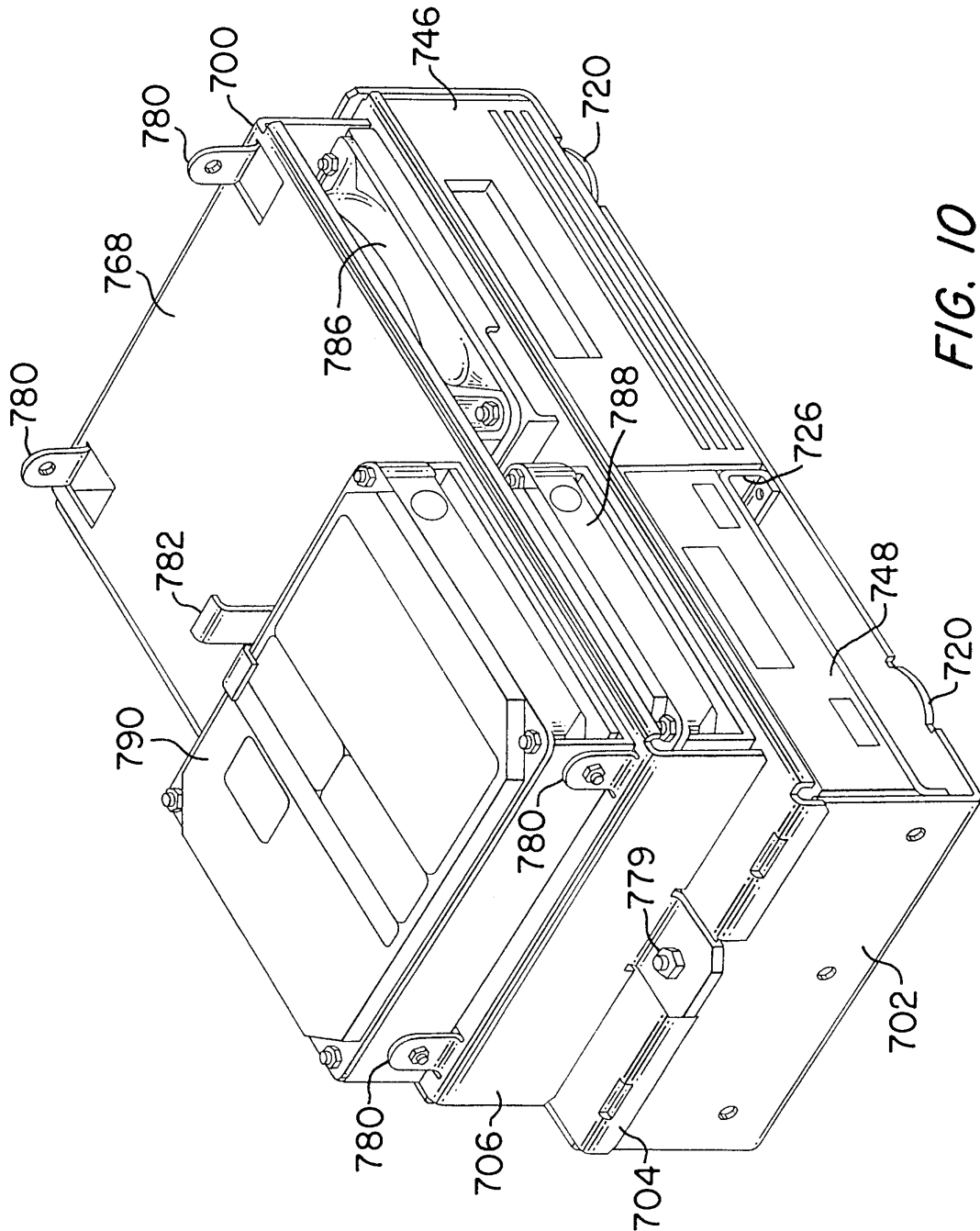


FIG. 9B

12/158



**FIG. 10**  
MEDIA DRIVE ASSEMBLY

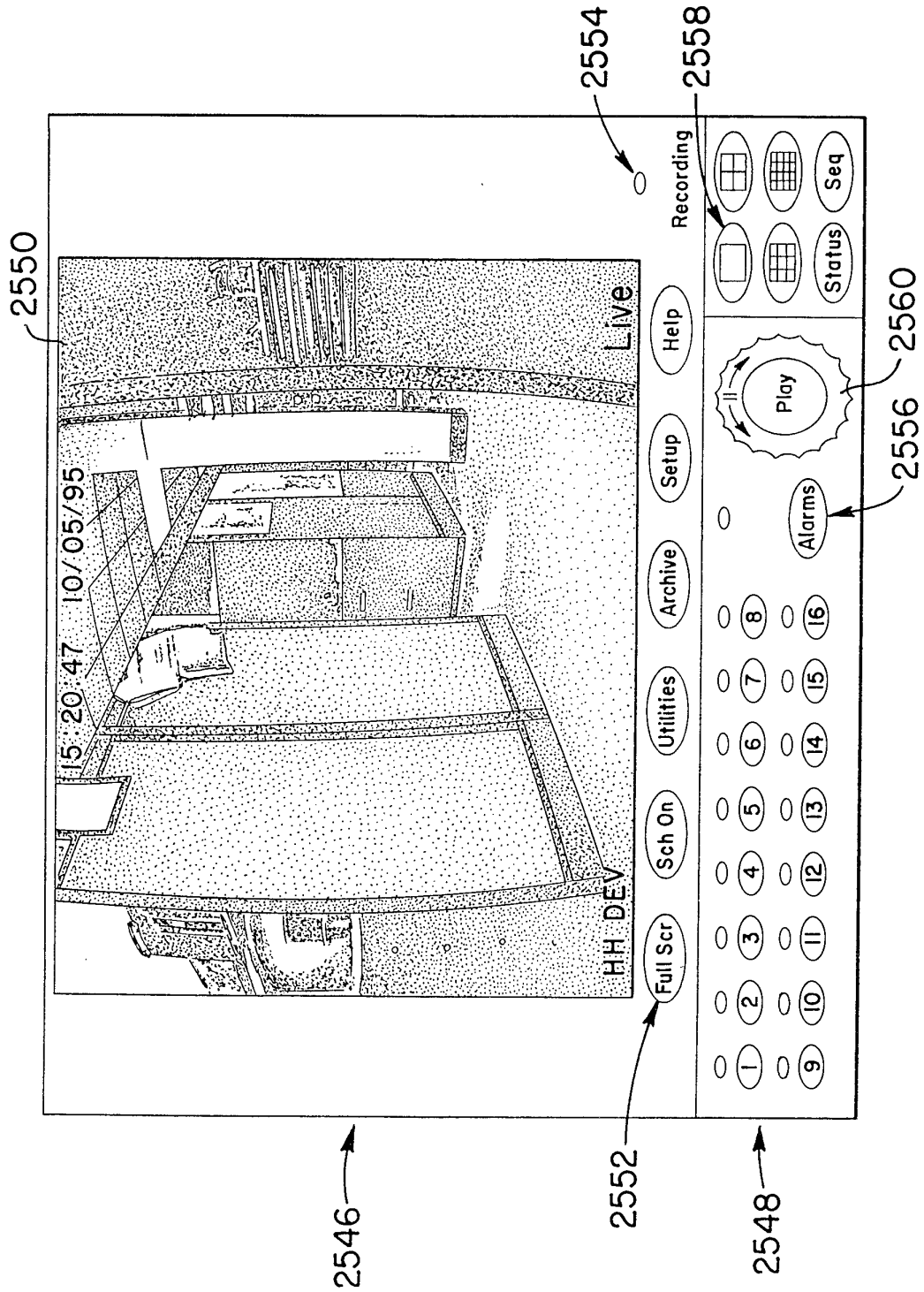


FIG. 11

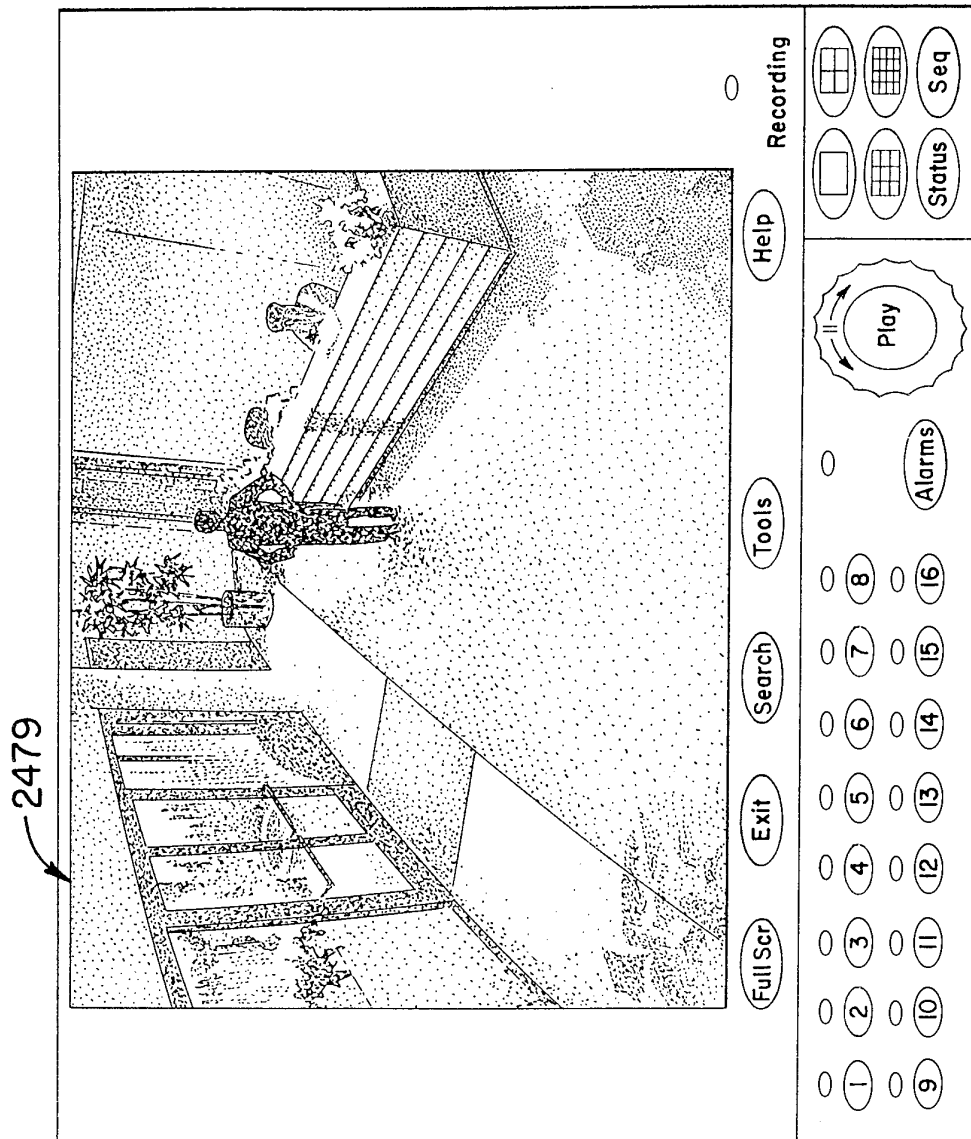


FIG. 12

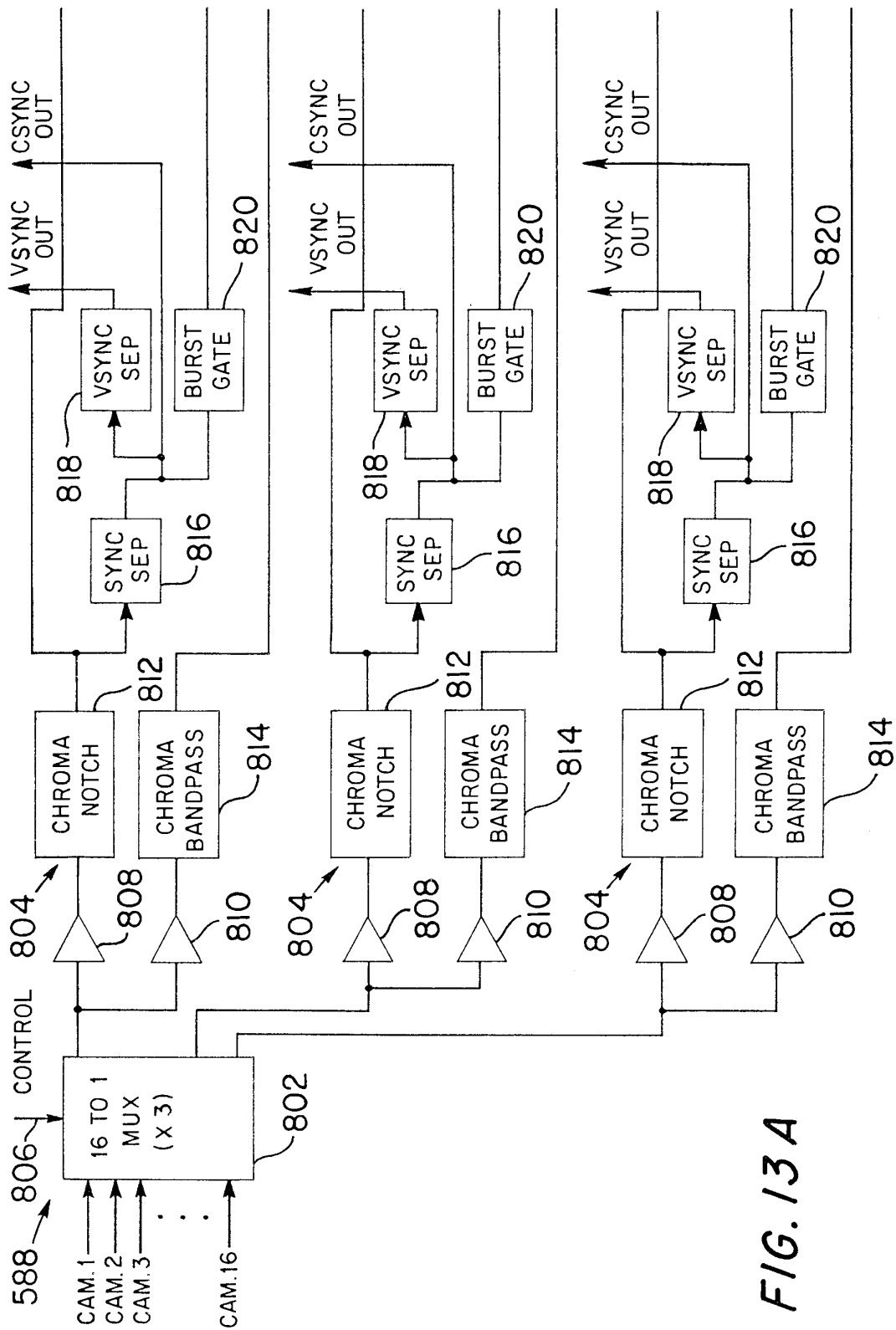


FIG. 13A

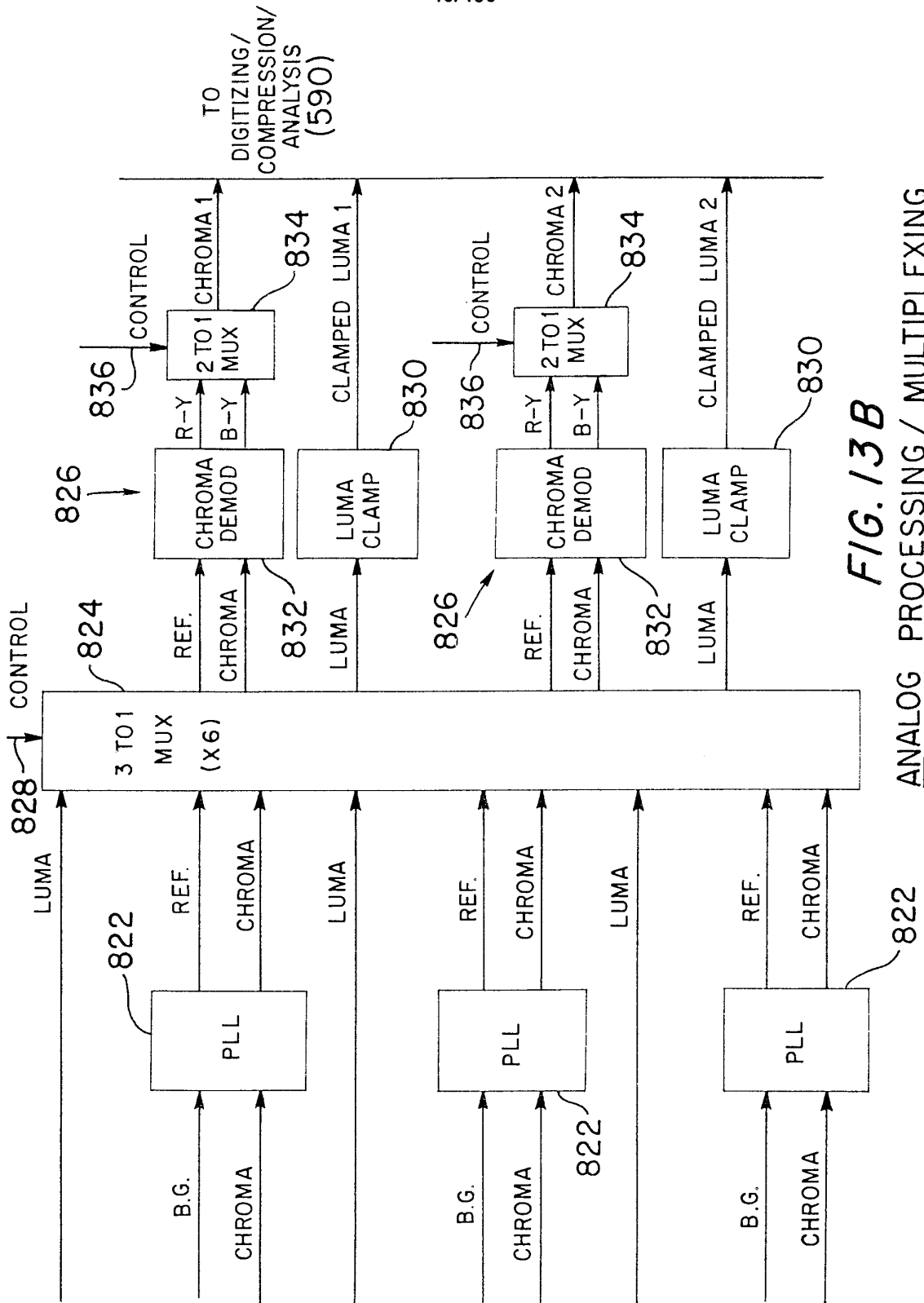
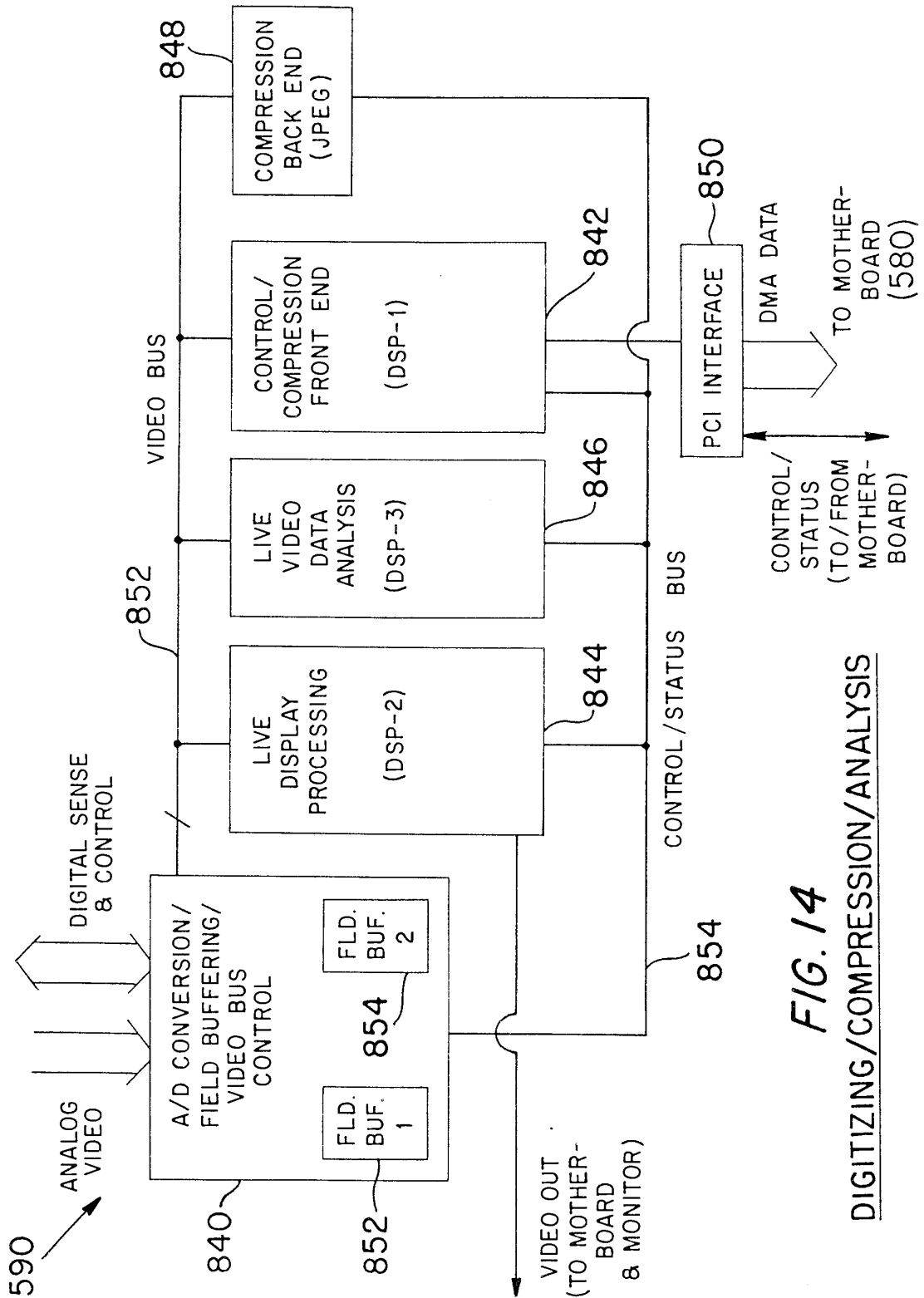


FIG. 13B

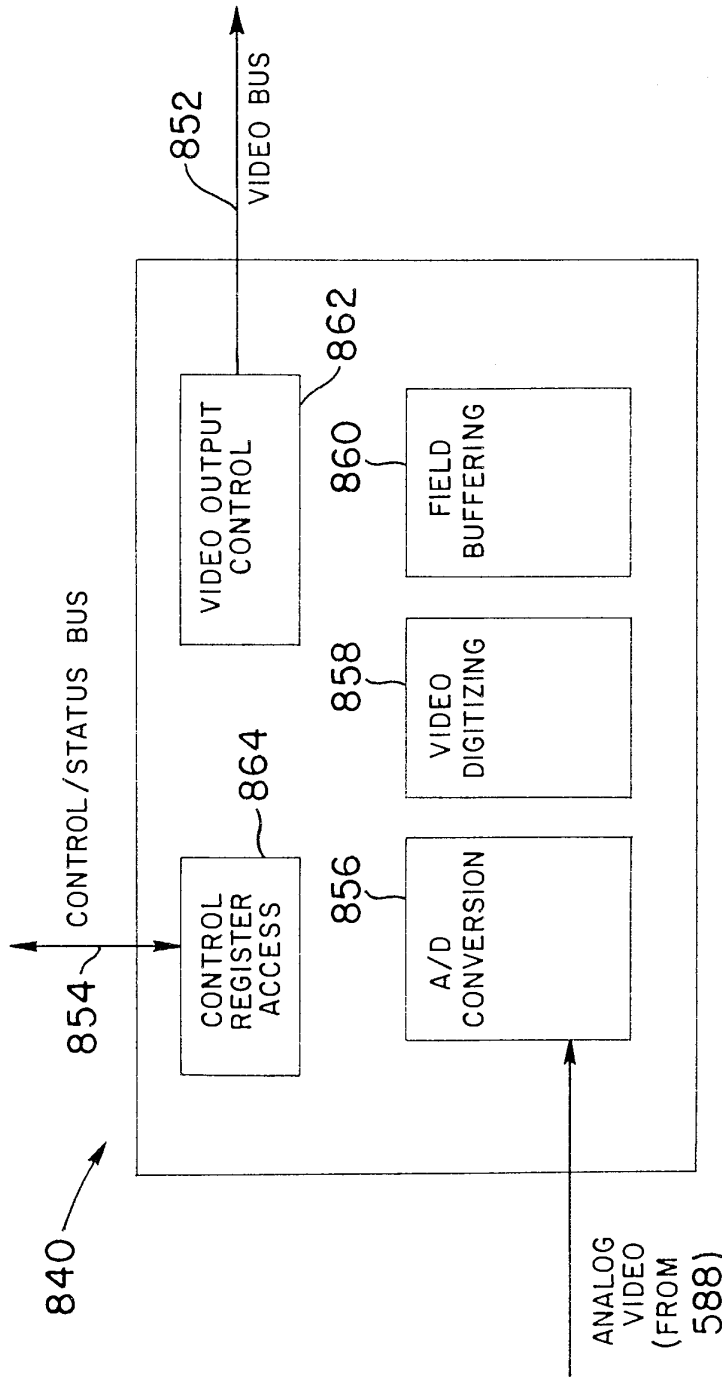
ANALOG PROCESSING / MULTIPLEXING



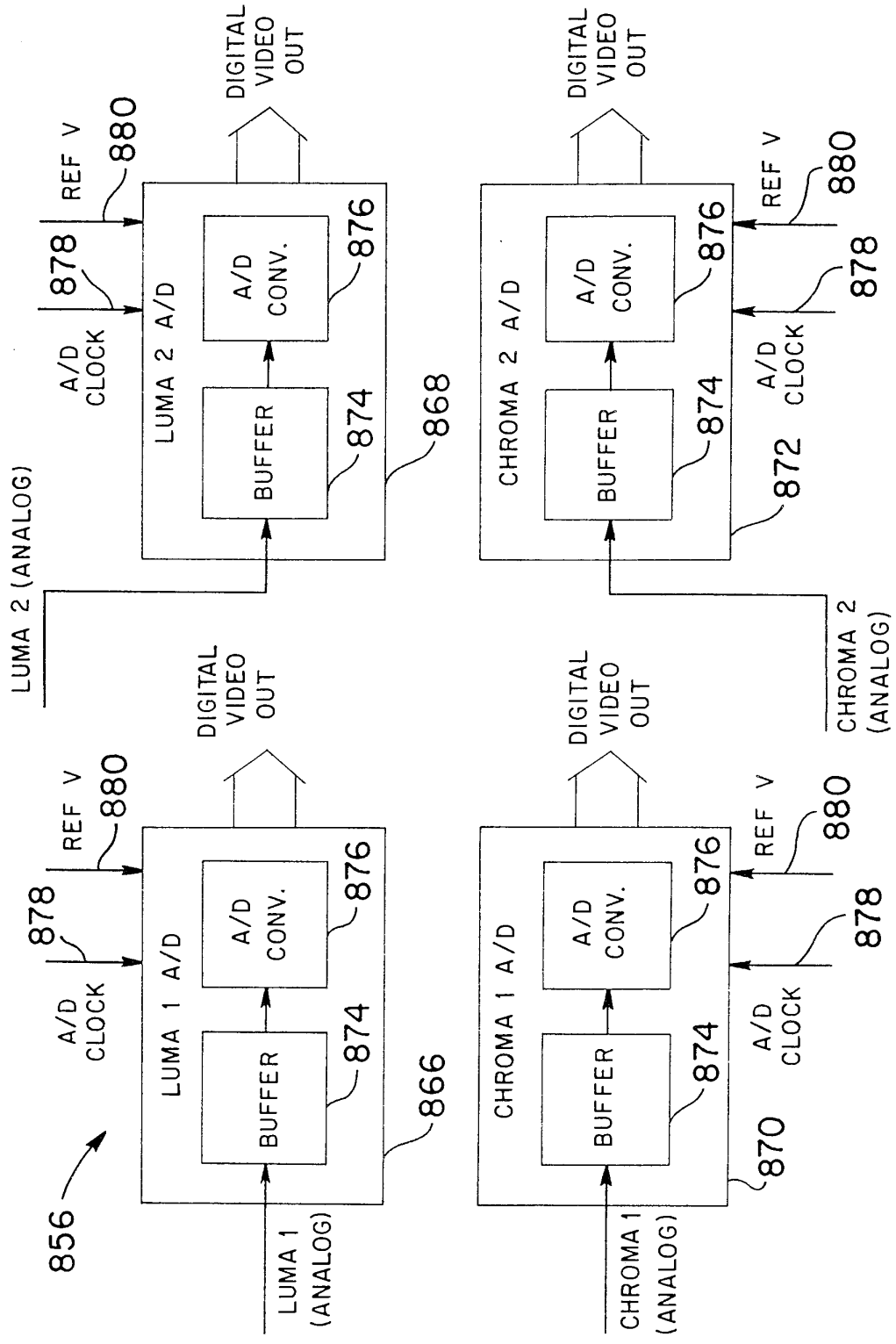
17/158



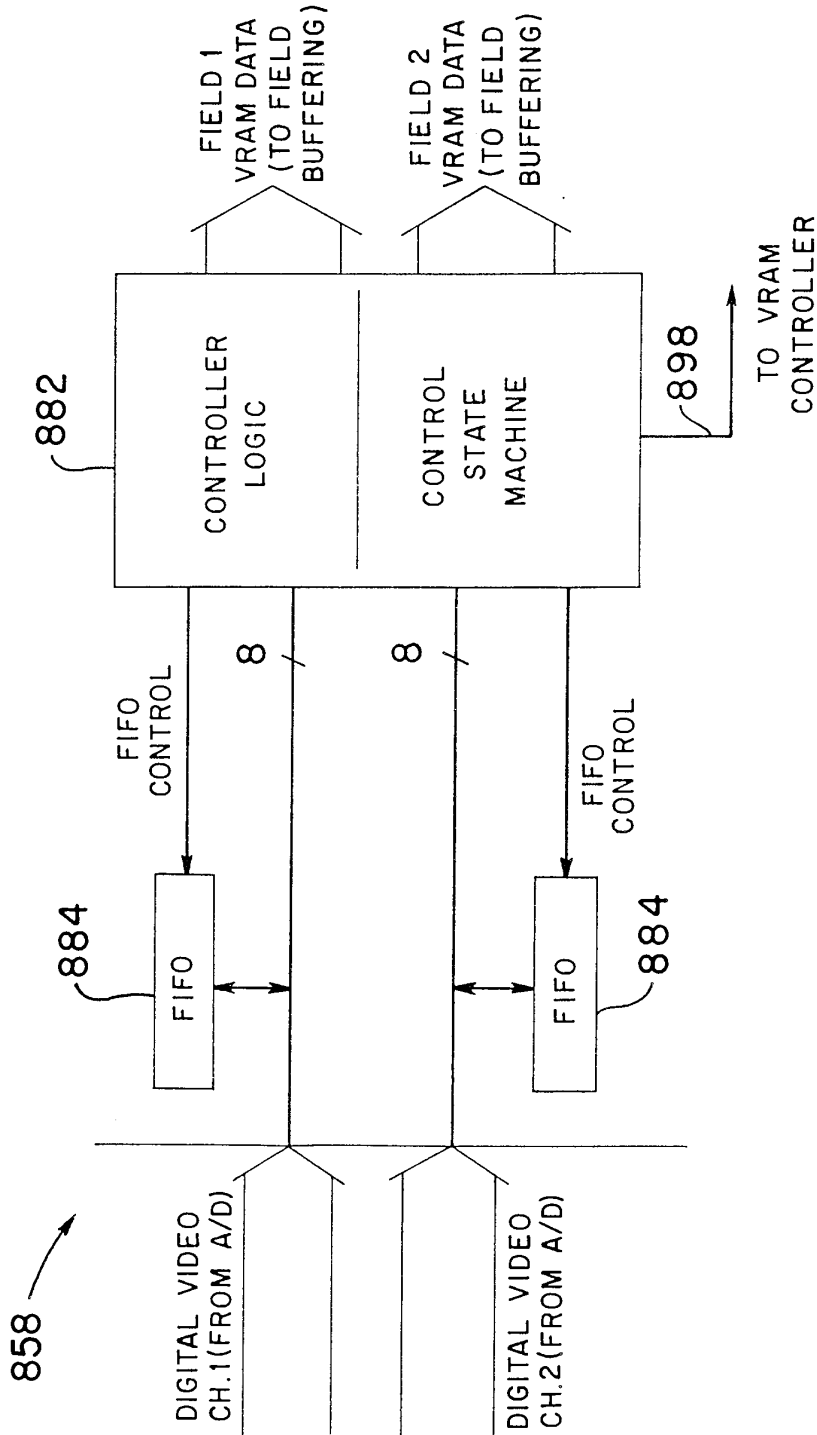
**FIG. 14**  
DIGITIZING/COMPRESSION/ANALYSIS



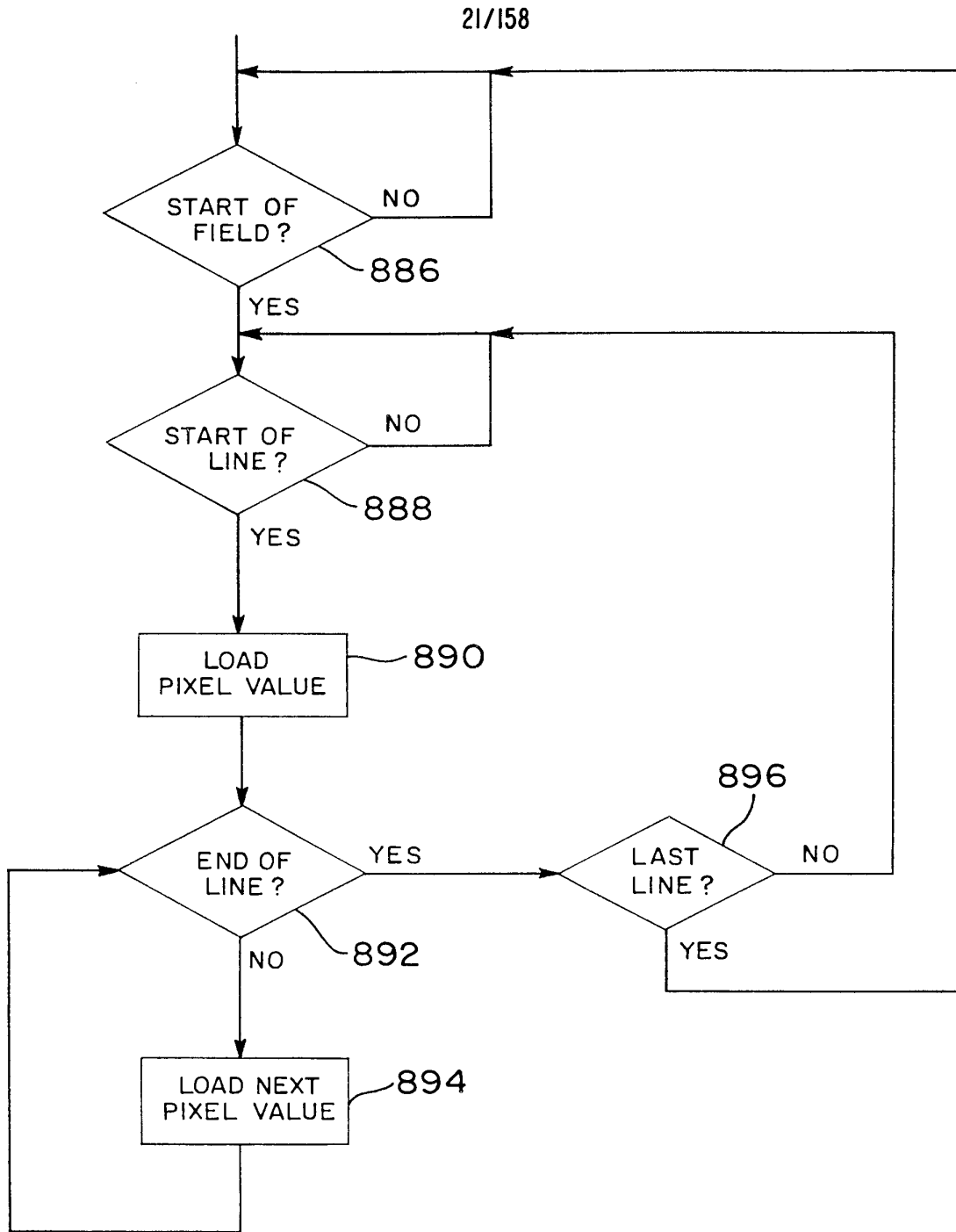
**FIG. 15**  
A/D CONVERSION/FIELD BUFFERING/VIDEO BUS CONTROL



**FIG. 16**  
A/D CONVERSION

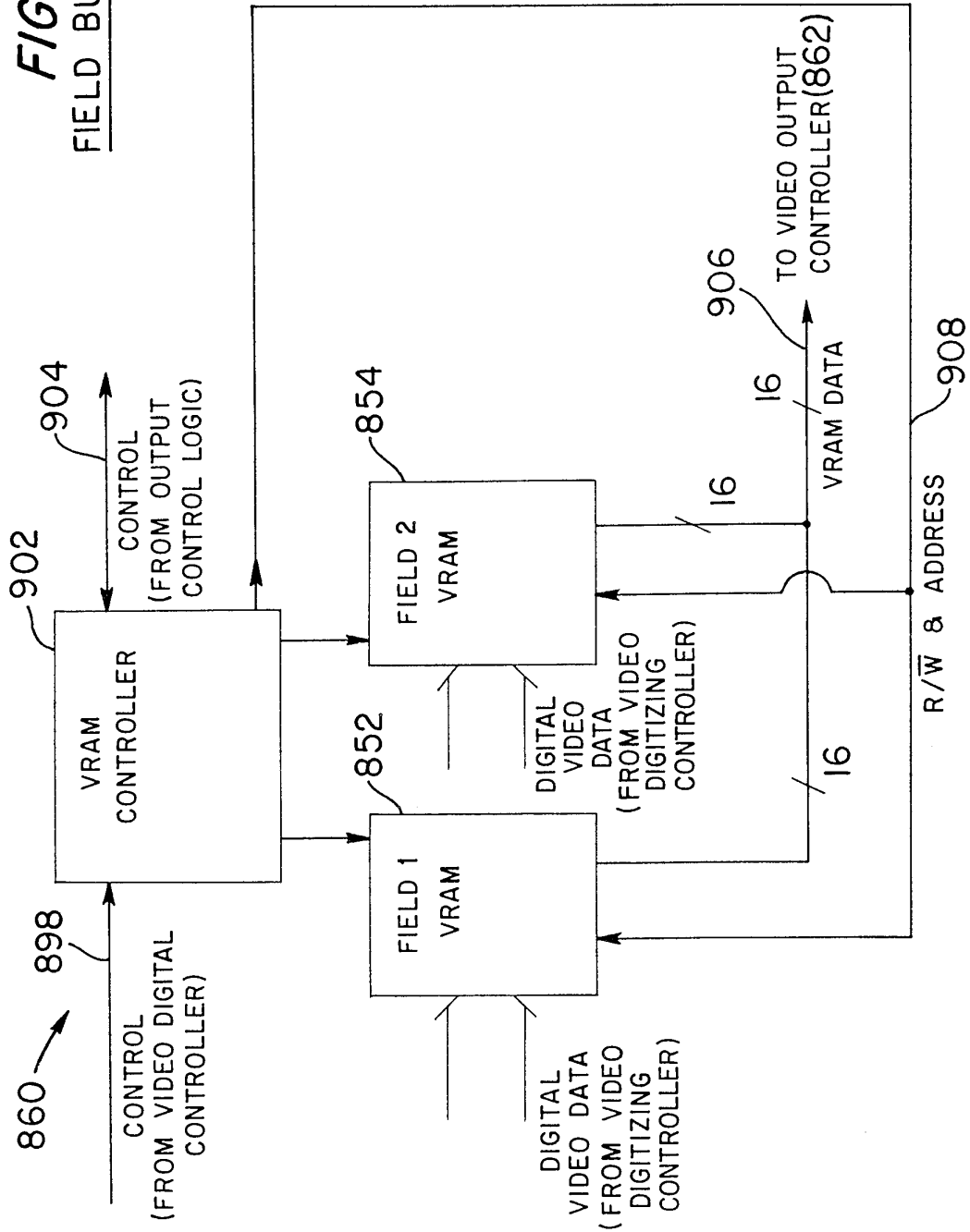


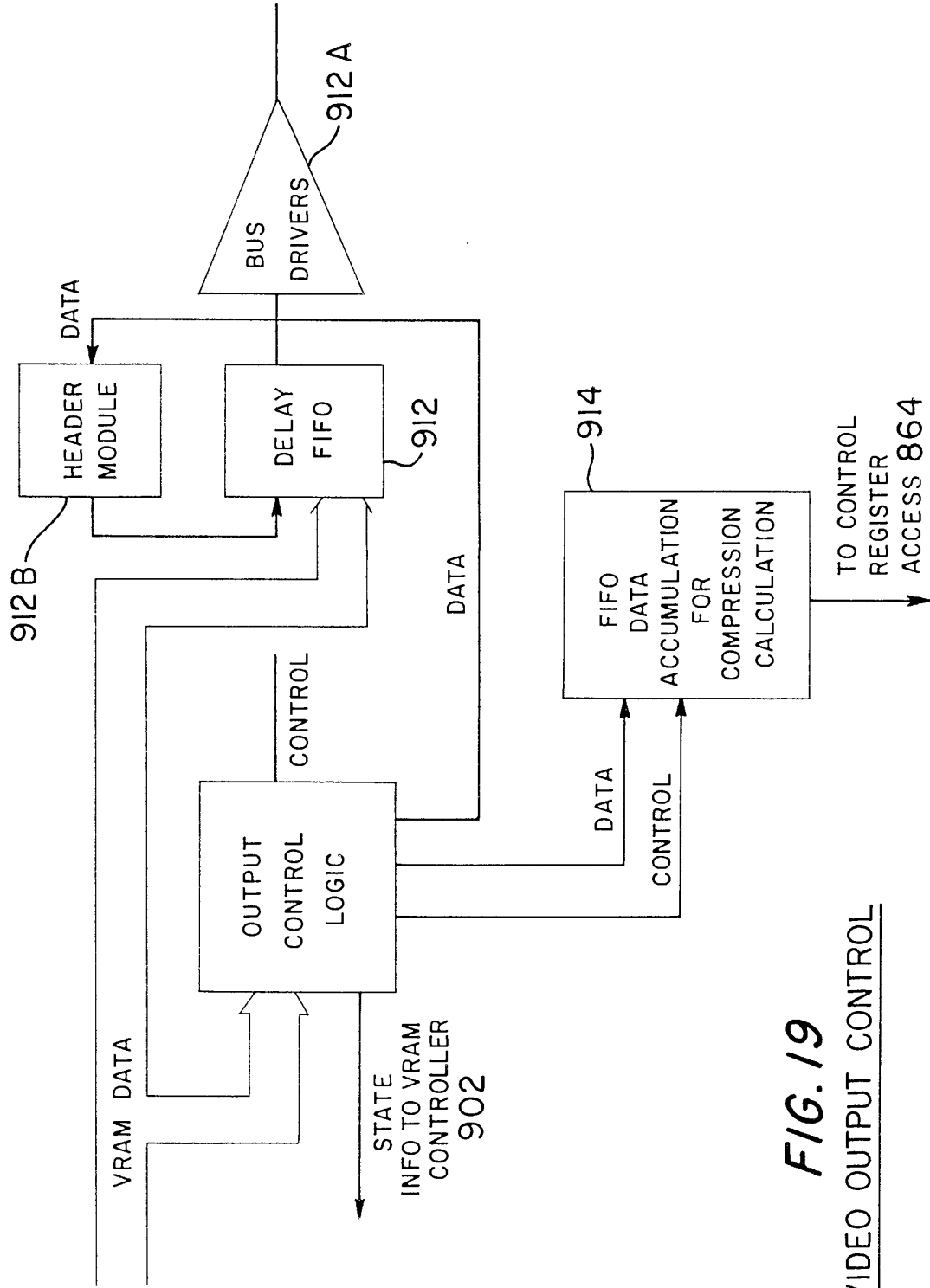
**FIG. 17**  
VIDEO DIGITIZING CONTROLLER



**FIG. 17 A**  
CONTROLLER LOGIC  
(VIDEO DIGITIZING CONTROLLER)

**FIG. 18**  
**FIELD BUFFERING**





**FIG. 19**  
VIDEO OUTPUT CONTROL

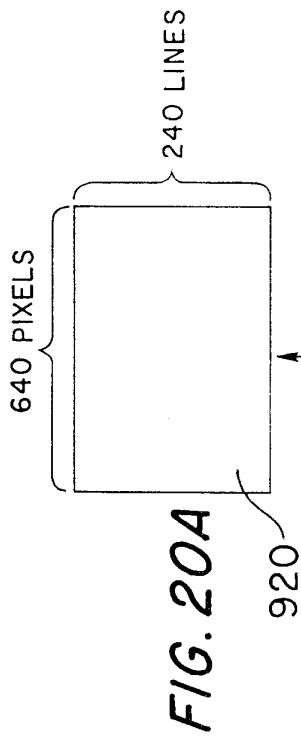


FIG. 20A

FIELD OF VIDEO DATA

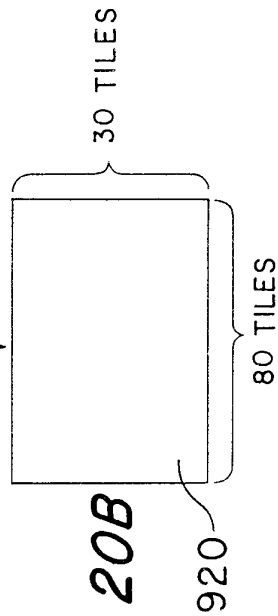


FIG. 20B

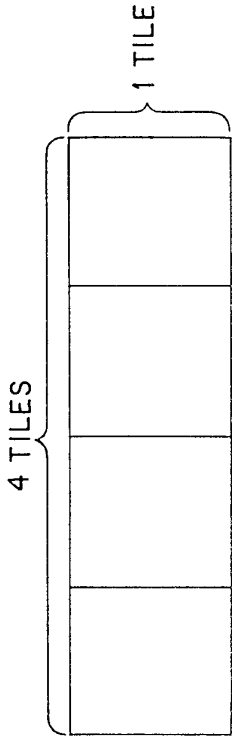


FIG. 22

MINIMUM CODING UNIT (MCU)  
(IMAGE PLANE)

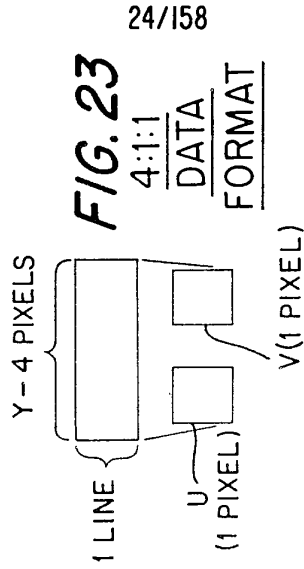


FIG. 23

24/158

4:1:1

DATA  
FORMAT

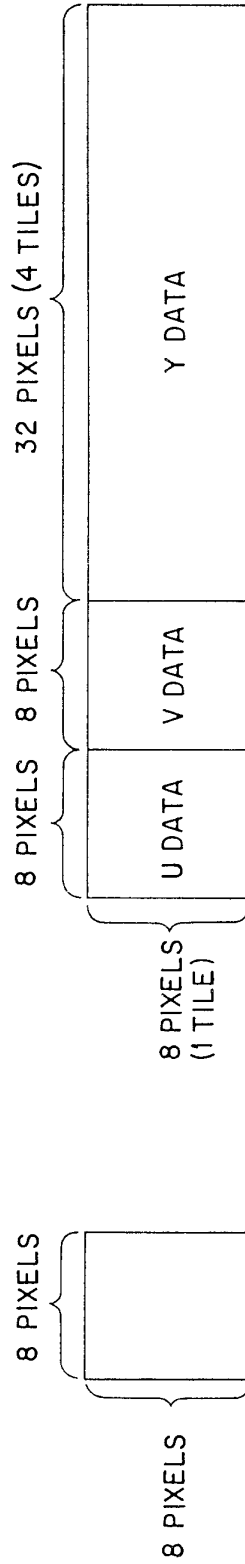


FIG. 24

MINIMUM CODING UNIT (MCU)  
(COLOR VIDEO DATA)

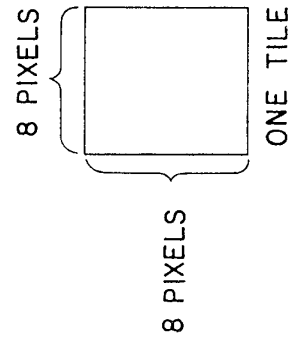
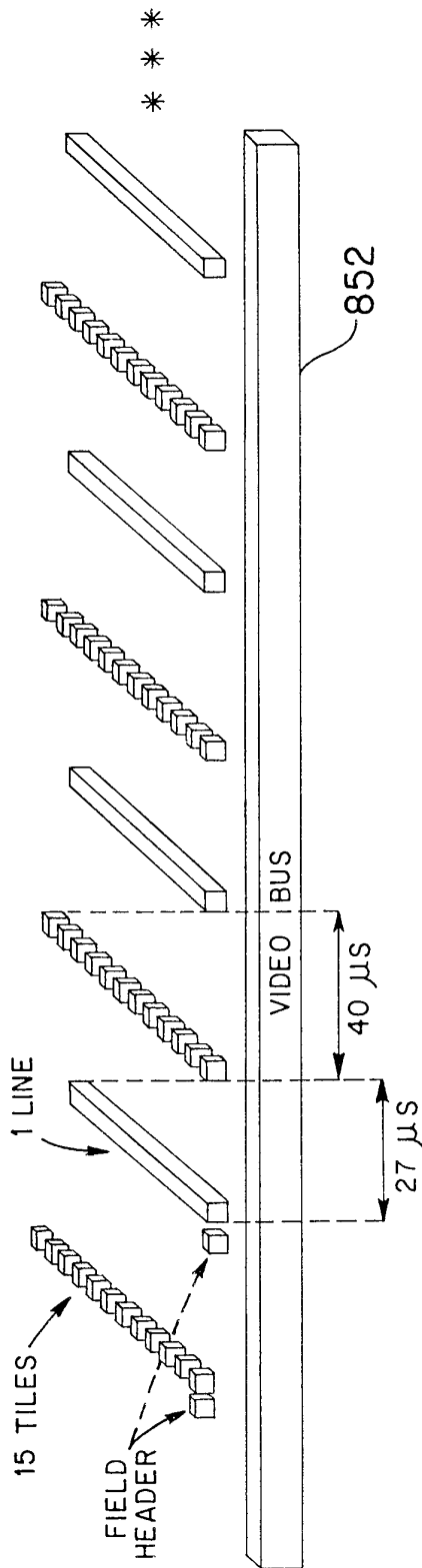


FIG. 21

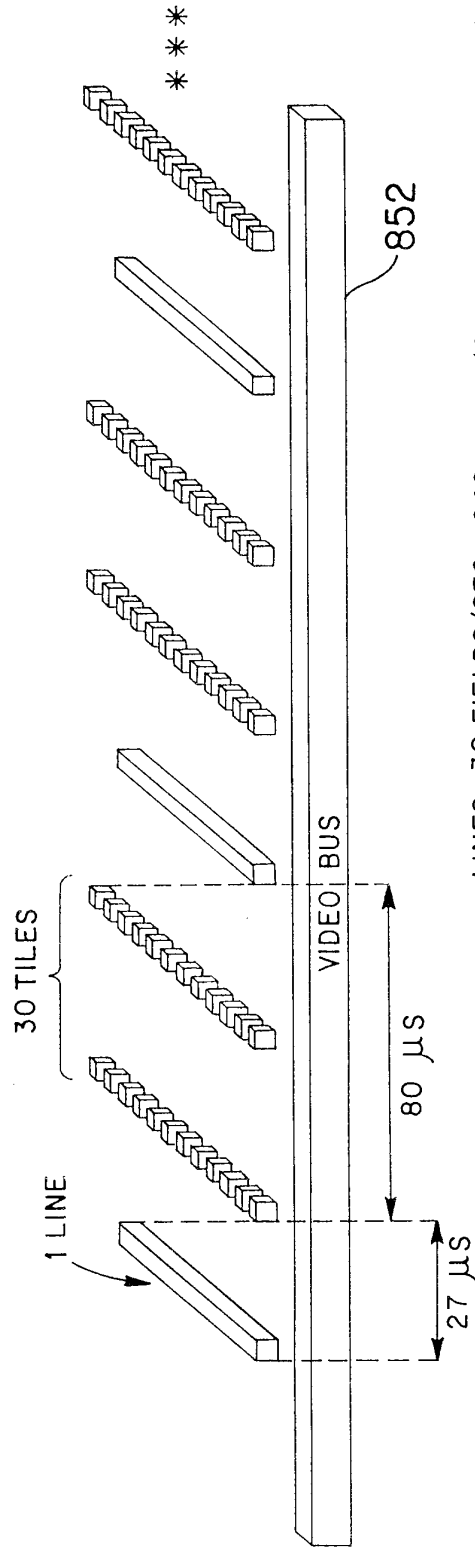




3/4 FIELD MODE: } 45 FIELDS/SEC.; 240 LINES / FIELD; 3600 TILES/FIELD  
 LINES }  
 TILES }

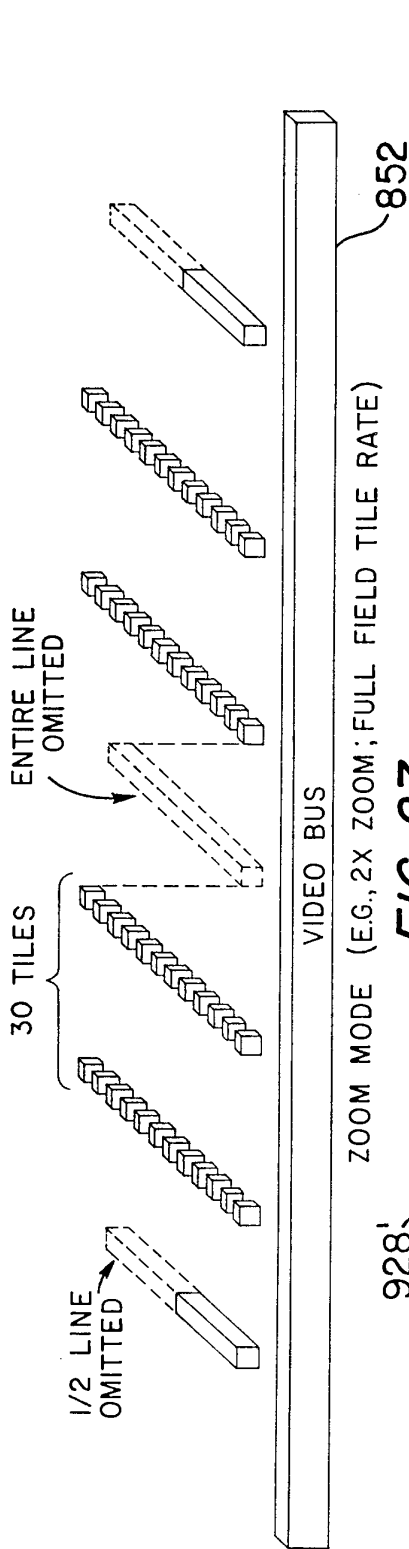
FIG. 25

25/158

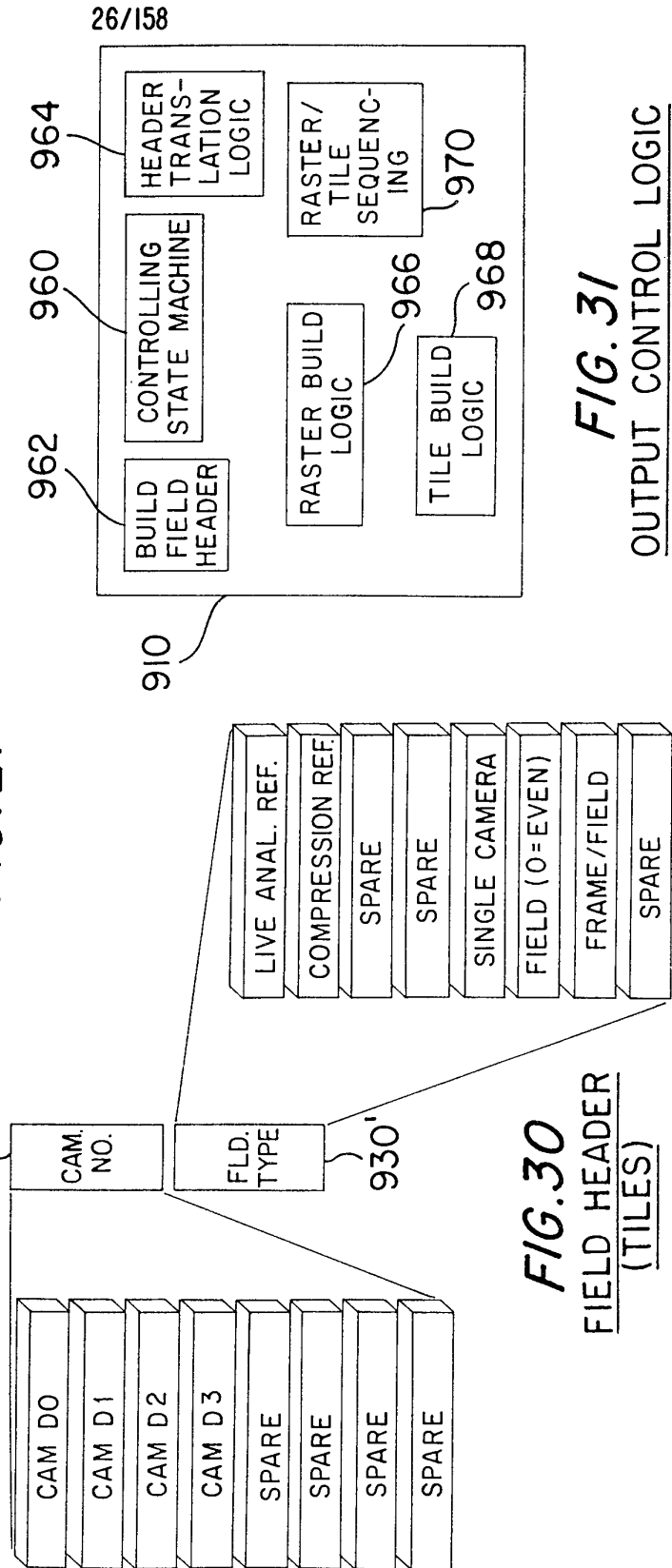


FULL FIELD MODE: LINES - 30 FIELDS/SEC.; 240 LINES/2 FIELDS; 3600 TILES/FIELD  
 TILES - 60 FIELDS/SEC.

FIG. 26



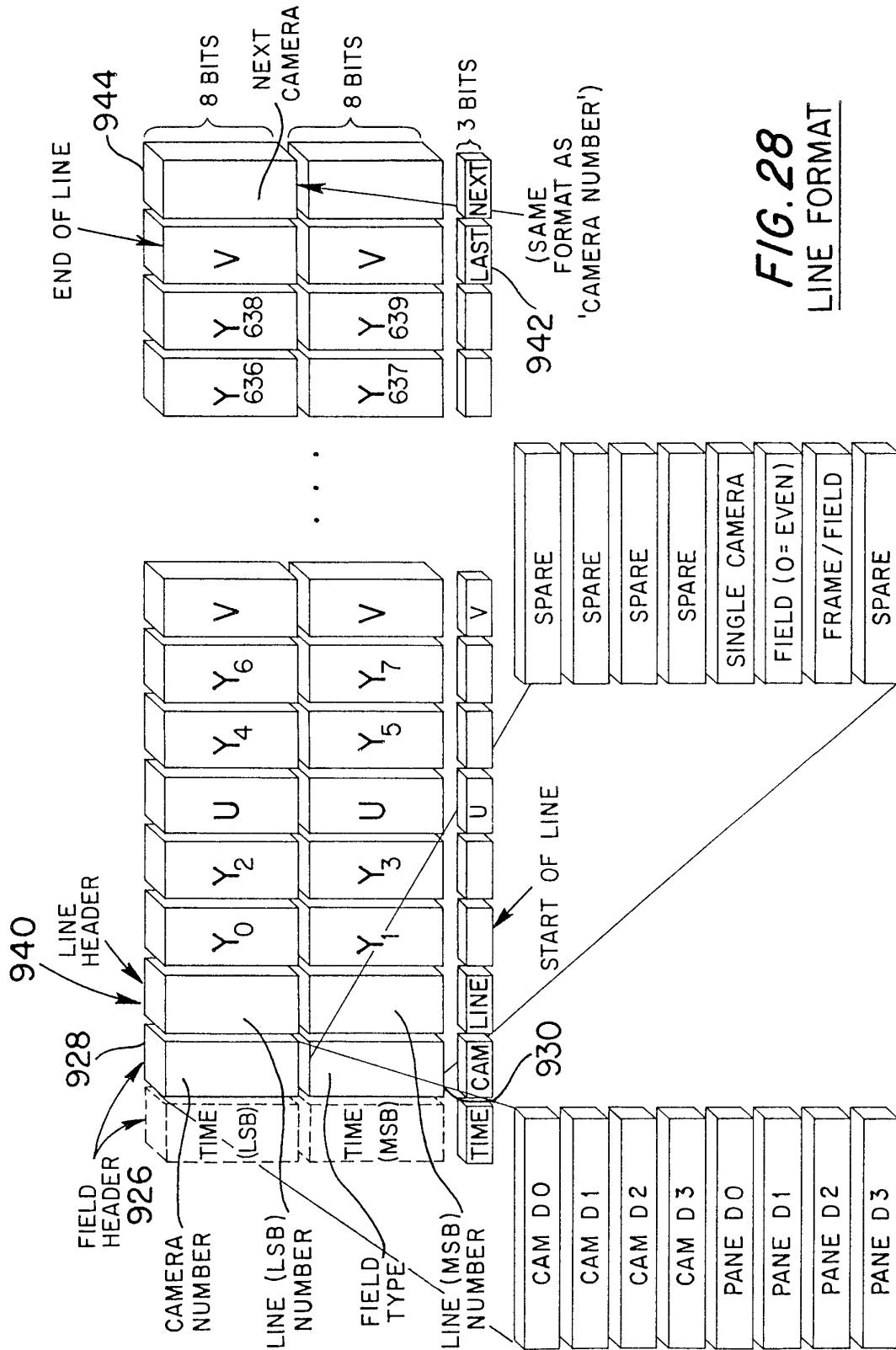
**FIG. 27**



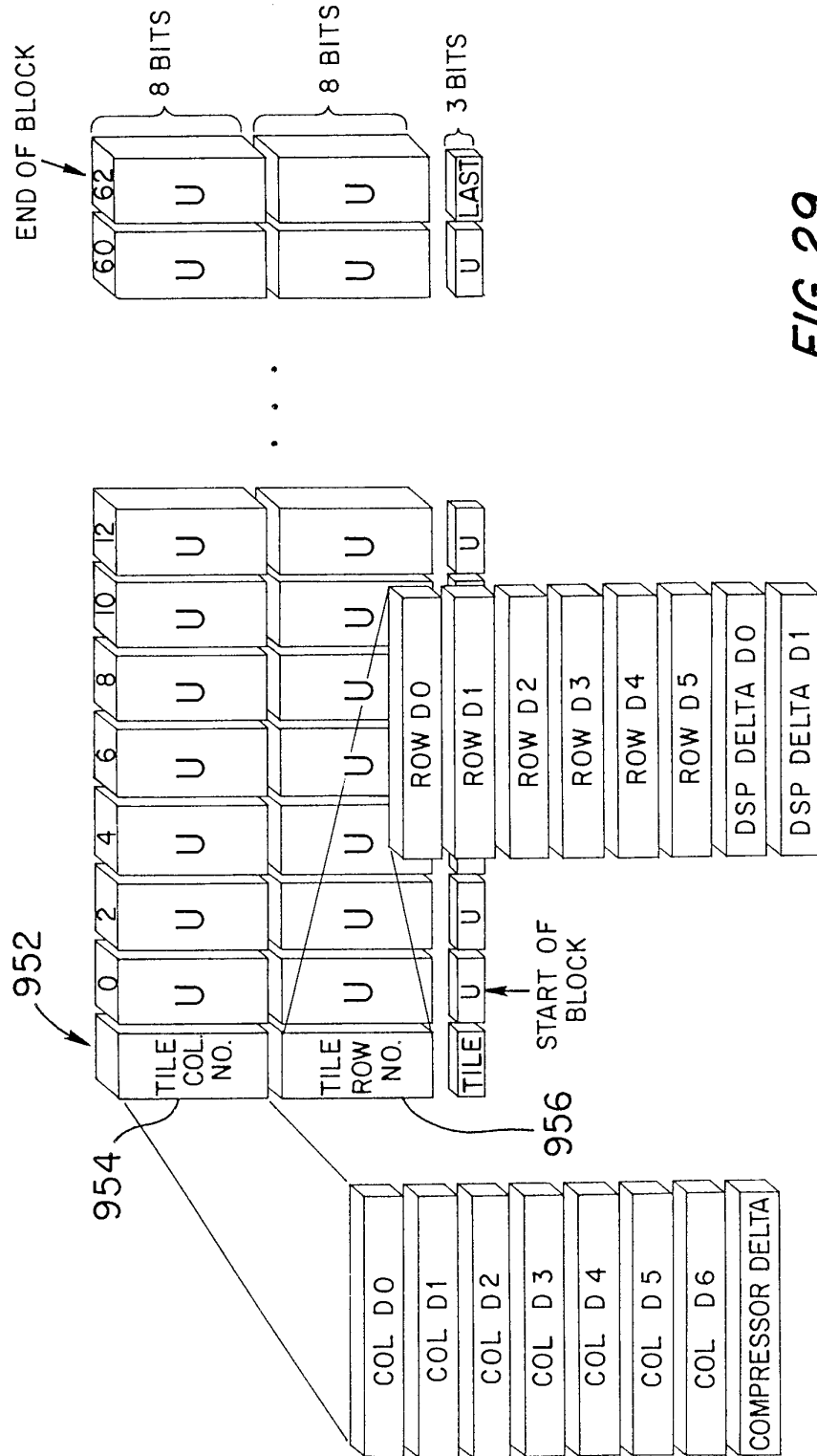
**FIG. 31**  
OUTPUT CONTROL LOGIC

**FIG. 30**  
FIELD HEADER (TILES)

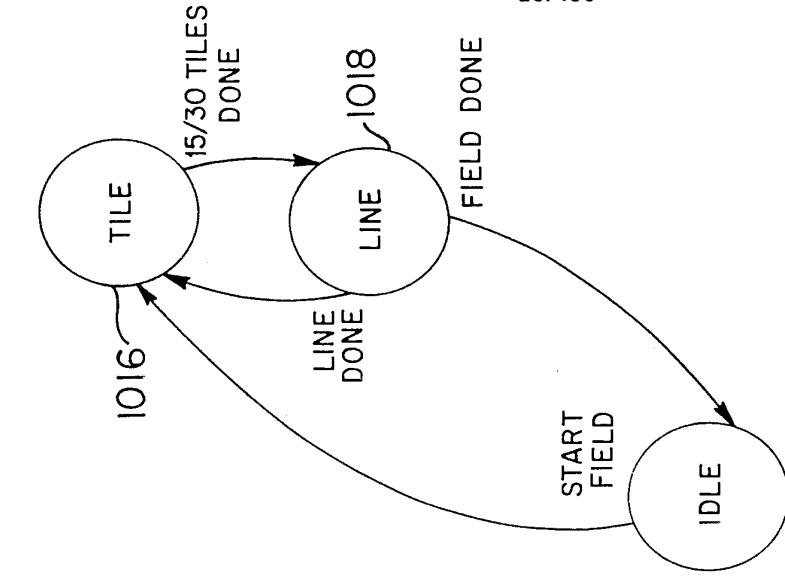
27/158



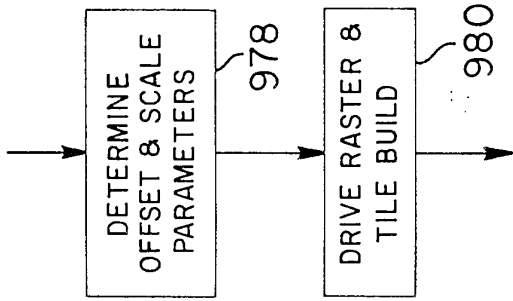
**FIG. 28**  
LINE FORMAT



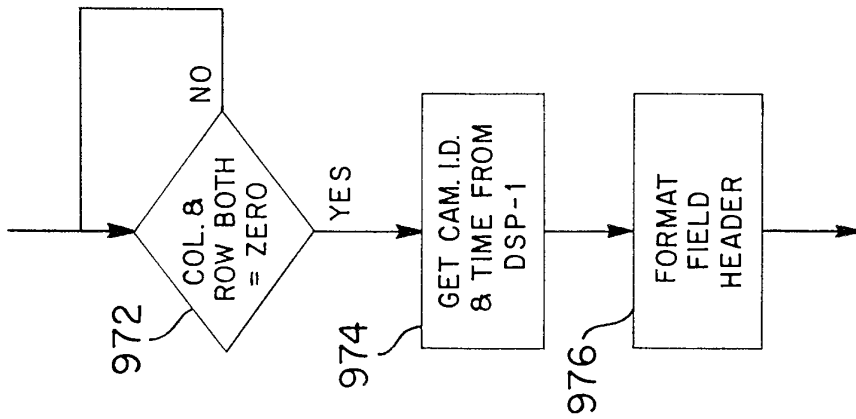
**FIG. 29**  
TILE FORMAT



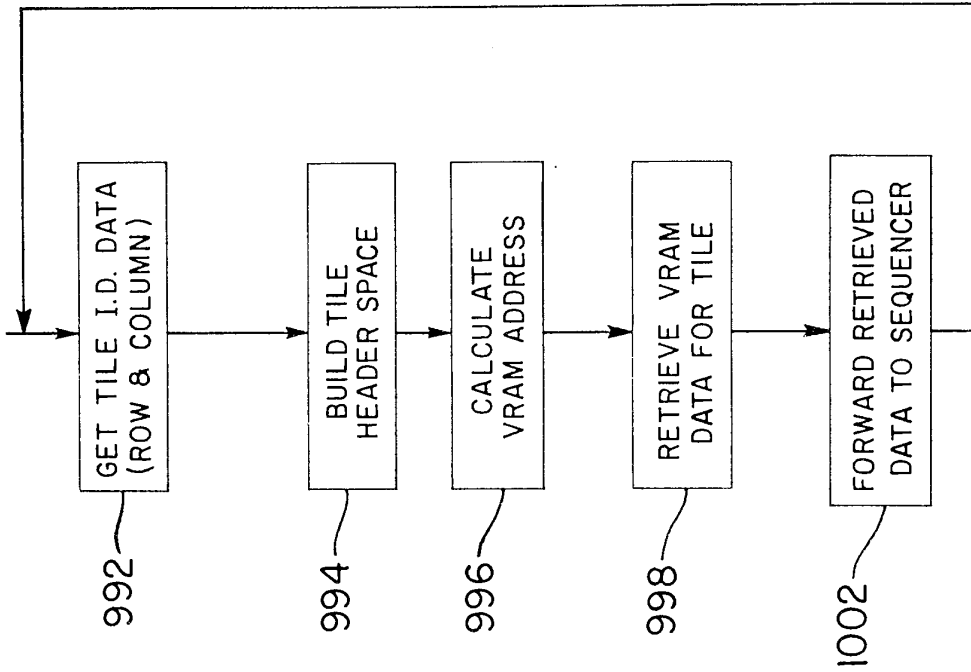
**FIG. 35**  
CONTROLLING STATE  
MACHINE  
(VIDEO BUS CONTROL)



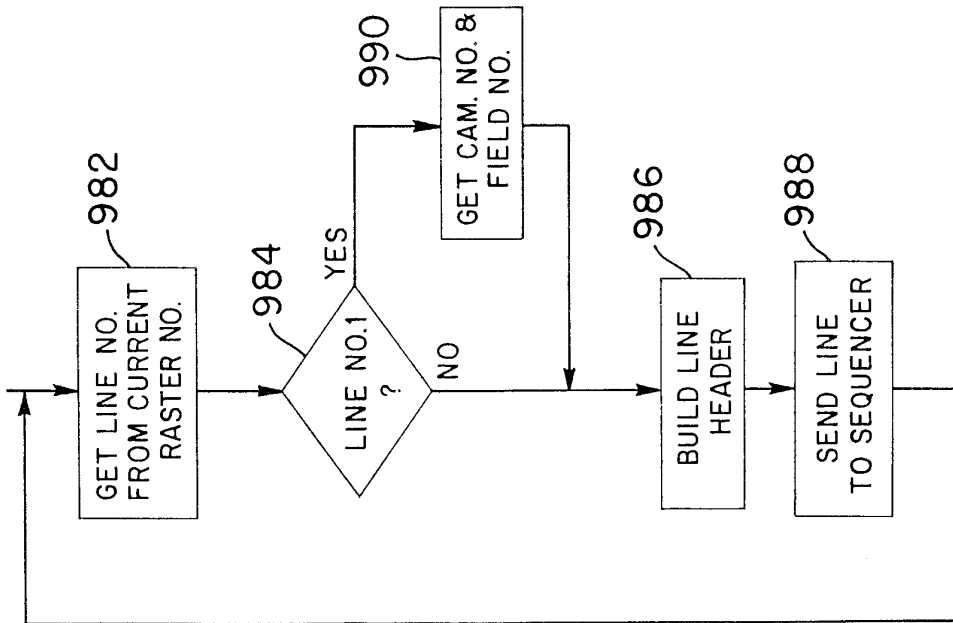
**FIG. 31B**  
HEADER TRANS-  
LATE LOGIC



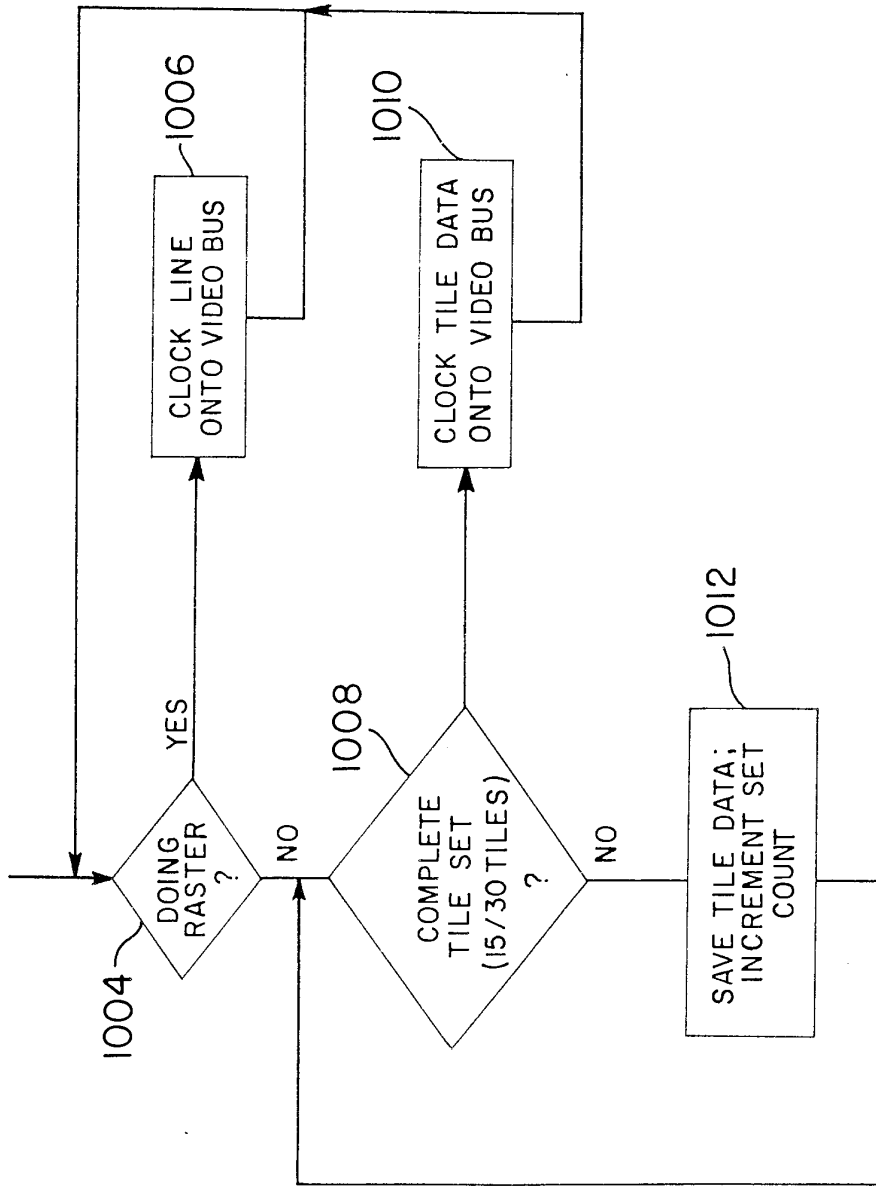
**FIG. 31A**  
BUILD FIELD HEADER



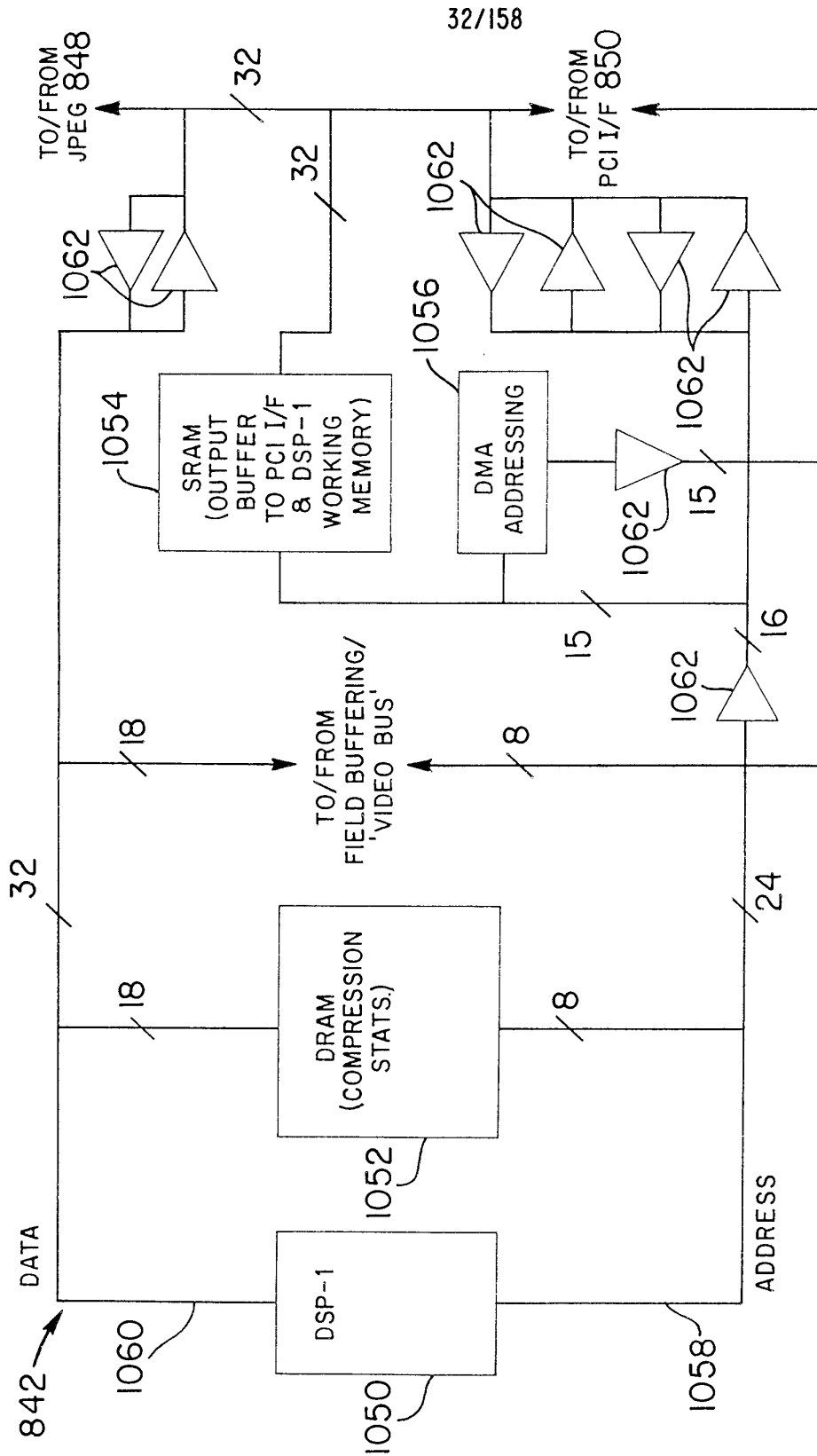
**FIG. 33**  
TILE BUILD LOGIC



**FIG. 32**  
RASTER BUILD LOGIC

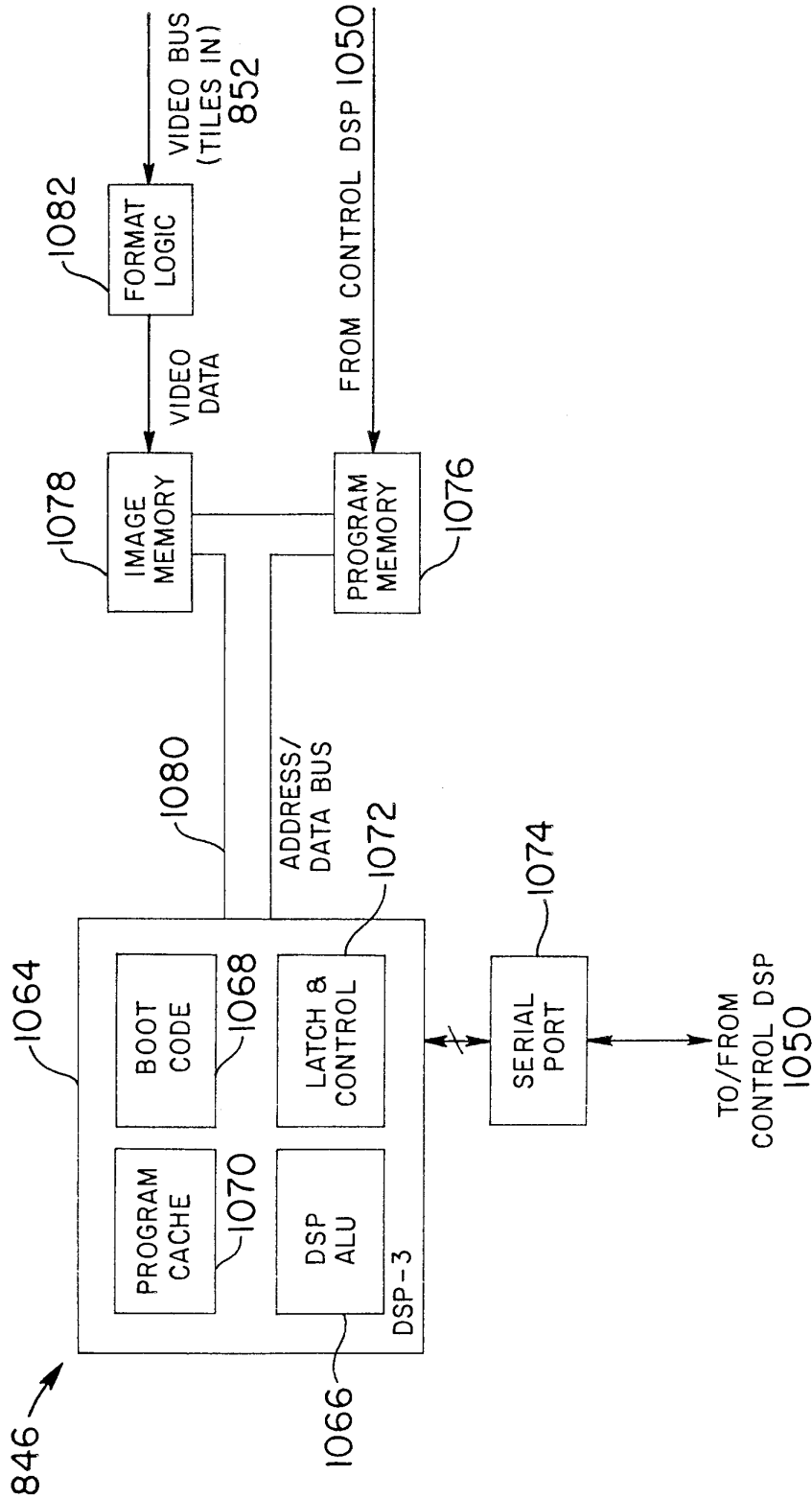


**FIG. 34**  
RASTER/TILE SEQUENCING

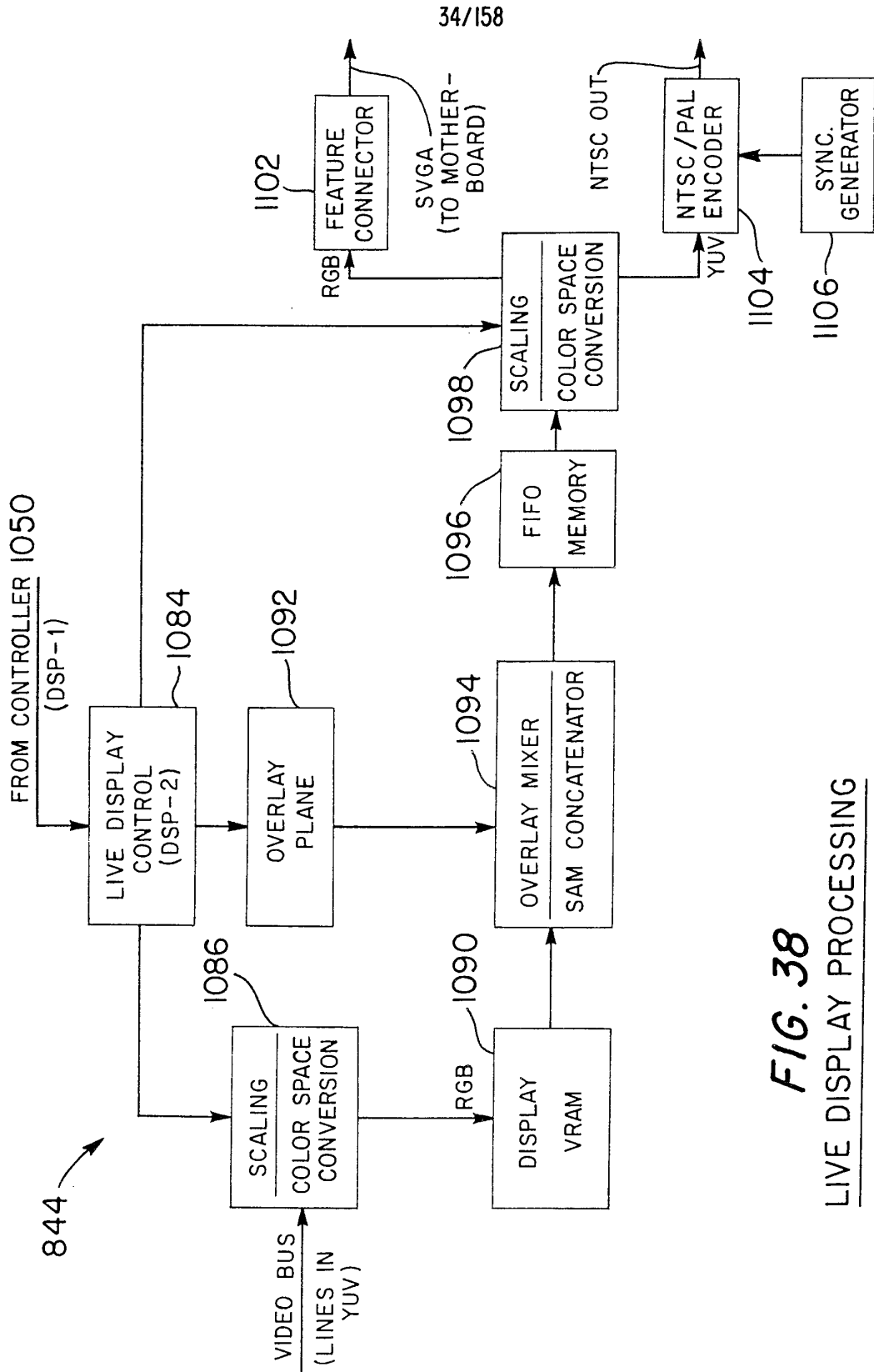


**FIG. 36**  
CONTROL/COMPRESSION FRONT END



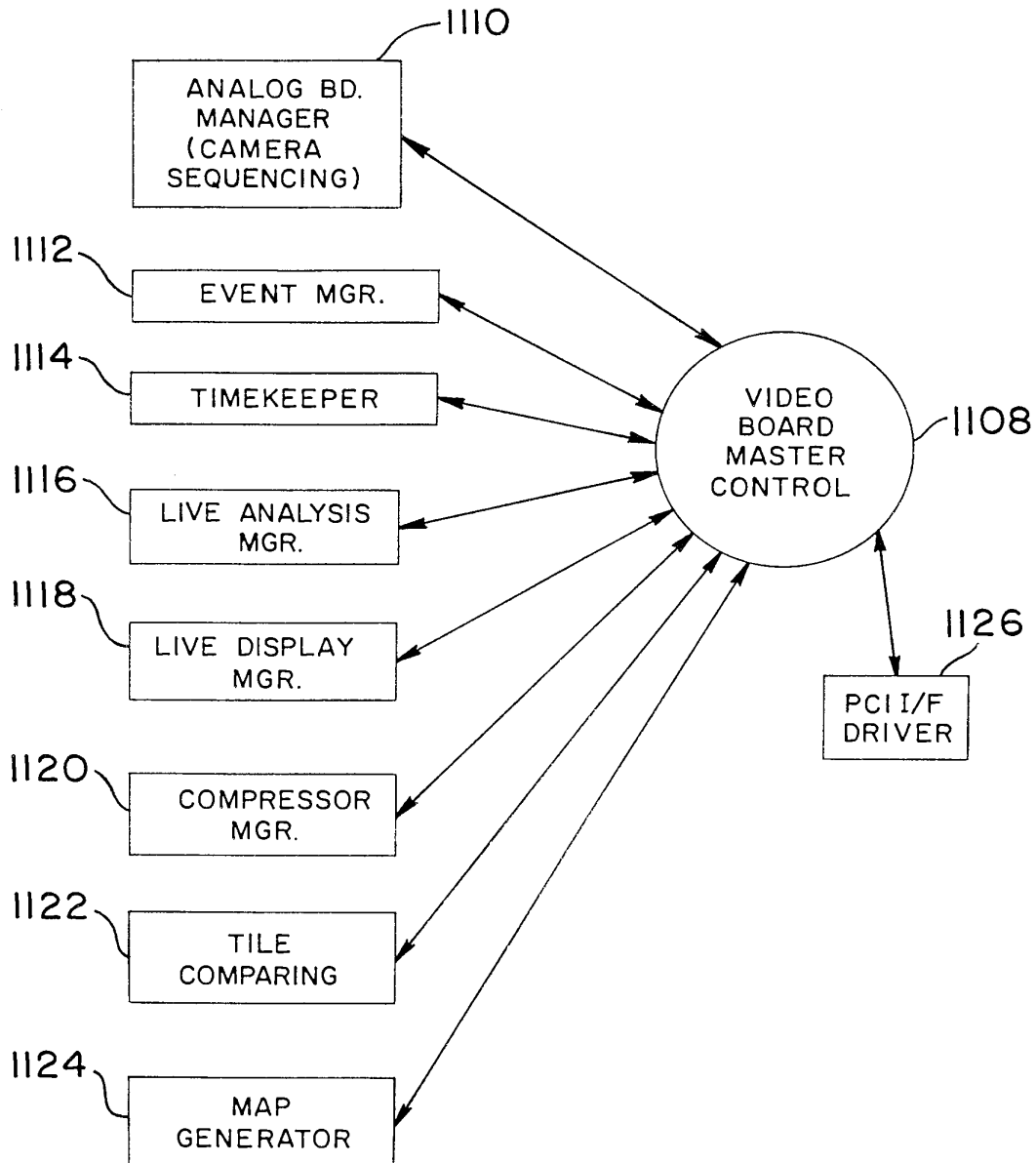


**FIG. 37**  
LIVE VIDEO DATA ANALYSIS



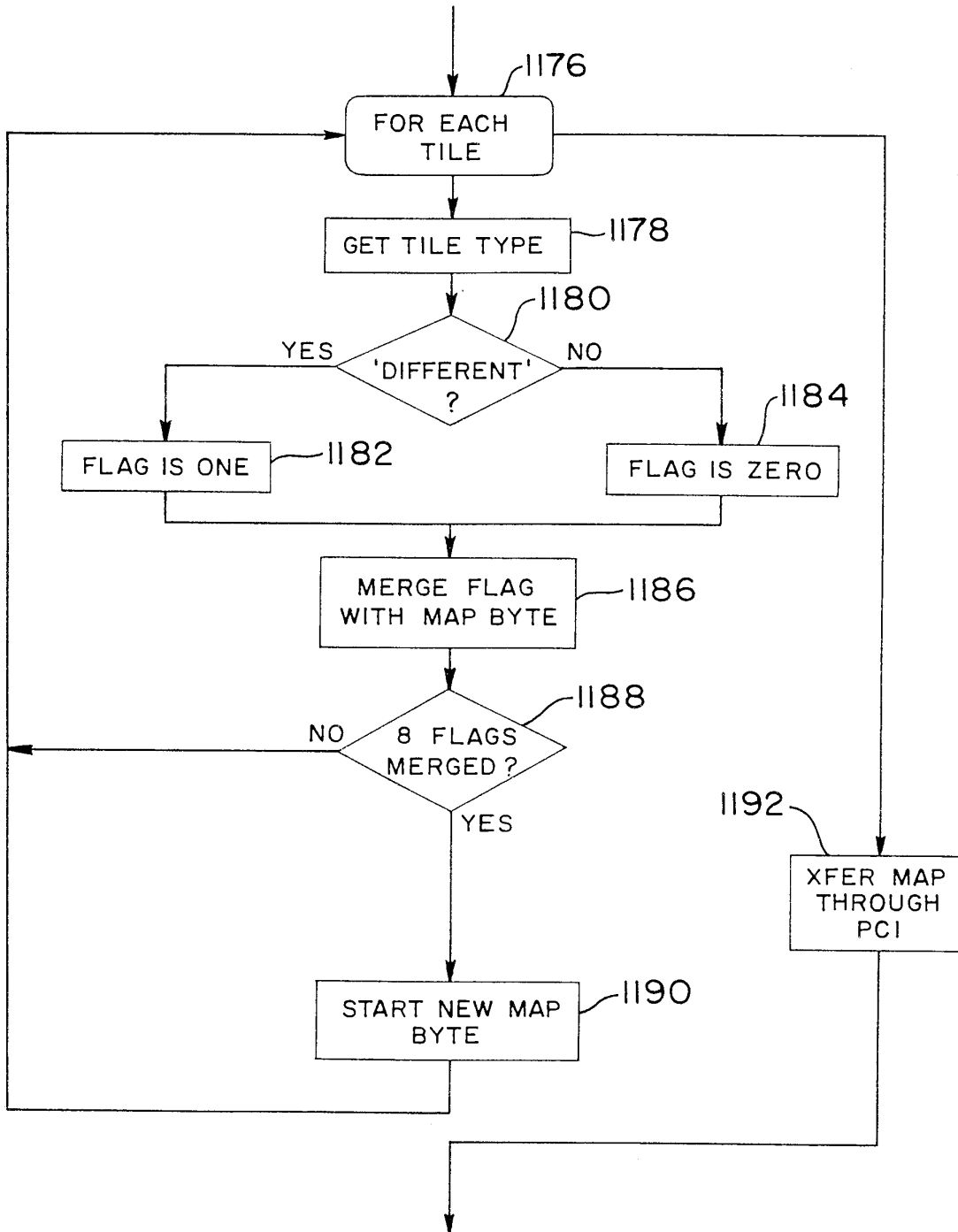
**FIG. 38**  
LIVE DISPLAY PROCESSING

35/158



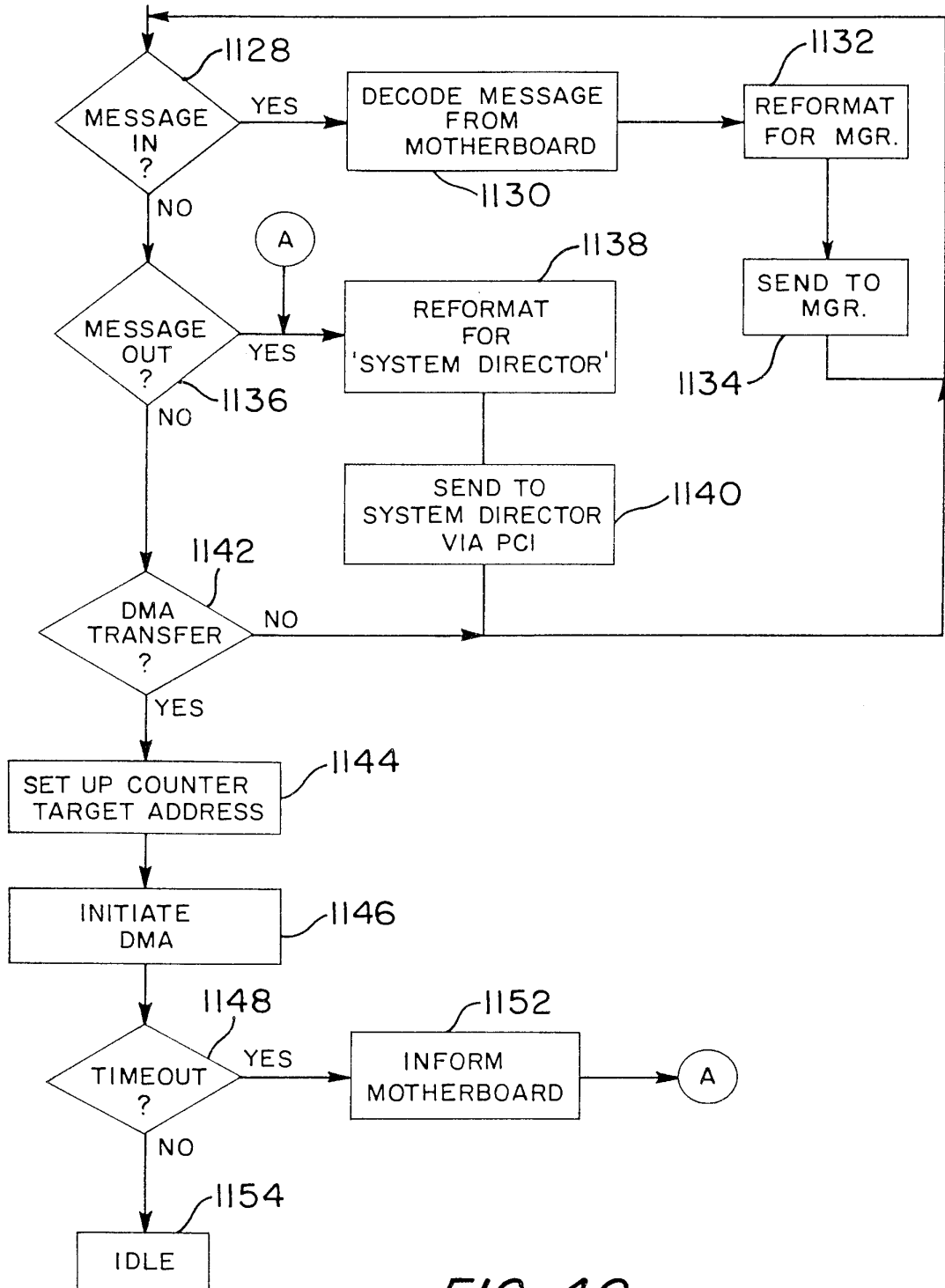
**FIG. 39**  
DSP-1 (VIDEO BOARD CONTROLLER)  
SOFTWARE OVERVIEW

36/158

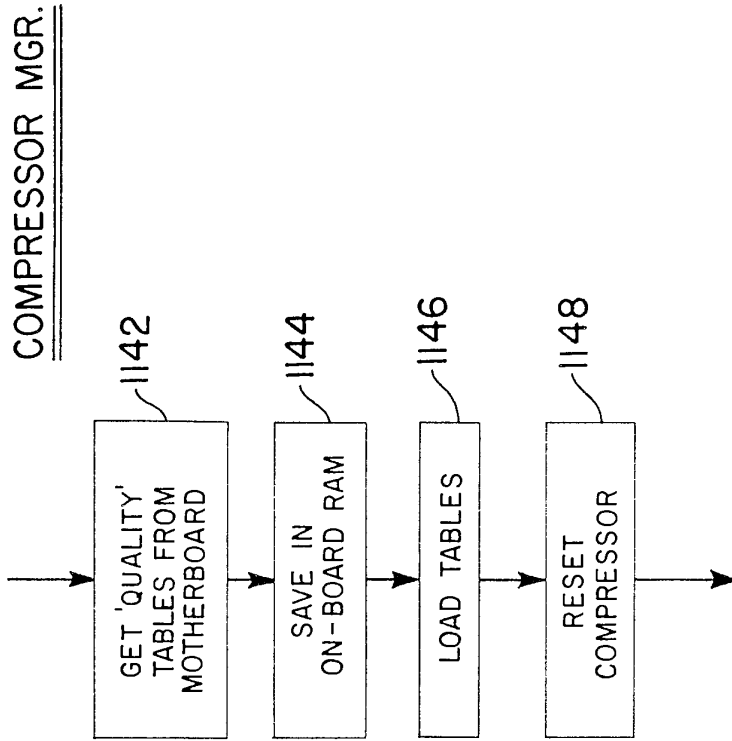


**FIG. 39 A**  
MAP GENERATOR

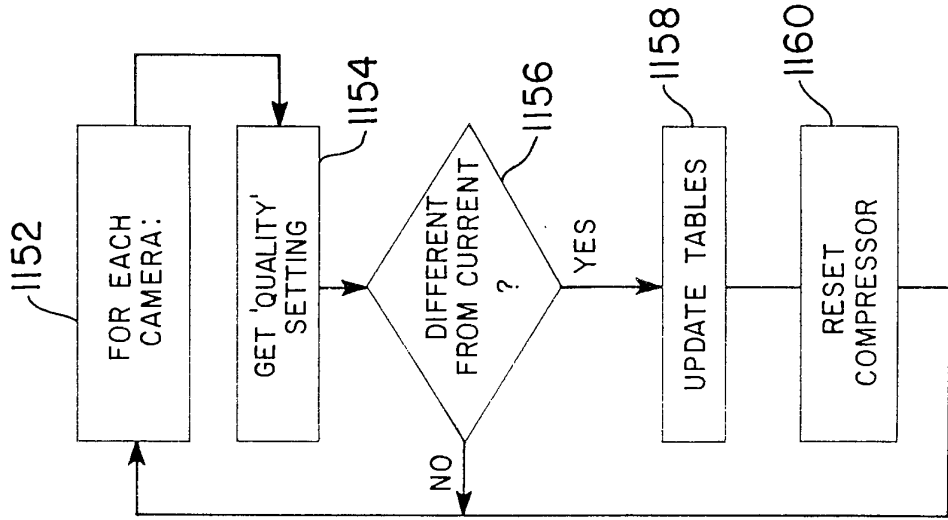
37/158



**FIG. 40**  
PCI INTERFACE DRIVER

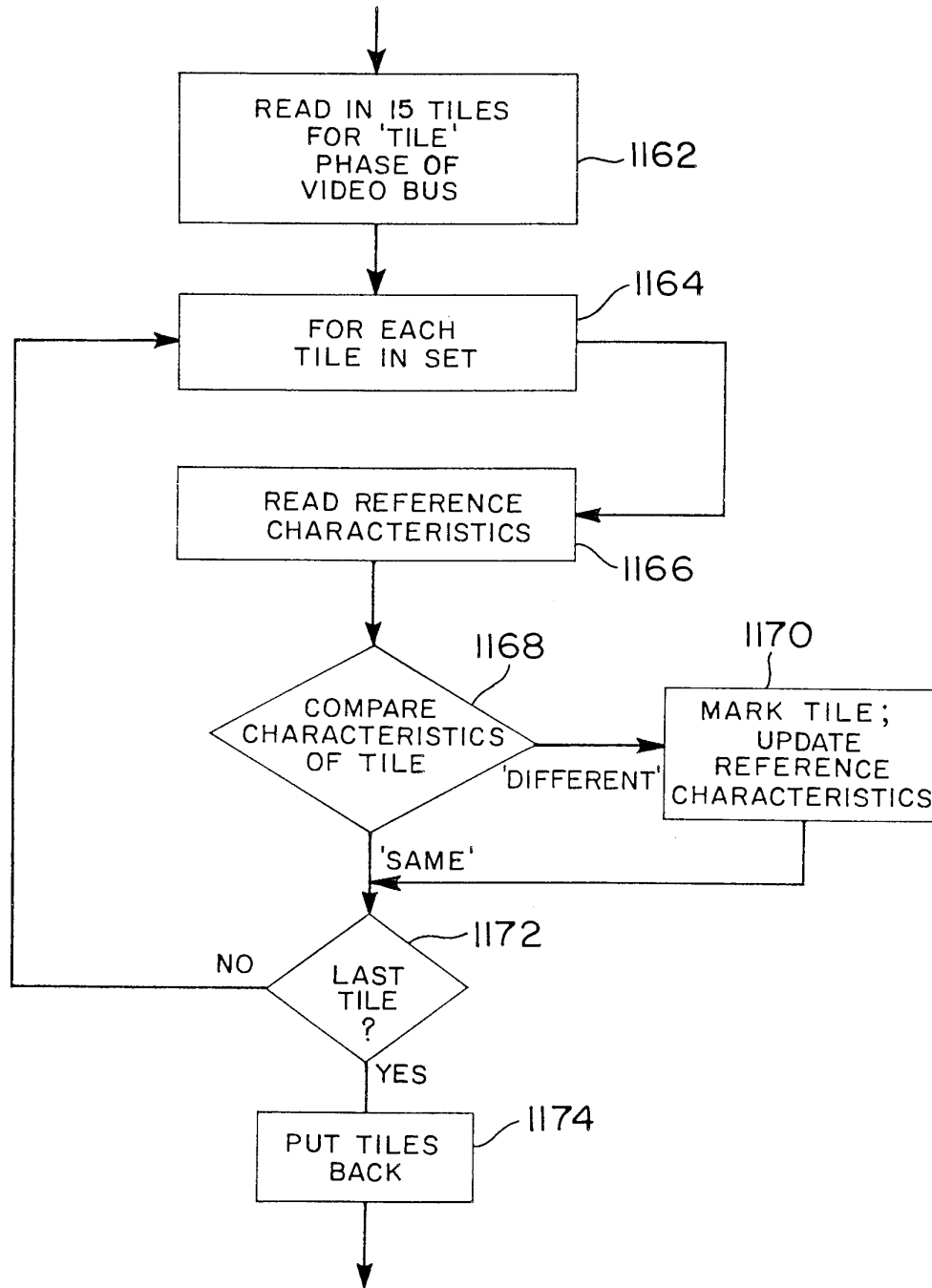


**FIG. 41A**  
SET-UP



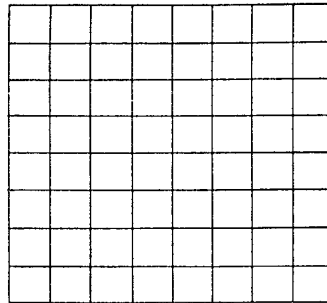
**FIG. 41B**  
OPERATIONS

39/158

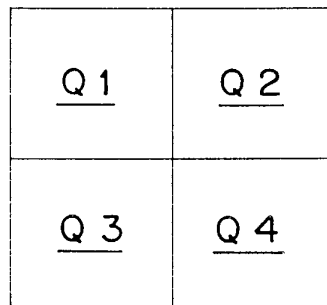


**FIG. 42**  
TILE COMPARING

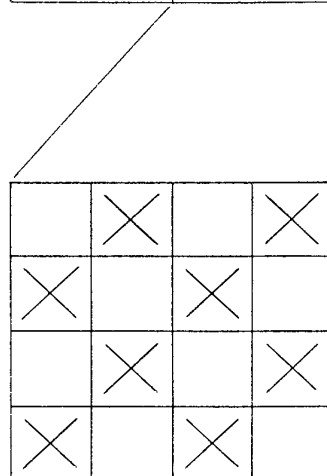
40/158



*FIG. 43A*  
TILE

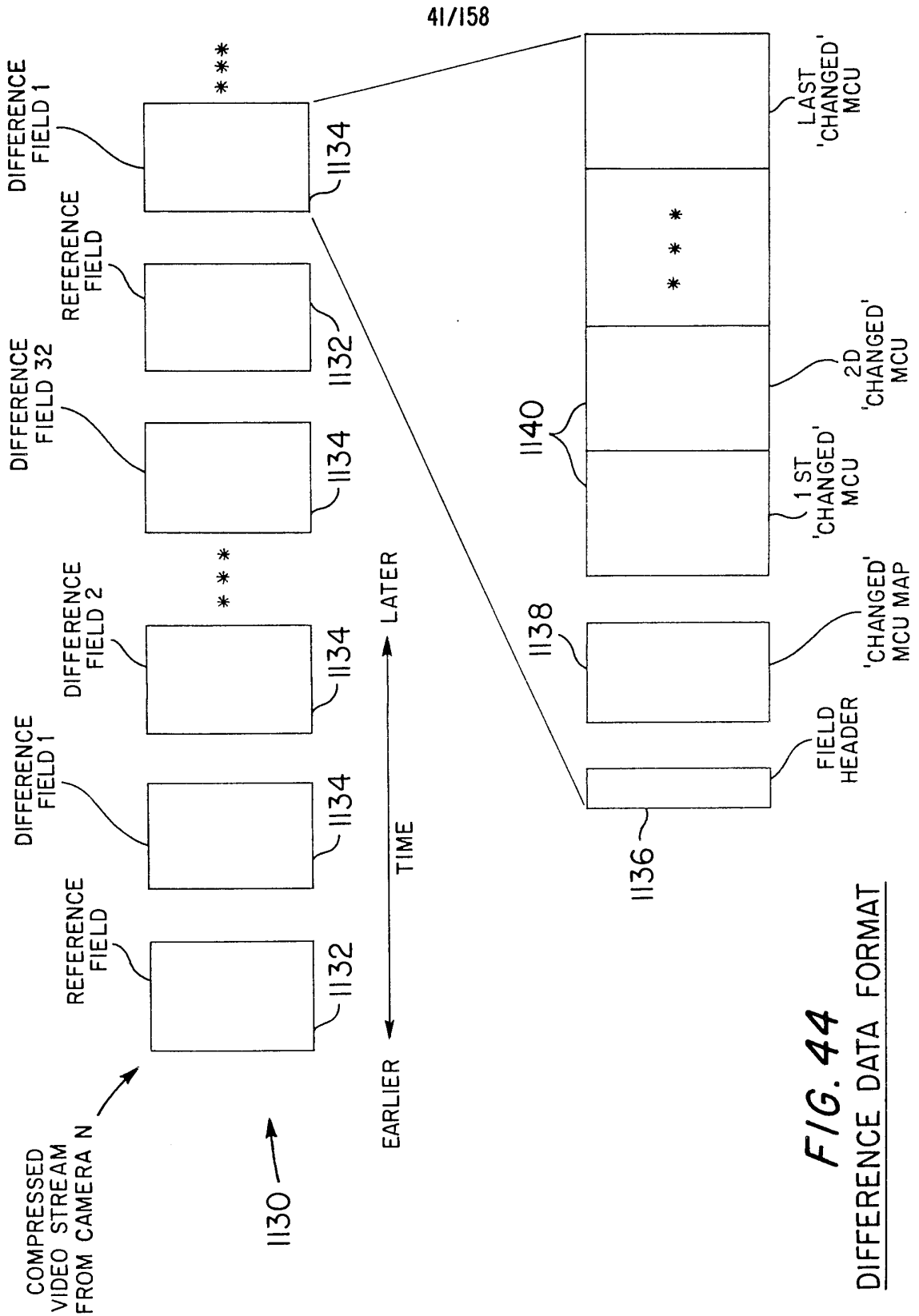


*FIG. 43B*  
TILE QUADRANTS



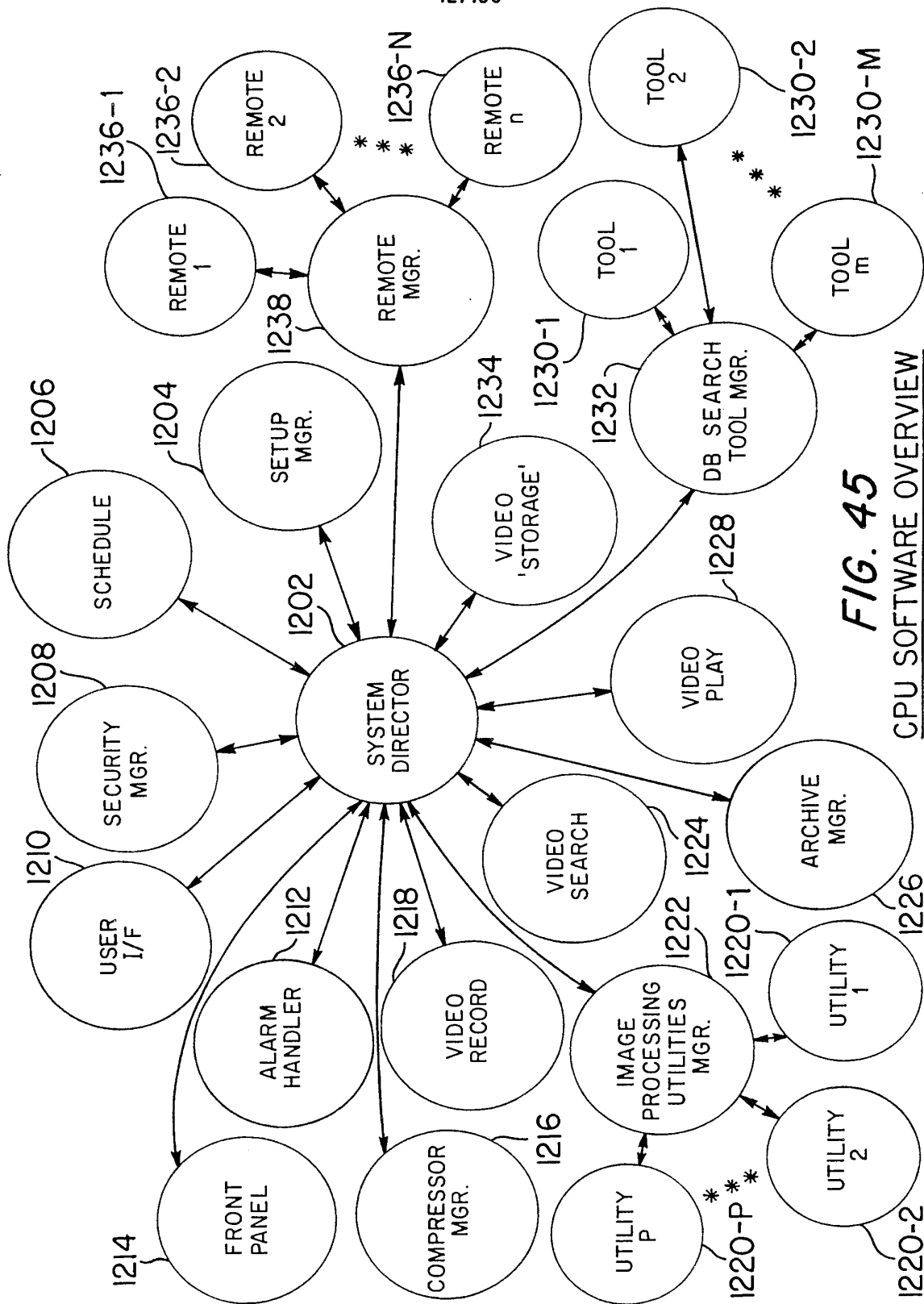
*FIG. 43C*  
'CHECKER-BOARD'  
SUBSAMPLING



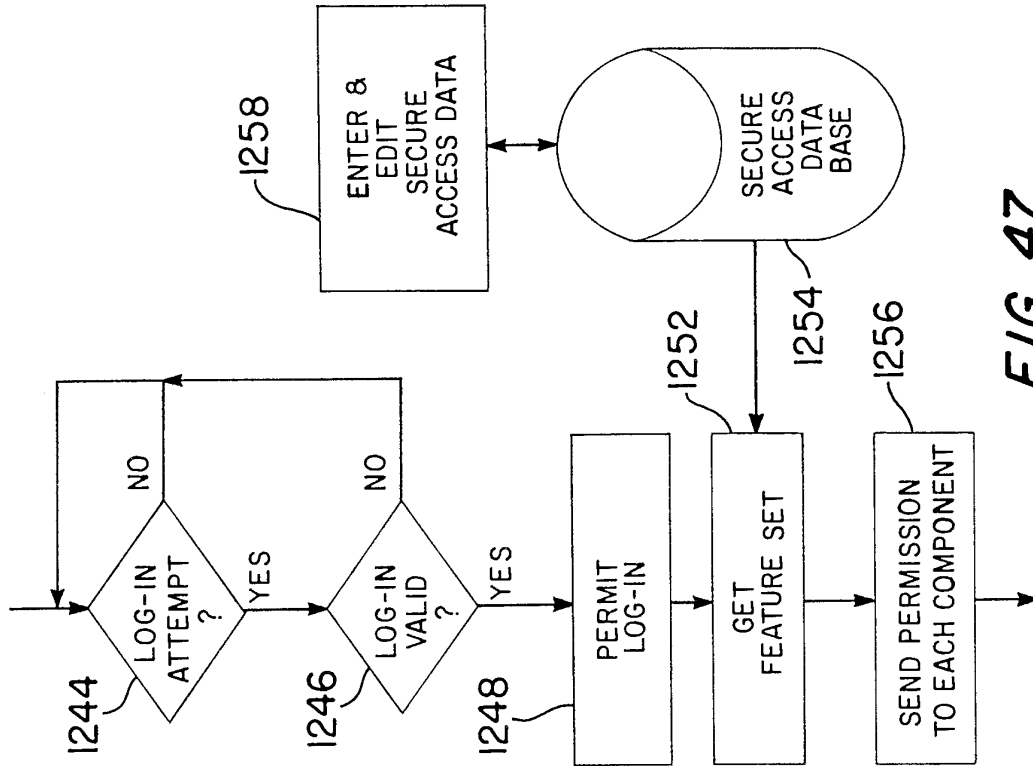


**FIG. 44**  
DIFFERENCE DATA FORMAT

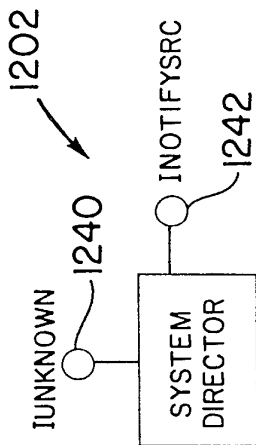
42/158



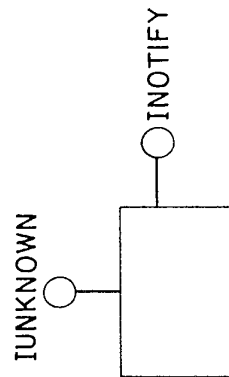
**FIG. 45**  
CPU SOFTWARE OVERVIEW



**FIG. 47**  
SECURITY MGR.

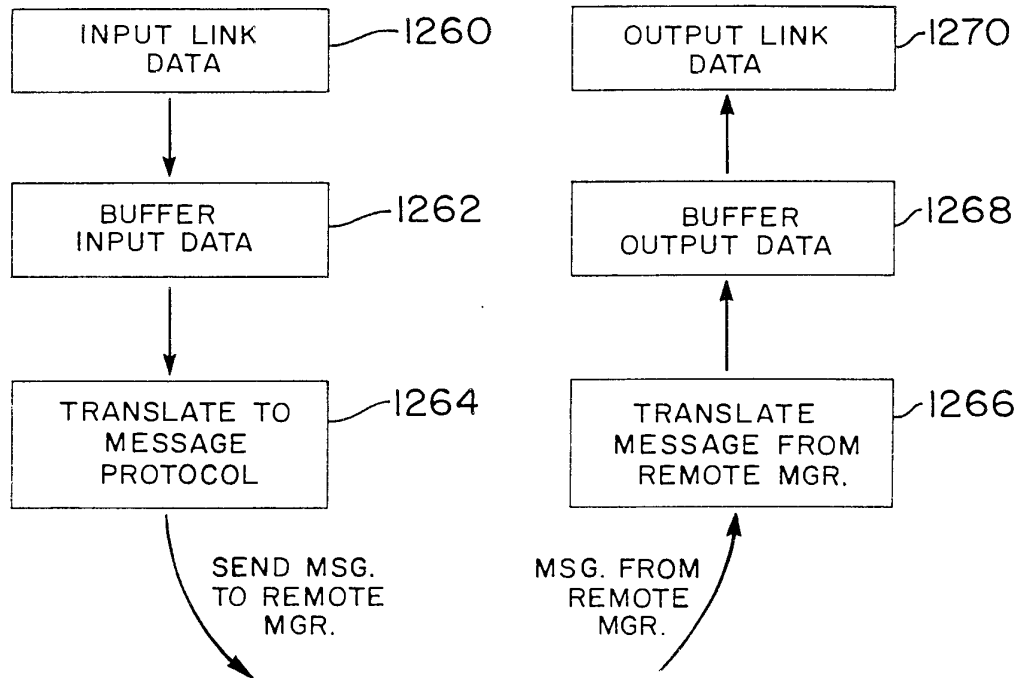


**FIG. 46A**  
SYSTEM DIRECTOR OBJECT

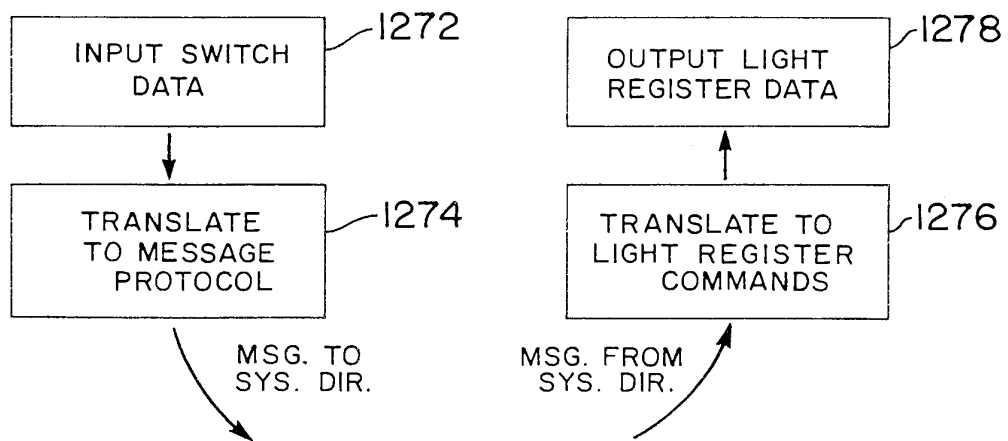


**FIG. 46B**  
OTHER S/W COMPONENTS

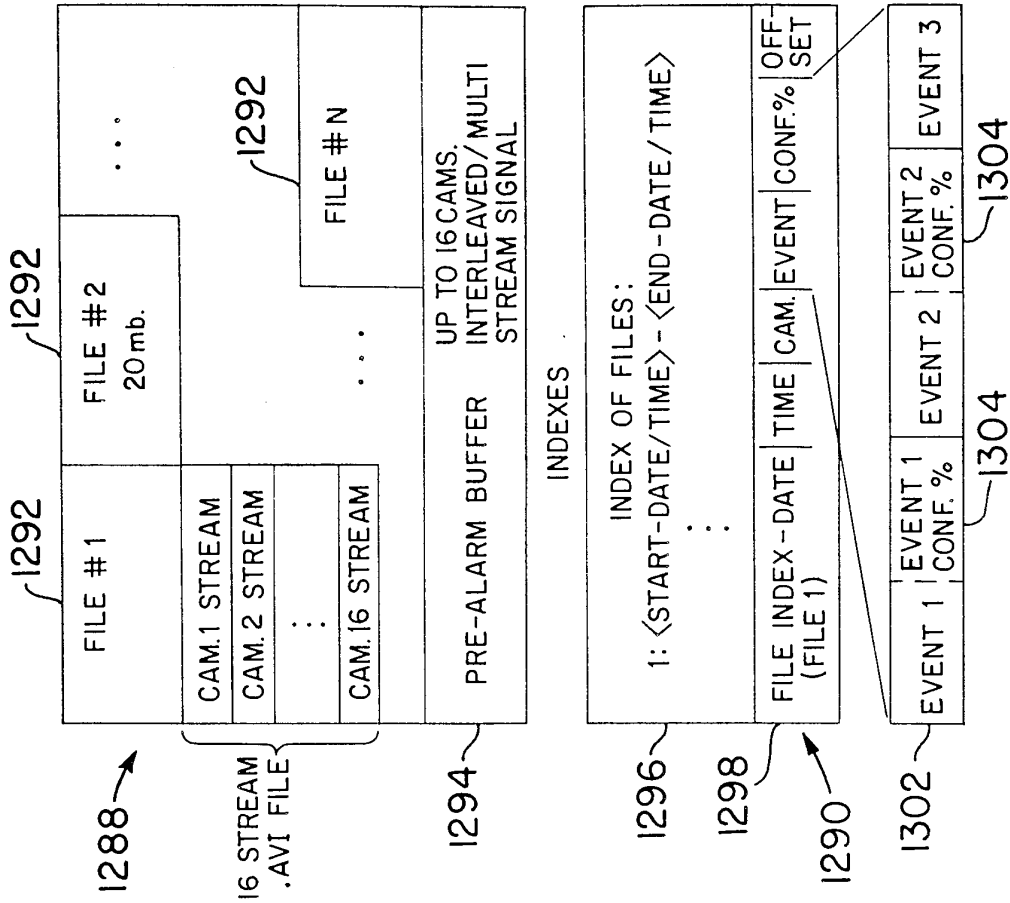
44/158



**FIG. 48**  
REMOTE OBJECT INSTANCE

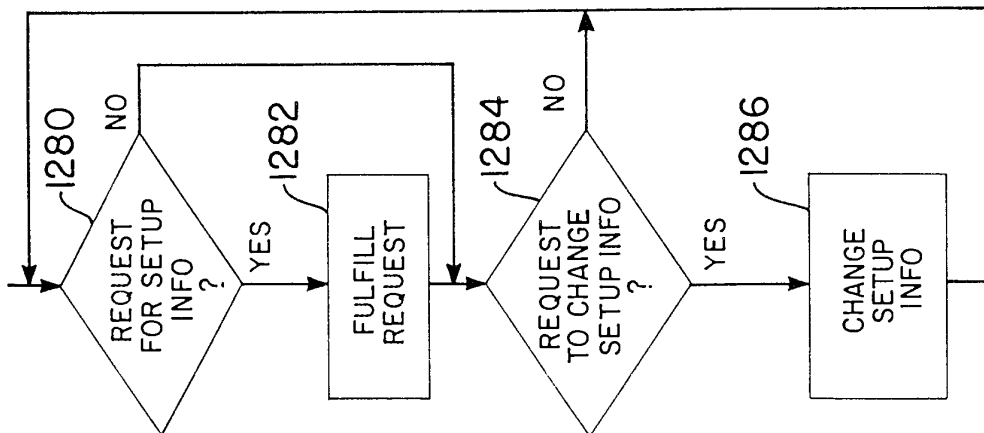


**FIG. 49**  
FRONT PANEL  
 (SOFTWARE OBJECT)

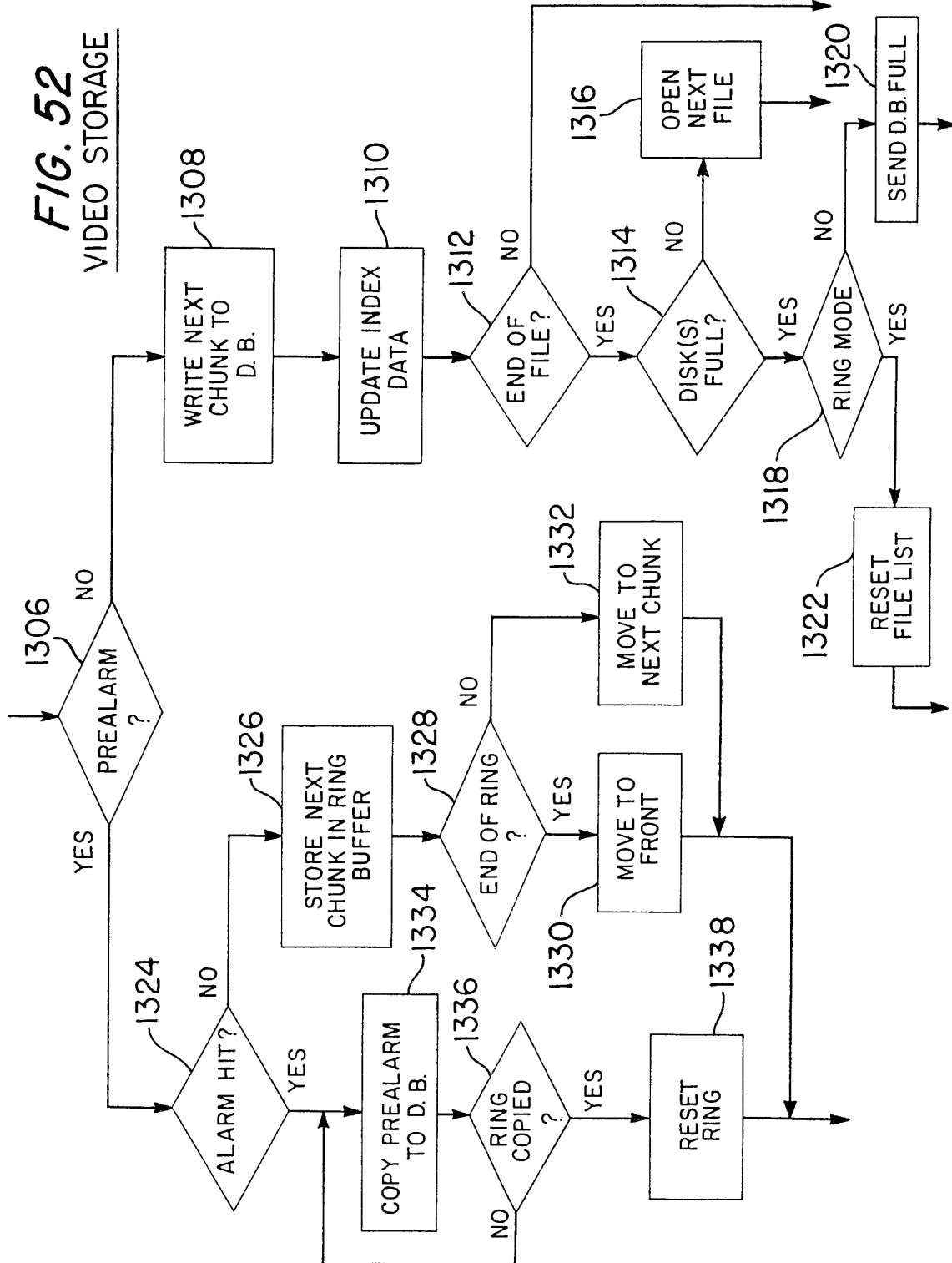


**FIG. 51**

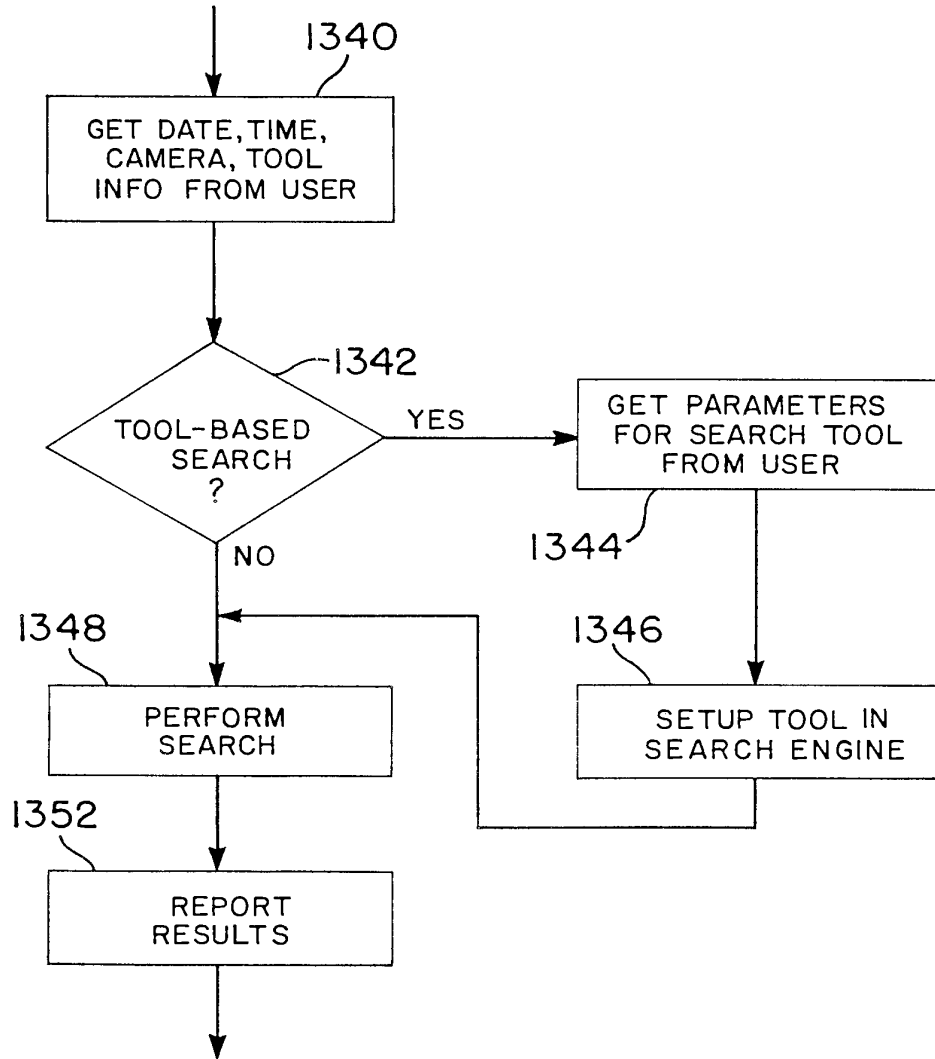
VIDEO DATA FORMAT ON DISK



**FIG. 50**  
SETUP MGR.

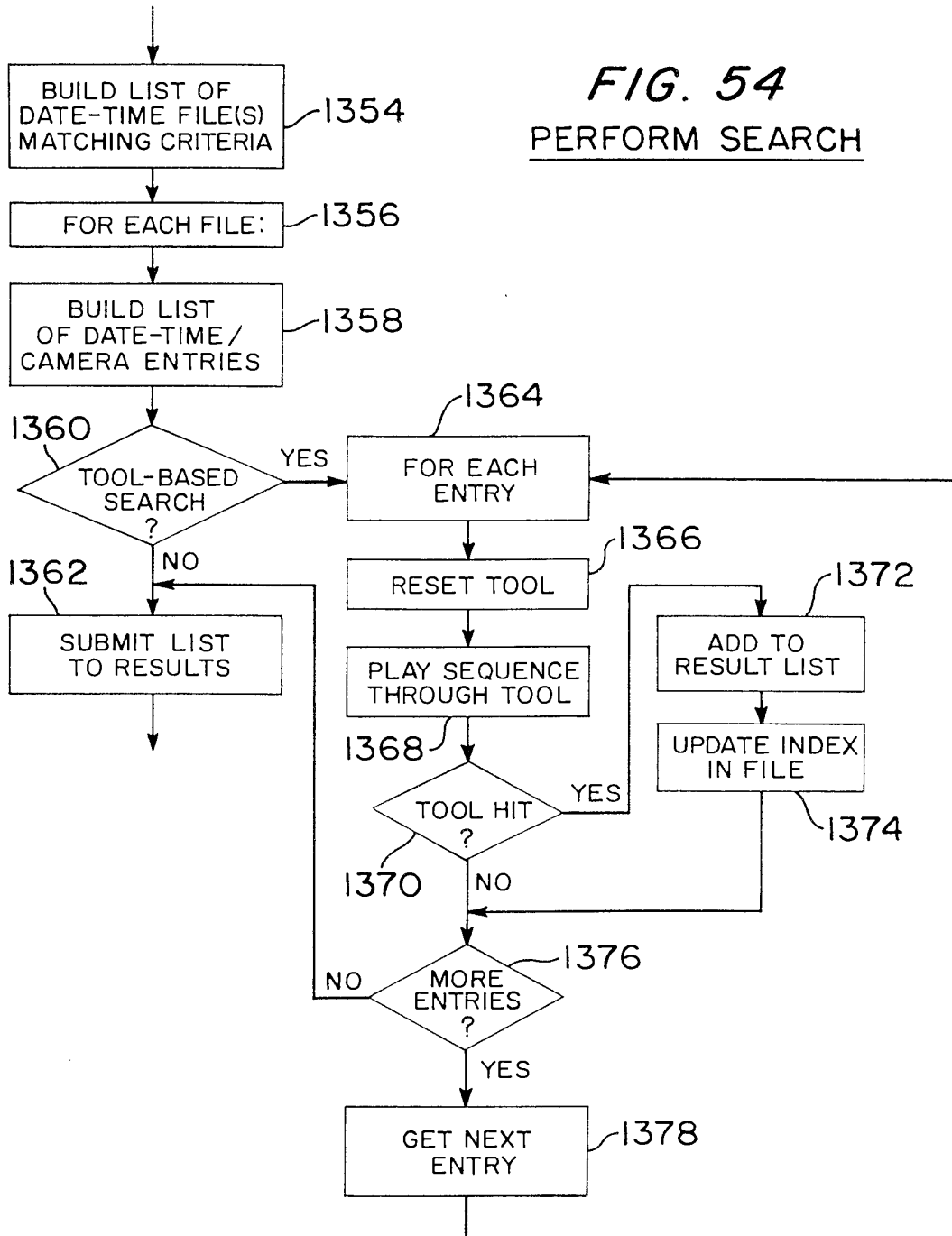


47/158

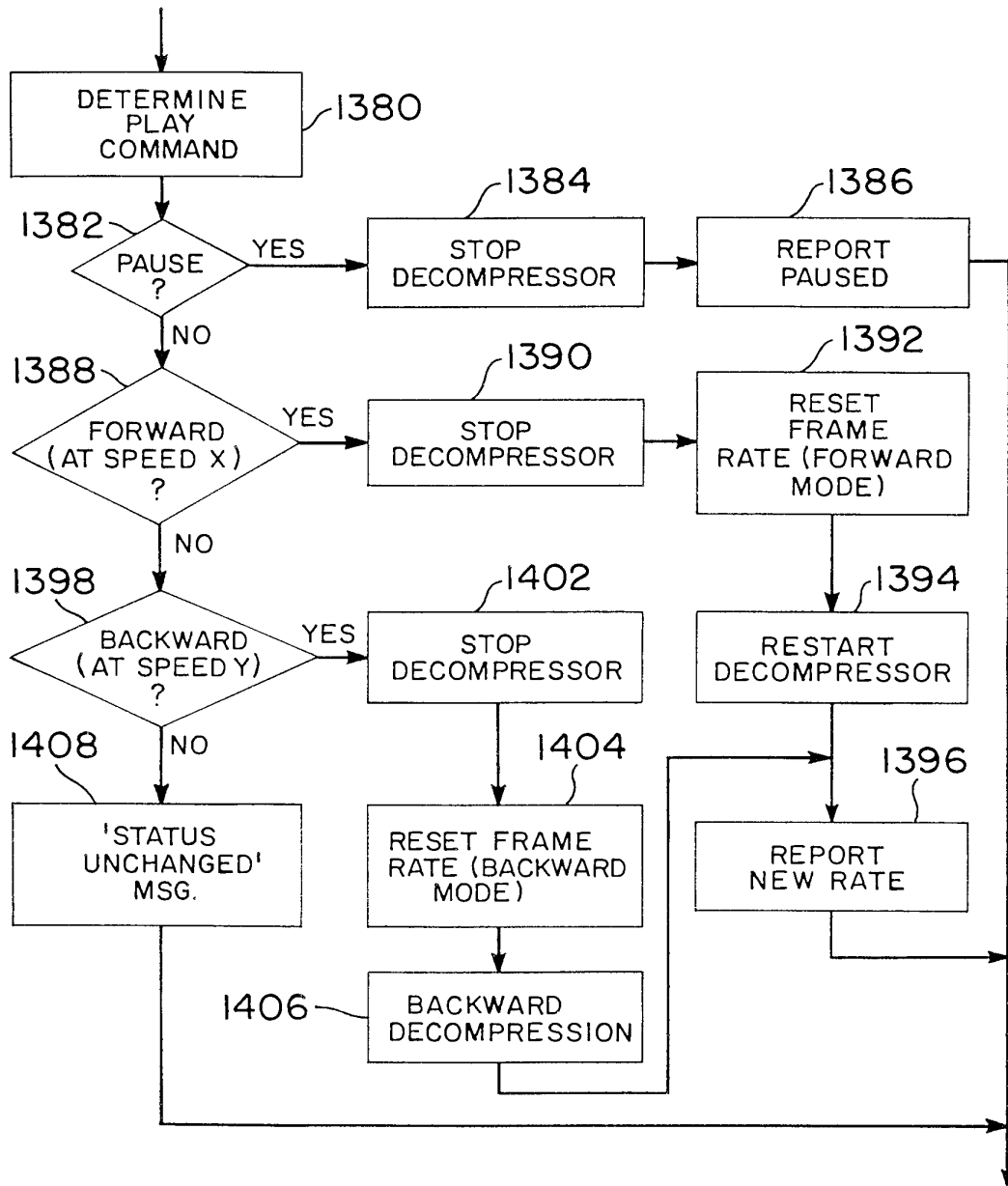


**FIG. 53**  
VIDEO SEARCH

**FIG. 54**  
**PERFORM SEARCH**

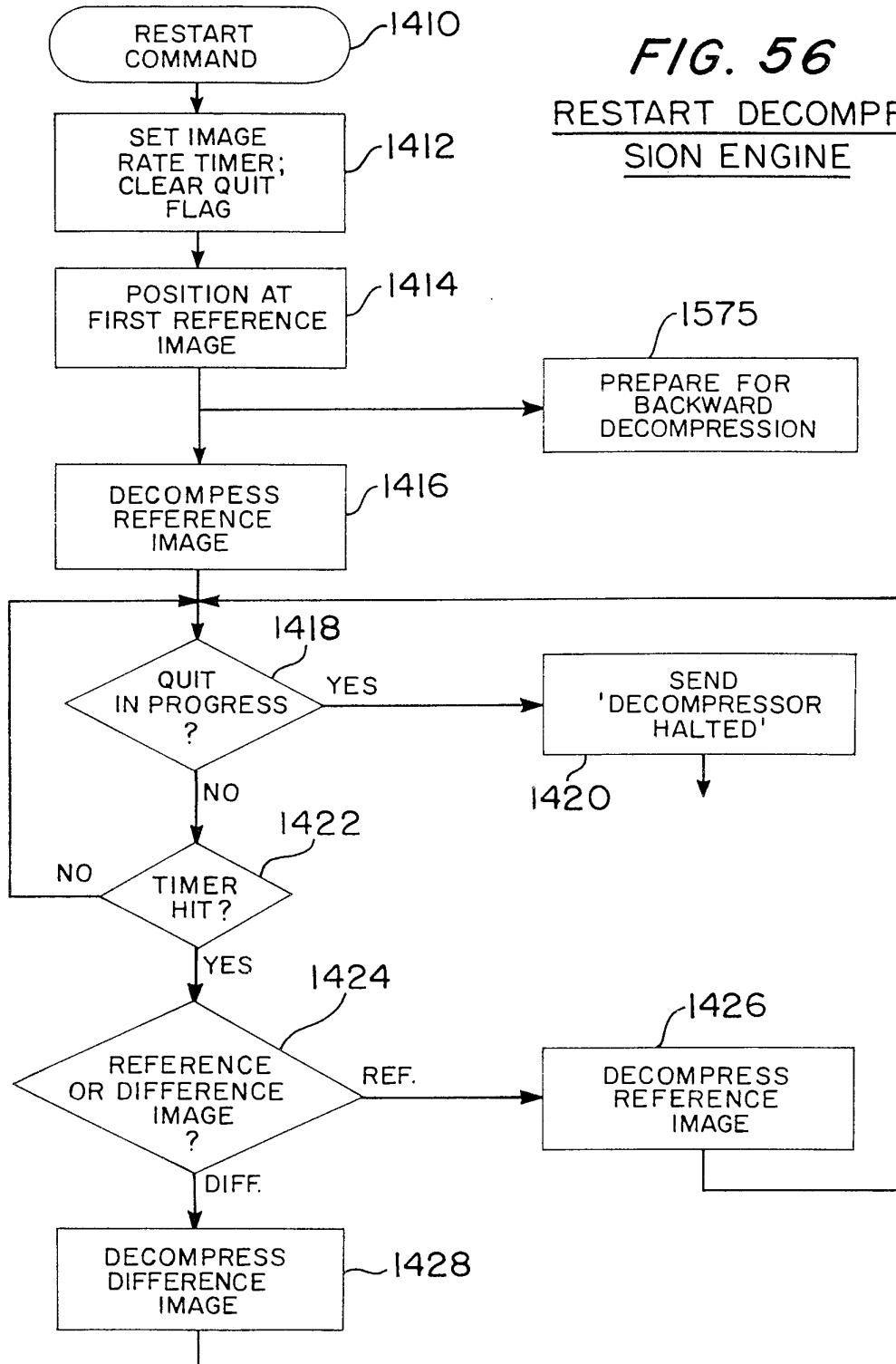


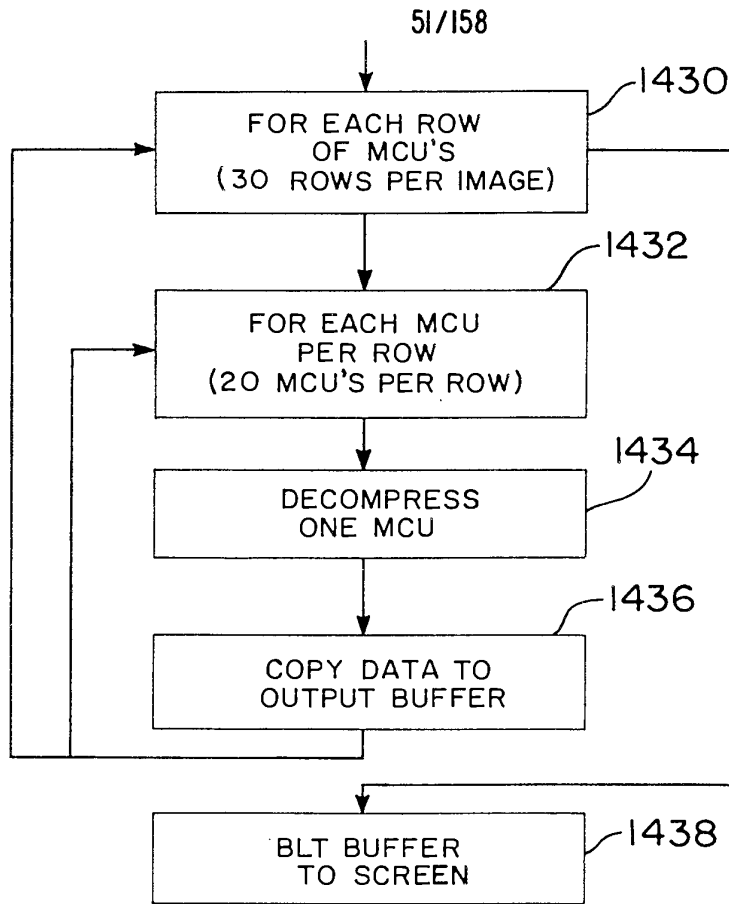




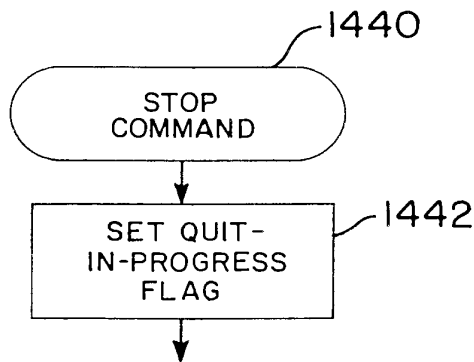
**FIG. 55**  
VIDEO PLAY

**FIG. 56**  
RESTART DECOMPRES-  
SION ENGINE

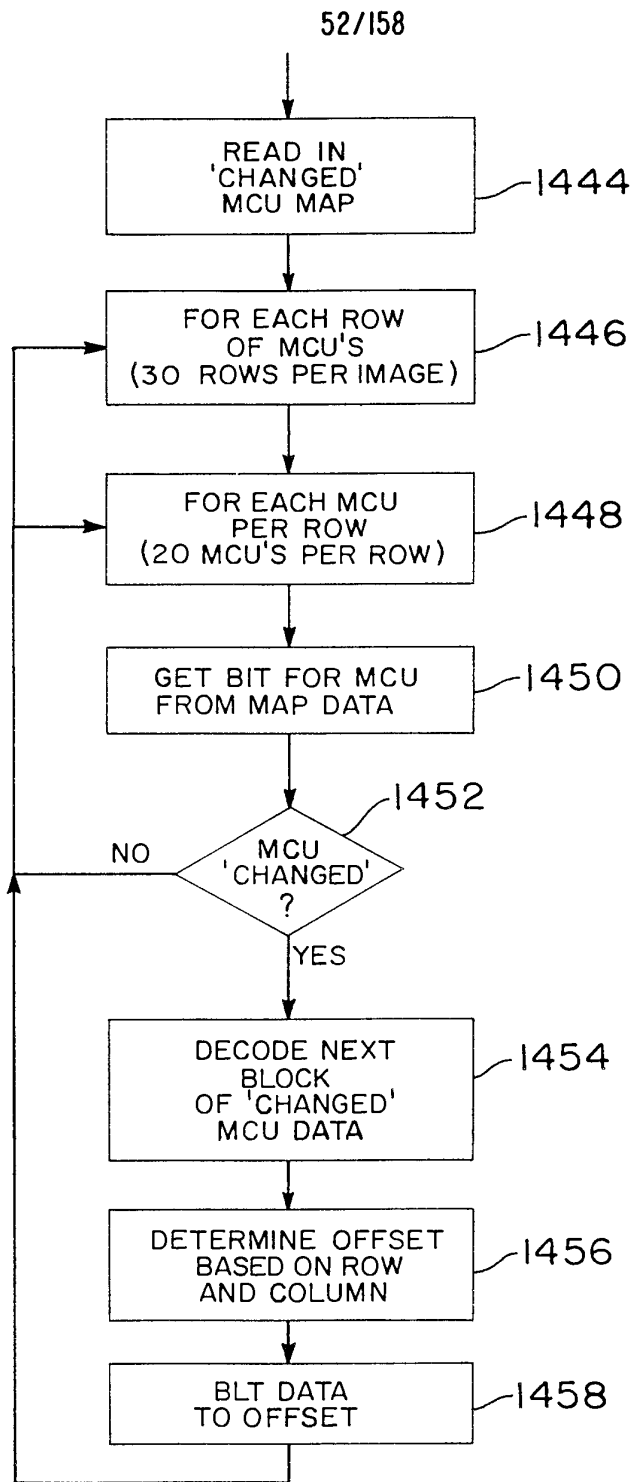




**FIG. 57**  
DECOMPRESS REFERENCE IMAGE



**FIG. 58**  
STOP DECOMPRESSOR



**FIG. 59**

DECOMPRESS DIFFERENCE IMAGE

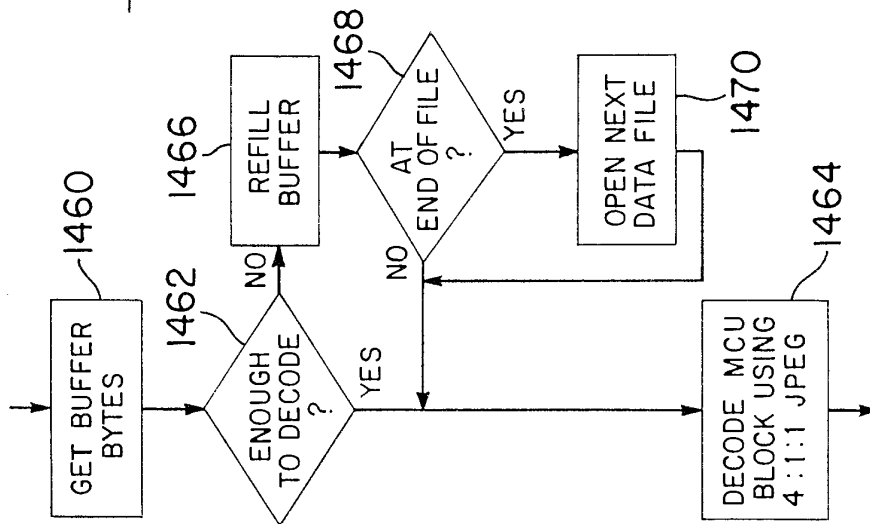


FIG. 60

DECODE 'CHANGED' MCU BLOCK

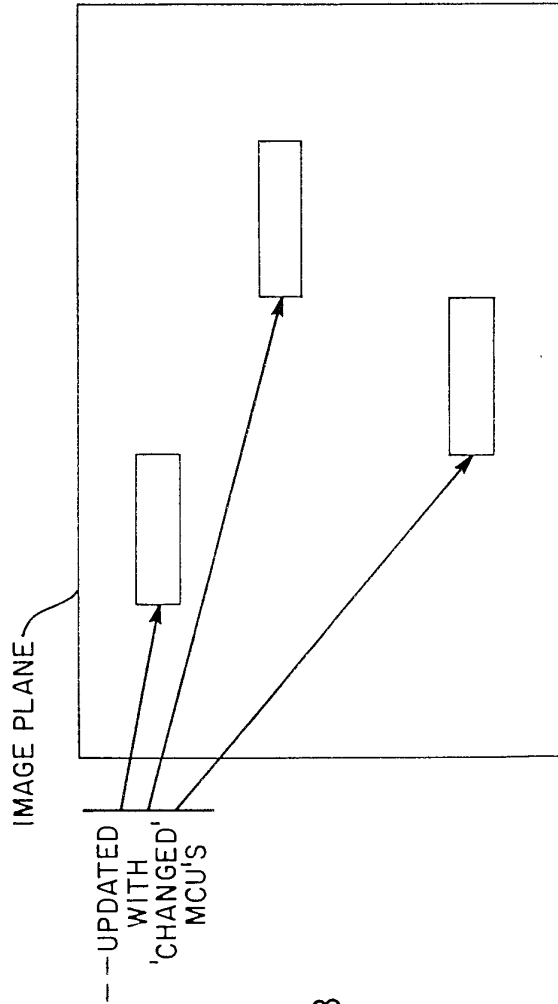
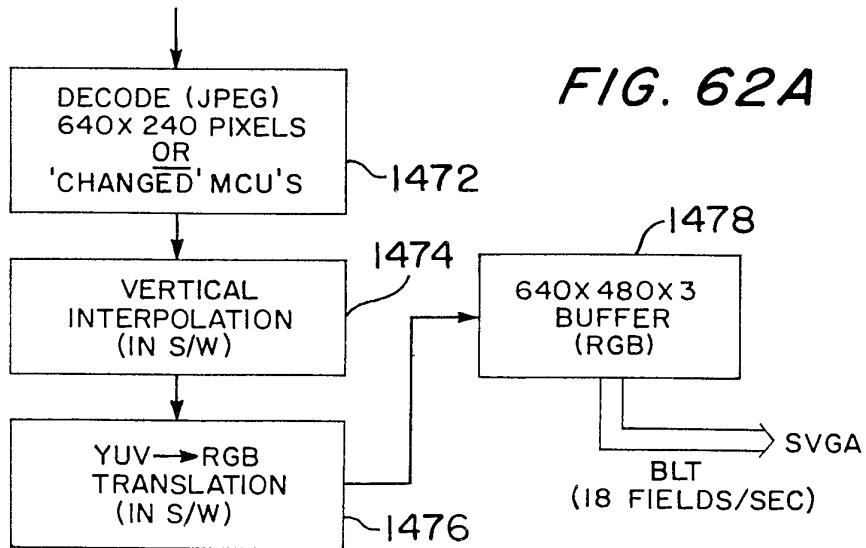


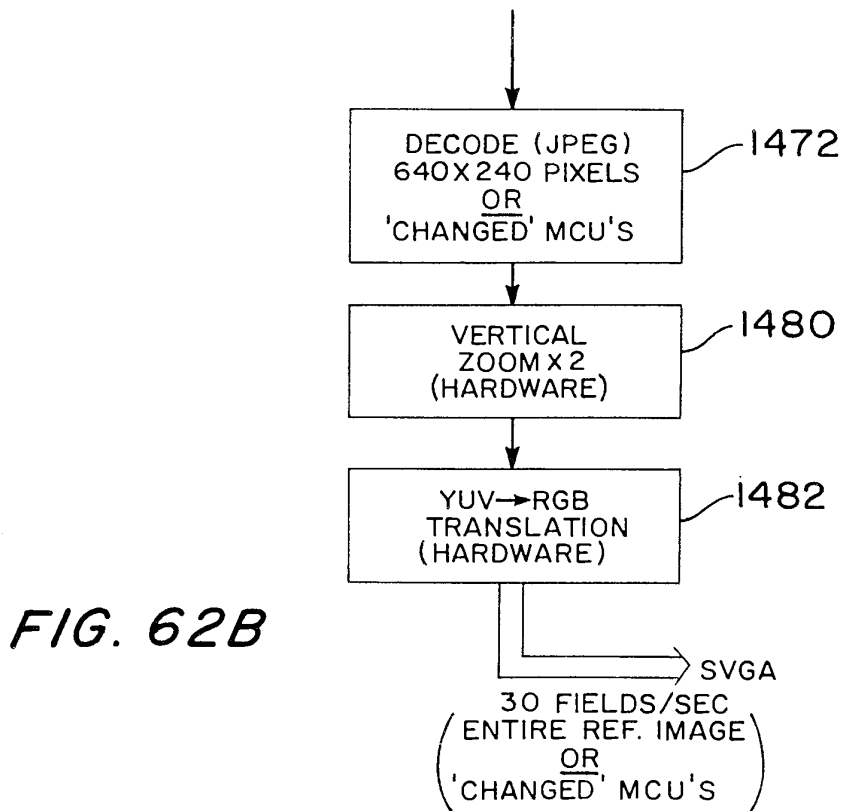
FIG. 61

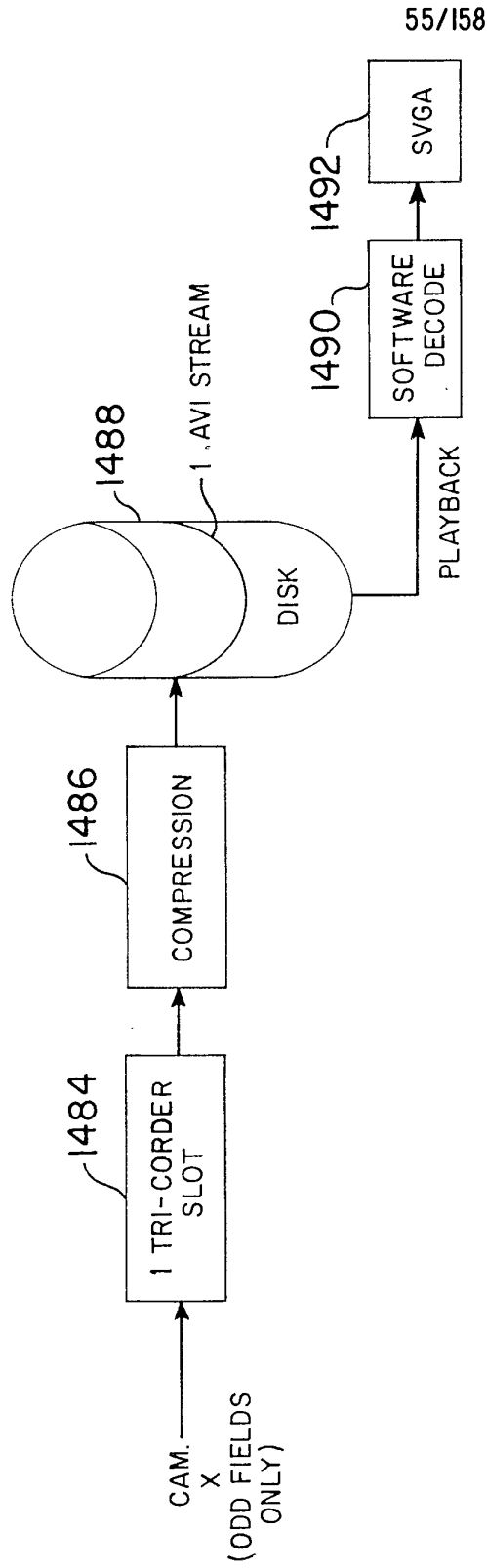
DECOMPRESSION USES 'POSTAGE STAMPS'

54/158



VIDEO DATA REFRESH - PLAYBACK





**FIG. 63A**

VERTICAL RESOLUTION  
OPTIONS - PLAYBACK

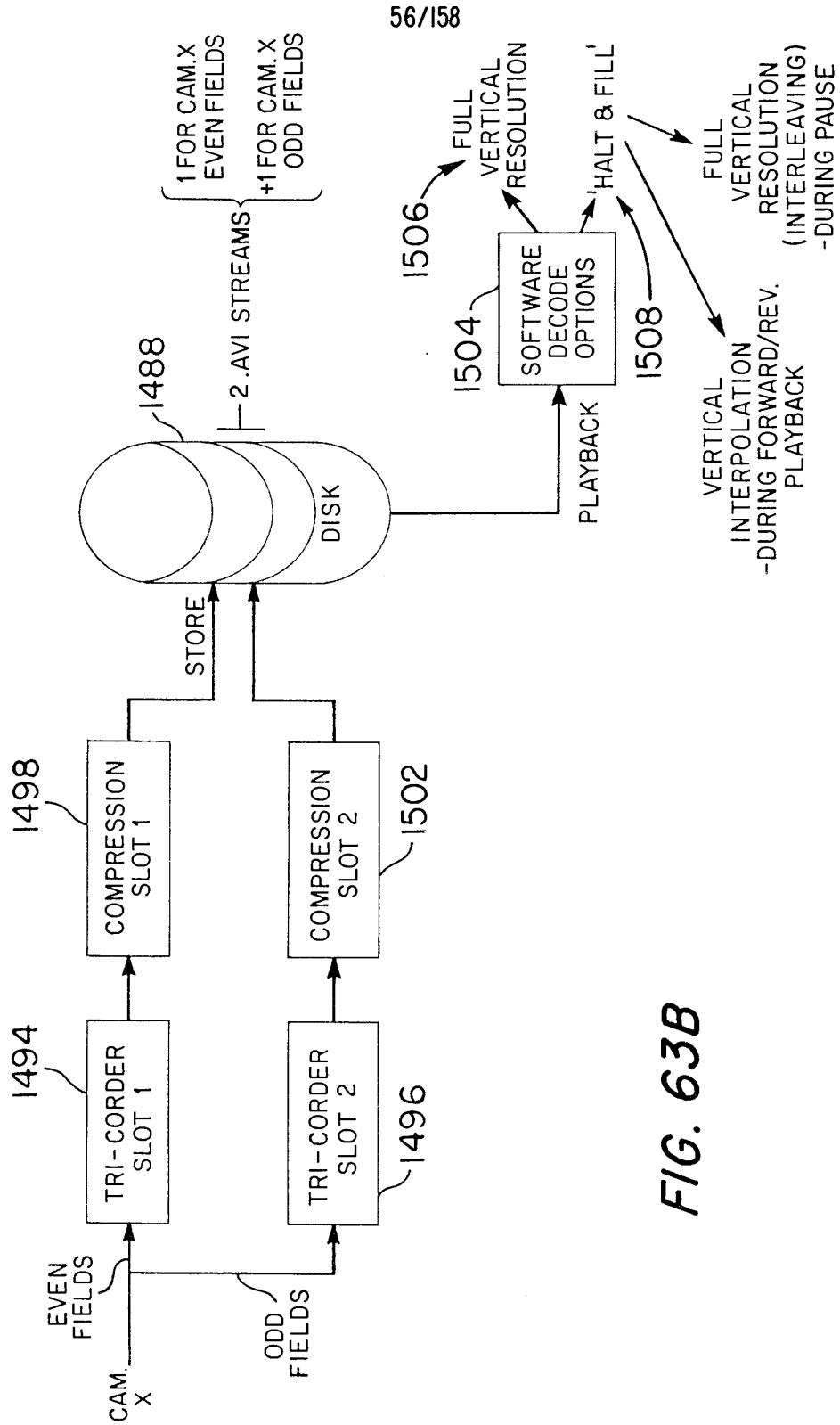


FIG. 63B



FIG. 64A

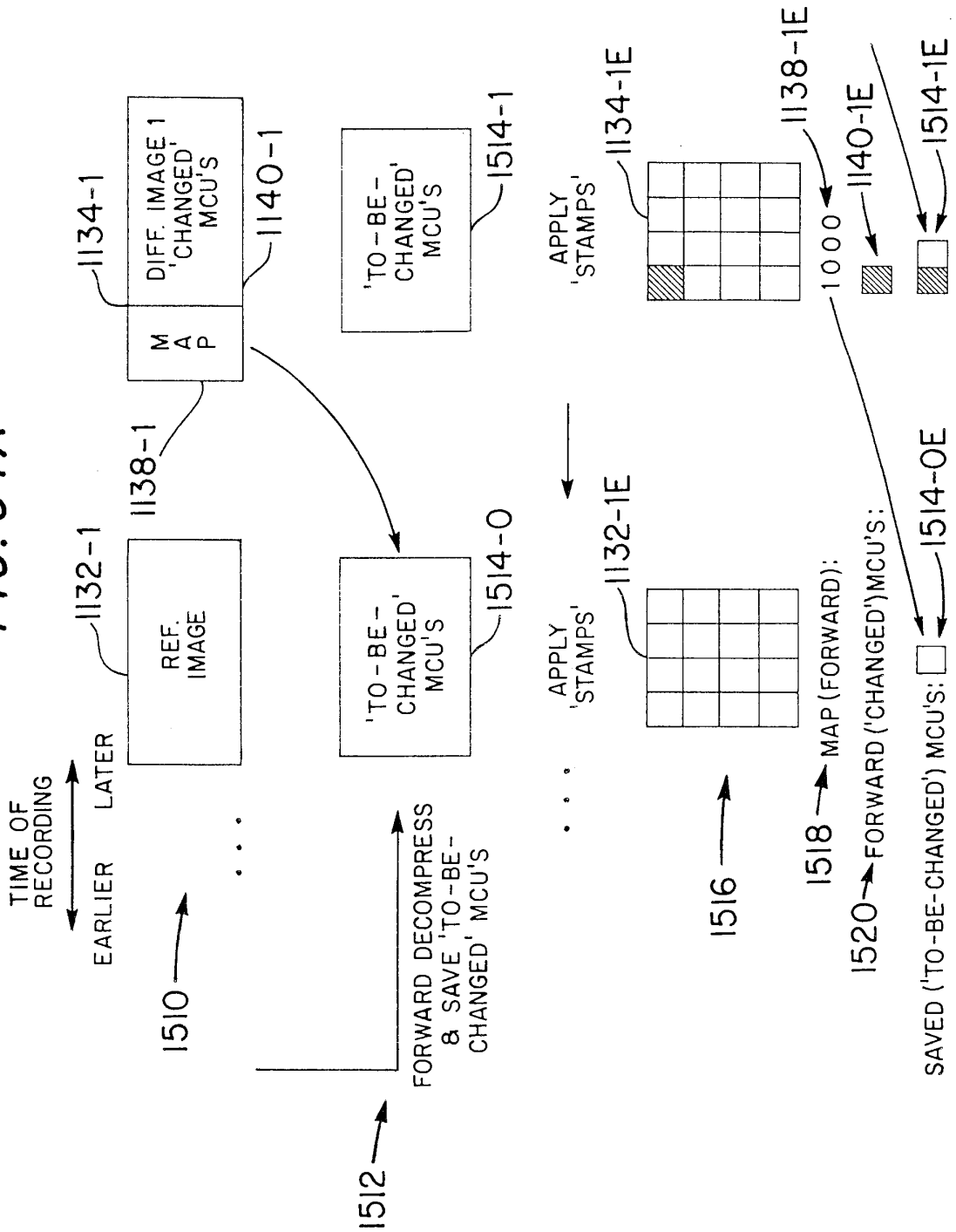
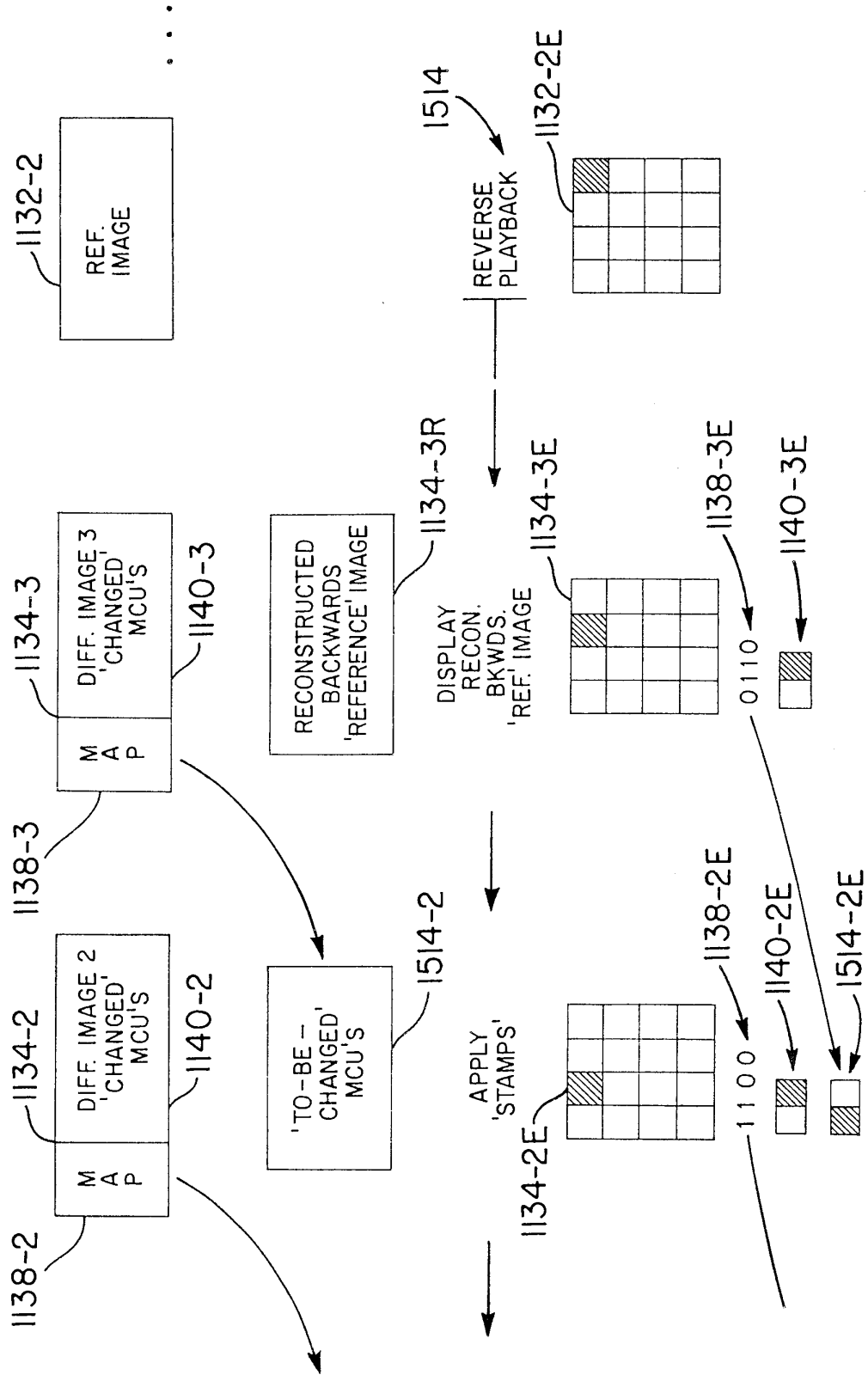
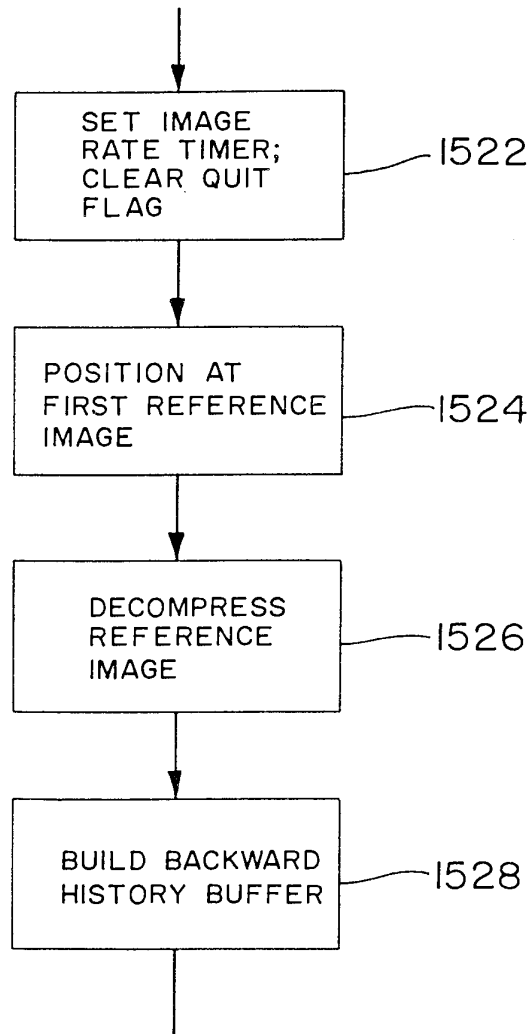


FIG. 64B

PICTORIAL ILLUSTRATION OF BACKWARDS DECOMPRESSION



59/158



**FIG. 65A**  
BACKWARD DECOMPRESSION

60/158

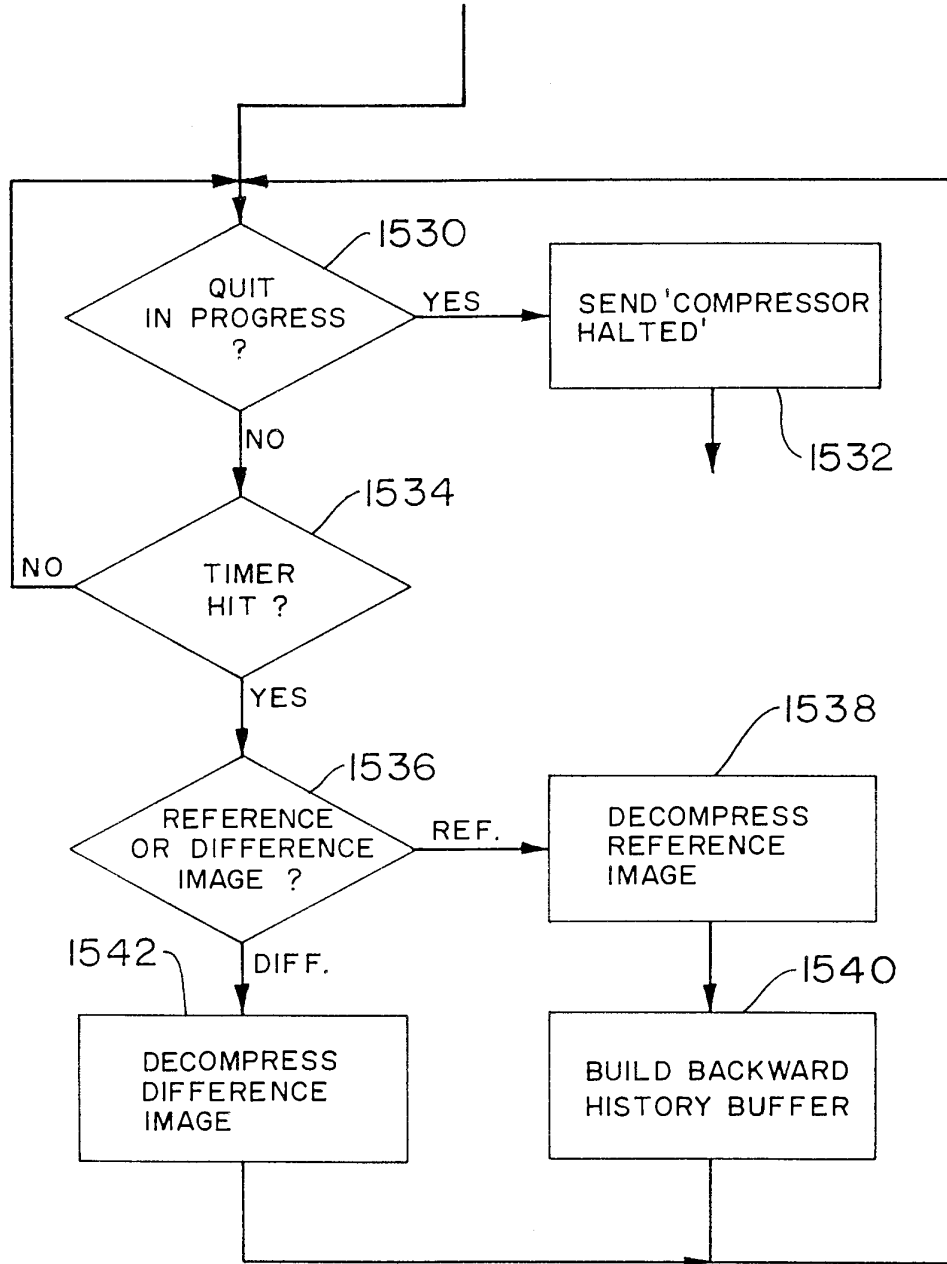
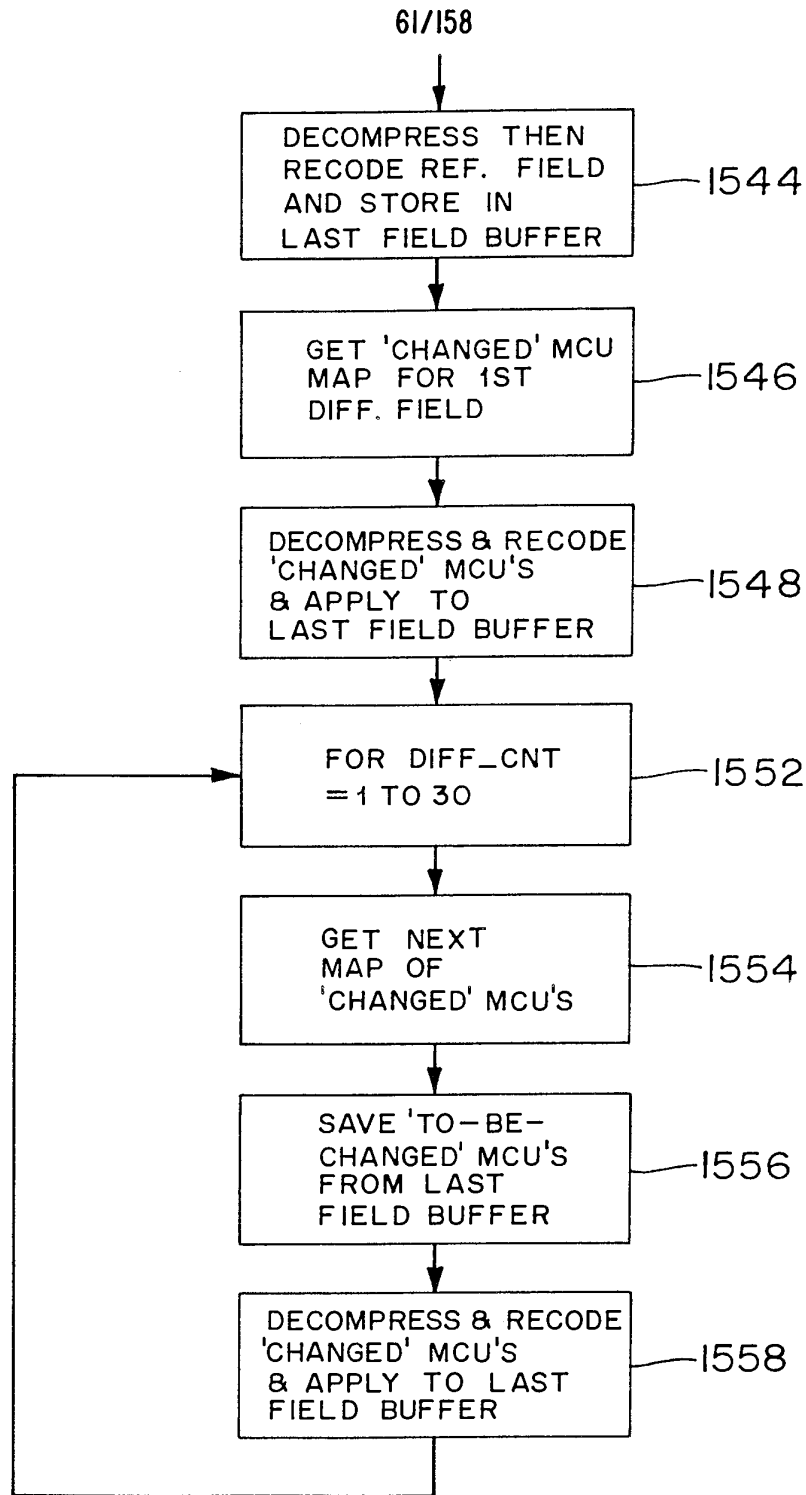
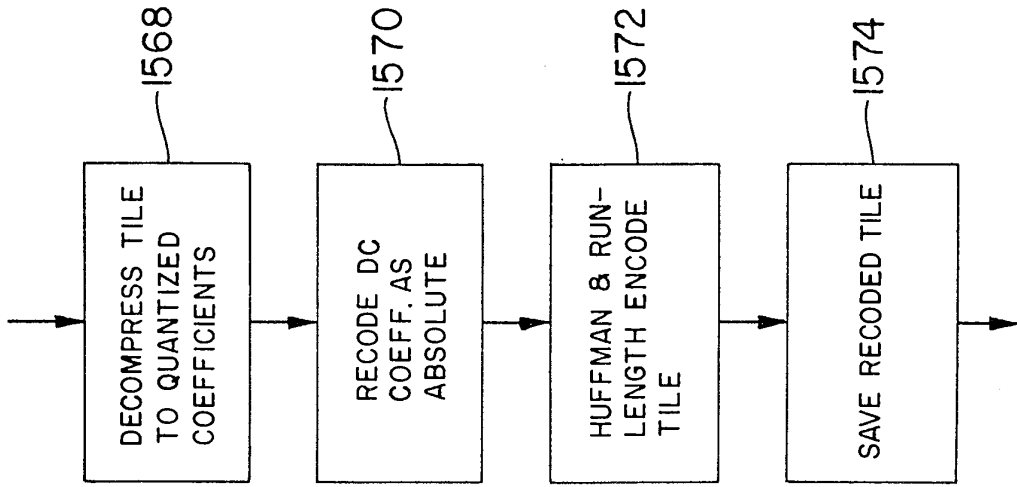


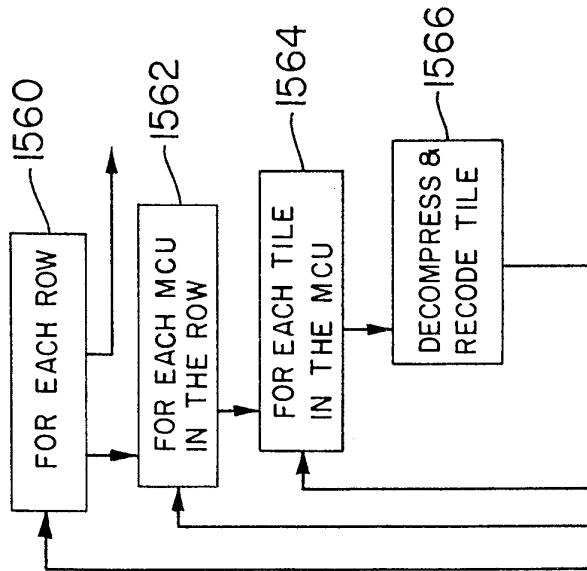
FIG. 65B



**FIG. 66** BUILD BACKWARD HISTORY BUFFER

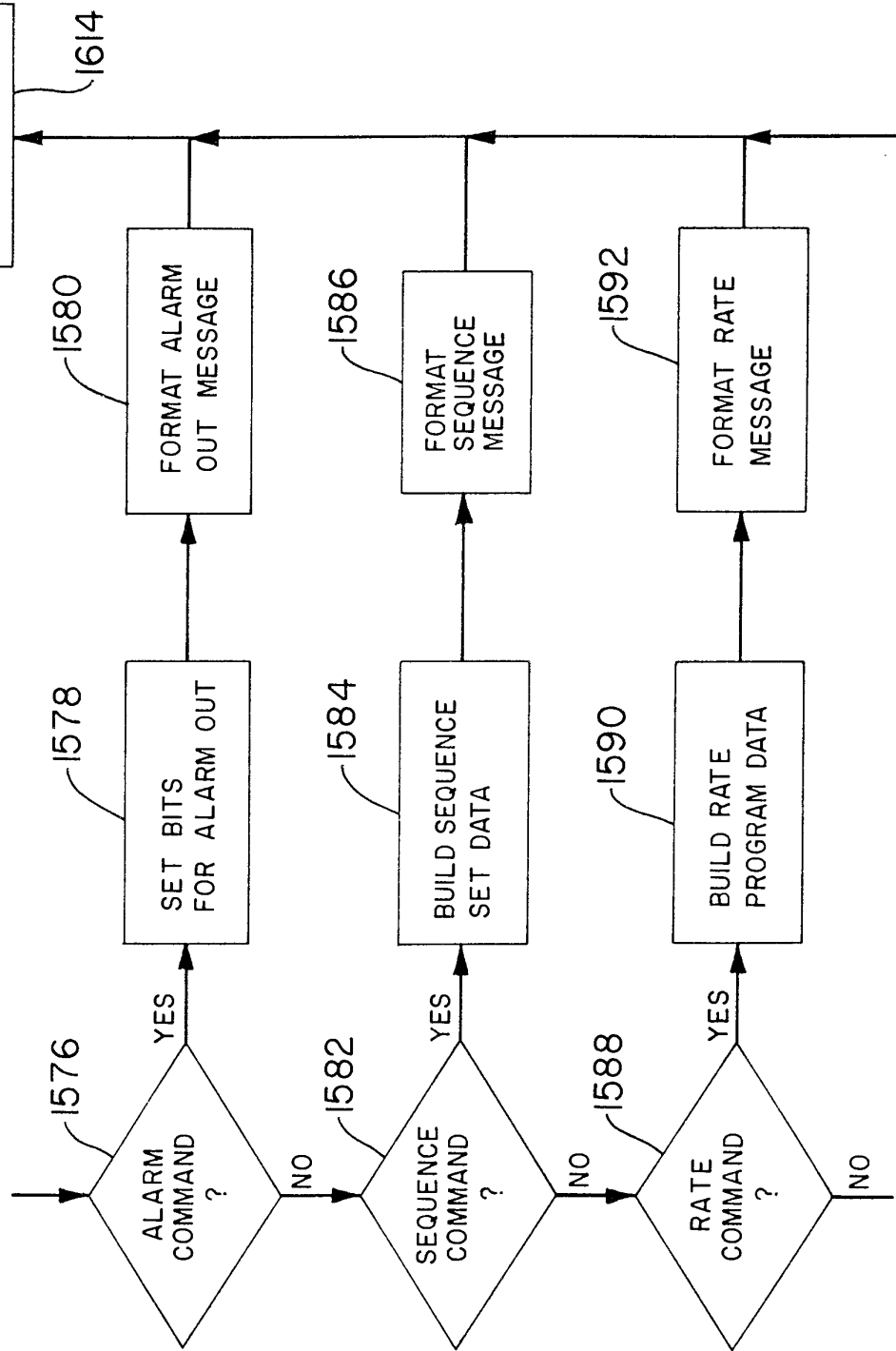


**FIG. 68**  
DECOMPRESS & RECODE TILE



**FIG. 67**  
DECOMPRESS/RECODE REF. FIELD

**FIG. 69A**  
COMPRESSOR MGR.  
(COMMAND HANDLING)



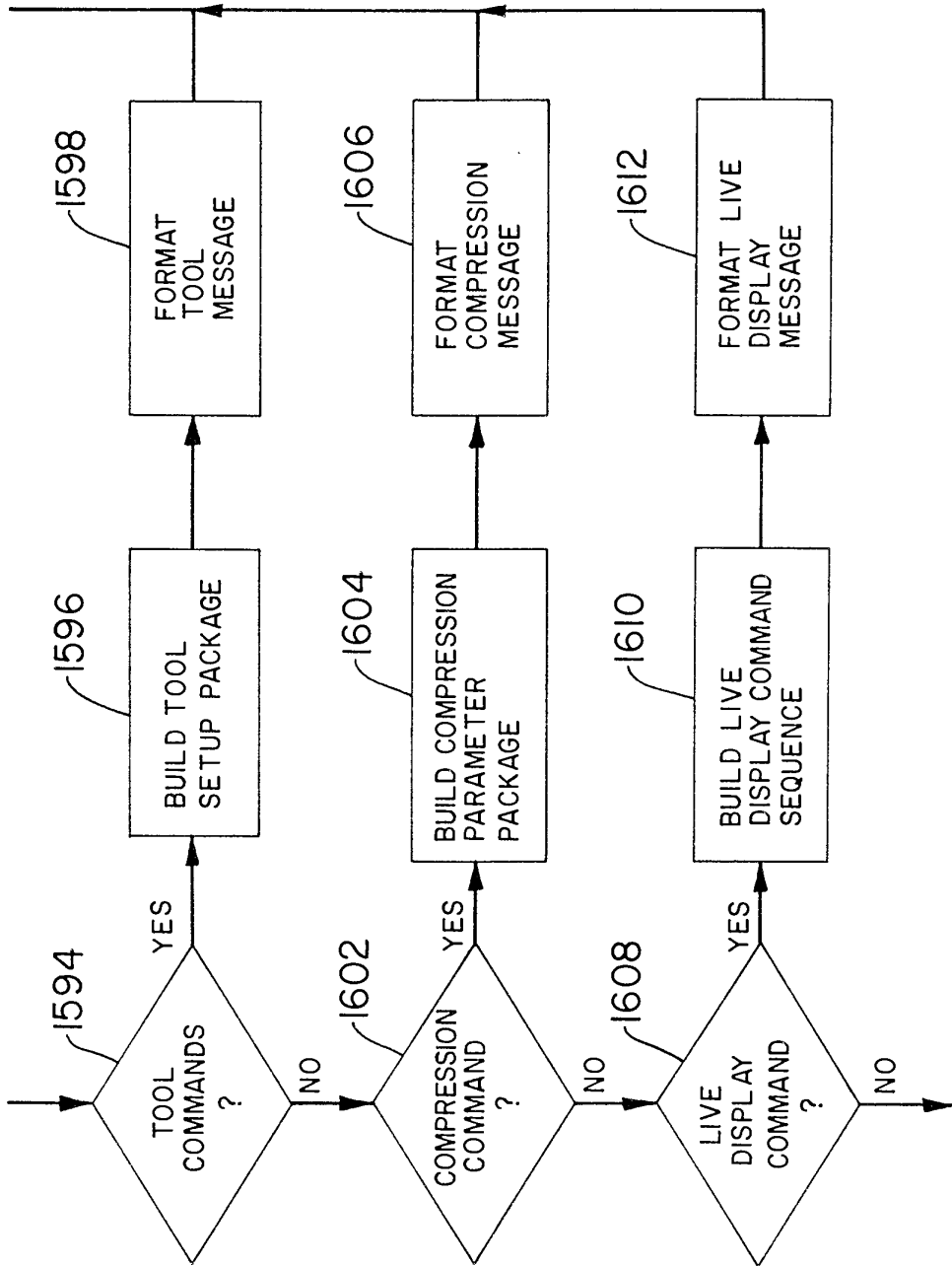
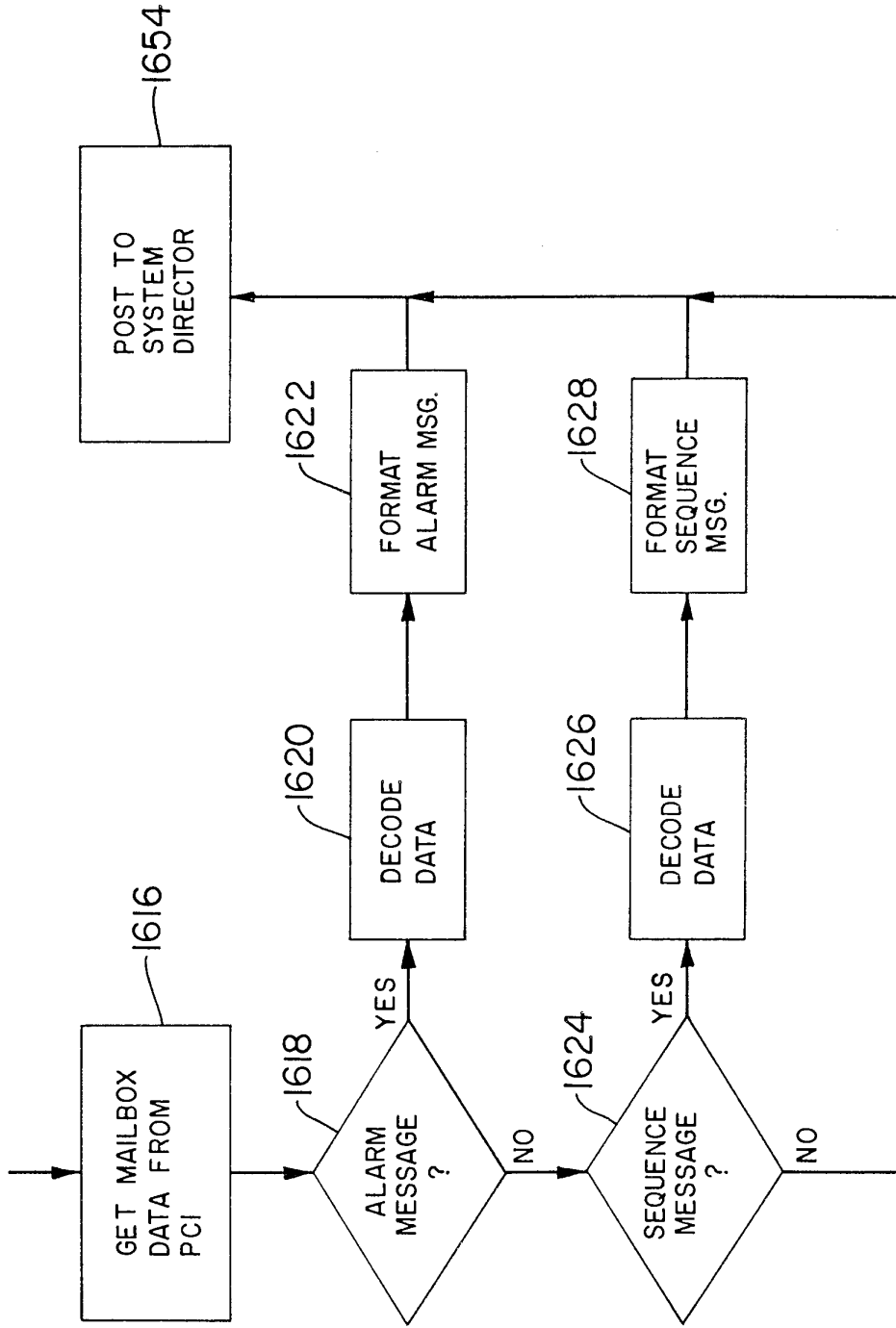


FIG. 69B





**FIG. 70A**  
COMPRESSOR MGR.  
(STATUS MSG. HANDLING)

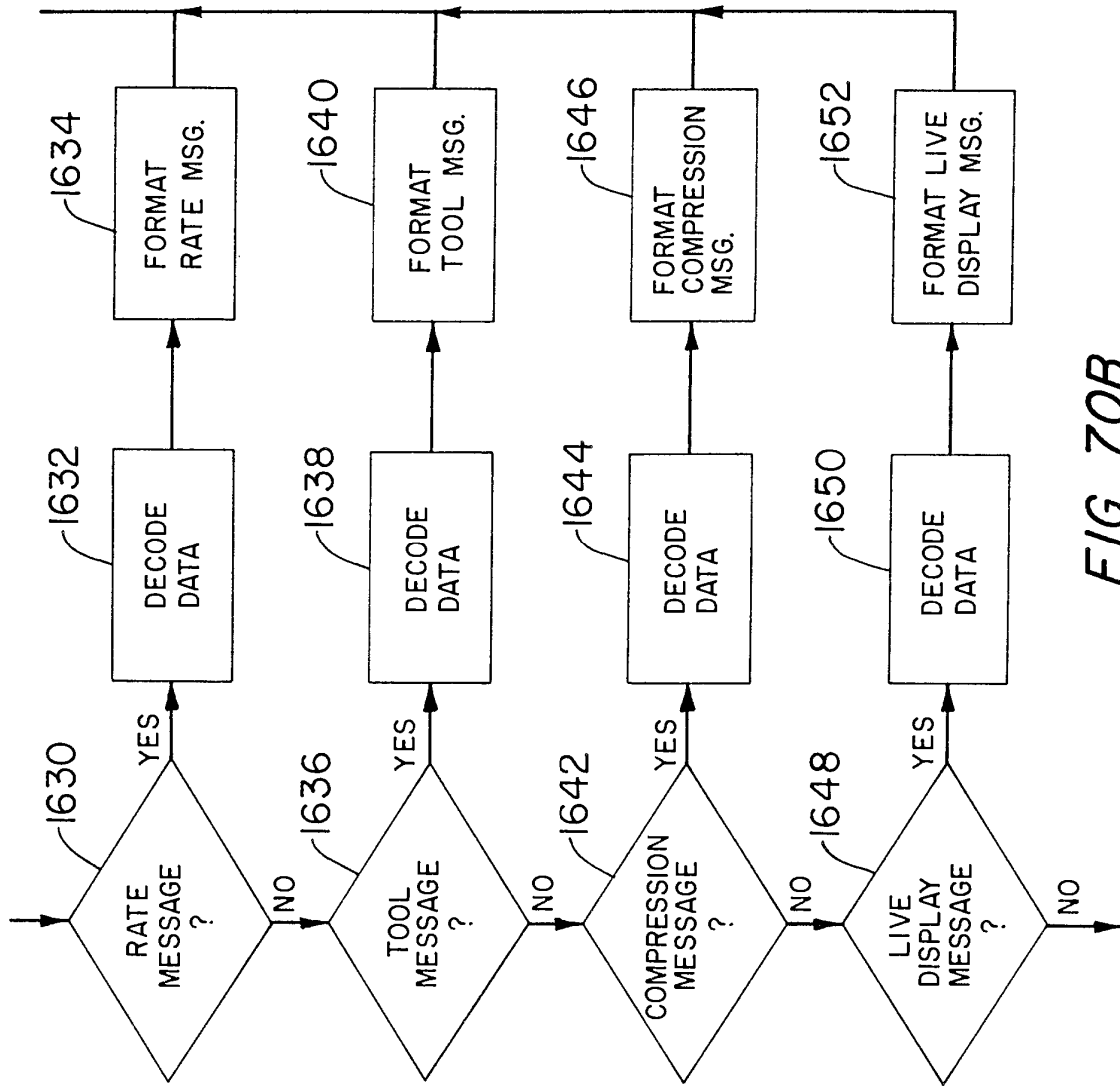
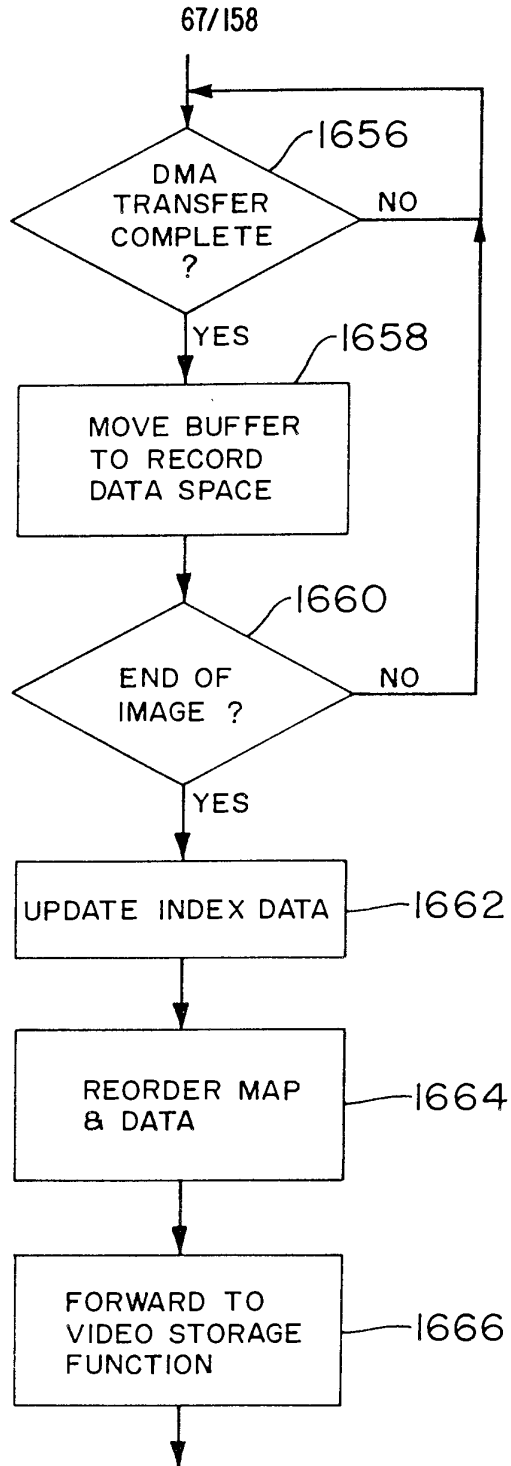
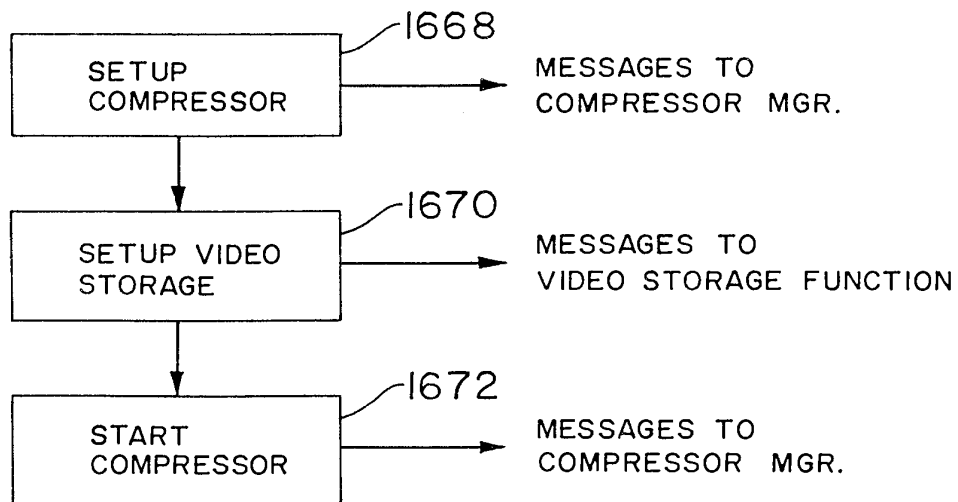
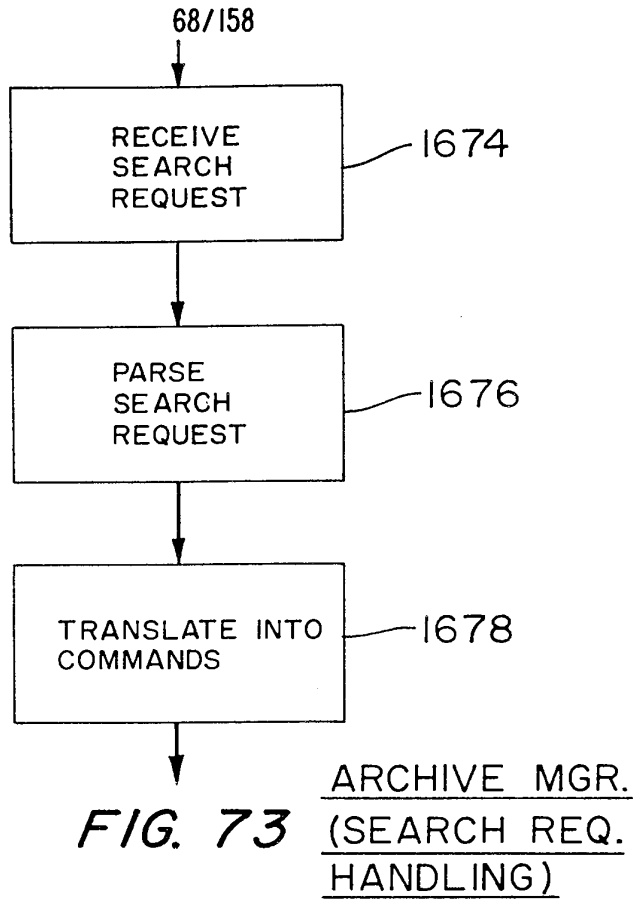


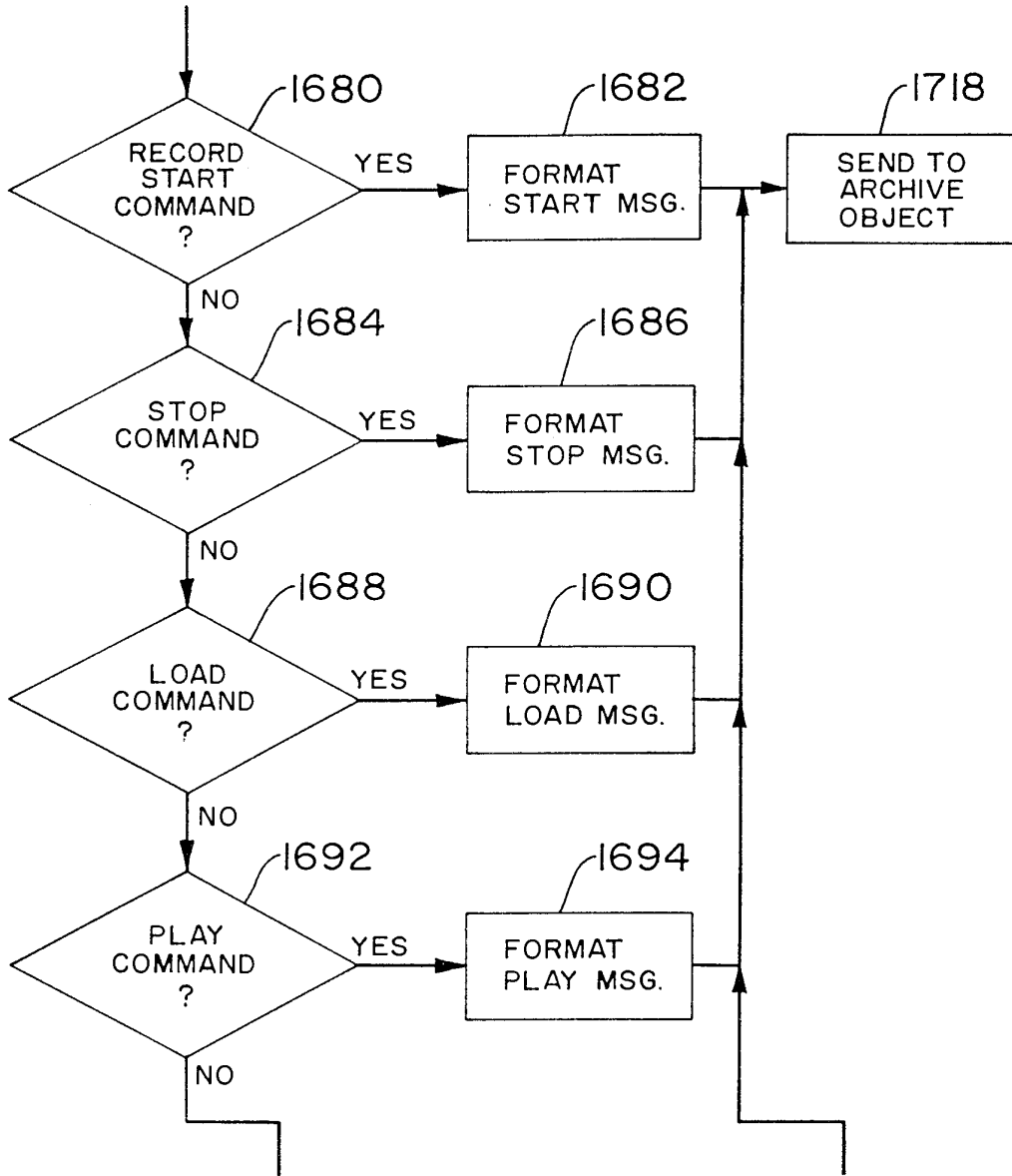
FIG. 70B



**FIG. 71**  
COMPRESSOR MGR.  
(VIDEO DATA HANDLING)



**FIG. 72**  
VIDEO RECORD FUNCTION



**FIG. 74A**  
ARCHIVE MGR.  
(COMMAND HANDLING)

70/158

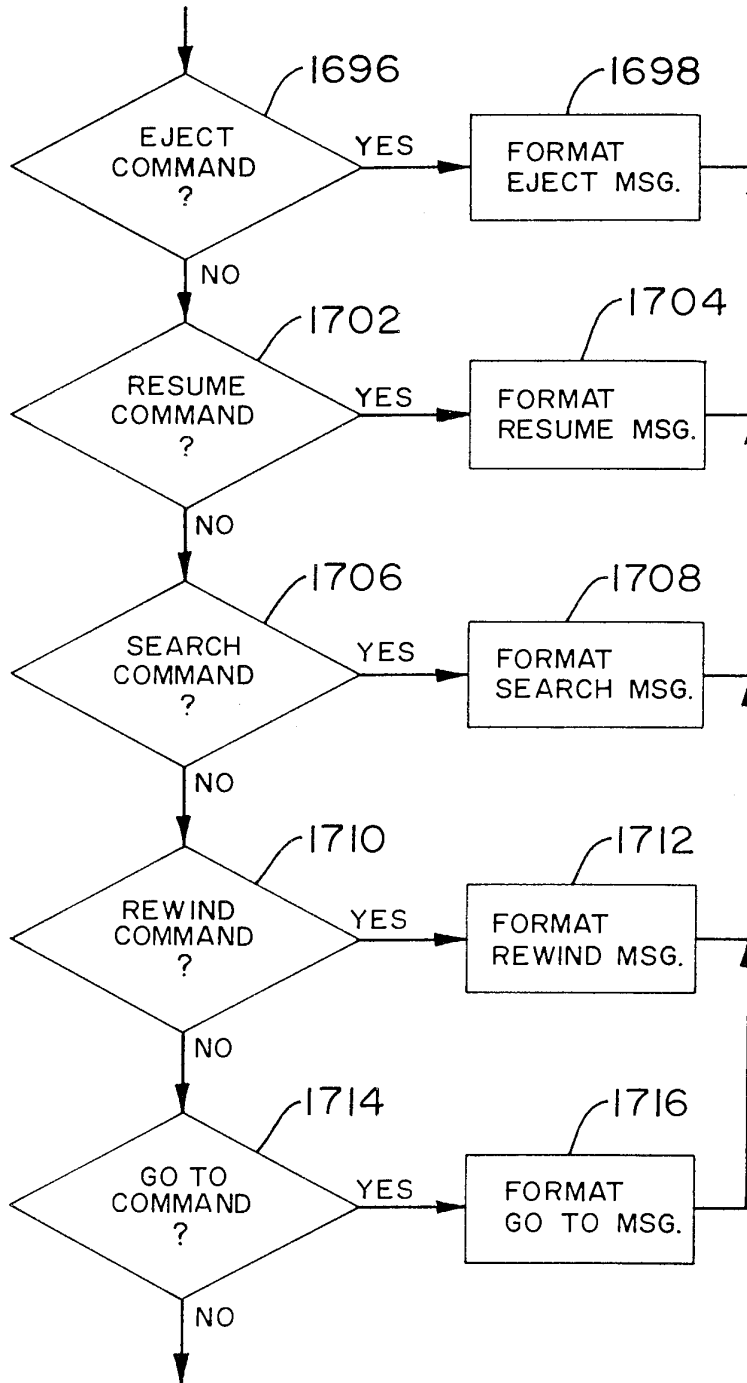
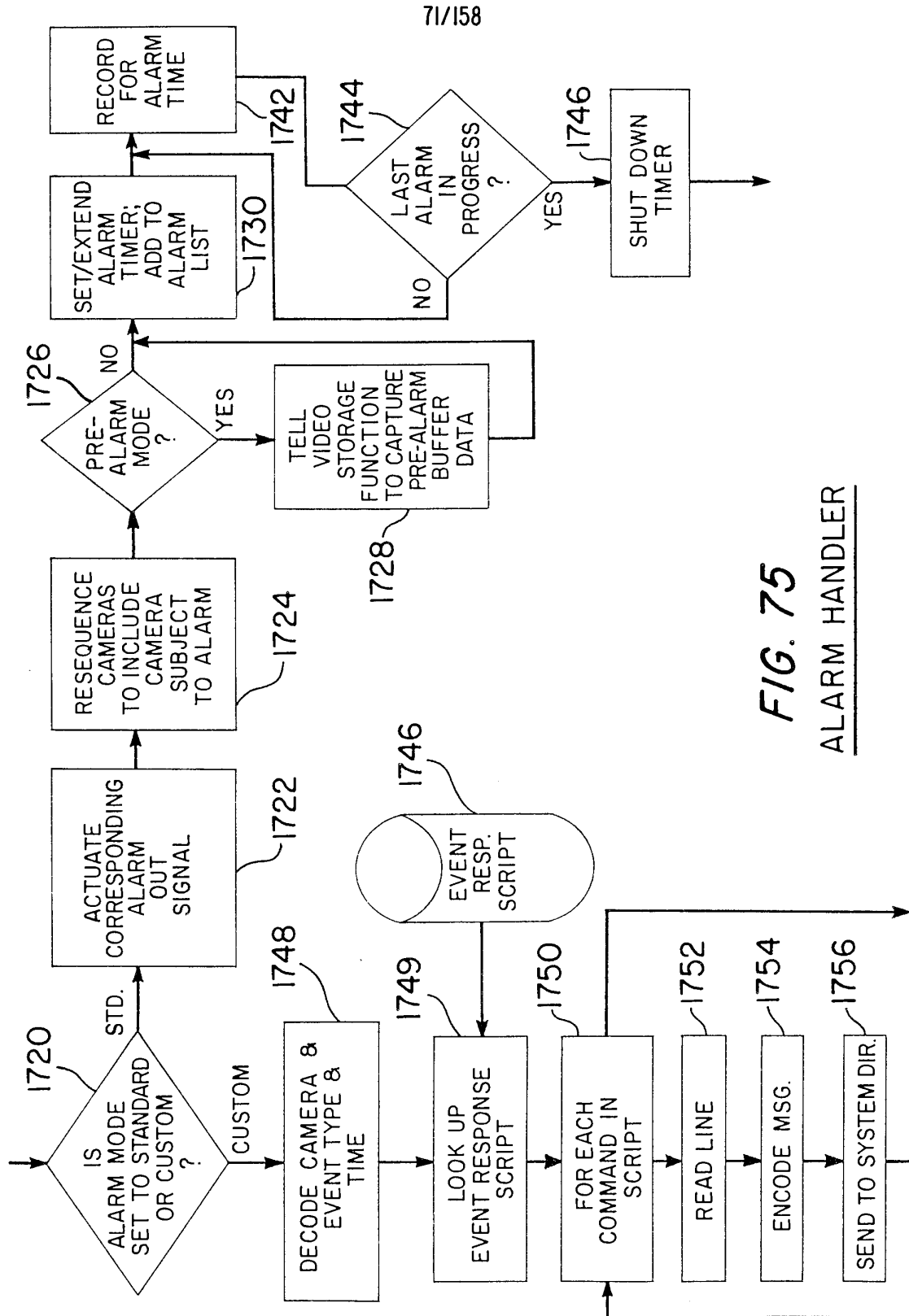
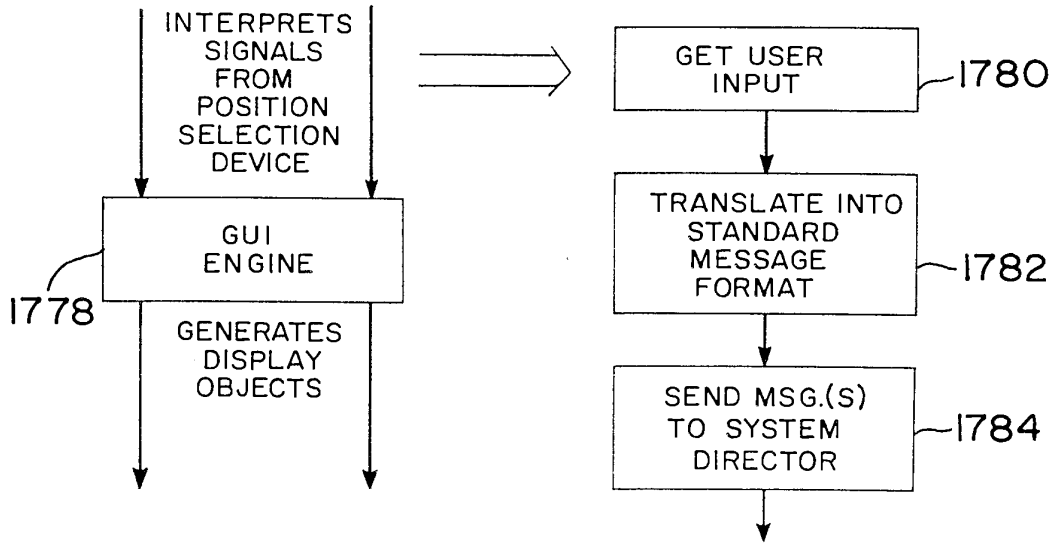


FIG. 74B

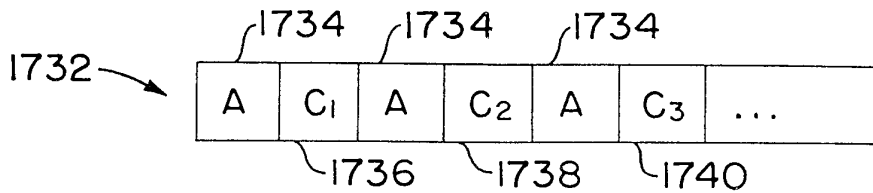


**FIG. 75**  
ALARM HANDLER

72/158

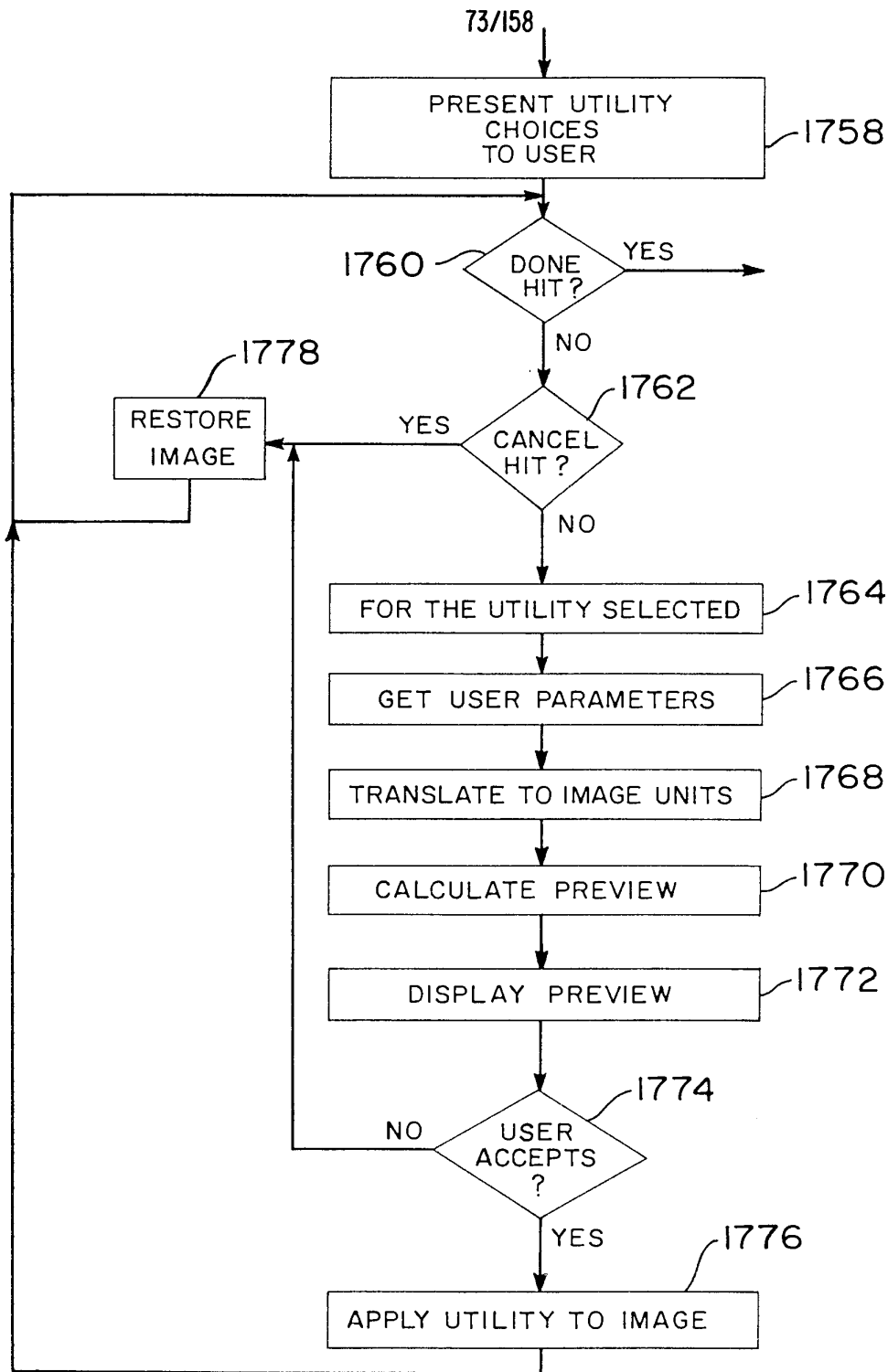


**FIG. 78**  
USER INTERFACE



**FIG. 76**  
STANDARD FIELD  
RECORDING SEQUENCE FOR ALARM  
CONDITION

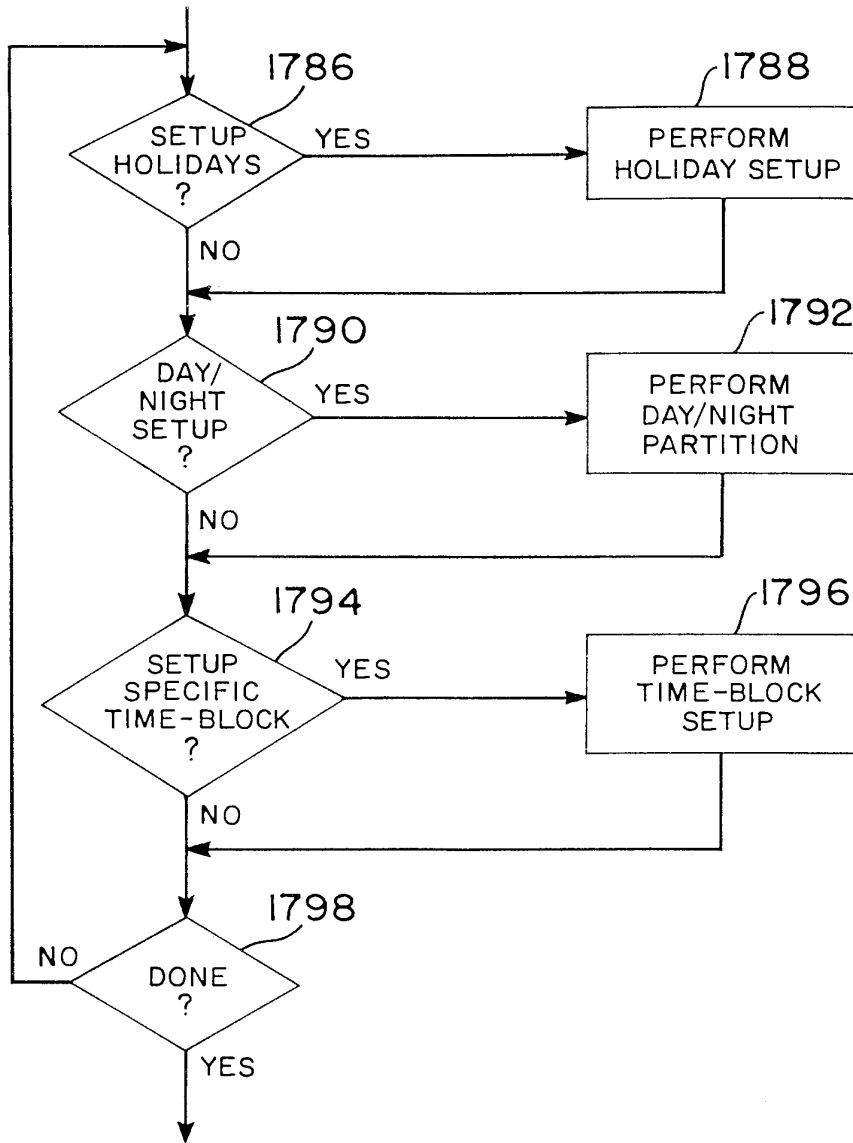




**FIG. 77**

IMAGE PROCESSING UTILITIES MGR.

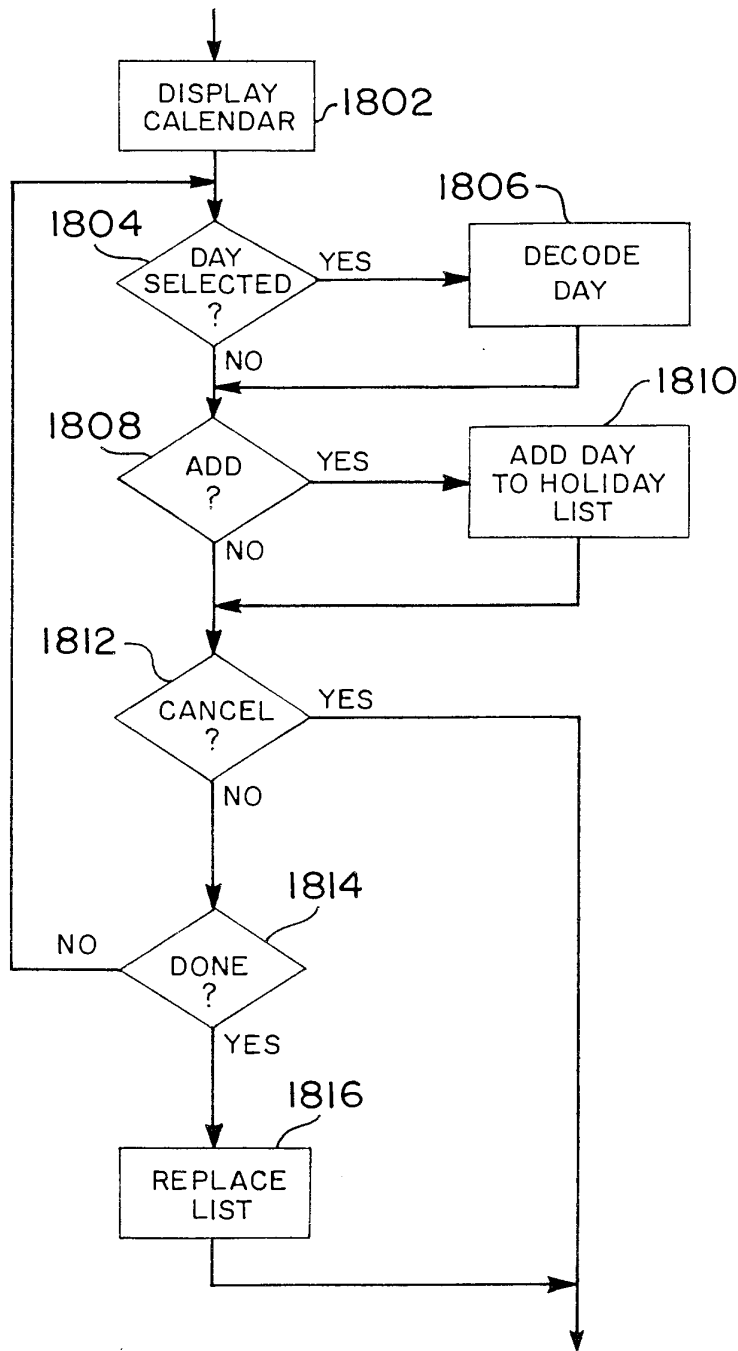
74/158



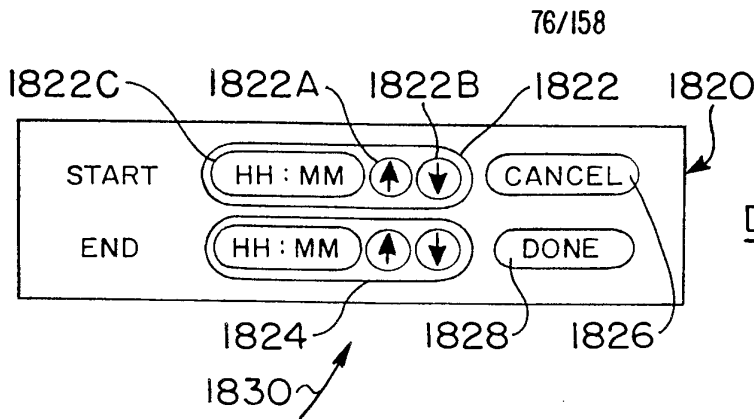
**FIG. 79**

SCHEDULING: SETUP: MAIN OPTIONS

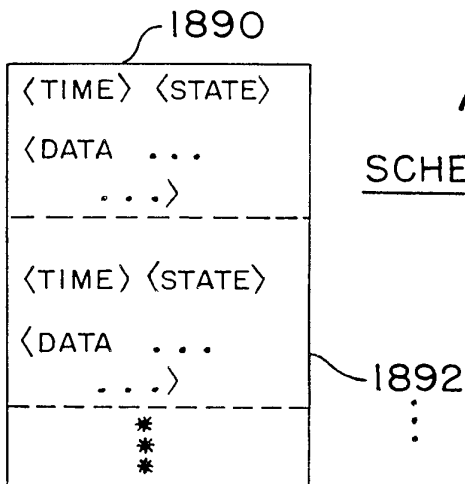
75/158



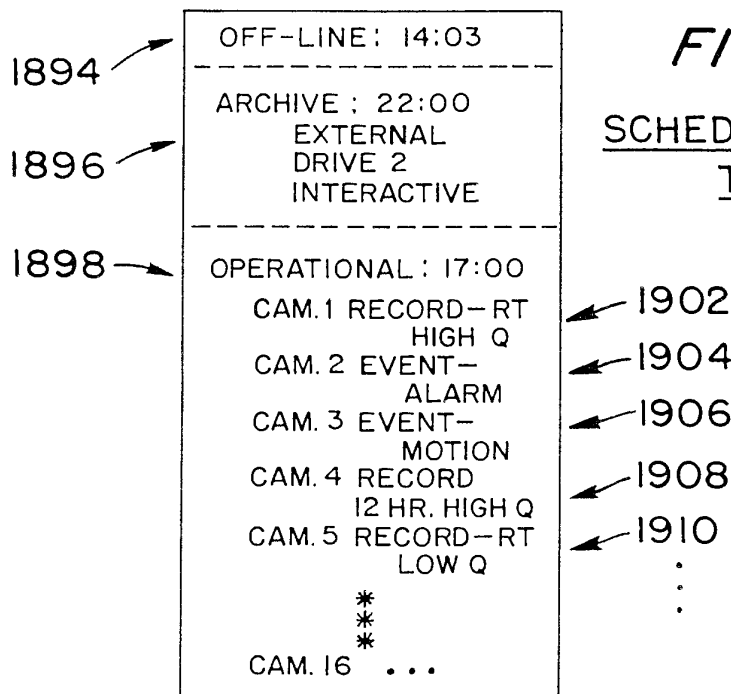
**FIG. 80**  
SCHEDULING: HOLIDAY SETUP



**FIG. 81**  
DAY/NIGHT PARTITION

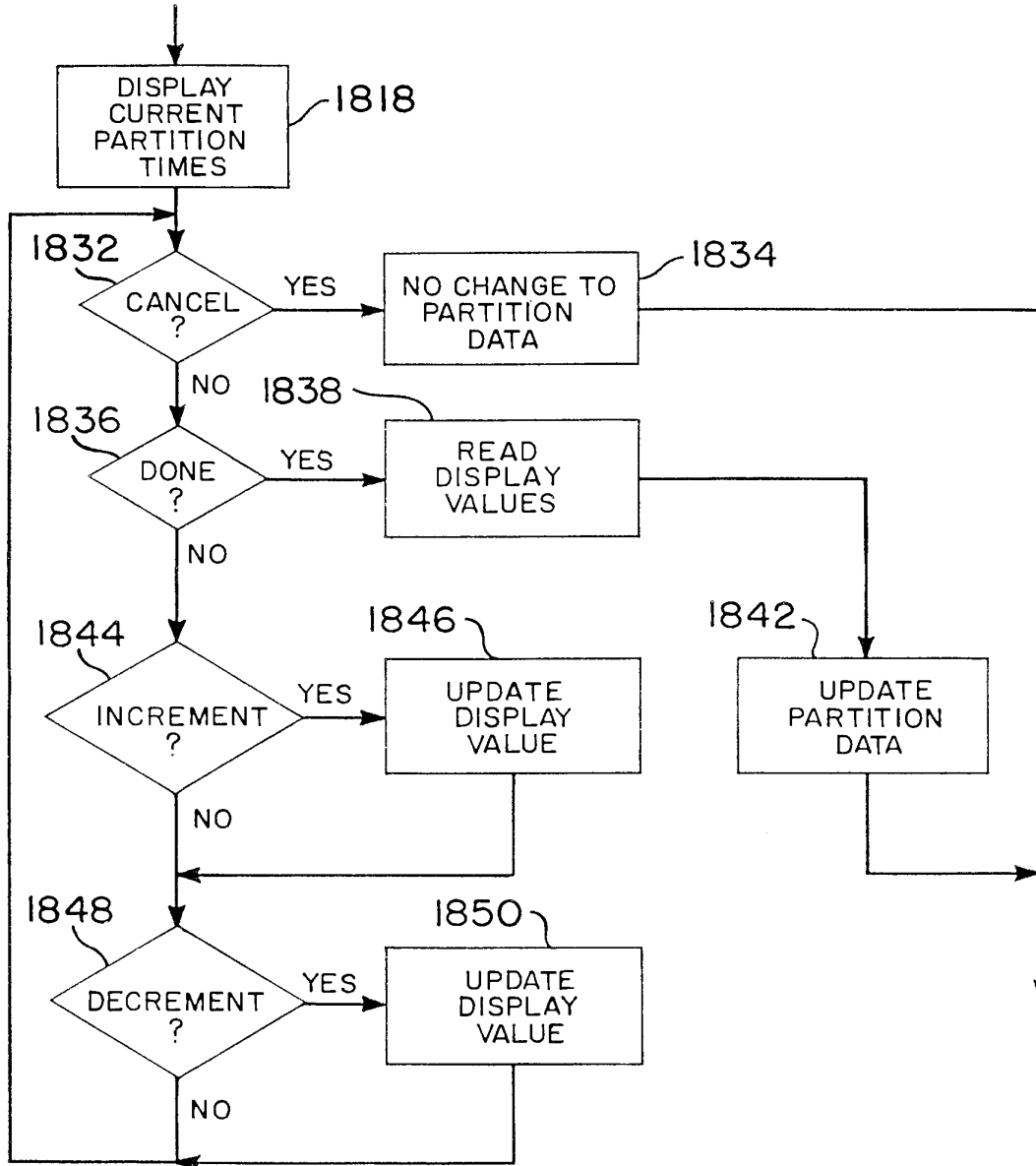


**FIG. 85**  
SCHEDULE QUEUE



**FIG. 86**  
SCHEDULE SCRIPT/TABLE

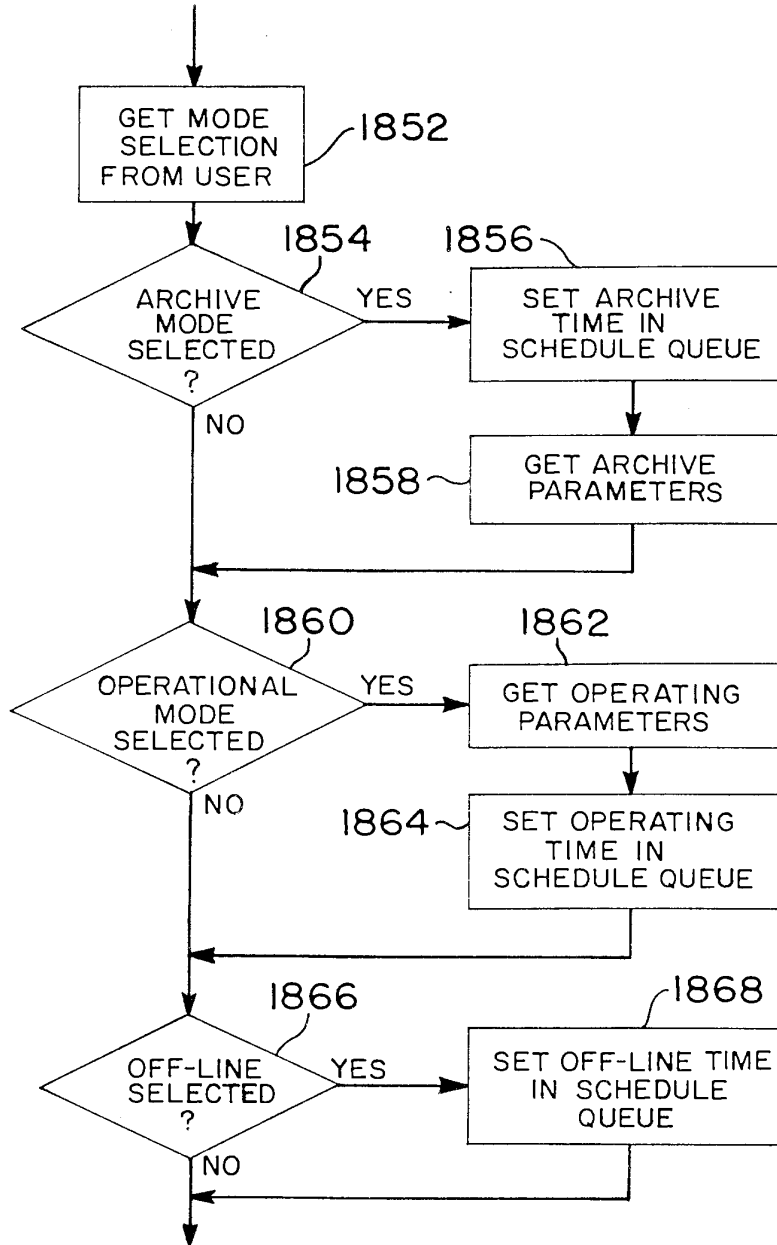
77/158



*FIG. 82*

DAY/NIGHT PARTITION

78/158



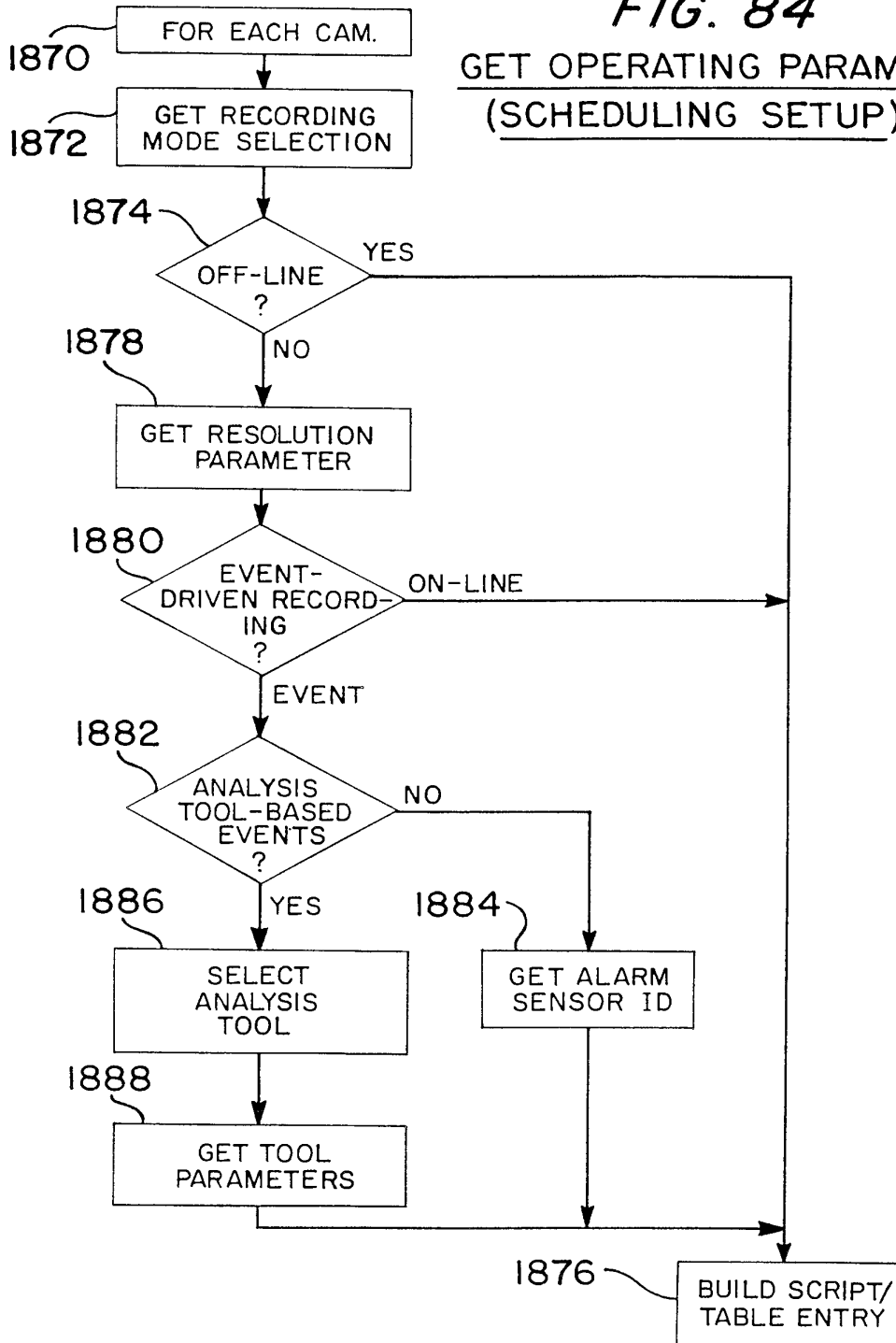
**FIG. 83**

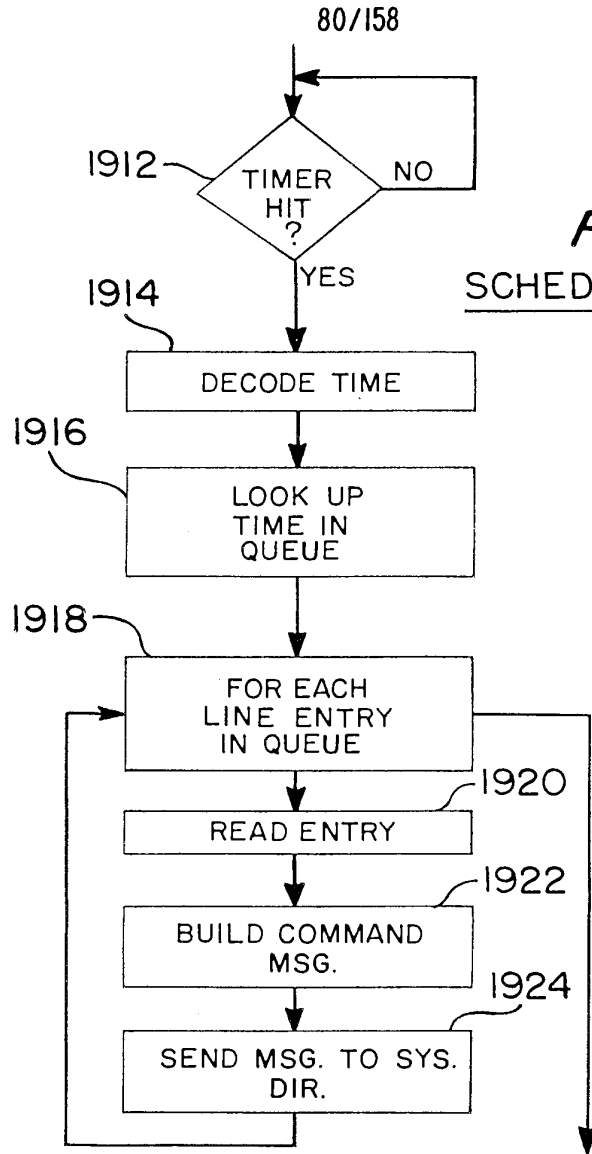
**SCHEDULING SETUP: OPTION SELECTION**

79/158

**FIG. 84**

GET OPERATING PARAMETERS  
(SCHEDULING SETUP)





**FIG. 87**  
SCHEDULE EXECUTION

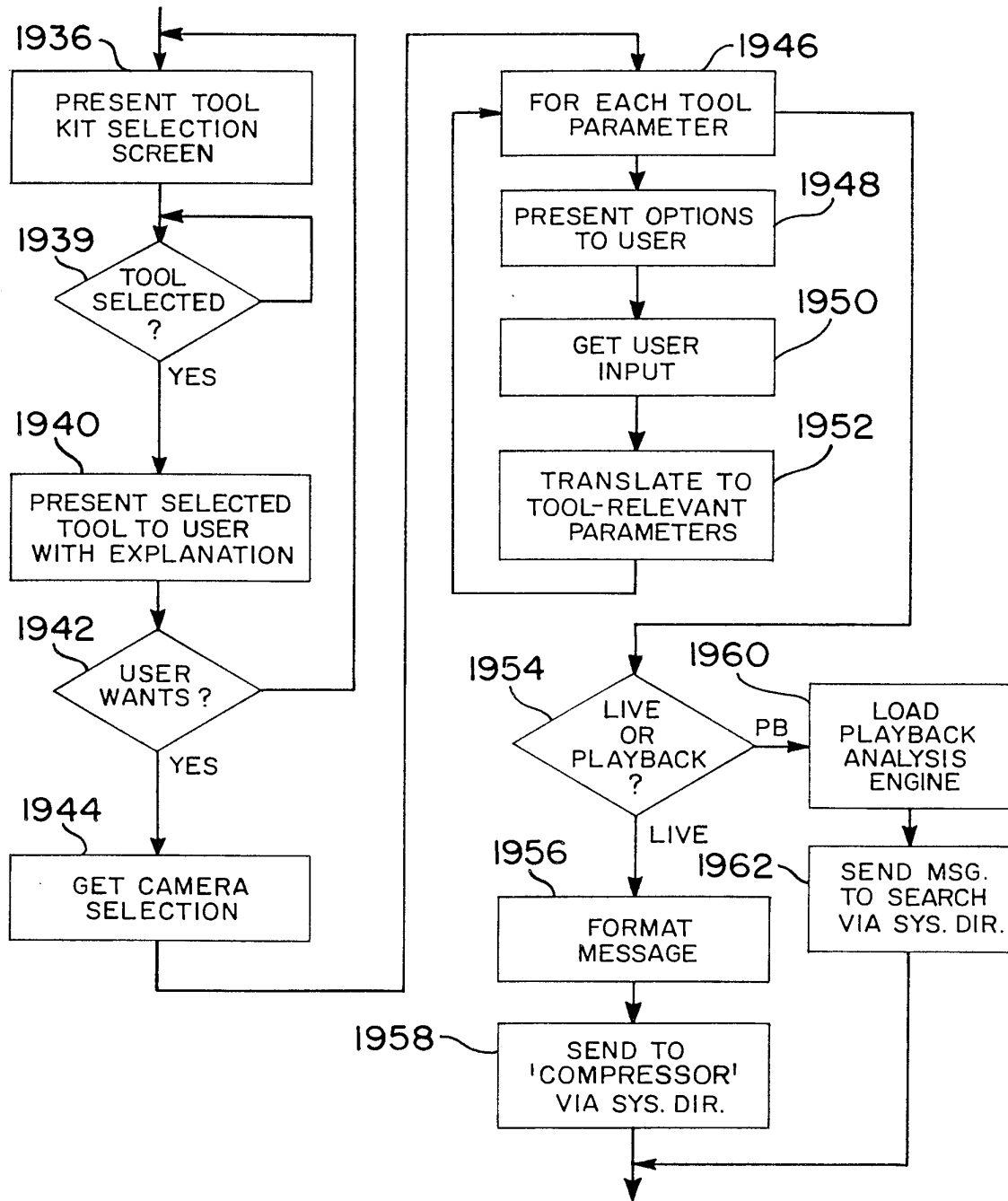
**FIG. 88**

IMAGE ANALYSIS TOOLS-OVERVIEW

1926		1932	1934
USER I/F		EXECUTION	RESULTS / CONSEQUENCES
1928 SELECT TOOL	SETUP TOOL	- LIVE - PLAYBACK	
1930			

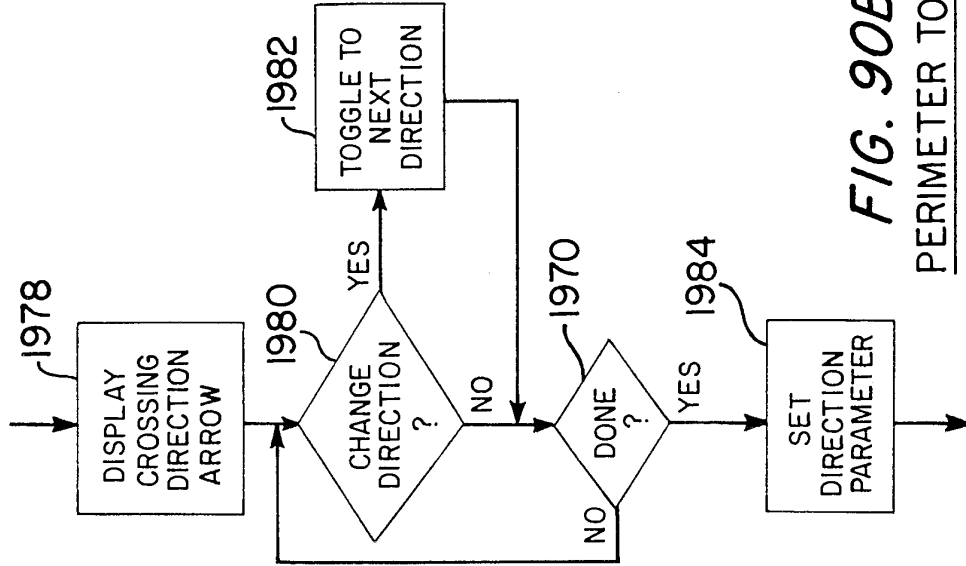
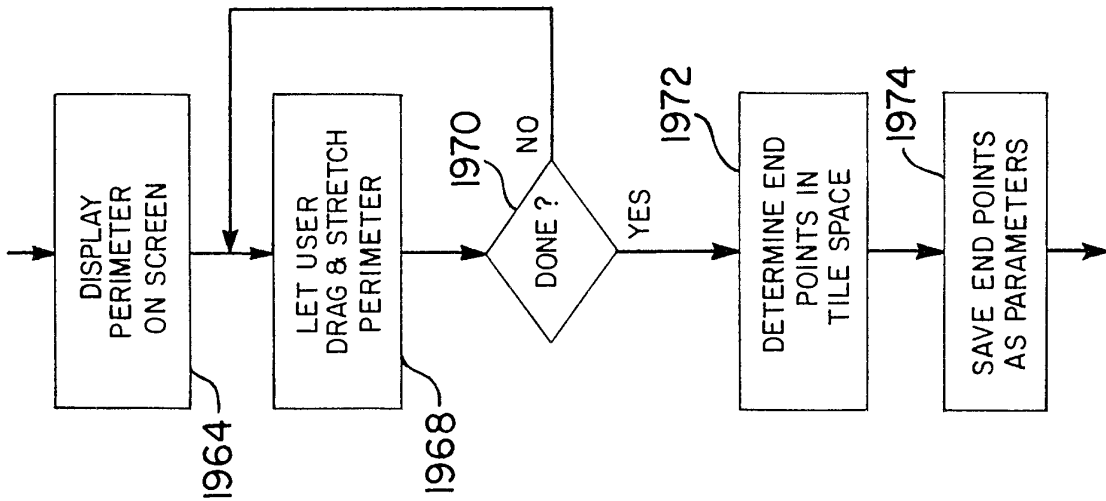


81/158



**FIG. 89**  
SELECT & SETUP ANALYSIS TOOL

**FIG. 90A**  
PERIMETER TOOL:  
PARAMETER SETTING:  
PERIMETER SIZE  
& LOCATION



**FIG. 90B**  
PERIMETER TOOL:  
PARAMETER SETTING:  
CROSSING DIRECTION

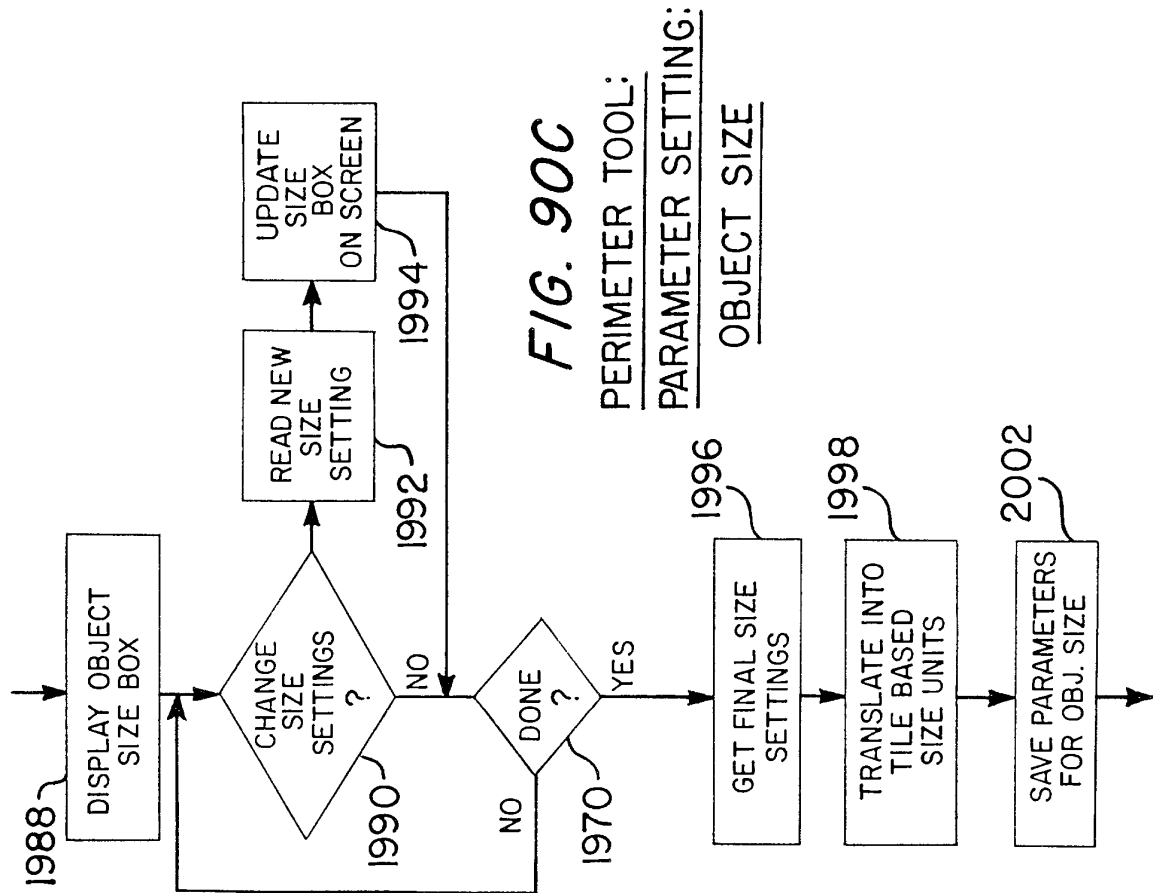
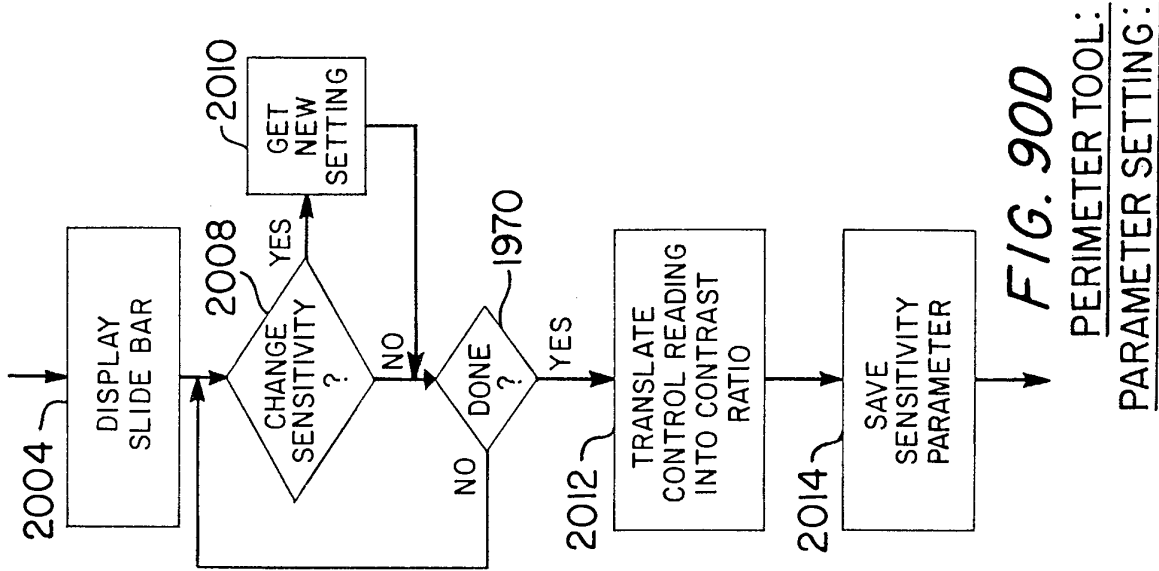
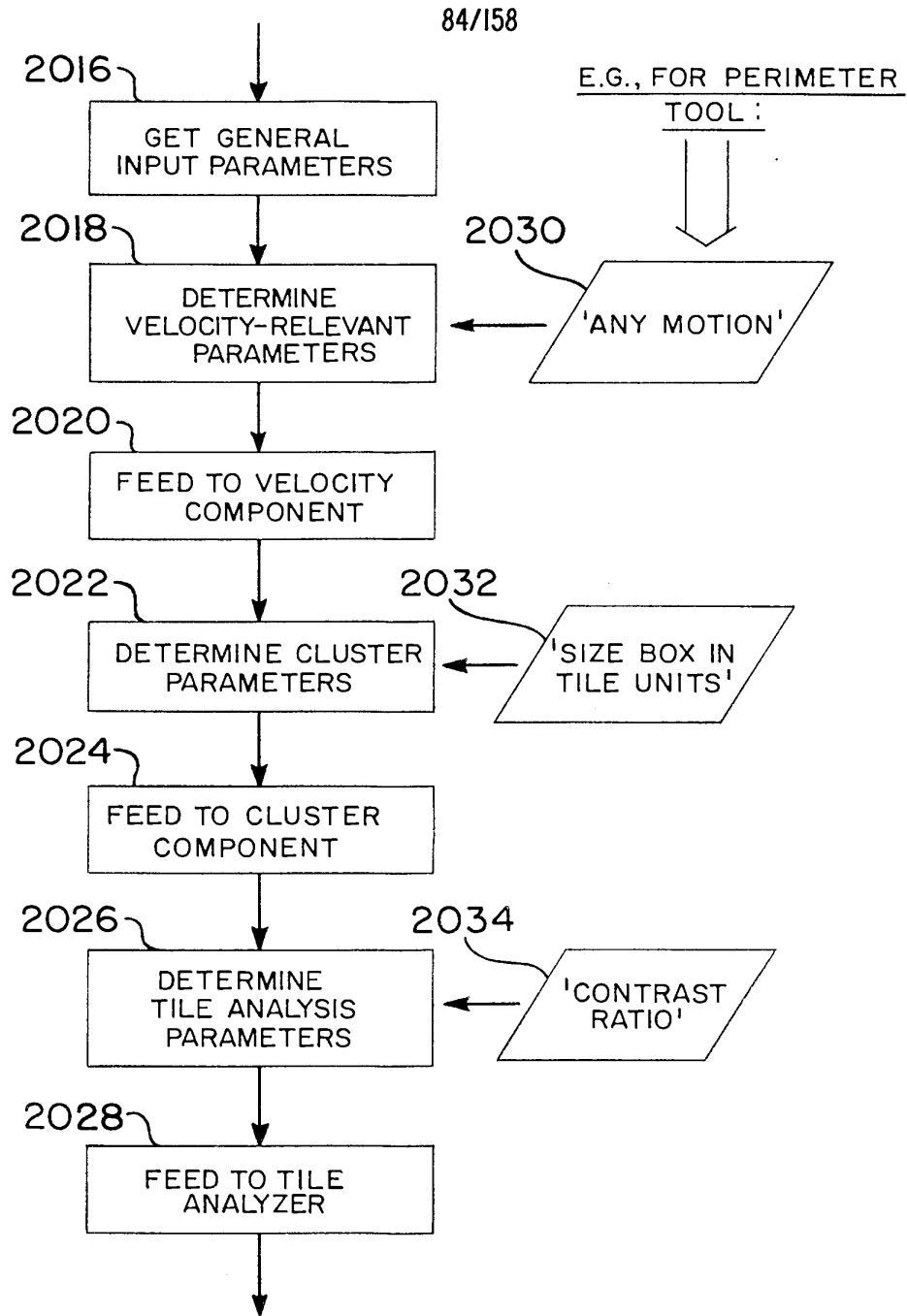


FIG. 90C

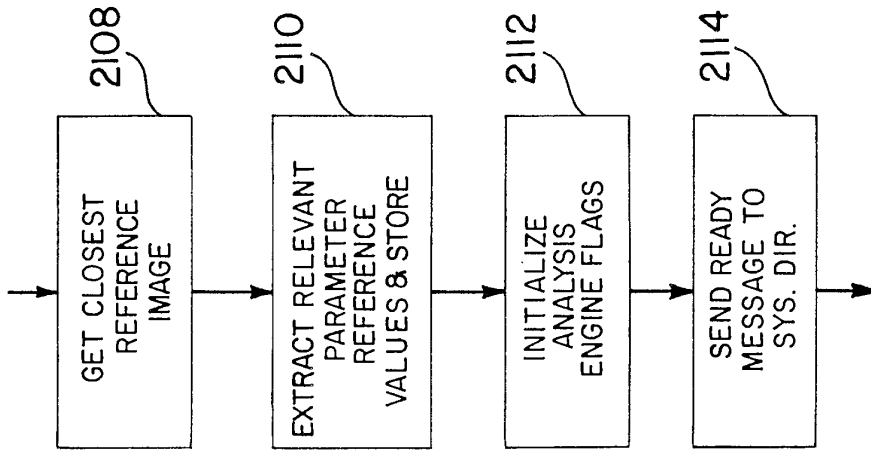
PERIMETER TOOL:  
PARAMETER SETTING:  
OBJECT SIZE

FIG. 90D

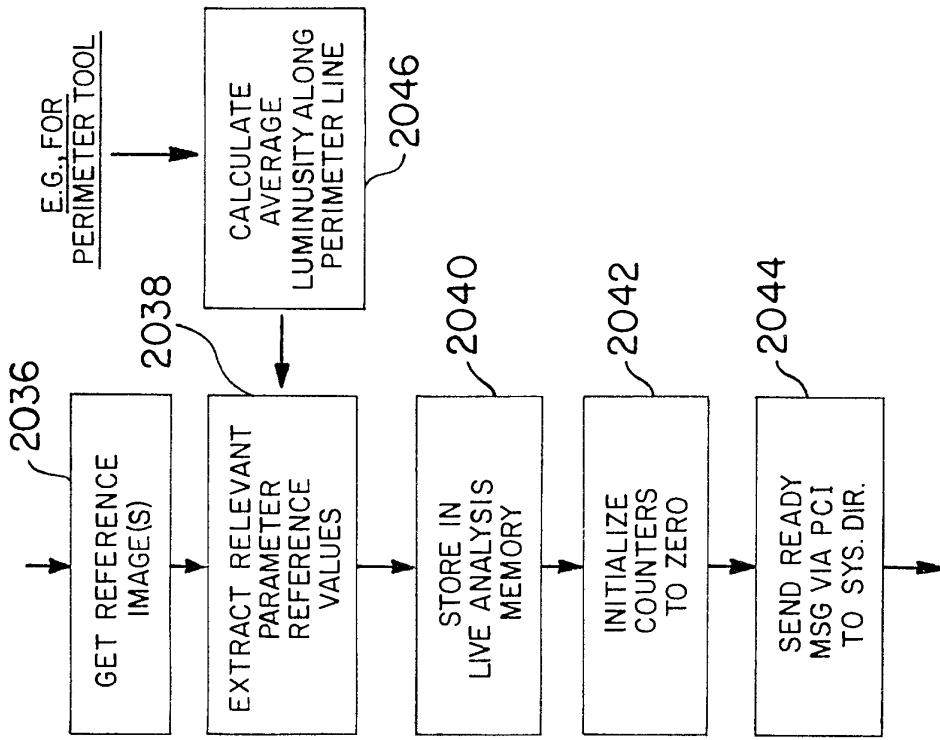
PERIMETER TOOL:  
PARAMETER SETTING:



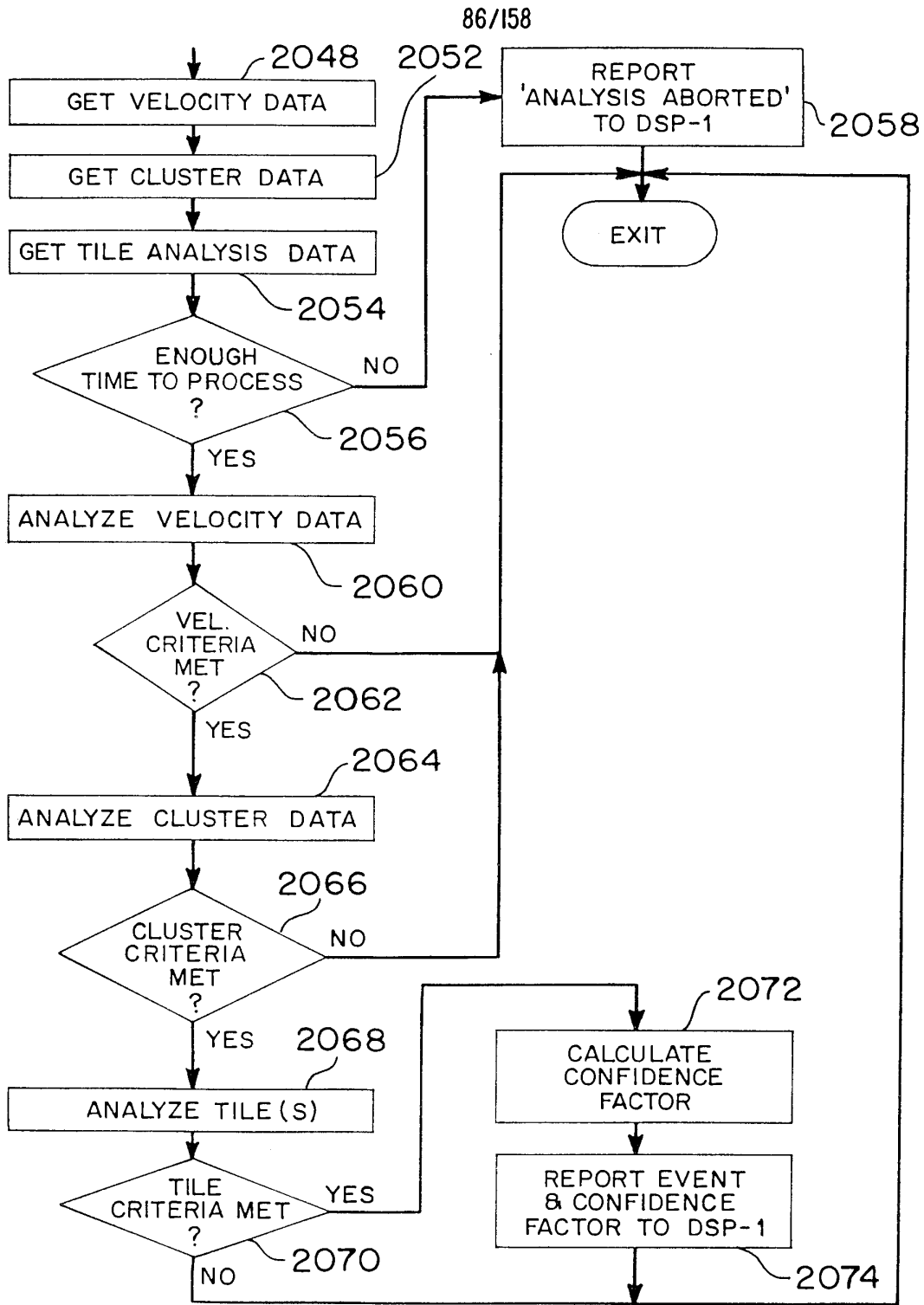
**FIG. 91**  
LOADING ANALYSIS ENGINE



**FIG. 94**  
INITIALIZE SEARCH ANALYSIS

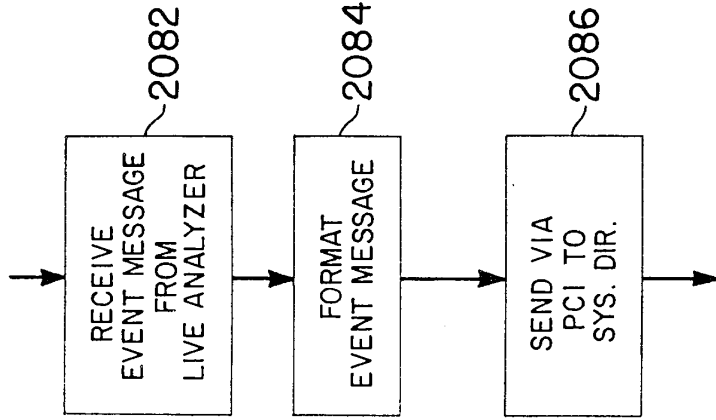


**FIG. 92**  
INITIALIZE LIVE ANALYSIS

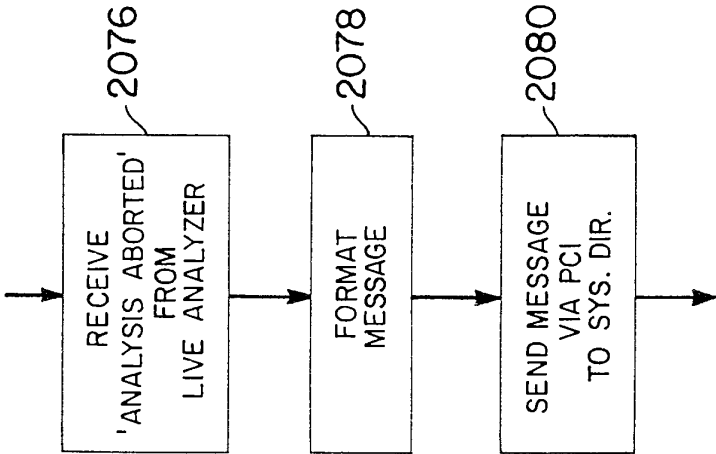


**FIG. 93A**  
 LIVE ANALYSIS OPERATION (PERIMETER TOOL)

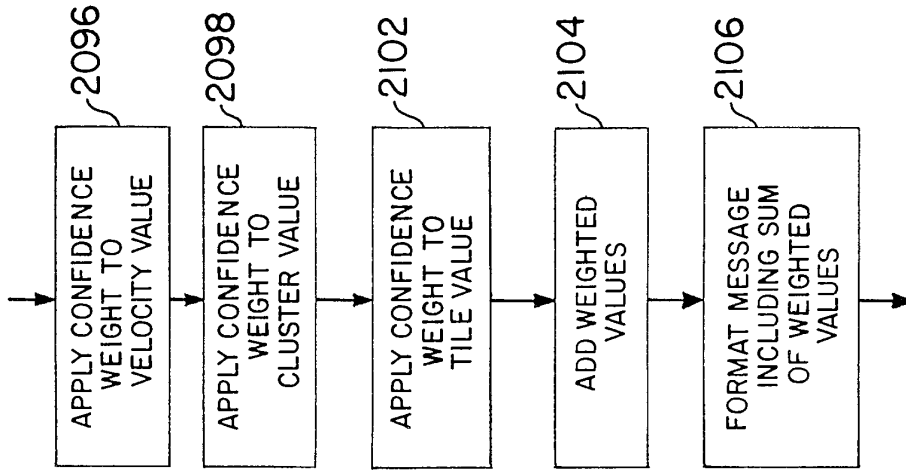
87/158



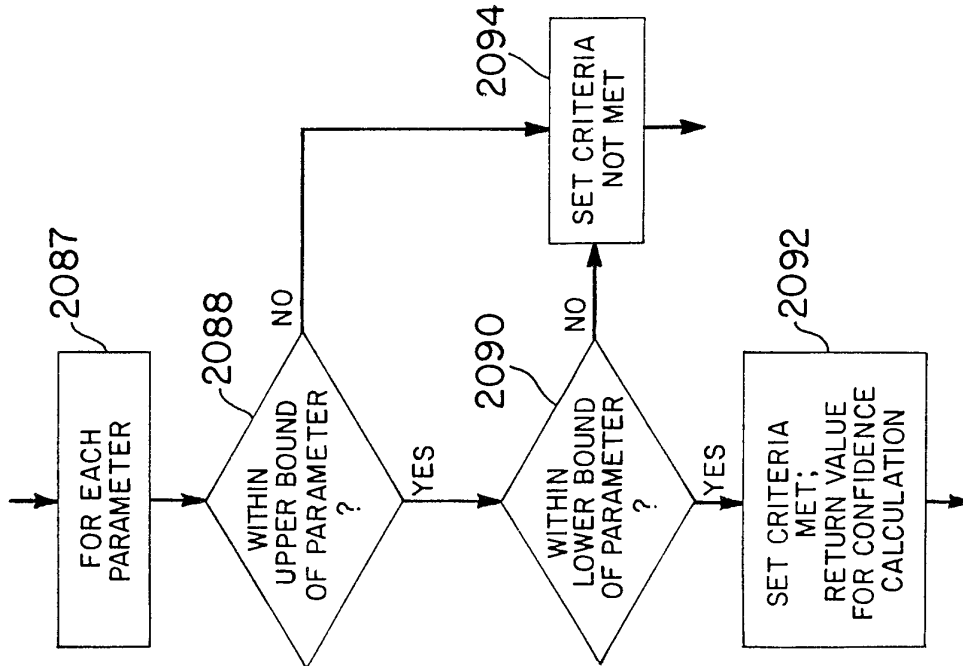
**FIG. 93C**  
(DSP-1)



**FIG. 93B**  
(DSP-1)

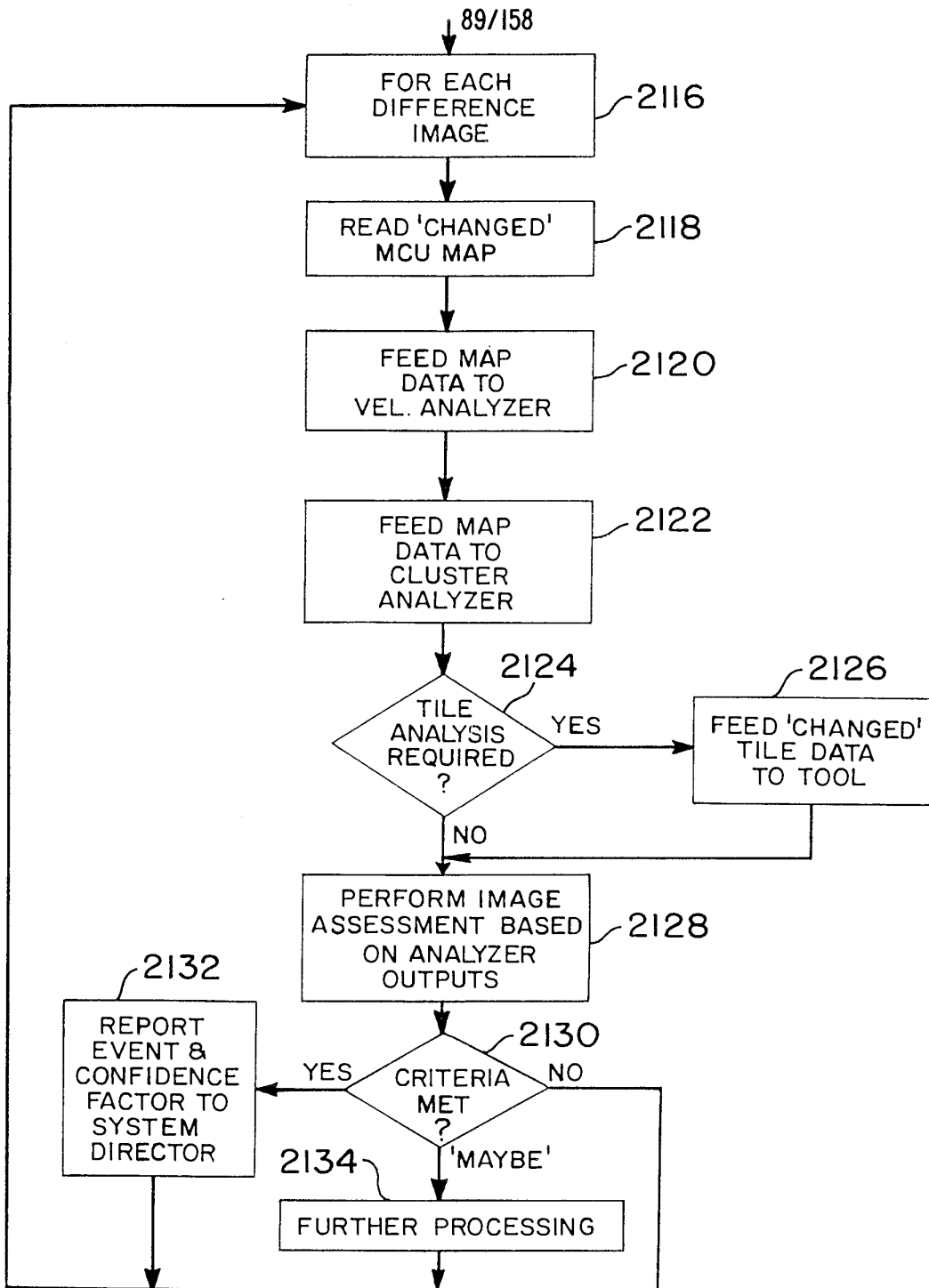


**FIG. 93E**  
CONFIDENCE FACTOR CALCULATION

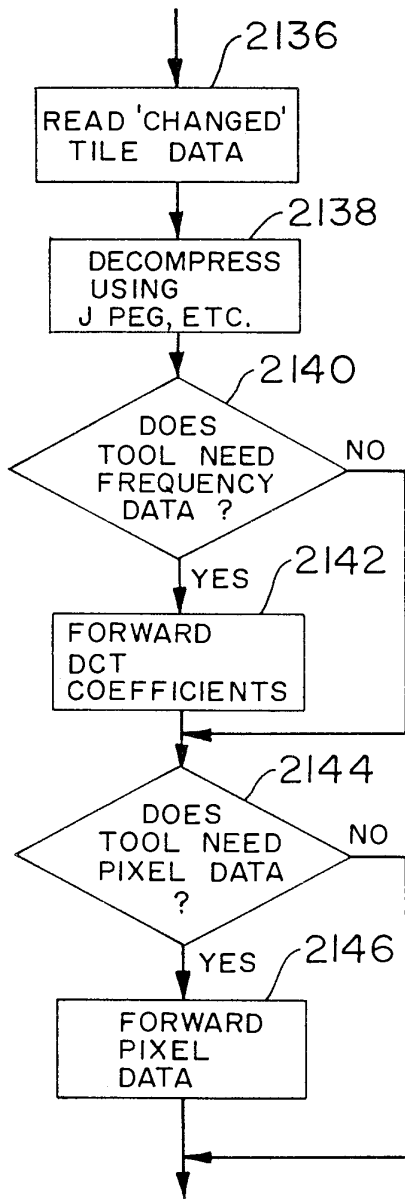


**FIG. 93D**  
CRITERIA MET?

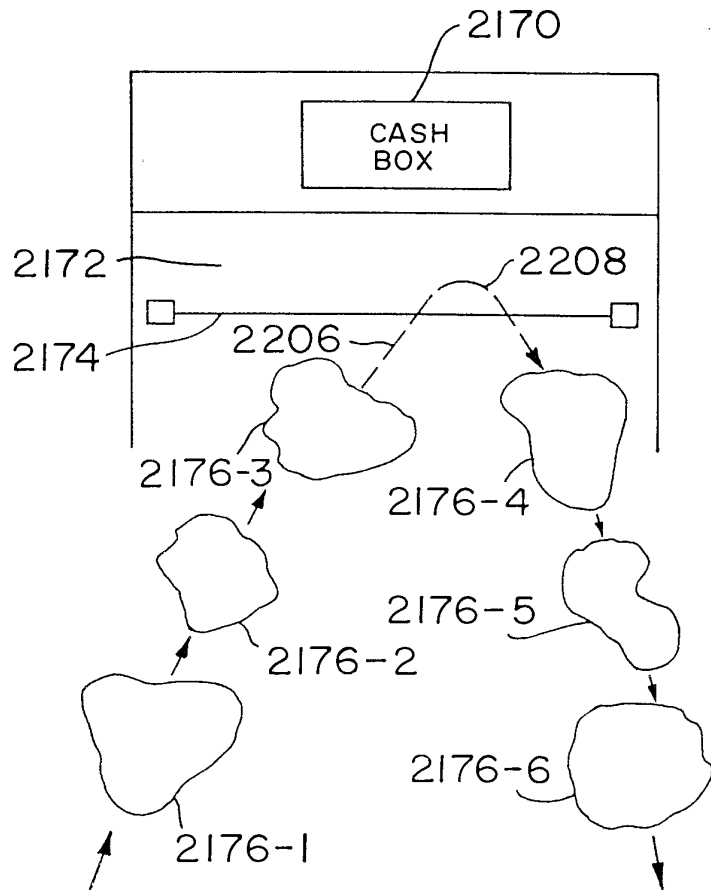




**FIG. 95A**  
PLAYBACK ANALYSIS OPERATION

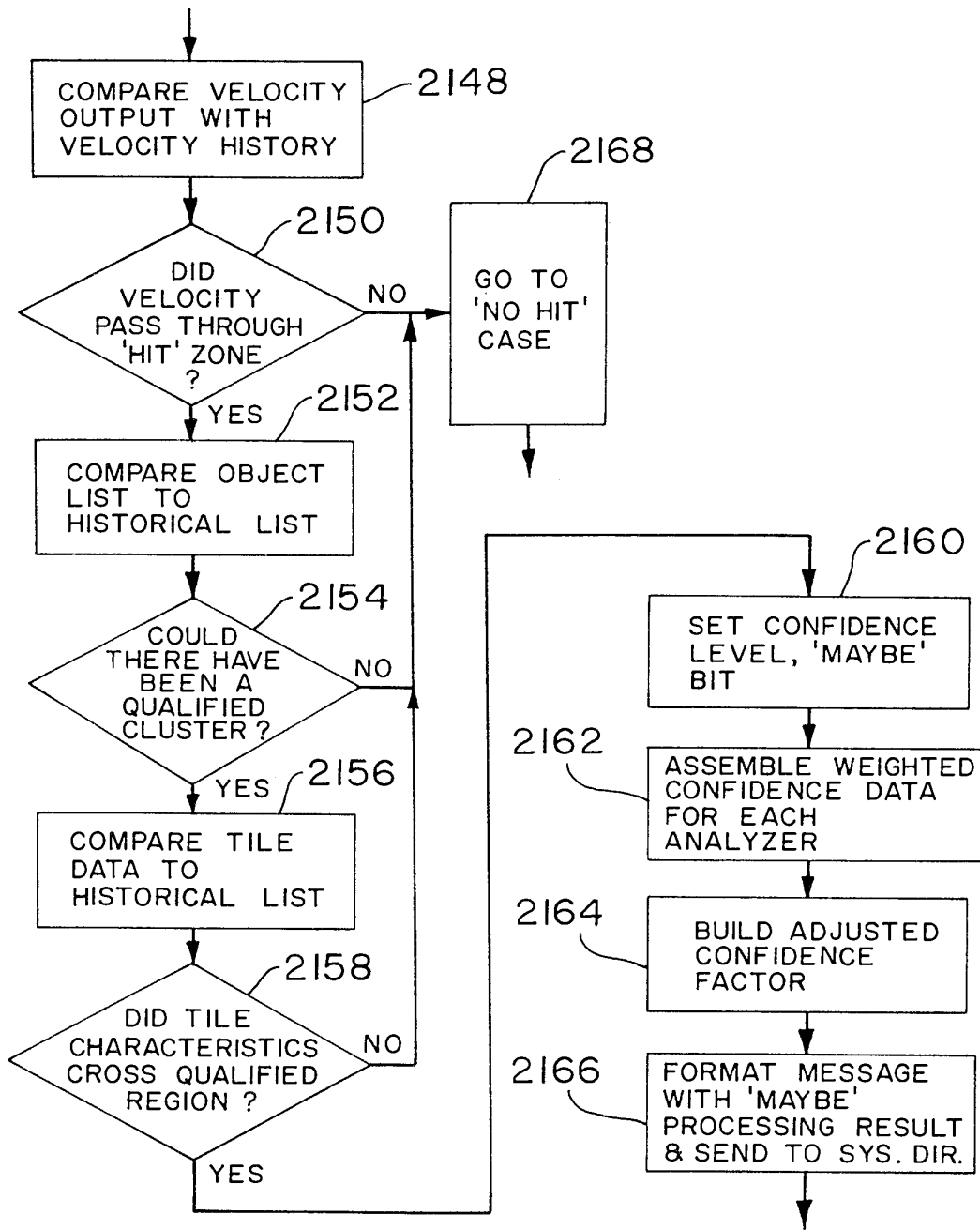


**FIG. 95B**  
FEED 'CHANGED'  
TILE DATA

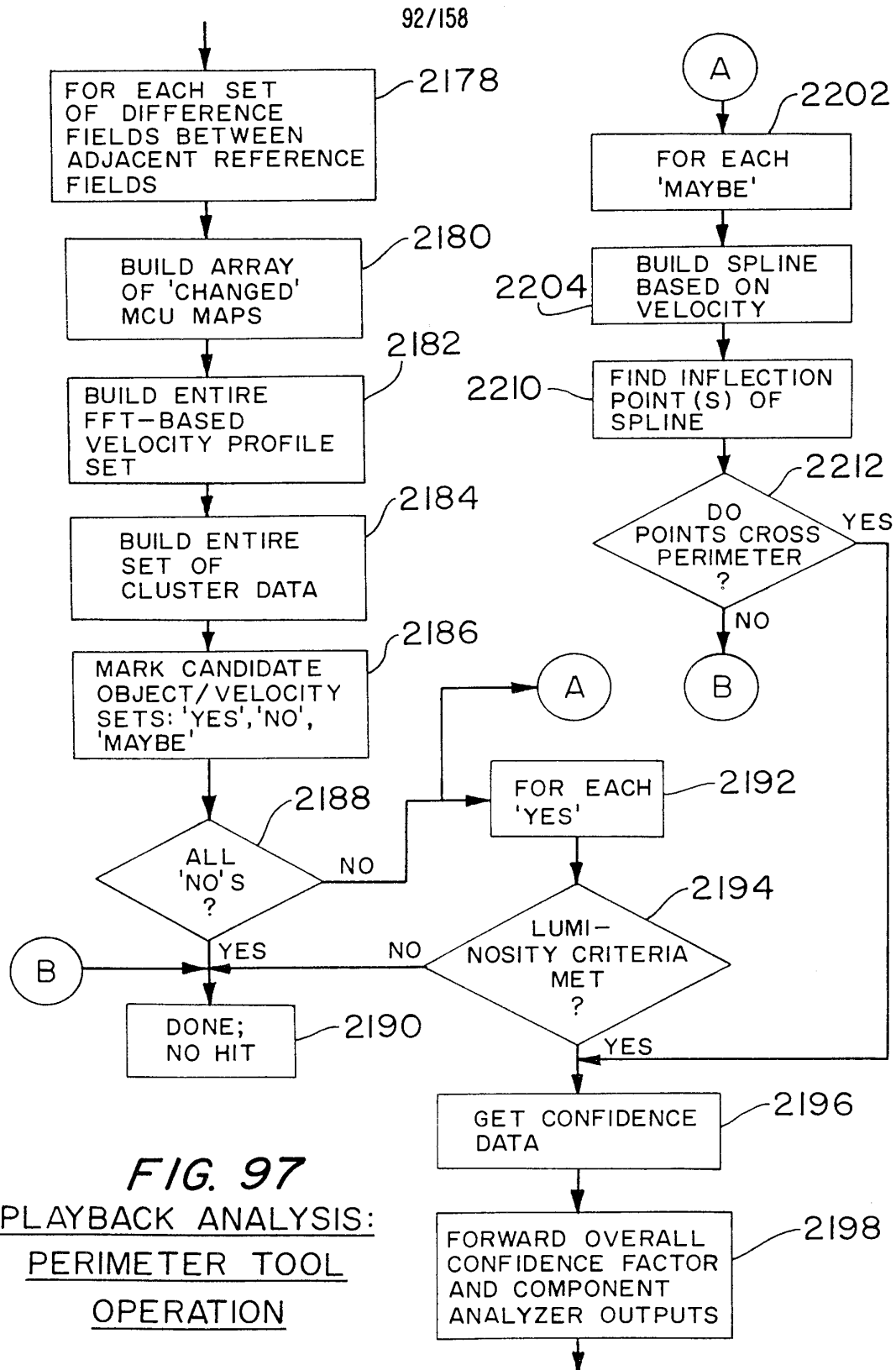


**FIG. 96**  
PLAYBACK ANALYSIS--  
CURVE-FITTING EXAMPLE

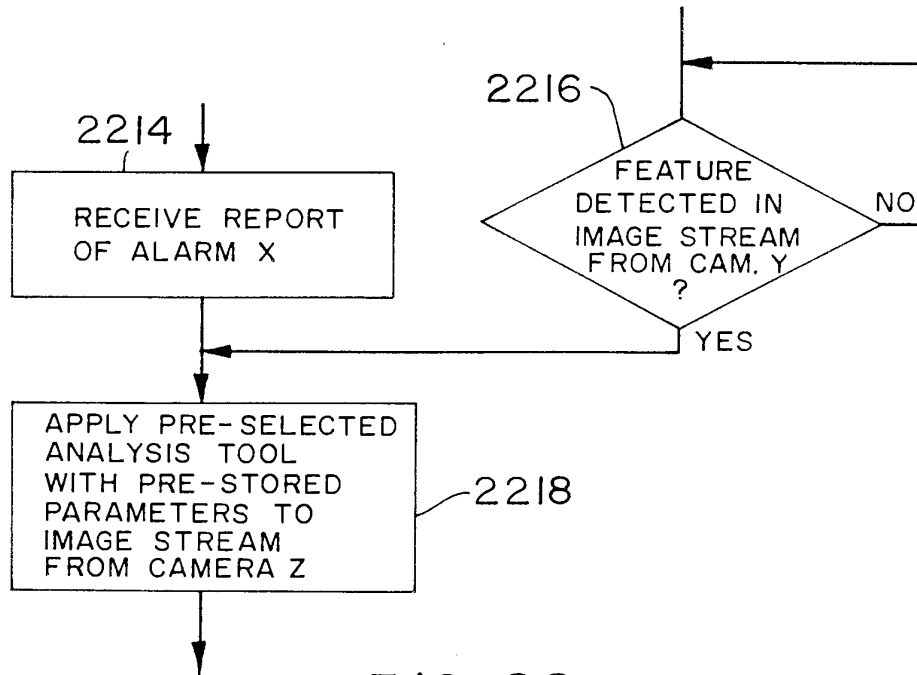
91/158



**FIG. 95C**  
PROCESSING  
THE 'MAYBE' CASE



93/158

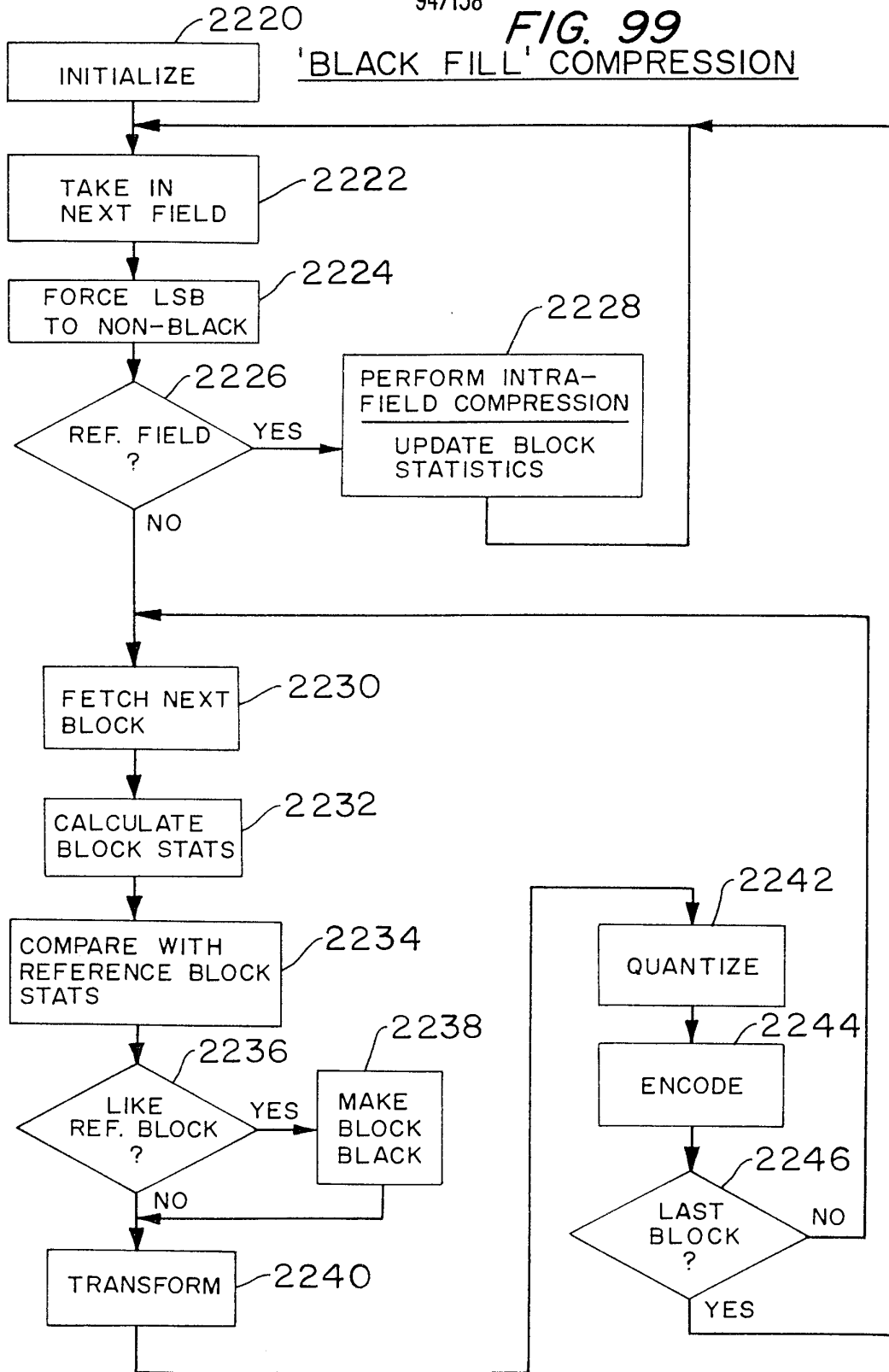


*FIG. 98*  
EVENT-ACTUATED  
LIVE ANALYSIS TOOL

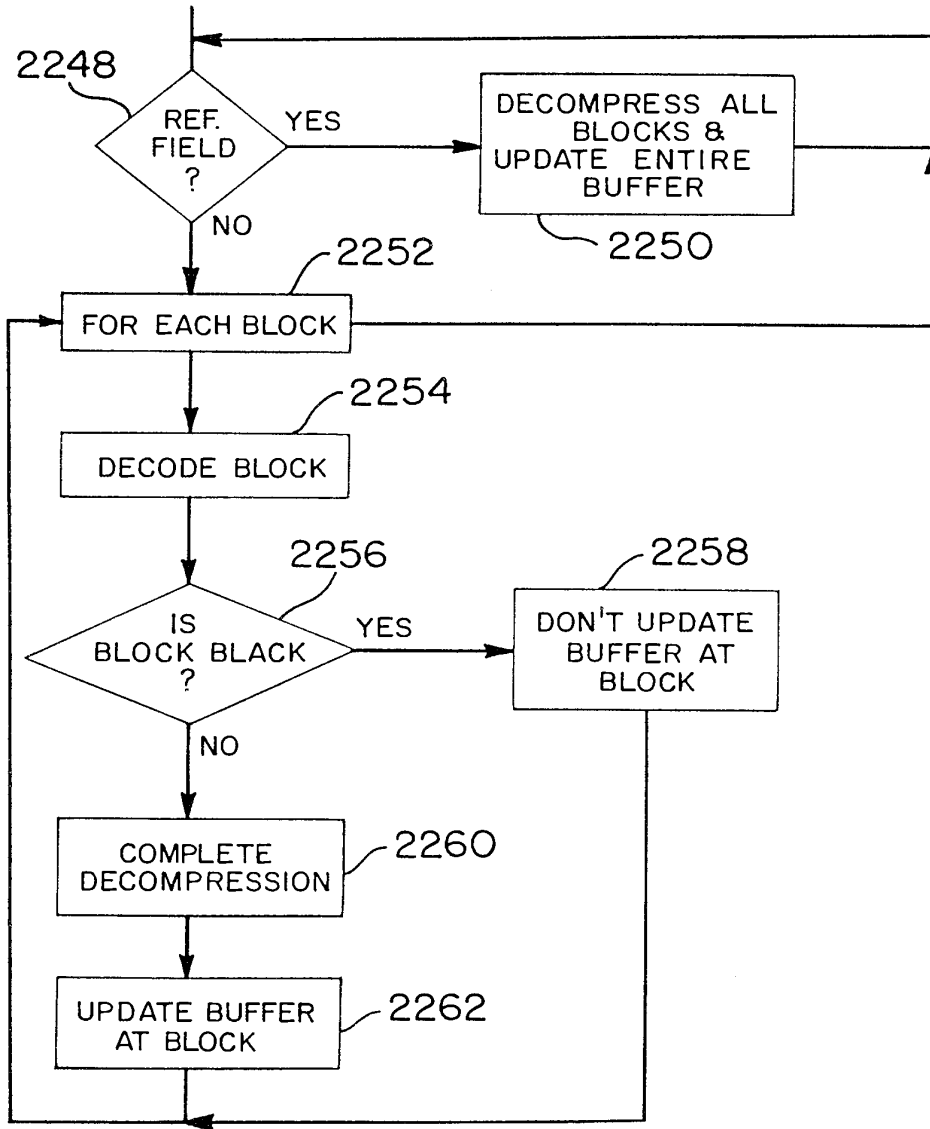
94/158

FIG. 99

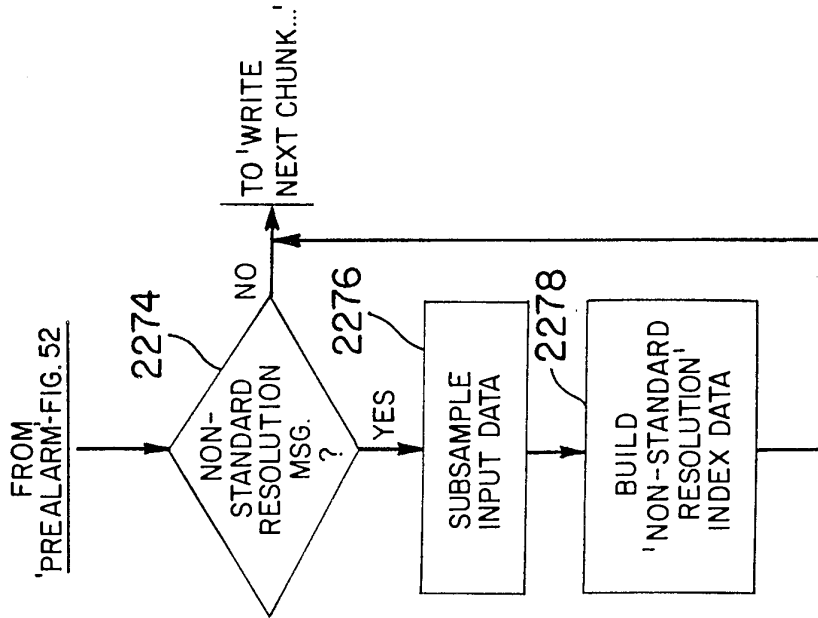
'BLACK FILL' COMPRESSION



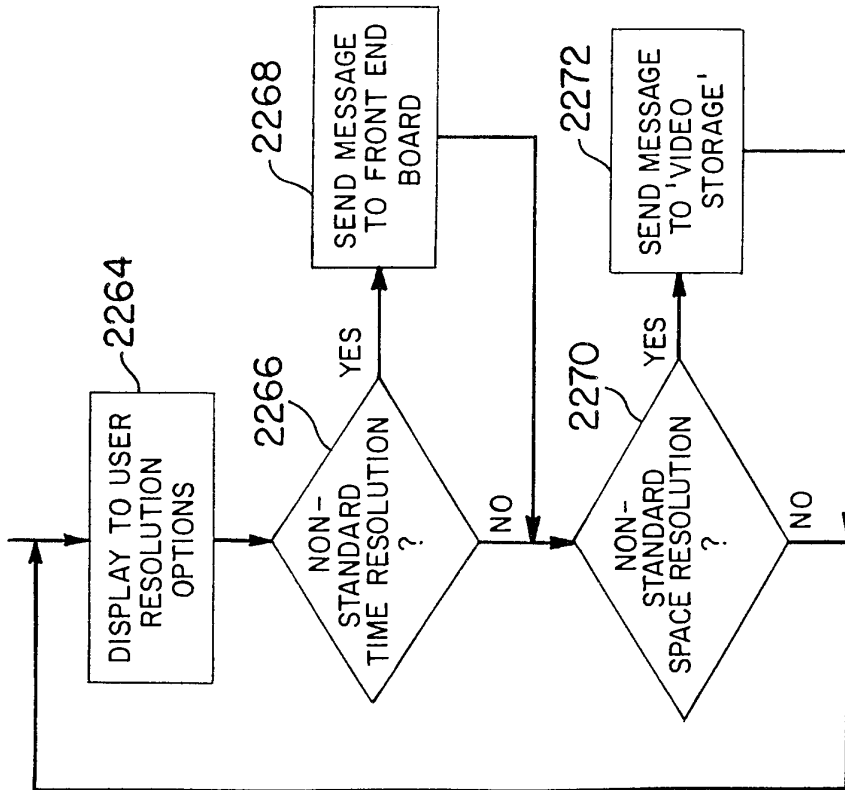
95/158



**FIG. 100**  
'BLACK FILL' DECOMPRESSION



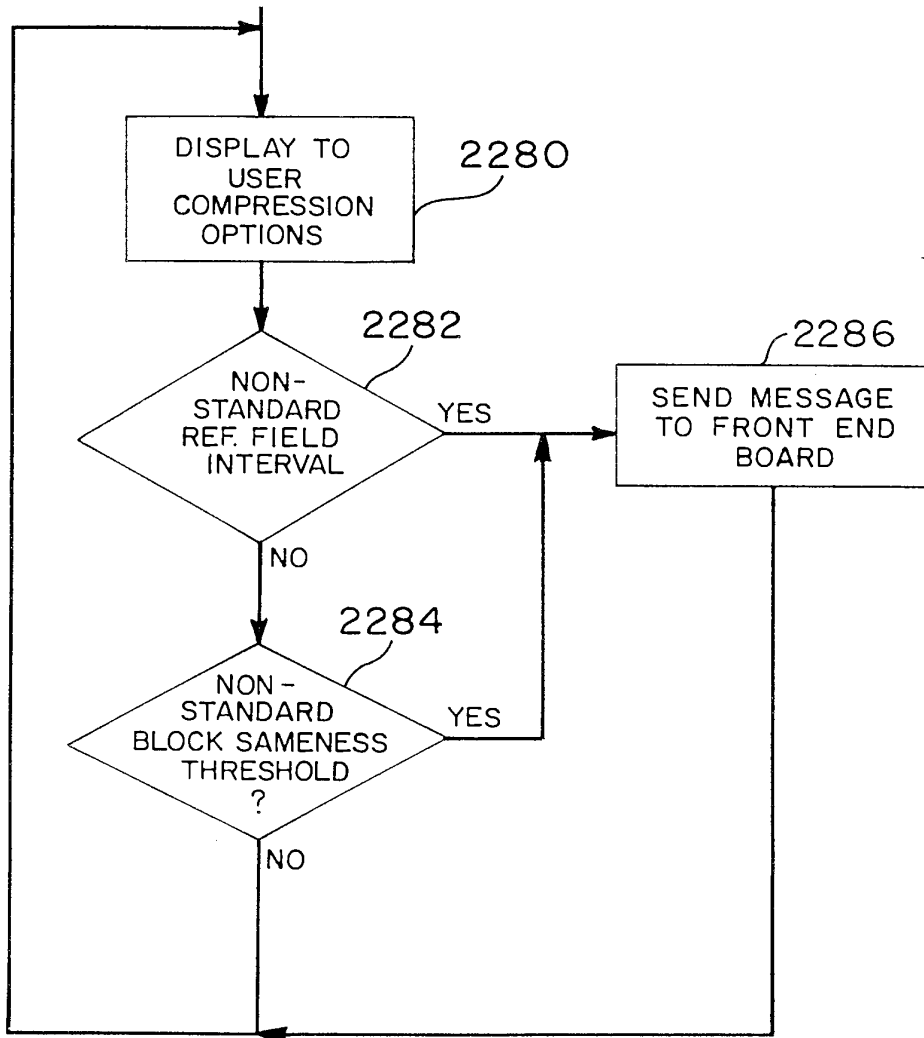
**FIG. 101B**  
VIDEO RESOLUTION - OPERATION



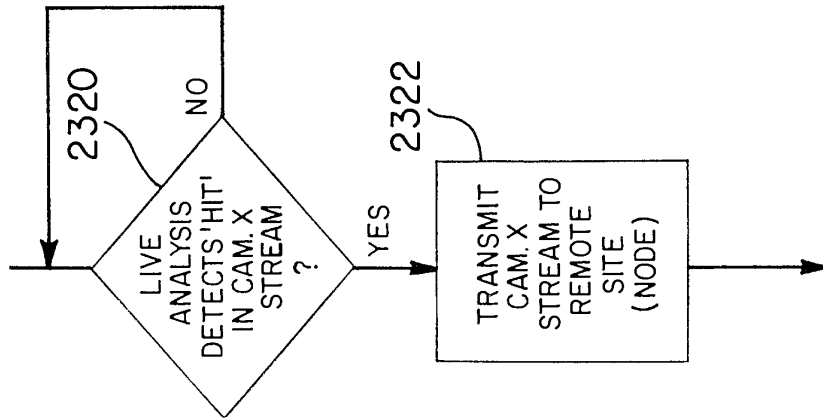
**FIG. 101A**  
VIDEO RESOLUTION - SETUP



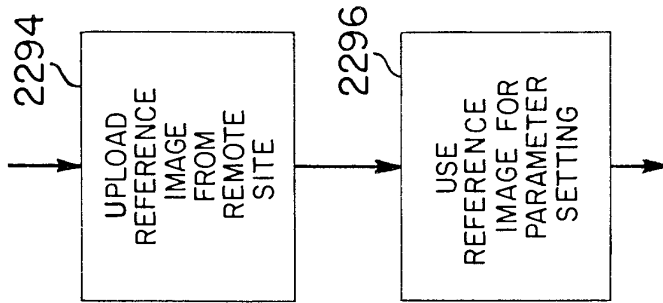
97/158



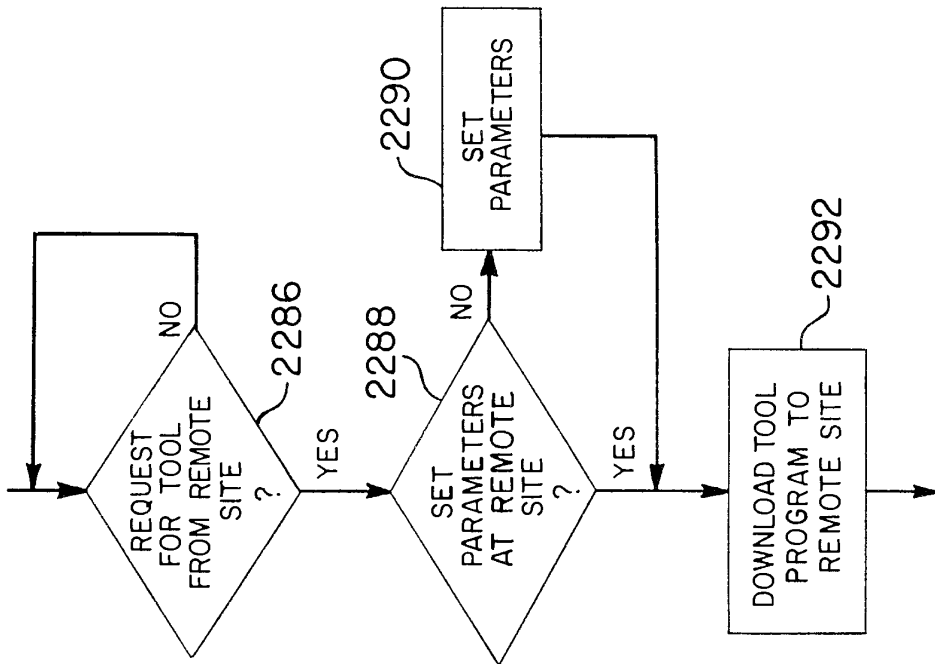
**FIG. 102**  
SETTING COMPRESSION PARAMETERS



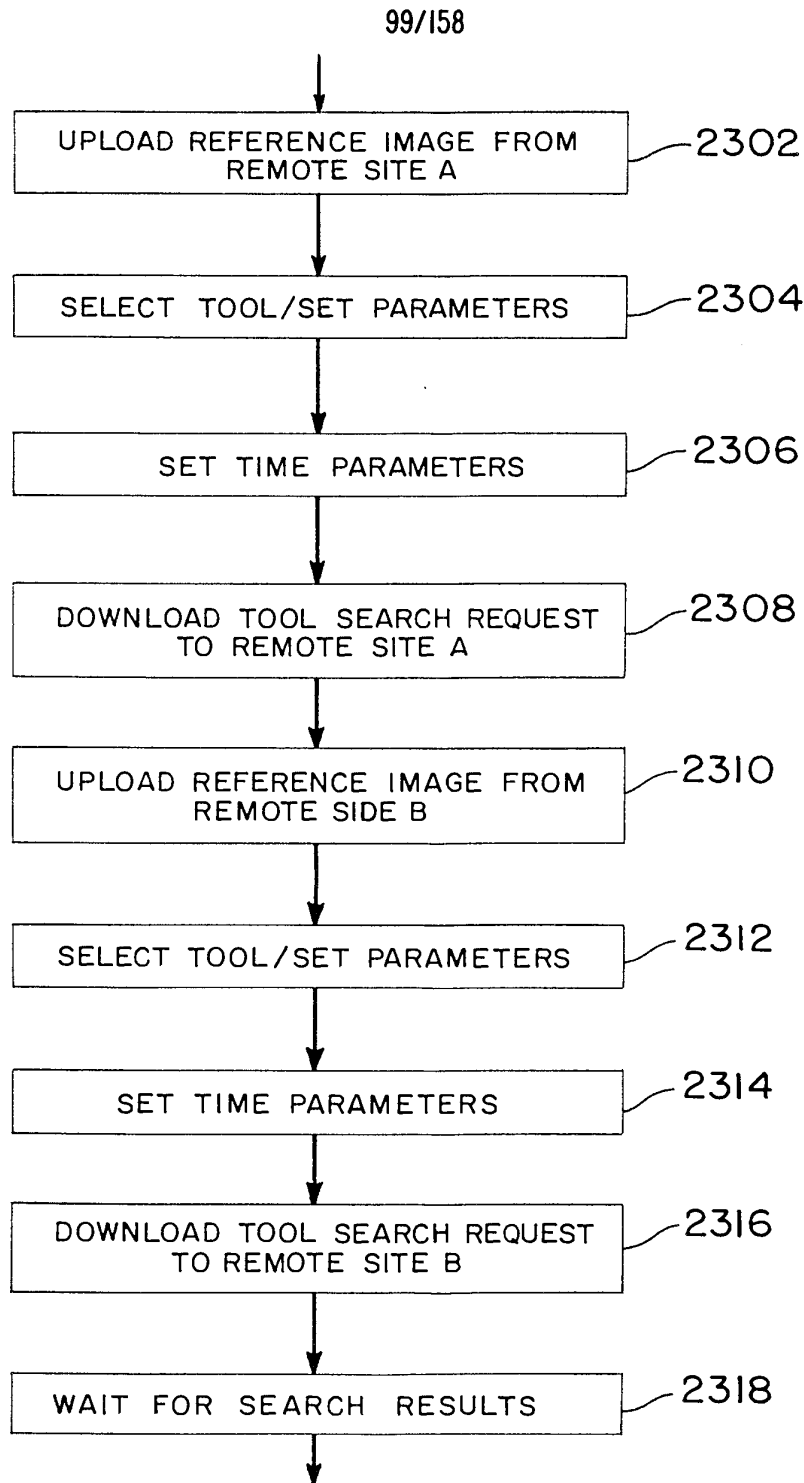
**FIG. 104**  
SOFT-ALARM-  
ACTUATED  
STORAGE



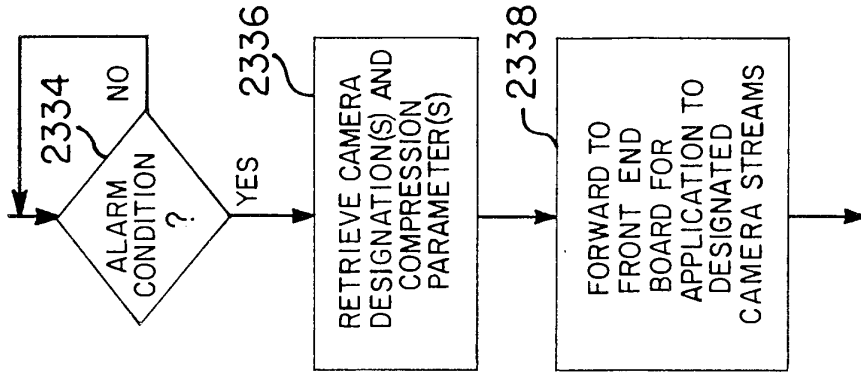
**FIG. 103B**  
DOWNLOADING  
'SET PARAMETERS'



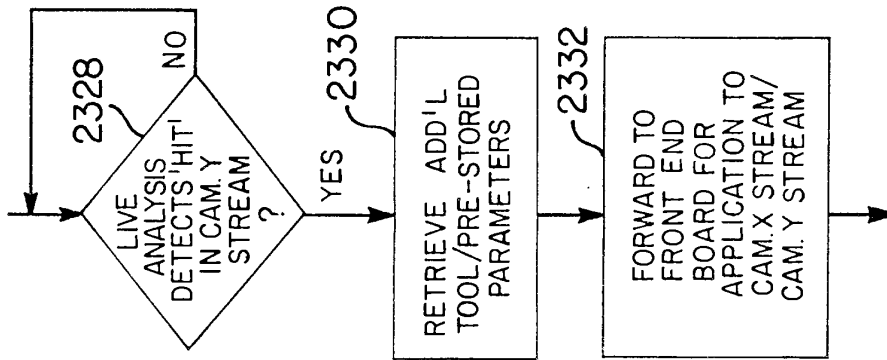
**FIG. 103A**  
DOWNLOADING SEARCH  
TOOLS ON REQUEST



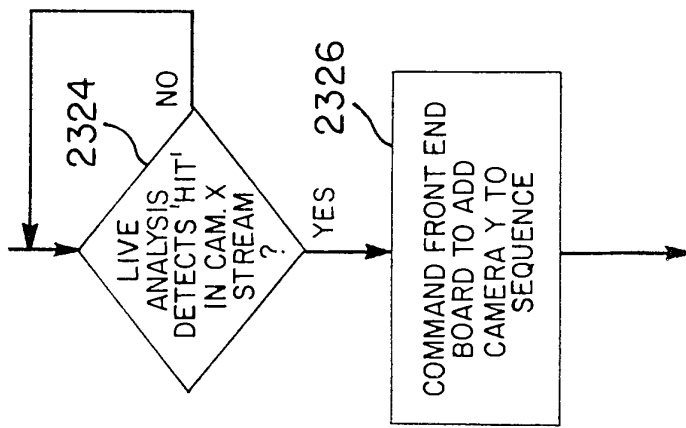
**FIG. 103C**  
DOWNLOADING SEARCH TOOLS TO MULTIPLE SITES



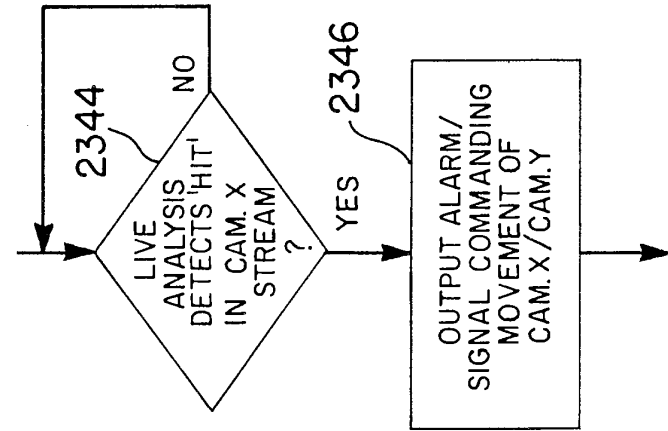
**FIG. 107**  
ALARM - ACTUATED  
CHANGE IN  
COMPRESSION



**FIG. 106**  
SOFT-ALARM - ACTUATED  
LIVE ANALYSIS

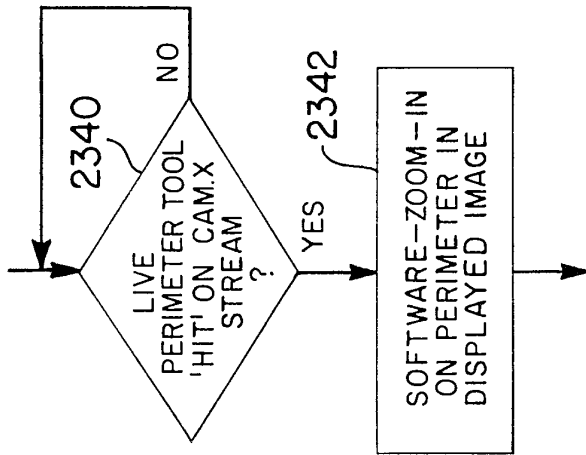


**FIG. 105**  
SOFT-ALARM - ACTUATED  
CAMERA SEQUENCING



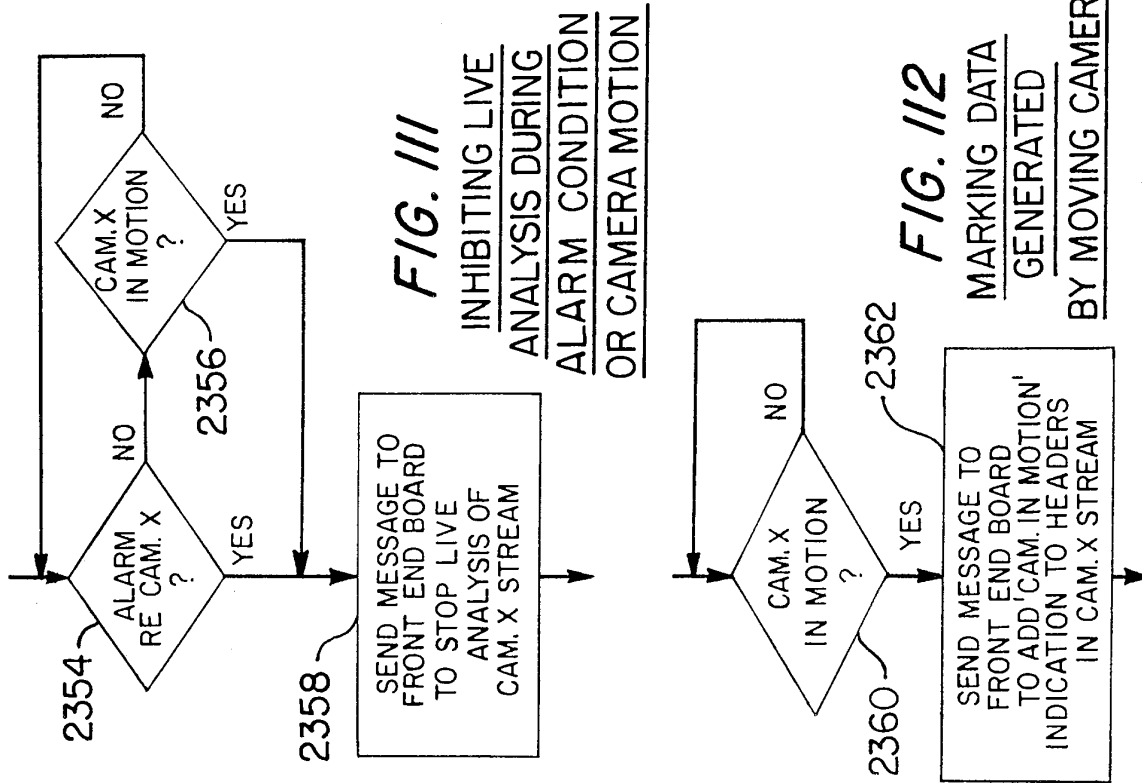
**FIG. 109**

SOFT-ALARM-ACTUATED  
CAMERA TARGETING



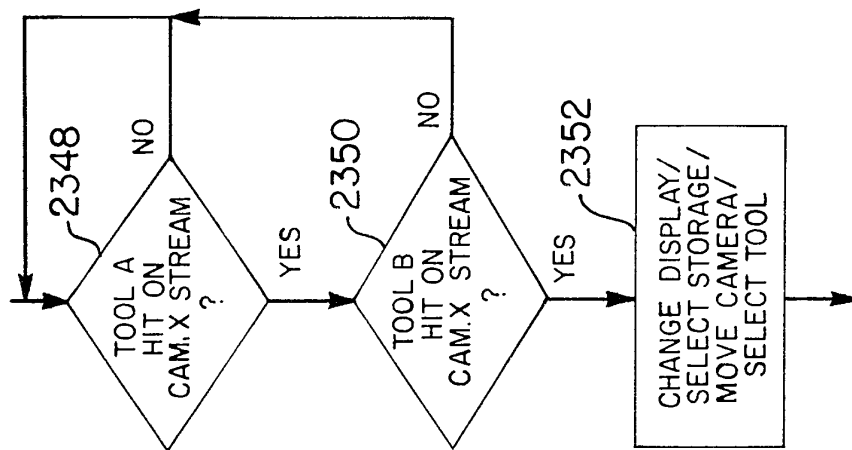
**FIG. 108**

SOFT-ALARM-ACTUATED  
ZOOM-IN



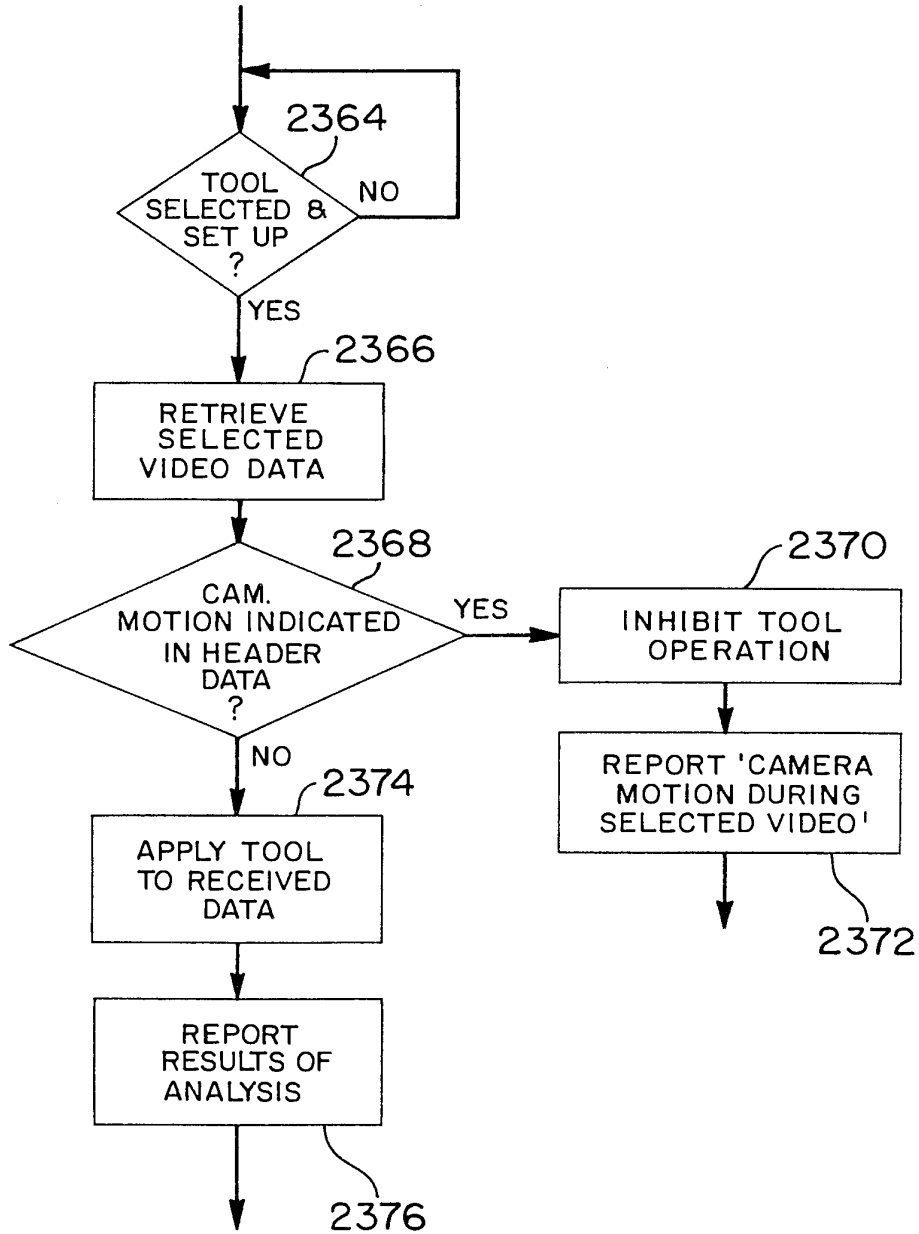
**FIG. III**  
INHIBITING LIVE ANALYSIS DURING ALARM CONDITION OR CAMERA MOTION

**FIG. I12**  
MARKING DATA GENERATED BY MOVING CAMERA



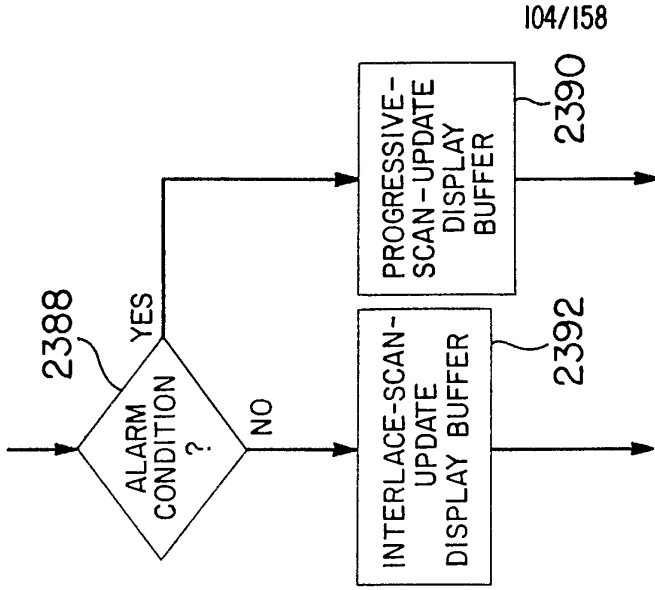
**FIG. I10**  
SYSTEM RESPONSE TO HITS BY MULTIPLE TOOLS

103/158



**FIG. 112A**

INHIBITING PLAYBACK ANALYSIS OF DATA GENERATED  
BY MOVING CAMERA



104/158

FIG. 115

EVENT-SENSITIVE  
DISPLAY BUFFER  
UPDATING

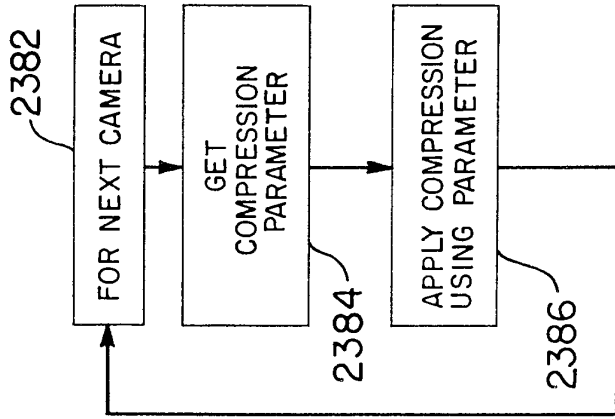


FIG. 114

VARYING  
COMPRESSION  
STREAM-BY-STREAM

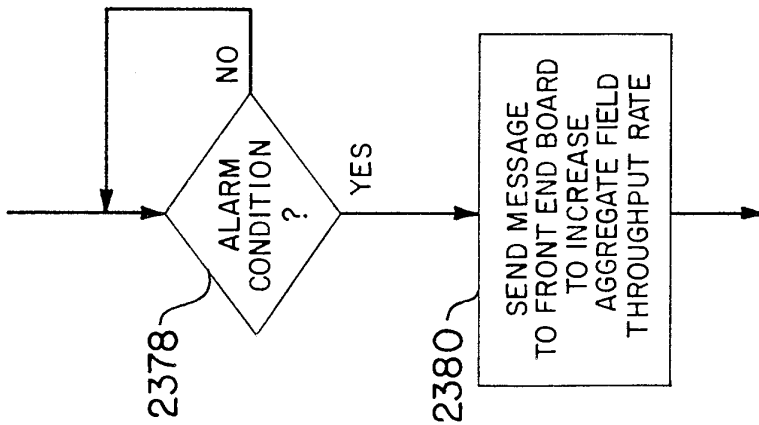
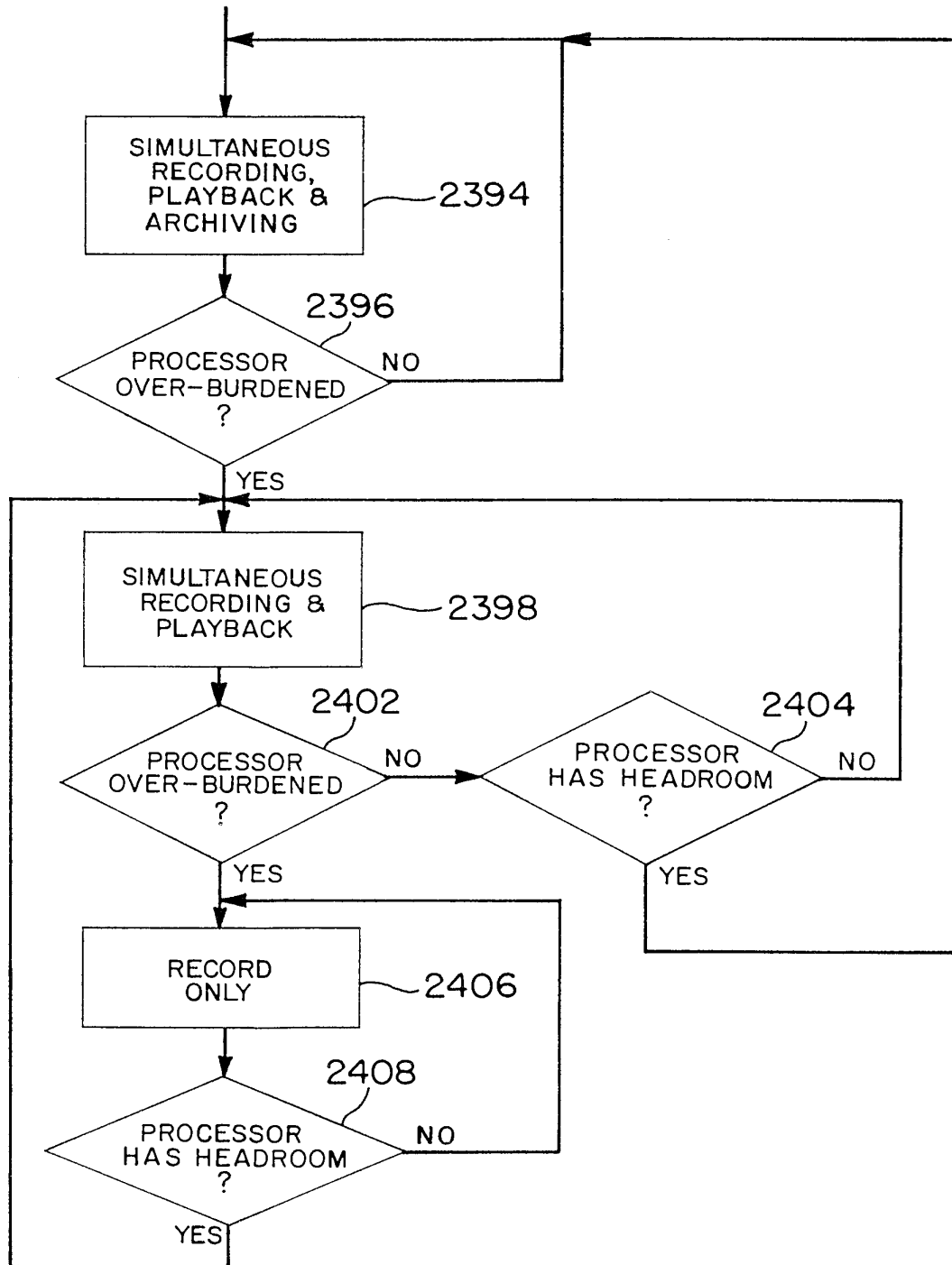


FIG. 113

ALARM-ACTUATED INCREASE  
IN AGGREGATE FIELD CAPTURE  
RATE

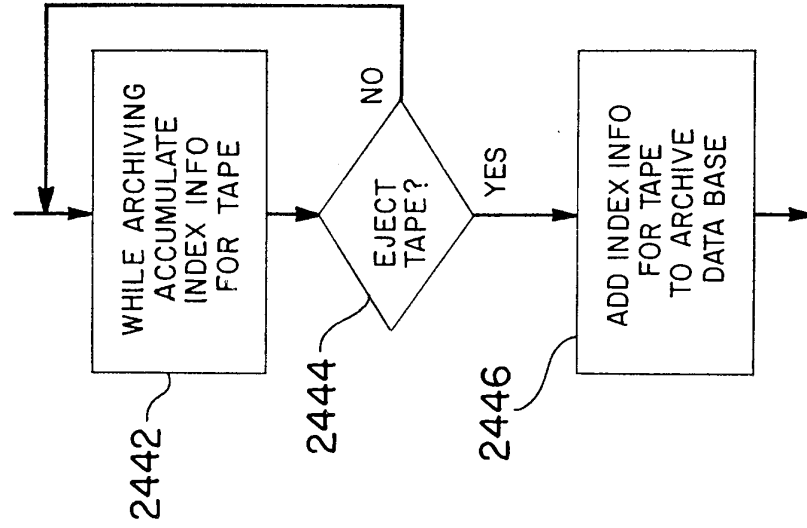


105/158

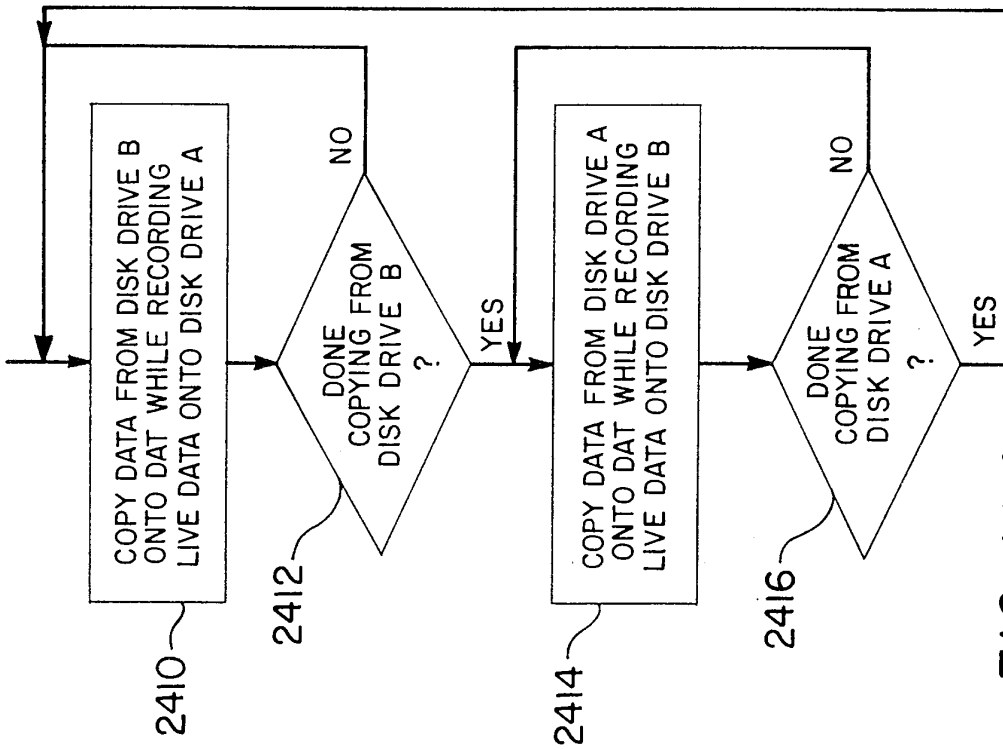


**FIG. 116**

PRIORITIZING AMONG RECORDING/PLAYBACK/  
ARCHIVING

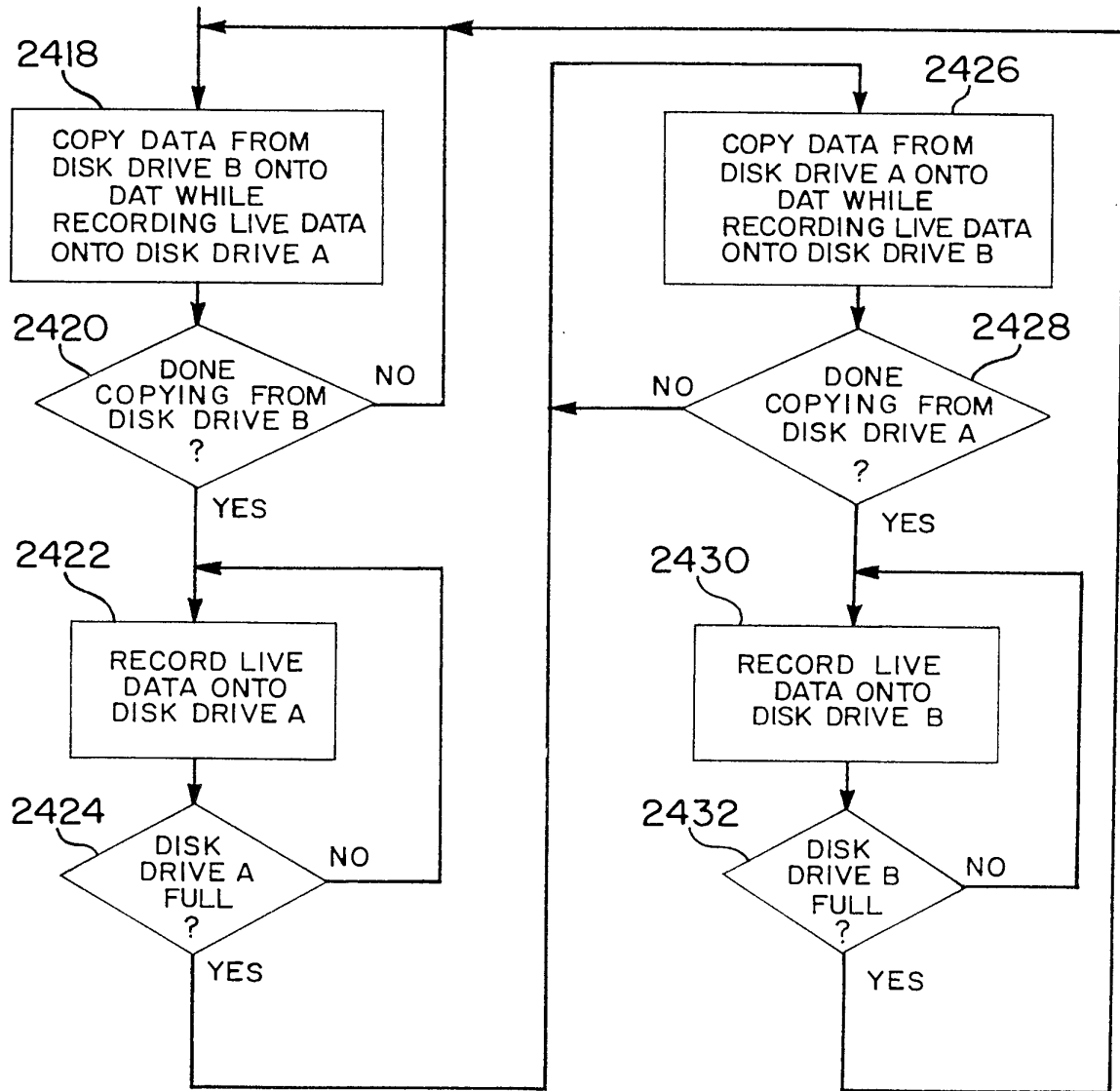


**FIG. 119**  
BUILDING ARCHIVE TAPE DATABASE



**FIG. 117A**  
ARCHIVING SEQUENCE

107/158



*FIG. 117B*

ARCHIVING SEQUENCE (ALTERNATIVE)

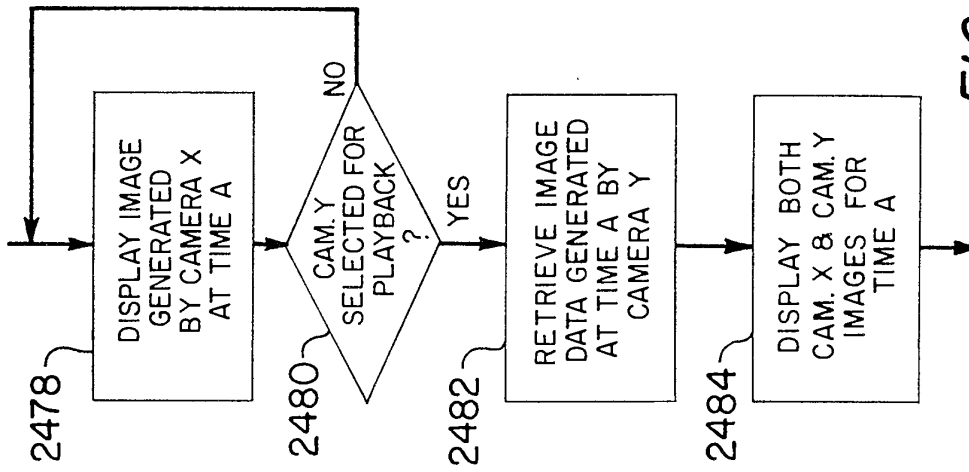


FIG. 122

CONTEXT-SENSITIVE PLAYBACK

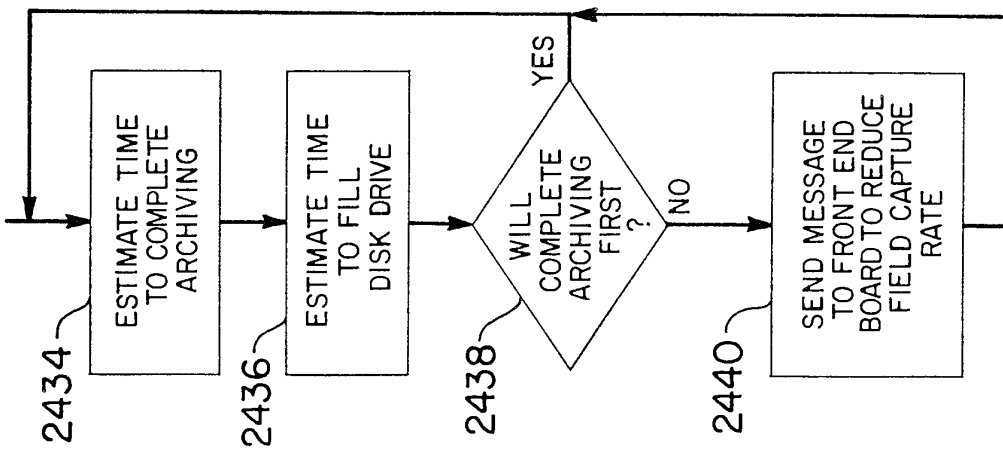
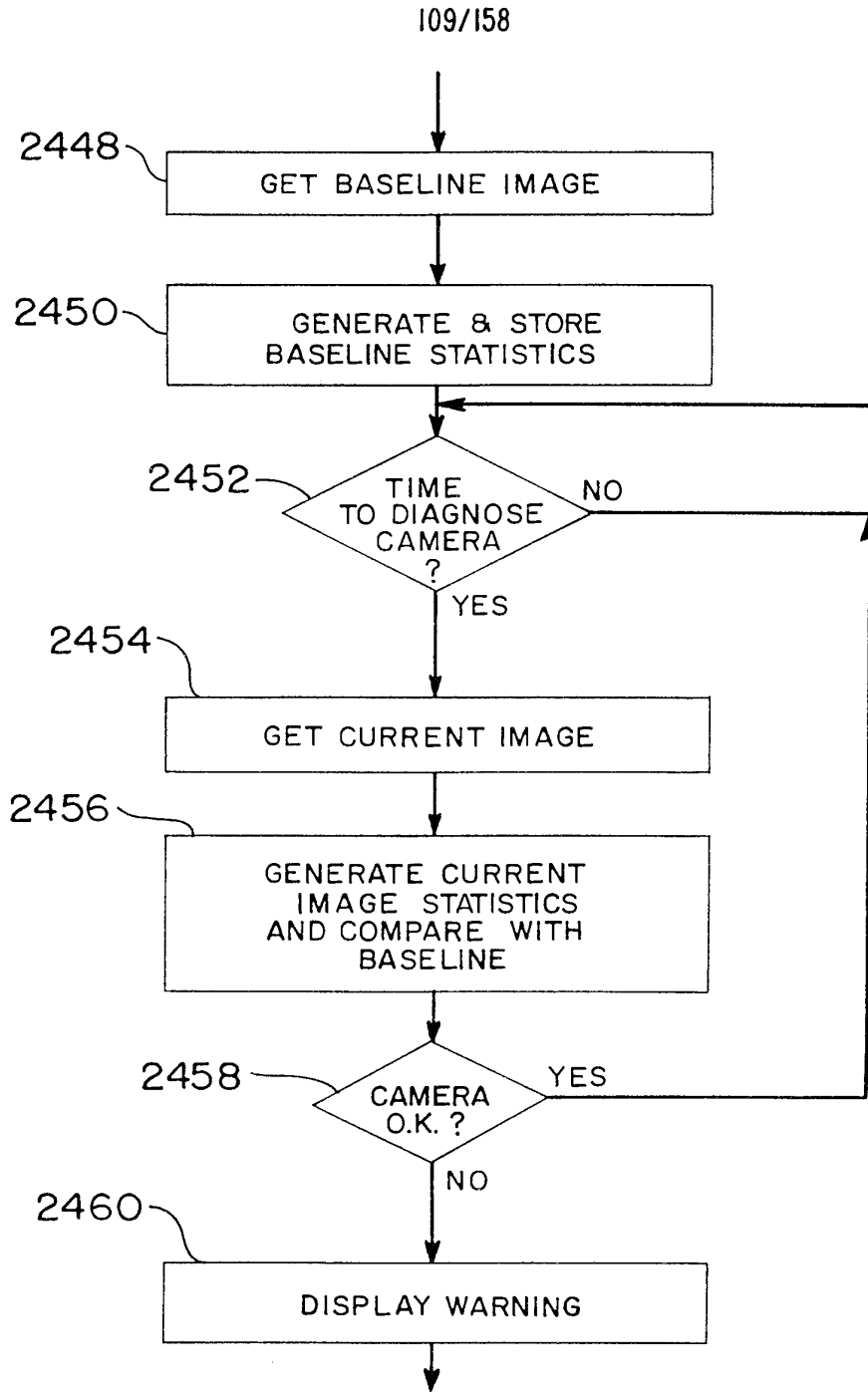
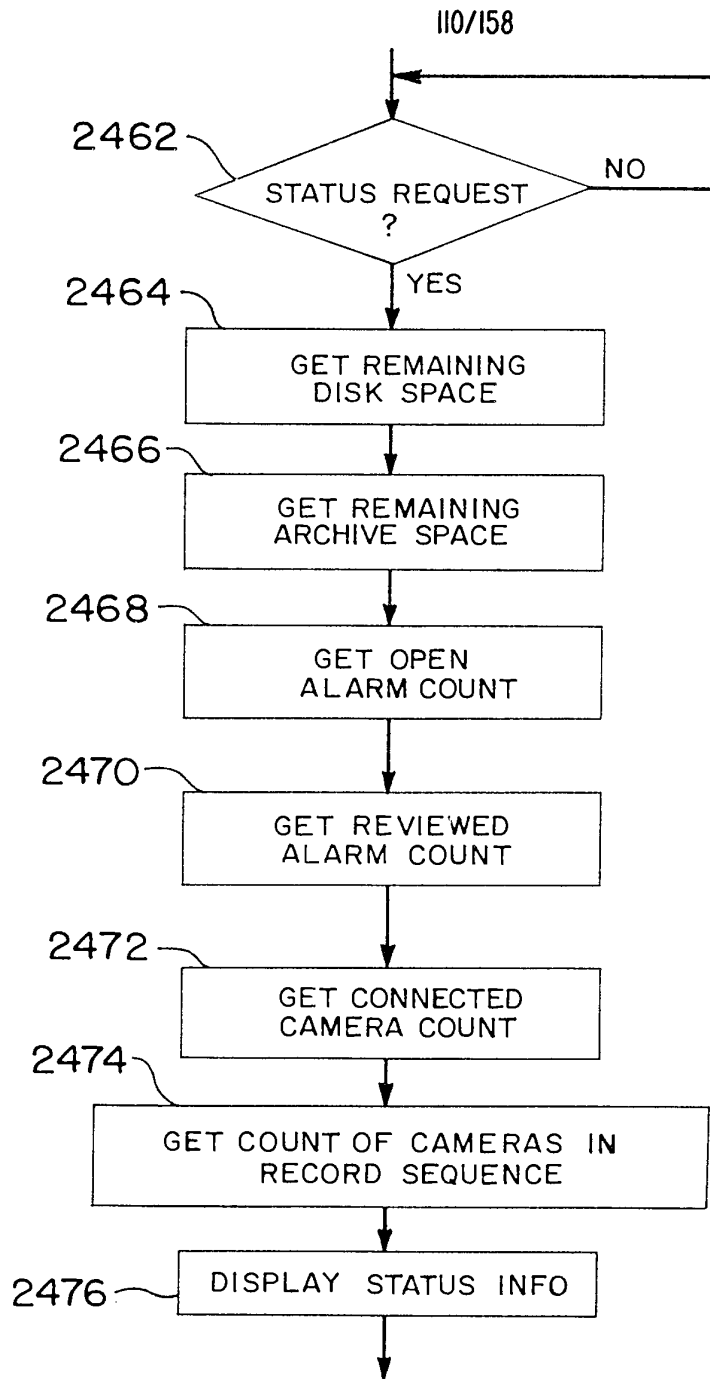


FIG. 118

REDUCING STORAGE RATE TO ACCOMMODATE ARCHIVING



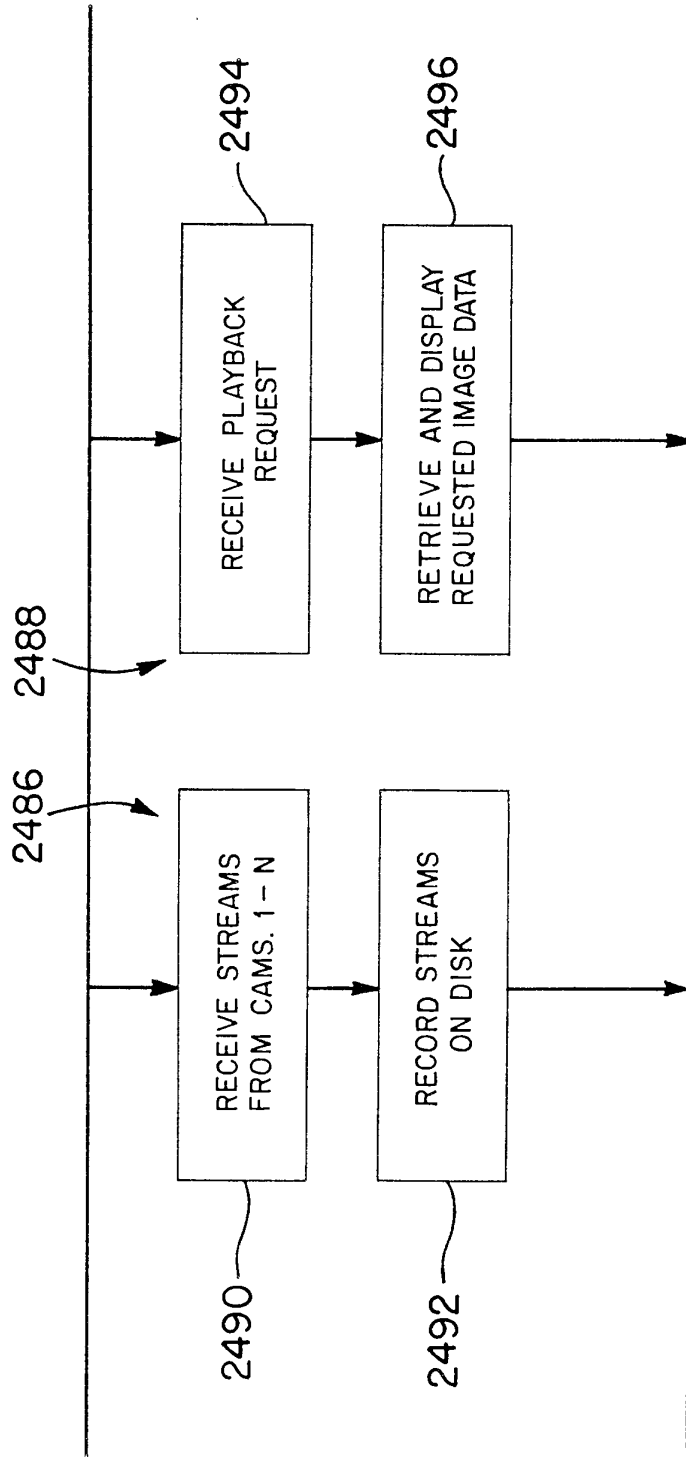
**FIG. 120**  
CAMERA AUTO-DIAGNOSIS



*FIG. 121*

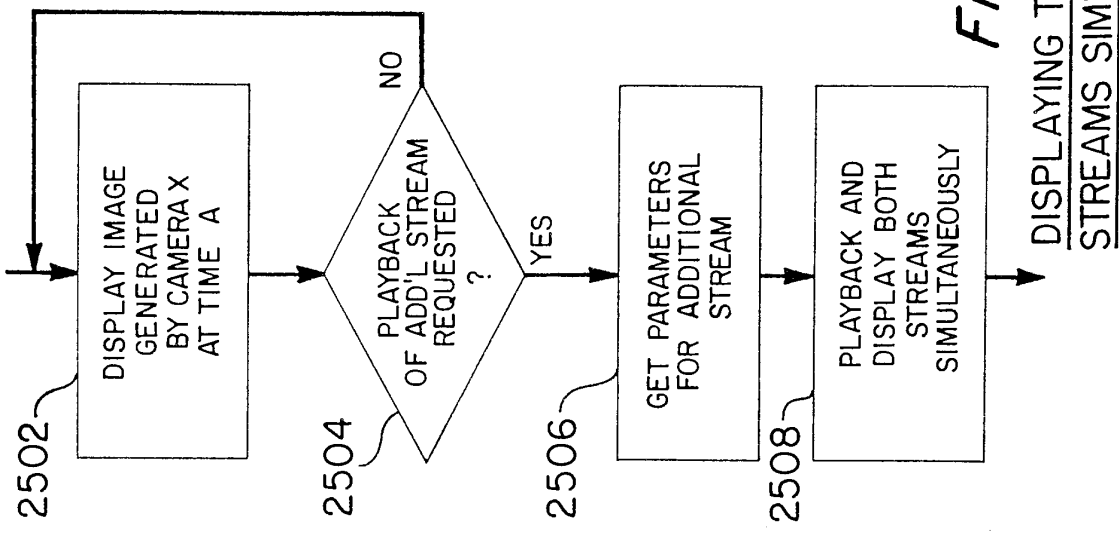
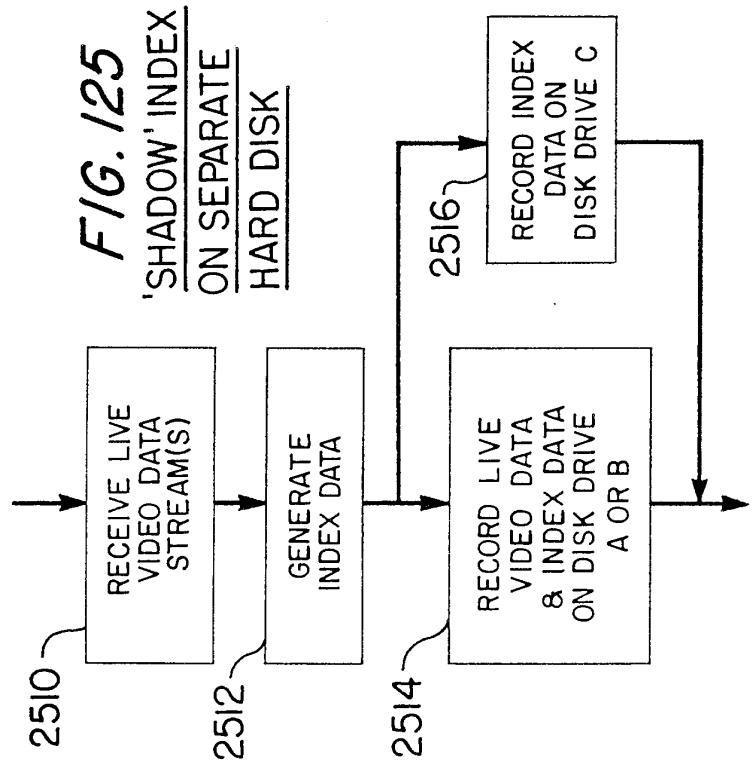
BUILD STATUS DISPLAY

III/158

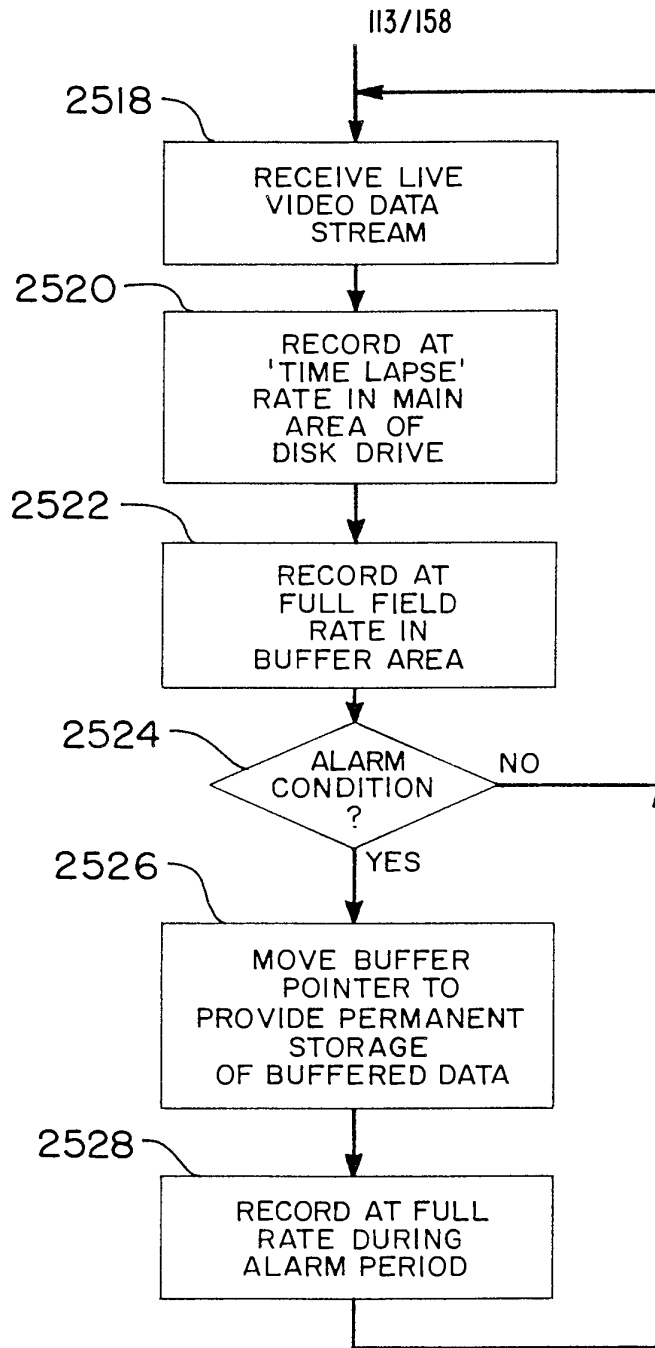


*FIG. 123*  
SIMULTANEOUS RECORDING AND PLAYBACK

112/158

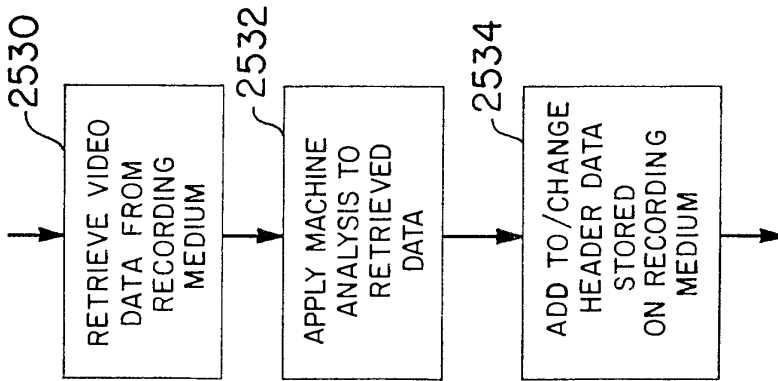




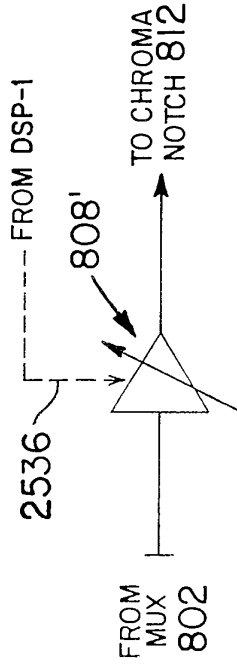


**FIG. 126**

FULL-RATE PRE-ALARM BUFFERING DURING TIME-LAPSE RECORDING



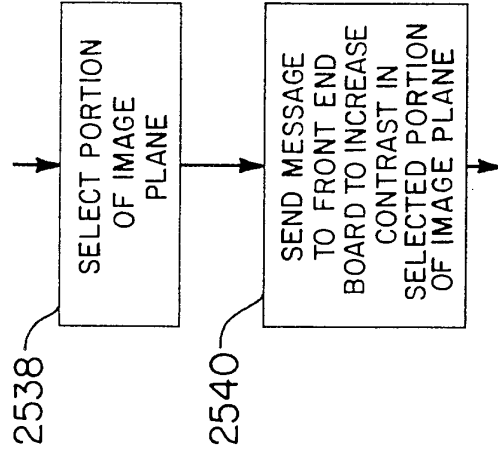
**FIG. 127**  
MACHINE ANALYSIS OF STORED VIDEO DATA



**FIG. 128(a)**

SELECTIVE CONTRAST ENHANCEMENT

**FIG. 128(b)**



115/158

FIG. 129

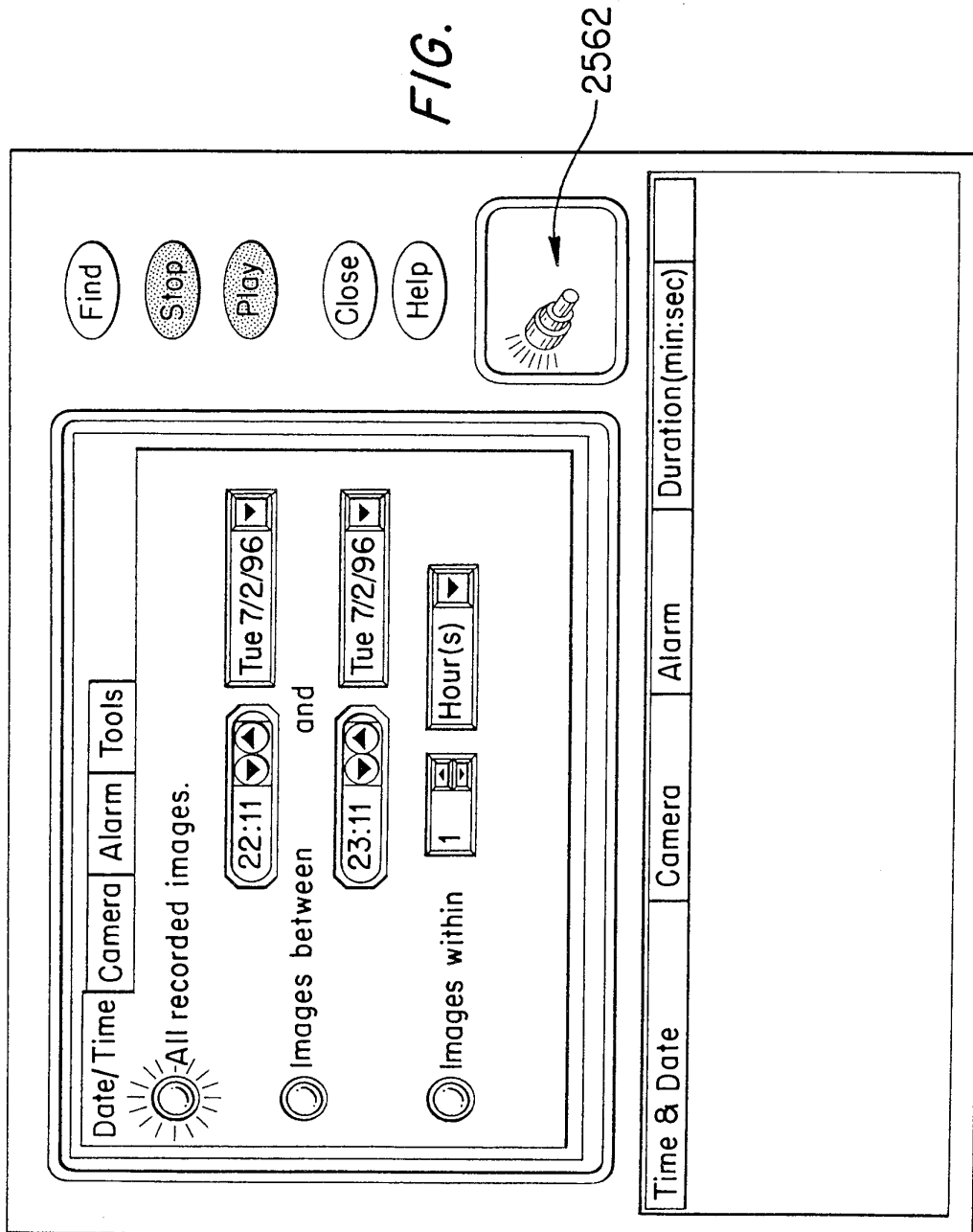
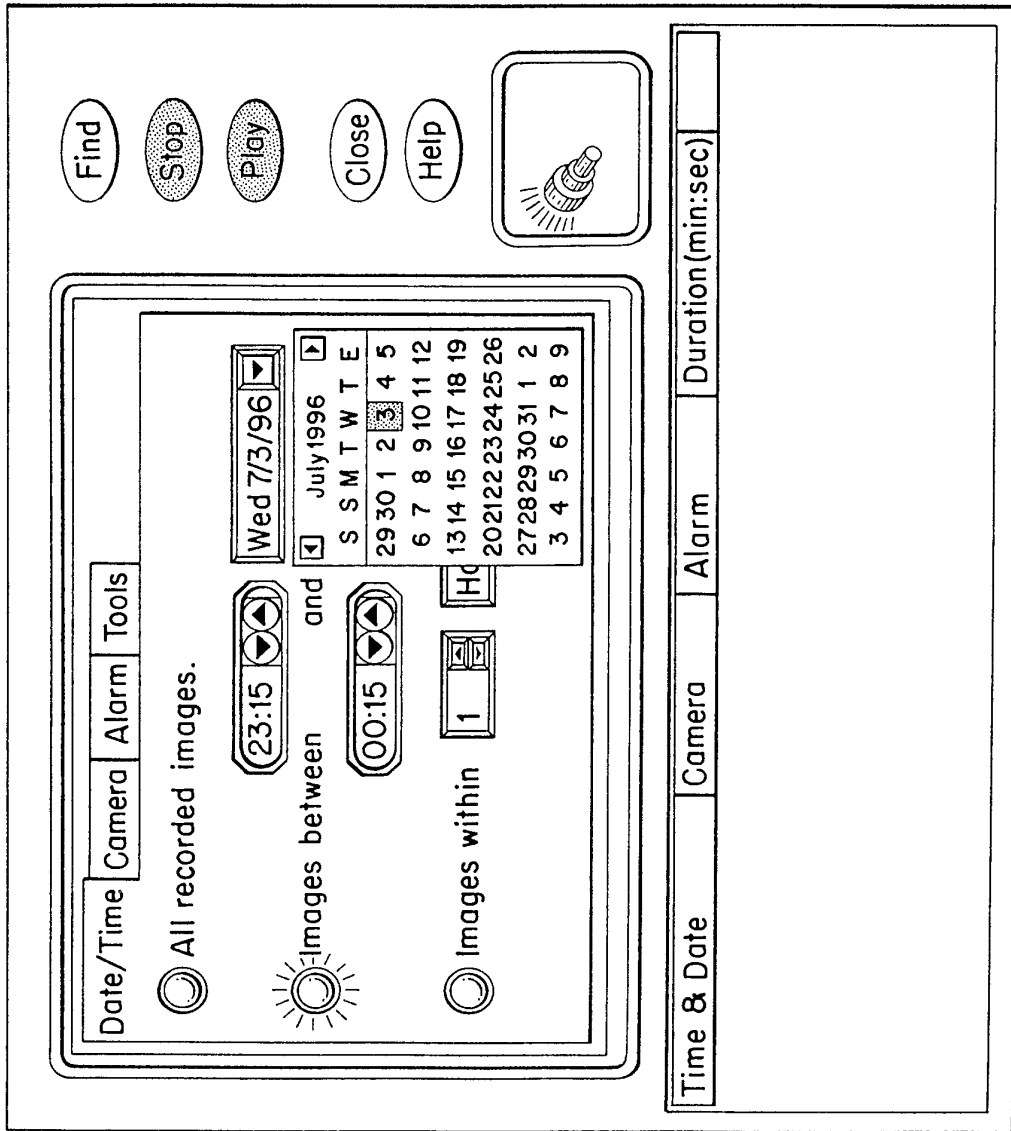
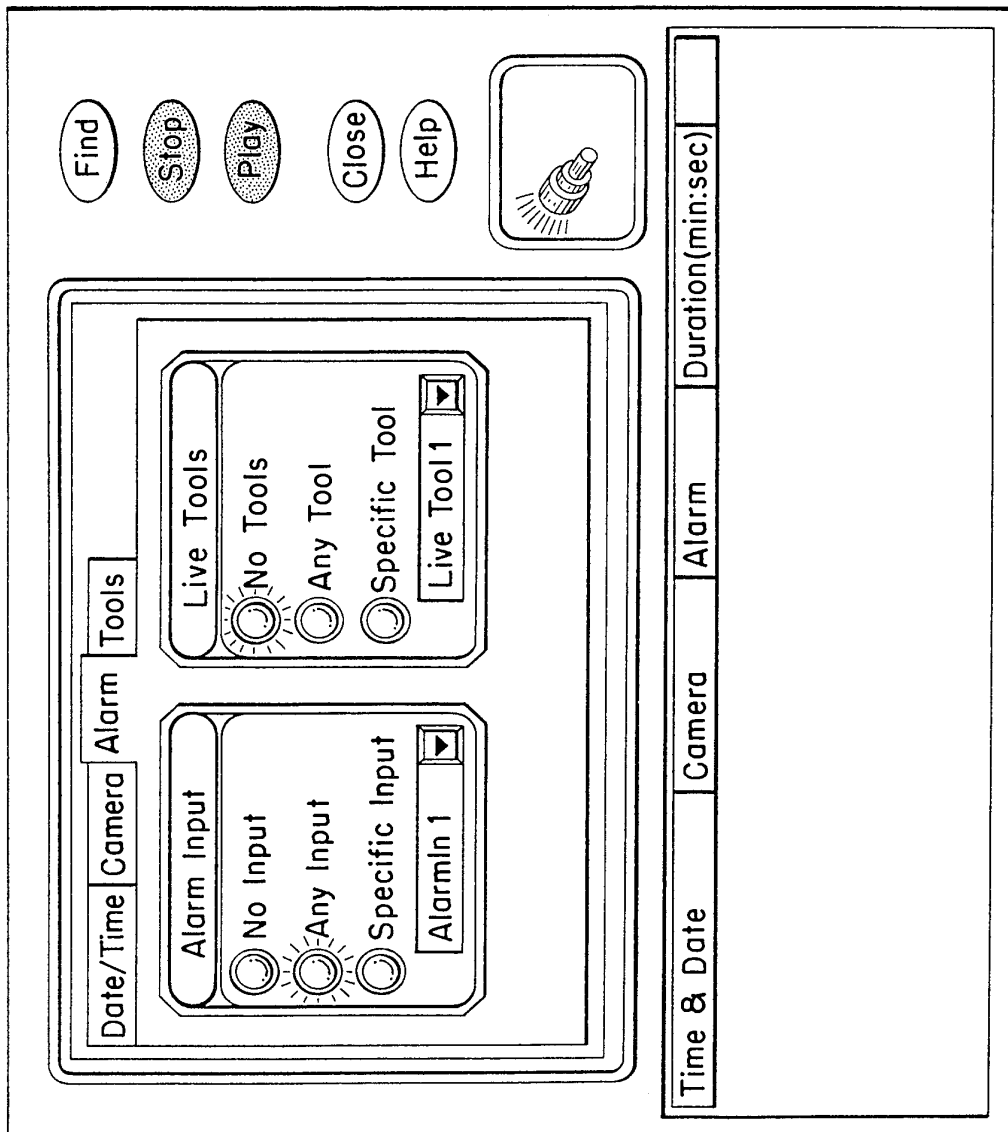


FIG. 130



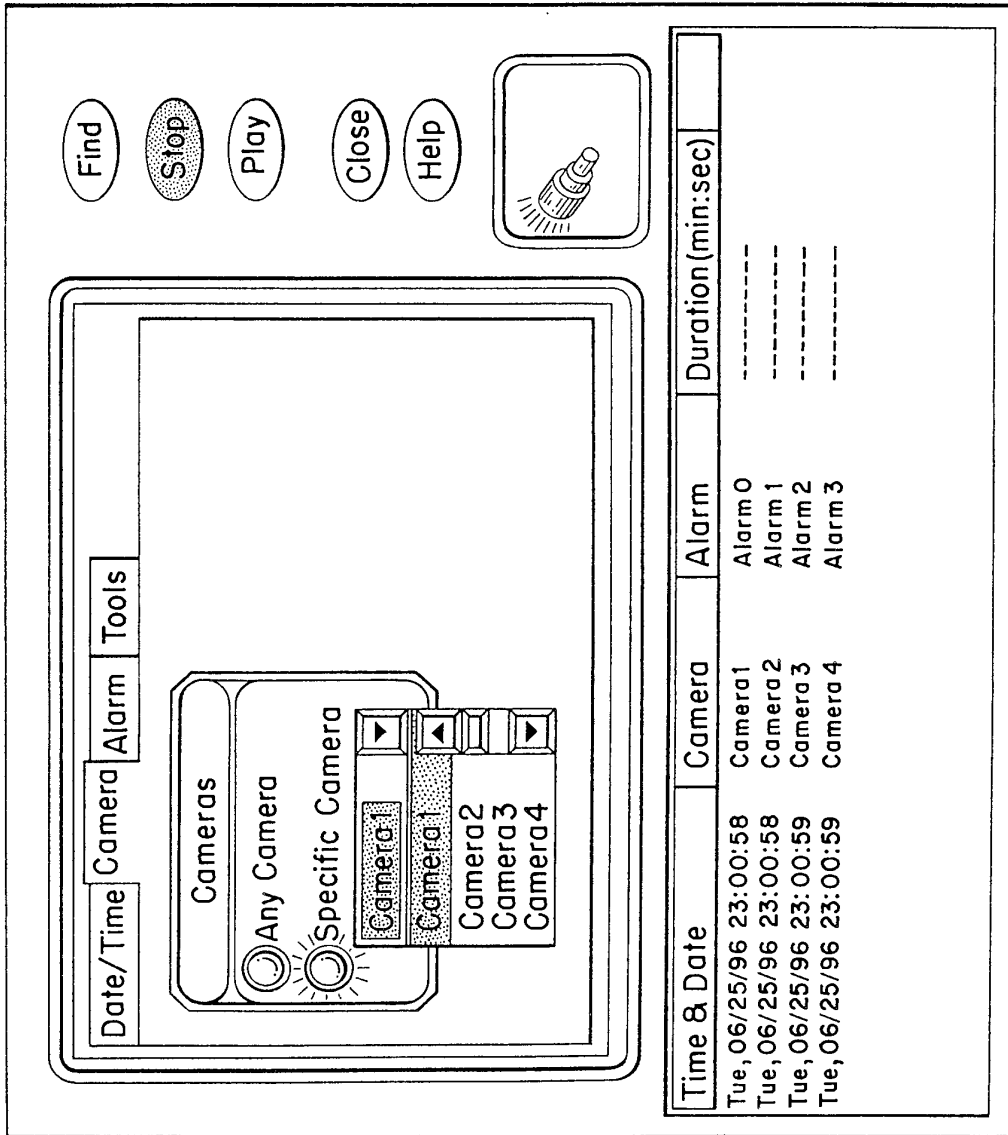
117/158

FIG. 131



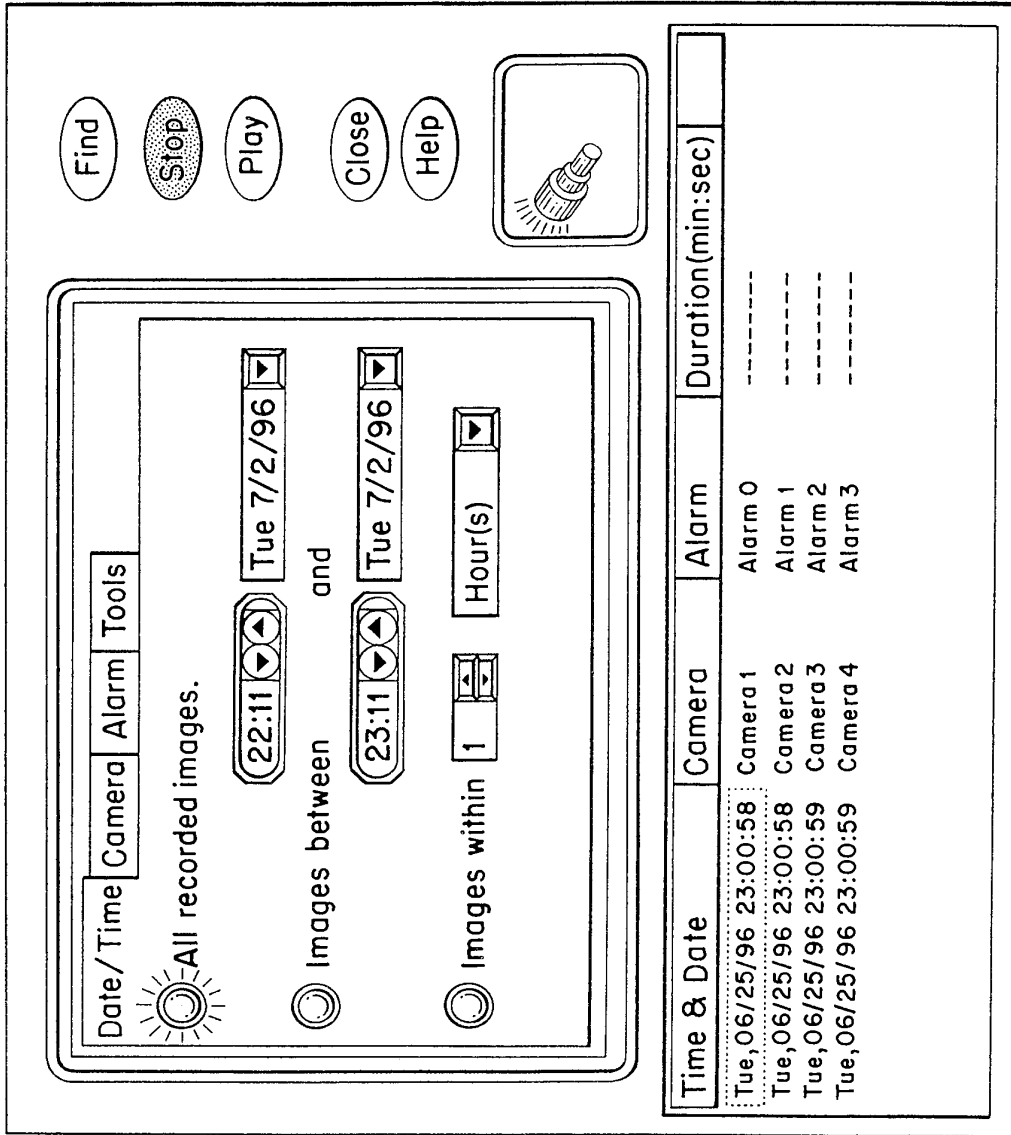
118/158

FIG. 132



119/158

FIG. 133



120/158

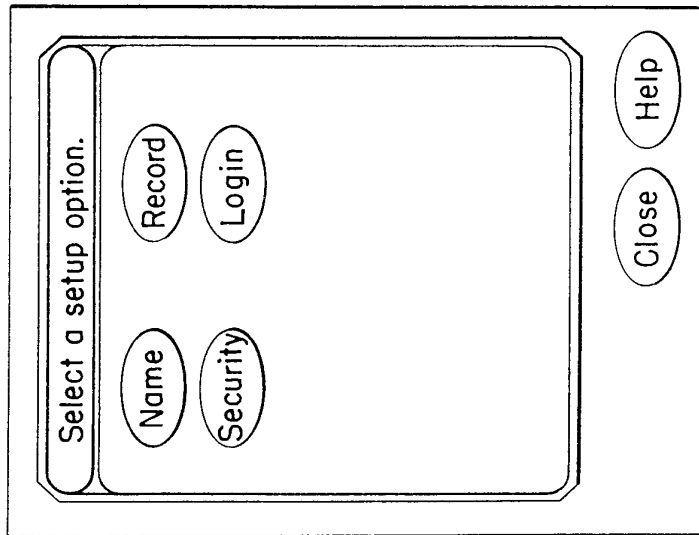


FIG. 134



121/158

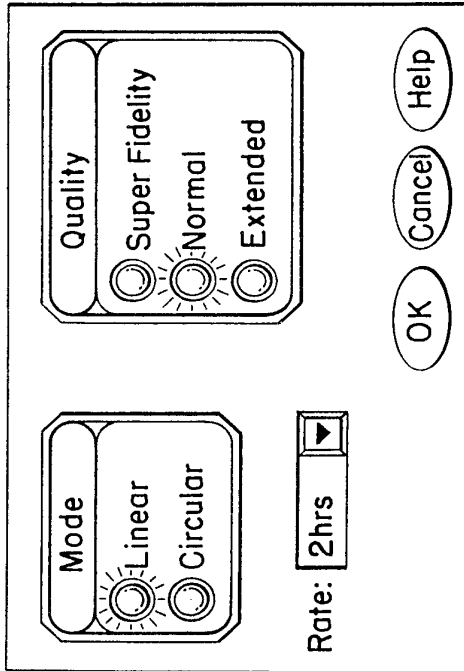


FIG. 135

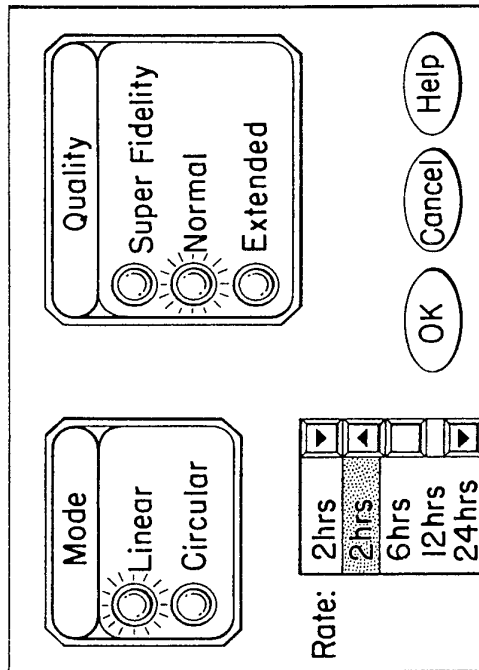


FIG. 136

123/158

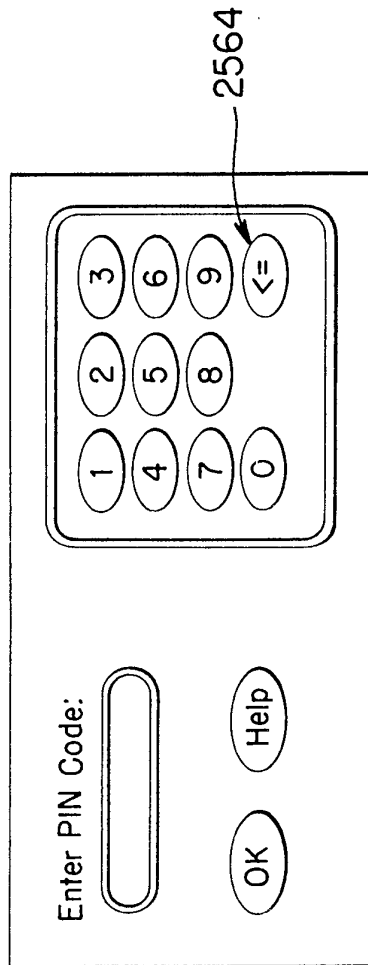
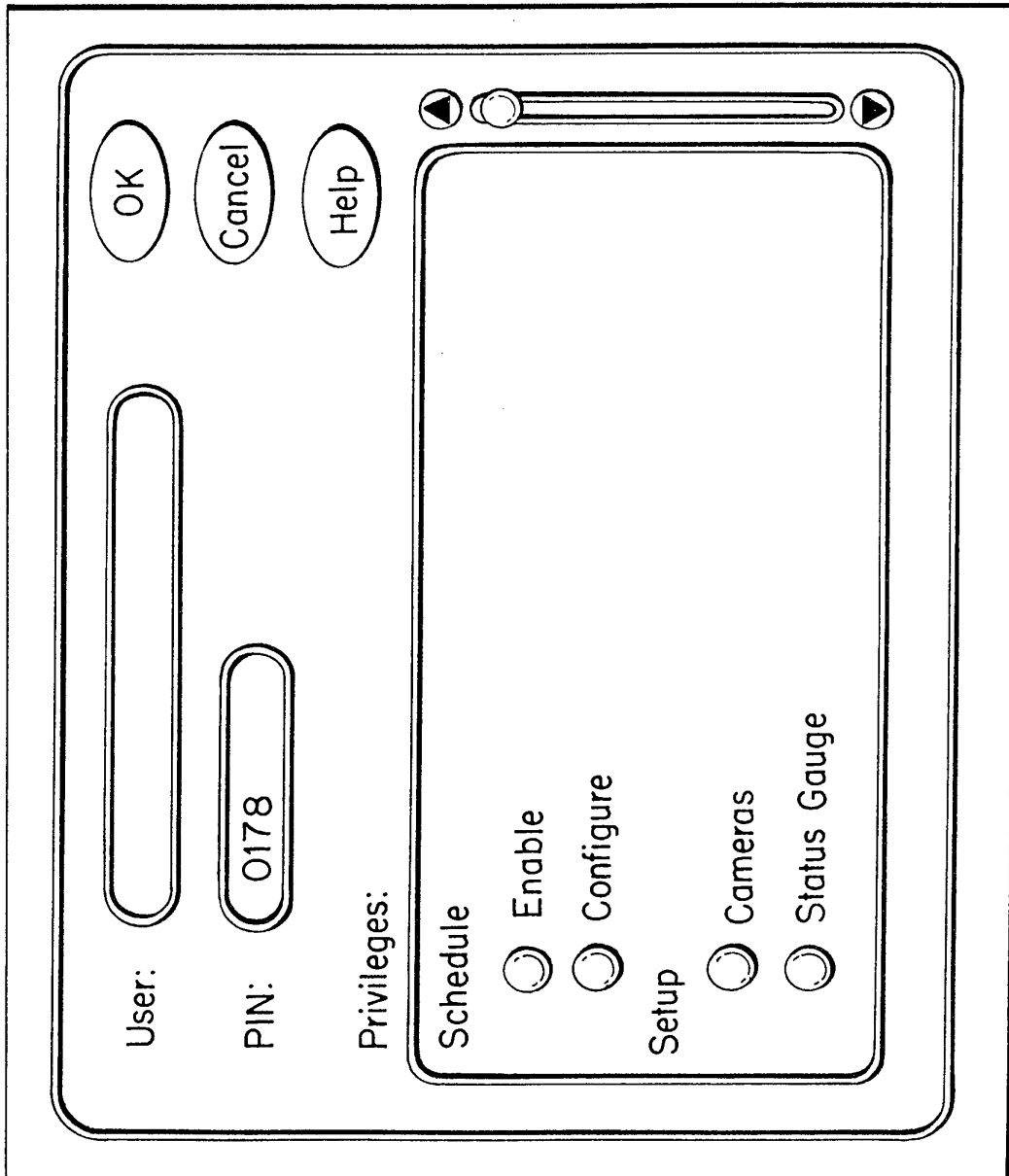


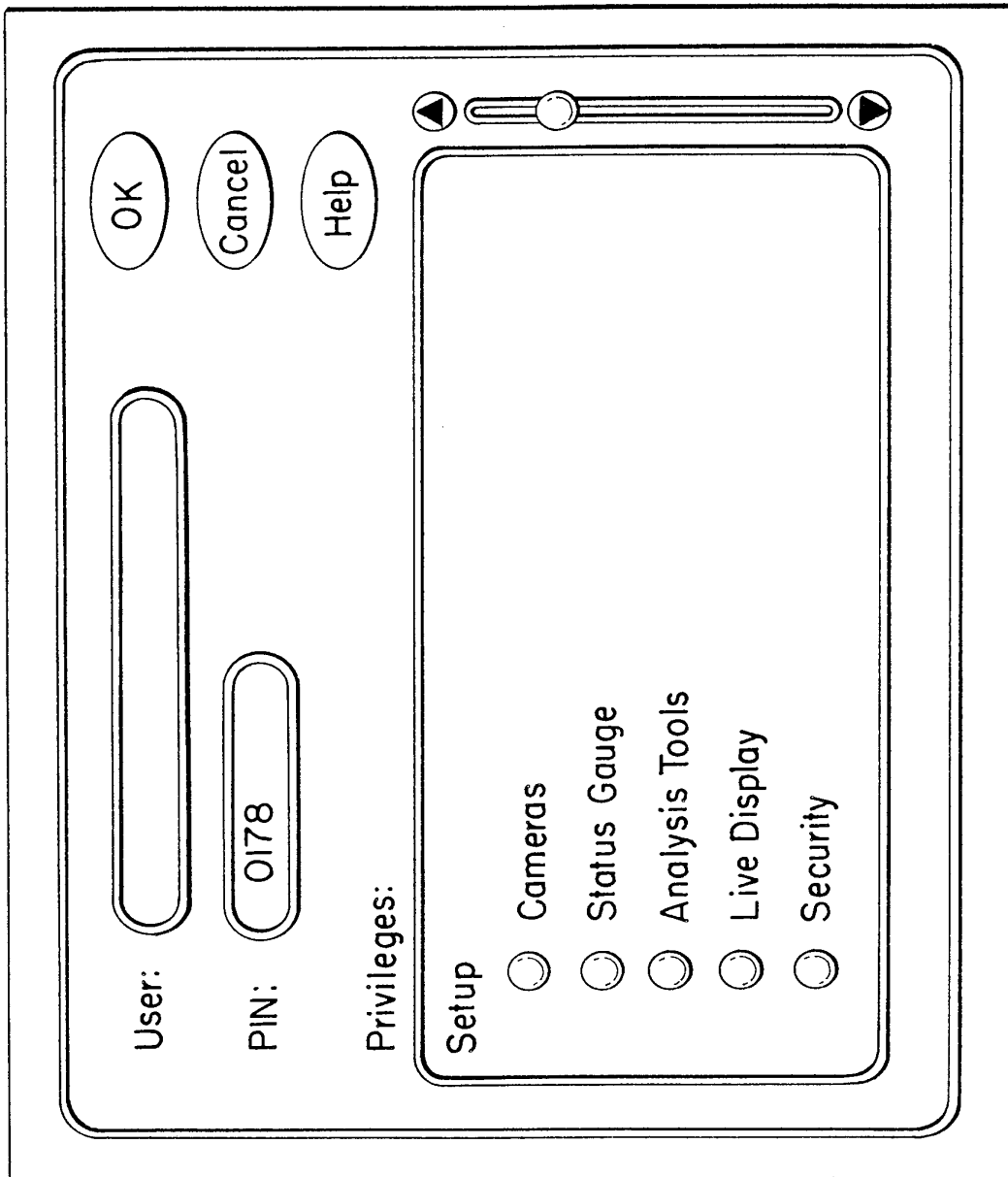
FIG. 137

FIG. 138



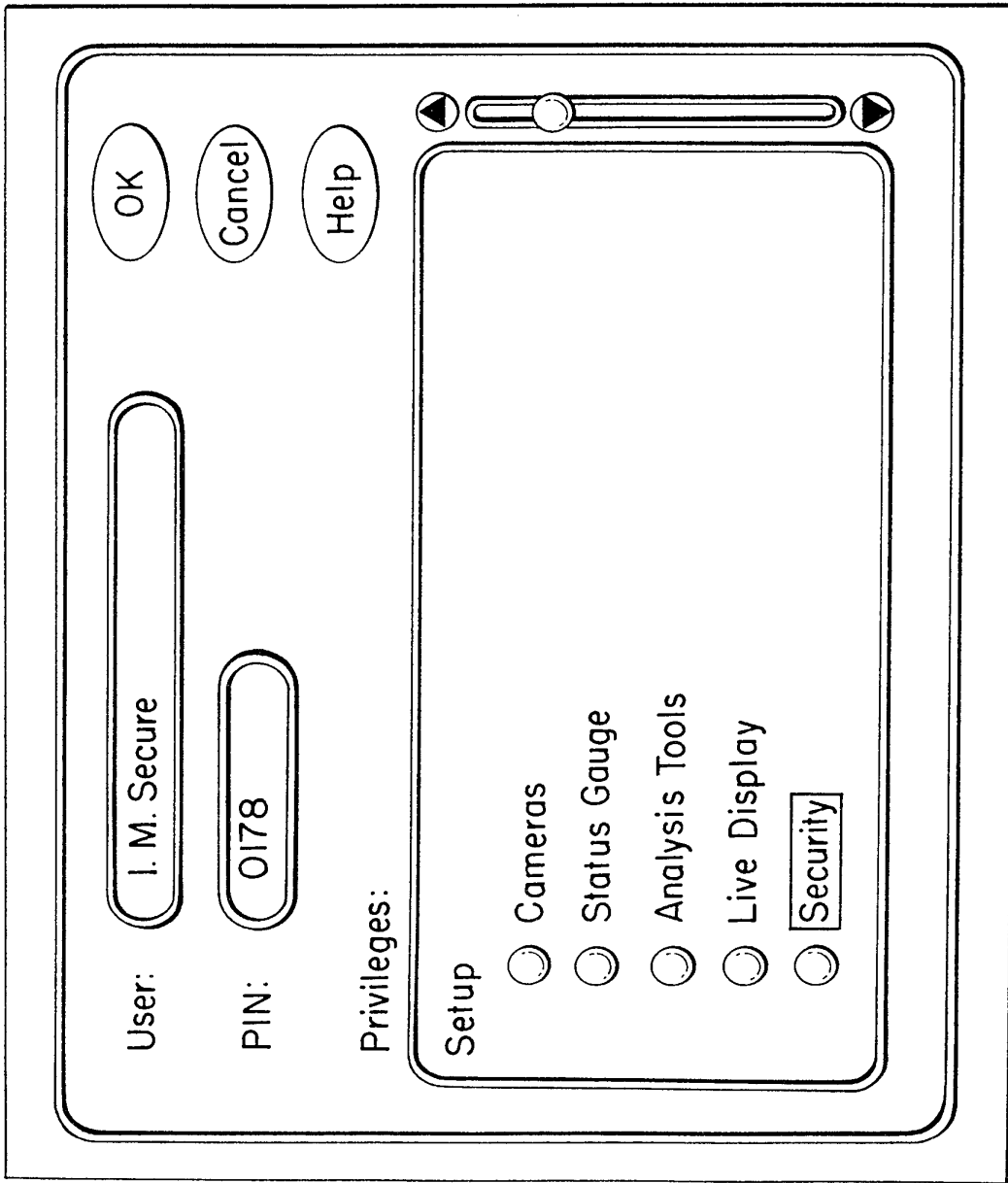
125/158

FIG. 139



126/158

FIG. 140



127/158

FIG. 141

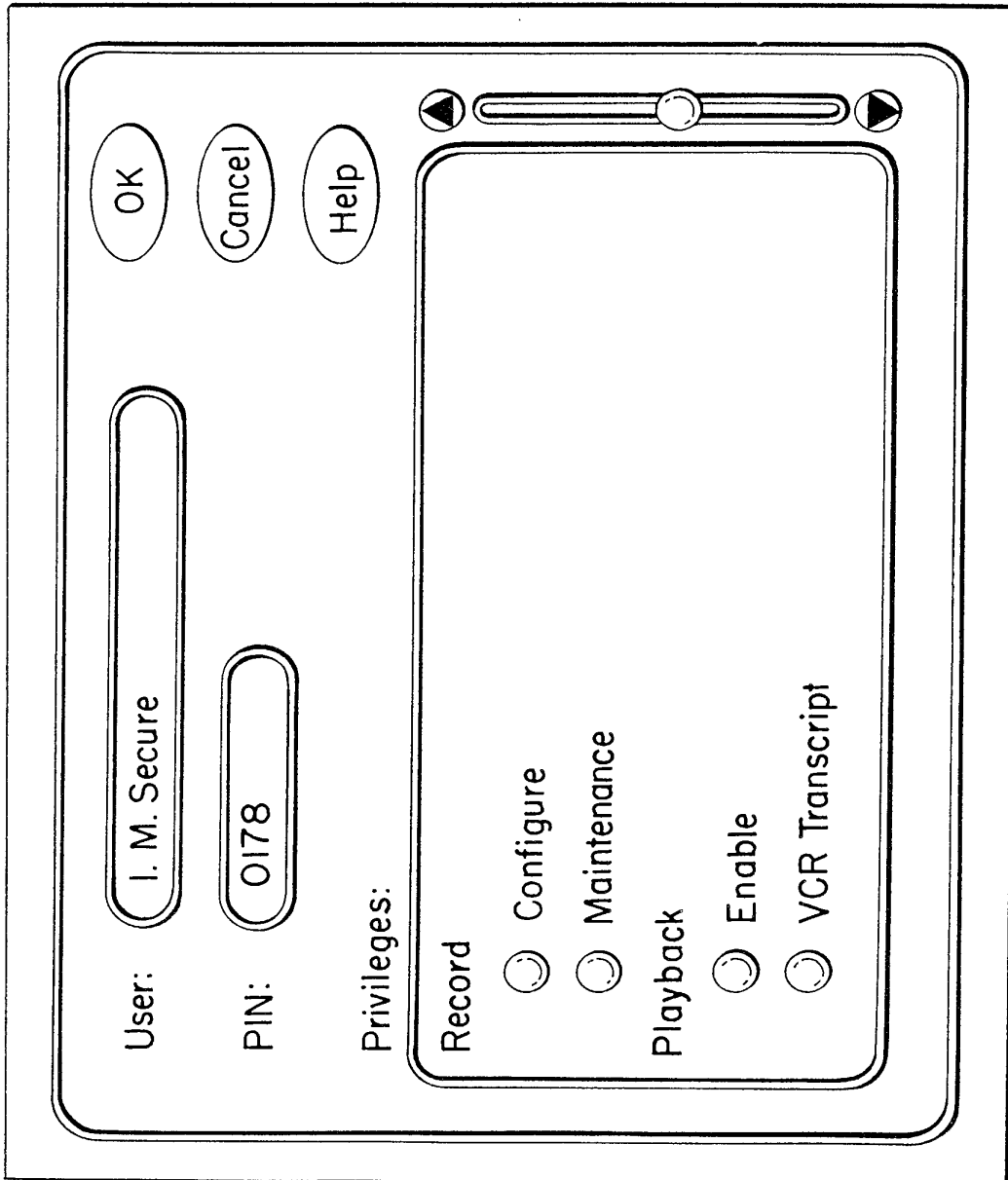


FIG. 142

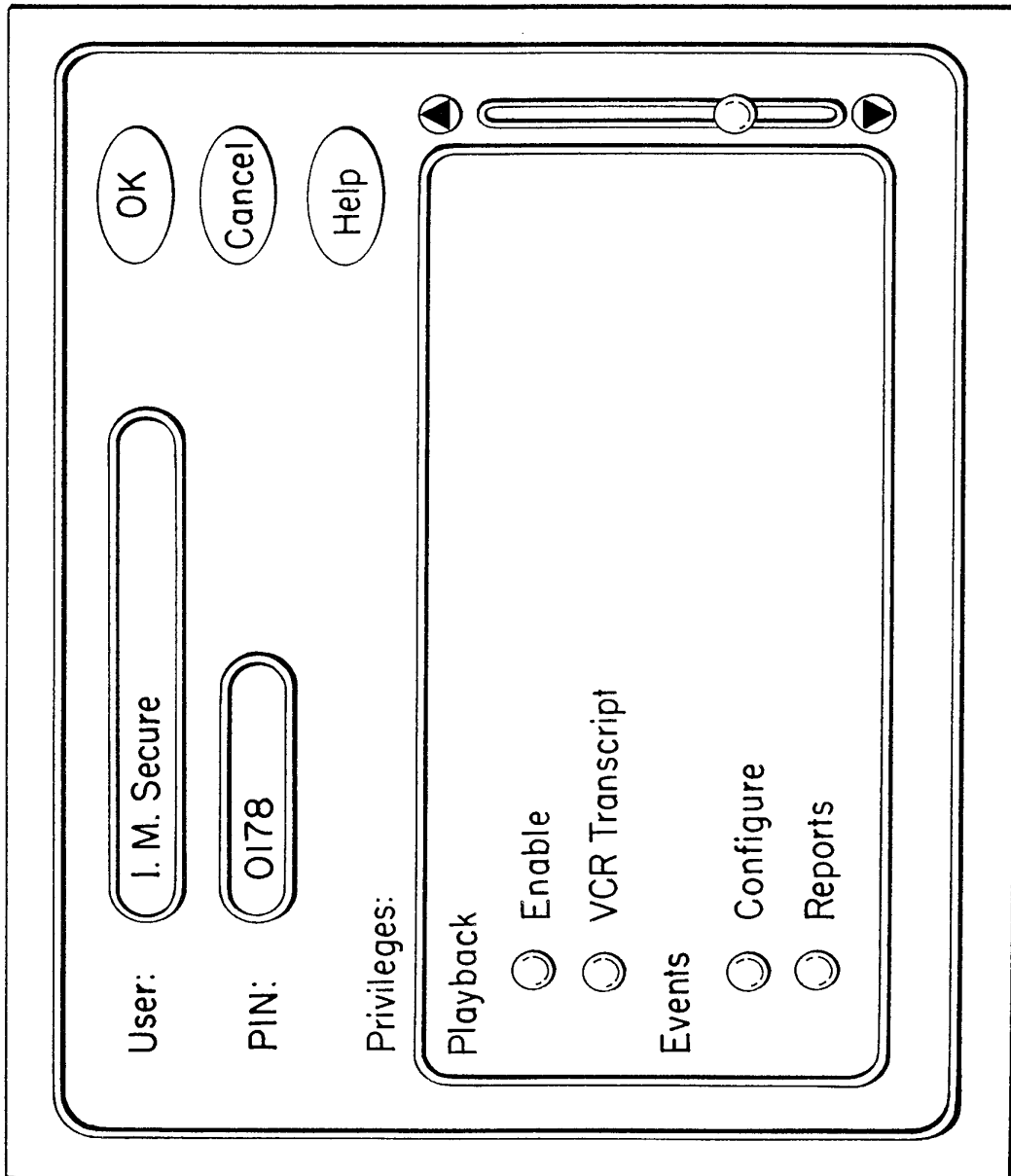
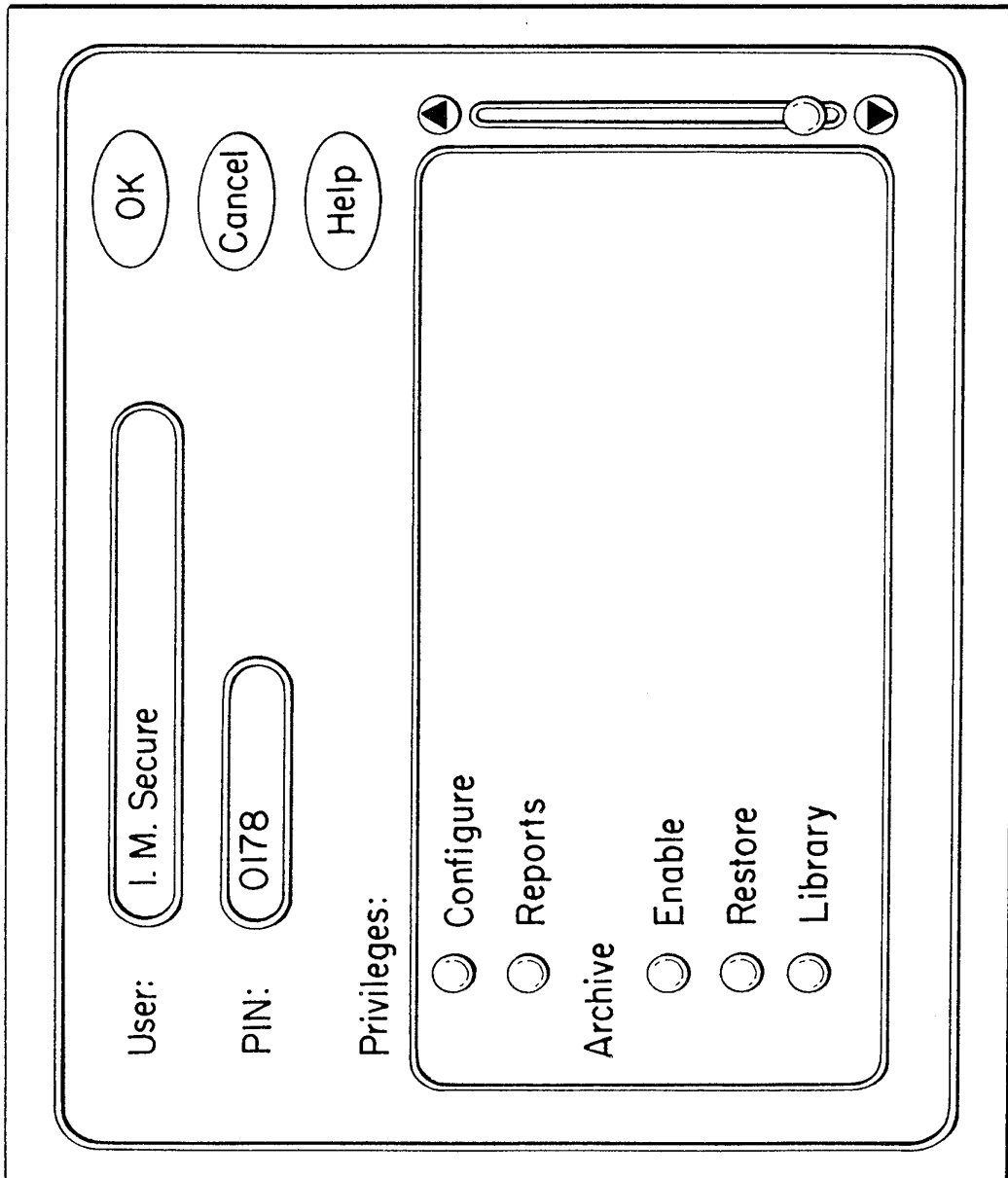




FIG. 143



130/158

FIG. 144

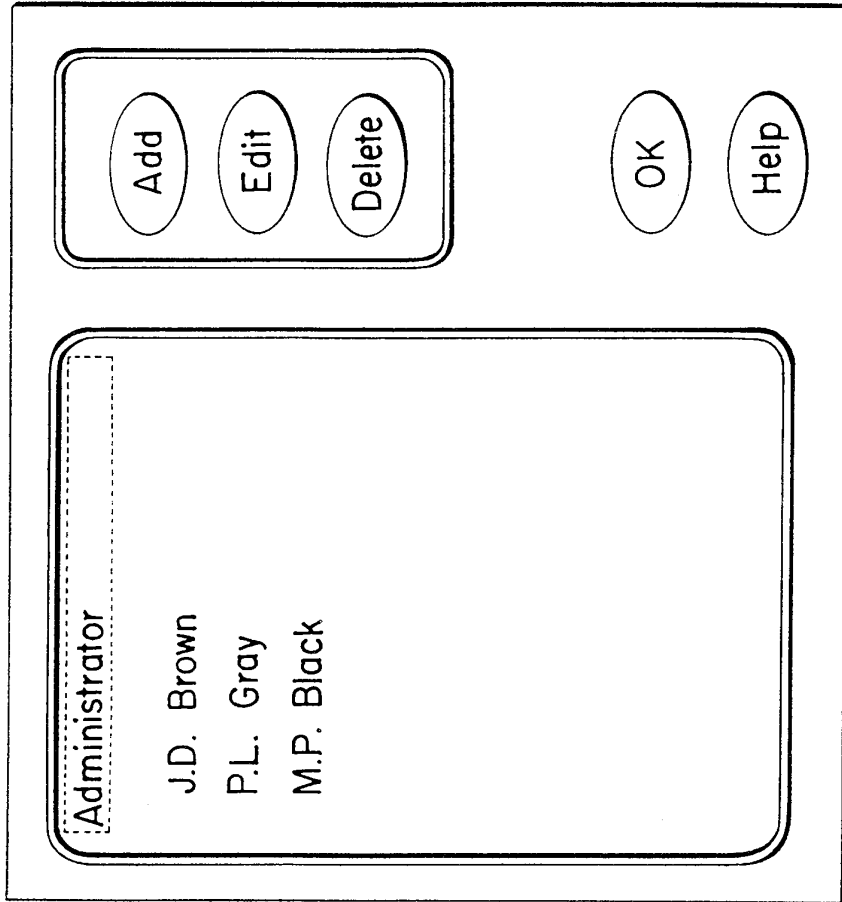
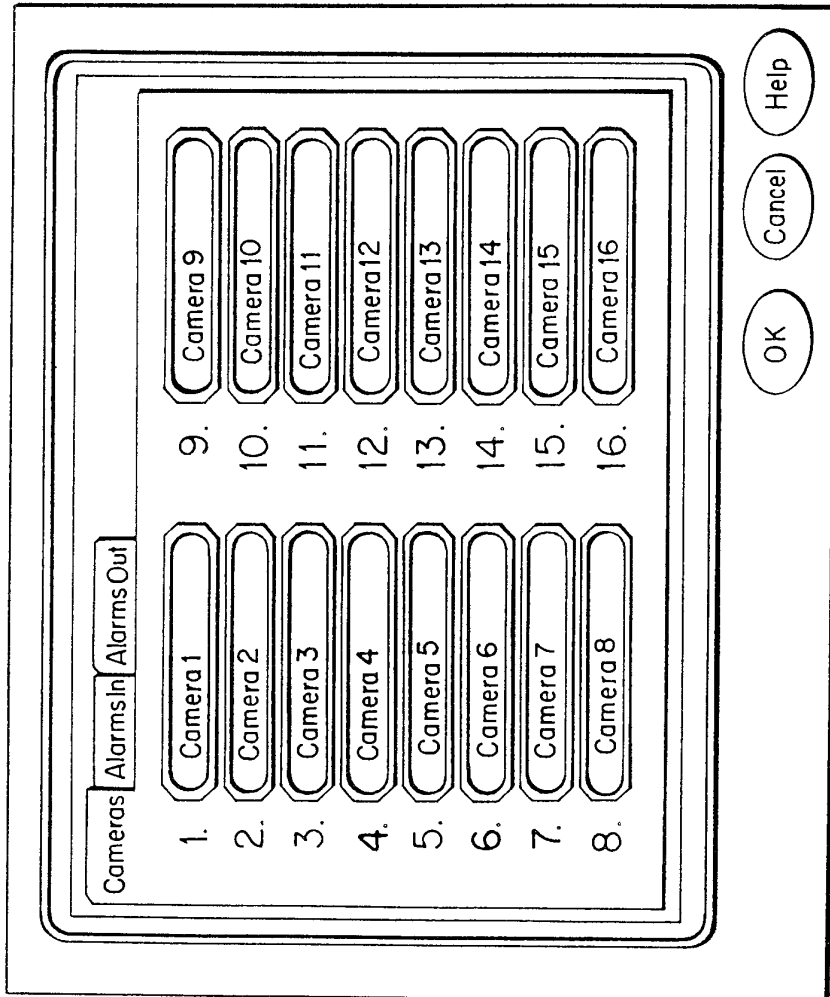
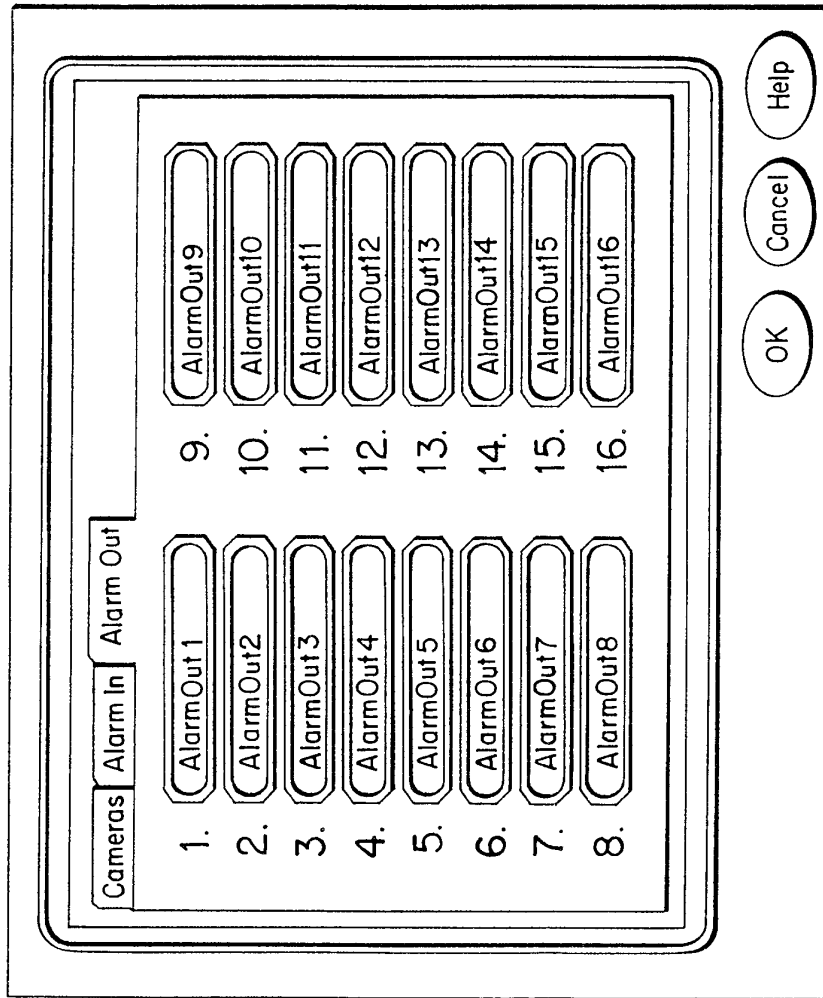


FIG. 145



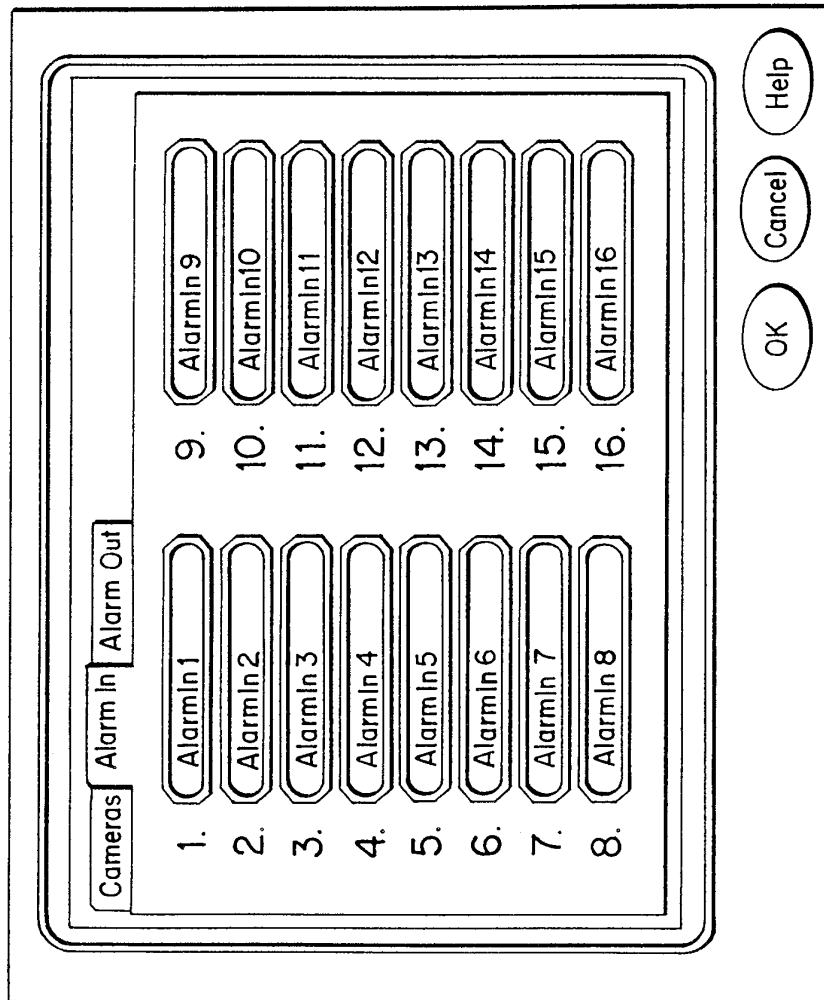
132/158

FIG. 146



133/158

FIG. 147



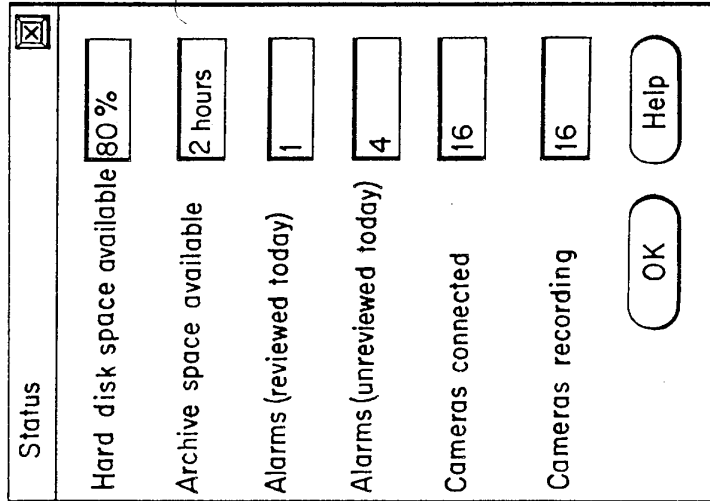


FIG. 149

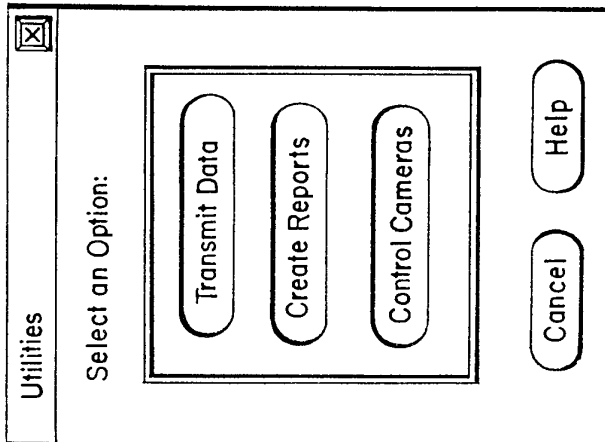
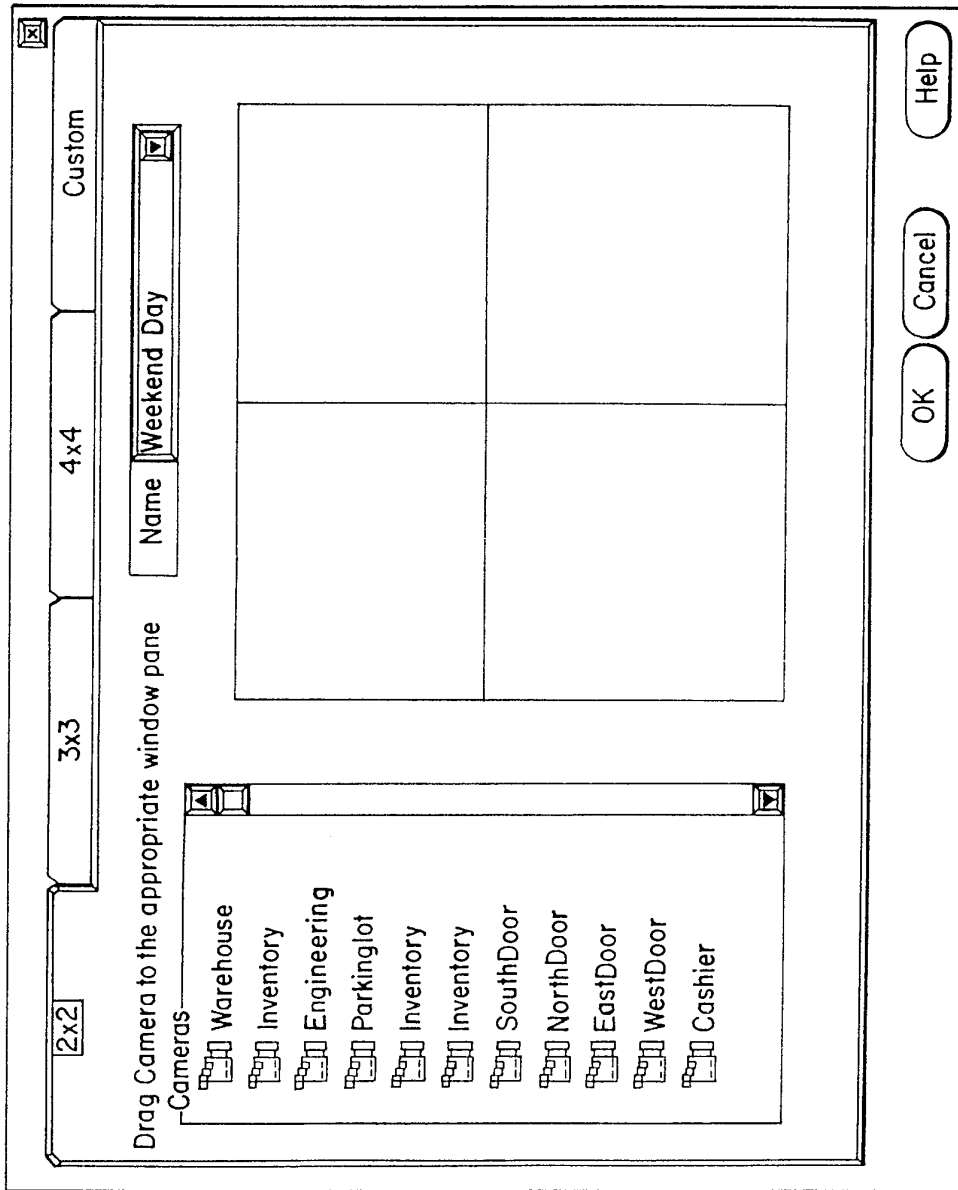


FIG. 148

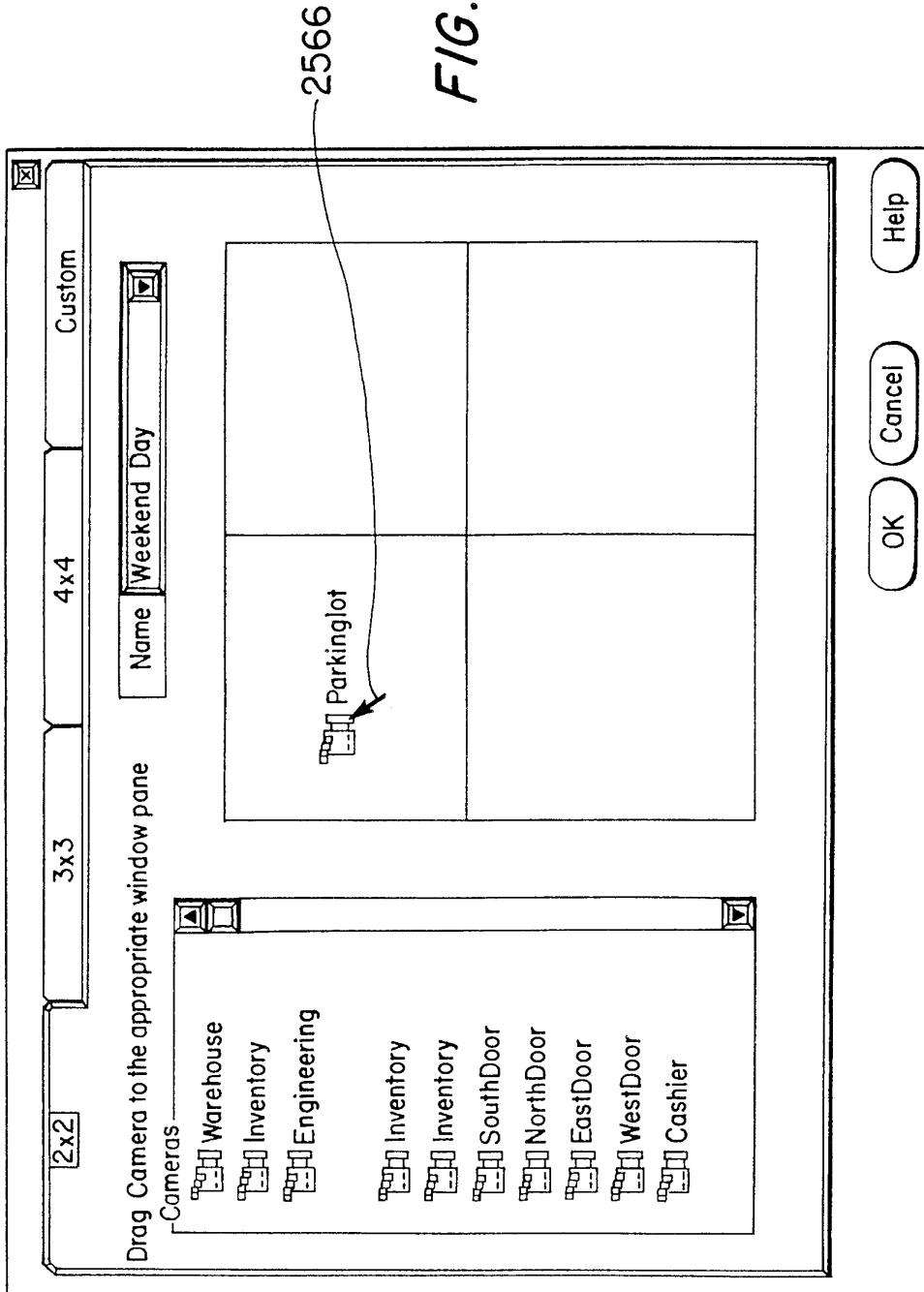
135/158

FIG. 150



136/158

FIG. 151





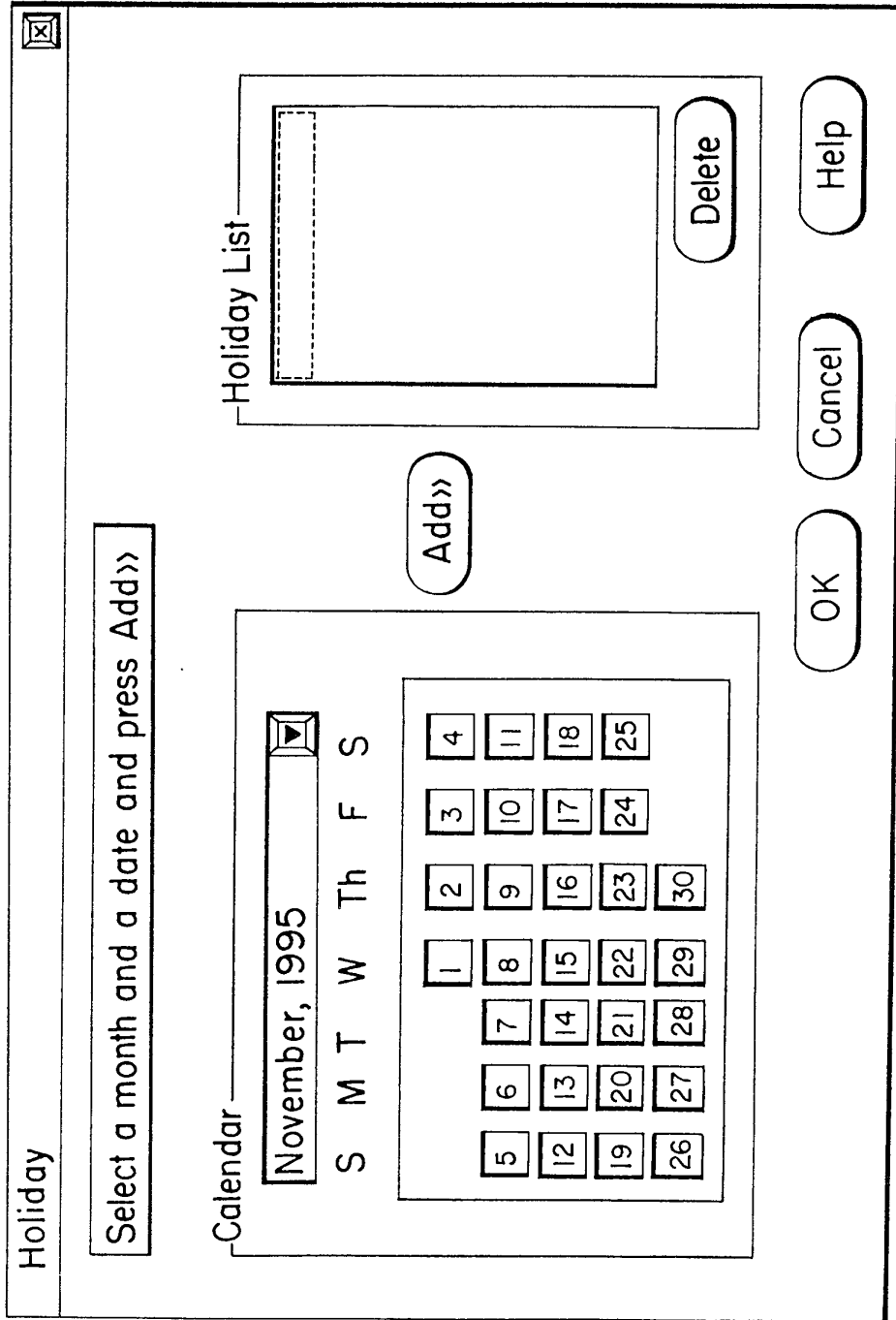
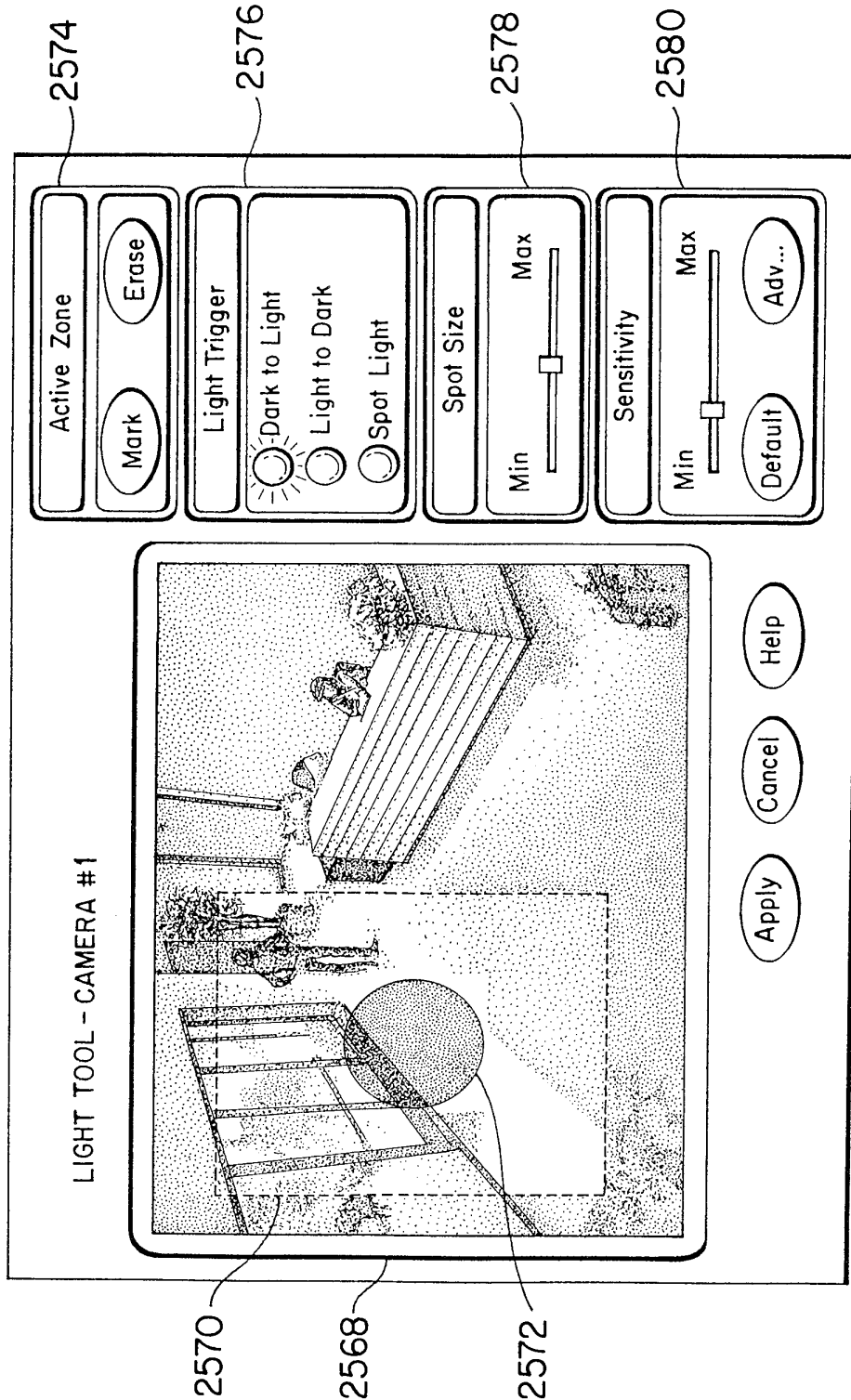


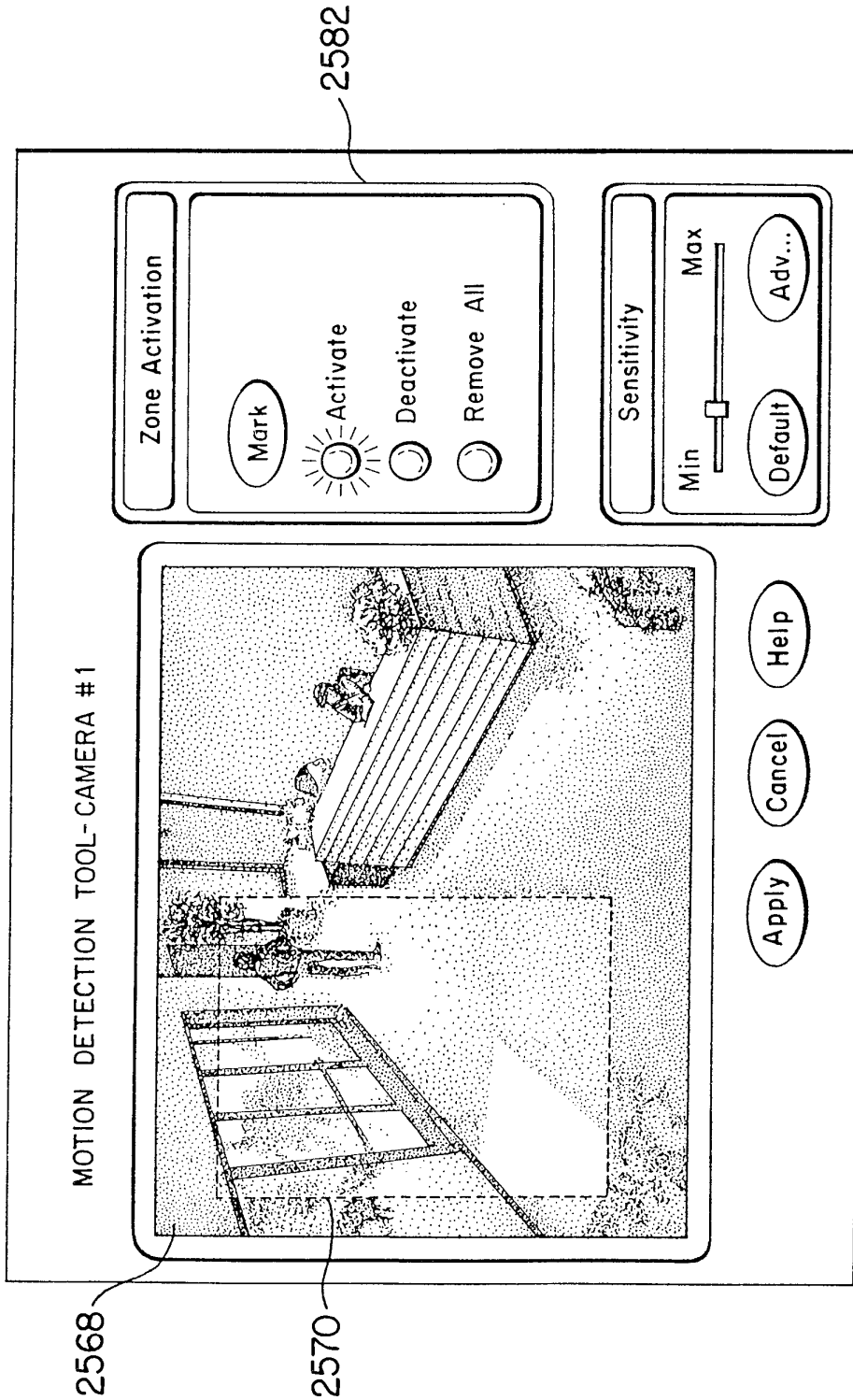
FIG. 152

138/158



LIGHT TOOL SETUP SCREEN

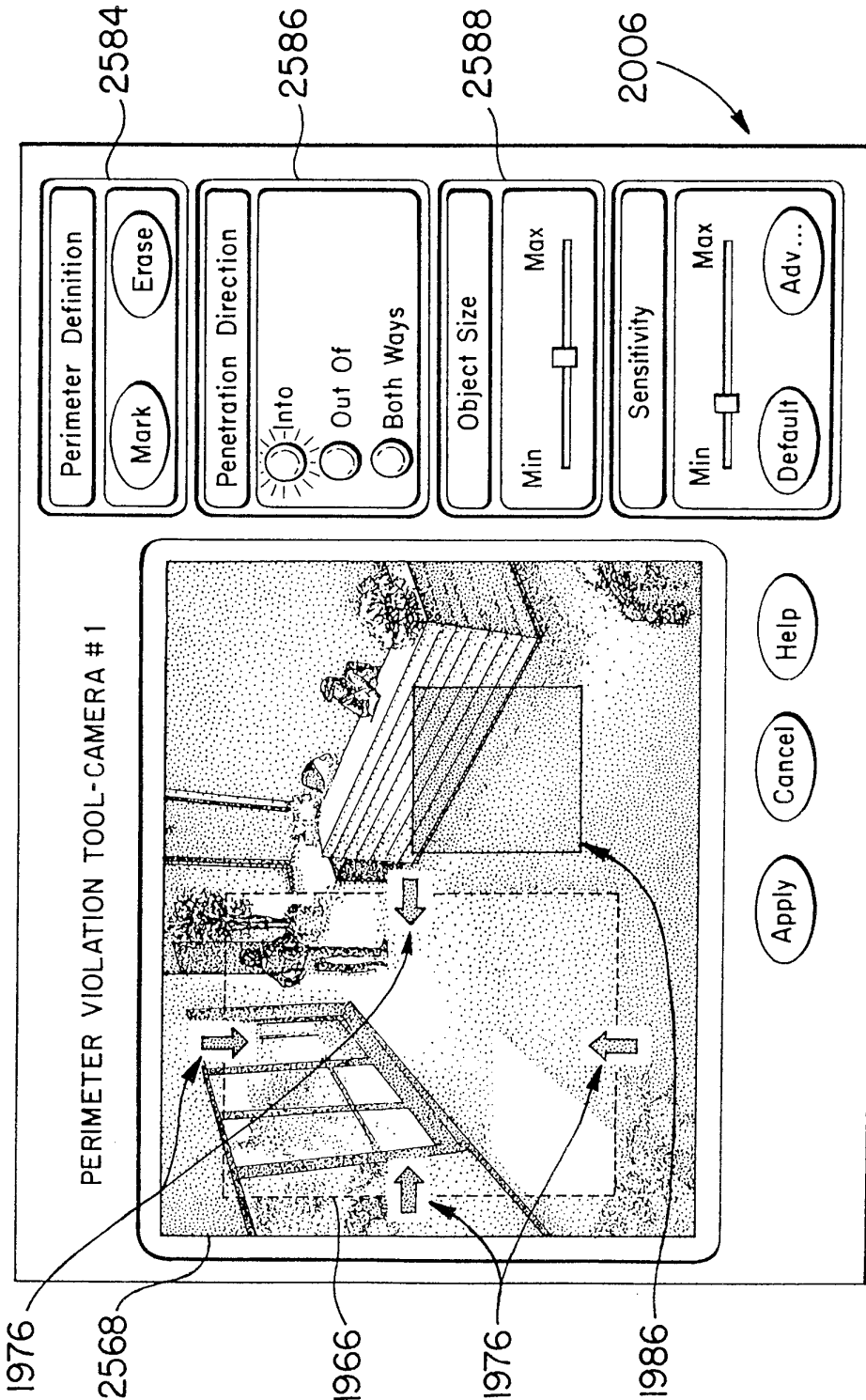
FIG. 153



MOTION DETECTION TOOL SETUP SCREEN

FIG. 154

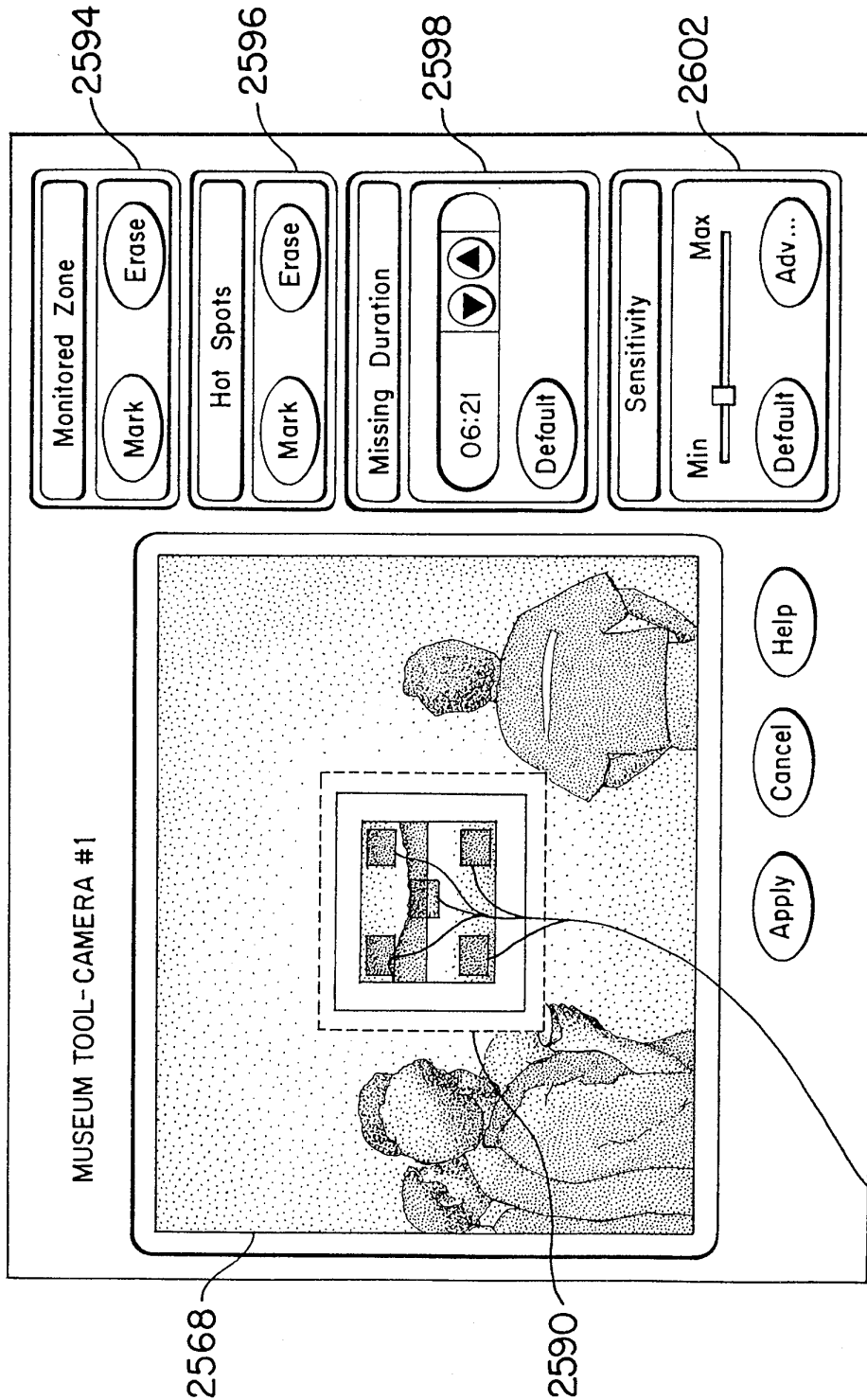
140/158



PERIMETER VIOLATION TOOL SETUP SCREEN

FIG. 155

141/158



MUSEUM TOOL SETUP SCREEN

FIG. 156

142/158

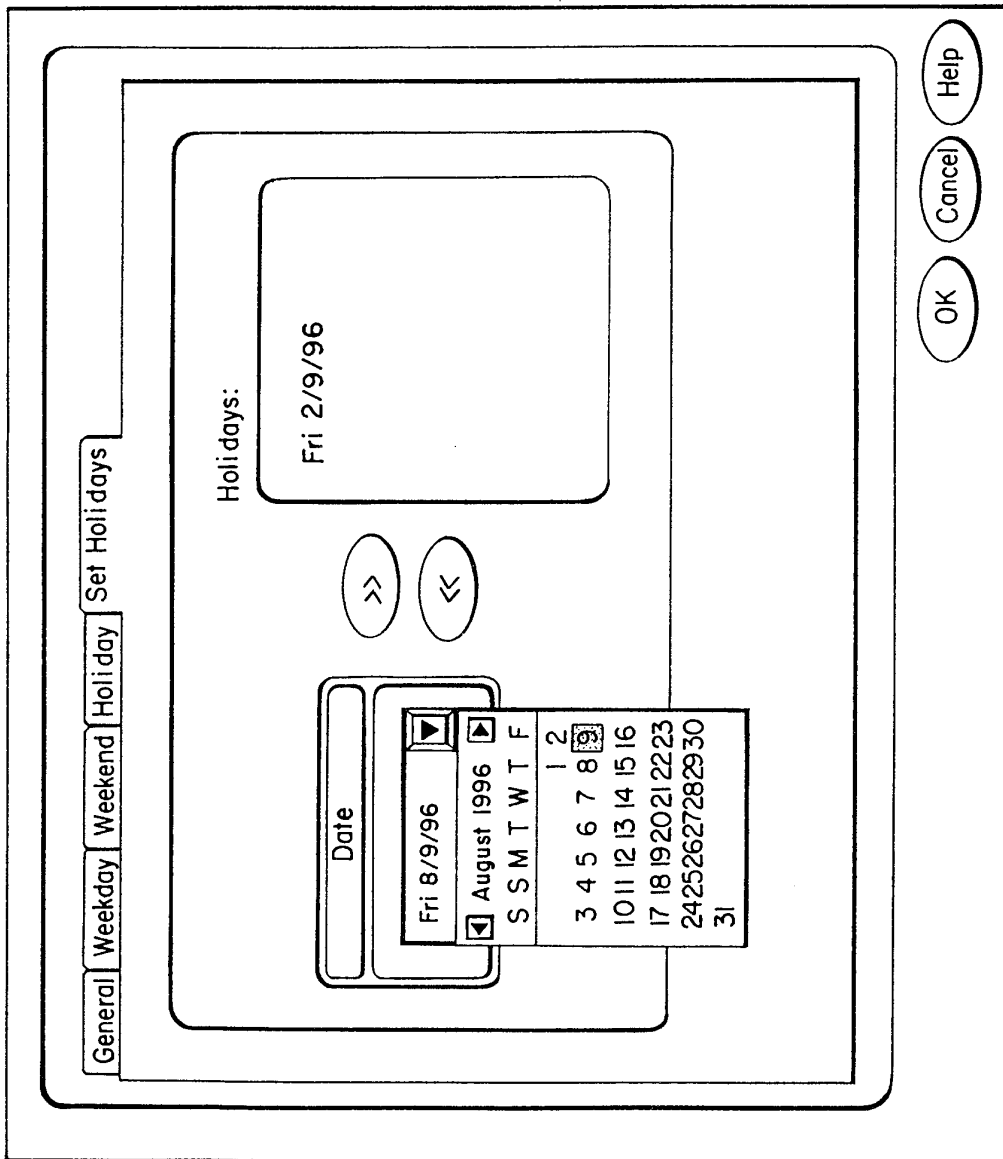


FIG. 157

143/158

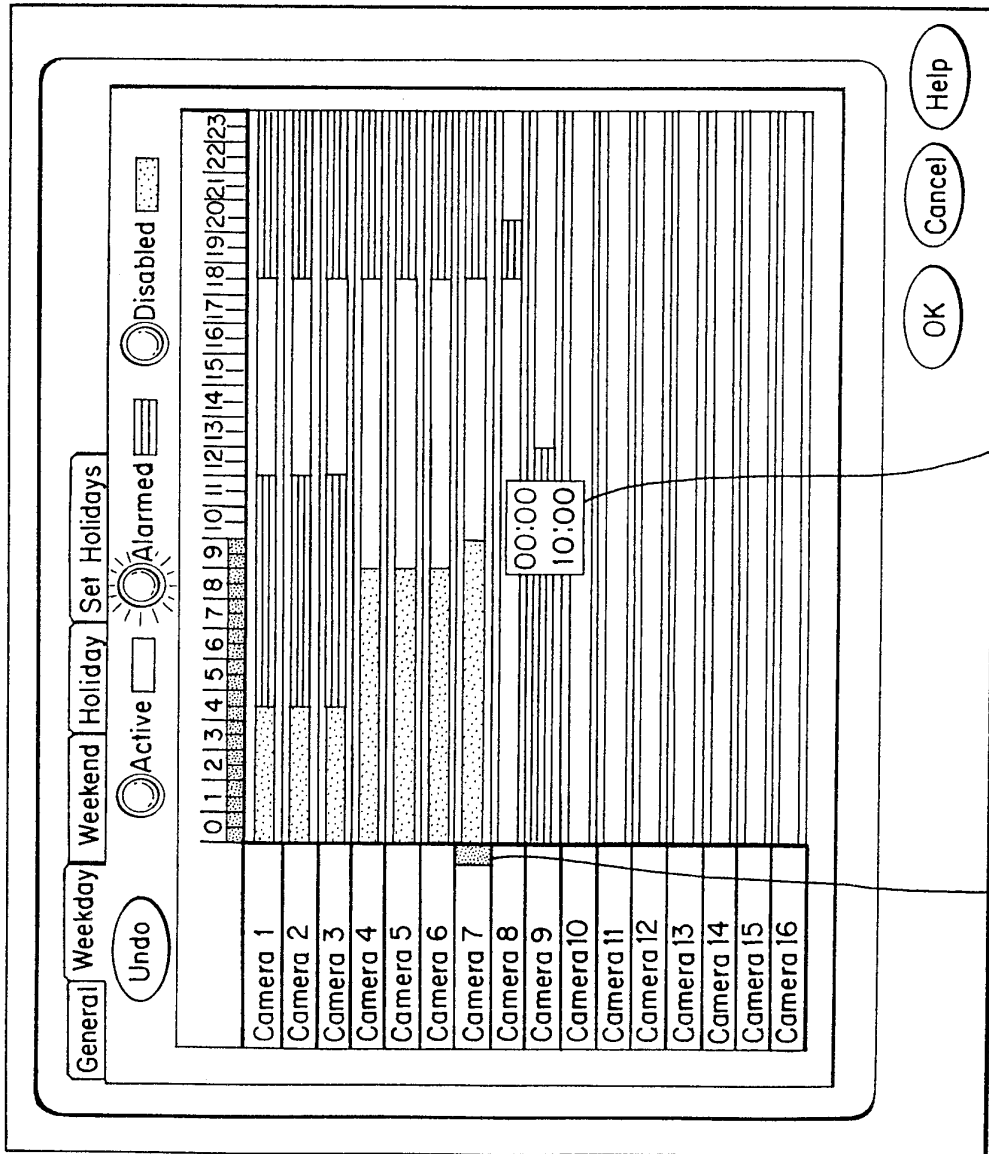


FIG. 158

144/158

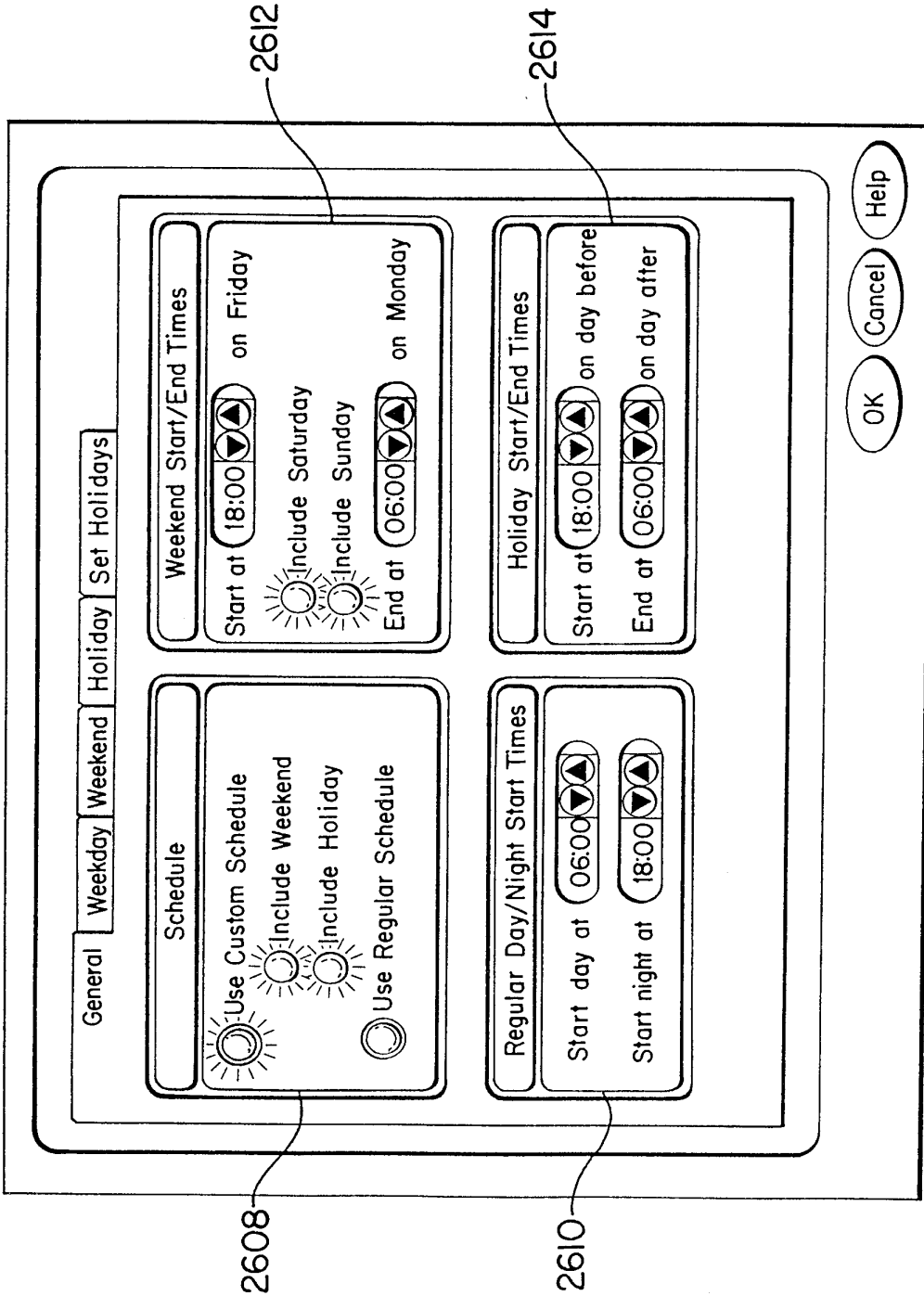


FIG. 159



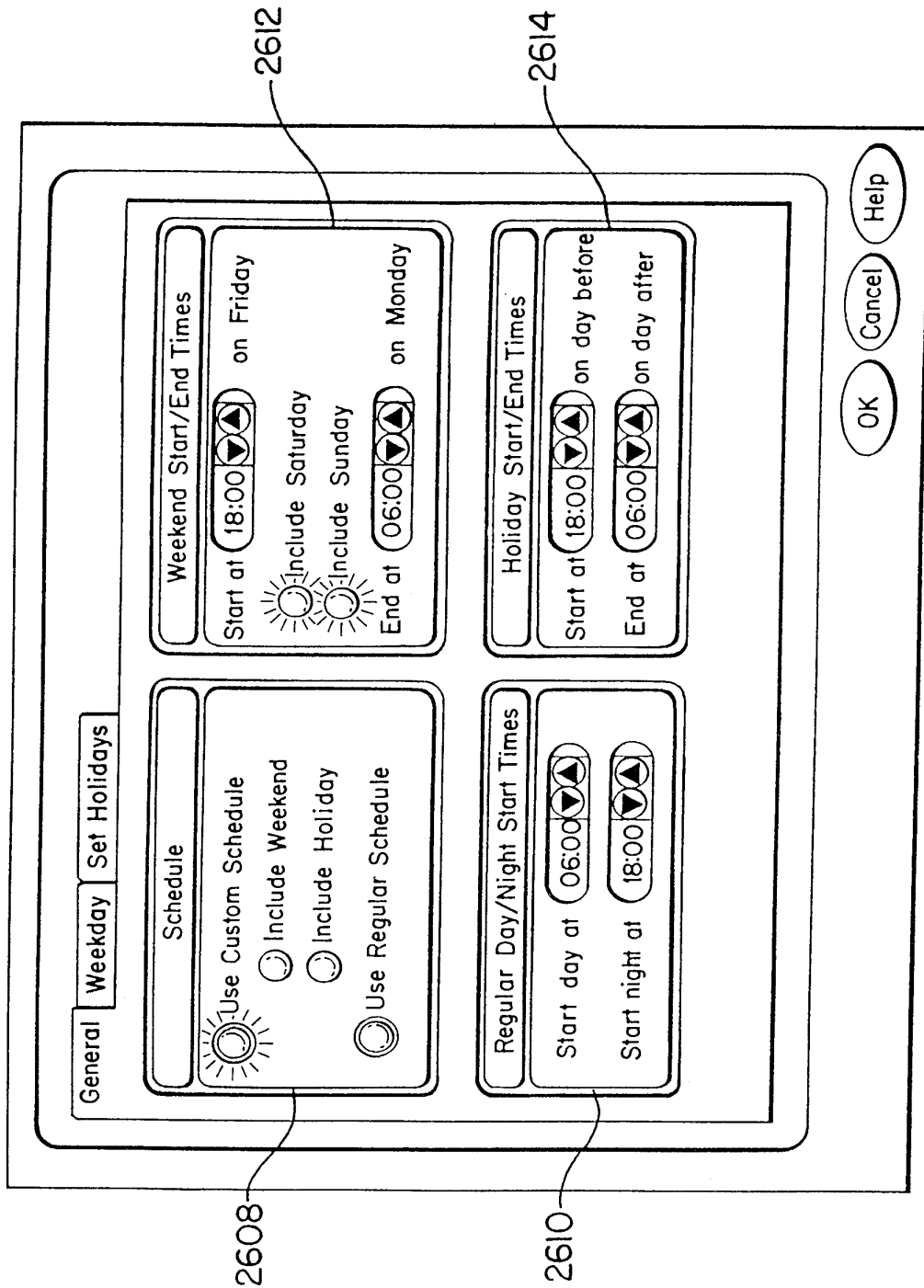


FIG. 160

146/158

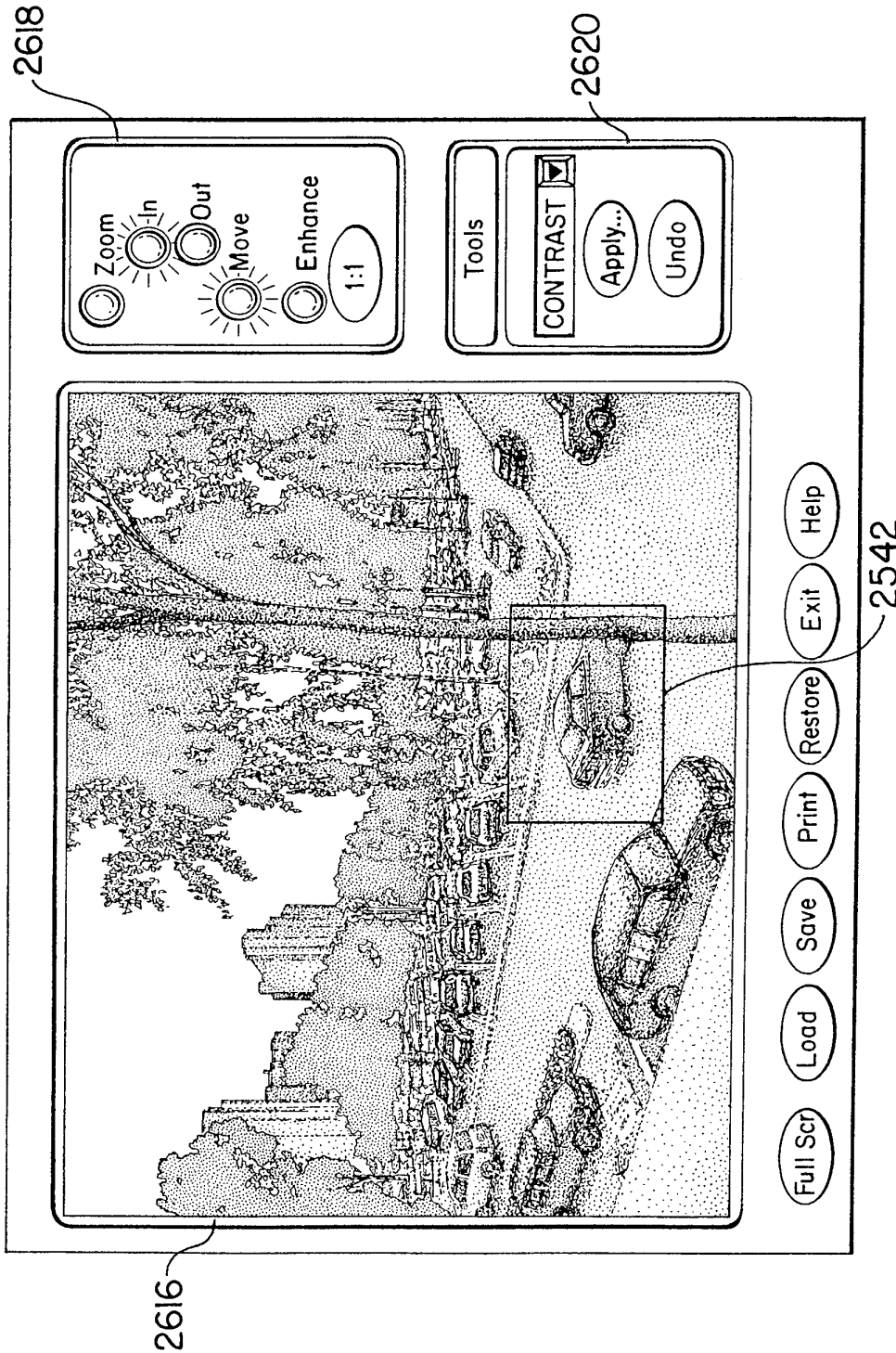


FIG. 161

IMAGE PROCESSING UTILITY SCREEN

147/158

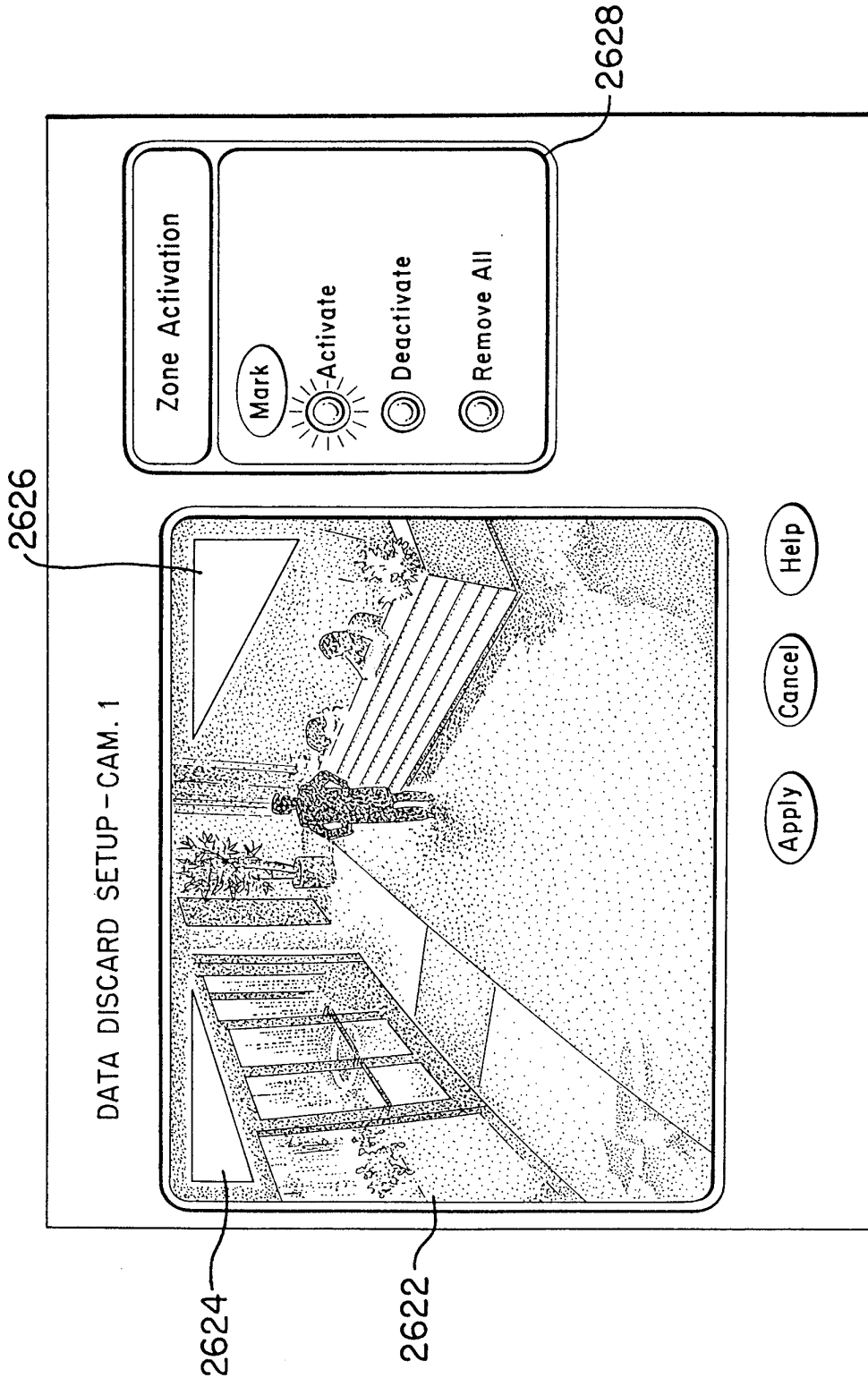


FIG. 162

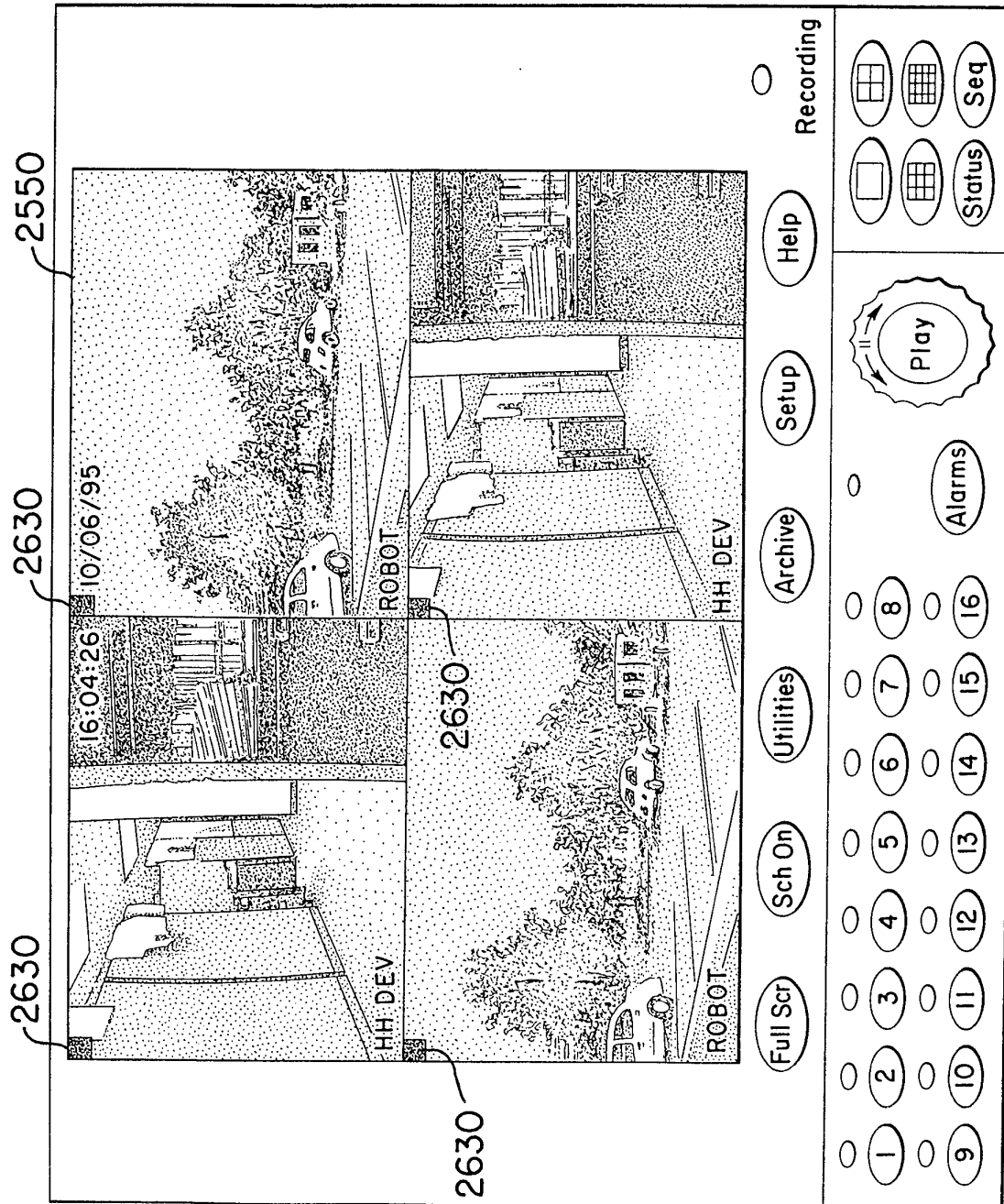


FIG. 163

149/158

FIG. 164

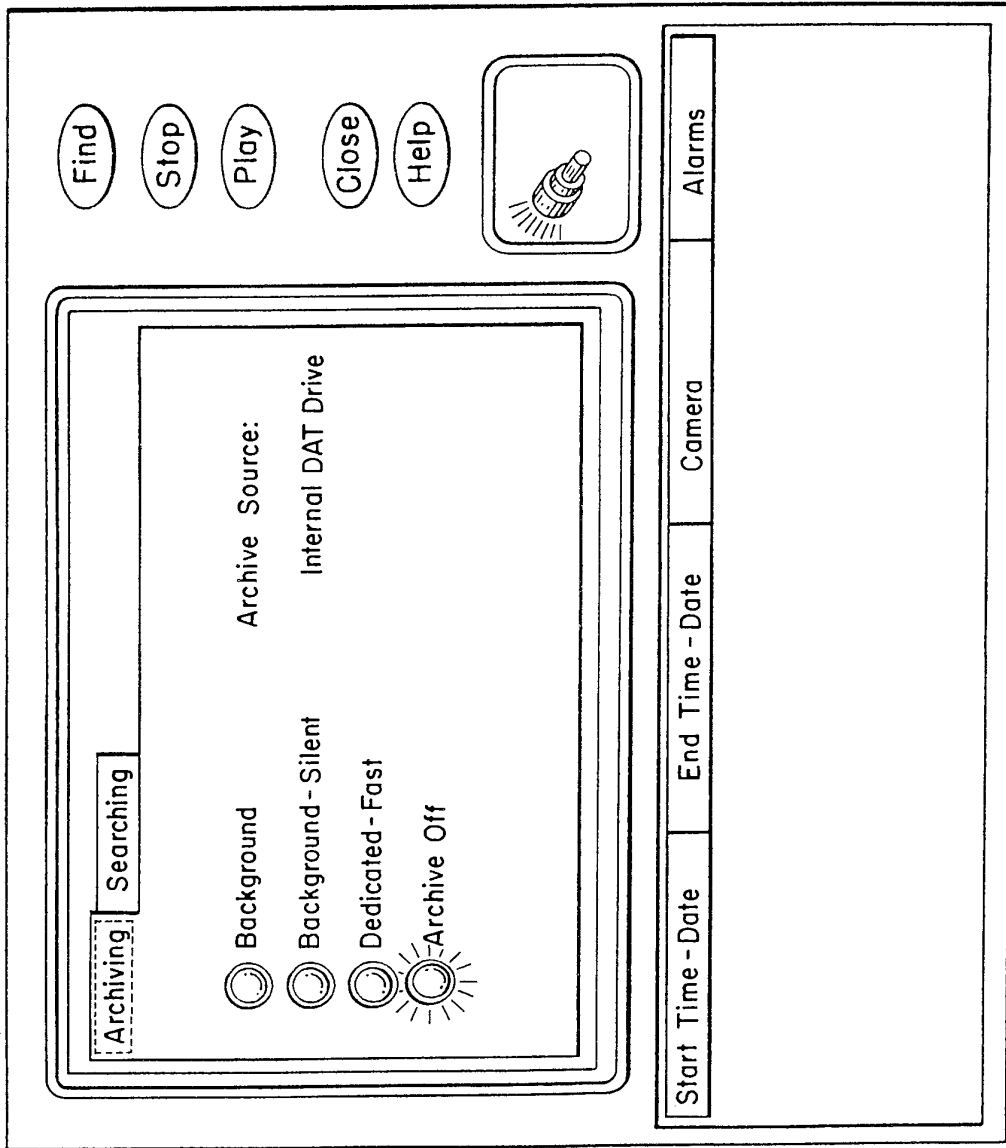


FIG. 165

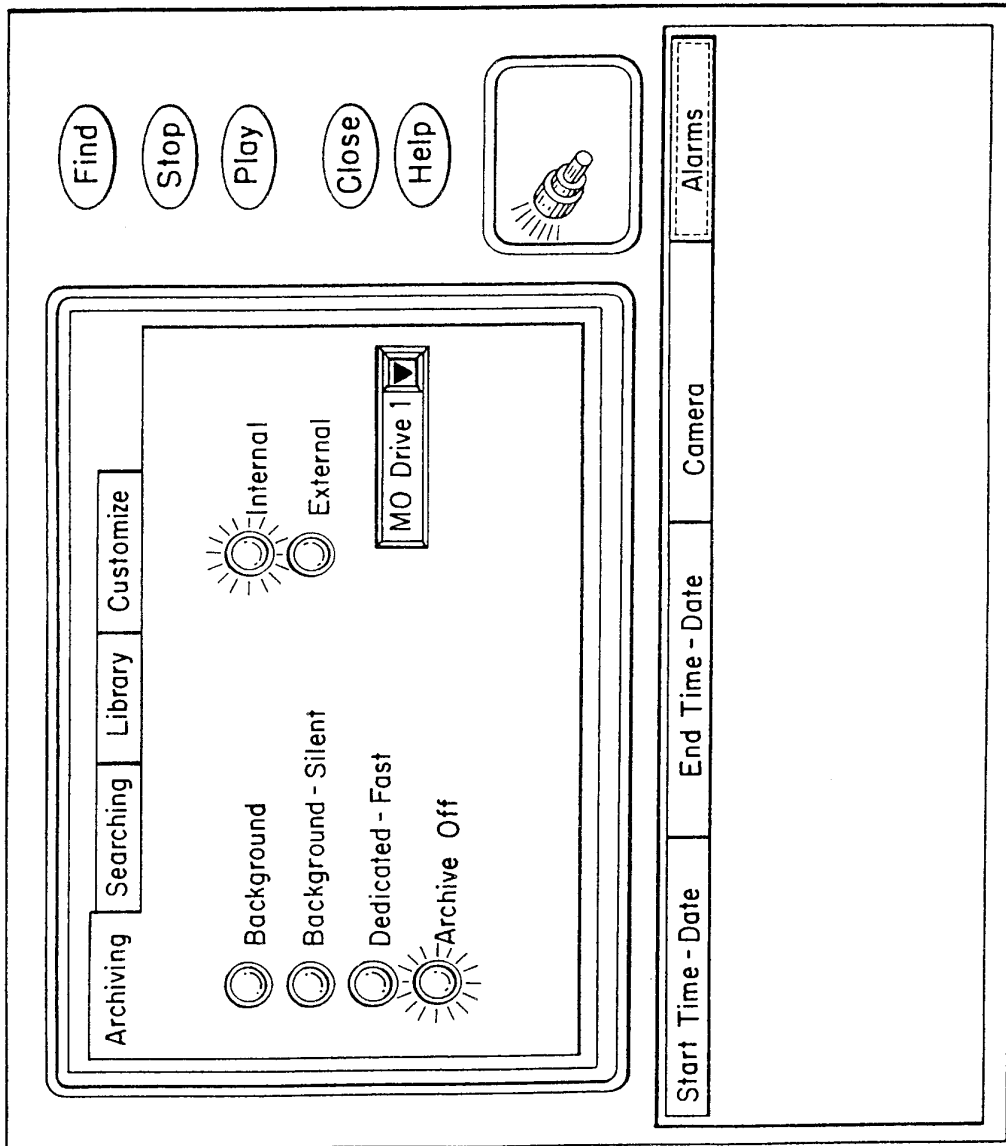
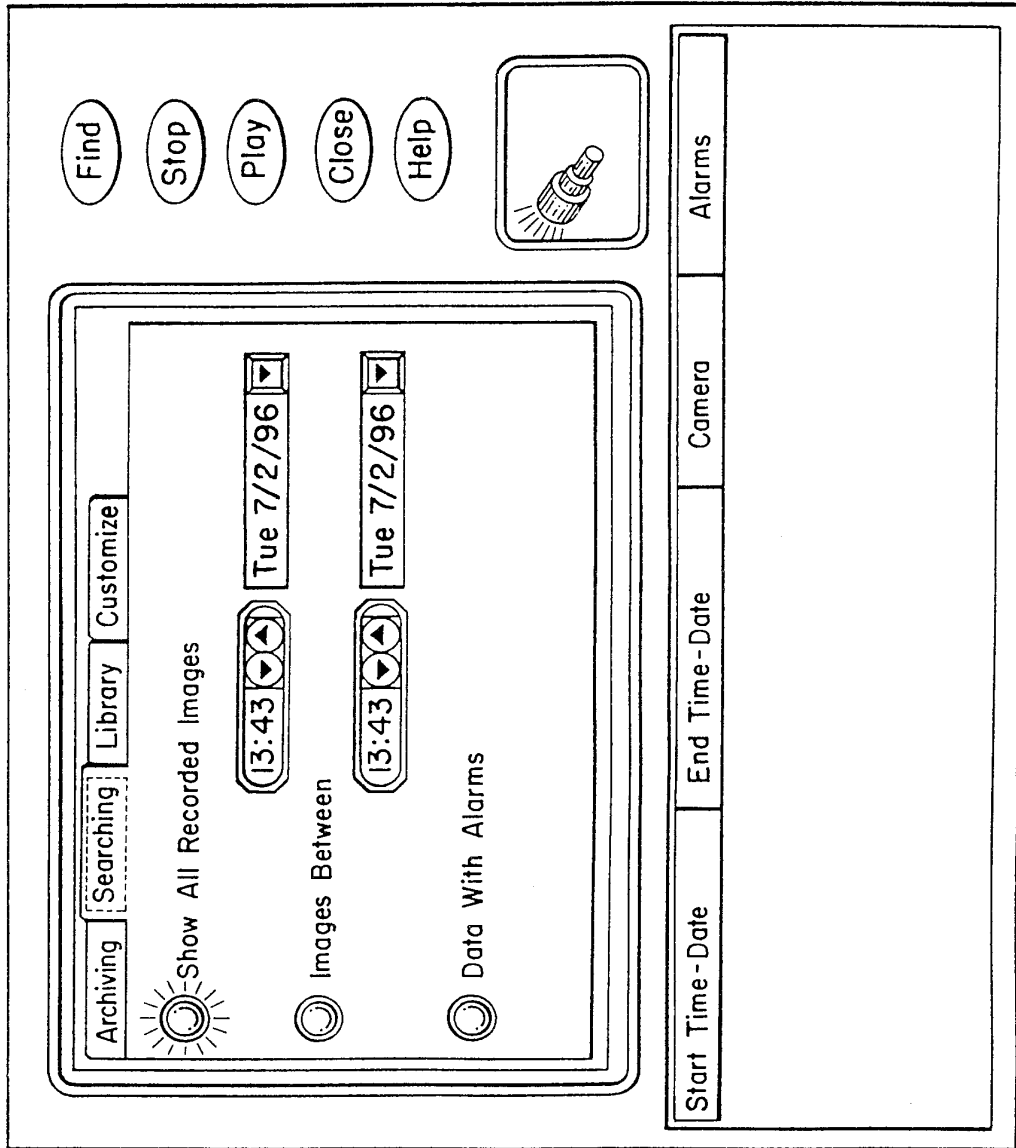
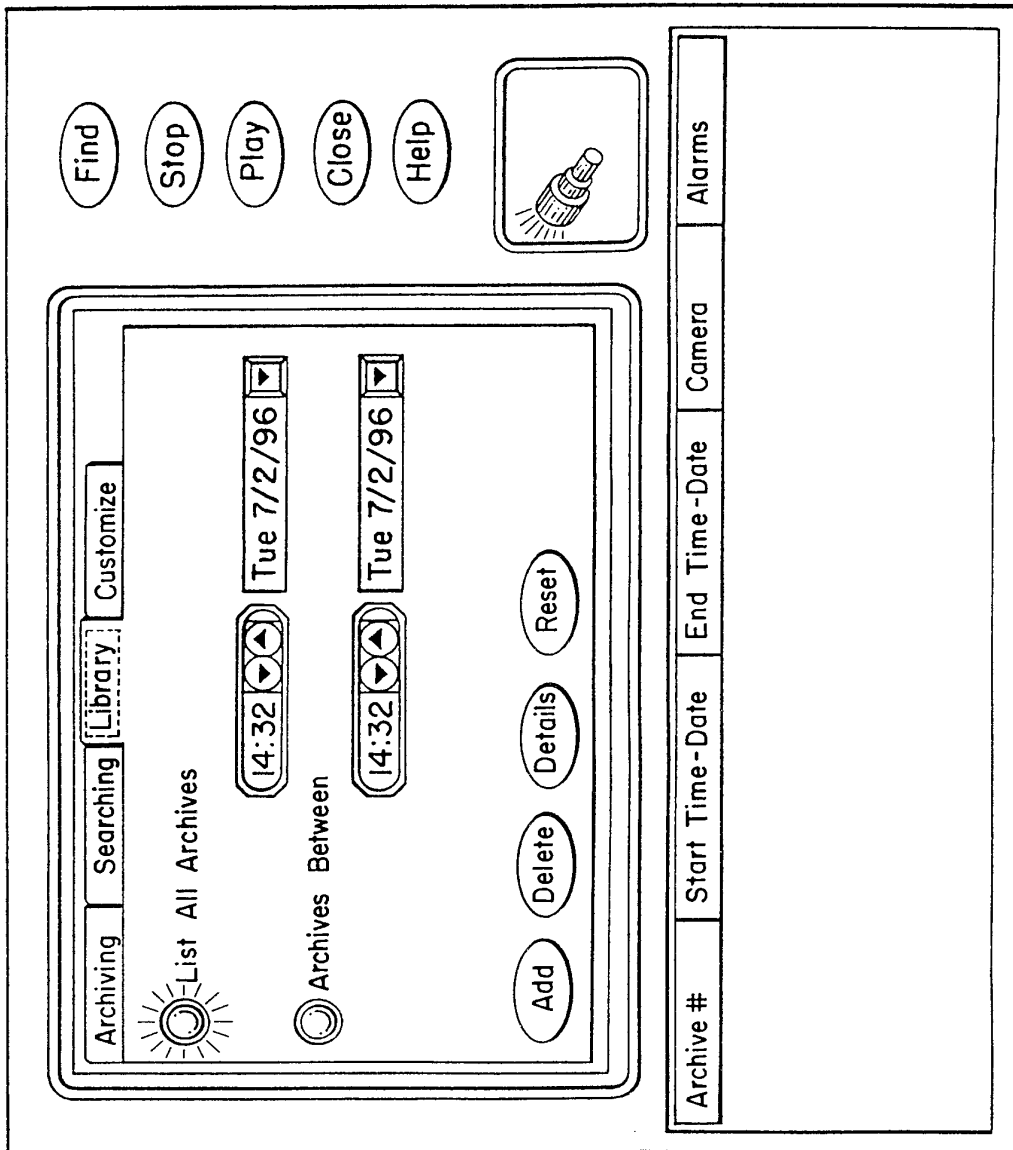


FIG. 166



152/158

FIG. 167





153/158

FIG. 168

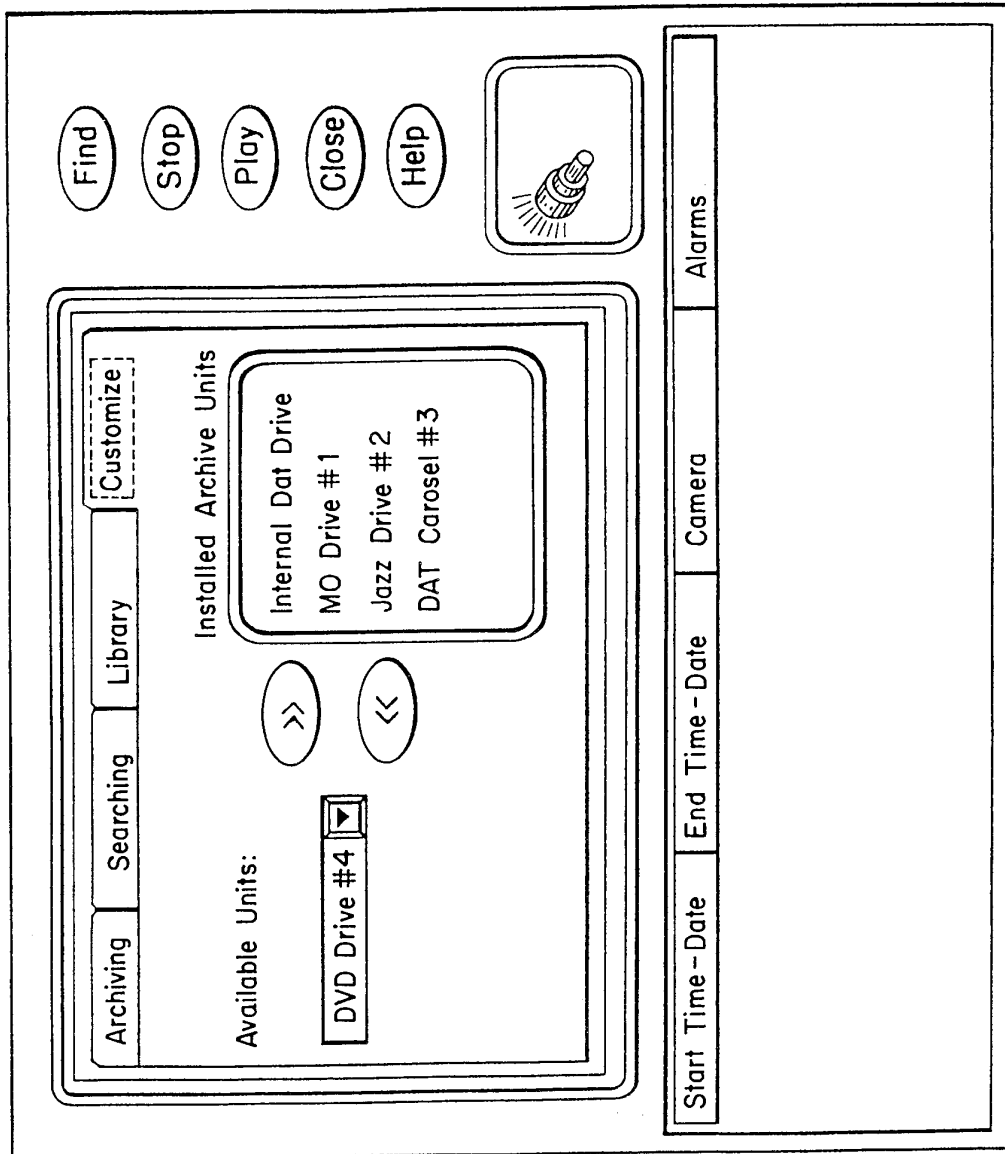


FIG. 169

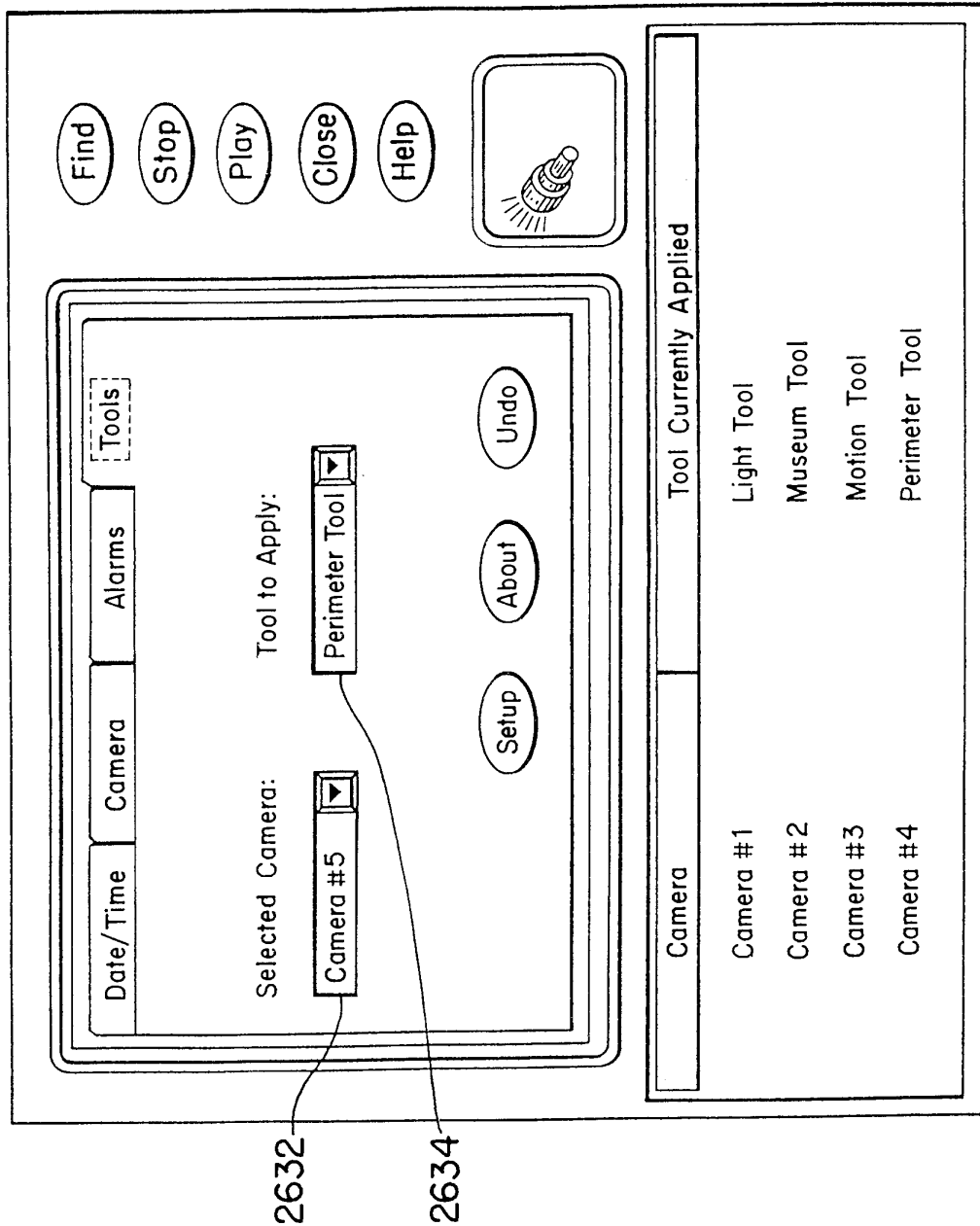
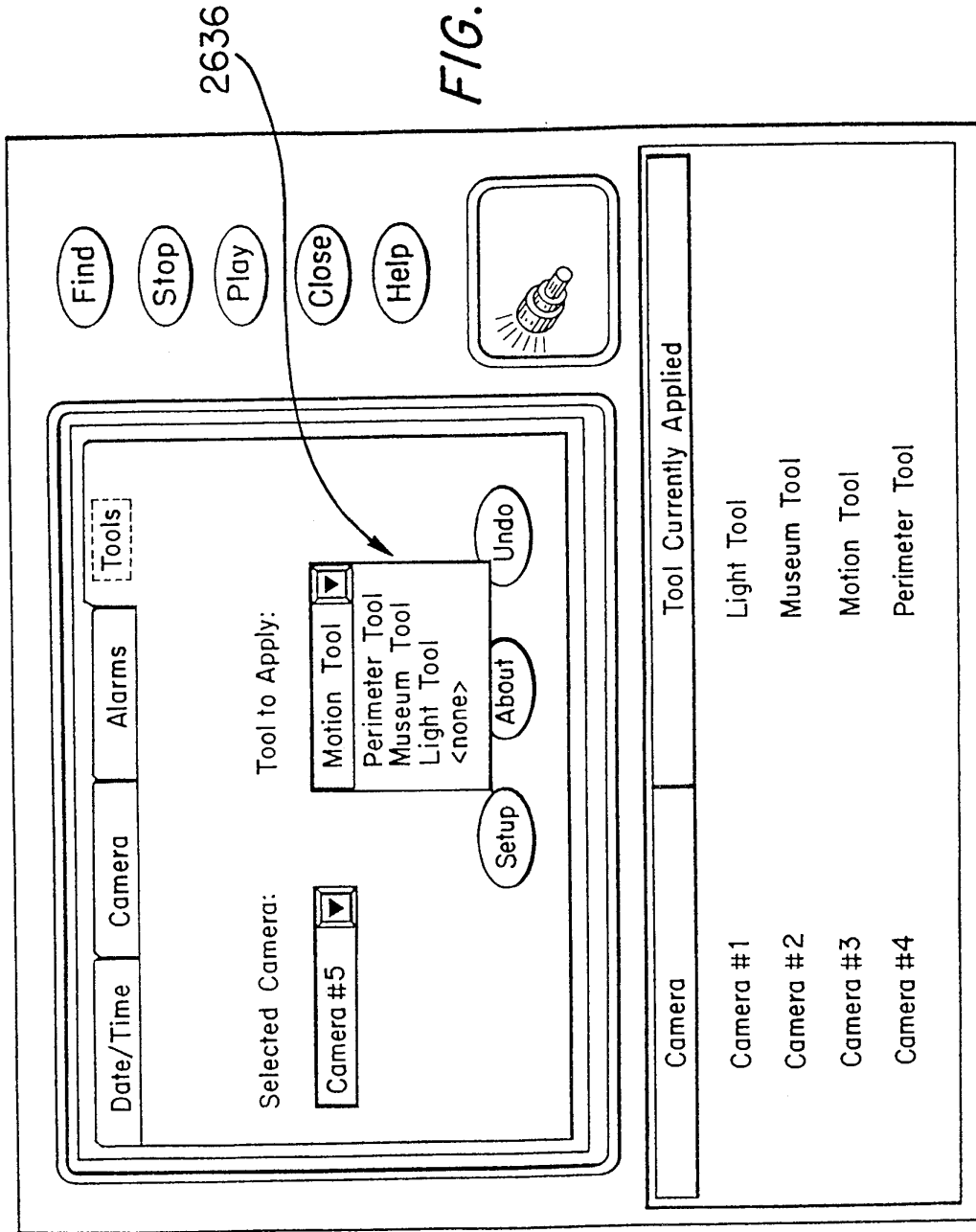


FIG. 170



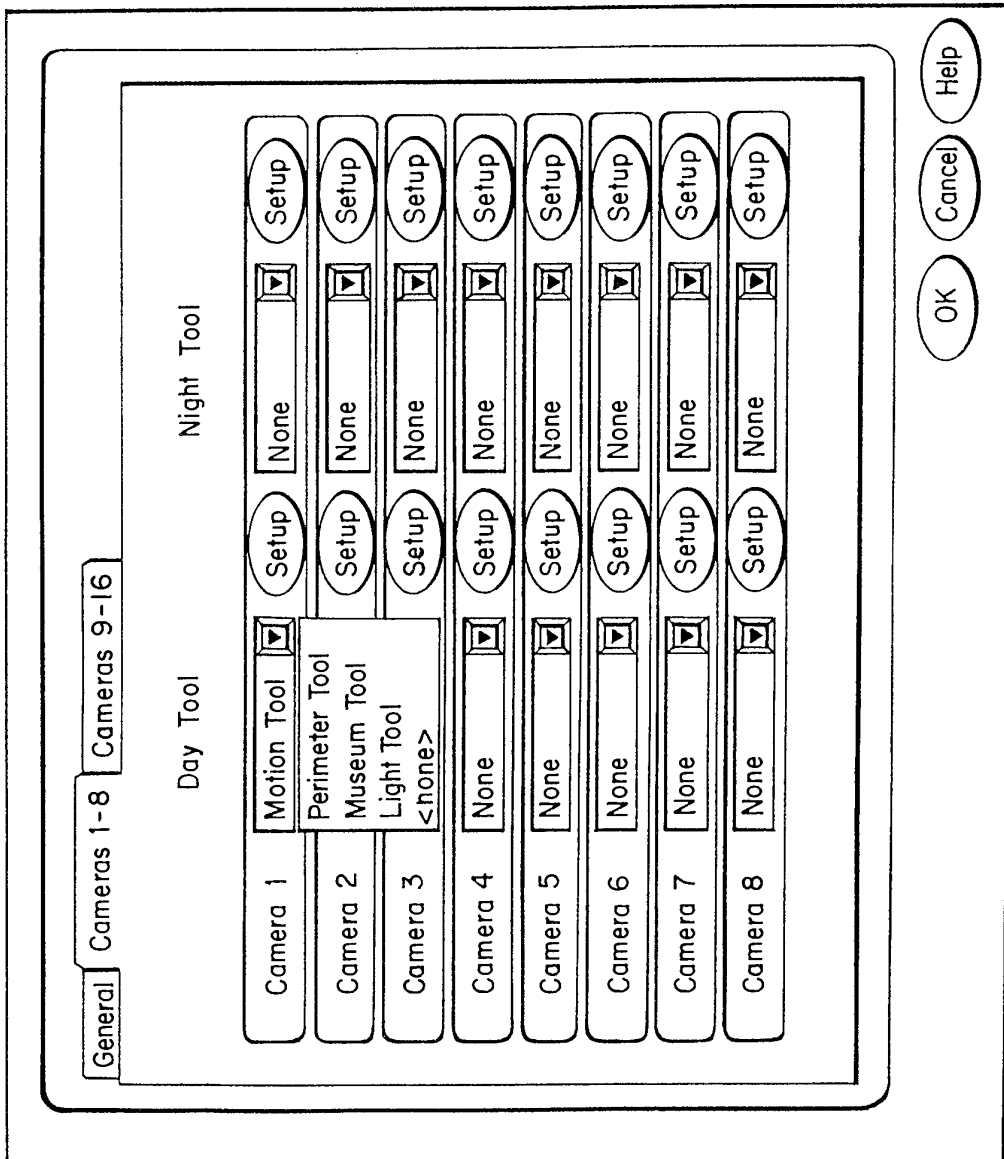


FIG. 171

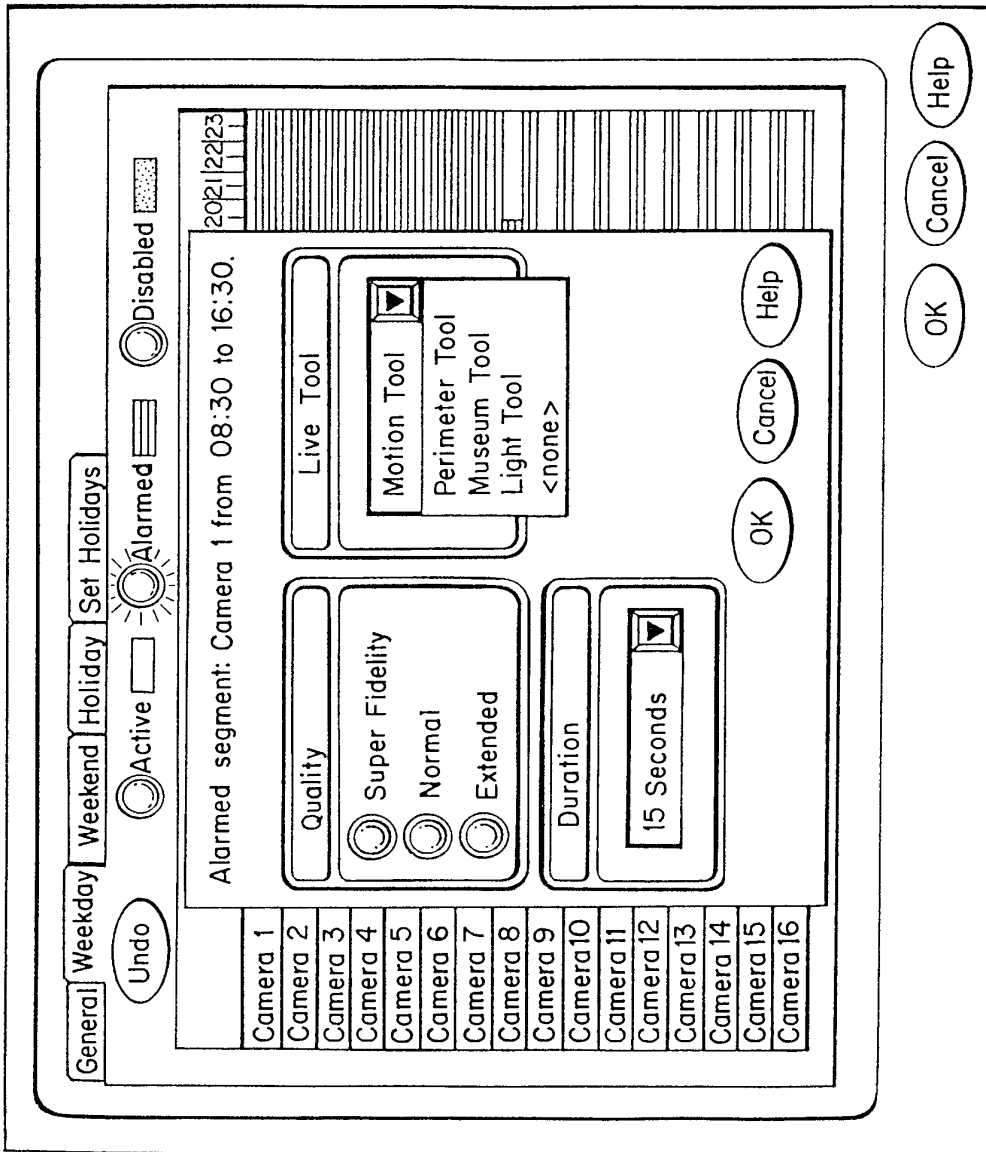
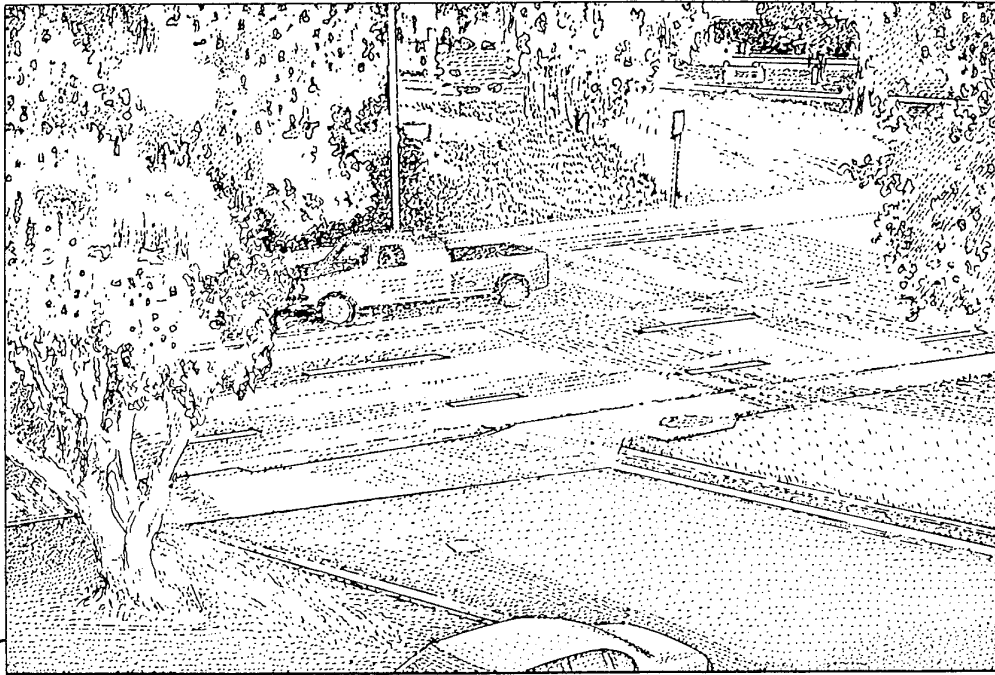


FIG. 172

158/158

### Sensormatic Video Digital Recorder



Date:	08/28/96	Alarm:	On	System:	Local
Time:	16:22:24	Print Date:	08/28/96	ID:	4444
Camera:	Driveway	Print Time:	16:22:24		

2640

2642

*FIG. 173*