

**Petitioner Bluehouse Global Ltd.**

**Ex. 1001**



(12) **United States Patent**  
**Sasagawa et al.**

(10) **Patent No.:** **US 9,281,405 B2**  
(45) **Date of Patent:** **Mar. 8, 2016**

(54) **SEMICONDUCTOR DEVICE AND METHOD FOR MANUFACTURING THE SAME**

USPC ..... 257/43  
See application file for complete search history.

(71) Applicant: **Semiconductor Energy Laboratory Co., Ltd.**, Atsugi-shi, Kanagawa-ken (JP)

(56) **References Cited**

(72) Inventors: **Shinya Sasagawa**, Chigasaki (JP); **Hideomi Suzawa**, Atsugi (JP)

U.S. PATENT DOCUMENTS

(73) Assignee: **Semiconductor Energy Laboratory Co., Ltd.**, Kanagawa-ken (JP)

5,648,662 A 7/1997 Zhang et al.  
5,731,856 A 3/1998 Kim et al.

(Continued)

(\* ) Notice: Subject to any disclaimer, the term of this patent is extended or adjusted under 35 U.S.C. 154(b) by 0 days.

FOREIGN PATENT DOCUMENTS

CN 102257621 A 11/2011  
EP 1737044 A 12/2006

(Continued)

(21) Appl. No.: **14/337,583**

(22) Filed: **Jul. 22, 2014**

OTHER PUBLICATIONS

(65) **Prior Publication Data**

US 2014/0332801 A1 Nov. 13, 2014

Kaneko.K et al., "Highly Reliable BEOL-Transistor with Oxygen-controlled InGaZnO and Gate/Drain Offset Design for High/Low Voltage Bridging I/O Operations", IEDM 11: Technical Digest of International Electron Devices Meeting, Dec. 1, 2011, pp. 155-158.

(Continued)

**Related U.S. Application Data**

(62) Division of application No. 13/716,891, filed on Dec. 17, 2012, now Pat. No. 8,790,961.

*Primary Examiner* — David S Blum

(74) *Attorney, Agent, or Firm* — Robinson Intellectual Property Law Office; Eric J. Robinson

(30) **Foreign Application Priority Data**

Dec. 23, 2011 (JP) ..... 2011-282438  
Dec. 23, 2011 (JP) ..... 2011-282511

(57) **ABSTRACT**

(51) **Int. Cl.**  
**H01L 29/80** (2006.01)  
**H01L 31/0288** (2006.01)  
(Continued)

A bottom-gate transistor with a short channel length and a method for manufacturing the transistor are provided. A bottom-gate transistor with a short channel length in which portions of a source electrode and a drain electrode which are proximate to a channel formation region are thinner than other portions thereof was devised. In addition, the portions of the source electrode and the drain electrode which are proximate to the channel formation region are formed in a later step than the other portions thereof, whereby a bottom-gate transistor with a short channel length can be manufactured.

(52) **U.S. Cl.**  
CPC ..... **H01L 29/7869** (2013.01); **H01L 29/1033** (2013.01); **H01L 29/24** (2013.01);  
(Continued)

(58) **Field of Classification Search**  
CPC ..... H01L 29/78; H01L 29/166477; H01L 29/7869

**22 Claims, 17 Drawing Sheets**

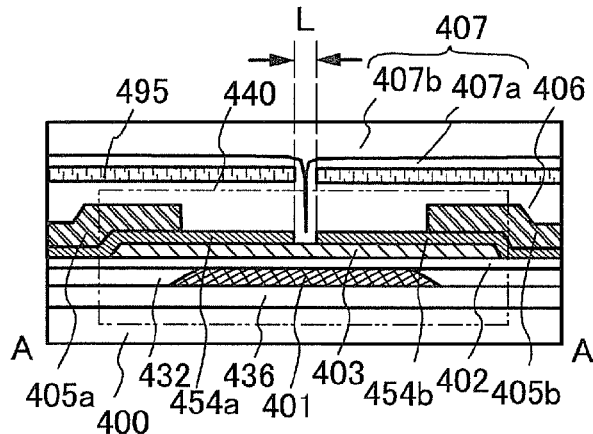



(56)

## References Cited

## FOREIGN PATENT DOCUMENTS

JP	2002-076356	A	3/2002
JP	2002-289859	A	10/2002
JP	2003-086000	A	3/2003
JP	2003-086808	A	3/2003
JP	2004-103957	A	4/2004
JP	2004-273614	A	9/2004
JP	2004-273732	A	9/2004
JP	2010-166030	A	7/2010
JP	2011-124556	A	6/2011
JP	2011-238333	A	11/2011
KR	2011-0104057	A	9/2011
KR	2012-0084783	A	7/2012
TW	201041049		11/2010
TW	201138105		11/2011
WO	WO-2004/114391		12/2004
WO	WO-2010/071034		6/2010
WO	WO-2011/058866		5/2011

## OTHER PUBLICATIONS

Invitation to pay additional fees (application No. PCT/JP2012/082594), International Searching Authority, dated Jan. 15, 2013.

Fortunato.E et al., "Wide-Bandgap High-Mobility ZnO Thin-Film Transistors Produced at Room Temperature", Appl. Phys. Lett. (Applied Physics Letters), Sep. 27, 2004, vol. 85, No. 13, pp. 2541-2543.

Dembo.H et al., "RFCPUs on Glass and Plastic Substrates Fabricated by TFT Transfer Technology", IEDM 05: Technical Digest of International Electron Devices Meeting, Dec. 5, 2005, pp. 1067-1069.

Ikeda.T et al., "Full-Functional System Liquid Crystal Display Using CG-Silicon Technology", SID Digest '04 : SID International Symposium Digest of Technical Papers, 2004, vol. 35, pp. 860-863.

Nomura.K et al., "Room-Temperature Fabrication of Transparent Flexible Thin-Film Transistors Using Amorphous Oxide Semiconductors", Nature, Nov. 25, 2004, vol. 432, pp. 488-492.

Park.J et al., "Improvements in the Device Characteristics of Amorphous Indium Gallium Zinc Oxide Thin-Film Transistors by Ar Plasma Treatment", Appl. Phys. Lett. (Applied Physics Letters), Jun. 26, 2007, vol. 90, No. 26, pp. 262106-1-262106-3.

Takahashi.M et al., "Theoretical Analysis of IGZO Transparent Amorphous Oxide Semiconductor", IDW '08 : Proceedings of the 15th International Display Workshops, Dec. 3, 2008, pp. 1637-1640.

Hayashi.R et al., "42.1: Invited Paper: Improved Amorphous In—Ga—Zn—O TFTs", SID Digest '08 : SID International Symposium Digest of Technical Papers, May 20, 2008, vol. 39, pp. 621-624.

Prins.M et al., "A Ferroelectric Transparent Thin-Film Transistor", Appl. Phys. Lett. (Applied Physics Letters), Jun. 17, 1996, vol. 68, No. 25, pp. 3650-3652.

Nakamura.M et al., "The phase relations in the In<sub>2</sub>O<sub>3</sub>—Ga<sub>2</sub>ZnO<sub>4</sub>—ZnO system at 1350° C.", Journal of Solid State Chemistry, Aug. 1, 1991, vol. 93, No. 2, pp. 298-315.

Kimizuka.N et al., "Syntheses and Single-Crystal Data of Homologous Compounds, In<sub>2</sub>O<sub>3</sub>(ZnO)<sub>m</sub> (m=3, 4, and 5), InGaO<sub>3</sub>(ZnO)<sub>3</sub>, and Ga<sub>2</sub>O<sub>3</sub>(ZnO)<sub>m</sub> (m=7, 8, 9, and 16) in the In<sub>2</sub>O<sub>3</sub>—ZnGa<sub>2</sub>O<sub>4</sub>—ZnO System", Journal of Solid State Chemistry, Apr. 1, 1995, vol. 116, No. 1, pp. 170-178.

Nomura.K et al., "Thin-Film Transistor Fabricated in Single-Crystalline Transparent Oxide Semiconductor", Science, May 23, 2003, vol. 300, No. 5623, pp. 1269-1272.

Masuda.S et al., "Transparent thin film transistors using ZnO as an active channel layer and their electrical properties", J. Appl. Phys. (Journal of Applied Physics), Feb. 1, 2003, vol. 93, No. 3, pp. 1624-1630.

Asakuma.N et al., "Crystallization and Reduction of Sol-Gel-Derived Zinc Oxide Films by Irradiation With Ultraviolet Lamp", Journal of Sol-Gel Science and Technology, 2003, vol. 26, pp. 181-184.

Osada.T et al., "15.2: Development of Driver-Integrated Panel using Amorphous In—Ga—Zn—Oxide TFT", SID Digest '09 : SID Inter-

Nomura.K et al., "Carrier transport in transparent oxide semiconductor with intrinsic structural randomness probed using single-crystalline InGaO<sub>3</sub>(ZnO)<sub>5</sub> films", Appl. Phys. Lett. (Applied Physics Letters), Sep. 13, 2004, vol. 85, No. 11, pp. 1993-1995.

Li.C et al., "Modulated Structures of Homologous Compounds InMO<sub>3</sub>(ZnO)<sub>m</sub> (M=In, Ga; m=Integer) Described by Four-Dimensional Superspace Group", Journal of Solid State Chemistry, 1998, vol. 139, pp. 347-355.

Son.K et al., "42.4L: Late-News Paper: 4 Inch QVGA AMOLED Driven by the Threshold Voltage Controlled Amorphous GIZO (Ga<sub>2</sub>O<sub>3</sub>—In<sub>2</sub>O<sub>3</sub>—ZnO) TFT", SID Digest '08 : SID International Symposium Digest of Technical Papers, May 20, 2008, vol. 39, pp. 633-636.

Lee.J et al., "World's Largest (15-Inch) XGA AMLCD Panel Using IGZO Oxide TFT", SID Digest '08 : SID International Symposium Digest of Technical Papers, May 20, 2008, vol. 39, pp. 625-628.

Nowatari.H et al., "60.2: Intermediate Connector With Suppressed Voltage Loss for White Tandem OLEDs", SID Digest '09 : SID International Symposium Digest of Technical Papers, May 31, 2009, vol. 40, pp. 899-902.

Kanno.H et al., "White Stacked Electrophosphorescent Organic Light-Emitting Devices Employing MoO<sub>3</sub> as a Charge-Generation Layer", Adv. Mater. (Advanced Materials), 2006, vol. 18, No. 3, pp. 339-342.

Tsuda.K et al., "Ultra Low Power Consumption Technologies for Mobile TFT-LCDs", IDW '02 : Proceedings of the 9th International Display Workshops, Dec. 4, 2002, pp. 295-298.

Van de Walle.C, "Hydrogen as a Cause of Doping in Zinc Oxide", Phys. Rev. Lett. (Physical Review Letters), Jul. 31, 2000, vol. 85, No. 5, pp. 1012-1015.

Fung.T et al., "2-D Numerical Simulation of High Performance Amorphous In—Ga—Zn—O TFTs for Flat Panel Displays", AM-FPD '08 Digest of Technical Papers, Jul. 2, 2008, pp. 251-252, The Japan Society of Applied Physics.

Jeong.J et al., "3.1: Distinguished Paper: 12.1-Inch WXGA AMOLED Display Driven by Indium—Gallium—Zinc Oxide TFTs Array", SID Digest '08 : SID International Symposium Digest of Technical Papers, May 20, 2008, vol. 39, No. 1, pp. 1-4.

Park.J et al., "High performance amorphous oxide thin film transistors with self-aligned top-gate structure", IEDM 09: Technical Digest of International Electron Devices Meeting, Dec. 7, 2009, pp. 191-194.

Kurokawa.Y et al., "UHF RFCPUs on Flexible and Glass Substrates for Secure RFID Systems", Journal of Solid-State Circuits, 2008, vol. 43, No. 1, pp. 292-299.

Ohara.H et al., "Amorphous In—Ga—Zn—Oxide TFTs with Suppressed Variation for 4.0 inch QVGA AMOLED Display", AM-FPD '09 Digest of Technical Papers, Jul. 1, 2009, pp. 227-230, The Japan Society of Applied Physics.

Coates.D et al., "Optical Studies of the Amorphous Liquid-Cholesteric Liquid Crystal Transition: The "Blue Phase"", Physics Letters, Sep. 10, 1973, vol. 45A, No. 2, pp. 115-116.

Cho.D et al., "21.2: Al and Sn-Doped Zinc Indium Oxide Thin Film Transistors for AMOLED Back-Plane", SID Digest '09 : SID International Symposium Digest of Technical Papers, May 31, 2009, pp. 280-283.

Lee.M et al., "15.4: Excellent Performance of Indium—Oxide-Based Thin-Film Transistors by DC Sputtering", SID Digest '09 : SID International Symposium Digest of Technical Papers, May 31, 2009, pp. 191-193.

Jin.D et al., "65.2: Distinguished Paper: World-Largest (6.5") Flexible Full Color Top Emission AMOLED Display on Plastic Film and Its Bending Properties", SID Digest '09 : SID International Symposium Digest of Technical Papers, May 31, 2009, pp. 983-985.

Sakata.J et al., "Development of 4.0-In. AMOLED Display With Driver Circuit Using Amorphous In—Ga—Zn—Oxide TFTs", IDW '09 : Proceedings of the 16th International Display Workshops, 2009, pp. 689-692.

Park.J et al., "Amorphous Indium—Gallium—Zinc Oxide TFTs and

(56)

## References Cited

## OTHER PUBLICATIONS

- Park.S et al., "Challenge to Future Displays: Transparent AM-OLED Driven by PEALD Grown ZnO TFT", IMID '07 Digest, 2007, pp. 1249-1252.
- Godo.H et al., "Temperature Dependence of Characteristics and Electronic Structure for Amorphous In—Ga—Zn—Oxide TFT", AM-FPD '09 Digest of Technical Papers, Jul. 1, 2009, pp. 41-44.
- Osada.T et al., "Development of Driver-Integrated Panel Using Amorphous In—Ga—Zn—Oxide TFT", AM-FPD '09 Digest of Technical Papers, Jul. 1, 2009, pp. 33-36.
- Hirao.T et al., "Novel Top-Gate Zinc Oxide Thin-Film Transistors (ZnO TFTs) for AMLCDs", Journal of the SID, 2007, vol. 15, No. 1, pp. 17-22.
- Hosono.H, "68.3:Invited Paper:Transparent Amorphous Oxide Semiconductors for High Performance TFT", SID Digest '07 : SID International Symposium Digest of Technical Papers, 2007, vol. 38, pp. 1830-1833.
- Godo.H et al., "P-9:Numerical Analysis on Temperature Dependence of Characteristics of Amorphous In—Ga—Zn—Oxide TFT", SID Digest '09 : SID International Symposium Digest of Technical Papers, May 31, 2009, pp. 1110-1112.
- Ohara.H et al., "21.3:4.0 In. QVGA AMOLED Display Using In—Ga—Zn—Oxide TFTs With a Novel Passivation Layer", SID Digest '09 : SID International Symposium Digest of Technical Papers, May 31, 2009, pp. 284-287.
- Miyasaka.M, "SUFLTA Flexible Microelectronics on Their Way to Business", SID Digest '07 : SID International Symposium Digest of Technical Papers, 2007, vol. 38, pp. 1673-1676.
- Chern.H et al., "An Analytical Model for the Above-Threshold Characteristics of Polysilicon Thin-Film Transistors", IEEE Transactions on Electron Devices, Jul. 1, 1995, vol. 42, No. 7, pp. 1240-1246.
- Kikuchi.H et al., "39.1:Invited Paper:Optically Isotropic Nano-Structured Liquid Crystal Composites for Display Applications", SID Digest '09 : SID International Symposium Digest of Technical Papers, May 31, 2009, pp. 578-581.
- Asaoka.Y et al., "29.1:Polarizer-Free Reflective LCD Combined With Ultra Low-Power Driving Technology", SID Digest '09 : SID International Symposium Digest of Technical Papers, May 31, 2009, pp. 395-398.
- Lee.H et al., "Current Status of, Challenges to, and Perspective View of AM-OLED", IDW '06 : Proceedings of the 13th International Display Workshops, Dec. 7, 2006, pp. 663-666.
- Kikuchi.H et al., "62.2:Invited Paper:Fast Electro-Optical Switching in Polymer-Stabilized Liquid Crystalline Blue Phases for Display Application", SID Digest '07 : SID International Digest of Technical Papers, 2007, vol. 38, pp. 1737-1740.
- Nakamura.M, "Synthesis of Homologous Compound with New Long-Period Structure", NIRIM Newsletter, Mar. 1, 1995, vol. 150, pp. 1-4.
- Kikuchi.H et al., "Polymer-Stabilized Liquid Crystal Blue Phases", Nature Materials, Sep. 2, 2002, vol. 1, pp. 64-68.
- Kimizuka.N et al., "Spinel, YbFe<sub>2</sub>O<sub>4</sub>, and Yb<sub>2</sub>Fe<sub>3</sub>O<sub>7</sub> Types of Structures for Compounds in the In<sub>2</sub>O<sub>3</sub> and SC<sub>2</sub>O<sub>3</sub>-A<sub>2</sub>O<sub>3</sub>-B<sub>2</sub>O<sub>3</sub> Systems [A: Fe, Ga, or Al; B: Mg, Mn, Fe, Ni, Cu, or Zn] at Temperatures Over 1000 °C.", Journal of Solid State Chemistry, 1985, vol. 60, pp. 382-384.
- Kitzerow.H et al., "Observation of Blue Phases in Chiral Networks", Liquid Crystals, 1993, vol. 14, No. 3, pp. 911-916.
- Costello.M et al., "Electron Microscopy of a Cholesteric Liquid Crystal and Its Blue Phase", Phys. Rev. A (Physical Review. A), May 1, 1984, vol. 29, No. 5, pp. 2957-2959.
- Meiboom.S et al., "Theory of the Blue Phase of Cholesteric Liquid Crystals", Phys. Rev. Lett. (Physical Review Letters), May 4, 1981, vol. 46, No. 18, pp. 1216-1219.
- Park.Sang-Hee et al., "42.3: Transparent ZnO Thin Film Transistor for the Application of High Aperture Ratio Bottom Emission AM-OLED Display", SID Digest '08 : SID International Symposium Digest of Technical Papers, May 20, 2008, vol. 39, pp. 629-632.
- Orita.M et al., "Mechanism of Electrical Conductivity of Transparent InGaZnO<sub>4</sub>", Phys. Rev. B (Physical Review. B), Jan. 15, 2000, vol. 61, No. 3, pp. 1811-1816.
- Nomura.K et al., "Amorphous Oxide Semiconductors for High-Performance Flexible Thin-Film Transistors", Jpn. J. Appl. Phys. (Japanese Journal of Applied Physics), 2006, vol. 45, No. 5B, pp. 4303-4308.
- Janotti.A et al., "Native Point Defects in ZnO", Phys. Rev. B (Physical Review. B), Oct. 4, 2007, vol. 76, No. 16, pp. 165202-1-165202-22.
- Park.J et al., "Electronic Transport Properties of Amorphous Indium—Gallium—Zinc Oxide Semiconductor Upon Exposure to Water", Appl. Phys. Lett. (Applied Physics Letters) 2008, vol. 92, pp. 072104-1-072104-3.
- Hsieh.H et al., "P-29:Modeling of Amorphous Oxide Semiconductor Thin Film Transistors and Subgap Density of States", SID Digest '08 : SID International Symposium Digest of Technical Papers, May 20, 2008, vol. 39, pp. 1277-1280.
- Janotti.A et al., "Oxygen Vacancies in ZnO", Appl. Phys. Lett. (Applied Physics Letters), 2005, vol. 87, pp. 122102-1-122102-3.
- Oba.F et al., "Defect energetics in ZnO: A hybrid Hartree-Fock density functional study", Phys. Rev. B (Physical Review. B), 2008, vol. 77, pp. 245202-1-245202-6.
- Orita.M et al. "Amorphous transparent conductive oxide InGaO<sub>3</sub>(ZnO)<sub>m</sub> (m<4):a Zn<sub>4</sub>s conductor", Philosophical Magazine, 2001, vol. 81, No. 5, pp. 501-515.
- Hosono.H et al., "Working hypothesis to explore novel wide band gap electrically conducting amorphous oxides and examples", J. Non-Cryst. Solids (Journal of Non-Crystalline Solids), 1996, vol. 198-200, pp. 165-169.
- Mo.Y et al., "Amorphous Oxide TFT Backplanes for Large Size AMOLED Displays", IDW '08 : Proceedings of the 6th International Display Workshops, Dec. 3, 2008, pp. 581-584.
- Kim.S et al., "High-Performance oxide thin film transistors passivated by various gas plasmas", 214th ECS Meeting, 2008, No. 2317, ECS.
- Clarks et al., "First Principles Methods Using CASTEP", Zeitschrift für Kristallographie, 2005, vol. 220, pp. 567-570.
- Lany.S et al., "Dopability, Intrinsic Conductivity, and Nonstoichiometry of Transparent Conducting Oxides", Phys. Rev. Lett. (Physical Review Letters), Jan. 26, 2007, vol. 98, pp. 045501-1-045501-4.
- Park.J et al., "Dry etching of ZnO films and plasma-induced damage to optical properties", J. Vac. Sci. Technol. B (Journal of Vacuum Science & Technology B), Mar. 1, 2003, vol. 21, No. 2, pp. 800-803.
- Oh.M et al., "Improving the Gate Stability of ZnO Thin-Film Transistors With Aluminum Oxide Dielectric Layers", J. Electrochem. Soc. (Journal of the Electrochemical Society), 2008, vol. 155, No. 12, pp. H1009-H1014.
- Ueno.K et al., "Field-Effect Transistor on SrTiO<sub>3</sub> With Sputtered Al<sub>2</sub>O<sub>3</sub> Gate Insulator", Appl. Phys. Lett. (Applied Physics Letters), Sep. 1, 2003, vol. 83, No. 9, pp. 1755-1757.

# Explore Litigation Insights

Docket Alarm provides insights to develop a more informed litigation strategy and the peace of mind of knowing you're on top of things.

## Real-Time Litigation Alerts



Keep your litigation team up-to-date with **real-time alerts** and advanced team management tools built for the enterprise, all while greatly reducing PACER spend.

Our comprehensive service means we can handle Federal, State, and Administrative courts across the country.

## Advanced Docket Research



With over 230 million records, Docket Alarm's cloud-native docket research platform finds what other services can't. Coverage includes Federal, State, plus PTAB, TTAB, ITC and NLRB decisions, all in one place.

Identify arguments that have been successful in the past with full text, pinpoint searching. Link to case law cited within any court document via Fastcase.

## Analytics At Your Fingertips



Learn what happened the last time a particular judge, opposing counsel or company faced cases similar to yours.

Advanced out-of-the-box PTAB and TTAB analytics are always at your fingertips.

## API

Docket Alarm offers a powerful API (application programming interface) to developers that want to integrate case filings into their apps.

## LAW FIRMS

Build custom dashboards for your attorneys and clients with live data direct from the court.

Automate many repetitive legal tasks like conflict checks, document management, and marketing.

## FINANCIAL INSTITUTIONS

Litigation and bankruptcy checks for companies and debtors.

## E-DISCOVERY AND LEGAL VENDORS

Sync your system to PACER to automate legal marketing.