

UNITED STATES PATENT AND TRADEMARK OFFICE

---

BEFORE THE PATENT TRIAL AND APPEAL BOARD

---

INTEL CORPORATION,  
Petitioner,

v.

QUALCOMM INCORPORATED,  
Patent Owner.

---

Case IPR2018-01335  
Patent 8,838,949 B2

---

Before TREVOR M. JEFFERSON, DANIEL J. GALLIGAN, and  
AARON W. MOORE, *Administrative Patent Judges*.

GALLIGAN, *Administrative Patent Judge*.

DECISION  
Institution of *Inter Partes* Review  
35 U.S.C. § 314

## I. INTRODUCTION

Intel Corporation (“Petitioner”) filed a Petition requesting *inter partes* review of claims 10–17 of U.S. Patent No. 8,838,949 B2 (“the ’949 patent,” Ex. 1101). Paper 3 (“Pet.”). Qualcomm Incorporated (“Patent Owner”) filed a Preliminary Response. Paper 7 (“Prelim. Resp.”). Under 37 C.F.R. § 42.4(a), we have authority to determine whether to institute review.

The standard for instituting an *inter partes* review is set forth in 35 U.S.C. § 314(a), which provides that an *inter partes* review may not be instituted unless the information presented in the Petition and the Preliminary Response shows “there is a reasonable likelihood that the petitioner would prevail with respect to at least 1 of the claims challenged in the petition.”

After considering the Petition, the Preliminary Response, and associated evidence, we institute an *inter partes* review as to all challenged claims and on all grounds raised in the Petition.

### A. Related Matters

As required by 37 C.F.R. § 42.8(b)(2), each party identifies various judicial or administrative matters that would affect or be affected by a decision in this proceeding. Pet. 2–3; Paper 4, 2. Among those related matters are IPR2018-01334 and IPR2018-01336, each of which involves different claims of the ’949 patent.

### B. Real Parties in Interest

Petitioner identifies itself and Apple Inc. as real parties in interest. Pet. 2.

*C. The '949 Patent and Illustrative Claim*

The '949 patent generally relates to loading software from one processor to another in a multi-processor system. Ex. 1101, at [57]. One example disclosed in the '949 patent involves loading modem image executable data by first retrieving and processing an image header, which “includes information used to identify where the modem image executable data is to be eventually placed into the system memory of the secondary processor.” Ex. 1101, 8:9–21. Figure 3 of the '949 patent is reproduced below.

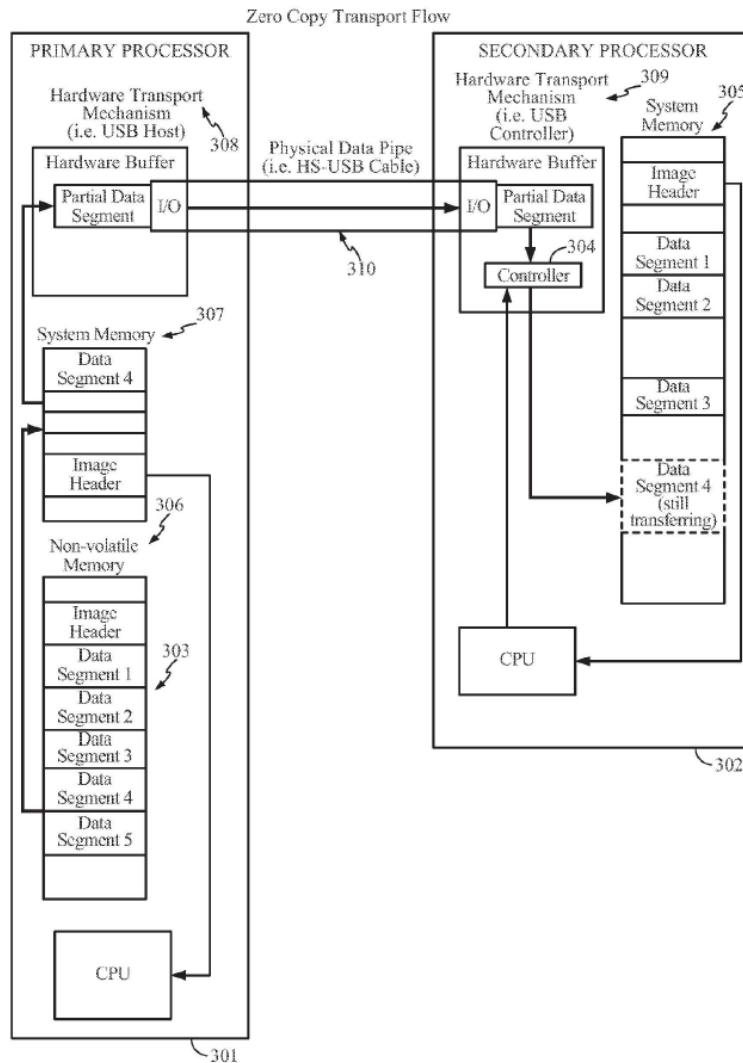

FIG. 3

Figure 3 shows “operational flow for an exemplary loading process for loading an executable image from a primary processor to a secondary processor according to one aspect of the present disclosure.” Ex. 1101, 4:10–13. Referring to various components depicted in Figure 3, the ’949 patent discloses the following:

The header information is used by the secondary processor 302 to program the scatter loader/direct memory access controller 304 receive address when receiving the actual executable data. Data segments are then sent from system memory 307 to the primary hardware transport mechanism 308. The segments are then sent from the hardware transport mechanism 308 of the primary processor 301 to a hardware transport mechanism 309 of the secondary processor 302 over an inter-chip communication bus 310 (e.g., a HS-USB cable.) The first segment transferred may be the image header, which contains information used by the secondary processor to locate the data segments into target locations in the system memory of the secondary processor 305. The image header may include information used to determine the target location information for the data.

Ex. 1101, 8:21–35.

Challenged claims 10 and 16 are independent and are reproduced below.

10. A method comprising:

receiving at a secondary processor, from a primary processor via an inter-chip communication bus, an image header for an executable software image for the secondary processor that is stored in memory coupled to the primary processor, the executable software image comprising the image header and at least one data segment, the image header and each data segment being received separately;

processing, by the secondary processor, the image header to determine at least one location within system memory to which the secondary processor is coupled to store each data segment;

receiving at the secondary processor, from the primary processor via the inter-chip communication bus, each data segment; and

scatter loading, by the secondary processor, each data segment [directly<sup>1</sup>] to the determined at least one location within the system memory, and each data segment being scatter loaded based at least in part on the processed image header.

16. An apparatus comprising:

means for receiving at a secondary processor, from a primary processor via an inter-chip communication bus, an image header for an executable software image for the secondary processor that is stored in memory coupled to the primary processor, the executable software image comprising the image header and at least one data segment, the image header and each data segment being received separately;

means for processing, by the secondary processor, the image header to determine at least one location within system memory to which the secondary processor is coupled to store each data segment;

means for receiving at the secondary processor, from the primary processor via the inter-chip communication bus, each data segment; and

means for scatter loading, by the secondary processor, each data segment directly to the determined at least one location within the system memory, and each data segment being scatter loaded based at least in part on the processed image header.

#### *D. References*

Petitioner relies upon the following references:

Bauer	US 2006/0288019 A1	Dec. 21, 2006	Ex. 1109
Zhao	US 2007/0140199 A1	June 21, 2007	Ex. 1113

---

<sup>1</sup> The issued patent recites “reedy,” which appears to be a printing error. The April 30, 2014 claim listing submitted by the applicants during prosecution states “directly.”

# Explore Litigation Insights

Docket Alarm provides insights to develop a more informed litigation strategy and the peace of mind of knowing you're on top of things.

## Real-Time Litigation Alerts



Keep your litigation team up-to-date with **real-time alerts** and advanced team management tools built for the enterprise, all while greatly reducing PACER spend.

Our comprehensive service means we can handle Federal, State, and Administrative courts across the country.

## Advanced Docket Research



With over 230 million records, Docket Alarm's cloud-native docket research platform finds what other services can't. Coverage includes Federal, State, plus PTAB, TTAB, ITC and NLRB decisions, all in one place.

Identify arguments that have been successful in the past with full text, pinpoint searching. Link to case law cited within any court document via Fastcase.

## Analytics At Your Fingertips



Learn what happened the last time a particular judge, opposing counsel or company faced cases similar to yours.

Advanced out-of-the-box PTAB and TTAB analytics are always at your fingertips.

## API

Docket Alarm offers a powerful API (application programming interface) to developers that want to integrate case filings into their apps.

## LAW FIRMS

Build custom dashboards for your attorneys and clients with live data direct from the court.

Automate many repetitive legal tasks like conflict checks, document management, and marketing.

## FINANCIAL INSTITUTIONS

Litigation and bankruptcy checks for companies and debtors.

## E-DISCOVERY AND LEGAL VENDORS

Sync your system to PACER to automate legal marketing.