



UNITED STATES PATENT AND TRADEMARK OFFICE

UNITED STATES DEPARTMENT OF COMMERCE
United States Patent and Trademark Office
Address: COMMISSIONER FOR PATENTS
P.O. Box 1450
Alexandria, Virginia 22313-1450
www.uspto.gov

APPLICATION NUMBER	FILING OR 371(C) DATE	FIRST NAMED APPLICANT	ATTY. DOCKET NO./TITLE
11/200,511	08/08/2005	David Champlin	

12811
Mahamedi Paradice Kreisman LLP (QCA)
1901 S. Bascom Ave.
Suite 600
Campbell, CA 95008

**CONFIRMATION NO. 2125
POA ACCEPTANCE LETTER**



Date Mailed: 03/25/2014

NOTICE OF ACCEPTANCE OF POWER OF ATTORNEY

This is in response to the Power of Attorney filed 03/18/2014.

The Power of Attorney in this application is accepted. Correspondence in this application will be mailed to the above address as provided by 37 CFR 1.33.

/dtvernon/

Office of Data Management, Application Assistance Unit (571) 272-4000, or (571) 272-4200, or 1-888-786-0101



UNITED STATES PATENT AND TRADEMARK OFFICE

UNITED STATES DEPARTMENT OF COMMERCE
United States Patent and Trademark Office
Address: COMMISSIONER FOR PATENTS
P.O. Box 1450
Alexandria, Virginia 22313-1450
www.uspto.gov

APPLICATION NUMBER	FILING OR 371(C) DATE	FIRST NAMED APPLICANT	ATTY. DOCKET NO./TITLE
11/200,511	08/08/2005	David Champlin	82592260

CONFIRMATION NO. 2125

POWER OF ATTORNEY NOTICE

22879
HEWLETT-PACKARD COMPANY
Intellectual Property Administration
3404 E. Harmony Road
Mail Stop 35
FORT COLLINS, CO 80528



Date Mailed: 03/25/2014

NOTICE REGARDING CHANGE OF POWER OF ATTORNEY

This is in response to the Power of Attorney filed 03/18/2014.

- The Power of Attorney to you in this application has been revoked by the assignee who has intervned as provided by 37 CFR 3.71. Future correspondence will be mailed to the new address of record(37 CFR 1.33).

/dtvernon/

Office of Data Management, Application Assistance Unit (571) 272-4000, or (571) 272-4200, or 1-888-786-0101

Under the Paperwork Reduction Act of 1995, no persons are required to respond to a collection of information unless it displays a valid OMB control number.

POWER OF ATTORNEY TO PROSECUTE APPLICATIONS BEFORE THE USPTO

I hereby revoke all previous powers of attorney given in the application identified in the attached statement under 37 CFR 3.73(c).

I hereby appoint:

 Practitioners associated with the Customer Number:

12811

OR

 Practitioner(s) named below (if more than ten patent practitioners are to be named, then a customer number must be used):

Name Registration	Number	Name Registration	Number

as attorney(s) or agent(s) to represent the undersigned before the United States Patent and Trademark Office (USPTO) in connection with any and all patent applications assigned only to the undersigned according to the USPTO assignment records or assignment documents attached to this form in accordance with 37 CFR 3.73(c).

Please change the correspondence address for the application identified in the attached statement under 37 CFR 3.73(c) to:

 The address associated with Customer Number:

12811

OR

<input type="checkbox"/> Firm or Individual Name			
Address			
City	State	Zip	
Country			
Telephone			Email

Assignee Name and Address:

QUALCOMM Incorporated
5775 Morehouse Drive
San Diego, CA 92121

A copy of this form, together with a statement under 37 CFR 3.73(c) (Form PTO/SB/96 or equivalent) is required to be filed in each application in which this form is used. The statement under 37 CFR 3.73(c) may be completed by one of the practitioners appointed in this form, and must identify the application in which this Power of Attorney is to be filed.

SIGNATURE of Assignee of Record

The individual whose signature and title is supplied below is authorized to act on behalf of the assignee

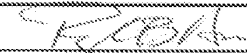
Signature		Date	19 SEP 2012
Name	Raymond B. Horn	Telephone	858-651-3679
Title	Vice President, Patent Counsel		

This collection of information is required by 37 CFR 1.31, 1.32 and 1.33. The information is required to obtain or retain a benefit by the public which is to file (and by the USPTO to process) an application. Confidentiality is governed by 35 U.S.C. 122 and 37 CFR 1.11 and 1.14. This collection is estimated to take 3 minutes to complete, including gathering, preparing, and submitting the completed application form to the USPTO. Time will vary depending upon the individual case. Any comments on the amount of time you require to complete this form and/or suggestions for reducing this burden, should be sent to the Chief Information Officer, U.S. Patent and Trademark Office, U.S. Department of Commerce, P.O. Box 1450, Alexandria, VA 22313-1450. DO NOT SEND FEES OR COMPLETED FORMS TO THIS ADDRESS. SEND TO: Commissioner for Patents, P.O. Box 1450, Alexandria, VA 22313-1450.

If you need assistance in completing the form, call 1-800-PTO-9199 and select option 2.

Under the Paperwork Reduction Act of 1995, no persons are required to respond to a collection of information unless it displays a valid OMB control number.

STATEMENT UNDER 37 CFR 3.73(c)Applicant/Patent Owner: David Champlin et al.Application No./Patent No.: 7844037 Filed/Issue Date: 11/30/2010Titled: METHOD AND DEVICE FOR ENABLING MESSAGE RESPONSES TO INCOMING PHONE CALLSQUALCOMM Incorporated, a Corporation

(Name of Assignee)

(Type of Assignee, e.g., corporation, partnership, university, government agency, etc.)

states that, for the patent application/patent identified above, it is (choose **one** of options 1, 2, 3 or 4 below):

1. The assignee of the entire right, title, and interest.
2. An assignee of less than the entire right, title, and interest (check applicable box):
- The extent (by percentage) of its ownership interest is ____%. Additional Statement(s) by the owners holding the balance of the interest **must be submitted** to account for 100% of the ownership interest.
- There are unspecified percentages of ownership. The other parties, including inventors, who together own the entire right, title and interest are:

Additional Statement(s) by the owner(s) holding the balance of the interest **must be submitted** to account for the entire right, title, and interest.

3. The assignee of an undivided interest in the entirety (a complete assignment from one of the joint inventors was made). The other parties, including inventors, who together own the entire right, title, and interest are:

Additional Statement(s) by the owner(s) holding the balance of the interest **must be submitted** to account for the entire right, title, and interest.

4. The recipient, via a court proceeding or the like (e.g., bankruptcy, probate), of an undivided interest in the entirety (a complete transfer of ownership interest was made). The certified document(s) showing the transfer is attached.

The interest identified in option 1, 2 or 3 above (not option 4) is evidenced by either (choose **one** of options A or B below):

- A. An assignment from the inventor(s) of the patent application/patent identified above. The assignment was recorded in the United States Patent and Trademark Office at Reel _____, Frame _____, or for which a copy thereof is attached.
- B. A chain of title from the inventor(s), of the patent application/patent identified above, to the current assignee as follows:

1. From: Champlin, Prasad, Chen, Ranga, Haitani To: Palm, Inc.The document was recorded in the United States Patent and Trademark Office at
Reel 017355, Frame 0334, or for which a copy thereof is attached.2. From: Champlin, Prasad, Chen, Ranga, Haitani To: Palm, Inc.The document was recorded in the United States Patent and Trademark Office at
Reel 031815, Frame 0341, or for which a copy thereof is attached.

[Page 1 of 2]

This collection of information is required by 37 CFR 3.73(b). The information is required to obtain or retain a benefit by the public which is to file (and by the USPTO to process) an application. Confidentiality is governed by 35 U.S.C. 122 and 37 CFR 1.11 and 1.14. This collection is estimated to take 12 minutes to complete, including gathering, preparing, and submitting the completed application form to the USPTO. Time will vary depending upon the individual case. Any comments on the amount of time you require to complete this form and/or suggestions for reducing this burden, should be sent to the Chief Information Officer, U.S. Patent and Trademark Office, U.S. Department of Commerce, P.O. Box 1450, Alexandria, VA 22313-1450. DO NOT SEND FEES OR COMPLETED FORMS TO THIS ADDRESS. **SEND TO: Commissioner for Patents, P.O. Box 1450, Alexandria, VA 22313-1450.**

If you need assistance in completing the form, call 1-800-PTO-9199 and select option 2.

Under the Paperwork Reduction Act of 1995, no persons are required to respond to a collection of information unless it displays a valid OMB control number.

STATEMENT UNDER 37 CFR 3.73(c)3. From: Palm, Inc. To: Hewlett-Packard Development Company, L.P.The document was recorded in the United States Patent and Trademark Office at
Reel 025204, Frame 0809, or for which a copy thereof is attached.4. From: Hewlett-Packard Development Company, L.P. To: Palm, Inc.The document was recorded in the United States Patent and Trademark Office at
Reel 030341, Frame 0459, or for which a copy thereof is attached.5. From: Palm, Inc. To: Hewlett-Packard Development Company, L.P.The document was recorded in the United States Patent and Trademark Office at
Reel 031837, Frame 0239, or for which a copy thereof is attached.6. From: Hewlett-Packard Development Company, L.P. To: Palm, Inc.The document was recorded in the United States Patent and Trademark Office at
Reel 031837, Frame 0544, or for which a copy thereof is attached. Additional documents in the chain of title are listed on a supplemental sheet(s). As required by 37 CFR 3.73(c)(1)(i), the documentary evidence of the chain of title from the original owner to the assignee was, or concurrently is being, submitted for recordation pursuant to 37 CFR 3.11.

[NOTE: A separate copy (i.e., a true copy of the original assignment document(s)) must be submitted to Assignment Division in accordance with 37 CFR Part 3, to record the assignment in the records of the USPTO. See MPEP 302.08]

The undersigned (whose title is supplied below) is authorized to act on behalf of the assignee.

/William L Paradise III/

Signature

William L Paradise III

Printed or Typed Name

March 18, 2014

Date

38,990

Title or Registration Number

STATEMENT UNDER 37 CFR 3.73(c)

7. From: Palm, Inc.

To: Hewlett-Packard Development Company, L.P.

The document was recorded in the United States Patent and Trademark Office at Reel 031837, Frame 0659, or for which a copy thereof is attached.

8. From: Hewlett-Packard Company, Hewlett-Packard Development Company, L.P.,
Palm, Inc.

To: QUALCOMM Incorporated

The document was recorded in the United States Patent and Trademark Office at Reel 032126, Frame 0541, or for which a copy thereof is attached.

“FEE ADDRESS” INDICATION FORM

Address to:
Mail Stop M Correspondence
Commissioner for Patents
P.O. Box 1450
Alexandria, VA 22313-1450

- OR -

Fax to:
571-273-6500

INSTRUCTIONS: The issue fee must have been paid for application(s) listed on this form. In addition, only an address represented by a Customer Number can be established as the fee address for maintenance fee purposes (hereafter, fee address). A fee address should be established when correspondence related to maintenance fees should be mailed to a different address than the correspondence address for the application. **When to check the first box below:** If you have a Customer Number to represent the fee address. **When to check the second box below:** If you have no Customer Number representing the desired fee address, in which case a completed Request for Customer Number (PTO/SB/125) must be attached to this form. For more information on Customer Numbers, see the Manual of Patent Examining Procedure (MPEP) § 403.

For the following listed application(s), please recognize as the “Fee Address” under the provisions of 37 CFR 1.363 the address associated with:

Customer Number: 23696

OR

The attached Request for Customer Number (PTO/SB/125) form.

PATENT NUMBER <small>(if known)</small>	APPLICATION NUMBER
7,844,037	11/200,511

Completed by (check one):

Applicant/Inventor /William L Paradise III/

Signature

Attorney or Agent of record William L Paradise III

Typed or printed name
38,990 (Reg. No.)

Assignee of record of the entire interest. See 37 CFR 3.71. 408-236-6646

Requester's telephone number
Statement under 37 CFR 3.73(b) is enclosed.
(Form PTO/SB/96)

Assignee recorded at Reel _____ Frame _____ March 18, 2014

Date

NOTE: Signatures of all the inventors or assignees of record of the entire interest or their representative(s) are required. Submit multiple forms if more than one signature is required, see below*.

* Total of _____ forms are submitted.

This collection of information is required by 37 CFR 1.363. The information is required to obtain or retain a benefit by the public which is to file (and by the USPTO to process) an application. Confidentiality is governed by 35 U.S.C. 122 and 37 CFR 1.11 and 1.14. This collection is estimated to take 5 minutes to complete, including gathering, preparing, and submitting the completed application form to the USPTO. Time will vary depending upon the individual case. Any comments on the amount of time you require to complete this form and/or suggestions for reducing this burden, should be sent to the Chief Information Officer, U.S. Patent and Trademark Office, U.S. Department of Commerce, P.O. Box 1450, Alexandria, VA 22313-1450. DO NOT SEND COMPLETED FORMS TO THIS ADDRESS. SEND TO: Mail Stop M Correspondence, Commissioner for Patents, P.O. Box 1450, Alexandria, VA 22313-1450.
If you need assistance in completing the form, call 1-800-PTO-9199 and select option 2.

Privacy Act Statement

The **Privacy Act of 1974 (P.L. 93-579)** requires that you be given certain information in connection with your submission of the attached form related to a patent application or patent. Accordingly, pursuant to the requirements of the Act, please be advised that: (1) the general authority for the collection of this information is 35 U.S.C. 2(b)(2); (2) furnishing of the information solicited is voluntary; and (3) the principal purpose for which the information is used by the U.S. Patent and Trademark Office is to process and/or examine your submission related to a patent application or patent. If you do not furnish the requested information, the U.S. Patent and Trademark Office may not be able to process and/or examine your submission, which may result in termination of proceedings or abandonment of the application or expiration of the patent.

The information provided by you in this form will be subject to the following routine uses:

1. The information on this form will be treated confidentially to the extent allowed under the Freedom of Information Act (5 U.S.C. 552) and the Privacy Act (5 U.S.C. 552a). Records from this system of records may be disclosed to the Department of Justice to determine whether disclosure of these records is required by the Freedom of Information Act.
2. A record from this system of records may be disclosed, as a routine use, in the course of presenting evidence to a court, magistrate, or administrative tribunal, including disclosures to opposing counsel in the course of settlement negotiations.
3. A record in this system of records may be disclosed, as a routine use, to a Member of Congress submitting a request involving an individual, to whom the record pertains, when the individual has requested assistance from the Member with respect to the subject matter of the record.
4. A record in this system of records may be disclosed, as a routine use, to a contractor of the Agency having need for the information in order to perform a contract. Recipients of information shall be required to comply with the requirements of the Privacy Act of 1974, as amended, pursuant to 5 U.S.C. 552a(m).
5. A record related to an International Application filed under the Patent Cooperation Treaty in this system of records may be disclosed, as a routine use, to the International Bureau of the World Intellectual Property Organization, pursuant to the Patent Cooperation Treaty.
6. A record in this system of records may be disclosed, as a routine use, to another federal agency for purposes of National Security review (35 U.S.C. 181) and for review pursuant to the Atomic Energy Act (42 U.S.C. 218(c)).
7. A record from this system of records may be disclosed, as a routine use, to the Administrator, General Services, or his/her designee, during an inspection of records conducted by GSA as part of that agency's responsibility to recommend improvements in records management practices and programs, under authority of 44 U.S.C. 2904 and 2906. Such disclosure shall be made in accordance with the GSA regulations governing inspection of records for this purpose, and any other relevant (*i.e.*, GSA or Commerce) directive. Such disclosure shall not be used to make determinations about individuals.
8. A record from this system of records may be disclosed, as a routine use, to the public after either publication of the application pursuant to 35 U.S.C. 122(b) or issuance of a patent pursuant to 35 U.S.C. 151. Further, a record may be disclosed, subject to the limitations of 37 CFR 1.14, as a routine use, to the public if the record was filed in an application which became abandoned or in which the proceedings were terminated and which application is referenced by either a published application, an application open to public inspection or an issued patent.
9. A record from this system of records may be disclosed, as a routine use, to a Federal, State, or local law enforcement agency, if the USPTO becomes aware of a violation or potential violation of law or regulation.

Electronic Acknowledgement Receipt

EFS ID:	18515356
Application Number:	11200511
International Application Number:	
Confirmation Number:	2125
Title of Invention:	METHOD AND DEVICE FOR ENABLING MESSAGE RESPONSES TO INCOMING PHONE CALLS
First Named Inventor/Applicant Name:	David Champlin
Customer Number:	22879
Filer:	William Leonard Paradice/Katayoun Ghazian
Filer Authorized By:	William Leonard Paradice
Attorney Docket Number:	82592260
Receipt Date:	18-MAR-2014
Filing Date:	08-AUG-2005
Time Stamp:	19:08:40
Application Type:	Utility under 35 USC 111(a)

Payment information:

Submitted with Payment	no
------------------------	----

File Listing:

Document Number	Document Description	File Name	File Size(Bytes)/ Message Digest	Multi Part /.zip	Pages (if appl.)
1	Power of Attorney	2012-09-19_QC_AIA_80_MPK.pdf	468057 1ce8affe6bc71267558c6f67aace52cd5605a32b	no	1

Warnings:

The page size in the PDF is too large. The pages should be 8.5 x 11 or A4. If this PDF is submitted, the pages will be resized upon entry into the Image File Wrapper and may affect subsequent processing

Information:

2	Assignee showing of ownership per 37 CFR 3.73.	QCP142786_373c_AF.pdf	154483 edfed5a50859f84f061b7a3ba2b17033fb81a726	no	3
---	--	-----------------------	--	----	---

Warnings:

Information:

3	Change of Address	QCP142786_Fee_Address_Change_AF.pdf	312080 576104fc563b5aff37ade6c9bfff25e3888f0863	no	2
---	-------------------	-------------------------------------	--	----	---

Warnings:

Information:

Total Files Size (in bytes):			934620
-------------------------------------	--	--	--------

This Acknowledgement Receipt evidences receipt on the noted date by the USPTO of the indicated documents, characterized by the applicant, and including page counts, where applicable. It serves as evidence of receipt similar to a Post Card, as described in MPEP 503.

New Applications Under 35 U.S.C. 111

If a new application is being filed and the application includes the necessary components for a filing date (see 37 CFR 1.53(b)-(d) and MPEP 506), a Filing Receipt (37 CFR 1.54) will be issued in due course and the date shown on this Acknowledgement Receipt will establish the filing date of the application.

National Stage of an International Application under 35 U.S.C. 371

If a timely submission to enter the national stage of an international application is compliant with the conditions of 35 U.S.C. 371 and other applicable requirements a Form PCT/DO/EO/903 indicating acceptance of the application as a national stage submission under 35 U.S.C. 371 will be issued in addition to the Filing Receipt, in due course.

New International Application Filed with the USPTO as a Receiving Office

If a new international application is being filed and the international application includes the necessary components for an international filing date (see PCT Article 11 and MPEP 1810), a Notification of the International Application Number and of the International Filing Date (Form PCT/RO/105) will be issued in due course, subject to prescriptions concerning national security, and the date shown on this Acknowledgement Receipt will establish the international filing date of the application.

UNITED STATES PATENT AND TRADEMARK OFFICE
CERTIFICATE OF CORRECTION

PATENT NO. : 7,844,037 B2
APPLICATION NO. : 11/200511
DATED : November 30, 2010
INVENTOR(S) : David Champlin et al.

Page 1 of 1

It is certified that error appears in the above-identified patent and that said Letters Patent is hereby corrected as shown below:

In column 1, line 41, before "DESCRIPTION" insert -- BRIEF --.

Signed and Sealed this
Third Day of July, 2012

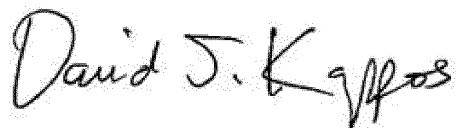
A handwritten signature in black ink that reads "David J. Kappos". The signature is written in a cursive style with a large initial 'D' and 'K'.

David J. Kappos
Director of the United States Patent and Trademark Office

IN THE UNITED STATES PATENT & TRADEMARK OFFICE

ATTORNEY DOCKET NUMBER: 82592260

IN RE APPLICATION OF: U.S. Patent No. 7,844,037

USPTO CONFIRMATION CODE: 2125

APPLICATION NO.: 11/200,511

FILED: Aug. 8, 2005

EXAMINER: Gerald Gauthier

GROUP ART UNIT: 2614

FOR: METHOD AND DEVICE FOR ENABLING MESSAGE RESPONSES TO
INCOMING PHONE CALLS

37 CFR 1.322 & 37 CFR 1.323 REQUEST FOR CERTIFICATE OF CORRECTION

HONORABLE COMMISSIONER OF PATENTS & TRADEMARKS

Sir:

The following is a request for a certificate of correction in Serial Number 11/200,511, now Patent Number 7,844,037.

A certificate of correction under 35 USC 254 is respectfully requested in the above-identified patent.

All errors were the fault of the USPTO, no fee required. In the event that a further fee is required, please charge the amount to Deposit Account No. 082025.

All errors were the fault of the applicant and, accordingly, please charge \$100.00 to our Deposit Account No. 082025. In the event that a further fee is required, please charge the amount to the same Deposit Account.

The errors were the fault of both the applicant and USPTO and, accordingly, please charge \$100.00 to our Deposit Account No. 082025. In the event that a further fee is required, please charge the amount to the same Deposit Account.

The exact location where the error appears in the patent and patent application is as follows:

In column 1, line 41, before "DESCRIPTION" insert -- BRIEF --.
(Specification filed on Aug. 8, 2005, page 3, line 1)

The requested correction is attached on Form PTO 1050.

Respectfully Submitted

April 7, 2012
DATE

/Scott A. Pojunas/
Name: Scott A Pojunas
Registration No.: 62590

Attorney/Agent of Record

HEWLETT-PACKARD COMPANY
Intellectual Property Administration
3404 E. Harmony Road
Mail Stop 35
Fort Collins, CO 80528

**UNITED STATES PATENT AND TRADEMARK OFFICE
CERTIFICATE OF CORRECTION**

Page 1 of 1

PATENT NO. : 7,844,037
APPLICATION NO. : 11/200,511
ISSUE DATE : Nov. 30, 2010
INVENTOR(S) : David Champlin et al.

It is certified that an error appears or errors appear in the above-identified patent and that said Letters Patent is hereby corrected as shown below:

In column 1, line 41, before "DESCRIPTION" insert - - BRIEF - - .

MAILING ADDRESS OF SENDER (Please do not use customer number below):

Hewlett-Packard Company
Intellectual Property Administration
3404 E. Harmony Road
Mail Stop 35
Fort Collins, CO 80528

This collection of information is required by 37 CFR 1.322, and 1.323, and 1.324. The information is required to obtain or retain a benefit by the public which is to file (and by the USPTO to process) an application. Confidentiality is governed by 35 U.S.C 122 and 37 CFR 1.14. This collection is estimated to take 1.0 hour to complete, including gathering, preparing, and submitting the completed application form to the USPTO. Time will vary depending upon the individual case. Any comments on the amount of time you require to complete this form and/or suggestions for reducing this burden, should be sent to the Chief Information Officer, U.S. Patent and Trademark Office, U.S. Department of Commerce, P.O. Box 1450, Alexandria, VA 22313-1450. **DO NOT SEND FEES OR COMPLETED FORMS TO THIS ADDRESS. SEND TO: Attention Certificate of Corrections Branch, Commissioner for Patent, P.O. Box 1450, Alexandria, VA 22313-1450.**

If you need assistance in completing the form, call 1-800-PTO-9199 and select option 2.

Electronic Acknowledgement Receipt

EFS ID:	12891716
Application Number:	11200511
International Application Number:	
Confirmation Number:	2125
Title of Invention:	METHOD AND DEVICE FOR ENABLING MESSAGE RESPONSES TO INCOMING PHONE CALLS
First Named Inventor/Applicant Name:	David Champlin
Customer Number:	22879
Filer:	Scott A. Pojunas/Alba Escobar
Filer Authorized By:	Scott A. Pojunas
Attorney Docket Number:	PALM.P0962
Receipt Date:	30-MAY-2012
Filing Date:	08-AUG-2005
Time Stamp:	14:10:53
Application Type:	Utility under 35 USC 111(a)

Payment information:

Submitted with Payment	no
------------------------	----

File Listing:

Document Number	Document Description	File Name	File Size(Bytes)/ Message Digest	Multi Part /.zip	Pages (if appl.)
1	Request for Certificate of Correction	SIGNEDCOC.pdf	431366 <small>f083ba92a154b51b0426bc2b5cb5f572bd0bfa48</small>	no	3

Warnings:

Information:

This Acknowledgement Receipt evidences receipt on the noted date by the USPTO of the indicated documents, characterized by the applicant, and including page counts, where applicable. It serves as evidence of receipt similar to a Post Card, as described in MPEP 503.

New Applications Under 35 U.S.C. 111

If a new application is being filed and the application includes the necessary components for a filing date (see 37 CFR 1.53(b)-(d) and MPEP 506), a Filing Receipt (37 CFR 1.54) will be issued in due course and the date shown on this Acknowledgement Receipt will establish the filing date of the application.

National Stage of an International Application under 35 U.S.C. 371

If a timely submission to enter the national stage of an international application is compliant with the conditions of 35 U.S.C. 371 and other applicable requirements a Form PCT/DO/EO/903 indicating acceptance of the application as a national stage submission under 35 U.S.C. 371 will be issued in addition to the Filing Receipt, in due course.

New International Application Filed with the USPTO as a Receiving Office

If a new international application is being filed and the international application includes the necessary components for an international filing date (see PCT Article 11 and MPEP 1810), a Notification of the International Application Number and of the International Filing Date (Form PCT/RO/105) will be issued in due course, subject to prescriptions concerning national security, and the date shown on this Acknowledgement Receipt will establish the international filing date of the application.



UNITED STATES PATENT AND TRADEMARK OFFICE

UNITED STATES DEPARTMENT OF COMMERCE
United States Patent and Trademark Office
Address: COMMISSIONER FOR PATENTS
P.O. Box 1450
Alexandria, Virginia 22313-1450
www.uspto.gov

APPLICATION NUMBER	FILING OR 371(C) DATE	FIRST NAMED APPLICANT	ATTY. DOCKET NO./TITLE
11/200,511	08/08/2005	David Champlin	PALM.P0962

CONFIRMATION NO. 2125

POA ACCEPTANCE LETTER

22879
HEWLETT-PACKARD COMPANY
Intellectual Property Administration
3404 E. Harmony Road
Mail Stop 35
FORT COLLINS, CO 80528



Date Mailed: 02/10/2011

NOTICE OF ACCEPTANCE OF POWER OF ATTORNEY

This is in response to the Power of Attorney filed 01/31/2011.

The Power of Attorney in this application is accepted. Correspondence in this application will be mailed to the above address as provided by 37 CFR 1.33.

/ddinh/

Office of Data Management, Application Assistance Unit (571) 272-4000, or (571) 272-4200, or 1-888-786-0101

POWER OF ATTORNEY TO PROSECUTE APPLICATIONS BEFORE THE USPTO

I hereby revoke all previous powers of attorney given in the application identified in the attached statement under 37 CFR 3.73(b).

I hereby appoint:

Practitioners associated with the Customer Number:

OR

Practitioner(s) named below (if more than ten patent practitioners are to be named, then a customer number must be used):

Name	Registration Number	Name	Registration Number

as attorney(s) or agent(s) to represent the undersigned before the United States Patent and Trademark Office (USPTO) in connection with any and all patent applications assigned only to the undersigned according to the USPTO assignment records or assignment documents attached to this form in accordance with 37 CFR 3.73(b).

Please change the correspondence address for the application identified in the attached statement under 37 CFR 3.73(b) to:

The address associated with Customer Number:

OR

Firm or Individual Name

Address

City

State

Zip

Country

Telephone

Email

Assignee Name and Address:

Hewlett-Packard Development Company, L.P.
11445 Compaq Center Drive West
Houston, TX 77070

A copy of this form, together with a statement under 37 CFR 3.73(b) (Form PTO/SB/96 or equivalent) is required to be filed in each application in which this form is used. The statement under 37 CFR 3.73(b) may be completed by one of the practitioners appointed in this form if the appointed practitioner is authorized to act on behalf of the assignee, and must identify the application in which this Power of Attorney is to be filed.

SIGNATURE of Assignee of Record

The individual whose signature and title is supplied below is authorized to act on behalf of the assignee

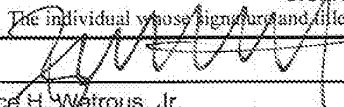
Signature		Date	1/12/11
Name	Bruce H. Watrous, Jr.	Telephone	(650) 857-4973
Title	Manager, HPQ Holdings, LLC, General Partner		

This collection of information is required by 37 CFR 1.31, 1.32 and 1.33. The information is required to obtain or retain a benefit by the public which is to file (and by the USPTO to process) an application. Confidentiality is governed by 35 U.S.C. 122 and 37 CFR 1.11 and 1.14. The collection is estimated to take 3 minutes to complete, including gathering, preparing, and submitting the completed application form to the USPTO. Time will vary depending upon the individual case. Any comments on the amount of time you require to complete this form and/or suggestions for reducing this burden, should be sent to the Chief Information Officer, U.S. Patent and Trademark Office, U.S. Department of Commerce, P.O. Box 1450, Alexandria, VA 22313-1450. DO NOT SEND FEES OR COMPLETED FORMS TO THIS ADDRESS. SEND TO: Commissioner for Patents, P.O. Box 1450, Alexandria, VA 22313-1450.

If you need assistance in completing the form, call 1-800-PTO-9199 and select option 2.

STATEMENT UNDER 37 CFR 3.73(b)

Applicant/Patent Owner: Hewlett-Packard Development Company, L.P.

Application No./Patent No.: 7844037 Filed/Issue Date: 11/30/2010

Titled: METHOD AND DEVICE FOR ENABLING MESSAGE RESPONSES TO INCOMING PHONE CALLS

Hewlett-Packard Development Company, L.P., a Limited Partnership
(Name of Assignee) (Type of Assignee, e.g., corporation, partnership, university, government agency, etc.)

states that it is:

1. the assignee of the entire right, title, and interest in;
2. an assignee of less than the entire right, title, and interest in
 (The extent (by percentage) of its ownership interest is _____ %); or
3. the assignee of an undivided interest in the entirety of (a complete assignment from one of the joint inventors was made)

the patent application/patent identified above, by virtue of either:

A. An assignment from the inventor(s) of the patent application/patent identified above. The assignment was recorded in the United States Patent and Trademark Office at Reel _____, Frame _____, or for which a copy therefore is attached.

OR

B. A chain of title from the inventor(s), of the patent application/patent identified above, to the current assignee as follows:

1. From: David Champiin et al. To: PALM, INC.

The document was recorded in the United States Patent and Trademark Office at
 Reel 017355, Frame 0334, or for which a copy thereof is attached.

2. From: PALM, INC. To: JPMORGAN CHASE BANK, N.A.

The document was recorded in the United States Patent and Trademark Office at
 Reel 020341, Frame 0285, or for which a copy thereof is attached.

3. From: JPMORGAN CHASE BANK, N.A. To: PALM, INC.

The document was recorded in the United States Patent and Trademark Office at
 Reel 024630, Frame 0474, or for which a copy thereof is attached.

Additional documents in the chain of title are listed on a supplemental sheet(s).

As required by 37 CFR 3.73(b)(1)(i), the documentary evidence of the chain of title from the original owner to the assignee was, or concurrently is being, submitted for recordation pursuant to 37 CFR 3.11.

[NOTE: A separate copy (i.e., a true copy of the original assignment document(s)) must be submitted to Assignment Division in accordance with 37 CFR Part 3, to record the assignment in the records of the USPTO. See MPEP 302.08]

The undersigned (whose title is supplied below) is authorized to act on behalf of the assignee.

/Ted McCullough/

1/21/11

Signature

Date

Theodore. C. McCullough

Senior IP Counsel

Printed or Typed Name

Title

This collection of information is required by 37 CFR 3.73(b). The information is required to obtain or retain a benefit by the public which is to file (and by the USPTO to process) an application. Confidentiality is governed by 35 U.S.C. 122 and 37 CFR 1.11 and 1.14. This collection is estimated to take 12 minutes to complete, including gathering, preparing, and submitting the completed application form to the USPTO. Time will vary depending upon the individual case. Any comments on the amount of time you require to complete this form and/or suggestions for reducing this burden, should be sent to the Chief Information Officer, U.S. Patent and Trademark Office, U.S. Department of Commerce, P.O. Box 1450, Alexandria, VA 22313-1450. DO NOT SEND FEES OR COMPLETED FORMS TO THIS ADDRESS. SEND TO: Commissioner for Patents, P.O. Box 1450, Alexandria, VA 22313-1450.

Regarding Patent / Application No. 7844037

B. Chain of title (cont.):

4. From: PALM, INC.

To: Hewlett-Packard Development Company, L.P.

Recorded at Reel: 025204 Frame: 0809

Electronic Acknowledgement Receipt

EFS ID:	9344388
Application Number:	11200511
International Application Number:	
Confirmation Number:	2125
Title of Invention:	METHOD AND DEVICE FOR ENABLING MESSAGE RESPONSES TO INCOMING PHONE CALLS
First Named Inventor/Applicant Name:	David Champlin
Customer Number:	30554
Filer:	Steven L. Webb/Andrew Graff
Filer Authorized By:	Steven L. Webb
Attorney Docket Number:	PALM.P0962
Receipt Date:	31-JAN-2011
Filing Date:	08-AUG-2005
Time Stamp:	16:15:05
Application Type:	Utility under 35 USC 111(a)

Payment information:

Submitted with Payment	no
------------------------	----

File Listing:

Document Number	Document Description	File Name	File Size(Bytes)/ Message Digest	Multi Part /.zip	Pages (if appl.)
1	Power of Attorney	11200511.pdf	303006 <small>d6d61c51790666aaac0c82712e9e103a4828f445</small>	no	3

Warnings:

Information:

This Acknowledgement Receipt evidences receipt on the noted date by the USPTO of the indicated documents, characterized by the applicant, and including page counts, where applicable. It serves as evidence of receipt similar to a Post Card, as described in MPEP 503.

New Applications Under 35 U.S.C. 111

If a new application is being filed and the application includes the necessary components for a filing date (see 37 CFR 1.53(b)-(d) and MPEP 506), a Filing Receipt (37 CFR 1.54) will be issued in due course and the date shown on this Acknowledgement Receipt will establish the filing date of the application.

National Stage of an International Application under 35 U.S.C. 371

If a timely submission to enter the national stage of an international application is compliant with the conditions of 35 U.S.C. 371 and other applicable requirements a Form PCT/DO/EO/903 indicating acceptance of the application as a national stage submission under 35 U.S.C. 371 will be issued in addition to the Filing Receipt, in due course.

New International Application Filed with the USPTO as a Receiving Office

If a new international application is being filed and the international application includes the necessary components for an international filing date (see PCT Article 11 and MPEP 1810), a Notification of the International Application Number and of the International Filing Date (Form PCT/RO/105) will be issued in due course, subject to prescriptions concerning national security, and the date shown on this Acknowledgement Receipt will establish the international filing date of the application.



UNITED STATES PATENT AND TRADEMARK OFFICE

UNITED STATES DEPARTMENT OF COMMERCE
United States Patent and Trademark Office
Address: COMMISSIONER FOR PATENTS
P.O. Box 1450
Alexandria, Virginia 22313-1450
www.uspto.gov

Table with 5 columns: APPLICATION NO., ISSUE DATE, PATENT NO., ATTORNEY DOCKET NO., CONFIRMATION NO.
Row 1: 11/200,511, 11/30/2010, 7844037, PALM.P0962, 2125

30554 7590 11/10/2010
MAHAMEDI PARADICE KREISMAN LLP
550 Winchester Boulevard
Suite 605
SAN JOSE, CA 95128

ISSUE NOTIFICATION

The projected patent number and issue date are specified above.

Determination of Patent Term Adjustment under 35 U.S.C. 154 (b)
(application filed on or after May 29, 2000)

The Patent Term Adjustment is 1481 day(s). Any patent to issue from the above-identified application will include an indication of the adjustment on the front page.

If a Continued Prosecution Application (CPA) was filed in the above-identified application, the filing date that determines Patent Term Adjustment is the filing date of the most recent CPA.

Applicant will be able to obtain more detailed information by accessing the Patent Application Information Retrieval (PAIR) WEB site (http://pair.uspto.gov).

Any questions regarding the Patent Term Extension or Adjustment determination should be directed to the Office of Patent Legal Administration at (571)-272-7702. Questions relating to issue and publication fee payments should be directed to the Application Assistance Unit (AAU) of the Office of Data Management (ODM) at (571)-272-4200.

APPLICANT(s) (Please see PAIR WEB site http://pair.uspto.gov for additional applicants):

- David Champlin, Menlo Park, CA;
Srikiran Prasad, Cupertino, CA;
Lang Chen, Oakland, CA;
Rajan Ranga, Palo Alto, CA;
Robert Haitani, Menlo Park, CA;

Substitute for Form 1449/PTO INFORMATION DISCLOSURE STATEMENT BY APPLICANT Page 1 of 1	Application No.	11/200,511
	Filed	8/8/2005
	First Inventor	Champlin, David
	Art Unit	2614
	Examiner	GAUTHIER, Gerald
	Atty. Docket No.	PALM.P0962

U.S. Patent Documents					
Examiner Initials*	US Patent Document		Name of Patentee or Applicant of Cited Document	Date of Publication	Relevant Pages, Columns, Lines
	Number	Kind			
/GG/	2006/0041470	A1	Fiho et al.	02-23-2006	
/GG/	2007/0143429	A1	Venkataraman et al.	06-21-2007	
/GG/	2009/0061833	A1	Ho et al.	03-05-2009	
/GG/	6,484,036		Sorkin et al.	11-19- 2008 ²⁰⁰⁷	

9/10/21

Foreign Patent Documents						
Examiner Initials*	Patent Document		Name of Patentee or Applicant of Cited Document	Date of Publication	Relevant Pages, Columns, Lines	Trans- lation
	Number	Kind				
/GG/	KR 102006009318	A	Pantech Co., Ltd.	08-24-2006		

/GG/	KR 102007007836	A	LG Electronics Inc.	07-31-2007		
------	-----------------	---	---------------------	------------	--	--

Non Patent Literature Documents		
Examiner Initials	Name of Author, Title of Item, Date, Page(s), Volume-Issue Number(s), Publisher, City and/or Country where Published	Trans- lation
/GG/	International Search Report and Written Opinion mailed January 29, 2009 for PCT/US2008/074320 [PALM.P1009WO] 14 pgs.	

Examiner Signature	/Gerald Gauthier/	Date Considered	06/15/2010
-------------------------------	-------------------	----------------------------	------------

*Examiner: Initial if reference considered, whether or not citation is in conformance with MPEP 609. Draw a line through citation if not in conformance and not considered. Include a copy of this form with next communication to applicant.

Substitute for Form 1449/PTO INFORMATION DISCLOSURE STATEMENT BY APPLICANT Page 1 of 1	Application No.	11/200,511
	Filed	8/8/2005
	First Inventor	Champlin, David
	Art Unit	2614
	Examiner	GAUTHIER, Gerald
	Atty. Docket No.	PALM.P0962

U.S. Patent Documents					
Examiner Initials*	US Patent Document		Name of Patentee or Applicant of Cited Document	Date of Publication	Relevant Pages, Columns, Lines
	Number	Kind			
/GG/	2006/0041470	A1	Fiho et al.	02-23-2006	
/GG/	2007/0143429	A1	Venkataraman et al.	06-21-2007	
/GG/	2009/0061833	A1	Ho et al.	03-05-2009	
/GG/	6,484,036		Sorkin et al.	11-19-2006	

Foreign Patent Documents						
Examiner Initials*	Patent Document		Name of Patentee or Applicant of Cited Document	Date of Publication	Relevant Pages, Columns, Lines	Trans- lation
	Number	Kind				
/GG/	KR-1020060093483	A	Pantech Co., Ltd.	08-24-2006		
	2006 009 3183					
/GG/	KR 1020070078369	A	LG Electronics Inc.	07-31-2007		
	2007 007 8369					

as 10/20
↓

Non Patent Literature Documents		
Examiner Initials	Name of Author, Title of Item, Date, Page(s), Volume-Issue Number(s), Publisher, City and/or Country where Published	Trans- lation
/GG/	International Search Report and Written Opinion mailed January 29, 2009 for PCT/US2008/074320 [PALM.P1009WO] 14 pgs.	

Examiner Signature	/Gerald Gauthier/	Date Considered	06/15/2010
-------------------------------	-------------------	----------------------------	------------

*Examiner: Initial if reference considered, whether or not citation is in conformance with MPEP 609. Draw a line through citation if not in conformance and not considered. Include a copy of this form with next communication to applicant.

PART B - FEE(S) TRANSMITTAL

Complete and send this form, together with applicable fee(s), to: **Mail** **Mail Stop ISSUE FEE**
Commissioner for Patents
P.O. Box 1450
Alexandria, Virginia 22313-1450
 or **Fax** **(571)-273-2885**

INSTRUCTIONS: This form should be used for transmitting the ISSUE FEE and PUBLICATION FEE (if required). Blocks 1 through 5 should be completed where appropriate. All further correspondence including the Patent, advance orders and notification of maintenance fees will be mailed to the current correspondence address as indicated unless corrected below or directed otherwise in Block 1, by (a) specifying a new correspondence address; and/or (b) indicating a separate "FEE ADDRESS" for maintenance fee notifications.

CURRENT CORRESPONDENCE ADDRESS (Note: Use Block 1 for any change of address)

30554 7590 09/23/2010

MAHAMEDI PARADICE KREISMAN LLP
 550 Winchester Boulevard
 Suite 605
 SAN JOSE, CA 95128

Note: A certificate of mailing can only be used for domestic mailings of the Fee(s) Transmittal. This certificate cannot be used for any other accompanying papers. Each additional paper, such as an assignment or formal drawing, must have its own certificate of mailing or transmission.

Certificate of Mailing or Transmission

I hereby certify that this Fee(s) Transmittal is being deposited with the United States Postal Service with sufficient postage for first class mail in an envelope addressed to the Mail Stop ISSUE FEE address above, or being facsimile transmitted to the USPTO (571) 273-2885, on the date indicated below.

_____ (Depositor's name)
_____ (Signature)
_____ (Date)

APPLICATION NO.	FILING DATE	FIRST NAMED INVENTOR	ATTORNEY DOCKET NO.	CONFIRMATION NO.
11/200.511	08/08/2005	David Champlin	PALM.P0962	2125

TITLE OF INVENTION: METHOD AND DEVICE FOR ENABLING MESSAGE RESPONSES TO INCOMING PHONE CALLS

APPLN. TYPE	SMALL ENTITY	ISSUE FEE DUE	PUBLICATION FEE DUE	PREV. PAID ISSUE FEE	TOTAL FEE(S) DUE	DATE DUE
nonprovisional	NO	\$1510	\$300	\$0	\$1810	12/23/2010

EXAMINER	ART UNIT	CLASS-SUBCLASS
GAUTHIER, GERALD	2614	379-088170

1. Change of correspondence address or indication of "Fee Address" (37 CFR 1.363).
 Change of correspondence address (or Change of Correspondence Address form PTO/SB/122) attached.
 "Fee Address" indication (or "Fee Address" Indication form PTO/SB/47; Rev 03-02 or more recent) attached. **Use of a Customer Number is required.**

2. For printing on the patent front page, list
 (1) the names of up to 3 registered patent attorneys or agents OR, alternatively,
 (2) the name of a single firm (having as a member a registered attorney or agent) and the names of up to 2 registered patent attorneys or agents. If no name is listed, no name will be printed.

1. Mahamedi Paradice Kreisman LLP
 2. _____
 3. _____

3. ASSIGNEE NAME AND RESIDENCE DATA TO BE PRINTED ON THE PATENT (print or type)
 PLEASE NOTE: Unless an assignee is identified below, no assignee data will appear on the patent. If an assignee is identified below, the document has been filed for recordation as set forth in 37 CFR 3.11. Completion of this form is NOT a substitute for filing an assignment.

(A) NAME OF ASSIGNEE: **Palm, Inc.** (B) RESIDENCE: (CITY and STATE OR COUNTRY) **Sunnyvale, California**

Please check the appropriate assignee category or categories (will not be printed on the patent): Individual Corporation or other private group entity Government

4a. The following fee(s) are submitted:
 Issue Fee
 Publication Fee (No small entity discount permitted)
 Advance Order - # of Copies _____

4b. Payment of Fee(s): (Please first reapply any previously paid issue fee shown above)
 A check is enclosed.
 Payment by credit card. Form PTO-2038 is attached.
 The Director is hereby authorized to charge the required fee(s), any deficiency, or credit any overpayment, to Deposit Account Number 501914 (enclose an extra copy of this form).

5. Change in Entity Status (from status indicated above)
 a. Applicant claims SMALL ENTITY status. See 37 CFR 1.27. b. Applicant is no longer claiming SMALL ENTITY status. See 37 CFR 1.27(g)(2).

NOTE: The Issue Fee and Publication Fee (if required) will not be accepted from anyone other than the applicant; a registered attorney or agent; or the assignee or other party in interest as shown by the records of the United States Patent and Trademark Office.

Authorized Signature: Zurvan Mahamedi Date: 10/19/2010
 Typed or printed name: Zurvan Mahamedi Registration No. 42,828

This collection of information is required by 37 CFR 1.311. The information is required to obtain or retain a benefit by the public which is to file (and by the USPTO to process) an application. Confidentiality is governed by 35 U.S.C. 122 and 37 CFR 1.14. This collection is estimated to take 12 minutes to complete, including gathering, preparing, and submitting the completed application form to the USPTO. Time will vary depending upon the individual case. Any comments on the amount of time you require to complete this form and/or suggestions for reducing this burden, should be sent to the Chief Information Officer, U.S. Patent and Trademark Office, U.S. Department of Commerce, P.O. Box 1450, Alexandria, Virginia 22313-1450. DO NOT SEND FEES OR COMPLETED FORMS TO THIS ADDRESS. SEND TO: Commissioner for Patents, P.O. Box 1450, Alexandria, Virginia 22313-1450.

Under the Paperwork Reduction Act of 1995, no persons are required to respond to a collection of information unless it displays a valid OMB control number.

Electronic Patent Application Fee Transmittal

Application Number:	11200511
Filing Date:	08-Aug-2005
Title of Invention:	METHOD AND DEVICE FOR ENABLING MESSAGE RESPONSES TO INCOMING PHONE CALLS
First Named Inventor/Applicant Name:	David Champlin
Filer:	Zurvan Mahamedi/kathleen farrell
Attorney Docket Number:	PALM.P0962

Filed as Large Entity

Utility under 35 USC 111(a) Filing Fees

Description	Fee Code	Quantity	Amount	Sub-Total in USD(\$)
Basic Filing:				
Pages:				
Claims:				
Miscellaneous-Filing:				
Petition:				
Patent-Appeals-and-Interference:				
Post-Allowance-and-Post-Issuance:				
Utility Appl issue fee	1501	1	1510	1510
Publ. Fee- early, voluntary, or normal	1504	1	300	300

Description	Fee Code	Quantity	Amount	Sub-Total in USD(\$)
Extension-of-Time:				
Miscellaneous:				
Total in USD (\$)				1810

Electronic Acknowledgement Receipt

EFS ID:	8657432
Application Number:	11200511
International Application Number:	
Confirmation Number:	2125
Title of Invention:	METHOD AND DEVICE FOR ENABLING MESSAGE RESPONSES TO INCOMING PHONE CALLS
First Named Inventor/Applicant Name:	David Champlin
Customer Number:	30554
Filer:	Zurvan Mahamedi/kathleen farrell
Filer Authorized By:	Zurvan Mahamedi
Attorney Docket Number:	PALM.P0962
Receipt Date:	19-OCT-2010
Filing Date:	08-AUG-2005
Time Stamp:	18:03:18
Application Type:	Utility under 35 USC 111(a)

Payment information:

Submitted with Payment	yes
Payment Type	Deposit Account
Payment was successfully received in RAM	\$1810
RAM confirmation Number	4732
Deposit Account	501914
Authorized User	

The Director of the USPTO is hereby authorized to charge indicated fees and credit any overpayment as follows:

Charge any Additional Fees required under 37 C.F.R. Section 1.21 (Miscellaneous fees and charges)

File Listing:					
Document Number	Document Description	File Name	File Size(Bytes)/ Message Digest	Multi Part /.zip	Pages (if appl.)
1	Issue Fee Payment (PTO-85B)	PALM_P0962_IFTrans_signed.pdf	185114 <small>85187b53f505aafb877cf598081a2645d41c344a</small>	no	1
Warnings:					
Information:					
2	Fee Worksheet (PTO-875)	fee-info.pdf	32120 <small>31a3a23d166e9e7b27e9cd7fa0a2f40b2498fe5</small>	no	2
Warnings:					
Information:					
Total Files Size (in bytes):			217234		
<p>This Acknowledgement Receipt evidences receipt on the noted date by the USPTO of the indicated documents, characterized by the applicant, and including page counts, where applicable. It serves as evidence of receipt similar to a Post Card, as described in MPEP 503.</p> <p><u>New Applications Under 35 U.S.C. 111</u> If a new application is being filed and the application includes the necessary components for a filing date (see 37 CFR 1.53(b)-(d) and MPEP 506), a Filing Receipt (37 CFR 1.54) will be issued in due course and the date shown on this Acknowledgement Receipt will establish the filing date of the application.</p> <p><u>National Stage of an International Application under 35 U.S.C. 371</u> If a timely submission to enter the national stage of an international application is compliant with the conditions of 35 U.S.C. 371 and other applicable requirements a Form PCT/DO/EO/903 indicating acceptance of the application as a national stage submission under 35 U.S.C. 371 will be issued in addition to the Filing Receipt, in due course.</p> <p><u>New International Application Filed with the USPTO as a Receiving Office</u> If a new international application is being filed and the international application includes the necessary components for an international filing date (see PCT Article 11 and MPEP 1810), a Notification of the International Application Number and of the International Filing Date (Form PCT/RO/105) will be issued in due course, subject to prescriptions concerning national security, and the date shown on this Acknowledgement Receipt will establish the international filing date of the application.</p>					



UNITED STATES PATENT AND TRADEMARK OFFICE

UNITED STATES DEPARTMENT OF COMMERCE
United States Patent and Trademark Office
Address: COMMISSIONER FOR PATENTS
P.O. Box 1450
Alexandria, Virginia 22313-1450
www.uspto.gov

NOTICE OF ALLOWANCE AND FEE(S) DUE

30554 7590 09/23/2010

MAHAMEDI PARADICE KREISMAN LLP
550 Winchester Boulevard
Suite 605
SAN JOSE, CA 95128

EXAMINER

GAUTHIER, GERALD

ART UNIT PAPER NUMBER

2614

DATE MAILED: 09/23/2010

Table with 5 columns: APPLICATION NO., FILING DATE, FIRST NAMED INVENTOR, ATTORNEY DOCKET NO., CONFIRMATION NO.

11/200,511 08/08/2005 David Champlin PALM.P0962 2125

TITLE OF INVENTION: METHOD AND DEVICE FOR ENABLING MESSAGE RESPONSES TO INCOMING PHONE CALLS

Table with 7 columns: APPLN. TYPE, SMALL ENTITY, ISSUE FEE DUE, PUBLICATION FEE DUE, PREV. PAID ISSUE FEE, TOTAL FEE(S) DUE, DATE DUE

nonprovisional NO \$1510 \$300 \$0 \$1810 12/23/2010

THE APPLICATION IDENTIFIED ABOVE HAS BEEN EXAMINED AND IS ALLOWED FOR ISSUANCE AS A PATENT. PROSECUTION ON THE MERITS IS CLOSED. THIS NOTICE OF ALLOWANCE IS NOT A GRANT OF PATENT RIGHTS. THIS APPLICATION IS SUBJECT TO WITHDRAWAL FROM ISSUE AT THE INITIATIVE OF THE OFFICE OR UPON PETITION BY THE APPLICANT. SEE 37 CFR 1.313 AND MPEP 1308.

THE ISSUE FEE AND PUBLICATION FEE (IF REQUIRED) MUST BE PAID WITHIN THREE MONTHS FROM THE MAILING DATE OF THIS NOTICE OR THIS APPLICATION SHALL BE REGARDED AS ABANDONED. THIS STATUTORY PERIOD CANNOT BE EXTENDED. SEE 35 U.S.C. 151. THE ISSUE FEE DUE INDICATED ABOVE DOES NOT REFLECT A CREDIT FOR ANY PREVIOUSLY PAID ISSUE FEE IN THIS APPLICATION. IF AN ISSUE FEE HAS PREVIOUSLY BEEN PAID IN THIS APPLICATION (AS SHOWN ABOVE), THE RETURN OF PART B OF THIS FORM WILL BE CONSIDERED A REQUEST TO REAPPLY THE PREVIOUSLY PAID ISSUE FEE TOWARD THE ISSUE FEE NOW DUE.

HOW TO REPLY TO THIS NOTICE:

I. Review the SMALL ENTITY status shown above.

If the SMALL ENTITY is shown as YES, verify your current SMALL ENTITY status:

- A. If the status is the same, pay the TOTAL FEE(S) DUE shown above.
B. If the status above is to be removed, check box 5b on Part B - Fee(s) Transmittal and pay the PUBLICATION FEE (if required) and twice the amount of the ISSUE FEE shown above, or

If the SMALL ENTITY is shown as NO:

- A. Pay TOTAL FEE(S) DUE shown above, or
B. If applicant claimed SMALL ENTITY status before, or is now claiming SMALL ENTITY status, check box 5a on Part B - Fee(s) Transmittal and pay the PUBLICATION FEE (if required) and 1/2 the ISSUE FEE shown above.

II. PART B - FEE(S) TRANSMITTAL, or its equivalent, must be completed and returned to the United States Patent and Trademark Office (USPTO) with your ISSUE FEE and PUBLICATION FEE (if required). If you are charging the fee(s) to your deposit account, section "4b" of Part B - Fee(s) Transmittal should be completed and an extra copy of the form should be submitted. If an equivalent of Part B is filed, a request to reapply a previously paid issue fee must be clearly made, and delays in processing may occur due to the difficulty in recognizing the paper as an equivalent of Part B.

III. All communications regarding this application must give the application number. Please direct all communications prior to issuance to Mail Stop ISSUE FEE unless advised to the contrary.

IMPORTANT REMINDER: Utility patents issuing on applications filed on or after Dec. 12, 1980 may require payment of maintenance fees. It is patentee's responsibility to ensure timely payment of maintenance fees when due.

PART B - FEE(S) TRANSMITTAL

**Complete and send this form, together with applicable fee(s), to: Mail Mail Stop ISSUE FEE
 Commissioner for Patents
 P.O. Box 1450
 Alexandria, Virginia 22313-1450
 or Fax (571)-273-2885**

INSTRUCTIONS: This form should be used for transmitting the ISSUE FEE and PUBLICATION FEE (if required). Blocks 1 through 5 should be completed where appropriate. All further correspondence including the Patent, advance orders and notification of maintenance fees will be mailed to the current correspondence address as indicated unless corrected below or directed otherwise in Block 1, by (a) specifying a new correspondence address; and/or (b) indicating a separate "FEE ADDRESS" for maintenance fee notifications.

CURRENT CORRESPONDENCE ADDRESS (Note: Use Block 1 for any change of address)

30554 7590 09/23/2010

MAHAMEDI PARADICE KREISMAN LLP
 550 Winchester Boulevard
 Suite 605
 SAN JOSE, CA 95128

Note: A certificate of mailing can only be used for domestic mailings of the Fee(s) Transmittal. This certificate cannot be used for any other accompanying papers. Each additional paper, such as an assignment or formal drawing, must have its own certificate of mailing or transmission.

Certificate of Mailing or Transmission

I hereby certify that this Fee(s) Transmittal is being deposited with the United States Postal Service with sufficient postage for first class mail in an envelope addressed to the Mail Stop ISSUE FEE address above, or being facsimile transmitted to the USPTO (571) 273-2885, on the date indicated below.

_____ (Depositor's name)
_____ (Signature)
_____ (Date)

APPLICATION NO.	FILING DATE	FIRST NAMED INVENTOR	ATTORNEY DOCKET NO.	CONFIRMATION NO.
11/200,511	08/08/2005	David Champlin	PALM.P0962	2125

TITLE OF INVENTION: METHOD AND DEVICE FOR ENABLING MESSAGE RESPONSES TO INCOMING PHONE CALLS

APPLN. TYPE	SMALL ENTITY	ISSUE FEE DUE	PUBLICATION FEE DUE	PREV. PAID ISSUE FEE	TOTAL FEE(S) DUE	DATE DUE
nonprovisional	NO	\$1510	\$300	\$0	\$1810	12/23/2010

EXAMINER	ART UNIT	CLASS-SUBCLASS
GAUTHIER, GERALD	2614	379-088170

<p>1. Change of correspondence address or indication of "Fee Address" (37 CFR 1.363).</p> <p><input type="checkbox"/> Change of correspondence address (or Change of Correspondence Address form PTO/SB/122) attached.</p> <p><input type="checkbox"/> "Fee Address" indication (or "Fee Address" Indication form PTO/SB/47; Rev 03-02 or more recent) attached. Use of a Customer Number is required.</p>	<p>2. For printing on the patent front page, list</p> <p>(1) the names of up to 3 registered patent attorneys or agents OR, alternatively, _____ 1</p> <p>(2) the name of a single firm (having as a member a registered attorney or agent) and the names of up to 2 registered patent attorneys or agents. If no name is listed, no name will be printed. _____ 2</p> <p>_____ 3</p>
---	---

3. ASSIGNEE NAME AND RESIDENCE DATA TO BE PRINTED ON THE PATENT (print or type)

PLEASE NOTE: Unless an assignee is identified below, no assignee data will appear on the patent. If an assignee is identified below, the document has been filed for recordation as set forth in 37 CFR 3.11. Completion of this form is NOT a substitute for filing an assignment.

(A) NAME OF ASSIGNEE _____ (B) RESIDENCE: (CITY and STATE OR COUNTRY) _____

Please check the appropriate assignee category or categories (will not be printed on the patent): Individual Corporation or other private group entity Government

<p>4a. The following fee(s) are submitted:</p> <p><input type="checkbox"/> Issue Fee</p> <p><input type="checkbox"/> Publication Fee (No small entity discount permitted)</p> <p><input type="checkbox"/> Advance Order - # of Copies _____</p>	<p>4b. Payment of Fee(s): (Please first reapply any previously paid issue fee shown above)</p> <p><input type="checkbox"/> A check is enclosed.</p> <p><input type="checkbox"/> Payment by credit card. Form PTO-2038 is attached.</p> <p><input type="checkbox"/> The Director is hereby authorized to charge the required fee(s), any deficiency, or credit any overpayment, to Deposit Account Number _____ (enclose an extra copy of this form).</p>
---	--

5. Change in Entity Status (from status indicated above)

a. Applicant claims SMALL ENTITY status. See 37 CFR 1.27. b. Applicant is no longer claiming SMALL ENTITY status. See 37 CFR 1.27(g)(2).

NOTE: The Issue Fee and Publication Fee (if required) will not be accepted from anyone other than the applicant; a registered attorney or agent; or the assignee or other party in interest as shown by the records of the United States Patent and Trademark Office.

Authorized Signature _____ Date _____

Typed or printed name _____ Registration No. _____

This collection of information is required by 37 CFR 1.311. The information is required to obtain or retain a benefit by the public which is to file (and by the USPTO to process) an application. Confidentiality is governed by 35 U.S.C. 122 and 37 CFR 1.14. This collection is estimated to take 12 minutes to complete, including gathering, preparing, and submitting the completed application form to the USPTO. Time will vary depending upon the individual case. Any comments on the amount of time you require to complete this form and/or suggestions for reducing this burden, should be sent to the Chief Information Officer, U.S. Patent and Trademark Office, U.S. Department of Commerce, P.O. Box 1450, Alexandria, Virginia 22313-1450. DO NOT SEND FEES OR COMPLETED FORMS TO THIS ADDRESS. SEND TO: Commissioner for Patents, P.O. Box 1450, Alexandria, Virginia 22313-1450.

Under the Paperwork Reduction Act of 1995, no persons are required to respond to a collection of information unless it displays a valid OMB control number.



UNITED STATES PATENT AND TRADEMARK OFFICE

UNITED STATES DEPARTMENT OF COMMERCE
United States Patent and Trademark Office
Address: COMMISSIONER FOR PATENTS
P.O. Box 1450
Alexandria, Virginia 22313-1450
www.uspto.gov

Table with 5 columns: APPLICATION NO., FILING DATE, FIRST NAMED INVENTOR, ATTORNEY DOCKET NO., CONFIRMATION NO.
Row 1: 11/200,511, 08/08/2005, David Champlin, PALM.P0962, 2125
Row 2: 30554, 7590, 09/23/2010, EXAMINER GAUTHIER, GERALD
Row 3: MAHAMEDI PARADICE KREISMAN LLP, 550 Winchester Boulevard, Suite 605, SAN JOSE, CA 95128, ART UNIT 2614, PAPER NUMBER
DATE MAILED: 09/23/2010

Determination of Patent Term Adjustment under 35 U.S.C. 154 (b)
(application filed on or after May 29, 2000)

The Patent Term Adjustment to date is 840 day(s). If the issue fee is paid on the date that is three months after the mailing date of this notice and the patent issues on the Tuesday before the date that is 28 weeks (six and a half months) after the mailing date of this notice, the Patent Term Adjustment will be 840 day(s).

If a Continued Prosecution Application (CPA) was filed in the above-identified application, the filing date that determines Patent Term Adjustment is the filing date of the most recent CPA.

Applicant will be able to obtain more detailed information by accessing the Patent Application Information Retrieval (PAIR) WEB site (http://pair.uspto.gov).

Any questions regarding the Patent Term Extension or Adjustment determination should be directed to the Office of Patent Legal Administration at (571)-272-7702. Questions relating to issue and publication fee payments should be directed to the Customer Service Center of the Office of Patent Publication at 1-(888)-786-0101 or (571)-272-4200.

Notice of Allowability	Application No.	Applicant(s)	
	11/200,511	CHAMPLIN ET AL.	
	Examiner	Art Unit	
	Gerald Gauthier	2614	

-- The MAILING DATE of this communication appears on the cover sheet with the correspondence address--

All claims being allowable, PROSECUTION ON THE MERITS IS (OR REMAINS) CLOSED in this application. If not included herewith (or previously mailed), a Notice of Allowance (PTOL-85) or other appropriate communication will be mailed in due course. **THIS NOTICE OF ALLOWABILITY IS NOT A GRANT OF PATENT RIGHTS.** This application is subject to withdrawal from issue at the initiative of the Office or upon petition by the applicant. See 37 CFR 1.313 and MPEP 1308.

1. This communication is responsive to 09/17/2010 Amendment.
2. The allowed claim(s) is/are 1,3-19,21,22 and 29-33.
3. Acknowledgment is made of a claim for foreign priority under 35 U.S.C. § 119(a)-(d) or (f).
 - a) All b) Some* c) None of the:
 1. Certified copies of the priority documents have been received.
 2. Certified copies of the priority documents have been received in Application No. _____ .
 3. Copies of the certified copies of the priority documents have been received in this national stage application from the International Bureau (PCT Rule 17.2(a)).

* Certified copies not received: _____.

Applicant has THREE MONTHS FROM THE "MAILING DATE" of this communication to file a reply complying with the requirements noted below. Failure to timely comply will result in ABANDONMENT of this application.
THIS THREE-MONTH PERIOD IS NOT EXTENDABLE.

4. A SUBSTITUTE OATH OR DECLARATION must be submitted. Note the attached EXAMINER'S AMENDMENT or NOTICE OF INFORMAL PATENT APPLICATION (PTO-152) which gives reason(s) why the oath or declaration is deficient.
5. CORRECTED DRAWINGS (as "replacement sheets") must be submitted.
 - (a) including changes required by the Notice of Draftsperson's Patent Drawing Review (PTO-948) attached
 - 1) hereto or 2) to Paper No./Mail Date _____.
 - (b) including changes required by the attached Examiner's Amendment / Comment or in the Office action of Paper No./Mail Date _____.

Identifying indicia such as the application number (see 37 CFR 1.84(c)) should be written on the drawings in the front (not the back) of each sheet. Replacement sheet(s) should be labeled as such in the header according to 37 CFR 1.121(d).
6. DEPOSIT OF and/or INFORMATION about the deposit of BIOLOGICAL MATERIAL must be submitted. Note the attached Examiner's comment regarding REQUIREMENT FOR THE DEPOSIT OF BIOLOGICAL MATERIAL.

Attachment(s)

- | | |
|--|---|
| <ol style="list-style-type: none"> 1. <input checked="" type="checkbox"/> Notice of References Cited (PTO-892) 2. <input type="checkbox"/> Notice of Draftsperson's Patent Drawing Review (PTO-948) 3. <input type="checkbox"/> Information Disclosure Statements (PTO/SB/08),
Paper No./Mail Date _____ 4. <input type="checkbox"/> Examiner's Comment Regarding Requirement for Deposit
of Biological Material | <ol style="list-style-type: none"> 5. <input type="checkbox"/> Notice of Informal Patent Application 6. <input type="checkbox"/> Interview Summary (PTO-413),
Paper No./Mail Date _____ . 7. <input type="checkbox"/> Examiner's Amendment/Comment 8. <input checked="" type="checkbox"/> Examiner's Statement of Reasons for Allowance 9. <input type="checkbox"/> Other _____. |
|--|---|

/Gerald Gauthier/
 Primary Examiner, Art Unit 2614

DETAILED ACTION

Allowable Claims

1. **Claims 1, 3-19, 21, 22, and 29-33** are allowed.

2. The following is an examiner's statement of reasons for allowance:

Regarding **claims 1, 19 and 30**, in combination with other limitations of the claims, the prior art of record fails to disclose or specifically suggested in response to receiving the incoming call, prompting a user of the first computing device to enter user input that instructs the first computing device to handle the incoming call by composing, while not answering the incoming call, a message to a user of the second computing device; and responsive to receiving the incoming call and the user entering the user input, automatically addressing the message to the second computing device using the message identifier determined from the incoming call.

Any comments considered necessary by applicant must be submitted no later than the payment of the issue fee and, to avoid processing delays, should preferably accompany the issue fee. Such submissions should be clearly labeled "Comments on Statement of Reasons for Allowance."

Conclusion

3. Any inquiry concerning this communication or earlier communications from the examiner should be directed to Gerald Gauthier whose telephone number is (571) 272-7539. The examiner can normally be reached on 8:00 AM to 4:30 PM.

If attempts to reach the examiner by telephone are unsuccessful, the examiner's supervisor, Fan Tsang can be reached on (571) 272-7547. The fax phone number for the organization where this application or proceeding is assigned is 571-273-8300.

Information regarding the status of an application may be obtained from the Patent Application Information Retrieval (PAIR) system. Status information for published applications may be obtained from either Private PAIR or Public PAIR. Status information for unpublished applications is available through Private PAIR only. For more information about the PAIR system, see <http://pair-direct.uspto.gov>. Should you have questions on access to the Private PAIR system, contact the Electronic Business Center (EBC) at 866-217-9197 (toll-free). If you would like assistance from a USPTO Customer Service Representative or access to the automated information system, call 800-786-9199 (IN USA OR CANADA) or 571-272-1000.

/Gerald Gauthier/
Primary Examiner, Art Unit 2614

GG
September 21, 2010

Notice of References Cited	Application/Control No. 11/200,511	Applicant(s)/Patent Under Reexamination CHAMPLIN ET AL.	
	Examiner Gerald Gauthier	Art Unit 2614	Page 1 of 1

U.S. PATENT DOCUMENTS

*	Document Number Country Code-Number-Kind Code	Date MM-YYYY	Name	Classification
*	A US-5,724,408 A	03-1998	Morganstein, Sanford J.	379/88.2
*	B US-6,404,860 B1	06-2002	Casellini, Theodore E.	379/88.17
*	C US-6,768,789 B1	07-2004	Wilk, Daniel	379/67.1
*	D US-6,804,334 B1	10-2004	Beasley et al.	379/88.17
	E US-			
	F US-			
	G US-			
	H US-			
	I US-			
	J US-			
	K US-			
	L US-			
	M US-			

FOREIGN PATENT DOCUMENTS

*	Document Number Country Code-Number-Kind Code	Date MM-YYYY	Country	Name	Classification
	N				
	O				
	P				
	Q				
	R				
	S				
	T				

NON-PATENT DOCUMENTS

*	Include as applicable: Author, Title Date, Publisher, Edition or Volume, Pertinent Pages)
U	
V	
W	
X	

*A copy of this reference is not being furnished with this Office action. (See MPEP § 707.05(a).)
Dates in MM-YYYY format are publication dates. Classifications may be US or foreign.

Index of Claims 	Application/Control No. 11200511	Applicant(s)/Patent Under Reexamination CHAMPLIN ET AL.
	Examiner Gerald Gauthier	Art Unit 2614

✓	Rejected	-	Cancelled	N	Non-Elected	A	Appeal
=	Allowed	÷	Restricted	I	Interference	O	Objected

Claims renumbered in the same order as presented by applicant
 CPA
 T.D.
 R.1.47

CLAIM		DATE								
Final	Original	02/24/2009	07/22/2009	01/20/2010	06/15/2010	09/21/2010				
1	1	✓	✓	✓	=	=				
	2	✓	✓	-	-	-				
2	3	✓	✓	✓	=	=				
3	4	✓	✓	✓	=	=				
4	5	✓	✓	✓	=	=				
5	6	✓	✓	✓	=	=				
6	7	✓	✓	✓	=	=				
7	8	✓	✓	✓	=	=				
8	9	✓	✓	✓	=	=				
9	10	✓	✓	✓	=	=				
10	11	✓	✓	✓	=	=				
11	12	✓	✓	✓	=	=				
12	13	✓	✓	✓	=	=				
13	14	✓	✓	✓	=	=				
14	15	✓	✓	✓	=	=				
15	16	✓	✓	✓	=	=				
16	17	✓	✓	✓	=	=				
17	18	✓	✓	✓	=	=				
19	19	✓	✓	✓	=	=				
	20	✓	✓	-	-	-				
20	21	✓	✓	✓	=	=				
21	22	✓	✓	✓	=	=				
	23	✓	✓	-	-	-				
	24	✓	✓	✓	✓	-				
	25	✓	✓	✓	✓	-				
	26	✓	✓	✓	✓	-				
	27	✓	✓	✓	✓	-				
	28	✓	✓	✓	✓	-				
18	29		✓	✓	=	=				
22	30		✓	✓	=	=				
23	31		✓	✓	=	=				
24	32		✓	✓	=	=				
25	33		✓	✓	=	=				

Issue Classification 	Application/Control No. 11200511	Applicant(s)/Patent Under Reexamination CHAMPLIN ET AL.
	Examiner Gerald Gauthier	Art Unit 2614

ORIGINAL						INTERNATIONAL CLASSIFICATION														
CLASS		SUBCLASS				CLAIMED					NON-CLAIMED									
379		88.17				H	0	4	M	1 / 64 (2006.01.01)										
CROSS REFERENCE(S)																				
CLASS	SUBCLASS (ONE SUBCLASS PER BLOCK)																			
379	88.19	88.21	88.22																	
455	412.1																			
705	26																			
709	238																			

Claims renumbered in the same order as presented by applicant
 CPA
 T.D.
 R.1.47

Final	Original	Final	Original	Final	Original	Final	Original	Final	Original	Final	Original	Final	Original	Final	Original
1	1	16	17	25	33										
	2	17	18												
2	3	19	19												
3	4		20												
4	5	20	21												
5	6	21	22												
6	7		23												
7	8		24												
8	9		25												
9	10		26												
10	11		27												
11	12		28												
12	13	18	29												
13	14	22	30												
14	15	23	31												
15	16	24	32												

NONE	Total Claims Allowed:	
(Assistant Examiner)	(Date)	25
/Gerald Gauthier/ Primary Examiner. Art Unit 2614	09/20/2010	O.G. Print Claim(s) O.G. Print Figure
(Primary Examiner)	(Date)	1 4

Search Notes 	Application/Control No. 11200511	Applicant(s)/Patent Under Reexamination CHAMPLIN ET AL.
	Examiner Gerald Gauthier	Art Unit 2614

SEARCHED			
Class	Subclass	Date	Examiner
379	67.1	2/24/09	JCA
379	88.13	2/24/09	JCA
455	414.4	2/24/09	JCA
370	356	7/22/2009	GG
379	76, 88.19, 88.21, 93.23, 202.01, 257	7/22/2009	GG
455	412.1, 415, 445	7/22/2009	GG
705	26	7/22/2009	GG
709	238	7/22/2009	GG
725	134	7/22/2009	GG
379	88.19, 88.22, 93.17, 211.01, 215.01	1/20/2010	GG
455	567	1/20/2010	GG
725	111	1/20/2010	GG
327	108	6/15/2010	GG
340	7.21, 7.22	6/15/2010	GG
370	352, 384	6/15/2010	GG
379	71, 88.22, 88.23, 88.25, 157, 215.01	6/15/2010	GG
709	206, 224, 238	6/15/2010	GG
715	246	6/15/2010	GG
379	88.17, 88.19, 88.21, 88.22	9/21/2010	GG

SEARCH NOTES		
Search Notes	Date	Examiner
Searched East and Google Patents	2/24/09	JCA
EAST: (US-PGPUB; USPAT; USOCR)	7/22/2009	GG
EAST: (US-PGPUB; USPAT; USOCR; FPRS; EPO; JPO; DERWENT; IBM_TDB)	1/20/2010	GG
EAST: (US-PGPUB; USPAT; USOCR; FPRS; EPO; JPO; DERWENT; IBM_TDB)	6/15/2010	GG
EAST: (US-PGPUB; USPAT; USOCR; FPRS; EPO; JPO; DERWENT; IBM_TDB)	9/21/2010	GG
Inventor's Name Search	9/21/2010	GG

INTERFERENCE SEARCH

	/Gerald Gauthier/ Primary Examiner. Art Unit 2614
--	--

Class	Subclass	Date	Examiner
379	88.17, 88.19, 88.21, 88.22	9/21/2010	GG
455	412.1	9/21/2010	GG
705	26	9/21/2010	GG
709	238	9/21/2010	GG
	Interference Search History (see attached)	9/21/2010	GG

	/Gerald Gauthier/ Primary Examiner. Art Unit 2614
--	--

EAST Search History

EAST Search History (Prior Art)

Ref #	Hits	Search Query	DBs	Default Operator	Plurals	Time Stamp
L1	0	receiv\$3 same incoming same call same user same first same computing same device same input same handle same answering same message same second same responsive same enter \$3 same address\$3 same identifier	US-PGPUB; USPAT; USOCR	OR	ON	2010/09/20 19:07
L3	2217	personal adj message	US-PGPUB; USPAT; USOCR	OR	ON	2010/09/20 19:08
L4	7	3 with (incoming adj call)	US-PGPUB; USPAT; USOCR	OR	ON	2010/09/20 19:08
L6	21	incoming near5 communication with voice with call with identifier	US-PGPUB; USPAT; USOCR; FPRS; EPO; JPO; DERWENT; IBM_TDB	OR	ON	2010/09/20 19:17
L7	1	incoming with communication with voice with call with identifier with computing with device	US-PGPUB; USPAT; USOCR; FPRS; EPO; JPO; DERWENT; IBM_TDB	OR	ON	2010/09/20 19:17
L8	14	incoming with communication with voice with call with computing with device	US-PGPUB; USPAT; USOCR; FPRS; EPO; JPO; DERWENT; IBM_TDB	OR	ON	2010/09/20 19:17
L9	19	incoming with communication with voice with computing with device	US-PGPUB; USPAT; USOCR; FPRS; EPO; JPO; DERWENT; IBM_TDB	OR	ON	2010/09/20 19:17

L10	2971	incoming with call with (response reply) with message	US-PGPUB; USPAT; USOCR; FPRS; EPO; JPO; DERWENT; IBM_TDB	OR	ON	2010/09/20 19:17
L11	2221	(incoming adj call) with (response reply) with message	US-PGPUB; USPAT; USOCR; FPRS; EPO; JPO; DERWENT; IBM_TDB	OR	ON	2010/09/20 19:17
L12	193	L11 same identif\$4	US-PGPUB; USPAT; USOCR; FPRS; EPO; JPO; DERWENT; IBM_TDB	OR	ON	2010/09/20 19:17
L13	829	(incoming adj call) with ((response reply) near message)	US-PGPUB; USPAT; USOCR; FPRS; EPO; JPO; DERWENT; IBM_TDB	OR	ON	2010/09/20 19:17
L14	62	L13 same identif\$4	US-PGPUB; USPAT; USOCR; FPRS; EPO; JPO; DERWENT; IBM_TDB	OR	ON	2010/09/20 19:17
L15	3	L14 same option	US-PGPUB; USPAT; USOCR; FPRS; EPO; JPO; DERWENT; IBM_TDB	OR	ON	2010/09/20 19:17
L16	567	(calling caller) same customiz\$3 same (greeting message) same (identification id identif\$3)	US-PGPUB; USPAT; USOCR; FPRS; EPO; JPO; DERWENT; IBM_TDB	OR	ON	2010/09/20 19:17
L17	148	L16 same incoming	US-PGPUB; USPAT; USOCR; FPRS; EPO; JPO; DERWENT; IBM_TDB	OR	ON	2010/09/20 19:17

L18	67001	incoming near call	US-PGPUB; USPAT; USOCR; FPRS; EPO; JPO; DERWENT; IBM_TDB	OR	ON	2010/09/20 19:17
L19	53753	text near message	US-PGPUB; USPAT; USOCR; FPRS; EPO; JPO; DERWENT; IBM_TDB	OR	ON	2010/09/20 19:17
L20	738	L18 with L19	US-PGPUB; USPAT; USOCR; FPRS; EPO; JPO; DERWENT; IBM_TDB	OR	ON	2010/09/20 19:17
L21	72	L20 with respon\$4	US-PGPUB; USPAT; USOCR; FPRS; EPO; JPO; DERWENT; IBM_TDB	OR	ON	2010/09/20 19:17
L22	7	incoming near call near5 input near5 message near5 device	US-PGPUB; USPAT; USOCR; FPRS; EPO; JPO; DERWENT; IBM_TDB	OR	ON	2010/09/20 19:17
L23	1	incoming near call near5 input near5 message near5 address\$3	US-PGPUB; USPAT; USOCR; FPRS; EPO; JPO; DERWENT; IBM_TDB	OR	ON	2010/09/20 19:17
L24	1994	input near5 message near5 address\$3	US-PGPUB; USPAT; USOCR; FPRS; EPO; JPO; DERWENT; IBM_TDB	OR	ON	2010/09/20 19:17
L25	63	L24 with call	US-PGPUB; USPAT; USOCR; FPRS; EPO; JPO; DERWENT; IBM_TDB	OR	ON	2010/09/20 19:17

L26	1319	user near5 input near5 (generat\$3 compos\$3) near5 (reply message)	US-PGPUB; USPAT; USOCR; FPRS; EPO; JPO; DERWENT; IBM_TDB	OR	ON	2010/09/20 19:17
L27	10	L26 with ((telephone phone) adj number)	US-PGPUB; USPAT; USOCR; FPRS; EPO; JPO; DERWENT; IBM_TDB	OR	ON	2010/09/20 19:17
L28	31	L26 same ((telephone phone) adj number)	US-PGPUB; USPAT; USOCR; FPRS; EPO; JPO; DERWENT; IBM_TDB	OR	ON	2010/09/20 19:17
L29	2598	message with response with incoming with call	US-PGPUB; USPAT; USOCR; FPRS; EPO; JPO; DERWENT; IBM_TDB	OR	ON	2010/09/20 19:17
L30	1	L26 same L29	US-PGPUB; USPAT; USOCR; FPRS; EPO; JPO; DERWENT; IBM_TDB	OR	ON	2010/09/20 19:17
L31	11	L26 and L29	US-PGPUB; USPAT; USOCR; FPRS; EPO; JPO; DERWENT; IBM_TDB	OR	ON	2010/09/20 19:17
L32	1910	message with response with (incoming adj call)	US-PGPUB; USPAT; USOCR; FPRS; EPO; JPO; DERWENT; IBM_TDB	OR	ON	2010/09/20 19:17
L33	1910	L32 and L29	US-PGPUB; USPAT; USOCR; FPRS; EPO; JPO; DERWENT; IBM_TDB	OR	ON	2010/09/20 19:17

L34	6	L26 and L32	US-PGPUB; USPAT; USOCR; FPRS; EPO; JPO; DERWENT; IBM_TDB	OR	ON	2010/09/20 19:17
L35	2221	message with (reply response) with (incoming adj call)	US-PGPUB; USPAT; USOCR; FPRS; EPO; JPO; DERWENT; IBM_TDB	OR	ON	2010/09/20 19:17
L36	417	(379/88.23).CCLS.	US-PGPUB; USPAT; USOCR; FPRS; EPO; JPO; DERWENT; IBM_TDB	OR	OFF	2010/09/20 19:17
L38	19	L35 and L36	US-PGPUB; USPAT; USOCR; FPRS; EPO; JPO; DERWENT; IBM_TDB	OR	ON	2010/09/20 19:17
L39	2007	option with generat \$3 with message	US-PGPUB; USPAT; USOCR; FPRS; EPO; JPO; DERWENT; IBM_TDB	OR	ON	2010/09/20 19:17
L40	52	L39 same (incoming adj call)	US-PGPUB; USPAT; USOCR; FPRS; EPO; JPO; DERWENT; IBM_TDB	OR	ON	2010/09/20 19:17

9/20/2010 7:20:18 PM
H:\workspaces\11200511.wsp

EAST Search History

EAST Search History (Interference)

Ref #	Hits	Search Query	DBs	Default Operator	Plurals	Time Stamp
L2	0	receiv\$3 same incoming same call same user same first same computing same device same input same handle same answering same message same second same responsive same enter\$3 same address\$3 same identifier	US-PGPUB; USPAT; UPAD	OR	ON	2010/09/20 19:07

9/ 20/ 2010 7:21:20 PM

H:\ workspaces\ 11200511.wsp

Atty. Docket No. PALM.P0962

PATENT

IN THE UNITED STATES PATENT OFFICE

In Re Patent Application of

First Named Inventor: Champlin, David

Application No.: 11/200,511

Filed: 8/8/2005

For: METHOD AND DEVICE FOR ENABLING
MESSAGE RESPONSES TO INCOMING
PHONE CALLS

Examiner: GAUTHIER,
Gerald

Art Unit: 2614

Confirmation 2125
No.:

OK TO ENTER: /GG/

Mail Stop AF
Commissioner for Patents
P.O. Box 1450
Alexandria, VA 22313-1450

AMENDMENT AND RESPONSE

Dear Sir:

In response to the final Office Action mailed June 17, 2010 (the "Office Action"), the Applicant respectfully requests that the above-identified application be amended as set forth below. Entry of this Amendment is proper because it places the application in condition for allowance.

Amendment to the Claims begin on page 2 of this paper.

Remarks begin on page 9 of this paper.



UNITED STATES PATENT AND TRADEMARK OFFICE

UNITED STATES DEPARTMENT OF COMMERCE
 United States Patent and Trademark Office
 Address: COMMISSIONER FOR PATENTS
 P.O. Box 1450
 Alexandria, Virginia 22313-1450
 www.uspto.gov

BIB DATA SHEET

CONFIRMATION NO. 2125

SERIAL NUMBER 11/200,511	FILING or 371(c) DATE 08/08/2005 RULE	CLASS 379	GROUP ART UNIT 2614	ATTORNEY DOCKET NO. PALM.P0962		
APPLICANTS David Champlin, Menlo Park, CA; Srikan Prasad, Cupertino, CA; Lang Chen, Oakland, CA; Rajan Ranga, Palo Alto, CA; Robert Haitani, Menlo Park, CA;						
** CONTINUING DATA ***** ** FOREIGN APPLICATIONS ***** ** IF REQUIRED, FOREIGN FILING LICENSE GRANTED ** 09/01/2005						
Foreign Priority claimed <input type="checkbox"/> Yes <input checked="" type="checkbox"/> No 35 USC 119(a-d) conditions met <input type="checkbox"/> Yes <input checked="" type="checkbox"/> No Verified and Acknowledged <u>/GERALD GAUTHIER/</u> <small>Examiner's Signature</small>		<input type="checkbox"/> Met after Allowance Initials _____	STATE OR COUNTRY CA	SHEETS DRAWINGS 4	TOTAL CLAIMS 28	INDEPENDENT CLAIMS 3
ADDRESS MAHAMEDI PARADICE KREISMAN LLP 550 Winchester Boulevard Suite 605 SAN JOSE, CA 95128 UNITED STATES						
TITLE Method and device for enabling message responses to incoming phone calls						
FILING FEE RECEIVED 2010	FEES: Authority has been given in Paper No. _____ to charge/credit DEPOSIT ACCOUNT No. _____ for following:		<input type="checkbox"/> All Fees			
			<input type="checkbox"/> 1.16 Fees (Filing)			
			<input type="checkbox"/> 1.17 Fees (Processing Ext. of time)			
			<input type="checkbox"/> 1.18 Fees (Issue)			
			<input type="checkbox"/> Other _____			
			<input type="checkbox"/> Credit			

Atty. Docket No. PALM.P0962

PATENT

IN THE UNITED STATES PATENT OFFICE

In Re Patent Application of

First Named Inventor: Champlin, David

Application No.: 11/200,511

Filed: 8/8/2005

For: METHOD AND DEVICE FOR ENABLING
MESSAGE RESPONSES TO INCOMING
PHONE CALLS

Examiner: GAUTHIER,
Gerald

Art Unit: 2614

Confirmation 2125
No.:

Mail Stop AF
Commissioner for Patents
P.O. Box 1450
Alexandria, VA 22313-1450

AMENDMENT AND RESPONSE

Dear Sir:

In response to the final Office Action mailed June 17, 2010 (the "Office Action"), the Applicant respectfully requests that the above-identified application be amended as set forth below. Entry of this Amendment is proper because it places the application in condition for allowance.

Amendment to the Claims begin on page 2 of this paper.

Remarks begin on page 9 of this paper.

IN THE CLAIMS

1. (Previously Presented) A method for operating a first computing device, the method being implemented by one or more processors of the computing device and comprising:

receiving, from a second computing device, an incoming call to initiate a voice-exchange session;

in response to receiving the incoming call, determining a message identifier associated with the second computing device, wherein the message identifier is determined based at least in part on data provided with the incoming call;

in response to receiving the incoming call, prompting a user of the first computing device to enter user input that instructs the first computing device to handle the incoming call by composing, while not answering the incoming call, a message to a user of the second computing device; and

responsive to receiving the incoming call and the user entering the user input, automatically addressing the message to the second computing device using the message identifier determined from the incoming call.

2. CANCELED

3. (Previously Presented) The method of claim 1, further comprising: generating a graphic user-interface feature that prompts the user to elect to have the message at least partially composed in response to the incoming call.

4. (Previously Presented) The method of claim 1, wherein automatically

addressing the message includes using the message identifier to identify and enter an address for an instant message.

5. (Previously Presented) The method of claim 4, wherein automatically addressing the message includes using the message identifier to enter at least an address for the message in a Short Message Service format.

6. (Previously Presented) The method of claim 5, wherein the message is composed using a Short Message Service application, and the message identifier is a phone number.

7. (Previously Presented) The method of claim 4, wherein determining the message identifier includes determining the message identifier from a phone number of the second computing device.

8. (Previously Presented) The method of claim 1, further comprising: verifying that the second computing device is enabled for receiving the message.

9. (Previously Presented) The method of claim 8, wherein:
verifying that the second computing device is enabled for receiving the message includes (i) identifying a phone number of the other computing device used for the incoming call, and (ii) determining that the phone number is associated with a message-enabled device that can handle a text or instant message response.

10. (Previously Presented) The method of claim 9, wherein determining that the phone number is associated with a message enabled device includes

accessing a contact record of a caller of the incoming call using the data provided with the incoming call, and using the contact record to verify that the phone number is capable of being used to receive the message.

11. (Previously Presented) The method of claim 10, wherein the message is an instant or text message, and wherein using the contact record to verify that the phone number is capable of being used to receive the instant or text message includes checking the contact record associated with the caller to see whether the phone number of the incoming call is for a mobile telephony device that can handle the instant or text message.

12. (Original) The method of claim 10, wherein determining that the phone number is associated with the message enabled device is performed programmatically and automatically.

13. (Previously Presented) The method of claim 1,
transmitting the message to the second computing device using a phone number of the incoming call as the address for either a new instant message or a new text message.

14. (Previously Presented) The method of claim 13, wherein transmitting the message includes using either an instant or text messaging application for transmitting the new instant message or the new text message.

15. (Previously Presented) The method of claim 14, further comprising launching either the instant or text messaging application automatically, in response to one of (i) receiving the incoming call, or (ii) receiving the input

from the user of the first computing device.

16. (Previously Presented) The method of claim 1, further comprising enabling the user of the first computing device to provide content manually for the message.

17. (Previously Presented) The method of claim 1, further comprising enabling the user of the first computing device to trigger insertion of pre-formulated content for the message.

18. (Previously Presented) The method of claim 1, further comprising: automatically and programmatically providing at least a portion of a body of the message.

19. (Previously Presented) A computing device comprising:
one or more communication components, at a first computing device,
for handling voice and messaging communications over wireless
networks; and
one or more processors configured to:

handle an incoming phone call from a second computing
device;

in response to receiving the incoming phone call, (a)
prompt a user of the first computing device to enter user input
that instructs the first computing device on how to handle the
incoming call, including providing the user with an option to (i)
answer the call, or (ii) send the second computing device a

message without answering the incoming call;

in response to receiving the incoming phone call,
determine a phone number of the second computing device
based, at least in part, on the incoming phone call; and

in response to receiving the user input to send the second
computing device the message without answering the incoming
phone call, programmatically generate at least an address of the
message to be transmitted to the second computing device
using the phone number identified from the received phone call.

20. CANCELED

21. (Previously Presented) The computing device of claim 19, wherein the one or more processors are configured to enable a text message to be generated as the message to be sent to the second computing device without answering the incoming phone call.

22. (Previously Presented) The computing device of claim 19, wherein the one or more processors are configured to enable the message that is to be sent to the second computing device to include a message body of a format selected from one or more of text, image or audio.

23-28. CANCELED

29. (Previously Presented) The method of claim 1, wherein the first computing device is the intended recipient of the incoming call.

30. (Previously Presented) A computing device comprising:

one or more processors;

one or more wireless communication ports that communicate with the one or more processors to enable the device to handle both voice and messaging communications over one or more wireless networks;

wherein the one or more processors are configured to:

receive an incoming telephony communication over one of the wireless communication ports from another computing device;

in response to receiving the incoming telephony communication, determine a message identifier of the other computing device, wherein the message identifier is determined based at least in part on data provided with the incoming telephony communication; and

enable a user to elect to respond to the incoming telephony communication by programmatically addressing a message to the other computing device using the message identifier that is communicated with the incoming telephony communication,

wherein the computing device, in response to receiving the incoming telephony communication, displays a user interface that enables the user to elect to respond to the incoming telephony communication by sending a instant message or text message or answering the incoming telephony communication.

31. (Previously Presented) The computing device of claim 30, further comprising a display, and wherein the one or more processors are configured to generate on the display the user-interface, wherein the user interface further enables the user to elect to extend an amount of time in which the computing device waits before answering the incoming telephony communication by initiating voice mail.

32. (Previously Presented) The computing device of claim 30, further comprising memory resources that store a plurality of contact records on the computing device, and wherein the one or more processors are configured to make a determination as to whether a phone number of the incoming telephony communication is associated with a message enabled device.

33. (Previously Presented) The computing device of claim 32, wherein the one or more processors are configured to make the determination by accessing a corresponding one of the plurality of contact records of the caller using the data provided with the incoming telephony communication, and using the corresponding contact record to verify that the phone number is capable of being used to receive the message.

REMARKS

Applicant requests entry of this Amendment, as it places the application in condition for allowance.

Claims 1, 3-19, 21-22 and 29-33 are pending. Claim 24-28 have been cancelled. Claims 1, 3-19, 21, 22 and 29-33 are allowed.

Summary of the Office Action

Claims 24-28 stand rejected under 35 U.S.C. 103(a) as being obvious over US Pub. No. 2002/0067714 ("Crain"). These claims have been cancelled. All pending claims have been indicated as being allowable.

CONCLUSION

A Notice of Allowance is respectfully requested. If there are any questions or comments that the Examiner wishes to direct to Applicant's attorney, the Examiner is invited to call Applicant's attorney at (408) 551-6632.

If an extension of time is required in connection herewith, applicant hereby petitions for such extension.

Applicant hereby authorizes Deposit Account No. 50-1914 to be charged for any fee due in connection with this submission, including any extension of time fee.

Respectfully submitted,
MAHAMEDI PARADICE KREISMAN, LLP

September 17, 2010
Date

/Zurvan Mahamedi/
Zurvan Mahamedi, Reg. No. 42,828

MAHAMEDI PARADICE KREISMAN LLP
550 Winchester Blvd., Suite 605
San Jose, CA 95128
Tel. 408-236-6640 Fax 408-236-6641

Electronic Acknowledgement Receipt

EFS ID:	8447326
Application Number:	11200511
International Application Number:	
Confirmation Number:	2125
Title of Invention:	Method and device for enabling message responses to incoming phone calls
First Named Inventor/Applicant Name:	David Champlin
Customer Number:	30554
Filer:	Zurvan Mahamedi/kathleen farrell
Filer Authorized By:	Zurvan Mahamedi
Attorney Docket Number:	PALM.P0962
Receipt Date:	17-SEP-2010
Filing Date:	08-AUG-2005
Time Stamp:	19:24:33
Application Type:	Utility under 35 USC 111(a)

Payment information:

Submitted with Payment	no
------------------------	----

File Listing:

Document Number	Document Description	File Name	File Size(Bytes)/ Message Digest	Multi Part /.zip	Pages (if appl.)
1		PALM_P0962_Response.pdf	71880 <small>5ab6eca34f719c2104388cddbcbce43b8e68f3d6</small>	yes	10

Multipart Description/PDF files in .zip description			
Document Description	Start	End	
Amendment After Final	1	1	
Claims	2	8	
Applicant Arguments/Remarks Made in an Amendment	9	10	

Warnings:

Information:

Total Files Size (in bytes):	71880
-------------------------------------	-------

This Acknowledgement Receipt evidences receipt on the noted date by the USPTO of the indicated documents, characterized by the applicant, and including page counts, where applicable. It serves as evidence of receipt similar to a Post Card, as described in MPEP 503.

New Applications Under 35 U.S.C. 111

If a new application is being filed and the application includes the necessary components for a filing date (see 37 CFR 1.53(b)-(d) and MPEP 506), a Filing Receipt (37 CFR 1.54) will be issued in due course and the date shown on this Acknowledgement Receipt will establish the filing date of the application.

National Stage of an International Application under 35 U.S.C. 371

If a timely submission to enter the national stage of an international application is compliant with the conditions of 35 U.S.C. 371 and other applicable requirements a Form PCT/DO/EO/903 indicating acceptance of the application as a national stage submission under 35 U.S.C. 371 will be issued in addition to the Filing Receipt, in due course.

New International Application Filed with the USPTO as a Receiving Office

If a new international application is being filed and the international application includes the necessary components for an international filing date (see PCT Article 11 and MPEP 1810), a Notification of the International Application Number and of the International Filing Date (Form PCT/RO/105) will be issued in due course, subject to prescriptions concerning national security, and the date shown on this Acknowledgement Receipt will establish the international filing date of the application.

Under the Paperwork Reduction Act of 1995, no persons are required to respond to a collection of information unless it displays a valid OMB control number.

PATENT APPLICATION FEE DETERMINATION RECORD Substitute for Form PTO-875					Application or Docket Number 11/200,511		Filing Date 08/08/2005		<input type="checkbox"/> To be Mailed		
APPLICATION AS FILED – PART I											
(Column 1)			(Column 2)			SMALL ENTITY <input type="checkbox"/>		OR		OTHER THAN SMALL ENTITY	
FOR		NUMBER FILED	NUMBER EXTRA		RATE (\$)	FEE (\$)	OR		RATE (\$)	FEE (\$)	
<input type="checkbox"/> BASIC FEE <small>(37 CFR 1.16(a), (b), or (c))</small>		N/A	N/A		N/A				N/A		
<input type="checkbox"/> SEARCH FEE <small>(37 CFR 1.16(k), (l), or (m))</small>		N/A	N/A		N/A		N/A				
<input type="checkbox"/> EXAMINATION FEE <small>(37 CFR 1.16(o), (p), or (q))</small>		N/A	N/A		N/A		N/A				
TOTAL CLAIMS <small>(37 CFR 1.16(i))</small>		minus 20 =	*		X \$ =		OR		X \$ =		
INDEPENDENT CLAIMS <small>(37 CFR 1.16(h))</small>		minus 3 =	*		X \$ =		OR		X \$ =		
<input type="checkbox"/> APPLICATION SIZE FEE <small>(37 CFR 1.16(s))</small>		If the specification and drawings exceed 100 sheets of paper, the application size fee due is \$250 (\$125 for small entity) for each additional 50 sheets or fraction thereof. See 35 U.S.C. 41(a)(1)(G) and 37 CFR 1.16(s).									
<input type="checkbox"/> MULTIPLE DEPENDENT CLAIM PRESENT <small>(37 CFR 1.16(j))</small>											
* If the difference in column 1 is less than zero, enter "0" in column 2.											
APPLICATION AS AMENDED – PART II					SMALL ENTITY		OR		OTHER THAN SMALL ENTITY		
(Column 1)		(Column 2)		(Column 3)		RATE (\$)	ADDITIONAL FEE (\$)	OR		RATE (\$)	ADDITIONAL FEE (\$)
09/17/2010		CLAIMS REMAINING AFTER AMENDMENT		HIGHEST NUMBER PREVIOUSLY PAID FOR							
Total <small>(37 CFR 1.16(o))</small>		* 25		Minus ** 33		= 0		OR		X \$52=	0
Independent <small>(37 CFR 1.16(h))</small>		* 3		Minus *** 4		= 0		OR		X \$220=	0
<input type="checkbox"/> Application Size Fee <small>(37 CFR 1.16(s))</small>											
<input type="checkbox"/> FIRST PRESENTATION OF MULTIPLE DEPENDENT CLAIM <small>(37 CFR 1.16(j))</small>											
					TOTAL ADD'L FEE		OR		TOTAL ADD'L FEE		0
(Column 1)		(Column 2)		(Column 3)		RATE (\$)	ADDITIONAL FEE (\$)	OR		RATE (\$)	ADDITIONAL FEE (\$)
		CLAIMS REMAINING AFTER AMENDMENT		HIGHEST NUMBER PREVIOUSLY PAID FOR							
Total <small>(37 CFR 1.16(o))</small>		*		Minus **		=		OR		X \$ =	
Independent <small>(37 CFR 1.16(h))</small>		*		Minus ***		=		OR		X \$ =	
<input type="checkbox"/> Application Size Fee <small>(37 CFR 1.16(s))</small>											
<input type="checkbox"/> FIRST PRESENTATION OF MULTIPLE DEPENDENT CLAIM <small>(37 CFR 1.16(j))</small>											
					TOTAL ADD'L FEE		OR		TOTAL ADD'L FEE		
* If the entry in column 1 is less than the entry in column 2, write "0" in column 3.											
** If the "Highest Number Previously Paid For" IN THIS SPACE is less than 20, enter "20".											
*** If the "Highest Number Previously Paid For" IN THIS SPACE is less than 3, enter "3".											
The "Highest Number Previously Paid For" (Total or Independent) is the highest number found in the appropriate box in column 1.											
Legal Instrument Examiner: /DENISE HOPKINS/											

This collection of information is required by 37 CFR 1.16. The information is required to obtain or retain a benefit by the public which is to file (and by the USPTO to process) an application. Confidentiality is governed by 35 U.S.C. 122 and 37 CFR 1.14. This collection is estimated to take 12 minutes to complete, including gathering, preparing, and submitting the completed application form to the USPTO. Time will vary depending upon the individual case. Any comments on the amount of time you require to complete this form and/or suggestions for reducing this burden, should be sent to the Chief Information Officer, U.S. Patent and Trademark Office, U.S. Department of Commerce, P.O. Box 1450, Alexandria, VA 22313-1450. DO NOT SEND FEES OR COMPLETED FORMS TO THIS ADDRESS. **SEND TO: Commissioner for Patents, P.O. Box 1450, Alexandria, VA 22313-1450.**

If you need assistance in completing the form, call 1-800-PTO-9199 and select option 2.



UNITED STATES PATENT AND TRADEMARK OFFICE

UNITED STATES DEPARTMENT OF COMMERCE
United States Patent and Trademark Office
Address: COMMISSIONER FOR PATENTS
P.O. Box 1450
Alexandria, Virginia 22313-1450
www.uspto.gov

Table with 5 columns: APPLICATION NO., FILING DATE, FIRST NAMED INVENTOR, ATTORNEY DOCKET NO., CONFIRMATION NO.

11/200,511 08/08/2005 David Champlin PALM.P0962 2125

30554 7590 06/17/2010
MAHAMEDI PARADICE KREISMAN LLP
550 Winchester Boulevard
Suite 605
SAN JOSE, CA 95128

Table with 1 column: EXAMINER

GAUTHIER, GERALD

Table with 2 columns: ART UNIT, PAPER NUMBER

2614

Table with 2 columns: MAIL DATE, DELIVERY MODE

06/17/2010 PAPER

Please find below and/or attached an Office communication concerning this application or proceeding.

The time period for reply, if any, is set in the attached communication.

DETAILED ACTION

Claim Rejections - 35 USC § 103

1. The following is a quotation of 35 U.S.C. 103(a) which forms the basis for all obviousness rejections set forth in this Office action:

(a) A patent may not be obtained though the invention is not identically disclosed or described as set forth in section 102 of this title, if the differences between the subject matter sought to be patented and the prior art are such that the subject matter as a whole would have been obvious at the time the invention was made to a person having ordinary skill in the art to which said subject matter pertains. Patentability shall not be negated by the manner in which the invention was made.

2. The factual inquiries set forth in *Graham v. John Deere Co.*, 383 U.S. 1, 148 USPQ 459 (1966), that are applied for establishing a background for determining obviousness under 35 U.S.C. 103(a) are summarized as follows:

1. Determining the scope and contents of the prior art.
2. Ascertaining the differences between the prior art and the claims at issue.
3. Resolving the level of ordinary skill in the pertinent art.
4. Considering objective evidence present in the application indicating obviousness or nonobviousness.

3. This application currently names joint inventors. In considering patentability of the claims under 35 U.S.C. 103(a), the examiner presumes that the subject matter of the various claims was commonly owned at the time any inventions covered therein were made absent any evidence to the contrary. Applicant is advised of the obligation under 37 CFR 1.56 to point out the inventor and invention dates of each claim that was not commonly owned at the time a later invention was made in order for the examiner to consider the applicability of 35 U.S.C. 103(c) and potential 35 U.S.C. 102(e), (f) or (g) prior art under 35 U.S.C. 103(a).

4. Claims 24-28 are rejected under 35 U.S.C. 103(a) as being unpatentable over Crain et al. (US 2002/0067714 A1).

Regarding **claim 24**, Crain discloses a method for operating a computing device, the method being implemented by one or more processors of the computing device [paragraph 0002] and comprising:

identifying a phone number of a caller of an incoming phone call [The system identifies the caller ID using CLID/CNID or ANI information, paragraph 0045];

in response to receiving the incoming phone call, prompting a user of the computing device to answer the incoming phone call or generate a message reply to the incoming phone call [The subscriber has a choice between answering the call at a designated forwarding number, diverting the call to voice mail, forwarding the call to an affirmatively-entered number, requesting the caller to call back within a specified period of time and initiate a computer generated voice message, paragraph 0059]; and

in response to the user providing input to generate the message reply to the incoming call, initiating the message reply by automatically opening a message and then addressing the message to the phone number of the caller of the incoming phone call [In response to the option 36 which initiate a computer-generated voice that informs the caller that the subscriber is on the telephone and to please call back in a specific number of minutes paragraph 0047].

Crain fails to disclose all the claimed limitations in a single embodiment.

Hence the prior art includes each element claimed, although in a single prior art reference, with the only difference between the claimed invention and the prior art being the lack of actual combination of the elements in one embodiment of a single prior art reference.

The prior art performs the same function as it does separately of.

Therefore one of ordinary skill in the art could have combined the elements as claimed by known methods, and that in combination, each element merely performs the same function as it does separately.

The results of the combination would have been predictable and resulted in having a computer device performing all the claimed limitations.

Therefore, the claimed subject would have been obvious to a person having ordinary skill in the art at the time the invention was made.

Regarding **claims 25-28**, Crain discloses a method, wherein initiating the message reply includes addressing a SMS message to the phone number of the caller [paragraph 0047].

Allowable Subject Matter

5. **Claims 1, 3-19, 21, 22 and 29-33** are allowed.

Response to Arguments

6. Applicant's arguments with respect to claims 1, 3-19, 21, 22 and 24-33 have been considered but are moot in view of the new ground(s) of rejection.

Conclusion

7. Applicant's amendment necessitated the new ground(s) of rejection presented in this Office action. Accordingly, **THIS ACTION IS MADE FINAL**. See MPEP § 706.07(a). Applicant is reminded of the extension of time policy as set forth in 37 CFR 1.136(a).

A shortened statutory period for reply to this final action is set to expire THREE MONTHS from the mailing date of this action. In the event a first reply is filed within TWO MONTHS of the mailing date of this final action and the advisory action is not mailed until after the end of the THREE-MONTH shortened statutory period, then the shortened statutory period will expire on the date the advisory action is mailed, and any extension fee pursuant to 37 CFR 1.136(a) will be calculated from the mailing date of the advisory action. In no event, however, will the statutory period for reply expire later than SIX MONTHS from the date of this final action.

8. Any inquiry concerning this communication or earlier communications from the examiner should be directed to Gerald Gauthier whose telephone number is (571) 272-7539. The examiner can normally be reached on 8:00 AM to 4:30 PM.

If attempts to reach the examiner by telephone are unsuccessful, the examiner's supervisor, Fan Tsang can be reached on (571) 272-7547. The fax phone number for the organization where this application or proceeding is assigned is 571-273-8300.

Information regarding the status of an application may be obtained from the Patent Application Information Retrieval (PAIR) system. Status information for published applications may be obtained from either Private PAIR or Public PAIR. Status information for unpublished applications is available through Private PAIR only. For more information about the PAIR system, see <http://pair-direct.uspto.gov>. Should you have questions on access to the Private PAIR system, contact the Electronic Business Center (EBC) at 866-217-9197 (toll-free). If you would like assistance from a USPTO Customer Service Representative or access to the automated information system, call 800-786-9199 (IN USA OR CANADA) or 571-272-1000.

/Gerald Gauthier/
Primary Examiner, Art Unit 2614

June 17, 2010

Notice of References Cited	Application/Control No. 11/200,511	Applicant(s)/Patent Under Reexamination CHAMPLIN ET AL.	
	Examiner Gerald Gauthier	Art Unit 2614	Page 1 of 2

U.S. PATENT DOCUMENTS

*		Document Number Country Code-Number-Kind Code	Date MM-YYYY	Name	Classification
*	A	US-4,922,526 A	05-1990	Morganstein et al.	379/157
*	B	US-5,396,544 A	03-1995	Gilbert et al.	379/88.23
*	C	US-5,585,749 A	12-1996	Pace et al.	327/108
*	D	US-5,751,707 A	05-1998	Voit et al.	370/384
*	E	US-5,748,100 A	05-1998	Gutman et al.	340/7.22
*	F	US-5,805,978 A	09-1998	Souissi et al.	340/7.21
*	G	US-5,844,967 A	12-1998	Lee, Seung-Ku	379/88.23
*	H	US-5,884,193 A	03-1999	Kaplan, Diego	455/565
*	I	US-5,894,505 A	04-1999	Koyama, Mitsuhiro	379/67.1
*	J	US-5,943,401 A	08-1999	Risner et al.	379/88.22
*	K	US-5,991,290 A	11-1999	Malik, Naeem Iqbal	370/352
*	L	US-6,081,845 A	06-2000	Kanemaki et al.	709/238
*	M	US-2001/0003826 A1	06-2001	Iwata, Shinichiro	709/206

FOREIGN PATENT DOCUMENTS

*		Document Number Country Code-Number-Kind Code	Date MM-YYYY	Country	Name	Classification
	N					
	O					
	P					
	Q					
	R					
	S					
	T					

NON-PATENT DOCUMENTS

*		Include as applicable: Author, Title Date, Publisher, Edition or Volume, Pertinent Pages)
	U	
	V	
	W	
	X	

*A copy of this reference is not being furnished with this Office action. (See MPEP § 707.05(a).)
Dates in MM-YYYY format are publication dates. Classifications may be US or foreign.

Notice of References Cited	Application/Control No. 11/200,511	Applicant(s)/Patent Under Reexamination CHAMPLIN ET AL.	
	Examiner Gerald Gauthier	Art Unit 2614	Page 2 of 2

U.S. PATENT DOCUMENTS

*		Document Number Country Code-Number-Kind Code	Date MM-YYYY	Name	Classification
*	A	US-2002/0067714 A1	06-2002	Crain et al.	370/352
*	B	US-6,647,108 B1	11-2003	Wurster et al.	379/215.01
*	C	US-6,680,935 B1	01-2004	Kung et al.	370/352
*	D	US-6,823,184 B1	11-2004	Nelson, Lester D.	455/418
*	E	US-6,839,877 B2	01-2005	Iwata, Shinichiro	715/246
*	F	US-7,009,990 B1	03-2006	Adams et al.	370/429
*	G	US-7,027,583 B2	04-2006	Uranaka et al.	379/220.01
*	H	US-7,051,099 B2	05-2006	Ziegler et al.	709/224
*	I	US-7,218,710 B1	05-2007	Ali et al.	379/88.23
*	J	US-7,286,649 B1	10-2007	Nelson et al.	379/71
*	K	US-7,570,747 B2	08-2009	Nakatsu, Makoto	379/88.25
	L	US-			
	M	US-			

FOREIGN PATENT DOCUMENTS

*		Document Number Country Code-Number-Kind Code	Date MM-YYYY	Country	Name	Classification
	N					
	O					
	P					
	Q					
	R					
	S					
	T					

NON-PATENT DOCUMENTS

*		Include as applicable: Author, Title Date, Publisher, Edition or Volume, Pertinent Pages)
	U	
	V	
	W	
	X	

*A copy of this reference is not being furnished with this Office action. (See MPEP § 707.05(a).)
Dates in MM-YYYY format are publication dates. Classifications may be US or foreign.

EAST Search History

EAST Search History (Prior Art)

Ref #	Hits	Search Query	DBs	Default Operator	Plurals	Time Stamp
S18	7	incoming near call near5 input near5 message near5 device	US-PGPUB; USPAT; USOCR; FPRS; EPO; JPO; DERWENT; IBM_TDB	OR	ON	2010/06/11 13:55
S19	0	incoming near call near5 input near5 message near5 address\$3	US-PGPUB; USPAT; USOCR; FPRS; EPO; JPO; DERWENT; IBM_TDB	OR	ON	2010/06/11 14:55
S20	1928	input near5 message near5 address\$3	US-PGPUB; USPAT; USOCR; FPRS; EPO; JPO; DERWENT; IBM_TDB	OR	ON	2010/06/11 14:55
S21	61	S20 with call	US-PGPUB; USPAT; USOCR; FPRS; EPO; JPO; DERWENT; IBM_TDB	OR	ON	2010/06/11 14:55
S22	1260	user near5 input near5 (generat\$3 compos\$3) near5 (reply message)	US-PGPUB; USPAT; USOCR; FPRS; EPO; JPO; DERWENT; IBM_TDB	OR	ON	2010/06/14 08:21
S23	8	S22 with ((telephone phone) adj number)	US-PGPUB; USPAT; USOCR; FPRS; EPO; JPO; DERWENT; IBM_TDB	OR	ON	2010/06/14 08:21
S24	28	S22 same ((telephone phone) adj number)	US-PGPUB; USPAT; USOCR; FPRS; EPO; JPO; DERWENT; IBM_TDB	OR	ON	2010/06/14 08:22
S25	2553	message with response with incoming with call	US-PGPUB; USPAT; USOCR; FPRS; EPO; JPO; DERWENT; IBM_TDB	OR	ON	2010/06/14 08:34

S26	1	S22 same S25	US-PGPUB; USPAT; USOCR; FPRS; EPO; JPO; DERWENT; IBM_TDB	OR	ON	2010/06/14 08:34
S27	11	S22 and S25	US-PGPUB; USPAT; USOCR; FPRS; EPO; JPO; DERWENT; IBM_TDB	OR	ON	2010/06/14 08:34
S28	1880	message with response with (incoming adj call)	US-PGPUB; USPAT; USOCR; FPRS; EPO; JPO; DERWENT; IBM_TDB	OR	ON	2010/06/14 08:36
S29	1880	S28 and S25	US-PGPUB; USPAT; USOCR; FPRS; EPO; JPO; DERWENT; IBM_TDB	OR	ON	2010/06/14 08:36
S30	6	S22 and S28	US-PGPUB; USPAT; USOCR; FPRS; EPO; JPO; DERWENT; IBM_TDB	OR	ON	2010/06/14 08:36
S31	2187	message with (reply response) with (incoming adj call)	US-PGPUB; USPAT; USOCR; FPRS; EPO; JPO; DERWENT; IBM_TDB	OR	ON	2010/06/14 08:39
S32	411	(379/88.23).CCLS.	US-PGPUB; USPAT; USOCR; FPRS; EPO; JPO; DERWENT; IBM_TDB	OR	OFF	2010/06/14 08:39
S34	19	S31 and S32	US-PGPUB; USPAT; USOCR; FPRS; EPO; JPO; DERWENT; IBM_TDB	OR	ON	2010/06/14 08:39
S35	1923	option with generat \$3 with message	US-PGPUB; USPAT; USOCR; FPRS; EPO; JPO; DERWENT; IBM_TDB	OR	ON	2010/06/14 10:57
S36	50	S35 same (incoming adj call)	US-PGPUB; USPAT; USOCR; FPRS; EPO; JPO; DERWENT; IBM_TDB	OR	ON	2010/06/14 11:00

6/ 15/ 2010 8:12:03 AM

C:\ Documents and Settings\ ggauthier\ My Documents\ EAST\ workspaces\ 11200511.wsp

Substitute for Form 1449/PTO INFORMATION DISCLOSURE STATEMENT BY APPLICANT Page 1 of 1	Application No.	11/200,511
	Filed	8/8/2005
	First Inventor	Champlin, David
	Art Unit	2614
	Examiner	GAUTHIER, Gerald
	Atty. Docket No.	PALM.P0962

U.S. Patent Documents					
Examiner Initials*	US Patent Document		Name of Patentee or Applicant of Cited Document	Date of Publication	Relevant Pages, Columns, Lines
	Number	Kind			
/GG/	2006/0041470	A1	Fiho et al.	02-23-2006	
/GG/	2007/0143429	A1	Venkataraman et al.	06-21-2007	
/GG/	2009/0061833	A1	Ho et al.	03-05-2009	
/GG/	6,484,036		Sorkin et al.	11-19-2006	

Foreign Patent Documents						
Examiner Initials*	Patent Document		Name of Patentee or Applicant of Cited Document	Date of Publication	Relevant Pages, Columns, Lines	Trans- lation
	Number	Kind				
/GG/	KR 1020060093183	A	Pantech Co., Ltd.	08-24-2006		

/GG/	KR 1020070078369	A	LG Electronics Inc.	07-31-2007		
------	------------------	---	---------------------	------------	--	--

Non Patent Literature Documents		
Examiner Initials	Name of Author, Title of Item, Date, Page(s), Volume-Issue Number(s), Publisher, City and/or Country where Published	Trans- lation
/GG/	International Search Report and Written Opinion mailed January 29, 2009 for PCT/US2008/074320 [PALM.P1009WO] 14 pgs.	

Examiner Signature	/Gerald Gauthier/	Date Considered	06/15/2010
-------------------------------	-------------------	----------------------------	------------

*Examiner: Initial if reference considered, whether or not citation is in conformance with MPEP 609. Draw a line through citation if not in conformance and not considered. Include a copy of this form with next communication to applicant.

Index of Claims 	Application/Control No. 11200511	Applicant(s)/Patent Under Reexamination CHAMPLIN ET AL.
	Examiner Gerald Gauthier	Art Unit 2614

✓	Rejected	-	Cancelled	N	Non-Elected	A	Appeal
=	Allowed	÷	Restricted	I	Interference	O	Objected

Claims renumbered in the same order as presented by applicant
 CPA
 T.D.
 R.1.47

CLAIM		DATE							
Final	Original	02/24/2009	07/22/2009	01/20/2010	06/15/2010				
	1	✓	✓	✓	=				
	2	✓	✓	-	-				
	3	✓	✓	✓	=				
	4	✓	✓	✓	=				
	5	✓	✓	✓	=				
	6	✓	✓	✓	=				
	7	✓	✓	✓	=				
	8	✓	✓	✓	=				
	9	✓	✓	✓	=				
	10	✓	✓	✓	=				
	11	✓	✓	✓	=				
	12	✓	✓	✓	=				
	13	✓	✓	✓	=				
	14	✓	✓	✓	=				
	15	✓	✓	✓	=				
	16	✓	✓	✓	=				
	17	✓	✓	✓	=				
	18	✓	✓	✓	=				
	19	✓	✓	✓	=				
	20	✓	✓	-	-				
	21	✓	✓	✓	=				
	22	✓	✓	✓	=				
	23	✓	✓	-	-				
	24	✓	✓	✓	✓				
	25	✓	✓	✓	✓				
	26	✓	✓	✓	✓				
	27	✓	✓	✓	✓				
	28	✓	✓	✓	✓				
	29		✓	✓	=				
	30		✓	✓	=				
	31		✓	✓	=				
	32		✓	✓	=				
	33		✓	✓	=				

Search Notes 	Application/Control No. 11200511	Applicant(s)/Patent Under Reexamination CHAMPLIN ET AL.
	Examiner Gerald Gauthier	Art Unit 2614

SEARCHED			
Class	Subclass	Date	Examiner
379	67.1	2/24/09	JCA
379	88.13	2/24/09	JCA
455	414.4	2/24/09	JCA
370	356	7/22/2009	GG
379	76, 88.19, 88.21, 93.23, 202.01, 257	7/22/2009	GG
455	412.1, 415, 445	7/22/2009	GG
705	26	7/22/2009	GG
709	238	7/22/2009	GG
725	134	7/22/2009	GG
379	88.19, 88.22, 93.17, 211.01, 215.01	1/20/2010	GG
455	567	1/20/2010	GG
725	111	1/20/2010	GG
327	108	6/15/2010	GG
340	7.21, 7.22	6/15/2010	GG
370	352, 384	6/15/2010	GG
379	71, 88.22, 88.23, 88.25, 157, 215.01	6/15/2010	GG
709	206, 224, 238	6/15/2010	GG
715	246	6/15/2010	GG

SEARCH NOTES		
Search Notes	Date	Examiner
Searched East and Google Patents	2/24/09	JCA
EAST: (US-PGPUB; USPAT; USOCR)	7/22/2009	GG
EAST: (US-PGPUB; USPAT; USOCR; FPRS; EPO; JPO; DERWENT; IBM_TDB)	1/20/2010	GG
EAST: (US-PGPUB; USPAT; USOCR; FPRS; EPO; JPO; DERWENT; IBM_TDB)	6/15/2010	GG

INTERFERENCE SEARCH			
Class	Subclass	Date	Examiner

	/Gerald Gauthier/ Primary Examiner. Art Unit 2614
--	--

Atty. Docket No. PALM.P0962

PATENT

IN THE UNITED STATES PATENT OFFICE

In Re Patent Application of

First Named Inventor: Champlin, David-

Application No.: 11/200,511

Filed: 8/8/2005

For: METHOD AND DEVICE FOR ENABLING
MESSAGE RESPONSES TO INCOMING
PHONE CALLS

Examiner: GAUTHIER,
Gerald

Art Unit: 2614

Confirmation 2125
No.:

Mail Stop Amendment
Commissioner for Patents
P.O. Box 1450
Alexandria, VA 22313-1450

AMENDMENT AND RESPONSE

Dear Sir:

In response to the Office Action mailed January 26, 2010 (the "Office Action"), once extended by a one month extension of time, the Applicant respectfully requests reconsideration of the application in view of the following amendments and remarks.

Amendment to the Claims begin on page 2 of this paper.

Remarks begin on page 10 of this paper.

CERTIFICATE OF ELECTRONIC TRANSMITTAL

I hereby certify that this document is being transmitted electronically via EFS-Web with the United State Patent and Trademark Office on April 26, 2010.

Date: April 26, 2010

/Zurvan Mahamedi/

Zurvan Mahamedi. Reg. No. 42.828

IN THE CLAIMS

1. (Currently Amended) A method for operating a first computing device, the method being implemented by one or more processors of the computing device and comprising:

receiving, from a second computing device, an incoming call to initiate a voice-exchange session;

in response to receiving the incoming call, determining a message identifier associated with the second computing device, wherein the message identifier is determined based at least in part on data provided with the incoming call;

in response to receiving the incoming call, prompting a user of the first computing device to enter user input that instructs the first computing device to handle the incoming call by composing, while not answering the incoming call, a message to a user of the second computing device; and

responsive to receiving the incoming call and the user entering the user input, automatically ~~composing~~ addressing the message to the second computing device using the message identifier determined from the incoming call.

2. CANCELED

3. (Previously Presented) The method of claim 1, further comprising: generating a graphic user-interface feature that prompts the user to elect to have the message at least partially composed in response to the incoming call.

4. (Currently Amended) The method of claim 1, wherein automatically ~~composing-addressing~~ the message includes using the message identifier to identify and enter ~~entering at least a portion of~~ an address for an instant text message.

5. (Currently Amended) The method of claim 4, wherein automatically ~~composing-addressing~~ the message includes using the message identifier to entering-enter ~~at least a portion of~~ an address for the message in a Short Message Service format.

6. (Previously Presented) The method of claim 5, wherein the message is composed using a Short Message Service application, and the message identifier is a phone number.

7. (Previously Presented) The method of claim 4, wherein determining the message identifier includes determining the message identifier from a phone number of the second computing device.

8. (Previously Presented) The method of claim 1, further comprising: verifying that the second computing device is enabled for receiving the message.

9. (Previously Presented) The method of claim 8, wherein:
verifying that the second computing device is enabled for receiving the message includes (i) identifying a phone number of the other computing device used for the incoming call, and (ii) determining that the phone number is associated with a message-enabled device that can handle a text

or instant message response.

10. (Previously Presented) The method of claim 9, wherein determining that the phone number is associated with a message enabled device includes accessing a contact record of a caller of the incoming call using the data provided with the incoming call, and using the contact record to verify that the phone number is capable of being used to receive the message.

11. (Previously Presented) The method of claim 10, wherein the message is an instant or text message, and wherein using the contact record to verify that the phone number is capable of being used to receive the instant or text message includes checking the contact record associated with the caller to see whether the phone number of the incoming call is for a mobile telephony device that can handle the instant or text message.

12. (Original) The method of claim 10, wherein determining that the phone number is associated with the message enabled device is performed programmatically and automatically.

13. (Previously Presented) The method of claim 1,
transmitting the message to the second computing device using a phone number of the incoming call as the address for either a new instant message or a new text message.

14. (Previously Presented) The method of claim 13, wherein transmitting the message includes using either an instant or text messaging application for transmitting the new instant message or the new text message.

15. (Previously Presented) The method of claim 14, further comprising launching either the instant or text messaging application automatically, in response to one of (i) receiving the incoming call, or (ii) receiving the input from the user of the first computing device.

16. (Previously Presented) The method of claim 1, further comprising enabling the user of the first computing device to provide content manually for the message.

17. (Previously Presented) The method of claim 1, further comprising enabling the user of the first computing device to trigger insertion of pre-formulated content for the message.

18. (Previously Presented) The method of claim 1, further comprising: automatically and programmatically providing at least a portion of a body of the message.

19. (Currently Amended) A computing device comprising:
one or more communication components, at a first computing device,
for handling voice and messaging communications over wireless
networks; and
one or more processors configured to:
handle an incoming phone call from a second computing
device;
in response to receiving the incoming phone call, (a)
prompt a user of the first computing device to enter user input

that instructs the first computing device on how to handle the incoming call, including providing the user with an option to (i) answer the call, or (ii) send the second computing device a message without answering the incoming call;

in response to receiving the incoming phone call, determine a phone number of the second computing device based, at least in part, on the incoming phone call; and

in response to receiving the user input to send the second computing device the message without answering the incoming phone call, programmatically generate at least a ~~portion~~an address of the message to be transmitted to the second computing device using the phone number identified from the received phone call.

20. CANCELED

21. (Previously Presented) The computing device of claim 19, wherein the one or more processors are configured to enable a text message to be generated as the message to be sent to the second computing device without answering the incoming phone call.

22. (Currently Amended) The computing device of claim 19, wherein the one or more processors are configured to enable the message that is to be sent to the second computing device to include a message body of a format selected from one or more of text, image ~~and~~or audio.

23. CANCELED

24. (Currently Amended) A method for operating a computing device, the method being implemented by one or more processors of the computing device and comprising:

identifying a phone number of a caller of an incoming phone call;

in response to receiving the incoming phone call, prompting a user of the computing device to answer the incoming phone call or generate a message reply to the incoming phone call; and

in response to the user providing input to generate the message reply to the incoming call, initiating the message reply by automatically opening a message and then addressing the message to the phone number of the caller of the incoming phone call.

25. (Currently Amended) The method of claim 24, wherein initiating the message reply ~~by opening a message and addressing the message to the phone number~~ includes addressing a SMS message to the phone number of the caller.

26. (Original) The method of claim 25, further comprising enabling a user to specify a message body for the SMS message.

27. (Original) The method of claim 24, further comprising enabling a user of the computing device to send the message and then answer the call after sending the message.

28. (Original) The method of claim 24, further comprising enabling a user

of the computing device to send the message and then decline answering the call after sending the message.

29. (Previously Presented) The method of claim 1, wherein the first computing device is the intended recipient of the incoming call.

30. (Currently Amended) A computing device comprising:

one or more processors;

one or more wireless communication ports that communicate with the one or more processors to enable the device to handle both voice and messaging communications over one or more wireless networks;

wherein the one or more processors are configured to:

receive an incoming telephony communication over one of the wireless communication ports from another computing device;

in response to receiving the incoming telephony communication, determine a message identifier of the other computing device, wherein the message identifier is determined based at least in part on data provided with the incoming telephony communication; and

enable a user to elect to respond to the incoming telephony communication by ~~programmatic~~ programmatically addressing a message to the other computing device using the message identifier that is communicated with the incoming telephony communication,

wherein the computing device, in response to receiving the incoming telephony communication, displays a user interface that enables the user to elect to respond to the incoming telephony communication by sending a instant message or text message or answering the incoming telephony communication.

31. (Previously Presented) The computing device of claim 30, further comprising a display, and wherein the one or more processors are configured to generate on the display the user-interface, wherein the user interface further enables the user to elect to extend an amount of time in which the computing device waits before answering the incoming telephony communication by initiating voice mail.

32. (Previously Presented) The computing device of claim 30, further comprising memory resources that store a plurality of contact records on the computing device, and wherein the one or more processors are configured to make a determination as to whether a phone number of the incoming telephony communication is associated with a message enabled device.

33. (Previously Presented) The computing device of claim 32, wherein the one or more processors are configured to make the determination by accessing a corresponding one of the plurality of contact records of the caller using the data provided with the incoming telephony communication, and using the corresponding contact record to verify that the phone number is capable of being used to receive the message.

REMARKS

Summary of the Office Action

Claim Rejections - 35 USC § 103

Claims 1, 3-19, 21, 22 and 24-33 stand rejected under 35 U.S.C. 103(a) as being obvious over US Pub. No. 2002/087794 ("Fostick") in view of U.S. Patent No. US 6,219,413 ("Burg").

Detailed Remarks

Applicant requests reconsideration of the rejection in view of the amendments and remarks presented.

With regard to Claim 1, it states:

responsive to receiving the incoming call and the user entering the user input, automatically addressing the message to the second computing device using the message identifier determined from the incoming call.

Respectfully, the cited references do not disclose or suggest this feature. In particular, Applicant notes that the Examiner has correctly identified that Fostick's disclosure does not provide for an SMS response to an "incoming call". Moreover, it is Applicant's contention that Burg does not teach "responsive to receiving the incoming call and the user entering the user input, automatically addressing the message..." In fact, Burg teaches away. Column 9, line 28-35 of Burg provides that the caller-ID information is provided to the called party in order to enable "a more specific response", but the disclosure does not provide for "automatically addressing the message". Burg does not address a message "using the message identifier determined from the

incoming call.” Accordingly, Applicant submits an embodiment of claim 1 recites features which are not disclosed or suggested in the cited art.

Independent Claim 19 recites:

in response to receiving the user input to send the second computing device the message without answering the incoming phone call, programmatically **generate at least an address of the message to be transmitted to the second computing device** using the phone number identified from the received phone call

As explained, the cited art does not disclose or suggest the aforementioned feature.

Independent Claim 24 recites:

in response to the user providing input to generate the message reply to the incoming call, initiating the message reply by automatically opening a message and then addressing the message to the phone number of the caller of the incoming phone call

Neither reference discloses “automatically opening a message and then addressing the message to the phone number of the caller of the incoming phone call.”

Claim 30 recites:

enable a user to elect to respond to the incoming telephony communication **by programmatically addressing a message to the other computing device using the message identifier that is communicated with the incoming telephony communication**

Respectfully, the cited art does not disclose the aforementioned feature.

The remaining claims are dependent claims, and for reasons that include those stated above, are distinguishable from the cited art for at least those reasons stated above.

For example, in making the rejection to Claims 8-12, the

Examiner has referenced Fostick, pg. 2, para. 32-33, pg. 3, para. 40-41. Respectfully, Applicant submits these portions of Fostick are not relevant to "verifying that the second computing device is enabled for receiving the message." Fostick lacks any disclosure for verifying that, for example, that either MS 10 or MR 12 "verify" that the other device is enabled to receive messages.

Certainly, Claim 9 recites that "verifying" is performed by "determining that the phone number is associated with a message-enabled device that can handle a text or instant message response." The portions cited in Fostick by the Examiner do not pertain to this feature. Applicant respectfully submits that this feature is not disclosed by the cited art.

Even more specifically, Claim 10 recites "accessing a contact record of a caller of the incoming call using the data provided with the incoming call". Applicant submits this feature is not disclosed by the cited art.

For all of the reasons stated, a Notice of Allowance is requested.

CONCLUSION

For the reasons set forth above, it is respectfully submitted that all of the pending claims are in condition for allowance.

The Examiner is respectfully requested to contact the undersigned by telephone if it is believed that such contact would further the examination of the present application.

To the extent necessary, a petition for an extension of time under 37 C.F.R. § 1.136 is hereby made. Please charge any fee shortages or credit any overages to Deposit Account No. 50-1914.

Respectfully submitted,
MAHAMEDI PARADICE KREISMAN, LLP

April 26, 2010
Date

/Zurvan Mahamedi/
Zurvan Mahamedi, Reg. No. 42,828

MAHAMEDI PARADICE KREISMAN LLP
550 Winchester Blvd., Suite 605
San Jose, CA 95128
Tel. 408-236-6640 Fax 408-236-6641

Electronic Acknowledgement Receipt

EFS ID:	7493035
Application Number:	11200511
International Application Number:	
Confirmation Number:	2125
Title of Invention:	Method and device for enabling message responses to incoming phone calls
First Named Inventor/Applicant Name:	David Champlin
Customer Number:	30554
Filer:	Zurvan Mahamedi
Filer Authorized By:	
Attorney Docket Number:	PALM.P0962
Receipt Date:	27-APR-2010
Filing Date:	08-AUG-2005
Time Stamp:	02:40:21
Application Type:	Utility under 35 USC 111(a)

Payment information:

Submitted with Payment	no
------------------------	----

File Listing:

Document Number	Document Description	File Name	File Size(Bytes)/ Message Digest	Multi Part /.zip	Pages (if appl.)
1	Amendment/Req. Reconsideration-After Non-Final Reject	PALM__P0962_NFOA_1_26_2010_v2.pdf	101750 <small>393f1cdeb88f2936d95279f2aeb20e3767c272d</small>	no	13

Warnings:

Information:

Total Files Size (in bytes):

101750

This Acknowledgement Receipt evidences receipt on the noted date by the USPTO of the indicated documents, characterized by the applicant, and including page counts, where applicable. It serves as evidence of receipt similar to a Post Card, as described in MPEP 503.

New Applications Under 35 U.S.C. 111

If a new application is being filed and the application includes the necessary components for a filing date (see 37 CFR 1.53(b)-(d) and MPEP 506), a Filing Receipt (37 CFR 1.54) will be issued in due course and the date shown on this Acknowledgement Receipt will establish the filing date of the application.

National Stage of an International Application under 35 U.S.C. 371

If a timely submission to enter the national stage of an international application is compliant with the conditions of 35 U.S.C. 371 and other applicable requirements a Form PCT/DO/EO/903 indicating acceptance of the application as a national stage submission under 35 U.S.C. 371 will be issued in addition to the Filing Receipt, in due course.

New International Application Filed with the USPTO as a Receiving Office

If a new international application is being filed and the international application includes the necessary components for an international filing date (see PCT Article 11 and MPEP 1810), a Notification of the International Application Number and of the International Filing Date (Form PCT/RO/105) will be issued in due course, subject to prescriptions concerning national security, and the date shown on this Acknowledgement Receipt will establish the international filing date of the application.

Under the Paperwork Reduction Act of 1995, no persons are required to respond to a collection of information unless it displays a valid OMB control number.

PATENT APPLICATION FEE DETERMINATION RECORD Substitute for Form PTO-875					Application or Docket Number 11/200,511		Filing Date 08/08/2005		<input type="checkbox"/> To be Mailed	
APPLICATION AS FILED – PART I										
(Column 1)			(Column 2)		SMALL ENTITY <input type="checkbox"/> OR			OTHER THAN SMALL ENTITY		
FOR	NUMBER FILED	NUMBER EXTRA	RATE (\$)	FEE (\$)	OR			RATE (\$)	FEE (\$)	
<input type="checkbox"/> BASIC FEE (37 CFR 1.16(a), (b), or (c))	N/A	N/A	N/A		OR			N/A		
<input type="checkbox"/> SEARCH FEE (37 CFR 1.16(k), (l), or (m))	N/A	N/A	N/A		OR			N/A		
<input type="checkbox"/> EXAMINATION FEE (37 CFR 1.16(o), (p), or (q))	N/A	N/A	N/A		OR			N/A		
TOTAL CLAIMS (37 CFR 1.16(i))	minus 20 =	*	X \$ =		OR			X \$ =		
INDEPENDENT CLAIMS (37 CFR 1.16(h))	minus 3 =	*	X \$ =		OR			X \$ =		
<input type="checkbox"/> APPLICATION SIZE FEE (37 CFR 1.16(s))	If the specification and drawings exceed 100 sheets of paper, the application size fee due is \$250 (\$125 for small entity) for each additional 50 sheets or fraction thereof. See 35 U.S.C. 41(a)(1)(G) and 37 CFR 1.16(s).				OR					
<input type="checkbox"/> MULTIPLE DEPENDENT CLAIM PRESENT (37 CFR 1.16(j))					OR					
* If the difference in column 1 is less than zero, enter "0" in column 2.										
APPLICATION AS AMENDED – PART II										
(Column 1)			(Column 2)		(Column 3)			SMALL ENTITY OR OTHER THAN SMALL ENTITY		
AMENDMENT	04/27/2010	CLAIMS REMAINING AFTER AMENDMENT		HIGHEST NUMBER PREVIOUSLY PAID FOR	PRESENT EXTRA	RATE (\$)	ADDITIONAL FEE (\$)		RATE (\$)	ADDITIONAL FEE (\$)
	Total (37 CFR 1.16(i))	* 29	Minus	** 33	= 0	X \$ =		OR	X \$52=	0
	Independent (37 CFR 1.16(h))	* 4	Minus	***4	= 0	X \$ =		OR	X \$220=	0
	<input type="checkbox"/> Application Size Fee (37 CFR 1.16(s))									
	<input type="checkbox"/> FIRST PRESENTATION OF MULTIPLE DEPENDENT CLAIM (37 CFR 1.16(j))									
						TOTAL ADD'L FEE		OR	TOTAL ADD'L FEE	0
AMENDMENT		CLAIMS REMAINING AFTER AMENDMENT		HIGHEST NUMBER PREVIOUSLY PAID FOR	PRESENT EXTRA	RATE (\$)	ADDITIONAL FEE (\$)		RATE (\$)	ADDITIONAL FEE (\$)
	Total (37 CFR 1.16(i))	*	Minus	**	=	X \$ =		OR	X \$ =	
	Independent (37 CFR 1.16(h))	*	Minus	***	=	X \$ =		OR	X \$ =	
	<input type="checkbox"/> Application Size Fee (37 CFR 1.16(s))									
	<input type="checkbox"/> FIRST PRESENTATION OF MULTIPLE DEPENDENT CLAIM (37 CFR 1.16(j))									
						TOTAL ADD'L FEE		OR	TOTAL ADD'L FEE	
* If the entry in column 1 is less than the entry in column 2, write "0" in column 3.										
** If the "Highest Number Previously Paid For" IN THIS SPACE is less than 20, enter "20".										
*** If the "Highest Number Previously Paid For" IN THIS SPACE is less than 3, enter "3".										
The "Highest Number Previously Paid For" (Total or Independent) is the highest number found in the appropriate box in column 1.										
						Legal Instrument Examiner: /DEBRA a. SAVOY/				

This collection of information is required by 37 CFR 1.16. The information is required to obtain or retain a benefit by the public which is to file (and by the USPTO to process) an application. Confidentiality is governed by 35 U.S.C. 122 and 37 CFR 1.14. This collection is estimated to take 12 minutes to complete, including gathering, preparing, and submitting the completed application form to the USPTO. Time will vary depending upon the individual case. Any comments on the amount of time you require to complete this form and/or suggestions for reducing this burden, should be sent to the Chief Information Officer, U.S. Patent and Trademark Office, U.S. Department of Commerce, P.O. Box 1450, Alexandria, VA 22313-1450. DO NOT SEND FEES OR COMPLETED FORMS TO THIS ADDRESS. **SEND TO: Commissioner for Patents, P.O. Box 1450, Alexandria, VA 22313-1450.**

If you need assistance in completing the form, call 1-800-PTO-9199 and select option 2.

Substitute for Form 1449/PTO INFORMATION DISCLOSURE STATEMENT BY APPLICANT Page 1 of 1	Application No.	11/200,511
	Filed	8/8/2005
	First Inventor	Champlin, David
	Art Unit	2614
	Examiner	GAUTHIER, Gerald
	Atty. Docket No.	PALM.P0962

U.S. Patent Documents					
Examiner Initials*	US Patent Document		Name of Patentee or Applicant of Cited Document	Date of Publication	Relevant Pages, Columns, Lines
	Number	Kind			
	2006/0041470	A1	Fiho et al.	02-23-2006	
	2007/0143429	A1	Venkataraman et al.	06-21-2007	
	2009/0061833	A1	Ho et al.	03-05-2009	
	6,484,036		Sorkin et al.	11-19-2006	

Foreign Patent Documents						
Examiner Initials*	Patent Document		Name of Patentee or Applicant of Cited Document	Date of Publication	Relevant Pages, Columns, Lines	Trans- lation
	Number	Kind				
	KR 1020060093183	A	Pantech Co., Ltd.	08-24-2006		
	KR 1020070078369	A	LG Electronics Inc.	07-31-2007		

Non Patent Literature Documents		
Examiner Initials	Name of Author, Title of Item, Date, Page(s), Volume-Issue Number(s), Publisher, City and/or Country where Published	Trans- lation
	International Search Report and Written Opinion mailed January 29, 2009 for PCT/US2008/074320 [PALM.P1009WO] 14 pgs.	

Examiner Signature		Date Considered	
-------------------------------	--	----------------------------	--

*Examiner: Initial if reference considered, whether or not citation is in conformance with MPEP 609. Draw a line through citation if not in conformance and not considered. Include a copy of this form with next communication to applicant.

(19) 대한민국특허청(KR)
(12) 공개특허공보(A)

(51) Int. Cl.
H04L 12/18
H04L 12/12

(11) 공개번호 10-2006-0093183
(43) 공개일자 2006년08월24일

H04B 7/28

(21) 출원번호 10-2005-0014000
(22) 출원일자 2005년02월21일
(71) 출원인 주식회사 팬택
서울특별시 영등포구 여의도동 25-12 신승센터빌딩

(72) 발명자 정윤수
서울 관악구 봉천10동 872-10
김성국
서울 강서구 방화2동 방화12단지 1201동 505호

(74) 대리인 김영철

심사청구 : 없음

(54) 이동통신 단말기의 지피에스 기능을 이용한 홈 네트워크 시스템 및 방법

요약

본 발명은 이동통신 단말기의 지피에스 기능을 이용한 홈 네트워크 시스템 및 방법에 관한 것이다.

본 발명은 생활가전, 주방기기, 방범/보안 등 정보가전기기와 안방, 부엌, 거실, 현관 등 집안의 각 공간을 인터넷을 통해 연결하여 상호간에 정보를 전달해 유선전화, 이동통신 단말기 등을 통해서 관리하고 작동제어하는 홈 네트워크 서버를 구비한 네트워크 시스템에 있어서, 지피에스(GPS, Global Positioning System) 기능에 따라 자신의 위치정보를 획득하며, 상기 홈 네트워크 서버가 설치된 특정의 위치를 등록하고 상기 홈 네트워크 서버에서 수행하고자 하는 이벤트를 설정한 후, 상기 획득한 자신의 위치정보에 의해 상기 홈 네트워크 서버로부터 소정의 반경 거리 내에 도달하였음이 확인되면, 상기 이벤트 내용 및 그 실행명령을 나타내는 단문 메시지를 작성하여 전송하는 이동통신 단말기와; 상기 이동통신 단말기와 연동하여 홈 네트워크 서버 및 이동중인 해당 단말기의 위치정보를 전송하는 지피에스 시스템과; 상기 이동통신 단말기의 요청에 따라 단문 메시지를 상기 홈 네트워크 서버로 라우팅하는 단문 메시지 센터를 포함하는 시스템 및 그 방법을 구비하여 구성된다.

따라서, 본 발명은 지피에스 기능(GPS, Global Positioning System)을 제공하는 이동통신 단말기에 있어서, 지피에스 기능을 이용하여 사용자가 홈 네트워크 서버가 구비된 집 근처 소정 반경 내에 도달하였는지 여부를 파악하고, 그에 따라 홈 네트워크 서버로 단문 메시지를 전송하여 사용자가 집에 도착하기 이전에 특정의 이벤트를 미리 실행하게 함으로써, 사용자의 위치에 따라 특정의 이벤트를 자동으로 실행하여 예약 설정에 의한 이벤트 실행에 비해 사용자의 정확한 도착시간을 예측할 수 있어 효율적으로 홈 네트워크를 제어할 수 있고, 인터넷망이나 전력선 모뎀을 이용하지 않고 무선망을 이용하여 자동으로 홈 네트워크 서버를 제어 및 관리할 수 있는 효과가 있다.

도표도

도1

망세서

도면의 간단한 설명

도1은 도1은 본 발명 이동통신 단말기의 지피에스 기능을 이용한 홈 네트워크 시스템을 보인 블록도.

도2는 본 발명 이동통신 단말기의 지피에스 기능을 이용한 홈 네트워크 방법의 동작과정을 보인 순서도.

도면의 주요 부분에 대한 부호의 설명

- 10 : 이동통신 단말기
- 20 : 이동통신망
- 30 : 지피에스 시스템
- 40 : 지피에스 위성
- 50 : 단문 메시지 센터
- 60 : 인터넷망
- 70 : 홈 네트워크 서버
- 80 : 각종 정보가전기기

발명의 상세한 설명

발명의 목적

발명이 속하는 기술분야 및 그 분야의 종래기술

본 발명은 이동통신 단말기에 관한 것으로, 특히 지피에스 기능(GPS, Global Positioning System)을 제공하는 이동통신 단말기에 있어서, 지피에스 기능을 이용하여 사용자가 홈 네트워크 서버가 구비된 집 근처 소정 반경 내에 도달하였는지 여부를 파악하고, 그에 따라 홈 네트워크 서버로 단문 메시지를 전송하여 사용자가 집에 도착하기 이전에 특정의 이벤트를 미리 실행하게 함으로써, 사용자의 위치에 따라 특정의 이벤트를 자동으로 실행하여 예약 설정에 의한 이벤트 실행에 비해 사용자의 정확한 도착시간을 예측할 수 있어 효율적으로 홈 네트워크를 제어할 수 있고, 인터넷망이나 전력선 모델을 이용하지 않고 무선망을 이용하여 자동으로 홈 네트워크 서버를 제어 및 관리할 수 있는 이동통신 단말기의 지피에스 기능을 이용한 홈 네트워크 시스템 및 방법에 관한 것이다.

홈 네트워크(Home Network)란 TV, 냉장고, 에어컨 등 집안의 가전제품과 안방, 부엌, 거실, 현관 등 집안의 각 공간을 인터넷을 통해 연결하여 상호간에 정보를 전달해 유선전화, 이동통신 단말기 등을 통해서도 작동제어가 가능하도록 하는 미래형 가전 시스템을 말하는 것으로, 홈 네트워크는 가정 내의 정보가전기기가 네트워크로 연결돼 기기, 시간, 장소에 구애받지 않고 서비스가 이뤄지는 미래 가정환경을 구현한다.

현재 홈 네트워크 인터페이스 기술은 블루투스, 홈 RF, IrDA 등의 무선기술과 홈 PNA, IEEE1394, PLC, 이더넷 등의 유선기술이 보완과 경쟁관계를 형성하면서 기술 및 콘텐츠가 개발되고 있으며, 이때 각 정보가전기기 간에는 전화선, 동축 케이블, UTP, 무선채널, 전력선 등을 이용하여 네트워크를 구현한다.

예를 들어, 홈 네트워크를 설치하면 방에 앉아서 초인종을 누른 사람이나 세탁 종료 여부 등을 확인 할 수 있는 것은 물론, 유선전화, PDA(Personal Digital Assistants)나 이동통신 단말기를 이용하여 집에서 리모콘으로 TV를 조정하듯 외부에서 자신의 집을 모니터링 할 수 있고 퇴근 전에 사무실에서 집안 온도를 조정하고 바깥에서 신호를 통해 밥을 짓거나 건강 검진도 자동으로 받아 볼 수 있게 된다.

그런데, 종래 홈 네트워크 상에서 사용자가 유선전화, PDA, 이동통신 단말기 등을 이용하여 홈 네트워크를 제어하는 서버에 접속한 경우에만, 사용자의 명령에 따라 각종 정보가전기기가 동작하도록 설정되어 있어, 사용자가 집 근처에 도달하였을 경우 사용자가 서버에 접속하는 것을 잊거나 접속하지 않더라도 사용자가 지정한 명령에 따라 동작하지 않아 불편한 문제점이 있었다.

발명이 이루고자 하는 기술적 과제

따라서, 본 발명은 상기와 같은 종래의 문제점을 해결하기 위하여 제안한 것으로, 지피에스 기능(GPS, Global Positioning System)을 제공하는 이동통신 단말기에 있어서, 지피에스 기능을 이용하여 사용자가 홈 네트워크 서버가 구비된 집 근처 소정 반경 내에 도달하였는지 여부를 파악하고, 그에 따라 홈 네트워크 서버로 단문 메시지를 전송하여 사용자가 집에 도착하기 이전에 특정의 이벤트를 미리 실행하도록 하는 시스템 및 방법을 제공함에 그 목적이 있다.

발명의 구성 및 작용

이와 같은 목적을 달성하기 위한 본 발명은, 생활가전, 주방기기, 방범/보안 등 정보가전기기와 안방, 부엌, 거실, 현관 등 집안의 각 공간을 인터넷을 통해 연결하여 상호간에 정보를 전달해 유선전화, 이동통신 단말기 등을 통해서 관리하고 작동제어하는 홈 네트워크 서버를 구비한 네트워크 시스템에 있어서, 지피에스 기능에 따라 자신의 위치정보를 획득하며, 상기 홈 네트워크 서버가 설치된 특정의 위치를 등록하고 상기 홈 네트워크 서버에서 수행하고자 하는 이벤트를 설정한 후, 상기 획득한 자신의 위치정보에 의해 상기 홈 네트워크 서버로부터 소정의 반경 거리 내에 도달하였음이 확인되면, 상기 이벤트 내용 및 그 실행명령을 나타내는 단문 메시지를 작성하여 전송하는 이동통신 단말기와; 상기 이동통신 단말기와 연동하여 홈 네트워크 서버 및 이동통신 해당 단말기의 위치정보를 전송하는 지피에스 시스템과; 상기 이동통신 단말기의 요청에 따라 단문 메시지를 상기 홈 네트워크 서버로 라우팅하는 단문 메시지 센터를 포함하는 것을 특징으로 한다.

또한, 본 발명은 이동통신 단말기를 이용하여 홈 네트워크 서버가 설치된 특정 위치를 등록하고 해당 홈 네트워크 서버에서 수행하고자 하는 이벤트를 설정하는 단계와; 이동통신 단말기에서 현재 자신의 위치를

파악하는 단계와; 상기 파악 결과, 이동통신 단말기가 상기 홈 네트워크 서버로부터 소정의 반경 거리 내에 도달하면, 홈 네트워크 서버로 이벤트 내용을 포함하는 단문 메시지를 전송하여 해당 이벤트를 실행하는 단계를 포함하는 것을 특징으로 한다.

이하, 본 발명에 따른 실시예를 첨부한 도면을 참조하여 상세히 설명하면 다음과 같다.

도1은 본 발명 이동통신 단말기의 지피에스 기능을 이용한 홈 네트워크 시스템을 보인 블록도로서, 이에 도시한 바와 같이, 이동통신 단말기(10), 이동통신망(20), 지피에스(GPS, Global Positioning System) 시스템(30), 지피에스 위성(40), 단문 메시지 센터(SMSC, Short Message Service Center)(50), 인터넷망(60), 홈 네트워크 서버(70), 각종 정보가전기(80)로 구성한다.

이동통신 단말기(10)는 지피에스 기능을 지원하여 지피에스 위성(40) 및 지피에스 시스템(30)과의 연동을 통해 자신의 위치정보를 획득할 수 있으며, 본 발명에 따라 홈 네트워크 서버(70)가 설치된 특정의 위치를 등록하고 해당 홈 네트워크 서버(70)에서 수행하고자 하는 이벤트를 설정한 후, 상기 획득된 자신의 위치 정보에 의해 상기 홈 네트워크 서버(70)로부터 소정의 반경 거리 내에 도달하였는지 여부를 파악하여 상기 이벤트 내용 및 그 실행을 명령하는 단문 메시지를 상기 홈 네트워크 서버(70)로 전송함으로써, 상기 이벤트에 따라 상기 홈 네트워크 서버(70)를 제어한다.

즉, 지피에스 수신부(11)는 지피에스 위성(40)으로부터 지피에스 위성신호를 수신하고, 무선 송수신부(12)는 안테나를 통해 이동통신 시스템측과 무선신호를 송수신하며, 코덱(codec)부(13)는 무선신호로부터 추출하여 신호처리된 디지털 음성신호를 아날로그 음성신호로 변환하여 스피커(14)를 통해 출력하거나 마이크(15)로부터 아날로그 음성신호를 입력받아 그 역의 동작을 수행한다.

메모리부(16)는 운영 프로그램 및 각종 응용 프로그램, 각종 데이터를 저장하고, 키패드부(17)는 각종 키 입력 및 명령을 입력받으며, 디스플레이부(18)는 액정화면을 통해 키 입력 및 명령 처리 결과를 표시한다.

그리고, 주제어부(19)는 음성통화, 데이터 통신 등 단말기의 운용과 관련된 전반적인 제어를 담당하고, 본 발명에 따라 홈 네트워크 제어 모드를 위한 사용자 인터페이스를 제공하여 사용자가 홈 네트워크 서버(70)가 설치된 위치를 등록하고 해당 홈 네트워크 서버(70)에서 수행하고자 하는 이벤트를 설정받으며, 해당 단말기(10)가 홈 네트워크 서버(70)의 위치로부터 소정의 반경 거리 내에 도달한 경우 사용자가 기설정된 이벤트의 내용 및 그 실행을 나타내는 단문 메시지를 작성한 후 상기 작성된 단문 메시지를 상기 홈 네트워크 서버(70)로 전송한다.

즉, 상기 주제어부(19)는 지피에스 수신부(11)에서 지피에스 위성(40)로부터 수신한 지피에스 위성신호를 소정 시간 주기로 이동통신망(20)을 통해 지피에스 시스템(30)으로 전송한 후 다시 상기 지피에스 시스템(30)으로부터 현재 자신의 위치정보를 전달받아 현재 자신의 위치를 파악하고, 그 파악된 위치를 홈 네트워크 서버(70)의 위치간의 거리를 비교하여 상기 홈 네트워크 서버(70)와 소정의 반경 거리 내에 도달하게 되면, 단문 메시지 처리부(미도시)를 제어하여 사용자가 기설정된 이벤트의 내용 및 그 실행을 나타내는 단문 메시지를 작성하여 단문 메시지 서버(50)와 연동을 통해 상기 홈 네트워크 서버(70)로 전송하게 된다.

이동통신망(20)은 기지국(BTS/BSC), 교환기(MSC), 홈위치등록기(HLR), 가입자 데이터베이스 등을 포함하여 인터넷망(60)과 연동하여 이동통신 서비스를 제공하고, 지피에스 시스템(30)은 지피에스 수신기가 탑재된 단말기로부터 지피에스 위성의 지피에스 위성신호에 따라 계산한 해당 단말기의 위치정보 및 그와 관련한 다양한 콘텐츠를 제공하며, 지피에스 위성(40)은 지피에스 수신기가 탑재된 블록정의 단말기로 지피에스 위성신호를 전송한다.

단문 메시지 센터(SMSC, Short Message Service Center)(50)는 단문 메시지를 라우팅하는 역할을 하고, 홈 네트워크 서버(70)는 TV, 냉장고, 에어컨 등 집안의 가전제품과 안방, 부엌, 거실, 현관 등 집안의 각 공간을 인터넷을 통해 연결하여 상호간에 정보를 전달해 유선전화, 이동통신 단말기 등을 통해서 관리하고 작동제어하는 역할을 한다.

한편, 도2는 본 발명 이동통신 단말기의 지피에스 기능을 이용한 홈 네트워크 방법의 동작과정을 보인 순서도로서, 이에 도시한 바와 같이, 이동통신 단말기를 이용하여 홈 네트워크 서버가 설치된 특정 위치를 등록하고 해당 홈 네트워크 서버에서 수행하고자 하는 이벤트를 설정하는 단계(S20)와; 이동통신 단말기에서 현재 자신의 위치를 파악하는 단계(S21)와; 상기 파악 결과, 이동통신 단말기가 상기 홈 네트워크 서버로부터 소정의 반경 거리 내에 도달하면, 홈 네트워크 서버로 이벤트 내용을 포함하는 단문 메시지를 전송하여 해당 이벤트를 실행하는 단계(S22, S23)로 구성한다.

본 발명이 적용된 이동통신 단말기는 '홈 네트워크 제어 모드'라는 메뉴를 추가하여, 사용자가 사용자 인터페이스를 통해 관리하고자 하는 홈 네트워크 서버(70)가 설치된 위치를 등록하거나 상기 홈 네트워크 서버(70)에서 수행하고자 하는 이벤트를 설정할 수 있도록 하는 응용프로그램을 추가된 것으로 가정한다.

따라서, 사용자는 이동통신 단말기의 메뉴를 이동하여 '홈 네트워크 제어 모드'로 진입한 후, 홈 네트워크 서버(70)가 설치된 자신의 집이나 기타 특정의 위치를 등록하고, 상기 홈 네트워크 서버(70)에서 수행하고자 하는 소정의 이벤트를 설정한다(S20).

여기서, 사용자는 지피에스 시스템(30) 및 지피에스 위성(40)과 연동하여 자신이 위치한 홈 네트워크 서버(70)의 위치정보를 획득하여 등록하게 되며, 상기 소정의 이벤트는 특정 생활가전 혹은 주방기기를 동작시키거나 냉난방을 가동하는 등의 홈 네트워크 서버(70)의 제어에 의해 구동되는 이벤트를 말한다.

그 다음, 이동통신 단말기(10)에서 지피에스 시스템(30) 및 지피에스 위성(40)과의 연동을 통해 이동중인 자신의 현재 위치를 파악하여(S21), '홈 네트워크 제어 모드'에서 등록된 홈 네트워크 서버(70)의 위치를 기준으로 이동통신 단말기를 소유한 사용자가 소정의 반경 거리 내에 도달하였는지 여부를 확인한다(S22).

즉, 상기 이동통신 단말기(10)의 제어어부(19)에서 지피에스 위성(40)으로부터 수신한 지피에스 위성신호를 소정 시간 주기로 이동통신망(20)을 통해 지피에스 시스템(30)으로 전송한 후 상기 지피에스 시스템(30)에서 계산된 현재 자신의 위치정보를 전달받아 위치를 파악한 다음, 그 파악된 위치정보와 상기 단계(S20)에서 홈 네트워크 서버(70)에 대하여 등록된 위치간의 거리를 소정 시간 간격으로 비교하여 상기 홈 네트워크 서버(70)의 소정의 반경 거리 내에 해당 이동통신 단말기(10)가 도달하는지 여부를 확인함으로써, 사용자가 외출후 귀가하는 도중에 소정의 반경 거리 내에 이르게 되면 상기 홈 네트워크 서버(70)에서 기설정된 이벤트를 실행할 수 있도록 준비를 한다.

그 다음, 사용자의 이동통신 단말기(10)가 홈 네트워크 서버(70)의 위치로부터 소정의 반경 거리 내에 도달하게 되면, 제어어부(19)에서 단문 메시지 처리부(미도시)를 제어하여 사용자가 기설정된 이벤트의 내용 및 그 실행을 나타내는 단문 메시지를 작성하여 이동통신망(20)을 통해 단문 메시지 서버(50)로 요청하고, 이에 상기 단문 메시지 서버(50)에서 해당 단문 메시지를 홈 네트워크 서버(70)로 라우팅함으로써, 상기 홈 네트워크 서버(70)에서 해당 단문 메시지를 확인 후 디코딩 등의 처리를 하여 해당 단문 메시지에 포함된 명령대로 사용자가 등록된 이벤트를 실행하게 된다(S23).

따라서, 본 발명에 의해 홈 네트워크 서버(70)는 사용자가 집에 도착하기 이전에 특정의 이벤트를 미리 실행함으로써, 사용자의 위치에 따라 특정의 이벤트를 자동으로 실행하여 예약 설정에 의한 이벤트 실행에 비해 사용자의 정확한 도착시간을 예측하고, 그에 따라 각종 정보가전기기(80)를 효율적으로 관리할 수 있게 된다.

발명의 효과

이상에서 설명한 바와 같이, 본 발명은 지피에스 기능(GPS, Global Positioning System)을 제공하는 이동통신 단말기에 있어서, 지피에스 기능을 이용하여 사용자가 홈 네트워크 서버가 구비된 집 근처 소정 반경 내에 도달하였는지 여부를 파악하고, 그에 따라 홈 네트워크 서버로 단문 메시지를 전송하여 사용자가 집에 도착하기 이전에 특정의 이벤트를 미리 실행하게 함으로써, 사용자의 위치에 따라 특정의 이벤트를 자동으로 실행하여 예약 설정에 의한 이벤트 실행에 비해 사용자의 정확한 도착시간을 예측할 수 있어 효율적으로 홈 네트워크를 제어할 수 있고, 인터넷망이나 전력선 모뎀을 이용하지 않고 무선망을 이용하여 자동으로 홈 네트워크 서버를 제어 및 관리할 수 있는 효과가 있다.

청구의 범위

청구항 1

생활가전, 주방기기, 방범/보안 등 정보가전기기와 안방, 부엌, 거실, 현관 등 집안의 각 공간을 인터넷을 통해 연결하여 상호간에 정보를 전달해 유선전화, 이동통신 단말기 등을 통해서 관리하고 작동제어하는 홈 네트워크 서버를 구비한 네트워크 시스템에 있어서, 지피에스(GPS, Global Positioning System) 기능에 따라 자신의 위치정보를 획득하며, 상기 홈 네트워크 서버가 설치된 특정의 위치를 등록하고 상기 홈 네트워크 서버에서 수행하고자 하는 이벤트를 설정한 후, 상기 획득한 자신의 위치정보에 의해 상기 홈 네트워크 서버로부터 소정의 반경 거리 내에 도달하였음이 확인되면, 상기 이벤트 내용 및 그 실행명령을 나타내는 단문 메시지를 작성하여 전송하는 이동통신 단말기와; 상기 이동통신 단말기와 연동하여 홈 네트워크 서버 및 이동통신망인 해당 단말기의 위치정보를 전송하는 지피에스 시스템과; 상기 이동통신 단말기의 요청에 따라 단문 메시지를 상기 홈 네트워크 서버로 라우팅하는 단문 메시지 센터를 포함하는 것을 특징으로 하는 이동통신 단말기의 지피에스 기능을 이용한 홈 네트워크 시스템.

청구항 2

이동통신 단말기를 이용하여 홈 네트워크 서버가 설치된 특정 위치를 등록하고 해당 홈 네트워크 서버에서 수행하고자 하는 이벤트를 설정하는 단계와; 이동통신 단말기에서 현재 자신의 위치를 파악하는 단계와; 상기 파악 결과, 이동통신 단말기가 상기 홈 네트워크 서버로부터 소정의 반경 거리 내에 도달하면, 홈 네트워크 서버로 이벤트 내용을 포함하는 단문 메시지를 전송하여 해당 이벤트를 실행하는 단계를 포함하는 것을 특징으로 하는 이동통신 단말기의 지피에스 기능을 이용한 홈 네트워크 방법.

청구항 3

제2항에 있어서, 상기 이동통신 단말기에서 현재 자신의 위치를 파악하는 단계는, 제어어부에서 지피에스 위성으로부터 수신한 지피에스 위성신호를 소정 시간 주기로 이동통신망을 통해 지피에스 시스템으로 전송한 후 상기 지피에스 시스템에서 계산된 현재 자신의 위치정보를 전달받아 위치를 파악하는 것을 특징으로 하는 이동통신 단말기의 지피에스 기능을 이용한 홈 네트워크 방법.

도면

도면1

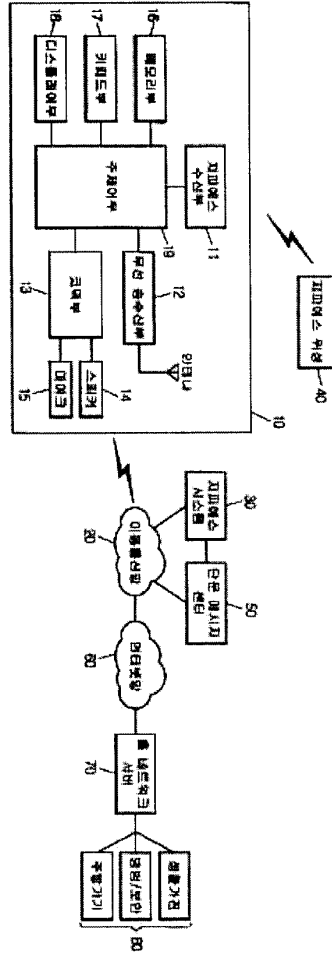

도면2

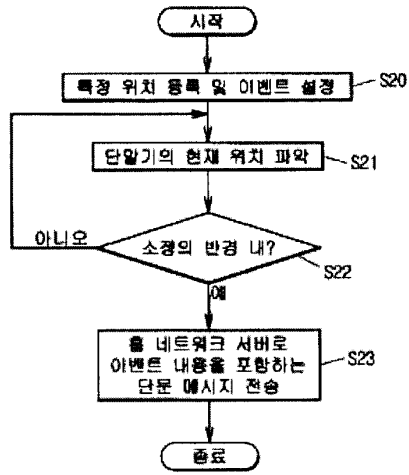

(19) 대한민국특허청(KR)
(12) 공개특허공보(A)

(51) Int. Cl.
H04Q 7/24

(11) 공개번호 10-2007-0078369
(43) 공개일자 2007년07월31일

(21) 출원번호	10-2007-0003498
(22) 출원일자	2007년01월11일
(30) 우선권주장	60/762,123 2006년01월26일 미국(US) 60/795,201 2006년04월27일 미국(US)
(71) 출원인	엘지전자 주식회사 서울특별시 영등포구 여의도동 20번지
(72) 발명자	심동희 서울 영등포구 신길1동 454-1 금송리빌딩 503호 최재혁 경기 고양시 덕양구 화정동 868번지 달빛마을 현대아파트 403동1301호
(74) 대리인	박장원

심사청구 : 없음

(54) 위치정보 시스템에서의 단말간 트리거 위치 서비스요청방법

요약

본 발명은 SUPL(Secure User Plane Location) 기반의 위치정보 시스템에서 단말간 트리거 위치 서비스 요청방법에 관한 것이다. 본 발명은 제1단말로부터 특정 영역에서 제2단말의 트리거 서비스가 요청되면 상기 제1단말의 네트워크가 제2단말의 제2네트워크로 상기 트리거 서비스 요청을 전달하고, 상기 제2네트워크는 제2단말과 측위 세션을 개시하고, 측위 메시지를 교환하여 상기 제2단말의 위치를 계산한 후 상기 계산된 위치를 제1단말에 지정한 특정 영역과 비교하여, 특정 영역에서의 지역 이벤트 발생을 제1단말로 통지한다.

도표도

도 8

색인어

SUPL, 트리거 위치 서비스, 측위 세션

명세서

도면의 간단한 설명

- 도 1은 본 발명에 따른 위치정보 시스템에서의 단말간 트리거 위치 서비스 요청방법 의 제1실시예.
- 도 2는 본 발명에 따른 위치정보 시스템에서의 단말간 트리거 위치 서비스 요청방법의 제2실시예.
- 도 3은 본 발명에 따른 위치정보 시스템에서의 단말간 트리거 위치 서비스 요청방법의 제3실시예.
- 도 4는 본 발명에 따른 위치정보 시스템에서의 단말간 트리거 위치 서비스 요청방법의 제4실시예.
- 도 5는 본 발명에 따른 위치정보 시스템에서의 단말간 트리거 위치 서비스 요청방법의 제5실시예.
- 도 6은 본 발명에 따른 위치정보 시스템에서의 단말간 트리거 위치 서비스 요청방법의 제6실시예.
- 도 7은 본 발명에 따른 위치정보 시스템에서의 단말간 트리거 위치 서비스 요청방법의 제7실시예로서, 위치관련 요청이 지역 이벤트(area event)인 경우를 나타낸 도면.
- 도 8은 본 발명에 따른 위치정보 시스템에서의 단말간 트리거 위치 서비스 요청방법의 제8실시예로서, 위

치관련 요청이 주기적인(periodic) 경우를 나타낸 도면.

발명의 상세한 설명

발명의 목적

발명이 속하는 기술분야 및 그 분야의 종래기술

본 발명은 SUPL(Secure User Plane Location) 기반의 위치정보 시스템에 관한 것으로서, 특히 두 단말간의 트리거 위치 서비스(Triggered Location Service) 요청 방법에 관한 것이다.

이동통신 시스템에서는 단말의 위치를 계산하기 위한 관련 기능부를 이동통신 네트워크에 구비하여, 주기적으로 또는 요청에 따라 단말의 위치를 일정 개체(entity)에 전달하는 위치 서비스(Location Service)를 제공하고 있다.

상기 위치 서비스와 관련된 네트워크 구조는 3GPP/L4 3GPP2등의 내부 네트워크 구조에 따라 상이하며, 현재 단말의 위치를 계산하는 방법으로는 단말이 속한 셀의 ID를 전달하는 셀-ID 방식, 단말로부터 각 기지국으로 전파가 도달되는 시간을 측정하여 삼각측량을 이용하여 단말의 위치를 계산하는 방법 및 GPS를 이용한 방법들이 있다.

그런데, 상기 위치 서비스를 사용자에게 제공하기 위해서는 상당한 시그널링과 위치(location) 정보가 이동 단말과 위치 서버사이에서 전달되어야 한다. 최근 위치 서비스를 제공하기 위한 표준화된 위치 기술들(Positioning technologies), 즉, 이동 단말의 위치에 기반한 위치 서비스가 빠르게 확산되고 있다. 상기 위치 기술들은 통상 사용자 평면과 제어평면을 통하여 제공될 수 있는데, 상기 위치기술의 밑 예로 사용자 평면을 통해 위치 서비스를 제공하는 SUPL(secure User Plane Location)이 알려져 있다.

상기 SUPL은 이동국의 위치 계산에 필요한 위치 정보를 전달하는 효율적인 방법으로서, GPS 어시스턴스(assistance)와 같은 위치 어시스턴스 정보를 전달하기 위해 그리고 이동 단말과 네트워크사이에서 위치 기술(Positioning technology) 관련 프로토콜을 운반하기 위하여, 사용자 평면 데이터 베어러(bearer)를 사용한다.

일반적으로 위치 정보 시스템에서 위치 서비스와 관련된 SPUL 네트워크는 크게 SUPL 에이전트(Agent), SLP(SUPL Location Platform) 및 SET(SUPL Enabled Terminal)등을 포함한다. 상기 SUPL 에이전트는 실제 측정된 위치정보를 사용하는 논리적(logical)인 서비스 액세스 포인트를 나타내고, 상기 SLP는 위치정보를 얻기 위하여 네트워크 자원들을 액세스하는 네트워크 부분의 SUPL 서비스 액세스 포인트를 나타낸다. 또한, 상기 SET는 SUPL인터페이스를 사용하는 SUPL 네트워크와 통신할 수 있는 소자로서, 예를들어 UMTS의 UE(User Terminal), GSM의 MS (이동국), IS-95 MS 또는 SET 기능이 내재된 랩탑 컴퓨터(Laptop Computer) 나 PDA (Personal Digital Assistants)등 중의 하나일 수 있다. 또한 상기 SET는 WLAN (Wideband LAN)을 통해 접속하는 다양한 이동 단말일 수도 있다. 상기 SET는 사용자 평면 베어러를 통해 네트워크와 연동되어 SUPL에서 정의하는 절차들을 지원한다.

위치정보 시스템과 같은 이동통신 시스템에서 사용자가 원래 등록된 홈 네트워크(Home Network)라고 하고 사용자가 이동하여 상기 홈 네트워크가 아닌 다른 지역에 위치하였을 때 해당 지역의 네트워크를 방문 네트워크(Visited Network)라고 한다. 그리고, 상기 홈 네트워크내의 SLP를 H-SLP라고 하고 상기 방문 네트워크내의 SLP를 V-SLP라고 한다. 이때 네트워크에서 SUPL절차를 시작하는 경우 외부 클라이언트가 처음 접속하는 SLP를 R-SLP(Requesting SLP)라고 하며, 이것은 논리적인 개체로서 H-SLP와 동일할 수도 있고 그렇지 않을 수도 있다. 아울러 현재 위치추적을 목표로 하는 SET를 목표(target) SET로 정의한다.

또한, 상기 트워크에서 위치서버인 SLP는 실제 위치를 계산하는 개체인 SPC(SUPL Positioning Center)와 위치정보를 계산하는 미외의 SLP의 역할, 예를들어 로밍 및 자원 관리등의 역할을 담당하는 SLC(SUPL Location Center)로 구성된다. 따라서, SET는 SLC를 거쳐 SPC와의 통신을 통해 위치정보를 계산할 수도 있고(SLP를 R-SLP와 바로 접속을 열어 위치정보를 계산할 수도 있다(non-proxy mode)).

그러나, 종래 SUPL을 기반으로 하는 트리거 위치 서비스(Triggered Location Service)에서는 사용자 단말을 통해 원하는 상대방의 트리거 위치 서비스를 요청하는 방법을 제시하지 못하고 있다.

또한, 종래 SUPL을 기반으로 한 지역 이벤트(area event) 관련 트리거 위치 서비스에서는 자신의 위치와 관련된 영역을 정의하여 트리거 위치 서비스 (Triggered Location Service)를 요청하는 방법은 제시하지 못하고 있다.

발명이 이루고자 하는 기술적 과제

따라서, 본 발명의 목적은 사용자 단말을 통해 원하는 상대방의 트리거 위치 서비스를 요청할 수 있는 방법을 제공하는데 있다.

본 발명의 다른 목적은 단말의 위치와 관련된 영역을 정의하여 트리거 위치 서비스(Triggered Location Service)를 요청하는 방법을 제공하는데 있다.

상기와 같은 목적을 달성하기 위하여, 본 발명에 따른 위치정보 시스템에서의 단말간 트리거 위치 서비스 요청방법은, 제1단말이 특정 영역에서 제2단말의 트리거 서비스를 요청하는 단계와; 상기 제1단말의 네트워크가 제2단말의 제2네트워크로 상기 트리거 서비스 요청을 전달하는 단계와; 상기 제2네트워크가 제2단말과 측위 세션을 개시하고, 측위 메시지를 교환하여 상기 제2단말의 위치를 계산하는 단계와; 상기 제2네트워크가 상기 계산된 위치를 제1단말이 지정한 특정 영역과 비교하여, 특정 영역에서의 지역 이벤트 발생을 제1단말로 통지하는 단계를 포함한다.

바람직하게, 상기 제1,제2네트워크는 위치서버를 나타내고, 상기 제1,제2단말은 SET(SUPL Enabled

Terminal)를 나타낸다.

바람직하게, 상기 트리거 서비스는 세션 시작 메시지를 통해 요청된다.

바람직하게, 상기 세션 시작 메시지는 session-id, SET capabilities, 위치식별자, msid, request type, defined area 및 event type을 포함한다.

바람직하게, 상기 request type은 서비스 요청이 특정 위치와 관련된 트리거 서비스임을 나타낸다.

바람직하게, 상기 defined area는 특정 지역을 나타내며, 상기 event type은 어떠한 지역 이벤트를 원하는 지를 나타낸다. 이때, 상기 defined area는 좌표나 지역이름을 포함한다.

바람직하게, 상기 트리거 서비스 요청은 RLP메시지를 통해 제1네트워크에서 제2네트워크로 전달된다.

바람직하게, 상기 방법은 제2단말과의 측위 세션이 개시되면 제2네트워크가 RLP메시지를 통해 제1네트워크로 트리거 세션이 시작되었음을 알리는 단계와; 상기 제1네트워크가 제1단말로 세션 종료 메시지를 전송하여 제1단말과 제1네트워크간의 연결을 종료하는 단계를 추가로 포함한다.

상기와 같은 목적을 달성하기 위하여, 본 발명에 따른 위치정보 시스템에서의 단말간 트리거 위치 서비스 요청방법은, 제1단말이 제1위치서버로 제2단말의 트리거 서비스를 요청하는 단계와; 상기 제1위치서버가 제2위치서버로 트리거 서비스를 전달하는 단계와; 상기 제2위치서버가 제2단말과 측위 세션을 개시하여 제2단말의 위치를 계산하는 단계와; 상기 제2위치서버가 상기 제1단말의 트리거 서비스 요청타입에 따라 상기 제1위치서버를 통해 주기적인 위치추적 서비스 또는 지역관련 위치추적 서비스를 제공하는 단계를 포함한다.

바람직하게, 상기 트리거 서비스는 SET 초기화 메시지를 통해 요청된다.

바람직하게, 상기 SET 초기화 메시지는 session-id, 목표 SETid, 트리거 모드, 트리거 정보를 포함한다.

바람직하게, 상기 트리거 모드는 다른 SET의 트리거 서비스(SET initiated trigger service of another SET type)를 나타내며, 주기적 이벤트(Periodic event) 또는 지역 이벤트(area event) 파라미터를 포함한다.

바람직하게, 상기 트리거 정보는 트리거 세션의 파라미터를 나타내며, 주기적 파라미터와 지역 이벤트 파라미터를 포함한다.

바람직하게, 상기 주기적 파라미터는 주기정보를 포함하고, 상기 지역 이벤트 파라미터는 defined area 및 event type을 포함한다.

바람직하게, 상기 제1위치서버는 SET 초기화 메시지에 포함된 제2단말의 식별자를 이용하여 제2위치서버를 결정한다.

바람직하게, 상기 제2위치서버는 제1단말의 트리거 서비스 요청을 분석하여, 제1단말이 주기적인 트리거 서비스를 요청한 것으로 판단되면 각 주기마다 상기 제2단말의 위치를 제1위치서버를 통해 제1단말로 보고한다.

바람직하게, 상기 제2위치서버는 상기 제1단말이 지역이벤트 트리거 서비스를 요청한 것으로 판되면, 상기 계산된 위치를 제1단말이 지정한 특정 영역과 비교하여, 특정 영역에서의 지역 이벤트 발생을 제1단말로 통지한다.

상기와 같은 목적을 달성하기 위하여, 본 발명에 따른 위치정보 시스템에서의 단말간 트리거 위치 서비스 요청방법은, 제1단말이 SET 초기화 메시지를 통해 제1위치서버로 제2단말의 위치추적을 요청하는 단계와; 상기 제1위치서버가 위치 요청 메시지를 통해 제2서버로 제2단말의 위치추적 요청을 전달하는 단계와; 상기 제2위치서버가 주기적으로 제2단말과 위치추적 절차를 수행하여 제2단말의 위치를 계산하는 단계와; 상기 제1위치서버가 제2위치서버에서 계산된 제2단말의 위치값들을 각 위치 응답 메시지를 통해 수신하여, 상기 제1단말로 보고하는 단계를 포함한다.

바람직하게, 상기 제1위치서버는 SET 초기화 메시지에 포함된 제2단말의 식별자를 이용하여 제2위치서버를 결정한다.

바람직하게, 상기 제1,제2위치서버는 각각 제1,제2단말의 홈 네트워크에 존재하며, SLP(SUP Location Platform)을 나타낸다.

바람직하게, 상기 SET 초기화 메시지는 session-id, 제2단말의 id, 트리거 모드 및 트리거 정보를 포함한다.

바람직하게, 상기 트리거 모드는 다른 SET의 트리거 서비스(SET initiated trigger service of another SET type)를 나타내며, 주기적 이벤트(Periodic event) 또는 지역 이벤트(area event) 파라미터를 포함한다.

바람직하게, 상기 트리거 정보는 트리거 세션의 파라미터를 나타내며, 주기적 파라미터와 지역 이벤트 파라미터를 포함한다.

발명의 구성 및 작용

본 발명은 SUP Location Platform을 나타낸다. 그러나, 본 발명은 다른 표준에 따라 동작하는 무선 통신 시스템에도 적용되어 질 수 있다. 이하, 본 발명의 바람직한 실시 예들을 자세히 설명하면 다음과 같다.

본 발명은 SUP Location Platform 기반의 위치정보 시스템에서, 사용자가 단말을 통해 원하는 상대방의 지역 이벤트(area event)에 관련된 트리거 위치 서비스 (Triggered Location Service)를 요청하는 방법을 제안한다. 이를 위하여 사용하는 지역 이벤트 관련 트리거 위치 서비스를 요청할 때, 상기 지역 이벤트를 위한 영역을 현

재 자신의 위치와 관련된 일정 영역 또는 자신의 위치와 상관없는 특정 영역을 지정할 수 있다.

도 1은 본 발명에 따른 위치정보 시스템에서의 단말간 트리거 위치 서비스(Triggered Location Service) 요청방법의 제1실시예를 나타낸다. 특히 본 발명의 제1실시예는 서비스를 요청하는 SET1의 현재 위치와 관련된 일정 영역에서 SET2의 지역 이벤트를 확인하는 방법을 나타낸다. 이때, 상기 SLP는 네트워크측에 해당하고, SET는 단말측에 해당한다.

도 1에 도시된 바와같이, 먼저 SET1에 있는 SUPL에이전트는 SET1에서 동작하고 있는 어플리케이션으로부터 위치관련 요청을 수신한다.

상기 위치관련 요청이 수신되면, SET1은 현재 어떤 네트워크에도 데이터 접속이 설정되어 있지 않은 경우 패킷 데이터 네트워크에 연결한다(S10).

일단 데이터 접속이 설정되면, SET1은 네트워크로부터 제공된 기본주소(default address)를 이용하여 위치 서버인 SLP1과 안전한(secure) IP연결을 설정하고, 상기 SLP1과 측위(위치측정) 세션을 시작하기 위하여 세션시작 메시지 즉, SUPL START메시지를 전송한다(S11). 상기 SUPL START메시지에는 session-id, SET capabilities, 위치 식별자(location identifier : lid), msid, 요청타입(request type), 정의된 지역(defined area) 및 이벤트 타입(event type) 등이 포함되어 있다. 여기서, 상기 요청타입(request type)은 서비스 요청이 SET1의 위치와 관련된 트리거 서비스임을 나타내며, 상기 정의된 지역(defined area)은 SET1의 위치로부터 얼마의 영역을 정의하는지를 나타내며, 상기 이벤트 타입(event type)은 어떠한 지역 이벤트(나감, 들어감 또는 존재)인지를 나타낸다. 또한, 상기 SET capabilities에는 지원하는 측위방식(예를 들어, SET-Assisted A-GPS, SET Based A-GPS)과 그와 관련된 측위 프로토콜(예를 들어 RRLP, RRC, TIA-801)이 포함되어 있다. 그리고, 만약 이전에 계산한 위치가 SET1이 요청한 QoP(Quality of Position)를 만족하면 SLP1은 바로 단계(S16)로 진행한다.

만약, 이전에 계산한 위치가 요청한 QoP를 만족하지 않으면 SLP1은 라우팅 정보를 이용하여 SET1이 로밍되지 않았음을 확인하고(현재 서비스 지역내에 있음)(S12), 상기 수신한 msid에 기초하여 SET2와 관련된 위치서버 즉, SLP2를 결정한다.

이후 SLP1은 상기 SUPL START메시지에 포함되어 있는 SET1이 지원하는 측위방식과의 일관성을 유지하기 위해 적절한 측위방식을 결정하고, 그 결정된 측위방식에서 요구된다면 SLP1은 SUPL START메시지에 포함된 지원 가능한 측위 프로토콜(예를 들어, RRLP, RRC, TIA-801)을 사용한다. 이러한 일련의 동작이 끝나면 SLP1은 상기 결정된 측위방식이 포함된 세션응답 메시지 즉, SUPL RESPONSE메시지를 SET1으로 전송한다(S13). 상기 SUPL RESPONSE메시지에는 session-id는 포함되어 있지만 SET1이 새로운 연결을 설정할 필요가 없기 때문에 SLP1의 주소는 포함되지 않는다.

또한, 상기 SUPL START메시지에 포함된 정보 즉 lid에 의해 계산된 대략적인(coarse) 위치결과가 SET1이 요청한 QoP를 만족하면, SLP1은 바로 단계(S16)로 진행한다.

상기 SUPL RESPONSE메시지를 수신한 SET1은 응답으로 세션 측위 초기화 메시지 즉, SUPL POS INIT를 SLP1으로 전송한다(S14). 상기 SUPL POS INIT메시지에는 적어도 session-id, SET capabilities 및 위치 식별자(lid)가 포함되어 있다.

상기 SUPL POS INIT메시지를 수신한 SLP1은 SET1과 측위절차 메시지(SUPL POS메시지) 연속적으로 교환하여 SET1의 위치를 계산한다(S15). 이때, 상기 위치 계산은 SLP1이 SET1으로부터 수신한 측정값을 기초로 수행하거나(SET-Assisted), SET1이 SLP1으로부터 획득된 어시스턴스 데이터를 기초로 수행한다(SET-Based).

SUPL 측위(positioning) 절차가 완료되면 SLP1은 RLP프로토콜 메시지(RLP SSRLR)를 이용하여 SET2의 위치서버인 SLP2에게 트리거 서비스(Triggered Service)를 요청한다(S16). 상기 RLP SSRLR메시지에는 session-id, msid, request type, defined area 및 event type을 포함되어 있다. 상기 request type은 상기 서비스 요청이 SET1의 위치와 관련된 트리거 서비스임을 나타내고, 상기 defined area는 상기 계산된 SET1의 위치와 그 위치로부터 얼마의 영역을 정의하는지를 나타내며, 상기 event type은 어떠한 지역 이벤트(나감, 들어감, 존재)를 원하는지를 나타낸다. 만약, SET1이 요청한 트리거 서비스에 대해 권한이 있는 경우 SLP2는 수신한 client-id를 통해 SET1을 인증하고, 수신한 msid를 통해 가입자 프라이버시를 적용한다.

상기 RLP SSRLR메시지를 수신한 SLP2는 SET 룩업 테이블을 이용하여 SET2가 SUPL을 지원하는지 확인하고, 라우팅 정보를 이용하여 SET2가 현재 서비스 지역내에 있는지(SET가 로밍되었는지) 확인한다(S17).

확인결과 SET2가 SUPL을 지원하고 로밍되지 않은 경우 SLP2는 세션 초기화 메시지(SUPL INIT)를 이용하여 SET2와 위치 세션을 개시한다(S18). 상기 SUPL INIT메시지에는 적어도 session-id, proxy/non proxy mode indicator, 사용할 positioning방법(posmethod), 지역 이벤트 트리거 서비스임을 나타내는 서비스 타입(service type)이 포함되어 있다. 또한, 상기 SUPL INIT메시지에는 희망하는 QoP가 포함될 수도 있다.

상기 SUPL INIT메시지를 수신한 SET2는 현재 자신이 어떤 네트워크에도 데이터 접속이 설정되어 있지 않은 경우 패킷 데이터 네트워크에 연결하고(S19), 상기 SLP2와 측위 세션을 시작하기 위하여 세션 트리거 시작 메시지(SUPL TRIGGERED START)를 전송한다(S20). 상기 SUPL TRIGGERED START메시지에는 적어도 session-id, SET capabilities 및 위치 식별자(lid)가 포함된다.

만약, 수신한 SUPL TRIGGERED START메시지에 포함된 정보(e.g., lid)에 의해 계산된 대략적인(coarse)가 위치결과가 SET2가 요청한 QoP를 만족하면, SLP2는 단계(S21)를 수행한 후 SUPL POS절차를 수행하지 않은 상태에서 바로 상기 대략적인 위치결과와 SLP1으로부터 수신한 지정된 위치 이벤트를 비교한다(S22).

반면에 상기 계산된 대략적인(coarse)가 위치결과가 SET2가 요청한 QoP를 만족하지 않으면, SLP2는 트리거 세션이 개시되었음을 알리기 위하여 SET2로 SUPL TRIGGERED RESPONSE메시지를 전송한다. 상기 SUPL TRIGGERED RESPONSE메시지에는 트리거 세션에서 사용될 측위방식이 포함된다.

이후 SET2와 SLP2사이에는 주기적으로 측위 세션이 발생되는데(S22), 상기 측위 세션이 시작되면 SET2와

SLP2사이에서 성공적으로 측위 절차 메시지(SUPL POS)들이 교환된다. 이때, 상기 위치 계산은 SLP2가 SET2로부터 수신한 측정값을 기초로 수행하거나(SET-Assisted), SET2가 SLP2으로부터 획득된 머시시스템스 데이터를 기초로 수행한다(SET-Based). 각 측위세션이 종료되면 SLP2는 계산된 SET2의 위치와 상기 SLP1으로부터 수신한 지정된 위치를 비교한다. 비교결과 상기 계산된 SET2의 위치가 상기 SET1이 지정하여 SLP1을 통해 수신된 위치값인 defined area에 해당하면 다음 단계로 진행하고 해당하지 않으면 상기 단계(S22)를 반복적으로 수행한다.

만약, 상기 계산된 SET2의 위치가 상기 SET1이 지정하여 SLP1을 통해 수신된 위치인 defined area에 해당하면, SLP2는 SET2로 세션 종료 메시지(SUPL END)를 전송하여 측위 세션을 종료하고(S23), 상기 SET2의 위치비교 결과값(posresult)을 RLP SSRLIR메시지에 포함시켜 SLP1으로 전송한다(S24).

따라서, SLP1은 SET2의 위치비교 결과값(posresult)을 SUPL END메시지에 포함시켜 SET1으로 전송하고(S25), 상기 SET1은 SLP1과 안전한 IP연결을 해지하고, 이 세션과 관련된 모든 자원을 해제한다.

도 2는 본 발명에 따른 위치정보 시스템에서의 단말간 트리거 위치 서비스 요청방법의 제2실시예를 나타낸다. 본 발명의 제2실시예는 상기 제1실시예와 아주 유사하지만 SLP2로 RLP메시지를 전송하기 전에 SLP1과 SET1간의 연결을 종료하는 점이 상이하다. 즉, 제1실시예에서는 SET1과 SLP1간의 IP연결이 단계(S25)가 수행될 때까지 유지되어 불필요하게 무선자원이 낭비되기 때문에, 본 발명의 제2실시예에서는 측위절차가 종료되면 바로 SUPL END메시지를 전송하여 SET1과 SLP1간의 IP연결을 종료한다.

따라서, SET1과 SLP1간의 측위 절차가 완료되면 SLP1은 SET1과 SLP1간의 연결을 종료하기 위하여 SUPL END 메시지를 SET1으로 전송한 후(S30) RLP프로토콜 메시지(RLP SSRLIR)를 이용하여 SET2의 위치서버인 SLP2에게 트리거 서비스(Triggered Service)를 요청한다. 이하 단계(S16-S24)는 제1실시예와 동일하며 그 상세한 설명은 생략하기로 한다.

이후, SLP2로부터 원하는 SET2의 트리거 결과(posresult)가 수신되면(S24), SLP1은 해당 트리거 결과를 SUPL 보고 메시지(SUPL REPORT)를 통해 SET1에게 전송한다(S31). 상기 SUPL REPORT메시지는 WAP PUSH 또는 SMS 트리거 등을 통해 전송된다.

도 3은 본 발명에 따른 위치정보 시스템에서의 단말간 트리거 위치 서비스 요청방법의 제3실시예를 나타낸다. 본 발명의 제3실시예는 SUPL END메시지를 전송하여 SET1과 SLP1간의 IP연결을 종료한다는 점에서 상기 제2실시예와 유사하지만, 상기 SUPL END메시지를 전송하는 시점이 다르다.

즉, 본 발명의 제2실시예에서는 SLP1과 SET1간의 측위절차가 종료된 후에 바로 SUPL END메시지가 전송되지만, 본 발명의 제3실시예에서는 SLP2로부터 SLP2와 SET2간의 측위세션이 시작될 것이라는 확인되었을 때만 바로 전송된다. 이러한 확인은 SLP2가 SET2로부터 SUPL TRIGGERED START메시지를 수신하여 SLP2가 SLP1으로 RLP SSRLIR END메시지를 수신함으로써 달성된다.

따라서, SET2로부터 SUPL TRIGGERED START메시지가 수신되면 SLP1으로 RLP SSRLIR END메시지를 전송한 후(S40) SLP2는 트리거 세션이 개시되었음을 알리기 위하여 SET2로 SUPL TRIGGERED RESPONSE메시지를 전송한다(S41). 이후의 동작(S21-S24)은 제2실시예와 동일하며 그 상세한 설명은 생략한다.

상기 RLP SSRLIR END메시지를 수신한 SLP1은 SET1과 SLP1간의 연결을 종료하기 위하여 SUPL END메시지를 SET1으로 전송하고(S41), 이후, 상기 SLP2로부터 원하는 SET2의 트리거 결과(posresult)가 수신되면(S24) 해당 트리거 결과를 SUPL 보고 메시지(SUPL REPORT)를 통해 SET1에게 전송한다(S42). 상기 SUPL REPORT메시지는 WAP PUSH 또는 SMS 트리거 등을 통해 전송된다.

도 4는 본 발명에 따른 위치정보 시스템에서의 단말간 트리거 위치 서비스 요청방법의 제4실시예를 나타낸다. 특히 본 발명의 제4실시예는 SET1이 지정한 특정 영역에서 SET2의 지역 이벤트를 확인하는 방법으로서, SET1과 SLP1간의 측위절차가 수행되지 않는다.

도 4에 도시된 바와같이, SET1에 있는 SUPL에이전트는 SET1에서 동작하고 있는 어플리케이션으로부터 위치 관련 요청을 수신한다. 상기 위치관련 요청이 수신되면, SET1은 현재 어떤 네트워크에도 데이터 접속이 설정되어 있지 않은 경우 패킷 데이터 네트워크에 연결한다(S50).

일단 데이터 접속이 설정되면, SET1은 네트워크로부터 제공된 기본주소를 이용하여 위치서버인 SLP1과 안전한 IP연결을 설정하고, 상기 SLP1과 측위(위치측정) 세션을 시작하기 위하여 SUPL START메시지를 전송한다(S51). 상기 SUPL START메시지에는 session-id, SET capabilities, tid, msid, request type, defined area 및 event type 등이 포함되어 있다. 여기서, 상기 request type은 상기 서비스 요청이 특정 위치와 관련된 트리거 서비스를 나타내며, 상기 defined area는 특정 지역을 나타내며, 상기 event type은 SET1이 어떠한 지역 이벤트(나감, 들어감, 존재)인지를 원하는지를 나타낸다. 바람직하게, 상기 defined area는 예를들면 좌표 나 지역이름등을 포함한다.

또한, 상기 SET capabilities에는 지원하는 측위방식(예를들어, SET-Assisted A-GPS, SET Based A-GPS)과 그와 관련된 측위 프로토콜(예를들어 RRLP, RRC, TIA-801)이 포함되어 있다.

상기 SUPL START메시지를 수신한 SLP1은 라우팅 정보를 이용하여 SET1이 로밍되지 않았음을 확인하고(현재 서비스 지역내에 있음)(S52), 상기 수신한 msid에 기초하여 SET2와 관련된 위치서버 즉, SLP2를 결정한다.

상기 SLP1은 RLP프로토콜 메시지(RLP SSRLIR)를 이용하여 SET2의 위치서버인 SLP2에게 트리거 서비스(Triggered Service)를 요청한다(S53). 상기 RLP SSRLIR메시지에는 session-id, msid, request type, defined area 및 event type을 포함되어 있다. 상기 request type은 상기 서비스 요청이 특정 위치와 관련된 트리거 서비스를 나타내며, 상기 defined area는 특정 지역을 나타내며, 상기 event type은 SET1이 어떠한 지역 이벤트(나감, 들어감, 존재)를 원하는지를 나타낸다. 만약, SET1이 요청한 트리거 서비스에 대해 권한이 있는 경우 SLP2는 수신한 client-id를 통해 SET1을 인증하고, 수신한 msid를 통해 가입자 프라이버시를 적용한다.

상기 RLP SSRLIR메시지를 수신한 SLP2는 SET 록업 테이블을 이용하여 SET2가 SUPL을 지원하는지 확인하고,

라우팅 정보를 이용하여 SET2가 현재 서비스 지역내에 있는지(SET가 로밍되었는지) 확인한다(S54).

확인결과 SET2가 SUPL을 지원하고 로밍되지 않은 경우 SLP2는 세션 초기화 메시지(SUPL INIT)를 이용하여 SET2와 위치 세션을 개시한다(S55). 상기 SUPL INIT메시지에는 적어도 session-id, proxy/non proxy mode indicator, 사용할 positioning방법(posmethod), 지역 이벤트 트리거 서비스임을 나타내는 서비스 타입(service type)이 포함되어 있다. 또한, 상기 SUPL INIT메시지에는 희망하는 QoP가 포함될 수도 있다.

상기 SUPL INIT메시지를 수신한 SET2는 현재 자신이 어떤 네트워크에도 데이터 접속이 설정되어 있지 않은 경우 패킷 데이터 네트워크에 연결하고(S56), 상기 SLP2와 측위 세션을 시작하기 위하여 세션 트리거 시작 메시지(SUPL TRIGGERED START)를 전송한다(S57). 상기 SUPL TRIGGERED START메시지에는 적어도 session-id, SET capabilities 및 위치 식별자(lid)가 포함된다.

만약, 수신한 SUPL TRIGGERED START메시지에 포함된 정보(e.g., lid)에 의해 계산된 대략적인(coarse)가 위치결과가 SET2가 요청한 QoP를 만족하면, 단계(S58)를 수행한 후 SUPL POS절차를 수행하지 않은 상태에서 바로 상기 위치결과와 SLP1으로부터 수신한 지정된 위치 이벤트를 비교한다(S59).

반면에 상기 계산된 대략적인(coarse)가 위치결과가 SET2가 요청한 QoP를 만족하지 않으면, SLP2는 트리거 세션이 개시되었음을 알리기 위하여 SET2로 SUPL TRIGGERED RESPONSE메시지를 전송한다(S58). 상기 SUPL TRIGGERED RESPONSE메시지에는 트리거 세션에서 사용될 측위방식이 포함된다.

이후 SET2와 SLP2사이에는 주기적으로 측위 세션이 발생되는데(S59), 상기 측위 세션이 시작되면 SET2와 SLP2사이에 성공적으로 측위 절차 메시지(SUPL POS)들이 교환된다. 이때, 상기 위치 계산은 SLP2가 SET2으로부터 수신한 측정값을 기초로 수행하거나(SET-Assisted), SET2가 SLP2로부터 획득된 머시스턴스 데이터를 기초로 수행한다(SET-Based). 각 측위세션이 종료되면 SLP2는 계산된 SET2의 위치와 상기 SLP1로부터 수신한 위치인 defined area를 비교한다. 비교결과 상기 계산된 SET2의 위치가 상기 defined area에 해당하면 다음 단계로 진행하고 해당하지 않으면 상기 단계(S59)를 반복적으로 수행한다.

만약, 상기 계산된 SET2의 위치가 상기 SET1이 지정한 특정 위치에 해당하면, SLP2는 SET2로 세션 종료 메시지(SUPL END)를 전송하여 측위 세션을 종료하고(S60), 상기 SET2의 위치비교 결과값(posresult)을 RLP SSRLIR메시지에 포함시켜 SLP1으로 전송한다(S61).

따라서, SLP1은 SET2의 위치비교 결과값(posresult)을 SUPL END메시지에 포함시켜 SET1으로 전송하고(S62), 상기 SET1은 SLP1과 안전한 IP연결을 해지하고, 이 세션과 관련된 모든 자원을 해제한다.

도 5는 본 발명에 따른 위치정보 시스템에서의 단말간 트리거 위치 서비스 요청방법의 제5실시예를 나타낸다. 본 발명의 제5실시예는 상기 제4실시예와 아주 유사하지만 SLP2로 RLP메시지를 전송하기 전에 SLP1과 SET1간의 연결을 종료하는 점이 상이하다. 즉, 제4실시예에서는 단계(S62)가 수행될 때까지 SET1과 SLP1간의 IP연결이 유지되어 불필요하게 무선자원이 낭비된다.

따라서, SLP1은 SET1으로 SUPL END메시지를 전송하여 SET1과 SLP1간의 IP연결을 종료한 후(S70) RLP프로토콜 메시지(RLP SSRLIR)를 이용하여 SET2의 위치서버인 SLP2에게 트리거 서비스(Triggered Service)를 요청한다. 이하 단계(S53~S61)는 제4실시예와 동일하며 그 상세한 설명은 생략하기로 한다.

이후, SLP2로부터 원하는 SET2의 트리거 결과(posresult)가 수신되면(S53), SLP1은 해당 트리거 결과를 SUPL 보고 메시지(SUPL REPORT)를 통해 SET1에게 전송한다(S71). 상기 SUPL REPORT메시지는 WAP PUSH 또는 SMS 트리거 등을 통해 전송된다.

도 6은 본 발명에 따른 위치정보 시스템에서의 단말간 트리거 위치 서비스 요청방법의 제6실시예를 나타낸다. 본 발명의 제6실시예는 SUPL END메시지를 전송하여 SET1과 SLP1간의 IP연결을 종료한다는 점에서 상기 제5실시예와 유사하지만, 상기 SUPL END메시지를 전송하는 시점이 다르다.

즉, 본 발명의 제5실시예에서는 SLP1과 SET1간의 측위절차가 종료된 후에 바로 SUPL END메시지가 전송되지만, 본 발명의 제6실시예에서는 SLP2로부터 SLP2와 SET1간의 측위세션이 시작될 것이 확인되었을 때만 바로 전송된다. 이러한 확인은 SLP2가 SET2로부터 SUPL TRIGGERED START메시지를 수신하여 SLP2가 SLP1으로 RLP SSRLIR END메시지를 수신함으로써 달성된다.

따라서, SET2로부터 SUPL TRIGGERED START메시지가 수신되면 SLP1으로 RLP SSRLIR END메시지를 전송한 후(S80) SLP2는 트리거 세션이 개시되었음을 알리기 위하여 SET2로 SUPL TRIGGERED RESPONSE메시지를 전송한다(S81). 이후의 동작(S58~S61)은 제5실시예와 동일하며 그 상세한 설명은 생략한다.

상기 RLP SSRLIR END메시지를 수신한 SLP1은 SET1과 SLP1간의 연결을 종료하기 위하여 SUPL END메시지를 SET1으로 전송하고(S81), 이후, 상기 SLP2로부터 원하는 SET2의 트리거 결과(posresult)가 수신되면(S61) 해당 트리거 결과를 SUPL 보고 메시지(SUPL REPORT)를 통해 SET1에게 전송한다(S82). 상기 SUPL REPORT메시지는 WAP PUSH 또는 SMS 트리거 등을 통해 전송된다.

도 7은 본 발명에 따른 위치정보 시스템에서의 단말간 트리거 위치 서비스 요청방법의 제7실시예를 나타낸다.

도 7에 도시된 바와같이, SET1에 있는 SUPL에이전트는 SET1에서 동작하고 있는 어플리케이션으로부터 목표(target) SET의 위치관련 요청을 수신한다. 바람직하게, 상기 위치관련 요청은 SET2의 위치를 위한 주기적인(periodic) 또는 지역적(area)인 이벤트 요청을 의미한다. 이때 도 7은 위치관련 요청이 지역적(area)인 이벤트 요청인 경우를 나타낸다.

상기 위치관련 요청이 수신되면, SET1은 현재 어떤 네트워크에도 데이터 접속이 설정되어 있지 않은 경우 패킷 데이터 네트워크에 연결한다(S90).

상기 데이터 접속이 설정되면, SET1은 홈 네트워크로부터 제공된 기본(default)주소를 이용하여 위치서버인 SLP1과 안전한 IP연결을 설정하고, 목표 SET2의 측위 세션을 시작하기 위하여 상기 SLP1으로 SET초기화(SUPL SET INIT) 메시지를 전송한다(S91).

상기 SUPL SET INIT메시지에는 session-id, target SETid, 트리거 모드(triggered mode) 및 트리거 정보(trigger information)등이 포함되어 있다. 여기서, 상기 target SETid는 목표 SET2의 식별자이고, 상기 트리거 모드는 다른 SET의 트리거 서비스(SET initiated trigger service of another SET type)를 나타내며, 주기적 이벤트(Periodic event) 또는 지역 이벤트(area event) 파라미터를 포함한다. 상기 triggered service mode는 도 1~도 6에 도시된 요청 타입과 동일하게 사용된다. 상기 트리거 정보는 트리거 세션의 파라미터들을 나타내며, 주기적 파라미터들(Periodic Parameters)과 지역 이벤트 파라미터들(Area Event Parameters)을 포함한다. 일 예로 주기적 파라미터에는 트리거 주기가 포함되며, 상기 지역 이벤트 파라미터는 defined area 및 event type을 포함한다.

상기 SLP1은 상기 트리거 서비스 요청을 받았음을 확인하기(acknowledge)위하여 SUPL END메시지를 SET1으로 전송하고(S92), 상기 SUPL END메시지에 따라 SET1은 안전한 IP연결을 해제하고 이 세션에 관련된 모든 무선자원을 해제한다. 또한, 상기 SLP1은 SUPL SET INIT메시지에 포함된 목표 SETid(라우팅 정보)를 이용하여 목표 SET2의 위치서버(SLP2)를 결정한다(S93). 즉, SLP1은 로컬 DNS서버 또는 SET2 어드레스 정보를 SLP2 접촉(contact)에 사용할 수 있는 정보로 해석(translate)할 수 있는 다른 개체에 접촉하여 SLP2를 결정한다.

일단 SLP2가 결정되면, SLP1은 목표 SET2의 위치서버(SLP2)로 트리거 위치 요청 메시지(triggered location request message)를 전송한다(S94). 상기 트리거 위치 요청 메시지에는 상기 session-id, target SETid, 트리거 모드(triggered mode) 및 트리거 정보(trigger information)등이 포함될 것이다.

따라서, 상기 트리거 위치 요청 메시지로 수신한 SLP2는 수신한 트리거 모드(triggered mode) 및 트리거 정보(trigger information)를 이용하여 상기 SET1이 요청한 트리거 서비스 종류(Periodic 또는 area event)를 판단할 수 있다. 이러한 판단을 기초로 도 7에 도시된 실시예 또는 후술할 도 8에 도시된 실시예를 수행한다.

상기 SLP2는 SET1이 요청한 트리거 서비스에 대해 권한이 있는 경우 상기 SET1을 인증하고 SET1에 대하여 가입자 프라이버시를 적용한다. 만약, SET1이 인증되고 통지 및 검증이 요구되면, SLP2는 SET2로 트리거 위치 요청(network initiated triggered location request) 메시지를 전송하며, SET2의 위치를 계산하기 위하여 SUPL 위치측정 방법(SUPL positioning method)을 이용하여 측위절차(network initiated positioning procedures)를 수행한다(S95).

그런데, 만약 이전에 계산한 위치가 SET1이 요청한 QoP(Quality of Position)를 만족하고, 통지 및 검증이 요구되지 않은 경우 SLP2는 상기 단계(S95)를 수행하지 않고 바로 다음 단계(S96)로 진행한다.

상기 SET2의 위치계산이 완료되면 SLP2는 상기 계산된 위치를 트리거 정보의 defined area와 비교하며, 해당 영역에서 지역 이벤트가 발생되었는지 체크한다. 체크결과, 지역 이벤트가 발생되면 SLP2는 SLP1으로 트리거 위치 응답(triggered location response) 메시지를 전송하고(S96), 상기 SLP1은 수신한 SET2의 위치정보(Position information)를 SUPL REPORT메시지를 통해 SET1으로 전송한다(S97).

도 8은 본 발명에 따른 위치정보 시스템에서의 단말간 트리거 위치 서비스 요청방법의 제8실시예로서, 도 7에서 위치관련 요청이 주기적인(periodic) 경우를 나타낸다.

즉, SET1에 있는 SUPL 에이전트는 SET1에서 동작하고 있는 어플리케이션으로부터 주기적인(periodic) 이벤트 요청을 수신한다.

상기 주기적인 위치요청이 수신되면, SET1은 패킷 데이터 네트워크에 연결한후(S100), 홈 네트워크로부터 제공된 기본 주소를 이용하여 SLP1과 안전한 IP연결을 설정하고, 목표 SET2의 측위 세션을 시작하기 위해 SLP1으로 SUPL SET INIT 메시지를 전송한다(S101).

상기 SUPL SET INIT메시지에는 도 7에서와 같이 session-id, target SETid, 트리거 모드(triggered mode) 및 트리거 정보(trigger information)등이 포함된다. 여기서, 상기 트리거 모드는 주기적 이벤트(Periodic event)로 설정되고, 상기 트리거 정보는 주기적 파라미터들(Periodic Parameters), 예를들면 트리거 주기가 포함된다.

상기 SLP1은 SUPL SET INIT메시지에 포함된 목표 SETid(라우팅 정보)를 이용하여 목표 SET2의 위치서버(SLP2)를 결정한다(S102)

일단 SLP2가 결정되면, SLP1은 목표 SET2의 위치서버(SLP2)로 트리거 위치 요청 메시지(triggered location request message)를 전송한다(S103). 상기 트리거 위치 요청 메시지에는 상기 session-id, target SETid, 트리거 모드(triggered mode) 및 트리거 정보(trigger information)등이 포함된다.

상기 SLP2는 SET1을 인증하고 SET1에 대하여 가입자 프라이버시를 적용하는데, 만약, SET1이 인증되고 통지 및 검증이 요구되면, SLP2는 SET2로 트리거 위치 요청(network initiated triggered location request) 메시지를 전송하며, SET2의 위치를 계산하기 위한 측위절차(network initiated positioning procedures)를 수행한다(S104).

그런데, 만약 이전에 계산한 위치가 SET1이 요청한 QoP(Quality of Position)를 만족하고, 통지 및 검증이 요구되지 않은 경우 SLP2는 상기 단계(S95)를 수행하지 않고 바로 다음 단계(S109)로 진행한다.

따라서, SLP2는 상기 트리거 정보에 포함된 주기정보를 근거로 각 주기마다 SET2의 위치를 계산하며, 그 계산된 위치를 트리거 위치 응답(triggered location response) 메시지에 포함시켜 SLP1으로 전송하고(S105, S107)로 전송하고, 상기 SLP1은 수신한 SET2의 위치를 SUPL REPORT메시지를 통해 SET1으로 전송한다(S106, S108).

이후 마지막 주기에서 상기 SET2의 위치계산이 종료되면, 마찬가지로 SLP2는 그 계산된 위치를 트리거 위치 응답 메시지를 통해 SLP1으로 전송하고(S109)로 전송하고, 상기 SLP1은 수신한 SET2의 위치를 SUPL REPORT메시지를 통해 SET1으로 전송한다(S110). 여기서 인덱스(index)는 각 주기를 나타낸다.

본 발명에서 SET는 SUPL네트워크와 통신할 수 있는 소자로서, UMTS의 UE(User Equipment), GSM의 MS(Mobile Station) 또는 IS-95 MS 중의 하나일 수 있으며, 본 발명에서는 단말과 동일한 의미로 사용된다.

발명의 효과

상술한 바와같이 본 발명은 SUPL에 기반한 위치정보 시스템에서 사용자가 자신의 단말을 이용하여 원하는 상대방의 트리거 위치 서비스(Triggered Location Service)를 요청함으로써 사용자에게 보다 편리함을 제공할 수 있다.

본 발명은 도면에 도시된 실시예를 참고로 설명되었으나 이는 예시적인 것에 불과하며, 본 기술 분야의 통상의 지식을 가진 자라면 이로부터 다양한 변형 및 균등한 타 실시예가 가능하다는 점을 이해할 것이다. 따라서, 본 발명의 진정한 기술적 보호 범위는 첨부된 특허청구범위의 기술적 사상에 의해 정해져야 할 것이다.

경구의 범위

청구항 1

제1단말이 특정 영역에서 제2단말의 트리거 서비스를 요청하는 단계와;

상기 제1단말의 제1네트워크가 제2단말의 제2네트워크로 상기 트리거 서비스 요청을 전달하는 단계와;

상기 제2네트워크가 제2단말과 축회 세션을 개시하여 제2단말의 위치를 계산하는 단계와;

상기 제2네트워크가 상기 계산된 위치를 제1단말이 지정한 특정 영역과 비교하여, 특정 영역에서의 지역 이벤트 발생을 제1단말로 통지하는 단계를 포함하는 것을 특징으로 하는 위치정보 시스템에서의 단말간 트리거 위치 서비스 요청방법.

청구항 2

제1항에 있어서, 상기 제1,제2네트워크는

위치서버를 나타내는 것을 특징으로 하는 위치정보 시스템에서의 단말간 트리거 위치 서비스 요청방법.

청구항 3

제1항에 있어서, 상기 제1,제2단말은

SET(SUPL Enabled Terminal)를 나타내는 것을 특징으로 하는 위치정보 시스템에서의 단말간 트리거 위치 서비스 요청방법.

청구항 4

제2항에 있어서, 상기 위치서버는

SLP(SUPL Location Platform)를 나타내는 것을 특징으로 하는 위치정보 시스템에서의 단말간 트리거 위치 서비스 요청방법.

청구항 5

제3항에 있어서, 상기 SET는

UMTS의 UE(User Equipment), GSM의 MS(Mobile Station) 또는 IS-95 MS 중의 어느 하나인 것을 특징으로 하는 위치정보 시스템에서의 단말간 트리거 위치 서비스 요청방법.

청구항 6

제1항에 있어서, 상기 트리거 서비스는

세션 시작 메시지를 통해 요청되는 것을 특징으로 하는 위치정보 시스템에서의 단말간 트리거 위치 서비스 요청방법.

청구항 7

제6항에 있어서, 상기 세션 시작 메시지는

session-id, SET capabilities, 위치식별자, msid, request type, defined area 및 event type을 포함하는 것을 특징으로 하는 위치정보 시스템에서의 단말간 트리거 위치 서비스 요청방법.

청구항 8

제7항에 있어서, 상기 request type은

서비스 요청이 특정 위치와 관련된 트리거 서비스임을 나타내는 것을 특징으로 하는 위치정보 시스템에서의 단말간 트리거 위치 서비스 요청방법.

청구항 9

제7항에 있어서, 상기 defined area는 특정 지역을 나타내며, 상기 event type은 어떠한 지역 이벤트를 원하는지를 나타내는 것을 특징으로 하는 위치정보 시스템에서의 단말간 트리거 위치 서비스 요청방법.

청구항 10

제9항에 있어서, 상기 def ined area는
좌표나 지역이름을 포함하는 것을 특징으로 하는 위치정보 시스템에서의 단말간 트리거 위치 서비스 요청
방법.

청구항 11

제1항에 있어서, 상기 트리거 서비스 요청은
RLP메시지를 통해 제1네트워크에서 제2네트워크로 전달되는 것을 특징으로 하는 위치정보 시스템에서의 단
말간 트리거 위치 서비스 요청방법.

청구항 12

제1항에 있어서, 상기 제2단말과의 측위 세션이 개시되면 제2네트워크가 RLP메시지를 통해 제1네트워크로
트리거 세션이 시작되었음을 알리는 단계와;

상기 네1네트워크가 제1단말로 세션 종료 메시지를 전송하여 제1단말과 제1네트워크간의 연결을 종료하는
단계를 추가로 포함하는 것을 특징으로 하는 위치정보 시스템에서의 단말간 트리거 위치 서비스 요청방법.

청구항 13

제1항에 있어서, 상기 제2네트워크는

상기 계산된 위치가 상기 제1단말이 지정한 특정 영역에 해당할 때까지 제2단말의 위치계산 및 비교동작을
반복적으로 수행하는 것을 특징으로 하는 위치정보 시스템에서의 단말간 트리거 위치 서비스 요청방법.

청구항 14

제1항에 있어서, 상기 제1네트워크는

세션 보고 메시지를 통해 상기 결과값을 제1단말로 전달하는 것을 특징으로 하는 위치정보 시스템에서의
단말간 트리거 위치 서비스 요청방법.

청구항 15

제14항에 있어서, 상기 세션 보고 메시지는

WAP PUSH 또는 SMS 트리거 등을 통해 전송되는 것을 특징으로 하는 위치정보 시스템에서의 단말간 트리거
위치 서비스 요청방법.

청구항 16

제1항에 있어서, 상기 통지 단계는

제2네트워크가 상기 계산된 위치가 제1단말이 지정한 특정 영역에 해당하는지 비교하는 단계와;

상기 계산된 위치가 상기 제1단말이 지정한 특정 영역에 해당할 경우 그 결과값을 제1네트워크를 통해 제1
단말로 전송하는 단계를 포함하는 것을 특징으로 하는 위치정보 시스템에서의 단말간 트리거 위치 서비스
요청방법.

청구항 17

제1단말이 제1위치서버로 제2단말의 트리거 서비스를 요청하는 단계와;

상기 제1위치서버가 제2위치서버로 트리거 서비스 요청을 전달하는 단계와;

상기 제2위치서버가 제2단말과 측위 세션을 개시하여 제2단말의 위치를 계산하는 단계와;

상기 제2위치서버가 상기 제1단말의 트리거 서비스 타입에 따라 상기 제1위치서버를 통해 주기적인 위치추
적 서비스 또는 지역관련 위치추적 서비스를 제공하는 단계를 포함하는 것을 특징으로 하는 위치정보 시스
템에서의 단말간 트리거 위치 서비스 요청방법.

청구항 18

제17항에 있어서, 상기 제1위치서버가 상기 트리거 서비스를 요청한 제2단말의 ID를 이용하여 제2위치서
버를 결정하는 단계를 추가로 포함하는 것을 특징으로 하는 위치정보 시스템에서의 단말간 트리거 위치 서
비스 요청방법.

청구항 19

제17항에 있어서, 상기 제1, 제2위치서버는

SLP(SUPL Location Platform)를 나타내는 것을 특징으로 하는 위치정보 시스템에서의 단말간 트리거 위치
서비스 요청방법.

청구항 20

제17항에 있어서, 상기 트리거 서비스는

SET 초기화 메시지를 통해 요청되는 것을 특징으로 하는 위치정보 시스템에서의 단말간 트리거 위치 서비

스 요청방법.

청구항 21

제17항에 있어서, 상기 SET 초기화 메시지는

session-id, 목표 SETid, 트리거 모드, 트리거 정보를 포함하는 것을 특징으로 하는 위치정보 시스템에서의 단말간 트리거 위치 서비스 요청방법.

청구항 22

제21항에 있어서, 상기 트리거 모드는

다른 SET의 트리거 서비스를 나타내며, 주기적 이벤트 또는 지역 이벤트 파라미터를 포함하는 것을 특징으로 하는 위치정보 시스템에서의 단말간 트리거 위치 서비스 요청방법.

청구항 23

제21항에 있어서, 상기 트리거 정보는

트리거 세션의 파라미터를 나타내며, 주기적 파라미터와 지역 이벤트 파라미터를 포함하는 것을 특징으로 하는 위치정보 시스템에서의 단말간 트리거 위치 서비스 요청방법.

청구항 24

제23항에 있어서, 상기 주기적 파라미터는

주기정보를 포함하고, 상기 지역 이벤트 파라미터는 특정 지역을 나타내는 defined area 및 어떠한 지역 이벤트를 원하는지를 나타내는 이벤트 타입(event type)을 포함하는 것을 특징으로 하는 위치정보 시스템에서의 단말간 트리거 위치 서비스 요청방법.

청구항 25

제24항에 있어서, 상기 defined area는

좌표나 지역이름을 포함하는 것을 특징으로 하는 위치정보 시스템에서의 단말간 트리거 위치 서비스 요청방법.

청구항 26

제17항에 있어서, 상기 제2위치서버는

제1단말의 트리거 서비스 요청을 분석하여, 제1단말이 주기적인 트리거 서비스를 요청한 것으로 판단되면 각 주기마다 상기 제2단말의 위치를 제1위치서버를 통해 제1단말로 보고하는 것을 특징으로 하는 위치정보 시스템에서의 단말간 트리거 위치 서비스 요청방법.

청구항 27

제17항에 있어서, 상기 제2위치서버는

상기 제1단말이 지역이벤트 트리거 서비스를 요청한 것으로 판단되면, 상기 계산된 위치를 제1단말이 지정한 특정 영역과 비교하여, 특정 영역에서의 지역 이벤트 발생을 제1단말로 통지하는 것을 특징으로 하는 위치정보 시스템에서의 단말간 트리거 위치 서비스 요청방법.

청구항 28

제1단말이 SET 초기화 메시지를 통해 제1위치서버로 제2단말의 위치추적을 요청하는 단계와;

상기 제1위치서버가 위치 요청 메시지를 통해 제2서버로 제2단말의 위치추적 요청을 전달하는 단계와;

상기 제2위치서버가 주기적으로 제2단말과 위치추적절차를 수행하여 제2단말의 위치를 계산하는 단계와;

상기 제1위치서버가 제2위치서버에서 계산된 제2단말의 위치값들을 각 위치 응답 메시지를 통해 수신하며, 상기 제1단말로 보고하는 단계를 포함하는 것을 특징으로 하는 위치정보 시스템에서의 단말간 트리거 위치 서비스 요청방법.

청구항 29

제28항에 있어서, 상기 제2위치서버가 상기 계산된 제2단말의 위치를 제1위치서버로 전송하는 단계를 추가로 포함하는 것을 특징으로 하는 위치정보 시스템에서의 단말간 트리거 위치 서비스 요청방법.

청구항 30

제28항에 있어서, 상기 제2위치서버로부터 제2단말의 마지막 위치가 수신되면, 제1위치서버가 해당 위치값을 포함하는 세션 종료 메시지를 제1단말로 전송하는 단계를 추가로 포함하는 것을 특징으로 하는 위치정보 시스템에서의 단말간 트리거 위치 서비스 요청방법.

청구항 31

제28항에 있어서, 상기 제1위치서버가 상기 SET 초기화 메시지에 포함된 제2단말의 식별자를 이용하여 제2위치서버를 결정하는 단계를 추가로 포함하는 것을 특징으로 하는 위치정보 시스템에서의 단말간 트리거 위치 서비스 요청방법.

청구항 32

제28항에 있어서, 상기 제1,제2위치서버는

각각 제1,제2단말의 홈 네트워크에 존재하며, SLP(SUPL Location Platform)을 나타내는 것을 특징으로 하는 위치정보 시스템에서의 단말간 트리거 위치 서비스 요청방법.

청구항 33

제28항에 있어서, 상기 SET 초기화 메시지는

session-id, 제2단말의 id, 트리거 모드 및 트리거 정보를 포함하는 것을 특징으로 하는 위치정보 시스템에서의 단말간 트리거 위치 서비스 요청방법.

청구항 34

제33항에 있어서, 상기 트리거 모드는

다른 SET의 트리거 서비스를 나타내며, 주기적 이벤트 또는 지역 이벤트 파라미터를 포함하는 것을 특징으로 하는 위치정보 시스템에서의 단말간 트리거 위치 서비스 요청방법.

청구항 35

제33항에 있어서, 상기 트리거 정보는

트리거 세션의 파라미터들을 나타내며, 주기적 파라미터와 지역 이벤트 파라미터를 포함하는 것을 특징으로 하는 위치정보 시스템에서의 단말간 트리거 위치 서비스 요청방법.

청구항 36

제34항에 있어서, 상기 주기적 파라미터는

주기정보를 포함하며, 상기 지역 이벤트 파라미터는 특정 지역을 나타내는 defined area 및 어떠한 지역 이벤트를 원하는지를 나타내는 이벤트 타입(event type)을 포함하는 것을 특징으로 하는 위치정보 시스템에서의 단말간 트리거 위치 서비스 요청방법.

청구항 37

제36항에 있어서, 상기 defined area는

좌표나 지역이름을 포함하는 것을 특징으로 하는 위치정보 시스템에서의 단말간 트리거 위치 서비스 요청방법.

도면

도면1

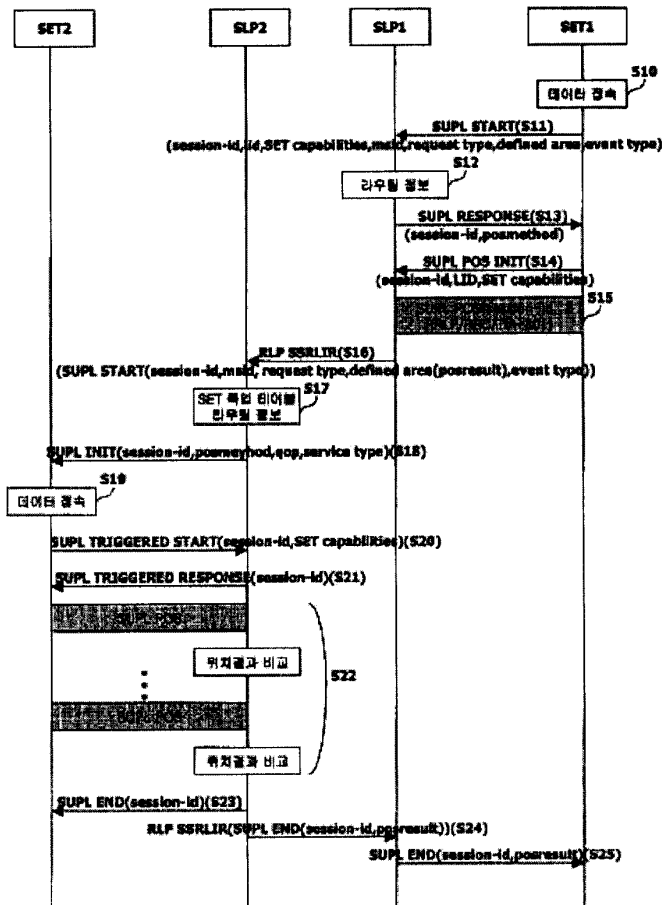

도 2

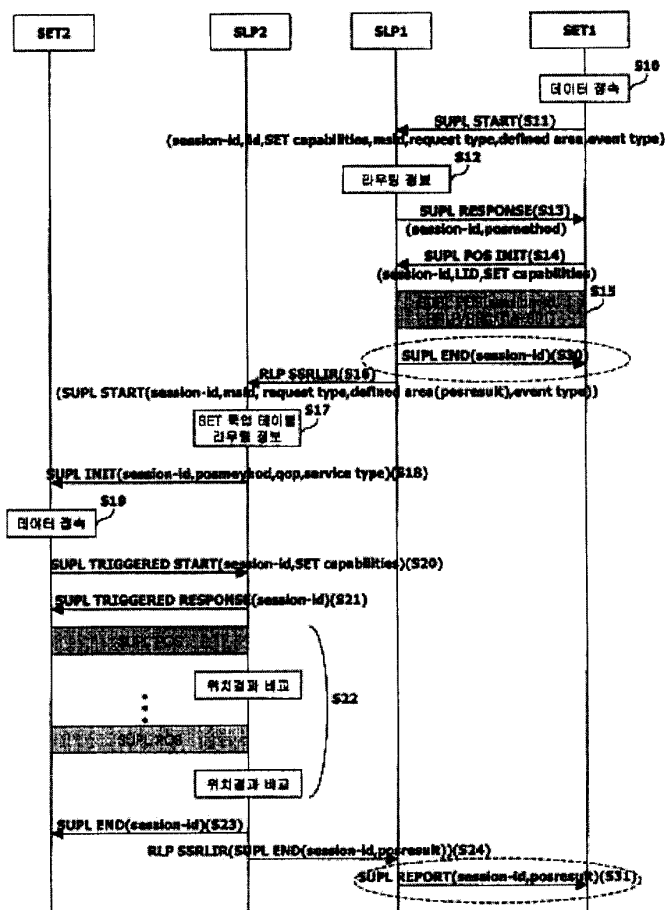

도 2

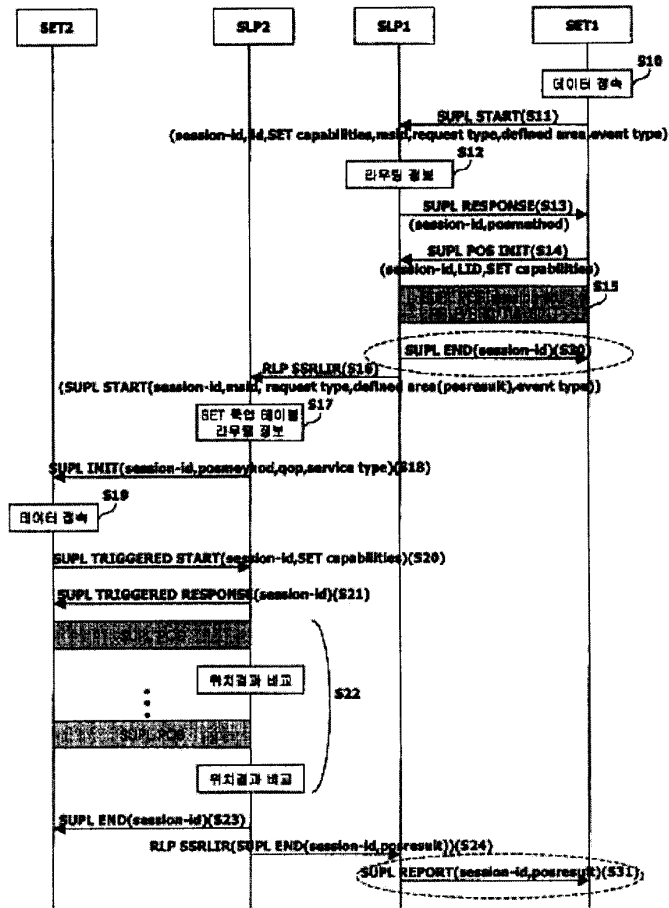

도 3

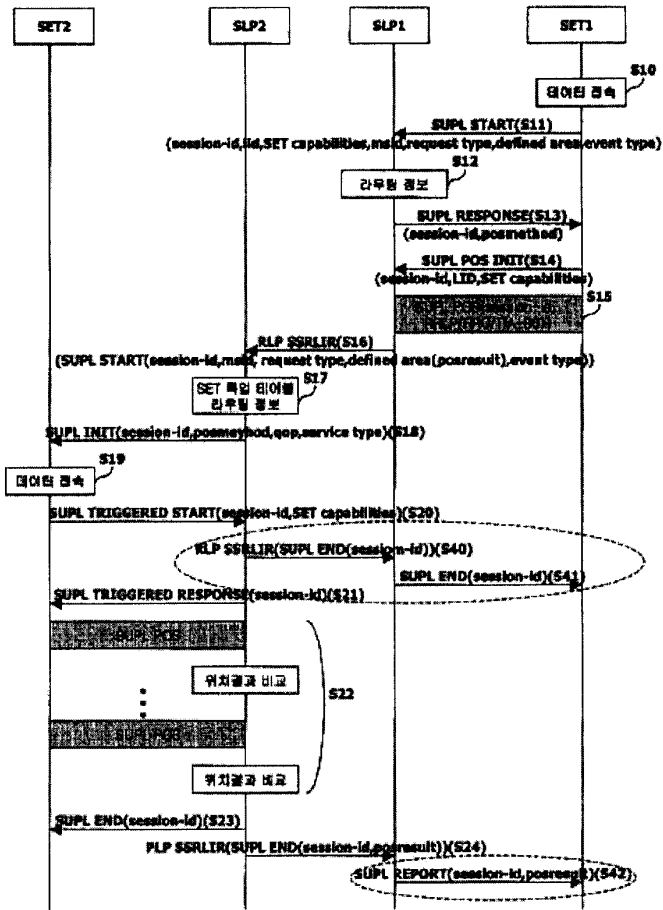

도 11A

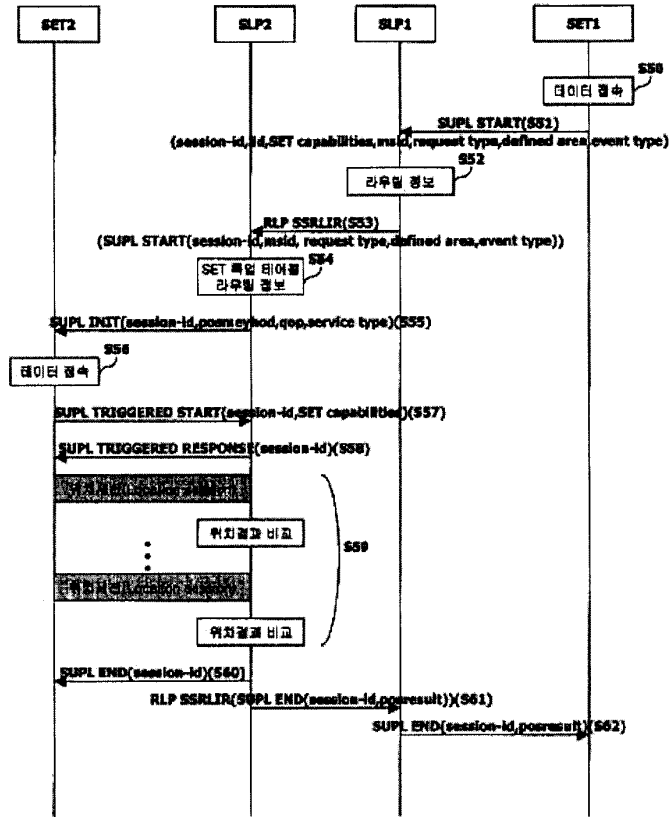

도 108

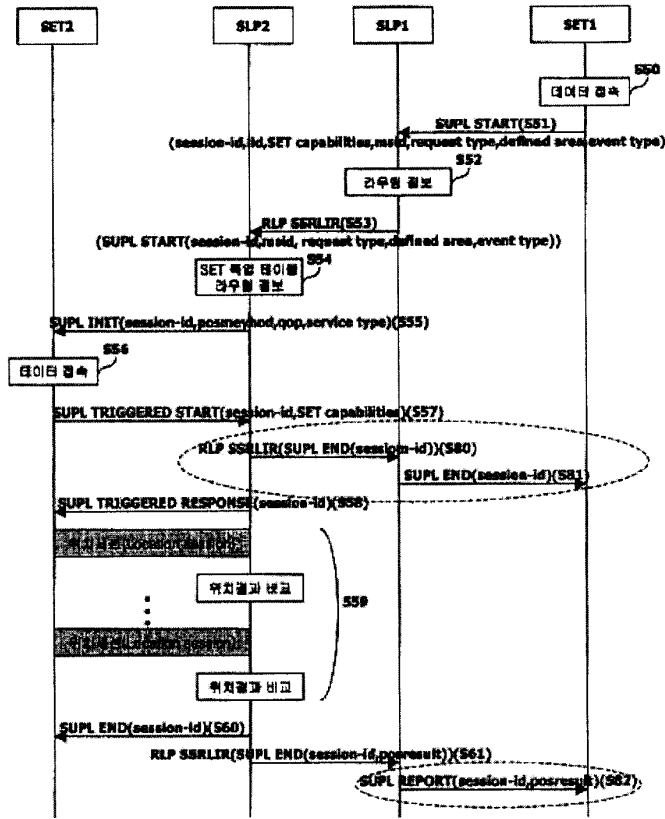

도면7

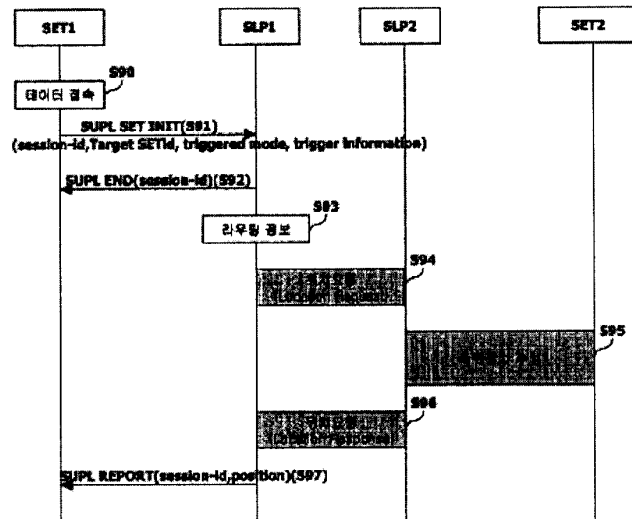

도면8

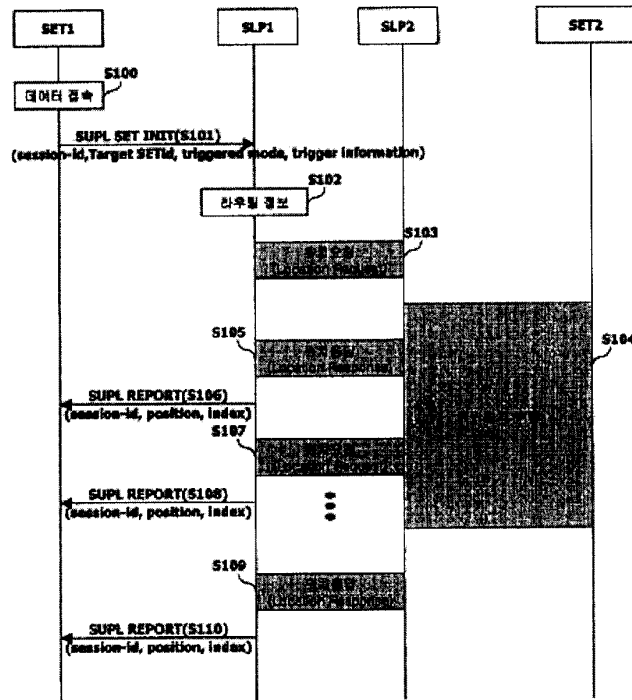

PATENT COOPERATION TREATY

From the INTERNATIONAL SEARCHING AUTHORITY



PCT

To:
 MAHAMEDI, Van
 Suite 201 4880 Stevens Creek Blvd. San Jose CA 95128 USA

Received
 FEB 02 2009



Intellectual Property Law

NOTIFICATION OF TRANSMITTAL OF
 THE INTERNATIONAL SEARCH REPORT AND
 THE WRITTEN OPINION OF THE INTERNATIONAL
 SEARCHING AUTHORITY, OR THE DECLARATION

(PCT Rule 44.1)

Date of mailing (day/month/year) 29 JANUARY 2009 (29.01.2009)	
Applicant's or agent's file reference PALM_1009WO 4297 PALM PCT	FOR FURTHER ACTION See paragraphs 1 and 4 below
International application No. PCT/US2008/074320	International filing date (day/month/year) 26 AUGUST 2008 (26.08.2008)
Applicant PALM INC. et al	

- The applicant is hereby notified that the international search report and the written opinion of the International Searching Authority have been established and are transmitted herewith.
Filing of amendments and statement under Article 19:
 The applicant is entitled, if he so wishes, to amend the claims of the international application (see Rule 46):
When? The time limit for filing such amendments is normally two months from the date of transmittal of the international search report.
Where? Directly to the International Bureau of WIPO, 34 chemin des Colombettes
 1211 Geneva 20, Switzerland, Facsimile No.: +41 22 338 82 70
For more detailed instructions, see the notes on the accompanying sheet.
- The applicant is hereby notified that no international search report will be established and that the declaration under Article 17(2)(a) to that effect and the written opinion of the International Searching Authority are transmitted herewith.
- With regard to the protest** against payment of (an) additional fee(s) under Rule 40.2, the applicant is notified that:
 - the protest together with the decision thereon has been transmitted to the International Bureau together with the applicant's request to forward the texts of both the protest and the decision thereon to the designated Offices.
 - no decision has been made yet on the protest; the applicant will be notified as soon as a decision is made.
- Reminders**
 Shortly after the expiration of **18 months** from the priority date, the international application will be published by the International Bureau. If the applicant wishes to avoid or postpone publication, a notice of withdrawal of the international application, or of the priority claim, must reach the International Bureau as provided in Rules 90bis.1 and 90bis.3, respectively, before the completion of the technical preparations for international publication.
 The applicant may submit comments on an informal basis on the written opinion of the International Searching Authority to the International Bureau. The International Bureau will send a copy of such comments to all designated Offices unless an international preliminary examination report has been or is to be established. These comments would also be made available to the public but not before the expiration of 30 months from the priority date.
 Within **19 months** from the priority date, but only in respect of some designated Offices, a demand for international preliminary examination must be filed if the applicant wishes to postpone the entry into the national phase **until 30 months** from the priority date (in some Offices even later); otherwise, the applicant must, **within 20 months** from the priority date, perform the prescribed acts for entry into the national phase before those designated Offices.
 In respect of other designated Offices, the time limit of **30 months** (or later) will apply even if no demand is filed within 19 months.
 See the Annex to Form PCT/IB/301 and, for details about the applicable time limits, Office by Office, see the *PCT Applicant's Guide*, Volume II, National Chapters and the WIPO Internet site.

Name and mailing address of the ISA/KR  Korean Intellectual Property Office Government Complex-Daejeon, 139 Seonsa-ro, Seo-gu, Daejeon 302-701, Republic of Korea Facsimile No. 82-42-472-7140	Authorized officer COMMISSIONER Telephone No. 82-42-481-8552	
---	--	---

NOTES TO FORM PCT/ISA/220

These Notes are intended to give the basic instructions concerning the filing of amendments under Article 19. The Notes are based on the requirements of the Patent Cooperation Treaty, the Regulations and the Administrative Instructions under that Treaty. In case of discrepancy between these Notes and those requirements, the latter are applicable. For more detailed information, see also the *PCT Applicant's Guide*, a publication of WIPO.

In these Notes, "Article", "Rule" and "Section" refer to the provisions of the PCT, the PCT Regulations and the PCT Administrative Instructions, respectively.

INSTRUCTIONS CONCERNING AMENDMENTS UNDER ARTICLE 19

The applicant has, after having received the international search report and the written opinion of the International Searching Authority, one opportunity to amend the claims of the international application. It should however be emphasized that, since all parts of the international application (claims, description and drawings) may be amended during the international preliminary examination procedure, there is usually no need to file amendments of the claims under Article 19 except where, e.g. the applicant wants the latter to be published for the purposes of provisional protection or has another reason for amending the claims before international publication. Furthermore, it should be emphasized that provisional protection is available in some States only (see *PCT Applicant's Guide*, Volume I/A, Annexes B1 and B2).

The attention of the applicant is drawn to the fact that amendments to the claims under Article 19 are not allowed where the International Searching Authority has declared, under Article 17(2), that no international search report would be established (see *PCT Applicant's Guide*, Volume I/A, paragraph 296).

What parts of the international application may be amended ?

Under Article 19, only the claims may be amended.

During the international phase, the claims may also be amended (or further amended) under Article 34 before the International Preliminary Examining Authority. The description and drawings may only be amended under Article 34 before the International Preliminary Examining Authority.

Upon entry into the national phase, all parts of the international application may be amended under Article 28 or, where applicable, Article 41.

When ? Within 2 months from the date of transmittal of the international search report or 16 months from the priority date, whichever time limit expires later. It should be noted, however, that the amendments will be considered as having been received on time if they are received by the International Bureau after the expiration of the applicable time limit but before the completion of the technical preparations for international publication (Rule 46.1).

Where not to file the amendments ?

The amendments may only be filed with the International Bureau and not with the receiving Office or the International Searching Authority (Rule 46.2).

Where a demand for international preliminary examination has been/is filed, see below.

How ? Either by cancelling one or more entire claims, by adding one or more new claims or by amending the text of one or more of the claims as filed.

A replacement sheet must be submitted for each sheet of the claims which, on account of an amendment or amendments, differs from the sheet originally filed.

All the claims appearing on a replacement sheet must be numbered in Arabic numerals. Where a claim is cancelled, no renumbering of the other claims is required. In all cases where claims are renumbered, they must be renumbered consecutively (Section 205(b)).

The amendments must be made in the language in which the international application is to be published.

What documents must/may accompany the amendments ?

Letter (Section 205(b)):

The amendments must be submitted with a letter.

The letter will not be published with the international application and the amended claims. It should not be confused with the "Statement under Article 19(1)" (see below, under "Statement under Article 19(1)").

The letter must be in English or French, at the choice of the applicant. However, if the language of the international application is English, the letter must be in English; if the language of the international application is French, the letter must be in French.

NOTES TO FORM PCT/ISA/220 (continued)

The letter must indicate the differences between the claims as filed and the claims as amended. It must, in particular, indicate, in connection with each claim appearing in the international application (it being understood that identical indications concerning several claims may be grouped), whether

- (i) the claim is unchanged;
- (ii) the claim is cancelled;
- (iii) the claim is new;
- (iv) the claim replaces one or more claims as filed;
- (v) the claim is the result of the division of a claim as filed.

The following examples illustrate the manner in which amendments must be explained in the accompanying letter:

1. [Where originally there were 48 claims and after amendment of some claims there are 51]:
"Claims 1 to 29, 31, 32, 34, 35, 37 to 48 replaced by amended claims bearing the same numbers; claims 30, 33 and 36 unchanged; new claims 49 to 51 added."
2. [Where originally there were 15 claims and after amendment of all claims there are 11]:
"Claims 1 to 15 replaced by amended claims 1 to 11."
3. [Where originally there were 14 claims and the amendments consist in cancelling some claims and in adding new claims]:
"Claims 1 to 6 and 14 unchanged; claims 7 to 13 cancelled; new claims 15, 16 and 17 added." or
"Claims 7 to 13 cancelled; new claims 15, 16 and 17 added; all other claims unchanged."
4. [Where various kinds of amendments are made]:
"Claims 1 - 10 unchanged; claims 11 to 13, 18 and 19 cancelled; claims 14, 15 and 16 replaced by amended claim 14; claim 17 subdivided into amended claims 15, 16 and 17; new claims 20 and 21 added."

"Statement under Article 19(1)" (Rule 46.4)

The amendments may be accompanied by a statement explaining the amendments and indicating any impact that such amendments might have on the description and the drawings (which cannot be amended under Article 19(1)).

The statement will be published with the international application and the amended claims.

It must be in the language in which the international application is to be published.

It must be brief, not exceeding 500 words if in English or if translated into English.

It should not be confused with and does not replace the letter indicating the differences between the claims as filed and as amended. It must be filed on a separate sheet and must be indentified as such by a heading, preferably by using the words "Statement under Article 19(1)."

It may not contain any disparaging comments on the international search report or the relevance of citations contained in that report. Reference to citations, relevant to a given claim, contained in the international search report may be made only in connection with an amendment of that claim.

Consequence if a demand for international preliminary examination has already been filed

If, at the time of filing any amendments and any accompanying statement, under Article 19, a demand for international preliminary examination has already been submitted, the applicant must preferably, at the time of filing the amendments (and any statement) with the International Bureau, also file with the International Preliminary Examining Authority a copy of such amendments (and of any statement) and, where required, a translation of such amendments for the proceduer before that Authority (see Rules 55.3(a) and 62.2, first sentence). For further information, see the Notes to the demand form (PCT/IPEA/401).

If a demand for international preliminary examination is made, the written opinion of the International Searching Authority will, except in certain cases where the International Preliminary Examining Authority did not act as International Searching Authority and where it has notified the International Bureau under Rule 66.1bis(b), be considered to be a written opinion of the International Preliminary Examining Authority. If a demand is made, the applicant may submit to the International Preliminary Examining Authority a reply to the written opinion together, where appropriate, with amendments before the expiration of 3 months from the date of mailing of Form PCT/ISA/220 or before the expiration of 22 months from the priority date, whichever expires later (Rule 43bis.1(c)).

Consequence with regard to translation of the international application for entry into the national phase

The applicant's attention is drawn to the fact that, upon entry into the national phase, a translation of the claims as amended under Article 19 may have to be furnished to the designated/elected Offices, instead of, or in addition to, the translation of the claims as filed.

For further details on the requirements of each designated/elected Office, see the *PCT Applicant's Guide*, Volume II.

* Attention

Copies of the documents cited in the international search report can be searched in the following Korean Intellectual Property Office English website for three months from the date of mailing of the international search report.

<http://www.kipo.go.kr/kpo/eng/> => Patent Search => PCT-Service

ID : PCT international application number

PW : **A4YE3PJG**

PATENT COOPERATION TREATY

From the
INTERNATIONAL SEARCHING AUTHORITY

To:
MAHAMEDI, Van

Suite 201 4880 Stevens Creek Blvd. San Jose CA 95129 USA

PCT

**WRITTEN OPINION OF THE
INTERNATIONAL SEARCHING AUTHORITY
(PCT Rule 43bis.1)**

Date of mailing
(day/month/year) **29 JANUARY 2009 (29.01.2009)**

Applicant's or agent's file reference
PALM_1009WO

FOR FURTHER ACTION
See paragraph 2 below

International application No.
PCT/US2008/074320

International filing date (day/month/year)
26 AUGUST 2008 (26.08.2008)

Priority date(day/month/year)
30 AUGUST 2007 (30.08.2007)

International Patent Classification (IPC) or both national classification and IPC

H04B 1/40(2006.01)i

Applicant

PALM INC. et al

1. This opinion contains indications relating to the following items:

- Box No. I Basis of the opinion
- Box No. II Priority
- Box No. III Non-establishment of opinion with regard to novelty, inventive step and industrial applicability
- Box No. IV Lack of unity of invention
- Box No. V Reasoned statement under Rule 43bis.1(a)(i) with regard to novelty, inventive step or industrial applicability; citations and explanations supporting such statement
- Box No. VI Certain documents cited
- Box No. VII Certain defects in the international application
- Box No. VIII Certain observations on the international application

2. **FURTHER ACTION**

If a demand for international preliminary examination is made, this opinion will be considered to be a written opinion of the International Preliminary Examining Authority ("IPEA") except that this does not apply where the applicant chooses an Authority other than this one to be the IPEA and the chosen IPEA has notified the International Bureau under Rule 66.1bis(b) that written opinions of this International Searching Authority will not be so considered.

If this opinion is, as provided above, considered to be a written opinion of the IPEA, the applicant is invited to submit to the IPEA a written reply together, where appropriate, with amendments, before the expiration of 3 months from the date of mailing of Form PCT/ISA/220 or before the expiration of 22 months from the priority date, whichever expires later.
For further options, see Form PCT/ISA/220.

3. For further details, see notes to Form PCT/ISA/220.

Name and mailing address of the ISA/KR
 Korean Intellectual Property Office
Government Complex-Daejeon, 139
Seonsa-ro, Seo-gu, Daejeon 302
-701, Republic of Korea
Facsimile No. 82-42-472-7140

Date of completion of this opinion
29 JANUARY 2009 (29.01.2009)

Authorized officer
JANG, JIN HWAN

Telephone No.82-42-481-5711



WRITTEN OPINION OF THE
INTERNATIONAL SEARCHING AUTHORITY

International application No.

PCT/US2008/074320

Box No. 1 Basis of this opinion

1. With regard to the **language**, this opinion has been established on the basis of :
 - the international application in the language in which it was filed
 - a translation of the international application into _____, which is the language of a translation furnished for the purposes of international search (Rules 12.3(a) and 23.1(b))
2. This opinion has been established taking into account the **rectification of an obvious mistake** authorized by or notified to this Authority under Rule 91 (Rule 43bis.1(a))
3. With regard to any **nucleotide and/or amino acid sequence** disclosed in the international application, this opinion has been established on the basis of:
 - a. type of material
 - a sequence listing
 - table(s) related to the sequence listing
 - b. format of material
 - on paper
 - in electronic form
 - c. time of filing/furnishing
 - contained in the international application as filed.
 - filed together with the international application in electronic form.
 - furnished subsequently to this Authority for the purposes of search.
4. In addition, in the case that more than one version or copy of a sequence listing and/or table relating thereto has been filed or furnished, the required statements that the information in the subsequent or additional copies is identical to that in the application as filed or does not go beyond the application as filed, as appropriate, were furnished.
5. Additional comments:

**WRITTEN OPINION OF THE
INTERNATIONAL SEARCHING AUTHORITY**

International application No.

PCT/US2008/074320

Box No. V Reasoned statement under Rule 43bis.1(a)(i) with regard to novelty, inventive step or industrial applicability; citations and explanations supporting such statement

1. Statement

Novelty (N)	Claims	<u>1-25</u>	YES
	Claims	<u>NONE</u>	NO
Inventive step (IS)	Claims	<u>NONE</u>	YES
	Claims	<u>1-25</u>	NO
Industrial applicability (IA)	Claims	<u>1-25</u>	YES
	Claims	<u>NONE</u>	NO

2. Citations and explanations :

The following documents are referred to:
D1: US 2006-0041470 A1 23 February 2006
D2: KR 10-2007-0078369 A 31 July 2007

The present invention relates to a mobile computing device processing a message incoming into or outgoing from the mobile computing device. A trigger may be detected in association with the message and an operation. The mobile computing device automatically performs or initiates the operation in response to detecting the trigger.

D1 discloses a method and apparatus, including computer program products, for supporting the transmission of short messages between mobile communication devices and computing systems. The computer program product at a first computing system includes techniques for receiving a notification of a triggering event, generating a short message based on the notification, the generated short message including advertisement content, and sending the generated short message to a mobile communications device.

D2 discloses that a method for requesting a triggered location service between terminals in a location information system is provided to allow a user to request a triggered location service of a desired party by using his/her terminal

1. Novelty

Claim 1 differs from D1 and D2 in the features of "detecting location information, and automatically performing the location-based function using the location information".

Therefore, claim 1 meets the requirements of PCT Article 33(2) with respect to novelty.

Claims 8, 12, 16 and 20 also meet the criteria set out in PCT Article 33(2) because these claims have specific features corresponding to those of claim 1.

Dependent claims 2-7, 9-11, 13-15, 17-19, and 21-25 are also novel because these claims have additional features to independent claims 1, 8, 12, 16 and 20, respectively.

2. Inventive Step

2.1 Concerning Claims 1-7

Claim 1 discloses a method for performing a location-based function, the method comprising: detecting location information in a body of the incoming message; and in response to detecting the location information, automatically performing the location.

However, D1 shows a method comprising: in a first computing system, receiving a notification of a triggering event; generating a short message based on the notification, the generated short message including advertisement content; and sending the generated short message to a mobile communications device (see Fig.3 and corresponding specifications in D1).

(Continued on Supplemental Box)

**WRITTEN OPINION OF THE
INTERNATIONAL SEARCHING AUTHORITY**

International application No.

PCT/US2008/074320

Box No. VIII Certain observations on the international application

The following observations on the clarity of the claims, description, and drawings or on the question whether the claims are fully supported by the description, are made:

Claim 18, referring to claim 16, is not clear because claim 16 does not include the data element described in claim 18. Thus, it is understood that claim 18 should refer to claim 17 instead of claim 16.

Therefore, claim 18 does not meet the requirements of PCT Article 6.

WRITTEN OPINION OF THE
INTERNATIONAL SEARCHING AUTHORITY

International application No.

PCT/US2008/074320

Supplemental Box

In case the space in any of the preceding boxes is not sufficient.

Continuation of :

(Box V)

D2 shows a method for requesting a triggered location service related to an area event. When a triggered service of a second terminal is requested in a certain area from a first terminal, a network of the first terminal transfers the triggered service request to a second network of the second terminal. The second network initiates a positioning session with the second terminal, exchanges positioning messages and calculates a location of the second terminal, then compares the calculated location with a certain area set by the first terminal, and notifies area event occurrence in the certain area to the first terminal (see claim 1 in D2).

Thus, it is obvious to a person skilled in the art to arrive at the present invention by applying the features in D1 and D2.

Therefore, claim 1 is not inventive, nor does it meet the criteria of PCT Article 33(3).

Claim 2 specifies the features of cited claim 1, detecting location information including detecting a trigger that indicates a presence of the location information. However, D2 shows that a service request is a triggered service related to a certain location. Thus, it is obvious to a person skilled in the art to arrive at the present invention by applying the features in D1 and D2.

Therefore, claim 2 is not inventive, nor does it meet the criteria of PCT Article 33(3).

Claims 3-5 specify the features of cited claims 2, 3, and 1 respectively, trigger (claim 3), the designated set of characters (claim 4), and receiving the incoming message (claim 5). However, D1 and D2 show that the event triggering can be obtained by using a message. Thus, it is obvious to a person skilled in the art to arrive at the present invention by applying the features in D1 and D2.

Therefore, claims 3-5 are not inventive, nor do they meet the criteria of PCT Article 33(3).

Claims 6-7 specify the features of cited claims 1 and 6 respectively, detecting the location information (claim 6) and performing the location function (claim 7). However, D2 shows event triggering by using location information. Thus, it is obvious to a person skilled in the art to arrive at the present invention by applying the features in D1 and D2.

Therefore, claims 6-7 are not inventive, nor do they meet the criteria of PCT Article 33(3).

2.2 Concerning Claims 8-11

Claim 8 discloses a method for performing a location-based function on a mobile computing device, the method comprising: detecting an outgoing message, detecting a trigger for performing location based function; responsive to detecting the trigger, performing the location based function to generate a result; and including data corresponding to the result in the outgoing message.

However, D1 shows a method comprising: receiving a notification of a triggering event; generating a short message based on the notification, the generated short message including advertisement content; and sending the generated short message to a mobile communications device. D2 shows a triggered service related to a certain location.

Thus, it is obvious to a person skilled in the art to arrive at the present invention by applying the features in D1 and D2. Therefore, claim 8 is not inventive, nor does it meet the criteria of PCT Article 33(3).

(Continued on Supplemental Box)

WRITTEN OPINION OF THE
INTERNATIONAL SEARCHING AUTHORITY

International application No.

PCT/US2008/074320

Supplemental Box

In case the space in any of the preceding boxes is not sufficient.

Continuation of :

(Supplemental Box)

Claims 9-11 specify the features of cited claim 8, detecting one of an SMS, an instant message, an email, or MMS (claim 9), detecting a trigger (claim 10), and performing the location based function (claim 11). However, D1 and D2 show that the service triggering request can be obtained by using a message. D2 shows event triggering by using location information. Thus, it is obvious to a person skilled in the art to arrive at the present invention by applying the features in D1 and D2.

Therefore, claim 9-11 are not inventive, nor do they meet the criteria of PCT Article 33(3).

2.3 Concerning Claims 12-15

Claim 12 discloses a message stored in a computer-readable medium, the message comprising: a body of the message having a text content; a data element included in a header or in the body of the message that is recognizable, by a device that handles the messages, as a trigger to initiate or automatically perform a function identified or associated with the trigger. However, D1 shows generating a short message based on the notification of a triggering event. In addition, D2 shows that the service triggering request can be obtained by using an RLP message. Thus, it is obvious to a person skilled in the art to arrive at the present invention by applying the features in D1 and D2.

Therefore, claim 12 is not inventive, nor does it meet the criteria of PCT Article 33(3).

Claims 13-15 specify the features of cited claim 12 that the trigger corresponds to a set of one or more characters (claim 13), the message is one of an SMS or MMS type message (claim 14), and the text content is a pre-formulated message (claim 15). However, these features are well known in the field of message transmission for mobile communications. Thus, it is obvious to a person skilled in the art to arrive at the present invention by applying the features in D1 and D2.

Therefore, claim 13-15 are not inventive, nor do they meet the criteria of PCT Article 33(3).

2.4 Concerning Claims 16-19

Claims 16-17 disclose a method for performing message operations on a mobile computing device, and the features of the method of claims 16-17 essentially correspond to those of the message of claim 12. The same reasoning as in claim 12 applies to claims 16 and 17. Thus, it is obvious to a person skilled in the art to arrive at the present invention by applying the features in D1 and D2.

Therefore, claims 16 and 17 are not inventive, nor do they meet the criteria of PCT Article 33(3).

Claims 18 and 19 specify the features of cited claims 16 and 18, respectively. However, these features are well known in the field of message transmission for mobile communications(Considering the context, it is understood that claim 18 should refer to claim 17 instead of claim 16. Thus, this written opinion considered that claim 18 refers to claim 17).

Thus, it is obvious to a person skilled in the art to arrive at the present invention by applying the features in D1 and D2.

Therefore, claims 18 and 19 are not inventive, nor do they meet the criteria of PCT Article 33(3).

(Continued on Supplemental Box)

Supplemental Box

In case the space in any of the preceding boxes is not sufficient.
Continuation of :

(Supplemental Box)

2.5 Concerning Claims 20-25

Claim 20 discloses a mobile computing device comprising: processing resources, a memory, a wireless communication sub-system, a message application to be operable on the mobile computing device, a trigger detect component, and one or more action components. However, processing resources, a memory, and a wireless communication sub-system are well known components for a person skilled in the art of wireless communications. And the features of the device of claim 20 essentially correspond to those of the method of claim 16. Thus, the same reasoning as in claim 16 applies to claim 20.

It is obvious to a person skilled in the art to arrive at the present invention by applying the features in D1 and D2. Therefore, claim 20 is not inventive, nor does it meet the criteria of PCT Article 33(3).

Claim 21 specifies the features of cited claim 20 that the processing resources enable a trigger insert component that inserts a trigger into an outgoing message for causing another device receiving the outgoing message to initiate or automatically perform a corresponding action.

D2 shows that the triggered location service request is transferred from the first network to the second network through an RLP message. Thus, it is obvious to a person skilled in the art to arrive at the present invention by applying the features in D1 and D2.

Therefore, claim 21 is not inventive, nor does it meet the criteria of PCT Article 33(3).

Claim 22 specifies the features of the cited claim 20 that the processing resources enable the trigger detect component to inspect an outgoing message for presence of another trigger, and another action component is configured to initiate or perform an action identified by the detected trigger of the outgoing message. However, these features are slight constructional changes in the technology of triggering an event in D1 and D2, which come within the scope of the customary practice followed by person skilled in the art.

Therefore, claim 22 is not inventive, nor does it meet the criteria of PCT Article 33(3).

Claims 23 and 24 specify the features of the cited claim 20. However, these features are well known in the field of message transmission for mobile communications. Thus, it is obvious to a person skilled in the art to arrive at the present invention by applying the features in D1 and D2.

Therefore, claims 23 and 24 are not inventive, nor do they meet the criteria of PCT Article 33(3).

Claim 25 specifies the features of cited claim 24 that the data provided in the incoming message is location information provided by a GPR, and the action is a location-based function. However, D2 shows event triggering by using location information. Thus, it is obvious to a person skilled in the art to arrive at the present invention by applying the features in D1 and D2.

Therefore, claim 25 is not inventive, nor does it meet the criteria of PCT Article 33(3).

3. Industrial Applicability

Claims 1-25 have industrial applicability and meet the requirement of PCT Article 33(4).

PATENT COOPERATION TREATY

PCT

INTERNATIONAL SEARCH REPORT

(PCT Article 18 and Rules 43 and 44)

Applicant's or agent's file reference PALM_1009WO	FOR FURTHER ACTION see Form PCT/ISA/220 as well as, where applicable, item 5 below.	
International application No. PCT/US2008/074320	International filing date (<i>day/month/year</i>) 26 AUGUST 2008 (26.08.2008)	(Earliest) Priority Date (<i>day/month/year</i>) 30 AUGUST 2007 (30.08.2007)
Applicant PALM INC. et al		

This International search report has been prepared by this International Searching Authority and is transmitted to the applicant according to Article 18. A copy is being transmitted to the International Bureau.

This international search report consists of a total of 3 sheets.

It is also accompanied by a copy of each prior art document cited in this report.

1. **Basis of the report**

a. With regard to the **language**, the international search was carried out on the basis of :

- the international application in the language in which it was filed
 a translation of the international application into _____, which is the language of a translation furnished for the purposes of international search (Rules 12.3(a) and 23.1(b))

b. This international search report has been established taking into account the **rectification of an obvious mistake** authorized by or notified to this Authority under Rule 91 (Rule 43.6bis(a)).

c. With regard to any **nucleotide and/or amino acid sequence** disclosed in the international application, see Box No. I.

2. **Certain claims were found unsearchable** (See Box No. II)

3. **Unity of invention is lacking** (See Box No. III)

4. With regard to the **title**,

- the text is approved as submitted by the applicant.
 the text has been established by this Authority to read as follows:

5. With regard to the **abstract**,

- the text is approved as submitted by the applicant.
 the text has been established, according to Rule 38.2, by this Authority as it appears in Box No. IV. The applicant may, within one month from the date of mailing of this international search report, submit comments to this Authority.

6. With regard to the drawings,

- a. the figure of the **drawings** to be published with the abstract is Figure No. 1
 as suggested by the applicant.
 because the applicant failed to suggest a figure.
 because this figure better characterizes the invention.
- b. none of the figure is to be published with the abstract.

INTERNATIONAL SEARCH REPORT

International application No.
PCT/US2008/074320**A. CLASSIFICATION OF SUBJECT MATTER****H04B 1/40(2006.01);**

According to International Patent Classification (IPC) or to both national classification and IPC

B. FIELDS SEARCHEDMinimum documentation searched (classification system followed by classification symbols)
IPC H04B 1/40Documentation searched other than minimum documentation to the extent that such documents are included in the fields searched
Korean Utility models and applications for Utility Models since 1975
Japanese Utility models and applications for Utility Models since 1975Electronic data base consulted during the international search (name of data base and, where practicable, search terms used)
eKIPASS(KIPO internal) "mobile, trigger, message, event, location, GPS"**C. DOCUMENTS CONSIDERED TO BE RELEVANT**

Category*	Citation of document, with indication, where appropriate, of the relevant passages	Relevant to claim No.
Y	US 2006-0041470 A1 (NEWTON MEYER FLEURY FILHO et al.) 23 February 2006 See abstract, figures 1-3, paragraphs [0007]-[0047], and claims 1-16.	1-25
Y	KR 10-2007-0078369 A (LG ELECTRONICS INC.) 31 July 2007 See abstract, figures 1-8 and corresponding specifications, and claims 1-16.	1-25
A	US 6484036 B1 (GREGORY B. SORKIN et al.) 19 November 2002 See abstract, figures 1-2, column 1 line 44-column 6 line 12, and claims 1-13.	1-25
A	KR 10-2006-0093183 A (PANTECH CO., LTD.) 24 August 2006 See abstract, figures 1-2 and corresponding specifications, and claims 1-3.	1-25

 Further documents are listed in the continuation of Box C. See patent family annex.

* Special categories of cited documents:

"A" document defining the general state of the art which is not considered to be of particular relevance

"E" earlier application or patent but published on or after the international filing date

"L" document which may throw doubts on priority claim(s) or which is cited to establish the publication date of citation or other special reason (as specified)

"O" document referring to an oral disclosure, use, exhibition or other means

"P" document published prior to the international filing date but later than the priority date claimed

"T" later document published after the international filing date or priority date and not in conflict with the application but cited to understand the principle or theory underlying the invention

"X" document of particular relevance; the claimed invention cannot be considered novel or cannot be considered to involve an inventive step when the document is taken alone

"Y" document of particular relevance; the claimed invention cannot be considered to involve an inventive step when the document is combined with one or more other such documents, such combination being obvious to a person skilled in the art

"&" document member of the same patent family

Date of the actual completion of the international search

29 JANUARY 2009 (29.01.2009)

Date of mailing of the international search report

29 JANUARY 2009 (29.01.2009)

Name and mailing address of the ISA/KR

Korean Intellectual Property Office
Government Complex-Daejeon, 139 Seonsa-ro, Seo-gu, Daejeon 302-701, Republic of Korea

Facsimile No. 82-42-472-7140

Authorized officer

JANG, JIN HWAN

Telephone No. 82-42-481-5711



INTERNATIONAL SEARCH REPORT
Information on patent family members

International application No.
PCT/US2008/074320

Patent document cited in search report	Publication date	Patent family member(s)	Publication date
US 2006-041470 A1	23.02.2006	None	
KR 10-2007-0078369 A	31.07.2007	WO 2007-086702 A1	02.08.2007
US 6484036 B1	19.11.2002	None	
KR 10-2006-0093183 A	24.08.2006	None	

Electronic Patent Application Fee Transmittal

Application Number:	11200511				
Filing Date:	08-Aug-2005				
Title of Invention:	Method and device for enabling message responses to incoming phone calls				
First Named Inventor/Applicant Name:	David Champlin				
Filer:	Zurvan Mahamedi/Chris Fitting				
Attorney Docket Number:	PALM.P0962				
Filed as Large Entity					
Utility under 35 USC 111(a) Filing Fees					
Description	Fee Code	Quantity	Amount	Sub-Total in USD(\$)	
Basic Filing:					
Pages:					
Claims:					
Miscellaneous-Filing:					
Petition:					
Patent-Appeals-and-Interference:					
Post-Allowance-and-Post-Issuance:					
Extension-of-Time:					

Description	Fee Code	Quantity	Amount	Sub-Total in USD(\$)
Miscellaneous:				
Submission- Information Disclosure Stmt	1806	1	180	180
Total in USD (\$)				180

Electronic Acknowledgement Receipt

EFS ID:	6896179
Application Number:	11200511
International Application Number:	
Confirmation Number:	2125
Title of Invention:	Method and device for enabling message responses to incoming phone calls
First Named Inventor/Applicant Name:	David Champlin
Customer Number:	30554
Filer:	Zurvan Mahamedi/Chris Fitting
Filer Authorized By:	Zurvan Mahamedi
Attorney Docket Number:	PALM.P0962
Receipt Date:	27-JAN-2010
Filing Date:	08-AUG-2005
Time Stamp:	21:38:54
Application Type:	Utility under 35 USC 111(a)

Payment information:

Submitted with Payment	yes
Payment Type	Deposit Account
Payment was successfully received in RAM	\$180
RAM confirmation Number	6596
Deposit Account	501914
Authorized User	

The Director of the USPTO is hereby authorized to charge indicated fees and credit any overpayment as follows:

Charge any Additional Fees required under 37 C.F.R. Section 1.21 (Miscellaneous fees and charges)

File Listing:					
Document Number	Document Description	File Name	File Size(Bytes)/ Message Digest	Multi Part /.zip	Pages (if appl.)
1		P0962_SupplIDS_012710.pdf	172940 d2ecfbde2329e22381c8491faf5af757b14b4919	yes	3
Multipart Description/PDF files in .zip description					
		Document Description	Start	End	
		Transmittal Letter	1	2	
		Information Disclosure Statement (IDS) Filed (SB/08)	3	3	
Warnings:					
Information:					
2	Foreign Reference	KR_10_2006_0093183.pdf	639161 ca8028d4fd2d12594e3ef5cba269df15b309eba1	no	6
Warnings:					
Information:					
3	Foreign Reference	KR_10_2007_0078369.pdf	2113134 d90bb0be7edef76155639b968e674d5a3d53a03e	no	19
Warnings:					
Information:					
4	NPL Documents	P1009WO_ISR_Writ_Opin_012909.pdf	1292459 03dac2d79149baafc6de23858717eccaa122089	no	14
Warnings:					
Information:					
5	Fee Worksheet (PTO-875)	fee-info.pdf	29811 debd2625e7579c0f245a14a403ca31f845d7cddf	no	2
Warnings:					
Information:					
Total Files Size (in bytes):			4247505		

This Acknowledgement Receipt evidences receipt on the noted date by the USPTO of the indicated documents, characterized by the applicant, and including page counts, where applicable. It serves as evidence of receipt similar to a Post Card, as described in MPEP 503.

New Applications Under 35 U.S.C. 111

If a new application is being filed and the application includes the necessary components for a filing date (see 37 CFR 1.53(b)-(d) and MPEP 506), a Filing Receipt (37 CFR 1.54) will be issued in due course and the date shown on this Acknowledgement Receipt will establish the filing date of the application.

National Stage of an International Application under 35 U.S.C. 371

If a timely submission to enter the national stage of an international application is compliant with the conditions of 35 U.S.C. 371 and other applicable requirements a Form PCT/DO/EO/903 indicating acceptance of the application as a national stage submission under 35 U.S.C. 371 will be issued in addition to the Filing Receipt, in due course.

New International Application Filed with the USPTO as a Receiving Office

If a new international application is being filed and the international application includes the necessary components for an international filing date (see PCT Article 11 and MPEP 1810), a Notification of the International Application Number and of the International Filing Date (Form PCT/RO/105) will be issued in due course, subject to prescriptions concerning national security, and the date shown on this Acknowledgement Receipt will establish the international filing date of the application.

IN THE UNITED STATES PATENT OFFICE

In Re Patent Application of

First Named Inventor: Champlin, David

Examiner: GAUTHIER,
Gerald

Application No.: 11/200,511

Art Unit: 2614

Filed: 8/8/2005

For: METHOD AND DEVICE FOR
ENABLING MESSAGE RESPONSES TO
INCOMING PHONE CALLS

Confirmation No.: 2125

Mail Stop Amendment
Commissioner for Patents
P.O. Box 1450
Alexandria, VA 22313-1450

SUPPLEMENTAL INFORMATION DISCLOSURE STATEMENT UNDER 37 C.F.R. 1.97

Sir:

Enclosed is an Information Disclosure Citation Form 1449/PTO together with a copy of each reference cited therein, excluding U.S. Patents and Published U.S. Patent Applications. It is respectfully requested that the cited references be considered and that the enclosed copy of the Form 1449/PTO be initialed by the Examiner to indicate such consideration and a copy thereof returned to applicant.

This Information Disclosure Statement is being submitted under one of the following (as indicated by an "X" to the left of the appropriate paragraph):

_____ 37 C.F.R. §1.97(b). No fee is believed to be due.

 X 37 C.F.R. §1.97(c).

 X Authorization is hereby given to charge Deposit Account No. 501914 for the fee of \$180.00 under 37 C.F.R. §1.17(p) for the submission of this Information Disclosure Statement; **or**

_____ A statement pursuant to 37 C.F.R. §1.97(e) is attached hereto.

_____ 37 C.F.R. §1.97(d). Authorization is hereby given to charge Deposit Account No. 501914 for the fee of \$180.00 and a statement pursuant to 37 C.F.R. §1.97(e) is enclosed.

_____ 37 C.F.R. §1.97(i). Applicants are submitting references before the grant of a patent to be placed in the file but not considered by the Patent Office.

Pursuant to 37 C.F.R.1.97(h), the submission of this Information Disclosure Statement is not to be construed as an admission that the information cited in this statement is material to patentability.

The Commissioner is hereby authorized to charge any fee deficiency in connection with this submission to Deposit Account No. 501914.

Respectfully submitted,

MAHAMEDI PARADICE KREISMAN LLP

Date 1/27/2010

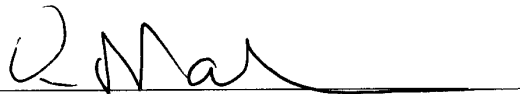

Van Mahamedi, Reg. No. 42828
Mahamedi Paradice Kreisman LLP
550 South Winchester Blvd., Suite 605
San Jose, CA 95128
Tel. 408-551-6632



UNITED STATES PATENT AND TRADEMARK OFFICE

UNITED STATES DEPARTMENT OF COMMERCE
United States Patent and Trademark Office
Address: COMMISSIONER FOR PATENTS
P.O. Box 1450
Alexandria, Virginia 22313-1450
www.uspto.gov

APPLICATION NO.	FILING DATE	FIRST NAMED INVENTOR	ATTORNEY DOCKET NO.	CONFIRMATION NO.
-----------------	-------------	----------------------	---------------------	------------------

11/200,511	08/08/2005	David Champlin	PALM.P0962	2125
------------	------------	----------------	------------	------

30554 7590 01/26/2010
 MAHAMEDI PARADICE KREISMAN LLP
 550 Winchester Boulevard
 Suite 605
 SAN JOSE, CA 95128

EXAMINER

GAUTHIER, GERALD

ART UNIT	PAPER NUMBER
----------	--------------

2614

MAIL DATE	DELIVERY MODE
-----------	---------------

01/26/2010

PAPER

Please find below and/or attached an Office communication concerning this application or proceeding.

The time period for reply, if any, is set in the attached communication.

DETAILED ACTION

Claim Rejections - 35 USC § 103

1. The following is a quotation of 35 U.S.C. 103(a) which forms the basis for all obviousness rejections set forth in this Office action:

(a) A patent may not be obtained though the invention is not identically disclosed or described as set forth in section 102 of this title, if the differences between the subject matter sought to be patented and the prior art are such that the subject matter as a whole would have been obvious at the time the invention was made to a person having ordinary skill in the art to which said subject matter pertains. Patentability shall not be negated by the manner in which the invention was made.

2. The factual inquiries set forth in *Graham v. John Deere Co.*, 383 U.S. 1, 148 USPQ 459 (1966), that are applied for establishing a background for determining obviousness under 35 U.S.C. 103(a) are summarized as follows:

1. Determining the scope and contents of the prior art.
2. Ascertaining the differences between the prior art and the claims at issue.
3. Resolving the level of ordinary skill in the pertinent art.
4. Considering objective evidence present in the application indicating obviousness or nonobviousness.

3. This application currently names joint inventors. In considering patentability of the claims under 35 U.S.C. 103(a), the examiner presumes that the subject matter of the various claims was commonly owned at the time any inventions covered therein were made absent any evidence to the contrary. Applicant is advised of the obligation under 37 CFR 1.56 to point out the inventor and invention dates of each claim that was not commonly owned at the time a later invention was made in order for the examiner to consider the applicability of 35 U.S.C. 103(c) and potential 35 U.S.C. 102(e), (f) or (g) prior art under 35 U.S.C. 103(a).

4. Claims 1, 3-19, 21, 22 and 24-33 are rejected under 35 U.S.C. 103(a) as being unpatentable over Fostick et al. (US 2002/087794 A1) in view of Burg (US 6,219,413 B1).

Regarding **claim 1**, Fostick discloses a method for operating a first computing device, the method being implemented by one or more processors of the computing device and comprising:

receiving from a second computing device, an incoming call to initiate a voice-exchange session (pg. 3, para. 36);

in response to receiving the incoming call, determining a message identifier associated with the second computing device (pg. 3, para. 37), wherein the message identifier is determined based at least in part on data provided with the incoming call (pg. 3, para. 36-37) (SMS message).

Fostick fails to disclose a reply message to the incoming call.

However, Burg teaches in response to receiving the incoming call, prompting a user of the first computing device to enter user input that instructs the first computing device to handle the incoming call by composing, while not answering the incoming call, a message to a user of the second computing device [When the telephony gateway notifies the called party of the incoming call, it also provides the called party with the options of accepting the call, declining to accept the call, or responding to the call by providing a response message to the calling party, column 3, lines 4-20]; and

responsive to the user input, automatically composing the message to the second computing device, using the message identifier determined from the incoming call [If the called party desires to compose and send a text message to the calling party, the text message is sent as a digital data stream by the called party's computer 100 to network service provider 150 and telephony gateway 156, column 7, lines 25-35].

Therefore, it would have been obvious to one of the ordinary skill in the art at the time the invention was made to modify the invention of Fostick using the teaching of auto response to an incoming call as taught by Burg.

This modification of the invention enables the system to automatically entering at least a portion of an address, for a message to the computing device of the caller so that the user would know the identity of the caller for any calls that are automatically responded to.

Regarding **claims 3, 22 and 31**, Fostick discloses further comprising: generating a graphic user-interface feature that prompts the user to elect to have the message at least partially composed in response to the incoming call (pg. 1, para. 8) (pg. 3, para. 42-43) (user response keys)(pg. 1, para. 8) (pg. 3, para. 42-43) (user response keys).

Regarding **claim 4**, Fostick discloses wherein automatically composing the message includes entering at least a portion of an address for an instant text message (pg. 3, para. 37) (SMSC).

Regarding **claims 5 and 25**, Fostick discloses wherein automatically composing the message includes entering at least a portion of an address for the message in a Short Message Service format (pg. 3, para. 37) (SMSC).

Regarding **claims 6, 21 and 26**, Fostick discloses wherein the message is composed using a Short Message Service application, and the message identifier is a phone number (pg. 3, para. 40) (pg. 2, para. 18).

Regarding **claims 7 and 27**, Fostick discloses wherein determining the message identifier includes determining the message identifier from a phone number of the second computing device (pg. 3, para. 40) (pg. 2, para. 18).

Regarding **claims 8 and 28**, Fostick discloses further comprising verifying that the second computing device is enabled for receiving the message (pg. 2, para. 32-33).

Regarding **claim 9**, Fostick discloses wherein verifying that the second computing device is enabled for receiving the message includes (i) identifying a phone number of the other computing device used for the incoming call (pg. 3, para. 40) (pg. 2,

para. 18), and (ii) determining that the phone number is associated with a message-enabled device that can handle an instant message response (pg. 2, para. 32-33).

Regarding **claim 10**, Fostick discloses wherein determining that the phone number is associated with a message enabled device includes accessing a contact record of a caller of the incoming call using the data provided with the incoming call, and using the contact record to verify that the phone number is capable of being used to receive the message (pg. 3, para. 40-41).

Regarding **claims 11 and 32**, Fostick discloses wherein the message is an instant or text message, and wherein using the contact record to verify that the phone number is capable of being used to receive the instant or text message includes checking the contact record associated with the caller to see whether the phone number of the incoming call is for a mobile telephony device that can handle the instant or text message (pg. 3, para. 40-41).

Regarding **claim 12**, Fostick discloses wherein determining that the phone number is associated with the message enabled device is performed programmatically and automatically (pg. 3, para. 40-42).

Regarding **claim 13**, Fostick discloses transmitting the message to the second computing device using a phone number of the incoming call as the address for either a new instant message or a new text message (pg. 3, para. 40-41).

Regarding **claims 14 and 33**, Fostick discloses wherein transmitting the message includes using either an instant or text messaging application for transmitting the new instant message or the new text message (pg. 3, para. 40-41).

Regarding **claim 15**, Fostick discloses further comprising launching either the instant or text messaging application automatically (pg. 3, para. 40-42), in response to one of (i) receiving the incoming call (pg. 3, para. 36), or (ii) receiving the input from the user of the first computing device (pg. 3, para. 36-37).

Regarding **claim 16**, Fostick discloses further comprising enabling the user of the first computing device to provide content manually for the message (It is known to one skilled in the art how to manually generate and send a text message).

Regarding **claim 17**, Fostick discloses further comprising enabling the user of the first computing device to trigger insertion of pre-formulated content for the message (pg. 4, para. 41-42).

Regarding **claim 18**, Fostick discloses further comprising automatically and programmatically providing at least a portion of a body of the message pg. 4, para. 41-42).

Regarding **claim 19**, the combination of Fostick and Burg discloses all the limitations of claim 19 as stated in claim 1's rejection above.

Regarding **claim 24**, the combination of Fostick and Burg discloses all the limitations of claim 24 as stated in claim 1's rejection above.

Regarding **claim 29**, Fostick discloses wherein the first computing device is the intended recipient of the incoming call (pg. 3, para. 36-37) (automatic handling server).

Regarding **claim 30**, the combination of Fostick and Burg discloses all the limitations of claim 30 as stated in claim 1's rejection above.

Response to Arguments

5. Applicant's arguments with respect to claims 1, 3-19, 21, 22 and 24-33 have been considered but are moot in view of the new ground(s) of rejection.

Conclusion

6. Any inquiry concerning this communication or earlier communications from the examiner should be directed to Gerald Gauthier whose telephone number is (571) 272-7539. The examiner can normally be reached on 8:00 AM to 4:30 PM.

If attempts to reach the examiner by telephone are unsuccessful, the examiner's supervisor, Fan Tsang can be reached on (571) 272-7547. The fax phone number for the organization where this application or proceeding is assigned is 571-273-8300.

Information regarding the status of an application may be obtained from the Patent Application Information Retrieval (PAIR) system. Status information for published applications may be obtained from either Private PAIR or Public PAIR. Status information for unpublished applications is available through Private PAIR only. For more information about the PAIR system, see <http://pair-direct.uspto.gov>. Should you have questions on access to the Private PAIR system, contact the Electronic Business Center (EBC) at 866-217-9197 (toll-free). If you would like assistance from a USPTO Customer Service Representative or access to the automated information system, call 800-786-9199 (IN USA OR CANADA) or 571-272-1000.

/Gerald Gauthier/
Primary Examiner, Art Unit 2614

Notice of References Cited	Application/Control No. 11/200,511	Applicant(s)/Patent Under Reexamination CHAMPLIN ET AL.	
	Examiner Gerald Gauthier	Art Unit 2614	Page 1 of 1

U.S. PATENT DOCUMENTS

*	Document Number Country Code-Number-Kind Code	Date MM-YYYY	Name	Classification
*	A US-4,996,704 A	02-1991	Brunson, Gordon R.	379/88.19
*	B US-6,055,305 A	04-2000	Norman et al.	379/211.01
*	C US-6,219,413 B1	04-2001	Burg, Frederick Murray	379/215.01
*	D US-6,229,878 B1	05-2001	Moganti, Madhav	379/67.1
*	E US-6,430,271 B1	08-2002	DeJesus et al.	379/88.22
*	F US-2005/0227740 A1	10-2005	Orbach, Julian James	455/567
*	G US-2006/0020993 A1	01-2006	Hannum et al.	725/111
*	H US-7,634,069 B2	12-2009	Randall et al.	379/93.17
I	US-			
J	US-			
K	US-			
L	US-			
M	US-			

FOREIGN PATENT DOCUMENTS

*	Document Number Country Code-Number-Kind Code	Date MM-YYYY	Country	Name	Classification
N					
O					
P					
Q					
R					
S					
T					

NON-PATENT DOCUMENTS

*	Include as applicable: Author, Title Date, Publisher, Edition or Volume, Pertinent Pages)
U	
V	
W	
X	

*A copy of this reference is not being furnished with this Office action. (See MPEP § 707.05(a).)
Dates in MM-YYYY format are publication dates. Classifications may be US or foreign.

<i>Index of Claims</i> 	Application/Control No. 11200511	Applicant(s)/Patent Under Reexamination CHAMPLIN ET AL.
	Examiner Gerald Gauthier	Art Unit 2614

✓	Rejected	-	Cancelled	N	Non-Elected	A	Appeal
=	Allowed	÷	Restricted	I	Interference	O	Objected

Claims renumbered in the same order as presented by applicant
 CPA
 T.D.
 R.1.47

CLAIM		DATE									
Final	Original	02/24/2009	07/22/2009	01/20/2010							
	1	✓	✓	✓							
	2	✓	✓	-							
	3	✓	✓	✓							
	4	✓	✓	✓							
	5	✓	✓	✓							
	6	✓	✓	✓							
	7	✓	✓	✓							
	8	✓	✓	✓							
	9	✓	✓	✓							
	10	✓	✓	✓							
	11	✓	✓	✓							
	12	✓	✓	✓							
	13	✓	✓	✓							
	14	✓	✓	✓							
	15	✓	✓	✓							
	16	✓	✓	✓							
	17	✓	✓	✓							
	18	✓	✓	✓							
	19	✓	✓	✓							
	20	✓	✓	-							
	21	✓	✓	✓							
	22	✓	✓	✓							
	23	✓	✓	-							
	24	✓	✓	✓							
	25	✓	✓	✓							
	26	✓	✓	✓							
	27	✓	✓	✓							
	28	✓	✓	✓							
	29		✓	✓							
	30		✓	✓							
	31		✓	✓							
	32		✓	✓							
	33		✓	✓							

Search Notes 	Application/Control No. 11200511	Applicant(s)/Patent Under Reexamination CHAMPLIN ET AL.
	Examiner Gerald Gauthier	Art Unit 2614

SEARCHED			
Class	Subclass	Date	Examiner
379	67.1	2/24/09	JCA
379	88.13	2/24/09	JCA
455	414.4	2/24/09	JCA
370	356	7/22/2009	GG
379	76, 88.19, 88.21, 93.23, 202.01, 257	7/22/2009	GG
455	412.1, 415, 445	7/22/2009	GG
705	26	7/22/2009	GG
709	238	7/22/2009	GG
725	134	7/22/2009	GG
379	88.19, 88.22, 93.17, 211.01, 215.01	1/20/2010	GG
455	567	1/20/2010	GG
725	111	1/20/2010	GG

SEARCH NOTES		
Search Notes	Date	Examiner
Searched East and Google Patents	2/24/09	JCA
EAST: (US-PGPUB; USPAT; USOCR)	7/22/2009	GG
EAST: (US-PGPUB; USPAT; USOCR; FPRS; EPO; JPO; DERWENT; IBM_TDB)	1/20/2010	GG

INTERFERENCE SEARCH			
Class	Subclass	Date	Examiner

	/Gerald Gauthier/ Primary Examiner. Art Unit 2614
--	--

EAST Search History**EAST Search History (Prior Art)**

Ref #	Hits	Search Query	DBs	Default Operator	Plurals	Time Stamp
S14	63837	incoming near call	US-PGPUB; USPAT; USOCR; FPPS; EPO; JPO; DERWENT; IBM_TDB	OR	ON	2010/01/20 07:27
S15	47388	text near message	US-PGPUB; USPAT; USOCR; FPPS; EPO; JPO; DERWENT; IBM_TDB	OR	ON	2010/01/20 07:28
S16	632	S14 with S15	US-PGPUB; USPAT; USOCR; FPPS; EPO; JPO; DERWENT; IBM_TDB	OR	ON	2010/01/20 07:28
S17	65	S16 with respon\$4	US-PGPUB; USPAT; USOCR; FPPS; EPO; JPO; DERWENT; IBM_TDB	OR	ON	2010/01/20 07:28

1/ 20/ 2010 2:21:03 PM

C:\ Documents and Settings\ ggauthier\ My Documents\ EAST\ workspaces\ 11200511.wsp

Atty. Docket No. PALM.P0962

PATENT

IN THE UNITED STATES PATENT OFFICE

In Re Patent Application of

First Named Inventor: Champlin, David

Application No.: 11/200,511

Filed: 8/8/2005

For: METHOD AND DEVICE FOR
ENABLING MESSAGE RESPONSES TO
INCOMING PHONE CALLS

Examiner: GAUTHIER,
Gerald

Art Unit: 2614

Confirmation 2125
No.:

Mail Stop Amendment
Commissioner for Patents
P.O. Box 1450
Alexandria, VA 22313-1450

AMENDMENT AND RESPONSE

Dear Sir:

In response to the Office Action mailed July 24, 2009 (the "Office Action"), once extended by a one month extension of time, the Applicant respectfully requests reconsideration of the application in view of the following amendments and remarks.

Amendment to the Claims begin on page 2 of this paper.

Remarks begin on page 11 of this paper.

CERTIFICATE OF ELECTRONIC TRANSMITTAL

I hereby certify that this document is being transmitted electronically via EFS-Web with the United State Patent and Trademark Office on November 24, 2009.

11/24/09
Date

Van Mahamedi
Van Mahamedi, Reg. No. 42,828

Atty. Docket No. PALM.P0962

PATENT

IN THE UNITED STATES PATENT OFFICE

In Re Patent Application of

First Named Inventor: Champlin, David

Application No.: 11/200,511

Filed: 8/8/2005

For: METHOD AND DEVICE FOR
ENABLING MESSAGE RESPONSES TO
INCOMING PHONE CALLS

Examiner: GAUTHIER,
Gerald

Art Unit: 2614

Confirmation 2125
No.:

Mail Stop Amendment
Commissioner for Patents
P.O. Box 1450
Alexandria, VA 22313-1450

AMENDMENT AND RESPONSE

Dear Sir:

In response to the Office Action mailed July 24, 2009 (the "Office Action"), once extended by a one month extension of time, the Applicant respectfully requests reconsideration of the application in view of the following amendments and remarks.

Amendment to the Claims begin on page 2 of this paper.

Remarks begin on page 11 of this paper.

CERTIFICATE OF ELECTRONIC TRANSMITTAL

I hereby certify that this document is being transmitted electronically via EFS-Web with the United State Patent and Trademark Office on November 24, 2009.

11/24/09
Date

Van Mahamedi
Van Mahamedi, Reg. No. 42,828

IN THE CLAIMS

1. (Currently amended) A method for operating a first computing device, the method being implemented by one or more processors of the computing device and comprising:

receiving, from a second computing device, an incoming call from another computing device to initiate a voice-exchange session;

in response to receiving the incoming call, determining a message identifier associated with of the second computing device of the caller, wherein the message identifier is determined based at least in part on data provided with the incoming call;

[[and]]

in response to receiving the incoming call, prompting a user of the first computing device to enter user input that instructs the first computing device to handle the incoming call by composing, while not answering the incoming call, a message to a user of the second computing device; and

responsive to the user input, automatically entering at least a portion of an address, for a composing the message to the second computing device of the caller, using the message identifier determined from the incoming call.

2. CANCELED

3. (Currently Amended) The method of claim 1, further comprising:

generating a graphic user-interface feature that prompts the user to elect to have the message at least partially composed in response to the incoming call;and

generating the message in response to a user input electing to have the message at least partially composed.

4. (Currently amended) The method of claim 1, wherein automatically composing the message includes entering at least a portion of an address for ~~includes~~ programmatically addressing an instant text message.
5. (Currently amended) The method of claim 4, wherein automatically composing the message includes entering at least a portion of an address for the message ~~the instant text message is in~~ a Short Message Service format.
6. (Currently amended) The method of claim 5, wherein the ~~instant text message is~~ composed using application ~~corresponds to~~ a Short Message Service application, and the ~~instant text message identifier~~ is a phone number.
7. (Currently amended) The method of claim 4, ~~wherein programmatically addressing a message to the other computing device~~ wherein determining the message identifier includes determining the message identifier from a phone number of the ~~other second~~ second computing device.
8. (Currently amended) The method of claim 1, further comprising:
verifying that ~~a device of the other second~~ second computing device is enabled for receiving the message.
9. (Currently amended) The method of claim 8, wherein:
verifying that ~~a device of the other second~~ second computing device is enabled for receiving the message includes (i) identifying a phone number of the other computing device used for the incoming call, and (ii) determining that the phone number is associated with a message-enabled device that can handle a text or instant message

response.

10. (Currently amended) The method of claim 9, wherein determining that the phone number is associated with a message enabled device includes accessing a contact record of ~~[[the]]~~ a caller of the incoming call using the data provided with the incoming call, and using the contact record to verify that the phone number is capable of being used to receive the message.

11. (Previously Presented) The method of claim 10, wherein the message is an instant or text message, and wherein using the contact record to verify that the phone number is capable of being used to receive the instant or text message includes checking the contact record associated with the caller to see whether the phone number of the incoming call is for a mobile telephony device that can handle the instant or text message.

12. (Original) The method of claim 10, wherein determining that the phone number is associated with the message enabled device is performed programmatically and automatically.

13. (Currently amended) The method of claim 1, ~~wherein:~~
transmitting ~~[[a]]~~ the message to the other second computing device ~~is based upon~~
using a phone number of the incoming call as the address for either a new instant
message or a new text message.

14. (Currently amended) The method of claim 13, wherein transmitting the message
includes using ~~a phone number of the incoming call as the address for a new instant or~~
~~text message includes launching~~ either an instant or text messaging application for

~~transmitting the new instant message or the new text message, and initiating a new message using the phone number of [[the]] caller as the address of the new message.~~

15. (Currently amended) The method of claim 14, ~~wherein~~ further comprising launching either the instant or text messaging application ~~and initiating a new message are performed~~ automatically, in response to one of (i) receiving the incoming call, or (ii) receiving [[an]]the input from [[a]] the user of the ~~computing telephony~~ first computing device, ~~indicating a desire to send the instant message as a response to the incoming call.~~

16. (Currently amended) The method of claim 1, further comprising enabling [[a]] the user of the first computing device to provide content manually for the message.

17. (Currently amended) The method of claim 1, further comprising enabling [[a]] the user of the first computing device to trigger insertion of pre-formulated content for the message.

18. (Currently amended) The method of claim 1, further comprising:
automatically and programmatically providing at least a portion of a body of the message.

19. (Currently amended) A computing device comprising:
one or more communication components, at a first computing device, for handling voice and messaging communications over wireless networks; and
one or more processors configured to:
handle receive, an incoming phone call from a second computing device
~~originating from another device;~~

in response to receiving the incoming phone call, (a) prompt a user of the first computing device to enter user input that instructs the first computing device on how to handle the incoming call, including providing the user with an option to (i) answer the call, or (ii) send the second computing device a message without answering the incoming call;

in response to receiving the incoming phone call, ~~determining~~ determine a phone number of the ~~other~~ second computing device based, at least in part, on the ~~received~~ incoming phone call; and

in response to receiving the user input to send the second computing device the message without answering the incoming phone call, programmatically generate at least a portion of [[a]] the message to be transmitted to the second computing ~~other~~ device using the phone number identified from the received phone call.

20. CANCELED

21. (Currently Amended) The computing device of claim 19, wherein the one or more processors are configured to enable a text message to be generated as the message to be sent to the second computing device without answering the incoming phone call.

22. (Currently Amended) The computing device of claim 19, wherein the one or more processors are configured to enable the message that is to be sent to the second computing device to include ~~to be generated containing~~ a message body of a format selected from one or more of text, image and audio.

23. CANCELED

24. (Currently amended) A method for operating a computing device, the method being implemented by one or more processors of the computing device and comprising:
identifying a phone number of a caller of an incoming phone call;
in response to receiving the incoming phone call, prompting a user of the computing device to answer the incoming phone call or generate a message reply to the incoming phone call; and

initiating the message reply by opening a message and addressing the message to the phone number of the caller of the incoming phone call.

25. (Original) The method of claim 24, wherein initiating the message reply by opening a message and addressing the message to the phone number includes addressing a SMS message to the phone number of the caller.

26. (Original) The method of claim 25, further comprising enabling a user to specify a message body for the SMS message.

27. (Original) The method of claim 24, further comprising enabling a user of the computing device to send the message and then answer the call after sending the message.

28. (Original) The method of claim 24, further comprising enabling a user of the computing device to send the message and then decline answering the call after sending the message.

29. (Currently amended) The method of claim 1, wherein the first computing device is the intended recipient of the incoming call.

30. (Currently amended) A computing device comprising:

- one or more processors;
- one or more wireless communication ports that communicate with the one or more processors to enable the device to handle both voice and messaging communications over one or more wireless networks;

wherein the one or more processors are configured to:

- receive an incoming telephony communication over one of the wireless communication ports from another computing device;
- in response to receiving the incoming telephony communication, determine a message identifier of the other computing device, wherein the message identifier is determined based at least in part on data provided with the incoming telephony communication; and
- enable a user to elect to respond to the incoming telephony communication by programmatic addressing a message to the other computing device using the message identifier that is communicated with the incoming telephony communication,

wherein the computing device, in response to receiving the incoming telephony communication, displays a user interface that enables the user to elect to respond to the incoming telephony communication by sending a instant message or text message or answering the incoming telephony communication.

31. (Currently amended) The computing device of claim 30, further comprising a display, and wherein the one or more processors are configured to generate on the display

~~a graphic the user-interface feature that prompts the user to elect to have a message generated in response to the incoming telephony communication, wherein the user interface further enables the user to elect to extend an amount of time in which the computing device waits before answering the incoming telephony communication by initiating voice mail.~~

32. (Previously Presented) The computing device of claim 30, further comprising memory resources that store a plurality of contact records on the computing device, and wherein the one or more processors are configured to make a determination as to whether a phone number of the incoming telephony communication is associated with a message enabled device.

33. (Previously Presented) The computing device of claim 32, wherein the one or more processors are configured to make the determination by accessing a corresponding one of the plurality of contact records of the caller using the data provided with the incoming telephony communication, and using the corresponding contact record to verify that the phone number is capable of being used to receive the message.

REMARKS

By this amendment, Claims 1-2, 4, 6-10, 13-19, 24, and 29-31 have been amended, no claims have been added, and Claims 2 and 23 have been cancelled. Consequently, Claims 1, 3-22, and 24-33 are currently pending in the application.

All issues raised by the Office Action are addressed below.

Detailed Remarks

Claims 1-33 were rejected under 35 U.S.C. § 103(a) for allegedly being unpatentable over U.S. Patent App. Pub. No. 2002/0187794 A1 by Fostick et al. (hereafter *Fostick*) in view of U.S. Patent App. Pub. No. 2004/0203794 A1 by Brown et al. (hereafter *Brown*).

The amended Claims recite limitations that are not disclosed, taught, or suggested by *Fostick* or *Brown*, either individually or in combination.

Claim 1

Claim 1 recites:

A method for operating a first computing device, the method being implemented by one or more processors of the computing device and comprising:
receiving, from a second computing device, an incoming call to initiate a voice-exchange session;
in response to receiving the incoming call, determining a message identifier associated with the second computing device, wherein the message identifier is determined based at least in part on data provided with the incoming call;
in response to receiving the incoming call, prompting a user of the first computing device to enter user input that instructs the first computing device to handle the incoming call by composing, while not answering the incoming call, a message to a user of the second computing device; and
responsive to the user input, automatically composing the message to the second computing device using the message identifier determined from the incoming call.

At least the above-underlined portions of Claim 1 are not disclosed, taught, or suggested by *Fostick* or *Brown*, either individually or in combination.

The approach of *Fostick*

Fostick is directed towards improved management of SMS messages, and in particular, automatic replies, forwarding, saving, and deleting of SMS messages on a SMS enabled device (see Abstract). Importantly, *Fostick* lacks any teaching or suggestion of initiating a SMS message in response to receiving an incoming phone call. Indeed, the Office acknowledges that *Fostick* fails to disclose a reply message to an incoming call (see Office Action).

The approach of *Brown*

Brown is directed towards providing an automatic response to a telephone call (see title). *Brown* is cited to show an approach where, in response to answering a phone call, a message is automatically played within the voice-exchange session of the phone call, and then the call is disconnected (see step 210 of FIG. 2, step 210 of FIG. 3, step 510 of FIG. 5, step 510 of FIG. 6, and paragraph 27).

Differences between Claim 1 and the cited art

While Claim 1 and the cited art are generally directed towards approaches for responding to communications, there are distinctions between the limitations of Claim 1 and the disclosures of the cited references of the cited art. Among the distinctions, Claim 1 recites:

“in response to receiving the incoming call, prompting a user of the first computing device to enter user input that instructs the first computing device to handle the incoming call by composing, while not answering the incoming call, a message to a user of the second computing device”

This element is not suggested by *Fostick*, because, as acknowledged by the Office, *Fostick* fails to disclose sending a reply message to an incoming call.

Moreover, this element is not suggested by the cited portion of *Brown*, because the cited portion of *Brown* discloses an approach where a message is transmitted over the voicepath of the incoming call (see step 210 of FIG. 2, step 210 of FIG. 3, step 510 of FIG. 5, step 510 of FIG. 6). Consequently, the cited portion of *Brown* teaches away from the express limitation of handling “the incoming call by composing, while not answering the incoming call, a message to a user of the second computing device.”

Brown does disclose another approach where a text message is transmitted to a caller in response to a call from the caller being sent to voicemail or ignored (see steps 406 and 408 of FIG. 4). However, *Brown* teaches:

In block 402 of FIG. 4, the user requests that incoming telephone calls be automatically responded to with a text response. As in block 302, the user may request this function by actuating a key or key sequence that is pre-programmed to start the auto-response function. For example, wireless phones 100 with integral auto-response modules 108 may also include one or more auto-response buttons 118 that would start the auto-response function until further notice (see paragraph 30 of *Brown*, emphasis added).

Such an approach teaches away from the express limitations of Claim 1, as Claim 1 requires “(a) prompting a user of the first computing device to enter user input that instructs the first computing device to handle the incoming call by composing...” Instead of showing the features of this element, *Brown* discloses an approach where the user is not prompted to respond to an incoming call, since the user has previously instructed that

all incoming calls be automatically responded to by a text message. Thus, in the approach of *Brown*, there is no action taught or suggested that is analogous to requesting user input in response to an incoming call, let alone, “in response to receiving the incoming call, prompting a user of the first computing device to enter user input that instructs the first computing device to handle the incoming call by composing, while not answering the incoming call, a message to a user of the second computing device;” as required by Claim 1.

Consequently, it is respectfully submitted that *Fostick* or *Brown*, either individually or in combination, fail to disclose, teach, or suggest at least one element recited by Claim 1. As a result, Claim 1 is patentable over the cited art and is in condition for allowance.

Claim 19

Claim 19 recites:

A computing device comprising:
one or more communication components, at a first computing device, for handling voice and messaging communications over wireless networks; and
one or more processors configured to:
 handle an incoming phone call from a second computing device;
 in response to receiving the incoming phone call, (a) prompt a user of the first computing device to enter user input that instructs the first computing device on how to handle the incoming call, including providing the user with an option to (i) answer the call, (ii) send the second computing device a message without answering the incoming call;
 in response to receiving the incoming phone call, determine a phone number of the second computing device based, at least in part, on the incoming phone call; and
 in response to receiving the user input to send the second computing device the message without answering the incoming phone call, programmatically generate at least a portion of the message to be transmitted to the second computing device using the phone number identified from the received phone call.

At least the above-underlined portions of Claim 19 are not disclosed, taught, or suggested by *Fostick* or *Brown*, either individually or in combination.

The above-underlined portions of Claim 19 recite features similar to those discussed above with reference to Claim 1. Therefore, Claim 19 is patentable over the cited art for at least the same reasons discussed above in reference to Claim 1. Consequently, it is respectfully submitted that Claim 19 is patentable over the cited art and is in condition for allowance.

Claim 24

Claim 24 recites:

A method for operating a computing device, the method being implemented by one or more processors of the computing device and comprising:
identifying a phone number of a caller of an incoming phone call;
in response to receiving the incoming phone call, prompting a user of the computing device to answer the incoming phone call or generate a message reply to the incoming phone call; and
initiating the message reply by opening a message and addressing the message to the phone number of the caller of the incoming phone call.

At least the above-underlined portions of Claim 24 are not disclosed, taught, or suggested by *Fostick* or *Brown*, either individually or in combination.

The above-underlined portions of Claim 24 recite features similar to those discussed above with reference to Claim 1. Therefore, Claim 24 is patentable over the cited art for at least the same reasons discussed above in reference to Claim 1. Consequently, it is respectfully submitted that Claim 24 is patentable over the cited art and is in condition for allowance.

Claim 30

Claim 30 recites:

A computing device comprising:
one or more processors;
one or more wireless communication ports that communicate with the one or more processors to enable the device to handle both voice and messaging communications over one or more wireless networks;
wherein the one or more processors are configured to:
 receive an incoming telephony communication over one of the wireless communication ports from another computing device;
 in response to receiving the incoming telephony communication, determine a message identifier of the other computing device, wherein the message identifier is determined based at least in part on data provided with the incoming telephony communication; and
 enable a user to elect to respond to the incoming telephony communication by programmatic addressing a message to the other computing device using the message identifier that is communicated with the incoming telephony communication,
 wherein the computing device, in response to receiving the incoming telephony communication, displays a user interface that enables the user to elect to respond to the incoming telephony communication by sending a instant message or text message or answering the incoming telephony communication.

At least the above-underlined portions of Claim 30 are not disclosed, taught, or suggested by *Fostick* or *Brown*, either individually or in combination.

The above-underlined portions of Claim 30 recite features similar to those discussed above with reference to Claim 1. Therefore, Claim 30 is patentable over the cited art for at least the same reasons discussed above in reference to Claim 1. Consequently, it is respectfully submitted that Claim 30 is patentable over the cited art and is in condition for allowance.

Claims 2-18, 20-23, 25-29, and 31-33

Claims 2-18, 20-23, 25-29, and 31-33 are dependent claims, each of which directly depends on one of the independent claims discussed above. Each of Claims 2-

18, 20-23, 25-29, and 31-33 is therefore allowable for the reasons given above for the claim on which it depends. In addition, each of 2-18, 20-23, 25-29, and 31-33 introduces one or more additional limitations that may independently render it patentable.

For example, Claim 31 recites, “wherein the user interface further enables the user to elect to extend an amount of time in which the computing device waits before answering the incoming telephony communication by initiating voice mail.” Neither *Fostick* nor *Brown* disclose, teach, or suggest this feature.

CONCLUSION

For the reasons set forth above, it is respectfully submitted that all of the pending claims are in condition for allowance. Therefore, the issuance of a formal Notice of Allowance is believed next in order, and that action is most earnestly solicited.

The Examiner is respectfully requested to contact the undersigned by telephone if it is believed that such contact would further the examination of the present application.

To the extent necessary, a petition for an extension of time under 37 C.F.R. § 1.136 is hereby made. Please charge any fee shortages or credit any overages to Deposit Account No. 50-1914.

Respectfully submitted,
MAHAMEDI PARADICE KREISMAN, LLP

11/24/09
Date

Van Mahamedi, Reg. No. 42,828

MAHAMEDI PARADICE KREISMAN LLP
550 Winchester Blvd., Suite 605
San Jose, CA 95128
Tel. 408-236-6640 Fax 408-236-6641

Electronic Patent Application Fee Transmittal

Application Number:	11200511			
Filing Date:	08-Aug-2005			
Title of Invention:	Method and device for enabling message responses to incoming phone calls			
First Named Inventor/Applicant Name:	David Champlin			
Filer:	Zurvan Mahamedi			
Attorney Docket Number:	PALM.P962			
Filed as Large Entity				
Utility under 35 USC 111(a) Filing Fees				
Description	Fee Code	Quantity	Amount	Sub-Total in USD(\$)
Basic Filing:				
Pages:				
Claims:				
Miscellaneous-Filing:				
Petition:				
Patent-Appeals-and-Interference:				
Post-Allowance-and-Post-Issuance:				
Extension-of-Time:				
Extension - 1 month with \$0 paid	1251	1	130	130

Description	Fee Code	Quantity	Amount	Sub-Total in USD(\$)
Miscellaneous:				
Total in USD (\$)				130

Electronic Acknowledgement Receipt

EFS ID:	6522971
Application Number:	11200511
International Application Number:	
Confirmation Number:	2125
Title of Invention:	Method and device for enabling message responses to incoming phone calls
First Named Inventor/Applicant Name:	David Champlin
Customer Number:	30554
Filer:	Zurvan Mahamedi
Filer Authorized By:	
Attorney Docket Number:	PALM.P962
Receipt Date:	25-NOV-2009
Filing Date:	08-AUG-2005
Time Stamp:	01:05:20
Application Type:	Utility under 35 USC 111(a)

Payment information:

Submitted with Payment	yes
Payment Type	Deposit Account
Payment was successfully received in RAM	\$130
RAM confirmation Number	7788
Deposit Account	501914
Authorized User	

The Director of the USPTO is hereby authorized to charge indicated fees and credit any overpayment as follows:
 Charge any Additional Fees required under 37 C.F.R. Section 1.16 (National application filing, search, and examination fees)
 Charge any Additional Fees required under 37 C.F.R. Section 1.17 (Patent application and reexamination processing fees)

Charge any Additional Fees required under 37 C.F.R. Section 1.19 (Document supply fees)
 Charge any Additional Fees required under 37 C.F.R. Section 1.20 (Post Issuance fees)
 Charge any Additional Fees required under 37 C.F.R. Section 1.21 (Miscellaneous fees and charges)

File Listing:

Document Number	Document Description	File Name	File Size(Bytes)/ Message Digest	Multi Part /.zip	Pages (if appl.)
1	Amendment/Req. Reconsideration-After Non-Final Reject	_1124220245_001.pdf	1248950	no	17
			406dfad33f21449e5937881b0d7d2efda33c85c		

Warnings:

Information:

2	Fee Worksheet (PTO-875)	fee-info.pdf	29913	no	2
			d180553b6a0dbdc2a1f6d58ec70ed08e15bd3d16		

Warnings:

Information:

Total Files Size (in bytes): 1278863

This Acknowledgement Receipt evidences receipt on the noted date by the USPTO of the indicated documents, characterized by the applicant, and including page counts, where applicable. It serves as evidence of receipt similar to a Post Card, as described in MPEP 503.

New Applications Under 35 U.S.C. 111

If a new application is being filed and the application includes the necessary components for a filing date (see 37 CFR 1.53(b)-(d) and MPEP 506), a Filing Receipt (37 CFR 1.54) will be issued in due course and the date shown on this Acknowledgement Receipt will establish the filing date of the application.

National Stage of an International Application under 35 U.S.C. 371

If a timely submission to enter the national stage of an international application is compliant with the conditions of 35 U.S.C. 371 and other applicable requirements a Form PCT/DO/EO/903 indicating acceptance of the application as a national stage submission under 35 U.S.C. 371 will be issued in addition to the Filing Receipt, in due course.

New International Application Filed with the USPTO as a Receiving Office

If a new international application is being filed and the international application includes the necessary components for an international filing date (see PCT Article 11 and MPEP 1810), a Notification of the International Application Number and of the International Filing Date (Form PCT/RO/105) will be issued in due course, subject to prescriptions concerning national security, and the date shown on this Acknowledgement Receipt will establish the international filing date of the application.

Under the Paperwork Reduction Act of 1995, no persons are required to respond to a collection of information unless it displays a valid OMB control number.

PATENT APPLICATION FEE DETERMINATION RECORD Substitute for Form PTO-875					Application or Docket Number 11/200,511	Filing Date 08/08/2005	<input type="checkbox"/> To be Mailed	
APPLICATION AS FILED – PART I								
(Column 1)			(Column 2)		SMALL ENTITY <input type="checkbox"/> OR		OTHER THAN SMALL ENTITY	
FOR	NUMBER FILED	NUMBER EXTRA	RATE (\$)	FEE (\$)	OR	RATE (\$)	FEE (\$)	
<input checked="" type="checkbox"/> BASIC FEE <small>(37 CFR 1.16(a), (b), or (c))</small>	N/A	N/A	N/A			N/A	300	
<input type="checkbox"/> SEARCH FEE <small>(37 CFR 1.16(k), (l), or (m))</small>	N/A	N/A	N/A			N/A		
<input type="checkbox"/> EXAMINATION FEE <small>(37 CFR 1.16(o), (p), or (q))</small>	N/A	N/A	N/A			N/A		
TOTAL CLAIMS <small>(37 CFR 1.16(i))</small>	minus 20 =	*	X \$ =		OR	X \$ =		
INDEPENDENT CLAIMS <small>(37 CFR 1.16(h))</small>	minus 3 =	*	X \$ =			X \$ =		
<input type="checkbox"/> APPLICATION SIZE FEE <small>(37 CFR 1.16(s))</small>	If the specification and drawings exceed 100 sheets of paper, the application size fee due is \$250 (\$125 for small entity) for each additional 50 sheets or fraction thereof. See 35 U.S.C. 41(a)(1)(G) and 37 CFR 1.16(s).							
<input type="checkbox"/> MULTIPLE DEPENDENT CLAIM PRESENT <small>(37 CFR 1.16(j))</small>								
* If the difference in column 1 is less than zero, enter "0" in column 2.								
			TOTAL			TOTAL	300	
APPLICATION AS AMENDED – PART II								
(Column 1)			(Column 2)		SMALL ENTITY OR		OTHER THAN SMALL ENTITY	
AMENDMENT	11/25/2009	CLAIMS REMAINING AFTER AMENDMENT	HIGHEST NUMBER PREVIOUSLY PAID FOR	PRESENT EXTRA	RATE (\$)	ADDITIONAL FEE (\$)	RATE (\$)	ADDITIONAL FEE (\$)
	Total <small>(37 CFR 1.16(o))</small>	* 29	Minus	** 33	= 0	X \$ =	OR X \$2=	0
	Independent <small>(37 CFR 1.16(h))</small>	* 4	Minus	***4	= 0	X \$ =	OR X \$220=	0
	<input type="checkbox"/> Application Size Fee <small>(37 CFR 1.16(s))</small>							
	<input type="checkbox"/> FIRST PRESENTATION OF MULTIPLE DEPENDENT CLAIM <small>(37 CFR 1.16(j))</small>							
			TOTAL ADD'L FEE			TOTAL ADD'L FEE	0	
(Column 1)			(Column 2)		SMALL ENTITY OR		OTHER THAN SMALL ENTITY	
AMENDMENT		CLAIMS REMAINING AFTER AMENDMENT	HIGHEST NUMBER PREVIOUSLY PAID FOR	PRESENT EXTRA	RATE (\$)	ADDITIONAL FEE (\$)	RATE (\$)	ADDITIONAL FEE (\$)
	Total <small>(37 CFR 1.16(o))</small>	*	Minus	**	=	X \$ =	OR X \$ =	
	Independent <small>(37 CFR 1.16(h))</small>	*	Minus	***	=	X \$ =	OR X \$ =	
	<input type="checkbox"/> Application Size Fee <small>(37 CFR 1.16(s))</small>							
	<input type="checkbox"/> FIRST PRESENTATION OF MULTIPLE DEPENDENT CLAIM <small>(37 CFR 1.16(j))</small>							
			TOTAL ADD'L FEE			TOTAL ADD'L FEE		
* If the entry in column 1 is less than the entry in column 2, write "0" in column 3.								
** If the "Highest Number Previously Paid For" IN THIS SPACE is less than 20, enter "20".								
*** If the "Highest Number Previously Paid For" IN THIS SPACE is less than 3, enter "3".								
The "Highest Number Previously Paid For" (Total or Independent) is the highest number found in the appropriate box in column 1.								
					Legal Instrument Examiner: /GLORIA TRAMMELL/			

This collection of information is required by 37 CFR 1.16. The information is required to obtain or retain a benefit by the public which is to file (and by the USPTO to process) an application. Confidentiality is governed by 35 U.S.C. 122 and 37 CFR 1.14. This collection is estimated to take 12 minutes to complete, including gathering, preparing, and submitting the completed application form to the USPTO. Time will vary depending upon the individual case. Any comments on the amount of time you require to complete this form and/or suggestions for reducing this burden, should be sent to the Chief Information Officer, U.S. Patent and Trademark Office, U.S. Department of Commerce, P.O. Box 1450, Alexandria, VA 22313-1450. DO NOT SEND FEES OR COMPLETED FORMS TO THIS ADDRESS. **SEND TO: Commissioner for Patents, P.O. Box 1450, Alexandria, VA 22313-1450.**

If you need assistance in completing the form, call 1-800-PTO-9199 and select option 2.



UNITED STATES PATENT AND TRADEMARK OFFICE

UNITED STATES DEPARTMENT OF COMMERCE
United States Patent and Trademark Office
Address: COMMISSIONER FOR PATENTS
P.O. Box 1450
Alexandria, Virginia 22313-1450
www.uspto.gov

Table with 5 columns: APPLICATION NO., FILING DATE, FIRST NAMED INVENTOR, ATTORNEY DOCKET NO., CONFIRMATION NO.
Row 1: 11/200,511, 08/08/2005, David Champlin, PALM.P962, 2125
Row 2: 30554, 7590, 07/24/2009, EXAMINER GAUTHIER, GERALD
Row 3: SHEMWELL MAHAMEDI LLP, 4880 STEVENS CREEK BOULEVARD, SUITE 201, SAN JOSE, CA 95129-1034, ART UNIT 2614, PAPER NUMBER
Row 4: MAIL DATE 07/24/2009, DELIVERY MODE PAPER

Please find below and/or attached an Office communication concerning this application or proceeding.

The time period for reply, if any, is set in the attached communication.

DETAILED ACTION

Claim Rejections - 35 USC § 103

1. The following is a quotation of 35 U.S.C. 103(a) which forms the basis for all obviousness rejections set forth in this Office action:

(a) A patent may not be obtained though the invention is not identically disclosed or described as set forth in section 102 of this title, if the differences between the subject matter sought to be patented and the prior art are such that the subject matter as a whole would have been obvious at the time the invention was made to a person having ordinary skill in the art to which said subject matter pertains. Patentability shall not be negated by the manner in which the invention was made.

2. The factual inquiries set forth in *Graham v. John Deere Co.*, 383 U.S. 1, 148 USPQ 459 (1966), that are applied for establishing a background for determining obviousness under 35 U.S.C. 103(a) are summarized as follows:

1. Determining the scope and contents of the prior art.
2. Ascertaining the differences between the prior art and the claims at issue.
3. Resolving the level of ordinary skill in the pertinent art.
4. Considering objective evidence present in the application indicating obviousness or nonobviousness.

3. This application currently names joint inventors. In considering patentability of the claims under 35 U.S.C. 103(a), the examiner presumes that the subject matter of the various claims was commonly owned at the time any inventions covered therein were made absent any evidence to the contrary. Applicant is advised of the obligation under 37 CFR 1.56 to point out the inventor and invention dates of each claim that was not commonly owned at the time a later invention was made in order for the examiner to consider the applicability of 35 U.S.C. 103(c) and potential 35 U.S.C. 102(e), (f) or (g) prior art under 35 U.S.C. 103(a).

4. Claims 1-33 are rejected under 35 U.S.C. 103(a) as being unpatentable over Fostick et al. (US 2002/087794 A1) in view of Brown et al. (US 2004/0203794 A1).

Regarding claim 1, Fostick discloses a method for operating a computing device, the method being implemented by one or more processors of the computing device and comprising:

receiving an incoming call from another computing device to initiate a voice-exchange session (pg. 3, para. 36);

in response to receiving the incoming call, determining a message identifier of the computing device of the caller (pg. 3, para. 37), wherein the message identifier is determined based at least in part on data provided with the incoming call (pg. 3, para. 36-37) (SMS message).

Fostick fails to disclose a reply message to the incoming call.

However, Brown teaches responsive to user input, automatically entering at least a portion of an address, for a message to the computing device of the caller, using the message identifier determined from the incoming call [The function continues in block 210, where an auto-response message is transmitted over the voice path. Typically, the auto-response message is recorded earlier by the user for later use, paragraph 0027].

Therefore, it would have been obvious to one of the ordinary skill in the art at the time the invention was made to modify the invention of Fostick using the teaching of auto response to an incoming call as taught by Brown.

This modification of the invention enables the system to automatically entering at least a portion of an address, for a message to the computing device of the caller so that the user would know the identity of the caller for any calls that are automatically responded to.

Regarding claims 2, 20 and 29, Fostick discloses further comprising, in response to receiving the incoming call, enabling a user of the computing device to elect to compose and transmit the message (pg. 3, para. 36-37) (automatic handling server).

Regarding claims 3, 22 and 31, Fostick discloses further comprising: generating a graphic user-interface feature that prompts the user to elect to have the message at least partially composed in response to the incoming call (pg. 1, para. 8) (pg. 3, para. 42-43) (user response keys); and

generating the message in response to a user-input electing to have the message at least partially composed (pg. 1, para. 8) (pg. 3, para. 42-43) (user response keys).

Regarding claim 4, Fostick discloses wherein automatically entering at least a portion of an address includes programmatically addressing an instant text message (pg. 3, para. 37) (SMSC).

Regarding claims 5 and 25, Fostick discloses wherein the instant text message is in a Short Message Service format (pg. 3, para. 37) (SMSC).

Regarding claims 6, 21 and 26, Fostick discloses wherein the instant text message application corresponds to a Short Message Service application, and the instant text message identifier is a phone number (pg. 3, para. 40) (pg. 2, para. 18).

Regarding claims 7, 23 and 27, Fostick discloses wherein programmatically addressing a message to the other computing device includes determining the message identifier from a phone number of the other computing device (pg. 3, para. 40) (pg. 2, para. 18).

Regarding claims 8 and 28, Fostick discloses further comprising verifying that a device of the other computing device is enabled for receiving the message (pg. 2, para. 32-33).

Regarding claim 9, Fostick discloses wherein verifying that a device of the other computing device is enabled for receiving the message includes (i) identifying a phone number of the other computing device used for the incoming call (pg. 3, para. 40) (pg. 2, para. 18), and (ii) determining that the phone number is associated with a message-enabled device that can handle an instant message response (pg. 2, para. 32-33).

Regarding claim 10, Fostick discloses wherein determining that the phone number is associated with a message enabled device includes accessing a contact record of the caller using the data provided with the incoming call, and using the contact record to verify that the phone number is capable of being used to receive the message (pg. 3, para. 40-41).

Regarding claims 11 and 32, Fostick discloses wherein the message is an instant or text message, and wherein using the contact record to verify that the phone number is

capable of being used to receive the instant or text message includes checking the contact record associated with the caller to see whether the phone number of the incoming call is for a mobile telephony device that can handle the instant or text message (pg. 3, para. 40-41).

Regarding claim 12, Fostick discloses wherein determining that the phone number is associated with the message enabled device is performed programmatically and automatically (pg. 3, para. 40-42).

Regarding claim 13, Fostick discloses wherein transmitting a message to the other computing device is based upon using a phone number of the incoming call as the address for a new instant message (pg. 3, para. 40-41).

Regarding claims 14 and 33, Fostick discloses wherein using a phone number of the incoming call as the address for a new instant or text message includes launching either an instant or text messaging application (pg. 3, para. 40-41), and initiating a new message using the phone number of the caller as the address of the new message (pg. 3, para. 40-41).

Regarding claim 15, Fostick discloses wherein launching either the instant or text messaging application and initiating a new message are performed automatically (pg. 3, para. 40-42), in response to one of (i) receiving the incoming call (pg. 3, para. 36), or (ii)

receiving an input from a user of the computing telephony device indicating a desire to send the instant message as a response to the incoming call (pg. 3, para. 36-37).

Regarding claim 16, Fostick discloses further comprising enabling a user of the computing device to provide content manually for the message (It is known to one skilled in the art how to manually generate and send a text message).

Regarding claim 17, Fostick discloses further comprising enabling a user of the computing device to trigger insertion of pre-formulated content for the message (pg. 4, para. 41-42).

Regarding claim 18, Fostick discloses further comprising automatically and programmatically providing at least a portion of a body of message pg. 4, para. 41-42).

Regarding claim 19, the combination of Fostick and Brown discloses all the limitations of claim 19 as stated in claim 1's rejection above.

Regarding claim 24, the combination of Fostick and Brown discloses all the limitations of claim 24 as stated in claim 1's rejection above.

Regarding claim 30, the combination of Fostick and Brown discloses all the limitations of claim 30 as stated in claim 1's rejection above.

Response to Arguments

5. Applicant's arguments with respect to claims 1-33 have been considered but are moot in view of the new ground(s) of rejection.

Conclusion

6. Any inquiry concerning this communication or earlier communications from the examiner should be directed to Gerald Gauthier whose telephone number is (571) 272-7539. The examiner can normally be reached on 8:00 AM to 4:30 PM.

If attempts to reach the examiner by telephone are unsuccessful, the examiner's supervisor, Fan Tsang can be reached on (571) 272-7547. The fax phone number for the organization where this application or proceeding is assigned is 571-273-8300.

Information regarding the status of an application may be obtained from the Patent Application Information Retrieval (PAIR) system. Status information for published applications may be obtained from either Private PAIR or Public PAIR. Status information for unpublished applications is available through Private PAIR only. For more information about the PAIR system, see <http://pair-direct.uspto.gov>. Should you have questions on access to the Private PAIR system, contact the Electronic Business Center (EBC) at 866-217-9197 (toll-free). If you would like assistance from a USPTO Customer Service Representative or access to the automated information system, call 800-786-9199 (IN USA OR CANADA) or 571-272-1000.

/Gerald Gauthier/

Application/Control Number: 11/200,511
Art Unit: 2614

Page 9

Primary Examiner, Art Unit 2614

Notice of References Cited	Application/Control No. 11/200,511	Applicant(s)/Patent Under Reexamination CHAMPLIN ET AL.	
	Examiner Gerald Gauthier	Art Unit 2614	Page 1 of 2

U.S. PATENT DOCUMENTS

*		Document Number Country Code-Number-Kind Code	Date MM-YYYY	Name	Classification
*	A	US-4,996,704 A	02-1991	Brunson, Gordon R.	379/88.19
*	B	US-6,055,305 A	04-2000	Norman et al.	379/211.01
*	C	US-6,229,878 B1	05-2001	Moganti, Madhav	379/67.1
*	D	US-6,430,271 B1	08-2002	DeJesus et al.	379/88.22
*	E	US-6,697,473 B2	02-2004	Batten, Bobby G.	379/199
*	F	US-6,795,530 B1	09-2004	Gilbert et al.	379/76
*	G	US-2004/0203794 A1	10-2004	Brown et al.	455/445
*	H	US-2004/0230494 A1	11-2004	Lotvin et al.	705/026
*	I	US-2005/0201533 A1	09-2005	Emam et al.	379/088.19
*	J	US-2005/0216949 A1	09-2005	Candelora et al.	725/134
*	K	US-2006/0015644 A1	01-2006	Cernohous et al.	709/238
*	L	US-7,010,288 B2	03-2006	Brown et al.	455/412.1
*	M	US-2006/0215829 A1	09-2006	Schwartz, Paul M.	379/207.02

FOREIGN PATENT DOCUMENTS

*		Document Number Country Code-Number-Kind Code	Date MM-YYYY	Country	Name	Classification
	N					
	O					
	P					
	Q					
	R					
	S					
	T					

NON-PATENT DOCUMENTS

*		Include as applicable: Author, Title Date, Publisher, Edition or Volume, Pertinent Pages)
	U	
	V	
	W	
	X	

*A copy of this reference is not being furnished with this Office action. (See MPEP § 707.05(a).)
Dates in MM-YYYY format are publication dates. Classifications may be US or foreign.

Notice of References Cited	Application/Control No. 11/200,511	Applicant(s)/Patent Under Reexamination CHAMPLIN ET AL.	
	Examiner Gerald Gauthier	Art Unit 2614	Page 2 of 2

U.S. PATENT DOCUMENTS

*		Document Number Country Code-Number-Kind Code	Date MM-YYYY	Name	Classification
*	A	US-7,136,466 B1	11-2006	Gao, Xiaofeng	379/93.23
*	B	US-2007/0003027 A1	01-2007	Brandt, Marc	379/088.14
*	C	US-2007/0081657 A1	04-2007	Turner, R. Brough	379/257
*	D	US-2007/0121607 A1	05-2007	Gao, Xiaofeng	370/356
*	E	US-2007/0258567 A1	11-2007	Koch, Robert A.	379/088.21
*	F	US-2008/0253549 A1	10-2008	Loveland, Shawn D.	379/202.01
*	G	US-2009/0005023 A1	01-2009	Toorn, Fredrik	455/415
	H	US-			
	I	US-			
	J	US-			
	K	US-			
	L	US-			
	M	US-			

FOREIGN PATENT DOCUMENTS

*		Document Number Country Code-Number-Kind Code	Date MM-YYYY	Country	Name	Classification
	N					
	O					
	P					
	Q					
	R					
	S					
	T					

NON-PATENT DOCUMENTS

*		Include as applicable: Author, Title Date, Publisher, Edition or Volume, Pertinent Pages)
	U	
	V	
	W	
	X	

*A copy of this reference is not being furnished with this Office action. (See MPEP § 707.05(a).)
Dates in MM-YYYY format are publication dates. Classifications may be US or foreign.

Search Notes 	Application/Control No. 11200511	Applicant(s)/Patent Under Reexamination CHAMPLIN ET AL.
	Examiner Gerald Gauthier	Art Unit 2614

SEARCHED			
Class	Subclass	Date	Examiner
379	67.1	2/24/09	JCA
379	88.13	2/24/09	JCA
455	414.4	2/24/09	JCA
370	356	7/22/2009	GG
379	76, 88.19, 88.21, 93.23, 202.01, 257	7/22/2009	GG
455	412.1, 415, 445	7/22/2009	GG
705	26	7/22/2009	GG
709	238	7/22/2009	GG
725	134	7/22/2009	GG

SEARCH NOTES		
Search Notes	Date	Examiner
Searched East and Google Patents	2/24/09	JCA
EAST: (US-PGPUB; USPAT; USOCR)	7/22/2009	GG

INTERFERENCE SEARCH			
Class	Subclass	Date	Examiner

	/Gerald Gauthier/ Primary Examiner. Art Unit 2614
--	--

EAST Search History**EAST Search History (Prior Art)**

Ref #	Hits	Search Query	DBs	Default Operator	Plurals	Time Stamp
L2	18	incoming near5 communication with voice with call with identifier	US-PGPUB; USPAT; USOCR; FPRS; EPO; JPO; DERWENT; IBM_TDB	OR	ON	2009/07/22 09:17
L3	0	incoming with communication with voice with call with identifier with computing with device	US-PGPUB; USPAT; USOCR; FPRS; EPO; JPO; DERWENT; IBM_TDB	OR	ON	2009/07/22 09:24
L4	10	incoming with communication with voice with call with computing with device	US-PGPUB; USPAT; USOCR; FPRS; EPO; JPO; DERWENT; IBM_TDB	OR	ON	2009/07/22 09:25
L5	14	incoming with communication with voice with computing with device	US-PGPUB; USPAT; USOCR; FPRS; EPO; JPO; DERWENT; IBM_TDB	OR	ON	2009/07/22 09:25
L6	2720	incoming with call with (response reply) with message	US-PGPUB; USPAT; USOCR; FPRS; EPO; JPO; DERWENT; IBM_TDB	OR	ON	2009/07/22 09:33
L7	2060	(incoming adj call) with (response reply) with message	US-PGPUB; USPAT; USOCR; FPRS; EPO; JPO; DERWENT; IBM_TDB	OR	ON	2009/07/22 09:33
L8	179	7 same identif\$4	US-PGPUB; USPAT; USOCR; FPRS; EPO; JPO; DERWENT; IBM_TDB	OR	ON	2009/07/22 09:34

EAST Search History

L9	775	(incoming adj call) with ((response reply) near message)	US-PGPUB; USPAT; USOCR; FPRS; EPO; JPO; DERWENT; IBM_TDB	OR	ON	2009/07/22 09:35
L10	58	9 same identif\$4	US-PGPUB; USPAT; USOCR; FPRS; EPO; JPO; DERWENT; IBM_TDB	OR	ON	2009/07/22 09:35
L11	3	10 same option	US-PGPUB; USPAT; USOCR; FPRS; EPO; JPO; DERWENT; IBM_TDB	OR	ON	2009/07/22 09:57
L12	506	(calling caller) same customiz\$3 same (greeting message) same (identification id identif\$3)	US-PGPUB; USPAT; USOCR; FPRS; EPO; JPO; DERWENT; IBM_TDB	OR	ON	2009/07/22 10:03
L13	134	12 same incoming	US-PGPUB; USPAT; USOCR; FPRS; EPO; JPO; DERWENT; IBM_TDB	OR	ON	2009/07/22 10:05

7/ 22/ 2009 2:13:04 PM

C:\ Documents and Settings\ ggauthier\ My Documents\ EAST\ workspaces\ 11200511.wsp

Index of Claims 	Application/Control No. 11200511	Applicant(s)/Patent Under Reexamination CHAMPLIN ET AL.
	Examiner Gerald Gauthier	Art Unit 2614

✓	Rejected	-	Cancelled	N	Non-Elected	A	Appeal
=	Allowed	÷	Restricted	I	Interference	O	Objected

Claims renumbered in the same order as presented by applicant
 CPA
 T.D.
 R.1.47

CLAIM		DATE							
Final	Original	02/24/2009	07/22/2009						
	1	✓	✓						
	2	✓	✓						
	3	✓	✓						
	4	✓	✓						
	5	✓	✓						
	6	✓	✓						
	7	✓	✓						
	8	✓	✓						
	9	✓	✓						
	10	✓	✓						
	11	✓	✓						
	12	✓	✓						
	13	✓	✓						
	14	✓	✓						
	15	✓	✓						
	16	✓	✓						
	17	✓	✓						
	18	✓	✓						
	19	✓	✓						
	20	✓	✓						
	21	✓	✓						
	22	✓	✓						
	23	✓	✓						
	24	✓	✓						
	25	✓	✓						
	26	✓	✓						
	27	✓	✓						
	28	✓	✓						
	29		✓						
	30		✓						
	31		✓						
	32		✓						
	33		✓						

Atty. Docket No. PALM.0962

PATENT

IN THE UNITED STATES PATENT OFFICE

In Re Patent Application of

First Named Inventor: Champlin et al.

Application No.: 11/200,511

Filed: 8/8/2005

For: METHOD AND DEVICE FOR ENABLING
MESSAGE RESPONSES TO INCOMING PHONE
CALLS

Examiner: Arnott, James C.

Art Unit: 4182

Confirmation 2125
No.:

Mail Stop Amendment
Commissioner for Patents
P.O. Box 1450
Alexandria, VA 22313-1450

RESPONSE TO OFFICE ACTION

Dear Sir/Madam:

In response to the Office Action mailed February 27, 2009 (the "Office Action"), applicant respectfully requests that the above-identified application be amended as set forth below.

Amendment to the Claims: Begins on page 2 of this paper.

Remarks: Begin on page 9 of this paper.

IN THE CLAIMS:

1. (Currently Amended) A method for operating a computing device, the method being implemented by one or more processors of the computing device and comprising:

receiving an incoming ~~communication call~~ from another computing device to initiate a voice-exchange session;

in response to receiving the incoming call, determining a message identifier of the ~~other~~ computing device of the caller, wherein the message identifier is determined based at least in part on data provided with the incoming ~~call-communication~~; and

~~transmitting responsive to user input, automatically entering at least a portion of an address, for a message to the other-computing device of the caller,~~ using the message identifier determined from the incoming ~~call-communication~~.

2. (Currently Amended) The method of claim 1, further comprising, in response to receiving the incoming ~~communication call~~, enabling a user of the computing device to elect to compose and transmit the message. ~~between at least (i) generating the message, or (ii) not generating the message.~~

3. (Currently Amended) The method of claim 1, further comprising:

generating a graphic user-interface feature that prompts the user to elect to have a the message ~~generated at least partially composed~~ in response to the incoming ~~call-communication~~; and

~~wherein generating the message is performed~~ in response to a user-input electing to have the message at least partially composed-generated.

4. (Currently Amended) The method of claim 1, wherein automatically entering at least a

~~portion of an address programmatically addressing a message to the other computing device~~
includes programmatically addressing an instant text message.

5. (Original) The method of claim 4, wherein the instant text message is in a Short Message Service format.

6. (Original) The method of claim 5, wherein the instant text message application corresponds to a Short Message Service application, and the instant text message identifier is a phone number.

7. (Original) The method of claim 4, wherein programmatically addressing a message to the other computing device includes determining the message identifier from a phone number of the other computing device.

8. (Original) The method of claim 1, further comprising verifying that a device of the other computing device is enabled for receiving the message.

9. (Currently Amended) The method of claim 8, wherein:

~~receiving an incoming communication includes receiving an incoming call; and~~
verifying that a device of the other computing device is enabled for receiving the message includes (i) identifying a phone number of the other computing device used for the incoming call, and (ii) determining that the phone number is associated with a message-enabled device that can handle ~~an a text or~~ instant message response.

10. (Original) The method of claim 9, wherein determining that the phone number is associated with a message enabled device includes accessing a contact record of the caller using the data provided with the incoming call, and using the contact record to verify that the phone

number is capable of being used to receive the message.

11. (Currently Amended) The method of claim 10, wherein the message is an instant or text message, and wherein using the contact record to verify that the phone number is capable of being used to receive the instant or text message includes checking the contact record associated with the caller to see whether the phone number of the incoming call is for a mobile telephony device that can handle the instant or text message.

12. (Original) The method of claim 10, wherein determining that the phone number is associated with the message enabled device is performed programmatically and automatically.

13. (Currently Amended) The method of claim 1, wherein:

~~receiving an incoming communication from another computing device includes receiving an incoming call from the other computing device; and~~

transmitting a message to the other computing device is based upon using a phone number of the incoming call as the address for a new instant message.

14. (Currently Amended) The method of claim 13, wherein using a phone number of the incoming call as the address for a new instant or text message includes launching either an instant or text messaging application, and initiating a new message using the phone number of the caller as the address of the new message.

15. (Currently Amended) The method of claim 14, wherein launching ~~an~~ either the instant or text messaging application and initiating a new message are performed automatically, in response to one of (i) receiving the incoming call, or (ii) receiving an input from a user of the computing telephony device indicating a desire to send the instant message as a response to the

incoming call.

16. (Currently Amended) The method of claim 1, further comprising enabling a user of the computing ~~telephony~~ device to provide content manually for the message.

17. (Currently Amended) The method of claim 1, further comprising enabling a user of the computing ~~telephony~~ device to trigger insertion of pre-formulated content for the message.

18. (Original) The method of claim 1, further comprising automatically and programmatically providing at least a portion of a body of message.

19. (Currently Amended) A computing device comprising:
one or more communication components for handling voice and messaging communications over wireless networks;
one or more processors configured to:
 receive an incoming phone call originating from another device;
 determining a phone number of the other device based, at least in part, on the received phone call; and
 programmatically generate at least a portion of a message to be transmitted to the other device using the ~~identified~~ phone number identified from the received phone call.

20. (Original) The computing device of claim 19, wherein the one or more processors are configured to enable the message to be generated prior to the incoming phone call being resolved.

21. (Original) The computing device of claim 19, wherein the one or more processors are configured to enable a text message to be generated.

22. (Original) The computing device of claim 19, wherein the one or more processors are configured to enable the message to be generated containing a message body of a format selected from one or more of text, image and audio.

23. (Original) The computing device of claim 19, further comprising a display, and wherein the one or more processors enable the message to be generated by prompting the user on the screen to generate the message as one of one or more options to handling the incoming phone call.

24. (Currently Amended) A method for operating a computing device, the method being implemented by one or more processors of the computing device and comprising:

identifying a phone number of a caller of an incoming phone call;

prompting a user of the computing device to generate a message reply to the incoming phone call; and

initiating the message reply by opening a message and addressing the message to the phone number of the caller of the incoming phone call.

25. (Original) The method of claim 24, wherein initiating the message reply by opening a message and addressing the message to the phone number includes addressing a SMS message to the phone number of the caller.

26. (Original) The method of claim 25, further comprising enabling a user to specify a message body for the SMS message.

27. (Original) The method of claim 24, further comprising enabling a user of the computing device to send the message and then answer the call after sending the message.

28. (Original) The method of claim 24, further comprising enabling a user of the computing device to send the message and then decline answering the call after sending the message.

29. (New) The method of claim 1, wherein the computing device is the intended recipient of the incoming call.

30. (New) A computing device comprising:

one or more processors;

one or more wireless communication ports that communicate with the one or more processors to enable the device to handle both voice and messaging communications over one or more wireless networks;

wherein the one or more processors are configured to:

receive an incoming telephony communication over one of the wireless communication ports from another computing device;

in response to receiving the incoming telephony communication, determine a message identifier of the other computing device, wherein the message identifier is determined based at least in part on data provided with the incoming telephony communication; and

enable a user to elect to respond to the incoming telephony communication by programmatic addressing a message to the other computing device using the message identifier that is communicated with the incoming telephony communication.

31. (New) The computing device of claim 30, further comprising a display, and wherein the one or more processors are configured to generate on the display a graphic user-interface feature

that prompts the user to elect to have a message generated in response to the incoming telephony communication.

32. (New) The computing device of claim 30, further comprising memory resources that store a plurality of contact records on the computing device, and wherein the one or more processors are configured to make a determination as to whether a phone number of the incoming telephony communication is associated with a message enabled device.

33. (New) The computing device of claim 32, wherein the one or more processors are configured to make the determination by accessing a corresponding one of the plurality of contact records of the caller using the data provided with the incoming telephony communication, and using the corresponding contact record to verify that the phone number is capable of being used to receive the message.

REMARKS

Applicant respectfully requests reconsideration of this application. Claims 1-4, 9, 11, 13-17, 19 and 24 has been amended. New Claims 29-33 have been added. No new matter has been added.

Summary of The Office Action

- Claims 1-28 have been rejected under 35 U.S.C. § 102(b) as being anticipated by U.S. Patent Publication No. 2002/0187794 to Fostick et al. (“Fostick”).

Detailed Remarks

Claim Rejections – 35 U.S.C. § 102

Claims 1-28 stand rejected under 35 U.S.C. § 102(b) as being anticipated by Fostick.

Claim 1 recites, in part:

“responsive to user input, automatically entering at least a portion of an address, for a message to the computing device of the caller, using the message identifier ***determined from the incoming call.***”

Applicant submits that Fostick does not disclose or suggest this limitation. Fostick does disclose an SMS Center that intercepts *SMS messages* sent from a message sender to a message recipient, and queries an automatic reply message server (ARMS) for automatic reply messages (Fostick, paragraphs, [0002], [0036] and [0041]). However, nowhere does Fostick suggest or disclose that the SMS Center is capable of receiving incoming *calls*, much less sending automatic reply messages in response to such calls. Thus, even assuming arguendo that the SMS Center, in Fostick, corresponds to a computing device, as suggested by the Office Action, Fostick still does not suggest or disclose “automatically entering at least a portion of an address, for a message to the computing device of the caller, using the message identifier *determined from the*

incoming call,” as recited in Claim 1. Applicant therefore respectfully submits that Fostick does not disclose or suggest at least the above-recited limitation, and therefore does not anticipate Claim 1, nor dependent Claims 2-18.

Claim 19 recites, in part:

“programmatically generate at least a portion of a message to be transmitted to the other device using the phone number *identified from the received phone call.*”

Applicant respectfully submits that, for at least the reasons given with respect to Claim 1, Fostick does not disclose or suggest the above-recited limitation, and therefore does not anticipate Claim 19, nor dependent Claims 20-23.

Claim 24 recites, in part:

“prompting a user of the computing device to generate a message reply to *the incoming phone call;*”

Applicant respectfully submits that, for at least the reasons given with respect to Claim 1, Fostick does not disclose or suggest the above-recited limitation, and therefore does not anticipate Claim 24, nor dependent Claims 25-28.

CONCLUSION

A Notice of Allowance is respectfully requested. If there are any questions or comments that the Examiner wishes to direct to Applicant's attorney, the Examiner is invited to call Applicant's attorney at (408) 551-6632.

If there are any additional charges, please charge them to Deposit Account No. 50-1914.

Respectfully submitted,

SHEMWELL MAHAMEDI LLP

Date: 5/27/09

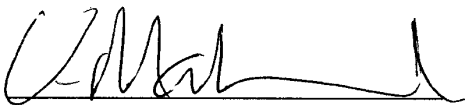

Van Mahamedi, Reg. No. 42,828
Tel. 408-551-6632

Electronic Patent Application Fee Transmittal

Application Number:	11200511
Filing Date:	08-Aug-2005
Title of Invention:	Method and device for enabling message responses to incoming phone calls
First Named Inventor/Applicant Name:	David Champlin
Filer:	Zurvan Mahamedi/Tom Shea
Attorney Docket Number:	PALM.P962

Filed as Large Entity

Utility under 35 USC 111(a) Filing Fees

Description	Fee Code	Quantity	Amount	Sub-Total in USD(\$)
Basic Filing:				
Pages:				
Claims:				
Claims in excess of 20	1202	5	52	260
Independent claims in excess of 3	1201	1	220	220

Miscellaneous-Filing:

Petition:

Patent-Appeals-and-Interference:

Post-Allowance-and-Post-Issuance:

Description	Fee Code	Quantity	Amount	Sub-Total in USD(\$)
Extension-of-Time:				
Miscellaneous:				
Total in USD (\$)				480

Electronic Acknowledgement Receipt

EFS ID:	5409256
Application Number:	11200511
International Application Number:	
Confirmation Number:	2125
Title of Invention:	Method and device for enabling message responses to incoming phone calls
First Named Inventor/Applicant Name:	David Champlin
Customer Number:	30554
Filer:	Zurvan Mahamedi/Tom Shea
Filer Authorized By:	Zurvan Mahamedi
Attorney Docket Number:	PALM.P962
Receipt Date:	27-MAY-2009
Filing Date:	08-AUG-2005
Time Stamp:	21:29:42
Application Type:	Utility under 35 USC 111(a)

Payment information:

Submitted with Payment	yes
Payment Type	Deposit Account
Payment was successfully received in RAM	\$480
RAM confirmation Number	7286
Deposit Account	501914
Authorized User	

The Director of the USPTO is hereby authorized to charge indicated fees and credit any overpayment as follows:

Charge any Additional Fees required under 37 C.F.R. Section 1.16 (National application filing, search, and examination fees)

Charge any Additional Fees required under 37 C.F.R. Section 1.21 (Miscellaneous fees and charges)

File Listing:					
Document Number	Document Description	File Name	File Size(Bytes)/ Message Digest	Multi Part /.zip	Pages (if appl.)
1		PALM_0962_ROA_2-27-2009_A F.pdf	672574 714b58fc405309eb7d4ca3e8317d59c6ecc0e5a8	yes	11
Multipart Description/PDF files in .zip description					
		Document Description	Start	End	
		Amendment/Req. Reconsideration-After Non-Final Reject	1	1	
		Claims	2	8	
		Applicant Arguments/Remarks Made in an Amendment	9	11	
Warnings:					
Information:					
2	Fee Worksheet (PTO-875)	fee-info.pdf	31549 1573ba44f857f61560ec44e45a8d371c64b19a01	no	2
Warnings:					
Information:					
Total Files Size (in bytes):			704123		
<p>This Acknowledgement Receipt evidences receipt on the noted date by the USPTO of the indicated documents, characterized by the applicant, and including page counts, where applicable. It serves as evidence of receipt similar to a Post Card, as described in MPEP 503.</p> <p><u>New Applications Under 35 U.S.C. 111</u> If a new application is being filed and the application includes the necessary components for a filing date (see 37 CFR 1.53(b)-(d) and MPEP 506), a Filing Receipt (37 CFR 1.54) will be issued in due course and the date shown on this Acknowledgement Receipt will establish the filing date of the application.</p> <p><u>National Stage of an International Application under 35 U.S.C. 371</u> If a timely submission to enter the national stage of an international application is compliant with the conditions of 35 U.S.C. 371 and other applicable requirements a Form PCT/DO/EO/903 indicating acceptance of the application as a national stage submission under 35 U.S.C. 371 will be issued in addition to the Filing Receipt, in due course.</p> <p><u>New International Application Filed with the USPTO as a Receiving Office</u> If a new international application is being filed and the international application includes the necessary components for an international filing date (see PCT Article 11 and MPEP 1810), a Notification of the International Application Number and of the International Filing Date (Form PCT/RO/105) will be issued in due course, subject to prescriptions concerning national security, and the date shown on this Acknowledgement Receipt will establish the international filing date of the application.</p>					

Under the Paperwork Reduction Act of 1995, no persons are required to respond to a collection of information unless it displays a valid OMB control number.

PATENT APPLICATION FEE DETERMINATION RECORD Substitute for Form PTO-875					Application or Docket Number 11/200,511		Filing Date 08/08/2005		<input type="checkbox"/> To be Mailed		
APPLICATION AS FILED – PART I											
(Column 1)			(Column 2)			SMALL ENTITY <input type="checkbox"/> OR		OTHER THAN SMALL ENTITY			
FOR	NUMBER FILED	NUMBER EXTRA	RATE (\$)	FEE (\$)		RATE (\$)	FEE (\$)				
<input type="checkbox"/> BASIC FEE (37 CFR 1.16(a), (b), or (c))	N/A	N/A	N/A			N/A					
<input type="checkbox"/> SEARCH FEE (37 CFR 1.16(k), (l), or (m))	N/A	N/A	N/A			N/A					
<input type="checkbox"/> EXAMINATION FEE (37 CFR 1.16(o), (p), or (q))	N/A	N/A	N/A			N/A					
TOTAL CLAIMS (37 CFR 1.16(i))	minus 20 =	*	X \$ =		OR	X \$ =					
INDEPENDENT CLAIMS (37 CFR 1.16(h))	minus 3 =	*	X \$ =			X \$ =					
<input type="checkbox"/> APPLICATION SIZE FEE (37 CFR 1.16(s))	If the specification and drawings exceed 100 sheets of paper, the application size fee due is \$250 (\$125 for small entity) for each additional 50 sheets or fraction thereof. See 35 U.S.C. 41(a)(1)(G) and 37 CFR 1.16(s).										
<input type="checkbox"/> MULTIPLE DEPENDENT CLAIM PRESENT (37 CFR 1.16(j))											
			TOTAL			TOTAL					
* If the difference in column 1 is less than zero, enter "0" in column 2.											
APPLICATION AS AMENDED – PART II											
(Column 1)			(Column 2)		(Column 3)		SMALL ENTITY OR		OTHER THAN SMALL ENTITY		
AMENDMENT	05/27/2009	CLAIMS REMAINING AFTER AMENDMENT		HIGHEST NUMBER PREVIOUSLY PAID FOR	PRESENT EXTRA	RATE (\$)	ADDITIONAL FEE (\$)		RATE (\$)	ADDITIONAL FEE (\$)	
	Total (37 CFR 1.16(i))	* 33	Minus	** 28	= 5	X \$ =		OR	X \$2=	260	
	Independent (37 CFR 1.16(h))	* 4	Minus	***3	= 1	X \$ =		OR	X \$220=	220	
	<input type="checkbox"/> Application Size Fee (37 CFR 1.16(s))										
	<input type="checkbox"/> FIRST PRESENTATION OF MULTIPLE DEPENDENT CLAIM (37 CFR 1.16(j))										
						TOTAL ADD'L FEE			TOTAL ADD'L FEE		480
AMENDMENT		CLAIMS REMAINING AFTER AMENDMENT		HIGHEST NUMBER PREVIOUSLY PAID FOR	PRESENT EXTRA	RATE (\$)	ADDITIONAL FEE (\$)		RATE (\$)	ADDITIONAL FEE (\$)	
	Total (37 CFR 1.16(i))	*	Minus	**	=	X \$ =		OR	X \$ =		
	Independent (37 CFR 1.16(h))	*	Minus	***	=	X \$ =		OR	X \$ =		
	<input type="checkbox"/> Application Size Fee (37 CFR 1.16(s))										
	<input type="checkbox"/> FIRST PRESENTATION OF MULTIPLE DEPENDENT CLAIM (37 CFR 1.16(j))										
						TOTAL ADD'L FEE			TOTAL ADD'L FEE		
* If the entry in column 1 is less than the entry in column 2, write "0" in column 3.											
** If the "Highest Number Previously Paid For" IN THIS SPACE is less than 20, enter "20".											
*** If the "Highest Number Previously Paid For" IN THIS SPACE is less than 3, enter "3".											
The "Highest Number Previously Paid For" (Total or Independent) is the highest number found in the appropriate box in column 1.											

Legal Instrument Examiner:
/MARCIA J. GORDON/

This collection of information is required by 37 CFR 1.16. The information is required to obtain or retain a benefit by the public which is to file (and by the USPTO to process) an application. Confidentiality is governed by 35 U.S.C. 122 and 37 CFR 1.14. This collection is estimated to take 12 minutes to complete, including gathering, preparing, and submitting the completed application form to the USPTO. Time will vary depending upon the individual case. Any comments on the amount of time you require to complete this form and/or suggestions for reducing this burden, should be sent to the Chief Information Officer, U.S. Patent and Trademark Office, U.S. Department of Commerce, P.O. Box 1450, Alexandria, VA 22313-1450. DO NOT SEND FEES OR COMPLETED FORMS TO THIS ADDRESS. **SEND TO: Commissioner for Patents, P.O. Box 1450, Alexandria, VA 22313-1450.**

If you need assistance in completing the form, call 1-800-PTO-9199 and select option 2.



UNITED STATES PATENT AND TRADEMARK OFFICE

UNITED STATES DEPARTMENT OF COMMERCE
United States Patent and Trademark Office
Address: COMMISSIONER FOR PATENTS
P.O. Box 1450
Alexandria, Virginia 22313-1450
www.uspto.gov

APPLICATION NO.	FILING DATE	FIRST NAMED INVENTOR	ATTORNEY DOCKET NO.	CONFIRMATION NO.
-----------------	-------------	----------------------	---------------------	------------------

11/200,511	08/08/2005	David Champlin	PALM.P962	2125
------------	------------	----------------	-----------	------

30554 7590 02/27/2009
 SHEMWELL MAHAMEDI LLP
 4880 STEVENS CREEK BOULEVARD
 SUITE 201
 SAN JOSE, CA 95129-1034

EXAMINER

ARNOTT, JAMES C

ART UNIT	PAPER NUMBER
----------	--------------

4182

MAIL DATE	DELIVERY MODE
-----------	---------------

02/27/2009

PAPER

Please find below and/or attached an Office communication concerning this application or proceeding.

The time period for reply, if any, is set in the attached communication.

DETAILED ACTION

1. This is in response to application filed on 8/08/2005 in which claims 1-28 are presented for examination.

Status of claims

2. Claims 1-28 are pending of which claims 1, 19, and 24 are in independent form.

Claim Rejections - 35 USC § 102

The following is a quotation of the appropriate paragraphs of 35 U.S.C. 102 that form the basis for the rejections under this section made in this Office action:

A person shall be entitled to a patent unless –

(b) the invention was patented or described in a printed publication in this or a foreign country or in public use or on sale in this country, more than one year prior to the date of application for patent in the United States.

3. **Claims 1-28** are rejected under 35 U.S.C. 102(b) as anticipated by Fostick et al. (Hereinafter referred to as Fostick) (US 2002/0187794 A1)

Regarding claim 1, Fostick discloses a method for operating a computing device, the method comprising: receiving an incoming communication from another computing device to initiate a voice-exchange session (pg. 3, para. 36); in response to receiving the incoming call, determining a message identifier of the other computing device (pg. 3, para. 37), wherein the message identifier is determined based at least in part on data provided with the incoming communication (pg. 3, para. 36-37) (SMS message); and transmitting a message to the other computing device using the message identifier determined from the incoming communication (pg. 3, para. 36-37) (SMS message)

reply).

Regarding claim 2, Fostick discloses further comprising, in response to receiving the incoming communication, enabling a user of the computing device to elect between at least (i) generating the message, or (ii) not generating the message (pg. 3, para. 36-37) (automatic handling server).

Regarding claim 3, Fostick discloses further comprising: generating a graphic user-interface feature that prompts the user to elect to have a message generated in response to the incoming communication, and wherein generating the message is performed in response to a user-input electing to have the message generated (pg. 1, para. 8) (pg. 3, para. 42-43) (user response keys).

Regarding claim 4, Fostick discloses wherein programmatically addressing a message to the other computing device includes programmatically addressing an instant text message (pg. 3, para. 37) (SMSC).

Regarding claim 5, Fostick discloses wherein the instant text message is in a Short Message Service format (pg. 3, para. 37) (SMSC).

Regarding claim 6, Fostick discloses wherein the instant text message application corresponds to a Short Message Service application, and the instant text message identifier is a phone number (pg. 3, para. 40) (pg. 2, para. 18).

Regarding claim 7, Fostick discloses wherein programmatically addressing a message to the other computing device includes determining the message identifier from a phone number of the other computing device (pg. 3, para. 40) (pg. 2, para. 18).

Regarding claim 8, Fostick discloses further comprising verifying that a device of the

other computing device is enabled for receiving the message (pg. 2, para. 32-33).

Regarding claim 9, Fostick discloses wherein: receiving an incoming communication includes receiving an incoming call (pg. 3, para. 36); and verifying that a device of the other computing device is enabled for receiving the message includes (i) identifying a phone number of the other computing device used for the incoming call (pg. 3, para. 40) (pg. 2, para. 18), and (ii) determining that the phone number is associated with a message-enabled device that can handle an instant message response (pg. 2, para. 32-33).

Regarding claim 10, Fostick discloses wherein determining that the phone number is associated with a message enabled device includes accessing a contact record of the caller using the data provided with the incoming call, and using the contact record to verify that the phone number is capable of being used to receive the message (pg. 3, para. 40-41).

Regarding claim 11, Fostick discloses wherein the message is an instant message, and wherein using the contact record to verify that the phone number is capable of being used to receive the message includes checking the contact record associated with the caller to see whether the phone number of the incoming call is for a mobile telephony device that can handle the instant message (pg. 3, para. 40-41).

Regarding claim 12, Fostick discloses wherein determining that the phone number is associated with the message enabled device is performed programmatically and automatically (pg. 3, para. 40-42).

Regarding claim 13, Fostick discloses wherein: receiving an incoming communication

from another computing device includes receiving an incoming call from the other computing device (pg. 3, para. 36); and transmitting a message to the other computing device is based upon using a phone number of the incoming call as the address for a new instant message (pg. 3, para. 40-41).

Regarding claim 14, Fostick discloses wherein using a phone number of the incoming call as the address for a new instant message includes launching an instant messaging application (pg. 3, para. 40-41), and initiating a new message using the phone number of the caller as the address of the new message (pg. 3, para. 40-41).

Regarding claim 15, Fostick discloses wherein launching an instant messaging application and initiating a new message are performed automatically (pg. 3, para. 40-42), in response to one of (i) receiving the incoming call (pg. 3, para. 36), or (ii) receiving an input from a user of the computing telephony device indicating a desire to send the instant message as a response to the incoming call (pg. 3, para. 36-37).

Regarding claim 16, Fostick discloses further comprising enabling a user of the computing telephony device to provide content manually for the message (It is known to one skilled in the art how to manually generate and send a text message).

Regarding claim 17, Fostick discloses further comprising enabling a user of the computing telephony device to trigger insertion of pre-formulated content for the message (pg. 4, para. 41-42).

Regarding claim 18, Fostick discloses further comprising automatically and programmatically providing at least a portion of a body of message pg. 4, para. 41-42).

Regarding claim 19, Fostick discloses a computing device comprising:

one or more communication components for handling voice and messaging communications over wireless networks (pg. 1, para. 5); one or more processors configured to: receive an incoming phone call originating from another device (pg. 1, para. 5) (It is noted that mobile phones contain processing devices); determining a phone number of the other device (pg. 3, para. 40); and generate a message to be transmitted to the other device using the identified phone number (pg. 3, para. 41-42) (reply message).

Regarding claim 20, Fostick discloses wherein the one or more processors are configured to enable the message to be generated prior to the incoming phone call being resolved (pg. 3, para. 40) (ARM stored messages).

Regarding claim 21, Fostick discloses wherein the one or more processors are configured to enable a text message to be generated (pg. 3, para. 40) (ARM stored messages).

Regarding claim 22, Fostick discloses wherein the one or more processors are configured to enable the message to be generated containing a message body of a format selected from one or more of text, image and audio (pg. 3, para. 40) (ARM stored messages).

Regarding claim 23, Fostick discloses further comprising a display, and wherein the one or more processors enable the message to be generated by prompting the user on the screen to generate the message as one of one or more options to handling the incoming phone call (pg. 1, para. 8).

Regarding claim 24, Fostick discloses a method for operating a computing device, the

method comprising:

identifying a phone number of a caller of an incoming phone call (pg. 3, para. 40) (associated number); prompting a user of the computing device to generate a message reply to the incoming phone call (pg. 1, para. 8); and initiating the message reply by opening a message and addressing the message to the phone number of the caller of the incoming phone call (pg. 3, para. 41-42).

Regarding claim 25, Fostick discloses wherein initiating the message reply by opening a message and addressing the message to the phone number includes addressing a SMS message to the phone number of the caller (pg. 3, para. 40).

Regarding claim 26, Fostick discloses further comprising enabling a user to specify a message body for the SMS message (pg. 3, para. 41-42).

Regarding claim 27, Fostick discloses further comprising enabling a user of the computing device to send the message and then answer the call after sending the message (It is known to one skilled in the art to reply to a received SMS message).

Regarding claim 28, Fostick discloses, further comprising enabling a user of the computing device to send the message and then decline answering the call after sending the message (It is known to one skilled in the art to reply to a received SMS message and then decline to answer an incoming call).

Conclusion

Any inquiry concerning this communication or earlier communications from the examiner should be directed to JAMES ARNOTT whose telephone number is (571)270-5850. The examiner can normally be reached on flex.

If attempts to reach the examiner by telephone are unsuccessful, the examiner's supervisor, Tsang Fan can be reached on (571)272-7547. The fax phone number for the organization where this application or proceeding is assigned is 571-273-8300.

Information regarding the status of an application may be obtained from the Patent Application Information Retrieval (PAIR) system. Status information for published applications may be obtained from either Private PAIR or Public PAIR. Status information for unpublished applications is available through Private PAIR only. For more information about the PAIR system, see <http://pair-direct.uspto.gov>. Should you have questions on access to the Private PAIR system, contact the Electronic Business Center (EBC) at 866-217-9197 (toll-free). If you would like assistance from a USPTO Customer Service Representative or access to the automated information system, call 800-786-9199 (IN USA OR CANADA) or 571-272-1000.

/JCA/

/Temesghen Ghebretinsae/

Primary Examiner, Art Unit 2611 2/25/09B

Notice of References Cited	Application/Control No. 11/200,511	Applicant(s)/Patent Under Reexamination CHAMPLIN ET AL.	
	Examiner JAMES ARNOTT	Art Unit 4182	Page 1 of 1

U.S. PATENT DOCUMENTS

*	Document Number Country Code-Number-Kind Code	Date MM-YYYY	Name	Classification
*	A US-2002/0187794 A1	12-2002	Fostick et al.	455/466
	B US-			
	C US-			
	D US-			
	E US-			
	F US-			
	G US-			
	H US-			
	I US-			
	J US-			
	K US-			
	L US-			
	M US-			

FOREIGN PATENT DOCUMENTS

*	Document Number Country Code-Number-Kind Code	Date MM-YYYY	Country	Name	Classification
	N				
	O				
	P				
	Q				
	R				
	S				
	T				

NON-PATENT DOCUMENTS

*	Include as applicable: Author, Title Date, Publisher, Edition or Volume, Pertinent Pages)
	U
	V
	W
	X

*A copy of this reference is not being furnished with this Office action. (See MPEP § 707.05(a).)
Dates in MM-YYYY format are publication dates. Classifications may be US or foreign.

<i>Index of Claims</i> 	Application/Control No. 11200511	Applicant(s)/Patent Under Reexamination CHAMPLIN ET AL.
	Examiner JAMES ARNOTT	Art Unit 4182

✓	Rejected	-	Cancelled	N	Non-Elected	A	Appeal
=	Allowed	÷	Restricted	I	Interference	O	Objected

Claims renumbered in the same order as presented by applicant
 CPA
 T.D.
 R.1.47

CLAIM		DATE									
Final	Original	02/24/2009									
	1	✓									
	2	✓									
	3	✓									
	4	✓									
	5	✓									
	6	✓									
	7	✓									
	8	✓									
	9	✓									
	10	✓									
	11	✓									
	12	✓									
	13	✓									
	14	✓									
	15	✓									
	16	✓									
	17	✓									
	18	✓									
	19	✓									
	20	✓									
	21	✓									
	22	✓									
	23	✓									
	24	✓									
	25	✓									
	26	✓									
	27	✓									
	28	✓									

Search Notes 	Application/Control No. 11200511	Applicant(s)/Patent Under Reexamination CHAMPLIN ET AL.
	Examiner JAMES ARNOTT	Art Unit 4182

SEARCHED			
Class	Subclass	Date	Examiner
379	67.1	2/24/09	JCA
379	88.13	2/24/09	JCA
455	414.4	2/24/09	JCA

SEARCH NOTES		
Search Notes	Date	Examiner
Searched East and Google Patents	2/24/09	JCA

INTERFERENCE SEARCH			
Class	Subclass	Date	Examiner

--	--

Substitute for Form 1449/PTO INFORMATION DISCLOSURE STATEMENT BY APPLICANT Page 1 of 1	Application No.	11/200,511
	Filed	8/8/2005
	First Inventor	Champlin, David
	Art Unit	2645
	Examiner	
	Atty. Docket No.	PALM.P0962

Foreign Patent Documents						
Examiner Initials*	Patent Document		Name of Patentee or Applicant of Cited Document	Date of Publication	Relevant Pages, Columns, Lines	Trans- lation
	Number	Kind				
	EP 0611239	A1	IBM Corporation	08/17/1994		

Non Patent Literature Documents		
Examiner Initials	Name of Author, Title of Item, Date, Page(s), Volume-Issue Number(s), Publisher, City and/or Country where Published	Trans- lation
	International Search Report and Written Opinion of the International Searching Authority in International Application PCT/US2006/030827, European Patent Office, January 15, 2007, 15 pages.	
	Internet Telephony Manager (ITM) User Guide, XP002413107, December 1, 1996, pgs. 1-5.	
	Nokia 6630 User's Guide, XP002413106, March 28, 2005, pgs. 1-109.	
	Sharma, A.K., Juneja, D., and Bishnoi, C., Intelligent Agents in Call Management System, Integration of Knowledge Intensive Multi-Agent Systems International Conference, XP010793134, April 18, 2005, pgs. 9-14.	

Examiner Signature	/James Arnott/	Date Considered	02/23/2009
-------------------------------	----------------	----------------------------	------------

*Examiner: Initial if reference considered, whether or not citation is in conformance with MPEP 609. Draw a line through citation if not in conformance and not considered. Include a copy of this form with next communication to applicant.

ALL REFERENCES CONSIDERED EXCEPT WHERE LINED THROUGH. /J.A./

EAST Search History

Ref #	Hits	Search Query	DBs	Default Operator	Plurals	Time Stamp
L1	1	"20050123118".pn.	US-PGPUB; USPAT	OR	OFF	2009/02/24 10:57
S1	2065579	text message or SMS	USPAT	OR	OFF	2009/02/23 16:11
S2	66191	(cellular or mobile) near4 (phone or telephone)	USPAT	OR	OFF	2009/02/23 16:12
S3	59894	(send or sending) same S1	USPAT	OR	OFF	2009/02/23 16:12
S4	78483	(receive or receiving) same S1	USPAT	OR	OFF	2009/02/23 16:13
S5	964	S1 same S2 same S3 same S4	USPAT	OR	OFF	2009/02/23 16:13
S6	356	number same S5	USPAT	OR	OFF	2009/02/23 16:14
S7	449197	instant message	USPAT	OR	OFF	2009/02/23 16:14
S8	300	S6 same S7	USPAT	OR	OFF	2009/02/23 16:14
S9	89696	alert or notification	USPAT	OR	OFF	2009/02/23 16:14
S10	45	S8 same S9	USPAT	OR	OFF	2009/02/23 16:15
S11	779	379/67.1.ccls.	USPAT	OR	OFF	2009/02/23 16:15
S12	545	379/88.13.ccls.	USPAT	OR	OFF	2009/02/23 16:18
S13	174	455/414.4.ccls.	USPAT	OR	OFF	2009/02/23 16:19
S15	1	"20020155826".pn.	US-PGPUB; USPAT	OR	OFF	2009/02/23 16:41
S16	21	instant same message same addressed same phone near4 number	US-PGPUB; USPAT	OR	OFF	2009/02/23 16:44
S19	1	"20050141687".pn.	US-PGPUB; USPAT	OR	OFF	2009/02/23 17:25

EAST Search History

S20	1	"20020187794".pn.	US- PGPUB; USPAT	OR	OFF	2009/02/23 17:52
S21	1	"20040240642".pn.	US- PGPUB; USPAT	OR	OFF	2009/02/23 17:59
S22	1	"6757365".pn.	US- PGPUB; USPAT	OR	OFF	2009/02/23 18:03

2/ 24/ 2009 10:59:02 AM

C:\ Documents and Settings\jarnott\ My Documents\ EAST\ Workspaces\ 11200511
\ 11200511.wsp



UNITED STATES PATENT AND TRADEMARK OFFICE

UNITED STATES DEPARTMENT OF COMMERCE
 United States Patent and Trademark Office
 Address: COMMISSIONER FOR PATENTS
 P.O. Box 1450
 Alexandria, Virginia 22313-1450
 www.uspto.gov

BIB DATA SHEET

CONFIRMATION NO. 2125

SERIAL NUMBER 11/200,511	FILING or 371(c) DATE 08/08/2005 RULE	CLASS 379	GROUP ART UNIT 4182	ATTORNEY DOCKET NO. PALM.P962	
APPLICANTS David Champlin, Menlo Park, CA; Srikan Prasad, Cupertino, CA; Lang Chen, Oakland, CA; Rajan Ranga, Palo Alto, CA; Robert Haitani, Menlo Park, CA; ** CONTINUING DATA ***** ** FOREIGN APPLICATIONS ***** ** IF REQUIRED, FOREIGN FILING LICENSE GRANTED ** 09/01/2005					
Foreign Priority claimed <input type="checkbox"/> Yes <input checked="" type="checkbox"/> No 35 USC 119(a-d) conditions met <input type="checkbox"/> Yes <input checked="" type="checkbox"/> No Verified and Acknowledged <u>/JAMES C ARNOTT/</u> <small>Examiner's Signature</small>	<input type="checkbox"/> Met after Allowance Initials _____	STATE OR COUNTRY CA	SHEETS DRAWINGS 4	TOTAL CLAIMS 28	INDEPENDENT CLAIMS 3
ADDRESS SHEMWELL MAHAMEDI LLP 4880 STEVENS CREEK BOULEVARD SUITE 201 SAN JOSE, CA 95129-1034 UNITED STATES					
TITLE Method and device for enabling message responses to incoming phone calls					
FILING FEE RECEIVED 1530	FEES: Authority has been given in Paper No. _____ to charge/credit DEPOSIT ACCOUNT No. _____ for following:		<input type="checkbox"/> All Fees <input type="checkbox"/> 1.16 Fees (Filing) <input type="checkbox"/> 1.17 Fees (Processing Ext. of time) <input type="checkbox"/> 1.18 Fees (Issue) <input type="checkbox"/> Other _____ <input type="checkbox"/> Credit		

Atty. Docket No. PALM.P0962

PATENT

IN THE UNITED STATES PATENT OFFICE

In Re Patent Application of

First Named Inventor: Champlin, David

Application No.: 11/200,511

Filed: 8/8/2005

For: METHOD AND DEVICE FOR
ENABLING MESSAGE RESPONSES TO
INCOMING PHONE CALLS

Examiner:

Art Unit: 2645

Confirmation No.: 2125

Commissioner for Patents
P.O. Box 1450
Alexandria, VA 22313-1450

INFORMATION DISCLOSURE STATEMENT UNDER 37 CFR 1.97

Sir:

Enclosed is an Information Disclosure Citation Form 1449/PTO together with a copy of each reference cited therein, excluding U.S. Patents and Published U.S. Patent Applications. It is respectfully requested that the cited references be considered and that the enclosed copy of the Form 1449/PTO be initialed by the Examiner to indicate such consideration and a copy thereof returned to applicant.

This Information Disclosure Statement is being submitted pursuant to 37 CFR 1.97(b). No fee is believed to be due.

Pursuant to 37 CFR 1.97(h), the submission of this Information Disclosure Statement is not to be construed as an admission that the information cited in this statement is material to patentability.

The Commissioner is hereby authorized to charge any fee deficiency in connection with this submission to Deposit Account No. 501914.

Respectfully submitted,

SHEMWELL MAHAMEDI LLP

Date February 26, 2007

/Zurvan Mahamedi/
Zurvan Mahamedi, Reg. No. 42,828
Tel. 408-236-6640

Substitute for Form 1449/PTO INFORMATION DISCLOSURE STATEMENT BY APPLICANT Page 1 of 1	Application No.	11/200,511
	Filed	8/8/2005
	First Inventor	Champlin, David
	Art Unit	2645
	Examiner	
	Atty. Docket No.	PALM.P0962

Foreign Patent Documents						
Examiner Initials*	Patent Document		Name of Patentee or Applicant of Cited Document	Date of Publication	Relevant Pages, Columns, Lines	Trans- lation
	Number	Kind				
	EP 0611239	A1	IBM Corporation	08/17/1994		

Non Patent Literature Documents		
Examiner Initials	Name of Author, Title of Item, Date, Page(s), Volume-Issue Number(s), Publisher, City and/or Country where Published	Trans- lation
	International Search Report and Written Opinion of the International Searching Authority in International Application PCT/US2006/030827, European Patent Office, January 15, 2007, 15 pages.	
	Internet Telephony Manager (ITM) User Guide, XP002413107, December 1, 1996, pgs. 1-5.	
	Nokia 6630 User's Guide, XP002413106, March 28, 2005, pgs. 1-109.	
	Sharma, A.K., Juneja, D., and Bishnoi, C., Intelligent Agents in Call Management System, Integration of Knowledge Intensive Multi-Agent Systems International Conference, XP010793134, April 18, 2005, pgs. 9-14.	

Examiner Signature		Date Considered	
-------------------------------	--	----------------------------	--

*Examiner: Initial if reference considered, whether or not citation is in conformance with MPEP 609. Draw a line through citation if not in conformance and not considered. Include a copy of this form with next communication to applicant.



EUROPEAN PATENT APPLICATION

(21) Application number : **94480004.4**

(51) Int. Cl.⁵ : **H04M 3/00**

(22) Date of filing : **14.01.94**

(30) Priority : **10.02.93 US 15938**

(43) Date of publication of application :
17.08.94 Bulletin 94/33

(84) Designated Contracting States :
DE FR GB

(71) Applicant : **INTERNATIONAL BUSINESS MACHINES CORPORATION**
Old Orchard Road
Armonk, N.Y. 10504 (US)

(72) Inventor : **Inniss, Hadyn**
31452 Orchard Creek
Farmington Hills, Michigan 48334 (US)
Inventor : **Scaggs, Sheila**
5401 Glacier Court
Ft. Worth, TX 76134-4320 (US)
Inventor : **Welch, Robert P.**
3405 Fox Glen Drive
Colleyville, TX 76034 (US)

(74) Representative : **de Pena, Alain**
Compagnie IBM France
Département de Propriété Intellectuelle
F-06610 La Gaude (FR)

(54) Method and system for automatically updating telephone response mechanisms.

(57) A telephone response mechanism provides a response to a caller and an opportunity for the caller to leave a message. The telephone response mechanism is utilized when a telephone call arrives with no one to answer it.

The response is made up of three portions. A first portion is automatically generated by a data processing system based upon the time of day, e.g. "Good morning".

A second portion is a recorded message identifying the person being called, e.g. "This is John Doe. I am not currently available." The third portion is created from information obtained from a database on the data processing system, such as a calendar database or a personnel database. The third portion explains to the caller where the user (the person being called) is or when the user will return. The third portion is automatically updated whenever the user updates the database. A lockout feature is provided to deny the telephone response mechanism access to selected entries in the database.

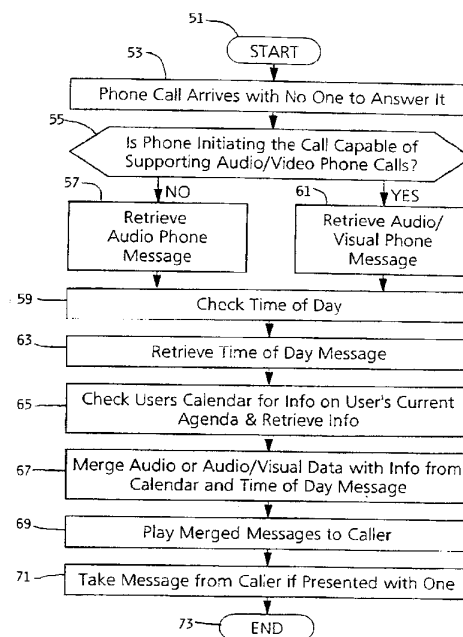

Fig. 2

Jouve, 18, rue Saint-Denis, 75001 PARIS

EP 0 611 239 A1

Field Of The Invention

The present invention relates to method and system that automatically provide a response to unanswered telephone calls, such as with electronic phone mail systems.

5

Background Of The Invention

Electronic phone mail systems provide answering capabilities for incoming telephone calls. An incoming telephone call triggers a response mechanism in the electronic phone mail system that provides a prerecorded response to the caller and that provides an opportunity for the caller to leave a message for the phone mail user who is being called.

The prerecorded response typically identifies the person being called and provides other information to elicit the caller to leave a message. For example, the system generated response could say: "Hello. John Doe is not currently available. Please leave a message after you hear the tone." Alternatively, the user can record a more personal message in the user's own voice. For example, the response could say: "Hello. This is John Doe. I am not currently available. Please leave a message after you hear the tone."

Frequently, a user desires to provide more information to a caller. The message recorded by the user can provide limited information on the whereabouts of the user, such as: "Hello. This is John Doe. I am in the office today, but either on the telephone or away from my desk. Please leave a message after you hear the tone." However, with this type of response providing a caller with information on the user, effective phone mail use requires the user to update the phone mail response each day. Updating requires the user to dial in a series of codes or passwords. This process takes several minutes each day. Many users perceive this as a bother and provide callers only with identifying information. Furthermore, prior art telephone response mechanisms do not inform the caller when the user will be available.

Therefore, what is needed is a phone mail response mechanism that would provide useful information to a caller, and that would automatically update this information without the user.

Summary of the Invention

It is an object of the present invention to provide a telephone response mechanism that provides information to a caller, such as when the caller will be available.

It is a further object of the present invention to provide a method and system for automatically updating the information provided by a telephone response mechanism.

The method of the present invention automatically updates a telephone response mechanism. The telephone response mechanism provides a response to a caller and an opportunity for the caller to leave a message. The method includes retrieving a first response portion. The method also retrieves information from a preselected database on a data processing system and creates a second response portion from the information. Then, the method plays the first response portion and the second response portion to the caller.

In one aspect of the present invention, the step of retrieving a first response portion further includes the step of retrieving a prerecorded message. In another aspect, the step of retrieving information from the preselected database further includes the step of retrieving the information from a calendar of a user who is being called. In still another aspect of the present invention, the method further includes the step of determining if access to the information on the database by the telephone response mechanism is authorized and if authorized, then the information is retrieved from the database.

The system of the present invention is for automatically updating a telephone response mechanism. The system includes means for retrieving a first response portion. There is also means for retrieving information from a preselected database on a data processing system and for creating a second response portion from the information. The system further includes means for playing the first response portion and the second response portion to the caller.

With the present invention, a caller is provided with information that assists the caller in communicating with the user. By selecting the database that is accessed by the telephone response mechanism, the user can provide a caller with information on the whereabouts of the user, when the user is likely to return, and even telephone numbers where the user can be currently reached.

The telephone response mechanism is automatically updated whenever the database is updated. This simplifies the use of the telephone response mechanism by the user, encouraging its use. The user need only be concerned with providing or denying access to specific entries to the telephone response mechanism.

The present invention combines recorded messages (recorded by either a data processing system or a user) with system generated data such as time of day and also with information retrieved from databases. A

single response is played to a caller by merging the various portions together.

Brief Description Of The Drawings

- 5 Fig. 1 is a schematic diagram of a data processing system on which the present invention can be practiced.
 Fig. 2 is a flow chart showing the method of the present invention, in accordance with a preferred embodiment.

Description of the Preferred Embodiment

10 In Fig. 1, there is shown a schematic diagram of a data processing system 11, upon which the present invention can be practiced. The data processing system 11 includes plural individual computers 13 which are connected together in a local area network (LAN) 15. Each computer 13 includes a user interface, which has a display screen 17 and a keyboard 19. Each computer 13 may also be coupled to a storage device 21 and to a printer or output device 23. One or more of such storage devices 21 may be utilized, in accordance with the present invention, to store applications or resource objects which may be periodically accessed by any user within the data processing system 11.

The data processing system 11 may also include a mainframe computer 25 that is coupled to one of the computers 13 by a communication link 27. The mainframe computer 25 may also be coupled to a storage device 29 which may serve as a remote storage for the computers.

A first telephone 31 is connected to the data processing system 11. The first telephone 31 is also connected to a second telephone 33 over a conventional telephone line 35. The telephone line may be of the plain old telephone type (POTS) which utilizes audio carrier frequencies, or it may be of the multiplexed type which utilizes a digital carrier such as T-1. The telephones 31, 33 may support, in addition to audio capabilities, visual capabilities.

The data processing system 11 provides a telephone response mechanism, or phone mail system, for the telephone 31. The telephone response mechanism is automatically activated upon the occurrence of the first telephone 31 receiving a call from another telephone such as the second telephone 33. When activated, the telephone response mechanism provides a message or response to the caller. This response generally contains a greeting and identifies the user who has been called. After playing the response to the caller, the telephone response mechanism provides an opportunity for the caller to leave a message for the user.

With the present invention, the response provided to the caller is made up of several portions, which the user may configure. A first portion of the response provides a greeting based upon the time of day. A second portion of the response identifies the user to the caller. A third portion of the response provides information to the caller, which information is drawn from a data base on the data processing system 11. All of the portions are merged together to provide the response.

The first portion is automatically provided by the data processing system, based upon the time of day. The data processing system 11 has a clock which allows the data processing system to determine the time of day. Once the time of day is known, then the data processing system generates the first portion of the response. For example, in the morning, the first portion would be "Good morning". In the afternoon, the first portion would be "Good after-noon".

The second portion of the response identifies the user. Many phone mail systems have a default message for each user. If a user does nothing, then the second portion could be: "John Doe is not currently available." The default second portion is generated by the data processing system in a common voice for all users.

Alternatively, the user can record a personal message which is played in the user's voice instead of the default for the second portion. To record a personal second portion, the user accesses the phone mail system through either the telephone 31 or through one of the computers 13. The user then records a personal phone mail greeting stub. For example, this could be, "This is John Doe. I am not currently available."

The third portion of the response is automatically drawn from a database on the data processing system 11. The user provides the information to the telephone response mechanism whenever the database is updated. For example, the telephone response mechanism can utilize the calendar of the user to provide a caller information on when the user will be available, or information on where the user is.

The user might make the following typical entries into the calendar database for a particular day:

55

9-10am, meeting with boss, room 256,	phone access = YES
12-1pm, lunch,	phone access = YES
2-3pm, new product meeting, room 211,	phone access = NO.

5

As the user makes entries into the calendar, the user determines if the information in the individual entries can be supplied to a caller. This is done by setting phone access to either YES or NO. A YES setting permits the telephone response mechanism to access and provide the information to a caller. A NO setting precludes the telephone response mechanism from accessing and providing the information to a caller.

10

The response is typically audio. However, the response can include visual messages if the telephone equipment in use supports visual capabilities.

Referring now to Fig. 2, the method for answering a telephone call to the user's telephone 31 will be described. In the flow chart of Fig. 2, the following graphical conventions are observed: a rectangle for either a process or function and a diamond (step 55 is a stretched diamond) for a decision. These conventions are well understood by programmers skilled in the art of data processing and user interfaces and the flow charts are sufficient to enable a programmer skilled in the art to write code in any suitable computer programming language, such as BASIC, PASCAL or C for a computer such as the IBM Personal System / 2 (PS/2) family of computers which supports these languages.

15

The method starts, step 51. A phone call arrives at the telephone 31 with no one to answer it, step 53. The method proceeds to step 55, wherein the method determines if the phone initiating the call is capable of supporting audio/visual phone calls. If NO, then the method proceeds to step 57 to retrieve the audio phone message. This is the second portion of the response, which in the example is "This is John Doe. I am not currently available." The method then proceeds to step 59. If the result of step 55 is YES, then the method proceeds to step 61 to retrieve an audio/visual phone message. Then method then proceeds to step 59.

20

25

In step 59, the method checks the time of day. In step 63, the method retrieves the time of day message, which is either "good morning", "good afternoon" or some other time of day greeting.

In step 65, the method checks the specified database such as the user's calendar for information on the user's current agenda and retrieves the information, if permitted, to provide the third portion of the message. The time of day is used to determine which entry from the calendar is utilized. If the time of day is 9:30am, then the entry from 9-10am is utilized to create the third portion. If Phone Access = YES, then the calendar entry is utilized to make up the third portion of the response. If Phone Access = NO, then the calendar entry is not utilized. The third portion instead asks the caller to leave a message.

30

The first, second and third portions are all merged together in the respective order in step 67. Then, the merged message portions are played to the caller, step 69. For example, if a call is made at 9:30am, the response would be:

35

"Good morning!" (This is the first portion of the response obtained from the time of day.) "This is John Doe. I am not currently available." (This is the second portion obtained from the recording by the user.) "I am in a meeting that will end at 10:00am. Please call me then or leave a message now." (This is the third portion which is created from the calendar entry by the data processing system.)

40

Alternatively, the third portion could provide even more information. For example, "I am in a meeting in room 256 until 10:00am. Please call me there, leave a message or call me later."

If the call is made at 12:30pm, then the response would be:

"Good afternoon!" (This is the first portion of the response.) "This is John Doe. I am not currently available." (This is the second portion of the response.) "I am at lunch. I will be back at 1:00. Please call me then or leave a message now." (This is the third portion of the response.)

45

If the call is made at 2:30pm, then the response would be: "Good afternoon!" (This is the first portion of the response.) "This is John Doe. I am not currently available." (This is the second portion of the response.) "Please leave a message after you hear the tone." (This is the third portion of the response.)

50

The third portion of the response is a default message that is utilized when access to the calendar entry is denied. Likewise, if the call is made at 4:00pm, the response is the same as for a call made at 2:30pm. This is because there is no calendar entry at 4:00pm from which to make the third portion of the response.

Thus, the present invention provides a caller with additional information regarding the user who is being called. This additional information assists the caller in communicating with the user.

55

The present invention requires only a minimal amount of effort from the user to maintain an updated response. This is because the user need only maintain the database in an updated condition, something that the user is likely to do irregardless of the telephone response mechanism. The present invention automatically updates the response of the telephone response mechanism based upon the data-base. For each entry in the

database, the user can either allow or block access to the entry by the telephone response mechanism.

Although the present invention has been described as providing a response with first, second and third portions, variations in the response are certainly possible. For example, the first portion (e.g. "Good morning") need not be provided at all. Instead, the second portion of the response could include a greeting such as: "Hello. This is John Doe..."

Although the present invention has been described with a calendar as the database that is used to provide the information for a telephone response, other databases can be used as well. For example, a personnel database could be utilized to automatically refer a caller to a user's secretary, associate or supervisor by name and telephone number.

The audio information making up each portion of the response can be generated by the data processing system, using for example, text-to-speech conversions. Alternatively, the user can record the first and second portions. The user can also record a set or library of words or sounds for the data processing to use to generate the third portion, as the information in the third portion is typically varied and wide ranging. For example, to generate the third portion from the information obtained from the calendar database, a standard third portion could be utilized: "I am . I will be back at . Please call me then or leave a message." The first blank is filled with the type of engagement noted on the calendar, e.g. "at a meeting". The second blank is filled with the time that the engagement is scheduled to end, e.g. "10:00am".

The foregoing disclosure and the showings made in the drawings are merely illustrative of the principles of this invention and are not to be interpreted in a limiting sense.

Claims

1. A method of automatically updating a telephone response mechanism, said telephone response mechanism providing a response to a caller and an opportunity for the caller to leave a message, characterized in that it comprises the steps of:
 - a) retrieving a first response portion;
 - b) retrieving information from a preselected data-base on a data processing system and creating a second response portion from said information; and
 - c) playing said first response portion and said second response portion to said caller.
2. The method of claim 1 wherein said step of retrieving a first response portion further comprises the step of retrieving a prerecorded message.
3. The method of claim 1 or 2 wherein said step of retrieving information from said preselected database further comprises the step of retrieving said information from a calendar of a user who is being called, or from a personnel database.
4. The method of claims 1 to 3 further comprising the step of determining if access to said information on said data base by said telephone response mechanism is authorized and if authorized, then retrieving said information from said data base.
5. The method of claim 1 to 4 further comprising the steps of:
 - a) determining the time of day when said caller calls;
 - b) creating a third response portion relating to the time of day; and
 - c) playing said third response portion along with said first and second response portions.
6. A system for automatically updating a telephone response mechanism, said telephone response mechanism providing a response to a caller and an opportunity for the caller to leave a message, said system characterized in that it comprises :
 - a) means for retrieving a first response portion;
 - b) means for retrieving information from a preselected database on a data processing system and creating a second response portion from said information; and
 - c) means for playing said first response portion and said second response portion to said caller.
7. The system of claim 6 wherein said means for retrieving a first response portion further comprises means for retrieving a prerecorded message.
8. The system of claim 6 or 7 wherein said means for retrieving information from said preselected database

further comprises means for retrieving said information from a calendar of a user who is being called, or from a personnel database.

5 9. The system of claims 6 to 8 further comprising means for determining if access to said information on said database by said telephone response mechanism is authorized and if authorized, then for retrieving said information from said database.

10 10. The system of claims 6 to 9 further comprising:
a) means for determining the time of day when said caller calls;
b) means for creating a third response portion relating to the time of day; and
c) means for playing said third response portion along with said first and second response portions.

15

20

25

30

35

40

45

50

55

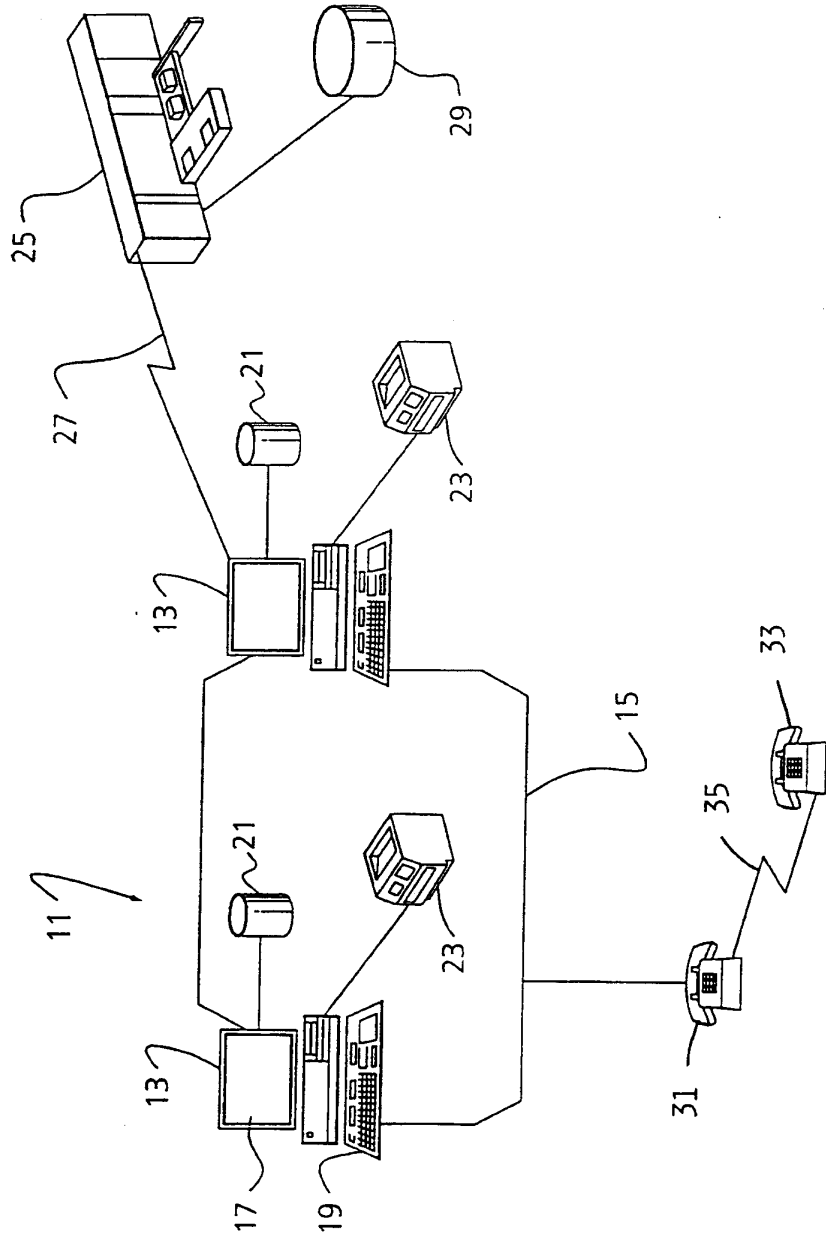

Fig. 1

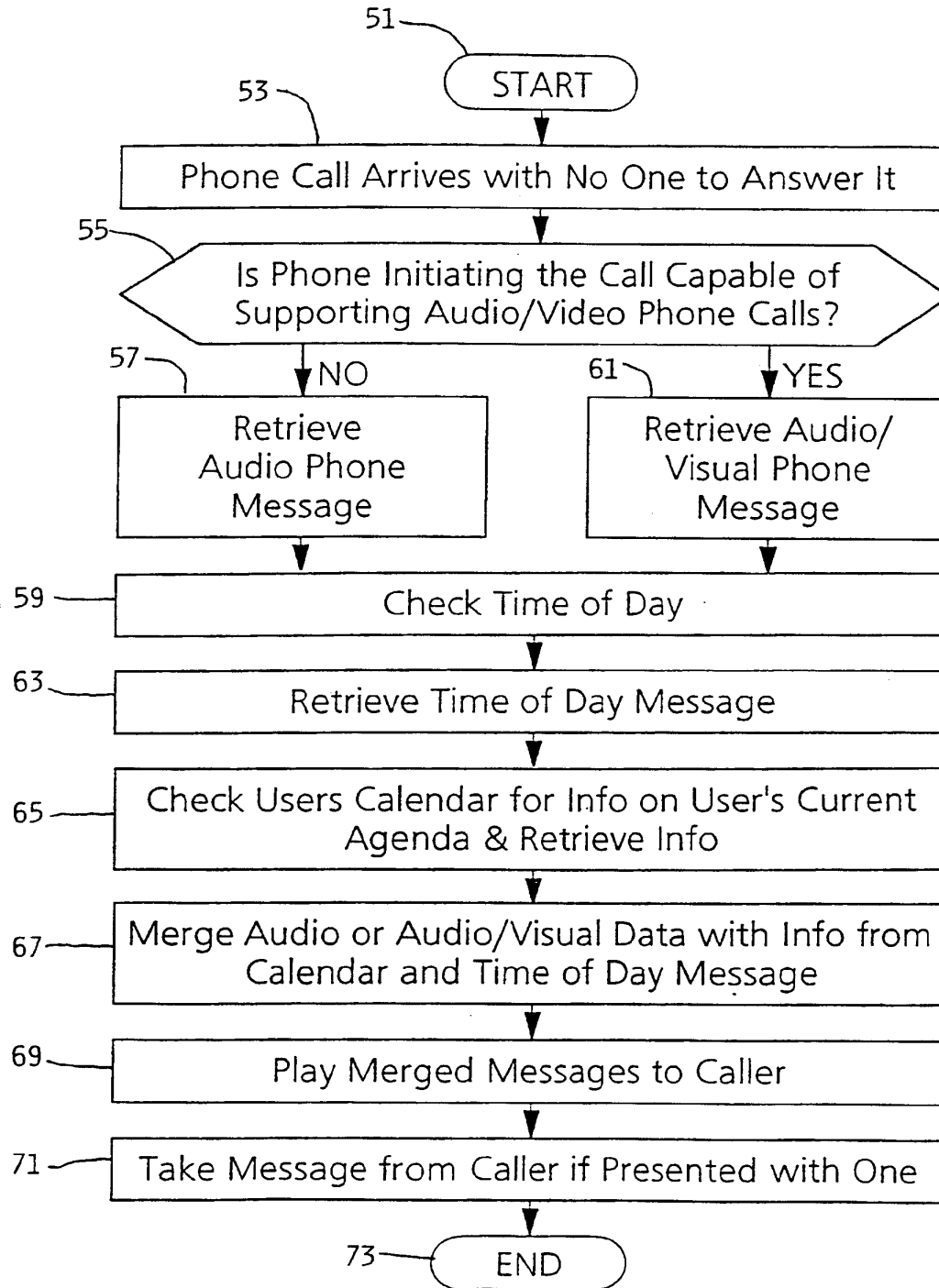

Fig. 2



European Patent Office

EUROPEAN SEARCH REPORT

Application Number

DOCUMENTS CONSIDERED TO BE RELEVANT			EP 94480004.4
Category	Citation of document with indication, where appropriate, of relevant passages	Relevant to claim	CLASSIFICATION OF THE APPLICATION (Int. Cl.5)
A	<p><u>US - A - 4 327 251</u> (FOMENKO et al.) * Abstract; column 1, line 6 - column 2, line 20; fig. 1; claim 1 *</p>	1, 6	H 04 M 3/00
A	<p><u>DE - A - 3 541 898</u> (GRUNDIG E.M.V.) * Absftract; column 1, line 52 - column 2, line 36; claim 1 *</p>	1, 6	
A	<p><u>US - A - 5 036 533</u> (CARTER et. al.) * Abstract; column 1, lines 14-55; fig. 1-3; claim 1 *</p>	1, 6	
The present search report has been drawn up for all claims			<p>TECHNICAL FIELDS SEARCHED (Int. Cl.5)</p> <p>H 04 M</p>
<p>Office of origin VIENNA</p>		<p>Date of completion of the search 17-05-1994</p>	<p>Examiner BADICS</p>
<p>CATEGORY OF CITED DOCUMENTS</p> <p>X : particularly relevant if taken alone Y : particularly relevant if combined with another document of the same category A : technological background O : non-written disclosure P : intermediate document</p>		<p>T : theory or principle underlying the invention E : earlier patent document, but published on, or after the filing date D : document cited in the application L : document cited for other reasons & : member of the same patent family, corresponding document</p>	

EPO FORM 1503 01.82 (1/90-01)

Electronic Acknowledgement Receipt

EFS ID:	1545053
Application Number:	11200511
International Application Number:	
Confirmation Number:	2125
Title of Invention:	Method and device for enabling message responses to incoming phone calls
First Named Inventor/Applicant Name:	David Champlin
Customer Number:	30554
Filer:	Zurvan Mahamedi/S S
Filer Authorized By:	Zurvan Mahamedi
Attorney Docket Number:	PALM-0962
Receipt Date:	26-FEB-2007
Filing Date:	08-AUG-2005
Time Stamp:	17:13:12
Application Type:	Utility

Payment information:

Submitted with Payment	no
------------------------	----

File Listing:

Document Number	Document Description	File Name	File Size(Bytes)	Multi Part /.zip	Pages (if appl.)
1	Information Disclosure Statement (IDS) Filed	PALMP0962_IDS.pdf	132302	no	2

Warnings:

Information:					
This is not an USPTO supplied IDS fillable form					
2	NPL Documents	1_PALMP0962_ISR.pdf	1258787	no	15
Warnings:					
Information:					
3	Foreign Reference	2_EP_0611239A1.pdf	925157	no	10
Warnings:					
Information:					
4	NPL Documents	3_ITM_UserGuide.pdf	841089	no	6
Warnings:					
Information:					
5	NPL Documents	4_Nokia6630UserGuide.pdf	5582060	no	110
Warnings:					
Information:					
6	NPL Documents	5_Intell_Agents.pdf	763783	no	6
Warnings:					
Information:					
Total Files Size (in bytes):			9503178		
<p>This Acknowledgement Receipt evidences receipt on the noted date by the USPTO of the indicated documents, characterized by the applicant, and including page counts, where applicable. It serves as evidence of receipt similar to a Post Card, as described in MPEP 503.</p> <p><u>New Applications Under 35 U.S.C. 111</u> If a new application is being filed and the application includes the necessary components for a filing date (see 37 CFR 1.53(b)-(d) and MPEP 506), a Filing Receipt (37 CFR 1.54) will be issued in due course and the date shown on this Acknowledgement Receipt will establish the filing date of the application.</p> <p><u>National Stage of an International Application under 35 U.S.C. 371</u> If a timely submission to enter the national stage of an international application is compliant with the conditions of 35 U.S.C. 371 and other applicable requirements a Form PCT/DO/EO/903 indicating acceptance of the application as a national stage submission under 35 U.S.C. 371 will be issued in addition to the Filing Receipt, in due course.</p> <p><u>New International Application Filed with the USPTO as a Receiving Office</u> If a new international application is being filed and the international application includes the necessary components for an international filing date (see PCT Article 11 and MPEP 1810), a Notification of the International Application Number and of the International Filing Date (Form PCT/RO/105) will be issued in due course, subject to prescriptions concerning national security, and the date shown on this Acknowledgement Receipt will establish the international filing date of the application.</p>					



UNITED STATES PATENT AND TRADEMARK OFFICE

UNITED STATES DEPARTMENT OF COMMERCE
United States Patent and Trademark Office
Address: COMMISSIONER FOR PATENTS
P.O. Box 1450
Alexandria, Virginia 22313-1450
www.uspto.gov

APPLICATION NUMBER	FILING OR 371(c) DATE	FIRST NAMED APPLICANT	ATTY. DOCKET NO./TITLE
11/200,511	08/08/2005	David Champlin	PALM-0962

CONFIRMATION NO. 2125

30554
SHEMWELL MAHAMEDI LLP
4880 STEVENS CREEK BOULEVARD
SUITE 201
SAN JOSE, CA95129

Title: Method and device for enabling message responses to incoming phone calls

Publication No. US-2007-0036286-A1

Publication Date: 02/15/2007

NOTICE OF PUBLICATION OF APPLICATION

The above-identified application will be electronically published as a patent application publication pursuant to 37 CFR 1.211, et seq. The patent application publication number and publication date are set forth above.

The publication may be accessed through the USPTO's publically available Searchable Databases via the Internet at www.uspto.gov. The direct link to access the publication is currently <http://www.uspto.gov/patft/>.

The publication process established by the Office does not provide for mailing a copy of the publication to applicant. A copy of the publication may be obtained from the Office upon payment of the appropriate fee set forth in 37 CFR 1.19(a)(1). Orders for copies of patent application publications are handled by the USPTO's Office of Public Records. The Office of Public Records can be reached by telephone at (703) 308-9726 or (800) 972-6382, by facsimile at (703) 305-8759, by mail addressed to the United States Patent and Trademark Office, Office of Public Records, Alexandria, VA 22313-1450 or via the Internet.

In addition, information on the status of the application, including the mailing date of Office actions and the dates of receipt of correspondence filed in the Office, may also be accessed via the Internet through the Patent Electronic Business Center at www.uspto.gov using the public side of the Patent Application Information and Retrieval (PAIR) system. The direct link to access this status information is currently <http://pair.uspto.gov/>. Prior to publication, such status information is confidential and may only be obtained by applicant using the private side of PAIR.

Further assistance in electronically accessing the publication, or about PAIR, is available by calling the Patent Electronic Business Center at 703-305-3028.

Pre-Grant Publication Division, 703-605-4283



Attorney Docket No.: PALM-0962

IN THE UNITED STATES PATENT AND TRADEMARK OFFICE

Applicant(s): David CHAMPLIN, et al.

Confirmation No.: 2125

Application No.: 11/200,511

Group Art Unit: 2645

Filed: August 8, 2005

Examiner: Not yet assigned

Title: METHOD AND DEVICE FOR ENABLING
MESSAGE RESPONSES TO INCOMING
PHONE CALLS

RESPONSE TO NOTICE TO FILE MISSING PARTS OF APPLICATION

Mail Stop Missing Parts
Commissioner for Patents
P.O. Box 1450
Alexandria, VA 22313-1450

Sir:

This is in response to a Notice to File Missing Parts of Application under 37 CFR 1.53(f). Enclosed is a copy of said Notice and the following documents and fees to complete the filing requirements of the above-identified application.

(X) Executed Declaration. The above-identified application is the same application which the inventor executed by signing the enclosed declaration.

(X) Statutory basic filing fee **\$300.00** (X) Utility () Design

(X) Search fee **\$500.00**

(X) Examination fee **\$200.00**

(X) Additional claim fees of **\$400.00**

(X) Missing Parts Surcharge = **\$130.00**

() ___ sheets of substitute drawings in compliance with 37 CFR 1.84.

() Extension of Time Request for reply to Notice of Missing Parts is requested.

() one month = \$110.00

() two months = \$400.00

() three months = \$920.00

() four months = \$1,440.00

Throughout the pendency of this application, please charge any additional fees, including any required extension of time fees, and credit all overpayments to deposit account 50-1914. A duplicate of this sheet is enclosed.

I hereby certify that this correspondence is being deposited with the United States Postal Service with sufficient postage as first class mail in an envelope addressed to: Mail Stop Missing Parts, Commissioner for Patents, P.O. Box 1450, Alexandria VA 22313-1450 or facsimile transmitted to the U.S. Patent and Trademark Office on the date shown below.

Date of Deposit: November 1, 2005
Typed Name: Van Mahamedi

Signature: 

Respectfully submitted,

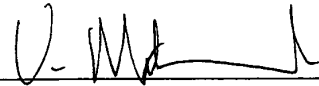
By 
Van Mahamedi

Reg. No. 42,828
Date: November 1, 2005
Telephone No.: (408) 551-6632
SHEMWELL MAHAMEDI LLP
4880 Stevens Creek Boulevard, Suite 201
San Jose, CA 95129

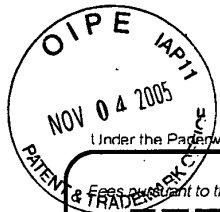

Under the Paperwork Reduction Act of 1995, no persons are required to respond to a collection of information unless it displays a valid OMB control number.

Effective on 12/08/2004.
 Fees pursuant to the Consolidated Appropriations Act, 2005 (H.R. 4818).

FEE TRANSMITTAL For FY 2005

Applicant claims small entity status. See 37 CFR 1.27

TOTAL AMOUNT OF PAYMENT		(\$)	1,530.00
Application Number	11/200,511		
Filing Date	August 8, 2005		
First Named Inventor	David CHAMPLIN, et al.		
Examiner Name	Not Yet Assigned		
Art Unit	2645		
Attorney Docket No.	PALM-0962		

METHOD OF PAYMENT (check all that apply)

Check Credit Card Money Order None Other (please identify): _____

Deposit Account Deposit Account Number: 50-1914 Deposit Account Name: Shemwell Mahamedi LLP

For the above-identified deposit account, the Director is hereby authorized to: (check all that apply)

Charge fee(s) indicated below Charge fee(s) indicated below, except for the filing fee

Charge any additional fee(s) or underpayments of fee(s) under 37 CFR 1.16 and 1.17 Credit any overpayments

WARNING: Information on this form may become public. Credit card information should not be included on this form. Provide credit card information and authorization on PTO-2038.

FEE CALCULATION

1. BASIC FILING, SEARCH, AND EXAMINATION FEES

Application Type	FILING FEES		SEARCH FEES		EXAMINATION FEES		Fees Paid (\$)
	Fee (\$)	Small Entity Fee (\$)	Fee (\$)	Small Entity Fee (\$)	Fee (\$)	Small Entity Fee (\$)	
Utility	300	150	500	250	200	100	1,000.00
Design	200	100	100	50	130	65	_____
Plant	200	100	300	150	160	80	_____
Reissue	300	150	500	250	600	300	_____
Provisional	200	100	0	0	0	0	_____

2. EXCESS CLAIM FEES

Fee Description	Fee (\$)	Small Entity Fee (\$)
Each claim over 20 (including Reissues)	50	25
Each independent claim over 3 (including Reissues)	200	100
Multiple dependent claims	360	180

Total Claims 28 - 20 or HP = 8 **Extra Claims** 8 **Fee (\$)** 50.00 **Fee Paid (\$)** 400.00

HP = highest number of total claims paid for, if greater than 20.

Indep. Claims 3 - 3 or HP = 0 **Extra Claims** 0 **Fee (\$)** _____ **Fee Paid (\$)** _____

HP = highest number of independent claims paid for, if greater than 3.

3. APPLICATION SIZE FEE

If the specification and drawings exceed 100 sheets of paper (excluding electronically filed sequence or computer listings under 37 CFR 1.52(e)), the application size fee due is \$250 (\$125 for small entity) for each additional 50 sheets or fraction thereof. See 35 U.S.C. 41(a)(1)(G) and 37 CFR 1.16(s).

Total Sheets	Extra Sheets	Number of each additional 50 or fraction thereof	Fee (\$)	Fee Paid (\$)
<u>29</u>	<u>0</u>	<u>0</u>	<u>0</u>	<u>0</u>

4. OTHER FEE(S)

Description	Fee (\$)	Fees Paid (\$)
Non-English Specification, \$130 fee (no small entity discount)	130	_____
Other (e.g., late filing surcharge): <u>Late filing surcharge</u>	130	130.00

SUBMITTED BY

Signature		Registration No. (Attorney/Agent)	42,828	Telephone	408-236-6640
Name (Print/Type)	Van Mahamedi	Date	November 1, 2005		

This collection of information is required by 37 CFR 1.136. The information is required to obtain or retain a benefit by the public which is to file (and by the USPTO to process) an application. Confidentiality is governed by 35 U.S.C. 122 and 37 CFR 1.14. This collection is estimated to take 30 minutes to complete, including gathering, preparing, and submitting the completed application form to the USPTO. Time will vary depending upon the individual case. Any comments on the amount of time you require to complete this form and/or suggestions for reducing this burden, should be sent to the Chief Information Officer, U.S. Patent and Trademark Office, U.S. Department of Commerce, P.O. Box 1450, Alexandria, VA 22313-1450. DO NOT SEND FEES OR COMPLETED FORMS TO THIS ADDRESS. SEND TO: Commissioner for Patents, P.O. Box 1450, Alexandria, VA 22313-1450.

If you need assistance in completing the form, call 1-800-PTO-9199 and select option 2.

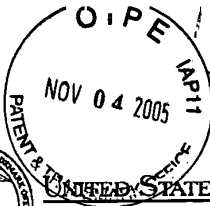

Page 1 of 2
PALM 962
JEW

UNITED STATES PATENT AND TRADEMARK OFFICE

UNITED STATES DEPARTMENT OF COMMERCE
United States Patent and Trademark Office
Address: COMMISSIONER FOR PATENTS
P.O. Box 1450
Alexandria, Virginia 22313-1450
www.uspto.gov

APPLICATION NUMBER	FILING OR 371 (c) DATE	FIRST NAMED APPLICANT	ATTORNEY DOCKET NUMBER
11/200,511	08/08/2005	David Champlin	PALM-0962

30554
SHEMWELL GREGORY & COURTNEY LLP
4880 STEVENS CREEK BOULEVARD
SUITE 201
SAN JOSE, CA 95129

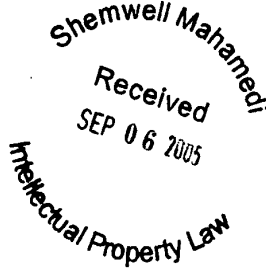

CONFIRMATION NO. 2125
FORMALITIES
LETTER

Date Mailed: 09/01/2005

11/07/2005 GWORDDF1 00000016 11200511

01 FC:1011	300.00 OP
02 FC:1051	130.00 OP
03 FC:1111	500.00 OP
04 FC:1311	200.00 OP

NOTICE TO FILE MISSING PARTS OF NONPROVISIONAL APPLICATION

05 FC:1202	400.00 OP	FILED UNDER 37 CFR 1.53(b)
------------	-----------	----------------------------

Filing Date Granted

Items Required To Avoid Abandonment:

An application number and filing date have been accorded to this application. The item(s) indicated below, however, are missing. Applicant is given **TWO MONTHS** from the date of this Notice within which to file all required items and pay any fees required below to avoid abandonment. Extensions of time may be obtained by filing a petition accompanied by the extension fee under the provisions of 37 CFR 1.136(a).

- The statutory basic filing fee is missing. Applicant must submit \$ 300 to complete the basic filing fee for a non-small entity. If appropriate, applicant may make a written assertion of entitlement to small entity status and pay the small entity filing fee (37 CFR 1.27).
- The oath or declaration is missing. A properly signed oath or declaration in compliance with 37 CFR 1.63, identifying the application by the above Application Number and Filing Date, is required. Note: If a petition under 37 CFR 1.47 is being filed, an oath or declaration in compliance with 37 CFR 1.63 signed by all available joint inventors, or if no inventor is available by a party with sufficient proprietary interest, is required.

The applicant needs to satisfy supplemental fees problems indicated below.

The required item(s) identified below must be timely submitted to avoid abandonment:

- Additional claim fees of \$400 as a non-small entity, including any required multiple dependent claim fee, are required. Applicant must submit the additional claim fees or cancel the additional claims for which fees are due.
- To avoid abandonment, a surcharge (for late submission of filing fee, search fee, examination fee or oath or declaration) as set forth in 37 CFR 1.16(f) of \$130 for a non-small entity, must be submitted with the missing items identified in this letter.

SUMMARY OF FEES DUE:

Total additional fee(s) required for this application is \$1530 for a Large Entity

SHEMWELL GREGORY & COURTNEY LLP

DOCKETED 10 Sep By: 18
Action File Missing Parts
Due Date 01 NOV 05
Final Action 01 APR 06

- \$300 Statutory basic filing fee.
- \$130 Surcharge.

- The application search fee has not been paid. Applicant must submit \$500 to complete the search fee.
- The application examination fee has not been paid. Applicant must submit \$200 to complete the examination fee for a large entity

- Total additional claim fee(s) for this application is \$400
 - \$400 for 8 total claims over 20.

Replies should be mailed to: Mail Stop Missing Parts
Commissioner for Patents
P.O. Box 1450
Alexandria VA 22313-1450

*A copy of this notice **MUST** be returned with the reply.*



Office of Initial Patent Examination (571) 272-4000, or 1-800-PTO-9199, or 1-800-972-6382
PART 2 - COPY TO BE RETURNED WITH RESPONSE



Attorney Docket No.: PALM-0962

IN THE UNITED STATES PATENT AND TRADEMARK OFFICE

Applicant(s): David CHAMPLIN, et al.

Confirmation No.: 2125

Application No.: 11/200,511

Group Art Unit: 2645

Filed: August 8, 2005

Examiner: Not yet assigned

Title: METHOD AND DEVICE FOR ENABLING
MESSAGE RESPONSES TO INCOMING
PHONE CALLS

RESPONSE TO NOTICE TO FILE MISSING PARTS OF APPLICATION

Mail Stop Missing Parts
Commissioner for Patents
P.O. Box 1450
Alexandria, VA 22313-1450

Sir:

This is in response to a Notice to File Missing Parts of Application under 37 CFR 1.53(f). Enclosed is a copy of said Notice and the following documents and fees to complete the filing requirements of the above-identified application.

(X) Executed Declaration. The above-identified application is the same application which the inventor executed by signing the enclosed declaration.

(X) Statutory basic filing fee **\$300.00** (X) Utility () Design

(X) Search fee **\$500.00**

(X) Examination fee **\$200.00**

(X) Additional claim fees of **\$400.00**

(X) Missing Parts Surcharge = **\$130.00**

() ___ sheets of substitute drawings in compliance with 37 CFR 1.84.

() Extension of Time Request for reply to Notice of Missing Parts is requested.

() one month = \$110.00

() two months = \$400.00

() three months = \$920.00

() four months = \$1,440.00

Throughout the pendency of this application, please charge any additional fees, including any required extension of time fees, and credit all overpayments to deposit account 50-1914. A duplicate of this sheet is enclosed.

I hereby certify that this correspondence is being deposited with the United States Postal Service with sufficient postage as first class mail in an envelope addressed to: Mail Stop Missing Parts, Commissioner for Patents, P.O. Box 1450, Alexandria VA 22313-1450 or facsimile transmitted to the U.S. Patent and Trademark Office on the date shown below.

Date of Deposit: November 1, 2005
Typed Name: Van Mahamedi

Signature: 

Respectfully submitted,

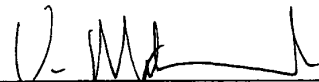
By 
Van Mahamedi

Reg. No. 42,828
Date: November 1, 2005
Telephone No.: (408) 551-6632
SHEMWELL MAHAMEDI LLP
4880 Stevens Creek Boulevard, Suite 201
San Jose, CA 95129

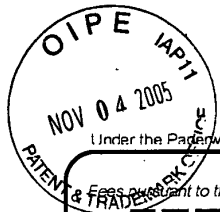

Under the Paperwork Reduction Act of 1995, no persons are required to respond to a collection of information unless it displays a valid OMB control number.

Effective on 12/08/2004.
 Fees pursuant to the Consolidated Appropriations Act, 2005 (H.R. 4818).

FEE TRANSMITTAL For FY 2005

Applicant claims small entity status. See 37 CFR 1.27

TOTAL AMOUNT OF PAYMENT		(\$)	1,530.00
Application Number	11/200,511		
Filing Date	August 8, 2005		
First Named Inventor	David CHAMPLIN, et al.		
Examiner Name	Not Yet Assigned		
Art Unit	2645		
Attorney Docket No.	PALM-0962		

METHOD OF PAYMENT (check all that apply)

Check Credit Card Money Order None Other (please identify): _____

Deposit Account Deposit Account Number: 50-1914 Deposit Account Name: Shemwell Mahamedi LLP

For the above-identified deposit account, the Director is hereby authorized to: (check all that apply)

Charge fee(s) indicated below Charge fee(s) indicated below, except for the filing fee

Charge any additional fee(s) or underpayments of fee(s) under 37 CFR 1.16 and 1.17 Credit any overpayments

WARNING: Information on this form may become public. Credit card information should not be included on this form. Provide credit card information and authorization on PTO-2038.

FEE CALCULATION

1. BASIC FILING, SEARCH, AND EXAMINATION FEES

Application Type	FILING FEES		SEARCH FEES		EXAMINATION FEES		Fees Paid (\$)
	Fee (\$)	Small Entity Fee (\$)	Fee (\$)	Small Entity Fee (\$)	Fee (\$)	Small Entity Fee (\$)	
Utility	300	150	500	250	200	100	1,000.00
Design	200	100	100	50	130	65	_____
Plant	200	100	300	150	160	80	_____
Reissue	300	150	500	250	600	300	_____
Provisional	200	100	0	0	0	0	_____

2. EXCESS CLAIM FEES

Fee Description	Fee (\$)	Small Entity Fee (\$)
Each claim over 20 (including Reissues)	50	25
Each independent claim over 3 (including Reissues)	200	100
Multiple dependent claims	360	180

Total Claims 28 - 20 or HP = 8 **Extra Claims** 8 **Fee (\$)** 50.00 **Fee Paid (\$)** 400.00

HP = highest number of total claims paid for, if greater than 20.

Indep. Claims 3 - 3 or HP = 0 **Extra Claims** 0 **Fee (\$)** _____ **Fee Paid (\$)** _____

HP = highest number of independent claims paid for, if greater than 3.

3. APPLICATION SIZE FEE

If the specification and drawings exceed 100 sheets of paper (excluding electronically filed sequence or computer listings under 37 CFR 1.52(e)), the application size fee due is \$250 (\$125 for small entity) for each additional 50 sheets or fraction thereof. See 35 U.S.C. 41(a)(1)(G) and 37 CFR 1.16(s).

Total Sheets	Extra Sheets	Number of each additional 50 or fraction thereof	Fee (\$)	Fee Paid (\$)
<u>29</u>	<u>0</u>	<u>0</u>	<u>0</u>	<u>0</u>

4. OTHER FEE(S)

Description	Fee (\$)	Fees Paid (\$)
Non-English Specification, \$130 fee (no small entity discount)	130	_____
Other (e.g., late filing surcharge): <u>Late filing surcharge</u>	130	130.00

SUBMITTED BY

Signature		Registration No. (Attorney/Agent) 42,828	Telephone 408-236-6640
Name (Print/Type)	Van Mahamedi	Date November 1, 2005	

This collection of information is required by 37 CFR 1.136. The information is required to obtain or retain a benefit by the public which is to file (and by the USPTO to process) an application. Confidentiality is governed by 35 U.S.C. 122 and 37 CFR 1.14. This collection is estimated to take 30 minutes to complete, including gathering, preparing, and submitting the completed application form to the USPTO. Time will vary depending upon the individual case. Any comments on the amount of time you require to complete this form and/or suggestions for reducing this burden, should be sent to the Chief Information Officer, U.S. Patent and Trademark Office, U.S. Department of Commerce, P.O. Box 1450, Alexandria, VA 22313-1450. DO NOT SEND FEES OR COMPLETED FORMS TO THIS ADDRESS. SEND TO: Commissioner for Patents, P.O. Box 1450, Alexandria, VA 22313-1450.

If you need assistance in completing the form, call 1-800-PTO-9199 and select option 2.

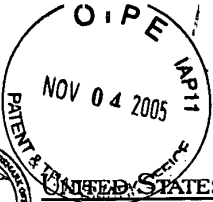

Page 1 of 2
PALM 962
JEW

UNITED STATES PATENT AND TRADEMARK OFFICE

UNITED STATES DEPARTMENT OF COMMERCE
United States Patent and Trademark Office
Address: COMMISSIONER FOR PATENTS
P.O. Box 1450
Alexandria, Virginia 22313-1450
www.uspto.gov

APPLICATION NUMBER	FILING OR 371 (c) DATE	FIRST NAMED APPLICANT	ATTORNEY DOCKET NUMBER
11/200,511	08/08/2005	David Champlin	PALM-0962

30554
SHEMWELL GREGORY & COURTNEY LLP
4880 STEVENS CREEK BOULEVARD
SUITE 201
SAN JOSE, CA 95129

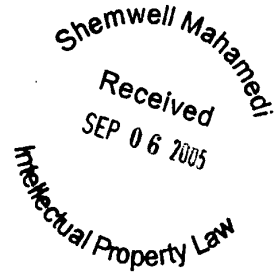

CONFIRMATION NO. 2125
FORMALITIES LETTER

Date Mailed: 09/01/2005

11/07/2005 GWORDDF1 00000016 11200511

01 FC:1011	300.00 OP
02 FC:1051	130.00 OP
03 FC:1111	500.00 OP
04 FC:1311	200.00 OP

NOTICE TO FILE MISSING PARTS OF NONPROVISIONAL APPLICATION

05 FC:1202 400.00 OP FILED UNDER 37 CFR 1.53(b)

Filing Date Granted

Items Required To Avoid Abandonment:

An application number and filing date have been accorded to this application. The item(s) indicated below, however, are missing. Applicant is given **TWO MONTHS** from the date of this Notice within which to file all required items and pay any fees required below to avoid abandonment. Extensions of time may be obtained by filing a petition accompanied by the extension fee under the provisions of 37 CFR 1.136(a).

- The statutory basic filing fee is missing. Applicant must submit \$ 300 to complete the basic filing fee for a non-small entity. If appropriate, applicant may make a written assertion of entitlement to small entity status and pay the small entity filing fee (37 CFR 1.27).
- The oath or declaration is missing. A properly signed oath or declaration in compliance with 37 CFR 1.63, identifying the application by the above Application Number and Filing Date, is required. Note: If a petition under 37 CFR 1.47 is being filed, an oath or declaration in compliance with 37 CFR 1.63 signed by all available joint inventors, or if no inventor is available by a party with sufficient proprietary interest, is required.

The applicant needs to satisfy supplemental fees problems indicated below.

The required item(s) identified below must be timely submitted to avoid abandonment:

- Additional claim fees of \$400 as a non-small entity, including any required multiple dependent claim fee, are required. Applicant must submit the additional claim fees or cancel the additional claims for which fees are due.
- To avoid abandonment, a surcharge (for late submission of filing fee, search fee, examination fee or oath or declaration) as set forth in 37 CFR 1.16(f) of \$130 for a non-small entity, must be submitted with the missing items identified in this letter.

SUMMARY OF FEES DUE:

Total additional fee(s) required for this application is \$1530 for a Large Entity

SHEMWELL GREGORY & COURTNEY LLP

DOCKETED 10 Sep By: 18
Action File Missing Parts
Due Date 01 NOV 05
Final Action 01 APR 06

- \$300 Statutory basic filing fee.
- \$130 Surcharge.

- The application search fee has not been paid. Applicant must submit \$500 to complete the search fee.
- The application examination fee has not been paid. Applicant must submit \$200 to complete the examination fee for a large entity

- Total additional claim fee(s) for this application is \$400
 - \$400 for 8 total claims over 20.

Replies should be mailed to: Mail Stop Missing Parts
Commissioner for Patents
P.O. Box 1450
Alexandria VA 22313-1450

*A copy of this notice **MUST** be returned with the reply.*

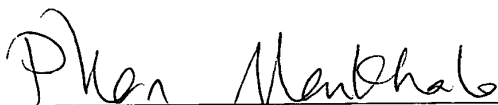

Office of Initial Patent Examination (571) 272-4000, or 1-800-PTO-9199, or 1-800-972-6382
PART 2 - COPY TO BE RETURNED WITH RESPONSE

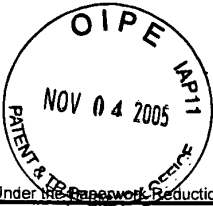

Approved for use through 07/31/2006. OMB 0651-0032
 U.S. Patent and Trademark Office; U.S. DEPARTMENT OF COMMERCE

Under the Paperwork Reduction Act of 1995, no persons are required to respond to a collection of information unless it contains a valid OMB control number.

DECLARATION FOR UTILITY OR DESIGN PATENT APPLICATION (37 CFR 1.63) <input type="checkbox"/> Declaration Submitted With Initial Filing OR <input checked="" type="checkbox"/> Declaration Submitted after Initial Filing (surcharge (37 CFR 1.16 (e)) required)	Attorney Docket Number	PALM-0962
	First Named Inventor	David CHAMPLIN et al.
	<i>COMPLETE IF KNOWN</i>	
	Application Number	11/200,511
	Filing Date	August 8, 2005
	Art Unit	Not Yet Assigned
	Examiner Name	Not Yet Assigned

I hereby declare that:

Each inventor's residence, mailing address, and citizenship are as stated below next to their name.

I believe the inventor(s) named below to be the original and first inventor(s) of the subject matter which is claimed and for which a patent is sought on the invention entitled:

Method and Device for Enabling Message Responses to Incoming Phone Calls

(Title of the Invention)

the specification of which

is attached hereto

OR

was filed on (MM/DD/YYYY) 08/08/2005 as United States Application Number or PCT International Application Number 11/200,511 and was amended on (MM/DD/YYYY) (if applicable).

I hereby state that I have reviewed and understand the contents of the above identified specification, including the claims, as amended by any amendment specifically referred to above.

I acknowledge the duty to disclose information which is material to patentability as defined in 37 CFR 1.56, including for continuation-in-part applications, material information which became available between the filing date of the prior application and the national or PCT international filing date of the continuation-in-part application.

I hereby claim foreign priority benefits under 35 U.S.C. 119(a)-(d) or (f), or 365(b) of any foreign application(s) for patent, inventor's or plant breeder's rights certificate(s), or 365(a) of any PCT international application which designated at least one country other than the United States of America, listed below and have also identified below, by checking the box, any foreign application for patent, inventor's or plant breeder's rights certificate(s), or any PCT international application having a filing date before that of the application on which priority is claimed.

Prior Foreign Application Number(s)	Country	Foreign Filing Date (MM/DD/YYYY)	Priority	Certified Copy Attached?	
			Not Claimed	YES	NO
			<input type="checkbox"/>	<input type="checkbox"/>	<input type="checkbox"/>
			<input type="checkbox"/>	<input type="checkbox"/>	<input type="checkbox"/>
			<input type="checkbox"/>	<input type="checkbox"/>	<input type="checkbox"/>
			<input type="checkbox"/>	<input type="checkbox"/>	<input type="checkbox"/>

Additional foreign application numbers are listed on a supplemental priority data sheet PTO/SB/02B attached hereto.

[Page 1 of 2]

This collection of information is required by 35 U.S.C. 115 and 37 CFR 1.63. The information is required to obtain or retain a benefit by the public which is to file (and by the USPTO to process) an application. Confidentiality is governed by 35 U.S.C. 122 and 37 CFR 1.11 and 1.14. This collection is estimated to take 21 minutes to complete, including gathering, preparing, and submitting the completed application form to the USPTO. Time will vary depending upon the individual case. Any comments on the amount of time you require to complete this form and/or suggestions for reducing this burden, should be sent to the Chief Information Officer, U.S. Patent and Trademark Office, U.S. Department of Commerce, P.O. Box 1450, Alexandria, VA 22313-1450. DO NOT SEND FEES OR COMPLETED FORMS TO THIS ADDRESS. SEND TO: Commissioner for Patents, P.O. Box 1450, Alexandria, VA 22313-1450.

If you need assistance completing the form, call 1-800-PTO-9199 and select option 2.

DECLARATION — Utility or Design Patent Application

Direct all correspondence to:		<input checked="" type="checkbox"/> The address associated with Customer Number:	30554	OR	<input type="checkbox"/> Correspondence address below
Name					
Address					
City		State		ZIP	
Country		Telephone		Email	
I hereby declare that all statements made herein of my own knowledge are true and that all statements made on information and belief are believed to be true; and further that these statements were made with the knowledge that willful false statements and the like so made are punishable by fine or imprisonment, or both, under 18 U.S.C. 1001 and that such willful false statements may jeopardize the validity of the application or any patent issued thereon.					
NAME OF SOLE OR FIRST INVENTOR:			<input type="checkbox"/> A petition has been filed for this unsigned inventor		
Given Name (first and middle [if any])			Family Name or Surname		
David			Champlin		
Inventor's Signature				Date	
<i>David Champlin</i>				10/25/2005	
Residence: City		State	Country	Citizenship	
Menlo Park		CA	USA	US Citizen	
Mailing Address					
2225 Sharon Road Apt. #224					
City		State		Zip	Country
Menlo Park		CA		94025	USA
NAME OF SECOND INVENTOR:			<input type="checkbox"/> A petition has been filed for this unsigned inventor		
Given Name (first and middle [if any])			Family Name or Surname		
Srikiran			Prasad		
Inventor's Signature				Date	
Residence: City		State	Country	Citizenship	
Cupertino		CA	USA	US Citizen	
Mailing Address					
5600 Stevens Creek Blvd. #108					
City		State		Zip	Country
Cupertino		CA		95014	USA
<input checked="" type="checkbox"/> Additional inventors or a legal representative are being named on the 1 supplemental sheet(s) PTO/SB/02A or 02LR attached hereto.					

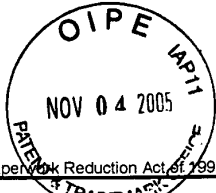

Under the Paperwork Reduction Act of 1995, no persons are required to respond to a collection of information unless it contains a valid OMB control number.

DECLARATION	ADDITIONAL INVENTOR(S) Supplemental Sheet
Page <u>1</u> of <u>1</u>	

Name of Additional Joint Inventor, if any:		<input type="checkbox"/> A petition has been filed for this unsigned inventor	
Given Name (first and middle (if any))		Family Name or Surname	
Lang		Chen	
Inventor's Signature			Date
Oakland Residence: City	CA State	USA Country	US Citizen Citizenship
2537 Scenic Avenue Mailing Address			
Oakland City	CA State	94602 Zip	USA Country
Name of Additional Joint Inventor, if any:		<input type="checkbox"/> A petition has been filed for this unsigned inventor	
Given Name (first and middle (if any))		Family Name or Surname	
Rajan		Ranga	
Inventor's Signature			Date
Palo Alto Residence: City	CA State	USA Country	US Citizen Citizenship
915 Bautista Court Mailing Address			
Palo Alto City	CA State	94303 Zip	USA Country
Name of Additional Joint Inventor, if any:		<input type="checkbox"/> A petition has been filed for this unsigned inventor	
Given Name (first and middle (if any))		Family Name or Surname	
Robert		Haitani	
Inventor's Signature			Date
Menlo Park Residence: City	CA State	USA Country	US Citizen Citizenship
2315 Crest Lane Mailing Address			
Menlo Park City	CA State	94025 Zip	USA Country

This collection of information is required by 35 U.S.C. 115 and 37 CFR 1.63. The information is required to obtain or retain a benefit by the public which is to file (and by the USPTO to process) an application. Confidentiality is governed by 35 U.S.C. 122 and 37 CFR 1.11 and 1.14. This collection is estimated to take 21 minutes to complete, including gathering, preparing, and submitting the completed application form to the USPTO. Time will vary depending upon the individual case. Any comments on the amount of time you require to complete this form and/or suggestions for reducing this burden, should be sent to the Chief Information Officer, U.S. Patent and Trademark Office, U.S. Department of Commerce, P.O. Box 1450, Alexandria, VA 22313-1450. DO NOT SEND FEES OR COMPLETED FORMS TO THIS ADDRESS. SEND TO: Commissioner for Patents, P.O. Box 1450, Alexandria, VA 22313-1450.

If you need assistance in completing the form, call 1-800-PTO-9199 (1-800-786-9199) and select option 2.

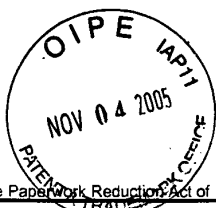

PTO/SB/01 (04-05)
 Approved for use through 07/31/2006. OMB 0651-0032
 U.S. Patent and Trademark Office; U.S. DEPARTMENT OF COMMERCE

Under the Paperwork Reduction Act of 1995, no persons are required to respond to a collection of information unless it contains a valid OMB control number.

DECLARATION FOR UTILITY OR DESIGN PATENT APPLICATION (37 CFR 1.63)	Attorney Docket Number	PALM-0962
	First Named Inventor	David CHAMPLIN et al.
	<i>COMPLETE IF KNOWN</i>	
	Application Number	11/200,511
	Filing Date	August 8, 2005
	Art Unit	Not Yet Assigned
	Examiner Name	Not Yet Assigned

Declaration Submitted With Initial Filing **OR** Declaration Submitted after Initial Filing (surcharge (37 CFR 1.16 (e)) required)

I hereby declare that:

Each inventor's residence, mailing address, and citizenship are as stated below next to their name.

I believe the inventor(s) named below to be the original and first inventor(s) of the subject matter which is claimed and for which a patent is sought on the invention entitled:

Method and Device for Enabling Message Responses to Incoming Phone Calls

(Title of the Invention)

the specification of which

is attached hereto

OR

was filed on (MM/DD/YYYY) as United States Application Number or PCT International

Application Number and was amended on (MM/DD/YYYY) (if applicable).

I hereby state that I have reviewed and understand the contents of the above identified specification, including the claims, as amended by any amendment specifically referred to above.

I acknowledge the duty to disclose information which is material to patentability as defined in 37 CFR 1.56, including for continuation-in-part applications, material information which became available between the filing date of the prior application and the national or PCT international filing date of the continuation-in-part application.

I hereby claim foreign priority benefits under 35 U.S.C. 119(a)-(d) or (f), or 365(b) of any foreign application(s) for patent, inventor's or plant breeder's rights certificate(s), or 365(a) of any PCT international application which designated at least one country other than the United States of America, listed below and have also identified below, by checking the box, any foreign application for patent, inventor's or plant breeder's rights certificate(s), or any PCT international application having a filing date before that of the application on which priority is claimed:

Prior Foreign Application Number(s)	Country	Foreign Filing Date (MM/DD/YYYY)	Priority Not Claimed	Certified Copy Attached?	
				YES	NO
			<input type="checkbox"/>	<input type="checkbox"/>	<input type="checkbox"/>
			<input type="checkbox"/>	<input type="checkbox"/>	<input type="checkbox"/>
			<input type="checkbox"/>	<input type="checkbox"/>	<input type="checkbox"/>
			<input type="checkbox"/>	<input type="checkbox"/>	<input type="checkbox"/>

Additional foreign application numbers are listed on a supplemental priority data sheet PTO/SB/02B attached hereto.

[Page 1 of 2]

This collection of information is required by 35 U.S.C. 115 and 37 CFR 1.63. The information is required to obtain or retain a benefit by the public which is to file (and by the USPTO to process) an application. Confidentiality is governed by 35 U.S.C. 122 and 37 CFR 1.11 and 1.14. This collection is estimated to take 21 minutes to complete, including gathering, preparing, and submitting the completed application form to the USPTO. Time will vary depending upon the individual case. Any comments on the amount of time you require to complete this form and/or suggestions for reducing this burden, should be sent to the Chief Information Officer, U.S. Patent and Trademark Office, U.S. Department of Commerce, P.O. Box 1450, Alexandria, VA 22313-1450. DO NOT SEND FEES OR COMPLETED FORMS TO THIS ADDRESS. SEND TO: Commissioner for Patents, P.O. Box 1450, Alexandria, VA 22313-1450.

If you need assistance completing the form, call 1-800-PTO-9199 and select option 2.

Under the Paperwork Reduction Act of 1995, no persons are required to respond to a collection of information unless it contains a valid OMB control number.

DECLARATION — Utility or Design Patent Application

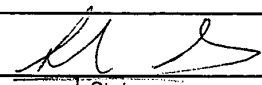
Direct all correspondence to:		<input checked="" type="checkbox"/> The address associated with Customer Number:	30554	OR	<input type="checkbox"/> Correspondence address below
Name					
Address					
City		State		ZIP	
Country		Telephone		Email	
I hereby declare that all statements made herein of my own knowledge are true and that all statements made on information and belief are believed to be true; and further that these statements were made with the knowledge that willful false statements and the like so made are punishable by fine or imprisonment, or both, under 18 U.S.C. 1001 and that such willful false statements may jeopardize the validity of the application or any patent issued thereon.					
NAME OF SOLE OR FIRST INVENTOR:			<input type="checkbox"/> A petition has been filed for this unsigned inventor		
Given Name (first and middle [if any])			Family Name or Surname		
David			Champlin		
Inventor's Signature				Date	
Residence: City		State	Country		Citizenship
Menlo Park		CA	USA		US Citizen
Mailing Address					
2225 Sharon Road Apt. #224					
City		State		Zip	Country
Menlo Park		CA		94025	USA
NAME OF SECOND INVENTOR:			<input type="checkbox"/> A petition has been filed for this unsigned inventor		
Given Name (first and middle [if any])			Family Name or Surname		
Srikiran			Prasad		
Inventor's Signature				Date	
				10/26/05	
Residence: City		State	Country		Citizenship
Cupertino		CA	USA		US Citizen
Mailing Address					
5600 Stevens Creek Blvd. #108					
City		State		Zip	Country
Cupertino		CA		95014	USA
<input checked="" type="checkbox"/> Additional inventors or a legal representative are being named on the 1 supplemental sheet(s) PTO/SB/02A or 02LR attached hereto.					

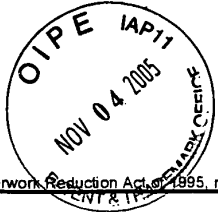

PTO/SB/02A (09-04)

Approved for use through 07/31/2006. OMB 0651-0032

U.S. Patent and Trademark Office; U.S. DEPARTMENT OF COMMERCE

Under the Paperwork Reduction Act of 1995, no persons are required to respond to a collection of information unless it contains a valid OMB control number.

DECLARATION	ADDITIONAL INVENTOR(S) Supplemental Sheet
Page <u>1</u> of <u>1</u>	

Name of Additional Joint Inventor, if any:		<input type="checkbox"/> A petition has been filed for this unsigned inventor	
Given Name (first and middle (if any))		Family Name or Surname	
Lang		Chen	
Inventor's Signature <i>[Signature]</i>		Date <i>11/12/05</i>	
Oakland Residence: City	CA State	USA Country	US Citizen Citizenship
2537 Scenic Avenue Mailing Address			
Oakland City	CA State	94602 Zip	USA Country
Name of Additional Joint Inventor, if any:		<input type="checkbox"/> A petition has been filed for this unsigned inventor	
Given Name (first and middle (if any))		Family Name or Surname	
Rajan		Ranga	
Inventor's Signature		Date	
Palo Alto Residence: City	CA State	USA Country	US Citizen Citizenship
915 Bautista Court Mailing Address			
Palo Alto City	CA State	94303 Zip	USA Country
Name of Additional Joint Inventor, if any:		<input type="checkbox"/> A petition has been filed for this unsigned inventor	
Given Name (first and middle (if any))		Family Name or Surname	
Robert		Haitani	
Inventor's Signature		Date	
Menlo Park Residence: City	CA State	USA Country	US Citizen Citizenship
2315 Crest Lane Mailing Address			
Menlo Park City	CA State	94025 Zip	USA Country

This collection of information is required by 35 U.S.C. 115 and 37 CFR 1.63. The information is required to obtain or retain a benefit by the public which is to file (and by the USPTO to process) an application. Confidentiality is governed by 35 U.S.C. 122 and 37 CFR 1.11 and 1.14. This collection is estimated to take 21 minutes to complete, including gathering, preparing, and submitting the completed application form to the USPTO. Time will vary depending upon the individual case. Any comments on the amount of time you require to complete this form and/or suggestions for reducing this burden, should be sent to the Chief Information Officer, U.S. Patent and Trademark Office, U.S. Department of Commerce, P.O. Box 1450, Alexandria, VA 22313-1450. DO NOT SEND FEES OR COMPLETED FORMS TO THIS ADDRESS. SEND TO: Commissioner for Patents, P.O. Box 1450, Alexandria, VA 22313-1450.

If you need assistance in completing the form, call 1-800-PTO-9199 (1-800-786-9199) and select option 2.

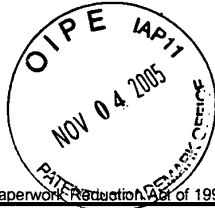

PTO/SB/01 (04-05)
 Approved for use through 07/31/2006. OMB 0651-0032
 U.S. Patent and Trademark Office; U.S. DEPARTMENT OF COMMERCE

Under the Paperwork Reduction Act of 1995, no persons are required to respond to a collection of information unless it contains a valid OMB control number.

DECLARATION FOR UTILITY OR DESIGN PATENT APPLICATION (37 CFR 1.63) <input type="checkbox"/> Declaration Submitted With Initial Filing OR <input checked="" type="checkbox"/> Declaration Submitted after Initial Filing (surcharge (37 CFR 1.16 (e)) required)	Attorney Docket Number	PALM-0962
	First Named Inventor	David CHAMPLIN et al.
	<i>COMPLETE IF KNOWN</i>	
	Application Number	11/200,511
	Filing Date	August 8, 2005
	Art Unit	Not Yet Assigned
Examiner Name	Not Yet Assigned	

I hereby declare that:

Each inventor's residence, mailing address, and citizenship are as stated below next to their name.

I believe the inventor(s) named below to be the original and first inventor(s) of the subject matter which is claimed and for which a patent is sought on the invention entitled:

Method and Device for Enabling Message Responses to Incoming Phone Calls

(Title of the Invention)

the specification of which

is attached hereto

OR

was filed on (MM/DD/YYYY) 08/08/2005 as United States Application Number or PCT International Application Number 11/200,511 and was amended on (MM/DD/YYYY) (if applicable).

I hereby state that I have reviewed and understand the contents of the above identified specification, including the claims, as amended by any amendment specifically referred to above.

I acknowledge the duty to disclose information which is material to patentability as defined in 37 CFR 1.56, including for continuation-in-part applications, material information which became available between the filing date of the prior application and the national or PCT international filing date of the continuation-in-part application.

I hereby claim foreign priority benefits under 35 U.S.C. 119(a)-(d) or (f), or 365(b) of any foreign application(s) for patent, inventor's or plant breeder's rights certificate(s), or 365(a) of any PCT international application which designated at least one country other than the United States of America, listed below and have also identified below, by checking the box, any foreign application for patent, inventor's or plant breeder's rights certificate(s), or any PCT international application having a filing date before that of the application on which priority is claimed.

Prior Foreign Application Number(s)	Country	Foreign Filing Date (MM/DD/YYYY)	Priority Not Claimed	Certified Copy Attached?	
				YES	NO
			<input type="checkbox"/>	<input type="checkbox"/>	<input type="checkbox"/>
			<input type="checkbox"/>	<input type="checkbox"/>	<input type="checkbox"/>
			<input type="checkbox"/>	<input type="checkbox"/>	<input type="checkbox"/>
			<input type="checkbox"/>	<input type="checkbox"/>	<input type="checkbox"/>

Additional foreign application numbers are listed on a supplemental priority data sheet PTO/SB/02B attached hereto.

[Page 1 of 2]

This collection of information is required by 35 U.S.C. 115 and 37 CFR 1.63. The information is required to obtain or retain a benefit by the public which is to file (and by the USPTO to process) an application. Confidentiality is governed by 35 U.S.C. 122 and 37 CFR 1.11 and 1.14. This collection is estimated to take 21 minutes to complete, including gathering, preparing, and submitting the completed application form to the USPTO. Time will vary depending upon the individual case. Any comments on the amount of time you require to complete this form and/or suggestions for reducing this burden, should be sent to the Chief Information Officer, U.S. Patent and Trademark Office, U.S. Department of Commerce, P.O. Box 1450, Alexandria, VA 22313-1450. DO NOT SEND FEES OR COMPLETED FORMS TO THIS ADDRESS. SEND TO: **Commissioner for Patents, P.O. Box 1450, Alexandria, VA 22313-1450.**

If you need assistance completing the form, call 1-800-PTO-9199 and select option 2.

Under the Paperwork Reduction Act of 1995, no persons are required to respond to a collection of information unless it contains a valid OMB control number.

DECLARATION — Utility or Design Patent Application

Direct all correspondence to:	<input checked="" type="checkbox"/> The address associated with Customer Number:	<input type="checkbox"/> OR	<input type="checkbox"/> Correspondence address below
		30554	
Name			
Address			
City		State	ZIP
Country	Telephone	Email	
I hereby declare that all statements made herein of my own knowledge are true and that all statements made on information and belief are believed to be true; and further that these statements were made with the knowledge that willful false statements and the like so made are punishable by fine or imprisonment, or both, under 18 U.S.C. 1001 and that such willful false statements may jeopardize the validity of the application or any patent issued thereon.			
NAME OF SOLE OR FIRST INVENTOR:		<input type="checkbox"/> A petition has been filed for this unsigned inventor	
Given Name (first and middle [if any])		Family Name or Surname	
David		Champlin	
Inventor's Signature			Date
Residence: City	State	Country	Citizenship
Menlo Park	CA	USA	US Citizen
Mailing Address 2225 Sharon Road Apt. #224			
City	State	Zip	Country
Menlo Park	CA	94025	USA
NAME OF SECOND INVENTOR:		<input type="checkbox"/> A petition has been filed for this unsigned inventor	
Given Name (first and middle [if any])		Family Name or Surname	
Srikiran		Prasad	
Inventor's Signature			Date
Residence: City	State	Country	Citizenship
Cupertino	CA	USA	US Citizen
Mailing Address 5600 Stevens Creek Blvd. #108			
City	State	Zip	Country
Cupertino	CA	95014	USA
<input checked="" type="checkbox"/> Additional inventors or a legal representative are being named on the 1 supplemental sheet(s) PTO/SB/02A or 02LR attached hereto.			

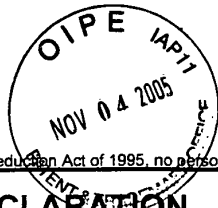

Under the Paperwork Reduction Act of 1995, no persons are required to respond to a collection of information unless it contains a valid OMB control number.

DECLARATION	ADDITIONAL INVENTOR(S) Supplemental Sheet
	Page <u>1</u> of <u>1</u>

Name of Additional Joint Inventor, if any:		<input type="checkbox"/> A petition has been filed for this unsigned inventor	
Given Name (first and middle (if any))		Family Name or Surname	
Lang		Chen	
Inventor's Signature			Date
Oakland Residence: City	CA State	USA Country	US Citizen Citizenship
2537 Scenic Avenue Mailing Address			
Oakland City	CA State	94602 Zip	USA Country
Name of Additional Joint Inventor, if any:		<input type="checkbox"/> A petition has been filed for this unsigned inventor	
Given Name (first and middle (if any))		Family Name or Surname	
Rajan		Ranga	
Inventor's Signature			Date 10/19/2005
Palo Alto Residence: City	CA State	USA Country	US Citizen Citizenship
915 Bautista Court Mailing Address			
Palo Alto City	CA State	94303 Zip	USA Country
Name of Additional Joint Inventor, if any:		<input type="checkbox"/> A petition has been filed for this unsigned inventor	
Given Name (first and middle (if any))		Family Name or Surname	
Robert		Haltani	
Inventor's Signature			Date
Menlo Park Residence: City	CA State	USA Country	US Citizen Citizenship
2315 Crest Lane Mailing Address			
Menlo Park City	CA State	94025 Zip	USA Country

This collection of information is required by 35 U.S.C. 115 and 37 CFR 1.63. The information is required to obtain or retain a benefit by the public which is to file (and by the USPTO to process) an application. Confidentiality is governed by 35 U.S.C. 122 and 37 CFR 1.11 and 1.14. This collection is estimated to take 21 minutes to complete, including gathering, preparing, and submitting the completed application form to the USPTO. Time will vary depending upon the individual case. Any comments on the amount of time you require to complete this form and/or suggestions for reducing this burden, should be sent to the Chief Information Officer, U.S. Patent and Trademark Office, U.S. Department of Commerce, P.O. Box 1450, Alexandria, VA 22313-1450. DO NOT SEND FEES OR COMPLETED FORMS TO THIS ADDRESS. SEND TO: **Commissioner for Patents, P.O. Box 1450, Alexandria, VA 22313-1450.**

If you need assistance in completing the form, call 1-800-PTO-9199 (1-800-786-9199) and select option 2.

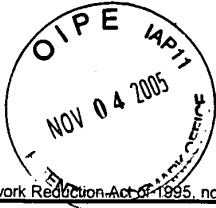

Approved for use through 07/31/2006. OMB 0651-0032
 U.S. Patent and Trademark Office; U.S. DEPARTMENT OF COMMERCE

Under the Paperwork Reduction Act of 1995, no persons are required to respond to a collection of information unless it contains a valid OMB control number.

DECLARATION FOR UTILITY OR DESIGN PATENT APPLICATION (37 CFR 1.63) <input type="checkbox"/> Declaration Submitted With Initial Filing OR <input checked="" type="checkbox"/> Declaration Submitted after Initial Filing (surcharge (37 CFR 1.16 (e)) required)	Attorney Docket Number	PALM-0962
	First Named Inventor	David CHAMPLIN et al.
	<i>COMPLETE IF KNOWN</i>	
	Application Number	11/200,511
	Filing Date	August 8, 2005
	Art Unit	Not Yet Assigned
	Examiner Name	Not Yet Assigned

I hereby declare that:

Each inventor's residence, mailing address, and citizenship are as stated below next to their name.

I believe the inventor(s) named below to be the original and first inventor(s) of the subject matter which is claimed and for which a patent is sought on the invention entitled:

Method and Device for Enabling Message Responses to Incoming Phone Calls

(Title of the Invention)

the specification of which

is attached hereto

OR

was filed on (MM/DD/YYYY) 08/08/2005 as United States Application Number or PCT International

Application Number 11/200,511 and was amended on (MM/DD/YYYY) (if applicable).

I hereby state that I have reviewed and understand the contents of the above identified specification, including the claims, as amended by any amendment specifically referred to above.

I acknowledge the duty to disclose information which is material to patentability as defined in 37 CFR 1.56, including for continuation-in-part applications, material information which became available between the filing date of the prior application and the national or PCT international filing date of the continuation-in-part application.

I hereby claim foreign priority benefits under 35 U.S.C. 119(a)-(d) or (f), or 365(b) of any foreign application(s) for patent, inventor's or plant breeder's rights certificate(s), or 365(a) of any PCT international application which designated at least one country other than the United States of America, listed below and have also identified below, by checking the box, any foreign application for patent, inventor's or plant breeder's rights certificate(s), or any PCT international application having a filing date before that of the application on which priority is claimed.

Prior Foreign Application Number(s)	Country	Foreign Filing Date (MM/DD/YYYY)	Priority Not Claimed		Certified Copy Attached?	
			YES	NO	YES	NO
			<input type="checkbox"/>	<input type="checkbox"/>	<input type="checkbox"/>	<input type="checkbox"/>
			<input type="checkbox"/>	<input type="checkbox"/>	<input type="checkbox"/>	<input type="checkbox"/>
			<input type="checkbox"/>	<input type="checkbox"/>	<input type="checkbox"/>	<input type="checkbox"/>
			<input type="checkbox"/>	<input type="checkbox"/>	<input type="checkbox"/>	<input type="checkbox"/>

Additional foreign application numbers are listed on a supplemental priority data sheet PTO/SB/02B attached hereto.

[Page 1 of 2]

This collection of information is required by 35 U.S.C. 115 and 37 CFR 1.63. The information is required to obtain or retain a benefit by the public which is to file (and by the USPTO to process) an application. Confidentiality is governed by 35 U.S.C. 122 and 37 CFR 1.11 and 1.14. This collection is estimated to take 21 minutes to complete, including gathering, preparing, and submitting the completed application form to the USPTO. Time will vary depending upon the individual case. Any comments on the amount of time you require to complete this form and/or suggestions for reducing this burden, should be sent to the Chief Information Officer, U.S. Patent and Trademark Office, U.S. Department of Commerce, P.O. Box 1450, Alexandria, VA 22313-1450. DO NOT SEND FEES OR COMPLETED FORMS TO THIS ADDRESS. SEND TO: Commissioner for Patents, P.O. Box 1450, Alexandria, VA 22313-1450.

If you need assistance completing the form, call 1-800-PTO-9199 and select option 2.

Under the Paperwork Reduction Act of 1995, no persons are required to respond to a collection of information unless it contains a valid OMB control number.

DECLARATION — Utility or Design Patent Application

Direct all correspondence to:		<input checked="" type="checkbox"/> The address associated with Customer Number:	30554	OR	<input type="checkbox"/> Correspondence address below
Name					
Address					
City			State		ZIP
Country		Telephone		Email	
I hereby declare that all statements made herein of my own knowledge are true and that all statements made on information and belief are believed to be true; and further that these statements were made with the knowledge that willful false statements and the like so made are punishable by fine or imprisonment, or both, under 18 U.S.C. 1001 and that such willful false statements may jeopardize the validity of the application or any patent issued thereon.					
NAME OF SOLE OR FIRST INVENTOR:			<input type="checkbox"/> A petition has been filed for this unsigned inventor		
Given Name (first and middle [if any])			Family Name or Surname		
David			Champlin		
Inventor's Signature					Date
Residence: City		State	Country	Citizenship	
Menlo Park		CA	USA	US Citizen	
Mailing Address					
2225 Sharon Road Apt. #224					
City		State		Zip	Country
Menlo Park		CA		94025	USA
NAME OF SECOND INVENTOR:			<input type="checkbox"/> A petition has been filed for this unsigned inventor		
Given Name (first and middle [if any])			Family Name or Surname		
Srikiran			Prasad		
Inventor's Signature					Date
Residence: City		State	Country	Citizenship	
Cupertino		CA	USA	US Citizen	
Mailing Address					
5600 Stevens Creek Blvd. #108					
City		State		Zip	Country
Cupertino		CA		95014	USA
<input checked="" type="checkbox"/> Additional inventors or a legal representative are being named on the 1 supplemental sheet(s) PTO/SB/02A or 02LR attached hereto.					

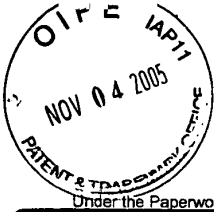

Under the Paperwork Reduction Act of 1995, no persons are required to respond to a collection of information unless it contains a valid OMB control number.

DECLARATION	ADDITIONAL INVENTOR(S) Supplemental Sheet
	Page 1 of 1

Name of Additional Joint Inventor, if any:		<input type="checkbox"/> A petition has been filed for this unsigned inventor	
Given Name (first and middle (if any))		Family Name or Surname	
Lang		Chen	
Inventor's Signature			Date
Oakland Residence: City	CA State	USA Country	US Citizen Citizenship
2537 Scenic Avenue Mailing Address			
Oakland City	CA State	94602 Zip	USA Country
Name of Additional Joint Inventor, if any:		<input type="checkbox"/> A petition has been filed for this unsigned inventor	
Given Name (first and middle (if any))		Family Name or Surname	
Rajan		Ranga	
Inventor's Signature			Date
Palo Alto Residence: City	CA State	USA Country	US Citizen Citizenship
915 Bautista Court Mailing Address			
Palo Alto City	CA State	94303 Zip	USA Country
Name of Additional Joint Inventor, if any:		<input type="checkbox"/> A petition has been filed for this unsigned inventor	
Given Name (first and middle (if any))		Family Name or Surname	
Robert		Haitani	
Inventor's Signature <i>Robert Haitani</i>			Date 7/25/05
Menlo Park Residence: City	CA State	USA Country	US Citizen Citizenship
2315 Crest Lane Mailing Address			
Menlo Park City	CA State	94025 Zip	USA Country

This collection of information is required by 35 U.S.C. 115 and 37 CFR 1.63. The information is required to obtain or retain a benefit by the public which is to file (and by the USPTO to process) an application. Confidentiality is governed by 35 U.S.C. 122 and 37 CFR 1.11 and 1.14. This collection is estimated to take 21 minutes to complete, including gathering, preparing, and submitting the completed application form to the USPTO. Time will vary depending upon the individual case. Any comments on the amount of time you require to complete this form and/or suggestions for reducing this burden, should be sent to the Chief Information Officer, U.S. Patent and Trademark Office, U.S. Department of Commerce, P.O. Box 1450, Alexandria, VA 22313-1450. DO NOT SEND FEES OR COMPLETED FORMS TO THIS ADDRESS. SEND TO: Commissioner for Patents, P.O. Box 1450, Alexandria, VA 22313-1450.

If you need assistance in completing the form, call 1-800-PTO-9199 (1-800-786-9199) and select option 2.

UNITED STATES PATENT AND TRADEMARK OFFICE

UNITED STATES DEPARTMENT OF COMMERCE
 United States Patent and Trademark Office
 Address: COMMISSIONER FOR PATENTS
 P.O. Box 1450
 Alexandria, Virginia 22313-1450
 www.uspto.gov

APPLICATION NUMBER	FILING OR 371 (c) DATE	FIRST NAMED APPLICANT	ATTORNEY DOCKET NUMBER
11/200,511	08/08/2005	David Champlin	PALM-0962

CONFIRMATION NO. 2125
**FORMALITIES
 LETTER**

30554
 SHEMWELL GREGORY & COURTNEY LLP
 4880 STEVENS CREEK BOULEVARD
 SUITE 201
 SAN JOSE, CA 95129

Date Mailed: 09/01/2005

NOTICE TO FILE MISSING PARTS OF NONPROVISIONAL APPLICATION
FILED UNDER 37 CFR 1.53(b)
Filing Date Granted
Items Required To Avoid Abandonment:

An application number and filing date have been accorded to this application. The item(s) indicated below, however, are missing. Applicant is given **TWO MONTHS** from the date of this Notice within which to file all required items and pay any fees required below to avoid abandonment. Extensions of time may be obtained by filing a petition accompanied by the extension fee under the provisions of 37 CFR 1.136(a).

- The statutory basic filing fee is missing.
Applicant must submit \$ 300 to complete the basic filing fee for a non-small entity. If appropriate, applicant may make a written assertion of entitlement to small entity status and pay the small entity filing fee (37 CFR 1.27).
- The oath or declaration is missing. *A properly signed oath or declaration in compliance with 37 CFR 1.63, identifying the application by the above Application Number and Filing Date, is required.*
Note: If a petition under 37 CFR 1.47 is being filed, an oath or declaration in compliance with 37 CFR 1.63 signed by all available joint inventors, or if no inventor is available by a party with sufficient proprietary interest, is required.

The applicant needs to satisfy supplemental fees problems indicated below.

The required item(s) identified below must be timely submitted to avoid abandonment:

- Additional claim fees of **\$400** as a non-small entity, including any required multiple dependent claim fee, are required. Applicant must submit the additional claim fees or cancel the additional claims for which fees are due.
- To avoid abandonment, a surcharge (for late submission of filing fee, search fee, examination fee or oath or declaration) as set forth in 37 CFR 1.16(f) of \$130 for a non-small entity, must be submitted with the missing items identified in this letter.

SUMMARY OF FEES DUE:

Total additional fee(s) required for this application is **\$1530** for a Large Entity

- \$300 Statutory basic filing fee.
- \$130 Surcharge.

- The application search fee has not been paid. Applicant must submit \$500 to complete the search fee.
- The application examination fee has not been paid. Applicant must submit \$200 to complete the examination fee for a large entity

- Total additional claim fee(s) for this application is \$400
 - \$400 for 8 total claims over 20.

Replies should be mailed to: Mail Stop Missing Parts
Commissioner for Patents
P.O. Box 1450
Alexandria VA 22313-1450

*A copy of this notice **MUST** be returned with the reply.*

Phen Markhel

Office of Initial Patent Examination (571) 272-4000, or 1-800-PTO-9199, or 1-800-972-6382
PART 3 - OFFICE COPY

080805

18351 U.S. PTO

PTO/SB/05 (04-05)

Approved for use through 07/31/2006. OMB 0651-0032 U.S. Patent and Trademark Office. U.S. DEPARTMENT OF COMMERCE

Under the Paperwork Reduction Act of 1995, no persons are required to respond to a collection of information unless it displays a valid OMB control number.

11/200511 U.S. PTO

080805

UTILITY PATENT APPLICATION TRANSMITTAL <small>(Only for new nonprovisional applications under 37 CFR 1.53(b))</small>	Attorney Docket No.	PALM-0962
	First Inventor	CHAMPLIN, D.
	Title	METHOD AND DEVICE FOR ENABLING MESSAGE RESPONSES TO INCOMING PHONE CALLS
	Express Mail Label No.	EV 652317855 US

APPLICATION ELEMENTS <small>See MPEP chapter 600 concerning utility patent application contents.</small>	ADDRESS TO: Commissioner for Patents P.O. Box 1450 Alexandria VA 22313-1450
--	---

1. Fee Transmittal Form (e.g., PTO/SB/17)
(Submit an original and a duplicate for fee processing)
2. Applicant claims small entity status.
See 37 CFR 1.27.
3. Specification [Total Pages 25]
Both the claims and abstract must start on a new page
(For information on the preferred arrangement, see MPEP 608.01(a))
4. Drawing(s) (35 U.S.C. 113) [Total Sheets 4]
5. Oath or Declaration [Total Sheets _____]
 - a. Newly executed (original or copy)
 - b. A copy from a prior application (37 CFR 1.63(d))
(for continuation/divisional with Box 18 completed)
 - i. DELETION OF INVENTOR(S)
Signed statement attached deleting inventor(s)
name in the prior application, see 37 CFR 1.63(d)(2) and 1.33(b).
6. Application Data Sheet. See 37 CFR 1.76
7. CD-ROM or CD-R in duplicate, large table or Computer Program (Appendix)
 Landscape Table on CD
8. Nucleotide and/or Amino Acid Sequence Submission
(if applicable, items a. - c. are required)
 - a. Computer Readable Form (CRF)
 - b. Specification Sequence Listing on:
 - i. CD-ROM or CD-R (2 copies); or
 - ii. Paper
 - c. Statements verifying identity of above copies

ACCOMPANYING APPLICATION PARTS

9. Assignment Papers (cover sheet & document(s))
Name of Assignee _____
10. 37 CFR 3.73(b) Statement Power of Attorney
(when there is an assignee)
11. English Translation Document *(if applicable)*
12. Information Disclosure Statement (PTO/SB/08 or PTO-1449)
 Copies of citations attached
13. Preliminary Amendment
14. Return Receipt Postcard (MPEP 503)
(Should be specifically itemized)
15. Certified Copy of Priority Document(s)
(if foreign priority is claimed)
16. Nonpublication Request under 35 U.S.C. 122(b)(2)(B)(i).
Applicant must attach form PTO/SB/35 or equivalent.
17. Other: _____

18. If a CONTINUING APPLICATION, check appropriate box, and supply the requisite information below and in the first sentence of the specification following the title, or in an Application Data Sheet under 37 CFR 1.76:

Continuation Divisional Continuation-in-part (CIP) of prior application No.: _____

Prior application information: Examiner: _____ Art Unit: _____

19. CORRESPONDENCE ADDRESS

The address associated with Customer Number: 30554 OR Correspondence address below

Name			
Address			
City	State	Zip Code	
Country	Telephone	Email	

Signature		Date	August 8, 2005
Name (Print/Type)	Van Mahamedi	Registration No. (Attorney/Agent)	42,828

This collection of information is required by 37 CFR 1.53(b). The information is required to obtain or retain a benefit by the public which is to file (and by the USPTO to process) an application. Confidentiality is governed by 35 U.S.C. 122 and 37 CFR 1.11 and 1.14. This collection is estimated to take 12 minutes to complete, including gathering, preparing, and submitting the completed application form to the USPTO. Time will vary depending upon the individual case. Any comments on the amount of time you require to complete this form and/or suggestions for reducing this burden, should be sent to the Chief Information Officer, U.S. Patent and Trademark Office, U.S. Department of Commerce, P.O. Box 1450, Alexandria, VA 22313-1450. DO NOT SEND FEES OR COMPLETED FORMS TO THIS ADDRESS. SEND TO: Commissioner for Patents, P.O. Box 1450, Alexandria, VA 22313-1450.

If you need assistance in completing the form, call 1-800-PTO-9199 and select option 2.

1

METHOD AND DEVICE FOR ENABLING MESSAGE RESPONSES TO INCOMING PHONE CALLS

Inventor(s):
David Champlin
Kirin Prasad
Larry Chen
Rajan Ranga
Robert Haitani

Transmittal of Patent Application for Filing

Certification Under 37 C.F.R. §1.10 (if applicable)

11(EV652317855US)

8/8/05

"Express Mail" Label Number

Date

I hereby certify that this application, and any other documents referred to as enclosed herein are being deposited in an envelope with the United States Postal Service "Express Mail Post Office to Addressee" service under 37 CFR §1.10 on the date indicated above and addressed to Mail Stop Patent Application, Commissioner for Patents, P.O. Box 1450, Alexandria, VA 22313-1450

Van Mahamedi

(Print Name of Person Mailing Application)

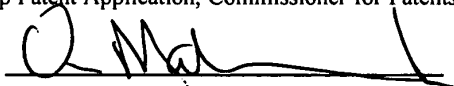

(Signature of Person Mailing Application)

TECHNICAL FIELD

[001] The disclosed embodiments relate generally to the field of messaging, and more particularly, to a method and apparatus for enabling message responses to incoming calls.

BACKGROUND

[002] Communication devices have evolved to include numerous types of communication capabilities and functionality. For example, handheld devices exist that operate as cellular phones, messaging terminals, Internet devices, while including personal information management (PIM) software and photo-management applications. Additionally, Internet Protocol services exist that can transform Internet-enabled machines into telephony devices. Even stand-alone telephones that connect to traditional Public Switched Telephone Networks (PSTN) now carry software to assist the user in making and managing phone calls.

[003] Mobile phone networks have traditionally been limited to voice communications, but new technologies such as GSM (Global System for Mobile Communications) have enabled mobile phone networks to also include data communications. For example, SMS (Short Message Service) messaging provides a software-independent protocol to send short text messages composed of either: 160-7 bit characters; 70-16 bit characters; or 140 octets of binary data. Individual SMS messages thus require a relatively small network bandwidth and devices can receive messages, even when connected to a voice call. The number of SMS messages a user receives has continually increased because many new types of network devices have joined mobile phone networks. These devices include, for example, PDAs, hybrid PDA / mobile phone devices, and other text messaging devices using GSM networks. Additionally, PSTN devices also exist that support messaging applications such as SMS.

BRIEF DESCRIPTION OF THE DRAWINGS

[004] FIG. 1 is a diagram illustrating a computing device issuing a message response to an incoming caller, according to one or more embodiments of the invention.

[005] FIG. 2 illustrates components for use in a computing device configured according to an embodiment of the invention.

[006] FIG. 3 is a hardware diagram for use with one or more embodiments of the invention.

[007] FIG. 4 illustrates a message for handling incoming calls with message replies, under an embodiment of the invention.

[008] FIG. 5 illustrates an optional process that may be performed in order to determine or verify that a caller using a message-enabled device, under an embodiment of the invention.

[009] FIG. 6A and FIG. 6B illustrate timelines for different usage scenarios, under one or more embodiments of the invention.

DETAILED DESCRIPTION

[010] Embodiments described herein enable message replies to be made to incoming callers. In an embodiment, a device that receives an incoming phone call, for example, may be used to transmit a message as a reply to the caller. For example, rather than pick up a phone call or forward the phone call to voicemail, the user may simply generate a text (or other form of) message to the caller.

[011] Embodiments of the invention recognize that in some cases, a user answering or not answering a phone call is inconvenient, either to the recipient of the phone call, or the caller. As such, embodiments described herein provide an alternative of messaging the caller of an incoming phone call, rather answering the phone call or forwarding the phone call to voicemail.

[012] Embodiments described herein have particular application to mobile computing devices that offer voice and data capabilities on cellular networks. In this context, embodiments described herein allow the user of the device handling the incoming call to communicate with the caller without actually accepting the call. This can save both the caller and the recipient time, and “minutes” on their respective cellular plans. Furthermore, if the recipient of the incoming call cannot accept the incoming call, the recipient is saved the trouble of having to respond to a voicemail message or having to find the time to return a call.

[013] While one or more embodiments of the invention are described for use with mobile, cellular devices, other telephony and computing devices are contemplated for use with embodiments of the invention. For example, some phones that connect to traditional wireline phone networks have capability to transmit and receive messages.

[014] In one embodiment, a computing device is configured to receive an incoming communication from another computing device. The incoming communication may be for

purpose of initiating a voice-exchange session. In response to receiving the incoming call, the computing device may identify or determine a message identifier of the other computing device. The message identifier is determined based at least in part on data provided with the incoming communication. The computing device may programmatically address a message to the other computing device using the message identifier determined from the incoming communication.

[015] According to an embodiment, a computing device is configured to provide a message reply to an incoming phone call. In one embodiment, the computing device identifies a phone number of a caller of the incoming call. The computing device may prompt the user of the computing device to generate a message reply to the incoming phone call. The computing device may then initiate the message reply by opening a message and addressing the message to the phone number of the caller of the incoming phone call.

[016] A voice-exchange includes any data transfer method in which a user's speech or utterance is transmitted across a network to the location of another device or user in real-time (e.g. instantaneous) or near real-time (e.g. less than three seconds). Examples of voice-exchange includes standard telephony practice. Another example of voice-exchange is when a voice transmission is recorded and transmitted as an instant message or file to be received and played back at the recipient. In the latter case, the recipient may not be able to interrupt the speaker, due to time delay, while in the former case, the recipient can interact with the speaker as if they were standing next to each other.

[017] As used herein, the term "instant message" or "instant messaging" means messages that when transmitted to a recipient, or rendered on a device of the recipient immediately, nearly immediately, or alternatively without user-action.

[018] Numerous types of computer telephony devices exist. One type of computer telephony

device for use with an embodiment is a wireless, mobile computing device, sometimes called the “smart phone”. Such devices are generally small to fit in one hand, and provide cellular telephony features in combination with other applications, such as contact applications for managing contact records, calendar applications for managing and scheduling events, task applications for keeping lists, and camera applications for capturing images. Another type of computer telephony device contemplated with an embodiment is a desktop computer that is configured to include real-time voice data exchange (e.g. through use of Internet Protocol telephony). Still further, other types of computer telephony devices exist, including standalone devices that connect directly to a telephone network (whether Internet Protocol or Public Switch Telephone System) and provide software interfaces and applications.

[019] Embodiments provide that methods, techniques and actions performed by the communication device are performed programmatically, or as a computer-implemented method. Programmatically means through the use of code, or computer-executable instructions. A programmatically performed step may or may not be automatic.

[020] One or more embodiments described herein may be implemented using modules. A module may include a program, a subroutine, a portion of a program, or a software component or a hardware component capable of performing one or more stated tasks or functions. As used herein, a module can exist on a hardware component independently of other modules, or a module can be a shared element or process of other modules, programs or machines. A module may reside on one machine, such as on a client or on a server, or a module may be distributed amongst multiple machines, such as on multiple clients or server machines.

[021] Furthermore, one or more embodiments described herein may be implemented through the use of instructions that are executable by one or more processors. These instructions may be

carried on a computer-readable medium. Machines shown in figures below provide examples of processing resources and computer-readable mediums on which instructions for implementing embodiments of the invention can be carried and/or executed. In particular, the numerous machines shown with embodiments of the invention include processor(s) and various forms of memory for holding data and instructions. Examples of computer-readable mediums include permanent memory storage devices, such as hard drives on personal computers or servers. Other examples of computer storage mediums include portable storage units, such as CD or DVD units, flash memory (such as carried on many cell phones and personal digital assistants (PDAs)), and magnetic memory. Computers, terminals, network enabled devices (e.g. mobile devices such as cell phones) are all examples of machines and devices that utilize processors, memory, and instructions stored on computer-readable mediums.

[022] FIG. 1 is a diagram illustrating a computing device issuing a message response to an incoming caller, according to one or more embodiments of the invention. In FIG. 1, an initiating computing device 120 (“calling device”) places a call 112 to a recipient computing device 110. Rather than answer the call or perform some other action like forwarding the call to voicemail, one or more embodiments described herein provide that the recipient computing device 110 issues a message response 122 to the calling device 120. In one embodiment, the message response 122 is an alternative to the user of the recipient device 110 having to decline or not answer the incoming call 112.

[023] In an embodiment, the message response 122 is an instant message, meaning that the contents of the message are rendered immediately when received on the calling device 110. One implementation provides that a content of the message response is text. For example, the user of the receiving device 110 may insert or compose a text message (e.g. “Call me later”). A text

message response may be provided using a Short Message Service (SMS) format and application. Other embodiments provide for other types of content data to be included in the message, including MMS (Multimedia Messaging Service), EMS (Enhanced Messaging Service), or any data protocol capable of encapsulating messages for transport between networked devices. Thus, one alternative implementation provides that the user may send an image that communicates information. For example, the user may send an image of a clock showing a particular time, indicating that user's desire to be called back at a particular time. Still further, the user may include audio in the message response 122. For example, the user may send a voice blurb or a chime to indicate a message to the user of the caller device 120.

[024] FIG. 1 illustrates implementation of embodiments of the invention with cellular telephony devices, since such devices normally handle both message transmissions and/or receptions over cellular networks. However, there are telephones VoIP (voice-over IP) phones and phones that connect to Public Switched Telephony Networks (PSTN) that can handle messaging. For example, some PSTN phones may support SMS message handling. Thus, embodiments of the invention may extend to devices and networks other than those that are used on cellular networks.

[025] Furthermore, telephone calls are just one example of a voice-exchange session. Embodiments of the invention may be implemented in the context of other types of voice-exchange sessions. For example, caller device 120 may initially communicate a walkie-talkie communication to the recipient device 110, for which recipient device 110 sends back, for example, a text message response.

[026] COMPONENT OVERVIEW

[027] FIG. 2 illustrates components for use in a computing device configured according to an embodiment of the invention. In FIG. 2, a computing device 200 includes a phone application 210 and a messaging component 220. A message response module 250 may be incorporated to operate in connection with both the phone application 210 and the messaging component 220. According to an embodiment, the message response module 250 triggers initiation of a message response 254 to the incoming call 204. In one implementation, computing device 200 corresponds to a hybrid mobile device having telephonic and messaging capability over cellular networks (sometimes called a “smart phone”). The phone application 210 may correspond to a software element that manages voice data exchanged over one or more wireless communication components 318 (see FIG. 3). In one embodiment, messaging component 220 is an instant messaging application.

[028] One example of a messaging application that is suitable for use with an embodiment is an SMS application, for sending and receiving text instant messages. Alternative instant text messaging applications may also be used. As another example, the messaging application 220 may correspond to a media-based messaging application, such as a Multimedia Messaging Service (MMS) application, for sending and receiving image data.

[029] With reference to FIG. 2, computing device 200 may receive an incoming call 204, which is handled by the phone application 210. At an initial time, the incoming call 204 may include call data 212, which is identified by the phone application 210. In one embodiment, call data 212 includes identification information of the caller (e.g. “Caller ID” information). As such, call data 212 may include (i) a name of the caller, and/or (ii) a phone number used by the caller. The phone application 210 may identify call data 212 from the incoming call 204 while causing

transmission of audio rings/chimes, rendering of image data containing the Caller ID information on a display of the device, and/or other incoming call notification (e.g. vibration).

[030] The act of sending message response 254 to incoming call 204 may involve the following operations: (i) opening a new message for message response 254, (ii) addressing the message, (iii) including a message content 242 or body for the message, and (iv) instructing the messaging component 220 to send the message response. The message response module 230 may perform at least some of these operations by communicating message creation data 222 to the messaging component 220. The message creation data 222 may be generated at one time, or submitted in spurts based on the occurrence of other events. As such, some or all of the steps of sending the message response 254 may be performed automatically.

[031] Alternatively, some or all of the steps of sending the message response 254 may be performed automatically, after input triggers are provided from the user 202. For example, in one case, the user may designate a setting on the computing device 200 to handle all incoming calls with a message response (e.g. “on vacation”).

[032] As another alternative, in one implementation, the message creation data 222 is generated in response to a trigger from a user 202. The phone application 210, message response module 230, or some other component may prompt the user to message respond to a caller in response to receipt of call data 202. The prompt may occur shortly after the incoming call 204 is received, such as with or before the first “ring” generated on the computing device 200 for the incoming call. For example, the user may be able to elect message response as one option along with other options of answering or declining the incoming call 204.

[033] The message creation data 222 may be based on call data 212. In one embodiment, the message creation data 222 may include (i) control data to cause the messaging application 220 to

open a new message, and (ii) an address along with other data/instructions for addressing the newly created message. The message content 242 may be provided by a programmatic source 244, and/or by the user 202. In one embodiment, user 202 provides all of the message content 244. In another embodiment, the programmatic source 244 generates the content, in response to a user-input or other trigger. For example, the programmatic source 244 may generate a macro message in response to a user selecting to have incoming call 202 handled by the message response 254. Alternatively, content 242 may be a combination of content provided by the programmatic source 244 and the user. For example, the programmatic source may provide a template content that the user fills in. To illustrate, a portion of the message content 244 may correspond to “please call me in ____ minutes.” The portion of the message content 244 provided by user 202 may correspond to “5”.

[034] An embodiment provides that the address provided by the message creation data 222 is a phone number of the incoming caller. In one embodiment, no verification or check is performed to determine if the device used by the caller is message enabled. For example, the user may manually make this selection in response to seeing the number being used by the caller. If the user recognizes the number as belonging to a cell phone, for example, the user may be assured that the caller’s device is message-enabled. Otherwise, the message response 254 may be transmitted, but not received by the caller.

[035] In another embodiment, a programmatic verification step is performed to see if the caller’s device is enabled to receive the message response 254. In one embodiment, the message response module 250 (or other programmatic element) may match the number of the caller to a field of a given contact record stored with a contact database 230 on the computing device. If, for example, the contact record information identifies the number of the incoming call as belonging

to a “mobile” number, the messaging response module 250 may do one or more of the following: (i) provide an indication that message response is available, (ii) enable the user to elect message response option, and/or (iii) programmatically initiate a new message addressed to the number of the caller.

[036] Conversely, if the number of the incoming call is not identifiable as being message-enabled, embodiments provide that (i) a message or other indication is provided to the user warning that the caller’s device is not message enabled, or (ii) the message response feature is disabled. One embodiment may distinguish between not knowing whether the device of the caller can receive messages, and knowing definitively that the caller’s device cannot receive incoming messages. For example, in the former case, no action may be taken so that the message response feature is enabled, or a warning may be provided to the user indicating that the caller’s device may not be message-enabled. In the latter case, message response may be disabled. Numerous other scenarios are possible and contemplated under embodiments of the invention.

[037] HARDWARE DIAGRAM

[038] FIG. 3 is a hardware diagram for use with one or more embodiments of the invention. In FIG. 3, a computing device 300 includes one or more processors 310, one or more memory components 320, and a display 330. One or more communication components 318 may enable receipt of call data 204 (FIG. 2), voice exchanges, and message responses 254 (FIG. 2). In one embodiment, the communication components 318 are for wireless communications, and cellular network communications in particular.

[039] The communication components 318 may configure computing device 300 to transmit and receive communications on Code Division Multiple Access (CDMA) networks, Global System for Mobile Communications (GSM) networks, and/or other types of cellular networks.

The communication components 318 may include a Subscriber Identity Module (SIM) card, an input/output controller, a radio frequency transceiver, and an input/output controller. Combined, communication components 318 may enable voice-exchange, as well as text and other kinds of message data exchanges.

[040] The processors 310 may retrieve from the memory components 320 instructions (“application instructions 322”) for executing operations such as described in FIG. 2. With reference to FIG. 2, the application instructions 322 may correspond to execution of phone application 210, messaging application 220 and message response module 230. Phone and/or message data 332 generated from execution of these applications may be signaled to the display 330 so that they can be viewed by the user.

[041] Input mechanisms 340 may enable the user to enter message input 342. The message input 342 may correspond to input triggers, corresponding to, for example: (i) decisions of the user to message reply to an incoming call, (ii) to include a specific pre-formulated message content 242, and/or (iii) to send the message response 254. As an alternative or additional functionality, message input 342 generated by the input mechanisms may include one or more manual entry items, including for example: (i) address and/or phone number of the recipient, and (ii) some or all of the message content 242 (FIG. 2).

[042] When used to compose message content 242 (FIG. 2), input mechanisms 340 may have any one of a variety of forms. For example, input mechanisms 340 may correspond to a set of hard or soft keys (soft keys may be iconic in form and displayed through use of a contact-sensitive display) arranged in the form of a QWERTY keyboard or other layout. The message input 342 may correspond to alphanumeric content, including phrases, keywords, or images that can be generated through use of keyboards (e.g. happy face). As another example, input

mechanism 340 may correspond to a microphone, so that the message input is a voice file. Still further, the input mechanism 340 may correspond to a camera or other image capturing device, which captures an image for the message response 354.

[043] According to one embodiment, components 318 receive call data 352 when a phone call or other voice-exchange session is initiated. Subsequently, such as in response to a call pick-up, voice data 362 may be received and transmitted. In one embodiment, a message 354 is transmitted as an alternative to the voice data 362 being exchanged. In another implementation, the message 354 is provided prior to the voice data exchange 362. For example, as described below, transmission of message 354 may result in an understanding between the caller and the recipient that the call pick-up will be delayed.

[044] METHODOLOGY

[045] FIG. 4 illustrates a message for handling incoming calls with message replies, under an embodiment of the invention. An embodiment such as described in FIG. 4 may be performed using components and elements such as described in FIG. 2 and other figures. Accordingly, reference may be made to elements of other figures for purpose of illustrating a suitable element or component for performing a step or sub-step being described.

[046] In step 410, an incoming call is received. The call may be transmitted over a cellular network, from one mobile device to another.

[047] Step provides that caller information is identified on the recipient device. This information may correspond to "Caller ID" information, which may include a name of the caller, and a phone number of the device being used to make the call.

[048] According to one embodiment, reply options are provided to the user in step 430. For example, the user may be provided the options of answering the call, declining the call, or

message responding to the call. Under one implementation, a graphic-user interface may be generated to enable the user to make the decision on how the call should be answered. The user may signal his or her decision by actuating, for example, a soft key that indicates one of the actions.

[049] A decision is made in step 435 as to whether the user has elected the message response. If the message response was not elected, step 440 provides an elected or default reply action is performed. This may correspond to the phone call being answered, or forwarding the phone call to another phone number or voicemail.

[050] If the user makes a decision in step 435 to message reply to the incoming call, then step 450 provides that a corresponding one of the messaging applications is opened, or otherwise presented in a state of use for the user.

[051] In step 460, a message reply is addressed to the incoming caller. This step may include a new message being created and then addressed. Alternatively, an existing message (such as one stored in a draft folder) may be addressed. In an embodiment such as shown by FIG. 2, the message response module 250 may signal control data to the message application 210 to cause the message creation, and to cause the message application to use the phone number of the incoming caller in the address field of the newly created message.

[052] Step 470 provides that the message body is inserted. Depending on the implementation, the message body may be created by (i) user-input, (ii) programmatically, or (iii) through a combination of user-input and programmatic creation. Programmatic content in the message body may be, for example, in the form of a template (text or image) or in the form of a macro. The macro may be triggered by user-input.

[053] In step 480, the message is transmitted to the caller. The message may be transmitted automatically in response to an event, such upon completion of the message. Alternatively, the message may be transmitted through manual input from the user.

[054] FIG. 5 illustrates an optional process that may be performed in order to determine or verify that a caller using a message-enabled device, under an embodiment of the invention. In step 510, the caller's phone number is identified. As mentioned, an embodiment provides that the Caller ID information may be used to identify the phone number used by the caller of the incoming call.

[055] In step 520, a database of contact records may be accessed to determine (i) a contact record that contains the phone number of the incoming call, and (ii) information provided in the contact record that indicates whether the device is message-enabled. With reference to FIG. 1, contact records stored in, for example, contact database 130 may be scanned for a contact record that contains the phone number of the incoming caller. The field assigned to the identified phone number may be the indicator of whether the device of the caller is message-enabled.

[056] In step 525, the determination is made as to whether the device of the caller is message-enabled. For example, if the phone number of the incoming call is matched to a contact record, and the number is listed in the contact record as belonging to a mobile, cellular device, the determination in step 525 may be that the caller's device is message-enabled. Step 540 provides that a message response feature is provided as an option to the user if the determination in step 535 is that the caller's device is message-enabled.

[057] One embodiment provides that if the determination in step 525 is negative, then step 530 provides that no message-response options are provided to the user. For example, step 530 may

be performed in response to the determination that (i) that the caller's device is not message-enabled, or (ii) unknown. Alternatively, unknown numbers may be treated as message-enabled.

[058] While an embodiment such as described with FIG. 4 illustrates the use of multiple reply options, alternative implementations may be used where no reply option is provided. For example, the user may designate (i) message replies are to be generated for all incoming calls, or (ii) message replies are to be generated for all callers whom are known to be using a message-enabled device; or (iii) message replies are to be generated for a specific caller or set of callers. Thus, the user may remove the need to decide through manual input whether a particular call should be message replied. Additionally, message generation may correspond to (i) the message being created and addressed, or (ii) the message being created, addressed, and transmitted. In the latter case, pre-formulated or programmatically generated content may be inserted as message content 242 (FIG. 2).

[059] USAGE SCENARIOS

[060] FIG. 6A and FIG. 6B illustrate timelines for different usage scenarios, under one or more embodiments of the invention. In particular, FIG. 6A and FIG. 6B illustrate different show message responses where the manner in which an incoming phone call is resolved differently. In the case of FIG. 6A, the incoming call is declined, while in FIG. 6B, the incoming call is answered.

[061] In FIG. 6A, a timeline is shown for an embodiment in which the user can message response the user in connection with declining to answer the incoming call. At an initial time, the incoming call 602 is received. One embodiment provides that a call notification 606 is generated. The call notification 606 may display, for example, information on the caller or the caller's number. The call notification 606 may also present options as to whether the user can answer the

call, decline the call, and/or message reply the call. In the scenario shown by FIG. 6A, the user elects to message reply the user with an SMS message 608. In one implementation, the SMS message 608 may occur at a later time in order to give the user a chance to enter input as part of the message body. The SMS message 608 may include content entered or selected by the user that communicates the user's intent to have the caller call back at a later time. At a time when the caller receives the SMS message 608, termination 610 may occur, at the option of the user.

[062] FIG. 6B illustrates a timeline where a message response is provided in connection with the recipient of an incoming call answering the call. At the initial time, the incoming call 612 is received. As with the previous scenario, the call notification 616 may occur to provide the user with the opportunity to answer, decline, or message reply to the incoming call. In the scenario shown, the user replies to the incoming call with a SMS message 618 subsequent to the call notification 616 occurring. In this scenario, the user wants to answer the call, but would like to have more time. The SMS message 618 may communicate this intent through content entered or selected by the user. At a delayed interval, the call pickup 620 occurs. In a scenario shown by FIG. 6B, the user may need to delay voicemail forwarding or pickup, so that the incoming call and "ring" for an extended duration.

[063] Numerous other usage scenarios are contemplated with embodiments of the invention. For example, a user may elect to automatically message reply all incoming calls when the user is unavailable (e.g. "on vacation"). Alternatively, the user may elect to have all calls from a particular caller message replied automatically, with a standard message for that caller or class of callers (e.g. "use my other number"). Examples such as described enable users the convenience of initiating a communication with a phone call, but communicating using less intrusive or more rapid communication responses as a substitute for a conversation. Still further, the user may

maintain a list of preformed text message responses. In response to an incoming call, the user may scroll the device and select one of the preformed responses, such as “Call back” or “Try me tomorrow at home”.

[064] Although illustrative embodiments of the invention have been described in detail herein with reference to the accompanying drawings, it is to be understood that the invention is not limited to those precise embodiments. As such, many modifications and variations will be apparent to practitioners skilled in this art. Accordingly, it is intended that the scope of the invention be defined by the following claims and their equivalents. Furthermore, it is contemplated that a particular feature described either individually or as part of an embodiment can be combined with other individually described features, or parts of other embodiments, even if the other features and embodiments make no mention of the particular feature. This, the absence of describing combinations should not preclude the inventor from claiming rights to such combinations.

What is claimed is:

1. A method for operating a computing device, the method comprising:
receiving an incoming communication from another computing device to initiate a voice-exchange session;
in response to receiving the incoming call, determining a message identifier of the other computing device, wherein the message identifier is determined based at least in part on data provided with the incoming communication; and
transmitting a message to the other computing device using the message identifier determined from the incoming communication.
2. The method of claim 1, further comprising, in response to receiving the incoming communication, enabling a user of the computing device to elect between at least (i) generating the message, or (ii) not generating the message.
3. The method of claim 1, further comprising:
generating a graphic user-interface feature that prompts the user to elect to have a message generated in response to the incoming communication, and wherein generating the message is performed in response to a user-input electing to have the message generated.
4. The method of claim 1, wherein programmatically addressing a message to the other computing device includes programmatically addressing an instant text message.
5. The method of claim 4, wherein the instant text message is in a Short Message Service format.
6. The method of claim 5, wherein the instant text message application corresponds to a Short Message Service application, and the instant text message identifier is a phone number.

7. The method of claim 4, wherein programmatically addressing a message to the other computing device includes determining the message identifier from a phone number of the other computing device.

8. The method of claim 1, further comprising verifying that a device of the other computing device is enabled for receiving the message.

9. The method of claim 8, wherein:

receiving an incoming communication includes receiving an incoming call; and

verifying that a device of the other computing device is enabled for receiving the message includes (i) identifying a phone number of the other computing device used for the incoming call, and (ii) determining that the phone number is associated with a message-enabled device that can handle an instant message response.

10. The method of claim 9, wherein determining that the phone number is associated with a message enabled device includes accessing a contact record of the caller using the data provided with the incoming call, and using the contact record to verify that the phone number is capable of being used to receive the message.

11. The method of claim 10, wherein the message is an instant message, and wherein using the contact record to verify that the phone number is capable of being used to receive the message includes checking the contact record associated with the caller to see whether the phone number of the incoming call is for a mobile telephony device that can handle the instant message.

12. The method of claim 10, wherein determining that the phone number is associated with

the message enabled device is performed programmatically and automatically.

13. The method of claim 1, wherein:

receiving an incoming communication from another computing device includes receiving an incoming call from the other computing device; and

transmitting a message to the other computing device is based upon using a phone number of the incoming call as the address for a new instant message.

14. The method of claim 13, wherein using a phone number of the incoming call as the address for a new instant message includes launching an instant messaging application, and initiating a new message using the phone number of the caller as the address of the new message.

15. The method of claim 14, wherein launching an instant messaging application and initiating a new message are performed automatically, in response to one of (i) receiving the incoming call, or (ii) receiving an input from a user of the computing telephony device indicating a desire to send the instant message as a response to the incoming call.

16. The method of claim 1, further comprising enabling a user of the computing telephony device to provide content manually for the message.

17. The method of claim 1, further comprising enabling a user of the computing telephony device to trigger insertion of pre-formulated content for the message.

18. The method of claim 1, further comprising automatically and programmatically providing at least a portion of a body of message.

19. A computing device comprising:

one or more communication components for handling voice and messaging communications over wireless networks;

one or more processors configured to:

receive an incoming phone call originating from another device;

determining a phone number of the other device; and

generate a message to be transmitted to the other device using the identified phone number.

20. The computing device of claim 19, wherein the one or more processors are configured to enable the message to be generated prior to the incoming phone call being resolved.

21. The computing device of claim 19, wherein the one or more processors are configured to enable a text message to be generated.

22. The computing device of claim 19, wherein the one or more processors are configured to enable the message to be generated containing a message body of a format selected from one or more of text, image and audio.

23. The computing device of claim 19, further comprising a display, and wherein the one or more processors enable the message to be generated by prompting the user on the screen to generate the message as one of one or more options to handling the incoming phone call.

24. A method for operating a computing device, the method comprising:

identifying a phone number of a caller of an incoming phone call;

prompting a user of the computing device to generate a message reply to the incoming phone call; and

initiating the message reply by opening a message and addressing the message to the phone number of the caller of the incoming phone call.

25. The method of claim 24, wherein initiating the message reply by opening a message and addressing the message to the phone number includes addressing a SMS message to the phone number of the caller.

26. The method of claim 25, further comprising enabling a user to specify a message body for the SMS message.

27. The method of claim 24, further comprising enabling a user of the computing device to send the message and then answer the call after sending the message.

28. The method of claim 24, further comprising enabling a user of the computing device to send the message and then decline answering the call after sending the message.

ABSTRACT

A computing device is configured to receive an incoming communication from another computing device. The incoming communication may be for purpose of initiating a voice-exchange session. In response to receiving the incoming call, the computing device may identify or determine a message identifier of the other computing device. The message identifier is determined based at least in part on data provided with the incoming communication. The computing device may programmatically address a message to the other computing device using the message identifier determined from the incoming communication.

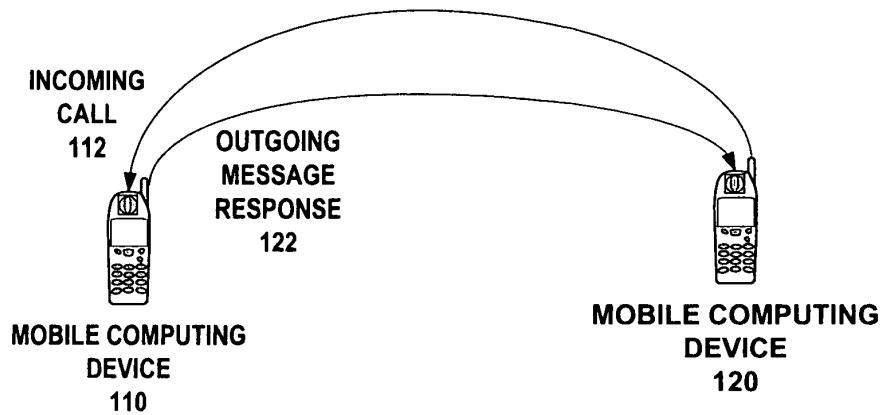

FIG. 1

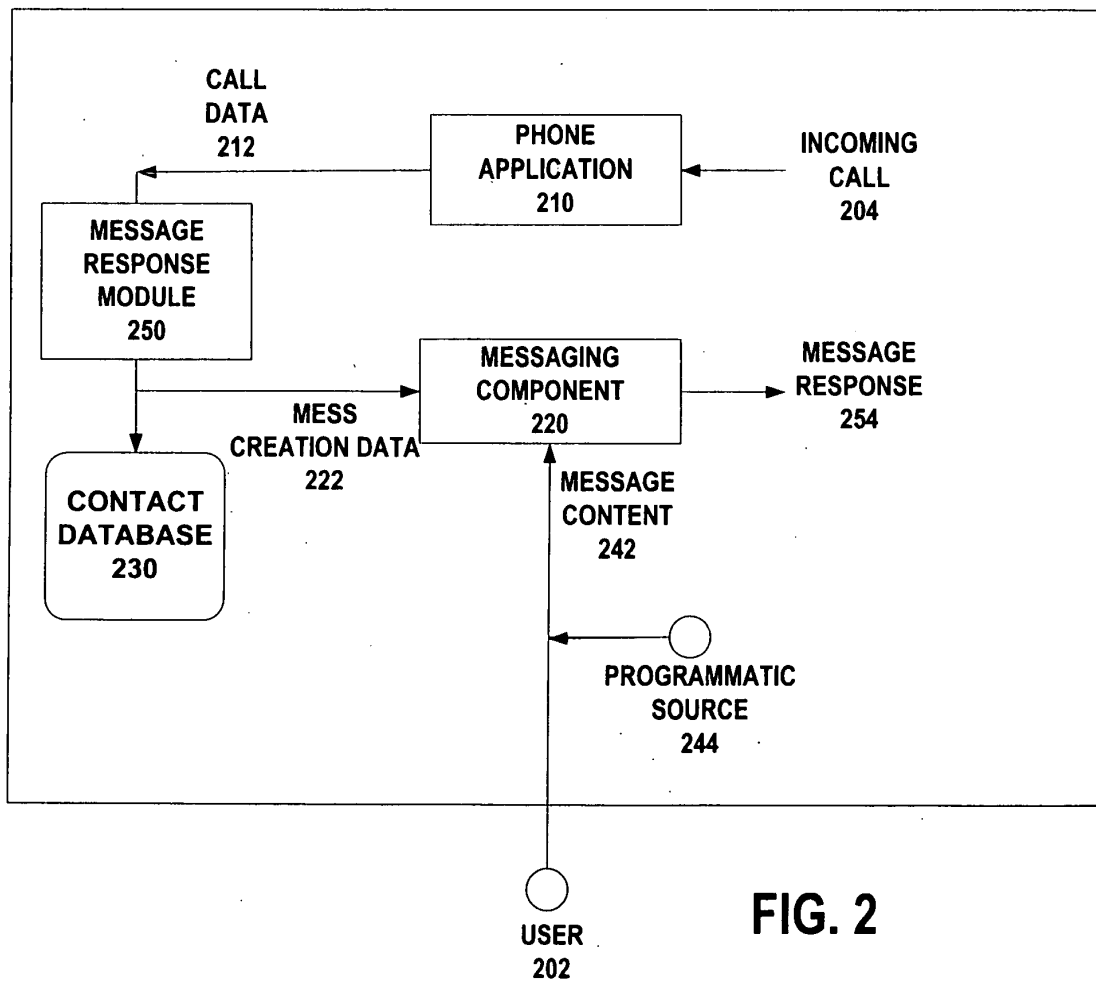

FIG. 2

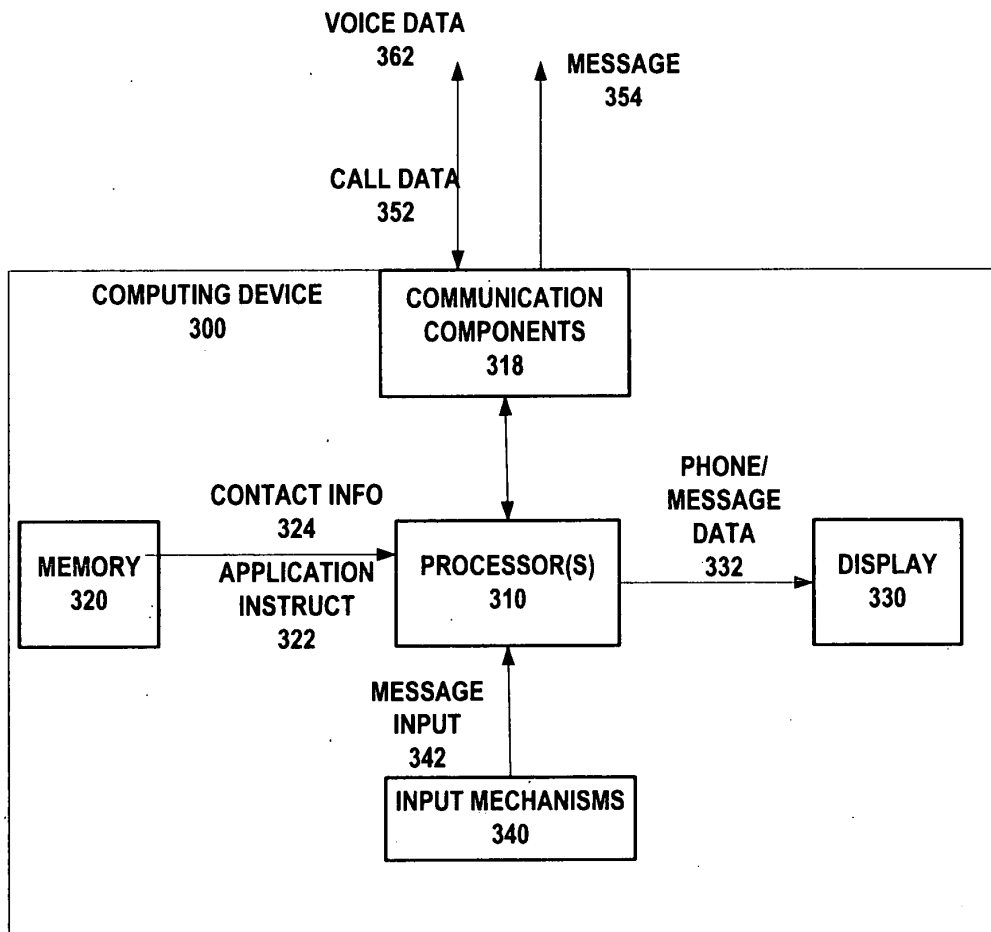

FIG. 3

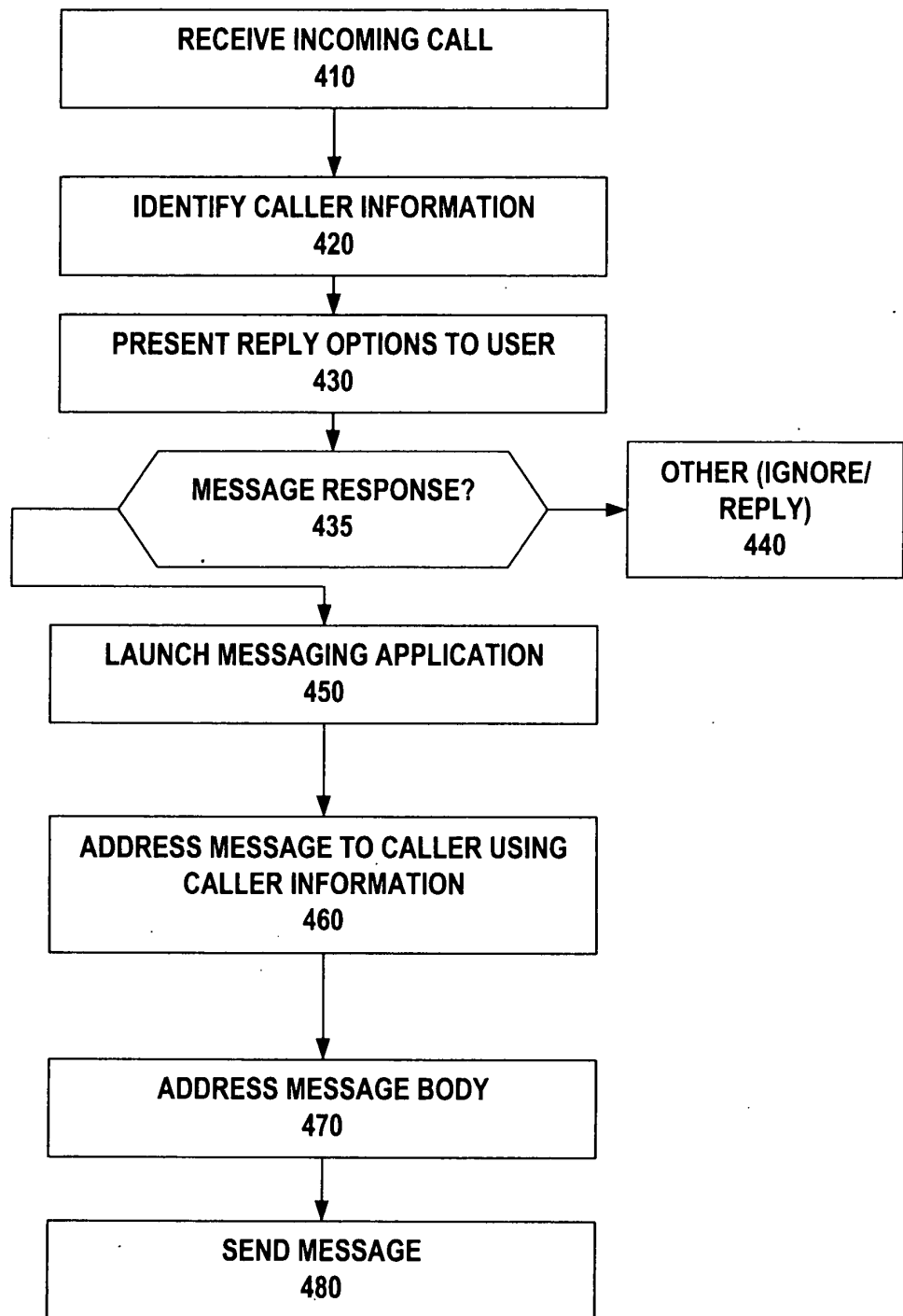

FIG. 4

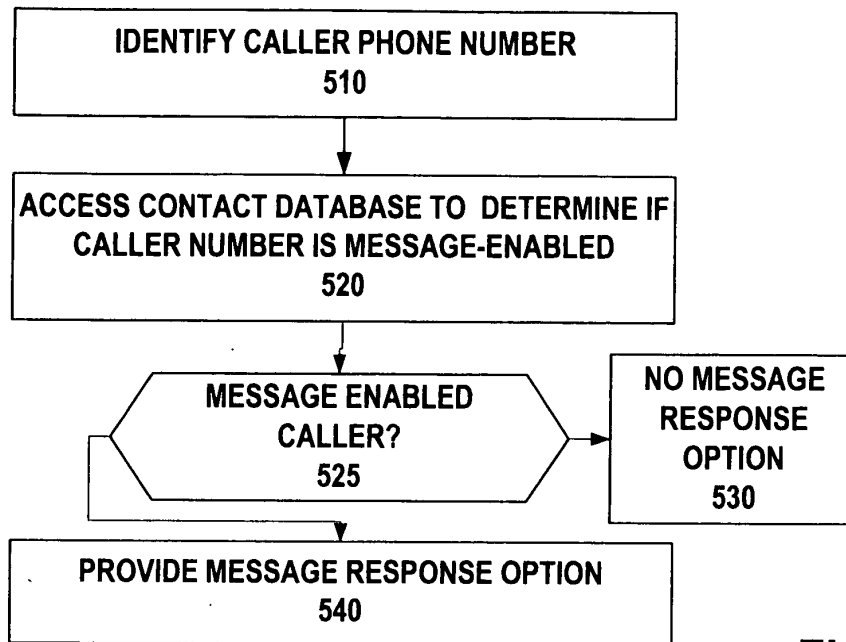

FIG. 5

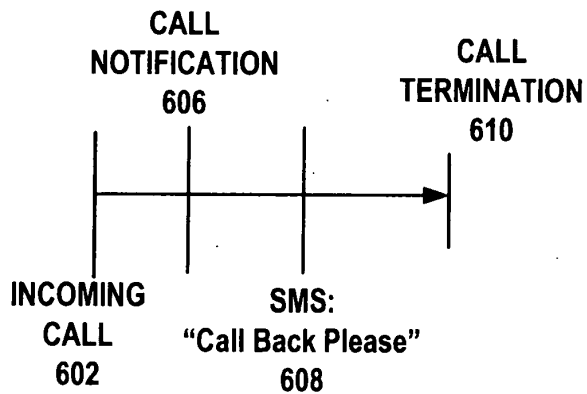

FIG. 6A

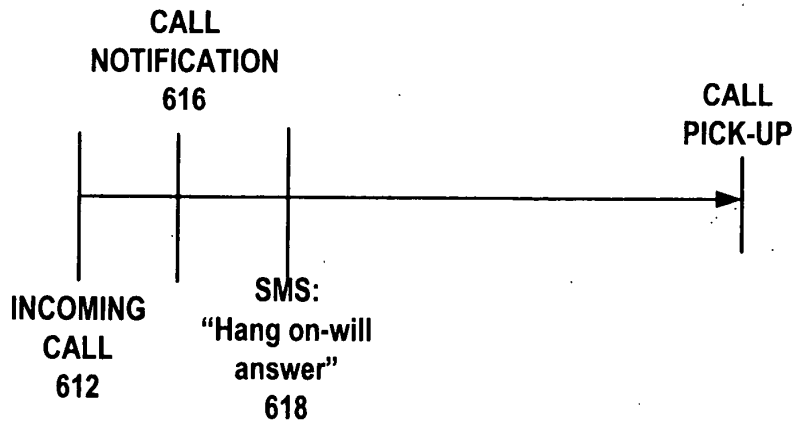

FIG. 6B

Under the Paperwork Reduction Act of 1995, no persons are required to respond to a collection of information unless it displays a valid OMB control number.

PATENT APPLICATION FEE DETERMINATION RECORD					Application or Docket Number 11200511		
Substitute for Form PTO-875							
APPLICATION AS FILED – PART I							
(Column 1)			(Column 2)		SMALL ENTITY OR OTHER THAN SMALL ENTITY		
FOR	NUMBER FILED	NUMBER EXTRA	RATE (\$)	FEE (\$)	RATE (\$)	FEE (\$)	
BASIC FEE (37 CFR 1.16(a), (b), or (c))	N/A	N/A	N/A		N/A	300	
SEARCH FEE (37 CFR 1.16(k), (l), or (m))	N/A	N/A	N/A		N/A	500	
EXAMINATION FEE (37 CFR 1.16(o), (p), or (q))	N/A	N/A	N/A		N/A	200	
TOTAL CLAIMS (37 CFR 1.16(f))	28	minus 20 = 8	X =		X 50 =	400	
INDEPENDENT CLAIMS (37 CFR 1.16(h))	3	minus 3 = 0	X =		X =	0	
APPLICATION SIZE FEE (37 CFR 1.16(s))	If the specification and drawings exceed 100 sheets of paper, the application size fee due is \$250 (\$125 for small entity) for each additional 50 sheets or fraction thereof. See 35 U.S.C. 41(a)(1)(G) and 37 CFR 1.16(s).						
MULTIPLE DEPENDENT CLAIM PRESENT (37 CFR 1.16(j))			N/A		N/A		
* If the difference in column 1 is less than zero, enter "0" in column 2.			TOTAL		TOTAL	1400	
APPLICATION AS AMENDED – PART II							
(Column 1)		(Column 2)		(Column 3)		SMALL ENTITY OR OTHER THAN SMALL ENTITY	
AMENDMENT A	CLAIMS REMAINING AFTER AMENDMENT	HIGHEST NUMBER PREVIOUSLY PAID FOR	PRESENT EXTRA	RATE (\$)	ADDITIONAL FEE (\$)	RATE (\$)	ADDITIONAL FEE (\$)
	Total (37 CFR 1.16(i))	Minus	**	=		X =	
	Independent (37 CFR 1.16(h))	Minus	***	=		X =	
	Application Size Fee (37 CFR 1.16(s))						
	FIRST PRESENTATION OF MULTIPLE DEPENDENT CLAIM (37 CFR 1.16(j))						
TOTAL ADD'L FEE				TOTAL ADD'L FEE		TOTAL ADD'L FEE	
(Column 1)		(Column 2)		(Column 3)		SMALL ENTITY OR OTHER THAN SMALL ENTITY	
AMENDMENT B	CLAIMS REMAINING AFTER AMENDMENT	HIGHEST NUMBER PREVIOUSLY PAID FOR	PRESENT EXTRA	RATE (\$)	ADDITIONAL FEE (\$)	RATE (\$)	ADDITIONAL FEE (\$)
	Total (37 CFR 1.16(i))	Minus	**	=		X =	
	Independent (37 CFR 1.16(h))	Minus	***	=		X =	
	Application Size Fee (37 CFR 1.16(s))						
	FIRST PRESENTATION OF MULTIPLE DEPENDENT CLAIM (37 CFR 1.16(j))						
TOTAL ADD'L FEE				TOTAL ADD'L FEE		TOTAL ADD'L FEE	

* If the entry in column 1 is less than the entry in column 2, write "0" in column 3.
 ** If the "Highest Number Previously Paid For" IN THIS SPACE is less than 20, enter "20".
 *** If the "Highest Number Previously Paid For" IN THIS SPACE is less than 3, enter "3".
 The "Highest Number Previously Paid For" (Total or Independent) is the highest number found in the appropriate box in column 1.

This collection of information is required by 37 CFR 1.16. The information is required to obtain or retain a benefit by the public which is to file (and by the USPTO to process) an application. Confidentiality is governed by 35 U.S.C. 122 and 37 CFR 1.14. This collection is estimated to take 12 minutes to complete, including gathering, preparing, and submitting the completed application form to the USPTO. Time will vary depending upon the individual case. Any comments on the amount of time you require to complete this form and/or suggestions for reducing this burden, should be sent to the Chief Information Officer, U.S. Patent and Trademark Office, U.S. Department of Commerce, P.O. Box 1450, Alexandria, VA 22313-1450. DO NOT SEND FEES OR COMPLETED FORMS TO THIS ADDRESS. SEND TO: Commissioner for Patents, P.O. Box 1450, Alexandria, VA 22313-1450.

If you need assistance in completing the form, call 1-800-PTO-9199 and select option 2.