

DOCKET NO.: 107131.00564US4

Filed on behalf of Intel Corporation

By: David Cavanaugh, Reg. No. 36,476  
Richard Goldenberg, Reg. No. 38,895  
Theodoros Konstantakopoulos, Reg. No. 74,155  
Wilmer Cutler Pickering Hale and Dorr LLP  
60 State Street  
Boston, MA 02109  
Tel: (617) 526-6000  
Email: David.cavanaugh@wilmerhale.com  
Richard.goldenberg@wilmerhale.com  
Theodoros.konstantakopoulos@wilmerhale.com

UNITED STATES PATENT AND TRADEMARK OFFICE

---

BEFORE THE PATENT TRIAL AND APPEAL BOARD

---

Intel Corporation  
Petitioner

v.

Qualcomm Incorporated  
Patent Owner

Case IPR2018-01240

U.S. Patent No. 8,698,558

**PETITIONER'S DEMONSTRATIVES FOR ORAL HEARING**

Date: October 23, 2019

Respectfully Submitted,

/Theodoros Konstantakopoulos/  
Theodoros Konstantakopoulos  
Reg. No. 74,155

**United States Patent and Trademark Office  
Before the Patent Trial and Appeal Board**

**Intel Corporation  
Petitioner,  
v.  
Qualcomm Incorporated  
Patent Owner**

**Case: IPR2018-01152, IPR2018-01153, IPR2018-01154,  
IPR2018-01240**

***Petition for Inter Partes Review of U.S. Patent No. 8,698,558***

**October 28, 2019**

# U.S. Patent No. 8,698,558 (“558 Patent”)

(10) Patent No.: **US 8,698,558 B2**  
(45) Date of Patent: **Apr. 15, 2014**

(54) **LOW-VOLTAGE POWER-EFFICIENT ENVELOPE TRACKER**

(75) Inventors: **Lennart K Mathe, San Diego, CA (US); Thomas Domenick Marra, San Diego, CA (US); Todd R Sutton, Del Mar, CA (US)**

(73) Assignee: **QUALCOMM Incorporated, San Diego, CA (US)**

(\* ) Notice: Subject to any disclaimer, the term of this patent is extended or adjusted under 35 U.S.C. 154(b) by 38 days.

(21) Appl. No.: **13/167,659**

(22) Filed: **Jun. 23, 2011**

  
US008698558B2

(12) **United States Patent**  
Mathe et al.

(10) Patent No.: **US 8,698,558 B2**  
(45) Date of Patent: **Apr. 15, 2014**

(54) **LOW-VOLTAGE POWER-EFFICIENT ENVELOPE TRACKER**

(75) Inventors: **Lennart K Mathe, San Diego, CA (US); Thomas Domenick Marra, San Diego, CA (US); Todd R Sutton, Del Mar, CA (US)**

(73) Assignee: **QUALCOMM Incorporated, San Diego, CA (US)**

(\* ) Notice: Subject to any disclaimer, the term of this patent is extended or adjusted under 35 U.S.C. 154(b) by 38 days.

(21) Appl. No.: **13/167,659**

(22) Filed: **Jun. 23, 2011**

(65) **Prior Publication Data**  
US 2012/0326783 A1 Dec. 27, 2012

(51) Int. Cl. **H03F 3/217** (2006.01)

(52) U.S. Cl. **330/251; 330/136; 330/297**

(58) **Field of Classification Search**  
USPC **330/10, 136, 207 A, 251, 297**  
See application file for complete search history.

(56) **References Cited**  
U.S. PATENT DOCUMENTS

5,915,417 A *	5/1999	Malysa	330/10
6,500,426 B1	10/2001	Mathe et al.	
6,661,217 B2	12/2003	Kinball et al.	
6,792,252 B2	9/2004	Kinball et al.	
6,838,931 B2 *	1/2005	Malysa et al.	330/10
7,061,313 B2	6/2006	Kinball et al.	
7,068,984 B2	6/2006	Mathe et al.	
7,368,985 B2	5/2008	Kusinski	

20 Claims, 6 Drawing Sheets

INTEL 1001

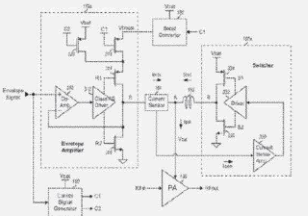

Ex. 1001



# Outline

- Overview of Petitions
- “Envelope Amplifier” Claims (1-14)
  - Alleged Invention
  - Chu / Choi 2010 / Myers
  - PO’s Claim Construction
- “Switcher” Claims (15-20)
  - Alleged Invention
  - Kwak
  - Kwak’s Feedforward Path Increases the Inductor Current
  - Fig. 5 v. Fig. 6
  - Claims 16 and 19

# Overview of the Petitions

	IPR2018-01152	IPR2018-01153	IPR2018-01154	IPR2018-01240
<b>“Envelope Amplifier” Claims</b>	Claims 12-14	Claims 1-9		Claims 10-11
<b>“Switcher” Claims</b>			Claims 15-20	

For ease of reference, citations herein are to single IPR case and/or exhibit numbers, but are not intended to be limiting.

# Overview of the Petitions and Prior Art

	IPR2018-01152	IPR2018-01153	IPR2018-01154	IPR2018-01240
Claims 1-9		Chu + Choi 2010 + Myers		
Claims 6, 8		Chu + Choi 2010		
Claim 10				Chu + Choi 2010 + Hannington
Claim 11				Chu + Choi 2010 + Myers + Hannington
<del>Claims 12, 14*</del>	Chu			
Claim 13	Chu + Choi 2010			
Claim 13	Chu + Choi 2010 + Myers			
<del>Claim 14*</del>	Chu + Blanken			
Claims 15, 17, 18, 20			Kwak	
Claim 16			Kwak (§103)	
Claim 19			Kwak + Choi 2010	

\* Patent Owner conceded that these claims are invalid

# Outline

- Overview of Petitions
- **“Envelope Amplifier” Claims (1-14)**
  - **Alleged Invention**
  - Chu / Choi 2010 / Myers
  - PO’s Claim Construction
- “Switcher” Claims (15-20)
  - Alleged Invention
  - Kwak
  - Kwak’s Feedforward Path Increases the Inductor Current
  - Fig. 5 v. Fig. 6
  - Claims 16 and 19

# '558 Patent – Figure 3

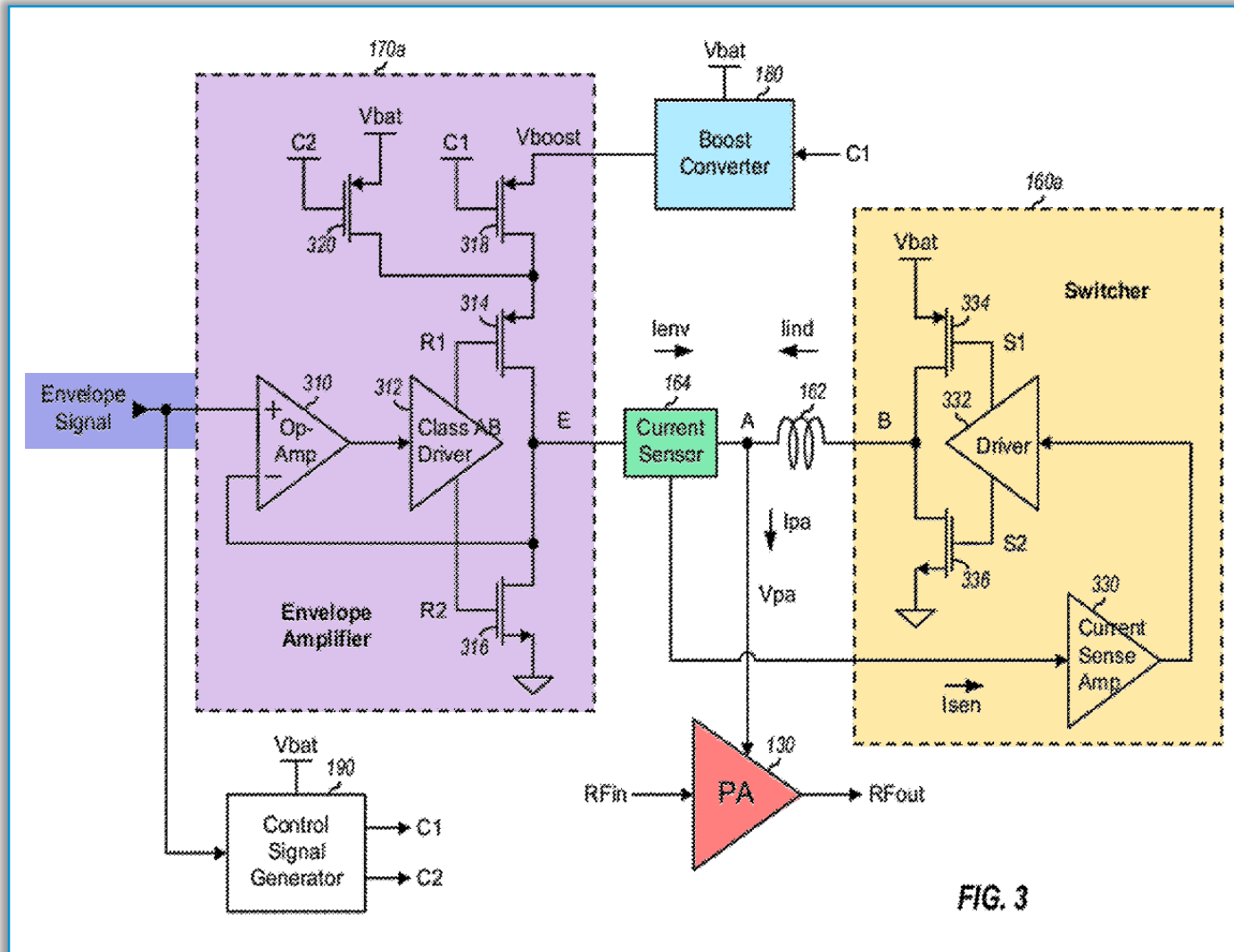
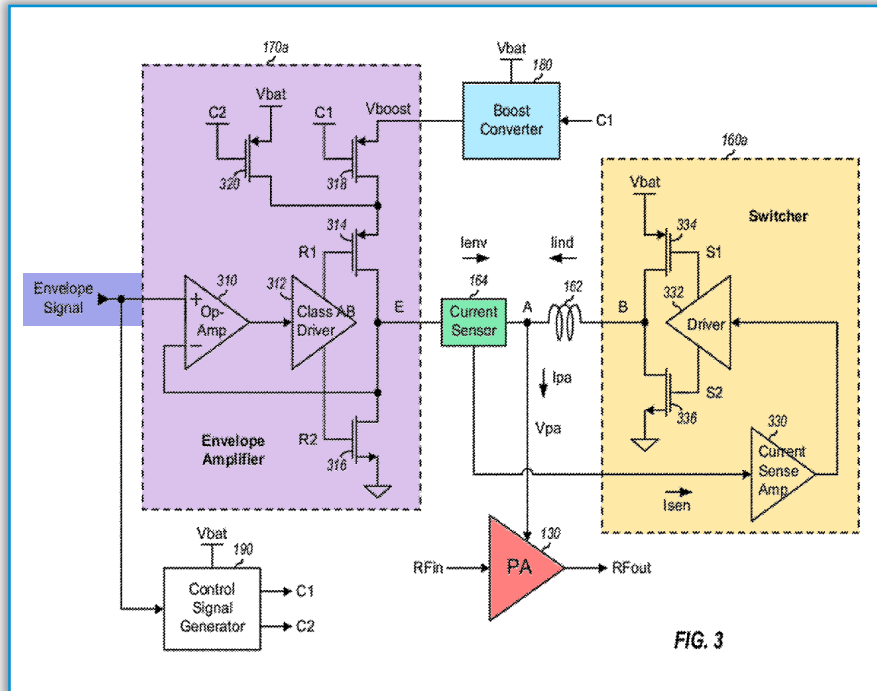

FIG. 3

# Claims 6 and 7



Ex. 1101 ('558 patent) at Fig. 3

6. An apparatus for wireless communication, comprising:  
 a power amplifier operative to receive and amplify an input radio frequency (RF) signal and provide an output RF signal; and  
 a supply generator operative to receive an envelope signal and a first supply voltage, to generate a boosted supply voltage having a higher voltage than the first supply voltage, and to generate a second supply voltage for the power amplifier based on the envelope signal and the boosted supply voltage, wherein the supply generator incorporates an operational amplifier (op-amp) operative to receive the envelope signal and provide an amplified signal, a driver operative to receive the amplified signal and provide a first control signal and a second control signal, a P-channel metal oxide semiconductor (PMOS) transistor having a gate receiving a first control signal, a source receiving the boosted supply voltage or the first supply voltage, and a drain providing the second supply voltage, and an N-channel metal oxide semiconductor (NMOS) transistor having a gate receiving the second control signal, a drain providing the second supply voltage, and a source coupled to circuit ground.

Ex. 1101 ('558 patent) at 11:42-63

7. The apparatus of claim 6, wherein the supply generator is operative to generate the second supply voltage based on the envelope signal and either the boosted supply voltage or the first supply voltage.

Ex. 1101 ('558 patent) at 11:64-67

# Outline

- Overview of Petitions
- **“Envelope Amplifier” Claims (1-14)**
  - Alleged Invention
  - **Chu / Choi 2010 / Myers**
  - PO’s Claim Construction
- “Switcher” Claims (15-20)
  - Alleged Invention
  - Kwak
  - Kwak’s Feedforward Path Increases the Inductor Current
  - Fig. 5 v. Fig. 6
  - Claims 16 and 19

# Patent Owner Concedes that Claims 12 and 14 Are Invalid

UNITED STATES PATENT AND TRADEMARK OFFICE

BEFORE THE PATENT TRIAL AND APPEAL BOARD

Intel Corporation  
Petitioner

v.

Qualcomm Incorporated  
Patent Owner

Case IPR2018-01152  
Patent 8,698,558

PATENT OWNER RESPONSE TO PETITION FOR  
REVIEW PURSUANT TO 37 C.F.R.

## I. INTRODUCTION

Petitioner raises four grounds against three claims. Ground I is directed to claims 12 and 14, and Ground II is directed to claim 14. Patent Owner does not contest these grounds and agrees to cancel claims 12 and 14.

Paper 16 (POR) at 1



# Claim Construction Dispute

- Patent Owner argues that all envelope amplifier claims (1-14) require “selective boost”
- Petitioner argues that claims 6, 8, 11, and 13 do not require selective boost

<b>If the Board agrees with Petitioner on CC</b>	<b>If the Board agrees with Patent Owner on CC</b>
<b>Claims 1-9 and 13 are invalid over Chu, Choi 2010, and Myers</b>	<b>Claims 1-9 and 13 are invalid over Chu, Choi 2010, and Myers</b>
<b>Claims 6, 8, and 13 are invalid over Chu and Choi 2010</b>	
<b>Claims 10 and 11 are invalid over Chu, Choi 2010, Myers, and Hanington</b>	<b>Claims 10 and 11 are invalid over Chu, Choi 2010, Myers, and Hanington</b>
<b>Claim 10 is invalid over Chu, Choi 2010, and Hanington</b>	

# Chu + Choi 2010 And Chu + Choi 2010 + Myers Teach All Limitations Of Claims 1-11 and 13

- Patent Owner does not dispute that the limitations of claims 1-11 and 13 were all known in the prior art (e.g., in Chu, Choi 2010, and Myers).
- Patent Owner disputes whether a person of skill would have been motivated to combine these references in the manner described in the petitions.

Moreover, Grounds I and II rely upon the combination of Chu and Choi 2010, with Ground II additionally relying on Myers. Both grounds are flawed because Petitioner has failed to meet its burden of establishing a motivation to combine Chu, a reference striving to increase the efficiency of a power amplifier, with Choi 2010, a reference striving to prevent the degradation of output power at the cost of efficiency. The prior art is silent regarding *how* to combine Chu and

IPR2018-01153, Paper 16 (POR) at 1

Petitioner additionally fails to meet its burden of establishing a motivation to combine Chu/Choi 2010 with Myers. Choi 2010 is premised on building a circuit

IPR2018-01153, Paper 16 (POR) at 2

# Claims That Do Not Require “Selective Boost” (Claims 6, 8, 13) Are Obvious Over Chu + Choi 2010

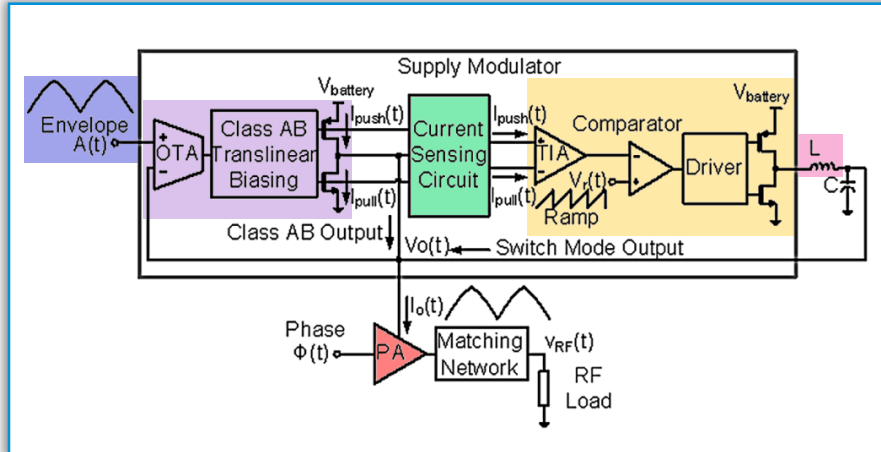

Ex. 1104 (Chu) at Fig. 4

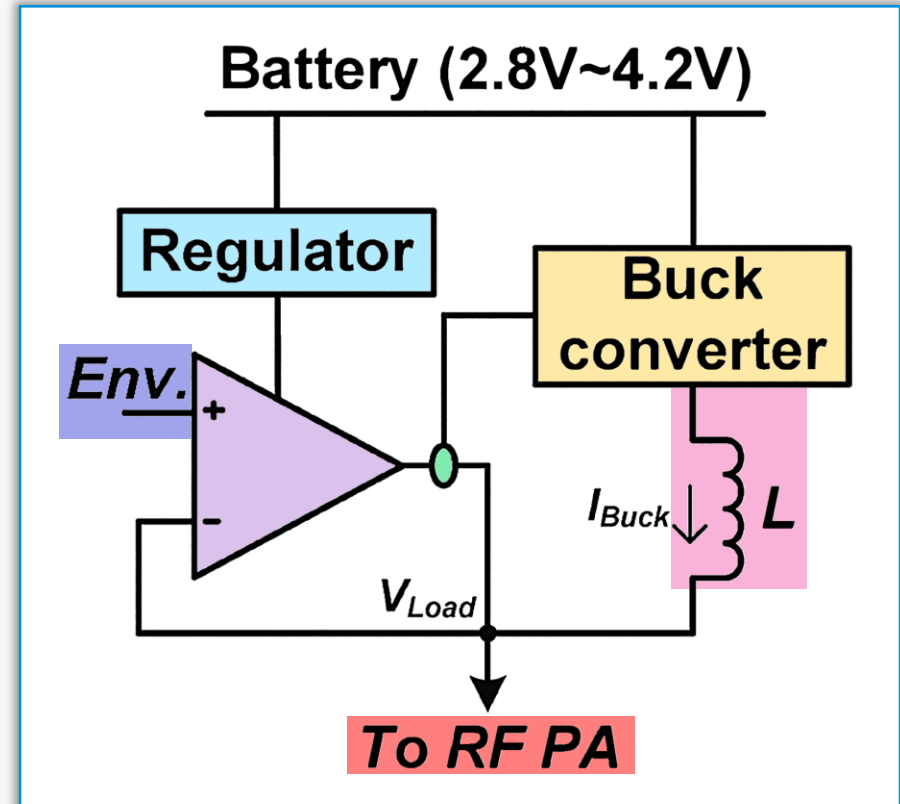

Ex. 1106 (Choi 2010) at Fig. 5

\* Claim 10 is obvious over Chu + Choi 2010 + Hanington

# Patent Owner Concedes that Chu Teaches Almost All Limitations of Claims 1-11 and 13

- Patent Owner argues that Chu is missing only these limitations:
  - “boosted voltage” / “boost converter”
  - “selective boost”

linear supply modulator at backed-off power levels.” *Id.* at 2817. Chu does not include any discussion or illustration of a voltage boost mechanism for boosting a battery voltage.

# Asserted Prior Art – Chu (Ex. 1104)

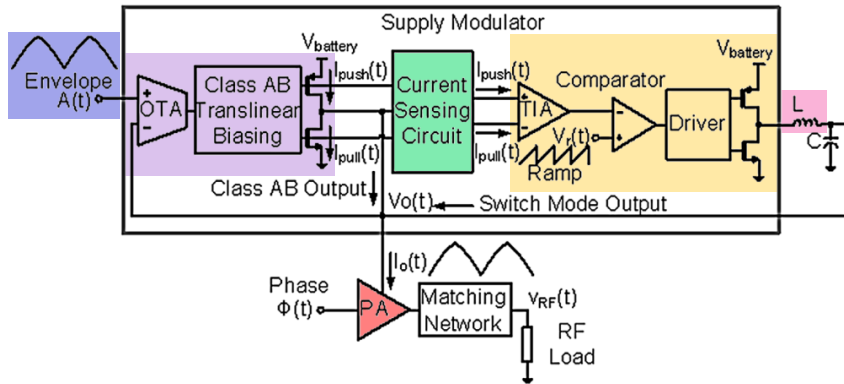

A combined class-AB and switch-mode regulator based supply modulator with a master-slave architecture achieving wide bandwidth and low ripple is presented.

Ex. 1104 (Chu) at 2809

A two-stage class-AB amplifier with a common-source output stage, as shown in Fig. 14, is used for the linear amplifier.

Ex. 1104 (Chu) at 2814

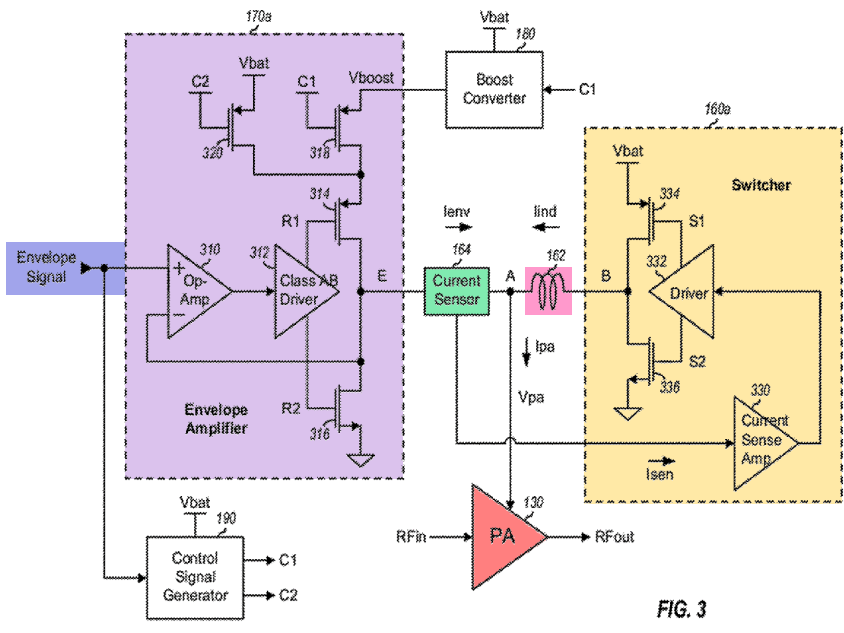

FIG. 3

In the master-slave regulator configuration, the switch-mode regulator serves as the slave stage, as shown in Fig. 15, and is driven by the class-AB amplifier sensed output currents.

Ex. 1104 (Chu) at 2815

A high GBW linear amplifier in voltage follower configuration ensures that output node  $V_o(t)$  tracks the reference envelope voltage  $A(t)$ .

Ex. 1104 (Chu) at 2810

Fig. 4 shows the block diagram of the proposed master-slave linear and switch-mode combined supply modulator loaded with a PA.

Ex. 1104 (Chu) at 2810

Ex. 1101 ('558 patent) at Fig. 3; Ex. 1104 (Chu) at Fig. 4

IPR2018-01153, Paper 3 (Petition) at 28-33, 38-56.



# Choi 2010 Teaches “Boosted Voltage”

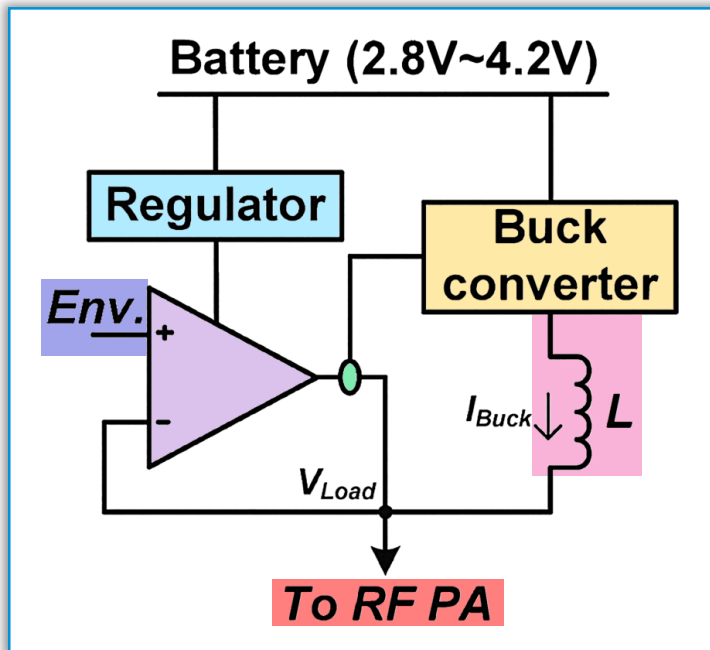

Ex. 1106 (Choi 2010) at Fig. 5

a new supply modulator architecture employing a hybrid switching amplifier and a **boost converter** is proposed.

Ex. 1106 (Choi 2010) at 1074

As the load voltage is regulated by the linear amplifier, boosting up the supply voltage of the linear amplifier results in a stable supply voltage to the RF PA regardless of the battery depletion. Thus, the **additional 5V boost converter** ... is coupled to the supply of the linear amplifier, while that of the switching amplifier is directly connected to the battery.

Ex. 1106 (Choi 2010) at 1075

# Claims 6, 8, 13 – Do Not Require “Selective Boost” – are Obvious Over Chu + Choi 2010

Claim 6	Chu	Choi 2010
An apparatus for wireless communication, comprising:	✓	
a power amplifier operative to receive and amplify an input radio frequency (RF) signal and provide an output RF signal; and	✓	
a supply generator operative to receive an envelope signal and a first supply voltage,	✓	
<b>to generate a boosted supply voltage having a higher voltage than the first supply voltage, and to generate a second supply voltage for the power amplifier based on the envelope signal and the boosted supply voltage,</b>		✓
wherein the supply generator incorporates an operational amplifier (op-amp) operative to receive the envelope signal and provide an amplified signal, a driver operative to receive the amplified signal and provide a first control signal and a second control signal,	✓	
a P-channel metal oxide semiconductor (PMOS) transistor having a gate receiving a first control signal, a source receiving <b>the boosted supply voltage</b> or the first supply voltage, and a drain providing the second supply voltage,	✓	✓
and an N-channel metal oxide semiconductor (NMOS) transistor having a gate receiving the second control signal, a drain providing the second supply voltage, and a source coupled to circuit ground.	✓	



# Motivation to Combine: Institution Decision

For each of the proposed grounds, we find that Petitioner provides sufficient articulated rationales for combining the references. Pet. 61–63 (Chu and Blanken), 67–71 (Chu and Choi 2010), 75–79 (Chu, Choi 2010, and Myers); Ex. 1003 ¶¶ 115–117, 127–129, 138–140.

IPR2018-01152, Paper 9 (Institution Decision) at 22.

# Response To Argument In Sur-Reply



**Arthur W. Kelley**

Patent Owner's  
Expert

“[T]he Petition failed to explain how a POSA would combine Chu and Choi 2010 without destroying the benefits of one or the other.”

IPR2018-01153, Paper 22 (Sur-Reply) at 1

**Q.** And so in designing a power management circuit, you're balancing those competing concerns **providing enough power for the load while at the same time being as efficient as you can be.** Is that fair?

**A.** I'm not sure I'd characterize them as being competing. **There's certainly simultaneous concerns. You worry about both of those in terms of making your power supply work properly.**

Ex. 1128 (Kelley Tr.) at 13:12-20

In the proposed architecture, **the efficiency degradation by the additional boost converter is not serious** because the load current provided by the linear amplifier is about 30% of the overall load current. Assuming that  $\eta_{linear}/\eta_{boost}/\eta_{switch}$  of each block are 50%, 90% and 90%, respectively, **the efficiency of the proposed supply modulator is 76.5%, while that of the conventional HSA without the boost converter is 78%.** When

Ex. 1106 (Choi 2010) at 1076, IPR2018-01153, Paper 3 (Petition) at 43;  
see also, Paper 19 (Petitioner's Reply) at 10-15

# Motivation to Combine: Chu + Choi 2010



**Alyssa B. Apsel Ph.D.**

Professor & Director  
Elec. and Comp. Eng. Dept.  
Cornell University

94. Moreover, one of ordinary skill in the art would have been motivated to use a boost converter to prevent distortion as the battery becomes depleted and the voltage provided by the battery falls. It would have been desirable to operate Chu's linear amplifier with a boosted voltage so that (1) when the battery voltage starts depleting, Chu's linear amplifier is more robust, and/or (2) when the battery voltage is lower than the peak voltage magnitude of the amplified reference envelope voltage  $A(t)$ , distortion of the amplified reference envelope voltage is prevented. These advantages are specifically taught by Choi 2010, and would have

Ex. 1103 (Apsel Decl.) at ¶ 94

# Motivation to Combine: Chu + Choi 2010



**Arthur W. Kelley**  
Patent Owner's  
Expert

**Q.** Now, Choi 2010 does talk about battery degradation, right?

**A. Right.**

**Q.** And Choi 2010 says you can use this boost converter to address the battery degradation problem, right?

**A. Yes.**

Ex. 1128 (Kelley Tr.) at 105:20-106:4

**Q.** Choi 2010's boost converter prevents a linear amplifier's output power from degrading when the battery depletes, right?

**A. That's true.**

Ex. 1128 (Kelley Tr.) at 156:3-6

# Motivation to Combine: Chu + Choi 2010



**Alyssa B. Apsel Ph.D.**

Professor & Director  
Elec. and Comp. Eng. Dept.  
Cornell University

95. Using a boost converter to power a PA to prevent distortion of the amplified signal was also common and well known in the prior art. For example, the **Maehara** patent discloses using a boost converter, referred to as a “step-up converter,” in an amplifying circuit to prevent distortion. *See* Ex. 1118 at Abstract (“An amplifying circuit according to the present invention has an amplifying unit for amplifying an input signal to produce an amplified signal, a battery for generating a constant voltage (a first voltage), ***a step-up converter for always generating an increased voltage*** (or a second voltage) by increasing the constant voltage . . . . [B]ecause the increased voltage is always generated by the step-up converter . . . ***any distortion of the amplified signal can be prevented.***”) (emphasis added). Similarly, a 2008 datasheet for a Maxim amplifier taught using a boost

Ex. 1103 (Apsel Decl.) at ¶ 95

# Motivation to Combine: Chu + Choi 2010



**Alyssa B. Apsel Ph.D.**

Professor & Director  
Elec. and Comp. Eng. Dept.  
Cornell University

96. . . . . A person of ordinary skill in the art would have understood that the output of a battery is not binary (i.e., not either fully on or fully off) but instead will decay over time until the battery's voltage output approaches zero. Given this state of battery technology in the prior art, it was obvious to use a boost converter to boost a falling battery voltage and provide the boosted voltage to circuit components, such as Chu's envelope amplifier, to maintain operation and minimize distortion as battery voltages drop.

Ex. 1103 (Apsel Decl.) at ¶ 96



# Motivation to Combine: Chu + Choi 2010



**Arthur W. Kelley**

Patent Owner's  
Expert

- Q.** If the battery voltage gets too low, the output signal will become distorted, right?
- A.** **The output signal of the power amplifier. That's right. If you don't have enough battery voltage, Chu will not function and the power amplifier will not be able to perform.**

Ex. 1128 (Kelley Tr.) at 165:17-22

# Motivation to Combine: Chu + Choi 2010



**Alyssa B. Apsel Ph.D.**

Professor & Director  
Elec. and Comp. Eng. Dept.  
Cornell University

added). Similarly, a 2008 datasheet for a Maxim amplifier taught using a boost converter to extend battery life and maintain output levels when the battery voltage drops. Ex. 1115 [Maxim Integrated Products, Inc., *MAX9738 –16VP-P Class G Amplifier with Inverting Boost Converter*, Datasheet 19-3700, Rev. 0 (March 2008) (“Maxim”)] at 8 (“The MAX9738 Class G power amplifier with inverting boost converter is the latest in linear amplifier technology. The Class G output stage offers improved performance over a Class AB amplifier while increasing efficiency to extend battery life. The integrated inverting boost converter generates a negative supply capable of delivering up to 400mA. The negative supply is only used when the output signal requires a larger supply voltage differential. As the battery voltage drops, the boost converter output becomes more negative to maintain amplifier output swing all the way down to  $V_{BAT} = 2.7V$ .”). Such references, including Maehara and Maxim, would have further

Ex. 1103 (Apsel Decl.) at ¶ 95



# Motivation to Combine: Chu + Choi 2010



**Alyssa B. Apstel Ph.D.**

Professor & Director  
Elec. and Comp. Eng. Dept.  
Cornell University

generator would have yielded only expected, predictable results. Combining the teachings of Choi 2010 with Chu would have been: (a) a combination of prior-art elements according to **known methods to yield predictable results**, because a person of ordinary skill in the art would have understood, for example, the effect on the output of an envelope amplifier from modifying that amplifier to receive a boosted supply voltage; (b) **a simple substitution of one known element** (a battery supply) **for another** (a boosted supply or a combination of a boosted supply and battery voltage) **to obtain predictable results**; (c) **a use of a known technique** (operating an envelope amplifier with a boosted power supply) to improve a similar device (Chu's envelope amplifier) in the same way disclosed by Choi 2010; (d) an application of a known technique (providing a boosted voltage) to a known device (Chu's envelope amplifier) that was **ready for improvement to yield predictable results**; and (e) **obvious to try**—a choice of different envelope trackers, from a finite number of identified, **predictable solutions, with a reasonable expectation of success**.

# Motivation to Combine: Chu + Choi 2010

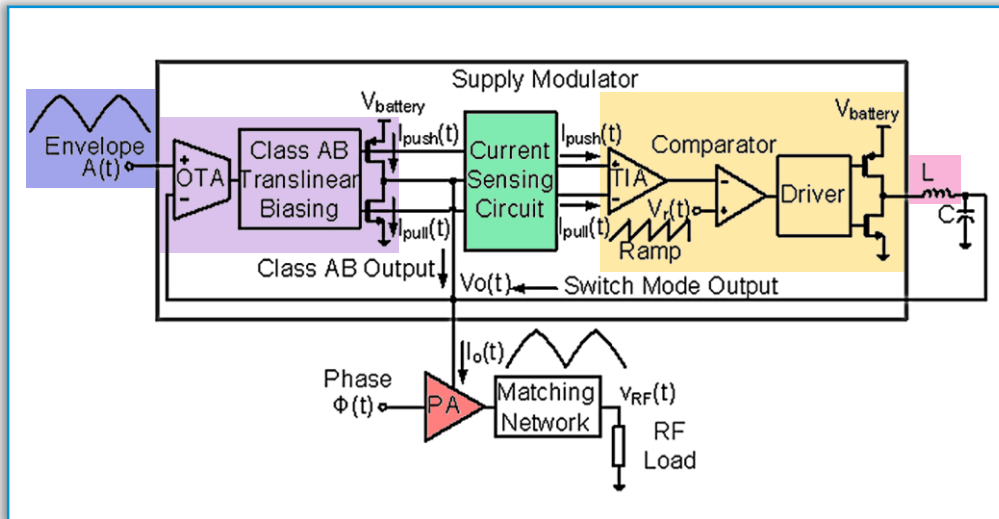

Ex. 1104 (Chu) at Fig. 4

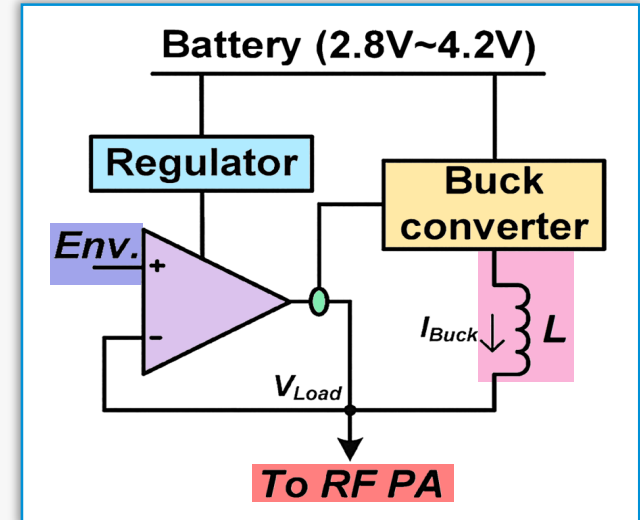

Ex. 1106 (Choi 2010) at Fig. 5



**Arthur W. Kelley**  
Patent Owner's  
Expert

- Q. And as shown in Figure 4, that PMOS transistor receives  $V_{bat}$ , right?
- A. **That's true.**
- Q. Now, if instead between  $V_{bat}$  and the source of that PMOS transistor we place the boost converter of Choi Figure 5 -- do you have that in mind?
- A. **Okay.**
- Q. In that circumstance, then the source of the PMOS transistor in the linear amplifier of Choi -- of Chu Figure 4 would receive the boosted supply voltage, right?
- A. **That – if you were to choose to do that one spot, then Chu's amplifier would receive the boosted supply voltage, but nothing else.**

Ex. 1128 (Kelley Tr.) at 54:3-17

# Claims That Require “Selective Boost” (Claims 1-5, 7, 9) Are Obvious Over Chu + Choi 2010 + Myers

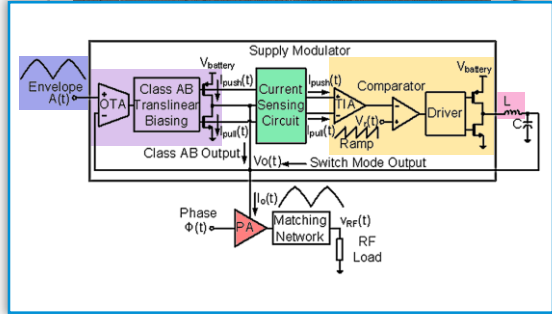
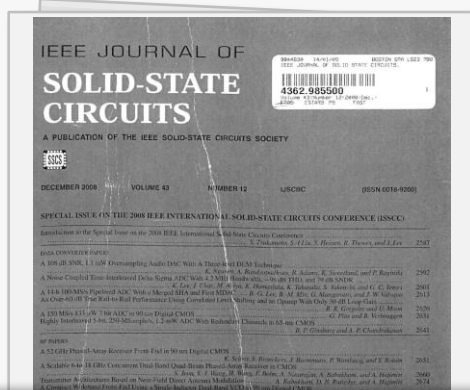

Ex. 1104 (Chu) at Fig. 4

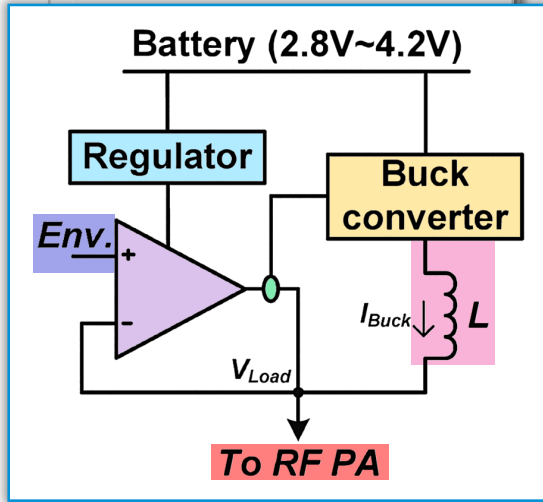
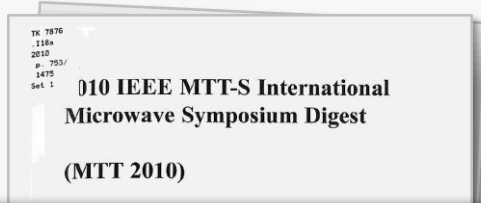

Ex. 1106 (Choi 2010) at Fig. 5

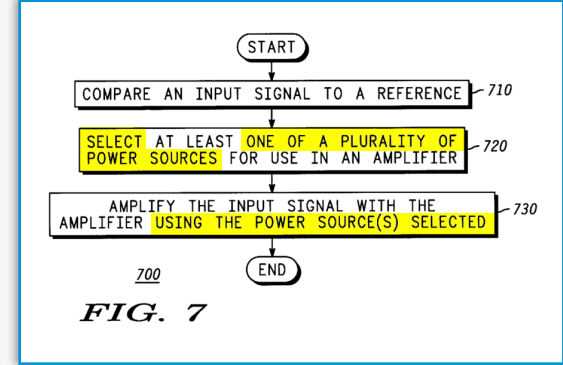
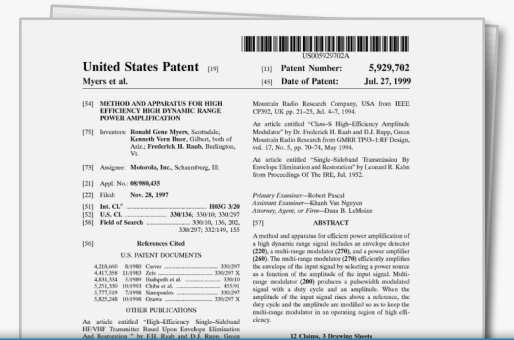





FIG. 7

Ex. 1112 (Myers) at Fig. 7

\* Claim 11 is obvious over Chu + Choi 2010 + Myers + Hanington

# Claims 1-5, 7, 9 – Require “Selective Boost” – are Obvious Over Chu + Choi 2010 + Myers

Claim 7	Chu	Choi 2010	Myers
7. The apparatus of claim 6, wherein the supply generator is operative to generate the second supply voltage based on the envelope signal and <b>either</b> the <b>boosted supply voltage</b> <b>or</b> the <b>first supply voltage</b> .			

# Motivation to Combine: Institution Decision

For each of the proposed grounds, we find that Petitioner provides sufficient articulated rationales for combining the references. Pet. 61–63 (Chu and Blanken), 67–71 (Chu and Choi 2010), 75–79 (Chu, Choi 2010, and Myers); Ex. 1003 ¶¶ 115–117, 127–129, 138–140.

IPR2018-01152, Paper 9 (Institution Decision) at 22.

We also are not persuaded by Patent Owner's argument that Chu teaches away from the use of a selective boost based on a sentence describing Chu's use of a single voltage boost. Prelim. Resp. 34–35. On the present record, Patent Owner has not shown persuasively that the differences between Chu/Choi 2010 and Myers undermines their combination or that the Chu's teaching rise to the level of teaching away.

IPR2018-01153, Paper 9 (Institution Decision) at 24.

# Asserted Prior Art – Myers (Ex. 1112) Teaches “Selective Boost”

United States Patent [19]  
Myers et al.



US005929702A  
[11] Patent Number: 5,929,702  
[45] Date of Patent: Jul. 27, 1999

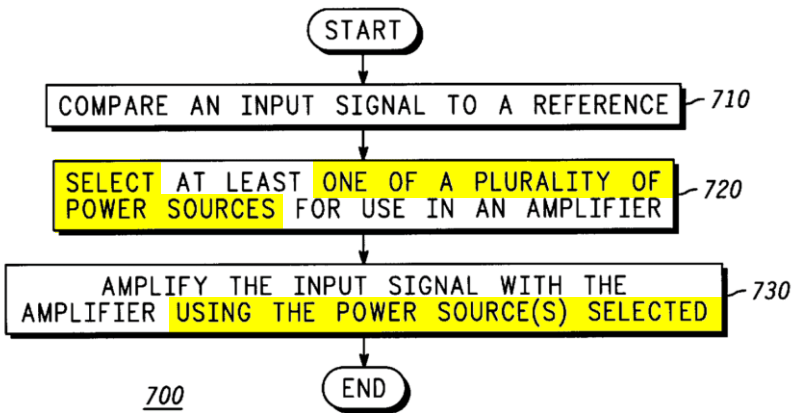

**FIG. 7**

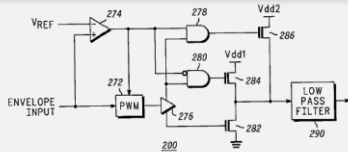

Ex. 1112 (Myers) at Fig. 7

INTEL 1112

FIG. 7 shows a flowchart for a method of amplifying a signal in accordance with a preferred embodiment of the present invention. Method 700 begins with step 710 when an input signal is compared to a reference. Then in step 720, as a result of the comparison in step 710, at least one of a plurality of power sources is selected for use in an amplifier. Then in step 730, the input signal is amplified with the amplifier that uses the power sources selected.

Method 700 as shown in FIG. 7 is a method which selects a power source to be used in an amplifier where the selection is a function of the amplitude of the input signal. This allows an amplifier to be operated in a more efficient range because a power source can be chosen close to the amplitude of the input signal.

Ex. 1112 (Myers) at 9:8-21

pulsewidth modulator. In step 840 a second power source is selected for use in a pulsewidth modulator, where the second power source has a voltage greater than the first power source selected in step 830. After either step 830 or 840,

Ex. 1112 (Myers) at 9:29-32



# Motivation to Combine: Chu + Choi 2010 + Myers



**Alyssa B. Apsel Ph.D.**

Professor & Director  
Elec. and Comp. Eng. Dept.  
Cornell University

133. Therefore, a person of ordinary skill in the art would have been motivated to combine the selection functionality of Myers with the Chu envelope amplifier, as modified by Choi 2010, so that: (1) when a boosted voltage is not required, Chu's linear amplifier operates efficiently with the battery voltage, and (2) when the battery voltage is lower than the peak voltage magnitude of the amplified reference envelope voltage  $A(t)$ , Chu's linear amplifier operates with the boosted voltage to prevent distortion of the amplified reference envelope voltage  $A(t)$ . Modifying Chu to selectively use either the battery or boosted voltages as

Ex. 1103 (Apsel Decl.) at ¶ 133

# Motivation to Combine: Chu + Choi 2010 + Myers



**Arthur W. Kelley**

Patent Owner's  
Expert

**Q.** And so in designing a power management circuit, you're balancing those competing concerns **providing enough power for the load while at the same time being as efficient as you can be.** Is that fair?

**A.** I'm not sure I'd characterize them as being competing. **There's certainly simultaneous concerns. You worry about both of those in terms of making your power supply work properly.**

Ex. 1128 (Kelley Tr.) at 13:12-20.

**Q.** And so Myers does disclose switching between a first mode and a second mode based upon the envelope signal with respect to a reference, right?

**A.** **That's right.**

**Q.** And that means that it would switch both to the high power and to the low power, right?

**A.** **It could.**

Ex. 1128 (Kelley Tr.) at 270:13-271:5



# Motivation to Combine: Chu + Choi 2010 + Myers



**Arthur W. Kelley**

Patent Owner's  
Expert

**Q.** ...If I implemented the boost converter of Choi in Chu such that Chu operated off of battery power until the battery depleted and then I switched to using boost, that would save power, right?

**A.** That would extend the useful life of the battery.

**Q.** Right. By conserving power during the portion of time where it's operating off of the battery only, right?

**A.** By both conserving power during the time it's operating off the battery and then you turn on the boost, and it lets you more fully deplete the battery before you run out of battery.

**Q.** Okay. And you would agree with me that extending the useful life of a battery is something that is good, right?

**A.** Yes.

Ex. 1128 (Kelley Tr.) at 281:6-282:2

# Motivation to Combine: Chu + Choi 2010 + Myers



**Alyssa B. Apsel Ph.D.**

Professor & Director  
Elec. and Comp. Eng. Dept.  
Cornell University

134. Finally, adding the selectable power sources of Myers to the Chu envelope amplifier (in view of Choi 2010) would have yielded only expected, predictable results. Using the power selection method disclosed in Myers with Chu, as modified by Choi 2010 to include the boost converter, would have been: (a) a combination of prior-art elements (providing a battery supply and a boosted supply) according to known methods to yield predictable results, because a POSA would have understood, for example, allowing the envelope amplifier to selectively receive either a battery supply or a boosted supply would satisfy the power requirements of the power amplifier while improving battery preservation; (b) a simple substitution of one known element (operating with one power supply) for another (switching operation between two power supplies) to obtain predictable results; (c) a use of a known technique (operating an envelope amplifier with either a boosted power supply or a battery power supply) to improve a similar device (the envelope amplifier of Chu) in the same way; (d) an application of a known technique (selectively receive either a boosted power supply or a battery power supply) to a known device (the envelope amplifier of Chu) ready for improvement to yield predictable results; and (e) obvious to try—a choice of one type of power supply from a finite number of identified, predictable solutions, with a reasonable expectation of success.

# Motivation to Combine: Chu + Choi 2010 + Myers



**Arthur W. Kelley**

Patent Owner's  
Expert

**Q.** It was within the skill of the person of ordinary skill to build the circuit that would switch between the Vbat shown in Choi — sorry — shown in Chu Figure 4 and the boosted voltage of the boost converter from Choi Figure 5, correct?

**A.** If you decided to do that, yes.

Ex. 1128 (Kelley Tr.) at 284:6-12

# Outline

- Overview of Petitions
- **“Envelope Amplifier” Claims (1-14)**
  - Alleged Invention
  - Chu / Choi 2010 / Myers
  - **PO’s Claim Construction**
- “Switcher” Claims (15-20)
  - Alleged Invention
  - Kwak
  - Kwak’s Feedforward Path Increases the Inductor Current
  - Fig. 5 v. Fig. 6
  - Claims 16 and 19

# The Plain Claim Language Supports Petitioner's Construction

6. An apparatus for wireless communication, comprising:

\*\*\*

... a P-channel metal oxide semiconductor (PMOS) transistor having a gate receiving a first control signal, **a source receiving the boosted supply voltage or the first supply voltage** . . . .

Ex. 1101 ('558 patent) at 11:56-59

- Plain meaning of “or” is to claim alternatives.

# The Plain Claim Language Supports Petitioner's Construction

Petitioner's construction seemingly rests entirely on the word "or." The use of "or" is sometimes an acceptable mechanism for claiming alternatives such that only one of the limitations need be found in the prior art to support anticipation.

*See In re Gaubert*, 524 F.2d 1222, 187 USPQ 664 (CCPA 1975). Nevertheless,

IPR2018-01153, Paper 19 (POR) at 20

- Patent Owner concedes that the plain meaning of "or" in patent claims is to claim alternatives.

# Patent Owner's Construction Excludes "Always Boost" Embodiment

US008698558B2

(12) **United States Patent**  
Mathe et al.

(10) **Patent No.:** US 8,698,558 B2  
(45) **Date of Patent:** Apr. 15, 2014

(54) **LOW-VOLTAGE POWER-EFFICIENT ENVELOPE TRACKER**

(75) Inventors: **Lennart K Mathe**, San Diego, CA (US);  
**Thomas Duncnick Marra**, San Diego, CA (US); **Todd R Sutton**, Del Mar, CA (US)

(73) Assignee: **QUALCOMM Incorporated**, San Diego, CA (US)

(\*) Notice: Subject to any disclaimer, the term of this patent is extended or adjusted under 35 U.S.C. 154(b) by 38 days.

(21) Appl. No.: 13/167,659

(22) Filed: Jun. 23, 2011

(65) **Prior Publication Data**  
US 2012/0326783 A1 Dec. 27, 2012

(51) Int. Cl. **H03F 3/217** (2006.01)

(52) U.S. Cl. 330/251; 330/136; 330/297

(58) **Field of Classification Search**  
USPC 330/10, 136, 207 A, 251, 297  
See application file for complete search history.

(56) **References Cited**  
U.S. PATENT DOCUMENTS  
5,915,417 A \* 5/1999 Malya ..... 330/10  
6,300,826 B1 10/2001 Mathe et al.  
6,661,217 B2 12/2003 Kimball et al.  
6,792,252 B2 9/2004 Kimball et al.  
6,838,931 B2\* 1/2005 Malya et al. .... 330/10  
7,061,313 B2 6/2004 Kimball et al.  
7,068,984 B2 6/2006 Mathe et al.  
7,308,985 B2 5/2008 Kosinski

7,679,433 B1 3/2010 Li  
7,755,471 B2\* 7/2010 Sun  
7,932,786 B2\* 4/2011 Elia  
8,030,955 B2\* 10/2011 Okubo et al.  
8,337,499 B2\* 8/2012 Chen et al.  
2005/046475 A1 3/2005 Matsumoto et al.  
2005/015208 A1 6/2005 Tanaka et al.  
2008/079436 A1 11/2008 Murtajani  
2010/0691793 A1 1/2010 Van Zyll et al.  
2011/0095827 A1 4/2011 Tanaka et al.  
2012/0293253 A1\* 11/2012 Khatir et al. .... 330/127

Primary Examiner: (74) Attorney, Agent, (57) Techniques for offset described. In one design, amplifier and a boost a boosted supply volt supply voltage (e.g., a filer generates a second signal and the boost first supply voltage). A second supply volt includes a switcher, amplifier. The switch provides a first supply current. The envelope amplifier provides a second supply current based on an envelope signal. The power amplifier receives a total supply current including the first and second supply currents. In one design, the switcher enlarges the second supply current and adds an offset to generate a larger first supply current than without the offset.

20 Claims, 6 Drawing Sheets

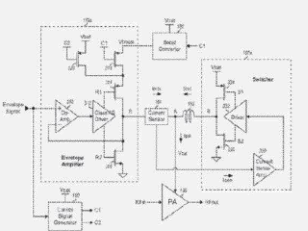

INTEL 1001

In another design of supporting operation with a lower battery voltage, the entire envelope tracker is operated based on the Vboost voltage from boost converter 180. In this

Ex. 1101 ('558 patent) at 8:24-26

# Patent Owner's Construction Excludes "Always Boost" Embodiment



**Arthur W. Kelley**

Patent Owner's  
Expert

**Q.** If you're right that the selective boost and the or means I have to be able to use either boost or first, then under that circumstance, claim [6] and 13 would not cover the embodiment at column 8 line 24 that uses Vboost alone. Is that fair?

**A.** **I think that's fair.**

Ex. 1128 (Kelley Tr.) at 134:12-18



# Patent Owner's Construction Is Narrower Than Judge Sabraw's Construction Under Phillips

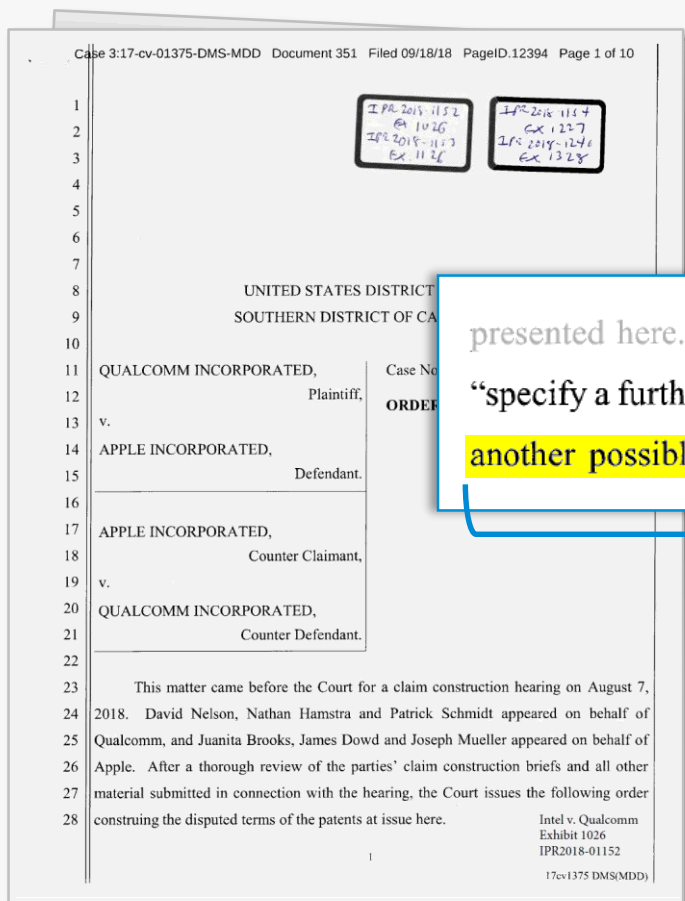

presented here. Contrary to the requirement of 35 U.S.C. § 112 ¶ 4,<sup>3</sup> claim 7 does not “specify a further limitation” on claim 6. Rather, it expands the scope of claim 6 to include another possible combination as the basis for the second supply voltage. Under these

Ex. 1126 (Markman Order), at 6

“Selective Boost”

# Patent Owner's Construction Is Narrower Than Judge Sabraw's Construction Under Phillips



**Arthur W. Kelley**

Patent Owner's  
Expert

- Q.** And just to be clear, you're giving an opinion that is contrary to Judge Sabraw's claim construction, right?
- A.** I understand what the Judge did. And I've reached a different conclusion.

Ex. 1128 (Kelley Tr.) at 147:10-15

# Outline

- Overview of Petitions
- “Envelope Amplifier” Claims (1-14)
  - Alleged Invention
  - Chu / Choi 2010 / Myers
  - PO’s Claim Construction
- **“Switcher” Claims (15-20)**
  - **Alleged Invention**
  - Kwak
  - Kwak’s Feedforward Path Increases the Inductor Current
  - Fig. 5 v. Fig. 6
  - Claims 16 and 19

# Claim 15

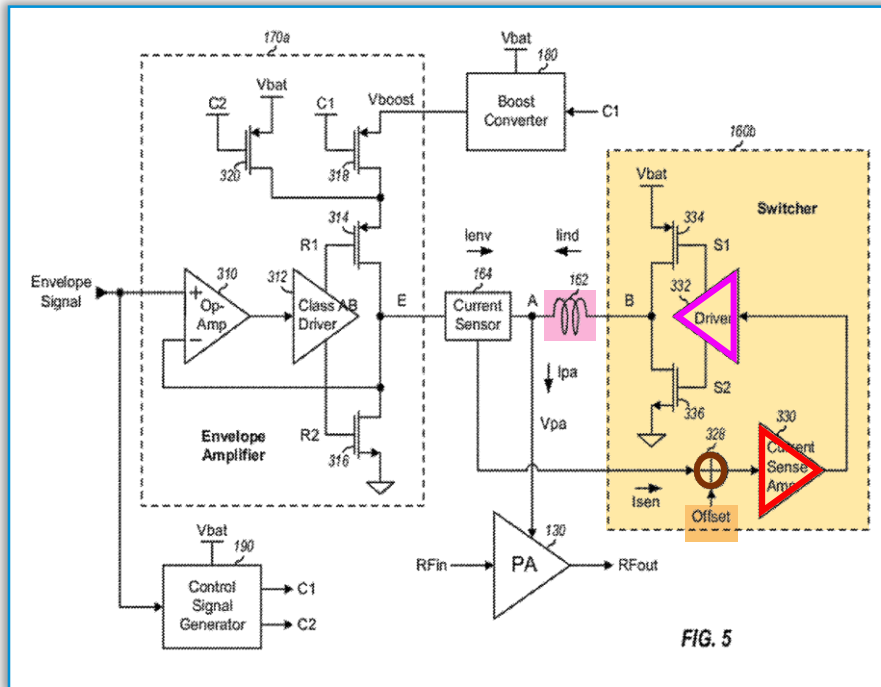

Ex. 1101 ('558 patent) at Fig. 5

15. An apparatus comprising:  
an inductor operative to receive a switching signal and provide a supply current; and  
a switcher operative to sense an input current and generate the switching signal to charge and discharge the inductor to provide the supply current, the switcher adding an offset to the input current to generate a larger supply current via the inductor than without the offset, wherein the switcher comprises  
a summer operative to sum the input current and an offset current and provide a summed current,  
a current sense amplifier operative to receive the summed current and provide a sensed signal, and  
a driver operative to receive the sensed signal and provide at least one control signal used to generate the switching signal for the inductor.

Ex. 1201 ('558 patent) at 13:19-34

# Outline

- Overview of Petitions
- “Envelope Amplifier” Claims (1-14)
  - Alleged Invention
  - Chu / Choi 2010 / Myers
  - PO’s Claim Construction
- **“Switcher” Claims (15-20)**
  - Alleged Invention
  - **Kwak**
  - Kwak’s Feedforward Path Increases the Inductor Current
  - Fig. 5 v. Fig. 6
  - Claims 16 and 19

# Asserted Prior Art – Kwak (Ex. 1211)

IEEE JOURNAL OF  
**SOLID-STATE  
CIRCUITS**

DECEMBER 2007

ISSCBC

(ISSN 0018-9200)

## A 2 W CMOS Hybrid Switching Amplitude Modulator for EDGE Polar Transmitters

Tae-Woo Kwak, *Student Member, IEEE*, Min-Chul Lee, *Student Member, IEEE*, and Gyu-Hyeong Cho, *Member, IEEE*

A 2-W CMOS Hybrid Switching Amplitude Modulator for EDGE Polar Transmitters	Tae-Woo Kwak, Min-Chul Lee, and Gyu-Hyeong Cho	2666
A Zero-Crossing-Based 8-bit 200-MSa/s Pipelined ADC	L. Brooks and H.-S. Lee	2677
A 10-bit 205-MSa/s 1.0- $\mu\text{m}^2$ 90-nm CMOS Pipeline ADC for Flat Panel Display Applications	S.-C. Lee, E.-D. Jeon, J.-K. Kwon, and J. Kim	2688
A 56-mW Continuous-Time Quadrature Cascaded $\Sigma\Delta$ Modulator With 77-dB DR in a Near-Zero-IF 30-MHz Band	L. J. Beyens, R. Batten, R. H. M. van Veldhoven, and G. van der Weide	2696
A Single-Inductor Switching DC-DC Converter With Five Outputs and Ordered Power-Distributive Control	H.-P. Lee, C.-S. Chae, K.-C. Lee, S.-W. Wang, G.-H. Cho, and G.-H. Cho	2706
<b>WRAP-UP</b>		
40-GHz High-Gain Distributed Amplifiers With Cascaded Gain Stages in 0.18- $\mu\text{m}$ CMOS	J.-C. Chien and L.-H. Lu	2715
A 40-44-GHz 3 $\times$ Oversampling CMOS CDR/16-DEMUX	N. Nedovic	2726
A Fully Integrated 4 $\times$ 10-Gbit DWDM Optoelectronic Transceiver Implemented in a Standard 0.13- $\mu\text{m}$ CMOS SOI Technology	A. Narasimka, B. Anjali, V. Liang, T. J. Stehoda, S. Abdalla, E. Bahmter, S. Glorckner, D. Guckenberger, M. Harrison, R. G. M. P. Koumans, D. Kucharski, A. Mekki, S. Mirzaidi, D. Song, and T. Pingree	2736

(Contents Continued on Back Cover)

IEEE  
INTEL 1211

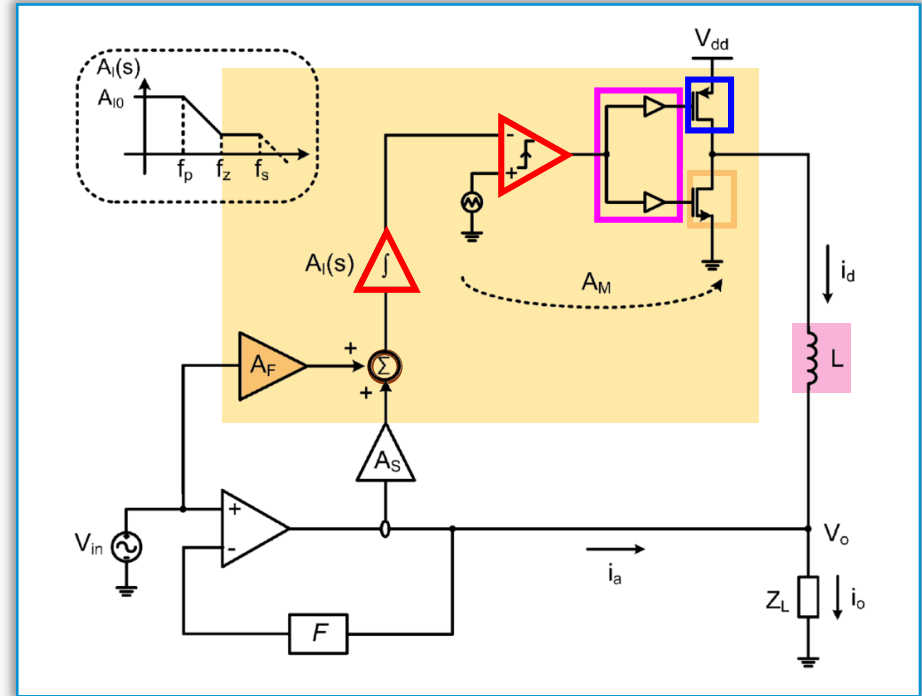

Ex. 1211 (Kwak) at Fig. 5

# Claims 15-20

- Kwak anticipates claims 15, 17-18, and 20
- Kwak renders obvious claim 16
- Kwak + Choi 2010 render obvious claim 19

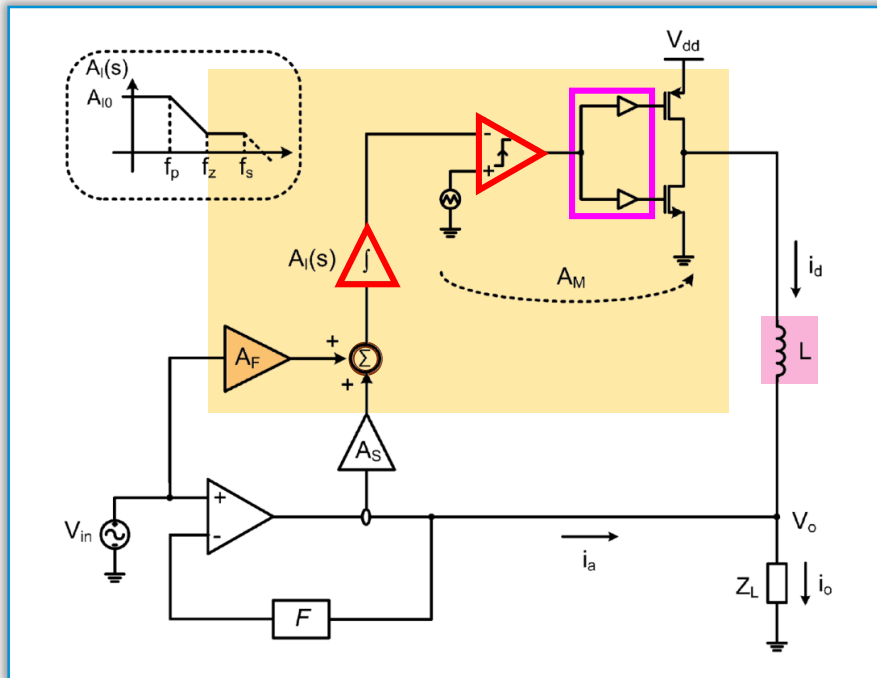

Ex. 1211 (Kwak) at Fig. 5

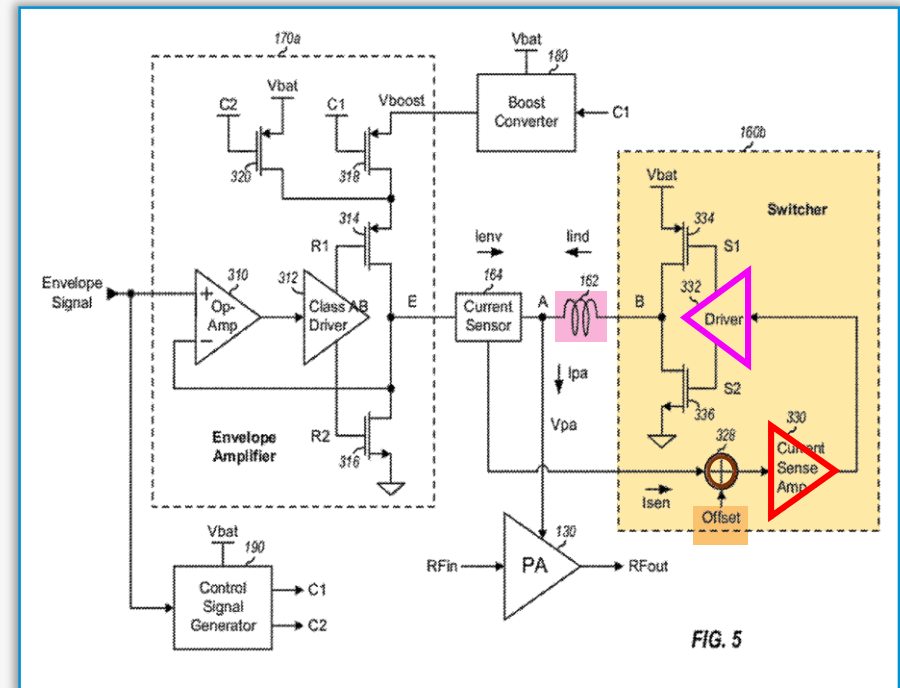

Ex. 1101 ('558 patent) at Fig. 5

# Patent Owner Concedes That Kwak Teaches All Limitations of Claim 15 Except “Offset”

**15.** An apparatus comprising:  
an inductor operative to receive a switching signal and provide a supply current; and  
a switcher operative to sense an input current and generate the switching signal to charge and discharge the inductor to provide the supply current, the switcher adding an offset to the input current to generate a larger supply current via the inductor than without the offset, wherein the switcher comprises  
a summer operative to sum the input current and an offset current and provide a summed current,  
a current sense amplifier operative to receive the summed current and provide a sensed signal, and  
a driver operative to receive the sensed signal and provide at least one control signal used to generate the switching signal for the inductor.



# Patent Owner Concedes That Kwak Teaches All Limitations of Claim 15 Except “Offset”



**Arthur W. Kelley**

Patent Owner's  
Expert

**A. I think that in a broad sense, whether Kwak is doing the offset, as described in Claim 15, is the heart of the matter. Sure.**

IPR2018-01154, Ex. 1229 (Kelley Tr.) at 189:3-5

# Outline

- Overview of Petitions
- “Envelope Amplifier” Claims (1-14)
  - Alleged Invention
  - Chu / Choi 2010 / Myers
  - PO’s Claim Construction
- **“Switcher” Claims (15-20)**
  - Alleged Invention
  - Kwak
  - **Kwak’s Feedforward Path Increases the Inductor Current**
  - Fig. 5 v. Fig. 6
  - Claims 16 and 19

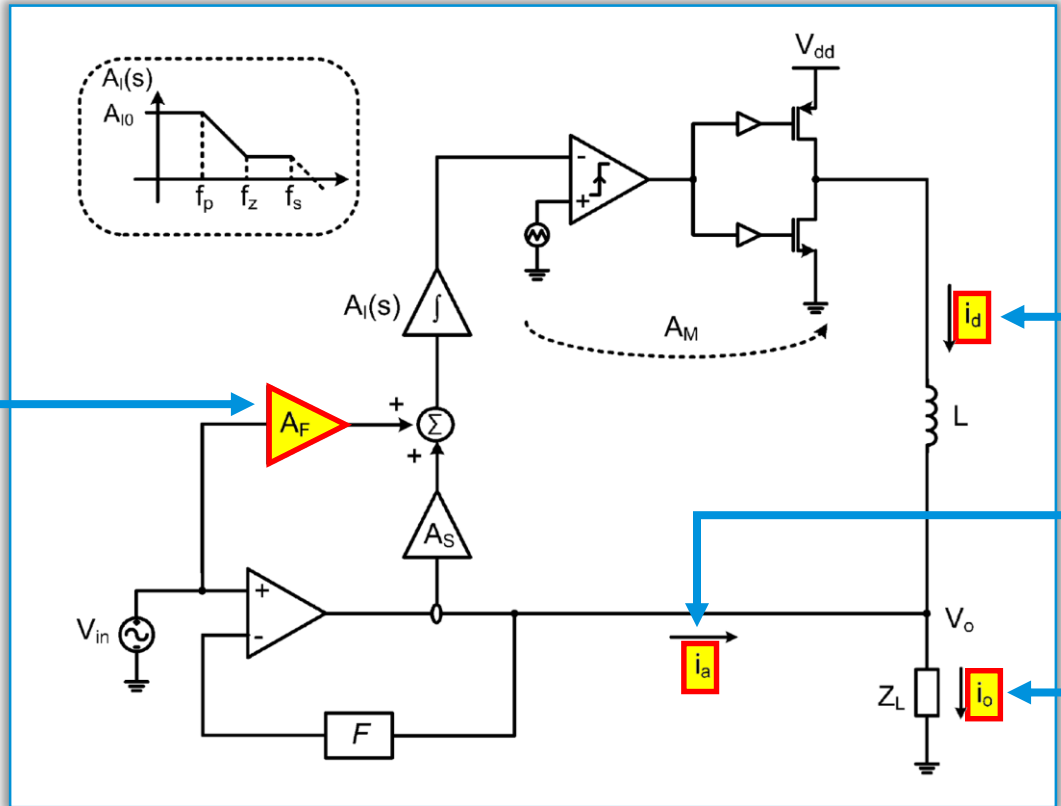

**Kwak's  
Feedforward Path**

**Switcher/Inductor  
Current**

**Linear Amplifier  
Current**

**Total/Output  
Current**

Ex. I211 (Kwak) at Fig. 5

$$i_o = i_a + i_d$$

Ex. I211 (Kwak) at 2666

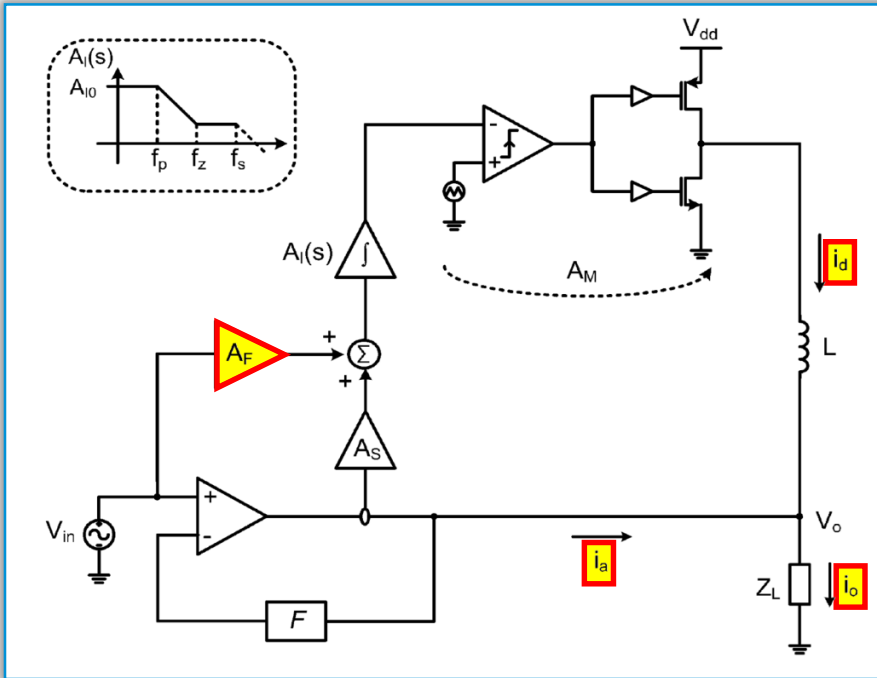

Ex. 1211 (Kwak) at Fig. 5

Assuming that the current loop  $\beta (\equiv i_d/i_a)$  has a large loop gain and a wide bandwidth, the linear amplifier only delivers the switching ripple current of the switching amplifier because the switching amplifier supplies most of the output current through the relation of  $i_o = i_a + i_d = (1 + \beta) \cdot i_a$ . In reality, however, as shown in Fig. 2(b), the output current of the switching amplifier ( $i_d$ ) is slower and less than the output current ( $i_o$ ) because of the finite loop gain  $\beta$ . Thus, the linear amplifier must provide some amount of signal current in addition to the ripple current to compensate for the distortion that results from the phase lag of the switching stage in the high-frequency region. With the magnitude of loop gain  $|\beta|$ , the phase of loop gain  $\theta$ , and the output current  $i_o$  at a specific frequency, the required output current of the linear amplifier  $i_a$  and the phase delay of the switching stage  $\alpha$  are given by

Ex. 1211 (Kwak) at 2666

$$i_o = i_a + i_d$$

Ex. 1211 (Kwak) at 2666

# Kelley Drawings

$$i_o = i_a + i_d$$

Ex. 1211 (Kwak) at 2666

- The Parties agree that activating Kwak's feedforward path:
  - Decreases  $i_a$
  - Does not change  $i_o$
- Kwak explains that  $i_a$  does not only compensate for *phase change*, i.e., switching ripple current. It also provides signal current. Ex. 1211 (Kwak) at 2666

Paper 19 (Petitioner's Reply) at 10-11.

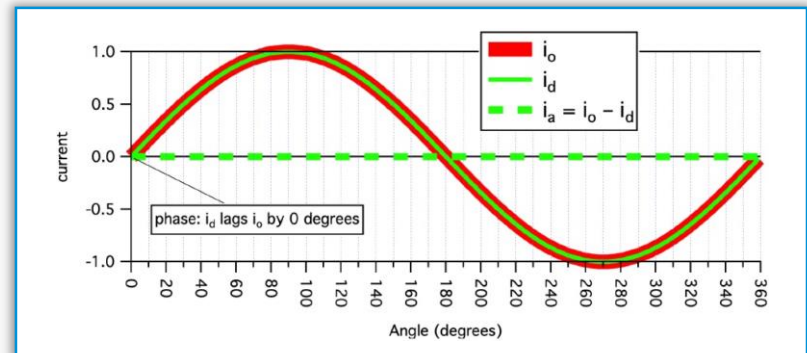
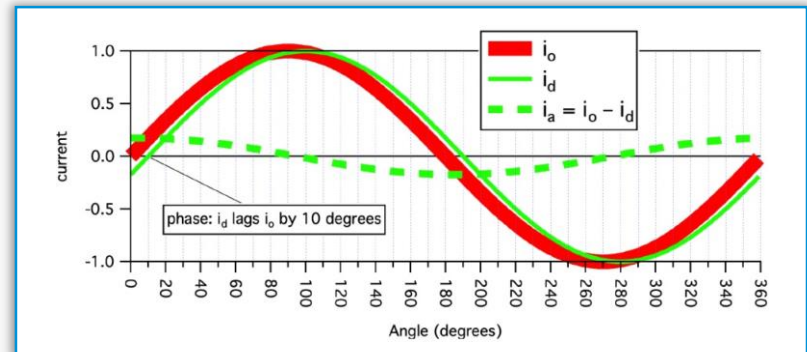
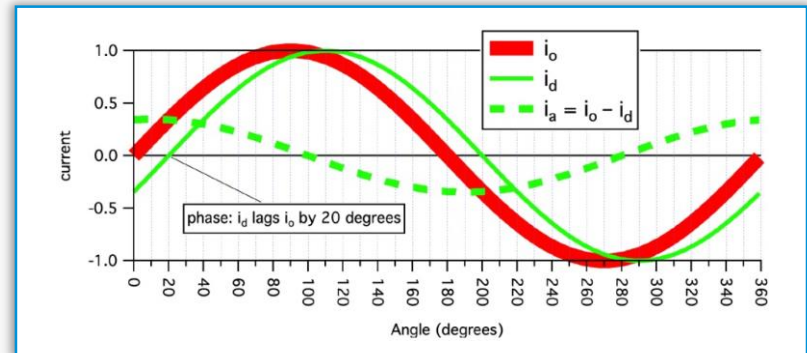

IPR2018-01154, Ex. 2002 (Dr. Kelley Decl.) at ¶¶76-80

# Patent Owner Admissions



**Arthur W. Kelley**

Patent Owner's  
Expert

**Q.** So the assumption that the amplitude, the peak to peak amplitude of  $I_d$  equals  $I_o$ , Kwak at Page 2673 bottom of the left column says that it is not correct, right?

*MR. SAUER: Objection; form.*

**A.** Again, my waveforms are an illustration of how to do math with sine waves.

**They are not meant to directly reproduce Figure 11 of Kwak.**

Ex. 1229 (Kelley Tr.) at 195:9-15

# Patent Owner Admissions

- Activating Kwak's feedforward path decreases the magnitude of the linear amplifier current ( $i_a$ )



**Arthur W. Kelley**

Patent Owner's  
Expert

71. Kwak's feedforward path does not cause the switcher to generate a larger current than the switcher would without the feedforward path. The Kwak feedforward loop only reduces the current from the linear amplifier— $i_a$  in the parlance of Kwak—needed to “compensate for the distortion that results from the phase lag of the switching stage in the high-frequency region.” *See id.* at 2666, 2668-2670. Kwak does not disclose or suggest that the reduction in such compensation current can increase the amount of current generated from the switcher.

Ex. 2002 (Kelley Decl.) at ¶ 71

# Patent Owner Admissions

- Activating Kwak's feedforward path does not change the output current ( $i_o$ )

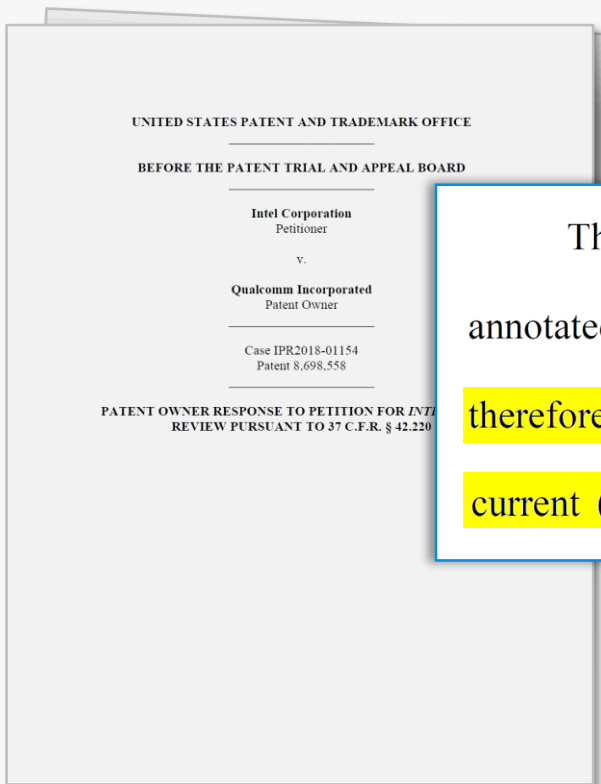

The supply current ( $i_d$ ) through the inductor is circled in green in Petitioner's annotated drawing (above). The output current ( $i_o$ ) remains constant, and can therefore be determined by summing the supply current ( $i_d$ ) and the linear amplifier current ( $i_a$ ). Kwak's Equation (4) provides the equation for calculating output

IPR2018-01154, Paper 9 (POR) at 27-28



# Patent Owner Admissions



**Arthur W. Kelley**

Patent Owner's  
Expert

Q. And a person of ordinary skill would understand that it would be desirable from an efficiency standpoint to have the switcher produce as much energy as possible, right?

*MR. SAUER: Objection; form.*

A. **I think it would be better phrased the switcher provides as much current as possible.**

Ex. 1229 (Kelley Tr.) at 245:15-21

A. **The switcher is trying to provide most of the current  $I_o$  by way of  $I_d$ .**

Ex. 1229 (Kelley Tr.) at 252:3-4

# Kwak Discloses “Offset”: Equation 4

$$i_o = \frac{A_{vf} \cdot v_{in}}{Z_L} = \underbrace{i_a + (A_S \cdot i_a + A_F \cdot v_{in}) \cdot A_I \cdot A_M}_{i_d} \cdot \frac{1}{Z_L + sL} \quad (4)$$

$$i_o = \frac{A_{vf} \cdot v_{in}}{Z_L} = i_a + (A_S \cdot i_a + A_F \cdot v_{in}) \cdot A_I \cdot A_M \cdot \frac{1}{Z_L + sL} \quad (4)$$

Using basic math, the portion of the total output current provided by the switcher ( $i_d$ ) must be represented by the terms *after*  $i_a$  in Kwak’s equation (4):

$$(A_S \cdot i_a + A_F \cdot v_{in}) \cdot A_I \cdot A_M \cdot \frac{1}{Z_L + sL}$$

According to this expression, the supply current from the switcher ( $i_d$ ) is proportional to the offset current ( $A_F$ ): as the offset ( $A_F$ ) increases, so will the supply current from the switcher ( $i_d$ ). Ex. 1203 at ¶103.

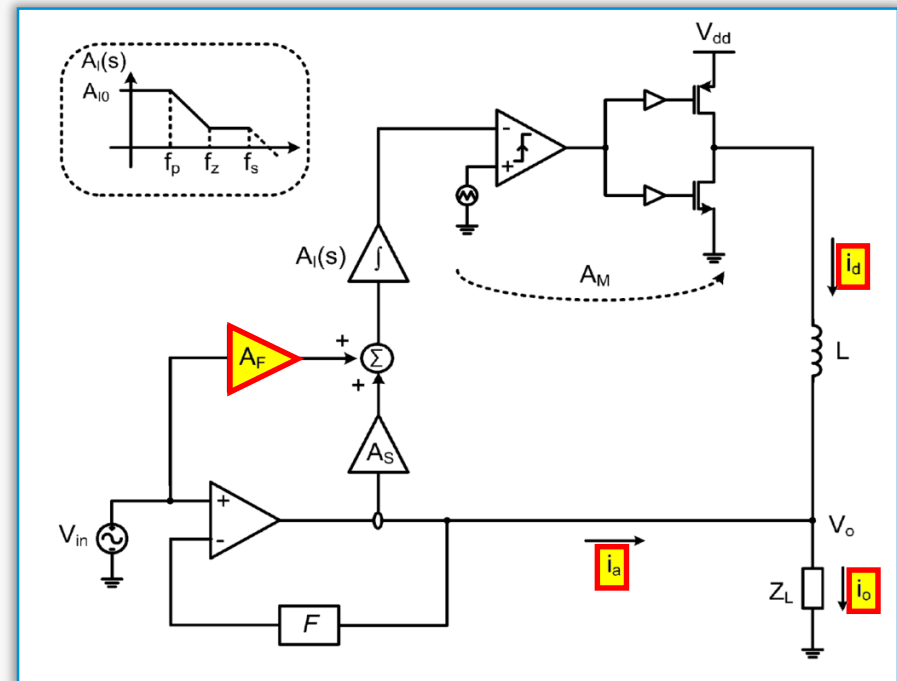

Ex. 1211 (Kwak) at Fig. 5

# Kwak Discloses “Offset”: Equation 4

$$i_o = \frac{A_{vf} \cdot v_{in}}{Z_L} = \underbrace{i_a + (A_S \cdot i_a + A_F \cdot v_{in}) \cdot A_I \cdot A_M \cdot \frac{1}{Z_L + sL}}_{i_d} \quad (4)$$

Kwak also describes this effect of the offset when it explains “the effect of the feedforward path,” which is the structure that supplies the offset. Ex. 1211 at 2673. Kwak explains that the feedforward path causes “the output current of the linear amplifier” ( $i_a$ ) to be “reduced to about half.”  $i_d$ . This means the output current of the switcher ( $i_d$ ) must increase: the overall current requirements of the PA do not change when the offset (feedforward path) is added, since they are determined by the input signal, so when the offset causes the envelope amplifier to provide less current, the switcher must make up the difference. See Ex. 1201 at

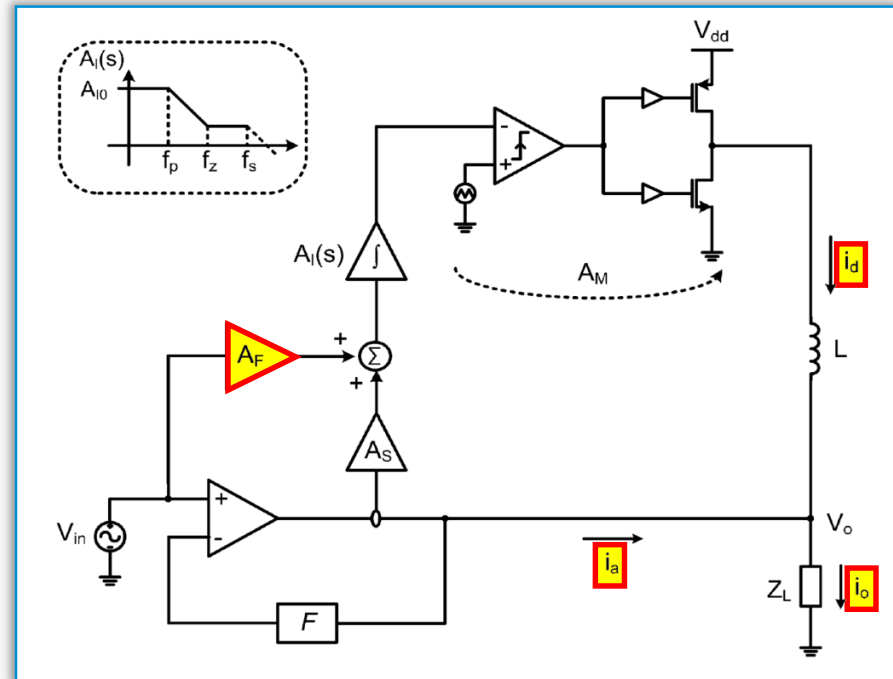

Ex. 1211 (Kwak) at Fig. 5

# Kwak Discloses “Offset”: Figure 11

Voltage corresponding to the output current,  $i_o$

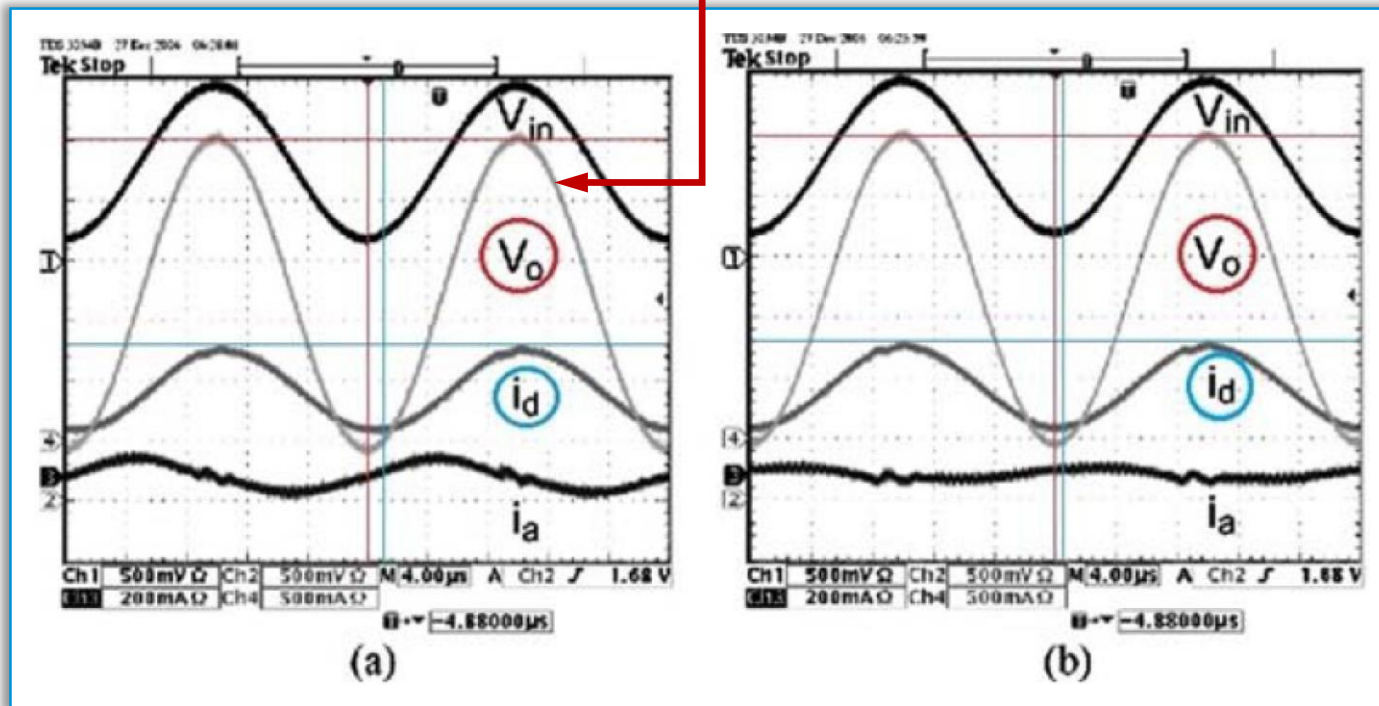

$$i_o = i_a + i_d$$

# Kwak Discloses “Offset”: Figure 11

highlight that the magnitude and phase of output ( $V_o$ ) remain constant with and without the feedforward path. Ex. 2002 at ¶87.

IPR2018-01154, Paper 16 (POR) at 31



**Arthur W. Kelley**  
Patent Owner's  
Expert

Q. But the minimum values of  $V_o$  are the same in 11(a) and 11(b), right?  
A. I understand that they're the same.

Ex. 1229 (Kelley Tr.) at 207:9-11

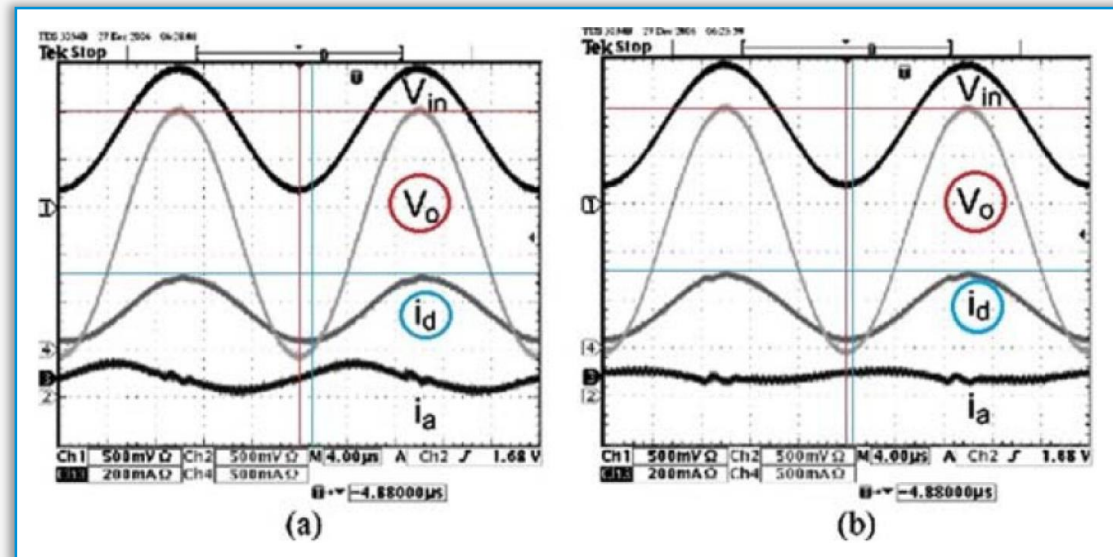

IPR2018-01154, Paper 19 (Petitioner's Reply) at 15-16.

Ex. 1211 (Kwak) at Fig. 11 (annotated by PO)

# Kwak Discloses “Offset”: Figure 11



**Arthur W. Kelley**  
Patent Owner's  
Expert

denote the relative phase of ( $i_d$ ). Horizontal blue lines are placed at the maximum value of supply current ( $i_d$ ). As can be seen above, the horizontal blue lines are located at the same location on both charts, at exactly  $3 \frac{3}{5}$  voltage divisions from the bottom of the chart. This demonstrates that Kwak's own testing results

Ex. 2002 (Kelley Decl.) at ¶ 87

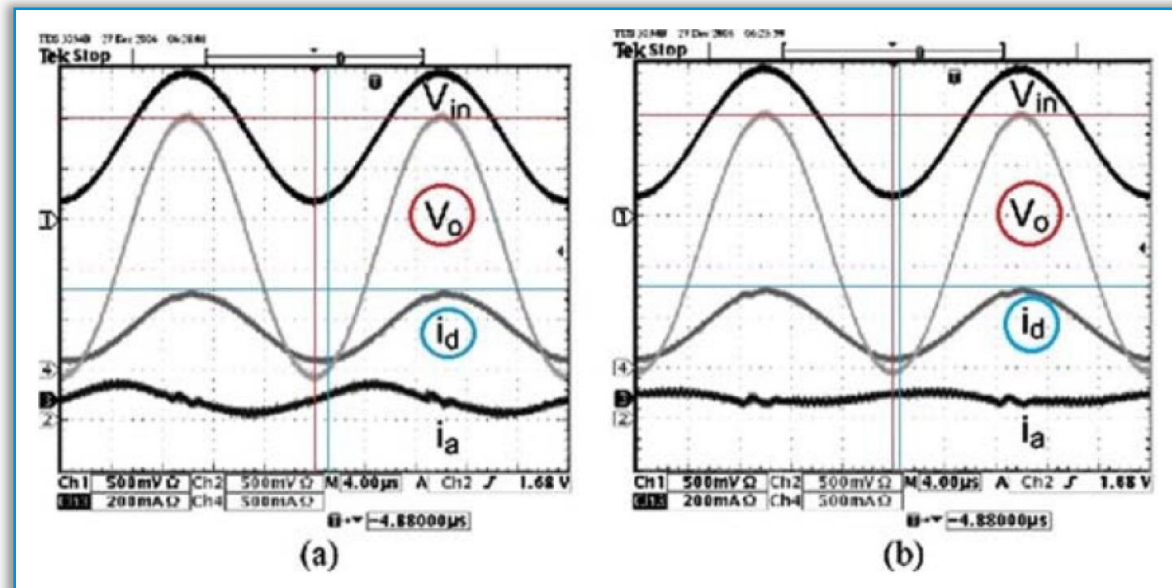



# Kwak Discloses “Offset”: Figure 11

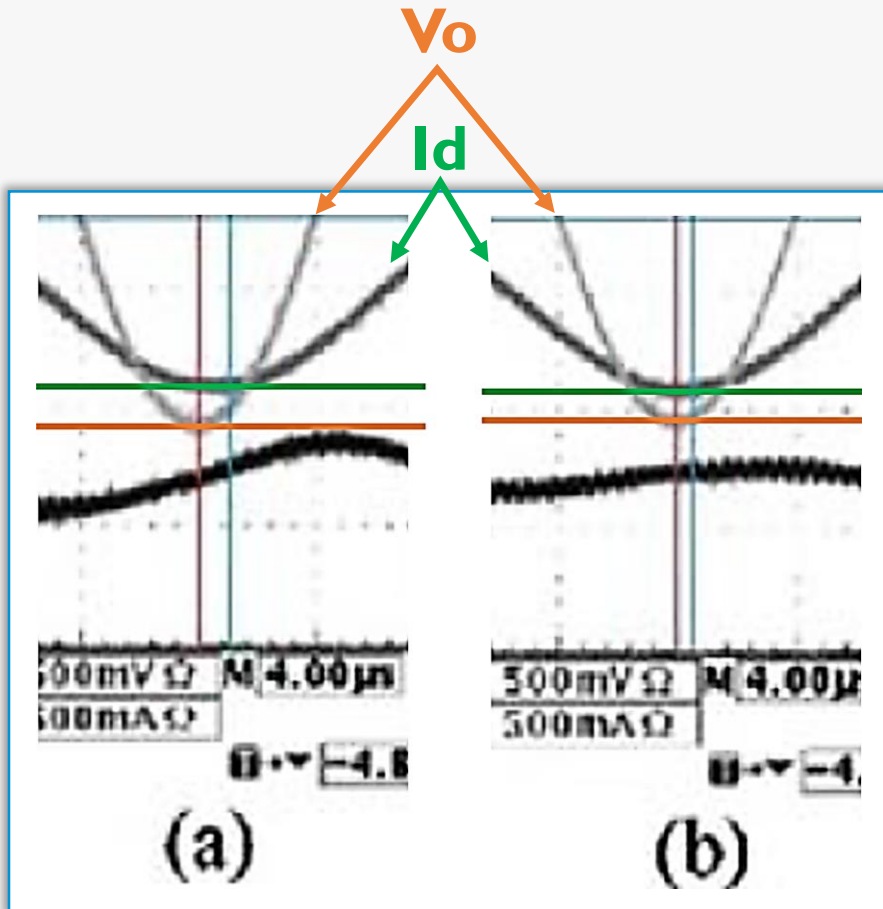

Ex. 1211 (Kwak) at Fig. 11 (excerpted and annotated)

- Q. Let me ask it to you this way: is it true, yes or no, that the vertical distance between the lowest point of  $V_o$  and the lowest point of  $I_d$  in (a) is greater than the vertical distance between the lowest point of  $V_o$  and the lowest point of  $I_d$  in (b)?
- A. **Yes. That's what produces the current  $I_a$ .**

Ex. 1229 (Kelley Tr.) at 217:12-19



# Kwak Discloses “Offset”: Figure 11

Voltage corresponding to the output current,  $i_o$

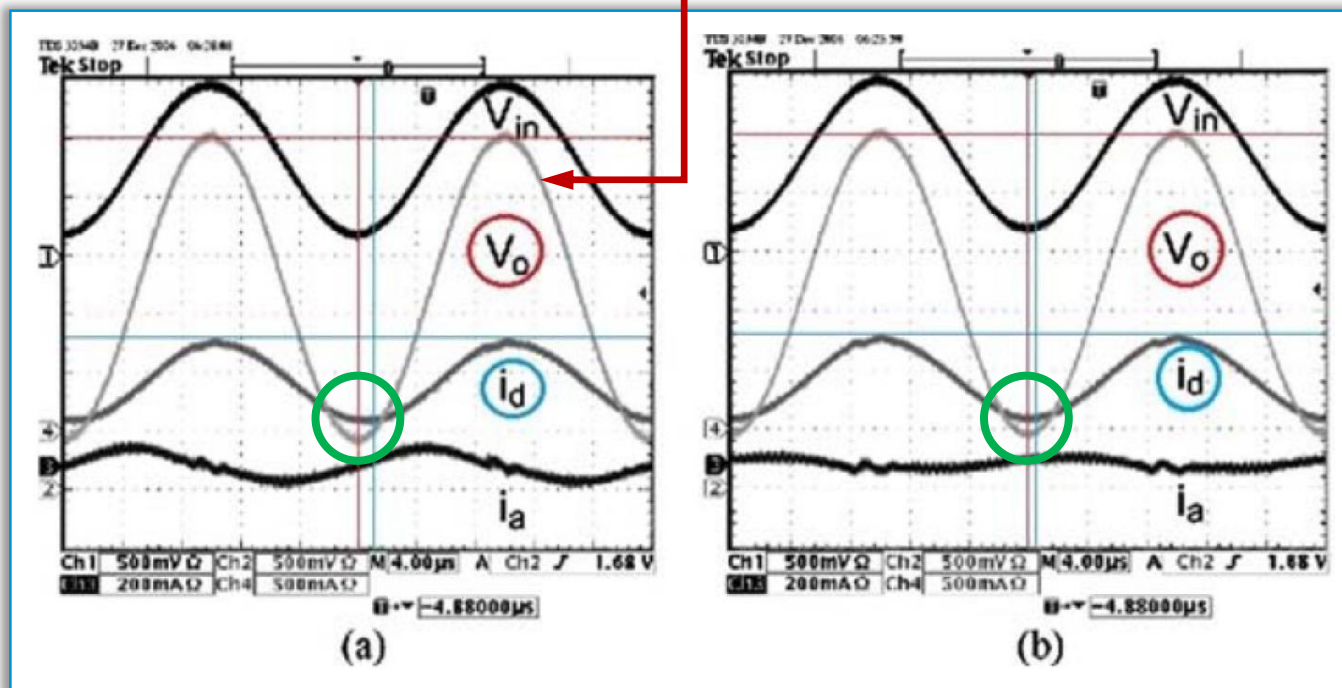

IPR2018-01154, Paper 16 (POR) at 32; Ex. 1211 (Kwak) at Fig. 11  
(annotated by PO - green circle added by Petitioner)

$$i_o = i_a + i_d$$

# Summary

- Patent Owner's inherency argument is waived
  - Raised for the first time in Sur-Reply
  - Petitioner does not rely on inherency
- Kwak's text, equations and figures all show that the feedforward path increases the inductor current

# Outline

- Overview of Petitions
- “Envelope Amplifier” Claims (1-14)
  - Alleged Invention
  - Chu / Choi 2010 / Myers
  - PO’s Claim Construction
- **“Switcher” Claims (15-20)**
  - Alleged Invention
  - Kwak
  - Kwak’s Feedforward Path Increases the Inductor Current
  - **Fig. 5 v. Fig. 6**
  - Claims 16 and 19

# Kwak Fig. 5

Petition for *Inter Partes* Review of U.S. Patent No. 8,698,558  
IPR2018-01154

DOCKET NO.: 0107131-00564US3  
Filed on behalf of Intel Corporation  
By: David L. Cavanaugh, Reg. No. 36,476  
Richard Goldenberg, Reg. No. 38,895  
Wilmer Cutler Pickering Hale and Dorr LLP  
60 State Street  
Boston, Massachusetts 02109  
Email: david.cavanaugh@wilmerhale.com  
richard.goldenberg@wilmerhale.com

UNITED STATES PATENT AND TRADE  
BEFORE THE PATENT TRIAL AND AP

Intel Corporation  
Petitioner  
v.  
Qualcomm Incorporated  
Patent Owner  
Case IPR2018-01154

PETITION FOR *INTER PARTES* REVIEW OF  
U.S. PATENT NO. 8,698,558  
CHALLENGING CLAIMS 15-20

by sensing and amplifying the output current of the former.”). As shown in Figure 5 (and as explained in detail in the specific grounds section below), Kwak discloses the internal structure of the supply generator, including the miscellaneous claim elements that the Examiner found were missing from the prior art during prosecution (operational amplifier, driver, and PMOS and NMOS transistors). Ex. 1203 at ¶¶71-72.

# Kwak Fig. 5

- (c) “a switcher operative to sense an input current and generate the switching signal to charge and discharge the inductor to provide the supply current, the switcher adding an offset to the input current to generate a larger supply current via the inductor than without the offset,”

Kwak discloses this limitation. Kwak discloses a switcher, highlighted in yellow below:

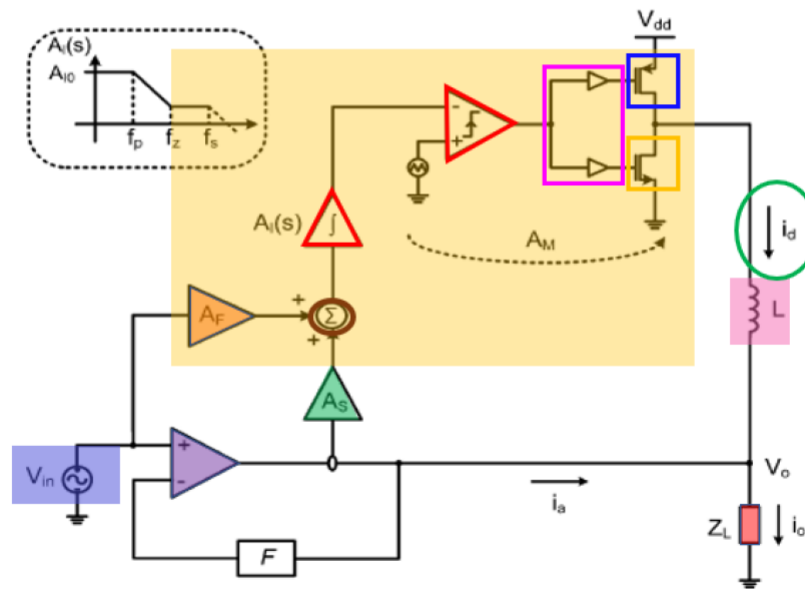

Fig. 5. Hybrid switching amplifier with the feedforward path.

Kwak – Figure 5

# Kwak Fig. 5

IN THE UNITED STATES PATENT AND TRADEMARK OFFICE

BEFORE THE PATENT TRIAL AND APPEALS BOARD

Intel Corporation  
Petitioner

v.

Qualcomm Incorporated  
Patent Owner

IPR2018-01154  
U.S. Patent No. 8,698,558

PETITIONER'S REPLY

The Petition then continues: “*The switcher adds an offset to the input current*, which will ultimately generate a larger supply current via the inductor than without the offset,” (Petition, 43) and points explicitly to the feed forward path of Fig. 5. *See, Id.*:

Kwak discloses that *the driver  $A_F$  (highlighted in orange) supplies an increase in current—i.e., an offset current—in a “feed forward” path*. Ex. 1211 at 2668 (“*If we add a feedforward path, like the one shown in Fig. 5*”, the input signal can directly control the switching amplifier. Such a path is faster than the feedback current path formed by sensing the output current of the linear amplifier.”); *id.* at 2668-69 (“the gain of the feedforward path  $A_F(s)$ ”).

# Kwak Fig. 5

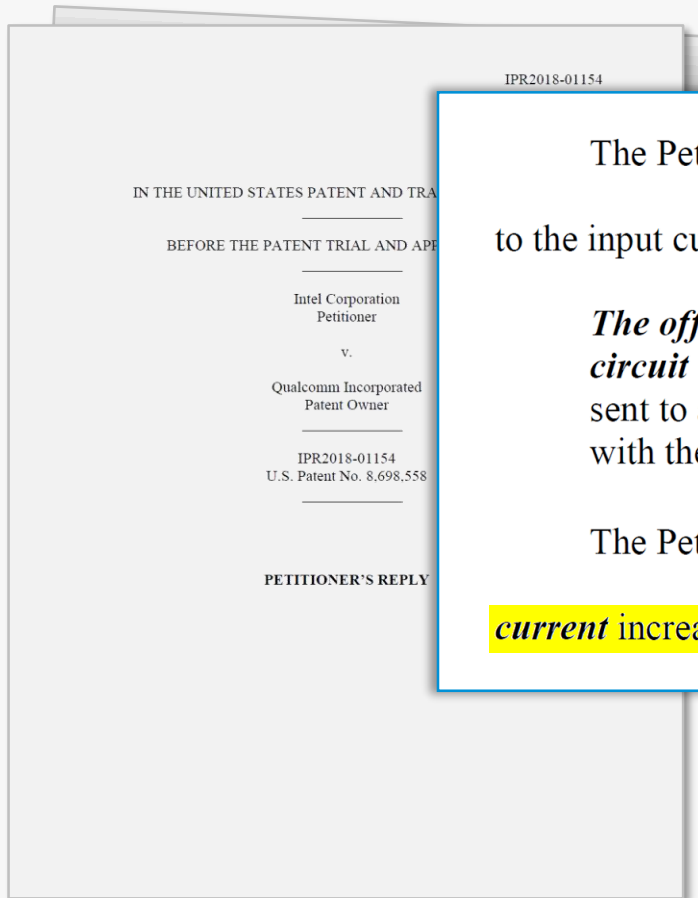

The Petition then explains where in Fig. 5, Kwak's switcher adds the offset to the input current. *See*, Petition, 43:

*The offset current is added to the sensed signal by the summing circuit ( $\Sigma$ , outlined in brown), and the summing circuit's output is sent to an integrator AI(s) (the left) triangle outlined in red, labeled with the integral sign  $\int$ ).*

The Petition also explains that "Figure 5 shows *how the added offset current* increases the supply current provided via the inductor." Petition, 45.

# Kwak Fig. 6 Is An Implementation of Fig. 5



**Alyssa B. Apsel Ph.D.**

Professor & Director  
Elec. and Comp. Eng. Dept.  
Cornell University

50. As I explained in my first Declaration, “Figure 6 of Kwak—which is *a detailed implementation* of the type of circuit shown in Figure 5—show these same features [shown in Figure 5] (with similar components in both figures highlighted...as in Figure 5).” Ex. 1203, ¶ 96. Indeed, Kwak itself is clear that the

Ex. 1203 (Apsel Decl.) at ¶ 50



# Kwak Fig. 6 Is An Implementation of Fig. 5

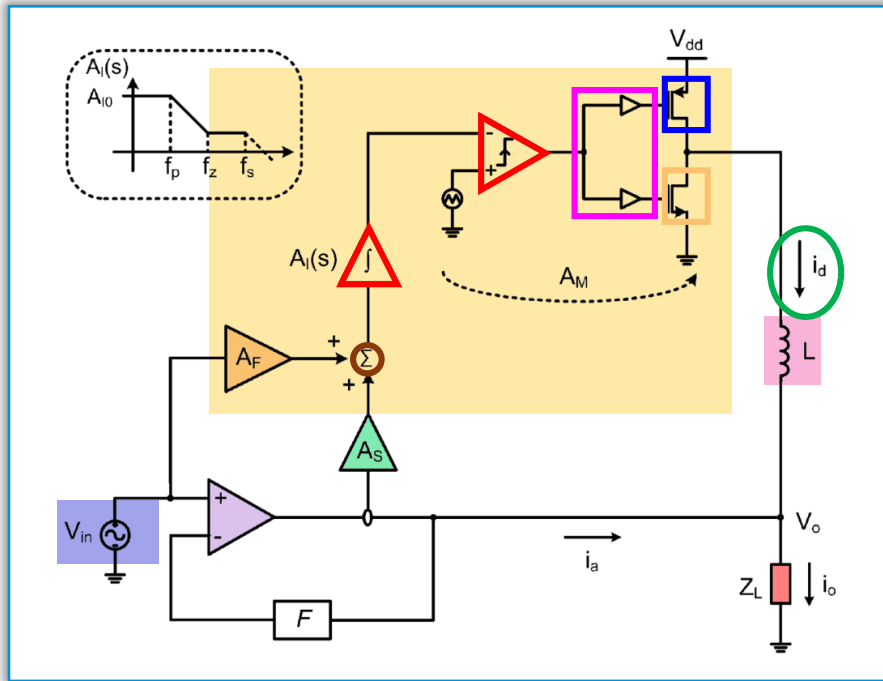

Ex. 1211 (Kwak) at Fig. 5

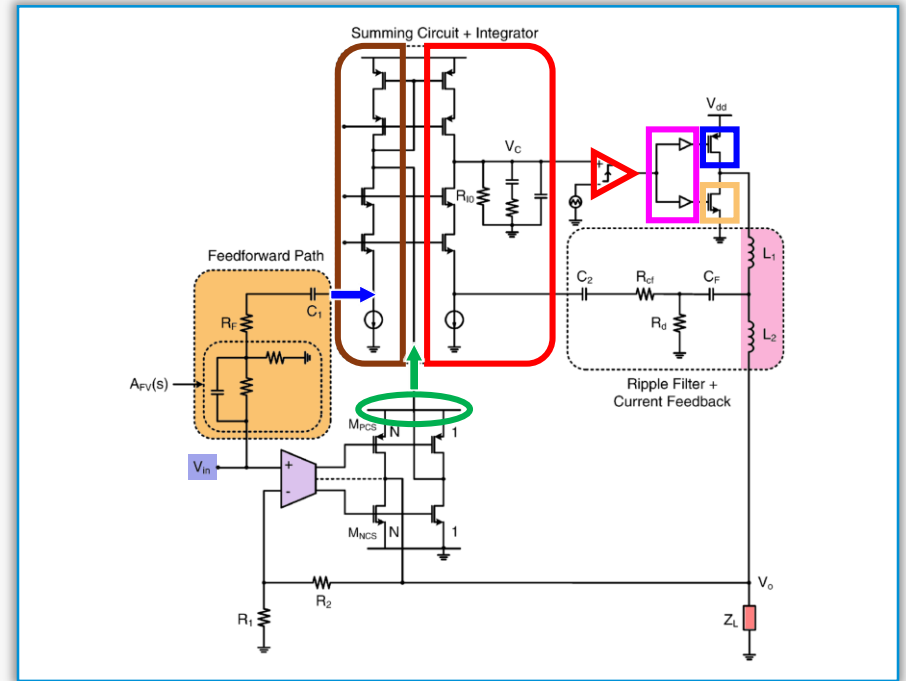

Ex. 1211 (Kwak) at Fig. 6

# Outline

- Overview of Petitions
- “Envelope Amplifier” Claims (1-14)
  - Alleged Invention
  - Chu / Choi 2010 / Myers
  - PO’s Claim Construction
- **“Switcher” Claims (15-20)**
  - Alleged Invention
  - Kwak
  - Kwak’s Feedforward Path Increases the Inductor Current
  - Fig. 5 v. Fig. 6
  - **Claims 16 and 19**

# Claim 16

**16.** The apparatus of claim 15, wherein the switcher operates based on a first supply voltage, and wherein the offset is determined based on the first supply voltage.

Ex. 1201 ('558 Patent) at 14:1-3

UNITED STATES PATENT AND TRADEMARK OFFICE  
BEFORE THE PATENT TRIAL AND APPEAL BOARD

Intel Corporation  
Petitioner

v.

Qualcomm Incorporated  
Patent Owner

U.S. Patent No. 8,698,558  
Claims 15-20

Case IPR2018-01154

DECLARATION OF ALYSSA APSEL, PH.D.  
ON BEHALF OF PETITIONER

power supply. In this obvious implementation, the transfer function of the amplifier (i.e., the relationship of the output versus the inputs) would depend on the supply voltage ( $V_{dd}$ ). More specifically, the gain of each stage of the amplifier device will depend on the drain current of each stage, which in turn depends on the drain-to-source voltage ( $V_{DS}$ ) and the supply voltage ( $V_{dd}$ ) (Ex. 1224 at p. 22; equation 2.20). For example, if  $V_{dd}$  increases, the output current of the amplifier would increase. As a result, the offset current from the  $A_F$  block would be determined based on, among other things, the first supply voltage (as well as on the input voltage  $V_{in}$ ), and Kwak therefore discloses this limitation.

IPR2018-01154, Paper 3 (Petition) at 60-61; Paper 19 (Petitioner's Reply) at 25

Ex. 1203 (Dr. Apsel Decl.) at ¶128

# Claim 16



**Arthur W. Kelley**

Patent Owner's  
Expert

**16.** The apparatus of claim **15**, wherein the switcher operates based on a first supply voltage, and wherein the offset is determined based on the first supply voltage.

Ex. 1201 ('558 Patent) at 14:1-3

**Q.** Okay. So let me ask it to you this way: One way to implement the triangle of Figure 5, labeled A(f) would be as an amplifier, right?

**A.** In an alternate implementation you might do that.

Ex. 1229 (Kelley Tr.) at 225:20-226:2

**Q.** If the circuit A(f) was implemented as a linear amplifier, you could use the V<sub>dd</sub> power supply to power that amplifier, right?

**A.** That's right.

Ex. 1229 (Kelley Tr.) at 227:7-10

# Claim 19

**19.** The apparatus of claim **18**, further comprising:  
a boost converter operative to receive the first supply voltage and provide a boosted supply voltage having a higher voltage than the first supply voltage, wherein the envelope amplifier operates based on the first supply voltage or the boosted supply voltage.

Ex. 1201 ('558 Patent) at 14:1-3

- Patent Owner does not challenge Petitioner's mapping of claim 19 to Kwak and Choi 2010
- Patent Owner does not dispute the benefits identified in the Petition with regard to the motivation to combine Kwak and Choi 2010

# Claim 19

Moreover, Choi 2010 disparages the use of a PWM control such as the circuit disclosed in Kwak by describing the benefits of using a hysteretic operation as opposed to PWM. *Id.* at ¶111; Ex. 1206 at 1334 (“Compared with pulse-width

\* \* \*

WiMAX and 3GPP LTE.”). Conversely, Kwak disparages the use of a hysteretic operation such as the one in Choi 2010 when it describes the benefits of using PWM modulation. *Id.*; *see also* Ex. 1211 at 2667 (“Compared with pulsewidth

POR at 42

- Patent Owner’s argument misrepresents the record because Petitioner does not propose bodily incorporating Choi 2010 into Kwak
- Petitioner argues instead that Choi 2010’s boosted supply is applicable to Kwak for the reasons discussed in Petition, which the PO did not dispute

# BACKUP

# Motivation to Combine: Chu + Choi 2010

94. Moreover, one of ordinary skill in the art would have been motivated to use a boost converter to prevent distortion as the battery becomes depleted and the voltage provided by the battery falls. It would have been desirable to operate Chu's linear amplifier with a boosted voltage so that (1) when the battery voltage starts depleting, Chu's linear amplifier is more robust, and/or (2) when the battery voltage is lower than the peak voltage magnitude of the amplified reference envelope voltage  $A(t)$ , distortion of the amplified reference envelope voltage is prevented. These advantages are specifically taught by Choi 2010, and would have motivated a person of ordinary skill in the art to modify Chu with Choi 2010 to take advantage of them. *See* Ex. 1107 at 1074 ("An integrated boost converter keeps a stable operation of the PA supply modulator. Even at the battery depletion from 4.2V to 2.8V, there is no significant degradation of output power and linearity in the power amplifier."); *id.* ("By boosting up the supply voltage of the linear amplifier to 5V regardless of the battery voltage variation, while that of the buck converter is still coupled to the battery in the HSA, the supply modulator dynamically regulates the PA with the peak voltage of 4.5V."); *id.* at 1077 ("For the additional boost converter, the proposed supply modulator presents the robust performance over the battery voltage variation while the efficiency degradation is minimized.").

95. Using a boost converter to power a PA to prevent distortion of the amplified signal was also common and well known in the prior art. For example, the Maehara patent discloses using a boost converter, referred to as a "step-up converter," in an amplifying circuit to prevent distortion. *See* Ex. 1118 at Abstract \*\*\*  
added). Similarly, a 2008 datasheet for a Maxim amplifier taught using a boost converter to extend battery life and maintain output levels when the battery voltage drops. Ex. 1115 [Maxim Integrated Products, Inc., *MAX9738 -16VP-P Class G* \*\*\*  
2.7V.]). Such references, including Maehara and Maxim, would have further confirmed the advantages of modifying Chu's supply modulator to incorporate the boost converter of Choi 2010, and thus further confirm the motivation for this modification. Because boost converters had been used to improve numerous similar devices, a person of ordinary skill in the art would have recognized that this same technique would also improve the Chu's supply modulator. Indeed, references such as Maehara and Maxim would have confirmed to a person of ordinary skill in the art that the results of incorporating Choi 2010's boost converter into Chu's supply modulator were entirely predictable, and in line with the results to be expected from the express teaching of Choi 2010.



# Motivation to Combine: Chu + Choi 2010

96. It was also well known in the art that the voltage output of a battery declines over time with use. Specifically, it was known that a battery will start at a fully charged voltage output level, but that the voltage level output by the battery will decline over time as the battery becomes depleted through use. A person of ordinary skill in the art would have understood that the output of a battery is not binary (i.e., not either fully on or fully off) but instead will decay over time until the battery's voltage output approaches zero. Given this state of battery technology in the prior art, it was obvious to use a boost converter to boost a falling battery voltage and provide the boosted voltage to circuit components, such as Chu's envelope amplifier, to maintain operation and minimize distortion as battery voltages drop.

97. Finally, adding the Choi 2010 boost converter to Chu's supply generator would have yielded only expected, predictable results. Combining the teachings of Choi 2010 with Chu would have been: (a) a combination of prior-art elements according to known methods to yield predictable results, because a person of ordinary skill in the art would have understood, for example, the effect on the output of an envelope amplifier from modifying that amplifier to receive a boosted supply voltage; (b) a simple substitution of one known element (a battery supply) for another (a boosted supply or a combination of a boosted supply and battery voltage) to obtain predictable results; (c) a use of a known technique (operating an envelope amplifier with a boosted power supply) to improve a similar device (Chu's envelope amplifier) in the same way disclosed by Choi 2010; (d) an application of a known technique (providing a boosted voltage) to a known device (Chu's envelope amplifier) that was ready for improvement to yield predictable results; and (e) obvious to try—a choice of different envelope trackers, from a finite number of identified, predictable solutions, with a reasonable expectation of success.

Ex. 1103 (Apsel Decl.) at ¶¶ 96-97

# Motivation to Combine: Chu+ Choi 2010+Myers

130. Chu, Choi 2010, and Myers are all from the same field of endeavor (hybrid power supply modulators). Combining the Chu envelope amplifier with the Choi 2010 boost converter would have been obvious for the reasons stated above regarding limitation 13(a). Combining the Chu envelope amplifier as modified by Choi 2010 with the selection functionality of Myers would have had further advantages: Myers “selects a power source to be used in an amplifier where the selection is a function of the amplitude of the input signal,” i.e., how much power is needed for the specific input signal, which “allows an amplifier to be operated in a more efficient range because a power source can be chosen *close to the amplitude of the input signal*.” Ex. 1012 at 9:18-21. Choosing a power source close to the amplitude of the input signal avoids the waste of power that would occur by supplying an unnecessarily high voltage. *See id.*

131. Moreover, a person of ordinary skill in the art would have understood that the selection of the power source may be based on the battery voltage, as described in Myers, when implementing the envelope amplifier of Chu with the boost converter of Choi 2010. For example, a person of ordinary skill in the art would have known that, when the voltage requirements of the amplified envelope signal is *lower* than the battery voltage, the envelope tracker of Chu as modified by Choi 2010 should use the battery voltage, because the battery voltage is sufficient to support the voltage needs of the P.A. and using the boosted the voltage would unnecessarily provide extra power and deplete the battery more quickly. Conversely, a person of ordinary skill in the art would also have understood the common-sense notion that, when the voltage magnitude of the amplified envelope signal is *greater* than the battery voltage, then it would be necessary to operate the envelope tracker of Chu (as modified by Choi 2010) with a boosted voltage closer to the amplitude of the input signal, in order to supply the PA with the necessary output voltage. A person of ordinary skill in the art would have understood that using a boosted supply in this circumstance prevents distortion of the amplified envelope signal.

Ex. 1103 (Apsel Decl.) at ¶¶ 130-131

# Motivation to Combine: Chu+ Choi 2010+Myers

132. Myers teaches the advantages of choosing the power source based on the amplitude of the input signal—it “allows an amplifier to be operated in a more efficient range”—and suggests that high efficiency is important to battery life. Ex.

\*\*\*

on the Vbat voltage the remaining time in order to improve efficiency.”). A person of ordinary skill in the art would have known that one purpose of including the ability to select between a battery voltage and a boosted supply voltage was to preserve battery voltage.

133. Therefore, a person of ordinary skill in the art would have been motivated to combine the selection functionality of Myers with the Chu envelope amplifier, as modified by Choi 2010, so that: (1) when a boosted voltage is not required, Chu’s linear amplifier operates efficiently with the battery voltage, and (2) when the battery voltage is lower than the peak voltage magnitude of the amplified reference envelope voltage  $A(t)$ , Chu’s linear amplifier operates with the boosted voltage to prevent distortion of the amplified reference envelope voltage  $A(t)$ . Modifying Chu to selectively use either the battery or boosted voltages as taught by Myers would have been a particularly obvious approach in view of the well-known state of battery technology, i.e., that batteries do not operate solely at a fixed output voltage level and instead start out operating an initial fully charged level and then experience reduced output voltage over time as the battery is discharged.

134. Finally, adding the selectable power sources of Myers to the Chu envelope amplifier (in view of Choi 2010) would have yielded only expected, predictable results. Using the power selection method disclosed in Myers with Chu, as modified by Choi 2010 to include the boost converter, would have been: (a) a combination of prior-art elements (providing a battery supply and a boosted supply) according to known methods to yield predictable results, because a POSA would have understood, for example, allowing the envelope amplifier to selectively receive either a battery supply or a boosted supply would satisfy the power requirements of the power amplifier while improving battery preservation; (b) a simple substitution of one known element (operating with one power supply) for another (switching operation between two power supplies) to obtain predictable results; (c) a use of a known technique (operating an envelope amplifier with either a boosted power supply or a battery power supply) to improve a similar device (the envelope amplifier of Chu) in the same way; (d) an application of a known technique (selectively receive either a boosted power supply or a battery power supply) to a known device (the envelope amplifier of Chu) ready for improvement to yield predictable results; and (e) obvious to try—a choice of one type of power supply from a finite number of identified, predictable solutions, with a reasonable expectation of success.

Ex. 1103 (Apsel Decl.) at ¶¶ 132-134

**CERTIFICATE OF SERVICE**

I hereby certify that on October 23, 2019, I caused a true and correct copy of the foregoing material:

- PETITIONER'S DEMONSTRATIVE FOR ORAL HEARING

to be served upon the following by ELECTRONIC MAIL:

[jmsauer@jonesday.com](mailto:jmsauer@jonesday.com)  
[dcochran@jonesday.com](mailto:dcochran@jonesday.com)  
[dmaiorana@jonesday.com](mailto:dmaiorana@jonesday.com)  
[jrnightingale@jonesday.com](mailto:jrnightingale@jonesday.com)  
[mwjohnson@jonesday.com](mailto:mwjohnson@jonesday.com)

/Theodoros Konstantakopoulos/  
Theodoros Konstantakopoulos  
Reg. No. 74,155

Date: October 23, 2019

Wilmer Cutler Pickering Hale and Dorr LLP  
7 World Trade Center  
250 Greenwich Street  
New York, NY 10007  
212-295-6367