



United States Patent [19]

[11] Patent Number: **5,416,342**

Edmond et al.

[45] Date of Patent: **May 16, 1995**

[54] **BLUE LIGHT-EMITTING DIODE WITH HIGH EXTERNAL QUANTUM EFFICIENCY**

[75] Inventors: **John A. Edmond, Apex; Hua-Shuang Kong, Raleigh, both of N.C.**

[73] Assignee: **Cree Research, Inc., Durham, N.C.**

[21] Appl. No.: **81,668**

[22] Filed: **Jun. 23, 1993**

[51] Int. Cl.⁶ **H01L 33/00**

[52] U.S. Cl. **257/76; 257/77; 257/98; 257/99; 257/101; 257/103**

[58] Field of Search **257/76, 77, 91, 95, 257/98, 99, 101, 103, 102, 623**

[56] **References Cited**

U.S. PATENT DOCUMENTS

4,918,497	4/1990	Edmond	357/17
5,027,168	6/1991	Edmond	357/17
5,063,421	11/1991	Suzuki et al.	257/77
5,187,547	2/1993	Niina et al.	257/77
5,243,204	9/1993	Suzuki et al.	257/77

FOREIGN PATENT DOCUMENTS

58-64074	4/1983	Japan	257/77
0221673	1/1990	Japan	257/77
0471278	3/1992	Japan	257/77
4112583	4/1992	Japan	257/77

OTHER PUBLICATIONS

K. H. Huang, et al., **Twofold Efficiency Improvement in High Performance AlGaInP Light-Emitting Diodes**

in the 555-620 nm Spectral Region Using a Thick GaP Window Layer, *Appl. Phys. Lett.*, vol. 61, No. 9, Aug. 1992, pp. 1045-1047.

Primary Examiner—William Mintel
Attorney, Agent, or Firm—Bell, Seltzer, Park & Gibson

[57] **ABSTRACT**

A light emitting diode is disclosed that emits light in the blue portion of the visible spectrum with high external quantum efficiency. The diode comprises a single crystal silicon carbide substrate having a first conductivity type, a first epitaxial layer of silicon carbide on the substrate and having the same conductivity type as the substrate, and a second epitaxial layer of silicon carbide on the first epitaxial layer and having the opposite conductivity type from the first layer. The first and second epitaxial layers forming a p-n junction, and the diode includes ohmic contacts for applying a potential difference across the p-n junction. The second epitaxial layer has side walls and a top surface that forms the top surface of the diode, and the second epitaxial layer has a thickness sufficient to increase the solid angle at which light emitted by the junction will radiate externally from the side walls, but less than the thickness at which internal absorption in said second layer would substantially reduce the light emitted from said top surface of the diode.

53 Claims, 5 Drawing Sheets

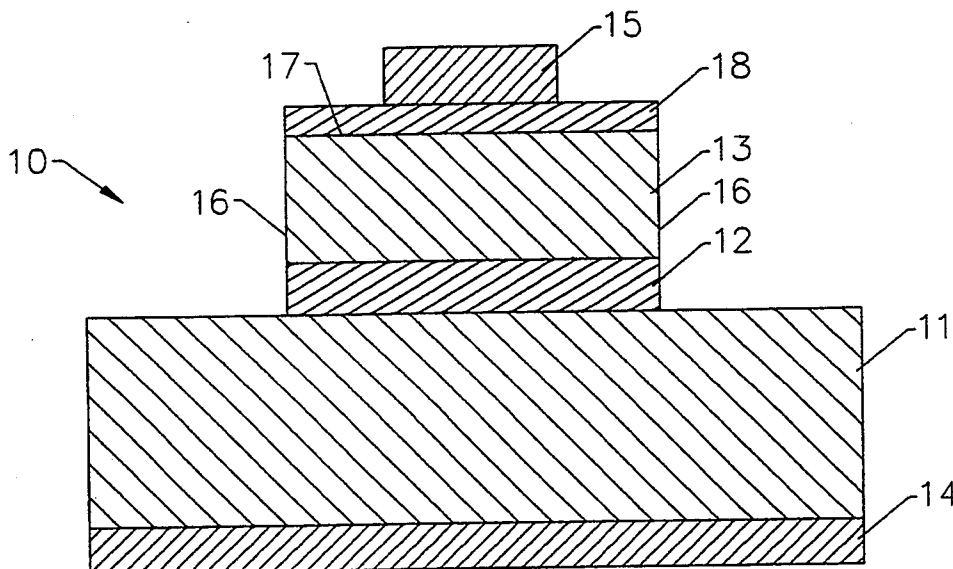

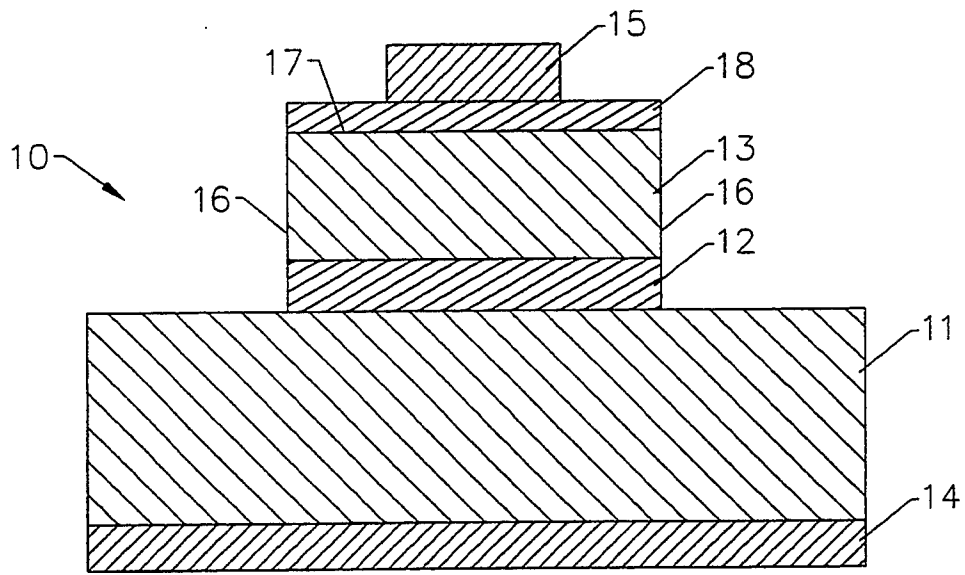

FIG. 1.

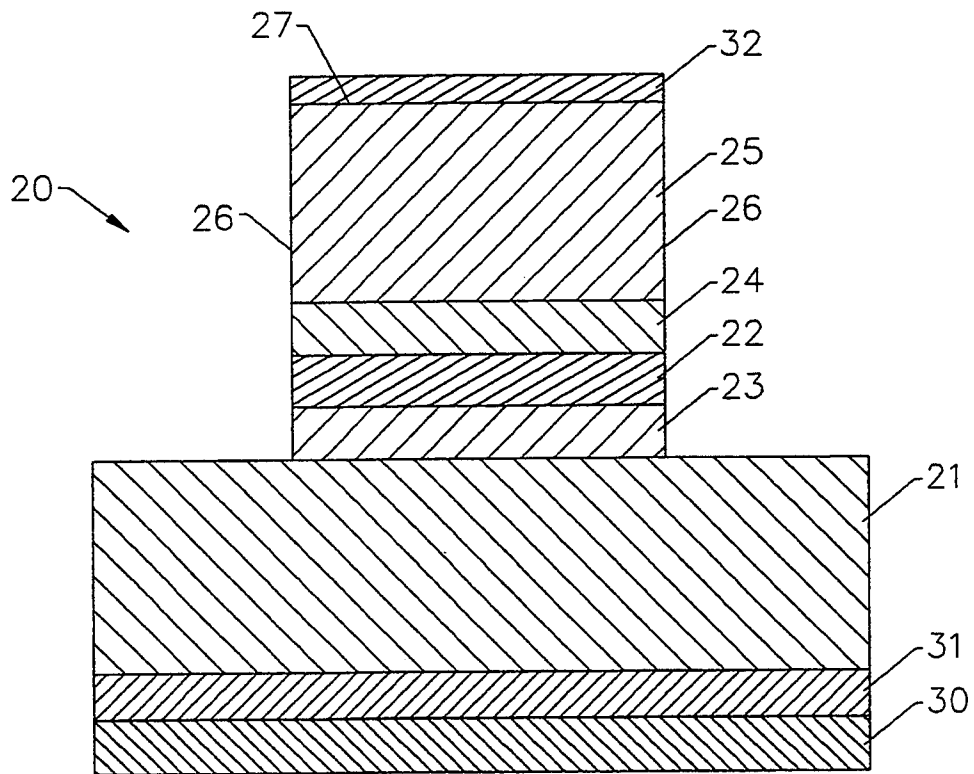

FIG. 2.

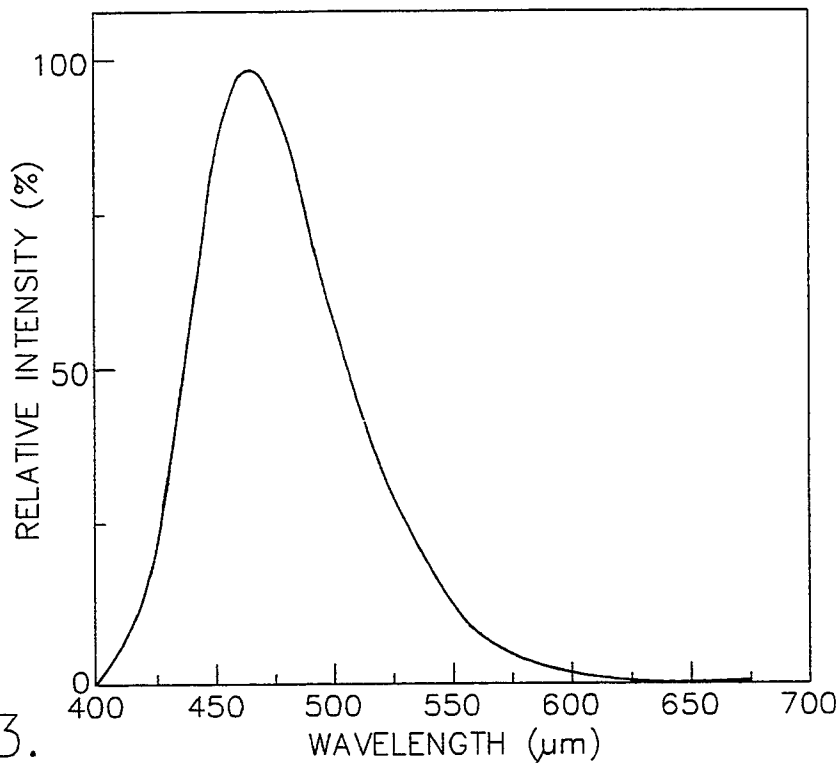

FIG. 3.

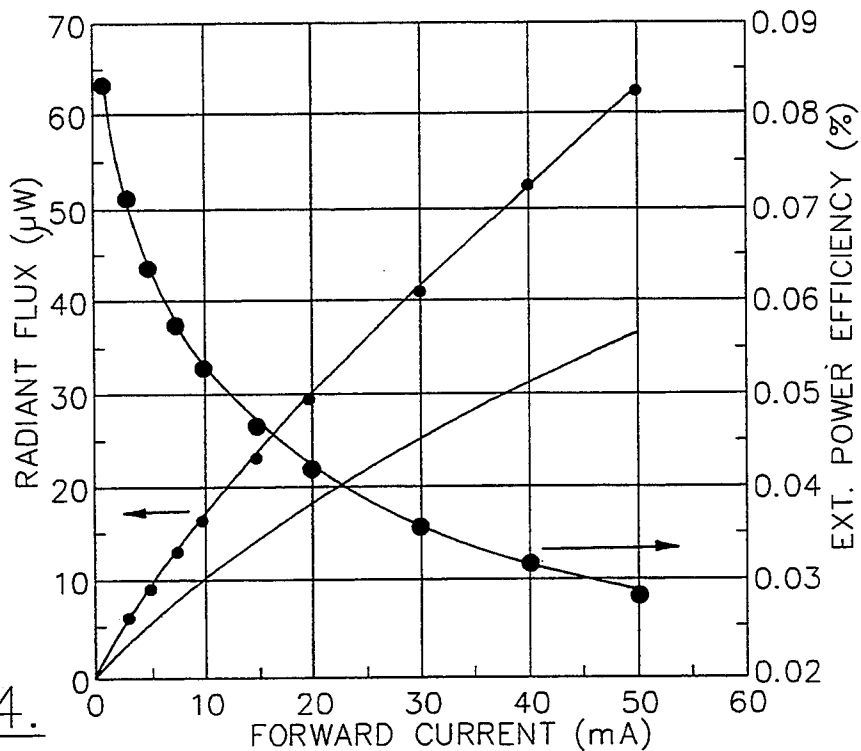

FIG. 4.

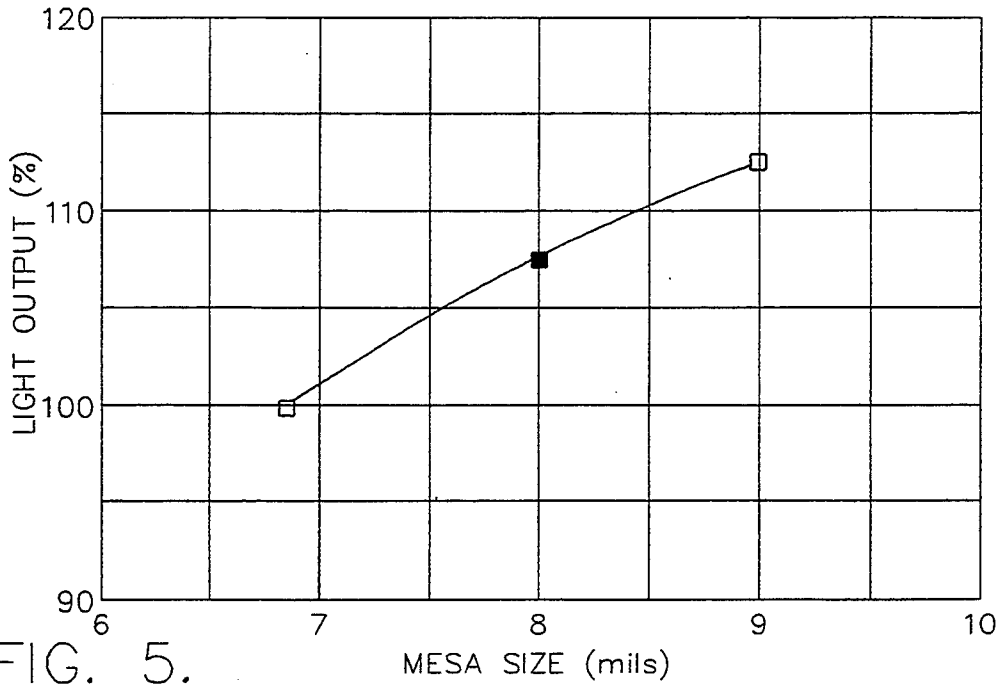

FIG. 5.

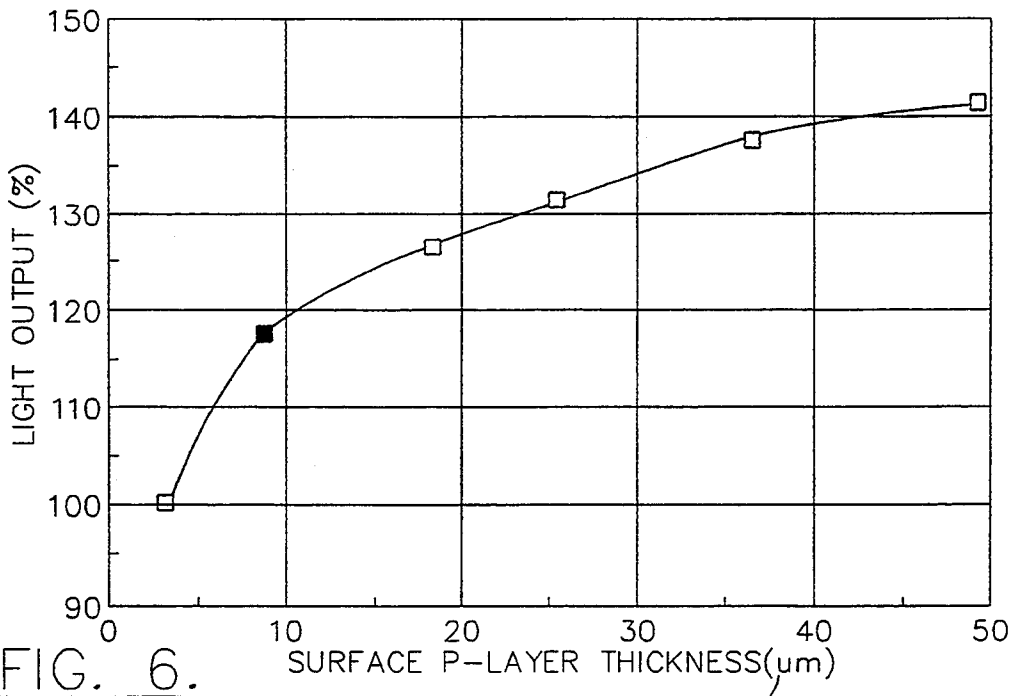

FIG. 6.

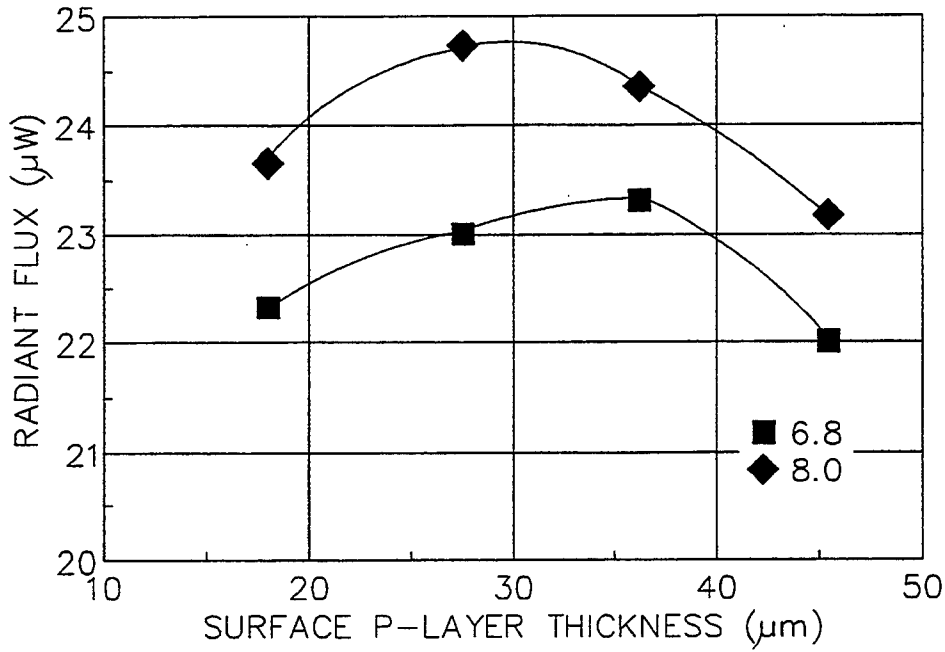

FIG. 7.

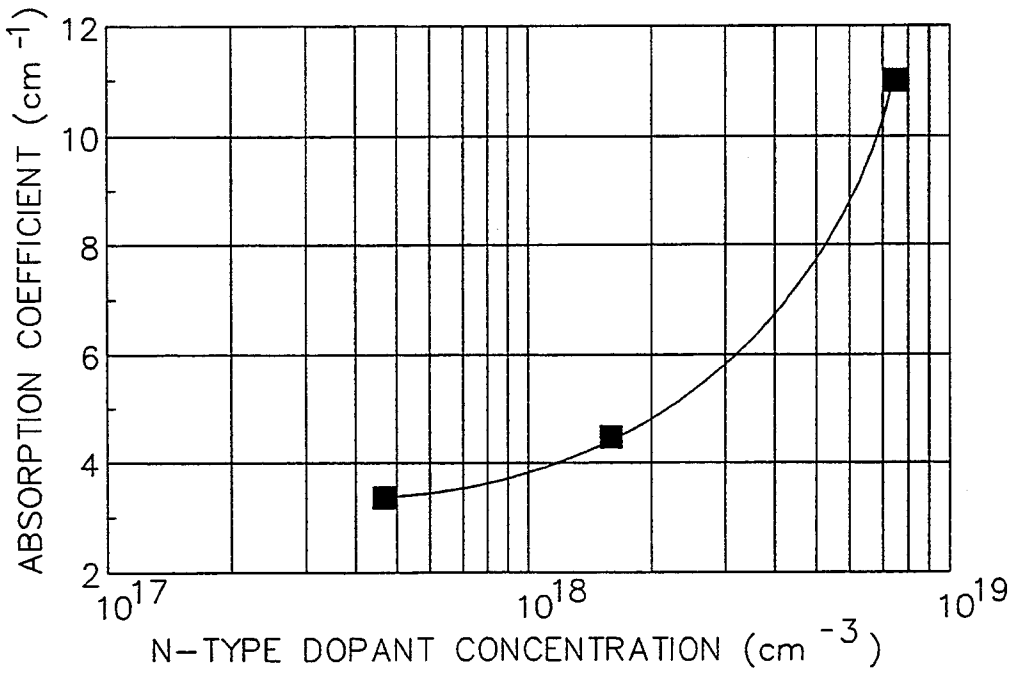

FIG. 8.

Explore Litigation Insights

Docket Alarm provides insights to develop a more informed litigation strategy and the peace of mind of knowing you're on top of things.

Real-Time Litigation Alerts



Keep your litigation team up-to-date with **real-time alerts** and advanced team management tools built for the enterprise, all while greatly reducing PACER spend.

Our comprehensive service means we can handle Federal, State, and Administrative courts across the country.

Advanced Docket Research



With over 230 million records, Docket Alarm's cloud-native docket research platform finds what other services can't. Coverage includes Federal, State, plus PTAB, TTAB, ITC and NLRB decisions, all in one place.

Identify arguments that have been successful in the past with full text, pinpoint searching. Link to case law cited within any court document via Fastcase.

Analytics At Your Fingertips



Learn what happened the last time a particular judge, opposing counsel or company faced cases similar to yours.

Advanced out-of-the-box PTAB and TTAB analytics are always at your fingertips.

API

Docket Alarm offers a powerful API (application programming interface) to developers that want to integrate case filings into their apps.

LAW FIRMS

Build custom dashboards for your attorneys and clients with live data direct from the court.

Automate many repetitive legal tasks like conflict checks, document management, and marketing.

FINANCIAL INSTITUTIONS

Litigation and bankruptcy checks for companies and debtors.

E-DISCOVERY AND LEGAL VENDORS

Sync your system to PACER to automate legal marketing.